

MARKS PUBLISHED FOR OPPOSITION

The following marks are published in compliance with section 12(a) of the Trademark Act of 1946. Applications for the registration of marks in more than one class have been filed as provided in section 30 of said act as amended by Public Law 772, 87th Congress, approved Oct. 9, 1962, 76 Stat. 769. Opposition under section 13 may be filed within thirty days of the date of this publication. See rules 2.101 to 2.105.

A separate fee of three hundred dollars (\$300.00) for opposing each mark in each class must accompany the opposition.

SECTION 1.— INTERNATIONAL CLASSIFICATION

The short titles associated below with the international class numbers are terms designed merely for quick identification and are not an official part of the international classification. The full names of international classes are given in section 6.1 of the trademark rules of practice.

The designation "U.S. Cl." appearing in this section refers to the U.S. class in effect prior to Sep. 1, 1973 rather than the international class which applies to applications filed on or after that date. For adoption of international classification see notice in the OFFICIAL GAZETTE of Jun. 26, 1973 (911 O.G. TM 210).

Application in more than one class

SN 76-695,781. BEST TIRES, LLC, LOUISVILLE, KY. FILED 2-11-2009.



NO CLAIM IS MADE TO THE EXCLUSIVE RIGHT TO USE "BEST TIRES", APART FROM THE MARK AS SHOWN.

THE COLOR(S) BLACK, WHITE, RED, AND SILVER IS/ARE CLAIMED AS A FEATURE OF THE MARK.

THE COLORS BLACK AND SILVER CHROME ARE CLAIMED AS A FEATURE OF THE MARK, THE TIRES ARE BLACK, THE TIRE RIMS AND DIAMOND PATTERN METAL PLATE ARE SILVER CHROME ON A WHITE BACKGROUND. THE WORDING "BEST TIRES" IS IN THE COLOR RED.

CLASS 35—ADVERTISING AND BUSINESS

FOR RETAIL STORE SERVICES IN THE FIELD OF TIRES (U.S. CLS. 100, 101 AND 102).

CLASS 37—CONSTRUCTION AND REPAIR

FOR VEHICLE MAINTENANCE SERVICES, NAMELY, REPAIR OF TIRES, TIRE ROTATION, TESTING OF BATTERIES, REPLACEMENT OF BATTERIES, REPAIR OF WHEELS, WHEEL ALIGNMENT, WINDSHIELD WIPER REPLACEMENT, LIGHT BULB REPLACEMENT, AIR FILTER REPLACEMENT, OIL FILTER REPLACEMENT AND OIL CHANGE USING OIL LUBRICANTS (U.S. CLS. 100, 103 AND 106).

JACQUELINE A. LAVINE, EXAMINING ATTORNEY

SN 76-704,051. SEXY SWEET FEET, LLC, LAS VEGAS, NV. FILED 8-9-2010.

SEXY SWEET FEET

THE MARK CONSISTS OF STANDARD CHARACTERS WITHOUT CLAIM TO ANY PARTICULAR FONT, STYLE, SIZE, OR COLOR.

CLASS 18—LEATHER GOODS

FOR SHOE TOTE BAGS (U.S. CLS. 1, 2, 3, 22 AND 41).

CLASS 25—CLOTHING

FOR SHOES (U.S. CLS. 22 AND 39).
LINDA ESTRADA, EXAMINING ATTORNEY

SN 76-704,052. SEXY SWEET FEET, LLC, LAS VEGAS, NV. FILED 8-9-2010.



THE COLOR(S) BLACK, WHITE AND PINK IS/ARE CLAIMED AS A FEATURE OF THE MARK.

THE MARK CONSISTS OF THE FOLLOWING: A LOGO FEATURING AN ANIMATED STYLE WOMAN STANDING STRAIGHT FORWARD; HOWEVER HER HEAD IS TURNED TO THE SIDE SEEING A PROFILE VIEW OF HER FACE. HER LEFT HAND IS ON HER HIP. HER RIGHT HAND IS HOLDING A BAG THAT CONTAINS A PAIR OF HEELS IN THE COLOR WHITE. HER HAIR IS LONG AND HAS CURLED ENDS. SHE IS WEARING A DRESS THAT IS ABOVE HER KNEES. SHE IS ALSO WEARING A PAIR OF FLAT SHOES. HER BODY, HAIR, AND THE SHOES SHE IS

HOLDING ARE LIGHT PINK. HER DRESS, BAG AND SHOES SHE IS WEARING ARE A DARKER PINK. THE WORDS "SEXY SWEET FEET" ALSO APPEAR IN THE LOGO. THE SECOND "E" IN "SWEET" HAS A PAIR OF BALLERINA STYLE SHOES HANGING DOWN FROM THE LETTER. THE WORDS SEXY AND FEET ARE IN PINK AND THE WORD SWEET IS IN WHITE. THE BALLERINA STYLE SHOES HANGING FROM THE WORD "SWEET" ARE PINK. THE ELEMENTS OF THE MARK ARE FEATURED AGAINST A BLACK SQUARE BACKGROUND.

CLASS 18—LEATHER GOODS

FOR SHOE TOTE BAGS (U.S. CLS. 1, 2, 3, 22 AND 41).

CLASS 25—CLOTHING

FOR SHOES (U.S. CLS. 22 AND 39).
LINDA ESTRADA, EXAMINING ATTORNEY

SN 76-704,155. ONEPOINT MOBILE SURVEYS INC, NEW YORK, NY. FILED 8-18-2010.



THE MARK CONSISTS OF THE LITERAL ELEMENT "ONEPOINT" REPRESENTED IN STYLIZED FONT, LOCATED BELOW A DESIGN ELEMENT CONSISTING OF THE LETTERS "O" AND "P" REPRESENTED IN STYLIZED FONT AND LINKED TOGETHER.

CLASS 9—ELECTRICAL AND SCIENTIFIC APPARATUS

FOR COMPUTER APPLICATION SOFTWARE FOR MOBILE PHONES, NAMELY, SOFTWARE FOR ENABLING THE CREATION OF MOBILE SURVEYS ONLINE THROUGH AN ONLINE BROWSER (U.S. CLS. 21, 23, 26, 36 AND 38).

FIRST USE 1-0-2009; IN COMMERCE 1-0-2009.

CLASS 42—SCIENTIFIC AND COMPUTER SERVICES

FOR PLATFORM AS A SERVICE (PAAS) FEATURING COMPUTER SOFTWARE PLATFORMS FOR ENABLING THE CREATION OF MOBILE SURVEYS ONLINE THROUGH AN ONLINE BROWSER AND COMPUTER SERVICES, ACTING AS AN APPLICATION SERVICE PROVIDER TO HOST COMPUTER APPLICATION SOFTWARE FOR CREATING SEARCHABLE DATABASES OF INFORMATION AND DATA TO ALLOW USERS TO PERFORM, ON-LINE, THE COLLECTING AND ANALYZING OF DIFFERENT TYPES OF OPINION SURVEYS (U.S. CLS. 100 AND 101).

FIRST USE 1-0-2009; IN COMMERCE 1-0-2009.
RONALD DELGIZZI, EXAMINING ATTORNEY

SN 76-704,212. APPLGATE FARM HOMEMADE ICE CREAM, INC., UPPER MONTCLAIR, NJ. FILED 8-23-2010.

APPLEGATE

THE MARK CONSISTS OF STANDARD CHARACTERS WITHOUT CLAIM TO ANY PARTICULAR FONT, STYLE, SIZE, OR COLOR.

OWNER OF U.S. REG. NOS. 1,988,083, 3,379,973 AND 3,379,974.

CLASS 30—STAPLE FOODS

FOR ICE CREAM, BAKED GOODS, NAMELY, PIES AND CAKES; COOKIES, BISCUITS AND CONFECTIONARIES, NAMELY, COOKIES AND CHOCOLATES (U.S. CL. 46).

CLASS 43—HOTEL AND RESTAURANT SERVICES

FOR RESTAURANT SERVICES (U.S. CLS. 100 AND 101).

INGA ERVIN, EXAMINING ATTORNEY

SN 76-704,213. APPLGATE FARM HOMEMADE ICE CREAM, INC., UPPER MONTCLAIR, NJ. FILED 8-23-2010.

APPLEGATE ICE CREAM

THE MARK CONSISTS OF STANDARD CHARACTERS WITHOUT CLAIM TO ANY PARTICULAR FONT, STYLE, SIZE, OR COLOR.

OWNER OF U.S. REG. NOS. 1,988,083, 3,379,973 AND 3,379,974.

NO CLAIM IS MADE TO THE EXCLUSIVE RIGHT TO USE "ICE CREAM", APART FROM THE MARK AS SHOWN.

CLASS 30—STAPLE FOODS

FOR ICE CREAM, BAKED GOODS, NAMELY, PIES AND CAKES; COOKIES, BISCUITS AND CONFECTIONARIES, NAMELY, COOKIES AND CHOCOLATES (U.S. CL. 46).

CLASS 43—HOTEL AND RESTAURANT SERVICES

FOR RESTAURANT SERVICES (U.S. CLS. 100 AND 101).

INGA ERVIN, EXAMINING ATTORNEY

SN 76-704,451. TASTY COCKTAILS, LLC, HENDERSON, NV. FILED 9-13-2010.

STRAWBERRY BUTTERFLY

THE MARK CONSISTS OF STANDARD CHARACTERS WITHOUT CLAIM TO ANY PARTICULAR FONT, STYLE, SIZE, OR COLOR.

NO CLAIM IS MADE TO THE EXCLUSIVE RIGHT TO USE "STRAWBERRY", APART FROM THE MARK AS SHOWN.

CLASS 32—LIGHT BEVERAGES

FOR DRINKS, NAMELY, FRUIT JUICES, FRUIT DRINKS, NON-ALCOHOLIC HONEY-BASED BEVERAGES, NON-ALCOHOLIC MALT BEVERAGES, BEER, SMOOTHIES AND FRUIT FLAVORED BEVERAGES (U.S. CLS. 45, 46 AND 48).

CLASS 33—WINES AND SPIRITS

FOR DRINKS, NAMELY, ALCOHOLIC BEVERAGES CONTAINING FRUIT, WINE, RUM, FLAVOR INFUSED WHISKEY, WINE COOLERS, DISTILLED SPIRITS AND FLAVORED BREWED MALT BEVERAGES (U.S. CLS. 47 AND 49).

JEFFREY LOOK, EXAMINING ATTORNEY

SN 76-704,454. TASTY COCKTAILS, LLC, HENDERSON, NV. FILED 9-13-2010.

UP ALL NIGHT

THE MARK CONSISTS OF STANDARD CHARACTERS WITHOUT CLAIM TO ANY PARTICULAR FONT, STYLE, SIZE, OR COLOR.

CLASS 32—LIGHT BEVERAGES

FOR DRINKS, NAMELY, FRUIT JUICES, FRUIT DRINKS, NON-ALCOHOLIC HONEY-BASED BEVERAGES, NON-ALCOHOLIC MALT BEVERAGES, BEER, SMOOTHIES AND FRUIT FLAVORED BEVERAGES (U.S. CLS. 45, 46 AND 48).

CLASS 33—WINES AND SPIRITS

FOR DRINKS, NAMELY, ALCOHOLIC BEVERAGES CONTAINING FRUIT, WINE, RUM, FLAVOR INFUSED WHISKEY, WINE COOLERS, DISTILLED SPIRITS AND FLAVORED BREWED MALT BEVERAGES (U.S. CLS. 47 AND 49).

JEFFREY LOOK, EXAMINING ATTORNEY

SN 76-704,456. TASTY COCKTAILS, LLC, HENDERSON, NV. FILED 9-13-2010.

MANGO KUSH

THE MARK CONSISTS OF STANDARD CHARACTERS WITHOUT CLAIM TO ANY PARTICULAR FONT, STYLE, SIZE, OR COLOR.

NO CLAIM IS MADE TO THE EXCLUSIVE RIGHT TO USE "MANGO", APART FROM THE MARK AS SHOWN.

CLASS 32—LIGHT BEVERAGES

FOR DRINKS, NAMELY, FRUIT JUICES, FRUIT DRINKS, NON-ALCOHOLIC HONEY-BASED BEVERAGES, NON-ALCOHOLIC MALT BEVERAGES, BEER, SMOOTHIES AND FRUIT FLAVORED BEVERAGES (U.S. CLS. 45, 46 AND 48).

CLASS 33—WINES AND SPIRITS

FOR DRINKS, NAMELY, ALCOHOLIC BEVERAGES CONTAINING FRUIT, WINE, RUM, FLAVOR INFUSED WHISKEY, WINE COOLERS, DISTILLED SPIRITS AND FLAVORED BREWED MALT BEVERAGES (U.S. CLS. 47 AND 49).

JEFFREY LOOK, EXAMINING ATTORNEY

SN 76-705,739. EYES WIDE OPEN (EWO) CORPORATION, ENCINO, CA. FILED 12-20-2010.

PAWGGLES

THE MARK CONSISTS OF STANDARD CHARACTERS WITHOUT CLAIM TO ANY PARTICULAR FONT, STYLE, SIZE, OR COLOR.

CLASS 25—CLOTHING

FOR SHIRTS, PANTS, DRESSES, SKIRTS, SHORTS, SOCKS, JACKETS, AND SLIPPER SOCKS (U.S. CLS. 22 AND 39).

CLASS 28—TOYS AND SPORTING GOODS

FOR PUPPETS; STUFFED AND PLUSH TOYS; TOY FIGURES; BENDABLE TOYS; CHILDREN'S MULTIPLE ACTIVITY TOYS; AND INFANT TOYS (U.S. CLS. 22, 23, 38 AND 50).

RAUL CORDOVA, EXAMINING ATTORNEY

SN 76-705,822. MEDITERRANEA ITALIA SRL, 00197 ROME, ITALY, FILED 12-28-2010.



THE MARK CONSISTS OF THE STYLIZED WORDING "FORTUNA", APPEARING BELOW THE REPRESENTATION OF A PANELED HERALDIC SHIELD WITH A CROWN, WITH SUNBURST DESIGNS APPEARING IN THE UPPER-LEFT AND LOWER-RIGHT QUADRANTS OF THE SHIELD AND WITH STYLIZED, TWISTED RIBBON DESIGNS APPEARING IN THE TOP-RIGHT AND LOWER-LEFT QUADRANTS OF THE SHIELD.

THE ENGLISH TRANSLATION OF "FORTUNA" IS "FORTUNE".

CLASS 29—MEATS AND PROCESSED FOODS

FOR PRESERVED, DRIED AND COOKED FRUITS AND VEGETABLES; OLIVE OIL; LEGUMES, NAMELY, PROCESSED, CANNED, PRESERVED, DRIED AND COOKED BEANS, PEANUTS, PEAS, LENTILS AND ALFALFA (U.S. CL. 46).

FIRST USE 9-22-1993; IN COMMERCE 9-22-1993.

CLASS 30—STAPLE FOODS

FOR VINEGAR (U.S. CL. 46).

FIRST USE 9-22-1993; IN COMMERCE 9-22-1993.
KEVIN CORWIN, EXAMINING ATTORNEY

SN 76-706,243. CARDENAS MARKETS, INC., ONTARIO, CA.
FILED 2-2-2011.

CASA CARDENAS

THE MARK CONSISTS OF STANDARD CHARACTERS WITHOUT CLAIM TO ANY PARTICULAR FONT, STYLE, SIZE, OR COLOR.

OWNER OF U.S. REG. NOS. 3,649,112, 3,694,472 AND OTHERS.

THE ENGLISH TRANSLATION OF "CASA CARDENAS" IS "HOUSE OF CARDENAS".

CLASS 3—COSMETICS AND CLEANING PREPARATIONS

FOR HOUSEMARK FOR A FULL LINE OF CLEANING PRODUCTS, NAMELY, CONCENTRATED LAUNDRY DETERGENT, DISH SOAP AND DISHWASHING DETERGENT (U.S. CLS. 1, 4, 6, 50, 51 AND 52).

CLASS 16—PAPER GOODS AND PRINTED MATTER

FOR HOUSEMARK FOR A FULL LINE OF BATHROOM TISSUE, FACIAL TISSUE, PAPER TOWELS, PAPER NAPKINS, AND PAPER TABLE CLOTHS (U.S. CLS. 2, 5, 22, 23, 29, 37, 38 AND 50).

CLASS 29—MEATS AND PROCESSED FOODS

FOR HOUSEMARK FOR A FULL LINE OF PREPARED FOODS, NAMELY, FROZEN AND NON-FROZEN ENTREES, SIDE DISHES AND APPETIZERS CONSISTING PRIMARILY OF CHEESE, MEAT, POULTRY, FISH AND/OR VEGETABLES, FROZEN PACKAGED ENTREES AND MEALS CONSISTING PRIMARILY OF MEAT, FISH, POULTRY OR VEGETABLES; FRUIT PRESERVES; CANNED PROCESSED TOMATOES, TOMATO PASTES, CANNED PROCESSED OLIVES AND VEGETABLES; OLIVE OIL, BACON; CANNED TUNA; FROZEN PACKAGED CHICKEN, FROZEN PACKAGED BEEF; FROZEN PACKAGED PORK ENTREES CONSISTING PRIMARILY OF PORK WITH PASTA OR RICE; FRUIT JAMS (U.S. CL. 46).

CLASS 30—STAPLE FOODS

FOR HOUSEMARK FOR A FULL LINE OF FROZEN, PREPARED OR PACKAGED MEALS CONSISTING PRIMARILY OF PASTA OR RICE; PASTA; FROZEN CONFECTIONS; FROZEN YOGURT, ICE CREAM; MACARONI AND CHEESE; MIXES FOR BAKERY GOODS; NOODLES, SAUCE, AND SEASONING TOPPINGS COMBINED IN UNITARY PACKAGES; FROZEN PIZZAS; SALAD DRESSINGS; SOY SAUCE, SALSA, HOT SAUCE, TACO SAUCE, SEASONING AND COOKING SAUCES; SAUCES; COOKIES; CRACKERS; COFFEE; TEA, COCOA MIX; FRUIT FLAVORING SYRUP, RICE MIXES; CROUTONS, COOKIE MIX, DOUGH; RAVIOLI, FROZEN PIZZA, MARINADES, VINEGAR, SALAD DRESSING, PROCESSED CEREALS, CANDY, TORTILLA CHIPS (U.S. CL. 46).

CLASS 32—LIGHT BEVERAGES

FOR HOUSEMARK FOR A FULL LINE OF SOFT DRINKS (U.S. CLS. 45, 46 AND 48).

CLASS 33—WINES AND SPIRITS

FOR HOUSEMARK FOR A FULL LINE OF ALCOHOLIC BEVERAGES, NAMELY, TEQUILA AND PREPARED ALCOHOLIC COCKTAILS (U.S. CLS. 47 AND 49).

LESLIE RICHARDS, EXAMINING ATTORNEY

SN 76-706,655. APPLICATION SALES CORP., NAPLES, FL.
FILED 3-7-2011.

POWERCAM

THE MARK CONSISTS OF STANDARD CHARACTERS WITHOUT CLAIM TO ANY PARTICULAR FONT, STYLE, SIZE, OR COLOR.

CLASS 6—METAL GOODS

FOR MANUALLY OPERATED INDUSTRIAL METAL VALVES, NAMELY, BUTTERFLY ISOLATION DAMPER VALVES FOR PRESSURE CONTROL, POLLUTION CONTROL, TIGHT SHUT-OFF, HIGH TEMPERATURE REFRACTORY AND SPECIALTY APPLICATIONS (U.S. CLS. 2, 12, 13, 14, 23, 25 AND 50).

FIRST USE 10-3-1991; IN COMMERCE 3-23-1992.

CLASS 7—MACHINERY

FOR VALVES BEING PART OF INDUSTRIAL MACHINES, NAMELY, ELECTRIC OR PNEUMATIC BUTTERFLY ISOLATION DAMPER VALVES FOR PRESSURE CONTROL, POLLUTION CONTROL, TIGHT SHUT-OFF, HIGH TEMPERATURE REFRACTORY AND SPECIALTY APPLICATIONS (U.S. CLS. 13, 19, 21, 23, 31, 34 AND 35).

FIRST USE 10-3-1991; IN COMMERCE 3-23-1992.

ELLEN PERKINS, EXAMINING ATTORNEY

SN 76-706,682. SPECIALTY METRICS, LLC, MAITLAND, FL.
FILED 3-8-2011.

SPECIALTY METRICS

THE MARK CONSISTS OF STANDARD CHARACTERS WITHOUT CLAIM TO ANY PARTICULAR FONT, STYLE, SIZE, OR COLOR.

CLASS 35—ADVERTISING AND BUSINESS

FOR MEDICAL COST MANAGEMENT SERVICES (U.S. CLS. 100, 101 AND 102).

FIRST USE 1-1-2011; IN COMMERCE 1-1-2011.

CLASS 45—PERSONAL AND LEGAL SERVICES

FOR REGULATORY COMPLIANCE CONSULTING IN THE FIELD OF MEDICARE (U.S. CLS. 100 AND 101).

FIRST USE 1-1-2011; IN COMMERCE 1-1-2011.

INGA ERVIN, EXAMINING ATTORNEY

SN 76-706,700. INTER-CORUS AG, CH-6330 CHAM, SWITZERLAND, FILED 3-8-2011.

YOGAKITCHEN

THE MARK CONSISTS OF STANDARD CHARACTERS WITHOUT CLAIM TO ANY PARTICULAR FONT, STYLE, SIZE, OR COLOR.

CLASS 16—PAPER GOODS AND PRINTED MATTER

FOR COOK BOOKS (U.S. CLS. 2, 5, 22, 23, 29, 37, 38 AND 50).

CLASS 30—STAPLE FOODS

FOR BLENDS OF SPICES (U.S. CL. 46).

CLASS 41—EDUCATION AND ENTERTAINMENT

FOR EDUCATIONAL CLASSES, NAMELY, COOKING COURSES (U.S. CLS. 100, 101 AND 107).
DORITT L. CARROLL, EXAMINING ATTORNEY

SN 76-707,410. GONZALEZ AND TAPANES FOODS, INC., MOONACHIE, NJ. FILED 4-26-2011.

BLUE ROCK

THE MARK CONSISTS OF STANDARD CHARACTERS WITHOUT CLAIM TO ANY PARTICULAR FONT, STYLE, SIZE, OR COLOR.
OWNER OF U.S. REG. NOS. 2,209,170 AND 2,453,757.

CLASS 4—LUBRICANTS AND FUELS

FOR CANDLES (U.S. CLS. 1, 6 AND 15).
FIRST USE 0-0-1998; IN COMMERCE 0-0-1998.

CLASS 29—MEATS AND PROCESSED FOODS

FOR FROZEN VEGETABLES; SALAMI; BACALAO, BEING PRESERVED FISH (U.S. CL. 46).
FIRST USE 0-0-1998; IN COMMERCE 0-0-1998.
JAMES MACFARLANE, EXAMINING ATTORNEY

SN 76-706,701. INTER-CORUS AG, CH-6330 CHAM, SWITZERLAND, FILED 3-8-2011.

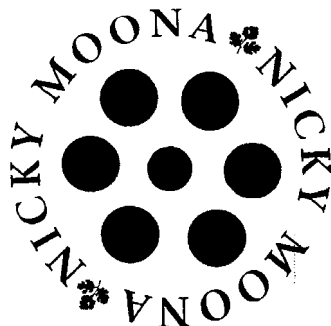

THE NAME "NICKY MOONA" DOES NOT IDENTIFY A LIVING INDIVIDUAL.

THE MARK CONSISTS OF THE WORDING "NICKY MOONA" SURROUNDING SIX CIRCLES AND SEPARATED BY CLUSTERS OF LEAVES.

CLASS 16—PAPER GOODS AND PRINTED MATTER

FOR COOK BOOKS (U.S. CLS. 2, 5, 22, 23, 29, 37, 38 AND 50).

CLASS 30—STAPLE FOODS

FOR BLENDS OF SPICES (U.S. CL. 46).

CLASS 41—EDUCATION AND ENTERTAINMENT

FOR EDUCATIONAL CLASSES, NAMELY, COOKING COURSES (U.S. CLS. 100, 101 AND 107).
DORITT L. CARROLL, EXAMINING ATTORNEY

SN 77-083,813. NATURA WORLD INC., CAMBRIDGE, ONTARIO, FILED 1-16-2007.

NATURA

THE MARK CONSISTS OF STANDARD CHARACTERS WITHOUT CLAIM TO ANY PARTICULAR FONT, STYLE, SIZE, OR COLOR.

PRIORITY CLAIMED UNDER SEC. 44(D) ON CANADA APPLICATION NO. 1330757, FILED 1-9-2007, REG. NO. TMA744,132, DATED 7-28-2009, EXPIRES 7-28-2024.

"NATURA" IS TRANSLATED INTO ENGLISH AS "NATURE".

CLASS 30—STAPLE FOODS

FOR BEVERAGES, NAMELY, COFFEE, TEA AND HOT CHOCOLATE (U.S. CL. 46).

CLASS 32—LIGHT BEVERAGES

FOR NON-ALCOHOLIC BEVERAGES, NAMELY, CARBONATED BEVERAGES, COFFEE-FLAVORED SOFT DRINKS, COLAS; DRINKING WATER; FRUIT-BASED SOFT DRINKS FLAVORED WITH TEA; FRUIT JUICES; SPORTS DRINKS (U.S. CLS. 45, 46 AND 48).
JOHN LINCOSKI, EXAMINING ATTORNEY

SN 77-206,744. JUN JI, ONTARIO, CA. FILED 6-14-2007.

LINDA ESTRADA, EXAMINING ATTORNEY

BLACK JACK

THE MARK CONSISTS OF STANDARD CHARACTERS WITHOUT CLAIM TO ANY PARTICULAR FONT, STYLE, SIZE, OR COLOR.

OWNER OF U.S. REG. NO. 2,840,647.

NO CLAIM IS MADE TO THE EXCLUSIVE RIGHT TO USE "JACK", APART FROM THE MARK AS SHOWN.

CLASS 7—MACHINERY

FOR HYDRAULIC JACKS, ENGINE HOISTS, INDUSTRIAL PRESS MACHINES, JACK STANDS, NAMELY, STANDS FOR MAINTAINING A VEHICLE IN A RAISED POSITION AFTER IT HAS BEEN LIFTED BY A HYDRAULIC JACK (U.S. CLS. 13, 19, 21, 23, 31, 34 AND 35).
FIRST USE 12-1-2003; IN COMMERCE 12-1-2003.

CLASS 8—HAND TOOLS

FOR MANUALLY OPERATED SCISSOR JACKS AND JACK STANDS, NAMELY, DEVICES FOR MAINTAINING A VEHICLE IN A RAISED POSITION AFTER IT HAS BEEN LIFTED BY A HAND JACK (U.S. CLS. 23, 28 AND 44).

FIRST USE 12-1-2003; IN COMMERCE 12-1-2003.
GIANCARLO CASTRO, EXAMINING ATTORNEY

SN 77-229,111. JUMPTV INC., TORONTO, CANADA, FILED 7-13-2007.

JUMPER

THE MARK CONSISTS OF STANDARD CHARACTERS WITHOUT CLAIM TO ANY PARTICULAR FONT, STYLE, SIZE, OR COLOR.

CLASS 9—ELECTRICAL AND SCIENTIFIC APPARATUS

FOR COMPUTER SOFTWARE FOR PLAYING VIDEO AND AUDIO CONTENT OVER THE INTERNET, BUT EXCLUDING COMPUTER SOFTWARE FOR PLAYING MOTION PICTURE FILMS OVER THE INTERNET (U.S. CLS. 21, 23, 26, 36 AND 38).

CLASS 38—COMMUNICATION

FOR STREAMING OF AUDIO AND VIDEO MATERIAL OVER THE INTERNET, BUT EXCLUDING STREAMING OF MOTION PICTURE FILMS OVER THE INTERNET (U.S. CLS. 100, 101 AND 104).

CLASS 42—SCIENTIFIC AND COMPUTER SERVICES

FOR PROVIDING TEMPORARY USE OF NON-DOWNLOADABLE COMPUTER SOFTWARE FOR PLAYING EDUCATIONAL AND ENTERTAINMENT CONTENT VIA THE INTERNET, BUT EXCLUDING PROVIDING USE OF COMPUTER SOFTWARE FOR PLAYING MOTION PICTURE FILMS OVER THE INTERNET (U.S. CLS. 100 AND 101).

SN 77-230,488. BASS PRO INTELLECTUAL PROPERTY, L.L.C, SPRINGFIELD, MO. FILED 7-16-2007.

HOBBS CREEK

THE MARK CONSISTS OF STANDARD CHARACTERS WITHOUT CLAIM TO ANY PARTICULAR FONT, STYLE, SIZE, OR COLOR.

CLASS 25—CLOTHING

FOR FISHING WADERS AND FISHING VESTS (U.S. CLS. 22 AND 39).

FIRST USE 0-0-1992; IN COMMERCE 0-0-1992.

CLASS 28—TOYS AND SPORTING GOODS

FOR FISHING RODS, FISHING REELS, COMBINATION FISHING RODS AND REELS, AND FISHING LINE (U.S. CLS. 22, 23, 38 AND 50).

FIRST USE 0-0-1992; IN COMMERCE 0-0-1992.
COLLEEN DOMBROW, EXAMINING ATTORNEY

SN 77-251,547. SUNDANCE REHABILITATION CORPORATION, IRVINE, CA. FILED 8-9-2007.

Pathways to Wellness

THE MARK CONSISTS OF STANDARD CHARACTERS WITHOUT CLAIM TO ANY PARTICULAR FONT, STYLE, SIZE, OR COLOR.

NO CLAIM IS MADE TO THE EXCLUSIVE RIGHT TO USE "WELLNESS", APART FROM THE MARK AS SHOWN.

CLASS 41—EDUCATION AND ENTERTAINMENT

FOR COMPREHENSIVE THERAPEUTIC SERVICES, NAMELY, INDIVIDUAL PHYSICAL FITNESS TRAINING (U.S. CLS. 100, 101 AND 107).

FIRST USE 11-1-2002; IN COMMERCE 11-1-2002.

CLASS 44—MEDICAL, BEAUTY AND AGRICULTURAL SERVICES

FOR SPECIALIZED PHYSICAL WELLNESS REHABILITATION FEATURING EXERCISE AND PHYSICAL, OCCUPATIONAL, SPEECH THERAPY FOR OLDER ADULTS (U.S. CLS. 100 AND 101).

FIRST USE 11-1-2002; IN COMMERCE 11-1-2002.
MICHELE SWAIN, EXAMINING ATTORNEY

SN 77-274,743. JENAVALVE TECHNOLOGY GMBH, MUNICH, FED REP GERMANY, FILED 9-7-2007.

JenaValve

THE MARK CONSISTS OF STANDARD CHARACTERS WITHOUT CLAIM TO ANY PARTICULAR FONT, STYLE, SIZE, OR COLOR.

PRIORITY CLAIMED UNDER SEC. 44(D) ON ERPNTY TM OFC APPLICATION NO. 006254081, FILED 9-7-2007, REG. NO. 006254081, DATED 5-27-2009, EXPIRES 9-7-2017.

PRIORITY CLAIMED UNDER SEC. 44(D) ON FED REP GERMANY APPLICATION NO. 30715774.1/1, FILED 3-8-2007, REG. NO. 30715774, DATED 7-12-2007, EXPIRES 3-31-2017.

CLASS 5—PHARMACEUTICALS

FOR NATURAL AND BIOLOGIC VALVES FOR USE IN THE REPAIR OF CARDIAC DEFECTS (U.S. CLS. 6, 18, 44, 46, 51 AND 52).

CLASS 6—METAL GOODS

FOR PACKAGING FOR MEDICAL AND VETERINARY APPARATUS, NAMELY, PACKAGING MADE FROM METALLIC FOIL (U.S. CLS. 2, 12, 13, 14, 23, 25 AND 50).

CLASS 10—MEDICAL APPARATUS

FOR CARDIAC APPARATUS AND INSTRUMENTS, NAMELY, STENT AND STENTED VALVE LOADING UNITS, AND PARTS AND FITTINGS THEREFOR; STENT AND STENTED VALVE RETRIEVAL UNITS, AND PARTS AND FITTINGS THEREFOR; ARTIFICIAL VALVES AND ARTIFICIAL CARDIAC VALVES FOR USE IN THE REPAIR OF CARDIAC DEFECTS, AND PARTS AND FITTINGS THEREFOR; STENTS AND PARTS AND FITTINGS THEREFOR; ARTIFICIAL STENTS AND PARTS AND FITTINGS THEREFOR; CARDIAC STENTS AND PARTS AND FITTINGS THEREFOR; MEDICAL AND VETERINARY APPARATUS FOR USE IN CARDIAC VALVE REPLACEMENT PROCEDURES AND PARTS AND FITTINGS THEREFOR; MEDICAL AND VETERINARY APPARATUS FOR USE IN AORTIC VALVE REPAIR AND REPLACEMENT PROCEDURES AND PARTS AND FITTINGS THEREFOR; AORTIC VALVE REPLACEMENT STENTS AND PARTS AND FITTINGS THEREFOR; CATHETERS, BALLOON CATHETERS, PIGTAIL CATHETERS AND PARTS AND FITTINGS THEREFOR; CATHETER GUIDANCE SYSTEMS, NAMELY, GUIDE WIRES FOR CATHETERS AND PIGTAIL CATHETERS, AND PARTS AND FITTINGS THEREFOR; FLEXIBLE AND NON-FLEXIBLE TIPS AND TIP ENDS FOR CATHETER DELIVERY SYSTEMS, AND PARTS AND FITTINGS THEREFOR; TIPS AND TIP ENDS FOR CATHETER DELIVERY SYSTEMS COMPRISING OF ONE OR MORE OF A STENT, VALVE, BALLOON, STENT RETAINING MECHANISM, STENT RELEASE MECHANISM, AND COOLANT, AND PARTS AND FITTINGS THEREFOR; CATHETER HANDLES COMPRISING OF MULTIPLE PARTS FOR CATHETER APPARATUS, AND PARTS AND FITTINGS THEREFOR; FLEXIBLE AND NON-FLEXIBLE CARTRIDGES FOR CATHETER DELIVERY SYSTEMS, AND PARTS AND FITTINGS THEREFOR; CARTRIDGES FOR CATHETER DELIVERY SYSTEMS COMPRISING OF ONE OR MORE OF A STENT, VALVE, BALLOON, STENT RETAINING MECHANISM, STENT RELEASE MECHANISM, AND COOLANT, AND PARTS AND FITTINGS THEREFOR; AND STRUCTURAL PARTS FOR ALL OF THE FOREGOING GOODS (U.S. CLS. 26, 39 AND 44).

CLASS 16—PAPER GOODS AND PRINTED MATTER

FOR PRINTED MATTER, NAMELY, PROMOTIONAL LITERATURE AND BROCHURES RELATING TO MEDICAL AND VETERINARY APPARATUS AND PROCEDURES; MEDICAL AND VETERINARY PUBLICATIONS, NAMELY, PRINT PRESENTATIONS, MEDICAL JOURNALS AND VETERINARY JOURNALS AND A SERIES OF ARTICLES THEREFOR; PRINTED PERIODICALS RELATING TO MEDICAL AND VETERINARY APPARATUS AND PROCEDURES, AND A SERIES OF ARTICLES THEREFOR; PACKAGING FOR MEDICAL AND VETERINARY APPARATUS, NAMELY, PACKAGING MADE FROM PAPER AND CARDBOARD; PRINTED MATTER FOR USE WITH MEDICAL AND VETERINARY APPARATUS, NAMELY, INSTRUCTIONAL LEAFLETS AND INFORMATION SHEETS, AND BROCHURES (U.S. CLS. 2, 5, 22, 23, 29, 37, 38 AND 50).

CLASS 41—EDUCATION AND ENTERTAINMENT

FOR PROVIDING ONLINE NON-DOWNLOADABLE MEDICAL AND VETERINARY EDUCATIONAL PRESENTATIONS (U.S. CLS. 100, 101 AND 107).

CLASS 44—MEDICAL, BEAUTY AND AGRICULTURAL SERVICES

FOR MEDICAL SERVICES; VETERINARY SERVICES; MEDICAL AND VETERINARY DIAGNOSIS AND TREATMENT; PROVIDING MEDICAL AND VETERINARY INFORMATION, NAMELY, MEDICAL AND VETERINARY INFORMATION REGARDING MEDICAL AND VETERINARY PROCEDURES; PROVIDING MEDICAL AND VETERINARY INFORMATION, NAMELY, MEDICAL AND VETERINARY INFORMATION REGARDING CARDIAC PROCEDURES; PROVIDING INFORMATION, NAMELY, MEDICAL AND VETERINARY INFORMATION REGARDING SURGICAL PROCEDURES; MEDICAL AND VETERINARY SERVICES REGARDING DIAGNOSIS AND TREATMENT FOR REPLACEMENT OF CARDIAC VALVES; CONDUCTING SURGICAL PROCEDURES, NAMELY, CARDIAC VALVE REPLACEMENT SURGERY; PROVISION OF INFORMATION RELATING TO SUTURING; MEDICAL AND VETERINARY SUTURING SERVICES (U.S. CLS. 100 AND 101).

TRACY CROSS, EXAMINING ATTORNEY

SN 77-344,893. VIBRANT HEALTH PRODUCTS, INC., DBA SILVER HILLS BAKERY, ABBOTSFORD, CANADA, FILED 12-5-2007.

THE WHOLE TRUTH

THE MARK CONSISTS OF STANDARD CHARACTERS WITHOUT CLAIM TO ANY PARTICULAR FONT, STYLE, SIZE, OR COLOR.

PRIORITY CLAIMED UNDER SEC. 44(D) ON CANADA APPLICATION NO. 1,374,286, FILED 11-30-2007, REG. NO. TMA797,475, DATED 5-13-2011, EXPIRES 5-13-2026.

CLASS 30—STAPLE FOODS

FOR BAKERY PRODUCTS, NAMELY, BREAD AND BAGELS (U.S. CL. 46).

CLASS 35—ADVERTISING AND BUSINESS

FOR WHOLESALE DISTRIBUTORSHIPS DEALING IN BAKERY PRODUCTS (U.S. CLS. 100, 101 AND 102).

LINDSEY RUBIN, EXAMINING ATTORNEY

SN 77-373,177. ASB MANUFACTURING INC., SWIFT CURRENT, CANADA, FILED 1-16-2008.

SN 77-353,147. 5 STAR UNIVERSE, INC., LAGUNA NIGUEL, CA. FILED 12-15-2007.



THE MARK CONSISTS OF A FIVE POINT STYLIZED STAR WITH THE OUTLINE OF THE NUMBER "5" INTEGRATED INTO THE DESIGN.

CLASS 16—PAPER GOODS AND PRINTED MATTER

FOR PHOTO STORAGE BOXES; PAPER GIFT BAGS; FABRIC GIFT BAGS; PLACE CARDS; PRINTED NOVELTY WINE LABELS (U.S. CLS. 2, 5, 22, 23, 29, 37, 38 AND 50).

FIRST USE 8-24-2007; IN COMMERCE 8-24-2007.

CLASS 25—CLOTHING

FOR WEARING APPAREL, NAMELY, SHIRTS, INCLUDING T-SHIRTS, HALTER AND TANK TOPS, KNIT SHIRTS; JACKETS; COATS; JEANS; PANTS; NECKTIES; NECKWEAR; WRISTBANDS; ATHLETIC FOOTWEAR; ATHLETIC SHOES; BOOTIES; BOOTS; SHOES; SANDALS; FLIP FLOPS; SCHOOL AND ATHLETIC UNIFORMS; BATHING SUITS; BATHING TRUNKS; BOARD SHORTS; RASH GUARDS; HATS, CAPS; SUN VISORS; HEAD BANDS; BOXER SHORTS; BRIEFS; SOCKS; GLOVES; MITTENS; BODY SUITS; PAJAMAS; INFANT WEAR; CHILDREN'S AND INFANTS' CLOTH BIBS; PLAY SUITS; BELTS; UNDERGARMENTS (U.S. CLS. 22 AND 39).

FIRST USE 8-24-2007; IN COMMERCE 8-24-2007.

CLASS 35—ADVERTISING AND BUSINESS

FOR PROMOTING THE GOODS AND SERVICES OF OTHERS VIA A GLOBAL COMPUTER NETWORK; COMPUTERIZED ON-LINE ORDERING FEATURING GENERAL MERCHANDISE AND GENERAL CONSUMER GOODS; CONSUMER RESEARCH; ON-LINE ADVERTISING ON COMPUTER COMMUNICATION NETWORKS; PROVIDING ON-LINE DIRECTORY INFORMATION SERVICES ALSO FEATURING HYPERLINKS TO OTHER WEB SITES (U.S. CLS. 100, 101 AND 102).

FIRST USE 8-24-2007; IN COMMERCE 8-24-2007.
AISHA SALEM, EXAMINING ATTORNEY



PRIORITY CLAIMED UNDER SEC. 44(D) ON CANADA APPLICATION NO. 1375564, FILED 12-11-2007, REG. NO. TMA786284, DATED 1-4-2011, EXPIRES 1-4-2026.

NO CLAIM IS MADE TO THE EXCLUSIVE RIGHT TO USE "CONE CADDY" AND "WWW.CONECADDY.COM", APART FROM THE MARK AS SHOWN.

THE MARK CONSISTS OF THE IMAGE OF A CONE, ALONG WITH THE WORDING "CONE CADDY WWW.CONECADDY.COM" WITH THE BACKGROUND OF AN OVAL SHAPE.

CLASS 8—HAND TOOLS

FOR HAND-OPERATED DEVICES FOR PICKING UP AND DROPPING MARKER PYLONS AND TRAFFIC CONES (U.S. CLS. 23, 28 AND 44).

CLASS 9—ELECTRICAL AND SCIENTIFIC APPARATUS

FOR SAFETY MARKERS, NAMELY, PYLONS; TRAFFIC SAFETY CONES (U.S. CLS. 21, 23, 26, 36 AND 38).

CLASS 28—TOYS AND SPORTING GOODS

FOR SPORTING GOODS, NAMELY, PYLONS FOR MAKING GOAL AND REGULATION LINES IN INDOOR AND OUTDOOR PLAYING FIELDS (U.S. CLS. 22, 23, 38 AND 50).

KATHY DE JONGE, EXAMINING ATTORNEY

SN 77-377,959. ZERO MOTORCYCLES, INC., SCOTTS VALLEY, CA. FILED 1-22-2008.

ZENERGY

THE MARK CONSISTS OF STANDARD CHARACTERS WITHOUT CLAIM TO ANY PARTICULAR FONT, STYLE, SIZE, OR COLOR.

CLASS 9—ELECTRICAL AND SCIENTIFIC APPARATUS

FOR BATTERIES, ELECTRIC, FOR VEHICLES; BATTERIES FOR VEHICLES (U.S. CLS. 21, 23, 26, 36 AND 38).

CLASS 12—VEHICLES

FOR ELECTRIC VEHICLES, NAMELY, MOTORCYCLES; ELECTRIC DRIVES FOR VEHICLES (U.S. CLS. 19, 21, 23, 31, 35 AND 44).

CHRISTINE COOPER, EXAMINING ATTORNEY

SN 77-381,959. ZENITH DEVELOPMENT INCORPORATED,
LOS ANGELES, CA. FILED 1-28-2008.

SN 77-423,967. STEMCELL TECHNOLOGIES INC., VAN-
COUVER, CANADA, FILED 3-17-2008.

BILLION DOLLAR BABE

THE MARK CONSISTS OF STANDARD CHARACTERS
WITHOUT CLAIM TO ANY PARTICULAR FONT, STYLE,
SIZE, OR COLOR.
SEC. 2(F).

CLASS 3—COSMETICS AND CLEANING PRE- PARATIONS

FOR COLOGNES, PERFUMES AND COSMETICS (U.S.
CLS. 1, 4, 6, 50, 51 AND 52).
FIRST USE 12-1-1998; IN COMMERCE 12-1-1998.

CLASS 14—JEWELRY

FOR JEWELRY (U.S. CLS. 2, 27, 28 AND 50).
FIRST USE 12-1-1998; IN COMMERCE 12-1-1998.
MARY CRAWFORD, EXAMINING ATTORNEY

SN 77-401,569. DEMOS MEDICAL PUBLISHING, LLC, NEW
YORK, NY. FILED 2-20-2008.



OWNER OF U.S. REG. NOS. 3,033,694 AND 3,033,695.
THE MARK CONSISTS OF THE WORD "DEMOS" CON-
TAINED WITHIN TWO LINES, ONE ABOVE AND ONE
BELOW THE WORDING.

CLASS 9—ELECTRICAL AND SCIENTIFIC APPARATUS

FOR ELECTRONIC PUBLICATIONS, NAMELY,
BOOKS, NEWSPAPERS, MAGAZINES, NEWSLETTERS,
JOURNALS, PAMPHLETS, MANUALS AND PERIODI-
CALS IN THE FIELDS OF MEDICAL, HEALTH AND
WELLNESS TOPICS RECORDED ON COMPUTER ME-
DIA (U.S. CLS. 21, 23, 26, 36 AND 38).
FIRST USE 5-8-2007; IN COMMERCE 5-8-2007.

CLASS 41—EDUCATION AND ENTERTAIN- MENT

FOR PUBLICATION OF TEXTS, BOOKS, MAGAZINES
AND OTHER PRINTED MATTER; ON-LINE PUBLISH-
ING OF ELECTRONIC PUBLICATIONS IN THE FIELD
OF MEDICAL, HEALTH AND WELLNESS TOPICS (U.S.
CLS. 100, 101 AND 107).
FIRST USE 12-31-2001; IN COMMERCE 12-31-2001.
FRED CARL, EXAMINING ATTORNEY



PRIORITY CLAIMED UNDER SEC. 44(D) ON CANADA
APPLICATION NO. 1382908, FILED 2-11-2008, REG. NO.
TMA750,826, DATED 10-22-2009, EXPIRES 10-22-2024.

OWNER OF U.S. REG. NOS. 1,936,773 AND 2,055,646.
NO CLAIM IS MADE TO THE EXCLUSIVE RIGHT TO
USE "STEMCELL TECHNOLOGIES", APART FROM THE
MARK AS SHOWN.

THE MARK CONSISTS OF THE WORDING "STEMCELL
TECHNOLOGIES" AND DESIGN OF THE LETTER "S"
WITH A CIRCLE, AND PARTIAL RECTANGLE WITH
CIRCLES.

CLASS 1—CHEMICALS

FOR CELL GROWTH MEDIA, TISSUE CULTURE
MEDIA, CYTOKINES, ANTIBODIES, AND REAGENTS
FOR SCIENTIFIC, RESEARCH OR LABORATORY USE;
DIAGNOSTIC REAGENTS FOR SCIENTIFIC, RE-
SEARCH OR LABORATORY USE; TISSUE CULTURE
MEDIA, GROWTH FACTORS, GROWTH MEDIA, SER-
UM, AND NUTRITIONAL SUPPLEMENTS FOR THE IN
VITRO CULTURING, DEVELOPMENT, MAINTEN-
ANCE, EXPANSION, ASSAY OR MANIPULATION OF
CELLS; ANTIBODY COMPLEXES FOR CONNECTING
TWO OR MORE DIFFERENT CELL TYPES OR SUB-
STANCES FOR SCIENTIFIC, RESEARCH OR LABORA-
TORY USE; CELL SEPARATION REAGENTS,
MAGNETIC CELL SEPARATION SOLUTIONS; CELL
GROWTH MEDIA STIMULANT COATINGS MADE OF
BIOLOGICAL MATERIALS FOR USE IN THE GROWTH,
EXPANSION, DIFFERENTIATION OR MANIPULATION
OF CELLS, MICROORGANISMS, TISSUES OR ORGANS
FOR LABORATORY USE OR RESEARCH USE OR USE
IN THE MANUFACTURING OF BIOTECHNOLOGY
PRODUCTS; MOLECULAR TAGS, NAMELY, PROTEIN
COMPLEXES, NON-BIOLOGICAL MOLECULAR COM-
PLEXES AND MAGNETIC PARTICLES FOR LABORA-
TORY AND SCIENTIFIC USE; REAGENTS AND KITS
COMPRISED OF REAGENTS, ANTIBODIES, PROTEIN
COMPLEXES, NON-BIOLOGICAL MOLECULAR COM-
PLEXES OR MAGNETIC PARTICLES FOR LABELING
ANTIBODIES WITH FLUOROCHROMES OR OTHER
MOLECULES FOR LABORATORY AND SCIENTIFIC
USE; REAGENTS THAT COMPLEMENT BISPECIFIC
IMMUNE COMPLEXES COMPRISED OF MONOCLO-
NAL ANTIBODIES, REAGENTS USED TO CROSS-LINK
BIOLOGICAL AGENTS SUCH AS CELLS, GROWTH
FACTORS, TOXINS, ANTIGENS, VIRUSES AND EXTRA
CELLULAR MATRIX MOLECULES, SPECIALIZED LI-
QUID AND SEMI-LIQUID MEDIA AND SUPPORT
REAGENTS FOR GROWTH, CLONING OR EXPERI-
MENTAL ANALYSIS OF CELLS AND NEUROSPHERES
FOR LABORATORY AND SCIENTIFIC USE (U.S. CLS. 1,
5, 6, 10, 26 AND 46).

CLASS 5—PHARMACEUTICALS

FOR CELL GROWTH MEDIA, TISSUE CULTURE
MEDIA, CYTOKINES, ANTIBODIES, AND REAGENTS
FOR MEDICAL, CLINICAL, OR MEDICAL DIAGNO-
STIC USE; DIAGNOSTIC REAGENTS FOR MEDICAL
AND CLINICAL USE; ANTIBODY COMPLEXES FOR
CONNECTING TWO OR MORE DIFFERENT CELL
TYPES OR SUBSTANCES FOR MEDICAL, CLINICAL
OR MEDICAL DIAGNOSTIC USE (U.S. CLS. 6, 18, 44, 46,
51 AND 52).

CLASS 9—ELECTRICAL AND SCIENTIFIC APPARATUS

FOR SCIENTIFIC INSTRUMENTS CONSISTING OF COMPUTER HARDWARE AND SOFTWARE FOR THE AUTOMATED MAGNETIC SEPARATION OF BIOLOGICAL AND NON-BIOLOGICAL MATERIALS; MAGNETIC CELL SEPARATION EQUIPMENT, NAMELY, MAGNETIC CELL SEPARATORS FOR LABORATORY USE; COMPUTER SOFTWARE FOR USE IN PREPARING, ANALYZING AND COMMUNICATING MEDICAL REPORTS; LABORATORY EQUIPMENT, NAMELY, LABORATORY GLASSWARE, CULTURE DISHES, WELLS IN THE NATURE OF PLASTIC TRAYS WITH DEPRESSIONS; AND BIOREACTORS IN THE NATURE OF FERMENTATION REACTORS FOR CELL CULTURING (U.S. CLS. 21, 23, 26, 36 AND 38).

CLASS 42—SCIENTIFIC AND COMPUTER SERVICES

FOR RESEARCH CONSULTATION, RESEARCH AND DEVELOPMENT SERVICES BOTH IN THE FIELD OF HEMATOLOGY, IMMUNOLOGY, CANCER RESEARCH, DEVELOPMENTAL BIOLOGY AND LIFE SCIENCE; CONTRACT ASSAYS SERVICES AND PROFICIENCY TESTING SERVICES BOTH RELATING TO RESEARCH AND DEVELOPMENT SERVICES IN THE FIELD OF HEMATOLOGY, IMMUNOLOGY, CANCER RESEARCH, DEVELOPMENTAL BIOLOGY AND LIFE SCIENCE (U.S. CLS. 100 AND 101).

CLASS 44—MEDICAL, BEAUTY AND AGRICULTURAL SERVICES

FOR MEDICAL SERVICES, NAMELY, MEDICAL DIAGNOSTIC SERVICES, CANCER THERAPY SERVICES, AND TRANSPLANT SERVICES (U.S. CLS. 100 AND 101).
DAVID C. REIHNER, EXAMINING ATTORNEY

SN 77-426,303. METRONIA, S.A., 89 - 28034 MADRID, SPAIN, FILED 3-19-2008.



PRIORITY CLAIMED UNDER SEC. 44(D) ON SPAIN APPLICATION NO. 2813793, FILED 2-15-2008, REG. NO. 2813793, DATED 10-22-2008, EXPIRES 2-15-2018.

NO CLAIM IS MADE TO THE EXCLUSIVE RIGHT TO USE "MONITOR ONLINE" AS TO THE GOODS IN CLASS 9, APART FROM THE MARK AS SHOWN.

THE COLOR(S) YELLOW AND BLUE IS/ARE CLAIMED AS A FEATURE OF THE MARK.

THE MARK CONSISTS OF A BLUE BACKGROUND WITH YELLOW WORDING READING "MON MONITOR ONLINE". THE "O" IN "MON" IS IN THE FORM OF A GLOBE WITH MERIDIAN LINES AND THERE ARE LINES EXTENDING OUTWARD WITH SMALLER GLOBES OF THE SAME DESIGN AT THE END OF EACH LINE IN THE NATURE OF A SATELLITE DESIGN, ALL IN YELLOW.

CLASS 9—ELECTRICAL AND SCIENTIFIC APPARATUS

FOR ELECTRONIC EQUIPMENT FOR BINGO FACILITIES, NAMELY, GAMING MACHINES; VIDEO AND SOUND EQUIPMENT, NAMELY, VIDEO GAME MACHINES; SLOT MACHINES; EQUIPMENT FOR DATA PROCESSING, NAMELY, DATA PROCESSORS, CENTRAL PROCESSING UNITS; APPARATUS FOR THE RECORDING, TRANSMISSION OR REPRODUCTION OF SOUND OR IMAGES; MAGNETIC CARDS; ENCODED ELECTRONIC CHIP CARDS (U.S. CLS. 21, 23, 26, 36 AND 38).

CLASS 28—TOYS AND SPORTING GOODS

FOR BINGO GAME PLAYING EQUIPMENT; GAMES, NAMELY, BOARD GAMES, CARD GAMES (U.S. CLS. 22, 23, 38 AND 50).
ELLEN BURNS, EXAMINING ATTORNEY

SN 77-433,190. ETERNAL ASIA SUPPLY CHAIN MANAGEMENT (USA) CORP, JAMAICA, NY. FILED 3-27-2008.



NO CLAIM IS MADE TO THE EXCLUSIVE RIGHT TO USE "ASIA" THE NON-LATIN CHARACTERS THAT TRANSLITERATE TO "YA TONG", APART FROM THE MARK AS SHOWN.

THE MARK CONSISTS OF STYLIZED ENGLISH LETTERS "EA" FOLLOWED BY CHINESE CHARACTERS OVER THE ENGLISH WORDS "ETERNAL ASIA".

THE NON-LATIN CHARACTER(S) IN THE MARK TRANSLITERATE INTO YI YA TONG, AND THIS MEANS "HARMONIOUS ASIAN TRANSPORT" IN ENGLISH.

CLASS 35—ADVERTISING AND BUSINESS

FOR ADVERTISING SERVICES; BUSINESS MANAGEMENT; IMPORT-EXPORT AGENCIES; PUBLICITY AGENTS; PRODUCTION OF TELEVISION COMMERCIALS; PLANNING AND CONDUCTING OF TRADE FAIRS, EXHIBITIONS AND PRESENTATIONS FOR ECONOMIC OR ADVERTISING PURPOSES; BUSINESS MANAGEMENT OF HOTELS; COMPILATION AND SYSTEMIZATION OF INFORMATION INTO COMPUTER DATABASES; PROMOTIONAL SERVICES, NAMELY, CONDUCTING EXHIBITIONS AND SHOWS, AND RELATED CONSULTING, ALL FOR COMMERCIAL PURPOSES; BUSINESS RESEARCH; BUSINESS MARKETING SERVICES; CONSUMER MARKET RESEARCH AND ANALYSIS; PUBLICITY AGENCY SERVICES; PROVISION OF INFORMATION RELATING TO MARKET SURVEYS AND ANALYSIS; WHOLESALE AND RETAIL STORE SERVICES AND DISTRIBUTORSHIP SERVICES FEATURING AUTOMOBILES, MOTORCYCLES AND ACCESSORIES, AND COMPUTER HARDWARE, TEXTILES, CLOTHES, ARTS AND WORKS OF ART, MECHANICAL PRODUCTS, CHEMICAL PRODUCTS, PRODUCTS FOR DOMESTIC USE, HOUSEHOLD PRODUCTS AND INFORMATION TECHNOLOGY PRODUCTS; ARRANGING CUSTOMS CLEARANCE; TRANSPORT LOGISTICS SERVICES, NAMELY, ARRANGING THE TRANSPORTATION OF GOODS FOR OTHERS AND CONSULTANCY SERVICES RELATING TO THE AFORESAID (U.S. CLS. 100, 101 AND 102).

FIRST USE 1-2-2008; IN COMMERCE 1-2-2008.

CLASS 39—TRANSPORTATION AND STORAGE

FOR SUPPLY CHAIN MANAGEMENT; TRANSPORT BY AIR, OCEAN, TRUCK AND RAIL; PACKAGING ARTICLES TO THE ORDER AND SPECIFICATION OF OTHERS; STORAGE OF GOODS; COORDINATING TRAVEL ARRANGEMENTS FOR INDIVIDUALS AND FOR GROUPS; PROVISION OF LOGISTICS SERVICES IN RELATION TO FREIGHT FORWARD, DELIVERY DOCUMENTS, PACKAGES, RAW MATERIALS, AND OTHER FREIGHT FOR THIRD PARTIES BY AIR, RAIL, SHIP OR TRUCK; TRANSPORTATION OF PEOPLE AND GOODS BY MOTOR VEHICLES, NAMELY, LORRY, BUS, TAXI, RAILWAY, BOAT AND AIRPLANES; VEHICLE RENTAL; RENTAL OF VEHICLES FOR CARRYING HEAVY GOODS (U.S. CLS. 100 AND 105).

FIRST USE 1-2-2008; IN COMMERCE 1-2-2008.
JASON TURNER, EXAMINING ATTORNEY

SN 77-485,286. SHARKWATER PRODUCTIONS INC., TORONTO, ONTARIO, CANADA, FILED 5-28-2008.

SHARKWATER

THE MARK CONSISTS OF STANDARD CHARACTERS WITHOUT CLAIM TO ANY PARTICULAR FONT, STYLE, SIZE, OR COLOR.

PRIORITY CLAIMED UNDER SEC. 44(D) ON CANADA APPLICATION NO. 1373884, FILED 11-28-2007, REG. NO. TMA779780, DATED 10-14-2010, EXPIRES 10-14-2025.

CLASS 9—ELECTRICAL AND SCIENTIFIC APPARATUS

FOR MOTION PICTURE FILMS AND DIGIBETA AUDIO/VIDEO RECORDINGS, HIGH DEFINITION CAMERA AUDIO/VIDEO RECORDINGS AND VHS RECORDINGS, ALL CONTAINING LIVE ACTION PROGRAMS IN THE FIELD OF OCEANOGRAPHY, MARINE BIOLOGY, WILDLIFE, ECOLOGY, CLIMATE AND ENVIRONMENTALISM, OR A COMBINATION THEREOF; AUDIO RECORDINGS, NAMELY, DOWNLOADABLE DIGITAL AUDIO MADE AVAILABLE VIA THE INTERNET COMPRISING MUSIC AND SPOKEN WORD IN THE FIELD OF OCEANOGRAPHY, MARINE BIOLOGY, WILDLIFE, ECOLOGY, CLIMATE AND ENVIRONMENTALISM, OR A COMBINATION THEREOF; AUDIO RECORDINGS, NAMELY, COMPACT DISCS COMPRISING MUSIC AND SPOKEN WORD IN THE FIELD OF OCEANOGRAPHY, MARINE BIOLOGY, WILDLIFE, ECOLOGY, CLIMATE AND ENVIRONMENTALISM, OR A COMBINATION THEREOF; DIGITAL VIDEO DISCS OF STANDARD AND HIGH DEFINITION CONTAINING LIVE ACTION PROGRAMS (U.S. CLS. 21, 23, 26, 36 AND 38).

CLASS 16—PAPER GOODS AND PRINTED MATTER

FOR BOOKS IN THE FIELD OF OCEANOGRAPHY, MARINE BIOLOGY, WILDLIFE, ECOLOGY, CLIMATE AND ENVIRONMENTALISM, OR A COMBINATION THEREOF; PRINTED MATTER, NAMELY, EVENT PROGRAMMES, POSTERS, POSTCARDS; AND STICKERS (U.S. CLS. 2, 5, 22, 23, 29, 37, 38 AND 50).

CLASS 25—CLOTHING

FOR SHIRTS (U.S. CLS. 22 AND 39).

CLASS 38—COMMUNICATION

FOR STREAMING OR BROADCASTING OF LIVE-ACTION MOTION PICTURE FILMS OVER THE INTERNET; STREAMING OR BROADCASTING OF LIVE-ACTION MOTION PICTURE FILMS VIA ELECTRONIC DEVICES CAPABLE OF RECEIVING AND STORING AND/OR DISPLAYING ELECTRONIC MEDIA; VIDEO-ON DEMAND TRANSMISSION SERVICES, NAMELY, STREAMING OR BROADCASTING OF NON-DOWNLOADABLE LIVE-ACTION MOTION PICTURE FILMS VIA A VIDEO-ON-DEMAND SERVICE (U.S. CLS. 100, 101 AND 104).

CLASS 41—EDUCATION AND ENTERTAINMENT

FOR ENTERTAINMENT SERVICES, NAMELY, WEBCASTS AND VIDEO PODCASTS OF LIVE-ACTION MOTION PICTURES; PROVIDING NON-DOWNLOADABLE LIVE-ACTION MOTION PICTURE FILMS OVER THE INTERNET VIA A VIDEO-ON-DEMAND SERVICE; PROVIDING ONLINE NON-DOWNLOADABLE LIVE-ACTION MOTION PICTURE FILMS TO ELECTRONIC DEVICES CAPABLE OF RECEIVING AND STORING AND/OR DISPLAYING ELECTRONIC MEDIA VIA A VIDEO-ON-DEMAND SERVICE; PROVIDING NON-DOWNLOADABLE LIVE-ACTION MOTION PICTURE FILMS VIA A VIDEO-ON-DEMAND SERVICE; DISTRIBUTION OF LIVE-ACTION MOTION PICTURE FILMS; PRODUCTION OF LIVE-ACTION MOTION PICTURE FILMS; PROVIDING AN ON-LINE COMPUTER DATABASE IN THE FIELD OF GENERAL INTEREST ENTERTAINMENT NEWS; AUDIO RECORDINGS, NAMELY, NON-DOWNLOADABLE DIGITAL AUDIO MADE AVAILABLE VIA THE INTERNET COMPRISING MUSIC AND SPOKEN WORD IN THE FIELD OF OCEANOGRAPHY, MARINE BIOLOGY, WILDLIFE, ECOLOGY, CLIMATE AND ENVIRONMENTALISM, OR A COMBINATION THEREOF (U.S. CLS. 100, 101 AND 107).

DOMINIC FATHY, EXAMINING ATTORNEY

SN 77-486,160. HIGH ROAD FOR HUMAN RIGHTS EDUCATION PROJECT, SALT LAKE CITY, UT. FILED 5-29-2008.

HIGH ROAD FOR HUMAN RIGHTS

THE MARK CONSISTS OF STANDARD CHARACTERS WITHOUT CLAIM TO ANY PARTICULAR FONT, STYLE, SIZE, OR COLOR.

NO CLAIM IS MADE TO THE EXCLUSIVE RIGHT TO USE "HUMAN RIGHTS", APART FROM THE MARK AS SHOWN.

CLASS 35—ADVERTISING AND BUSINESS

FOR CHARITABLE ASSOCIATION SERVICES, NAMELY, ORGANIZING NATIONAL, REGIONAL AND LOCAL CHAPTERS AND PROMOTING THE INTERESTS OF A GROUP OF PERSONS CONCERNED WITH HUMAN RIGHTS, PREVENTING, AMELIORATING AND ELIMINATING HUMAN RIGHTS VIOLATIONS, PREVENTING, AMELIORATING AND ELIMINATING OPPRESSION, PREVENTING, AMELIORATING AND ELIMINATING ABUSE, PREVENTING, AMELIORATING AND ELIMINATING TORTURE, PREVENTING, AMELIORATING AND ELIMINATING HUMAN TRAFFICKING, PREVENTING, AMELIORATING AND ELIMINATING SLAVERY, PREVENTING, AMELIORATING AND ELIMINATING GENOCIDE, PROTECTING THE ENVIRONMENT, REVERSING CLIMATE CHANGE, REVERSING GLOBAL WARMING, IMPROVING ENERGY USE, SOCIAL WELFARE, SOCIAL REFORM, AND PUBLIC POLICY REFORM; CHARITABLE ASSOCIATION SERVICES, NAMELY, ORGANIZING ADVERTISING EXHIBITIONS RELATED TO HUMAN

RIGHTS, PREVENTING, AMELIORATING AND ELIMINATING HUMANS RIGHTS VIOLATIONS, PREVENTING, AMELIORATING AND ELIMINATING OPPRESSION, PREVENTING, AMELIORATING AND ELIMINATING ABUSE, PREVENTING, AMELIORATING AND ELIMINATING TORTURE, PREVENTING, AMELIORATING AND ELIMINATING HUMAN TRAFFICKING, PREVENTING, AMELIORATING AND ELIMINATING SLAVERY, PREVENTING, AMELIORATING AND ELIMINATING GENOCIDE, PROTECTING THE ENVIRONMENT, REVERSING CLIMATE CHANGE, REVERSING GLOBAL WARMING, IMPROVING ENERGY USE, SOCIAL WELFARE, SOCIAL REFORM, AND PUBLIC POLICY REFORM; PROMOTING PUBLIC AWARENESS IN THE FIELDS OF HUMAN RIGHTS, PREVENTING, AMELIORATING AND ELIMINATING HUMANS RIGHTS VIOLATIONS, PREVENTING, AMELIORATING AND ELIMINATING OPPRESSION, PREVENTING, AMELIORATING AND ELIMINATING ABUSE, PREVENTING, AMELIORATING AND ELIMINATING TORTURE, PREVENTING, AMELIORATING AND ELIMINATING HUMAN TRAFFICKING, PREVENTING, AMELIORATING AND ELIMINATING SLAVERY, PREVENTING, AMELIORATING AND ELIMINATING GENOCIDE, PROTECTING THE ENVIRONMENT, REVERSING CLIMATE CHANGE, REVERSING GLOBAL WARMING, IMPROVING ENERGY USE, SOCIAL WELFARE, SOCIAL REFORM, AND PUBLIC POLICY REFORM; PUBLIC ADVOCACY SERVICES, NAMELY, PROMOTING AWARENESS OF HUMAN RIGHTS, PREVENTING, AMELIORATING AND ELIMINATING HUMANS RIGHTS VIOLATIONS, PREVENTING, AMELIORATING AND ELIMINATING OPPRESSION, PREVENTING, AMELIORATING AND ELIMINATING ABUSE, PREVENTING, AMELIORATING AND ELIMINATING TORTURE, PREVENTING, AMELIORATING AND ELIMINATING HUMAN TRAFFICKING, PREVENTING, AMELIORATING AND ELIMINATING SLAVERY, PREVENTING, AMELIORATING AND ELIMINATING GENOCIDE, PROTECTING THE ENVIRONMENT, REVERSING CLIMATE CHANGE, REVERSING GLOBAL WARMING, IMPROVING ENERGY USE, SOCIAL WELFARE, SOCIAL REFORM, AND PUBLIC POLICY REFORM; ADVERTISING AND PROMOTIONAL SERVICES IN THE NATURE OF SEEKING MEDIA SUPPORT AND NEWS COVERAGE IN THE FIELDS OF HUMAN RIGHTS, PREVENTING, AMELIORATING AND ELIMINATING HUMANS RIGHTS VIOLATIONS, PREVENTING, AMELIORATING AND ELIMINATING OPPRESSION, PREVENTING, AMELIORATING AND ELIMINATING ABUSE, PREVENTING, AMELIORATING AND ELIMINATING TORTURE, PREVENTING, AMELIORATING AND ELIMINATING HUMAN TRAFFICKING, PREVENTING, AMELIORATING AND ELIMINATING SLAVERY, PREVENTING, AMELIORATING AND ELIMINATING GENOCIDE, PROTECTING THE ENVIRONMENT, REVERSING CLIMATE CHANGE, REVERSING GLOBAL WARMING, IMPROVING ENERGY USE, SOCIAL WELFARE, SOCIAL REFORM, AND PUBLIC POLICY REFORM; CONSULTING, PROVIDING ONLINE INFORMATION AND LINKS TO WEBSITES OF OTHERS ABOUT ADMINISTRATIVE COORDINATION OF ORGANIZATIONS AND PERSONS PROVIDING HUMANITARIAN ACTIVITIES RELATED TO HUMAN RIGHTS, PREVENTING, AMELIORATING AND ELIMINATING HUMANS RIGHTS VIOLATIONS, PREVENTING, AMELIORATING AND ELIMINATING OPPRESSION, PREVENTING, AMELIORATING AND ELIMINATING ABUSE, PREVENTING, AMELIORATING AND ELIMINATING TORTURE, PREVENTING, AMELIORATING AND ELIMINATING HUMAN TRAFFICKING, PREVENTING, AMELIORATING AND ELIMINATING SLAVERY, PREVENTING, AMELIORATING AND ELIMINATING GENOCIDE, PROTECTING THE ENVIRONMENT, REVERSING CLIMATE CHANGE, REVERSING GLOBAL WARMING, IMPROVING ENERGY USE, SOCIAL WELFARE, SOCIAL REFORM, AND PUBLIC POLICY REFORM; PROVIDING CONSULTING, ONLINE INFORMATION AND LINKS TO WEBSITES OF OTHERS IN THE FIELD OF ENERGY EFFICIENCY; PROMOTING PUBLIC AWARENESS OF HUMAN RIGHTS, PREVENTING, AMELIORATING AND ELIMINATING HUMANS RIGHTS VIOLATIONS, PREVENTING, AMELIORATING AND ELIMINATING OPPRESSION, PREVENTING, AMELIORATING AND ELIMINATING ABUSE, PREVENTING, AMELIORATING AND ELIMINATING TORTURE, PREVENTING, AMELIORATING AND ELIMINATING HUMAN TRAFFICKING, PREVENTING, AMELIORATING AND ELIM-

INATING SLAVERY, PREVENTING, AMELIORATING AND ELIMINATING GENOCIDE, PROTECTING THE ENVIRONMENT, REVERSING CLIMATE CHANGE, REVERSING GLOBAL WARMING, IMPROVING ENERGY USE, SOCIAL WELFARE, SOCIAL REFORM, AND PUBLIC POLICY REFORM VIA RALLIES, SPEECHES, PROTESTS AND MARCHES; AND DISTRIBUTORSHIP SERVICES IN THE FIELD OF BOOKS, WRITTEN ARTICLES, BROCHURES, PAMPHLETS, AND FLYERS (U.S. CLS. 100, 101 AND 102).

CLASS 41—EDUCATION AND ENTERTAINMENT

FOR EDUCATIONAL AND ENTERTAINMENT SERVICES, NAMELY, ARRANGING AND PROVIDING INSTRUCTION, TRAINING, CONFERENCES, SEMINARS, SYMPOSIUMS, WORKSHOPS, CLASSES AND FESTIVALS IN THE FIELDS OF HUMAN RIGHTS, PREVENTING, AMELIORATING AND ELIMINATING HUMANS RIGHTS VIOLATIONS, PREVENTING, AMELIORATING AND ELIMINATING OPPRESSION, PREVENTING, AMELIORATING AND ELIMINATING ABUSE, PREVENTING, AMELIORATING AND ELIMINATING TORTURE, PREVENTING, AMELIORATING AND ELIMINATING HUMAN TRAFFICKING, PREVENTING, AMELIORATING AND ELIMINATING SLAVERY, PREVENTING, AMELIORATING AND ELIMINATING GENOCIDE, PROTECTING THE ENVIRONMENT, REVERSING CLIMATE CHANGE, REVERSING GLOBAL WARMING, IMPROVING ENERGY USE, SOCIAL WELFARE, SOCIAL REFORM, AND PUBLIC POLICY REFORM; AND PUBLICATION OF BOOKS, WRITTEN ARTICLES, BROCHURES, PAMPHLETS, AND FLYERS ABOUT HUMAN RIGHTS, PREVENTING, AMELIORATING AND ELIMINATING HUMANS RIGHTS VIOLATIONS, PREVENTING, AMELIORATING AND ELIMINATING OPPRESSION, PREVENTING, AMELIORATING AND ELIMINATING ABUSE, PREVENTING, AMELIORATING AND ELIMINATING TORTURE, PREVENTING, AMELIORATING AND ELIMINATING HUMAN TRAFFICKING, PREVENTING, AMELIORATING AND ELIMINATING SLAVERY, PREVENTING, AMELIORATING AND ELIMINATING GENOCIDE, PROTECTING THE ENVIRONMENT, REVERSING CLIMATE CHANGE, REVERSING GLOBAL WARMING, IMPROVING ENERGY USE, SOCIAL WELFARE, SOCIAL REFORM, AND PUBLIC POLICY REFORM (U.S. CLS. 100, 101 AND 107).

NELSON SNYDER, EXAMINING ATTORNEY

SN 77-512,235. ICUE CORP., SOUTHAMPTON, PA. FILED 7-1-2008.

iSendit

THE MARK CONSISTS OF STANDARD CHARACTERS WITHOUT CLAIM TO ANY PARTICULAR FONT, STYLE, SIZE, OR COLOR.

CLASS 35—ADVERTISING AND BUSINESS

FOR BUSINESS MARKETING CONSULTING SERVICES; COMPUTERIZED DATABASE MANAGEMENT OF DOCUMENTS FOR OTHERS; RECORDS MANAGEMENT SERVICES, NAMELY, CONFIGURATION CONTROL, CUSTOMIZATION AND INDEXING OF DOCUMENTS FOR OTHERS; BUSINESS MANAGEMENT OF MARKETING CAMPAIGNS VIA AN ELECTRONIC INTERFACE FOR OTHERS (U.S. CLS. 100, 101 AND 102).

CLASS 38—COMMUNICATION

FOR COMMUNICATIONS SERVICES, NAMELY, ELECTRONIC TRANSMISSION OF PRE-STORED DATA AND DOCUMENTS FROM A CUSTOMER TO BE SENT TO OTHERS UPON REQUEST; ELECTRONIC BUSINESS MESSAGING SERVICES FOR OTHERS, NAMELY, TRANSMISSION OF PRE-STORED DATA AND DOCUMENTS FROM A CUSTOMER TO BE SENT TO OTHERS UPON REQUEST (U.S. CLS. 100, 101 AND 104).

CLASS 42—SCIENTIFIC AND COMPUTER SERVICES

FOR DEVELOPMENT OF MESSAGING INTERFACES FOR RECEIVING INFORMATION REQUESTS AND RESPONDING WITH RELEVANT INFORMATION IN ELECTRONIC FORM; PROVIDING TEMPORARY USE OF ON-LINE NON-DOWNLOADABLE MESSAGING INTERFACE SOFTWARE FOR RECEIVING INFORMATION REQUESTS AND RESPONDING WITH RELEVANT INFORMATION IN ELECTRONIC FORM (U.S. CLS. 100 AND 101).

KATHERINE CHANG, EXAMINING ATTORNEY

SN 77-543,718. STEMCELL TECHNOLOGIES INC., VANCOUVER, CANADA, FILED 8-11-2008.



PRIORITY CLAIMED UNDER SEC. 44(D) ON CANADA APPLICATION NO. 1382909, FILED 2-11-2008, REG. NO. TMA759466, DATED 2-15-2010, EXPIRES 2-15-2025.

THE MARK CONSISTS OF DESIGN OF THE LETTER "S" WITH A CIRCLE, AND A PARTIAL RECTANGLE WITH MANY LITTLE CIRCLES.

CLASS 1—CHEMICALS

FOR CELL GROWTH MEDIA, TISSUE CULTURE MEDIA, CYTOKINES, ANTIBODIES, AND REAGENTS FOR SCIENTIFIC, RESEARCH OR LABORATORY USE; DIAGNOSTIC REAGENTS FOR SCIENTIFIC, RESEARCH OR LABORATORY USE; TISSUE CULTURE MEDIA, GROWTH FACTORS, GROWTH MEDIA, SERUM, AND NUTRITIONAL SUPPLEMENTS FOR THE IN VITRO CULTURING, DEVELOPMENT, MAINTENANCE, EXPANSION, ASSAY OR MANIPULATION OF CELLS; ANTIBODY COMPLEXES FOR CONNECTING TWO OR MORE DIFFERENT CELL TYPES OR SUBSTANCES FOR SCIENTIFIC, RESEARCH OR LABORATORY USE; CELL SEPARATION REAGENTS, MAGNETIC CELL SEPARATION SOLUTIONS; CELL GROWTH MEDIA STIMULANT COATINGS MADE OF BIOLOGICAL MATERIALS FOR USE IN THE GROWTH, EXPANSION, DIFFERENTIATION OR MANIPULATION OF CELLS, MICROORGANISMS, TISSUES OR ORGANS FOR LABORATORY USE OR RESEARCH USE OR USE IN THE MANUFACTURING OF BIOTECHNOLOGY PRODUCTS; MOLECULAR TAGS, NAMELY, PROTEIN COMPLEXES, NON-BIOLOGICAL MOLECULAR COMPLEXES AND MAGNETIC PARTICLES FOR LABORATORY AND SCIENTIFIC USE; REAGENTS AND KITS COMPRISED OF REAGENTS, ANTIBODIES, PROTEIN COMPLEXES, NON-BIOLOGICAL MOLECULAR COMPLEXES OR MAGNETIC PARTICLES FOR LABELING ANTIBODIES WITH FLUOROCHROMES OR OTHER MOLECULES FOR LABORATORY AND SCIENTIFIC USE; REAGENTS THAT COMPLEMENT BISPECIFIC IMMUNE COMPLEXES COMPRISED OF MONOCLONAL ANTIBODIES, REAGENTS USED TO CROSS-LINK BIOLOGICAL AGENTS SUCH AS CELLS, GROWTH FACTORS, TOXINS, ANTIGENS, VIRUSES AND EXTRA CELLULAR MATRIX MOLECULES, SPECIALIZED LIQUID AND SEMI-LIQUID MEDIA AND SUPPORT REAGENTS FOR GROWTH, CLONING OR EXPERIMENTAL ANALYSIS OF CELLS AND NEUROSPHERES FOR LABORATORY AND SCIENTIFIC USE (U.S. CLS. 1, 5, 6, 10, 26 AND 46).

CLASS 5—PHARMACEUTICALS

FOR CELL GROWTH MEDIA, TISSUE CULTURE MEDIA, CYTOKINES, ANTIBODIES, AND REAGENTS FOR MEDICAL, CLINICAL, OR MEDICAL DIAGNOSTIC USE; DIAGNOSTIC REAGENTS FOR MEDICAL AND CLINICAL USE; ANTIBODY COMPLEXES FOR CONNECTING TWO OR MORE DIFFERENT CELL TYPES OR SUBSTANCES FOR MEDICAL, CLINICAL OR MEDICAL DIAGNOSTIC USE (U.S. CLS. 6, 18, 44, 46, 51 AND 52).

CLASS 9—ELECTRICAL AND SCIENTIFIC APPARATUS

FOR SCIENTIFIC INSTRUMENTS CONSISTING OF COMPUTER HARDWARE AND SOFTWARE FOR THE AUTOMATED MAGNETIC SEPARATION OF BIOLOGICAL AND NON-BIOLOGICAL MATERIALS; MAGNETIC CELL SEPARATION EQUIPMENT, NAMELY, MAGNETIC CELL SEPARATORS FOR LABORATORY USE; COMPUTER SOFTWARE FOR USE IN PREPARING, ANALYZING AND COMMUNICATING MEDICAL REPORTS; LABORATORY EQUIPMENT, NAMELY, LABORATORY GLASSWARE, CULTURE DISHES, WELLS IN THE NATURE OF PLASTIC TRAYS WITH DEPRESSIONS; AND BIOREACTORS IN THE NATURE OF FERMENTATION REACTORS FOR CELL CULTURING (U.S. CLS. 21, 23, 26, 36 AND 38).

CLASS 42—SCIENTIFIC AND COMPUTER SERVICES

FOR RESEARCH CONSULTATION, RESEARCH AND DEVELOPMENT SERVICES BOTH IN THE FIELD OF HEMATOLOGY, IMMUNOLOGY, CANCER RESEARCH, DEVELOPMENTAL BIOLOGY AND LIFE SCIENCE; CONTRACT ASSAYS SERVICES AND PROFICIENCY TESTING SERVICES BOTH RELATING TO RESEARCH AND DEVELOPMENT SERVICES IN THE FIELD OF HEMATOLOGY, IMMUNOLOGY, CANCER RESEARCH, DEVELOPMENTAL BIOLOGY AND LIFE SCIENCE (U.S. CLS. 100 AND 101).

CLASS 44—MEDICAL, BEAUTY AND AGRICULTURAL SERVICES

FOR MEDICAL SERVICES, NAMELY, MEDICAL DIAGNOSTIC SERVICES, CANCER THERAPY SERVICES, AND TRANSPLANT SERVICES (U.S. CLS. 100 AND 101).
JOHN DALIER, EXAMINING ATTORNEY

SN 77-551,251. SOURCE INTERLINK MAGAZINES, LLC.,
NEW YORK, NY. FILED 8-20-2008.



THE MARK CONSISTS OF THE LETTERS "L" AND "R" IN STYLIZED FORM.

CLASS 9—ELECTRICAL AND SCIENTIFIC APPARATUS

FOR EYEWEAR, NAMELY, SUN AND OPTICAL GLASSES (U.S. CLS. 21, 23, 26, 36 AND 38).

CLASS 14—JEWELRY

FOR JEWELRY, NAMELY, WATCHES, EARRINGS, BRACELETS, NECKLACES, PINS, PENDANTS (U.S. CLS. 2, 27, 28 AND 50).

CLASS 18—LEATHER GOODS

FOR HANDBAGS, CLUTCH PURSES, SHOPPING BAGS MADE OF LEATHER, POUCHES, TOTE BAGS, TRAVEL BAGS, COSMETIC BAGS SOLD EMPTY, BACKPACKS, ATTACHES, SATCHELS, BELT BAGS, WALLETS AND TOILETRY CASES SOLD EMPTY (U.S. CLS. 1, 2, 3, 22 AND 41).

DOMINIC J. FERRAIUOLO, EXAMINING ATTORNEY

SN 77-585,494. LEONE INTERNATIONAL MARKETING INC., VANCOUVER, CANADA, FILED 10-3-2008.

LEONE

THE MARK CONSISTS OF STANDARD CHARACTERS WITHOUT CLAIM TO ANY PARTICULAR FONT, STYLE, SIZE, OR COLOR.

OWNER OF U.S. REG. NO. 1,515,913.
THE ENGLISH TRANSLATION OF "LEONE" IN THE MARK IS "LION".

CLASS 25—CLOTHING

FOR CLOTHING, NAMELY, SHIRTS, BLOUSES, PANTS, SKIRTS, SHORTS, DRESSES, SUITS, UNDERGARMENTS, SWIM WEAR, JACKETS AND COATS (U.S. CLS. 22 AND 39).

FIRST USE 7-30-1987; IN COMMERCE 7-30-1987.

CLASS 35—ADVERTISING AND BUSINESS

FOR MAIL ORDER SERVICES, IN THE FIELD OF CLOTHING, CLOTHING ACCESSORIES, FOOTWEAR, STATIONERY, JEWELRY, COSMETICS, PERFUME AND CONFECTIONARIES (U.S. CLS. 100, 101 AND 102).

FIRST USE 7-30-1987; IN COMMERCE 7-30-1987.

MATTHEW MCDOWELL, EXAMINING ATTORNEY

SN 77-598,666. ONECHANGE FOUNDATION, OTTAWA, CANADA, FILED 10-23-2008.

PSST!

THE MARK CONSISTS OF STANDARD CHARACTERS WITHOUT CLAIM TO ANY PARTICULAR FONT, STYLE, SIZE, OR COLOR.

PRIORITY CLAIMED UNDER SEC. 44(D) ON CANADA APPLICATION NO. 1409730, FILED 9-5-2008, REG. NO. TMA764,206, DATED 4-14-2010, EXPIRES 4-14-2025.

CLASS 9—ELECTRICAL AND SCIENTIFIC APPARATUS

FOR (BASED ON INTENT TO USE) (BASED ON 44(E)) TIRE PRESSURE GAUGES (U.S. CLS. 21, 23, 26, 36 AND 38).

CLASS 35—ADVERTISING AND BUSINESS

FOR (BASED ON 44(E)) PROMOTING PUBLIC UNDERSTANDING OF ENVIRONMENTAL ISSUES AND THE POTENTIAL IMPACT OF INDIVIDUALS AND COMMUNITIES ON ENERGY CONSERVATION THROUGH MEDIA CAMPAIGNS AND DOOR-TO-DOOR CANVASSING; RUNNING PUBLIC AWARENESS CAMPAIGNS RELATING TO ENVIRONMENTAL PROTECTION, CLIMATE CHANGE, AND ENERGY CONSERVATION (U.S. CLS. 100, 101 AND 102).

CLASS 41—EDUCATION AND ENTERTAINMENT

FOR (BASED ON INTENT TO USE) (BASED ON 44(E)) EDUCATION TO INCREASE PUBLIC UNDERSTANDING OF ENVIRONMENTAL ISSUES AND THE POTENTIAL IMPACT OF INDIVIDUALS AND COMMUNITIES ON ENERGY CONSERVATION THROUGH WORKSHOPS AND DISTRIBUTION OF EDUCATIONAL WRITTEN MATERIAL RELATED THERETO; DEVELOPMENT AND PROVISION OF EDUCATIONAL PROGRAMS FOR PROTECTION AND PRESERVATION OF THE ENVIRONMENT THROUGH ENERGY CONSERVATION AND TO EDUCATE INSTITUTIONS, INDUSTRIES, BUSINESS AND INDIVIDUALS ABOUT THEIR POTENTIAL TO PRESERVE THE ENVIRONMENT (U.S. CLS. 100, 101 AND 107).

GISELLE AGOSTO, EXAMINING ATTORNEY

SN 77-629,495. SUIXTIL LIMITED, HONG KONG, HONG KONG, FILED 12-9-2008.



OWNER OF HONG KONG REG. NO. 300985799, DATED 11-2-2007, EXPIRES 11-2-2017.
THE MARK CONSISTS OF THE STYLIZED WORD "SUIXTIL".

CLASS 18—LEATHER GOODS

FOR TRAVELLING CASES; LUGGAGE INSERTS, NAMELY, PACKING CUBES; ALL PURPOSE SPORT BAGS; WALLETS; NOTECASES, NAMELY, BUSINESS CARD CASES AND BRIEFCASE-TYPE PORTFOLIOS (U.S. CLS. 1, 2, 3, 22 AND 41).

CLASS 25—CLOTHING

FOR CLOTHING, NAMELY, PANTS, SHIRTS, TIES, LONG AND SHORT SLEEVE T-SHIRTS AND POLO SHIRTS, JUMPERS, PULL-OVERS, FOOTWEAR, HATS, CAPS, GLOVES, SCARVES, BELTS, WOVEN COATS AND JACKETS, LEATHER COATS AND JACKETS, SUITS (U.S. CLS. 22 AND 39).

ANDREA BUTLER, EXAMINING ATTORNEY

SN 77-629,669. WHITEFOX TECHNOLOGIES LIMITED, LONDON, UNITED KINGDOM, FILED 12-9-2008.



THE MARK CONSISTS OF STANDARD CHARACTERS WITHOUT CLAIM TO ANY PARTICULAR FONT, STYLE, SIZE, OR COLOR.

PRIORITY CLAIMED UNDER SEC. 44(D) ON ERP N CMNTY TM OFC APPLICATION NO. 6976311, FILED 6-10-2008, REG. NO. 6976311, DATED 7-21-2009, EXPIRES 6-10-2018.

CLASS 9—ELECTRICAL AND SCIENTIFIC APPARATUS

FOR SURVEYING INSTRUMENTS; PHOTOGRAPHIC APPARATUS AND INSTRUMENTS, NAMELY, PHOTOGRAPHIC CAMERAS, EXPOSURE METERS, FILTERS, SLIDES, TRANSPARENCIES, LENSES, VIEWFINDERS; MEASURING APPARATUS AND INSTRUMENTS, NAMELY, GAS SENSORS FOR MEASURING GAS CONCENTRATION, RADIATION-MEASURING INSTRUMENTS, MEASURING CUPS, MEASURING BUCKETS, MEASURING TAPES, MEASURING RULES, DISTANCE MEASURING APPARATUS, INSTRUMENTS FOR MEASURING AUTOMOBILE, MANUFACTURING, AVIATION AND INDUSTRIAL EMISSIONS, INCLUDING GREENHOUSE GASES AND CO₂; ELECTRONIC-BASED INSTRUMENTS FOR MEASURING ENVIRONMENTAL PARAMETERS INCLUDING HUMIDITY, MOLD, BACTERIA, AIR QUALITY AND WATER QUALITY, INSTRUMENTS FOR MEASURING CONCENTRATIONS OF COMPONENTS IN GAS, VAPOR AND LIQUIDS; FUEL CELLS; PROTON EXCHANGE MEMBRANES BEING FUEL CELL MEMBRANES; POWER CABLES; PHOTOVOLTAIC CELLS AND MODULES; ELECTRICAL CELLS AND BATTERIES; BATTERY CHARGERS; ACCUMULATORS; ANODE BATTERIES; ANODES; CLOTHING FOR PROTECTION AGAINST ACCIDENTS AND/OR FIRE; COMPUTERS; ELECTRIC INSTALLATIONS FOR THE REMOTE CONTROL OF INDUSTRIAL OPERATIONS; LIGHT CONDUCTING FILAMENTS; COMPUTER DATABASE AND APPLICATIONS SOFTWARE FOR USE IN THE RESEARCH, DESIGN AND PRODUCTION OF ALTERNATIVE SOURCES OF FUEL, POWER GENERATION, WATER TREATMENT AND PURIFICATION, AND MEASURING ENERGY OUTPUT FOR USE IN THE FIELDS OF ALTERNATIVE FUEL PRODUCTION, POWER GENERATION, WATER TREATMENT AND PURIFICATION AND PRINTED CIRCUITS; ELECTRIC RESISTANCES; TEMPERATURE INDICATORS; WATER LEVEL INDICATORS; COMPUTER PROGRAMMES FOR USE IN THE RESEARCH, DESIGN AND PRODUCTION OF ALTERNATIVE SOURCES OF FUEL, POWER GENERATION, WATER TREATMENT AND PURIFICATION, AND MEASURING ENERGY OUTPUT FOR USE IN THE FIELDS OF ALTERNATIVE FUEL PRODUCTION, POWER GENERATION, WATER TREATMENT AND PURIFICATION; BLANK MAGNETIC TAPES; PRESSURE MEASURING APPARATUS; SEPARATION COLUMNS FOR GAS CHROMATOGRAPHY; HYDROMETERS; SEMI-PERMEABLE MEMBRANES FOR SCIENTIFIC USE, NAMELY, LABORATORY SEMI-PERMEABLE MEMBRANES FOR SCIENTIFIC USE; GAS SEPARATION MEMBRANES; HOLLOW FIBRE MEMBRANE ELEMENTS FOR SCIENTIFIC USE, NAMELY, LABORATORY HOLLOW FIBRE MEMBRANE ELEMENTS FOR SCIENTIFIC USE; MEMBRANES FOR FILTRATION, NAMELY, LABORATORY MEMBRANES FOR FILTRATION; FILTRATION MEMBRANES FOR LABORATORY APPARATUS, NAMELY, LABORATORY FILTRATION MEMBRANES FOR LABORATORY APPARATUS; APPARATUS FOR USE IN FUEL DISPENSING INCLUDING SUCH APPARATUS INCORPORATING MEMBRANE ELEMENTS ALLOWING FILTRATION OR SEPARATION OF PARTICLES OR COMPONENTS IN A FUEL, NAMELY, CONTROLLED VOLUME PUMPS, FUEL PUMPS FOR SERVICE STATIONS; FILTERING APPARATUS FOR LIQUIDS, GASES, VAPOURS AND WATERS, NAMELY, PURIFICATION AND FILTRATION APPARATUS INCORPORATING MEMBRANES FOR SCIENTIFIC PURPOSES FOR USE IN THE ENERGY AND ENGINEERING INDUSTRIES (U.S. CLS. 21, 23, 26, 36 AND 38).

CLASS 11—ENVIRONMENTAL CONTROL APPARATUS

FOR GAS SEPARATION EQUIPMENT, NAMELY, GAS SEPARATION EQUIPMENT USED FOR OBTAINING NITROGEN, OXYGEN, CARBON DIOXIDE, ARGON, NEON, HELIUM, XENON AND HYDROGEN BY SEPARATING AIR COMPONENTS BY PRESSURE SWING ADSORPTION; GAS SEPARATION EQUIPMENT USED FOR OBTAINING NITROGEN, OXYGEN, CARBON DIOXIDE, ARGON, NEON, HELIUM, KRYPTON, XENON AND HYDROGEN BY SEPARATING AIR COMPONENTS CRYOGENICALLY; GAS SEPARATION EQUIPMENT USED FOR OBTAINING NITROGEN, OXYGEN, CARBON DIOXIDE, ARGON, NEON, HE-

LIUM, KRYPTON, XENON AND HYDROGEN BY SEPARATING AIR COMPONENTS VIA COOLING METHODS; GAS SEPARATION EQUIPMENT USED FOR OBTAINING NITROGEN, OXYGEN, CARBON DIOXIDE, ARGON, NEON, HELIUM, KRYPTON, XENON AND HYDROGEN BY SEPARATING AIR COMPONENTS BY MEANS OF SERIAL MEMBRANE MODULES AND LABORATORY MEMBRANES FOR SEPARATING DIFFERENT COMPONENTS OR MOLECULES WITHIN A GAS; INSTALLATIONS AND APPARATUS FOR LIGHTING, NAMELY, ELECTRIC LIGHTING FIXTURES; INSTALLATIONS AND APPARATUS FOR HEATING, NAMELY, HEATING INSTALLATIONS; INSTALLATIONS AND APPARATUS FOR COOKING, NAMELY, ELECTRIC AND GAS OVENS, MICROWAVE OVENS; COOLING UNITS FOR INDUSTRIAL PURPOSES; COOLING EVAPORATORS; INSTALLATIONS AND APPARATUS FOR DESALINATION, NAMELY, DESALINATION UNITS; INSTALLATIONS AND APPARATUS FOR DRYING, NAMELY, INDUSTRIAL DRYERS FOR HEATING AND DEHUMIDIFYING; INSTALLATIONS AND APPARATUS FOR VENTILATING, NAMELY, VENTILATING FANS FOR COMMERCIAL AND INDUSTRIAL USE; INSTALLATIONS AND APPARATUS FOR AIR CONDITIONING, NAMELY, AIR CONDITIONERS; INSTALLATIONS AND APPARATUS FOR WATER SUPPLY, NAMELY, WATER PURIFYING APPARATUS, INDUSTRIAL WATER PURIFYING APPARATUS, WATER DESALINATION PLANTS, WATER FILTERING APPARATUS, WATER DISTILLATION UNITS, REGULATING ACCESSORIES FOR WATER SUPPLY, NAMELY, METERED VALVES; INSTALLATIONS AND APPARATUS FOR GAS SEPARATION, NAMELY, FLUID SEPARATION APPARATUS FOR SEPARATION OF GAS FROM LIQUID IN A CHEMICAL OR OIL REFINERY, AND MEMBRANES, FILTERS, MODULES FOR SEPARATING GASES AND PARTICLES WITHIN GASES; INCINERATORS; HEAT ACCUMULATORS; COOLING AND FREEZING APPARATUS, NAMELY, EVAPORATIVE AIR COOLERS AND FREEZERS; WATER TREATMENT APPARATUS AND INSTALLATIONS, NAMELY, CARTRIDGE FILTRATION UNITS, CHEMICAL STERILIZATION UNITS, REVERSE OSMOSIS FILTRATION UNITS, ULTRAVIOLET STERILIZATION UNITS; DISTILLATION APPARATUS AND COLUMNS, NAMELY, ALCOHOL, GAS AND WATER DISTILLATION UNITS; DUST EXHAUSTING AND REMOVING INSTALLATIONS FOR INDUSTRIAL PURPOSES, NAMELY, AIR AND WATER FILTERS FOR INDUSTRIAL PURPOSES; CHIMNEY FLUES; FUEL ECONOMIZERS, NAMELY, GAS AND FUEL REGULATORS; INSTALLATIONS RELATING TO MEMBRANE FILTRATION AND SEPARATION TECHNOLOGY FOR LIQUIDS, GASES, VAPOURS AND WATER, NAMELY, PURIFICATION AND FILTRATION APPARATUS, NAMELY, MODULES AND MEMBRANE CARTRIDGES FOR SEPARATION AND PURIFICATION; FILTERING APPARATUS FOR LIQUIDS, GASES, VAPOURS AND WATERS, NAMELY, PURIFICATION AND FILTRATION APPARATUS INCORPORATING MEMBRANES FOR INDUSTRIAL USE AND FOR USE IN THE ENERGY AND ENGINEERING INDUSTRIES; APPARATUS FOR USE IN PURIFICATION, DEHYDRATION AND PRODUCTION OF FUELS AND BIOFUELS, INCLUDING ETHANOL, FUEL GAS, FUEL OIL AND MINERAL FUEL, NAMELY, ETHANOL, FUEL GAS, FUEL OIL AND MINERAL FUEL PURIFICATION MACHINES; APPARATUS INCORPORATING MEMBRANES FOR USE IN PURIFICATION OF FUELS AND BIOFUELS, INCLUDING ETHANOL, FUEL GAS, FUEL OIL AND MINERAL FUEL; APPARATUS FOR USE IN PURIFICATION OF AIR AND OF WATER, NAMELY, WATER AND AIR PURIFICATION UNITS (U.S. CLS. 13, 21, 23, 31 AND 34).

CLASS 42—SCIENTIFIC AND COMPUTER SERVICES

FOR RESEARCH AND DEVELOPMENT RELATING TO THE ENERGY SUPPLY INDUSTRIES AND CONSERVATION OF ENERGY; DEVELOPMENT AND SCIENTIFIC RESEARCH RELATING TO THE ENERGY SUPPLY INDUSTRIES AND THE CONSERVATION OF ENERGY; CONSULTANCY AND ADVISORY SERVICES IN THE FIELDS OF CHEMICAL AND INDUSTRIAL ENGINEERING RELATING TO THE DESIGN, APPLICATION, INTEGRATION AND FUNCTION OF MEMBRANE TECHNOLOGY AND MEMBRANE PROCESSES; CONSULTANCY RELATING TO COMPUTER PROGRAMMING, DESIGN OF COMPUTER SOFTWARE, ENGINEERING, ENGINEERING DRAWING; CONSULTANCY AND ADVISORY SERVICES RELATING TO POLLUTION CONTROL, NAMELY, TESTING AND RESEARCH ON PREVENTION OF POLLUTION, REDUCTION OF EMISSIONS AND ENERGY CONSUMPTION; CONSULTANCY AND ADVISORY SERVICES RELATING TO MANUFACTURING EFFICIENCY, NAMELY, CONSULTING RELATING TO THE DESIGN OF WORKPLACE FACILITIES AND EQUIPMENT TO OPTIMIZE EFFICIENCY OF INDUSTRIAL PROCESSES; OIL-WELL TESTING; WELL-BORE SURVEYING SERVICES (U.S. CLS. 100 AND 101).

DEBRA LEE, EXAMINING ATTORNEY

SN 77-636,336. BLUE PLANET ENVIRONMENTAL INC., RICHMOND HILL, CANADA, FILED 12-18-2008.

BLUEPLANET

THE MARK CONSISTS OF STANDARD CHARACTERS WITHOUT CLAIM TO ANY PARTICULAR FONT, STYLE, SIZE, OR COLOR.

CLASS 7—MACHINERY

FOR ELECTROMAGNETIC FLUID PUMPS FOR RESIDENTIAL AND COMMERCIAL APPLICATIONS, NAMELY, FISH FARMING TANKS AND HOME AND COMMERCIAL AQUARIUM TANKS; LAUNDRY MACHINE ADD-ONS, NAMELY, APPARATUS FOR INFUSING AIR INTO WATER ADAPTED FOR USE WITH LAUNDRY MACHINE (U.S. CLS. 13, 19, 21, 23, 31, 34 AND 35).

CLASS 11—ENVIRONMENTAL CONTROL APPARATUS

FOR LAWN AND GARDEN WATERING TOOLS, NAMELY, GARDEN SPRINKLERS, WATER DISPENSING WANDS, WATER DISPERSION NOZZLES, OXYGENATING NOZZLES, PRESSURE REGULATORS, WATER DISPENSING SHOWER HEADS; PET AND ANIMAL WASHING TOOLS, NAMELY, WATER DISPENSING WANDS, SPRAYERS, SHOWER HEADS; HYDROPONICS AND AGRICULTURAL EQUIPMENT, NAMELY, PUMPS, LIGHTING, AND TRAYS FOR HOLDING APPARATUS FOR INFUSING AIR INTO WATER ADAPTED FOR AGRICULTURAL USE; DEVICE FOR INFUSING FLUID WITH OXYGEN AND GENERATING BUBBLES IN FLUID, NAMELY, A WATER PROCESSING UNIT HAVING A WATER INLET, A GAS DIFFUSER HOUSED IN THE UNIT FOR MIXING GAS WITH INFLOWING WATER, A GAS DIFFUSION CHAMBER AND A WATER DISCHARGE OUTLET FOR USE IN SPRAYING; WATER PURIFICATION, STERILIZATION, OZONATION AND WATER BODY REMEDIATION SYSTEMS COMPRISING A WATER PROCESSING UNIT HAVING A WATER INTAKE TUBE, A GAS DIFFUSER HOUSED IN THE INTAKE TUBE FOR PROVIDING GAS TO BE TRANSFERRED TO THE WATER AND FOR PROVIDING THE MEANS TO ADVANCE THE WATER THROUGH THE INTAKE TUBE, AND A CONNECTOR TUBE CONNECTING THE INTAKE TUBE TO A WATER DISCHARGE TUBE HAVING A SECTION TO ALLOW DISPERSION OF EXCESS GASES FROM THE WATER, WATER PUMPS, AIR COMPRESSORS, AIR BLOWERS; WATER RECYCLING SYSTEMS COMPRISING HOUSEHOLD EFFLUENT AEROBIC BREAKDOWN PROCESSORS COUPLED WITH FLUID OXYGENATING UNITS ALLOWING TREATED EFFLUENT TO BE REUSED AS RECYCLED WATER IN HOUSEHOLD WATER CONSUMPTION DEVICES, NAMELY, WASHING MACHINES AND TOILETS; RESIDENTIAL WATER MANAGEMENT SYSTEMS COMPRISING TIMERS, SHOWERHEADS THAT INDICATE DURATION OF USE, APPARATUS FOR INFUSING AIR INTO WATER ADAPTED FOR USE WITH HOUSEHOLD WATER USING DEVICES TO REDUCE OVERALL VOLUME OF WATER PASSING THROUGH SAID DEVICES; RESIDENTIAL WATER MANAGEMENT EQUIPMENT, NAMELY, TIMERS, SHOWERHEADS THAT INDICATE DURATION OF USE, APPARATUS FOR INFUSING AIR INTO WATER ADAPTED FOR USE WITH HOUSEHOLD WATER USING DEVICES TO REDUCE OVERALL VOLUME OF WATER PASSING THROUGH (U.S. CLS. 13, 21, 23, 31 AND 34).

NAAKWAMA ANKRAH, EXAMINING ATTORNEY

SN 77-650,079. JOEY TOMATO'S (CANADA) INC., VANCOUVER, CANADA, FILED 1-15-2009.

A BETTER, FULLER GLASS OF WINE

THE MARK CONSISTS OF STANDARD CHARACTERS WITHOUT CLAIM TO ANY PARTICULAR FONT, STYLE, SIZE, OR COLOR.

PRIORITY CLAIMED UNDER SEC. 44(D) ON CANADA APPLICATION NO. 1403317, FILED 7-15-2008, REG. NO. TMA775936, DATED 8-31-2010, EXPIRES 8-31-2025.

CLASS 21—HOUSEWARES AND GLASS

FOR WINE GLASSES; WINE CORKSCREWS; PROMOTIONAL ITEMS, NAMELY, COFFEE MUGS; WINE STORAGE DEVICES, NAMELY, WINE COOLERS (U.S. CLS. 2, 13, 23, 29, 30, 33, 40 AND 50).

CLASS 33—WINES AND SPIRITS

FOR WINE (U.S. CLS. 47 AND 49).

CLASS 35—ADVERTISING AND BUSINESS

FOR PROCUREMENT SERVICES, NAMELY, PURCHASING OF WINE FOR OTHERS; WHOLESALE, RETAIL, AND ONLINE RETAIL AND ONLINE WHOLESALE STORE SERVICES FEATURING WINE AND WINE ACCESSORIES SUCH AS WINE BOTTLES, WINE GLASSES, WINE CORKSCREWS, AND WINE STORAGE AND SHIPPING DEVICES; GROUP BUYING CLUB SERVICES; ADVERTISING SERVICES, NAMELY, PROMOTING THE WINES OF OTHERS; CLUB SERVICES, NAMELY, PROMOTING THE INTERESTS OF WINE ENTHUSIASTS; PROVIDING A WEBSITE FEATURING INFORMATION REGARDING WINE CLUB SPECIAL EVENTS AND MEETINGS FOR BUSINESS PURPOSES; ARRANGEMENT AND CONDUCTING SPECIAL EVENTS IN THE NATURE OF DINNERS AND PARTIES FEATURING WINE, FOR BUSINESS PURPOSES (U.S. CLS. 100, 101 AND 102).

CLASS 41—EDUCATION AND ENTERTAINMENT

FOR PROVIDING A WEBSITE FEATURING INFORMATION REGARDING WINE CLUB SPECIAL EVENTS AND MEETINGS FOR SOCIAL ENTERTAINMENT PURPOSES; ARRANGING AND CONDUCTING WINE TASTINGS, GUIDED TOURS OF WINERIES, AND ARRANGEMENT AND CONDUCTING SPECIAL EVENTS IN THE NATURE OF DINNERS AND PARTIES FEATURING WINE, FOR SOCIAL ENTERTAINMENT PURPOSES (U.S. CLS. 100, 101 AND 107).

LAURA HAMMEL, EXAMINING ATTORNEY

SN 77-650,538. PROTUS IP SOLUTIONS, INC., OTTAWA, CANADA, FILED 1-15-2009.



PRIORITY CLAIMED UNDER SEC. 44(D) ON CANADA APPLICATION NO. 1415899, FILED 10-27-2008, REG. NO. TMA760825, DATED 3-4-2010, EXPIRES 3-4-2025.

OWNER OF U.S. REG. NO. 2,790,079.

THE MARK CONSISTS OF THE WORD "CAMPAIGNER" WITH THE IMAGE OF ENVELOPES, A CURSOR AND RECTANGLES TO THE LEFT OF THE WORDING.

CLASS 16—PAPER GOODS AND PRINTED MATTER

FOR DRAFTING TEMPLATES IN THE NATURE OF E-MAIL AND NEWSLETTER TEMPLATES FOR USE BY OTHERS IN E-MAIL DIRECT MARKETING CAMPAIGNS (U.S. CLS. 2, 5, 22, 23, 29, 37, 38 AND 50).

CLASS 35—ADVERTISING AND BUSINESS

FOR PROVISION OF INTERNET-RELATED DIRECT E-MAIL MARKETING AND ADVERTISING SERVICES FOR OTHERS INVOLVING THE DELIVERY OF MASS AND CUSTOMIZED E-MAILS, INFORMATIONAL NEWSLETTERS FEATURING INFORMATION OF INTEREST TO THIRD PARTIES, NAMELY, IN THE FIELDS OF FINANCE AND FINANCIAL PRODUCTS AND SERVICES, BUSINESS, POLITICAL DISCOURSE AND POLITICAL CAMPAIGNS, CHARITABLE AND NON-PROFIT INITIATIVES, MEMBERSHIP-BASED ORGANIZATIONS, RELIGION AND RELIGIOUS ORGANIZATIONS, RETAIL GOODS AND SERVICES, WHOLESALE PRODUCTS, HOME IMPROVEMENT, SELF IMPROVEMENT, REAL ESTATE, INSURANCE, MORTGAGE, ADVERTISING AND MARKETING, SOCIAL MEDIA, EDUCATION, SCHOOLS, UNIVERSITIES, PROFESSIONAL SERVICES, LAW, MEDICINE, HEALTHCARE, TECHNOLOGY, COMPUTING, MEDIA AND MEDIA CONTENT, SPECIAL INTERESTS, NATURE WILDLIFE, TRUCKING, NUTRITION, PHARMACEUTICALS, SPAS AND SPA SERVICES, TELECOMMUNICATIONS, BUSINESS AND CONSUMER PRODUCTS AND SERVICES, TRAVEL, AND HOSPITALITY, AND ADVERTISING NEWSLETTERS; E-MAIL LIST MANAGEMENT FOR BUILDING, SEGMENTING, ARRANGING FOR OPT-OUT AND PERMISSION MANAGEMENT FOR USE IN E-MAIL DIRECT MARKETING CAMPAIGNS FOR OTHERS (U.S. CLS. 100, 101 AND 102).

CLASS 42—SCIENTIFIC AND COMPUTER SERVICES

FOR COMPUTER SERVICES, NAMELY, AUTOMATION FOR OTHERS OF E-MAIL DIRECT MARKETING CAMPAIGNS (U.S. CLS. 100 AND 101).

DAVID COLLIER, EXAMINING ATTORNEY

SN 77-650,573. PROTUS IP SOLUTIONS, INC., OTTAWA, CANADA, FILED 1-15-2009.

PROTUS

PRIORITY CLAIMED UNDER SEC. 44(D) ON CANADA APPLICATION NO. 1415900, FILED 10-27-2008, REG. NO. TMA761045, DATED 3-8-2010, EXPIRES 3-8-2025.

OWNER OF U.S. REG. NOS. 3,152,825, 3,161,562 AND 3,190,969.

THE MARK CONSISTS OF THE STYLIZED WORD "PROTUS".

CLASS 16—PAPER GOODS AND PRINTED MATTER

FOR DRAFTING TEMPLATES IN THE NATURE OF E-MAIL AND NEWSLETTER TEMPLATES FOR USE BY OTHERS IN E-MAIL DIRECT MARKETING CAMPAIGNS (U.S. CLS. 2, 5, 22, 23, 29, 37, 38 AND 50).

CLASS 35—ADVERTISING AND BUSINESS

FOR PROVISION OF INTERNET-RELATED DIRECT E-MAIL MARKETING AND ADVERTISING SERVICES FOR OTHERS INVOLVING THE DELIVERY OF MASS AND CUSTOMIZED E-MAILS, INFORMATIONAL NEWSLETTERS FEATURING INFORMATION OF INTEREST TO THIRD PARTIES, NAMELY, IN THE FIELDS OF FINANCE AND FINANCIAL PRODUCTS AND SERVICES, BUSINESS, POLITICAL DISCOURSE AND POLITICAL CAMPAIGNS, CHARITABLE AND NON-PROFIT INITIATIVES, MEMBERSHIP-BASED ORGANIZATIONS, RELIGION AND RELIGIOUS ORGANIZATIONS, RETAIL GOODS AND SERVICES, WHOLESALE PRODUCTS, HOME IMPROVEMENT, SELF IMPROVEMENT, REAL ESTATE, INSURANCE, MORTGAGE, ADVERTISING AND MARKETING, SOCIAL MEDIA, EDUCATION, SCHOOLS, UNIVERSITIES, PROFESSIONAL SERVICES, LAW, MEDICINE, HEALTHCARE, TECHNOLOGY, COMPUTING, MEDIA AND MEDIA CONTENT, SPECIAL INTERESTS, NATURE WILDLIFE, TRUCKING, NUTRITION, PHARMACEUTICALS, SPAS AND SPA SERVICES, TELECOMMUNICATIONS, BUSINESS AND CONSUMER PRODUCTS AND SERVICES, TRAVEL, AND HOSPITALITY, AND ADVERTISING NEWSLETTERS; E-MAIL LIST MANAGEMENT FOR BUILDING, SEGMENTING, ARRANGING FOR OPT-OUT AND PERMISSION MANAGEMENT FOR USE IN E-MAIL DIRECT MARKETING CAMPAIGNS FOR OTHERS (U.S. CLS. 100, 101 AND 102).

CLASS 38—COMMUNICATION

FOR PROVISION OF AN INTERNET-BASED FACSIMILE SOLUTION, NAMELY, FACSIMILE TRANSMISSION AND RETRIEVAL SERVICES, NAMELY, PROVIDING E-MAIL BASED FACSIMILE SERVICES FROM EXISTING E-MAIL ACCOUNTS WITHOUT THE NEED TO HAVE A FACSIMILE MACHINE OR ADDITIONAL HARDWARE OR SOFTWARE; MESSAGING SERVICES, NAMELY, PROVIDING PROCESSING OF HIGH VOLUME VOICE, E-MAIL AND FACSIMILE MESSAGES; TELECOMMUNICATION SERVICES, NAMELY, INTERNET PBX SERVICES (U.S. CLS. 100, 101 AND 104).

CLASS 42—SCIENTIFIC AND COMPUTER SERVICES

FOR COMPUTER SERVICES, NAMELY, AUTOMATION FOR OTHERS OF E-MAIL DIRECT MARKETING CAMPAIGNS (U.S. CLS. 100 AND 101).

DAVID COLLIER, EXAMINING ATTORNEY

SN 77-653,793. GELDA SCIENTIFIC AND INDUSTRIAL DEVELOPMENT CORPORATION, MISSISSAUGA, ONTARIO, CANADA, FILED 1-21-2009.

CASABLANCA

THE MARK CONSISTS OF STANDARD CHARACTERS WITHOUT CLAIM TO ANY PARTICULAR FONT, STYLE, SIZE, OR COLOR.

PRIORITY CLAIMED UNDER SEC. 44(D) ON CANADA APPLICATION NO. 1407160, FILED 8-13-2008, REG. NO. TMA793105, DATED 3-16-2011, EXPIRES 3-16-2026.

CLASS 29—MEATS AND PROCESSED FOODS

FOR (BASED ON 44(E)) PREPARED INDIAN FOOD ENTREES CONSISTING PRIMARILY OF BEANS OR PEAS; PREPARED INDIAN FOOD ENTREES CONSISTING PRIMARILY OF VEGETABLES, NAMELY, PAO BHAJI, PALAK PANEER, AND CHANA MASALA; PREPARED INDIAN FOOD APPETIZERS, NAMELY, POTATO STICKS; PREPARED MAIN COURSE INDIAN FOODS CONSISTING PRIMARILY OF MEAT, FISH, POULTRY OR VEGETABLES, NAMELY, MATAR, MAKHANI, PANEER, PALAK, BHAJI, CHOLLE, RAJIMA, PAKODA, DAL, MASALA (U.S. CL. 46).

CLASS 30—STAPLE FOODS

FOR (BASED ON USE IN COMMERCE) (BASED ON 44(E)) INDIAN FOODS, NAMELY, BAKED GOODS IN THE NATURE OF BREAD, NAMELY, CHAPATTIS; CONDIMENTS USED WITH INDIAN FOODS, NAMELY, CONDIMENTS CONTAINING PICKLED MANGO, GARLIC, AND LEMON; GINGER PUREE; GARLIC PUREE; GARLIC-GINGER PUREE; CHUTNEY; INDIAN FOOD SWEETS, NAMELY, GULAB JAMUN AND ROSSOGOLLA; PREPARED MAIN COURSE INDIAN FOODS CONSISTING PRIMARILY OF PASTA OR RICE, NAMELY, MATAR, MAKHANI, PANEER, PALAK, BHAJI, CHOLLE, RAJIMA, PAKODA, DAL, MASALA; INDIAN FOOD BREAD CONTAINING PANEER (U.S. CL. 46).

FIRST USE 0-0-2008; IN COMMERCE 0-0-2008.

RONALD MCMORROW, EXAMINING ATTORNEY

SN 77-656,553. CHRISTIAN AID, LONDON, ENGLAND,
FILED 1-26-2009.

INSPIRATION

THE MARK CONSISTS OF STANDARD CHARACTERS WITHOUT CLAIM TO ANY PARTICULAR FONT, STYLE, SIZE, OR COLOR.

PRIORITY CLAIMED UNDER SEC. 44(D) ON ERPN CMNTY TM OFC APPLICATION NO. 007380278, FILED 11-10-2008, REG. NO. 007380678, DATED 5-16-2011, EXPIRES 11-10-2018.

CLASS 9—ELECTRICAL AND SCIENTIFIC APPARATUS

FOR MOUSE PADS; ELECTRONIC PUBLICATIONS BEING DOWNLOADABLE FROM THE INTERNET AND RECORDED ON CD-ROM IN THE NATURE OF NEWSPAPERS, NEWSLETTERS, PERIODICALS, JOURNALS AND REPORTS, IN THE FIELD OF POVERTY, MALNUTRITION, HUNGER, DISEASE, SICKNESS AND DISTRESS, AND THEIR ALLEVIATION, AND IN THE FIELDS OF INTERNATIONAL DEVELOPMENT, CLIMATE CHANGE, THE ENVIRONMENT, HUMAN RIGHTS, CONFLICT, GLOBAL DISASTERS, GEOGRAPHY, TRADE, CITIZENSHIP AND FUNDRAISING; DIGITAL MUSIC DOWNLOADABLE FROM THE INTERNET AND RECORDED ON CD-ROM, G3 MOBILE PHONE TRANSMITTED IMAGES, NAMELY, DOWNLOADABLE GRAPHICS FOR MOBILE PHONES; SUNGLASSES (U.S. CLS. 21, 23, 26, 36 AND 38).

CLASS 14—JEWELRY

FOR JEWELRY ALL BEING SOLD FOR CHARITABLE PURPOSES OR FUNDRAISING FOR CHARITABLE PURPOSES ONLY; CHARITY RUBBER OR SILICON WRIST BANDS IN THE NATURE OF A BRACELET (U.S. CLS. 2, 27, 28 AND 50).

CLASS 16—PAPER GOODS AND PRINTED MATTER

FOR PRINTED MATTER, NAMELY, NEWSPAPERS, NEWSLETTERS, PERIODICALS, JOURNALS, BROCHURES, POSTERS, BOOKS, AND PRINTED INSTRUCTIONAL AND TEACHING MATERIALS IN THE FIELD OF POVERTY, MALNUTRITION, HUNGER, DISEASE, SICKNESS AND DISTRESS, AND THEIR ALLEVIATION, AND IN THE FIELDS OF INTERNATIONAL DEVELOPMENT, CLIMATE CHANGE, THE ENVIRONMENT, HUMAN RIGHTS, CONFLICT, GLOBAL DISASTERS, GEOGRAPHY, TRADE, CITIZENSHIP AND FUNDRAISING; PAPER BADGES, CALENDARS, PHOTOGRAPHS; STATIONERY ALL RELATING TO CHARITABLE PURPOSES, CHARITABLE ACTIVITIES, CHARITABLE GOALS OR FUNDRAISING FOR CHARITABLE PURPOSES ONLY (U.S. CLS. 2, 5, 22, 23, 29, 37, 38 AND 50).

CLASS 25—CLOTHING

FOR CLOTHING, NAMELY, TOPS, T-SHIRTS, SWEATSHIRTS, SHIRTS, JUMPERS, BOTTOMS, TROUSERS, SHORTS, SOCKS AND JACKETS, HEADWEAR AND FOOTWEAR (U.S. CLS. 22 AND 39).

CLASS 35—ADVERTISING AND BUSINESS

FOR CHARITABLE SERVICES, NAMELY, PROVIDING VOLUNTEERING PLACEMENT SERVICES AND PROVIDING VOLUNTEERING OPPORTUNITIES FOR COMMUNITY SERVICE PROJECTS; RECRUITMENT OF VOLUNTEERS FOR COMMUNITY SERVICE PROJECTS; PROVISION OF INFORMATION AND ADVICE RELATING TO VOLUNTEERING FOR COMMUNITY SERVICE PROJECTS; CHARITABLE SERVICES, NAMELY, ORGANIZATION AND MANAGEMENT OF ACTIVITIES BY VOLUNTEERS RELATING TO COMMUNITY PROJECTS; PROMOTING PUBLIC AWARENESS OF AND CONDUCTING PUBLIC AWARENESS CAMPAIGNS IN RELATION TO POVERTY, MALNUTRITION, HUNGER, DISEASE, SICKNESS AND DISTRESS, AND THEIR ALLEVIATION, AND IN RELATION TO INTERNATIONAL DEVELOPMENT, CLIMATE CHANGE, THE ENVIRONMENT, HUMAN RIGHTS, CONFLICT, GLOBAL DISASTERS, TRADE, AND CITIZENSHIP; ONLINE RETAIL STORE SERVICES FEATURING JEWELRY FOR CHARITABLE PURPOSES OR FUNDRAISING FOR CHARITABLE PURPOSES ONLY, CHARITY WRIST BANDS, PRINTED MATTER, CAMPAIGNING MATERIALS, CLOTHING, HEADGEAR AND FOOTWEAR, CLOTHING ACCESSORIES, BAGS FOR CHARITABLE PURPOSES OR FUNDRAISING FOR CHARITABLE PURPOSES ONLY, WALLETS FOR CHARITABLE PURPOSES OR FUNDRAISING FOR CHARITABLE PURPOSES ONLY, UMBRELLAS FOR CHARITABLE PURPOSES OR FUNDRAISING FOR CHARITABLE PURPOSES ONLY, BADGES, BALLOONS, VIDEOS, DVDS, CDS, CD ROMS, SUNGLASSES, MUSIC, DOMESTIC AND FARM ANIMALS, FOOD, BEVERAGES, TOILETS, FLAGS, MEDICAL EQUIPMENT, PHARMACEUTICAL PRODUCTS, FIRST AID KITS, INSECT AND MOSQUITO NETS, SEEDS, SEED PRESS, FISHING NETS, WORMS, FERTILIZER, FARM EQUIPMENT, WELLS, BUILDING MATERIALS, GARDENING TOOLS, LIVESTOCK, GAMES FOR CHARITABLE PURPOSES OR FUNDRAISING FOR CHARITABLE PURPOSES ONLY, ELECTRONIC GAMES FOR CHARITABLE PURPOSES OR FUNDRAISING FOR CHARITABLE PURPOSES ONLY, COMPUTER ACCESSORIES, ELECTRONIC PUBLICATIONS, SOFTWARE, DOWNLOADABLE VIDEOS, MOBILE PHONE IMAGES AND RINGS TONES, DESKTOP BACKGROUNDS AND PC SCREENSAVERS, CHRISTMAS TREES AND DECORATIONS FOR CHARITABLE PURPOSES OR FUNDRAISING FOR CHARITABLE PURPOSES ONLY, AND IRRIGATION SYSTEMS; PROMOTION OF FINANCIAL SERVICES, AND EDUCATION AND TRAINING SERVICES, CONSTRUCTION SERVICES AND MEDICAL SERVICES, ON BEHALF OF THIRD PARTIES; POLITICAL LOBBYING SERVICES, NAMELY, PROMOTING THE INTERESTS OF THE POOR IN THE FIELDS OF LEGISLATION AND REGULATION; LOBBYING IN RELATION TO RAISING AWARENESS OF THE EFFECTS OF EXTREME POVERTY, AND THE PROVISION OF INFORMATION IN RELATION TO ALL OF THE FOREGOING SERVICES (U.S. CLS. 100, 101 AND 102).

CLASS 36—INSURANCE AND FINANCIAL

FOR CHARITABLE FUNDRAISING SERVICES; PROVIDING GRANTS FOR THE ALLEVIATION OF POVERTY, MALNUTRITION, HUNGER, DISEASE, SICKNESS OR DISTRESS AND FOR THE PROMOTION OF INTERNATIONAL DEVELOPMENT; DEBIT CARD SERVICES; FINANCIAL MANAGEMENT SERVICES, NAMELY, MANAGEMENT AND MONITORING OF CHARITABLE FUNDS FOR USE IN THE FIELD OF ALLEVIATION OF HUNGER, DISEASE, SICKNESS AND DISTRESS, AND IN RELATION TO INTERNATIONAL DEVELOPMENT, CLIMATE CHANGE, THE ENVIRONMENT, HUMAN RIGHTS, CONFLICT, GLOBAL DISASTERS, GEOGRAPHY, TRADE AND CITIZENSHIP; FINANCIAL CONSULTING SERVICES IN THE FIELD OF PLANNED GIVING FOR NON-PROFIT AND CHARITABLE ORGANIZATIONS; TAX PAYMENT PROCESSING SERVICES AND PAYMENT OF THOSE FUNDS TO THE CHARITY; INVESTMENT TRUST SERVICES; BANKING SERVICES, NAMELY, DEPOSIT TAKING SERVICES; ON-LINE FINANCIAL SERVICES, NAMELY, CREDIT CARD SERVICES, PAYROLL GIVING AND DIRECT DEBIT SERVICES (U.S. CLS. 100, 101 AND 102).

SN 77-656,569. CHRISTIAN AID, LONDON, ENGLAND, FILED 1-26-2009.

**INSPIRATION. STOP
POVERTY. START HERE.**

THE MARK CONSISTS OF STANDARD CHARACTERS WITHOUT CLAIM TO ANY PARTICULAR FONT, STYLE, SIZE, OR COLOR.

PRIORITY CLAIMED UNDER SEC. 44(D) ON ERPN CMNTY TM OFC APPLICATION NO. 007387707, FILED 11-12-2008, REG. NO. 007387707, DATED 5-16-2011, EXPIRES 11-12-2018.

CLASS 41—EDUCATION AND ENTERTAINMENT

FOR PRODUCTION OF VIDEO, RADIO AND TELEVISION PROGRAMMES AND STREAMED VIDEOS FOR ONLINE USE; EDUCATIONAL AND TRAINING SERVICES, NAMELY, PROVIDING COURSES, CLASSES AND WORKSHOPS ALL IN THE FIELDS OF POVERTY, MALNUTRITION, HUNGER, DISEASE, SICKNESS AND DISTRESS, AND THEIR ALLEVIATION, AND IN THE FIELDS OF INTERNATIONAL DEVELOPMENT, CLIMATE CHANGE, THE ENVIRONMENT, HUMAN RIGHTS, CONFLICT, GLOBAL DISASTERS, GEOGRAPHY, TRADE, CITIZENSHIP AND FUNDRAISING; PUBLISHING OF BOOKS, TEXTS, LEAFLETS, REPORTS, NEWSPAPERS, NEWSLETTERS AND MAGAZINES; PROVIDING ELECTRONIC COMPUTER GAMES SERVICES PROVIDED VIA THE INTERNET, PROVISION OF ON-LINE PUBLICATIONS, NAMELY, NEWSPAPERS, NEWSLETTERS, PERIODICALS, JOURNALS AND REPORTS, IN THE FIELD OF POVERTY, MALNUTRITION, HUNGER, DISEASE, SICKNESS AND DISTRESS, AND THEIR ALLEVIATION, AND IN THE FIELDS OF INTERNATIONAL DEVELOPMENT, CLIMATE CHANGE, THE ENVIRONMENT, HUMAN RIGHTS, CONFLICT, GLOBAL DISASTERS, GEOGRAPHY, TRADE, CITIZENSHIP AND FUNDRAISING, AND PROVISION OF NON-DOWNLOADABLE PRE-RECORDED DIGITAL MUSIC FROM THE INTERNET; ORGANIZING EDUCATIONAL SEMINARS, CONFERENCES AND EXHIBITIONS ALL IN THE FIELDS OF POVERTY, MALNUTRITION, HUNGER, DISEASE, SICKNESS AND DISTRESS, AND THEIR ALLEVIATION, AND IN THE FIELDS OF INTERNATIONAL DEVELOPMENT, CLIMATE CHANGE, THE ENVIRONMENT, HUMAN RIGHTS, CONFLICT, GLOBAL DISASTERS, GEOGRAPHY, TRADE, CITIZENSHIP AND FUNDRAISING (U.S. CLS. 100, 101 AND 107).

CLASS 44—MEDICAL, BEAUTY AND AGRICULTURAL SERVICES

FOR HEALTH CARE SERVICES, NAMELY, HEALTH SCREENING; INFORMATION AND ADVISORY SERVICES RELATING TO HEALTH; COUNSELING RELATING TO NUTRITION AND DIETARY NEEDS; MEDICAL AND PSYCHOLOGICAL COUNSELING (U.S. CLS. 100 AND 101).

AMY HELLA, EXAMINING ATTORNEY

CLASS 9—ELECTRICAL AND SCIENTIFIC APPARATUS

FOR MOUSE PADS; ELECTRONIC PUBLICATIONS BEING DOWNLOADABLE FROM THE INTERNET AND RECORDED ON CD-ROM IN THE NATURE OF NEWSPAPERS, NEWSLETTERS, PERIODICALS, JOURNALS AND REPORTS, IN THE FIELD OF POVERTY, MALNUTRITION, HUNGER, DISEASE, SICKNESS AND DISTRESS, AND THEIR ALLEVIATION, AND IN THE FIELDS OF INTERNATIONAL DEVELOPMENT, CLIMATE CHANGE, THE ENVIRONMENT, HUMAN RIGHTS, CONFLICT, GLOBAL DISASTERS, GEOGRAPHY, TRADE, CITIZENSHIP AND FUNDRAISING; DIGITAL MUSIC DOWNLOADABLE FROM THE INTERNET AND RECORDED ON CD-ROM, G3 MOBILE PHONE TRANSMITTED IMAGES, NAMELY, DOWNLOADABLE GRAPHICS FOR MOBILE PHONES; SUN GLASSES (U.S. CLS. 21, 23, 26, 36 AND 38).

CLASS 14—JEWELRY

FOR JEWELRY ALL BEING SOLD FOR CHARITABLE PURPOSES OR FUNDRAISING FOR CHARITABLE PURPOSES ONLY; CHARITY RUBBER OR SILICON WRIST BANDS IN THE NATURE OF A BRACELET (U.S. CLS. 2, 27, 28 AND 50).

CLASS 16—PAPER GOODS AND PRINTED MATTER

FOR PRINTED MATTER, NAMELY, NEWSPAPERS, NEWSLETTERS, PERIODICALS, JOURNALS, BROCHURES, POSTERS, BOOKS, AND PRINTED INSTRUCTIONAL AND TEACHING MATERIALS IN THE FIELD OF POVERTY, MALNUTRITION, HUNGER, DISEASE, SICKNESS AND DISTRESS, AND THEIR ALLEVIATION, AND IN THE FIELDS OF INTERNATIONAL DEVELOPMENT, CLIMATE CHANGE, THE ENVIRONMENT, HUMAN RIGHTS, CONFLICT, GLOBAL DISASTERS, GEOGRAPHY, TRADE, CITIZENSHIP AND FUNDRAISING; PAPER BADGES, CALENDARS, PHOTOGRAPHS; STATIONERY ALL RELATING TO CHARITABLE PURPOSES, CHARITABLE ACTIVITIES, CHARITABLE GOALS OR FUNDRAISING FOR CHARITABLE PURPOSES ONLY (U.S. CLS. 2, 5, 22, 23, 29, 37, 38 AND 50).

CLASS 25—CLOTHING

FOR CLOTHING, NAMELY, TOPS, T-SHIRTS, SWEATSHIRTS, SHIRTS, JUMPERS, BOTTOMS, TROUSERS, SHORTS, SOCKS AND JACKETS, HEADWEAR AND FOOTWEAR (U.S. CLS. 22 AND 39).

CLASS 35—ADVERTISING AND BUSINESS

FOR CHARITABLE SERVICES, NAMELY, PROVIDING VOLUNTEERING PLACEMENT SERVICES AND PROVIDING VOLUNTEERING OPPORTUNITIES FOR COMMUNITY SERVICE PROJECTS; RECRUITMENT OF VOLUNTEERS FOR COMMUNITY SERVICE PROJECTS; PROVISION OF INFORMATION AND ADVICE RELATING TO VOLUNTEERING FOR COMMUNITY SERVICE PROJECTS; CHARITABLE SERVICES, NAMELY, ORGANIZATION AND MANAGEMENT OF ACTIVITIES BY VOLUNTEERS RELATING TO COMMUNITY PROJECTS; PROMOTING PUBLIC AWARENESS OF AND CONDUCTING PUBLIC AWARENESS CAMPAIGNS IN RELATION TO POVERTY, MALNUTRITION, HUNGER, DISEASE, SICKNESS AND DISTRESS, AND THEIR ALLEVIATION, AND IN RELATION TO INTERNATIONAL DEVELOPMENT, CLIMATE CHANGE, THE ENVIRONMENT, HUMAN RIGHTS, CONFLICT, GLOBAL DISASTERS, TRADE, AND CITIZENSHIP; ONLINE RETAIL STORE SERVICES FEATURING JEWELRY FOR CHARITABLE PURPOSES OR FUNDRAISING FOR CHARITABLE PURPOSES ONLY, CHARITY WRIST BANDS, PRINTED MATTER, CAMPAIGNING MATERIALS, CLOTHING, HEADGEAR AND FOOTWEAR, CLOTHING ACCESSORIES, BAGS FOR CHARITABLE PURPOSES OR FUNDRAISING FOR CHARITABLE PURPOSES ONLY, WALLETTS FOR CHARITABLE PURPOSES OR FUNDRAISING FOR CHARITABLE PURPOSES ONLY, UMBRELLAS FOR CHARITABLE PURPOSES OR FUNDRAISING FOR CHARITABLE PURPOSES ONLY, BADGES, BALLOONS, VIDEOS, DVDS, CDS, CD ROMS, SUNGLASSES, MUSIC, DOMESTIC AND FARM ANIMALS, FOOD, BEVERAGES, TOILETS, FLAGS, MEDICAL EQUIPMENT, PHARMACEUTICAL PRODUCTS, FIRST AID KITS, INSECT AND MOSQUITO NETS, SEEDS, SEED PRESS, FISHING NETS, WORMS, FERTILIZER, FARM EQUIPMENT, WELLS, BUILDING MATERIALS, GARDENING TOOLS, LIVESTOCK, GAMES FOR CHARITABLE PURPOSES OR FUNDRAISING FOR CHARITABLE PURPOSES ONLY, ELECTRONIC GAMES FOR CHARITABLE PURPOSES OR FUNDRAISING FOR CHARITABLE PURPOSES ONLY, COMPUTER ACCESSORIES, ELECTRONIC PUBLICATIONS, SOFTWARE, DOWNLOADABLE VIDEOS, MOBILE PHONE IMAGES AND RINGS TONES, DESKTOP BACKGROUNDS AND PC SCREENSAVERS, CHRISTMAS TREES AND DECORATIONS FOR CHARITABLE PURPOSES OR FUNDRAISING FOR CHARITABLE PURPOSES ONLY, AND IRRIGATION SYSTEMS; PROMOTION OF FINANCIAL SERVICES, AND EDUCATION AND TRAINING SERVICES, CONSTRUCTION SERVICES AND MEDICAL SERVICES, ON BEHALF OF THIRD PARTIES; POLITICAL LOBBYING SERVICES, NAMELY, PROMOTING THE INTERESTS OF THE POOR IN THE FIELDS OF LEGISLATION AND REGULATION; LOBBYING IN RELATION TO RAISING AWARENESS OF THE EFFECTS OF EXTREME POVERTY, AND THE PROVISION OF INFORMATION IN RELATION TO ALL OF THE FOREGOING SERVICES (U.S. CLS. 100, 101 AND 102).

CLASS 36—INSURANCE AND FINANCIAL

FOR CHARITABLE FUNDRAISING SERVICES; PROVIDING GRANTS FOR THE ALLEVIATION OF POVERTY, MALNUTRITION, HUNGER, DISEASE, SICKNESS OR DISTRESS AND FOR THE PROMOTION OF INTERNATIONAL DEVELOPMENT; DEBIT CARD SERVICES; FINANCIAL MANAGEMENT SERVICES, NAMELY, MANAGEMENT AND MONITORING OF CHARITABLE FUNDS FOR USE IN THE FIELD OF ALLEVIATION OF HUNGER, DISEASE, SICKNESS AND DISTRESS, AND IN RELATION TO INTERNATIONAL DEVELOPMENT, CLIMATE CHANGE, THE ENVIRONMENT, HUMAN RIGHTS, CONFLICT, GLOBAL DISASTERS, GEOGRAPHY, TRADE AND CITIZENSHIP; FINANCIAL CONSULTING SERVICES IN THE FIELD OF PLANNED GIVING FOR NON-PROFIT AND CHARITABLE ORGANIZATIONS; TAX PAYMENT PROCESSING SERVICES AND PAYMENT OF THOSE FUNDS TO THE CHARITY; INVESTMENT TRUST SERVICES; BANKING SERVICES, NAMELY, DEPOSIT TAKING SERVICES; ON-LINE FINANCIAL SERVICES, NAMELY, CREDIT CARD SERVICES, PAYROLL GIVING AND DIRECT DEBIT SERVICES (U.S. CLS. 100, 101 AND 102).

CLASS 41—EDUCATION AND ENTERTAINMENT

FOR PRODUCTION OF VIDEO, RADIO AND TELEVISION PROGRAMMES AND STREAMED VIDEOS FOR ONLINE USE; EDUCATIONAL AND TRAINING SERVICES, NAMELY, PROVIDING COURSES, CLASSES AND WORKSHOPS ALL IN THE FIELDS OF POVERTY, MALNUTRITION, HUNGER, DISEASE, SICKNESS AND DISTRESS, AND THEIR ALLEVIATION, AND IN THE FIELDS OF INTERNATIONAL DEVELOPMENT, CLIMATE CHANGE, THE ENVIRONMENT, HUMAN RIGHTS, CONFLICT, GLOBAL DISASTERS, GEOGRAPHY, TRADE, CITIZENSHIP AND FUNDRAISING; PUBLISHING OF BOOKS, TEXTS, LEAFLETS, REPORTS, NEWSPAPERS, NEWSLETTERS AND MAGAZINES; PROVIDING ELECTRONIC COMPUTER GAMES SERVICES PROVIDED VIA THE INTERNET, PROVISION OF ON-LINE PUBLICATIONS, NAMELY, NEWSPAPERS, NEWSLETTERS, PERIODICALS, JOURNALS AND REPORTS, IN THE FIELD OF POVERTY, MALNUTRITION, HUNGER, DISEASE, SICKNESS AND DISTRESS, AND THEIR ALLEVIATION, AND IN THE FIELDS OF INTERNATIONAL DEVELOPMENT, CLIMATE CHANGE, THE ENVIRONMENT, HUMAN RIGHTS, CONFLICT, GLOBAL DISASTERS, GEOGRAPHY, TRADE, CITIZENSHIP AND FUNDRAISING, AND PROVISION OF NON-DOWNLOADABLE PRE-RECORDED DIGITAL MUSIC FROM THE INTERNET; ORGANIZING EDUCATIONAL SEMINARS, CONFERENCES AND EXHIBITIONS ALL IN THE FIELDS OF POVERTY, MALNUTRITION, HUNGER, DISEASE, SICKNESS AND DISTRESS, AND THEIR ALLEVIATION, AND IN THE FIELDS OF INTERNATIONAL DEVELOPMENT, CLIMATE CHANGE, THE ENVIRONMENT, HUMAN RIGHTS, CONFLICT, GLOBAL DISASTERS, GEOGRAPHY, TRADE, CITIZENSHIP AND FUNDRAISING (U.S. CLS. 100, 101 AND 107).

CLASS 44—MEDICAL, BEAUTY AND AGRICULTURAL SERVICES

FOR HEALTH CARE SERVICES, NAMELY, HEALTH SCREENING; INFORMATION AND ADVISORY SERVICES RELATING TO HEALTH; COUNSELING RELATING TO NUTRITION AND DIETARY NEEDS; MEDICAL AND PSYCHOLOGICAL COUNSELING (U.S. CLS. 100 AND 101).

AMY HELLA, EXAMINING ATTORNEY

SN 77-668,482. MTU AERO ENGINES GMBH, 80995 MÜNICH, FED REP GERMANY, FILED 2-11-2009.



PRIORITY CLAIMED UNDER SEC. 44(D) ON FED REP GERMANY APPLICATION NO. 302008053398, FILED 8-12-2008, REG. NO. 302008053398, DATED 8-12-2008, EXPIRES 8-31-2018.

OWNER OF U.S. REG. NO. 3,147,090.

THE MARK CONSISTS OF THREE PARTIALLY JUXTAPOSED CRESCENT SHAPES.

CLASS 7—MACHINERY

FOR AEROPLANE ENGINES, NAMELY, JET ENGINES AND TURBOPROP ENGINES; GAS TURBINE ENGINES NOT FOR LAND VEHICLES AND PARTS THEREFOR, NAMELY, SHAFT OUTPUT DRIVING GEARS, TURBO BLOWERS, EXHAUST GAS TURBOCHARGERS, MECHANICALLY DRIVEN COMPRESSORS, BRUSHES; TRANSMISSION COMPONENTS EXCEPT FOR LAND VEHICLES, NAMELY, HYDRAULIC TRANSMISSION COMPONENTS FOR AIRCRAFT ENGINES, NAMELY, PUMPS, VALVES, LINES AND HOSES AND MACHINE COUPLINGS, CENTRIFUGES, BEARINGS AND BUSHINGS FOR SHAFTS, AXLES, ROTORS; OIL AND FUEL FILTERS, FILTERS FOR USE IN AIRCRAFT ENGINES AND GAS TURBINES; LIQUID PUMPS FOR OIL AND WATER AND FUEL PUMPS FOR AIRCRAFT ENGINES, PUMP DRIVING GEARS; RADIAL AND AXIAL BLOWERS AND FANS BEING ENGINE PARTS; GUIDE GRIDS FOR TURBO ENGINES; GAS FLOW CONTROLS FOR USE IN AIRCRAFT ENGINES AND GAS TURBINES, NAMELY, GAS REGULATORS, THROTTLES AND NOZZLES, AXIAL AND RADIAL TURBINES; SOUND ABSORBERS, NAMELY, MUFFLERS; FUEL PIPES BEING ENGINE PARTS, FUEL INJECTION PUMPS, NOZZLES AND VALVES; PNEUMATIC STARTING MOTORS, FIXED AND DETACHABLE MACHINE COUPLINGS, COGGED WHEELS BEING ENGINE PARTS, MOTOR STARTERS, IGNITERS FOR IGNITING A FUEL MIXTURE IN AN INTERNAL COMBUSTION ENGINE, IGNITION APPARATUS, NAMELY, SPARK PLUGS; PROFILED TUBES AND MANIFOLDS FOR USE IN AIRCRAFT ENGINES AND GAS TURBINES; HOUSINGS AND ASSEMBLY DEVICES FOR DRIVES, NAMELY, MACHINE TOOLS FOR ASSEMBLING DRIVES; CONTROL GEAR, NAMELY, HYDRAULIC AND PNEUMATIC CONTROLS FOR AIRCRAFT ENGINES AND GAS TURBINES; GASKETS AND SEALING RINGS, NAMELY, LABYRINTH AND AXIAL FACE END GASKETS AND SEALING RINGS BEING ENGINE PARTS; COMPRESSOR ROTORS FOR AIRCRAFT TURBO ENGINES AND AIRCRAFT GAS TURBINES; DISCS, NAMELY, ROTOR AND BLADE WHEELS FOR AIRCRAFT; STATORS, NAMELY, DEVICES WHERE STATOR BLADES ARE PLACED BEING ENGINE PARTS; HOUSINGS, NAMELY, CASES FOR AIRCRAFT TURBO ENGINE AND AIRCRAFT GAS TURBINES; BLADES FOR AIRCRAFT TURBO ENGINES; PROPELLING NOZZLES FOR FLIGHT DRIVES; STRUCTURAL PARTS AND COMPONENT PARTS FOR THE AFORESAID GOODS ALL SOLD AS A UNIT; COMPONENT PARTS OF TURBO ENGINES MADE OF FIBER REINFORCED COMPOSITES, CERAMICS AND METALS, NAMELY, TURBINE SHAFTS, ROTOR WHEELS AND BLADES, STATOR BLADES AND CASINGS, ALL FOR AIRCRAFT ENGINES AND AIRCRAFT TURBINES; METAL WORKING MACHINES; ENGINE AND TURBINE PARTS, NAMELY, OIL, FUEL AND COOLANT COOLERS FOR AIRCRAFT ENGINES AND GAS TURBINES; AND RADIATORS FOR AIRCRAFT ENGINES AND GAS TURBINES; FLAME ARRESTORS USED TO PREVENT THE SPREAD OF FLAMES FROM THE THRUST CHAMBERS OF JET ENGINES; BURNERS, NAMELY, JET BURNERS FOR TURBINE ENGINE AND GAS TURBINES (U.S. CLS. 13, 19, 21, 23, 31, 34 AND 35).

CLASS 9—ELECTRICAL AND SCIENTIFIC APPARATUS

FOR ELECTRONIC REGULATING, CONTROL AND MONITORING DEVICES AND INSTRUMENTS, NAMELY, ELECTRONICALLY CONTROLLED REGULATING VALVES, ELECTRONICALLY CONTROLLED CONTROL VALVES, ELECTRONIC SENSORS, ELECTRONIC INDICATORS AND COMPUTERS FOR FUEL FEED OF AEROPLANE ENGINES AND GAS TURBINES; TESTING, DIAGNOSIS AND PROGNOSIS SYSTEMS COMPRISED OF SENSORS, DATA RECORDERS, DATA ANALYZERS, TEST SIGNAL GENERATORS AND COMPUTERS FOR AEROPLANE ENGINES AND GAS TURBINES; ELECTRONIC AND ELECTRIC REGULATORS, NAMELY, VOLTAGE REGULATORS, ELECTRIC CURRENT REGULATORS AND FREQUENCY REGULATORS, ELECTRONIC CONTROL DEVICES AND INSTRUMENTS, NAMELY, ELECTRONIC CONTROLLERS FOR AERO ENGINES AND GAS TURBINES; PROTECTIVE EYEGLASSES; FUEL GAUGES; FUEL REGULATORS, NAMELY, REGULATORS FOR FUEL PRESSURE OR FUEL FLOW USED IN AIRCRAFT ENGINES AND GAS TURBINES (U.S. CLS. 21, 23, 26, 36 AND 38).

CLASS 11—ENVIRONMENTAL CONTROL APPARATUS

FOR COMBUSTION CHAMBERS (U.S. CLS. 13, 21, 23, 31 AND 34).

CLASS 16—PAPER GOODS AND PRINTED MATTER

FOR PAPER, CARDBOARD AND GOODS MADE OF THESE MATERIALS, NAMELY, PACKAGING, WRAPPING AND PACKING MATERIALS; PRINTED MATTER, NAMELY, PROSPECTUSES, PAMPHLETS, BOOKS, MANUALS, NEWSLETTERS, REPORTS, JOURNALS, TEACHING MATERIAL AND LEAFLETS, CATALOGS, BROCHURES, NEWSPAPERS AND MAGAZINES IN THE FIELD OF AERO ENGINES AND GAS TURBINES AS WELL AS PARTS THEREOF, AND WITH REGARD TO DESIGN, DEVELOPMENT, MANUFACTURE, REPAIR, MAINTENANCE, SERVICE, ASSEMBLY, DISMANTLING, OVERHAULING AND TESTING OF AERO ENGINES AND GAS TURBINES AS WELL AS PARTS THEREOF; BOOKBINDING MATERIALS; PHOTOGRAPHS; STATIONERY; OFFICE REQUISITES, NAMELY, PAPER PADS, PENS, PENCILS AND FELT MARKERS; PRINTED INSTRUCTIONAL AND TEACHING MATERIAL IN THE FIELD OF AERO ENGINES AND GAS TURBINES AS WELL AS PARTS THEREOF, AND WITH REGARD TO DESIGN, DEVELOPMENT, MANUFACTURE, REPAIR, MAINTENANCE, SERVICE, ASSEMBLY, DISMANTLING, OVERHAULING AND TESTING OF AERO ENGINES AND GAS TURBINES AS WELL AS PARTS THEREOF (U.S. CLS. 2, 5, 22, 23, 29, 37, 38 AND 50).

CLASS 17—RUBBER GOODS

FOR PLASTIC MATERIALS FOR PACKING, NAMELY, PLASTIC FILM FOR WRAPPING AND WEATHER-SEALING AIRCRAFT ENGINES, GAS TURBINES AND PARTS THEREOF, EXPANDED PLASTIC PELLETS FOR PACKAGING, PLASTIC BUBBLE PACKS FOR WRAPPING OR PACKAGING (U.S. CLS. 1, 5, 12, 13, 35 AND 50).

CLASS 25—CLOTHING

FOR CLOTHING, NAMELY, T-SHIRTS, FLEECE JACKETS, RAIN JACKETS; HEADGEAR, NAMELY, BASEBALL CAPS (U.S. CLS. 22 AND 39).

CLASS 37—CONSTRUCTION AND REPAIR

FOR REPAIR, MAINTENANCE, DISASSEMBLY, RESTORATION, SERVICING, AND OVERHAUL OF AEROPLANE ENGINES AND GAS TURBINES, AND PARTS THEREFOR (U.S. CLS. 100, 103 AND 106).

CLASS 40—MATERIAL TREATMENT

FOR TREATMENT OF METALS, CERAMICS AND COMPOSITE MATERIALS NAMELY, CARBON FIBER REINFORCED POLYMER RESIN MATRIX COMPOSITES; WORKING OF METALS, NAMELY, BROACHING, MILL CUTTING, DRILLING, NAMELY, LASER DRILLING OF METAL, ECF DRILLING, NAMELY, ECCENTRIC CUTTING FRAME DRILLING, GRINDING AND ABRADING; ELECTROPLATING; SOLDERING; WELDING, NAMELY, INERTIA FRICTION WELDING, LINEAR FRICTION WELDING AND HIGH FREQUENCY INDUCTION WELDING; COATING BY ELECTROPLATING; REMOVAL OF PROTECTIVE COATINGS; APPLICATION OF PROTECTIVE COATINGS; METAL CASTING; METAL TEMPERING; CUSTOM MANUFACTURE OF AERO ENGINES, NAMELY, JET ENGINES AND PROPELLER TURBO JET ENGINES, GAS TURBINES, NAMELY, SHAFT OUTPUT ENGINES AND PARTS THEREOF, NAMELY, TURBO COMPRESSORS, TURBO CHARGER, MECHANICALLY DRIVEN COMPRESSORS, TRANSMISSION COMPONENTS, LIQUID AND FUEL PUMPS, PUMP DRIVES, RADIAL AND AXIAL BLOWERS, FANS, GUIDE GRIDS FOR TURBO ENGINES, GAS FLOW CONTROL, AXIAL AND RADIAL TURBINES, SOUND ABSORBERS, FUEL PIPES, FUEL REGULATORS, FUEL GAUGE DEVICES, FUEL INJECTION PUMPS, NOZZLE AND VALVES, PNEUMATIC STARTING MOTORS, FIXED AND DETACHABLE MACHINE COUPLINGS, HYDRAULIC TRANSMISSION COMPONENTS AND COUPLINGS, OIL AND FUEL FILTERS, FLUID FILTERS, CENTRIFUGES, BEARINGS FOR SHAFTS, AXLES, ROTORS AND TRANSMISSION COMPONENTS, COGGED WHEELS, IGNITERS, IGNITION DEVICES, PROFILED TUBES AND MANIFOLDS, HOUSINGS, ASSEMBLY DEVICES FOR DRIVES, CONTROL GEAR, GASKETS, NAMELY, BRUSHES, LABYRINTH AND ROTATING MECHANICAL SEAL, GASKET RINGS, COMPRESSOR ROTORS, DISCS, STATORS, ROTORS, INTEGRALLY BLADED ROTORS AND HOUSINGS FOR TURBO ENGINES, BLADES, NAMELY, VANES AND ROTOR BLADES FOR TURBO ENGINES, AND THRUST-NOZZLES FOR AERO ENGINES AS WELL AS COMPONENTS AND PARTS OF THE AFORESAID GOODS; MANUFACTURE AND ASSEMBLY OF AEROPLANE ENGINES AND GAS TURBINES, AND PARTS THEREFOR (U.S. CLS. 100, 103 AND 106).

CLASS 41—EDUCATION AND ENTERTAINMENT

FOR EDUCATION, NAMELY, PROVIDING SEMINARS, WORKSHOPS, SYMPOSIA AND TRAINING COURSES IN THE FIELD OF AERO ENGINES AND GAS TURBINES AS WELL AS PARTS THEREOF, AND WITH REGARD TO DESIGN, DEVELOPMENT, MANUFACTURE, REPAIR, MAINTENANCE, SERVICE, ASSEMBLY, DISMANTLING, OVERHAULING AND TESTING OF AERO ENGINES AND GAS TURBINES AS WELL AS PARTS THEREOF; PROVIDING ONLINE NON-DOWNLOADABLE PUBLICATIONS IN THE NATURE OF MAGAZINES, MANUALS, NEWSPAPERS, IN THE FIELD OF AERO ENGINES AND GAS TURBINES AS WELL AS PARTS THEREOF, AND WITH REGARD TO DESIGN, DEVELOPMENT, MANUFACTURE, REPAIR, MAINTENANCE, SERVICE, ASSEMBLY, DISMANTLING, OVERHAULING AND TESTING OF AERO ENGINES AND GAS TURBINES AS WELL AS PARTS THEREOF; DESKTOP PUBLISHING FOR OTHERS (U.S. CLS. 100, 101 AND 107).

CLASS 42—SCIENTIFIC AND COMPUTER SERVICES

FOR TECHNOLOGICAL CONSULTANCY IN THE FIELD OF AEROPLANE ENGINES AND GAS TURBINES, AND PARTS THEREFOR AND WITH REGARD TO THE DESIGN, DEVELOPMENT, MANUFACTURE, REPAIR, MAINTENANCE, INSPECTION, ASSEMBLY, DISASSEMBLY, RESTORATION, SERVICING, OVERHAUL AND TESTING OF AEROPLANE ENGINES AND GAS TURBINES, AND PARTS THEREFOR; SCIENTIFIC AND INDUSTRIAL RESEARCH IN THE FIELD OF AEROPLANE ENGINES AND GAS TURBINES, AND PARTS THEREFOR, AND WITH REGARD TO THE DESIGN, DEVELOPMENT, MANUFACTURE, REPAIR,

MAINTENANCE, INSPECTION, ASSEMBLY, DISASSEMBLY, RESTORATION, SERVICING, OVERHAUL AND TESTING OF AEROPLANE ENGINES AND GAS TURBINES, AND PARTS THEREFOR; MONITORING, DIAGNOSIS AND PROGNOSIS FOR AEROPLANE ENGINES, NAMELY, JET ENGINES, PROPELLER TURBOJET ENGINES, GAS TURBINES AND PARTS THEREFOR; DESIGN, MAINTENANCE, DEVELOPMENT AND UPDATING OF COMPUTER SOFTWARE PROGRAMS FOR DATA AND INFORMATION PROCESSING; RESEARCH AND DEVELOPMENT IN THE FIELD OF PRINCIPLES AND PROPERTIES OF PHYSICAL MATERIALS AND IN THE FIELD OF CONSTRUCTION PRINCIPLES; ENGINEERING SERVICES IN THE AFORESAID FIELDS; ENGINEERING PROJECT MANAGEMENT SERVICES RELATING TO ENGINEERING PROJECTS; DEVELOPMENT OF TECHNICAL COMPUTATION AND ANALYSIS PROCEDURES RELATING TO ENGINEERING PROJECTS; ENGINEERING SERVICES, NAMELY, CONDUCTING AND DEVELOPMENT OF STRUCTURAL DAMAGE ANALYSES; DESIGN, DEVELOPMENT AND TESTING OF AEROPLANE ENGINES, NAMELY, JET ENGINES, PROPELLER TURBOJET ENGINES, GAS TURBINES, NAMELY, SHAFT OUTPUT DRIVING GEAR AND PARTS THEREFOR, NAMELY, TURBO COMPRESSORS, EXHAUST GAS TURBOCHARGERS, MECHANICALLY DRIVEN COMPRESSORS, TRANSMISSION COMPONENTS, LIQUID AND FUEL PUMPS, PUMP DRIVING GEAR, RADIAL AND AXIAL BLOWERS, FANS, GUIDE GRIDS FOR TURBO ENGINES, GAS FLOW CONTROLS, AXIAL AND RADIAL TURBINES, SOUND ABSORBERS, FUEL PIPES, FUEL REGULATORS, FUEL GAUGE DEVICES, FUEL INJECTION PUMPS, NOZZLES AND VALVES, PNEUMATIC STARTING MOTORS, FIXED AND DETACHABLE MACHINE COUPLINGS, HYDRAULIC TRANSMISSION COMPONENTS AND MACHINE COUPLINGS, OIL AND FUEL FILTERS, LIQUID FILTERS, CENTRIFUGES, BEARINGS FOR SHAFTS, AXLES, ROTORS AND TRANSMISSION COMPONENTS, COGGED WHEELS, IGNITERS, IGNITION DEVICES, PROFILE AND DISTRIBUTOR PIPES, MACHINE HOUSINGS, ASSEMBLY DEVICES FOR DRIVING GEAR, CONTROL GEAR, GASKETS, NAMELY, BRUSHES, LABYRINTH AND AXIAL FACE ENDS, SEALING RINGS, COMPRESSOR ROTORS, DISCS, STATORS, ROTORS, INTEGRAL ROTORS AND HOUSINGS, NAMELY, FOR TURBO ENGINES, BLADES, NAMELY, GUIDE BLADES AND MOVING ROTOR BLADES FOR TURBO ENGINES, PROPELLING NOZZLES FOR AEROPLANE ENGINES, AND COMPONENTS FOR THE AFORESAID GOODS; DESIGN, DEVELOPMENT, INSPECTION AND TESTING OF AEROPLANE ENGINES AND GAS TURBINES, AND PARTS THEREFOR (U.S. CLS. 100 AND 101).

FONG HSU, EXAMINING ATTORNEY

SN 77-674,923. CITY PUBLIC SERVICE, SAN ANTONIO, TX.
FILED 2-20-2009.

SOLARTRICITY

THE MARK CONSISTS OF STANDARD CHARACTERS WITHOUT CLAIM TO ANY PARTICULAR FONT, STYLE, SIZE, OR COLOR.

CLASS 35—ADVERTISING AND BUSINESS

FOR PROCUREMENT, NAMELY, PURCHASING SOLAR GENERATED ELECTRICITY FOR OTHERS; RETAIL DISTRIBUTORSHIPS FEATURING SOLAR GENERATED ELECTRICITY (U.S. CLS. 100, 101 AND 102).

CLASS 39—TRANSPORTATION AND STORAGE

FOR SOLAR GENERATED ELECTRICITY DISTRIBUTION; UTILITY SERVICES, NAMELY, TRANSMISSION OF SOLAR GENERATED ELECTRICITY (U.S. CLS. 100 AND 105).

ESTHER A. BORSUK, EXAMINING ATTORNEY

SN 77-709,614. URRUTICOECHEA VELASCO, JOSE IGNACIO, ALHAURIN DE LA TORRE, SPAIN, FILED 4-8-2009.



SN 77-685,230. ALIBABA GROUP HOLDING LIMITED, GEORGE TOWN, GRAND CAYMAN, CAYMAN ISLANDS, FILED 3-6-2009.

ALI-ADVANCE

THE MARK CONSISTS OF STANDARD CHARACTERS WITHOUT CLAIM TO ANY PARTICULAR FONT, STYLE, SIZE, OR COLOR.

OWNER OF TAIWAN REG. NO. 01402039, DATED 3-16-2010, EXPIRES 3-15-2020.

NO CLAIM IS MADE TO THE EXCLUSIVE RIGHT TO USE "ESCUELA GNOSTICA", APART FROM THE MARK AS SHOWN.

THE COLOR(S) BROWN IS/ARE CLAIMED AS A FEATURE OF THE MARK.

THE MARK CONSISTS OF THREE BROWN SPIRALS SURROUNDING A CENTRAL BROWN DOT WHICH ARE ENCLOSED BY A BROWN SQUARE OVERLAPPING A BROWN TRIANGLE WHICH ARE ENCLOSED BY A BROWN CIRCLE WITH BROWN ARROWS POINTING IN A CLOCKWISE PATTERN AROUND THE CIRCLE WITH THE WORDS "ESCUELA GNOSTICA UNIVERSAL (E.G.U.)" IN BROWN SURROUNDING THE OUTER PERIMETER OF THE CIRCLE.

THE ENGLISH TRANSLATION OF "ESCUELA GNOSTICA UNIVERSAL" IN THE MARK IS "UNIVERSAL GNOSTIC SCHOOL".

CLASS 35—ADVERTISING AND BUSINESS

FOR ADVERTISING (U.S. CLS. 100, 101 AND 102).

CLASS 38—COMMUNICATION

FOR TELECOMMUNICATIONS, NAMELY, PROVIDING INTERNET ACCESS VIA BROADBAND OPTICAL OR WIRELESS NETWORKS; PROVIDING ELECTRONIC BULLETIN BOARD SERVICES, NAMELY, AN ONLINE COMMUNITY BULLETIN BOARD FOR THE TRANSACTION OF BUSINESS AMONG AND BETWEEN THIRD PARTIES; PROVIDING ELECTRONIC BULLETIN BOARDS FOR THE POSTING AND TRANSMISSION OF MESSAGES AMONG AND BETWEEN COMPUTER USERS CONCERNING PRODUCTS, SERVICES AND BUSINESS OPPORTUNITIES; PROVIDING ONLINE CHAT ROOM SERVICES FOR TRANSMISSION OF MESSAGES AMONG COMPUTER USERS CONCERNING BUSINESS OPPORTUNITIES; PROVIDING ELECTRONIC MAIL AND ELECTRONIC MAIL FORWARDING SERVICES (U.S. CLS. 100, 101 AND 104).

CLASS 42—SCIENTIFIC AND COMPUTER SERVICES

FOR SCIENTIFIC AND TECHNOLOGICAL SERVICES AND RESEARCH AND DESIGN RELATING THERETO IN THE FIELD OF TELECOMMUNICATIONS SOFTWARE AND HARDWARE DESIGN, INTERNET TECHNOLOGY, THE DESIGN OF WEBSITES FOR ADVERTISING, SOFTWARE DESIGN AND E-COMMERCE SOFTWARE AND HARDWARE DESIGN; INDUSTRIAL ANALYSIS AND RESEARCH SERVICES IN THE FIELD OF TELECOMMUNICATIONS SOFTWARE AND HARDWARE DESIGN, INTERNET TECHNOLOGY, THE DESIGN OF WEBSITES FOR ADVERTISING, SOFTWARE DESIGN AND E-COMMERCE SOFTWARE AND HARDWARE DESIGN; DESIGN AND DEVELOPMENT OF COMPUTER HARDWARE AND SOFTWARE (U.S. CLS. 100 AND 101).

ARETHA SOMERVILLE, EXAMINING ATTORNEY

CLASS 5—PHARMACEUTICALS

FOR ANTIBACTERIAL PHARMACEUTICALS; ANTI-MICROBIAL PREPARATIONS FOR INHIBITING MICROBIOLOGICAL DECOMPOSITION IN FOOD, BEVERAGES, ANIMAL FEED AND PHARMACEUTICALS; BANDAGES IMPREGNATED WITH A PHARMACEUTICAL OR THERAPEUTIC SUBSTANCE, NAMELY, NATURAL PLANTS, MINERALS AND VITAMINS; BIOMETALLIC COMPOUNDS USED AS COMPONENT IN PHARMACEUTICAL PREPARATIONS FOR THE TREATMENT OF RESPIRATORY DISEASES AND DISORDERS, INFECTIOUS DISEASES, HORMONAL DISORDERS AND FOR THE PREVENTION OF OSTEOPOROSIS, DISORDERS OF THE NERVOUS SYSTEM, THE IMMUNE SYSTEM, THE CARDIO-VASCULAR SYSTEM, THE METABOLIC SYSTEM, THE RESPIRATORY SYSTEM, THE MUSCULO-SKELETAL SYSTEM, THE GENITOURINARY SYSTEM, INFLAMMATORY DISORDERS, OCULAR DISORDERS OR DISEASES, BACTERIA-BASED DISEASES, DIABETES, BLOOD DISORDERS, PAIN, INFLAMMATION, SEPSIS, ALOPECIA, OBESITY AND COGNITIVE DISORDERS AND VIRAL, METABOLIC, ENDOCRINE, MUSCULO-SKELETAL, CARDIOVASCULAR, CARDIOPULMONARY, GENITOURINARY, SEXUAL DYSFUNCTION, ONCOLOGICAL, HEPATOLOGICAL, OPHTHALMIC, RESPIRATORY, NEUROLOGICAL, GASTROINTESTINAL, HORMONAL, DERMATOLOGICAL, PSYCHIATRIC AND IMMUNE SYSTEM RELATED DISEASES AND DISORDERS; DERMATOLOGICAL PHARMACEUTICAL PRODUCTS; DRUG DELIVERY AGENTS CONSISTING OF COMPOUNDS THAT FACILITATE DELIVERY OF A WIDE RANGE OF PHARMACEUTICALS; DRUG DELIVERY AGENTS IN THE FORM OF A COATING FOR TABLETS AND CAPSULES THAT FACILITATES THE DELIVERY OF PHARMACEUTICALS; HOMEOPATHIC PHARMACEUTICALS FOR USE IN TREATMENT OF RESPIRATORY DISEASES AND DISORDERS, INFECTIOUS DISEASES, HORMONAL DISORDERS AND FOR THE PREVENTION OF OSTEOPOROSIS, DISORDERS OF THE NERVOUS SYSTEM, THE IMMUNE SYSTEM, THE CARDIO-VASCULAR SYSTEM, THE METABOLIC SYSTEM, THE RESPIRATORY SYSTEM, THE MUSCULO-SKELETAL SYSTEM, THE GENITOURINARY SYSTEM, INFLAMMATORY DISORDERS, OCULAR DISORDERS OR DIS-

EASES, BACTERIA-BASED DISEASES, DIABETES, BLOOD DISORDERS, PAIN, INFLAMMATION, SEPSIS, ALOPECIA, OBESITY AND COGNITIVE DISORDERS AND VIRAL, METABOLIC, ENDOCRINE, MUSCULOSKELETAL, CARDIOVASCULAR, CARDIOPULMONARY, GENITOURINARY, SEXUAL DYSFUNCTION, ONCOLOGICAL, HEPATOLOGICAL, OPHTHALMIC, RESPIRATORY, NEUROLOGICAL, GASTROINTESTINAL, HORMONAL, DERMATOLOGICAL, PSYCHIATRIC AND IMMUNE SYSTEM RELATED DISEASES AND DISORDERS; INHALED PHARMACEUTICAL PREPARATIONS FOR THE TREATMENT OF RESPIRATORY DISEASES AND DISORDERS; PHARMACEUTICAL PREPARATIONS FOR THE TREATMENT OF INFECTIOUS DISEASES; PHARMACEUTICAL PREPARATIONS FOR THE TREATMENT OF HORMONAL DISORDERS AND FOR THE PREVENTION OF OSTEOPOROSIS; PHARMACEUTICAL PREPARATIONS FOR THE PREVENTION AND TREATMENT OF DISORDERS OF THE NERVOUS SYSTEM, THE IMMUNE SYSTEM, THE CARDIOVASCULAR SYSTEM, THE METABOLIC SYSTEM, THE RESPIRATORY SYSTEM, THE MUSCULO-SKELETAL SYSTEM, THE GENITOURINARY SYSTEM, FOR THE TREATMENT OF INFLAMMATORY DISORDERS, FOR USE IN DERMATOLOGY, ONCOLOGY, HEMATOLOGY AND IN TISSUE AND ORGAN TRANSPLANTATION, IN OPHTHALMOLOGY AND FOR GASTROENTEROLOGICAL DISORDERS, PHARMACEUTICAL PREPARATIONS FOR THE PREVENTION AND TREATMENT OF OCULAR DISORDERS OR DISEASES, FOR THE TREATMENT OF BACTERIA-BASED DISEASES, AND FOR THE TREATMENT OF DIABETES, AND ANTI-INFECTIVE PREPARATIONS, ANTIVIRAL PREPARATIONS, ANTIBIOTICS, ANTIFUNGAL PREPARATIONS AND VACCINES, PHARMACEUTICAL PREPARATIONS FOR SKIN CARE; PHARMACEUTICAL PREPARATIONS AND SUBSTANCES FOR THE TREATMENT OF INFECTIOUS DISEASES, BLOOD DISORDERS, PAIN, INFLAMMATION, SEPSIS, ALOPECIA, OBESITY AND COGNITIVE DISORDERS; PHARMACEUTICAL PREPARATIONS AND SUBSTANCES FOR THE TREATMENT OF VIRAL, METABOLIC, ENDOCRINE, MUSCULOSKELETAL, CARDIOVASCULAR, CARDIOPULMONARY, GENITOURINARY, SEXUAL DYSFUNCTION, ONCOLOGICAL, HEPATOLOGICAL, OPHTHALMIC, RESPIRATORY, NEUROLOGICAL, GASTROINTESTINAL, HORMONAL, DERMATOLOGICAL, PSYCHIATRIC AND IMMUNE SYSTEM RELATED DISEASES AND DISORDERS; PHARMACEUTICAL PREPARATIONS AND SUBSTANCES FOR THE TREATMENT OF DAMAGED SKIN AND TISSUE; PHARMACEUTICAL PRODUCTS FOR THE TREATMENT OF BONE DISEASES; PHARMACEUTICAL PRODUCTS FOR THE TREATMENT OF VIRAL AND INFECTIOUS DISEASES; PHARMACEUTICAL PRODUCTS FOR THE TREATMENT OF JOINT DISEASE; PHARMACEUTICAL PRODUCTS FOR THE PREVENTION AND TREATMENT OF CANCER; PHARMACEUTICAL SKIN LOTIONS; PLANT EXTRACTS FOR MEDICAL, VETERINARY AND PHARMACEUTICAL PURPOSES; POTASSIUM PREPARATIONS FOR PHARMACEUTICAL PURPOSES; VITAMIN AND MINERAL PREPARATIONS FOR USE AS INGREDIENTS IN THE FOOD AND PHARMACEUTICAL INDUSTRY; YEAST OR YEAST EXTRACTS FOR MEDICAL, VETERINARY OR PHARMACEUTICAL PURPOSES (U.S. CLS. 6, 18, 44, 46, 51 AND 52).

CLASS 41—EDUCATION AND ENTERTAINMENT

FOR EDUCATIONAL SERVICES, NAMELY, CLASSES, SEMINARS, WORKSHOPS AND LECTURES IN THE FIELDS OF MEDICAL, HOMEOPATHIC AND PHARMACEUTICAL PROCEDURES AND MEDICAL, HOMEOPATHIC AND PHARMACEUTICAL TREATMENTS; TEACHING, TRAINING, TUTORING AND COURSES OF INSTRUCTION AT THE UNDERGRADUATE, GRADUATE, AND POST-GRADUATE LEVEL (U.S. CLS. 100, 101 AND 107).

CLASS 44—MEDICAL, BEAUTY AND AGRICULTURAL SERVICES

FOR MEDICAL AND PHARMACEUTICAL CONSULTATION; HEALTH CARE SERVICES, NAMELY, HOSPITALS, LONG TERM CARE FACILITIES, MEDICAL CLINICS, WELLNESS CENTERS, NAMELY, MEDICAL CLINICS, WELLNESS PROGRAMS; HEALTH MAINTENANCE ORGANIZATIONS AND MANAGED HEALTH CARE SERVICES ORGANIZATIONS; CHIROPRACTIC SERVICES; AND PSYCHOLOGICAL CONSULTATION (U.S. CLS. 100 AND 101).

TIMOTHY FINNEGAN, EXAMINING ATTORNEY

SN 77-715,054. SWISSONE SAFETY SA, SION, SWITZERLAND, FILED 4-16-2009.

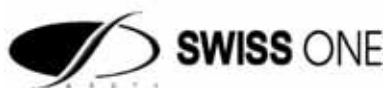

OWNER OF SWITZERLAND REG. NO. 471268, DATED 6-22-2009, EXPIRES 9-23-2019.

NO CLAIM IS MADE TO THE EXCLUSIVE RIGHT TO USE "SWISS" OR "SAFETY", APART FROM THE MARK AS SHOWN.

CLASS 9—ELECTRICAL AND SCIENTIFIC APPARATUS

FOR PROTECTIVE HELMETS; PROTECTIVE HELMETS FOR USE IN FACTORIES; PROTECTIVE HELMETS FOR USE IN WELDING; SPORTS HELMETS, NAMELY, SKI HELMETS, BIKING HELMETS AND MOTORCYCLE HELMETS; DRIVING HELMETS; SOUNDPROOF PROTECTIVE HELMETS; PROTECTIVE CLOTHING FOR NON-MEDICAL USE, NAMELY, CLOTHING AND SHOES FOR PROTECTION AGAINST ACCIDENTS, IRRADIATION AND FIRE; PINCE-NEZ, PINCE-NEZ CORDS, PINCE-NEZ CASES; CORRECTIVE OPTICAL LENSES; PROTECTIVE FACE-SHIELDS; RADIATION SCREENS FOR INDUSTRIAL PURPOSES; CONTAINERS FOR CONTACT LENSES; NETS FOR PROTECTION AGAINST ACCIDENTS; LIFE NETS; SAFETY APPARATUS, NAMELY, FLUORESCENT SCREENS; GLOVES FOR PROTECTION AGAINST X-RAYS FOR INDUSTRIAL PURPOSES; PROTECTIVE GLOVES FOR NON-MEDICAL USE; PROTECTIVE EYESHADES, KNEE-PADS FOR WORKERS; BULLET-PROOF WAISTCOATS; CLOTHING FOR PROTECTION AGAINST FIRE; CLOTHING FOR PROTECTION AGAINST ACCIDENTS, IRRADIATION AND FIRE; SAFETY RESTRAINTS; LASERS, NOT FOR MEDICAL PURPOSES; CONTACT LENSES; OPTICAL LENSES, NAMELY, EYEGGLASS LENSES, SPECTACLE AND GOGGLE LENSES; SUNGLASS LENSES; FILTERS, NAMELY, RESPIRATORY MASKS FOR NON-MEDICAL PURPOSES; SHIELDS, NAMELY, PROTECTIVE FACE SHIELDS FOR PROTECTIVE HELMETS; VISORS FOR PROTECTIVE HELMETS; SPECTACLES; SPECTACLE FRAMES; SPECTACLE CASES; SPECTACLE GLASSES; SUNGLASSES; SAFETY GOGGLES AND SPECTACLES; SIGHTING TELESCOPES FOR FIREARMS; FACTORY PROTECTIVE EYEGASSES; PROTECTIVE EYEGASSES FOR MILITARY PURPOSES; PROTECTIVE MASKS, NAMELY, GAS MASKS, RESPIRATORS OTHER THAN FOR ARTIFICIAL RESPIRATION, FACTORY PROTECTIVE MASKS, PROTECTIVE MASKS FOR MILITARY PURPOSES; FILTERS FOR RESPIRATORY MASKS; SUN FILTERS, NAMELY, OPTICAL FILTERS FOR SCREENING OUT ULTRAVIOLET LIGHT AND INFRA RED LIGHT; OPTICAL CORRECTIVE FILTERS; FACTORY PROTECTIVE FILTERS, NAMELY, SAFETY RESPIRATORY MASK FILTERS; RESPIRATORY MASK FILTERS FOR WELDING HELMETS; EYEPieces FOR PROTECTION AGAINST THE SUN; CORRECTIVE EYEPieces; FACTORY PROTECTIVE EYEPieces; PROTECTIVE EYEPieces FOR WELDING; RESPIRATORS FOR

FILTERING AIR, NOT BEING FOR ARTIFICIAL RESPIRATION; BREATHING APPARATUS, NAMELY, DISPOSABLE HALF MASK RESPIRATOR AND ITS FILTER NOT BEING FOR ARTIFICIAL RESPIRATION; OPTICAL GLASS, NAMELY, PRESCRIPTION LENSES OF MINERAL OR PLASTIC; PROTECTIVE EYEWEAR, NAMELY, GLASSES FOR MOTORCYCLING, SKIING, CLIMBING, SURFING, SNOWBOARDING, BIKING, BASKETBALL, BASEBALL, CYCLING, SWIMMING, GOLF AND TENNIS; PROTECTIVE SUN MASKS, NAMELY, GOGGLES TO PROTECT AGAINST ULTRAVIOLET (UV) AND IRRADIATION (IR) RAYS FOR MOTORCYCLING, SKIING, DIVING, AND SAILING; MOTORCYCLE GOGGLES; SPORT GOGGLES FOR SKIING, CLIMBING, SURFING, SNOWBOARDING, BIKING AND DIVING; PROTECTIVE EAR PLUGS FOR DIVERS; PROTECTIVE TEETH PROTECTORS, NAMELY, MOUTH GUARDS FOR ATHLETIC USE, ALL OF THE AFORESAID GOODS BEING OF SWISS ORIGIN (U.S. CLS. 21, 23, 26, 36 AND 38).

CLASS 10—MEDICAL APPARATUS

FOR EAR PLUGS FOR MEDICAL PURPOSES; FILTERS FOR ULTRAVIOLET RAYS FOR MEDICAL PURPOSES; GLOVES FOR MEDICAL PURPOSES; MASKS FOR USE BY MEDICAL PERSONNEL, ALL OF THE AFORESAID GOODS BEING OF SWISS ORIGIN (U.S. CLS. 26, 39 AND 44).

KATHERINE CHANG, EXAMINING ATTORNEY

SN 77-739,672. ING DIRECT BANCORP, WILMINGTON, DE. FILED 5-18-2009.



NO CLAIM IS MADE TO THE EXCLUSIVE RIGHT TO USE "SECURITY" AND "GUARANTEE", APART FROM THE MARK AS SHOWN.

THE COLOR(S) ORANGE AND LIGHT ORANGE IS/ARE CLAIMED AS A FEATURE OF THE MARK.

THE MARK CONSISTS OF A ROUND ORANGE SEAL HAVING AN IRREGULAR BORDER WITH A PAIR OF ORANGE DROPLETS POSITIONED TO THE LEFT OF THE SEAL, A SINGLE ORANGE DROPLET POSITIONED TO THE UPPER RIGHT OF THE SEAL, A PAIR OF ORANGE DROPLETS POSITIONED TO THE LOWER RIGHT OF THE SEAL, AND THE WORDS "ORANGE" AND "SECURITY" IN UPPER CASE LIGHT ORANGE LETTERS POSITIONED AROUND THE INTERIOR EDGE OF THE ROUND SEAL AND THE WORD "GUARANTEE" IN UPPER CASE LIGHT ORANGE LETTERS POSITIONED ACROSS THE DIAMETER OF THE SEAL.

CLASS 36—INSURANCE AND FINANCIAL

FOR PROVIDING FRAUD REIMBURSEMENT SERVICES IN THE FIELD OF DEBIT CARDS, ON-LINE BANKING ACCOUNTS, SAVINGS ACCOUNTS, AND SECURITIES ACCOUNTS, NAMELY, MUTUAL FUNDS; PROVIDING REIMBURSEMENT SERVICES FOR LATE OR INCORRECTLY EXECUTED ELECTRONIC TRANSACTIONS INVOLVING MONEY TRANSFERS OR ELECTRIC CHECKS (U.S. CLS. 100, 101 AND 102).

FIRST USE 3-13-2007; IN COMMERCE 3-13-2007.

CLASS 45—PERSONAL AND LEGAL SERVICES

FOR PROVIDING FRAUD DETECTION AND MONITORING SERVICES FOR ON-LINE BANKING ACCOUNTS, SAVINGS ACCOUNTS, AND SECURITIES ACCOUNTS, NAMELY, MUTUAL FUNDS; PROVIDING ADVICE IN THE FIELDS OF FRAUD AND IDENTITY THEFT (U.S. CLS. 100 AND 101).

FIRST USE 3-13-2007; IN COMMERCE 3-13-2007.

ANGELA M. MICHELI, EXAMINING ATTORNEY

SN 77-739,693. ING DIRECT BANCORP, WILMINGTON, DE. FILED 5-18-2009.

ORANGE SECURITY GUARANTEE

THE MARK CONSISTS OF STANDARD CHARACTERS WITHOUT CLAIM TO ANY PARTICULAR FONT, STYLE, SIZE, OR COLOR.

NO CLAIM IS MADE TO THE EXCLUSIVE RIGHT TO USE "SECURITY GUARANTEE", APART FROM THE MARK AS SHOWN.

CLASS 36—INSURANCE AND FINANCIAL

FOR PROVIDING FRAUD REIMBURSEMENT SERVICES IN THE FIELD OF DEBIT CARDS, ON-LINE BANKING ACCOUNTS, SAVINGS ACCOUNTS, AND SECURITIES ACCOUNTS, NAMELY, MUTUAL FUNDS; PROVIDING REIMBURSEMENT SERVICES FOR LATE OR INCORRECTLY EXECUTED ELECTRONIC TRANSACTIONS INVOLVING MONEY TRANSFERS OR ELECTRIC CHECKS (U.S. CLS. 100, 101 AND 102).

FIRST USE 3-13-2007; IN COMMERCE 3-13-2007.

CLASS 45—PERSONAL AND LEGAL SERVICES

FOR PROVIDING FRAUD DETECTION AND MONITORING SERVICES FOR ON-LINE BANKING ACCOUNTS, SAVINGS ACCOUNTS, AND SECURITIES ACCOUNTS, NAMELY, MUTUAL FUNDS; PROVIDING ADVICE IN THE FIELDS OF FRAUD AND IDENTITY THEFT (U.S. CLS. 100 AND 101).

FIRST USE 3-13-2007; IN COMMERCE 3-13-2007.

ANGELA M. MICHELI, EXAMINING ATTORNEY

SN 77-741,827. NOMACORC SA, THIMISTER-CLERMONT, BELGIUM, FILED 5-21-2009.

NOMASENSE

THE MARK CONSISTS OF STANDARD CHARACTERS WITHOUT CLAIM TO ANY PARTICULAR FONT, STYLE, SIZE, OR COLOR.

PRIORITY CLAIMED UNDER SEC. 44(D) ON ERPN CMNTY TM OFC APPLICATION NO. 007415607, FILED 11-24-2008, REG. NO. 007415607, DATED 6-16-2009, EXPIRES 6-16-2019.

OWNER OF ERPN CMNTY TM OFC REG. NO. 007415617, DATED 6-16-2009, EXPIRES 6-16-2019.

CLASS 6—METAL GOODS

FOR CLOSURES OF METAL FOR CONTAINERS AND BOTTLES (U.S. CLS. 2, 12, 13, 14, 23, 25 AND 50).

SN 77-752,108, MATT SORGER MINISTRIES, SELDEN, NY.
FILED 6-4-2009.

CLASS 9—ELECTRICAL AND SCIENTIFIC APPARATUS

FOR ELECTRICAL AND/OR OPTO-ELECTRICAL APPARATUS AND INSTRUMENTS, NAMELY, OXYGEN ANALYZERS NOT FOR MEDICAL USE; TESTING APPARATUS AND INSTRUMENTS, NAMELY, OXYGEN SENSORS AND OXYGEN CONCENTRATION SENSORS AND OXYGEN DETECTION PROBES FOR WINE OXYGEN MANAGEMENT EQUIPMENT; ANALYTICAL APPARATUS AND INSTRUMENTS, NAMELY, POLYMERIC OPTICAL FIBERS, OXYGEN SENSORS AND OXYGEN CONCENTRATION SENSORS AND OXYGEN DETECTION PROBES; ALL AFOREMENTIONED GOODS IN PARTICULAR FOR TESTING AND ANALYZING OF CLOSURES FOR CONTAINERS AND BOTTLES (U.S. CLS. 21, 23, 26, 36 AND 38).

CLASS 17—RUBBER GOODS

FOR PLASTICS IN EXTRUDED FORM FOR USE IN MANUFACTURE (U.S. CLS. 1, 5, 12, 13, 35 AND 50).

CLASS 20—FURNITURE AND ARTICLES NOT OTHERWISE CLASSIFIED

FOR CLOSURES NOT OF METAL AND NOT OF PAPER FOR CONTAINERS AND BOTTLES; SYNTHETIC PLASTIC CLOSURES FOR CONTAINERS AND BOTTLES; SCREW CAPS NOT OF METAL FOR BOTTLES AND CONTAINERS; SYNTHETIC PLASTIC EXTRUSIONS FOR USE AS CLOSURES FOR BOTTLES (U.S. CLS. 2, 13, 22, 25, 32 AND 50).

CLASS 35—ADVERTISING AND BUSINESS

FOR BUSINESS AUDITING OF BUSINESSES INVOLVED IN TECHNOLOGICAL RESEARCH (U.S. CLS. 100, 101 AND 102).

CLASS 42—SCIENTIFIC AND COMPUTER SERVICES

FOR SCIENTIFIC RESEARCH SERVICES AND TECHNOLOGY RESEARCH AND TECHNOLOGICAL CONSULTATION IN THE TECHNOLOGY FIELDS OF MACHINES RELATED TO OENOLOGY, VITICULTURE, AND PACKAGING AND NEW PRODUCT RESEARCH; RESEARCH AND DESIGN FOR OTHERS RELATING THERETO, ALL IN THE FIELDS OF OENOLOGY, VITICULTURE AND PACKAGING TECHNOLOGY; INDUSTRIAL ANALYSIS AND RESEARCH SERVICES IN THE FIELDS OF OENOLOGY, VITICULTURE AND PACKAGING TECHNOLOGY; DESIGN AND DEVELOPMENT OF COMPUTER HARDWARE AND SOFTWARE IN THE FIELDS OF OENOLOGY, VITICULTURE AND PACKAGING TECHNOLOGY; LABORATORY SERVICES, NAMELY, LABORATORY RESEARCH IN THE FIELDS OF OENOLOGY, VITICULTURE AND PACKAGING TECHNOLOGY; ANALYTICAL SERVICES, NAMELY, AUDITING AND TRAINING; TECHNOLOGICAL CONSULTATION IN THE TECHNOLOGY FIELDS OF MACHINES RELATED TO OENOLOGY, VITICULTURE AND PACKAGING TECHNOLOGY; AND QUALITY CONTROL FOR OTHERS (U.S. CLS. 100 AND 101).
ANDREA HACK, EXAMINING ATTORNEY

POWER FOR LIFE

THE MARK CONSISTS OF STANDARD CHARACTERS WITHOUT CLAIM TO ANY PARTICULAR FONT, STYLE, SIZE, OR COLOR.

CLASS 16—PAPER GOODS AND PRINTED MATTER

FOR RELIGIOUS MAGAZINE (U.S. CLS. 2, 5, 22, 23, 29, 37, 38 AND 50).
FIRST USE 1-1-2006; IN COMMERCE 1-1-2006.

CLASS 41—EDUCATION AND ENTERTAINMENT

FOR ENTERTAINMENT SERVICES IN THE NATURE OF ONGOING RELIGIOUS TELEVISION SHOW (U.S. CLS. 100, 101 AND 107).
FIRST USE 4-1-2007; IN COMMERCE 4-1-2007.

CLASS 45—PERSONAL AND LEGAL SERVICES

FOR EVANGELICAL AND MINISTERIAL SERVICES (U.S. CLS. 100 AND 101).
FIRST USE 4-1-2007; IN COMMERCE 4-1-2007.
MARIAM MAHMOUDI, EXAMINING ATTORNEY

SN 77-762,641, INTERTEK GROUP PLC., LONDON, UNITED KINGDOM, FILED 6-18-2009.



NO CLAIM IS MADE TO THE EXCLUSIVE RIGHT TO USE "GREEN INITIATIVE", APART FROM THE MARK AS SHOWN.

THE MARK CONSISTS OF A MAPLE LEAF IN A QUOTATION BOX ABOVE THE WORDING "THINK GREEN INITIATIVE".

CLASS 35—ADVERTISING AND BUSINESS

FOR PROVIDING A DATABASE FOR TRACKING, MONITORING AND VIEWING REPORTS FOR COMMERCIAL PURPOSES RELATING TO THE ENVIRONMENTAL IMPACT AND PERFORMANCE OF MANUFACTURING FACILITIES; ADVISORY AND CONSULTANCY SERVICES RELATING TO THE AFORESAID SERVICES (U.S. CLS. 100, 101 AND 102).

CLASS 42—SCIENTIFIC AND COMPUTER SERVICES

FOR ENVIRONMENTAL TESTING, NAMELY, MEASURING THE ENVIRONMENTAL IMPACT OF MANUFACTURING FACILITIES; COMPILING INFORMATION AND DATA FOR SCIENTIFIC PURPOSES, NAMELY, FOR MEASURING THE ENVIRONMENTAL IMPACT OF MANUFACTURING FACILITIES; ANALYZING AND EVALUATING INFORMATION AND DATA FOR SCIENTIFIC PURPOSES RELATING TO THE ENVIRONMENTAL IMPACT OF MANUFACTURING FACILITIES; SCIENTIFIC DATA ANALYSIS IN THE NATURE OF BENCHMARKING AND COMPARING THE ENVIRONMENTAL IMPACT OF MANUFACTURING FACILITIES; CONSULTING IN THE FIELDS OF ENVIRONMENTAL ASSESSMENT AND COMPLIANCE, NAMELY, CONSULTING SERVICES RELATING TO THE ENVIRONMENTAL IMPACT OF MANUFACTURING FACILITIES; PROVIDING A DATABASE FOR TRACKING, MONITORING, AND VIEWING REPORTS FOR SCIENTIFIC PURPOSES RELATING TO THE ENVIRONMENTAL IMPACT AND PERFORMANCE OF MANUFACTURING FACILITIES; CONSULTING SERVICES, NAMELY, SCIENTIFIC ENVIRONMENTAL ASSESSMENTS AND EVALUATIONS RELATING TO MANUFACTURING FACILITIES; CONSULTING SERVICES, NAMELY, SCIENTIFIC ASSESSMENT AND EVALUATION OF MANUFACTURING FACILITIES FOR ENVIRONMENTAL IMPACT; CONSULTING SERVICES IN THE NATURE OF ASSESSMENT AND EVALUATION OF MANUFACTURING FACILITIES TO DETERMINE COMPLIANCE WITH ENVIRONMENTAL STANDARDS; DEVELOPING VOLUNTARY STANDARDS FOR MANUFACTURING FACILITIES; DEVELOPING VOLUNTARY STANDARDS FOR THE CONTROL OF THE ENVIRONMENTAL IMPACT OF MANUFACTURING FACILITIES; CONSULTING SERVICES IN THE NATURE OF ON-LINE ASSESSMENTS RELATING TO THE EVALUATION OF MANUFACTURING FACILITIES FOR ENVIRONMENTAL IMPACT; PROVISION OF SCIENTIFIC INFORMATION RELATING TO THE ENVIRONMENTAL IMPACT OF MANUFACTURING FACILITIES; ADVISORY AND CONSULTANCY SERVICES RELATING TO ALL THE AFORESAID SERVICES (U.S. CLS. 100 AND 101).

CLASS 45—PERSONAL AND LEGAL SERVICES

FOR PREPARING ENVIRONMENTAL COMPLIANCE REPORTS, NAMELY, PREPARING AND GENERATING REPORTS RELATING TO THE ENVIRONMENTAL IMPACT AND PERFORMANCE OF MANUFACTURING FACILITIES (U.S. CLS. 100 AND 101).

CHARLOTTE CORWIN, EXAMINING ATTORNEY

SN 77-762,644. CHERRYHILL MFG CORP, PENN RUN, PA. FILED 6-18-2009.

U-SAND

THE MARK CONSISTS OF STANDARD CHARACTERS WITHOUT CLAIM TO ANY PARTICULAR FONT, STYLE, SIZE, OR COLOR.

CLASS 3—COSMETICS AND CLEANING PREPARATIONS

FOR SANDPAPER (U.S. CLS. 1, 4, 6, 50, 51 AND 52). FIRST USE 5-3-2001; IN COMMERCE 5-8-2001.

CLASS 7—MACHINERY

FOR ELECTRIC FLOOR SANDER FOR SANDING AND POLISHING FLOORS (U.S. CLS. 13, 19, 21, 23, 31, 34 AND 35).

FIRST USE 5-3-2001; IN COMMERCE 5-8-2001.

KATHERINE STOIDES, EXAMINING ATTORNEY

SN 77-768,696. PINEDA COVALIN, S.A. DE C.V., MEXICO CITY, D.F., MEXICO, FILED 6-25-2009.



OWNER OF MEXICO REG. NO. 956790, DATED 9-29-2006, EXPIRES 8-15-2016.

OWNER OF MEXICO REG. NO. 953859, DATED 9-21-2006, EXPIRES 8-15-2016.

OWNER OF U.S. REG. NO. 2,541,397.

NO CLAIM IS MADE TO THE EXCLUSIVE RIGHT TO USE "MEXICO", APART FROM THE MARK AS SHOWN.

THE MARK CONSISTS OF THE WORDS "PINEDA COVALIN MEXICO" ON A STYLIZED BACKGROUND.

THE WORDING "PINEDA COVALIN" HAS NO MEANING IN A FOREIGN LANGUAGE.

CLASS 9—ELECTRICAL AND SCIENTIFIC APPARATUS

FOR (BASED ON INTENT TO USE) (BASED ON 44(E)) OPTICAL APPARATUS AND INSTRUMENTS, NAMELY, EYE GLASSES FOR OPTICAL OR OPHTHALMIC USE AND ALL OF THE FOLLOWING GOODS: SUNGLASSES; READING GLASSES; SPECTACLES; SPORTS GOGGLES AND SAFETY GOGGLES; SPORTS GLASSES; CONTACT LENSES; GLASSES FRAMES; LENSES FOR GLASSES; CHAINS FOR EYE GLASSES; CORDS FOR EYE GLASSES; CASES ADAPTED FOR EYE GLASSES; CASES FOR CONTACT LENSES; OPTICAL GLASS BEING LENSES FOR EYE GLASSES; SCIENTIFIC AND TECHNICAL APPARATUS, NAMELY, OPTICAL MIRRORS; MAGNIFYING GLASSES BEING OPTICS; PINCE-NEZ; STRUCTURAL PARTS FOR THE AFORESAID GOODS AND ACCESSORIES FOR THE AFORESAID GOODS, NAMELY, SPECTACLE CASES AND EYE GLASS CASES (U.S. CLS. 21, 23, 26, 36 AND 38).

CLASS 14—JEWELRY

FOR (BASED ON INTENT TO USE) (BASED ON 44(E)) JEWELLERY; COSTUME JEWELLERY; WATCHES BEING JEWELRY; GOODS IN PRECIOUS METALS OR COATED THEREWITH NOT INCLUDED IN OTHER CLASSES, NAMELY, PERSONAL ORNAMENTS OF PRECIOUS METAL, AMULETS, BRACELETS, RINGS, EARRINGS, CUFF LINKS, PINS BEING JEWELRY, MEDALLIONS, NECKLACES, TIE PINS AND CLIPS, (BASED ON INTENT TO USE) CLOCKS; PRECIOUS STONES; PRECIOUS METALS AND THEIR ALLOYS; GOODS IN PRECIOUS METALS OR COATED THEREWITH, NAMELY, CLOCK CASES, JEWELRY BOXES OF PRECIOUS METAL, SCULPTURES OF PRECIOUS METAL, WATCH CASES, WATCH CHAINS, WATCH CRYSTALS BEING CRYSTAL COMPONENTS FOR WATCHES, NAMELY, WATCH FACE COVERS, WATCH STRAPS AND WRISTWATCHES; JEWELLERY BOXES; KEY CHAINS AS JEWELLERY; KEY CHAINS OF PRECIOUS METAL; KEY CHAIN HOLDERS FOR KEY CHAINS AS JEWELLERY (U.S. CLS. 2, 27, 28 AND 50).

CLASS 18—LEATHER GOODS

FOR (BASED ON INTENT TO USE) LEATHER AND IMITATIONS OF LEATHER, AND GOODS MADE OF THESE MATERIALS, NAMELY, BAGS, HANDBAGS, SHOULDER BAGS, TOTE BAGS AND BEACH BAGS; BAGS, NAMELY, HANDBAGS, SHOULDER BAGS, TOTE BAGS, AND BEACH BAGS; BEAUTY CASES AND VANITY CASES ALL SOLD EMPTY; PURSES; WALLETS; KEY CASES; UMBRELLAS; STRUCTURAL PARTS FOR THE AFORESAID GOODS, AND ACCESSORIES FOR THE AFORESAID GOODS, NAMELY, LEATHER KEY CHAINS, IMITATION LEATHER KEY CHAINS, KEY CASES SOLD AS A UNIT WITH KEY CHAINS, ALL PURPOSE CARRYING BAGS SOLD AS A UNIT WITH KEY CHAINS, KEY CHAIN HOLDERS FOR LEATHER AND IMITATION LEATHER KEY CHAINS, CREDIT CARD CASES AND HOLDERS, WALLETS INCLUDING CARD HOLDERS, AND BUSINESS CARD HOLDERS IN THE NATURE OF CARD CASES (U.S. CLS. 1, 2, 3, 22 AND 41).

CLASS 24—FABRICS

FOR (BASED ON INTENT TO USE) TEXTILES AND TEXTILE GOODS, NAMELY, PILLOWCASES, HANDKERCHIEFS OF TEXTILE, HAND TOWELS OF TEXTILE, FACE TOWELS OF TEXTILE, BED BLANKETS, COVERS FOR CUSHIONS, BED SHEETS OF TEXTILE, TABLE NAPKINS OF TEXTILE; BED COVERS; TABLE COVERS OF TEXTILE; BED LINEN, TABLE LINEN AND BATH LINEN (U.S. CLS. 42 AND 50).

CLASS 25—CLOTHING

FOR (BASED ON INTENT TO USE) (BASED ON 44(E)) CLOTHING, NAMELY, SHIRTS, PANTS, SWEATSHIRTS, DRESSES, BATH ROBES, BELTS, BEACH CLOTHING, NAMELY, BATHING SUITS, SHORTS, PANTS, SKIRTS, SHIRTS, PAREOS, SUN DRESSES, SWIMSUIT COVER UPS; COATS, COLLARS, CAMISOLES, JACKETS, JERSEYS, CLOTHING OF LEATHER, NAMELY, PANTS, VESTS, JACKETS, DRESSES, SKIRTS; CLOTHING OF IMITATIONS OF LEATHER, NAMELY, PANTS, VESTS, JACKETS, DRESSES, SKIRTS; LEGGINGS, WAISTCOATS, SHAWLS, SUITS, SKIRTS, NECKTIES, AND SWEATERS; FOOTWEAR; HEADGEAR, NAMELY, HATS, CAPS, CAP PEAKS, CAP VISORS; BERETS; NECKTIES; SILK SCARVES; KERCHIEFS (U.S. CLS. 22 AND 39).

ANDREA HACK, EXAMINING ATTORNEY

SN 77-775,102. ACUMEN LEARNING, LLC, OREM, UT. FILED 7-6-2009.

ACUMEN LEARNING

THE MARK CONSISTS OF STANDARD CHARACTERS WITHOUT CLAIM TO ANY PARTICULAR FONT, STYLE, SIZE, OR COLOR.

NO CLAIM IS MADE TO THE EXCLUSIVE RIGHT TO USE "LEARNING", APART FROM THE MARK AS SHOWN.

CLASS 16—PAPER GOODS AND PRINTED MATTER

FOR PRINTED MATTER, NAMELY, BOOKS, BOOKLETS, E-BOOKS, WORKBOOKS, MANUALS, CLASSROOM INSTRUCTION MATERIALS, FACILITATOR GUIDES, NEWSLETTERS, REPORTS, SURVEYS, ARTICLES, COLUMNS, WHITE PAPERS, OVERHEADS, CHARTS, TABLES, HANDOUTS AND PAMPHLETS FEATURING INFORMATION IN THE FIELDS OF FINANCIAL CONSIDERATIONS IN BUSINESS, UNDERSTANDING FINANCIAL STATEMENTS, BUSINESS MANAGEMENT, BUSINESS STRATEGIES AND DECISION-MAKING, AND BUSINESS PERFORMANCE ANALYSIS (U.S. CLS. 2, 5, 22, 23, 29, 37, 38 AND 50).

FIRST USE 11-30-2002; IN COMMERCE 11-30-2002.

CLASS 35—ADVERTISING AND BUSINESS

FOR PROVIDING BUSINESS INFORMATION VIA WEBSITES IN THE FIELDS OF BUSINESS MANAGEMENT, BUSINESS STRATEGIES AND DECISION-MAKING AND BUSINESS PERFORMANCE ANALYSIS (U.S. CLS. 100, 101 AND 102).

FIRST USE 11-30-2002; IN COMMERCE 11-30-2002.

CLASS 36—INSURANCE AND FINANCIAL

FOR PROVIDING FINANCIAL INFORMATION VIA WEBSITES IN THE FIELD OF FINANCIAL STATEMENTS, BUSINESS FINANCIAL INFORMATION AND FINANCIAL FACTORS IN BUSINESS PLANNING AND ACTIVITIES (U.S. CLS. 100, 101 AND 102).

FIRST USE 11-30-2002; IN COMMERCE 11-30-2002.

CLASS 41—EDUCATION AND ENTERTAINMENT

FOR CONDUCTING WORKSHOPS, SEMINARS AND TRAINING IN THE FIELDS OF KEY FINANCIAL CONSIDERATIONS IN BUSINESS, UNDERSTANDING FINANCIAL STATEMENTS AND FINANCIAL FACTORS IN BUSINESS PLANNING AND ACTIVITIES; ON-LINE JOURNALS, NAMELY, BLOGS FEATURING BUSINESS AND FINANCIAL INFORMATION (U.S. CLS. 100, 101 AND 107).

FIRST USE 11-30-2002; IN COMMERCE 11-30-2002.

REGINA DRUMMOND, EXAMINING ATTORNEY

SN 77-776,300. ELVIS PRESLEY ENTERPRISES, INC., MEMPHIS, TN. FILED 7-8-2009.

THE KING

THE MARK CONSISTS OF STANDARD CHARACTERS WITHOUT CLAIM TO ANY PARTICULAR FONT, STYLE, SIZE, OR COLOR.

THE "KING" DOES NOT IDENTIFY A LIVING INDIVIDUAL.

CLASS 9—ELECTRICAL AND SCIENTIFIC APPARATUS

FOR DOWNLOADABLE RING TONES, GAMES, AND GRAPHICS FOR MOBILE PHONES; MOBILE PHONE ACCESSORIES, NAMELY, CELL PHONE FACEPLATES AND CELL PHONE COVERS; PRE-RECORDED VIDEO CASSETTES, AUDIO TAPES, CDS AND DVDS FEATURING OR ASSOCIATED WITH CELEBRITIES AND PUBLIC FIGURES; SUNGLASSES; COMPUTER GAME SOFTWARE AND ONLINE DOWNLOADABLE COMPUTER GAME PROGRAMS; VIDEO GAME SOFTWARE; VIDEO GAME DISCS (U.S. CLS. 21, 23, 26, 36 AND 38).

CLASS 14—JEWELRY

FOR JEWELRY (U.S. CLS. 2, 27, 28 AND 50).

CLASS 16—PAPER GOODS AND PRINTED MATTER

FOR ADDRESS BOOKS, HOLIDAY/GREETING CARDS, ART PRINTS, GRAPHIC AND PRINTED ART REPRODUCTIONS, PAPER GIFT BAGS, WRITING INSTRUMENTS, LOOSE LEAF BINDERS, BOOKENDS, NON-FICTION AND REFERENCE BOOKS ABOUT THE GRACELAND MANSION AND ELVIS PRESLEY, CHILDREN'S ACTIVITY BOOKS, GIFT WRAPPING PAPER, BUMPER STICKERS, CALENDARS, CREDIT CARDS WITHOUT MAGNETIC CODING, NONMAGNETICALLY ENCODED TELEPHONE CALLING CARDS, BANK CHECKS, DEBIT GIFT CARDS WITHOUT MAGNETIC CODING, CHECKBOOK COVERS, COMIC BOOKS, COMMEMORATIVE STAMP SHEETS THAT ARE NOT ISSUED BY THE US POSTAL OFFICE, DECALS, LETTER OPENERS, PAPER MERCHANDISE BAGS, PICTURES, PHOTOGRAPHIC PRINTS, PICTURE BOOKS, RECIPE BOOKS, RUBBER STAMPS, STATIONERY, STICKERS, TEMPORARY TATTOOS, TRADING CARDS, CHALK BOARDS FOR HOME AND/OR SCHOOL USE (U.S. CLS. 2, 5, 22, 23, 29, 37, 38 AND 50).
TIMOTHY FINNEGAN, EXAMINING ATTORNEY

CLASS 41—EDUCATION AND ENTERTAINMENT

FOR PROVIDING VOCATIONAL AND JOB TRAINING SERVICES IN THE FIELDS OF RETAIL AND ONLINE SALES PRACTICES, CUSTOMER SERVICE, FOOD PREPARATION AND SERVICE, JANITORIAL AND CUSTODIAL SERVICES, HOUSEKEEPING, ANIMAL CARE AND MAINTENANCE, LANDSCAPING, CARPENTRY, AUTOMOTIVE MAINTENANCE AND REPAIRS, CULINARY ARTS, AND OFFICE SKILLS AND ADMINISTRATION FOR INDIVIDUALS WITH INTELLECTUAL, PHYSICAL AND DEVELOPMENTAL DISABILITIES, AT-RISK CHILDREN AND YOUTH WITH EMOTIONAL OR BEHAVIORAL PROBLEMS OR MEDICALLY COMPLEX NEEDS AND THEIR FAMILIES, AND PERSONS WITH BRAIN INJURIES AND OTHER INJURIES AND ILLNESSES; PROVIDING IN-PERSON AND IN-HOME FAMILY-BASED EDUCATIONAL SERVICES TO PREPARE AND TRAIN INDIVIDUALS IN CARING FOR INTELLECTUALLY, PHYSICALLY AND DEVELOPMENTALLY DISABLED PERSONS; PROVIDING ALTERNATIVE EDUCATION SERVICES IN THE FORM OF SCHOOL-BASED SERVICES, NAMELY, ACADEMIC AND VOCATIONAL INSTRUCTION, ONE-ON-ONE TUTORING, EXTRACURRICULAR ACTIVITIES AND EDUCATIONAL COUNSELING FOR INDIVIDUALS WITH INTELLECTUAL, PHYSICAL AND DEVELOPMENTAL DISABILITIES, AT-RISK CHILDREN AND YOUTH WITH EMOTIONAL OR BEHAVIORAL PROBLEMS OR MEDICALLY COMPLEX NEEDS AND THEIR FAMILIES, AND PERSONS WITH BRAIN INJURIES AND OTHER INJURIES AND ILLNESSES; PROVIDING INFORMATION REGARDING TRAINING IN CARING FOR INTELLECTUALLY, PHYSICALLY AND DEVELOPMENTALLY DISABLED INDIVIDUALS (U.S. CLS. 100, 101 AND 107).

FIRST USE 3-0-1998; IN COMMERCE 3-0-1998.

CLASS 43—HOTEL AND RESTAURANT SERVICES

FOR PROVIDING ASSISTED AND SUPPORTED LIVING FACILITIES (U.S. CLS. 100 AND 101).

FIRST USE 3-0-1998; IN COMMERCE 3-0-1998.

CLASS 44—MEDICAL, BEAUTY AND AGRICULTURAL SERVICES

FOR PROVIDING HEALTH CARE SERVICES TO INTELLECTUALLY, PHYSICALLY AND DEVELOPMENTALLY DISABLED INDIVIDUALS AND SURVIVORS OF INJURIES AND ILLNESSES, NAMELY, PROVIDING REHABILITATION NURSING CARE, SUB-ACUTE MEDICAL SUPPORT SERVICES, PHYSICAL REHABILITATION THERAPY SERVICES, NUTRITIONAL SUPERVISION AND PLANNING SERVICES, THERAPEUTIC SERVICES, NEUROBEHAVIORAL THERAPY, COUNSELING AND POST-ACUTE CARE (U.S. CLS. 100 AND 101).

FIRST USE 3-0-1998; IN COMMERCE 3-0-1998.

THE MENTOR NETWORK**CLASS 45—PERSONAL AND LEGAL SERVICES**

FOR PROVIDING HOME AND COMMUNITY-BASED COUNSELING AND PERSONAL SUPPORT SERVICES, NAMELY, EARLY INTERVENTION SERVICES, COUNSELING SERVICES IN THE NATURE OF EARLY INTERVENTION, AND PROVIDING INFORMATION AND COUNSELING ON AVAILABLE RESOURCES FOR EARLY INTERVENTION; PROVIDING FOSTER CARE SERVICES; PROVIDING CASE MANAGEMENT SERVICES, NAMELY, COORDINATION OF SOCIAL SERVICES FOR INDIVIDUALS WITH INTELLECTUAL, PHYSICAL AND DEVELOPMENTAL DISABILITIES, AT-RISK CHILDREN AND YOUTH WITH EMOTIONAL OR BEHAVIORAL PROBLEMS OR MEDICALLY COMPLEX NEEDS AND THEIR FAMILIES, AND PERSONS WITH BRAIN INJURIES AND OTHER INJURIES AND ILLNESSES (U.S. CLS. 100 AND 101).

FIRST USE 3-0-1998; IN COMMERCE 3-0-1998.

ROSELLE HERRERA, EXAMINING ATTORNEY

SN 77-779,875. NATIONAL MENTOR HOLDINGS, INC.,
BOSTON, MA. FILED 7-13-2009.

THE MARK CONSISTS OF STANDARD CHARACTERS WITHOUT CLAIM TO ANY PARTICULAR FONT, STYLE, SIZE, OR COLOR.

OWNER OF U.S. REG. NOS. 1,376,444 AND 2,446,728.

NO CLAIM IS MADE TO THE EXCLUSIVE RIGHT TO USE "NETWORK", APART FROM THE MARK AS SHOWN.

SN 77-787,144. RITCHIE, DR. STEWART J., ABBOTSFORD, BC, CANADA, FILED 7-22-2009.

PLATINUM BROODING

THE MARK CONSISTS OF STANDARD CHARACTERS WITHOUT CLAIM TO ANY PARTICULAR FONT, STYLE, SIZE, OR COLOR.

PRIORITY CLAIMED UNDER SEC. 44(D) ON CANADA APPLICATION NO. 1,441,547, FILED 6-15-2009, REG. NO. TMA790,197, DATED 2-9-2011, EXPIRES 2-9-2026.

NO CLAIM IS MADE TO THE EXCLUSIVE RIGHT TO USE "BROODING", APART FROM THE MARK AS SHOWN.

CLASS 9—ELECTRICAL AND SCIENTIFIC APPARATUS

FOR (BASED ON 44(E)) ELECTRONIC INSTRUCTIONAL, EDUCATIONAL, AND TEACHING MATERIALS IN THE FIELD OF BROOD MANAGEMENT DOWNLOADABLE VIA THE INTERNET (U.S. CLS. 21, 23, 26, 36 AND 38).

CLASS 16—PAPER GOODS AND PRINTED MATTER

FOR (BASED ON USE IN COMMERCE)(BASED ON 44(E)) PRINTED INSTRUCTIONAL, EDUCATIONAL, AND TEACHING MATERIALS IN THE FIELD OF BROOD MANAGEMENT; PUBLICATIONS, NAMELY, BULLETINS IN THE FIELD OF BROOD MANAGEMENT (U.S. CLS. 2, 5, 22, 23, 29, 37, 38 AND 50).

FIRST USE 9-10-2007; IN COMMERCE 9-10-2007.

CLASS 41—EDUCATION AND ENTERTAINMENT

FOR (BASED ON USE IN COMMERCE) (BASED ON 44(E)) EDUCATION SERVICES, NAMELY, PROVIDING CLASSES, SEMINARS AND WORKSHOPS IN THE FIELD OF BROOD MANAGEMENT; (BASED ON INTENT TO USE) EDUCATION SERVICES, NAMELY, PROVIDING ON-LINE CLASSES, SEMINARS AND WORKSHOPS IN THE FIELD OF BROOD MANAGEMENT (U.S. CLS. 100, 101 AND 107).

FIRST USE 9-10-2007; IN COMMERCE 9-10-2007.

CLASS 44—MEDICAL, BEAUTY AND AGRICULTURAL SERVICES

FOR (BASED ON USE IN COMMERCE) (BASED ON 44(E)) CONSULTATION IN THE FIELD OF BROOD MANAGEMENT (U.S. CLS. 100 AND 101).

FIRST USE 9-10-2007; IN COMMERCE 9-10-2007.

MATTHEW EINSTEIN, EXAMINING ATTORNEY

SN 77-795,408. DITIGAL RISK, LLC, MAITLAND, FL. FILED 8-3-2009.

360° RISK ANALYTICS

THE MARK CONSISTS OF STANDARD CHARACTERS WITHOUT CLAIM TO ANY PARTICULAR FONT, STYLE, SIZE, OR COLOR.

NO CLAIM IS MADE TO THE EXCLUSIVE RIGHT TO USE "RISK ANALYTICS", APART FROM THE MARK AS SHOWN.

CLASS 35—ADVERTISING AND BUSINESS

FOR BUSINESS RISK MANAGEMENT, NAMELY, RISK MITIGATION MANAGEMENT FOR CONSUMER LENDING (U.S. CLS. 100, 101 AND 102).

FIRST USE 10-31-2005; IN COMMERCE 10-31-2005.

CLASS 36—INSURANCE AND FINANCIAL

FOR FINANCIAL RISK MANAGEMENT, NAMELY, RISK MITIGATION FOR CONSUMER LENDING; CREDIT RISK MANAGEMENT, FINANCIAL SERVICES; NAMELY, LOAN DEFAULT MITIGATION SERVICES; FINANCIAL LOAN CONSULTATION; FINANCIAL PORTFOLIO ANALYSIS SERVICES; UNDERWRITING AND ADMINISTRATION OF COMMERCIAL COLLATERAL LIABILITY INSURANCE (U.S. CLS. 100, 101 AND 102).

FIRST USE 10-31-2005; IN COMMERCE 10-31-2005.

CLASS 42—SCIENTIFIC AND COMPUTER SERVICES

FOR PROVIDING QUALITY CONTROL SERVICES FOR THE MORTGAGE INDUSTRY (U.S. CLS. 100 AND 101).

FIRST USE 10-31-2005; IN COMMERCE 10-31-2005.

ANDREW LEASER, EXAMINING ATTORNEY

SN 77-795,461. TITANX ENGINE COOLING HOLDING AB, SÖLVESBORG, SWEDEN, FILED 8-3-2009.

TitanX

THE MARK CONSISTS OF STANDARD CHARACTERS WITHOUT CLAIM TO ANY PARTICULAR FONT, STYLE, SIZE, OR COLOR.

PRIORITY CLAIMED UNDER SEC. 44(D) ON SWEDEN APPLICATION NO. 2009/00959, FILED 2-5-2009, REG. NO. 008469256, DATED 2-8-2011, EXPIRES 8-4-2019.

CLASS 7—MACHINERY

FOR FANS FOR MOTORS FOR LAND VEHICLES; FANS FOR ENGINES FOR LAND VEHICLES; HEAT EXCHANGERS BEING PARTS OF MACHINES; RADIATORS FOR MOTORS FOR LAND VEHICLES; RADIATORS FOR ENGINES FOR LAND VEHICLES; HYDRAULIC CONTROLS FOR APPARATUS FOR HEATING, REFRIGERATING, AERATING, VENTILATING, AIR-CONDITIONING, DEMISTING OF VEHICLES; PNEUMATIC CONTROLS FOR APPARATUS FOR HEATING, REFRIGERATING, AERATING, VENTILATING, AIR-CONDITIONING, DEMISTING OF VEHICLES; HEAT EXCHANGERS FOR USE IN VEHICLES (U.S. CLS. 13, 19, 21, 23, 31, 34 AND 35).

CLASS 11—ENVIRONMENTAL CONTROL APPARATUS

FOR AIR CONDITIONING APPARATUS FOR USE IN VEHICLES; AIR CONDITIONERS FOR VEHICLES; CENTRAL HEATING RADIATORS; ELECTRIC FANS FOR USE IN VEHICLES; HEAT ACCUMULATORS FOR USE IN VEHICLES; HEATING APPARATUS FOR DEFROSTING WINDOWS OF VEHICLES (U.S. CLS. 13, 21, 23, 31 AND 34).

MICHAEL SOUDERS, EXAMINING ATTORNEY

SN 77-795,520. TITANX ENGINE COOLING HOLDING AB, SÖLVESBORG, SWEDEN, FILED 8-3-2009.



PRIORITY CLAIMED UNDER SEC. 44(D) ON SWEDEN APPLICATION NO. 2009/00960, FILED 2-5-2009, REG. NO. 008469587, DATED 2-17-2010, EXPIRES 8-4-2019.

THE MARK CONSISTS OF THE STYLIZED LETTERS "TITANX", WITH THE LETTERS "TITAN" IN A DARKER SHADE THAN THE LETTER "X." AN ARC PROJECTS ABOVE THE WORD "TITAN," BEGINNING TO THE LEFT OF THE FIRST LETTER OF "TITAN" AND ENDING AT THE TOP OF THE LETTER "X", THE ARC BEING DEPICTED IN GRADIENTS OF DARKER SHADE TO LIGHTER SHADE FROM LEFT TO RIGHT.

CLASS 7—MACHINERY

FOR FANS FOR MOTORS FOR LAND VEHICLES; FANS FOR ENGINES FOR LAND VEHICLES; HEAT EXCHANGERS BEING PARTS OF MACHINES; RADIATORS FOR MOTORS FOR LAND VEHICLES; RADIATORS FOR ENGINES FOR LAND VEHICLES; HYDRAULIC CONTROLS FOR APPARATUS FOR HEATING, REFRIGERATING, AERATING, VENTILATING, AIR-CONDITIONING, DEMISTING OF VEHICLES; PNEUMATIC CONTROLS FOR APPARATUS FOR HEATING, REFRIGERATING, AERATING, VENTILATING, AIR-CONDITIONING, DEMISTING OF VEHICLES; HEAT EXCHANGERS FOR USE IN VEHICLES (U.S. CLS. 13, 19, 21, 23, 31, 34 AND 35).

CLASS 11—ENVIRONMENTAL CONTROL APPARATUS

FOR AIR CONDITIONING APPARATUS FOR USE IN VEHICLES; AIR CONDITIONERS FOR VEHICLES; CENTRAL HEATING RADIATORS; ELECTRIC FANS FOR USE IN VEHICLES; HEAT ACCUMULATORS FOR USE IN VEHICLES; HEATING APPARATUS FOR DEFROSTING WINDOWS OF VEHICLES (U.S. CLS. 13, 21, 23, 31 AND 34).

MICHAEL SOUDERS, EXAMINING ATTORNEY

SN 77-805,053. VERICOM CORPORATION, ROSWELL, GA. FILED 8-14-2009.

CHANNELCARE

THE MARK CONSISTS OF STANDARD CHARACTERS WITHOUT CLAIM TO ANY PARTICULAR FONT, STYLE, SIZE, OR COLOR.

CLASS 35—ADVERTISING AND BUSINESS

FOR DEVELOPMENT, OPERATION, ADMINISTRATION, AND CONSULTATION OF DIGITAL SIGNAGE SYSTEMS AND DIGITAL ADVERTISEMENT SYSTEMS FOR OTHERS, NAMELY, PROVIDING ADVERTISING SPACE AND DIGITAL GRAPHIC AND AUDIO-VISUAL CONTENT BY ELECTRONIC MEANS AND GLOBAL COMPUTER INFORMATION NETWORKS (U.S. CLS. 100, 101 AND 102).

FIRST USE 8-15-2005; IN COMMERCE 8-15-2005.

CLASS 37—CONSTRUCTION AND REPAIR

FOR INSTALLATION AND MAINTENANCE OF DIGITAL SIGNAGE, GRAPHICS, AND AUDIO VISUAL PRODUCTS SOLD THEREWITH, NAMELY, HARDWARE AND EQUIPMENT (U.S. CLS. 100, 103 AND 106). FIRST USE 8-15-2005; IN COMMERCE 8-15-2005. NAKIA HENRY, EXAMINING ATTORNEY

SN 77-809,860. LG ELECTRONICS INC., SEOUL, REPUBLIC OF KOREA, FILED 8-21-2009.

COLD WATER OPTIMIZER

THE MARK CONSISTS OF STANDARD CHARACTERS WITHOUT CLAIM TO ANY PARTICULAR FONT, STYLE, SIZE, OR COLOR.

NO CLAIM IS MADE TO THE EXCLUSIVE RIGHT TO USE "COLD WATER", APART FROM THE MARK AS SHOWN.

CLASS 7—MACHINERY

FOR ELECTRIC WASHING MACHINES FOR HOUSEHOLD PURPOSES (U.S. CLS. 13, 19, 21, 23, 31, 34 AND 35).

CLASS 11—ENVIRONMENTAL CONTROL APPARATUS

FOR ELECTRIC LAUNDRY DRYERS (U.S. CLS. 13, 21, 23, 31 AND 34).

LINDA POWELL, EXAMINING ATTORNEY

SN 77-818,411. WFTA, LLC, BUTLER, KY. FILED 9-2-2009.

WISDOM FOR THE AGES

THE MARK CONSISTS OF STANDARD CHARACTERS WITHOUT CLAIM TO ANY PARTICULAR FONT, STYLE, SIZE, OR COLOR.

CLASS 40—MATERIAL TREATMENT

FOR CUSTOM MANUFACTURE OF WOOD AND PLASTIC PLAQUES FEATURING PERSONAL INFORMATION ABOUT AN INDIVIDUAL (U.S. CLS. 100, 103 AND 106).

CLASS 42—SCIENTIFIC AND COMPUTER SERVICES

FOR PROVIDING A WEBSITE FEATURING TECHNOLOGY THAT ENABLES USERS TO CREATE PERSONALIZED WEB PAGES FEATURING BIOGRAPHICAL AND INSPIRATIONAL INFORMATION FOR THE PURPOSE OF MEMORIALIZING FRIENDS AND FAMILY MEMBERS (U.S. CLS. 100 AND 101).

WENDY GOODMAN, EXAMINING ATTORNEY

SN 77-820,275. PROFESSIONALS GLOBAL LIMITED, BACHUS MARSH VIC, AUSTRALIA, FILED 9-4-2009.



OWNER OF AUSTRALIA REG. NO. 1317694, DATED 2-21-2011, EXPIRES 8-28-2019.

NO CLAIM IS MADE TO THE EXCLUSIVE RIGHT TO USE "GLOBAL", APART FROM THE MARK AS SHOWN.

THE MARK CONSISTS OF THE WORDS "PROFESSIONALS" AND "GLOBAL" IN A STYLIZED FONT. A LINE APPEARS UNDERNEATH THE TERM "PROFESSIONALS GLOBAL". A FIVE-POINT STAR DESIGN PAINTED WITH BRUSHSTROKES APPEARS TO THE LEFT OF THE TERM "PROFESSIONALS GLOBAL".

CLASS 9—ELECTRICAL AND SCIENTIFIC APPARATUS

FOR ELECTRONIC PUBLICATIONS, NAMELY, DOWNLOADABLE MAGAZINES, NEWSLETTERS, BROCHURES, REPORTS AND GUIDES RELATING TO REAL ESTATE; ELECTRONIC DATABASES RECORDED ON COMPUTER MEDIA FEATURING REAL ESTATE AND PRODUCTS AND SERVICES RELATING TO REAL ESTATE; ELECTRONIC NOTICE BOARDS; MULTIMEDIA FILES, NAMELY, MULTIMEDIA FILES WHICH ARE EITHER DOWNLOADABLE OR RECORDED ON COMPUTER MEDIA, FEATURING REAL ESTATE AND INFORMATION RELATING TO REAL ESTATE; MULTIMEDIA PRESENTATION KITS COMPRISING PRERECORDED ELECTRONIC MEDIA FEATURING MATERIALS AND MANUALS IN THE FIELD OF REAL ESTATE, SOLD TOGETHER AS UNITS; PRERECORDED ELECTRONIC MEDIA, NAMELY, CD-ROMS, TAPES, DIGITAL VIDEO DISCS, DIGITAL VERSATILE DISCS, COMPACT DISCS, LASER VIDEO DISCS, FLOPPY DISKS, PHONOGRAPH RECORDS, AUDIO TAPES, AUDIO CASSETTES, MAGNETIC DATA CARRIERS AND OPTICAL DATA CARRIERS, FEATURING CONTENT RELATING TO REAL ESTATE; CASES AND CONTAINERS FOR RECORDED MEDIA; RECORDED VIDEO FILMS FEATURING EDUCATIONAL AND TRAINING MATERIALS RELATING TO REAL ESTATE; ELECTRONIC AGENDAS; ELECTRONIC DIARIES; ELECTRONIC ORGANIZERS; MOUSE PADS; MAGNETS INCLUDING DECORATIVE MAGNETS; CARDS, LABELS AND TAGS CARRYING MAGNETICALLY, OPTICALLY OR ELECTRONICALLY RECORDED OR ENCODED INFORMATION ABOUT PROPERTIES OR FOR USE IN PROVIDING ACCESS TO PROPERTIES; CARDS, LABELS AND TAGS CARRYING MAGNETICALLY, OPTICALLY OR ELECTRONICALLY RECORDED OR ENCODED INFORMATION ALL FOR USE IN PROVIDING ELECTRONIC SYSTEM USER IDENTIFICATION AND VALIDATION; COMPUTER SOFTWARE AND COMPUTER PROGRAMS AND DOWNLOADABLE SOFTWARE AND PROGRAMS AND SOFTWARE AND PROGRAMS IN THE FIELD OF REAL ESTATE, FOR USE IN OR ASSISTING WITH THE MANAGEMENT OF PROPERTIES, ADVERTISING AND UPDATING ADVERTISEMENTS ABOUT PROPERTIES OR IN PROPERTY RELATED TRANSACTIONS (U.S. CLS. 21, 23, 26, 36 AND 38).

CLASS 43—HOTEL AND RESTAURANT SERVICES

FOR TEMPORARY ACCOMMODATION SERVICES, NAMELY, LOCATING, RESERVING, BOOKING AND ARRANGING OF HOLIDAY ACCOMMODATION AND TOURIST ACCOMMODATION; PROVIDING INFORMATION, VIA ONLINE OR IN-PERSON MEANS, CONCERNING SERVICES FOR PROVIDING FOOD AND DRINK, AND TEMPORARY ACCOMMODATION, INCLUDING PROVISION OF INFORMATION RELATING TO THE AVAILABILITY OF ACCOMMODATION; CONSULTANCY AND ADVISORY SERVICES RELATING TO TEMPORARY ACCOMMODATION; RENTAL OF FURNITURE AND HOUSEHOLD FURNISHINGS FOR USE IN TEMPORARY ACCOMMODATION (U.S. CLS. 100 AND 101).

DAVID H. STINE, EXAMINING ATTORNEY

SN 77-820,293. PROFESSIONALS GLOBAL LIMITED, BACHUS MARSH VIC, AUSTRALIA, FILED 9-4-2009.



OWNER OF AUSTRALIA REG. NO. 1317694, DATED 2-21-2011, EXPIRES 8-28-2019.

NO CLAIM IS MADE TO THE EXCLUSIVE RIGHT TO USE "GLOBAL", APART FROM THE MARK AS SHOWN.

THE MARK CONSISTS OF THE WORDS "PROFESSIONALS" AND "GLOBAL" IN A STYLIZED FONT. A LINE APPEARS UNDERNEATH THE TERM "PROFESSIONALS GLOBAL". A FIVE-POINT STAR DESIGN PAINTED WITH BRUSHSTROKES APPEARS TO THE LEFT OF THE TERM "PROFESSIONALS GLOBAL".

CLASS 16—PAPER GOODS AND PRINTED MATTER

FOR PRINTED MATTER AND PRINTED PUBLICATIONS, NAMELY, BOOKS, GUIDES, MAGAZINES, NEWSLETTERS, PAMPHLETS, BROCHURES, FLYERS, LEAFLETS AND EVENT PROGRAMS FEATURING REAL ESTATE AND REAL PROPERTY; PRINTED INSTRUCTIONAL AND TEACHING MATERIALS, NAMELY, TRAINING MANUALS AND GUIDES IN THE FIELD OF REAL ESTATE AND REAL PROPERTY; PRINTED PUBLICITY AND ADVERTISING MATERIALS, NAMELY, BROCHURES, GUIDES, BOOKLETS, POSTERS, CARDS AND SIGNAGE FEATURING REAL PROPERTY; STATIONERY; STICKERS; PRINTED PAPER AND CARDBOARD SIGNAGE AND PRINTED SIGNS; FRAMED AND UNFRAMED PRINTS, PICTURES, PHOTOGRAPHS AND POSTERS; MOUNTED AND UNMOUNTED PRINTS, PICTURES, PHOTOGRAPHS AND POSTERS; DESK SETS; WRITING INSTRUMENTS AND CASES THEREFOR; LETTER OPENERS; PRINTING BLOCKS; RUBBER STAMPS AND INK STAMPS; PAPERWEIGHTS; CALENDARS; BLANK JOURNALS; DIARIES; CARDS FEATURING INFORMATION ABOUT OR PICTURES OF PROPERTY; CASES FOR DRAWING INSTRUMENTS; STATIONERY CONTAINERS, CASES AND FOLDERS; LEATHER BOOK COVERS FOR DIARIES (U.S. CLS. 2, 5, 22, 23, 29, 37, 38 AND 50).

CLASS 35—ADVERTISING AND BUSINESS

FOR ORGANIZATION OF HOUSING AND REAL ESTATE DISPLAYS AND EXHIBITIONS FOR PROMOTION OR ADVERTISING PURPOSES; REAL ESTATE AUCTIONEERING; ADVERTISING, MARKETING, MARKETING RESEARCH, MARKETING STUDIES, PUBLICITY, PUBLIC RELATIONS AND PROMOTIONAL SERVICES RELATING TO REAL ESTATE AND BUSINESSES AND PROPERTY; PROMOTING THE REAL ESTATE OF OTHERS, NAMELY, RESIDENTIAL PROPERTIES, COMMERCIAL PROPERTIES, RESIDENCES, HOUSES, FLATS, APARTMENTS, TOWN HOUSES, HOLIDAY PROPERTIES, LAND, FARMS, OFFICES, OFFICE SPACE, CAR PARKS, STORAGE SPACES, FACTORIES, WAREHOUSES, PROPERTIES FOR SALE, LEASE OR RENT BY PREPARING, PLACING AND DISSEMINATING ADVERTISING VIA ON-LINE AND PRINTED FORMATS; DISSEMINATION OF ADVERTISING MATERIAL; RENTAL OF ADVERTISING SPACE; COMPILATION OF ADVERTISEMENTS; ON-LINE ADVERTISING ON A COMPUTER NETWORK; ADVERTISING SERVICES PROMOTING THE GOODS AND SERVICES OF OTHERS; ADVERTISING AND MARKETING THE PROPERTY DEVELOPMENTS OF OTHERS; ORGANIZING OF HOUSING AND REAL ESTATE DISPLAYS, VIEWINGS AND EXHIBITIONS FOR PROMOTION OR ADVERTISING PURPOSES; BUSINESS MANAGEMENT SERVICES, NAMELY, BUSINESS MANAGEMENT OF REAL ESTATE FOR INVESTORS AND OTHERS; FRANCHISING AND FRANCHISOR SERVICES, NAMELY, PROVIDING BUSINESS ADVICE AND ASSISTANCE IN THE ESTABLISHMENT, OPERATION AND MANAGEMENT OF REAL ESTATE BUSINESSES; BUSINESS ADVICE, ASSISTANCE AND DEVELOPMENT; BUSINESS ADMINISTRATION SERVICES; BUSINESS CONSULTANCY AND ADVISORY SERVICES, NAMELY, CONSULTANCY SERVICES RELATING TO MANAGEMENT OF A REAL ESTATE BUSINESS, THE SUPPLY OF QUALITY MANAGEMENT SYSTEMS, BUSINESS RISK MANAGEMENT CONSULTANCY, BUSINESS EFFICIENCY CONSULTANCY; PROCUREMENT SERVICES FOR OTHERS, PERTAINING TO THE PURCHASING OF GOODS AND SERVICES AND PROCUREMENT OF CONTRACTS ON BEHALF OF FRANCHISEES, LANDLORDS OR TENANTS, IN THE FIELDS OF GROUP PURCHASING, SELECTION AND PROCUREMENT OF GOODS AND SERVICES BASED ON ENERGY EFFICIENCY, WATER EFFICIENCY, CARBON OFFSETTING, WASTE REDUCTION AND OTHER SUSTAINABILITY AND ENVIRONMENTAL CONSIDERATIONS AND CRITERIA; PROCUREMENT OF ENERGY, WATER, WASTE MANAGEMENT AND CLEANING SERVICES AND PRODUCTS FOR OTHERS; EFFICIENCY EXPERTS; BUSINESS EFFICIENCY ADVISORY SERVICES, NAMELY, EFFICIENCY AND PROCESS AUDITING; ENERGY, WATER, RESOURCE USE MANAGEMENT FOR RESIDENTIAL AND COMMERCIAL BUILDINGS, COMPLEXES AND OTHER PROPERTIES; ORGANIZATION OF EXHIBITIONS AND TRADE FAIRS FOR COMMERCIAL OR ADVERTISING PURPOSES; DIRECTORY INFORMATION SERVICES, INCLUDING PROVISION OF ONLINE DIRECTORIES IN THE FIELDS OF REAL ESTATE AND PROPERTY MANAGEMENT; PROVISION OF ON-LINE BUSINESS LISTINGS AND CLASSIFIED ADS FOR THE GOODS/SERVICES OF OTHERS; COLLECTION, PREPARATION, COMPILATION, STORAGE, PROCESSING, RETRIEVAL AND PROVISION OF BUSINESS INFORMATION AND BUSINESS LISTINGS, INCLUDING COMPILATION OF BUSINESS LISTINGS FOR PUBLISHING ON THE INTERNET; PROVISION OF ADVERTISING SPACE ON A WEBSITE RELATING TO PROPERTY, ELECTRONIC PUBLICATIONS RELATING TO PROPERTY, DOWNLOADABLE PUBLICATIONS RELATING TO PROPERTY OR PRINTED PUBLICATIONS RELATING TO PROPERTY; RENTAL OF ADVERTISING SPACE ON THE INTERNET; COMPILATION OF INFORMATION INTO COMPUTER DATABASES; PROVISION OF COMPUTER ASSISTED BUSINESS INFORMATION; COMPUTERIZED DATABASE MANAGEMENT; SYSTEMIZATION OF INFORMATION INTO COMPUTER DATABASES; CONDUCT OF BUSINESS STUDIES AND PREPARATION OF BUSINESS REPORTS; ECONOMIC FORECASTING AND ANALYSIS FOR BUSINESS PURPOSES; MARKET ANALYSIS, RESEARCH AND MONITORING SERVICES FOR BUSINESS PURPOSES; BUSINESS ADVISORY SERVICES; BUSINESS PLANNING AND ANALYSIS SERVICES; BUSINESS MANAGEMENT AND BUSINESS

ADMINISTRATION SERVICES; BUSINESS SURVEYS, APPRAISALS AND RESEARCH; BUSINESS REFERRALS SERVICES; BUSINESS NETWORKING SERVICES; FRANCHISING CONSULTANCY AND BUSINESS SUPPORT SERVICES; FRANCHISING SERVICES, NAMELY, GROUP PURCHASING AND GROUP ADVERTISING; PROVIDING STATISTICAL INFORMATION RELATING TO REAL ESTATE FOR BUSINESS OR COMMERCIAL PURPOSES; RETAIL STORE SERVICES AND WHOLESALE DISTRIBUTORSHIP SERVICES IN THE FIELD OF PRODUCTS AND SYSTEMS TO MONITOR AND IMPROVE ENERGY AND RESOURCE EFFICIENCY AND REDUCE WASTE AND EMISSIONS; BUSINESS APPRAISALS; ENERGY USE AND ENVIRONMENTAL IMPACT MANAGEMENT SERVICES FOR THE REAL PROPERTY HOLDINGS OF OTHERS, COMPRISING REVIEW OF ENERGY USE PERFORMANCE AND ENERGY EFFICIENCY IMPROVEMENTS OF PROPERTIES, SETTING ENVIRONMENTAL GOALS FOR PROPERTIES, MONITORING PROGRESS TOWARDS THOSE GOALS, RECOMMENDING IMPROVEMENTS IN THE PERFORMANCE OF SYSTEMS WITHIN PROPERTIES, PROVIDING GUIDELINES AND PLANS TO TENANTS, SUPPLIERS, MANAGERS AND OWNERS, PROVIDING DATA ON EFFICIENCIES AND INEFFICIENCIES AND USE OF ENERGY, WATER AND OTHER RESOURCES AND CREATION OF WASTE TO TENANTS, SUPPLIERS, MANAGERS AND OWNERS; BUSINESS SERVICES RELATING TO THE ACQUISITION/DISPOSAL OF BUSINESSES NOT INVOLVING REAL ESTATE (U.S. CLS. 100, 101 AND 102).

CLASS 36—INSURANCE AND FINANCIAL

FOR REAL ESTATE AGENCY SERVICES AND REAL ESTATE BROKERAGE SERVICES; LEASING AND RENTAL OF REAL ESTATE, HOUSES, APARTMENTS, FARMS, OFFICE SPACE, SHOPPING PREMISES, AND INDUSTRIAL PREMISES; FINANCIAL APPRAISALS, EVALUATIONS AND ESTIMATES FOR FINANCIAL OR INSURANCE PURPOSES, IN THE FIELDS OF REAL ESTATE, PROPERTY AND LAND; REAL ESTATE MANAGEMENT; REAL ESTATE SELECTION AND/OR ACQUISITION FOR OTHERS; REAL ESTATE INVESTMENT SERVICES; REAL ESTATE INVESTMENT MANAGEMENT SERVICES; REAL ESTATE MANAGEMENT SERVICES INCLUDING COLLECTION OF RENT AND USAGE FEES; BROKERAGE OF CARBON DIOXIDE AND OTHER GREENHOUSE GAS EMISSION CREDITS, ALLOWANCES OR OFFSETS ON BEHALF OF PROPERTY OWNERS OR USERS; PROPERTY MANAGEMENT SERVICES; INSURANCE RISK MANAGEMENT, ENVIRONMENTAL INSURANCE RISK MANAGEMENT; INSURANCE BROKERAGE SERVICES IN THE FIELD OF ENVIRONMENTAL INSURANCE SERVICES; MANAGING THE FINANCIAL RISK RESULTING FROM EXPOSURE TO ENVIRONMENTAL LIABILITIES, SPECIFICALLY IN RELATION TO THE SALE, PURCHASE AND MANAGEMENT OF REAL ESTATE; REAL ESTATE BROKERAGE SERVICES IN THE FIELD OF ACQUISITION AND DISPOSAL OF COMMERCIAL, INDUSTRIAL AND DOMESTIC PROPERTIES; MORTGAGE BROKERAGE AND REAL PROPERTY INSURANCE BROKERAGE; PROVIDING INFORMATION, CONSULTATION SERVICES AND ADVISORY SERVICES, ALL REGARDING REAL ESTATE, CREDIT, LOANS, MORTGAGES AND/OR REAL PROPERTY INSURANCE; FINANCIAL SPONSORSHIP SERVICES, NAMELY, FINANCIAL SPONSORSHIP OF EDUCATIONAL, ENTERTAINMENT, SPORTING AND CULTURAL ACTIVITIES; REAL ESTATE BROKERAGE LISTING SERVICES; AND PROVIDING INFORMATION IN ANY FORMAT IN THE FIELDS OF REAL ESTATE (U.S. CLS. 100, 101 AND 102).

DAVID H. STINE, EXAMINING ATTORNEY

SN 77-824,856. WELOXY LIMITED, LONDON, UNITED KINGDOM, FILED 9-11-2009.

SN 77-844,084. NEXT HYDROGEN CORPORATION, MISSISSAUGA, ON, CANADA, FILED 10-8-2009.

The logo for Weloxy features the word "weloxy" in a lowercase, sans-serif font. The letter "o" is stylized with a diagonal gap on its left side and two crescent-shaped horns protruding from its lower left, giving it a unique, futuristic appearance.

PRIORITY CLAIMED UNDER SEC. 44(D) ON ERPN CMNTY TM OFC APPLICATION NO. 8452633, FILED 7-7-2009, REG. NO. 8452633, DATED 4-5-2010, EXPIRES 7-27-2019.

THE MARK CONSISTS OF THE WORD "WELOXY", THE "O" OF WHICH HAS A DIAGONAL GAP ON THE LEFT SIDE WITH TWO CONVERGENT, CRESCENT-SHAPED HORNS PROTRUDING FROM THE LOWER LEFT, OUTER RIM OF THE "O".

CLASS 35—ADVERTISING AND BUSINESS

FOR ADVERTISING; ADVERTISING AND INFORMATION DISTRIBUTION SERVICES, NAMELY, PROVIDING CLASSIFIED ADVERTISING SPACE VIA THE GLOBAL COMPUTER NETWORK; PROMOTING THE GOODS AND SERVICES OF OTHERS OVER THE INTERNET; COMPILATION AND MANAGEMENT OF ON-LINE COMPUTER DATABASES AND ON-LINE SEARCHABLE DATABASES; ADVERTISING SERVICES, NAMELY, PROVIDING INFORMATION, ADVICE AND CONSULTATION IN THE FIELD OF ADVERTISING; PROVIDING AN ON-LINE COMMERCIAL INFORMATION DIRECTORY REGARDING COLLEGIATE LIFE, GENERAL INTEREST, CLASSIFIEDS, VIRTUAL COMMUNITY, SOCIAL NETWORKING, PHOTO SHARING, AND TRANSMISSION OF PHOTOGRAPHIC IMAGES (U.S. CLS. 100, 101 AND 102).

CLASS 38—COMMUNICATION

FOR ELECTRONIC DATA TRANSMISSION AND INSTANT MESSAGING SERVICES (U.S. CLS. 100, 101 AND 104).

CLASS 41—EDUCATION AND ENTERTAINMENT

FOR ONLINE ENTERTAINMENT, NAMELY, PROVIDING VIDEO GAMES; PROVIDING INFORMATION, ADVICE AND CONSULTATION IN THE FIELD OF MUSIC PRODUCTION (U.S. CLS. 100, 101 AND 107).

CLASS 42—SCIENTIFIC AND COMPUTER SERVICES

FOR DESIGN AND DEVELOPMENT OF COMPUTER HARDWARE AND SOFTWARE; COMPUTER SERVICES, NAMELY, HOSTING ON-LINE WEB FACILITIES FOR OTHERS; COMPUTER SERVICES IN THE NATURE OF CUSTOMISED WEB PAGES FEATURING USER-DEFINED INFORMATION, PERSONAL PROFILES AND INFORMATION; PROVIDING TEMPORARY USE OF WEB-BASED SOFTWARE USED TO PROVIDE ACCESS TO DATA STORAGE USED FOR MANAGEMENT OF USER LINKS TO THIRD PARTY WEBSITES; PROVIDING INFORMATION, ADVICE AND CONSULTATION IN THE FIELD OF COMPUTER SOFTWARE AND HARDWARE DESIGN AND DEVELOPMENT (U.S. CLS. 100 AND 101).

JENNIFER VASQUEZ, EXAMINING ATTORNEY

The logo for Next Hydrogen consists of the words "NEXT HYDROGEN" in a clean, uppercase, sans-serif font.

THE MARK CONSISTS OF STANDARD CHARACTERS WITHOUT CLAIM TO ANY PARTICULAR FONT, STYLE, SIZE, OR COLOR.

PRIORITY CLAIMED UNDER SEC. 44(D) ON CANADA APPLICATION NO. 1442884, FILED 7-16-2009, REG. NO. TMA795700, DATED 4-15-2011, EXPIRES 4-15-2026.

NO CLAIM IS MADE TO THE EXCLUSIVE RIGHT TO USE "HYDROGEN", APART FROM THE MARK AS SHOWN.

CLASS 9—ELECTRICAL AND SCIENTIFIC APPARATUS

FOR ELECTROLYSERS (U.S. CLS. 21, 23, 26, 36 AND 38).

CLASS 35—ADVERTISING AND BUSINESS

FOR IN-PERSON RETAIL STORE SERVICES FEATURING WATER ELECTROLYSER EQUIPMENT AND INTEGRATED GREEN HYDROGEN PRODUCTION APPARATUS; TELEPHONIC RETAIL STORE SERVICES FEATURING WATER ELECTROLYSER EQUIPMENT AND INTEGRATED GREEN HYDROGEN PRODUCTION APPARATUS; ONLINE RETAIL STORE SERVICES FEATURING WATER ELECTROLYSER EQUIPMENT AND INTEGRATED GREEN HYDROGEN PRODUCTION APPARATUS (U.S. CLS. 100, 101 AND 102).

CLASS 37—CONSTRUCTION AND REPAIR

FOR INSTALLATION AND MAINTENANCE OF WATER ELECTROLYSER EQUIPMENT AND INTEGRATED GREEN HYDROGEN PRODUCTION APPARATUS; AND CONSULTING SERVICES REGARDING CUSTOMIZATION OF WATER ELECTROLYSER EQUIPMENT AND INTEGRATED GREEN HYDROGEN PRODUCTION APPARATUS (U.S. CLS. 100, 103 AND 106).

CLASS 40—MATERIAL TREATMENT

FOR ELECTROLYSIS SERVICES, NAMELY, PRODUCING HYDROGEN FROM WATER FOR THIRD PARTY USERS OF HYDROGEN (U.S. CLS. 100, 103 AND 106).

CLASS 41—EDUCATION AND ENTERTAINMENT

FOR TRAINING IN THE OPERATION OF WATER ELECTROLYSER EQUIPMENT AND INTEGRATED GREEN HYDROGEN PRODUCTION APPARATUS AND CONSULTING SERVICES RELATED THERETO (U.S. CLS. 100, 101 AND 107).

CLASS 42—SCIENTIFIC AND COMPUTER SERVICES

FOR CONSULTING SERVICES REGARDING DESIGN OF WATER ELECTROLYSER EQUIPMENT AND INTEGRATED GREEN HYDROGEN PRODUCTION APPARATUS (U.S. CLS. 100 AND 101).

KIMBERLY PERRY, EXAMINING ATTORNEY

SN 77-844,967. TIME WARNER CABLE INC., NEW YORK, NY. FILED 10-9-2009.

A TU MANERA

THE MARK CONSISTS OF STANDARD CHARACTERS WITHOUT CLAIM TO ANY PARTICULAR FONT, STYLE, SIZE, OR COLOR.

THE ENGLISH TRANSLATION OF THE WORDS "A TU MANERA" IN THE MARK IS "YOUR WAY".

CLASS 38—COMMUNICATION

FOR CABLE TELEVISION BROADCASTING; CABLE TELEVISION TRANSMISSION; TELECOMMUNICATION SERVICES, NAMELY, LOCAL AND LONG DISTANCE TRANSMISSION OF VOICE, DATA, GRAPHICS BY MEANS OF TELEPHONE, TELEGRAPHIC, CABLE AND SATELLITE TRANSMISSIONS; LOCAL AND LONG DISTANCE TELEPHONE SERVICES; TELEPHONE COMMUNICATION SERVICES; ELECTRONIC, ELECTRIC AND DIGITAL TRANSMISSION OF VOICE, DATA, IMAGES, SIGNALS AND MESSAGES; INTERNET TELEPHONE SERVICES; ELECTRONIC VOICE MESSAGING, NAMELY, THE RECORDING AND SUBSEQUENT TRANSMISSION OF VOICE MESSAGES BY TELEPHONE; TELEPHONE VOICE MESSAGING SERVICES; WEB MESSAGING; PROVIDING HIGH SPEED ACCESS TO AREA NETWORKS AND A GLOBAL COMPUTER INFORMATION NETWORK; INTERACTIVE TELEVISION TRANSMISSION SERVICES AND TELEVISION ON DEMAND TRANSMISSION SERVICES AND WIRELESS COMMUNICATION SERVICES, NAMELY, TEXT AND NUMERIC WIRELESS DIGITAL MESSAGING SERVICES, WIRELESS BROADBAND COMMUNICATION SERVICES, TRANSMISSION OF GRAPHICS TO MOBILE TELEPHONES, WIRELESS DIGITAL MESSAGING SERVICES, WIRELESS ELECTRONIC TRANSMISSION OF VOICE SIGNALS, DATA, FACSIMILES, IMAGES AND INFORMATION, WIRELESS FACSIMILE MAIL SERVICES, WIRELESS PBX SERVICES, WIRELESS TELEPHONE TELECOMMUNICATIONS SERVICES, NAMELY, WIRELESS MOBILE TELEPHONE SERVICES AND WIRELESS VOICE MAIL SERVICES, ALL DELIVERED OVER CABLE NETWORKS (U.S. CLS. 100, 101 AND 104).

CLASS 41—EDUCATION AND ENTERTAINMENT

FOR TELEVISION ON DEMAND IN THE NATURE OF PROVISION OF TELEVISION PROGRAMS VIA VIDEO-ON-DEMAND SERVICES; PRODUCTION OF TELEVISION PROGRAMS, TELEVISION PROGRAMMING SERVICES (U.S. CLS. 100, 101 AND 107).

SCOTT BIBB, EXAMINING ATTORNEY

SN 77-850,962. THE EGYPTIAN TELECOMMUNICATIONS COMPANY FOR INFORMATION SYSTEMS, CAIRO, EGYPT, FILED 10-16-2009.



THE MARK CONSISTS OF "XCEED" AND DESIGN.

CLASS 35—ADVERTISING AND BUSINESS

FOR BUSINESS OUTSOURCING SERVICES, NAMELY, MANAGEMENT AND OPERATION OF CUSTOMER CONTACTS FOR OTHERS BY TELEPHONE, INTERNET, FACSIMILE, AND MAIL; PROVIDING TELEMARKETING SERVICES FOR OTHERS; BUSINESS DATA MANAGEMENT ENTRY AND RECORDING SERVICES; PROVIDING ADMINISTRATIVE PROCESSING OF PURCHASE ORDER SERVICES FOR OTHERS IN THE FIELD OF INFORMATION TECHNOLOGY AND TELECOMMUNICATIONS; PROVIDING INFORMATION AND DATA COMPILING AND ANALYZING RELATING TO BUSINESS MANAGEMENT; COMPUTERIZED ON-LINE ORDERING SERVICES FOR OTHERS IN THE FIELD OF INFORMATION TECHNOLOGY AND TELECOMMUNICATIONS (U.S. CLS. 100, 101 AND 102).

FIRST USE 0-0-2003; IN COMMERCE 0-0-2003.

CLASS 36—INSURANCE AND FINANCIAL

FOR PROVIDING WARRANTY CLAIM ADMINISTRATION SERVICES, NAMELY, PROCESSING WARRANTY CLAIMS IN THE FIELD OF INFORMATION TECHNOLOGY AND TELECOMMUNICATIONS; BUSINESS CREDIT VERIFICATION SERVICES FOR OTHERS IN THE FIELD OF INFORMATION TECHNOLOGY AND TELECOMMUNICATIONS (U.S. CLS. 100, 101 AND 102).

FIRST USE 0-0-2003; IN COMMERCE 0-0-2003.

CLASS 42—SCIENTIFIC AND COMPUTER SERVICES

FOR PROVIDING TECHNICAL SUPPORT, NAMELY, TROUBLESHOOTING IN THE NATURE OF DIAGNOSING HARDWARE AND SOFTWARE PROBLEMS; PROVIDING COMPUTER SUPPORT HELP DESK SERVICES FOR OTHERS (U.S. CLS. 100 AND 101).

FIRST USE 0-0-2003; IN COMMERCE 0-0-2003.

DAVID C. REIHNER, EXAMINING ATTORNEY

SN 77-864,201. SPENCERTOWN RECORDS, LLC, FLORAL PARK, NY. FILED 11-3-2009.

SPENCERTOWN FILMS

THE MARK CONSISTS OF STANDARD CHARACTERS WITHOUT CLAIM TO ANY PARTICULAR FONT, STYLE, SIZE, OR COLOR.

NO CLAIM IS MADE TO THE EXCLUSIVE RIGHT TO USE "FILMS", APART FROM THE MARK AS SHOWN.

CLASS 9—ELECTRICAL AND SCIENTIFIC APPARATUS

FOR FILMS, CURRENTLY FORMATTED AS PRE-RECORDED DVDS FEATURING MOTION PICTURE FILMS IN A VARIETY OF INSPIRATIONAL AND ENTERTAINMENT FIELDS, NAMELY, ANIMATION, COMEDY, DOCUMENTARIES, MUSIC AND DRAMA (U.S. CLS. 21, 23, 26, 36 AND 38).

CLASS 41—EDUCATION AND ENTERTAINMENT

FOR ENTERTAINMENT SERVICES, NAMELY, PRODUCTION OF MOTION PICTURE FILMS FOR DVD (U.S. CLS. 100, 101 AND 107).

MICHELLE DUBOIS, EXAMINING ATTORNEY

SN 77-870,111. PUBLIC MOBILE INC., TORONTO, ONTARIO, CANADA, FILED 11-11-2009.

SN 77-871,268. SEARS BRANDS, LLC, HOFFMAN ESTATES, IL. FILED 11-12-2009.

EVERYBODY TALK

THE MARK CONSISTS OF STANDARD CHARACTERS WITHOUT CLAIM TO ANY PARTICULAR FONT, STYLE, SIZE, OR COLOR.

PRIORITY CLAIMED UNDER SEC. 44(D) ON CANADA APPLICATION NO. 1450241, FILED 9-1-2009, REG. NO. TMA799181, DATED 6-2-2011, EXPIRES 6-2-2026.

CLASS 9—ELECTRICAL AND SCIENTIFIC APPARATUS

FOR MOBILE TELEPHONES, TELEPHONES AND MODEMS AND ACCESSORIES THEREFOR, NAMELY, BATTERIES, BATTERY CHARGERS, CIGARETTE LIGHTER ADAPTERS, HANDS-FREE HEADSETS, CARRYING CASES AND BELT CLIPS (U.S. CLS. 21, 23, 26, 36 AND 38).

CLASS 38—COMMUNICATION

FOR WIRELESS TELECOMMUNICATIONS SERVICES, NAMELY, PROVIDING MOBILE PHONE SERVICE (U.S. CLS. 100, 101 AND 104).

WILLIAM VERHOSEK, EXAMINING ATTORNEY

SN 77-870,126. PUBLIC MOBILE INC., TORONTO, ONTARIO, CANADA, FILED 11-11-2009.

À VOUS LA PAROLE

THE MARK CONSISTS OF STANDARD CHARACTERS WITHOUT CLAIM TO ANY PARTICULAR FONT, STYLE, SIZE, OR COLOR.

PRIORITY CLAIMED UNDER SEC. 44(D) ON CANADA APPLICATION NO. 1450242, FILED 9-1-2009, REG. NO. TMA798866, DATED 5-31-2011, EXPIRES 5-31-2026.

THE ENGLISH TRANSLATION OF "À VOUS LA PAROLE" IN THE MARK IS "YOU SPEAK".

CLASS 9—ELECTRICAL AND SCIENTIFIC APPARATUS

FOR MOBILE TELEPHONES, TELEPHONES AND MODEMS AND ACCESSORIES THEREFOR, NAMELY, BATTERIES, BATTERY CHARGERS, CIGARETTE LIGHTER ADAPTERS, HANDS-FREE HEADSETS, CARRYING CASES AND BELT CLIPS (U.S. CLS. 21, 23, 26, 36 AND 38).

CLASS 38—COMMUNICATION

FOR WIRELESS TELECOMMUNICATIONS SERVICES, NAMELY, TRANSMISSION OF IMAGES, AUDIO AND VIDEO VIA THE TELEPHONE AND THE INTERNET (U.S. CLS. 100, 101 AND 104).

WILLIAM VERHOSEK, EXAMINING ATTORNEY

LAURA SCOTT

THE MARK CONSISTS OF STANDARD CHARACTERS WITHOUT CLAIM TO ANY PARTICULAR FONT, STYLE, SIZE, OR COLOR.

THE NAME(S), PORTRAIT(S), AND/OR SIGNATURE(S) SHOWN IN THE MARK DOES NOT IDENTIFY A PARTICULAR LIVING INDIVIDUAL.

CLASS 14—JEWELRY

FOR COSTUME JEWELRY (U.S. CLS. 2, 27, 28 AND 50).

CLASS 18—LEATHER GOODS

FOR HANDBAGS AND PURSES (U.S. CLS. 1, 2, 3, 22 AND 41).

CLASS 25—CLOTHING

FOR JEANS, PANTS, OVERALLS, SHORTS, SHORTS, TOPS, SHIRTS, VESTS, SPORTSHIRTS, SWEATERS, JACKETS, COATS, HEADWEAR, FOOTWEAR, UNDERWEAR, BRASSIERES, SOCKS, DRESSES, SKIRTS, JUMPERS, NIGHTGOWNS, PAJAMAS, ROBES, GLOVES, BELTS AND SCARVES (U.S. CLS. 22 AND 39).

MARY CRAWFORD, EXAMINING ATTORNEY

SN 77-871,682. PROXIMATE GLOBAL INC., NEW YORK, NY. FILED 11-12-2009.

FACE2FACE

THE MARK CONSISTS OF STANDARD CHARACTERS WITHOUT CLAIM TO ANY PARTICULAR FONT, STYLE, SIZE, OR COLOR.

CLASS 35—ADVERTISING AND BUSINESS

FOR PROVIDING CONSUMER INFORMATION SERVICES IN THE FIELD OF ENTERTAINMENT SERVICES FOR PRODUCTS, SERVICES, EVENTS, ACTIVITIES, FACILITIES AND LOCATIONS; MONITORING SERVICES FOR BUSINESS PURPOSES TO ASCERTAIN THE GEOGRAPHIC LOCATIONS OF PERSONS; OPERATING ON-LINE MARKETPLACES FOR BUYERS AND SELLERS OF GOODS AND/OR SERVICES (U.S. CLS. 100, 101 AND 102).

CLASS 45—PERSONAL AND LEGAL SERVICES

FOR MONITORING SERVICES FOR NON-BUSINESS PURPOSES TO ASCERTAIN THE GEOGRAPHIC LOCATIONS OF PERSONS (U.S. CLS. 100 AND 101).

MICHAEL ENGEL, EXAMINING ATTORNEY

SN 77-888,977. UD TRUCKS CORPORATION, SAITAMA-KEN, JAPAN, FILED 12-8-2009.



PRIORITY CLAIMED UNDER SEC. 44(D) ON JAPAN APPLICATION NO. 2009-087567, FILED 11-18-2009, REG. NO. 5386741, DATED 1-28-2011, EXPIRES 1-28-2021.

THE MARK CONSISTS OF CIRCLES AS CARRIERS OR AS SINGLE LINE BORDERS; THE CIRCLE ALSO HAS THE STYLIZED WORD "UD" INSIDE THE DESIGN.

CLASS 7—MACHINERY

FOR PARTS OF NON-ELECTRIC PRIME MOVERS FOR LAND VEHICLES (U.S. CLS. 13, 19, 21, 23, 31, 34 AND 35).

CLASS 12—VEHICLES

FOR NON-ELECTRIC PRIME MOVERS FOR LAND VEHICLE NOT INCLUDING THEIR PARTS; DRIVE SHAFTS, AXLES OR SPINDLES FOR LAND VEHICLES; WHEEL OR AXLE BEARINGS FOR LAND VEHICLES; SHAFT COUPLINGS OR CONNECTORS FOR LAND VEHICLES; POWER TRANSMISSIONS AND GEARINGS FOR LAND VEHICLES; SHOCK ABSORBERS FOR LAND VEHICLES; SHOCK ABSORBING OR SUSPENSION SPRINGS FOR LAND VEHICLES; BRAKES FOR LAND VEHICLES; AC MOTORS OR DC MOTORS FOR LAND VEHICLES NOT INCLUDING THEIR PARTS; BUSES, TRUCKS AND OTHER MOTOR VEHICLES, NAMELY, AUTOMOBILES, VANS, SPORT UTILITY VEHICLES, AND THEIR STRUCTURAL PARTS AND FITTINGS THEREFOR (U.S. CLS. 19, 21, 23, 31, 35 AND 44).

CLASS 36—INSURANCE AND FINANCIAL

FOR DEBT COLLECTION AGENCIES; LOANS FINANCING FOR BUYING BUSES, TRUCKS AND OTHER MOTOR VEHICLES; INSURANCE SERVICES, NAMELY, UNDERWRITING BUSES, TRUCKS AND OTHER MOTOR VEHICLES INSURANCE AND PROVIDING INFORMATION WITH RESPECT THERETO; APPRAISAL OF USED TRUCKS, BUSES AND OTHER MOTOR VEHICLES AND PROVIDING APPRAISAL INFORMATION THERETO (U.S. CLS. 100, 101 AND 102).

NAAKWAMA ANKRAH, EXAMINING ATTORNEY

SN 77-895,389. BW CREATIVE WOOD INDUSTRIES LTD., MAPLE RIDGE, B.C., CANADA, FILED 12-17-2009.



PRIORITY CLAIMED UNDER SEC. 44(D) ON CANADA APPLICATION NO. 1,461,101, FILED 12-1-2009, REG. NO. TMA793600, DATED 3-22-2011, EXPIRES 3-22-2026.

NO CLAIM IS MADE TO THE EXCLUSIVE RIGHT TO USE "STAIR", APART FROM THE MARK AS SHOWN.

THE MARK CONSISTS OF THREE EXCLAMATION POINTS FOLLOWED BY "STAIR" AND "SIMPLE".

CLASS 6—METAL GOODS

FOR INTERIOR AND EXTERIOR RAILING SYSTEMS PRIMARILY COMPOSED OF METAL RAILS, METAL STRUCTURAL SUPPORTS IN THE NATURE OF METAL BALUSTERS, METAL NEWEL POSTS, METAL PORCH POSTS, METAL BALL TOPS, METAL POST CAPS AND METAL PANELS (U.S. CLS. 2, 12, 13, 14, 23, 25 AND 50).

CLASS 19—NON-METALLIC BUILDING MATERIALS

FOR INTERIOR AND EXTERIOR RAILING SYSTEMS PRIMARILY COMPOSED OF NON-METAL RAILS, NON-METAL STRUCTURAL SUPPORTS IN THE NATURE OF NON-METAL BALUSTERS, NON-METAL NEWEL POSTS, NON-METAL PORCH POSTS, NON-METAL BALL TOPS, NON-METAL POST CAPS AND NON-METAL PANELS (U.S. CLS. 1, 12, 33 AND 50).

WANDA KAY PRICE, EXAMINING ATTORNEY

SN 77-895,779. OMNIFONE LIMITED, LONDON W4 2NL, GREAT BRITAIN, FILED 12-17-2009.

OMNIPLAY

THE MARK CONSISTS OF STANDARD CHARACTERS WITHOUT CLAIM TO ANY PARTICULAR FONT, STYLE, SIZE, OR COLOR.

PRIORITY CLAIMED UNDER SEC. 44(D) ON ERP CMNTY TM OFC APPLICATION NO. EU008409005, FILED 7-6-2009, REG. NO. 008409005, DATED 4-26-2010, EXPIRES 7-6-2019.

CLASS 9—ELECTRICAL AND SCIENTIFIC APPARATUS

FOR COMPUTER SOFTWARE FOR OPERATION AND FUNCTIONING OF MOBILE TELEPHONES, SMARTPHONES, PDAS, WIRELESS INFORMATION DEVICES; COMPUTER SOFTWARE FOR OPERATION AND FUNCTIONING OF SERVERS; COMPUTER SOFTWARE FOR MOBILE TELEPHONES, SMARTPHONES, PDAS, WIRELESS INFORMATION DEVICES THAT ENABLES CONTENT TO BE SEARCHED FOR, DOWNLOADED, STORED, ACCESSED BY, PLAYED BACK BY, OR SHARED BETWEEN MOBILE TELEPHONES, SMARTPHONES, PDAS, WIRELESS INFORMATION DEVICES; DIGITAL RIGHTS MANAGEMENT SOFTWARE TO PROTECT DATA AGAINST UNAUTHORIZED LISTENING, VIEWING, SHARING, USE OR PIRACY; DOWNLOADABLE CONTENT FOR MOBILE TELEPHONES, SMARTPHONES, PDAS, WIRELESS INFORMATION DEVICES, NAMELY, AUDIO, AUDIOVISUAL, MUSIC, MULTIMEDIA MATERIALS, GAMING AND VIDEO CONTENT ALL IN THE NATURE OF MUSIC, RING TONES, MUSIC VIDEOS, MOVIES, ENTERTAINMENT FILMS, CURRENT EVENTS NEWS, SPORTS, GAMES, CULTURAL EVENTS; DOWNLOADABLE TELEVISION PROGRAMS IN THE FIELD OF NEWS, COMEDY, VARIETY, MUSIC, SPORTS, GAMES AND CULTURAL EVENTS FOR MOBILE TELEPHONES, SMARTPHONES, PDAS, WIRELESS INFORMATION DEVICES; AND DOWNLOADABLE ENTERTAINMENT-RELATED AUDIO/VIDEO PROGRAMS IN THE FIELD OF NEWS, COMEDY, VARIETY, MUSIC, SPORTS, GAMES AND CULTURAL EVENTS FOR MOBILE TELEPHONES, SMARTPHONES, PDAS, WIRELESS INFORMATION DEVICES (U.S. CLS. 21, 23, 26, 36 AND 38).

CLASS 35—ADVERTISING AND BUSINESS

FOR RETAILING SERVICES BEING THE BRINGING TOGETHER, FOR THE BENEFIT OF OTHERS, OF A VARIETY OF DOWNLOADABLE AUDIO, AUDIOVISUAL, MUSIC, MULTIMEDIA, GAMING AND VIDEO CONTENT FOR SALE, WHICH ENABLES USERS OF MOBILE TELEPHONES, SMARTPHONES, PDAS AND WIRELESS INFORMATION DEVICES TO CONVENIENTLY SEARCH FOR, PURCHASE BY DOWNLOAD, VIEW, AND PURCHASE THAT CONTENT, INCLUDING SUCH SERVICES PROVIDED OVER A WIRELESS NETWORK FROM A COMPUTER SERVER; INFORMATION AND ADVISORY SERVICES RELATED TO THE AFORESAID SERVICES, NAMELY, CONSUMER INFORMATION AND ADVICE FOR SHOPPERS OF DOWNLOADABLE AUDIO, AUDIOVISUAL, MUSIC, MULTIMEDIA, GAMING AND VIDEO CONTENT (U.S. CLS. 100, 101 AND 102).

CLASS 38—COMMUNICATION

FOR ELECTRONIC DATA TRANSMISSION, NAMELY, DELIVERY OF DOWNLOADABLE CONTENT BY TELECOMMUNICATIONS; SUBSCRIPTION BASED ELECTRONIC CONTENT TRANSMISSION SERVICES; MESSAGE TRANSMISSION SERVICES; ELECTRONIC DATA TRANSMISSION, NAMELY, DELIVERY BY TELECOMMUNICATIONS OF DOWNLOADABLE CONTENT PROTECTED AGAINST UNAUTHORIZED LISTENING, VIEWING, SHARING, USE OR PIRACY (U.S. CLS. 101 AND 104).

CLASS 41—EDUCATION AND ENTERTAINMENT

FOR ENTERTAINMENT SERVICES PROVIDED OVER A WIRELESS NETWORK, NAMELY, PROVIDING WEBSITES FEATURING NON-DOWNLOADABLE PRE-RECORDED ONLINE AUDIO AND AUDIOVISUAL CONTENT IN THE FIELDS OF MUSIC, MUSIC VIDEOS, MOVIES, CURRENT EVENTS NEWS, SPORTS, GAMES, CULTURAL EVENTS; PROVIDING ONLINE NON-DOWNLOADABLE TELEVISION PROGRAMS IN THE FIELD OF NEWS, COMEDY, VARIETY, MUSIC, SPORTS, GAMES AND CULTURAL EVENTS; AND PROVIDING ONLINE NON-DOWNLOADABLE ENTERTAINMENT-RELATED AUDIO/VIDEO PROGRAMS IN THE FIELD OF NEWS, COMEDY, VARIETY, MUSIC, SPORTS, GAMES AND CULTURAL EVENTS; PROVIDING ELECTRONIC ENTERTAINMENT AND EDUCATIONAL CONTENT, NAMELY, PROVIDING WEBSITES FEATURING NON-DOWNLOADABLE PRE-RECORDED ONLINE EDUCATIONAL AUDIO, AUDIOVISUAL, MUSIC, MULTIMEDIA MATERIALS, GAMING AND VIDEO CONTENT ALL IN THE NATURE OF MUSIC, RING TONES, MUSIC VIDEOS, MOVIES, ENTERTAINMENT FILMS, CURRENT EVENTS NEWS, SPORTS, GAMES AND CULTURAL EVENTS; PROVIDING ELECTRONIC ENTERTAINMENT AND EDUCATIONAL CONTENT, NAMELY, PROVIDING ONLINE NON-DOWNLOADABLE TELEVISION PROGRAMS IN THE FIELD OF NEWS, COMEDY, VARIETY, MUSIC, SPORTS, GAMES AND CULTURAL EVENTS AND ONLINE NON-DOWNLOADABLE ENTERTAINMENT-RELATED AUDIO/VIDEO PROGRAMS IN THE FIELD OF NEWS, COMEDY, VARIETY, MUSIC, SPORTS, GAMES AND CULTURAL EVENTS; PUBLISHING CONTENT FOR DOWNLOAD OVER WIRELESS NETWORKS, NAMELY, ELECTRONIC PUBLICATIONS AND AUDIO, AUDIOVISUAL, MUSIC, MULTIMEDIA, GAMING AND VIDEO CONTENT (U.S. CLS. 100, 101 AND 107).

CLASS 42—SCIENTIFIC AND COMPUTER SERVICES

FOR COMPUTER PROGRAMMING; SOFTWARE DESIGN, DEBUGGING AND DEPLOYMENT; MAINTENANCE OF COMPUTER SOFTWARE, NAMELY, DIGITAL RIGHTS MANAGEMENT SOFTWARE; ONLINE COMPUTER SERVICES, NAMELY, PROVIDING ONLINE NON-DOWNLOADABLE APPLICATIONS FOR OPERATION AND FUNCTIONING OF MOBILE TELEPHONES, SMARTPHONES, WIRELESS INFORMATION DEVICES, COMPUTERS, PCS, LAPTOPS AND IN-CAR COMPUTERS; CREATING AND MAINTAINING CONTENT-RICH SITES WITH DOWNLOADABLE CONTENT, NAMELY, WEBSITES AND WAP WEBSITES; OPERATING SEARCH ENGINES; PROVIDING CONTENT DATABASES THAT ALLOW THE DELIVERY OF INDIVIDUAL MUSIC TRACKS ON A USER-REQUEST BASIS, NAMELY, PROVIDING A WEBSITE ALLOWING USERS TO UPLOAD AND DOWNLOAD MUSIC; ONLINE NON-DOWNLOADABLE APPLICATIONS FOR OPERATION AND FUNCTIONING OF MOBILE TELEPHONES, SMARTPHONES, WIRELESS INFORMATION DEVICES, COMPUTERS, PCS, LAPTOPS AND IN-CAR COMPUTERS (U.S. CLS. 100 AND 101).

DOMINIC FATHY, EXAMINING ATTORNEY

SN 77-899,727. BEATS ELECTRONICS, LLC, SANTA MONICA, CA. FILED 12-22-2009.



THE MARK CONSISTS OF A LOWER CASE "D" AND LOWER CASE "B".

CLASS 9—ELECTRICAL AND SCIENTIFIC APPARATUS

FOR AUDIO AND VIDEO EQUIPMENT, NAMELY, MEDIA PLAYERS, DVD PLAYERS, CD PLAYERS, MEDIA PLAYERS FOR AUTOMOBILES, DVD PLAYERS FOR AUTOMOBILES, CD PLAYERS FOR AUTOMOBILES; AUDIO SPEAKERS; CAR AUDIO SPEAKERS; LOUDSPEAKERS; LOUDSPEAKER CABINETS; HORNS FOR LOUDSPEAKERS; RACKS FOR LOUDSPEAKERS; ELECTRIC ACTUATORS; STANDS SPECIALLY ADAPTED FOR STEREOS AND AUDIO SPEAKERS, NAMELY, FLOOR STANDS AND TABLE TOP STANDS FOR LOUDSPEAKERS; SURROUND SOUND SYSTEMS; AUDIO EQUIPMENT, NAMELY, AMPLIFIERS, SUBWOOFERS, SURROUND SOUND SYSTEMS; PRE-AMPLIFIERS; AMPLIFIERS; SOUND AMPLIFIERS; AUDIO AMPLIFIERS; RACKS FOR AMPLIFIERS; HIGH-FIDELITY STEREO SYSTEMS COMPRISED OF AMPLIFIERS, LOUDSPEAKERS, RECEIVERS AND TUNERS; SIGNAL PROCESSORS, NAMELY, SIGNAL SEPARATING DISTRIBUTING, GENERATING AND CONVERTING CIRCUITS ALL FOR AUDIO SIGNALS, VIDEO SIGNALS OR AUDIO-VIDEO SIGNALS; ELECTRO ACOUSTIC TRANSDUCERS; AUDIO MIXERS; ELECTRONIC AUDIO MIXERS; SOUND MIXERS; SOUND MIXERS WITH INTEGRATED AMPLIFIERS; ACOUSTIC CONDUITS; ACOUSTIC COUPLERS; ACOUSTIC COUPLING DEVICES; ACOUSTIC MEMBRANES; ACOUSTIC METERS; ACOUSTIC SEPARATION UNITS; APPARATUS FOR WIRELESS TRANSMISSION OF ACOUSTIC INFORMATION; WAVE REFLECTORS FOR ACOUSTIC SPEAKERS, LIGHTING APPARATUS, AND AIR FLOW DEVICES; ELECTRICAL PICKUPS FOR USE WITH

MUSICAL INSTRUMENTS; MUSICAL JUKE BOXES; MUSICAL INSTRUMENT ADAPTORS; MUSICAL INSTRUMENT AMPLIFIERS; MUSICAL INSTRUMENT CONNECTORS; METRONOMES; TIME CLOCKS BEING TIME RECORDING DEVICES; TELEPRINTERS; SCALES; MICROMETERS, SIGNAL BELLS, SOUND LOCATING INSTRUMENTS, NAMELY, SOUND ALARMS, SOUND LEVEL METERS; PROJECTION SCREENS; AUTOMATIC SWITCHBOARDS; AUTOMATIC TURNSTILES; STEREO PLAYERS AND EQUIPMENT, NAMELY, STEREO TUNERS, STEREO AMPLIFIERS; STEREO RECEIVERS; PERSONAL STEREO; RECORD PLAYERS AND EQUIPMENT, NAMELY, NEEDLES FOR RECORD PLAYERS, ELECTRICAL PHONOGRAPH RECORD TURNTABLE CARTRIDGES, PHONOGRAPHIC RECORD CLEANING KITS COMPRISED PRIMARILY OF REPLACEMENT STYLUS NEEDLES AND ALSO INCLUDING CLEANING SOLUTION AND BRUSHES; AUDIO AND VIDEO COMPONENTS, NAMELY, LIMITERS AND COMPRESSORS, BOXES SPECIALLY ADAPTED FOR HOUSING AUDIO EQUIPMENT, SOFTWARE TO CONTROL AND IMPROVE AUDIO EQUIPMENT SOUND QUALITY; VIDEO EQUIPMENT, NAMELY, VIDEO RECEIVERS, COMBINATION VIDEO PLAYERS AND RECORDERS, DIGITAL VIDEO RECORDERS, DISTRIBUTION AMPLIFIERS FOR VIDEO SIGNALS; VIDEO EQUIPMENT COMPONENTS, NAMELY, COMPONENT VIDEO CABLES, ELECTRONIC SCALERS FOR VIDEO SIGNALS, ELECTRONIC INTERCONNECTERS FOR VIDEO SIGNALS; MICROPHONES; ELECTRONIC CABLES, NAMELY, AUDIO AND VIDEO ELECTRIC CABLES AND CABLE CONNECTORS; POWER CABLES AND CABLE CONNECTORS; SOUND AND VIDEO RECORDING APPARATUS; HOME THEATER EQUIPMENT AND COMPONENTS, NAMELY, TELEVISIONS, SOUND SYSTEMS AND SOUND ELEMENTS FOR TELEVISIONS AND RADIOS COMPRISED OF SURROUND SOUND SYSTEMS, SOUND SYSTEMS COMPRISING REMOTE CONTROLS, AMPLIFIERS, LOUDSPEAKERS AND COMPONENTS THEREFOR; AUDIO SPEAKERS FOR HOME THEATER SYSTEMS; CELLULAR PHONES; PORTABLE ELECTRONIC DEVICES AND RELATED ACCESSORIES, NAMELY, PORTABLE MEDIA PLAYERS, PORTABLE DVD PLAYERS, PORTABLE CD PLAYERS, PORTABLE DIGITAL AUDIO PLAYERS, PORTABLE DIGITAL VIDEO PLAYERS; PORTABLE MP3 PLAYERS; PORTABLE MP4 PLAYERS; PROTECTIVE CARRYING CASES FOR PORTABLE MUSIC PLAYERS; PERSONAL DIGITAL ASSISTANTS (PDA); SMART PHONES; CELL PHONES; HEADSETS FOR MOBILE PHONES; PORTABLE TELEPHONES AND ACCESSORIES, NAMELY, CASES FOR CELLULAR TELEPHONES, DECORATIVE CHARMS FOR CELLULAR TELEPHONES, FITTED PLASTIC FILMS KNOWN AS SKINS FOR COVERING AND PROVIDING A SCRATCH PROOF BARRIER OR PROTECTION FOR PORTABLE TELEPHONES; COMPACT DISC PLAYERS; EYEWEAR AND SUNGLASSES; HEADPHONES; COMPUTERS; LAPTOP COMPUTERS; COMPUTER HARDWARE; COMPUTER SOFTWARE, NAMELY, SOFTWARE FOR PROCESSING DIGITAL MUSIC FILES AND SOFTWARE FOR BROWSING OR EDITING VIDEO, IMAGES AND SOUND; COMPUTER ACCESSORIES, NAMELY, BLANK USB FLASH DRIVES, USB HUBS, KEYBOARDS, COMPUTER MONITORS, COMPUTER MOUSE, AUDIO SPEAKERS FOR COMPUTERS; ELECTRONIC DEVICES, NAMELY, TELEVISIONS, RADIOS, MP3 PLAYERS, MP4 PLAYERS, ALL WITH SOUND ELEMENTS; PERSONAL HEADPHONES FOR USE WITH SOUND TRANSMITTING SYSTEMS; DIGITAL EQUIPMENT, NAMELY, DIGITAL AUDIO PLAYERS, DIGITAL VIDEO PLAYERS, DIGITAL AUDIO PLAYERS FOR AUTOMOBILES, SPEAKERS FOR COMPUTERS; AUDIO RECORDINGS FEATURING MUSIC; COMPUTER SOFTWARE FOR PROCESSING DIGITAL MUSIC FILES; DIGITAL PHOTO FRAMES FOR DISPLAYING DIGITAL PICTURES, VIDEO CLIPS AND MUSIC; DOWNLOADABLE MUSIC VIA THE INTERNET AND WIRELESS DEVICES; DOWNLOADABLE MP3 OR MP4 FILES, MP3 OR MP4 RECORDINGS AND DOWNLOADABLE POD CASTS FEATURING MUSIC, AUDIO BOOKS IN THE FIELD OF MUSIC AND ENTERTAINMENT, AND NEWS BROADCASTS; VIDEO RECORDINGS FEATURING MUSIC; MUSIC-COMPOSITION SOFTWARE; VISUAL RECORDINGS AND AUDIO VISUAL RECORDINGS FEATURING MUSIC; DOWNLOADABLE VISUAL RECORDINGS FEATURING MUSIC AND MUSICAL BASED ENTERTAINMENT; DOWNLOADABLE CELLULAR PHONE RINGTONES;

APPARATUS FOR RECORDING, TRANSMISSION OR REPRODUCTION OF SOUND OR IMAGES (U.S. CLS. 21, 23, 26, 36 AND 38).

CLASS 25—CLOTHING

FOR CLOTHING, NAMELY, BLOUSES, DRESSES, BOTTOMS, COATS, FOUL WEATHER GEAR, GLOVES, HOSIERY, JACKETS, JEANS, LINGERIE, MITTENS, NECKTIES, NECKWEAR, NIGHTWEAR, PAJAMAS, PANTS, PULLOVERS, RAINWEAR, ROBES, SCARVES, SHIRTS, SHORTS, SKIRTS, SKORTS, SOCKS, SWEAT-SHIRTS, SWEATERS, SWIMWEAR, T-SHIRTS, TRACK SUITS, UNDERGARMENTS, VESTS, POLO SHIRTS, SWEAT PANTS, JERSEYS, BELTS; FOOTWEAR; HEADGEAR, NAMELY, CAPS, HATS, VISORS, SKULLCAPS, BEANIES (U.S. CLS. 22 AND 39).

ANDREW LEASER, EXAMINING ATTORNEY

SN 77-900,422, THINDATA INC., TORONTO, ONTARIO, CANADA, FILED 12-23-2009.

The logo for Thindata 11 features the word "Thindata" in a grey, sans-serif font. To its right is a stylized "11" where the first "1" is yellow and the second "1" is blue, both enclosed in white square outlines.

THE COLOR(S) GREY, WHITE, YELLOW AND BLUE IS/ ARE CLAIMED AS A FEATURE OF THE MARK.

THE MARK CONSISTS OF THE FOLLOWING: THE WORD "THINDATA" IN GREY, THE FIRST NUMBER "1" IN THE COLOR WHITE WITHIN A YELLOW ENCLOSED DESIGN, AND THE SECOND NUMBER "1" IN THE COLOR WHITE WITHIN A BLUE ENCLOSED DESIGN.

CLASS 35—ADVERTISING AND BUSINESS

FOR DIGITAL AND DATABASE MARKETING AGENCY AND RELATED SERVICES, NAMELY, PROVISION TO CUSTOMERS OF STRATEGY, CREATIVE, MANAGEMENT AND MEASUREMENT OF ONLINE AND OFFLINE MARKETING TOOLS, ADVERTISING CAMPAIGNS AND ADVERTISING PROGRAMS, NAMELY, PREPARATION OF MARKETING EMAILS FOR OTHERS, DATA AND ANALYTIC SERVICES FOR IDENTIFYING THE KEY PERFORMANCE INDICATORS THAT CAN BE MONITORED, TRENDED AND REVIEWED OVER TIME TO MEASURE BUSINESS AND MARKETING SUCCESS AND QUANTIFY ACTUAL CAMPAIGNS BENEFITS AND RESULTS (U.S. CLS. 100, 101 AND 102).

CLASS 42—SCIENTIFIC AND COMPUTER SERVICES

FOR MULTI-CHANNEL DATABASE-DRIVEN MARKETING AUTOMATION TECHNOLOGIES AND STRATEGIC SOLUTIONS AND RELATED PRODUCTS, NAMELY, PROVIDING A WEBSITE FEATURING NON-DOWNLOADABLE SOFTWARE APPLICATIONS THAT HELPS OPTIMIZE RESULTS BY PERFORMING PREDICTIVE ANALYTICS, REPORTING OF RESULTS, AND CAMPAIGN MANAGEMENT; PROVIDING TEMPORARY USE OF ONLINE, NON-DOWNLOADABLE SOFTWARE FOR USE IN PLANIFICATION, EXECUTION, ANALYSIS AND HONING OF EMAIL MARKETING CAMPAIGNS; PROVIDING TEMPORARY USE OF ONLINE, NON-DOWNLOADABLE COMPUTER SOFTWARE FOR USE IN ANALYTICS AND PREDICTIVE MODELING TO DISSEMINATE ONE-ON-ONE MARKETING MESSAGES VIA EMAIL, MOBILE PHONES, WEB AND SOCIAL MEDIA SITES AND ON CUSTOMIZABLE PRINTED MATERIALS IN THE NATURE OF NEWSPAPERS, MAGAZINES, CATALOGUES, FLYERS, BROCHURES, BOOKS, AND POSTERS; PROVIDING TEMPORARY USE OF ONLINE NON-DOWNLOADABLE SOFTWARE FOR ADVERTISING CAMPAIGN AND LIST MANAGEMENT, EMAIL TESTING, ADVERTISING CAMPAIGN ANALYSIS AND EMAIL REPORTING (U.S. CLS. 100 AND 101).

KAREN BRACEY, EXAMINING ATTORNEY

SN 77-904,919. STAHL- UND APPARATEBAU SPECHT OHG, HATZFELD, FED REP GERMANY, FILED 1-5-2010.

XEOOS

THE MARK CONSISTS OF STANDARD CHARACTERS WITHOUT CLAIM TO ANY PARTICULAR FONT, STYLE, SIZE, OR COLOR.

CLASS 4—LUBRICANTS AND FUELS

FOR FIRE LIGHTERS, NAMELY, FIRE LIGHTERS MADE OF PARAFFIN (U.S. CLS. 1, 6 AND 15).

CLASS 11—ENVIRONMENTAL CONTROL APPARATUS

FOR FURNACES, OTHER THAN FOR EXPERIMENTAL PURPOSES; PROTECTIVE GRIDS, BEING PARTS OF A HOT-AIR SPACE HEATING APPARATUS; SPARK PROTECTIVE PLATES AND BASE PLATES FOR FURNACES; CHIMNEY FLUES; HOT-AIR SPACE HEATING APPARATUS FOR SOLID, LIQUID OR GASEOUS FUELS, NAMELY, WOOD, PAPERBOARD, ETHANOL, SPIRIT, BUTANE AND PROPANE; RADIATORS; HEAT ACCUMULATORS; HEAT EXCHANGERS NOT BEING PARTS OF MACHINES; WATER HEATERS; HEATING INSTALLATIONS FOR WATER; HUMIDIFIERS FOR FURNACES AND CENTRAL HEATING RADIATORS; ELECTRIC APPARATUS FOR ROASTING FOOD; RO-TISSERIES; ROASTING SPITS; GRILLS AND BARBECUE GRILLS (U.S. CLS. 13, 21, 23, 31 AND 34).

CLASS 21—HOUSEWARES AND GLASS

FOR UTENSILS FOR BARBECUES, NAMELY, FORKS, SERVING SPOONS, SKEWERS AND TONGS, DUST PANS AND HAND BRUSHES FOR GRILLS AND BARBECUE GRILLS (U.S. CLS. 2, 13, 23, 29, 30, 33, 40 AND 50).

SUNG IN, EXAMINING ATTORNEY

SN 77-908,058. INTERNATIONAL BRAND LICENSING AG, 1000 LAUSANNE, SWITZERLAND, FILED 1-8-2010.



OWNER OF SWITZERLAND REG. NO. 487983, DATED 8-15-2001, EXPIRES 3-5-2021.

OWNER OF U.S. REG. NOS. 1,404,944, 3,170,813 AND OTHERS.

THE MARK CONSISTS OF A STYLIZED ENSIGN COMPOSED OF ALTERNATING BLACK AND WHITE HORIZONTAL STRIPES, WITH THE LEFT SIDE OF THE PARALLELOGRAM BEING SMALLER THAN THE RIGHT. A BLACK RING SHAPE SITS ATOP OF THE PARALLELOGRAM, SLIGHTLY RIGHT OF CENTER.

CLASS 25—CLOTHING

FOR CLOTHING, NAMELY, SCARVES, WRISTBANDS, HEADBANDS, GLOVES, SOCKS, TRACKSUITS, SHORTS, T-SHIRTS, SWEATSHIRTS, PULLOVERS; FOOTWEAR; HEADWEAR (U.S. CLS. 22 AND 39).

CLASS 28—TOYS AND SPORTING GOODS

FOR IN-LINE SKATES, SKATE BOARDS, SKIS, SKI BINDINGS, SKI POLES, SNOWBOARDS; PROTECTIVE SPORTS EQUIPMENT, NAMELY, SHIN GUARDS, KNEE GUARDS AND ELBOW GUARDS (U.S. CLS. 22, 23, 38 AND 50).

LEIGH LOWRY, EXAMINING ATTORNEY

SN 77-908,094. DEMAND ENERGY NETWORKS, INC., LIBERTY LAKE, WA. FILED 1-8-2010.

DISPATCHABLE LOAD

THE MARK CONSISTS OF STANDARD CHARACTERS WITHOUT CLAIM TO ANY PARTICULAR FONT, STYLE, SIZE, OR COLOR.

CLASS 7—MACHINERY

FOR DC MOTORS (U.S. CLS. 13, 19, 21, 23, 31, 34 AND 35).

CLASS 9—ELECTRICAL AND SCIENTIFIC APPARATUS

FOR POWER STORAGE PRODUCTS AND EQUIPMENT, NAMELY, BATTERIES; BATTERY CHARGE DEVICES, NAMELY, BATTERY CHARGE CONTROLLERS; ELECTRONIC CIRCUITS, NAMELY, ENERGY MONITORING CIRCUITS; ELECTRICAL ENERGY CONVERSION PRODUCTS, NAMELY, CIRCUITRY FOR TRANSFORMING ELECTRICAL ENERGY STORED BY A BATTERY INTO AC POWER AND CIRCUITRY FOR TRANSFORMING ELECTRICAL ENERGY PROVIDED BY AN ELECTRICAL POWER GRID INTO DC POWER SUITABLE FOR STORAGE BY A BATTERY (U.S. CLS. 21, 23, 26, 36 AND 38).

KATHERINE M. DUBRAY, EXAMINING ATTORNEY

SN 77-909,872. OMANDER & CO. AB, SE-211 44 MALMO, SWEDEN, FILED 1-12-2010.

YOMOY

THE MARK CONSISTS OF STANDARD CHARACTERS WITHOUT CLAIM TO ANY PARTICULAR FONT, STYLE, SIZE, OR COLOR.

PRIORITY CLAIMED UNDER SEC. 44(D) ON ERPNCMNTY TM OFC APPLICATION NO. 008422503, FILED 7-13-2009, REG. NO. 008422503, DATED 1-21-2010, EXPIRES 7-13-2019.

CLASS 21—HOUSEWARES AND GLASS

FOR HOUSEHOLD OR KITCHEN UTENSILS, NAMELY, WINE RACKS, BOTTLE OPENERS, WINE COOLERS, COOKIE STAMPS, CAKE MOULDS, BREAD BASKETS, BREAD BINS, SOAP BASKETS, DISHWASHING BRUSHES, BRUSHES FOR CLEANING PURPOSES, WHISKS, MIXERS, STRAINERS, BEATERS, FRYING PANS, CLOTHES PEGS, COASTERS NOT OF PAPER AND NOT BEING TABLE LINEN, COCKTAIL STIRRERS, DISPENSERS FOR PAPER TOWELS, DISPENSERS FOR LIQUID SOAP, DISPENSERS FOR CANDY, ICE CUBE MOULDS, KNIFE HOLDERS, NAPKIN HOLDERS, NAPKIN RINGS, SHAKERS, WATERING DEVICES, NAMELY, WATERING CANS, COOKING PINS AND GRILLS; CONTAINERS FOR HOUSEHOLD OR KITCHEN USE, COMBS AND SPONGES FOR HOUSEHOLD PURPOSES; HAIR BRUSHES; BEVERAGE GLASSWARE; PORCELAIN BEVERAGEWARE; PORCELAIN BOWLS; EARTHENWARE MUGS AND BOWLS; FIGURINES MADE OF GLASS, PORCELAIN OR EARTHENWARE; FLY SWATTERS; INSECT TRAPS (U.S. CLS. 2, 13, 23, 29, 30, 33, 40 AND 50).

CLASS 28—TOYS AND SPORTING GOODS

FOR GAMES AND PLAYTHINGS, NAMELY, ELECTRICAL TOYS, BOARD GAMES, MANIPULATIVE CUBE TYPE PUZZLES, PUZZLES, JIGSAW PUZZLES, DICE, BALLS FOR GAMES, CARDS, BUILDING BLOCKS, BUILDING GAMES, CHESS GAMES, MAZES, CHECKERBOARDS, DARTS, RING GAMES; GYMNASIAC AND SPORTING ARTICLES, NAMELY, GOLF EQUIPMENT, HOCKEY EQUIPMENT, BALLS FOR SPORTS, BOARDS, AND GLOVES; DECORATION FOR CHRISTMAS TREES; PARTY NOVELTIES, NAMELY, PRACTICAL JOKES, PARTY FAVORS IN THE NATURE OF SMALL TOYS, BALLOONS; DOLLS (U.S. CLS. 22, 23, 38 AND 50).

CLASS 35—ADVERTISING AND BUSINESS

FOR ADVERTISING; PROMOTION, ADVERTISING AND MARKETING OF ON-LINE WEBSITES; ADVERTISING AND MARKETING OF ON-LINE WEBSITES PROVIDING GIFTS TO CONSUMERS AND BUSINESSES; ONLINE DEMONSTRATION OF GOODS (U.S. CLS. 100, 101 AND 102).

MATTHEW KLINE, EXAMINING ATTORNEY

SN 77-911,473. SEE VIRTUAL WORLDS, LLC, LOS ANGELES, CA. FILED 1-13-2010.



NO CLAIM IS MADE TO THE EXCLUSIVE RIGHT TO USE "VIRTUAL WORLDS", APART FROM THE MARK AS SHOWN.

THE COLOR(S) RED, ORANGE, YELLOW, WHITE, GRAY AND BLACK IS/ARE CLAIMED AS A FEATURE OF THE MARK.

THE MARK CONSISTS OF A STYLIZED EYE WITH AN IRIS IN THE COLORS RED, ORANGE AND YELLOW WITH A BLACK PUPIL. THE REMAINING PORTION OF THE EYEBALL IS IN THE COLOR BLACK AND THE OUTSIDE OF THE EYE INCLUDING THE EYELASHES IS IN VARIOUS SHADES OF BLACK, WHITE AND GRAY. THE WORDING "SEE VIRTUAL WORLDS" APPEARS AT THE BOTTOM IN THE COLOR GRAY WITH THE WORD "SEE" ABOVE THE WORDING "VIRTUAL WORLDS".

CLASS 41—EDUCATION AND ENTERTAINMENT

FOR ENTERTAINMENT SERVICES, NAMELY, PROVIDING VIRTUAL ENVIRONMENTS IN WHICH USERS CAN INTERACT FOR RECREATIONAL, LEISURE OR ENTERTAINMENT PURPOSES (U.S. CLS. 100, 101 AND 107).

FIRST USE 12-1-2009; IN COMMERCE 12-1-2009.

CLASS 42—SCIENTIFIC AND COMPUTER SERVICES

FOR COMPUTER PROGRAMMING SERVICES, NAMELY, CONTENT CREATION FOR VIRTUAL WORLDS AND THREE DIMENSIONAL PLATFORMS (U.S. CLS. 100 AND 101).

FIRST USE 1-12-2010; IN COMMERCE 1-12-2010.

JAMES LOVELACE, EXAMINING ATTORNEY

SN 77-912,289. LONDON DRUGS LIMITED, RICHMOND, BC, CANADA, FILED 1-14-2010.

BETTERCARE

THE MARK CONSISTS OF STANDARD CHARACTERS WITHOUT CLAIM TO ANY PARTICULAR FONT, STYLE, SIZE, OR COLOR.

OWNER OF CANADA REG. NO. 580939, DATED 5-7-2003, EXPIRES 5-7-2018.

OWNER OF CANADA REG. NO. 796435, DATED 5-2-2011, EXPIRES 5-2-2026.

CLASS 16—PAPER GOODS AND PRINTED MATTER

FOR (BASED ON 44(E) PURSUANT TO CANADIAN FOREIGN REGISTRATION NUMBER 580939) PRINTED PUBLICATIONS, NAMELY, PAMPHLETS AND BROCHURES RELATING TO HEALTH, DENTAL, HOME, PET, AUTO, AND TRAVEL INSURANCE (U.S. CLS. 2, 5, 22, 23, 29, 37, 38 AND 50).

CLASS 35—ADVERTISING AND BUSINESS

FOR (BASED ON 44(E) PURSUANT TO CANADIAN FOREIGN REGISTRATION NUMBER 796435) RETAIL DRUG STORE, PHARMACY AND DEPARTMENT STORE SERVICES; ADVERTISING SERVICES, NAMELY, PROMOTING THE GOODS AND SERVICES OF OTHERS THROUGH IN-STORE PROMOTIONS, SALES FLYERS, AND BY PLACING ADVERTISEMENTS AND PROMOTIONAL DISPLAYS IN ELECTRONIC SITES ACCESSED THROUGH COMPUTER NETWORKS (U.S. CLS. 100, 101 AND 102).

CLASS 36—INSURANCE AND FINANCIAL

FOR (BASED ON 44(E) PURSUANT TO CANADIAN FOREIGN REGISTRATION NUMBER 796435) INSURANCE AGENCY SERVICES RELATING TO HEALTH, DENTAL, HOME, PET, AUTO, AND TRAVEL INSURANCE (U.S. CLS. 100, 101 AND 102).

REBECCA EISINGER, EXAMINING ATTORNEY

SN 77-919,095. NAZAARKUT SULTAN ALI, LEICESTER, UNITED KINGDOM, FILED 1-25-2010.

SN 77-919,676. BUNKSPEED CORPORATION CALIFORNIA, DBA BUNKSPEED, CARLSBAD, CA. FILED 1-25-2010.

WHAT WORKS

THE MARK CONSISTS OF STANDARD CHARACTERS WITHOUT CLAIM TO ANY PARTICULAR FONT, STYLE, SIZE, OR COLOR.

PRIORITY CLAIMED UNDER SEC. 44(D) ON UNITED KINGDOM APPLICATION NO. 2527183, FILED 9-28-2009, REG. NO. 2527183, DATED 1-15-2010, EXPIRES 9-28-2019.

CLASS 35—ADVERTISING AND BUSINESS

FOR ADVERTISING IN PERIODICALS, BROCHURES AND NEWSPAPERS; PROMOTING THE GOODS AND SERVICES OF OTHERS BY ARRANGING FOR SPONSORS TO AFFILIATE THEIR GOODS AND SERVICES WITH AN AWARDS PROGRAM, A SPORTS COMPETITION AND SPORTING ACTIVITIES (U.S. CLS. 100, 101 AND 102).

CLASS 41—EDUCATION AND ENTERTAINMENT

FOR ARRANGING OF BEAUTY CONTESTS; CONSULTING SERVICES IN THE FIELDS OF FITNESS AND EXERCISE; EDITING OF RADIO AND TELEVISION PROGRAMS; EDUCATION SERVICES, NAMELY, PROVIDING ON-LINE TUTORIALS IN THE FIELD OF SPORTS, FITNESS, HEALTH, BEAUTY, PSYCHOLOGY, PARENTING AND COMPUTER SKILLS; EDUCATION SERVICES, NAMELY, PROVIDING CLASSES AND WORKSHOPS IN THE FIELD OF SPORTS, FITNESS, HEALTH, BEAUTY, PSYCHOLOGY, PARENTING AND COMPUTER SKILLS; ENTERTAINMENT SERVICES, NAMELY, PROVIDING ONLINE ELECTRONIC GAMES; INFORMATION ABOUT EDUCATION; INFORMATION RELATING TO ENTERTAINMENT AND EDUCATION, PROVIDED ON-LINE FROM A COMPUTER DATABASE OR THE INTERNET; ORGANISATION OF SPORTS COMPETITIONS; ORGANIZING AND ARRANGING EXHIBITIONS FOR ENTERTAINMENT PURPOSES; ORGANIZING CULTURAL AND ARTS EVENTS; ORGANIZING EXHIBITIONS FOR CULTURAL AND EDUCATIONAL PURPOSES; PRODUCTION AND DISTRIBUTION OF TELEVISION SHOWS AND MOVIES; PRODUCTION OF RADIO AND TELEVISION PROGRAMS; PROVIDING A WEB SITE FEATURING INFORMATION ON EXERCISE AND FITNESS; PROVIDING A WEB SITE FEATURING SPORTING INFORMATION; PROVIDING AN INTERNET WEBSITE PORTAL IN THE FIELD OF ENTERTAINMENT, CULTURAL AND SPORTING EVENTS; PROVIDING INFORMATION ON PHYSICAL EXERCISE; PROVIDING INFORMATION, NEWS AND COMMENTARY IN THE FIELD OF ENTERTAINMENT; PROVIDING INFORMATION, NEWS AND COMMENTARY IN THE FIELD OF RECREATION AND LEISURE ACTIVITIES; PROVIDING NEWS AND INFORMATION IN THE FIELD OF SPORTS; PROVIDING NEWS IN THE NATURE OF CURRENT EVENT REPORTING; PROVISION OF INFORMATION RELATING TO TELEVISION, MOTION PICTURE FILM, AUDIO AND RADIO PRODUCTION; PUBLICATION AND EDITING OF PRINTED MATTER; PUBLICATION OF BOOKS; PUBLISHING OF ELECTRONIC PUBLICATIONS; RENTAL OF FILMS; RENTAL OF SOUND RECORDINGS; TELEVISION PROGRAM SYNDICATION (U.S. CLS. 100, 101 AND 107).

MARLENE BELL, EXAMINING ATTORNEY



The logo for "Bunkspeed Move" features the word "Bunkspeed" in a bold, sans-serif font, with a curved line arching over the top of the letters. The word "Move" is positioned to the right of "Bunkspeed" in a similar bold, sans-serif font.

OWNER OF U.S. REG. NO. 3,074,263.

THE MARK CONSISTS OF THE WORDING "BUNKSPEED MOVE" WITH AN ARCH DESIGN CURVING UPWARD ABOVE THE WORD "BUNKSPEED".

CLASS 9—ELECTRICAL AND SCIENTIFIC APPARATUS

FOR COMPUTER GRAPHICS SOFTWARE (U.S. CLS. 21, 23, 26, 36 AND 38).

CLASS 42—SCIENTIFIC AND COMPUTER SERVICES

FOR COMPUTER AIDED GRAPHIC DESIGN; COMPUTER GRAPHICS SERVICES; GRAPHIC ART DESIGN (U.S. CLS. 100 AND 101).

LAURA KOVALSKY, EXAMINING ATTORNEY

SN 77-919,692. BUNKSPEED CORPORATION CALIFORNIA, DBA BUNKSPEED, CARLSBAD, CA. FILED 1-25-2010.



The logo for "Bunkspeed Drive" features the word "Bunkspeed" in a bold, sans-serif font, with a curved line arching over the top of the letters. The word "Drive" is positioned to the right of "Bunkspeed" in a similar bold, sans-serif font.

OWNER OF U.S. REG. NO. 3,074,263.

THE MARK CONSISTS OF THE WORDING "BUNKSPEED DRIVE" WITH AN ARCH DESIGN CURVING UPWARD ABOVE THE WORD "BUNKSPEED".

CLASS 9—ELECTRICAL AND SCIENTIFIC APPARATUS

FOR COMPUTER GRAPHICS SOFTWARE (U.S. CLS. 21, 23, 26, 36 AND 38).

CLASS 42—SCIENTIFIC AND COMPUTER SERVICES

FOR COMPUTER AIDED GRAPHIC DESIGN; COMPUTER GRAPHICS SERVICES; GRAPHIC ART DESIGN (U.S. CLS. 100 AND 101).

LAURA KOVALSKY, EXAMINING ATTORNEY

SN 77-921,672. VERIZON TRADEMARK SERVICES LLC, ARLINGTON, VA. FILED 1-27-2010.

DEIRDRE ROBERTSON, EXAMINING ATTORNEY

ALTOGETHER BETTER

THE MARK CONSISTS OF STANDARD CHARACTERS WITHOUT CLAIM TO ANY PARTICULAR FONT, STYLE, SIZE, OR COLOR.

CLASS 38—COMMUNICATION

FOR COLOCATION SERVICES, NAMELY, THE PROVISION OF A SECURE ENVIRONMENTALLY-CONTROLLED FACILITY AND TECHNICAL MONITORING FOR THE TELECOMMUNICATIONS EQUIPMENT OF OTHERS; PROVIDING INFORMATION IN THE FIELD OF THE SECURE TRANSMISSION OF DATA AND INFORMATION (U.S. CLS. 100, 101 AND 104).

CLASS 42—SCIENTIFIC AND COMPUTER SERVICES

FOR COMPUTER SERVICES, NAMELY, REMOTE AND ON-SITE MANAGEMENT OF THE COMMUNICATIONS NETWORKS OF OTHERS; CONSULTING IN THE FIELDS OF INFORMATION TECHNOLOGY AND THE TECHNICAL OPERATION OF COMPUTER NETWORKS AND IP NETWORKS; DESIGN FOR OTHERS IN THE FIELDS OF INFORMATION TECHNOLOGY, COMPUTER NETWORKS AND IP NETWORKS; APPLICATION SERVICE PROVIDER (ASP) SERVICES, NAMELY, HOSTING COMPUTER SOFTWARE APPLICATIONS OF OTHERS; PROVIDING TEMPORARY USE OF NON-DOWNLOADABLE NETWORK AUDITING SOFTWARE IN THE FIELDS OF SECURE COMMUNICATIONS AND DATA NETWORKS; TECHNICAL COMPUTER CONSULTATION IN THE FIELD OF COMPUTER AND NETWORK SECURITY, SECURE TRANSMISSION OF DATA, AND DATA ENCRYPTION AND DECRYPTION; PROVIDING INFORMATION IN THE FIELD OF INTERNET AND NETWORK SECURITY; ON-LINE SECURITY SERVICES, NAMELY, PROVIDING SECURITY AND ANONYMITY FOR ELECTRONICALLY TRANSMITTED CREDIT CARD TRANSACTIONS; COMPUTER AND NETWORK DIAGNOSTIC SERVICES; COMPUTER SERVICES, NAMELY, DATA RECOVERY SERVICES; TECHNICAL SUPPORT SERVICES, NAMELY, TROUBLESHOOTING OF COMPUTER NETWORK AND SOFTWARE PROBLEMS; TECHNICAL SUPPORT SERVICES, NAMELY, TROUBLESHOOTING IN THE NATURE OF DIAGNOSING COMPUTER HARDWARE PROBLEMS; TECHNICAL SUPPORT SERVICES, NAMELY, PROVIDING COMPUTER BACKUP PROGRAMS AND FACILITIES; NETWORK AND INTERNET SECURITY SERVICES, NAMELY, RESTRICTING ACCESS TO AND BY COMPUTER NETWORKS TO AND OF UNDESIRED WEBSITES, MEDIA, INDIVIDUALS, AND FACILITIES, AND PROVIDING FOR THE BACKUP OF SUCH DATA; PROVIDING INFORMATION IN THE FIELDS OF COMPUTER, NETWORK AND INTERNET SECURITY, AND PREVENTION OF COMPUTER THREATS; COMPUTER SERVICES, NAMELY, ON-LINE SCANNING, DETECTING, QUARANTINING AND ELIMINATING VIRUSES, WORMS, TROJANS, SPYWARE, ADWARE, MALWARE AND UNAUTHORIZED DATA AND PROGRAMS ON COMPUTERS, ELECTRONIC DEVICES AND COMMUNICATIONS NETWORKS; COMPUTER SECURITY SERVICES, NAMELY, PROVIDING USER AUTHENTICATION SERVICES TO OTHERS IN THE FIELD OF VOICE AND DATA COMMUNICATION SERVICES VIA COMPUTER NETWORK IN THE NATURE OF RESTRICTING ACCESS TO AND BY COMPUTER NETWORKS TO AND OF UNDESIRED WEB SITES, MEDIA AND INDIVIDUALS AND FACILITIES; OPERATING ELECTRONIC INFORMATION NETWORKS; DATA CENTER SERVICES, NAMELY, MANAGING ELECTRONIC DATA AND INFORMATION TECHNOLOGY INFRASTRUCTURE FOR OTHERS (U.S. CLS. 100 AND 101).

SN 77-921,847. SARCASM, INC., SHELBY TOWNSHIP, MI. FILED 1-27-2010.



OWNER OF U.S. REG. NO. 3,712,952.

THE MARK CONSISTS OF A CIRCULAR SPIRAL DESIGN ENDING WITH A SHADED CIRCLE IN THE INTERIOR OF THE SPIRAL.

CLASS 9—ELECTRICAL AND SCIENTIFIC APPARATUS

FOR COMPUTER CURSOR CONTROL DEVICES, NAMELY, COMPUTER MOUSE; COMPUTER CURSOR CONTROL DEVICES, NAMELY, TOUCH PADS; COMPUTER HARDWARE AND COMPUTER PERIPHERAL DEVICES; COMPUTER HARDWARE AND COMPUTER PERIPHERALS; COMPUTER HARDWARE AND PERIPHERAL DEVICES; COMPUTER HARDWARE AND PERIPHERALS; COMPUTER KEYBOARDS; COMPUTER KEYPADS; COMPUTER MICE; COMPUTER MOUSE; COMPUTER MOUSE, NAMELY, TOUCHPADS; COMPUTER MOUSE, NAMELY, TRACKBALLS; COMPUTER PERIPHERAL DEVICES; COMPUTER TERMINALS, KEYBOARDS AND PRINTERS; KEYBOARD AND PRINT OUT APPARATUS FOR USE WITH COMPUTERS; KEYBOARDS; KEYBOARDS FOR MOBILE PHONES; MULTIFUNCTION KEYBOARDS (U.S. CLS. 21, 23, 26, 36 AND 38).

CLASS 16—PAPER GOODS AND PRINTED MATTER

FOR ADHESIVE NOTE PAPER; ART PAPER; BLANK PAPER NOTEBOOKS; BUMPER STICKERS; CALLIGRAPHY PAPER; CHILDREN'S WALL STICKERS AND MURALS; COASTERS MADE OF PAPER; COASTERS OF PAPER; CONSTRUCTION PAPER; COPIER PAPER; COPY PAPER; COPYING PAPER; CORRUGATED BOARD AND PAPER CONTAINERS; CORRUGATED PAPER; CORRUGATED PAPER PANELS LAMINATED WITH BLEACHED WHITE PAPER PRIMARILY FOR APPLICATION OF PRINTED MEDIA FOR FURTHER USE IN SIGNAGE APPLICATIONS; CORRUGATED PAPER PANELS LAMINATED WITH KRAFT LINERBOARD PRIMARILY FOR LAMINATION WITH DECORATIVE OVERLAYS FOR FURTHER USE IN THE CONSTRUCTION OF WALL PARTITIONS, ROOM DIVIDERS, DESKTOPS AND TABLETOPS; CRAFT PAPER; CREPE PAPER; DECORATIVE PAPER BOWS FOR WRAPPING; DECORATIVE PAPER CENTERPIECES; DECORATIVE STICKERS FOR HELMETS; DIGITAL PRINTING PAPER; DRAWING PAPER; ENVELOPE PAPER; GIFT WRAP PAPER; GIFT WRAPPING PAPER; GIFT-WRAPPING PAPER; IMPRESSION STAMPS; INK STAMPS; KRAFT PAPER; MARKING STAMPS; NOTE PAPER; NOTE PAPERS; NOTEBOOK PAPER; RUBBER DOCUMENT STAMPS; RUBBER STAMP; RUBBER STAMPS; STICKER ALBUMS; STICKERS; STICKERS; STICKERS AND DECALCOMANIAS; STICKERS AND STICKER ALBUMS; STICKERS AND TRANSFERS (U.S. CLS. 2, 5, 22, 23, 29, 37, 38 AND 50).

FIRST USE 10-15-2009; IN COMMERCE 1-11-2010.

CLASS 21—HOUSEWARES AND GLASS

FOR BEER MUGS; COFFEE CUPS, TEA CUPS AND MUGS; CUPS AND MUGS; EARTHENWARE MUGS; GLASS MUGS; MUGS; MUGS, NOT OF PRECIOUS METAL; PORCELAIN MUGS (U.S. CLS. 2, 13, 23, 29, 30, 33, 40 AND 50).

FIRST USE 10-15-2009; IN COMMERCE 1-11-2010.

CLASS 25—CLOTHING

FOR A-SHIRTS; APPAREL FOR DANCERS, NAMELY, TEE SHIRTS, SWEATSHIRTS, PANTS, LEGGINGS, SHORTS AND JACKETS; ATHLETIC APPAREL, NAMELY, SHIRTS, PANTS, JACKETS, FOOTWEAR, HATS AND CAPS, ATHLETIC UNIFORMS; BALLOON PANTS; BODY SHIRTS; BUTTON-FRONT ALOHA SHIRTS; CAMOUFLAGE PANTS; CAMOUFLAGE SHIRTS; CAMP SHIRTS; CAPRI PANTS; CARGO PANTS; CHEF'S HATS; CLOTHING FOR ATHLETIC USE, NAMELY, PADDED PANTS; CLOTHING FOR ATHLETIC USE, NAMELY, PADDED SHIRTS; DENIMS; DRESS SHIRTS; FISHING SHIRTS; GIFT PACKAGES SOLD AS A UNIT CONSISTING PRIMARILY OF A SWEATSHIRT AND ALSO INCLUDING A PHOTO FRAME, A COFFEE MUG, AND A TOTE BAG; GOLF PANTS, SHIRTS AND SKIRTS; GOLF SHIRTS; GYM PANTS; HATS; HATS FOR INFANTS, BABIES, TODDLERS AND CHILDREN; HOODED SWEAT SHIRTS; HUNTING PANTS; HUNTING SHIRTS; JOGGING PANTS; KNIT SHIRTS; LEATHER PANTS; LEG SHIELDING DEVICE, ATTACHABLE TO AND DETACHABLE FROM A PERSON'S PANTS, COMPRISED OF PADDING TO SHIELD THE LEGS FROM FLYING DEBRIS WHEN MOWING WITH A STRING TRIMMER; LONG-SLEEVED SHIRTS; LOUNGE PANTS; MOISTURE-WICKING SPORTS PANTS; NIGHT SHIRTS; NON-DISPOSABLE CLOTH TRAINING PANTS; NURSE PANTS; OPEN-NECKED SHIRTS; OVER SHIRTS; PANTS; PAPER HATS FOR USE AS CLOTHING ITEMS; PARTY HATS; PETTIPANTS; PIQUE SHIRTS; POLO SHIRTS; RAIN HATS; RUGBY SHIRTS; SCIENTIFIC AND TECHNOLOGICAL APPAREL, NAMELY, SHIRTS, PANTS, JACKETS, FOOTWEAR, HATS AND CAPS, UNIFORMS; SEDGE HATS (SUGE-GASA); SHIRT FRONTS; SHIRT YOKES; SHIRTS; SHIRTS AND SHORT-SLEEVED SHIRTS; SHIRTS FOR INFANTS, BABIES, TODDLERS AND CHILDREN; SHIRTS FOR SUITS; SHORT-SLEEVED OR LONG-SLEEVED T-SHIRTS; SHORT-SLEEVED SHIRTS; SKI PANTS; SLEEP PANTS; SLEEP SHIRTS; SMALL HATS; SNOW PANTS; SNOWBOARD PANTS; SPORT SHIRTS; SPORTS PANTS; SPORTS SHIRTS; SPORTS SHIRTS WITH SHORT SLEEVES; STRETCH PANTS; SWEAT

PANTS; SWEAT SHIRTS; T-SHIRTS; TAP PANTS; TEE SHIRTS; TOBOGGAN HATS, PANTS AND CAPS; TRACK PANTS; TRAVEL CLOTHING CONTAINED IN A PACKAGE COMPRISING REVERSIBLE JACKETS, PANTS, SKIRTS, TOPS AND A BELT OR SCARF; TRIATHLON CLOTHING, NAMELY, TRIATHLON TIGHTS, TRIATHLON SHORTS, TRIATHLON SINGLET, TRIATHLON SHIRTS, TRIATHLON SUITS; TURTLE NECK SHIRTS; WATERPROOF JACKETS AND PANTS; WEARABLE GARMENTS AND CLOTHING, NAMELY, SHIRTS; WIND PANTS; WIND SHIRTS; WOMEN'S HATS AND HOODS; WOOLLY HATS; YOGA PANTS; YOGA SHIRTS (U.S. CLS. 22 AND 39).

FIRST USE 10-15-2009; IN COMMERCE 1-11-2010.
ANNE FARRELL, EXAMINING ATTORNEY

SN 77-923,118. MONDOBIOTECH AG, STANS, SWITZERLAND, FILED 1-29-2010.

SwissAir

THE MARK CONSISTS OF STANDARD CHARACTERS WITHOUT CLAIM TO ANY PARTICULAR FONT, STYLE, SIZE, OR COLOR.

OWNER OF SWITZERLAND REG. NO. 555384, DATED 2-12-2007, EXPIRES 9-11-2016.

CLASS 5—PHARMACEUTICALS

FOR MEDICINES, PHARMACEUTICAL PREPARATIONS, VETERINARY PREPARATIONS, PHARMACEUTICAL PRODUCTS, CHEMICAL PREPARATIONS FOR USE IN MEDICINE, CHEMICAL PREPARATIONS FOR MEDICAL SCIENCE FOR USE IN OR ON THE HUMAN OR ANIMAL BODY, CHEMICAL PRODUCTS FOR CURATIVE PURPOSES, NAMELY, EFFECTIVE COMPOUNDS, ALL OF THE FOREGOING FOR THE TREATMENT OF INFECTIOUS DISEASES, RESPIRATORY INFECTIONS, CENTRAL NERVOUS SYSTEM INFECTIONS, GASTROINTESTINAL INFECTIONS, GENITOURINARY INFECTIONS, OCULAR INFECTIONS, DERMATOLOGICAL INFECTIONS, IMMUNE SYSTEM INFECTIONS, LIVER INFECTIONS, HEPATIC INFECTIONS, TUBERCULOSIS, LUNG DISEASES, ASTHMA, HYPERTENSION, CARDIOVASCULAR DISEASES, IMMUNOLOGIC DISEASES, AUTOIMMUNE DISEASES, IMMUNOLOGIC DEFICIENCY SYNDROMES, CANCER, TUMORS, PROLIFERATIVE DISEASES, INFLAMMATORY DISEASES, INFLAMMATORY BOWEL DISEASES, INFLAMMATORY CONNECTIVE TISSUE DISEASES, PSORIASIS, OPHTHALMOLOGIC DISEASES, FIBROTIC DISEASES, METABOLIC DISEASES, DENTAL AND ORAL DISEASES, NEUROLOGICAL DISEASES, ALZHEIMERS DISEASE, HUNTINGTONS DISEASE, PARKINSON, CEREBRAL PALSY, NEUROLOGICAL DISORDERS, BRAIN INJURY, SPINAL CORD INJURY, SEIZURE DISORDERS; SANITARY PREPARATIONS FOR MEDICAL USE; PHARMACEUTICAL PRODUCTS FOR TREATING RARE DISEASES, NAMELY, FOR THE TREATMENT OF INFECTIOUS DISEASES, RESPIRATORY INFECTIONS, CENTRAL NERVOUS SYSTEM INFECTIONS, GASTROINTESTINAL INFECTIONS, GENITOURINARY INFECTIONS, OCULAR INFECTIONS, DERMATOLOGICAL INFECTIONS, IMMUNE SYSTEM INFECTIONS, LIVER INFECTIONS, HEPATIC INFECTIONS, TUBERCULOSIS, LUNG DISEASES, ASTHMA, HYPERTENSION, CARDIOVASCULAR DISEASES, IMMUNOLOGIC DISEASES, AUTOIMMUNE DISEASES, IMMUNOLOGIC DEFICIENCY SYNDROMES, CANCER, TUMORS, PROLIFERATIVE DISEASES, INFLAMMATORY DISEASES, INFLAMMATORY BOWEL DISEASES, INFLAMMATORY CONNECTIVE TISSUE DISEASES, PSORIASIS, OPHTHALMOLOGIC DISEASES, FIBROTIC DISEASES, METABOLIC DISEASES, DENTAL AND ORAL DISEASES, NEUROLOGICAL DISEASES, ALZHEIMERS DISEASE, HUNTINGTONS DISEASE, PARKINSON,

CEREBRAL PALSY, NEUROLOGICAL DISORDERS, BRAIN INJURY, SPINAL CORD INJURY, AND SEIZURE DISORDERS; DIETETIC FOODS ADAPTED FOR MEDICAL USE; DIETETIC FOODS AND BEVERAGES ADAPTED FOR HEALTH CARE USE AND HUMAN AND VETERINARY MEDICAL USE; DISINFECTANTS FOR MEDICAL PURPOSES; PREPARATIONS FOR DESTROYING VERMIN, FUNGICIDES, HERBICIDES; DIAGNOSTICS, NAMELY, DIAGNOSTIC PREPARATIONS FOR MEDICAL AND VETERINARY USE; DIAGNOSTIC AGENTS FOR VETERINARY USE, X-RAY CONTRAST AGENTS FOR MEDICAL USE, DIAGNOSTIC AGENTS FOR MEDICAL USE, MEDICAL PREPARATIONS FOR MOUTH CARE, MEDICAL PREPARATIONS FOR SKIN CARE (U.S. CLS. 6, 18, 44, 46, 51 AND 52).

SN 77-923,346. GENTING INTERNATIONAL MANAGEMENT LIMITED, DOUGLAS 1M2 4RB, UNITED KINGDOM, FILED 1-29-2010.

CLASS 35—ADVERTISING AND BUSINESS

FOR ADVICE IN THE RUNNING OF ESTABLISHMENTS AS FRANCHISES; PROMOTING COLLABORATION WITH THE SCIENTIFIC COMMUNITY TO ACHIEVE ADVANCES IN THE FIELD OF MEDICAL AND CLINICAL RESEARCH; ADVERTISING AND PROMOTIONAL SERVICES, NAMELY, MARKETING SCIENTIFIC PROJECTS IN MEDICAL, PHARMACEUTICAL, PHARMACOLOGICAL, BIOCHEMICAL AND MEDICINE-TECHNOLOGICAL AREAS ON BEHALF OF OTHERS (U.S. CLS. 100, 101 AND 102).

CLASS 42—SCIENTIFIC AND COMPUTER SERVICES

FOR MEDICAL AND SCIENTIFIC DEVELOPMENT AND RESEARCH SERVICES IN THE FIELD OF MEDICAL, BIOCHEMICAL, PHARMACEUTICAL AND MEDICINE-TECHNOLOGICAL RESEARCH; DEVELOPMENT OF PHARMACEUTICAL PREPARATIONS AND MEDICINES; PHARMACEUTICAL DRUG DEVELOPMENT SERVICES; PHARMACEUTICAL PRODUCT EVALUATION; PHARMACEUTICAL RESEARCH AND DEVELOPMENT; PHARMACEUTICAL RESEARCH SERVICES; SERVICES OF A MEDICAL, BACTERIOLOGICAL, BIOCHEMICAL LABORATORY IN THE FIELD OF MEDICINE; SERVICES OF A MEDICAL LABORATORY; COMMISSIONED RESEARCH AND DEVELOPMENT OF NEW DRUGS AND MEDICINES; SCIENTIFIC CONTRACT RESEARCH; MEDICAL CONTRACT RESEARCH; CONDUCTING RESEARCH AND DEVELOPMENT WORK IN MEDICAL, PHARMACEUTICAL, PHARMACOLOGICAL, BIOCHEMICAL AND MEDICINE-TECHNOLOGICAL AREA ON BEHALF OF THIRD PARTIES; MEDICAL AND SCIENTIFIC RESEARCH, NAMELY, CONDUCTING CLINICAL TRIALS AND CLINICAL STUDIES (U.S. CLS. 100 AND 101).

CLASS 44—MEDICAL, BEAUTY AND AGRICULTURAL SERVICES

FOR SERVICES OF A HOSPITAL; SERVICES OF PRACTICING PHYSICIANS, SERVICES OF A PHARMACIST TO MAKE UP PRESCRIPTIONS (U.S. CLS. 100 AND 101).

JAMES GRIFFIN, EXAMINING ATTORNEY



OWNER OF SINGAPORE REG. NO. T0813645C, DATED 9-29-2008, EXPIRES 9-29-2018.

OWNER OF SINGAPORE REG. NO. T0813644E, DATED 9-29-2008, EXPIRES 9-29-2018.

OWNER OF SINGAPORE REG. NO. T0813642I, DATED 9-29-2008, EXPIRES 9-29-2018.

OWNER OF SINGAPORE REG. NO. T0813634H, DATED 9-29-2008, EXPIRES 9-29-2018.

THE MARK CONSISTS OF GLOBE DESIGN COMPOSED OF LETTERS "R" AND "W" IN STYLIZED FORMAT.

CLASS 16—PAPER GOODS AND PRINTED MATTER

FOR POSTCARDS, NOTE BOOKS, DIARIES, DESK DIARIES, LEATHER COVERED DIARIES, WALL CHARTS FOR USE AS DIARIES, ADHESIVE PRINTED STICKERS, CAR STICKERS, PLASTIC STICKERS, PAPER STICKERS, GIFT BAGS MADE OF PAPER AND CARDBOARD, GIFT BAGS MADE OF PLASTICS, GIFT WRAPPING PAPER, RIBBONS OF PAPER, BOOKS IN THE FIELD OF GOLF AND GOLF INSTRUCTION FOR GOLFERS, GOLF COURSE PLANNERS, NAMELY, DRAWING AND ILLUSTRATION PAPER FOR USE IN PLANNING GOLF COURSE LAYOUT, DESKTOP ORGANIZERS, LETTER OPENERS, PENCIL OR PEN HOLDERS, FIGURINES OF PAPER MACHE, STATIONERY, PLASTIC MATERIAL FOR PACKAGING, NAMELY, PLASTIC BUBBLE PACKS, MINIATURE MODELS OF PAPER OR CARDBOARD, NAMELY, ARCHITECTURAL MODELS, THREE-DIMENSIONAL EDUCATIONAL MODELS NOT BEING TOY MODELS, COASTERS MADE OF PAPER OR CARDBOARD, DESK CALENDARS, LOOSE-LEAF BINDERS CONTAINING APPOINTMENT CALENDARS, CARD-SIZED CALENDARS, PRINTED DOOR KNOB HANG TAGS MADE OF CARDBOARD AND PAPER, PAPER GIFT TAGS, PENCILS, PENS, RULERS, NAMELY, DRAFTING RULERS, DRAWING RULERS, UNGRADUATED RULERS, ERASERS, GREETING CARDS, PAPER PENNANTS, PAPER DISPLAY CARDS FOR ADVERTISING PURPOSES, PRINTED PAPER SIGNS, PAPER BANNERS, POSTERS, TICKETS OF PAPER, NAMELY, ENTRY TICKETS, PASSENGER TICKETS, PRICE TICKETS, PRINTED TICKETS, LETTERHEAD PAPER (U.S. CLS. 2, 5, 22, 23, 29, 37, 38 AND 50).

CLASS 28—TOYS AND SPORTING GOODS

FOR BEACH TOYS, NAMELY, SAND TOYS, BEACH BALLS, SHAPED GOLF BAG COVERS, GOLF GLOVES, GOLF BAGS, WITH OR WITHOUT WHEELS, GOLF BALL MARKERS, GOLF TEES, GOLF BALLS, GOLF PUTTERS, DIVOT REPAIR TOOLS FOR GOLFERS, TOYS, NAMELY, SOFT SCULPTURE TOYS AND PLUSH TOYS, INFLATABLE TOYS, STUFFED TOYS, GAMES, NAMELY, BOARD GAMES, ACTION SKILL GAMES, CARD GAMES, INFLATABLE MATS FOR RECREATIONAL USE, NAMELY, PERSONAL EXERCISE MATS, YOGA MATS, GOLF PUTTING PRACTICE MATS, PLAYING CARDS, PLUSH TOYS, GAMBLING CHIPS, ROULETTE CHIPS, GAMES INVOLVING GAMING, NAMELY, CARD GAMES, EQUIPMENT SOLD AS A UNIT FOR PLAYING CRAPS GAMES (U.S. CLS. 22, 23, 38 AND 50).

CLASS 43—HOTEL AND RESTAURANT SERVICES

FOR ARRANGING OF TEMPORARY ACCOMMODATIONS, NAMELY, HOTELS, RESORTS, SERVICED APARTMENTS, CONDOMINIUMS AND RESIDENTIAL HOMES IN VACATION AND RESORT COMMUNITIES; TRAVEL AGENCIES FOR ARRANGING AND RESERVATION OF TEMPORARY ACCOMMODATION; HOSPITALITY SERVICES, NAMELY, PROVIDING TEMPORARY HOUSING; DAY-CARE CENTERS AND DAY-NURSERY SERVICES; PREPARATION AND PROVISION OF FOOD AND DRINK; PROVISION OF HOSPITALITY SERVICES, NAMELY, PROVIDING COCKTAIL LOUNGE, BAR, CAFE, RESTAURANT, COFFEE BAR, SNACK BAR, WINE BAR, BISTRO SERVICES; PROVIDING PERSONALIZED INFORMATION ABOUT TEMPORARY ACCOMMODATIONS FOR TRAVEL VIA THE INTERNET; PROVIDING INFORMATION IN THE FIELD OF DINING AND DRINKS (U.S. CLS. 100 AND 101).

MARY CRAWFORD, EXAMINING ATTORNEY

SN 77-925,495. LEONARD, KATHY, DALLAS, TX. FILED 2-2-2010.

FREEMAN LEONARD

THE MARK CONSISTS OF STANDARD CHARACTERS WITHOUT CLAIM TO ANY PARTICULAR FONT, STYLE, SIZE, OR COLOR.

CLASS 41—EDUCATION AND ENTERTAINMENT

FOR PROVIDING ENTERTAINMENT, AMUSEMENT AND RECREATIONAL SERVICES, NAMELY, CONDUCTING LIVE BLACKJACK CARD GAME TOURNAMENTS, AMUSEMENT ARCADE SERVICES, PROVIDING RECREATIONAL AREAS IN THE NATURE OF CHILDREN'S PLAY AREAS; PROVIDING ENTERTAINMENT, AMUSEMENT AND RECREATIONAL FACILITIES, NAMELY, CASINO FACILITIES, GOLF FACILITIES, AMUSEMENT FACILITIES, SPORTS FACILITIES; PROVIDING FACILITIES FOR CASINO GAMBLING, CASINO GAMING, CABARETS, DISCOTHEQUES, NIGHTCLUBS, CINEMAS AND THEATRES; CASINO GAMBLING AND GAMING SERVICES; CABARET SERVICES, DISCOTHEQUE SERVICES, NIGHTCLUB SERVICES, CINEMA THEATER SERVICES, MOVIE THEATER SERVICES; ORGANIZATION OF EDUCATIONAL, CULTURAL OR ENTERTAINMENT EVENTS, RECREATIONAL ACTIVITIES, COMPETITIONS, AND CONTESTS, NAMELY, SPECIAL EVENT PLANNING, GOLF TOURNAMENTS, BLACKJACK COMPETITIONS, CASINO AND GAMING CONTESTS; ORGANIZING AND PROVIDING ENTERTAINMENT SERVICES IN THE NATURE OF LIVE PERFORMANCES BY ENTERTAINERS, MUSICAL GROUPS AND SINGERS AND LIVE PERFORMANCES FEATURING PRE-RECORDED VOCAL OR INSTRUMENTAL PERFORMANCE VIEWED ON A BIG SCREEN; RADIO ENTERTAINMENT, NAMELY, PRODUCTION OF RADIO PROGRAMS; TELEVISION ENTERTAINMENT, NAMELY, PRODUCTION OF TELEVISION PROGRAMS; ARRANGING AND PROVIDING ENTERTAINMENT SHOWS, NAMELY, FASHION SHOWS, MAGIC SHOWS, LIGHT SHOWS; STAGE PERFORMANCES, NAMELY, LIVE STAGE PERFORMANCES IN THE NATURE OF CONCERTS; ORGANIZATION OF PARADES AND FAIRS FOR ENTERTAINMENT PURPOSES; EXHIBITION AND DEMONSTRATION SERVICES FOR ENTERTAINMENT, CULTURAL AND EDUCATIONAL PURPOSES, NAMELY, ORGANIZATION OF EXHIBITIONS FOR ENTERTAINMENT, CULTURAL OR EDUCATIONAL PURPOSES, EDUCATIONAL AND ENTERTAINMENT DEMONSTRATIONS; PUBLICATION OF NEWSLETTERS, PERIODICALS, BOOKS, MAGAZINES; PROVIDING ENTERTAINMENT INFORMATION VIA ONLINE DATABASES AND THE INTERNET (U.S. CLS. 100, 101 AND 107).

CLASS 35—ADVERTISING AND BUSINESS

FOR MARKETING SERVICES TO END USERS ON A CONTRACT BASIS, NAMELY, MARKETING PLANNING, MARKETING STRATEGY, MEDIA PLANNING AND BUYING, PROJECT MANAGEMENT, MARKETING RESEARCH AND MARKETING ANALYTICS; RECRUITING AND PLACEMENT OF MARKETING, ADVERTISING AND CREATIVE PROFESSIONALS ON A TEMPORARY AND PERMANENT BASIS (U.S. CLS. 100, 101 AND 102).

CLASS 42—SCIENTIFIC AND COMPUTER SERVICES

FOR SERVICES TO END USERS ON A CONTRACT BASIS, NAMELY, GRAPHIC DESIGN, WEB SITE DESIGN (U.S. CLS. 100 AND 101).

EUGENIA MARTIN, EXAMINING ATTORNEY

SN 77-926,121. ANVIL KNITWEAR, INC., NEW YORK, NY. FILED 2-2-2010.

TRACK MY T

THE MARK CONSISTS OF STANDARD CHARACTERS WITHOUT CLAIM TO ANY PARTICULAR FONT, STYLE, SIZE, OR COLOR.

NO CLAIM IS MADE TO THE EXCLUSIVE RIGHT TO USE "T", APART FROM THE MARK AS SHOWN.

CLASS 25—CLOTHING

FOR CLOTHING, NAMELY, SHIRTS, T-SHIRTS (U.S. CLS. 22 AND 39).
FIRST USE 11-24-2009; IN COMMERCE 11-24-2009.

CLASS 35—ADVERTISING AND BUSINESS

FOR PROVIDING INFORMATION IN THE FIELD OF SUPPLY CHAIN MANAGEMENT FOR CLOTHING VIA THE INTERNET; PROVIDING INFORMATION IN THE FIELD OF SUPPLY CHAIN MANAGEMENT FOR T-SHIRTS AND ORGANIC CLOTHING (U.S. CLS. 100, 101 AND 102).
FIRST USE 11-13-2009; IN COMMERCE 11-13-2009.

CLASS 40—MATERIAL TREATMENT

FOR PROVIDING INFORMATION IN THE FIELD OF MANUFACTURING OF CLOTHING AND CLOTHING RAW MATERIALS VIA THE INTERNET (U.S. CLS. 100, 103 AND 106).
FIRST USE 11-13-2009; IN COMMERCE 11-13-2009.

CLASS 41—EDUCATION AND ENTERTAINMENT

FOR PROVIDING EDUCATIONAL INFORMATION IN THE FIELD OF MANUFACTURING OF CLOTHING AND SUPPLY CHAIN MANAGEMENT OF CLOTHING FOR ACADEMIC PURPOSES AND DISTRIBUTION OF LESSON PLANS IN CONNECTION THEREWITH (U.S. CLS. 100, 101 AND 107).
FIRST USE 11-13-2009; IN COMMERCE 11-13-2009.
ELIZABETH KAJUBI, EXAMINING ATTORNEY

SN 77-926,325. WE'RE GLAD YOU'RE HERE!, PORTLAND, OR. FILED 2-2-2010.

WE'RE GLAD YOU'RE HERE!

THE MARK CONSISTS OF STANDARD CHARACTERS WITHOUT CLAIM TO ANY PARTICULAR FONT, STYLE, SIZE, OR COLOR.

CLASS 41—EDUCATION AND ENTERTAINMENT

FOR CHARITABLE OUTREACH SERVICES, NAMELY, PROVIDING COMPANIONSHIP THROUGH LIVE MUSICAL PRESENTATION TO THE ELDERLY, DISABLED AND OTHERS RESIDING IN NURSING HOMES, ASSISTED CARE FACILITIES AND OTHER INSTITUTIONS (U.S. CLS. 100, 101 AND 107).

CLASS 45—PERSONAL AND LEGAL SERVICES

FOR CHARITABLE OUTREACH SERVICES PROVIDING COUNSELING SERVICES TO THE ELDERLY, DISABLED AND OTHERS RESIDING IN NURSING HOMES, ASSISTED CARE FACILITIES AND OTHER INSTITUTIONS, NAMELY, CHRISTIAN MINISTRY, RELIGIOUS AND SPIRITUAL PRAYER SERVICES, COMPANIONSHIP TO ALLEVIATE LONELINESS AND ADVANCE THE CHRISTIAN FAITH (U.S. CLS. 100 AND 101).
GINA FINK, EXAMINING ATTORNEY

SN 77-926,717. DELTA FOODS S.A., 14565 AGHIOS STEFANOS ATTICA, GREECE, FILED 2-3-2010.



THE COLOR(S) RED, BLUE AND WHITE IS/ARE CLAIMED AS A FEATURE OF THE MARK.

THE MARK CONSISTS OF A BLUE TRIANGLE CONTAINING A WOMAN CARRYING A BUCKET AND A BUSH IN WHITE; THREE BROKEN HORIZONTAL LINES IN RED; THE WORD "DELTA" IN RED.

CLASS 5—PHARMACEUTICALS

FOR FOOD FOR BABIES; DAIRY PRODUCTS FOR BABIES, POWDERED MILK FOR BABIES (U.S. CLS. 6, 18, 44, 46, 51 AND 52).

CLASS 29—MEATS AND PROCESSED FOODS

FOR DAIRY PRODUCTS, EXCLUDING ICE CREAM, ICE MILK AND FROZEN YOGURT; DAIRY-BASED BEVERAGES, DAIRY BASED FOOD BEVERAGES, DAIRY DESSERTS, DAIRY BASED DIPS, DAIRY BASED SPREADS, MILK AND MILK PRODUCTS, EXCLUDING ICE CREAM, ICE MILK AND FROZEN YOGURT; CHOCOLATE MILK, MILK-BASED ENERGY DRINKS, MILK POWDER, MILK BEVERAGES CONTAINING FRUITS, FLAVORED DAIRY BASED BEVERAGES, DIETETIC PRODUCTS, NAMELY, LOW CALORIE YOGURTS AND LOW CALORIE MILK, MILK AND CREAM MIXTURE FOR COFFEE, MILK BASED BEVERAGE CONTAINING COFFEE, YOGURT, YOGURT DRINKS, YOGURT BASED BEVERAGES, YOGURT WITH FRUITS, YOGURT WITH CEREALS, NAMELY, YOGURT CONTAINING CEREAL, CHEESE AND CHEESE PRODUCTS, NAMELY, CHEESE POWDER, CHEESE SPREADS, CREAM CHEESE, CREAM, CREAM FRAICHE, CREAM POWDER, WHIPPED CREAM, BUTTER (U.S. CL. 46).

CLASS 30—STAPLE FOODS

FOR ICE MILK, MILK SHAKE, COCOA BEVERAGES WITH MILK, COFFEE BEVERAGES WITH MILK, FROZEN YOGURT, ICE CREAM, ICE CREAM DRINKS, ICE CREAM MIXES, ICE CREAM POWDER (U.S. CL. 46).
DAVID C. REIHNER, EXAMINING ATTORNEY

SN 77-926,923. DELTA FOODS S.A., 14565 AGHIOS STEFANOS ATTICA, GREECE, FILED 2-3-2010.

DELTA Advance

THE MARK CONSISTS OF STANDARD CHARACTERS WITHOUT CLAIM TO ANY PARTICULAR FONT, STYLE, SIZE, OR COLOR.

NO CLAIM IS MADE TO THE EXCLUSIVE RIGHT TO USE "ADVANCE", APART FROM THE MARK AS SHOWN.

CLASS 5—PHARMACEUTICALS

FOR FOOD FOR BABIES; DAIRY PRODUCTS FOR BABIES, POWDERED MILK FOR BABIES (U.S. CLS. 6, 18, 44, 46, 51 AND 52).

CLASS 29—MEATS AND PROCESSED FOODS

FOR DAIRY PRODUCTS, EXCLUDING ICE CREAM, ICE MILK AND FROZEN YOGURT; DAIRY-BASED BEVERAGES, DAIRY BASED FOOD BEVERAGES, DAIRY DESSERTS, DAIRY BASED DIPS, DAIRY BASED SPREADS, MILK AND MILK PRODUCTS, EXCLUDING ICE CREAM, ICE MILK AND FROZEN YOGURT; CHOCOLATE MILK, MILK-BASED ENERGY DRINKS, MILK POWDER, MILK BEVERAGES CONTAINING FRUITS, FLAVORED DAIRY BASED BEVERAGES, DIETIC PRODUCTS, NAMELY, LOW CALORIE YOGURTS AND LOW CALORIE MILK, MILK AND CREAM MIXTURE FOR COFFEE, MILK BASED BEVERAGE CONTAINING COFFEE, YOGURT, YOGURT DRINKS, YOGURT BASED BEVERAGES, YOGURT WITH FRUITS, YOGURT WITH CEREALS, NAMELY, YOGURT CONTAINING CEREAL, CHEESE AND CHEESE PRODUCTS, NAMELY, CHEESE POWDER, CHEESE SPREADS, CREAM CHEESE, CREAM, CREAM FRAICHE, CREAM POWDER, WHIPPED CREAM, BUTTER (U.S. CL. 46).

DAVID C. REIHNER, EXAMINING ATTORNEY

SN 77-927,979. BOARD OF CERTIFICATION FOR EMERGENCY NURSING, DES PLAINES, IL. FILED 2-4-2010.



THE MARK CONSISTS OF A DIAMOND-SHAPED DESIGN ELEMENT COMPRISING TWO DIAMONDS AND A RECTANGULAR-SHAPE AND BEARING "BCEN" AND "BOARD OF CERTIFICATION FOR EMERGENCY NURSING".

SEC. 2(F) AS TO "BOARD OF CERTIFICATION FOR EMERGENCY NURSING".

CLASS 16—PAPER GOODS AND PRINTED MATTER

FOR PUBLICATIONS, NAMELY, NEWSLETTERS, BROCHURES, BOOKLETS AND TEACHING MATERIALS IN THE FIELD OF EMERGENCY NURSING (U.S. CLS. 2, 5, 22, 23, 29, 37, 38 AND 50).

FIRST USE 8-1-1997; IN COMMERCE 8-1-1997.

CLASS 42—SCIENTIFIC AND COMPUTER SERVICES

FOR CERTIFICATION SERVICES, NAMELY, TESTING, ANALYSIS AND EVALUATION OF THE KNOWLEDGE, SKILLS AND ABILITIES OF OTHERS FOR THE PURPOSES OF CERTIFICATION IN THE FIELD OF EMERGENCY NURSING (U.S. CLS. 100 AND 101).

FIRST USE 8-1-1997; IN COMMERCE 8-1-1997.

DAVID TAYLOR, EXAMINING ATTORNEY

SN 77-927,512. GLOBAL OFFICE SOLUTIONS, L.L.C., NOVI, MI. FILED 2-3-2010.

Global Office Solutions

THE MARK CONSISTS OF STANDARD CHARACTERS WITHOUT CLAIM TO ANY PARTICULAR FONT, STYLE, SIZE, OR COLOR.

NO CLAIM IS MADE TO THE EXCLUSIVE RIGHT TO USE "OFFICE", APART FROM THE MARK AS SHOWN. SEC. 2(F).

CLASS 35—ADVERTISING AND BUSINESS

FOR RETAIL STORE SERVICES, CATALOG ORDERING SERVICES AND COMPUTERIZED ONLINE RETAIL STORE SERVICES FEATURING A FULL LINE OF OFFICE SUPPLIES, OFFICE PRODUCTS, OFFICE FURNITURE, BUSINESS EQUIPMENT INCLUDING COMPUTER HARDWARE, COPIERS, PRINTERS, FAX MACHINES, MULTI-FUNCTION PERIPHERALS, DOCUMENT AND PRINT MANAGEMENT SUPPLIES, JANITORIAL SUPPLIES, AND PROMOTIONAL MERCHANDISE (U.S. CLS. 100, 101 AND 102).

FIRST USE 10-27-1998; IN COMMERCE 10-27-1998.

CLASS 42—SCIENTIFIC AND COMPUTER SERVICES

FOR INTERIOR DECORATION CONSULTATION; INTERIOR DESIGN SERVICES, INCLUDING OFFICE SPACE PLANNING, INTERIOR DESIGN SERVICES, INCLUDING BUSINESS SPACE DESIGN AND SPACE PLANNING (U.S. CLS. 100 AND 101).

FIRST USE 10-27-1998; IN COMMERCE 10-27-1998.

BILL DAWE, EXAMINING ATTORNEY

SN 77-928,438. MANZIMVULA VENTURES INC., VANCOUVER, BC, CANADA, FILED 2-4-2010.



PRIORITY CLAIMED UNDER SEC. 44(D) ON CANADA APPLICATION NO. 1454789, FILED 10-8-2009, REG. NO. TMA795941, DATED 4-19-2011, EXPIRES 4-19-2026.

NO CLAIM IS MADE TO THE EXCLUSIVE RIGHT TO USE "VALUES BASED CONSULTING", APART FROM THE MARK AS SHOWN.

THE COLOR(S) BLACK, WHITE, GOLD, DARK BLUE, RED, BROWN, GREEN, AND LIGHT BLUE IS/ARE CLAIMED AS A FEATURE OF THE MARK.

THE MARK CONSISTS OF THE WORDS "MANZIMVULA

VALUES BASED CONSULTING" IN BLACK SURROUNDED BY A CIRCLE CONTAINING A WHITE TREE SILHOUETTE, THREE WHITE HORIZONTAL LINES AND TWENTY VERTICAL STRIPES OF VARYING WIDTHS. FOR PURPOSES OF IDENTIFYING THE VERTICAL STRIPE COLORS, THE STRIPES ARE REFERRED TO AS NUMBERS 1 TO 20 FROM LEFT TO RIGHT. STRIPES 1, 4, 10, 13, 16 AND 18 ARE GOLD, STRIPES 2 AND 12 ARE DARK BLUE, STRIPES 3, 8, 11 AND 17 ARE RED, STRIPES 5 AND 19 ARE BROWN, STRIPES 6, 15 AND 20 ARE GREEN AND STRIPES 7, 9 AND 14 ARE LIGHT BLUE.

THE ENGLISH TRANSLATION OF THE WORD "MANZIMVULA" IN THE MARK IS "PLACE OF WATER".

SN 77-928,455. SILVER SPRING NETWORKS, INC., REDWOOD CITY, CA. FILED 2-4-2010.

CUSTOMERIQ

THE MARK CONSISTS OF STANDARD CHARACTERS WITHOUT CLAIM TO ANY PARTICULAR FONT, STYLE, SIZE, OR COLOR.

CLASS 16—PAPER GOODS AND PRINTED MATTER

FOR NEWSLETTERS AND MANUALS IN THE FILED OF BUSINESS MANAGEMENT; BOOKS IN THE FIELD OF BUSINESS MANAGEMENT (U.S. CLS. 2, 5, 22, 23, 29, 37, 38 AND 50).

CLASS 35—ADVERTISING AND BUSINESS

FOR BUSINESS MANAGEMENT SERVICES; BUSINESS MANAGEMENT CONSULTING SERVICES; PROJECT MANAGEMENT IN THE FIELDS OF CORPORATE INFRASTRUCTURE AND BUSINESS MANAGEMENT AND ORGANIZATION; BUSINESS CONSULTATION IN THE FIELDS OF BUSINESS PLAN DEVELOPMENT, DEVELOPMENT OF COMMUNICATION PLANS AND STRATEGIC PLANNING SERVICES; EMPLOYMENT COUNSELING AND RECRUITING SERVICES; OPERATION OF A WEBSITE PROVIDING INFORMATION IN THE FIELDS OF SOCIALLY RESPONSIBLE BUSINESS MODELS AND BUSINESS MANAGEMENT (U.S. CLS. 100, 101 AND 102).

CLASS 41—EDUCATION AND ENTERTAINMENT

FOR EDUCATIONAL SERVICES, NAMELY, TRAINING SERVICES AND CONDUCTING AND FACILITATING SEMINARS AND CONFERENCES, ALL IN THE FIELDS OF PERSONAL DEVELOPMENT, RECRUITMENT AND RETENTION OF EMPLOYEES, BUSINESS MANAGEMENT AND STRATEGIES, EMPLOYEE COACHING AND MENTORING AND DEVELOPMENT OF BUSINESS TRAINING SYSTEMS; PERSONAL DEVELOPMENT COACHING, EXECUTIVE COACHING AND BUSINESS COACHING (U.S. CLS. 100, 101 AND 107).

CLASS 42—SCIENTIFIC AND COMPUTER SERVICES

FOR COMPUTER PROJECT MANAGEMENT SERVICES IN THE FIELDS OF TECHNOLOGY DEVELOPMENT AND DEPLOYMENT AND PRODUCT DEVELOPMENT (U.S. CLS. 100 AND 101).

CLASS 45—PERSONAL AND LEGAL SERVICES

FOR OPERATION OF A WEBSITE PROVIDING INFORMATION IN THE FIELD OF PERSONAL DEVELOPMENT (U.S. CLS. 100 AND 101).
TRACY CROSS, EXAMINING ATTORNEY

CLASS 9—ELECTRICAL AND SCIENTIFIC APPARATUS

FOR COMPUTER SOFTWARE AND NETWORKING EQUIPMENT, NAMELY, NETWORK HARDWARE AND SOFTWARE FOR DATA COLLECTION APPLICATIONS, NAMELY, DISTRIBUTION AUTOMATION AND DEMAND SIDE MANAGEMENT APPLICATIONS; SOFTWARE FOR ENABLING PUBLIC UTILITIES TO COMMUNICATE WITH AND CONTROL IN-HOME APPLIANCES AND ELECTRONIC DEVICES; SOFTWARE FOR ENABLING ENERGY CONSUMERS, INCLUDING PUBLIC UTILITY CUSTOMERS, TO TRACK, VIEW, AND MONITOR ENERGY CONSUMPTION INFORMATION, NAMELY, INFORMATION RELATED TO USAGE ANALYSIS, COST ANALYSIS, BILL ANALYSIS, BILL ESTIMATION, ENERGY BUDGETING, NEIGHBORHOOD COMPARISONS, COMMUNITY ANALYSIS, ENVIRONMENTAL ANALYSIS, RATE COMPARISONS, WEATHER MODELING, AND HVAC MODELING, AS WELL AS TO RECEIVE ENERGY-RELATED REPORTS (U.S. CLS. 21, 23, 26, 36 AND 38).

CLASS 42—SCIENTIFIC AND COMPUTER SERVICES

FOR COMPUTER SERVICES FOR OTHERS, NAMELY, IMPLEMENTING AND OPERATING COMPUTER NETWORKS COMPRISED OF COMPUTER HARDWARE AND SOFTWARE FOR SECURING, MONITORING AND MANAGING MACHINE TO MACHINE NETWORKS; COMPUTER SERVICES FOR OTHERS, NAMELY, IMPLEMENTING AND OPERATING COMPUTER NETWORKS COMPRISED OF COMPUTER HARDWARE AND SOFTWARE FOR RECEIVING AND TRANSMITTING ENERGY-RELATED INFORMATION AND REQUESTS BETWEEN AND AMONG COMMODITY METERS, SECURING, MONITORING AND MANAGING UTILITY DISTRIBUTION EQUIPMENT AND MONITORING CUSTOMER UTILITY USAGE; COMPUTER SOFTWARE DESIGN; TECHNICAL SUPPORT, NAMELY, MONITORING OF NETWORK SYSTEMS AND TROUBLESHOOTING IN THE NATURE OF DIAGNOSING COMPUTER HARDWARE AND SOFTWARE PROBLEMS; DESIGN AND DEVELOPMENT OF COMPUTER SYSTEMS FOR THE COLLECTION, STORAGE AND TRANSMISSION OF DATA; SOFTWARE AS A SERVICE (SAAS) SERVICES, NAMELY, HOSTING SOFTWARE FOR USE BY OTHERS FOR SECURING, MONITORING AND MANAGING MACHINE TO MACHINE NETWORKS; SOFTWARE AS A SERVICE (SAAS) SERVICES, NAMELY, HOSTING SOFTWARE FOR USE BY OTHERS FOR RECEIVING AND TRANSMITTING ENERGY-RELATED INFORMATION AND REQUESTS BETWEEN AND AMONG UTILITY METERS, SECURING, MONITORING AND MANAGING UTILITY DISTRIBUTION AUTOMATION AND DEMAND RESPONSE DATA AND MONITORING CUSTOMER UTILITY USAGE; SOFTWARE AS A SERVICE (SAAS) SERVICES, NAMELY, HOSTING SOFTWARE THAT ALLOWS ENERGY CONSUMERS, INCLUDING PUBLIC UTILITY CUSTOMERS, TO VIEW AND MONITOR ENERGY CONSUMPTION (U.S. CLS. 100 AND 101).

FONG HSU, EXAMINING ATTORNEY

SN 77-930,370. GOLDSTEIN'S BAGEL BAKERY, INC., SIERRA MADRE, CA. FILED 2-8-2010.

SN 77-935,645. INDIANAPOLIS POWER & LIGHT COMPANY, INDIANAPOLIS, IN. FILED 2-15-2010.



NO CLAIM IS MADE TO THE EXCLUSIVE RIGHT TO USE "JAVA" OR "COFFEE", APART FROM THE MARK AS SHOWN.

THE COLOR(S) GOLD, BROWN, AND WHITE IS/ARE CLAIMED AS A FEATURE OF THE MARK.

THE MARK CONSISTS OF THE DESIGN OF A GOLD AND BROWN COFFEE CUP CONTAINING GOLD AND BROWN COFFEE WITH GOLD STEAM AND THREE WHITE SPARKLES, ALL SURROUNDED BY A CIRCLE WITH THE TOP HALF APPEARING IN GOLD AND CONTAINING THE WORDING "JAVA GOLD" APPEARING IN BROWN AND TWO BROWN CIRCLES, WITH A BROWN AND GOLD BORDER WITH SMALL GOLD CIRCLES APPEARING ON THE OUTERMOST PART, THE BOTTOM HALF OF THE CIRCLE APPEARS IN BROWN AND CONTAINS THE WORDING "COFFEE" APPEARING IN GOLD WITH A GOLD BORDER, ALL AGAINST A BROWN BACKGROUND.

CLASS 25—CLOTHING

FOR (BASED ON USE IN COMMERCE) SHIRTS; SHORT-SLEEVED SHIRTS; SPORT SHIRTS; T-SHIRTS (BASED ON INTENT TO USE) BASEBALL CAPS AND HATS; CAPS WITH VISORS; HATS; SPORTS CAPS AND HATS (U.S. CLS. 22 AND 39).

FIRST USE 12-0-2009; IN COMMERCE 12-0-2009.

CLASS 30—STAPLE FOODS

FOR COFFEE; COFFEE BASED BEVERAGES; COFFEE BEANS; COFFEE BEVERAGES WITH MILK; COFFEE-BASED BEVERAGE CONTAINING MILK; COFFEE-BASED BEVERAGES; GROUND COFFEE BEANS; ICED COFFEE; PREPARED COFFEE AND COFFEE-BASED BEVERAGES; ROASTED COFFEE BEANS; UNROASTED COFFEE (U.S. CL. 46).

FIRST USE 3-31-2010; IN COMMERCE 3-31-2010.
CHRISTINE MARTIN, EXAMINING ATTORNEY



THE MARK CONSISTS OF A LIGHTNING BOLT WITH EYES, MOUTH AND ARMS.

CLASS 35—ADVERTISING AND BUSINESS

FOR PROVIDING BUSINESS INFORMATION AND ADVICE OVER THE INTERNET IN FIELDS OF ENVIRONMENTAL IMPROVEMENT AND DEGRADATION, ENERGY USAGE AND EFFICIENCY; PROMOTING PUBLIC AWARENESS OF ENVIRONMENTAL ISSUES AND INITIATIVES, ENERGY USAGE AND EFFICIENCY OVER THE INTERNET AND BY PARTICIPATING IN COMMUNITY EVENTS, NAMELY, FAIRS, SPORTING EVENTS, AND CULTURAL EVENTS; PROVISION OF INFORMATION, ADVICE, AND CONSULTANCY IN RELATION TO ENVIRONMENTAL IMPROVEMENT AND DEGRADATION, ENERGY USAGE AND EFFICIENCY OVER THE INTERNET (U.S. CLS. 100, 101 AND 102).

CLASS 39—TRANSPORTATION AND STORAGE

FOR PUBLIC UTILITY SERVICES (U.S. CLS. 100 AND 105).

CLASS 41—EDUCATION AND ENTERTAINMENT

FOR EDUCATIONAL SERVICES, NAMELY, CONDUCTING INFORMATIONAL CLASSES IN THE FIELD OF ENERGY USAGE, ELECTRICITY AND ENERGY SAFETY; ONLINE JOURNALS, NAMELY, BLOGS FEATURING INFORMATION AND ADVICE IN THE FIELDS OF ENVIRONMENTAL AWARENESS, ENERGY USAGE, EFFICIENCY, AND ELECTRICITY AND ENERGY SAFETY (U.S. CLS. 100, 101 AND 107).

RAUL CORDOVA, EXAMINING ATTORNEY

SN 77-935,646. INDIANAPOLIS POWER & LIGHT COMPANY, INDIANAPOLIS, IN. FILED 2-15-2010.

BOLTY

THE MARK CONSISTS OF STANDARD CHARACTERS WITHOUT CLAIM TO ANY PARTICULAR FONT, STYLE, SIZE, OR COLOR.

CLASS 35—ADVERTISING AND BUSINESS

FOR PROVIDING BUSINESS INFORMATION AND ADVICE OVER THE INTERNET IN FIELDS OF ENVIRONMENTAL IMPROVEMENT AND DEGRADATION, ENERGY USAGE AND EFFICIENCY; PROMOTING PUBLIC AWARENESS OF ENVIRONMENTAL ISSUES AND INITIATIVES, ENERGY USAGE AND EFFICIENCY OVER THE INTERNET AND BY PARTICIPATING IN COMMUNITY EVENTS, NAMELY, FAIRS, SPORTING EVENTS, AND CULTURAL EVENTS; PROVISION OF INFORMATION, ADVICE, AND CONSULTANCY IN RELATION TO ENVIRONMENTAL IMPROVEMENT AND DEGRADATION, ENERGY USAGE AND EFFICIENCY OVER THE INTERNET (U.S. CLS. 100, 101 AND 102).

CLASS 39—TRANSPORTATION AND STORAGE

FOR PUBLIC UTILITY SERVICES (U.S. CLS. 100 AND 105).

CLASS 41—EDUCATION AND ENTERTAINMENT

FOR EDUCATIONAL SERVICES, NAMELY, CONDUCTING INFORMATIONAL CLASSES IN THE FIELD OF ENERGY USAGE, ELECTRICITY AND ENERGY SAFETY; ONLINE JOURNALS, NAMELY, BLOGS FEATURING INFORMATION AND ADVICE IN THE FIELDS OF ENVIRONMENTAL AWARENESS, ENERGY USAGE, EFFICIENCY, AND ELECTRICITY AND ENERGY SAFETY (U.S. CLS. 100, 101 AND 107).
RAUL CORDOVA, EXAMINING ATTORNEY

SN 77-936,830. BARCO UNIFORMS, INC., GARDENA, CA. FILED 2-16-2010.

LOVE WHAT YOU WEAR

THE MARK CONSISTS OF STANDARD CHARACTERS WITHOUT CLAIM TO ANY PARTICULAR FONT, STYLE, SIZE, OR COLOR.

CLASS 10—MEDICAL APPARATUS

FOR MEDICAL WEARING APPAREL, NAMELY, SCRUB TOPS, SCRUB PANTS, AND SURGICAL CAPS (U.S. CLS. 26, 39 AND 44).

CLASS 25—CLOTHING

FOR UNIFORMS; CORPORATE IDENTITY UNIFORMS; SPA UNIFORMS; SCRUBS NOT FOR MEDICAL PURPOSES; MEDICAL WEARING APPAREL, NAMELY, UNDERSHIRTS FOR SCRUBS, WARM UP SUITS, LAB COATS, AND CONSULTATION COATS AND JACKETS (U.S. CLS. 22 AND 39).
ELI HELLMAN, EXAMINING ATTORNEY

SN 77-938,190. OCP HOLDINGS, LLC, ELK GROVE VILLAGE, IL. FILED 2-17-2010.

ONE CLICK POLITICS

THE MARK CONSISTS OF STANDARD CHARACTERS WITHOUT CLAIM TO ANY PARTICULAR FONT, STYLE, SIZE, OR COLOR.

NO CLAIM IS MADE TO THE EXCLUSIVE RIGHT TO USE "POLITICS", APART FROM THE MARK AS SHOWN.

CLASS 38—COMMUNICATION

FOR ONLINE WEBSITE SERVICES PROVIDING COMMUNICATIONS TO THIRD PARTIES, NAMELY, ELECTRONIC TRANSMISSION OF EMAIL AND TEXT MESSAGES TO ELECTED REPRESENTATIVES OR GOVERNMENT OFFICIALS; ONLINE WEBSITE SERVICES PROVIDING ELECTRONIC COMMUNICATIONS TO THIRD PARTIES, NAMELY, PROVIDING MESSAGING SERVICES VIA THE INTERNET (U.S. CLS. 100, 101 AND 104).

FIRST USE 6-4-2010; IN COMMERCE 6-4-2010.

CLASS 42—SCIENTIFIC AND COMPUTER SERVICES

FOR ONLINE WEBSITE SERVICES PROVIDING COMMUNICATIONS TO THIRD PARTIES, NAMELY, PROVIDING AN INTERACTIVE ONLINE USER INTERFACE WEB SITE THAT ALLOWS FOR THE TRANSMISSION OF ELECTRONIC AND EMAIL MESSAGES TO ELECTED REPRESENTATIVES OR GOVERNMENT OFFICIALS (U.S. CLS. 100 AND 101).

FIRST USE 6-4-2010; IN COMMERCE 6-4-2010.

JENNIFER MARTIN, EXAMINING ATTORNEY

SN 77-941,146. PALTEC TRUCK EQUIPMENT COMPANY, BIRMINGHAM, AL. FILED 2-22-2010.

PALFLEET TRUCK EQUIPMENT

THE MARK CONSISTS OF STANDARD CHARACTERS WITHOUT CLAIM TO ANY PARTICULAR FONT, STYLE, SIZE, OR COLOR.

NO CLAIM IS MADE TO THE EXCLUSIVE RIGHT TO USE "TRUCK EQUIPMENT", APART FROM THE MARK AS SHOWN.

CLASS 35—ADVERTISING AND BUSINESS

FOR RETAIL STORE SERVICES FEATURING TRUCK MOUNTED LIFTING, LOADING AND SERVICE EQUIPMENT; DISTRIBUTORSHIPS IN THE FIELD OF TRUCK MOUNTED LIFTING, LOADING AND SERVICE EQUIPMENT (U.S. CLS. 100, 101 AND 102).

CLASS 37—CONSTRUCTION AND REPAIR

FOR REPAIR, MAINTENANCE, INSTALLATION AND PAINTING OF TRUCK MOUNTED LIFTING EQUIPMENT, TRUCK MOUNTED LOADING EQUIPMENT AND TRUCK MOUNTED SERVICE EQUIPMENT (U.S. CLS. 100, 103 AND 106).

ELIZABETH KAJUBI, EXAMINING ATTORNEY

SN 77-941,621. NEXTER SYSTEMS, ROANNE, FRANCE, FILED 2-22-2010.

SN 77-941,639. J.V. DRIVER CORPORATION INC., LEDUC, ALBERTA, CANADA, FILED 2-22-2010.

CAESAR

THE MARK CONSISTS OF STANDARD CHARACTERS WITHOUT CLAIM TO ANY PARTICULAR FONT, STYLE, SIZE, OR COLOR.

CLASS 12—VEHICLES

FOR MILITARY EARTH WHEELED OR TRACKED VEHICLES, NAMELY, TRUCKS, TRACTORS; AIR LOCOMOTION VEHICLES, NAMELY, MILITARY AIRCRAFT, FREIGHT PLANES, FIGHTER PLANES, HELICOPTERS, AND UNMANNED AIRBORNE VEHICLES, NAMELY, UNMANNED AIRBORNE DRONES, AND REMOTELY OPERATED AERIAL VEHICLES; WATER LOCOMOTION VEHICLES, NAMELY, MILITARY SHIPS, FAST VEDETTEs, FREIGHTERS, SUBMARINES; VEHICLES, NAMELY, TRUCKS AND TRACTORS THAT ARE WEAPON SYSTEM EQUIPPED, ANTI-AIRCRAFT GUN EQUIPPED, MORTAR EQUIPPED, GRENADE LAUNCHER EQUIPPED, GUN EQUIPPED, ROCKET LAUNCHER EQUIPPED, MISSILE LAUNCHER EQUIPPED, SELF-ACTING ARTILLERY EQUIPPED, FIELD ARTILLERY EQUIPPED AND STRUCTURAL PARTS THEREOF (U.S. CLS. 19, 21, 23, 31, 35 AND 44).

CLASS 13—FIREARMS

FOR FIREARMS, NAMELY, RIFLES, PISTOLS, GRENADE LAUNCHERS, ROCKET LAUNCHERS AND NON RECOIL GUNS; AUTOMATIC WEAPONS, NAMELY, MACHINE GUNS AND SUBMACHINE GUNS; MEDIUM CALIBER EQUIPPED GUNS; ANTI-AIRCRAFT GUN'S DEFENSE, NAMELY, ANTI-AIRCRAFT ARMORED TURRETS, TOWED ANTI-AIRCRAFT GUNS; NEAR DEFENSE GUN; MACHINE GUN TURRETS; MORTARS; FIELD ARTILLERY, NAMELY, TOWED ANTI-AIRCRAFT GUNS; MULTIPLE ROCKET LAUNCHERS; ARMORED TURRETS FOR NAVAL GUNS; AMMUNITIONS AND PROJECTILES, NAMELY, MEDIUM-BORE GUN CARTRIDGE, GRENADES, ARTILLERY'S SHELLS, MORTAR'S SHELLS, KINETIC PROJECTILES, GUIDED MISSILES, ROCKETS, BOMBS AND TORPEDOES; WEAPONS SET UP ON A VEHICLE, NAMELY, GUN EQUIPPED FOR ATTACHMENT TO A TANK, GUN EQUIPPED FOR ATTACHMENT TO A TRUCK, ARTILLERY GUNS EQUIPPED FOR ATTACHMENT TO A TRUCK, MORTAR GUN EQUIPPED FOR ATTACHMENT TO A TRUCK, GUN FOR ATTACHMENT TO A TRACTOR, MORTAR EQUIPPED GUN FOR ATTACHMENT TO A TRACTOR AND ROCKET LAUNCHER EQUIPPED FOR ATTACHMENT TO A TRUCK; EXPLOSIVES, NAMELY, HIGH EXPLOSIVES, INITIATING EXPLOSIVES, SECONDARY EXPLOSIVES, COMPOSITE EXPLOSIVES, AND EXPLOSIVE LOADING EQUIPMENT, NAMELY, BLANK CARTRIDGES; FIREWORKS; ARMORED TANKS AS WEAPONS; TANKS THAT ARE WEAPON SYSTEM EQUIPPED, ANTI-AIRCRAFT GUN EQUIPPED, MORTAR EQUIPPED, GRENADE LAUNCHER EQUIPPED, GUN EQUIPPED, ROCKET LAUNCHER EQUIPPED, MISSILE LAUNCHER EQUIPPED, SELF-ACTING ARTILLERY EQUIPPED, FIELD ARTILLERY EQUIPPED AND STRUCTURAL PARTS THEREOF; TRACTION TOWERS, NAMELY, FIRING PLATFORM ON TRACKED WHEELS; TANKS THAT ARE WEAPON SYSTEM EQUIPPED, ANTI-AIRCRAFT GUN EQUIPPED, MORTAR EQUIPPED, GRENADE LAUNCHER EQUIPPED, GUN EQUIPPED, ROCKET LAUNCHER EQUIPPED, MISSILE LAUNCHER EQUIPPED, SELF-ACTING ARTILLERY EQUIPPED, FIELD ARTILLERY EQUIPPED AND STRUCTURAL PARTS THEREOF (U.S. CLS. 2 AND 9).

SETH A. RAPPAPORT, EXAMINING ATTORNEY

THINK SAFE, WORK SAFE, BE SAFE

THE MARK CONSISTS OF STANDARD CHARACTERS WITHOUT CLAIM TO ANY PARTICULAR FONT, STYLE, SIZE, OR COLOR.

CLASS 37—CONSTRUCTION AND REPAIR

FOR INDUSTRIAL CONSTRUCTION SERVICES, NAMELY, CONSTRUCTION AND MAINTENANCE OF INDUSTRIAL PLANTS, COMMERCIAL BUILDINGS, WAREHOUSES, ROADS AND STREETS; CIVIL AND STRUCTURAL CONSTRUCTION SERVICES, NAMELY, PROVISION OF EARTHWORKS, CONCRETE, REBAR, STRUCTURAL STEEL; ELECTRICAL AND INSTRUMENTATION SERVICES, NAMELY, MAINTENANCE OF OPERATING PLANTS AND GENERAL INDUSTRIAL INSTALLATIONS; REFRACTORY AND TILE INSTALLATION SERVICES; CRANE RENTAL AND LEASING FOR CONSTRUCTION PURPOSES; CONSTRUCTION SUPERVISION, NAMELY, PROVIDING MANPOWER SERVICES; AND CONSTRUCTION PLANNING AND CONSULTING SERVICES (U.S. CLS. 100, 103 AND 106).

CLASS 39—TRANSPORTATION AND STORAGE

FOR HEAVY HAUL AND FREIGHT TRANSPORTATION BY ROAD AND AIR (U.S. CLS. 100 AND 105).

CLASS 40—MATERIAL TREATMENT

FOR CUSTOM FABRICATION OF TANK AND PRESSURE VESSELS, PIPES AND METAL; MACHINE SHOP SERVICES, NAMELY, MACHINING PARTS FOR OTHERS (U.S. CLS. 100, 103 AND 106).

ANNE E. GUSTASON, EXAMINING ATTORNEY

SN 77-941,688. J.V. DRIVER CORPORATION INC., LEDUC, ALBERTA, CANADA, FILED 2-22-2010.



THE MARK CONSISTS OF THE TERM "DRIVER'S" CONTAINED WITHIN OBLONG GEOMETRIC DESIGNS PARTIALLY FRAMED BY STYLIZED PIPING WITH A STYLIZED LEAF DESIGN IN THE BOTTOM RIGHT CORNER.

CLASS 37—CONSTRUCTION AND REPAIR

FOR INDUSTRIAL CONSTRUCTION SERVICES, NAMELY, CONSTRUCTION AND MAINTENANCE OF INDUSTRIAL PLANTS, COMMERCIAL BUILDINGS, WAREHOUSES, ROADS AND STREETS; CIVIL AND STRUCTURAL CONSTRUCTION SERVICES, NAMELY, PROVISION OF EARTHWORKS, CONCRETE, REBAR, STRUCTURAL STEEL; PIPING AND MECHANICAL SERVICES, NAMELY, MAJOR EQUIPMENT INSTALLATION; ELECTRICAL AND INSTRUMENTATION SERVICES, NAMELY, MAINTENANCE OF OPERATING PLANTS AND GENERAL INDUSTRIAL INSTALLATIONS; INSULATION, REFRACTORY AND TILE INSTALLATION SERVICES; CRANE RENTAL AND LEASING FOR CONSTRUCTION PURPOSES; CONSTRUCTION SUPERVISION, NAMELY, PROVIDING MANPOWER SERVICES; INDUSTRIAL CONSTRUCTION PRESERVATION AND RESTORATION SERVICES, NAMELY, CORROSION COATINGS AND CONCRETE RESTORATION; SCAFFOLDING SERVICES, NAMELY, SCAFFOLDING ERECTION AND DISMANTLEMENT; MODULE CONSTRUCTION SERVICES, NAMELY, THE CONSTRUCTION, INSTALLATION, ALTERATION AND REPAIR OF STEEL BUILDINGS, METAL DECKING AND PLANKING (U.S. CLS. 100, 103 AND 106).

CLASS 39—TRANSPORTATION AND STORAGE

FOR HEAVY HAUL AND FREIGHT TRANSPORTATION BY ROAD AND AIR; MARSHALING SERVICES, NAMELY, STORAGE OF DRY AND BULK GOODS; PRODUCT WAREHOUSING SERVICES (U.S. CLS. 100 AND 105).

CLASS 40—MATERIAL TREATMENT

FOR CUSTOM FABRICATION SERVICES, NAMELY, PIPE FABRICATION, STEEL FABRICATION, TANK AND PRESSURE VESSEL FABRICATION, AND METAL FABRICATION; MACHINE SHOP SERVICES, NAMELY, MACHINING PARTS FOR OTHERS; CUSTOM MANUFACTURING SERVICES IN THE FIELD OF SKID AND ASSEMBLY LOADERS (U.S. CLS. 100, 103 AND 106).

CLASS 42—SCIENTIFIC AND COMPUTER SERVICES

FOR HYDRO-STATIC TESTING (U.S. CLS. 100 AND 101).
ANNE E. GUSTASON, EXAMINING ATTORNEY

SN 77-941,944. CAPRICO, LLC, AVON, CO. FILED 2-22-2010.

SOMETHING GOOD IS GOING TO HAPPEN

THE MARK CONSISTS OF STANDARD CHARACTERS WITHOUT CLAIM TO ANY PARTICULAR FONT, STYLE, SIZE, OR COLOR.

CLASS 25—CLOTHING

FOR A-SHIRTS; BABY BODYSUITS; BABY TOPS; BODY LINEN; BODY SHAPERS; CHILDREN'S AND INFANTS' CLOTH BIBS; CHILDREN'S CLOTH EATING BIBS; CLOTH BIBS; CLOTHING ITEMS, NAMELY, ADHESIVE POCKETS THAT MAY BE AFFIXED DIRECTLY TO THE BODY AS A DECORATIVE PIECE OF CLOTHING WITH UTILITY; HATS FOR INFANTS, BABIES, TODDLERS AND CHILDREN; INFANT AND TODDLER ONE PIECE CLOTHING; ONE PIECE GARMENT FOR INFANTS AND TODDLERS; PLASTIC BABY BIBS; SCARVES; SHIRTS FOR INFANTS, BABIES, TODDLERS AND CHILDREN; SHORT-SLEEVED OR LONG-SLEEVED T-SHIRTS; T-SHIRTS; WOMEN'S HATS AND HOODS; WOMEN'S TOPS, NAMELY, CAMIS (U.S. CLS. 22 AND 39).

CLASS 40—MATERIAL TREATMENT

FOR IMPRINTING MESSAGES ON T-SHIRTS; IMPRINTING MESSAGES ON WEARING APPAREL, ACCESSORIES AND MUGS; T-SHIRT EMBROIDERING SERVICES (U.S. CLS. 100, 103 AND 106).
B. PARADEWELAI, EXAMINING ATTORNEY

SN 77-942,076. LMG MEDIA LIMITED, HAVANT, HAMPSHIRE, GREAT BRITAIN, FILED 2-23-2010.

FILEHIPPO

THE MARK CONSISTS OF STANDARD CHARACTERS WITHOUT CLAIM TO ANY PARTICULAR FONT, STYLE, SIZE, OR COLOR.
OWNER OF UNITED KINGDOM REG. NO. 2514818, DATED 4-28-2009, EXPIRES 4-28-2019.

CLASS 9—ELECTRICAL AND SCIENTIFIC APPARATUS

FOR COMPUTER SOFTWARE FOR USE IN BROWSING THE INTERNET, MESSAGING AND CHAT, ANTI-MALWARE, AND NETWORKING; COMPUTER SOFTWARE FOR USE IN BROWSING THE INTERNET, MESSAGING AND CHAT, ANTI-MALWARE, AND NETWORKING THAT MAY BE DOWNLOADED FROM A GLOBAL COMPUTER NETWORK; COMPUTER FREeware AND SHAREWARE PROGRAMS FOR BROWSING THE INTERNET, MESSAGING AND CHAT, ANTI-MALWARE, AND NETWORKING; COMPUTER SOFTWARE FOR FILTERING AND REMOVING VIRUSES FROM A COMPUTER; COMPUTER SERVERS FOR WEB HOSTING; ALL OF THE AFORESAID GOODS OFFERED VIA THE INTERNET (U.S. CLS. 21, 23, 26, 36 AND 38).

CLASS 35—ADVERTISING AND BUSINESS

FOR BUSINESS CONSULTING SERVICES; MARKET ANALYSIS; ONLINE DATA PROCESSING SERVICES; BUSINESS MANAGEMENT AND ORGANIZATION CONSULTING SERVICES; PROVIDING VIRTUAL ONLINE SUPPORT STAFF SERVICES FOR BUSINESSES; COMPILATION OF INFORMATION AND DATA INTO COMPUTER DATABASES; SYSTEMIZATION OF INFORMATION INTO COMPUTER DATABASES; ALL OF THE AFORESAID SERVICES OFFERED VIA THE INTERNET (U.S. CLS. 100, 101 AND 102).

CLASS 39—TRANSPORTATION AND STORAGE

FOR TEMPORARY ELECTRONIC STORAGE OF INFORMATION AND DATA; ELECTRONIC STORAGE OF DATA; ALL OF THE AFORESAID SERVICES OFFERED VIA THE INTERNET (U.S. CLS. 100 AND 105).

CLASS 42—SCIENTIFIC AND COMPUTER SERVICES

FOR DESIGN AND DEVELOPMENT OF COMPUTER HARDWARE AND SOFTWARE FOR USE IN BROWSING THE INTERNET, MESSAGING AND CHAT, ANTI-MALWARE, AND NETWORKING; COMPUTER PROGRAMMING; INSTALLATION, MAINTENANCE AND REPAIR OF COMPUTER SOFTWARE FOR USE IN BROWSING THE INTERNET, MESSAGING AND CHAT, ANTI-MALWARE, AND NETWORKING; UPGRADING COMPUTER SOFTWARE FOR USE IN BROWSING THE INTERNET, MESSAGING AND CHAT, ANTI-MALWARE, AND NETWORKING; COMPUTER CONSULTANCY SERVICES, COMPUTER SYSTEMS ANALYSIS, ADVICE AND CONSULTANCY SERVICES IN RELATION TO THE USE OF COMPUTER SOFTWARE FOR USE IN BROWSING THE INTERNET, MESSAGING AND CHAT, ANTI-MALWARE, AND NETWORKING; EXPERT CONSULTANCY AND INFORMATION SERVICES IN CONNECTION WITH COMPUTER NETWORKS; ALL OF THE AFORESAID SERVICES OFFERED VIA THE INTERNET (U.S. CLS. 100 AND 101).

JUSTINE D. PARKER, EXAMINING ATTORNEY

SN 77-942,730. BARCO UNIFORMS, INC., GARDENA, CA. FILED 2-23-2010.

GRAFX BY BARCO

THE MARK CONSISTS OF STANDARD CHARACTERS WITHOUT CLAIM TO ANY PARTICULAR FONT, STYLE, SIZE, OR COLOR.

NO CLAIM IS MADE TO THE EXCLUSIVE RIGHT TO USE "GRAPHICS", APART FROM THE MARK AS SHOWN.

CLASS 10—MEDICAL APPARATUS

FOR MEDICAL UNIFORMS, NAMELY, OPERATING ROOM AND MEDICAL TREATMENT APPAREL; MEDICAL WEARING APPAREL, NAMELY, SCRUB TOPS AND SCRUB BOTTOMS; SURGICAL CAPS (U.S. CLS. 26, 39 AND 44).

CLASS 25—CLOTHING

FOR MEDICAL UNIFORMS, NAMELY, TEE SHIRTS FOR WEAR UNDER SCRUBS, WARM UP SUITS, LAB COATS, CONSULTATION COATS AND JACKETS (U.S. CLS. 22 AND 39).

ELI HELLMAN, EXAMINING ATTORNEY

SN 77-946,390. STARRAGHECKERT AG, RORSCHACHERBERG, SWITZERLAND, FILED 2-26-2010.

eeMC

THE MARK CONSISTS OF STANDARD CHARACTERS WITHOUT CLAIM TO ANY PARTICULAR FONT, STYLE, SIZE, OR COLOR.

PRIORITY CLAIMED UNDER SEC. 44(D) ON ERPNCMNTY TM OFC APPLICATION NO. 008603292, FILED 10-8-2009, REG. NO. 008603292, DATED 10-1-2010, EXPIRES 10-8-2019.

CLASS 7—MACHINERY

FOR MACHINES, IN PARTICULAR MACHINES FOR MACHINING METALS, NAMELY, METALWORKING MACHINE TOOLS, CUTTING MACHINES, MILLING MACHINES, DRILLING MACHINES, AND LATHES; MACHINE TOOLS, NAMELY, METALWORKING MACHINE TOOLS, CUTTING MACHINES, MILLING MACHINES, DRILLING MACHINES, AND LATHES, AND MACHINING CENTERS COMPOSED THEREFROM FOR MACHINING PARTS AND JIB BORING MACHINES, INCLUDING PARTS OF THE AFORESAID MACHINES; TOOLS, NAMELY, MACHINE TOOLS FOR THE CUTTING AND FORMING OF MATERIALS AND POWER OPERATED METALWORKING MACHINE TOOLS, NAMELY, MILLING TOOLS AND DRILLING TOOLS BEING PARTS OR COMPONENT PARTS OF MACHINE TOOLS AND MACHINING CENTERS COMPOSED THEREFROM (U.S. CLS. 13, 19, 21, 23, 31, 34 AND 35).

CLASS 35—ADVERTISING AND BUSINESS

FOR CONSULTING SERVICES IN THE FIELD OF COST SAVING; CONSULTING SERVICES IN THE FIELD OF ENERGY CONSUMPTION AND USAGE CONSERVATION TO IMPROVE ENERGY EFFICIENCY (U.S. CLS. 100, 101 AND 102).

CLASS 37—CONSTRUCTION AND REPAIR

FOR ASSEMBLY, INSTALLATION, REPAIR, COMMISSIONING, MAINTENANCE, SERVICING, AND OVERHAULING OF MACHINES FOR MACHINING METALS, MACHINE TOOLS, MILLING MACHINES, AND MACHINING CENTERS COMPOSED THEREFROM, MACHINING PARTS AND JIG BORING MACHINES, MACHINING CENTERS, AND PARTS AND MODULES THEREFOR; CONSULTING SERVICES RELATING TO INSTALLATION OF SOLAR ENERGY SYSTEMS FOR ENERGY CONSERVATION (U.S. CLS. 100, 103 AND 106).

CLASS 42—SCIENTIFIC AND COMPUTER SERVICES

FOR ENGINEERING AND COMPUTER SOFTWARE PROGRAMMING FOR OTHERS IN THE MANUFACTURING SECTOR, IN PARTICULAR IN CONNECTION WITH MACHINING PROCESSES USING MACHINE TOOLS; COMPUTER PROGRAMMING, NAMELY, PROGRAMMING OF COMPUTER SOFTWARE FOR OTHERS FOR CONTROLLING MACHINING PROCESSES OF MACHINES FOR THE CUTTING OF METALS, MILLING MACHINES, LATHES, JIB BORING MACHINES, AND MACHINING CENTERS; CONSULTING SERVICES RELATING TO ENGINEERING IN THE FIELD OF ENERGY CONSERVATION (U.S. CLS. 100 AND 101).

ALICIA COLLINS, EXAMINING ATTORNEY

SN 77-946,758. AMERICAN POMERANIAN CLUB, INC.,
AKA APC, HIGHLAND, UT. FILED 2-28-2010.



NO CLAIM IS MADE TO THE EXCLUSIVE RIGHT TO USE "CLUB", APART FROM THE MARK AS SHOWN.

THE MARK CONSISTS OF THE WORDING "AMERICAN POMERANIAN CLUB" IN A BELT WHICH IS TUCKED INTO ITSELF SHOWING BELT HOLES WITH A BUCKLE AT THE BOTTOM FORMING A CIRCLE. THE BELT SURROUNDS AN ILLUSTRATION OF A POMERANIAN SIDE VIEW WHICH IS FACING LEFT IN THE CENTER OF THE BELT.

SEC. 2(F) AS TO "AMERICAN POMERANIAN CLUB" AND THE REPRESENTATION OF THE POMERANIAN DOG.

CLASS 14—JEWELRY

FOR (BASED ON USE IN COMMERCE) JEWELRY; LAPEL PINS; MEDALS AND MEDALLIONS (U.S. CLS. 2, 27, 28 AND 50).

FIRST USE 1-1-1990; IN COMMERCE 1-1-1990.

CLASS 16—PAPER GOODS AND PRINTED MATTER

FOR (BASED ON USE IN COMMERCE) MAGAZINES FEATURING THE POMERANIAN.; PRINTED INSTRUCTIONAL, EDUCATIONAL, AND TEACHING MATERIALS IN THE FIELD OF BREEDER, EXHIBITOR AND JUDGES' EDUCATION WITH RESPECT TO THE POMERANIAN (U.S. CLS. 2, 5, 22, 23, 29, 37, 38 AND 50).

FIRST USE 6-30-1989; IN COMMERCE 6-30-1989.

CLASS 25—CLOTHING

FOR (BASED ON INTENT TO USE) APRONS; BEACHWEAR; HATS; JACKETS; PANTS; SCARVES; SHIRTS; SHORT SETS; SKIRTS AND DRESSES; SLEEPWEAR; SOCKS; T-SHIRTS; TIES (U.S. CLS. 22 AND 39).

CLASS 35—ADVERTISING AND BUSINESS

FOR (BASED ON USE IN COMMERCE) ASSOCIATION SERVICES, NAMELY, PROMOTING THE INTERESTS OF THE HEALTH AND WELFARE OF THE POMERANIAN BREED IN SUPPORT OF MAINTAINING THE BREED STANDARD FOR THE POMERANIAN; PROMOTING AND ENCOURAGING EDUCATION AND INFORMATION RELATING TO THE POMERANIAN; PROMOTING RESPONSIBLE AND ETHICAL DOG OWNERSHIP, CARE, TRAINING AND BREEDING (U.S. CLS. 100, 101 AND 102).

FIRST USE 6-30-1989; IN COMMERCE 6-30-1989.

CLASS 41—EDUCATION AND ENTERTAINMENT

FOR (BASED ON USE IN COMMERCE) DOG SHOWS; EDUCATION SERVICES, NAMELY, PROVIDING MENTORING, TUTORING, CLASSES, SEMINARS AND WORKSHOPS IN THE FIELD OF BREEDING, OWNING, JUDGING, EXHIBITING, AND CARING FOR THE POMERANIAN (U.S. CLS. 100, 101 AND 107).

FIRST USE 6-30-1989; IN COMMERCE 6-30-1989.

TIMOTHY FINNEGAN, EXAMINING ATTORNEY

SN 77-946,774. SIMPSON, CHRISTOPHER ALAN, LONDON,
UNITED KINGDOM, FILED 2-28-2010.

ITSFRIDAY

THE MARK CONSISTS OF STANDARD CHARACTERS WITHOUT CLAIM TO ANY PARTICULAR FONT, STYLE, SIZE, OR COLOR.

OWNER OF ERP CMNTY TM OFC REG. NO. 007168206,
DATED 2-2-2009, EXPIRES 8-19-2018.

CLASS 35—ADVERTISING AND BUSINESS

FOR BUSINESS INFORMATION SERVICES, NAMELY, PROVIDING AN ONLINE DIRECTORY LISTING OF LOCAL BUSINESS AND THEIR GOODS AND SERVICES WITH LINKS TO THEIR WEBSITES; COMPILATION OF ADVERTISEMENTS FOR USE AS WEB PAGES ON THE INTERNET; BUSINESS AND ADVERTISING SERVICES PROVIDED VIA COMPUTER AND COMMUNICATION NETWORKS, INCLUDING THE INTERNET, NAMELY, ONLINE ADVERTISEMENTS, ON-LINE ADVERTISING AND MARKETING SERVICES; COMPUTERIZED ON-LINE ORDERING SERVICES IN THE FIELDS OF GOODS RELATED TO SPORTS, CULTURE, ENTERTAINMENT, FAMILY, AND TRAVEL; AUCTIONEERING SERVICES PROVIDED ON THE INTERNET; ELECTRONIC BILLBOARD ADVERTISING; PROVIDING ADVERTISING SPACE IN ELECTRONIC PUBLICATIONS AND ON WEB SITES FOR ADVERTISEMENT OF THE GOODS AND SERVICES OF OTHERS; PROVIDING ADVERTISING SPACE ON THE INTERNET; MARKET RESEARCH SERVICES; CONSULTING, INFORMATION AND ADVISORY SERVICES RELATING TO THE AFORESAID; PROVIDING HOTEL RATE COMPARISON INFORMATION (U.S. CLS. 100, 101 AND 102).

CLASS 39—TRANSPORTATION AND STORAGE

FOR TRAVEL AGENCY SERVICES, NAMELY, ON-LINE TRANSPORTATION RESERVATION AND TRAVEL TICKET RESERVATION SERVICES; PROVIDING AN ON-LINE COMPUTER DATABASE IN THE FIELD OF TRAVEL INFORMATION SERVICES, ON-LINE TRANSPORTATION RESERVATION AND TRAVEL TICKET RESERVATION SERVICES (U.S. CLS. 100 AND 105).

CLASS 41—EDUCATION AND ENTERTAINMENT

FOR PROVISION OF INFORMATION RELATING TO EDUCATION, ENTERTAINMENT, RECREATION AND LEISURE ACTIVITIES, ORGANIZING CULTURAL EXHIBITIONS, RADIO AND TELEVISION PRODUCTION, AND SPORTING EVENTS; PROVISION OF INFORMATION RELATING TO EDUCATION, ENTERTAINMENT, RECREATION AND LEISURE ACTIVITIES, ORGANIZING CULTURAL EXHIBITIONS, RADIO AND TELEVISION PRODUCTION, AND SPORTING EVENTS, ON-LINE FROM COMPUTER DATABASES OR FACILITIES PROVIDED ON THE INTERNET; ALL THE AFORESAID RELATING TO GEOGRAPHICAL LOCATIONS, PLACES OF INTEREST, SHOPS, MARKETS, THEATRE, CINEMA, CONCERTS, TRAINING, EVENTS, HOLIDAYS, THE ARTS, CONFERENCES, EXHIBITIONS, COMPETITIONS, CONTESTS, CARNIVALS, PAGEANTS, DISPLAYS, SHOWS, FASHION SHOWS, PROGRAMS, PERFORMANCES AND/OR TO CONSUMER NEWS; RESERVATION SERVICES FOR EDUCATION, ENTERTAINMENT, RECREATION, CULTURE, CINEMA, CONCERT, AND THEATRE, NAMELY, TICKET AGENCY SERVICES, ARRANGING FOR TICKET RESERVATIONS FOR SHOWS, SPORTS, CULTURAL AND OTHER ENTERTAINMENT EVENTS; PUBLISHING AND PUBLICATION SERVICES, NAMELY, NON-DOWNLOADABLE ELECTRONIC PUBLICATIONS IN THE NATURE OF ELECTRONIC GUIDE BOOKS IN THE FIELDS OF GEOGRAPHICAL LOCATIONS, PLACES OF INTEREST, SHOPS, MARKETS, HOBBIES, THEATRE, CINEMA, CONCERTS, RESTAURANTS, TRAVEL, HOTELS, TRAINING, EVENTS, HOLIDAYS, THE ARTS, CONFERENCES, EXHIBITIONS, COMPETITIONS, CONTESTS, CARNIVALS, PAGEANTS, DISPLAYS, SHOWS, FASHION SHOWS, PROGRAMS, PERFORMANCES AND/OR CONSUMER NEWS; NEWS REPORTING SERVICES, NAMELY, THE REPORTING OF ENTERTAINMENT AND SPORTS NEWS (U.S. CLS. 100, 101 AND 107).

CLASS 43—HOTEL AND RESTAURANT SERVICES

FOR PROVIDING INFORMATION ON HOTEL AND RESTAURANT RESERVATION SERVICES, PROVIDING ADVICE TO TOURISTS AND BUSINESS TRAVELERS ON HOTEL AND RESTAURANT DESTINATIONS, PROVIDING ONLINE REVIEWS OF RESTAURANTS AND HOTELS, PROVIDING PERSONALIZED INFORMATION ABOUT HOTELS (U.S. CLS. 100 AND 101).

KATHERINE E. HALMEN, EXAMINING ATTORNEY

SN 77-947,069. DSW SHOE WAREHOUSE, INC., COLUMBUS, OH. FILED 3-1-2010.

SHOE LOVER

THE MARK CONSISTS OF STANDARD CHARACTERS WITHOUT CLAIM TO ANY PARTICULAR FONT, STYLE, SIZE, OR COLOR.

NO CLAIM IS MADE TO THE EXCLUSIVE RIGHT TO USE "SHOE", APART FROM THE MARK AS SHOWN.

CLASS 35—ADVERTISING AND BUSINESS

FOR RETAIL STORE SERVICES, IN THE FIELD OF FOOTWEAR, HOSIERY AND CLOTHING ACCESSORIES (U.S. CLS. 100, 101 AND 102).

CLASS 36—INSURANCE AND FINANCIAL

FOR FINANCIALLY-RELATED CARD IMPLEMENTED SERVICES, NAMELY, ISSUING STORED VALUE CARDS THAT MAY BE REDEEMED FOR THE PURCHASE OF GOODS (U.S. CLS. 100, 101 AND 102).

APRIL HESIK, EXAMINING ATTORNEY

SN 77-947,686. THE HARTZ MOUNTAIN CORPORATION, SECAUCUS, NJ. FILED 3-1-2010.



OWNER OF U.S. REG. NOS. 843,089, 2,135,204 AND OTHERS.

THE COLOR(S) ORANGE AND WHITE IS/ARE CLAIMED AS A FEATURE OF THE MARK.

THE MARK CONSISTS OF THE WORD "HARTZ" IN THE COLOR WHITE WITHIN AN ORANGE RECTANGLE.

SEC. 2(F).

CLASS 3—COSMETICS AND CLEANING PREPARATIONS

FOR NON-MEDICATED, NON-VETERINARY GROOMING PREPARATIONS FOR DOGS AND CATS, NAMELY, SHAMPOOS AND CONDITIONERS, OATMEAL SHAMPOO, ALL PURPOSE SHAMPOO, WHITENER SHAMPOO, PUPPY SHAMPOO, SHAMPOO WITH ANTI-HAIRBALL BEADS, SHAMPOO WITH HERBAL BEADS AND SHAMPOO WITH VITAMIN BEADS; PET STAIN AND ODOR REMOVERS FOR RUGS AND CARPETS; NON-MEDICATED SKIN BALMS AND SKIN CARE PREPARATIONS FOR PETS (U.S. CLS. 1, 4, 6, 50, 51 AND 52).

FIRST USE 1-15-2004; IN COMMERCE 1-15-2004.

CLASS 5—PHARMACEUTICALS

FOR MEDICATED FLEA AND TICK SHAMPOO FOR PETS; MEDICATED SHAMPOO AND CONDITIONER; MEDICATED BEAUTIFYING SHAMPOO AND CONDITIONING SHAMPOO; FLEA AND TICK COLLARS FOR DOGS AND CATS; FLEA AND TICK KILLER SPRAY; FLEA, TICK AND MOSQUITO ERADICATION DROPS FOR DOGS AND CATS; ANTI-ITCH HYDROCORTISONE SPRAY; FLEA AND TICK KILLER POWDER FOR CARPETS; FLEA AND TICK SPRAY AND FOGGER FOR USE IN THE HOME; MEDICATED FLEA AND TICK SHAMPOO FOR DOGS WITH ENCAPSULATED OATMEAL; JOINT MAINTENANCE AND THERAPY PREPARATIONS FOR DOGS AND CATS IN THE FORM OF NUTRACEUTICALS, NAMELY, THE COMBINATION OF GLUCOSAMINE AND CARTILAGE; ENTERIC COATED ASPIRIN FOR DOGS; VETERINARY PREPARATIONS FOR THE TREATMENT OF EAR MITES; SPRAYS USED TO TRAIN DOGS TO KEEP OFF FURNITURE; VITAMINS FOR PETS; INSECTICIDAL SHAMPOOS FOR PETS; WORMERS FOR PETS, NAMELY, MEDICATED PREPARATIONS TO RID PETS OF DIGESTIVE TRACT PARASITES, HAIR BALL REMEDIES IN THE NATURE OF MEDICATED CAT SHAMPOO (U.S. CLS. 6, 18, 44, 46, 51 AND 52).

FIRST USE 1-15-2004; IN COMMERCE 1-15-2004.

CLASS 8—HAND TOOLS

FOR GROOMING TOOLS FOR DOGS AND CATS, NAMELY, NAIL TRIMMERS AND NAIL FILES (U.S. CLS. 23, 28 AND 44).

FIRST USE 1-15-2004; IN COMMERCE 1-15-2004.

CLASS 16—PAPER GOODS AND PRINTED MATTER

FOR DISPOSABLE HOUSEBREAKING PADS MADE FROM SUPER ABSORBENT POLYMERS (SAP) FOR USE IN TRAINING PUPPIES; DISPOSABLE HOUSEBREAKING PUPPY TRAINING PADS MADE FROM SUPER ABSORBENT POLYMERS (SAP) (U.S. CLS. 2, 5, 22, 23, 29, 37, 38 AND 50).

FIRST USE 1-15-2004; IN COMMERCE 1-15-2004.

CLASS 18—LEATHER GOODS

FOR ACCESSORIES FOR PETS, NAMELY, COLLARS, LEADS AND LEASHES; PET PRODUCTS IN THE NATURE OF A RESTRAINING DEVICE, NAMELY, TIE OUT STAKES AND TIE OUT CHAINS FOR PETS; RAW HIDE CHEWS FOR DOGS (U.S. CLS. 1, 2, 3, 22 AND 41).

FIRST USE 1-15-2004; IN COMMERCE 1-15-2004.

CLASS 20—FURNITURE AND ARTICLES NOT OTHERWISE CLASSIFIED

FOR PET FOOD CAN COVERS IN THE FORM OF PLASTIC LIDS; BED FOR CATS AND DOGS AND SMALL ANIMALS; PET PILLOWS (U.S. CLS. 2, 13, 22, 25, 32 AND 50).

FIRST USE 1-15-2004; IN COMMERCE 1-15-2004.

CLASS 21—HOUSEWARES AND GLASS

FOR GROOMING SUPPLIES, NAMELY, BRUSHES FOR PETS, COMBS AND PET COMBING RAKE UTENSILS; PET CLEANSING APPARATUS, NAMELY, HOSE NOZZLES AND NYLON MESH GLOVES SOLD AS A UNIT FOR WASHING PETS; FEEDING DISHES FOR DOGS AND CATS; BIRD AND SMALL ANIMAL FEEDING BOTTLES SOLD EMPTY AND BIRD AND SMALL ANIMAL FEEDING DISHES; PLASTIC WATER BOTTLES FOR ANIMALS, SOLD EMPTY; CAT LITTER PANS; PET ITEMS PRIMARILY CONSISTING OF PAPER, NAMELY, GRAVEL PAPER FOR BIRD CAGES; CAT BOX HAND TOOLS, NAMELY, SCOOPS FOR THE DISPOSAL OF AND FOR SCOOPING UP PET CAT EXCREMENT IN CAT LITTER (U.S. CLS. 2, 13, 23, 29, 30, 33, 40 AND 50).

FIRST USE 1-15-2004; IN COMMERCE 1-15-2004.

CLASS 24—FABRICS

FOR FABRIC HOUSEBREAKING PUPPY TRAINING PADS MADE FROM SUPER ABSORBENT POLYMERS (SAP), NAMELY, NON-REUSABLE HOUSEBREAKING PADS; BEDDING FOR SMALL ANIMALS, NAMELY, PET BLANKETS (U.S. CLS. 42 AND 50).

FIRST USE 1-15-2004; IN COMMERCE 1-15-2004.

CLASS 28—TOYS AND SPORTING GOODS

FOR PET TOYS (U.S. CLS. 22, 23, 38 AND 50).
FIRST USE 1-15-2004; IN COMMERCE 1-15-2004.

CLASS 31—NATURAL AGRICULTURAL PRODUCTS

FOR BIRD FOOD; SMALL ANIMAL FOOD; EDIBLE PET TREATS AND SNACKS; PET BISCUITS; FOOD FOR ANIMAL PETS, NAMELY, HAMSTERS, BIRDS; LIVE ANIMALS, NAMELY, GERBILS, GUINEA PIGS, AND RABBITS; CUTTLEBONE FOR BIRDS; LITTER FOR SMALL ANIMALS (U.S. CLS. 1 AND 46).

FIRST USE 1-15-2004; IN COMMERCE 1-15-2004.

CLASS 41—EDUCATION AND ENTERTAINMENT

FOR PROVIDING ON-LINE NON-DOWNLOADABLE PUBLICATIONS, NAMELY, NEWSLETTERS FOR THE GENERAL PUBLIC IN THE FIELD OF PET PRODUCTS AND PET HEALTH; PROVIDING ON-LINE, NON-DOWNLOADABLE INFORMATIONAL NEWSLETTERS FOR THE GENERAL PUBLIC IN THE FIELD OF PET PRODUCTS AND PET HEALTH (U.S. CLS. 100, 101 AND 107).

FIRST USE 1-15-2004; IN COMMERCE 1-15-2004.
COLLEEN DOMBROW, EXAMINING ATTORNEY

SN 77-948,103. MXI CORP., RENO, NV. FILED 3-2-2010.



NO CLAIM IS MADE TO THE EXCLUSIVE RIGHT TO USE "HEALTHY CHOCOLATE", APART FROM THE MARK AS SHOWN.

THE MARK CONSISTS OF A COCOA BEAN AND THREE ACAI BERRIES ABOVE THE TEXT "XOCAI HEALTHY CHOCOLATE".

CLASS 30—STAPLE FOODS

FOR CHOCOLATE AND CHOCOLATES; CHOCOLATE BARS; CHOCOLATE-BASED READY-TO-EAT FOOD BARS; CHOCOLATES AND CHOCOLATE BASED READY TO EAT CANDIES AND SNACKS; CHOCOLATES CONTAINING NUTRIENTS; COCOA MIXES; COCOA-BASED BEVERAGES; COOKIES; HOT CHOCOLATE (U.S. CL. 46).

FIRST USE 11-9-2009; IN COMMERCE 11-9-2009.

CLASS 35—ADVERTISING AND BUSINESS

FOR MULTI-LEVEL MARKETING BUSINESS SERVICES (U.S. CLS. 100, 101 AND 102).

FIRST USE 8-0-2009; IN COMMERCE 8-0-2009.
APRIL HESIK, EXAMINING ATTORNEY

SN 77-951,344. QUANTUM SIGNAL, LLC, ANN ARBOR, MI. FILED 3-5-2010.

SN 77-957,797. ETYMONIC DESIGN INCORPORATED, DORCHESTER, ONTARIO, CANADA, FILED 3-12-2010.



THE COLOR(S) DARK BLUE, LIGHT BLUE, BLACK, SILVER, AND WHITE IS/ARE CLAIMED AS A FEATURE OF THE MARK.

THE MARK CONSISTS OF THE TERM "REACTOR" IN LIGHT BLUE AND HIGHLIGHTED IN SILVER AND WHITE; BENEATH APPEARS A DESIGN COMPRISED OF THREE HORIZONTAL LINES IN DARK BLUE AND HIGHLIGHTED IN SILVER AND WHITE ON EITHER SIDE OF A DESIGN CONSISTING OF THREE TRIANGLES INSIDE A PARTIAL CIRCLE; THE TRIANGLES ARE LIGHT BLUE AT THE CENTER AND BLEND INTO DARK BLUE AT THEIR EXTREMITIES, AND ARE SET AGAINST A BLACK BACKGROUND, OUTLINED AND HIGHLIGHTED IN DARK BLUE, WHITE AND SILVER; BENEATH APPEARS THE TERM "ZERO" IN LIGHT BLUE AND DARK BLUE INSIDE A QUADRILATERAL IN BLACK AND HIGHLIGHTED AND OUTLINED IN WHITE, DARK BLUE, AND SILVER. THE BACKGROUND OF THE ENTIRE MARK IS TRANSLUCENT.

CLASS 9—ELECTRICAL AND SCIENTIFIC APPARATUS

FOR COMPUTER VIDEO GAME SOFTWARE; COMPUTER GRAPHICS SOFTWARE FOR USE IN VIDEO GAMES, ARTIFICIAL INTELLIGENCE, CUSTOMIZABLE TRAINING APPLICATIONS, AND COMPUTER BASED SIMULATIONS (U.S. CLS. 21, 23, 26, 36 AND 38). FIRST USE 3-3-2005; IN COMMERCE 3-3-2005.

CLASS 42—SCIENTIFIC AND COMPUTER SERVICES

FOR COMPUTER SOFTWARE DEVELOPMENT FOR OTHERS IN THE FIELDS OF VIDEO GAMES, ARTIFICIAL INTELLIGENCE, CUSTOMIZABLE TRAINING APPLICATIONS, AND COMPUTER BASED SIMULATIONS; TECHNICAL SUPPORT SERVICES, NAMELY, TROUBLESHOOTING OF COMPUTER SOFTWARE PROBLEMS, AND PROVIDING COMPUTER SOFTWARE CONSULTATION REGARDING THE USE AND FUNCTIONALITY OF SOFTWARE (U.S. CLS. 100 AND 101). FIRST USE 3-3-2005; IN COMMERCE 3-3-2005. JIM RINGLE, EXAMINING ATTORNEY



PRIORITY CLAIMED UNDER SEC. 44(D) ON CANADA APPLICATION NO. 1472842, FILED 3-9-2010, REG. NO. TMA791618, DATED 2-25-2011, EXPIRES 2-25-2026.

THE MARK CONSISTS OF THE STYLIZED WORDING "AXIOM" AND THE DESIGN OF TWO TRIANGLES. THE STYLIZED LETTER "A" IN "AXIOM" IS OVERSIZED AND THE TRIANGLES APPEAR TO THE RIGHT OF THE LETTER "A" AND BELOW "XIOM".

CLASS 9—ELECTRICAL AND SCIENTIFIC APPARATUS

FOR APPARATUS AND INSTRUMENTS FOR MEASURING AND RECORDING THE PERFORMANCE OF HEARING AIDS; MEASUREMENT EQUIPMENT CONTAINING A CONTROLLED SOUND SOURCE AND AN ELECTRONIC MEASURING AND DISPLAY DEVICE, FOR MEASURING AND RECORDING THE PERFORMANCE OF HEARING AIDS (U.S. CLS. 21, 23, 26, 36 AND 38).

CLASS 10—MEDICAL APPARATUS

FOR MEDICAL APPARATUS AND INSTRUMENTS FOR MEASURING AND RECORDING THE PERFORMANCE OF HEARING AIDS WHILE IN USE BY PATIENTS (U.S. CLS. 26, 39 AND 44). JENNY PARK, EXAMINING ATTORNEY

SN 77-957,953. POMWONDERFUL LLC, LOS ANGELES, CA. FILED 3-12-2010.

POMx RECOVERY

THE MARK CONSISTS OF STANDARD CHARACTERS WITHOUT CLAIM TO ANY PARTICULAR FONT, STYLE, SIZE, OR COLOR.

OWNER OF U.S. REG. NOS. 3,208,934, 3,562,517 AND OTHERS.

NO CLAIM IS MADE TO THE EXCLUSIVE RIGHT TO USE "RECOVERY", APART FROM THE MARK AS SHOWN.

CLASS 5—PHARMACEUTICALS

FOR DIETARY SUPPLEMENTAL DRINKS (U.S. CLS. 6, 18, 44, 46, 51 AND 52).

CLASS 32—LIGHT BEVERAGES

FOR SPORTS DRINKS; NON-ALCOHOLIC FRUIT JUICE BEVERAGES; NON-ALCOHOLIC BEVERAGES CONTAINING FRUIT JUICES; FRUIT JUICE; FRUIT JUICES; FRUIT JUICE CONCENTRATES (U.S. CLS. 45, 46 AND 48). PAUL F. GAST, EXAMINING ATTORNEY

SN 77-958,738. INTELLECTUAL ASSET GROUP, LLC, FARMINGTON HILLS, MI. FILED 3-15-2010.



NO CLAIM IS MADE TO THE EXCLUSIVE RIGHT TO USE "INTELLECTUAL ASSET GROUP", APART FROM THE MARK AS SHOWN.

THE COLOR(S) BLUE AND GRAY IS/ARE CLAIMED AS A FEATURE OF THE MARK.

THE MARK CONSISTS OF STYLIZED GRAY LETTERS "I", "A", AND "G" WITH EACH LETTER DISPOSED WITHIN A CORRESPONDING UPPER AND LOWER BLUE SEMI-CIRCLE. BELOW ARE THE WORDS "INTELLECTUAL ASSET GROUP" IN GRAY.

CLASS 36—INSURANCE AND FINANCIAL

FOR PATENT MONETIZATION SERVICES ON BEHALF OF PATENT OWNERS, NAMELY, BROKERAGE OF PATENT SALES (U.S. CLS. 100, 101 AND 102).

FIRST USE 5-19-2009; IN COMMERCE 5-19-2009.

CLASS 45—PERSONAL AND LEGAL SERVICES

FOR OUTBOUND PATENT LICENSING (U.S. CLS. 100 AND 101).

FIRST USE 5-19-2009; IN COMMERCE 5-19-2009.
MICHELLE DUBOIS, EXAMINING ATTORNEY

SN 77-959,858. MOBILITIE, LLC, NEWPORT BEACH, CA. FILED 3-16-2010.

LEASE-TO-SUIT

THE MARK CONSISTS OF STANDARD CHARACTERS WITHOUT CLAIM TO ANY PARTICULAR FONT, STYLE, SIZE, OR COLOR.

SEC. 2(F).

CLASS 35—ADVERTISING AND BUSINESS

FOR TELECOMMUNICATIONS NETWORK MANAGEMENT SERVICES, NAMELY, THE OPERATION AND ADMINISTRATION OF TELECOMMUNICATION SYSTEMS AND WIRELESS AND WIRELINE NETWORKS FOR TELECOMMUNICATIONS SERVICE PROVIDERS AND CARRIERS WITH ACCESS TO TELECOMMUNICATIONS INFRASTRUCTURE; BUSINESS MANAGEMENT IN THE FIELD OF DESIGN, DEVELOPMENT, LEASING AND ENGINEERING OF TELECOMMUNICATIONS NETWORKS, NETWORK INFRASTRUCTURE AND EQUIPMENT USED THEREIN (U.S. CLS. 100, 101 AND 102).

FIRST USE 8-31-2004; IN COMMERCE 8-31-2004.

CLASS 37—CONSTRUCTION AND REPAIR

FOR INSTALLATION OF TELECOMMUNICATIONS NETWORKS AND EQUIPMENT USED THEREIN FOR THE WIRELINE AND WIRELESS INDUSTRIES (U.S. CLS. 100, 103 AND 106).

FIRST USE 8-31-2004; IN COMMERCE 8-31-2004.

CLASS 38—COMMUNICATION

FOR LEASING OF TELECOMMUNICATIONS NETWORK INFRASTRUCTURE SYSTEMS TO WIRELINE AND WIRELESS TELECOMMUNICATIONS SERVICE PROVIDERS; PROVIDING ACCESS TO TELECOMMUNICATIONS NETWORKS TO TELECOMMUNICATIONS SERVICE PROVIDERS; PROVIDING WIRELESS TRANSPORT SOLUTIONS AND NETWORKING SERVICES TO THE GLOBAL TELECOMMUNICATIONS INDUSTRY, NAMELY, PROVIDING FIBER OPTIC NETWORK SERVICES AND PROVIDING THIRD PARTY SERVICE PROVIDERS ACCESS TO TELECOMMUNICATIONS NETWORKS AND WIRELESS COMMUNICATIONS NETWORKS THAT USE RADIO FREQUENCY INFRASTRUCTURE (TOWER) SYSTEMS TO TRANSMIT VOICE, DATA, GRAPHICS, IMAGES, AUDIO AND VIDEO (U.S. CLS. 100, 101 AND 104).

FIRST USE 8-31-2004; IN COMMERCE 8-31-2004.

CLASS 42—SCIENTIFIC AND COMPUTER SERVICES

FOR DESIGN AND DEVELOPMENT OF TELECOMMUNICATIONS NETWORKS FOR THE WIRELESS AND WIRELESS INDUSTRIES; DESIGN AND DEVELOPMENT OF WIRELESS TELECOMMUNICATIONS NETWORKS FOR THE WIRELINE AND WIRELESS INDUSTRIES; ENGINEERING OF TELECOMMUNICATIONS NETWORKS AND EQUIPMENT USED THEREIN FOR THE WIRELINE AND WIRELESS INDUSTRIES (U.S. CLS. 100 AND 101).

FIRST USE 8-31-2004; IN COMMERCE 8-31-2004.
DAWN HAN, EXAMINING ATTORNEY

SN 77-959,893. GUSPRO INC., CHATHAM, ONTARIO, CANADA, FILED 3-16-2010.

BFD

THE MARK CONSISTS OF STANDARD CHARACTERS WITHOUT CLAIM TO ANY PARTICULAR FONT, STYLE, SIZE, OR COLOR.

PRIORITY CLAIMED UNDER SEC. 44(D) ON CANADA APPLICATION NO. 1454631, FILED 10-7-2009, REG. NO. TMA776684, DATED 9-9-2010, EXPIRES 9-9-2025.

CLASS 7—MACHINERY

FOR HOCKEY AND FIGURE ICE SKATE BLADE SHARPENING AND SHAPING MACHINES, MACHINE PARTS, NAMELY, FORM DRESSING GRINDING WHEELS FOR HOCKEY AND FIGURE ICE SKATE BLADE SHARPENING AND SHAPING MACHINES (U.S. CLS. 13, 19, 21, 23, 31, 34 AND 35).

CLASS 37—CONSTRUCTION AND REPAIR

FOR REPAIR OF FORM DRESSING GRINDING WHEELS FOR HOCKEY AND FIGURE ICE SKATE BLADE SHARPENING AND SHAPING MACHINES (U.S. CLS. 100, 103 AND 106).

CLASS 40—MATERIAL TREATMENT

FOR CUSTOM MANUFACTURE OF FORM DRESSING GRINDING WHEELS FOR HOCKEY AND FIGURE ICE SKATE BLADE SHARPENING AND SHAPING MACHINES (U.S. CLS. 100, 103 AND 106).
KIM SAITO, EXAMINING ATTORNEY

SN 77-960,752. THE JAMES DYSON FOUNDATION, MALMESBURY, WILTSHIRE, UNITED KINGDOM, FILED 3-17-2010.

SN 77-960,467. SAVARIA CONCORD LIFTS INC., BRAMPTON, ONTARIO, CANADA, FILED 3-16-2010.



THE COLOR(S) GREEN IS/ARE CLAIMED AS A FEATURE OF THE MARK.

THE MARK CONSISTS OF A CIRCLE DESIGN WITH A CURLED TAIL BEGINNING AT THE BOTTOM OF THE CIRCLE AND ENDING IN THE CENTER OF THE CIRCLE WHICH IS TO THE LEFT OF THE WORD "SAVARIA" ALL IN THE COLOR GREEN.

CLASS 7—MACHINERY

FOR ELEVATORS, VERTICAL LIFTS, HORIZONTAL LIFTS, INCLINED LIFTS, STAIR LIFTS, AND WHEELCHAIR LIFTS FOR BUILDINGS (U.S. CLS. 13, 19, 21, 23, 31, 34 AND 35).

CLASS 9—ELECTRICAL AND SCIENTIFIC APPARATUS

FOR AUTOMATIC ELECTRIC DOOR OPENERS (U.S. CLS. 21, 23, 26, 36 AND 38).

CLASS 10—MEDICAL APPARATUS

FOR MEDICAL EQUIPMENT, NAMELY, STAIR CHAIRS (U.S. CLS. 26, 39 AND 44).

CLASS 12—VEHICLES

FOR VAN CONVERSION KITS COMPRISED OF CHAIRS LIFTS, RAMPS, CHAIR GUIDES, MARKERS AND DECALS, ACCESSIBILITY CONTROLLERS, MODIFIED SEATING, AND MODIFIED FLOORING TO MAKE STRUCTURAL CHANGES TO VANS, CONVERSION VANS AND DISABILITY-ADAPTED LAND VEHICLES; ELECTRIC POWERED SCOOTERS (U.S. CLS. 19, 21, 23, 31, 35 AND 44).

CLASS 37—CONSTRUCTION AND REPAIR

FOR VAN AND VEHICLE CONVERSION SERVICES FOR OTHERS, NAMELY, INSTALLING SPECIALTY AUTOMOTIVE EQUIPMENT (U.S. CLS. 100, 103 AND 106).

CLASS 40—MATERIAL TREATMENT

FOR MANUFACTURING SERVICES, NAMELY, CUSTOM MANUFACTURE OF ELEVATORS, VERTICAL LIFTS, HORIZONTAL LIFTS, INCLINED LIFTS, STAIR LIFTS, STAIR CHAIRS, AND WHEELCHAIR LIFTS FOR THIRD PARTY INSTALLERS (U.S. CLS. 100, 103 AND 106).

ELLEN PERKINS, EXAMINING ATTORNEY

**FOUNDATION JAMES
DYSON**

PRIORITY CLAIMED UNDER SEC. 44(D) ON ERPN CMNTY TM OFC APPLICATION NO. 008560716, FILED 9-18-2009, REG. NO. 008560716, DATED 6-8-2010, EXPIRES 9-8-2020.

NO CLAIM IS MADE TO THE EXCLUSIVE RIGHT TO USE "FOUNDATION", APART FROM THE MARK AS SHOWN.

THE NAME(S), PORTRAIT(S), AND/OR SIGNATURE(S) SHOWN IN THE MARK IDENTIFIES "JAMES DYSON", WHOSE CONSENT(S) TO REGISTER IS MADE OF RECORD.

THE MARK CONSISTS OF THE WORD "JAMES" IN THE UPPER PART, THE WORD "DYSON" IN THE MIDDLE PART AND THE WORD "FOUNDATION" WHICH IS 90 DEGREE ROTATED LEFT TO THE LEFT PART.

CLASS 7—MACHINERY

FOR VACUUM CLEANERS; PARTS AND FITTINGS FOR VACUUM CLEANERS (U.S. CLS. 13, 19, 21, 23, 31, 34 AND 35).

CLASS 9—ELECTRICAL AND SCIENTIFIC APPARATUS

FOR ELECTRONIC PUBLICATIONS, NAMELY, BOOKS, ARTICLES, MAGAZINES, MANUALS, NEWSLETTERS FEATURING SCIENCE, DESIGN AND ENGINEERING RECORDED ON COMPUTER MEDIA; ELECTRONIC DOWNLOADABLE PUBLICATIONS, NAMELY, BOOKS, ARTICLES, MAGAZINES, MANUALS, NEWSLETTERS FEATURING SCIENCE, DESIGN AND ENGINEERING PROVIDED ONLINE FROM COMPUTER DATABASES OR THE INTERNET; COMPUTER SOFTWARE DOWNLOADABLE FROM THE INTERNET FOR USE IN SCIENCE, DESIGN AND ENGINEERING TRAINING AND EDUCATION (U.S. CLS. 21, 23, 26, 36 AND 38).

CLASS 16—PAPER GOODS AND PRINTED MATTER

FOR PRINTED EDUCATIONAL MATERIALS IN THE FIELD OF SCIENCE, DESIGN AND ENGINEERING; PRINTED MATERIALS FOR USE IN SCHOOLS OR COLLEGES FOR EDUCATIONAL PURPOSES IN THE FIELD OF SCIENCE, DESIGN AND ENGINEERING; PRINTED MATTER, NAMELY, BOOKS, ARTICLES, MAGAZINES, MANUALS AND NEWSLETTERS IN THE FIELD OF SCIENCE, DESIGN AND ENGINEERING; BOOKS AND PRINTED MATTER IN THE NATURE OF ARTICLES, MAGAZINES, MANUALS AND NEWSLETTERS RELATING TO SCIENCE, DESIGN AND ENGINEERING (U.S. CLS. 2, 5, 22, 23, 29, 37, 38 AND 50).

CLASS 36—INSURANCE AND FINANCIAL

FOR CHARITABLE FUNDRAISING; FUNDING OF BURSARIES FOR EDUCATION OR TRAINING (U.S. CLS. 100, 101 AND 102).

CLASS 41—EDUCATION AND ENTERTAINMENT

FOR ORGANIZATION OF COMPETITIONS RELATING TO THE TEACHING OF SCIENCE, DESIGN AND ENGINEERING; EDUCATION AND TRAINING SERVICES, NAMELY, CONDUCTING CLASSES, WORKSHOPS AND SEMINARS IN THE FIELD OF SCIENCE, DESIGN AND ENGINEERING; EDUCATIONAL TRAINING SEMINARS IN THE FIELD OF SCIENCE, DESIGN AND ENGINEERING; EDUCATIONAL WORKSHOPS IN THE FIELD OF SCIENCE, DESIGN AND ENGINEERING; ARRANGING AND ORGANIZING WORKSHOPS AND TRAINING WITHIN SCHOOLS AND COLLEGES IN THE FIELD OF SCIENCE, DESIGN AND ENGINEERING; DISTRIBUTING EDUCATIONAL MATERIALS FOR USE IN CONNECTION WITH PROVIDING EDUCATIONAL WORKSHOPS IN THE FIELD OF SCIENCE, DESIGN AND ENGINEERING; LOANING OF EDUCATIONAL MATERIALS IN THE NATURE OF BOOKS FOR EDUCATIONAL PURPOSES; PUBLICATION OF ELECTRONIC PUBLICATIONS ONLINE; PUBLICATION OF ELECTRONIC BOOKS AND JOURNALS; ORGANIZATION OF COMPETITIONS RELATING TO SCIENCE, DESIGN OR ENGINEERING (U.S. CLS. 100, 101 AND 107).

CLASS 42—SCIENTIFIC AND COMPUTER SERVICES

FOR PROVIDING EDUCATIONAL INFORMATION RELATING TO SCIENCE, DESIGN AND ENGINEERING (U.S. CLS. 100 AND 101).

SUZANNE BLANE, EXAMINING ATTORNEY

SN 77-961,864. UFIT CO., LTD., MINATO-KU, TOKYO, JAPAN, FILED 3-18-2010.

KnowledgeOn

THE MARK CONSISTS OF STANDARD CHARACTERS WITHOUT CLAIM TO ANY PARTICULAR FONT, STYLE, SIZE, OR COLOR.

CLASS 35—ADVERTISING AND BUSINESS

FOR ADVERTISING SERVICES; BUSINESS MANAGEMENT AND BUSINESS MANAGEMENT ASSISTANCE IN THE OPERATION OF CLERICAL SERVICES, ACCOUNTING SERVICES, OPERATION OF FINANCIAL ORGANIZATIONS, COMPUTER SYSTEM OPERATION SERVICES, COMPUTER SYSTEM MONITORING SERVICES, COMPUTER SYSTEM DEVELOPMENT, COMPUTER SYSTEM CONSTRUCTION, SALES MANAGEMENT, PRODUCTION MANAGEMENT, LOGISTICS MANAGEMENT, AND INFORMATION COMPUTERIZATION SERVICES; PAPERWORK AGENCIES, NAMELY, PROVIDING TEMPORARY CLERICAL PERSONNEL SERVICES AND CALL HANDLING SERVICES, NAMELY, TELEPHONE ANSWERING SERVICES; COMPUTER INFORMATION PROCESSING, NAMELY, COMPUTER DATA PROCESSING (U.S. CLS. 100, 101 AND 102).

CLASS 42—SCIENTIFIC AND COMPUTER SERVICES

FOR PROVIDING ON-LINE NON-DOWNLOADABLE SOFTWARE FOR USE IN DATABASE MANAGEMENT, SPREADSHEET PROCESSING, WORD PROCESSING, DIGITIZATION PROCESSING, COMMUNICATION PROCESSING, AND ELECTRONIC LEARNING (U.S. CLS. 100 AND 101).

ELIZABETH KAJUBI, EXAMINING ATTORNEY

SN 77-964,718. RESTORATION HARDWARE, INC., CORTE MADERA, CA. FILED 3-22-2010.

BISTRO

THE MARK CONSISTS OF STANDARD CHARACTERS WITHOUT CLAIM TO ANY PARTICULAR FONT, STYLE, SIZE, OR COLOR.

CLASS 6—METAL GOODS

FOR CABINET KNOBS, DRAWER PULLS AND HOOKS MADE OF NICKEL (U.S. CLS. 2, 12, 13, 14, 23, 25 AND 50).

FIRST USE 2-0-2002; IN COMMERCE 2-0-2002.

CLASS 11—ENVIRONMENTAL CONTROL APPARATUS

FOR BATHROOM LIGHTING FIXTURES, TUB AND SHOWER VALVE AND TRIM SETS, FAUCET SETS, HANDHELD SHOWERS; AND STRUCTURAL AND REPLACEMENT PARTS FOR THE AFOREMENTIONED GOODS (U.S. CLS. 13, 21, 23, 31 AND 34).

FIRST USE 7-0-2003; IN COMMERCE 7-0-2003.

CLASS 20—FURNITURE AND ARTICLES NOT OTHERWISE CLASSIFIED

FOR MIRRORS AND SHELVING (U.S. CLS. 2, 13, 22, 25, 32 AND 50).

FIRST USE 2-0-2002; IN COMMERCE 2-0-2002.

CLASS 21—HOUSEWARES AND GLASS

FOR BATH HARDWARE AND ACCESSORIES, NAMELY, TOWEL BARS, TOWEL RINGS, TISSUE HOLDERS, SOAP DISHES (U.S. CLS. 2, 13, 23, 29, 30, 33, 40 AND 50).

FIRST USE 6-0-2002; IN COMMERCE 6-0-2002.

GISELLE AGOSTO, EXAMINING ATTORNEY

SN 77-965,502. VAYANT TRAVEL TECHNOLOGIES LLC, LEWES CITY, DE. FILED 3-22-2010.

VAYANT

THE MARK CONSISTS OF STANDARD CHARACTERS WITHOUT CLAIM TO ANY PARTICULAR FONT, STYLE, SIZE, OR COLOR.

THE WORDING "VAYANT" HAS NO MEANING IN A FOREIGN LANGUAGE.

CLASS 9—ELECTRICAL AND SCIENTIFIC APPARATUS

FOR COMPUTER HARDWARE; COMPUTER SOFTWARE FOR SEARCHING THE INTERNET FOR AIRLINE TICKET AND TRAVEL PRICE INFORMATION; COMPUTER SOFTWARE TO OPTIMIZE INTERNET SEARCH ENGINES; COMPUTER SOFTWARE TO MANAGE AIRLINE AND TRANSPORTATION COMPANY OPERATIONS; COMPUTER SOFTWARE TO OPTIMIZE TICKET DISTRIBUTION IN THE TRAVEL INDUSTRY (U.S. CLS. 21, 23, 26, 36 AND 38).

CLASS 42—SCIENTIFIC AND COMPUTER SERVICES

FOR COMPUTER SERVICES, NAMELY, PROVIDING SEARCH ENGINES FOR OBTAINING TRAVEL DATA ON A GLOBAL COMPUTER NETWORK; SOFTWARE AS A SERVICE (SAAS) SERVICES FEATURING SOFTWARE IN THE FIELD OF TRAVEL; APPLICATION SERVICE PROVIDER (ASP) FEATURING SOFTWARE FOR USE IN THE FIELD OF TRAVEL; PROVIDING TEMPORARY USE OF NON-DOWNLOADABLE SOFTWARE FOR SEARCHING THE INTERNET AND ONLINE SOURCES FOR AIRLINE TICKET AND TRAVEL PRICE INFORMATION; PROVIDING TEMPORARY USE OF NON-DOWNLOADABLE SOFTWARE FOR OPTIMIZING INTERNET SEARCH ENGINES; PROVIDING TEMPORARY USE OF NON-DOWNLOADABLE COMPUTER SOFTWARE FOR MANAGING AIRLINE AND TRANSPORTATION COMPANY OPERATIONS (U.S. CLS. 100 AND 101).

DAVID C. REIHNER, EXAMINING ATTORNEY

POINT, A SPHERE WITH A BLUE-COLORED CENTER APPEARS FROM THE RIGHT-HAND SIDE OF THE FRAME, AND BEGINS TO MOVE LEFT TOWARD THE CENTER OF THE IMAGE. AS THE SPHERE APPEARS, THE LIQUID CURVES UP TOWARD THE UPPER RIGHT-HAND CORNER OF THE SCREEN, BEFORE CURVING SHARPLY BACK TOWARD THE CENTER OF THE SCREEN. THE LIQUID THEN POURS AROUND AND INTO THE SPHERE AT THE CENTER OF THE SCREEN. ONCE THE LIQUID HAS POURED INTO THE SPHERE, THE SPHERE INCREASES IN SIZE, AND MOVES TO THE UPPER-CENTER OF THE SCREEN. THE BLACK, WHITE, AND GRAY IN THE IMAGE ARE NOT CLAIMED AS A FEATURE OF THE MARK, AND ARE MEANT TO REPRESENT BACKGROUND, OUTLINING, SHADING AND/OR TRANSPARENT AREAS ONLY.

CLASS 9—ELECTRICAL AND SCIENTIFIC APPARATUS

FOR CELLULAR OR MOBILE PHONES; CELLULAR OR MOBILE PHONES FEATURING THE CAPACITY TO FUNCTION IN ANY NUMBER OF EXTRA WAYS BEYOND JUST AS A PHONE, NAMELY, TO FUNCTION AS A CAMERA, TO PERFORM INSTANT MESSAGING, TO CONDUCT MULTIMEDIA MESSAGING, TO ACCESS AND COMMUNICATE WITH E-MAIL, TO ACCESS AND COMMUNICATE WITH THE INTERNET, TO ACCESS AND COMMUNICATE DATA, TO FUNCTION AS A RADIO, TO RECORD, PLAY, TRANSMIT, RECEIVE, AND/OR MANAGE MUSIC, TO RECORD, PLAY, TRANSMIT, RECEIVE, EDIT, AND/OR MANAGE AUDIO OR VOICE, TO RECORD, PLAY, TRANSMIT, RECEIVE, EDIT, AND/OR MANAGE VIDEO, TO CREATE, VIEW, TRANSMIT, RECEIVE, EDIT, AND/OR MANAGE PHOTOGRAPHS OR PICTURES, TO UPLOAD, VIEW, TRANSMIT, RECEIVE, EDIT, AND/OR MANAGE GRAPHICS OR IMAGES, TO PLAY ELECTRONIC GAMES, TO UPLOAD PHOTOGRAPHS AND TEXT ONTO ONLINE JOURNALS OR WEB LOGS ALSO KNOWN AS BLOGS, TO MANAGE A CALENDAR AND CONTACT INFORMATION AND OTHERWISE FUNCTION AS A PERSONAL DIGITAL ASSISTANT (PDA), TO EFFECTUATE PRINTING, TO PERFORM SATELLITE NAVIGATION, TO VIEW ELECTRONIC CITY GUIDES, TO FUNCTION AS A REMOTE CONTROL FOR COMPUTERS AND RUN MULTIMEDIA PRESENTATIONS, TO TRANSMIT VIDEO, SOUND, AND/OR DATA TO WEBSITES, AND/OR TO OTHERWISE FUNCTION AS A MOBILE MULTIMEDIA AND COMMUNICATIONS APPARATUS FOR RECORDING, TRANSMISSION, PROCESSING, AND REPRODUCTION OF SOUND, IMAGES, OR DATA; DOWNLOADABLE ELECTRONIC MANUALS IN THE FIELD OF CELLULAR OR MOBILE PHONES AND MOBILE MULTIMEDIA AND COMMUNICATIONS DEVICES; PERSONAL COMPUTER CARDS THAT ENABLE COMPUTERS AND LAPTOP COMPUTERS TO GAIN WIRELESS ACCESS TO, AND COMMUNICATE WITH, E-MAIL, THE INTERNET, INTRANETS, OR PRIVATE COMPUTER NETWORKS; COMPUTER APPLICATION SOFTWARE FOR CELLULAR OR MOBILE PHONES AND MOBILE MULTIMEDIA AND COMMUNICATIONS DEVICES; DOWNLOADABLE COMPUTER APPLICATION SOFTWARE FOR CELLULAR OR MOBILE PHONES AND MOBILE MULTIMEDIA AND COMMUNICATIONS DEVICES; DOWNLOADABLE MUSICAL RECORDINGS, ELECTRONIC GAMES, RINGTONES, WALLPAPERS, THEMES, AND MOVIES, ALL DOWNLOADABLE TO COMPUTERS AND CELLULAR OR MOBILE PHONES AND MOBILE MULTIMEDIA AND COMMUNICATIONS DEVICES VIA THE INTERNET; CAMERA DEVICES ADAPTED FOR USE WITH CELLULAR OR MOBILE PHONES AND MOBILE MULTIMEDIA AND COMMUNICATIONS DEVICES; DEVICES THAT ALLOW IMAGES FROM CELLULAR OR MOBILE PHONES AND MOBILE MULTIMEDIA AND COMMUNICATIONS DEVICES TO BE SHOWN ON TELEVISIONS, DISPLAY SCREENS OR COMPUTER MONITORS; DEVICES THAT ALLOW AUDIO FROM CELLULAR OR MOBILE PHONES AND MOBILE MULTIMEDIA AND COMMUNICATIONS DEVICES TO BE HEARD ON STEREO SYSTEMS; AUDIO SPEAKERS FOR LISTENING TO MUSIC OR AUDIO FROM MOBILE OR CELLULAR PHONES AND MOBILE MULTIMEDIA AND COMMUNICATIONS DEVICES; COMBINATION AMPLIFIER AND SPEAKER SYSTEM FOR LISTENING TO MUSIC OR AUDIO FROM MOBILE OR CELLULAR PHONES AND MOBILE MULTIMEDIA AND COMMUNICATIONS DEVICES.

SN 77-965,694. SONY ERICSSON MOBILE COMMUNICATIONS AB, LUND, SWEDEN, FILED 3-23-2010.

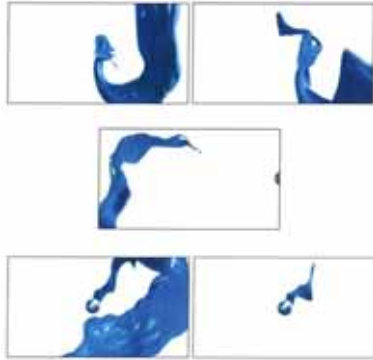

PRIORITY CLAIMED UNDER SEC. 44(D) ON ERPN CMNTY TM OFC APPLICATION NO. 8581911, FILED 9-29-2009, REG. NO. 008581911, DATED 5-6-2011, EXPIRES 9-29-2019.

OWNER OF U.S. REG. NOS. 2,895,153, 3,690,610 AND OTHERS.

THE COLOR(S) BLUE IS/ARE CLAIMED AS A FEATURE OF THE MARK.

THE MARK IS A MOTION MARK - FIVE FRAMES OF WHICH ARE SHOWN IN THE DRAWING - WHICH RUNS WITHIN A TIME FRAME OF APPROXIMATELY 6 SECONDS. IN THE MARK, A STREAM OF BLUE-COLORED LIQUID MOVES INTO THE SCREEN FROM THE UPPER RIGHT-HAND CORNER, DOWN THE RIGHT SIDE OF THE SCREEN, CURVES UP TOWARD THE MIDDLE OF THE SCREEN, AND THEN CONTINUES ON TOWARD THE UPPER LEFT-HAND CORNER. ONCE AT THE UPPER LEFT OF THE SCREEN, THE LIQUID THEN CURVES DOWN AND MOVES ALONG THE LEFT SIDE OF THE SCREEN BEFORE CURVING TO THE RIGHT AND MOVING ALONG THE BOTTOM OF THE SCREEN. AT THIS

NICATIONS DEVICES; RADIO TRANSMITTERS; COMPUTER GAMES FOR USE WITH CELLULAR OR MOBILE PHONES AND MOBILE MULTIMEDIA AND COMMUNICATIONS DEVICES; ACCESSORIES FOR CELLULAR OR MOBILE PHONES AND MOBILE MULTIMEDIA AND COMMUNICATIONS DEVICES IN THE NATURE OF HEADSETS AND DEVICES FOR HANDS-FREE USE SUCH AS EARPHONES AND HEADPHONES; ACCESSORIES FOR CELLULAR OR MOBILE PHONES AND MOBILE MULTIMEDIA AND COMMUNICATIONS DEVICES IN THE NATURE OF CHARGERS, BATTERIES, CASES, COVERS, HOLDERS, DOCKING STANDS, CABLES, POWER PACKS, AND TRIPODS; REMOTE CONTROLS FOR ELECTRONIC COMMUNICATIONS AND TELECOMMUNICATIONS APPARATUS AND INSTRUMENTS; AND DIGITAL PHOTO FRAMES FOR DISPLAYING DIGITAL PICTURES, VIDEO CLIPS AND/OR MUSIC (U.S. CLS. 21, 23, 26, 36 AND 38).

CLASS 38—COMMUNICATION

FOR TELECOMMUNICATIONS SERVICES IN THE NATURE OF TRANSMISSION OF SOUND, PICTURE, IMAGE, VIDEO, AND DATA SIGNALS, SUCH TRANSMISSION ENABLED BY MEANS OF THE INTERNET AND WIRELESS TECHNOLOGY, PROVIDED IN RESPONSE TO COMMANDS FROM COMPUTERS AND CELLULAR OR MOBILE PHONES AND MOBILE MULTIMEDIA AND COMMUNICATIONS DEVICES; TRANSMISSION OF SOUND, PICTURE, IMAGE, VIDEO, AND DATA SIGNALS TO PERSONALIZE OR ENHANCE CELLULAR OR MOBILE PHONES AND MOBILE MULTIMEDIA AND COMMUNICATIONS DEVICES, SUCH TRANSMISSION ENABLED BY MEANS OF THE INTERNET AND WIRELESS TECHNOLOGY, PROVIDED IN RESPONSE TO COMMANDS FROM COMPUTERS AND CELLULAR OR MOBILE PHONES AND MOBILE MULTIMEDIA AND COMMUNICATIONS DEVICES; TELECOMMUNICATIONS SERVICES, NAMELY, PROVIDING A WEBSITE THAT ENABLES TRANSMISSION OF SOUND, PICTURE, GRAPHIC, IMAGE, AND VIDEO SIGNALS TO THE WEBSITE, WHERE THE SIGNALS MAY BE EDITED AND THEN TRANSMITTED TO COMPUTERS AND CELLULAR OR MOBILE PHONES AND MOBILE MULTIMEDIA AND COMMUNICATIONS DEVICES; PROVIDING INFORMATION ON CALLING PLANS AND SERVICES OF OTHERS IN THE FIELD OF CELLULAR OR MOBILE PHONES AND MOBILE MULTIMEDIA AND COMMUNICATIONS DEVICES; PROVIDING ACCESS VIA THE INTERNET AND CELLULAR OR MOBILE PHONES AND MOBILE MULTIMEDIA AND COMMUNICATIONS DEVICES TO MUSIC, GAMES, RINGTONES, WALLPAPERS, THEMES, AND MOVIES FOR THE PURPOSE OF PLAYING, VIEWING AND/OR DOWNLOADING THE MUSIC, ELECTRONIC GAMES, RINGTONES, WALLPAPERS, THEMES, AND MOVIES; PROVIDING ONLINE FORUMS FOR TRANSMISSION OF MESSAGES AMONG COMPUTER USERS CONCERNING CELLULAR OR MOBILE PHONES AND MOBILE MULTIMEDIA AND COMMUNICATIONS DEVICES, AND ACCESSORIES AND APPLICATIONS FOR SUCH PHONES AND DEVICES; AND PROVIDING LINKS TO WEBSITES OF OTHERS IN THE FIELD OF CELLULAR OR MOBILE PHONES AND MOBILE MULTIMEDIA AND COMMUNICATIONS DEVICES, AND ACCESSORIES AND APPLICATIONS FOR SUCH PHONES AND DEVICES; AND PROVIDING NEWS, INFORMATION, COMMENTARY, AND PHOTOGRAPHIC AND VIDEO CONTENT IN THE FIELD OF CELLULAR OR MOBILE PHONES AND ACCESSORIES AND APPLICATIONS FOR SUCH PHONES (U.S. CLS. 100, 101 AND 104).

CLASS 41—EDUCATION AND ENTERTAINMENT

FOR ENTERTAINMENT IN THE NATURE OF TENNIS TOURNAMENTS; ENTERTAINMENT IN THE NATURE OF SOCCER TOURNAMENTS; ENTERTAINMENT FEATURING EXHIBITION SPORTING EVENTS, SPECIFICALLY, A MODIFIED FORM OF THE GAME OF TENNIS PERFORMED AS A FLOOR SHOW IN NIGHT CLUBS OR VENUES PREPARED IN THE STYLE OF A NIGHT CLUB, SUCH EVENTS BEING PERFORMED IN A WAY THAT INTERPRETS THE GAME OF TENNIS AS A NIGHT CLUB ACTIVITY BY PLAYING THE GAME RAPIDLY, IN THE DARK, UNDER ULTRAVIOLET LIGHT, WITH LIGHT AND MUSIC SHOWS, AND ALSO FEATURING FASHION SHOWS AND DISC JOCKEY PERFORMANCES; ENTERTAINMENT SERVICES, NAMELY, NON-DOWNLOADABLE MUSIC, ELECTRONIC GAMES, RINGTONES, WALLPAPERS, THEMES, AND MOVIES PRESENTED TO MOBILE MULTIMEDIA AND COMMUNICATIONS DEVICES VIA A GLOBAL COMPUTER NETWORK AND WIRELESS NETWORKS; ENTERTAINMENT IN THE NATURE OF CONDUCTING CONTESTS REGARDING THE CREATION OF PERSONALIZED ELECTRONIC CHARACTERS OR CARICATURES; ONLINE JOURNALS, NAMELY, BLOGS FEATURING CONTENT IN THE FIELD OF CELLULAR OR MOBILE PHONES AND MOBILE MULTIMEDIA AND COMMUNICATIONS DEVICES, AND ACCESSORIES AND APPLICATIONS FOR SUCH PHONES (U.S. CLS. 100, 101 AND 107).

JASON BLAIR, EXAMINING ATTORNEY

SN 77-965,826. SONY ERICSSON MOBILE COMMUNICATIONS AB, LUND, SWEDEN, FILED 3-23-2010.

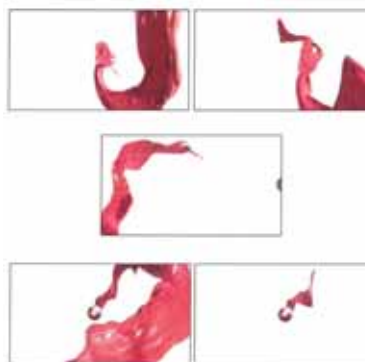

PRIORITY CLAIMED UNDER SEC. 44(D) ON ERP CMNTY TM OFC APPLICATION NO. 8582207, FILED 9-29-2009, REG. NO. 008582207, DATED 5-6-2011, EXPIRES 9-29-2019.

OWNER OF U.S. REG. NOS. 2,895,153, 3,690,610 AND OTHERS.

THE COLOR(S) CHERRY RED IS/ARE CLAIMED AS A FEATURE OF THE MARK.

THE MARK IS A MOTION MARK - FIVE FRAMES OF WHICH ARE SHOWN IN THE DRAWING - WHICH RUNS WITHIN A TIME FRAME OF APPROXIMATELY 6 SECONDS. IN THE MARK, A STREAM OF CHERRY RED-COLORED LIQUID MOVES INTO THE SCREEN FROM THE UPPER RIGHT-HAND CORNER, DOWN THE RIGHT SIDE OF THE SCREEN, CURVES UP TOWARD THE MIDDLE OF THE SCREEN, AND THEN CONTINUES ON TOWARD THE UPPER LEFT-HAND CORNER. ONCE AT THE UPPER LEFT OF THE SCREEN, THE LIQUID THEN CURVES DOWN AND MOVES ALONG THE LEFT SIDE OF THE SCREEN BEFORE CURVING TO THE RIGHT AND MOVING ALONG THE BOTTOM OF THE SCREEN. AT THIS POINT, A SPHERE WITH A CHERRY RED-COLORED CENTER APPEARS FROM THE RIGHT-HAND SIDE OF THE FRAME, AND BEGINS TO MOVE LEFT TOWARD THE CENTER OF THE IMAGE. AS THE SPHERE APPEARS, THE LIQUID CURVES UP TOWARD THE UPPER RIGHT-HAND CORNER OF THE SCREEN, BEFORE CURVING SHARPLY

BACK TOWARD THE CENTER OF THE SCREEN. THE LIQUID THEN POURS AROUND AND INTO THE SPHERE AT THE CENTER OF THE SCREEN. ONCE THE LIQUID HAS Poured INTO THE SPHERE, THE SPHERE INCREASES IN SIZE, AND MOVES TO THE UPPER-CENTER OF THE SCREEN. THE BLACK, WHITE, AND GRAY IN THE IMAGE ARE NOT CLAIMED AS A FEATURE OF THE MARK, AND ARE MEANT TO REPRESENT BACKGROUND, OUTLINING, SHADING AND/OR TRANSPARENT AREAS ONLY.

CLASS 9—ELECTRICAL AND SCIENTIFIC APPARATUS

FOR CELLULAR OR MOBILE PHONES; CELLULAR OR MOBILE PHONES FEATURING THE CAPACITY TO FUNCTION IN ANY NUMBER OF EXTRA WAYS BEYOND JUST AS A PHONE, NAMELY, TO FUNCTION AS A CAMERA, TO PERFORM INSTANT MESSAGING, TO CONDUCT MULTIMEDIA MESSAGING, TO ACCESS AND COMMUNICATE WITH E-MAIL, TO ACCESS AND COMMUNICATE WITH THE INTERNET, TO ACCESS AND COMMUNICATE DATA, TO FUNCTION AS A RADIO, TO RECORD, PLAY, TRANSMIT, RECEIVE, AND/OR MANAGE MUSIC, TO RECORD, PLAY, TRANSMIT, RECEIVE, EDIT, AND/OR MANAGE AUDIO OR VOICE, TO RECORD, PLAY, TRANSMIT, RECEIVE, EDIT, AND/OR MANAGE VIDEO, TO CREATE, VIEW, TRANSMIT, RECEIVE, EDIT, AND/OR MANAGE PHOTOGRAPHS OR PICTURES, TO UPLOAD, VIEW, TRANSMIT, RECEIVE, EDIT, AND/OR MANAGE GRAPHICS OR IMAGES, TO PLAY ELECTRONIC GAMES, TO UPLOAD PHOTOGRAPHS AND TEXT ONTO ONLINE JOURNALS OR WEB LOGS ALSO KNOWN AS BLOGS, TO MANAGE A CALENDAR AND CONTACT INFORMATION AND OTHERWISE FUNCTION AS A PERSONAL DIGITAL ASSISTANT (PDA), TO EFFECTUATE PRINTING, TO PERFORM SATELLITE NAVIGATION, TO VIEW ELECTRONIC CITY GUIDES, TO FUNCTION AS A REMOTE CONTROL FOR COMPUTERS AND RUN MULTIMEDIA PRESENTATIONS, TO TRANSMIT VIDEO, SOUND, AND/OR DATA TO WEBSITES, AND/OR TO OTHERWISE FUNCTION AS A MOBILE MULTIMEDIA AND COMMUNICATIONS APPARATUS FOR RECORDING, TRANSMISSION, PROCESSING, AND REPRODUCTION OF SOUND, IMAGES, OR DATA; DOWNLOADABLE ELECTRONIC MANUALS IN THE FIELD OF CELLULAR OR MOBILE PHONES AND MOBILE MULTIMEDIA AND COMMUNICATIONS DEVICES; PERSONAL COMPUTER CARDS THAT ENABLE COMPUTERS AND LAPTOP COMPUTERS TO GAIN WIRELESS ACCESS TO, AND COMMUNICATE WITH, E-MAIL, THE INTERNET, INTRANETS, OR PRIVATE COMPUTER NETWORKS; COMPUTER APPLICATION SOFTWARE FOR CELLULAR OR MOBILE PHONES AND MOBILE MULTIMEDIA AND COMMUNICATIONS DEVICES; DOWNLOADABLE COMPUTER APPLICATION SOFTWARE FOR CELLULAR OR MOBILE PHONES AND MOBILE MULTIMEDIA AND COMMUNICATIONS DEVICES; DOWNLOADABLE MUSICAL RECORDINGS, ELECTRONIC GAMES, RINGTONES, WALLPAPERS, THEMES, AND MOVIES, ALL DOWNLOADABLE TO COMPUTERS AND CELLULAR OR MOBILE PHONES AND MOBILE MULTIMEDIA AND COMMUNICATIONS DEVICES VIA THE INTERNET; CAMERA DEVICES ADAPTED FOR USE WITH CELLULAR OR MOBILE PHONES AND MOBILE MULTIMEDIA AND COMMUNICATIONS DEVICES; DEVICES THAT ALLOW IMAGES FROM CELLULAR OR MOBILE PHONES AND MOBILE MULTIMEDIA AND COMMUNICATIONS DEVICES TO BE SHOWN ON TELEVISIONS, DISPLAY SCREENS OR COMPUTER MONITORS; DEVICES THAT ALLOW AUDIO FROM CELLULAR OR MOBILE PHONES AND MOBILE MULTIMEDIA AND COMMUNICATIONS DEVICES TO BE HEARD ON STEREO SYSTEMS; AUDIO SPEAKERS FOR LISTENING TO MUSIC OR AUDIO FROM MOBILE OR CELLULAR PHONES AND MOBILE MULTIMEDIA AND COMMUNICATIONS DEVICES; COMBINATION AMPLIFIER AND SPEAKER SYSTEM FOR LISTENING TO MUSIC OR AUDIO FROM MOBILE OR CELLULAR PHONES AND MOBILE MULTIMEDIA AND COMMUNICATIONS DEVICES; RADIO TRANSMITTERS; COMPUTER GAMES FOR USE WITH CELLULAR OR MOBILE PHONES AND MOBILE MULTIMEDIA AND COMMUNICATIONS DEVICES; ACCESSORIES FOR CELLULAR OR MOBILE PHONES AND MOBILE MULTIMEDIA AND COMMUNICATIONS DEVICES IN THE

NATURE OF HEADSETS AND DEVICES FOR HANDS-FREE USE SUCH AS EARPHONES AND HEADPHONES; ACCESSORIES FOR CELLULAR OR MOBILE PHONES AND MOBILE MULTIMEDIA AND COMMUNICATIONS DEVICES IN THE NATURE OF CHARGERS, BATTERIES, CASES, COVERS, HOLDERS, DOCKING STANDS, CABLES, POWER PACKS, AND TRIPODS; REMOTE CONTROLS FOR ELECTRONIC COMMUNICATIONS AND TELECOMMUNICATIONS APPARATUS AND INSTRUMENTS; AND DIGITAL PHOTO FRAMES FOR DISPLAYING DIGITAL PICTURES, VIDEO CLIPS AND/OR MUSIC (U.S. CLS. 21, 23, 26, 36 AND 38).

CLASS 38—COMMUNICATION

FOR TELECOMMUNICATIONS SERVICES IN THE NATURE OF TRANSMISSION OF SOUND, PICTURE, IMAGE, VIDEO, AND DATA SIGNALS, SUCH TRANSMISSION ENABLED BY MEANS OF THE INTERNET AND WIRELESS TECHNOLOGY, PROVIDED IN RESPONSE TO COMMANDS FROM COMPUTERS AND CELLULAR OR MOBILE PHONES AND MOBILE MULTIMEDIA AND COMMUNICATIONS DEVICES; TRANSMISSION OF SOUND, PICTURE, IMAGE, VIDEO, AND DATA SIGNALS TO PERSONALIZE OR ENHANCE CELLULAR OR MOBILE PHONES AND MOBILE MULTIMEDIA AND COMMUNICATIONS DEVICES, SUCH TRANSMISSION ENABLED BY MEANS OF THE INTERNET AND WIRELESS TECHNOLOGY, PROVIDED IN RESPONSE TO COMMANDS FROM COMPUTERS AND CELLULAR OR MOBILE PHONES AND MOBILE MULTIMEDIA AND COMMUNICATIONS DEVICES; TELECOMMUNICATIONS SERVICES, NAMELY, PROVIDING A WEBSITE THAT ENABLES TRANSMISSION OF SOUND, PICTURE, GRAPHIC, IMAGE, AND VIDEO SIGNALS TO THE WEBSITE, WHERE THE SIGNALS MAY BE EDITED AND THEN TRANSMITTED TO COMPUTERS AND CELLULAR OR MOBILE PHONES AND MOBILE MULTIMEDIA AND COMMUNICATIONS DEVICES; PROVIDING INFORMATION ON CALLING PLANS AND SERVICES OF OTHERS IN THE FIELD OF CELLULAR OR MOBILE PHONES AND MOBILE MULTIMEDIA AND COMMUNICATIONS DEVICES; PROVIDING ACCESS VIA THE INTERNET AND CELLULAR OR MOBILE PHONES AND MOBILE MULTIMEDIA AND COMMUNICATIONS DEVICES TO MUSIC, GAMES, RINGTONES, WALLPAPERS, THEMES, AND MOVIES FOR THE PURPOSE OF PLAYING, VIEWING AND/OR DOWNLOADING THE MUSIC, ELECTRONIC GAMES, RINGTONES, WALLPAPERS, THEMES, AND MOVIES; PROVIDING ONLINE FORUMS FOR TRANSMISSION OF MESSAGES AMONG COMPUTER USERS CONCERNING CELLULAR OR MOBILE PHONES AND MOBILE MULTIMEDIA AND COMMUNICATIONS DEVICES, AND ACCESSORIES AND APPLICATIONS FOR SUCH PHONES AND DEVICES; AND PROVIDING LINKS TO WEBSITES OF OTHERS IN THE FIELD OF CELLULAR OR MOBILE PHONES AND MOBILE MULTIMEDIA AND COMMUNICATIONS DEVICES, AND ACCESSORIES AND APPLICATIONS FOR SUCH PHONES AND DEVICES; AND PROVIDING NEWS, INFORMATION, COMMENTARY, AND PHOTOGRAPHIC AND VIDEO CONTENT IN THE FIELD OF CELLULAR OR MOBILE PHONES AND ACCESSORIES AND APPLICATIONS FOR SUCH PHONES (U.S. CLS. 100, 101 AND 104).

CLASS 41—EDUCATION AND ENTERTAINMENT

FOR ENTERTAINMENT IN THE NATURE OF TENNIS TOURNAMENTS; ENTERTAINMENT IN THE NATURE OF SOCCER TOURNAMENTS; ENTERTAINMENT FEATURING EXHIBITION SPORTING EVENTS, SPECIFICALLY, A MODIFIED FORM OF THE GAME OF TENNIS PERFORMED AS A FLOOR SHOW IN NIGHT CLUBS OR VENUES PREPARED IN THE STYLE OF A NIGHT CLUB, SUCH EVENTS BEING PERFORMED IN A WAY THAT INTERPRETS THE GAME OF TENNIS AS A NIGHT CLUB ACTIVITY BY PLAYING THE GAME RAPIDLY, IN THE DARK, UNDER ULTRAVIOLET LIGHT, WITH LIGHT AND MUSIC SHOWS, AND ALSO FEATURING FASHION SHOWS AND DISC JOCKEY PERFORMANCES; ENTERTAINMENT SERVICES, NAMELY, NON-DOWNLOADABLE MUSIC, ELECTRONIC GAMES, RINGTONES, WALLPAPERS, THEMES,

AND MOVIES PRESENTED TO MOBILE MULTIMEDIA AND COMMUNICATIONS DEVICES VIA A GLOBAL COMPUTER NETWORK AND WIRELESS NETWORKS; ENTERTAINMENT IN THE NATURE OF CONDUCTING CONTESTS REGARDING THE CREATION OF PERSONALIZED ELECTRONIC CHARACTERS OR CARICATURES; ONLINE JOURNALS, NAMELY, BLOGS FEATURING CONTENT IN THE FIELD OF CELLULAR OR MOBILE PHONES AND MOBILE MULTIMEDIA AND COMMUNICATIONS DEVICES, AND ACCESSORIES AND APPLICATIONS FOR SUCH PHONES (U.S. CLS. 100, 101 AND 107).

JASON BLAIR, EXAMINING ATTORNEY

CLASS 9—ELECTRICAL AND SCIENTIFIC APPARATUS

FOR CELLULAR OR MOBILE PHONES; CELLULAR OR MOBILE PHONES FEATURING THE CAPACITY TO FUNCTION IN ANY NUMBER OF EXTRA WAYS BEYOND JUST AS A PHONE, NAMELY, TO FUNCTION AS A CAMERA, TO PERFORM INSTANT MESSAGING, TO CONDUCT MULTIMEDIA MESSAGING, TO ACCESS AND COMMUNICATE WITH E-MAIL, TO ACCESS AND COMMUNICATE WITH THE INTERNET, TO ACCESS AND COMMUNICATE DATA, TO FUNCTION AS A RADIO, TO RECORD, PLAY, TRANSMIT, RECEIVE, AND/OR MANAGE MUSIC, TO RECORD, PLAY, TRANSMIT, RECEIVE, EDIT, AND/OR MANAGE AUDIO OR VOICE, TO RECORD, PLAY, TRANSMIT, RECEIVE, EDIT, AND/OR MANAGE VIDEO, TO CREATE, VIEW, TRANSMIT, RECEIVE, EDIT, AND/OR MANAGE PHOTOGRAPHS OR PICTURES, TO UPLOAD, VIEW, TRANSMIT, RECEIVE, EDIT, AND/OR MANAGE GRAPHICS OR IMAGES, TO PLAY ELECTRONIC GAMES, TO UPLOAD PHOTOGRAPHS AND TEXT ONTO ONLINE JOURNALS OR WEB LOGS ALSO KNOWN AS BLOGS, TO MANAGE A CALENDAR AND CONTACT INFORMATION AND OTHERWISE FUNCTION AS A PERSONAL DIGITAL ASSISTANT (PDA), TO EFFECTUATE PRINTING, TO PERFORM SATELLITE NAVIGATION, TO VIEW ELECTRONIC CITY GUIDES, TO FUNCTION AS A REMOTE CONTROL FOR COMPUTERS AND RUN MULTIMEDIA PRESENTATIONS, TO TRANSMIT VIDEO, SOUND, AND/OR DATA TO WEBSITES, AND/OR TO OTHERWISE FUNCTION AS A MOBILE MULTIMEDIA AND COMMUNICATIONS APPARATUS FOR RECORDING, TRANSMISSION, PROCESSING, AND REPRODUCTION OF SOUND, IMAGES, OR DATA; DOWNLOADABLE ELECTRONIC MANUALS IN THE FIELD OF CELLULAR OR MOBILE PHONES AND MOBILE MULTIMEDIA AND COMMUNICATIONS DEVICES; PERSONAL COMPUTER CARDS THAT ENABLE COMPUTERS AND LAPTOP COMPUTERS TO GAIN WIRELESS ACCESS TO, AND COMMUNICATE WITH, E-MAIL, THE INTERNET, INTRANETS, OR PRIVATE COMPUTER NETWORKS; COMPUTER APPLICATION SOFTWARE FOR CELLULAR OR MOBILE PHONES AND MOBILE MULTIMEDIA AND COMMUNICATIONS DEVICES; DOWNLOADABLE COMPUTER APPLICATION SOFTWARE FOR CELLULAR OR MOBILE PHONES AND MOBILE MULTIMEDIA AND COMMUNICATIONS DEVICES; DOWNLOADABLE MUSICAL RECORDINGS, ELECTRONIC GAMES, RINGTONES, WALLPAPERS, THEMES, AND MOVIES, ALL DOWNLOADABLE TO COMPUTERS AND CELLULAR OR MOBILE PHONES AND MOBILE MULTIMEDIA AND COMMUNICATIONS DEVICES VIA THE INTERNET; CAMERA DEVICES ADAPTED FOR USE WITH CELLULAR OR MOBILE PHONES AND MOBILE MULTIMEDIA AND COMMUNICATIONS DEVICES; DEVICES THAT ALLOW IMAGES FROM CELLULAR OR MOBILE PHONES AND MOBILE MULTIMEDIA AND COMMUNICATIONS DEVICES TO BE SHOWN ON TELEVISIONS, DISPLAY SCREENS OR COMPUTER MONITORS; DEVICES THAT ALLOW AUDIO FROM CELLULAR OR MOBILE PHONES AND MOBILE MULTIMEDIA AND COMMUNICATIONS DEVICES TO BE HEARD ON STEREO SYSTEMS; AUDIO SPEAKERS FOR LISTENING TO MUSIC OR AUDIO FROM MOBILE OR CELLULAR PHONES AND MOBILE MULTIMEDIA AND COMMUNICATIONS DEVICES; COMBINATION AMPLIFIER AND SPEAKER SYSTEM FOR LISTENING TO MUSIC OR AUDIO FROM MOBILE OR CELLULAR PHONES AND MOBILE MULTIMEDIA AND COMMUNICATIONS DEVICES; RADIO TRANSMITTERS; COMPUTER GAMES FOR USE WITH CELLULAR OR MOBILE PHONES AND MOBILE MULTIMEDIA AND COMMUNICATIONS DEVICES; ACCESSORIES FOR CELLULAR OR MOBILE PHONES AND MOBILE MULTIMEDIA AND COMMUNICATIONS DEVICES IN THE NATURE OF HEADSETS AND DEVICES FOR HANDS-FREE USE SUCH AS EARPHONES AND HEADPHONES; ACCESSORIES FOR CELLULAR OR MOBILE PHONES AND MOBILE MULTIMEDIA AND COMMUNICATIONS DEVICES IN THE NATURE OF CHARGERS, BATTERIES, CASES, COVERS, HOLDERS, DOCKING STANDS, CABLES, POWER PACKS, AND TRIPODS; REMOTE CONTROLS FOR ELECTRONIC COMMUNICATIONS AND TELECOMMUNICATIONS APPARATUS AND INSTRUMENTS; AND DIGITAL PHOTO FRAMES FOR DISPLAYING DIGITAL PICTURES, VIDEO CLIPS AND/OR MUSIC (U.S. CLS. 21, 23, 26, 36 AND 38).

SN 77-965,855. SONY ERICSSON MOBILE COMMUNICATIONS AB, LUND, SWEDEN, FILED 3-23-2010.

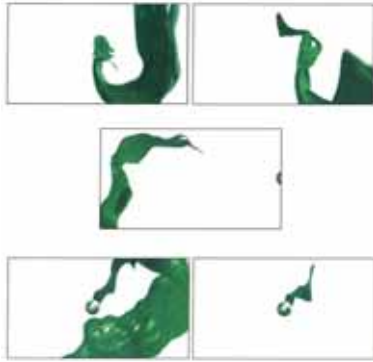

PRIORITY CLAIMED UNDER SEC. 44(D) ON ERP CMNTY TM OFC APPLICATION NO. 8582595, FILED 9-29-2009, REG. NO. 008582595, DATED 5-6-2011, EXPIRES 9-29-2019.

OWNER OF U.S. REG. NOS. 2,895,153, 3,690,610 AND OTHERS.

THE COLOR(S) GREEN IS/ARE CLAIMED AS A FEATURE OF THE MARK.

THE MARK IS A MOTION MARK - FIVE FRAMES OF WHICH ARE SHOWN IN THE DRAWING - WHICH RUNS WITHIN A TIME FRAME OF APPROXIMATELY 6 SECONDS. IN THE MARK, A STREAM OF GREEN-COLORED LIQUID MOVES INTO THE SCREEN FROM THE UPPER RIGHT-HAND CORNER, DOWN THE RIGHT SIDE OF THE SCREEN, CURVES UP TOWARD THE MIDDLE OF THE SCREEN, AND THEN CONTINUES ON TOWARD THE UPPER LEFT-HAND CORNER. ONCE AT THE UPPER LEFT OF THE SCREEN, THE LIQUID THEN CURVES DOWN AND MOVES ALONG THE LEFT SIDE OF THE SCREEN BEFORE CURVING TO THE RIGHT AND MOVING ALONG THE BOTTOM OF THE SCREEN. AT THIS POINT, A SPHERE WITH A GREEN-COLORED CENTER APPEARS FROM THE RIGHT-HAND SIDE OF THE FRAME, AND BEGINS TO MOVE LEFT TOWARD THE CENTER OF THE IMAGE. AS THE SPHERE APPEARS, THE LIQUID CURVES UP TOWARD THE UPPER RIGHT-HAND CORNER OF THE SCREEN, BEFORE CURVING SHARPLY BACK TOWARD THE CENTER OF THE SCREEN. THE LIQUID THEN POURS AROUND AND INTO THE SPHERE AT THE CENTER OF THE SCREEN. ONCE THE LIQUID HAS POURED INTO THE SPHERE, THE SPHERE INCREASES IN SIZE, AND MOVES TO THE UPPER-CENTER OF THE SCREEN. THE BLACK, WHITE, AND GRAY IN THE IMAGE ARE NOT CLAIMED AS A FEATURE OF THE MARK, AND ARE MEANT TO REPRESENT BACKGROUND, OUTLINING, SHADING AND/OR TRANSPARENT AREAS ONLY.

CLASS 38—COMMUNICATION

FOR TELECOMMUNICATIONS SERVICES IN THE NATURE OF TRANSMISSION OF SOUND, PICTURE, IMAGE, VIDEO, AND DATA SIGNALS, SUCH TRANSMISSION ENABLED BY MEANS OF THE INTERNET AND WIRELESS TECHNOLOGY, PROVIDED IN RESPONSE TO COMMANDS FROM COMPUTERS AND CELLULAR OR MOBILE PHONES AND MOBILE MULTIMEDIA AND COMMUNICATIONS DEVICES; TRANSMISSION OF SOUND, PICTURE, IMAGE, VIDEO, AND DATA SIGNALS TO PERSONALIZE OR ENHANCE CELLULAR OR MOBILE PHONES AND MOBILE MULTIMEDIA AND COMMUNICATIONS DEVICES; TELECOMMUNICATIONS SERVICES, NAMELY, PROVIDING A WEBSITE THAT ENABLES TRANSMISSION OF SOUND, PICTURE, GRAPHIC, IMAGE, AND VIDEO SIGNALS TO THE WEBSITE, WHERE THE SIGNALS MAY BE EDITED AND THEN TRANSMITTED TO COMPUTERS AND CELLULAR OR MOBILE PHONES AND MOBILE MULTIMEDIA AND COMMUNICATIONS DEVICES; PROVIDING INFORMATION ON CALLING PLANS AND SERVICES OF OTHERS IN THE FIELD OF CELLULAR OR MOBILE PHONES AND MOBILE MULTIMEDIA AND COMMUNICATIONS DEVICES; PROVIDING ACCESS VIA THE INTERNET AND CELLULAR OR MOBILE PHONES AND MOBILE MULTIMEDIA AND COMMUNICATIONS DEVICES TO MUSIC, GAMES, RINGTONES, WALLPAPERS, THEMES, AND MOVIES FOR THE PURPOSE OF PLAYING, VIEWING AND/OR DOWNLOADING THE MUSIC, ELECTRONIC GAMES, RINGTONES, WALLPAPERS, THEMES, AND MOVIES; PROVIDING ONLINE FORUMS FOR TRANSMISSION OF MESSAGES AMONG COMPUTER USERS CONCERNING CELLULAR OR MOBILE PHONES AND MOBILE MULTIMEDIA AND COMMUNICATIONS DEVICES, AND ACCESSORIES AND APPLICATIONS FOR SUCH PHONES AND DEVICES; AND PROVIDING LINKS TO WEBSITES OF OTHERS IN THE FIELD OF CELLULAR OR MOBILE PHONES AND MOBILE MULTIMEDIA AND COMMUNICATIONS DEVICES, AND ACCESSORIES AND APPLICATIONS FOR SUCH PHONES AND DEVICES; AND PROVIDING NEWS, INFORMATION, COMMENTARY, AND PHOTOGRAPHIC AND VIDEO CONTENT IN THE FIELD OF CELLULAR OR MOBILE PHONES AND ACCESSORIES AND APPLICATIONS FOR SUCH PHONES (U.S. CLS. 100, 101 AND 104).

CLASS 41—EDUCATION AND ENTERTAINMENT

FOR ENTERTAINMENT IN THE NATURE OF TENNIS TOURNAMENTS; ENTERTAINMENT IN THE NATURE OF SOCCER TOURNAMENTS; ENTERTAINMENT FEATURING EXHIBITION SPORTING EVENTS, SPECIFICALLY, A MODIFIED FORM OF THE GAME OF TENNIS PERFORMED AS A FLOOR SHOW IN NIGHT CLUBS OR VENUES PREPARED IN THE STYLE OF A NIGHT CLUB, SUCH EVENTS BEING PERFORMED IN A WAY THAT INTERPRETS THE GAME OF TENNIS AS A NIGHT CLUB ACTIVITY BY PLAYING THE GAME RAPIDLY, IN THE DARK, UNDER ULTRAVIOLET LIGHT, WITH LIGHT AND MUSIC SHOWS, AND ALSO FEATURING FASHION SHOWS AND DISC JOCKEY PERFORMANCES; ENTERTAINMENT SERVICES, NAMELY, NON-DOWNLOADABLE MUSIC, ELECTRONIC GAMES, RINGTONES, WALLPAPERS, THEMES, AND MOVIES PRESENTED TO MOBILE MULTIMEDIA AND COMMUNICATIONS DEVICES VIA A GLOBAL COMPUTER NETWORK AND WIRELESS NETWORKS; ENTERTAINMENT IN THE NATURE OF CONDUCTING CONTESTS REGARDING THE CREATION OF PERSONALIZED ELECTRONIC CHARACTERS OR CARICATURES; ONLINE JOURNALS, NAMELY, BLOGS FEATURING CONTENT IN THE FIELD OF CELLULAR OR MOBILE PHONES AND MOBILE MULTIMEDIA AND COMMUNICATIONS DEVICES, AND ACCESSORIES AND APPLICATIONS FOR SUCH PHONES (U.S. CLS. 100, 101 AND 107).

JASON BLAIR, EXAMINING ATTORNEY

SN 77-965,878. SONY ERICSSON MOBILE COMMUNICATIONS AB, LUND, SWEDEN, FILED 3-23-2010.

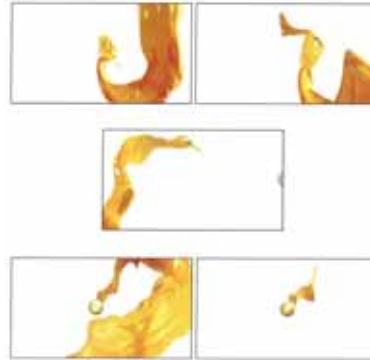

PRIORITY CLAIMED UNDER SEC. 44(D) ON ERPN CMNTY TM OFC APPLICATION NO. 8582504, FILED 9-29-2009, REG. NO. 008582504, DATED 5-6-2011, EXPIRES 9-29-2019.

OWNER OF U.S. REG. NOS. 2,895,153, 3,690,610 AND OTHERS.

THE COLOR(S) ORANGE IS/ARE CLAIMED AS A FEATURE OF THE MARK.

THE MARK IS A MOTION MARK - FIVE FRAMES OF WHICH ARE SHOWN IN THE DRAWING - WHICH RUNS WITHIN A TIME FRAME OF APPROXIMATELY 6 SECONDS. IN THE MARK, A STREAM OF ORANGE-COLORED LIQUID MOVES INTO THE SCREEN FROM THE UPPER RIGHT-HAND CORNER, DOWN THE RIGHT SIDE OF THE SCREEN, CURVES UP TOWARD THE MIDDLE OF THE SCREEN, AND THEN CONTINUES ON TOWARD THE UPPER LEFT-HAND CORNER. ONCE AT THE UPPER LEFT OF THE SCREEN, THE LIQUID THEN CURVES DOWN AND MOVES ALONG THE LEFT SIDE OF THE SCREEN BEFORE CURVING TO THE RIGHT AND MOVING ALONG THE BOTTOM OF THE SCREEN. AT THIS POINT, A SPHERE WITH AN ORANGE-COLORED CENTER APPEARS FROM THE RIGHT-HAND SIDE OF THE FRAME, AND BEGINS TO MOVE LEFT TOWARD THE CENTER OF THE IMAGE. AS THE SPHERE APPEARS, THE LIQUID CURVES UP TOWARD THE UPPER RIGHT-HAND CORNER OF THE SCREEN, BEFORE CURVING SHARPLY BACK TOWARD THE CENTER OF THE SCREEN. THE LIQUID THEN POURS AROUND AND INTO THE SPHERE AT THE CENTER OF THE SCREEN. ONCE THE LIQUID HAS POURED INTO THE SPHERE, THE SPHERE INCREASES IN SIZE, AND MOVES TO THE UPPER-CENTER OF THE SCREEN. THE BLACK, WHITE, AND GRAY IN THE IMAGE ARE NOT CLAIMED AS A FEATURE OF THE MARK, AND ARE MEANT TO REPRESENT BACKGROUND, OUTLINING, SHADING AND/OR TRANSPARENT AREAS ONLY.

CLASS 9—ELECTRICAL AND SCIENTIFIC APPARATUS

FOR CELLULAR OR MOBILE PHONES; CELLULAR OR MOBILE PHONES FEATURING THE CAPACITY TO FUNCTION IN ANY NUMBER OF EXTRA WAYS BEYOND JUST AS A PHONE, NAMELY, TO FUNCTION AS A CAMERA, TO PERFORM INSTANT MESSAGING, TO CONDUCT MULTIMEDIA MESSAGING, TO ACCESS AND COMMUNICATE WITH E-MAIL, TO ACCESS AND COMMUNICATE WITH THE INTERNET, TO ACCESS AND COMMUNICATE DATA, TO FUNCTION AS A RADIO, TO RECORD, PLAY, TRANSMIT, RECEIVE, AND/OR MANAGE MUSIC, TO RECORD, PLAY, TRANSMIT, RECEIVE, EDIT, AND/OR MANAGE AUDIO OR VOICE, TO RECORD, PLAY, TRANSMIT, RECEIVE, EDIT, AND/OR MANAGE VIDEO, TO CREATE, VIEW, TRANSMIT, RECEIVE, EDIT, AND/OR MANAGE PHOTOGRAPHS OR PICTURES, TO UPLOAD, VIEW, TRANSMIT, RECEIVE, EDIT, AND/OR MANAGE GRAPHICS OR IMAGES, TO PLAY ELECTRONIC GAMES, TO UPLOAD PHOTOGRAPHS AND TEXT ONTO ONLINE JOURNALS OR WEB LOGS ALSO KNOWN AS BLOGS, TO MANAGE A CALENDAR AND CONTACT INFORMATION AND OTHERWISE FUNC-

TION AS A PERSONAL DIGITAL ASSISTANT (PDA), TO EFFECTUATE PRINTING, TO PERFORM SATELLITE NAVIGATION, TO VIEW ELECTRONIC CITY GUIDES, TO FUNCTION AS A REMOTE CONTROL FOR COMPUTERS AND RUN MULTIMEDIA PRESENTATIONS, TO TRANSMIT VIDEO, SOUND, AND/OR DATA TO WEBSITES, AND/OR TO OTHERWISE FUNCTION AS A MOBILE MULTIMEDIA AND COMMUNICATIONS APPARATUS FOR RECORDING, TRANSMISSION, PROCESSING, AND REPRODUCTION OF SOUND, IMAGES, OR DATA; DOWNLOADABLE ELECTRONIC MANUALS IN THE FIELD OF CELLULAR OR MOBILE PHONES AND MOBILE MULTIMEDIA AND COMMUNICATIONS DEVICES; PERSONAL COMPUTER CARDS THAT ENABLE COMPUTERS AND LAPTOP COMPUTERS TO GAIN WIRELESS ACCESS TO, AND COMMUNICATE WITH, E-MAIL, THE INTERNET, INTRANETS, OR PRIVATE COMPUTER NETWORKS; COMPUTER APPLICATION SOFTWARE FOR CELLULAR OR MOBILE PHONES AND MOBILE MULTIMEDIA AND COMMUNICATIONS DEVICES; DOWNLOADABLE COMPUTER APPLICATION SOFTWARE FOR CELLULAR OR MOBILE PHONES AND MOBILE MULTIMEDIA AND COMMUNICATIONS DEVICES; DOWNLOADABLE MUSICAL RECORDINGS, ELECTRONIC GAMES, RINGTONES, WALLPAPERS, THEMES, AND MOVIES, ALL DOWNLOADABLE TO COMPUTERS AND CELLULAR OR MOBILE PHONES AND MOBILE MULTIMEDIA AND COMMUNICATIONS DEVICES VIA THE INTERNET; CAMERA DEVICES ADAPTED FOR USE WITH CELLULAR OR MOBILE PHONES AND MOBILE MULTIMEDIA AND COMMUNICATIONS DEVICES; DEVICES THAT ALLOW IMAGES FROM CELLULAR OR MOBILE PHONES AND MOBILE MULTIMEDIA AND COMMUNICATIONS DEVICES TO BE SHOWN ON TELEVISIONS, DISPLAY SCREENS OR COMPUTER MONITORS; DEVICES THAT ALLOW AUDIO FROM CELLULAR OR MOBILE PHONES AND MOBILE MULTIMEDIA AND COMMUNICATIONS DEVICES TO BE HEARD ON STEREO SYSTEMS; AUDIO SPEAKERS FOR LISTENING TO MUSIC OR AUDIO FROM MOBILE OR CELLULAR PHONES AND MOBILE MULTIMEDIA AND COMMUNICATIONS DEVICES; COMBINATION AMPLIFIER AND SPEAKER SYSTEM FOR LISTENING TO MUSIC OR AUDIO FROM MOBILE OR CELLULAR PHONES AND MOBILE MULTIMEDIA AND COMMUNICATIONS DEVICES; RADIO TRANSMITTERS; COMPUTER GAMES FOR USE WITH CELLULAR OR MOBILE PHONES AND MOBILE MULTIMEDIA AND COMMUNICATIONS DEVICES; ACCESSORIES FOR CELLULAR OR MOBILE PHONES AND MOBILE MULTIMEDIA AND COMMUNICATIONS DEVICES IN THE NATURE OF HEADSETS AND DEVICES FOR HANDS-FREE USE SUCH AS EARPHONES AND HEADPHONES; ACCESSORIES FOR CELLULAR OR MOBILE PHONES AND MOBILE MULTIMEDIA AND COMMUNICATIONS DEVICES IN THE NATURE OF CHARGERS, BATTERIES, CASES, COVERS, HOLDERS, DOCKING STANDS, CABLES, POWER PACKS, AND TRIPODS; REMOTE CONTROLS FOR ELECTRONIC COMMUNICATIONS AND TELECOMMUNICATIONS APPARATUS AND INSTRUMENTS; AND DIGITAL PHOTO FRAMES FOR DISPLAYING DIGITAL PICTURES, VIDEO CLIPS AND/OR MUSIC (U.S. CLS. 21, 23, 26, 36 AND 38).

CLASS 38—COMMUNICATION

FOR TELECOMMUNICATIONS SERVICES IN THE NATURE OF TRANSMISSION OF SOUND, PICTURE, IMAGE, VIDEO, AND DATA SIGNALS, SUCH TRANSMISSION ENABLED BY MEANS OF THE INTERNET AND WIRELESS TECHNOLOGY, PROVIDED IN RESPONSE TO COMMANDS FROM COMPUTERS AND CELLULAR OR MOBILE PHONES AND MOBILE MULTIMEDIA AND COMMUNICATIONS DEVICES; TRANSMISSION OF SOUND, PICTURE, IMAGE, VIDEO, AND DATA SIGNALS TO PERSONALIZE OR ENHANCE CELLULAR OR MOBILE PHONES AND MOBILE MULTIMEDIA AND COMMUNICATIONS DEVICES, SUCH TRANSMISSION ENABLED BY MEANS OF THE INTERNET AND WIRELESS TECHNOLOGY, PROVIDED IN RESPONSE TO COMMANDS FROM COMPUTERS AND CELLULAR OR MOBILE PHONES AND MOBILE MULTIMEDIA AND COMMUNICATIONS DEVICES; TELECOMMUNICATIONS SERVICES, NAMELY, PROVIDING A WEBSITE THAT ENABLES TRANSMISSION OF SOUND, PICTURE, GRAPHIC, IMAGE, AND VIDEO SIGNALS TO THE WEBSITE, WHERE THE SIGNALS

MAY BE EDITED AND THEN TRANSMITTED TO COMPUTERS AND CELLULAR OR MOBILE PHONES AND MOBILE MULTIMEDIA AND COMMUNICATIONS DEVICES; PROVIDING INFORMATION ON CALLING PLANS AND SERVICES OF OTHERS IN THE FIELD OF CELLULAR OR MOBILE PHONES AND MOBILE MULTIMEDIA AND COMMUNICATIONS DEVICES; PROVIDING ACCESS VIA THE INTERNET AND CELLULAR OR MOBILE PHONES AND MOBILE MULTIMEDIA AND COMMUNICATIONS DEVICES TO MUSIC, GAMES, RINGTONES, WALLPAPERS, THEMES, AND MOVIES FOR THE PURPOSE OF PLAYING, VIEWING AND/OR DOWNLOADING THE MUSIC, ELECTRONIC GAMES, RINGTONES, WALLPAPERS, THEMES, AND MOVIES; PROVIDING ONLINE FORUMS FOR TRANSMISSION OF MESSAGES AMONG COMPUTER USERS CONCERNING CELLULAR OR MOBILE PHONES AND MOBILE MULTIMEDIA AND COMMUNICATIONS DEVICES, AND ACCESSORIES AND APPLICATIONS FOR SUCH PHONES AND DEVICES; AND PROVIDING LINKS TO WEBSITES OF OTHERS IN THE FIELD OF CELLULAR OR MOBILE PHONES AND MOBILE MULTIMEDIA AND COMMUNICATIONS DEVICES, AND ACCESSORIES AND APPLICATIONS FOR SUCH PHONES AND DEVICES; AND PROVIDING NEWS, INFORMATION, COMMENTARY, AND PHOTOGRAPHIC AND VIDEO CONTENT IN THE FIELD OF CELLULAR OR MOBILE PHONES AND ACCESSORIES AND APPLICATIONS FOR SUCH PHONES (U.S. CLS. 100, 101 AND 104).

CLASS 41—EDUCATION AND ENTERTAINMENT

FOR ENTERTAINMENT IN THE NATURE OF TENNIS TOURNAMENTS; ENTERTAINMENT IN THE NATURE OF SOCCER TOURNAMENTS; ENTERTAINMENT FEATURING EXHIBITION SPORTING EVENTS, SPECIFICALLY, A MODIFIED FORM OF THE GAME OF TENNIS PERFORMED AS A FLOOR SHOW IN NIGHT CLUBS OR VENUES PREPARED IN THE STYLE OF A NIGHT CLUB, SUCH EVENTS BEING PERFORMED IN A WAY THAT INTERPRETS THE GAME OF TENNIS AS A NIGHT CLUB ACTIVITY BY PLAYING THE GAME RAPIDLY, IN THE DARK, UNDER ULTRAVIOLET LIGHT, WITH LIGHT AND MUSIC SHOWS, AND ALSO FEATURING FASHION SHOWS AND DISC JOCKEY PERFORMANCES; ENTERTAINMENT SERVICES, NAMELY, NON-DOWNLOADABLE MUSIC, ELECTRONIC GAMES, RINGTONES, WALLPAPERS, THEMES, AND MOVIES PRESENTED TO MOBILE MULTIMEDIA AND COMMUNICATIONS DEVICES VIA A GLOBAL COMPUTER NETWORK AND WIRELESS NETWORKS; ENTERTAINMENT IN THE NATURE OF CONDUCTING CONTESTS REGARDING THE CREATION OF PERSONALIZED ELECTRONIC CHARACTERS OR CARICATURES; ONLINE JOURNALS, NAMELY, BLOGS FEATURING CONTENT IN THE FIELD OF CELLULAR OR MOBILE PHONES AND MOBILE MULTIMEDIA AND COMMUNICATIONS DEVICES, AND ACCESSORIES AND APPLICATIONS FOR SUCH PHONES (U.S. CLS. 100, 101 AND 107).

JASON BLAIR, EXAMINING ATTORNEY

SN 77-965,941. SONY ERICSSON MOBILE COMMUNICATIONS AB, LUND, SWEDEN, FILED 3-23-2010.

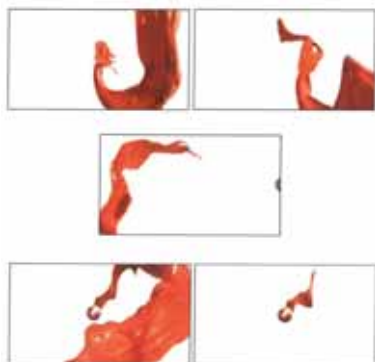

PRIORITY CLAIMED UNDER SEC. 44(D) ON ERP CMNTY TM OFC APPLICATION NO. 8581977, FILED 9-29-2009, REG. NO. 008581977, DATED 3-18-2011, EXPIRES 9-29-2019.

OWNER OF U.S. REG. NOS. 2,895,153, 3,690,610 AND OTHERS.

THE COLOR(S) RED IS/ARE CLAIMED AS A FEATURE OF THE MARK.

THE MARK IS A MOTION MARK - FIVE FRAMES OF WHICH ARE SHOWN IN THE DRAWING - WHICH RUNS WITHIN A TIME FRAME OF APPROXIMATELY 6 SECONDS. IN THE MARK, A STREAM OF RED-COLORED LIQUID MOVES INTO THE SCREEN FROM THE UPPER RIGHT-HAND CORNER, DOWN THE RIGHT SIDE OF THE SCREEN, CURVES UP TOWARD THE MIDDLE OF THE SCREEN, AND THEN CONTINUES ON TOWARD THE UPPER LEFT-HAND CORNER. ONCE AT THE UPPER LEFT OF THE SCREEN, THE LIQUID THEN CURVES DOWN AND MOVES ALONG THE LEFT SIDE OF THE SCREEN BEFORE CURVING TO THE RIGHT AND MOVING ALONG THE BOTTOM OF THE SCREEN. AT THIS POINT, A SPHERE WITH A RED-COLORED CENTER APPEARS FROM THE RIGHT-HAND SIDE OF THE FRAME, AND BEGINS TO MOVE LEFT TOWARD THE CENTER OF THE IMAGE. AS THE SPHERE APPEARS, THE LIQUID CURVES UP TOWARD THE UPPER RIGHT-HAND CORNER OF THE SCREEN, BEFORE CURVING SHARPLY BACK TOWARD THE CENTER OF THE SCREEN. THE LIQUID THEN POURS AROUND AND INTO THE SPHERE AT THE CENTER OF THE SCREEN. ONCE THE LIQUID HAS POURED INTO THE SPHERE, THE SPHERE INCREASES IN SIZE, AND MOVES TO THE UPPER-CENTER OF THE SCREEN. THE BLACK, WHITE, AND GRAY IN THE IMAGE ARE NOT CLAIMED AS A FEATURE OF THE MARK, AND ARE MEANT TO REPRESENT BACKGROUND, OUTLINING, SHADING AND/OR TRANSPARENT AREAS ONLY.

CLASS 9—ELECTRICAL AND SCIENTIFIC APPARATUS

FOR CELLULAR OR MOBILE PHONES; CELLULAR OR MOBILE PHONES FEATURING THE CAPACITY TO FUNCTION IN ANY NUMBER OF EXTRA WAYS BEYOND JUST AS A PHONE, NAMELY, TO FUNCTION AS A CAMERA, TO PERFORM INSTANT MESSAGING, TO CONDUCT MULTIMEDIA MESSAGING, TO ACCESS AND COMMUNICATE WITH E-MAIL, TO ACCESS AND COMMUNICATE WITH THE INTERNET, TO ACCESS AND COMMUNICATE DATA, TO FUNCTION AS A RADIO, TO RECORD, PLAY, TRANSMIT, RECEIVE, AND/OR MANAGE MUSIC, TO RECORD, PLAY, TRANSMIT, RECEIVE, EDIT, AND/OR MANAGE AUDIO OR VOICE, TO RECORD, PLAY, TRANSMIT, RECEIVE, EDIT, AND/OR MANAGE VIDEO, TO CREATE, VIEW, TRANSMIT, RECEIVE, EDIT, AND/OR MANAGE PHOTOGRAPHS OR PICTURES, TO UPLOAD, VIEW, TRANSMIT, RECEIVE, EDIT, AND/OR MANAGE GRAPHICS OR IMAGES, TO PLAY ELECTRONIC GAMES, TO UPLOAD PHOTOGRAPHS AND TEXT ONTO ONLINE JOURNALS OR WEB LOGS ALSO KNOWN AS BLOGS, TO MANAGE A CALENDAR AND CONTACT INFORMATION AND OTHERWISE FUNC-

TION AS A PERSONAL DIGITAL ASSISTANT (PDA), TO EFFECTUATE PRINTING, TO PERFORM SATELLITE NAVIGATION, TO VIEW ELECTRONIC CITY GUIDES, TO FUNCTION AS A REMOTE CONTROL FOR COMPUTERS AND RUN MULTIMEDIA PRESENTATIONS, TO TRANSMIT VIDEO, SOUND, AND/OR DATA TO WEBSITES, AND/OR TO OTHERWISE FUNCTION AS A MOBILE MULTIMEDIA AND COMMUNICATIONS APPARATUS FOR RECORDING, TRANSMISSION, PROCESSING, AND REPRODUCTION OF SOUND, IMAGES, OR DATA; DOWNLOADABLE ELECTRONIC MANUALS IN THE FIELD OF CELLULAR OR MOBILE PHONES AND MOBILE MULTIMEDIA AND COMMUNICATIONS DEVICES; PERSONAL COMPUTER CARDS THAT ENABLE COMPUTERS AND LAPTOP COMPUTERS TO GAIN WIRELESS ACCESS TO, AND COMMUNICATE WITH, E-MAIL, THE INTERNET, INTRANETS, OR PRIVATE COMPUTER NETWORKS; COMPUTER APPLICATION SOFTWARE FOR CELLULAR OR MOBILE PHONES AND MOBILE MULTIMEDIA AND COMMUNICATIONS DEVICES; DOWNLOADABLE COMPUTER APPLICATION SOFTWARE FOR CELLULAR OR MOBILE PHONES AND MOBILE MULTIMEDIA AND COMMUNICATIONS DEVICES; DOWNLOADABLE MUSICAL RECORDINGS, ELECTRONIC GAMES, RINGTONES, WALLPAPERS, THEMES, AND MOVIES, ALL DOWNLOADABLE TO COMPUTERS AND CELLULAR OR MOBILE PHONES AND MOBILE MULTIMEDIA AND COMMUNICATIONS DEVICES VIA THE INTERNET; CAMERA DEVICES ADAPTED FOR USE WITH CELLULAR OR MOBILE PHONES AND MOBILE MULTIMEDIA AND COMMUNICATIONS DEVICES; DEVICES THAT ALLOW IMAGES FROM CELLULAR OR MOBILE PHONES AND MOBILE MULTIMEDIA AND COMMUNICATIONS DEVICES TO BE SHOWN ON TELEVISIONS, DISPLAY SCREENS OR COMPUTER MONITORS; DEVICES THAT ALLOW AUDIO FROM CELLULAR OR MOBILE PHONES AND MOBILE MULTIMEDIA AND COMMUNICATIONS DEVICES TO BE HEARD ON STEREO SYSTEMS; AUDIO SPEAKERS FOR LISTENING TO MUSIC OR AUDIO FROM MOBILE OR CELLULAR PHONES AND MOBILE MULTIMEDIA AND COMMUNICATIONS DEVICES; COMBINATION AMPLIFIER AND SPEAKER SYSTEM FOR LISTENING TO MUSIC OR AUDIO FROM MOBILE OR CELLULAR PHONES AND MOBILE MULTIMEDIA AND COMMUNICATIONS DEVICES; ACCESSORIES FOR CELLULAR OR MOBILE PHONES AND MOBILE MULTIMEDIA AND COMMUNICATIONS DEVICES IN THE NATURE OF HEADSETS AND DEVICES FOR HANDSFREE USE SUCH AS EARPHONES AND HEADPHONES; ACCESSORIES FOR CELLULAR OR MOBILE PHONES AND MOBILE MULTIMEDIA AND COMMUNICATIONS DEVICES IN THE NATURE OF CHARGERS, BATTERIES, CASES, COVERS, HOLDERS, DOCKING STANDS, CABLES, POWER PACKS, AND TRIPODS; REMOTE CONTROLS FOR ELECTRONIC COMMUNICATIONS AND TELECOMMUNICATIONS APPARATUS AND INSTRUMENTS; AND DIGITAL PHOTO FRAMES FOR DISPLAYING DIGITAL PICTURES, VIDEO CLIPS AND/OR MUSIC (U.S. CLS. 21, 23, 26, 36 AND 38).

CLASS 38—COMMUNICATION

FOR TELECOMMUNICATIONS SERVICES IN THE NATURE OF TRANSMISSION OF SOUND, PICTURE, IMAGE, VIDEO, AND DATA SIGNALS, SUCH TRANSMISSION ENABLED BY MEANS OF THE INTERNET AND WIRELESS TECHNOLOGY, PROVIDED IN RESPONSE TO COMMANDS FROM COMPUTERS AND CELLULAR OR MOBILE PHONES AND MOBILE MULTIMEDIA AND COMMUNICATIONS DEVICES; TRANSMISSION OF SOUND, PICTURE, IMAGE, VIDEO, AND DATA SIGNALS TO PERSONALIZE OR ENHANCE CELLULAR OR MOBILE PHONES AND MOBILE MULTIMEDIA AND COMMUNICATIONS DEVICES, SUCH TRANSMISSION ENABLED BY MEANS OF THE INTERNET AND WIRELESS TECHNOLOGY, PROVIDED IN RESPONSE TO COMMANDS FROM COMPUTERS AND CELLULAR OR MOBILE PHONES AND MOBILE MULTIMEDIA AND COMMUNICATIONS DEVICES; TELECOMMUNICATIONS SERVICES, NAMELY, PROVIDING A WEBSITE THAT ENABLES TRANSMISSION OF SOUND, PICTURE, GRAPHIC, IMAGE, AND VIDEO SIGNALS TO THE WEBSITE, WHERE THE SIGNALS

MAY BE EDITED AND THEN TRANSMITTED TO COMPUTERS AND CELLULAR OR MOBILE PHONES AND MOBILE MULTIMEDIA AND COMMUNICATIONS DEVICES; PROVIDING INFORMATION ON CALLING PLANS AND SERVICES OF OTHERS IN THE FIELD OF CELLULAR OR MOBILE PHONES AND MOBILE MULTIMEDIA AND COMMUNICATIONS DEVICES; PROVIDING ACCESS VIA THE INTERNET AND CELLULAR OR MOBILE PHONES AND MOBILE MULTIMEDIA AND COMMUNICATIONS DEVICES TO MUSIC, GAMES, RINGTONES, WALLPAPERS, THEMES, AND MOVIES FOR THE PURPOSE OF PLAYING, VIEWING AND/OR DOWNLOADING THE MUSIC, ELECTRONIC GAMES, RINGTONES, WALLPAPERS, THEMES, AND MOVIES; PROVIDING ONLINE FORUMS FOR TRANSMISSION OF MESSAGES AMONG COMPUTER USERS CONCERNING CELLULAR OR MOBILE PHONES AND MOBILE MULTIMEDIA AND COMMUNICATIONS DEVICES, AND ACCESSORIES AND APPLICATIONS FOR SUCH PHONES AND DEVICES; AND PROVIDING LINKS TO WEBSITES OF OTHERS IN THE FIELD OF CELLULAR OR MOBILE PHONES AND MOBILE MULTIMEDIA AND COMMUNICATIONS DEVICES, AND ACCESSORIES AND APPLICATIONS FOR SUCH PHONES AND DEVICES; AND PROVIDING NEWS, INFORMATION, COMMENTARY, AND PHOTOGRAPHIC AND VIDEO CONTENT IN THE FIELD OF CELLULAR OR MOBILE PHONES AND ACCESSORIES AND APPLICATIONS FOR SUCH PHONES (U.S. CLS. 100, 101 AND 104).

SN 77-966,023. SONY ERICSSON MOBILE COMMUNICATIONS AB, LUND, SWEDEN, FILED 3-23-2010.

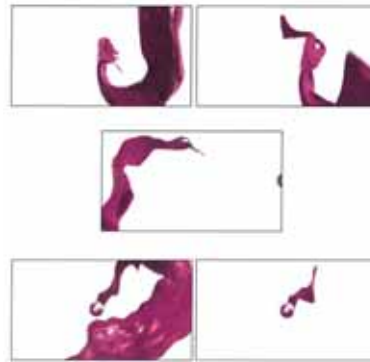

PRIORITY CLAIMED UNDER SEC. 44(D) ON ERPNTY TM OFC APPLICATION NO. 8582389, FILED 9-29-2009, REG. NO. 008582389, DATED 5-6-2011, EXPIRES 9-29-2019.

OWNER OF U.S. REG. NOS. 2,895,153, 3,690,610 AND OTHERS.

THE COLOR(S) PURPLE IS/ARE CLAIMED AS A FEATURE OF THE MARK.

THE MARK IS A MOTION MARK - FIVE FRAMES OF WHICH ARE SHOWN IN THE DRAWING - WHICH RUNS WITHIN A TIME FRAME OF APPROXIMATELY 6 SECONDS. IN THE MARK, A STREAM OF PURPLE-COLORED LIQUID MOVES INTO THE SCREEN FROM THE UPPER RIGHT-HAND CORNER, DOWN THE RIGHT SIDE OF THE SCREEN, CURVES UP TOWARD THE MIDDLE OF THE SCREEN, AND THEN CONTINUES ON TOWARD THE UPPER LEFT-HAND CORNER. ONCE AT THE UPPER LEFT OF THE SCREEN, THE LIQUID THEN CURVES DOWN AND MOVES ALONG THE LEFT SIDE OF THE SCREEN BEFORE CURVING TO THE RIGHT AND MOVING ALONG THE BOTTOM OF THE SCREEN. AT THIS POINT, A SPHERE WITH A PURPLE-COLORED CENTER APPEARS FROM THE RIGHT-HAND SIDE OF THE FRAME, AND BEGINS TO MOVE LEFT TOWARD THE CENTER OF THE IMAGE. AS THE SPHERE APPEARS, THE LIQUID CURVES UP TOWARD THE UPPER RIGHT-HAND CORNER OF THE SCREEN, BEFORE CURVING SHARPLY BACK TOWARD THE CENTER OF THE SCREEN. THE LIQUID THEN POURS AROUND AND INTO THE SPHERE AT THE CENTER OF THE SCREEN. ONCE THE LIQUID HAS Poured INTO THE SPHERE, THE SPHERE INCREASES IN SIZE, AND MOVES TO THE UPPER-CENTER OF THE SCREEN. THE BLACK, WHITE, AND GRAY IN THE IMAGE ARE NOT CLAIMED AS A FEATURE OF THE MARK, AND ARE MEANT TO REPRESENT BACKGROUND, OUTLINING, SHADING AND/OR TRANSPARENT AREAS ONLY.

CLASS 41—EDUCATION AND ENTERTAINMENT

FOR ENTERTAINMENT IN THE NATURE OF TENNIS TOURNAMENTS; ENTERTAINMENT IN THE NATURE OF SOCCER TOURNAMENTS; ENTERTAINMENT FEATURING EXHIBITION SPORTING EVENTS, SPECIFICALLY, A MODIFIED FORM OF THE GAME OF TENNIS PERFORMED AS A FLOOR SHOW IN NIGHT CLUBS OR VENUES PREPARED IN THE STYLE OF A NIGHT CLUB, SUCH EVENTS BEING PERFORMED IN A WAY THAT INTERPRETS THE GAME OF TENNIS AS A NIGHT CLUB ACTIVITY BY PLAYING THE GAME RAPIDLY, IN THE DARK, UNDER ULTRAVIOLET LIGHT, WITH LIGHT AND MUSIC SHOWS, AND ALSO FEATURING FASHION SHOWS AND DISC JOCKEY PERFORMANCES; ENTERTAINMENT SERVICES, NAMELY, NON-DOWNLOADABLE MUSIC, ELECTRONIC GAMES, RINGTONES, WALLPAPERS, THEMES, AND MOVIES PRESENTED TO MOBILE MULTIMEDIA AND COMMUNICATIONS DEVICES VIA A GLOBAL COMPUTER NETWORK AND WIRELESS NETWORKS; ENTERTAINMENT IN THE NATURE OF CONDUCTING CONTESTS REGARDING THE CREATION OF PERSONALIZED ELECTRONIC CHARACTERS OR CARICATURES; ONLINE JOURNALS, NAMELY, BLOGS FEATURING CONTENT IN THE FIELD OF CELLULAR OR MOBILE PHONES AND MOBILE MULTIMEDIA AND COMMUNICATIONS DEVICES, AND ACCESSORIES AND APPLICATIONS FOR SUCH PHONES (U.S. CLS. 100, 101 AND 107).

JASON BLAIR, EXAMINING ATTORNEY

CLASS 9—ELECTRICAL AND SCIENTIFIC APPARATUS

FOR CELLULAR OR MOBILE PHONES; CELLULAR OR MOBILE PHONES FEATURING THE CAPACITY TO FUNCTION IN ANY NUMBER OF EXTRA WAYS BEYOND JUST AS A PHONE, NAMELY, TO FUNCTION AS A CAMERA, TO PERFORM INSTANT MESSAGING, TO CONDUCT MULTIMEDIA MESSAGING, TO ACCESS AND COMMUNICATE WITH E-MAIL, TO ACCESS AND COMMUNICATE WITH THE INTERNET, TO ACCESS AND COMMUNICATE DATA, TO FUNCTION AS A RADIO, TO RECORD, PLAY, TRANSMIT, RECEIVE, AND/OR MANAGE MUSIC, TO RECORD, PLAY, TRANSMIT, RECEIVE, EDIT, AND/OR MANAGE AUDIO OR VOICE, TO RECORD, PLAY, TRANSMIT, RECEIVE, EDIT, AND/OR MANAGE VIDEO, TO CREATE, VIEW, TRANSMIT, RECEIVE, EDIT, AND/OR MANAGE PHOTOGRAPHS OR PICTURES, TO UPLOAD, VIEW, TRANSMIT, RECEIVE, EDIT, AND/OR MANAGE GRAPHICS OR IMAGES, TO PLAY ELECTRONIC GAMES, TO UPLOAD PHOTOGRAPHS AND TEXT ONTO ONLINE JOURNALS OR WEB LOGS ALSO KNOWN AS BLOGS, TO MANAGE A CALENDAR AND CONTACT INFORMATION AND OTHERWISE FUNC-

TION AS A PERSONAL DIGITAL ASSISTANT (PDA), TO EFFECTUATE PRINTING, TO PERFORM SATELLITE NAVIGATION, TO VIEW ELECTRONIC CITY GUIDES, TO FUNCTION AS A REMOTE CONTROL FOR COMPUTERS AND RUN MULTIMEDIA PRESENTATIONS, TO TRANSMIT VIDEO, SOUND, AND/OR DATA TO WEBSITES, AND/OR TO OTHERWISE FUNCTION AS A MOBILE MULTIMEDIA AND COMMUNICATIONS APPARATUS FOR RECORDING, TRANSMISSION, PROCESSING, AND REPRODUCTION OF SOUND, IMAGES, OR DATA; DOWNLOADABLE ELECTRONIC MANUALS IN THE FIELD OF CELLULAR OR MOBILE PHONES AND MOBILE MULTIMEDIA AND COMMUNICATIONS DEVICES; PERSONAL COMPUTER CARDS THAT ENABLE COMPUTERS AND LAPTOP COMPUTERS TO GAIN WIRELESS ACCESS TO, AND COMMUNICATE WITH, E-MAIL, THE INTERNET, INTRANETS, OR PRIVATE COMPUTER NETWORKS; COMPUTER APPLICATION SOFTWARE FOR CELLULAR OR MOBILE PHONES AND MOBILE MULTIMEDIA AND COMMUNICATIONS DEVICES; DOWNLOADABLE COMPUTER APPLICATION SOFTWARE FOR CELLULAR OR MOBILE PHONES AND MOBILE MULTIMEDIA AND COMMUNICATIONS DEVICES; DOWNLOADABLE MUSICAL RECORDINGS, ELECTRONIC GAMES, RINGTONES, WALLPAPERS, THEMES, AND MOVIES, ALL DOWNLOADABLE TO COMPUTERS AND CELLULAR OR MOBILE PHONES AND MOBILE MULTIMEDIA AND COMMUNICATIONS DEVICES VIA THE INTERNET; CAMERA DEVICES ADAPTED FOR USE WITH CELLULAR OR MOBILE PHONES AND MOBILE MULTIMEDIA AND COMMUNICATIONS DEVICES; DEVICES THAT ALLOW IMAGES FROM CELLULAR OR MOBILE PHONES AND MOBILE MULTIMEDIA AND COMMUNICATIONS DEVICES TO BE SHOWN ON TELEVISIONS, DISPLAY SCREENS OR COMPUTER MONITORS; DEVICES THAT ALLOW AUDIO FROM CELLULAR OR MOBILE PHONES AND MOBILE MULTIMEDIA AND COMMUNICATIONS DEVICES TO BE HEARD ON STEREO SYSTEMS; AUDIO SPEAKERS FOR LISTENING TO MUSIC OR AUDIO FROM MOBILE OR CELLULAR PHONES AND MOBILE MULTIMEDIA AND COMMUNICATIONS DEVICES; COMBINATION AMPLIFIER AND SPEAKER SYSTEM FOR LISTENING TO MUSIC OR AUDIO FROM MOBILE OR CELLULAR PHONES AND MOBILE MULTIMEDIA AND COMMUNICATIONS DEVICES; RADIO TRANSMITTERS; COMPUTER GAMES FOR USE WITH CELLULAR OR MOBILE PHONES AND MOBILE MULTIMEDIA AND COMMUNICATIONS DEVICES; ACCESSORIES FOR CELLULAR OR MOBILE PHONES AND MOBILE MULTIMEDIA AND COMMUNICATIONS DEVICES IN THE NATURE OF HEADSETS AND DEVICES FOR HANDS-FREE USE SUCH AS EARPHONES AND HEADPHONES; ACCESSORIES FOR CELLULAR OR MOBILE PHONES AND MOBILE MULTIMEDIA AND COMMUNICATIONS DEVICES IN THE NATURE OF CHARGERS, BATTERIES, CASES, COVERS, HOLDERS, DOCKING STANDS, CABLES, POWER PACKS, AND TRIPODS; REMOTE CONTROLS FOR ELECTRONIC COMMUNICATIONS AND TELECOMMUNICATIONS APPARATUS AND INSTRUMENTS; AND DIGITAL PHOTO FRAMES FOR DISPLAYING DIGITAL PICTURES, VIDEO CLIPS AND/OR MUSIC (U.S. CLS. 21, 23, 26, 36 AND 38).

CLASS 38—COMMUNICATION

FOR TELECOMMUNICATIONS SERVICES IN THE NATURE OF TRANSMISSION OF SOUND, PICTURE, IMAGE, VIDEO, AND DATA SIGNALS, SUCH TRANSMISSION ENABLED BY MEANS OF THE INTERNET AND WIRELESS TECHNOLOGY, PROVIDED IN RESPONSE TO COMMANDS FROM COMPUTERS AND CELLULAR OR MOBILE PHONES AND MOBILE MULTIMEDIA AND COMMUNICATIONS DEVICES; TRANSMISSION OF SOUND, PICTURE, IMAGE, VIDEO, AND DATA SIGNALS TO PERSONALIZE OR ENHANCE CELLULAR OR MOBILE PHONES AND MOBILE MULTIMEDIA AND COMMUNICATIONS DEVICES, SUCH TRANSMISSION ENABLED BY MEANS OF THE INTERNET AND WIRELESS TECHNOLOGY, PROVIDED IN RESPONSE TO COMMANDS FROM COMPUTERS AND CELLULAR OR MOBILE PHONES AND MOBILE MULTIMEDIA AND COMMUNICATIONS DEVICES; TELECOMMUNICATIONS SERVICES, NAMELY, PROVIDING A WEBSITE THAT ENABLES TRANSMISSION OF SOUND, PICTURE, GRAPHIC, IMAGE, AND VIDEO SIGNALS TO THE WEBSITE, WHERE THE SIGNALS

MAY BE EDITED AND THEN TRANSMITTED TO COMPUTERS AND CELLULAR OR MOBILE PHONES AND MOBILE MULTIMEDIA AND COMMUNICATIONS DEVICES; PROVIDING INFORMATION ON CALLING PLANS AND SERVICES OF OTHERS IN THE FIELD OF CELLULAR OR MOBILE PHONES AND MOBILE MULTIMEDIA AND COMMUNICATIONS DEVICES; PROVIDING ACCESS VIA THE INTERNET AND CELLULAR OR MOBILE PHONES AND MOBILE MULTIMEDIA AND COMMUNICATIONS DEVICES TO MUSIC, GAMES, RINGTONES, WALLPAPERS, THEMES, AND MOVIES FOR THE PURPOSE OF PLAYING, VIEWING AND/OR DOWNLOADING THE MUSIC, ELECTRONIC GAMES, RINGTONES, WALLPAPERS, THEMES, AND MOVIES; PROVIDING ONLINE FORUMS FOR TRANSMISSION OF MESSAGES AMONG COMPUTER USERS CONCERNING CELLULAR OR MOBILE PHONES AND MOBILE MULTIMEDIA AND COMMUNICATIONS DEVICES, AND ACCESSORIES AND APPLICATIONS FOR SUCH PHONES AND DEVICES; AND PROVIDING LINKS TO WEBSITES OF OTHERS IN THE FIELD OF CELLULAR OR MOBILE PHONES AND MOBILE MULTIMEDIA AND COMMUNICATIONS DEVICES, AND ACCESSORIES AND APPLICATIONS FOR SUCH PHONES AND DEVICES; AND PROVIDING NEWS, INFORMATION, COMMENTARY, AND PHOTOGRAPHIC AND VIDEO CONTENT IN THE FIELD OF CELLULAR OR MOBILE PHONES AND ACCESSORIES AND APPLICATIONS FOR SUCH PHONES (U.S. CLS. 100, 101 AND 104).

CLASS 41—EDUCATION AND ENTERTAINMENT

FOR ENTERTAINMENT IN THE NATURE OF TENNIS TOURNAMENTS; ENTERTAINMENT IN THE NATURE OF SOCCER TOURNAMENTS; ENTERTAINMENT FEATURING EXHIBITION SPORTING EVENTS, SPECIFICALLY, A MODIFIED FORM OF THE GAME OF TENNIS PERFORMED AS A FLOOR SHOW IN NIGHT CLUBS OR VENUES PREPARED IN THE STYLE OF A NIGHT CLUB, SUCH EVENTS BEING PERFORMED IN A WAY THAT INTERPRETS THE GAME OF TENNIS AS A NIGHT CLUB ACTIVITY BY PLAYING THE GAME RAPIDLY, IN THE DARK, UNDER ULTRAVIOLET LIGHT, WITH LIGHT AND MUSIC SHOWS, AND ALSO FEATURING FASHION SHOWS AND DISC JOCKEY PERFORMANCES; ENTERTAINMENT SERVICES, NAMELY, NON-DOWNLOADABLE MUSIC, ELECTRONIC GAMES, RINGTONES, WALLPAPERS, THEMES, AND MOVIES PRESENTED TO MOBILE MULTIMEDIA AND COMMUNICATIONS DEVICES VIA A GLOBAL COMPUTER NETWORK AND WIRELESS NETWORKS; ENTERTAINMENT IN THE NATURE OF CONDUCTING CONTESTS REGARDING THE CREATION OF PERSONALIZED ELECTRONIC CHARACTERS OR CARICATURES; ONLINE JOURNALS, NAMELY, BLOGS FEATURING CONTENT IN THE FIELD OF CELLULAR OR MOBILE PHONES AND MOBILE MULTIMEDIA AND COMMUNICATIONS DEVICES, AND ACCESSORIES AND APPLICATIONS FOR SUCH PHONES (U.S. CLS. 100, 101 AND 107).

JASON BLAIR, EXAMINING ATTORNEY

SN 77-966,038. SONY ERICSSON MOBILE COMMUNICATIONS AB, LUND, SWEDEN, FILED 3-23-2010.

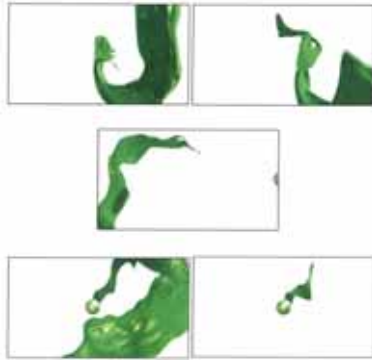

PRIORITY CLAIMED UNDER SEC. 44(D) ON ERP NCNTY TM OFC APPLICATION NO. 8582538, FILED 9-29-2009, REG. NO. 008582538, DATED 5-6-2011, EXPIRES 9-29-2019.

OWNER OF U.S. REG. NOS. 2,895,153, 3,690,610 AND OTHERS.

THE COLOR(S) LIME GREEN IS/ARE CLAIMED AS A FEATURE OF THE MARK.

THE MARK IS A MOTION MARK - FIVE FRAMES OF WHICH ARE SHOWN IN THE DRAWING - WHICH RUNS WITHIN A TIME FRAME OF APPROXIMATELY 6 SECONDS. IN THE MARK, A STREAM OF LIME GREEN-COLORED LIQUID MOVES INTO THE SCREEN FROM THE UPPER RIGHT-HAND CORNER, DOWN THE RIGHT SIDE OF THE SCREEN, CURVES UP TOWARD THE MIDDLE OF THE SCREEN, AND THEN CONTINUES ON TOWARD THE UPPER LEFT-HAND CORNER. ONCE AT THE UPPER LEFT OF THE SCREEN, THE LIQUID THEN CURVES DOWN AND MOVES ALONG THE LEFT SIDE OF THE SCREEN BEFORE CURVING TO THE RIGHT AND MOVING ALONG THE BOTTOM OF THE SCREEN. AT THIS POINT, A SPHERE WITH A LIME GREEN-COLORED CENTER APPEARS FROM THE RIGHT-HAND SIDE OF THE FRAME, AND BEGINS TO MOVE LEFT TOWARD THE CENTER OF THE IMAGE. AS THE SPHERE APPEARS, THE LIQUID CURVES UP TOWARD THE UPPER RIGHT-HAND CORNER OF THE SCREEN, BEFORE CURVING SHARPLY BACK TOWARD THE CENTER OF THE SCREEN. THE LIQUID THEN POURS AROUND AND INTO THE SPHERE AT THE CENTER OF THE SCREEN. ONCE THE LIQUID HAS POURED INTO THE SPHERE, THE SPHERE INCREASES IN SIZE, AND MOVES TO THE UPPER-CENTER OF THE SCREEN. THE BLACK, WHITE, AND GRAY IN THE IMAGE ARE NOT CLAIMED AS A FEATURE OF THE MARK, AND ARE MEANT TO REPRESENT BACKGROUND, OUTLINING, SHADING AND/OR TRANSPARENT AREAS ONLY.

CLASS 9—ELECTRICAL AND SCIENTIFIC APPARATUS

FOR CELLULAR OR MOBILE PHONES; CELLULAR OR MOBILE PHONES FEATURING THE CAPACITY TO FUNCTION IN ANY NUMBER OF EXTRA WAYS BEYOND JUST AS A PHONE, NAMELY, TO FUNCTION AS A CAMERA, TO PERFORM INSTANT MESSAGING, TO CONDUCT MULTIMEDIA MESSAGING, TO ACCESS AND COMMUNICATE WITH E-MAIL, TO ACCESS AND COMMUNICATE WITH THE INTERNET, TO ACCESS AND COMMUNICATE DATA, TO FUNCTION AS A RADIO, TO RECORD, PLAY, TRANSMIT, RECEIVE, AND/OR MANAGE MUSIC, TO RECORD, PLAY, TRANSMIT, RECEIVE, EDIT, AND/OR MANAGE AUDIO OR VOICE, TO RECORD, PLAY, TRANSMIT, RECEIVE, EDIT, AND/OR MANAGE VIDEO, TO CREATE, VIEW, TRANSMIT, RECEIVE, EDIT, AND/OR MANAGE PHOTOGRAPHS OR PICTURES, TO UPLOAD, VIEW, TRANSMIT, RECEIVE, EDIT, AND/OR MANAGE GRAPHICS OR IMAGES, TO PLAY ELECTRONIC GAMES, TO UPLOAD PHOTOGRAPHS AND TEXT ONTO ONLINE JOURNALS OR WEB LOGS ALSO KNOWN AS BLOGS, TO MANAGE A CALENDAR AND CONTACT INFORMATION AND OTHERWISE FUNC-

TION AS A PERSONAL DIGITAL ASSISTANT (PDA), TO EFFECTUATE PRINTING, TO PERFORM SATELLITE NAVIGATION, TO VIEW ELECTRONIC CITY GUIDES, TO FUNCTION AS A REMOTE CONTROL FOR COMPUTERS AND RUN MULTIMEDIA PRESENTATIONS, TO TRANSMIT VIDEO, SOUND, AND/OR DATA TO WEBSITES, AND/OR TO OTHERWISE FUNCTION AS A MOBILE MULTIMEDIA AND COMMUNICATIONS APPARATUS FOR RECORDING, TRANSMISSION, PROCESSING, AND REPRODUCTION OF SOUND, IMAGES, OR DATA; DOWNLOADABLE ELECTRONIC MANUALS IN THE FIELD OF CELLULAR OR MOBILE PHONES AND MOBILE MULTIMEDIA AND COMMUNICATIONS DEVICES; PERSONAL COMPUTER CARDS THAT ENABLE COMPUTERS AND LAPTOP COMPUTERS TO GAIN WIRELESS ACCESS TO, AND COMMUNICATE WITH, E-MAIL, THE INTERNET, INTRANETS, OR PRIVATE COMPUTER NETWORKS; COMPUTER APPLICATION SOFTWARE FOR CELLULAR OR MOBILE PHONES AND MOBILE MULTIMEDIA AND COMMUNICATIONS DEVICES; DOWNLOADABLE COMPUTER APPLICATION SOFTWARE FOR CELLULAR OR MOBILE PHONES AND MOBILE MULTIMEDIA AND COMMUNICATIONS DEVICES; DOWNLOADABLE MUSICAL RECORDINGS, ELECTRONIC GAMES, RINGTONES, WALLPAPERS, THEMES, AND MOVIES, ALL DOWNLOADABLE TO COMPUTERS AND CELLULAR OR MOBILE PHONES AND MOBILE MULTIMEDIA AND COMMUNICATIONS DEVICES VIA THE INTERNET; CAMERA DEVICES ADAPTED FOR USE WITH CELLULAR OR MOBILE PHONES AND MOBILE MULTIMEDIA AND COMMUNICATIONS DEVICES; DEVICES THAT ALLOW IMAGES FROM CELLULAR OR MOBILE PHONES AND MOBILE MULTIMEDIA AND COMMUNICATIONS DEVICES TO BE SHOWN ON TELEVISIONS, DISPLAY SCREENS OR COMPUTER MONITORS; DEVICES THAT ALLOW AUDIO FROM CELLULAR OR MOBILE PHONES AND MOBILE MULTIMEDIA AND COMMUNICATIONS DEVICES TO BE HEARD ON STEREO SYSTEMS; AUDIO SPEAKERS FOR LISTENING TO MUSIC OR AUDIO FROM MOBILE OR CELLULAR PHONES AND MOBILE MULTIMEDIA AND COMMUNICATIONS DEVICES; COMBINATION AMPLIFIER AND SPEAKER SYSTEM FOR LISTENING TO MUSIC OR AUDIO FROM MOBILE OR CELLULAR PHONES AND MOBILE MULTIMEDIA AND COMMUNICATIONS DEVICES; ACCESSORIES FOR CELLULAR OR MOBILE PHONES AND MOBILE MULTIMEDIA AND COMMUNICATIONS DEVICES IN THE NATURE OF HEADSETS AND DEVICES FOR HANDSFREE USE SUCH AS EARPHONES AND HEADPHONES; ACCESSORIES FOR CELLULAR OR MOBILE PHONES AND MOBILE MULTIMEDIA AND COMMUNICATIONS DEVICES IN THE NATURE OF CHARGERS, BATTERIES, CASES, COVERS, HOLDERS, DOCKING STANDS, CABLES, POWER PACKS, AND TRIPODS; REMOTE CONTROLS FOR ELECTRONIC COMMUNICATIONS AND TELECOMMUNICATIONS APPARATUS AND INSTRUMENTS; AND DIGITAL PHOTO FRAMES FOR DISPLAYING DIGITAL PICTURES, VIDEO CLIPS AND/OR MUSIC (U.S. CLS. 21, 23, 26, 36 AND 38).

CLASS 38—COMMUNICATION

FOR TELECOMMUNICATIONS SERVICES IN THE NATURE OF TRANSMISSION OF SOUND, PICTURE, IMAGE, VIDEO, AND DATA SIGNALS, SUCH TRANSMISSION ENABLED BY MEANS OF THE INTERNET AND WIRELESS TECHNOLOGY, PROVIDED IN RESPONSE TO COMMANDS FROM COMPUTERS AND CELLULAR OR MOBILE PHONES AND MOBILE MULTIMEDIA AND COMMUNICATIONS DEVICES; TRANSMISSION OF SOUND, PICTURE, IMAGE, VIDEO, AND DATA SIGNALS TO PERSONALIZE OR ENHANCE CELLULAR OR MOBILE PHONES AND MOBILE MULTIMEDIA AND COMMUNICATIONS DEVICES, SUCH TRANSMISSION ENABLED BY MEANS OF THE INTERNET AND WIRELESS TECHNOLOGY, PROVIDED IN RESPONSE TO COMMANDS FROM COMPUTERS AND CELLULAR OR MOBILE PHONES AND MOBILE MULTIMEDIA AND COMMUNICATIONS DEVICES; TELECOMMUNICATIONS SERVICES, NAMELY, PROVIDING A WEBSITE THAT ENABLES TRANSMISSION OF SOUND, PICTURE, GRAPHIC, IMAGE, AND VIDEO SIGNALS TO THE WEBSITE, WHERE THE SIGNALS

MAY BE EDITED AND THEN TRANSMITTED TO COMPUTERS AND CELLULAR OR MOBILE PHONES AND MOBILE MULTIMEDIA AND COMMUNICATIONS DEVICES; PROVIDING INFORMATION ON CALLING PLANS AND SERVICES OF OTHERS IN THE FIELD OF CELLULAR OR MOBILE PHONES AND MOBILE MULTIMEDIA AND COMMUNICATIONS DEVICES; PROVIDING ACCESS VIA THE INTERNET AND CELLULAR OR MOBILE PHONES AND MOBILE MULTIMEDIA AND COMMUNICATIONS DEVICES TO MUSIC, GAMES, RINGTONES, WALLPAPERS, THEMES, AND MOVIES FOR THE PURPOSE OF PLAYING, VIEWING AND/OR DOWNLOADING THE MUSIC, ELECTRONIC GAMES, RINGTONES, WALLPAPERS, THEMES, AND MOVIES; PROVIDING ONLINE FORUMS FOR TRANSMISSION OF MESSAGES AMONG COMPUTER USERS CONCERNING CELLULAR OR MOBILE PHONES AND MOBILE MULTIMEDIA AND COMMUNICATIONS DEVICES; AND ACCESSORIES AND APPLICATIONS FOR SUCH PHONES AND DEVICES; AND PROVIDING NEWS, INFORMATION, COMMENTARY, AND PHOTOGRAPHIC AND VIDEO CONTENT IN THE FIELD OF CELLULAR OR MOBILE PHONES AND ACCESSORIES AND APPLICATIONS FOR SUCH PHONES (U.S. CLS. 100, 101 AND 104).

CLASS 41—EDUCATION AND ENTERTAINMENT

FOR ENTERTAINMENT IN THE NATURE OF TENNIS TOURNAMENTS; ENTERTAINMENT IN THE NATURE OF SOCCER TOURNAMENTS; ENTERTAINMENT FEATURING EXHIBITION SPORTING EVENTS, SPECIFICALLY, A MODIFIED FORM OF THE GAME OF TENNIS PERFORMED AS A FLOOR SHOW IN NIGHT CLUBS OR VENUES PREPARED IN THE STYLE OF A NIGHT CLUB, SUCH EVENTS BEING PERFORMED IN A WAY THAT INTERPRETS THE GAME OF TENNIS AS A NIGHT CLUB ACTIVITY BY PLAYING THE GAME RAPIDLY, IN THE DARK, UNDER ULTRAVIOLET LIGHT, WITH LIGHT AND MUSIC SHOWS, AND ALSO FEATURING FASHION SHOWS AND DISC JOCKEY PERFORMANCES; ENTERTAINMENT SERVICES, NAMELY, NON-DOWNLOADABLE MUSIC, ELECTRONIC GAMES, RINGTONES, WALLPAPERS, THEMES, AND MOVIES PRESENTED TO MOBILE MULTIMEDIA AND COMMUNICATIONS DEVICES VIA A GLOBAL COMPUTER NETWORK AND WIRELESS NETWORKS; ENTERTAINMENT IN THE NATURE OF CONDUCTING CONTESTS REGARDING THE CREATION OF PERSONALIZED ELECTRONIC CHARACTERS OR CARICATURES; ONLINE JOURNALS, NAMELY, BLOGS FEATURING CONTENT IN THE FIELD OF CELLULAR OR MOBILE PHONES AND MOBILE MULTIMEDIA AND COMMUNICATIONS DEVICES, AND ACCESSORIES AND APPLICATIONS FOR SUCH PHONES (U.S. CLS. 100, 101 AND 107).

JASON BLAIR, EXAMINING ATTORNEY

SN 77-968,037, CLOCKWORK IP, LLC, SARASOTA, FL.
FILED 3-25-2010.



OWNER OF U.S. REG. NOS. 2,647,104, 2,762,676 AND 3,544,214.

NO CLAIM IS MADE TO THE EXCLUSIVE RIGHT TO USE "ALLIANCE", APART FROM THE MARK AS SHOWN.

THE MARK CONSISTS OF THE IMAGE OF A BULLDOG HEAD WEARING A HAT WITHIN A CIRCLE AND OVERLAYING ON THE TOP OF THE WORD "BUYMAX", BETWEEN THE "Y" AND THE "M", ALSO APPEARING WITHIN TWO PARALLEL LINES, WITH THE WORD "ALLIANCE" WRITTEN BELOW, WITHIN A GEOMETRIC SHAPE WHICH APPEARS TO BE A METAL PLATE FASTENED BY A SCREW ON EITHER END.

CLASS 35—ADVERTISING AND BUSINESS

FOR BUYING CLUBS AND ON-LINE BUYING CLUBS; PROMOTING THE GOODS AND SERVICES OF OTHERS BY MEANS OF A LOYALTY REWARDS PROGRAM; AND ADVERTISING, MARKETING AND PROMOTIONAL SERVICES RELATED TO RESIDENTIAL CONTRACTORS FOR THE PURPOSE OF FACILITATING NETWORKING OPPORTUNITIES FOR BUSINESS PURPOSES (U.S. CLS. 100, 101 AND 102).

FIRST USE 10-14-2008; IN COMMERCE 10-14-2008.

CLASS 41—EDUCATION AND ENTERTAINMENT

FOR EDUCATIONAL SERVICES, NAMELY, ON-LINE TRAINING PROGRAMS IN THE FIELDS OF HVAC, PLUMBING, ROOFING AND ELECTRICAL CONTRACTING SERVICES (U.S. CLS. 100, 101 AND 107).

FIRST USE 10-14-2008; IN COMMERCE 10-14-2008.

DAVID COLLIER, EXAMINING ATTORNEY

SN 77-969,007, PARENT PREP SCHOOL, LLC, AUSTIN, TX.
FILED 3-25-2010.

PARENT PREP SCHOOL

THE MARK CONSISTS OF STANDARD CHARACTERS WITHOUT CLAIM TO ANY PARTICULAR FONT, STYLE, SIZE, OR COLOR.

NO CLAIM IS MADE TO THE EXCLUSIVE RIGHT TO USE "PARENT", APART FROM THE MARK AS SHOWN.

CLASS 9—ELECTRICAL AND SCIENTIFIC APPARATUS

FOR COMPUTER APPLICATION SOFTWARE FOR MOBILE PHONES, PORTABLE MEDIA PLAYERS AND HANDHELD COMPUTERS, NAMELY, SOFTWARE THAT POPULATES AN ELECTRONIC CALENDAR WITH INFORMATION RELATING TO PREGNANCY, PARENTING AND INFANT CARE; PRE-RECORDED VIDEOS, AUDIO AND VIDEO RECORDINGS, AND DOWNLOADABLE VIDEO RECORDINGS ALL FEATURING INFORMATION ON PREGNANCY, PARENTING AND INFANT CARE (U.S. CLS. 21, 23, 26, 36 AND 38).

CLASS 41—EDUCATION AND ENTERTAINMENT

FOR PROVIDING A WEBSITE FEATURING INSTRUCTIONAL INFORMATION IN THE FIELDS OF PREGNANCY, PARENTING AND INFANT CARE (U.S. CLS. 100, 101 AND 107).

BERYL GARDNER, EXAMINING ATTORNEY

SN 77-969,344. ZYNGA INC., SAN FRANCISCO, CA. FILED 3-26-2010.

The logo for "Mafia Wars" features the words "Mafia Wars" in a bold, black, serif font. The letters are slightly shadowed to create a 3D effect, with the shading appearing to come from the top and left, giving the text a raised appearance.

THE MARK CONSISTS OF THE WORDS "MAFIA WARS" WITH SHADING AROUND THE EDGES TO SUGGEST A RAISED SURFACE.

CLASS 16—PAPER GOODS AND PRINTED MATTER

FOR ART PAPER, DECALS, GIFT BAGS, GREETING CARDS, MEMO PADS, STATIONERY, STICKERS, TOILET PAPER, WRAPPING PAPER, AND WRITING PAPER (U.S. CLS. 2, 5, 22, 23, 29, 37, 38 AND 50).

CLASS 21—HOUSEWARES AND GLASS

FOR BEER MUGS, BEVERAGE GLASSWARE, BEVERAGE STIRRERS, BOTTLE OPENERS, BOWLS, COFFEE CUPS, TEA CUPS AND MUGS, CONTAINERS FOR ICE, DISHES, FLOWER POTS, NAPKIN HOLDERS, PANS, SALT SHAKERS, AND TOOTH BRUSHES (U.S. CLS. 2, 13, 23, 29, 30, 33, 40 AND 50).

BRIAN CALLAGHAN, EXAMINING ATTORNEY

CLASS 35—ADVERTISING AND BUSINESS

FOR BUSINESS CONSULTATION; PERSONAL MANAGEMENT AND COMPENSATION CONSULTATION; CONSULTATION SERVICES FOR THE EVALUATION AND MANAGEMENT OF EMPLOYEES; HUMAN RESOURCES CONSULTATION; BUSINESS RESEARCH AND SURVEYS, NAMELY, CREATION, ADMINISTRATION, INTERPRETATION AND EVALUATION OF ONLINE SURVEYS TO MEASURE EMPLOYEE COMMITMENT, SATISFACTION, PROFESSIONAL DEVELOPMENT AND MORALE; BUSINESS CONSULTING SERVICES, NAMELY, ADVISING OTHERS ON THE STRUCTURE AND ADMINISTRATION OF HUMAN RESOURCES PLANS AND PROGRAMS; BUSINESS ADMINISTRATIVE CONSULTING; BUSINESS ORGANIZATION CONSULTING; BUSINESS MANAGEMENT; BUSINESS MANAGEMENT CONSULTING; PERSONNEL MANAGEMENT; PERSONNEL MANAGEMENT CONSULTANCY; MARKETING CONSULTANCY; MONITORING FOR OTHERS THE EFFECTIVENESS OF HUMAN CAPITAL PRACTICES ON BUSINESS PERFORMANCE; CONSULTATION SERVICES IN DIAGNOSING AND MEASURING HUMAN RESOURCES PERFORMANCE; PROVIDING HUMAN RESOURCES ADMINISTRATION SERVICES FOR OTHER BUSINESSES; SERVING AS A HUMAN RESOURCES DEPARTMENT FOR OTHERS (U.S. CLS. 100, 101 AND 102).
FIRST USE 12-1-2004; IN COMMERCE 3-31-2005.

CLASS 36—INSURANCE AND FINANCIAL

FOR INSURANCE CONSULTATION AND ADMINISTRATION; CONSULTATION AND ADMINISTRATION OF EMPLOYEE PENSION PLANS AND EMPLOYEE BENEFITS PLANS; INSURANCE BROKERAGE SERVICE; PROVIDING INFORMATION VIA ELECTRONIC MEANS TO EMPLOYEES AND EMPLOYERS ON EMPLOYEE BENEFITS, HEALTH BENEFITS AND GROUP BENEFITS; CONSULTING AND ADMINISTRATION SERVICES IN THE FIELD OF HEALTH INSURANCE; FINANCIAL CONSULTING IN THE FIELD OF EMPLOYEE DEFINED BENEFIT PLANS, ACTUARIAL PLANS, ASSET MANAGEMENT, INVESTMENTS, OUTSOURCING EMPLOYEE BENEFITS ADMINISTRATION, AND GOVERNMENTAL REPORTING AND COMPLIANCE CONCERNING DEFINED BENEFIT PLANS; COMPILING, ORGANIZING AND PROVIDING TO OTHERS VIA ELECTRONIC MEANS EMPLOYEE BENEFITS PLAN SURVEY DATA (U.S. CLS. 100, 101 AND 102).
FIRST USE 12-1-2004; IN COMMERCE 3-31-2005.
JOHN WILKE, EXAMINING ATTORNEY

SN 78-565,629. MERCER (US) INC., NEW YORK, NY. FILED 2-11-2005.

MERCER HR SERVICES

THE MARK CONSISTS OF STANDARD CHARACTERS WITHOUT CLAIM TO ANY PARTICULAR FONT, STYLE, SIZE, OR COLOR.

OWNER OF U.S. REG. NO. 3,532,408.

NO CLAIM IS MADE TO THE EXCLUSIVE RIGHT TO USE "HR SERVICES", APART FROM THE MARK AS SHOWN.

SN 78-934,366. NAKHEEL CO LLC, DUBAI, UNITED ARAB EMIR., FILED 7-20-2006.



PRIORITY CLAIMED UNDER SEC. 44(D) ON UNITED ARAB EMIR. APPLICATION NO. 82833, FILED 7-12-2006, REG. NO. 87888, DATED 4-20-2008, EXPIRES 7-12-2016.

OWNER OF UNITED ARAB EMIR. REG. NO. 46630, DATED 5-8-2004, EXPIRES 10-21-2013.

THE COLOR(S) BLUE AND WHITE IS/ARE CLAIMED AS A FEATURE OF THE MARK.

THE MARK CONSISTS OF THE WORDING "THE WORLD" IN BLUE, UNDER A STYLIZED VERSION OF THE WORLD IN THE COLORS WHITE AND BLUE.

CLASS 36—INSURANCE AND FINANCIAL

FOR REAL ESTATE SERVICES, NAMELY, REAL ESTATE LISTING, LEASING OF REAL ESTATE, MANAGEMENT OF REAL ESTATE; REAL ESTATE BROKERAGE SERVICES; REAL ESTATE AND LAND ACQUISITION; ADVISORY AND CONSULTANCY SERVICES AND PROVIDING FINANCIAL INFORMATION RELATING TO THE LISTING, LEASING, MANAGING, SALES AND PURCHASES OF COMMERCIAL AND RESIDENTIAL PROPERTY AS WELL AS BROKERAGE SERVICES, REAL ESTATE AND LAND ACQUISITION (U.S. CLS. 100, 101 AND 102).

CLASS 37—CONSTRUCTION AND REPAIR

FOR REAL ESTATE DEVELOPMENT SERVICES; CONSTRUCTION OF COMMERCIAL AND RESIDENTIAL BUILDINGS AND PROPERTIES; REPAIR AND MAINTENANCE SERVICES FOR COMMERCIAL AND RESIDENTIAL BUILDINGS AND PROPERTIES; ADVISORY AND CONSULTANCY SERVICES AND PROVIDING INFORMATION ON REAL ESTATE DEVELOPMENT SERVICES AND CONSTRUCTION, REPAIR AND MAINTENANCE OF COMMERCIAL AND RESIDENTIAL BUILDINGS (U.S. CLS. 100, 103 AND 106).

DAVID HOFFMAN, EXAMINING ATTORNEY

SN 78-981,415. THE UNIVERSITY OF BRITISH COLUMBIA, VANCOUVER, CANADA, FILED 10-21-2004.



PRIORITY CLAIMED UNDER SEC. 44(D) ON CANADA APPLICATION NO. 1,214,284, FILED 4-22-2004, REG. NO. TMA751627, DATED 10-29-2009, EXPIRES 10-29-2024.

THE MARK CONSISTS OF A BIRD HEAD DESIGN ABOVE THE LETTERS "UBC" AND THE WORD "THUNDERBIRDS".

CLASS 6—METAL GOODS

FOR PIGGY BANKS MADE OF PRECIOUS METAL (U.S. CLS. 2, 12, 13, 14, 23, 25 AND 50).

CLASS 9—ELECTRICAL AND SCIENTIFIC APPARATUS

FOR DECORATIVE MAGNETS (U.S. CLS. 21, 23, 26, 36 AND 38).

CLASS 14—JEWELRY

FOR JEWELRY AND ACCESSORIES, NAMELY, WATCHES, LAPEL PINS, STICK PINS, RINGS, EARRINGS; CLOCKS (U.S. CLS. 2, 27, 28 AND 50).

CLASS 16—PAPER GOODS AND PRINTED MATTER

FOR STATIONERY AND ACCESSORIES, NAMELY, PENS; PRINTED MATTER, NAMELY, MAGAZINES AND BOOKS FEATURING SPORTS AND EDUCATION; BOOKLETS FEATURING SPORTS AND EDUCATION; EDUCATIONAL BOOKS IN THE FIELD OF UNIVERSITY LEVEL COURSES OF STUDY; TEACHING MANUALS IN THE FIELD OF UNIVERSITY LEVEL COURSES OF STUDY; UNIVERSITY YEARBOOKS; PRINTED UNIVERSITY SCHEDULES FEATURING SPORTS, EDUCATION AND CULTURAL EVENTS; POSTERS; BUMPER STICKERS; DECALS; MEMO PADS; SCRIBBLE PADS; WRITING PADS; AGENDAS; STICKERS; PRINTED CALENDARS; COOKBOOKS (U.S. CLS. 2, 5, 22, 23, 29, 37, 38 AND 50).

CLASS 21—HOUSEWARES AND GLASS

FOR HOUSEWARES, NAMELY, DRINKING GLASSES, CUPS, MUGS, SHOT GLASSES (U.S. CLS. 2, 13, 23, 29, 30, 33, 40 AND 50).

CLASS 24—FABRICS

FOR BLANKET THROWS AND BLANKETS FOR OUTDOOR USE; TOWELS (U.S. CLS. 42 AND 50).

CLASS 41—EDUCATION AND ENTERTAINMENT

FOR ORGANIZATION OF UNIVERSITY SPORTS COMPETITIONS AND UNIVERSITY SPORTS EVENTS (U.S. CLS. 100, 101 AND 107).

STEVEN R. FINE, EXAMINING ATTORNEY

SN 79-068,210. AMADEUS ALEXANDER MAY, SWITZERLAND, FILED 12-3-2008.



PRIORITY DATE OF 7-1-2008 IS CLAIMED. OWNER OF INTERNATIONAL REGISTRATION 1001172 DATED 12-3-2008, EXPIRES 12-3-2018.

NO CLAIM IS MADE TO THE EXCLUSIVE RIGHT TO USE "IMMUNE MANAGEMENT", APART FROM THE MARK AS SHOWN.

THE MARK CONSISTS OF A SHADED CIRCLE FEATURING THE WORDING "TOTAL IMMUNE MANAGEMENT" IN STYLIZED LETTERS CURVED AROUND THE DESIGN ELEMENT OF A POLYGON FIGURE AND TWO SHADED, CURVED ARROWS.

CLASS 1—CHEMICALS

FOR CHEMICALS, NAMELY, CHEMICALS FOR USE IN THE MANUFACTURE OF FERMENTATION EXTRACTS; FERMENTS FOR CHEMICAL USE, NAMELY, FERMENTATION EXTRACTS (U.S. CLS. 1, 5, 6, 10, 26 AND 46).

CLASS 3—COSMETICS AND CLEANING PREPARATIONS

FOR FACE AND BODY CARE COSMETICS, HAIR LOTIONS, BLEACHING PREPARATIONS AND OTHER SUBSTANCES, NAMELY, SOFTENERS FOR LAUNDRY USE; CLEANING, POLISHING, SCOURING PREPARATIONS FOR USE ON SKIN; ABRASIVE PREPARATIONS FOR USE ON SKIN; SOAPS, NAMELY, SKIN SOAPS; PERFUMERY; ESSENTIAL OILS; DENTIFRICES (U.S. CLS. 1, 4, 6, 50, 51 AND 52).

CLASS 5—PHARMACEUTICALS

FOR FERMENTS FOR PHARMACEUTICAL PURPOSES; PHARMACEUTICAL PREPARATIONS FOR TREATMENT OF INFLAMMATORY CONDITIONS, IMMUNE DISEASES AND ENZYME UNDERPRODUCTION; AND VETERINARY PREPARATIONS, NAMELY, PAIN RELIEF MEDICATION, TREATMENT OF SKIN AND HAIR, TREATMENT OF INFLAMMATORY CONDITIONS, IMMUNE DISEASES; HEALTH CARE PREPARATIONS, NAMELY, LIQUID FOR TREATING INFLAMMATORY CONDITIONS, IMMUNE DISEASES AND ENZYME UNDERPRODUCTION; FOOD FOR BABIES; DIETETIC SUBSTANCES, NAMELY, DIETETIC FOOD FOR MEDICAL USE; MINERAL FOOD SUPPLEMENTS; FOOD SUPPLEMENTS MADE WITH AMINO-ACIDS; FOOD SUPPLEMENTS MADE WITH MINERALS; FOOD SUPPLEMENTS MADE WITH TRACE ELEMENTS; FOOD SUPPLEMENTS MADE FOR MEDICAL PURPOSES; VITAMIN PREPARATIONS; DIETARY SUPPLEMENTS MADE WITH VITAMINS (U.S. CLS. 6, 18, 44, 46, 51 AND 52).

CLASS 30—STAPLE FOODS

FOR DIETETIC SUBSTANCES OR FOOD SUPPLEMENTS NOT FOR MEDICAL USE MADE WITH CARBOHYDRATES, FOOD FIBERS, WITH ADDED VITAMINS, MINERAL SUBSTANCES, TRACE ELEMENTS, EITHER ALONE OR IN COMBINATION, NAMELY, GRANOLA BASED SNACK BARS; COFFEE; TEA; COCOA; SUGAR; RICE; TAPIOCA; SAGO; ARTIFICIAL COFFEE; FLOURS AND CEREAL PREPARATIONS, NAMELY, CEREAL BASED ENERGY BARS; BREAD, PASTRY, CONFECTIONERY, NAMELY, PASTILLES; EDIBLE ICES; CHOCOLATES AND CHOCOLATE GOODS, NAMELY, CHOCOLATE CHIPS, CHOCOLATE FLAKES AND CHOCOLATE BARS; HONEY, TREACLE; YEAST, BAKING-POWDER; SALT, MUSTARD; VINEGAR, SAUCES; SPICES; ICE FOR REFRESHMENTS (U.S. CL. 46).

CLASS 44—MEDICAL, BEAUTY AND AGRICULTURAL SERVICES

FOR MEDICAL SERVICES; VETERINARY SERVICES; HYGIENIC AND BEAUTY CARE FOR HUMAN BEINGS OR ANIMALS, NAMELY, NUTRITIONAL CONSULTANCY, HEALTH CONSULTANCY, HEALTH AND BEAUTY CARE, HEALTH AND BEAUTY SERVICES (U.S. CLS. 100 AND 101).

JULIE VEPPUMTHARA, EXAMINING ATTORNEY

SN 79-069,678. ANDREW SMITH, AUSTRALIA, FILED 5-14-2009.

MapMy

THE MARK CONSISTS OF STANDARD CHARACTERS WITHOUT CLAIM TO ANY PARTICULAR FONT, STYLE, SIZE, OR COLOR.

OWNER OF INTERNATIONAL REGISTRATION 1004782 DATED 5-14-2009, EXPIRES 5-14-2019.

CLASS 9—ELECTRICAL AND SCIENTIFIC APPARATUS

FOR APPLICATION SOFTWARE FOR THE INPUT, CAPTURE, STORING, PROCESSING AND DISPLAYING OF INFORMATION, DATA, ADS, COORDINATES AND MEDIA IN LISTS, PAGES AND ON A GRAPHICAL INFORMATION SYSTEM OR MAP ON COMPUTERS AND MOBILE DEVICES; COMMUNICATION SOFTWARE FOR ELECTRONICALLY CAPTURING, PROCESSING AND DISTRIBUTING VOICE, VOICE COMMANDS, MEDIA, DATA, COORDINATES AND INFORMATION ACROSS COMPUTERS AND MOBILE DEVICES; COMPUTER GAMES ENTERTAINMENT SOFTWARE FOR RUNNING COMPUTER GAMES ON COMPUTERS AND MOBILE DEVICES; COMPUTER GRAPHICS SOFTWARE TO MANIPULATE IMAGES ON COMPUTERS AND MOBILE DEVICES; COMPUTER PROGRAMS AND RECORDED SOFTWARE FOR SEARCHING, DOWNLOADING, RECORDING AND PLAYING MUSIC AND SOUNDS ON PC AND MOBILE DEVICES; COMPUTER SOFTWARE FOR ANALYZING DATA, NAMELY, ADDRESS AND PROPERTY INFORMATION, STOCK MARKET INFORMATION, AND DISPLAYING RESULTS ON COMPUTER AND MOBILE DEVICES; COMPUTER SOFTWARE FOR MANAGING NETWORKS, AUTHORIZING ACCESS AND SECURITY ON COMPUTER AND MOBILE DEVICES; COMPUTER SOFTWARE FOR PUBLISHING ADS, BLOGS, VIDEO AND MEDIA FILES ON PC AND MOBILE DEVICES; COMPUTER SOFTWARE FOR COMMUNICATION PURPOSES BETWEEN MICROCOMPUTERS AND MOBILE DEVICES; INTERACTIVE COMPUTER SOFTWARE FOR REAL TIME CHAT, VIDEO STREAMING, MAPS, ADVERTISING AND GAMMING; COMPUTER SOFTWARE FOR MANAGING THE LOCATION OF A DEVICE AND DEVICES IN A REGION, AND MAPPING AND SATELLITE IMAGERY SOFTWARE (U.S. CLS. 21, 23, 26, 36 AND 38).

CLASS 42—SCIENTIFIC AND COMPUTER SERVICES

FOR WRITING, DESIGN, CREATION, ENGINEERING, RENTING AND UPGRADING OF SOFTWARE AND HARDWARE FOR THE CAPTURE, PROCESSING, STORAGE AND DISPLAY OF INFORMATION, DATA, ADS, COORDINATES AND MEDIA ON WEB PAGES, GEOGRAPHICAL INFORMATION SYSTEMS AND MAPS, ON COMPUTERS, MOBILE DEVICES, NAVIGATION OR GPS SYSTEMS; WRITING, DESIGN, CREATION, ENGINEERING, RENTING AND UPGRADING OF COMPUTER SOFTWARE AND HARDWARE FOR MAPPING, NAVIGATION AND COMMUNICATIONS; WRITING, DESIGN, CREATION, ENGINEERING, RENTING AND UPGRADING OF COMPUTER AND MICROCOMPUTER NAVIGATION COMPONENTS AND HARDWARE; MAPPING SOFTWARE AND HARDWARE DESIGN AND TECHNICAL CONSULTANCY; INSTALLATION AND MAINTENANCE OF COMPUTER SOFTWARE FOR PUBLISHING, MAPPING AND COMMUNICATIONS; ONLINE PROVISION OF WEB-BASED NON-DOWNLOADABLE SOFTWARE FOR THE CAPTURE, PROCESSING AND DISPLAY OF INFORMATION, DATA, ADS, COORDINATES AND MEDIA ON WEBPAGES AND GEOGRAPHICAL INFORMATION SYSTEMS, MAPS AND NAVIGATION AND GPS SYSTEMS (U.S. CLS. 100 AND 101).

MARILYN IZZI, EXAMINING ATTORNEY

SN 79-073,621, TERBERG GROUP B.V., NETHERLANDS,
FILED 6-9-2009.

SN 79-074,078, LODESTAR ANSTALT, LIECHTENSTEIN,
FILED 8-19-2009.



OWNER OF INTERNATIONAL REGISTRATION 1015316
DATED 6-9-2009, EXPIRES 6-9-2019.

NO CLAIM IS MADE TO THE EXCLUSIVE RIGHT TO
USE "GREEN LEASE", APART FROM THE MARK AS
SHOWN.

THE COLOR(S) GREEN AND WHITE IS/ARE CLAIMED
AS A FEATURE OF THE MARK.

THE MARK CONSISTS OF THE WORDS "GREEN" AND
"LEASE" AND A PICTURE OF A SEDAN CAR, ALL OF
WHICH ARE IN COLOR WHITE AND ARE INSIDE THE
GREEN CIRCLE, WITH THE INNER GREEN CIRCLE
HAVING A WHITE CIRCULAR BORDER WHICH IS THEN
BORDERED BY A GREEN OUTER EDGE, AND THE TWO
WINDOWS AND TWO WHEEL CAPS OF TIRES OF THE
SEDAN CAR ARE IN COLOR GREEN WHILE THE TIRES
ARE IN WHITE.

CLASS 35—ADVERTISING AND BUSINESS

FOR BUSINESS ADMINISTRATION RELATING TO
THE LEASING OF ENVIRONMENTALLY FRIENDLY
AUTOMOBILE VEHICLES; PROVIDING OFFICE FUNC-
TIONS RELATING TO THE LEASING OF ENVIRON-
MENTALLY FRIENDLY AUTOMOBILE VEHICLES;
MEDIATION OF TRADE BUSINESS FOR THIRD PART-
IES IN THE NATURE OF BUSINESS MEDIATION
WITH REGARD TO THE PURCHASE AND SALE OF
ENVIRONMENTALLY FRIENDLY AUTOMOBILE VE-
HICLES; BUSINESS OPERATION AND ADMINISTRA-
TIVE MANAGEMENT OF A FLEET OF AUTOMOBILE
VEHICLES (U.S. CLS. 100, 101 AND 102).

CLASS 36—INSURANCE AND FINANCIAL

FOR FINANCING OF ENVIRONMENTALLY
FRIENDLY AUTOMOBILES; FINANCIAL OPERATION
OF A FLEET OF AUTOMOBILE VEHICLES, NAMELY,
FINANCIAL MANAGEMENT OF A FLEET OF AUTO-
MOBILE VEHICLES (U.S. CLS. 100, 101 AND 102).

CLASS 39—TRANSPORTATION AND STO- RAGE

FOR EXTERNAL CAR FLEET MANAGEMENT,
NAMELY, MANAGEMENT OF VEHICULAR TRAFFIC
FLOW THROUGH ADVANCED COMMUNICATIONS
NETWORK AND TECHNOLOGY; TOWING AWAY
AND STORAGE OF AUTOMOBILE VEHICLES; LEAS-
ING OF ENVIRONMENTALLY FRIENDLY AUTOMO-
BILE VEHICLES; SERVICES OF A LEASING COMPAN-
Y IN RELATION TO VEHICLES, NAMELY, RENTAL AND
LEASING OF AUTOMOBILE VEHICLES (U.S. CLS. 100
AND 105).

NAPOLÉON SHARMA, EXAMINING ATTORNEY



PRIORITY DATE OF 7-21-2009 IS CLAIMED.
OWNER OF INTERNATIONAL REGISTRATION 1016534
DATED 8-19-2009, EXPIRES 8-19-2019.

THE MARK CONSISTS OF A SWORD PIERCING A
HEART BORDERED BY CLOVER AROUND WHICH IS
DRAPED A BANNER CONTAINING THE STYLIZED
WORD "UNTAMED".

CLASS 32—LIGHT BEVERAGES

FOR BEERS; MINERAL AND AERATED WATERS;
COLA; SOFT DRINKS, NAMELY, POP, LEMONADE,
CARBONATED SOFT DRINKS, LOW CALORIE SOFT
DRINKS, NON-CARBONATED SOFT DRINKS, FRUIT
DRINKS AND FRUIT JUICES; SYRUPS AND OTHER
PREPARATIONS FOR MAKING BEERS, MINERAL AND
AERATED WATERS, COLA AND SOFT DRINKS,
NAMELY, POP, LEMONADE, CARBONATED SOFT
DRINKS, LOW CALORIE SOFT DRINKS, NON-CARBO-
NATED SOFT DRINKS, FRUIT DRINKS AND FRUIT
JUICES (U.S. CLS. 45, 46 AND 48).

CLASS 33—WINES AND SPIRITS

FOR ALCOHOLIC BEVERAGES, NAMELY, WINE,
RUM; GIN, VODKA, WHISKEY, BOURBON, CACHAÇA,
TEQUILA, MESCAL, ALCOHOLIC BITTERS, BRANDY,
HARD CIDER, DISTILLED SPIRITS, DISTILLED LI-
QUEUR, ALCOHOLIC APERITIF BITTERS, APERITIF
WINES, APERITIFS WITH A DISTILLED ALCOHOLIC
LIQUEUR BASE, APERITIFS WITH A WINE BASE,
SAKE AND PREPARED ALCOHOLIC COCKTAILS (U.S.
CLS. 47 AND 49).

DAVID TOOLEY, EXAMINING ATTORNEY

SN 79-074,079, LODESTAR ANSTALT, FL-9490 VADUZ,
LIECHTENSTEIN, FILED 8-19-2009.

UNTAMED

PRIORITY DATE OF 7-16-2009 IS CLAIMED.
OWNER OF INTERNATIONAL REGISTRATION 1016535
DATED 8-19-2009, EXPIRES 8-19-2019.

CLASS 32—LIGHT BEVERAGES

FOR BEERS; MINERAL AND AERATED WATERS; COLA; SOFT DRINKS, NAMELY, POP, LEMONADE, CARBONATED SOFT DRINKS, LOW CALORIE SOFT DRINKS, NON-CARBONATED SOFT DRINKS, FRUIT DRINKS AND FRUIT JUICES; SYRUPS AND OTHER PREPARATIONS FOR MAKING BEERS, MINERAL AND AERATED WATERS, COLA AND SOFT DRINKS, NAMELY, POP, LEMONADE, CARBONATED SOFT DRINKS, LOW CALORIE SOFT DRINKS, NON-CARBONATED SOFT DRINKS, FRUIT DRINKS AND FRUIT JUICES (U.S. CLS. 45, 46 AND 48).

CLASS 33—WINES AND SPIRITS

FOR ALCOHOLIC BEVERAGES, NAMELY, WINE, RUM; GIN, VODKA, WHISKEY, BOURBON, CACHAÇA, TEQUILA, MESCAL, ALCOHOLIC BITTERS, BRANDY, HARD CIDER, DISTILLED SPIRITS, DISTILLED LIQUEUR, ALCOHOLIC APERITIF BITTERS, APERITIF WINES, APERITIFS WITH A DISTILLED ALCOHOLIC LIQUEUR BASE, APERITIFS WITH A WINE BASE, SAKE AND PREPARED ALCOHOLIC COCKTAILS (U.S. CLS. 47 AND 49).

DAVID TOOLEY, EXAMINING ATTORNEY

SN 79-077,782. INTERNATIONAL BUSINESS MACHINES CORPORATION, ARMONK, NY. FILED 9-25-2009.

SMARTER CITIES

THE MARK CONSISTS OF STANDARD CHARACTERS WITHOUT CLAIM TO ANY PARTICULAR FONT, STYLE, SIZE, OR COLOR.

PRIORITY DATE OF 3-25-2009 IS CLAIMED.

OWNER OF INTERNATIONAL REGISTRATION 1026091 DATED 9-25-2009, EXPIRES 9-25-2019.

CLASS 9—ELECTRICAL AND SCIENTIFIC APPARATUS

FOR COMPUTERS; COMPUTER HARDWARE; COMPUTER SOFTWARE FOR DATA MANAGEMENT AND DATA ANALYSIS IN THE FIELD OF IMPROVING CITY SYSTEMS AND INFRASTRUCTURE, INCLUDING TRANSPORTATION SYSTEMS, POLICING AND EMERGENCY RESPONSE SYSTEMS, POWER AND WATER MANAGEMENT SYSTEMS, HUMAN SERVICE COMPUTING SYSTEMS IN HEALTHCARE, EDUCATION AND SOCIAL SERVICES, AND CITY GOVERNANCE AND ADMINISTRATION; COMPUTER OPERATING SYSTEM SOFTWARE; COMPUTER SOFTWARE FOR PROVIDING USER ACCESS TO A GLOBAL COMPUTER NETWORK; COMPUTER DATABASE MANAGEMENT SOFTWARE; DOCUMENT MANAGEMENT COMPUTER SOFTWARE; AND INSTRUCTION MANUALS SOLD AS A UNIT THEREWITH (U.S. CLS. 21, 23, 26, 36 AND 38).

CLASS 16—PAPER GOODS AND PRINTED MATTER

FOR PRINTED INSTRUCTIONAL AND TEACHING MATERIAL, MANUALS, BOOKS, PAMPHLETS, INFORMATION BULLETINS, NEWSPAPER INSERTS, BOOKLETS; ALL IN THE FIELDS OF INFORMATION TECHNOLOGY, COMPUTER HARDWARE AND SOFTWARE SYSTEMS AND RELATED SERVICES (U.S. CLS. 2, 5, 22, 23, 29, 37, 38 AND 50).

CLASS 35—ADVERTISING AND BUSINESS

FOR BUSINESS MANAGEMENT AND CONSULTANCY; BUSINESS INFORMATION, ORGANIZATION OF EXHIBITIONS FOR COMMERCIAL OR ADVERTISING PURPOSES (U.S. CLS. 100, 101 AND 102).

CLASS 41—EDUCATION AND ENTERTAINMENT

FOR EDUCATIONAL SERVICES, NAMELY, ARRANGING CONFERENCES, SEMINARS, AND EXHIBITION SERVICES FOR EDUCATIONAL PURPOSES; EDUCATIONAL SERVICES, NAMELY, CONDUCTING OF COURSES, SEMINARS, CONFERENCES AND WORKSHOPS IN THE FIELD OF COMPUTERS, INFORMATION TECHNOLOGY, TELECOMMUNICATION NETWORKS AND GLOBAL COMPUTER NETWORKS; TRAINING IN THE FIELD OF COMPUTER OPERATION AND INFORMATION TECHNOLOGY (U.S. CLS. 100, 101 AND 107).

PAUL MORENO, EXAMINING ATTORNEY

SN 79-077,829. MICHAEL METRY, SWITZERLAND, FILED 12-2-2009.

ADWEARTISEMENT
Human advertising

PRIORITY DATE OF 11-9-2009 IS CLAIMED.
OWNER OF INTERNATIONAL REGISTRATION 1026227 DATED 12-2-2009, EXPIRES 12-2-2019.

NO CLAIM IS MADE TO THE EXCLUSIVE RIGHT TO USE "HUMAN ADVERTISING", APART FROM THE MARK AS SHOWN.

CLASS 18—LEATHER GOODS

FOR LEATHER AND IMITATION LEATHER, GOODS MADE FROM LEATHER OR IMITATION LEATHER, NAMELY, WALLETS, PURSES, TOTE BAGS, BACKPACKS, VANITY CASES SOLD EMPTY, WRISTLET BAGS, BRIEFCASES; ANIMAL SKINS AND HIDES; LUGGAGE AND TRUNKS; UMBRELLAS, PARASOLS AND WALKING STICKS; WHIPS, HARNESES AND SADDLERY; LEATHER AND IMITATION LEATHER BAGS (U.S. CLS. 1, 2, 3, 22 AND 41).

CLASS 25—CLOTHING

FOR CLOTHING, NAMELY, SUITS, BATHROBES, SWIMWEAR, BIKINI'S, BLAZERS, BLOUSES, BELTS, SCARVES, GLOVES, SHIRTS, PANTS, TROUSERS, HOT PANTS, GARTER BELTS, GIRDLES, SUSPENDERS, JACKETS, COATS, JEANS, JERSEYS, COATED PULL-OVERS, HOODED SWEATSHIRTS, DRESSES, FROCKS, GOWNS, BANDANNAS, TIES, MINISKIRTS, OVERALLS, MEN'S AND WOMEN'S UNDERGARMENTS, POLO SHIRTS, SWEATERS, PULLOVERS, JERSEYS, RAIN WEAR, RAIN PANTS, RAIN COATS, RAIN BOOTS, SKIRTS, SHIRTS, SHORTS, CARDIGANS, STOCKINGS, SWEAT SHIRTS, THONGS, G STRINGS, TOPS, JUMPERS, DRESSES, JOGGING PANTS, TIGHTS, T-SHIRTS, CAPES, GOWNS, SHAWLS, UNDER SHIRTS, SOCKS, BOXERS, WINTER COATS, AND WINTER JACKETS, FOOTWEAR; HEADGEAR, NAMELY, CAPS, HATS, BANDANNAS, HEAD SCARVES, DO RAGS AND BASEBALL CAPS; HEADWEAR; HATS, CAPS, HEADBANDS, NECKBANDS AND COLLARS, ALL OF LEATHER AND IMITATION LEATHER (U.S. CLS. 22 AND 39).

CLASS 35—ADVERTISING AND BUSINESS

FOR ADVERTISING SERVICES; BUSINESS ADMINISTRATION AND MANAGEMENT; PROVIDING OFFICE FUNCTIONS (U.S. CLS. 100, 101 AND 102).

JOHN SCHUYLER YARD, EXAMINING ATTORNEY

SN 79-078,693. GORACON ENGINEERING GMBH, 48565 STEINFURT, FED REP GERMANY, FILED 10-10-2009.



PRIORITY DATE OF 8-12-2009 IS CLAIMED.
OWNER OF INTERNATIONAL REGISTRATION 1028235 DATED 10-10-2009, EXPIRES 10-10-2019.
THE COLOR(S) BLUE AND GRAY IS/ARE CLAIMED AS A FEATURE OF THE MARK.
THE COLOR BLUE APPEARS IN THE STYLIZED WORDING "G-CONNECT". THE COLOR GRAY APPEARS IN THE CURVE WITHIN THE LETTER "G".

CLASS 6—METAL GOODS

FOR ASCENDING LADDERS OF METAL (U.S. CLS. 2, 12, 13, 14, 23, 25 AND 50).

CLASS 7—MACHINERY

FOR ELEVATORS; HYDRAULIC LIFTS AND WINCHES FOR TRANSPORTING PASSENGERS AND LOADS; ELEVATING WORK PLATFORMS; CONVEYOR EQUIPMENT, NAMELY, CONVEYOR BELTS AND LIFTING APPARATUS, NAMELY, LIFTING WORK PLATFORMS (U.S. CLS. 13, 19, 21, 23, 31, 34 AND 35).

CLASS 37—CONSTRUCTION AND REPAIR

FOR INSTALLATION AND REPAIR OF ELEVATORS, LIFTS, WINCHES, CLIMBING AIDS, CONVEYOR EQUIPMENT AND INSPECTION DEVICES FOR ROOFS AND FACADES (U.S. CLS. 100, 103 AND 106).
EVELYN BRADLEY, EXAMINING ATTORNEY

SN 79-079,374. ROBERTO CAVALLI S.P.A., ITALY, FILED 12-23-2009.



PRIORITY DATE OF 12-21-2009 IS CLAIMED.
OWNER OF INTERNATIONAL REGISTRATION 1030022 DATED 12-23-2009, EXPIRES 12-23-2019.
THE MARK CONSISTS OF A STYLIZED LETTER "C" AND THE WORDS "JUST CAVALLI".

CLASS 8—HAND TOOLS

FOR TABLEWARE, NAMELY, KNIVES, FORKS AND SPOONS; STERLING SILVER TABLE FORKS (U.S. CLS. 23, 28 AND 44).

CLASS 9—ELECTRICAL AND SCIENTIFIC APPARATUS

FOR OPTICAL, NAMELY, SPECTACLES AND SUNGLASSES, SPECTACLES FRAMES AND CASES, SPECTACLES GLASSES, SPECTACLES HOLDERS, SPECTACLE LENS BLANKS, SPECTACLE LENSES, ANTI-DAZZLE SPECTACLES, ANTI-GLARE SPECTACLES, POLARIZING SPECTACLE, PROTECTIVE SPECTACLE, OPHTHALMIC FRAMES AND CASES THEREOF, SUNGLASSES LENS, SUNGLASSES CHAIN AND CORDS; APPARATUS FOR RECORDING, TRANSMISSION OR REPRODUCTION OF SOUND AND IMAGE; BLANK MAGNETIC DATA CARRIER, BLANK RECORDABLE OPTICAL DISC, AUTOMATIC VENDING MACHINES AND MECHANISM FOR COIN-OPERATED APPARATUS; CASH REGISTER; CALCULATING MACHINES, DATA PROCESSING EQUIPMENT AND COMPUTERS; FIRE EXTINGUISHERS (U.S. CLS. 21, 23, 26, 36 AND 38).

CLASS 11—ENVIRONMENTAL CONTROL APPARATUS

FOR APPARATUS FOR LIGHTING, NAMELY, LAMPS, GAS LAMPS, INCANDESCENT LAMPS AND THEIR FITTINGS, INFRARED LAMP FIXTURES, LAMP BASES, LAMP BULBS, LAMP CHIMNEYS, LAMP FINIALS, LAMP REFLECTORS, LAMP SHADES, LAMP WHOSE LIGHT CAN BE TURNED IN ALL DIRECTIONS, LAMPS FOR OUTDOOR USE, MERCURY LAMPS, OIL LAMPS, OVERHEAD LAMPS, SOLDERING LAMPS, SUN LAMPS, ULTRAVIOLET LAMPS NOT FOR MEDICAL PURPOSES, ULTRAVIOLET RAY LAMPS, NOT FOR MEDICAL PURPOSES, UV HALOGEN METAL VAPOUR LAMPS; TOOLS, COMPONENTS AND SUPPLIES FOR USE IN MAKING SIGNS, NAMELY, FLUORESCENT, HID, LED AND INCANDESCENT BULBS, LAMPS AND FIXTURES (U.S. CLS. 13, 21, 23, 31 AND 34).

CLASS 16—PAPER GOODS AND PRINTED MATTER

FOR BOND PAPER, ILLUSTRATION PAPER, WRITING PAPER, WRITING PAPER PADS, EXERCISE BOOKS, ENVELOPES, DRAWING BOOKS, SKETCH BOOKS, CALENDARS, ERASERS, MAGNETIC BOARDS, PENCIL SHARPENERS, PENCIL CASES, PEN CASES, GLUE FOR STATIONERY USE, PAPER CUTTERS, PAPERWEIGHTS, PAPER FASTENERS, FILE FOLDERS, DESK SETS, DESK TOP ORGANIZERS, PAPER BAGS; PERIODICALS, NAMELY, MAGAZINES, NEWSPAPERS, NEWSLETTERS, JOURNALS AND BULLETINS IN THE FIELD OF MUSIC, EDUCATION, INFORMATIONAL MATERIALS, CURRENT EVENTS, HERITAGE, HISTORY, GEOGRAPHY, POLITICS, BUSINESS, FINANCE, INSURANCE, COMMERCE, AGRICULTURE, INDUSTRY, RELIGION, THE HOME, FAMILY, CHILDCARE, CRAFTS, RECREATION, TRAVEL, SCIENCE TECHNOLOGY, COMMUNICATIONS, THE MEDIA, GOVERNMENT, THE MILITARY, PEOPLE, GAMES, SPORTS, WEATHER, ENTERTAINMENT, HEALTH, LIFESTYLE, FASHION, LEISURE, SHOPPING AND OTHER TOPICS OF GENERAL INTEREST; ARTISTS' PASTELS, PAINT-BRUSHES, PENS, PENCILS, ANNIVERSARY BOOKS, RECIPE BOOKS, GUEST BOOKS; ALBUMS, NAMELY, PHOTO ALBUMS, SOUVENIR ALBUMS, NAMELY, BRAG BOOKS; ADDRESS BOOKS, ANNOUNCEMENT CARDS, APPOINTMENT BOOKS, BABY BOOKS; CARDS, NAMELY, GREETING CARDS, VISITING CARDS; PATTERNS FOR MAKING CLOTHES; PAPER PATCHES FOR CLOTHING (U.S. CLS. 2, 5, 22, 23, 29, 37, 38 AND 50).

CLASS 19—NON-METALLIC BUILDING MATERIALS

FOR BUILDING MATERIALS, NOT OF METAL, NAMELY, CERAMIC TILES, EARTHENWARE TILES, ROOFING TILES, FIRE PLACE BRICKS; NON-METALLIC SHUTTERS, ARCHITECTURAL ELEMENTS, NAMELY, NON-METAL ROOF LIGHTS AND WALL PANELS (U.S. CLS. 1, 12, 33 AND 50).

CLASS 20—FURNITURE AND ARTICLES NOT OTHERWISE CLASSIFIED

FOR FURNITURE, MIRRORS, PICTURE FRAMES; FURNITURE GOODS, NAMELY, CHAIRS, CUPBOARDS, CUSHIONS, DESKS, DIVANS, DRESSERS, TABLES, PILLOWS, DISPLAY UNITS, TELEVISION STANDS, POUFS, SALES AND DISPLAY COUNTERS, SPORTS BAR AND HOSPITALITY UNIT, SHOWCASES, WALL UNITS, WARDROBES, INFLATABLE FURNITURE, LAWN FURNITURE, LIBRARY FURNITURE, LIVING ROOM FURNITURE, METAL FURNITURE AND FURNITURE FOR CAMPING, BEDROOM FURNITURE, BATHROOM FURNITURE, KITCHEN FURNITURE, CABINET DOORS FOR FURNITURE, CABINET DOORS FOR FURNITURE CABINETS, CABINET DRAWERS FOR FURNITURE CABINETS, DRAWERS, FURNITURE CHESTS, OFFICE FURNITURE, OUTDOOR FURNITURE, PATIO FURNITURE, PET FURNITURE, FURNITURE FOR GARDEN, SCHOOL FURNITURE, TOOL BOXES NOT OF METAL, TOOL CHESTS NOT OF METAL, TOOL CHESTS NOT OF METAL, TOWEL CLOSETS, TOY BOXES, UPHOLSTERED FURNITURE, WASHSTAND OF WOOD, CORK, REED, CANE, WICKER, HORN, BONE, IVORY, WHALEBONE, SHELL, AMBER, MOTHER-OF-PEARL, MEERSCHAUM, AND SUBSTITUTES FOR ALL THESE MATERIALS, OR OF PLASTICS (U.S. CLS. 2, 13, 22, 25, 32 AND 50).

CLASS 21—HOUSEWARES AND GLASS

FOR HOUSEHOLD AND KITCHEN UTENSILS AND HOUSEHOLD CONTAINERS NOT OF PRECIOUS METAL OR COATED THEREWITH; COMBS AND BATH SPONGES; BRUSHES, NAMELY, HAIR, NAIL AND TOOTH BRUSHES, COSMETIC BRUSHES, BATH BRUSHES, BILLIARD TABLE BRUSHES, BLACKING BRUSHES, BRUSHES FOR PARQUET FLOORS, DISHWASHING BRUSHES, FLOOR BRUSHES, LAMP GLASS BRUSHES, LIP BRUSHES, SCRAPING BRUSHES, SCRUBBING BRUSHES, SHAVING BRUSHES, SHOE BRUSHES, TOILET BRUSHES; MATERIALS FOR BRUSH-MAKING, ARTICLES FOR CLEANING PURPOSES, NAMELY, CLEANING SPONGES, CLEANING RAGS, CLEANING SWABS FOR COMMERCIAL USES, CLEANING, DUSTING AND POLISHING CLOTHS, CLOTHS FOR CLEANING, METAL WOOL FOR CLEANING, STEEL WOOL FOR CLEANING; STEEL WOOL; UNWORKED OR SEMI-WORKED GLASS, EXCEPT GLASS FOR BUILDING; GLASSWARE, PORCELAIN AND EARTHENWARE, NAMELY, ORNAMENT OF CHINA, CRYSTAL, EARTHENWARE, TERRA COTTA, GLASS, PORCELAIN; PLAQUES OF GLASS, PORCELAIN OR EARTHENWARE; PORCELAIN FLOWER POTS, PORCELAIN KNOBS, PORCELAIN MUGS, PORCELAIN OR EARTHENWARE DOORKNOBS; SCULPTURES OF CHINA, CRYSTAL, EARTHENWARE, TERRA COTTA, GLASS, PORCELAIN; STATUES OF CHINA, CRYSTAL, EARTHENWARE, TERRA COTTA, GLASS, PORCELAIN; STATUETTES OF CHINA, CRYSTAL, EARTHENWARE, TERRA COTTA, GLASS, PORCELAIN; WALL PLAQUES MADE OF CHINA, CRYSTAL, EARTHENWARE, TERRA COTTA, GLASS, PORCELAIN, WORKS OF ART MADE OF PORCELAIN (U.S. CLS. 2, 13, 23, 29, 30, 33, 40 AND 50).

CLASS 23—YARNS AND THREADS

FOR YARNS AND THREADS FOR TEXTILE USE (U.S. CL. 43).

CLASS 24—FABRICS

FOR TEXTILES AND TEXTILE GOODS, NOT INCLUDED IN OTHER CLASSES, NAMELY, CASHMERE FABRIC, CHEMICAL FIBRE FABRIC, CHENILLE FABRIC, CHEVIOT FABRIC, COTTON BASE MIXED FABRICS, COTTON FABRIC, COVERED RUBBER YARN FABRIC, CURTAIN FABRIC, CURTAINS MADE OF TEXTILE FABRICS, ELASTIC FABRICS FOR CLOTHING, ELASTIC YARN MIXED FABRICS, ESPARTO FABRICS; FABRIC FLAGS, FABRIC FOR BOOTS AND SHOES, FABRIC FOR WRAPPING BUNDLES, FABRIC OF IMITATION ANIMAL SKIN, FABRIC THAT MAY OR MAY NOT HAVE PRINTED PATTERNS AND DESIGNS

THEREON FOR USE IN TEXTILE APPLICATIONS, NAMELY, THE MANUFACTURE OF APPAREL, UPHOLSTERY, SIGNAGE, FLAGS, BANNERS AND WALL-PAPER, FABRIC USED IN HOME DECORATIVE ITEMS WITH INSPIRATIONAL MESSAGES IMPRINTED OR WOVEN INTO THE FABRICS, FELT AND NON-WOVEN TEXTILE FABRICS, FIBRE GLASS FABRIC FOR TEXTILE USE, FIBRE GLASS MESH-WOVEN REINFORCEMENT FABRIC FOR USE IN REINFORCING PLASTIC, RUBBER, METAL, BITUMEN, PLASTER, PAPER AND TEXTILES, FIBRE GLASS REINFORCEMENT FABRICS FOR USE IN LAND, SEA AND AEROSPACE APPLICATIONS, FIREPROOF UPHOLSTERY FABRICS, FOU-LARD, FURNISHING AND UPHOLSTERY FABRICS, GAUZE FABRIC, GIFT WRAP OF FABRIC, HAND SPUN SILK FABRICS, HAND-TOWELS MADE OF TEXTILES FABRICS, HEAT-ACTIVATED ADHESIVE FABRICS, HEMP BASE MIXED FABRICS, HEMP YARN FABRICS, HEMP-COTTON MIXED FABRICS, HEMP-SILK MIXED FABRICS, HEMP-WOOL MIXED FABRICS, INORGANIC FIBER MIXED FABRICS, INTERIOR DECORATION FABRICS, JEANS FABRIC, JERSEY FABRICS FOR CLOTHING, JERSEY MATERIAL, JUTE FABRICS, KIT COMPRISED OF FABRICS FOR MAKING QUILTS, KNITTED FABRIC, LINEN, LINGERIE FABRIC, MESH-WOVEN FABRIC, MIXED FIBER FABRICS; NYLON FABRIC, PILED FABRIC, POLYESTER FABRIC, RAMIE FABRIC, RAYON FABRICS, REGENERATED FIBER YARN FABRICS, WOOL BASE MIXED FABRIC, WOOL YARN FABRIC, WOOL-COTTON MIXED FABRICS, ZEPHYR FABRIC, BED AND TABLE LINEN, WALL HANGINGS OF TEXTILE, BEAVER SKIN BED BLANKETS, BEAVER SKIN BLANKET TROWS, BED BLANKETS, BLANKETS FOR OUTDOOR USE, CASHMERE BLANKETS, CHILDREN'S BLANKETS, LAP BLANKETS, PET BLANKETS, RECEIVING BLANKETS, SILK BED BLANKETS, SILK BLANKETS, TRAVELLING BLANKETS (U.S. CLS. 42 AND 50).

CLASS 27—FLOOR COVERINGS

FOR CARPETS, RUGS, MATS AND MATTING, LINOLEUM FOR COVERING EXISTING FLOORS; NON-TEXTILE WALL HANGINGS (U.S. CLS. 19, 20, 37, 42 AND 50).

CLASS 28—TOYS AND SPORTING GOODS

FOR DOLLS, MASCOT DOLLS, FACE MASKS, BOARD GAMES, BALLOONS, BASE-BALLS, TABLE TENNIS KITS, COMPRISING NETS, BALLS, PADDLES, POST SETS AND RACKETS, HOCKEY STICKS, BOWLING BALLS, SKIS, SOCCER BALLS, AND BALLS FOR GAMES, ACTION FIGURES AND ACCESSORIES THEREOF, AMUSEMENT GAME MACHINES, BOARD GAMES, CARD GAMES, CHRISTMAS TREE DECORATIONS, CONSTRUCTION TOYS; PLAYING CARD CASES MADE OF LEATHER (U.S. CLS. 22, 23, 38 AND 50).

CLASS 29—MEATS AND PROCESSED FOODS

FOR MEAT, FISH, POULTRY AND GAME; MEAT EXTRACTS; PRESERVED, DRIED AND COOKED FRUIT AND VEGETABLES; JELLIES, JAMS, COM-POTES; EGGS, MILK AND MILK PRODUCTS EXCLUDING ICE CREAM, ICE MILK AND FROZEN YOGURT; EDIBLE OILS AND FATS (U.S. CL. 46).

CLASS 30—STAPLE FOODS

FOR COFFEE, TEA, SUGAR, RICE, TAPIOCA, SAGO, ARTIFICIAL COFFEE, BREAD, PASTRY AND CONFECTIONERY, NAMELY, PASTILLES, FLAVOURED ICES; HONEY, TREACLE, YEAST, BAKING-POWDER, SALT, MUSTARD, VINEGAR, SAUCES; SPICES; ICE FOR REFRESHMENT (U.S. CL. 46).

CLASS 31—NATURAL AGRICULTURAL PRODUCTS

FOR AGRICULTURAL, HORTICULTURAL AND FORESTRY PRODUCTS AND GRAINS, NAMELY, AGRICULTURAL GRAINS FOR PLANTING, AGRICULTURAL SEEDS, BULBS FOR AGRICULTURAL PURPOSES, SPORES AND SPAWN FOR AGRICULTURAL PURPOSES, BULBS FOR HORTICULTURAL PURPOSES, SEEDS FOR HORTICULTURAL PURPOSES, FRESH FRUIT AND VEGETABLES; SEEDS AND BULBS, NATURAL PLANTS AND FLOWERS; ANIMAL FOODSTUFFS, MALT FOR BREWING AND DISTILLING (U.S. CLS. 1 AND 46).

CLASS 32—LIGHT BEVERAGES

FOR BEERS, MINERAL AND AERATED WATERS AND OTHER NON-ALCOHOLIC BEVERAGES, NAMELY, ALCOHOL-FREE BEERS, BEER, ALE, LAGER, STOUT, PORTER, SHANDY, BEER-BASED COOLERS, BLACK BEER TOASTED-MALT BEER, BREWED MALT-BASED ALCOHOLIC BEVERAGE IN THE NATURE OF A BEER, COFFEE-FLAVORED BEER, DE-ALCOHOLISED BEER, EXTRACTS OF HOPS FOR MAKING BEER, FLAVORED BEERS, GINGER BEER, HOP EXTRACTS FOR MANUFACTURING BEER, MALT LIQUOR BEER OR ALE, PALE BEER; CARBONATED WATERS, COCONUT WATER, ESSENCES FOR MAKING FLAVOURED MINERAL WATER NOT IN THE NATURE OF ESSENTIAL OILS, FLAVORED WATERS, GLACIAL WATER, SCENTED WATER FOR MAKING BEVERAGES, SELTZER WATER, SODA WATER, SPARKLING WATER, SPRING WATER, STILL WATERS, WATER BEVERAGES; FRUIT DRINK AND FRUIT JUICES; SYRUPS AND OTHER PREPARATIONS FOR MAKING BEVERAGES, NAMELY, COCONUT-BASED NON-ALCOHOLIC BEVERAGES, ESSENCES FOR MAKING NON-ALCOHOLIC BEVERAGES NOT IN THE NATURE OF ESSENTIAL OILS; KVASS NON-ALCOHOLIC BEVERAGES, NON-ALCOHOLIC BEVERAGES, NAMELY, CARBONATED BEVERAGES, NON-ALCOHOLIC BEVERAGES CONTAINING FRUIT JUICES, NON-ALCOHOLIC BEVERAGES WITH TEA FLAVOR, NON-ALCOHOLIC FRUIT EXTRACTS USED IN THE PREPARATION OF BEVERAGES, NON-ALCOHOLIC FRUIT JUICE BEVERAGES, NON-ALCOHOLIC HONEY-BASED BEVERAGES, NON-ALCOHOLIC MALT BEVERAGE, NON-ALCOHOLIC RICE-BASED BEVERAGES NOT BEING MILK SUBSTITUTES, NON-ALCOHOLIC FRUIT EXTRACTS USED IN THE PREPARATION OF BEVERAGES, PREPARED ENTREES CONSISTING OF FRUIT DRINKS AND FRUIT JUICES, FRUIT-BASED BEVERAGES, NON-ALCOHOLIC FRUIT JUICE BEVERAGES, VEGETABLE JUICES, VEGETABLE-FRUIT JUICES AND SMOOTHIES FRUIT BEVERAGES, FRUIT PREDOMINATING, SYRUPS FOR MAKING NON-ALCOHOLIC BEVERAGES (U.S. CLS. 45, 46 AND 48).

CLASS 42—SCIENTIFIC AND COMPUTER SERVICES

FOR SCIENTIFIC AND TECHNOLOGICAL SERVICES AND RESEARCH AND DESIGN SERVICES RELATING THERETO, NAMELY, FASHION DESIGN CONSULTING SERVICES, CUSTOM DESIGN OF CLOTHING; INTERIOR DESIGN SERVICES, NAMELY, SPACE PLANNING, FURNITURE SELECTION, MATERIAL AND SURFACE SELECTION; COMPUTER SERVICES, NAMELY, CREATING AN ON-LINE COMMUNITY FOR REGISTERED USERS TO PARTICIPATE IN DISCUSSIONS, GET FEEDBACK FROM THEIR PEERS, FORM VIRTUAL COMMUNITIES, AND ENGAGE IN SOCIAL NETWORKING FEATURING SOCIAL MEDIA AND TOPICS ON JEWELRY AND FASHION ACCESSORIES (U.S. CLS. 100 AND 101).

PAUL MORENO, EXAMINING ATTORNEY

SN 79-079,462. ROBERTO CAVALLI S.P.A., MILANO, ITALY, FILED 12-23-2009.

roberto cavalli

PRIORITY DATE OF 12-21-2009 IS CLAIMED.
OWNER OF INTERNATIONAL REGISTRATION 1030290
DATED 12-23-2009, EXPIRES 12-23-2019.
OWNER OF U.S. REG. NOS. 2,937,821, 3,432,649 AND OTHERS.

THE NAME(S), PORTRAIT(S), AND/OR SIGNATURE(S) SHOWN IN THE MARK IDENTIFIES "ROBERTO CAVALLI", WHOSE CONSENT(S) TO REGISTER IS MADE OF RECORD.

THE MARK CONSISTS OF THE STYLIZED WORDING "ROBERTO CAVALLI".

CLASS 8—HAND TOOLS

FOR TABLEWARE, NAMELY, KNIVES, FORKS AND SPOONS; STERLING SILVER TABLE FORKS (U.S. CLS. 23, 28 AND 44).

CLASS 11—ENVIRONMENTAL CONTROL APPARATUS

FOR APPARATUS FOR LIGHTING, NAMELY, LAMPS, GAS LAMPS, INCANDESCENT LAMPS AND THEIR FITTINGS, INFRARED LAMP FIXTURES, LAMP BASES, LAMP BULBS, LAMP CHIMNEYS, LAMP FINIALS, LAMP REFLECTORS, LAMP SHADES, LAMP WHOSE LIGHT CAN BE TURNED IN ALL DIRECTIONS, LAMPS FOR OUTDOOR USE, MERCURY LAMPS, OIL LAMPS, OVERHEAD LAMPS, SOLDERING LAMPS, SUN LAMPS, ULTRAVIOLET LAMPS NOT FOR MEDICAL PURPOSES, ULTRAVIOLET RAY LAMPS, NOT FOR MEDICAL PURPOSES, UV HALOGEN METAL VAPOUR LAMPS; TOOLS, COMPONENTS AND SUPPLIES FOR USE IN MAKING SIGNS, NAMELY, FLUORESCENT, HID, LED AND INCANDESCENT BULBS, LAMPS AND FIXTURES (U.S. CLS. 13, 21, 23, 31 AND 34).

CLASS 16—PAPER GOODS AND PRINTED MATTER

FOR BOND PAPER, ILLUSTRATION PAPER, WRITING PAPER, WRITING PAPER PADS, EXERCISE BOOKS, ENVELOPES, DRAWING BOOKS, SKETCH BOOKS, CALENDARS, ERASERS, MAGNETIC BOARDS, PENCIL SHARPENERS, PENCIL CASES, PEN CASES, GLUE FOR STATIONERY USE, PAPER CUTTERS, PAPERWEIGHTS, PAPER FASTENERS, FILE FOLDERS, DESK SETS, DESK TOP ORGANIZERS, PAPER BAGS; PERIODICALS, NAMELY, MAGAZINES, NEWSPAPERS, NEWSLETTERS, JOURNALS AND BULLETINS IN THE FIELD OF MUSIC, EDUCATION, INFORMATIONAL MATERIALS, CURRENT EVENTS, HERITAGE, HISTORY, GEOGRAPHY, POLITICS, BUSINESS, FINANCE, INSURANCE, COMMERCE, AGRICULTURE, INDUSTRY, RELIGION, THE HOME, FAMILY, CHILDCARE, CRAFTS, RECREATION, TRAVEL, SCIENCE TECHNOLOGY, COMMUNICATIONS, THE MEDIA, GOVERNMENT, THE MILITARY, PEOPLE, GAMES, SPORTS, WEATHER, ENTERTAINMENT, HEALTH, LIFESTYLE, FASHION, LEISURE, SHOPPING AND OTHER TOPICS OF GENERAL INTEREST; ARTISTS' PASTELS, PAINTBRUSHES, PENS, PENCILS, ANNIVERSARY BOOKS, RECIPE BOOKS, GUEST BOOKS; ALBUMS, NAMELY, PHOTO ALBUMS, SOUVENIR ALBUMS, NAMELY, BRAG BOOKS; ADDRESS BOOKS, ANNOUNCEMENT CARDS, APPOINTMENT BOOKS, BABY BOOKS; CARDS, NAMELY, GREETING CARDS, VISITING CARDS; PATTERNS FOR MAKING CLOTHES; PAPER PATCHES FOR CLOTHING (U.S. CLS. 2, 5, 22, 23, 29, 37, 38 AND 50).

CLASS 19—NON-METALLIC BUILDING MATERIALS

FOR BUILDING MATERIALS, NOT OF METAL, NAMELY, CERAMIC TILES, EARTHENWARE TILES, ROOFING TILES, FIRE PLACE BRICKS; NON-METALLIC SHUTTERS, ARCHITECTURAL ELEMENTS, NAMELY, NON-METAL ROOF LIGHTS AND WALL PANELS (U.S. CLS. 1, 12, 33 AND 50).

CLASS 23—YARNS AND THREADS

FOR YARNS AND THREADS FOR TEXTILE USE (U.S. CL. 43).

CLASS 24—FABRICS

FOR TEXTILES AND TEXTILE GOODS, NOT INCLUDED IN OTHER CLASSES, NAMELY, CASHMERE FABRIC, CHEMICAL FIBRE FABRIC, CHENILLE FABRIC, CHEVIOT FABRIC, COTTON BASE MIXED FABRICS, COTTON FABRIC, COVERED RUBBER YARN FABRIC FOR TEXTILE USE; CURTAIN FABRIC, CURTAINS MADE OF TEXTILE FABRICS, ELASTIC FABRICS FOR CLOTHING, ELASTIC YARN MIXED FABRICS, ESPARTO FABRICS; FABRIC FLAGS, FABRIC FOR BOOTS AND SHOES, FABRIC FOR WRAPPING BUNDLES, FABRIC OF IMITATION ANIMAL SKIN, FABRIC THAT MAY OR MAY NOT HAVE PRINTED PATTERNS AND DESIGNS THEREON FOR USE IN TEXTILE APPLICATIONS, NAMELY, THE MANUFACTURE OF APPAREL, UPHOLSTERY, SIGNAGE, FLAGS, BANNERS AND WALLPAPER, FABRIC USED IN HOME DECORATIVE ITEMS WITH INSPIRATIONAL MESSAGES IMPRINTED OR WOVEN INTO THE FABRICS, FELT AND NON-WOVEN TEXTILE FABRICS, FIBREGLASS FABRIC FOR TEXTILE USE, FIBREGLASS MESH-WOVEN REINFORCEMENT FABRIC FOR USE IN REINFORCING PLASTIC, RUBBER, METAL, BITUMEN, PLASTER, PAPER AND TEXTILES, FIBREGLASS REINFORCEMENT FABRICS FOR USE IN LAND, SEA AND AEROSPACE APPLICATIONS, FIREPROOF UPHOLSTERY FABRICS, FOULARD FABRIC, FURNISHING AND UPHOLSTERY FABRICS, GAUZE FABRIC, GIFT WRAP OF FABRIC, HAND SPUN SILK FABRICS, HAND-TOWELS MADE OF TEXTILES FABRICS, HEAT-ACTIVATED ADHESIVE FABRICS, HEMP BASE MIXED FABRICS, HEMP YARN FABRICS, HEMP-COTTON MIXED FABRICS, HEMP-SILK MIXED FABRICS, HEMP-WOOL MIXED FABRICS, INORGANIC FIBER MIXED FABRICS, INTERIOR DECORATION FABRICS, JEANS FABRIC, JERSEY FABRICS FOR CLOTHING, JERSEY MATERIAL FABRIC, JUTE FABRICS, KIT COMPRISED OF FABRICS FOR MAKING QUILTS, KNITTED FABRIC, LINEN FABRIC, LINGERIE FABRIC, MESH WOVEN FABRIC, MIXED FIBER FABRICS; NYLON FABRIC, PILED FABRIC, POLYESTER FABRIC, RAMIE FABRIC, RAYON FABRICS, REGENERATED FIBER YARN FABRICS, WOOL BASE MIXED FABRIC, WOOL YARN FABRIC, WOOL-COTTON MIXED FABRICS, ZEPHYR FABRIC (U.S. CLS. 42 AND 50).

CLASS 28—TOYS AND SPORTING GOODS

FOR DOLLS, MASCOT DOLLS, FACE MASKS, BOARD GAMES, BALLOONS, BASE-BALLS, TABLE TENNIS KITS, COMPRISING NETS, BALLS, PADDLES, POST SETS AND RACKETS, HOCKEY STICKS, BOWLING BALLS, SKIS, SOCCER BALLS, AND BALLS FOR GAMES, ACTION FIGURES AND ACCESSORIES THEREOF, AMUSEMENT GAME MACHINES, BOARD GAMES, CARD GAMES, CHRISTMAS TREE DECORATIONS, CONSTRUCTION TOYS; PLAYING CARD CASES MADE OF LEATHER (U.S. CLS. 22, 23, 38 AND 50).

CLASS 31—NATURAL AGRICULTURAL PRODUCTS

FOR AGRICULTURAL, HORTICULTURAL AND FORESTRY PRODUCTS AND GRAINS, NAMELY, AGRICULTURAL GRAINS FOR PLANTING, AGRICULTURAL SEEDS, BULBS FOR AGRICULTURAL PURPOSES, SPORES AND SPAWN FOR AGRICULTURAL PURPOSES, BULBS FOR HORTICULTURAL PURPOSES, SEEDS FOR HORTICULTURAL PURPOSES, FRESH FRUIT AND VEGETABLES; SEEDS AND BULBS, NATURAL PLANTS AND FLOWERS; ANIMAL FOODSTUFFS, MALT FOR BREWING AND DISTILLING (U.S. CLS. 1 AND 46).

CLASS 32—LIGHT BEVERAGES

FOR BEERS, MINERAL AND AERATED WATERS AND OTHER NON-ALCOHOLIC BEVERAGES, NAMELY, ALCOHOL-FREE BEERS, BEER, ALE, LAGER, STOUT, PORTER, SHANDY, BEER-BASED COOLERS, BLACK BEER TOASTED-MALT BEER, BREWED MALT-BASED ALCOHOLIC BEVERAGE IN THE NATURE OF A BEER, COFFEE-FLAVORED BEER, DE-ALCOHOLISED BEER, EXTRACTS OF HOPS FOR MAKING BEER, FLAVORED BEERS, GINGER BEER, HOP EXTRACTS FOR MANUFACTURING BEER, MALT LIQUOR BEER OR ALE, PALE BEER; CARBONATED WATERS, COCONUT WATER, ESSENCES FOR MAKING FLAVOURED MINERAL WATER NOT IN THE NATURE OF ESSENTIAL OILS, FLAVORED WATERS, GLACIAL WATER, SCENTED WATER FOR MAKING BEVERAGES, SELTZER WATER, SODA WATER, SPARKLING WATER, SPRING WATER, STILL WATERS, WATER BEVERAGES; FRUIT DRINK AND FRUIT JUICES; SYRUPS AND OTHER PREPARATIONS FOR MAKING BEVERAGES, NAMELY, COCONUT-BASED NON-ALCOHOLIC BEVERAGES, ESSENCES FOR MAKING NON-ALCOHOLIC BEVERAGES NOT IN THE NATURE OF ESSENTIAL OILS; KVASS NON-ALCOHOLIC BEVERAGES, NON-ALCOHOLIC BEVERAGES, NAMELY, CARBONATED BEVERAGES, NON-ALCOHOLIC BEVERAGES CONTAINING FRUIT JUICES, NON-ALCOHOLIC BEVERAGES WITH TEA FLAVOR, NON-ALCOHOLIC FRUIT EXTRACTS USED IN THE PREPARATION OF BEVERAGES, NON-ALCOHOLIC FRUIT JUICE BEVERAGES, NON-ALCOHOLIC HONEY-BASED BEVERAGES, NON-ALCOHOLIC MALT BEVERAGE, NON-ALCOHOLIC RICE-BASED BEVERAGES NOT BEING MILK SUBSTITUTES, NON-ALCOHOLIC FRUIT EXTRACTS USED IN THE PREPARATION OF BEVERAGES, PREPARED ENTREES CONSISTING OF FRUIT DRINKS AND FRUIT JUICES, FRUIT-BASED BEVERAGES, NON-ALCOHOLIC FRUIT JUICE BEVERAGES, VEGETABLE JUICES, VEGETABLE-FRUIT JUICES AND SMOOTHIES FRUIT BEVERAGES, FRUIT PREDOMINATING, SYRUPS FOR MAKING NON-ALCOHOLIC BEVERAGES (U.S. CLS. 45, 46 AND 48).

CLASS 42—SCIENTIFIC AND COMPUTER SERVICES

FOR SCIENTIFIC AND TECHNOLOGICAL SERVICES AND RESEARCH AND DESIGN SERVICES RELATING THERETO, NAMELY, FASHION DESIGN CONSULTING SERVICES, CUSTOM DESIGN OF CLOTHING; INTERIOR DESIGN SERVICES, NAMELY, SPACE PLANNING, FURNITURE SELECTION, MATERIAL AND SURFACE SELECTION; COMPUTER SERVICES, NAMELY, CREATING AN ON-LINE COMMUNITY FOR REGISTERED USERS TO PARTICIPATE IN DISCUSSIONS, GET FEEDBACK FROM THEIR PEERS, FORM VIRTUAL COMMUNITIES, AND ENGAGE IN SOCIAL NETWORKING FEATURING SOCIAL MEDIA AND TOPICS ON JEWELRY AND FASHION ACCESSORIES (U.S. CLS. 100 AND 101).

PAUL MORENO, EXAMINING ATTORNEY

SN 79-079,598. CUPIRE PADESA, S.L., E-32330 ORENSE, SPAIN, FILED 1-4-2010.



PRIORITY DATE OF 7-7-2009 IS CLAIMED.
OWNER OF INTERNATIONAL REGISTRATION 1030595 DATED 1-4-2010, EXPIRES 1-4-2020.
THE COLOR(S) GREY, RED, BLACK AND WHITE IS/ARE CLAIMED AS A FEATURE OF THE MARK.
THE MARK CONSISTS OF THE WORDING "THERMOSLATE" WITH THE DESIGN OF A RED CIRCLE WITH THREE WHITE BARS AS THE "O" AND THE LETTERING "THERM" IN GREY AND THE LETTERING "SLATE" IN BLACK.

CLASS 6—METAL GOODS

FOR COMMON METALS AND THEIR ALLOYS; BUILDING MATERIALS OF METAL, NAMELY, METAL REINFORCEMENT MATERIALS FOR BUILDING, METAL ROOFS FOR BUILDING, METAL WALLS FOR BUILDING, METAL FLOORS FOR BUILDING; TRANSPORTABLE BUILDINGS OF METAL; MATERIALS OF METAL FOR RAILWAY TRACKS; NON-ELECTRIC CABLES AND WIRES OF COMMON METAL; IRON-MONGERY AND SMALL ITEMS OF METAL HARDWARE, NAMELY, METAL SUPPORTS, METAL BRACKETS, HOOKS OF METAL AND NAILS OF METAL; PIPES AND TUBES OF METAL; METAL SAFES; ORES, NAMELY, IRON ORES, ALUMINUM ORES, COPPER ORES, AND ZINC ORES (U.S. CLS. 2, 12, 13, 14, 23, 25 AND 50).

CLASS 11—ENVIRONMENTAL CONTROL APPARATUS

FOR SOLAR WATER HEATERS, SOLAR POOL HEATERS, SOLAR CENTRAL HEATERS, SOLAR SPACE HEATERS, STEAM GENERATORS, SOLAR SAUNAS, SOLAR COOKERS, SOLAR STOVES, SOLAR OVENS, SOLAR FOOD DRYERS, ELECTRIC FOOD DRYERS, ELECTRIC STOVES, ELECTRIC OVENS, SOLAR REFRIGERATORS, SOLAR DESALINATORS, SOLAR AIR CONDITIONERS; SOLAR STILL, SOLAR WATER DISTILLERS; SOLAR SANITARY WATER HEATERS, SOLAR SHOWERS (U.S. CLS. 13, 21, 23, 31 AND 34).

CLASS 19—NON-METALLIC BUILDING MATERIALS

FOR NON-METAL BUILDING MATERIALS, NAMELY, LUMBER; RIGID PIPES, NOT OF METAL, FOR BUILDING; ASPHALT, PITCH AND BITUMEN; NON-METALLIC TRANSPORTABLE BUILDINGS; NON-METAL MONUMENTS (U.S. CLS. 1, 12, 33 AND 50).

KRISTIN DAHLING, EXAMINING ATTORNEY

SN 79-080,205. EXANE, F-75008 PARIS, FRANCE, FILED 11-3-2009.



THE MARK CONSISTS OF STANDARD CHARACTERS WITHOUT CLAIM TO ANY PARTICULAR FONT, STYLE, SIZE, OR COLOR.

PRIORITY DATE OF 5-7-2009 IS CLAIMED.
OWNER OF INTERNATIONAL REGISTRATION 1032226 DATED 11-3-2009, EXPIRES 11-3-2019.

CLASS 9—ELECTRICAL AND SCIENTIFIC APPARATUS

FOR COMPUTER SOFTWARE AND COMPUTER SOFTWARE PACKAGES FOR USE IN THE FINANCIAL FIELD, NAMELY, FOR DIRECTING ORDERS FOR SECURITIES TRADES AND FOR RECEIVING, PROCESSING, TRANSMITTING AND DISPLAYING FINANCIAL DATA AND INFORMATION AND FOR USE AS ANALYTICAL TOOLS FOR INVESTMENT PORTFOLIOS TO CALCULATE THE INVESTMENT PERFORMANCE AND FINANCIAL RETURNS OF A SET OF TRANSACTIONS; CALCULATING MACHINES USED EXCLUSIVELY IN THE FINANCIAL AREA; PRERECORDED MAGNETIC, OPTICAL, AND ELECTRONIC DATA CARRIERS FEATURING FINANCIAL DATA AND INFORMATION; COMPUTER INTERFACES EXCLUSIVELY IN THE FINANCIAL AREA; DOWNLOADABLE ELECTRONIC PUBLICATIONS, NAMELY, NEWSLETTERS AND MAGAZINES IN THE FIELD OF FINANCE (U.S. CLS. 21, 23, 26, 36 AND 38).

CLASS 16—PAPER GOODS AND PRINTED MATTER

FOR PRINTED PUBLICATIONS, NAMELY, NEWSLETTERS AND MAGAZINES IN THE FIELD OF FINANCE; INSTRUCTION MANUALS IN THE FIELD OF FINANCE (U.S. CLS. 2, 5, 22, 23, 29, 37, 38 AND 50).

CLASS 35—ADVERTISING AND BUSINESS

FOR BUSINESS MANAGEMENT ASSISTANCE; BUSINESS APPRAISALS; MARKET STUDIES; MARKET RESEARCH; STATISTICAL SERVICES, NAMELY, COMPILATION OF STATISTICS AND PROVIDING STATISTICAL INFORMATION; ECONOMIC FORECASTING; COMPUTERIZED FILE MANAGEMENT; DATABASE MANAGEMENT; STORAGE OF DATA AND INFORMATION BY ELECTRONIC AND COMPUTER MEANS; DATA AND INFORMATION PROCESSING BY ELECTRONIC AND COMPUTER MEANS, NAMELY, INPUT, UPDATING (U.S. CLS. 100, 101 AND 102).

CLASS 36—INSURANCE AND FINANCIAL

FOR FINANCIAL ESTIMATES, NAMELY, PROVIDING FINANCIAL EVALUATION, TRACKING, ANALYSIS, FORECASTING, CONSULTANCY, ADVISORY AND RESEARCH SERVICES RELATING TO SECURITIES AND OTHER FINANCIAL INSTRUMENTS; FINANCIAL CONSULTANCY, NAMELY, SERVICES FOR SELECTION, RATING, CLASSIFICATION OF COMPANIES; FINANCIAL AFFAIRS, NAMELY, FINANCIAL INFORMATION, MANAGEMENT AND ANALYSIS SERVICES; FINANCIAL INFORMATION; SERVICES FOR INVESTING AND MANAGING TRANSFERABLE SECURITY PORTFOLIOS (U.S. CLS. 100, 101 AND 102).

CLASS 38—COMMUNICATION

FOR COMMUNICATIONS SERVICES, NAMELY, PROVIDING MULTIPLE USER ACCESS TO DATA ON THE INTERNET OR ANY OTHER SECURED COMMUNICATION NETWORK IN THE FIELD OF FINANCIAL, ECONOMIC AND BANKING INFORMATION (U.S. CLS. 100, 101 AND 104).

CLASS 41—EDUCATION AND ENTERTAINMENT

FOR SOFTWARE PUBLISHING; PROVIDING OF TRAINING FOR IMPLEMENTING COMPUTER PROGRAMS (U.S. CLS. 100, 101 AND 107).

CLASS 42—SCIENTIFIC AND COMPUTER SERVICES

FOR RECOVERY OF DATABASES; COMPUTER SOFTWARE CONSULTANCY EXCLUSIVELY IN THE FINANCIAL AREA; MAINTENANCE OF COMPUTER SOFTWARE EXCLUSIVELY IN THE FINANCIAL AREA; COMPUTER SOFTWARE DESIGN EXCLUSIVELY IN THE FINANCIAL AREA; RENTAL OF COMPUTER SOFTWARE EXCLUSIVELY IN THE FINANCIAL AREA; INSTALLING COMPUTER SOFTWARE EXCLUSIVELY IN THE FINANCIAL AREA; UPDATING OF COMPUTER SOFTWARE EXCLUSIVELY IN THE FINANCIAL AREA (U.S. CLS. 100 AND 101).

JAMES A. RAUEN, EXAMINING ATTORNEY

SN 79-080,288. BLUE & GREEN MARINE LTD, UNITED KINGDOM, FILED 9-16-2009.



PRIORITY DATE OF 3-16-2009 IS CLAIMED.
OWNER OF INTERNATIONAL REGISTRATION 1032490 DATED 9-16-2009, EXPIRES 9-16-2019.

NO CLAIM IS MADE TO THE EXCLUSIVE RIGHT TO USE "MARINE", APART FROM THE MARK AS SHOWN.

THE COLOR(S) DARK BLUE, LIGHT GREY-BLUE AND GREEN IS/ARE CLAIMED AS A FEATURE OF THE MARK.

THE MARK COMPRISES THREE RIBBON-LIKE ELEMENTS ABOVE THE WORDS "BLUE & GREEN MARINE"; THE RIBBON-LIKE ELEMENTS BEING DARK BLUE, LIGHT GREY-BLUE AND GREEN IN COLOUR; THE WORDS "BLUE, & AND MARINE" ARE BLUE; THE WORD "GREEN" IS GREEN.

CLASS 6—METAL GOODS

FOR MOORING BUOYS, PADLOCKS, KEYRINGS, HINGES, TURNBUCKLES, LADDERS, WEATHER VANES, WINDOW FRAMELATCHES, METAL BLOCKS FOR LIFTING AND RIGGING, ALL OF COMMON METAL; BUCKLES, SHACKLES, BOLTS AND CLAMPS, ALL OF COMMON METAL; METAL CHAINS OF COMMON METAL, NON-ELECTRIC METAL CABLES, WIRE ROPES; HOOKS, FLOATING DOCKS ALL OF COMMON METAL FOR MOORING BOATS, LADDERS OF METAL, MASTS OF METAL; ANCHORS, ROWLOCKS OF COMMON METALS AND THEIR ALLOYS NOT INCLUDED IN ANY OTHER CLASSES (U.S. CLS. 2, 12, 13, 14, 23, 25 AND 50).

CLASS 9—ELECTRICAL AND SCIENTIFIC APPARATUS

FOR MARINE RADAR EQUIPMENT, NAMELY, RADAR DISPLAY, TURNING UNITS AND ANTENNAS, AND SHIP-TO-SHORE/SHIP AND SHIP TO SATELLITE TO SHORE/SHIP TELECOMMUNICATIONS EQUIPMENT AND APPARATUS, NAMELY, TRANSCEIVERS, AERIALS, SPEAKERS AND MICROPHONES; NAVIGATIONAL AND CONTROL COMPUTER HARDWARE AND SOFTWARE; MARINE ELECTRONIC AND ELECTRICAL APPARATUS AND EQUIPMENT ASSOCIATED WITH ANTI-FOULING EQUIPMENT, NAMELY, ULTRASONIC TRANSDUCERS AND CONTROL EQUIPMENT; ULTRASOUND DEVICES, NAMELY, AQUATIC ANTI FOULING SYSTEMS, MARINE DEPTH SOUNDERS, ELECTRONIC FISH FINDERS; MAGNETIC RECORDING MEDIA, USB DATA STORAGE DEVICES, CD-ROMS, AND OTHER ELECTRONIC RECORDING MEDIA, ALL CONTAINING DIGITAL MAP DATA OR COMPUTER PROGRAMMES AND SOFTWARE FOR NAVIGATIONAL OR COMMUNICATIONS PURPOSES OR FOR DETECTION OR LOCATING PURPOSES; COMPUTER SOFTWARE FOR PROVIDING MAP, NAVIGATION, TRAFFIC, WEATHER AND POINT-OF-INTEREST INFORMATION VIA A COMMUNICATIONS NETWORK; NAUTICAL SIGNALLING APPARATUS AND INSTRUMENTS, NAMELY, NAVIGATION LIGHTS AND SIGNALLING LIGHTS; APPARATUS FOR RECORDING, TRANSMITTING AND REPRODUCING SOUND OR IMAGES; APPARATUS AND INSTRUMENTS FOR THE SUPPLY, DISTRIBUTION, TRANSFORMATION, ACCUMULATION, REGULATION OR CONTROL OF ELECTRIC CURRENT; BATTERIES; CHARGERS FOR ELECTRIC BATTERIES; MARINE ELECTRICAL SWITCHING AND WIRING EQUIPMENT; SOLAR CELLS; MARINE RADIO COMMUNICATION APPARATUS, RADAR; SWITCHES, SWITCHBOARDS AND SWITCH PANELS, ALL BEING ELECTRIC; MARKING BUOYS AND SIGNALLING BUOYS; BINOCULARS, NAUTICAL OPTICAL INSTRUMENTS, NAMELY, BINOCULARS, TELESCOPES AND COMPASSES; SUNGLASSES AND SPORTS GLASSES; METEOROLOGICAL INSTRUMENTS; GLOBAL POSITIONING SATELLITE (GPS) NAVIGATION SIGNAL RECEIVERS; PARTS AND FITTINGS FOR ALL THE AFORESAID GOODS (U.S. CLS. 21, 23, 26, 36 AND 38).

CLASS 12—VEHICLES

FOR NAUTICAL VEHICLES, NAMELY, YACHTS, SHIPS, DINGHIES, LAUNCHES AND BOATS; INCLINED WAYS FOR BOATS EQUIPPED WITH ULTRA-SOUND ANTIFOULING SYSTEMS; RUDDERS; RUDDERS EQUIPPED WITH ULTRA-SOUND DEVICE ANTIFOULING SYSTEMS; SHOCK-ABSORBERS AND FENDERS ALL FOR BOATS AND SHIPS; SHOCK-ABSORBERS AND FENDERS ALL FOR BOATS AND SHIPS EQUIPPED WITH ULTRA-SOUND DEVICE ANTI FOULING SYSTEMS; PONTOONS, NAMELY, MARINA PONTOONS, HARBOR PONTOONS AND WATERWAY PONTOONS; PONTOONS, NAMELY, MARINA PONTOONS, HARBOR PONTOONS AND WATERWAY PONTOONS EQUIPPED WITH ULTRA-SOUND DEVICES (U.S. CLS. 19, 21, 23, 31, 35 AND 44).

JAMES A. RAUEN, EXAMINING ATTORNEY

SN 79-080,347. DURAVIT AG, FED REP GERMANY, FILED 3-2-2010.

THE MARK CONSISTS OF STANDARD CHARACTERS WITHOUT CLAIM TO ANY PARTICULAR FONT, STYLE, SIZE, OR COLOR.

OWNER OF INTERNATIONAL REGISTRATION 1032680
DATED 3-2-2010, EXPIRES 3-2-2020.
THE WORDING "INIPI" HAS NO MEANING IN A
FOREIGN LANGUAGE.

CLASS 11—ENVIRONMENTAL CONTROL APPARATUS

FOR SANITARY INSTALLATIONS IN THE NATURE OF SINKS, IN PARTICULAR WASH BASINS AND WASH STANDS AND STORAGE TRAYS ESPECIALLY DESIGNED THEREFOR; BIDETS, WATER CLOSETS, TOILET SEATS, URINALS, BATH TUBS, SHOWER TRAYS, SHOWER CUBICLES, SAUNAS IN THE NATURE OF SAUNA CUBICLES, SANITARY INSTALLATIONS IN THE NATURE OF STEAM CUBICLES AND STEAM CABINS; SANITARY INSTALLATIONS IN THE NATURE OF CABINS WITH INFRARED LAMPS FOR USE AS HEAT ROOMS; TAPS AND CONTROL FITTINGS IN THE NATURE OF SHOWER CONTROL VALVES, TUB CONTROL VALVES, FAUCETS FOR WATER SUPPLY AND SANITARY INSTALLATIONS; LIGHTING APPARATUS FOR SAUNA CUBICLES, STEAM CUBICLES AND STEAM CABINS AND CABINS WITH INFRARED LIGHT (U.S. CLS. 13, 21, 23, 31 AND 34).

CLASS 19—NON-METALLIC BUILDING MATERIALS

FOR NON-METAL WALL CLADDING FOR CONSTRUCTION AND BUILDING, IN PARTICULAR NON-METAL SHELTER STRUCTURES IN THE NATURE OF PRE-FABRICATED SAUNA CABINS AND HEAT CABINS OF WOOD AND PLASTIC, AND PARTS THEREFOR IN THE NATURE OF FLOOR BOARDS, NON-METAL WINDOWS, PLASTIC CONDUIT FOR DRAINAGE, WOOD SHEETS IN THE NATURE OF WOOD BOARDS (U.S. CLS. 1, 12, 33 AND 50).
ROBIN MITTLER, EXAMINING ATTORNEY

SN 79-080,489, DIRK HÜBSCH, 51105 KÖLN, FED REP GERMANY, AND MICHAEL JENSEN, 63075 OFFENBACH, FED REP GERMANY, FILED 12-4-2009.

Leadingheads

THE MARK CONSISTS OF STANDARD CHARACTERS WITHOUT CLAIM TO ANY PARTICULAR FONT, STYLE, SIZE, OR COLOR.

PRIORITY DATE OF 6-5-2009 IS CLAIMED.
OWNER OF INTERNATIONAL REGISTRATION 1033039
DATED 12-4-2009, EXPIRES 12-4-2019.

CLASS 9—ELECTRICAL AND SCIENTIFIC APPARATUS

FOR COMPUTER SOFTWARE FOR USE IN DATABASE MANAGEMENT, AND FOR CONTENT MANAGEMENT IN THE FIELD OF INFORMATION, NEWS, LECTURES, VIDEO LECTURES; SOFTWARE PROGRAMS RECORDED ON DATA CARRIERS CONTAINING STORED PROGRAM-TECHNICAL INSTRUCTIONS FOR DATABASE MANAGEMENT AND CONTENT MANAGEMENT; COMPUTER HARDWARE AS WELL AS DOCUMENTATION FOR INFORMATION TECHNOLOGY AND DATA PROCESSING STORED ON DATA CARRIERS SOLD AS A UNIT THEREWITH; DOWNLOADABLE ELECTRONIC PUBLICATIONS, NAMELY, WRITTEN DOCUMENTS FOR INFORMATION TECHNOLOGY AND DATA PROCESSING; SOFTWARE PROGRAMS FOR THE MANAGEMENT OF DATA BANKS IN THE AREAS OF BUSINESS AND PRIVATE COMPUTER NETWORKS AS WELL AS FOR THE CONSTRUCTION AND THE INTERMEDIATION OF COMMERCIAL CONTACTS AND PRIVATE CONTACTS; PROGRAM-TECHNICAL INSTRUCTIONS FOR OPERATION OF COMPUTER HARDWARE AND SOFTWARE STORED ON DATA CARRIERS; COMPUTER HARDWARE AS WELL AS DOCUMENTATIONS FOR THE PURPOSE OF BUSINESS AND PRIVATE COMPUTER NETWORKS STORED ON DATA CARRIERS; DOWNLOADABLE ELECTRONIC PUBLICATIONS, NAMELY, NEWSLETTERS, LECTURES AND VIDEO-LECTURES IN THE FIELDS OF BUSINESS AND PRIVATE COMPUTER NETWORKS (U.S. CLS. 21, 23, 26, 36 AND 38).

CLASS 16—PAPER GOODS AND PRINTED MATTER

FOR PAPER, CARDBOARD, CARDBOARD AND GOODS FROM THESE MATERIALS, NOT INCLUDED IN OTHER CLASSES, NAMELY, PACKAGING AND PACKING PAPER; PRINTED PRODUCTS, IN PARTICULAR BOOKS, MAGAZINES AND JOURNALS IN THE FIELDS OF PERSONAL INFORMATION REPORTING ON PERSONS, THEIR PROFESSION, AND THEIR BUSINESS, NEWS CONCERNING PROFESSIONAL SERVICES OF BUSINESS PERSONS AND NEWS ABOUT UP-TO-DATE INNOVATIONS, AND LECTURES CONCERNING THE AFORE-MENTIONED FIELDS, INDIVIDUAL STORIES, PERSONAL HISTORIES/BIOGRAPHIES, SCIENCE, MATH, BUSINESS, EDUCATION, LAW, SEMINARS, ARCHITECTURE, ENGINEERING, TAXATION, MEDICINE, FINANCE, MANAGEMENT AND/OR CULTURAL MATTER; TEACHING MEANS AND INSTRUCTION MEANS, NAMELY, INSTRUCTION SHEETS AND MANUALS IN THE FIELD OF BUSINESS-SEMINARS, SEMINARS FOR EDUCATION, LAW, SCIENCE, ARCHITECTURE, ENGINEERING, TAXATION, MEDICINE, FINANCE, MANAGEMENT (U.S. CLS. 2, 5, 22, 23, 29, 37, 38 AND 50).

CLASS 35—ADVERTISING AND BUSINESS

FOR ADVERTISEMENT; MANAGEMENT; ENTERPRISE MANAGEMENT; OFFICE WORK; ADVERTISEMENT FOR SERVICES IN THE AREA OF PREPARATION AND INTERMEDIATION OF PRIVATE AND BUSINESS CONTACTS; BUSINESS ORGANIZATIONAL AND ECONOMIC CONSULTANCY, NAMELY, ECONOMIC FEASIBILITY STUDIES, FORECASTING AND ANALYSIS ON THE APPLICATION, USE AND MAINTENANCE OF SOFTWARE PROGRAMS OR PROGRAM-TECHNICAL SOFTWARE SOLUTIONS FOR INFORMATION TECHNOLOGY AND DATA PROCESSING; SYSTEMIZATION AND COMPILATION OF DATA IN COMPUTER DATA BASES; INTERMEDIATION OF CONTRACTS FOR THIRD PARTIES RELATING TO THE PERFORMANCE OF ECONOMIC CONSULTANCY ON THE INTERNET; PROVISION OF ON-LINE CONSULTANCY IN THE ECONOMIC FIELD ON THE INTERNET, NAMELY, PROVIDING INFORMATION AND ANALYSIS IN THE FIELD OF ECONOMICS;

INTERMEDIATION OF CONTRACTS FOR THIRD PARTIES RELATING TO THE SALES AND USES OF SOFTWARE PROGRAMS, PROGRAM-TECHNICAL SOFTWARE SOLUTIONS FOR INFORMATION TECHNOLOGY AND DATA PROCESSING, AND THE SERVING OF SOFTWARE PROGRAMS AND PROGRAM-TECHNICAL SOFTWARE SOLUTIONS FOR INFORMATION TECHNOLOGY AND DATA PROCESSING; ECONOMIC CONSULTANCY ALSO ON THE INTERNET, NAMELY, EXPERT ANALYSIS AND MANAGEMENT CONSULTING IN ECONOMICS (U.S. CLS. 100, 101 AND 102).

CLASS 36—INSURANCE AND FINANCIAL

FOR INSURANCE SERVICES, NAMELY, INSURANCE BROKERAGE, INSURANCE SUBROGATION, INSURANCE AGENCY SERVICES; FINANCIAL AFFAIRS, NAMELY, FINANCIAL INFORMATION, MANAGEMENT AND ANALYSIS SERVICES; MONETARY AFFAIRS, NAMELY, ACQUISITION AND TRANSFER OF MONETARY CLAIMS, MONEY ORDER SERVICES; REAL ESTATE AFFAIRS, NAMELY, REAL ESTATE ESCROW SERVICES, REAL ESTATE LISTING AND REAL ESTATE INVESTMENT (U.S. CLS. 100, 101 AND 102).

CLASS 38—COMMUNICATION

FOR TELECOMMUNICATION SERVICES, NAMELY, PERSONAL COMMUNICATION SERVICES, ISDN SERVICES, TELECOMMUNICATIONS ACCESS SERVICES, DATA TRANSMISSION AND RECEPTION SERVICES VIA TELECOMMUNICATION MEANS, TELECOMMUNICATIONS GATEWAY SERVICES; SERVICES OF AN INFORMATION DISTRIBUTION CENTRE ON THE INTERNET, NAMELY, TRANSMISSION OF INFORMATION THROUGH TELECOMMUNICATIONS; ELECTRONIC TRANSMISSION OF NEWS, INFORMATION, PICTURES AND TEXTS OF ALL KIND; PROVISION OF ACCESS TO DATABASES CONTAINING SOFTWARE FOR INFORMATION TECHNOLOGY IN THE FIELDS OF BUSINESS AND PRIVATE NETWORKS AS WELL AS FOR THE PROVISION AND THE INTERMEDIATION OF COMMERCIAL CONTACTS AND PRIVATE CONTACTS; PROVISION OF ACCESS TO SOFTWARE STORED IN DATA NETWORKS; PROVISION OF ACCESS TO INFORMATION STORED ELECTRONICALLY IN CENTRAL FILES FOR REMOTE CONSULTATION IN THE FIELD OF ECONOMICS (U.S. CLS. 100, 101 AND 104).

CLASS 41—EDUCATION AND ENTERTAINMENT

FOR EDUCATION SERVICES, NAMELY, PROVIDING CLASSES, SEMINARS, WORKSHOPS IN THE FIELD OF BUSINESS, LANGUAGES, SCIENCE, EDUCATION, LAW, ARCHITECTURE, ENGINEERING, TAXATION, MEDICINE, FINANCE, MANAGEMENT, CULTURAL MATTER; TEACHING IN THE FIELD OF BUSINESS, LANGUAGES SCIENCE, EDUCATION, LAW, ARCHITECTURE, ENGINEERING, TAXATION, MEDICINE, FINANCE, MANAGEMENT, CULTURAL MATTER; ENTERTAINMENT SERVICES, NAMELY, OFFERING, LECTURES, VIDEO-LECTURES; SPORTS AND CULTURAL ACTIVITIES, NAMELY, ORGANIZING COMMUNITY SPORTING AND CULTURAL EVENTS; ARRANGING OF SEMINARS AND ORGANIZATION OF CONGRESSES FOR EDUCATION AND TRAINING PURPOSES; SERVICES OF A PUBLISHING COMPANY, NAMELY, PUBLICATION OF BOOKS, MAGAZINES, EXPOS, NEWSPAPERS AND OTHER PRINTED PRODUCT IN THE NATURE OF PERIODICALS, CATALOGS, BROCHURES, PAMPHLETS EXCEPT ADVERTISING SLOGANS; PUBLICATION OF PUBLISHING AND PRINTING PRODUCTS, NAMELY, BOOKS, MAGAZINES, PERIODICALS, CATALOGS, BROCHURES, PAMPHLETS ALSO IN ELECTRONIC FORM ON THE INTERNET AND OTHER DATA NETWORKS, EXCLUDING FOR ADVERTISING PURPOSES; ORGANIZATION OF EDUCATIONAL EVENTS, NAMELY, CONFERENCES, TALKS IN THE NATURE OF LIVE EDUCATIONAL SPEECHES, SEMINARS AND EDUCATIONAL WORKSHOPS; PROVIDING CONTINUING EDUCATION COURSES IN THE FIELD OF BUSINESS, MATH, LAN-

GUAGES, SCIENCE, EDUCATION, LAW ARCHITECTURE, ENGINEERING, TAXATION, MEDICINE, FINANCE, MANAGEMENT, CULTURAL MATTER; PROVIDING PERSONAL, PROFESSIONAL AND GROUP COACHING IN THE FIELD OF BUSINESS, MATH, LANGUAGES, SCIENCE, EDUCATION, LAW ARCHITECTURE, ENGINEERING, TAXATION, MEDICINE, FINANCE, MANAGEMENT, CULTURAL MATTER; EDUCATIONAL SERVICES, NAMELY, THE PRESENTATION OF TALKS AND PANEL DISCUSSIONS, ALL IN THE FIELD OF PUBLIC INTEREST CONCERNING EDUCATION SYSTEM, DIFFERENT CULTURES; EDUCATION IN THE FIELD OF BUSINESS, MATH, LANGUAGES, SCIENCE, EDUCATION, LAW ARCHITECTURE, ENGINEERING, TAXATION, MEDICINE, FINANCE, MANAGEMENT, CULTURAL MATTER RENDERED THROUGH CORRESPONDENCE COURSES; EDUCATIONAL SERVICES, NAMELY, CONDUCTING DISTANCE LEARNING INSTRUCTION AT THE SECONDARY, COLLEGE AND GRADUATE LEVELS (U.S. CLS. 100, 101 AND 107).

CLASS 42—SCIENTIFIC AND COMPUTER SERVICES

FOR DEVELOPMENT OF DATABASE SOFTWARE, AS WELL AS SOFTWARE FOR INVESTIGATIONS, AND SEARCHING DATABASES FOR SCIENCE AND RESEARCH PURPOSES; RECORDING DATA FOR OTHERS ON OPTICAL, DIGITAL AND MAGNETIC MEDIA FOR ELECTRONIC STORAGE OF DATA IN DATABASES; RENTING OF COMPUTER SOFTWARE, IN PARTICULAR OF PROGRAMS FOR DATA PROCESSING; COMPUTER PROGRAMMING; PROVIDING TEMPORARY USE OF ONLINE NON-DOWNLOADABLE SOFTWARE FOR USE IN SEARCHING ELECTRONIC MEMORIES RELATING TO NEWS, INFORMATION, PICTURES AND TEXTS OF ALL KIND; INSTALLATION AND MAINTENANCE FOR DATA PROCESSING PROGRAMS; TECHNICAL CONSULTANCY FOR THE APPLICATION, USE AND MAINTENANCE OF DATA PROCESSING PROGRAMS; MAINTENANCE OF PROGRAM-TECHNICAL SOFTWARE AND TECHNOLOGICAL SOLUTIONS FOR INFORMATION TECHNOLOGY AND DATA PROCESSING; PROVIDING TEMPORARY USE OF ONLINE NON-DOWNLOADABLE SOFTWARE FOR THE INTERMEDIATION OF CONTACTS; COMPUTER PROGRAMMING FOR INFORMATION TECHNOLOGY IN THE AREAS OF BUSINESS AND PRIVATE NETWORKS AS WELL AS FOR THE CONSTRUCTION AND INTERMEDIATION OF COMMERCIAL CONTACTS AND PRIVATE CONTACTS (U.S. CLS. 100 AND 101).

CLASS 45—PERSONAL AND LEGAL SERVICES

FOR LICENSING OF COMPUTER SOFTWARE, IN PARTICULAR OF PROGRAMS FOR THE DATA PROCESSING (U.S. CLS. 100 AND 101).
RON FAIRBANKS, EXAMINING ATTORNEY

SN 79-080,913. DR.-ING. FRANK TRIESCH, 04328 LEIPZIG, FED REP GERMANY, FILED 2-5-2010.

airtainer

THE MARK CONSISTS OF STANDARD CHARACTERS WITHOUT CLAIM TO ANY PARTICULAR FONT, STYLE, SIZE, OR COLOR.

PRIORITY DATE OF 8-7-2009 IS CLAIMED.

OWNER OF INTERNATIONAL REGISTRATION 1034200 DATED 2-5-2010, EXPIRES 2-5-2020.

CLASS 11—ENVIRONMENTAL CONTROL APPARATUS

FOR STEAM HEATING APPARATUS, STEAM GENERATING INSTALLATIONS, REFRIGERATING INSTALLATIONS, VENTILATING EXHAUST FANS, AND REGULATING ACCESSORIES FOR HEATING SYSTEMS, NAMELY, AIR VALVES, IN PARTICULAR AIR VALVES FOR STEAM HEATING INSTALLATIONS; STEAM ACCUMULATORS; AIR FILTERS FOR DOMESTIC USE OR INDUSTRIAL INSTALLATIONS, GAS CONDENSERS OTHER THAN PARTS OF MACHINES; AIR CONDITIONING APPARATUS, IN PARTICULAR FOR CONDITIONING OF AIR FOR GAS TURBINES, AIR CONDITIONING INSTALLATIONS; REFRIGERATORS; ELECTRIC AIR HEATERS; FILTERS FOR AIR CONDITIONING, AIR FILTERING INSTALLATIONS, AIR COOLING APPARATUS, AIR PURIFYING APPARATUS AND MACHINES; APPARATUS THAT REDUCE MOISTURE IN AIR, NAMELY, DEHUMIDIFIERS; VENTILATION APPARATUS FOR AIR CONDITIONING INSTALLATIONS; ELECTRIC FANS FOR AIR CONDITIONING INSTALLATIONS, EVAPORATORS, HEAT PUMPS, HEAT REGENERATORS, HEAT ACCUMULATORS, HEAT EXCHANGERS NOT BEING PARTS OF MACHINES (U.S. CLS. 13, 21, 23, 31 AND 34).

CLASS 35—ADVERTISING AND BUSINESS

FOR WHOLESALE AND RETAIL STORES SERVICES FEATURING APPARATUS FOR HEATING, STEAM GENERATING, REFRIGERATING, DRYING, AND VENTILATING, IN PARTICULAR AIR VALVES FOR STEAM HEATING INSTALLATIONS, STEAM ACCUMULATORS, FILTERS FOR HOUSEHOLD OR INDUSTRIAL INSTALLATIONS, GAS CONDENSERS OTHER THAN PARTS OF MACHINES, AIR CONDITIONING INSTALLATIONS, AIR CONDITIONING APPARATUS, COOLING INSTALLATIONS AND MACHINES, REFRIGERATORS, AIR HEATERS, FILTERS FOR AIR CONDITIONING, AIR FILTERING INSTALLATIONS, AIR COOLING APPARATUS, AIR PURIFYING APPARATUS AND MACHINES, AIR DRYERS, VENTILATION FOR AIR CONDITIONING INSTALLATIONS, DRYING APPARATUS AND INSTALLATIONS, FANS FOR PARTS OF AIR CONDITIONING INSTALLATIONS, EVAPORATORS, HEAT PUMPS, HEAT REGENERATORS, HEAT ACCUMULATORS, HEAT EXCHANGERS NOT PARTS OF MACHINES, AND PARTS, COMPONENTS AND ACCESSORIES FOR USE WITH ALL THE AFORESAID GOODS; ONLINE MAIL ORDER SERVICES OF AN E-COMMERCE PROVIDER FEATURING APPARATUS FOR HEATING, STEAM GENERATING, REFRIGERATING, DRYING, AND VENTILATING, IN PARTICULAR AIR VALVES FOR STEAM HEATING INSTALLATIONS, STEAM ACCUMULATORS, FILTERS FOR HOUSEHOLD OR INDUSTRIAL INSTALLATIONS, GAS CONDENSERS OTHER THAN PARTS OF MACHINES, AIR CONDITIONING INSTALLATIONS, AIR CONDITIONING APPARATUS, COOLING INSTALLATIONS AND MACHINES, REFRIGERATORS, AIR HEATERS, FILTERS FOR AIR CONDITIONING, AIR FILTERING INSTALLATIONS, AIR COOLING APPARATUS, AIR PURIFYING APPARATUS AND MACHINES, AIR DRYERS, VENTILATION FOR AIR CONDITIONING INSTALLATIONS, DRYING APPARATUS AND INSTALLATIONS, FANS FOR AIR CONDITIONING INSTALLATIONS, EVAPORATORS, HEAT PUMPS, HEAT REGENERATORS, HEAT ACCUMULATORS, HEAT EXCHANGERS NOT PARTS OF MACHINES, AND PARTS, COMPONENTS AND ACCESSORIES FOR USE WITH ALL THE AFORESAID GOODS; COMMERCIAL INFORMATION AND ADVICE TO CONSUMERS ABOUT APPARATUS FOR HEATING, STEAM GENERATING, REFRIGERATING, DRYING, AND VENTILATING, IN PARTICULAR AIR VALVES FOR STEAM HEATING INSTALLATIONS, STEAM ACCUMULATORS, FILTERS FOR HOUSEHOLD OR INDUSTRIAL INSTALLATIONS, GAS CONDENSERS OTHER THAN PARTS OF MACHINES, AIR CONDITIONING INSTALLATIONS, AIR CONDITIONING APPARATUS, COOLING INSTALLATIONS AND MACHINES, REFRIGERATORS, AIR HEATERS, FILTERS FOR AIR CONDITIONING, AIR FILTERING INSTALLATIONS, AIR COOLING APPARATUS, AIR PURIFYING APPARATUS AND MACHINES, AIR DRYERS, VENTILATION FOR AIR CONDITIONING INSTALLATIONS, DRYING APPARATUS AND INSTALLATIONS, FANS FOR AIR CONDITIONING

INSTALLATIONS, EVAPORATORS, HEAT PUMPS, HEAT REGENERATORS, HEAT ACCUMULATORS, HEAT EXCHANGERS NOT PARTS OF MACHINES, AND PARTS, COMPONENTS AND ACCESSORIES FOR ALL THE AFORESAID GOODS; ADVERTISING IN RADIO, TELEVISION, CINEMA, PRINT, VIDEO TEXT, ONLINE AND TELETXT ADVERTISING FOR APPARATUS FOR HEATING, STEAM GENERATING, REFRIGERATING, DRYING, AND VENTILATING, IN PARTICULAR AIR VALVES FOR STEAM HEATING INSTALLATIONS, STEAM ACCUMULATORS, FILTERS FOR HOUSEHOLD OR INDUSTRIAL INSTALLATIONS, GAS CONDENSERS OTHER THAN PARTS OF MACHINES, AIR CONDITIONING INSTALLATIONS, AIR CONDITIONING APPARATUS, COOLING INSTALLATIONS AND MACHINES, REFRIGERATORS, AIR HEATERS, FILTERS FOR AIR CONDITIONING, AIR FILTERING INSTALLATIONS, AIR COOLING APPARATUS, AIR PURIFYING APPARATUS AND MACHINES, AIR DRYERS, VENTILATION FOR AIR CONDITIONING INSTALLATIONS, DRYING APPARATUS AND INSTALLATIONS, FANS FOR AIR CONDITIONING INSTALLATIONS, EVAPORATORS, HEAT PUMPS, HEAT REGENERATORS, HEAT ACCUMULATORS, HEAT EXCHANGERS NOT PARTS OF MACHINES, AND PARTS, FITTINGS AND ACCESSORIES FOR ALL THE AFORESAID GOODS; TELEPHONE ORDER-TAKING SERVICES FOR OTHERS FOR ORDER PLACEMENT OF APPARATUS FOR HEATING, STEAM GENERATING, REFRIGERATING, DRYING, AND VENTILATING, IN PARTICULAR AIR VALVES FOR STEAM HEATING INSTALLATIONS, STEAM ACCUMULATORS, FILTERS FOR HOUSEHOLD OR INDUSTRIAL INSTALLATIONS, GAS CONDENSERS OTHER THAN PARTS OF MACHINES, AIR CONDITIONING INSTALLATIONS, AIR CONDITIONING APPARATUS, COOLING INSTALLATIONS AND MACHINES, REFRIGERATORS, AIR HEATERS, FILTERS FOR AIR CONDITIONING, AIR FILTERING INSTALLATIONS, AIR COOLING APPARATUS, AIR PURIFYING APPARATUS AND MACHINES, AIR DRYERS, VENTILATION FOR AIR CONDITIONING INSTALLATIONS, DRYING APPARATUS AND INSTALLATIONS, FANS FOR AIR CONDITIONING INSTALLATIONS, EVAPORATORS, HEAT PUMPS, HEAT REGENERATORS, HEAT ACCUMULATORS, HEAT EXCHANGERS NOT PARTS OF MACHINES, AND PARTS, COMPONENTS AND ACCESSORIES FOR ALL THE AFORESAID GOODS; ADVERTISING IN RADIO, TELEVISION, CINEMA, PRINT, VIDEO TEXT, ONLINE AND TELETXT ADVERTISING FOR APPARATUS FOR HEATING, STEAM GENERATING, REFRIGERATING, DRYING, AND VENTILATING, IN PARTICULAR AIR VALVES FOR STEAM HEATING INSTALLATIONS, STEAM ACCUMULATORS, FILTERS FOR HOUSEHOLD OR INDUSTRIAL INSTALLATIONS, GAS CONDENSERS OTHER THAN PARTS OF MACHINES, AIR CONDITIONING INSTALLATIONS, AIR CONDITIONING APPARATUS, COOLING INSTALLATIONS AND MACHINES, REFRIGERATORS, AIR HEATERS, FILTERS FOR AIR CONDITIONING, AIR FILTERING INSTALLATIONS, AIR COOLING APPARATUS, AIR PURIFYING APPARATUS AND MACHINES, AIR DRYERS, VENTILATION FOR AIR CONDITIONING INSTALLATIONS, DRYING APPARATUS AND INSTALLATIONS, FANS FOR AIR CONDITIONING INSTALLATIONS, EVAPORATORS, HEAT PUMPS, HEAT REGENERATORS, HEAT ACCUMULATORS, HEAT EXCHANGERS NOT PARTS OF MACHINES, AND PARTS, FITTINGS AND ACCESSORIES FOR ALL THE AFORESAID GOODS; AND INFORMATION MANAGEMENT SERVICES, NAMELY, PREPARING INVOICES FOR APPARATUS FOR HEATING, STEAM GENERATING, REFRIGERATING, DRYING, AND VENTILATING, IN PARTICULAR AIR VALVES FOR STEAM HEATING INSTALLATIONS, STEAM ACCUMULATORS, FILTERS FOR HOUSEHOLD OR INDUSTRIAL INSTALLATIONS, GAS CONDENSERS OTHER THAN PARTS OF MACHINES, AIR CONDITIONING INSTALLATIONS, AIR CONDITIONING APPARATUS, COOLING INSTALLATIONS AND MACHINES, REFRIGERATORS, AIR HEATERS, FILTERS FOR AIR CONDITIONING, AIR FILTERING INSTALLATIONS, AIR COOLING APPARATUS, AIR PURIFYING APPARATUS AND MACHINES, AIR DRYERS, VENTILATION FOR AIR CONDITIONING INSTALLATIONS, DRYING APPARATUS AND INSTALLATIONS, FANS FOR AIR CONDITIONING INSTALLATIONS, EVAPORATORS, HEAT PUMPS, HEAT REGENERATORS, HEAT ACCUMULATORS, HEAT EXCHANGERS NOT PARTS OF

MACHINES, AND PARTS, COMPONENTS AND ACCESSORIES FOR ALL THE AFORESAID GOODS; ADVERTISING IN RADIO, TELEVISION, CINEMA, PRINT, VIDEO TEXT, ONLINE AND TELETXT ADVERTISING FOR APPARATUS FOR HEATING, STEAM GENERATING, REFRIGERATING, DRYING, AND VENTILATING, IN PARTICULAR AIR VALVES FOR STEAM HEATING INSTALLATIONS, STEAM ACCUMULATORS, FILTERS FOR HOUSEHOLD OR INDUSTRIAL INSTALLATIONS, GAS CONDENSERS OTHER THAN PARTS OF MACHINES, AIR CONDITIONING INSTALLATIONS, AIR CONDITIONING APPARATUS, COOLING INSTALLATIONS AND MACHINES, REFRIGERATORS, AIR HEATERS, FILTERS FOR AIR CONDITIONING, AIR FILTERING INSTALLATIONS, AIR COOLING APPARATUS, AIR PURIFYING APPARATUS AND MACHINES, AIR DRYERS, VENTILATION FOR AIR CONDITIONING INSTALLATIONS, DRYING APPARATUS AND INSTALLATIONS, FANS FOR AIR CONDITIONING INSTALLATIONS, EVAPORATORS, HEAT PUMPS, HEAT REGENERATORS, HEAT ACCUMULATORS, HEAT EXCHANGERS NOT PARTS OF MACHINES, AND PARTS, FITTINGS AND ACCESSORIES FOR ALL THE AFORESAID GOODS; WINDOW DISPLAY ARRANGEMENT SERVICES FOR PRODUCT MERCHANDISING (U.S. CLS. 100, 101 AND 102).

CLASS 37—CONSTRUCTION AND REPAIR

FOR BUILDING CONSTRUCTION; INSTALLATION SERVICES, IN PARTICULAR THE INSTALLATION, MAINTENANCE, CLEANING AND REPAIR OF APPARATUS FOR HEATING, STEAM GENERATING, REFRIGERATING, DRYING, AND VENTILATING, IN PARTICULAR AIR VALVES FOR STEAM HEATING INSTALLATIONS, STEAM ACCUMULATORS, FILTERS FOR HOUSEHOLD OR INDUSTRIAL INSTALLATIONS, GAS CONDENSERS OTHER THAN PARTS OF MACHINES, AIR CONDITIONING INSTALLATIONS, AIR CONDITIONING APPARATUS, COOLING INSTALLATIONS AND MACHINES, REFRIGERATORS, AIR HEATERS, FILTERS FOR AIR CONDITIONING, AIR FILTERING INSTALLATIONS, AIR COOLING APPARATUS, AIR PURIFYING APPARATUS AND MACHINES, AIR DRYERS, VENTILATION FOR AIR CONDITIONING INSTALLATIONS, APPARATUS THAT REDUCE MOISTURE IN AIR, FANS FOR CONDITIONING INSTALLATIONS, EVAPORATORS, HEAT PUMPS, HEAT REGENERATORS, HEAT ACCUMULATORS, HEAT EXCHANGERS NOT PARTS OF MACHINES, AND PARTS, COMPONENTS AND ACCESSORIES FOR ALL THE AFORESAID GOODS (U.S. CLS. 100, 103 AND 106).

DOMINIC FATHY, EXAMINING ATTORNEY

SN 79-081,127. ZHEJIANG LEIPAI MOTOR VEHICLE PARTS CO., LTD., CHINA, FILED 3-9-2010.

LEIPAI

OWNER OF INTERNATIONAL REGISTRATION 1034830 DATED 3-9-2010, EXPIRES 3-9-2020.

THE WORDING "LEIPAI" HAS NO MEANING IN A FOREIGN LANGUAGE.

CLASS 6—METAL GOODS

FOR LOCKS OF METAL, OTHER THAN ELECTRIC; LOCKS OF METAL FOR VEHICLES; PADLOCKS; DOOR HANDLES OF METAL; METAL KEYS FOR LOCKS; RINGS OF COMMON METAL FOR KEYS; METAL SAFES IN THE NATURE OF STRONG BOXES; IRON-MONGERY, NAMELY, METAL NUTS AND METAL WASHERS; UPRIGHT SIGNBOARDS OF COMMON METAL; METAL SCREWS FOR VEHICLES (U.S. CLS. 2, 12, 13, 14, 23, 25 AND 50).

CLASS 9—ELECTRICAL AND SCIENTIFIC APPARATUS

FOR SIGNAL LANTERNS, NAMELY, VEHICLE TRAFFIC SIGNALS; VOLTAGE REGULATORS FOR VEHICLES; ELECTRIC SWITCHES; ELECTRIC LOCKS; ELECTRIC ACCUMULATORS FOR VEHICLES; NAVIGATION APPARATUS FOR VEHICLES; PROTECTIVE HELMETS; ELECTRIC THEFT PREVENTION INSTALLATIONS IN THE NATURE OF THEFT ALARMS; MAGNETIC ENCODED CARDS; ELECTRIC ENCODED LOCKS (U.S. CLS. 21, 23, 26, 36 AND 38).

CLASS 12—VEHICLES

FOR METAL DOOR HANDLES FOR VEHICLES; CAPS FOR VEHICLE PETROL TANKS; ANTI-THEFT ALARMS FOR VEHICLES, REVERSING ALARMS FOR VEHICLES, NAMELY, BACK-UP WARNING ALARMS FOR VEHICLES; ANTI-THEFT DEVICES FOR VEHICLES; REAR-VIEW MIRRORS; TURN SIGNALS FOR VEHICLES (U.S. CLS. 19, 21, 23, 31, 35 AND 44).

JAMES MACFARLANE, EXAMINING ATTORNEY

SN 79-081,225. PETER HUBER KÄLTEMASCHINENBAU GMBH, 77656 OFFENBURG, FED REP GERMANY, FILED 3-12-2010.

Minichiller

THE MARK CONSISTS OF STANDARD CHARACTERS WITHOUT CLAIM TO ANY PARTICULAR FONT, STYLE, SIZE, OR COLOR.

OWNER OF INTERNATIONAL REGISTRATION 1035120 DATED 3-12-2010, EXPIRES 3-12-2020.

SEC. 2(F).

CLASS 7—MACHINERY

FOR PUMPS, NAMELY, CIRCULATION PUMPS, FOR HEATING AND COOLING APPARATUS AND FOR TEMPERATURE CONTROL SYSTEMS (U.S. CLS. 13, 19, 21, 23, 31, 34 AND 35).

CLASS 9—ELECTRICAL AND SCIENTIFIC APPARATUS

FOR TEMPERATURE-REGULATING APPARATUS IN THE NATURE OF COLD AND HOT BATHS FOR LABORATORY USE, CIRCULATORY COOLERS FOR LABORATORY USE, COLD AND/OR HEAT THERMOSTATS, BATH THERMOSTATS, PENDANT THERMOSTATS AND CIRCULATORY THERMOSTATS (U.S. CLS. 21, 23, 26, 36 AND 38).

CLASS 11—ENVIRONMENTAL CONTROL APPARATUS

FOR TEMPERATURE CONTROL SYSTEMS INCLUDING COLD AND HOT BATHS COMPRISING WATER AND OIL HEATERS AND WATER AND OIL COOLERS, CIRCULATORY COOLERS BEING WATER AND OIL COOLERS, COLD AND/OR HEAT THERMOSTATS, BATH THERMOSTATS, PENDANT THERMOSTATS AND CIRCULATORY THERMOSTATS; COLD AND HOT BATH CONTAINERS BEING STRUCTURAL PARTS OF WATER AND OIL HEATERS AND WATER AND OIL COOLERS (U.S. CLS. 13, 21, 23, 31 AND 34).

MELISSA VALLILLO, EXAMINING ATTORNEY

SN 79-081,245. RIEMANN TRADING APS, DK-3400 HILLER-ØD, DENMARK, FILED 3-17-2010.



OWNER OF INTERNATIONAL REGISTRATION 1035163 DATED 3-17-2010, EXPIRES 3-17-2020.

THE COLOR(S) DARK BLUE (PANTONE P 2735C / P BLUE 072U) AND CYAN BLUE (PANTONE: P CYAN C / P CYAN U) IS/ARE CLAIMED AS A FEATURE OF THE MARK.

THE MARK CONSISTS OF A DROP SHAPE ENCLOSED A SERIES OF CONCENTRIC CIRCLES IN CYAN BLUE (PANTONE: P CYAN C / P CYAN U). THE COLOR OF THE DROP SHAPE CHANGES GRADUALLY FROM DARK BLUE (PANTONE: P 2735C / P BLUE 072U) TO CYAN BLUE (PANTONE: P CYAN C / P CYAN U).

CLASS 3—COSMETICS AND CLEANING PREPARATIONS

FOR DEODORANTS FOR PERSONAL USE; TOILETRIES, NAMELY, ANTIPERSPIRANTS (U.S. CLS. 1, 4, 6, 50, 51 AND 52).

CLASS 5—PHARMACEUTICALS

FOR PHARMACEUTICAL PREPARATIONS FOR THE TREATMENT AND PREVENTION OF EXCESSIVE PERSPIRATION; PHARMACEUTICAL PREPARATIONS FOR USE IN TREATING FOOT PERSPIRATION; PHARMACEUTICAL PREPARATIONS FOR USE IN TREATING HAND PERSPIRATION (U.S. CLS. 6, 18, 44, 46, 51 AND 52).

DARRYL SPRUILL, EXAMINING ATTORNEY

SN 79-081,323. FABER INDUSTRIE S.P.A., ITALY, FILED 1-5-2010.



PRIORITY DATE OF 10-14-2009 IS CLAIMED. OWNER OF INTERNATIONAL REGISTRATION 1035402 DATED 1-5-2010, EXPIRES 1-5-2020.

OWNER OF U.S. REG. NOS. 3,344,451, 3,344,452 AND 3,574,101.

NO CLAIM IS MADE TO THE EXCLUSIVE RIGHT TO USE "COMPOSITES CRAFTED AT", APART FROM THE MARK AS SHOWN.

THE MARK CONSISTS OF THE WORDING "CLEVER COMPOSITES CRAFTED AT FABER" INSIDE TWO CONCENTRIC OVALS, THE OUTER COMPOSED OF A LINE AND THE INNER ONE COMPOSED OF SHADED SCALLOPS FACING INWARD TOWARD THE WORDING.

CLASS 6—METAL GOODS

FOR HIGH PRESSURE GAS CYLINDERS FOR PRESSURIZED GASES MADE OF STEEL AND COMPOSITE MATERIAL AND SOLD EMPTY (U.S. CLS. 2, 12, 13, 14, 23, 25 AND 50).

CLASS 9—ELECTRICAL AND SCIENTIFIC APPARATUS

FOR DIVING EQUIPMENT AND APPARATUS, NAMELY, AIR ANALYSIS APPARATUS, MARINE COMPASSES, GAS TESTING INSTRUMENTS, MANOMETERS, PRESSURE GAUGES, PRESSURE INDICATORS, DECOMPRESSION CHAMBERS, GAS METER, FIRE EXTINGUISHERS, FIRE EXTINGUISHING APPARATUS, LIFE-SAVING RAFTS, RESPIRATORS OTHER THAN FOR ARTIFICIAL RESPIRATION, RESPIRATORY MASKS OTHER THAN FOR ARTIFICIAL RESPIRATION, DIVING SUITS, LIFE NETS, FILTERS FOR RESPIRATORY MASKS, FLOATS FOR BATHING AND SWIMMING FOR SAFETY PURPOSES, GLOVES FOR DIVERS, BREATHING APPARATUS FOR UNDERWATER SWIMMING, SELF-RESCUE APPARATUS IN THE NATURE OF OXYGEN TRANSVASING APPARATUS, EAR PLUGS FOR DIVERS, LIFE BUOYS, LIFE JACKETS, LIFE BELTS, GOGGLES FOR SPORTS IN THE NATURE OF DIVING, NOSE CLIPS FOR DIVERS AND SWIMMERS, AND PROTECTIVE HELMETS FOR SPORTS (U.S. CLS. 21, 23, 26, 36 AND 38).

CLASS 12—VEHICLES

FOR TANKS FOR COMPRESSED NATURAL GAS (CNG) AND HYDROGEN CYLINDERS FOR COMPRESSED NATURAL GAS VEHICLES AND HYDROGEN LAND VEHICLES (U.S. CLS. 19, 21, 23, 31, 35 AND 44).

SUZANNE BLANE, EXAMINING ATTORNEY

SN 79-081,552. SEITENBACHER GMBH & CO. NATURKOST, FED REP GERMANY, FILED 1-13-2010.

Harry P.

THE MARK CONSISTS OF STANDARD CHARACTERS WITHOUT CLAIM TO ANY PARTICULAR FONT, STYLE, SIZE, OR COLOR.

PRIORITY DATE OF 7-15-2009 IS CLAIMED.

OWNER OF INTERNATIONAL REGISTRATION 1035914 DATED 1-13-2010, EXPIRES 1-13-2020.

THE NAME(S), PORTRAIT(S), AND/OR SIGNATURE(S) SHOWN IN THE MARK DOES NOT IDENTIFY A PARTICULAR LIVING INDIVIDUAL.

CLASS 5—PHARMACEUTICALS

FOR PHARMACEUTICAL PREPARATIONS AND HEALTHCARE PRODUCTS, NAMELY, PROTEIN SUPPLEMENTS, MINERAL SUPPLEMENTS, NUTRITIONAL SUPPLEMENTS, MEAL REPLACEMENT BARS, MEAL REPLACEMENT SNACKS, MEAL REPLACEMENT DRINKS, MEAL REPLACEMENT POWDERS, MEAL REPLACEMENT SHAKES, MEAL REPLACEMENT AND DIETARY SUPPLEMENT DRINK MIXES, GLUTEN-FREE FOOD TO ACCOMMODATE SPECIAL MEDICAL AND HEALTH CONDITIONS; DIETETIC FOODS ADAPTED FOR MEDICAL USE; DIETARY AND HERBAL FOOD SUPPLEMENTS FOR MEDICAL USE; VITAMIN PREPARATIONS AND VITAMIN PRODUCTS, NAMELY, VITAMIN DROPS, VITAMIN FORTIFIED BEVERAGES, VITAMIN SUPPLEMENTS, VITAMIN TABLETS, VITAMINS; ENERGY PREPARATIONS AND ENERGY PRODUCTS, NAMELY, ENERGY BOOSTING BARS FOR USE AS A MEAL SUBSTITUTE, HIGHLY CAFFEINATED ENERGY PILLS; MEDICINAL NON-ALCOHOLIC ENERGY DRINKS CONTAINING PROTEIN AND/OR CARBOHYDRATE; NON-ALCOHOLIC MINERAL AND GLUCOSE DRINKS FOR MEDICAL USE; DIETETIC BEVERAGES IN THE FORM OF POWDER FOR MEDICAL PURPOSES; ALL THE AFORESAID GOODS INCLUDED IN THIS CLASS (U.S. CLS. 6, 18, 44, 46, 51 AND 52).

CLASS 29—MEATS AND PROCESSED FOODS

FOR DIETETIC FOOD NOT FOR MEDICAL PURPOSES, BASED ON PROTEINS, FATS, WITH ADDED VITAMINS, MINERALS FOR ACIDS AND TRACE ELEMENTS, EITHER INDIVIDUALLY OR IN COMBINATION, INCLUDED IN THIS CLASS, NAMELY, PROTEIN BASED NUTRIENT-DENSE SNACK BARS, PROTEIN POWDERS FOR HUMAN CONSUMPTION FOR USE AS A FOOD ADDITIVE, PROTEINS BEING FOODSTUFFS FOR HUMAN CONSUMPTION, MILK-BASED ENERGY DRINKS, MILK PROTEINS; NUTRITIONAL SUPPLEMENTS NOT FOR MEDICAL PURPOSES, BASED ON PROTEINS, FATS, WITH ADDED VITAMINS, MINERALS FOR ACIDS AND TRACE ELEMENTS, EITHER INDIVIDUALLY OR IN COMBINATION, INCLUDED IN THIS CLASS; MILK POWDER, NAMELY, WHOLE MILK AND/OR SKIMMED MILK POWDER FOR HUMAN CONSUMPTION (U.S. CL. 46).

CLASS 30—STAPLE FOODS

FOR DIETETIC SUBSTANCES FOR NON-MEDICAL USE, MAINLY CONTAINING CARBOHYDRATE OR ROUGHAGE, NAMELY, GRANOLA SNACKS, GRANOLA-BASED SNACK FOODS, GRANOLA-BASED SNACK BARS, COOKIES AND CRACKERS; DIETARY SUPPLEMENTS FOR NON-MEDICAL USE, MAINLY CONTAINING CARBOHYDRATE OR ROUGHAGE, NAMELY, CEREAL BASED ENERGY BARS NOT FOR USE AS A MEAL REPLACEMENT, CEREAL BASED SNACK FOODS; FLOUR AND CEREAL PRODUCTS EXCEPT FOODSTUFFS FOR ANIMALS, IN PARTICULAR ROUGHAGE PRODUCTS, NAMELY, PROCESSED CEREALS, MUESLI, PROCESSED EDIBLE BRAN, WHEAT GERM, CEREAL BASED ENERGY BARS NOT FOR USE AS A MEAL REPLACEMENT, CEREAL BASED SNACK FOODS; CONFECTIONARY, IN PARTICULAR MADE OF DEXTROSE OR FRUCTOSE, NAMELY, THE ADDITION OF NATURAL FRUIT POWDER AND/OR MILK POWDER AND/OR COFFEE AND/OR CACAO AND/OR MINERALS; SUGAR, NAMELY, GLUCOSE, DEXTROSE, FRUIT SUGAR AND FRUCTOSE; NUTRITIONAL SNACK BARS, NAMELY, GRANOLA-BASED SNACK BARS, CEREAL BASED ENERGY BARS NOT FOR USE AS A MEAL REPLACEMENT; NUTRITIONAL FOOD BARS, NAMELY, READY TO EAT CEREAL DERIVED FOOD BARS; CONFECTIONARY MADE OF SUGAR; SWEETS; CHOCOLATE GOODS, NAMELY, CHOCOLATE, BEVERAGES WITH A CHOCOLATE BASE, CHOCOLATE BARS, CHOCOLATE CANDIES, CHOCOLATE BASED READY TO EAT SNACKS, CHOCOLATE BASED READY TO EAT FOOD BARS (U.S. CL. 46).

CLASS 32—LIGHT BEVERAGES

FOR MINERAL AND AERATED WATERS; NON-ALCOHOLIC DRINKS, NAMELY, ISOTONIC BEVERAGES AND ENERGY DRINKS FOR SPORTS AND FITNESS, NOT FOR MEDICAL PURPOSES, INCLUDED IN THIS CLASS; FRUIT DRINKS, FRUIT JUICES AND PREPARATIONS FOR MAKING BEVERAGES, NAMELY, VEGETABLE DRINKS, VEGETABLE JUICE, ISOTONIC DRINKS, SPORT DRINKS, PROTEIN DRINKS FOR USE AS A FOOD FILLERS AND NOT FOR USE AS A MEAL REPLACEMENT, CARBOHYDRATE DRINKS FOR USE AS A FOOD FILLERS; NON-ALCOHOLIC ENERGY DRINKS CONTAINING PROTEIN AND/OR CARBOHYDRATE; NON-ALCOHOLIC MINERAL AND GLUCOSE DRINKS; POWDERS USED IN THE PREPARATION OF ISOTONIC SPORTS DRINKS, SPORTS BEVERAGES, ENERGY DRINKS AND FRUIT-BASED BEVERAGES (U.S. CLS. 45, 46 AND 48).
WARREN L. OLANDRIA, EXAMINING ATTORNEY

SN 79-081,650. ELEOUSA, ROYBON, FRANCE, FILED 3-16-2010.



PRIORITY DATE OF 10-19-2009 IS CLAIMED.
OWNER OF INTERNATIONAL REGISTRATION 1036188 DATED 3-16-2010, EXPIRES 3-16-2020.

THE COLOR(S) YELLOW, WHITE, BLUE, DARK BLUE AND LIGHT BLUE IS/ARE CLAIMED AS A FEATURE OF THE MARK.

THE MARK CONSISTS OF THE STYLIZED WORDING "THEOTOKOS", WITH "THEO" APPEARING IN DARK BLUE AND "TOKOS" APPEARING IN LIGHT BLUE; BENEATH THE WORDING "THEOTOKOS" APPEARS THE STYLIZED WORDING "DONNEZ DU SENS A VOS RENCONTRES!" IN THE COLOR BLUE; TO THE LEFT OF ALL AFOREMENTIONED APPEARS A DESIGN FEATURING TWO ROUGHLY RECTANGULAR UPRIGHT SHAPES WITH EACH HAVING A NOTCH IN THE SIDE FACING THE OTHER RECTANGULAR ELEMENT AND EACH HAVING AN INTERIOR CIRCLE ABOVE THE NOTCHED PORTION; THE LEFT RECTANGULAR DESIGN APPEARS IN THE COLOR DARK BLUE WITH A YELLOW CIRCLE DESIGN AND THE RIGHT RECTANGULAR DESIGN APPEARS IN THE COLOR LIGHT BLUE WITH A WHITE CIRCLE DESIGN.

THE ENGLISH TRANSLATION OF "THEOTOKOS, DONNEZ DU SENS A VOS RENCONTRES" IN THE MARK IS "THEOTOKOS, GIVE SENSE TO YOUR ENCOUNTERS!".

CLASS 35—ADVERTISING AND BUSINESS

FOR BUSINESS MANAGEMENT; BUSINESS ADMINISTRATION; BUSINESS MANAGEMENT AND ORGANIZATION CONSULTANCY; DOCUMENT REPRODUCTION; EMPLOYMENT AGENCIES; COMPUTERIZED FILES MANAGEMENT; ORGANIZATION OF EXHIBITIONS FOR COMMERCIAL OR ADVERTISING PURPOSES; ONLINE ADVERTISING ON A COMPUTER NETWORK; RENTAL OF ADVERTISING TIME ON ANY COMMUNICATION MEDIA; PUBLICATION OF ADVERTISING TEXTS; RENTAL OF ADVERTISING SPACE; DISSEMINATION OF ADVERTISING MATTER; PUBLIC RELATIONS (U.S. CLS. 100, 101 AND 102).

CLASS 38—COMMUNICATION

FOR PROVIDING ACCESS TO A GLOBAL COMPUTER NETWORK; RENTAL OF TELECOMMUNICATION APPARATUS; TELECONFERENCING SERVICES; RENTAL OF ACCESS TIME TO GLOBAL COMPUTER NETWORKS (U.S. CLS. 100, 101 AND 104).

CLASS 41—EDUCATION AND ENTERTAINMENT

FOR PUBLICATION OF BOOKS; LENDING LIBRARIES; VIDEOTAPE FILM PRODUCTION; RENTAL OF MOTION PICTURES; RENTAL OF SOUND RECORDINGS; RENTAL OF VIDEO CASSETTE RECORDERS OR OF RADIO AND TELEVISION SETS; VIDEOTAPE EDITING; PHOTOGRAPHY SERVICES; ORGANIZATION OF EXHIBITIONS FOR CULTURAL OR EDUCATIONAL PURPOSES; BOOKING OF SEATS FOR SHOWS; GAMBLING SERVICES; ELECTRONIC PUBLISHING OF BOOKS AND PERIODICALS ONLINE (U.S. CLS. 100, 101 AND 107).

CLASS 42—SCIENTIFIC AND COMPUTER SERVICES

FOR DESIGN AND DEVELOPMENT OF COMPUTER HARDWARE AND SOFTWARE; RESEARCH AND DEVELOPMENT OF NEW PRODUCTS FOR THIRD PARTIES; COMPUTER PROGRAMMING; COMPUTER CONSULTING; CONVERSION OF COMPUTER PROGRAMS AND DATA OTHER THAN PHYSICAL CONVERSION; CONVERSION OF DATA OR DOCUMENTS FROM PHYSICAL TO ELECTRONIC MEDIA (U.S. CLS. 100 AND 101).

CLASS 45—PERSONAL AND LEGAL SERVICES

FOR MARRIAGE BUREAUS; HOROSCOPE CASTING (U.S. CLS. 100 AND 101).
KEVIN CORWIN, EXAMINING ATTORNEY

SN 79-082,685, HOLDIJK + HAAMBERG GMBH, 48599 GRONAU, FED REP GERMANY, FILED 12-18-2009.



PRIORITY DATE OF 6-22-2009 IS CLAIMED.
OWNER OF INTERNATIONAL REGISTRATION 1039048 DATED 12-18-2009, EXPIRES 12-18-2019.

NO CLAIM IS MADE TO THE EXCLUSIVE RIGHT TO USE "EDELSTAHL MASCHINENBAU", APART FROM THE MARK AS SHOWN.

THE COLOR(S) BLUE, WHITE AND RED IS/ARE CLAIMED AS A FEATURE OF THE MARK.

THE MARK CONSISTS OF THE DESIGN OF A LIONS HEAD AND THE WORDING "HOLDIJK HAAMBERG" IN WHITE ON BLUE BACKGROUND WITH ROUNDED EDGES AND THE WORDING "EDELSTAHL MASCHINENBAU" BELOW IT IN RED, OUTLINED BY A BLUE LINE.

THE ENGLISH TRANSLATION OF "HOLDIJK HAAMBERG EDELSTAHL MASCHINENBAU" IN THE MARK IS "HOLDIJK HAAMBERG STAINLESS STEEL MECHANICAL ENGINEERING". THE WORDING "HOLDIJK HAAMBERG" HAS NO MEANING IN A FOREIGN LANGUAGE.

CLASS 7—MACHINERY

FOR MACHINES INTENDED FOR PROCESSING OF MEAT, NAMELY, ELECTRIC MEAT MINCING MACHINES, ELECTRIC MEAT MIXERS, SAUSAGE CASING MACHINES, FILLING MACHINES FOR SAUSAGES, MACHINES USED IN MEAT PROCESSING, NAMELY, SALTING AND NETTING, CHITTERLING DEFATTING MACHINES, CHITTERLING RINSING TUBES, NAMELY, MACHINES ENABLING TURNING CHITTERLINGS AND MANURE REMOVAL THEREOF WITHOUT POLLUTING THE INTESTINES, CHITTERLING CASING PULLER, MEAT WASHING MACHINES, NAMELY, STOMACHS FOR MEAT, MACHINES ENABLING GUTTING OF SHEEP, PRODUCTION LINE OF MACHINES FOR PORK CASINGS CONSISTING OF CASING MACHINES, PRODUCTION LINE OF MACHINES FOR BEEF CASINGS CONSISTING OF CASING MACHINES, GENERAL PURPOSE MACHINES FOR BEEF AND PORK, NAMELY, CLEARING MACHINES AND MACHINES FOR CLEANING BEEF, MUTTON AND PORK CASINGS, PLATE LIFTING AND WASHING MACHINES FOR CONTAINERS, ALL THE ABOVE-MENTIONED MACHINES FOR USE IN INDUSTRIAL MEAT PACKING, PROCESSING MEAT, PROCESSING CASINGS AND INDUSTRIAL PRODUCTS FOR PROCESSING CASINGS AND BY-PRODUCTS (U.S. CLS. 13, 19, 21, 23, 31, 34 AND 35).

CLASS 35—ADVERTISING AND BUSINESS

FOR BUSINESS INTERMEDIARY AND PROFESSIONAL ADVISORY SERVICES IN THE FIELD OF SELLING PRODUCTS AND RENDERING SERVICES IN CONNECTION WITH RETAIL SALES, PURCHASE OF, IMPORTING AND EXPORTING OF MACHINES AND UTENSILS INTENDED FOR PROCESSING MEAT, NAMELY, ELECTRIC MEAT MINCING MACHINES, ELECTRIC MEAT MIXERS, SAUSAGE CASING MACHINES, FILLING MACHINES (SAUSAGES), MACHINES USED IN SALTING AND NETTING, CHITTERLING DEFATTING MACHINES, CHITTERLING RINSING TUBES, PARTICULARLY MACHINES ENABLING TURNING CHITTERLINGS AND MANURE REMOVAL THEREOF WITHOUT POLLUTING THE INTESTINES, CASING PULLER, WASHING MACHINES, HOT AND COLD WATER RECYCLING MACHINES, STOMACH WASHING MACHINES, MACHINES ENABLING GUTTING OF SHEEP, PRODUCTION LINES FOR PORK CASINGS CONSISTING ESSENTIALLY OF CASING MACHINES, PRODUCTION LINES FOR BEEF CASINGS CONSISTING ESSENTIALLY OF CASING MACHINES, GENERAL PURPOSE MACHINES (FOR BEEF AND PORK), PARTICULARLY, CLEARING MACHINES AND MACHINES FOR CLEANING BEEF, MUTTON AND PORK CASINGS, PLATE LIFT AND WASHING MACHINES FOR CONTAINERS, ALL ABOVE-MENTIONED MACHINES FOR USE IN MEAT PACKING, PROCESSING MEAT, PROCESSING CASINGS AND INDUSTRIAL PRODUCTS FOR PROCESSING CASINGS AND BY-PRODUCTS (U.S. CLS. 100, 101 AND 102).

JASON TURNER, EXAMINING ATTORNEY

SN 79-082,696, SWISS LINE FASHION AG, CH-2560 NIDAU, SWITZERLAND, FILED 4-20-2010.



PRIORITY DATE OF 3-22-2010 IS CLAIMED.
OWNER OF INTERNATIONAL REGISTRATION 1039070 DATED 4-20-2010, EXPIRES 4-20-2020.

NO CLAIM IS MADE TO THE EXCLUSIVE RIGHT TO USE "SWISS" AND "LINE" AND "INTELLIGENT FOOTWEAR", APART FROM THE MARK AS SHOWN.

THE MARK CONSISTS OF THE WORDING "SWISS LINE" WITH A DESIGN WITH OVERALL RECTANGULAR SHAPE IN BETWEEN THE WORDS "SWISS" AND "LINE" AND A VERTICAL ZIGZAG LINE SPLITTING THE RECTANGULAR DESIGN THROUGH THE CENTER. UNDERNEATH IS THE WORDING "INTELLIGENT FOOTWEAR".

CLASS 3—COSMETICS AND CLEANING PREPARATIONS

FOR COSMETICS (U.S. CLS. 1, 4, 6, 50, 51 AND 52).

CLASS 9—ELECTRICAL AND SCIENTIFIC APPARATUS

FOR SUNGLASSES (U.S. CLS. 21, 23, 26, 36 AND 38).

CLASS 14—JEWELRY

FOR JEWELLERY; WATCHES (U.S. CLS. 2, 27, 28 AND 50).

CLASS 18—LEATHER GOODS

FOR LEATHER GOODS, NAMELY, LEATHER HANDBAGS, LEATHER BRIEFCASES, LEATHER BACKPACKS, LEATHER TRAVELLING BAGS, LEATHER MESSENGER BAGS (U.S. CLS. 1, 2, 3, 22 AND 41).

CLASS 25—CLOTHING

FOR CLOTHING, NAMELY, LEATHER BELTS, T-SHIRTS, POLO SHIRTS, SWEATERS, SHIRTS, BERMUDA SHORTS, JACKETS, SUIT COATS, BLAZERS, INTELLIGENT SHOES, INTELLIGENT TRACK AND FIELD SHOES, INTELLIGENT TRAINING SHOES, INTELLIGENT MOUNTAINEERING SHOES, KNITTED SWEATERS, KNITTED TOPS, KNITTED SCARVES, KNITTED JACKETS (U.S. CLS. 22 AND 39).

CLASS 28—TOYS AND SPORTING GOODS

FOR SPORTING ARTICLES, NAMELY, SKATEBOARDS AND INLINE SKATES (U.S. CLS. 22, 23, 38 AND 50).

SHAILA SETTLES, EXAMINING ATTORNEY

SN 79-082,794. THE JAVELIN GROUP LIMITED, LONDON, UNITED KINGDOM, FILED 4-22-2010.

JAVELIN

THE MARK CONSISTS OF STANDARD CHARACTERS WITHOUT CLAIM TO ANY PARTICULAR FONT, STYLE, SIZE, OR COLOR.

OWNER OF INTERNATIONAL REGISTRATION 1039423 DATED 4-22-2010, EXPIRES 4-22-2020.

CLASS 35—ADVERTISING AND BUSINESS

FOR GATHERING AND ANALYSIS OF DATA IN THE FIELD OF THE LOCATION OF RETAIL STORES, MALLS AND SHOPPING CENTERS; BUSINESS RESEARCH, NAMELY, GATHERING AND ANALYSIS OF INFORMATION RELATING TO RETAIL LOCATIONS; PREPARATION OF BUSINESS REPORTS; BUSINESS CONSULTANCY SERVICES RELATING TO THE LOCATION OF STORES, MALLS AND SHOPPING CENTERS; BUSINESS MANAGEMENT CONSULTANCY; BUSINESS INFORMATION AND RESEARCH SERVICES; BUSINESS APPRAISALS; BUSINESS ADMINISTRATION SERVICES; BUSINESS MANAGEMENT ASSISTANCE, NAMELY, ASSISTANCE IN MANAGEMENT OF BUSINESS ACTIVITIES; BUSINESS ORGANIZATION CONSULTANCY; BUSINESS STRATEGY DEVELOPMENT CONSULTANCY; PERSONNEL MANAGEMENT SERVICES (U.S. CLS. 100, 101 AND 102).

CLASS 42—SCIENTIFIC AND COMPUTER SERVICES

FOR IT CONSULTANCY SERVICES; COMPUTER CONSULTANCY SERVICES; COMPUTER PROGRAMMING; DEVELOPMENT, SUPPORT AND OPERATION OF WEBSITES; DESIGN AND DEVELOPMENT OF COMPUTER HARDWARE AND SOFTWARE (U.S. CLS. 100 AND 101).

FLORENTINA BLANDU, EXAMINING ATTORNEY

SN 79-082,904. BEIJING KASLY; INVESTMENT MANAGEMENT CO., LTD., BEIJING, CHINA, FILED 4-26-2010.

Deepure 帝泊洱

OWNER OF INTERNATIONAL REGISTRATION 1039687 DATED 4-26-2010, EXPIRES 4-26-2020.

THE MARK CONSISTS OF THE WORDING "DEEPURE" IN ENGLISH AND IN CHINESE CHARACTERS SHOWN IN STYLIZED FORM. A SWOOSH IS UNDER THE WORD DEEPURE AND A LEAF DESIGN IS IN THE D IN DEEPURE AND A STAR AND LEAF DESIGN IS IN THE CHINESE CHARACTERS.

THE ENGLISH TRANSLATION OF THE FOREIGN WORD(S) IN THE MARK IS: THE CHARACTERS INDIVIDUALLY TRANSLATE TO "EMPEROR", "BERTH", AND "INLET", BUT HAVE NO MEANING WHEN COMBINED.

THE TRANSLITERATION OF THE NON-LATIN CHARACTERS IN THE MARK IS "DI", "BO", "ER".

CLASS 30—STAPLE FOODS

FOR COFFEE; COFFEE-BASED BEVERAGES; CHOCOLATE-BASED BEVERAGES WITH MILK; CHOCOLATE FOOD BEVERAGES NOT BEING DAIRY-BASED OR VEGETABLE BASED; TEA; TEA SUBSTITUTE; TEA-BASED BEVERAGES; ICED TEA; NUTRITION LIQUID, NOT FOR MEDICAL PURPOSE, NAMELY, MOLASSES SYRUP, CHOCOLATE SYRUP, FLAVORING SYRUP, GOLDEN SYRUP, STARCH SYRUP, TABLE SYRUP, HONEY, HONEY FOR FOOD, HONEY SUBSTITUTES, ROYAL JELLY FOR FOOD PURPOSES, ROYAL JELLY FOR HUMAN CONSUMPTION NOT FOR MEDICAL PURPOSES, AND PROPOLIS FOR HUMAN CONSUMPTION; EDIBLE ICES; ICE CREAM (U.S. CL. 46).

CLASS 32—LIGHT BEVERAGES

FOR FRUIT NECTARS BEING NON-ALCOHOLIC; FRUIT JUICES; WATER BEVERAGES, BOTTLED DRINKING WATER, BOTTLED WATER, DRINKING WATER, TABLE WATER, BOTTLED ARTESIAN WATER, DRINKING WATER WITH VITAMINS, GLACIAL WATER, MAGNETICALLY TREATED WATER FOR HUMAN CONSUMPTION AND NOT FOR MEDICAL PURPOSES, MINERAL AND AERATED WATER, PURIFIED BOTTLED DRINKING WATER, SELTZER WATER, SPARKLING WATER, MINERAL WATER, SODA WATER, DISTILLED DRINKING WATER; ISOTONIC BEVERAGES; PLANT BEVERAGES, NAMELY, VEGETABLE DRINKS, VEGETABLE JUICE, AND VEGETABLE-FRUIT JUICES; PREPARATIONS FOR MAKING BEVERAGES, NAMELY, ESSENCES FOR MAKING NON-ALCOHOLIC BEVERAGES AND SCENTED WATER FOR MAKING BEVERAGES (U.S. CLS. 45, 46 AND 48).

PAUL MORENO, EXAMINING ATTORNEY

SN 79-082,967. VERNON SYSTEMS LIMITED, AUCKLAND, NEW ZEALAND, FILED 4-19-2010.

THE MARK CONSISTS OF STANDARD CHARACTERS WITHOUT CLAIM TO ANY PARTICULAR FONT, STYLE, SIZE, OR COLOR.

OWNER OF INTERNATIONAL REGISTRATION 1039889 DATED 4-19-2010, EXPIRES 4-19-2020.

CLASS 9—ELECTRICAL AND SCIENTIFIC APPARATUS

FOR COMPUTER SOFTWARE AND DOWNLOADABLE COMPUTER SOFTWARE FOR USE IN CATALOGUING, MANAGING AND HANDLING MULTI-MEDIA OF ANY VARIETY OF COLLECTABLE ITEMS SUCH AS FINE ART, COINS, AND HISTORICAL DOCUMENTS FOR USE BY MUSEUMS, GALLERIES, CULTURAL HERITAGE ORGANIZATIONS OR INDIVIDUALS; COMPUTER SOFTWARE FOR DATABASE MANAGEMENT FOR DATABASES CATALOGUING, MANAGING AND HANDLING MULTI-MEDIA OF ANY VARIETY OF COLLECTABLE ITEMS SUCH AS FINE ART, COINS, AND HISTORICAL DOCUMENTS FOR USE BY MUSEUMS, GALLERIES, CULTURAL HERITAGE ORGANIZATIONS OR INDIVIDUALS (U.S. CLS. 21, 23, 26, 36 AND 38).

CLASS 42—SCIENTIFIC AND COMPUTER SERVICES

FOR DESIGN AND DEVELOPMENT OF COMPUTER SOFTWARE FOR OTHERS FOR USE IN CATALOGUING, MANAGING AND HANDLING MULTI-MEDIA FEATURING ANY VARIETY OF COLLECTABLE ITEMS SUCH AS FINE ART, COINS, AND HISTORICAL DOCUMENTS FOR USE BY MUSEUMS, GALLERIES, CULTURAL HERITAGE ORGANIZATIONS OR INDIVIDUALS; INSTALLATION AND MAINTENANCE OF COMPUTER SOFTWARE FOR USE IN CATALOGUING, MANAGING AND HANDLING MULTI-MEDIA OF ANY VARIETY OF COLLECTABLE ITEMS SUCH AS FINE ART, COINS, AND HISTORICAL DOCUMENTS FOR USE BY MUSEUMS, GALLERIES, CULTURAL HERITAGE ORGANIZATIONS OR INDIVIDUALS (U.S. CLS. 100 AND 101).

DANIEL CAPSHAW, EXAMINING ATTORNEY

SN 79-083,491. TRUST MISSION, PARIS, FRANCE, FILED 12-21-2009.

TRUSTMISSION

OWNER OF INTERNATIONAL REGISTRATION 0859051 DATED 6-14-2005, EXPIRES 6-14-2015.

THE MARK CONSISTS OF THE WORDING "TRUSTMISSION" IN A STYLIZED FONT.

CLASS 9—ELECTRICAL AND SCIENTIFIC APPARATUS

FOR COMPUTER HARDWARE AND SOFTWARE ALLOWING INTEROPERABILITY BETWEEN ANY KIND OF OPERATORS RECEIVING AND TRANSMITTING ANY KIND OF DOCUMENTS; CERTIFICATION DATA PROCESSING EQUIPMENT FOR USE IN VERIFYING THE DEPOSIT, RECEIPT, SHIPMENT, STORAGE, SEAL, PLACEMENT IN THE SAFE BOX AND PLACEMENT IN THE RECEIVERSHIP OF DOCUMENTS RECEIVED AND TRANSMITTED TO THE COMPUTER NETWORK (U.S. CLS. 21, 23, 26, 36 AND 38).

CLASS 35—ADVERTISING AND BUSINESS

FOR PROVIDING OFFICE FUNCTIONS AND E-COMMERCE OFFICE FUNCTIONS, NAMELY, OFFICE FUNCTIONS ON-LINE IN THE NATURE OF COMPUTERIZED DATABASE MANAGEMENT, AND RELOCATION SERVICES FOR BUSINESSES; COLLECTING OF DATA FOR BUSINESS PURPOSES, STAPLING, ADDRESSING OF PHYSICAL ENVELOPES AND ADDRESSING BY TYPING OF ELECTRONIC ENVELOPES, AND FRANKING OF GOODS, NAMELY, LETTERS, PARCELS, PRINTED INVOICES UNDER ELECTRONIC DATA INTERCHANGE FORMAT AND PORTABLE DOCUMENT FORMAT, FAX PRINT-OUTS, E-MAIL PRINT-OUTS AND PRINTED DOCUMENT PACKETS; DUPLICATION OF PRINTED MATTERS; SYSTEMATIZATION, COMPILATION, AND MANAGEMENT IN THE NATURE OF UPDATING AND ADMINISTERING DATA IN COMPUTER DATABASES; ADMINISTRATION, BILLING AND RECONCILIATION OF ACCOUNTS ON BEHALF OF OTHERS, THESE SERVICES BEING PART OF AN ELECTRONIC TRADE SYSTEM THAT RECEIVES FOR HANDLING THE ELECTRONICALLY TRANSMITTED ORDER TRANSACTIONS AND ORDER PLACEMENT AND INVOICE MANAGEMENT; MAIL SORTING, HANDLING AND RECEIVING SERVICES FOR RETURN MANAGEMENT, NAMELY, MANAGEMENT OF RETURNED LETTERS; FOLLOW-UP SERVICES, NAMELY, THE ELECTRONIC TRACKING OF SHIPMENTS, NAMELY, PARCELS SENT BY COURIER, LETTERS AND DOCUMENTS; PROVIDING OF INFORMATION AND DATA VIA DATABASES, THE INTERNET, OR BOTH, ALL RELATING TO LOGISTICS MANAGEMENT IN THE FIELDS OF LETTER MAIL, PARCEL AND EXPRESS MAIL AND PARCEL SERVICES, DISTRIBUTION OF NEWSPAPERS AND MAGAZINES, AND LOGISTICS MANAGEMENT IN THE FIELDS OF SHIPMENT AND DELIVERY OF SECURED MAIL AND SECURED FAX; ELECTRONIC DATA PROCESSING FOR THIRD PARTIES; ELECTRONIC NOTIFICATION SERVICE IN THE FIELDS OF COURIER AND INVOICE UNDER ELECTRONIC DATA INTERCHANGE FORMAT AND PORTABLE DOCUMENT FORMAT, NAMELY, PROVIDING INFORMATION IN THE FORM OF E-MAIL NOTIFICATIONS CONCERNING THE STATUS OF DELIVERIES FOR THE MONITORING AND TRACKING OF SHIPMENT, NAMELY, OF LETTERS, PARCELS SENT BY COURIER AND DOCUMENTS; PROVISION OF A WEBSITE FOR THE MONITORING AND TRACKING OF SHIPMENT, NAMELY, OF LETTERS, PARCELS SENT BY COURIER AND DOCUMENTS; ELECTRONIC BILLING AND INVOICING; ELECTRONIC DATA PROCESSING FOR THIRD PARTIES FOR THE ADMINISTRATION AND THE MANAGEMENT OF SHIPMENTS, NAMELY, PARCELS SENT BY COURIER, LETTERS, INVOICES AND DOCUMENTS; ARCHIVING SYSTEM IN THE NATURE OF COMPUTERIZED DATABASE MANAGEMENT OF ARCHIVED INFORMATION; ELECTRONIC SIGNA-

TURE VERIFICATION SERVICES PROVIDED IN CONNECTION WITH BANKING AND FINANCIAL SERVICES (U.S. CLS. 100, 101 AND 102).

SN 79-083,623. IBX GROUP AB, SWEDEN, FILED 5-12-2010.

CLASS 38—COMMUNICATION

FOR TELECOMMUNICATION SERVICES, NAMELY, PROVIDING ACCESS TO TELECOMMUNICATIONS NETWORKS, PROVIDING ACCESS TO THIRD PARTIES PLACING ORDERS ONLINE OR VIA THE INTERNET; PROVIDING INTERNET ACCESS TO PLATFORMS AND PORTALS ON THE INTERNET; ELECTRONIC MAIL SERVICES; FAX SERVICES, NAMELY, FACSIMILE TRANSMISSION; INTERNET AND ONLINE SERVICES, NAMELY, ELECTRONIC TRANSMISSION OF MESSAGES, IMAGES AND DATA AS WELL AS ELECTRONIC AND DIGITAL TRANSMISSION OF DATA, IMAGES, VOICE, SIGNALS, MESSAGES AND DOCUMENTS VIA COMPUTER TERMINALS; DELIVERY OF MESSAGES BY ELECTRONIC TRANSMISSION; ELECTRONIC STORE-AND-FORWARD MESSAGING; WEB-MESSAGING, NAMELY, FORWARDING OF MESSAGES OF ANY KIND TO INTERNET ADDRESSES; PROVIDING ACCESS TO A GLOBAL COMPUTER NETWORK AND TO AN ELECTRONIC DATA BASE (U.S. CLS. 100, 101 AND 104).

CLASS 39—TRANSPORTATION AND STORAGE

FOR COURIER SERVICES AND INVOICE SERVICES; COLLECTION IN THE NATURE OF PICK UP, STORAGE, TRANSPORTATION AND DELIVERY OF DOCUMENTS, PACKAGES, PARCELS, PACKETS AND LETTERS FOR OTHERS BY AIR, RAIL, SHIP OR TRUCK; POSTAL, MAIL AND EXPRESS SERVICES, NAMELY, PARCEL DELIVERY, PACKAGING ARTICLES FOR TRANSPORTATION; PROVIDING ON-LINE INFORMATION IN THE FIELDS OF TRANSPORTATION, AND THE TRANSPORT OF GOODS IN THE NATURE OF DOCUMENTS, LETTERS, INVOICES, PACKAGES AND PARCELS; PROVIDING DATABASES FEATURING INFORMATION IN THE FIELD OF THE TRANSPORTATION, PACKAGING ARTICLES FOR TRANSPORTATION AND STORAGE OF COURIERED GOODS AND INVOICES FOR TRANSPORTATION; PROVIDING INTERNET STORAGE OF ELECTRONIC MEDIA, NAMELY, IMAGES, TEXT AND AUDIO DATA; WORLDWIDE DELIVERY OF DOCUMENTS, LETTERS AND PARCELS; INTERNATIONAL PARCEL AND ENVELOPE PICK-UP AND ROUTING SHIPPING SERVICES (U.S. CLS. 100 AND 105).

CLASS 42—SCIENTIFIC AND COMPUTER SERVICES

FOR DEVELOPING, UPDATING AND DESIGN OF COMPUTER SOFTWARE; DEVELOPING COMPUTER PROGRAMS IN DATA NETWORKS FOR THIRD PARTIES; NETWORK MANAGEMENT, NAMELY, DATA WAREHOUSING; DATA ADMINISTRATION ON SERVERS, NAMELY, DESIGN AND DEVELOPMENT OF DATABASES; DIGITAL DATA PREPARATION AND PROCESSING, NAMELY, CROSS-PLATFORM CONVERSION OF DIGITAL CONTENT INTO OTHER FORMS OF DIGITAL CONTENT; ELECTRONIC DATA PROCESSING FOR THIRD PARTIES; UPDATING AND INSTALLATION OF COMPUTER SOFTWARE; COMPUTER SERVICES, NAMELY, DATA RECOVERY SERVICES; WEB SITE HOSTING SERVICES; COMPUTER SERVICE, NAMELY, ACTING AS AN APPLICATION SERVICE PROVIDER IN THE FIELD OF KNOWLEDGE MANAGEMENT TO HOST COMPUTER APPLICATION SOFTWARE FOR USE IN THE STORAGE OF DATA AND INFORMATION; PROVIDING OF SEARCH ENGINES FOR OBTAINING DATA ON THE INTERNET; DATA CONVERSION OF ELECTRONIC COMPUTER PROGRAM DATA OR OTHER ELECTRONIC INFORMATION; COMPUTER SERVICES, NAMELY, CREATING INDEXES OF INFORMATION, SITES AND OTHER RESOURCES AVAILABLE ON THE INTERNET; COMPUTER SERVICES, NAMELY, REDIRECTING ELECTRONIC MAIL TO CHANGED PERSONAL ELECTRONIC ADDRESSES (U.S. CLS. 100 AND 101).
ANDREA HACK, EXAMINING ATTORNEY



THE MARK CONSISTS OF STANDARD CHARACTERS WITHOUT CLAIM TO ANY PARTICULAR FONT, STYLE, SIZE, OR COLOR.

OWNER OF INTERNATIONAL REGISTRATION 1041585 DATED 5-12-2010, EXPIRES 5-12-2020.

CLASS 9—ELECTRICAL AND SCIENTIFIC APPARATUS

FOR COMPUTER SOFTWARE FOR MANAGING THE PROCUREMENT OR PURCHASING PROCESS FOR CORPORATIONS OR OTHER BUSINESSES; COMPUTER SOFTWARE FOR MANAGING THE PROCUREMENT OR PURCHASING PROCESS FOR CORPORATIONS OR OTHER BUSINESSES THAT MAY BE DOWNLOADED FROM A GLOBAL COMPUTER NETWORK (U.S. CLS. 21, 23, 26, 36 AND 38).

CLASS 35—ADVERTISING AND BUSINESS

FOR PROVIDING AN ON-LINE COMPUTER DATABASE IN THE FIELD OF BUSINESS INFORMATION AND BUSINESS CONTACTS; ADVERTISING; CONSULTANCY WITH RESPECT TO PARTICIPATION IN E-COMMERCE; CUSTOMER SERVICE INFORMATION IN CONNECTION WITH THE SALE OF OFFICE REQUISITES; THE BRINGING TOGETHER FOR THE BENEFIT OF OTHERS, OF A VARIETY OF GOODS AND SERVICES, ENABLING CUSTOMERS TO CONVENIENTLY VIEW AND PURCHASE THOSE GOODS AND SERVICES FROM AN INTERNET WEB SITE PARTICULARLY SPECIALIZING IN THE MARKETING OF THE SALE OF GOODS AND SERVICES OF OTHERS; BUSINESS ADMINISTRATION AND PLANNING; COMMERCIAL CONSULTANCY; PROCURING OF CONTRACTS FOR THE PURCHASE AND SALE OF GOODS (U.S. CLS. 100, 101 AND 102).

CLASS 36—INSURANCE AND FINANCIAL

FOR FINANCIAL CONSULTANCY (U.S. CLS. 100, 101 AND 102).

JAY FLOWERS, EXAMINING ATTORNEY

SN 79-083,919. FOSHAN NANHAI KERI; ELECTRONIC CO., LTD., GUANGDONG PROVINCE, CHINA, FILED 5-26-2010.



OWNER OF INTERNATIONAL REGISTRATION 1042534 DATED 5-26-2010, EXPIRES 5-26-2020.

CLASS 7—MACHINERY

FOR SPRAYING MACHINES; AERATING PUMPS FOR AQUARIA; DISHWASHERS; ELECTRIC FOOD BLENDERS FOR HOUSEHOLD PURPOSES; STEAM CLEANING MACHINES; ELECTRIC MACHINES AND APPARATUS FOR CARPET SHAMPOOING (U.S. CLS. 13, 19, 21, 23, 31, 34 AND 35).

CLASS 9—ELECTRICAL AND SCIENTIFIC APPARATUS

FOR MAGNETIC IDENTITY CARDS; SIGNALLING DEVICES, NAMELY, TRAFFIC-LIGHT APPARATUS; ELECTRIC WIRES; ELECTRIC TRANSFORMERS; ELECTRICAL SWITCHES; SOUND ALARMS (U.S. CLS. 21, 23, 26, 36 AND 38).

CLASS 11—ENVIRONMENTAL CONTROL APPARATUS

FOR AQUARIUM LIGHTS; ELECTRIC COOKING OVENS; ELECTRIC COOKING STOVES FOR HOUSEHOLD PURPOSES; ELECTRICAL COOKING BOILERS; MICROWAVE OVENS FOR COOKING; ELECTRIC ROOM DEODORIZING UNITS; AIR CONDITIONING INSTALLATIONS, NAMELY AIR HUMIDIFIERS; AQUARIUM HEATERS; ORNAMENTAL FOUNTAINS; FUMIGATION APPARATUS, NOT FOR MEDICAL PURPOSES, COMPRISING A CONTAINMENT ENCLOSURE SPECIALLY ADAPTED FOR CONTAINING AN ATOMIZED SPRAY MECHANISM, FOR USE IN CLEANING AND SANITIZING OBJECTS; STERILIZERS, NOT FOR MEDICAL PURPOSES (U.S. CLS. 13, 21, 23, 31 AND 34).
JAMES MACFARLANE, EXAMINING ATTORNEY

SN 79-084,085. PRESENSIA SAS, FRANCE, FILED 5-6-2010.



OWNER OF INTERNATIONAL REGISTRATION 1042835 DATED 5-6-2010, EXPIRES 5-6-2020.

NO CLAIM IS MADE TO THE EXCLUSIVE RIGHT TO USE "FRAGRANCE SYSTEMS" IN INTERNATIONAL CLASS 011, APART FROM THE MARK AS SHOWN.

THE MARK CONSISTS OF THE WORDING "SCENTYS FRAGRANCE SYSTEMS" BELOW A DESIGN OF WAVY LINES AND AN EGG SHAPE.

CLASS 9—ELECTRICAL AND SCIENTIFIC APPARATUS

FOR DATA PROCESSING EQUIPMENT AND COMPUTERS; COMPUTER PERIPHERAL DEVICES (U.S. CLS. 21, 23, 26, 36 AND 38).

CLASS 11—ENVIRONMENTAL CONTROL APPARATUS

FOR AIR OR WATER PURIFYING APPARATUS AND MACHINES (U.S. CLS. 13, 21, 23, 31 AND 34).

CLASS 38—COMMUNICATION

FOR TELECOMMUNICATION SERVICES, NAMELY, TRANSMISSION AND DISSEMINATION OF VOICE, DATA, GRAPHICS, IMAGES, AUDIO, AND VIDEO BY MEANS OF TELECOMMUNICATIONS NETWORKS, WIRELESS COMMUNICATION NETWORKS, AND THE INTERNET; TELECOMMUNICATIONS BY E-MAIL; PROVIDING TELECOMMUNICATIONS CONNECTIONS TO A GLOBAL COMPUTER NETWORK; RENTAL OF TELECOMMUNICATION EQUIPMENT (U.S. CLS. 100, 101 AND 104).

ANNE MADDEN, EXAMINING ATTORNEY

SN 79-084,435. GENOVIS AB, SWEDEN, FILED 6-11-2010.

FeOdot

PRIORITY DATE OF 12-11-2009 IS CLAIMED.
OWNER OF INTERNATIONAL REGISTRATION 1043620 DATED 6-11-2010, EXPIRES 6-11-2020.

THE WORDING "FEODOT" HAS NO MEANING IN A FOREIGN LANGUAGE.

CLASS 1—CHEMICALS

FOR CHEMICAL REAGENTS OTHER THAN FOR MEDICAL OR VETERINARY PURPOSES; CHEMICALS USED IN INDUSTRY AND SCIENCE (U.S. CLS. 1, 5, 6, 10, 26 AND 46).

CLASS 5—PHARMACEUTICALS

FOR CHEMICAL REAGENTS FOR MEDICAL OR VETERINARY PURPOSES, NAMELY, BIOCHEMICAL AND BIOLOGICAL CONTRAST AGENTS AND DRUG DELIVERY AGENTS FOR PRE CLINICAL USE (U.S. CLS. 6, 18, 44, 46, 51 AND 52).

NAKWAMA ANKRAH, EXAMINING ATTORNEY

SN 79-085,502. OLAWORKS, INC., SEOUL 135-919, REPUBLIC OF KOREA, FILED 6-15-2010.

ScanSearch

THE MARK CONSISTS OF STANDARD CHARACTERS WITHOUT CLAIM TO ANY PARTICULAR FONT, STYLE, SIZE, OR COLOR.

PRIORITY DATE OF 12-15-2009 IS CLAIMED.
OWNER OF INTERNATIONAL REGISTRATION 1046191 DATED 6-15-2010, EXPIRES 6-15-2020.

CLASS 9—ELECTRICAL AND SCIENTIFIC APPARATUS

FOR COMPUTER SEARCH ENGINE SOFTWARE FOR INTEGRATION OF WEBSITE INFORMATION; DOWNLOADABLE COMPUTER SOFTWARE FOR MANAGING, CLASSIFYING, ARRANGING AND TAGGING DIGITAL DATA; COMPUTER SOFTWARE FOR WIRELESS CONTENT DELIVERY; COMPUTER PROGRAMS FOR THE ENABLING OF ACCESS OR ENTRANCE CONTROL; RECORDED COMPUTER SOFTWARE FOR MANAGING, CLASSIFYING, ARRANGING AND TAGGING DIGITAL DATA; RECORDED COMPUTER OPERATING PROGRAMS; COMPUTER PROGRAMS FOR MANAGING, CLASSIFYING, ARRANGING AND TAGGING DIGITAL DATA, AND FOR DOCUMENT MANAGEMENT; COMPUTER SOFTWARE FOR PROCESSING IMAGES, GRAPHICS AND TEXT; COMPUTER PROGRAMS FOR EDITING IMAGES, SOUND AND VIDEO (U.S. CLS. 21, 23, 26, 36 AND 38).

CLASS 42—SCIENTIFIC AND COMPUTER SERVICES

FOR PROVIDING SEARCH ENGINES FOR THE INTERNET; PROVIDING ONLINE, NON-DOWNLOADABLE INTERNET SECURITY SOFTWARE, NAMELY, ONLINE, NON-DOWNLOADABLE COMPUTER PROGRAMS ENABLING SAFE AND SECURE USE OF THE INTERNET; CONVERSION OF DATA OR DOCUMENTS FROM PHYSICAL TO ELECTRONIC MEDIA; DATA CONVERSION OF COMPUTER PROGRAMS AND DATA, NOT PHYSICAL CONVERSION; RECOVERY OF COMPUTER DATA; COMPUTER SOFTWARE DEVELOPMENT; RENTAL OF COMPUTER SOFTWARE; DESIGN OF COMPUTER SOFTWARE; RESEARCH OF COMPUTER SOFTWARE; MAINTENANCE OF COMPUTER SOFTWARE; COMPUTER PROGRAMMING; DEVELOPMENT OF COMPUTER PROGRAMS; DUPLICATION OF COMPUTER PROGRAMS (U.S. CLS. 100 AND 101).
FRED CARL, EXAMINING ATTORNEY

CLASS 35—ADVERTISING AND BUSINESS

FOR INFORMATION RETRIEVAL SERVICES ON THE INTERNET FOR OTHERS; COMPILATION OF INFORMATION INTO COMPUTER DATABASES; SYSTEMIZATION OF INFORMATION INTO COMPUTER DATABASES; MANAGEMENT AND COMPILATION OF COMPUTERIZED DATABASES; COMPUTERIZED FILE MANAGEMENT; PROVIDING DATA, NAMELY, PROVIDING A DATABASE FEATURING BUSINESS INFORMATION; NEWS CLIPPING SERVICES; DATABASE MANAGEMENT SERVICES, NAMELY, SERVICES FOR MANAGING, CLASSIFYING, ARRANGING AND TAGGING DIGITAL DATA (U.S. CLS. 100, 101 AND 102).

SN 79-085.732. "KRONOPOL" SPÓLKA Z OGRANICZONA ODPOWIEDZIALNOSCIA, POLAND, FILED 6-18-2010.



PRIORITY DATE OF 3-12-2010 IS CLAIMED.
OWNER OF INTERNATIONAL REGISTRATION 1046712 DATED 6-18-2010, EXPIRES 6-18-2020.
THE COLOR(S) GRAY AND CLARET RED IS/ARE CLAIMED AS A FEATURE OF THE MARK.

THE MARK CONSISTS OF THE WORD "PLATINIUM" IN STYLIZED CLARET RED LETTERING WITH THREE CLARET RED BARS ABOVE IT ALL ON A GRAY RECTANGULAR BACKGROUND. THE BOTTOM PORTION OF THE RECTANGULAR BACKGROUND IS CLARET RED.

THE WORDING "PLATINIUM" HAS NO MEANING IN A FOREIGN LANGUAGE.

CLASS 38—COMMUNICATION

FOR TRANSMISSION OF INFORMATION VIA NATIONAL AND INTERNATIONAL NETWORKS; TRANSMISSION OF NEWS; DATA COMMUNICATION, NAMELY, TRANSMISSION OF DATA BY TELECOMMUNICATIONS NETWORKS, WIRELESS COMMUNICATION NETWORKS, THE INTERNET, INFORMATION SERVICE NETWORKS AND DATA NETWORKS; MESSAGE SENDING; RADIO COMMUNICATIONS OF DATA; PROVIDING ACCESS TO WIRELESS INTERNET; PROVIDING ACCESS TO ONLINE DATABASES; MOBILE RADIO COMMUNICATIONS; TELECOMMUNICATIONS BY MOBILE PHONES; PROVIDING E-MAIL; PROVIDING ACCESS TO DATABASES; TRANSMISSION AND RECEPTION OF DATABASE INFORMATION VIA THE TELECOMMUNICATION NETWORK; DATA COMMUNICATIONS VIA INTERNET; TRANSMISSION OF MOVING PICTURES VIA INTERNET; TRANSMISSION OF MESSAGES AND IMAGES VIA INTERNET; TRANSMISSION OF IMAGES AND VOICE VIA INTERNET; PROVIDING USER ACCESS TO A GLOBAL COMPUTER NETWORK; PROVIDING TELECOMMUNICATIONS CONNECTIONS TO A GLOBAL COMPUTER NETWORK; ELECTRONIC BULLETIN BOARD SERVICES; COMMUNICATION SERVICES FOR THE ELECTRONIC TRANSMISSION OF DATA; ELECTRONIC MESSAGE SENDING; CELLULAR TELEPHONE COMMUNICATION; ELECTRONIC MAIL; COMPUTER DATA TRANSMISSION SERVICES, NAMELY, ELECTRONIC TRANSMISSION OF DATA AND DOCUMENTS AMONG USERS OF COMPUTERS; COMPUTER AIDED TRANSMISSION OF MESSAGES AND IMAGES; COMMUNICATIONS BY COMPUTER TERMINALS; TELECONFERENCING SERVICES; WIRELESS INTERNET BROADCASTING; INTERNET BROADCASTING (U.S. CLS. 100, 101 AND 104).

CLASS 19—NON-METALLIC BUILDING MATERIALS

FOR BOARDS OF WOOD, NAMELY, WOODEN STRIPS FOR PANELLING; WOOD PANELLING; SEMI-WORKED SHAPED WOOD; NON-METAL FLOOR TILES; FLOOR BOARDS IN THE NATURE OF PARQUET FLOORING; FLOORING BOARDS OF WOOD; NON-METAL LATHS; MOSAIC OF GLASS, NATURAL STONE AND STONE TILE FOR CONSTRUCTIONS PURPOSES; PARQUET FLOORS; NON-METAL FLOORS (U.S. CLS. 1, 12, 33 AND 50).

CLASS 37—CONSTRUCTION AND REPAIR

FOR MAINTENANCE AND REPAIR OF FLOORING AND PARQUET FLOORING; INSTALLATION SERVICES, NAMELY, LAYING OF FLOORS; CARPENTRY SERVICES (U.S. CLS. 100, 103 AND 106).

KATHLEEN M. VANSTON, EXAMINING ATTORNEY

SN 79-085.901. CHARGEPOINT TECHNOLOGY LIMITED, UNITED KINGDOM, FILED 12-15-2009.

CHARGEBOTTLE

THE MARK CONSISTS OF STANDARD CHARACTERS WITHOUT CLAIM TO ANY PARTICULAR FONT, STYLE, SIZE, OR COLOR.

OWNER OF INTERNATIONAL REGISTRATION 1047190
DATED 12-15-2009, EXPIRES 12-15-2019.

CLASS 6—METAL GOODS

FOR VALVES OF METAL, OTHER THAN PARTS OF MACHINES; MANUALLY OPERATED METAL SPLIT BUTTERFLY VALVES AND MANUALLY OPERATED METAL VALVES FOR CONTROLLING THE FLOW OF SUBSTANCES; CONTAINMENT VALVES NOT BEING PARTS OF MACHINES, NAMELY, METAL VALVES FOR CONTROLLING THE CONTAINED TRANSFER OF SUBSTANCES, METAL COUPLING DEVICES OTHER THAN PARTS OF MACHINES FOR USE WITH INTEGRATED MATERIAL HANDLING EQUIPMENT, NAMELY, COUPLINGS OF METAL FOR CONTAINERS; METAL COUPLING DEVICES FOR THE CONTAINED TRANSFER OF PRODUCTS, NAMELY, COUPLING OF METAL FOR CONTAINERS; METAL CLOSURES FOR CONTAINERS; CONTAINERS OF METAL FOR STORAGE, TRANSPORT, TRANSFER; CONTAINERS OF METAL FOR STORAGE AND TRANSPORT OF POTENT SUBSTANCES; BOTTLES AND OTHER CONTAINERS OF METAL FOR USE IN TRANSFERRING SUBSTANCES BETWEEN CONTAINERS (U.S. CLS. 2, 12, 13, 14, 23, 25 AND 50).

CLASS 20—FURNITURE AND ARTICLES NOT OTHERWISE CLASSIFIED

FOR NON-METAL VALVES, OTHER THAN PARTS OF MACHINES FOR CONTAINERS AND VALVES OF PLASTIC BEING OTHER THAN MACHINE PARTS; NON-METALLIC BUTTERFLY VALVES BEING USED FOR THE CONTAINED TRANSFER OF SUBSTANCES OTHER THAN MACHINE PARTS; NON-METAL CONTAINER CLOSURES; NON-METAL CONTAINERS FOR USE IN THE CONTAINED TRANSFER OF SUBSTANCES FOR COMMERCIAL OR INDUSTRIAL USE; NON-METAL CONTAINERS FOR THE HANDLING OF POWDERS, GASES AND LIQUIDS FOR COMMERCIAL OR INDUSTRIAL USE; CONTAINERS NOT OF METAL FOR USE WITH POTENT SUBSTANCES FOR COMMERCIAL OR INDUSTRIAL USE (U.S. CLS. 2, 13, 22, 25, 32 AND 50).

CLASS 21—HOUSEWARES AND GLASS

FOR BOTTLES SOLD EMPTY (U.S. CLS. 2, 13, 23, 29, 30, 33, 40 AND 50).

CLASS 42—SCIENTIFIC AND COMPUTER SERVICES

FOR INDUSTRIAL ANALYSIS AND RESEARCH SERVICES IN THE FIELD OF INTEGRATED MATERIAL HANDLING; SERVICES RELATING TO THE TRANSFER OF SUBSTANCES, NAMELY, TROUBLE SHOOTING IN THE NATURE OF DIAGNOSING PROBLEMS WITH THE USE OF INTEGRATED MATERIAL HANDLING EQUIPMENT (U.S. CLS. 100 AND 101).

JULIE VEPPUMTHARA, EXAMINING ATTORNEY

SN 79-085,947. DIRK DAMMERS, FED REP GERMANY,
FILED 7-16-2010.

Cinewall

THE MARK CONSISTS OF STANDARD CHARACTERS WITHOUT CLAIM TO ANY PARTICULAR FONT, STYLE, SIZE, OR COLOR.

PRIORITY DATE OF 1-18-2010 IS CLAIMED.
OWNER OF INTERNATIONAL REGISTRATION 1047359
DATED 7-16-2010, EXPIRES 7-16-2020.

CLASS 6—METAL GOODS

FOR METAL ASSEMBLY RAILS; ALUMINUM COVER AND FASTENING RAILS; SMALL ITEMS OF METAL HARDWARE, NAMELY, METAL FASTENING ELEMENTS, BRACKETS, SCREWS, HINGES, HOOKS, CABINET DOOR HANDLES; NON-ELECTRIC CABLES AND WIRES OF COMMON METAL; PIPES AND TUBES OF METAL (U.S. CLS. 2, 12, 13, 14, 23, 25 AND 50).

CLASS 19—NON-METALLIC BUILDING MATERIALS

FOR NON-METAL BUILDING PANELS FOR FURNITURE, NAMELY, WOOD PANELS, LEATHER PANELS, SYNTHETIC LEATHER PANELS, VARNISH PANELS, GLASS PANELS, PLASTIC PANELS, STONE PANELS, LAMINATE PANELS (U.S. CLS. 1, 12, 33 AND 50).

CLASS 20—FURNITURE AND ARTICLES NOT OTHERWISE CLASSIFIED

FOR MULTI-FUNCTIONAL WALL FURNISHINGS, NAMELY, MULTI-FUNCTIONAL WALL UNITS CONSISTING OF NON-METAL WALL PANELS, NON-METAL SHELVING FOR USE WITH MULTI-FUNCTIONAL WALL UNITS, NON-METAL CABINETS AND NON-METAL CABINET DOORS FOR USE WITH MULTI-FUNCTIONAL WALL UNITS, ASSEMBLY RAILS FOR USE WITH MULTI-FUNCTIONAL WALL UNITS (U.S. CLS. 2, 13, 22, 25, 32 AND 50).

MICHAEL ENGEL, EXAMINING ATTORNEY

SN 79-086,128. SUEZ ENVIRONNEMENT, FRANCE, FILED
7-27-2010.

BLUE ORANGE

THE MARK CONSISTS OF STANDARD CHARACTERS WITHOUT CLAIM TO ANY PARTICULAR FONT, STYLE, SIZE, OR COLOR.

PRIORITY DATE OF 3-22-2010 IS CLAIMED.
OWNER OF INTERNATIONAL REGISTRATION 1047799
DATED 7-27-2010, EXPIRES 7-27-2020.

CLASS 36—INSURANCE AND FINANCIAL

FOR INVESTMENT MANAGEMENT, NAMELY, CAPITAL INVESTMENTS; CAPITAL INVESTMENT CONSULTING; SPONSORSHIP OF THE RESEARCH AND DEVELOPMENT ENDEAVORS OF THIRD PARTIES IN THE FIELD OF TECHNOLOGICAL RESEARCH AND SUSTAINABLE DEVELOPMENT (U.S. CLS. 100, 101 AND 102).

CLASS 42—SCIENTIFIC AND COMPUTER SERVICES

FOR SCIENTIFIC AND TECHNOLOGICAL RESEARCH, NAMELY, ENGINEERING SERVICES IN THE FIELD OF PROCESSING WATER, WASTE AND SUSTAINABLE DEVELOPMENT; TECHNICAL AUDITING IN THE FIELD OF SUSTAINABLE DEVELOPMENT; TECHNICAL ENGINEERING CONSULTING IN THE FIELD OF SUSTAINABLE DEVELOPMENT; QUALITY EVALUATIONS FOR OTHERS, GEOLOGICAL ESTIMATES AND TECHNICAL RESEARCH IN THE FIELDS OF THE ENVIRONMENT SUCH AS MANAGING WATER RESOURCES, WATER TREATMENT, COLLECTING AND PROCESSING OF WASTE, PROCESSING AIR (U.S. CLS. 100 AND 101).

TRACY WHITTAKER-BROWN, EXAMINING ATTORNEY

SN 79-086,355. ANDERMATT BIOCONTROL AG, SWITZERLAND, FILED 7-9-2010.

TOPCAT

THE MARK CONSISTS OF STANDARD CHARACTERS WITHOUT CLAIM TO ANY PARTICULAR FONT, STYLE, SIZE, OR COLOR.

OWNER OF INTERNATIONAL REGISTRATION 0759794 DATED 5-28-2001, EXPIRES 5-28-2021.

CLASS 6—METAL GOODS

FOR TRAPS FOR WILD ANIMALS (U.S. CLS. 2, 12, 13, 14, 23, 25 AND 50).

CLASS 21—HOUSEWARES AND GLASS

FOR MOUSE TRAPS, RAT TRAPS (U.S. CLS. 2, 13, 23, 29, 30, 33, 40 AND 50).

JAMES MACFARLANE, EXAMINING ATTORNEY

SN 79-086,514. BAREM PAZAR ARASTIRMA VE ÖZEL EĞİTİM MERKEZİ LIMITED SIRKETİ, TURKEY, FILED 7-19-2010.



OWNER OF INTERNATIONAL REGISTRATION 1048841 DATED 7-19-2010, EXPIRES 7-19-2020.

THE COLOR(S) PINK AND BLACK IS/ARE CLAIMED AS A FEATURE OF THE MARK.

THE WORD "DIGI" IS WRITTEN IN COLOR PINK AND THE WORD "PANEL" IS WRITTEN IN COLOR BLACK.

CLASS 35—ADVERTISING AND BUSINESS

FOR ADVERTISING; BUSINESS MANAGEMENT; BUSINESS ADMINISTRATION; OFFICE FUNCTIONS (U.S. CLS. 100, 101 AND 102).

CLASS 41—EDUCATION AND ENTERTAINMENT

FOR EDUCATION, NAMELY, CLASSES AND SEMINARS IN THE FIELD OF MARKETING RESEARCH; PROVIDING OF TRAINING IN THE USE OF TECHNIQUES FOR RESEARCH DESIGN AND INTERPRETING MARKETING AND SOCIAL RESEARCH FINDINGS (U.S. CLS. 100, 101 AND 107).

JASON BLAIR, EXAMINING ATTORNEY

SN 79-086,683. AUTOMOBILI LAMBORGHINI HOLDING S.P.A., ITALY, FILED 7-8-2010.

RADICARBON

THE MARK CONSISTS OF STANDARD CHARACTERS WITHOUT CLAIM TO ANY PARTICULAR FONT, STYLE, SIZE, OR COLOR.

PRIORITY DATE OF 2-12-2010 IS CLAIMED.
OWNER OF INTERNATIONAL REGISTRATION 1049297 DATED 7-8-2010, EXPIRES 7-8-2020.

CLASS 12—VEHICLES

FOR AUTOMOBILES AND PARTS THEREOF (U.S. CLS. 19, 21, 23, 31, 35 AND 44).

CLASS 17—RUBBER GOODS

FOR THERMOSET AND THERMOPLASTIC COMPOSITE SHEETS REINFORCED WITH SHORT CARBON FIBER AND BLACK GLASS FIBER FOR USE IN THE MANUFACTURE OF OTHER GOODS (U.S. CLS. 1, 5, 12, 13, 35 AND 50).

ALICE BENMAMAN, EXAMINING ATTORNEY

SN 79-086,757. SOPHIE MAUCHET, PARIS, FRANCE, FILED 4-29-2010.

narcocheck

OWNER OF INTERNATIONAL REGISTRATION 1049529 DATED 4-29-2010, EXPIRES 4-29-2020.

CLASS 5—PHARMACEUTICALS

FOR PHARMACEUTICAL PREPARATIONS AND CHEMICAL PREPARATIONS FOR MEDICAL OR PHARMACEUTICAL USE, NAMELY, RAPID URINE, SALIVA AND BLOOD TESTS FOR DETECTING DRUG MOLECULES OR NARCOTICS, FOR MEDICAL USE OR LABORATORY TESTS; CHEMICAL REAGENTS FOR DETECTING DRUG MOLECULES OR NARCOTICS FOR MEDICAL USE (U.S. CLS. 6, 18, 44, 46, 51 AND 52).

CLASS 9—ELECTRICAL AND SCIENTIFIC APPARATUS

FOR MEASURING, SIGNALING AND REGULATING, AND SUPERVISION APPARATUS AND DIAGNOSTIC APPARATUS NOT FOR MEDICAL USE, NAMELY, APPARATUS FOR DETECTING DRUG SUBSTANCES OR NARCOTICS, MEASURING APPARATUS FOR TESTS FOR DETECTING NARCOTICS ON SURFACES, OBJECTS AND CLOTHING, MEASURING APPARATUS FOR TESTS FOR IDENTIFYING NARCOTIC SUBSTANCES TO BE CARRIED OUT ON SUSPECTED POWDERS OR SUBSTANCES FOR CONTROLLING FORCES AND MORE GENERALLY FOR ENTERPRISES AND INDIVIDUALS; MEASURING APPARATUS FOR RAPID URINARY AND SALIVA TESTS, FOR USE AS A MEANS OF PREVENTION AGAINST ACCIDENTS (U.S. CLS. 21, 23, 26, 36 AND 38).

CLASS 10—MEDICAL APPARATUS

FOR SURGICAL AND MEDICAL APPARATUS AND INSTRUMENTS, NAMELY, DIAGNOSTIC APPARATUS FOR MEDICAL USE, IN PARTICULAR FOR DETECTING DRUG MOLECULES OR NARCOTICS (U.S. CLS. 26, 39 AND 44).

SOPHIA S. KIM, EXAMINING ATTORNEY

SN 79-086,824. SOCIETE DES PRODUITS MARNIER LAPOSTOLLE, PARIS, FRANCE, FILED 7-27-2010.



PRIORITY DATE OF 4-19-2010 IS CLAIMED.
OWNER OF INTERNATIONAL REGISTRATION 1049606 DATED 7-27-2010, EXPIRES 7-27-2020.
THE COLOR(S) WHITE, BLACK AND RED IS/ARE CLAIMED AS A FEATURE OF THE MARK.
THE MARK CONSISTS OF THE LETTERS "LVGM" INSIDE OF A RED RECTANGULAR BACKGROUND WHERE THE LETTERS "LV" APPEAR IN WHITE STYLIZED FONT CENTERED ABOVE THE LETTER "GM" IN BLACK STYLIZED FONT.

CLASS 33—WINES AND SPIRITS

FOR ALCOHOLIC BEVERAGES EXCEPT BEERS; APERITIFS, ALCOHOLIC BEVERAGES CONTAINING FRUIT, PREPARED ALCOHOLIC COCKTAILS; DIGESTERS, NAMELY, LIQUEURS AND SPIRITS; LIQUEURS, WINES, SPIRITS, EAUX DE VIE (U.S. CLS. 47 AND 49).

CLASS 43—HOTEL AND RESTAURANT SERVICES

FOR BAR SERVICES (U.S. CLS. 100 AND 101).
TINA BROWN, EXAMINING ATTORNEY

SN 79-086,934. VECTOR 3, S.A., SPAIN, FILED 7-12-2010.



OWNER OF INTERNATIONAL REGISTRATION 1049951 DATED 7-12-2010, EXPIRES 7-12-2020.
NO CLAIM IS MADE TO THE EXCLUSIVE RIGHT TO USE "BOX", APART FROM THE MARK AS SHOWN.
THE MARK CONSISTS OF A PARTIALLY SHADED RECTANGLE, THE UNSHADED PORTIONS OF WHICH FORM THE STYLIZED WORDING "VECTOR BOX" WITH THE "O" OF EACH WORD CONSISTING OF AN UNSHADED CIRCLE. THE STIPPLING IN THE DRAWING IS FOR SHADING PURPOSES ONLY.

CLASS 9—ELECTRICAL AND SCIENTIFIC APPARATUS

FOR RECORDED COMPUTER SOFTWARE FOR USE IN REGULATING THE CONTENT OF TELEVISION SHOWS AND OTHER AUDIOVISUAL MEDIA THAT IS TRANSMITTED; COMPUTER PROGRAMS FOR AUTOMATING TELEVISION BROADCASTS, NAMELY, FOR CONTROLLING THE DISTRIBUTION OF TELEVISION BROADCASTS (U.S. CLS. 21, 23, 26, 36 AND 38).

CLASS 42—SCIENTIFIC AND COMPUTER SERVICES

FOR DESIGN AND DEVELOPMENT OF SOFTWARE, NAMELY, PROGRAMMING COMPUTER SOFTWARE FOR OTHERS FOR USE IN REGULATING THE TRANSMISSION OF TELEVISION CONTENT AND THE CONTENT OF AUDIOVISUAL MEDIA, AND PROGRAMMING COMPUTER SOFTWARE FOR OTHERS FOR USE IN THE AUTOMATION OF THE DISTRIBUTION OF TELEVISION BROADCASTS (U.S. CLS. 100 AND 101).

JOHN KELLY, EXAMINING ATTORNEY

SN 79-087,027. MACROVIEW BUSINESS TECHNOLOGY PTY LIMITED, AUSTRALIA, FILED 8-25-2010.

MACROVIEW CLAUSEBANK

THE MARK CONSISTS OF STANDARD CHARACTERS WITHOUT CLAIM TO ANY PARTICULAR FONT, STYLE, SIZE, OR COLOR.

PRIORITY DATE OF 2-26-2010 IS CLAIMED.
OWNER OF INTERNATIONAL REGISTRATION 1050251 DATED 8-25-2010, EXPIRES 8-25-2020.

CLASS 9—ELECTRICAL AND SCIENTIFIC APPARATUS

FOR COMPUTER SOFTWARE, HARDWARE, AND PERIPHERALS FOR USE IN DOCUMENT AUTOMATION, ELECTRONIC DOCUMENT MANAGEMENT, AND ELECTRONIC DOCUMENT CREATION (U.S. CLS. 21, 23, 26, 36 AND 38).

CLASS 42—SCIENTIFIC AND COMPUTER SERVICES

FOR COMPUTER PROGRAMMING CONSULTANCY SERVICES IN THE FIELD OF DOCUMENT AUTOMATION, ELECTRONIC DOCUMENT MANAGEMENT, AND ELECTRONIC DOCUMENT CREATION (U.S. CLS. 100 AND 101).

REBECCA POVARCHUK, EXAMINING ATTORNEY

SN 79-087,050. ZHEJIANG LINISI SANITARY WARE CO., LTD., CHINA, FILED 8-11-2010.

OWNER OF INTERNATIONAL REGISTRATION 1050316 DATED 8-11-2010, EXPIRES 8-11-2020.

THE MARK CONSISTS OF THE WORD "LINISI" IN STYLIZED FONT.

THE WORD(S) "LINISI" HAS NO MEANING IN A FOREIGN LANGUAGE.

CLASS 11—ENVIRONMENTAL CONTROL APPARATUS

FOR HYDRANTS; GLASS STRUCTURAL PLATES SOLD AS PARTS OF OVENS; DESICCATING APPARATUS, NAMELY, DESICCATING UNITS FOR PRODUCING DRIED FRUITS; BATH FITTINGS, NAMELY, BATH TUBS; LIGHTING APPARATUS, NAMELY, LIGHTING INSTALLATIONS; PARTS OF SANITARY INSTALLATIONS, NAMELY, BATHROOM SINKS FOR HAND WASHING; ELECTRIC RADIATORS (U.S. CLS. 13, 21, 23, 31 AND 34).

CLASS 21—HOUSEWARES AND GLASS

FOR CLOTHES DRYING RACKS; KITCHEN UTENSILS, NOT OF PRECIOUS METAL, NAMELY, SERVING LADLES; BRUSHES, NAMELY, WASHING BRUSHES; SOAP DISPENSERS; TOILET PAPER HOLDERS; GLASSWARE FOR EVERYDAY USE, NAMELY, CUPS, PLATES, KETTLES, AND GLASS JARS; TOILET UTENSILS, NAMELY, TOILET BRUSHES; TRASH CANS; TOUGHENED GLASS, NAMELY, TEMPERED GLASS; DOORS AND WINDOWS GLASS CLEANER, NAMELY, CLEANING SPONGES FOR DOOR AND WINDOW GLASS (U.S. CLS. 2, 13, 23, 29, 30, 33, 40 AND 50).

ANDREW RHIM, EXAMINING ATTORNEY

SN 79-087,056. KUNSTDÜNGER SRL, ITALY, FILED 7-26-2010.

ANGELFRAME

THE MARK CONSISTS OF STANDARD CHARACTERS WITHOUT CLAIM TO ANY PARTICULAR FONT, STYLE, SIZE, OR COLOR.

PRIORITY DATE OF 5-27-2010 IS CLAIMED.

OWNER OF INTERNATIONAL REGISTRATION 1050333 DATED 7-26-2010, EXPIRES 7-26-2020.

CLASS 6—METAL GOODS

FOR COMMON METALS AND THEIR ALLOYS (U.S. CLS. 2, 12, 13, 14, 23, 25 AND 50).

CLASS 20—FURNITURE AND ARTICLES NOT OTHERWISE CLASSIFIED

FOR FURNITURE, MIRRORS, PICTURE FRAMES (U.S. CLS. 2, 13, 22, 25, 32 AND 50).

ROBIN CHOSID, EXAMINING ATTORNEY

SN 79-087,180. STELLA LUNA FASHION INC., 20000 SHANGHAI, CHINA, FILED 5-11-2010.



S
S by STELLALUNA

PRIORITY DATE OF 1-21-2010 IS CLAIMED.
OWNER OF INTERNATIONAL REGISTRATION 1050629 DATED 5-11-2010, EXPIRES 5-11-2020.

THE MARK CONSISTS OF A LARGE STYLIZED LETTER "S" APPEARING ABOVE THE STYLIZED WORDING "S BY STELLALUNA".

THE ENGLISH TRANSLATION OF "STELLALUNA" IN THE MARK IS "STAR MOON".

CLASS 14—JEWELRY

FOR SILVER ORNAMENTS; JEWELRY; JEWELRY BROOCHES; CHAIN NECKLACES; RINGS; EARRINGS; KEY RINGS OF PRECIOUS METAL; WRISTWATCHES; PRECIOUS METALS, UNWROUGHT OR SEMI-WROUGHT; JEWELRY BOXES OF PRECIOUS METAL (U.S. CLS. 2, 27, 28 AND 50).

CLASS 18—LEATHER GOODS

FOR ANIMAL SKINS; PELTS; SCHOOL SATCHELS; WALLETS; RUCKSACKS; POCKET WALLETS; HANDBAGS; VALISES; TEXTILE SHOPPING BAGS; LEATHER SHOPPING BAGS; BRIEFCASES; UMBRELLAS; CANES; LEATHER, UNWORKED OR SEMI-WORKED; PURSES; TRIMMINGS OF LEATHER FOR FURNITURE; LEATHER LEADS; FUR PELTS; HANDBAGS MADE OF FUR; SADDLE TREES; GUT FOR MAKING SAUSAGE CASINGS (U.S. CLS. 1, 2, 3, 22 AND 41).

CLASS 25—CLOTHING

FOR CLOTHING, NAMELY, SUITS, JACKETS, DRESSES, SKIRTS, UNDERWEAR, SWIMSUITS, T-SHIRTS, PARKAS, SPORTS UNIFORMS, SHORTS; LAYETTES; SHOES; BOOTS; CLIMBING SHOES; HEADWEAR FOR WEAR; HOSIERY; GLOVES; NECKTIES; SCARVES; BELTS; FOOTBALL SHOES; BABIES' PANTS; LEOTARDS; WATERPROOF JACKETS AND PANTS; MASQUERADE COSTUMES; GYMNASIAC SHOES; FOOTWEAR; CHASUBLES; SASHES FOR WEAR; WIMPLES; MANIPLES; SHOWER CAPS; SLEEP MASKS; WEDDING VEILS (U.S. CLS. 22 AND 39).

CLASS 35—ADVERTISING AND BUSINESS

FOR IMPORT-EXPORT AGENCIES; AUCTIONEERING; SALES PROMOTION FOR OTHERS; PROCUREMENT SERVICES, NAMELY, PURCHASING CLOTHING, HEADGEAR, FOOTWEAR, JEWELRY, AND HANDBAGS FOR OTHERS; BUSINESS INQUIRIES; COMMERCIAL INFORMATION AGENCIES; PROVIDING BUSINESS INFORMATION; ORGANIZATION OF EXHIBITIONS FOR COMMERCIAL OR ADVERTISING PURPOSES; ADVERTISING; ADVERTISING BY MAIL ORDER; BUSINESS MANAGEMENT CONSULTATION, EMPLOYMENT AGENCIES, RELOCATION SERVICES FOR BUSINESSES; SYSTEMIZATION OF INFORMATION INTO COMPUTER DATABASES, ACCOUNTING, RENTAL OF VENDING MACHINES, SPONSORSHIP SEARCH (U.S. CLS. 100, 101 AND 102).

JERI J. FICKES, EXAMINING ATTORNEY

SN 79-087,439. BLACK STUDIO S.R.L., ITALY, FILED 8-6-2010.



PRIORITY DATE OF 5-10-2010 IS CLAIMED.
OWNER OF INTERNATIONAL REGISTRATION 1051345 DATED 8-6-2010, EXPIRES 8-6-2020.

THE MARK CONSISTS OF A SIGN COMPOSED OF THE

STYLIZED ILLUSTRATION OF A SHIELD INSIDE WHICH IS THE ILLUSTRATION OF A STYLIZED EAGLE WITH PARTIALLY SPREAD WINGS OVERLAPPING VERTICAL RADIAL LINES. PRESENT NEAR THE LEFT SIDE OF THE HEAD OF THE EAGLE ARE FOUR STYLIZED STARS AND SAID EAGLE HAS IN ITS BEAK THE ILLUSTRATION OF A TAPE CONTAINING THE WORDING "DOWN TO EARTH" IN FANCY CHARACTERS, IN THE RIGHT CLAW SEVERAL BANK NOTES DEPICTING THE STYLIZED DOLLAR, IN THE LEFT CLAW THE ILLUSTRATION OF THREE THUNDERBOLTS AND, IN THE STOMACH, THE STYLIZED ILLUSTRATION OF ANOTHER SHIELD OF A SMALLER SIZE SHOWING INSIDE THE WORDING "SHIELD" IN FANCY CHARACTERS UNDER WHICH THERE ARE A SERIES OF VERTICAL LINES, SAID EAGLE BEING PLACED ABOVE THE WORDING "MADE IN HELL" IN FANCY CHARACTERS.

CLASS 18—LEATHER GOODS

FOR UNWORKED OR SEMI-WORKED LEATHER SOLD IN BULKS; FUR-SKINS; LUGGAGE; HANDBAGS; SHOULDER BAGS; GARMENT BAGS FOR TRAVEL; TRAVELLING BAGS; BEACH BAGS; CLUTCH BAGS; ALL PURPOSE SPORTS BAGS; ATTACHE CASES; SCHOOL BAGS; TOTE BAGS; TEXTILE SHOPPING BAGS; CARD CASES, NAMELY, NOTE CARD CASES; VANITY CASES NOT FITTED; KEY CASES; KNAPSACKS; RUCKSACKS; BRIEFCASES; PURSES; WALLET; POUCHES OF LEATHER FOR PACKAGING; TRAVELLING TRUNKS; SUITCASES; UMBRELLAS; PARASOLS; WALKING STICKS; DOG COLLARS; WHIPS (U.S. CLS. 1, 2, 3, 22 AND 41).

CLASS 25—CLOTHING

FOR SOCKS, STOCKINGS, TIGHTS, UNDERWEAR, BEACHWEAR, LEGGINGS, FOUNDATION GARMENTS, PULLOVERS, GLOVES, CARDIGANS, JERSEYS, SWEATERS, TROUSERS, SKIRTS, JACKETS, JERKINS, SHIRTS, VESTS, WAISTCOATS, JUMPERS, TRACK SUITS, BLOUSES, BLOUSONS, JEANS, SWEAT PANTS, GYM SUITS, KNICKERS, PANTS, SHORTS, T-SHIRTS, SWEAT-SHIRTS, SUITS AND DRESSES, OVERCOATS, COATS, ANORAKS, RAINWEAR, BELTS, SUSPENDERS, INFANTWEAR, DANCE SHOES AND COSTUMES, SKIWEAR, NECKWEAR, LOUNGEWEAR, SLEEPWEAR, FOOTWEAR, HEADWEAR (U.S. CLS. 22 AND 39).
CHERYL CLAYTON, EXAMINING ATTORNEY

SN 79-087,495. HIGH TECH COATINGS GMBH, A-4663
LAAKIRCHEN, AUSTRIA, FILED 7-16-2010.

ADAPTOCOAT

THE MARK CONSISTS OF STANDARD CHARACTERS WITHOUT CLAIM TO ANY PARTICULAR FONT, STYLE, SIZE, OR COLOR.

PRIORITY DATE OF 2-10-2010 IS CLAIMED.
OWNER OF INTERNATIONAL REGISTRATION 1051457
DATED 7-16-2010, EXPIRES 7-16-2020.

CLASS 6—METAL GOODS

FOR COMMON METALS AND THEIR ALLOYS; METAL BUILDING MATERIALS; NAMELY, SCAFFOLDING OF METAL, FLANGES OF METAL, MASTS OF METAL, POLES OF METAL, RAILS OF METAL, SOFFITS, BOLTS, GIRDERS AND JOISTS OF METAL, BINDINGS OF METAL, NON-ELECTRIC CABLES AND WIRES OF COMMON METAL; IRONMONGERY, NAMELY, IRON GATES AND INGOTS, SMALL ITEMS OF METAL HARDWARE, NAMELY, METAL NAILS AND SCREWS, NUTS OF METAL, BUCKLES OF COMMON METAL, PEGS OF METAL, VICE CLAWS OF METAL; PIPES AND TUBES OF METAL; GOODS OF COMMON METAL, NAMELY, METAL CABLE CLIPS, THREAD OF METAL FOR TYING-UP PURPOSES, CONTAINERS OF METAL FOR INDUSTRIAL PACKAGING, FOR STORAGE OF CHEMICALS AND FOR STORAGE AND TRANSPORTATION OF GOODS; FERRULES OF METAL; ORES, NAMELY, CHROME ORES, IRON ORES (U.S. CLS. 2, 12, 13, 14, 23, 25 AND 50).

CLASS 7—MACHINERY

FOR MACHINES AND MACHINE TOOLS, NAMELY, FOR THE CUTTING AND FORMING OF MATERIALS; COMPRESSORS, NAMELY, PUMPS, PISTON PUMPS, SCREW PUMPS, GEAR PUMPS, VANE PUMPS, ROTARY LOBE PUMPS, PROGRESSIVE CAVITY PUMPS, HYDRAULIC PUMPS, SCROLL PUMPS; MOTORS AND ENGINES EXCEPT FOR LAND VEHICLES; MACHINE COUPLING AND TRANSMISSION COMPONENTS EXCEPT FOR LAND VEHICLES; COATING PLANTS, NAMELY, POWDER COATING SPRAY GUNS; COMPRESSORS FOR MACHINES; COMPRESSORS FOR REFRIGERATORS; ELECTRIC COMPRESSORS; COMPRESSORS, NAMELY, SUPERCHARGERS (U.S. CLS. 13, 19, 21, 23, 31, 34 AND 35).

CLASS 12—VEHICLES

FOR AIRCRAFT, HELICOPTERS, LOCOMOTIVES, AND VANS; APPARATUS FOR LOCOMOTION BY LAND, AIR OR WATER, NAMELY, AIRPLANES, BOATS AND AUTOMOBILES (U.S. CLS. 19, 21, 23, 31, 35 AND 44).
KEVIN DINALLO, EXAMINING ATTORNEY

SN 79-087,526. PAULANER BRAUEREI GMBH & CO. KG,
FED REP GERMANY, FILED 8-10-2010.



PRIORITY DATE OF 2-10-2010 IS CLAIMED.
OWNER OF INTERNATIONAL REGISTRATION 1051567
DATED 8-10-2010, EXPIRES 8-10-2020.

THE COLOR(S) DARK BLUE, GOLD, RED AND WHITE IS/ARE CLAIMED AS A FEATURE OF THE MARK.

THE MARK CONSISTS OF THE FOLLOWING: THE BUST OF A MAN IN GOLD AND BLUE WITHIN FIVE CONCENTRIC CIRCLES OF RED, WHITE, GOLD, BLUE AND GOLD.

CLASS 32—LIGHT BEVERAGES

FOR BEERS; MINERAL AND AERATED WATERS; OTHER NON-ALCOHOLIC DRINKS, NAMELY, NON-ALCOHOLIC BEER (U.S. CLS. 45, 46 AND 48).

CLASS 33—WINES AND SPIRITS

FOR ALCOHOLIC BEVERAGES EXCEPT BEERS (U.S. CLS. 47 AND 49).

CLASS 43—HOTEL AND RESTAURANT SERVICES

FOR RESTAURANTS AND MOBILE CAFES FOR PROVIDING FOOD AND DRINK; PROVIDING TEMPORARY ACCOMMODATION (U.S. CLS. 100 AND 101).
WILLIAM BRECKENFELD, EXAMINING ATTORNEY

SN 79-087,602. EVATINI DI DANIELA TRAMPINI, ITALY, FILED 8-12-2010.



PRIORITY DATE OF 7-30-2010 IS CLAIMED.
OWNER OF INTERNATIONAL REGISTRATION 1051842 DATED 8-12-2010, EXPIRES 8-12-2020.

THE MARK CONSISTS OF THE WORDING "EVATINI" IN STYLIZED FONT.

THE WORDING "EVATINI" HAS NO MEANING IN A FOREIGN LANGUAGE.

CLASS 14—JEWELRY

FOR PRECIOUS METALS AND THEIR ALLOYS AND GOODS IN PRECIOUS METALS OR COATED THEREWITH, NOT INCLUDED IN OTHER CLASSES, NAMELY, CLOCKS, EARRINGS, CLOCKS CASES, EAR CLIPS; JEWELLERY, PRECIOUS STONES; HOROLOGICAL AND CHRONOMETRIC INSTRUMENTS (U.S. CLS. 2, 27, 28 AND 50).

CLASS 25—CLOTHING

FOR CLOTHING, NAMELY, SHIRTS, PANTS, HATS, CAPS, COATS, PULLOVERS, OVERALLS; FOOTWEAR; HEADGEAR, NAMELY, HATS, CAPS (U.S. CLS. 22 AND 39).

AISHA SALEM, EXAMINING ATTORNEY

SN 79-087,540. ANDRE-ROUALDES CATHERINE, FRANCE, FILED 9-14-2010.



OWNER OF INTERNATIONAL REGISTRATION 1051636 DATED 9-14-2010, EXPIRES 9-14-2020.

THE NAME(S), PORTRAIT(S), AND/OR SIGNATURE(S) SHOWN IN THE MARK IDENTIFIES A LIVING INDIVIDUAL, WHOSE CONSENT(S) TO REGISTER IS MADE OF RECORD.

CLASS 3—COSMETICS AND CLEANING PREPARATIONS

FOR SOAPS FOR HOUSEHOLD USE; PERFUMERY, ESSENTIAL OILS, COSMETICS, HAIR LOTIONS, DENTIFRICES (U.S. CLS. 1, 4, 6, 50, 51 AND 52).

CLASS 14—JEWELRY

FOR PRECIOUS METALS AND THEIR ALLOYS, JEWELRY, PRECIOUS STONES, TIMEPIECES AND CHRONOMETRIC INSTRUMENTS (U.S. CLS. 2, 27, 28 AND 50).

CLASS 18—LEATHER GOODS

FOR LEATHER AND IMITATION LEATHER, BRIEFCASES, WALLETS, PURSES NOT OF PRECIOUS METAL, HANDBAGS, TRAVELING BAGS, BACKPACKS, GARMENT BAGS FOR TRAVEL (U.S. CLS. 1, 2, 3, 22 AND 41).

CLASS 24—FABRICS

FOR BATH LINEN, BED LINEN, HOUSEHOLD LINEN, TABLE LINEN, FACE TOWELS (U.S. CLS. 42 AND 50).

CLASS 25—CLOTHING

FOR CLOTHING, NAMELY, TOPS, BOTTOMS, FOOTWEAR, HEADWEAR (U.S. CLS. 22 AND 39).
DAVID TOOLEY, EXAMINING ATTORNEY

SN 79-087,932. MOBISYS MOBILE INFORMATIONSSYSTEME GMBH, FED REP GERMANY, FILED 6-14-2010.



THE MARK CONSISTS OF STANDARD CHARACTERS WITHOUT CLAIM TO ANY PARTICULAR FONT, STYLE, SIZE, OR COLOR.

PRIORITY DATE OF 12-16-2009 IS CLAIMED.
OWNER OF INTERNATIONAL REGISTRATION 1052689 DATED 6-14-2010, EXPIRES 6-14-2020.

CLASS 9—ELECTRICAL AND SCIENTIFIC APPARATUS

FOR COMPUTER OPERATING SOFTWARE FOR INTEGRATION OF MOBILE COMPUTERS AND COMPUTER DEVICES IN BUSINESS PROCESS SOFTWARE SYSTEMS, SUCH AS ENTERPRISE RESOURCE PLANNING (ERP) SOFTWARE; COMPUTER SOFTWARE FOR THE COLLECTION, EDITING, ORGANIZING, MODIFYING, BOOK MARKING, TRANSMISSION, STORAGE AND SHARING OF DATA INFORMATION IN BUSINESS PROCESS SOFTWARE SYSTEMS, SUCH AS ENTERPRISE RESOURCE PLANNING (ERP) SOFTWARE; COMPUTER SOFTWARE FOR COMMUNICATING WITH USERS OF HAND-HELD COMPUTERS, NAMELY, SOFTWARE FOR INTEGRATION OF MOBILE COMPUTERS AND COMPUTER DEVICES IN BUSINESS PROCESS SOFTWARE SYSTEMS, SUCH AS ENTERPRISE RESOURCE PLANNING (ERP) SOFTWARE; COMPUTER SOFTWARE FOR WIRELESS CONTENT DELIVERY OF DATA USED FOR AND BY BUSINESS PROCESS SOFTWARE SYSTEMS, SUCH AS ENTERPRISE RESOURCE PLANNING (ERP) SOFTWARE (U.S. CLS. 21, 23, 26, 36 AND 38).

CLASS 38—COMMUNICATION

FOR ELECTRONIC DATA TRANSMISSION OF BUSINESS PROCESS SOFTWARE SYSTEMS; RENTAL OF TELECOMMUNICATION APPARATUS FOR BUSINESS PROCESS SOFTWARE SYSTEMS (U.S. CLS. 100, 101 AND 104).

CLASS 42—SCIENTIFIC AND COMPUTER SERVICES

FOR COMPUTER HARDWARE AND SOFTWARE RENTAL FOR BUSINESS PROCESS SOFTWARE SYSTEMS; COMPUTER HARDWARE AND SOFTWARE CONSULTING SERVICES FOR BUSINESS PROCESS SOFTWARE SYSTEMS; COMPUTER PROGRAMMING AND SOFTWARE DESIGN OF BUSINESS PROCESS SOFTWARE SYSTEMS; COMPUTER SOFTWARE CONSULTANCY FOR BUSINESS PROCESS SOFTWARE SYSTEMS; COMPUTER SOFTWARE DEVELOPMENT OF BUSINESS PROCESS SOFTWARE SYSTEMS; DESIGN AND DEVELOPMENT OF WIRELESS COMMUNICATION SYSTEMS FOR TRANSMISSION AND RECEPTION OF VOICE, DATA AND VIDEO FOR BUSINESS PROCESS SOFTWARE SYSTEMS; SYSTEMS ENGINEERING OF BUSINESS PROCESS SOFTWARE SYSTEMS; COMPUTER SOFTWARE INSTALLATION AND MAINTENANCE OF BUSINESS PROCESS SOFTWARE SYSTEMS (U.S. CLS. 100 AND 101).

ANDREW LEASER, EXAMINING ATTORNEY

SN 79-087,954. GRUPPO SANTA RITA S.R.L., ITALY, FILED 8-6-2010.



PRIORITY DATE OF 8-3-2010 IS CLAIMED.
OWNER OF INTERNATIONAL REGISTRATION 1052760 DATED 8-6-2010, EXPIRES 8-6-2020.

NO CLAIM IS MADE TO THE EXCLUSIVE RIGHT TO USE "GIRARROSTI", APART FROM THE MARK AS SHOWN.

THE COLOR(S) YELLOW AND RED IS/ARE CLAIMED AS A FEATURE OF THE MARK.

THE MARK CONSISTS OF THE WORDING "GIRARROSTI S. RITA" IN STYLIZED FONT, INCLUDING THE PLACEMENT OF A STYLIZED BIRD'S FOOT BENEATH THE LETTER "G". THE STYLIZED LETTERING AND DESIGN ELEMENTS OF THE MARK ARE PRESENTED IN YELLOW WITH RED OUTLINING.

THE ENGLISH TRANSLATION OF "GIRARROSTI S. RITA" IN THE MARK IS "SAINT RITA SPIT-ROASTERS".

CLASS 29—MEATS AND PROCESSED FOODS

FOR MEAT, FISH, POULTRY AND GAME; MEAT EXTRACTS; PRESERVED, FROZEN, DRIED AND COOKED FRUITS AND VEGETABLES; JELLIES, JAMS, COMPOTES; EGGS, MILK AND MILK PRODUCTS EXCLUDING ICE CREAM, ICE MILK AND FROZEN YOGURT; EDIBLE OILS AND FATS (U.S. CL. 46).

CLASS 30—STAPLE FOODS

FOR COFFEE, TEA, COCOA, SUGAR, RICE, TAPIOCA, SAGO, ARTIFICIAL COFFEE; FLOUR AND PREPARATIONS MADE FROM CEREALS, NAMELY, CEREAL-BASED SNACK FOODS, BREAD (U.S. CL. 46).

CLASS 35—ADVERTISING AND BUSINESS

FOR RETAIL STORE SERVICES AND ON-LINE RETAIL STORE SERVICES FEATURING MEAT, FISH, POULTRY AND GAME, MEAT EXTRACTS, PRESERVED, FROZEN, DRIED AND COOKED FRUITS AND VEGETABLES, JELLIES, JAMS, COMPOTES, EGGS, MILK AND MILK PRODUCTS, EDIBLE OILS AND FATS, COFFEE, TEA, COCOA, SUGAR, RICE, TAPIOCA, SAGO, ARTIFICIAL COFFEE, FLOUR AND PREPARATIONS MADE FROM CEREALS, BREAD, PASTRY AND CONFECTIONERY, ICES, HONEY, TREATLE, YEAST, BAKING-POWDER, SALT, MUSTARD, VINEGAR, SAUCES BEING CONDIMENTS, SPICES, ICE, UNPROCESSED GRAINS, LIVE ANIMALS, FRESH FRUITS AND VEGETABLES (U.S. CLS. 100, 101 AND 102).

STEVEN PEREZ, EXAMINING ATTORNEY

SN 79-087,986. LA POSTE, FRANCE, FILED 5-28-2010.

DOCAPOST DPS

THE MARK CONSISTS OF STANDARD CHARACTERS WITHOUT CLAIM TO ANY PARTICULAR FONT, STYLE, SIZE, OR COLOR.

PRIORITY DATE OF 12-1-2009 IS CLAIMED.
OWNER OF INTERNATIONAL REGISTRATION 1052844 DATED 5-28-2010, EXPIRES 5-28-2020.

CLASS 9—ELECTRICAL AND SCIENTIFIC APPARATUS

FOR RECORDED COMPUTER SOFTWARE FOR ENSURING THE SECURITY OF ELECTRONIC MAIL, FOR ALLOWING USERS TO PERFORM ELECTRONIC BUSINESS TRANSACTIONS VIA A GLOBAL COMPUTER NETWORK, BUSINESS PROCESS FLOW MANAGEMENT, BUSINESS PROCESS OPTIMIZATION, INCOMING MAIL MANAGEMENT AND PROCESSES; ELECTRONIC NETWORK DEVICES NECESSARY FOR ELECTRONIC PAYMENT FOR AND FRANKING OF POSTAL ITEMS, NAMELY, MULTI-FUNCTIONAL ELECTRONIC PAYMENT TERMINALS, POSTAGE STAMP METERS AND TIME AND DATE STAMPING MACHINES; APPARATUS TO CHECK FRANKING, NAMELY, SOFTWARE FOR USE WITH FRANKING MACHINES; COMPUTERS; DATA PROCESSING AND WORD PROCESSING COMPUTERS; COMPUTER SOFTWARE FOR INFORMATION OR DATA CAPTURE, DATA STORAGE, AND FOR USE WITH DATA PROCESSING INSTRUMENTS; BLANK TAPES FOR STORAGE OF COMPUTER DATA; DATA PROCESSING EQUIPMENT; MESSAGE TRANSMISSION EQUIPMENT, NAMELY, TELEPHONE APPARATUS AND TELEPHONE SETS, FACSIMILE MACHINES, CELLULAR PHONES, TELECOPYING MACHINES, WIRELESS COMMUNICATION DEVICES FOR VOICE, DATA OR IMAGE TRANSMISSION, VIDEO TRANSMISSION APPARATUS, APPARATUS FOR TRANSMISSION OF COMMUNICATION; PACKAGED DOWNLOADABLE SOFTWARE FOR USE IN DESKTOP PUBLISHING, DIGITAL DOCUMENT PUBLISHING, ELECTRONIC ARCHIVING OF DOCUMENTS AND DATA, EQUIPMENT FOR DATA PROCESSING AND INTERNET ACCESS, NAMELY, DATA PROCESSORS, COMPUTERS, COMPUTER MONITORS, COMPUTER HARDWARE, COMPUTER PERIPHERALS, COMPUTER MODEMS, COMMUNICATION SOFTWARE FOR PROVIDING ACCESS TO THE INTERNET; DATE REGISTRATION APPARATUS UNDER THE EUROPEAN SYSTEM, NAMELY, TIME AND DATE STAMPING MACHINES; AUTOMATIC VENDING MACHINES; BLANK COMPACT DISKS CD-ROMS FOR DATA RECORDING, BLANK FLOPPY COMPUTER DISCS, APPARATUS FOR RECORDING OR REPRODUCTION OF SOUND AND IMAGES (U.S. CLS. 21, 23, 26, 36 AND 38).

CLASS 16—PAPER GOODS AND PRINTED MATTER

FOR PRINTED MATTER, NAMELY, STATIONERY; ADHESIVES GLUES FOR STATIONERY PURPOSES; WRAPPING PAPER; PAPER BAGS, PAPER SHEETS FOR PACKAGING, STATIONERY ENVELOPES; POSTAGE STAMPS; SEALING STAMPS; STAMP STANDS; FRANKING MACHINES FOR STICKING POSTAGE STAMPS OR PRINTING THE FRANKING; INKING PADS; OBLITERATING STAMPS; POSTAGE PREPAID ENVELOPES, POSTAGE PREPAID POSTCARDS AND POST PREPAID PARCELS, NAMELY, PAPER POUCHES FOR PACKAGING, CARDBOARD BOXES, PAPER CONTAINERS, PAPER BOXES, STORAGE CONTAINER MADE OF PAPER; NON-TEXTILE LABELS, NAMELY, ADHESIVE LABELS, PAPER LABELS, SHIPPING LABELS, ADDRESS LABELS, BLANK OR PARTIALLY PRINTED PAPER LABELS, PAPER LABELS, BAR CODE LABELS; PAPER SHEETS FOR TAKING NOTES; BOTTLE WRAPPERS OF CARDBOARD OR PAPER, PLASTIC MATERIALS FOR PACKAGING NOT INCLUDED IN OTHER CLASSES, NAMELY, PLASTIC BAGS, AND PLASTIC FILMS AND SHEETS, NAMELY, PLASTIC BUBBLE PACKS, FOOD WRAPPING PLASTIC FILM FOR HOUSEHOLD USE (U.S. CLS. 2, 5, 22, 23, 29, 37, 38 AND 50).

CLASS 35—ADVERTISING AND BUSINESS

FOR DIRECT MAIL ADVERTISING SERVICES BY MEANS OF MAIL SHOTS FOR THE PURPOSE OF ATTRACTING CUSTOMERS AND PROVIDING CUSTOMER CARE, COMPUTERIZED FILE MANAGEMENT; SYSTEMIZATION OF INFORMATION INTO COMPUTER DATABASES; COMPILATION OF INFORMATION INTO COMPUTER DATABASES; TRANSCRIPTION SERVICES, NAMELY, MESSAGE TRANSCRIPTION, STENOGRAPHIC TRANSCRIPTION, CONFERENCE CALL TRANSCRIPTION SERVICES, TRANSCRIPTION OF WRITTEN COMMUNICATIONS, ARRANGING SUBSCRIPTIONS TO DATA COMMUNICATIONS SERVICES; ARRANGING SUBSCRIPTIONS TO A DATABASE; ARRANGING OF SUBSCRIPTIONS FOR A DATABASE SERVER CENTER; ARRANGING SUBSCRIPTIONS TO A DATA TRANSMISSION OR COMPUTER NETWORK SERVICE PROVIDER, PARTICULARLY FOR THE INTERNET; ARRANGING SUBSCRIPTIONS TO ELECTRONIC NEWSPAPERS; ARRANGING SUBSCRIPTIONS TO TELECOMMUNICATION SERVICES; DATABASE MANAGEMENT, NAMELY, DATABASE UPDATING SERVICES; DOCUMENT REPRODUCTION; RENTAL OF PHOTOCOPYING MACHINES; OFFICE MACHINES AND EQUIPMENT RENTAL; OFFICE FUNCTIONS; WORD PROCESSING; INFORMATION COMPILATION INTO DATABANKS AND/OR COMPUTER DATABASES; ACCOUNTING; DRAWING UP OF STATEMENTS OF ACCOUNTS FOR BUSINESSES; BOOK-KEEPING; ADVERTISING; SALES PROMOTION FOR OTHERS; DISTRIBUTION OF PROSPECTUSES AND SAMPLES; PUBLICITY MATERIAL RENTAL; ADVERTISEMENT SERVICES BY MAIL AND DIRECT MAIL ADVERTISING; DISSEMINATION OF ADVERTISING MATTER; DIRECT MAIL ADVERTISING; UPDATING AND DISSEMINATION OF ADVERTISING DOCUMENTATION; ORGANIZATION OF EXHIBITIONS FOR COMMERCIAL OR ADVERTISING PURPOSES; BUSINESS MANAGEMENT ASSISTANCE FOR INDUSTRIAL AND COMMERCIAL COMPANIES; BUSINESS CONSULTING, INFORMATION OR INQUIRIES; SERVICE BUREAU FOR STATISTICAL ANALYSIS, MECHANICAL DATA PROCESSING AND STENO TYPING WORK FOR OTHERS; OPERATION OF ADMINISTRATIVE DATA BANKS; SERVICES INVOLVING THE RECORDING, TRANSCRIPTION, COMPOSITION OR SYSTEMIZATION OF WRITTEN COMMUNICATIONS AND RECORDINGS, RETAIL STORE SERVICES FEATURING STAMPS AND PHILATELY GOODS; RETAIL ONLINE STORES AND ON-LINE ORDERING SERVICES FEATURING STAMPS AND PHILATELY GOODS, MAIL ORDER SERVICES FEATURING STAMPS AND PHILATELY GOODS (U.S. CLS. 100, 101 AND 102).

CLASS 38—COMMUNICATION

FOR TELECOMMUNICATIONS, NAMELY, TELECOMMUNICATIONS CONSULTATION, TELECOMMUNICATION BY E-MAIL, TELECOMMUNICATION ACCESS SERVICES; ELECTRONIC TRANSMISSION OF MESSAGES, TELEGRAMS; ELECTRONIC TRANSMISSION OF DATA, IMAGES, DOCUMENTS, POSTCARDS BY MEANS OF COMPUTER TERMINALS AND ALL OTHER TRANSMISSION SYSTEMS SUCH AS TERRESTRIAL TRANSMISSION, CABLE, SATELLITE, THE INTERNET; COMMUNICATIONS BY COMPUTER TERMINALS; COMPUTER AIDED TRANSMISSION OF MESSAGES OR IMAGES; TRANSMISSION OF MESSAGES, TRANSMISSION OF DIGITAL FILES, TRANSMISSION OF SOUND, VIDEO AND INFORMATION, COMMUNICATION SERVICES, NAMELY, TRANSMISSION OF VOICE, AUDIO, VISUAL IMAGES AND DATA BY TELECOMMUNICATIONS NETWORKS, WIRELESS COMMUNICATION NETWORKS, THE INTERNET, INFORMATION SERVICES NETWORKS AND DATA NETWORKS; ELECTRONIC EXCHANGE OF COMPUTERIZED DATA ACCESSIBLE VIA TELECOMMUNICATION NETWORKS; ELECTRONIC MAIL; ELECTRONIC MESSAGING; ELECTRONIC TRANSMISSION OF INFORMATION HELD IN DATA BANKS AND IMAGE BANKS BY ELECTRONIC COMMUNICATIONS NETWORKS, BY SATELLITE, VIA THE TELECOMMUNICATION NETWORK, DIGITAL NETWORKS, NATIONAL AND INTERNATIONAL NETWORKS, COMPUTERS CONNECTED TO THE SAME TELEMATIC NETWORK; TELECOMMUNICATION INFORMATION, NAMELY, INFORMATION ABOUT TELECOMMUNICATION; RADIO, TELEGRAPH OR TELEPHONE COMMUNICATIONS SERVICES; RENTAL OF MESSAGE SENDING APPARATUS, NAMELY, RENTAL OF TELECOMMUNICATION EQUIPMENT; ROUTING SERVICES FOR TELECOMMUNICATIONS; ELECTRONIC BULLETIN BOARD SERVICES; FACSIMILE TRANSMISSION, NEWS AGENCY SERVICES FOR ELECTRONIC TRANSMISSION; NEWS AGENCIES, NAMELY, THE TRANSMISSION OF NEWS ITEMS TO NEWS REPORTING ORGANIZATIONS, PROVIDING USER ACCESS TO COMPUTER PROGRAMS IN DATA NETWORKS ACCESSIBLE BY ACCESS CODE VIA PERSONAL PAGE NETWORK INTERFACES; ELECTRONIC TRANSMISSION OF DATA AND DOCUMENTS IN THE NATURE OF PERIODICAL PUBLICATIONS AND OTHER PRINTED MATTER RELATING TO THE INTERNET VIA COMPUTERS AND VIA A COMMUNICATION NETWORK; PROVIDING ELECTRONIC COMMUNICATION TRANSMISSION SERVICES IN REAL TIME BETWEEN COMPUTER USERS ON THE INTERNET AND THE WORLD WIDE WEB; TELECOMMUNICATION CONNECTIONS TO THE INTERNET; COMPUTER TRANSMISSION OF INFORMATION ACCESSED VIA A CODE OVER THE INTERNET OR AN INTERNET-TYPE NETWORK TO ALLOW SUBSCRIBERS TO FIND OUT THEIR ACCOUNT BALANCE AND TRANSACTIONS CARRIED OUT; TRANSMISSION AND REPORTING OF MESSAGES, NAMELY, ELECTRONIC MESSAGE TRANSMISSION, TECHNICAL CONSULTING IN THE FIELD OF DATA TRANSMISSION (U.S. CLS. 100, 101 AND 104).

CLASS 39—TRANSPORTATION AND STORAGE

FOR FREIGHTING, NAMELY, FREIGHT BROKERAGE, FREIGHT LOADING, FREIGHT TRANSPORT BY TRUCK, TRAIN, SHIP AND AIR AND FREIGHT TRANSPORTATION CONSULTATION; DELIVERY OF PARCELS AND GOODS, PACKAGING OF GOODS, NAMELY, MERCHANDISE PACKAGING FOR OTHERS; DELIVERY OF MAIL, NEWSPAPERS, PARCELS; DELIVERY OF MERCHANDISE PARCELS; PACKAGING OF GOODS FOR TRANSPORTATION; TRANSPORTATION INFORMATION; STORAGE INFORMATION, NAMELY, STORAGE INFORMATION CONSULTANCY SERVICES; FREIGHT FORWARDING; DELIVERY OF GOODS BY MAIL ORDER; COURIER SERVICES FOR MESSAGES AND GOODS; HIGH-SPEED TRANSPORT OF MAIL BY AIR AND TRAIN; TRANSPORTATION AND STORAGE OF GOODS (U.S. CLS. 100 AND 105).

CLASS 40—MATERIAL TREATMENT

FOR PRINTING, DIGITAL PRINTING, LITHOGRAPHIC PRINTING, OFFSET PRINTING (U.S. CLS. 100, 103 AND 106).

CLASS 42—SCIENTIFIC AND COMPUTER SERVICES

FOR TECHNICAL CONSULTING AND ADVICE AND CONSULTATION IN THE FIELD OF TELECOMMUNICATIONS TECHNOLOGY AND COMPUTER NETWORKS; TECHNICAL ANALYSIS AND EVALUATION IN THE FIELD OF DATA TRANSMISSION NETWORK TECHNOLOGY; COMPUTER PROGRAMMING; SOFTWARE DEVELOPMENT DESIGN SERVICES; DEVELOPMENT OF WIRELESS AND ELECTRONIC COMMUNICATION SYSTEMS; RECOVERY OF COMPUTER DATA, DESIGN OF COMPUTER SYSTEMS, DATA CONVERSION OF DATA AND COMPUTER PROGRAMS, NOT PHYSICAL CONVERSION, HOSTING OF WEB SITES (U.S. CLS. 100 AND 101).

CLASS 45—PERSONAL AND LEGAL SERVICES

FOR AUTHENTICATION, ISSUANCE AND VALIDATION OF DIGITAL CERTIFICATES; SECURITY CONSULTANCY (U.S. CLS. 100 AND 101).
CARYN GLASSER, EXAMINING ATTORNEY

SN 79-088,088. FUNDACIÓN CASTILLA-LA MANCHA, TIERRA DE VIÑEDOS, E-13700 CIUDAD REAL, SPAIN, FILED 8-9-2010.



OWNER OF INTERNATIONAL REGISTRATION 1053129 DATED 8-9-2010, EXPIRES 8-9-2020.

THE COLOR(S) LIGHT GREEN, DARK GREEN, BLACK, RED, BROWN AND WHITE IS/ARE CLAIMED AS A FEATURE OF THE MARK.

THE MARK CONSISTS OF A STYLIZED DESIGN OF A LIGHT GREEN GRAPE, WITH A WIDE BLACK HAT WITH A DARK GREEN GRAPEVINE LEAF WITH A BROWN STEM, ON TOP OF THE GRAPE DESIGN. THE GRAPE DESIGN IS STYLIZED TO LOOK LIKE A FACE AND HAS LARGE EYES CONSISTING PRIMARILY OF THE COLORS BLACK AND WHITE, WITH A BLACK BEARD AND BLACK MOUSTACHE. THE FACE HAS A SMILE AND WITHIN ITS MOUTH CAN BE SEEN A RED TONGUE AND WHITE TEETH, THE WORDING "DON DE LA MANCHA" IS SHOWN IN THE COLOR BLACK AND THE LETTERS "UVA" ARE SHOWN IN COLOR LIGHT GREEN.

THE ENGLISH TRANSLATION OF THE FOREIGN WORD(S) IN THE MARK IS MR. GRAPE OF LA MANCHA.

CLASS 32—LIGHT BEVERAGES

FOR FRUIT DRINKS AND FRUIT JUICES, GRAPES JUICE BEVERAGES, MUSTS; SYRUPS FOR MAKING BEVERAGES AND OTHER NON-ALCOHOLIC BEVERAGES; PREPARATIONS FOR MAKING FRUIT DRINKS (U.S. CLS. 45, 46 AND 48).

CLASS 35—ADVERTISING AND BUSINESS

FOR IMPORT AND EXPORT AGENCIES IN THE FIELD OF FOODSTUFFS AND BEVERAGES (U.S. CLS. 100, 101 AND 102).

CLASS 44—MEDICAL, BEAUTY AND AGRICULTURAL SERVICES

FOR AGRICULTURE SERVICES, NAMELY, GIVING AGRICULTURAL ADVICE; HORTICULTURE SERVICES (U.S. CLS. 100 AND 101).

LINDA E. BLOHM, EXAMINING ATTORNEY

SN 79-088,111. RATTI S.P.A, ITALY, FILED 8-2-2010.

RATTI

THE MARK CONSISTS OF STANDARD CHARACTERS WITHOUT CLAIM TO ANY PARTICULAR FONT, STYLE, SIZE, OR COLOR.

PRIORITY DATE OF 5-20-2010 IS CLAIMED.

OWNER OF INTERNATIONAL REGISTRATION 1053217 DATED 8-2-2010, EXPIRES 8-2-2020.

CLASS 24—FABRICS

FOR TEXTILE FABRICS FOR THE MANUFACTURE OF CLOTHING; TEXTILE FABRICS FOR LINGERIE; TEXTILE FABRICS FOR HOME AND COMMERCIAL INTERIORS, NAMELY, BROCADE, CASHMERE FABRIC, CHENILLE FABRIC, COTTON FABRIC, CREPE CLOTH, DAMASK, ELASTIC FABRIC FOR CLOTHING, ELASTIC YARN MIXED FABRICS, FIBERGLASS FABRIC FOR TEXTILE USE, FLANNEL, FUSTIAN, TAFFETA, VELVET, GAUZE FABRIC, JEANS FABRIC, JERSEY MATERIAL, JUTE FABRICS, KNITTED FABRICS, KNITTED FABRICS OF SILK YARN, LINEN, SEMI-SYNTHETIC FIBER FABRICS, SILK BASE MIXED FABRICS, SILK FABRICS, SYNTHETIC FIBER FABRICS, SILK-COTTON MIXED FABRICS, SILK-WOOL MIXED FABRICS, WOOLEN FABRIC, COTTON BASE MIXED FABRIC, MIXED FIBER FABRICS, WOOL BASE MIXED FABRICS, WOOL-COTTON MIXED FABRICS; BATH LINEN; BATH TOWELS; BEACH TOWELS; BED AND TABLE LINEN; WALL HANGINGS OF TEXTILE; BED BLANKETS; BED COVERS; BED SHEETS; CANVAS FOR TAPESTRY OR EMBROIDERY; CURTAIN FABRIC; FACE TOWELS MADE OF TEXTILE MATERIALS; HOUSEHOLD LINEN; INTERIOR DECORATION FABRICS; KITCHEN LINENS; PILLOW CASES; QUILTS OF TEXTILE; TAPESTRIES OF TEXTILE; UNFITTED FABRIC FURNITURE COVERS; UNFITTED FABRIC FURNITURE COVERS, NAMELY, COVERS FOR SOFAS (U.S. CLS. 42 AND 50).

CLASS 25—CLOTHING

FOR CLOTHING, NAMELY, SKIRTS, TROUSERS, JACKETS, SHIRTS, HOSIERY, SWIMSUITS, BATHING SUITS, GYMNASIIC SUITS, SUITS, DRESSES, OVERCOATS, RAINCOATS, VESTS, BANDANAS, OVERALLS, SWEATERS, T-SHIRTS, CORSETS, GARTERS, PETTICOATS, PAJAMAS, DRESSING GOWNS, BRASSIERES; GLOVES BEING CLOTHING; NECKTIES; SCARVES; NECKERCHIEFS; HEADGEAR, NAMELY, HEADWEAR, HATS AND CAPS (U.S. CLS. 22 AND 39).

EVELYN BRADLEY, EXAMINING ATTORNEY

SN 79-088,182. PUTIAN SANJIAN PLASTIC METALS CO., LTD, CHINA, FILED 9-24-2010.



OWNER OF INTERNATIONAL REGISTRATION 1053444 DATED 9-24-2010, EXPIRES 9-24-2020.

THE MARK CONSISTS OF THE WORDING "CASP" AND A CHEVRON ANGLE BEHIND THE LETTER "C".

CLASS 11—ENVIRONMENTAL CONTROL APPARATUS

FOR LIGHTS FOR VEHICLES; LIGHT BULBS FOR DIRECTIONAL SIGNALS FOR VEHICLES; VEHICLE HEADLIGHTS; ANTI-DAZZLE DEVICES FOR AUTOMOBILES, NAMELY, WINDSHIELD VISORS; ANTI-GLARE DEVICES FOR AUTOMOBILES, NAMELY, WINDSHIELD VISORS; VEHICLE REFLECTORS; AIR-CONDITIONING INSTALLATIONS FOR VEHICLES, AND VENTILATING INSTALLATIONS FOR VEHICLES, NAMELY, DEFROSTING APPARATUS AND AIR FILTERING APPARATUS FOR VEHICLE PASSENGER COMPARTMENT; PRESSURE WATER TANKS, NAMELY, TOILET TANKS, HOT WATER TANKS AND SEPTIC TANKS; FOUNTAINS, NAMELY, WATER FOUNTAINS AND ORNAMENTAL FOUNTAINS; FUEL ECONOMIZERS, NAMELY, COMPONENT PARTS OF HEATING BOILERS THAT IMPROVE EFFICIENCY (U.S. CLS. 13, 21, 23, 31 AND 34).

CLASS 12—VEHICLES

FOR HUBS FOR VEHICLE WHEELS; VEHICLE BUMPERS; REARVIEW MIRRORS; WINDSHIELD WIPERS; UPHOLSTERY FOR VEHICLES; DIRECTION SIGNALS FOR VEHICLES; TURN SIGNALS FOR VEHICLES; CAPS FOR VEHICLE PETROL TANKS; SUN-BLINDS ADAPTED FOR VEHICLES (U.S. CLS. 19, 21, 23, 31, 35 AND 44).

APRIL ROACH, EXAMINING ATTORNEY

SN 79-088,191. ANNA PERENNA SRL (LIMITED LIABILITY COMPANY), ITALY, FILED 6-14-2010.



Sora Anna
La Regina
della
Cucina Romana

PRIORITY DATE OF 12-15-2009 IS CLAIMED.

OWNER OF INTERNATIONAL REGISTRATION 1053466 DATED 6-14-2010, EXPIRES 6-14-2020.

NO CLAIM IS MADE TO THE EXCLUSIVE RIGHT TO USE "CUCINA ROMANA", APART FROM THE MARK AS SHOWN.

THE NAME(S), PORTRAIT(S), AND/OR SIGNATURE(S) SHOWN IN THE MARK IDENTIFIES ANNA DENTE, WHOSE CONSENT(S) TO REGISTER IS MADE OF RECORD.

THE ENGLISH TRANSLATION OF THE FOREIGN WORD(S) IN THE MARK IS MRS. ANNA THE QUEEN OF THE ROMAN CUISINE.

CLASS 29—MEATS AND PROCESSED FOODS

FOR MEAT; MEAT EXTRACTS; FISH; PRESERVED, FROZEN, DRIED AND COOKED FRUITS AND VEGETABLES; JELLIES, JAMS, COMPOTES; EGGS, MILK AND MILK PRODUCTS EXCLUDING ICE CREAM, ICE MILK AND FROZEN YOGURT; EDIBLE OILS AND FATS (U.S. CL. 46).

CLASS 30—STAPLE FOODS

FOR COFFEE, TEA, COCOA, SUGAR, RICE, TAPIOCA, SAGO, ARTIFICIAL COFFEE; FLOUR AND PREPARATIONS MADE FROM CEREALS, NAMELY, PASTA AND PIZZA; BREAD, PASTRIES, COOKIES, EDIBLE ICES, HONEY, TREACLE, YEAST, BAKING-POWDER, SALT, MUSTARD, VINEGAR, SAUCES, SPICES; ICE (U.S. CL. 46).

CLASS 33—WINES AND SPIRITS

FOR ALCOHOLIC BEVERAGES, EXCEPT BEER (U.S. CLS. 47 AND 49).

CLASS 43—HOTEL AND RESTAURANT SERVICES

FOR PROVIDING OF FOOD AND DRINK; TEMPORARY ACCOMMODATIONS (U.S. CLS. 100 AND 101).
KATHRYN COWARD, EXAMINING ATTORNEY

SN 79-088,262. BDI-BIOENERGY INTERNATIONAL AG, AUSTRIA, FILED 8-12-2010.



PRIORITY DATE OF 3-1-2010 IS CLAIMED.
OWNER OF INTERNATIONAL REGISTRATION 1053667 DATED 8-12-2010, EXPIRES 8-12-2020.

OWNER OF U.S. REG. NO. 3,131,524.
THE MARK CONSISTS OF THE LETTERS "BDI" FOLLOWED BY A STYLIZED BIRD INSIDE OF AN OVAL.

CLASS 4—LUBRICANTS AND FUELS

FOR FUELS (U.S. CLS. 1, 6 AND 15).

CLASS 37—CONSTRUCTION AND REPAIR

FOR CONSTRUCTION OF PROCESS ENGINEERING PLANTS, IN PARTICULAR PLANTS FOR PROCESSING RENEWABLE RAW MATERIALS SUCH AS VEGETABLE AND ANIMAL FATS, USED EDIBLE OILS OR WASTE FATS; CONSTRUCTION OF PLANTS FOR PRODUCING FATTY ACID ALKYL ESTERS, NAMELY, BIODIESEL; CONSTRUCTION OF PLANTS FOR ENVIRONMENTAL RELATED TECHNOLOGIES (U.S. CLS. 100, 103 AND 106).

CLASS 39—TRANSPORTATION AND STORAGE

FOR SUPPLY, NAMELY, SHIPMENT AND DELIVERY OF PREFABRICATED PROCESS-ENGINEERING PLANTS AND COMPONENT PARTS THEREOF, IN PARTICULAR PLANTS FOR PROCESSING RENEWABLE RAW MATERIALS SUCH AS VEGETABLE AND ANIMAL FATS, USED EDIBLE OILS OR WASTE FATS (U.S. CLS. 100 AND 105).

CLASS 42—SCIENTIFIC AND COMPUTER SERVICES

FOR DEVELOPMENT OF TECHNOLOGIES FOR PROCESSING RENEWABLE RAW MATERIALS (U.S. CLS. 100 AND 101).

SCOTT BIBB, EXAMINING ATTORNEY

SN 79-088,487. PICOCHIP DESIGNS LIMITED, UNITED KINGDOM, FILED 8-9-2010.

PICOARRAY

OWNER OF INTERNATIONAL REGISTRATION 1054353 DATED 8-9-2010, EXPIRES 8-9-2020.

CLASS 9—ELECTRICAL AND SCIENTIFIC APPARATUS

FOR SEMI-CONDUCTORS, PROGRAMMABLE COMPUTER CHIPS, COMPUTER DATA PROCESSORS; WIRELESS COMMUNICATIONS PROCESSORS, NAMELY, SIGNAL PROCESSORS; INTEGRATED CIRCUITS; RADIO FREQUENCY COMPONENTS, NAMELY, TRANSCEIVERS, TRANSMITTERS AND RECEIVERS, REPEATERS USED IN LONG RANGE COMMUNICATION, RADIOS USED FOR WIRELESS/CELLULAR COMMUNICATIONS AND WIRELESS/CELLULAR BASESTATIONS; ELECTRONIC COMPONENTS FOR COMPUTERS, NAMELY, SIGNAL PROCESSORS, WIRELESS TRANSMITTERS, AND WIRELESS RECEIVERS; ELECTRONIC COMPONENTS FOR WIRELESS CELLULAR BASESTATIONS, NAMELY, SIGNAL PROCESSORS, TRANSCIVERS, WIRELESS TRANSMITTERS, WIRELESS RECEIVERS, AND REPEATERS FOR USE IN WIRELESS CELLULAR BASESTATIONS AND FEMTOCELLS, NAMELY, A SMALL CELLULAR BASESTATION USED TO CONNECT TO A SERVICE PROVIDER'S NETWORK VIA BROADBAND; BROADBAND WIRELESS EQUIPMENT, NAMELY, TELECOMMUNICATIONS BASESTATION EQUIPMENT FOR CELLULAR AND FIXED NETWORKING AND COMMUNICATIONS APPLICATIONS; COMPUTER HARDWARE; COMPUTER SOFTWARE FOR WIRELESS CONTENT DELIVERY; COMPUTER SOFTWARE FOR USE IN CONNECTION WITH WIRELESS DEVICES, NAMELY, FOR CONTROLLING AND MANAGING WIRELESS CELLULAR BASESTATIONS AND FEMTOCELLS; OPERATING FIRMWARE FOR EMBEDDING WITHIN, AND TO ENABLE THE FUNCTION OF, WIRELESS CELLULAR BASESTATION AND FEMTOCELLS; DATA PROCESSING EQUIPMENT; COMPUTER CHIPS FOR EMBEDDED USE IN CONSUMER ELECTRONIC GOODS; MASSIVELY PARALLEL COMPUTER DATA PROCESSORS; PARTS AND FITTINGS FOR ALL THE AFORESAID GOODS (U.S. CLS. 21, 23, 26, 36 AND 38).

CLASS 42—SCIENTIFIC AND COMPUTER SERVICES

FOR COMPUTER SOFTWARE, HARDWARE AND FIRMWARE DESIGN SERVICES; COMPUTER CHIP AND PROCESSOR DESIGN SERVICES; CONSULTANCY AND ADVISORY SERVICES IN RESPECT OF DATA PROCESSORS, COMPUTER CHIPS AND COMPUTER APPARATUS AND EQUIPMENT (U.S. CLS. 100 AND 101).

THOMAS MANOR, EXAMINING ATTORNEY

SN 79-088,488. PICOCHIP DESIGNS LIMITED, UNITED KINGDOM, FILED 8-9-2010.

PICOXCELL

OWNER OF INTERNATIONAL REGISTRATION 1054354 DATED 8-9-2010, EXPIRES 8-9-2020.

CLASS 9—ELECTRICAL AND SCIENTIFIC APPARATUS

FOR SEMI-CONDUCTORS, PROGRAMMABLE COMPUTER CHIPS, COMPUTER DATA PROCESSORS; WIRELESS COMMUNICATIONS PROCESSORS, NAMELY, SIGNAL PROCESSORS; INTEGRATED CIRCUITS; RADIO FREQUENCY COMPONENTS, NAMELY, TRANSCEIVERS, TRANSMITTERS AND RECEIVERS, REPEATERS USED IN LONG RANGE COMMUNICATION, RADIOS USED FOR WIRELESS/CELLULAR COMMUNICATIONS AND WIRELESS/CELLULAR BASESTATIONS; ELECTRONIC COMPONENTS FOR COMPUTERS, NAMELY, SIGNAL PROCESSORS, WIRELESS TRANSMITTERS, AND WIRELESS RECEIVERS; ELECTRONIC COMPONENTS FOR WIRELESS CELLULAR BASESTATIONS, NAMELY, SIGNAL PROCESSORS, TRANSCIVERS, WIRELESS TRANSMITTERS, WIRELESS RECEIVERS, AND REPEATERS FOR USE IN WIRELESS CELLULAR BASESTATIONS AND FEMTOCELLS, NAMELY, A SMALL CELLULAR BASESTATION USED TO CONNECT TO A SERVICE PROVIDER'S NETWORK VIA BROADBAND; BROADBAND WIRELESS EQUIPMENT, NAMELY, TELECOMMUNICATIONS BASESTATION EQUIPMENT FOR CELLULAR AND FIXED NETWORKING AND COMMUNICATIONS APPLICATIONS; COMPUTER HARDWARE; COMPUTER SOFTWARE FOR WIRELESS CONTENT DELIVERY; COMPUTER SOFTWARE FOR USE IN CONNECTION WITH WIRELESS DEVICES, NAMELY, FOR CONTROLLING AND MANAGING WIRELESS CELLULAR BASESTATIONS AND FEMTOCELLS; OPERATING FIRMWARE FOR EMBEDDING WITHIN, AND TO ENABLE THE FUNCTION OF, WIRELESS CELLULAR BASESTATION AND FEMTOCELLS; DATA PROCESSING EQUIPMENT; COMPUTER CHIPS FOR EMBEDDED USE IN CONSUMER ELECTRONIC GOODS; MASSIVELY PARALLEL COMPUTER DATA PROCESSORS; PARTS AND FITTINGS FOR ALL THE AFORESAID GOODS (U.S. CLS. 21, 23, 26, 36 AND 38).

CLASS 42—SCIENTIFIC AND COMPUTER SERVICES

FOR COMPUTER SOFTWARE, HARDWARE AND FIRMWARE DESIGN SERVICES; COMPUTER CHIP AND PROCESSOR DESIGN SERVICES; CONSULTANCY AND ADVISORY SERVICES IN RESPECT OF DATA PROCESSORS, COMPUTER CHIPS AND COMPUTER APPARATUS AND EQUIPMENT (U.S. CLS. 100 AND 101).

THOMAS MANOR, EXAMINING ATTORNEY

SN 79-088,514. SEC CARBON, LIMITED, JAPAN, FILED 4-2-2010.

SECC

THE MARK CONSISTS OF STANDARD CHARACTERS WITHOUT CLAIM TO ANY PARTICULAR FONT, STYLE, SIZE, OR COLOR.

OWNER OF INTERNATIONAL REGISTRATION 1054414 DATED 4-2-2010, EXPIRES 4-2-2020.

CLASS 1—CHEMICALS

FOR GRAPHITE IN RAW OR SEMI-FINISHED FORM FOR USE IN THE MANUFACTURE OF BATTERIES; ARTIFICIAL GRAPHITE FOR INDUSTRIAL PURPOSES; NATURAL GRAPHITE FOR INDUSTRIAL PURPOSES; CARBON FOR INDUSTRIAL PURPOSES (U.S. CLS. 1, 5, 6, 10, 26 AND 46).

CLASS 9—ELECTRICAL AND SCIENTIFIC APPARATUS

FOR ELECTRODES FOR ELECTRIC FURNACE STEEL MAKING, ELECTRODES FOR NONFERROUS SMELTING AND REFINING, ELECTRODES FOR ELECTROLYZING, GRAPHITE ELECTRODES FOR DISCHARGE MACHINING, CATHODE BLOCK FOR ALUMINUM SMELTING, ELECTRODES (U.S. CLS. 21, 23, 26, 36 AND 38).

CLASS 11—ENVIRONMENTAL CONTROL APPARATUS

FOR HEATING ELEMENTS FOR INDUSTRIAL FURNACES, NAMELY, COMPONENT PARTS OF INDUSTRIAL FURNACES USED FOR NON FERROUS SMELTING AND REFINING, NAMELY, GAS INJECTION PIPES MADE OF GRAPHITE FOR DEGASSING SYSTEM (U.S. CLS. 13, 21, 23, 31 AND 34).

CLASS 19—NON-METALLIC BUILDING MATERIALS

FOR BRICKS; REFRACTORY BLOCKS, NOT OF METAL; REFRACTORY BRICKS, NOT OF METAL; REFRACTORY CASTABLE MIXES, NOT OF METAL; REFRACTORY CONCRETE; REFRACTORY CONSTRUCTION MATERIALS, NOT OF METAL (U.S. CLS. 1, 12, 33 AND 50).

CHRISTOPHER BUONGIORNO, EXAMINING ATTORNEY

SN 79-088,662. OTTO BOCK HEALTHCARE GMBH, FED REP GERMANY, FILED 5-6-2010.



THE MARK CONSISTS OF STANDARD CHARACTERS WITHOUT CLAIM TO ANY PARTICULAR FONT, STYLE, SIZE, OR COLOR.

OWNER OF INTERNATIONAL REGISTRATION 1054750 DATED 5-6-2010, EXPIRES 5-6-2020.

THE ENGLISH TRANSLATION OF "GENIUM" IN THE MARK IS DERIVED FROM THE LATIN "IN GENIUM" WHICH MEANS "TO BE TALENTED IN SOMETHING".

CLASS 9—ELECTRICAL AND SCIENTIFIC APPARATUS

FOR DATA PROCESSORS AND SOFTWARE USED FOR THE CONTROL OF KNEE JOINT PROsthESIS; CONTROLLING APPARATUS IN THE NATURE OF COMPUTER HARDWARE FOR ARTIFICIAL LIMBS; APPARATUS, NAMELY, DATA PROCESSORS AND COMPUTER SOFTWARE USED FOR MEASURING, ESTABLISHING AND ANALYZING MUSCLE ACTIVITY (U.S. CLS. 21, 23, 26, 36 AND 38).

CLASS 10—MEDICAL APPARATUS

FOR ARTIFICIAL KNEE JOINTS, NAMELY, KNEE JOINT PROsthESIS (U.S. CLS. 26, 39 AND 44).

CLASS 42—SCIENTIFIC AND COMPUTER SERVICES

FOR DESIGN AND DEVELOPMENT OF COMPUTER HARDWARE AND SOFTWARE AND INSTALLATION AND CUSTOMIZATION OF COMPUTER SOFTWARE TO INDIVIDUAL NEEDS (U.S. CLS. 100 AND 101).

CLASS 44—MEDICAL, BEAUTY AND AGRICULTURAL SERVICES

FOR HYGIENIC AND BEAUTY CARE FOR HUMAN BEINGS (U.S. CLS. 100 AND 101).
SUE LAWRENCE, EXAMINING ATTORNEY

SN 79-088,716. REINNEVATE LIMITED, UNITED KINGDOM, FILED 5-20-2010.



THE MARK CONSISTS OF STANDARD CHARACTERS WITHOUT CLAIM TO ANY PARTICULAR FONT, STYLE, SIZE, OR COLOR.

PRIORITY DATE OF 12-2-2009 IS CLAIMED.

OWNER OF INTERNATIONAL REGISTRATION 1054923 DATED 5-20-2010, EXPIRES 5-20-2020.

THE WORDING "ALVETEX" HAS NO MEANING IN A FOREIGN LANGUAGE.

CLASS 9—ELECTRICAL AND SCIENTIFIC APPARATUS

FOR CELL CULTURE APPARATUS AND INSTRUMENTS FOR LABORATORY OR RESEARCH MEDICAL USE; LABORATORY APPARATUS, NAMELY, CELL CULTURE LABORATORY VESSELS, PLATES HAVING MULTI-WELL ARRAYS, PETRI DISHES, CELL CULTURE WELL INSERTS, LABORATORY GLASSWARE, CELL FACTORIES, CELL CULTURE FLASKS AND BIOREACTORS FOR USE IN THE SEPARATION OF ANTIBODIES; REACTION UNITS FOR CELL BASED ASSAY RESEARCH, ROUTINE CELL CULTURES, CELL PASSAGING RESEARCH AND PERFUSION CELL CULTURE SYSTEMS RESEARCH CONTAINING CHEMICAL OR BIOLOGICAL REAGENTS; CELL CULTURE SCAFFOLDS, NAMELY, MICROSPUN FIBRES AND MICRO-POROUS POLYSTYRENE SUBSTRATES COATED WITH EXTRA-CELLULAR MATRICES FOR USE IN THREE-DIMENSIONAL CELL CULTURING; DEEP WELL PLATES, NAMELY, DEEP RESERVOIR PETRI DISHES WITH AND WITHOUT WELL INSERT CRADLES USED IN LABORATORY RESEARCH (U.S. CLS. 21, 23, 26, 36 AND 38).

CLASS 40—MATERIAL TREATMENT

FOR TREATMENT OF HUMAN, ANIMAL AND PLANT CELLS, BACTERIA AND ANTIBODY MATERIALS BY CULTURING SUCH CELLS IN THREE DIMENSIONS; MATERIAL TREATMENT INVOLVING THREE DIMENSIONAL CELL CULTURE PROCESSES AND IN-VITRO STEM CELL DIFFERENTIATION (U.S. CLS. 100, 103 AND 106).

CLASS 42—SCIENTIFIC AND COMPUTER SERVICES

FOR SCIENTIFIC RESEARCH AND DESIGN SERVICES IN THE FIELD OF THREE DIMENSIONAL CELL CULTURE AND ANALYTICAL PROCESSES; INDUSTRIAL ANALYSIS AND RESEARCH SERVICES IN THE FIELD OF CELL CULTURE, CELL BIOLOGY, TOXICITY AND SAFETY TESTING, TISSUE AND DISEASE MODELLING AND DRUG EFFICACY; LABORATORY SERVICES, NAMELY, ANALYSIS AND RESEARCH IN THE FIELD OF CELL AND TISSUE CULTURES AND THEIR TREATMENT; BIOTECHNOLOGY RESEARCH; LABORATORY SERVICES RELATING TO THE PRODUCTION OF ANTIBODIES; GROWING CELL CULTURES FOR RESEARCH PURPOSES; TESTING PHARMACEUTICAL, MEDICAL AND BIOLOGICAL AGENTS FOR OTHERS; CONSULTANCY RELATING TO BIOTECHNOLOGY (U.S. CLS. 100 AND 101).

MARLENE BELL, EXAMINING ATTORNEY

SN 79-088,725. STEPOVER GMBH, FED REP GERMANY, FILED 7-21-2010.

STEP OVER

THE MARK CONSISTS OF STANDARD CHARACTERS WITHOUT CLAIM TO ANY PARTICULAR FONT, STYLE, SIZE, OR COLOR.

PRIORITY DATE OF 2-3-2010 IS CLAIMED.

OWNER OF INTERNATIONAL REGISTRATION 1054940 DATED 7-21-2010, EXPIRES 7-21-2020.

CLASS 9—ELECTRICAL AND SCIENTIFIC APPARATUS

FOR DATA PROCESSING EQUIPMENT AND COMPUTERS; COMPUTER PERIPHERAL EQUIPMENT, IN PARTICULAR DEVICES ADAPTED FOR ELECTRONIC RECORDING OF A USER INPUT, IN PARTICULAR A SIGNATURE; COMPUTER PROGRAMS FOR OPERATING DEVICES FOR ELECTRONIC RECORDING OF USER INPUT, IN PARTICULAR A SIGNATURE; COMPUTER SOFTWARE, IN PARTICULAR COMPUTER SOFTWARE FOR OPERATING DEVICES FOR ELECTRONIC RECORDING OF A USER INPUT, IN PARTICULAR A SIGNATURE; COMPUTER SOFTWARE FOR ELECTRONIC RECORDING OF A USER INPUT, IN PARTICULAR A SIGNATURE, COMPUTER SOFTWARE FOR ELECTRONIC PROCESSING OF A USER INPUT, IN PARTICULAR A SIGNATURE; ELECTRONIC PENS FOR USE IN VISUAL DISPLAY UNITS; STRUCTURAL AND REPLACEMENT PARTS FOR THE AFOREMENTIONED GOODS; DOWNLOADABLE ELECTRONIC PUBLICATIONS, NAMELY, INSTRUCTION MANUALS CONCERNING EQUIPMENT AND COMPUTER SOFTWARE FOR ELECTRONIC RECORDING AND PROCESSING OF A USER INPUT, IN PARTICULAR A SIGNATURE (U.S. CLS. 21, 23, 26, 36 AND 38).

CLASS 16—PAPER GOODS AND PRINTED MATTER

FOR BOOKS IN THE FIELD OF EQUIPMENT AND COMPUTER SOFTWARE FOR ELECTRONIC RECORDING AND PROCESSING OF A USER INPUT, IN PARTICULAR A SIGNATURE; PRINTED MATTER, NAMELY, MAGAZINES AND BROCHURES IN THE FIELD OF EQUIPMENT AND COMPUTER SOFTWARE FOR ELECTRONIC RECORDING AND PROCESSING OF A USER INPUT, IN PARTICULAR A SIGNATURE; AND PRINTED PUBLICATIONS, NAMELY, MANUALS CONCERNING EQUIPMENT AND COMPUTER SOFTWARE FOR ELECTRONIC RECORDING AND PROCESSING OF A USER INPUT, IN PARTICULAR A SIGNATURE (U.S. CLS. 2, 5, 22, 23, 29, 37, 38 AND 50).

CLASS 42—SCIENTIFIC AND COMPUTER SERVICES

FOR DESIGN AND DEVELOPMENT OF COMPUTER HARDWARE AND SOFTWARE; VERIFYING ELECTRONIC SIGNATURES IN CONNECTION WITH HARDWARE AND SOFTWARE FOR INSURANCE COMPANIES, BANKS, COMMERCE AND HEALTH CARE; SERVICES FOR TECHNICAL VERIFYING, CERTIFYING, AUTHORIZING AND ENCRYPTING, IN PARTICULAR IN THE FIELD OF HAND WRITTEN SIGNATURES IN CONNECTION WITH HARDWARE AND SOFTWARE FOR INSURANCE COMPANIES, BANKS, COMMERCE AND HEALTH CARE; TECHNICAL CONSULTANCY IN THE FIELD OF VERIFYING, CERTIFYING, AUTHORIZING AND ENCRYPTING, IN PARTICULAR IN THE FIELD OF HAND WRITTEN SIGNATURES IN CONNECTION WITH HARDWARE AND SOFTWARE FOR INSURANCE COMPANIES, BANKS, COMMERCE AND HEALTH CARE; UPDATING OF SOFTWARE; COMPUTER HARDWARE CONSULTANCY AND COMPUTER SOFTWARE CONSULTANCY; COMPUTER SOFTWARE DESIGN; SERVICES OF A CERTIFICATE AUTHORITY IN THE NATURE OF A TRUST CENTER, IN PARTICULAR OUTPUT AND MANAGEMENT OF DIGITAL KEYS AND DIGITAL SIGNATURES IN CONNECTION WITH HARDWARE AND SOFTWARE FOR INSURANCE COMPANIES, BANKS, COMMERCE AND HEALTH CARE; MAINTENANCE OF COMPUTER SOFTWARE (U.S. CLS. 100 AND 101).

SUZANNE BLANE, EXAMINING ATTORNEY

SN 79-088,738. OTTO BOCK HEALTHCARE GMBH, FED REP GERMANY, FILED 5-10-2010.

genium
Bionic Prosthetic System

OWNER OF INTERNATIONAL REGISTRATION 1054985 DATED 5-10-2010, EXPIRES 5-10-2020.

NO CLAIM IS MADE TO THE EXCLUSIVE RIGHT TO USE "BIONIC PROSTHETIC SYSTEM", APART FROM THE MARK AS SHOWN.

THE ENGLISH TRANSLATION OF "GENIUM" IN THE MARK IS DERIVED FROM THE LATIN "IN GENIUM" WHICH MEANS "TO BE TALENTED IN SOMETHING".

CLASS 9—ELECTRICAL AND SCIENTIFIC APPARATUS

FOR DATA PROCESSORS AND SOFTWARE USED FOR THE CONTROL OF KNEE JOINT PROSTHESIS; CONTROLLING APPARATUS IN THE NATURE OF COMPUTER HARDWARE FOR ARTIFICIAL LIMBS; APPARATUS, NAMELY, DATA PROCESSORS AND COMPUTER SOFTWARE USED FOR MEASURING, ESTABLISHING AND ANALYZING MUSCLE ACTIVITY (U.S. CLS. 21, 23, 26, 36 AND 38).

CLASS 10—MEDICAL APPARATUS

FOR ARTIFICIAL KNEE JOINTS, NAMELY, KNEE JOINT PROSTHESIS (U.S. CLS. 26, 39 AND 44).

CLASS 42—SCIENTIFIC AND COMPUTER SERVICES

FOR DESIGN AND DEVELOPMENT OF COMPUTER HARDWARE AND SOFTWARE AND INSTALLATION AND CUSTOMIZATION OF COMPUTER SOFTWARE TO INDIVIDUAL NEEDS (U.S. CLS. 100 AND 101).

CLASS 44—MEDICAL, BEAUTY AND AGRICULTURAL SERVICES

FOR HYGIENIC AND BEAUTY CARE FOR HUMAN BEINGS (U.S. CLS. 100 AND 101).

SUE LAWRENCE, EXAMINING ATTORNEY

SN 79-088,787. TOVARYSTVO Z OBMEZHENOJU VIDPOVIDALNISTYU "KRAJTEX-SERVIS", ODESA 65069, UKRAINE, FILED 9-7-2010.

SN 79-088,744. THE PROVOST, FELLOWS, FOUNDATION SCHOLARS, AND THE OTHER MEMBERS OF BOARD OF THE COLLEGE OF THE HOLY AND UNDIVIDED TRINITY OF QUEEN ELIZABETH NEAR DUBLIN, IRELAND, FILED 5-14-2010.



OWNER OF INTERNATIONAL REGISTRATION 1054998 DATED 5-14-2010, EXPIRES 5-14-2020.

NO CLAIM IS MADE TO THE EXCLUSIVE RIGHT TO USE "SCIENCE GALLERY" AS TO CLASS 41, APART FROM THE MARK AS SHOWN.

THE MARK CONSISTS OF THE WORDS "SCIENCE GALLERY" AND DESIGN. THE TERM "SCIENCE" APPEARS WITHIN A CIRCLE. TO THE RIGHT OF THE CIRCLE IS A SQUARE AND WITHIN THE SQUARE IS THE TERM "GALLERY".

CLASS 25—CLOTHING

FOR ARTICLES OF CLOTHING, NAMELY, T-SHIRTS, SWEATSHIRTS, SWEATPANTS, SWEATERS, PANTS, SKIRTS, DRESSES, TOPS, SHORTS, SKIRTS, SOCKS, SCARVES AND UNDERWEAR; HEADGEAR, NAMELY, HATS AND CAPS; AND FOOTWEAR (U.S. CLS. 22 AND 39).

CLASS 41—EDUCATION AND ENTERTAINMENT

FOR EDUCATIONAL SERVICES, NAMELY, PROVIDING CLASSES, SEMINARS AND WORKSHOPS IN THE FIELDS OF SCIENCE AND TECHNOLOGY; PROVIDING TRAINING IN THE FIELDS OF SCIENCE AND TECHNOLOGY; ENTERTAINMENT SERVICES, NAMELY, PROVIDING OF GUIDED TOURS OF MUSEUMS AND OF EXHIBITIONS DEALING WITH THE TOPICS OF SCIENCE AND TECHNOLOGY; ORGANIZING COMMUNITY SPORTING AND CULTURAL ACTIVITIES; ARRANGING AND CONDUCTING EDUCATIONAL COLLOQUIUMS, CONFERENCES, SEMINARS AND SYMPOSIA IN THE FIELDS OF SCIENCE AND TECHNOLOGY; ARRANGING AND CONDUCTING TRAINING AND EDUCATIONAL WORKSHOPS IN THE FIELDS OF SCIENCE AND TECHNOLOGY; MUSEUM SERVICES AND PRESENTING EDUCATIONAL EXHIBITIONS IN THE FIELDS OF SCIENCE AND TECHNOLOGY; PUBLICATION OF BOOKS, JOURNALS AND OTHER TEXTS (U.S. CLS. 100, 101 AND 107).

MARLENE BELL, EXAMINING ATTORNEY



PRIORITY DATE OF 3-22-2010 IS CLAIMED. OWNER OF INTERNATIONAL REGISTRATION 1055085 DATED 9-7-2010, EXPIRES 9-7-2020.

NO CLAIM IS MADE TO THE EXCLUSIVE RIGHT TO USE "SKIN", APART FROM THE MARK AS SHOWN.

THE COLOR(S) WHITE, PURPLE AND LIGHT PURPLE IS/ARE CLAIMED AS A FEATURE OF THE MARK.

THE MARK CONSISTS OF THE FOLLOWING: A WHITE INSCRIPTION "BEAUTY SKIN FRANKLY BEAUTIFUL!" ON THE PURPLE RECTANGLE; ROUNDED WHITE ORIGINAL GRAPHIC ELEMENT ON THE PURPLE RECTANGLE; AN ORIGINAL PATTERN OF LIGHT PURPLE RECTANGLE.

CLASS 3—COSMETICS AND CLEANING PREPARATIONS

FOR BLEACHING PREPARATIONS AND OTHER SUBSTANCES, NAMELY, LAUNDRY BLUEING, COLOR-BRIGHTENING CHEMICALS FOR HOUSEHOLD LAUNDRY PURPOSES, SACHETS FOR PERFUMING LINEN, LAUNDRY GLAZE, LAUNDRY PREPARATIONS, LAUNDRY SOAKING PREPARATIONS, LAUNDRY STARCH, STARCH GLAZE FOR LAUNDRY PURPOSES, DETERGENTS OTHER THAN FOR USE IN MANUFACTURING OPERATIONS AND FOR MEDICAL PURPOSES, FABRIC SOFTENERS FOR LAUNDRY USE, LAUNDRY SOAKING PREPARATIONS, FOR LAUNDRY USE; CLEANING, POLISHING, SCOURING AND ABRASIVE PREPARATIONS; SOAPS FOR BODY CARE AND FOOT PERSPIRATION; PERFUMERY, ESSENTIAL OILS, COSMETICS, HAIR LOTIONS; DENTIFRICES (U.S. CLS. 1, 4, 6, 50, 51 AND 52).

CLASS 5—PHARMACEUTICALS

FOR PHARMACEUTICAL PREPARATIONS FOR THE TREATMENT OF SKIN DISEASES ON THE HUMAN BODY; VETERINARY PREPARATIONS FOR THE TREATMENT OF THE SKIN ON THE BODY OF ANIMALS; SANITARY PREPARATIONS FOR MEDICAL PURPOSES; DIETETIC FOODS ADAPTED FOR MEDICAL USE, FOOD FOR BABIES; MEDICAL PLASTERS; MATERIALS FOR DRESSINGS, NAMELY, BANDAGES FOR DRESSING; MATERIAL FOR STOPPING TEETH, DENTAL WAX; DISINFECTANTS, NAMELY, FOR SANITARY PURPOSES; PREPARATIONS FOR DESTROYING VERMIN; FUNGICIDES, HERBICIDES (U.S. CLS. 6, 18, 44, 46, 51 AND 52).

MARY I. SPARROW, EXAMINING ATTORNEY

SN 79-089,145. LAGO S.P.A., ITALY, FILED 5-14-2010.

LAGO

THE MARK CONSISTS OF STANDARD CHARACTERS WITHOUT CLAIM TO ANY PARTICULAR FONT, STYLE, SIZE, OR COLOR.

PRIORITY DATE OF 12-1-2009 IS CLAIMED.

OWNER OF INTERNATIONAL REGISTRATION 1056119 DATED 5-14-2010, EXPIRES 5-14-2020.

THE ENGLISH TRANSLATION OF THE FOREIGN WORD(S) IN THE MARK IS LAKE.

CLASS 11—ENVIRONMENTAL CONTROL APPARATUS

FOR LAMPS; LAMP SHADES; LIGHTING FIXTURES, NAMELY, ARC LAMPS; CHANDELIERS; DOWN LIGHTERS, NAMELY, RECESSED LIGHTING FIXTURES; ELECTRIC LIGHTING FIXTURES; ELECTRIC LIGHTING FIXTURES, NAMELY, SCONCES; ELECTRIC TRACK LIGHTING UNITS; PICTURE LIGHTS; WATER, ELECTRIC BEVERAGE, AND KEROSENE HEATERS; GAS, WOOD BURNING, AND ELECTRIC STOVES; AIR CONDITIONERS, AIR COOLERS; ELECTRIC, VENTILATING EXHAUST, AND CEILING FANS; GAS, WOOD BURNING, AND ELECTRIC OVENS; ELECTRIC TOASTERS, AND ELECTRIC COOKWARE BROILERS, ALL FOR DOMESTIC USE (U.S. CLS. 13, 21, 23, 31 AND 34).

CLASS 20—FURNITURE AND ARTICLES NOT OTHERWISE CLASSIFIED

FOR FURNITURE, NAMELY, CHAIRS; ARM CHAIRS; TABLES; COFFEE-TABLES; SHOW-CASES IN THE NATURE OF CABINETS FOR DISPLAYING ARTICLES; CLOTHES-HANGERS; VALETS IN THE NATURE OF FURNITURE FOR HOLDING CLOTHING AND PERSONAL EFFECTS; MAGAZINE RACKS FOR PERSONAL AND COMMERCIAL USE; TOWEL RACKS; TOWEL-HANGERS, NAMELY, TOWEL HOOKS NOT OF METAL; MIRRORS; MIRROR FRAMES; UMBRELLA STANDS; TELEPHONE HOLDERS, NAMELY, TABLES FOR HOLDING TELEPHONES; SERVING TROLLEYS FOR FOOD; FURNITURE IN THE NATURE OF CABINETS FOR HOLDING CDS AND DVDS; PLASMA TV MONITOR STANDS; LAMP TABLES; SIDE TABLES; FOLDING TABLES; CONTAINERS SPECIALLY ADAPTED FOR STORING AND TRANSPORTING FOLDING CHAIRS; HUTCHES; BUFFETS; SIDE BOARDS; SOFAS; BENCHES; STOOLS; FOOT RESTS; CONSOLES, NAMELY, TABLES DESIGNED TO BE PLACED AGAINST A WALL; HOLDERS, NAMELY, BOOK HOLDERS; SHELVES; CHESTS OF DRAWERS; LOUNGE CHAIRS; BEDS; SOFA BEDS; DIVANS; LOVESEATS; OTTOMANS; FURNITURE CUSHIONS; PILLOWS; PLASTIC STORAGE BOXES; MAGAZINE STANDS; COMPUTER KEYBOARD TRAYS; PICTURE FRAMES; FURNITURE IN THE NATURE OF ENTERTAINMENT UNITS; WINE RACKS (U.S. CLS. 2, 13, 22, 25, 32 AND 50).

CLASS 21—HOUSEWARES AND GLASS

FOR CLEANING CLOTHS; SPONGES FOR TOILET PURPOSES AND FOR HOUSEHOLD PURPOSES; SMALL DOMESTIC UTENSILS AND CONTAINERS, NAMELY, ICE BUCKETS, SALT, PEPPER AND MUSTARD CRUET SETS MADE OF NON-PRECIOUS METALS, SALT CELLARS, PEPPER GRINDERS, GRAVY BOATS, EGG HOLDERS, APPLE GRATERS, TRAYS, BOWLS; ICE PAILS, CRUET SETS OF NON-PRECIOUS METALS; DINNERWARE OF PLASTIC MATERIAL, NAMELY, PLATES, DISHES, CUPS, SAUCERS; TEA AND COFFEE POTS, DRINKING GLASSES, TUMBLERS, PITCHERS, BOTTLES, CARAFES, DECANTERS, GLASS JARS, POTS, FLOWER VASES, GLASS BOXES, TEA CANISTERS; ACCESSORIES FOR THE BATHROOM, NAMELY, SOAP DISHES, GLASS HOLDERS, TOWEL RAILS, TOILET TISSUE HOLDERS, TOILET BRUSH HOLDERS, BOXES AND CONTAINERS FOR COTTON PADS, TISSUE AND COSMETICS; HOUSEHOLD AND KITCHEN UTENSILS AND CONTAINERS, NAMELY, SPATULAS, SIEVES, STRAINERS, BRUSHES FOR DISHWASHING, TOILET BRUSHES; FRYING PANS, KNIFE BLOCKS, SERVING FORKS, SUGAR BOWLS, JUGS, PLATES, DUSTPANS, SAUCEPANS, SERVING SPOONS, SLOTTED SERVING SPOONS, WIRE WHISKS, NON ELECTRIC EGG BEATERS, COLANDERS, ROLLING PINS, CORKSCREWS, ALL PURPOSE PORTABLE HOUSEHOLD CONTAINERS (U.S. CLS. 2, 13, 23, 29, 30, 33, 40 AND 50).

CLASS 24—FABRICS

FOR TEXTILE FABRIC FOR MAKING CLOTHES, CURTAIN AND HOUSEHOLD LINEN, PILLOW CASES, BED CANOPIES, FABRIC BED AND TABLE COVERS, QUILTS, CURTAINS, TEXTILE WALL HANGINGS, TEXTILE TAPESTRIES, CLOTH FLAGS, FELT CLOTHS, BATH LINEN, FABRIC TABLE RUNNERS, TEXTILE PLACE MATS, TEXTILE DISH MATS AND CARAFE MATS, BED SPREADS, BED PADS, BED LINEN, TOWELS, FACE CLOTH NAPKINS, WASHCLOTHS, FABRIC HANDKERCHIEFS, TABLE LINEN, CLOTH COASTERS AND FABRIC COASTERS, CLOTH DOILIES, PLAIDS IN THE NATURE OF WOVEN FABRIC, CLOTH AND TEXTILE NAPKINS, KITCHEN TOWELS, OVEN MITTS, BARBECUE MITTS, MOSQUITO NETS, BROCADE, CALICO, DAMASK, DISH CLOTHS, DIMITY, DRAPERIES, DUVET, FLANNEL, FUSTIAN, TAFFETA, TULLE, VELVET, COTTON FABRIC, UPHOLSTERY FABRIC, WOOLEN FABRIC, UNFITTED FABRIC FURNITURE COVERS, DECORATIVE THROWS (U.S. CLS. 42 AND 50).

CLASS 25—CLOTHING

FOR CLOTHING, NAMELY, PULLOVERS, CARDIGANS, SWEATERS, TROUSERS, SKIRTS, JACKETS, BLOUSES, SHIRTS, JEANS, SWEATPANTS, SHORTS, SWEATSHIRTS, SUITS, DRESSES, OVERCOATS, COATS, RAINCOATS, BELTS, JERSEYS, NECKWEAR, SCARVES, SOCKS AND STOCKINGS, TIGHTS, VESTS, WAISTCOATS, JUMPERS, TRACKSUITS, BLOUSONS, GYM SUITS, KNICKERS, T-SHIRTS, ANORAKS, SUSPENDERS, LOUNGEWEAR, UNDERWEAR, BRASSIERES, CORSETS, PETTICOATS, NIGHTGOWNS, DRESSING GOWNS, BATH ROBES, BEACHWEAR, SLEEPWEAR, HEADWEAR, OVERALLS, HATS AND CAPS, GLOVES, SHOES, SANDALS, BOOTS AND SLIPPERS (U.S. CLS. 22 AND 39).

CLASS 27—FLOOR COVERINGS

FOR CARPETS, CARPET TILES, CARPET TILES FOR COVERING FLOORS, CARPETING, RUGS, FLOOR MATS AND MATTING, FLOOR COVERINGS, FLOOR COVERINGS OF RUBBER AND SYNTHETIC RUBBER, RESILIENT HARD SURFACE COVERINGS FOR FLOORS, VINYL FLOOR COVERINGS (U.S. CLS. 19, 20, 37, 42 AND 50).

REBECCA POVARCHUK, EXAMINING ATTORNEY

SN 79-089,180. SEPTEM PRODUCTS CO., LTD., JAPAN,
FILED 2-17-2010.

S e P • T e M

OWNER OF INTERNATIONAL REGISTRATION 1056210
DATED 2-17-2010, EXPIRES 2-17-2020.

THE MARK CONSISTS OF THE WORDING "SEP" IN STYLIZED FONT, WITH THE "E" APPEARING SMALLER THAN THE "S" AND "P" AND RAISED TO THE HORIZONTAL MIDPOINT OF THE ADJACENT LETTERS, FOLLOWED BY A SHADED CIRCLE, ALSO AT THE HORIZONTAL MIDPOINT OF THE ADJACENT LETTERS, FOLLOWED BY THE WORDING "TEM" IN STYLIZED FONT, AND ALSO WITH THE "E" APPEARING SMALLER AND RAISED TO THE HORIZONTAL MIDPOINT OF THE ADJACENT LETTERS.

THE WORDING "SEP TEM" HAS NO MEANING IN A FOREIGN LANGUAGE.

CLASS 3—COSMETICS AND CLEANING PREPARATIONS

FOR SOAPS AND DETERGENTS; NATURAL PERFUMERY MADE FROM PLANTS; NATURAL PERFUMERY PREPARED FROM ANIMAL EXTRACTS; SYNTHETIC PERFUMERY; COMPOUND PERFUMERY; FOOD FLAVORINGS PREPARED FROM ESSENTIAL OILS; INCENSES AND FRAGRANCES; COSMETICS AND NON-MEDICATED TOILETRIES; FALSE NAILS; FALSE EYELASHES; DENTIFRICES; POLISHING PREPARATIONS; SHOE AND BOOT CREAM; SHOE BLACK; PAINT STRIPPING PREPARATIONS (U.S. CLS. 1, 4, 6, 50, 51 AND 52).

CLASS 21—HOUSEWARES AND GLASS

FOR UNWORKED OR SEMI-WORKED GLASS; NON-ELECTRIC COOKING POTS AND PANS; NON-ELECTRIC, NON-METAL COFFEE POTS; JAPANESE CAST IRON KETTLES, NON-ELECTRIC (TETSUBIN); NON-ELECTRIC KETTLES; NON-METAL TABLEWARE IN THE NATURE OF PLATES, SERVING DISHES, DISPOSABLE SERVING SPOONS, SOUP BOWLS; ICE PAILS; NON-ELECTRIC WHISKS; COOKING STRAINERS; NON-METAL PEPPER POTS, SUGAR BOWLS AND SALT SHAKERS; NON-METAL EGG CUPS; NON-METAL NAPKIN HOLDERS AND NAPKIN RINGS; NON-METAL TRAYS; NON-METAL TOOTHPICK HOLDERS; COLANDERS; SHAKERS, NAMELY, SALT SHAKERS, COCKTAIL SHAKERS; JAPANESE STYLE COOKED RICE SCOOPS (SHAMOJI); HAND-OPERATED COFFEE GRINDERS AND PEPPER MILLS; COOKING FUNNELS; JAPANESE STYLE PERSONAL DINING TRAYS OR STANDS (ZEN); BOTTLE OPENERS; COOKING GRATERS; TART SCOOPS; PAN MATS IN THE NATURE OF TRIVETS; CHOPSTICKS; CHOPSTICK CASES; SERVING LADLES AND DIPPERS; COOKING SIEVES AND SIFTERS; CHOPPING BOARDS FOR KITCHEN USE; ROLLING PINS FOR COOKING PURPOSES; COOKING UTENSILS, NAMELY, GRILLS; TOOTHPICKS; CITRUS JUICERS IN THE NATURE OF LEMON SQUEEZERS; NON-ELECTRIC WAFFLE IRONS; CLEANING TOOLS AND WASHING UTENSILS IN THE NATURE OF DISHWASHING BRUSHES, CLEANING BRUSHES FOR HOUSEHOLD USE; NON-ELECTRIC PORTABLE ICE BOXES IN THE NATURE OF COOLERS FOR FOOD AND BEVERAGES; RICE CHESTS; FOOD PRESERVING JARS OF GLASS; DRINKING FLASKS; VACUUM BOTTLES IN THE NATURE OF INSULATED FLASKS; GLOVES FOR HOUSEHOLD PURPOSES; COSMETIC AND TOILET UTENSILS, NAMELY, COSMETIC BRUSHES, TOILET BRUSHES; PIG BRISTLES, NAMELY, HOG BRISTLES FOR BRUSHES; CLOTHES BRUSHES; SHOE BRUSHES; SHOE HORNS; SHOE SHINE CLOTHS; HANDY SHOE SHINERS IN THE NATURE OF SHOE SHINE CLOTHS; SHOE-TREES IN THE NATURE OF STRETCHERS; INDUSTRIAL PACKA-

GING CONTAINERS OF GLASS, SPECIFICALLY EXCLUDING GLASS STOPPERS, LIDS AND COVERS; INDUSTRIAL PACKAGING CONTAINERS OF CERAMICS; GLASS STOPPERS FOR INDUSTRIAL PACKAGING CONTAINERS; GLASS COVERS AND LIDS FOR INDUSTRIAL PACKAGING CONTAINERS; IRONING BOARDS; TAILORS' SPRAYERS; IRONING BOARDS (KOTEDAI); FEEDING VESSELS FOR PETS; BRUSHES FOR PETS; BIRD CAGES; BIRD BATHS; FLOWER POTS; WATERING CANS; CINDER SIFTERS FOR HOUSEHOLD PURPOSES; COAL SCUTTLES; BOXES OF METAL FOR DISPENSING PAPER TOWELS; BOOT JACKS; SOAP DISPENSERS; CHAMBER POTS; TOILET PAPER HOLDERS; NON-METAL PIGGY BANKS; MOUSE TRAPS; FLY SWATTERS; STIRRERS FOR HOT BATH-TUB WATER (YUKAKIBO); BATHROOM STOOLS; BATHROOM PAILS; NON-METAL CANDLE EXTINGUISHERS AND CANDLESTICKS; FLOWER VASES; CERAMICS IN THE NATURE OF CERAMIC FIGURINES; PERFUME BURNERS (U.S. CLS. 2, 13, 23, 29, 30, 33, 40 AND 50).

CLASS 42—SCIENTIFIC AND COMPUTER SERVICES

FOR TESTING, INSPECTION OR RESEARCH OF PHARMACEUTICALS, COSMETICS OR FOODSTUFF (U.S. CLS. 100 AND 101).

CLASS 44—MEDICAL, BEAUTY AND AGRICULTURAL SERVICES

FOR BEAUTY SALONS; HAIRDRESSING SALONS; MASSAGE AND THERAPEUTIC SHIATSU MASSAGE; MOXIBUSTION; TREATMENT TO JOINT-DISLOCATION, SPRAIN, BONE-FRACTURE OR THE LIKE (JUDO-SEIFUKU); ACUPUNCTURE; MEDICAL SERVICES; PROVIDING MEDICAL INFORMATION; PHYSICAL THERAPY; DENTISTRY; PREPARATION AND DISPENSING OF MEDICATIONS; DIETARY AND NUTRITIONAL GUIDANCE (U.S. CLS. 100 AND 101).

KAREN SEVERSON, EXAMINING ATTORNEY

SN 79-089,382. KIND HÖRGERÄTE GMBH & CO. KG, FED
REP GERMANY, FILED 7-28-2010.

 **HearingAidWorld**

PRIORITY DATE OF 6-29-2010 IS CLAIMED.

OWNER OF INTERNATIONAL REGISTRATION 1056788
DATED 7-28-2010, EXPIRES 7-28-2020.

THE MARK CONSISTS OF A CIRCULAR GLOBE DESIGN WITH LONGITUDE AND LATITUDE LINES AND THE WORDING "HEARINGAIDWORLD".

CLASS 10—MEDICAL APPARATUS

FOR MEDICAL APPARATUS AND INSTRUMENTS, NAMELY, MEDICAL HEARING INSTRUMENTS AND PARTS OF SUCH DEVICES, HEARING PROTECTORS WITH LEVEL DEPENDENT ATTENUATION AND ELECTRONIC SOUND REPRODUCTION AND HEARING PROTECTORS USING ACTIVE NOISE CANCELLATION; PARTS OF ACOUSTIC APPARATUS FOR THE HEARING-IMPAIRED, NAMELY, CERUMEN PROTECTION SYSTEMS; MEDICAL APPARATUS AND INSTRUMENTS, NAMELY, PASSIVE HEARING PROTECTION IN THE FORM OF EAR PLUGS FOR MEDICAL PURPOSES; OTOLOGICAL APPARATUS AND INSTRUMENTS AS WELL AS THEIR PARTS AND APPARATUS FOR REPRODUCING SOUNDS AND NOISES FOR THE TREATMENT OF TINNITUS; HEARING AIDS AND THEIR PARTS; HEARING AID GLASSES (U.S. CLS. 26, 39 AND 44).

CLASS 35—ADVERTISING AND BUSINESS

FOR OPERATION OF VIRTUAL EMPORIA, NAMELY, AN ONLINE RETAIL STORE FEATURING ELECTRONICS, HEADPHONES, OTOLOGICAL APPARATUS AND INSTRUMENTS AND THEIR PARTS AS WELL AS HEARING AIDS AND HEARING PROTECTION DEVICES; ARRANGING OF CONTRACTS CONCERNING THE PURCHASE OF GOODS AND THE RENDERING OF SERVICES FOR THIRD PARTIES; ADVERTISING AND SALES PROMOTION, IN PARTICULAR VIA THE INTERNET (U.S. CLS. 100, 101 AND 102).

CLASS 44—MEDICAL, BEAUTY AND AGRICULTURAL SERVICES

FOR SERVICES OF A HEARING-AID ACOUSTICIAN, IN PARTICULAR MEASURING OF THE SENSE OF HEARING, AND CONDUCTING OF AUDIOMETRY AND LINGUISTIC TESTS; CONSULTANCY IN THE FIELD OF HEARING AIDS, NAMELY, IN HEARING ACOUSTICS AND HEARING PERFORMANCE, WITH SUCH CONSULTANCY PROVIDED BOTH IN-PERSON AND ONLINE (U.S. CLS. 100 AND 101).

KRISTIN CARLSON, EXAMINING ATTORNEY

SN 79-089,385. ACKERMANN HAIDER, ANTWERPEN, BELGIUM, FILED 8-23-2010.

HAIDER ACKERMANN

THE MARK CONSISTS OF STANDARD CHARACTERS WITHOUT CLAIM TO ANY PARTICULAR FONT, STYLE, SIZE, OR COLOR.

OWNER OF INTERNATIONAL REGISTRATION 1056791 DATED 8-23-2010, EXPIRES 8-23-2020.

OWNER OF U.S. REG. NO. 3,335,368.

CLASS 3—COSMETICS AND CLEANING PREPARATIONS

FOR SOAP; PERFUMERY; ESSENTIAL OILS; COSMETICS; HAIR LOTIONS (U.S. CLS. 1, 4, 6, 50, 51 AND 52).

CLASS 18—LEATHER GOODS

FOR GOODS MADE OF LEATHER AND IMITATIONS OF LEATHER, NAMELY, HANDBAGS, SHOULDER BAGS, CLUTCHES, PURSES, POUCHES, SHOPPING BAGS, BRIEFCASES, SPORT BAGS, GENERAL PURPOSE TROLLEY BAGS, SUITCASES, ATTACHE CASES, GARMENT BAGS FOR TRAVEL, CREDIT CARD HOLDERS, CREDIT CARD CASES, COIN PURSES, WALLETS, KEY CASES, KEY CHAINS; UMBRELLAS AND PARASOLS (U.S. CLS. 1, 2, 3, 22 AND 41).

MIDGE BUTLER, EXAMINING ATTORNEY

SN 79-089,443. AZIENDA AGROFORESTALE FONTE ZOPPA DI PIERO LUZI & C. SOCIETA' AGRICOLA IN ACCOMANDITA SEMPLICE, CIVITANOVA MARCHE (MACERATA), ITALY, FILED 9-30-2010.

FONTE ZOPPA

THE MARK CONSISTS OF STANDARD CHARACTERS WITHOUT CLAIM TO ANY PARTICULAR FONT, STYLE, SIZE, OR COLOR.

OWNER OF INTERNATIONAL REGISTRATION 1056861 DATED 9-30-2010, EXPIRES 9-30-2020.

THE ENGLISH TRANSLATION OF THE WORD "FONTE ZOPPA" IN THE MARK IS "SOURCE LAME".

CLASS 29—MEATS AND PROCESSED FOODS

FOR EDIBLE OILS, IN PARTICULAR OLIVE OIL (U.S. CL. 46).

CLASS 33—WINES AND SPIRITS

FOR WINES, SPIRITS AND LIQUEURS (U.S. CLS. 47 AND 49).

JOSETTE BEVERLY, EXAMINING ATTORNEY

SN 79-089,501. ALOYS F. DORNBRACHT GMBH & CO. KG, FED REP GERMANY, FILED 7-2-2010.

ATT Ambiance Tuning Technique

THE MARK CONSISTS OF STANDARD CHARACTERS WITHOUT CLAIM TO ANY PARTICULAR FONT, STYLE, SIZE, OR COLOR.

PRIORITY DATE OF 2-17-2010 IS CLAIMED.

OWNER OF INTERNATIONAL REGISTRATION 1057005 DATED 7-2-2010, EXPIRES 7-2-2020.

CLASS 6—METAL GOODS

FOR SANITARY FITTINGS OF METAL, NAMELY, HANDLES FOR SINKS, SHOWER DOORS, BATHTUBS (U.S. CLS. 2, 12, 13, 14, 23, 25 AND 50).

CLASS 9—ELECTRICAL AND SCIENTIFIC APPARATUS

FOR SCIENTIFIC, NAUTICAL, SURVEYING, PHOTOGRAPHIC, CINEMATOGRAPHIC, OPTICAL, WEIGHING, MEASURING, SIGNALING, CHECKING AND SUPERVISION, LIFE-SAVING AND TEACHING APPARATUS AND INSTRUMENTS, NAMELY, ELECTRIC AND ELECTRONIC FITTINGS FOR SUPPLYING, DISTRIBUTING, CONTROLLING, AND REGULATING WATER, NAMELY, ELECTRIC THERMOSTATS WITH AND WITHOUT REGULATORS, WATER HEATER CONTROLS, WATER LEVEL INDICATORS, WATER FILTER CONTROLLERS, AND FITTINGS WITH MOTION DETECTORS AND INFRARED SENSORS; APPARATUS AND INSTRUMENTS FOR CONDUCTING, SWITCHING, TRANSFORMING, ACCUMULATING, REGULATING OR CONTROLLING ELECTRICITY; APPARATUS FOR RECORDING, TRANSMISSION OR REPRODUCTION OF SOUND OR IMAGES; BLANK MAGNETIC DATA CARRIERS; PRE-RECORDED MAGNETIC DATA CARRIERS FEATURING MUSIC; BLANK RECORDING DISCS; PRE-RECORDED DISCS FEATURING MUSIC; AUTOMATIC VENDING MACHINES AND MECHANISMS FOR COIN-OPERATED APPARATUS; CASH REGISTERS, CALCULATING MACHINES, DATA PROCESSING EQUIPMENT AND COMPUTERS; FIRE-EXTINGUISHING APPARATUS; ELECTRONIC LIGHT CONTROLS, ELECTRONIC VOICE CONTROLS, ELECTRONIC ACOUSTIC CONTROLS (U.S. CLS. 21, 23, 26, 36 AND 38).

CLASS 11—ENVIRONMENTAL CONTROL APPARATUS

FOR ELECTRIC AND ELECTRONIC FITTINGS FOR SUPPLYING, DISTRIBUTING, CONTROLLING AND REGULATING WATER, NAMELY, CONTROL VALVES, METERED VALVES, COUPLERS, BIBBS, USED TO DISTRIBUTE, CONTROL, AND REGULATE WATER SUPPLY, RADIANT HEATERS, BATH-WATER PURIFYING APPARATUS FOR HOUSEHOLD PURPOSES, FLOW RESTRICTORS FOR REVERSE OSMOSIS WATER PURIFICATION UNITS, AND HOT WATER TANKS; ELECTRONIC SPRAYERS FOR SINKS AND PARTS AND FIXTURES THEREFOR, ELECTRONIC SPRAYERS FOR DISSEMINATING PERFUMES AND DISINFECTANTS; APPARATUS FOR LIGHTING, NAMELY, LIGHTING INSTALLATIONS, LAMPS; APPARATUS FOR HEATING, NAMELY, WATER HEATER, KEROSENE HEATER; APPARATUS FOR STEAM GENERATING;

APPARATUS FOR COOKING, NAMELY, COOKING OVENS; APPARATUS FOR REFRIGERATING; APPARATUS FOR DRYING, NAMELY, CLOTHES DRYER, HAIR DRYER, APPARATUS FOR VENTILATING, NAMELY, EXHAUST FANS, EXHAUST HOODS, APPARATUS FOR WATER SUPPLY, NAMELY, HOT WATER TANKS, WATER PURIFICATION TANKS, AND APPARATUS FOR SANITARY PURPOSES, NAMELY, TOILETS, BIDETS, URINALS, SINKS; SANITARY FITTINGS OF METAL AND PLASTIC FOR TOILETS, BATHROOMS AND KITCHENS, NAMELY, FITTINGS FOR SUPPLYING, DISTRIBUTING, CONTROLLING AND REGULATING WATER, INCLUDING REGULATING WATER TEMPERATURE IN THE NATURE OF PLASTIC TOILET TANK BALLS, PLASTIC KITCHEN SINK SPRAYERS, PRESSURE REGULATORS, COUPLERS, BIBS USED TO DISTRIBUTE, CONTROL AND REGULATE WATER SOLD AS A UNIT, DRAINS, FAUCET FILTERS, SPOUTS, SINK STRAINERS, TRAPS, COUPLERS USED FOR THE SUPPLY, DISTRIBUTION, CONTROL AND REGULATION OF WATER, MIXERS FOR REGULATING FLOW, DISTRIBUTION AND TEMPERATURE OF WATER, SHOWER HEADS, SETS COMPRISING SHOWER HEADS AND PARTS AND FIXTURES THEREFOR, SETS COMPRISING HAND HELD SHOWER HEADS AND PARTS AND FIXTURES THEREFOR; INSTANTANEOUS WATER HEATERS, WATER TREATMENT INSTALLATIONS, WASH-HAND BASINS IN THE NATURE OF SINKS, WASHSTAND INSTALLATIONS IN THE NATURE OF SINKS, BIDETS, TOILET INSTALLATIONS, URINALS, WASH-HAND BASINS IN THE NATURE OF SINK, TOILET SEATS, PREASSEMBLED INSTALLATION UNITS FOR SHOWERS COMPRISED OF SHOWER HEADS AND SPRAYERS; SHOWER DEVICES, NAMELY, SHOWER MIXERS, CONTROL VALVES, SHOWER LIGHTS; SHOWER CUBICLES OF PLASTIC WITH INTEGRATED SHOWER FITTINGS AND SHOWER INSTALLATIONS; SANITARY FITTINGS OF METAL, PLASTIC AND GLASS, NAMELY, BATH TUB HANDLES; COMPONENTS FOR SANITARY INSTALLATIONS, NAMELY, ASSEMBLY ELEMENTS FOR SANITARY UNITS IN THE NATURE OF PIPES BEING PART OF SANITARY FACILITIES; CONNECTING PILARS FOR SANITARY UNITS; BATH TUBS AND BASINS IN THE NATURE OF SINKS OF PLASTIC, CERAMIC AND METAL FOR SANITARY PURPOSES, INCLUDING BATH TUBS AND SINKS WITH SWIRL NOZZLES AND/OR AERATING NOZZLES, NOZZLE FITTINGS AND PUMPS FOR TUBS WITH SWIRL NOZZLES; BLOWING MACHINES IN THE NATURE OF HOT AIR BLOWERS, INCLUDING BLOWING MACHINES WITH HEATING MECHANISMS FOR HEATING THE BLAST AIR, FOR AERATING BATHING WATER IN TUBS, HEATING MECHANISMS AND FILTERS FOR BATHING WATER, STEAM ROOM INSTALLATIONS AND ACCESSORIES THEREFOR, IN THE NATURE OF STEAM VALVES, ACCUMULATORS; FITTINGS FOR STEAM BATHS IN THE NATURE OF STEAM VALVES, ACCUMULATORS, STEAM GENERATORS, VAPORIZATION APPARATUS IN THE NATURE OF ELECTRIC VAPORIZER; WATER SOFTENING APPARATUS, LIGHTING DEVICES FOR TUBS, LIGHTING DEVICES FOR STEAM BATHS AND SHOWERS; MOBILE COMPACT-WHIRL APPARATUS FOR FITTING IN BATH TUBS, WITH MOTORS, PUMPS AND NOZZLE SYSTEMS BEING CONSTRUCTION UNITS (U.S. CLS. 13, 21, 23, 31 AND 34).

CLASS 20—FURNITURE AND ARTICLES NOT OTHERWISE CLASSIFIED

FOR FURNITURE, BATHROOM FURNITURE, IN PARTICULAR TOWEL RACKS, SHELVES, STORAGE VANITIES, SUSPENDED CABINETS, CONTAINER TROLLEYS, DRESSING TABLES, MEDICINE CABINETS, MIRRORS, MIRRORING CABINETS, PICTURE FRAMES; GOODS OF WOOD, CORK, REED, CANE, WICKER, HORN, BONE, IVORY, WHALEBONE, SHELL, AMBER, MOTHER-OF-PEARL, MEERSCHAUM AND SUBSTITUTES FOR ALL THESE MATERIALS, OR OF PLASTICS, NAMELY, DRAWER PULLS, FIGURINES, CURTAIN HOLDERS, HANDLES FOR FURNITURE, BRACKETS FOR SHELVES, NON-METAL HANDLES, NON-METAL KNOBS, NON-METAL WINDOW TRIMS;

SANITARY FITTINGS OF PLASTIC, NAMELY, STORAGE UNITS, HANDLES FOR DOORS, HANDLES FOR FURNITURE, MIRRORING STORAGE UNITS; FURNITURE, WINDOW AND DOOR FITTINGS OF PLASTIC; FITTINGS FOR SANITARY INSTALLATIONS, NAMELY, SINK LINERS, SINK MATS, AND NON-METAL WALL HOOKS, NON-METAL TOWEL HOOKS, NON-METAL BATHTUB HANDLES; SANITARY FITTINGS OF METAL, NAMELY, METAL STORAGE CABINETS, BRACKETS SOLD AS A UNIT WITH SHELVES, AND MIRRORING STORAGE CABINETS (U.S. CLS. 2, 13, 22, 25, 32 AND 50).

CLASS 21—HOUSEWARES AND GLASS

FOR HOUSEHOLD OR KITCHEN UTENSILS, NAMELY, SPATULAS, GRATERS, AND CONTAINERS NOT OF PRECIOUS METAL OR COATED THEREWITH; COMBS AND SPONGES, NAMELY, SCOURING SPONGES, CLEANING SPONGES, SCRUB SPONGES, BATH SPONGES; BRUSHES, NAMELY, HOUSEHOLD CLEANING BRUSHES, TOILET BRUSHES, EYE BROW BRUSHES, TOOTH BRUSHES, NAIL BRUSHES, HAIR-BRUSHES, CLOTHES BRUSHES, CAKE BRUSHES, BRUSHES FOR PETS, BRUSHES FOR FOOTWEAR; BRUSH-MAKING MATERIALS; ARTICLES FOR CLEANING PURPOSES, NAMELY, MOPS, BROOMS, STEELWOOL FOR CLEANING, CLEANING CLOTHS, CLEANING PADS; STEELWOOL; UNWORKED OR SEMI-WORKED GLASS EXCEPT GLASS USED IN BUILDING; GLASSWARE, PORCELAIN AND EARTH-WARE, NAMELY, GLASS SOAP DISHES, SOAP, TOWEL AND TOILET ROLL HOLDERS, TOILET BRUSHES AND HOLDERS THEREFOR; SANITARY FITTINGS OF METAL, NAMELY, SOAP DISHES, SOAP HOLDERS, TOWEL HOOKS AND TOWEL HOLDERS BOTH IN THE NATURE OF TOWEL RINGS, TOWEL BARS, TOWEL RAILS, TOILET PAPER HOLDERS; SANITARY FITTINGS OF PLASTIC, NAMELY, SOAP DISHES, SOAP HOLDERS, TOILET PAPER HOLDERS, TOWEL HOOKS AND TOWEL HOLDERS BOTH IN THE NATURE OF TOWEL RINGS, TOWEL BARS, TOWEL RAILS; WASH BASINS (U.S. CLS. 2, 13, 23, 29, 30, 33, 40 AND 50).

TOBY BULLOFF, EXAMINING ATTORNEY

SN 79-089,655. ALRWAQ MEDIA PUBLIQ RELATION LIMITED, QATAR, FILED 7-26-2010.



PRIORITY DATE OF 4-1-2010 IS CLAIMED.
OWNER OF INTERNATIONAL REGISTRATION 1057386 DATED 7-26-2010, EXPIRES 7-26-2020.

NO CLAIM IS MADE TO THE EXCLUSIVE RIGHT TO USE THE NON-LATIN CHARACTERS THAT TRANSLITERATE TO "ISLAAM ONLINE.NET" AND "ISLAMONLINE.NET", APART FROM THE MARK AS SHOWN.

THE COLOR(S) YELLOW, BLUE, GREEN, RED IS/ARE CLAIMED AS A FEATURE OF THE MARK.

THE MARK CONSISTS OF A YELLOW GLOBE WITH BLUE LINES, BLUE OUTLINING AND A RED ORBIT SET AGAINST TWO GREEN SQUARES WITH BLUE OUTLINING. THERE IS THE BLUE WORDING "ISLAMONLINE" AND "NET", SEPARATED BY A RED DOT TO THE LEFT OF THE GLOBE DESIGN. THE BLUE ARABIC CHARACTERS TRANSLATING TO "ISLAMONLINE" AND "NET" ARE ABOVE, ALSO SEPARATED BY A RED DOT. THERE IS A RED HORIZONTAL LINE BELOW TO THE RIGHT OF THE LITERAL ELEMENTS.

THE NON-LATIN CHARACTERS IN THE MARK TRANSLITERATE TO "ISLAAM ONLINE.NET" AND THIS MEANS "ISLAMONLINE.NET" IN ENGLISH.

CLASS 35—ADVERTISING AND BUSINESS

FOR ADVERTISING; BUSINESS MANAGEMENT; BUSINESS ADMINISTRATION; OFFICE FUNCTIONS (U.S. CLS. 100, 101 AND 102).

CLASS 38—COMMUNICATION

FOR TELECOMMUNICATIONS, NAMELY, TELECOMMUNICATION ACCESS SERVICES, TRANSMISSION OF WEBCASTS; RENTAL OF ACCESS TIME TO GLOBAL COMPUTER NETWORKS; COMMUNICATION OF DATA BY MEANS OF TELECOMMUNICATIONS, NAMELY, BY ELECTRONIC MAIL AND MOBILE PHONES; ELECTRONIC COMMUNICATION SERVICES, NAMELY, COMMUNICATIONS BY ELECTRONIC COMPUTER TERMINALS, INFORMATION TRANSMISSION VIA ELECTRONIC COMMUNICATIONS NETWORKS (U.S. CLS. 100, 101 AND 104).

CLASS 41—EDUCATION AND ENTERTAINMENT

FOR EDUCATIONAL SERVICES, NAMELY, CLASSES AND SEMINARS IN THE FIELD OF RELIGION AND INFORMATION TECHNOLOGY; ONLINE EDUCATIONAL SERVICES, NAMELY, CLASSES AND SEMINARS IN THE FIELD OF RELIGION AND INFORMATION TECHNOLOGY; TRAINING SERVICES, NAMELY, CLASSES AND SEMINARS IN THE FIELD OF RELIGION AND INFORMATION TECHNOLOGY; NEWS REPORTERS SERVICES; NEWS SYNDICATION REPORTING (U.S. CLS. 100, 101 AND 107).

CLASS 45—PERSONAL AND LEGAL SERVICES

FOR PROVISION OF RELIGIOUS INFORMATION (U.S. CLS. 100 AND 101).

CHRISIE B. KING, EXAMINING ATTORNEY

SN 79-090,081. REGGIO CHILDREN - CENTRO INTERNAZIONALE PER LA DIFESA E LA PROMOZIONE DEI DIRITTI E DELLE POTENZIALITA' DEI BAMBINI E DELLE BAMBINE S.R.L., ITALY, FILED 8-26-2010.

CENTRO INTERNAZIONALE LORIS MALAGUZZI

THE MARK CONSISTS OF STANDARD CHARACTERS WITHOUT CLAIM TO ANY PARTICULAR FONT, STYLE, SIZE, OR COLOR.

PRIORITY DATE OF 8-6-2010 IS CLAIMED.

OWNER OF INTERNATIONAL REGISTRATION 1058598 DATED 8-26-2010, EXPIRES 8-26-2020.

NO CLAIM IS MADE TO THE EXCLUSIVE RIGHT TO USE "CENTRO INTERNAZIONALE", APART FROM THE MARK AS SHOWN.

"LORIS MALAGUZZI" DOES NOT IDENTIFY A LIVING INDIVIDUAL.

THE ENGLISH TRANSLATION OF "CENTRO INTERNAZIONALE" IN THE MARK IS "INTERNATIONAL CENTRE".

CLASS 41—EDUCATION AND ENTERTAINMENT

FOR EDUCATIONAL SERVICES, NAMELY, EDUCATIONAL PROGRAMS FOR CHILDREN IN THE NATURE OF PRE-SCHOOLS, TEACHING AND CONDUCTING DISTANCE LEARNING PROGRAMS AND COURSES IN THE FIELD OF EDUCATION, PEDAGOGY, LEARNING PROCESSES AND EXPRESSIVE LANGUAGES TEACHING; PUBLICATION OF BOOKS; ORGANIZATION OF EXHIBITIONS FOR CULTURAL OR EDUCATIONAL PURPOSES (U.S. CLS. 100, 101 AND 107).

CLASS 42—SCIENTIFIC AND COMPUTER SERVICES

FOR TESTING OF GOODS AND SERVICES OF OTHERS FOR THE PURPOSE OF CERTIFICATION; ACCREDITATION SERVICES IN THE NATURE OF ADMINISTERING STANDARDS FOR CERTIFYING OF TEACHING METHODOLOGY PROCEDURES; DESIGNING OF FURNITURE AND GAMES FOR CHILDREN, AND DESIGN CONSULTATION SERVICES RELATING THERETO (U.S. CLS. 100 AND 101).

DAVID ELTON, EXAMINING ATTORNEY

SN 79-090,176. THE BROOKE HOSPITAL FOR ANIMALS, UNITED KINGDOM, FILED 10-20-2010.

BROOKE

THE MARK CONSISTS OF STANDARD CHARACTERS WITHOUT CLAIM TO ANY PARTICULAR FONT, STYLE, SIZE, OR COLOR.

PRIORITY DATE OF 4-21-2010 IS CLAIMED.

OWNER OF INTERNATIONAL REGISTRATION 1058841 DATED 10-20-2010, EXPIRES 10-20-2020.

CLASS 36—INSURANCE AND FINANCIAL

FOR CHARITABLE SERVICES, NAMELY, FUNDRAISING FOR THE WELFARE OF EQUINE ANIMALS (U.S. CLS. 100, 101 AND 102).

CLASS 41—EDUCATION AND ENTERTAINMENT

FOR EDUCATION SERVICES, NAMELY, PROVIDING EDUCATIONAL PROGRAMMES, COURSES, CONFERENCES, SEMINARS, AND E-LEARNING FACILITIES IN THE FIELD OF VETERINARY PROFESSION AND VETERINARY CARE MATTERS; PROVISION OF TRAINING IN THE FIELD OF VETERINARY PROFESSION AND VETERINARY CARE MATTERS; PROVIDING ONLINE NON-DOWNLOADABLE ELECTRONIC PUBLICATIONS IN THE NATURE OF E-BOOKS, BROCHURES, PAMPHLETS AND REPORTS AND PUBLISHING PRINTED MATTER, IN THE FIELD OF ANIMAL CARE, ANIMAL HOSPITAL MANAGEMENT AND VETERINARY TEXTS; ORGANISING EDUCATIONAL CONFERENCES AND SEMINARS AND ORGANISING OF EDUCATIONAL COMPETITIONS, ALL RELATING TO ANIMAL CARE, THE MANAGEMENT OF ANIMAL CARE, THE MANAGEMENT OF ANIMAL HOSPITALS OR VETERINARY MEDICINE (U.S. CLS. 100, 101 AND 107).

CLASS 44—MEDICAL, BEAUTY AND AGRICULTURAL SERVICES

FOR VETERINARY SERVICES; VETERINARY ADVISORY, CONSULTANCY, AND INFORMATION SERVICES; PROVIDING INFORMATION AND ADVISORY SERVICES RELATING TO DIAGNOSTIC, PROPHYLACTIC AND THERAPEUTIC PROPERTIES OF VETERINARY PHARMACEUTICALS; PROVIDING HEALTH INFORMATION CONCERNING VETERINARY PRODUCTS, EQUIPMENT AND DEVICES; VETERINARY ASSISTANCE; PROVIDING CONSULTANCY, ADVICE AND INFORMATION RELATING TO VETERINARY CARE (U.S. CLS. 100 AND 101).

COLLEEN DOMBROW, EXAMINING ATTORNEY

SN 79-091,217. PROTEOMEDIX AG, SWITZERLAND, FILED 11-24-2010.

ProteoMediX

THE MARK CONSISTS OF STANDARD CHARACTERS WITHOUT CLAIM TO ANY PARTICULAR FONT, STYLE, SIZE, OR COLOR.

PRIORITY DATE OF 6-4-2010 IS CLAIMED.

OWNER OF INTERNATIONAL REGISTRATION 1061603 DATED 11-24-2010, EXPIRES 11-24-2020.

CLASS 1—CHEMICALS

FOR CHEMICALS USED IN INDUSTRY, SCIENCE AND PHOTOGRAPHY; UNPROCESSED ARTIFICIAL RESINS, UNPROCESSED PLASTICS; FERTILIZERS; FIRE EXTINGUISHING COMPOSITIONS; TEMPERING PREPARATIONS; CHEMICAL SUBSTANCES FOR PRESERVING FOODSTUFFS; ADHESIVES FOR INDUSTRIAL PURPOSES (U.S. CLS. 1, 5, 6, 10, 26 AND 46).

CLASS 5—PHARMACEUTICALS

FOR PHARMACEUTICAL AND VETERINARY PRODUCTS, NAMELY, PHARMACEUTICAL PRODUCTS FOR THE PREVENTION AND TREATMENT OF CANCER, PHARMACEUTICAL PRODUCTS FOR THE TREATMENT OF VIRAL AND INFECTIOUS DISEASES, FOR THE TREATMENT OF CANCER, AND DIAGNOSTIC PREPARATIONS FOR MEDICAL OR VETERINARY PURPOSES; SANITARY PREPARATIONS FOR MEDICAL PURPOSES; DIETETIC SUBSTANCES FOR MEDICAL USE, NAMELY, FOOD, BEVERAGE; FOOD FOR BABIES; MEDICAL PLASTERS, MATERIALS FOR DRESSINGS, NAMELY, GAUZE, BANDAGES; MATERIAL FOR DENTAL FILLINGS AND DENTAL IMPRESSIONS; ALL PURPOSE DISINFECTANTS; PESTICIDES; FUNGICIDES, HERBICIDES (U.S. CLS. 6, 18, 44, 46, 51 AND 52).

CLASS 42—SCIENTIFIC AND COMPUTER SERVICES

FOR SCIENTIFIC AND TECHNOLOGICAL SERVICES, NAMELY, SCIENTIFIC RESEARCH, ANALYSIS, AND TESTING IN THE FIELD OF HEALTHCARE; INDUSTRIAL ANALYSIS AND RESEARCH SERVICES IN THE FIELD OF HEALTHCARE; DESIGN AND DEVELOPMENT OF COMPUTERS AND SOFTWARE (U.S. CLS. 100 AND 101).

COURTNEY ALVAREZ, EXAMINING ATTORNEY

SN 79-091,369. EASIWARE SAS, FRANCE, FILED 10-15-2010.

Easiware

THE MARK CONSISTS OF STANDARD CHARACTERS WITHOUT CLAIM TO ANY PARTICULAR FONT, STYLE, SIZE, OR COLOR.

OWNER OF INTERNATIONAL REGISTRATION 1061968 DATED 10-15-2010, EXPIRES 10-15-2020.

CLASS 9—ELECTRICAL AND SCIENTIFIC APPARATUS

FOR DATA PROCESSING EQUIPMENT AND COMPUTERS; COMPUTER SOFTWARE RECORDED ON DATA MEDIA OR ON DATABASE SERVER FOR ENTERPRISE MANAGEMENT AND ORGANIZATION AND FOR CUSTOMER RELATIONSHIP MANAGEMENT; COMPUTER PERIPHERAL DEVICES (U.S. CLS. 21, 23, 26, 36 AND 38).

CLASS 35—ADVERTISING AND BUSINESS

FOR BUSINESS MANAGEMENT; BUSINESS ADMINISTRATION; BUSINESS MANAGEMENT AND ENTERPRISE ORGANIZATION CONSULTANCY; BOOK-KEEPING; COMPUTERIZED FILE MANAGEMENT (U.S. CLS. 100, 101 AND 102).

CLASS 38—COMMUNICATION

FOR RENTAL OF ACCESS TIME TO A DATABASE SERVER CENTER (U.S. CLS. 100, 101 AND 104).

CLASS 42—SCIENTIFIC AND COMPUTER SERVICES

FOR ENGINEERING SERVICES, NAMELY, RESEARCH IN THE FIELDS OF SCIENCE AND TECHNOLOGY; ENGINEERING SERVICES, NAMELY, EVALUATIONS AND ASSESSMENTS OF COMPUTER, SOFTWARE AND DATA PROCESSING EQUIPMENTS; DESIGN AND DEVELOPMENT OF COMPUTERS AND SOFTWARE; RESEARCH AND DEVELOPMENT OF NEW PRODUCTS FOR OTHERS; DEVELOPMENT, DESIGN, INSTALLATION, MAINTENANCE, UPDATING OR RENTAL OF SOFTWARE; COMPUTER PROGRAMMING; CONSULTANCY IN THE FIELD OF COMPUTER HARDWARE; DATA CONVERSION OF COMPUTER PROGRAMS AND DATA OTHER THAN PHYSICAL CONVERSION; CONVERSION OF DATA OR DOCUMENTS FROM PHYSICAL TO ELECTRONIC MEDIA (U.S. CLS. 100 AND 101).

JULIE VEPPUMTHARA, EXAMINING ATTORNEY

SN 79-091,440. PATRIK LARSSON, SWEDEN, FILED 8-24-2010.

Carbonopoly

THE MARK CONSISTS OF STANDARD CHARACTERS WITHOUT CLAIM TO ANY PARTICULAR FONT, STYLE, SIZE, OR COLOR.

PRIORITY DATE OF 8-19-2010 IS CLAIMED.

OWNER OF INTERNATIONAL REGISTRATION 1062197 DATED 8-24-2010, EXPIRES 8-24-2020.

CLASS 9—ELECTRICAL AND SCIENTIFIC APPARATUS

FOR BLANK RECORDABLE MEDIA, NAMELY, BLANK RECORDABLE DISCS; COMPUTERS (U.S. CLS. 21, 23, 26, 36 AND 38).

CLASS 16—PAPER GOODS AND PRINTED MATTER

FOR PAPER; CARDBOARD BOXES; PRINTED MATTER, NAMELY, BOOKS, MAGAZINES, BROCHURES FEATURING SCIENCE; PRINTED INSTRUCTIONAL AND TEACHING MATERIALS IN THE FIELD OF SCIENCE (U.S. CLS. 2, 5, 22, 23, 29, 37, 38 AND 50).

CLASS 28—TOYS AND SPORTING GOODS

FOR BOARD GAMES; PARTY GAMES (U.S. CLS. 22, 23, 38 AND 50).

CLASS 41—EDUCATION AND ENTERTAINMENT

FOR TEACHING IN THE FIELD OF SCIENCE; EDUCATION SERVICES, NAMELY, CONDUCTING CLASSES, SEMINARS, CONFERENCES, WORKSHOPS IN THE FIELD OF SCIENCE (U.S. CLS. 100, 101 AND 107).

MICHAEL WIENER, EXAMINING ATTORNEY

SN 79-091,577. ZATARA NOMINEES PTY LTD, SYDNEY NSW 2001, AUSTRALIA, AND NEDSYP NOMINEES PTY LTD, SYDNEY NSW 2001, AUSTRALIA, FILED 10-8-2010.

UNIFIED WEAPONS MASTER

THE MARK CONSISTS OF STANDARD CHARACTERS WITHOUT CLAIM TO ANY PARTICULAR FONT, STYLE, SIZE, OR COLOR.

PRIORITY DATE OF 4-30-2010 IS CLAIMED.

OWNER OF INTERNATIONAL REGISTRATION 1062383 DATED 10-8-2010, EXPIRES 10-8-2020.

NO CLAIM IS MADE TO THE EXCLUSIVE RIGHT TO USE "WEAPONS", APART FROM THE MARK AS SHOWN.

CLASS 9—ELECTRICAL AND SCIENTIFIC APPARATUS

FOR PROTECTIVE CLOTHING NAMELY, BODY ARMOR; BODY ARMOR WHICH PROVIDES AN ELECTRICAL SIGNAL; PROTECTIVE HEADGEAR, NAMELY, PROTECTIVE HELMETS; ; ARTICLES FOR PROTECTING THE FACE AND EYES, NAMELY, FACE PROTECTION SHIELDS; ELECTRONIC SCORING SYSTEMS COMPRISING INTERACTIVE COMPUTERS; RECORDING APPARATUS IN THE NATURE OF AUDIO RECORDERS, VIDEO RECORDERS, ELECTRONIC DATA RECORDERS, AND VIDEO MONITORS; COMMUNICATION APPARATUS, NAMELY, HEADPHONES, MICROPHONES, COMMUNICATIONS HEADSETS FOR USE WITH COMMUNICATION RADIOS, INTERCOM SYSTEMS, OR OTHER COMMUNICATIONS NETWORK TRANSCIVERS, AND AUDIO SPEAKERS; ELECTRICAL AND ELECTRONIC DISPLAY APPARATUS, NAMELY, ELECTRONIC DISPLAY BOARDS, PLASMA DISPLAY BOARDS, ELECTRONIC DISPLAY SCREENS; COMPUTER GRAPHICS APPARATUS, NAMELY, COMPUTER GRAPHICS BOARDS, COMPUTER GRAPHICS SOFTWARE; SENSOR APPARATUS COMPRISING ELECTRIC SENSORS FOR MOVEMENT, FORCE AND POSITION; SOFTWARE, NAMELY, COMPUTER GAME SOFTWARE; VIDEO RECORDINGS FEATURING BOXING AND MARTIAL ARTS; AUDIO RECORDINGS FEATURING BOXING AND MARTIAL ARTS; PRERECORDED DVDS FEATURING BOXING, MARTIAL ARTS AND FIGHTING MATCHES (U.S. CLS. 21, 23, 26, 36 AND 38).

CLASS 25—CLOTHING

FOR FOOTWEAR, CLOTHING, NAMELY, PANTS, JACKETS, TRACK SUITS, MARTIAL ARTS UNIFORMS, SHIRTS AND SHORTS, LEGGINGS, GLOVES; HEADGEAR, NAMELY, HEADWEAR, HATS AND CAPS, ALL THE AFORESAID FOR MARTIAL ARTS (U.S. CLS. 22 AND 39).

CLASS 28—TOYS AND SPORTING GOODS

FOR GAMES AND TOYS, NAMELY, BOARD GAMES, ACTION FIGURE TOYS, DOLLS AND CARD GAMES; TOY WEAPONS; TOY SWORDS; TOY SPEARS; TOY STAFFS; TOY BOWS AND ARROWS; TOYS, NAMELY, BATTERY-POWERED COMPUTER GAMES WITH LCD SCREENS WHICH FEATURE ANIMATION AND SOUND EFFECTS; AND STAND ALONE VIDEO GAME MACHINES; SPORTS TRAINING EQUIPMENT FOR USE IN MARTIAL ARTS, NAMELY, FACE MASKS, PROTECTIVE PADDING AND PROTECTIVE SHIN GUARDS (U.S. CLS. 22, 23, 38 AND 50).

CLASS 41—EDUCATION AND ENTERTAINMENT

FOR INSTRUCTION, COACHING AND TRAINING IN SPORTS; RENTAL OF SPORTS EQUIPMENT; ADVISORY SERVICES RELATING TO THE ORGANIZATION OF SPORTING EVENTS, NAMELY, BOXING AND MARTIAL ARTS; BOOKING OF TICKETS FOR SPORTS EVENTS; HANDICAPPING OR SEEDING OF SPORTS EVENTS; PROVIDING SPORTS FACILITIES; ORGANIZING SPORTING EVENTS, NAMELY, BOXING AND MARTIAL ARTS; PROVIDING INFORMATION REGARDING SPORTING EVENTS; RENTAL OF SPORTS EQUIPMENT FOR USE AT SPORTING EVENTS NAMELY, BOXING AND MARTIAL ARTS; ARRANGING AND CONDUCTING OF SPORTING EVENTS, NAMELY, BOXING AND MARTIAL ARTS; EDUCATION SERVICES, NAMELY, CLASSES AND SEMINARS IN THE FIELD OF BOXING AND MARTIAL ARTS; ENTERTAINMENT IN THE NATURE OF BOXING, MARTIAL ARTS TOURNAMENTS; PROVIDING AN ONGOING REALITY BASED TELEVISION PROGRAM; PROVISION OF ENTERTAINMENT FACILITIES, NAMELY, FACILITIES FOR BOXING AND MARTIAL ARTS TOURNAMENTS; HEALTH CLUB SERVICES FOR PROVIDING EQUIPMENT AND INSTRUCTION IN PHYSICAL FITNESS AND EXERCISE (U.S. CLS. 100, 101 AND 107).

KELLY CHOE, EXAMINING ATTORNEY

SN 79-091,925. VOLKSWAGEN AKTIENGESELLSCHAFT, FED REP GERMANY, FILED 10-9-2010.

KICKSTEP

THE MARK CONSISTS OF STANDARD CHARACTERS WITHOUT CLAIM TO ANY PARTICULAR FONT, STYLE, SIZE, OR COLOR.

PRIORITY DATE OF 4-21-2010 IS CLAIMED.

OWNER OF INTERNATIONAL REGISTRATION 1063363 DATED 10-9-2010, EXPIRES 10-9-2020.

CLASS 9—ELECTRICAL AND SCIENTIFIC APPARATUS

FOR CONTACT LENSES, SPECTACLES, SPECTACLE CASES, BINOCULARS, MAGNIFYING GLASSES, SUNGLASSES, STIMULATORS FOR STEERING AND CONTROLLING VEHICLES, VOLTAGE REGULATORS FOR VEHICLES, VEHICLE BREAKDOWN WARNING TRIANGLES, VEHICLE BREAKDOWN WARNING LAMPS AND THEIR STRUCTURAL PARTS THEREFOR, CIGAR LIGHTERS FOR AUTOMOBILES, ELECTRIC BATTERIES AND THEIR STRUCTURAL PARTS THEREFOR, ELECTRIC ACCUMULATORS AND THEIR STRUCTURAL PARTS THEREFOR, FUEL CELLS AND THEIR STRUCTURAL PARTS THEREFOR, CHARGERS FOR ELECTRIC BATTERIES, BURGLAR ALARMS, ANTI-THEFT ALARMS, EXCLUDING ANTI-THEFT ALARMS FOR VEHICLES, FIRE ALARMS, SMOKE ALARMS, GAS ALARMS, SPEED INDICATORS, MEASURING APPARATUS AND MEASURING INSTRUMENTS FOR MEASURING, SPEED, WEIGHT, PRESSURE, REVOLUTION COUNTERS, ELECTRONIC CONTROL MECHANISMS FOR, SPEED, WEIGHT, PRESSURE AND POWER AND VOLTAGE SUPPLY UNITS FOR VEHICLE HEADLIGHTS AND THEIR STRUCTURAL PARTS THEREFOR, CONTROL MECHANISMS AND POWER AND VOLTAGE SUPPLY UNITS FOR VEHICLE LIGHTS AND THEIR STRUCTURAL PARTS THEREFOR, ELECTRONIC CONTROLS FOR INTERNAL COMBUSTION ENGINES AND ELECTRIC MOTORS FOR LAND VEHICLES, LIFE SAVING APPARATUS AND EQUIPMENT, NAMELY, LIFE-SAVING RAFTS, FIRE ESCAPE LADDERS, SAFETY NETS, SAFETY TARPULINS, LIFE BELTS, LIFE BUOYS, LIFE JACKETS, ACID HYDROMETERS, FUSES, ELECTRIC RELAYS, LASERS NOT FOR MEDICAL PURPOSES, LASER POINTERS, SOLAR BATTERIES, COMPASSES, NAVIGATION SYSTEMS, SPIRIT LEVELS, APPARATUS FOR RECORDING, TRANSMISSION AND REPRODUCTION OF SOUND AND IMAGES, AERIALS, RADIOS, TELEVISION APPARATUS, TELEPHONE APPARATUS, VIDEO TELEPHONES, PROJECTION APPARATUS, CINEMATOGRAPHIC CAMERAS, CAMERAS, PHOTOCOPIERS, ELECTRONIC TRANSLATION APPARATUS, ELECTRONIC POCKET TRANSLATORS, EXPOSED CAMERA FILMS, BLANK MAGNETIC, ELECTRONIC AND OPTICAL DATA CARRIERS EXCEPT UNEXPOSED FILMS, BLANK RECORDING DISCS, INTEGRATED CIRCUIT CARDS, MAGNETICALLY ENCODED PREPAID TELEPHONE CARDS, AUTOMATIC VENDING MACHINES, MECHANISMS FOR COIN OPERATED APPARATUS, AUTOMATIC BANKING MACHINES, CASH REGISTERS, CALCULATORS, DATA PROCESSING APPARATUS, COMPUTERS, ELECTRONIC CALENDARS AND ORGANIZERS, FACSIMILE APPARATUS, COMPUTER MONITORS, COMPUTER PERIPHERY DEVICES, POCKET CALCULATORS, RECORDED AND DOWNLOADABLE COMPUTER OPERATING PROGRAMS, FIRE EXTINGUISHERS, AMUSEMENT APPARATUS ADAPTED FOR USE WITH AN EXTERNAL DISPLAY SCREEN OR MONITOR AND APPARATUS FOR GAMES ADAPTED FOR USE WITH EXTERNAL SCREENS OR MONITORS (U.S. CLS. 21, 23, 26, 36 AND 38).

CLASS 12—VEHICLES

FOR VEHICLES FOR LOCOMOTION BY LAND, AIR AND WATER, NAMELY, CARS, SCOOTERS, TRUCKS, BICYCLES, MOTORCYCLES AND THEIR STRUCTURAL PARTS THEREFOR INCLUDED IN THIS CLASS, MOTORIZED LAND VEHICLES AND THEIR STRUCTURAL PARTS THEREFOR INCLUDED IN THIS CLASS, TRAILERS AND SEMI TRAILERS FOR VEHICLES AND THEIR STRUCTURAL PARTS THEREFOR INCLUDED IN THIS CLASS, ENGINES FOR LAND VEHICLES, RIMS FOR LAND VEHICLE WHEELS AND THEIR STRUCTURAL PARTS THEREFOR, ALARM SYSTEMS FOR VEHICLES, ANTI-THEFT DEVICES FOR VEHICLES, ALARM SYSTEMS FOR MOTORIZED LAND VEHICLES, ANTI-THEFT DEVICES FOR MOTORIZED LAND VEHICLES, TRICYCLES, SCOOTERS, BICYCLES, MOPEDS, MOTORCYCLES AND THEIR STRUCTURAL PARTS THEREFOR INCLUDED IN THIS CLASS, SIDE CARS, MOTORS, ELECTRIC FOR BICYCLES AND SCOOTERS, BICYCLE STANDS, BRAKES FOR BICYCLES AND CYCLES; RIMS FOR WHEELS OF BICYCLES AND CYCLES, BICYCLE FORK, BELLS FOR BICYCLES

AND CYCLES, CHAINS FOR BICYCLES AND CYCLES, BASKETS ADAPTED FOR CYCLES, HANDLE BARS FOR BICYCLES AND CYCLES, MOTORS FOR CYCLES, CYCLE HUBS FOR WHEELS, BICYCLE PARTS, NAMELY, DRESS GUARDS FOR BICYCLES AND CYCLES, PEDALS FOR CYCLES, PUMPS FOR BICYCLES AND CYCLES, WHEELS FOR BICYCLES AND CYCLES, FRAMES FOR BICYCLES AND CYCLES, BICYCLE TIRES, BICYCLE SADDLES, INNER TUBES FOR BICYCLES AND CYCLES, SPOKES FOR BICYCLES AND CYCLES, PANNIERS BAGS ADAPTED FOR CYCLES, SADDLES FOR BICYCLES, CYCLES OR MOTORCYCLES, INNER TUBES FOR PNEUMATIC TIRES, TUBELESS TIRES FOR BICYCLES AND CYCLES, MUDGUARDS, CYCLE MUDGUARDS, TRANSMISSIONS FOR LAND VEHICLES, REDUCTION GEARS FOR LAND VEHICLES, GEARS FOR CYCLES, MOTORS FOR CYCLES AND CYCLE STANDS (U.S. CLS. 19, 21, 23, 31, 35 AND 44).

CLASS 28—TOYS AND SPORTING GOODS

FOR SCALE MODEL VEHICLES, SCALE MODEL AUTOMOBILES AND TOY AUTOMOBILES, TOY VEHICLES FOR CHILDREN, TOY SCOOTERS, PLAYING CARDS, BALLS FOR SPORTS, STUFFED TOY ANIMALS AND OTHER STUFFED TOYS, APPARATUS FOR ELECTRONIC GAMES INCLUDING APPARATUS FOR VIDEO GAMES OTHER THAN THOSE ADAPTED FOR USE WITH EXTERNAL SCREENS OR MONITORS, AUTOMATIC AMUSEMENT GAME MACHINES BEING COIN-OPERATED MACHINES, ORNAMENTS FOR CHRISTMAS TREES, EXCEPT ILLUMINATION ARTICLES AND CONFECTIONERY, KALEIDOSCOPES, SKATEBOARDS AND ROLLER SKATES (U.S. CLS. 22, 23, 38 AND 50).
DOMINIC FATHY, EXAMINING ATTORNEY

SN 79-091,981. SEELEN A/S, DENMARK, FILED 9-27-2010.

SEELEN

THE MARK CONSISTS OF STANDARD CHARACTERS WITHOUT CLAIM TO ANY PARTICULAR FONT, STYLE, SIZE, OR COLOR.

PRIORITY DATE OF 4-14-2010 IS CLAIMED.

OWNER OF INTERNATIONAL REGISTRATION 1063468 DATED 9-27-2010, EXPIRES 9-27-2020.

THE ENGLISH TRANSLATION OF "SEELEN" IN THE MARK IS "SOULS".

CLASS 7—MACHINERY

FOR PACKING MACHINES, PALLETIZING MACHINES, MACHINES FOR STACKING AND COMPRESSION OF GOODS, PACKAGING MACHINERY, PALLET PACKING MACHINES, CONVEYORS (MACHINES), BELT CONVEYORS, ROLLER CONVEYORS (MACHINES), BELTS FOR MACHINES, PNEUMATIC CONTROL MECHANISMS FOR MACHINES, PARTS AND FITTINGS FOR PACKING, PACKAGING, AND PALLETIZING MACHINES AND CONVEYORS, NAMELY, MOTORS, BEARINGS (U.S. CLS. 13, 19, 21, 23, 31, 34 AND 35).

CLASS 9—ELECTRICAL AND SCIENTIFIC APPARATUS

FOR ELECTRONIC MONITORS FOR MONITORING THE OPERATION OF MACHINES, ELECTRONIC CONTROL SYSTEMS IN THE FORM OF COMPUTER SOFTWARE AND HARDWARE FOR CONTROL OF MACHINES' MOVEMENTS, ELECTRONIC CONTROL SYSTEMS IN THE FORM OF COMPUTER SOFTWARE AND HARDWARE FOR TROUBLESHOOTING OF MACHINES' MOVEMENTS, DOWNLOADABLE COMPUTER SOFTWARE FOR SURVEILLANCE OF AUTOMATED PRODUCTION AND DISTRIBUTION FACILITIES, DOWNLOADABLE COMPUTER SOFTWARE FOR COLLECTION OF DATA (U.S. CLS. 21, 23, 26, 36 AND 38).

CLASS 37—CONSTRUCTION AND REPAIR

FOR INSTALLATION, MAINTENANCE AND REPAIR OF MACHINES; RECONSTRUCTION OF WORN OR PARTLY WORN MACHINES; INSTALLATION AND REPAIR OF ELECTRICAL APPARATUS AND INSTRUMENTS; PROVIDING INFORMATION ABOUT INSTALLATION, MAINTENANCE AND REPAIR OF MACHINES AND ELECTRICAL APPARATUS AND INSTRUMENTS (U.S. CLS. 100, 103 AND 106).

KIMBERLY FRYE, EXAMINING ATTORNEY

CLASS 39—TRANSPORTATION AND STORAGE

FOR RAILWAY TRANSPORT; PROVIDING RAILWAY TRANSPORT INFORMATION; PROVIDING INFORMATION CONCERNING RAILWAY DIAGRAMS, CONNECTIONS AND FARES; PROVIDING INFORMATION CONCERNING RAILWAY SEAT RESERVATIONS; CAR TRANSPORT; PROVIDING CAR TRANSPORT INFORMATION; PROVIDING INFORMATION CONCERNING CAR TRANSPORT AND CAR SEAT RESERVATION; PROVIDING INFORMATION CONCERNING FARE OF ROADS, TOLLWAY FARE, RUNNING DISTANCE AND BACKUP; MARINE TRANSPORT; PROVIDING MARINE TRANSPORT INFORMATION; PROVIDING INFORMATION CONCERNING MARINE TRANSPORT DIAGRAMS AND FARES; PROVIDING INFORMATION CONCERNING MARINE SEAT RESERVATIONS; AIR TRANSPORT; PROVIDING AIR TRANSPORT INFORMATION; PROVIDING INFORMATION CONCERNING AIRFARE; PROVIDING INFORMATION CONCERNING AIR DIAGRAM AND AIRFARE; PROVIDING INFORMATION CONCERNING AVAILABILITY OF AIR SEATS; PROVIDING INFORMATION CONCERNING AIRPLANE SEAT RESERVATION; PACKAGE TOUR CONDUCTING; PLANNING PACKAGE TOURS; PROVIDING ADVICE AND INFORMATION CONCERNING PACKAGE TOUR CONDUCTING; TOUR CONDUCTING OR ESCORTING; TRAVEL AGENCIES OR TRAVEL LIAISON SERVICES EXCLUDING THOSE FOR LODGING, NAMELY, MAKING RESERVATIONS AND BOOKINGS FOR TRANSPORTATION; ADVISEMENT OF TRAVEL EXCLUDING THOSE FOR LODGING CONCERNING ORGANIZATION OF TRAVEL, ARRANGING TRAVEL TOURS; TOURIST OFFICE SERVICES, NAMELY, PROVIDING INFORMATION CONCERNING TOURIST SPOTS AND TOURIST FACILITIES; PROVIDING INFORMATION CONCERNING TRAVEL EXCLUDING THOSE FOR LODGING CONCERNING ORGANIZATION OF TRAVEL, ARRANGING TRAVEL TOURS; PROVIDING INFORMATION CONCERNING AGENCIES THAT OFFER PASSPORTS AND VISAS AND PROCEDURES FOR OBTAINING PASSPORTS AND VISAS (U.S. CLS. 100 AND 105).

SN 79-092,237. JTB CORP., JAPAN, FILED 12-6-2010.



OWNER OF INTERNATIONAL REGISTRATION 1064159 DATED 12-6-2010, EXPIRES 12-6-2020.

OWNER OF U.S. REG. NOS. 1,690,535, 2,143,617 AND OTHERS.

THE COLOR(S) GRAY, RED AND BLACK IS/ARE CLAIMED AS A FEATURE OF THE MARK.

THE MARK CONSISTS OF THE STYLIZED LETTERS "JTB," WITH THE UPPER PORTION OF THE LETTER "J" APPEARING IN GRAY, AND THE LOWER PORTION IN RED. THE LETTERS "T" AND "B" ARE IN THE COLOR RED. BELOW THIS WORDING IS THE STYLIZED WORDING "PERFECT MOMENTS, ALWAYS" IN THE COLOR BLACK.

CLASS 43—HOTEL AND RESTAURANT SERVICES

FOR PROVIDING TEMPORARY ACCOMMODATION; PROVIDING CAMP SITES; PROVIDING INFORMATION CONCERNING CAMPGROUND FACILITIES, NAMELY, TRAILER SITES; PROVIDING INFORMATION CONCERNING TEMPORARY ACCOMMODATION BY COMPUTER TERMINALS; ARRANGING RESERVATIONS FOR TEMPORARY ACCOMMODATION BY COMPUTER TERMINALS; AGENCY SERVICES FOR THE RESERVATION OF TEMPORARY ACCOMMODATION, NAMELY, PROVIDING ACCOMMODATION BUREAUX WHICH ARRANGE RESERVATIONS FOR HOTELS OR BOARDING HOUSES; PROVIDING INFORMATION CONCERNING THE AVAILABILITY OF TEMPORARY ACCOMMODATION; PROVIDING FOODS AND BEVERAGES, NAMELY, PREPARATION OF FOODS AND BEVERAGES, RESTAURANT SERVICES, BAR SERVICES, AND INFORMATION SERVICES THEREFOR; PROVIDING AN AGENCY THAT MAKES RESTAURANT RESERVATIONS FOR OTHERS; PROVIDING INFORMATION CONCERNING RESTAURANTS; PROVIDING INFORMATION CONCERNING PLACE OF RESTAURANTS; BOARDING FOR ANIMALS; AGENCIES FOR ARRANGING ANIMAL BOARDING; PROVIDING INFORMATION CONCERNING BOARDING FOR ANIMALS; RETIREMENT HOME AND INFORMATION SERVICES THEREFOR; PROVIDING CONFERENCE ROOMS AND INFORMATION SERVICES THEREFOR; PROVIDING FACILITIES FOR EXHIBITIONS AND INFORMATION SERVICES THEREFOR; RENTAL OF TOWELS FOR RECREATIONAL USE AND INFORMATION SERVICES THEREFOR (U.S. CLS. 100 AND 101).

ALLISON SCHRODY, EXAMINING ATTORNEY

SN 79-092,238. GUANGZHOU ETON ELECTROMECHANICAL CO., LTD., GUANGZHOU, GUANGDONG, CHINA, FILED 12-20-2010.



PRIORITY DATE OF 8-27-2010 IS CLAIMED.
OWNER OF INTERNATIONAL REGISTRATION 1064160 DATED 12-20-2010, EXPIRES 12-20-2020.

NO CLAIM IS MADE TO THE EXCLUSIVE RIGHT TO USE THE NON-LATIN CHARACTERS THAT TRANSLITERATE TO JI AND DIAN, APART FROM THE MARK AS SHOWN.

THE MARK CONSISTS OF THE STYLIZED LETTERS "ETON", WITH THE LETTER "E" FORMED BY TWO INTERSECTING RECTANGLES WITH A CIRCLE BETWEEN THEM. THE LETTERS ARE UNDERLINED, APPEAR TO THE LEFT OF A RECTANGLE FORMED BY HORIZONTAL BARS, AND ABOVE FOUR CHINESE CHARACTERS.

THE NON-LATIN CHARACTERS IN THE MARK TRANSLITERATE TO YI, DONG, JI AND DIAN, AND THIS MEANS "SHE", "EAST", "ENGINE" AND "ELECTRICITY" IN ENGLISH. THE COMBINATION OF THE CHARACTERS THAT TRANSLITERATE TO JI AND DIAN MEANS "ELECTRO-MECHANICAL" IN ENGLISH.

CLASS 7—MACHINERY

FOR WRAPPING MACHINES; CARTON SEALING MACHINES FOR INDUSTRIAL PURPOSES; KITCHEN MACHINES, NAMELY, ELECTRIC STANDING MIXERS; ELECTRIC FOOD PROCESSORS (U.S. CLS. 13, 19, 21, 23, 31, 34 AND 35).

CLASS 11—ENVIRONMENTAL CONTROL APPARATUS

FOR ELECTRIC DEEP FRYERS; HOT PLATES; ELECTRIC GRIDDLES; REFRIGERATING MACHINES; BAKING OVENS; ELECTRIC PRESSURE COOKERS; STEAM HEATING APPARATUS FOR INDUSTRIAL PURPOSES (U.S. CLS. 13, 21, 23, 31 AND 34).

LIEF MARTIN, EXAMINING ATTORNEY

SN 79-092,253. INFOMED SA, SWITZERLAND, FILED 1-7-2011.

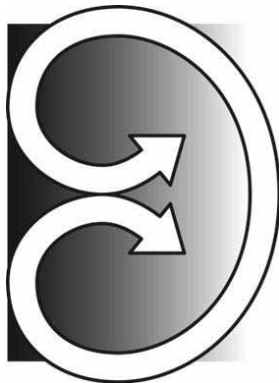

PRIORITY DATE OF 7-28-2010 IS CLAIMED.
OWNER OF INTERNATIONAL REGISTRATION 1064189 DATED 1-7-2011, EXPIRES 1-7-2021.

THE MARK CONSISTS OF A CURVED LINE DESIGN WITH ARROWS ON EACH END WITH A RECTANGULAR BACKGROUND.

CLASS 9—ELECTRICAL AND SCIENTIFIC APPARATUS

FOR COMPUTER HARDWARE AND SOFTWARE FOR THE OPERATION AND MAINTENANCE OF MEDICAL, SURGICAL, DENTAL AND VETERINARY INSTRUMENTS, DEVICES AND ACCESSORIES; HARDWARE AND SOFTWARE FOR RECORDING AND ACCESSING DATA IN CONNECTION WITH MEDICAL, SURGICAL, DENTAL AND VETERINARY TREATMENTS (U.S. CLS. 21, 23, 26, 36 AND 38).

CLASS 10—MEDICAL APPARATUS

FOR MEDICAL, SURGICAL, DENTAL AND VETERINARY APPARATUS AND INSTRUMENTS, NAMELY, BLOOD PURIFYING DEVICES AND APPARATUS (U.S. CLS. 26, 39 AND 44).

CLASS 37—CONSTRUCTION AND REPAIR

FOR CORRECTIVE MAINTENANCE AND MAINTENANCE OF MEDICAL, SURGICAL, DENTAL AND VETERINARY APPARATUS AND INSTRUMENTS (U.S. CLS. 100, 103 AND 106).

KAPIL BHANOT, EXAMINING ATTORNEY

SN 79-092,427. ESTAMP, SAU, SPAIN, FILED 11-8-2010.

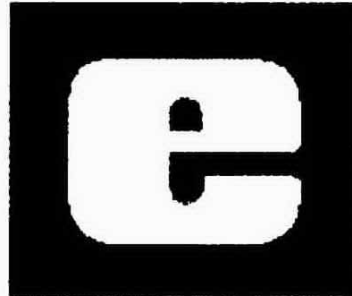

PRIORITY DATE OF 10-29-2010 IS CLAIMED.
OWNER OF INTERNATIONAL REGISTRATION 1064714 DATED 11-8-2010, EXPIRES 11-8-2020.

THE MARK CONSISTS OF THE LETTER "E" ENCLOSED IN A SQUARE.

CLASS 6—METAL GOODS

FOR COMMON METALS AND THEIR ALLOYS; IRONMONGERY, AND SMALL ITEMS OF METAL HARDWARE, NAMELY, NAILS, SCREWS, NUTS AND WASHERS; PIPES AND TUBES OF METAL (U.S. CLS. 2, 12, 13, 14, 23, 25 AND 50).

CLASS 12—VEHICLES

FOR VEHICLES, NAMELY, AUTOMOBILES, SNOWMOBILE TRACKS, MOTORCYCLES, TRACTORS; PARTS AND ACCESSORIES FOR AUTOMOBILES, IN PARTICULAR, THERMAL AND ACOUSTIC PROTECTION SCREENS FOR PROTECTING PARTS OF THE VEHICLE FROM THERMAL AND ACOUSTIC EMISSIONS (U.S. CLS. 19, 21, 23, 31, 35 AND 44).

CLASS 42—SCIENTIFIC AND COMPUTER SERVICES

FOR SCIENTIFIC AND TECHNOLOGICAL SERVICES AND RESEARCH AND DESIGN RELATING THERETO, NAMELY, SCIENTIFIC RESEARCH, ANALYSIS, TESTING IN THE FIELD OF THERMAL AND ACOUSTIC PROTECTION SCREENS FOR PROTECTING PARTS OF THE VEHICLE FROM THERMAL AND ACOUSTIC EMISSIONS; INDUSTRIAL ANALYSIS AND RESEARCH SERVICES IN THE FIELD OF THERMAL AND ACOUSTIC PROTECTION SCREENS FOR PROTECTING PARTS OF THE VEHICLE FROM THERMAL AND ACOUSTIC EMISSIONS (U.S. CLS. 100 AND 101).

ALYSSA STEEL, EXAMINING ATTORNEY

SN 79-092,459. SCHOELLER ARCA SYSTEMS GMBH, FED REP GERMANY, FILED 7-16-2010.

Smart Carriers

PRIORITY DATE OF 2-12-2010 IS CLAIMED.
OWNER OF INTERNATIONAL REGISTRATION 1064838 DATED 7-16-2010, EXPIRES 7-16-2020.

NO CLAIM IS MADE TO THE EXCLUSIVE RIGHT TO USE "CARRIERS", APART FROM THE MARK AS SHOWN. THE MARK CONSISTS OF THE WORDING "SMART CARRIERS" WHERE THE LETTER "S" IN THE TERM "SMART" IS CREATED BY TWO ANGLES AND THE LETTER "C" IN THE TERM "CARRIERS" IS CREATED BY A SINGLE ANGLE.

CLASS 20—FURNITURE AND ARTICLES NOT OTHERWISE CLASSIFIED

FOR BOXES, CONTAINERS, CRATES AND PALLETS MADE OF PLASTIC (U.S. CLS. 2, 13, 22, 25, 32 AND 50).

CLASS 37—CONSTRUCTION AND REPAIR

FOR CLEANING OF REUSABLE PACKAGINGS, REUSABLE CONTAINERS AND REUSABLE PALLETS (U.S. CLS. 100, 103 AND 106).

CLASS 39—TRANSPORTATION AND STORAGE

FOR LOGISTIC SERVICES FOR REUSABLE TRANSPORT SYSTEMS, IN PARTICULAR RETURN, PROVISION AND DELIVERY OF REUSABLE PACKAGINGS, REUSABLE CONTAINERS AND REUSABLE PALLETS BETWEEN PRODUCER AND RETAIL, RENTAL OF REUSABLE TRANSPORT PACKAGINGS, IN PARTICULAR OF REUSABLE CONTAINERS AND REUSABLE PALLETS (U.S. CLS. 100 AND 105).

RICHARD WHITE, EXAMINING ATTORNEY

SN 79-092,506. L.K BENNETT LIMITED, UNITED KINGDOM, FILED 12-10-2010.

LIFE IS THE OCCASION

THE MARK CONSISTS OF STANDARD CHARACTERS WITHOUT CLAIM TO ANY PARTICULAR FONT, STYLE, SIZE, OR COLOR.

PRIORITY DATE OF 12-2-2010 IS CLAIMED.
OWNER OF INTERNATIONAL REGISTRATION 1064945 DATED 12-10-2010, EXPIRES 12-10-2020.

CLASS 14—JEWELRY

FOR PRECIOUS METALS AND THEIR ALLOYS AND GOODS IN PRECIOUS METALS OR COATED THEREWITH, NOT INCLUDED IN OTHER CLASSES, NAMELY, JEWELLERY CASES OF PRECIOUS METALS; JEWELLERY, PRECIOUS STONES; HOROLOGICAL AND CHRONOMETRIC INSTRUMENTS (U.S. CLS. 2, 27, 28 AND 50).

CLASS 18—LEATHER GOODS

FOR BAGS, NAMELY, SPORTS BAGS, EVENING BAGS; CLUTCH BAGS, DOLLY BAGS; COSMETIC BAGS SOLD EMPTY, GARMENT BAGS FOR TRAVEL, OVERNIGHT BAGS, HOLDALLS, TOTE BAGS, SHOULDER BAGS, LARGE PURSES; HANDBAGS, SHOPPING BAGS, WHEELED SHOPPING BAGS, TRAVELLING BAGS; SUITCASES, ATTACHE CASES, BRIEFCASES, VANITY CASES SOLD EMPTY; SATCHELS, HAVERSACKS, RUCKSACKS; LUGGAGE TRUNKS; WALLETS, PURSES, CREDIT CARD CASES; KEY CASES; UMBRELLAS, PARASOLS (U.S. CLS. 1, 2, 3, 22 AND 41).

CLASS 25—CLOTHING

FOR CLOTHING, NAMELY, SUITS, DRESSES, SKIRTS, UNDERWEAR, LOUNGEWEAR, LINGERIE, CAMISOLES, BRASSIERES, CORSETS, HOSIERY, PETTICOATS, NIGHTGOWNS, PAJAMAS, PULLOVERS, DRESSING GOWNS, BATHROBES, GLOVES, CARDIGANS, JERSEYS, TIES, FOULARDS, SCARVES, SWEATERS, SOCKS, STOCKINGS, TROUSERS, JERKINS, GILETS, SHIRTS, VESTS, JUMPERS, TRACKSUITS, BLOUSES, JEANS, PANTS, SHORTS, T-SHIRTS, PANTIES, SWEATSHIRTS, JACKETS, JUMPSUITS, WAISTCOATS, PONCHOS, PLAYSUITS, COATS, OVERCOATS, CLOAKS, ANORAKS, RAINCOATS, WRAPS, SHRUGS, SHAWLS, BATH SUITS; FOOTWEAR; HEADGEAR, NAMELY, HATS, CAPS, TIARAS, HEADBANDS, FASCINATORS, SUN HATS, RAIN HATS, WEDDING HATS, FORMAL WEAR HATS, HEAD DRESSES, BERETS, BEANIE HATS; BELTS (U.S. CLS. 22 AND 39).

SCOTT BIBB, EXAMINING ATTORNEY

SN 79-093,141. KARL STORZ GMBH & CO. KG, FED REP GERMANY, FILED 11-25-2010.

S.E.T.S.

THE MARK CONSISTS OF STANDARD CHARACTERS WITHOUT CLAIM TO ANY PARTICULAR FONT, STYLE, SIZE, OR COLOR.

PRIORITY DATE OF 6-5-2010 IS CLAIMED.
OWNER OF INTERNATIONAL REGISTRATION 1066630 DATED 11-25-2010, EXPIRES 11-25-2020.

CLASS 10—MEDICAL APPARATUS

FOR MEDICAL APPARATUS AND INSTRUMENTS, NAMELY, SURGICAL INSTRUMENTS AND APPARATUS FOR THE DIAGNOSTIC AND OPERATIVE HYSTEROGRAPHY (U.S. CLS. 26, 39 AND 44).

CLASS 16—PAPER GOODS AND PRINTED MATTER

FOR PRINTED MATERIAL, NAMELY, CATALOGUES, MAGAZINES, JOURNALS, BROCHURES AND INFORMATIONAL FLYERS, LETTERS AND SHEETS IN THE FIELD OF MEDICAL TECHNOLOGY; BINDERS; PRINTED TEACHING AND INSTRUCTIONAL MANUALS IN THE FIELD OF MEDICAL TECHNOLOGY; PHOTOGRAPHS (U.S. CLS. 2, 5, 22, 23, 29, 37, 38 AND 50).

ANNE MADDEN, EXAMINING ATTORNEY

SN 79-093,232. SAMSON AG, FED REP GERMANY, FILED 11-5-2010.

TROVIS SOLUTION



PRIORITY DATE OF 9-3-2010 IS CLAIMED.
OWNER OF INTERNATIONAL REGISTRATION 1066891 DATED 11-5-2010, EXPIRES 11-5-2020.

NO CLAIM IS MADE TO THE EXCLUSIVE RIGHT TO USE "SOLUTION", APART FROM THE MARK AS SHOWN. THE COLOR(S) BLACK, GREEN AND GREY IS/ARE CLAIMED AS A FEATURE OF THE MARK.

THE MARK CONSISTS OF "TROVIS SOLUTION" IN THE COLOR BLACK, IN BETWEEN THE "S" AND "L" ARE TWO ARROWS THAT FORM THE SHAPE OF AN O WITH THE LEFT SIDE BEING GRAY AND THE RIGHT SIDE BEING GREEN. UNDERNEATH THE WORDING ARE A SERIES OF 26 SQUARE GREEN SHAPES IN A STRAIGHT LINE.

CLASS 9—ELECTRICAL AND SCIENTIFIC APPARATUS

FOR MEASURING, SIGNALING, CHECKING, SUPERVISION AND MONITORING UNITS, APPARATUS AND INSTRUMENTS AS WELL AS PARTS THEREOF, NAMELY, FLOW REGULATORS, THERMOMETERS, ELECTRICAL AND ELECTRONIC CONTROLLERS FOR STOVES, COOLERS, VENTILATORS, AIR CONDITIONERS AND PASTEURIZERS; TRANSDUCERS, HEAT FLOW METERS, STEAM FLOW METERS, THERMOSTATS, SENSORS FOR DETERMINING HEAT TEMPERATURE; MOISTURE CLOCKS, NAMELY, HUMIDISTATS AND PARTS THEREFOR FOR USE AS STEAM MEASURING AND CONTROL DEVICES, PROGRAMMED SWITCHES, DIGITAL COMPACT CONTROLLERS FOR USE IN THE HEATING, AIR CONDITIONING, AND VENTILATION FIELD OR IN INDUSTRIAL PROCESS TECHNOLOGY IN CONNECTION WITH PIPELINES, DIGITAL ANALOG CONVERTERS, PRESSURE SWITCHES, ENGINE COOLANT REGULATORS; APPARATUS AND INSTRUMENTS FOR CONDUCTING, SWITCHING, TRANSFORMING, ACCUMULATING, REGULATING OR CONTROLLING OF ELECTRICITY, NAMELY, ELECTRICAL REGULATORS; ELECTRICAL SWITCHES; ELECTRICAL CONTROLLERS FOR MACHINE TOOLS; APPARATUS FOR RECORDING, TRANSMISSION OR REPRODUCTION OF SOUND OR IMAGES; BLANK MAGNETIC DATA CARRIERS; DATA PROCESSING APPARATUS AND COMPUTERS; COMPUTER OPERATING SYSTEM PROGRAMS; COMPUTER SOFTWARE USE IN REGULATING AND DESIGNING HEATING, AIR CONDITIONING, AND VENTILATION SYSTEMS AND FOR REGULATING AND DESIGNING THE FLOW OF LIQUIDS AND GASES IN PIPELINES; SEMICONDUCTOR CHIPS; MAGNETIC ENCODERS (U.S. CLS. 21, 23, 26, 36 AND 38).

CLASS 42—SCIENTIFIC AND COMPUTER SERVICES

FOR TECHNOLOGICAL DESIGN SERVICES IN THE FIELD OF MEASURING, CONTROLLING, REGULATING AND MONITORING OF INDUSTRIAL PROCESSES; INDUSTRIAL ANALYSIS AND RESEARCH SERVICES IN THE FIELD OF MEASURING, CONTROLLING, REGULATING AND MONITORING OF INDUSTRIAL PROCESSES; DESIGN AND DEVELOPMENT OF COMPUTER HARDWARE AND SOFTWARE; INSTALLATION OF COMPUTER SOFTWARE; UPDATING OF COMPUTER SOFTWARE; MAINTENANCE OF COMPUTER SOFTWARE; COMPUTER SYSTEMS ANALYSIS; COMPUTER SYSTEM DESIGN; CONSULTANCY IN THE FIELD OF COMPUTER HARDWARE; CONSULTATION SERVICES IN THE FIELDS OF SELECTION, IMPLEMENTATION AND USE OF COMPUTER HARDWARE FOR OTHERS; DUPLICATION OF COMPUTER PROGRAMS; TECHNICAL SUPPORT, NAMELY, PROVIDING BACKUP COMPUTER PROGRAMS; ADJUSTMENT OF COMPUTER PROGRAMS TO CONTROL SYSTEMS; MAINTENANCE OF DATABASE SOFTWARE (U.S. CLS. 100 AND 101).

JACQUELINE A. LAVINE, EXAMINING ATTORNEY

SN 79-093,818. MILANESI GIOVANNI BATTISTA, ITALY, FILED 12-6-2010.

GIANNI MILANESI
MILANO

OWNER OF INTERNATIONAL REGISTRATION 1067783 DATED 12-6-2010, EXPIRES 12-6-2020.

NO CLAIM IS MADE TO THE EXCLUSIVE RIGHT TO USE "MILANO", APART FROM THE MARK AS SHOWN.

THE NAME(S), PORTRAIT(S), AND/OR SIGNATURE(S) SHOWN IN THE MARK IDENTIFIES MILANESI GIOVANNI BATTISTA, WHOSE CONSENT(S) TO REGISTER IS MADE OF RECORD.

THE MARK CONSISTS OF THE WORDING "GIANNI MILANESI MILANO"; THE WORDS "GIANNI MILANESI" ARE IN THE FIRST LINE WHILE THE WORD "MILANO", IN SMALLER TYPES, IS IN THE SECOND LINE.

CLASS 18—LEATHER GOODS

FOR BAGS, HANDBAGS, WALLETS (U.S. CLS. 1, 2, 3, 22 AND 41).

CLASS 25—CLOTHING

FOR SHOES, SANDALS, BOOTS, BOOTIES, MULES; LEATHER BELTS (U.S. CLS. 22 AND 39).

ALLISON HOLTZ, EXAMINING ATTORNEY

SN 79-093,917. PBS S.R.L., ITALY, FILED 10-11-2010.

AVEC MODÉRATION

THE MARK CONSISTS OF STANDARD CHARACTERS WITHOUT CLAIM TO ANY PARTICULAR FONT, STYLE, SIZE, OR COLOR.

PRIORITY DATE OF 9-6-2010 IS CLAIMED.

OWNER OF INTERNATIONAL REGISTRATION 1068084 DATED 10-11-2010, EXPIRES 10-11-2020.

THE ENGLISH TRANSLATION OF THE FOREIGN WORDS IN THE MARK IS "WITH MODERATION".

CLASS 18—LEATHER GOODS

FOR LEATHER GOODS, NAMELY, LEATHER BAGS AND WALLETS, LEATHER SUITCASES, LEATHER HANDBAGS, HANDBAGS FOR LADIES, LEATHER SHOULDER BELTS (U.S. CLS. 1, 2, 3, 22 AND 41).

CLASS 25—CLOTHING

FOR CLOTHING, NAMELY, LEATHER SHOES, SANDALS AND BEACH SHOES, WOMEN'S SHOES, WOMEN'S SHOES, NAMELY, FOLDABLE FLATS, FOULARDS, FOOTWEAR FOR WOMEN, WOMEN'S CLOTHING, NAMELY, DRESSES, SKIRTS, BLOUSES; FOOTWEAR AND HATS (U.S. CLS. 22 AND 39).

CHRISTOPHER BUONGIORNO, EXAMINING ATTORNEY

SN 79-093,923. DIGIT VERLAG GMBH, 56814 BRUTTIG-FANKEL, FED REP GERMANY, FILED 12-18-2010.



OWNER OF INTERNATIONAL REGISTRATION 1068100 DATED 12-18-2010, EXPIRES 12-18-2020.
THE MARK CONSISTS OF AN ARROW ABOVE A TRIANGLE.

CLASS 9—ELECTRICAL AND SCIENTIFIC APPARATUS

FOR SCIENTIFIC, NAUTICAL, SURVEYING, PHOTOGRAPHIC, CINEMATOGRAPHIC, OPTICAL, WEIGHING, MEASURING, SIGNALLING, CHECKING, SUPERVISION, LIFE-SAVING AND TEACHING APPARATUS AND INSTRUMENTS, NAMELY, SURVEYING INSTRUMENTS, CAMERAS, CINEMATOGRAPHIC PROJECTORS, EYE GLASSES, WEIGHING MACHINES, DISTANCE MEASURING APPARATUS, AND LIFE PRESERVERS; APPARATUS AND INSTRUMENTS FOR CONDUCTING, SWITCHING, TRANSFORMING, ACCUMULATING, REGULATING OR CONTROLLING ELECTRICITY, NAMELY, ELECTRICAL SWITCHES, ACCUMULATORS, AND VOLTAGE REGULATORS; APPARATUS FOR RECORDING, TRANSMISSION OR REPRODUCTION OF SOUND OR IMAGES; BLANK MAGNETIC DATA CARRIERS; PRERECORDED MAGNETIC DATA CARRIERS FEATURING MUSIC; BLANK RECORDABLE OPTICAL DISCS; AUTOMATIC VENDING MACHINES AND MECHANISMS FOR COIN OPERATED APPARATUS; CASH REGISTERS, CALCULATING MACHINES, DATA PROCESSING EQUIPMENT AND COMPUTERS; FIRE-EXTINGUISHING APPARATUS (U.S. CLS. 21, 23, 26, 36 AND 38).

CLASS 16—PAPER GOODS AND PRINTED MATTER

FOR PAPER, CARDBOARD AND GOODS MADE FROM THESE MATERIALS, NOT INCLUDED IN OTHER CLASSES, NAMELY, PAPER BAGS, PAPER DOILIES, CARDBOARD BOXES, AND CARDBOARD CONTAINERS; PRINTED MATTER, NAMELY, BOOKS IN THE FIELD OF MATH; BOOKBINDING MATERIAL, PHOTOGRAPHS; STATIONERY; ADHESIVES FOR STATIONERY OR HOUSEHOLD PURPOSES; ARTISTS' MATERIALS, NAMELY, PAINT BRUSHES; TYPEWRITERS AND OFFICE REQUISITES EXCEPT FURNITURE, NAMELY, CORRECTING FLUID FOR TYPE, STAPLERS, AND RUBBER BANDS; PRINTED INSTRUCTIONAL AND TEACHING MATERIAL, EXCEPT APPARATUS IN THE FIELD OF MATH; PLASTIC MATERIALS FOR PACKAGING NOT INCLUDED IN OTHER CLASSES, NAMELY, PLASTIC BUBBLE PACKS FOR PACKAGING AND PLASTIC BAGS FOR PACKAGING; PRINTERS' TYPE; PRINTING BLOCKS (U.S. CLS. 2, 5, 22, 23, 29, 37, 38 AND 50).

CLASS 38—COMMUNICATION

FOR TELECOMMUNICATIONS SERVICES, NAMELY, PERSONAL COMMUNICATIONS SERVICES (U.S. CLS. 100, 101 AND 104).

CLASS 41—EDUCATION AND ENTERTAINMENT

FOR EDUCATION INFORMATION; PROVIDING OF HORSE TRAINING; ENTERTAINMENT IN THE NATURE OF BEAUTY PAGEANTS; ORGANIZING COMMUNITY SPORTING AND CULTURAL EVENTS (U.S. CLS. 100, 101 AND 107).

CLASS 42—SCIENTIFIC AND COMPUTER SERVICES

FOR SCIENTIFIC AND TECHNOLOGICAL SERVICES AND RESEARCH AND DESIGN RELATING THERETO, NAMELY, SCIENTIFIC RESEARCH, CONSULTING IN THE FIELD OF INFORMATION TECHNOLOGY AND DESIGN OF INFORMATION TECHNOLOGY SYSTEMS; INDUSTRIAL CHEMICAL ANALYSIS AND SCIENTIFIC RESEARCH SERVICES; DESIGN AND DEVELOPMENT OF COMPUTER HARDWARE AND SOFTWARE (U.S. CLS. 100 AND 101).

COLLEEN DOMBROW, EXAMINING ATTORNEY

SN 79-093,981. XIAMEN WANHENGXIN IMP. & EXP. CO., LTD., CHINA, FILED 11-15-2010.

WHIX

THE MARK CONSISTS OF STANDARD CHARACTERS WITHOUT CLAIM TO ANY PARTICULAR FONT, STYLE, SIZE, OR COLOR.

PRIORITY DATE OF 7-7-2010 IS CLAIMED.

OWNER OF INTERNATIONAL REGISTRATION 1068188 DATED 11-15-2010, EXPIRES 11-15-2020.

OWNER OF U.S. REG. NO. 3,754,955.

CLASS 7—MACHINERY

FOR MECHANICAL SEALS; ADHESIVE BANDS FOR PULLEYS; BELTS FOR MACHINES; TRANSMISSION CHAINS, OTHER THAN FOR LAND VEHICLES; TRANSMISSIONS FOR MACHINES; SHAFT COUPLINGS AS PARTS OF MACHINES; HYDRAULIC CONTROLS FOR MACHINES, MOTORS AND ENGINES; PNEUMATIC CONTROLS FOR MACHINES, MOTORS AND ENGINES; DYNAMOS; PULLEYS BEING PARTS OF MACHINES (U.S. CLS. 13, 19, 21, 23, 31, 34 AND 35).

CLASS 12—VEHICLES

FOR AIR PUMPS OF AUTOMOBILES; SHOCK ABSORBING SPRINGS FOR MOTOR CARS; VEHICLE WHEELS; CHAINS FOR MOTOR CARS; WHEEL HUBS FOR MOTOR CARS; ELECTRIC MOTORS FOR MOTOR CARS; AUTOMOBILE BUMPERS; LAND VEHICLE PARTS, NAMELY, AXLES; CLUTCHES FOR LAND VEHICLES; GEARS FOR VEHICLES; LAND VEHICLE SUSPENSION PARTS, NAMELY, COIL SPRINGS; LAND VEHICLE SUSPENSION PARTS, NAMELY, LEAF SPRINGS; MOTORS FOR LAND VEHICLES; VEHICLE WHEEL HUB ASSEMBLIES; BRAKE SEGMENTS FOR MOTOR CARS; FORK LIFT TRUCKS; VEHICLE PARTS, NAMELY, SHOCK ABSORBERS; HYDRAULIC CIRCUITS FOR VEHICLES; TRANSMISSION CHAINS FOR LAND VEHICLES (U.S. CLS. 19, 21, 23, 31, 35 AND 44).

CHRISIE B. KING, EXAMINING ATTORNEY

SN 79-094,258. BRAVO PREMIUM LLC, RU-196105 SAINT-PETERSBURG, RUSSIAN FED., FILED 10-19-2010.

CHATEAU AMORE

THE MARK CONSISTS OF STANDARD CHARACTERS WITHOUT CLAIM TO ANY PARTICULAR FONT, STYLE, SIZE, OR COLOR.

PRIORITY DATE OF 8-4-2010 IS CLAIMED.

OWNER OF INTERNATIONAL REGISTRATION 1068896 DATED 10-19-2010, EXPIRES 10-19-2020.

THE ENGLISH TRANSLATION OF "CHATEAU AMORE" IN THE MARK IS "LOVE CASTLE".

CLASS 32—LIGHT BEVERAGES

FOR NON-ALCOHOLIC APERITIFS; BEVERAGES, NAMELY, MINERAL AND AERATED WATER; NATURAL MINERAL WATER; NON-ALCOHOLIC BEVERAGES, NAMELY, KVASS; NON-ALCOHOLIC COCKTAILS; NON-ALCOHOLIC COCKTAILS BASED ON NATURAL FRUIT AND BERRY AND CITRUS AND VEGETABLES JUICE, ALSO WITH SPICES; CONCENTRATES FOR NON-ALCOHOLIC BEVERAGES BASED ON NATURAL FRUITS AND SYNTHETIC RAW MATERIALS AND NATURE-IDENTICAL AROMATIC FLAVORINGS, NAMELY, NON-ALCOHOLIC COCKTAILS, NON-ALCOHOLIC MALT BEVERAGES, NON-ALCOHOLIC FRUIT JUICE BEVERAGES; CONCENTRATES FOR NON-ALCOHOLIC BEVERAGES, NAMELY, NON-ALCOHOLIC COCKTAILS, NON-ALCOHOLIC MALT BEVERAGES, NON-ALCOHOLIC FRUIT JUICE BEVERAGES; LEMONADES; SOFT DRINK, NAMELY, PEANUT MILK; SPARKLING AND STILL NON-ALCOHOLIC BEVERAGES, NAMELY, STILL WATER AND SPARKLING WATER; SPARKLING NON-ALCOHOLIC BEVERAGES BASED ON FRUIT AND BERRY JUICES AND EXTRACTS AND ON VINES AND CITRUS EXTRACTS; ISOTONIC BEVERAGES; NON-ALCOHOLIC HONEY-BASED BEVERAGES; WHEY BEVERAGES; NON-ALCOHOLIC FRUIT JUICE BEVERAGES; NON-ALCOHOLIC BEVERAGES BASED ON NATURAL FRUIT AND BERRY, CITRUS, VEGETABLE JUICES, NAMELY, NON-ALCOHOLIC FRUIT JUICE BEVERAGES, NON-ALCOHOLIC VEGETABLE JUICES; NATURAL AROMATIC FLAVORED NON-ALCOHOLIC BEVERAGES, NAMELY, NON-ALCOHOLIC COCKTAILS, NON-ALCOHOLIC MALT BEVERAGES, NON-ALCOHOLIC FRUIT JUICE BEVERAGES; MINERAL WATER BEVERAGES; MILK OF ALMONDS FOR BEVERAGE; FRUIT NECTARS, NON-ALCOHOLIC; ORGEAT, NAMELY, ORANGE AND ALMOND FLAVORED NON ALCOHOLIC BEVERAGE; BEER; NON-ALCOHOLIC BEER; POWDERS USED IN THE PREPARATION OF NON-ALCOHOLIC CARBONATED BEVERAGES; SPRING WATER; SODA WATER; SOFT DRINK, NAMELY, SARSAPARILLA; SYRUPS FOR MAKING LEMONADE; SYRUPS FOR MAKING BEVERAGES; CIDER, NON-ALCOHOLIC; BEVERAGE, NAMELY, TOMATO JUICE; BEVERAGE, NAMELY, VEGETABLE JUICES; FRUIT JUICES; PREPARATIONS FOR MAKING AERATED WATER; NON-ALCOHOLIC ESSENCES USED IN THE PREPARATIONS OF LIQUEURS; PREPARATIONS FOR MAKING MINERAL WATER; PREPARATIONS FOR MAKING BEVERAGES, NAMELY, FRUIT-BASED BEVERAGES, SOFT DRINKS, NON-ALCOHOLIC COCKTAILS; MUST; GRAPE MUST, UNFERMENTED; BEER WORT; MALT WORT; PASTILLES FOR EFFERVESCING BEVERAGES; BEVERAGES, NAMELY, SHERBETS; NON-ALCOHOLIC FRUIT EXTRACTS USED IN THE PREPARATION OF BEVERAGES; EXTRACTS OF HOPS FOR MAKING BEER; ESSENCES FOR MAKING NON-ALCOHOLIC BEVERAGES (U.S. CLS. 45, 46 AND 48).

CLASS 33—WINES AND SPIRITS

FOR APERITIFS; BALSAMS, NAMELY, LIQUOR MADE FROM BALSAMS; BRANDY; WINE; WINE-BASED BEVERAGE, NAMELY, PIQUETTE; WHISKY; VODKA; GIN; ALCOHOLIC BEVERAGES, NAMELY, DIGESTIFS; PREPARED ALCOHOLIC COCKTAILS, INCLUDING COCKTAILS WITH LOW ALCOHOL; PREPARED ALCOHOL COCKTAILS WITH VODKA AND BITTERS; STRONG LIQUEURS AND DESSERT LIQUEURS AND EMULSIVE LIQUEURS; ALCOHOLIC BEVERAGES, EXCEPT BEER; ALCOHOLIC BEVERAGES CONTAINING FRUIT; BEVERAGES, NAMELY, SPIRITS; DISTILLED BEVERAGES, NAMELY, DISTILLED LIQUOR; MEAD, NAMELY, HYDROMEL, ALCOHOLIC BEVERAGES OF FRUIT WITH LOW ALCOHOL; PEPPERMINT LIQUEURS; ALCOHOLIC BITTERS; BEVERAGES, NAMELY, FRUIT AND FRUIT-BASED SPIRITS; BEVERAGES, NAMELY, VEGETABLE JUICES-BASED SPIRITS; RUM; SAKE; HARD CIDER; RICE ALCOHOL, NAMELY, DISTILLED SPIRITS OF RICE; ALCOHOLIC EXTRACTS; FRUIT EXTRACTS, ALCOHOLIC; ALCOHOLIC ESSENCES (U.S. CLS. 47 AND 49).

KRISTIN CARLSON, EXAMINING ATTORNEY

SN 79-094,884. SPIL GAMES INTANGIBLES B.V., NETHERLANDS, FILED 12-28-2010.

SPIL GAMES

THE MARK CONSISTS OF STANDARD CHARACTERS WITHOUT CLAIM TO ANY PARTICULAR FONT, STYLE, SIZE, OR COLOR.

PRIORITY DATE OF 8-10-2010 IS CLAIMED.

OWNER OF INTERNATIONAL REGISTRATION 1070529 DATED 12-28-2010, EXPIRES 12-28-2020.

NO CLAIM IS MADE TO THE EXCLUSIVE RIGHT TO USE "GAMES", APART FROM THE MARK AS SHOWN.

CLASS 9—ELECTRICAL AND SCIENTIFIC APPARATUS

FOR COMPUTERS AND COMPUTER PERIPHERALS, COMPUTER AUXILIARY EQUIPMENT AND PARTS, NAMELY, MONITORS, DISC DRIVES, PRINTERS, CD-ROM AND DVD WRITERS AND ELECTRONIC AUDIO, VIDEO AND DATA RECORDERS, COMPUTER DRAWING TABLETS, KEYBOARDS AND COMPUTER MICE; REGISTERED PRE-RECORDED COMPUTER PROGRAMS FEATURING GAMES; DATA CARRIERS, IMAGE AND SOUND CARRIERS FEATURING COMPUTER AND VIDEO GAMES; CD-ROM PRE-RECORDED REGISTERED SOFTWARE PROGRAMS FEATURING COMPUTER GAMES; COMPUTER GAME DEVICES, NAMELY, CD-ROM COMPUTER GAME HARDWARE AND CONTROLLING AND OPERATING PANELS THEREFOR; APPARATUS FOR RECORDING, TRANSMISSION OR REPRODUCTION OF SOUND OR IMAGES; PRE-RECORDED ELECTRONIC, OPTICAL AND MAGNETIC DATA CARRIERS AND RECORDING DISCS FEATURING COMPUTER GAMES; AUTOMATIC VENDING MACHINES AND MECHANISMS FOR COIN-OPERATED APPARATUS; CALCULATING MACHINES, DATA PROCESSING EQUIPMENT AND COMPUTERS; VIDEO GAMES SOFTWARE FOR PERSONAL USE; BLANK ELECTRONIC DATA CARRIERS; BLANK MAGNETIC DATA CARRIERS; BLANK OPTICAL DATA CARRIERS, BLANK MAGNETIC DISCS AND ROM CASSETTES FOR THE STORAGE OF VIDEO GAME PROGRAMS FOR PERSONAL USE; COMPUTER GAME JOYSTICKS; GAMING CONSOLES AND ACCESSORIES FOR VIDEO, COMPUTER AND ELECTRONIC GAMES FOR PERSONAL USE, NAMELY, CONTROLLERS, DISPLAYS, BUTTON PANELS, ELECTRICAL WIRING, AND COMPUTER HARDWARE AND GAME SOFTWARE ASSOCIATED THEREWITH; PORTABLE HAND-HELD GAMING DEVICES FOR PLAYING GAMES ADAPTED FOR USE WITH EXTERNAL LCD SCREENS; BLANK ROM CASSETTES FOR THE RECORDING OF PROGRAMS; PERIPHERAL DEVICES FOR PORTABLE

GAMING APPARATUS FOR USE WITH EXTERNAL LCD SCREENS, NAMELY, CONTROLLERS, DISPLAYS, BUTTON PANELS, SUPPORTS, ELECTRICAL WIRING, FOR USE WITH EXTERNAL DISPLAY SCREEN OR MONITOR, VIDEO GAME DISCS; VIDEO GAME INTERACTIVE CONTROL FLOOR PADS OR MATS, VIDEO GAME INTERACTIVE REMOTE CONTROL UNITS, VIDEO GAME INTERACTIVE HAND HELD REMOTE CONTROLS FOR PLAYING ELECTRONIC GAMES, VIDEO GAME JOYSTICKS, VIDEO GAME MACHINES FOR USE WITH TELEVISIONS, VIDEO GAME MACHINES FOR USE WITH EXTERNAL DISPLAY SCREEN OR MONITOR, VIRTUAL REALITY GAME SOFTWARE; SOFTWARE FOR CREATING STRIP CARTOONS; SOFTWARE FOR CREATING MERCHANDISING PRODUCTS (U.S. CLS. 21, 23, 26, 36 AND 38).

CLASS 35—ADVERTISING AND BUSINESS

FOR ADVERTISING AGENCIES AND ADVERTISEMENT SERVICES; MARKETING SERVICES AND BUSINESS MANAGEMENT SUPPORT IN CONNECTION TO THE SALES OF ARTICLES AND SERVICES BY THE INTERNET; SELLING OF ADVERTISING SPACE; RENTAL OF ADVERTISING SPACE ON WEB SITES AND INTERNET; PROVISION OF ADVERTISING SPACE BY ELECTRONIC MEANS AND GLOBAL INFORMATION NETWORKS; RETAIL STORE AND WHOLESALE DISTRIBUTORSHIP SERVICES IN THE FIELD OF COMPUTER HARDWARE AND SOFTWARE INCLUDING COMPUTER GAMES AND GAME CONSOLES; BUSINESS ADMINISTRATION AND MANAGEMENT; ADMINISTRATIVE PROCESSING OF PURCHASE ORDERS, ALSO VIA INTERNET; ON-LINE RETAIL STORE SERVICES FEATURING PHYSICAL AND VIRTUAL MERCHANDISE IN CONNECTION WITH WEBSITES FEATURING GAMES AND GAMING; BUSINESS SERVICES, NAMELY, PROVIDING COMPUTER DATABASES REGARDING THE PURCHASE AND SALE OF A WIDE VARIETY OF GOODS AND SERVICES FOR OTHERS; MANAGEMENT AND COMPILATION OF COMPUTERIZED DATABASES (U.S. CLS. 100, 101 AND 102).

CLASS 41—EDUCATION AND ENTERTAINMENT

FOR PROVIDING A SEARCHABLE INTERNET DATABASE FOR GAMES AND ON-LINE GAMING; ENTERTAINMENT, NAMELY, ENTERTAINMENT MEDIA PRODUCTION SERVICES FOR MOTION PICTURES, TELEVISION PROGRAMS AND INTERNET PROGRAMS; CONDUCTING ALTERNATE REALITY GAMES VIA THE INTERNET, ENTERTAINMENT SERVICES VIA ONGOING INTERNET PROTOCOL TELEVISION IN THE FIELD OF GAMES, SPORTS, NEWS, COMEDY AND SHOWS, ENTERTAINMENT VIA INTERNET NAMELY, ON-LINE COMPUTER GAMING; PROVIDING INTERNET WEBSITE PORTAL IN THE FIELD OF ENTERTAINMENT INCLUDING GAMING, CULTURAL AND SPORTING EVENTS; INFORMATION RELATING TO ENTERTAINMENT AND EDUCATION, PROVIDED ON-LINE FROM A COMPUTER DATABASE OR THE INTERNET; ON-LINE ENTERTAINMENT SERVICES OF PROVIDING GAMES AND GAMES FOR COMPUTING; ENTERTAINMENT SERVICES NAMELY, PROVIDING TEMPORARY USE OF NON-DOWNLOADABLE INTERACTIVE GAMES; ON-LINE ENTERTAINMENT SERVICES NAMELY, ARRANGING AND CONDUCTING TOURNAMENTS, CHAMPIONSHIPS, VIRTUAL SPORTS AND COMPETITIONS IN THE FIELD OF COMPUTER GAMES; RENTAL OF ELECTRONIC GAME APPARATUS (U.S. CLS. 100, 101 AND 107).

FRED CARL, EXAMINING ATTORNEY

SN 79-095,056. FREIBURG WIRTSCHAFT TOURISTIK UND MESSE GMBH & CO. KG, FED REP GERMANY, FILED 2-11-2011.

INTERSOLAR

THE MARK CONSISTS OF STANDARD CHARACTERS WITHOUT CLAIM TO ANY PARTICULAR FONT, STYLE, SIZE, OR COLOR.

PRIORITY DATE OF 8-13-2010 IS CLAIMED.
OWNER OF INTERNATIONAL REGISTRATION 1070924 DATED 2-11-2011, EXPIRES 2-11-2021.
OWNER OF U.S. REG. NO. 3,294,260.

CLASS 35—ADVERTISING AND BUSINESS

FOR ORGANISATION OF TRADE FAIRS AND EXHIBITIONS FOR COMMERCIAL OR ADVERTISING PURPOSES IN THE FIELD OF SOLAR TECHNOLOGY (U.S. CLS. 100, 101 AND 102).

CLASS 41—EDUCATION AND ENTERTAINMENT

FOR PROVIDING OF TRAINING AND FURTHER TRAINING IN THE FIELD OF SOLAR ENERGY; ARRANGING AND CONDUCTING OF CONFERENCES IN THE FIELD OF SOLAR ENERGY; PUBLICATION OF MAGAZINES, CATALOGUES, PROSPECTUSES, PAMPHLETS, INCLUDING ON THE INTERNET (U.S. CLS. 100, 101 AND 107).

JERI J. FICKES, EXAMINING ATTORNEY

SN 79-095,222. BEABA, FRANCE, FILED 3-3-2011.

CAMELE'O

THE MARK CONSISTS OF STANDARD CHARACTERS WITHOUT CLAIM TO ANY PARTICULAR FONT, STYLE, SIZE, OR COLOR.

PRIORITY DATE OF 11-25-2010 IS CLAIMED.
OWNER OF INTERNATIONAL REGISTRATION 1071502 DATED 3-3-2011, EXPIRES 3-3-2021.

CLASS 20—FURNITURE AND ARTICLES NOT OTHERWISE CLASSIFIED

FOR BABY CHANGING TABLES (U.S. CLS. 2, 13, 22, 25, 32 AND 50).

CLASS 21—HOUSEWARES AND GLASS

FOR BABY BATHS, PORTABLE (U.S. CLS. 2, 13, 23, 29, 30, 33, 40 AND 50).

MICHAEL WIENER, EXAMINING ATTORNEY

SN 79-095,407. STUDER & CO. AG, DISTILLERIE, ESCHOLZMATT, SWITZERLAND, FILED 1-25-2011.



OWNER OF INTERNATIONAL REGISTRATION 0925385 DATED 5-29-2007, EXPIRES 5-29-2017.

THE MARK CONSISTS OF THE FRONT VIEW OF A HOUSE WITH A TREE ON EITHER SIDE WITH THE STYLIZED TERM "STUDER" UNDERNEATH.

CLASS 32—LIGHT BEVERAGES

FOR MINERAL AND AERATED WATERS; OTHER NON-ALCOHOLIC DRINKS, NAMELY, COFFEE-FLAVORED SOFT DRINKS, SOFT DRINKS AND SPORTS DRINKS; FRUIT DRINKS AND FRUIT JUICES; SYRUPS FOR MAKING BEVERAGES; OTHER PREPARATIONS FOR MAKING BEVERAGES, NAMELY, CONCENTRATES AND POWDERS USED IN THE PREPARATION OF ENERGY DRINKS AND FRUIT-FLAVORED BEVERAGES, AND PREPARATIONS FOR MAKING BEVERAGES, NAMELY, FRUIT JUICES (U.S. CLS. 45, 46 AND 48).

CLASS 33—WINES AND SPIRITS

FOR ALCOHOLIC BEVERAGES, EXCEPT BEER (U.S. CLS. 47 AND 49).
BRENDAN MCCAULEY, EXAMINING ATTORNEY

SN 79-096,011. KARL STORZ GMBH & CO. KG, FED REP GERMANY, FILED 2-4-2011.

S-PORT

THE MARK CONSISTS OF STANDARD CHARACTERS WITHOUT CLAIM TO ANY PARTICULAR FONT, STYLE, SIZE, OR COLOR.

PRIORITY DATE OF 8-12-2010 IS CLAIMED.
OWNER OF INTERNATIONAL REGISTRATION 1073583 DATED 2-4-2011, EXPIRES 2-4-2021.
OWNER OF U.S. REG. NO. 3,845,471.

CLASS 10—MEDICAL APPARATUS

FOR SURGICAL AND MEDICAL APPARATUS FOR USE IN GENERAL AND ENDOSCOPIC SURGERY (U.S. CLS. 26, 39 AND 44).

CLASS 16—PAPER GOODS AND PRINTED MATTER

FOR PRINTED MATERIAL, NAMELY, CATALOGUES, MAGAZINES, JOURNALS, BROCHURES AND INFORMATIONAL FLYERS, LETTERS AND SHEETS IN THE FIELD OF MEDICAL TECHNOLOGY; PRINTED TEACHING AND INSTRUCTIONAL MANUALS IN THE FIELD OF MEDICAL TECHNOLOGY; PHOTOGRAPHS (U.S. CLS. 2, 5, 22, 23, 29, 37, 38 AND 50).
MICHAEL WEBSTER, EXAMINING ATTORNEY

SN 79-096,518. DAVID BROWN GEAR SYSTEMS LIMITED, UNITED KINGDOM, FILED 11-20-2010.

WINDSERVE

THE MARK CONSISTS OF STANDARD CHARACTERS WITHOUT CLAIM TO ANY PARTICULAR FONT, STYLE, SIZE, OR COLOR.

PRIORITY DATE OF 7-8-2010 IS CLAIMED.
OWNER OF INTERNATIONAL REGISTRATION 1074772 DATED 11-20-2010, EXPIRES 11-20-2020.

CLASS 7—MACHINERY

FOR MECHANICAL POWER TRANSMISSIONS FOR MACHINES; GEARS FOR MACHINES; GEAR BOXES OTHER THAN FOR LAND VEHICLES; GEAR MOTORS NOT FOR LAND VEHICLES; MACHINERY AND TOOLS FOR MANUFACTURING GEARS AND GEAR BOXES, NAMELY, GEAR CUTTING AND FINISHING MACHINES; POWER SCREW JACKS; LIFTING APPARATUS, NAMELY, LIFTING INSTALLATIONS FOR THE TRANSPORT OF GOODS OR PEOPLE; MECHANICAL AND FLUID COUPLINGS FOR MACHINES; MECHANICAL ACTUATORS FOR MACHINES; ELECTRIC MOTORS NOT FOR LAND VEHICLES; HYDRAULIC MOTORS OTHER THAN FOR LAND VEHICLES; HYDRAULIC PUMPS; HYDRAULIC VALVES AS MACHINE COMPONENTS; HYDRAULIC CONTROL EQUIPMENT, NAMELY, HYDRAULIC CONTROLS FOR MACHINES, MOTORS AND ENGINES, NOT FOR LAND VEHICLES; HYDRAULIC TURBINES; TURBINES FOR POWER GENERATION; STRUCTURAL PARTS OF TURBINES, NAMELY, TURBINE BLADES FOR POWER GENERATION; GEARS AND GEAR BOXES FOR USE WITH TURBINES FOR POWER GENERATION; PUMPS AS PARTS OF MACHINES, MOTORS AND ENGINES.VF (U.S. CLS. 13, 19, 21, 23, 31, 34 AND 35).

CLASS 37—CONSTRUCTION AND REPAIR

FOR MAINTENANCE, INSTALLATION, RECONDITIONING AND REPAIR SERVICES OF MACHINERY AND POWER TRANSMISSIONS, GEARS, GEAR BOXES, MECHANICAL AND FLUID COUPLINGS, ELECTRIC MOTORS, HYDRAULIC APPARATUS, TURBINES FOR POWER GENERATION, PUMPS AND PARTS THEREOF (U.S. CLS. 100, 103 AND 106).

TRACY FLETCHER, EXAMINING ATTORNEY

SN 79-096,592. ESSILOR INTERNATIONAL (COMPAGNIE GENERALE D'OPTIQUE), FRANCE, FILED 3-22-2011.

OPTIFOG

THE MARK CONSISTS OF STANDARD CHARACTERS WITHOUT CLAIM TO ANY PARTICULAR FONT, STYLE, SIZE, OR COLOR.

PRIORITY DATE OF 9-27-2010 IS CLAIMED.
OWNER OF INTERNATIONAL REGISTRATION 1074944 DATED 3-22-2011, EXPIRES 3-22-2021.

CLASS 3—COSMETICS AND CLEANING PREPARATIONS

FOR SOLUTIONS AND OTHER PREPARATIONS FOR CLEANING AND MAINTAINING SPECTACLE LENSES AND OPHTHALMIC LENSES OTHER THAN CONTACT LENSES; ANTI-FOG MAINTENANCE SOLUTIONS AND OTHER PREPARATIONS FOR SPECTACLE LENSES AND OPHTHALMIC LENSES OTHER THAN CONTACT LENSES (U.S. CLS. 1, 4, 6, 50, 51 AND 52).

CLASS 9—ELECTRICAL AND SCIENTIFIC APPARATUS

FOR OPHTHALMIC LENSES; SPECTACLE LENSES; TREATED OPHTHALMIC LENSES AND SPECTACLE LENSES; OPHTHALMIC LENSES AND SPECTACLE LENSES COATED WITH AN ANTI-FOG LAYER; OPHTHALMIC LENSES AND SPECTACLE LENSES WITH ANTI-FOG PROPERTIES; COATINGS FOR OPHTHALMIC LENSES AND SPECTACLE LENSES (U.S. CLS. 21, 23, 26, 36 AND 38).

ALLISON HOLTZ, EXAMINING ATTORNEY

SN 79-097,122. MODECA B.V., NETHERLANDS, FILED 12-29-2010.

MODECA

THE MARK CONSISTS OF STANDARD CHARACTERS WITHOUT CLAIM TO ANY PARTICULAR FONT, STYLE, SIZE, OR COLOR.

OWNER OF INTERNATIONAL REGISTRATION 1076438 DATED 12-29-2010, EXPIRES 12-29-2020.

CLASS 25—CLOTHING

FOR BRIDAL CLOTHING, NAMELY, WEDDING DRESSES, WEDDING GOWNS, EVENING WEAR, NAMELY, EVENING DRESSES AND EVENING GOWNS; CELEBRATION CEREMONY CLOTHING, NAMELY, CEREMONIAL DRESSES FOR FORMAL CEREMONY OR CELEBRATION; WOMAN'S CEREMONIAL DRESS; VEILS; FOOTWEAR, NAMELY, SHOES; HEADGEAR, NAMELY, CAPS, HATS (U.S. CLS. 22 AND 39).

CLASS 35—ADVERTISING AND BUSINESS

FOR RETAIL STORE SERVICES FEATURING EVENING WEAR, CEREMONY CLOTHING AND BRIDAL CLOTHING (U.S. CLS. 100, 101 AND 102).
SANDRA BUJA, EXAMINING ATTORNEY

SN 79-097,165. FIVES CELES, FRANCE, FILED 1-25-2011.

EcoTransFlux

THE MARK CONSISTS OF STANDARD CHARACTERS WITHOUT CLAIM TO ANY PARTICULAR FONT, STYLE, SIZE, OR COLOR.

PRIORITY DATE OF 10-7-2010 IS CLAIMED.

OWNER OF INTERNATIONAL REGISTRATION 1076572 DATED 1-25-2011, EXPIRES 1-25-2021.

CLASS 11—ENVIRONMENTAL CONTROL APPARATUS

FOR HIGH POWER DENSITY TRANSVERSE-FLUX INDUCTION HEATING APPARATUS (U.S. CLS. 13, 21, 23, 31 AND 34).

CLASS 37—CONSTRUCTION AND REPAIR

FOR INSTALLATION AND REPAIR OF HIGH POWER DENSITY TRANSVERSE-FLUX INDUCTION HEATING APPARATUS (U.S. CLS. 100, 103 AND 106).

JENNIFER VASQUEZ, EXAMINING ATTORNEY

SN 79-097,193. SAUER-DANFOSS APS, DENMARK, FILED 1-31-2011.

TUROLLA

THE MARK CONSISTS OF STANDARD CHARACTERS WITHOUT CLAIM TO ANY PARTICULAR FONT, STYLE, SIZE, OR COLOR.

PRIORITY DATE OF 9-1-2010 IS CLAIMED.

OWNER OF INTERNATIONAL REGISTRATION 1076633 DATED 1-31-2011, EXPIRES 1-31-2021.

CLASS 7—MACHINERY

FOR HYDRAULIC PUMPS FOR BOATS, BEING MACHINES; ELECTRIC MOTORS NOT FOR LAND VEHICLES; GENERATORS OF ELECTRICITY; HYDRAULIC MOTORS FOR BOATS; HYDRAULIC TRANSMISSIONS NOT FOR LAND VEHICLES; VALVES BEING MACHINE PARTS; HYDRAULIC TRANSMISSIONS COMPRISING A HYDRAULIC PUMP AND HYDRAULIC MOTORS NOT FOR LAND VEHICLES; GEAR PUMPS FOR USE IN BOATS; HYDRAULIC PUMPS AS PART OF MOTORS FOR LAND VEHICLES; PARTS AND FITTINGS FOR ALL THE AFORESAID GOODS, ALL INCLUDED IN THIS CLASS (U.S. CLS. 13, 19, 21, 23, 31, 34 AND 35).

CLASS 9—ELECTRICAL AND SCIENTIFIC APPARATUS

FOR ELECTRICAL AND ELECTRONIC CONTROLS COMPRISING ELECTROHYDRAULIC VALVES, ELECTRICAL ACTUATORS, ELECTRICAL SENSORS, AND PARTS THEREOF, ALL THE AFORESAID BEING FOR THE CONTROL OF HYDRAULIC TRANSMISSIONS, HYDRAULIC POWER APPARATUS FOR STATIONARY USE AND MOTOR VEHICLES AND THEIR WORKING IMPLEMENTS; MICROPROCESSOR BASED CONTROLLERS; MICROPROCESSOR BASED CONTROLLERS COMPRISED OF SENSORS/TRANSDUCERS AND ELECTRICAL ACTUATOR INPUTS, ELECTROHYDRAULIC VALVES, OPERATOR PANEL DISPLAYS, MICROPROCESSOR CONTROLLERS AND SERIAL OUTPUT PORTS; PARTS AND FITTINGS FOR ALL THE AFORESAID GOODS, ALL INCLUDED IN THIS CLASS (U.S. CLS. 21, 23, 26, 36 AND 38).

CLASS 12—VEHICLES

FOR HYDRAULIC MOTORS FOR LAND VEHICLES; ELECTRIC MOTORS FOR LAND VEHICLES; HYDRAULIC TRANSMISSIONS COMPRISING OF A HYDRAULIC PUMP AND HYDRAULIC MOTORS FOR LAND VEHICLES; GEAR DRIVES FOR USE IN LAND VEHICLES; GEAR PUMPS FOR USE IN LAND VEHICLES; FAN DRIVES FOR USE IN LAND VEHICLES; GEAR BOXES FOR USE WITH HYDRAULIC AND HYDROSTATIC TRANSMISSIONS AND PARTS THEREFOR FOR USE WITH LAND VEHICLES; PARTS AND FITTINGS FOR ALL THE AFORESAID GOODS, ALL INCLUDED IN THIS CLASS (U.S. CLS. 19, 21, 23, 31, 35 AND 44).

MICHAEL WIENER, EXAMINING ATTORNEY

SN 85-004,302. ED BLUM, LONDON WC2, UNITED KINGDOM, FILED 4-1-2010.

THE LAUGHTER CLINIC

THE MARK CONSISTS OF STANDARD CHARACTERS WITHOUT CLAIM TO ANY PARTICULAR FONT, STYLE, SIZE, OR COLOR.

OWNER OF UNITED KINGDOM REG. NO. 2468447, DATED 5-9-2008, EXPIRES 10-3-2017.

NO CLAIM IS MADE TO THE EXCLUSIVE RIGHT TO USE "CLINIC" IN INTERNATIONAL CLASS(ES) 9, 16, 28, AND 41 ONLY, APART FROM THE MARK AS SHOWN.

CLASS 9—ELECTRICAL AND SCIENTIFIC APPARATUS

FOR PRE-RECORDED DVDS FEATURING COMEDY; PRE-RECORDED CDS FEATURING COMEDY MATERIAL; OPTICAL DATA CARRIERS FEATURING COMEDY MATERIAL; APPARATUS FOR RECORDING, TRANSMITTING OR REPRODUCING SOUND OR IMAGES; MAGNETIC DATA-CARRIERS FEATURING COMEDY MATERIAL; BLANK RECORDING DISCS; MOTION PICTURE FILMS FEATURING COMEDY; COMPUTER SOFTWARE FEATURING COMEDY MATERIAL AND COMPUTER HARDWARE; COMPUTER AND ELECTRONIC GAMES IN THE FORM OF CD ROM GAMES; VIDEO GAMES IN THE FORM OF DISCS AND PROGRAMS; COMPUTER MOUSE PADS; MOBILE TELEPHONE AND RELATED ACCESSORIES IN THE NATURE OF HEADSETS, PROTECTIVE CASINGS, BATTERIES AND DOWNLOADS IN THE NATURE OF GRAPHICS AND RINGTONES; DOWNLOADABLE MP3 FILES AND AUDIO BOOKS, NAMELY, ONLINE DOWNLOADS; SUNGLASSES; MOVIES AND OTHER MEDIA DOWNLOADED FROM THE INTERNET FEATURING COMEDY MATERIAL; AND STRUCTURAL PARTS AND FITTINGS FOR THE AFORESAID GOODS; SWIMMING FLOATS FOR SAFETY PURPOSES (U.S. CLS. 21, 23, 26, 36 AND 38).

CLASS 16—PAPER GOODS AND PRINTED MATTER

FOR PAPER, CARDBOARD AND GOODS MADE FROM THESE MATERIALS, NAMELY, CARDBOARD TUBES; PRINTED MATTER, NAMELY, BOOKS AND MAGAZINES IN THE FIELD OF COMEDY; BOOKBINDING MATERIAL; PHOTOGRAPHS; ADHESIVES FOR STATIONERY OR HOUSEHOLD PURPOSES; PAINT BRUSHES; TYPEWRITERS AND OFFICE REQUISITES EXCEPT FURNITURE, NAMELY, STAPLERS, HOLE PUNCHES, RUBBER BANDS; PRINTED INSTRUCTIONAL AND TEACHING MATERIAL EXCEPT APPARATUS IN THE FIELD OF COMEDY; PLASTIC MATERIALS FOR PACKAGING IN THE FORM OF BAGS AND BUBBLE PACKS; PRINTERS' TYPE; PRINTING BLOCKS; PRINTED MATTER AND PAPER GOODS, NAMELY, BOOKS FEATURING CHARACTERS FROM ANIMATED, ACTION ADVENTURE, COMEDY AND DRAMA FEATURES, COMIC BOOKS, CHILDREN'S BOOKS, JOKE BOOKS, MAGAZINES FEATURING CHARACTERS FROM ANIMATED, ACTION ADVENTURE, COMEDY AND DRAMA FEATURES, COLOURING BOOKS, CHILDREN'S ACTIVITY BOOKS; STATIONERY, WRITING PAPER, ENVELOPES, NOTEBOOKS, DIARIES, NOTE CARDS, GREETING CARDS, TRADING CARDS, LITHOGRAPHS; PENS, PENCILS, CASES THEREFOR, ERASERS, CRAYONS, MARKERS, COLOURED PENCILS, PAINTING SETS FOR CHILDREN, CHALK AND CHALKBOARDS, DECALS, HEAT TRANSFERS; POSTERS; UNMOUNTED AND MOUNTED PHOTOGRAPHS; BOOK COVERS, BOOK MARKS, CALENDARS, GIFT WRAPPING PAPER; PAPER PARTY FAVORS AND PAPER PARTY DECORATIONS, NAMELY, PAPER NAPKINS, PAPER DOILIES, PAPER PLACE MATS, CREPE PAPER, INVITATIONS, PAPER TABLE CLOTHS, PAPER CAKE DECORATIONS; PRINTED TRANSFERS FOR EMBROIDERY OR FABRIC APPLIQUES; PRINTED PATTERNS FOR COSTUMES, PAJAMAS, SWEATSHIRTS AND T-SHIRTS; BOOKLETS SOLD WITH PRE-RECORDED AUDIO TAPES AS A UNIT, IN THE FIELD OF COMEDY (U.S. CLS. 2, 5, 22, 23, 29, 37, 38 AND 50).

CLASS 25—CLOTHING

FOR SHOES, HEADGEAR, NAMELY, CAPS AND HATS; CLOTHING FOR MEN, NAMELY, SHIRTS, T-SHIRTS, SWEATSHIRTS, JOGGING SUITS, TROUSERS, PANTS, SHORTS, TANK TOPS, RAINWEAR, SWEATERS, JACKETS, COATS, RAINCOATS, SNOW SUITS, TIES, ROBES, HATS, CAPS, SUN-VISORS, BELTS, SCARVES, SLEEPWEAR, PYJAMAS, BOOTS, SHOES, SNEAKERS, SANDALS, SLIPPER SOCKS, SWIMWEAR AND MASQUERADE COSTUMES; MASKS SOLD IN CONNECTION WITH MASQUERADE COSTUMES. CLOTHING FOR WOMEN AND CHILDREN, NAMELY, SHIRTS, T-SHIRTS, SWEATSHIRTS, JOGGING SUITS, TROUSERS, PANTS, SHORTS, TANK TOPS, RAINWEAR, CLOTH BIBS, SKIRTS, BLOUSES; DRESSES, SUSPENDERS, SWEATERS, JACKETS, COATS, RAINCOATS, SNOW SUITS, TIES, ROBES, HATS, CAPS, SUN-VISORS, BELTS, SCARVES, SLEEPWEAR, PYJAMAS, LINGERIE, UNDERWEAR, BOOTS, SHOES, SNEAKERS, SANDALS, BOOTIES, SLIPPER SOCKS, SWIMWEAR AND MASQUERADE COSTUMES; MASKS SOLD IN CONNECTION WITH MASQUERADE COSTUMES (U.S. CLS. 22 AND 39).

CLASS 28—TOYS AND SPORTING GOODS

FOR TOYS, GAMES AND PLAYTHINGS, NAMELY, CRIB TOYS AND CONSTRUCTION TOYS; NOVELTY TOYS, NAMELY, NOVELTY FACE MASKS AND DISPENSERS OF STREAM MATERIALS; GYMNASIAC AND SPORTING ARTICLES, NAMELY, SPRINGBOARDS, TRESTLES, AND PARALLEL BARS; DECORATIONS FOR CHRISTMAS TREES; TOYS AND SPORTING GOODS, NAMELY, GAMES AND PLAYTHINGS, NAMELY, ACTION FIGURES AND ACCESSORIES THEREFOR; PLUSH TOYS; BALLOONS; BATHTUB TOYS; RIDE-ON TOYS; EQUIPMENT SOLD AS A UNIT FOR PLAYING CARD GAMES; TOY VEHICLES; DOLLS; ELECTRONIC HAND-HELD GAME UNITS OTHER THAN THOSE ADAPTED FOR USE WITH AN EXTERNAL DISPLAY OR MONITOR; GAME EQUIPMENT SOLD AS A UNIT FOR PLAYING A BOARD GAME, A CARD GAME, A MANIPULATIVE GAME, A PARLOR GAME, A PARLOR-TYPE COMPUTER GAME, AN ACTION TYPE TARGET GAME; STAND ALONE VIDEO OUTPUT GAME MACHINES; JIGSAW AND MANIPULATIVE PUZZLES; PAPER FACE MASKS; SKATEBOARDS; ICE SKATES; WATER-SQUIRTING TOYS; BALLS, NAMELY, PLAYGROUND BALLS, SOCCER BALLS, BASEBALLS, BASKETBALLS; BASEBALL GLOVES; KICKBOARD FLOTATION DEVICES FOR RECREATIONAL USE; SURFBOARDS; SWIM BOARDS FOR RECREATIONAL USE; SWIM FINS; TOY ZIP GUNS; TOY BAKEWARE AND COOKWARE; PLAYING CARDS; PARTY FAVORS, NAMELY, PAPER HATS; FLYING DISCS FOR USE AS PLAYTHINGS (U.S. CLS. 22, 23, 38 AND 50).

CLASS 41—EDUCATION AND ENTERTAINMENT

FOR PROVIDING OF EDUCATION IN THE FORM OF TUTORING IN THE FIELD OF COMEDY; TRAINING IN THE FIELD OF COMEDY; ENTERTAINMENT SERVICES IN THE NATURE OF CONTINUING LIVE-ACTION, COMEDY, DRAMA AND ANIMATED TELEVISION PROGRAMS; PRODUCTION OF LIVE-ACTION COMEDY, DRAMA AND ANIMATED TELEVISION PROGRAMS; PRODUCTION OF LIVE-ACTION, COMEDY, DRAMA AND ANIMATED MOTION PICTURE THEATRICAL FILMS; PRODUCTION OF THEATRICAL PERFORMANCES, BOTH ANIMATED AND LIVE ACTION; EDUCATION AND ENTERTAINMENT SERVICES PROVIDED VIA A GLOBAL COMPUTER NETWORK IN THE FORM OF TUTORING IN THE FIELD OF COMEDY; PROVIDING TEMPORARY USE OF NON-DOWNLOADABLE ELECTRONIC GAMES, NAMELY, ELECTRONIC GAME SERVICES PROVIDED VIA A GLOBAL COMPUTER NETWORK; PROVIDING ON-LINE PUBLICATIONS IN THE FORM OF INTERACTIVE ENCYCLOPEDIAS IN THE FIELD OF COMEDY; PUBLICATION OF ELECTRONIC BOOKS AND JOURNALS ON-LINE; HOSTING AND ORGANISATION OF LIVE COMEDY SHOWS; FILM PRODUCTION SERVICES (U.S. CLS. 100, 101 AND 107).

TINA MAI, EXAMINING ATTORNEY

SN 85-007,233. RRM COMPOSITES LLC, DENVER, CO. FILED 4-6-2010.

SN 85-008,074. ITOYS LTD., TAIPEI CITY 114, TAIWAN, FILED 4-7-2010.



THE MARK CONSISTS OF THREE ARROWS FORMING A CIRCLE AROUND A GLOBE.

CLASS 19—NON-METALLIC BUILDING MATERIALS

FOR COMPOSITE BUILDING MATERIALS, NAMELY, FENCING, DECKING, POSTS, RAILS, PICKETS, BOARDS AND MODULAR DECKING TO SERVE AS GROUND COVER MADE USING WHEAT STRAW AND RECYCLED PLASTICS (U.S. CLS. 1, 12, 33 AND 50).
FIRST USE 4-30-2010; IN COMMERCE 4-30-2010.

CLASS 40—MATERIAL TREATMENT

FOR MANUFACTURING SERVICES FOR OTHERS IN THE FIELD OF COMPOSITE BUILDING MATERIALS (U.S. CLS. 100, 103 AND 106).
FIRST USE 4-30-2010; IN COMMERCE 4-30-2010.
ROBERT STRUCK, EXAMINING ATTORNEY

SN 85-007,257. RRM COMPOSITES LLC, DENVER, CO. FILED 4-6-2010.



REMOVING FOOTPRINTS FROM OUR WORLD

THE MARK CONSISTS OF THE WORDING "REMOVING FOOTPRINTS FROM OUR WORLD" BELOW A SERIES OF SEVEN FOOTPRINTS.

CLASS 19—NON-METALLIC BUILDING MATERIALS

FOR COMPOSITE BUILDING MATERIALS, NAMELY, FENCING, DECKING, POSTS, RAILS, PICKETS, BOARDS AND MODULAR DECKING TO SERVE AS GROUND COVER MADE USING WHEAT STRAW AND RECYCLED PLASTICS (U.S. CLS. 1, 12, 33 AND 50).
FIRST USE 4-30-2010; IN COMMERCE 4-30-2010.

CLASS 40—MATERIAL TREATMENT

FOR MANUFACTURING SERVICES FOR OTHERS IN THE FIELD OF COMPOSITE BUILDING MATERIALS (U.S. CLS. 100, 103 AND 106).
FIRST USE 4-30-2010; IN COMMERCE 4-30-2010.
ROBERT STRUCK, EXAMINING ATTORNEY

HELLO CITY

THE MARK CONSISTS OF STANDARD CHARACTERS WITHOUT CLAIM TO ANY PARTICULAR FONT, STYLE, SIZE, OR COLOR.

CLASS 9—ELECTRICAL AND SCIENTIFIC APPARATUS

FOR SMART CARD READERS; ELECTRONIC CARD READERS; RADIO FREQUENCY IDENTIFICATION TAGS; RADIO FREQUENCY IDENTIFICATION READERS; MAGNETIC CODED GIFT CARDS (U.S. CLS. 21, 23, 26, 36 AND 38).

CLASS 16—PAPER GOODS AND PRINTED MATTER

FOR CARDS NOT MAGNETICALLY ENCODED FOR USE IN BUSINESS TRANSACTIONS (U.S. CLS. 2, 5, 22, 23, 29, 37, 38 AND 50).

CLASS 18—LEATHER GOODS

FOR KNAPSACKS, FANNY PACKS AND HANDBAGS (U.S. CLS. 1, 2, 3, 22 AND 41).

CLASS 42—SCIENTIFIC AND COMPUTER SERVICES

FOR SOFTWARE DEVELOPMENT AND DESIGN; INTERACTIVE SOFTWARE DEVELOPMENT AND DESIGN; INTERNET INTERACTIVE SOFTWARE DEVELOPMENT AND DESIGN (U.S. CLS. 100 AND 101).
SUSAN LESLIE DUBOIS, EXAMINING ATTORNEY

SN 85-009,372. SONOMA TANNING LLC, SANTA ROSA, CA. FILED 4-8-2010.



THE MARK CONSISTS OF A STYLIZED LETTER "B", A PERIOD AFTER THE LETTER "B" AND A CURVED LINE OVER THE LETTERS "BRONZ".

CLASS 3—COSMETICS AND CLEANING PREPARATIONS

FOR AFTER SHAVE LOTIONS; AFTER-SUN LOTIONS; AGE RETARDANT LOTION; AROMATHERAPY BODY CARE PRODUCTS, NAMELY, BODY LOTION, SHOWER GEL, CUTICLE CREAM, SHAMPOO, CONDITIONER, NON-MEDICATED LIP BALM, SOAP, BODY POLISH, BODY AND FOOT SCRUB AND NON-MEDICATED FOOT CREAM; AROMATHERAPY LOTIONS; BATH BEADS; BATH CREAM; BATH CRYSTALS; BATH FIZZIES; BATH FLAKES; BATH FOAM; BATH FOAMS; BATH GEL; BATH GELS; BATH LOTION; BATH MILKS; BATH OIL; BATH OILS; BATH OILS AND BATH SALTS; BATH OILS FOR COSMETIC PURPOSES; BATH PEARLS; BATH POWDER; BATH SALTS; BATH SALTS; BATH SOAPS; BATH SOAPS IN LIQUID, SOLID OR GEL FORM; BATHING LOTIONS; BEAUTY CREAMS FOR BODY CARE; BEAUTY LOTIONS; BODY AND BEAUTY CARE COSMETICS; BODY BUTTER; BODY CREAM; BODY CREAM SOAP; BODY CREAMS; BODY EMULSIONS; BODY GLITTER; BODY LOTION; BODY LOTIONS; BODY MASK LOTION; BUBBLE BATH; COSMETIC CREAMS FOR SKIN CARE; COSMETIC PREPARATIONS FOR SKIN RENEWAL; COSMETIC PREPARATIONS, NAMELY, FIRMLING LOTIONS; COSMETIC PREPARATIONS, NAMELY, SKIN BALSAMS; COSMETIC PRODUCTS IN THE FORM OF AEROSOLS FOR SKIN CARE; COSMETIC SUN-TANNING PREPARATIONS; COSMETIC SUNTAN LOTIONS; COSMETICS IN THE FORM OF MILKS, LOTIONS AND EMULSIONS; COSMETICS, NAMELY, LIP PRIMER; COSMETICS, NAMELY, LIP REPAIRERS; EYE LOTIONS; FACE AND BODY LOTIONS; FACE MILK AND LOTIONS; FOAM BATH; FOAMS CONTAINING COSMETICS AND SUNSCREENS; GIFT BASKETS CONTAINING NON-MEDICATED BATH PREPARATIONS AND COSMETIC PREPARATIONS; INDOOR SUN TANNING PREPARATIONS; LIP BALM; LIP BALM; LIP CREAM; LIP GLOSS; LIP GLOSS PALETTE; LIP LINER; LIP POLISHER; LIQUID BATH SOAPS; LIQUID SOAP USED IN FOOT BATH; NON-MEDICATED HERBAL BODY CARE PRODUCTS, NAMELY, BODY OILS, SALVES, AND LIP BALMS; NON-MEDICATED LIP BALM THAT DOES NOT CONTAIN BEESWAX; NON-MEDICATED LIP CARE PREPARATIONS; NON-MEDICATED LIP PROTECTORS; SELF-TANNING PREPARATIONS; SHOWER AND BATH FOAM; SHOWER AND BATH GEL; SKIN BRONZER; SKIN CARE PREPARATIONS, NAMELY, BODY BALM; SKIN GELS FOR ACCELERATING, ENHANCING OR EXTENDING TANS; SUN TAN GEL; SUN TAN LOTION; SUN TAN OIL; SUN-TANNING OILS; SUN-TANNING OILS AND LOTIONS; SUN-TANNING PREPARATIONS; SUNSCREEN CREAM; SUNSCREEN CREAMS; SUNTAN CREAMS; TANNING AND AFTER-SUN MILKS, GELS AND OILS; TANNING CREAMS; TANNING GELS; TANNING MILKS; TANNING OILS; WATERPROOF SUNSCREEN (U.S. CLS. 1, 4, 6, 50, 51 AND 52).

CLASS 44—MEDICAL, BEAUTY AND AGRICULTURAL SERVICES

FOR SKIN TANNING SERVICE FOR HUMANS FOR COSMETIC PURPOSES; TANNING SALONS (U.S. CLS. 100 AND 101).

EDWARD NELSON, EXAMINING ATTORNEY

SN 85-018,119, LEGAL SERVICES CORPORATION, WASHINGTON, DC. FILED 4-20-2010.

**AMERICA'S PARTNER FOR
EQUAL JUSTICE**

THE MARK CONSISTS OF STANDARD CHARACTERS WITHOUT CLAIM TO ANY PARTICULAR FONT, STYLE, SIZE, OR COLOR.

OWNER OF U.S. REG. NO. 2,788,127.

SEC. 2(F) AS TO "AMERICA'S".

CLASS 35—ADVERTISING AND BUSINESS

FOR PROMOTING PUBLIC INTEREST IN EQUAL ACCESS TO JUSTICE AND CIVIL LEGAL SERVICES FOR LOW-INCOME PEOPLE IN THE UNITED STATES, UNITED STATES' TERRITORIES AND POSSESSIONS AND FOREIGN OR QUASI-FOREIGN AREAS COVERED BY UNITED STATES STATUTE OR AGREEMENT; PUBLIC ADVOCACY, NAMELY, PROMOTING INTEREST IN AND AWARENESS OF THE LACK OF AND NEED FOR EQUAL ACCESS TO JUSTICE AND CIVIL LEGAL SERVICES FOR LOW-INCOME PEOPLE IN THE UNITED STATES, UNITED STATES' TERRITORIES AND POSSESSIONS AND FOREIGN OR QUASI-FOREIGN AREAS COVERED BY UNITED STATES STATUTE OR AGREEMENT; PROMOTING PUBLIC AWARENESS OF AND INTEREST IN IMPROVEMENTS TO THE EFFICIENCY AND EFFECTIVENESS OF ACCESS TO JUSTICE AND CIVIL LEGAL SERVICES FOR LOW-INCOME PEOPLE AND DELIVERY THEREOF; PROVIDING REFERRALS TO AND ARRANGING FOR COURT-APPOINTED LEGAL COUNSEL AND CIVIL LEGAL SERVICES FOR LOW-INCOME PEOPLE; BUSINESS MANAGEMENT CONSULTING SERVICES FOR THE MANAGEMENT AND ADMINISTRATION OF DELIVERING CIVIL LEGAL SERVICES FOR LOW-INCOME PEOPLE; PROVIDING BUSINESS INFORMATION ONLINE RELATING TO THE BUSINESS MANAGEMENT AND ADMINISTRATION OF DELIVERING CIVIL LEGAL SERVICES FOR LOW-INCOME PEOPLE; ACCOUNT AUDITING SERVICES FOR CHARITABLE FUNDING OF GRANTS TO NON-PROFIT ENTITIES FOR THE PROVISION OF CIVIL LEGAL SERVICES FOR LOW-INCOME PEOPLE; POLITICAL CONSULTANCY (U.S. CLS. 100, 101 AND 102).

FIRST USE 6-12-1999; IN COMMERCE 7-0-1999.

CLASS 36—INSURANCE AND FINANCIAL

FOR CHARITABLE SERVICES, NAMELY, PROVIDING FUNDING THROUGH GRANTS TO NON-PROFIT ENTITIES FOR THE PROVISION OF CIVIL LEGAL SERVICES FOR LOW-INCOME PEOPLE AND RELATED INFORMATION REGARDING CHARITABLE FUNDING SERVICES AVAILABLE FOR LOW-INCOME INDIVIDUALS, FAMILIES, GROUPS OR OTHER ENTITIES QUALIFIED FOR SUCH SERVICES UNDER LAW; CHARITABLE SERVICES, NAMELY, PROVIDING FUNDING THROUGH GRANTS TO NON-PROFIT ENTITIES FOR THE USE OF TECHNOLOGY IN THE DELIVERY OF CIVIL LEGAL SERVICES FOR LOW-INCOME PEOPLE AND RELATED INFORMATION REGARDING CHARITABLE FUNDING SERVICES; CHARITABLE FINANCIAL MANAGEMENT SERVICES, NAMELY, PROVIDING FINANCIAL OVERSIGHT IN CONNECTION WITH CHARITABLE FUNDING OF GRANTS TO NON-PROFIT ENTITIES, INDIVIDUALS OR OTHER LEGALLY QUALIFIED ENTITIES FOR THE PROVISION OF CIVIL LEGAL SERVICES FOR LOW-INCOME PEOPLE; PROVIDING INFORMATION ONLINE REGARDING CHARITABLE FUNDING OF GRANTS TO NON-PROFIT, GOVERNMENTAL, AND PRIVATE GROUPS, ENTITIES, INDIVIDUALS OR OTHER LEGALLY QUALIFIED ENTITIES FOR THE PROVISION OF CIVIL LEGAL SERVICES FOR LOW-INCOME PEOPLE (U.S. CLS. 100, 101 AND 102).

FIRST USE 6-12-1999; IN COMMERCE 7-0-1999.

CLASS 41—EDUCATION AND ENTERTAINMENT

FOR TRAINING SERVICES IN THE FIELDS OF CIVIL LEGAL SERVICES FOR LOW-INCOME PEOPLE AND THE DELIVERY, PROVISION AND MANAGEMENT THEREOF; NON-DOWNLOADABLE EMAIL NEWSLETTER IN THE FIELDS OF CIVIL LEGAL SERVICES FOR LOW-INCOME PEOPLE, THE DELIVERY, PROVISION AND MANAGEMENT THEREOF, AND NEWS ITEMS RELATED THERETO; PROVIDING ON-LINE NON-DOWNLOADABLE EMAIL NEWSLETTER IN THE FIELDS OF PREVENTING FRAUD, WASTE AND ABUSE IN THE FIELD OF CIVIL LEGAL SERVICES FOR LOW-INCOME PEOPLE (U.S. CLS. 100, 101 AND 107).

FIRST USE 6-12-1999; IN COMMERCE 7-0-1999.

CLASS 45—PERSONAL AND LEGAL SERVICES

FOR LEGAL SERVICES; PROVIDING INFORMATION REGARDING CIVIL LEGAL SERVICES AND DELIVERY OF FREE AND LOW-COST CIVIL LEGAL SERVICES; PROVIDING ON-LINE INFORMATION IN THE FIELDS OF PREVENTING FRAUD, WASTE AND ABUSE IN THE FIELD OF CIVIL LEGAL SERVICES FOR LOW-INCOME PEOPLE; LEGAL RESEARCH SERVICES; LEGAL SERVICES, NAMELY, LEGAL COMPLIANCE AND AUDIT CONSULTATION RELATING TO THE CHARITABLE FUNDING OF GRANTS, CONTRACTS AND OTHER RELATED ACTIVITIES; REVIEWING STANDARDS AND PRACTICES TO ENSURE COMPLIANCE WITH CIVIL AND CRIMINAL FRAUD LAWS AND REGULATIONS, OTHER CRIMINAL LAWS, AND OTHER LAWS AND REGULATIONS GOVERNING THE DELIVERY OF FREE AND LOW-COST CIVIL LEGAL SERVICES (U.S. CLS. 100 AND 101).

FIRST USE 6-12-1999; IN COMMERCE 7-0-1999.
SOPHIA S. KIM, EXAMINING ATTORNEY

CLASS 35—ADVERTISING AND BUSINESS

FOR PROMOTING PUBLIC INTEREST IN EQUAL ACCESS TO JUSTICE AND CIVIL LEGAL SERVICES FOR LOW-INCOME PEOPLE IN THE UNITED STATES, UNITED STATES' TERRITORIES AND POSSESSIONS AND FOREIGN OR QUASI-FOREIGN AREAS COVERED BY UNITED STATES STATUTE OR AGREEMENT; PUBLIC ADVOCACY, NAMELY, PROMOTING INTEREST IN AND AWARENESS OF THE LACK OF AND NEED FOR EQUAL ACCESS TO JUSTICE AND CIVIL LEGAL SERVICES FOR LOW-INCOME PEOPLE IN THE UNITED STATES, UNITED STATES' TERRITORIES AND POSSESSIONS AND FOREIGN OR QUASI-FOREIGN AREAS COVERED BY UNITED STATES STATUTE OR AGREEMENT; PROMOTING PUBLIC AWARENESS OF AND INTEREST IN IMPROVEMENTS TO THE EFFICIENCY AND EFFECTIVENESS OF ACCESS TO JUSTICE AND CIVIL LEGAL SERVICES FOR LOW-INCOME PEOPLE AND DELIVERY THEREOF; PROVIDING REFERRALS TO AND ARRANGING FOR COURT-APPOINTED LEGAL COUNSEL AND CIVIL LEGAL SERVICES FOR LOW-INCOME PEOPLE; BUSINESS MANAGEMENT CONSULTING SERVICES FOR THE MANAGEMENT AND ADMINISTRATION OF DELIVERING CIVIL LEGAL SERVICES FOR LOW-INCOME PEOPLE; PROVIDING BUSINESS INFORMATION ON-LINE RELATING TO THE BUSINESS MANAGEMENT AND ADMINISTRATION OF DELIVERING CIVIL LEGAL SERVICES FOR LOW-INCOME PEOPLE; ACCOUNT AUDITING SERVICES FOR CHARITABLE FUNDING OF GRANTS TO NON-PROFIT ENTITIES FOR THE PROVISION OF CIVIL LEGAL SERVICES FOR LOW-INCOME PEOPLE; POLITICAL CONSULTANCY (U.S. CLS. 100, 101 AND 102).

FIRST USE 6-10-1999; IN COMMERCE 7-0-1999.

CLASS 36—INSURANCE AND FINANCIAL

FOR CHARITABLE SERVICES, NAMELY, PROVIDING FUNDING THROUGH GRANTS TO NON-PROFIT ENTITIES FOR THE PROVISION OF CIVIL LEGAL SERVICES FOR LOW-INCOME PEOPLE AND RELATED INFORMATION REGARDING CHARITABLE FUNDING SERVICES AVAILABLE FOR LOW-INCOME INDIVIDUALS, FAMILIES, GROUPS OR OTHER ENTITIES QUALIFIED FOR SUCH SERVICES UNDER LAW; CHARITABLE SERVICES, NAMELY, PROVIDING FUNDING THROUGH GRANTS TO NON-PROFIT ENTITIES FOR THE USE OF TECHNOLOGY IN THE DELIVERY OF CIVIL LEGAL SERVICES FOR LOW-INCOME PEOPLE AND RELATED INFORMATION REGARDING CHARITABLE FUNDING SERVICES; CHARITABLE FINANCIAL MANAGEMENT SERVICES, NAMELY, PROVIDING FINANCIAL OVERSIGHT IN CONNECTION WITH CHARITABLE FUNDING OF GRANTS TO NON-PROFIT ENTITIES, INDIVIDUALS OR OTHER LEGALLY QUALIFIED ENTITIES FOR THE PROVISION OF CIVIL LEGAL SERVICES FOR LOW-INCOME PEOPLE; PROVIDING INFORMATION ON-LINE REGARDING CHARITABLE FUNDING OF GRANTS TO NON-PROFIT, GOVERNMENTAL, AND PRIVATE GROUPS, ENTITIES, INDIVIDUALS OR OTHER LEGALLY QUALIFIED ENTITIES FOR THE PROVISION OF CIVIL LEGAL SERVICES FOR LOW-INCOME PEOPLE (U.S. CLS. 100, 101 AND 102).

FIRST USE 6-10-1999; IN COMMERCE 7-0-1999.

CLASS 41—EDUCATION AND ENTERTAINMENT

FOR TRAINING SERVICES IN THE FIELDS OF CIVIL LEGAL SERVICES FOR LOW-INCOME PEOPLE AND THE DELIVERY, PROVISION AND MANAGEMENT THEREOF; NON-DOWNLOADABLE EMAIL NEWSLETTER IN THE FIELDS OF CIVIL LEGAL SERVICES FOR LOW-INCOME PEOPLE, THE DELIVERY, PROVISION AND MANAGEMENT THEREOF, AND NEWS ITEMS RELATED THERETO; PROVIDING ON-LINE NON-DOWNLOADABLE EMAIL NEWSLETTER IN THE FIELDS OF PREVENTING FRAUD, WASTE AND ABUSE IN THE FIELD OF CIVIL LEGAL SERVICES FOR LOW-INCOME PEOPLE (U.S. CLS. 100, 101 AND 107).

FIRST USE 6-10-1999; IN COMMERCE 7-0-1999.

SN 85-018,136. LEGAL SERVICES CORPORATION, WASHINGTON, DC. FILED 4-20-2010.

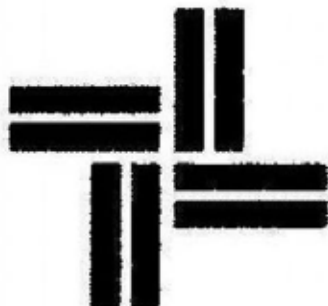

OWNER OF U.S. REG. NO. 2,383,338.
THE MARK CONSISTS OF A PINWHEEL DESIGN COMPRISED OF FOUR SETS OF TWO BARS.

CLASS 45—PERSONAL AND LEGAL SERVICES

FOR LEGAL SERVICES; PROVIDING INFORMATION REGARDING CIVIL LEGAL SERVICES AND DELIVERY OF FREE AND LOW-COST CIVIL LEGAL SERVICES; PROVIDING ON-LINE INFORMATION IN THE FIELDS OF PREVENTING FRAUD, WASTE AND ABUSE IN THE FIELD OF CIVIL LEGAL SERVICES FOR LOW-INCOME PEOPLE; LEGAL RESEARCH SERVICES; LEGAL SERVICES, NAMELY, LEGAL COMPLIANCE AND AUDIT CONSULTATION RELATING TO THE CHARITABLE FUNDING OF GRANTS, CONTRACTS AND OTHER RELATED ACTIVITIES; REVIEWING STANDARDS AND PRACTICES TO ENSURE COMPLIANCE WITH CIVIL AND CRIMINAL FRAUD LAWS AND REGULATIONS, OTHER CRIMINAL LAWS, AND OTHER LAWS AND REGULATIONS GOVERNING THE DELIVERY OF FREE AND LOW-COST CIVIL LEGAL SERVICES (U.S. CLS. 100 AND 101).

FIRST USE 6-10-1999; IN COMMERCE 7-0-1999.
SOPHIA S. KIM, EXAMINING ATTORNEY

SN 85-019,272. LEGAL SERVICES CORPORATION, WASHINGTON, DC. FILED 4-21-2010.



OWNER OF U.S. REG. NO. 2,383,338.
THE MARK CONSISTS OF THE LETTERS "LSC" ADJACENT TO A PINWHEEL DESIGN COMPRISED OF FOUR SETS OF TWO BARS.

CLASS 35—ADVERTISING AND BUSINESS

FOR PROMOTING PUBLIC INTEREST IN EQUAL ACCESS TO JUSTICE AND CIVIL LEGAL SERVICES FOR LOW-INCOME PEOPLE IN THE UNITED STATES, UNITED STATES' TERRITORIES AND POSSESSIONS AND FOREIGN OR QUASI-FOREIGN AREAS COVERED BY UNITED STATES STATUTE OR AGREEMENT; PUBLIC ADVOCACY, NAMELY, PROMOTING INTEREST IN AND AWARENESS OF THE LACK OF AND NEED FOR EQUAL ACCESS TO JUSTICE AND CIVIL LEGAL SERVICES FOR LOW-INCOME PEOPLE IN THE UNITED STATES, UNITED STATES' TERRITORIES AND POSSESSIONS AND FOREIGN OR QUASI-FOREIGN AREAS COVERED BY UNITED STATES STATUTE OR AGREEMENT; PROMOTING PUBLIC AWARENESS OF AND INTEREST IN IMPROVEMENTS TO THE EFFICIENCY AND EFFECTIVENESS OF ACCESS TO JUSTICE AND CIVIL LEGAL SERVICES FOR LOW-INCOME PEOPLE AND DELIVERY THEREOF; PROVIDING REFERRALS TO AND ARRANGING FOR COURT-APPOINTED LEGAL COUNSEL AND CIVIL LEGAL SERVICES FOR LOW-INCOME PEOPLE; BUSINESS MANAGEMENT CONSULTING SERVICES FOR THE MANAGEMENT AND ADMINISTRATION OF DELIVERING CIVIL LEGAL SERVICES FOR LOW-INCOME PEOPLE; PROVIDING BUSINESS INFORMATION ON-LINE RELATING TO THE BUSINESS MANAGEMENT AND ADMINISTRATION OF DELIVERING CIVIL LEGAL SERVICES FOR LOW-INCOME PEOPLE; ACCOUNT AUDITING SERVICES FOR CHARITABLE FUNDING OF GRANTS TO NON-PROFIT ENTITIES FOR THE PROVISION OF CIVIL LEGAL SERVICES FOR LOW-INCOME PEOPLE; POLITICAL CONSULTANCY (U.S. CLS. 100, 101 AND 102).

FIRST USE 6-10-1999; IN COMMERCE 7-0-1999.

CLASS 36—INSURANCE AND FINANCIAL

FOR CHARITABLE SERVICES, NAMELY, PROVIDING FUNDING THROUGH GRANTS TO NON-PROFIT ENTITIES FOR THE PROVISION OF CIVIL LEGAL SERVICES FOR LOW-INCOME PEOPLE AND RELATED INFORMATION REGARDING CHARITABLE FUNDING SERVICES AVAILABLE FOR LOW-INCOME INDIVIDUALS, FAMILIES, GROUPS OR OTHER ENTITIES QUALIFIED FOR SUCH SERVICES UNDER LAW; CHARITABLE SERVICES, NAMELY, PROVIDING FUNDING THROUGH GRANTS TO NON-PROFIT ENTITIES FOR THE USE OF TECHNOLOGY IN THE DELIVERY OF CIVIL LEGAL SERVICES FOR LOW-INCOME PEOPLE AND RELATED INFORMATION REGARDING CHARITABLE FUNDING SERVICES; CHARITABLE FINANCIAL MANAGEMENT SERVICES, NAMELY, PROVIDING FINANCIAL OVERSIGHT IN CONNECTION WITH CHARITABLE FUNDING OF GRANTS TO NON-PROFIT ENTITIES, INDIVIDUALS OR OTHER LEGALLY QUALIFIED ENTITIES FOR THE PROVISION OF CIVIL LEGAL SERVICES FOR LOW-INCOME PEOPLE; PROVIDING INFORMATION ON-LINE REGARDING CHARITABLE FUNDING OF GRANTS TO NON-PROFIT, GOVERNMENTAL, AND PRIVATE GROUPS, ENTITIES, INDIVIDUALS OR OTHER LEGALLY QUALIFIED ENTITIES FOR THE PROVISION OF CIVIL LEGAL SERVICES FOR LOW-INCOME PEOPLE (U.S. CLS. 100, 101 AND 102).

FIRST USE 6-10-1999; IN COMMERCE 7-0-1999.

CLASS 41—EDUCATION AND ENTERTAINMENT

FOR TRAINING SERVICES IN THE FIELDS OF CIVIL LEGAL SERVICES FOR LOW-INCOME PEOPLE AND THE DELIVERY, PROVISION AND MANAGEMENT THEREOF; NON-DOWNLOADABLE EMAIL NEWSLETTER IN THE FIELDS OF CIVIL LEGAL SERVICES FOR LOW-INCOME PEOPLE, THE DELIVERY, PROVISION AND MANAGEMENT THEREOF, AND NEWS ITEMS RELATED THERETO; PROVIDING ON-LINE NON-DOWNLOADABLE EMAIL NEWSLETTER IN THE FIELDS OF PREVENTING FRAUD, WASTE AND ABUSE IN THE FIELD OF CIVIL LEGAL SERVICES FOR LOW-INCOME PEOPLE (U.S. CLS. 100, 101 AND 107).

FIRST USE 6-10-1999; IN COMMERCE 7-0-1999.

CLASS 45—PERSONAL AND LEGAL SERVICES

FOR LEGAL SERVICES; PROVIDING INFORMATION REGARDING CIVIL LEGAL SERVICES AND DELIVERY OF FREE AND LOW-COST CIVIL LEGAL SERVICES; PROVIDING ON-LINE INFORMATION IN THE FIELDS OF PREVENTING FRAUD, WASTE AND ABUSE IN THE FIELD OF CIVIL LEGAL SERVICES FOR LOW-INCOME PEOPLE; LEGAL RESEARCH SERVICES; LEGAL SERVICES, NAMELY, LEGAL COMPLIANCE AND AUDIT CONSULTATION RELATING TO THE CHARITABLE FUNDING OF GRANTS, CONTRACTS AND OTHER RELATED ACTIVITIES; REVIEWING STANDARDS AND PRACTICES TO ENSURE COMPLIANCE WITH CIVIL AND CRIMINAL FRAUD LAWS AND REGULATIONS, OTHER CRIMINAL LAWS, AND OTHER LAWS AND REGULATIONS GOVERNING THE DELIVERY OF FREE AND LOW-COST CIVIL LEGAL SERVICES (U.S. CLS. 100 AND 101).

FIRST USE 6-10-1999; IN COMMERCE 7-0-1999.
SOPHIA S. KIM, EXAMINING ATTORNEY

SN 85-023,060. BMB DATA CONSULTING SERVICES INC.,
OTTAWA, ONTARIO, CANADA, FILED 4-26-2010.

PMO2

THE MARK CONSISTS OF STANDARD CHARACTERS WITHOUT CLAIM TO ANY PARTICULAR FONT, STYLE, SIZE, OR COLOR.

CLASS 16—PAPER GOODS AND PRINTED MATTER

FOR PRINTED PUBLICATIONS, NAMELY, BOOKS, MAGAZINES AND NEWSLETTERS IN THE FIELD OF PROJECT MANAGEMENT (U.S. CLS. 2, 5, 22, 23, 29, 37, 38 AND 50).

CLASS 35—ADVERTISING AND BUSINESS

FOR PROJECT MANAGEMENT SERVICES FOR OTHERS FOR BUSINESS PURPOSES IN THE FIELD OF INFORMATION TECHNOLOGY PORTFOLIO MANAGEMENT; BUSINESS CONSULTING SERVICES IN THE FIELD OF PROJECT MANAGEMENT; BUSINESS SERVICES, NAMELY, BUSINESS CONSULTATION SERVICES IN THE FIELD OF INFORMATION TECHNOLOGY PORTFOLIO MANAGEMENT (U.S. CLS. 100, 101 AND 102).

CLASS 41—EDUCATION AND ENTERTAINMENT

FOR TRAINING SERVICES IN THE FIELD OF PORTFOLIO AND PROJECT MANAGEMENT; EDUCATIONAL SERVICES, NAMELY, CONDUCTING SEMINARS AND WORKSHOPS FOR BUSINESSES IN THE FIELD OF INFORMATION TECHNOLOGY PORTFOLIO MANAGEMENT AND PROJECT MANAGEMENT (U.S. CLS. 100, 101 AND 107).

AMY KERTGATE, EXAMINING ATTORNEY

SN 85-026,113. THE ROYAL PARKS, LONDON, GREAT
BRITAIN, FILED 4-29-2010.



THE MARK CONSISTS OF A HIGHLY STYLIZED, ROYAL CROWN MADE UP ENTIRELY OF LEAVES; THE LOWER PORTION OF THE CROWN CONSISTS OF TWO STYLIZED MAPLE LEAVES, THE RAISED PART OF THE CROWN IS MADE FROM FOUR CURVED OAK-LEAF PAIRS; AND THE TOPMOST PIECE DISPLAYS AN OAK LEAF STANDING ON ITS STEM.

CLASS 16—PAPER GOODS AND PRINTED MATTER

FOR PRINTED MATTER, NAMELY, PRINTED MAGAZINES, CHILDREN'S BOOKS, PAMPHLETS, PERIODICALS, NEWSPAPERS, NEWSLETTERS, CATALOGUES AND BROCHURES IN THE FIELDS OF CULTURE, MUSIC, ARTS, FOOD, HERITAGE, HORTICULTURE, SPORT, HEALTH, WILDLIFE, LEISURE, ROYALTY, FICTION, ENTERTAINMENT, ARBORICULTURE, PLAY, EDUCATION, PETS, HISTORY, ARCHITECTURE, AGRICULTURE, ENVIRONMENTAL AND SUSTAINABILITY STUDIES; BOOKS IN THE FIELDS OF CULTURE, MUSIC, ARTS, FOOD, HERITAGE, HORTICULTURE, SPORT, HEALTH, WILDLIFE, LEISURE, ROYALTY, FICTION, ENTERTAINMENT, ARBORICULTURE, PLAY, EDUCATION, PETS, HISTORY, ARCHITECTURE, AGRICULTURE, ENVIRONMENTAL AND SUSTAINABILITY STUDIES; MAGAZINES AND JOURNALS IN THE FIELDS OF CULTURE, MUSIC, ARTS, FOOD, HERITAGE, HORTICULTURE, SPORT, HEALTH, WILDLIFE, LEISURE, ROYALTY, FICTION, ENTERTAINMENT, ARBORICULTURE, PLAY, EDUCATION, PETS, HISTORY, ARCHITECTURE, AGRICULTURE, ENVIRONMENTAL AND SUSTAINABILITY STUDIES; PAPER: CARDBOARD AND GOODS MADE FROM CARDBOARD, NAMELY, BOXES OF CARDBOARD, CONTAINERS FOR STORAGE OR TRANSPORT MADE OF CARDBOARD, BOTTLE WRAPPERS OF CARDBOARD, PLACARDS OF CARDBOARD, PRINTED ADVERTISING BOARDS OF CARDBOARD, CARDBOARD SIGNBOARDS, CARDBOARD CARTONS; SONG BOOKS; APPOINTMENT BOOKS; ADDRESS BOOKS; MEMORANDUM BOOKS; PRINTED PERSONAL ORGANIZERS FOR ORGANISING PERSONAL TIME AND TO-DO LISTS; CALENDARS; DIARIES; BOOK BINDING MATERIAL; PRINTED CERTIFICATES; PRINTED CHARTS FOR DISPLAYING DATA; GRAPHIC IMAGES, NAMELY, PHOTOGRAPHS, PICTURES AND DIAGRAMS IN THE FIELDS OF CULTURE, MUSIC, ARTS, FOOD, HERITAGE, HORTICULTURE, SPORT, HEALTH, WILDLIFE, LEISURE, ROYALTY, FICTION, ENTERTAINMENT, ARBORICULTURE, PLAY, EDUCATION, PETS, HISTORY, ARCHITECTURE, AGRICULTURE, ENVIRONMENTAL AND SUSTAINABILITY STUDIES; PRINTED TICKETS; ENVELOPES; PAPER BAGS; STICKERS; ADHESIVE LABELS OR PRINTED LABELS, BAR CODE LABELS, PAPER LABELS OR SHIPPING LABELS; TAGS; STATIONERY; WRITING IMPLEMENTS; PENS; PENCILS; WRITING PAPER; ENVELOPES; PAPER CLIPS, PAPERWEIGHTS; COASTERS MADE OF PAPER; ANNOUNCEMENT CARDS, BLANK NOTE CARDS, BUSINESS CARDS, CARDS BEARING UNIVERSAL GREETINGS, CHRISTMAS CARDS, CORRESPONDENCE CARDS, GREETING CARDS, MUSICAL GREETING CARDS, HOLIDAY CARDS, INVITATION CARDS, POST CARDS AND TRADING CARDS; GREETING CARDS; GIFT WRAP; PAPER RIBBONS; PAPER GIFT TAGS; MAPS; POSTERS; PHOTOGRAPHS; PRINTS; PHOTOGRAPHS AND PHOTOGRAPH ALBUMS; ARTISTS' MATERIALS, NAMELY, MOULDS FOR MODELLING CLAYS, ARTISTS' BRUSHES, ARTISTS' PASTELS, ARTISTS' PENCILS, ARTISTS' PENS, CANVAS PANELS FOR ARTISTS; PAINT-BRUSHES; MODELLING CLAY; ADHESIVES FOR STATIONERY AND HOUSEHOLD PURPOSES; TYPE-WRITERS AND OFFICE REQUISITES, NAMELY, ADHESIVE TAPE DISPENSERS, CORRECTING FLUID FOR TYPE, ELECTRIC PAPER HOLE PUNCHES AND PARTS THEREFOR, NAMELY, BORING BITS, PROTECTION PLATES, AND GRINDERS, FINGER-STALLS, FRANKING MACHINES, ENVELOPE SEALING MACHINES, PAPER EMBOSSERS, PAPER FOLDING MACHINES, PAPER TRIMMERS, PUNCHES, RUBBER BANDS AND STAPLERS; PRINTERS' TYPE AND PRINTING BLOCKS; CHARTS, NAMELY, NON-ELECTRIC CHART POINTERS, CHARTS IN THE FIELDS OF CULTURE, MUSIC, ARTS, FOOD, HERITAGE, HORTICULTURE, SPORT, HEALTH, WILDLIFE, LEISURE, ROYALTY, ENTERTAINMENT, ARBORICULTURE, EDUCATION, PETS, HISTORY, ARCHITECTURE, AGRICULTURE, ENVIRONMENTAL AND SUSTAINABILITY STUDIES FOR DISPLAYING DATA, FLIP CHART CASES, PRINTED CHARTS FOR DISPLAYING DATA, REVOLVING CIRCULAR CHARTS FOR DISPLAYING DATA; BROCHURES IN THE FIELDS OF CULTURE, MUSIC, ARTS, FOOD, HERITAGE, HORTICULTURE, SPORT, HEALTH, WILDLIFE, LEISURE, ROYALTY, FICTION, ENTERTAINMENT, ARBORICULTURE, PLAY, EDUCATION, PETS, HIS-

TORY, ARCHITECTURE, AGRICULTURE, ENVIRONMENTAL AND SUSTAINABILITY STUDIES; CATALOGUES IN THE FIELDS OF CULTURE, MUSIC, ARTS, FOOD, HERITAGE, HORTICULTURE, SPORT, HEALTH, WILDLIFE, LEISURE, ROYALTY, FICTION, ENTERTAINMENT, ARBORICULTURE, PLAY, EDUCATION, PETS, HISTORY, ARCHITECTURE, AGRICULTURE, ENVIRONMENTAL AND SUSTAINABILITY STUDIES AND ADVERTISING MATERIAL, NAMELY, ADVERTISING PAMPHLETS, BROCHURES, FLYERS AND LEAFLETS SOLD TO THE PUBLIC, ADVERTISING SIGNS OF PAPER OR CARDBOARD, PRINTED ADVERTISING BOARDS OF PAPER OR CARDBOARD; PAPER TOWELS; PAPER NAPKINS; PAPER FLAGS; PRINTED INSTRUCTIONAL, EDUCATIONAL AND TEACHING MATERIAL IN THE FIELDS OF CULTURE, MUSIC, ARTS, FOOD, HERITAGE, HORTICULTURE, SPORT, HEALTH, WILDLIFE, LEISURE, ROYALTY, FICTION, ENTERTAINMENT, ARBORICULTURE, PLAY, EDUCATION, PETS, HISTORY, ARCHITECTURE, AGRICULTURE, ENVIRONMENTAL AND SUSTAINABILITY STUDIES; PLASTIC BAGS FOR PACKAGING, PLASTIC BUBBLE PACKS FOR PACKAGING, ENVELOPES OR POUCHES FOR MERCHANDISE PACKAGING; SEALING STAMPS AND SEALING WAX; PARTS AND FITTINGS FOR PRINTED PERSONAL ORGANIZERS FOR ORGANIZING PERSONAL TIME AND TO-DO LISTS, ADHESIVE LABELS OR PRINTED LABELS, BAR CODE LABELS, PAPER LABELS OR SHIPPING LABELS, SOFTWARE PROGRAMS AND DATA PROCESSING PROGRAMS IN PRINTED FORM, ARTISTS' MATERIALS, NAMELY, MOULDS FOR MODELLING CLAYS, ARTISTS' BRUSHES, ARTISTS' PASTELS, ARTISTS' PENCILS, ARTISTS' PENS, CANVAS PANELS FOR ARTISTS, PAPER FLAGS, PRINTED INSTRUCTIONAL, EDUCATIONAL AND TEACHING MATERIAL IN THE FIELDS OF CULTURE, MUSIC, ARTS, FOOD, HERITAGE, HORTICULTURE, SPORT, HEALTH, WILDLIFE, LEISURE, ROYALTY, FICTION, ENTERTAINMENT, ARBORICULTURE, PLAY, EDUCATION, PETS, HISTORY, ARCHITECTURE, AGRICULTURE, ENVIRONMENTAL AND SUSTAINABILITY STUDIES, PLASTIC BAGS FOR PACKAGING, PLASTIC BUBBLE PACKS FOR PACKAGING, ENVELOPES OR POUCHES FOR MERCHANDISE PACKAGING (U.S. CLS. 2, 5, 22, 23, 29, 37, 38 AND 50).

CLASS 24—FABRICS

FOR TEXTILE AND TEXTILE GOODS, NAMELY, FABRICS FOR TEXTILE USE, NON-WOVEN TEXTILE FABRICS, TEXTILE FABRICS FOR THE MANUFACTURE OF CLOTHING, TEXTILE FABRICS FOR LINGERIE, TEXTILE FABRICS FOR HOME AND COMMERCIAL INTERIORS, TEXTILE FABRICS FOR USE IN THE MANUFACTURE OF GARMENTS, BAGS, JACKETS, GLOVES AND APPAREL, BANNERS AND FLAGS OF TEXTILE, BED AND TABLE LINEN OF TEXTILE, WALL HANGINGS OF TEXTILE, CURTAINS MADE OF TEXTILE FABRICS, TOWELS OF TEXTILES, GIFT WRAP OF TEXTILE, PLACE MATS MADE OF TEXTILE, LABELS OF TEXTILE FOR IDENTIFYING CLOTHING, PRINTED TEXTILE LABELS, LAMINATED TEXTILES TO BE AFFIXED TO THE SURFACE OF FURNITURE, QUILTS OF TEXTILE, TABLE CLOTH, LINEN AND NAPKINS OF TEXTILE, TEXTILE FABRIC INCORPORATING WATERPROOF AND GAS PERMEABLE MEMBRANE MADE OF EXPANDED POLYETRAFLUOROETHYLENE (EPTFE) FOR THE PROTECTION OF SENSITIVE EQUIPMENT AND PACKAGING FROM CONTAMINATES, TEXTILE FABRIC OF ANIMAL SKINS IMITATIONS, TEXTILE HANDKERCHIEFS, TEXTILE HANG TAGS; TOWELS AND FACE CLOTHS; BATHROOM FURNISHINGS, NAMELY, BATH LINENS; BATH LINEN; KITCHEN LINENS, NAMELY, TABLECLOTHS, NAPKINS AND PLACE-MATS, TEA TOWELS; CLOTH FLAGS, CLOTH LABELS, CLOTHS USED FOR WRAPPING GOODS, COTTON CLOTH, DISH CLOTHS, FACE CLOTHS, LINEN CLOTH, WOOLLEN CLOTH, DUST CLOTHS, CLEANING CLOTHS; TABLE CLOTHS, NAPKINS AND PLACE-MATS; FABRICS, NAMELY, FABRICS MADE PRIMARILY OF WOOL, COTTON, RAYON, POLYESTER, CASHMERE, CHIFFON, SILK, DENIM, ZEPHYR OR NYLON; FABRICS FOR USE AS FLAGS, TABLE RUNNERS, TABLE TOPPERS, GIFT WRAP; FABRICS OF LINEN, CHEMICAL FIBER; UPHOLSTERY FABRICS; LINEN AND DAMASK; BED LINENS; DUVETS; BEDCOVERS; BED LINEN; BEDSPREADS; BEDDING;

SHEETS; PILLOW CASES; BLANKETS; QUILTS; CURTAINS; TAPESTRIES OF TEXTILE; TRACED CLOTHS FOR TAPESTRY AND EMBROIDERY (U.S. CLS. 42 AND 50).

CLASS 25—CLOTHING

FOR UNIFORMS; ARTICLES OF OUTERWEAR, NAMELY, COATS, JACKETS, OVERCOATS AND RAINWEAR; SHIRTS; COATS; JACKETS; TROUSERS; SWEATSHIRTS; JEANS; T-SHIRTS; VESTS; SHORTS; SKIRTS; BLOUSES; OVERCOATS; RAINWEAR; WATERPROOF CLOTHING, NAMELY, WATER PROOF BOOTS, WATER REPELLING FOOTWEAR, WATER SOCKS; SWEATERS; PULLOVERS; CARDIGANS; TIES; BELTS; SCARVES; SPORTS CLOTHING, NAMELY, COMBATIVE SPORTS UNIFORMS, MOISTURE-WICKING SPORTS SHIRTS, MOISTURE-WICKING SPORTS PANTS, MOISTURE-WICKING SPORTS BRAS, SPORT COATS, SPORTS SHIRTS, SPORTS PANTS, SPORT STOCKINGS, SPORTS BRAS, SPORTS JACKETS AND JERSEYS, SPORTS OVER UNIFORMS, SPORTS VESTS, SWIMWEAR; SWIMWEAR; PYJAMAS; FOOTWEAR; SHOES; BOOTS; BOOTS FOR SPORTS; RUNNING SHOES; CAPS; HATS; HEADGEAR, NAMELY, HEADWEAR, HATS AND CAPS, EAR MUFFS; SUN VISORS; BODY SUITS; SOCKS; GLOVES; SWEAT SHIRTS; TIES; WORK WEAR, NAMELY, WORK SHOES AND BOOTS, APRONS (U.S. CLS. 22 AND 39).

JILL C. ALT, EXAMINING ATTORNEY

SN 85-033,421. RITIKA PVT. LTD., GURGAON, HARYANA, INDIA, FILED 5-7-2010.

RITU KUMAR

THE NAME(S), PORTRAIT(S), AND/OR SIGNATURE(S) SHOWN IN THE MARK IDENTIFIES "RITU KUMAR", WHOSE CONSENT(S) TO REGISTER IS MADE OF RECORD.

THE MARK CONSISTS OF "RITU KUMAR" IN STYLIZED FORM.

CLASS 18—LEATHER GOODS

FOR GOODS MADE OF LEATHER, NAMELY, HANDBAGS AND WALLETS (U.S. CLS. 1, 2, 3, 22 AND 41).

CLASS 25—CLOTHING

FOR CLOTHING, NAMELY, SHIRTS, T-SHIRT, PANTS, SKIRTS AND TOPS; READYMADE CLOTHING, NAMELY, JACKETS, COATS, DRESSES, LEGGINGS, TROUSERS, CORSETS AND BLOUSES; NECKTIES, SCARVES, SAREES, KURTAS BEING LONG SHIRTS TRADITIONAL TO SOUTH ASIAN MENSWEAR, SCARVES, STOLE, FOOTWEAR AND HEADWEAR, LEATHER BELTS (U.S. CLS. 22 AND 39).

JULIE GUTTADAURO, EXAMINING ATTORNEY

SN 85-034,146. HAZELDEN FOUNDATION, CENTER CITY, MN. FILED 5-10-2010.

ABOUT MY DRINKING

THE MARK CONSISTS OF STANDARD CHARACTERS WITHOUT CLAIM TO ANY PARTICULAR FONT, STYLE, SIZE, OR COLOR.

CLASS 9—ELECTRICAL AND SCIENTIFIC APPARATUS

FOR ELECTRONIC PUBLICATIONS, NAMELY, MANUALS, CD ROMS, AND DVDS IN THE FIELD OF ADDICTION PREVENTION AND TREATMENT RECORDED ON COMPUTER MEDIA (U.S. CLS. 21, 23, 26, 36 AND 38).

CLASS 16—PAPER GOODS AND PRINTED MATTER

FOR PRINTED EDUCATIONAL MATERIALS IN THE FIELD OF ADDICTION PREVENTION AND TREATMENT (U.S. CLS. 2, 5, 22, 23, 29, 37, 38 AND 50).

CLASS 41—EDUCATION AND ENTERTAINMENT

FOR EDUCATION SERVICES, NAMELY, PROVIDING ONLINE EDUCATIONAL TRAINING ASSESSMENT IN THE FIELD OF ADDICTION PREVENTION, EDUCATION, INTERVENTION, AND SELF-GUIDED ABSTINENCE AND PEER SUPPORT, AND DISTRIBUTION OF TRAINING MATERIALS AND EDUCATIONAL MATERIALS IN CONNECTION THEREWITH; DEVELOPING CURRICULUM FOR OTHERS AND DISTRIBUTION OF TRAINING MATERIALS AND EDUCATIONAL MATERIALS IN CONNECTION THEREWITH IN THE FIELDS OF ADDICTION PREVENTION DISTRIBUTED THEREWITH (U.S. CLS. 100, 101 AND 107).

JOSETTE BEVERLY, EXAMINING ATTORNEY

SN 85-035,114. UD TRUCKS NORTH AMERICA, INC., IRVING, TX. FILED 5-11-2010.

UDXtra

THE MARK CONSISTS OF STANDARD CHARACTERS WITHOUT CLAIM TO ANY PARTICULAR FONT, STYLE, SIZE, OR COLOR.

CLASS 1—CHEMICALS

FOR CHEMICALS, NAMELY, ANTIFREEZES AND COOLANTS (U.S. CLS. 1, 5, 6, 10, 26 AND 46).
FIRST USE 12-1-1999; IN COMMERCE 1-1-2000.

CLASS 4—LUBRICANTS AND FUELS

FOR CHEMICALS, NAMELY, ENGINE OIL (U.S. CLS. 1, 6 AND 15).
FIRST USE 12-1-1999; IN COMMERCE 1-1-2000.
SANI KHOURI, EXAMINING ATTORNEY

SN 85-035,324. ZOTT GMBH & CO. KG, MERTINGEN, FED REP GERMANY, FILED 5-11-2010.

ZOTT

THE MARK CONSISTS OF STANDARD CHARACTERS WITHOUT CLAIM TO ANY PARTICULAR FONT, STYLE, SIZE, OR COLOR.

OWNER OF FED REP GERMANY REG. NO. 30601075, DATED 2-2-2006, EXPIRES 1-31-2016.

OWNER OF U.S. REG. NO. 1,228,631.

THE WORDING "ZOTT" HAS NO MEANING IN A FOREIGN LANGUAGE.

CLASS 29—MEATS AND PROCESSED FOODS

FOR MILK AND MILK PRODUCTS, NAMELY, FRESH MILK, SOUR MILK, BUTTERMILK, YOGURT, YOGURT BLENDED WITH FRUIT, YOGURT WITH CHOCOLATE OR COCOA ADDITIVES, KEFIR, CREAM, BUTTER, CURD CHEESE, CURD CHEESE WITH FRUITS OR HERBS, MILK POWDER AND WHEY POWDER FOR HUMAN CONSUMPTION, DIETETIC YOGURT NOT FOR MEDICAL USE; CHEESE AND CHEESE PREPARATIONS, NAMELY, CHEESE FOOD, CHEESE SPREADS, COTTAGE CHEESE, CREAM CHEESE, PROCESSED CHEESE, FRUIT COMPOTE (U.S. CL. 46).

CLASS 30—STAPLE FOODS

FOR NON-ALCOHOLIC MILK SHAKES, PUDDINGS, CHEESE SAUCE, DESSERTS CONSISTING MAINLY OF MILK AND FLAVOURINGS WITH GELATIN AND STARCH AS BINDING AGENTS, NAMELY, SOUFFLES, PUDDINGS, MOUSSE AND ICE CREAM DESSERTS; DESSERTS, NAMELY, BAKERY DESSERTS, FLAVOURED AND SWEETENED GELATIN DESSERTS, FLAN, ICE CREAM DESSERTS, TIRAMISU (U.S. CL. 46).
GRETCHEN ULRICH, EXAMINING ATTORNEY

SN 85-035,633. BRICKELL FINANCIAL SERVICES-MOTOR CLUB, INC., MIAMI, FL. FILED 5-11-2010.

DRIVE ON

THE MARK CONSISTS OF STANDARD CHARACTERS WITHOUT CLAIM TO ANY PARTICULAR FONT, STYLE, SIZE, OR COLOR.

CLASS 37—CONSTRUCTION AND REPAIR

FOR EMERGENCY ROADSIDE REPAIR SERVICES; EMERGENCY ROADSIDE ASSISTANCE SERVICES, NAMELY, RESPONDING TO CALLS FOR ROADSIDE ASSISTANCE, FLAT TIRE CHANGING, EMERGENCY FUEL SUPPLYING AND BATTERY JUMP STARTING (U.S. CLS. 100, 103 AND 106).

FIRST USE 6-14-2010; IN COMMERCE 6-14-2010.

CLASS 39—TRANSPORTATION AND STORAGE

FOR EMERGENCY ROADSIDE ASSISTANCE SERVICES, NAMELY, TOWING, WINCH-OUT AND KEY DELIVERY SERVICES (U.S. CLS. 100 AND 105).

FIRST USE 6-14-2010; IN COMMERCE 6-14-2010.

CLASS 45—PERSONAL AND LEGAL SERVICES

FOR EMERGENCY ROADSIDE ASSISTANCE SERVICES, NAMELY, OPENING OF LOCKS (U.S. CLS. 100 AND 101).

BRIAN PINO, EXAMINING ATTORNEY

SN 85-036,559. DAVID DAWES NEE II FOUNDATION, DBA THE DAVE NEE FOUNDATION, NEW YORK, NY. FILED 5-12-2010.

UNCOMMON COUNSEL

THE MARK CONSISTS OF STANDARD CHARACTERS WITHOUT CLAIM TO ANY PARTICULAR FONT, STYLE, SIZE, OR COLOR.

NO CLAIM IS MADE TO THE EXCLUSIVE RIGHT TO USE "COUNSEL", APART FROM THE MARK AS SHOWN.

CLASS 41—EDUCATION AND ENTERTAINMENT

FOR EDUCATIONAL SERVICES, NAMELY, CONDUCTING SEMINARS, CONFERENCES, PANEL DISCUSSIONS AND WORKSHOPS IN THE FIELD OF DIAGNOSIS AND TREATMENT OF DEPRESSION AND SUICIDE PREVENTION FOR ADOLESCENTS AND YOUNG ADULTS, AND DISTRIBUTION OF EDUCATIONAL MATERIALS IN CONNECTION WITH THIS FIELD (U.S. CLS. 100, 101 AND 107).

FIRST USE 2-1-2009; IN COMMERCE 2-1-2009.

CLASS 45—PERSONAL AND LEGAL SERVICES

FOR PROVIDING SUPPORTIVE EMOTIONAL COUNSELING AND EMOTIONAL SUPPORT SERVICES FOR LAW STUDENTS IN THE FIELD OF DEPRESSION AND SUICIDE PREVENTION AMONG LAW STUDENTS; PROVIDING INFORMATION IN THE FIELD OF EMOTIONAL COUNSELING FOR LAW STUDENTS FOR SUICIDE PREVENTION AMONG LAW STUDENTS (U.S. CLS. 100 AND 101).

FIRST USE 2-1-2009; IN COMMERCE 2-1-2009.
ASMAT KHAN, EXAMINING ATTORNEY

SN 85-036,777. THE IDOCTORS, INC., SHREVEPORT, LA. FILED 5-12-2010.

I DOCTORS

THE MARK CONSISTS OF STANDARD CHARACTERS WITHOUT CLAIM TO ANY PARTICULAR FONT, STYLE, SIZE, OR COLOR.

CLASS 9—ELECTRICAL AND SCIENTIFIC APPARATUS

FOR SMARTPHONES, CELLULAR PHONES AND PORTABLE LISTENING DEVICES, NAMELY, MP3 PLAYERS, AND ACCESSORIES FOR SMARTPHONES, CELLULAR PHONES AND MP3 PLAYERS, NAMELY, BATTERIES, EAR BUDS, EAR PHONES, MICROPHONES, BACKPLATES FOR CELLPHONES, SMART PHONES AND MP3 PLAYERS, CARRYING CASES, HOLDERS AND PROTECTIVE CASES SPECIALLY ADAPTED FOR USE WITH SMART PHONES, CELL PHONES, AND MP3 PLAYERS (U.S. CLS. 21, 23, 26, 36 AND 38).

FIRST USE 4-5-2009; IN COMMERCE 1-13-2010.

CLASS 37—CONSTRUCTION AND REPAIR

FOR REPAIR AND MAINTENANCE OF SMARTPHONES, CELL PHONES, AND MP3 PLAYER RELATED HARDWARE (U.S. CLS. 100, 103 AND 106).

FIRST USE 4-5-2009; IN COMMERCE 1-13-2010.

CLASS 42—SCIENTIFIC AND COMPUTER SERVICES

FOR REPAIR AND MAINTENANCE OF COMPUTER SOFTWARE FOR SMARTPHONES, CELL PHONES AND MP3 PLAYERS (U.S. CLS. 100 AND 101).

FIRST USE 4-5-2009; IN COMMERCE 1-13-2010.

SARA BENJAMIN, EXAMINING ATTORNEY

SN 85-038,118. AUBREY DANIELS INTERNATIONAL, ATLANTA, GA. FILED 5-13-2010.

Coaching for Rapid Change

THE MARK CONSISTS OF STANDARD CHARACTERS WITHOUT CLAIM TO ANY PARTICULAR FONT, STYLE, SIZE, OR COLOR.

CLASS 35—ADVERTISING AND BUSINESS

FOR CONSULTING SERVICES IN THE FIELDS OF SALES AND MARKETING FOR SALES COACHES (U.S. CLS. 100, 101 AND 102).

FIRST USE 10-1-2007; IN COMMERCE 7-1-2008.

CLASS 41—EDUCATION AND ENTERTAINMENT

FOR PROVIDING MANAGEMENT TRAINING COURSES IN THE FIELDS OF SALES AND MARKETING FOR SALES COACHES (U.S. CLS. 100, 101 AND 107).

FIRST USE 10-1-2007; IN COMMERCE 7-1-2008.

PAULA MAHONEY, EXAMINING ATTORNEY

SN 85-041,537. GIFTCRAFT LTD., BRAMPTON, CANADA,
FILED 5-18-2010.



PRIORITY CLAIMED UNDER SEC. 44(D) ON CANADA
APPLICATION NO. 1,480,360, FILED 5-10-2010.

THE MARK CONSISTS OF THE STYLIZED WORDS
"SIMPLY YOU" WITH A "." FOLLOWING THE WORD
"YOU".

CLASS 3—COSMETICS AND CLEANING PREPARATIONS

FOR BODY CARE PRODUCTS, NON-MEDICATED HAND WASH, HAND CLEANSER, HAND LOTION, HAND CREAM, NON-MEDIATED LIQUID SOAP AND NON-MEDICATED BAR SOAP, BODY WASH, BODY LOTION, SHOWER GEL, BUBBLE BATH, HOME FRAGRANCE, SCENTED ROOM SPRAYS, SCENTED STICKS AND REEDS SOLD WITH SCENTED OILS AS A UNIT FOR USE IN ROOM SCENT DIFFUSERS; PERSONAL FRAGRANCE PRODUCTS, NAMELY, PERFUMES, COLOGNES AND EAU DE TOILETTE (U.S. CLS. 1, 4, 6, 50, 51 AND 52).

CLASS 4—LUBRICANTS AND FUELS

FOR SCENTED CANDLES (U.S. CLS. 1, 6 AND 15).

CLASS 14—JEWELRY

FOR JEWELRY, BRACELETS, EARRINGS, PENDANTS, NECKLACES, RINGS, JEWELRY CASES, JEWELRY BOXES, JEWELRY CHAINS, BROACHES, CHOKES IN THE NATURE OF NECKLACES, TIME PIECES IN THE NATURE OF WATCHES, CLOCKS, WATCHES (U.S. CLS. 2, 27, 28 AND 50).

CLASS 18—LEATHER GOODS

FOR BAGS, NAMELY, HANDBAGS, PURSES, TOTE BAGS, COSMETIC BAGS SOLD EMPTY, DUFFEL BAGS, BACK PACKS, MESSENGER BAGS, WALLETS, IDENTIFICATION CARD CASES, LUGGAGE TAGS, UMBRELLAS, PARASOLS, COIN PURSES, WRIST BAGS IN THE NATURE OF PURSES, BELT BAGS, TOILETRY BAGS SOLD EMPTY, GARMENT BAGS FOR TRAVEL, CARRY-ON BAGS, TRAVEL BAGS, FLIGHT BAGS, OVERNIGHT BAGS, DIAPER BAGS, CREDIT CARD CASES, POCKETBOOKS, JEWELRY BAGS IN THE NATURE OF ORGANIZERS FOR TRAVEL PURPOSES (U.S. CLS. 1, 2, 3, 22 AND 41).

CLASS 21—HOUSEWARES AND GLASS

FOR MUGS, BOWLS, DISHES, PLATES, TEAPOTS, TEA BAG HOLDERS IN THE NATURE OF SMALL DISHES, CUPS, SAUCERS, CANDLEHOLDERS, COVERED CONTAINERS, IN THE NATURE OF CASSEROLE DISHES, SERVING TRAYS, VASES, SERVING DISHES, SERVING PLATTERS, TRIVETS, COASTERS NOT OF PAPER AND NOT BEING TABLE LINEN, NAPKIN HOLDERS, SALT AND PEPPER SHAKERS, CAKE STANDS, COOKWARE, NAMELY, POTS AND PANS, FIGURINE SETS COMPRISING NATIVITY SCENES MADE OF CHINA, CRYSTAL, EARTHENWARE, GLASS, PORCELAIN OR TERRA COTTA; FIGURINES MADE OF CHINA, CRYSTAL, EARTHENWARE, GLASS, PORCELAIN OR TERRA COTTA; WORKS OF ART MADE OF CHINA, CRYSTAL, EARTHENWARE, GLASS, PORCELAIN OR TERRA COTTA; NON-METAL COIN AND BILL BANKS, ORNAMENTS MADE OF CHINA, CRYSTAL, EARTHENWARE, GLASS, PORCELAIN OR TERRA COTTA; DECORATIVE PLATES, DECORATIVE BOWLS, PLAQUES MADE OF CHINA, CRYSTAL, EARTHENWARE, GLASS, PORCELAIN OR TERRA COTTA; GLASS BOXES (U.S. CLS. 2, 13, 23, 29, 30, 33, 40 AND 50).

CLASS 35—ADVERTISING AND BUSINESS

FOR PRODUCT MERCHANDISING, RETAIL AND WHOLESALE SERVICES PROVIDED THROUGH DIRECT SOLICITATION BY SALES AGENTS DIRECTED TO END-USERS FEATURING JEWELRY, GIFT ITEMS, CANDLES, HANDBAGS, FASHION ACCESSORIES, HOME AND PERSONAL FRAGRANCE, TABLEWARE, HOUSE WARES, OUTDOOR HOME AND GARDEN ACCESSORIES, OUTDOOR FURNITURE, NAMELY, CHAIRS, LOUNGES, TABLES, STANDS, HAMMOCKS, DECK CHAIRS, BEACH CHAIRS, CHAIR CUSHIONS, LOUNGE CHAIRS, FLOATING RECREATIONAL LOUNGE CHAIRS, CHAISE LOUNGES, TABLES DESIGNED TO HOLD GAS GRILLS, TABLE UMBRELLAS, OUTDOOR DINING TABLES, OUTDOOR END TABLES, BIRD FEEDING TABLES, HAMMOCK STANDS, PLANT STANDS, TOWEL STANDS, UMBRELLA STANDS, POT STANDS, OUTDOOR HOME ACCESSORIES, NAMELY, OUTDOOR LIGHTING, OUTDOOR GLASSWARE, DISHES, BARBECUES, ELECTRIC TORCHES FOR LIGHTING, LANTERNS FOR LIGHTING, LIGHTERS PRIMARILY FOR LIGHTING GRILLS, FIREPLACES AND CANDLES, LIGHTING FIXTURES WITH MOTION DETECTION, OUTDOOR LIGHTING, NAMELY, PAVER LIGHTS, SOLAR LIGHT FIXTURES, NAMELY, OUTDOOR SOLAR POWERED LIGHTING UNITS AND FIXTURES, BARBECUE GRILLS, COOKING UTENSILS, NAMELY, BARBECUE BRANDERS, UTENSILS FOR BARBECUES, NAMELY, FORKS, TONGS, TURNERS, BARBECUE MITTS, CANDLE TORCHES, PATIO TORCHES; DIRECT SALES ORGANIZATION AND PLANNING, NAMELY, OFFERING ADVERTISING, PROMOTION, TECHNICAL ASSISTANCE IN THE NATURE OF BUSINESS MANAGEMENT ASSISTANCE IN THE ESTABLISHMENT AND OPERATION OF RETAIL ON-LINE, CATALOGUE, AND HOME PARTY DISTRIBUTION BUSINESSES; AND THE ADMINISTRATION OF AN INCENTIVE AWARDS PROGRAM TO PROMOTE THE SALE OF PRODUCTS OF OTHERS (U.S. CLS. 100, 101 AND 102).

SHAILA SETTLES, EXAMINING ATTORNEY

SN 85-047,032. FLEXIANT LIMITED, LIVINGSTON EH54 6GU, UNITED KINGDOM, FILED 5-25-2010.



PRIORITY CLAIMED UNDER SEC. 44(D) ON ERPN CMNTY TM OFC APPLICATION NO. 008800872, FILED 1-8-2010, REG. NO. 008800872, DATED 5-7-2010, EXPIRES 1-8-2020.

THE MARK CONSISTS OF A BLACK STAR WITH FIVE POINTS AND THE LETTER "X" IN BLACK AND WHITE INCORPORATED INTO THE STAR DESIGN.

CLASS 9—ELECTRICAL AND SCIENTIFIC APPARATUS

FOR DOWNLOADABLE COMPUTER PROGRAMS AND SOFTWARE FOR THE PURPOSE OF CONNECTION TO AND ADMINISTRATION OF CLOUD-BASED COMPUTER NETWORKS (U.S. CLS. 21, 23, 26, 36 AND 38).

CLASS 42—SCIENTIFIC AND COMPUTER SERVICES

FOR HOSTING WEB SERVERS FOR USE IN THE FIELD OF CLOUD COMPUTING; RENTING WEB SERVERS; RENTAL SERVICES FOR WEB SERVERS; RENTAL SERVICES FOR COMPUTER EQUIPMENT; COMPUTER RENTAL; RENTAL OF COMPUTER HARDWARE AND OF COMPUTER PERIPHERAL APPARATUS; RENTAL OF COMPUTER SOFTWARE; SOFTWARE IMPLEMENTATION; SOFTWARE DESIGN; SOFTWARE DEVELOPMENT; SOFTWARE ENGINEERING; UPDATING OF COMPUTER SOFTWARE; UPGRADING OF COMPUTER SOFTWARE; WRITING OF COMPUTER SOFTWARE; TECHNICAL ADVISORY AND CONSULTANCY SERVICES RELATING TO COMPUTER SOFTWARE; TECHNICAL ADVISORY AND CONSULTANCY SERVICES RELATING TO COMPUTERS; TECHNICAL ADVISORY AND CONSULTANCY SERVICES RELATING TO WEB SERVERS; TECHNICAL ADVISORY AND CONSULTANCY SERVICES RELATING TO HOSTING OR RENTING WEB SERVERS (U.S. CLS. 100 AND 101).

CLASS 45—PERSONAL AND LEGAL SERVICES

FOR COMPUTER LICENSING; COMPUTER SOFTWARE LICENSING (U.S. CLS. 100 AND 101).
ANN E. SAPPENFIELD, EXAMINING ATTORNEY

SN 85-047,864. CONGRATS BOOKS INC., POMPAN BEACH, FL. FILED 5-26-2010.

CLICK. PRINT. TRAIN.
INSTANT, SIMPLE, AND
AFFORDABLE SOLUTIONS FOR
ALL YOUR TRAINING NEEDS

THE MARK CONSISTS OF STANDARD CHARACTERS WITHOUT CLAIM TO ANY PARTICULAR FONT, STYLE, SIZE, OR COLOR.

CLASS 9—ELECTRICAL AND SCIENTIFIC APPARATUS

FOR COMPUTER AND SOFTWARE PRODUCTS, NAMELY, SERIES OF DOWNLOADABLE BOOKS AND MULTIMEDIA FILES FEATURING TRAINING PROGRAMS, ALL IN THE FIELD OF BUSINESS DEVELOPMENT FOR CONSUMERS, INDIVIDUALS, BUSINESS OWNERS, TRAINERS, SUPERVISORS, MANAGERS, DIRECTORS, VPS, PRESIDENTS, CORPORATIONS BOTH PUBLIC AND PRIVATE; COMPUTER AND SOFTWARE PRODUCTS, NAMELY, SERIES OF BOOKS AND MULTIMEDIA FILES FEATURING TRAINING PROGRAMS, ALL IN THE FIELD OF BUSINESS DEVELOPMENT AND RECORDED ON COMPUTER MEDIA FOR CONSUMERS, INDIVIDUALS, BUSINESS OWNERS, TRAINERS, SUPERVISORS, MANAGERS, DIRECTORS, VPS, PRESIDENTS, CORPORATIONS BOTH PUBLIC AND PRIVATE; AUDIO AND VIDEO RECORDINGS FEATURING BUSINESS EDUCATION AND TRAINING FOR CONSUMERS, INDIVIDUALS, BUSINESS OWNERS, TRAINERS, SUPERVISORS, MANAGERS, DIRECTORS, VPS, PRESIDENTS, CORPORATIONS BOTH PUBLIC AND PRIVATE; AUDIO AND VIDEO RECORDINGS FEATURING BUSINESS EDUCATION AND TRAINING, NAMELY, TRAINING IN THE FIELDS OF WORKPLACE SKILLS, CUSTOM BRANDING AND CUSTOMER SERVICE FOR CONSUMERS, INDIVIDUALS, BUSINESS OWNERS, TRAINERS, SUPERVISORS, MANAGERS, DIRECTORS, VPS, PRESIDENTS, CORPORATIONS BOTH PUBLIC AND PRIVATE; DOWNLOADABLE MULTIMEDIA FILES FEATURING COMPUTER BASED TRAINING SESSIONS IN THE FIELD OF CUSTOMER SERVICE, MOTIVATION, SAFETY, HUMAN RESOURCES, GENERAL BUSINESS EDUCATION, AND DEVELOPING AND FACILITATING CUSTOMIZED IN-COMPANY LEADERSHIP, EMPLOYEE, AND EXECUTIVE DEVELOPMENT PROGRAMS, AND EXECUTIVE AND EMPLOYEE COACHING SERVICES FOR CONSUMERS, INDIVIDUALS, BUSINESS OWNERS, TRAINERS, SUPERVISORS, MANAGERS, DIRECTORS, VPS, PRESIDENTS, CORPORATIONS BOTH PUBLIC AND PRIVATE; AUDIO BOOKS IN THE FIELD OF CUSTOMER SERVICE, BUSINESS EDUCATION AND TRAINING SERVICES, MOTIVATION, RELAXATION, POSITIVE OUTLOOK AND GENERAL WORK-LIFE BALANCE (U.S. CLS. 21, 23, 26, 36 AND 38).

FIRST USE 3-31-2008; IN COMMERCE 12-1-2009.

CLASS 41—EDUCATION AND ENTERTAINMENT

FOR EDUCATION AND ENTERTAINMENT SERVICES, NAMELY, DEVELOPING AND CONDUCTING GENERIC AS WELL AS CUSTOMIZED IN-COMPANY LEADERSHIP AND EMPLOYEE AND EXECUTIVE DEVELOPMENT PROGRAMS IN THE NATURE OF EDUCATION SERVICES, NAMELY, PROVIDING CLASSES, SEMINARS, AND WORKSHOPS IN THE FIELD OF CUSTOMER SERVICE, SAFETY, HUMAN RESOURCES, GENERAL BUSINESS EDUCATION, AND DEVELOPING AND FACILITATING CUSTOMIZED IN-COMPANY LEADERSHIP, EMPLOYEE, AND EXECUTIVE DEVELOPMENT PROGRAMS, AND EXECUTIVE AND EMPLOYEE COACHING SERVICES, AND PUBLIC AND IN-COMPANY KEYNOTE PRESENTATIONS TO BUSINESS LEADERS, FOR CONSUMERS, INDIVIDUALS, BUSINESS OWNERS, TRAINERS, SUPERVISORS, MANAGERS, DIRECTORS, VPS, PRESIDENTS, CORPORATIONS BOTH PUBLIC AND PRIVATE; PROVIDING OF LIVE AND ONLINE TRAINING PROGRAMS IN THE FIELD OF CUSTOMER SERVICE, SAFETY, HUMAN RESOURCES, GENERAL BUSINESS EDUCATION, AND DEVELOPING AND FACILITATING CUSTOMIZED IN-COMPANY LEADERSHIP, EMPLOYEE, AND EXECUTIVE AND EMPLOYEE COACHING SERVICES, AND PUBLIC AND IN-COMPANY KEYNOTE PRESENTATIONS TO BUSINESS LEADERS, FOR CONSUMERS, INDIVIDUALS, BUSINESS OWNERS, TRAINERS, SUPERVISORS, MANAGERS, DIRECTORS, VPS, PRESIDENTS, CORPORATIONS BOTH PUBLIC AND PRIVATE; EDUCATION SERVICES, NAMELY, PROVIDING LIVE AND ON-LINE CLASSES AND PRESENTATIONS IN THE FIELD OF CUSTOMER SERVICE, SAFETY, HUMAN RESOURCES, GENERAL BUSINESS EDUCATION, AND DEVELOPING AND FACILITATING CUSTOMIZED IN-COMPANY LEADERSHIP, EMPLOYEE, AND EXECUTIVE

TIVE DEVELOPMENT PROGRAMS, AND EXECUTIVE AND EMPLOYEE COACHING SERVICES, AND PUBLIC AND IN-COMPANY KEYNOTE PRESENTATIONS TO BUSINESS LEADERS, AND DISTRIBUTION OF PRINTED MATERIALS IN CONNECTION THEREWITH IN HARD COPY OR ELECTRONIC FORMAT ON THE SAME TOPICS FOR CONSUMERS, INDIVIDUALS, BUSINESS OWNERS, TRAINERS, SUPERVISORS, MANAGERS, DIRECTORS, VPS, PRESIDENTS, CORPORATIONS BOTH PUBLIC AND PRIVATE; PROVIDING PROFESSIONAL COACHING AND GROUP COACHING SERVICES IN THE FIELD OF CUSTOMER SERVICE, SAFETY, HUMAN RESOURCES, GENERAL BUSINESS EDUCATION, AND DEVELOPING AND FACILITATING CUSTOMIZED IN-COMPANY LEADERSHIP, EMPLOYEE, AND EXECUTIVE DEVELOPMENT PROGRAMS, AND EXECUTIVE AND EMPLOYEE COACHING SERVICES, AND PUBLIC AND IN-COMPANY KEYNOTE PRESENTATIONS TO BUSINESS LEADERS, FOR CONSUMERS, INDIVIDUALS, BUSINESS OWNERS, TRAINERS, SUPERVISORS, MANAGERS, DIRECTORS, VPS, PRESIDENTS, CORPORATIONS BOTH PUBLIC AND PRIVATE; PROVIDING ON-LINE NON-DOWNLOADABLE PUBLICATIONS IN THE NATURE OF BOOKLETS, ADVICE BOOKS AND MANUALS IN THE FIELD OF CUSTOMER SERVICE, SAFETY, HUMAN RESOURCES, GENERAL BUSINESS EDUCATION, AND DEVELOPING AND FACILITATING CUSTOMIZED IN-COMPANY LEADERSHIP, EMPLOYEE, AND EXECUTIVE DEVELOPMENT PROGRAMS, AND EXECUTIVE AND EMPLOYEE COACHING SERVICES, AND PUBLIC AND IN-COMPANY KEYNOTE PRESENTATIONS TO BUSINESS LEADERS, FOR CONSUMERS, INDIVIDUALS, BUSINESS OWNERS, TRAINERS, SUPERVISORS, MANAGERS, DIRECTORS, VPS, PRESIDENTS, CORPORATIONS BOTH PUBLIC AND PRIVATE (U.S. CLS. 100, 101 AND 107).

FIRST USE 3-31-2008; IN COMMERCE 12-1-2009.

KATHERINE CONNOLLY, EXAMINING ATTORNEY

CLASS 35—ADVERTISING AND BUSINESS

FOR RETAIL STORE SERVICES FEATURING FOOD; VENDING IN THE FIELD OF FOOD (U.S. CLS. 100, 101 AND 102).

CLASS 43—HOTEL AND RESTAURANT SERVICES

FOR SERVICES FOR PROVIDING FOOD AND DRINK; CAFE, RESTAURANT, TEAROOM AND BAR SERVICES (U.S. CLS. 100 AND 101).

KATHERINE STOIDES, EXAMINING ATTORNEY

SN 85-053,725. LOTUS BAKERIES, LEMBEKE, BELGIUM, FILED 6-3-2010.



SN 85-053,703. LOTUS BAKERIES, LEMBEKE, BELGIUM, FILED 6-3-2010.



OWNER OF U.S. REG. NOS. 1,395,984, 1,724,030 AND 2,706,258.

NO CLAIM IS MADE TO THE EXCLUSIVE RIGHT TO USE "COFFEE CART", APART FROM THE MARK AS SHOWN.

THE COLOR(S) RED, WHITE AND LIGHT BROWN IS/ ARE CLAIMED AS A FEATURE OF THE MARK.

THE MARK CONSISTS OF THE WORDS "LOTUS BISCOFF COFFEE CART" IN WHICH "LOTUS" AND A FLOWER DESIGN ARE WRITTEN IN WHITE AND ARE SHOWN IN A RED SHIELD DESIGN, THE WORD "BISCOFF" IS WRITTEN IN LIGHT BROWN STYLIZED LETTERS WITH RED SHADOW EFFECT, THERE IS A RED HORIZONTAL LINE UNDER WHICH THE WORDS "COFFEE CART" ARE WRITTEN IN RED.

CLASS 30—STAPLE FOODS

FOR CAKES, PASTRY, BISCUITS, COOKIES; SPREADS CONTAINING BISCUITS OR COOKIES NOT INCLUDING FRUITS OR CHEESE OR VEGETABLE-BASED OR DAIRY BASED SPREADS; ICE CREAM; COFFEE, TEA, COCOA, SUGAR, TAPIOCA, SAGO, ARTIFICIAL COFFEE; BREAD, CONFECTIONERY MADE OF SUGAR, EDIBLE ICES; HONEY, TREACLE, YEAST, BAKING POWDER, SALT, MUSTARD, VINEGAR, SPICES; ICE (U.S. CL. 46).

OWNER OF U.S. REG. NOS. 1,395,984, 1,724,030 AND 2,706,258.

NO CLAIM IS MADE TO THE EXCLUSIVE RIGHT TO USE "COFFEE", APART FROM THE MARK AS SHOWN. THE COLOR(S) RED, WHITE AND LIGHT BROWN IS/ ARE CLAIMED AS A FEATURE OF THE MARK.

THE MARK CONSISTS OF THE WORDS "LOTUS BISCOFF COFFEE CORNER" IN WHICH "LOTUS" AND A FLOWER DESIGN ARE WRITTEN IN WHITE AND ARE SHOWN IN A RED SHIELD DESIGN, THE WORD "BISCOFF" IS WRITTEN IN LIGHT BROWN STYLIZED LETTERS WITH RED SHADOW EFFECT, THERE IS A RED HORIZONTAL LINE UNDER WHICH THE WORDS "COFFEE CORNER" ARE WRITTEN IN RED.

CLASS 30—STAPLE FOODS

FOR CAKES, PASTRY, BISCUITS, COOKIES; SPREADS CONTAINING BISCUITS OR COOKIES NOT INCLUDING FRUITS OR CHEESE OR VEGETABLE-BASED OR DAIRY BASED SPREADS; ICE CREAM; COFFEE, TEA, COCOA, SUGAR, TAPIOCA, SAGO, ARTIFICIAL COFFEE; BREAD, CONFECTIONERY MADE OF SUGAR, EDIBLE ICES; HONEY, TREACLE, YEAST, BAKING POWDER, SALT, MUSTARD, VINEGAR, SPICES; ICE (U.S. CL. 46).

CLASS 35—ADVERTISING AND BUSINESS

FOR RETAIL STORE SERVICES FEATURING FOOD; VENDING IN THE FIELD OF FOOD (U.S. CLS. 100, 101 AND 102).

CLASS 43—HOTEL AND RESTAURANT SERVICES

FOR SERVICES FOR PROVIDING FOOD AND DRINK; CAFE, RESTAURANT, TEAROOM AND BAR SERVICES (U.S. CLS. 100 AND 101).

KATHERINE STOIDES, EXAMINING ATTORNEY

SN 85-054,792. FUTURALLIA, CHASSENEUIL DU POITOU, FRANCE, FILED 6-4-2010.

FUTURALLIA

THE MARK CONSISTS OF THE WORD "FUTURALLIA" WITH TWO LINKED RINGS IN BETWEEN THE "R" AND "A".

CLASS 9—ELECTRICAL AND SCIENTIFIC APPARATUS

FOR COMPUTER SOFTWARE FOR USE IN CORPORATE EVENT MANAGEMENT (U.S. CLS. 21, 23, 26, 36 AND 38).

CLASS 35—ADVERTISING AND BUSINESS

FOR BUSINESS MEETING PLANNING, PERSONNEL RECRUITMENT, BUSINESS ORGANIZATION CONSULTING, ARRANGING AND CONDUCTING BUSINESS CONFERENCES, BUSINESS NETWORKING (U.S. CLS. 100, 101 AND 102).

CLASS 38—COMMUNICATION

FOR PROVIDING ACCESS TO DATABASES RELATED TO THE ORGANIZATION OF FORUMS, COLLOQUIUMS AND BUSINESS MEETINGS; PROVIDING AN ONLINE FORUM FOR BUSINESS MATCHMAKING BUSINESS SPEED DATING AND BUSINESS TO BUSINESS MEETINGS (U.S. CLS. 100, 101 AND 104).

CLASS 41—EDUCATION AND ENTERTAINMENT

FOR PARTY PLANNING; ENTERTAINMENT SERVICES, NAMELY, CONDUCTING PARTIES (U.S. CLS. 100, 101 AND 107).

ROBERT C. CLARK JR., EXAMINING ATTORNEY

SN 85-057,972. COHEN, DOMINIQUE, LOS ANGELES, CA. FILED 6-9-2010.



THE MARK CONSISTS OF A CUSTOM DESIGNED LARGE STARBURST AND SIX SMALLER STARBURST DESIGNS THAT APPEAR AT THE TOP OF THE MARK. THE WORD "LIGHTSTYLE" APPEARS UNDERNEATH THE LARGE STARBURST.

CLASS 14—JEWELRY

FOR JEWELRY (U.S. CLS. 2, 27, 28 AND 50).

CLASS 18—LEATHER GOODS

FOR HANDBAGS (U.S. CLS. 1, 2, 3, 22 AND 41).

FLORENTINA BLANDU, EXAMINING ATTORNEY

SN 85-058,925. VERONA HOLDINGS, LLC, DEL MAR, CA. FILED 6-9-2010.



Peace Through Strength

THE MARK CONSISTS OF A PEACE SYMBOL WITH A FLEXED ARM AND BICEP WOVEN THROUGH IT, WITH THE WORDING "PEACE THROUGH STRENGTH" UNDER THE DESIGN.

CLASS 16—PAPER GOODS AND PRINTED MATTER

FOR BUMPER STICKERS; PAPER BANNERS; PAPER FLAGS; POSTERS (U.S. CLS. 2, 5, 22, 23, 29, 37, 38 AND 50).

CLASS 21—HOUSEWARES AND GLASS

FOR MUGS (U.S. CLS. 2, 13, 23, 29, 30, 33, 40 AND 50).

CLASS 25—CLOTHING

FOR APRONS; BANDANAS; HATS; HEADWEAR; JACKETS; SHIRTS; SWEAT SHIRTS; SWIMSUITS; T-SHIRTS; VISORS (U.S. CLS. 22 AND 39).

DEZMONA MIZELLE, EXAMINING ATTORNEY

SN 85-062,348. RXEOB, RICHMOND, VA. FILED 6-14-2010.

EMWELLICS

THE MARK CONSISTS OF STANDARD CHARACTERS WITHOUT CLAIM TO ANY PARTICULAR FONT, STYLE, SIZE, OR COLOR.

CLASS 9—ELECTRICAL AND SCIENTIFIC APPARATUS

FOR DOWNLOADABLE COMPUTER APPLICATION SOFTWARE FOR MOBILE PHONES IN THE FIELD OF HEALTHCARE DATA MANAGEMENT, NAMELY, SOFTWARE FOR MANAGING PATIENT MEDICAL INFORMATION RELATING TO PHARMACEUTICALS AND HEALTH CONDITIONS (U.S. CLS. 21, 23, 26, 36 AND 38).

CLASS 44—MEDICAL, BEAUTY AND AGRICULTURAL SERVICES

FOR PROVIDING INFORMATION IN THE FIELD OF HEALTHCARE (U.S. CLS. 100 AND 101).
TARA PATE, EXAMINING ATTORNEY

SN 85-065,688. OHIO VALLEY ATHLETIC CONFERENCE INC., BELLAIRE, OH. FILED 6-17-2010.



OWNER OF U.S. REG. NO. 3,738,753.

NO CLAIM IS MADE TO THE EXCLUSIVE RIGHT TO USE "FOUNDED 1943" AND DESIGNS OF THE MAPS OF OHIO AND WEST VIRGINIA, APART FROM THE MARK AS SHOWN.

THE COLOR(S) BLUE, RED, GOLD, BLACK, WHITE AND GRAY IS/ARE CLAIMED AS A FEATURE OF THE MARK.

THE MARK CONSISTS OF A SEAL WITH TWO CIRCLES SHOWN IN BLACK, THE WORDING "OHIO VALLEY ATHLETIC CONFERENCE" IN BLACK BETWEEN THE TWO CIRCLES, THE WORDING "FOUNDED 1943" IN BLACK AT THE TOP OF THE INNER CIRCLE, A DEPICTION OF THE STATES OHIO AND WEST VIRGINIA IN RED AND GOLD, RESPECTIVELY, WITH THE WORDING "OVAC" IN WHITE OVER THE STATES. THE BORDERS OF THE STATES AND THE LETTERING "OVAC" ARE IN BLUE, AND A STAR IS SHOWN IN BLUE AT THE PLACE WHERE WHEELING, WEST VIRGINIA WOULD BE ON THE MAP. ON THE SIDES OF THE SEAL ARE TWO BANNERS IN GOLD, GRAY AND BLACK AND TWO TORCHES IN RED, GOLD AND BLACK.

SEC. 2(F) AS TO "OHIO VALLEY ATHLETIC CONFERENCE".

CLASS 25—CLOTHING

FOR ATHLETIC APPAREL, NAMELY, SHIRTS, PANTS, JACKETS, FOOTWEAR, HATS AND CAPS, ATHLETIC UNIFORMS (U.S. CLS. 22 AND 39).

FIRST USE 12-1-1993; IN COMMERCE 12-1-1993.

CLASS 35—ADVERTISING AND BUSINESS

FOR ADVERTISEMENT AND PUBLICITY SERVICES BY TELEVISION, RADIO, MAIL; ADVERTISEMENT FOR OTHERS ON THE INTERNET; ADVERTISING AND MARKETING; ADVERTISING AND PUBLICITY SERVICES, NAMELY, PROMOTING THE GOODS, SERVICES, BRAND IDENTITY AND COMMERCIAL INFORMATION AND NEWS OF THIRD PARTIES THROUGH PRINT, AUDIO, VIDEO, DIGITAL AND ON-LINE MEDIUM; ADVERTISING IN PERIODICALS, BROCHURES AND NEWSPAPERS (U.S. CLS. 100, 101 AND 102).

FIRST USE 12-1-1993; IN COMMERCE 12-1-1993.

CLASS 41—EDUCATION AND ENTERTAINMENT

FOR ENCOURAGING AMATEUR SPORTS AND PHYSICAL EDUCATION BY ORGANIZING, SANCTIONING, CONDUCTING, REGULATING AND GOVERNING AMATEUR ATHLETIC PROGRAMS AND ACTIVITIES; ENTERTAINMENT SERVICES, NAMELY, ORGANIZING AND CONDUCTING AN ARRAY OF ATHLETIC EVENTS RENDERED LIVE AND RECORDED FOR THE PURPOSE OF DISTRIBUTION THROUGH BROADCAST MEDIA; INSTITUTING, REGULATING AND AWARDED AMATEUR ATHLETIC CHAMPIONSHIPS; MAINTAINING RECORDS AND CERTIFYING RECORD PERFORMANCES OF AMATEUR ATHLETES (U.S. CLS. 100, 101 AND 107).

FIRST USE 12-1-1993; IN COMMERCE 12-1-1993.

FRED CARL, EXAMINING ATTORNEY

SN 85-068,028. FUZION TECHNOLOGIES, LLC, FORT COLLINS, CO. FILED 6-21-2010.



NO CLAIM IS MADE TO THE EXCLUSIVE RIGHT TO USE "Z", APART FROM THE MARK AS SHOWN. THE MARK CONSISTS OF A STYLIZED "Z".

CLASS 1—CHEMICALS

FOR ADJUVANT FOR USE WITH AGRICULTURAL CHEMICALS; FERTILIZERS FOR AGRICULTURAL USE (U.S. CLS. 1, 5, 6, 10, 26 AND 46).

FIRST USE 12-28-2009; IN COMMERCE 12-28-2009.

CLASS 5—PHARMACEUTICALS

FOR PESTICIDES FOR AGRICULTURAL, COMMERCIAL, INDUSTRIAL, DOMESTIC USE (U.S. CLS. 6, 18, 44, 46, 51 AND 52).

FIRST USE 9-9-2009; IN COMMERCE 11-10-2009.

HOWARD B. LEVINE, EXAMINING ATTORNEY

SN 85-068,662. CRYSTAL SPRING HOG EQUIPMENT LTD., MANITOBA, CANADA, FILED 6-22-2010.

INFOCUS MANUFACTURING

THE MARK CONSISTS OF STANDARD CHARACTERS WITHOUT CLAIM TO ANY PARTICULAR FONT, STYLE, SIZE, OR COLOR.

PRIORITY CLAIMED UNDER SEC. 44(D) ON CANADA APPLICATION NO. 1478607, FILED 4-27-2010, REG. NO. TMA796794, DATED 5-6-2011, EXPIRES 5-6-2026.

NO CLAIM IS MADE TO THE EXCLUSIVE RIGHT TO USE "MANUFACTURING", APART FROM THE MARK AS SHOWN.

CLASS 9—ELECTRICAL AND SCIENTIFIC APPARATUS

FOR MEASURING APPARATUS, NAMELY, RAIN GAUGES (U.S. CLS. 21, 23, 26, 36 AND 38).

CLASS 11—ENVIRONMENTAL CONTROL APPARATUS

FOR PORTABLE FIREPLACES (U.S. CLS. 13, 21, 23, 31 AND 34).

CLASS 19—NON-METALLIC BUILDING MATERIALS

FOR GARDEN ORNAMENTS, NAMELY, CAST STONE GARDEN ORNAMENTS (U.S. CLS. 1, 12, 33 AND 50).

CLASS 20—FURNITURE AND ARTICLES NOT OTHERWISE CLASSIFIED

FOR SHELVING; CHAIRS; FURNITURE, NAMELY, KITCHEN CHAIRS, STACKING STOOLS AND INSTITUTIONAL STACKING CHAIRS (U.S. CLS. 2, 13, 22, 25, 32 AND 50).

CLASS 28—TOYS AND SPORTING GOODS

FOR SNOW SLEDS FOR RECREATIONAL USE (U.S. CLS. 22, 23, 38 AND 50).
GEORGE LORENZO, EXAMINING ATTORNEY

SN 85-068,697. CRYSTAL SPRING HOG EQUIPMENT LTD., MANITOBA, CANADA, FILED 6-22-2010.



PRIORITY CLAIMED UNDER SEC. 44(D) ON CANADA APPLICATION NO. 1476808, FILED 4-27-2010, REG. NO. TMA796,795, DATED 6-5-2011, EXPIRES 5-6-2026.

NO CLAIM IS MADE TO THE EXCLUSIVE RIGHT TO USE "MANUFACTURING", APART FROM THE MARK AS SHOWN.

THE MARK CONSISTS OF A RECTANGULAR BOX CONTAINING THE WORD "INFOCUS", FOLLOWED BY THE WORD "MANUFACTURING".

CLASS 9—ELECTRICAL AND SCIENTIFIC APPARATUS

FOR MEASURING APPARATUS, NAMELY, RAIN GAUGES (U.S. CLS. 21, 23, 26, 36 AND 38).

CLASS 11—ENVIRONMENTAL CONTROL APPARATUS

FOR PORTABLE FIREPLACE (U.S. CLS. 13, 21, 23, 31 AND 34).

CLASS 19—NON-METALLIC BUILDING MATERIALS

FOR GARDEN ORNAMENTS, NAMELY, CAST STONE GARDEN ORNAMENTS (U.S. CLS. 1, 12, 33 AND 50).

CLASS 20—FURNITURE AND ARTICLES NOT OTHERWISE CLASSIFIED

FOR SHELVING; CHAIRS; FURNITURE, NAMELY, KITCHEN CHAIRS, STACKING STOOLS AND INSTITUTIONAL STACKING CHAIRS (U.S. CLS. 2, 13, 22, 25, 32 AND 50).

CLASS 28—TOYS AND SPORTING GOODS

FOR SNOW SLEDS FOR RECREATIONAL USE (U.S. CLS. 22, 23, 38 AND 50).
GEORGE LORENZO, EXAMINING ATTORNEY

SN 85-071,954. CRYO-CELL INTERNATIONAL, INC., OLD-SMAR, FL. FILED 6-25-2010.



OWNER OF U.S. REG. NO. 3,496,023.
THE MARK CONSISTS OF THE WORDS CRYO-CELL.

CLASS 39—TRANSPORTATION AND STORAGE

FOR BIOMEDICAL SERVICES, NAMELY, STORAGE OF HUMAN BLOOD, HUMAN UMBILICAL CORD BLOOD, HUMAN UMBILICAL CORD BLOOD STEM CELLS, AND HUMAN MENSTRUAL STEM CELLS FOR MEDICAL, THERAPEUTIC, BIOTECHNOLOGICAL, COSMETIC AND PHARMACEUTICAL USE (U.S. CLS. 100 AND 105).

CLASS 44—MEDICAL, BEAUTY AND AGRICULTURAL SERVICES

FOR BANKING SERVICES FOR HUMAN BLOOD, HUMAN UMBILICAL CORD BLOOD, HUMAN UMBILICAL CORD BLOOD STEM CELLS, AND HUMAN MENSTRUAL STEM CELLS FOR MEDICAL, THERAPEUTIC, BIOTECHNOLOGICAL, COSMETIC AND PHARMACEUTICAL USE; COLLECTION AND PRESERVATION OF HUMAN BLOOD, MENSTRUAL BLOOD, UMBILICAL CORD BLOOD, UMBILICAL CORD STEM CELLS, AND MENSTRUAL STEM CELLS FOR MEDICAL, THERAPEUTIC, AND PHARMACEUTICAL USE (U.S. CLS. 100 AND 101).

ZACHARY BELLO, EXAMINING ATTORNEY

SN 85-072,306. YAIXA MARIA CISNEROS, LOUISVILLE, KY. FILED 6-26-2010.

Polymita

THE MARK CONSISTS OF STANDARD CHARACTERS WITHOUT CLAIM TO ANY PARTICULAR FONT, STYLE, SIZE, OR COLOR.

CLASS 9—ELECTRICAL AND SCIENTIFIC APPARATUS

FOR ACCOUNTING SOFTWARE FOR USE IN THE CONSTRUCTION INDUSTRY FOR CONTRACT BIDDING AND JOB ACCOUNTING; AN OPTICAL METROLOGY INSPECTION SYSTEM COMPRISED OF A LIGHT SOURCE, ONE OR MORE CAMERAS AND SENSORS IN COMMUNICATION WITH COMPUTER SOFTWARE AND HARDWARE; ANTI-SPYWARE SOFTWARE; AUTOMATED DEBRIS MANAGEMENT SYSTEM SOFTWARE FOR USE IN CLEANING UP AFTER MAJOR DISASTERS; AUTOMATED MICROSCOPE AND OPERATING SOFTWARE SOLD AS A UNIT FOR USE IN LABORATORY OPERATIONS; AUTOMATED PROCESS CONTROL SYSTEM, NAMELY, MICRO-PROCESSOR BASED HARDWARE AND SOFTWARE USED TO MONITOR THE STATUS OF INDUSTRIAL MACHINERY, NAMELY, TURBINES, GENERATORS AND COMPRESSORS; AUTOMATED PROCESS CONTROL SYSTEM, NAMELY, MICRO-PROCESSOR BASED HARDWARE AND SOFTWARE USED TO MONITOR THE STATUS OF INDUSTRIAL PROCESSES, NAMELY, POWER GENERATION, ELECTRICAL DISTRIBUTION AND OIL AND GAS PROCESSING; AUTOMATED SYSTEMS, NAMELY, SOFTWARE, HARDWARE AND COMMUNICATIONS DEVICES FOR PLANNING, SCHEDULING, CONTROLLING, MONITORING AND PROVIDING INFORMATION ON TRANSPORTATION ASSETS AND PARTS THEREOF; BATTERY MONITORING DEVICES THAT MAY BE ATTACHED TO A BATTERY TO MONITOR THE PERFORMANCE OF THE BATTERY AND OPERATING SOFTWARE FOR USE THEREWITH, SOLD AS A UNIT; BROADBAND POWER LINE COMMUNICATION SYSTEMS FOR TRANSFERRING BROADBAND DATA OVER ELECTRICAL POWER LINES, COMPRISED OF COMPUTER HARDWARE, SOFTWARE AND MODEMS; BUILDING SECURITY SYSTEMS COMPRISING SOFTWARE AND HARDWARE FOR PROVIDING PICTURE, VIDEO, ALARM STATUS, BUILDING PLANS, AND OTHER INFORMATION TO A REMOTE STATION; CHILDREN'S EDUCATIONAL SOFTWARE; COMMUNICATION SOFTWARE FOR PROVIDING ACCESS TO THE INTERNET; COMMUNICATION SOFTWARE TO ACCESS DATA STORED ON AN OXIMETER AND TRANSFER DATA TO ANOTHER DEVICE; COMMUNICATIONS SOFTWARE FOR CONNECTING COMPUTER NETWORK USERS AND GLOBAL COMPUTER NETWORKS; COMPILER SOFTWARE; COMPONENTS FOR GAMING MACHINES THAT GENERATE OR DISPLAY WAGER OUTCOMES, NAMELY, CONTROLLERS, DISPLAYS, BUTTON PANELS, BOLSTERS, ELECTRICAL WIRING, AND COMPUTER HARDWARE AND SOFTWARE ASSOCIATED THEREWITH; COMPONENTS FOR GAMING MACHINES, NAMELY, CONTROLLERS, DISPLAYS, BUTTON PANELS, BOLSTERS, ELECTRICAL WIRING, AND COMPUTER HARDWARE AND SOFTWARE ASSOCIATED THEREWITH; COMPUTER ANTI-VIRUS SOFTWARE; COMPUTER APPLICATION SOFTWARE FOR MOBILE PHONES, NAMELY, COMMUNICATION SOFTWARE FOR PROVIDING ACCESS TO THE INTERNET, TO ACCESS DATA STORED AND TRANSFER DATA TO ANOTHER DEVICE, AND FOR CONNECTING MOBILE PHONE USERS AND NETWORKS; COMPUTER APPLICATION SOFTWARE FOR MOBILE PHONES, PORTABLE MEDIA PLAYERS, HANDHELD COMPUTERS, DESKTOP COMPUTERS, LAP-TOP COMPUTERS AND SERVER COMPUTER, NAMELY, SOFTWARE THAT PROVIDES REAL-TIME, INTEGRATED BUSINESS PROCESS MANAGEMENT INTELLIGENCE BY COMBINING INFORMATION FROM VARIOUS DATABASES AND PRESENTING IT IN AN EASY-TO-UNDERSTAND USER INTERFACE; COMPUTER APPLICATION SOFTWARE FOR MOBILE PHONES, PORTABLE MEDIA PLAYERS, HANDHELD COMPUTERS, DESKTOP COMPUTERS, LAP-TOP COMPUTERS AND SERVER COMPUTER, NAMELY, SOFTWARE THAT PROVIDES REAL-TIME, INTEGRATED BUSINESS PROCESS MANAGEMENT INTELLIGENCE BY COMBINING INFORMATION FROM VARIOUS DATABASES AND PRESENTING IT IN AN EASY-TO-UNDERSTAND USER INTERFACE; COMPUTER COMMUNICATIONS SOFTWARE TO ALLOW CUSTOMERS TO ACCESS BANK ACCOUNT INFORMATION AND TRANSACT BANK BUSINESS; COMPUTER DATABASE MANAGEMENT SOFTWARE FOR USE IN PERSONALIZING THE CONTENT OF E-MAIL COMMUNICATIONS; COMPUTER E-COMMERCE SOFTWARE TO ALLOW USERS TO PERFORM ELEC-

TRONIC BUSINESS TRANSACTIONS VIA A GLOBAL COMPUTER NETWORK; COMPUTER GAME SOFTWARE; COMPUTER GAME SOFTWARE DOWNLOADABLE FROM A GLOBAL COMPUTER NETWORK; COMPUTER GAME SOFTWARE FOCUSING ON ACHIEVING A SET OF GOALS, POSITIONS, OWNERSHIP, AND CREDENTIALS, AND PROFESSIONAL AND SOCIAL STATUS, AND GOOD FORTUNE NECESSARY TO SUCCEED PROFESSIONALLY AND PERSONALLY, AND NOT REFERRING EITHER TO A GROUP OF SOFTWARE FOR USE IN COMMERCE OR TO A GROUP OF OFFICES; COMPUTER GAME SOFTWARE FOR GAMING MACHINES INCLUDING SLOT MACHINES OR VIDEO LOTTERY TERMINALS; COMPUTER GAME SOFTWARE FOR GAMING MACHINES, NAMELY, SLOT MACHINES AND VIDEO LOTTERY TERMINALS; COMPUTER GAME SOFTWARE FOR PERSONAL COMPUTERS AND HOME VIDEO GAME CONSOLES; COMPUTER GAME SOFTWARE FOR USE ON MOBILE AND CELLULAR PHONES; COMPUTER GAME SOFTWARE FOR USE WITH PERSONAL COMPUTERS, HOME VIDEO GAME CONSOLES USED WITH TELEVISIONS, AND FOR ARCADE-BASED VIDEO GAME CONSOLES; COMPUTER GAME SOFTWARE, NAMELY, A COMPUTER CRAPS GAME; COMPUTER GRAPHICS SOFTWARE; COMPUTER HARDWARE AND COMPUTER SOFTWARE FOR RETAIL INVENTORY MANAGEMENT, SOLD AS A UNIT; COMPUTER HARDWARE AND COMPUTER SOFTWARE PROGRAMS FOR THE INTEGRATION OF TEXT, AUDIO, GRAPHICS, STILL IMAGES AND MOVING PICTURES INTO AN INTERACTIVE DELIVERY FOR MULTIMEDIA APPLICATIONS; COMPUTER HARDWARE AND PERIPHERAL DEVICES AND COMPUTER SOFTWARE FOR DATA COMMUNICATION AND TRANSLATING AND TRANSMITTING DATA SOLD THEREWITH; COMPUTER HARDWARE AND SOFTWARE FOR MEDICAL IMAGING APPARATUS; COMPUTER HARDWARE AND SOFTWARE FOR PROCESSING DIGITAL MUSIC FILES; COMPUTER HARDWARE AND SOFTWARE FOR SETTING UP AND CONFIGURING LOCAL AREA NETWORKS; COMPUTER HARDWARE AND SOFTWARE FOR SETTING UP AND CONFIGURING WIDE AREA NETWORKS; COMPUTER HARDWARE AND SOFTWARE SOLD AS A UNIT FOR TESTING OF EMBEDDED COMPUTER SYSTEMS; COMPUTER HARDWARE AND SOFTWARE SYSTEM FOR REMOTELY MONITORING ENVIRONMENTAL CONDITIONS AND CONTROLLING DEVICES WITHIN A BUILDING, FACILITY, GROUNDS, OR DESIGNATED SPATIAL AREA; COMPUTER HARDWARE AND SOFTWARE SYSTEM FOR TRACKING PEOPLE, OBJECTS AND PETS USING GPS DATA ON A DEVICE ON THE TRACKED PEOPLE, OBJECTS AND PETS; COMPUTER HARDWARE AND SOFTWARE USED FOR THE CONTROL OF VOICE CONTROLLED INFORMATION AND COMMUNICATION DEVICES; COMPUTER HARDWARE AND SOFTWARE, FOR USE WITH MEDICAL PATIENT MONITORING EQUIPMENT, FOR RECEIVING, PROCESSING, TRANSMITTING AND DISPLAYING DATA; COMPUTER OPERATING SOFTWARE; COMPUTER PROCESSING SOFTWARE TO PROCESS THE IMAGE COLORS WITH THE COLOR AND INTENSITY AND INTERPRET THE RESULTS AS TENDENCIES OF THE ORGANS, GLANDS AND TISSUES ACCORDING TO THE IRIDODOLOGY CHARTS; COMPUTER PROGRAMS AND COMPUTER SOFTWARE FOR ELECTRONICALLY TRADING SECURITIES; COMPUTER PROGRAMS RECORDED ON DATA MEDIA (SOFTWARE) DESIGNED FOR USE IN CONSTRUCTION AND AUTOMATED MANUFACTURING (CAD/CAM); COMPUTER SCREEN SAVER SOFTWARE; COMPUTER SEARCH ENGINE SOFTWARE; COMPUTER SOFTWARE AND COMPUTER HARDWARE FOR USE IN LANGUAGE LOCALIZATION, BY MEANS OF LANGUAGE TRANSLATION, SUBTITLING, DUBBING, CLOSED CAPTIONING AND TELETXT FOR FEATURE FILMS, TELEVISION PROGRAMS, VIDEOS AND DIGITAL MEDIA IN GENERAL; COMPUTER SOFTWARE AND FIRMWARE FOR GAMES OF CHANCE ON ANY COMPUTERIZED PLATFORM, INCLUDING DEDICATED GAMING CONSOLES, VIDEO BASED SLOT MACHINES, REEL BASED SLOT MACHINES, AND VIDEO LOTTERY TERMINALS; COMPUTER SOFTWARE AND FIRMWARE FOR OPERATING SYSTEM PROGRAMS; COMPUTER SOFTWARE AND HARDWARE FOR DISSEMINATING ADVERTISING FOR OTHERS ON EMPLOYEE EARNINGS AND THIRD PARTY PAPER PAYROLL STUBS AND CHECKS AND ON ELECTRONIC PAYROLL PAYMENTS; COMPUTER

SOFTWARE AND HARDWARE THAT PROVIDES REAL-TIME, INTEGRATED BUSINESS PROCESS MANAGEMENT INTELLIGENCE BY COMBINING INFORMATION FROM VARIOUS DATABASES AND PRESENTING IT IN AN EASY-TO-UNDERSTAND USER INTERFACE; COMPUTER SOFTWARE DEVELOPMENT TOOLS; COMPUTER SOFTWARE FEATURING MUSICAL SOUND RECORDINGS AND MUSICAL VIDEO RECORDINGS; COMPUTER SOFTWARE FOR ACCESSING INFORMATION DIRECTORIES THAT MAY BE DOWNLOADED FROM THE GLOBAL COMPUTER NETWORK; COMPUTER SOFTWARE FOR ADMINISTRATION OF COMPUTER LOCAL AREA NETWORKS; COMPUTER SOFTWARE FOR ADMINISTRATION OF COMPUTER NETWORKS; COMPUTER SOFTWARE FOR APPLICATION AND DATABASE INTEGRATION; COMPUTER SOFTWARE FOR COMMUNICATING WITH USERS OF HAND-HELD COMPUTERS; COMPUTER SOFTWARE FOR COMPUTER SYSTEM AND APPLICATION DEVELOPMENT, DEPLOYMENT AND MANAGEMENT; COMPUTER SOFTWARE FOR CONTROLLING AND MANAGING ACCESS SERVER APPLICATIONS; COMPUTER SOFTWARE FOR CONTROLLING AND MANAGING PATIENT MEDICAL INFORMATION; COMPUTER SOFTWARE FOR CONTROLLING SELF-SERVICE TERMINALS; COMPUTER SOFTWARE FOR CONTROLLING THE OPERATION OF AUDIO AND VIDEO DEVICES; COMPUTER SOFTWARE FOR CREATING AND EDITING MUSIC AND SOUNDS; COMPUTER SOFTWARE FOR CREATING SEARCHABLE DATABASES OF INFORMATION AND DATA; COMPUTER SOFTWARE FOR ENCRYPTION; COMPUTER SOFTWARE FOR INTERPRETATION OF NEURO AND BRAIN SCANS PROVIDED BY DIAGNOSTIC IMAGING EQUIPMENT; COMPUTER SOFTWARE FOR MANIPULATING DIGITAL AUDIO INFORMATION FOR USE IN AUDIO MEDIA APPLICATIONS; COMPUTER SOFTWARE FOR ORGANIZING AND VIEWING DIGITAL IMAGES AND PHOTOGRAPHS; COMPUTER SOFTWARE FOR PROCESSING DIGITAL IMAGES; COMPUTER SOFTWARE FOR PROCESSING DIGITAL MUSIC FILES; COMPUTER SOFTWARE FOR PROVIDING AN ON-LINE DATABASE IN THE FIELD OF TRANSACTION PROCESSING TO UPLOAD TRANSACTIONAL DATA, PROVIDE STATISTICAL ANALYSIS, AND PRODUCE NOTIFICATIONS AND REPORTS; COMPUTER SOFTWARE FOR PULMONARY, CARDIOVASCULAR AND EDEMA ANALYSIS FOR USE IN SMALL ANIMAL RESEARCH STUDIES; COMPUTER SOFTWARE FOR REDISTRICTING, NAMELY, AGGREGATING SMALLER GEOGRAPHICAL AREAS INTO MULTIPLE LARGER AREAS; COMPUTER SOFTWARE FOR SCIENTIFIC ANALYSIS OF GENETIC SEQUENCES; COMPUTER SOFTWARE FOR THE COLLECTION, EDITING, ORGANIZING, MODIFYING, BOOK MARKING, TRANSMISSION, STORAGE AND SHARING OF DATA AND INFORMATION; COMPUTER SOFTWARE FOR THE CREATION OF FIREWALLS; COMPUTER SOFTWARE FOR THE DATABASING, VISUALIZATION, MANIPULATION, VIRTUAL REALITY IMMERSION AND INTEGRATION OF GEOGRAPHIC INFORMATION WITH ON-LINE MEMBER COMMUNITIES; COMPUTER SOFTWARE FOR THE FIELD OF WAREHOUSING AND DISTRIBUTION, TO MANAGE TRANSACTIONAL DATA, PROVIDE STATISTICAL ANALYSIS, AND PRODUCE NOTIFICATIONS AND REPORTS; COMPUTER SOFTWARE FOR THE MANAGEMENT OF COMMERCIAL PRINTING COMPANIES IN THE FIELD OF COST ESTIMATING, PRODUCTION PLANNING, SCHEDULING PRODUCTION, BINDING, SHIPPING AND ANALYSIS OF THE PRINTING JOB; COMPUTER SOFTWARE FOR USE IN CUSTOMER RELATIONSHIP MANAGEMENT (CRM); COMPUTER SOFTWARE FOR USE IN PROCESSING SEMICONDUCTOR WAFERS; COMPUTER SOFTWARE FOR USE IN PROGRAMMING FACSIMILE MACHINES; COMPUTER SOFTWARE FOR USE IN RELATION TO DIGITAL ANIMATION AND SPECIAL EFFECTS OF IMAGES; COMPUTER SOFTWARE FOR USE IN THE ENCRYPTION AND DECRYPTION OF DIGITAL FILES, INCLUDING AUDIO, VIDEO, TEXT, BINARY, STILL IMAGES, GRAPHICS AND MULTIMEDIA FILES; COMPUTER SOFTWARE FOR USE IN THE SAFEGUARDING OF DIGITAL FILES, INCLUDING AUDIO, VIDEO, TEXT, BINARY, STILL IMAGES, GRAPHICS AND MULTIMEDIA FILES; COMPUTER SOFTWARE FOR VISUALIZATION IN THE NATURE OF GRAPHICAL REPRESENTATION AND ANALYSIS OF SATELLITES; COMPUTER SOFTWARE FOR WIRELESS CONTENT

DELIVERY; COMPUTER SOFTWARE THAT PROVIDES REAL-TIME, INTEGRATED BUSINESS PROCESS MANAGEMENT INTELLIGENCE BY COMBINING INFORMATION FROM VARIOUS DATABASES AND PRESENTING IT IN AN EASY-TO-UNDERSTAND USER INTERFACE; COMPUTER SOFTWARE THAT PROVIDES REAL-TIME, INTEGRATED BUSINESS PROCESS MANAGEMENT INTELLIGENCE BY COMBINING INFORMATION FROM VARIOUS DATABASES AND PRESENTING IT IN AN EASY-TO-UNDERSTAND USER INTERFACE THAT MAY BE DOWNLOADED FROM A GLOBAL COMPUTER NETWORK; COMPUTER SOFTWARE PLATFORMS FOR BUSINESS PROCESS MANAGEMENT; COMPUTER SOFTWARE THAT ALLOWS PEOPLE OR ORGANIZATIONS TO CREATE A VOTING EVENT, VOTE ON THE ISSUE, CHANGE THEIR VOTE AT WILL AND TRACK THE INPUT AND DISPLAY IT IN A UNIQUE GRAPHICAL WAY; COMPUTER SOFTWARE THAT ASSISTS COMPUTERS IN DEPLOYING PARALLEL APPLICATIONS AND PERFORMING PARALLEL COMPUTATIONS; COMPUTER SOFTWARE THAT PROVIDES REAL-TIME, INTEGRATED BUSINESS MANAGEMENT INTELLIGENCE BY COMBINING INFORMATION FROM VARIOUS DATABASES AND PRESENTING IT IN AN EASY-TO-UNDERSTAND USER INTERFACE; COMPUTER SOFTWARE THAT PROVIDES WEB-BASED ACCESS TO APPLICATIONS AND SERVICES THROUGH A WEB OPERATING SYSTEM OR PORTAL INTERFACE; COMPUTER SOFTWARE TO AUTOMATE DATA WAREHOUSING; COMPUTER SOFTWARE TO CONTROL AND IMPROVE COMPUTER AND AUDIO EQUIPMENT SOUND QUALITY; COMPUTER SOFTWARE TO ENABLE THE TRANSMISSION OF PHOTOGRAPHS TO MOBILE TELEPHONES; COMPUTER SOFTWARE TO ENHANCE THE AUDIO-VISUAL CAPABILITIES OF MULTIMEDIA APPLICATIONS, NAMELY, FOR THE INTEGRATION OF TEXT, AUDIO, GRAPHICS, STILL IMAGES AND MOVING PICTURES; COMPUTER SOFTWARE TO MAINTAIN AND OPERATE COMPUTER SYSTEM; COMPUTER SOFTWARE TO MONITOR AND CONTROL FACTORY MANUFACTURING PROCESSES; COMPUTER SOFTWARE, NAMELY, AN APPLICATION ALLOWING SALES AND FIELD SERVICE EMPLOYEES TO UPDATE AND RECEIVE DATA STORED IN AN ENTERPRISE'S COMPUTER DATABASES IN REAL TIME, USING A MOBILE DEVICE, WITH FULL TELEPHONY INTEGRATION WITH THE TELEPHONE AND/OR SOFTWARE FEATURES OF THE MOBILE DEVICE; COMPUTER SOFTWARE, NAMELY, ELECTRONIC FINANCIAL PLATFORM THAT ACCOMMODATES MULTIPLE TYPES OF PAYMENT AND DEBT TRANSACTIONS IN AN INTEGRATED MOBILE PHONE, PDA, AND WEB BASED ENVIRONMENT; COMPUTER SOFTWARE, NAMELY, GAME ENGINE SOFTWARE FOR VIDEO GAME DEVELOPMENT AND OPERATION; COMPUTER SOFTWARE, NAMELY, SOFTWARE DEVELOPMENT TOOLS FOR THE CREATION OF MOBILE INTERNET APPLICATIONS AND CLIENT INTERFACES; COMPUTER TELEPHONY SOFTWARE; COMPUTER-GAMING SOFTWARE; CONTROL SYSTEM FOR THE REMOTE OBSERVATION, MANAGEMENT AND OPERATION OF CRANES, COMPRISING COMPUTERS, SOFTWARE, ELECTROMECHANICAL CONTROLS, AND VIDEO DISPLAY SCREENS; CREDIT SCREENING SOFTWARE; DATA COMPRESSION SOFTWARE; DATABASE MANAGEMENT SOFTWARE FOR BUSINESS PROCESS MANAGEMENT; DAY AND NIGHT VISION SYSTEMS PRIMARILY COMPRISING DAY AND NIGHT SENSORS, DAY AND NIGHT CAMERAS, POWER SOURCES, COMMUNICATION MEANS, MONITORS AND OPERATING SOFTWARE; DECODER SOFTWARE; DESKTOP PUBLISHING SOFTWARE; DIGITAL TELEPHONE PLATFORMS AND SOFTWARE; DOWNLOADABLE COMPUTER GAME SOFTWARE VIA A GLOBAL COMPUTER NETWORK AND WIRELESS DEVICES; DOWNLOADABLE COMPUTER SOFTWARE THAT PROVIDES REAL-TIME, INTEGRATED BUSINESS PROCESS MANAGEMENT INTELLIGENCE BY COMBINING INFORMATION FROM VARIOUS DATABASES AND PRESENTING IT IN AN EASY-TO-UNDERSTAND USER INTERFACE; DOWNLOADABLE COMPUTER SOFTWARE IN THE FIELD OF MEMORY TRAINING ACTIVITIES SOLD AS A UNIT WITH POSITIONABLE FIGURES; DOWNLOADABLE ELECTRONIC DATA FILES AND DATABASES, NAMELY, BUSINESS AND TAX FORMS, FOR USE WITH COMPUTER SOFTWARE; DOWNLOADABLE SOFTWARE THAT PROVIDES REAL-TIME, INTEGRATED BUSINESS PROCESS MAN-

AGEMENT INTELLIGENCE BY COMBINING INFORMATION FROM VARIOUS DATABASES AND PRESENTING IT IN AN EASY-TO-UNDERSTAND USER INTERFACE; DOWNLOADABLE SOFTWARE IN THE NATURE OF A MOBILE APPLICATION THAT PROVIDES REAL-TIME, INTEGRATED BUSINESS PROCESS MANAGEMENT INTELLIGENCE BY COMBINING INFORMATION FROM VARIOUS DATABASES AND PRESENTING IT IN AN EASY-TO-UNDERSTAND USER INTERFACE; EDUCATIONAL SOFTWARE FEATURING INSTRUCTION IN BUSINESS PROCESS MANAGEMENT; ELECTRICAL APPARATUS FOR TESTING THE STATE OF OPERABILITY OF ELECTRONIC SIRENS AND PUBLIC ADDRESS SYSTEMS; ELECTRICAL ENERGY UTILIZATION METERING DEVICES COMPLETE WITH RELATED SOFTWARE; ELECTRICAL LEAK DETECTION HARDWARE AND OPERATING SOFTWARE; ELECTRONIC COMMUNICATIONS SYSTEMS COMPRISED OF COMPUTER HARDWARE AND SOFTWARE FOR THE TRANSMISSION OF DATA BETWEEN TWO POINTS; ELECTRONIC GAME SOFTWARE; ELECTRONIC GAME SOFTWARE FOR CELLULAR TELEPHONES; ELECTRONIC GAME SOFTWARE FOR HANDHELD ELECTRONIC DEVICES; ELECTRONIC GAME SOFTWARE FOR WIRELESS DEVICES; ELECTRONIC GAME SOFTWARE, NAMELY, AN ELECTRONIC CRAPS GAME; ELECTRONIC GAME SOFTWARE, NAMELY, AN ELECTRONIC VIDEO CRAPS GAME; ELECTRONIC SOFTWARE UPDATES, NAMELY, DOWNLOADABLE COMPUTER SOFTWARE AND ASSOCIATED DATA FILES FOR UPDATING COMPUTER SOFTWARE IN THE FIELDS OF BUSINESS PROCESS MANAGEMENT, PROVIDED VIA COMPUTER AND COMMUNICATION NETWORKS; ELECTRONIC TEST INSTRUMENT AND ASSOCIATED SOFTWARE FOR USE IN LEAK, FLOW AND FUNCTIONAL TESTING; ELEVATOR PERFORMANCE MONITORING SYSTEM, NAMELY, EMBEDDED SOFTWARE IN CONTROLLERS FOR MONITORING ELEVATOR FUNCTIONS; ENTERPRISE SOFTWARE IN THE NATURE OF A DATABASE FOR NON-TRANSACTIONAL DATA AND A SEARCH ENGINE FOR DATABASE CONTENT; ENVIRONMENTALLY FRIENDLY AUTOMATION SYSTEMS, NAMELY, EMBEDDED OPERATING SYSTEMS AND PC BASED SOFTWARE, FOR MONITORING SPECIFIED CONDITIONS AND CONTROLLING RESPECTIVE INNOVATIVE DEVICES WITHIN A DESIGNATED AREA; FACILITIES MANAGEMENT SOFTWARE, NAMELY, SOFTWARE TO CONTROL BUILDING ENVIRONMENT, ACCESS AND SECURITY SYSTEMS; FACTORY AUTOMATION SOFTWARE, NAMELY, SOFTWARE TO INTEGRATE MANUFACTURING MACHINE OPERATIONS, TRACK PROBLEMS AND GENERATE PRODUCTION REPORTS; FREE-SPACE OPTICS TRANSMISSION SYSTEMS, ETHERNET SWITCHES AND ROUTERS, AND SOFTWARE SOLD BOTH AS COMPONENTS THEREOF AND SEPARATELY, NAMELY, SOFTWARE ADAPTED AND ARRANGED FOR OPERATING, INSTALLING, TESTING, DIAGNOSING AND MANAGING THE FOREGOING TELECOMMUNICATION EQUIPMENT; GAME SOFTWARE; GAMING SOFTWARE THAT GENERATES OR DISPLAYS WAGER OUTCOMES OF GAMING MACHINES; GLOBAL POSITIONING SYSTEM (GPS) CONSISTING OF COMPUTERS, COMPUTER SOFTWARE, TRANSMITTERS, RECEIVERS, AND NETWORK INTERFACE DEVICES; GRAPHICAL USER INTERFACE SOFTWARE; HARDWARE AND SOFTWARE ADAPTER FOR COUPLING A GPS RECEIVER TO THE MICROPHONE INPUT OF A DIGITAL CAMCORDER; HOME AND OFFICE AUTOMATION SYSTEMS COMPRISING WIRELESS AND WIRED CONTROLLERS, CONTROLLED DEVICES, AND SOFTWARE FOR LIGHTING, HVAC, SECURITY, SAFETY AND OTHER HOME AND OFFICE MONITORING AND CONTROL APPLICATIONS; INDUSTRIAL PROCESS CONTROL SOFTWARE; INDUSTRIAL PROCESSED CONTROL SOFTWARE FOR GENERATING COMPUTER READABLE MARKINGS FOR APPLICATION TO BOARD LUMBER; INTEGRATED BATTERY BACKUP SYSTEMS COMPRISING A BATTERY, AN ELECTRONIC MEASUREMENT APPARATUS FOR USE IN THE MEASUREMENT OF BATTERY HEALTH AND PERFORMANCE, AND A REMOTE COMPUTER SOFTWARE PROGRAM THAT USES THE FOREGOING DATA TO TREND, PREDICT, AND STORE DATA RELATED TO THE HEALTH OF THE BATTERY; INTEGRATED SUITE OF GLOBAL TAX MANAGEMENT SOFTWARE; INTERACTIVE COMPUTER KIOSKS COMPRISING COMPUTERS, COMPUTER HARDWARE, COMPUTER PERIPHERALS, AND COM-

PUTER OPERATING SOFTWARE, FOR USE IN MANAGEMENT OF BUSINESS MONETARY TRANSACTIONS; INTERACTIVE GAME SOFTWARE; INTERACTIVE MULTIMEDIA SOFTWARE FEATURING AUDIO AND VIDEO INFORMATION FOR DENTISTS ON THE SUBJECT OF TREATMENTS, PROCEDURES AND ALTERNATIVES RELATED TO DENTISTRY; INTERACTIVE MULTIMEDIA SOFTWARE FEATURING AUDIO AND VIDEO INFORMATION FOR PATIENTS ON THE SUBJECT OF TREATMENTS, PROCEDURES AND ALTERNATIVES RELATED TO DENTISTRY; INTERACTIVE VIDEO GAMES OF VIRTUAL REALITY COMPRISED OF COMPUTER HARDWARE FOR USE WITH AN EXTERNAL MONITOR AND SOFTWARE; LAN (LOCAL AREA NETWORK) OPERATING SOFTWARE; LIGHTING CONTROL SOFTWARE FOR USE IN COMMERCIAL AND INDUSTRIAL FACILITIES; MEDICAL IMAGING SOFTWARE THAT RECORDS, MONITORS AND ANALYZES DATA USING A CATHETER BASED ULTRASOUND IMAGING PROBE; MEDICAL RESEARCH EQUIPMENT, NAMELY, COMPUTERS, GAMMA CAMERAS, COLLIMATORS, APERTURE PLATES AND COMPUTER SOFTWARE, ALL SOLD TOGETHER AS A UNIT FOR USE IN HIGH RESOLUTION, HIGH SENSITIVITY TOMOGRAPHIC IMAGE PROCESSING AND IMAGING IN THE FIELD OF NUCLEAR MEDICINE; MEDICAL SOFTWARE FOR PROCESSING AND DISPLAYING BREAST IMAGES ON MEDICAL RESONANCE IMAGING MACHINES (MRI'S); MEDICAL SOFTWARE FOR PROCESSING AND DISPLAYING IMAGES ON ULTRASOUND MEDICAL IMAGING MACHINES; MEDICAL SOFTWARE FOR CONTROLLING AND MANAGING PATIENT MEDICAL INFORMATION AND THAT PROVIDES REAL-TIME, INTEGRATED BUSINESS MANAGEMENT INTELLIGENCE RELATED TO HEALTH INSTITUTIONS BY COMBINING INFORMATION FROM VARIOUS DATABASES AND PRESENTING IT IN AN EASY-TO-UNDERSTAND USER INTERFACE; MEDICAL WORKSTATION COMPRISED OF COMPUTER HARDWARE AND SOFTWARE FOR GATHERING AND TRANSMITTING PATIENT IMAGE DATA FOR USE DURING SURGICAL PROCEDURES; MUSIC-COMPOSITION SOFTWARE; NETWORK ACCESS SERVER OPERATING SOFTWARE; OPERATING AND USER INSTRUCTIONS STORED IN DIGITAL FORM FOR COMPUTERS AND COMPUTER SOFTWARE, IN PARTICULAR ON FLOPPY DISKS OR CD-ROM; OPTICAL COMMUNICATIONS SYSTEMS COMPRISED OF OPTICAL AND ELECTRONIC HARDWARE AND COMPUTER SOFTWARE FOR THE TRANSMISSION OF DATA BETWEEN TWO POINTS; OPTICAL DISCS CONTAINING SOFTWARE AND PROGRAMMING, USED TO SET-UP AND CALIBRATE TELEVISIONS AND VIDEO OUTPUT DEVICES; PATTERN RECOGNITION SYSTEMS COMPOSED OF COMPUTER CHIPS, COMPUTER HARDWARE AND SOFTWARE; PIPELINE COMMUNICATION SYSTEMS FOR TRANSMITTING DATA OVER OIL, GAS, WATER AND HEAT DISTRIBUTION PIPELINE NETWORKS, COMPRISED OF COMPUTER HARDWARE, SOFTWARE, MODEMS AND COMMUNICATION CABLES; POWER SUPPLIES FOR LIGHTS, SIRENS AND PUBLIC ADDRESS SYSTEMS; PUBLIC ADDRESS (PA) AND SOUND SYSTEM ACCESSORIES, NAMELY, MICROPHONE STANDS, SPEAKER STANDS, MICROPHONE CABLES, SPEAKER CABLES, SPEAKER BOXES AND SOUND MIXERS; PUBLIC ADDRESS SYSTEMS; PUBLIC TELEPHONES; PUBLIC-ADDRESS SYSTEMS AND INSTRUMENTS; RADIO TRANSMITTERS, RECEIVERS, AND CONTROLLERS FOR MONITORING AND CONTROLLING PUBLIC LIGHTING; RECONFIGURABLE CASINO AND LOTTERY GAMING EQUIPMENT, NAMELY, GAMING MACHINES AND OPERATIONAL COMPUTER GAME SOFTWARE THEREFOR; SCIENTIFIC APPARATUS FOR USE WITH MEMBRANE FILTRATION, NAMELY, WATER FILTER CONTROLLERS AND COMPUTER SOFTWARE FOR DETECTING AND MEASURING WATER QUALITY; SOFTWARE DEFINED RADIO; SOFTWARE FOR CONFIGURING, QUOTING AND ORDERING ELECTRICAL DISTRIBUTION PRODUCTS; SOFTWARE FOR DOSIMETRY PURPOSES IN THE FIELD OF RADIOTHERAPY; SOFTWARE FOR ENSURING THE SECURITY OF ELECTRONIC MAIL; SOFTWARE FOR MEDICAL IMAGING EQUIPMENT, NAMELY, FOR INTERPRETING THE RESULTS OF CT SCANNERS; SOFTWARE FOR MONITORING AND CONTROLLING COMMUNICATION BETWEEN COMPUTERS AND AUTOMATED MACHINE SYSTEMS; SOFTWARE FOR OPTICAL CHARACTER RECOGNI-

TION; SOFTWARE FOR PROCESSING DIGITAL IMAGES OF THE ANATOMY FOR DIAGNOSIS AND TREATMENT; SOFTWARE FOR PROCESSING IMAGES, GRAPHICS AND TEXT; SOFTWARE FOR THE OPERATIONAL MANAGEMENT OF PORTABLE MAGNETIC AND ELECTRONIC CARDS; SOFTWARE PROGRAMMABLE MICROPROCESSORS; SOFTWARE TO CONTROL AND IMPROVE AUDIO EQUIPMENT SOUND QUALITY; SOFTWARE UTILIZING BIDIRECTIONAL COMMUNICATION VIA ETHERNET AND INTERNET TO MONITOR AND/OR CONFIGURE PROGRAMMABLE LOGIC CONTROLS FOR WINE CELLARS; TAX MANAGEMENT DATA COLLECTION SOFTWARE; TAX MANAGEMENT SOFTWARE; TELECOMMUNICATIONS EQUIPMENT, NAMELY, FIBER-OPTIC TRANSCIEVERS, FIBER OPTIC REPEATERS, CONVERTERS AND OPTIMIZERS, WAVE DIVISION MULTIPLEXERS, FREE-SPACE OPTICS TRANSMISSION SYSTEMS, SWITCHES INCLUDING ETHERNET SWITCHES AND ROUTERS, FIBER-TO-THE-HOME AND ETHERNET-OVER-VDSL ACCESS AGGREGATORS, TERMINATORS AND REPEATERS, AND REMOTE PRESENCE MANAGEMENT PRODUCTS, NAMELY, SWITCHES, AND CONSOLE, ALARM, SENSOR AND POWER MANAGEMENT DEVICES, AND SOFTWARE SOLD BOTH AS COMPONENTS THEREOF AND SEPARATELY, NAMELY, SOFTWARE ADAPTED AND ARRANGED FOR OPERATING, INSTALLING, TESTING, DIAGNOSING AND MANAGING THE FORGOING TELECOMMUNICATION EQUIPMENT; TELECOMMUNICATIONS HARDWARE AND SOFTWARE FOR MONITORING AND ALERTING REMOTE SENSOR STATUS VIA THE INTERNET; TRAFFIC MANAGEMENT EQUIPMENT, NAMELY, DISPLAY MONITORS, COMPUTERS, AUTO COMPASSES, AND SOFTWARE TO MANAGE TRAFFIC; TURBINE CONTROL SYSTEMS COMPRISING ELECTRONIC SENSORS AND RELATED SOFTWARE; ULTRASONIC BONE DENSITOMETER WITH COMPUTER, PRINTER, AND COMPUTER SOFTWARE FOR USE THEREWITH, SOLD AS A UNIT, FOR SCIENTIFIC USE; UPI (UNIVERSAL PERIPHERAL INTERFACE) SOFTWARE; USB (UNIVERSAL SERIAL BUS) OPERATING SOFTWARE; VEHICLE DETECTION EQUIPMENT, NAMELY, DISPLAY MONITORS, COMPUTERS, IMAGE SENSORS, VIDEO CAMERAS, AND OPERATING SYSTEM AND APPLICATION SOFTWARE TO DETECT VEHICLE LOCATION; VEHICLE TRACKING DEVICES COMPRISED OF CELLULAR RADIO MODULES, COMPUTER SOFTWARE AND COMPUTER HARDWARE, SENSORS, TRANSMITTERS, RECEIVERS AND GLOBAL POSITIONING SATELLITE RECEIVERS, ALL FOR USE IN CONNECTION WITH VEHICLE TRACKING, VEHICLE MONITORING AND ANTI-THEFT VEHICLE ALARMS; VIDEO GAME SOFTWARE; VIDEO GAME SOFTWARE, NAMELY, A VIDEO CRAPS GAME; VIDEO INJECTION SYSTEM, NAMELY, OPTICAL AND ELECTRONIC HARDWARE AND COMPUTER SOFTWARE, SIMULATING THE EFFECTS OF TRACER ROUND FLY-OUTS AND BURSTS ON TARGET, WHICH ALLOWS FOR ON-VEHICLE PRECISION GUNNERY WITHOUT EXPENDING ACTUAL AMMUNITION; VIRTUAL REALITY GAME SOFTWARE; VIRTUAL REALITY SOFTWARE THAT PROVIDES REAL-TIME, INTEGRATED BUSINESS PROCESS MANAGEMENT INTELLIGENCE BY COMBINING INFORMATION FROM VARIOUS DATABASES AND PRESENTING IT IN AN EASY-TO-UNDERSTAND USER INTERFACE; VPN (VIRTUAL PRIVATE NETWORK) OPERATING SOFTWARE; WAN (WIDE AREA NETWORK) OPERATING SOFTWARE; WEB SITE DEVELOPMENT SOFTWARE; WIRELESS COMMUNICATION DEVICE FEATURING VOICE, DATA AND IMAGE TRANSMISSION INCLUDING VOICE, TEXT AND PICTURE MESSAGING, A VIDEO AND STILL IMAGE CAMERA, ALSO FUNCTIONAL TO PURCHASE MUSIC, GAMES, VIDEO AND SOFTWARE APPLICATIONS OVER THE AIR FOR DOWNLOADING TO THE DEVICE (U.S. CLS. 21, 23, 26, 36 AND 38).

CLASS 35—ADVERTISING AND BUSINESS

FOR AD SERVING, NAMELY, PLACING ADVERTISEMENTS ON WEBSITES FOR OTHERS USING SPECIALIZED COMPUTER SOFTWARE; ADVERTISEMENT AND PUBLICITY SERVICES BY TELEVISION, RADIO, MAIL; ADVERTISING AND PUBLICITY SERVICES; ADVERTISING AND PUBLICITY SERVICES, NAMELY, PROMOTING THE GOODS, SERVICES, BRAND IDENTITY AND COMMERCIAL INFORMATION AND NEWS OF THIRD PARTIES THROUGH PRINT, AUDIO, VIDEO, DIGITAL AND ON-LINE MEDIUM; ADVERTISING BY TRANSMISSION OF ON-LINE PUBLICITY FOR THIRD PARTIES THROUGH ELECTRONIC COMMUNICATIONS NETWORKS; ADVERTISING SERVICES, NAMELY, PROMOTING AND MARKETING THE GOODS AND SERVICES OF OTHERS THROUGH ALL PUBLIC COMMUNICATION MEANS; ADVERTISING SERVICES, PUBLIC RELATIONS AND MARKETING SERVICES, NAMELY, PROMOTING AND MARKETING THE GOODS AND SERVICES OF OTHERS THROUGH ALL PUBLIC COMMUNICATION MEANS; ADVERTISING TEXT PUBLICATION SERVICES; ADVERTISING THROUGH ALL PUBLIC COMMUNICATION MEANS; AN INTERACTIVE WEB SITE FOR USERS TO REVIEW AND RATE INTERNET CONTENT, PEOPLE, COMPANIES, PRODUCTS AND/OR SERVICES UTILIZING A SOFTWARE APPLICATION TO AWARD POINTS WHEREBY WEB SITE USERS ARE ELIGIBLE TO EXCHANGE POINTS EARNED FOR PROMOTIONAL ITEMS CONSISTING OF COUPONS, REBATES, DISCOUNTS OR SPECIAL OFFERINGS ON GOODS AND/OR SERVICE PROVIDED BY WEB SITE SPONSORS; ARRANGING FOR THE PROVISION OF PUBLIC UTILITY SERVICES FOR RENTAL PROPERTIES OF OTHERS; ARRANGING OF SUBSCRIPTIONS FOR THE PUBLICATIONS OF OTHERS; ARRANGING SUBSCRIPTIONS OF THE ONLINE PUBLICATIONS OF OTHERS; ASSISTING WITH THE FORMATION, NEGOTIATION, AND MANAGEMENT OF CONTRACTS WITH PUBLIC SECTOR ENTITIES; ASSOCIATION SERVICES, NAMELY, PROMOTING THE PUBLIC INTEREST AND AWARENESS IN CANCER RESEARCH AND EDUCATION; CHARITABLE SERVICES, NAMELY, COORDINATION OF THE PROCUREMENT AND DISTRIBUTION OF HOLIDAY GIFT DONATIONS FROM THE GENERAL PUBLIC TO ORPHANED CHILDREN; CHARITABLE SERVICES, NAMELY, PROMOTING PUBLIC AWARENESS ABOUT POVERTY IN THE UNITED STATES THROUGH A MEDIA FAST PROGRAM CONDUCTED BY YOUNG PEOPLE; CHARITABLE SERVICES, NAMELY, PROMOTING PUBLIC AWARENESS ABOUT THE DANGERS OF DRIVING WHILE DROWSY; CHARITABLE SERVICES, NAMELY, PROMOTING PUBLIC AWARENESS OF BLACK MUSIC; CONDUCTING PUBLIC OPINION POLLS; CONSULTING SERVICES RELATING TO PUBLICITY; CUSTOM WRITING SERVICES COMPRISING PUBLIC RELATIONS AND MARKETING MATERIALS FOR THE AUDIO, VIDEO AND TECHNOLOGY INDUSTRIES; DATA PROCESSING IN FIELD OF SERIAL PUBLICATIONS; DIRECTING ORDERS FOR SECURITIES TRADES BY MEANS OF COMPUTER SOFTWARE WHICH AUTOMATICALLY DIRECTS TRADES TO THE BEST LOCATION FOR EXECUTING SUCH ORDERS; DISSEMINATION OF ADVERTISING FOR OTHERS VIA PUBLIC AND PRIVATE WIRELESS NETWORKS FOR DISPLAY ON MOBILE DEVICES; DISTRIBUTION OF PUBLICITY MATERIALS (FLYERS, PROSPECTUSES, BROCHURES, SAMPLES, PARTICULARLY FOR CATALOGUE LONG DISTANCE SALES) WHETHER CROSS BORDER OR NOT; DISTRIBUTION OF PUBLICITY MATERIALS, NAMELY, FLYERS, PROSPECTUSES, BROCHURES, SAMPLES, PARTICULARLY FOR CATALOGUE LONG DISTANCE SALES; DISTRIBUTION OF SAMPLES FOR PUBLICITY PURPOSES; MARKETING AND CONSULTING SERVICES IN THE FIELD OF PROMOTING AND TRACKING THE GOODS, SERVICES, AND BRANDS OF OTHERS THROUGH ALL PUBLIC COMMUNICATION MEANS, PARTICULARLY SPECIALIZING IN THE USE OF MOBILE, SOCIAL, AND PRINT MEDIA TO DRIVE CONSUMER INTEREST, ENGAGEMENT AND ACTION; MERCHANDISING SERVICES FOR INDUCING THE PURCHASING PUBLIC TO BUY THE GOODS OF OTHERS THROUGH A PROMOTIONAL GIFT REDEMPTION PROGRAM; ON-LINE BUSINESS DIRECTORIES FEATURING HEALTH INSTITUTIONS; ONLINE MEDIA MONITORING SERVICES USING COMPUTER SOFTWARE TO AUTOMATICALLY MONITOR INTERNET

WEBSITES AND ONLINE PUBLICATIONS FOR CUSTOMER-SPECIFIED TOPICS AND TO CAPTURE RELEVANT CONTENT ON THOSE TOPICS, AND PROVIDING DOCUMENTATION AND ANALYSIS OF THAT ONLINE CONTENT TO OTHERS FOR BUSINESS PURPOSES; OUTSOURCING IN THE FIELD OF SALES AND MARKETING OF COMPUTER SOFTWARE; PRODUCTION OF TELEVISION COMMERCIALS AND PUBLIC SERVICE ANNOUNCEMENTS; PROMOTING PUBLIC AWARENESS IN THE FIELD OF SOCIAL WELFARE; PROMOTING PUBLIC AWARENESS OF ENVIRONMENTAL ISSUES AND INITIATIVES; PROMOTING PUBLIC AWARENESS OF ENVIRONMENTAL MATTERS; PROMOTING PUBLIC AWARENESS OF NEPHROTIC SYNDROME AND FOCAL SEGMENTAL GLOMERULOSCLEROSIS (FSGS); PROMOTING PUBLIC AWARENESS OF SHOPPING LOCALLY; PROMOTING PUBLIC AWARENESS OF THE NEED FOR BUSINESS PROCESS MANAGEMENT; PROMOTING PUBLIC AWARENESS OF THE UNIQUENESS AND DIVERSITY OF HUMANITY THROUGH A NATIONAL ANNUAL DAY EVENT; PROMOTING PUBLIC AWARENESS OF BUSINESS PROCESS MANAGEMENT; PROMOTING PUBLIC AWARENESS OF BUSINESS PROCESS MANAGEMENT; PROMOTING PUBLIC INTEREST IN EDUCATION, RECOGNITION, CAREER ADVANCEMENT, AND LEADERSHIP FOR ELITE MANAGERS AND EXECUTIVES IN CORPORATIONS AND PROFESSIONAL SERVICE FIRMS; PROMOTING THE CHARITABLE GIVING OF OTHERS, NAMELY, TRACKING AND PUBLICIZING CHARITABLE DONATIONS AND RANDOM ACTS OF KINDNESS; PROMOTING, ADVERTISING AND MARKETING THE ON-LINE DATABASES AND ELECTRONIC PUBLICATIONS OF OTHERS; PROMOTIONAL MARKETING AND REPRESENTATION SERVICES FOR SALES TO THE PUBLIC SECTOR; PROVIDING A WEB SITE FEATURING CONSUMER INFORMATION ON VARIOUS PUBLICATIONS AND PROVIDING HYPERLINKS TO ON-LINE RETAILERS THAT SELL THE PUBLICATIONS; PROVIDING AN INTERNET WEBSITE FEATURING NEWS AND INFORMATION IN THE FIELD OF NATURAL RESOURCE MANAGEMENT RELATING TO THE ENVIRONMENT AND PUBLIC LANDS; PROVIDING PUBLIC SECTOR BUSINESS AND MARKET INTELLIGENCE; PROVIDING PUBLIC SECTOR CHANNEL STRATEGY DEVELOPMENT AND MANAGEMENT SERVICES; PROVIDING PUBLIC SECTOR CONTRACT VEHICLE MANAGEMENT; PROVIDING PUBLIC SECTOR GO-TO-MARKET ADVICE AND STRATEGIES; PUBLIC ADVOCACY TO PROMOTE AWARENESS OF BUSINESS PROCESS MANAGEMENT; PUBLIC OPINION POLLING; PUBLIC OPINION SURVEYS; PUBLIC POLICY RESEARCH SERVICES; PUBLIC RELATIONS; PUBLIC RELATIONS, ADVERTISING AND MARKETING SERVICES FOR THE TOURISM AND CONVENTION INDUSTRY, NAMELY, ORGANIZING AND HOSTING SITE INSPECTIONS AND FAMILIARIZATION TOURS FOR WHOLESALERS, TOUR OPERATORS, TRAVEL AGENTS, MEETING AND INCENTIVE TRAVEL PLANNERS AND TRAVEL MEDIA; PUBLICATION OF PUBLICITY MATERIALS; PUBLICATION OF PUBLICITY TEXTS; PUBLICITY AGENTS; PUBLICITY AND SALES PROMOTION RELATING TO GOODS AND SERVICES, OFFERED AND ORDERED BY TELECOMMUNICATION OR THE ELECTRONIC WAY; PUBLICITY AND SALES PROMOTION SERVICES; PUBLICITY BUREAU SERVICES; PUBLICITY CONSULTATION; RENTAL OF ALL PUBLICITY AND MARKETING PRESENTATION MATERIALS; RENTAL OF PUBLICITY MATERIAL; SERVICES WITH REGARD TO PRODUCT PRESENTATION TO THE PUBLIC; TESTING, ANALYSIS AND EVALUATION OF THE BROAD KNOWLEDGE, EXPERIENCE AND PROFESSIONAL JUDGMENT OF PUBLIC RELATIONS PROFESSIONALS FOR PURPOSES OF CAREER ENHANCEMENT AND ADVANCEMENT IN THE FIELD OF PUBLIC RELATIONS; VALUE-ADDED RESELLER SERVICES, NAMELY, DISTRIBUTORSHIP SERVICES FEATURING COMPUTER SOFTWARE; WRITING OF PUBLICITY TEXTS (U.S. CLS. 100, 101 AND 102).

TARA PATE, EXAMINING ATTORNEY

SN 85-075,002. QWIKI, INC., PALO ALTO, CA. FILED 6-30-2010.

QWIKI

THE MARK CONSISTS OF STANDARD CHARACTERS WITHOUT CLAIM TO ANY PARTICULAR FONT, STYLE, SIZE, OR COLOR.

CLASS 41—EDUCATION AND ENTERTAINMENT

FOR PROVIDING AN ON-LINE NON-DOWNLOADABLE PUBLICATION FOR PROVIDING INTERACTIVE NARRATED REFERENCE MATERIALS IN THE NATURE OF AN INTERACTIVE ENCYCLOPEDIA FEATURING TEXT, AUDIO, VIDEO, PHOTOGRAPHS AND ANIMATION IN THE FIELD OF GENERAL REFERENCE (U.S. CLS. 100, 101 AND 107).

CLASS 42—SCIENTIFIC AND COMPUTER SERVICES

FOR COMPUTER SERVICES, NAMELY, PROVIDING SEARCH ENGINES FOR ELECTRONIC COMMUNICATIONS NETWORKS; PROVIDING TEMPORARY USE OF NON-DOWNLOADABLE SOFTWARE, NAMELY, PROVIDING SEARCH ENGINE SOFTWARE THAT CREATES INTERACTIVE MEDIA IN THE NATURE OF VISUAL GUIDES WITH DATA, INFORMATION, AUDIO, VIDEO AND PHOTOS FEATURING INFORMATION WITH RESPECT TO A VARIETY OF TOPICS; PROVIDING TEMPORARY USE OF NON-DOWNLOADABLE SOFTWARE, NAMELY, PROVIDING SEARCH ENGINE SOFTWARE FOR GENERATING INTERACTIVE MEDIA IN THE NATURE OF DATA, INFORMATION, AUDIO, VIDEO AND PHOTOS FROM KEYWORD OR STRING-BASED INPUT; PROVIDING TEMPORARY USE OF NON-DOWNLOADABLE SOFTWARE FOR BUILDING BIOGRAPHICAL INFORMATION WEBSITES ABOUT A PERSON OR BUSINESS; PROVIDING TEMPORARY USE OF NON-DOWNLOADABLE SOFTWARE FOR DELIVERING PERSONALIZED NEWS FEEDS (U.S. CLS. 100 AND 101).

ANDREA K. NADELMAN, EXAMINING ATTORNEY

SN 85-075,088. MEDWINDS, S.L.U., ALARÓ (BALEARES), SPAIN, FILED 6-30-2010.

MEDWINDS

OWNER OF ERPN CMNTY TM OFC REG. NO. 9193152, DATED 11-29-2010, EXPIRES 6-22-2020.

THE MARK CONSISTS OF THE STYLIZED WORD "MEDWINDS" WITH A HORIZONTALLY SQUIGGLY LINE BELOW THE LETTERS "DWIN" OF THE WORD "MEDWINDS". THE COLOR WHITE APPEARING IN THE BACKGROUND OF THE MARK REPRESENTS TRANSPARENT AREAS AND THEREFORE IS NOT PART OF THE MARK.

CLASS 18—LEATHER GOODS

FOR ANIMAL SKINS AND HIDES; BRIEFCASES; FUR; HANDBAGS; HARNESES AND SADDLERY; IMITATION LEATHER; LEATHER; PARASOLS; PURSES; RUCKSACKS; SUITCASES; TANNED LEATHER; TRUNKS; UMBRELLAS AND THEIR PARTS; WALKING STICKS; WALLETS; WHIPS (U.S. CLS. 1, 2, 3, 22 AND 41).

CLASS 25—CLOTHING

FOR ANORAKS; BEACHWEAR; BELTS; BERMUDA SHORTS; BIKINIS; BLOUSES; BOXER SHORTS; CARDIGANS; COATS; FOOTWEAR; FUR JACKETS; GLOVES; GOLF SHIRTS; HEADWEAR; JACKETS; JEANS; JERSEYS; JUMPSUITS; NECKTIES; POLO SHIRTS; SCARVES; SKIRTS; SOCKS; SPORT COATS; SWEAT SHIRTS; SWIMWEAR; T-SHIRTS; TENNIS WEAR; TROUSERS; UNDERSHIRTS; UNDERWEAR (U.S. CLS. 22 AND 39).

CLASS 35—ADVERTISING AND BUSINESS

FOR ADMINISTRATIVE HOTEL MANAGEMENT; ADVERTISING SERVICES; BUSINESS ADMINISTRATION AND MANAGEMENT; BUSINESS MANAGEMENT ASSISTANCE TO INDUSTRIAL OR COMMERCIAL COMPANIES; COMMERCIAL BUSINESS MANAGEMENT; IMPORT AND EXPORT AGENCIES; ON-LINE RETAIL STORE SERVICES FEATURING GOODS MADE OF LEATHER AND IMITATIONS OF LEATHER, ANIMAL SKINS, HIDES, BAGS, TRUNKS, TRAVELING BAGS, HANDBAGS, BACKPACKS, BRIEFCASES, PORTFOLIOS, WALLETS, PURSES NOT MADE OF PRECIOUS METAL, UMBRELLAS AND THEIR PARTS, PARASOLS, WALKING STICKS, WHIPS, HARNESES AND SADDLERY, BELTS, CLOTHING, FOOTWEAR, HEADGEAR, JEWELRY, IMITATION JEWELRY, PERFUMES AND BEAUTY ARTICLES; PUBLIC RELATIONS; RETAIL STORE SERVICES FEATURING GOODS MADE OF LEATHER AND IMITATIONS OF LEATHER, ANIMAL SKINS, HIDES, BAGS, TRUNKS, TRAVELING BAGS, HANDBAGS, BACKPACKS, BRIEFCASES, PORTFOLIOS, WALLETS, PURSES NOT MADE OF PRECIOUS METAL, UMBRELLAS AND THEIR PARTS, PARASOLS, WALKING STICKS, WHIPS, HARNESES AND SADDLERY, BELTS, CLOTHING, FOOTWEAR, HEADGEAR, JEWELRY, IMITATION JEWELRY, PERFUMES AND BEAUTY ARTICLES (U.S. CLS. 100, 101 AND 102).

JACLYN KIDWELL WALKER, EXAMINING ATTORNEY

SN 85-077,124. BARON & BARON, INC., HUNTINGTON BEACH, CA. FILED 7-2-2010.

Auto Jewelry

THE MARK CONSISTS OF STANDARD CHARACTERS WITHOUT CLAIM TO ANY PARTICULAR FONT, STYLE, SIZE, OR COLOR.

NO CLAIM IS MADE TO THE EXCLUSIVE RIGHT TO USE "AUTO", APART FROM THE MARK AS SHOWN.

CLASS 6—METAL GOODS

FOR METAL LICENSE PLATES, METAL KEY CHAINS (U.S. CLS. 2, 12, 13, 14, 23, 25 AND 50).

CLASS 12—VEHICLES

FOR METAL LICENSE PLATE FRAMES, TRAILER HITCH COVERS; METAL EMBLEMS FOR VEHICLES (U.S. CLS. 19, 21, 23, 31, 35 AND 44).

ROBERT C. CLARK JR., EXAMINING ATTORNEY

SN 85-078,668. SYBARITIC GLOBAL AESTHETICS, LLC, BLOOMINGTON, MN. FILED 7-6-2010.

SLIMAVATAR

THE MARK CONSISTS OF STANDARD CHARACTERS WITHOUT CLAIM TO ANY PARTICULAR FONT, STYLE, SIZE, OR COLOR.

CLASS 11—ENVIRONMENTAL CONTROL APPARATUS

FOR PERSONAL ENVIRONMENTALLY CONTROLLED CAPSULE, NAMELY, A SPA CHAMBER IN WHICH A PERSON CAN RECLINE FOR RELAXATION, AND HAVING ONE OR MORE SELECTIVELY ENGAGEABLE SOURCES OF HEAT, LIGHT, VIBRATION, STEAM, SHOWER, AND/OR SOUND (U.S. CLS. 13, 21, 23, 31 AND 34).

CLASS 44—MEDICAL, BEAUTY AND AGRICULTURAL SERVICES

FOR PROVIDING WEIGHT LOSS PROGRAM SERVICES INCLUDING DIET AND CALORIE GOAL PLANNING AND PROGRESS CHARTS IN ASSOCIATION WITH THE SAME FOR RECORDING ACTIVITIES AND DIET AND WEIGHT RESULTS ON A GLOBAL NETWORK; WEIGHT MANAGEMENT SERVICES, PROVIDING WEIGHT LOSS AND/OR WEIGHT MAINTENANCE PROGRAMS (U.S. CLS. 100 AND 101).

NAKIA HENRY, EXAMINING ATTORNEY

SN 85-078,814. INITIATIVE FOR AFFORDABLE HOUSING, INC., DECATUR, GA. FILED 7-6-2010.

RITZY RAGS

THE MARK CONSISTS OF STANDARD CHARACTERS WITHOUT CLAIM TO ANY PARTICULAR FONT, STYLE, SIZE, OR COLOR.

NO CLAIM IS MADE TO THE EXCLUSIVE RIGHT TO USE "RAGS" AS TO CLASSES 25 AND 35, APART FROM THE MARK AS SHOWN.

CLASS 16—PAPER GOODS AND PRINTED MATTER

FOR CHECKBOOK COVERS MADE OF CLOTH (U.S. CLS. 2, 5, 22, 23, 29, 37, 38 AND 50).

CLASS 18—LEATHER GOODS

FOR BAGS, NAMELY, POCKETBOOKS, PURSES, TOTE BAGS (U.S. CLS. 1, 2, 3, 22 AND 41).

CLASS 22—CORDAGE AND FIBERS

FOR HAMMOCKS (U.S. CLS. 1, 2, 7, 19, 22, 42 AND 50).

CLASS 24—FABRICS

FOR PLACEMATS NOT OF PAPER, TOWELS, HOT-PADS (U.S. CLS. 42 AND 50).

CLASS 25—CLOTHING

FOR CLOTHING, NAMELY, APRONS, SCARVES, BELTS (U.S. CLS. 22 AND 39).

CLASS 27—FLOOR COVERINGS

FOR RUGS, DOORMATS (U.S. CLS. 19, 20, 37, 42 AND 50).

CLASS 35—ADVERTISING AND BUSINESS

FOR RETAIL STORE SERVICES AND ONLINE RETAIL STORE SERVICES, EACH FEATURING RUGS, BAGS, NAMELY, POCKETBOOKS, PURSES, TOTE BAGS, HOTPADS, APRONS, HAMMOCKS, PLACEMATS, SCARVES, BELTS, DOORMATS, TOWELS, CHECKBOOK COVERS; JOB PLACEMENT SERVICES (U.S. CLS. 100, 101 AND 102).

CLASS 41—EDUCATION AND ENTERTAINMENT

FOR EDUCATIONAL SERVICES, NAMELY, PROVIDING INDIVIDUALS WITH BASIC JOB SKILLS TRAINING (U.S. CLS. 100, 101 AND 107).
SHAUNIA CARLYLE, EXAMINING ATTORNEY

CLASS 43—HOTEL AND RESTAURANT SERVICES

FOR BAR AND RESTAURANT SERVICES; BREWPUB SERVICES (U.S. CLS. 100 AND 101).
FIRST USE 9-1-1997; IN COMMERCE 9-1-1997.
KAREN SEVERSON, EXAMINING ATTORNEY

SN 85-079,696. SAVE.TV LTD., SW1H 0RG LONDON, GREAT BRITAIN, FILED 7-7-2010.

save.tv

SN 85-079,640. MILWAUKEE BREWING COMPANY, MILWAUKEE, WI. FILED 7-7-2010.



NO CLAIM IS MADE TO THE EXCLUSIVE RIGHT TO USE "MILWAUKEE BREWING CO.", APART FROM THE MARK AS SHOWN.

THE MARK CONSISTS OF A STYLIZED LETTER "M", IN WHICH TWO BREWING KETTLES OR TANKS ALSO APPEAR, ABOVE THE WORDING "MILWAUKEE" ABOVE THE WORDING "BREWING CO". THE "O" IN "CO" FEATURES A STAR IN THE CENTER OF THE LETTER AND A HORIZONTAL LINE APPEARS UNDER THE LETTER "O". ALL OF THE AFOREMENTIONED APPEARS IN A QUADRILATERAL.

CLASS 32—LIGHT BEVERAGES

FOR BEER, ALE, LAGER, STOUT AND PORTER (U.S. CLS. 45, 46 AND 48).
FIRST USE 9-1-1997; IN COMMERCE 9-1-1997.

CLASS 40—MATERIAL TREATMENT

FOR BREWERY SERVICES (U.S. CLS. 100, 103 AND 106).
FIRST USE 9-1-1997; IN COMMERCE 9-1-1997.

THE MARK CONSISTS OF STANDARD CHARACTERS WITHOUT CLAIM TO ANY PARTICULAR FONT, STYLE, SIZE, OR COLOR.

OWNER OF FED REP GERMANY REG. NO. 005014881, DATED 8-26-2008, EXPIRES 3-29-2016.

CLASS 9—ELECTRICAL AND SCIENTIFIC APPARATUS

FOR VIDEO RECORDER; APPARATUS FOR RECORDING, TRANSMISSION AND REPRODUCTION OF SOUND AND IMAGES; BLANK MAGNETIC DATA CARRIERS; PRERECORDED MAGNETIC DATA CARRIERS FEATURING TEXTS, SPEECH, MUSIC, AND FILMS; COMPUTER PERIPHERALS; BLANK VIDEO CASSETTES; PRERECORDED VIDEOCASSETTES FEATURING MUSIC, TEXTS, SPEECH AND FILMS; AMUSEMENT APPARATUS ADAPTED FOR USE WITH TELEVISION RECEIVERS ONLY; DOWNLOADABLE ELECTRONIC PUBLICATIONS IN THE NATURE OF MAGAZINES OR NEWSLETTERS IN THE FIELD OF TELEVISION, TELEVISION PROGRAM GUIDES, MOVIE GUIDES AND ENTERTAINMENT (U.S. CLS. 21, 23, 26, 36 AND 38).

CLASS 35—ADVERTISING AND BUSINESS

FOR COMPUTERIZED DATABASE MANAGEMENT; MANAGEMENT AND COMPILATION OF COMPUTERIZED DATABASES (U.S. CLS. 100, 101 AND 102).

CLASS 38—COMMUNICATION

FOR PROVIDING TELECOMMUNICATIONS CONNECTIVITY FOR TRANSFER OF MESSAGES, TEXTS, GRAPHICS, AUDIOVISUAL AND MULTIMEDIA INFORMATION, DOCUMENTS, DATABASES AND COMPUTER PROGRAMS; PROVIDING REMOTE OR INTERNET ACCESS; ACCESS TO DATABASES AND ACCESS TO ELECTRONIC SITES; ELECTRONIC TRANSMISSION OF MESSAGES TO INTERNET ADDRESSES VIA ELECTRONIC COMMUNICATIONS NETWORKS AND RENTING APPARATUS FOR SUCH COMMUNICATIONS; PROVIDING AND OPERATING CHAT LINES, NAMELY, PROVIDING ON-LINE CHAT ROOMS AND ELECTRONIC BULLETIN BOARDS FOR TRANSMISSION OF MESSAGES AMONG USERS IN THE FIELD OF GENERAL INTEREST; PROVIDING ACCESS TO DATABASES (U.S. CLS. 100, 101 AND 104).

CLASS 42—SCIENTIFIC AND COMPUTER SERVICES

FOR WRITING PROGRAMS FOR DATA PROCESSING; RENTAL OF WEB SERVERS; RENTAL OF APPARATUS FOR DATA PROCESSING; RENTAL OF COMPUTER SOFTWARE; PROVIDING NON-DOWNLOADABLE COMPUTER PROGRAMS FOR USE AS ELECTRONIC PROGRAM GUIDES OR AS A NETWORK DIGITAL VIDEO RECORDER OR AS REMOTE STORAGE DIGITAL VIDEO RECORDER; COMPUTER SERVICES, NAMELY, PROVIDING TEMPORARY USE OF ON-LINE NON-DOWNLOADABLE SOFTWARE AND APPLICATIONS FOR DATA STORAGE; PROVIDING TEMPORARY USE OF WEB-BASED SOFTWARE APPLICATIONS FOR DATA STORAGE AND DATA MANAGEMENT ON SERVERS; RENTAL OF STORAGE AREAS OF COMPUTER, NAMELY, RENTAL OF DATABASE SERVERS FOR OTHERS (U.S. CLS. 100 AND 101).

H. M. FISHER, EXAMINING ATTORNEY

SN 85-080,505, DENT FIX CORPORATION, DBA DENT FIX EQUIPMENT, LAWNSDALE, CA. FILED 7-8-2010.



SN 85-079,894, CISCO TECHNOLOGY, INC., SAN JOSE, CA. FILED 7-7-2010.

FLIP

THE MARK CONSISTS OF STANDARD CHARACTERS WITHOUT CLAIM TO ANY PARTICULAR FONT, STYLE, SIZE, OR COLOR.

OWNER OF U.S. REG. NOS. 3,684,301, 3,789,499 AND OTHERS.

CLASS 9—ELECTRICAL AND SCIENTIFIC APPARATUS

FOR CAMCORDER CASES; CAMCORDER TRIPODS AND MOUNTS; POWER SUPPLIES AND ADAPTORS FOR CAMCORDERS; COMPUTER HARDWARE AND SOFTWARE FOR VIEWING, DISPLAYING, MANAGING AND ORGANIZING VIDEOS AND IMAGES ON A TELEVISION OR OTHER DISPLAY SCREEN; COMPUTER SOFTWARE TO ENABLE UPLOADING, POSTING, SHOWING, DISPLAYING, TAGGING, AND OTHERWISE TRANSMITTING IMAGES AND AUDIOVISUAL WORKS OVER THE INTERNET OR OTHER COMMUNICATIONS NETWORK AND BETWEEN CAMCORDERS AND COMPUTERS (U.S. CLS. 21, 23, 26, 36 AND 38).

FIRST USE 5-1-2007; IN COMMERCE 5-1-2007.

CLASS 35—ADVERTISING AND BUSINESS

FOR ON-LINE RETAIL STORE SERVICES FEATURING CAMCORDERS, CAMCORDER CASES, CAMCORDER TRIPODS AND MOUNT, CAMCORDER POWER SUPPLIES AND ADAPTORS, AND COMPUTER SOFTWARE TO ENABLE UPLOADING, POSTING, SHOWING, DISPLAYING, TAGGING, EDITING, ORGANIZING AND TRANSMITTING IMAGES AND AUDIOVISUAL WORKS OVER THE INTERNET OR OTHER COMMUNICATION NETWORKS (U.S. CLS. 100, 101 AND 102).

FIRST USE 5-1-2007; IN COMMERCE 5-1-2007.
DOMINIC FATHY, EXAMINING ATTORNEY

NO CLAIM IS MADE TO THE EXCLUSIVE RIGHT TO USE "DENT FIX EQUIPMENT", APART FROM THE MARK AS SHOWN.

THE COLOR(S) YELLOW, WHITE, GRAY AND BLACK IS/ARE CLAIMED AS A FEATURE OF THE MARK.

THE MARK CONSISTS OF A RECTANGLE WITH SLIGHTLY ROUNDED CORNERS SET AGAINST A BLACK BACKGROUND WITH THE WORDS "DENT FIX EQUIPMENT" CONTAINED WITHIN THE RECTANGLE. THE RECTANGLE'S BOTTOM HALF IS COMPLETELY BLACK WHILE THE UPPER HALF GRADUALLY SHIFTS TO A GRAY COLOR SHADE. THE RECTANGLE IS OUTLINED IN GRAY. THERE ARE THREE LINES OF TEXT WITH ONE WORD PLACED ON EACH LINE READING FROM TOP TO BOTTOM. EACH LINE OF TEXT OCCUPIES APPROXIMATELY ONE THIRD OF THE ENTIRE RECTANGLE. THE TOP LINE OF TEXT CONTAINS THE WORD "DENT" IN WHITE, AND ADJUSTED SO THE LETTER "T" IS ALIGNED WITH THE RIGHT EDGE OF THE RECTANGLE. TO THE LEFT OF THE "D" IS A WEDGE REPRESENTING ONE QUARTER OF A CIRCLE IN YELLOW. IMMEDIATELY BELOW THE WEDGE AND "D" ARE TWO SIMILARLY DESIGNED YELLOW WEDGES WHICH IN CONJUNCTION TOGETHER FORM A CIRCLE WITH TWO INTERSECTING BLACK LINES RUNNING PERPENDICULAR THROUGH THE DIAMETER OF THE CIRCLE. ALSO ON THE SECOND LINE OF TEXT, TO THE RIGHT OF THE WEDGES, IS THE WORD "FIX" WRITTEN IN SIMILAR WHITE LETTERING AS USED FOR THE TERM "DENT". THE THIRD LINE OF TEXT DEPICTS THE WORD "EQUIPMENT" IN WHITE AND SPANNING THE LENGTH OF THE RECTANGLE, BUT WRITTEN IN SMALLER TYPEFACE THAN THE OTHER WORDS.

CLASS 7—MACHINERY

FOR POWER TOOLS, NAMELY, SPOT WELD DRILLS, LASER WELD CUTTERS, AND ELECTRIC GRINDERS (U.S. CLS. 13, 19, 21, 23, 31, 34 AND 35).

FIRST USE 1-1-2001; IN COMMERCE 1-1-2001.

CLASS 9—ELECTRICAL AND SCIENTIFIC APPARATUS

FOR ELECTRIC WELDING MACHINES, NAMELY, ELECTRICAL DENT REMOVAL STUD WELDERS; TRAM GAUGES, NAMELY, LENGTH MEASURING GAUGES FOR USE IN AUTOMOTIVE BODY REPAIR (U.S. CLS. 21, 23, 26, 36 AND 38).

FIRST USE 1-1-2001; IN COMMERCE 1-1-2001.
JIM RINGLE, EXAMINING ATTORNEY

SN 85-083,267. MYOB ENTERPRISES LLC, TOWSON, MD.
FILED 7-13-2010.

myob

THE MARK CONSISTS OF STANDARD CHARACTERS WITHOUT CLAIM TO ANY PARTICULAR FONT, STYLE, SIZE, OR COLOR.

CLASS 11—ENVIRONMENTAL CONTROL APPARATUS

FOR LIGHTING FIXTURES; LAMPS; LANTERNS; LAMP SHADES; LAMP BASES; LAMP FINIALS; ELECTRIC STRING LIGHTS; NIGHT LIGHTS; FLASHLIGHTS; ELECTRIC FANS; REPLACEMENT PARTS FOR THE FOREGOING (U.S. CLS. 13, 21, 23, 31 AND 34).

CLASS 16—PAPER GOODS AND PRINTED MATTER

FOR OFFICE SUPPLIES, NAMELY, LETTER-OPENERS, APPOINTMENT BOOKS, BLACKBOARDS, CHALK, ERASERS, DRAWING BOARDS AND EASELS, DRY ERASE WRITING BOARDS AND WRITING SURFACES, MAGNETIC BOARDS, MAT BOARDS, NOTE BOARDS, PUSH PINS, CALENDARS, DESK PADS, MEMO PADS, CLIP BOARDS, DESK BASKETS FOR DESK ACCESSORIES, FILE TRAYS, DESK MOUNTED STATIONARY CABINETS, DESK SETS, DESKTOP ORGANIZERS, DESKTOP PLANNERS, APPOINTMENT BOOKS, LAP BOARDS FOR READING AND WRITING, FILE BOXES FOR STORAGE OF BUSINESS AND PERSONAL RECORDS AND CARDBOARD BOXES; LETTER RACKS; BOOK HOLDERS; BLANK JOURNALS; DIARIES; BRAG BOOKS; PHOTO STORAGE BOXES; STICKERS; FRAMED ART PRINTS AND PICTURES; PRINTS; MURALS; COLLAGES; MOUNTED POSTERS; PAPER BOARD; PAPER SIGNBOARDS; WRAPPING PAPER; GIFT BAGS; MOUNTING BOARDS; BLOTTERS; BOOKENDS; HAT BOXES OF CARDBOARD; LUNCH BAGS; SHELF PAPER; DECALS FOR USE AS WALL DECOR; STENCILS FOR USE AS WALL DECOR (U.S. CLS. 2, 5, 22, 23, 29, 37, 38 AND 50).

CLASS 20—FURNITURE AND ARTICLES NOT OTHERWISE CLASSIFIED

FOR FURNITURE, FURNITURE HARDWARE AND REPLACEMENT PARTS THEREFOR, NAMELY, DRAWER SLIDES, METAL CAPPED FEET FOR FURNITURE; PICTURE FRAMES; MIRRORS; INDOOR NON-TEXTILE BLINDS; FITTED FABRIC FURNITURE COVERS; BULLETIN BOARDS; MATTRESSES; PILLOWS; BOLSTERS; CUSHIONS; CHAIR PADS; MATTRESS TOPPERS; SLEEPING BAGS AND PADS THEREFOR; BABY CHANGING MATS; BABY HEAD SUPPORT CUSHIONS; BUMPER GUARDS FOR CRIBS; INFANT BOUNCERS AND WALKERS; WINDOW BLINDS; WINDOW SHADES; DRAPERY HARDWARE, NAMELY, TRAVERSE RODS, POLES, CURTAIN HOOKS, CURTAIN RINGS, CURTAIN RODS AND FINIALS; WALL DECOR, NAMELY, DECORATIVE MOBILES, SOFT SCULPTURE WALL DECORATIONS, VINYL WALL APPLIQUES; DISPLAY BOARDS; DISPLAY CASES; STORAGE AND ORGANIZATIONAL PRODUCTS AND ACCESSORIES, NAMELY, METAL STORAGE CABINETS, NON-METAL BINS, SHELVES FOR STORAGE, STORAGE RACKS; BOXES NOT OF METAL, NAMELY, PLASTIC BOXES, PLASTIC BINS, NON-METAL LOCK BOXES, NON-METAL CABINETS; EMBROIDERY FRAMES; PLASTIC SIGNBOARDS; FIRE SCREENS FOR DOMESTIC USE; TOWEL RACKS, TOWEL STANDS AND NON-METAL TOWEL HOOKS; GARMENT STORAGE RACKS; COAT STANDS; HAT RACKS; FITTED FABRIC SLIP COVERS FOR FURNITURE; RUG STAYS, NAMELY, NON-METAL STAIR RODS FOR SECURING CARPET TO STAIRS (U.S. CLS. 2, 13, 22, 25, 32 AND 50).

CLASS 24—FABRICS

FOR FABRICS FOR TEXTILE USE; UPHOLSTERY FABRICS; DRAPERIES; TEXTILE WALL HANGINGS; FABRIC WINDOW COVERINGS AND TREATMENTS, NAMELY, CURTAINS, DRAPERIES, SHEERS, SWAGS AND VALANCES; BATH, BED AND TABLE LINENS; SHOWER CURTAINS; SHOWER CURTAIN LINERS; BEDDING, NAMELY, BED BLANKETS, BED LINENS, BED SHEETS, BED SKIRTS, DUVET COVERS, COMFORTERS, COVERLETTES; THROWS; AFGHANS; COVERS FOR CUSHIONS AND PILLOWS; PILLOWS; TABLE PADS; TOWELS; WASH CLOTHS; BED PADS; MATTRESS PADS (U.S. CLS. 42 AND 50).

CLASS 27—FLOOR COVERINGS

FOR FLOOR COVERINGS; CARPETS; RUGS; FLOOR MATS; DOOR MATS; RUG STAYS, NAMELY, FLOOR MATS, NAMELY, RUBBER OR POLYMER STAIR TREADS, AND FLOOR MATS IN THE NATURE OF NON-SLIP PADS FOR USE UNDER RUGS TO PREVENT SLIPPAGE; TEXTILE AND NON-TEXTILE WALL COVERINGS; WALLPAPERS (U.S. CLS. 19, 20, 37, 42 AND 50).

CLASS 35—ADVERTISING AND BUSINESS

FOR RETAIL AND ONLINE STORE SERVICES FEATURING A WIDE VARIETY OF CONSUMER GOODS OF OTHERS; RETAIL AND ONLINE GIFT REGISTRY SERVICES; HOME FURNISHING RETAIL STORE SERVICES (U.S. CLS. 100, 101 AND 102).

CLASS 36—INSURANCE AND FINANCIAL

FOR CHARITABLE FUNDRAISING SERVICES (U.S. CLS. 100, 101 AND 102).

CLASS 37—CONSTRUCTION AND REPAIR

FOR REFINISHING OF FURNITURE; FURNITURE RESTORATION, REPAIR, MAINTENANCE AND FINISHING (U.S. CLS. 100, 103 AND 106).

CLASS 40—MATERIAL TREATMENT

FOR APPLYING FINISHES TO FABRIC; CLOTH DYEING; CUSTOM QUILTING; CUTTING OF FABRIC; EMBROIDERY SERVICES; PREPARATION AND TREATMENT OF FABRIC; SEWING SERVICES; WATERPROOFING OF FABRIC; FIREPROOFING OF FABRIC (U.S. CLS. 100, 103 AND 106).

CLASS 42—SCIENTIFIC AND COMPUTER SERVICES

FOR INTERIOR DECORATING SERVICES; COMPUTER AIDED DESIGN FOR OTHERS (U.S. CLS. 100 AND 101).

LAURIE KAUFMAN, EXAMINING ATTORNEY

SN 85-083,268. MYOB ENTERPRISES LLC, TOWSON, MD.
FILED 7-13-2010.

myob make your own bedroom

THE MARK CONSISTS OF STANDARD CHARACTERS WITHOUT CLAIM TO ANY PARTICULAR FONT, STYLE, SIZE, OR COLOR.

CLASS 11—ENVIRONMENTAL CONTROL APPARATUS

FOR LIGHTING FIXTURES; LAMPS; LANTERNS; LAMP SHADES; LAMP BASES; LAMP FINIALS; ELECTRIC STRING LIGHTS; NIGHT LIGHTS; FLASHLIGHTS; ELECTRIC FANS; REPLACEMENT PARTS FOR THE FOREGOING (U.S. CLS. 13, 21, 23, 31 AND 34).

CLASS 16—PAPER GOODS AND PRINTED MATTER

FOR OFFICE SUPPLIES, NAMELY, LETTER-OPENERS, APPOINTMENT BOOKS, BLACKBOARDS, CHALK, ERASERS, DRAWING BOARDS AND EASELS, DRY ERASE WRITING BOARDS AND WRITING SURFACES, MAGNETIC BOARDS, MAT BOARDS, NOTE BOARDS, PUSH PINS, CALENDARS, DESK PADS, MEMO PADS, CLIP BOARDS, DESK BASKETS FOR DESK ACCESSORIES, FILE TRAYS, DESK MOUNTED STATIONARY CABINETS, DESK SETS, DESKTOP ORGANIZERS, DESKTOP PLANNERS, APPOINTMENT BOOKS, LAP BOARDS FOR READING AND WRITING, FILE BOXES FOR STORAGE OF BUSINESS AND PERSONAL RECORDS AND CARDBOARD BOXES; LETTER RACKS; BOOK HOLDERS; BLANK JOURNALS; DIARIES; BRAG BOOKS; PHOTO STORAGE BOXES; STICKERS; FRAMED ART PRINTS AND PICTURES; PRINTS; MURALS; COLLAGES; MOUNTED POSTERS; PAPER BOARD; PAPER SIGNBOARDS; WRAPPING PAPER; GIFT BAGS; MOUNTING BOARDS; BLOTTERS; BOOKENDS; HAT BOXES OF CARDBOARD; LUNCH BAGS; SHELF PAPER; DECALS FOR USE AS WALL DECOR; STENCILS FOR USE AS WALL DECOR (U.S. CLS. 2, 5, 22, 23, 29, 37, 38 AND 50).

CLASS 20—FURNITURE AND ARTICLES NOT OTHERWISE CLASSIFIED

FOR FURNITURE, FURNITURE HARDWARE AND REPLACEMENT PARTS THEREFOR, NAMELY, DRAWER SLIDES, METAL CAPPED FEET FOR FURNITURE; PICTURE FRAMES; MIRRORS; INDOOR NON-TEXTILE BLINDS; FITTED FABRIC FURNITURE COVERS; BULLETIN BOARDS; MATTRESSES; PILLOWS; BOLSTERS; CUSHIONS; CHAIR PADS; MATTRESS TOPPERS; SLEEPING BAGS AND PADS THEREFOR; BABY CHANGING MATS; BABY HEAD SUPPORT CUSHIONS; BUMPER GUARDS FOR CRIBS; INFANT BOUNCERS AND WALKERS; WINDOW BLINDS; WINDOW SHADES; DRAPERY HARDWARE, NAMELY, TRAVERSE RODS, POLES, CURTAIN HOOKS, CURTAIN RINGS, CURTAIN RODS AND FINIALS; WALL DECOR, NAMELY, DECORATIVE MOBILES, SOFT SCULPTURE WALL DECORATIONS, VINYL WALL APPLIQUES; DISPLAY BOARDS; DISPLAY CASES; STORAGE AND ORGANIZATIONAL PRODUCTS AND ACCESSORIES, NAMELY, METAL STORAGE CABINETS, NON-METAL BINS, SHELVES FOR STORAGE, STORAGE RACKS; BOXES NOT OF METAL, NAMELY, PLASTIC BOXES, PLASTIC BINS, NON-METAL LOCK BOXES, NON-METAL CABINETS; EMBROIDERY FRAMES; PLASTIC SIGNBOARDS; FIRE SCREENS FOR DOMESTIC USE; TOWEL RACKS, TOWEL STANDS AND NON-METAL TOWEL HOOKS; GARMENT STORAGE RACKS; COAT STANDS; HAT RACKS; FITTED FABRIC SLIP COVERS FOR FURNITURE; RUG STAYS, NAMELY, NON-METAL STAIR RODS FOR SECURING CARPET TO STAIRS (U.S. CLS. 2, 13, 22, 25, 32 AND 50).

CLASS 24—FABRICS

FOR FABRICS FOR TEXTILE USE; UPHOLSTERY FABRICS; DRAPERIES; TEXTILE WALL HANGINGS; FABRIC WINDOW COVERINGS AND TREATMENTS, NAMELY, CURTAINS, DRAPERIES, SHEERS, SWAGS AND VALANCES; BATH, BED AND TABLE LINENS; SHOWER CURTAINS; SHOWER CURTAIN LINERS; BEDDING, NAMELY, BED LINENS, BED SHEETS, BED SKIRTS, DUVET COVERS, COMFORTERS, COVERLETTES; THROWS; AFGHANS; COVERS FOR CUSHIONS AND PILLOWS; PILLOWS; TABLE PADS; TOWELS; WASH CLOTHS; BED PADS; MATTRESS PADS (U.S. CLS. 42 AND 50).

CLASS 27—FLOOR COVERINGS

FOR FLOOR COVERINGS; CARPETS; RUGS; FLOOR MATS; DOOR MATS; RUG STAYS, NAMELY, FLOOR MATS, NAMELY, RUBBER OR POLYMER STAIR TREADS, AND FLOOR MATS IN THE NATURE OF NON-SLIP PADS FOR USE UNDER RUGS TO PREVENT SLIPPAGE; TEXTILE AND NON-TEXTILE WALL COVERINGS; WALLPAPERS (U.S. CLS. 19, 20, 37, 42 AND 50).

CLASS 35—ADVERTISING AND BUSINESS

FOR RETAIL AND ONLINE STORE SERVICES FEATURING A WIDE VARIETY OF CONSUMER GOODS OF OTHERS; RETAIL AND ONLINE GIFT REGISTRY SERVICES; HOME FURNISHING RETAIL STORE SERVICES (U.S. CLS. 100, 101 AND 102).

CLASS 36—INSURANCE AND FINANCIAL

FOR CHARITABLE FUNDRAISING SERVICES (U.S. CLS. 100, 101 AND 102).

CLASS 37—CONSTRUCTION AND REPAIR

FOR REFINISHING OF FURNITURE; FURNITURE RESTORATION, REPAIR, MAINTENANCE AND FINISHING (U.S. CLS. 100, 103 AND 106).

CLASS 40—MATERIAL TREATMENT

FOR APPLYING FINISHES TO FABRIC; CLOTH DYEING; CUSTOM QUILTING; CUTTING OF FABRIC; EMBROIDERY SERVICES; PREPARATION AND TREATMENT OF FABRIC; SEWING SERVICES; WATERPROOFING OF FABRIC; FIREPROOFING OF FABRIC (U.S. CLS. 100, 103 AND 106).

CLASS 42—SCIENTIFIC AND COMPUTER SERVICES

FOR INTERIOR DECORATING SERVICES; COMPUTER AIDED DESIGN FOR OTHERS (U.S. CLS. 100 AND 101).

LAURIE KAUFMAN, EXAMINING ATTORNEY

SN 85-084,518. MITSUBISHI POLYESTER FILM, INC., GREER, SC. FILED 7-14-2010.

REPROCESS

THE MARK CONSISTS OF STANDARD CHARACTERS WITHOUT CLAIM TO ANY PARTICULAR FONT, STYLE, SIZE, OR COLOR.

CLASS 17—RUBBER GOODS

FOR POLYESTER FILM CONTAINING RECYCLED MATERIAL, NAMELY, POLYESTER SHEETS FOR USE IN THE MANUFACTURE OF LABELS (U.S. CLS. 1, 5, 12, 13, 35 AND 50).

CLASS 37—CONSTRUCTION AND REPAIR

FOR COLLECTING POLYESTER FILM LABEL BACKING FOR RECYCLING (U.S. CLS. 100, 103 AND 106).

ROBERT STRUCK, EXAMINING ATTORNEY

SN 85-084,900. AMOCAT TRADING, L.L.C., LAKEWOOD, WA. FILED 7-14-2010.

SN 85-085,633. JOHN O'DONNELL ASSOCIATES, LLC, IRVINE, CA. FILED 7-15-2010.

AMOCAT

THE MARK CONSISTS OF STANDARD CHARACTERS WITHOUT CLAIM TO ANY PARTICULAR FONT, STYLE, SIZE, OR COLOR.

CLASS 29—MEATS AND PROCESSED FOODS

FOR PROCESSED FOODS, NAMELY, CANNED AND PRESERVED FRUITS AND VEGETABLES (U.S. CL. 46). FIRST USE 1-1-1895; IN COMMERCE 1-1-1895.

CLASS 35—ADVERTISING AND BUSINESS

FOR ADVERTISING AND BUSINESS SERVICES, NAMELY, IMPORT AND EXPORT AGENCIES WITH RESPECT TO GROCERY AND GROCERY-RELATED ITEMS (U.S. CLS. 100, 101 AND 102). FIRST USE 1-1-1895; IN COMMERCE 1-1-1895. DAWN HAN, EXAMINING ATTORNEY

SN 85-085,303. CORTEXA AUTOMATION LLC, NEW YORK, NY. FILED 7-15-2010.

THE MARK CONSISTS OF THE LETTERS "H" AND "R" SURROUNDING AN IMAGE OF A HOUSE.

CLASS 9—ELECTRICAL AND SCIENTIFIC APPARATUS

FOR AUTOMATED EQUIPMENT FOR SMART HOMES, NAMELY, ELECTRONIC CONTROLLERS FOR REMOTELY CONTROLLING LIGHTING SYSTEMS, THERMOSTATS, AUDIO AND VIDEO SYSTEMS, GARAGE DOOR OPENERS, WINDOW SHADE OPERATING SYSTEMS, SPRINKLER SYSTEMS, BURGLARY ALARMS, CLOSED CIRCUIT TV SYSTEMS FOR SECURITY AND SURVEILLANCE, AND FIRE, SMOKE AND LEAK DETECTORS AND FOR PROVIDING USERS WITH EMAIL NOTIFICATIONS REGARDING SAID SYSTEMS (U.S. CLS. 21, 23, 26, 36 AND 38).

CLASS 11—ENVIRONMENTAL CONTROL APPARATUS

FOR AUTOMATED EQUIPMENT FOR SMART HOMES, NAMELY, HVAC UNITS (U.S. CLS. 13, 21, 23, 31 AND 34). EDWARD FENNESSY, EXAMINING ATTORNEY

IONFLY

THE MARK CONSISTS OF STANDARD CHARACTERS WITHOUT CLAIM TO ANY PARTICULAR FONT, STYLE, SIZE, OR COLOR.

CLASS 9—ELECTRICAL AND SCIENTIFIC APPARATUS

FOR PORTABLE ELECTRONIC DEVICES, NAMELY, MP3 PLAYERS, CD PLAYERS, DVD PLAYERS, PORTABLE TELEVISIONS, CALCULATORS, MOBILE TELEPHONES, HANDHELD PERSONAL COMPUTERS, DIGITAL CAMERAS, PERSONAL DIGITAL ASSISTANTS, GLOBAL POSITIONING SYSTEMS, AND REPLACEMENT PARTS FOR ALL OF THE FOREGOING; PROTECTIVE COVERS AND CASES FOR MOBILE PHONES, PERSONAL DIGITAL ASSISTANTS, HANDHELD PERSONAL COMPUTERS, GLOBAL POSITIONING SYSTEMS AND PORTABLE MEDIA PLAYERS; HEADPHONES; BATTERY CHARGERS; HOLSTERS FOR CARRYING MOBILE PHONES, PERSONAL DIGITAL ASSISTANTS, HANDHELD PERSONAL COMPUTERS, AND PORTABLE MEDIA PLAYERS (U.S. CLS. 21, 23, 26, 36 AND 38).

CLASS 35—ADVERTISING AND BUSINESS

FOR RETAIL OUTLETS FEATURING ELECTRONIC DEVICES AND ACCESSORIES; ON-LINE RETAIL STORE SERVICES FEATURING ELECTRONIC DEVICES AND ACCESSORIES (U.S. CLS. 100, 101 AND 102).

CLASS 36—INSURANCE AND FINANCIAL

FOR PROVIDING EXTENDED WARRANTIES FOR PORTABLE ELECTRONIC DEVICES (U.S. CLS. 100, 101 AND 102).

CLASS 37—CONSTRUCTION AND REPAIR

FOR MAINTENANCE AND REPAIR OF PORTABLE ELECTRONIC DEVICES (U.S. CLS. 100, 103 AND 106). ADA HAN, EXAMINING ATTORNEY

SN 85-086,046. ALPHA MEDIA GROUP INC., NEW YORK, NY. FILED 7-15-2010.

CIRCUS MAXIMUS

THE MARK CONSISTS OF STANDARD CHARACTERS WITHOUT CLAIM TO ANY PARTICULAR FONT, STYLE, SIZE, OR COLOR.

OWNER OF U.S. REG. NOS. 2,072,696, 3,068,330 AND OTHERS.

CLASS 16—PAPER GOODS AND PRINTED MATTER

FOR MAGAZINE SECTION DEALING WITH MEN'S LIFESTYLE AND POPULAR CULTURE (U.S. CLS. 2, 5, 22, 23, 29, 37, 38 AND 50).

FIRST USE 8-0-1998; IN COMMERCE 8-0-1998.

CLASS 41—EDUCATION AND ENTERTAINMENT

FOR ENTERTAINMENT SERVICES AND INFORMATION SERVICES, NAMELY, PROVIDING AN ONLINE MAGAZINE IN THE FIELD OF MEN'S LIFESTYLE AND POPULAR CULTURE; PROVIDING ONLINE PUBLICATIONS IN THE NATURE OF ONLINE MAGAZINES IN THE FIELD OF AUTOMOBILES AND OTHER MOTORIZED VEHICLES, ATHLETIC EQUIPMENT, ELECTRONIC EQUIPMENT, ELECTRONIC GADGETS, EXERCISE EQUIPMENT, CAMERAS, ELECTRONIC GOODS, CLOTHING, ACCESSORIES, JEWELRY, LUGGAGE, SPORTS AND RECREATIONAL ACTIVITIES, ALL OF INTEREST TO MALE CONSUMERS; PROVIDING A WEBSITE FOR ENTERTAINMENT PURPOSES WHERE USERS CAN VIEW PHOTOGRAPHS, MOVIES, AND VIDEOS FEATURING AUTOMOBILES AND OTHER MOTORIZED VEHICLES, ATHLETIC EQUIPMENT, ELECTRONIC EQUIPMENT, ELECTRONIC GADGETS, EXERCISE EQUIPMENT, CAMERAS, ELECTRONIC GOODS, CLOTHING, ACCESSORIES, JEWELRY, LUGGAGE, SPORTS AND RECREATIONAL ACTIVITIES, ALL OF INTEREST TO MALE CONSUMERS; VIDEO-TAPING; ARRANGING OF BEAUTY CONTESTS; VIDEOTAPE FILM PRODUCTION; EDUCATION SERVICES, NAMELY, PROVIDING A WEBSITE, ARTICLES, NEWS AND INFORMATION IN THE FIELD OF MEN'S LIFESTYLE AND POPULAR CULTURE; PROVIDING OF TRAINING IN THE FIELD OF MEN'S LIFESTYLE AND POPULAR CULTURE; ENTERTAINMENT SERVICES, NAMELY, PROVIDING A WEBSITE, ARTICLES, NEWS, BLOGS AND INFORMATION IN THE FIELD OF MEN'S LIFESTYLE AND POPULAR CULTURE; ORGANIZING AND CONDUCTING SPORTING AND CULTURAL ACTIVITIES IN THE NATURE OF SOCIAL EVENTS AND CONTESTS RELATED TO MEN'S LIFESTYLE; VIDEOTAPING; PROVIDING ONLINE NON-DOWNLOADABLE ELECTRONIC PUBLICATIONS IN THE FIELD OF MEN'S LIFESTYLES AND POPULAR CULTURE; ARRANGING OF BEAUTY CONTESTS; ORGANIZATION OF PAGEANTS, BEAUTY COMPETITIONS AND AMATEUR SPORTING EVENTS; VIDEOTAPE FILM PRODUCTION; PUBLICATION OF ON-LINE JOURNALS IN THE FIELD OF MEN'S LIFESTYLES AND POPULAR CULTURE (U.S. CLS. 100, 101 AND 107).

FIRST USE 8-0-2008; IN COMMERCE 8-0-2008.

JULIE GUTTADAURO, EXAMINING ATTORNEY

SN 85-086,091. HANSEN BEVERAGE COMPANY, CORONA, CA. FILED 7-16-2010.

MONSTER BLACK ATTACK

THE MARK CONSISTS OF STANDARD CHARACTERS WITHOUT CLAIM TO ANY PARTICULAR FONT, STYLE, SIZE, OR COLOR.

OWNER OF U.S. REG. NOS. 3,044,314, 3,134,842 AND OTHERS.

CLASS 5—PHARMACEUTICALS

FOR NUTRITIONAL SUPPLEMENTS IN LIQUID FORM (U.S. CLS. 6, 18, 44, 46, 51 AND 52).

CLASS 32—LIGHT BEVERAGES

FOR BEVERAGES, NAMELY, CARBONATED SOFT DRINKS; NON-ALCOHOLIC CARBONATED AND NON-CARBONATED SOFT DRINKS AND ENERGY DRINKS ENHANCED WITH VITAMINS, MINERALS, NUTRIENTS, PROTEINS, AMINO ACIDS AND/OR HERBS; CARBONATED AND NON-CARBONATED ENERGY DRINKS AND SPORTS DRINKS, FRUIT JUICE DRINKS HAVING A JUICE CONTENT OF 50% OR LESS BY VOLUME THAT ARE SHELF-STABLE; ALL THE FOREGOING GOODS EXCLUDE PERISHABLE BEVERAGE PRODUCTS THAT CONTAIN FRUIT JUICE OR SOY, WHETHER SUCH PRODUCTS ARE PASTEURIZED OR NOT (U.S. CLS. 45, 46 AND 48).

LEIGH LOWRY, EXAMINING ATTORNEY

SN 85-086,104. HANSEN BEVERAGE COMPANY, CORONA, CA. FILED 7-16-2010.

MONSTER SHOT

THE MARK CONSISTS OF STANDARD CHARACTERS WITHOUT CLAIM TO ANY PARTICULAR FONT, STYLE, SIZE, OR COLOR.

OWNER OF U.S. REG. NOS. 3,044,314, 3,134,842 AND OTHERS.

NO CLAIM IS MADE TO THE EXCLUSIVE RIGHT TO USE "SHOT", APART FROM THE MARK AS SHOWN.

CLASS 5—PHARMACEUTICALS

FOR NUTRITIONAL SUPPLEMENTS IN LIQUID FORM (U.S. CLS. 6, 18, 44, 46, 51 AND 52).

CLASS 32—LIGHT BEVERAGES

FOR BEVERAGES, NAMELY, CARBONATED SOFT DRINKS; NON-ALCOHOLIC CARBONATED DRINKS ENHANCED WITH VITAMINS, MINERALS, NUTRIENTS, PROTEINS, AMINO ACIDS AND/OR HERBS; CARBONATED AND NON-CARBONATED ENERGY DRINKS AND SPORTS DRINKS, FRUIT JUICE DRINKS HAVING A JUICE CONTENT OF 50% OR LESS BY VOLUME THAT ARE SHELF-STABLE; ALL THE FOREGOING GOODS EXCLUDE PERISHABLE BEVERAGE PRODUCTS THAT CONTAIN FRUIT JUICE OR SOY, WHETHER SUCH PRODUCTS ARE PASTEURIZED OR NOT (U.S. CLS. 45, 46 AND 48).

LEIGH LOWRY, EXAMINING ATTORNEY

SN 85-086,115. HANSEN BEVERAGE COMPANY, CORONA, CA. FILED 7-16-2010.

MONSTER PERFORMANCE

THE MARK CONSISTS OF STANDARD CHARACTERS WITHOUT CLAIM TO ANY PARTICULAR FONT, STYLE, SIZE, OR COLOR.

OWNER OF U.S. REG. NOS. 3,044,314, 3,134,842 AND OTHERS.

CLASS 5—PHARMACEUTICALS

FOR NUTRITIONAL SUPPLEMENTS IN LIQUID FORM (U.S. CLS. 6, 18, 44, 46, 51 AND 52).

SN 85-086,117. HANSEN BEVERAGE COMPANY, CORONA, CA. FILED 7-16-2010.

CLASS 32—LIGHT BEVERAGES

FOR BEVERAGES, NAMELY, CARBONATED SOFT DRINKS; NON-ALCOHOLIC CARBONATED AND NON-CARBONATED SOFT DRINKS AND ENERGY DRINKS ENHANCED WITH VITAMINS, MINERALS, NUTRIENTS, PROTEINS, AMINO ACIDS AND/OR HERBS; CARBONATED AND NON-CARBONATED ENERGY DRINKS AND SPORTS DRINKS, FRUIT JUICE DRINKS HAVING A JUICE CONTENT OF 50% OR LESS BY VOLUME THAT ARE SHELF-STABLE; ALL THE FOREGOING GOODS EXCLUDE PERISHABLE BEVERAGE PRODUCTS THAT CONTAIN FRUIT JUICE OR SOY, WHETHER SUCH PRODUCTS ARE PASTEURIZED OR NOT (U.S. CLS. 45, 46 AND 48).

LEIGH LOWRY, EXAMINING ATTORNEY

MONSTER BLUE ICE

THE MARK CONSISTS OF STANDARD CHARACTERS WITHOUT CLAIM TO ANY PARTICULAR FONT, STYLE, SIZE, OR COLOR.

OWNER OF U.S. REG. NOS. 3,044,314, 3,134,842 AND OTHERS.

CLASS 5—PHARMACEUTICALS

FOR NUTRITIONAL SUPPLEMENTS IN LIQUID FORM (U.S. CLS. 6, 18, 44, 46, 51 AND 52).

CLASS 32—LIGHT BEVERAGES

FOR BEVERAGES, NAMELY, CARBONATED SOFT DRINKS; NON-ALCOHOLIC CARBONATED AND NON-CARBONATED SOFT DRINKS AND ENERGY DRINKS ENHANCED WITH VITAMINS, MINERALS, NUTRIENTS, PROTEINS, AMINO ACIDS AND/OR HERBS; CARBONATED AND NON-CARBONATED ENERGY DRINKS AND SPORTS DRINKS, FRUIT JUICE DRINKS HAVING A JUICE CONTENT OF 50% OR LESS BY VOLUME THAT ARE SHELF-STABLE; ALL THE FOREGOING GOODS EXCLUDE PERISHABLE BEVERAGE PRODUCTS THAT CONTAIN FRUIT JUICE OR SOY, WHETHER SUCH PRODUCTS ARE PASTEURIZED OR NOT (U.S. CLS. 45, 46 AND 48).

LEIGH LOWRY, EXAMINING ATTORNEY

SN 85-086,116. HANSEN BEVERAGE COMPANY, CORONA, CA. FILED 7-16-2010.

MONSTER GIRL

SN 85-086,126. HANSEN BEVERAGE COMPANY, CORONA, CA. FILED 7-16-2010.

LOBO MONSTER HITMAN

THE MARK CONSISTS OF STANDARD CHARACTERS WITHOUT CLAIM TO ANY PARTICULAR FONT, STYLE, SIZE, OR COLOR.

OWNER OF U.S. REG. NOS. 3,044,314, 3,134,842 AND OTHERS.

NO CLAIM IS MADE TO THE EXCLUSIVE RIGHT TO USE "GIRL", APART FROM THE MARK AS SHOWN.

THE MARK CONSISTS OF STANDARD CHARACTERS WITHOUT CLAIM TO ANY PARTICULAR FONT, STYLE, SIZE, OR COLOR.

OWNER OF U.S. REG. NOS. 3,044,314, 3,134,842 AND OTHERS.

CLASS 5—PHARMACEUTICALS

FOR NUTRITIONAL SUPPLEMENTS IN LIQUID FORM (U.S. CLS. 6, 18, 44, 46, 51 AND 52).

CLASS 5—PHARMACEUTICALS

FOR NUTRITIONAL SUPPLEMENTS IN LIQUID FORM (U.S. CLS. 6, 18, 44, 46, 51 AND 52).

CLASS 32—LIGHT BEVERAGES

FOR BEVERAGES, NAMELY, CARBONATED SOFT DRINKS; NON-ALCOHOLIC CARBONATED AND NON-CARBONATED SOFT DRINKS AND ENERGY DRINKS ENHANCED WITH VITAMINS, MINERALS, NUTRIENTS, PROTEINS, AMINO ACIDS AND/OR HERBS; CARBONATED AND NON-CARBONATED ENERGY DRINKS AND SPORTS DRINKS, FRUIT JUICE DRINKS HAVING A JUICE CONTENT OF 50% OR LESS BY VOLUME THAT ARE SHELF-STABLE; ALL THE FOREGOING GOODS EXCLUDE PERISHABLE BEVERAGE PRODUCTS THAT CONTAIN FRUIT JUICE OR SOY, WHETHER SUCH PRODUCTS ARE PASTEURIZED OR NOT (U.S. CLS. 45, 46 AND 48).

LEIGH LOWRY, EXAMINING ATTORNEY

CLASS 32—LIGHT BEVERAGES

FOR BEVERAGES, NAMELY, CARBONATED SOFT DRINKS; NON-ALCOHOLIC CARBONATED AND NON-CARBONATED SOFT DRINKS AND ENERGY DRINKS ENHANCED WITH VITAMINS, MINERALS, NUTRIENTS, PROTEINS, AMINO ACIDS AND/OR HERBS; CARBONATED AND NON-CARBONATED ENERGY DRINKS AND SPORTS DRINKS, FRUIT JUICE DRINKS HAVING A JUICE CONTENT OF 50% OR LESS BY VOLUME THAT ARE SHELF-STABLE; ALL THE FOREGOING GOODS EXCLUDE PERISHABLE BEVERAGE PRODUCTS THAT CONTAIN FRUIT JUICE OR SOY, WHETHER SUCH PRODUCTS ARE PASTEURIZED OR NOT (U.S. CLS. 45, 46 AND 48).

LEIGH LOWRY, EXAMINING ATTORNEY

SN 85-086,154. THE UNIVERSITY CENTER OF GREENVILLE, INC., GREENVILLE, SC. FILED 7-16-2010.

SN 85-086,157. THE UNIVERSITY CENTER OF GREENVILLE, INC., GREENVILLE, SC. FILED 7-16-2010.

SIMHUB



THE MARK CONSISTS OF STANDARD CHARACTERS WITHOUT CLAIM TO ANY PARTICULAR FONT, STYLE, SIZE, OR COLOR.

THE MARK CONSISTS OF THE WORD "SIMHUB" WITH A FLOWERS REPRESENTING THE DOT OF THE LETTER "I".

CLASS 9—ELECTRICAL AND SCIENTIFIC APPARATUS

FOR INSTRUMENTS AND DEVICES FOR EDUCATIONAL, TRAINING, CONFERENCES, AND SEMINAR PURPOSES, NAMELY, COMPUTER SOFTWARE APPLICATIONS FOR PROVIDING INTERACTIVE EDUCATIONAL PRESENTATIONS USED WITH VIRTUAL WORLD, AUGMENTED REALITY, EDUCATIONAL SIMULATION, EDUCATIONAL GAMING, OR SERIOUS GAMING PROGRAMS UTILIZING EXISTING THIRD-PARTY SOFTWARE PLATFORMS IN THE FIELDS OF NURSING, PRIMARY, SECONDARY AND HIGHER EDUCATION, ACCOUNTING, BUSINESS, POLITICAL SCIENCE, SOCIOLOGY, CRIMINAL JUSTICE, ENGINEERING, SOCIAL SERVICES, INTELLECTUAL TECHNOLOGY, PUBLIC ADMINISTRATION, HEALTH/HEALTHCARE, STATISTICS, PSYCHIATRY AND LIBRARY AND INFORMATION SCIENCE; DEVICES, NAMELY, COMPUTER APPLICATION SOFTWARE FOR MOBILE PHONES, PORTABLE MEDIA PLAYERS AND HANDHELD COMPUTERS, VIRTUAL WORLD SOFTWARE APPLICATIONS AND SOFTWARE FOR SIMULATION, ALL FOR USE IN EDUCATIONAL TRAINING OF INDIVIDUALS OR GROUPS IN THE FIELDS OF NURSING, PRIMARY, SECONDARY AND HIGHER EDUCATION, ACCOUNTING, BUSINESS, POLITICAL SCIENCE, SOCIOLOGY, CRIMINAL JUSTICE, ENGINEERING, SOCIAL SERVICES, INTELLECTUAL TECHNOLOGY, PUBLIC ADMINISTRATION, HEALTH/HEALTHCARE, STATISTICS, PSYCHIATRY AND LIBRARY AND INFORMATION SCIENCE (U.S. CLS. 21, 23, 26, 36 AND 38).

CLASS 9—ELECTRICAL AND SCIENTIFIC APPARATUS

FOR INSTRUMENTS AND DEVICES FOR EDUCATIONAL, TRAINING, CONFERENCES, AND SEMINAR PURPOSES, NAMELY, COMPUTER SOFTWARE APPLICATIONS FOR PROVIDING INTERACTIVE EDUCATIONAL PRESENTATIONS USED WITH VIRTUAL WORLD, AUGMENTED REALITY, EDUCATIONAL SIMULATION, EDUCATIONAL GAMING, OR SERIOUS GAMING PROGRAMS UTILIZING EXISTING THIRD-PARTY SOFTWARE PLATFORMS IN THE FIELDS OF NURSING, PRIMARY, SECONDARY AND HIGHER EDUCATION, ACCOUNTING, BUSINESS, POLITICAL SCIENCE, SOCIOLOGY, CRIMINAL JUSTICE, ENGINEERING, SOCIAL SERVICES, INTELLECTUAL TECHNOLOGY, PUBLIC ADMINISTRATION, HEALTH/HEALTHCARE, STATISTICS, PSYCHIATRY AND LIBRARY AND INFORMATION SCIENCE; DEVICES, NAMELY, COMPUTER APPLICATION SOFTWARE FOR MOBILE PHONES, PORTABLE MEDIA PLAYERS AND HANDHELD COMPUTERS, VIRTUAL WORLD SOFTWARE APPLICATIONS AND SOFTWARE FOR SIMULATION, ALL FOR USE IN EDUCATIONAL TRAINING OF INDIVIDUALS OR GROUPS IN THE FIELDS OF NURSING, PRIMARY, SECONDARY AND HIGHER EDUCATION, ACCOUNTING, BUSINESS, POLITICAL SCIENCE, SOCIOLOGY, CRIMINAL JUSTICE, ENGINEERING, SOCIAL SERVICES, INTELLECTUAL TECHNOLOGY, PUBLIC ADMINISTRATION, HEALTH/HEALTHCARE, STATISTICS, PSYCHIATRY AND LIBRARY AND INFORMATION SCIENCE (U.S. CLS. 21, 23, 26, 36 AND 38).

CLASS 41—EDUCATION AND ENTERTAINMENT

FOR EDUCATIONAL SERVICES, NAMELY, PRODUCTION OF NEW EDUCATIONAL MEDIA IN THE NATURE OF MULTIMEDIA EDUCATIONAL SOFTWARE FOR USE WITH VIRTUAL WORLDS, AUGMENTED REALITY, EDUCATIONAL SIMULATION, INTERACTIVE EDUCATIONAL GAMING OR SERIOUS GAMING, AS WELL AS CONDUCTING CLASSES, SEMINARS, CONFERENCES, MEETINGS, TRAINING AND WORKSHOPS IN THE FIELDS OF NURSING, PRIMARY, SECONDARY AND HIGHER EDUCATION, ACCOUNTING, BUSINESS DEVELOPMENT, POLITICAL SCIENCE, SOCIOLOGY, CRIMINAL JUSTICE, ENGINEERING, SOCIAL SERVICES, INTELLECTUAL TECHNOLOGY, PUBLIC ADMINISTRATION, HEALTH/HEALTHCARE, STATISTICS, PSYCHIATRY, LIBRARY AND INFORMATION SCIENCE AND DISTRIBUTING TRAINING MATERIALS IN CONNECTION THEREWITH FOR CONFERENCE, CLASSROOM AND VIRTUAL ENVIRONMENTS (U.S. CLS. 100, 101 AND 107).

BRIAN CALLAGHAN, EXAMINING ATTORNEY

CLASS 41—EDUCATION AND ENTERTAINMENT

FOR EDUCATIONAL SERVICES, NAMELY, PRODUCTION OF NEW EDUCATIONAL MEDIA IN THE NATURE OF MULTIMEDIA EDUCATIONAL SOFTWARE FOR USE WITH VIRTUAL WORLDS, AUGMENTED REALITY, EDUCATIONAL SIMULATION, INTERACTIVE EDUCATIONAL GAMING OR SERIOUS GAMING, AS WELL AS CONDUCTING CLASSES, SEMINARS, CONFERENCES, MEETINGS, TRAINING AND WORKSHOPS IN THE FIELDS OF NURSING, PRIMARY, SECONDARY AND HIGHER EDUCATION, ACCOUNTING, BUSINESS DEVELOPMENT, POLITICAL SCIENCE, SOCIOLOGY, CRIMINAL JUSTICE, ENGINEERING, SOCIAL SERVICES, INTELLECTUAL TECHNOLOGY, PUBLIC ADMINISTRATION, HEALTH/HEALTHCARE, STATISTICS, PSYCHIATRY, LIBRARY AND INFORMATION SCIENCE AND DISTRIBUTING TRAINING MATERIALS IN CONNECTION THEREWITH FOR CONFERENCE, CLASSROOM AND VIRTUAL ENVIRONMENTS (U.S. CLS. 100, 101 AND 107).

BRIAN CALLAGHAN, EXAMINING ATTORNEY

SN 85-086,660. HANSEN BEVERAGE COMPANY, CORONA, CA. FILED 7-16-2010.

MONSTER BLO-BACK

THE MARK CONSISTS OF STANDARD CHARACTERS WITHOUT CLAIM TO ANY PARTICULAR FONT, STYLE, SIZE, OR COLOR.

OWNER OF U.S. REG. NOS. 3,044,314, 3,134,842 AND OTHERS.

CLASS 5—PHARMACEUTICALS

FOR NUTRITIONAL SUPPLEMENTS IN LIQUID FORM (U.S. CLS. 6, 18, 44, 46, 51 AND 52).

CLASS 32—LIGHT BEVERAGES

FOR BEVERAGES, NAMELY, CARBONATED SOFT DRINKS; NON-ALCOHOLIC CARBONATED AND NON-CARBONATED SOFT DRINKS AND ENERGY DRINKS ENHANCED WITH VITAMINS, MINERALS, NUTRIENTS, PROTEINS, AMINO ACIDS AND/OR HERBS; CARBONATED AND NON-CARBONATED ENERGY DRINKS AND SPORTS DRINKS, FRUIT JUICE DRINKS HAVING A JUICE CONTENT OF 50% OR LESS BY VOLUME THAT ARE SHELF-STABLE; ALL THE FOREGOING GOODS EXCLUDE PERISHABLE BEVERAGE PRODUCTS THAT CONTAIN FRUIT JUICE OR SOY, WHETHER SUCH PRODUCTS ARE PASTEURIZED OR NOT (U.S. CLS. 45, 46 AND 48).

LEIGH LOWRY, EXAMINING ATTORNEY

SN 85-086,827. JOHN O'DONNELL ASSOCIATES, LLC, IRVINE, CA. FILED 7-16-2010.

DEVICECAMP

THE MARK CONSISTS OF STANDARD CHARACTERS WITHOUT CLAIM TO ANY PARTICULAR FONT, STYLE, SIZE, OR COLOR.

CLASS 9—ELECTRICAL AND SCIENTIFIC APPARATUS

FOR PORTABLE ELECTRONIC DEVICES, NAMELY, MP3 PLAYERS, CD PLAYERS, DVD PLAYERS, PORTABLE TELEVISIONS, CALCULATORS, MOBILE TELEPHONES, HANDHELD PERSONAL COMPUTERS, DIGITAL CAMERAS, PERSONAL DIGITAL ASSISTANTS, GLOBAL POSITIONING SYSTEMS, AND REPLACEMENT PARTS FOR ALL OF THE FOREGOING; PROTECTIVE COVERS AND CASES FOR MOBILE PHONES, PERSONAL DIGITAL ASSISTANTS, HANDHELD PERSONAL COMPUTERS, GLOBAL POSITIONING SYSTEMS AND PORTABLE MEDIA PLAYERS; HEADPHONES; BATTERY CHARGERS; HOLSTERS FOR CARRYING MOBILE PHONES, PERSONAL DIGITAL ASSISTANTS, HANDHELD PERSONAL COMPUTERS, AND PORTABLE MEDIA PLAYERS (U.S. CLS. 21, 23, 26, 36 AND 38).

CLASS 35—ADVERTISING AND BUSINESS

FOR RETAIL OUTLETS FEATURING ELECTRONIC DEVICES AND ACCESSORIES; ON-LINE RETAIL STORE SERVICES FEATURING ELECTRONIC DEVICES AND ACCESSORIES (U.S. CLS. 100, 101 AND 102).

CLASS 36—INSURANCE AND FINANCIAL

FOR PROVIDING EXTENDED WARRANTIES FOR PORTABLE ELECTRONIC DEVICES (U.S. CLS. 100, 101 AND 102).

CLASS 37—CONSTRUCTION AND REPAIR

FOR MAINTENANCE AND REPAIR OF PORTABLE ELECTRONIC DEVICES (U.S. CLS. 100, 103 AND 106).
ADA HAN, EXAMINING ATTORNEY

SN 85-087,473. AHR SENIOR LIVING LLC, SOUTHFIELD, MI. FILED 7-19-2010.



OWNER OF U.S. REG. NOS. 3,397,833 AND 3,397,843.
THE MARK CONSISTS OF THE WORDS "AMERICAN HOUSE" NEXT TO A STYLIZED FLAG WITH A SINGLE STAR AND THREE CURVED BARS.

CLASS 16—PAPER GOODS AND PRINTED MATTER

FOR NEWSLETTERS AND BROCHURES IN THE FIELD OF SENIOR LIVING COMMUNITIES, ASSISTED LIVING FACILITIES, AND RETIREMENT HOMES (U.S. CLS. 2, 5, 22, 23, 29, 37, 38 AND 50).

FIRST USE 5-22-2010; IN COMMERCE 5-22-2010.

CLASS 43—HOTEL AND RESTAURANT SERVICES

FOR PROVIDING ASSISTANCE TO SENIOR CITIZENS SEEKING TO DETERMINE SENIOR LIVING FACILITIES APPROPRIATE FOR THEIR NEEDS; PROVIDING INDEPENDENT LIVING RESIDENCES AND LIVING FACILITIES; PROVIDING ASSISTED LIVING FACILITIES; RETIREMENT HOMES (U.S. CLS. 100 AND 101).

FIRST USE 3-31-2010; IN COMMERCE 3-31-2010.

ROBERT C. CLARK JR., EXAMINING ATTORNEY

SN 85-087,495. REALAUCTION.COM, LLC, PLANTATION, FL. FILED 7-19-2010.

REALTAX

THE MARK CONSISTS OF STANDARD CHARACTERS WITHOUT CLAIM TO ANY PARTICULAR FONT, STYLE, SIZE, OR COLOR.

CLASS 9—ELECTRICAL AND SCIENTIFIC APPARATUS

FOR DATABASE MANAGEMENT SOFTWARE IN THE FIELD OF TAX MANAGEMENT (U.S. CLS. 21, 23, 26, 36 AND 38).

CLASS 35—ADVERTISING AND BUSINESS

FOR BILLING OF REAL AND TANGIBLE PERSONAL PROPERTY TAXES (U.S. CLS. 100, 101 AND 102).

CLASS 36—INSURANCE AND FINANCIAL

FOR COLLECTION OF REAL AND TANGIBLE PERSONAL PROPERTY TAXES; BILL PAYMENT SERVICES, NAMELY, DISBURSEMENT OF REAL AND TANGIBLE PERSONAL PROPERTY TAXES (U.S. CLS. 100, 101 AND 102).

DEBRA LEE, EXAMINING ATTORNEY

SN 85-087,990, ORACLE INTERNATIONAL CORPORATION, REDWOOD CITY, CA. FILED 7-19-2010.

EXALOGIC

THE MARK CONSISTS OF STANDARD CHARACTERS WITHOUT CLAIM TO ANY PARTICULAR FONT, STYLE, SIZE, OR COLOR.

CLASS 9—ELECTRICAL AND SCIENTIFIC APPARATUS

FOR COMPUTER HARDWARE AND SOFTWARE PLATFORMS FOR MANAGING CLOUD COMPUTING NETWORKS; COMPUTER HARDWARE AND SOFTWARE USED TO ENABLE AND MANAGE CLOUD COMPUTING NETWORKS (U.S. CLS. 21, 23, 26, 36 AND 38).

CLASS 37—CONSTRUCTION AND REPAIR

FOR TECHNICAL SUPPORT SERVICES, NAMELY, TROUBLESHOOTING IN THE NATURE OF THE REPAIR OF COMPUTER HARDWARE; UPDATING AND UPGRADING OF COMPUTER HARDWARE (U.S. CLS. 100, 103 AND 106).

CLASS 42—SCIENTIFIC AND COMPUTER SERVICES

FOR COMPUTER SERVICES, NAMELY, CONSULTATION IN THE FIELD OF COMPUTER HARDWARE AND SOFTWARE; TECHNICAL SUPPORT SERVICES, NAMELY, TROUBLESHOOTING IN THE NATURE OF DIAGNOSING COMPUTER HARDWARE AND SOFTWARE PROBLEMS; REPAIR OF COMPUTER SOFTWARE; UPDATING AND UPGRADING OF COMPUTER SOFTWARE FOR OTHERS (U.S. CLS. 100 AND 101).

TEJBIR SINGH, EXAMINING ATTORNEY

SN 85-087,994, ORACLE INTERNATIONAL CORPORATION, REDWOOD CITY, CA. FILED 7-19-2010.

ORACLE EXALOGIC

THE MARK CONSISTS OF STANDARD CHARACTERS WITHOUT CLAIM TO ANY PARTICULAR FONT, STYLE, SIZE, OR COLOR.

OWNER OF U.S. REG. NOS. 3,116,749 AND 3,192,864.

CLASS 9—ELECTRICAL AND SCIENTIFIC APPARATUS

FOR COMPUTER HARDWARE AND SOFTWARE PLATFORMS FOR MANAGING CLOUD COMPUTING NETWORKS; COMPUTER HARDWARE AND SOFTWARE USED TO ENABLE AND MANAGE CLOUD COMPUTING NETWORKS (U.S. CLS. 21, 23, 26, 36 AND 38).

CLASS 37—CONSTRUCTION AND REPAIR

FOR TECHNICAL SUPPORT SERVICES, NAMELY, TROUBLESHOOTING IN THE NATURE OF THE REPAIR OF COMPUTER HARDWARE; UPDATING AND UPGRADING OF COMPUTER HARDWARE (U.S. CLS. 100, 103 AND 106).

CLASS 42—SCIENTIFIC AND COMPUTER SERVICES

FOR COMPUTER SERVICES, NAMELY, CONSULTATION IN THE FIELD OF COMPUTER HARDWARE AND SOFTWARE; TECHNICAL SUPPORT SERVICES, NAMELY, TROUBLESHOOTING IN THE NATURE OF DIAGNOSING COMPUTER HARDWARE AND SOFTWARE PROBLEMS; REPAIR OF COMPUTER SOFTWARE; UPDATING AND UPGRADING OF COMPUTER SOFTWARE FOR OTHERS (U.S. CLS. 100 AND 101).

TEJBIR SINGH, EXAMINING ATTORNEY

SN 85-088,306, JANICE M. HELSON, LOUISVILLE, KY. AND RACHEL ANNETTE HELSON, LOUISVILLE, KY. FILED 7-20-2010.

BHP

THE MARK CONSISTS OF STANDARD CHARACTERS WITHOUT CLAIM TO ANY PARTICULAR FONT, STYLE, SIZE, OR COLOR.

CLASS 16—PAPER GOODS AND PRINTED MATTER

FOR BLANK JOURNAL BOOKS; BLANK NOTE CARDS; BOOKLETS IN THE FIELD OF PHILANTHROPY; BOOKS IN THE FIELD OF PHILANTHROPY; ILLUSTRATED CHILDREN'S BOOKS IN THE FIELD OF PHILANTHROPY; BROCHURES ABOUT PHILANTHROPY; PRINTED INSTRUCTIONAL, EDUCATIONAL AND TEACHING MATERIALS IN THE FIELD OF PHILANTHROPY; MAGAZINE SECTIONS IN THE FIELD OF PHILANTHROPY; ADDRESS BOOKS AND DIARIES; CALENDARS AND PLANNERS; GUEST BOOKS; PAPER NAME TAGS AND BADGES; PAPER PARTY ORNAMENTS; GREETING CARDS; POSTERS; DECALS AND STICKERS; COIN ALBUMS, PHOTOGRAPHIC ALBUMS, STICKER ALBUMS, STAMP ALBUMS, WEDDING ALBUMS, AND SCRAP BOOKS; CARTOON AND COMIC BOOKS AND STRIPS; GRAPHIC NOVELS (U.S. CLS. 2, 5, 22, 23, 29, 37, 38 AND 50).

CLASS 28—TOYS AND SPORTING GOODS

FOR DOLLS, DOLL'S CLOTHING AND ACCESSORIES THEREFOR; EDUCATIONAL TOYS FOR TEACHING PHILANTHROPY PRINCIPLES AND ACTIVITIES; STUFFED AND PLUSH DOLLS, ANIMALS AND PUPPETS; ACTION SKILL GAMES; ARCADE GAMES; EDUCATIONAL CARD GAMES; HORSESHOE GAMES; GAMES PLAYED WITH CARDS AND GAME COMPONENTS (U.S. CLS. 22, 23, 38 AND 50).

ADA HAN, EXAMINING ATTORNEY

SN 85-089,369. MRS. LAURALICIOUS, LLC, WEST LINN, OR. FILED 7-21-2010.



NO CLAIM IS MADE TO THE EXCLUSIVE RIGHT TO USE "DAIRY LACTOSE FREE", APART FROM THE MARK AS SHOWN.

THE MARK CONSISTS OF THE WORDS "DAIRY LACTOSE FREE" AND THE IMAGE OF A COW.

CLASS 29—MEATS AND PROCESSED FOODS

FOR SOUPS AND PREPARATIONS FOR MAKING SOUPS; FROZEN, PREPARED, OR PACKAGED MEALS CONSISTING PRIMARILY OF MEAT, FISH, POULTRY OR VEGETABLES; ALL FOREGOING GOODS BEING DAIRY LACTOSE FREE (U.S. CL. 46).

CLASS 30—STAPLE FOODS

FOR BREAD; BREAD CRUMBS; BURRITOS; CAKE MIXES; COOKIES; CRACKERS; DONUTS; FLOUR; FROSTING MIXES; FROSTINGS; GRANOLA; GRAVY MIXES; MIXES FOR BAKERY GOODS; OATMEAL; PANCAKE MIXES; PASTA; PIE CRUSTS; PIZZA CRUST; PIZZA CRUST MIXES; PIZZA DOUGH; PROCESSED CEREALS; READY TO EAT, CEREAL DERIVED FOOD BARS; READY-TO-EAT CEREALS; SAUCE MIXES; TORTILLAS; WAFFLES; FROZEN, PREPARED, OR PACKAGED MEALS CONSISTING PRIMARILY OF PASTA OR RICE; ALL FOREGOING GOODS BEING DAIRY LACTOSE FREE (U.S. CL. 46).

WANDA KAY PRICE, EXAMINING ATTORNEY

SN 85-089,381. MRS. LAURALICIOUS, LLC, WEST LINN, OR. FILED 7-21-2010.



NO CLAIM IS MADE TO THE EXCLUSIVE RIGHT TO USE "GFCF FOODS", APART FROM THE MARK AS SHOWN.

THE MARK CONSISTS OF THE LETTERS "GFCF", THE WORD "FOODS", AND THE IMAGES OF THREE WHEAT STALKS AND A BEVERAGE CARTON. THE BACKGROUND IS A SHADED RECTANGLE.

CLASS 29—MEATS AND PROCESSED FOODS

FOR SOUPS AND PREPARATIONS FOR MAKING SOUPS; FROZEN, PREPARED, OR PACKAGED MEALS CONSISTING PRIMARILY OF MEAT, FISH, POULTRY OR VEGETABLES; ALL FOREGOING GOODS BEING GLUTEN FREE/CASEIN FREE (U.S. CL. 46).

CLASS 30—STAPLE FOODS

FOR BREAD; BREAD CRUMBS; BURRITOS; CAKE MIXES; COOKIES; CRACKERS; DONUTS; FLOUR; FROSTING MIXES; FROSTINGS; GRANOLA; GRAVY MIXES; MIXES FOR BAKERY GOODS; OATMEAL; PANCAKE MIXES; PASTA; PIE CRUSTS; PIZZA CRUST; PIZZA CRUST MIXES; PIZZA DOUGH; PROCESSED CEREALS; READY TO EAT, CEREAL DERIVED FOOD BARS; READY-TO-EAT CEREALS; SAUCE MIXES; TORTILLAS; WAFFLES; FROZEN, PREPARED, OR PACKAGED MEALS CONSISTING PRIMARILY OF PASTA OR RICE; ALL FOREGOING GOODS BEING GLUTEN FREE/CASEIN FREE (U.S. CL. 46).

WANDA KAY PRICE, EXAMINING ATTORNEY

SN 85-089,583. HOBSON, ROBERT A., NEWNAN, GA. FILED 7-21-2010.

IMMUNATOR

THE MARK CONSISTS OF STANDARD CHARACTERS WITHOUT CLAIM TO ANY PARTICULAR FONT, STYLE, SIZE, OR COLOR.

CLASS 5—PHARMACEUTICALS

FOR NUTRITIONAL AND DIETARY SUPPLEMENT DRINKS THAT RELIEVE AND PREVENT FATIGUE; DIETARY SUPPLEMENT DRINKS IN THE NATURE OF VITAMIN AND MINERAL BEVERAGES; VITAMIN AND MINERAL LIQUID DIETARY SUPPLEMENTS; NUTRITIONALLY FORTIFIED BEVERAGES (U.S. CLS. 6, 18, 44, 46, 51 AND 52).

CLASS 32—LIGHT BEVERAGES

FOR ENERGY DRINKS; DRINKING WATER WITH VITAMINS (U.S. CLS. 45, 46 AND 48).

GISELLE AGOSTO, EXAMINING ATTORNEY

SN 85-089,923. ALINEA, INC., DBA BLOX RACING AND BENEN INDUSTRIES, SAN FRANCISCO, CA. FILED 7-21-2010.

BENEN

THE MARK CONSISTS OF STANDARD CHARACTERS WITHOUT CLAIM TO ANY PARTICULAR FONT, STYLE, SIZE, OR COLOR.

THE ENGLISH TRANSLATION OF "BENEN" IN THE MARK IS "BONE" IN THE DUTCH LANGUAGE.

CLASS 7—MACHINERY

FOR FUEL RAILS FOR ENGINES; AUTOMOTIVE PARTS, NAMELY, MOUNTING BRACKETS SPECIALLY ADAPTED FOR RADIATORS (U.S. CLS. 13, 19, 21, 23, 31, 34 AND 35).

FIRST USE 2-1-2000; IN COMMERCE 2-1-2000.

CLASS 9—ELECTRICAL AND SCIENTIFIC APPARATUS

FOR ACCESSORIES FOR AUTOMOBILES, NAMELY, COVERS FOR ELECTRONIC ENGINE CONTROL UNITS (ECUS) (U.S. CLS. 21, 23, 26, 36 AND 38).

FIRST USE 9-1-1997; IN COMMERCE 9-1-1997.

CLASS 12—VEHICLES

FOR LAND VEHICLE SUSPENSION COMPONENTS, NAMELY, PILLAR BAR, TIE BAR, CROSS-MEMBER BRACE, AND STRUT TOWER BAR; ACCESSORIES FOR AUTOMOBILES, NAMELY, TOW HOOKS AND LICENSE PLATE FRAMES (U.S. CLS. 19, 21, 23, 31, 35 AND 44).

FIRST USE 9-1-1997; IN COMMERCE 9-1-1997.

CLASS 17—RUBBER GOODS

FOR ACCESSORIES FOR AUTOMOBILES, NAMELY, EXHAUST MANIFOLD INSULATING HEAT SHIELDS (U.S. CLS. 1, 5, 12, 13, 35 AND 50).

FIRST USE 9-1-1997; IN COMMERCE 9-1-1997.

Laurie Mayes, Examining Attorney

SN 85-090,180. H. J. HEINZ COMPANY, PITTSBURGH, PA. FILED 7-22-2010.



THE MARK CONSISTS OF OPEN KEYSTONE DESIGN. SEC. 2(F).

CLASS 29—MEATS AND PROCESSED FOODS

FOR PEANUT BUTTER, JAMS, JELLIES AND MARMALADES (U.S. CL. 46).

FIRST USE 1-31-2000; IN COMMERCE 1-31-2000.

CLASS 30—STAPLE FOODS

FOR MAYONNAISE, HONEY, BREAKFAST SYRUP (U.S. CL. 46).

FIRST USE 1-31-2000; IN COMMERCE 1-31-2000.

Kyle Peete, Examining Attorney

SN 85-090,198. STARBUCKS CORPORATION, DBA STARBUCKS COFFEE COMPANY, SEATTLE, WA. FILED 7-22-2010.

STARBUCKS REFRESHERS

THE MARK CONSISTS OF STANDARD CHARACTERS WITHOUT CLAIM TO ANY PARTICULAR FONT, STYLE, SIZE, OR COLOR.

OWNER OF U.S. REG. NOS. 1,452,359, 3,298,944 AND OTHERS.

NO CLAIM IS MADE TO THE EXCLUSIVE RIGHT TO USE "REFRESHERS", APART FROM THE MARK AS SHOWN.

CLASS 30—STAPLE FOODS

FOR COFFEE, COCOA AND ESPRESSO BEVERAGES, AND BEVERAGES MADE WITH A BASE OF COFFEE, COCOA AND/OR ESPRESSO; FLAVORING SYRUPS TO ADD TO BEVERAGES; READY-TO-DRINK COFFEE; TEA AND HERBAL TEA; TEA AND HERBAL TEA-BASED BEVERAGES; TEA AND HERBAL TEA-BASED BEVERAGES AND CONCENTRATES, WITH FRUIT FLAVORING; READY-TO-DRINK TEA; HERBAL TEA WITH FRUIT FLAVORING (U.S. CL. 46).

CLASS 32—LIGHT BEVERAGES

FOR FRUIT DRINKS AND SOFT DRINKS CONTAINING FRUIT JUICES; FRUIT JUICES, SPARKLING FRUIT AND JUICE-BASED BEVERAGES, NAMELY, NON-ALCOHOLIC BEVERAGES CONTAINING FRUIT JUICES AND SODA BEVERAGES IN THE NATURE OF SODA POPS; LIQUID AND POWDERED BEVERAGE MIXES FOR MAKING NON-ALCOHOLIC BEVERAGES CONTAINING FRUIT JUICES; SYRUPS AND POWDERS FOR MAKING FRUIT DRINKS (U.S. CLS. 45, 46 AND 48).

Richard White, Examining Attorney

SN 85-090,256. GHA LOYALTY SA, GENEVA, SWITZERLAND, FILED 7-22-2010.



PRIORITY CLAIMED UNDER SEC. 44(D) ON SWITZERLAND APPLICATION NO. 55942/2010, FILED 6-10-2010, REG. NO. 604636, DATED 6-10-2010, EXPIRES 6-10-2020.

THE COLOR(S) BLACK AND GOLD IS/ARE CLAIMED AS A FEATURE OF THE MARK.

THE MARK CONSISTS OF A BLACK BOX WITH THE GOLD LETTERS "GHA" IN THE BOX AND A STYLIZED "G" IN BLACK INSIDE A GOLD CIRCLE IN THE UPPER RIGHT HAND CORNER.

CLASS 35—ADVERTISING AND BUSINESS

FOR ADVERTISING, MARKETING AND PROMOTIONAL SERVICES IN THE NATURE OF INCENTIVE SCHEMES FOR HOTELS; ADVERTISING AND PROMOTIONAL SERVICES; COMPUTERIZED DATABASE MANAGEMENT; COMPILATION OF INFORMATION INTO COMPUTER DATABASES (U.S. CLS. 100, 101 AND 102).

CLASS 43—HOTEL AND RESTAURANT SERVICES

FOR ARRANGING, BOOKING AND RESERVATION OF TEMPORARY ACCOMMODATIONS; PROVIDING TEMPORARY ACCOMMODATION SERVICES; SERVICES FOR PROVIDING FOOD AND DRINK (U.S. CLS. 100 AND 101).

MICHAEL WEBSTER, EXAMINING ATTORNEY

SN 85-091,307. ANSON'S HERRENHAUS KG. DUSSELDORF, FED REP GERMANY, FILED 7-23-2010.

ANSON'S

THE MARK CONSISTS OF STANDARD CHARACTERS WITHOUT CLAIM TO ANY PARTICULAR FONT, STYLE, SIZE, OR COLOR.

OWNER OF U.S. REG. NOS. 2,980,838 AND 3,047,420.

CLASS 3—COSMETICS AND CLEANING PREPARATIONS

FOR SOAPS, NAMELY, DEODORANT SOAP, SKIN SOAP, LIQUID SOAPS, SOAPS FOR PERSONAL USE, SOAPS FOR BODY CARE; PERFUMERY, ESSENTIAL OILS, COSMETICS, HAIR LOTIONS; DENTIFRICES (U.S. CLS. 1, 4, 6, 50, 51 AND 52).

CLASS 18—LEATHER GOODS

FOR LEATHER AND IMITATIONS OF LEATHER, AND GOODS MADE OF THESE MATERIALS, NAMELY, BUSINESS CARD CASES, CALLING CARD CASES, CREDIT CARD CASES, DOCUMENT CASES, LUGGAGE TAGS, COSMETIC CASES SOLD EMPTY, LEATHER POUCHES; ANIMAL SKINS, HIDES, TRUNKS AND TRAVELING BAGS, SUITCASES, ANIMAL GAME BAGS, ATHLETIC BAGS, BARREL BAGS, BEACH BAGS, BOOK BAGS, DUFFEL BAGS, SHOULDER BAGS, TOTE BAGS, LEATHER BAGS FOR MERCHANDISE PACKAGING, TOOL BAGS SOLD EMPTY, HANDBAGS, BILLFOLDS, PURSES, WALLETS; KEY CASES, BACKPACKS, CLOTH POUCHES; UMBRELLAS; PARASOLS AND WALKING STICKS; WHIPS, HARNESS AND SADDLERY (U.S. CLS. 1, 2, 3, 22 AND 41).

CLASS 25—CLOTHING

FOR CLOTHING, NAMELY, APRONS, ASCOTS, BANDANAS, NECKERCHIEFS, BATHROBES, BATHING SUITS, BELTS FOR CLOTHING, BOAS, CAMISOLES, COATS, CORSETS, CUFFS, FROCKS, FUR STOLEES, GARTERS, GIRDLES, GLOVES, DRESSING GOWNS, HOSIERY, JACKETS, JERSEYS, JUMPERS, LEGGINGS, MITTENS, MUFFS, NECKTIES, OVERALLS, PAJAMAS, PANTS, PARKAS, PETTICOATS, SCARVES, SHAWLS, SHIRTS, SKIRTS, SOCKS, STOCKINGS, SWEATERS, SWIMSUITS, TEDDIES, T-SHIRTS, TIGHTS, UNDERWEAR, VEILS, AND VESTS; FOOTWEAR; HEADWEAR (U.S. CLS. 22 AND 39).

CLASS 35—ADVERTISING AND BUSINESS

FOR ADVERTISING; BUSINESS MANAGEMENT; BUSINESS ADMINISTRATION; PROVIDING OFFICE FUNCTIONS; RETAIL STORE SERVICES, ALSO VIA WEBSITES AND TELESHOPPING, IN RELATION TO CLOTHING, FOOTWEAR, HEADWEAR, SOAPS, PERFUMERY, ESSENTIAL OILS, COSMETICS, HAIR LOTIONS, DENTIFRICES, SUN GLASSES, LEATHER AND IMITATIONS OF LEATHER, AND GOODS MADE OF THESE MATERIALS, ANIMAL SKINS, HIDES, TRUNKS AND TRAVELLING BAGS, SUITCASES, BAGS, HANDBAGS, BILLFOLDS, PURSES, KEY CASES, BACKPACKS, POUCHES, UMBRELLAS, PARASOLS AND WALKING STICKS, WHIPS, HARNESS AND SADDLERY; PROMOTION SERVICES FOR OTHERS, NAMELY, ORGANIZATION AND REALIZATION OF PROMOTIONAL EVENTS AND CUSTOMER LOYALTY PROGRAMS; ALL OF THE FOREGOING EXCLUDING PROMOTING ECONOMIC DEVELOPMENT IN THE STATE OF INDIANA (U.S. CLS. 100, 101 AND 102).

TINA MAI, EXAMINING ATTORNEY

SN 85-091,381. SURMODICS, INC., EDEN PRAIRIE, MN. FILED 7-23-2010.

EUREKA

THE MARK CONSISTS OF STANDARD CHARACTERS WITHOUT CLAIM TO ANY PARTICULAR FONT, STYLE, SIZE, OR COLOR.

CLASS 2—PAINTS

FOR COATINGS FOR DENTAL, OCULAR, ORTHOPEDIC, BIOLOGICAL AND SURGICAL IMPLANTS, FOR PROVIDING A LUBRICIOUS AND BIOCOMPATIBLE SURFACE, SOLD SEPARATELY FROM THE IMPLANTS (U.S. CLS. 6, 11 AND 16).

CLASS 5—PHARMACEUTICALS

FOR DRUG DELIVERY MATRICES CONSISTING OF COMPOUNDS THAT FACILITATE DELIVERY OF A WIDE RANGE OF PHARMACEUTICALS; CELL AND TISSUE DELIVERY MATRICES CONSISTING OF COMPOUNDS THAT FACILITATE DELIVERY OF CELLS AND TISSUE TO THE BODY; NATURALLY BIODEGRADABLE MATRIX USED AS A CARRIER FOR PHARMACEUTICALS, CELLS AND TISSUE; COATINGS FOR BIOLOGICAL IMPLANTS AND SURGICAL IMPLANTS COMPRISED OF LIVING TISSUE, SOLD AS AN INTEGRAL PART OF THE IMPLANTS, FOR THE DELIVERY OF A WIDE RANGE OF PHARMACEUTICALS; MEDICAL DEVICES, NAMELY, IN SITU TISSUE OR BONE REPAIRER CONSISTING OF A NATURALLY BIODEGRADABLE MATRIX, NAMELY, BIOLOGICAL AND SURGICAL IMPLANTS BOTH COMPRISED OF LIVING TISSUE; MEDICAL DEVICES, NAMELY, IN SITU TISSUE OR BONE FILLER CONSISTING OF A NATURALLY BIODEGRADABLE MATRIX; MEDICAL DEVICES, NAMELY, IN SITU TISSUE OR BONE REPAIRER CONSISTING OF A NATURALLY BIODEGRADABLE MATRIX, NAMELY, DENTAL, ORTHOPEDIC, AND OCULAR IMPLANTS (U.S. CLS. 6, 18, 44, 46, 51 AND 52).

CLASS 10—MEDICAL APPARATUS

FOR MEDICAL DEVICES, NAMELY, STENTS, ORTHOPEDIC SCREWS, ORTHOPEDIC PINS, AND BONE GRAFT SUBSTITUTES THAT CONTAIN AND DELIVER A WIDE RANGE OF PHARMACEUTICALS; COATINGS FOR DENTAL IMPLANTS, ORTHOPEDIC IMPLANTS, OCULAR IMPLANTS AND SURGICAL IMPLANTS COMPRISED OF ARTIFICIAL MATERIALS, SOLD AS AN INTEGRAL PART OF THE IMPLANTS, FOR THE DELIVERY OF A WIDE RANGE OF PHARMACEUTICALS (U.S. CLS. 26, 39 AND 44).

COURTNEY ALVAREZ, EXAMINING ATTORNEY

CLASS 28—TOYS AND SPORTING GOODS

FOR ACCESSORY FOR MANUALLY-OPERATED EXERCISE EQUIPMENT, NAMELY, ACCESSORY ATTACHMENT TO INCREASE MUSCLE RESISTANCE; ATHLETIC EQUIPMENT, NAMELY, HAND WRAPS; ATHLETIC EQUIPMENT, NAMELY, MOUTH GUARDS; ATHLETIC EQUIPMENT, NAMELY, STRIKING BAGS; ATHLETIC EQUIPMENT, NAMELY, STRIKING SHIELDS; ATHLETIC EQUIPMENT, NAMELY, TRAINING DEVICES TO BE WORN ON THE BODY FOR SUPPORT; EXERCISE EQUIPMENT, NAMELY, ROWING MACHINES; EXERCISE EQUIPMENT, NAMELY, ABDOMINAL BOARDS; EXERCISE EQUIPMENT, NAMELY, CHEST EXPANDERS; EXERCISE EQUIPMENT, NAMELY, CHEST PULLS; EXERCISE EQUIPMENT, NAMELY, INFLATABLE BALLS; EXERCISE EQUIPMENT, NAMELY, MANUALLY OPERATED JOGGING MACHINES; EXERCISE EQUIPMENT, NAMELY, NECK AND SHOULDER SUPPORTED WEIGHTS FOR TWISTING AND LIFTING EXERCISES; EXERCISE EQUIPMENT, NAMELY, ROTARY ABDOMINAL BOARDS; EXERCISE EQUIPMENT, NAMELY, SHOULDER STRETCHER USING A CABLE; EXERCISE EQUIPMENT, NAMELY, SHOULDER STRETCHER USING RESISTANCE CABLES; EXERCISE EQUIPMENT, NAMELY, STAIR-STEPPING MACHINES; EXERCISE EQUIPMENT, NAMELY, STATIONARY CYCLES; EXERCISE EQUIPMENT, NAMELY, VIRTUAL REALITY TRAINING CYCLES; EXERCISING EQUIPMENT, NAMELY, MANUALLY OPERATED JOGGING MACHINES; EXERCISING EQUIPMENT, NAMELY, POWERED TREADMILLS FOR RUNNING; EXERCISING EQUIPMENT, NAMELY, PULLEYS; EXERCISING EQUIPMENT, NAMELY, ROWING MACHINES; EXERCISING EQUIPMENT, NAMELY, WEIGHT LIFTING MACHINES; FITNESS MACHINES AND EQUIPMENT, NAMELY, WEIGHTS, TREADMILLS, ROWING MACHINES, STAIR STEPPING MACHINES, RESISTANCE MACHINES, STATIONARY CYCLES; MANUALLY-OPERATED EXERCISE EQUIPMENT FOR PHYSICAL FITNESS PURPOSES (U.S. CLS. 22, 23, 38 AND 50).

SN 85-091.506. NARROW GATE ELECTRICAL SERVICES, LLC, WHITE HALL, MD. FILED 7-23-2010.

THE GATE

THE MARK CONSISTS OF STANDARD CHARACTERS WITHOUT CLAIM TO ANY PARTICULAR FONT, STYLE, SIZE, OR COLOR.

CLASS 41—EDUCATION AND ENTERTAINMENT

FOR ARRANGING PROFESSIONAL WORKSHOP AND TRAINING COURSES; ATHLETIC TRAINING SERVICES; PERSONAL FITNESS TRAINING SERVICES AND CONSULTANCY; PERSONAL TRAINING SERVICES, NAMELY, STRENGTH AND CONDITIONING TRAINING AND SPEED TRAINING; PHYSICAL FITNESS TRAINING SERVICES; PRACTICAL TRAINING IN THE FIELD OF WELDING; PROVIDING A WEBSITE FEATURING ONLINE SPORTS TRAINING AND TRAINING ADVICE AND THE RECORDING OF TRAINING AND WORKOUTS; PROVIDING ASSISTANCE, PERSONAL TRAINING AND PHYSICAL FITNESS CONSULTATION TO CORPORATE CLIENTS TO HELP THEIR EMPLOYEES MAKE PHYSICAL FITNESS, STRENGTH, CONDITIONING, AND EXERCISE ALTERATIONS IN THEIR DAILY LIVING; PROVIDING ASSISTANCE, PERSONAL TRAINING AND PHYSICAL FITNESS CONSULTATION TO INDIVIDUALS TO HELP THEM MAKE PHYSICAL FITNESS, STRENGTH, CONDITIONING, AND EXERCISE IMPROVEMENT IN THEIR DAILY LIVING; PROVIDING INFORMATION IN THE FIELD OF EXERCISE TRAINING (U.S. CLS. 100, 101 AND 107).

EMILY CARLSEN, EXAMINING ATTORNEY

SN 85-091,519. CLOCKWORK IP, LLC, SARASOTA, FL. FILED 7-23-2010.

SN 85-092,188. INDIANA FARM BUREAU, INC, INDIANAPOLIS, IN. FILED 7-24-2010.

CIRCUIT REJUVENATION

THE MARK CONSISTS OF STANDARD CHARACTERS WITHOUT CLAIM TO ANY PARTICULAR FONT, STYLE, SIZE, OR COLOR.

NO CLAIM IS MADE TO THE EXCLUSIVE RIGHT TO USE "CIRCUIT", APART FROM THE MARK AS SHOWN.

CLASS 35—ADVERTISING AND BUSINESS

FOR BUSINESS CONSULTATION AND BUSINESS MARKETING CONSULTATION FOR ELECTRICAL BUSINESSES (U.S. CLS. 100, 101 AND 102).

CLASS 37—CONSTRUCTION AND REPAIR

FOR ELECTRICAL REPAIR, MAINTENANCE, REPLACEMENT AND INSTALLATION SERVICES OF ELECTRICAL WIRING, OUTLETS, LIGHT FIXTURES, AND ELECTRICAL PANELS; ELECTRICAL CONTRACTING SERVICES (U.S. CLS. 100, 103 AND 106).
SANJEEV VOHRA, EXAMINING ATTORNEY

SN 85-091,719. BOXX ENTERTAINMENT, LLC, DENVER, CO. FILED 7-23-2010.

Movies4Less

THE MARK CONSISTS OF STANDARD CHARACTERS WITHOUT CLAIM TO ANY PARTICULAR FONT, STYLE, SIZE, OR COLOR.

CLASS 9—ELECTRICAL AND SCIENTIFIC APPARATUS

FOR VENDING MACHINES (U.S. CLS. 21, 23, 26, 36 AND 38).

CLASS 41—EDUCATION AND ENTERTAINMENT

FOR AUTOMATED DVD RENTAL SERVICES (U.S. CLS. 100, 101 AND 107).
RONALD AIKENS, EXAMINING ATTORNEY



NO CLAIM IS MADE TO THE EXCLUSIVE RIGHT TO USE "ANIMAL CARE", APART FROM THE MARK AS SHOWN.

THE MARK CONSISTS OF A FANCIFUL DRAWING OF FARM ANIMALS STARTING FROM LEFT TO RIGHT WITH A CHICK, FOLLOWED BY A COW, A SHEEP AND A PIG. BELOW THE DESIGN APPEARS THE TERM "CHAMPIONS OF ANIMAL CARE" WITH A CHICKEN TO THE RIGHT OF THE TERM "CARE".

CLASS 25—CLOTHING

FOR SHIRTS (U.S. CLS. 22 AND 39).
FIRST USE 6-30-2009; IN COMMERCE 6-30-2009.

CLASS 35—ADVERTISING AND BUSINESS

FOR ASSOCIATION SERVICES, NAMELY, PROMOTING THE INTERESTS OF AGRICULTURE AND ANIMAL HUSBANDRY (U.S. CLS. 100, 101 AND 102).
FIRST USE 6-30-2009; IN COMMERCE 6-30-2009.

CLASS 41—EDUCATION AND ENTERTAINMENT

FOR EDUCATIONAL SERVICES, NAMELY, CONDUCTING PROGRAMS IN THE FIELD OF AGRICULTURE AND ANIMAL HUSBANDRY (U.S. CLS. 100, 101 AND 107).
FIRST USE 6-30-2009; IN COMMERCE 6-30-2009.
CAROLINE WOOD, EXAMINING ATTORNEY

SN 85-092,778. SUCCESSFUL ENERGY PRACTICES INTERNATIONAL, LLC, SPRING BRANCH, TX. FILED 7-26-2010.

VWM

THE MARK CONSISTS OF STANDARD CHARACTERS WITHOUT CLAIM TO ANY PARTICULAR FONT, STYLE, SIZE, OR COLOR.

CLASS 35—ADVERTISING AND BUSINESS

FOR DATA COLLECTION FOR BUSINESS PURPOSES IN THE FIELDS OF THE OFFSHORE OIL AND GAS INDUSTRY; DATA PROCESSING SERVICES FOR THE OIL AND GAS INDUSTRY (U.S. CLS. 100, 101 AND 102).

CLASS 39—TRANSPORTATION AND STORAGE

FOR ELECTRONIC DATA STORAGE SERVICES FOR THE OFFSHORE OIL AND GAS INDUSTRY (U.S. CLS. 100 AND 105).

CLASS 42—SCIENTIFIC AND COMPUTER SERVICES

FOR PERFORMING OIL WELL DIAGNOSTICS; TECHNICAL SUPPORT SERVICES, NAMELY, MONITORING OF OIL AND GAS WELLS; TECHNICAL SUPPORT SERVICES, NAMELY, MONITORING COMPUTER SYSTEMS FOR OIL OR GAS WELLS AND OIL OR GAS FIELDS; DATA COLLECTION AND ANALYSIS OF STATUS INFORMATION FROM OIL AND GAS WELLS; DATA ANALYSIS OF OIL AND GAS WELL READINGS (U.S. CLS. 100 AND 101).

AISHA CLARKE, EXAMINING ATTORNEY

SN 85-093,227. NES FINANCIAL CORP., SAN JOSE, CA. FILED 7-26-2010.

eSTAC

THE MARK CONSISTS OF STANDARD CHARACTERS WITHOUT CLAIM TO ANY PARTICULAR FONT, STYLE, SIZE, OR COLOR.

SN 85-092,846. BLACKBAUD, INC., CHARELSTON, SC. FILED 7-26-2010.

BLACKBAUD SOCIAL

THE MARK CONSISTS OF STANDARD CHARACTERS WITHOUT CLAIM TO ANY PARTICULAR FONT, STYLE, SIZE, OR COLOR.

OWNER OF U.S. REG. NOS. 2,397,946, 3,713,342 AND 3,775,771.

NO CLAIM IS MADE TO THE EXCLUSIVE RIGHT TO USE "SOCIAL", APART FROM THE MARK AS SHOWN.

CLASS 9—ELECTRICAL AND SCIENTIFIC APPARATUS

FOR COMPUTER SOFTWARE FOR COMMUNICATING WITH USERS OF HAND-HELD COMPUTERS; COMPUTER SOFTWARE FOR THE COLLECTION, EDITING, ORGANIZING, MODIFYING, BOOK MARKING, TRANSMISSION, STORAGE AND SHARING OF DATA AND INFORMATION; COMPUTER SOFTWARE FOR USE IN CUSTOMER RELATIONSHIP MANAGEMENT (CRM); COMPUTER SOFTWARE FOR WIRELESS CONTENT DELIVERY; COMPUTER SOFTWARE TO ENABLE THE TRANSMISSION OF PHOTOGRAPHS TO MOBILE TELEPHONES (U.S. CLS. 21, 23, 26, 36 AND 38).

CLASS 42—SCIENTIFIC AND COMPUTER SERVICES

FOR APPLICATION SERVICE PROVIDER (ASP), NAMELY, HOSTING COMPUTER SOFTWARE APPLICATIONS OF OTHERS; COMPUTER SERVICE, NAMELY, ACTING AS AN APPLICATION SERVICE PROVIDER IN THE FIELD OF KNOWLEDGE MANAGEMENT TO HOST COMPUTER APPLICATION SOFTWARE FOR SEARCHING AND RETRIEVING INFORMATION FROM DATABASES AND COMPUTER NETWORKS; COMPUTER SERVICE, NAMELY, ACTING AS AN APPLICATION SERVICE PROVIDER IN THE FIELD OF KNOWLEDGE MANAGEMENT TO HOST COMPUTER APPLICATION SOFTWARE FOR THE COLLECTION, EDITING, ORGANIZING, MODIFYING, BOOK MARKING, TRANSMISSION, STORAGE AND SHARING OF DATA AND INFORMATION (U.S. CLS. 100 AND 101).

MARC LEIPZIG, EXAMINING ATTORNEY

CLASS 35—ADVERTISING AND BUSINESS

FOR ON-LINE ACCOUNTING SERVICES OF ASSETS FOR OTHERS (U.S. CLS. 100, 101 AND 102).

CLASS 36—INSURANCE AND FINANCIAL

FOR CREATING AND MAINTAINING TRUST AND FINANCIAL ESCROW ACCOUNTS FOR OTHERS; PROVIDING SECURE, ON-LINE TRUST AND FINANCIAL ESCROW ACCOUNT INFORMATION FOR OTHERS; PROVIDING INTERNAL REVENUE CODE SECTION 1031 LIKE-KIND FINANCIAL EXCHANGE TRANSACTIONAL INFORMATION; PROVIDING ON-LINE FINANCIAL ESCROW ACCOUNT INFORMATION FOR OTHERS; FINANCIAL TRACKING SERVICES OF ASSETS IN THE NATURE OF CASH FOR OTHERS (U.S. CLS. 100, 101 AND 102).

CLASS 39—TRANSPORTATION AND STORAGE

FOR PROVIDING ELECTRONIC DOCUMENT STORAGE FOR OTHERS (U.S. CLS. 100 AND 105).

DAWN HAN, EXAMINING ATTORNEY

SN 85-093,462. LJRD, LLC, LOS ANGELES, CA. FILED 7-27-2010.

THE FUTURE OF SMOKING

THE MARK CONSISTS OF STANDARD CHARACTERS WITHOUT CLAIM TO ANY PARTICULAR FONT, STYLE, SIZE, OR COLOR.

NO CLAIM IS MADE TO THE EXCLUSIVE RIGHT TO USE "SMOKING", APART FROM THE MARK AS SHOWN.

CLASS 9—ELECTRICAL AND SCIENTIFIC APPARATUS

FOR BATTERIES FOR ELECTRONIC CIGARETTES AND CIGARS; BATTERY CHARGERS FOR ELECTRONIC CIGARETTES AND CIGARS (U.S. CLS. 21, 23, 26, 36 AND 38).

FIRST USE 4-27-2010; IN COMMERCE 4-27-2010.

CLASS 34—SMOKERS' ARTICLES

FOR ELECTRONIC CIGARETTES; ELECTRONIC CIGARS; BATTERIES FOR ELECTRONIC CIGARETTES AND CIGARS SOLD AS A UNIT WITH ELECTRONIC CIGARETTES AND CIGARS; REFILL CARTRIDGES FOR ELECTRONIC CIGARETTES AND CIGARS; PARTS FOR ELECTRONIC CIGARETTES AND CIGARS, NAMELY, VAPORIZERS; BATTERY CHARGERS FOR ELECTRONIC CIGARETTES AND CIGARS SOLD AS A UNIT WITH ELECTRONIC CIGARETTES AND CIGARS; CASES FOR ELECTRONIC CIGARETTES AND CIGARS (U.S. CLS. 2, 8, 9 AND 17).

FIRST USE 4-27-2010; IN COMMERCE 4-27-2010.
DEBRA LEE, EXAMINING ATTORNEY

SN 85-095,623. UNKEFER, DEAN, NASHVILLE, TN. FILED 7-29-2010.

90 CHURCH

THE MARK CONSISTS OF STANDARD CHARACTERS WITHOUT CLAIM TO ANY PARTICULAR FONT, STYLE, SIZE, OR COLOR.

CLASS 9—ELECTRICAL AND SCIENTIFIC APPARATUS

FOR MOTION PICTURE FILMS ABOUT A DRUG ENFORCEMENT AGENCY IN NEW YORK DURING THE 1950S AND 1960S (U.S. CLS. 21, 23, 26, 36 AND 38).

CLASS 41—EDUCATION AND ENTERTAINMENT

FOR ENTERTAINMENT SERVICES, NAMELY, AN ON-GOING TELEVISION SERIES FEATURING A STORYLINE ABOUT A DRUG ENFORCEMENT AGENCY IN NEW YORK DURING THE 1950S AND 1960S (U.S. CLS. 100, 101 AND 107).

PRISCILLA MILTON, EXAMINING ATTORNEY

SN 85-096,521. ROADS SAFE HOLDINGS, INC., CHICAGO, IL. FILED 7-30-2010.

ROADSAFE

THE MARK CONSISTS OF STANDARD CHARACTERS WITHOUT CLAIM TO ANY PARTICULAR FONT, STYLE, SIZE, OR COLOR.

OWNER OF U.S. REG. NO. 3,652,009.

CLASS 37—CONSTRUCTION AND REPAIR

FOR RENTAL AND INSTALLATION OF CRASH SYSTEMS, NAMELY, TRUCK-MOUNTED IMPACT ATTENUATORS, CRASH CUSHIONS, SAND BARREL ARRAYS, AND WATER-FILLED BARRIERS; AND PAVEMENT MARKING SERVICES AND TRAFFIC SIGN INSTALLATION SERVICES; RENTAL, INSTALLATION AND RELOCATION OF TRAFFIC SAFETY DEVICES, NAMELY, BARRELS, WATER BARRIERS, AND BARRICADES; INSTALLATION AND RELOCATION OF MESSAGE BOARDS AND TRAFFIC SIGNAGE, AND TRAFFIC CONES, WITH ALL OF THE FOREGOING USED FOR THE MANAGEMENT AND CONTROL OF VEHICULAR AND PEDESTRIAN TRAFFIC (U.S. CLS. 100, 103 AND 106).

CLASS 45—PERSONAL AND LEGAL SERVICES

FOR RENTAL OF TRAFFIC SAFETY DEVICES, NAMELY, MESSAGE BOARDS AND TRAFFIC SIGNAGE, AND TRAFFIC CONES WITH ALL OF THE FOREGOING USED FOR THE MANAGEMENT AND CONTROL OF VEHICULAR AND PEDESTRIAN TRAFFIC (U.S. CLS. 100 AND 101).

ODESSA BIBBINS, EXAMINING ATTORNEY

SN 85-096,586. GENERATION HEALTH, INC., UPPER SADDLE RIVER, NJ. FILED 7-30-2010.

GENERATION HEALTH

THE MARK CONSISTS OF STANDARD CHARACTERS WITHOUT CLAIM TO ANY PARTICULAR FONT, STYLE, SIZE, OR COLOR.

NO CLAIM IS MADE TO THE EXCLUSIVE RIGHT TO USE "HEALTH", APART FROM THE MARK AS SHOWN.

CLASS 35—ADVERTISING AND BUSINESS

FOR ADMINISTERING DISCOUNT MEDICAL SERVICE PROGRAMS, NAMELY, NEGOTIATING CONTRACTS WITH PROVIDERS OF GENETIC TESTING TO ENABLE PARTICIPANT MEMBERS TO OBTAIN DISCOUNTS ON THE PURCHASE OF GENETIC TESTING SERVICES; ARRANGING OF MANAGED CARE CONTRACTUAL SERVICES IN THE FIELDS OF GENETIC TESTING SERVICES; MEDICAL BILLING SUPPORT SERVICES; MEDICAL CLAIMS MANAGEMENT SERVICES, NAMELY, RECEIVING, DATA ENTERING, AND RE-PRICING OF TRANSACTIONS THAT ARE ORIGINATED BY PHYSICIANS, HOSPITALS, AND ANCILLARY MEDICAL CARE PROVIDERS; MEDICAL COST MANAGEMENT; MEDICAL REFERRALS; COST MANAGEMENT FOR THE HEALTH BENEFIT PLANS OF OTHERS; ALL OF THE FOREGOING IN THE FIELD OF GENETIC TESTING BENEFIT MANAGEMENT SERVICES (U.S. CLS. 100, 101 AND 102).

CLASS 36—INSURANCE AND FINANCIAL

FOR PROVIDING A DATABASE FOR TRACKING, MONITORING, AND GENERATING REPORTS ON INFORMATION AND STATISTICS ABOUT PATIENT REIMBURSEMENT AND INSURANCE COVERAGE FOR MEDICAL AND GENETIC TESTING SERVICES (U.S. CLS. 100, 101 AND 102).

CLASS 41—EDUCATION AND ENTERTAINMENT

FOR CONSULTING SERVICES IN THE FIELD OF MEDICAL EDUCATION, NAMELY, IDENTIFYING EDUCATIONAL NEEDS AND DEVELOPING EDUCATIONAL PROGRAM CONTENT IN THE FIELD OF GENETIC TESTING (U.S. CLS. 100, 101 AND 107).

CLASS 44—MEDICAL, BEAUTY AND AGRICULTURAL SERVICES

FOR GENETIC TESTING FOR MEDICAL PURPOSES; MAINTAINING FILES AND RECORDS CONCERNING THE MEDICAL CONDITION OF INDIVIDUALS; MEDICAL AND PHARMACEUTICAL CONSULTATION; MEDICAL EVALUATION SERVICES, NAMELY, FUNCTIONAL ASSESSMENT PROGRAM FOR PATIENTS RECEIVING MEDICAL REHABILITATION SERVICES FOR PURPOSES OF GUIDING TREATMENT AND ASSESSING PROGRAM EFFECTIVENESS; ALL OF THE FOREGOING IN THE FIELD OF GENETIC TESTING BENEFITS MANAGEMENT SERVICES (U.S. CLS. 100 AND 101).

CLASS 45—PERSONAL AND LEGAL SERVICES

FOR CONSULTING SERVICES, NAMELY, CONDUCTING INSURANCE BENEFIT INVESTIGATIONS FOR PATIENTS IN THE FIELD OF GENETIC TESTING TO INFORM DOCTORS THAT A PATIENT'S GENETIC MAKE-UP, THROUGH A GENETIC TEST, CAN DETERMINE IF A DRUG PRESCRIPTION IS MEDICALLY APPROPRIATE, AS PRESCRIBED; VERIFYING AND MONITORING THE CREDENTIALS OF MEDICAL PROFESSIONALS, NAMELY, PROVIDERS OF GENETIC TESTING AT LABORATORIES (U.S. CLS. 100 AND 101).
AMY HELLA, EXAMINING ATTORNEY

SN 85-097,204. ROBBINS RESEARCH INTERNATIONAL, INC., ESCONDIDO, CA. FILED 7-30-2010.

**ANTHONY ROBBINS
BREAKTHROUGH**

THE MARK CONSISTS OF STANDARD CHARACTERS WITHOUT CLAIM TO ANY PARTICULAR FONT, STYLE, SIZE, OR COLOR.

OWNER OF U.S. REG. NOS. 1,852,682 AND 3,229,561.
THE NAME(S), PORTRAIT(S), AND/OR SIGNATURE(S) SHOWN IN THE MARK IDENTIFIES "ANTHONY ROBBINS", WHOSE CONSENT(S) TO REGISTER IS MADE OF RECORD.

CLASS 9—ELECTRICAL AND SCIENTIFIC APPARATUS

FOR AUDIO AND VIDEO RECORDINGS IN THE FIELD OF PERSONAL IMPROVEMENT (U.S. CLS. 21, 23, 26, 36 AND 38).

CLASS 41—EDUCATION AND ENTERTAINMENT

FOR EDUCATIONAL AND ENTERTAINMENT SERVICES, NAMELY, PROGRAMS ABOUT PERSONAL IMPROVEMENT ACCESSIBLE BY RADIO, TELEVISION, SATELLITE, AUDIO, VIDEO AND COMPUTER NETWORKS; EDUCATIONAL AND ENTERTAINMENT SERVICES, NAMELY, THE PRESENTATION OF SEMINARS, WORKSHOPS, PANEL DISCUSSIONS AND ONGOING TELEVISION AND RADIO SHOWS ALL IN THE FIELD OF PERSONAL IMPROVEMENT; EDUCATIONAL SERVICES, NAMELY, CONDUCTING CLASSES AND SEMINARS IN THE FIELD OF PERSONAL IMPROVEMENT (U.S. CLS. 100, 101 AND 107).

CLASS 45—PERSONAL AND LEGAL SERVICES

FOR PROVIDING A WEBSITE FEATURING INFORMATION IN THE FIELD OF PERSONAL IMPROVEMENT (U.S. CLS. 100 AND 101).
WON TEAK OH, EXAMINING ATTORNEY

SN 85-097,328. ROBBINS RESEARCH INTERNATIONAL, INC., ESCONDIDO, CA. FILED 7-30-2010.

**BREAKTHROUGH WITH TONY
ROBBINS**

THE MARK CONSISTS OF STANDARD CHARACTERS WITHOUT CLAIM TO ANY PARTICULAR FONT, STYLE, SIZE, OR COLOR.

OWNER OF U.S. REG. NOS. 1,852,682 AND 3,229,561.
THE NAME(S), PORTRAIT(S), AND/OR SIGNATURE(S) SHOWN IN THE MARK IDENTIFIES "TONY ROBBINS", WHOSE CONSENT(S) TO REGISTER IS MADE OF RECORD.

CLASS 9—ELECTRICAL AND SCIENTIFIC APPARATUS

FOR AUDIO AND VIDEO RECORDINGS IN THE FIELD OF PERSONAL IMPROVEMENT (U.S. CLS. 21, 23, 26, 36 AND 38).

CLASS 41—EDUCATION AND ENTERTAINMENT

FOR EDUCATIONAL AND ENTERTAINMENT SERVICES, NAMELY, PROGRAMS ABOUT PERSONAL IMPROVEMENT ACCESSIBLE BY RADIO, TELEVISION, SATELLITE, AUDIO, VIDEO AND COMPUTER NETWORKS; EDUCATIONAL AND ENTERTAINMENT SERVICES, NAMELY, THE PRESENTATION OF SEMINARS, WORKSHOPS, PANEL DISCUSSIONS AND ONGOING TELEVISION AND RADIO SHOWS ALL IN THE FIELD OF PERSONAL IMPROVEMENT; EDUCATIONAL SERVICES, NAMELY, CONDUCTING CLASSES AND SEMINARS IN THE FIELD OF PERSONAL IMPROVEMENT (U.S. CLS. 100, 101 AND 107).

CLASS 45—PERSONAL AND LEGAL SERVICES

FOR PROVIDING A WEBSITE FEATURING INFORMATION IN THE FIELD OF PERSONAL IMPROVEMENT (U.S. CLS. 100 AND 101).
WON TEAK OH, EXAMINING ATTORNEY

SN 85-097,330. ROBBINS RESEARCH INTERNATIONAL, INC., ESCONDIDO, CA. FILED 7-30-2010.

**BREAKTHROUGH WITH ANTHONY
ROBBINS**

THE MARK CONSISTS OF STANDARD CHARACTERS WITHOUT CLAIM TO ANY PARTICULAR FONT, STYLE, SIZE, OR COLOR.

OWNER OF U.S. REG. NOS. 1,852,682 AND 3,229,561.

THE NAME(S), PORTRAIT(S), AND/OR SIGNATURE(S) SHOWN IN THE MARK IDENTIFIES "ANTHONY ROBBINS", WHOSE CONSENT(S) TO REGISTER IS MADE OF RECORD.

**CLASS 9—ELECTRICAL AND SCIENTIFIC
APPARATUS**

FOR AUDIO AND VIDEO RECORDINGS IN THE FIELD OF PERSONAL IMPROVEMENT (U.S. CLS. 21, 23, 26, 36 AND 38).

**CLASS 41—EDUCATION AND ENTERTAIN-
MENT**

FOR EDUCATIONAL AND ENTERTAINMENT SERVICES, NAMELY, PROGRAMS ABOUT PERSONAL IMPROVEMENT ACCESSIBLE BY RADIO, TELEVISION, SATELLITE, AUDIO, VIDEO AND COMPUTER NETWORKS; EDUCATIONAL AND ENTERTAINMENT SERVICES, NAMELY, THE PRESENTATION OF SEMINARS, WORKSHOPS, PANEL DISCUSSIONS AND ONGOING TELEVISION AND RADIO SHOWS ALL IN THE FIELD OF PERSONAL IMPROVEMENT; EDUCATIONAL SERVICES, NAMELY, CONDUCTING CLASSES AND SEMINARS IN THE FIELD OF PERSONAL IMPROVEMENT (U.S. CLS. 100, 101 AND 107).

**CLASS 45—PERSONAL AND LEGAL SER-
VICES**

FOR PROVIDING A WEBSITE FEATURING INFORMATION IN THE FIELD OF PERSONAL IMPROVEMENT (U.S. CLS. 100 AND 101).

WON TEAK OH, EXAMINING ATTORNEY

SN 85-097,335. ROBBINS RESEARCH INTERNATIONAL, INC., ESCONDIDO, CA. FILED 7-30-2010.

TONY ROBBINS BREAKTHROUGH

THE MARK CONSISTS OF STANDARD CHARACTERS WITHOUT CLAIM TO ANY PARTICULAR FONT, STYLE, SIZE, OR COLOR.

OWNER OF U.S. REG. NOS. 1,852,682 AND 3,229,561.

THE NAME(S), PORTRAIT(S), AND/OR SIGNATURE(S) SHOWN IN THE MARK IDENTIFIES "TONY ROBBINS", WHOSE CONSENT(S) TO REGISTER IS MADE OF RECORD.

**CLASS 9—ELECTRICAL AND SCIENTIFIC
APPARATUS**

FOR AUDIO AND VIDEO RECORDINGS IN THE FIELD OF PERSONAL IMPROVEMENT (U.S. CLS. 21, 23, 26, 36 AND 38).

**CLASS 41—EDUCATION AND ENTERTAIN-
MENT**

FOR EDUCATIONAL AND ENTERTAINMENT SERVICES, NAMELY, PROGRAMS ABOUT PERSONAL IMPROVEMENT ACCESSIBLE BY RADIO, TELEVISION, SATELLITE, AUDIO, VIDEO AND COMPUTER NETWORKS; EDUCATIONAL AND ENTERTAINMENT SERVICES, NAMELY, THE PRESENTATION OF SEMINARS, WORKSHOPS, PANEL DISCUSSIONS AND ONGOING TELEVISION AND RADIO SHOWS ALL IN THE FIELD OF PERSONAL IMPROVEMENT; EDUCATIONAL SERVICES, NAMELY, CONDUCTING CLASSES AND SEMINARS IN THE FIELD OF PERSONAL IMPROVEMENT (U.S. CLS. 100, 101 AND 107).

**CLASS 45—PERSONAL AND LEGAL SER-
VICES**

FOR PROVIDING A WEBSITE FEATURING INFORMATION IN THE FIELD OF PERSONAL IMPROVEMENT (U.S. CLS. 100 AND 101).

WON TEAK OH, EXAMINING ATTORNEY

SN 85-098,008. 360E PRODUCTIONS, LLC, WEST HOLLYWOOD, CA. FILED 8-2-2010.

360e

THE MARK CONSISTS OF STANDARD CHARACTERS WITHOUT CLAIM TO ANY PARTICULAR FONT, STYLE, SIZE, OR COLOR.

CLASS 35—ADVERTISING AND BUSINESS

FOR ORGANIZATION OF BUSINESS CONVENTIONS; BUSINESS CONSULTATION AND MANAGEMENT REGARDING MARKETING ACTIVITIES AND LAUNCHING OF NEW PRODUCTS; MARKETING CONSULTATION IN THE FIELD OF FILM AND VIDEO PRODUCTION; BRANDING SERVICES, NAMELY, CONSULTING, DEVELOPMENT, MANAGEMENT AND MARKETING OF BRANDS FOR BUSINESSES; PROVIDING BUSINESS MANAGEMENT INFORMATION IN CONNECTION WITH CONSULTING AND ADVISORY SERVICES IN THE FIELD OF STRATEGIC PLANNING; MARKETING AND CONSULTING SERVICES IN THE FIELD OF PROMOTING AND TRACKING THE GOODS, SERVICES, AND BRANDS OF OTHERS THROUGH ALL PUBLIC COMMUNICATION MEANS, PARTICULARLY SPECIALIZING IN THE USE OF MOBILE, SOCIAL, AND PRINT MEDIA TO DRIVE CONSUMER INTEREST, ENGAGEMENT AND ACTION; ARRANGING AND CONDUCTING SPECIAL EVENTS FOR BUSINESS PURPOSES; SPECIAL EVENT PLANNING FOR BUSINESS PURPOSES; SPECIAL EVENT CONSULTATION FOR BUSINESS PURPOSES (U.S. CLS. 100, 101 AND 102).

FIRST USE 3-1-2008; IN COMMERCE 3-1-2008.

**CLASS 41—EDUCATION AND ENTERTAIN-
MENT**

FOR ARRANGING AND CONDUCTING SPECIAL EVENTS FOR SOCIAL ENTERTAINMENT PURPOSES; SPECIAL EVENT PLANNING FOR SOCIAL ENTERTAINMENT PURPOSES; SPECIAL EVENT CONSULTATION FOR SOCIAL ENTERTAINMENT PURPOSES; FILM AND VIDEO PRODUCTION; FILM AND VIDEO PRODUCTION CONSULTING SERVICES; MEDIA PRODUCTION SERVICES, NAMELY, VIDEO AND FILM PRODUCTION (U.S. CLS. 100, 101 AND 107).

FIRST USE 3-1-2008; IN COMMERCE 3-1-2008.

CLASS 42—SCIENTIFIC AND COMPUTER SERVICES

FOR DESIGNING THEME GRAPHICS AND MULTI-MEDIA SHOWS FOR CONVENTIONS, PRODUCT LAUNCHES, TRADE SHOWS, KEY NOTE ADDRESSES AND AWARD CEREMONIES FOR OTHERS (U.S. CLS. 100 AND 101).

FIRST USE 3-1-2008; IN COMMERCE 3-1-2008.
ANGELA DUONG, EXAMINING ATTORNEY

SN 85-098,152. DETLEF SCHOBERT, MUNICH, FED REP GERMANY, FILED 8-2-2010.

EXYD

THE MARK CONSISTS OF STANDARD CHARACTERS WITHOUT CLAIM TO ANY PARTICULAR FONT, STYLE, SIZE, OR COLOR.

OWNER OF FED REP GERMANY REG. NO. 004417234, DATED 3-29-2006, EXPIRES 5-27-2015.

THE WORDING "EXYD" HAS NO MEANING IN A FOREIGN LANGUAGE.

CLASS 40—MATERIAL TREATMENT

FOR METAL TREATMENT; TREATMENT OF METAL (U.S. CLS. 100, 103 AND 106).

CLASS 42—SCIENTIFIC AND COMPUTER SERVICES

FOR DESIGN AND DEVELOPMENT OF COMPUTER SOFTWARE; DESIGN AND WRITING OF COMPUTER SOFTWARE (U.S. CLS. 100 AND 101).

Laurie Kaufman, Examining Attorney

SN 85-098,242. GENERATION HEALTH, INC., UPPER SADDLE RIVER, NJ. FILED 8-2-2010.



NO CLAIM IS MADE TO THE EXCLUSIVE RIGHT TO USE "HEALTH", APART FROM THE MARK AS SHOWN.

THE MARK CONSISTS OF A SPIRAL DESIGN WITH A SMALL SHADOW AT THE BOTTOM WITH THE WORD "GENERATION" ABOVE THE WORD "HEALTH" TO THE RIGHT OF THE DESIGN.

CLASS 35—ADVERTISING AND BUSINESS

FOR ADMINISTERING DISCOUNT MEDICAL SERVICE PROGRAMS, NAMELY, NEGOTIATING CONTRACTS WITH PROVIDERS OF GENETIC TESTING TO ENABLE PARTICIPANT MEMBERS TO OBTAIN DISCOUNTS ON THE PURCHASE OF GENETIC TESTING SERVICES; ARRANGING OF MANAGED CARE CONTRACTUAL SERVICES IN THE FIELDS OF GENETIC TESTING SERVICES; MEDICAL BILLING SUPPORT SERVICES; MEDICAL CLAIMS MANAGEMENT SERVICES, NAMELY, RECEIVING, DATA ENTERING, AND RE-PRICING OF TRANSACTIONS THAT ARE ORIGINATED BY PHYSICIANS, HOSPITALS, AND ANCILLARY MEDICAL CARE PROVIDERS; MEDICAL COST MANAGEMENT; MEDICAL REFERRALS; COST MANAGEMENT FOR THE HEALTH BENEFIT PLANS OF OTHERS; ALL OF THE FOREGOING IN THE FIELD OF GENETIC TESTING BENEFIT MANAGEMENT SERVICES (U.S. CLS. 100, 101 AND 102).

CLASS 36—INSURANCE AND FINANCIAL

FOR PROVIDING A DATABASE FOR TRACKING, MONITORING, AND GENERATING REPORTS ON INFORMATION AND STATISTICS ABOUT PATIENT REIMBURSEMENT AND INSURANCE COVERAGE FOR MEDICAL AND GENETIC TESTING SERVICES (U.S. CLS. 100, 101 AND 102).

CLASS 41—EDUCATION AND ENTERTAINMENT

FOR CONSULTING SERVICES IN THE FIELD OF MEDICAL EDUCATION, NAMELY, IDENTIFYING EDUCATIONAL NEEDS AND DEVELOPING EDUCATIONAL PROGRAM CONTENT IN THE FIELD OF GENETIC TESTING (U.S. CLS. 100, 101 AND 107).

CLASS 44—MEDICAL, BEAUTY AND AGRICULTURAL SERVICES

FOR GENETIC TESTING FOR MEDICAL PURPOSES; MAINTAINING FILES AND RECORDS CONCERNING THE MEDICAL CONDITION OF INDIVIDUALS; MEDICAL AND PHARMACEUTICAL CONSULTATION; MEDICAL EVALUATION SERVICES, NAMELY, FUNCTIONAL ASSESSMENT PROGRAM FOR PATIENTS RECEIVING MEDICAL REHABILITATION SERVICES FOR PURPOSES OF GUIDING TREATMENT AND ASSESSING PROGRAM EFFECTIVENESS; ALL OF THE FOREGOING IN THE FIELD OF GENETIC TESTING BENEFITS MANAGEMENT SERVICES (U.S. CLS. 100 AND 101).

CLASS 45—PERSONAL AND LEGAL SERVICES

FOR CONSULTING SERVICES, NAMELY, CONDUCTING INSURANCE BENEFIT INVESTIGATIONS FOR PATIENTS IN THE FIELD OF GENETIC TESTING TO INFORM DOCTORS THAT A PATIENT'S GENETIC MAKE-UP, THROUGH A GENETIC TEST, CAN DETERMINE IF A DRUG PRESCRIPTION IS MEDICALLY APPROPRIATE, AS PRESCRIBED; VERIFYING AND MONITORING THE CREDENTIALS OF MEDICAL PROFESSIONALS, NAMELY, PROVIDERS OF GENETIC TESTING AT LABORATORIES (U.S. CLS. 100 AND 101).

Amy Hella, Examining Attorney

SN 85-098,338. TYRRELLS POTATO CHIPS LIMITED, LEOMINSTER, UNITED KINGDOM, FILED 8-2-2010.

CHIPS NOUVEAU

THE MARK CONSISTS OF STANDARD CHARACTERS WITHOUT CLAIM TO ANY PARTICULAR FONT, STYLE, SIZE, OR COLOR.

OWNER OF ERPN CMNTY TM OFC REG. NO. 008850976, DATED 6-22-2010, EXPIRES 2-2-2020.

OWNER OF U.S. REG. NOS. 3,656,329 AND 3,668,128. NO CLAIM IS MADE TO THE EXCLUSIVE RIGHT TO USE "CHIPS", APART FROM THE MARK AS SHOWN.

CLASS 29—MEATS AND PROCESSED FOODS

FOR PRESERVED, DRIED AND COOKED FRUITS AND VEGETABLES; EDIBLE OILS AND FATS; POTATO CRISPS, POTATO CHIPS, COOKED AND FRIED VEGETABLES, POTATO-BASED SNACK FOODS, ROASTED NUTS (U.S. CL. 46).

CLASS 30—STAPLE FOODS

FOR COFFEE, TEA, COCOA, SUGAR, RICE, TAPIOCA, SAGO, ARTIFICIAL COFFEE; FLOUR AND PREPARATIONS MADE FROM CEREALS, NAMELY, GRANOLA; BREAD, PASTRY; CONFECTIONERY, NAMELY, CANDY BARS, CHOCOLATE, FUDGE, GUM DROPS, JELLY BEANS, LICORICE, LOLLIPOPS, MARZIPAN, NOUGAT, ROCK CANDY AND TOFFEE; CEREAL BASED SNACK FOODS, HONEY, TREACLE; YEAST, BAKING POWDER, SALT, MUSTARD, VINEGAR, SAUCES; CONDIMENTS, NAMELY, BBQ SAUCE, KETCHUP, MAYONNAISE; SPICES; MUESLI, MUESLI BARS (U.S. CL. 46).

GINA HAYES, EXAMINING ATTORNEY

SN 85-098,777. HEALTH CARE REIT, INC., TOLEDO, OH. FILED 8-3-2010.

HEALTHY BUILDING

THE MARK CONSISTS OF STANDARD CHARACTERS WITHOUT CLAIM TO ANY PARTICULAR FONT, STYLE, SIZE, OR COLOR.

CLASS 36—INSURANCE AND FINANCIAL

FOR PROVIDING MORTGAGE AND LEASE FINANCING; PROVIDING CONSTRUCTION, WORKING CAPITAL AND ACCOUNTS RECEIVABLE LOAN FINANCING; PROVIDING LEASE AND LOAN FINANCING TO OWNERS, OPERATORS AND DEVELOPERS OF HEALTH CARE FACILITIES, MEDICAL OFFICE BUILDINGS AND COMMERCIAL REAL ESTATE; PROVIDING CAPITAL TO OWNERS, OPERATORS AND DEVELOPERS OF HEALTH CARE FACILITIES, MEDICAL OFFICE BUILDINGS AND COMMERCIAL REAL ESTATE; AND PROVIDING REAL ESTATE SERVICES, NAMELY, PROPERTY MANAGEMENT AND FACILITY LEASING SERVICES TO OWNERS, OPERATORS AND DEVELOPERS OF HEALTH CARE FACILITIES, MEDICAL OFFICE BUILDINGS AND COMMERCIAL REAL ESTATE (U.S. CLS. 100, 101 AND 102).

FIRST USE 10-7-2009; IN COMMERCE 10-7-2009.

CLASS 37—CONSTRUCTION AND REPAIR

FOR LAND DEVELOPMENT, CLINICAL, FACILITY, AND EQUIPMENT PLANNING SERVICES, NAMELY, PLANNING AND LAYING OUT OF HEALTH CARE FACILITIES, MEDICAL OFFICE BUILDINGS, AND COMMERCIAL REAL ESTATE; CONSTRUCTION PLANNING, CONSTRUCTION CONSULTING, AND CONSTRUCTION MANAGEMENT SERVICES FOR THE DEVELOPMENT AND CONSTRUCTION OF HEALTH CARE FACILITIES, MEDICAL OFFICE BUILDINGS, AND COMMERCIAL REAL ESTATE AND THE REDEVELOPMENT AND RENOVATION OF HEALTH CARE FACILITIES, MEDICAL OFFICE BUILDINGS, AND COMMERCIAL REAL ESTATE (U.S. CLS. 100, 103 AND 106).

FIRST USE 10-7-2009; IN COMMERCE 10-7-2009.

CLASS 42—SCIENTIFIC AND COMPUTER SERVICES

FOR INTERIOR DESIGN SERVICES FOR HEALTH CARE FACILITIES, MEDICAL OFFICE BUILDINGS, AND COMMERCIAL REAL ESTATE (U.S. CLS. 100 AND 101).

FIRST USE 10-7-2009; IN COMMERCE 10-7-2009.

KEVON CHISOLM, EXAMINING ATTORNEY

SN 85-099,542. RAIMUND SCHMITT VERPACHTUNGSGESSELLSCHAFT MBH & CO. KG, NUERNBERG, FED REP GERMANY, FILED 8-3-2010.

Beverage Manager

THE MARK CONSISTS OF STANDARD CHARACTERS WITHOUT CLAIM TO ANY PARTICULAR FONT, STYLE, SIZE, OR COLOR.

NO CLAIM IS MADE TO THE EXCLUSIVE RIGHT TO USE "BEVERAGE", APART FROM THE MARK AS SHOWN.

CLASS 16—PAPER GOODS AND PRINTED MATTER

FOR PRINTED MATTER, NAMELY, NEWSPAPERS, MAGAZINES, CATALOGS, BOOKS, INCLUDING BOOKS PUBLISHED IN LOOSE-LEAF FORM, PRINTED INSTRUCTIONAL AND TEACHING MATERIALS, PRINTED PERIODICALS, NEWSLETTERS AND BROCHURES, ALL IN THE FIELD OF BEER BREWING, BEVERAGES AND NUTRITION (U.S. CLS. 2, 5, 22, 23, 29, 37, 38 AND 50).

FIRST USE 11-25-2005; IN COMMERCE 11-25-2005.

CLASS 35—ADVERTISING AND BUSINESS

FOR ARRANGING TRADE FAIRS AND EXHIBITIONS FOR COMMERCIAL AND ADVERTISING PURPOSES IN THE FIELD OF BEER BREWING, BEVERAGES AND NUTRITION; COMPILING AND PROVIDING CUSTOMER ADDRESSES FOR MARKETING PURPOSES; COMPILING AND PROVIDING MARKETING AND SALES INFORMATION ON THE INTERNET; MARKETING OF ADVERTISEMENTS IN INTERNET AND PRINT MEDIA; PROVIDING SPACE AT A WEB SITE FOR ADVERTISEMENT OF THE GOODS AND SERVICES OF OTHERS; ADVERTISEMENT FOR OTHERS IN PRINT AND ON THE INTERNET; RENTAL OF ADVERTISING SPACE ON WEBSITES; COMPILATION AND SYSTEMIZATION OF DATA AND INFORMATION INTO COMPUTER DATABASES; DOCUMENTATION SERVICES, NAMELY, PROVIDING INFORMATION IN THE FIELD OF BEVERAGE INDUSTRY BUSINESS NEWS; ELECTRONIC PROVISION OF INFORMATION IN THE FIELD OF BEVERAGE INDUSTRY BUSINESS NEWS; PROVIDING AN INTERNET WEBSITE PORTAL IN THE FIELD OF BUSINESS NEWS; PROVIDING INFORMATION VIA THE INTERNET IN THE FIELD OF BUSINESS NEWS (U.S. CLS. 100, 101 AND 102).

CLASS 40—MATERIAL TREATMENT

FOR DOCUMENTATION SERVICES, NAMELY, PROVIDING INFORMATION IN THE FIELD OF BREWING BEER; ELECTRONIC PROVISION OF INFORMATION IN THE FIELD OF BREWING BEER; PROVIDING AN INTERNET WEBSITE PORTAL IN THE FIELD OF BREWING BEER; PROVIDING INFORMATION VIA THE INTERNET IN THE FIELD OF BREWING BEER (U.S. CLS. 100, 103 AND 106).

CLASS 41—EDUCATION AND ENTERTAINMENT

FOR CONDUCTING, ARRANGING AND ORGANIZING SEMINARS IN THE FIELD OF BEER BREWING, BEVERAGES AND NUTRITION FOR INSTRUCTION AND TRAINING PURPOSES; CONDUCTING, ARRANGING AND ORGANIZING FAIRS IN THE FIELDS OF BEER BREWING, BEVERAGES AND NUTRITION FOR ENTERTAINMENT PURPOSES; PUBLISHING OF PRINT MEDIA, NAMELY NEWSPAPERS, MAGAZINES, CATALOGS, BOOKS, INCLUDING BOOKS PUBLISHED IN LOOSE-LEAF FORM, PRINTED INSTRUCTIONAL AND TEACHING MATERIALS, PRINTED PERIODICALS, NEWSLETTERS AND BROCHURES AND ELECTRONIC PUBLICATIONS; PUBLISHING OF PRINTED TEXT IN THE NATURE OF NEWSPAPERS, MAGAZINES, CATALOGS, BOOKS, INCLUDING BOOKS PUBLISHED IN LOOSE-LEAF FORM, PRINTED INSTRUCTIONAL AND TEACHING MATERIALS, PRINTED PERIODICALS, NEWSLETTERS AND BROCHURES, EXCLUDING ADVERTISING TEXTS; PUBLISHING OF NEWSPAPERS, MAGAZINES, CATALOGS, BOOKS, INCLUDING BOOKS PUBLISHED IN LOOSE-LEAF FORM, PRINTED INSTRUCTIONAL AND TEACHING MATERIALS, PRINTED PERIODICALS, NEWSLETTERS AND BROCHURES; NON-DOWNLOADABLE ELECTRONIC PUBLICATIONS IN THE NATURE OF NEWSPAPERS, MAGAZINES, CATALOGS, BOOKS, INSTRUCTIONAL AND TEACHING MATERIALS, PERIODICALS, NEWSLETTERS AND BROCHURES IN THE FIELD OF BREWING BEER, BEVERAGES AND NUTRITION (U.S. CLS. 100, 101 AND 107).

FIRST USE 11-25-2005; IN COMMERCE 11-25-2005.

CLASS 42—SCIENTIFIC AND COMPUTER SERVICES

FOR DESIGN, DEVELOPMENT AND MAINTENANCE OF WEBSITES FOR OTHERS (U.S. CLS. 100 AND 101).

CLASS 44—MEDICAL, BEAUTY AND AGRICULTURAL SERVICES

FOR DOCUMENTATION SERVICES, NAMELY, PROVIDING INFORMATION IN THE FIELD OF NUTRITION; ELECTRONIC PROVISION OF INFORMATION IN THE FIELD OF NUTRITION; PROVIDING AN INTERNET WEBSITE PORTAL IN THE FIELD OF NUTRITION; PROVIDING INFORMATION VIA THE INTERNET IN THE FIELD OF NUTRITION (U.S. CLS. 100 AND 101).
KATHERINE CHANG, EXAMINING ATTORNEY

SN 85-099,689. BOOST MEDIA INTERNATIONAL PTY LIMITED, SYDNEY, NSW 2000, AUSTRALIA, FILED 8-4-2010.



NO CLAIM IS MADE TO THE EXCLUSIVE RIGHT TO USE "THE NEWSPAPER EXPO", APART FROM THE MARK AS SHOWN.

THE MARK CONSISTS OF THE WORDING "PRINTWORKS" IN LARGE LETTERING WITH THE SMALLER LETTERING "THE NEWSPAPER EXPO" UNDERNEATH. TO THE LEFT OF THE WORDING IS A DESIGN OF FOUR, THREE-DIMENSIONAL RECTANGLES.

CLASS 35—ADVERTISING AND BUSINESS

FOR BUSINESS CONSULTANCY AND ADVISORY SERVICES TO MEDIA COMPANIES IN RELATION TO GENERATING ADVERTISING REVENUE; MARKET ANALYSIS SERVICES RELATING TO THE SALE OF ADVERTISING SPACE; ORGANISATION OF EXHIBITIONS FOR COMMERCIAL OR ADVERTISING PURPOSES (U.S. CLS. 100, 101 AND 102).

CLASS 41—EDUCATION AND ENTERTAINMENT

FOR ARRANGING AND CONDUCTING SEMINARS AND CONFERENCES IN THE FIELD OF MARKETING FOR MEDIA COMPANIES; ARRANGING AND CONDUCTING TRAINING WORKSHOPS TO MEDIA COMPANIES IN THE FIELD OF ORGANISATION OF MARKETING SEMINARS, CONFERENCES OR EXHIBITIONS TO GENERATE ADVERTISING REVENUE; BUSINESS TRAINING IN THE FIELD OF SALES (U.S. CLS. 100, 101 AND 107).

COURTNEY ALVAREZ, EXAMINING ATTORNEY

SN 85-099,819. PJP INVESTMENTS, LLC, CRESTVIEW HILLS, KY. FILED 8-4-2010.

Absolute Action MMA

THE MARK CONSISTS OF STANDARD CHARACTERS WITHOUT CLAIM TO ANY PARTICULAR FONT, STYLE, SIZE, OR COLOR.

NO CLAIM IS MADE TO THE EXCLUSIVE RIGHT TO USE "ACTION MMA", APART FROM THE MARK AS SHOWN.

CLASS 25—CLOTHING

FOR T-SHIRTS (U.S. CLS. 22 AND 39).
FIRST USE 3-10-2010; IN COMMERCE 3-10-2010.

CLASS 41—EDUCATION AND ENTERTAINMENT

FOR ENTERTAINMENT SERVICES IN THE NATURE OF LIVE MIXED MARTIAL ARTS (MMA) EVENTS; ORGANIZING LIVE MIXED MARTIAL ARTS EVENTS AND COMPETITIONS; PRESENTATION OF MIXED MARTIAL ARTS (MMA) EVENTS (U.S. CLS. 100, 101 AND 107).

FIRST USE 3-10-2010; IN COMMERCE 3-10-2010.
DOMINIC J. FERRAIUOLO, EXAMINING ATTORNEY

SN 85-099,933. SEVEN SPECIALS, LLC, NORTH ADAMS, MA. FILED 8-4-2010.

SEVENLUNCHES

THE MARK CONSISTS OF STANDARD CHARACTERS WITHOUT CLAIM TO ANY PARTICULAR FONT, STYLE, SIZE, OR COLOR.

CLASS 9—ELECTRICAL AND SCIENTIFIC APPARATUS

FOR DOWNLOADABLE SOFTWARE IN THE NATURE OF A MOBILE APPLICATION FOR ASSISTING BUSINESSES IN THE FOOD, BEVERAGE, RESTAURANT AND HOSPITALITY INDUSTRIES IN ADVERTISING THEIR GOODS AND SERVICES (U.S. CLS. 21, 23, 26, 36 AND 38).

FIRST USE 5-31-2009; IN COMMERCE 5-31-2009.

CLASS 35—ADVERTISING AND BUSINESS

FOR ADVERTISING SERVICES, NAMELY, PROVIDING A SEARCHABLE ON-LINE ADVERTISING WEBSITE AND GUIDE FEATURING THE GOODS AND SERVICES OF BUSINESSES IN THE FOOD, BEVERAGE, RESTAURANT AND HOSPITALITY INDUSTRIES VIA THE INTERNET (U.S. CLS. 100, 101 AND 102).

FIRST USE 5-31-2009; IN COMMERCE 5-31-2009.
KRISTINA MORRIS, EXAMINING ATTORNEY

SN 85-100,468. NETWORK SERVICES, INC., PHOENIX, AZ. FILED 8-4-2010.

NetBasis

THE MARK CONSISTS OF STANDARD CHARACTERS WITHOUT CLAIM TO ANY PARTICULAR FONT, STYLE, SIZE, OR COLOR.

OWNER OF U.S. REG. NO. 2,874,134.

CLASS 36—INSURANCE AND FINANCIAL

FOR SERVICES PROVIDED TO GOVERNMENT TAX AGENCIES, ACCOUNTING FIRMS, FINANCIAL INSTITUTIONS, SHAREHOLDER SERVICES COMPANIES, MONEY MANAGERS AND OTHERS, NAMELY, CONSULTATION AND OTHER SERVICES IN THE NATURE OF FINANCIAL CALCULATING AND ADVICE SERVICES FOR RETRIEVING AND CALCULATING THE ADJUSTED COST BASIS OF INVESTMENTS REGARDLESS OF CAPITAL CHANGES; CONSULTATION AND OTHER SERVICES IN THE NATURE OF FINANCIAL CALCULATING AND ADVICE SERVICES FOR USE IN RETRIEVING AND CALCULATING HISTORICAL AND CURRENT COST BASIS INFORMATION, HISTORICAL AND CURRENT CORPORATE ACTION INFORMATION AND TAX LOT RELIEF METHOD CALCULATIONS (U.S. CLS. 100, 101 AND 102).

FIRST USE 7-1-1997; IN COMMERCE 11-5-1999.

CLASS 42—SCIENTIFIC AND COMPUTER SERVICES

FOR NON-DOWNLOADABLE COMPUTER PROGRAMS FOR USE BY GOVERNMENT TAX AGENCIES, ACCOUNTING FIRMS, FINANCIAL INSTITUTIONS, SHAREHOLDER SERVICES COMPANIES, MONEY MANAGERS AND OTHERS; NAMELY, SOFTWARE FOR USE IN RETRIEVING AND CALCULATING THE ADJUSTED COST BASIS OF INVESTMENTS REGARDLESS OF CAPITAL CHANGES; NON-DOWNLOADABLE SOFTWARE FOR USE IN RETRIEVING AND CALCULATING HISTORICAL AND CURRENT COST BASIS INFORMATION, HISTORICAL AND CURRENT CORPORATE ACTION INFORMATION AND TAX LOT RELIEF METHOD CALCULATIONS (U.S. CLS. 100 AND 101).

FIRST USE 7-1-1999; IN COMMERCE 11-5-1999.
MARILYN IZZI, EXAMINING ATTORNEY

SN 85-100,694. SHELL BRASIL LTDA, RIO DE JANEIRO - RJ, BRAZIL, FILED 8-5-2010.

RAIZEN

THE MARK CONSISTS OF STANDARD CHARACTERS WITHOUT CLAIM TO ANY PARTICULAR FONT, STYLE, SIZE, OR COLOR.

CLASS 1—CHEMICALS

FOR PETROLEUM ETHER FOR USE AS A SOLVENT; XYLENE FOR USE AS A SOLVENT; CHEMICAL ADDITIVES FOR FUELS, NAMELY, CARBURANTS (U.S. CLS. 1, 5, 6, 10, 26 AND 46).

CLASS 4—LUBRICANTS AND FUELS

FOR NON-CHEMICAL ADDITIVES FOR MOTOR FUEL; ALCOHOL FUEL; BENZENE FUEL; NON-CHEMICAL ADDITIVES FOR FUELS, NAMELY, CARBURANTS; VAPORIZED FUEL MIXTURES; FUEL; FUEL OIL; FUEL WITH AN ALCOHOLIC BASE; MOTOR FUEL; PETROLEUM ETHER FOR USE AS A FUEL; AUTOMOTIVE GAS OIL, NAMELY, DIESEL FUEL; GASOLINE; PETROL; LUBRICATING GREASE; INDUSTRIAL GREASE; LUBRICATING GRAPHITE; ALL PURPOSE LUBRICANTS; INDUSTRIAL LUBRICANTS; MOTOR VEHICLE LUBRICANTS; COMBUSTIBLE OIL; DIESEL OIL; INDUSTRIAL OIL; LUBRICATING OIL; MOTOR OIL; PETROLEUM; KEROSENE; XYLENE FOR USE AS A FUEL (U.S. CLS. 1, 6 AND 15).

JAMES GRIFFIN, EXAMINING ATTORNEY

SN 85-100,834. SHELL BRASIL LTDA, RIO DE JANEIRO - RJ, BRAZIL, FILED 8-5-2010.

RAIZEN

THE MARK CONSISTS OF STANDARD CHARACTERS WITHOUT CLAIM TO ANY PARTICULAR FONT, STYLE, SIZE, OR COLOR.

CLASS 35—ADVERTISING AND BUSINESS

FOR COST PRICE ANALYSIS; COMMERCIAL AND INDUSTRIAL MANAGEMENT ASSISTANCE; BUSINESS MANAGEMENT ASSISTANCE; BUSINESS APPRAISALS; PROVIDING AN ONLINE COMPUTER DATABASE IN THE FIELD OF BUSINESS AS IT RELATES TO ENERGY; PERSONNEL MANAGEMENT CONSULTANCY; BUSINESS ORGANIZATION CONSULTANCY; PROFESSIONAL BUSINESS CONSULTANCY IN THE FIELD OF IMPORT-EXPORT AGENCIES; CONDUCTING MARKETING STUDIES (U.S. CLS. 100, 101 AND 102).

CLASS 39—TRANSPORTATION AND STORAGE

FOR PROVIDING AN ONLINE COMPUTER DATABASE IN THE FIELD OF FUEL DISTRIBUTION (U.S. CLS. 100 AND 105).

CLASS 40—MATERIAL TREATMENT

FOR PROVIDING AN ONLINE COMPUTER DATABASE IN THE FIELD OF SUGAR, ALCOHOL AND ETHANOL FUEL PRODUCTION (U.S. CLS. 100, 103 AND 106).
JAMES GRIFFIN, EXAMINING ATTORNEY

SN 85-100,842. NATGASCAR LLC, CLEVELAND, OH, FILED 8-5-2010.

ECOWISE

THE MARK CONSISTS OF STANDARD CHARACTERS WITHOUT CLAIM TO ANY PARTICULAR FONT, STYLE, SIZE, OR COLOR.

CLASS 7—MACHINERY

FOR NATURAL GAS DISPENSING UNITS CONSISTING OF COMPRESSORS, HOSES, ELECTRIC MOTORS AND VALVES FOR REFUELING VEHICLES EQUIPPED FOR BURNING NATURAL GAS AS A TRANSPORTATION FUEL, AND PARTS THEREOF (U.S. CLS. 13, 19, 21, 23, 31, 34 AND 35).

CLASS 12—VEHICLES

FOR NATURAL GAS CONVERSION KIT, CONSISTING OF A HIGH PRESSURE STORAGE CYLINDER, HIGH PRESSURE AND LOW PRESSURE STEEL BRAIDED LINES, A REGULATOR, VALVES, A FUEL RAIL, FUEL INJECTORS, FUEL ADAPTORS, AND AN ELECTRONIC CONTROL UNIT AND ASSOCIATED WIRING THAT CONVERTS LIGHT DUTY TRUCKS AND AUTOMOBILES INTO COMPRESSED NATURAL GAS VEHICLES (U.S. CLS. 19, 21, 23, 31, 35 AND 44).
PAUL E. FAHRENKOPF, EXAMINING ATTORNEY

SN 85-100,925. SHELL BRASIL LTDA, RIO DE JANEIRO - RJ, BRAZIL, FILED 8-5-2010.

THE MARK CONSISTS OF THE STYLIZED WORD "RAIZEN".

CLASS 1—CHEMICALS

FOR PETROLEUM ETHER FOR USE AS A SOLVENT; XYLENE FOR USE AS A SOLVENT; CHEMICAL ADDITIVES FOR FUELS, NAMELY, CARBURANTS (U.S. CLS. 1, 5, 6, 10, 26 AND 46).

CLASS 4—LUBRICANTS AND FUELS

FOR NON-CHEMICAL ADDITIVES FOR MOTOR FUEL; ALCOHOL FUEL; BENZENE FUEL; NON-CHEMICAL ADDITIVES FOR FUELS, NAMELY, CARBURANTS; VAPORIZED FUEL MIXTURES; FUEL; FUEL OIL; FUEL WITH AN ALCOHOLIC BASE; MOTOR FUEL; PETROLEUM ETHER FOR USE AS A FUEL; AUTOMOTIVE GAS OIL, NAMELY, DIESEL FUEL; GASOLINE; PETROL; LUBRICATING GREASE; INDUSTRIAL GREASE; LUBRICATING GRAPHITE; ALL PURPOSE LUBRICANTS; INDUSTRIAL LUBRICANTS; MOTOR VEHICLE LUBRICANTS; COMBUSTIBLE OIL; DIESEL OIL; INDUSTRIAL OIL; LUBRICATING OIL; MOTOR OIL; PETROLEUM; KEROSENE; XYLENE FOR USE AS A FUEL (U.S. CLS. 1, 6 AND 15).
JAMES GRIFFIN, EXAMINING ATTORNEY

SN 85-101,029. H&H ASIA LTD., TAIPEI, TAIWAN, FILED 8-5-2010.

NATURAL ELEMENTS

THE MARK CONSISTS OF STANDARD CHARACTERS WITHOUT CLAIM TO ANY PARTICULAR FONT, STYLE, SIZE, OR COLOR.

CLASS 8—HAND TOOLS

FOR WOODEN COOKING SPOONS; MORTAR AND PESTLES; WOODEN FLATWARE, NAMELY, FORKS, SPOONS AND KNIVES; CUTLERY, NAMELY, FORKS, SPOONS AND KNIVES; FORKS; SPOONS; KITCHEN KNIVES AND TABLE KNIVES; NON-ELECTRIC HAND-OPERATED FOOD CHOPPERS; NON-ELECTRIC CAN OPENERS; PIZZA CUTTERS; EGG SLICERS; NON-ELECTRIC SHRIMP DEVEINERS AND PEELERS; LOBSTER AND CRAB CRACKERS; FISH BONE TWEEZERS FOR HOUSEHOLD USE; OYSTER SHUCKERS; MANDOLINS FOR CUTTING FOOD; CHERRY AND OLIVE PITTERS; NON-ELECTRIC FRUIT AND VEGETABLE PEELERS; ZESTERS; NON-ELECTRIC KNIFE SHARPENERS; HOUSEHOLD KITCHEN UTILITY SHEARS (U.S. CLS. 23, 28 AND 44).

CLASS 21—HOUSEWARES AND GLASS

FOR WOODEN HOUSEHOLD UTENSILS, NAMELY, SPATULAS, TURNERS, POT AND PAN SCRAPERS, ROLLING PINS, KITCHEN TONGS, SERVING SPOONS, MIXING SPOONS, SLOTTED SPOONS, BASTING SPOONS, PEPPER MILLS, SALT MILLS, SALT AND PEPPER SHAKERS, SALAD SERVERS; WOKS (NON-ELECTRIC); CHOPPING BOARDS FOR KITCHEN USE; WOODEN CHOPPING BOARDS FOR KITCHEN USE; SALT AND PEPPER SHAKERS; OIL AND VINEGAR CRUETS; SALAD BOWLS; WOODEN SALAD BOWLS; HOLDERS FOR HOUSEHOLD AND KITCHEN UTENSILS, NAMELY, HOLDERS FOR SPATULAS, TURNERS, POT AND PAN SCRAPERS, ROLLING PINS, KITCHEN TONGS, SERVING SPOONS, MIXING SPOONS, SLOTTED SPOONS, BASTING SPOONS, SALAD SERVERS, AND KNIVES, BARBECUE FORKS, BARBECUE TONGS, BARBECUE TURNERS, COOKING FORKS, SERVING FORKS, PASTA SERVING FORKS, GRATERS, CHEESE GRATERS, SIEVES, WHISKS, SKIMMERS, BRUSHES FOR BASTING MEAT, COOKING SKEWERS, COOKING ROASTING FORKS, GARLIC PRESSES, KITCHEN LADLES, COFFEE SCOOPS, TEA STRAINERS, NON-ELECTRIC EGG BEATERS, FOOD BASTERS, MELON BALLERS, BARBECUE SERVING AND COOKING FORKS, MIXING, BASTING AND SERVING SPOONS, BOTTLE OPENERS, CORKSCREWS, HAND-OPERATED GRINDERS, TART SCOOPS; GLASS STORAGE JARS; COOKWARE, NAMELY, POTS AND PANS; ROASTING PANS AND FRYING PANS; BAKING DISHES; CASSEROLE DISHES; ROASTING DISHES; SERVING DISHES; BAKE WARE; COOKING POT SETS; DISPENSERS FOR PAPER TOWELS; ROLLING PINS; UTENSILS FOR BARBECUES, NAMELY, FORKS, TONGS, TURNERS; COOKING FORKS; SERVING FORKS; PASTA SERVING FORKS; COOKING UTENSILS, NAMELY, BATTER DISPENSERS, GRILLS, WIRE BASKETS, GRATERS, CHEESE GRATERS, SIEVES, SPATULAS, STRAINERS, TURNERS, POT AND PAN SCRAPERS, ROLLING PINS, WHISKS, SKIMMERS, KITCHEN TONGS, SPLATTER SCREENS, AND NON-METAL FLEXIBLE LIDS DESIGNED FOR DRAINING OR PRESSING LIQUIDS FROM A FOOD CAN; BRUSHES FOR BASTING MEAT; COOKING FUNNELS; COOKING SKEWERS; COOKING ROASTING FORKS; GARLIC PRESSES; EGG SEPARATORS; SPOON RESTS; TRIVETS; KITCHEN LADLES; COFFEE SCOOPS; TEA STRAINERS; NON-ELECTRIC EGG BEATERS; LEMON SQUEEZERS; OIL CRUETS; SALAD SPINNERS; FLOUR SIFTERS; FOOD BASTERS; MELON BALLERS; BARBECUE, SERVING AND COOKING FORKS; MIXING, BASTING AND SERVING SPOONS; CREAMER PITCHERS; BOTTLE OPENERS; BREAD BOARDS; CORKSCREWS; HAND-OPERATED GRINDERS; TART SCOOPS; SERVING SPOONS; OVEN TO TABLE RACKS; POT LIDS; POT STANDS; BUTTER PANS; GLASS PANS; DINNERWARE (U.S. CLS. 2, 13, 23, 29, 30, 33, 40 AND 50).
ODESSA BIBBINS, EXAMINING ATTORNEY

SN 85-101,034. WÜRZBURG HOLDING S.A., L-1611 LUXEMBOURG, LUXEMBOURG, FILED 8-5-2010.

WATTWASH

THE MARK CONSISTS OF STANDARD CHARACTERS WITHOUT CLAIM TO ANY PARTICULAR FONT, STYLE, SIZE, OR COLOR.

PRIORITY CLAIMED UNDER SEC. 44(D) ON ERPN CMNTY TM OFC APPLICATION NO. 009161639, FILED 6-9-2010, REG. NO. 009161639, DATED 11-25-2010, EXPIRES 6-9-2020.

CLASS 9—ELECTRICAL AND SCIENTIFIC APPARATUS

FOR EYEGLASSES, SUNGLASSES, GOGGLES FOR SPORTS, SPECTACLE FRAMES, SPECTACLE CASES (U.S. CLS. 21, 23, 26, 36 AND 38).

CLASS 18—LEATHER GOODS

FOR HANDBAGS, SHOULDER BAGS, SPORTS BAGS, ATHLETIC BAGS, BEACH BAGS, BUM BAGS, SHOPPING BAGS, NAMELY, CANVAS SHOPPING BAGS, LEATHER SHOPPING BAGS AND TEXTILE SHOPPING BAGS, SCHOOL BAGS, SHOE BAGS FOR TRAVEL, TRAVELING BAGS (U.S. CLS. 1, 2, 3, 22 AND 41).

CLASS 25—CLOTHING

FOR SHIRTS, SHORTS, SLACKS, TROUSERS, PANTS, SUITS, SWEATERS, BLAZERS, JACKETS, BELTS, BOXER SHORTS, BRIEFS, SPORTS COATS, JOGGING SUITS, GLOVES, POLO SHIRTS, RAIN COATS, ROBES, TRUNKS, T-SHIRTS, WARM-UP SUITS, WRIST BANDS, BLOUSES, SKIRTS, CULOTTES, DRESSES, GAUCHOS, HALTERS, UNDERGARMENTS, BODY STOCKINGS, PANTYHOSE, LEOTARDS AND SCARVES; FOOTWEAR; HEADWEAR, NAMELY, HATS AND CAPS (U.S. CLS. 22 AND 39).

SANJEEV VOHRA, EXAMINING ATTORNEY

SN 85-101,591. SHELL BRASIL LTDA, RIO DE JANEIRO - RJ, BRAZIL, FILED 8-5-2010.



THE MARK CONSISTS OF THE STYLIZED WORD "RAIZEN".

CLASS 35—ADVERTISING AND BUSINESS

FOR COST PRICE ANALYSIS; COMMERCIAL AND INDUSTRIAL MANAGEMENT ASSISTANCE; BUSINESS MANAGEMENT ASSISTANCE; BUSINESS APPRAISALS; PROVIDING AN ONLINE COMPUTER DATABASE IN THE FIELD OF BUSINESS AS IT RELATES TO ENERGY; PERSONNEL MANAGEMENT CONSULTANCY; BUSINESS ORGANIZATION CONSULTANCY; PROFESSIONAL BUSINESS CONSULTANCY IN THE FIELD OF IMPORT-EXPORT AGENCIES; CONDUCTING MARKETING STUDIES (U.S. CLS. 100, 101 AND 102).

CLASS 39—TRANSPORTATION AND STORAGE

FOR PROVIDING AN ONLINE COMPUTER DATABASE IN THE FIELD OF FUEL DISTRIBUTION (U.S. CLS. 100 AND 105).

CLASS 40—MATERIAL TREATMENT

FOR PROVIDING AN ONLINE COMPUTER DATABASE IN THE FIELD OF SUGAR, ALCOHOL AND ETHANOL FUEL PRODUCTION (U.S. CLS. 100, 103 AND 106).

JAMES GRIFFIN, EXAMINING ATTORNEY

SN 85-102,274. CHEATCODES.COM LLC, MAPLE VALLEY, WA. FILED 8-6-2010.

GAMERID

THE MARK CONSISTS OF STANDARD CHARACTERS WITHOUT CLAIM TO ANY PARTICULAR FONT, STYLE, SIZE, OR COLOR.

CLASS 35—ADVERTISING AND BUSINESS

FOR COMPUTER SERVICES, NAMELY, PROVIDING ON-LINE COMPUTER DATABASES AND ONLINE SEARCHABLE DATABASES FEATURING CONSUMER INFORMATION ON TOPICS OF GENERAL INTEREST TO THE CONSUMING PUBLIC IN THE FIELD OF ENTERTAINMENT, NAMELY, MOVIES, ARTS, MUSIC AND SPORTS (U.S. CLS. 100, 101 AND 102).

CLASS 38—COMMUNICATION

FOR MESSAGING SERVICES, NAMELY, THE RECEIPT, RETRIEVAL AND TRANSMISSION OF DATA, DOCUMENTS, AND MESSAGES VIA COMPUTER NETWORKS, WIRELESS NETWORKS AND GLOBAL COMMUNICATION NETWORKS; PROVIDING ON-LINE CHAT ROOMS FOR TRANSMISSION OF MESSAGES AMONG COMPUTER USERS (U.S. CLS. 100, 101 AND 104).

CLASS 41—EDUCATION AND ENTERTAINMENT

FOR ENTERTAINMENT SERVICES, NAMELY, PROVIDING ON-LINE NON-DOWNLOADABLE MOVIES, ARTS, MUSIC AND SPORTS CONTENT VIA COMPUTER NETWORKS, WIRELESS NETWORKS AND GLOBAL COMMUNICATION NETWORKS; PROVIDING ENTERTAINMENT INFORMATION OVER COMPUTER NETWORKS, WIRELESS NETWORKS AND GLOBAL COMMUNICATION NETWORKS, NAMELY, PROVIDING WEB SITES FEATURING LINKS TO NEWS REPORTS IN THE FIELD OF ENTERTAINMENT, NAMELY, MOVIES, ARTS, MUSIC AND SPORTS (U.S. CLS. 100, 101 AND 107).

CLASS 42—SCIENTIFIC AND COMPUTER SERVICES

FOR COMPUTER SERVICES, NAMELY, DISTRIBUTING USER-GENERATED CONTENT ON COMPUTER NETWORKS, WIRELESS NETWORKS AND GLOBAL COMMUNICATION NETWORKS; HOSTING THE WEB SITES OF OTHERS ON A COMPUTER SERVER FOR AN ELECTRONIC OR OPTICAL COMMUNICATIONS NETWORK; COMPUTER SERVICES, NAMELY, ACTING AS AN APPLICATION SERVICE PROVIDER IN THE FIELD OF KNOWLEDGE MANAGEMENT TO HOST COMPUTER APPLICATION SOFTWARE FOR THE COLLECTION, EDITING, ORGANIZING, MODIFYING, BOOK MARKING, TRANSMISSION, STORAGE AND SHARING OF DATA AND INFORMATION (U.S. CLS. 100 AND 101).

CLASS 45—PERSONAL AND LEGAL SERVICES

FOR ON-LINE SOCIAL NETWORKING SERVICES IN THE FIELD OF ENTERTAINMENT, NAMELY, MOVIES, ARTS, MUSIC AND SPORTS (U.S. CLS. 100 AND 101).

ANDREA HACK, EXAMINING ATTORNEY

SN 85-102,760. RED BOX HOLDINGS LIMITED, DBA RED BOX HOLDINGS LIMITED, ROAD TOWN, TORTOLA, BR.VIRGIN ISLANDS, FILED 8-9-2010.



THE COLOR(S) BLACK, GREEN, DARK GRAY, AND GRAY IS/ARE CLAIMED AS A FEATURE OF THE MARK. THE MARK CONSISTS OF A BACKGROUND IN BLACK COLOR IN RECTANGLE SHAPE OF WHICH THE TOP LEFT CORNER AND RIGHT BOTTOM CORNER ARE ROUNDED AND THE STYLIZED WORDING "SPICEFORLIFE". THE LETTERS OF THE WORD "SPICE" ARE IN GREEN COLOR, THE LETTERS OF THE WORD "FOR" ARE IN DARK GRAY COLOR, THE LETTERS OF THE WORD "LIFE" ARE IN GRAY COLOR.

CLASS 21—HOUSEWARES AND GLASS

FOR HAND-OPERATED FOOD GRINDERS; HAND-OPERATED GRINDERS; HAND-OPERATED SPICE GRINDERS; PEPPER GRINDERS (U.S. CLS. 2, 13, 23, 29, 30, 33, 40 AND 50).

CLASS 30—STAPLE FOODS

FOR BARBECUE SAUCE; BARBEQUE SAUCE; CHEESE SAUCE; CHICKEN WING SAUCE; CHILI SAUCE; CHILI SEASONING; CINNAMON POWDER; CLOVE POWDER; CONDIMENT, NAMELY, PEPPER SAUCE; COOKING POWDER, NAMELY, BACON-FLAVORED SEASONING POWDER; CURRY POWDER; DRIED CHILI PEPPERS; EDIBLE SPICES; FLAVOURINGS AND SEASONINGS; FOOD SEASONINGS; GARDEN HERBS, PRESERVED; GINGER; HERB TEA; HOT CHILI PEPPER SAUCE; HOT PEPPER POWDER; HOT SAUCE; MUSTARD POWDER; PEPPER; PEPPER POWDER; PEPPER SPICE; PIZZA SAUCE; PRESERVED GARDEN HERBS AS SEASONINGS; PROCESSED GARLIC FOR USE AS SEASONING; PROCESSED HERBES DE PROVENCE; PROCESSED HERBS; SAUCE MIXES; SEASONING MIXES; SEASONINGS; SPICE BLENDS; SPICE RUBS; SPICES; STEAK SEASONING (U.S. CL. 46).

CLASS 31—NATURAL AGRICULTURAL PRODUCTS

FOR DRIED HERBS FOR DECORATIVE WREATHS AND SACHETS; FRESH CULINARY HERBS (U.S. CLS. 1 AND 46).

KATHLEEN LORENZO, EXAMINING ATTORNEY

SN 85-102,823, BISDEE, THOMAS BENJAMIN, COLCHESTER ESSEX, ENGLAND, FILED 8-9-2010.



PRIORITY CLAIMED UNDER SEC. 44(D) ON ERPN CMNTY TM OFC APPLICATION NO. 009009762, FILED 4-7-2010, REG. NO. 009009762, DATED 9-14-2010, EXPIRES 4-7-2020.

THE COLOR(S) BLACK, YELLOW, RED, PINK, WHITE, BROWN AND BEIGE IS/ARE CLAIMED AS A FEATURE OF THE MARK.

THE MARK CONSISTS OF AN ILLUSTRATION OF A FEMALE FIGURE WITH BLACK WINGS AND BEIGE SKIN WEARING A WHITE AND PINK TANK TOP. THE WINGS ARE CONSTRUCTED FROM COLORED PAINT BRUSH STROKES OF BLACK, RED AND BEIGE. HER FACE IS OBSCURED BY A RED HEXAKAIDECAGON SHAPE WHICH CAN ALSO BE DESCRIBED AS A RED CIRCLE WITH ZIGZAG EDGES. IN HER HANDS SHE IS HOLDING A WHITE, BLACK, AND BROWN SQUARE RECORD SLEEVE COVER AND SHE IS PULLING A CIRCULAR BLACK DISC FROM THE COVER. A STYLISED PINK AND WHITE LETTER "B" IS SUPERIMPOSED OVER THE RECORD COVER. THE FIGURE IS SITTING ON A YELLOW AND WHITE OVAL WITH BROWN, BLACK, PINK AND WHITE BRUSH STROKES OUTLINING THE OVAL. THE BLACK WORDING "KISSY SELL OUT" IS SUPERIMPOSED OVER THE OVAL.

CLASS 9—ELECTRICAL AND SCIENTIFIC APPARATUS

FOR PRE-RECORDED VIDEO DISCS, DIGITAL AUDIO AND VIDEO TAPES, PHONOGRAPH RECORDS, CDS, AUDIO AND VIDEO CASSETTES, DVDS AND DATA CARRIERS FEATURING MUSIC, MUSICAL PERFORMANCES, PERFORMANCES BY A DISC JOCKEY; BLANK MAGNETIC, OPTICAL AND FLOPPY DISCS AND TAPES FOR THE RECORDING OF SOUND AND IMAGES; APPARATUS FOR RECORDING, TRANSMISSION OR REPRODUCTION OF SOUND OR IMAGES; MUSIC AND VIDEO RECORDINGS DOWNLOADABLE FROM THE INTERNET OR FROM WEBSITES (U.S. CLS. 21, 23, 26, 36 AND 38).

CLASS 25—CLOTHING

FOR ARTICLES OF CLOTHING FOR MEN, WOMEN AND CHILDREN, NAMELY, HEADWEAR, FOOTWEAR, SHIRTS AND T-SHIRTS, SWEATSHIRTS, JACKETS, JOGGING TOPS, CASUAL TROUSERS, JOGGING BOTTOMS AND PANTS, BASEBALL CAPS, SCARVES, GLOVES, FLEECE BOTTOMS, FLEECE PULLOVERS, FLEECE TOPS AND FLEECE VESTS (U.S. CLS. 22 AND 39).

CLASS 41—EDUCATION AND ENTERTAINMENT

FOR ENTERTAINMENT SERVICES, NAMELY, LIVE MUSICAL PERFORMANCES, DRAMATIC THEATRE PRODUCTIONS, ON-GOING RADIO AND TELEVISION PROGRAMS IN THE FIELD OF MUSIC; LIVE PERFORMANCES IN THE NATURE OF DISC JOCKEYS FOR PARTIES AND SPECIAL EVENTS; ENTERTAINMENT MEDIA PRODUCTION SERVICES FOR LIVE MUSICAL PERFORMANCES, TELEVISION AND RADIO PROGRAMS, AUDIO RECORDINGS, VIDEO RECORDINGS AND CINEMATOGRAPHIC FILMS; AUDIO AND VIDEO RECORDING SERVICES (U.S. CLS. 100, 101 AND 107).

MARTHA FROMM, EXAMINING ATTORNEY

SN 85-102,835, REED EXHIBITIONS DEUTSCHLAND GMBH, DUSSELDORF, FED REP GERMANY, FILED 8-9-2010.



THE MARK CONSISTS OF THE WORD "FIBO" IN STYLIZED LETTERING WITH THE WORD "POWER" APPEARING WITHIN A SLANTED RECTANGLE TO THE RIGHT.

CLASS 35—ADVERTISING AND BUSINESS

FOR ADVERTISING AND PROMOTIONAL SERVICES; TRADE INFORMATION; PROVIDING AN ONLINE COMPUTER DATABASE FEATURING TRADE INFORMATION IN THE FIELD OF PHYSICAL FITNESS; ARRANGING AND CONDUCTING OF TRADE SHOWS IN THE FIELDS OF PHYSICAL FITNESS EDUCATION, SPORTS ENTERTAINMENT, SPORTS, BODYBUILDING AND WEIGHT TRAINING; EMPLOYMENT RECRUITING (U.S. CLS. 100, 101 AND 102).

CLASS 41—EDUCATION AND ENTERTAINMENT

FOR PUBLISHING OF ELECTRONIC PUBLICATIONS; EDUCATIONAL SERVICES, NAMELY, CONDUCTING SEMINARS, CONFERENCES, AND WORKSHOPS IN THE FIELDS OF SPORTS ENTERTAINMENT, SPORTS, BODYBUILDING AND WEIGHT TRAINING; ORGANIZATION OF EXHIBITIONS FOR CULTURAL OR EDUCATIONAL PURPOSES IN THE FIELDS OF SPORTS, BODYBUILDING AND WEIGHT TRAINING; EDUCATIONAL SERVICES, NAMELY, CONDUCTING CLASSES AND SEMINARS IN THE FIELD OF COMPUTER-AIDED INFORMATION RETRIEVAL; PROVIDING INFORMATION IN THE FIELDS OF EDUCATION, ENTERTAINMENT, AND SPORTS; EDUCATION AND ENTERTAINMENT SERVICES, NAMELY, PRODUCTION AND DISTRIBUTION OF ONGOING TELEVISION AND RADIO PROGRAMS IN THE FIELD OF SPORTS, BODYBUILDING, AND WEIGHT TRAINING; RADIO AND TELEVISION PROGRAM SYNDICATION; RADIO AND TELEVISION SHOW PRODUCTION; RENTAL OF VIDEO TAPES AND MOTION PICTURES (U.S. CLS. 100, 101 AND 107).

JIM RINGLE, EXAMINING ATTORNEY

SN 85-102,880. TRADE ONLY LIMITED, MIDDLETON, MANCHESTER, UNITED KINGDOM, FILED 8-9-2010.



NO CLAIM IS MADE TO THE EXCLUSIVE RIGHT TO USE "TRADE ONLY", APART FROM THE MARK AS SHOWN.

THE COLOR(S) LIGHT BLUE, MEDIUM BLUE, DARK BLUE, BLACK AND WHITE IS/ARE CLAIMED AS A FEATURE OF THE MARK.

THE MARK CONSISTS OF THE WORDS "TRADE ONLY" WITH THE WORD "TRADE" IN WHITE AND LIGHT BLUE AND THE WORD "ONLY" IN DARK BLUE AND BLACK. THE WORD "TRADE" IS INSIDE TWO OVALS. ONE OVAL IS INSIDE THE OTHER WITH THE WORD "TRADE" BISECTING THE OVALS. THE INNER OVAL IS WHITE WHICH GRADUATES TO MEDIUM BLUE WITH THE TOP HALF OF THE WORD "TRADE" IN WHITE. THE OUTER OVAL IS DARK BLUE WITH THE BOTTOM HALF OF THE WORD "TRADE" IN LIGHT BLUE. THE WORD "ONLY" IS INSIDE A RECTANGLE WHICH HAS A BORDER THAT GRADUATES FROM LIGHT BLUE TO DARK BLUE. THE INSIDE OF THE RECTANGLE GRADUATES FROM WHITE TO LIGHT BLUE.

CLASS 9—ELECTRICAL AND SCIENTIFIC APPARATUS

FOR COMPUTER HARDWARE; COMPUTER SOFTWARE FOR CARRYING OUT VIRTUAL SAMPLING, PRODUCT SEARCHING, PRODUCT SOURCING AND PLACING ORDERS; COMPUTER PERIPHERALS; DOWNLOADABLE ELECTRONIC PUBLICATIONS, NAMELY, NEWSLETTERS, MAGAZINES, BROCHURES AND CATALOGUES IN THE FIELD OF PROMOTIONAL PRODUCTS; RECORDED DISCS, DVDS, CD ROMS FEATURING INFORMATION ABOUT PROMOTIONAL PRODUCTS AND THE CARRYING OUT OF VIRTUAL SAMPLING, PRODUCT SEARCHING, PRODUCT SOURCING AND PLACING ORDERS; APPARATUS FOR RECORDING, TRANSMISSION OR REPRODUCTION OF SOUND OR IMAGES, NAMELY, DVD AND CD ROM RECORDING APPARATUS; BLANK MAGNETIC DATA CARRIERS (U.S. CLS. 21, 23, 26, 36 AND 38).

CLASS 42—SCIENTIFIC AND COMPUTER SERVICES

FOR ADVISORY SERVICES AND CONSULTANCY RELATING TO COMPUTER SOFTWARE; COMPUTER SOFTWARE DESIGN, DEVELOPMENT, CONFIGURATION, MAINTENANCE, SUPPORT, INSTALLATION AND UPDATING; TECHNICAL SUPPORT SERVICES, NAMELY, TROUBLESHOOTING OF COMPUTER SOFTWARE PROBLEMS; CREATING WEBSITES FOR OTHERS AND UPLOADING IT ONTO AN INTERNET SERVER; PROVIDING INFORMATION ABOUT COMPUTER SOFTWARE, COMPUTER HARDWARE AND COMPUTER PERIPHERALS VIA THE INTERNET; PROVIDING INFORMATION ABOUT COMPUTER WIRELESS NETWORKS AND COMPUTER GLOBAL COMMUNICATIONS NETWORKS; COMPUTER TECHNOLOGY SUPPORT SERVICES, NAMELY, HELP DESK SERVICES; PLANNING, DESIGN, DEVELOPMENT, MAINTENANCE AND OPTIMIZATION OF ONLINE WEBSITES FOR THIRD PARTIES (U.S. CLS. 100 AND 101).

DAWN FELDMAN, EXAMINING ATTORNEY

SN 85-102,930. BALFOUR BEATTY PLC, LONDON, ENGLAND, FILED 8-9-2010.

BULLET CELLS

NO CLAIM IS MADE TO THE EXCLUSIVE RIGHT TO USE "CELLS", APART FROM THE MARK AS SHOWN.

THE MARK CONSISTS OF THE WORDS "BULLET CELLS" IN A STYLIZED FONT APPEARING ABOVE A DISCHARGED BULLET WITH STREAK DESIGN.

CLASS 6—METAL GOODS

FOR MODULAR BUILDING STRUCTURES OF METAL; MODULAR PREFABRICATED BUILDING UNITS OF METALLIC MATERIALS FOR THE CONSTRUCTION OF BUILDINGS, NAMELY, PRISON CELLS AND PRISONS (U.S. CLS. 2, 12, 13, 14, 23, 25 AND 50).

CLASS 19—NON-METALLIC BUILDING MATERIALS

FOR MODULAR NON-METALLIC BUILDING STRUCTURES; MODULAR PREFABRICATED BUILDING UNITS OF NON-METALLIC MATERIALS FOR THE CONSTRUCTION OF BUILDINGS, NAMELY, PRISON CELLS AND PRISONS (U.S. CLS. 1, 12, 33 AND 50).

CLASS 37—CONSTRUCTION AND REPAIR

FOR CONSTRUCTION OF MODULAR BUILDINGS, NAMELY, PRISON CELLS AND PRISONS; REPAIR AND MAINTENANCE OF BUILDINGS, NAMELY, PRISON CELLS AND PRISONS; INFORMATION, CONSULTANCY AND ADVISORY SERVICES RELATING TO THE AFORESAID SERVICES (U.S. CLS. 100, 103 AND 106).

CLASS 42—SCIENTIFIC AND COMPUTER SERVICES

FOR DESIGN SERVICES RELATING TO THE CONSTRUCTION OF MODULAR BUILDINGS, NAMELY, PRISON CELLS AND PRISONS; PREPARATION OF TECHNICAL REPORTS RELATING TO MODULAR BUILDING DESIGN, NAMELY, PRISON CELLS AND PRISONS (U.S. CLS. 100 AND 101).

GISELLE AGOSTO, EXAMINING ATTORNEY

SN 85-102,989. ADVANCED MATERIALS AND MANUFACTURING TECHNOLOGIES, LLC, GRANITE BAY, CA. FILED 8-9-2010.



NO CLAIM IS MADE TO THE EXCLUSIVE RIGHT TO USE "ADVANCED MATERIALS" AND "MANUFACTURING TECHNOLOGIES", APART FROM THE MARK AS SHOWN.

THE MARK CONSISTS OF CAPITAL ITALICIZED AND BOLDLED LETTERS "A M T" WITH THE LETTER "M" EXTENDING ABOVE THE "A" THE "T" AND CONTAINING THE NUMERAL "2" SUPERIMPOSED WITHIN THE RIGHT TOP MARGIN; A SERIES OF THREE SPACED TAPERED STRIPES EXTENDING IN FRONT OF AND BEHIND THE LETTER "M" GIVING THE APPEARANCE OF SHADING

AND PERSPECTIVE ALONG A GENERALLY FLAT HORIZON; THE WORDS "ADVANCED", "MATERIALS & MANUFACTURING" AND "TECHNOLOGIES" SEPARATELY LISTED ADJACENT TO THE LETTER "T" WITH THE WORDS "MATERIALS & MANUFACTURING" BOLDED; THE PHRASE "MATERIALS, SCIENCE AND ENGINEERING FOR THE 21ST CENTURY. . . AND BEYOND" APPEARING IN A SINGLE LINE BENEATH BOTH THE LETTERS AND THE WORDS, SAID LINE PARTLY SUPERIMPOSED OVER THE STRIPES.

CLASS 35—ADVERTISING AND BUSINESS

FOR BUSINESS COLLABORATION SERVICES, NAMELY, PROVIDING FACILITATION IN THE DEVELOPMENT OF METAL MATRIX COMPOSITES FOR AEROSPACE, DEFENSE, OIL AND GAS EXPLORATION, AUTOMOTIVE, MOTORCYCLE, MINING, CONSTRUCTION, MEDICAL, RECREATION, SPORTING GOODS, AND ELECTRONIC APPLICATIONS (U.S. CLS. 100, 101 AND 102).

FIRST USE 8-0-2009; IN COMMERCE 8-0-2009.

CLASS 40—MATERIAL TREATMENT

FOR MANUFACTURING SERVICES FOR OTHERS IN THE FIELD OF METAL MATRIX COMPOSITES FOR AEROSPACE, DEFENSE, OIL AND GAS EXPLORATION, AUTOMOTIVE, MOTORCYCLE, MINING, CONSTRUCTION, MEDICAL, RECREATION, SPORTING GOODS, AND ELECTRONIC APPLICATIONS (U.S. CLS. 100, 103 AND 106).

FIRST USE 8-0-2009; IN COMMERCE 8-0-2009.

CLASS 42—SCIENTIFIC AND COMPUTER SERVICES

FOR ENGINEERING, DESIGN, RESEARCH, DEVELOPMENT AND TESTING SERVICES IN THE FIELD OF METAL MATRIX COMPOSITES FOR AEROSPACE, DEFENSE, OIL AND GAS EXPLORATION, AUTOMOTIVE, MOTORCYCLE, MINING, CONSTRUCTION, MEDICAL, RECREATION, SPORTING GOODS, AND ELECTRONIC APPLICATIONS; CONSULTING SERVICES IN THE FIELDS OF MATERIALS SCIENCE AND MANUFACTURING TECHNOLOGIES (U.S. CLS. 100 AND 101).

FIRST USE 8-0-2009; IN COMMERCE 8-0-2009.
INGA ERVIN, EXAMINING ATTORNEY

SN 85-102,994. INTERNATIONAL CASH EXCHANGE CARD LLC, NORTHBROOK, IL. FILED 8-9-2010.

FUEGO

THE MARK CONSISTS OF STANDARD CHARACTERS WITHOUT CLAIM TO ANY PARTICULAR FONT, STYLE, SIZE, OR COLOR.

THE ENGLISH TRANSLATION OF "FUEGO" IN THE MARK IS "FIRE".

CLASS 9—ELECTRICAL AND SCIENTIFIC APPARATUS

FOR MAGNETICALLY ENCODED DEBIT AND CREDIT CARDS (U.S. CLS. 21, 23, 26, 36 AND 38).

CLASS 36—INSURANCE AND FINANCIAL

FOR CREDIT CARD AND DEBIT CARD SERVICES; PAYMENT PROCESSING SERVICES, NAMELY, CREDIT CARD AND DEBIT CARD TRANSACTION PROCESSING SERVICES (U.S. CLS. 100, 101 AND 102).

FLORENTINA BLANDU, EXAMINING ATTORNEY

SN 85-103,212. WILLIAMSON INDUSTRIES, INC., MONROE, LA. FILED 8-9-2010.

LUMPERLINK

THE MARK CONSISTS OF STANDARD CHARACTERS WITHOUT CLAIM TO ANY PARTICULAR FONT, STYLE, SIZE, OR COLOR.

CLASS 35—ADVERTISING AND BUSINESS

FOR OPERATING AND ASSISTING IN THE OPERATION OF A DISTRIBUTION CENTER OR WAREHOUSE FACILITY, FEATURING MANAGEMENT OF RETURNED MERCHANDISE AND ORDER FULFILLMENT SERVICES, CONTAINER INVENTORY CONTROL AND MANAGEMENT, NAMELY, TOTE REPLENISHMENT, PALLET SORTING AND TRAILER-STRIPPING, BUSINESS AUDITING OF SHIPMENT ACCURACY, AND DATA COLLECTION AND MANAGEMENT FOR USE IN THE FIELD OF DISTRIBUTION CENTER AND WAREHOUSE FACILITY MANAGEMENT; BUSINESS CONSULTING AND MANAGEMENT SERVICES RELATING TO THE OPERATION OF A DISTRIBUTION CENTER OR WAREHOUSE AND SUPPLY CHAIN PROCESSES; EMPLOYMENT HIRING, RECRUITING, PLACEMENT AND STAFFING SERVICES (U.S. CLS. 100, 101 AND 102).

CLASS 39—TRANSPORTATION AND STORAGE

FOR LOADING AND UNLOADING CARGO (U.S. CLS. 100 AND 105).

BARBARA BROWN, EXAMINING ATTORNEY

SN 85-103,466. VIRTACORE SYSTEMS, INC., ASHBURN, VA. FILED 8-9-2010.

VIRTACORE

THE MARK CONSISTS OF STANDARD CHARACTERS WITHOUT CLAIM TO ANY PARTICULAR FONT, STYLE, SIZE, OR COLOR.

CLASS 9—ELECTRICAL AND SCIENTIFIC APPARATUS

FOR COMPUTER HARDWARE AND SOFTWARE FOR CLOUD COMPUTING, NAMELY, FOR PROVIDING AND MANAGING REMOTE SERVERS AND REMOTE INFRASTRUCTURE, NETWORKING AND DATA STORAGE SYSTEMS; COMPUTER SOFTWARE FOR MANAGING, TESTING, AND USING MULTIPLE OPERATING SYSTEMS, VIRTUALIZATION PLATFORMS AND COMPUTER NETWORK ENVIRONMENTS; COMPUTER SOFTWARE FOR PROVIDING AND MANAGING VIRTUAL INFRASTRUCTURE, NETWORKING, AND DATA STORAGE SYSTEMS ACROSS MULTIPLE OPERATING SYSTEMS, VIRTUALIZATION PLATFORMS AND COMPUTER NETWORK ENVIRONMENTS (U.S. CLS. 21, 23, 26, 36 AND 38).

CLASS 37—CONSTRUCTION AND REPAIR

FOR MAINTENANCE OF COMPUTER HARDWARE FOR CLOUD COMPUTING (U.S. CLS. 100, 103 AND 106).

CLASS 41—EDUCATION AND ENTERTAINMENT

FOR EDUCATION SERVICES, NAMELY, SEMINARS AND WEBINARS ON THE IMPLEMENTATION, USE AND MANAGEMENT OF CLOUD COMPUTING SYSTEMS AND VIRTUALIZED SERVERS, STORAGE AND APPLICATIONS (U.S. CLS. 100, 101 AND 107).

CLASS 42—SCIENTIFIC AND COMPUTER SERVICES

FOR COMPUTER SERVICES, NAMELY, REMOTE AND ON-SITE MANAGEMENT OF CLOUD COMPUTING SYSTEMS, DATA MANAGEMENT SERVICES AND APPLICATIONS FOR OTHERS; CONSULTING SERVICES IN THE FIELD OF CLOUD COMPUTING; TECHNICAL CONSULTING SERVICES IN THE FIELDS OF DATACENTER ARCHITECTURE, PUBLIC AND PRIVATE CLOUD COMPUTING SOLUTIONS, AND EVALUATION AND IMPLEMENTATION OF INTERNET TECHNOLOGY AND SERVICES; TECHNICAL SUPPORT SERVICES, NAMELY, REMOTE AND ON-SITE INFRASTRUCTURE MANAGEMENT SERVICES FOR MONITORING, ADMINISTRATION AND MANAGEMENT OF CLOUD COMPUTING INFORMATION TECHNOLOGY AND APPLICATION SYSTEMS; DESIGN, DEVELOPMENT AND MAINTENANCE OF REMOTE SERVERS AND REMOTE INFRASTRUCTURE, NETWORKING AND DATA STORAGE SYSTEMS FOR PUBLIC, PRIVATE AND HYBRID ENVIRONMENTS; DESIGN AND DEVELOPMENT OF COMPUTER HARDWARE AND SOFTWARE FOR CLOUD COMPUTING (U.S. CLS. 100 AND 101).

KAREN K. BUSH, EXAMINING ATTORNEY

SN 85-103,641. INTELLIGENT OPTICAL SYSTEMS, INC., TORRANCE, CA. FILED 8-9-2010.



OWNER OF U.S. REG. NOS. 2,461,555 AND 3,251,403.

THE MARK CONSISTS OF AN UNDULATING ARROW ENTERING A SPLIT MEMBER, WHICH IN TURN, HAS LEAD LINES TO EACH OF FIVE CIRCLES TOGETHER WITH THE LETTERS "IOS".

CLASS 9—ELECTRICAL AND SCIENTIFIC APPARATUS

FOR LASER ULTRASONIC SYSTEMS AND DEVICES COMPRISED OF ULTRASOUND SOURCE LASER, ULTRASOUND DETECTION LASER, INTERFEROMETER, POSITIONING APPARATUS, SYSTEM CONTROLLER, DATA RECORDER; OPTICAL FIBER CHEMICAL DETECTION SYSTEMS AND DEVICES COMPRISED OF CHEMICAL SENSOR OPTICAL SIGNAL SOURCE, OPTICAL SIGNAL DETECTOR, OPTICAL TO ELECTRICAL SIGNAL CONVERTER, DATA PROCESSOR, OUTPUT APPARATUS, ALARM; FLASHING LIGHT INCAPACITATING DEVICE (U.S. CLS. 21, 23, 26, 36 AND 38).

FIRST USE 4-30-2010; IN COMMERCE 4-30-2010.

CLASS 42—SCIENTIFIC AND COMPUTER SERVICES

FOR PRODUCT RESEARCH AND DEVELOPMENT AND RESEARCH AND DEVELOPMENT OF NEW PRODUCTS FOR OTHERS (U.S. CLS. 100 AND 101).

FIRST USE 3-31-2009; IN COMMERCE 3-31-2009.

MIDGE BUTLER, EXAMINING ATTORNEY

SN 85-103,509. CMT MATERIALS, INC., ATTLEBORO, MA. FILED 8-9-2010.

HYVAC

THE MARK CONSISTS OF STANDARD CHARACTERS WITHOUT CLAIM TO ANY PARTICULAR FONT, STYLE, SIZE, OR COLOR.

CLASS 1—CHEMICALS

FOR KITS CONSISTING OF UNPROCESSED EPOXY RESINS, CATALYSTS AND SPHERES FOR MAKING SYNTACTIC FOAM VACUUM FIXTURE MATERIALS (U.S. CLS. 1, 5, 6, 10, 26 AND 46).

FIRST USE 9-1-2008; IN COMMERCE 9-1-2008.

CLASS 7—MACHINERY

FOR SYNTACTIC FOAM VACUUM FIXTURES FOR USE ON MACHINES FOR USE IN GENERAL INDUSTRIAL AND MANUFACTURING (U.S. CLS. 13, 19, 21, 23, 31, 34 AND 35).

FIRST USE 9-1-2008; IN COMMERCE 9-1-2008.

MARGERY A. TIERNEY, EXAMINING ATTORNEY

SN 85-103,687. ALL IN LEARNING, INC., DENTON, TX. FILED 8-10-2010.



NO CLAIM IS MADE TO THE EXCLUSIVE RIGHT TO USE "LEARNING", APART FROM THE MARK AS SHOWN.

THE MARK CONSISTS OF 4 SMALL CIRCLES TOUCHING OR INTERSECTING AND INSIDE A LARGER CIRCLE. THE WORDING "ALL IN LEARNING" APPEARS TO THE RIGHT OF THE DESIGN.

CLASS 41—EDUCATION AND ENTERTAINMENT

FOR EDUCATIONAL SERVICES, NAMELY, PROVIDING LIVE TRAINING TO K-12 AND COLLEGE-LEVEL EDUCATORS, USING SPECIFIC LEARNING THEORIES, FOR USE IN EVALUATING STUDENT PERFORMANCE AND ASSISTING IN INSTRUCTIONAL COURSE WORK, AND DISTRIBUTING CONTENT AND COURSE MATERIALS IN CONNECTION THEREWITH (U.S. CLS. 100, 101 AND 107).

FIRST USE 11-1-2009; IN COMMERCE 11-1-2009.

CLASS 42—SCIENTIFIC AND COMPUTER SERVICES

FOR PROVIDING TEMPORARY USE OF ON-LINE NON-DOWNLOADABLE SOFTWARE FOR USE BY K-12 AND COLLEGE-LEVEL EDUCATORS IN EVALUATING STUDENT PERFORMANCE AND ASSISTING IN INSTRUCTIONAL COURSE WORK (U.S. CLS. 100 AND 101).

FIRST USE 11-1-2009; IN COMMERCE 11-1-2009.
WILLIAM BRECKENFELD, EXAMINING ATTORNEY

SN 85-103,904. HYDROGEN-XT, INC., PEARLAND, TX.
FILED 8-10-2010.

POMEGRANET

THE MARK CONSISTS OF STANDARD CHARACTERS WITHOUT CLAIM TO ANY PARTICULAR FONT, STYLE, SIZE, OR COLOR.

CLASS 9—ELECTRICAL AND SCIENTIFIC APPARATUS

FOR FUEL COMMUNICATION SYSTEMS FOR HYDROGEN-BASED FUEL DISTRIBUTION, COMPRISED OF COMPUTER HARDWARE AND SOFTWARE (U.S. CLS. 21, 23, 26, 36 AND 38).

CLASS 35—ADVERTISING AND BUSINESS

FOR BUSINESS SERVICES, NAMELY, THE OPERATION AND ADMINISTRATION OF FUEL COMMUNICATION SYSTEMS FOR HYDROGEN-BASED FUEL DISTRIBUTION EQUIPMENT AND FACILITIES FOR OTHERS (U.S. CLS. 100, 101 AND 102).

CLASS 42—SCIENTIFIC AND COMPUTER SERVICES

FOR DEVELOPMENT OF ELECTRONIC FUEL COMMUNICATION SYSTEMS FOR OTHERS USED IN HYDROGEN-BASED FUEL DISTRIBUTION COMPRISED OF COMPUTER HARDWARE, SOFTWARE, MODEMS AND COMMUNICATION CABLES (U.S. CLS. 100 AND 101).

PAULA MAHONEY, EXAMINING ATTORNEY

SN 85-104,137. GREENFIX AMERICA, LLC, BRAWLEY, CA.
FILED 8-10-2010.

GREENFIX

THE MARK CONSISTS OF STANDARD CHARACTERS WITHOUT CLAIM TO ANY PARTICULAR FONT, STYLE, SIZE, OR COLOR.

OWNER OF U.S. REG. NOS. 2,381,366 AND 2,481,503.

CLASS 1—CHEMICALS

FOR POLYMER COMPOSITIONS APPLIED TO SOIL AND TURF TO ATTRACT, STORE, CONSERVE, AND PROVIDE MOISTURE IN AND TO SOIL, TURF, CUTTINGS AND SEEDLINGS, TO PREVENT WATER, MOISTURE AND NUTRIENT RUN-OFF, LEACHING AND LOSS, TO REDUCE WATER CONSUMPTION, TO REDUCE IRRIGATION REQUIREMENTS, TO PROMOTE HEALTHY ROOT DEVELOPMENT AND FASTER SEED GERMINATION, AND TO REDUCE EVAPOTRANSPIRATION; FIRE RETARDANT AND FIRE SUPPRESSION COMPOSITIONS FOR AGRICULTURAL USE; FIRE RETARDANT AND FIRE SUPPRESSION COMPOSITIONS USED IN EROSION CONTROL BLANKETS, AERIAL AGRICULTURAL APPLICATIONS, GROUND MECHANICAL HYDRO-SEEDING (MULCHING) APPLICATIONS AND AGRICULTURAL FIRE PROOFING APPLICATIONS (U.S. CLS. 1, 5, 6, 10, 26 AND 46).

CLASS 4—LUBRICANTS AND FUELS

FOR AGRICULTURAL PLANT FIBER FOR USE IN BIO-FUELS (U.S. CLS. 1, 6 AND 15).

CLASS 5—PHARMACEUTICALS

FOR AGRICULTURAL PLANT FIBER FOR USE IN ANIMAL FEED (U.S. CLS. 6, 18, 44, 46, 51 AND 52).

CLASS 19—NON-METALLIC BUILDING MATERIALS

FOR AGRICULTURAL PRODUCTS, NAMELY, EROSION CONTROL BLANKETS; GRASS SEEDS; AGRICULTURAL PLANT FIBER FOR USE IN EROSION CONTROL BLANKETS (U.S. CLS. 1, 12, 33 AND 50).

LESLEY LAMOTHE, EXAMINING ATTORNEY

SN 85-104,243. THWAPR, INC., NEW YORK, NY. FILED 8-10-2010.

SHARE TO PHONE

THE MARK CONSISTS OF STANDARD CHARACTERS WITHOUT CLAIM TO ANY PARTICULAR FONT, STYLE, SIZE, OR COLOR.

CLASS 38—COMMUNICATION

FOR TRANSMITTING THIRD PARTY OR USER-CREATED AUDIO AND VIDEO CONTENT AND IMAGES VIA WIRELESS COMMUNICATION DEVICES AND THE GLOBAL COMPUTER NETWORK TO INDIVIDUAL USERS OR GROUPS OF USERS; BROADCASTING IMAGES AND VIDEO CONTENT TO INDIVIDUAL USERS OR GROUPS OF USERS VIA THE INTERNET UTILIZING WIRELESS COMMUNICATION DEVICES (U.S. CLS. 100, 101 AND 104).

CLASS 42—SCIENTIFIC AND COMPUTER SERVICES

FOR PLATFORM AS A SERVICE (PAAS) FEATURING COMPUTER SOFTWARE PLATFORMS THAT ALLOW USERS TO VIEW THIRD PARTY AND USER-CREATED VIDEOS AND IMAGES THAT CAN BE SENT TO INDIVIDUAL USERS OR GROUPS OF USERS VIA WIRED AND WIRELESS NETWORKS (U.S. CLS. 100 AND 101).

CLASS 45—PERSONAL AND LEGAL SERVICES

FOR ELECTRONIC SOCIAL NETWORKING SERVICES (U.S. CLS. 100 AND 101).
BARBARA GAYNOR, EXAMINING ATTORNEY

SN 85-104,248. HARQEN LLC, MILWAUKEE, WI. FILED 8-10-2010.

VOICE ADVANTAGE

THE MARK CONSISTS OF STANDARD CHARACTERS WITHOUT CLAIM TO ANY PARTICULAR FONT, STYLE, SIZE, OR COLOR.

NO CLAIM IS MADE TO THE EXCLUSIVE RIGHT TO USE "VOICE", APART FROM THE MARK AS SHOWN.

CLASS 35—ADVERTISING AND BUSINESS

FOR AUDIO ASSET MANAGEMENT, NAMELY, MANAGEMENT OF DATABASES CONTAINING AUDIO DATA (U.S. CLS. 100, 101 AND 102).

CLASS 38—COMMUNICATION

FOR TRANSMISSION OF AUDIO DATA VIA A GLOBAL COMPUTER NETWORK OR THE INTERNET (U.S. CLS. 100, 101 AND 104).

CLASS 39—TRANSPORTATION AND STORAGE

FOR AUDIO ASSET MANAGEMENT, NAMELY, STORAGE OF ELECTRONIC MEDIA IN THE NATURE OF AUDIO DATA; AUDIO ASSET MANAGEMENT, NAMELY, STORAGE SERVICES FOR ARCHIVING ELECTRONIC AUDIO DATA (U.S. CLS. 100 AND 105).
EVELYN BRADLEY, EXAMINING ATTORNEY

SN 85-104,274. THWAPR, INC., NEW YORK, NY. FILED 8-10-2010.



THE MARK CONSISTS OF THE WORDS "SHARE TO PHONE" ON A FOUR-SIDED BACKGROUND WITH AN IMAGE OF AN ELECTRONIC DEVICE TO THE LEFT OF THE WORDING.

CLASS 38—COMMUNICATION

FOR TRANSMITTING THIRD PARTY OR USER-CREATED AUDIO AND VIDEO CONTENT AND IMAGES VIA WIRELESS COMMUNICATION DEVICES AND THE GLOBAL COMPUTER NETWORK TO INDIVIDUAL USERS OR GROUPS OF USERS; BROADCASTING IMAGES AND VIDEO CONTENT TO INDIVIDUAL USERS OR GROUPS OF USERS VIA THE INTERNET UTILIZING WIRELESS COMMUNICATION DEVICES (U.S. CLS. 100, 101 AND 104).

CLASS 42—SCIENTIFIC AND COMPUTER SERVICES

FOR PLATFORM AS A SERVICE (PAAS) FEATURING COMPUTER SOFTWARE PLATFORMS THAT ALLOW USERS TO VIEW THIRD PARTY AND USER-CREATED VIDEOS AND IMAGES THAT CAN BE SENT TO INDIVIDUAL USERS OR GROUPS OF USERS VIA WIRED AND WIRELESS NETWORKS (U.S. CLS. 100 AND 101).

CLASS 45—PERSONAL AND LEGAL SERVICES

FOR ELECTRONIC SOCIAL NETWORKING SERVICES (U.S. CLS. 100 AND 101).
BARBARA GAYNOR, EXAMINING ATTORNEY

SN 85-104,287. THWAPR, INC., NEW YORK, NY. FILED 8-10-2010.

SHARE TO PHONE...MOBILIZE AND MONETIZE

THE MARK CONSISTS OF STANDARD CHARACTERS WITHOUT CLAIM TO ANY PARTICULAR FONT, STYLE, SIZE, OR COLOR.

CLASS 38—COMMUNICATION

FOR TRANSMITTING THIRD PARTY OR USER-CREATED AUDIO AND VIDEO CONTENT AND IMAGES VIA WIRELESS COMMUNICATION DEVICES AND THE GLOBAL COMPUTER NETWORK TO INDIVIDUAL USERS OR GROUPS OF USERS; BROADCASTING IMAGES AND VIDEO CONTENT TO INDIVIDUAL USERS OR GROUPS OF USERS VIA THE INTERNET UTILIZING WIRELESS COMMUNICATION DEVICES (U.S. CLS. 100, 101 AND 104).

CLASS 42—SCIENTIFIC AND COMPUTER SERVICES

FOR PLATFORM AS A SERVICE (PAAS) FEATURING COMPUTER SOFTWARE PLATFORMS THAT ALLOW USERS TO VIEW THIRD PARTY AND USER-CREATED VIDEOS AND IMAGES THAT CAN BE SENT TO INDIVIDUAL USERS OR GROUPS OF USERS VIA WIRED AND WIRELESS NETWORKS (U.S. CLS. 100 AND 101).

CLASS 45—PERSONAL AND LEGAL SERVICES

FOR ELECTRONIC SOCIAL NETWORKING SERVICES (U.S. CLS. 100 AND 101).
BARBARA GAYNOR, EXAMINING ATTORNEY

SN 85-104,332. LZ DELTA, LLC, SCOTTSDALE, AZ. FILED 8-10-2010.

GO AZ Motorcycles

THE MARK CONSISTS OF STANDARD CHARACTERS WITHOUT CLAIM TO ANY PARTICULAR FONT, STYLE, SIZE, OR COLOR.

OWNER OF U.S. REG. NOS. 3,705,270 AND 3,714,745.

NO CLAIM IS MADE TO THE EXCLUSIVE RIGHT TO USE "AZ MOTORCYCLES", APART FROM THE MARK AS SHOWN.

CLASS 25—CLOTHING

FOR MOTORCYCLE GLOVES; CLOTHING, NAMELY, T-SHIRTS, POLO SHIRTS, SWEATERS, SWEATSHIRTS, SOCKS, SHOES, CAPS, BELTS, PANTS, JERSEYS AND SHORTS (U.S. CLS. 22 AND 39).

FIRST USE 6-26-2008; IN COMMERCE 6-26-2008.

CLASS 37—CONSTRUCTION AND REPAIR

FOR AUTOMOTIVE MAINTENANCE AND REPAIR; MOTORCYCLE CUSTOMIZATION SERVICES (U.S. CLS. 100, 103 AND 106).

FIRST USE 6-26-2008; IN COMMERCE 6-26-2008.

CLASS 39—TRANSPORTATION AND STORAGE

FOR MOTORCYCLE RENTAL (U.S. CLS. 100 AND 105).

FIRST USE 6-28-2008; IN COMMERCE 6-28-2008.

MARY BOAGNI, EXAMINING ATTORNEY

SN 85-104,341. GNLD INTERNATIONAL, LLC, FREMONT, CA. FILED 8-10-2010.

NEO-LIFE

THE MARK CONSISTS OF STANDARD CHARACTERS WITHOUT CLAIM TO ANY PARTICULAR FONT, STYLE, SIZE, OR COLOR.

OWNER OF U.S. REG. NO. 1,279,595.

CLASS 3—COSMETICS AND CLEANING PREPARATIONS

FOR LAUNDRY DETERGENTS, CARPET AND FLOOR CLEANERS, LEATHER AND VINYL CLEANERS AND CONDITIONERS, CAR SHAMPOOS AND POLISHES; SOAPS, DETERGENTS AND LIQUID CLEANERS FOR DISHWASHING, HOUSEHOLD AND AUTOMOBILE USE; GENTLE FACIAL CLEANSERS, BODY AND FACIAL SOAPS, BATH OILS, SKIN MOISTURIZER, NON-MEDICATED HAND, BODY AND FACIAL LOTIONS AND CREAMS AND GELS; SKIN TONERS, ALOE VERA GEL FOR COSMETIC PURPOSES, EYE GELS, NON-MEDICATED COLLAGEN CREAMS FOR SKIN APPLICATION, HAIR LOTIONS, SHAMPOOS, RINSES AND CONDITIONERS, COSMETIC SUNTAN AND SUNSCREEN PREPARATIONS (U.S. CLS. 1, 4, 6, 50, 51 AND 52).

CLASS 5—PHARMACEUTICALS

FOR NUTRITIONAL AND DIETARY FOOD SUPPLEMENTS, COMPRISED OF VITAMINS, MINERALS, PROTEINS, AMINO ACIDS, ENZYMES, FIBER, ALOE VERA, FISH OILS, HERBS, HERBAL EXTRACTS, FRUIT EXTRACTS, VEGETABLE EXTRACTS, AND GRAIN CONCENTRATES; HERBAL SUPPLEMENTS; DIETARY SUPPLEMENT DRINK MIXES CONTAINING PROTEIN, ALOE VERA AND FIBER BLENDS; MEAL REPLACEMENT DRINK MIXES AND WEIGHT LOSS DIETARY AND NUTRITIONAL SUPPLEMENTS; NUTRITIONALLY FORTIFIED BEVERAGES (U.S. CLS. 6, 18, 44, 46, 51 AND 52).

CLASS 29—MEATS AND PROCESSED FOODS

FOR FRUIT AND VEGETABLE BASED SNACK FOODS; PRESERVED, DRIED, COOKED AND PROCESSED FRUITS AND VEGETABLES; DAIRY BASED BEVERAGES; EDIBLE OILS AND FATS, PROCESSED FOOD BARS PRIMARILY CONSISTING OF EXTRACTS OF FRUITS AND VEGETABLES, NUTS, AND SEEDS; HERBAL SOUPS (U.S. CL. 46).

CLASS 30—STAPLE FOODS

FOR CEREAL BASED AND RICE BASED SNACK FOODS AND FOOD BARS, PROCESSED HERBS, FRUIT TEAS, TEA-BASED BEVERAGES WITH FRUIT FLAVORING (U.S. CL. 46).

CLASS 32—LIGHT BEVERAGES

FOR NON-ALCOHOLIC BEVERAGES, NAMELY, FRUIT JUICES, FRUIT DRINKS AND FRUIT BEVERAGES, NON-ALCOHOLIC BEVERAGES WITH TEA FLAVOR; HERBAL JUICES (U.S. CLS. 45, 46 AND 48).

STEVEN JACKSON, EXAMINING ATTORNEY

SN 85-104,694. LAS VEGAS AFTER DARK, INC., LAS VEGAS, NV. FILED 8-11-2010.

LAS VEGAS AFTER DARK

THE MARK CONSISTS OF STANDARD CHARACTERS WITHOUT CLAIM TO ANY PARTICULAR FONT, STYLE, SIZE, OR COLOR.

NO CLAIM IS MADE TO THE EXCLUSIVE RIGHT TO USE "LAS VEGAS", APART FROM THE MARK AS SHOWN.

CLASS 24—FABRICS

FOR TEXTILES AND FABRICS, NAMELY, COTTON CLOTH, DENIM, POLYESTER, HANDKERCHIEFS AND SILK TEXTILES (U.S. CLS. 42 AND 50).

CLASS 25—CLOTHING

FOR CLOTHING, NAMELY, HATS, PANTS, JEANS, SWEATPANTS, SHORTS, SHIRTS, T-SHIRTS, SWEATSHIRTS, JACKETS, SKIRTS, DRESSES AND HEADWEAR, NAMELY, HEAD WRAPS FOR MEN AND WOMEN (U.S. CLS. 22 AND 39).

CLASS 35—ADVERTISING AND BUSINESS

FOR ON-LINE RETAIL STORE SERVICES FEATURING CLOTHING AND PROMOTIONAL ITEMS OR MATERIALS; PROMOTING THE NIGHT CLUBS OF OTHERS (U.S. CLS. 100, 101 AND 102).

CLASS 45—PERSONAL AND LEGAL SERVICES

FOR PERSONAL CONCIERGE SERVICES FOR OTHERS COMPRISING MAKING REQUESTED PERSONAL ARRANGEMENTS AND RESERVATIONS, RUNNING ERRANDS AND PROVIDING CUSTOMER SPECIFIC INFORMATION TO MEET INDIVIDUAL NEEDS, ALL RENDERED IN BUSINESS ESTABLISHMENTS, OFFICE BUILDINGS, HOTELS, RESIDENTIAL COMPLEXES AND HOMES (U.S. CLS. 100 AND 101).

MARIA-VICTORIA SUAREZ, EXAMINING ATTORNEY

SN 85-104,902. CAMERON INTERNATIONAL CORPORATION, HOUSTON, TX. FILED 8-11-2010.



THE MARK CONSISTS OF A STYLIZED LETTER "G".

CLASS 6—METAL GOODS

FOR MANUALLY OPERATED METAL BALL VALVES (U.S. CLS. 2, 12, 13, 14, 23, 25 AND 50).

FIRST USE 9-1-1962; IN COMMERCE 9-1-1962.

CLASS 7—MACHINERY

FOR BALL VALVES BEING PARTS OF MACHINES (U.S. CLS. 13, 19, 21, 23, 31, 34 AND 35).

FIRST USE 9-1-1962; IN COMMERCE 9-1-1962.

CLASS 9—ELECTRICAL AND SCIENTIFIC APPARATUS

FOR AUTOMATIC BALL VALVES (U.S. CLS. 21, 23, 26, 36 AND 38).

FIRST USE 9-1-1962; IN COMMERCE 9-1-1962.
SUSAN STIGLITZ, EXAMINING ATTORNEY

SN 85-105,299. JEN + KIM SHOES, LOS ANGELES, CA. FILED 8-11-2010.

Jen + Kim

THE MARK CONSISTS OF STANDARD CHARACTERS WITHOUT CLAIM TO ANY PARTICULAR FONT, STYLE, SIZE, OR COLOR.

THE NAME(S), PORTRAIT(S), AND/OR SIGNATURE(S) SHOWN IN THE MARK IDENTIFIES JENNIFFER BONAPARTIS AND KIMBERLY DINGMAN, WHOSE CONSENT(S) TO REGISTER IS MADE OF RECORD.

CLASS 25—CLOTHING

FOR SHOES (U.S. CLS. 22 AND 39).
FIRST USE 10-0-2005; IN COMMERCE 10-0-2005.

CLASS 42—SCIENTIFIC AND COMPUTER SERVICES

FOR CUSTOM DESIGN OF SHOES BASED ON PERSONAL SELECTIONS MADE BY THE CUSTOMER (U.S. CLS. 100 AND 101).

FIRST USE 10-0-2005; IN COMMERCE 10-0-2005.
MICHAEL ENGEL, EXAMINING ATTORNEY

SN 85-105,534. C. WONDER LLC, NEW YORK, NY. FILED 8-11-2010.

C. WONDER

THE MARK CONSISTS OF STANDARD CHARACTERS WITHOUT CLAIM TO ANY PARTICULAR FONT, STYLE, SIZE, OR COLOR.

CLASS 6—METAL GOODS

FOR KEY FOBS OF COMMON METAL (U.S. CLS. 2, 12, 13, 14, 23, 25 AND 50).

CLASS 18—LEATHER GOODS

FOR LEATHER GOODS, NAMELY, BRIEFCASES; CASUAL SPORT BAGS; ALL-PURPOSE ATHLETIC BAGS; SPORTS BAGS; LUGGAGE; BACKPACKS; DUFFLE BAGS; FANNY PACKS; BOOK BAGS; MESSENGER BAGS; PURSES; WALLETS; KEY CASES; UMBRELLAS; LEATHER KEY CHAINS; BRIEFCASE-TYPE PORTFOLIOS; COSMETIC CASES SOLD EMPTY; UMBRELLAS; LUGGAGE TAGS; HAND BAGS; TOTE BAGS (U.S. CLS. 1, 2, 3, 22 AND 41).

CLASS 20—FURNITURE AND ARTICLES NOT OTHERWISE CLASSIFIED

FOR KEY FOBS NOT OF METAL (U.S. CLS. 2, 13, 22, 25, 32 AND 50).

FLORENTINA BLANDU, EXAMINING ATTORNEY

SN 85-105,556. LZ DELTA, LLC, SCOTTSDALE, AZ. FILED 8-11-2010.



OWNER OF U.S. REG. NOS. 3,705,270 AND 3,714,745.
NO CLAIM IS MADE TO THE EXCLUSIVE RIGHT TO USE "AZ MOTORCYCLES", APART FROM THE MARK AS SHOWN.

THE COLOR(S) BLACK, BLUE, BROWN, RED, YELLOW AND WHITE IS/ARE CLAIMED AS A FEATURE OF THE MARK.

THE MARK CONSISTS OF A TRIANGULAR SHIELD WITH CURVED SIDES FORMED BY BROWN AND WHITE LINES. A BROWN, FIVE-POINT STAR IS IN THE MIDDLE OF THE SHIELD. RED AND YELLOW LINES RADIATE FROM THE TOP OF THE STAR. A BLUE BACKGROUND IS BEHIND THE LOWER HALF OF THE STAR. THE WORDING, "GO AZ MOTORCYCLES" IS CENTERED IN BLACK OVER THE LOWER THIRD OF THE SHIELD.

CLASS 25—CLOTHING

FOR MOTORCYCLE GLOVES; CLOTHING, NAMELY, T-SHIRTS, POLO SHIRTS, SWEATERS, SWEATSHIRTS, SOCKS, SHOES, CAPS, BELTS, PANTS, JERSEYS AND SHORTS (U.S. CLS. 22 AND 39).
FIRST USE 6-26-2008; IN COMMERCE 6-26-2008.

CLASS 37—CONSTRUCTION AND REPAIR

FOR AUTOMOTIVE MAINTENANCE AND REPAIR; MOTORCYCLE CUSTOMIZATION SERVICES (U.S. CLS. 100, 103 AND 106).
FIRST USE 6-26-2008; IN COMMERCE 6-26-2008.

CLASS 39—TRANSPORTATION AND STORAGE

FOR MOTORCYCLE RENTAL (U.S. CLS. 100 AND 105).
FIRST USE 6-26-2008; IN COMMERCE 6-26-2008.
MARY BOAGNI, EXAMINING ATTORNEY

SN 85-105,612. POWERCLOUD SYSTEMS, INC., PALO ALTO, CA. FILED 8-11-2010.

POWERCLOUD

THE MARK CONSISTS OF STANDARD CHARACTERS WITHOUT CLAIM TO ANY PARTICULAR FONT, STYLE, SIZE, OR COLOR.

CLASS 9—ELECTRICAL AND SCIENTIFIC APPARATUS

FOR COMPUTER SOFTWARE FOR USE IN MANAGING AND FACILITATING COMPUTER AND DATA NETWORK OPERATIONS AND COMMUNICATIONS ALL IN CONNECTION WITH DATA COMMUNICATION; COMPUTER HARDWARE AND PERIPHERAL DEVICES (U.S. CLS. 21, 23, 26, 36 AND 38).

CLASS 42—SCIENTIFIC AND COMPUTER SERVICES

FOR APPLICATION SERVICE PROVIDER, NAMELY, PROVIDING, MANAGING, AND MAINTAINING APPLICATIONS AND SOFTWARE IN THE FIELD OF DATA COMMUNICATIONS (U.S. CLS. 100 AND 101).
MARGERY A. TIERNEY, EXAMINING ATTORNEY

SN 85-105,927. GEIS, ALEXANDRA L., NEW YORK, NY. FILED 8-12-2010.

COZY COUTURE

THE MARK CONSISTS OF STANDARD CHARACTERS WITHOUT CLAIM TO ANY PARTICULAR FONT, STYLE, SIZE, OR COLOR.

NO CLAIM IS MADE TO THE EXCLUSIVE RIGHT TO USE "COUTURE" FOR INTERNATIONAL CLASSES 18, 24, AND 25, APART FROM THE MARK AS SHOWN.

CLASS 9—ELECTRICAL AND SCIENTIFIC APPARATUS

FOR CHILDREN'S PRERECORDED COMPACT DISCS (U.S. CLS. 21, 23, 26, 36 AND 38).

CLASS 18—LEATHER GOODS

FOR TOTE BAGS (U.S. CLS. 1, 2, 3, 22 AND 41).

CLASS 21—HOUSEWARES AND GLASS

FOR CANTEENS (U.S. CLS. 2, 13, 23, 29, 30, 33, 40 AND 50).

CLASS 24—FABRICS

FOR TOWELS (U.S. CLS. 42 AND 50).

CLASS 25—CLOTHING

FOR CLOTHING, NAMELY, T-SHIRTS AND CAPS (U.S. CLS. 22 AND 39).
WILLIAM P. SHANAHAN, EXAMINING ATTORNEY

SN 85-106,056. SOTERIA SYSTEMS, LLC, DENVER, CO. FILED 8-12-2010.

FORSSE

THE MARK CONSISTS OF STANDARD CHARACTERS WITHOUT CLAIM TO ANY PARTICULAR FONT, STYLE, SIZE, OR COLOR.

CLASS 9—ELECTRICAL AND SCIENTIFIC APPARATUS

FOR EMERGENCY ALERT SOFTWARE AND HARDWARE, NAMELY, A SYSTEM COMPRISING ELECTRONIC TRANSMITTERS, ELECTRONIC RECEIVERS, CIRCUIT BOARDS, MICROPROCESSORS, CELLULAR TELEPHONES AND COMPUTER SOFTWARE, ALL FOR USE IN REQUESTING ASSISTANCE AND TRANSMITTING SUBSCRIBER LOCATION AND PERSONAL DATA IN AN EMERGENCY; CENTRAL DISPATCH SECURITY SYSTEM COMPOSED OF TRANSMITTERS AND RECEIVERS FOR SENDING AND RECEIVING EMERGENCY SIGNALS (U.S. CLS. 21, 23, 26, 36 AND 38).
FIRST USE 5-25-2010; IN COMMERCE 5-25-2010.

CLASS 38—COMMUNICATION

FOR EMERGENCY COMMUNICATION SERVICES FOR SUMMONING AID ON RECEIPT OF SIGNALS MANUALLY INITIATED BY A PERSON UNDERGOING AN EMERGENCY AND TRANSMITTED OVER PHONE LINES, NAMELY, THE TRANSMISSION, RECEPTION AND PROCESSING OF CODED AND EMERGENCY SIGNALS (U.S. CLS. 100, 101 AND 104).

FIRST USE 5-25-2010; IN COMMERCE 5-25-2010.
ADA HAN, EXAMINING ATTORNEY

SN 85-106,079. SAN-X CO., LTD., CHIYODA-KU, TOKYO, JAPAN, FILED 8-12-2010.



THE MARK CONSISTS OF A STYLIZED FIGURE OF A BEAR WITH STYLIZED LETTERS "RILAKKUMA" UNDERNEATH.

CLASS 16—PAPER GOODS AND PRINTED MATTER

FOR PENS, PENCILS, NOTEBOOKS, PICTURES AND OTHER STATIONERY PRODUCTS, NAMELY, PENCIL CASES AND STICKERS (U.S. CLS. 2, 5, 22, 23, 29, 37, 38 AND 50).

CLASS 18—LEATHER GOODS

FOR BACKPACKS, TOTE BAGS, WALLETS AND UMBRELLAS (U.S. CLS. 1, 2, 3, 22 AND 41).

CLASS 25—CLOTHING

FOR BELTS, SOCKS, T-SHIRTS, SWEATSHIRTS, SHIRTS, JACKETS, SHORTS, PANTS, SHOES, SLIPPERS AND SANDALS (U.S. CLS. 22 AND 39).

CLASS 28—TOYS AND SPORTING GOODS

FOR PLUSH TOYS AND DOLLS (U.S. CLS. 22, 23, 38 AND 50).
FRANK LATTUCA, EXAMINING ATTORNEY

SN 85-106,934. HELIX BIOMEDIX, BOTHELL, WA. FILED 8-13-2010.

MD3 Copper

THE MARK CONSISTS OF STANDARD CHARACTERS WITHOUT CLAIM TO ANY PARTICULAR FONT, STYLE, SIZE, OR COLOR.

NO CLAIM IS MADE TO THE EXCLUSIVE RIGHT TO USE "COPPER", APART FROM THE MARK AS SHOWN.

CLASS 3—COSMETICS AND CLEANING PREPARATIONS

FOR SKIN CARE PRODUCTS, NAMELY, CREAMS IN THE NATURE OF SKIN CREAMS IN LIQUID AND IN SOLID FORM, MOISTURIZERS IN THE NATURE OF SKIN MOISTURIZERS, SERUMS IN THE NATURE OF BEAUTY SERUMS, NON-MEDICATED SERUMS, NON-MEDICATED ANTI-AGING SERUMS, CLEANSERS IN THE NATURE OF FACIAL CLEANSERS, SKIN CLEANSERS, SKIN LIGHTENERS IN THE NATURE OF SKIN LIGHTENING CREAMS, SKIN LIGHTENING SERUMS, MASKS IN THE NATURE OF FACIAL BEAUTY MASKS, SKIN MOISTURIZER MASKS AND LOTIONS IN THE NATURE OF BATH LOTION, EYE LOTION, FACIAL LOTION, ALL OF WHICH CONTAIN COPPER AS AN INGREDIENT (U.S. CLS. 1, 4, 6, 50, 51 AND 52).

FIRST USE 8-13-2010; IN COMMERCE 8-13-2010.

CLASS 5—PHARMACEUTICALS

FOR MEDICINAL CREAMS FOR SKIN CARE WHICH CONTAIN COPPER; MEDICATED SKIN CARE PREPARATIONS, NAMELY, CREAMS, LOTIONS AND CLEANSERS, ALL OF WHICH CONTAIN COPPER AS AN INGREDIENT; MEDICINAL CLEANSERS FOR SKIN AND WOUNDS WHICH CONTAIN COPPER, MEDICATED SUNBURN LOTIONS WHICH CONTAIN COPPER; PHARMACEUTICAL SKIN LOTIONS WHICH CONTAIN COPPER (U.S. CLS. 6, 18, 44, 46, 51 AND 52).

FIRST USE 8-13-2010; IN COMMERCE 8-13-2010.

CIMMERIAN COLEMAN, EXAMINING ATTORNEY

SN 85-107,124. MARIMON INTERNATIONAL, LLC, MINNEAPOLIS, MN. FILED 8-13-2010.

Marimon

THE MARK CONSISTS OF STANDARD CHARACTERS WITHOUT CLAIM TO ANY PARTICULAR FONT, STYLE, SIZE, OR COLOR.

CLASS 14—JEWELRY

FOR JEWELRY AND IMITATION JEWELRY (U.S. CLS. 2, 27, 28 AND 50).

FIRST USE 5-30-2009; IN COMMERCE 5-30-2009.

CLASS 18—LEATHER GOODS

FOR PURSES (U.S. CLS. 1, 2, 3, 22 AND 41).
FIRST USE 5-30-2009; IN COMMERCE 5-30-2009.

CLASS 35—ADVERTISING AND BUSINESS

FOR WHOLESALE AND RETAIL STORE SERVICES AND ON-LINE RETAIL AND WHOLESALE STORE SERVICES FEATURING ACCESSORIES IN THE NATURE OF JEWELRY AND HANDBAGS (U.S. CLS. 100, 101 AND 102).

FIRST USE 5-30-2009; IN COMMERCE 5-30-2009.
LINDA POWELL, EXAMINING ATTORNEY

SN 85-107,142. MINORONZONI S.R.L., PONTE SAN PIETRO (BG), ITALY, FILED 8-13-2010.

MariaSoleBlanca

PRIORITY CLAIMED UNDER SEC. 44(D) ON ITALY APPLICATION NO. IT-MI2010C00, FILED 2-26-2010.

THE NAME SHOWN IN THE MARK IDENTIFIES "MARIA SOLE BLANCA RONZONI", WHOSE CONSENT IS MADE OF RECORD.

THE MARK CONSISTS OF THE MARK "MARIASOLE-BLANCA" IN STYLIZED LETTERING.

CLASS 18—LEATHER GOODS

FOR BAGS, NAMELY, HANDBAGS, GARMENT BAGS FOR TRAVEL; SUITCASES; RUCKSACKS; WALLETS; PURSES; LEATHERWARE, NAMELY, BRIEFCASES; TRUNKS; HAND LUGGAGE; KEY CASES; COSMETIC CASES SOLD EMPTY; ANIMAL HIDES; PARASOLS; BEACH UMBRELLAS; UMBRELLAS; WALKING STICKS; LEATHER AND GOODS MADE OF LEATHER, NAMELY, WALLETS AND PURSES (U.S. CLS. 1, 2, 3, 22 AND 41).

CLASS 25—CLOTHING

FOR CLOTHING FOR MEN, WOMEN AND CHILDREN, NAMELY, SHIRTS, BLOUSES, SKIRTS, TAILLEURS, JACKETS, TROUSERS, SHORTS, JERSEYS, T-SHIRTS, SWEATSHIRTS, PULLOVERS; UNDERWEAR; HOUSECOATS; NIGHTDRESSES; PYJAMAS; STOCKINGS; SINGLET; FOUNDATION CLOTHING, NAMELY, CORSETS; SUSPENDERS; UNDERPANTS; BRASSIERES; PETTICOATS; HATS; CAPS; GLOVES; BELTS; FOULARDS; SCARVES; NECKTIES; WATER-PROOF CLOTHING, NAMELY, JACKETS AND COATS; OVERCOATS; TOPCOATS; SWIMSUITS; TRACKSUITS; WINDCHEATERS; SHOES; SANDALS, SLIPPERS; CLOTHING OF LEATHER, NAMELY, JACKETS AND PANTS (U.S. CLS. 22 AND 39).

HEATHER BIDDULPH, EXAMINING ATTORNEY

SN 85-107,280. GRAND VALLEY STATE UNIVERSITY, ALLENDALE, MI. FILED 8-13-2010.

GREAT WINE & FOOD SYMPOSIUM

THE MARK CONSISTS OF STANDARD CHARACTERS WITHOUT CLAIM TO ANY PARTICULAR FONT, STYLE, SIZE, OR COLOR.

NO CLAIM IS MADE TO THE EXCLUSIVE RIGHT TO USE "SYMPOSIUM", APART FROM THE MARK AS SHOWN.

SEC. 2(F) AS TO "GREAT WINE & FOOD".

CLASS 36—INSURANCE AND FINANCIAL

FOR FUNDRAISING SERVICES, NAMELY, RAISING FUNDS FOR PROVIDING EDUCATIONAL, INFORMATIVE, AND ENTERTAINING PROGRAMS FOR THE BENEFIT OF NON-PROFIT ORGANIZATIONS (U.S. CLS. 100, 101 AND 102).

FIRST USE 0-0-1989; IN COMMERCE 0-0-1989.

CLASS 41—EDUCATION AND ENTERTAINMENT

FOR ENTERTAINMENT SERVICES, NAMELY, PROVIDING FOOD AND WINE TASTING (U.S. CLS. 100, 101 AND 107).

FIRST USE 0-0-1989; IN COMMERCE 0-0-1989.
KEVON CHISOLM, EXAMINING ATTORNEY

SN 85-107,540. STEARNS LENDING, INC., SANTA ANA, CA. FILED 8-13-2010.

STEARNS

THE MARK CONSISTS OF STANDARD CHARACTERS WITHOUT CLAIM TO ANY PARTICULAR FONT, STYLE, SIZE, OR COLOR.

OWNER OF U.S. REG. NO. 2,926,090.
SEC. 2(F).

CLASS 35—ADVERTISING AND BUSINESS

FOR BUSINESS MANAGEMENT CONSULTATION IN THE FIELD OF GOVERNMENT CONTRACTING; AND BUSINESS AUDITING (U.S. CLS. 100, 101 AND 102).

FIRST USE 11-24-2004; IN COMMERCE 11-24-2004.

CLASS 36—INSURANCE AND FINANCIAL

FOR FINANCIAL SERVICES, NAMELY, MORTGAGE LENDING, MORTGAGE BANKING, AND MORTGAGE BROKERAGE SERVICES IN THE NATURE OF PURCHASING AND SELLING OF MORTGAGE-BACKED SECURITIES, PRIVATE AND PUBLIC SALES OF MORTGAGE LOANS AND MORTGAGE LOAN PORTFOLIOS, SERVICING OF LOAN PORTFOLIOS, AND BROKERING OF MORTGAGE LOAN SERVICES; REAL ESTATE TITLE INSURANCE UNDERWRITING SERVICES; AND REAL ESTATE ESCROW SERVICES (U.S. CLS. 100, 101 AND 102).

FIRST USE 11-24-2004; IN COMMERCE 11-24-2004.

CLASS 45—PERSONAL AND LEGAL SERVICES

FOR REAL ESTATE SETTLEMENT SERVICES; TITLE SEARCHING SERVICES (U.S. CLS. 100 AND 101).

FIRST USE 11-24-2004; IN COMMERCE 11-24-2004.
ANDREA HACK, EXAMINING ATTORNEY

SN 85-107,548. TRAILER WHEEL & FRAME CO., HOUSTON, TX. FILED 8-13-2010.



OWNER OF U.S. REG. NO. 3,590,014.

NO CLAIM IS MADE TO THE EXCLUSIVE RIGHT TO USE "CO.", APART FROM THE MARK AS SHOWN.

THE MARK CONSISTS OF A DIAMOND CONTAINING A TRAILER CONNECTED TO A FLATBED PICKUP TRUCK DEPICTED AT OR ABOUT THE CENTER OF THE DIAMOND; AN ELONGATED RECTANGLE IS POSITIONED OVER A PART OF THE LOWER HALF OF THE SHADED DIAMOND AND BELOW THE DEPICTION OF THE TRAILER AND TRUCK; THE PHRASE "TRAILER WHEEL & FRAME CO." IS WRITTEN INSIDE THE ELONGATED RECTANGLE.

SEC. 2(F) AS TO "TRAILER WHEEL & FRAME".

CLASS 35—ADVERTISING AND BUSINESS

FOR RETAIL STORE SERVICES FEATURING TRAILERS, TRAILER AND TRUCK PARTS, AND TRAILER AND TRUCK ACCESSORIES; ON-LINE RETAIL STORE SERVICES FEATURING TRAILERS, TRAILER AND TRUCK PARTS, AND TRAILER AND TRUCK ACCESSORIES (U.S. CLS. 100, 101 AND 102).

FIRST USE 10-20-1994, THE MARK WAS FIRST USED ANYWHERE IN A DIFFERENT FORM OTHER THAN THAT SOUGHT TO BE REGISTERED AT LEAST AS EARLY AS 00/00/1972; IN COMMERCE 10-20-1994, THE MARK WAS FIRST USED IN COMMERCE IN A DIFFERENT FORM OTHER THAN THAT SOUGHT TO BE REGISTERED AT LEAST AS EARLY AS 00/00/1972.

CLASS 37—CONSTRUCTION AND REPAIR

FOR TRAILER MAINTENANCE, REPAIR, AND SERVICING; INSTALLATION OF TRUCK PARTS AND ACCESSORIES, NOT INCLUDING SOFTWARE INSTALLATION; INSTALLATION OF TRAILER PARTS AND ACCESSORIES, NOT INCLUDING SOFTWARE INSTALLATION (U.S. CLS. 100, 103 AND 106).

FIRST USE 10-20-1994, THE MARK WAS FIRST USED ANYWHERE IN A DIFFERENT FORM OTHER THAN THAT SOUGHT TO BE REGISTERED AT LEAST AS EARLY AS 00/00/1972; IN COMMERCE 10-20-1994, THE MARK WAS FIRST USED IN COMMERCE IN A DIFFERENT FORM OTHER THAN THAT SOUGHT TO BE REGISTERED AT LEAST AS EARLY AS 00/00/1972.

CLASS 39—TRANSPORTATION AND STORAGE

FOR TRUCK AND TRAILER RENTAL AND LEASING SERVICES (U.S. CLS. 100 AND 105).

FIRST USE 10-20-1994, THE MARK WAS FIRST USED ANYWHERE IN A DIFFERENT FORM OTHER THAN THAT SOUGHT TO BE REGISTERED AT LEAST AS EARLY AS 00/00/1972; IN COMMERCE 10-20-1994, THE MARK WAS FIRST USED IN COMMERCE IN A DIFFERENT FORM OTHER THAN THAT SOUGHT TO BE REGISTERED AT LEAST AS EARLY AS 00/00/1972.

MAYUR VAGHANI, EXAMINING ATTORNEY

SN 85-108,341. TOOTSIE ROLL INDUSTRIES, LLC, CHICAGO, IL. FILED 8-16-2010.

ROLL WITH IT

THE MARK CONSISTS OF STANDARD CHARACTERS WITHOUT CLAIM TO ANY PARTICULAR FONT, STYLE, SIZE, OR COLOR.

OWNER OF U.S. REG. NOS. 623,182, 1,369,332 AND 1,988,251.

CLASS 41—EDUCATION AND ENTERTAINMENT

FOR PROVIDING A WEBSITE FOR ENTERTAINMENT PURPOSES WHERE USERS CAN VIEW AND POST TEXT FEATURING PERSONAL STORIES USING HUMOR (U.S. CLS. 100, 101 AND 107).

CLASS 45—PERSONAL AND LEGAL SERVICES

FOR PROVIDING A SOCIAL NETWORKING WEBSITE FOR ENTERTAINMENT PURPOSES WHERE USERS CAN VIEW AND POST TEXT FEATURING PERSONAL STORIES (U.S. CLS. 100 AND 101).

PAULA MAHONEY, EXAMINING ATTORNEY

SN 85-108,459. INFRAGISTICS, INC., WINDSOR, NJ. FILED 8-16-2010.



THE MARK CONSISTS OF A LOWER CASE LETTER "I" AND AN UPPER-CASE LETTER "G" JOINED TOGETHER AT THE BASE OF THE "I" AND THE TOP OF THE "G". THE "G" IS ROTATED 90 DEGREES TO THE LEFT SUCH THAT THE LETTER "I" FORMS THE TOP OF THE LETTER "G". THE LETTER "G" FORMS A SPIRAL STRUCTURE TOWARDS THE CENTER OF THE MARK, WITH THE LOWER CASE "I" FORMING THE LEFT SIDE OF THE SPIRAL. THE LOWER RIGHT CORNER OF THE SPIRAL IS A SHARP RIGHT ANGLE WHILE THE LOWER LEFT AND UPPER RIGHT CORNERS ARE ROUNDED ON THE OUTER EDGES.

CLASS 9—ELECTRICAL AND SCIENTIFIC APPARATUS

FOR COMPUTER SOFTWARE, NAMELY, COMPONENT BASED DEVELOPMENT TOOLS, AND PRESENTATION LAYER COMPONENT DEVELOPMENT SOFTWARE FOR BUILDING AN INTERFACE FOR COMPUTER SOFTWARE APPLICATIONS, INTERNET SOFTWARE APPLICATIONS, XML WEB SERVICES AND WEB SITE SOFTWARE (U.S. CLS. 21, 23, 26, 36 AND 38).

CLASS 42—SCIENTIFIC AND COMPUTER SERVICES

FOR COMPUTER SERVICES, NAMELY, PROVIDING TECHNICAL INFORMATION, PROGRAMMING, MAINTENANCE AND UPDATING OF COMPONENT-BASED DEVELOPMENT SOFTWARE TOOLS AND PRESENTATION LAYER COMPONENT DEVELOPMENT SOFTWARE FOR BUILDING AN INTERFACE FOR COMPUTER SOFTWARE APPLICATIONS, INTERNET SOFTWARE APPLICATIONS, XML WEB SERVICES AND WEBSITE SOFTWARE (U.S. CLS. 100 AND 101).

SOPHIA S. KIM, EXAMINING ATTORNEY

SN 85-108,514. COMCAST CORPORATION, PHILADELPHIA, PA. FILED 8-16-2010.

XFINITY

THE MARK CONSISTS OF STANDARD CHARACTERS WITHOUT CLAIM TO ANY PARTICULAR FONT, STYLE, SIZE, OR COLOR.

OWNER OF U.S. REG. NOS. 3,850,803 AND 3,944,290.

CLASS 37—CONSTRUCTION AND REPAIR

FOR INSTALLATION, MAINTENANCE AND REPAIR OF HOME AND BUSINESS SECURITY MONITORING EQUIPMENT, COMPUTER HARDWARE, AUDIO-VIDEO SYSTEMS AND COMPONENTS THEREOF (U.S. CLS. 100, 103 AND 106).

CLASS 45—PERSONAL AND LEGAL SERVICES

FOR HOME AND BUSINESS SECURITY MONITORING USING WIRELESS AND WIRED SENSORS FOR GLASS BREAKAGE, MOTION DETECTORS, CAMERAS, POOL ALARMS, WATER ALARMS AND SHUTOFF VALVES, GATE, DOOR AND WINDOW CONTACT SENSORS (U.S. CLS. 100 AND 101).
SIMON TENG, EXAMINING ATTORNEY

CLASS 37—CONSTRUCTION AND REPAIR

FOR MAINTENANCE, REPAIR, AND INSTALLATION OF COMPUTER HARDWARE, MULTIPLEXERS, MODEMS, PSEUDOWIRE GATEWAYS, CARRIER ETHERNET ACCESS EQUIPMENT WORKING IN CONJUNCTION AS AN INTEGRATED SYSTEM FOR THE TRANSPORT AND AGGREGATION OF DATA, VOICE AND FIBER AND COPPER INFRASTRUCTURE, ANTENNAS FOR WIRELESS COMMUNICATIONS APPARATUS, TRANSCEIVERS, ASYNCHRONOUS TRANSFER MODE NETWORK TERMINATION UNITS AND MULTISERVICE ACCESS CONCENTRATORS, ETHERNET BRIDGE, INTERNET PROTOCOL ROUTERS, PRODUCTS THAT ENABLES TRANSPORT OF NON-INTERNET PROTOCOL TRAFFIC OVER AN INTERNET PROTOCOL-BASED NETWORK, ROUTERS, MODEMS, SWITCHES FOR VOICE AND DATA AND PACKET SWITCHING, CONVERTERS, SHARING DEVICES, HUBS, REPEATERS, BRIDGES, ROUTERS, CONNECTORS, PATCH PANELS, TERMINAL SERVERS, MONITORING AND TEST, EQUIPMENT, VIDEOCONFERENCING EQUIPMENT, VIDEO GATEWAYS FOR LAN VIDEOCONFERENCING, VIDEO INTERFACE UNITS, VIDEO STATIONS, VIDEO INTERFACE CARDS; COMPUTER NETWORK SECURITY HARDWARE, LOCAL AREA NETWORKS CONSISTING OF MODULAR INTELLIGENT HUBS, MODEM ELIMINATORS, MODEM SHARERS, PRINTER SHARERS, PORT SHARERS, SYNCHRONOUS INTERFACE CONVERTERS, ASYNCHRONOUS-TO-SYNCHRONOUS CONVERTERS, SERIAL/PARALLEL CONVERTERS, INTERFACE CONVERTERS, FIBER OPTIC CONVERTERS, DATA COMPRESSORS, NAMELY, DATA COMMUNICATION EQUIPMENT CONNECTED BETWEEN COMPUTERS AND MODEMS TO COMPRESS DATA, CARRIER CONTROL SIMULATORS, TERMINAL ADAPTORS, TAIL END ADAPTORS, POWER SUPPLY ADAPTORS, LIGHTING ARRESTORS, LOOP GENERATORS, DATA/VOICE SEPARATORS, SPOOLERS, REMOTE ACCESS SWITCHES, TRUNK ACCESSERS AND DIAGNOSTIC TESTING APPARATUSES FOR USE WITH THE ABOVE; TECHNICAL SUPPORT, NAMELY, TROUBLESHOOTING IN THE NATURE OF THE REPAIR OF COMPUTER HARDWARE (U.S. CLS. 100, 103 AND 106).

CLASS 42—SCIENTIFIC AND COMPUTER SERVICES

FOR MAINTENANCE, REPAIR, AND INSTALLATION OF COMPUTER SOFTWARE; TECHNICAL SUPPORT, NAMELY, TROUBLESHOOTING IN THE NATURE OF DIAGNOSING COMPUTER HARDWARE AND SOFTWARE PROBLEMS (U.S. CLS. 100 AND 101).
KAREN K. BUSH, EXAMINING ATTORNEY

SN 85-108,661. RAD DATA COMMUNICATIONS LTD., TEL AVIV, ISRAEL, FILED 8-16-2010.

RADCARE

THE MARK CONSISTS OF STANDARD CHARACTERS WITHOUT CLAIM TO ANY PARTICULAR FONT, STYLE, SIZE, OR COLOR.

SN 85-108,719. MATTHEW JOHNSTON, DBA SUPLOVE, COSTA MESA, CA. FILED 8-16-2010.

Suplove

THE MARK CONSISTS OF STANDARD CHARACTERS WITHOUT CLAIM TO ANY PARTICULAR FONT, STYLE, SIZE, OR COLOR.

CLASS 12—VEHICLES

FOR (BASED ON INTENT TO USE) CANOE PADDLES; KAYAK PADDLES; OUTRIGGER PADDLES (U.S. CLS. 19, 21, 23, 31, 35 AND 44).

CLASS 25—CLOTHING

FOR (BASED ON USE IN COMMERCE) SURF WEAR (U.S. CLS. 22 AND 39).
FIRST USE 11-30-2008; IN COMMERCE 4-1-2010.

CLASS 28—TOYS AND SPORTING GOODS

FOR (BASED ON USE IN COMMERCE) LEASHES USED IN CONJUNCTION WITH SURFING; PADDLE BOARDS; PADDLE SURFBOARDS; PADDLES FOR USE WITH SURFBOARDS; STAND-UP SURF PADDLES; SURF BOARDS; SURF FINNS; SURF PADDLES (U.S. CLS. 22, 23, 38 AND 50).
FIRST USE 11-30-2008; IN COMMERCE 4-1-2010.

CLASS 41—EDUCATION AND ENTERTAINMENT

FOR (BASED ON INTENT TO USE) INSTRUCTION IN THE FIELD OF STAND UP PADDLE; PHYSICAL FITNESS INSTRUCTION; PROVIDING A WEB SITE FEATURING INFORMATION NEEDED FOR THE SPORT OF SURFING, NAMELY, WAVE CONDITIONS, WAVE LOCATIONS AND DURATION OF SURFING SESSION; RENTAL OF SURF BOARDS (U.S. CLS. 100, 101 AND 107).

LINDA M. KING, EXAMINING ATTORNEY

SN 85-109,270. C. UYEMURA & CO., LTD., OSAKA-SHI, OSAKA, JAPAN, FILED 8-17-2010.

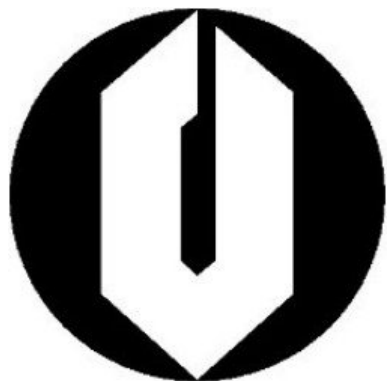

THE MARK CONSISTS OF A STYLIZED LETTER "U" WITHIN A CIRCLE.

CLASS 1—CHEMICALS

FOR INDUSTRIAL CHEMICALS; DETERGENTS FOR USE IN THE MANUFACTURING PROCESSES, NAMELY, DETERGENTS FOR INDUSTRIAL USE; DEGREASING PREPARATIONS FOR USE IN THE MANUFACTURING PROCESSES, NAMELY, FOR INDUSTRIAL USE; CHEMICALS FOR USE WITH ELECTROPLATING BATHS AND ELECTROLESS PLATING BATHS (U.S. CLS. 1, 5, 6, 10, 26 AND 46).
FIRST USE 0-0-1983; IN COMMERCE 4-0-1984.

CLASS 3—COSMETICS AND CLEANING PREPARATIONS

FOR ABRASIVES PREPARATIONS FOR INDUSTRIAL PURPOSES; ABRASIVE POWDERS, LIQUIDS AND PASTE FOR BUFFING, CHEMICAL AND ELECTROCHEMICAL POLISHING; ABRASIVE SOLID IN THE NATURE OF SPONGE AND CLOTH FOR BUFFING, CHEMICAL AND ELECTROCHEMICAL POLISHING; RUST REMOVING PREPARATIONS; FURBISHING PREPARATIONS, NAMELY, SHINING PREPARATIONS POLISH (U.S. CLS. 1, 4, 6, 50, 51 AND 52).
FIRST USE 0-0-1983; IN COMMERCE 4-0-1984.

CLASS 9—ELECTRICAL AND SCIENTIFIC APPARATUS

FOR ELECTROPLATING MACHINES; ELECTROLESS-PLATING MACHINES; ELECTRODES; ANODES; ELECTROLYSERS; DOWNLOADABLE ELECTRONIC PUBLICATIONS IN THE NATURE OF MAGAZINES IN THE FIELD OF ELECTRONICS AND CHEMISTRY; AUTOMATIC MEASURING APPARATUS FOR MEASURING CONCENTRATION AND PH LEVELS OF PLATING SOLUTIONS; AUTOMATIC MEASURING APPARATUS FOR MEASURING CONCENTRATION AND PH LEVELS OF CHEMICAL TREATMENT SOLUTIONS; AUTOMATIC LIQUID LEVEL AND CONCENTRATION AND PH LEVEL ADJUSTMENT CONTROL APPARATUS FOR PLATING SOLUTIONS; AUTOMATIC LIQUID LEVEL AND CONCENTRATION AND PH LEVEL ADJUSTMENT CONTROL APPARATUS FOR CHEMICAL TREATMENT SOLUTIONS; CONCENTRATION MANAGEMENT APPARATUS, NAMELY, LIQUID ANALYZERS AND ELECTRONIC CONTROLLERS TO MANAGE CONCENTRATION OF PLATING SOLUTIONS; CONCENTRATION MANAGEMENT APPARATUS, NAMELY, LIQUID ANALYZERS AND ELECTRONIC CONTROLLERS TO MANAGE CONCENTRATION OF CHEMICAL TREATMENT SOLUTIONS; COMPUTER PROGRAMS RECORDED ON DATA MEDIA SOFTWARE DESIGNED FOR USE IN ANALYZING CURRENT DISTRIBUTION OF ELECTROCHEMICAL CELLS; COMPUTER PROGRAMS RECORDED ON DATA MEDIA SOFTWARE DESIGNED FOR MANAGING CONCENTRATION OF PLATING SOLUTIONS AUTOMATICALLY; COMPUTER SOFTWARE FOR CONTROLLING AND MANAGING SURFACE FINISHING APPLICATIONS IN THE SURFACE FINISHING INDUSTRY (U.S. CLS. 21, 23, 26, 36 AND 38).

FIRST USE 0-0-1983; IN COMMERCE 4-0-1984.
ERIN FALK, EXAMINING ATTORNEY

SN 85-109,368. C. UYEMURA & CO., LTD., OSAKA-SHI, OSAKA, JAPAN, FILED 8-17-2010.

UYEMURA

THE MARK CONSISTS OF THE WORD "UYEMURA" IN STYLIZED LETTERING.

THE WORDING "UYEMURA" HAS NO MEANING IN A FOREIGN LANGUAGE.

SEC. 2(F).

CLASS 1—CHEMICALS

FOR (BASED ON USE IN COMMERCE) INDUSTRIAL CHEMICALS; DETERGENTS FOR USE IN THE MANUFACTURING PROCESSES, NAMELY, DETERGENTS FOR INDUSTRIAL USE; DEGREASING PREPARATIONS FOR USE IN THE MANUFACTURING PROCESSES, NAMELY, FOR INDUSTRIAL USE; CHEMICALS FOR USE WITH ELECTROPLATING BATHS AND ELECTROLESS PLATING BATHS (U.S. CLS. 1, 5, 6, 10, 26 AND 46).
FIRST USE 6-0-2003; IN COMMERCE 6-0-2003.

CLASS 3—COSMETICS AND CLEANING PREPARATIONS

FOR (BASED ON INTENT TO USE) ABRASIVES PREPARATIONS FOR INDUSTRIAL PURPOSES; ABRASIVE POWDERS, LIQUIDS AND PASTE FOR BUFFING, CHEMICAL AND ELECTROCHEMICAL POLISHING; ABRASIVE SOLID IN THE NATURE OF SPONGE AND CLOTH FOR BUFFING, CHEMICAL AND ELECTROCHEMICAL POLISHING; RUST REMOVING PREPARATIONS; FURBISHING PREPARATIONS, NAMELY, SHINING PREPARATIONS POLISH (U.S. CLS. 1, 4, 6, 50, 51 AND 52).

CLASS 9—ELECTRICAL AND SCIENTIFIC APPARATUS

SN 85-110,366. ZAMZEE CO., REDWOOD CITY, CA. FILED 8-18-2010.

FOR (BASED ON USE IN COMMERCE) ELECTROPLATING MACHINES; ELECTROLESSPLATING MACHINES; ELECTRODES; ANODES; ELECTROLYSERS; DOWNLOADABLE ELECTRONIC PUBLICATIONS IN THE NATURE OF MAGAZINES IN THE FIELD OF ELECTRONICS AND CHEMISTRY; AUTOMATIC MEASURING APPARATUS FOR MEASURING CONCENTRATION AND PH LEVELS OF PLATING SOLUTIONS; AUTOMATIC MEASURING APPARATUS FOR MEASURING CONCENTRATION AND PH LEVELS OF CHEMICAL TREATMENT SOLUTIONS; AUTOMATIC LIQUID LEVEL AND CONCENTRATION AND PH LEVEL ADJUSTMENT CONTROL APPARATUS FOR PLATING SOLUTIONS; AUTOMATIC LIQUID LEVEL AND CONCENTRATION AND PH LEVEL ADJUSTMENT CONTROL APPARATUS FOR CHEMICAL TREATMENT SOLUTIONS; CONCENTRATION MANAGEMENT APPARATUS, NAMELY, LIQUID ANALYZERS AND ELECTRONIC CONTROLLERS TO MANAGE CONCENTRATION OF PLATING SOLUTIONS; CONCENTRATION MANAGEMENT APPARATUS, NAMELY, LIQUID ANALYZERS AND ELECTRONIC CONTROLLERS TO MANAGE CONCENTRATION OF CHEMICAL TREATMENT SOLUTIONS; COMPUTER PROGRAMS RECORDED ON DATA MEDIA SOFTWARE DESIGNED FOR USE IN ANALYZING CURRENT DISTRIBUTION OF ELECTROCHEMICAL CELLS; COMPUTER PROGRAMS RECORDED ON DATA MEDIA SOFTWARE DESIGNED FOR MANAGING CONCENTRATION OF PLATING SOLUTIONS AUTOMATICALLY; COMPUTER SOFTWARE FOR CONTROLLING AND MANAGING SURFACE FINISHING APPLICATIONS IN THE SURFACE FINISHING INDUSTRY (U.S. CLS. 21, 23, 26, 36 AND 38).

FIRST USE 6-0-2003; IN COMMERCE 6-0-2003.
ERIN FALK, EXAMINING ATTORNEY

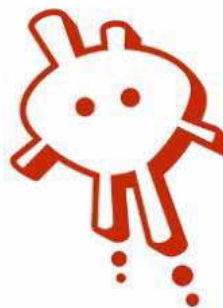

SN 85-109,724. FALCON PICTURE GROUP, LLC, EAST DUNDEE, IL. FILED 8-17-2010.

TRUTH & LIFE DRAMATIZED AUDIO BIBLE

THE MARK CONSISTS OF STANDARD CHARACTERS WITHOUT CLAIM TO ANY PARTICULAR FONT, STYLE, SIZE, OR COLOR.

NO CLAIM IS MADE TO THE EXCLUSIVE RIGHT TO USE "DRAMATIZED AUDIO BIBLE", APART FROM THE MARK AS SHOWN.

CLASS 9—ELECTRICAL AND SCIENTIFIC APPARATUS

FOR DIGITAL MATERIALS, NAMELY, CDS, DOWNLOADABLE MP3 FILES AND MP3 RECORDINGS, DVDS, VIDEO CASSETTES AND VIDEO DISCS ALL FEATURING BIBLE AND RELIGIOUS REFERENCE MATERIALS (U.S. CLS. 21, 23, 26, 36 AND 38).

CLASS 38—COMMUNICATION

FOR STREAMING OF AUDIO AND VIDEO MATERIALS ON THE INTERNET FEATURING BIBLE AND RELIGIOUS REFERENCE MATERIALS (U.S. CLS. 100, 101 AND 104).

JULIE WATSON, EXAMINING ATTORNEY

THE COLOR(S) ORANGE AND WHITE IS/ARE CLAIMED AS A FEATURE OF THE MARK.

THE MARK CONSISTS OF A DRAWING OF A CHARACTER WITH AN ORANGE OUTLINE AND WHITE ON THE INSIDE WITH TWO ORANGE DOTS REPRESENTING EYES, AND FOUR ORANGE DOTS UNDERNEATH THE CHARACTER.

CLASS 9—ELECTRICAL AND SCIENTIFIC APPARATUS

FOR DOWNLOADABLE SOFTWARE IN THE NATURE OF A MOBILE APPLICATION ENCOURAGING PHYSICAL ACTIVITY AND IMPROVE HEALTH BY AWARDED POINTS THAT MAY BE EXCHANGED FOR GOODS OR SERVICES, SUCH AS VIRTUAL GOODS, DIGITAL CONTENT, MERCHANDISE, COUPONS, REBATES, DISCOUNTS OR SPECIAL OFFERINGS, PROVIDED OR MADE AVAILABLE BY APPLICANT OR BY THIRD PARTY SPONSORS, WEB SITES, RETAILERS OR DONORS (U.S. CLS. 21, 23, 26, 36 AND 38).

CLASS 42—SCIENTIFIC AND COMPUTER SERVICES

FOR COMPUTER SERVICES, NAMELY, PROVIDING AN INTERACTIVE WEB SITE THAT ENCOURAGES USERS TO ENGAGE IN PHYSICAL ACTIVITIES AND IMPROVE HEALTH BY AWARDED POINTS THAT MAY BE EXCHANGED FOR GOODS OR SERVICES, SUCH AS VIRTUAL GOODS, DIGITAL CONTENT, MERCHANDISE, COUPONS, REBATES, DISCOUNTS OR SPECIAL OFFERINGS, PROVIDED OR MADE AVAILABLE BY APPLICANT OR BY THIRD PARTY SPONSORS, WEB SITES, RETAILERS OR DONORS (U.S. CLS. 100 AND 101).

STEVEN JACKSON, EXAMINING ATTORNEY

SN 85-110,797. ABLE PLANET, INCORPORATED, WHEAT RIDGE, CO. FILED 8-18-2010.

SN 85-110,811. ABLE PLANET, INCORPORATED, WHEAT RIDGE, CO. FILED 8-18-2010.



THE MARK CONSISTS OF A HAND CREATING THE SIGN LANGUAGE SYMBOL FOR THE LETTER X.

CLASS 9—ELECTRICAL AND SCIENTIFIC APPARATUS

FOR AUDIO AND COMMUNICATION DEVICES FOR IMPROVING ACOUSTIC CLARITY AND AUDIO TRANSMISSION AND RECEPTION FOR ASSISTING PERSONS WITH SENSORY OR COGNITIVE IMPAIRMENTS AND TO PRESERVE HEARING LEVELS, NAMELY, WIRED AND WIRELESS ADAPTED HEADPHONES AND HEADSETS FOR USE IN AUDIO, CELLULAR VOICE OVER INTERNET PROTOCOL AND TELECOMMUNICATIONS; AND CORDED AND CORDLESS ADAPTED TELEPHONES (U.S. CLS. 21, 23, 26, 36 AND 38).

CLASS 10—MEDICAL APPARATUS

FOR ASSISTIVE LISTENING DEVICE FOR THE HEARING IMPAIRED; ELECTRIC HEARING AIDS; ELECTRICAL HEARING AIDS; ELECTRICALLY OPERATED HEARING AIDS; HEARING AIDS; HEARING AIDS FOR THE DEAF; WIRELESS TRANSMITTERS AND RECEIVERS FOR USE WITH HEARING AIDS (U.S. CLS. 26, 39 AND 44).

CLASS 18—LEATHER GOODS

FOR ALL PURPOSE BAGS, NAMELY, SPORTS, ATHLETIC, CARRY-ALL, DUFFLE, GYM, HIKING, MESH SHOPPING AND TOTE BAGS; BACKPACKS; POUCHES AND BAGS SOLD EMPTY FOR ATTACHMENT TO BACKPACKS; SACK PACKS, NAMELY, DRAWSTRING BAGS USED AS BACKPACKS; SOUVENIR BAGS; TRAVEL BAGS (U.S. CLS. 1, 2, 3, 22 AND 41).

CLASS 25—CLOTHING

FOR ARTICLES OF CLOTHING AND ATHLETIC APPAREL, NAMELY, SHIRTS, PANTS, JACKETS, FOOTWEAR, HATS AND CAPS, ATHLETIC UNIFORMS; HEADGEAR, NAMELY, BASEBALL TYPE HATS OR BEANIES; HOODED SWEAT SHIRTS; JERSEYS; LONG-SLEEVED SHIRTS; MOISTURE-WICKING SPORTS SHIRTS; SHORT-SLEEVED OR LONG-SLEEVED T-SHIRTS; SPORTS JERSEYS, SWEATERS (U.S. CLS. 22 AND 39).

ARETHA SOMERVILLE, EXAMINING ATTORNEY



THE MARK CONSISTS OF A HAND CREATING THE SIGN LANGUAGE SYMBOL FOR THE LETTER "X" ON TOP OF THE WORD "EXTREME". THE ENTIRE WORD CAPITALIZED WITH THE "X" SLIGHTLY LARGER AND ON A SLIGHT SLANT.

CLASS 9—ELECTRICAL AND SCIENTIFIC APPARATUS

FOR AUDIO AND COMMUNICATION DEVICES FOR IMPROVING ACOUSTIC CLARITY AND AUDIO TRANSMISSION AND RECEPTION FOR ASSISTING PERSONS WITH SENSORY OR COGNITIVE IMPAIRMENTS AND TO PRESERVE HEARING LEVELS, NAMELY, WIRED AND WIRELESS ADAPTED HEADPHONES AND HEADSETS FOR USE IN AUDIO, CELLULAR VOICE OVER INTERNET PROTOCOL AND TELECOMMUNICATIONS; AND CORDED AND CORDLESS ADAPTED TELEPHONES (U.S. CLS. 21, 23, 26, 36 AND 38).

CLASS 10—MEDICAL APPARATUS

FOR ASSISTIVE LISTENING DEVICE FOR THE HEARING IMPAIRED; ELECTRIC HEARING AIDS; ELECTRICAL HEARING AIDS; ELECTRICALLY OPERATED HEARING AIDS; HEARING AIDS; HEARING AIDS FOR THE DEAF; WIRELESS TRANSMITTERS AND RECEIVERS FOR USE WITH HEARING AIDS (U.S. CLS. 26, 39 AND 44).

CLASS 18—LEATHER GOODS

FOR ALL PURPOSE BAGS, NAMELY, SPORTS, ATHLETIC, CARRY-ALL, DUFFLE, GYM, HIKING, MESH SHOPPING AND TOTE BAGS; BACKPACKS; POUCHES AND BAGS SOLD EMPTY FOR ATTACHMENT TO BACKPACKS; SACK PACKS, NAMELY, DRAWSTRING BAGS USED AS BACKPACKS; SOUVENIR BAGS; TRAVEL BAGS (U.S. CLS. 1, 2, 3, 22 AND 41).

CLASS 25—CLOTHING

FOR ARTICLES OF CLOTHING AND ATHLETIC APPAREL, NAMELY, SHIRTS, PANTS, JACKETS, FOOTWEAR, HATS AND CAPS, ATHLETIC UNIFORMS; HEADGEAR, NAMELY, BASEBALL TYPE HATS OR BEANIES; HOODED SWEAT SHIRTS; JERSEYS; LONG-SLEEVED SHIRTS; MOISTURE-WICKING SPORTS SHIRTS; SHORT-SLEEVED OR LONG-SLEEVED T-SHIRTS; SPORTS JERSEYS, SWEATERS (U.S. CLS. 22 AND 39).

ARETHA SOMERVILLE, EXAMINING ATTORNEY

SN 85-110,923. ANDERSEN & ASSOCIATES, WIXOM, MI.
FILED 8-19-2010.

MICHAEL SOUDERS, EXAMINING ATTORNEY

ULTRASTORE

THE MARK CONSISTS OF STANDARD CHARACTERS WITHOUT CLAIM TO ANY PARTICULAR FONT, STYLE, SIZE, OR COLOR.

CLASS 7—MACHINERY

FOR CONVEYOR AND TRANSPORT SYSTEM CONSISTING PRIMARILY OF CONVEYORS, CAROUSEL MOUNTED STORAGE BINS, PACKAGE IDENTIFICATION SENSORS, AND CONTINUOUSLY ROTATABLE CAROUSELS AND CAROUSEL DRIVE MOTORS FOR MOVING GOODS INTO AND OUT OF TEMPORARY STORAGE AREAS (U.S. CLS. 13, 19, 21, 23, 31, 34 AND 35).

CLASS 9—ELECTRICAL AND SCIENTIFIC APPARATUS

FOR COMPUTER SYSTEM CONSISTING PRIMARILY OF COMPUTER HARDWARE INCLUDING DATA INPUT/OUTPUT TERMINALS, COMPUTER SOFTWARE ASSIGNING AND TRACKING UNIQUE PACKAGE IDENTIFIERS, AND MEMORY DEVICES FOR STORAGE AND RETRIEVAL OF IDENTIFIERS FOR MONITORING THE POSITION OF ITEMS IN A CONVEYOR AND TRANSPORT SYSTEM (U.S. CLS. 21, 23, 26, 36 AND 38).

MICHAEL SOUDERS, EXAMINING ATTORNEY

SN 85-110,970. ANDERSEN & ASSOCIATES, WIXOM, MI.
FILED 8-19-2010.

ULTRASERT

THE MARK CONSISTS OF STANDARD CHARACTERS WITHOUT CLAIM TO ANY PARTICULAR FONT, STYLE, SIZE, OR COLOR.

CLASS 7—MACHINERY

FOR CONVEYOR AND PRINTING AND HANDLING SYSTEM CONSISTING PRIMARILY OF CONVEYOR, PRINTING MACHINE, CONVEYOR SUPPORT STAND, PACKAGE LOCATION SENSORS AND DOCUMENT INSERTION ARM THAT PRINTS AND INSERTS DOCUMENTS INTO A PACKAGE MOVING ON A CONVEYOR (U.S. CLS. 13, 19, 21, 23, 31, 34 AND 35).

FIRST USE 4-27-2010; IN COMMERCE 4-27-2010.

CLASS 9—ELECTRICAL AND SCIENTIFIC APPARATUS

FOR CONVEYOR AND PRINTING AND HANDLING SYSTEM CONSISTING PRIMARILY OF CONVEYOR CONTROL SOFTWARE AND HARDWARE, PRINTING MACHINE, PACKAGE LOCATION SENSORS, CONVEYOR, CONVEYOR SUPPORT STAND, AND DOCUMENT INSERTION ARM THAT PRINTS AND INSERTS DOCUMENTS INTO A PACKAGE MOVING ON A CONVEYOR (U.S. CLS. 21, 23, 26, 36 AND 38).

FIRST USE 4-27-2010; IN COMMERCE 4-27-2010.

SN 85-111,455. SOUTHDATA, INC., MOUNT AIRY, NC.
FILED 8-19-2010.

SOUTHDATA

THE MARK CONSISTS OF STANDARD CHARACTERS WITHOUT CLAIM TO ANY PARTICULAR FONT, STYLE, SIZE, OR COLOR.

CLASS 35—ADVERTISING AND BUSINESS

FOR DIRECT MAIL ADVERTISING SERVICES (U.S. CLS. 100, 101 AND 102).
FIRST USE 7-0-1985; IN COMMERCE 7-0-1985.

CLASS 39—TRANSPORTATION AND STORAGE

FOR WAREHOUSING SERVICES, NAMELY, STORAGE OF NON-ELECTRONIC DOCUMENTS FOR OTHERS; POSTAL SERVICES, NAMELY, PRESORTING, STUFFING, SEALING, POSTAGE METERING, BUNDLING AND DELIVERING MAIL TO POST OFFICE (U.S. CLS. 100 AND 105).

FIRST USE 7-0-2007; IN COMMERCE 7-0-2007.

CLASS 40—MATERIAL TREATMENT

FOR PRINTING SERVICES, NAMELY, CUSTOM PRINTING OF REMITTANCE DOCUMENT PRODUCTS, INCLUDING PAYMENT COUPON BOOKS AND BILLING STATEMENTS, CUSTOM PRINTING OF MARKETING COMMUNICATIONS, ANNUAL REPORTS, PROGRAM ENROLLMENT PACKETS, TAX DOCUMENTS, IDENTIFICATION CARDS, PRODUCT GUIDES, BUSINESS FORMS AND EMPLOYEE BENEFIT GUIDES; DOCUMENT SCANNING AND DIGITAL IMAGING SERVICES (U.S. CLS. 100, 103 AND 106).

FIRST USE 7-0-1985; IN COMMERCE 7-0-1985.

DOMINIC J. FERRAIUOLO, EXAMINING ATTORNEY

SN 85-112,311. INGENIOUS GROUP, INC., NEW HARTFORD, CT. FILED 8-20-2010.



ingenious Group

OWNER OF U.S. REG. NO. 2,884,183.
NO CLAIM IS MADE TO THE EXCLUSIVE RIGHT TO USE "GROUP", APART FROM THE MARK AS SHOWN.

THE MARK CONSISTS OF THE STYLIZED WORDING "INGENIOUS GROUP" BELOW A LOWERCASE "I" AND DOT CONTAINING A SPIRAL DESIGN.

SN 85-112,631. MARK W. CROSS & CO., LLC, ALPHARETTA, GA. FILED 8-20-2010.

CLASS 9—ELECTRICAL AND SCIENTIFIC APPARATUS

FOR COMPUTER SOFTWARE FOR USE IN SURVEYING INDIVIDUALS AND ASSESSING AND TESTING INDIVIDUALS TO MEASURE THEIR SKILLS, KNOWLEDGE, PROGRESS, PRODUCTIVITY, AND SUITABILITY FOR WORK IN PARTICULAR AREAS, WHICH SOFTWARE MAY BE DOWNLOADED FROM A GLOBAL COMPUTER NETWORK OR DELIVERED IN HARD COPY FORM (U.S. CLS. 21, 23, 26, 36 AND 38).

FIRST USE 2-1-2007; IN COMMERCE 2-1-2007.

CLASS 42—SCIENTIFIC AND COMPUTER SERVICES

FOR PROVIDING CUSTOMIZED WEB-BASED APPLICATIONS FOR BUSINESSES OR OTHER ORGANIZATIONS FOR SURVEYING INDIVIDUALS AND ASSESSING AND TESTING INDIVIDUALS TO MEASURE THEIR SKILLS, KNOWLEDGE, PROGRESS, PRODUCTIVITY, AND SUITABILITY IN PARTICULAR AREAS (U.S. CLS. 100 AND 101).

FIRST USE 2-1-2007; IN COMMERCE 2-1-2007.
NELSON SNYDER, EXAMINING ATTORNEY

MARK CROSS 1845

THE MARK CONSISTS OF STANDARD CHARACTERS WITHOUT CLAIM TO ANY PARTICULAR FONT, STYLE, SIZE, OR COLOR.

NO CLAIM IS MADE TO THE EXCLUSIVE RIGHT TO USE "1845", APART FROM THE MARK AS SHOWN.

THE NAME(S), PORTRAIT(S), AND/OR SIGNATURE(S) SHOWN IN THE MARK DOES NOT IDENTIFY A PARTICULAR LIVING INDIVIDUAL.

CLASS 3—COSMETICS AND CLEANING PREPARATIONS

FOR COLOGNES AND PERFUMES (U.S. CLS. 1, 4, 6, 50, 51 AND 52).

CLASS 9—ELECTRICAL AND SCIENTIFIC APPARATUS

FOR EYEWEAR (U.S. CLS. 21, 23, 26, 36 AND 38).

CLASS 14—JEWELRY

FOR WATCHES (U.S. CLS. 2, 27, 28 AND 50).

CLASS 18—LEATHER GOODS

FOR LEATHER GOODS, NAMELY, HANDBAGS, KEY CASES, CLUTCH BAGS AND CLUTCH PURSES, NAME CARD CASES, PURSES, WALLETS, BILLFOLDS, LEATHER BRIEFCASES, LUGGAGE, PORTFOLIOS, CAR KEY FOB CASES, CURRENCY CASES, CREDIT CARD CASES, TICKET CASES, COSMETIC CASES SOLD EMPTY, GROOMING CASES SOLD EMPTY (U.S. CLS. 1, 2, 3, 22 AND 41).

CLASS 25—CLOTHING

FOR WOMEN'S CLOTHING AND APPAREL, NAMELY, DRESSES, JACKETS, SKIRTS, TROUSERS, SWEATERS, KERCHIEFS, NECKERCHIEFS, SCARVES, AND FOOTWEAR; AND MEN'S CLOTHING AND APPAREL, NAMELY, SUITS, JACKETS, TROUSERS, KNITWEAR, DRESS AND SPORT SHIRTS, NECKWEAR, NECKTIES, AND FOOTWEAR (U.S. CLS. 22 AND 39).

MORGAN WYNNE, EXAMINING ATTORNEY

SN 85-112,586. SMITH, KEVIN, TROY, MI. FILED 8-20-2010.

V20C

THE MARK CONSISTS OF STANDARD CHARACTERS WITHOUT CLAIM TO ANY PARTICULAR FONT, STYLE, SIZE, OR COLOR.

CLASS 9—ELECTRICAL AND SCIENTIFIC APPARATUS

FOR SOFTWARE FOR DEVELOPING CONSUMER PRODUCTS (U.S. CLS. 21, 23, 26, 36 AND 38).

CLASS 42—SCIENTIFIC AND COMPUTER SERVICES

FOR PRODUCT DEVELOPMENT CONSULTATION; SERVICES OF DEVELOPING NEW PRODUCTS USING A CO-CREATION DEVELOPMENTAL PROCESS; SERVICES OF UPSTREAM PRODUCT DEVELOPMENT; NEW PRODUCT DESIGN SERVICES (U.S. CLS. 100 AND 101).

JOHN KELLY, EXAMINING ATTORNEY

SN 85-113,467. VEXPRO, LLC, NAPLES, FL. FILED 8-23-2010.

VEXPRO

NO CLAIM IS MADE TO THE EXCLUSIVE RIGHT TO USE "PRO", APART FROM THE MARK AS SHOWN.

THE MARK CONSISTS OF THE WORDS "VEX PRO" SEPARATED BY VARYING SIZE DOTS.

CLASS 11—ENVIRONMENTAL CONTROL APPARATUS

FOR HAND HELD ELECTRIC HAIR DRYERS (U.S. CLS. 13, 21, 23, 31 AND 34).

CLASS 21—HOUSEWARES AND GLASS

FOR PLASTIC BOWLS AND PLASTIC STORAGE ORGANIZER CONTAINERS FOR COLORING, CUTTING AND STYLING HAIR (U.S. CLS. 2, 13, 23, 29, 30, 33, 40 AND 50).

HOWARD B. LEVINE, EXAMINING ATTORNEY

SN 85-113,700. ANYWIRE CORPORATION, KYOTO, JAPAN, FILED 8-23-2010.

Anywire

THE MARK CONSISTS OF STANDARD CHARACTERS WITHOUT CLAIM TO ANY PARTICULAR FONT, STYLE, SIZE, OR COLOR.

OWNER OF JAPAN REG. NO. 4580632, DATED 6-28-2002, EXPIRES 6-28-2012.

CLASS 7—MACHINERY

FOR MACHINE ELEMENTS NOT FOR LAND VEHICLES, NAMELY, BEARINGS, SHAFT COUPLINGS AND CONNECTORS, VALVES (U.S. CLS. 13, 19, 21, 23, 31, 34 AND 35).

CLASS 9—ELECTRICAL AND SCIENTIFIC APPARATUS

FOR ELECTRICAL POWER DISTRIBUTION UNITS; ELECTRONIC CONTROL SYSTEMS FOR MACHINES; ELECTRIC WIRES AND CABLES; REMOTE CONTROL TELEMETERING MACHINES AND INSTRUMENTS; COMPUTERS; COMPUTER CENTRAL PROCESSING UNITS; ELECTRONIC CIRCUITS; COMPUTER PERIPHERAL DEVICES; ELECTRONIC CIRCUITS; INTEGRATED CIRCUITS (U.S. CLS. 21, 23, 26, 36 AND 38).

PATRICIA EVANKO, EXAMINING ATTORNEY

SN 85-113,709. ANYWIRE CORPORATION, KYOTO, JAPAN, FILED 8-23-2010.



OWNER OF JAPAN REG. NO. 4786411, DATED 7-16-2004, EXPIRES 7-16-2014.

THE COLOR(S) RED AND BLACK IS/ARE CLAIMED AS A FEATURE OF THE MARK.

THE MARK CONSISTS OF THE STYLIZED WORD "ANYWIRE" WITH THE "A" APPEARING IN RED, WITH THE REMAINING PORTION OF THE MARK APPEARING IN BLACK.

CLASS 7—MACHINERY

FOR MACHINE ELEMENTS NOT FOR LAND VEHICLES, NAMELY, BEARINGS, SHAFT COUPLINGS AND CONNECTORS, VALVES (U.S. CLS. 13, 19, 21, 23, 31, 34 AND 35).

CLASS 9—ELECTRICAL AND SCIENTIFIC APPARATUS

FOR ELECTRICAL POWER DISTRIBUTION UNITS; ELECTRONIC CONTROL SYSTEMS FOR MACHINES; ELECTRIC WIRES AND CABLES; REMOTE CONTROL TELEMETERING MACHINES AND INSTRUMENTS; COMPUTERS; COMPUTER CENTRAL PROCESSING UNITS; ELECTRONIC CIRCUITS; COMPUTER PERIPHERAL DEVICES; ELECTRONIC CIRCUITS; INTEGRATED CIRCUITS (U.S. CLS. 21, 23, 26, 36 AND 38).

PATRICIA EVANKO, EXAMINING ATTORNEY

SN 85-113,780. NUDY'S EAST SIDE CAFE, LTD., WAYNE, PA. FILED 8-23-2010.

Nudy's
C a f e

NO CLAIM IS MADE TO THE EXCLUSIVE RIGHT TO USE "CAFÉ", APART FROM THE MARK AS SHOWN.

THE MARK CONSISTS OF THE WORD "NUDY'S" OVER THE WORD "CAFÉ" WITH THE LETTER "E" IN "CAFÉ" HAVING AN ACCENT.

CLASS 35—ADVERTISING AND BUSINESS

FOR RESTAURANT FRANCHISING, NAMELY, OFFERING BUSINESS MANAGEMENT ASSISTANCE IN THE ESTABLISHMENT AND/OR OPERATION OF RESTAURANTS (U.S. CLS. 100, 101 AND 102).

FIRST USE 11-1-2001; IN COMMERCE 11-1-2001.

CLASS 43—HOTEL AND RESTAURANT SERVICES

FOR CAFE-RESTAURANTS (U.S. CLS. 100 AND 101).

FIRST USE 11-1-2001; IN COMMERCE 11-1-2001.

JAMES STEIN, EXAMINING ATTORNEY

SN 85-113,793. WHITLEY, BILL, CHARLOTTE, NC. FILED 8-23-2010.

SN 85-114,061. BRAND U MEDIA, INC, MONTREAL, QC, CANADA, FILED 8-23-2010.



THE COLOR(S) AQUAMARINE, ORANGE, PURPLE AND WHITE IS/ARE CLAIMED AS A FEATURE OF THE MARK.

THE MARK CONSISTS OF THE WORDS "THE STORY" IN AQUAMARINE WITH A TARGET FORMING THE LETTER "O" AND AN ORANGE ARROW ON THE TARGET. THE WORD "ADVANTAGE" IS IN PURPLE, AND THE ENTIRE MARK IS AGAINST A WHITE BACKGROUND.

CLASS 16—PAPER GOODS AND PRINTED MATTER

FOR WRITTEN ARTICLES, BROCHURES, MAGAZINES, MANUALS, NEWSLETTERS, NEWSPAPERS, PAMPHLETS AND PERIODICALS, PRINTED EDUCATIONAL, INSTRUCTIONAL AND TEACHING MATERIALS, SERIES OF BOOKS AND WORKBOOKS IN THE FIELDS OF BUSINESS DEVELOPMENT, COMMUNICATION, CONFLICT RESOLUTION, LEADERSHIP, MANAGEMENT, MARKETING, MOTIVATION, PERFORMANCE AND PERSONAL EMPOWERMENT; AGENDAS; BOOKMARKS; CALENDARS; DESK DIARIES; EVENT, PHOTOGRAPH AND SCRAPBOOK ALBUMS; PROMOTIONAL POSTCARDS AND POSTERS; DECALS AND STICKERS; PENS AND PENCILS (U.S. CLS. 2, 5, 22, 23, 29, 37, 38 AND 50).

CLASS 41—EDUCATION AND ENTERTAINMENT

FOR ARRANGING AND CONDUCTING EDUCATIONAL CONFERENCES; CONDUCTING SEMINARS AND WORKSHOPS, PROVIDING EDUCATIONAL AND MOTIVATIONAL SPEAKERS, AND PERSONAL COACHING SERVICES, ALL IN THE FIELDS OF BUSINESS DEVELOPMENT, COMMUNICATION, CONFLICT RESOLUTION, LEADERSHIP, MANAGEMENT, MARKETING, MOTIVATION, PERFORMANCE AND PERSONAL EMPOWERMENT (U.S. CLS. 100, 101 AND 107).

IRA J. GOODSALD, EXAMINING ATTORNEY



THE MARK CONSISTS OF THE LETTERS "H", "D", "R", "S", AND "H" IN STYLIZED FORM.

CLASS 18—LEATHER GOODS

FOR SPORTS BAGS, TRAVEL BAGS (U.S. CLS. 1, 2, 3, 22 AND 41).

CLASS 25—CLOTHING

FOR CLOTHING, NAMELY, T-SHIRTS, LONG SLEEVE SHIRTS, TANK TOPS, HOODED SWEATSHIRTS, SWEATSHIRTS, JACKETS, PANTS, SHORTS, WARM-UP SUITS, DRESSES, CAPS, BEANIES, SOCKS, WRIST AND HEAD BANDS, LADIES' UNDERWEAR, MEN'S UNDERWEAR, LEATHER AND CLOTH BELTS, BATHING SUITS (U.S. CLS. 22 AND 39).

AISHA CLARKE, EXAMINING ATTORNEY

SN 85-114,499. STRANDED FOODIE, LLC, RALEIGH, NC. FILED 8-24-2010.

FIND OR MAKE WHAT YOU'RE MISSING

THE MARK CONSISTS OF STANDARD CHARACTERS WITHOUT CLAIM TO ANY PARTICULAR FONT, STYLE, SIZE, OR COLOR.

CLASS 25—CLOTHING

FOR CLOTHING, NAMELY, APRONS, TOQUES, BASEBALL CAPS, VISORS; SHIRTS, NAMELY, POLO SHIRTS, T-SHIRTS, AND CHEF'S COATS (U.S. CLS. 22 AND 39).

CLASS 35—ADVERTISING AND BUSINESS

FOR ONLINE RETAIL STORE SERVICES FEATURING FOOD, BOOKS, AND CLOTHING (U.S. CLS. 100, 101 AND 102).

MICHAEL LITZAU, EXAMINING ATTORNEY

SN 85-114,732. JAS WORLDWIDE S.A.R.L., MUNSBACH, LUXEMBOURG, FILED 8-24-2010.



PRIORITY CLAIMED UNDER SEC. 44(D) ON ERPN CMNTY TM OFC APPLICATION NO. 9316993, FILED 8-16-2010, REG. NO. 009316993, DATED 1-7-2011, EXPIRES 8-16-2020.

THE MARK CONSISTS OF THE LETTERS "ORBIS" WITHIN AN OVAL SHAPE RIGHT NEXT TO THE BUBBLED LETTERS "JAS" WITH THE WORDS "TOTAL SUPPLY CHAIN SOLUTION VISIBILITY" UNDERNEATH.

CLASS 9—ELECTRICAL AND SCIENTIFIC APPARATUS

FOR COMPUTER PROGRAMS AND COMPUTER SOFTWARE, NAMELY, COMPUTER PROGRAMS AND COMPUTER SOFTWARE DESIGNED FOR USE IN MANAGING TRANSPORTATION, FREIGHT, PACKAGING AND STORAGE OF GOODS AND TRAVEL ARRANGEMENT (U.S. CLS. 21, 23, 26, 36 AND 38).

CLASS 39—TRANSPORTATION AND STORAGE

FOR TRANSPORT OF GOODS; PACKAGING AND STORAGE OF GOODS; TRAVEL ARRANGEMENT (U.S. CLS. 100 AND 105).

CLASS 42—SCIENTIFIC AND COMPUTER SERVICES

FOR SCIENTIFIC AND TECHNOLOGICAL SERVICES, NAMELY, SCIENTIFIC RESEARCH AND DEVELOPMENT RELATED TO TRANSPORTATION, FREIGHT MANAGEMENT, PACKAGING AND STORAGE OF GOODS AND TRAVEL ARRANGEMENT; INDUSTRIAL ANALYSIS AND RESEARCH SERVICES IN THE FIELD OF COMPUTER SYSTEMS IN RELATION TO TRANSPORTATION, FREIGHT MANAGEMENT, PACKAGING AND STORAGE OF GOODS AND TRAVEL ARRANGEMENT; DESIGN AND DEVELOPMENT OF COMPUTER HARDWARE AND SOFTWARE IN RELATION TO TRANSPORTATION, FREIGHT MANAGEMENT, PACKAGING AND STORAGE OF GOODS AND TRAVEL ARRANGEMENT (U.S. CLS. 100 AND 101).

JENNIFER VASQUEZ, EXAMINING ATTORNEY

SN 85-114,801. RICO INDUSTRIES, INC., NILES, IL. FILED 8-24-2010.

LIL' SPORTS BRAT

THE MARK CONSISTS OF STANDARD CHARACTERS WITHOUT CLAIM TO ANY PARTICULAR FONT, STYLE, SIZE, OR COLOR.

NO CLAIM IS MADE TO THE EXCLUSIVE RIGHT TO USE "SPORTS", APART FROM THE MARK AS SHOWN.

CLASS 5—PHARMACEUTICALS

FOR AIR FRESHENERS (U.S. CLS. 6, 18, 44, 46, 51 AND 52).

CLASS 14—JEWELRY

FOR KEY CHAINS AS JEWELLERY (U.S. CLS. 2, 27, 28 AND 50).

CLASS 18—LEATHER GOODS

FOR COIN PURSES (U.S. CLS. 1, 2, 3, 22 AND 41).
DOMINICK J. SALEMI, EXAMINING ATTORNEY

SN 85-114,909. IDEA NUOVA, INC., NEW YORK, NY. FILED 8-24-2010.

AMERICAN STYLES

THE MARK CONSISTS OF STANDARD CHARACTERS WITHOUT CLAIM TO ANY PARTICULAR FONT, STYLE, SIZE, OR COLOR.

NO CLAIM IS MADE TO THE EXCLUSIVE RIGHT TO USE "STYLES", APART FROM THE MARK AS SHOWN.

CLASS 20—FURNITURE AND ARTICLES NOT OTHERWISE CLASSIFIED

FOR PILLOWS (U.S. CLS. 2, 13, 22, 25, 32 AND 50).

CLASS 24—FABRICS

FOR BED BLANKETS; BED SHEETS; BLANKET THROWS; COMFORTERS; PILLOW CASES; PILLOW SHAMS (U.S. CLS. 42 AND 50).

HEATHER SAPP, EXAMINING ATTORNEY

SN 85-115,534. SYNIVERSE TECHNOLOGIES, INC., TAMPA, FL. FILED 8-25-2010.

SYNIVERSE GR INDEX

THE MARK CONSISTS OF STANDARD CHARACTERS WITHOUT CLAIM TO ANY PARTICULAR FONT, STYLE, SIZE, OR COLOR.

OWNER OF U.S. REG. NOS. 3,109,723, 3,780,123 AND OTHERS.

NO CLAIM IS MADE TO THE EXCLUSIVE RIGHT TO USE "INDEX", APART FROM THE MARK AS SHOWN.

CLASS 35—ADVERTISING AND BUSINESS

FOR BUSINESS DATA ANALYSIS, NAMELY, PROVIDING ANALYSIS OF GLOBAL ROAMING MOBILE TELEPHONE COMMUNICATIONS TO BUSINESSES (U.S. CLS. 100, 101 AND 102).

CLASS 38—COMMUNICATION

FOR PROVIDING INFORMATION ABOUT TELECOMMUNICATION RELATING TO MOBILE TELEPHONE COMMUNICATION IN THE NATURE OF GLOBAL ROAMING ACTIVITY OF MOBILE TELEPHONE USERS (U.S. CLS. 100, 101 AND 104).

CLASS 42—SCIENTIFIC AND COMPUTER SERVICES

FOR MEASURING GLOBAL ROAMING ACTIVITY OF MOBILE USERS IN THE NATURE OF MEASUREMENT EVALUATION IN THE TELECOMMUNICATIONS FIELD, NAMELY, MEASUREMENT EVALUATION OF THE GLOBAL ROAMING ACTIVITY OF MOBILE TELEPHONE USERS (U.S. CLS. 100 AND 101).

BRENDAN MCCAULEY, EXAMINING ATTORNEY

SN 85-115,614. MOORE, DAVID L., HOUSTON, TX. FILED 8-25-2010.

PENPARKE ENTERPRISES

THE MARK CONSISTS OF STANDARD CHARACTERS WITHOUT CLAIM TO ANY PARTICULAR FONT, STYLE, SIZE, OR COLOR.

NO CLAIM IS MADE TO THE EXCLUSIVE RIGHT TO USE "ENTERPRISES", APART FROM THE MARK AS SHOWN.

CLASS 14—JEWELRY

FOR JEWELRY ACCESSORIES, NAMELY, RETENTION DEVICES OR FLEXIBLE GUARDS, USED TO PROTECT JEWELRY AGAINST LOSS, TWISTING AND TURNING FOR THE PURPOSE OF MAKING A STANDARD RING STAY ON THE FINGER IF TOO LARGE; JEWELRY BRACELET STORAGE BOXES (U.S. CLS. 2, 27, 28 AND 50).

CLASS 16—PAPER GOODS AND PRINTED MATTER

FOR DECORATIVE PAPER BOWS FOR WRAPPING (U.S. CLS. 2, 5, 22, 23, 29, 37, 38 AND 50).

CLASS 26—FANCY GOODS

FOR CELEBRATION BOWS FOR WRAPPING; ORNAMENTAL BOWS OF TEXTILE FOR DECORATION (U.S. CLS. 37, 39, 40, 42 AND 50).

SIMON TENG, EXAMINING ATTORNEY

SN 85-116,539. RUGBY ONLINE, LLC, VOORHEES, NJ. FILED 8-26-2010.



NO CLAIM IS MADE TO THE EXCLUSIVE RIGHT TO USE "RUGBY", APART FROM THE MARK AS SHOWN.

THE MARK CONSISTS OF A RUGBY BALL WITH CURVED LINES AND THE WORDING "WE ARE RUGBY" ENCLOSED WITHIN THE BALL.

CLASS 25—CLOTHING

FOR (BASED ON INTENT TO USE) BASEBALL CAPS AND HATS; RUGBY SHIRTS; SPORTS JERSEYS; TEE SHIRTS (U.S. CLS. 22 AND 39).

CLASS 41—EDUCATION AND ENTERTAINMENT

FOR (BASED ON USE IN COMMERCE) PROVIDING A WEBSITE CONTAINING INFORMATION RELATING TO THE SPORT OF RUGBY, INCLUDING TEAM INFORMATION, PLAYER STATISTICS AND NEWS (U.S. CLS. 100, 101 AND 107).

FIRST USE 8-15-2010; IN COMMERCE 8-15-2010.

MARTHA FROMM, EXAMINING ATTORNEY

SN 85-116,601. INTEUS INTERNATIONAL, NORWOOD, NJ. FILED 8-26-2010.

IEOLUS

THE MARK CONSISTS OF STANDARD CHARACTERS WITHOUT CLAIM TO ANY PARTICULAR FONT, STYLE, SIZE, OR COLOR.

CLASS 18—LEATHER GOODS

FOR ALL-PURPOSE CARRYING BAGS; HANDBAGS, POCKETBOOKS, SHOULDER BAGS, CLUTCH PURSES, CREDIT CARD CASES, KEY CASES, PURSES, SHOPPING BAGS MADE OF LEATHER, POUCHES OF LEATHER OR TEXTILE, TOTE BAGS, TRAVEL BAGS, COSMETIC BAGS SOLD EMPTY, BACKPACKS, DUFFLE BAGS, SLING BAGS, OVERNIGHT BAGS, OVERNIGHT CASES, WEEKENDER BAGS, CARRY-ON BAGS, ATTACHÉ CASES, SATCHELS, BELT BAGS, WALLETS, UMBRELLAS (U.S. CLS. 1, 2, 3, 22 AND 41).

CLASS 25—CLOTHING

FOR CLOTHING, NAMELY, COATS, RAINCOATS, PARKAS, BLAZERS, JACKETS, CARDIGANS, BOLEROS, SPORT COATS, WIND RESISTANT JACKETS, FUR STOLE, SUITS, VESTS, DRESSES, EVENING GOWNS, JUMPERS, SKIRTS, PANTS, SLACKS, TROUSERS, JEANS, SHORTS, JUMPSUITS, OVERALLS, GYM SUITS, JOGGING SUITS, SWEATPANTS, SWEATSHIRTS, SWEATERS, PULLOVERS, JERSEYS, SHIRTS, FORMAL SHIRTS, BLOUSES, TUNICS, T-SHIRTS, TANK TOPS, BODY SUITS, CAMISOLES, CHEMISES, UNDERSHIRTS, SLIPS, BRASSIERES, BUSTIERS, PANTIES, LINGERIE, NIGHTGOWNS, NEGLIGES, ROBES, PAJAMAS, HOSIERY, PANTYHOSE, TIGHTS, LEGGINGS, KNEE HIGH STOCKINGS, SOCKS, SCARVES, SHAWLS, NECKERCHIEFS, GLOVES, MITTENS, BELTS, SASHES, SWIMWEAR, BEACHWEAR, FOUNDATION GARMENTS, BODY SHAPERS, GARTER BELTS, SARONGS, HATS, CAPS, HOODS, BERETS, EAR MUFFS, HEADBANDS, SHOES, SANDALS, BOOTS, HIGH BOOTS, SLIPPERS, SNEAKERS, ATHLETIC SHOES, GALOSHES, SWIMWEAR, BATHING SUITS, BATHING TRUNKS, SKI WEAR, SKI SUITS, SKI PANTS, SKI GLOVES (U.S. CLS. 22 AND 39).

ALEXANDER L. POWERS, EXAMINING ATTORNEY

SN 85-116,639. TUSCO CORP., SARATOGA SPRINGS, NY.
FILED 8-26-2010.

SN 85-117,109. THE BENEFIT ADVANTAGE, INC., AUBURN
HILLS, MI. FILED 8-27-2010.

TUSCO

THE MARK CONSISTS OF STANDARD CHARACTERS
WITHOUT CLAIM TO ANY PARTICULAR FONT, STYLE,
SIZE, OR COLOR.

CLASS 6—METAL GOODS

FOR METAL PARTS FOR GAS TURBINES, NAMELY,
STUDS, NUTS, BOLTS, SCREWS, BOLTING PINS, AND
DOWEL PINS (U.S. CLS. 2, 12, 13, 14, 23, 25 AND 50).
FIRST USE 11-22-1978; IN COMMERCE 11-22-1978.

CLASS 7—MACHINERY

FOR GAS TURBINE PARTS, NAMELY, VALVE AS-
SEMBLIES, DIAPHRAGMS, RELIEF DIAPHRAGM AS-
SEMBLIES, PACKING RINGS, SEAL RINGS, SPILL
STRIPS, BALL BEARINGS, THRUST PLATES, GASKETS,
PISTON RINGS AND O-RINGS (U.S. CLS. 13, 19, 21, 23,
31, 34 AND 35).
FIRST USE 11-22-1978; IN COMMERCE 11-22-1978.
INGRID C. EULIN, EXAMINING ATTORNEY

SN 85-116,772. BLUE CROSS AND BLUE SHIELD ASSOCIA-
TION, AKA BLUECROSS BLUESHIELD ASSOCIATION,
CHICAGO, IL. FILED 8-26-2010.

AskBlue

THE MARK CONSISTS OF STANDARD CHARACTERS
WITHOUT CLAIM TO ANY PARTICULAR FONT, STYLE,
SIZE, OR COLOR.
OWNER OF U.S. REG. NO. 3,826,253.

CLASS 36—INSURANCE AND FINANCIAL

FOR PROVIDING AN INTERACTIVE WEB SITE FEAT-
URING INSURANCE PRODUCT INFORMATION (U.S.
CLS. 100, 101 AND 102).

CLASS 44—MEDICAL, BEAUTY AND AGRICULTURAL SERVICES

FOR PROVIDING AN INTERACTIVE WEB SITE FEAT-
URING HEALTH INFORMATION (U.S. CLS. 100 AND
101).
DANIEL CAPSHAW, EXAMINING ATTORNEY

TURN(K)EY

THE MARK CONSISTS OF STANDARD CHARACTERS
WITHOUT CLAIM TO ANY PARTICULAR FONT, STYLE,
SIZE, OR COLOR.

NO CLAIM IS MADE TO THE EXCLUSIVE RIGHT TO
USE "TURNKEY", APART FROM THE MARK AS SHOWN.

CLASS 16—PAPER GOODS AND PRINTED MATTER

FOR KITS COMPRISED OF PRINTED FORMS AND
WORKSHEETS RELATING TO THE DESIGN OF RE-
TIREDMENT PLANS AND PRINTED LEGAL FORMS
RELATING TO RETIREMENT PLANS (U.S. CLS. 2, 5,
22, 23, 29, 37, 38 AND 50).

CLASS 35—ADVERTISING AND BUSINESS

FOR BUSINESS ADMINISTRATION OF RETIREMENT
PLANS FOR OTHERS (U.S. CLS. 100, 101 AND 102).

CLASS 36—INSURANCE AND FINANCIAL

FOR DESIGN OF RETIREMENT PLANS FOR OTHERS
CONCERNING FINANCE (U.S. CLS. 100, 101 AND 102).
LINDA LAVACHE, EXAMINING ATTORNEY

SN 85-117,207. FAMOUS DAVE'S OF AMERICA, INC.,
MINNETONKA, MN. FILED 8-27-2010.

FAMOUS DAVE'S

THE MARK CONSISTS OF STANDARD CHARACTERS
WITHOUT CLAIM TO ANY PARTICULAR FONT, STYLE,
SIZE, OR COLOR.

OWNER OF U.S. REG. NOS. 2,360,550, 2,461,570 AND
OTHERS.

CLASS 16—PAPER GOODS AND PRINTED MATTER

FOR (BASED ON INTENT TO USE) COOKBOOKS (U.S.
CLS. 2, 5, 22, 23, 29, 37, 38 AND 50).

CLASS 21—HOUSEWARES AND GLASS

FOR (BASED ON USE IN COMMERCE) COOKING
UTENSILS, NAMELY, BARBEQUE TOOL SET COM-
PRISING BASTING BRUSH, FORK, SKEWER, SPATU-
LA, TONGS (U.S. CLS. 2, 13, 23, 29, 30, 33, 40 AND 50).
FIRST USE 0-0-2005; IN COMMERCE 0-0-2005.

CLASS 25—CLOTHING

FOR (BASED ON USE IN COMMERCE) T-SHIRTS;
HATS (U.S. CLS. 22 AND 39).
FIRST USE 0-0-1994; IN COMMERCE 0-0-1994.

CLASS 29—MEATS AND PROCESSED FOODS

FOR (BASED ON USE IN COMMERCE) PICKLES;
JERKY (U.S. CL. 46).
FIRST USE 0-0-2007; IN COMMERCE 0-0-2007.

CLASS 32—LIGHT BEVERAGES

FOR (BASED ON USE IN COMMERCE) NON-ALCO-
HOLIC COCKTAIL MIXES (U.S. CLS. 45, 46 AND 48).
FIRST USE 0-0-2006; IN COMMERCE 0-0-2006.
ADA HAN, EXAMINING ATTORNEY

SN 85-117,487. MACROGENICS, INC., ROCKVILLE, MD.
FILED 8-27-2010.



THE MARK CONSISTS OF A CHECK MARK SYMBOL,
STRAIGHT LINE AND CURVED LINE, AND THE TERM
"MACROGENICS". THE CURVED LINE APPEARS BE-
TWEEN THE LETTERS "O" AND "G" IN THE TERM
"MACROGENICS", THE CHECK MARK APPEARS ABOVE
THE LETTER "M" AND THE STRAIGHT LINE BELOW THE
LETTER "M".

SN 85-117,467. MACROGENICS, INC., ROCKVILLE, MD.
FILED 8-27-2010.

MACROGENICS

THE MARK CONSISTS OF STANDARD CHARACTERS
WITHOUT CLAIM TO ANY PARTICULAR FONT, STYLE,
SIZE, OR COLOR.

CLASS 5—PHARMACEUTICALS

FOR PHARMACEUTICAL PREPARATIONS AND SUB-
STANCES FOR THE TREATMENT OF AUTOIMMUNE
DISORDERS, INFLAMMATORY DISEASES AND CON-
DITIONS, METABOLIC DISORDERS, ALLERGIES, CAN-
CER, AND INFECTIOUS DISEASES (U.S. CLS. 6, 18, 44,
46, 51 AND 52).

CLASS 35—ADVERTISING AND BUSINESS

FOR PRODUCTION AND PRODUCT COMMERCIALI-
ZATION FOR THIRD PARTIES OF PHARMACEUTI-
CALS AND SUBSTANCES FOR THE TREATMENT OF
AUTOIMMUNE DISORDERS, INFLAMMATORY DIS-
EASES AND CONDITIONS, METABOLIC DISORDERS,
ALLERGIES, CANCER, AND INFECTIOUS DISEASES
(U.S. CLS. 100, 101 AND 102).

CLASS 42—SCIENTIFIC AND COMPUTER SERVICES

FOR DISCOVERY, RESEARCH, AND DEVELOPMENT
OF PHARMACEUTICALS AND SUBSTANCES FOR THE
TREATMENT OF AUTOIMMUNE DISORDERS, IN-
FLAMMATORY DISEASES AND CONDITIONS, META-
BOLIC DISORDERS, ALLERGIES, CANCER, AND
INFECTIOUS DISEASES; DISCOVERY, RESEARCH
AND DEVELOPMENT IN THE PHARMACEUTICAL
AND BIOTECHNOLOGY FIELDS; RESEARCH, DEVEL-
OPMENT, ENGINEERING AND TESTING SERVICES IN
THE FIELDS OF PHARMACEUTICAL AND BIOTECH-
NOLOGY FIELDS; PROVIDING MEDICAL AND SCIENTI-
FIC RESEARCH INFORMATION IN THE FIELD OF
PHARMACEUTICALS AND BIOTECHNOLOGY (U.S.
CLS. 100 AND 101).

HENRY S. ZAK, EXAMINING ATTORNEY

CLASS 5—PHARMACEUTICALS

FOR PHARMACEUTICAL PREPARATIONS AND SUB-
STANCES FOR THE TREATMENT OF AUTOIMMUNE
DISORDERS, INFLAMMATORY DISEASES AND CON-
DITIONS, METABOLIC DISORDERS, ALLERGIES, CAN-
CER, AND INFECTIOUS DISEASES (U.S. CLS. 6, 18, 44,
46, 51 AND 52).

CLASS 35—ADVERTISING AND BUSINESS

FOR PRODUCTION AND PRODUCT COMMERCIALI-
ZATION FOR THIRD PARTIES OF PHARMACEUTI-
CALS AND SUBSTANCES FOR THE TREATMENT OF
AUTOIMMUNE DISORDERS, INFLAMMATORY DIS-
EASES AND CONDITIONS, METABOLIC DISORDERS,
ALLERGIES, CANCER, AND INFECTIOUS DISEASES
(U.S. CLS. 100, 101 AND 102).

CLASS 42—SCIENTIFIC AND COMPUTER SERVICES

FOR DISCOVERY, RESEARCH, AND DEVELOPMENT
OF PHARMACEUTICALS AND SUBSTANCES FOR THE
TREATMENT OF AUTOIMMUNE DISORDERS, IN-
FLAMMATORY DISEASES AND CONDITIONS, META-
BOLIC DISORDERS, ALLERGIES, CANCER, AND
INFECTIOUS DISEASES; DISCOVERY, RESEARCH
AND DEVELOPMENT IN THE PHARMACEUTICAL
AND BIOTECHNOLOGY FIELDS; RESEARCH, DEVEL-
OPMENT, ENGINEERING AND TESTING SERVICES IN
THE FIELDS OF PHARMACEUTICAL AND BIOTECH-
NOLOGY FIELDS; PROVIDING MEDICAL AND SCIENTI-
FIC RESEARCH INFORMATION IN THE FIELD OF
PHARMACEUTICALS AND BIOTECHNOLOGY (U.S.
CLS. 100 AND 101).

HENRY S. ZAK, EXAMINING ATTORNEY

SN 85-117,504. MACROGENICS, INC., ROCKVILLE, MD.
FILED 8-27-2010.

BREAKTHROUGH BIOLOGICS,
LIFE CHANGING MEDICINES

THE MARK CONSISTS OF STANDARD CHARACTERS
WITHOUT CLAIM TO ANY PARTICULAR FONT, STYLE,
SIZE, OR COLOR.

NO CLAIM IS MADE TO THE EXCLUSIVE RIGHT TO
USE "BIOLOGICS" AND "MEDICINE", APART FROM THE
MARK AS SHOWN.

CLASS 5—PHARMACEUTICALS

FOR PHARMACEUTICAL PREPARATIONS AND SUBSTANCES FOR THE TREATMENT OF AUTOIMMUNE DISORDERS, INFLAMMATORY DISEASES AND CONDITIONS, METABOLIC DISORDERS, ALLERGIES, CANCER, AND INFECTIOUS DISEASES (U.S. CLS. 6, 18, 44, 46, 51 AND 52).

CLASS 35—ADVERTISING AND BUSINESS

FOR PRODUCTION AND PRODUCT COMMERCIALIZATION FOR THIRD PARTIES OF PHARMACEUTICALS AND SUBSTANCES FOR THE TREATMENT OF AUTOIMMUNE DISORDERS, INFLAMMATORY DISEASES AND CONDITIONS, METABOLIC DISORDERS, ALLERGIES, CANCER, AND INFECTIOUS DISEASES (U.S. CLS. 100, 101 AND 102).

CLASS 42—SCIENTIFIC AND COMPUTER SERVICES

FOR DISCOVERY, RESEARCH, AND DEVELOPMENT OF PHARMACEUTICALS AND SUBSTANCES FOR THE TREATMENT OF AUTOIMMUNE DISORDERS, INFLAMMATORY DISEASES AND CONDITIONS, METABOLIC DISORDERS, ALLERGIES, CANCER, AND INFECTIOUS DISEASES; DISCOVERY, RESEARCH AND DEVELOPMENT IN THE PHARMACEUTICAL AND BIOTECHNOLOGY FIELDS; RESEARCH, DEVELOPMENT, ENGINEERING AND TESTING SERVICES IN THE FIELDS OF PHARMACEUTICAL AND BIOTECHNOLOGY FIELDS; PROVIDING MEDICAL AND SCIENTIFIC RESEARCH INFORMATION IN THE FIELD OF PHARMACEUTICALS AND BIOTECHNOLOGY (U.S. CLS. 100 AND 101).

HENRY S. ZAK, EXAMINING ATTORNEY

SN 85-118,081. WINCHESTER CONSULTANCY LIMITED, SHEFFIELD, UNITED KINGDOM, FILED 8-28-2010.

FABSWINGERS

THE MARK CONSISTS OF STANDARD CHARACTERS WITHOUT CLAIM TO ANY PARTICULAR FONT, STYLE, SIZE, OR COLOR.

OWNER OF UNITED KINGDOM REG. NO. 2522868, DATED 12-25-2009, EXPIRES 8-5-2019.

CLASS 35—ADVERTISING AND BUSINESS

FOR ADVERTISING AND PROMOTIONAL SERVICES; ADVERTISING AND PROMOTING SOCIAL EVENTS AND VENUES; ADVERTISING AND PROMOTING ACCOMMODATION AND HOLIDAYS; ADVERTISING AND PROMOTING FILMS AND MOVIES; ADVERTISING AND PROMOTING ENTERTAINMENT; ONLINE RETAIL STORE SERVICES FEATURING CLOTHING, FASHION ACCESSORIES, TOYS AND ADULT TOYS; PROVIDING AN INTERNET WEBSITE PORTAL FEATURING PROMOTION AND ADVERTISING FOR HOME SERVICE PROVIDERS AND PRODUCT MANUFACTURERS; HOTEL INFORMATION SERVICES, NAMELY, PROVIDING INFORMATION IN THE NATURE OF PRICE COMPARISON RATING OF ACCOMMODATIONS; INFORMATION AND ADVISORY AND CONSULTANCY SERVICES RELATING TO ALL OF THE FOREGOING (U.S. CLS. 100, 101 AND 102).

CLASS 38—COMMUNICATION

FOR CHAT ROOM SERVICES FOR SOCIAL NETWORKING; PROVIDING INTERNET CHAT ROOMS; EMAIL SERVICES (U.S. CLS. 100, 101 AND 104).

CLASS 41—EDUCATION AND ENTERTAINMENT

FOR SOCIAL CLUB SERVICES, NAMELY, ARRANGING, ORGANIZING, AND HOSTING SOCIAL EVENTS, GET-TOGETHERS, AND PARTIES FOR CLUB MEMBERS; ENTERTAINMENT IN THE NATURE OF COMPETITIONS IN THE FIELD OF SOCIAL NETWORKING AND SEXUALITY; ENTERTAINMENT SERVICES, NAMELY, DISPLAYING A SERIES OF FILMS; FILM AND VIDEO PRODUCTION; EDUCATION SERVICES, NAMELY, PROVIDING WORKSHOPS AND SEMINARS IN THE FIELD OF SOCIAL NETWORKING AND SEXUALITY; TRAINING SERVICES IN THE FIELD OF SOCIAL NETWORKING AND SEXUALITY; PROVIDING AN INTERNET WEBSITE PORTAL IN THE FIELD OF ENTERTAINMENT; INFORMATION AND ADVISORY AND CONSULTANCY SERVICES RELATING TO ALL OF THE FOREGOING (U.S. CLS. 100, 101 AND 107).

CLASS 43—HOTEL AND RESTAURANT SERVICES

FOR ARRANGING OF TEMPORARY HOUSING AND HOTEL ACCOMMODATION IN CONNECTION WITH HOLIDAY TRAVEL; PROVIDING INFORMATION ABOUT HOTEL ACCOMMODATIONS; RENTAL OF PRIVATE HOMES AS TEMPORARY LIVING ACCOMMODATIONS FOR VACATION STAYS; AGENCY SERVICES FOR THE RESERVATION OF TEMPORARY ACCOMMODATION; CONSULTING SERVICES IN THE FIELD OF HOSPITALITY; PREPARING AND PROVISION OF FOOD AND DRINK; CAFE SERVICES; BAR SERVICES; INFORMATION AND ADVISORY AND CONSULTANCY SERVICES RELATING TO ALL OF THE FOREGOING (U.S. CLS. 100 AND 101).

CLASS 45—PERSONAL AND LEGAL SERVICES

FOR INTERNET BASED SOCIAL NETWORKING, INTRODUCTION, AND DATING SERVICES; DATING SERVICES; INFORMATION AND ADVISORY AND CONSULTANCY SERVICES RELATING TO ALL OF THE FOREGOING (U.S. CLS. 100 AND 101).

CHRISTINE COOPER, EXAMINING ATTORNEY

SN 85-118,883. TUSCO CORP., SARATOGA SPRINGS, NY, FILED 8-30-2010.



THE MARK CONSISTS OF THE WORD "TUSCO" IN A STYLIZED FORM.

CLASS 6—METAL GOODS

FOR METAL PARTS FOR GAS TURBINES, NAMELY, STUDS, NUTS, BOLTS, SCREWS, BOLTING PINS, AND DOWEL PINS (U.S. CLS. 2, 12, 13, 14, 23, 25 AND 50).

FIRST USE 11-22-1978; IN COMMERCE 11-22-1978.

CLASS 7—MACHINERY

FOR GAS TURBINE PARTS, NAMELY, VALVE ASSEMBLIES, DIAPHRAGMS, RELIEF DIAPHRAGM ASSEMBLIES, PACKING RINGS, SEAL RINGS, SPILL STRIPS, BALL BEARINGS, THRUST PLATES, GASKETS, PISTON RINGS AND O-RINGS (U.S. CLS. 13, 19, 21, 23, 31, 34 AND 35).

FIRST USE 11-22-1978; IN COMMERCE 11-22-1978.

INGRID C. EULIN, EXAMINING ATTORNEY

ELLEN B. AWRICH, EXAMINING ATTORNEY

SN 85-119,521. BARCLAYS BANK PLC, LONDON, UNITED KINGDOM, FILED 8-31-2010.

SN 85-119,936. INTELLISKIN USA, LLC, BEVERLY HILLS, CA. FILED 8-31-2010.

CB INSIGHT

THE MARK CONSISTS OF STANDARD CHARACTERS WITHOUT CLAIM TO ANY PARTICULAR FONT, STYLE, SIZE, OR COLOR.

NO CLAIM IS MADE TO THE EXCLUSIVE RIGHT TO USE "CB", APART FROM THE MARK AS SHOWN.

CLASS 36—INSURANCE AND FINANCIAL

FOR WEB-BASED COMPUTER SERVICES, NAMELY, PROVIDING AN ON-LINE COMPUTER DATABASE IN THE FIELD OF FINANCIAL INFORMATION TO ALLOW USERS TO EVALUATE THE CONVERTIBLE BOND MARKET (U.S. CLS. 100, 101 AND 102).

FIRST USE 11-0-2006; IN COMMERCE 11-0-2006.

CLASS 42—SCIENTIFIC AND COMPUTER SERVICES

FOR WEB-BASED COMPUTER SERVICES, NAMELY, PROVIDING ON-LINE NONDOWNLOADABLE SOFTWARE THAT ALLOWS USERS TO EVALUATE THE CONVERTIBLE BOND MARKET USING ANALYTICAL AND STATISTICAL MODELS; WEB-BASED COMPUTER SERVICES, NAMELY, PROVIDING SEARCH PLATFORMS TO ALLOW USERS TO REQUEST AND RECEIVE CONTENT IN ORDER TO EVALUATE THE CONVERTIBLE BOND MARKET (U.S. CLS. 100 AND 101).

FIRST USE 11-0-2006; IN COMMERCE 11-0-2006.

ANDREW LEASER, EXAMINING ATTORNEY

SN 85-119,817. ALASKO FOODS INC./ALIMENTS ALASKO INC., MONTREAL, QUEBEC, CANADA, FILED 8-31-2010.

BE ACTIVE.BE SMART!

THE MARK CONSISTS OF STANDARD CHARACTERS WITHOUT CLAIM TO ANY PARTICULAR FONT, STYLE, SIZE, OR COLOR.

PRIORITY CLAIMED UNDER SEC. 44(D) ON CANADA APPLICATION NO. 1,488,965, FILED 7-16-2010, REG. NO. TMA798795, DATED 5-30-2011, EXPIRES 5-30-2026.

CLASS 29—MEATS AND PROCESSED FOODS

FOR FROZEN FRUITS AND FROZEN VEGETABLES; PACKAGED FROZEN FRUITS AND PACKAGED FROZEN VEGETABLES; PACKAGED FRUIT FROZEN IN INDIVIDUAL SECTIONS, EITHER WHOLE OR CUT IN PIECES; FROZEN FRUIT PUREE ON A STICK, IN A HAND HELD CONTAINER OR IN A TUBE (U.S. CL. 46).

CLASS 32—LIGHT BEVERAGES

FOR NON-ALCOHOLIC ENERGY FRUIT JUICE IN A HAND HELD CONTAINER (U.S. CLS. 45, 46 AND 48).

INFINITE BALANCE

THE MARK CONSISTS OF STANDARD CHARACTERS WITHOUT CLAIM TO ANY PARTICULAR FONT, STYLE, SIZE, OR COLOR.

NO CLAIM IS MADE TO THE EXCLUSIVE RIGHT TO USE "BALANCE", APART FROM THE MARK AS SHOWN.

CLASS 25—CLOTHING

FOR SPORTS CLOTHING, NAMELY, SHIRTS, SHORTS, PANTS, JACKETS, WETSUITS, HATS, FOOTWEAR, SOCKS, UNDERGARMENTS, SPORTS BRAS (U.S. CLS. 22 AND 39).

CLASS 44—MEDICAL, BEAUTY AND AGRICULTURAL SERVICES

FOR PROVIDING A WEB SITE FEATURING INFORMATION ON HEALTH; PHYSICAL THERAPY (U.S. CLS. 100 AND 101).

MATTHEW PAPPAS, EXAMINING ATTORNEY

SN 85-120,202. PRL USA HOLDINGS, INC., WILMINGTON, DE. FILED 8-31-2010.



OWNER OF U.S. REG. NOS. 1,976,324, 2,419,959 AND OTHERS.

THE NAME(S), PORTRAIT(S), AND/OR SIGNATURE(S) SHOWN IN THE MARK IDENTIFIES AN INDIVIDUAL, WHOSE CONSENT(S) TO REGISTER IS MADE OF RECORD.

THE MARK CONSISTS OF A CROWN ATOP OF AN OLIVE WREATH, ATOP THE ROMAN NUMERAL SYMBOLS "LXVII", ATOP A LARGER OLIVE WREATH, ATOP A BANNER CONSISTING OF THE WORDS "LAUREN RALPH LAUREN".

CLASS 9—ELECTRICAL AND SCIENTIFIC APPARATUS

FOR (BASED ON INTENT TO USE) CARRYING CASES, NAMELY, COMPUTER SLEEVES (U.S. CLS. 21, 23, 26, 36 AND 38).

CLASS 18—LEATHER GOODS

FOR (BASED ON USE IN COMMERCE) HANDBAGS; ACCESSORIES, NAMELY, WALLETS, WRISTLET BAGS, COSMETIC CASES SOLD EMPTY (U.S. CLS. 1, 2, 3, 22 AND 41).

FIRST USE 8-0-2010; IN COMMERCE 8-0-2010.
MICHAEL WEBSTER, EXAMINING ATTORNEY

SN 85-120,485. NAPOLI FOODS, INC., CHESHIRE, CT.
FILED 9-1-2010.



NO CLAIM IS MADE TO THE EXCLUSIVE RIGHT TO USE "NAPOLI", "1980", AND "FINEST QUALITY FOODS", APART FROM THE MARK AS SHOWN.

THE MARK CONSISTS OF THE WORD "NAPOLI" WRITTEN IN STYLIZED FORM INSIDE A RECTANGULAR BAND THAT IS SUPERIMPOSED ON AN OVAL SHAPED RIBBON THAT PROTRUDES ABOVE AND BELOW THE RECTANGULAR BAND. THE UPPER PORTION OF THE RIBBON HAS THE WORD "1980" WRITTEN IN IT AND THE LOWER PORTION OF THE RIBBON HAS THE WORDS "FINEST QUALITY FOODS" WRITTEN IN CAPITAL LETTERS ON IT. IN THE SPACE BETWEEN THE UPPER PORTION OF THE RECTANGULAR BAND AND THE UPPER PORTION OF THE RIBBON IS A SCENE OF A VILLAGE CONSISTING OF BUILDINGS SURROUNDED BY TREES AND IN THE SPACE BETWEEN THE LOWER PORTION OF THE RECTANGULAR BAND AND THE LOWER PORTION OF THE RIBBON IS AN ARRANGEMENT OF VEGETABLES.

THE ENGLISH TRANSLATION OF THE WORD "NAPOLI" IN THE MARK IS "NAPLES".

CLASS 3—COSMETICS AND CLEANING PREPARATIONS

FOR OVEN CLEANERS, COIL CLEANERS, ALL PURPOSE CLEANERS, GLASS CLEANERS, CLEANERS FOR USE ON STAINLESS STEEL, HAND SOAP, DISH DETERGENT, DISHWASHER DETERGENT (U.S. CLS. 1, 4, 6, 50, 51 AND 52).

FIRST USE 1-2-1993; IN COMMERCE 1-2-1993.

CLASS 5—PHARMACEUTICALS

FOR DISINFECTANT BATHROOM AND KITCHEN CLEANERS AND AIR FRESHENERS (U.S. CLS. 6, 18, 44, 46, 51 AND 52).

FIRST USE 1-2-1993; IN COMMERCE 1-2-1993.

CLASS 16—PAPER GOODS AND PRINTED MATTER

FOR CARDBOARD BOXES, PAPER BAGS AND SACKS (U.S. CLS. 2, 5, 22, 23, 29, 37, 38 AND 50).

FIRST USE 1-2-1993; IN COMMERCE 1-2-1993.

CLASS 29—MEATS AND PROCESSED FOODS

FOR FOOD PRODUCTS, NAMELY, OLIVE OIL, VEGETABLE OILS, PROCESSED PEPPERS, PROCESSED OLIVES, PROCESSED ARTICHOKE, PROCESSED VEGETABLES AND MIXED VEGETABLES, CANNED VEGETABLES, CANNED BEANS, CANNED TOMATOES, CANNED TOMATO PASTE, CANNED TOMATO PUREE, CANNED PEELED TOMATOES, CANNED GROUND PEELED TOMATOES, CANNED FRUITS, CANNED AND TINNED FISH AND SHELLFISH, PROCESSED ANCHOVIES, MILK PRODUCTS, NAMELY, WHIPPING CREAM, CHEESE, NAMELY, SHREDDED MOZZARELLA, ROMANO AND PARMESAN CHEESES, MOZZARELLA, RICOTTA AND FETA CHEESES, LUNCHEON MEATS, BACON, HOTDOGS, FROZEN CHICKEN, FROZEN MEATBALLS; POTATO BASED GNOCCHI (U.S. CL. 46).

FIRST USE 1-2-1993; IN COMMERCE 1-2-1993.

CLASS 30—STAPLE FOODS

FOR FOOD PRODUCTS, NAMELY, FLOUR, DRIED AND FROZEN PASTA, RICE, POLENTA, FLOUR BASED GNOCCHI, BREAD CRUMBS, PASTA SAUCE, PIZZA SAUCE, PESTO, VINEGAR, WINE VINEGAR, SALAD DRESSING, CAPERS, AND PROCESSED GARLIC USED AS A SEASONING, SALT, PEPPER, SPICES, SPICE BLENDS (U.S. CL. 46).

FIRST USE 1-2-1993; IN COMMERCE 1-2-1993.

CLASS 35—ADVERTISING AND BUSINESS

FOR WHOLESALE DISTRIBUTORSHIP FOR THE FOOD SERVICE INDUSTRY, FEATURING FOOD, PAPER PRODUCTS, CLEANING PRODUCTS AND FOOD SERVICE DISPOSABLE PRODUCTS (U.S. CLS. 100, 101 AND 102).

FIRST USE 1-2-1993; IN COMMERCE 1-2-1993.

TOBY BULLOFF, EXAMINING ATTORNEY

SN 85-120,545. INTERNATIONAL RELIEF & DEVELOPMENT, ARLINGTON, VA. FILED 9-1-2010.

**INTERNATIONAL RELIEF &
DEVELOPMENT**

THE MARK CONSISTS OF STANDARD CHARACTERS WITHOUT CLAIM TO ANY PARTICULAR FONT, STYLE, SIZE, OR COLOR.

SEC. 2(F).

CLASS 35—ADVERTISING AND BUSINESS

FOR ADMINISTRATION OF FOOD AND AGRICULTURAL DEVELOPMENT AND AID PROGRAMS; ADMINISTRATION OF ECONOMIC DEVELOPMENT PROJECTS IN POST NATURAL DISASTER, CONFLICT AND POST CONFLICT ENVIRONMENTS; CHARITABLE SERVICES PROVIDED IN POST NATURAL DISASTER, CONFLICT AND POST CONFLICT ENVIRONMENTS FOR REBUILDING, IMPROVING AND RESTORING OF LOCAL CIVIC INSTITUTIONS AND DEMOCRACY, NAMELY, ORGANIZING AND CONDUCTING COMMUNITY SERVICE, LOCAL DEVELOPMENT AND CIVIC PROJECTS AIMED AT IMPROVING METHODOLOGIES TO SOLVE LOCAL COMMUNITY PROBLEMS AND PRIORITIZATION OF ACTIVITIES, FOSTERING GREATER CITIZEN PARTICIPATION IN CIVIL SOCIETY, FACILITATING COMMUNICATION AND CO-OPERATION BETWEEN DIFFERENT COMMUNITY SECTORS THROUGH COMMUNITY COMMITTEES AND LOCAL ECONOMIC DEVELOPMENT TEAMS; PROVIDING HIV/AIDS PREVENTION SERVICES IN THE NATURE OF CHARITABLE SERVICES FOR PROMOTING PUBLIC AWARENESS OF HIV/AIDS RELATED ISSUES (U.S. CLS. 100, 101 AND 102).

FIRST USE 3-0-1998; IN COMMERCE 3-0-1998.

CLASS 36—INSURANCE AND FINANCIAL

FOR CHARITABLE FUNDRAISING SERVICES; FINANCING SERVICES, NAMELY, PROVIDING LOANS AND GRANTS TO INDIVIDUALS IN DEVELOPING COUNTRIES FOR MICRO-ECONOMIC DEVELOPMENT; ADMINISTRATION OF PROGRAMS PROVIDING LOAN FINANCING AND GRANTS TO INDIVIDUALS IN DEVELOPING COUNTRIES FOR MICRO-ECONOMIC DEVELOPMENT; LOAN FINANCING, NAMELY, PROVIDING FINANCIAL ASSISTANCE TO FAMILIES TO ESTABLISH AND DEVELOP SMALL BUSINESSES (U.S. CLS. 100, 101 AND 102).

FIRST USE 3-0-1998; IN COMMERCE 3-0-1998.

CLASS 37—CONSTRUCTION AND REPAIR

FOR CONSTRUCTION MANAGEMENT AND SUPERVISION OF ROADS, POTABLE WATER SYSTEMS, SANITARY WATER SYSTEMS, SCHOOLS AND MEDICAL BUILDINGS FOR FOREIGN ASSISTANCE PROGRAMS; CONSTRUCTION PROJECT MANAGEMENT IN THE FIELD OF THE CONSTRUCTION OF ROADS, SCHOOLS, WATER AND SEWAGE UTILITY FACILITIES AND PIPELINES, AND HEALTH FACILITY BUILDINGS; CONSTRUCTION OF ROADS, SCHOOLS, WATER AND SEWAGE UTILITY FACILITIES AND PIPELINES, AND HEALTH FACILITY BUILDINGS (U.S. CLS. 100, 103 AND 106).

FIRST USE 4-0-2000; IN COMMERCE 4-0-2000.

CLASS 41—EDUCATION AND ENTERTAINMENT

FOR EDUCATIONAL SERVICES, NAMELY, TRAINING IN THE AREAS OF HEALTH, AGRICULTURE, NUTRITION, VOCATIONS, LOCAL GOVERNANCE AND DEMOCRACY; CAREER COUNSELING (U.S. CLS. 100, 101 AND 107).

FIRST USE 3-0-1998; IN COMMERCE 3-0-1998.

CLASS 43—HOTEL AND RESTAURANT SERVICES

FOR CHARITABLE SERVICES, NAMELY, PROVIDING FOOD AND TEMPORARY SHELTER TO THE POOR, REFUGEES AND TO DISASTER VICTIMS (U.S. CLS. 100 AND 101).

FIRST USE 3-0-1998; IN COMMERCE 3-0-1998.

CLASS 44—MEDICAL, BEAUTY AND AGRICULTURAL SERVICES

FOR CHARITABLE SERVICES, NAMELY, PROVIDING MEDICAL ASSISTANCE TO THE POOR, REFUGEES AND TO DISASTER VICTIMS; CHARITABLE SERVICES, NAMELY, PROVIDING HEALTH CARE EQUIPMENT AND SUPPLIES; MENTAL HEALTH SERVICES (U.S. CLS. 100 AND 101).

FIRST USE 3-0-1998; IN COMMERCE 3-0-1998.

CLASS 45—PERSONAL AND LEGAL SERVICES

FOR CHARITABLE SERVICES, NAMELY, PROVIDING CLOTHING TO THE POOR, REFUGEES AND TO DISASTER VICTIMS (U.S. CLS. 100 AND 101).

FIRST USE 3-0-1998; IN COMMERCE 3-0-1998.

TINA BROWN, EXAMINING ATTORNEY

SN 85-121,010. MATRIX-BIO, INC., WEST LAFAYETTE, IN. FILED 9-1-2010.

VERAMARKER

THE MARK CONSISTS OF STANDARD CHARACTERS WITHOUT CLAIM TO ANY PARTICULAR FONT, STYLE, SIZE, OR COLOR.

CLASS 5—PHARMACEUTICALS

FOR DIAGNOSTIC AND PROGNOSIS TESTING KITS COMPOSED PRIMARILY OF SOLUTIONS AND CHEMICALS IN THE NATURE OF MEDICAL DIAGNOSTIC REAGENTS TO CONDUCT METABOLITE PROFILING, INTENDED FOR MEDICAL DIAGNOSTIC PURPOSES (U.S. CLS. 6, 18, 44, 46, 51 AND 52).

CLASS 44—MEDICAL, BEAUTY AND AGRICULTURAL SERVICES

FOR MEDICAL DIAGNOSTIC TESTING SERVICES FOR DIAGNOSTIC AND PROGNOSTIC PURPOSES (U.S. CLS. 100 AND 101).

MEGHAN REINHART, EXAMINING ATTORNEY

SN 85-121,121. AIRTYME COMMUNICATIONS, LLC, HAUPAUGE, NY. FILED 9-1-2010.



NO CLAIM IS MADE TO THE EXCLUSIVE RIGHT TO USE "AIRTYME COMMUNICATIONS, LLC", APART FROM THE MARK AS SHOWN.

THE MARK CONSISTS OF THE WORDING "AIRTYME

COMMUNICATIONS, LLC CONNECTS. DELIVERS. EXPANDS." AND DESIGN. THE DESIGN CONSISTS OF A GLOBE WITH MERIDIANS AND PARALLELS. TO THE RIGHT OF THE DESIGN IS THE WORDING "AIRTYME COMMUNICATIONS, LLC CONNECTS. DELIVERS. EXPANDS.". THE LETTER "A" IN "AIRTYME" IS SUPERIMPOSED ON THE GLOBE. THE TERM "AIRTYME" APPEARS ABOVE THE WORDING "COMMUNICATIONS, LLC" WHICH IS ABOVE THE WORDING "CONNECTS. DELIVERS. EXPANDS.".

CLASS 9—ELECTRICAL AND SCIENTIFIC APPARATUS

FOR WIRELESS TELEPHONES AND WIRELESS TELEPHONE ACCESSORIES, NAMELY, CELL PHONE BATTERY CHARGERS, SPECIALTY HOLSTERS, HEADSETS, CASES AND BATTERIES (U.S. CLS. 21, 23, 26, 36 AND 38).

CLASS 35—ADVERTISING AND BUSINESS

FOR WHOLESALE AND RETAIL STORES SERVICES FEATURING WIRELESS PHONES, WIRELESS PHONE ACCESSORIES, TELECOMMUNICATIONS SERVICE PLANS AND TELECOMMUNICATIONS SERVICE ACTIVATION (U.S. CLS. 100, 101 AND 102).

MARLENE BELL, EXAMINING ATTORNEY

SN 85-121,948. LIQUID HOLDING COMPANY, INC., BRODHEADSVILLE, PA. FILED 9-2-2010.

JUST PUMP AND SPRAY

THE MARK CONSISTS OF STANDARD CHARACTERS WITHOUT CLAIM TO ANY PARTICULAR FONT, STYLE, SIZE, OR COLOR.

OWNER OF U.S. REG. NO. 3,490,705.

NO CLAIM IS MADE TO THE EXCLUSIVE RIGHT TO USE "PUMP AND SPRAY", APART FROM THE MARK AS SHOWN.

CLASS 1—CHEMICALS

FOR PLANT FERTILIZERS, PLANT GROWTH STIMULANTS, ANTI-TRANSPIRANTS AND ANTI-DESICCANTS (U.S. CLS. 1, 5, 6, 10, 26 AND 46).

CLASS 5—PHARMACEUTICALS

FOR INSECTICIDES, HERBICIDES AND FUNGICIDES (U.S. CLS. 6, 18, 44, 46, 51 AND 52).

SALLY SHIH, EXAMINING ATTORNEY

SN 85-122,120. CORREA, LESLIE, NEW YORK, NY. FILED 9-2-2010.



NO CLAIM IS MADE TO THE EXCLUSIVE RIGHT TO USE "CAPELLI", APART FROM THE MARK AS SHOWN.

THE MARK CONSISTS OF THE VERBIAGE "CAPELLI D'ORO" IN FANCIFUL SCRIPT FORMAT.

THE ENGLISH TRANSLATION OF "CAPELLI D'ORO" IN THE MARK IS "GOLDEN HAIR".

CLASS 3—COSMETICS AND CLEANING PREPARATIONS

FOR HAIR CARE PREPARATIONS (U.S. CLS. 1, 4, 6, 50, 51 AND 52).

FIRST USE 9-30-1988; IN COMMERCE 9-30-1988.

CLASS 44—MEDICAL, BEAUTY AND AGRICULTURAL SERVICES

FOR HAIR SALON SERVICES, NAMELY, HAIR CUTTING, STYLING, COLORING, AND HAIR EXTENSION SERVICES (U.S. CLS. 100 AND 101).

FIRST USE 9-30-1988; IN COMMERCE 9-30-1988.

JAMES GRIFFIN, EXAMINING ATTORNEY

SN 85-122,429. LOWE, KENNETH C, DBA THE HEALDSBURG MAP, HEALDSBURG, CA. FILED 9-3-2010.



NO CLAIM IS MADE TO THE EXCLUSIVE RIGHT TO USE "HEALDSBURG", "FOUNDED 1857" AND "SONOMA COUNTY", APART FROM THE MARK AS SHOWN.

THE MARK CONSISTS OF A CIRCULAR STAMP DESIGN WHERE THE CENTER OF THE CIRCLE CONTAINS A STYLIZED GAZEBO WITH OVERLAPPING CURVED LINES ABOVE IT FORMING CLOUDS AND WAVY AND CURVING LINES BELOW IT FORMING THE GROUND. THERE IS A CIRCULAR BORDER AROUND THE CENTER CIRCLE WITH THE WORD "HEALDSBURG" IN THE TOP HALF OF THE CIRCULAR BORDER AND THE WORDING "FOUNDED 1857" CENTERED IN THE BOTTOM PORTION OF THE CIRCULAR BORDER. THERE IS A STAR TO THE LEFT OF THE LETTER "H" AND TO THE RIGHT OF THE LETTER "G" IN THE WORD "HEALDSBURG". THERE ARE SEVERAL SMALL CIRCLES FORMING A BORDER AROUND THE OUTER PORTION OF THE CIRCULAR BORDER. THE WORDING "'SONOMA COUNTY'" APPEARS IN STYLIZED FONT INSIDE QUOTATION MARKS CENTERED BELOW THE BOTTOM PORTION OF THE OUTER CIRCULAR BORDER. THERE ARE SEVERAL SMALL CLUSTERS OF SPECKS POSITIONED AROUND THE MARK.

CLASS 16—PAPER GOODS AND PRINTED MATTER

FOR MAPS (U.S. CLS. 2, 5, 22, 23, 29, 37, 38 AND 50).

FIRST USE 10-1-2009; IN COMMERCE 11-1-2009.

CLASS 39—TRANSPORTATION AND STORAGE

FOR PROVIDING A WEB SITE AND WEB SITE LINKS TO GEOGRAPHIC INFORMATION, MAP IMAGES, AND TRIP ROUTING (U.S. CLS. 100 AND 105).

FIRST USE 10-1-2009; IN COMMERCE 10-1-2009.

TINA BROWN, EXAMINING ATTORNEY

SN 85-123,160. CONSUMER PRODUCTS INCORPORATED,
ST. LOUIS, MO. FILED 9-3-2010.

SN 85-122,518. COMPLETE TURBINE SERVICES, LLC, FORT
LAUDERDALE, FL. FILED 9-3-2010.

SHOOTING STARS PORTRAIT STUDIO

COMPLETE TURBINE SERVICE

THE MARK CONSISTS OF STANDARD CHARACTERS
WITHOUT CLAIM TO ANY PARTICULAR FONT, STYLE,
SIZE, OR COLOR.

NO CLAIM IS MADE TO THE EXCLUSIVE RIGHT TO
USE "SERVICE", APART FROM THE MARK AS SHOWN.
SEC. 2(F).

CLASS 37—CONSTRUCTION AND REPAIR

FOR AIRCRAFT ENGINE INSTALLATION, RE-
MOVAL, REPAIR, REPLACEMENT, AND MAINTEN-
ANCE SERVICES (U.S. CLS. 100, 103 AND 106).
FIRST USE 4-0-2003; IN COMMERCE 4-0-2003.

CLASS 42—SCIENTIFIC AND COMPUTER SERVICES

FOR AIRCRAFT ENGINE INSPECTION SERVICES
(U.S. CLS. 100 AND 101).
FIRST USE 4-0-2003; IN COMMERCE 4-0-2003.
RAMONA ORTIGA, EXAMINING ATTORNEY

SN 85-123,112. IMPACT HEALTH INTERNATIONAL, INC.,
MARIETTA, GA. FILED 9-3-2010.

IMPACT HEALTH INTERNATIONAL

THE MARK CONSISTS OF STANDARD CHARACTERS
WITHOUT CLAIM TO ANY PARTICULAR FONT, STYLE,
SIZE, OR COLOR.

NO CLAIM IS MADE TO THE EXCLUSIVE RIGHT TO
USE "HEALTH INTERNATIONAL", APART FROM THE
MARK AS SHOWN.

CLASS 41—EDUCATION AND ENTERTAIN- MENT

FOR PROVIDING CONTINUING PROFESSIONAL
EDUCATION COURSES, CLASSES, CONFERENCES,
SEMINARS AND WORKSHOPS TO DENTAL PRACTI-
TIONERS (U.S. CLS. 100, 101 AND 107).
FIRST USE 1-4-2007; IN COMMERCE 2-14-2007.

CLASS 44—MEDICAL, BEAUTY AND AGRI- CULTURAL SERVICES

FOR DENTISTRY SERVICES; TREATMENT OF DEN-
TAL CONDITIONS (U.S. CLS. 100 AND 101).
FIRST USE 1-4-2007; IN COMMERCE 2-14-2007.
NICHOLAS ALTREE, EXAMINING ATTORNEY

THE MARK CONSISTS OF STANDARD CHARACTERS
WITHOUT CLAIM TO ANY PARTICULAR FONT, STYLE,
SIZE, OR COLOR.

NO CLAIM IS MADE TO THE EXCLUSIVE RIGHT TO
USE "PORTRAIT STUDIO", APART FROM THE MARK AS
SHOWN.

CLASS 9—ELECTRICAL AND SCIENTIFIC APPARATUS

FOR (BASED ON INTENT TO USE) DVDS FEATUR-
ING PORTRAIT PHOTOGRAPHY (U.S. CLS. 21, 23, 26, 36
AND 38).

CLASS 40—MATERIAL TREATMENT

FOR (BASED ON INTENT TO USE) PHOTOGRAPHIC
SERVICES, NAMELY, PHOTOGRAPHIC ENLARGING
(U.S. CLS. 100, 103 AND 106).

CLASS 41—EDUCATION AND ENTERTAIN- MENT

FOR (BASED ON USE IN COMMERCE) PORTRAIT
PHOTOGRAPHY, PHOTOGRAPHIC SERVICES,
NAMELY, PHOTOGRAPHIC CAPTURE (U.S. CLS. 100,
101 AND 107).

FIRST USE 8-12-2008; IN COMMERCE 8-12-2008.
COLLEEN DOMBROW, EXAMINING ATTORNEY

SN 85-123,242. WINGS OF STEEL PRODUCTIONS, INC.,
NORTH HOLLYWOOD, CA. FILED 9-3-2010.

KBD STUDIO

THE MARK CONSISTS OF STANDARD CHARACTERS
WITHOUT CLAIM TO ANY PARTICULAR FONT, STYLE,
SIZE, OR COLOR.

NO CLAIM IS MADE TO THE EXCLUSIVE RIGHT TO
USE "STUDIO", APART FROM THE MARK AS SHOWN.

CLASS 9—ELECTRICAL AND SCIENTIFIC APPARATUS

FOR LEATHER CASES DESIGNED SPECIFICALLY
FOR SMART PHONES; AND LEATHER CASES DE-
SIGNER SPECIFICALLY FOR TABLET COMPUTERS
(U.S. CLS. 21, 23, 26, 36 AND 38).

CLASS 18—LEATHER GOODS

FOR LEATHER GOODS, NAMELY, PURSES, WAL-
LETS, BUSINESS CARD CASES, COSMETIC CASES
SOLD EMPTY, LEATHER CONDOM CASES SOLD
EMPTY, SHOULDER BELTS, AND LUGGAGE TAGS
(U.S. CLS. 1, 2, 3, 22 AND 41).

CLASS 25—CLOTHING

FOR CLOTHING, NAMELY, LEATHER SKIRTS AND JACKETS, TANK TOPS, T-SHIRTS, HOODED JACKETS, LONG SLEEVE SHIRTS, MENS SHIRTS, LEATHER BELTS, AND THERMAL UNDERWEAR (U.S. CLS. 22 AND 39).

CURTIS FRENCH, EXAMINING ATTORNEY

SN 85-123,775. MCMILLIN, MARTHA, ATLANTA, GA.
FILED 9-7-2010.

LOCAL FOOD DIVA

THE MARK CONSISTS OF STANDARD CHARACTERS WITHOUT CLAIM TO ANY PARTICULAR FONT, STYLE, SIZE, OR COLOR.

NO CLAIM IS MADE TO THE EXCLUSIVE RIGHT TO USE "LOCAL FOOD", APART FROM THE MARK AS SHOWN.

CLASS 35—ADVERTISING AND BUSINESS

FOR PROVIDING A WEBSITE THAT FEATURES BUSINESS INFORMATION ON PRODUCTS AND SERVICES OFFERED BY LOCAL FARMS, FARMERS MARKETS AND STORES PROVIDING SUSTAINABLE FOOD PRODUCTS; PROVIDING A WEBSITE WHERE USERS CAN POST REVIEWS AND RECOMMENDATIONS ON PRODUCTS AND SERVICES FOR COMMERCIAL PURPOSES IN THE FIELDS OF LOCAL FARMS, FARMERS MARKETS AND STORES PROVIDING SUSTAINABLE FOOD PRODUCTS (U.S. CLS. 100, 101 AND 102).

CLASS 41—EDUCATION AND ENTERTAINMENT

FOR PROVIDING A WEBSITE THAT FEATURES INFORMATION IN THE NATURE OF A BLOG ABOUT LOCAL FOOD ISSUES, LOCAL FARMS, FARMERS MARKETS, STORES PROVIDING SUSTAINABLE FOOD PRODUCTS, AND RECIPES FOR USE WITH SEASONAL FOOD PRODUCTS (U.S. CLS. 100, 101 AND 107).

SKYE YOUNG, EXAMINING ATTORNEY

SN 85-125,205. IBC REPRESENTATIONS LIMITED, HAMP-
SHIRE SP6 ING, UNITED KINGDOM, FILED 9-8-2010.

WORDS FOR YOU

THE MARK CONSISTS OF STANDARD CHARACTERS WITHOUT CLAIM TO ANY PARTICULAR FONT, STYLE, SIZE, OR COLOR.

CLASS 9—ELECTRICAL AND SCIENTIFIC APPARATUS

FOR COMPACT DISCS AND SOUND AND VIDEO RECORDINGS OF MUSIC AND POETRY; DIGITAL MUSIC DOWNLOADABLE FROM THE INTERNET; DOWNLOADABLE ELECTRONIC PUBLICATIONS, NAMELY, BOOKS, MAGAZINES, JOURNALS AND PERIODICALS RELATING TO MUSIC AND POETRY (U.S. CLS. 21, 23, 26, 36 AND 38).

CLASS 16—PAPER GOODS AND PRINTED MATTER

FOR PRINTED PUBLICATIONS, NAMELY, BOOKS, MAGAZINES, JOURNALS AND PERIODICALS RELATING TO MUSIC AND POETRY (U.S. CLS. 2, 5, 22, 23, 29, 37, 38 AND 50).

CLASS 41—EDUCATION AND ENTERTAINMENT

FOR ENTERTAINMENT IN THE NATURE OF LIVE POETRY READINGS; ENTERTAINMENT IN THE NATURE OF LIVE PERFORMANCES BY POETS IN THE FIELD OF POETRY; ENTERTAINMENT IN THE NATURE OF LIVE MUSIC PERFORMANCES FEATURING POETRY; ENTERTAINMENT SERVICES, NAMELY, LIVE MUSIC AND POETRY READING PERFORMANCES (U.S. CLS. 100, 101 AND 107).

DEIRDRE ROBERTSON, EXAMINING ATTORNEY

SN 85-125,447. NELSON JR., L. DOUGLAS, NEW YORK, NY.
FILED 9-8-2010.

GirlzSnap

THE MARK CONSISTS OF STANDARD CHARACTERS WITHOUT CLAIM TO ANY PARTICULAR FONT, STYLE, SIZE, OR COLOR.

CLASS 14—JEWELRY

FOR SMALL DECORATIVE OBJECTS MADE OF GLASS, PLASTIC AND METAL AS ORNAMENTAL EMBELLISHMENTS, NAMELY, JEWELRY AND CHARMS FOR ATTACHMENT TO WEARING APPAREL AND OTHER ACCESSORIES, NAMELY, T-SHIRTS, TOPS, DENIMS, TROUSERS, SWEAT SHIRTS, PANTS, COATS, DRESSES, BELTS, HATS, SOCKS, GLOVES, VEST, SCARVES, BATHING SUITS, PULLOVERS, WRISTBANDS AND KNITWEAR, NAMELY, SHIRTS, SWEATERS AND SCARVES (U.S. CLS. 2, 27, 28 AND 50).

CLASS 25—CLOTHING

FOR CLOTHING, NAMELY, T-SHIRTS, TOPS, DENIMS, TROUSERS, SWEAT SHIRTS, PANTS, COATS, DRESSES, BELTS, HATS, SOCKS, GLOVES, VESTS, SCARVES, BATHING SUITS, PULLOVERS, WRISTBANDS AND KNITWEAR, NAMELY, SHIRTS, SWEATERS AND SCARVES (U.S. CLS. 22 AND 39).

CLASS 26—FANCY GOODS

FOR SMALL DECORATIVE OBJECTS MADE OF GLASS, PLASTIC AND METAL AS ORNAMENTAL EMBELLISHMENTS IN THE NATURE OF SNAP FASTENERS FOR ATTACHMENT TO WEARING APPAREL AND OTHER ACCESSORIES, NAMELY, T-SHIRTS, TOPS, DENIMS, TROUSERS, SWEAT SHIRTS, PANTS, COATS, DRESSES, BELTS, HATS, SOCKS, GLOVES, VEST, SCARVES, BATHING SUITS, PULLOVERS, WRISTBANDS AND KNITWEAR, NAMELY, SHIRTS, SWEATERS AND SCARVES (U.S. CLS. 37, 39, 40, 42 AND 50).

RAMONA ORTIGA, EXAMINING ATTORNEY

SN 85-126,843. FOUR RESCUES, LLC, CHANTILLY, VA. FILED 9-10-2010.

ROOF TOP PLAY

SN 85-126,180. DRAKONTAS, LLC, GLENSIDE, PA. FILED 9-9-2010.



THE MARK CONSISTS OF THE STYLIZED LITERAL ELEMENT "LABFX". THERE A SEPARATE CURVED LINE INSIDE THE BOTTOM OF THE ROUNDING OF THE LETTER "F".

CLASS 9—ELECTRICAL AND SCIENTIFIC APPARATUS

FOR COMPUTER SOFTWARE FOR TASK GENERATION, TASK TRACKING, INFORMATION CONTRIBUTION, FORENSIC INFORMATION TOOLS, GENERATING TASKS ASSIGNMENT AND REPORTING OF INFORMATION TO ASSIST LAW ENFORCEMENT IN THE PREVENTION, INVESTIGATION, APPREHENSION, OR DETENTION OF INDIVIDUALS SUSPECTED OR CONVICTED OF OFFENSES AGAINST THE CRIMINAL LAWS AND FOR HOMELAND SECURITY (U.S. CLS. 21, 23, 26, 36 AND 38).

CLASS 42—SCIENTIFIC AND COMPUTER SERVICES

FOR PROVIDING A SECURE, WEB-BASED COMPUTERIZED SERVICE ENABLING INDIVIDUALS TO STORE AND TRANSMIT INFORMATION, INCLUDING FORENSIC TOOLS, TO ASSIST LAW ENFORCEMENT IN THE PREVENTION, INVESTIGATION, APPREHENSION, OR DETENTION OF INDIVIDUALS SUSPECTED OR CONVICTED OF OFFENSES AGAINST THE CRIMINAL LAWS AND FOR HOMELAND SECURITY (U.S. CLS. 100 AND 101).

ALYSSA STEEL, EXAMINING ATTORNEY

THE MARK CONSISTS OF STANDARD CHARACTERS WITHOUT CLAIM TO ANY PARTICULAR FONT, STYLE, SIZE, OR COLOR.

CLASS 43—HOTEL AND RESTAURANT SERVICES

FOR KENNEL SERVICES, NAMELY, PET BOARDING SERVICES (U.S. CLS. 100 AND 101).

CLASS 44—MEDICAL, BEAUTY AND AGRICULTURAL SERVICES

FOR PET CARE SERVICES, NAMELY, PET WALKING, PET BATHING, AND PET GROOMING (U.S. CLS. 100 AND 101).

JACQUELINE A. LAVINE, EXAMINING ATTORNEY

SN 85-126,943. TEAM COCO, BEVERLY HILLS, CA. FILED 9-10-2010.

TEAM COCO

THE MARK CONSISTS OF STANDARD CHARACTERS WITHOUT CLAIM TO ANY PARTICULAR FONT, STYLE, SIZE, OR COLOR.

PRIORITY CLAIMED UNDER SEC. 44(D) ON ERPNCMNTY TM OFC APPLICATION NO. 009351958, FILED 9-3-2010.

THE NAME(S), PORTRAIT(S), AND/OR SIGNATURE(S) SHOWN IN THE MARK IDENTIFIES CONAN O'BRIEN'S NICKNAME "COCO", WHOSE CONSENT(S) TO REGISTER IS MADE OF RECORD.

CLASS 9—ELECTRICAL AND SCIENTIFIC APPARATUS

FOR (BASED ON INTENT TO USE) SOUND RECORDINGS FEATURING COMEDY, HUMOR, COMEDY ENTERTAINMENT, VARIETY ENTERTAINMENT, INTERVIEWS AND TALK SHOW SEGMENTS; AUDIO-VISUAL RECORDINGS FEATURING COMEDY, HUMOR, COMEDY ENTERTAINMENT, VARIETY ENTERTAINMENT, INTERVIEWS, TALK SHOW SEGMENTS, AND CLIPS FROM A COMEDY AND VARIETY TELEVISION PROGRAM; DOWNLOADABLE SOUND RECORDINGS FEATURING COMEDY, HUMOR, COMEDY ENTERTAINMENT, VARIETY ENTERTAINMENT, INTERVIEWS, AND TALK SHOW SEGMENTS; DOWNLOADABLE AUDIO-VISUAL RECORDINGS FEATURING COMEDY, HUMOR, COMEDY ENTERTAINMENT, VARIETY ENTERTAINMENT, INTERVIEWS, TALK SHOW SEGMENTS, AND CLIPS FROM A COMEDY AND VARIETY TELEVISION PROGRAM; DOWNLOADABLE RINGTONES VIA A GLOBAL COMPUTER NETWORK AND WIRELESS DEVICES; VINYL COVERS SPECIALLY ADAPTED FOR CELL PHONES, MP3 PLAYERS, LAPTOPS, AND GAMING DEVICES ALL IN THE FORM OF MERCHANDISE TO PROMOTE COMEDY AND ENTERTAINMENT SERVICES AND A COMEDIAN; DOWNLOADABLE COMPUTER GRAPHICS IN THE NATURE OF WALLPAPER, ICONS, PHOTOGRAPHS, AND COMPUTER BANNERS FEATURING JOKES AND HUMOR FOR MOBILE PHONES; DOWNLOADABLE WIDGETS IN THE NATURE OF SOFTWARE APPLICATIONS USED TO CONVEY JOKES AND HUMOR; DOWNLOADABLE ELECTRONIC PUBLICATIONS, NAMELY, SOUVENIR BOOKS, SOUVENIR PROGRAMS, NEWSLETTERS, BOOKS, AND FANZINES FEATURING COMEDY, HUMOR, COMEDY ENTERTAINMENT, PHOTOGRAPHS AND INFORMATION ABOUT SHOWS FROM A COMEDY AND VARIETY PROGRAM; DOWNLOADABLE POSTERS AND PHOTOGRAPHS IN THE FIELD OF COMEDY AND HUMOR; DOWNLOADABLE PODCASTS IN THE FIELD OF COMEDY, HUMOR, COMEDY ENTERTAINMENT, VARIETY ENTERTAINMENT, INTERVIEWS, TALK SHOW SEGMENTS, AND CLIPS FROM A COMEDY AND VARIETY TELEVISION PROGRAM; MOTION PICTURE FILMS FEATURING COMEDY AND HUMOR; DIGITAL VIDEO DISCS FEATURING COMEDY, HUMOR, COMEDY ENTERTAINMENT, VARIETY ENTERTAINMENT, INTERVIEWS, TALK SHOW SEGMENTS AND CLIPS FROM A COMEDY AND VARIETY TELEVISION PROGRAM; VIDEO GAMES, NAMELY, COMPUTER GAME SOFTWARE, DOWNLOADABLE COMPUTER GAME PROGRAMS, DOWNLOADABLE COMPUTER GAME SOFTWARE VIA A GLOBAL COMPUTER NETWORK AND WIRELESS DEVICES; ELECTRONIC GAME PROGRAMS; MOBILE TELEPHONE AND PERSONAL ELECTRONIC DEVICE CASES AND COVERS; COMPUTER MOUSE PADS; USB HARDWARE AND SOFTWARE, NAMELY, PRE-RECORDED FLASH DRIVES FEATURING AUDIO AND AUDIO-VISUAL RECORDINGS FEATURING COMEDY, HUMOR, COMEDY ENTERTAINMENT, VARIETY ENTERTAINMENT, INTERVIEWS, TALK SHOW SEGMENTS, AND CLIPS FROM A COMEDY AND VARIETY TELEVISION PROGRAM (U.S. CLS. 21, 23, 26, 36 AND 38).

CLASS 16—PAPER GOODS AND PRINTED MATTER

FOR (BASED ON INTENT TO USE) PRINTED MATERIALS AND PRINTED PUBLICATIONS, NAMELY, SOUVENIR BOOKS, SOUVENIR PROGRAMS, NEWSLETTERS, BOOKS, AND FANZINES FEATURING COMEDY, HUMOR, COMEDY ENTERTAINMENT, PHOTOGRAPHS AND INFORMATION ABOUT SHOWS FROM A COMEDY AND VARIETY PROGRAM; POSTERS; COMIC BOOKS; COMICS; TRADING CARDS; CALENDARS; PENS AND WRITING INSTRUMENTS; DECALCOMANIAS; STICKERS; TEMPORARY TATTOOS (U.S. CLS. 2, 5, 22, 23, 29, 37, 38 AND 50).

CLASS 20—FURNITURE AND ARTICLES NOT OTHERWISE CLASSIFIED

FOR (BASED ON INTENT TO USE) PLASTIC KEY CHAINS (U.S. CLS. 2, 13, 22, 25, 32 AND 50).

CLASS 21—HOUSEWARES AND GLASS

FOR (BASED ON INTENT TO USE) CUPS, MUGS AND DRINKING GLASSES (U.S. CLS. 2, 13, 23, 29, 30, 33, 40 AND 50).

CLASS 25—CLOTHING

FOR (BASED ON INTENT TO USE) CLOTHING, NAMELY, TANK TOPS, JACKETS, HOODED SWEATSHIRTS, SWEATSHIRTS, AND HEADWEAR AND HEADGEAR, NAMELY, CAPS, BEANIES, ALL IN THE FORM OF MERCHANDISE TO PROMOTE COMEDY AND ENTERTAINMENT SERVICES AND A COMEDIAN, NONE OF WHICH ARE DEEMED TO BE HIGH-END LUXURY PRODUCTS; (BASED ON USE IN COMMERCE) CLOTHING, NAMELY, T-SHIRTS, IN THE FORM OF MERCHANDISE TO PROMOTE COMEDY AND ENTERTAINMENT SERVICES AND A COMEDIAN, NONE OF WHICH ARE DEEMED TO BE HIGH-END LUXURY PRODUCTS (U.S. CLS. 22 AND 39).

FIRST USE 3-0-2010; IN COMMERCE 3-0-2010.

CLASS 41—EDUCATION AND ENTERTAINMENT

FOR (BASED ON INTENT TO USE) ENTERTAINMENT SERVICES, NAMELY, A SERIES OF TELEVISION PROGRAMS FEATURING COMEDY, HUMOR, COMEDY SKITS, COMEDY ENTERTAINMENT, VARIETY ENTERTAINMENT, ENTERTAINMENT INTERVIEWS AND TALK; LIVE COMEDY PERFORMANCES; MOTION PICTURE FILM PRODUCTION; PRODUCTION OF TELEVISION PROGRAMS; PRODUCTION OF RADIO PROGRAMS; PRODUCTION OF WEBISODES AND VIDEOS FEATURING COMEDY, HUMOR, COMEDY SKITS, COMEDY ENTERTAINMENT, VARIETY ENTERTAINMENT, ENTERTAINMENT INTERVIEWS AND TALK FOR USE ON THE INTERNET AND WITH MOBILE COMMUNICATIONS DEVICES; PRODUCTION OF WEB-BASED TELEVISION AND RADIO PROGRAMS AND VIDEOS FEATURING COMEDY, HUMOR, COMEDY SKITS, COMEDY ENTERTAINMENT, VARIETY ENTERTAINMENT, ENTERTAINMENT INTERVIEWS AND TALK FOR USE ON THE INTERNET AND WITH MOBILE COMMUNICATIONS DEVICES; LIVE, TELEVISED AND MOVIE APPEARANCES BY A PROFESSIONAL ENTERTAINER AND COMEDIAN; ENTERTAINMENT SERVICES, NAMELY, PROVIDING NON-DOWNLOADABLE VIDEOS FEATURING APPEARANCES BY A PROFESSIONAL ENTERTAINER AND COMEDIAN VIA A GLOBAL COMPUTER NETWORK; PROVIDING A WEBSITE FEATURING NON-DOWNLOADABLE VIDEOS FEATURING THE APPEARANCES OF A COMEDIAN AND TALK SHOW HOST, AND OTHER APPEARANCES BY CELEBRITIES AND OTHER COMEDIANS, JOKES, COMIC STORIES, VARIETY ENTERTAINMENT, COMEDY ENTERTAINMENT, HUMOR, ENTERTAINMENT INTERVIEWS AND TALK, AND NON-DOWNLOADABLE AUDIO AND AUDIO-VISUAL RECORDINGS FEATURING COMEDY ROUTINES, ENTERTAINMENT INTERVIEWS, HUMOR, COMEDY, SEGMENTS OF TELEVISION PROGRAMS AND MOTION PICTURES, COMEDY AND CELEBRITY PHOTOGRAPHS, AND CELEBRITY BIOGRAPHIES; PROVIDING A WEBSITE FEATURING NON-DOWNLOADABLE TELEVISION PROGRAMS FEATURING COMEDY, HUMOR, COMEDY ENTERTAINMENT, VARIETY ENTERTAINMENT, ENTERTAINMENT INTERVIEWS AND TALK; WEB CASTS FEATURING COMEDY AND COMEDY-BASED ENTERTAINMENT, HUMOR, VARIETY ENTERTAINMENT, ENTERTAINMENT INTERVIEWS, TALK SHOWS, SEGMENTS OF TELEVISION PROGRAMS AND SEGMENTS OF MOTION PICTURES (U.S. CLS. 100, 101 AND 107).

KELLY BOULTON, EXAMINING ATTORNEY

SN 85-127,039. CREATIVE DISTINCTIONS, LLC, MIAMI, FL.
FILED 9-10-2010.



NO CLAIM IS MADE TO THE EXCLUSIVE RIGHT TO USE "MIAMI", APART FROM THE MARK AS SHOWN.

THE MARK CONSISTS OF A HEART SHAPE DESIGN LOCATED ABOVE THE STYLIZED WORD "MIAMI", BOTH SET AGAINST A CIRCULAR BACKGROUND.

CLASS 21—HOUSEWARES AND GLASS

FOR MUGS (U.S. CLS. 2, 13, 23, 29, 30, 33, 40 AND 50).

CLASS 25—CLOTHING

FOR CLOTHING, NAMELY, T-SHIRTS, PASHMINAS, CAPS (U.S. CLS. 22 AND 39).

TINA L. SNAPP, EXAMINING ATTORNEY

SN 85-128,200. DOI CHAANG COFFEE COMPANY INC.,
VANCOUVER, BC, CANADA, FILED 9-13-2010.

BEYOND FAIR TRADE

THE MARK CONSISTS OF STANDARD CHARACTERS WITHOUT CLAIM TO ANY PARTICULAR FONT, STYLE, SIZE, OR COLOR.

OWNER OF CANADA REG. NO. TMA775624, DATED 8-27-2010, EXPIRES 8-27-2020.

NO CLAIM IS MADE TO THE EXCLUSIVE RIGHT TO USE "FAIR TRADE", APART FROM THE MARK AS SHOWN.

CLASS 9—ELECTRICAL AND SCIENTIFIC APPARATUS

FOR COMPUTER SOFTWARE, NAMELY, EDUCATIONAL SOFTWARE CONTAINING INSTRUCTION IN THE HISTORY AND PRODUCTION OF COFFEE (U.S. CLS. 21, 23, 26, 36 AND 38).

CLASS 30—STAPLE FOODS

FOR GROUND AND WHOLE-BEAN COFFEE, HERBAL TEA, NON-HERBAL TEA, NON-ALCOHOLIC COFFEE AND ESPRESSO BEVERAGES AND NON-ALCOHOLIC COFFEE BASED BEVERAGES (U.S. CL. 46).

CLASS 35—ADVERTISING AND BUSINESS

FOR WHOLESALE, RETAIL AND ONLINE STORE SERVICES FEATURING GROUND AND WHOLE-BEAN COFFEE, HERBAL TEA, NON-HERBAL TEA, NON-ALCOHOLIC COFFEE AND ESPRESSO BEVERAGES, NON-ALCOHOLIC BEVERAGES WITH A BASE OF COFFEE, ACCESSORIES RELATED TO THE PREPARATION AND SERVING OF BEVERAGES, NAMELY, COFFEE BREWING EQUIPMENT, NAMELY, GRINDERS, MAKERS AND ROASTING OVENS, COFFEE AND TEA POTS, MUGS, CUPS AND SAUCERS, CLOTHING, NAMELY, T-SHIRTS, POLO SHIRTS, SWEATSHIRTS, CAPS, HATS, JACKETS, SHORTS AND APRONS, COMPUTER SOFTWARE, NAMELY, EDUCATIONAL SOFTWARE FEATURING INSTRUCTION IN THE HISTORY AND PRODUCTION OF COFFEE, BOOKS (U.S. CLS. 100, 101 AND 102).

CLASS 43—HOTEL AND RESTAURANT SERVICES

FOR SIT-DOWN AND TAKE OUT RESTAURANT SERVICES (U.S. CLS. 100 AND 101).

DEZMONA MIZELLE, EXAMINING ATTORNEY

SN 85-128,281. COOPER TECHNOLOGIES COMPANY,
HOUSTON, TX. FILED 9-13-2010.

ALL-PRO

THE MARK CONSISTS OF STANDARD CHARACTERS WITHOUT CLAIM TO ANY PARTICULAR FONT, STYLE, SIZE, OR COLOR.

CLASS 9—ELECTRICAL AND SCIENTIFIC APPARATUS

FOR SECURITY AND EMERGENCY LIGHTING FIXTURES, NAMELY, ILLUMINATED EXIT SIGNS, EMERGENCY WARNING LIGHTS, FLASHING AND STEADY SAFETY LIGHTS, MOTION SENSITIVE SECURITY LIGHTS; ILLUMINATED EXIT SIGNS; BALLAST FOR ELECTRIC LIGHTS; LIGHT EMITTING DIODES (LEDs); CATHODES; CATHODE RAY TUBES (U.S. CLS. 21, 23, 26, 36 AND 38).

FIRST USE 8-31-1998; IN COMMERCE 8-31-1998.

CLASS 11—ENVIRONMENTAL CONTROL APPARATUS

FOR ELECTRIC LIGHTING FIXTURES, NAMELY, RECESSED LIGHTING FIXTURES, TRACK LIGHTING FIXTURES, PENDANT LIGHTING FIXTURES, INDOOR AND OUTDOOR LIGHTING FIXTURES, CEILING LIGHTING FIXTURES, SURFACE MOUNTED LIGHTING FIXTURES, WALL LIGHTING FIXTURES, DECORATIVE LIGHTING FIXTURES, LANDSCAPE LIGHTING FIXTURES, ELECTRIC SCONCES, LIGHTING CANOPIES AND LIGHT EMITTING DIODES (LED), ALL FOR RESIDENTIAL, COMMERCIAL, INDUSTRIAL, ARCHITECTURAL, SIGNAL, LED, INCANDESCENT, HALOGEN, FLUORESCENT, METAL HALIDE, HIGH PRESSURE SODIUM, LOW PRESSURE SODIUM, INDUCTION, COLD CATHODE ILLUMINATION AND WAY MARKING LIGHTING APPLICATIONS; ELECTRIC LIGHTING COMPONENTS, NAMELY, SOCKETS, LIGHT SOCKET EXTENDERS, LAMP HOLDERS, LAMP TRACKS, HANGING BARS, BEAM CONCENTRATORS, HOUSINGS, TRIMS, MODULES, FILTERS AND LENSES, ALL FOR USE WITH ELECTRIC LIGHTING FIXTURES; MECHANICAL AND ELECTRO-MECHANICAL DEVICES, NAMELY, LOUVERS, SHUTTERS AND LAMP REFLECTORS FOR SHIELDING, DIRECTING AND CONTROLLING LIGHT, ALL FOR USE WITH ELECTRIC LIGHTING FIXTURES; LIGHT EMITTING DIODE (LED) ELECTRIC LIGHT BULBS; FLUORESCENT ELECTRIC LIGHT BULBS; HALOGEN LIGHT BULBS; INCANDESCENT LIGHT BULBS; METAL HALIDE LIGHT BULBS; HIGH PRESSURE SODIUM LIGHT BULBS; LOW PRESSURE SODIUM LIGHT BULB (U.S. CLS. 13, 21, 23, 31 AND 34).

FIRST USE 8-31-1998; IN COMMERCE 8-31-1998.
KEVIN CORWIN, EXAMINING ATTORNEY

SN 85-128,867. CREATING MY BEST LIFE, LLC, SOUTHPORT, CT. FILED 9-14-2010.

Thought Shapers

THE MARK CONSISTS OF STANDARD CHARACTERS WITHOUT CLAIM TO ANY PARTICULAR FONT, STYLE, SIZE, OR COLOR.

CLASS 14—JEWELRY

FOR JEWELRY, NAMELY, RUBBER, SILICON, CLOTH OR METAL WRISTBANDS IN THE NATURE OF A BRACELET, PINS, KEY CHAINS, AND RUBBER, SILICON OR METAL NECKLACES IN THE FORM OF DOG TAGS OR OTHER GEOMETRICAL SHAPES (U.S. CLS. 2, 27, 28 AND 50).

FIRST USE 10-10-2009; IN COMMERCE 1-21-2010.

CLASS 16—PAPER GOODS AND PRINTED MATTER

FOR PRINTED MATERIALS, NAMELY, CARDS IN THE NATURE OF GREETING CARDS, ENCLOSURE CARDS AND CORRESPONDENCE CARDS, NOTE-CARDS, POSTCARDS, STATIONERY, BINDERS, NOTE-PADS, BOOKMARKS, NOTEBOOKS, POSTERS, STICKERS, BUMPER STICKERS; BOOKS, WORKBOOKS, PRINTED TEACHING MATERIALS, AND JOURNALS IN THE FIELD OF INSPIRATION, SELF-ESTEEM AND PERSONAL DEVELOPMENT (U.S. CLS. 2, 5, 22, 23, 29, 37, 38 AND 50).

FIRST USE 10-10-2009; IN COMMERCE 1-21-2010.
NICHOLAS COLEMAN, EXAMINING ATTORNEY

SN 85-129,820. FEDERAL EXPRESS CORPORATION, MEMPHIS, TN. FILED 9-15-2010.

FEDEX TECHCONNECT

THE MARK CONSISTS OF STANDARD CHARACTERS WITHOUT CLAIM TO ANY PARTICULAR FONT, STYLE, SIZE, OR COLOR.

OWNER OF U.S. REG. NOS. 1,929,460, 3,413,407 AND OTHERS.

CLASS 35—ADVERTISING AND BUSINESS

FOR BUSINESS SERVICES, NAMELY, MANAGING INFORMATION IN THE FIELD OF PICK-UP, TRANSPORTATION AND DELIVERY OF DOCUMENTS, PACKAGES AND FREIGHT; ADVISORY AND CONSULTING SERVICES FOR SHIPMENT PROCESSING, PREPARING SHIPPING DOCUMENTS, SHIPMENT BILLING AND INVOICES, TRACKING DOCUMENTS, PACKAGES AND FREIGHT; ADVISORY AND CONSULTING SERVICES IN THE FIELD OF PROCURING PACKAGING SUPPLIES (U.S. CLS. 100, 101 AND 102).

CLASS 37—CONSTRUCTION AND REPAIR

FOR INSTALLATION, MAINTENANCE AND REPAIR OF COMPUTER HARDWARE; INSTALLATION AND REPAIR OF COMPUTERS, COMPUTER SYSTEMS AND COMPUTER BASED INFORMATION SYSTEMS FOR BUSINESSES (U.S. CLS. 100, 103 AND 106).

CLASS 39—TRANSPORTATION AND STORAGE

FOR SHIPPING SERVICES, NAMELY, PICK-UP, TRANSPORTATION, STORAGE AND DELIVERY OF DOCUMENTS, PACKAGES AND FREIGHT BY LAND AND AIR; CONSULTING SERVICES IN THE FIELD OF PACKAGING ARTICLES FOR TRANSPORTATION; CONSULTING SERVICES IN THE FIELD OF PARCEL SHIPPING SERVICES; CONSULTING SERVICES IN THE FIELD OF STORAGE, DISTRIBUTION, PICK-UP, AND PACKING FOR SHIPMENT OF DOCUMENTS, PACKAGES, RAW MATERIALS AND OTHER FREIGHT FOR OTHERS (U.S. CLS. 100 AND 105).

CLASS 42—SCIENTIFIC AND COMPUTER SERVICES

FOR CONSULTING SERVICES IN THE FIELD OF IDENTIFICATION, SUPPORT, AND IMPLEMENTATION OF COMPUTER BASED INFORMATION SYSTEMS FOR BUSINESS; COMPUTER SOFTWARE INSTALLATION, IMPLEMENTATION AND REPAIR SERVICES; PROVIDING ONLINE NON-DOWNLOADABLE INTERNET BASED SOFTWARE APPLICATIONS FOR PROVIDING TECHNICAL SYSTEMS DEVELOPMENT AND SUPPORT SERVICES IN THE FIELD OF PACKAGE, DOCUMENT AND FREIGHT PICK-UP, TRANSPORTATION, STORAGE AND DELIVERY; APPLICATION SERVICE PROVIDER FEATURING SOFTWARE FOR ENABLING INDIVIDUALS AND BUSINESSES TO REMOTELY SET UP ACCOUNTS AND UPLOAD INFORMATION FOR DELIVERY TO CUSTOMERS RE SHIPPING CAPABILITIES AND FUNCTIONALITIES, SHIPPING TRANSACTIONS, BILLING, BILL PAYMENT SYSTEMS AND ACCOUNTS, CLAIMS PROCESSING AND SCHEDULING AND TRACKING (U.S. CLS. 100 AND 101).

MICHAEL SOUDERS, EXAMINING ATTORNEY

SN 85-130,255. A360, LLC, FORT LAUDERDALE, FL. FILED 9-15-2010.

SN 85-130,621. MI PUEBLO SAN JOSE, INC., AKA MI PUEBLO, MI PUEBLO FOOD CENTER, AND MI PUEBLO FOODS, SAN JOSE, CA. FILED 9-15-2010.

BUILDING VALUE WORLDWIDE

THE MARK CONSISTS OF STANDARD CHARACTERS WITHOUT CLAIM TO ANY PARTICULAR FONT, STYLE, SIZE, OR COLOR.

NO CLAIM IS MADE TO THE EXCLUSIVE RIGHT TO USE "WORLDWIDE", APART FROM THE MARK AS SHOWN.

CLASS 35—ADVERTISING AND BUSINESS

FOR LOGISTICS MANAGEMENT IN THE FIELD OF CONSTRUCTION (U.S. CLS. 100, 101 AND 102).
FIRST USE 4-27-2010; IN COMMERCE 4-27-2010.

CLASS 37—CONSTRUCTION AND REPAIR

FOR CONSULTING SERVICES IN THE FIELD OF BUILDING CONSTRUCTION AND CONSTRUCTION MANAGEMENT; CONSTRUCTION PROJECT MANAGEMENT AND CONSTRUCTION PLANNING SERVICES; GENERAL CONSTRUCTION CONTRACTING (U.S. CLS. 100, 103 AND 106).
FIRST USE 4-27-2010; IN COMMERCE 4-27-2010.

MARLENE BELL, EXAMINING ATTORNEY

SN 85-130,504. STRYKER CORPORATOIN, KALAMAZOO, MI. AND STRYKER NV OPERATIONS LIMITED, DUBLIN 2, IRELAND, FILED 9-15-2010.

TENZING

THE MARK CONSISTS OF STANDARD CHARACTERS WITHOUT CLAIM TO ANY PARTICULAR FONT, STYLE, SIZE, OR COLOR.

CLASS 9—ELECTRICAL AND SCIENTIFIC APPARATUS

FOR POWER SUPPLY FOR USE WITH EMBOLIZATION COILS; MEDICAL ELECTRICAL CABLE USED IN AN ELECTRICAL CIRCUIT WITH A POWER SUPPLY AND EMBOLIZATION COILS (U.S. CLS. 21, 23, 26, 36 AND 38).

CLASS 10—MEDICAL APPARATUS

FOR MEDICAL EMBOLIZATION COILS (U.S. CLS. 26, 39 AND 44).
ADA HAN, EXAMINING ATTORNEY

MI PUEBLO FOOD CENTER

THE MARK CONSISTS OF STANDARD CHARACTERS WITHOUT CLAIM TO ANY PARTICULAR FONT, STYLE, SIZE, OR COLOR.

OWNER OF U.S. REG. NO. 3,576,655.

NO CLAIM IS MADE TO THE EXCLUSIVE RIGHT TO USE "FOOD CENTER", APART FROM THE MARK AS SHOWN.

THE ENGLISH TRANSLATION OF "MI PUEBLO" IN THE MARK IS "MY VILLAGE".

CLASS 16—PAPER GOODS AND PRINTED MATTER

FOR COUPON BOOKS; RECIPE BOOKS; REUSABLE PLASTIC SHOPPING BAGS TO CARRY PRODUCE FROM GROCERY STORES AND FARMER'S MARKETS (U.S. CLS. 2, 5, 22, 23, 29, 37, 38 AND 50).

CLASS 18—LEATHER GOODS

FOR REUSABLE TEXTILE SHOPPING BAGS TO CARRY PRODUCE FROM GROCERY STORES AND FARMER'S MARKETS (U.S. CLS. 1, 2, 3, 22 AND 41).

CLASS 43—HOTEL AND RESTAURANT SERVICES

FOR PROVIDING AN ONLINE COMPUTER DATABASE TO CONSUMERS CONCERNING RECIPES, INGREDIENTS AND COOKING INFORMATION (U.S. CLS. 100 AND 101).

BRENDAN MCCAULEY, EXAMINING ATTORNEY

SN 85-130,642. COFFEE CUP FUEL STOPS AND CONVENIENCE STORES, INC., ABERDEEN, SD. FILED 9-15-2010.

COFFEE CUP

THE MARK CONSISTS OF STANDARD CHARACTERS WITHOUT CLAIM TO ANY PARTICULAR FONT, STYLE, SIZE, OR COLOR.

OWNER OF U.S. REG. NO. 1,949,033.

SEC. 2(F) "COFFEE".

CLASS 35—ADVERTISING AND BUSINESS

FOR RETAIL CONVENIENCE STORES (U.S. CLS. 100, 101 AND 102).
FIRST USE 9-1-1983; IN COMMERCE 9-1-1983.

CLASS 37—CONSTRUCTION AND REPAIR

FOR VEHICLE FUELING SERVICES (U.S. CLS. 100, 103 AND 106).
FIRST USE 9-1-1983; IN COMMERCE 9-1-1983.
VIVIAN MICZNIK FIRST, EXAMINING ATTORNEY

SN 85-131,241. SMITH INTERNATIONAL, INC., HOUSTON, TX. FILED 9-16-2010.

DRS WELL CHRONICLE

THE MARK CONSISTS OF STANDARD CHARACTERS WITHOUT CLAIM TO ANY PARTICULAR FONT, STYLE, SIZE, OR COLOR.

OWNER OF U.S. REG. NO. 3,303,450.

NO CLAIM IS MADE TO THE EXCLUSIVE RIGHT TO USE "WELL", APART FROM THE MARK AS SHOWN.

CLASS 37—CONSTRUCTION AND REPAIR

FOR CONSULTING IN THE FIELD OF OIL AND GAS WELL DRILLING, NAMELY, PROVIDING BIT RECORDS, FIELD RUN REPORTS, DOWN HOLE MOTOR DATA, DIRECTIONAL DATA AND OTHER DRILLING DATA FROM WELLS (U.S. CLS. 100, 103 AND 106).

FIRST USE 7-5-2010; IN COMMERCE 7-5-2010.

CLASS 42—SCIENTIFIC AND COMPUTER SERVICES

FOR COMPUTER SERVICES, NAMELY, ELECTRONICALLY GATHERING, ANALYZING AND FORMATTING DATA TO TRACK, LOCATE, MONITOR AND LOG OPERATIONS IN THE OIL INDUSTRY; ENGINEERING SERVICES, NAMELY, ANALYZING AND REPORTING DATA IN THE FIELD OF OILFIELD DRILLING OPERATIONS; ENGINEERING SERVICES, NAMELY, ENGINEERING REPORT PREPARATION IN THE FIELD OF OILFIELD DRILLING OPERATIONS (U.S. CLS. 100 AND 101).

FIRST USE 7-5-2010; IN COMMERCE 7-5-2010.

ANDREA HACK, EXAMINING ATTORNEY

SN 85-131,426. LOCKHEED MARTIN CORPORATION, BETHESDA, MD. FILED 9-16-2010.

ETHICS MINUTE

THE MARK CONSISTS OF STANDARD CHARACTERS WITHOUT CLAIM TO ANY PARTICULAR FONT, STYLE, SIZE, OR COLOR.

NO CLAIM IS MADE TO THE EXCLUSIVE RIGHT TO USE "ETHICS", APART FROM THE MARK AS SHOWN.

CLASS 38—COMMUNICATION

FOR STREAMING OF VIDEO MATERIAL ON THE INTERNET FEATURING INSTRUCTIONAL VIDEOS IN THE FIELDS OF BUSINESS MANAGEMENT, HUMAN RESOURCES, BUSINESS DIVERSITY AND HARASSMENT, BUSINESS ETHICS, QUALITY ASSURANCE, SAFETY, CONFLICTS OF INTEREST, COMPUTER USAGE, BUSINESS ETIQUETTE, COMPLIANCE WITH BUSINESS LAWS AND REGULATIONS, AND BUSINESS COMMUNICATIONS (U.S. CLS. 100, 101 AND 104).

CLASS 41—EDUCATION AND ENTERTAINMENT

FOR BUSINESS TRAINING AND INSTRUCTION SERVICES, NAMELY, BUSINESS MANAGEMENT TRAINING, HUMAN RESOURCES TRAINING, BUSINESS DIVERSITY AND HARASSMENT TRAINING, BUSINESS ETHICS TRAINING, QUALITY ASSURANCE TRAINING, SAFETY TRAINING, CONFLICTS OF INTEREST TRAINING, COMPUTER USAGE TRAINING, BUSINESS ETIQUETTE TRAINING, BUSINESS TRAINING FOR COMPLIANCE WITH LAWS AND REGULATIONS, AND BUSINESS COMMUNICATIONS TRAINING; PRODUCTION OF VIDEO PROGRAMS; PRODUCTION AND DISTRIBUTION OF VIDEOS FEATURING AUDIOVISUAL PRESENTATIONS; PROVIDING A WEB SITE FEATURING NON-DOWNLOADABLE INSTRUCTIONAL VIDEOS IN THE FIELDS OF BUSINESS MANAGEMENT, HUMAN RESOURCES, BUSINESS DIVERSITY AND HARASSMENT, BUSINESS ETHICS, QUALITY ASSURANCE, SAFETY, CONFLICTS OF INTEREST, COMPUTER USAGE, BUSINESS ETIQUETTE, COMPLIANCE WITH BUSINESS LAWS AND REGULATIONS, AND BUSINESS COMMUNICATIONS (U.S. CLS. 100, 101 AND 107).

WARREN L. OLANDRIA, EXAMINING ATTORNEY

SN 85-131,890. NORTHERN FLOW, INC., SOUTH SALEM, NY. FILED 9-17-2010.

MASHREEL

THE MARK CONSISTS OF STANDARD CHARACTERS WITHOUT CLAIM TO ANY PARTICULAR FONT, STYLE, SIZE, OR COLOR.

CLASS 38—COMMUNICATION

FOR PROVIDING FORUMS FOR THE TRANSMISSION, SHARING AND EXCHANGE OF VIDEOS AND OTHER MULTIMEDIA CONTENT AMONG USERS IN THE FIELD OF GENERAL INTEREST VIA THE INTERNET (U.S. CLS. 100, 101 AND 104).

FIRST USE 8-31-2010; IN COMMERCE 8-31-2010.

CLASS 42—SCIENTIFIC AND COMPUTER SERVICES

FOR COMPUTER SERVICES, NAMELY, CREATING AN ONLINE COMMUNITY FOR REGISTERED USERS TO SHARE AND EXCHANGE VIDEOS AND OTHER MULTIMEDIA CONTENT AND TO ENGAGE IN SOCIAL NETWORKING IN CONNECTION WITH OUTDOOR ACTIVITIES AND RECREATION; PROVIDING A WEBSITE FEATURING TECHNOLOGY ENABLING USERS TO UPLOAD, POST, SHARE, DISPLAY AND VIEW VIDEOS AND OTHER MULTIMEDIA CONTENT; AND PROVIDING A WEBSITE THAT GIVES COMPUTER USERS THE ABILITY TO POST, SEARCH, VIEW, SHARE AND COMMENT ON VIDEOS AND OTHER MULTIMEDIA CONTENT VIA THE INTERNET (U.S. CLS. 100 AND 101).

FIRST USE 8-31-2010; IN COMMERCE 8-31-2010.
ROSELLE HERRERA, EXAMINING ATTORNEY

SN 85-131,966. AIRTYME COMMUNICATIONS, LLC, HAUPAUGE, NY. FILED 9-17-2010.

SN 85-132,432. OPENFEINT INC., MOUNTAIN VIEW, CA. FILED 9-17-2010.



NO CLAIM IS MADE TO THE EXCLUSIVE RIGHT TO USE "AIRTYME COMMUNICATIONS, LLC", APART FROM THE MARK AS SHOWN.

THE MARK CONSISTS OF THE WORDING "AIRTYME COMMUNICATIONS, LLC TYMING IS EVERYTHING" AND DESIGN. THE DESIGN CONSISTS OF A GLOBE WITH MERIDIANS AND PARALLELS. TO THE RIGHT OF THE DESIGN IS THE WORDING "AIRTYME COMMUNICATIONS, LLC TYMING IS EVERYTHING". THE LETTER "A" IN "AIRTYME" IS SUPERIMPOSED ON THE GLOBE. THE TERM "AIRTYME" APPEARS ABOVE THE WORDING "COMMUNICATIONS, LLC" WHICH IS ABOVE THE WORDING "TYMING IS EVERYTHING".

CLASS 9—ELECTRICAL AND SCIENTIFIC APPARATUS

FOR WIRELESS TELEPHONES AND WIRELESS TELEPHONE ACCESSORIES, NAMELY, CELL PHONE BATTERY CHARGERS, SPECIALTY HOLSTERS, HEADSETS, CASES AND BATTERIES (U.S. CLS. 21, 23, 26, 36 AND 38).

CLASS 35—ADVERTISING AND BUSINESS

FOR WHOLESALE AND RETAIL STORE SERVICES FEATURING WIRELESS PHONES, WIRELESS PHONE ACCESSORIES, TELECOMMUNICATIONS SERVICE PLANS AND TELECOMMUNICATIONS SERVICE ACTIVATION (U.S. CLS. 100, 101 AND 102).

MARLENE BELL, EXAMINING ATTORNEY

SN 85-132,036. AIRTYME COMMUNICATIONS, LLC, HAUPAUGE, NY. FILED 9-17-2010.

TYMING IS EVERYTHING

THE MARK CONSISTS OF STANDARD CHARACTERS WITHOUT CLAIM TO ANY PARTICULAR FONT, STYLE, SIZE, OR COLOR.

CLASS 9—ELECTRICAL AND SCIENTIFIC APPARATUS

FOR WIRELESS TELEPHONES AND WIRELESS TELEPHONE ACCESSORIES, NAMELY, CELL PHONE BATTERY CHARGERS, SPECIALTY HOLSTERS, HEADSETS, CASES AND BATTERIES (U.S. CLS. 21, 23, 26, 36 AND 38).

CLASS 35—ADVERTISING AND BUSINESS

FOR WHOLESALE AND RETAIL STORE SERVICES FEATURING WIRELESS PHONES, WIRELESS PHONE ACCESSORIES, TELECOMMUNICATIONS SERVICE PLANS AND TELECOMMUNICATIONS SERVICE ACTIVATION (U.S. CLS. 100, 101 AND 102).

MARLENE BELL, EXAMINING ATTORNEY

AURORA FEINT

THE MARK CONSISTS OF STANDARD CHARACTERS WITHOUT CLAIM TO ANY PARTICULAR FONT, STYLE, SIZE, OR COLOR.

THE NAME SHOWN IN THE MARK DOES NOT IDENTIFY A PARTICULAR LIVING INDIVIDUAL.

CLASS 9—ELECTRICAL AND SCIENTIFIC APPARATUS

FOR DOWNLOADABLE COMPUTER SOFTWARE FOR USE ON WIRELESS DEVICES AND COMPUTERS, NAMELY, COMPUTER GAME SOFTWARE AND SOFTWARE FOR CREATING COMPUTER GAMES; COMPUTER-GAME SOFTWARE, VIDEO GAME SOFTWARE; DOWNLOADABLE VIDEO GAMES AND COMPUTER GAMES; INTERACTIVE-VIDEO-GAME PROGRAMS; DOWNLOADABLE ELECTRONIC GAME PROGRAMS THAT MAY BE ACCESSED VIA THE INTERNET, COMPUTERS AND WIRELESS DEVICES; COMPUTER SOFTWARE TO ENABLE UPLOADING, POSTING, SHOWING, DISPLAYING, TAGGING, BLOGGING, SHARING OR OTHERWISE PROVIDING ELECTRONIC MEDIA OR INFORMATION REGARDING THE FIELDS OF VIRTUAL COMMUNITIES, ELECTRONIC GAMING, ENTERTAINMENT AND GENERAL INTEREST VIA THE INTERNET OR OTHER COMMUNICATIONS NETWORKS WITH THIRD PARTIES (U.S. CLS. 21, 23, 26, 36 AND 38).

CLASS 41—EDUCATION AND ENTERTAINMENT

FOR ENTERTAINMENT SERVICES, NAMELY, PROVIDING TEMPORARY USE OF NON-DOWNLOADABLE ELECTRONIC GAMES BY MEANS OF THE INTERNET OR OTHER WIRED OR WIRELESS NETWORKS; PROVIDING INFORMATION RELATING TO ELECTRONIC GAMES; PROVIDING ONLINE GAMES AND VIDEO GAMES; PROVIDING ONLINE ELECTRONIC GAMES THAT MAY BE ACCESSED VIA THE INTERNET, COMPUTERS, AND WIRELESS DEVICES (U.S. CLS. 100, 101 AND 107).

KELLEY WELLS, EXAMINING ATTORNEY

SN 85-133,458. THE VALSPAR CORPORATION, MINNEAPOLIS, MN. FILED 9-20-2010.

SCIENCE SIMPLIFIED

THE MARK CONSISTS OF STANDARD CHARACTERS WITHOUT CLAIM TO ANY PARTICULAR FONT, STYLE, SIZE, OR COLOR.

CLASS 1—CHEMICALS

FOR ARTIFICIAL RESINS, SYNTHETIC RESINS AND POLYMERS FOR USE IN THE MANUFACTURE OF PAINTS AND SURFACE COATINGS (U.S. CLS. 1, 5, 6, 10, 26 AND 46).

CLASS 2—PAINTS

FOR RAW NATURAL RESINS AND NATURAL RESINS FOR USE IN THE MANUFACTURE OF PAINTS AND SURFACE COATINGS; PAINTS (U.S. CLS. 6, 11 AND 16).

ERNEST SHOSHO, EXAMINING ATTORNEY

SN 85-133,581. LA FRESH, CHINO, CA. FILED 9-20-2010.

DIVAS & STUDS

THE MARK CONSISTS OF STANDARD CHARACTERS WITHOUT CLAIM TO ANY PARTICULAR FONT, STYLE, SIZE, OR COLOR.

CLASS 3—COSMETICS AND CLEANING PREPARATIONS

FOR DEODORIZERS FOR PETS; DISPOSABLE WIPES IMPREGNATED WITH CLEANSING CHEMICALS OR COMPOUNDS FOR PET HYGIENE; PET CARE KITS COMPRISING SHAMPOO, CONDITIONER, BODY SPRAY; PET FRAGRANCES; PET ODOR REMOVERS; PET SHAMPOO; PET SHAMPOO AND CONDITIONER (U.S. CLS. 1, 4, 6, 50, 51 AND 52).

CLASS 5—PHARMACEUTICALS

FOR MEDICATED GROOMING PREPARATION FOR PETS, NAMELY, DENTAL MITTS; EAR WIPES; EYE WIPES; SHAMPOO; AND CONDITIONER (U.S. CLS. 6, 18, 44, 46, 51 AND 52).

CLASS 24—FABRICS

FOR BATH MITTS; WASHING MITTS (U.S. CLS. 42 AND 50).

GEORGE LORENZO, EXAMINING ATTORNEY

SN 85-133,607. WAVE THE PLANET LLC, SAN DIEGO, CA. FILED 9-20-2010.

Flow House

THE MARK CONSISTS OF STANDARD CHARACTERS WITHOUT CLAIM TO ANY PARTICULAR FONT, STYLE, SIZE, OR COLOR.

NO CLAIM IS MADE TO THE EXCLUSIVE RIGHT TO USE "HOUSE", APART FROM THE MARK AS SHOWN.

CLASS 25—CLOTHING

FOR CLOTHING, NAMELY, T-SHIRTS, SWEAT-SHIRTS, SHIRTS, JACKETS, PANTS, SHORTS, HATS, BEACH-WEAR (U.S. CLS. 22 AND 39).

FIRST USE 9-0-2009; IN COMMERCE 9-0-2009.

CLASS 35—ADVERTISING AND BUSINESS

FOR RETAIL STORE SERVICES AND CONCESSIONS STANDS FEATURING BEACH RELATED PRODUCTS, WATER SPORTS RELATED PRODUCTS, CLOTHING, BEACHWEAR, GIFT ITEMS, SOUVENIRS, FOOD AND DRINK (U.S. CLS. 100, 101 AND 102).

FIRST USE 9-0-2009; IN COMMERCE 9-0-2009.

CLASS 41—EDUCATION AND ENTERTAINMENT

FOR AMUSEMENT AND WATER THEME PARK SERVICES, AMUSEMENT CENTERS, ENTERTAINMENT IN THE NATURE OF LIVE MUSICAL AND THEATRICAL STAGE PERFORMANCES, CONDUCTING ENTERTAINMENT EXHIBITIONS IN THE FIELD OF WATER SPORTS DEMONSTRATIONS, ENTERTAINMENT IN THE NATURE OF AMUSEMENT AND WATER THEME PARK RIDES, ARRANGING AND CONDUCTING WATER SPORTS COMPETITIONS (U.S. CLS. 100, 101 AND 107).

FIRST USE 9-0-2009; IN COMMERCE 9-0-2009.

CLASS 43—HOTEL AND RESTAURANT SERVICES

FOR RESTAURANTS; FOOD AND DRINK PREPARATION (U.S. CLS. 100 AND 101).

FIRST USE 9-0-2009; IN COMMERCE 9-0-2009.

JESSICA A. POWERS, EXAMINING ATTORNEY

SN 85-133,629. ALPHA MEDIA GROUP INC., NEW YORK, NY. FILED 9-20-2010.

24 HOURS TO LIVE

THE MARK CONSISTS OF STANDARD CHARACTERS WITHOUT CLAIM TO ANY PARTICULAR FONT, STYLE, SIZE, OR COLOR.

CLASS 16—PAPER GOODS AND PRINTED MATTER

FOR MAGAZINE SECTION FEATURING INTERVIEWS (U.S. CLS. 2, 5, 22, 23, 29, 37, 38 AND 50).

FIRST USE 1-31-2008; IN COMMERCE 1-31-2008.

CLASS 41—EDUCATION AND ENTERTAINMENT

FOR ENTERTAINMENT SERVICES AND INFORMATION SERVICES, NAMELY, PROVIDING A WEBSITE FEATURING ON-LINE MAGAZINES IN THE FIELDS OF GENERAL INTEREST, SPORTS, ENTERTAINMENT IN THE FIELD OF MEN'S LIFESTYLES AND POPULAR CULTURE FEATURING CELEBRITIES, ATHLETES AND PERSONS OF INTEREST; PROVIDING A WEBSITE FOR ENTERTAINMENT PURPOSES WHERE USERS CAN VIEW AND POST COMMENTS, VIDEOS AND PHOTOS FEATURING MATTER IN THE FIELD OF MEN'S LIFESTYLES AND POPULAR CULTURE (U.S. CLS. 100, 101 AND 107).

FIRST USE 2-13-2008; IN COMMERCE 2-13-2008.

JULIE GUTTADAURO, EXAMINING ATTORNEY

SN 85-133,697. LITTLE BLUE INSITE LLC, DARIEN, CT.
FILED 9-20-2010.

HCplexus

THE MARK CONSISTS OF STANDARD CHARACTERS WITHOUT CLAIM TO ANY PARTICULAR FONT, STYLE, SIZE, OR COLOR.

CLASS 9—ELECTRICAL AND SCIENTIFIC APPARATUS

FOR COMPUTER SOFTWARE FOR ACCESSING AND SEARCHING DATA IN ELECTRONIC COMPUTER DATABASES IN THE FIELDS OF MEDICAL INFORMATION, CLINICAL INFORMATION, FORMULARY INFORMATION, REGULATORY COMPLIANCE AND PATIENT EDUCATION; COMPUTER SOFTWARE FOR USE IN CLINICAL RESEARCH AND IN CONNECTION WITH REGULATORY COMPLIANCE THAT ORGANIZES, TRACKS AND ANALYSES DATA; COMPUTER SOFTWARE FOR USE BY HEALTH CARE PROFESSIONALS FOR THE DIAGNOSIS AND TREATMENT OF MEDICAL CONDITIONS, VERIFICATION OF INSURANCE COVERAGE FOR PATIENT TREATMENT, ORGANIZATION OF PERSONAL HEALTH RECORDS AND MANAGEMENT OF MEDICAL PRACTICES (U.S. CLS. 21, 23, 26, 36 AND 38).

CLASS 16—PAPER GOODS AND PRINTED MATTER

FOR PRINTED MATERIAL, NAMELY, DIRECTORIES AND GUIDES IN THE FIELDS OF MEDICAL INFORMATION, FORMULARY INFORMATION, CLINICAL AND MEDICAL REGULATORY COMPLIANCE, AND PATIENT EDUCATION (U.S. CLS. 2, 5, 22, 23, 29, 37, 38 AND 50).

CLASS 35—ADVERTISING AND BUSINESS

FOR DATA PROCESSING SERVICES; PROVIDING AN ON-LINE DIRECTORY INFORMATION SERVICE FEATURING INFORMATION REGARDING PHYSICIANS, PHARMACEUTICALS, HOSPITALS, PHARMACIES, INSURANCE PLANS, CLINICAL RESEARCH AND MEDICAL INFORMATION; MARKETING SERVICES, NAMELY, CONDUCTING MARKET RESEARCH (U.S. CLS. 100, 101 AND 102).

KAREN SEVERSON, EXAMINING ATTORNEY

SN 85-134,597. EQUILINE S.R.L., TREBASELEGHE (PD), ITALY, FILED 9-21-2010.

EQUILINE

THE MARK CONSISTS OF STANDARD CHARACTERS WITHOUT CLAIM TO ANY PARTICULAR FONT, STYLE, SIZE, OR COLOR.

CLASS 6—METAL GOODS

FOR METAL GUARD BARRIERS FOR USE IN KEEPING HORSES IN STABLE STALLS (U.S. CLS. 2, 12, 13, 14, 23, 25 AND 50).

CLASS 9—ELECTRICAL AND SCIENTIFIC APPARATUS

FOR RIDING HELMETS; BAGS SPECIALLY ADAPTED FOR RIDING HELMETS (U.S. CLS. 21, 23, 26, 36 AND 38).

CLASS 18—LEATHER GOODS

FOR BRIDLES; HARNESS FOR HORSES, HARNESSES AND SADDLERY; HORSE BLANKETS; HORSE BRIDLES; HORSE FLANKS AND SHANKS, NAMELY, HORSE PROTECTIVE PADDING AND LEG BOOTS FOR THE FLANKS AND LEGS; HORSE PROTECTIVE PADDING, NAMELY, PROTECTIVE PLASTIC HOOF PADS FOR HORSES FOR THE PROTECTION OF THE UNDERSIDE OF HORSES' HOOFS; HORSE HALTERS; HORSE RUGS; HORSE TAIL WRAPS; PADS FOR HORSE SADDLES; SADDLE BLANKETS; SADDLERY; SADDLERY OF LEATHER; FLEECE OR WOOL HORSE BANDAGES IN THE NATURE OF SPATS AND KNEE BANDAGES FOR HORSES; HORSE FLY VEILS IN THE NATURE OF HORSE EAR NETS; HORSE SADDLEPADS; HORSE SADDLES; PET CLOTHING AND APPAREL (U.S. CLS. 1, 2, 3, 22 AND 41).

CLASS 24—FABRICS

FOR FABRIC CURTAINS FOR USE AS BARRIERS IN STABLES, NAMELY, FABRIC STALL CURTAINS AND FABRIC STALL GUARDS IN THE NATURE OF CURTAINS (U.S. CLS. 42 AND 50).

CLASS 25—CLOTHING

FOR CLOTHING, NAMELY, MEN'S, WOMEN'S AND CHILDREN'S SPORTS JACKETS, SWEATSHIRTS, FLEECE JACKETS, BOMBER JACKETS, RIDING BREECHES, WOOLEN AND/OR COTTON BERETS, CAPS, RIDING JACKETS, RIDING/COMPETITION SHIRTS, RIDING/COMPETITION POLO SHIRTS, KNIT PULLOVERS, VESTS, RAIN JACKETS, RAIN PANTS, RAIN CAPS, T-SHIRTS, POLO SHIRTS, SHIRTS, RIDING PANTS, SOCKS, BELTS, SPORTSWEAR PANTS, COMPETITION TIES; SPORT SHOES FOR MEN, WOMEN AND CHILDREN; RIDING BOOTS FOR MEN, WOMEN AND CHILDREN; BAGS SPECIALLY ADAPTED FOR RIDING BOOTS (U.S. CLS. 22 AND 39).

CYNTHIA TRIPI, EXAMINING ATTORNEY

SN 85-134,916. EHR PATHWAY, LLC, WILDWOOD, MO.
FILED 9-21-2010.

EHR PATHWAY

THE MARK CONSISTS OF STANDARD CHARACTERS WITHOUT CLAIM TO ANY PARTICULAR FONT, STYLE, SIZE, OR COLOR.

NO CLAIM IS MADE TO THE EXCLUSIVE RIGHT TO USE "EHR", APART FROM THE MARK AS SHOWN.

CLASS 35—ADVERTISING AND BUSINESS

FOR STRATEGIC BUSINESS CONSULTING SERVICES, BUSINESS NETWORKING SERVICES, AND BUSINESS ADMINISTRATION SERVICES FOR HEALTH CARE PROVIDERS, NAMELY, SELECTION, IMPLEMENTATION, AND SUPPORT OF ELECTRONIC HEALTH RECORDS, HEALTH INFORMATION EXCHANGE, AND REPORTING SERVICES (U.S. CLS. 100, 101 AND 102).

FIRST USE 5-27-2010; IN COMMERCE 5-27-2010.

CLASS 42—SCIENTIFIC AND COMPUTER SERVICES

FOR PROVIDING AN INTERACTIVE WEB SITE THAT ENABLES USERS TO ENTER, ACCESS, TRACK, MONITOR, SHARE, AND GENERATE HEALTH AND MEDICAL INFORMATION AND REPORTS (U.S. CLS. 100 AND 101).

FIRST USE 5-27-2010; IN COMMERCE 5-27-2010.
AISHA CLARKE, EXAMINING ATTORNEY

SN 85-135,165. TRUELIGHT, LLC, BOSTON, MA. FILED 9-22-2010.



THE MARK CONSISTS OF A BACKGROUND CONSISTING OF SWIRLS OF LIGHT, AND THE WORD "TRUELIGHT" ABOVE A HORIZONTAL LINE THAT INTERSECTS A SEMICIRCLE.

CLASS 35—ADVERTISING AND BUSINESS

FOR ASSET MANAGEMENT SERVICES, NAMELY, AUCTIONING, LIQUIDATING AND REMARKETING ENERGY, RENEWABLE ENERGY AND ENERGY GENERATION ASSETS OF OTHERS (U.S. CLS. 100, 101 AND 102).

CLASS 36—INSURANCE AND FINANCIAL

FOR SERVICES OF PROVIDING AND ACQUIRING FUNDING FOR RENEWABLE GENERATION ASSETS AND PROJECTS OF OTHERS, NAMELY, SOURCING INVESTMENT CAPITAL, RAISING PRIVATE EQUITY, AND FINANCIAL MANAGEMENT RELATING TO FUNDING SERVICES (U.S. CLS. 100, 101 AND 102).

JULIE VEPPUMTHARA, EXAMINING ATTORNEY

SN 85-135,196. HEALTH CARE REIT, INC., TOLEDO, OH. FILED 9-22-2010.



OWNER OF U.S. REG. NOS. 1,652,587 AND 3,675,106.
NO CLAIM IS MADE TO THE EXCLUSIVE RIGHT TO USE "REIT", APART FROM THE MARK AS SHOWN.
THE COLOR(S) BLUE AND WHITE IS/ARE CLAIMED AS A FEATURE OF THE MARK.

THE MARK CONSISTS OF THE WORDING "HEALTHCARE REIT" IN A FONT DESIGN, WITH THE TWO WORDS DIVIDED BY A DIRECTION POINTER DESIGN IN WHITE WITHIN A SOLID BLUE CIRCLE. THE DIRECTION POINTER DESIGN IS POINTING TO THE RIGHT IN THE DRAWING OF THE MARK BUT MAY BE USED POINTING UP, DOWN OR TO THE RIGHT OR LEFT IS/ARE CLAIMED AS A FEATURE OF THE MARK.

SEC. 2(F) AS TO "HEALTHCARE REIT".

CLASS 37—CONSTRUCTION AND REPAIR

FOR LAND DEVELOPMENT, CLINICAL, FACILITY, AND EQUIPMENT PLANNING SERVICES, NAMELY, PLANNING AND LAYING OUT OF HEALTH CARE FACILITIES, MEDICAL OFFICE BUILDINGS, AND COMMERCIAL REAL ESTATE; CONSTRUCTION PLANNING, CONSTRUCTION CONSULTING, AND CONSTRUCTION MANAGEMENT SERVICES FOR THE DEVELOPMENT AND CONSTRUCTION OF HEALTH CARE FACILITIES, MEDICAL OFFICE BUILDINGS, AND COMMERCIAL REAL ESTATE AND THE REDEVELOPMENT AND RENOVATION OF HEALTH CARE FACILITIES, MEDICAL OFFICE BUILDINGS, AND COMMERCIAL REAL ESTATE (U.S. CLS. 100, 103 AND 106).

FIRST USE 1-15-2007; IN COMMERCE 1-15-2007.

CLASS 42—SCIENTIFIC AND COMPUTER SERVICES

FOR INTERIOR DESIGN SERVICES FOR HEALTH CARE FACILITIES, MEDICAL OFFICE BUILDINGS, AND COMMERCIAL REAL ESTATE (U.S. CLS. 100 AND 101).

FIRST USE 1-15-2007; IN COMMERCE 1-15-2007.
KEVON CHISOLM, EXAMINING ATTORNEY

SN 85-136,107. MERCK SHARP & DOHME CORP., WHITEHOUSE STATION, NJ. FILED 9-22-2010.

SMARTCELLS

THE MARK CONSISTS OF STANDARD CHARACTERS WITHOUT CLAIM TO ANY PARTICULAR FONT, STYLE, SIZE, OR COLOR.

CLASS 5—PHARMACEUTICALS

FOR PHARMACEUTICAL PREPARATIONS FOR THE TREATMENT OF ENDOCRINE DISORDERS; PHARMACEUTICAL PREPARATIONS IN THE FIELD OF ONCOLOGY; PHARMACEUTICAL PREPARATIONS FOR THE TREATMENT OF DIABETES (U.S. CLS. 6, 18, 44, 46, 51 AND 52).

CLASS 42—SCIENTIFIC AND COMPUTER SERVICES

FOR PHARMACEUTICAL AND BIOPHARMACEUTICAL RESEARCH AND DEVELOPMENT SERVICES (U.S. CLS. 100 AND 101).

REBECCA POVARCHUK, EXAMINING ATTORNEY

SN 85-136,940. TACO BELL CORP., IRVINE, CA. FILED 9-23-2010.

ICEQUAKE BLENDERS

THE MARK CONSISTS OF STANDARD CHARACTERS WITHOUT CLAIM TO ANY PARTICULAR FONT, STYLE, SIZE, OR COLOR.

CLASS 29—MEATS AND PROCESSED FOODS

FOR DAIRY BASED BEVERAGES; DAIRY BASED CHOCOLATE FOOD BEVERAGE (U.S. CL. 46).
FIRST USE 9-2-2010; IN COMMERCE 9-2-2010.

CLASS 32—LIGHT BEVERAGES

FOR ICE CREAM BASED BEVERAGES; SMOOTHIES (U.S. CLS. 45, 46 AND 48).
FIRST USE 9-2-2010; IN COMMERCE 9-2-2010.
HEATHER BIDDULPH, EXAMINING ATTORNEY

BOLTING AND BOLT TORQUEING; CONSTRUCTION SERVICES, NAMELY, ERECTION, REPAIR AND DISMANTLEMENT OF BLEACHERS, STADIUM AND THEATER SEATING, STAGING, BARRICADES, TURNSTILES AND RAMPS, T.V. TOWERS AND CHAIR RISERS; FIREPROOFING SERVICES, NAMELY, APPLICATION OF FIRE RETARDANT AND RESISTANT COATINGS AND MATERIALS TO LARGE-SCALE INDUSTRIAL AND COMMERCIAL BUILDINGS AND STRUCTURES IN THE NATURE OF BUILDINGS (U.S. CLS. 100, 103 AND 106).

FIRST USE 0-0-1961; IN COMMERCE 0-0-1961.

SN 85-136,978. BRAND SERVICES, LLC, KENNESAW, GA.
FILED 9-23-2010.

BRAND

THE MARK CONSISTS OF STANDARD CHARACTERS WITHOUT CLAIM TO ANY PARTICULAR FONT, STYLE, SIZE, OR COLOR.

OWNER OF U.S. REG. NOS. 1,815,144, 2,800,144 AND OTHERS.

CLASS 37—CONSTRUCTION AND REPAIR

FOR CONSTRUCTION SERVICES IN THE FIELD OF APPLICATION OF PAINT, COATINGS AND RESINS, NAMELY, SPECIALIZED INDUSTRIAL PAINTING CONTRACTOR SERVICES AND APPLICATION OF SPECIALIZED COATINGS AND RESIN SEALERS FOR LARGE-SCALE INDUSTRIAL SITE SURFACE PREPARATIONS, OIL FIELD, GAS, SHIPYARD AND MARINE FACILITIES; CONTRACTOR SERVICES IN THE FIELD OF APPLICATION OF PAINT, COATINGS AND RESINS, NAMELY, APPLICATION OF COATINGS, PAINT AND RESIN SEALERS TO MARINE VESSELS, HULL SURFACES, ABOVE GROUND STORAGE TANKS, AND DRILLING EQUIPMENT AND RISERS LOCATED ON MARINE EQUIPMENT; CONTRACTOR SERVICES, NAMELY, APPLICATION OF PROTECTIVE COATINGS FOR PREVENTING CORROSION UNDER INSULATION IN PETROCHEMICAL FACILITIES AND CHEMICAL PLANTS, APPLICATION OF PROTECTIVE THERMAL SPRAY COATINGS; CONSTRUCTION SERVICES IN THE FIELD OF INDUSTRIAL FACILITIES INSULATION SERVICES, NAMELY, INSTALLATION, MAINTENANCE AND REMOVAL OF THERMAL AND CRYOGENIC INSULATING MATERIALS AT REFINERY, PETROCHEMICAL AND POWER GENERATION FACILITIES, AND MARINE AND OFFSHORE FACILITIES; INSTALLATION OF INSULATION, CLADDING AND JACKETING FOR BOILERS, DUCTING AND PIPING AT REFINERY, PETROCHEMICAL AND POWER GENERATION FACILITIES, AND MARINE AND OFFSHORE FACILITIES; CONSTRUCTION SERVICES, NAMELY, ASBESTOS REMOVAL SERVICES AT REFINERY, PETROCHEMICAL AND POWER-GENERATION FACILITIES, AND MARINE AND OFF-SHORE FACILITIES; CONSTRUCTION SERVICES, NAMELY, LEAD REMOVAL SERVICES AT REFINERY, PETROCHEMICAL, POWER-GENERATION FACILITIES, AND MARINE AND OFF-SHORE FACILITIES; CONSTRUCTION SERVICES IN THE FIELD OF REFRACTORY SERVICES, NAMELY, INSTALLATION, REPAIR, AND MAINTENANCE OF REFRACTORY LININGS IN HIGH TEMPERATURE VESSELS, PARTICULARLY FLUID CATALYTIC CRACKING UNITS, REFORMERS, HYDRO CRACKERS, CRUDE UNITS, THERMAL REACTORS, BOILERS AND SULFUR RECOVERY UNITS; CONSTRUCTION SERVICES, NAMELY, CONCRETE POURING, FORMING AND SHORING FOR LARGE-SCALE CONCRETE INDUSTRIAL, COMMERCIAL OR PUBLIC BUILDINGS AND STRUCTURES; RENTAL OF CONCRETE FORMING AND SHORING EQUIPMENT; CONSTRUCTION CONSULTATION IN THE FIELD OF

CLASS 40—MATERIAL TREATMENT

FOR ABRASIVE BLASTING SERVICES, NAMELY, ROBOTIC SAND BLASTING AND SAND BLASTING FOR LARGE-SCALE INDUSTRIAL FACILITIES, REFINERY, PETROCHEMICAL AND POWER-GENERATION FACILITIES, AND MARINE AND OFFSHORE FACILITIES; DEMOLITION SERVICES, NAMELY, DEMOLITION OF REFRACTORY LININGS IN HIGH TEMPERATURE VESSELS; PIPE TAPPING SERVICES, NAMELY, DRILLING OR CUTTING HOLES IN OR CONNECTING TO EXISTING PIPING OR PRESSURIZED VESSELS WITHOUT DRAINING OR SPILLING THE CONTENTS OF THE PIPES OR VESSEL; MACHINE SHOP SERVICES, NAMELY, MACHINING PARTS FOR OTHERS THROUGH PIPE CUTTING AND PIPE BEVELING AT INDUSTRIAL AND COMMERCIAL FACILITIES (U.S. CLS. 100, 103 AND 106).

FIRST USE 11-0-2007; IN COMMERCE 11-0-2007.

CLASS 41—EDUCATION AND ENTERTAINMENT

FOR EDUCATIONAL SERVICES, NAMELY, CONDUCTING PROGRAMS IN THE FIELD OF SAFETY IN THE CONSTRUCTION INDUSTRY; TRAINING SERVICES IN THE FIELD OF SAFETY IN THE CONSTRUCTION INDUSTRY (U.S. CLS. 100, 101 AND 107).

FIRST USE 0-0-1983; IN COMMERCE 0-0-1983.

CLASS 42—SCIENTIFIC AND COMPUTER SERVICES

FOR ENGINEERING AND DESIGN OF FORMING AND SHORING EQUIPMENT AND SYSTEMS; ENGINEERING AND DESIGN OF WORK ACCESS AND SCAFFOLDING EQUIPMENT AND SYSTEMS; ENGINEERING AND DESIGN OF SPECIAL EVENT SCAFFOLDING, NAMELY, GRANDSTANDS AND ALUMINUM BLEACHERS, BARRICADES, STAGES AND TURNSTILES; INSPECTIONS OF PETROCHEMICAL FACILITIES AND CHEMICAL PLANTS FOR CORROSION UNDER INSULATION (U.S. CLS. 100 AND 101).

FIRST USE 0-0-1986; IN COMMERCE 0-0-1986.

CLASS 43—HOTEL AND RESTAURANT SERVICES

FOR SUPPLY AND RENTAL OF BLAST RESISTANT OFFICES AND POSITIVE PRESSURE WELDING ENCLOSURES, NAMELY, LEASING OF METAL AND NON-METAL BUILDINGS FOR TEMPORARY USE PURPOSES (U.S. CLS. 100 AND 101).

FIRST USE 11-0-2006; IN COMMERCE 11-0-2006.

KATHERINE E. HALMEN, EXAMINING ATTORNEY

SN 85-137,015. H & H CLOTHING, LLC, LAS VEGAS, NV.
FILED 9-23-2010.

HART & HUNTINGTON

THE MARK CONSISTS OF STANDARD CHARACTERS WITHOUT CLAIM TO ANY PARTICULAR FONT, STYLE, SIZE, OR COLOR.

CLASS 9—ELECTRICAL AND SCIENTIFIC APPARATUS

FOR MAGNETS; SUNGLASSES; SUNGLASS CASES; EYEGLASS CASES; EYEGLASSES; EYEGLASS FRAMES; PROTECTIVE HELMETS FOR SPORTS; GOGGLES FOR SPORTS; MOUSE PADS; COMPACT DISCS AND DIGITAL MEDIA FEATURING MUSIC AND SPOKEN WORD; AUDIO DISCS, VIDEO DISCS, LASER DISCS, DIGITAL DISCS, AND DOWNLOADABLE VIDEO FILES FEATURING MUSIC, AUDIO-VISUAL WORKS, SPORTING EVENTS, MOTORSPORTS, ACTION SPORTS AND DRAMATIC PERFORMANCES; DOWNLOADABLE RINGTONES VIA THE INTERNET, WIRELESS DEVICES AND MOBILE PHONES AND SOUND RECORDINGS FEATURING MUSIC AND OTHER SOUNDS; COMPUTER GAME CARTRIDGES, DISCS, AND SOFTWARE; VIDEO GAME CARTRIDGES, DISCS AND SOFTWARE; VIDEO GAME INTERACTIVE HAND HELD REMOTE CONTROLS FOR PLAYING ELECTRONIC GAMES; PRE-RECORDED ELECTRONIC AND DIGITAL MEDIA FEATURING MOTION PICTURES, TELEVISION PROGRAMS, SHOWS, CLIPS, USER GENERATED CONTENT, AUDIO-VISUAL MATERIAL, MUSIC AND PODCASTS IN THE FIELDS OF MUSIC, MOTORSPORTS, ACTION SPORTS AND SPORTING EVENTS, AND MATTERS OF GENERAL INTEREST WITH RESPECT THERETO; WALKIE-TALKIES; MOBILE PHONES; PERSONAL DIGITAL ASSISTANTS (PDAS); CARRYING CASES FOR MOBILE PHONES, SMARTPHONES, AND PERSONAL DIGITAL ASSISTANTS (U.S. CLS. 21, 23, 26, 36 AND 38).

CLASS 18—LEATHER GOODS

FOR HANDBAGS; TRAVELING BAGS; MESSENGER BAGS; DUFFLE BAGS; ATHLETIC BAGS; BOOK BAGS; SCHOOL BAGS; COSMETIC BAGS SOLD EMPTY; ALL-PURPOSE SPORTS BAGS; OVERNIGHT BAGS; LEATHER AND IMITATION LEATHER BAGS; ALL-PURPOSE CARRYING BAGS; TOTE BAGS; TEXTILE, LEATHER AND MESH SHOPPING BAGS; LUGGAGE; BACKPACKS; PURSES; WALLETS; KEY CASES (U.S. CLS. 1, 2, 3, 22 AND 41).

CLASS 25—CLOTHING

FOR CLOTHING, NAMELY, TOPS, BOTTOMS, SHIRTS, TANK TOPS, PANTS, JEANS, SHORTS, SWEAT SHIRTS, JACKETS, BELTS, COATS, JERSEYS, RAINWEAR, SWEAT PANTS, SWEATERS, PULLOVERS, DRESSES, SKIRTS, COVER-UPS, PAJAMAS, SLEEP WEAR, INFANT WEAR, BEACHWEAR, LOUNGE WEAR, SWIM WEAR, UNDERCLOTHES, PANTIES, BOXER SHORTS, BOXER BRIEFS, WRIST BANDS, SOCKS, SURF WEAR, SKI WEAR, GLOVES; HEAD WEAR; FOOTWEAR (U.S. CLS. 22 AND 39).

CLASS 35—ADVERTISING AND BUSINESS

FOR RETAIL STORE SERVICES AND ONLINE RETAIL STORE SERVICES FEATURING CLOTHING, SPORTSWEAR, HEADWEAR, FOOTWEAR, ACCESSORIES, SUNGLASSES, EYEGLASSES, DIGITAL MEDIA, CONSUMER ELECTRONICS, PRINTED MATTER, POSTERS, BAGS, WALLETS, PURSES, LEATHER GOODS, DECALS, JEWELRY, WATCHES, BELT BUCKLES, GAMES, HOUSE WARES, SOUVENIR ITEMS, KEY CHAINS, PERSONAL CARE PRODUCTS, AND DOWNLOADABLE SOUND, MUSIC, IMAGE, VIDEO, AND GAME FILES; RETAIL STORE AND ONLINE RETAIL STORE FEATURING A WIDE VARIETY OF CONSUMER GOODS OF OTHERS (U.S. CLS. 100, 101 AND 102).

H. M. FISHER, EXAMINING ATTORNEY

SN 85-137,325. THE TOPPS COMPANY, INC., NEW YORK, NY. FILED 9-24-2010.

SMASH ATAX

THE MARK CONSISTS OF STANDARD CHARACTERS WITHOUT CLAIM TO ANY PARTICULAR FONT, STYLE, SIZE, OR COLOR.

OWNER OF U.S. REG. NOS. 3,658,972, 3,703,325 AND 3,774,837.

CLASS 16—PAPER GOODS AND PRINTED MATTER

FOR TRADING CARDS AND STICKERS (U.S. CLS. 2, 5, 22, 23, 29, 37, 38 AND 50).

CLASS 28—TOYS AND SPORTING GOODS

FOR TOYS, NAMELY, TOY FIGURINES AND ACCESSORIES; GAMES, NAMELY, TRADING CARD GAMES, ACTION-TYPE TARGET GAMES, BOARD GAMES, ARCADE GAMES, PUZZLES AND ROLE-PLAYING GAMES (U.S. CLS. 22, 23, 38 AND 50).

CLASS 30—STAPLE FOODS

FOR CANDY (U.S. CL. 46).

CLASS 41—EDUCATION AND ENTERTAINMENT

FOR ENTERTAINMENT SERVICES, NAMELY, A CONTINUING LIVE ACTION AND ANIMATED TELEVISION SERIES AND ON-LINE COMPUTER GAMES AND ONLINE COMPUTER PUZZLE GAMES (U.S. CLS. 100, 101 AND 107).

LINDA ORNDORFF, EXAMINING ATTORNEY

SN 85-137,503. INCEPTRA LLC, WESTON, FL. FILED 9-24-2010.

SN 85-137,564. ZENOR INVESTMENTS LIMITED, TORTOLA, BR.VIRGIN ISLANDS, FILED 9-24-2010.



THE MARK CONSISTS OF A DIAMOND SHAPE, WITH THE TWO SIDES OF THE DIAMOND EACH MARKED BY FA SET OF FIVE PARALLEL VERTICAL LINES AND THE TOP AND BOTTOM OF THE DIAMOND MARKED EACH MARKED BY A SET OF FIVE PARALLEL HORIZONTAL LINES, WITH THE WORD "INCEPTRA" APPEARING TOWARD THE RIGHT.

CLASS 9—ELECTRICAL AND SCIENTIFIC APPARATUS

FOR SOFTWARE FOR GRAPHIC VISUALISATION IN TWO OR THREE DIMENSIONS, ESPECIALLY FOR COMPUTER-AIDED DESIGN, ANIMATION, SIMULATION, PUBLISHING, DOCUMENT SEARCHES, DEFEATURING, REMOTE MONITORING AND SURVEILLANCE; IMAGING SOFTWARE, NAMELY, COMPUTER SOFTWARE FOR PROCESSING DIGITAL IMAGES, COMPUTER SOFTWARE FOR PROCESSING IMAGES AND GRAPHICS, COMPUTER SOFTWARE FOR USE IN RELATION TO DIGITAL ANIMATION AND SPECIAL EFFECTS OF IMAGES; MAINTENANCE SOFTWARE, NAMELY, COMPUTER UTILITY PROGRAMS; SOFTWARE FOR PRESENTING KNOWLEDGE ABOUT INDUSTRIAL PRODUCTS, THEIR PRODUCTION, THEIR UTILISATION, THEIR MAINTENANCE, THEIR DOCUMENTATION, NAMELY, COMPUTER GRAPHICS SOFTWARE; COMPUTER SOFTWARE FOR THE DESIGN OF COMPUTER GAMES; COMPUTER GAME SOFTWARE; DATA EXCHANGE SOFTWARE, NAMELY, COMPUTER SOFTWARE FOR CREATING SEARCHABLE DATABASES OF INFORMATION AND DATA; EDUCATIONAL SOFTWARE FEATURING INSTRUCTION IN GRAPHIC VISUALIZATION OF PRODUCTS IN TWO OR THREE DIMENSIONS; TRAINING SOFTWARE FEATURING INSTRUCTION IN GRAPHIC VISUALIZATION OF PRODUCTS IN TWO OR THREE DIMENSIONS; TEACHING SOFTWARE FEATURING INSTRUCTION IN GRAPHIC VISUALIZATION OF PRODUCTS IN TWO OR THREE DIMENSIONS; PRE-RECORDED CDS, DVDS, FLOPPY DISCS AND DISKETTES FEATURING GRAPHIC VISUALIZATIONS OF PRODUCTS IN TWO OR THREE DIMENSIONS (U.S. CLS. 21, 23, 26, 36 AND 38).

CLASS 42—SCIENTIFIC AND COMPUTER SERVICES

FOR COMPUTER PROGRAMMING SERVICES; RENTAL OF COMPUTERS, COMPUTER PROGRAMS AND PERIPHERAL EQUIPMENT FOR COMPUTERS; ENGINEERING AND TECHNICAL CONSULTING SERVICES IN CONNECTION WITH THE NEW PRODUCT DESIGN AND MANUFACTURING TECHNOLOGY; SOFTWARE DESIGN, UPDATING AND MAINTENANCE SERVICES; TECHNICAL ASSISTANCE WITH COMPUTER COMPONENTS, NAMELY, ENABLING CUSTOMIZATION OF SOFTWARE FOR ADAPTING SAID SOFTWARE TO SPECIFIC REQUIREMENTS ARISING FROM CUSTOMERS' ACTIVITIES OR WORKING METHODS; CONSULTING SERVICES IN THE FIELD OF COMPUTING; COMPUTER SERVICES, NAMELY, REMOTE COMPUTER NETWORK MONITORING FOR TECHNICAL PURPOSES, INCLUDING THE MONITORING OF DATA, SIGNALS AND INFORMATION THROUGH DATA COMMUNICATION MEANS, VIA COMPUTER OR VIA TELECOMMUNICATIONS APPARATUS AND INSTRUMENTS (U.S. CLS. 100 AND 101).

SUSAN STIGLITZ, EXAMINING ATTORNEY

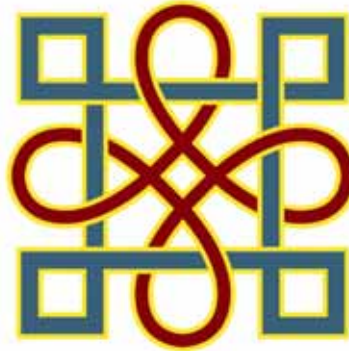

PRIORITY CLAIMED UNDER SEC. 44(D) ON HONG KONG APPLICATION NO. 301720467, FILED 9-22-2010, REG. NO. 301720467, DATED 9-22-2010, EXPIRES 9-21-2020.

THE COLOR(S) RED, BLUE, AND YELLOW IS/ARE CLAIMED AS A FEATURE OF THE MARK.

THE MARK CONSISTS OF A STYLIZED SQUARE-SHAPED DESIGN IN BLUE AND OUTLINE IN YELLOW WITH FOUR SMALLER SQUARES IN THE CORNERS. A STYLIZED FLOWER-SHAPED DESIGN IN RED AND OUTLINED IN YELLOW APPEARS INTERWOVEN IN THE SQUARE-SHAPED DESIGN WITH FOUR ELONGATED OVALS ON EACH SIDE AND A DIAMOND IN THE MIDDLE.

CLASS 16—PAPER GOODS AND PRINTED MATTER

FOR PRINTED MATTER, NAMELY, NEWSPAPERS, JOURNALS, MAGAZINES, BOOKS, PRINTED PERIODICALS, NEWSLETTERS, PAMPHLETS AND BROCHURES, ALL IN THE FIELDS OF FINANCE, SECURITIES, INVESTMENTS AND OTHER FINANCIAL INSTRUMENTS; LETTERHEAD PAPER; PHOTOGRAPHS; PICTURES; POSTERS; BUSINESS CARDS; GREETING CARDS; POSTCARDS; NOTEPADS; ADDRESS BOOKS; FOLDERS; CALENDARS; DIARIES; STICKERS; STATIONERY; PENS; PENCILS; BOOK MARKS; PRINTED INSTRUCTIONAL AND TEACHING MATERIALS IN THE FIELDS OF FINANCE, SECURITY AND INVESTMENT AND BUSINESS MANAGEMENT (U.S. CLS. 2, 5, 22, 23, 29, 37, 38 AND 50).

CLASS 35—ADVERTISING AND BUSINESS

FOR BUSINESS MANAGEMENT SERVICES; BUSINESS CONSULTANCY SERVICES; BUSINESS ADMINISTRATION; PROVIDING OFFICE FUNCTIONS; BUSINESS ADVICE RELATING TO FINANCIAL REORGANIZATION; ADMINISTRATION OF BUSINESS AFFAIRS, NAMELY, HELP IN THE MANAGEMENT OF BUSINESS AFFAIRS OR COMMERCIAL FUNCTIONS OF COMMERCIAL ENTERPRISES; ADVISORY SERVICES IN THE FIELD OF BUSINESS MANAGEMENT AND ORGANIZATION; ADVISORY SERVICES IN THE FIELD OF THE ACQUISITION OF BUSINESSES; BUSINESS ADVICE; BUSINESS ASSISTANCE RELATING TO THE FORMATION OF COMMERCIAL UNDERTAKINGS; BUSINESS CONSULTING AND INFORMATION SERVICES; BUSINESS RESEARCH AND DEVELOPMENT SERVICES; MARKETING SERVICES, NAMELY, CONSUMER MARKETING RESEARCH, MARKETING CONSULTING AND MARKETING PLAN DEVELOPMENT; ADVERTISING SERVICES; ADVERTISING CONSULTANCY SERVICES; RECRUITMENT SERVICES, NAMELY, PERSONNEL RECRUITMENT; EMPLOYMENT AGENCY SERVICES; BUSINESS INFORMATION, ADVISORY AND CONSULTANCY SERVICES, ALL RELATING TO THE AFORESAID SERVICES; BUSINESS APPRAISALS FOR FINANCIAL VALUATION (U.S. CLS. 100, 101 AND 102).

CLASS 36—INSURANCE AND FINANCIAL

FOR FINANCIAL SERVICES, NAMELY, FINANCIAL ANALYSES, FINANCIAL MANAGEMENT, FINANCIAL RESEARCH, FINANCIAL CONSULTING, FINANCIAL INFORMATION AND EVALUATION; LOAN FINANCING; CAPITAL INVESTMENTS; FUND INVESTMENTS; FUND MANAGEMENT, NAMELY, MANAGEMENT OF CAPITAL INVESTMENT FUNDS AND MANAGEMENT OF PRIVATE EQUITY FUNDS; MUTUAL FUND INVESTMENT; FIDUCIARY SERVICES, NAMELY, FIDUCIARY REPRESENTATIVE SERVICES; FIDUCIARY CONSULTANCY, NAMELY, CONSULTANCY IN THE FIELD OF FIDUCIARY REPRESENTATIVE SERVICES; INVESTMENT SERVICES, NAMELY, FINANCIAL INVESTMENT BROKERAGE, INVESTMENT OF FUNDS FOR OTHERS, INVESTMENT ADVICE AND CONSULTANCY; TRUST SERVICES, NAMELY, INVESTMENT AND TRUST COMPANY SERVICES, ESTATE TRUST MANAGEMENT AND PLANNING, FINANCIAL TRUST OPERATIONS; SERVICES FOR THE ESTABLISHMENT OF TRUSTS, NAMELY, FINANCIAL TRUST PLANNING; TRUST ADVISORY, NAMELY, TRUSTEE SERVICES; TRUST MANAGEMENT, NAMELY, REAL ESTATE INVESTMENT TRUST MANAGEMENT SERVICES, TRUST MANAGEMENT ACCOUNTS; TRUSTEESHIP, NAMELY, TRUSTEESHIP REPRESENTATIVES; ARRANGING OF INSURANCE, NAMELY, INSURANCE AGENCIES; INSURANCE BROKERAGE; INSURANCE CONSULTANCY; INSURANCE INFORMATION; INSURANCE UNDERWRITING, NAMELY, MEDICAL INSURANCE UNDERTAKING, HEALTH INSURANCE UNDERTAKING, LIFE INSURANCE UNDERTAKING, FIRE INSURANCE UNDERTAKING; INSURANCE FUND ADMINISTRATION, NAMELY, INSURANCE ADMINISTRATION IN THE FIELD OF HOME, ACCIDENT AND FIRE (U.S. CLS. 100, 101 AND 102).

JAMES STEIN, EXAMINING ATTORNEY

SN 85-137,650. NEW YORK BLOOD CENTER, INC., NEW YORK, NY. FILED 9-24-2010.

Donor Cola

THE MARK CONSISTS OF STANDARD CHARACTERS WITHOUT CLAIM TO ANY PARTICULAR FONT, STYLE, SIZE, OR COLOR.

NO CLAIM IS MADE TO THE EXCLUSIVE RIGHT TO USE "COLA", APART FROM THE MARK AS SHOWN.

CLASS 5—PHARMACEUTICALS

FOR RESTORATIVE NUTRITIONALLY FORTIFIED BEVERAGES FOR USE PRECEDING OR FOLLOWING BLOOD DONATIONS BY HUMANS (U.S. CLS. 6, 18, 44, 46, 51 AND 52).

CLASS 32—LIGHT BEVERAGES

FOR CARBONATED BEVERAGES CONTAINING NUTRIENTS FOR USE PRECEDING OR FOLLOWING BLOOD DONATIONS BY HUMANS (U.S. CLS. 45, 46 AND 48).

DANNEAN HETZEL, EXAMINING ATTORNEY

SN 85-138,000. HYDRONIX LIMITED, GUILDFORD, SURREY, UNITED KINGDOM, FILED 9-24-2010.

THERMO-TUFF

THE MARK CONSISTS OF STANDARD CHARACTERS WITHOUT CLAIM TO ANY PARTICULAR FONT, STYLE, SIZE, OR COLOR.

CLASS 9—ELECTRICAL AND SCIENTIFIC APPARATUS

FOR SCIENTIFIC, MEASURING APPARATUS AND INSTRUMENTS, NAMELY, TEMPERATURE SENSORS, AIR TEMPERATURE SENSORS; TEMPERATURE SENSORS BEING THERMOSTATS INCORPORATING BI-METALLIC DISCS; TEMPERATURE SENSORS BEING THERMOSTATS INCORPORATING EXPANSION RODS; TEMPERATURE SENSORS FOR INDUSTRIAL USE; TEMPERATURE SENSORS FOR SCIENTIFIC USE; TESTING INSTRUMENTS FOR TEMPERATURE MEASURING SENSORS; TEMPERATURE SENSORS FOR CENTRAL HEATING RADIATORS; TEMPERATURE SENSING APPARATUS (U.S. CLS. 21, 23, 26, 36 AND 38).

CLASS 42—SCIENTIFIC AND COMPUTER SERVICES

FOR SCIENTIFIC AND TECHNOLOGICAL SERVICES AND RESEARCH AND DESIGN RELATING THERETO, NAMELY, MEASURING THE TEMPERATURE OF CONCRETE, SAND, AGGREGATES, ASPHALT, ANIMAL FEED, CLAY BRICKS, FEED AND GRAIN; INDUSTRIAL ANALYSIS AND RESEARCH SERVICES IN THE FIELD OF MEASURING THE TEMPERATURE OF CONCRETE, SAND, AGGREGATES, ASPHALT, ANIMAL FEED, CLAY BRICKS, FEED AND GRAIN (U.S. CLS. 100 AND 101).

KRISTINA MORRIS, EXAMINING ATTORNEY

SN 85-138,734. HEALING OUT LOUD, HOUSTON, TX. FILED 9-27-2010.

HEALING OUT LOUD

THE MARK CONSISTS OF STANDARD CHARACTERS WITHOUT CLAIM TO ANY PARTICULAR FONT, STYLE, SIZE, OR COLOR.

CLASS 35—ADVERTISING AND BUSINESS

FOR PROMOTING PUBLIC AWARENESS OF ISSUES RELATED TO LESBIAN, GAY, BISEXUAL AND TRANSGENDERED INDIVIDUALS AND THEIR FAMILIES (U.S. CLS. 100, 101 AND 102).

CLASS 45—PERSONAL AND LEGAL SERVICES

FOR PROVIDING EMOTIONAL COUNSELING AND EMOTIONAL SUPPORT SERVICES FOR OTHERS IN THE FIELD OF ISSUES RELATED TO LESBIAN, GAY, BISEXUAL, AND TRANSGENDERED INDIVIDUALS AND THEIR FAMILIES (U.S. CLS. 100 AND 101).

EDWARD NELSON, EXAMINING ATTORNEY

SN 85-139,149. VISI INCORPORATED, EDEN PRAIRIE, MN.
FILED 9-27-2010.

INFRASTRUCTURE. SIMPLIFIED.

THE MARK CONSISTS OF STANDARD CHARACTERS WITHOUT CLAIM TO ANY PARTICULAR FONT, STYLE, SIZE, OR COLOR.

NO CLAIM IS MADE TO THE EXCLUSIVE RIGHT TO USE "INFRASTRUCTURE", APART FROM THE MARK AS SHOWN.

CLASS 9—ELECTRICAL AND SCIENTIFIC APPARATUS

FOR COMPUTER SOFTWARE PLATFORMS FOR GRID AND UTILITY COMPUTING AND FOR OPERATING DISTRIBUTED APPLICATIONS AND NETWORKS OF COMPUTERS (U.S. CLS. 21, 23, 26, 36 AND 38).

CLASS 42—SCIENTIFIC AND COMPUTER SERVICES

FOR HOSTING THE WEBSITES OF OTHERS; COMPUTER CO-LOCATION SERVICES, NAMELY, PROVIDING FACILITIES FOR THE LOCATION OF COMPUTER SERVERS WITH THE EQUIPMENT OF OTHERS; DISPLAYING THE WEB SITES AND IMAGES OF OTHERS ON A DEDICATED COMPUTER SERVER; E-MAIL SYSTEM DESIGN AND IMPLEMENTATION FOR OTHERS; INFORMATION TECHNOLOGY CONSULTATION; DESIGN, CREATION, HOSTING AND MAINTENANCE OF INTERNET SITES FOR THIRD PARTIES; COMPUTER SERVICES, NAMELY, PROVIDING VIRTUAL AND CLOUD COMPUTING ENVIRONMENTS ACCESSIBLE VIA THE INTERNET AND ORGANIZATIONAL NETWORKS FOR THE PURPOSE OF REMOTE MANAGEMENT IN THE NATURE OF CREATING AND OPERATING ON-LINE COMPUTER APPLICATIONS; PROVIDING A WEB-BASED SYSTEM AND ONLINE PORTAL FOR THIRD PARTIES TO REMOTELY MANAGE, ADMINISTER, MODIFY AND CONTROL VIRTUALIZED COMPUTING RESOURCES, DATA AND SOFTWARE APPLICATIONS IMPLEMENTED VIA DISTRIBUTED COMPUTING ENVIRONMENTS, AND TO REMOTELY MANAGE, ADMINISTER, MODIFY AND CONTROL GEOGRAPHIC DISTRIBUTION OF THE VIRTUALIZED COMPUTING RESOURCES, DATA AND SOFTWARE APPLICATIONS; PROVIDING A WEB-BASED SYSTEM AND ONLINE PORTAL FOR THIRD PARTIES TO REMOTELY MANAGE, ADMINISTER, MODIFY AND CONTROL DISASTER RECOVERY SOLUTIONS RELATING TO THEIR COMPUTER DEVICES, DATA AND SOFTWARE APPLICATIONS; PROVIDING NON-DOWNLOADABLE SOFTWARE, ACCESSIBLE OVER A GLOBAL COMPUTER NETWORK, FOR MANAGING COMPUTER APPLICATIONS AND FOR OPERATING DISTRIBUTED APPLICATIONS AND NETWORKS OF COMPUTERS; AND PROVIDING NON-DOWNLOADABLE SOFTWARE, ACCESSIBLE OVER A GLOBAL COMPUTER NETWORK, FOR ENABLING COMPUTER SYSTEM OPERATORS TO VIRTUALIZE THEIR COMPUTER SYSTEM RESOURCES, MANAGE, ADMINISTER, MODIFY, AND CONTROL THEIR VIRTUALIZED COMPUTING RESOURCES, AND ACCESS VIRTUALIZED GRID AND UTILITY COMPUTING RESOURCES, NAMELY, DISTRIBUTED CLOUD-BASED UTILITY COMPUTING RESOURCES, INFRASTRUCTURE-ON-DEMAND COMPUTING RESOURCES, METERED COMPUTING UTILITY RESOURCES, VIRTUALIZED GLOBALLY DISTRIBUTED COMPUTING RESOURCES, VIRTUALIZED DATACENTER RESOURCES, READY-APPLICATION-STACK COMPUTING RESOURCES, AND HIGH-AVAILABILITY COMPUTING RESOURCES; APPLICATION SERVICE PROVIDER, NAMELY, PROVIDING, HOSTING, MANAGING, DEVELOPING, AND MAINTAINING APPLICATIONS, SOFTWARE, WEBSITES, AND DATABASES FOR OTHERS IN THE FIELDS OF WIRELESS COMMUNICATION, MOBILE INFORMA-

TION ACCESS, AND REMOTE DATA MANAGEMENT FOR WIRELESS DELIVERY OF CONTENT TO HANDHELD COMPUTERS, LAPTOPS AND MOBILE ELECTRONIC DEVICES (U.S. CLS. 100 AND 101).
SARA BENJAMIN, EXAMINING ATTORNEY

SN 85-139,724. EMTURN, LLC, WASHINGTON, DC. FILED
9-28-2010.



THE MARK CONSISTS OF STYLIZED LETTERS "E" AND "T" SURROUNDED BY A BORDER FEATURING TRIANGLES ON THE LEFT AND RIGHT SIDES.

CLASS 18—LEATHER GOODS

FOR ALL PURPOSE SPORT BAGS; BACKPACKS; SHOE BAGS FOR TRAVEL; WAIST PACKS (U.S. CLS. 1, 2, 3, 22 AND 41).

CLASS 25—CLOTHING

FOR ATHLETIC UNIFORMS; CAPS; CLOTHING FOR ATHLETIC USE, NAMELY, PADDED PANTS; CLOTHING FOR ATHLETIC USE, NAMELY, PADDED SHIRTS; CLOTHING FOR ATHLETIC USE, NAMELY, PADDED SHORTS; FOOTWEAR; HATS; HEADBANDS; JACKETS; PANTS; PULLOVERS; SHIRTS; SHORTS; SOCKS; SWEAT SHIRTS; SWEATERS; TANK TOPS; VESTS; WARM UP SUITS; WRISTBANDS (U.S. CLS. 22 AND 39).

CLASS 28—TOYS AND SPORTING GOODS

FOR BASKETBALLS (U.S. CLS. 22, 23, 38 AND 50).
SUNG IN, EXAMINING ATTORNEY

SN 85-139,735. EMTURN, LLC, WASHINGTON, DC. FILED
9-28-2010.



THE COLOR(S) BLACK, RED AND WHITE IS/ARE CLAIMED AS A FEATURE OF THE MARK.

THE MARK CONSISTS OF THE FOLLOWING: BLACK STYLIZED LETTERS "E" AND "T" WITH A DIAGONAL WHITE HASH MARK ON THE LEFT HAND SIDE, SURROUNDED BY A RED BORDER FEATURING TRIANGLES ON THE LEFT AND RIGHT SIDES

CLASS 18—LEATHER GOODS

FOR ALL PURPOSE SPORT BAGS; BACKPACKS; SHOE BAGS FOR TRAVEL; WAIST PACKS (U.S. CLS. 1, 2, 3, 22 AND 41).

CLASS 25—CLOTHING

FOR ATHLETIC UNIFORMS; CAPS; CLOTHING FOR ATHLETIC USE, NAMELY, PADDED PANTS; CLOTHING FOR ATHLETIC USE, NAMELY, PADDED SHIRTS; CLOTHING FOR ATHLETIC USE, NAMELY, PADDED SHORTS; FOOTWEAR; HATS; HEADBANDS; JACKETS; PANTS; PULLOVERS; SHIRTS; SHORTS; SOCKS; SWEAT SHIRTS; SWEATERS; TANK TOPS; VESTS; WARM UP SUITS; WRISTBANDS (U.S. CLS. 22 AND 39).

CLASS 28—TOYS AND SPORTING GOODS

FOR BASKETBALLS (U.S. CLS. 22, 23, 38 AND 50).
SUNG IN, EXAMINING ATTORNEY

SN 85-142,153. PAHRTNERS DEAF SERVICES, LLC, GLENSIDE, PA. FILED 9-30-2010.

PAHRTNERS

THE MARK CONSISTS OF STANDARD CHARACTERS WITHOUT CLAIM TO ANY PARTICULAR FONT, STYLE, SIZE, OR COLOR.

CLASS 41—EDUCATION AND ENTERTAINMENT

FOR SIGN LANGUAGE INTERPRETATION AND PROVIDING INFORMATION IN THE FIELD OF SIGN LANGUAGE, EDUCATION AND TRAINING RELATED TO HEARING AND SPEECH DISABILITIES AND INTERPRETATION SERVICES FOR PERSONS WHO ARE DEAF AND HARD OF HEARING; EDUCATIONAL COMMUNICATION ASSESSMENTS, NAMELY, ASSESSING COMMUNICATION AND LANGUAGE SKILLS AND PROVIDING TRAINING REGARDING COMMUNICATION AND LANGUAGE DEVELOPMENT IN AMERICAN SIGN LANGUAGE; TRAINING FOR DEAF AND HARD OF HEARING PEOPLE WITH MENTAL RETARDATION OR EMOTIONAL, BEHAVIORAL, SOCIAL AND/OR DEVELOPMENTAL PROBLEMS IN THE FIELDS OF FOOD PREPARATION, COOKING, DIET, NUTRITION, EXERCISE, PERSONAL HYGIENE, SHOPPING, MONEY MANAGEMENT, USE OF PUBLIC TRANSPORTATION AND OTHER SKILLS NECESSARY FOR INDEPENDENT LIVING (U.S. CLS. 100, 101 AND 107).

CLASS 43—HOTEL AND RESTAURANT SERVICES

FOR PROVIDING HOUSING AND RESIDENTIAL SERVICES AND IN-HOME SUPPORT SERVICES FOR DEAF AND HARD OF HEARING PEOPLE WITH MENTAL RETARDATION OR EMOTIONAL, BEHAVIORAL, SOCIAL AND/OR DEVELOPMENTAL PROBLEMS IN THE NATURE OF PROVIDING RESIDENTIAL HOMES AND PROVIDING GUIDANCE, ASSISTANCE AND SUPPORT WITH FOOD PREPARATION AND COOKING (U.S. CLS. 100 AND 101).

CLASS 44—MEDICAL, BEAUTY AND AGRICULTURAL SERVICES

FOR MENTAL HEALTH SERVICES, PSYCHIATRIC EVALUATION AND COUNSELING, PSYCHOSOCIAL ASSESSMENTS, PSYCHOTHERAPEUTIC AND REHABILITATIVE TREATMENT, AND DRUG AND ALCOHOL TREATMENT, ALL FOR PEOPLE WHO ARE DEAF OR HARD OF HEARING WHO HAVE EMOTIONAL, BEHAVIORAL, SOCIAL AND/OR DEVELOPMENTAL PROBLEMS; MENTAL RETARDATION OR OTHER MENTAL ILLNESS; OUT-PATIENT PSYCHIATRIC COUNSELING AND SUPPORT FOR ADULTS, ADOLESCENTS AND CHILDREN WHO ARE DEAF, HARD OF HEARING OR DEAF-BLIND; GROUP THERAPY AND PSYCHOEDUCATION ON TOPICS SUCH AS ANGER MANAGEMENT, STRESS MANAGEMENT, CONFLICT RESOLUTION, POSITIVE COPING SKILLS, SYMPTOM MANAGEMENT, PROBLEM SOLVING AND EXPRESSING EMOTIONS; CLINICAL COMMUNICATION ASSESSMENTS, NAMELY, ASSESSING COMMUNICATION AND LANGUAGE SKILLS FOR PURPOSES OF GUIDING TREATMENT AND TRAINING IN LANGUAGE DEVELOPMENT TO MEET AN INDIVIDUAL'S NEEDS; PROVIDING IN-HOME SUPPORT SERVICES FOR DEAF AND HARD OF HEARING PEOPLE WITH MENTAL RETARDATION OR EMOTIONAL, BEHAVIORAL, SOCIAL AND/OR DEVELOPMENTAL PROBLEMS IN THE NATURE OF GUIDANCE, ASSISTANCE AND SUPPORT WITH DIET, NUTRITION, AND PERSONAL HYGIENE (U.S. CLS. 100 AND 101).

CLASS 45—PERSONAL AND LEGAL SERVICES

FOR PROVIDING CASE MANAGEMENT SERVICES AND ADVOCACY SERVICES AND IN-HOME SUPPORT SERVICES FOR PERSONS WHO ARE DEAF OR HARD OF HEARING AND WHO HAVE EMOTIONAL, BEHAVIORAL, SOCIAL AND/OR DEVELOPMENTAL PROBLEMS, MENTAL RETARDATION OR OTHER MENTAL ILLNESS, NAMELY, COORDINATION OF SOCIAL, PHYSICAL, MEDICAL, DENTAL, LEGAL AND PSYCHOLOGICAL SERVICES FOR SUCH PERSONS, COORDINATION OF CRISES SUPPORT, COORDINATION OF ACCESS TO WELLNESS AND RECREATIONAL ACTIVITIES, AND COORDINATION OF AND LINKAGE TO SERVICE PROVIDERS AND COMMUNITY RESOURCES; PROVIDING IN-HOME SUPPORT SERVICES FOR DEAF AND HARD OF HEARING PEOPLE WITH MENTAL RETARDATION OR EMOTIONAL, BEHAVIORAL, SOCIAL AND/OR DEVELOPMENTAL PROBLEMS IN THE NATURE OF PERSONAL SHOPPING AND OTHER NON-MEDICAL ASSISTED LIVING SERVICES FOR PERSONAL PURPOSES TO HELP INDIVIDUALS ACHIEVE SKILLS NECESSARY FOR INDEPENDENT LIVING; PROVIDING SELF-ADVOCACY SKILLS AND SOCIALIZATION SKILLS FOR PEOPLE WHO ARE DEAF OR HARD OF HEARING (U.S. CLS. 100 AND 101).

TOBY BULLOFF, EXAMINING ATTORNEY

SN 85-143,579. VUMANITY MEDIA, LLC, SANTA MONICA, CA. FILED 10-1-2010.

VUFANTASY

THE MARK CONSISTS OF STANDARD CHARACTERS WITHOUT CLAIM TO ANY PARTICULAR FONT, STYLE, SIZE, OR COLOR.

CLASS 38—COMMUNICATION

FOR TELEVISION SPORTS BROADCASTING (U.S. CLS. 100, 101 AND 104).

CLASS 41—EDUCATION AND ENTERTAINMENT

FOR ENTERTAINMENT IN THE FIELD OF SPORTS, NAMELY, ORGANIZING SPORTS COMPETITIONS (U.S. CLS. 100, 101 AND 107).

HANNO RITTNER, EXAMINING ATTORNEY

SN 85-147,948. WEBMD LLC, NEW YORK, NY. FILED 10-7-2010.



SN 85-147,526. GIGATHOUGHT, LLC, OVERLAND PARK, KS. FILED 10-7-2010.

NOUS

THE MARK CONSISTS OF STANDARD CHARACTERS WITHOUT CLAIM TO ANY PARTICULAR FONT, STYLE, SIZE, OR COLOR.

THE ENGLISH TRANSLATION OF "NOUS" IS "INTELLIGENCE," "INTELLECT" OR "MIND" IN GREEK AND "US" OR "WE" IN FRENCH.

CLASS 9—ELECTRICAL AND SCIENTIFIC APPARATUS

FOR COMPUTER SOFTWARE FOR ANALYSIS OF COMPUTER SYSTEMS; COMPUTER SOFTWARE FOR MANAGING UPGRADES TO COMPUTER SYSTEMS AND BUSINESS SOFTWARE APPLICATIONS; PROJECT PLANNING TOOLS, NAMELY, COMPUTER SOFTWARE FOR USE IN PLANNING, MANAGING AND INSTALLING UPGRADES TO COMPUTER SYSTEMS (U.S. CLS. 21, 23, 26, 36 AND 38).

CLASS 41—EDUCATION AND ENTERTAINMENT

FOR TRAINING SERVICES FOR MANAGING UPGRADES TO COMPUTER SYSTEMS (U.S. CLS. 100, 101 AND 107).

CLASS 42—SCIENTIFIC AND COMPUTER SERVICES

FOR COMPUTER SYSTEM ANALYSIS SERVICES; CONSULTING SERVICES RELATED TO SOFTWARE TOOLS FOR MANAGING UPGRADES TO COMPUTER SYSTEMS AND BUSINESS SOFTWARE APPLICATIONS AND PREPARING TECHNICAL DOCUMENTATION AND REPORTS RELATED THERETO (U.S. CLS. 100 AND 101).

DAVID H. STINE, EXAMINING ATTORNEY

THE MARK CONSISTS OF THE WORD "FIT" IN STYLIZED LETTERS WITH A RUNNING "I" INSIDE A RECTANGULAR OUTLINE.

CLASS 9—ELECTRICAL AND SCIENTIFIC APPARATUS

FOR ELECTRONIC GAME SOFTWARE; DOWNLOADABLE ELECTRONIC GAME PROGRAMS; VIDEO RECORDINGS FEATURING INFORMATION ON EXERCISE, FITNESS, NUTRITION AND LIFESTYLE, HEALTH RECORDS, MEDICAL NEWS AND INFORMATION; COMPUTER PROGRAMS FOR USE IN ACCESSING AN ONLINE PORTAL, SOCIAL NETWORKING, VIEWING VIDEOS AND PLAYING GAMES (U.S. CLS. 21, 23, 26, 36 AND 38).

CLASS 16—PAPER GOODS AND PRINTED MATTER

FOR PRINTED EDUCATIONAL MATERIAL FOR CHILDREN, TEENAGERS AND ADULTS, NAMELY, MAGAZINES, TEACHING AIDS, NAMELY, PAMPHLETS, PERIODICALS, MANUALS AND WORKBOOKS, ALL IN THE FIELD OF HEALTH, MEDICINE, FITNESS, DIET, EXERCISE, NUTRITION, AND LIFESTYLE (U.S. CLS. 2, 5, 22, 23, 29, 37, 38 AND 50).

CLASS 41—EDUCATION AND ENTERTAINMENT

FOR PROVIDING A WEB SITE FOR CHILDREN, TEENAGERS AND ADULTS FEATURING INFORMATION ON EXERCISE AND FITNESS; EDUCATIONAL SERVICES FOR CHILDREN, TEENAGERS AND ADULTS, NAMELY, CONDUCTING ON-LINE EXHIBITIONS AND DISPLAYS AND INTERACTIVE EXHIBITS IN THE FIELD OF EXERCISE, FITNESS, NUTRITION AND LIFESTYLE, HEALTH RECORDS, MEDICAL NEWS AND INFORMATION; ENTERTAINMENT SERVICES, NAMELY, PROVIDING PODCASTS AND VIDEO PODCASTS FOR CHILDREN, TEENAGERS AND ADULTS IN THE FIELD OF EXERCISE, FITNESS, NUTRITION AND LIFESTYLE, HEALTH RECORDS, MEDICAL NEWS AND INFORMATION; ON-LINE JOURNALS FOR CHILDREN, TEENAGERS AND ADULTS, NAMELY, BLOGS FEATURING INFORMATION ON EXERCISE, FITNESS, NUTRITION AND LIFESTYLE, HEALTH RECORDS, MEDICAL NEWS AND INFORMATION; ENTERTAINMENT SERVICES, NAMELY, PROVIDING ON-LINE COMPUTER GAMES; ENTERTAINMENT SERVICES, NAMELY, PROVIDING AN ONLINE HEALTH INCENTIVE AWARD PROGRAM FOR CHILDREN, TEENAGERS AND ADULTS DESIGNED TO REWARD PROGRAM PARTICIPANTS WHO EXERCISE IN ORDER TO MOTIVATE PARTICIPANTS TO ACHIEVE FITNESS GOALS (U.S. CLS. 100, 101 AND 107).

CLASS 42—SCIENTIFIC AND COMPUTER SERVICES

FOR COMPUTER SERVICES, NAMELY, CREATING AN ON-LINE COMMUNITY FOR REGISTERED USERS, NAMELY, CHILDREN, TEENAGERS AND/OR ADULTS, TO PARTICIPATE IN DISCUSSIONS, GET FEEDBACK FROM THEIR PEERS, FORM VIRTUAL COMMUNITIES, AND ENGAGE IN SOCIAL NETWORKING FEATURING INFORMATION ON EXERCISE, FITNESS, NUTRITION AND LIFESTYLE, HEALTH RECORDS, MEDICAL NEWS AND INFORMATION, INCENTIVE AWARD PROGRAMS DESIGNED TO REWARD PROGRAM PARTICIPANTS, ONLINE ACTIVITIES AND INTERACTIVE EXHIBITS (U.S. CLS. 100 AND 101).

CLASS 44—MEDICAL, BEAUTY AND AGRICULTURAL SERVICES

FOR PROVIDING A WEB SITE FOR CHILDREN, TEENAGERS AND ADULTS FEATURING INFORMATION ON NUTRITION; PROVIDING A WEB SITE FOR CHILDREN, TEENAGERS AND ADULTS FEATURING CONTENT REGARDING LIFESTYLE WELLNESS (U.S. CLS. 100 AND 101).

STEVEN JACKSON, EXAMINING ATTORNEY

SN 85-148,098. ROBERTA CHINSKY MATUSON, DBA HUMAN RESOURCE SOLUTIONS, FLORENCE, MA. FILED 10-8-2010.

SUDDENLY IN CHARGE

THE MARK CONSISTS OF STANDARD CHARACTERS WITHOUT CLAIM TO ANY PARTICULAR FONT, STYLE, SIZE, OR COLOR.

CLASS 35—ADVERTISING AND BUSINESS

FOR CONSULTING SERVICES IN THE FIELDS OF BUSINESS MANAGEMENT, BUSINESS LEADERSHIP DEVELOPMENT, BUSINESS, AND HUMAN RESOURCES (U.S. CLS. 100, 101 AND 102).

FIRST USE 8-0-2010; IN COMMERCE 8-0-2010.

CLASS 41—EDUCATION AND ENTERTAINMENT

FOR ON-LINE JOURNALS, NAMELY, BLOGS, IN THE FIELDS OF BUSINESS MANAGEMENT, LEADERSHIP, BUSINESS, AND HUMAN RESOURCES; EDUCATION SERVICES, NAMELY, PROVIDING WEBINARS IN THE NATURE OF ON-LINE SEMINARS IN THE FIELDS OF BUSINESS MANAGEMENT, LEADERSHIP, BUSINESS, AND HUMAN RESOURCES; EDUCATION SERVICES, NAMELY, CONDUCTING MANAGEMENT ROUNDTABLE-STYLE PANEL DISCUSSIONS IN THE FIELDS OF BUSINESS MANAGEMENT, LEADERSHIP, BUSINESS, AND HUMAN RESOURCES; TRAINING SERVICES IN THE FIELDS OF BUSINESS MANAGEMENT, LEADERSHIP, BUSINESS DEVELOPMENT, AND HUMAN RESOURCES; ENTERTAINMENT SERVICES, NAMELY, PROVIDING PODCASTS IN THE FIELDS OF BUSINESS MANAGEMENT, LEADERSHIP, BUSINESS, AND HUMAN RESOURCES (U.S. CLS. 100, 101 AND 107).

FIRST USE 8-0-2010; IN COMMERCE 8-0-2010.
MICHAEL GAAAFAR, EXAMINING ATTORNEY

SN 85-149,066. PARAS PHARMACEUTICALS LIMITED, AHMEDABAD, INDIA, FILED 10-9-2010.



NO CLAIM IS MADE TO THE EXCLUSIVE RIGHT TO USE "NEW" AND "SKIN", APART FROM THE MARK AS SHOWN.

THE MARK CONSISTS OF THE STYLIZED WORD "DERMI" LOCATED ABOVE A RECTANGLE WITH THE STYLIZED WORD "COOL" CONTAINED WITHIN THE RECTANGLE AND THE STYLIZED WORDS "SKIN DEFENSE" LOCATED BELOW THE RECTANGLE WITH THE STYLIZED WORD "NEW" LOCATED TO THE UPPER RIGHT CORNER OF THE WORD "DERMI". THE MARK APPEARS ON A MOTTLED BACKGROUND.

CLASS 3—COSMETICS AND CLEANING PREPARATIONS

FOR PERFUME-BASED AND NON-PERFUME-BASED TALC PREPARATION FOR SKIN APPLICATION FOR RELIEF FROM HEAT AND ITCHING, NAMELY, NON-MEDICATED TALCUM POWDER (U.S. CLS. 1, 4, 6, 50, 51 AND 52).

CLASS 5—PHARMACEUTICALS

FOR PERFUME-BASED AND NON-PERFUME-BASED TALC PREPARATION FOR SKIN APPLICATION FOR RELIEF FROM HEAT AND ITCHING, NAMELY, MEDICATED TALCUM POWDER (U.S. CLS. 6, 18, 44, 46, 51 AND 52).

APRIL HESIK, EXAMINING ATTORNEY

SN 85-149,716. VANCL (BEIJING) TECHNOLOGY CO., LTD., BEIJING, CHINA, FILED 10-11-2010.

VANCL

THE MARK CONSISTS OF STANDARD CHARACTERS WITHOUT CLAIM TO ANY PARTICULAR FONT, STYLE, SIZE, OR COLOR.

CLASS 18—LEATHER GOODS

FOR ANIMAL SKINS; PURSES; SCHOOL BAGS; REUSABLE SHOPPING BAGS; HANDBAGS; IMITATION LEATHER; UMBRELLAS; WALKING STICKS; SADDLERY; VALISES; POCKET WALLETS; ATTACHE CASES; UNFITTED VANITY CASES (U.S. CLS. 1, 2, 3, 22 AND 41).

CLASS 25—CLOTHING

FOR LAYETTES; SWIMSUITS; RAINCOATS; FOOTBALL SHOES; FOOTWEAR; HEADWEAR, NAMELY, CAPS; HOSIERY; GLOVES; NECKTIES; GIRDLES; SHOWER CAPS; SHIRTS; TROUSERS; SINGLETS; TOPCOATS; OUTER CLOTHING, NAMELY, OVERCOATS; TEE-SHIRTS; SUITS; FUR COATS AND JACKETS; FUR HATS; FUR STOLE; JACKETS; CAMISOLES; UNDERWEAR; PAJAMAS; BRASSIERES; SLIPPERS; SANDALS; SPORTS SHOES; SCARVES; SHAWLS (U.S. CLS. 22 AND 39).

CLASS 35—ADVERTISING AND BUSINESS

FOR ADVERTISING SERVICES; ONLINE RETAIL STORE SERVICES FEATURING CLOTHING FOR MEN, WOMEN, BABIES, AND CHILDREN, FOOTWEAR, OUTDOOR AND SPORTS GEAR, SUCH AS TENTS, YOGA MATS, YOGA BAGS, WATER BOTTLES, HATS, SLEEPING BAGS, BACKPACKS, BRAS, UNDERWEAR, PAJAMAS, SOCKS, BAGS, SUCH AS SUITCASES, HANDBAGS, AND WALLETS, APPAREL, JEWELRY, AND FASHION ACCESSORIES, SUCH AS GLASSES, EARRING, SCARVES, AND TIES; PROVIDING BUSINESS MARKETING INFORMATION; ADVERTISING AND PROMOTION SERVICES, NAMELY, PROMOTING THE SELLING OF GOODS AND SERVICES OF OTHERS THROUGH THE INTERNET; PROCUREMENT SERVICES, NAMELY, PURCHASING APPAREL ITEMS FOR OTHER BUSINESSES; PERSONNEL MANAGEMENT CONSULTATION; RELOCATION SERVICES FOR BUSINESSES (U.S. CLS. 100, 101 AND 102).

INGA ERVIN, EXAMINING ATTORNEY

CLASS 9—ELECTRICAL AND SCIENTIFIC APPARATUS

FOR DATA PROCESSORS, BLANK DATA MEDIA, NAMELY, OPTICAL DISCS, TAPES AND MAGNETIC DATA CARRIERS; APPARATUS FOR RECORDING AND REPRODUCING IMAGES DURING ENDOSCOPY; COMPUTER HARDWARE, SOFTWARE AND PERIPHERALS FOR DOCUMENTING, STORING AND TRANSMITTING THE RESULTS OF ENDOSCOPIC PROCEDURES; APPARATUS IN THE NATURE OF COMPUTER HARDWARE AND SOFTWARE FOR TRAINING, TEACHING AND INSTRUCTING PHYSICIANS IN THE FIELD OF ENDOSCOPIC EXAMINATION AND TREATMENT; ELECTRONIC TEST AND CHECK DEVICES FOR EXAMINING, TESTING AND CHECKING THE MECHANICAL FUNCTION, OPTICAL FUNCTION, MAGNETO-ELECTRICAL FUNCTION, POLARIZATION AND FREQUENCY OF MEDICAL APPARATUS AND INSTRUMENTS, NAMELY, SURGICAL AND MEDICAL INSTRUMENTS AND APPARATUS FOR GENERAL AND ENDOSCOPIC SURGERY; APPARATUS IN THE NATURE OF COMPUTER HARDWARE, SOFTWARE, AND PERIPHERALS USED FOR THE IDENTIFICATION OF PATIENTS DURING THERAPEUTIC EXAMINATION AND TREATMENT (U.S. CLS. 21, 23, 26, 36 AND 38).

CLASS 10—MEDICAL APPARATUS

FOR MEDICAL APPARATUS AND INSTRUMENTS, NAMELY, SURGICAL INSTRUMENTS AND APPARATUS FOR USE IN GENERAL AND ENDOSCOPIC SURGERY, NAMELY, NETWORKED APPARATUS AND INSTRUMENTS, VOICE, AND REMOTE-CONTROLLED APPARATUS, OPERATING ROOM INSTALLATIONS AND APPARATUS FOR CONTROLLING, MONITORING, SUPPORTING AND/OR DOCUMENTATION OF MEDICAL AND SURGICAL PROCEDURES, NAMELY, COMPUTER DISPLAYS AND COMPUTER MONITORS AND CONTROLLERS THEREFOR USED IN DIRECT ASSOCIATION WITH MEDICAL DIAGNOSIS DURING THE PROCESS OF DIAGNOSIS OF A CONDITION IN AN INDIVIDUAL; APPARATUS FOR POSITIONING PATIENTS AND MEDICAL DEVICES DURING THERAPEUTIC EXAMINATION AND TREATMENT (U.S. CLS. 26, 39 AND 44).

CLASS 16—PAPER GOODS AND PRINTED MATTER

FOR PRINTED MATERIAL, NAMELY, CATALOGUES, MAGAZINES, JOURNALS, BROCHURES AND INFORMATIONAL FLYERS, LETTERS AND SHEETS IN THE FIELD OF MEDICAL TECHNOLOGY AND INDUSTRIAL ENDOSCOPY; BINDERS; PRINTED TEACHING AND INSTRUCTIONAL MANUALS IN THE FIELDS OF MEDICAL TECHNOLOGY AND INDUSTRIAL ENDOSCOPY; PHOTOGRAPHS (U.S. CLS. 2, 5, 22, 23, 29, 37, 38 AND 50).

HOWARD B. LEVINE, EXAMINING ATTORNEY

SN 85-150,415. KARL STORZ GMBH & CO. KG, TUTTLINGEN, FED REP GERMANY, FILED 10-12-2010.

SN 85-150,442. GRAVITY, LLC, BATESVILLE, VA. FILED 10-12-2010.

**REAL LIFE WITH JENNIFER TILL**

PRIORITY CLAIMED UNDER SEC. 44(D) ON FED REP GERMANY APPLICATION NO. 302010022037, FILED 4-13-2010, REG. NO. 302010022037, DATED 9-16-2010, EXPIRES 4-30-2020.

OWNER OF U.S. REG. NOS. 2,813,349, 2,951,417 AND OTHERS.

THE MARK CONSISTS OF THE STYLIZED WORDING "MORE1", WITH THE "1" IN SUBSCRIPT, ON A SHADED BACKGROUND.

THE MARK CONSISTS OF STANDARD CHARACTERS WITHOUT CLAIM TO ANY PARTICULAR FONT, STYLE, SIZE, OR COLOR.

THE NAME(S), PORTRAIT(S), AND/OR SIGNATURE(S) SHOWN IN THE MARK IDENTIFIES "JENNIFER TILL", WHOSE CONSENT(S) TO REGISTER IS MADE OF RECORD.

CLASS 9—ELECTRICAL AND SCIENTIFIC APPARATUS

FOR AUDIO AND VIDEO RECORDINGS FEATURING PERSONAL IMPROVEMENT (U.S. CLS. 21, 23, 26, 36 AND 38).

FIRST USE 4-26-2009; IN COMMERCE 4-26-2009.

CLASS 41—EDUCATION AND ENTERTAINMENT

FOR EDUCATIONAL AND ENTERTAINMENT SERVICES, NAMELY, A CONTINUING PROGRAM ABOUT PERSONAL IMPROVEMENT ACCESSIBLE BY RADIO, TELEVISION, SATELLITE, AUDIO, VIDEO AND COMPUTER NETWORKS; EDUCATIONAL SERVICES, NAMELY, CONDUCTING PROGRAMS IN THE FIELD OF PERSONAL IMPROVEMENT; ENTERTAINMENT AND EDUCATIONAL SERVICES, NAMELY, THE PRESENTATION OF SEMINARS, LECTURES, WORKSHOPS AND PANEL DISCUSSIONS, AND ONGOING TELEVISION AND RADIO TALK SHOWS ALL IN THE FIELD OF PUBLIC INTEREST CONCERNING PERSONAL IMPROVEMENT; PROVIDING A WEBSITE FEATURING ENTERTAINMENT INFORMATION (U.S. CLS. 100, 101 AND 107).

FIRST USE 4-26-2009; IN COMMERCE 4-26-2009.
GENE MACIOL, EXAMINING ATTORNEY

SN 85-150,872. XYLECO, INC., WOBURN, MA. FILED 10-12-2010.

XYLECOL ACF

THE MARK CONSISTS OF STANDARD CHARACTERS WITHOUT CLAIM TO ANY PARTICULAR FONT, STYLE, SIZE, OR COLOR.

OWNER OF U.S. REG. NO. 3,785,336.

THE WORDING " XYLECOL ACF" HAS NO MEANING IN A FOREIGN LANGUAGE.

CLASS 1—CHEMICALS

FOR CHEMICALS OR CHEMICAL ADDITIVES FOR USE IN THE MANUFACTURE OF ENERGY AND COMBUSTIBLE FUELS; ETHANOL; BUTANOL; ALCOHOL FOR USE AS A FUEL ADDITIVE (U.S. CLS. 1, 5, 6, 10, 26 AND 46).

CLASS 4—LUBRICANTS AND FUELS

FOR FUELS; BIOFUELS; ENERGY, NAMELY, ELECTRICAL ENERGY; ETHANOL, BUTANOL, AND ALCOHOL FUELS AND MIXED FUELS (U.S. CLS. 1, 6 AND 15).

WILLIAM ROSSMAN, EXAMINING ATTORNEY

SN 85-150,825. XYLECO, INC., WOBURN, MA. FILED 10-12-2010.

ACF

THE MARK CONSISTS OF STANDARD CHARACTERS WITHOUT CLAIM TO ANY PARTICULAR FONT, STYLE, SIZE, OR COLOR.

THE WORDING "ACF" HAS NO MEANING IN A FOREIGN LANGUAGE.

CLASS 1—CHEMICALS

FOR CHEMICALS OR CHEMICAL ADDITIVES FOR USE IN THE MANUFACTURE OF ENERGY AND COMBUSTIBLE FUELS; ETHANOL; BUTANOL; ALCOHOL FOR USE AS A FUEL ADDITIVE (U.S. CLS. 1, 5, 6, 10, 26 AND 46).

CLASS 4—LUBRICANTS AND FUELS

FOR FUELS; BIO FUELS; ENERGY, NAMELY, ELECTRICAL ENERGY; ETHANOL, BUTANOL, AND ALCOHOL FUELS AND MIXED FUELS (U.S. CLS. 1, 6 AND 15).

WILLIAM ROSSMAN, EXAMINING ATTORNEY

SN 85-151,070. THE CENTER FOR HUMANE LIVING, PARADISE VALLEY, AZ. FILED 10-12-2010.



NO CLAIM IS MADE TO THE EXCLUSIVE RIGHT TO USE "THE CENTER FOR HUMANE LIVING", APART FROM THE MARK AS SHOWN.

THE MARK CONSISTS OF THE DESIGN OF AN OPEN HAND ABOVE THE WORDS "THE CENTER FOR HUMANE LIVING" ABOVE THE WORDS "AN OPEN HAND TO HUMANITY".

CLASS 25—CLOTHING

FOR CLOTHING FOR WEAR IN MARTIAL ARTS PRACTICES, NAMELY, SHIRTS, PANTS, SUITS, COATS, JACKETS, SWEATERS, BODY SUITS, SWEATSHIRTS, SWEATPANTS, SHORTS, TOPS, BOTTOMS, SLEEPWEAR, UNDERWEAR, LINGERIE, SWIMWEAR, BEACH COVER-UPS, SOCKS, GLOVES, NECKTIES, SCARVES, HATS, VISORS, AND FOOTWEAR (U.S. CLS. 22 AND 39).

CLASS 36—INSURANCE AND FINANCIAL

FOR CHARITABLE FUNDRAISING (U.S. CLS. 100, 101 AND 102).

CLASS 41—EDUCATION AND ENTERTAINMENT

FOR EDUCATIONAL SERVICES, NAMELY, CONDUCTING CLASSES IN THE FIELD OF MARTIAL ARTS, FITNESS, WELLNESS, SPIRITUALITY, SELF-HELP, HUMANITARIAN EFFORTS, ANTI-BULLYING AND PHILOSOPHY IN STUDIO AND VIA ELECTRONIC FORMAT (U.S. CLS. 100, 101 AND 107).

GRETCHEN ULRICH, EXAMINING ATTORNEY

SN 85-152,657. SERVICE LIGHTING & ELECTRICAL, DBA 1000BULBS.COM, GARLAND, TX. FILED 10-14-2010.



THE MARK CONSISTS OF CIRCLE WITH "PL & T" IN BLACK STYLIZED FONT WITHIN IT.

CLASS 9—ELECTRICAL AND SCIENTIFIC APPARATUS

FOR LIGHTING BALLASTS; TRANSFORMERS (U.S. CLS. 21, 23, 26, 36 AND 38).

CLASS 11—ENVIRONMENTAL CONTROL APPARATUS

FOR ELECTRIC LIGHTING FIXTURES; LAMPS; LIGHTBULBS (U.S. CLS. 13, 21, 23, 31 AND 34).

ROBERT STRUCK, EXAMINING ATTORNEY

SN 85-152,692. KINGDOM INVESTMENTS INTERNATIONAL, BEND, OR. FILED 10-14-2010.

**KINGDOM INVESTMENTS
INTERNATIONAL**

THE MARK CONSISTS OF STANDARD CHARACTERS WITHOUT CLAIM TO ANY PARTICULAR FONT, STYLE, SIZE, OR COLOR.

NO CLAIM IS MADE TO THE EXCLUSIVE RIGHT TO USE "INVESTMENTS INTERNATIONAL", APART FROM THE MARK AS SHOWN.

CLASS 35—ADVERTISING AND BUSINESS

FOR CHARITABLE SERVICES, NAMELY, ORGANIZING AND DEVELOPING PROJECTS THAT AIM TO IMPROVE THE LIVES OF UNDERPRIVILEGED AND IMPOVERISHED PEOPLE AND VICTIMS OF SEXUAL EXPLOITATION AND GENDER-BASED VIOLENCE, ORGANIZING AND DEVELOPING PROJECTS THAT AIM TO PROMOTE GLOBAL AWARENESS ABOUT HUMAN TRAFFICKING AND THE COMMERCIAL SEX INDUSTRY, PROVIDING EMPLOYMENT COUNSELING SERVICES FOR THOSE LIVING IN POVERTY IN THE AREAS OF PREPARING FOR, OBTAINING, MAINTAINING AND ADVANCING IN EMPLOYMENT OPPORTUNITIES (U.S. CLS. 100, 101 AND 102).

FIRST USE 2-0-2006; IN COMMERCE 2-0-2006.

CLASS 36—INSURANCE AND FINANCIAL

FOR CHARITABLE SERVICES, NAMELY, PROVIDING FUND-RAISING ACTIVITIES, SUPPLEMENTAL FUNDING, CAPITAL IMPROVEMENT FUNDING, SCHOLARSHIPS, FINANCIAL SUPPORT FOR MEDICAL RESEARCH AND PROCEDURES, AND FINANCIAL ASSISTANCE FOR PROGRAMS AND SERVICES FOR UNDERPRIVILEGED AND IMPOVERISHED PEOPLE AND FOR VICTIMS OF SEXUAL EXPLOITATION AND GENDER-BASED VIOLENCE (U.S. CLS. 100, 101 AND 102).

FIRST USE 6-0-2000; IN COMMERCE 6-0-2000.

KATHERINE STOIDES, EXAMINING ATTORNEY

SN 85-155,073. HAWAII FURNISHINGS PTE LTD, SINGAPORE, SINGAPORE, FILED 10-18-2010.

SCANTEAK

THE MARK CONSISTS OF STANDARD CHARACTERS WITHOUT CLAIM TO ANY PARTICULAR FONT, STYLE, SIZE, OR COLOR.

OWNER OF SINGAPORE REG. NO. T0907446Z, DATED 7-6-2009, EXPIRES 7-6-2019.

OWNER OF SINGAPORE REG. NO. T1013199D, DATED 10-13-2010, EXPIRES 10-13-2020.

OWNER OF U.S. REG. NO. 3,164,970.

CLASS 20—FURNITURE AND ARTICLES NOT OTHERWISE CLASSIFIED

FOR FURNITURE, MIRRORS, PICTURE FRAMES; FURNITURE PARTS AND FITTINGS NOT OF METAL; WOOD BOXES; WOODEN CRATES FOR FLOWERS AND FLOWERPOTS; FIGURINES STATUETTES OF WOOD; STATUES OF WOOD; DECORATIVE ORNAMENTS MADE OF WOOD; DECORATIONS OF WOOD FOR FOODSTUFFS; DECORATIONS OF WOOD FOR FESTIVITIES; CUSHIONS; PILLOWS; FITTED SEAT COVERS FOR FURNITURE; SEAT PADS FOR FURNITURE; DECORATIVE WIND CHIMES; CURTAIN RAILS; CURTAIN RINGS; CURTAIN RODS; CURTAIN ROLLERS; COAT HANGERS; COAT STANDS (U.S. CLS. 2, 13, 22, 25, 32 AND 50).

CLASS 35—ADVERTISING AND BUSINESS

FOR THE BRINGING TOGETHER, FOR THE BENEFIT OF OTHERS, OF A VARIETY OF GOODS, ENABLING CUSTOMERS TO CONVENIENTLY VIEW AND PURCHASE THOSE GOODS FROM A RETAIL OUTLET, A WHOLESALE OUTLET OR A DISTRIBUTOR OUTLET IN THE FIELD OF FURNITURE; THE BRINGING TOGETHER, FOR THE BENEFIT OF OTHERS, OF A VARIETY OF GOODS, ENABLING CUSTOMERS TO CONVENIENTLY VIEW AND PURCHASE THOSE GOODS FROM A GENERAL MERCHANDISE CATALOGUE BY MAIL ORDER OR BY MEANS OF TELECOMMUNICATION OR FROM A GENERAL MERCHANDISE WEB SITE IN THE GLOBAL COMMUNICATIONS NETWORK IN THE FIELD OF FURNITURE; PROCUREMENT SERVICES FOR OTHERS, NAMELY, PURCHASING FURNITURE FOR OTHERS; DIRECT MAIL ADVERTISING; DISSEMINATION OF ADVERTISING MATTER; COMMERCIAL ADMINISTRATION OF THE LICENSING OF THE GOODS AND SERVICES OF OTHERS; ADMINISTRATIVE PROCESSING OF PURCHASE ORDERS; ADVERTISING; ADVERTISING AGENCIES; ADVERTISING BY MAIL ORDER; UPDATING OF ADVERTISING MATERIAL; RENTAL OF ADVERTISING SPACE; PRESENTATION OF GOODS ON COMMUNICATION MEDIA, FOR RETAIL PURPOSES; DEMONSTRATION OF GOODS AND SERVICES BY ELECTRONIC MEANS ALSO FOR THE BENEFIT OF THE SO-CALLED TELESHOPPING AND HOMESHOPPING SERVICES; DISTRIBUTION OF SAMPLES; ONLINE ADVERTISING ON A COMPUTER NETWORK; RENTAL OF ADVERTISING TIME ON COMMUNICATION MEDIA; SALES PROMOTION FOR OTHERS; ADVISORY AND CONSULTANCY SERVICES RELATING TO THE AFORESAID (U.S. CLS. 100, 101 AND 102).
JAY FLOWERS, EXAMINING ATTORNEY

SN 85-156,588. KAREN WALKER LIMITED, PONSONBY, AUCKLAND, NEW ZEALAND, FILED 10-19-2010.



PRIORITY CLAIMED UNDER SEC. 44(D) ON NEW ZEALAND APPLICATION NO. 831998, FILED 10-18-2010, REG. NO. 831998, DATED 10-18-2010, EXPIRES 10-18-2020.
THE MARK CONSISTS OF A GIRL WALKING.

CLASS 14—JEWELRY

FOR JEWELRY, NAMELY, COSTUME JEWELRY AND PRECIOUS JEWELRY; PRECIOUS STONES; HOROLOGICAL AND CHRONOMETRIC INSTRUMENTS, NAMELY, WATCHES (U.S. CLS. 2, 27, 28 AND 50).

CLASS 25—CLOTHING

FOR CLOTHING, NAMELY, PANTS, SHIRTS, T-SHIRTS, SHORTS, SWEATSHIRTS, SKIRTS, SUITS, SUIT JACKETS, SUIT PANTS, TROUSERS, DRESSES, BELTS, SWEAT SUITS, LINGERIE, BRAS, JACKETS, COATS, SCARVES, GLOVES, MITTENS, NIGHTGOWNS, PAJAMAS, TOPS, JEANS, SWEATERS, JUMPERS, BLOUSES, VESTS, SHAWLS, HOSIERY; HEADGEAR, NAMELY, HATS, CAPS, BEANIES; FOOTWEAR, NAMELY, SHOES (U.S. CLS. 22 AND 39).

EVELYN BRADLEY, EXAMINING ATTORNEY

SN 85-157,068. AMETEK, INC., BERWYN, PA. FILED 10-20-2010.

AMECARE

THE MARK CONSISTS OF STANDARD CHARACTERS WITHOUT CLAIM TO ANY PARTICULAR FONT, STYLE, SIZE, OR COLOR.

CLASS 37—CONSTRUCTION AND REPAIR

FOR MAINTENANCE OF ELECTRONIC AND SCIENTIFIC INSTRUMENTS, NAMELY, CHEMICAL AND PHYSICAL PARAMETER ANALYZERS, DISPLAYS, CAMERAS, DETECTORS FOR SECURITY PURPOSES, AND AUTOMATION AND PROCESS CONTROL EQUIPMENT (U.S. CLS. 100, 103 AND 106).

CLASS 41—EDUCATION AND ENTERTAINMENT

FOR TRAINING IN THE USE AND OPERATION OF ELECTRONIC AND SCIENTIFIC INSTRUMENTS, NAMELY, CHEMICAL AND PHYSICAL PARAMETER ANALYZERS, DISPLAYS, CAMERAS, DETECTORS FOR SECURITY PURPOSES, AND AUTOMATION AND PROCESS CONTROL EQUIPMENT, AND ADVICE, INFORMATION AND CONSULTANCY RELATED THERETO (U.S. CLS. 100, 101 AND 107).

CLASS 42—SCIENTIFIC AND COMPUTER SERVICES

FOR TECHNICAL SUPPORT SERVICES IN THE FIELD OF ELECTRONIC AND SCIENTIFIC INSTRUMENTS, NAMELY, PROVIDING ADVICE, INFORMATION AND CONSULTANCY RELATING TO TROUBLESHOOTING IN THE NATURE OF DIAGNOSING PROBLEMS WITH EQUIPMENT, NAMELY, CHEMICAL AND PHYSICAL PARAMETER ANALYZERS, DISPLAYS, CAMERAS, DETECTORS FOR SECURITY PURPOSES, AND AUTOMATION AND PROCESS CONTROL EQUIPMENT (U.S. CLS. 100 AND 101).
BARBARA BROWN, EXAMINING ATTORNEY

SN 85-157,726. NATIONAL CENTER FOR PREVENTION AND RESEARCH SOLUTIONS, INC., SOUTH DAYTONA, FL. FILED 10-21-2010.



NO CLAIM IS MADE TO THE EXCLUSIVE RIGHT TO USE "RACING TEAM", APART FROM THE MARK AS SHOWN.

THE MARK CONSISTS OF AN OVAL WITH THE LETTERS "RAD" CENTERED WITHIN THE OVAL WITH THE LETTER "R" LARGER THAN THE "AD" AND A SWOOSH RUNNING FROM THE BOTTOM CENTER OF THE "R" THROUGH THE "A" AND THROUGH THE "D" ENDING OUTSIDE THE UPPER RIGHT SIDE OF THE "D" WITH THE WORD "RACING" UNDER THE "AD" AND THE WORD "TEAM" UNDER THE "NG" IN "RACING".

CLASS 35—ADVERTISING AND BUSINESS

FOR CHARITABLE SERVICES, NAMELY, ORGANIZING AND CONDUCTING VOLUNTEER PROGRAMS AND COMMUNITY SERVICE PROJECTS IN THE FIELD OF SUBSTANCE ABUSE PREVENTION (U.S. CLS. 100, 101 AND 102).

FIRST USE 12-11-2007; IN COMMERCE 12-11-2007.

CLASS 41—EDUCATION AND ENTERTAINMENT

FOR EDUCATIONAL AND ENTERTAINMENT SERVICES, NAMELY, PROVIDING A VOLUNTEER PROGRAM FEATURING MOTORSPORTS-THEMED EVENTS TO PROMOTE PUBLIC AWARENESS OF SUBSTANCE ABUSE PREVENTION (U.S. CLS. 100, 101 AND 107).

FIRST USE 12-11-2007; IN COMMERCE 12-11-2007.

MARLENE BELL, EXAMINING ATTORNEY

SN 85-158,222. MRAMOR, NANCY, ALLISON PARK, PA. FILED 10-21-2010.

Get Reel

THE MARK CONSISTS OF STANDARD CHARACTERS WITHOUT CLAIM TO ANY PARTICULAR FONT, STYLE, SIZE, OR COLOR.

CLASS 16—PAPER GOODS AND PRINTED MATTER

FOR BOOKS IN THE FIELD OF INSPIRATIONAL, NON-FICTION, SELF-REALIZATION, AND SELF-IMPROVEMENT (U.S. CLS. 2, 5, 22, 23, 29, 37, 38 AND 50).

CLASS 41—EDUCATION AND ENTERTAINMENT

FOR ENTERTAINMENT SERVICES, NAMELY, PROVIDING CONTINUING TELEVISION AND RADIO PROGRAMS FEATURING INSPIRATIONAL, NON-FICTION, SELF-REALIZATION, AND SELF-IMPROVEMENT INFORMATION (U.S. CLS. 100, 101 AND 107).

BARBARA BROWN, EXAMINING ATTORNEY

SN 85-158,248. HARRY DANIELL MERCHANDISE, LLC, BROOKLYN, NY. FILED 10-21-2010.

HARRY DANIELL

THE MARK CONSISTS OF STANDARD CHARACTERS WITHOUT CLAIM TO ANY PARTICULAR FONT, STYLE, SIZE, OR COLOR.

THE NAME(S), PORTRAIT(S), AND/OR SIGNATURE(S) SHOWN IN THE MARK IDENTIFIES "HARRY DANIELL", WHOSE CONSENT(S) TO REGISTER IS MADE OF RECORD.

CLASS 21—HOUSEWARES AND GLASS

FOR DISHES AND PLATES; SERVING DISHES; TEA SETS (U.S. CLS. 2, 13, 23, 29, 30, 33, 40 AND 50).

CLASS 24—FABRICS

FOR FABRIC WINDOW COVERINGS AND TREATMENTS, NAMELY, CURTAINS, DRAPERIES, SHEERS, SWAGS AND VALANCES; TABLE CLOTH OF TEXTILE (U.S. CLS. 42 AND 50).

CLASS 27—FLOOR COVERINGS

FOR CARPETS, RUGS, MATS AND MATTING, LINOLEUM FOR COVERING EXISTING FLOORS; NON-TEXTILE WALL COVERINGS; WALL PAPER (U.S. CLS. 19, 20, 37, 42 AND 50).

MICHELLE DUBOIS, EXAMINING ATTORNEY

SN 85-158,325. ADVANTUS, CORP., MEQUON, WI. FILED 10-21-2010.

YOUR OFFICE ORGANIZED IN AN INSTANT

THE MARK CONSISTS OF STANDARD CHARACTERS WITHOUT CLAIM TO ANY PARTICULAR FONT, STYLE, SIZE, OR COLOR.

CLASS 16—PAPER GOODS AND PRINTED MATTER

FOR OFFICE STORAGE AND ORGANIZATIONAL PRODUCTS, NAMELY, FILE FOLDERS, PERSONAL ORGANIZERS FOR SCHEDULING, PRINTED FINANCIAL DAILY PLANNERS, WALL FOLDERS MADE OF PAPER AND CARDBOARD TO HOLD MAGAZINES, PAPERS, DOCUMENTS AND CORRESPONDENCE; DESK ACCESSORIES, NAMELY, PENCIL HOLDERS, NAMELY, PENCIL CUPS, LETTER TRAYS, MAGAZINE FILE FOLDERS, DESKTOP BUSINESS CARD HOLDERS, WRITING PAPER HOLDERS AND FILE BOXES FOR STORAGE OF BUSINESS AND PERSONAL RECORDS (U.S. CLS. 2, 5, 22, 23, 29, 37, 38 AND 50).

CLASS 20—FURNITURE AND ARTICLES NOT OTHERWISE CLASSIFIED

FOR WALL FOLDERS TO HOLD MAGAZINES, NAMELY, MAGAZINE RACKS; DRAWER ORGANIZERS (U.S. CLS. 2, 13, 22, 25, 32 AND 50).

FRANK LATTUCA, EXAMINING ATTORNEY

SN 85-159,923. GENERAL DNA, INC., LAS VEGAS, NV.
FILED 10-25-2010.

SN 85-161,759. AXOLOTL CORPORATION, SAN JOSE, CA.
FILED 10-26-2010.

MASTER-CODE

THE MARK CONSISTS OF STANDARD CHARACTERS WITHOUT CLAIM TO ANY PARTICULAR FONT, STYLE, SIZE, OR COLOR.

CLASS 39—TRANSPORTATION AND STORAGE

FOR STORAGE, PROTECTION OF BIOLOGICAL MATERIALS, NAMELY, STORAGE OF HUMAN HAIR, NATURAL KERATIN FIBERS, TEETH AND BONE (U.S. CLS. 100 AND 105).

CLASS 44—MEDICAL, BEAUTY AND AGRICULTURAL SERVICES

FOR RECOVERY OF HUMAN DNA MATERIAL, NAMELY, COLLECTION OF HUMAN HAIR; PRESERVATION OF BIOLOGICAL MATERIALS, NAMELY, PRESERVATION OF HUMAN HAIR, NATURAL KERATIN FIBERS, TEETH AND BONE (U.S. CLS. 100 AND 101).

PAUL F. GAST, EXAMINING ATTORNEY

SN 85-160,853. SENECA FOODS CORPORATION, MARION, NY. FILED 10-25-2010.

CIMMARON

THE MARK CONSISTS OF STANDARD CHARACTERS WITHOUT CLAIM TO ANY PARTICULAR FONT, STYLE, SIZE, OR COLOR.

OWNER OF U.S. REG. NO. 1,658,329.

CLASS 29—MEATS AND PROCESSED FOODS

FOR CANNED AND BOTTLED BEANS (U.S. CL. 46).

CLASS 30—STAPLE FOODS

FOR SALSA; CONDIMENTS, NAMELY, RELISH (U.S. CL. 46).

LIEF MARTIN, EXAMINING ATTORNEY

AXOLOTL HEALTHCARE CONNECTED

THE MARK CONSISTS OF STANDARD CHARACTERS WITHOUT CLAIM TO ANY PARTICULAR FONT, STYLE, SIZE, OR COLOR.

OWNER OF U.S. REG. NO. 2,798,167.

NO CLAIM IS MADE TO THE EXCLUSIVE RIGHT TO USE "HEALTHCARE", APART FROM THE MARK AS SHOWN.

CLASS 38—COMMUNICATION

FOR SECURE DELIVERY OF MEDICAL RECORD DATA TO MEDICAL CARE PROVIDERS VIA FAX, DEDICATED ELECTRONIC MAILBOX, PRINT SERVERS, AND INTERFACES TO ELECTRONIC MEDICAL RECORDS (EMRS) (U.S. CLS. 100, 101 AND 104).

FIRST USE 0-0-2003; IN COMMERCE 0-0-2003.

CLASS 42—SCIENTIFIC AND COMPUTER SERVICES

FOR SOFTWARE AS A SERVICE (SAAS) SERVICES FEATURING SOFTWARE IN THE FIELD OF PATIENT MEDICAL INFORMATION MANAGEMENT; SOFTWARE AS A SERVICE (SAAS) SERVICES FEATURING SOFTWARE IN THE FIELD OF APPLICATION AND DATABASE INTEGRATION; SOFTWARE AS A SERVICE (SAAS) SERVICES FEATURING SOFTWARE FOR THE MINING, REPORTING AND ANALYSIS OF HEALTH INFORMATION EXCHANGE (HIE) DATA; SOFTWARE AS A SERVICE (SAAS) SERVICES FEATURING SOFTWARE IN THE FIELD OF CONTROLLED ACCESS SERVICE WHICH MAINTAINS DATABASES OF PATIENT HEALTH INFORMATION AND PROVIDES ACCESS TO SUCH INFORMATION TO HEALTH CARE PERSONNEL AND HEALTH CARE INSTITUTIONS; PROVIDING TEMPORARY USE OF NON-DOWNLOADABLE COMMUNICATIONS SOFTWARE FOR CONNECTING CLINICAL SYSTEMS FOR USE IN THE FIELD OF HEALTHCARE; PROVIDING TEMPORARY USE OF ONLINE NON-DOWNLOADABLE COMPUTER SOFTWARE FOR APPLICATION AND DATABASE INTEGRATION IN THE FIELD OF HEALTHCARE; PROVIDING TEMPORARY USE OF NON-DOWNLOADABLE COMPUTER SOFTWARE FOR CONTROLLING AND MANAGING PATIENT MEDICAL INFORMATION; PROVIDING TEMPORARY USE OF NON-DOWNLOADABLE COMPUTER SOFTWARE FOR THE COLLECTION, EDITING, ORGANIZING, MODIFYING, BOOK MARKING, TRANSMISSION, STORAGE AND SHARING OF DATA AND INFORMATION IN THE FIELD OF HEALTHCARE (U.S. CLS. 100 AND 101).

FIRST USE 0-0-2003; IN COMMERCE 0-0-2003.

H. M. FISHER, EXAMINING ATTORNEY

SN 85-161,867. INTO MY OWN, REDWOOD CITY, CA.
FILED 10-26-2010.

INTO MY OWN

THE MARK CONSISTS OF STANDARD CHARACTERS WITHOUT CLAIM TO ANY PARTICULAR FONT, STYLE, SIZE, OR COLOR.

CLASS 38—COMMUNICATION

FOR ELECTRONIC BULLETIN BOARD SERVICES FOR TRANSMISSION OF MESSAGES AMONG USERS IN THE FIELD OF PERSONAL DEVELOPMENT OF TEENAGERS (U.S. CLS. 100, 101 AND 104).

CLASS 41—EDUCATION AND ENTERTAINMENT

FOR WORKSHOPS AND SEMINARS RELATING TO PERSONAL DEVELOPMENT ISSUES AFFECTING TEENAGERS AND TEENAGE LIFE; ENTERTAINMENT SERVICES, NAMELY, BLOGS FEATURING PERSONAL DEVELOPMENT TOPICS OF INTEREST TO TEENAGERS (U.S. CLS. 100, 101 AND 107).

CLASS 45—PERSONAL AND LEGAL SERVICES

FOR PROVIDING A WEBSITE FEATURING NEWS AND INFORMATION IN THE FIELDS OF PERSONAL DEVELOPMENT, SELF-IMPROVEMENT, SELF-FULFILLMENT AND INTERPERSONAL COMMUNICATIONS OF INTEREST FOR TEENAGERS; PROVIDING A WEBSITE FEATURING NEWS AND INFORMATION IN THE FIELDS OF PERSONAL DEVELOPMENT FOR TEENAGERS (U.S. CLS. 100 AND 101).

WILLIAM BRECKENFELD, EXAMINING ATTORNEY

SN 85-164,916. LEE AND ASSOCIATES, INC., WASHINGTON, DC. FILED 10-29-2010.



THE MARK CONSISTS OF A CIRCLE FOLLOWED IMMEDIATELY BY THE LETTERS "LAI".

THE WORD "LAI" HAS NO MEANING IN A FOREIGN LANGUAGE.

CLASS 35—ADVERTISING AND BUSINESS

FOR ADVISORY SERVICES FOR OTHERS FOR BUSINESS PURPOSES IN THE FIELDS OF ARCHITECTURE, INTERIOR DESIGN AND URBAN PLANNING DESIGN; BUSINESS ADVISORY SERVICES IN THE FIELDS OF ARCHITECTURE, INTERIOR DESIGN AND URBAN PLANNING DESIGN; AND PROJECT MANAGEMENT SERVICES FOR OTHERS FOR BUSINESS PURPOSES IN THE FIELDS OF ARCHITECTURE, INTERIOR DESIGN, URBAN PLANNING DESIGN (U.S. CLS. 100, 101 AND 102).

FIRST USE 11-30-2009; IN COMMERCE 11-30-2009.

CLASS 42—SCIENTIFIC AND COMPUTER SERVICES

FOR URBAN DESIGN PLANNING SERVICES, LANDSCAPE ARCHITECTURAL DESIGN SERVICES; INDUSTRIAL DESIGN SERVICES; FURNITURE DESIGN SERVICES, GRAPHIC ILLUSTRATION AND DRAWING SERVICES, NAMELY, PROVIDING GRAPHIC ILLUSTRATIONS AND DRAWINGS OF COMMERCIAL AND INDUSTRIAL BUILDING DESIGNS, AND CONVERTING BUILDING DESIGNS AND MARKUPS TO ELECTRONIC CAD DRAWINGS; LIGHTING DESIGN AND TECHNOLOGY SPECIFICATIONS SERVICES PERTAINING TO PERMANENT OR TEMPORARY ARCHITECTURAL, THEATRICAL, ENTERTAINMENT, COMMERCIAL AND/OR RESIDENTIAL APPLICATIONS (U.S. CLS. 100 AND 101).

FIRST USE 11-30-2009; IN COMMERCE 11-30-2009.

KATHY DE JONGE, EXAMINING ATTORNEY

SN 85-163,811. L.H. HAYWARD & COMPANY, LLC, HARAHAN, LA. FILED 10-28-2010.



OWNER OF U.S. REG. NO. 1,646,164. NO CLAIM IS MADE TO THE EXCLUSIVE RIGHT TO USE "BRAND", APART FROM THE MARK AS SHOWN.

THE COLOR(S) RED AND GREEN IS/ARE CLAIMED AS A FEATURE OF THE MARK.

THE MARK CONSISTS OF A RED CAMELLIA FLOWER WITH GAPS DEPICTING THE EDGES OF PETALS AND GREEN LEAVES ON EITHER SIDE OF THE RED CAMELLIA FLOWER WITH GAPS DEPICTING THE VEINS IN THE LEAVES, AND THE WORD "CAMELLIA" IN RED BENEATH THE CAMELLIA FLOWER BELOW WHICH APPEARS THE WORD "BRAND" IN RED. THE COLOR WHITE, WHICH IS VISIBLE THROUGH PARTS OF THE MARK, REPRESENTS BACKGROUND ONLY AND IS NOT PART OF THE MARK.

CLASS 29—MEATS AND PROCESSED FOODS

FOR DRIED PULSES, NAMELY, PROCESSED BEANS (U.S. CL. 46).

FIRST USE 10-1-2007; IN COMMERCE 10-1-2007.

CLASS 30—STAPLE FOODS

FOR RICE, SPICES (U.S. CL. 46). FIRST USE 10-1-2007; IN COMMERCE 10-1-2007. EDWARD FENNESSY, EXAMINING ATTORNEY

SN 85-164,930. DAUGHTERS OF PENELOPE, WASHINGTON, DC. FILED 10-29-2010.

DAUGHTERS OF PENELOPE

THE MARK CONSISTS OF STANDARD CHARACTERS WITHOUT CLAIM TO ANY PARTICULAR FONT, STYLE, SIZE, OR COLOR.

CLASS 35—ADVERTISING AND BUSINESS

FOR ASSOCIATION SERVICES, NAMELY, ORGANIZING CHAPTERS OF A SORORITY AND PROMOTING THE INTERESTS OF MEMBERS THEREOF; ASSOCIATION SERVICES, NAMELY, PROMOTING THE INTERESTS OF INDIVIDUALS OF HELLENIC DESCENT AND HELLENIC CULTURE (U.S. CLS. 100, 101 AND 102).

FIRST USE 11-16-1929; IN COMMERCE 11-16-1929.

CLASS 41—EDUCATION AND ENTERTAINMENT

FOR PROVIDING INFORMATION IN THE FIELD OF HELLENIC CULTURE (U.S. CLS. 100, 101 AND 107).

FIRST USE 11-16-1929; IN COMMERCE 11-16-1929.

DAWN FELDMAN, EXAMINING ATTORNEY

SN 85-167,276. AMERICAN CHEMISTRY COUNCIL, INC., WASHINGTON, DC. FILED 11-2-2010.



OWNER OF U.S. REG. NOS. 2,588,516 AND 3,802,365. THE MARK CONSISTS OF "CHEMTREC THE RIGHT INFORMATION AT THE RIGHT TIME" WITH "CHEMTREC" UNDERLINED AND "THE RIGHT INFORMATION AT THE RIGHT TIME" BELOW THE UNDERLINING.

CLASS 37—CONSTRUCTION AND REPAIR

FOR PROVIDING INFORMATION AND CONSULTATION IN THE FIELDS OF HAZARDOUS WASTE DISPOSAL SERVICES, NAMELY, DISPOSAL OF CHEMICALS, RADIOACTIVE MATERIALS, AND OTHER HAZARDOUS MATERIALS, AND DANGEROUS GOODS IN BOTH EMERGENCY AND NON-EMERGENCY SITUATIONS (U.S. CLS. 100, 103 AND 106).

FIRST USE 10-27-2010; IN COMMERCE 10-27-2010.

CLASS 39—TRANSPORTATION AND STORAGE

FOR PROVIDING INFORMATION AND CONSULTATION IN THE FIELD OF TRANSPORTATION OF CHEMICALS, RADIOACTIVE MATERIALS, WASTE, AND OTHER HAZARDOUS MATERIALS AND DANGEROUS GOODS IN BOTH EMERGENCY AND NON-EMERGENCY SITUATIONS (U.S. CLS. 100 AND 105).

FIRST USE 10-27-2010; IN COMMERCE 10-27-2010.

CLASS 40—MATERIAL TREATMENT

FOR PROVIDING INFORMATION AND CONSULTATION IN THE FIELDS OF HANDLING AND DISPOSAL OF WASTE IN BOTH EMERGENCY AND NON-EMERGENCY SITUATIONS, NAMELY, DESTRUCTION OF WASTE, HAZARDOUS WASTE MANAGEMENT, AND WASTE MANAGEMENT (U.S. CLS. 100, 103 AND 106).

FIRST USE 10-27-2010; IN COMMERCE 10-27-2010.

CLASS 45—PERSONAL AND LEGAL SERVICES

FOR PROVIDING INFORMATION AND CONSULTATION IN THE FIELDS OF EMERGENCY RESPONSE FOR COMMUNITIES, NAMELY, SAFETY CONSULTING SERVICES IN THE FIELDS OF HAZARD ASSESSMENTS AND ABATEMENT PROCEDURES (U.S. CLS. 100 AND 101).

FIRST USE 10-27-2010; IN COMMERCE 10-27-2010.

PAUL E. FAHRENKOPF, EXAMINING ATTORNEY

SN 85-167,279. JOSČÁK, DR. TOMÁS, WIEN, AUSTRIA, FILED 11-2-2010.

DASCANOVA

THE MARK CONSISTS OF STANDARD CHARACTERS WITHOUT CLAIM TO ANY PARTICULAR FONT, STYLE, SIZE, OR COLOR.

PRIORITY CLAIMED UNDER SEC. 44(D) ON ERP CMNTY TM OFC APPLICATION NO. 009134818, FILED 5-27-2010, REG. NO. 009134818, DATED 11-8-2010, EXPIRES 5-27-2020.

THE ENGLISH TRANSLATION OF "DASCA" IN THE MARK IS "BOARD". THE ENGLISH TRANSLATION OF THE TERM "NOVA" IS "NEW".

CLASS 7—MACHINERY

FOR MACHINES AND MACHINE TOOLS, IN PARTICULAR FOR PRODUCTION OF PANELS, INCLUDING THE PRODUCTION OF WOOD BASED PANELS (U.S. CLS. 13, 19, 21, 23, 31, 34 AND 35).

CLASS 19—NON-METALLIC BUILDING MATERIALS

FOR NON-METALLIC BUILDING MATERIALS, IN PARTICULAR PANELS, INCLUDING WOOD BASED PANELS (U.S. CLS. 1, 12, 33 AND 50).

CLASS 20—FURNITURE AND ARTICLES NOT OTHERWISE CLASSIFIED

FOR FURNITURE; WOOD PRODUCTS, NAMELY, COMPOSITE PANELS, PARTICLEBOARD AND FIBERBOARD FOR USE IN FURTHER MANUFACTURING (U.S. CLS. 2, 13, 22, 25, 32 AND 50).

PAUL E. FAHRENKOPF, EXAMINING ATTORNEY

SN 85-167,791. KOHLER CO., KOHLER, WI. FILED 11-3-2010.

EVANDALE

THE MARK CONSISTS OF STANDARD CHARACTERS WITHOUT CLAIM TO ANY PARTICULAR FONT, STYLE, SIZE, OR COLOR.

CLASS 11—ENVIRONMENTAL CONTROL APPARATUS

FOR LAVATORIES (U.S. CLS. 13, 21, 23, 31 AND 34).

CLASS 20—FURNITURE AND ARTICLES NOT OTHERWISE CLASSIFIED

FOR FURNITURE; MIRRORS; BATHROOM VANITY UNITS COMPRISING VANITIES AND VANITY TOPS (U.S. CLS. 2, 13, 22, 25, 32 AND 50).

KATHERINE CONNOLLY, EXAMINING ATTORNEY

SN 85-169,519. PARKINGSOFT, LLC, BALTIMORE, MD.
FILED 11-4-2010.



The logo for ParkingSOFT features the word "ParkingSOFT" in a bold, sans-serif font. The word "Parking" is in a smaller font size than "SOFT". A thick, dark grey arc curves over the top of the letters "P" and "S", starting from the top of the "P" and ending at the top of the "S".

THE MARK CONSISTS OF THE WORD "PARKINGSOFT" WRITTEN IN BLOCK LETTERING WITH THE WORDS "SOFT" IN ALL CAPITAL LETTERS. THERE IS NO SPACE BETWEEN "PARKING" AND "SOFT". STARTING JUST AFTER THE "P" AND TRAILING LEFT TO RIGHT OVER THE LITERAL ELEMENT, TO THE TOP OF THE "T" THERE IS AN ARC PROJECTING UPWARD THAT IS NARROW AT ITS BEGINNING POINT AND GRADUALLY INCREASES IN THICKNESS THROUGH THE ARC TO ITS ENDING POINT. STARTING JUST AFTER THE END OF THE "G" AT THE BOTTOM SIDE OF THE LITERAL ELEMENT AND TRAILING RIGHT TO LEFT UNTIL IT ENDS UNDER THE "A", IS AN ARC PROJECTING DOWNWARD THAT IS THICKER AT ITS STARTING POINT AND GRADUALLY NARROWS THROUGH THE ARC TO ITS ENDING POINT.

CLASS 9—ELECTRICAL AND SCIENTIFIC APPARATUS

FOR EQUIPMENT USED IN THE PROVISION OF COMMERCIAL PARKING SERVICES, NAMELY, FIXED AND HAND HELD MACHINES THAT PRINT, DISPENSE, SCAN AND READ BARCODE READABLE TICKETS, TRACK PARKING CAPACITY, AND READ AND PROCESS CREDIT AND DEBIT CARD INFORMATION; AUTOMATED SECURITY GATES FOR INGRESS AND EGRESS (U.S. CLS. 21, 23, 26, 36 AND 38).

FIRST USE 12-1-2008; IN COMMERCE 12-1-2008.

CLASS 42—SCIENTIFIC AND COMPUTER SERVICES

FOR PROVIDING A WEBSITE FEATURING TEMPORARY USE OF NON-DOWNLOADABLE SOFTWARE FOR USE IN DATABASE, HUMAN RESOURCE AND FACILITY MANAGEMENT, TRACKING OF FINANCIAL DATA, READING AND STORING SALES DATA, GENERAL LEDGER MANAGEMENT, THE PROCESSING AND FORMATTING OF REPORTS AND SPREADSHEETS, THE FORMULATION OF STATISTICAL ANALYSIS, AND THE PROCESSING OF PRINTABLE PARKING VOUCHERS, PARKING VALIDATIONS, AND PARKING RECEIPTS IN THE FIELD OF COMMERCIAL PARKING (U.S. CLS. 100 AND 101).

FIRST USE 12-1-2008; IN COMMERCE 12-1-2008.
MICHAEL SOUDERS, EXAMINING ATTORNEY

SN 85-169,570. PARKINGSOFT, LLC, BALTIMORE, MD.
FILED 11-4-2010.



The logo for ParkingSOFT features the word "ParkingSOFT" in a bold, sans-serif font. The word "Parking" is in a smaller font size than "SOFT". A thick, dark grey arc curves over the top of the letters "P" and "S", starting from the top of the "P" and ending at the top of the "S".

THE MARK CONSISTS OF STANDARD CHARACTERS WITHOUT CLAIM TO ANY PARTICULAR FONT, STYLE, SIZE, OR COLOR.

CLASS 9—ELECTRICAL AND SCIENTIFIC APPARATUS

FOR EQUIPMENT USED IN THE PROVISION OF COMMERCIAL PARKING SERVICES, NAMELY, FIXED AND HAND HELD MACHINES THAT PRINT, DISPENSE, SCAN AND READ BARCODE READABLE TICKETS, TRACK PARKING CAPACITY, AND READ AND PROCESS CREDIT AND DEBIT CARD INFORMATION; AUTOMATED SECURITY GATES FOR INGRESS AND EGRESS (U.S. CLS. 21, 23, 26, 36 AND 38).

FIRST USE 4-30-2006; IN COMMERCE 4-30-2006.

CLASS 42—SCIENTIFIC AND COMPUTER SERVICES

FOR PROVIDING A WEBSITE FEATURING TEMPORARY USE OF NON-DOWNLOADABLE SOFTWARE FOR USE IN DATABASE, HUMAN RESOURCE AND FACILITY MANAGEMENT, TRACKING OF FINANCIAL DATA, READING AND STORING SALES DATA, GENERAL LEDGER MANAGEMENT, THE PROCESSING AND FORMATTING OF REPORTS AND SPREADSHEETS, THE FORMULATION OF STATISTICAL ANALYSIS, AND THE PROCESSING OF PRINTABLE PARKING VOUCHERS, PARKING VALIDATIONS, AND PARKING RECEIPTS IN THE FIELD OF COMMERCIAL PARKING (U.S. CLS. 100 AND 101).

FIRST USE 4-30-2006; IN COMMERCE 4-30-2006.
MICHAEL SOUDERS, EXAMINING ATTORNEY

SN 85-170,096. NIKE, INC., BEAVERTON, OR. FILED 11-5-2010.

MATA NO PEITO

THE MARK CONSISTS OF STANDARD CHARACTERS WITHOUT CLAIM TO ANY PARTICULAR FONT, STYLE, SIZE, OR COLOR.

THE ENGLISH TRANSLATION OF "MATA NO PEITO" IN THE MARK IS "THE FOREST IS IN MY HEART".

CLASS 18—LEATHER GOODS

FOR ALL-PURPOSE SPORTS BAGS, TOTE BAGS, DUFFLE BAGS, MESSENGER BAGS, BACKPACKS, PURSES, BAGS FOR CARRYING SHOES (U.S. CLS. 1, 2, 3, 22 AND 41).

CLASS 25—CLOTHING

FOR CLOTHING, NAMELY, T-SHIRTS, SHIRTS, SHORTS, TANK TOPS, JERSEYS, HOODED TOPS; SWEATSHIRTS, PULLOVERS, JACKETS, AND HEADWEAR (U.S. CLS. 22 AND 39).

CLASS 36—INSURANCE AND FINANCIAL

FOR TRADING OF CARBON DIOXIDE AND GREENHOUSE GAS EMISSION CREDITS, ALLOWANCES OR OFFSETS OF OTHERS FOR THE PURPOSES OF INVESTING IN ENVIRONMENTAL CONSERVATION PROJECTS (U.S. CLS. 100, 101 AND 102).

NAKIA HENRY, EXAMINING ATTORNEY

SN 85-172,124. UNITED STATES POSTAL SERVICE, WASHINGTON, DC. FILED S.R. 11-9-2010; AM. P.R. 6-8-2011.

SN 85-174,176. QVIVO LIMITED, ABERDEEN, HONG KONG, FILED 11-11-2010.

SEE IF IT FITS!

QVIVO

THE MARK CONSISTS OF STANDARD CHARACTERS WITHOUT CLAIM TO ANY PARTICULAR FONT, STYLE, SIZE, OR COLOR.

OWNER OF U.S. REG. NO. 3,264,242.

CLASS 9—ELECTRICAL AND SCIENTIFIC APPARATUS

FOR DOWNLOADABLE VIRTUAL GOODS, NAMELY, COMPUTER PROGRAMS FEATURING A VIRTUAL SIMULATOR USED TO DETERMINE PROPER PACKAGING FOR MAILING, SHIPPING AND DELIVERY (U.S. CLS. 21, 23, 26, 36 AND 38).

CLASS 35—ADVERTISING AND BUSINESS

FOR SORTING, HANDLING, AND RECEIVING PACKAGES AND LETTERS; ONLINE RETAIL STORE SERVICES FEATURING VIRTUAL MERCHANDISE FOR USE IN MAILING AND SHIPPING (U.S. CLS. 100, 101 AND 102).

CLASS 39—TRANSPORTATION AND STORAGE

FOR PICKUP, TRANSPORTATION AND DELIVERY OF PACKAGES AND DOCUMENTS BY VARIOUS MODES OF TRANSPORTATION (U.S. CLS. 100 AND 105).

JEFFERY COWARD, EXAMINING ATTORNEY

SN 85-172,437. SOUTHDATA, INC., MOUNT AIRY, NC. FILED 11-9-2010.

SCANRIGHT

THE MARK CONSISTS OF STANDARD CHARACTERS WITHOUT CLAIM TO ANY PARTICULAR FONT, STYLE, SIZE, OR COLOR.

CLASS 41—EDUCATION AND ENTERTAINMENT

FOR DIGITAL IMAGING SERVICES (U.S. CLS. 100, 101 AND 107).

CLASS 42—SCIENTIFIC AND COMPUTER SERVICES

FOR ELECTRONIC SCANNING OF DOCUMENTS (U.S. CLS. 100 AND 101).

DAWN HAN, EXAMINING ATTORNEY

THE MARK CONSISTS OF STANDARD CHARACTERS WITHOUT CLAIM TO ANY PARTICULAR FONT, STYLE, SIZE, OR COLOR.

PRIORITY CLAIMED UNDER SEC. 44(D) ON HONG KONG APPLICATION NO. 301691172, FILED 8-17-2010, REG. NO. 301691172, DATED 8-17-2010, EXPIRES 8-17-2020.

CLASS 9—ELECTRICAL AND SCIENTIFIC APPARATUS

FOR DOWNLOADABLE COMPUTER SOFTWARE FOR PURCHASING, DOWNLOADING, STORING, STREAMING AND PLAYING SOUND, MUSIC, IMAGE, VIDEO AND GAME FILES; DIGITAL MEDIA, NAMELY, DOWNLOADABLE AUDIO AND VIDEO RECORDINGS FEATURING MUSIC, MOVIES, TV DRAMA AND TV SHOWS; DOWNLOADABLE COMPUTER GAME PROGRAMS (U.S. CLS. 21, 23, 26, 36 AND 38).

CLASS 35—ADVERTISING AND BUSINESS

FOR RETAIL STORE SERVICES FEATURING PRE-RECORDED DIGITAL STORAGE MEDIA FOR ENTERTAINMENT IN THE FIELDS OF MUSIC, MOVIES, TV DRAMAS, TV SHOWS, COMPUTER GAMES, MAGAZINES AND BOOKS; ONLINE RETAIL STORE SERVICES FEATURING DOWNLOADABLE PRE-RECORDED AUDIO AND VIDEO FEATURING MUSIC, MOVIES, TV DRAMA, TV SHOWS AND COMPUTER GAME PROGRAMS FOR A FEE; PROVISION OF ADVERTISING SPACE THROUGH THE INTERNET AND GLOBAL COMPUTER INFORMATION NETWORKS (U.S. CLS. 100, 101 AND 102).

CLASS 38—COMMUNICATION

FOR TELECOMMUNICATIONS SERVICES, NAMELY, TRANSMISSION OF AUDIO AND VIDEO RECORDING AND COMPUTER GAME PROGRAMS BY MEANS OF TELECOMMUNICATIONS NETWORKS; STREAMING OF AUDIO AND VIDEO RECORDINGS THROUGH THE INTERNET AND GLOBAL COMPUTER INFORMATION NETWORKS; WEBCASTING SERVICES (U.S. CLS. 100, 101 AND 104).

BERYL GARDNER, EXAMINING ATTORNEY

SN 85-174,485. LUTRON ELECTRONICS CO., INC., COOPERSBURG, PA. FILED 11-11-2010.

LEDITORIAL

THE MARK CONSISTS OF STANDARD CHARACTERS WITHOUT CLAIM TO ANY PARTICULAR FONT, STYLE, SIZE, OR COLOR.

CLASS 9—ELECTRICAL AND SCIENTIFIC APPARATUS

FOR DOWNLOADABLE ELECTRONIC PUBLICATIONS, NAMELY, NEWSLETTERS IN THE FIELD OF LIGHT EMITTING DIODES, LIGHTING AND LIGHTING PRODUCTS (U.S. CLS. 21, 23, 26, 36 AND 38).

FIRST USE 9-16-2010; IN COMMERCE 9-16-2010.

CLASS 41—EDUCATION AND ENTERTAINMENT

FOR PROVIDING NON-DOWNLOADABLE ELECTRONIC PUBLICATIONS, NAMELY, NEWSLETTERS IN THE FIELD OF LIGHT EMITTING DIODES, LIGHTING AND LIGHTING PRODUCTS (U.S. CLS. 100, 101 AND 107).

FIRST USE 9-16-2010; IN COMMERCE 9-16-2010.

MATTHEW EINSTEIN, EXAMINING ATTORNEY

SN 85-175,654. JOBS FOR THE FUTURE, INC., AKA JFF, BOSTON, MA. FILED 11-12-2010.

Jobs for the Future

THE MARK CONSISTS OF STANDARD CHARACTERS WITHOUT CLAIM TO ANY PARTICULAR FONT, STYLE, SIZE, OR COLOR.

CLASS 16—PAPER GOODS AND PRINTED MATTER

FOR PUBLICATIONS, NAMELY, RESEARCH REPORTS, CASE STUDIES, NEWSLETTERS, AND POLICY BRIEFS IN THE FIELDS OF LOCAL, STATE, AND NATIONAL PRACTICE AND POLICY IN EDUCATION AND YOUTH DEVELOPMENT, WORKFORCE DEVELOPMENT, AND ECONOMIC OPPORTUNITY (U.S. CLS. 2, 5, 22, 23, 29, 37, 38 AND 50).

FIRST USE 12-31-1986; IN COMMERCE 12-31-1986.

CLASS 41—EDUCATION AND ENTERTAINMENT

FOR DEVELOPMENT OF EDUCATIONAL STRATEGIES AIMED AT IMPROVING THE PATHWAYS LEADING FROM HIGH SCHOOL TO COLLEGE TO FAMILY-SUSTAINING CAREERS (U.S. CLS. 100, 101 AND 107).

FIRST USE 12-31-1986; IN COMMERCE 12-31-1986.

GRETTA YAO, EXAMINING ATTORNEY

SN 85-174,533. IGPS COMPANY, LLC, ORLANDO, FL. FILED 11-11-2010.



OWNER OF U.S. REG. NOS. 3,737,596 AND 3,745,128.

NO CLAIM IS MADE TO THE EXCLUSIVE RIGHT TO USE "INTELLIGENT" AND "POOLING SYSTEMS", APART FROM THE MARK AS SHOWN.

THE COLOR(S) GREEN AND BLACK IS/ARE CLAIMED AS A FEATURE OF THE MARK.

THE MARK CONSISTS OF THE WORDS "IGPS BIOS", WHEREIN THE LETTER "I" AND THE WORD "BIOS" APPEAR IN GREEN, "GPS" APPEARS IN BLACK AND "BIOS" IS ENCLOSED BY GREEN STYLIZED PARENTHESES AND THE WORDS "INTELLIGENT GLOBAL POOLING SYSTEMS" RUNS BELOW THE OTHER WORDING, AND THE WORD "INTELLIGENT" APPEARS IN GREEN AND "GLOBAL POOLING SYSTEMS" APPEARS IN BLACK. THE WHITE IN THE MARK IS BACKGROUND AREA WHICH IS NOT A PART OF THE MARK.

CLASS 20—FURNITURE AND ARTICLES NOT OTHERWISE CLASSIFIED

FOR NON-METAL PALLETS DESIGNED FOR SHIPPING PHARMACEUTICAL AND BIOLOGICAL PRODUCTS AND WHICH CONTAIN ELECTRONIC TRACKING AND LOCATING DEVICES (U.S. CLS. 2, 13, 22, 25, 32 AND 50).

CLASS 39—TRANSPORTATION AND STORAGE

FOR RENTAL AND LEASING OF PALLETS DESIGNED FOR SHIPPING PHARMACEUTICAL AND BIOLOGICAL PRODUCTS; SORTING OF PALLETS, WHICH CONTAIN THE GOODS OF OTHERS, BY MEANS OF ELECTRONIC TRACKING AND LOCATING DEVICES FOR STORAGE AND SHIPPING PURPOSES; WAREHOUSING SERVICES, NAMELY, STORAGE OF PALLETS AND SHIPPING CONTAINERS FOR THE TRANSPORT OF THE GOODS OF OTHERS (U.S. CLS. 100 AND 105).

REBECCA GILBERT, EXAMINING ATTORNEY

SN 85-176,462. HON HAI PRECISION INDUSTRY CO., LTD., TAIPEI HSIEN, TAIWAN, FILED 11-15-2010.

LOGISCONN
LogisConn international Limited

NO CLAIM IS MADE TO THE EXCLUSIVE RIGHT TO USE "INTERNATIONAL LIMITED", APART FROM THE MARK AS SHOWN.

THE MARK CONSISTS OF THE WORD "LOGISCONN" ABOVE THE WORDING "LOGISCONN INTERNATIONAL LIMITED".

CLASS 35—ADVERTISING AND BUSINESS

FOR COMMERCIAL INFORMATION AGENCIES; BUSINESS INFORMATION; IMPORT AND EXPORT AGENCIES; PROCUREMENT, NAMELY, THE PURCHASING OF GOODS AND SERVICES FOR OTHER BUSINESSES; SALES PROMOTION SERVICES (U.S. CLS. 100, 101 AND 102).

CLASS 39—TRANSPORTATION AND STORAGE

FOR TRANSPORT AND STORAGE OF GOODS; FREIGHT FORWARDING SERVICES; FREIGHT LOADING SERVICES; FREIGHT TRANSPORTATION CONSULTATION IN THE FIELD OF FREIGHT TRANSPORTATION BY TRUCK, RAIL, AIR AND OCEAN; GLOBAL TRANSPORTATION OF FREIGHT FOR OTHERS BY ALL AVAILABLE MEANS; FREIGHT BROKERAGE; UNLOADING CARGO; PACKAGING OF GOODS FOR TRANSPORTATION; CAR TRANSPORT; RAILWAY TRANSPORT; MARINE TRANSPORT; AIR TRANSPORT; STORAGE OF GOODS; WAREHOUSING SERVICES; AND TRANSPORTATION INFORMATION (U.S. CLS. 100 AND 105).

JACLYN KIDWELL WALKER, EXAMINING ATTORNEY

SN 85-179,046, P 31 FITNESS LLC, SULPHUR SPRINGS, TX,
FILED 11-17-2010.

P31 FITNESS

THE MARK CONSISTS OF STANDARD CHARACTERS WITHOUT CLAIM TO ANY PARTICULAR FONT, STYLE, SIZE, OR COLOR.

NO CLAIM IS MADE TO THE EXCLUSIVE RIGHT TO USE "FITNESS", APART FROM THE MARK AS SHOWN.

CLASS 35—ADVERTISING AND BUSINESS

FOR PHYSICAL FITNESS AND FITNESS TRAINING STUDIO FRANCHISING, NAMELY, OFFERING BUSINESS MANAGEMENT ASSISTANCE IN THE ESTABLISHMENT AND/OR OPERATION OF PHYSICAL FITNESS AND FITNESS TRAINING STUDIOS (U.S. CLS. 100, 101 AND 102).

CLASS 41—EDUCATION AND ENTERTAINMENT

FOR PHYSICAL FITNESS STUDIO SERVICES, NAMELY, PROVIDING EXERCISE CLASSES, GROUP FITNESS CLASSES, AND PERSONAL FITNESS TRAINING TO OTHERS (U.S. CLS. 100, 101 AND 107).

LINDA MICKLEBURGH, EXAMINING ATTORNEY

SN 85-179,251, SILVERSTRIPE LIMITED, WELLINGTON,
NEW ZEALAND, FILED 11-17-2010.

DAWN

THE MARK CONSISTS OF STANDARD CHARACTERS WITHOUT CLAIM TO ANY PARTICULAR FONT, STYLE, SIZE, OR COLOR.

PRIORITY CLAIMED UNDER SEC. 44(D) ON NEW ZEALAND APPLICATION NO. 824486, FILED 5-20-2010, REG. NO. 824486, DATED 5-20-2010, EXPIRES 5-20-2020.

CLASS 9—ELECTRICAL AND SCIENTIFIC APPARATUS

FOR DOWNLOADABLE COMPUTER PROGRAMS, COMPUTER SOFTWARE AND INTERACTIVE COMPUTER SOFTWARE, NAMELY, COMPUTER PROGRAMS AND SOFTWARE TO ANALYZE, MONITOR AND RECORD OPERATIONAL INFORMATION FROM A WEBSITE FOR MONITORING WEBSITE PERFORMANCE AND STABILITY, TROUBLESHOOTING AND DEBUGGING (U.S. CLS. 21, 23, 26, 36 AND 38).

CLASS 42—SCIENTIFIC AND COMPUTER SERVICES

FOR COMPUTER PROGRAMMING; ONLINE PROVISION OF WEB-BASED APPLICATIONS, NAMELY, PROVIDING TEMPORARY USE OF NON-DOWNLOADABLE SOFTWARE WAS FOR ANALYZING, MONITORING AND RECORDING WEBSITE OPERATIONAL INFORMATION FOR MONITORING WEBSITE PERFORMANCE AND STABILITY, TROUBLESHOOTING AND DEBUGGING; HOSTING OF SOFTWARE AS A SERVICE (SAAS), NAMELY, HOSTING SOFTWARE FOR USE BY OTHERS FOR ANALYZING, MONITORING AND RECORDING WEBSITE OPERATIONAL INFORMATION FOR MONITORING WEBSITE PERFORMANCE AND STABILITY, TROUBLESHOOTING AND DEBUGGING; COMPILATION OF INFORMATION RELATING TO INFORMATION TECHNOLOGY; ADVISORY, CONSULTANCY AND INFORMATION SERVICES IN RELATION TO THE AFORESAID SERVICES; PROVISION OF THE AFORESAID SERVICES ONLINE VIA A WEBSITE, THE INTERNET OR OTHER COMPUTER NETWORKS AND/OR ACCESSIBLE BY MOBILE PHONE AND OTHER INTERNET-ENABLED DEVICES (U.S. CLS. 100 AND 101).

JULIE WATSON, EXAMINING ATTORNEY

SN 85-179,396, BENTALL LIMITED PARTNERSHIP, VANCOUVER, B.C., CANADA, FILED 11-17-2010.

BENTALL KENNEDY

THE MARK CONSISTS OF STANDARD CHARACTERS WITHOUT CLAIM TO ANY PARTICULAR FONT, STYLE, SIZE, OR COLOR.

OWNER OF U.S. REG. NOS. 1,649,676, 3,439,596 AND OTHERS.

THE NAME(S), PORTRAIT(S), AND/OR SIGNATURE(S) SHOWN IN THE MARK DOES NOT IDENTIFY A PARTICULAR LIVING INDIVIDUAL.

CLASS 36—INSURANCE AND FINANCIAL

FOR REAL ESTATE PORTFOLIO MANAGEMENT; REAL ESTATE ASSET MANAGEMENT; REAL ESTATE SERVICES, NAMELY, LEASING AND MANAGEMENT OF COMMERCIAL AND RESIDENTIAL PROPERTY, OFFICES, OFFICE SPACE AND HOTELS (U.S. CLS. 100, 101 AND 102).

CLASS 37—CONSTRUCTION AND REPAIR

FOR REAL ESTATE DEVELOPMENT SERVICES (U.S. CLS. 100, 103 AND 106).

JASON TURNER, EXAMINING ATTORNEY

SN 85-179,428, BENTALL LIMITED PARTNERSHIP, VANCOUVER, B.C., CANADA, FILED 11-17-2010.



Bentall Kennedy

OWNER OF U.S. REG. NOS. 1,649,676, 3,439,596 AND OTHERS.

THE NAME(S), PORTRAIT(S), AND/OR SIGNATURE(S) SHOWN IN THE MARK DOES NOT IDENTIFY A PARTICULAR LIVING INDIVIDUAL.

THE MARK CONSISTS OF THE WORDING "BENTALL KENNEDY" TO THE RIGHT OF A DESIGN COMPRISING NINETEEN STACKED ALTERNATING SHADED LINES, TOGETHER REPRESENTING A BUILDING, WITH A SILHOUETTE OF A TREE SUPERIMPOSED OVER THE LOWER 13 OF THE 19 LINES.

CLASS 36—INSURANCE AND FINANCIAL

FOR REAL ESTATE PORTFOLIO MANAGEMENT; REAL ESTATE ASSET MANAGEMENT; REAL ESTATE SERVICES, NAMELY, LEASING AND MANAGEMENT OF COMMERCIAL AND RESIDENTIAL PROPERTY, OFFICES, OFFICE SPACE AND HOTELS (U.S. CLS. 100, 101 AND 102).

CLASS 37—CONSTRUCTION AND REPAIR

FOR REAL ESTATE DEVELOPMENT SERVICES (U.S. CLS. 100, 103 AND 106).
JASON TURNER, EXAMINING ATTORNEY

SN 85-180,245. IRONHILL, L.L.C., WOODSTOCK, GA. FILED 11-18-2010.

Raised on a Roux

THE MARK CONSISTS OF STANDARD CHARACTERS WITHOUT CLAIM TO ANY PARTICULAR FONT, STYLE, SIZE, OR COLOR.

CLASS 16—PAPER GOODS AND PRINTED MATTER

FOR BOOKS FEATURING RECIPES AND INFORMATION IN THE FIELD OF COOKING; A SERIES OF WRITTEN ARTICLES FEATURING RECIPES AND INFORMATION IN THE FIELD OF COOKING; MAGAZINE AND RECIPE CARDS FEATURING RECIPES AND INFORMATION IN THE FIELD OF COOKING (U.S. CLS. 2, 5, 22, 23, 29, 37, 38 AND 50).
FIRST USE 8-2-2010; IN COMMERCE 8-2-2010.

CLASS 25—CLOTHING

FOR CLOTHING, NAMELY, T-SHIRTS, SWEATSHIRTS, CASUAL SHIRTS, APRONS, SPORT SHORTS, CASUAL SHORTS AND CASUAL PANTS; HEADGEAR, NAMELY, HATS, CAPS AND VISORS (U.S. CLS. 22 AND 39).
FIRST USE 11-2-2010; IN COMMERCE 11-2-2010.

CLASS 43—HOTEL AND RESTAURANT SERVICES

FOR PROVIDING A WEBSITE FEATURING INFORMATION IN THE FIELD OF RECIPES AND COOKING (U.S. CLS. 100 AND 101).
FIRST USE 6-19-2010; IN COMMERCE 6-19-2010.
MICHELE SWAIN, EXAMINING ATTORNEY

SN 85-180,814. KITTY LIKES TO SCRATCH PRODUCTIONS, INC., LOS ANGELES, CA. FILED 11-19-2010.

BAD BOY

THE MARK CONSISTS OF STANDARD CHARACTERS WITHOUT CLAIM TO ANY PARTICULAR FONT, STYLE, SIZE, OR COLOR.

CLASS 3—COSMETICS AND CLEANING PREPARATIONS

FOR COSMETICS, NAMELY, FRAGRANCES, PERFUMES, AND NON-MEDICATED FACE CARE PREPARATIONS (U.S. CLS. 1, 4, 6, 50, 51 AND 52).

CLASS 14—JEWELRY

FOR JEWELRY AND COSTUME JEWELRY, RINGS, BRACELETS, NECKLACES, TIE BARS, SCARF RINGS, PENDANTS, EAR CLIPS, TIE CLIPS, CUFF-LINKS OF PRECIOUS METAL, EARRINGS, KEY HOLDERS MADE OF PRECIOUS METALS, BROOCHES, LAPEL PINS, CLOCKS, WATCHES, CHRONOGRAPHS FOR USE AS WATCHES, CHRONOMETERS (U.S. CLS. 2, 27, 28 AND 50).
BRIDGETT SMITH, EXAMINING ATTORNEY

SN 85-181,208. DUVALEC, L-1471 LUXEMBOURG, LUXEMBOURG, FILED 11-19-2010.

DUKAN DIET

THE MARK CONSISTS OF STANDARD CHARACTERS WITHOUT CLAIM TO ANY PARTICULAR FONT, STYLE, SIZE, OR COLOR.

NO CLAIM IS MADE TO THE EXCLUSIVE RIGHT TO USE "DIET", APART FROM THE MARK AS SHOWN.

THE NAME SHOWN IN THE MARK IDENTIFIES "DR. PIERRE DUKAN" WHOSE CONSENT IS OF RECORD.

CLASS 3—COSMETICS AND CLEANING PREPARATIONS

FOR ANTI-AGING CREAMS; BODY AND BEAUTY CARE COSMETICS; BODY CREAM; NIGHT CREAM; COSMETIC PREPARATIONS FOR BODY CARE; COSMETIC PREPARATIONS FOR SLIMMING PURPOSES; COSMETIC PREPARATIONS, NAMELY, FIRING LOTIONS AND CREAMS; NON-MEDICATED SKIN CARE PREPARATIONS, NAMELY, CREAMS, LOTIONS, GELS, TONERS, CLEANERS AND PEELS; MAKE-UP PREPARATIONS FOR THE FACE AND BODY; BEAUTY MASKS; FOUNDATION CREAM; BLUSHER; EYE SHADOW; MASCARA; EYEBROW-PENCILS; LIPSTICK; NAIL VARNISH; MAKE-UP REMOVING MILK, GEL, LOTIONS AND CREAMS; EPILATORY STRIPS; HAIR REMOVING CREAMS; BATH OILS AND BATH SALTS; BATH GELS; BATH POWDER; BATHING LOTIONS; SHOWER GEL; SOAPS, NAMELY, BATH SOAPS, BODY SOAPS, FACE SOAPS, HAND SOAPS, SKIN SOAPS, DEODORANT SOAPS, ANTIPERSPIRANT SOAPS, DISINFECTANT SOAPS, SHAVING SOAPS; HAIR LOTIONS; COSMETIC PREPARATIONS FOR PROTECTING THE SKIN FROM THE SUN'S RAYS; SUN CARE LOTIONS; SUN CREAMS; SUN SCREEN PREPARATIONS; SUN TAN LOTION; SUNSCREEN CREAMS; SUNTAN CREAMS; WATERPROOF SUNSCREEN; COSMETIC PRODUCTS TAKEN ORALLY, NAMELY, PILLS THAT INDUCE BRONZING OF THE SKIN; COSMETIC SUNSCREEN PREPARATIONS; ESSENTIAL OILS FOR FOOD FLAVORINGS; NATURAL ESSENTIAL OILS; ESSENTIAL OILS FOR FLAVORING BEVERAGES; AROMATIC BODY CARE PRODUCTS, NAMELY, BODY LOTION, SHOWER GEL, CUTICLE CREAM, SHAMPOO, CONDITIONER, NON-MEDICATED LIP BALM, SOAP, BODY POLISH, BODY AND FOOT SCRUB AND NON-MEDICATED FOOT CREAM; AROMATIC ESSENTIAL OILS; PERFUMES; TOILET WATER; COLOGNES; PERFUMED CREAMS; DENTIFRICE (U.S. CLS. 1, 4, 6, 50, 51 AND 52).

CLASS 5—PHARMACEUTICALS

FOR FOOD SUPPLEMENTS; VITAMINS; MINERAL SUPPLEMENTS; DIETARY AND NUTRITIONAL SUPPLEMENTS; DIET CAPSULES; DIETARY AND NUTRITIONAL SUPPLEMENTS USED FOR WEIGHT LOSS; DIETARY SUPPLEMENTS IN THE NATURE OF WEIGHT LOSS POWDERS OR WEIGHT LOSS DRINKS; MEAL REPLACEMENT BARS; MEAL REPLACEMENT DRINKS; READY TO DRINK NUTRITIONAL BEVERAGES; MEAL REPLACEMENT POWDERS; MEAL REPLACEMENT SNACKS; AMINO ACIDS FOR NUTRITIONAL PURPOSES; PROTEIN SUPPLEMENTS; HERBAL SUPPLEMENTS; MEDICAL PREPARATIONS FOR SLIMMING PURPOSES (U.S. CLS. 6, 18, 44, 46, 51 AND 52).

CLASS 9—ELECTRICAL AND SCIENTIFIC APPARATUS

FOR COMPUTER APPLICATION SOFTWARE FOR MOBILE PHONES, NAMELY, SOFTWARE FOR PROVIDING DIET, NUTRITION, AND WEIGHT LOSS INFORMATION, TEXT, BARCODE, AND CATEGORY SEARCH CAPABILITY FOR FOOD PRODUCT SEARCHES, AND EXERCISE AND CALORIE CALCULATORS, DIARIES, AND DAILY INTAKE TARGETS; DOWNLOADABLE COMPUTER SOFTWARE FOR USE IN MOBILE COMMUNICATION DEVICES THAT PROVIDES DIET, NUTRITION, AND WEIGHT LOSS INFORMATION, TEXT, BARCODE, AND CATEGORY SEARCH CAPABILITY FOR FOOD PRODUCT SEARCHES, AND EXERCISE AND CALORIE CALCULATORS, DIARIES, AND DAILY INTAKE TARGETS; DOWNLOADABLE COMPUTER SOFTWARE FOR MOBILE COMMUNICATION DEVICES THAT PROVIDES DIET, NUTRITION, AND WEIGHT LOSS INFORMATION, TEXT, BARCODE, AND CATEGORY SEARCH CAPABILITY FOR FOOD PRODUCT SEARCHES, AND EXERCISE AND CALORIE CALCULATORS, DIARIES, AND DAILY INTAKE TARGETS (U.S. CLS. 21, 23, 26, 36 AND 38).

CLASS 16—PAPER GOODS AND PRINTED MATTER

FOR AGENDAS; PRINTED MATTER, NAMELY, BOOKS, NEWSPAPERS, PHOTOGRAPHS, MAGAZINES, PRINTED PERIODICALS, NEWSLETTERS, AND BROCHURES ALL IN THE FIELDS OF MEDICINE, DIET PROGRAMS, NUTRITION, COOKING, WEIGHT LOSS, BEAUTY, WELLNESS, AND LIFESTYLE; RECIPE BOOKS; MAGAZINES CONTAINING RECIPES; MAGAZINE SUPPLEMENTS TO NEWSPAPERS IN THE FIELD OF MEDICINE, DIET PROGRAMS, NUTRITION, COOKING, WEIGHT LOSS, BEAUTY, WELLNESS, AND LIFESTYLE; PUBLICATIONS, NAMELY, BOOKLETS, AND TEACHING MATERIALS IN THE FIELD OF MEDICINE, DIET PROGRAMS, NUTRITION, COOKING, WEIGHT LOSS, BEAUTY, WELLNESS, AND LIFESTYLE; BOOK COVERS; CALENDARS; DESK CALENDARS; COSMETIC REMOVING PAPER; NAPKIN PAPER; NAPKINS OF PAPER FOR REMOVING MAKE-UP; TISSUE PAPER; TISSUES OF PAPER FOR REMOVING MAKE-UP; TOILET TISSUE; STATIONERY; ADHESIVES FOR STATIONERY OR HOUSEHOLD PURPOSES; NON-TEXTILE PAPER LABELS; ADHESIVE LABELS; MERCHANDISE BAGS; NOTE BOOKS; ORGANIZERS FOR STATIONERY USE; PENS, PENCILS; PERSONAL MEDICAL RECORD BOOK WITH CALENDAR; PERSONAL ORGANIZERS (U.S. CLS. 2, 5, 22, 23, 29, 37, 38 AND 50).

CLASS 29—MEATS AND PROCESSED FOODS

FOR MEAT, FISH, POULTRY AND GAME, MEAT EXTRACTS, CANNED COOKED MEAT, HAM, CHARCUTERIE, HAMBURGER, PORK RINDS, HOT DOGS, LUNCHEON MEATS, FRANKFURTERS; PRESERVED, FROZEN, DRIED AND COOKED FRUITS AND VEGETABLES; CANNED FRUITS AND VEGETABLES; FRUIT AND VEGETABLE SALADS; SALADS, NAMELY, PRECUT VEGETABLE, FRUIT, GARDEN AND SEAFOOD SALADS; GHERKINS; SOUPS; PREPARED OR COOKED DISHES, MADE FROM MEAT, VEGETABLES, FISH, POULTRY OR GAME; JELLIES AND JAMS; COMPOTES; EGGS; EGG WHITES; MILK; CHEESE, CHEESE FOOD; COTTAGE CHEESE, HALF AND HALF; CREAM; SOUR CREAM; SOUR CREAM SUBSTITUTES; WHIPPED TOPPING; YOGURTS; NON-DAIRY CREAMER; CHEESE SPREADS; BUTTER; MARGARINE; MARGARINE SUBSTITUTES; COCOA BUTTER FOR FOOD PURPOSES; EDIBLE OILS AND FATS; PICKLES; FATS FOR FOOD; SEAFOOD; SHELLFISH, NOT LIVE; TOFU; PREPARATIONS FOR MAKING BOUILLON (U.S. CL. 46).

CLASS 30—STAPLE FOODS

FOR COFFEE; TEA, COCOA, SUGAR, RICE, TAPIOCA, ARTIFICIAL COFFEE; FLOUR, AND PREPARATIONS MADE FROM CEREALS, NAMELY, BOILED SWEETS, BONBONS, CANDIES, CANDY, CHOCOLATE, CHOCOLATE STICKS AND BARS, CHOCOLATES, CRYSTAL SUGAR PIECES, DRAGEES, NAMELY, SUGAR-COATED CANDY, FILLED CHOCOLATES, FONDANTS, FROZEN CONFECTIONERY, FROZEN SOY-BASED DESSERTS, FRUIT JELLIES, FUDGES, HALVAH, HARD CANDIES, MARZIPAN, NOUGATS, PASTILLES, SUGAR CANDY, SUGAR FREE SWEETS, SWEETS, TOFFEES; CEREAL PRODUCTS FOR FOOD, NAMELY, OAT FLAKES, PROCESSED SEMOLINA, BREAKFAST CEREALS; PASTA; BREAD; PASTRIES; VIENNESE PASTRIES AND CONFECTIONERY MADE OF SUGAR; BISCUITS; PANCAKES; WAFFLES; SANDWICHES; PIZZAS, QUICHES; PATE; ALMOND PASTES FOR CAKES; EDIBLE ICES; ICE; ICE CREAMS; SORBETS; DESSERTS, NAMELY, FROZEN ENTREMETS; SWEETS; YEAST EXTRACTS; BAKING-POWDER; SALT; MUSTARD; VINEGAR; SAUCES; SPICES; KETCHUP; GARDEN HERBS, PRESERVED; MEAT GRAVIES; TOMATO SAUCE; AROMATIC PREPARATIONS FOR FOOD, NAMELY FOOD FLAVORINGS OTHER THAN ESSENTIAL OILS; FLAVOURINGS OTHER THAN ESSENTIAL OILS, FOR CAKES AND FOR BEVERAGES, DRINKS ON THE BASE OF COFFEE, TEA, COCOA OR CHOCOLATE, NAMELY, COFFEE BASED BEVERAGES, BEVERAGES MADE OF TEA, COCOA BASED BEV-

ERAGES, CHOCOLATE BEVERAGES NOT BEING DAIRY BASED OR VEGETABLE BASED PREPARED PACKAGED ENTREES CONSISTING PRIMARILY OF PASTA OR RICE; FLAVORS FOR DRINKS AND FLAVORS FOR PASTRY, NAMELY, FLAVOR ENHANCERS USED IN FOOD AND BEVERAGE PRODUCTS; CHOCOLATES; FOOD ADDITIVES FOR NON-NUTRITIONAL PURPOSES FOR USE AS A FLAVORING; SPICES COMPRISING NATURAL OR SYNTHETIC AROMATIC OR FLAVORING SUBSTANCES; UNPROCESSED COFFEE BEANS; TEA LEAVES; UNPROCESSED TAPIOCA (U.S. CL. 46).

CLASS 31—NATURAL AGRICULTURAL PRODUCTS

FOR FRESH FRUITS AND VEGETABLES; RAW COCOA BEANS; SUGAR CANE; UNPROCESSED RICE; LIVE FISH EGGS; LIVE CRUSTACEANS; LIVE SEAFOOD; LIVE SHELLFISH; ADDITIVES TO FODDER, NOT FOR MEDICAL USE; UNPROCESSED FRUITS; UNPROCESSED VEGETABLES (U.S. CLS. 1 AND 46).

CLASS 32—LIGHT BEVERAGES

FOR NON-ALCOHOLIC BEVERAGES, NAMELY, DRINKING WATERS, MINERAL AND AERATED WATERS, VEGETABLE JUICES IN BEVERAGE FORM, FRUIT JUICE, FRUIT JUICES, CARBONATED SOFT DRINKS, ENERGY DRINKS AND HYPERTONIC SPORTS DRINKS; VEGETABLE CONCENTRATES FOR THE MIXING OF DRINKS; FRUIT JUICE CONCENTRATES; SYRUPS FOR MAKING CARBONATED BEVERAGES; ISOTONIC DRINKS; ENERGY DRINKS AND SPORTS DRINKS; WHEY BEVERAGES AND SYRUPS FOR MAKING WHEY-BASED BEVERAGES; ALCOHOLIC BEVERAGES, NAMELY, BEER (U.S. CLS. 45, 46 AND 48).

CLASS 38—COMMUNICATION

FOR PROVIDING AN ON-LINE FORUM FOR PARTICIPANTS IN HEALTH, NUTRITION, AND WEIGHT LOSS PROGRAMS; PROVIDING ON-LINE CHAT ROOMS AND ELECTRONIC BULLETIN BOARDS FOR TRANSMISSION OF MESSAGES AMONG USERS IN THE FIELD OF MEDICINE, HEALTH, DIET PROGRAMS, NUTRITION, WEIGHT LOSS, WELLNESS, BEAUTY AND LIFESTYLE; AUDIO AND VIDEO BROADCASTING SERVICES OVER THE INTERNET; CHAT ROOM SERVICES FOR SOCIAL NETWORKING; PROVIDING TELECOMMUNICATION CONNECTIVITY SERVICES FOR TRANSFER OF IMAGES, MESSAGES, AUDIO, VISUAL, AUDIOVISUAL AND MULTIMEDIA WORKS; TELECOMMUNICATION SERVICES, NAMELY, TRANSMISSION OF VOICE, DATA, GRAPHICS, SOUND AND VIDEO BY MEANS OF BROADBAND POWER LINE OR WIRELESS NETWORKS; WIRELESS COMMUNICATIONS SERVICES, NAMELY, TRANSMISSION OF GRAPHICS AND VIDEOS TO MOBILE TELEPHONES; TRANSMISSION AND DISTRIBUTION OF DATA OR AUDIO VISUAL IMAGES VIA A GLOBAL COMPUTER NETWORK OR THE INTERNET; VIDEO-ON-DEMAND TRANSMISSION SERVICES VIA THE INTERNET; COMMUNICATIONS SERVICES, NAMELY, TRANSMITTING STREAMED SOUND AND AUDIOVISUAL RECORDINGS VIA THE INTERNET; COMPUTER AIDED TRANSMISSION OF INFORMATION AND IMAGES; ELECTRONIC MESSAGING; MESSAGE SENDING AND RECEIVING SERVICES; PROVIDING ACCESS TO DATABASES; PROVIDING E-MAIL AND INSTANT MESSAGING SERVICES; TELEVISION AND RADIO BROADCASTING SERVICES; COMMUNICATION VIA RADIO AND TELEVISION TRANSMISSIONS; TRANSMISSION AND RECEIVING BY RADIO AND TELEVISION; NEWS AGENCY SERVICES FOR ELECTRONIC TRANSMISSION (U.S. CLS. 100, 101 AND 104).

CLASS 41—EDUCATION AND ENTERTAINMENT

FOR ARRANGEMENT OF TRAINING COURSES IN TEACHING INSTITUTES; ARRANGING AND CONDUCTING EDUCATIONAL CONFERENCES; BOOK AND REVIEW PUBLISHING; PUBLICATION OF BOOKS, MAGAZINES, ALMANACS AND JOURNALS; CONDUCTING EDUCATIONAL EXHIBITIONS IN THE NATURE OF MEDICINE, DIET PROGRAMS, NUTRITION, COOKING, WEIGHT LOSS, BEAUTY, WELLNESS, AND LIFESTYLE; CONSULTING SERVICES IN THE FIELD OF MEDICAL EDUCATION; EDUCATION SERVICES, NAMELY, MENTORING IN THE FIELD OF MEDICINE, DIET PROGRAMS, NUTRITION, COOKING, WEIGHT LOSS, BEAUTY, WELLNESS, AND LIFESTYLE; EDUCATION SERVICES, NAMELY, PROVIDING, CLASSES, SEMINARS, WORKSHOPS, TUTORING, AND MENTORING IN THE FIELD OF MEDICINE, DIET PROGRAMS, NUTRITION, COOKING, WEIGHT LOSS, BEAUTY, WELLNESS, AND LIFESTYLE; EDUCATIONAL SERVICES, NAMELY, DEVELOPING, ARRANGING, AND CONDUCTING EDUCATIONAL CONFERENCES AND PROGRAMS AND PROVIDING COURSES OF INSTRUCTION IN THE FIELD OF MEDICINE, DIET PROGRAMS, NUTRITION, COOKING, WEIGHT LOSS, BEAUTY, WELLNESS, AND LIFESTYLE; ORGANIZATION OF SEMINARS, WORKING GROUPS, RESEARCH GROUPS AND CONVENTIONS, IN THE FIELD OF MEDICINE, DIET PROGRAMS, NUTRITION, COOKING, WEIGHT LOSS, BEAUTY, WELLNESS, AND LIFESTYLE; ENTERTAINMENT SERVICES, NAMELY, PROVIDING ONGOING TELEVISION AND RADIO PROGRAMS IN THE FIELD OF MEDICINE, DIET PROGRAMS, NUTRITION, COOKING, WEIGHT LOSS, BEAUTY, WELLNESS, AND LIFESTYLE; RADIO ENTERTAINMENT PRODUCTION; TELEVISION SHOW PRODUCTION; TELEVISION, VIDEO AND MOVIE FILMING SERVICES; SPORTS TRAINING SERVICES; GYMNASIUM INSTRUCTION; HEALTH CLUB SERVICES, NAMELY, PROVIDING INSTRUCTION AND EQUIPMENT IN THE FIELD OF PHYSICAL EXERCISE; INFORMATION ON EDUCATION; ON-LINE JOURNALS, NAMELY, BLOGS FEATURING IN THE FIELD OF MEDICINE, DIET PROGRAMS, NUTRITION, COOKING, WEIGHT LOSS, BEAUTY, WELLNESS, AND LIFESTYLE; ON-LINE PUBLICATION OF MAGAZINES, JOURNALS, NEWSLETTERS, PAMPHLETS, BROCHURES, BOOKS, AND BOOKLETS IN THE FIELD OF MEDICINE, DIET PROGRAMS, NUTRITION, COOKING, WEIGHT LOSS, BEAUTY, WELLNESS, AND LIFESTYLE; PROVIDING A WEBSITE FEATURING NON-DOWNLOADABLE PUBLICATIONS IN THE NATURE BOOKS, MAGAZINES, BROCHURES IN THE FIELD OF MEDICINE, DIET PROGRAMS, NUTRITION, COOKING, WEIGHT LOSS, BEAUTY, WELLNESS, AND LIFESTYLE; NEWS AGENCIES, NAMELY, GATHERING AND DISSEMINATION OF NEWS (U.S. CLS. 100, 101 AND 107).

CLASS 42—SCIENTIFIC AND COMPUTER SERVICES

FOR DESIGN AND DEVELOPMENT OF COMPUTER HARDWARE AND SOFTWARE, COMPUTER SOFTWARE DEVELOPMENT IN THE FIELD OF MEDICINE, DIET PROGRAMS, NUTRITION, COOKING, WEIGHT LOSS, BEAUTY, WELLNESS, AND LIFESTYLE; COMPUTER SOFTWARE INSTALLATION AND MAINTENANCE; CREATING OF COMPUTER PROGRAMS; COMPUTER CONSULTATION; COMPUTER HARDWARE DEVELOPMENT; COMPUTER PROGRAMMING AND SOFTWARE DESIGN; BUILDING AND MAINTAINING WEBSITES; PROVIDING AN INTERACTIVE WEB SITE THAT ENABLES USERS TO ENTER, ACCESS, TRACK, MONITOR AND GENERATE HEALTH AND MEDICAL INFORMATION AND REPORTS; COMPUTER SERVICES, NAMELY, CREATING ON-LINE VIRTUAL COMMUNITIES FOR REGISTERED USERS TO ORGANIZE GROUPS AND EVENTS, PARTICIPATE IN DISCUSSIONS, AND ENGAGE IN SOCIAL, BUSINESS AND COMMUNITY NETWORKING; APPLICATION SERVICE PROVIDER (ASP) FEATURING SOFTWARE TO ENABLE OR FACILITATE THE UPLOADING, DOWNLOADING, STREAMING, POSTING, DISPLAYING, BLOGGING, LINKING, SHARING OR OTHERWISE PROVIDING ELECTRONIC MEDIA OR INFORMATION OVER COMMUNICATION NETWORKS; PROVIDING AN ONLINE NETWORK SERVICE THAT ENABLES USERS TO

TRANSFER PERSONAL IDENTITY DATA TO AND SHARE PERSONAL IDENTITY DATA WITH AND AMONG MULTIPLE WEBSITES; PROVIDING A WEB SITE FEATURING TECHNOLOGY THAT ENABLES ON-LINE USERS TO CREATE PERSONAL PROFILES FEATURING SOCIAL NETWORKING INFORMATION AND TO TRANSFER AND SHARE SUCH INFORMATION AMONG MULTIPLE WEBSITES ; CREATING AND MAINTAINING BLOGS FOR OTHERS; SCIENTIFIC SERVICES, NAMELY, SCIENTIFIC RESEARCH AND DEVELOPMENT, OLFACTORY RECEPTOR RESEARCH; TECHNOLOGICAL RESEARCH AND DEVELOPMENT SERVICES, NAMELY, INGREDIENT RESEARCH, DISCOVERY AND DEVELOPMENT OF INGREDIENTS, RECEPTOR TECHNOLOGY, AND RELATED PRODUCT RESEARCH; RESEARCH AND DESIGN OF NEW PRODUCTS ALL PERTAINING TO INGREDIENTS, AROMAS, FLAVORS, FLAVORINGS, FOODS, FOODSTUFFS, BEVERAGES AND BEVERAGE FLAVORING PRODUCTS; INDUSTRIAL ANALYSIS AND RESEARCH SERVICES PERTAINING TO AROMAS, FLAVORS, FLAVORINGS, FOODS, FOODSTUFFS, BEVERAGES AND BEVERAGE FLAVORING PRODUCTS; DESIGN AND DEVELOPMENT OF COMPUTER HARDWARE AND SOFTWARE FOR USE IN THE FIELD OF AROMAS, FLAVORS, FLAVORINGS, FOODS, FOODSTUFFS, BEVERAGES AND BEVERAGE FLAVORING PRODUCTS; RESEARCH AND ANALYSIS IN THE FIELD OF DIET AND NUTRITION DISEASES; RESEARCH ON FOOD; SCIENTIFIC CONSULTING AND RESEARCH SERVICES RELATING TO FOODS AND DIETARY SUPPLEMENTS; TECHNICAL CONSULTANCY IN RELATION TO RESEARCH SERVICES RELATING TO FOODS AND DIETARY SUPPLEMENTS; COSMETICS RESEARCH; DESIGN AND TESTING FOR NEW PRODUCT DEVELOPMENT; PROVIDING A WEBSITE THAT GIVES USERS THE ABILITY TO DOWNLOAD COMPUTER APPLICATION SOFTWARE FOR MOBILE PHONES; PROVIDING A WEBSITE THAT GIVES USERS THE ABILITY TO DOWNLOAD COMPUTER SOFTWARE FOR MOBILE COMMUNICATION DEVICES, FEATURING DIET, NUTRITION, AND WEIGHT LOSS INFORMATION, TEXT, BARCODE, AND CATEGORY SEARCH CAPABILITY FOR FOOD PRODUCT SEARCHES, AND EXERCISE AND CALORIE CALCULATORS, DIARIES, AND DAILY INTAKE TARGETS (U.S. CLS. 100 AND 101).

CLASS 43—HOTEL AND RESTAURANT SERVICES

FOR PROVIDING A WEBSITE FEATURING INFORMATION IN THE FIELD OF COOKING; RESTAURANT, BAR AND CATERING SERVICES; CONSULTANCY SERVICES IN THE FIELD OF MENU PLANNING FOR OTHERS; PROVIDING A DATABASE IN THE FIELD OF RECIPES AND COOKING INFORMATION; PROVIDING ADVICE TO TOURISTS AND BUSINESS TRAVELERS ON HOTEL AND RESTAURANT DESTINATIONS (U.S. CLS. 100 AND 101).

CLASS 44—MEDICAL, BEAUTY AND AGRICULTURAL SERVICES

FOR PROVIDING A WEBSITE FEATURING INFORMATION IN THE FIELD OF MEDICINE, DIET PROGRAMS, NUTRITION, WEIGHT LOSS, BEAUTY, WELLNESS, AND LIFESTYLE; PROVIDING INFORMATION IN THE FIELD OF MEDICINE, DIET PROGRAMS, NUTRITION, WEIGHT LOSS, BEAUTY, WELLNESS, AND LIFESTYLE; PROVIDING AN INTERACTIVE WEB SITE THAT ENABLES USERS TO ENTER, ACCESS, TRACK, MONITOR AND GENERATE HEALTH AND MEDICAL INFORMATION AND REPORTS; BEAUTY CONSULTATION SERVICES IN THE SELECTION AND USE OF COSMETICS, FRAGRANCES, BEAUTY AIDS, PERSONAL CARE PRODUCTS, AND BATH, BODY AND BEAUTY PRODUCTS; BEAUTY CONSULTATION SERVICES; DIETARY AND NUTRITIONAL GUIDANCE; DIETITIAN SERVICE; SERVICES RENDERED BY A DIETITIAN; MEDICAL ASSISTANCE CONSULTANCY PROVIDED BY DOCTORS AND OTHER SPECIALIZED MEDICAL PERSONNEL; MEDICAL SERVICES; NUTRITIONAL THERAPY SERVICES; PSYCHIATRIC SERVICES ; PSYCHOTHERAPY SERVICES ; PSYCHOLOGICAL CONSULTATION; CONSULTING SERVICES IN THE FIELD OF MENTAL HEALTH AND WELLNESS; KINESITHERAPY, MASSAGE THERAPY

SERVICES; CONSULTING SERVICES IN THE FIELD OF HEALTH, NUTRITION AND WEIGHT LOSS PROGRAMS; CONSULTING SERVICES IN THE FIELDS OF DIAGNOSTIC MEDICAL TESTING AND NUTRITION; CONSULTING TO INDIVIDUALS AND COMMUNITIES ENGAGED IN GROUP WEIGHT LOSS PROGRAMS; PROVIDING WEIGHT REDUCTION PLANNING, TREATMENT AND SUPERVISION THROUGH WEIGHT REDUCTION PROGRAMS FEATURING COUNSELING AND DIET PLANS; PROVIDING ADVICE, CONSULTATION AND INFORMATION IN THE FIELD OF WEIGHT CONTROL AND NUTRITION; COSMETIC ANALYSIS; COUNSELING SERVICES IN THE FIELDS OF HEALTH, NUTRITION, BEAUTY, WELLNESS, AND LIFESTYLE; WEIGHT MANAGEMENT SERVICES, NAMELY, PROVIDING WEIGHT LOSS AND/OR WEIGHT MAINTENANCE PROGRAMS; WEIGHT REDUCTION DIET PLANNING AND SUPERVISION; CONVALESCENCE HOMES; REST HOMES; WEIGHT LOSS CLINICS; WEIGHT LOSS CENTERS; PROVIDING A WEB SITE FEATURING INFORMATION ON HEALTH, NUTRITION AND MEDICAL INFORMATION; PROVIDING A WEBSITE FEATURING INFORMATION AND ADVICE IN THE FIELDS OF MEDICINE, WEIGHT LOSS, DIET PLANNING, BEAUTY, WELLNESS, AND LIFESTYLE; PROVIDING INFORMATION ABOUT DIETARY SUPPLEMENTS AND NUTRITION (U.S. CLS. 100 AND 101).
CHARLES L. JENKINS, EXAMINING ATTORNEY

SN 85-182,651. SURVITEC GROUP LIMITED, MERSEYSIDE CH41 1HQ, UNITED KINGDOM, FILED 11-22-2010.

SURVITEC

THE MARK CONSISTS OF STANDARD CHARACTERS WITHOUT CLAIM TO ANY PARTICULAR FONT, STYLE, SIZE, OR COLOR.

OWNER OF ERPN CMNTY TM OFC REG. NO. 9495417, DATED 5-3-2011, EXPIRES 11-4-2020.

CLASS 9—ELECTRICAL AND SCIENTIFIC APPARATUS

FOR LIFE RAFTS; LIFE JACKETS; LIFE PRESERVERS FOR BABIES; MARINE EVACUATION SYSTEMS COMPRISED PRIMARILY OF INFLATABLE LIFE RAFTS AND ESCAPE CHUTES; ANTI-G SUITS; LIFE PRESERVERS; ARMORED LIFE PRESERVERS; SURVIVAL WAISTCOATS FOR THE PREVENTION OF DROWNING; FLOATATION COLLARS; WATER IMMERSION SURVIVAL SUITS, NAMELY, INSULATED OVERALL WETSUITS AND DRY SUITS; LIQUID COOLING VESTS TO PREVENT INJURY DUE TO OVERHEATING; CHEMICAL, NUCLEAR AND RADIATION PROTECTIVE GARMENTS, NAMELY, SURVIVAL SUITS; FIRE RETARDANT COMBAT JACKETS AND PANTS FOR PROTECTION AGAINST FIRE; SAFETY NECK AND HEAD RESTRAINTS, OTHER THAN FOR VEHICLE SEATS; SELF-RESCUE, PARACHUTE OXYGEN BREATHING UNITS; HYPERBARIC OXYGEN CHAMBERS FOR NON-MEDICAL PURPOSES; LIFE SUPPORT SYSTEMS FOR AIRCRAFT, NAMELY, OXYGEN BREATHING UNITS; WAVE ENERGY CONVERTERS FOR CONVERTING MARINE WAVE ENERGY TO ELECTRICAL ENERGY (U.S. CLS. 21, 23, 26, 36 AND 38).

CLASS 19—NON-METALLIC BUILDING MATERIALS

FOR NON-METAL BUILDING MATERIALS, NAMELY, FASCINES; NON-METAL SHELTER STRUCTURES (U.S. CLS. 1, 12, 33 AND 50).

CLASS 25—CLOTHING

FOR OVERALLS; WATER IMMERSION WET SUITS; FIRE RETARDANT COMBAT JACKETS AND PANTS IN THE NATURE OF FATIGUES; COLD/EXTREME WEATHER CLOTHING, NAMELY, JACKETS, TOPS AND BOTTOMS (U.S. CLS. 22 AND 39).

CLASS 37—CONSTRUCTION AND REPAIR

FOR SERVICING, MODIFICATION AND REPAIR OF LIFE RAFTS, MARINE ESCAPE EQUIPMENT, FIRE EXTINGUISHERS, BREATHING EQUIPMENT AND COMPRESSORS; INSTALLATION OF LIFE RAFTS, MARINE ESCAPE EQUIPMENT, FIRE EXTINGUISHERS AND BREATHING EQUIPMENT (U.S. CLS. 100, 103 AND 106).

KHANH LE, EXAMINING ATTORNEY

SN 85-182,994. XENON ARC, INC., REDMOND, WA. FILED 11-22-2010.

DIRECTIBILITY

THE MARK CONSISTS OF STANDARD CHARACTERS WITHOUT CLAIM TO ANY PARTICULAR FONT, STYLE, SIZE, OR COLOR.

CLASS 35—ADVERTISING AND BUSINESS

FOR PROVIDING BUSINESS CONSULTING SERVICES (U.S. CLS. 100, 101 AND 102).

CLASS 42—SCIENTIFIC AND COMPUTER SERVICES

FOR PROVIDING TEMPORARY USE OF A WEB-BASED SOFTWARE APPLICATION TO CONNECT CHEMICAL SUPPLIERS TO ITS CUSTOMERS AND TO MANAGE THE SALE OF CHEMICAL AND OTHER PRODUCTS; PROVIDING TEMPORARY USE OF A WEB-BASED SOFTWARE APPLICATION TO MANAGE AND PROCESS CUSTOMER ORDERS, ORDER FULFILLMENT, PRODUCT RETURNS, WARRANTY INFORMATION, AND OTHER CUSTOMER REQUESTS; PROVIDING TEMPORARY USE OF A WEB-BASED SOFTWARE APPLICATION TO GENERATE CUSTOMIZED DATA REPORTS (U.S. CLS. 100 AND 101).

ANGELA DUONG, EXAMINING ATTORNEY

SN 85-182,989. YOO, DANIEL JHIN, EAST PALO ALTO, CA. FILED 11-22-2010.

enome

THE MARK CONSISTS OF STANDARD CHARACTERS WITHOUT CLAIM TO ANY PARTICULAR FONT, STYLE, SIZE, OR COLOR.

CLASS 9—ELECTRICAL AND SCIENTIFIC APPARATUS

FOR CHILDREN'S EDUCATIONAL SOFTWARE; COMPUTER PROGRAMS FOR USING THE INTERNET AND THE WORLD WIDE WEB; COMPUTER SOFTWARE, NAMELY, SOFTWARE DEVELOPMENT TOOLS FOR THE CREATION OF MOBILE INTERNET APPLICATIONS AND CLIENT INTERFACES (U.S. CLS. 21, 23, 26, 36 AND 38).

CLASS 35—ADVERTISING AND BUSINESS

FOR ADVERTISING AND COMMERCIAL INFORMATION SERVICES, VIA THE INTERNET (U.S. CLS. 100, 101 AND 102).

CLASS 41—EDUCATION AND ENTERTAINMENT

FOR DEVELOPING TRAINING SYSTEMS AND LEARNING METHODOLOGIES FOR OTHERS; EDUCATIONAL SERVICES, NAMELY, CONDUCTING DISTANCE LEARNING INSTRUCTION AT THE PRIMARY AND SECONDARY LEVELS; EDUCATIONAL SERVICES, NAMELY, CONDUCTING DISTANCE LEARNING INSTRUCTION AT THE SECONDARY, COLLEGE AND GRADUATE LEVELS; EDUCATIONAL SERVICES, NAMELY, CONDUCTING DISTANCE LEARNING INSTRUCTION AT THE UNIVERSITY LEVEL (U.S. CLS. 100, 101 AND 107).

CLASS 42—SCIENTIFIC AND COMPUTER SERVICES

FOR RESEARCH AND DEVELOPMENT OF ADVANCED LEARNING TECHNOLOGIES AND TEACHING METHODS (U.S. CLS. 100 AND 101).

B. PARADEWELAI, EXAMINING ATTORNEY

SN 85-184,195. GERBER, SCOTT LOUIS, SARASOTA, FL. FILED 11-23-2010.



NO CLAIM IS MADE TO THE EXCLUSIVE RIGHT TO USE "TUBE", APART FROM THE MARK AS SHOWN.

THE MARK CONSISTS OF A SMILING FACE WITH THE WORD "TUBE" ABOVE THE DESIGN AND "DUDE" BELOW.

CLASS 6—METAL GOODS

FOR WORKS OF ART OF COMMON METAL (U.S. CLS. 2, 12, 13, 14, 23, 25 AND 50).

CLASS 16—PAPER GOODS AND PRINTED MATTER

FOR STICKERS (U.S. CLS. 2, 5, 22, 23, 29, 37, 38 AND 50).

CLASS 21—HOUSEWARES AND GLASS

FOR MUGS (U.S. CLS. 2, 13, 23, 29, 30, 33, 40 AND 50).

SN 85-184,686. LOOP FOOD MANAGEMENT CORP., LONG ISLAND CITY, NY. FILED 11-24-2010.

CLASS 25—CLOTHING

FOR T-SHIRTS (U.S. CLS. 22 AND 39).
EUGENIA MARTIN, EXAMINING ATTORNEY

SN 85-184,471. BREAST HEALTH AND HEALING FOUNDATION, BELLEVILLE, NJ. FILED 11-24-2010.



LOBBY ME

THE MARK CONSISTS OF STANDARD CHARACTERS WITHOUT CLAIM TO ANY PARTICULAR FONT, STYLE, SIZE, OR COLOR.

THE COLOR(S) WHITE, RED, YELLOW, BLUE, BROWN, GREEN AND BLACK IS/ARE CLAIMED AS A FEATURE OF THE MARK.

THE MARK CONSISTS OF THE WORDING "THE BARN" IN STYLIZED LETTERING BELOW A DESIGN OF A BARN AND A DESIGN OF THE SUN AND THE SKY WITH BORDERS COMPRISING CIRCULAR LINES. THE WORDING "THE BARN" AND THE DESIGN OF THE BARN ARE RED. THE ROOF, THE WINDOW FRAME AND DOORS OF THE BARN ARE WHITE. THE BACKGROUND OF THE WORDING "THE BARN", THE DOTTED LINE WITHIN THE CIRCULAR AREA ABOVE THE DESIGN OF THE SKY, THE OUTLINE OF THE SKY AND THE CLOUDS IN THE SKY ARE ALL WHITE. THE DESIGN OF THE SUN AND THE RAYS EMITTING THEREFROM ARE YELLOW. THE SKY AND THE CIRCULAR DESIGN ABOVE THE SKY OUTLINE ARE BLUE. THE OUTLINE OF THE BARN, THE LATTICE ON THE DOORS OF THE BARN SOME OF THE INTERIOR OF THE WINDOW DESIGN AND THE EXTERIOR BORDERS OF THE BORDER DESIGNS ARE BLACK. THE MATERIAL LOCATED WITHIN THE DESIGN OF THE WINDOW OF THE BARN IS BROWN. THERE IS A GREEN HILL ON BOTH SIDES OF THE BARN.

CLASS 9—ELECTRICAL AND SCIENTIFIC APPARATUS

FOR COMPUTER APPLICATION SOFTWARE FOR MOBILE PHONES, NAMELY, SOFTWARE FOR SENDING ELECTRONIC MAIL MESSAGES TO CONGRESS OR OTHER LAWMAKERS AND POLICY MAKERS DIRECTLY FROM THE PHONE APPLICATION AND FOR PROVIDING ACCESS TO INTERNET WEBSITES WHICH FEATURE PUBLICLY AVAILABLE LEGISLATIVE INFORMATION THAT CITIZENS COULD USE TO SEND EMAIL MESSAGES TO MEMBERS OF CONGRESS OR OTHER LAWMAKERS AND POLICY MAKERS (U.S. CLS. 21, 23, 26, 36 AND 38).

CLASS 29—MEATS AND PROCESSED FOODS

FOR MILK, EGGNOG AND FRENCH FRIED POTATOES (U.S. CL. 46).

CLASS 36—INSURANCE AND FINANCIAL

FOR CHARITABLE FUND RAISING FOR MEDICAL RESEARCH REGARDING BREAST HEALTH AND HEALING IN THE FIELD OF BREAST CANCER AND BREAST CANCER AWARENESS (U.S. CLS. 100, 101 AND 102).

CLASS 30—STAPLE FOODS

FOR TAKE OUT FOODS NAMELY, HAMBURGER SANDWICHES, CHEESEBURGER SANDWICHES, HOT DOG SANDWICHES, SEAFOOD SANDWICHES, SANDWICHES OF MEAT, POULTRY, SALADS OR CHEESES; SANDWICH WRAPS, BAKERY GOODS, SPECIFICALLY DONUTS, BREAD, MUFFINS, CROISSANTS, CAKES, COOKIES AND BAGELS; PREPARED COFFEE FOR CONSUMPTION OFF THE PREMISES; COFFEE-BASED BEVERAGES AND ICE CREAM (U.S. CL. 46).

CLASS 41—EDUCATION AND ENTERTAINMENT

FOR CONDUCTING CONFERENCES AND SEMINARS IN THE FIELD OF ONCOLOGY, NAMELY, BREAST CANCER RESEARCH (U.S. CLS. 100, 101 AND 107).
MARY BOAGNI, EXAMINING ATTORNEY

CLASS 32—LIGHT BEVERAGES

FOR SOFT DRINKS, SMOOTHIES AND JUICES, NAMELY, ORANGE JUICE, LEMONADE, FRUIT PUNCH AND APPLE CIDER (U.S. CLS. 45, 46 AND 48).
JACQUELINE A. LAVINE, EXAMINING ATTORNEY

SN 85-184,980. B.B. P., LLC, MINNETONKA, MN. FILED 11-24-2010.

LEMONGRASS BOL DE LA VIE

THE MARK CONSISTS OF STANDARD CHARACTERS WITHOUT CLAIM TO ANY PARTICULAR FONT, STYLE, SIZE, OR COLOR.

NO CLAIM IS MADE TO THE EXCLUSIVE RIGHT TO USE "LEMONGRASS", APART FROM THE MARK AS SHOWN.

THE ENGLISH TRANSLATION OF "BOL DE LA VIE" IN THE MARK IS "BOWL OF LIFE".

CLASS 29—MEATS AND PROCESSED FOODS

FOR SOUPS AND BROTHS FOR CONSUMPTION ON OR OFF THE PREMISES (U.S. CL. 46).

CLASS 30—STAPLE FOODS

FOR ENTREES AND FOOD ITEMS CONSISTING OF NOODLES, RICE-BASED ENTREES, SANDWICHES AND DESSERTS COMPRISED OF SWEETENED RICE PORRIDGE DESSERTS AND BAKERY DESSERTS, FOR CONSUMPTION ON OR OFF THE PREMISES (U.S. CL. 46).

BARBARA GAYNOR, EXAMINING ATTORNEY

SN 85-186,021. FLOORING XTRA LIMITED, PAPATOETOE, AUCKLAND, NEW ZEALAND, FILED 11-29-2010.



OWNER OF NEW ZEALAND REG. NO. 791432, DATED 6-19-2008, EXPIRES 6-19-2018.

NO CLAIM IS MADE TO THE EXCLUSIVE RIGHT TO USE "FLOORING", APART FROM THE MARK AS SHOWN.

THE MARK CONSISTS OF THE WORDS "FLOORING XTRA" WITHIN A SHADED RECTANGLE. TWO CONVERGING ANGLED LINES FORM THE "X" IN THE WORD "XTRA".

CLASS 19—NON-METALLIC BUILDING MATERIALS

FOR FLOOR COVERINGS AND MATERIALS FOR COVERING FLOORS, NAMELY, WOOD FLOORING, LAMINATE FLOORING AND CERAMIC TILE FLOORING (U.S. CLS. 1, 12, 33 AND 50).

CLASS 27—FLOOR COVERINGS

FOR FLOOR COVERINGS AND MATERIALS FOR COVERING FLOORS, NAMELY, VINYL FLOOR COVERINGS, LINOLEUMS, CARPETS, RUGS, MATS, MATTING, CARPET TILES, HARD SURFACE COVERINGS FOR FLOORS AND RUBBER FLOOR COVERINGS AND MATTING (U.S. CLS. 19, 20, 37, 42 AND 50).

CLASS 35—ADVERTISING AND BUSINESS

FOR WHOLESALE AND RETAIL STORE SERVICES FEATURING HOME FURNISHINGS, FLOOR COVERINGS AND WINDOW TREATMENTS (U.S. CLS. 100, 101 AND 102).

CLASS 37—CONSTRUCTION AND REPAIR

FOR INSTALLATION, MAINTENANCE, REPAIR AND CLEANING OF HOME FURNISHINGS, FLOOR COVERINGS AND WINDOW TREATMENTS (U.S. CLS. 100, 103 AND 106).

CLASS 39—TRANSPORTATION AND STORAGE

FOR TRANSPORTING AND DELIVERING HOME FURNISHINGS, FLOOR COVERINGS AND WINDOW TREATMENTS (U.S. CLS. 100 AND 105).

BARBARA BROWN, EXAMINING ATTORNEY

SN 85-186,886. FORD MOTOR COMPANY, DEARBORN, MI. FILED 11-30-2010.

MOTOR CITY INNOVATION EXCHANGE

THE MARK CONSISTS OF STANDARD CHARACTERS WITHOUT CLAIM TO ANY PARTICULAR FONT, STYLE, SIZE, OR COLOR.

NO CLAIM IS MADE TO THE EXCLUSIVE RIGHT TO USE "MOTOR CITY" AND "EXCHANGE", APART FROM THE MARK AS SHOWN.

CLASS 35—ADVERTISING AND BUSINESS

FOR OPERATING AN ONLINE MARKETPLACE FEATURING THE FIELD OF INTELLECTUAL PROPERTY; ARRANGING, CONDUCTING AND PROMOTING TRADE SHOW EXHIBITIONS AND BUSINESS CONFERENCES IN THE FIELDS OF INTELLECTUAL PROPERTY, TECHNOLOGY TRANSFER AND TECHNOLOGY COLLABORATION (U.S. CLS. 100, 101 AND 102).

CLASS 36—INSURANCE AND FINANCIAL

FOR BROKERAGE IN THE FIELD OF INTELLECTUAL PROPERTY AND INTELLECTUAL PROPERTY THAT IS THE SUBJECT OF TECHNOLOGY TRANSFERS (U.S. CLS. 100, 101 AND 102).

CLASS 45—PERSONAL AND LEGAL SERVICES

FOR PROVIDING A WEBSITE FEATURING INFORMATION IN THE FIELD OF TECHNOLOGY COLLABORATION AND TECHNOLOGY TRANSFER, NAMELY, THE LICENSING AND TRANSFER OF INTELLECTUAL PROPERTY (U.S. CLS. 100 AND 101).

MICHAEL KEATING, EXAMINING ATTORNEY

SN 85-187,320. RME TRADING LIMITED, KOWLOON, HONG KONG, FILED 11-30-2010.

RME

THE MARK CONSISTS OF STANDARD CHARACTERS WITHOUT CLAIM TO ANY PARTICULAR FONT, STYLE, SIZE, OR COLOR.

CLASS 9—ELECTRICAL AND SCIENTIFIC APPARATUS

FOR INTERFACES FOR COMPUTERS, FOR USE WITH AUDIBLE DATA; AUDIO MIXING CONSOLES; AUDIO SIGNAL PROCESSORS; ANALOGUE TO DIGITAL AUDIO CONVERTERS (U.S. CLS. 21, 23, 26, 36 AND 38).

CLASS 15—MUSICAL INSTRUMENTS

FOR MUSICAL INSTRUMENTS INCORPORATING APPARATUS FOR MODIFYING AUDIO SIGNALS, MUSICAL INSTRUMENTS INCORPORATING APPARATUS FOR PRODUCING AUDIO SIGNALS; MUSICAL INSTRUMENTS (U.S. CLS. 2, 21 AND 36).
TARA PATE, EXAMINING ATTORNEY

SN 85-189,373. PINT SIZE PRODUCTIONS, LLC, AMHERST, NY. FILED 12-2-2010.



NO CLAIM IS MADE TO THE EXCLUSIVE RIGHT TO USE "PRODUCTIONS", APART FROM THE MARK AS SHOWN.

THE COLOR(S) GREEN, BLUE, WHITE AND PINK IS/ ARE CLAIMED AS A FEATURE OF THE MARK.

THE MARK CONSISTS OF THE WORD "PINT" IN GREEN WITH THE LETTER "I" IN "PINT" BEING ELONGATED, THE WORD "SIZE" WITH THE LETTERS "S", "Z" AND "E" IN BLUE AND WITH THE "I" IN SIZE IN WHITE LOCATED WITHIN THE ELONGATED "I" OF "PINT" AND THE WORD "PRODUCTIONS" IN WHITE, STYLIZED LETTERS LOCATED IN A PINK BOX BELOW THE WORDS "PINT" AND "SIZE".

CLASS 16—PAPER GOODS AND PRINTED MATTER

FOR BABY BOOKS; BOOKBINDINGS; CHILDREN'S BOOKS; CHILDREN'S STORYBOOKS; MEMORY BOOKS; PICTURE BOOKS; STORY BOOKS (U.S. CLS. 2, 5, 22, 23, 29, 37, 38 AND 50).
FIRST USE 6-19-2002; IN COMMERCE 6-19-2002.

CLASS 28—TOYS AND SPORTING GOODS

FOR PLUSH TOYS; STUFFED AND PLUSH TOYS; STUFFED TOY ANIMALS (U.S. CLS. 22, 23, 38 AND 50).
FIRST USE 6-19-2002; IN COMMERCE 6-19-2002.

CLASS 40—MATERIAL TREATMENT

FOR DIGITAL ON-DEMAND PRINTING SERVICES OF BOOKS AND OTHER DOCUMENTS; PRINTING OF BOOKS (U.S. CLS. 100, 103 AND 106).
FIRST USE 6-19-2002; IN COMMERCE 6-19-2002.

CLASS 41—EDUCATION AND ENTERTAINMENT

FOR BOOK PUBLISHING (U.S. CLS. 100, 101 AND 107).
FIRST USE 6-19-2002; IN COMMERCE 6-19-2002.

CLASS 45—PERSONAL AND LEGAL SERVICES

FOR PREPARATION OF CUSTOM MEMORY BOOKS, SCRAPBOOKS, PERSONAL ARCHIVES, FAMILY ARCHIVES, WEDDING ALBUMS, DIARIES, VACATION ALBUMS, FAMILY ALBUMS, FAMILY HISTORIES, PHOTOGRAPH ALBUMS, BIRTHDAY ALBUMS, AND SPECIAL EVENT ALBUMS FOR OTHERS (U.S. CLS. 100 AND 101).
FIRST USE 6-19-2002; IN COMMERCE 6-19-2002.

JENNY PARK, EXAMINING ATTORNEY

SN 85-190,380. FLORIDA SOUTHERN COLLEGE, LAKE-LAND, FL. FILED 12-3-2010.



THE MARK CONSISTS OF THE HEAD OF A SNAKE PARTIALLY ENCLOSED BY A DIAMOND-SHAPED BACKGROUND DESIGN.

CLASS 25—CLOTHING

FOR HOODED SWEATSHIRTS; JACKETS; PANTS; SHIRTS (U.S. CLS. 22 AND 39).
FIRST USE 9-1-2001; IN COMMERCE 10-22-2001.

CLASS 41—EDUCATION AND ENTERTAINMENT

FOR ENTERTAINMENT IN THE NATURE OF COMPETITIONS IN THE FIELD OF ATHLETICS; ENTERTAINMENT IN THE NATURE OF BASEBALL, BASKETBALL, CROSS COUNTRY RACING, GOLF, SOCCER, SOFTBALL, TENNIS, LACROSSE AND VOLLEYBALL GAMES (U.S. CLS. 100, 101 AND 107).
FIRST USE 9-1-2001; IN COMMERCE 9-27-2001.

NANCY CLARKE, EXAMINING ATTORNEY

SN 85-190,907. ANGEL MINISTRIES, RALEIGH, NC. FILED 12-5-2010.



NO CLAIM IS MADE TO THE EXCLUSIVE RIGHT TO USE "MINISTRIES", APART FROM THE MARK AS SHOWN.

THE MARK CONSISTS OF A STYLIZED RENDERING OF THE WORDING "ANGEL MINISTRIES" WITH CAPITAL LETTERS "A", "G", AND "L" WITH A FLYING ANGEL, TRUMPET AND BIBLE (BOOK) IN THE ANGEL'S ARM.

CLASS 9—ELECTRICAL AND SCIENTIFIC APPARATUS

FOR AUDIO RECORDINGS FEATURING MESSAGES OF BIBLICAL EXPOSITION (U.S. CLS. 21, 23, 26, 36 AND 38).

FIRST USE 11-30-1988; IN COMMERCE 11-30-1988.

CLASS 45—PERSONAL AND LEGAL SERVICES

FOR CHRISTIAN MINISTRY SERVICES (U.S. CLS. 100 AND 101).

FIRST USE 11-30-1988; IN COMMERCE 11-30-1988.
JEAN IM, EXAMINING ATTORNEY

SN 85-191,270. ILLINOIS TOOL WORKS INC., GLENVIEW, IL. FILED 12-6-2010.



OWNER OF U.S. REG. NOS. 3,749,732, 3,874,632 AND OTHERS.

THE COLOR(S) GREEN, WHITE, BLACK, AND GRAY IS/ARE CLAIMED AS A FEATURE OF THE MARK.

THE MARK CONSISTS OF A GREEN CIRCLE WITH A WHITE BORDER MADE FROM AN ARROW THAT ENDS HALFWAY AROUND THE CIRCLE WITH THE WORDING "THE SLIME PROMISE" IN GREEN AT THE TOP OF THE CIRCLE AND THE WORDING "SAFER FOR YOU AND YOUR TIRE" IN GREEN AT THE BOTTOM OF THE CIRCLE, WITH A FANCIFUL IMAGE OF A BLACK TIRE ON A GRAY BACKGROUND IN THE CENTER OF THE CIRCLE WITH A GREEN PLUS SIGN WITH A WHITE BORDER ON A GRAY BACKGROUND IN THE CENTER OF THE TIRE.

CLASS 1—CHEMICALS

FOR SEALANTS, NAMELY, AUTOMOTIVE TIRE INFLATOR SEALERS, TIRE PUNCTURE SEALANTS, TIRE SEALING COMPOUNDS (U.S. CLS. 1, 5, 6, 10, 26 AND 46).

CLASS 2—PAINTS

FOR COATINGS IN THE NATURE OF PROTECTANTS FOR AUTOMOBILE SURFACES, VINYL, LEATHER, PLASTIC, RUBBER, METAL AND PAINTED SURFACES (U.S. CLS. 6, 11 AND 16).

CLASS 3—COSMETICS AND CLEANING PREPARATIONS

FOR POLYMER SEALANT FOR CLEANING, SHINING AND PROTECTING AUTOMOBILE EXTERIOR SURFACES (U.S. CLS. 1, 4, 6, 50, 51 AND 52).

CLASS 7—MACHINERY

FOR AIR COMPRESSORS; COMPRESSED AIR BLOW GUNS AND NOZZLES THEREFOR FOR USE IN INFLATING VEHICLE TIRES; PARTS FOR COMPRESSED-AIR TOOLS, NAMELY, CHUCKS AND COUPLERS FOR USE WITH COMPRESSED AIR BLOW GUNS, NOZZLES, AND AIR HOSES FOR INFLATING VEHICLE TIRES (U.S. CLS. 13, 19, 21, 23, 31, 34 AND 35).

CLASS 9—ELECTRICAL AND SCIENTIFIC APPARATUS

FOR TIRE PRESSURE GAUGES (U.S. CLS. 21, 23, 26, 36 AND 38).

CLASS 12—VEHICLES

FOR TIRE LINERS; TIRE INFLATORS; INNER TUBES FOR VEHICLE TIRES; INNER TUBES FOR BICYCLES; ADHESIVE RUBBER PATCHES FOR REPAIRING TUBES OR TIRES VALVE STEMS AND VALVE CAPS FOR VEHICLE TIRES; TIRE PATCHES; TIRE PLUGS; TIRE PUMPS; PATCHES FOR REPAIRING INNER TUBES; REPAIR KITS FOR TIRES AND INNER TUBES CONSISTING OF TIRE PATCHES AND ADHESIVES; TIRE VALVE STEMS AND VALVE CAPS, TIRES (U.S. CLS. 19, 21, 23, 31, 35 AND 44).

LESLEY LAMOTHE, EXAMINING ATTORNEY

SN 85-191,958. NATIONAL BOARD FOR PROFESSIONAL TEACHING STANDARDS, INC., ARLINGTON, VA. FILED 12-7-2010.



OWNER OF U.S. REG. NO. 3,165,026.

NO CLAIM IS MADE TO THE EXCLUSIVE RIGHT TO USE "NETWORK AFFILIATES", APART FROM THE MARK AS SHOWN.

THE MARK CONSISTS OF TWO INNER CIRCLES WITHIN THE SHADE OF A CIRCLE. THE FIRST INNER CIRCLE SHOWS THE UPPER BODIES OF TWO HUMAN FIGURES, EACH IN THE RESEMBLANCE OF A STROKE-STYLE SWIMMING POSTURE, AND THE SECOND INNER CIRCLE HAS THE WORDS "NBPTS NETWORK AFFILIATES" AROUND THE BORDER OF THE CIRCLE WITH A PERIOD BETWEEN EACH WORD.

CLASS 41—EDUCATION AND ENTERTAINMENT

FOR ORGANIZING AND COORDINATING EDUCATIONAL EXHIBITIONS FOR COMMUNITIES OF CERTIFIED PROFESSIONAL TEACHERS, CERTIFIED EDUCATIONAL LEADERS AND OTHER PERSONS SUPPORTING EDUCATIONAL CERTIFICATION; PROVIDING SUPPORT SYSTEM SERVICES TO CERTIFIED TEACHERS AND EDUCATIONAL LEADERS, NAMELY, EDUCATIONAL MENTORING SERVICES IN THE FIELD OF TEACHING CERTIFICATION AND PROVIDING EDUCATIONAL SERVICES IN THE NATURE OF WORKSHOPS IN THE FIELD OF TEACHING CERTIFICATION (U.S. CLS. 100, 101 AND 107).

FIRST USE 11-0-2010; IN COMMERCE 11-0-2010.

CLASS 45—PERSONAL AND LEGAL SERVICES

FOR ORGANIZING AND CONDUCTING ONLINE SUPPORT GROUPS IN THE FIELD OF TEACHING (U.S. CLS. 100 AND 101).

FIRST USE 11-0-2010; IN COMMERCE 11-0-2010.

DOMINIC J. FERRAIUOLO, EXAMINING ATTORNEY

SN 85-192,136. BROCHURE HOLDERS INTERNATIONAL LIMITED, EARLS COLNE COLCHESTER, UNITED KINGDOM, FILED 12-7-2010.

BHI

THE MARK CONSISTS OF STANDARD CHARACTERS WITHOUT CLAIM TO ANY PARTICULAR FONT, STYLE, SIZE, OR COLOR.

OWNER OF ERPN CMNTY TM OFC REG. NO. 000803486, DATED 5-14-2001, EXPIRES 8-5-2018.

OWNER OF U.S. REG. NO. 1,827,450.

CLASS 16—PAPER GOODS AND PRINTED MATTER

FOR DESKTOP BUSINESS CARD HOLDERS; DOCUMENT HOLDERS, NAMELY, BROCHURE AND LEAFLET HOLDERS (U.S. CLS. 2, 5, 22, 23, 29, 37, 38 AND 50).

FIRST USE 8-31-1988; IN COMMERCE 8-31-1988.

CLASS 20—FURNITURE AND ARTICLES NOT OTHERWISE CLASSIFIED

FOR DISPLAY STANDS FOR BROCHURES, CARDS AND LEAFLETS (U.S. CLS. 2, 13, 22, 25, 32 AND 50).

FIRST USE 8-31-1988; IN COMMERCE 8-31-1988.

CYNTHIA SLOAN, EXAMINING ATTORNEY

SN 85-192,614. RECOGNITION WORKS LLC, KIRKLAND, WA. FILED 12-7-2010.



THE MARK CONSISTS OF "RW" STYLIZED FEATURING A SPEECH BUBBLE CONTAINING A STAR.

CLASS 35—ADVERTISING AND BUSINESS

FOR HUMAN RESOURCES CONSULTING SERVICES IN THE FIELD OF EMPLOYEE RECOGNITION AND REWARDS PROGRAMS (U.S. CLS. 100, 101 AND 102).

FIRST USE 1-8-2009; IN COMMERCE 6-23-2009.

CLASS 41—EDUCATION AND ENTERTAINMENT

FOR BUSINESS EDUCATION AND TRAINING SERVICES, NAMELY, CONDUCTING LEADERSHIP TRAINING WORKSHOPS AND SEMINARS FOR MANAGERS AND SUPERVISORS; EDUCATIONAL SERVICES, NAMELY, CONDUCTING TRAINING SEMINARS AND WORKSHOPS IN THE FIELD OF EMPLOYEE RECOGNITION, PRODUCTIVITY AND RETENTION (U.S. CLS. 100, 101 AND 107).

FIRST USE 1-8-2009; IN COMMERCE 6-23-2009.

BERYL GARDNER, EXAMINING ATTORNEY

SN 85-192,676. SCIENTIFIC LEARNING CORPORATION, OAKLAND, CA. FILED 12-7-2010.

SCILEARN

THE MARK CONSISTS OF STANDARD CHARACTERS WITHOUT CLAIM TO ANY PARTICULAR FONT, STYLE, SIZE, OR COLOR.

CLASS 9—ELECTRICAL AND SCIENTIFIC APPARATUS

FOR EDUCATIONAL SOFTWARE FEATURING INSTRUCTION IN READING, LANGUAGE, COGNITIVE AND OTHER LEARNING AND ACADEMIC SKILLS (U.S. CLS. 21, 23, 26, 36 AND 38).

CLASS 41—EDUCATION AND ENTERTAINMENT

FOR EDUCATIONAL SERVICES, NAMELY, PROVIDING TUTORING, PROGRESS MONITORING, SOFTWARE INSTRUCTION AND COACHING SERVICES IN THE FIELDS OF READING, LANGUAGE, COGNITIVE LEARNING AND ACADEMIC SKILLS DEVELOPMENT; CONDUCTING CLASSES, SEMINARS, WORKSHOPS AND ONLINE TRAINING IN THE FIELDS OF NEUROLOGICAL AND EDUCATIONAL PROCESSES AND CONTINUING PROFESSIONAL EDUCATION DIRECTED TOWARD INSTRUCTORS WHO TEACH READING, LANGUAGE, COGNITIVE LEARNING AND ACADEMIC SKILLS DEVELOPMENT (U.S. CLS. 100, 101 AND 107).

CLASS 42—SCIENTIFIC AND COMPUTER SERVICES

FOR PROVIDING ONLINE NONDOWNLOADABLE EDUCATIONAL SOFTWARE ACCESSED VIA A GLOBAL COMMUNICATIONS NETWORK FEATURING INSTRUCTION IN READING, LANGUAGE, COGNITIVE AND OTHER LEARNING AND ACADEMIC SKILLS (U.S. CLS. 100 AND 101).

JAMES LOVELACE, EXAMINING ATTORNEY

SN 85-192,681. SCIENTIFIC LEARNING CORPORATION, OAKLAND, CA. FILED 12-7-2010.

SCIENTIFIC LEARNING

THE MARK CONSISTS OF STANDARD CHARACTERS WITHOUT CLAIM TO ANY PARTICULAR FONT, STYLE, SIZE, OR COLOR.

OWNER OF U.S. REG. NOS. 2,290,820, 2,291,986 AND 2,555,616.

NO CLAIM IS MADE TO THE EXCLUSIVE RIGHT TO USE "LEARNING", APART FROM THE MARK AS SHOWN.

CLASS 9—ELECTRICAL AND SCIENTIFIC APPARATUS

FOR EDUCATIONAL SOFTWARE FEATURING INSTRUCTION IN READING, LANGUAGE, COGNITIVE AND OTHER LEARNING AND ACADEMIC SKILLS (U.S. CLS. 21, 23, 26, 36 AND 38).

FIRST USE 1-9-1997; IN COMMERCE 1-9-1997.

CLASS 41—EDUCATION AND ENTERTAINMENT

FOR EDUCATIONAL SERVICES, NAMELY, PROVIDING TUTORING, PROGRESS MONITORING, SOFTWARE INSTRUCTION AND COACHING SERVICES IN THE FIELDS OF READING, LANGUAGE, COGNITIVE LEARNING AND ACADEMIC SKILLS DEVELOPMENT; CONDUCTING CLASSES, SEMINARS, WORKSHOPS AND ONLINE TRAINING IN THE FIELDS OF NEUROLOGICAL AND EDUCATIONAL PROCESSES AND CONTINUING PROFESSIONAL EDUCATION DIRECTED TOWARD INSTRUCTORS WHO TEACH READING, LANGUAGE, COGNITIVE LEARNING AND ACADEMIC SKILLS DEVELOPMENT (U.S. CLS. 100, 101 AND 107).

FIRST USE 1-9-1997; IN COMMERCE 1-9-1997.

CLASS 42—SCIENTIFIC AND COMPUTER SERVICES

FOR PROVIDING ONLINE NONDOWNLOADABLE EDUCATIONAL SOFTWARE ACCESSED VIA A GLOBAL COMMUNICATIONS NETWORK FEATURING INSTRUCTION IN READING, LANGUAGE, COGNITIVE AND OTHER LEARNING AND ACADEMIC SKILLS (U.S. CLS. 100 AND 101).

FIRST USE 10-3-2008; IN COMMERCE 10-3-2008.
JAMES LOVELACE, EXAMINING ATTORNEY

SN 85-192,895. FLIGHT CENTRE LIMITED, BRISBANE, QLD, AUSTRALIA, FILED 12-8-2010.



NO CLAIM IS MADE TO THE EXCLUSIVE RIGHT TO USE "TRAVEL ASSOCIATES", APART FROM THE MARK AS SHOWN.

THE COLOR(S) BLUE, RED AND WHITE IS/ARE CLAIMED AS A FEATURE OF THE MARK.

THE MARK CONSISTS OF A BLUE OVAL WITH A RED BORDER WITH THE WORDS "TRAVEL ASSOCIATES" IN WHITE STACKED AND CENTERED IN THE OVAL SUPERIMPOSED OVER THE STYLIZED INITIALS "TA" IN BLUE.

CLASS 39—TRANSPORTATION AND STORAGE

FOR TRAVEL SERVICES BEING SERVICES OFFERED BY TRAVEL AGENTS, NAMELY, PASSENGER TRANSPORT SERVICES; AIR TRAVEL SERVICES, NAMELY, ARRANGING AIR TRANSPORTATION; CAR HIRE SERVICES, NAMELY, ARRANGING CAR TRANSPORT AND RENTAL OF CARS; ROAD TRANSPORT SERVICES, NAMELY, ARRANGING BUS TRANSPORT AND BUS CHARTERING; RAILWAY TRANSPORT SERVICES; SEA TRANSPORT SERVICES, NAMELY, ARRANGING BOAT CRUISES, BOAT CHARTERING, PASSENGER SHIP TRANSPORT, FERRY-BOAT TRANSPORT AND RENTAL OF BOATS; TRAVEL AGENCY SERVICES, NAMELY, MAKING RESERVATIONS AND BOOKINGS FOR TRANSPORTATION; TRAVEL AND TOUR TICKET RESERVATION SERVICES; TOURIST AGENCY SERVICES, NAMELY, PROVIDING TRAVEL AND TOUR INFORMATION; ORGANIZING SIGHTSEEING TOUR AND CRUISE ARRANGING SERVICES; ARRANGING TRAVEL TOURS, CAR RENTAL, TOURS AND CRUISES FOR HOLIDAY PACKAGES; AIR TRANSPORT SERVICES; TRAVEL AND TOURIST AGENCY SERVICES, NAMELY, PROVIDING AN ONLINE SEARCHABLE COMPUTER DATABASE FEATURING INFORMATION ON TRAVEL, AND MAKING ONLINE RESERVATIONS AND BOOKINGS FOR TRANSPORTATION; TRAVEL AND TOUR INFORMATION SERVICES (U.S. CLS. 100 AND 105).

CLASS 43—HOTEL AND RESTAURANT SERVICES

FOR TRAVEL AND TOURIST AGENCY SERVICES, NAMELY, MAKING ONLINE RESERVATIONS AND BOOKINGS FOR TEMPORARY LODGING; TRAVEL AGENCY SERVICES, NAMELY, ARRANGING TEMPORARY HOUSING ACCOMMODATIONS FOR HOLIDAY PACKAGES; PROVIDING TRAVEL LODGING INFORMATION SERVICES AND TRAVEL LODGING BOOKING AGENCY SERVICES FOR TRAVELERS (U.S. CLS. 100 AND 101).

KEVON CHISOLM, EXAMINING ATTORNEY

SN 85-193,616. INTUIT INC., MOUNTAIN VIEW, CA. FILED 12-8-2010.

EASYIMPORT

THE MARK CONSISTS OF STANDARD CHARACTERS WITHOUT CLAIM TO ANY PARTICULAR FONT, STYLE, SIZE, OR COLOR.

OWNER OF U.S. REG. NOS. 1,834,438, 3,260,318 AND OTHERS.

CLASS 35—ADVERTISING AND BUSINESS

FOR ELECTRONIC TAX RETURN FILING SERVICES; PROVISION OF INFORMATION CONCERNING TAXES, TAX RETURNS, TAX PLANNING, MANAGEMENT OF TAX FILES, PREPARATION OF TAX RETURNS, AND ELECTRONIC FILING OF TAX RETURNS; PROVIDING TAX ANALYSIS, CALCULATION, AND TAX RETURN PREPARATION SERVICES (U.S. CLS. 100, 101 AND 102).

CLASS 42—SCIENTIFIC AND COMPUTER SERVICES

FOR PROVIDING TEMPORARY USE OF ONLINE NON-DOWNLOADABLE COMPUTER SOFTWARE FOR TAX PLANNING, TAX CALCULATION, AND TAX RETURN PREPARATION AND FILING; PROVIDING TEMPORARY USE OF ONLINE NON-DOWNLOADABLE COMPUTER SOFTWARE FOR ORGANIZING, TRACKING AND REPORTING TAX-DEDUCTIBLE EXPENSES; TECHNICAL SUPPORT SERVICES, NAMELY, TROUBLESHOOTING PROBLEMS WITH COMPUTER SOFTWARE AND ONLINE SERVICES VIA TELEPHONE, E-MAIL AND OTHER MEANS (U.S. CLS. 100 AND 101).
APRIL ROACH, EXAMINING ATTORNEY

SN 85-195,421. JOINSET CO., LTD, ANSAN-SI KYEONGGI-DO, REPUBLIC OF KOREA, FILED 12-10-2010.

JOINSET

THE MARK CONSISTS OF STANDARD CHARACTERS WITHOUT CLAIM TO ANY PARTICULAR FONT, STYLE, SIZE, OR COLOR.

THE WORDING "JOINSET" HAS NO MEANING IN A FOREIGN LANGUAGE.

CLASS 1—CHEMICALS

FOR ADHESIVES FOR INDUSTRIAL PURPOSES, INSULATING ADHESIVE FOR ELECTRONIC INDUSTRIAL PURPOSES, ADHESIVE FOR ELECTRIC AND ELECTRONIC COMPONENTS, PHOTSENSITIVE ELECTRIC CONDUCTIVE PASTES, ELECTRIC CONDUCTIVE PASTES FOR INDUSTRIAL PURPOSES; FERRITE FOR MAGNETIC COILS; ELECTRIC CONDUCTIVE ADHESIVES FOR INDUSTRIAL PURPOSES (U.S. CLS. 1, 5, 6, 10, 26 AND 46).

CLASS 2—PAINTS

FOR PAINTS, ELECTRIC CONDUCTIVE PAINTS, ELECTRIC CONDUCTIVE INKS, SOLDER RESIST INKS FOR PRINTED CIRCUITS, COATINGS IN THE NATURE OF PAINTS (U.S. CLS. 6, 11 AND 16).

CLASS 9—ELECTRICAL AND SCIENTIFIC APPARATUS

FOR ELECTRONIC COMPONENTS, PASSIVE ELECTRONIC COMPONENTS, AND CERAMIC ELECTRONIC COMPONENTS FOR ELECTROMAGNETIC INTERFERENCE SUPPRESSION CIRCUITS; ELECTRONIC COMPONENTS, PASSIVE ELECTRONIC COMPONENTS, AND CERAMIC ELECTRONIC COMPONENTS FOR ELECTROMAGNETIC COMPATIBILITY CONTROL CIRCUITS; ELECTRONIC COMPONENTS, PASSIVE ELECTRONIC COMPONENTS, AND CERAMIC ELECTRONIC COMPONENTS FOR SURGE SUPPRESSION CIRCUITS; ELECTRONIC COMPONENTS, PASSIVE ELECTRONIC COMPONENTS, AND CERAMIC ELECTRONIC COMPONENTS FOR ELECTRICAL GROUNDING CIRCUITS; ELECTROMAGNETIC CONTROL COMPONENTS FOR MACHINE TOOLS, FERRITE BEADS, ELECTRICAL CERAMIC BEADS BEING ELECTRONIC COMPONENTS FOR PRINTED CIRCUIT BOARDS, ELECTRONIC CHIP BEADS BEING ELECTRONIC COMPONENTS FOR PRINTED CIRCUIT BOARDS, ELECTROMAGNETIC CONTROL FILTERS, FERRITE BEADS FILTERS, ELECTRICAL NOISE FILTERS, CAPACITORS, THERMISTORS, VARISTORS, ELECTRIC RESISTORS, FERRITE CORES, ELECTRICAL INDUCTORS, PIEZOELECTRIC TRANSDUCERS, PIEZOELECTRIC AND ELECTRICAL PIEZORESISTIVE SENSORS, ELECTRO-MAGNETIC ABSORBING AND SHIELDING MATERIALS, NAMELY, FERRITE AND CARBON THAT ABSORB ELECTROMAGNETIC ENERGY IN RADIO WAVES AND CHANGES SUCH ENERGY TO HEAT; ELECTRIC TERMINAL BLOCKS, ELECTRIC GROUND TERMINAL BLOCKS, ELECTROMAGNETIC INTERFERENCE SHIELDING GASKET BEING AN ELECTRONIC COMPONENT, ELECTRIC CONNECTORS, ELECTRIC CONTACT TERMINAL, ELECTROMAGNETIC INTERFERENCE SHIELDING CUSHION BEING AN ELECTRONIC COMPONENT, ELECTROMAGNETIC INTERFERENCE SHIELDING CASE FOR ELECTRONIC PRODUCTS, HEAT SINKS FOR USE IN COMPUTERS, HEAT SINKS FOR PRINTED CIRCUIT BOARDS, HEAT SINKS FOR SURFACE MOUNT ON PRINTED CIRCUIT BOARDS, HEAT SINKS FOR ELECTRONIC COMPONENTS, ELECTRICAL COOLING BLOCKS FOR ELECTRONIC PRODUCTS, METAL CHIP FOR HEAT TRANSFERRING FOR USE IN ELECTRONIC PRODUCTS; FLEXIBLE PRINTED CIRCUIT BOARD (U.S. CLS. 21, 23, 26, 36 AND 38).

CLASS 17—RUBBER GOODS

FOR SELF-ADHESIVE TAPES, ADHESIVE TAPES, ADHESIVE PLASTIC FILMS, ADHESIVE-COATED PLASTIC SHEETS, ALL FOR INDUSTRIAL AND COMMERCIAL USE; POLYMER FILMS FOR MANUFACTURING ELECTRONIC CIRCUITS, INSULATING TUBES, INSULATING SLEEVES, INSULATING COVERS, INSULATING PROTECTIVE MATERIALS IN THE NATURE OF INSULATING AND PROTECTIVE INTER-LAYER DIELECTRIC MATERIALS AND COATINGS FOR USE IN ELECTRONIC PRODUCTS, INSULATING PROTECTIVE SHEETS; ELECTRIC CONDUCTIVE TAPES FOR ELECTROMAGNETIC RADIATION SHIELDING IN ELECTRONIC PRODUCTS, ELECTROMAGNETIC INTERFERENCE CONDUCTIVE SHIELDING TAPES FOR ELECTROMAGNETIC RADIATION SHIELDING IN ELECTRONIC PRODUCTS (U.S. CLS. 1, 5, 12, 13, 35 AND 50).

FONG HSU, EXAMINING ATTORNEY

SN 85-198,249. DEVICOM INTERNATIONAL, INC., CERRITOS, CA. FILED 12-15-2010.

SNEAKERHEAD

THE MARK CONSISTS OF STANDARD CHARACTERS WITHOUT CLAIM TO ANY PARTICULAR FONT, STYLE, SIZE, OR COLOR.

OWNER OF U.S. REG. NO. 3,355,451.

CLASS 14—JEWELRY

FOR WATCHES, NECKLACES, KEY CHAINS OF PRECIOUS METAL (U.S. CLS. 2, 27, 28 AND 50).

CLASS 25—CLOTHING

FOR CLOTHING AND OTHER WEARABLE ARTICLES, NAMELY, T-SHIRTS, SHORTS, SWEATSHIRTS, JACKETS, HATS, CAPS, FOOTWEAR, BELTS (U.S. CLS. 22 AND 39).

MATTHEW EINSTEIN, EXAMINING ATTORNEY

SN 85-198,530. MIS QUALITY MANAGEMENT CORP., WILMINGTON, DE. FILED 12-15-2010.

MOODY'S RESEARCH LABS

THE MARK CONSISTS OF STANDARD CHARACTERS WITHOUT CLAIM TO ANY PARTICULAR FONT, STYLE, SIZE, OR COLOR.

OWNER OF U.S. REG. NOS. 871,342, 871,497 AND 3,840,504.

NO CLAIM IS MADE TO THE EXCLUSIVE RIGHT TO USE "RESEARCH LABS", APART FROM THE MARK AS SHOWN.

CLASS 9—ELECTRICAL AND SCIENTIFIC APPARATUS

FOR SOFTWARE FOR FINANCIAL AND CREDIT RISK ANALYSIS AND THE STRUCTURING, ANALYSIS, MANAGEMENT, MODELING AND SERVICING OF FINANCIAL INSTRUMENTS AND PORTFOLIOS (U.S. CLS. 21, 23, 26, 36 AND 38).

CLASS 16—PAPER GOODS AND PRINTED MATTER

FOR PRINTED PUBLICATIONS, NAMELY, WHITE PAPERS, ACADEMIC PAPERS AND REPORTS IN THE FIELD OF FINANCIAL ANALYSIS (U.S. CLS. 2, 5, 22, 23, 29, 37, 38 AND 50).

CLASS 36—INSURANCE AND FINANCIAL

FOR FINANCIAL SERVICES IN THE FIELD OF CREDIT RISK ASSESSMENT; PROVIDING RESEARCH AND INFORMATION IN THE FIELD OF FINANCIAL ANALYSIS, CONSULTING AND RISK MANAGEMENT (U.S. CLS. 100, 101 AND 102).

CLASS 41—EDUCATION AND ENTERTAINMENT

FOR ON-LINE, ELECTRONIC PUBLICATIONS, NAMELY, WHITE PAPERS, ACADEMIC PAPERS AND REPORTS IN THE FIELD OF FINANCIAL ANALYSIS (U.S. CLS. 100, 101 AND 107).

CLASS 42—SCIENTIFIC AND COMPUTER SERVICES

FOR SOFTWARE DEVELOPMENT SERVICES AND SOFTWARE OPTIMIZATION IN THE NATURE OF SOFTWARE CUSTOMIZATION SERVICES, ALL FOR SOFTWARE THAT IS USED IN FINANCIAL AND CREDIT RISK ANALYSIS AND FOR SOFTWARE USED IN STRUCTURING, ANALYZING, MANAGING, MODELING AND SERVICING FINANCIAL INSTRUMENTS AND PORTFOLIOS (U.S. CLS. 100 AND 101).

RAUL CORDOVA, EXAMINING ATTORNEY

SN 85-199,079. TROUBLE BROTHERS, LLC, SEATTLE, WA. FILED 12-15-2010.

Trouble Brothers

THE MARK CONSISTS OF STANDARD CHARACTERS WITHOUT CLAIM TO ANY PARTICULAR FONT, STYLE, SIZE, OR COLOR.

NO CLAIM IS MADE TO THE EXCLUSIVE RIGHT TO USE "BROTHERS", APART FROM THE MARK AS SHOWN.

CLASS 9—ELECTRICAL AND SCIENTIFIC APPARATUS

FOR COMPUTER GAME SOFTWARE FOR USE ON MOBILE AND CELLULAR PHONES; DOWNLOADABLE COMPUTER GAME SOFTWARE VIA A GLOBAL COMPUTER NETWORK AND WIRELESS DEVICES; ELECTRONIC GAME SOFTWARE FOR CELLULAR TELEPHONES; ELECTRONIC GAME SOFTWARE FOR HANDHELD ELECTRONIC DEVICES; ELECTRONIC GAME SOFTWARE FOR WIRELESS DEVICES (U.S. CLS. 21, 23, 26, 36 AND 38).

FIRST USE 9-20-2009; IN COMMERCE 12-15-2010.

CLASS 41—EDUCATION AND ENTERTAINMENT

FOR ENTERTAINMENT SERVICES, NAMELY, PROVIDING ON-LINE INTERACTIVE, COMPUTER, VIDEO AND ELECTRONIC GAMES; PROVIDING WEBSITES FEATURING CONTENT AND INFORMATION IN THE FIELD OF GAMES, INTERACTIVE GAME CONTENT, ELECTRONIC GAME CONTENT, COMPUTER GAME CONTENT OR VIDEO GAME CONTENT (U.S. CLS. 100, 101 AND 107).

FIRST USE 9-20-2009; IN COMMERCE 12-15-2010.
BRENDAN MCCAULEY, EXAMINING ATTORNEY

SN 85-199,166. AKI GMBH, WURZBURG, FED REP GERMANY, FILED 12-16-2010.

SN 85-199,925. POLYCOM, INC., PLEASANTON, CA. FILED 12-16-2010.



POLYCOM OPEN COLLABORATION NETWORK

PRIORITY CLAIMED UNDER SEC. 44(D) ON FED REP GERMANY APPLICATION NO. DE3020100667, FILED 11-16-2010, REG. NO. 302010066723, DATED 2-23-2011, EXPIRES 11-30-2020.

THE MARK CONSISTS OF THE WORD "PRINTAURUS" WITH THE LETTER "T" HAVING A HORIZONTAL CROSS-BAR FORMED AS AN ARC THAT EXTENDS UPWARDLY AT ITS ENDS.

THE WORDING "PRINTAURUS" HAS NO MEANING IN A FOREIGN LANGUAGE.

THE MARK CONSISTS OF STANDARD CHARACTERS WITHOUT CLAIM TO ANY PARTICULAR FONT, STYLE, SIZE, OR COLOR.

OWNER OF U.S. REG. NOS. 1,783,295, 1,912,272 AND OTHERS.

NO CLAIM IS MADE TO THE EXCLUSIVE RIGHT TO USE "OPEN COLLABORATION" AND "NETWORK", APART FROM THE MARK AS SHOWN.

CLASS 9—ELECTRICAL AND SCIENTIFIC APPARATUS

FOR COMPUTER, COMPUTER SOFTWARE RECORDED AND DOWNLOADABLE, IN PARTICULAR PRINT MANAGEMENT, PRINT CONTROL AND PRINT EDITING SOFTWARE, FORM DOCUMENT MANAGEMENT SOFTWARE AND SOFTWARE FOR CONTROLLING COMPUTER NETWORKS, PRINT SERVERS AND NETWORK PRINTERS (U.S. CLS. 21, 23, 26, 36 AND 38).

CLASS 38—COMMUNICATION

FOR INFORMATION TRANSMISSION VIA ELECTRONIC COMMUNICATIONS NETWORKS; PROVIDING TECHNICAL SUPPORT SERVICES REGARDING THE USAGE OF COMMUNICATIONS EQUIPMENT; TELECOMMUNICATION CONSULTATION IN THE NATURE OF TECHNICAL CONSULTING IN THE FIELD OF AUDIO, TEXT AND VISUAL DATA TRANSMISSION AND COMMUNICATION (U.S. CLS. 100, 101 AND 104).
FIRST USE 7-31-2010; IN COMMERCE 7-31-2010.

CLASS 42—SCIENTIFIC AND COMPUTER SERVICES

FOR COMPUTER HARDWARE AND SOFTWARE CONSULTANCY; COMPUTER PROGRAMMING, COMPUTER NETWORK CONFIGURATION SERVICES; COMPUTER SYSTEM MAINTENANCE AND ADMINISTRATION FOR OTHERS; INSTALLATION AND MAINTENANCE OF COMPUTER PROGRAMS FOR OTHERS (U.S. CLS. 100 AND 101).
BARNEY CHARLON, EXAMINING ATTORNEY

CLASS 42—SCIENTIFIC AND COMPUTER SERVICES

FOR DESIGN OF UNIFIED COMMUNICATIONS SERVICES (U.S. CLS. 100 AND 101).
FIRST USE 7-31-2010; IN COMMERCE 7-31-2010.
HEATHER THOMPSON, EXAMINING ATTORNEY

SN 85-199,408. WIMO LABS LLC, CHICAGO, IL. FILED 12-16-2010.

SN 85-201,765. HONEYWELL INTERNATIONAL INC., MORRISTOWN, NJ. FILED 12-20-2010.



REAL FRAMEWORK

THE MARK CONSISTS OF STANDARD CHARACTERS WITHOUT CLAIM TO ANY PARTICULAR FONT, STYLE, SIZE, OR COLOR.

THE MARK CONSISTS OF STANDARD CHARACTERS WITHOUT CLAIM TO ANY PARTICULAR FONT, STYLE, SIZE, OR COLOR.

CLASS 9—ELECTRICAL AND SCIENTIFIC APPARATUS

FOR WRISTBANDS SPECIALLY DESIGNED TO HOLD MOBILE TELEPHONES, TO HOLD MOBILE COMPUTERS, TO HOLD PERSONAL DIGITAL ASSISTANTS (PDA), AND TO HOLD MP3 PLAYERS (U.S. CLS. 21, 23, 26, 36 AND 38).

CLASS 9—ELECTRICAL AND SCIENTIFIC APPARATUS

FOR VIRTUAL REALITY MODELING AND SIMULATION SOFTWARE AND HARDWARE FOR DEMONSTRATING AND TESTING TECHNOLOGY IN THE FIELDS OF BUSINESS, MILITARY, DEFENSE, SPACE AND AVIATION (U.S. CLS. 21, 23, 26, 36 AND 38).

CLASS 14—JEWELRY

FOR WATCH BANDS (U.S. CLS. 2, 27, 28 AND 50).
JOHN KELLY, EXAMINING ATTORNEY

CLASS 42—SCIENTIFIC AND COMPUTER SERVICES

FOR DEVELOPMENT AND TESTING OF NEW TECHNOLOGY FOR OTHERS IN THE FIELDS OF BUSINESS, MILITARY, DEFENSE, SPACE AND AVIATION (U.S. CLS. 100 AND 101).
JACQUELINE A. LAVINE, EXAMINING ATTORNEY

SN 85-202,014. 1IN6, INC., SANTA CLARITA, CA. FILED 12-20-2010.

1IN6

THE MARK CONSISTS OF STANDARD CHARACTERS WITHOUT CLAIM TO ANY PARTICULAR FONT, STYLE, SIZE, OR COLOR.

CLASS 35—ADVERTISING AND BUSINESS

FOR REFERRALS IN THE FIELD OF COUNSELING FOR VICTIMS OF SEXUAL ABUSE (U.S. CLS. 100, 101 AND 102).

CLASS 41—EDUCATION AND ENTERTAINMENT

FOR PROVIDING CLASSES, TRAINING, AND PRESENTATIONS TO COUNSELORS, VOLUNTEERS, AND OTHER SUPPORT PROFESSIONALS TO ASSIST VICTIMS OF SEXUAL ABUSE; LENDING OF BOOKS AND OTHER PUBLICATIONS (U.S. CLS. 100, 101 AND 107).

CLASS 45—PERSONAL AND LEGAL SERVICES

FOR PROVIDING INFORMATION TO MEN WHO HAVE BEEN SEXUALLY ABUSED ABOUT HOW TO DEAL WITH AND PROCESS PERSONAL EMOTIONS AFTER BEING SEXUALLY ABUSED; PROVIDING INFORMATION TO THIRD PARTIES ABOUT HOW TO DEAL WITH AND PROCESS PERSONAL EMOTIONS TO ASSIST MEN WHO HAVE BEEN SEXUALLY ABUSED (U.S. CLS. 100 AND 101).

CIMMERIAN COLEMAN, EXAMINING ATTORNEY

SN 85-202,240. BIOLARGO, INC., LA MIRADA, CA. FILED 12-20-2010.

BioLargo

THE MARK CONSISTS OF STANDARD CHARACTERS WITHOUT CLAIM TO ANY PARTICULAR FONT, STYLE, SIZE, OR COLOR.

CLASS 1—CHEMICALS

FOR SOLUTIONS FOR CONTAMINATED WATER, NAMELY, CHEMICAL FOR THE TREATMENT OF WATER AND WASTE WATER; SOLUTIONS FOR CONTAMINATED WATER, NAMELY, IODINE FOR INDUSTRIAL CHEMICAL PURPOSES (U.S. CLS. 1, 5, 6, 10, 26 AND 46).

FIRST USE 2-6-2009; IN COMMERCE 6-19-2009.

CLASS 5—PHARMACEUTICALS

FOR ALL PURPOSE DISINFECTANTS (U.S. CLS. 6, 18, 44, 46, 51 AND 52).

FIRST USE 2-6-2009; IN COMMERCE 6-19-2009.
JENNIFER MARTIN, EXAMINING ATTORNEY

SN 85-202,269. BIOLARGO, INC., LA MIRADA, CA. FILED 12-20-2010.



THE MARK CONSISTS OF LETTERS "BIO" WITH A CRESCENT AND WATER DROPLETS.

CLASS 1—CHEMICALS

FOR SOLUTIONS FOR CONTAMINATED WATER, NAMELY, CHEMICAL FOR THE TREATMENT OF WATER AND WASTEWATER; SOLUTIONS FOR CONTAMINATED WATER, NAMELY, IODINE FOR INDUSTRIAL CHEMICAL PURPOSES (U.S. CLS. 1, 5, 6, 10, 26 AND 46).

FIRST USE 2-6-2009; IN COMMERCE 6-19-2009.

CLASS 5—PHARMACEUTICALS

FOR ALL PURPOSE DISINFECTANTS (U.S. CLS. 6, 18, 44, 46, 51 AND 52).

FIRST USE 2-6-2009; IN COMMERCE 6-19-2009.

JENNIFER MARTIN, EXAMINING ATTORNEY

SN 85-203,011. ANDIS COMPANY, STURTEVANT, WI. FILED 12-21-2010.

andis

OWNER OF U.S. REG. NOS. 1,215,675, 3,669,258 AND OTHERS.

THE MARK CONSISTS OF THE WORD "ANDIS" IN A STYLIZED FORMAT WITH A LINE BELOW THE WORD.

CLASS 7—MACHINERY

FOR BATTERY OPERATED GROOMING TOOLS FOR ANIMALS, NAMELY, HAIR BRUSHING AND SHEARING TOOLS FOR ANIMALS (U.S. CLS. 13, 19, 21, 23, 31, 34 AND 35).

FIRST USE 1-23-1991; IN COMMERCE 1-23-1991.

CLASS 8—HAND TOOLS

FOR ELECTRIC HAIR CLIPPERS AND TRIMMERS, BLADES SOLD AS A COMPONENT FOR ELECTRIC HAIR CLIPPERS AND TRIMMERS; ELECTRIC BEARD AND MOUSTACHE TRIMMERS; ELECTRIC ANIMAL HAIR CLIPPERS (U.S. CLS. 23, 28 AND 44).

FIRST USE 3-23-1987; IN COMMERCE 3-23-1987.

CLASS 9—ELECTRICAL AND SCIENTIFIC APPARATUS

FOR ELECTRIC HAIR CURLING IRONS, ELECTRIC HAIR STYLING BRUSHES AND ELECTRIC HAIR CURLING IRONS HAVING A HAIR STYLING ATTACHMENT; ELECTRIC STRAIGHTENING IRONS (U.S. CLS. 21, 23, 26, 36 AND 38).

FIRST USE 3-23-1987; IN COMMERCE 3-23-1987.

CLASS 11—ENVIRONMENTAL CONTROL APPARATUS

FOR HAND HELD ELECTRIC HAIR DRYERS; COMBINATION ELECTRIC HAIR DRYER AND STYLING BRUSH (U.S. CLS. 13, 21, 23, 31 AND 34).

FIRST USE 3-23-1987; IN COMMERCE 3-23-1987.
JESSICA FATHY, EXAMINING ATTORNEY

SN 85-203,039. USTRAVEL ALASKA, LLC, ANCHORAGE, AK. FILED 12-21-2010.

USTRAVEL

THE MARK CONSISTS OF STANDARD CHARACTERS WITHOUT CLAIM TO ANY PARTICULAR FONT, STYLE, SIZE, OR COLOR.

SEC. 2(F).

CLASS 35—ADVERTISING AND BUSINESS

FOR TRAVEL MANAGEMENT SERVICES (U.S. CLS. 100, 101 AND 102).

FIRST USE 12-0-1997; IN COMMERCE 12-0-1997.

CLASS 39—TRANSPORTATION AND STORAGE

FOR ARRANGING AND COORDINATING TRAVEL ARRANGEMENTS FOR INDIVIDUALS, GROUPS, AND BUSINESSES; BOOKING SEATS FOR TRAVEL FOR INDIVIDUALS, GROUPS, AND BUSINESSES (U.S. CLS. 100 AND 105).

FIRST USE 12-0-1997; IN COMMERCE 12-0-1997.

CLASS 43—HOTEL AND RESTAURANT SERVICES

FOR BOOKING TEMPORARY LODGING, RESTAURANTS, AND MEALS FOR INDIVIDUALS, GROUPS, AND BUSINESSES (U.S. CLS. 100 AND 101).

FIRST USE 12-0-1997; IN COMMERCE 12-0-1997.

JULIE VEPPUMTHARA, EXAMINING ATTORNEY

SN 85-203,049. STEM CELL SCIENCES HOLDINGS LIMITED, EDINBURGH, LOTHIAN, UNITED KINGDOM, FILED 12-21-2010.

STEM101

THE MARK CONSISTS OF STANDARD CHARACTERS WITHOUT CLAIM TO ANY PARTICULAR FONT, STYLE, SIZE, OR COLOR.

CLASS 1—CHEMICALS

FOR REAGENTS FOR SCIENTIFIC USE FOR USE IN BIOLOGICAL PROCESSING; BIOLOGICAL PREPARATIONS FOR SCIENTIFIC USE FOR USE IN CELL CULTURES; CULTURES OF CELL MEDIA FOR SCIENTIFIC USE; MEDIA FOR CELL CULTURE FOR USE IN NON-MEDICAL RESEARCH LABORATORIES; MEDIA FOR CELL CULTURE FOR USE IN THE BIOTECHNOLOGICAL INDUSTRY; BIOCHEMICALS FOR SCIENTIFIC USE, NAMELY, ANTIBODIES AND MONOCLONAL ANTIBODIES; PRODUCTS, NAMELY, KITS COMPRISING ANTIBODIES FOR USE IN SCIENCE; TISSUE CULTURE REAGENTS FOR SCIENTIFIC AND MEDICAL LABORATORY RESEARCH USE; CELL CULTURE REAGENTS; CELL CULTURE MEDIA FOR SCIENTIFIC USE; BIOLOGICAL TEST KITS FOR RESEARCH USE COMPRISING BUFFERS AND STANDARD SOLUTIONS; BIOLOGICAL REAGENTS FOR SCIENTIFIC USE FOR USE IN EMBRYOLOGY; BIOLOGICAL REAGENTS FOR SCIENTIFIC USE FOR USE IN MOLECULAR BIOLOGY (U.S. CLS. 1, 5, 6, 10, 26 AND 46).

CLASS 5—PHARMACEUTICALS

FOR REAGENTS FOR MEDICAL USE FOR USE IN BIOLOGICAL PROCESSING; REAGENTS FOR VETERINARY USE FOR USE IN BIOLOGICAL PROCESSING; BIOLOGICAL PREPARATIONS FOR MEDICAL USE FOR USE IN CELL CULTURES; CELL CULTURE MEDIA, NAMELY, CELL CULTURE REAGENTS FOR MEDICAL USE; ANTIBODIES FOR IMMUNODIAGNOSTIC MEDICAL USE; ANTIBODIES FOR IMMUNOLOGICAL THERAPEUTIC USE; MONOCLONAL ANTIBODIES FOR IMMUNODIAGNOSTIC MEDICAL USE; MONOCLONAL ANTIBODIES FOR IMMUNOLOGICAL THERAPEUTIC USE; PRODUCTS, NAMELY, KITS COMPRISING ANTIBODIES FOR USE IN IMMUNODIAGNOSTIC MEDICINE OR IMMUNOLOGICAL THERAPY (U.S. CLS. 6, 18, 44, 46, 51 AND 52).

REBECCA POVARCHUK, EXAMINING ATTORNEY

SN 85-203,086. STEM CELL SCIENCES HOLDINGS LIMITED, EDINBURGH, LOTHIAN, UNITED KINGDOM, FILED 12-21-2010.

STEM121

THE MARK CONSISTS OF STANDARD CHARACTERS WITHOUT CLAIM TO ANY PARTICULAR FONT, STYLE, SIZE, OR COLOR.

CLASS 1—CHEMICALS

FOR REAGENTS FOR SCIENTIFIC USE FOR USE IN BIOLOGICAL PROCESSING; BIOLOGICAL PREPARATIONS FOR SCIENTIFIC USE FOR USE IN CELL CULTURES; CULTURES OF CELL MEDIA FOR SCIENTIFIC USE; MEDIA FOR CELL CULTURE FOR USE IN NON-MEDICAL RESEARCH LABORATORIES; MEDIA FOR CELL CULTURE FOR USE IN THE BIOTECHNOLOGICAL INDUSTRY; BIOCHEMICALS FOR SCIENTIFIC USE, NAMELY, ANTIBODIES AND MONOCLONAL ANTIBODIES; PRODUCTS, NAMELY, KITS COMPRISING ANTIBODIES FOR USE IN SCIENCE; TISSUE CULTURE REAGENTS FOR SCIENTIFIC AND MEDICAL LABORATORY RESEARCH USE; CELL CULTURE REAGENTS; CELL CULTURE MEDIA FOR SCIENTIFIC USE; BIOLOGICAL TEST KITS FOR RESEARCH USE COMPRISING BUFFERS AND STANDARD SOLUTIONS; BIOLOGICAL REAGENTS FOR SCIENTIFIC USE FOR USE IN EMBRYOLOGY; BIOLOGICAL REAGENTS FOR SCIENTIFIC USE FOR USE IN MOLECULAR BIOLOGY (U.S. CLS. 1, 5, 6, 10, 26 AND 46).

CLASS 5—PHARMACEUTICALS

FOR REAGENTS FOR MEDICAL USE FOR USE IN BIOLOGICAL PROCESSING; REAGENTS FOR VETERINARY USE FOR USE IN BIOLOGICAL PROCESSING; BIOLOGICAL PREPARATIONS FOR MEDICAL USE FOR USE IN CELL CULTURES; CELL CULTURE MEDIA, NAMELY, CELL CULTURE REAGENTS FOR MEDICAL USE; ANTIBODIES FOR IMMUNODIAGNOSTIC MEDICAL USE; ANTIBODIES FOR IMMUNOLOGICAL THERAPEUTIC USE; MONOCLONAL ANTIBODIES FOR IMMUNODIAGNOSTIC MEDICAL USE; MONOCLONAL ANTIBODIES FOR IMMUNOLOGICAL THERAPEUTIC USE; PRODUCTS, NAMELY, KITS COMPRISING ANTIBODIES FOR USE IN IMMUNODIAGNOSTIC MEDICINE OR IMMUNOLOGICAL THERAPY (U.S. CLS. 6, 18, 44, 46, 51 AND 52).

REBECCA POVARCHUK, EXAMINING ATTORNEY

SN 85-203,101. STEM CELL SCIENCES HOLDINGS LIMITED, EDINBURGH, LOTHIAN, UNITED KINGDOM, FILED 12-21-2010.

STEM123

THE MARK CONSISTS OF STANDARD CHARACTERS WITHOUT CLAIM TO ANY PARTICULAR FONT, STYLE, SIZE, OR COLOR.

CLASS 1—CHEMICALS

FOR REAGENTS FOR SCIENTIFIC USE FOR USE IN BIOLOGICAL PROCESSING; BIOLOGICAL PREPARATIONS FOR SCIENTIFIC USE FOR USE IN CELL CULTURES; CULTURES OF CELL MEDIA FOR SCIENTIFIC USE; MEDIA FOR CELL CULTURE FOR USE IN NON-MEDICAL RESEARCH LABORATORIES; MEDIA FOR CELL CULTURE FOR USE IN THE BIOTECHNOLOGICAL INDUSTRY; BIOCHEMICALS FOR SCIENTIFIC USE, NAMELY, ANTIBODIES AND MONOCLONAL ANTIBODIES; PRODUCTS, NAMELY, KITS COMPRISING ANTIBODIES FOR USE IN SCIENCE; TISSUE CULTURE REAGENTS FOR SCIENTIFIC AND MEDICAL LABORATORY RESEARCH USE; CELL CULTURE REAGENTS; CELL CULTURE MEDIA FOR SCIENTIFIC USE; BIOLOGICAL TEST KITS FOR RESEARCH USE COMPRISING BUFFERS AND STANDARD SOLUTIONS; BIOLOGICAL REAGENTS FOR SCIENTIFIC USE FOR USE IN EMBRYOLOGY; BIOLOGICAL REAGENTS FOR SCIENTIFIC USE FOR USE IN MOLECULAR BIOLOGY (U.S. CLS. 1, 5, 6, 10, 26 AND 46).

CLASS 5—PHARMACEUTICALS

FOR REAGENTS FOR MEDICAL USE FOR USE IN BIOLOGICAL PROCESSING; REAGENTS FOR VETERINARY USE FOR USE IN BIOLOGICAL PROCESSING; BIOLOGICAL PREPARATIONS FOR MEDICAL USE FOR USE IN CELL CULTURES; CELL CULTURE MEDIA, NAMELY, CELL CULTURE REAGENTS FOR MEDICAL USE; ANTIBODIES FOR IMMUNODIAGNOSTIC MEDICAL USE; ANTIBODIES FOR IMMUNOLOGICAL THERAPEUTIC USE; MONOCLONAL ANTIBODIES FOR IMMUNODIAGNOSTIC MEDICAL USE; MONOCLONAL ANTIBODIES FOR IMMUNOLOGICAL THERAPEUTIC USE; PRODUCTS, NAMELY, KITS COMPRISING ANTIBODIES FOR USE IN IMMUNODIAGNOSTIC MEDICINE OR IMMUNOLOGICAL THERAPY (U.S. CLS. 6, 18, 44, 46, 51 AND 52).

REBECCA POVARCHUK, EXAMINING ATTORNEY

SN 85-203,242. USTRAVEL ALASKA, LLC, ANCHORAGE, AK. FILED 12-21-2010.

USTRAVEL

THE MARK CONSISTS OF THE WORD "USTRAVEL" WITH A SILHOUETTE OF A SUNRISE SPANNING "TRAVEL".

SEC. 2(F).

CLASS 35—ADVERTISING AND BUSINESS

FOR TRAVEL MANAGEMENT SERVICES (U.S. CLS. 100, 101 AND 102).

FIRST USE 12-0-1997; IN COMMERCE 12-0-1997.

CLASS 39—TRANSPORTATION AND STORAGE

FOR ARRANGING AND COORDINATING TRAVEL ARRANGEMENTS FOR INDIVIDUALS, GROUPS, AND BUSINESSES; BOOKING SEATS FOR TRAVEL FOR INDIVIDUALS, GROUPS, AND BUSINESSES (U.S. CLS. 100 AND 105).

FIRST USE 12-0-1997; IN COMMERCE 12-0-1997.

CLASS 43—HOTEL AND RESTAURANT SERVICES

FOR BOOKING TEMPORARY LODGING, RESTAURANTS, AND MEALS FOR INDIVIDUALS, GROUPS, AND BUSINESSES (U.S. CLS. 100 AND 101).

FIRST USE 12-0-1997; IN COMMERCE 12-0-1997.

JULIE VEPPUMTHARA, EXAMINING ATTORNEY

SN 85-203,803. 3D NETCO LLC, SILVER SPRING, MD. FILED 12-22-2010.

3NET

THE MARK CONSISTS OF STANDARD CHARACTERS WITHOUT CLAIM TO ANY PARTICULAR FONT, STYLE, SIZE, OR COLOR.

CLASS 9—ELECTRICAL AND SCIENTIFIC APPARATUS

FOR PRERECORDED AUDIOVISUAL RECORDINGS, AUDIOTAPES, VIDEO DISCS, COMPACT DISCS, DVDS AND MULTIMEDIA SOFTWARE RECORDED ON CD-ROM, ALL FEATURING SUBJECTS OF GENERAL HUMAN INTEREST; ELECTRONIC LEARNING GAMES IN THE NATURE OF ELECTRONIC GAME SOFTWARE FOR EDUCATIONAL PURPOSES; VIDEO GAME DISCS; COMPUTER GAME DISCS; ELECTRONIC GAME PROGRAMS; DOWNLOADABLE RING TONES, GRAPHICS, RING BACKS, ANIMATED RINGERS, VIDEO RINGERS AND ANIMATED SCREENSAVERS; DOWNLOADABLE PRERECORDED VIDEO CLIPS, PRERECORDED AUDIO CLIPS, TEXT AND GRAPHICS HELD IN ELECTRONIC PERSONAL COMPUTERS AND HANDHELD WIRELESS DEVICES, ALL FEATURING SUBJECTS OF GENERAL HUMAN INTEREST; SUNGLASSES (U.S. CLS. 21, 23, 26, 36 AND 38).

CLASS 38—COMMUNICATION

FOR COMMUNICATIONS SERVICES, NAMELY, TRANSMITTING STREAMED SOUND AND AUDIO-VISUAL RECORDINGS VIA THE INTERNET, CABLE NETWORKS, WIRELESS NETWORKS, SATELLITE, OR INTERACTIVE MULTIMEDIA NETWORKS; AUDIO AND VIDEO BROADCASTING SERVICES OVER THE INTERNET; TRANSMISSION OF INFORMATION IN THE AUDIO-VISUAL FIELD; TELEVISION BROADCASTING SERVICES; CABLE TELEVISION BROADCASTING; SATELLITE TELEVISION BROADCASTING; MOBILE MEDIA SERVICES IN THE NATURE OF ELECTRONIC TRANSMISSION OF ENTERTAINMENT MEDIA CONTENT; PODCASTING SERVICES; WEBCASTING SERVICES; VIDEO-ON-DEMAND TRANSMISSION SERVICES; PROVIDING ON-LINE CHAT ROOMS AND ELECTRONIC BULLETIN BOARDS FOR TRANSMISSION OF MESSAGES AMONG USERS IN THE FIELD OF GENERAL HUMAN INTEREST (U.S. CLS. 100, 101 AND 104).

CLASS 41—EDUCATION AND ENTERTAINMENT

FOR ENTERTAINMENT SERVICES, NAMELY, MULTIMEDIA PROGRAMS IN THE FIELD OF GENERAL HUMAN INTEREST, DISTRIBUTED VIA VARIOUS PLATFORMS ACROSS MULTIPLE FORMS OF TRANSMISSION MEDIA; PROVIDING ENTERTAINMENT INFORMATION REGARDING ONGOING TELEVISION PROGRAMS VIA A GLOBAL COMPUTER NETWORK; PRODUCTION OF TELEVISION PROGRAMS; PRODUCTION OF MULTIMEDIA PROGRAMS (U.S. CLS. 100, 101 AND 107).

MORGAN WYNNE, EXAMINING ATTORNEY

CLASS 9—ELECTRICAL AND SCIENTIFIC APPARATUS

FOR ANIMATED MOTION PICTURE FILMS FEATURING ENTERTAINMENT, NAMELY, ACTION, ADVENTURE, DRAMATIC, COMEDIC, CHILDREN'S AND DOCUMENTARY THEMES; COMPUTER AND VIDEO GAME PROGRAMS AND SOFTWARE, AND RELATED PROGRAMS AND SOFTWARE, NAMELY, SCREENSAVERS, DIGITAL MUSIC FILES, VIDEOS, FILMS AND OTHER MULTIMEDIA MATERIALS, ALL FEATURING ENTERTAINMENT, NAMELY, ACTION, ADVENTURE, DRAMATIC, COMEDIC, CHILDREN'S AND DOCUMENTARY THEMES, ALL DELIVERED VIA PRE-RECORDED DISCS AND OTHER PRE-RECORDED MEDIA AND VIA DOWNLOADABLE DELIVERY ON GLOBAL COMPUTER NETWORKS AND WIRELESS NETWORKS; PRE-RECORDED DISCS AND OTHER PRE-RECORDED DIGITAL AND ELECTRONIC MEDIA IN THE FIELD OF LIVE ACTION PROGRAMS, MOTION PICTURES, OR ANIMATION FEATURING ENTERTAINMENT, NAMELY, ACTION, ADVENTURE, DRAMATIC, COMEDIC, CHILDREN'S AND DOCUMENTARY THEMES (U.S. CLS. 21, 23, 26, 36 AND 38).

FIRST USE 10-19-2010; IN COMMERCE 10-19-2010.

CLASS 41—EDUCATION AND ENTERTAINMENT

FOR ENTERTAINMENT SERVICES, NAMELY, PROVIDING ONLINE COMPUTER AND VIDEO GAMES, PROVIDING A WEBSITE FEATURING USE OF NON-DOWNLOADABLE COMPUTER AND VIDEO GAMES, AND NEWS, INFORMATION, TIPS, HINTS, CONTESTS, COMPUTER INTERFACE THEMES AND ENHANCEMENTS, AUDIO-VISUAL CONTENT, MUSIC, FILMS, VIDEOS, TELEVISION PROGRAMS, ANIMATED SERIES, AND OTHER MULTIMEDIA MATERIALS, ALL NON-DOWNLOADABLE AND ALL IN THE FIELD OF COMPUTER GAMES AND VIDEO GAMES; PROVIDING INFORMATION, NEWS AND COMMENTARY IN THE FIELD OF COMPUTER GAMES AND VIDEO GAMES (U.S. CLS. 100, 101 AND 107).

FIRST USE 4-30-1999; IN COMMERCE 4-30-1999.
MARK PILARO, EXAMINING ATTORNEY

SN 85-204,405. TAKE-TWO INTERACTIVE SOFTWARE, INC., NEW YORK, NY. FILED 12-22-2010.

SN 85-204,430. OBERMAN, TIVOLI & PICKERT, INC., LOS ANGELES, CA. FILED 12-22-2010.



OWNER OF U.S. REG. NOS. 2,391,635, 3,631,311 AND OTHERS.

THE MARK CONSISTS OF AN OPEN CLIPBOARD IN A BLACK BOX WITH THE NUMBERS "123456789" IN A BOX ACROSS THE TOP. BENEATH IT IS A CALCULATOR KEY PAD WITH THE NUMBERS "0123456789 AND + =".

CLASS 9—ELECTRICAL AND SCIENTIFIC APPARATUS

FOR BUSINESS MANAGEMENT SOFTWARE AND COMPUTER PROGRAMS USED FOR TRACKING EMPLOYEE INFORMATION AND PRODUCTION SET EVENTS, PAYROLL PROCESSING AND PRODUCTION-RELATED ACCOUNTING IN THE ENTERTAINMENT INDUSTRY; DOWNLOADABLE ELECTRONIC NEWSLETTERS IN THE FIELD OF BUSINESS MANAGEMENT AND ADMINISTRATIVE SERVICES FOR THE ENTERTAINMENT INDUSTRY (U.S. CLS. 21, 23, 26, 36 AND 38).
FIRST USE 11-5-2008; IN COMMERCE 11-5-2008.

CLASS 16—PAPER GOODS AND PRINTED MATTER

FOR NEWSLETTERS IN THE FIELD OF BUSINESS MANAGEMENT AND ADMINISTRATIVE SERVICES FOR THE ENTERTAINMENT INDUSTRY; DIRECTORIES IN THE FIELD OF TELEVISION AND MOVIE PRODUCTION (U.S. CLS. 2, 5, 22, 23, 29, 37, 38 AND 50).
FIRST USE 11-5-2008; IN COMMERCE 11-5-2008.

CLASS 35—ADVERTISING AND BUSINESS

FOR MANAGEMENT AND ADMINISTRATIVE SERVICES FOR THE ENTERTAINMENT INDUSTRY, NAMELY, DATABASE MANAGEMENT, PRODUCTION SCHEDULING, PAYROLL PROCESSING AND ACCOUNTING AND TRACKING EMPLOYEE INFORMATION, NAMELY, PERSONNEL MANAGEMENT AND PRODUCTION SET EVENTS, NAMELY, CREW BOOKING SERVICES (U.S. CLS. 100, 101 AND 102).
FIRST USE 11-5-2008; IN COMMERCE 11-5-2008.
THEODORE MCBRIDE, EXAMINING ATTORNEY

SN 85-204,714. CASIO KEISANKI KABUSHIKI KAISHA, DBA CASIO COMPUTER CO., LTD., SHIBUYA-KU, TOKYO, JAPAN, FILED 12-23-2010.

CLASS 9—ELECTRICAL AND SCIENTIFIC APPARATUS

FOR DIGITAL CAMERA; DIGITAL CAMERA EQUIPPED WITH DIGITAL PHOTO IMAGE CONVERTERS; DIGITAL PHOTO IMAGE CONVERTERS; COMPUTER SOFTWARE FOR PROCESSING DIGITAL IMAGES; COMPUTER SOFTWARE FOR DOWNLOADING, TRANSMITTING AND EDITING IMAGES, GRAPHICS, SOUND, MEDIA AND MOVING PICTURES, CREATING SPECIAL EFFECTS AND INTEGRATING IMAGES, GRAPHICS, SOUND, MEDIA AND MOVING PICTURES INTO EMAIL GREETING CARDS, EMAIL MESSAGES, WEBSITES, COMPUTER APPLICATIONS AND MULTIMEDIA APPLICATIONS; COMPUTER SOFTWARE TO ENHANCE THE AUDIO-VISUAL CAPABILITIES OF COMPUTER AND MULTIMEDIA APPLICATIONS, NAMELY, FOR THE INTEGRATION OF TEXT, AUDIO, GRAPHICS, STILL IMAGES AND MOVING PICTURES; COMPUTER SOFTWARE FOR EXCHANGING DATA BETWEEN A PERSONAL COMPUTER AND A DIGITAL CAMERA; PRINTER FOR DIGITAL CAMERA; APPARATUS FOR RECORDING, SCANNING, PROCESSING, TRANSMITTING OR REPRODUCING SOUND OR IMAGES; MOVIE, VIDEO, SLIDE AND PICTURE PROJECTORS; VISUAL PRESENTERS, NAMELY, APPARATUS FOR TRANSMISSION OR REPRODUCTION OF IMAGES AND SOUND; BATTERIES; AC ADAPTORS FOR PLUGS (U.S. CLS. 21, 23, 26, 36 AND 38).

CLASS 42—SCIENTIFIC AND COMPUTER SERVICES

FOR HOSTING AN ONLINE COMMUNITY WEB SITE FEATURING DIGITAL IMAGES; CREATING AN ONLINE COMMUNITY FOR USERS TO PARTICIPATE IN PHOTOGRAPHY, IMAGES, GRAPHICS AND MEDIA COMPETITIONS, PROVIDING A WEBSITE THAT ALLOWS USERS TO UPLOAD, EXCHANGE, SHARE, POST, EDIT, FORMAT AND PRINT IMAGES, GRAPHICS, SOUND, MEDIA, AND MOVING PICTURES; PROVIDING A WEBSITE THAT GIVES USERS THE ABILITY TO CREATE CUSTOMIZED WEB PAGES FEATURING USER-DEFINED INFORMATION; FILE SHARING SERVICES, NAMELY, PROVIDING A WEBSITE FEATURING TECHNOLOGY ENABLING USERS TO UPLOAD AND DOWNLOAD DIGITAL PHOTO IMAGE; WEBSITE DESIGN, COMPUTER WEBSITE PROGRAMMING AND WEBSITE MAINTENANCE; PROVIDING ON-LINE NON-DOWNLOADABLE COMPUTER SOFTWARE FOR DIGITAL IMAGE CONVERSION; PLANNING, DEVELOPMENT AND MAINTENANCE FOR DIGITAL IMAGE CONVERSION SOFTWARE (U.S. CLS. 100 AND 101).
MARTHA FROMM, EXAMINING ATTORNEY

SN 85-207,092. AMONIX, INC., SEAL BEACH, CA. FILED 12-29-2010.

IMAGING SQUARE



The logo for AMONIX features the word "AMONIX" in a bold, black, sans-serif font. The letter "O" is replaced by a stylized sunburst or starburst design, consisting of a central circle with radiating lines of varying lengths, creating a star-like effect.

THE MARK CONSISTS OF STANDARD CHARACTERS WITHOUT CLAIM TO ANY PARTICULAR FONT, STYLE, SIZE, OR COLOR.

NO CLAIM IS MADE TO THE EXCLUSIVE RIGHT TO USE "IMAGING", APART FROM THE MARK AS SHOWN.

OWNER OF U.S. REG. NOS. 3,549,262 AND 3,633,778.
THE MARK CONSISTS OF THE WORD "AMONIX" IN BLOCK LETTERING AND A SUN DESIGN APPEARING IN THE OPENING OF THE LETTER "O" IN THE WORD "AMONIX".

CLASS 37—CONSTRUCTION AND REPAIR

FOR MAINTENANCE SERVICES IN THE FIELD OF SOLAR CELLS, SOLAR CELL MODULES, PHOTOVOLTAIC CELLS AND PHOTOVOLTAIC MODULES; INSTALLATION AND MAINTENANCE SERVICES IN THE FIELD OF SOLAR CELLS, SOLAR CELL MODULES, PHOTOVOLTAIC CELLS AND PHOTOVOLTAIC MODULES (U.S. CLS. 100, 103 AND 106).

FIRST USE 6-0-2010; IN COMMERCE 6-0-2010.

CLASS 42—SCIENTIFIC AND COMPUTER SERVICES

FOR DESIGN AND DEVELOPMENT SERVICES IN THE FIELD OF SOLAR CELLS, SOLAR CELL MODULES, PHOTOVOLTAIC CELLS AND PHOTOVOLTAIC MODULES; DESIGN, ENGINEERING, RESEARCH AND DEVELOPMENT SERVICES IN THE FIELD OF SOLAR CELLS, SOLAR CELL MODULES, PHOTOVOLTAIC CELLS AND PHOTOVOLTAIC MODULES; AND ENGINEERING SERVICES IN THE FIELD OF SOLAR CELLS, SOLAR CELL MODULES, PHOTOVOLTAIC CELLS AND PHOTOVOLTAIC MODULES (U.S. CLS. 100 AND 101).

FIRST USE 6-0-2010; IN COMMERCE 6-0-2010.

TARA PATE, EXAMINING ATTORNEY

SN 85-207,682. BLUEGLASS INTERACTIVE, INC., DBA COPYPRESS, TAMPA, FL. FILED 12-30-2010.

CopyPress

THE MARK CONSISTS OF STANDARD CHARACTERS WITHOUT CLAIM TO ANY PARTICULAR FONT, STYLE, SIZE, OR COLOR.

CLASS 35—ADVERTISING AND BUSINESS

FOR ADVERTISING AND COMMERCIAL INFORMATION SERVICES, VIA THE INTERNET; ADVERTISING AND MARKETING SERVICES, NAMELY, PROMOTING THE GOODS AND SERVICES OF OTHERS; ADVERTISING COPYWRITING; ADVERTISING ON THE INTERNET FOR OTHERS; ADVERTISING VIA ELECTRONIC MEDIA AND SPECIFICALLY THE INTERNET; ADVERTISING, INCLUDING ON-LINE ADVERTISING ON A COMPUTER NETWORK; COMPILATION, PRODUCTION AND DISSEMINATION OF ADVERTISING MATTER; CONSULTING SERVICES IN THE FIELD OF INTERNET MARKETING; DISSEMINATION OF ADVERTISING FOR OTHERS VIA THE INTERNET; INFORMATION, ADVISORY, CONSULTING, BUSINESS RESEARCH AND PLANNING SERVICES RELATING TO PUBLICITY, MARKETING COMMUNICATIONS, REPUTATION MANAGEMENT OR BUSINESS ADMINISTRATION, INCLUDING SUCH SERVICES PROVIDED ONLINE OR VIA THE INTERNET; INTERNET ADVERTISING SERVICES; ON-LINE ADVERTISING AND MARKETING SERVICES; PROMOTION, ADVERTISING AND MARKETING OF ON-LINE WEBSITES; PROVIDING ADVERTISING SERVICE TO DISTRIBUTE ADVERTISEMENTS FOR DISPLAY ON INTERNET, NAMELY, IN WEBSITES, SOCIAL CONVERSATIONS OVER THE INTERNET, E-MAILS, MICROBLOGS, BLOGS, ELECTRONIC MESSAGES, INSTANT MESSAGES, TEXT MESSAGES, MULTIMEDIA MESSAGES, SOCIAL NETWORKS, STATUS UPDATES, FORUMS, ELECTRONIC BULLETIN BOARDS; PROVIDING INFORMATION IN THE FIELD OF MARKETING AND ON-LINE MARKETING MEDIA VIA THE INTERNET; SOCIAL MEDIA STRATEGY AND MARKETING CONSULTANCY FOCUSING ON HELPING CLIENTS CREATE AND EXTEND THEIR PRODUCT AND BRAND STRATEGIES BY BUILDING VIRALLY ENGAGING MARKETING SOLUTIONS (U.S. CLS. 100, 101 AND 102).

FIRST USE 1-1-2010; IN COMMERCE 1-1-2010.

CLASS 42—SCIENTIFIC AND COMPUTER SERVICES

FOR CLOUD COMPUTING FEATURING SOFTWARE FOR DATABASE MANAGEMENT FOR USE IN COPYWRITING AND INTERNET MARKETING; COMPUTER SOFTWARE DEVELOPMENT IN THE FIELD OF IN COPYWRITING AND INTERNET MARKETING; CONSULTING SERVICES IN THE FIELD OF SOFTWARE AS A SERVICE (SAAS); SOFTWARE AS A SERVICE (SAAS) SERVICES FEATURING SOFTWARE FOR DATABASE MANAGEMENT FOR USE IN COPYWRITING AND INTERNET MARKETING (U.S. CLS. 100 AND 101).

FIRST USE 1-1-2010; IN COMMERCE 1-1-2010.

JULIE VEPPUMTHARA, EXAMINING ATTORNEY

SN 85-207,703. ORO AGRI INC, FORMERLY CITRUS OIL PRODUCTS, TROPHY CLUB, TX. FILED 12-30-2010.

PREV-AM

THE MARK CONSISTS OF STANDARD CHARACTERS WITHOUT CLAIM TO ANY PARTICULAR FONT, STYLE, SIZE, OR COLOR.

CLASS 1—CHEMICALS

FOR SOIL WETTING AGENTS AND SOIL PENETRANTS TO ASSIST WITH THE ABSORPTION OF WATER AND PESTICIDES (U.S. CLS. 1, 5, 6, 10, 26 AND 46).

FIRST USE 1-15-2002; IN COMMERCE 5-27-2003.

CLASS 5—PHARMACEUTICALS

FOR AGRICULTURAL PESTICIDES; HERBICIDES, INSECTICIDES, PESTICIDES AND FUNGICIDES FOR HOME, GARDEN AND LAWN USE AND FOR COMMERCIAL USE; PESTICIDES FOR AGRICULTURAL USE; FUNGICIDES FOR AGRICULTURAL USE (U.S. CLS. 6, 18, 44, 46, 51 AND 52).

FIRST USE 1-15-2002; IN COMMERCE 5-27-2003.

MICHAEL SOUDERS, EXAMINING ATTORNEY

SN 85-207,727. PILNET, NEW YORK, NY. FILED 12-30-2010.

PILNET

THE MARK CONSISTS OF STANDARD CHARACTERS WITHOUT CLAIM TO ANY PARTICULAR FONT, STYLE, SIZE, OR COLOR.

CLASS 9—ELECTRICAL AND SCIENTIFIC APPARATUS

FOR DOWNLOADABLE ELECTRONIC PUBLICATIONS, NAMELY, BOOKS, HANDBOOKS, MANUALS, ARTICLES, NEWSLETTERS, REPORTS, BROCHURES, BOOKLETS, TEACHING MATERIALS, COURSE GUIDES AND CURRICULA RELATED TO PUBLIC INTEREST LAW AND THE PROVISION OF LEGAL AID AND PRO BONO LEGAL SERVICES, LAWYERING SKILLS, LEGAL ETHICS AND CRITICAL THINKING (U.S. CLS. 21, 23, 26, 36 AND 38).

CLASS 16—PAPER GOODS AND PRINTED MATTER

FOR PRINTED MATERIALS, NAMELY, BOOKS, HANDBOOKS, MANUALS, ARTICLES, NEWSLETTERS, REPORTS, BROCHURES, BOOKLETS, TEACHING MATERIALS, COURSE GUIDES AND CURRICULA IN THE FIELDS OF PUBLIC INTEREST LAW AND THE PROVISION OF LEGAL AID AND PRO BONO LEGAL SERVICES, LAWYERING SKILLS, LEGAL ETHICS AND CRITICAL THINKING (U.S. CLS. 2, 5, 22, 23, 29, 37, 38 AND 50).

CLASS 35—ADVERTISING AND BUSINESS

FOR ADMINISTRATION OF EDUCATIONAL EXCHANGE PROGRAMS FOR FOREIGN LEGAL PROFESSIONALS TO STUDY AT LAW SCHOOLS IN THE UNITED STATES; INTERNSHIP PLACEMENT SERVICES FOR FOREIGN LEGAL PROFESSIONALS IN THE FIELDS OF LEGAL SERVICES AND PUBLIC INTEREST LAW; PLACEMENT OF INDIVIDUALS SEEKING SERVICE OPPORTUNITIES WITH ORGANIZATIONS ENGAGED IN PROVIDING LEGAL AID OR PRO BONO LEGAL SERVICE OR DEVELOPING, PROMOTING OR TEACHING PUBLIC INTEREST LAW; PROMOTING THE EXCHANGE OF INFORMATION AND RESOURCES WITHIN THE LEGAL COMMUNITY TO EDUCATE AND TO ACHIEVE ADVANCES IN THE FIELD OF PUBLIC INTEREST LAW AND LEGAL AID AND PRO BONO LEGAL SERVICES AROUND THE WORLD; PUBLIC ADVOCACY TO PROMOTE AWARENESS AND UNDERSTANDING OF PUBLIC INTEREST LAW AND THE PROVISION OF LEGAL AID AND PRO BONO LEGAL SERVICES; BUSINESS CONSULTING SERVICES TO ORGANIZATIONS ENGAGED IN EDUCATION OR SERVICES RELATED TO PUBLIC INTEREST LAW OR THE PROVISION OF LEGAL AID OR PRO BONO LEGAL SERVICES WITH RESPECT TO MANAGEMENT, MARKETING, AND FUNDRAISING; BUSINESS DEVELOPMENT SERVICES, NAMELY, PROVIDING START-UP SUPPORT FOR ORGANIZATIONS DEVELOPING, PROMOTING OR TEACHING PUBLIC INTEREST LAW OR PROVIDING LEGAL AID OR PRO BONO LEGAL SERVICES (U.S. CLS. 100, 101 AND 102).

CLASS 36—INSURANCE AND FINANCIAL

FOR CHARITABLE FUNDRAISING; PROVIDING GRANTS TO NON-GOVERNMENTAL ORGANIZATIONS AND OTHER INSTITUTIONS SUPPORTING LEGAL AND HUMAN RIGHTS REFORM (U.S. CLS. 100, 101 AND 102).

CLASS 41—EDUCATION AND ENTERTAINMENT

FOR DEVELOPMENT AND DISSEMINATION OF EDUCATIONAL MATERIALS IN THE FIELD OF PUBLIC INTEREST LAW AND THE PROVISION OF LEGAL AID AND PRO BONO LEGAL SERVICES, LAWYERING SKILLS, LEGAL ETHICS AND CRITICAL THINKING; ARRANGING, CONDUCTING AND PARTICIPATING IN PROFESSIONAL LECTURES, WORKSHOPS, SEMINARS, CONFERENCES, SYMPOSIA, PANEL DISCUSSIONS, PROGRAMS, AND TRAINING COURSES IN THE FIELDS OF PUBLIC INTEREST LAW AND THE PROVISION OF LEGAL AID AND PRO BONO LEGAL SERVICES, LAWYERING SKILLS, LEGAL ETHICS AND CRITICAL THINKING, AND DISTRIBUTION OF

PRINTED MATERIALS IN CONNECTION THEREWITH IN HARD COPY OR ELECTRONIC FORMAT ON THE SAME TOPICS; NON-DOWNLOADABLE ELECTRONIC PUBLICATIONS IN THE NATURE OF ARTICLES AND REPORTS IN THE FIELD OF PUBLIC INTEREST LAW; PROVIDING EDUCATION INFORMATION TO FOREIGN GOVERNMENTS, EDUCATIONAL INSTITUTIONS, AND EDUCATIONAL CREDENTIALING AUTHORITIES REGARDING LEGAL EDUCATION AND THE ROLE OF LEGAL AID AND PRO BONO STUDIES IN LEGAL EDUCATION (U.S. CLS. 100, 101 AND 107).

CLASS 42—SCIENTIFIC AND COMPUTER SERVICES

FOR PROVIDING A WEBSITE THAT GIVES COMPUTER USERS THE ABILITY TO SUBSCRIBE TO ONLINE NOTIFICATIONS AND DISCUSSIONS IN VARIOUS AREAS OF INTEREST IN THE FIELD OF PUBLIC INTEREST LAW AND THE PROVISION OF LEGAL AID AND PRO BONO LEGAL SERVICES (U.S. CLS. 100 AND 101).

CLASS 45—PERSONAL AND LEGAL SERVICES

FOR PROVIDING AN ON-LINE INTERACTIVE DATABASE FEATURING INFORMATION RELATED TO PUBLIC INTEREST LAW AND THE PROVISION OF LEGAL AID AND PRO BONO LEGAL SERVICES; CONSULTANCY SERVICES AND TECHNICAL ASSISTANCE IN THE FIELD OF PUBLIC INTEREST LAW AND THE PROVISION OF LEGAL AID AND PRO BONO LEGAL SERVICES; LEGAL RESEARCH AND ADVICE IN THE FIELDS OF PUBLIC INTEREST LAW AND THE PROVISION OF LEGAL AID AND PRO BONO LEGAL SERVICES, HUMAN RIGHTS, AND OTHER LEGAL AREAS; PROVIDING A WEB SITE AND ELECTRONIC DATABASE FEATURING COURT DECISIONS, TREATIES, AND OTHER LEGAL DOCUMENTS AND LEGAL RESOURCES RELATED TO PUBLIC INTEREST LAW AND THE PROVISION OF LEGAL AID AND PRO BONO LEGAL SERVICES; PROVIDING INFORMATION AND LEGAL SERVICES TO FOREIGN GOVERNMENTS, EDUCATIONAL INSTITUTIONS, AND EDUCATIONAL CREDENTIALING AUTHORITIES REGARDING PRO BONO LEGAL PROGRAMS AND THE ROLE OF LEGAL AID AND PRO BONO LEGAL PROGRAMS; ANALYSIS OF LEGISLATION, NAMELY, REVIEWING, COMMENTING ON, AND PARTICIPATING IN THE DRAFTING OF LEGISLATION AFFECTING HUMAN RIGHTS AND SOCIAL ISSUES (U.S. CLS. 100 AND 101).

ANGELA DUONG, EXAMINING ATTORNEY

SN 85-207,868. GENBBB, LLC, DBA GENCONNECT.COM, ASPEN, CO. FILED 12-30-2010.

genConnect

THE MARK CONSISTS OF STANDARD CHARACTERS WITHOUT CLAIM TO ANY PARTICULAR FONT, STYLE, SIZE, OR COLOR.

CLASS 35—ADVERTISING AND BUSINESS

FOR PROVIDING AN INTERNET WEBSITE PORTAL IN THE FIELD OF CAREER INFORMATION (U.S. CLS. 100, 101 AND 102).

FIRST USE 9-24-2008; IN COMMERCE 9-24-2008.

CLASS 36—INSURANCE AND FINANCIAL

FOR PROVIDING AN INTERNET WEBSITE PORTAL IN THE FIELD OF CHARITABLE FUNDRAISING (U.S. CLS. 100, 101 AND 102).

FIRST USE 9-24-2008; IN COMMERCE 9-24-2008.

CLASS 39—TRANSPORTATION AND STORAGE

FOR PROVIDING AN INTERNET WEBSITE PORTAL IN THE FIELD OF TRAVEL INFORMATION (U.S. CLS. 100 AND 105).

FIRST USE 9-24-2008; IN COMMERCE 9-24-2008.

CLASS 44—MEDICAL, BEAUTY AND AGRICULTURAL SERVICES

FOR PROVIDING AN INTERNET WEBSITE PORTAL IN THE FIELD OF MAINTAINING HEALTH AND A HEALTHY LIFESTYLE (U.S. CLS. 100 AND 101).

FIRST USE 9-24-2008; IN COMMERCE 9-24-2008.

CLASS 45—PERSONAL AND LEGAL SERVICES

FOR PROVIDING AN INTERNET WEBSITE PORTAL IN THE FIELD OF RELATIONSHIPS (U.S. CLS. 100 AND 101).

FIRST USE 9-24-2008; IN COMMERCE 9-24-2008.
ANNE E. GUSTASON, EXAMINING ATTORNEY

SN 85-210,641. AMERICAN EXPRESS MARKETING & DEVELOPMENT CORP., NEW YORK, NY. FILED 1-5-2011.

FOOD & WINE DIET

THE MARK CONSISTS OF STANDARD CHARACTERS WITHOUT CLAIM TO ANY PARTICULAR FONT, STYLE, SIZE, OR COLOR.

OWNER OF U.S. REG. NOS. 1,322,082, 2,087,436 AND 2,582,724.

NO CLAIM IS MADE TO THE EXCLUSIVE RIGHT TO USE "DIET", APART FROM THE MARK AS SHOWN.

SEC. 2(F) AS TO "FOOD & WINE".

CLASS 41—EDUCATION AND ENTERTAINMENT

FOR EDUCATIONAL SERVICES, NAMELY, CONDUCTING CLASSES, SEMINARS, CONFERENCES AND WORKSHOPS FEATURING RECIPES, COOKING INFORMATION AND HEALTHY EATING TIPS THROUGH A PROPER DIET AND FITNESS PROGRAM FROM CELEBRITY CHEFS ENCOURAGING HEALTHY LIFESTYLES (U.S. CLS. 100, 101 AND 107).

CLASS 43—HOTEL AND RESTAURANT SERVICES

FOR PROVIDING A DATABASE IN THE FIELD OF RECIPES, COOKING INFORMATION AND HEALTHY EATING TIPS FROM CELEBRITY CHEFS ENCOURAGING HEALTHY LIFESTYLES (U.S. CLS. 100 AND 101).

CLASS 44—MEDICAL, BEAUTY AND AGRICULTURAL SERVICES

FOR DIET PROGRAM, NAMELY, PROVIDING FOOD NUTRITION CONSULTATION BY CELEBRITY CHEFS ENCOURAGING HEALTHY LIFESTYLES (U.S. CLS. 100 AND 101).

ALICE BENMAMAN, EXAMINING ATTORNEY

SN 85-211,635. SEA CLIFF VENTURES INC., BELIZE CITY, BELIZE, FILED 1-6-2011.

MEETMELOCAL

THE MARK CONSISTS OF STANDARD CHARACTERS WITHOUT CLAIM TO ANY PARTICULAR FONT, STYLE, SIZE, OR COLOR.

CLASS 38—COMMUNICATION

FOR PROVIDING AN ONLINE CHAT ROOMS AND WEBCAM CHAT ROOMS FOR THE TRANSMISSION OF MESSAGES, VIDEOS AND DIGITAL PHOTO FILES AMONG COMPUTER USERS INTERESTED IN MEETING OTHER PEOPLE (U.S. CLS. 100, 101 AND 104).

CLASS 41—EDUCATION AND ENTERTAINMENT

FOR ENTERTAINMENT SERVICES, NAMELY, PROVIDING A WEBSITE FEATURING ADULT-THEMED NON-DOWNLOADABLE PHOTOGRAPHS, TEXT, VIDEOS AND LIVE WEBCAM VIDEOS; PROVIDING A WEBSITE AT WHICH THE GENERAL PUBLIC CAN RECEIVE ADVICE FROM AN INDIVIDUAL CONCERNING RELATIONSHIPS, SUCH ADVICE BEING FOR ENTERTAINMENT PURPOSES ONLY; ENTERTAINMENT SERVICES, NAMELY, CONDUCTING CONTESTS; ENTERTAINMENT SERVICES, NAMELY, PROVIDING WEBCASTS IN THE FIELD OF DATING AND RELATIONSHIPS (U.S. CLS. 100, 101 AND 107).

CLASS 42—SCIENTIFIC AND COMPUTER SERVICES

FOR COMPUTER SERVICES, NAMELY, HOSTING AN INTERACTIVE WEB SITE THAT ALLOWS USERS RECORD USER-DEFINED INFORMATION, PERSONAL PROFILES AND INFORMATION, AND TO DISPLAY VIDEO CONTENT (U.S. CLS. 100 AND 101).

CLASS 45—PERSONAL AND LEGAL SERVICES

FOR INTERNET-BASED DATING, SOCIAL INTRODUCTION AND SOCIAL NETWORKING SERVICES (U.S. CLS. 100 AND 101).

ROBIN CHOSID, EXAMINING ATTORNEY

SN 85-211,637. SEA CLIFF VENTURES INC., BELIZE CITY, BELIZE, FILED 1-6-2011.

SINGLESNOW

THE MARK CONSISTS OF STANDARD CHARACTERS WITHOUT CLAIM TO ANY PARTICULAR FONT, STYLE, SIZE, OR COLOR.

CLASS 38—COMMUNICATION

FOR PROVIDING AN ONLINE CHAT ROOMS AND WEBCAM CHAT ROOMS FOR THE TRANSMISSION OF MESSAGES, VIDEOS AND DIGITAL PHOTO FILES AMONG COMPUTER USERS INTERESTED IN MEETING OTHER PEOPLE (U.S. CLS. 100, 101 AND 104).

CLASS 41—EDUCATION AND ENTERTAINMENT

FOR ENTERTAINMENT SERVICES, NAMELY, PROVIDING A WEBSITE FEATURING ADULT-THEMED NON-DOWNLOADABLE PHOTOGRAPHS, TEXT, VIDEOS AND LIVE WEBCAM VIDEOS; PROVIDING A WEBSITE AT WHICH THE GENERAL PUBLIC CAN RECEIVE ADVICE FROM AN INDIVIDUAL CONCERNING RELATIONSHIPS, SUCH ADVICE BEING FOR ENTERTAINMENT PURPOSES ONLY; ENTERTAINMENT SERVICES, NAMELY, CONDUCTING CONTESTS; ENTERTAINMENT SERVICES, NAMELY, PROVIDING WEBCASTS IN THE FIELD OF DATING AND RELATIONSHIPS (U.S. CLS. 100, 101 AND 107).

CLASS 42—SCIENTIFIC AND COMPUTER SERVICES

FOR COMPUTER SERVICES, NAMELY, HOSTING AN INTERACTIVE WEB SITE THAT ALLOWS USERS RECORD USER-DEFINED INFORMATION, PERSONAL PROFILES AND INFORMATION, AND TO DISPLAY VIDEO CONTENT (U.S. CLS. 100 AND 101).

CLASS 45—PERSONAL AND LEGAL SERVICES

FOR INTERNET-BASED DATING, SOCIAL INTRODUCTION AND SOCIAL NETWORKING SERVICES (U.S. CLS. 100 AND 101).

ROBIN CHOSID, EXAMINING ATTORNEY

SN 85-211,642. SEA CLIFF VENTURES INC., BELIZE CITY, BELIZE, FILED 1-6-2011.

COMPANIONSPOT

THE MARK CONSISTS OF STANDARD CHARACTERS WITHOUT CLAIM TO ANY PARTICULAR FONT, STYLE, SIZE, OR COLOR.

CLASS 38—COMMUNICATION

FOR PROVIDING AN ONLINE CHAT ROOMS AND WEBCAM CHAT ROOMS FOR THE TRANSMISSION OF MESSAGES, VIDEOS AND DIGITAL PHOTO FILES AMONG COMPUTER USERS INTERESTED IN MEETING OTHER PEOPLE (U.S. CLS. 100, 101 AND 104).

CLASS 41—EDUCATION AND ENTERTAINMENT

FOR ENTERTAINMENT SERVICES, NAMELY, PROVIDING A WEBSITE FEATURING ADULT-THEMED NON-DOWNLOADABLE PHOTOGRAPHS, TEXT, VIDEOS AND LIVE WEBCAM VIDEOS; PROVIDING A WEBSITE AT WHICH THE GENERAL PUBLIC CAN RECEIVE ADVICE FROM AN INDIVIDUAL CONCERNING RELATIONSHIPS, SUCH ADVICE BEING FOR ENTERTAINMENT PURPOSES ONLY; ENTERTAINMENT SERVICES, NAMELY, CONDUCTING CONTESTS; ENTERTAINMENT SERVICES, NAMELY, PROVIDING WEBCASTS IN THE FIELD OF DATING AND RELATIONSHIPS (U.S. CLS. 100, 101 AND 107).

CLASS 42—SCIENTIFIC AND COMPUTER SERVICES

FOR COMPUTER SERVICES, NAMELY, HOSTING AN INTERACTIVE WEB SITE THAT ALLOWS USERS RECORD USER-DEFINED INFORMATION, PERSONAL PROFILES AND INFORMATION, AND TO DISPLAY VIDEO CONTENT (U.S. CLS. 100 AND 101).

CLASS 45—PERSONAL AND LEGAL SERVICES

FOR INTERNET-BASED DATING, SOCIAL INTRODUCTION AND SOCIAL NETWORKING SERVICES (U.S. CLS. 100 AND 101).

ROBIN CHOSID, EXAMINING ATTORNEY

SN 85-211,752. DAYBROOK RESOURCES CORPORATION, MORRISTOWN, NJ, FILED 1-6-2011.



THE MARK CONSISTS OF A DESIGN OF TWO STYLIZED FISH TAILS FORMING THE PERIMETER OF AN OVAL SURROUNDING THE WORD "DAYBROOK".

CLASS 5—PHARMACEUTICALS

FOR EDIBLE FISH OILS FOR MEDICAL PURPOSES AND AS NUTRITIONAL FOOD ADDITIVES FOR MEDICAL PURPOSES (U.S. CLS. 6, 18, 44, 46, 51 AND 52).

CLASS 29—MEATS AND PROCESSED FOODS

FOR EDIBLE OILS AND FATS, NAMELY, FISH OIL FOR HUMAN CONSUMPTION BUT NOT FOR MEDICINAL PURPOSES; FOOD ADDITIVES, NAMELY, NATURAL FOOD EXTRACTS DERIVED FROM FISH, FISH OIL OR FISH PROTEIN FOR HUMAN CONSUMPTION BUT NOT FOR MEDICINAL PURPOSES (U.S. CL. 46).

FIRST USE 0-0-1990; IN COMMERCE 0-0-1990.

CLASS 31—NATURAL AGRICULTURAL PRODUCTS

FOR FISH MEAL AND FISH OIL FOR FEED STUFFS, PET FOOD, AND AQUACULTURE AND ANIMAL FEEDS (U.S. CLS. 1 AND 46).

FIRST USE 0-0-1990; IN COMMERCE 0-0-1990.
SOPHIA S. KIM, EXAMINING ATTORNEY

SN 85-212,332. REAL VALUABLE, LLC, SAN FRANCISCO, CA. FILED 1-6-2011.

COFFEE TABLE

THE MARK CONSISTS OF STANDARD CHARACTERS WITHOUT CLAIM TO ANY PARTICULAR FONT, STYLE, SIZE, OR COLOR.

CLASS 9—ELECTRICAL AND SCIENTIFIC APPARATUS

FOR COMPUTER APPLICATION SOFTWARE FOR COMPUTERS, MOBILE PHONES, PORTABLE MEDIA PLAYERS, HANDHELD COMPUTERS, NAMELY, SOFTWARE FOR ELECTRONIC CATALOG SERVICES, NAMELY, FOR DOWNLOADING ELECTRONIC CATALOGS FEATURING CONSUMER GOODS (U.S. CLS. 21, 23, 26, 36 AND 38).

CLASS 35—ADVERTISING AND BUSINESS

FOR ELECTRONIC CATALOG SERVICES FEATURING CONSUMER GOODS (U.S. CLS. 100, 101 AND 102).
EUGENIA MARTIN, EXAMINING ATTORNEY

SN 85-212,823. JACK WILLS LIMITED, LONDON, UNITED KINGDOM, FILED 1-7-2011.

SEASONNAIRE

THE MARK CONSISTS OF STANDARD CHARACTERS WITHOUT CLAIM TO ANY PARTICULAR FONT, STYLE, SIZE, OR COLOR.

OWNER OF ERPN CMNTY TM OFC REG. NO. 7354863, DATED 6-10-2009, EXPIRES 10-29-2018.

CLASS 9—ELECTRICAL AND SCIENTIFIC APPARATUS

FOR SUNGLASSES, SPECTACLES, CASES FOR SUNGLASSES AND SPECTACLES; DIVERS' MASKS AND SPECTACLES FOR UNDERWATER SPORTS; SKI GOGGLES AND MASKS; PROTECTIVE SPORTS CLOTHING, NAMELY, DIVING SUITS AND PROTECTIVE HELMETS; CD AND DVD HOLDERS (U.S. CLS. 21, 23, 26, 36 AND 38).

CLASS 14—JEWELRY

FOR JEWELLERY AND IMITATION JEWELLERY; BRACELETS, NECKLACES, EARRINGS, WATCHES (U.S. CLS. 2, 27, 28 AND 50).

CLASS 18—LEATHER GOODS

FOR BAGS, NAMELY, ALL PURPOSE CARRYING BAGS, HANDBAGS, SHOULDER BAGS, TOILETRY BAGS SOLD EMPTY, KIT BAGS, RUCKSACKS, SPORTS BAGS, BEACH BAGS, SLING BAGS, HIP BAGS, TRAVEL BAGS, LUGGAGE, WALLETS, PURSES; CREDIT CARD HOLDERS (U.S. CLS. 1, 2, 3, 22 AND 41).

CLASS 25—CLOTHING

FOR MEN, WOMEN AND CHILDREN'S APPAREL, NAMELY, COATS, OVERCOATS, GILETS, SWEAT SHIRTS, JACKETS, BLAZERS, VESTS, CARDIGANS, SWEATERS, TANK TOPS, T-SHIRTS, POLO SHIRTS, CREW-SHIRTS, VEST-TOPS, WAISTCOATS, RUGBY SHIRTS, LONG-SLEEVED SHIRTS, DRESSES, PLAY-SUITS, BLOUSES, SKIRTS, SHORTS, SOCKS, TROUSERS, PANTS, SLACKS, JEANS, TRACK PANTS, SWEAT SUITS, SWEAT PANTS, SWEAT SHORTS, SWEAT TOPS, SKIWEAR, SKI PANTS, SKI SUITS, SKI JACKETS, UNDERWEAR, UNDERPANTS, BRAS, KNICKERS, BOXER SHORTS, BRIEFS, STOCKINGS, PANTYHOSE, LEGGINGS, NIGHTWEAR, PYJAMAS, DRESSING GOWNS, SCARVES, GLOVES, MITTENS, BELTS, LEGWARMERS, MUFFLERS, ROBES, TUNICS, SHAWLS; SWIMWEAR, SWIMMING TRUNKS, BIKINIS, TANKINIS, SWIMSUITS, BATHING SUITS; FOOTWEAR, HEADWEAR, NAMELY, HATS, CAPS, BONNETS, BEREETS, TURBANS; WET SUITS (U.S. CLS. 22 AND 39).

CLASS 35—ADVERTISING AND BUSINESS

FOR THE BRINGING TOGETHER, FOR THE BENEFIT OF OTHERS, OF SUNGLASSES, SPECTACLES, CASES FOR SUNGLASSES, DIVERS' MASKS AND SPECTACLES FOR UNDERWATER SPORTS, SKI GOGGLES AND MASKS, PROTECTIVE SPORTS CLOTHING, WET SUITS, CD AND DVD HOLDERS, JEWELLERY AND IMITATION JEWELLERY, BRACELETS, NECKLACES, EARRINGS, WATCHES, BAGS, HANDBAGS, SHOULDER BAGS, TOILETRY BAGS, KIT BAGS, RUCKSACKS, SPORTS BAGS, BEACH BAGS, SLING BAGS, HIP BAGS, TRAVEL BAGS, LUGGAGE, WALLETS, PURSES, CREDIT CARD HOLDERS, CLOTHING, FOOTWEAR AND/OR HEADGEAR, ENABLING CUSTOMERS CONVENIENTLY TO VIEW AND PURCHASE THOSE GOODS (U.S. CLS. 100, 101 AND 102).
DOMINIC FATHY, EXAMINING ATTORNEY

SN 85-213,585. DEBORAH LYNN GREEN, DBA GRACE BEAUTY SPEED ORGANIZATION, BALTIMORE, MD. FILED 1-9-2011.

Grace Beauty Speed Organization

THE MARK CONSISTS OF STANDARD CHARACTERS WITHOUT CLAIM TO ANY PARTICULAR FONT, STYLE, SIZE, OR COLOR.

NO CLAIM IS MADE TO THE EXCLUSIVE RIGHT TO USE "ORGANIZATION", APART FROM THE MARK AS SHOWN.

CLASS 25—CLOTHING

FOR T-SHIRTS, TANK TOPS, ACTIVE WEAR HOODED SWEATSHIRTS, TIGHTS, HATS (U.S. CLS. 22 AND 39).

FIRST USE 1-8-2011; IN COMMERCE 1-8-2011.

CLASS 41—EDUCATION AND ENTERTAINMENT

FOR ORGANIZING SPORTING EVENTS, NAMELY, LONG DISTANCE RUNNING FOR YOUNG GIRLS TO HELP IMPLEMENT HEALTHY LIFESTYLES, SELF-AWARENESS, SELF-IMAGE AND SELF-ESTEEM; HOSTING TRACK CLINICS, ROAD RACES; COLLEGE CONSULTING SERVICES, NAMELY, ASSISTING STUDENTS IN FINDING COLLEGES AND UNIVERSITIES AND COMPLETING THE APPLICATION PROCESS (U.S. CLS. 100, 101 AND 107).

FIRST USE 1-28-2010; IN COMMERCE 12-15-2010.
TIMOTHY FINNEGAN, EXAMINING ATTORNEY

SN 85-215,009. STEM CELL SCIENCES HOLDINGS LIMITED, EDINBURGH, LOTHIAN, UNITED KINGDOM, FILED 1-11-2011.

STEM111

THE MARK CONSISTS OF STANDARD CHARACTERS WITHOUT CLAIM TO ANY PARTICULAR FONT, STYLE, SIZE, OR COLOR.

CLASS 1—CHEMICALS

FOR REAGENTS FOR SCIENTIFIC USE FOR USE IN BIOLOGICAL PROCESSING; BIOLOGICAL PREPARATIONS FOR SCIENTIFIC USE FOR USE IN CELL CULTURES; CULTURES OF CELL MEDIA FOR SCIENTIFIC USE; MEDIA FOR CELL CULTURE FOR USE IN NON-MEDICAL RESEARCH LABORATORIES; MEDIA FOR CELL CULTURE FOR USE IN THE BIOTECHNOLOGICAL INDUSTRY; BIOCHEMICALS FOR SCIENTIFIC USE, NAMELY, ANTIBODIES AND MONOCLONAL ANTIBODIES; PRODUCTS, NAMELY, KITS COMPRISING ANTIBODIES FOR USE IN SCIENCE; TISSUE CULTURE REAGENTS FOR SCIENTIFIC AND MEDICAL LABORATORY RESEARCH USE; CELL CULTURE REAGENTS; CELL CULTURE MEDIA FOR SCIENTIFIC USE; BIOLOGICAL TEST KITS FOR RESEARCH USE COMPRISING BUFFERS AND STANDARD SOLUTIONS; BIOLOGICAL REAGENTS FOR SCIENTIFIC USE FOR USE IN EMBRYOLOGY; BIOLOGICAL REAGENTS FOR SCIENTIFIC USE FOR USE IN MOLECULAR BIOLOGY (U.S. CLS. 1, 5, 6, 10, 26 AND 46).

SN 85-215,003. STEM CELL SCIENCES HOLDINGS LIMITED, EDINBURGH, LOTHIAN, UNITED KINGDOM, FILED 1-11-2011.

STEM20

THE MARK CONSISTS OF STANDARD CHARACTERS WITHOUT CLAIM TO ANY PARTICULAR FONT, STYLE, SIZE, OR COLOR.

CLASS 1—CHEMICALS

FOR REAGENTS FOR SCIENTIFIC USE FOR USE IN BIOLOGICAL PROCESSING; BIOLOGICAL PREPARATIONS FOR SCIENTIFIC USE FOR USE IN CELL CULTURES; CULTURES OF CELL MEDIA FOR SCIENTIFIC USE; MEDIA FOR CELL CULTURE FOR USE IN NON-MEDICAL RESEARCH LABORATORIES; MEDIA FOR CELL CULTURE FOR USE IN THE BIOTECHNOLOGICAL INDUSTRY; BIOCHEMICALS FOR SCIENTIFIC USE, NAMELY, ANTIBODIES AND MONOCLONAL ANTIBODIES; PRODUCTS, NAMELY, KITS COMPRISING ANTIBODIES FOR USE IN SCIENCE; TISSUE CULTURE REAGENTS FOR SCIENTIFIC AND MEDICAL LABORATORY RESEARCH USE; CELL CULTURE REAGENTS; CELL CULTURE MEDIA FOR SCIENTIFIC USE; BIOLOGICAL TEST KITS FOR RESEARCH USE COMPRISING BUFFERS AND STANDARD SOLUTIONS; BIOLOGICAL REAGENTS FOR SCIENTIFIC USE FOR USE IN EMBRYOLOGY; BIOLOGICAL REAGENTS FOR SCIENTIFIC USE FOR USE IN MOLECULAR BIOLOGY (U.S. CLS. 1, 5, 6, 10, 26 AND 46).

CLASS 5—PHARMACEUTICALS

FOR REAGENTS FOR MEDICAL USE FOR USE IN BIOLOGICAL PROCESSING; REAGENTS FOR VETERINARY USE FOR USE IN BIOLOGICAL PROCESSING; BIOLOGICAL PREPARATIONS FOR MEDICAL USE FOR USE IN CELL CULTURES; CELL CULTURE MEDIA, NAMELY, CELL CULTURE REAGENTS FOR MEDICAL USE; ANTIBODIES FOR IMMUNODIAGNOSTIC MEDICAL USE; ANTIBODIES FOR IMMUNOLOGICAL THERAPEUTIC USE; MONOCLONAL ANTIBODIES FOR IMMUNODIAGNOSTIC MEDICAL USE; MONOCLONAL ANTIBODIES FOR IMMUNOLOGICAL THERAPEUTIC USE; PRODUCTS, NAMELY, KITS COMPRISING ANTIBODIES FOR USE IN IMMUNODIAGNOSTIC MEDICINE OR IMMUNOLOGICAL THERAPY (U.S. CLS. 6, 18, 44, 46, 51 AND 52).

REBECCA POVARCHUK, EXAMINING ATTORNEY

CLASS 5—PHARMACEUTICALS

FOR REAGENTS FOR MEDICAL USE FOR USE IN BIOLOGICAL PROCESSING; REAGENTS FOR VETERINARY USE FOR USE IN BIOLOGICAL PROCESSING; BIOLOGICAL PREPARATIONS FOR MEDICAL USE FOR USE IN CELL CULTURES; CELL CULTURE MEDIA, NAMELY, CELL CULTURE REAGENTS FOR MEDICAL USE; ANTIBODIES FOR IMMUNODIAGNOSTIC MEDICAL USE; ANTIBODIES FOR IMMUNOLOGICAL THERAPEUTIC USE; MONOCLONAL ANTIBODIES FOR IMMUNODIAGNOSTIC MEDICAL USE; MONOCLONAL ANTIBODIES FOR IMMUNOLOGICAL THERAPEUTIC USE; PRODUCTS, NAMELY, KITS COMPRISING ANTIBODIES FOR USE IN IMMUNODIAGNOSTIC MEDICINE OR IMMUNOLOGICAL THERAPY (U.S. CLS. 6, 18, 44, 46, 51 AND 52).

REBECCA POVARCHUK, EXAMINING ATTORNEY

SN 85-215,227. INPRO CORPORATION, MUSKEGO, WI, FILED 1-11-2011.

INPRO

THE MARK CONSISTS OF STANDARD CHARACTERS WITHOUT CLAIM TO ANY PARTICULAR FONT, STYLE, SIZE, OR COLOR.

CLASS 2—PAINTS

FOR PAINT AND PAINT PRIMERS (U.S. CLS. 6, 11 AND 16).

FIRST USE 9-1-1995; IN COMMERCE 9-1-1995.

CLASS 6—METAL GOODS

FOR NON-LUMINOUS AND NON MECHANICAL METAL SIGNS AND METAL HOLDERS FOR SIGNS; METAL PRIVACY SYSTEM PARTS COMPRISED OF CURTAIN CEILING TRACKS, TRACK CARRIERS, STIFFENERS, SPACERS, CLIPS, END CAPS, SUPPORT BRACKETS, TRACK PULLEY HOUSINGS, AND CORD GUIDES; METAL WALL AND DOOR PROTECTION PRODUCTS, NAMELY, HANDRAILS, GRAB BARS, WALL GUARDS, CORNER GUARDS, CHAIR RAILS, RUB RAILS, COVE BASES, KICK PLATES, FRAME GUARDS, EDGE PROTECTORS, KNOB PROTECTORS, AND WALL COVERING SHEETS; METAL ARCHITECTURAL EXPANSION JOINTS FOR FLOORS AND WALLS (U.S. CLS. 2, 12, 13, 14, 23, 25 AND 50).

FIRST USE 9-1-1995; IN COMMERCE 9-1-1995.

CLASS 11—ENVIRONMENTAL CONTROL APPARATUS

FOR SINKS, BATHTUB SURROUNDS, AND SHOWER SURROUNDS (U.S. CLS. 13, 21, 23, 31 AND 34).

FIRST USE 9-1-1995; IN COMMERCE 9-1-1995.

CLASS 19—NON-METALLIC BUILDING MATERIALS

FOR NON-LUMINOUS, NON-MECHANICAL SIGNS NOT OF METAL; NON-METAL CORNICES, NON-METAL DOOR AND WALL PROTECTION PRODUCTS, NAMELY, HANDRAILS, GRAB BARS, WALL GUARDS, CORNER GUARDS, CHAIR RAILS, RUB RAILS, COVE BASES, KICK PLATES, FRAME GUARDS, EDGE PROTECTORS, KNOB PROTECTORS, AND WALL COVERING SHEETS; NON-METAL ARCHITECTURAL EXPANSION JOINTS FOR FLOORS AND WALLS; BUILDING MATERIALS, NAMELY, NON-METAL COUNTERTOPS FOR FURTHER INSTALLATION, NON-METAL WINDOW SILLS, NON-METAL THRESHOLDS (U.S. CLS. 1, 12, 33 AND 50).

FIRST USE 9-1-1995; IN COMMERCE 9-1-1995.

CLASS 24—FABRICS

FOR PRIVACY CURTAINS, SHOWER CURTAINS, DRAPERIES, FABRIC VALANCES, BED SPREADS (U.S. CLS. 42 AND 50).

FIRST USE 9-1-1995; IN COMMERCE 9-1-1995.
CHARLES L. JENKINS, EXAMINING ATTORNEY

SN 85-216,991. CAMPUS CRUSADE FOR CHRIST, INC., AKA CAMPUS CRUSADE FOR CHRIST; CAMPUS CRUSADE FOR CHRIST INTERNATIONAL; CCCI, ORLANDO, FL. FILED 1-13-2011.

BOX OF LOVE

THE MARK CONSISTS OF STANDARD CHARACTERS WITHOUT CLAIM TO ANY PARTICULAR FONT, STYLE, SIZE, OR COLOR.

CLASS 29—MEATS AND PROCESSED FOODS

FOR ASSEMBLED FOOD KITS CONTAINING VARIOUS COMBINATIONS OF SELECTED FOOD ITEMS COMPRISING PRIMARILY MEAT, CANNED VEGETABLES, CANNED FRUIT, CANNED SOUP, RICE, PACKAGED MIXES FOR MUFFINS, BREAD STUFFING, DESSERT PUDDINGS, AND BAKED DESSERTS, FRESH VEGETABLES, FRESH FRUIT, NON-ALCOHOLIC BEVERAGES, AND OTHER FOOD PRODUCTS, TO BE DISTRIBUTED TO NEEDY PERSONS (U.S. CL. 46).

CLASS 35—ADVERTISING AND BUSINESS

FOR CHARITABLE SERVICES, NAMELY, COORDINATION OF THE PROCUREMENT AND DISTRIBUTION OF FOOD DONATIONS FROM INDIVIDUALS, NON-PROFIT ORGANIZATIONS, MANUFACTURERS, WHOLESALERS, AND RETAILERS TO ORGANIZATIONS PROVIDING FREE FOOD TO NEEDY PEOPLE (U.S. CLS. 100, 101 AND 102).

CLASS 36—INSURANCE AND FINANCIAL

FOR FUNDRAISING ACTIVITIES FOR THE DISTRIBUTION OF FOOD, GOODS AND RELIGIOUS MATERIALS TO NEEDY PERSONS (U.S. CLS. 100, 101 AND 102).

CLASS 43—HOTEL AND RESTAURANT SERVICES

FOR CHARITABLE SERVICES, NAMELY, PROVIDING FOOD TO NEEDY PERSONS (U.S. CLS. 100 AND 101).

CLASS 45—PERSONAL AND LEGAL SERVICES

FOR PROVIDING INFORMATION IN THE NATURE OF RELIGIOUS WORKS AND MATERIALS TO NEEDY PERSONS (U.S. CLS. 100 AND 101).

LINDA POWELL, EXAMINING ATTORNEY

SN 85-217,114. WAGGENER EDSTROM WORLDWIDE, INC., LAKE OSWEGO, OR. FILED 1-13-2011.

STUDIO D

THE MARK CONSISTS OF STANDARD CHARACTERS WITHOUT CLAIM TO ANY PARTICULAR FONT, STYLE, SIZE, OR COLOR.

OWNER OF U.S. REG. NOS. 3,236,340 AND 3,923,578.
NO CLAIM IS MADE TO THE EXCLUSIVE RIGHT TO USE "STUDIO", APART FROM THE MARK AS SHOWN.

CLASS 35—ADVERTISING AND BUSINESS

FOR PUBLIC RELATIONS SERVICES; MARKET RESEARCH SERVICES; MARKETING SERVICES, NAMELY, PLANNING PRODUCT LAUNCH CAMPAIGNS AND DEVELOPMENT OF BRANDS AND PRODUCT IDENTITY; CONSULTATIONS IN SALES AND CHANNEL MANAGEMENT; DEVELOPMENT OF COLLATERAL AND PROMOTIONAL MATERIALS AND PRESS KITS FOR OTHERS; BUSINESS CONSULTING WITH REGARD TO TRADE SHOWS AND PRODUCT LAUNCH EVENT MANAGEMENT; BUSINESS MONITORING, ANALYTICS, AND CONSULTING SERVICES IN THE FIELDS OF STRATEGY AND MARKETING USING ANALYTIC MODELS FOR THE UNDERSTANDING AND PREDICTING OF ONLINE COMMUNICATIONS AND MARKET TRENDS AND ACTIONS BASED ON THOSE COMMUNICATIONS, AND TO MEASURE THE IMPACT AND INFLUENCE OF ONLINE COMMUNICATIONS ON BRANDS AND BUSINESSES; BUSINESS MONITORING, ANALYTICS, AND CONSULTING SERVICES IN THE FIELD OF ONLINE COMMUNICATIONS PERTAINING TO BUSINESSES (U.S. CLS. 100, 101 AND 102).

FIRST USE 7-7-2008; IN COMMERCE 7-7-2008.

CLASS 41—EDUCATION AND ENTERTAINMENT

FOR OFFERING TRAINING PROGRAMS IN THE AREA OF PUBLIC RELATIONS, CONDUCTING TRAINING IN SALES AND MARKET CHANNELS, OFFERING SEMINARS AND WORKSHOPS INCLUDING CUSTOMIZED AND INSTRUCTIVE SESSIONS IN THE AREA OF MARKETING FEATURING VIDEOTAPES AND ON CAMERA INSTRUCTION; NEWS AGENCY SERVICES FEATURING THE CREATION, GATHERING, AND DISSEMINATION OF NEWS MATERIALS, NAMELY, PRESS RELEASES, NEWS ARTICLES, AND BACKGROUND INFORMATION FOR CLIENTS (U.S. CLS. 100, 101 AND 107).

FIRST USE 7-7-2008; IN COMMERCE 7-7-2008.

CLASS 42—SCIENTIFIC AND COMPUTER SERVICES

FOR WEBSITE DEVELOPMENT FOR OTHERS FEATURING TECHNICAL CONSULTATION IN THE AREA OF DIGITAL CONTENT; DESIGN, CREATION HOSTING AND MAINTENANCE OF WEBSITES FOR OTHERS; GRAPHIC DESIGN SERVICES (U.S. CLS. 100 AND 101).

FIRST USE 10-1-1996; IN COMMERCE 10-1-1996.
JENNY PARK, EXAMINING ATTORNEY

SN 85-217,406. DIVERSIFIED GLOBAL TECHNOLOGIES, LLC, WOONSOCKET, RI. FILED 1-13-2011.

GREEN RAIN

THE MARK CONSISTS OF STANDARD CHARACTERS WITHOUT CLAIM TO ANY PARTICULAR FONT, STYLE, SIZE, OR COLOR.

NO CLAIM IS MADE TO THE EXCLUSIVE RIGHT TO USE "GREEN", APART FROM THE MARK AS SHOWN.

CLASS 3—COSMETICS AND CLEANING PREPARATIONS

FOR DISPOSABLE FOAM WIPES IMPREGNATED WITH CLEANING CHEMICALS OR COMPOUNDS FOR INDUSTRIAL OR HOUSEHOLD USE (U.S. CLS. 1, 4, 6, 50, 51 AND 52).

CLASS 21—HOUSEWARES AND GLASS

FOR BATH PRODUCTS, NAMELY, BODY SPONGES AND FACIAL SPONGES; INDUSTRIAL AND HOUSEHOLD CLEANING PRODUCTS, NAMELY, HARD SURFACE CLEANING SPONGES, DISH AND POT CLEANING SPONGES, TUB AND TILE CLEANING SPONGES, FLOOR CLEANING SPONGES (U.S. CLS. 2, 13, 23, 29, 30, 33, 40 AND 50).

JAY FLOWERS, EXAMINING ATTORNEY

SN 85-217,490. CAMPUS CRUSADE FOR CHRIST, INC., AKA CAMPUS CRUSADE FOR CHRIST; CAMPUS CRUSADE FOR CHRIST INTERNATIONAL; CCCI, ORLANDO, FL. FILED 1-13-2011.

BOXES OF LOVE

THE MARK CONSISTS OF STANDARD CHARACTERS WITHOUT CLAIM TO ANY PARTICULAR FONT, STYLE, SIZE, OR COLOR.

CLASS 29—MEATS AND PROCESSED FOODS

FOR ASSEMBLED FOOD KITS CONTAINING VARIOUS COMBINATIONS OF SELECTED FOOD ITEMS COMPRISING PRIMARILY MEAT, CANNED VEGETABLES, CANNED FRUIT, CANNED SOUP, RICE, PACKAGED MIXES FOR MUFFINS, BREAD STUFFING, DESSERT PUDDINGS, AND BAKED DESSERTS, FRESH VEGETABLES, FRESH FRUIT, NON-ALCOHOLIC BEVERAGES, AND OTHER FOOD PRODUCTS, TO BE DISTRIBUTED TO NEEDY PERSONS (U.S. CL. 46).

CLASS 35—ADVERTISING AND BUSINESS

FOR CHARITABLE SERVICES, NAMELY, COORDINATION OF THE PROCUREMENT AND DISTRIBUTION OF FOOD DONATIONS FROM INDIVIDUALS, NON-PROFIT ORGANIZATIONS, MANUFACTURERS, WHOLESALE, AND RETAILERS TO ORGANIZATIONS PROVIDING FREE FOOD TO NEEDY PEOPLE (U.S. CLS. 100, 101 AND 102).

CLASS 36—INSURANCE AND FINANCIAL

FOR FUNDRAISING ACTIVITIES FOR THE DISTRIBUTION OF FOOD, GOODS AND RELIGIOUS MATERIALS TO NEEDY PERSONS (U.S. CLS. 100, 101 AND 102).

CLASS 43—HOTEL AND RESTAURANT SERVICES

FOR CHARITABLE SERVICES, NAMELY, PROVIDING FOOD TO NEEDY PERSONS (U.S. CLS. 100 AND 101).

CLASS 45—PERSONAL AND LEGAL SERVICES

FOR PROVIDING INFORMATION IN THE NATURE OF RELIGIOUS WORKS AND MATERIALS TO NEEDY PERSONS (U.S. CLS. 100 AND 101).

LINDA POWELL, EXAMINING ATTORNEY

SN 85-217,698. DIVERSIFIED GLOBAL TECHNOLOGIES, LLC, WOONSOCKET, RI. FILED 1-14-2011.

GREEN STORM

THE MARK CONSISTS OF STANDARD CHARACTERS WITHOUT CLAIM TO ANY PARTICULAR FONT, STYLE, SIZE, OR COLOR.

NO CLAIM IS MADE TO THE EXCLUSIVE RIGHT TO USE "GREEN", APART FROM THE MARK AS SHOWN.

CLASS 3—COSMETICS AND CLEANING PREPARATIONS

FOR DISPOSABLE FOAM WIPES IMPREGNATED WITH CLEANING CHEMICALS OR COMPOUNDS FOR INDUSTRIAL OR HOUSEHOLD USE (U.S. CLS. 1, 4, 6, 50, 51 AND 52).

CLASS 21—HOUSEWARES AND GLASS

FOR BATH PRODUCTS, NAMELY, BODY SPONGES AND FACIAL SPONGES; INDUSTRIAL AND HOUSEHOLD CLEANING PRODUCTS, NAMELY, HARD SURFACE CLEANING SPONGES, DISH AND POT CLEANING SPONGES, TUB AND TILE CLEANING SPONGES, FLOOR CLEANING SPONGES (U.S. CLS. 2, 13, 23, 29, 30, 33, 40 AND 50).

JAY FLOWERS, EXAMINING ATTORNEY

CLASS 42—SCIENTIFIC AND COMPUTER SERVICES

FOR CONSULTING SERVICES IN THE FIELD OF ENVIRONMENTAL ASSESSMENT AND PLANNING; ENVIRONMENTAL SERVICES, NAMELY, TECHNICAL CONSULTATION IN THE FIELD OF ENVIRONMENTAL SCIENCE, ENGINEERING SERVICES, DESIGN FOR OTHERS IN THE FIELD OF ENERGY ENGINEERING, DESIGNING AND TESTING OF ENERGY PRODUCTS FOR OTHERS; ENVIRONMENTAL TESTING AND INSPECTION SERVICES; PROFESSIONAL CONSULTING SERVICES IN THE FIELDS OF ENGINEERING, LAND USE PLANNING, SURVEYING, LANDSCAPE ARCHITECTURE, AND ENVIRONMENTAL SCIENCES; PROVIDING TECHNOLOGICAL AND SCIENTIFIC INFORMATION ABOUT ENVIRONMENTALLY-CONSCIOUS AND GREEN INNOVATIONS; PROVIDING TECHNOLOGICAL INFORMATION ABOUT ENVIRONMENTALLY-CONSCIOUS AND GREEN INNOVATIONS; TECHNICAL CONSULTANCY IN THE FIELD OF ENVIRONMENTAL SCIENCE (U.S. CLS. 100 AND 101).

FIRST USE 10-23-2010; IN COMMERCE 10-23-2010.

SHAUNIA CARLYLE, EXAMINING ATTORNEY

SN 85-220,821. PLASTIC TECHNOLOGIES, INC., AKA PTI, HOLLAND, OH. FILED 1-19-2011.

oPTI

THE MARK CONSISTS OF A LOWER CASE LETTER "O" NEXT TO THE CAPITAL LETTERS "PTI" TO COMPRISE THE MARK "OPTI".

CLASS 21—HOUSEWARES AND GLASS

FOR EMPTY PLASTIC BOTTLES (U.S. CLS. 2, 13, 23, 29, 30, 33, 40 AND 50).

FIRST USE 5-25-2011; IN COMMERCE 5-25-2011.

SN 85-222,221. ASIAINFO-LINKAGE, INC., SANTA CLARA, CA. FILED 1-20-2011.

CLASS 42—SCIENTIFIC AND COMPUTER SERVICES

FOR TECHNOLOGY CONSULTATION IN THE FIELD OF CONTAINER MANUFACTURING (U.S. CLS. 100 AND 101).

FIRST USE 5-19-2009; IN COMMERCE 8-0-2010.

DAVID COLLIER, EXAMINING ATTORNEY

SN 85-221,785. CIOTA, NOEL S., LONG BEACH, NY. FILED 1-20-2011.

Sustainocal

THE MARK CONSISTS OF STANDARD CHARACTERS WITHOUT CLAIM TO ANY PARTICULAR FONT, STYLE, SIZE, OR COLOR.

CLASS 37—CONSTRUCTION AND REPAIR

FOR CONSULTATION SERVICES IN THE FIELD OF CONSTRUCTION OF ENVIRONMENTALLY-CONSCIOUS BUILDINGS (U.S. CLS. 100, 103 AND 106).

FIRST USE 10-23-2010; IN COMMERCE 10-23-2010.



AsiaInfo Linkage

OWNER OF U.S. REG. NOS. 2,335,983, 2,989,918 AND OTHERS.

THE MARK CONSISTS OF THE WORDS "ASIAINFO LINKAGE" WITH A STYLIZED TRIANGLE APPEARING ABOVE THE WORDS.

CLASS 9—ELECTRICAL AND SCIENTIFIC APPARATUS

FOR COMPUTER SOFTWARE, NAMELY, SOFTWARE FOR USE IN BILLING, ACCOUNT SUPPORT AND MANAGEMENT, CLEARING AND SETTLEMENT OF FINANCIAL TRANSACTIONS, CUSTOMER RELATIONSHIP MANAGEMENT, PARTNERSHIP RELATIONSHIP MANAGEMENT, AUTOMATE DATA GATHERING AND WAREHOUSING TO MANAGE TRANSACTIONAL DATA, PROVIDE STATISTICAL ANALYSIS, AND PRODUCE NOTIFICATIONS AND REPORTS, DATA MINING, AND SECURITY, NAMELY, USER AUTHENTICATION AND CONTROLLING COMPUTER NETWORK ACCESS, FIREWALLS FOR PREVENTING INTRUSION AND HACKING, MOBILE DEVICE MANAGEMENT, E-MAIL; COMPUTER SOFTWARE PLATFORM FOR USE IN MOBILE E-COMMERCE, NAMELY, AN ELECTRONIC FINANCIAL PLATFORM THAT ACCOMMODATES MULTIPLE TYPES OF PAYMENT AND DEBT TRANSACTIONS IN AN INTEGRATED MOBILE DEVICE AND ALLOW USERS TO PERFORM ELECTRONIC BUSINESS TRANSACTIONS VIA A GLOBAL COMPUTER NETWORK; COMPUTER SOFTWARE PLATFORM FOR USE IN COMPUTER NETWORK MANAGEMENT AND ANALYTICS USED FOR PROCESS MANAGEMENT, OPERATIONS, NAMELY, FOR BILLING VERIFICATION, FRAUD DETECTION, MONITORING, MEASURING, ANALYZING, SECURITY MANAGING, NETWORK SURVEILLANCE, SIGNAL CLASSIFICATION, TRAFFIC MANAGING, CREATING AND MONITORING CALL DETAILED RECORDS, FRAUD DETECTION AND REPORTING INFORMATION EXTRACTED FROM NETWORKS, SWITCHES, OPERATING SYSTEMS, OF MOBILE DEVICES; COMPUTER SOFTWARE PLATFORM FOR USE IN ADVERTISING AND MARKETING ANALYSIS, USER TRAFFIC ANALYSIS, AND CUSTOMER SEGMENTATION AND PROFILING; COMPUTER SOFTWARE PLATFORM FOR USE IN CONTENT DELIVERY, NAMELY, VIDEO ON DEMAND, MUSIC ON DEMAND, TEXT ON DEMAND, AUDIO ON DEMAND, STREAMING MEDIA, APPLICATION MAP; COMPUTER SOFTWARE, NAMELY, SOFTWARE DEVELOPMENT TOOLS FOR NETWORK MANAGEMENT AND SECURITY (U.S. CLS. 21, 23, 26, 36 AND 38).

CLASS 35—ADVERTISING AND BUSINESS

FOR PROVIDING BUSINESS INTELLIGENCE CONSULTING SERVICES; OUTSOURCING SERVICES IN THE FIELD OF CUSTOMER RELATIONSHIP MANAGEMENT (CRM) (U.S. CLS. 100, 101 AND 102).

CLASS 38—COMMUNICATION

FOR TELECOMMUNICATIONS GATEWAY SERVICES; TELECONFERENCING AND ELECTRONIC MAIL SERVICES; ELECTRONIC TRANSMISSION OF VOICE, FACSIMILE, DATA AND INFORMATION; PROVISION OF TELECOMMUNICATIONS ACCESS TO COMPUTER DATABASES AND THE INTERNET (U.S. CLS. 100, 101 AND 104).

CLASS 42—SCIENTIFIC AND COMPUTER SERVICES

FOR COMPUTER CONSULTATION AND INTEGRATION OF COMPUTER SYSTEMS AND NETWORKS; DATA MANAGEMENT SERVICES, NAMELY, DATA FORMAT CONVERSION, DATA MERGING, DATA CLEANING TO REMOVE ERRONEOUS OR UNWANTED INFORMATION, DATA CORRECTION, DATA UPDATING, DATA PROCESSING SERVICES, AND DATA RECOVERY; COMPUTER PROGRAMMING SERVICES FOR OTHERS; DESIGN OF NETWORK MANAGEMENT CENTERS AND INTERNET BACKBONE INFRASTRUCTURE AND NETWORKS FOR OTHERS; NETWORK SUPPORT SERVICES IN THE FIELDS OF INTERNET ACCESS, INTERNET PROTOCOL TELEPHONY AND VIRTUAL PRIVATE NETWORKS (U.S. CLS. 100 AND 101).

DORITT L. CARROLL, EXAMINING ATTORNEY

SN 85-222,243. ASIAINFO-LINKAGE, INC., SANTA CLARA, CA. FILED 1-20-2011.



OWNER OF U.S. REG. NOS. 2,335,983, 2,989,918 AND OTHERS.

THE MARK CONSISTS OF THE WORDS "ASIAINFO LINKAGE" WITH A STYLIZED TRIANGLE APPEARING NEXT TO THE WORDS.

CLASS 9—ELECTRICAL AND SCIENTIFIC APPARATUS

FOR COMPUTER SOFTWARE, NAMELY, SOFTWARE FOR USE IN BILLING, ACCOUNT SUPPORT AND MANAGEMENT, CLEARING AND SETTLEMENT OF FINANCIAL TRANSACTIONS, CUSTOMER RELATIONSHIP MANAGEMENT, PARTNERSHIP RELATIONSHIP MANAGEMENT, AUTOMATE DATA GATHERING AND WAREHOUSING TO MANAGE TRANSACTIONAL DATA, PROVIDE STATISTICAL ANALYSIS, AND PRODUCE NOTIFICATIONS AND REPORTS, DATA MINING, AND SECURITY, NAMELY, USER AUTHENTICATION AND CONTROLLING COMPUTER NETWORK ACCESS, FIREWALLS FOR PREVENTING INTRUSION AND HACKING, MOBILE DEVICE MANAGEMENT, E-MAIL; COMPUTER SOFTWARE PLATFORM FOR USE IN MOBILE E-COMMERCE, NAMELY, AN ELECTRONIC FINANCIAL PLATFORM THAT ACCOMMODATES MULTIPLE TYPES OF PAYMENT AND DEBT TRANSACTIONS IN AN INTEGRATED MOBILE DEVICE AND ALLOW USERS TO PERFORM ELECTRONIC BUSINESS TRANSACTIONS VIA A GLOBAL COMPUTER NETWORK; COMPUTER SOFTWARE PLATFORM FOR USE IN COMPUTER NETWORK MANAGEMENT AND ANALYTICS USED FOR PROCESS MANAGEMENT, OPERATIONS, NAMELY, FOR BILLING VERIFICATION, FRAUD DETECTION, MONITORING, MEASURING, ANALYZING, SECURITY MANAGING, NETWORK SURVEILLANCE, SIGNAL CLASSIFICATION, TRAFFIC MANAGING, CREATING AND MONITORING CALL DETAILED RECORDS, FRAUD DETECTION AND REPORTING INFORMATION EXTRACTED FROM NETWORKS, SWITCHES, OPERATING SYSTEMS, OF MOBILE DEVICES; COMPUTER SOFTWARE PLATFORM FOR USE IN ADVERTISING AND MARKETING ANALYSIS, USER TRAFFIC ANALYSIS, AND CUSTOMER SEGMENTATION AND PROFILING; COMPUTER SOFTWARE PLATFORM FOR USE IN CONTENT DELIVERY, NAMELY, VIDEO ON DEMAND, MUSIC ON DEMAND, TEXT ON DEMAND, AUDIO ON DEMAND, STREAMING MEDIA, APPLICATION MAP; COMPUTER SOFTWARE, NAMELY, SOFTWARE DEVELOPMENT TOOLS FOR NETWORK MANAGEMENT AND SECURITY (U.S. CLS. 21, 23, 26, 36 AND 38).

CLASS 35—ADVERTISING AND BUSINESS

FOR PROVIDING BUSINESS INTELLIGENCE CONSULTING SERVICES; OUTSOURCING SERVICES IN THE FIELD OF CUSTOMER RELATIONSHIP MANAGEMENT (CRM) (U.S. CLS. 100, 101 AND 102).

CLASS 38—COMMUNICATION

FOR TELECOMMUNICATIONS GATEWAY SERVICES; TELECONFERENCING AND ELECTRONIC MAIL SERVICES; ELECTRONIC TRANSMISSION OF VOICE, FACSIMILE, DATA AND INFORMATION; PROVISION OF TELECOMMUNICATIONS ACCESS TO COMPUTER DATABASES AND THE INTERNET (U.S. CLS. 100, 101 AND 104).

CLASS 42—SCIENTIFIC AND COMPUTER SERVICES

FOR COMPUTER CONSULTATION AND INTEGRATION OF COMPUTER SYSTEMS AND NETWORKS; DATA MANAGEMENT SERVICES, NAMELY, DATA CONVERSION, DATA STORAGE AND RETRIEVAL, AND DATA RECOVERY; COMPUTER PROGRAMMING SERVICES FOR OTHERS; DESIGN OF NETWORK MANAGEMENT CENTERS AND INTERNET BACKBONE INFRASTRUCTURE AND NETWORKS FOR OTHERS; NETWORK SUPPORT SERVICES IN THE FIELDS OF INTERNET ACCESS, INTERNET PROTOCOL TELEPHONY AND VIRTUAL PRIVATE NETWORKS; AND NETWORK PERFORMANCE AUDITS SERVICES DEVELOPMENT AND IMPLEMENTATION OF OPERATING SYSTEMS (U.S. CLS. 100 AND 101).

DORITT L. CARROLL, EXAMINING ATTORNEY

SN 85-224,929. KNOLLMEYER, GREG M., DBA SPIRAL CHI CENTER, ANN ARBOR, MI. FILED 1-24-2011.



NO CLAIM IS MADE TO THE EXCLUSIVE RIGHT TO USE "CHI CENTER", APART FROM THE MARK AS SHOWN.

THE COLOR(S) BLUE, WHITE IS/ARE CLAIMED AS A FEATURE OF THE MARK.

THE MARK CONSISTS OF THE WORDS "SPIRAL CHI CENTER" IN BLUE UNDERNEATH A PICTURE OF TWO HANDS IN WHITE OUTLINED IN BLUE WITH THE PALMS FACING EACH OTHER AND A SPIRAL IN BLUE BETWEEN THE HANDS. A GRADIENT EMANATES FROM THE SPIRAL AND THE ENTIRE MARK IS ENCLOSED IN A BLUE SQUARE ON A BLuish BACKGROUND.

THE ENGLISH TRANSLATION OF "CHI" IN THE MARK IS "ENERGY".

SN 85-222,372. GET EDUCATED, INC., ESSEX JUNCTION, VT. FILED 1-20-2011.

GET EDUCATED

THE MARK CONSISTS OF STANDARD CHARACTERS WITHOUT CLAIM TO ANY PARTICULAR FONT, STYLE, SIZE, OR COLOR.

CLASS 35—ADVERTISING AND BUSINESS

FOR PROVIDING ONLINE ADVERTISING, PROMOTIONAL AND MARKETING SERVICES TO OTHERS IN THE FIELD OF ONLINE EDUCATION, NAMELY, ONLINE UNIVERSITIES, COLLEGES AND TRAINING PROGRAMS; PROVIDING AN ONLINE DIRECTORY INFORMATION SERVICE FEATURING INFORMATION REGARDING PROSPECTIVE STUDENT'S EVALUATION AND COMPARISON OF ONLINE UNIVERSITIES, COLLEGES AND/OR TRAINING PROGRAMS (U.S. CLS. 100, 101 AND 102).

FIRST USE 12-30-1998; IN COMMERCE 12-30-1998.

CLASS 41—EDUCATION AND ENTERTAINMENT

FOR PROVIDING ONLINE EDUCATIONAL INFORMATION FEATURING REVIEWS, RATINGS, AND RANKINGS OF ONLINE EDUCATION, NAMELY, ONLINE UNIVERSITIES, COLLEGES, AND TRAINING PROGRAMS; PROVIDING ONLINE INFORMATION FEATURING NEWS AND OTHER INFORMATION ABOUT ONLINE EDUCATION, NAMELY, ONLINE UNIVERSITIES, COLLEGES AND TRAINING PROGRAMS (U.S. CLS. 100, 101 AND 107).

FIRST USE 12-30-1998; IN COMMERCE 12-30-1998.
INGRID C. EULIN, EXAMINING ATTORNEY

CLASS 9—ELECTRICAL AND SCIENTIFIC APPARATUS

FOR VIDEO RECORDINGS AND DVDS FEATURING T'AI CHI AND QIGONG (U.S. CLS. 21, 23, 26, 36 AND 38).
FIRST USE 8-1-2006; IN COMMERCE 8-1-2006.

CLASS 16—PAPER GOODS AND PRINTED MATTER

FOR PRINTED INSTRUCTIONAL, EDUCATIONAL, AND TEACHING MATERIALS IN THE FIELD OF T'AI CHI AND QIGONG (U.S. CLS. 2, 5, 22, 23, 29, 37, 38 AND 50).

FIRST USE 8-1-2006; IN COMMERCE 8-1-2006.

CLASS 41—EDUCATION AND ENTERTAINMENT

FOR EDUCATIONAL SERVICES, NAMELY, CONDUCTING CLASSES, WORKSHOPS, AND PRIVATE LESSONS IN THE FIELD OF T'AI CHI AND QIGONG (U.S. CLS. 100, 101 AND 107).

FIRST USE 8-1-2006; IN COMMERCE 8-1-2006.

NAAKWAMA ANKRAH, EXAMINING ATTORNEY

SN 85-225,168. THE MAINSTREET COLLECTION, INC., WASHINGTON, NC. FILED 1-25-2011.

MSC Mainstreet Collection

THE MARK CONSISTS OF STANDARD CHARACTERS WITHOUT CLAIM TO ANY PARTICULAR FONT, STYLE, SIZE, OR COLOR.

NO CLAIM IS MADE TO THE EXCLUSIVE RIGHT TO USE "COLLECTION", APART FROM THE MARK AS SHOWN.

CLASS 8—HAND TOOLS

FOR SPREADER IN THE NATURE OF A SMALL KNIFE FOR BUTTER OR CHEESE (U.S. CLS. 23, 28 AND 44).

FIRST USE 1-0-2005; IN COMMERCE 1-0-2005.

CLASS 9—ELECTRICAL AND SCIENTIFIC APPARATUS

FOR LAPTOP CARRYING CASES (U.S. CLS. 21, 23, 26, 36 AND 38).

FIRST USE 1-0-2009; IN COMMERCE 1-0-2009.

CLASS 14—JEWELRY

FOR JEWELRY CASES (U.S. CLS. 2, 27, 28 AND 50).

FIRST USE 7-0-2008; IN COMMERCE 7-0-2008.

CLASS 16—PAPER GOODS AND PRINTED MATTER

FOR CHILDREN'S BOOKS; DRY ERASE WRITING BOARDS AND WRITING SURFACES; LUNCH BAGS; MINI PHOTO ALBUMS (U.S. CLS. 2, 5, 22, 23, 29, 37, 38 AND 50).

FIRST USE 7-0-2000; IN COMMERCE 7-0-2000.

CLASS 18—LEATHER GOODS

FOR COSMETIC BAGS SOLD EMPTY; COSMETIC CARRYING CASES SOLD EMPTY; COSMETIC CASES SOLD EMPTY; DUFFLE BAGS; TOTE BAGS; WALLETS (U.S. CLS. 1, 2, 3, 22 AND 41).

FIRST USE 1-0-2000; IN COMMERCE 1-0-2000.

CLASS 20—FURNITURE AND ARTICLES NOT OTHERWISE CLASSIFIED

FOR NON-METAL AND NON-LEATHER KEY CHAINS; NON-METAL FABRIC HANGING ORGANIZER (U.S. CLS. 2, 13, 22, 25, 32 AND 50).

FIRST USE 1-0-2008; IN COMMERCE 1-0-2008.

CLASS 21—HOUSEWARES AND GLASS

FOR BOWLS; CHEESE BOARD AND KNIFE SET; DESSERT PLATES; MUGS; TRIVETS (U.S. CLS. 2, 13, 23, 29, 30, 33, 40 AND 50).

FIRST USE 1-0-2005; IN COMMERCE 1-0-2005.

MELISSA VALLILLO, EXAMINING ATTORNEY

SN 85-225,198. FOLLETT CORPORATION, RIVER GROVE, IL. FILED 1-25-2011.

NOTEWORK

THE MARK CONSISTS OF STANDARD CHARACTERS WITHOUT CLAIM TO ANY PARTICULAR FONT, STYLE, SIZE, OR COLOR.

CLASS 35—ADVERTISING AND BUSINESS

FOR ON-LINE RETAIL STORE SERVICES IN THE FIELD OF DIGITAL BOOKS, TEXTBOOKS, AND EDUCATIONAL MATERIALS (U.S. CLS. 100, 101 AND 102).

CLASS 38—COMMUNICATION

FOR DELIVERY OF DIGITAL BOOKS, TEXTBOOKS, AND EDUCATIONAL MATERIALS OF OTHERS VIA THE INTERNET (U.S. CLS. 100, 101 AND 104).

CLASS 42—SCIENTIFIC AND COMPUTER SERVICES

FOR APPLICATION SERVICE PROVIDER FEATURING ELECTRONIC BOOK READER SOFTWARE FOR PURCHASING DIGITAL BOOKS, TEXTBOOKS, AND EDUCATIONAL MATERIALS, READING, ANNOTATING, AND SEARCHING DIGITAL BOOKS, TEXTBOOKS, AND EDUCATIONAL MATERIALS, SHARING WITH OTHERS BOOK ANNOTATIONS, CONTENT, AND NOTES, AND SORTING, ORGANIZING, AND SEARCHING STORED DIGITAL BOOKS, TEXTBOOKS, AND EDUCATIONAL MATERIALS; CREATING AND PROVIDING AN ONLINE COMMUNITY FOR REGISTERED USERS IN THE NATURE OF LEARNERS, STUDENTS, TEACHERS AND OTHER READERS TO POST AND EXCHANGE COMMENTS, REVIEWS, RATINGS, AND RECOMMENDATIONS ON TEXTBOOKS AND EDUCATIONAL MATERIALS AND TO SHARE BOOK ANNOTATIONS, NOTES, AND STUDY INFORMATION WITH OTHER USERS AND ENGAGE IN SOCIAL NETWORKING (U.S. CLS. 100 AND 101).

JULIE VEPPIUMTHARA, EXAMINING ATTORNEY

SN 85-225,338. ROMERO, MARY A., DBA GYM BUTTY, NORTH PALM BEACH, FL. AND ROMERO, RICHARD, DBA GYM BUTTY, NORTH PALM BEACH, FL. FILED 1-25-2011.



NO CLAIM IS MADE TO THE EXCLUSIVE RIGHT TO USE "GYM", APART FROM THE MARK AS SHOWN.

THE COLOR(S) BLUE, WHITE AND BLACK IS/ARE CLAIMED AS A FEATURE OF THE MARK.

THE MARK CONSISTS OF THE STYLIZED WORDING "GYM BUTTY" WITH A DESIGN OF THE UPPER TORSO OF A MAN IN BLUE AND OUTLINED IN BLACK FORMING THE LETTER "G" WITH HIS UPPER BODY AND ARMS. THE COLOR BLACK ALSO APPEARS IN THE LETTERS "YM BUTTY" AND OUTLINING THE TWO RECTANGLES BORDERING THE TEXT AND DESIGN. THE COLOR WHITE APPEARS AS BACKGROUND IN THE MARK INSIDE OF THE RECTANGLES.

CLASS 20—FURNITURE AND ARTICLES NOT OTHERWISE CLASSIFIED

FOR CHAIR MATS IN THE NATURE OF A PILLOW OR SEAT LINER (U.S. CLS. 2, 13, 22, 25, 32 AND 50).

CLASS 28—TOYS AND SPORTING GOODS

FOR PERSONAL EXERCISE MATS (U.S. CLS. 22, 23, 38 AND 50).

NATALIE POLZER, EXAMINING ATTORNEY

SN 85-225,863. SCOTT, ERIC, WOLFEBORO, NH. FILED 1-25-2011.



THE LIKENESS (OR, "PORTRAIT") IN THE MARK DOES NOT IDENTIFY A LIVING INDIVIDUAL.

THE MARK CONSISTS OF THE LITERAL ELEMENTS "THINK BALD!" WRITTEN ABOVE A CARICATURE OF THE HEAD OF A COMPLETELY BALD-HEADED MALE WITH FACIAL HAIR.

CLASS 3—COSMETICS AND CLEANING PREPARATIONS

FOR HAIR REMOVING CREAM, SHAVING BALM, SHAVING CREAMS, SHAVING GELS, SHAVING LOTION, WAX FOR REMOVING BODY HAIR, AND SHAVING PREPARATIONS (U.S. CLS. 1, 4, 6, 50, 51 AND 52).

CLASS 8—HAND TOOLS

FOR RAZOR BLADES, ELECTRONIC RAZORS AND STRAIGHT RAZORS (U.S. CLS. 23, 28 AND 44).
SETH A. RAPPAPORT, EXAMINING ATTORNEY

SN 85-226,335. APPCONOMY, INC., AUSTIN, TX. FILED 1-26-2011.

APPCONOMY

THE MARK CONSISTS OF STANDARD CHARACTERS WITHOUT CLAIM TO ANY PARTICULAR FONT, STYLE, SIZE, OR COLOR.

CLASS 9—ELECTRICAL AND SCIENTIFIC APPARATUS

FOR DOWNLOADABLE SOFTWARE IN THE NATURE OF A MOBILE APPLICATION FOR NOTIFICATIONS, MESSAGING, SMS, MMS, E-MAIL, SOCIAL AND BUSINESS NETWORKING, AND VIRTUAL CALENDARS FOR INDIVIDUALS, ORGANIZATIONS, AND BUSINESSES FOR PURPOSES OF COMMUNICATION, COLLABORATION, ORGANIZATION, AND SOCIAL AND BUSINESS NETWORKING (U.S. CLS. 21, 23, 26, 36 AND 38).

CLASS 41—EDUCATION AND ENTERTAINMENT

FOR ON-LINE JOURNALS, NAMELY, A BLOG CONTAINING TEXT, GRAPHICS, AUDIO, AND VIDEO CLIPS FEATURING NEWS, INFORMATION, TIPS, AND COMMENTARY IN THE FIELD OF SOFTWARE APPLICATIONS FOR USE WITH MOBILE AND STATIONARY CONSUMER ELECTRONIC DEVICES, NAMELY, MOBILE PHONES, HANDHELD COMPUTERS, PORTABLE AND HANDHELD DIGITAL ELECTRONIC DEVICES, HANDHELD COMMUNICATION DEVICES, ELECTRONIC HANDHELD UNITS, TELEPHONES, SMARTPHONES, PERSONAL DIGITAL ASSISTANTS, COMPUTERS, COMPUTER NETWORKS, AND GLOBAL COMMUNICATION NETWORKS (U.S. CLS. 100, 101 AND 107).

CLASS 42—SCIENTIFIC AND COMPUTER SERVICES

FOR DESIGNING AND DEVELOPING SOFTWARE APPLICATIONS AND COMPONENTS FOR INDIVIDUALS AND BUSINESSES FOR USE WITH MOBILE AND STATIONARY CONSUMER ELECTRONIC DEVICES, NAMELY, MOBILE PHONES, HANDHELD COMPUTERS, PORTABLE AND HANDHELD DIGITAL ELECTRONIC DEVICES, HANDHELD COMMUNICATION DEVICES, ELECTRONIC HANDHELD UNITS, TELEPHONES, SMARTPHONES, PERSONAL DIGITAL ASSISTANTS, COMPUTERS, COMPUTER NETWORKS, AND GLOBAL COMMUNICATION NETWORKS (U.S. CLS. 100 AND 101).

LAURIE KAUFMAN, EXAMINING ATTORNEY

SN 85-226,336. APPCONOMY, INC., AUSTIN, TX. FILED 1-26-2011.

THE APPS ARE THE ECONOMY!

THE MARK CONSISTS OF STANDARD CHARACTERS WITHOUT CLAIM TO ANY PARTICULAR FONT, STYLE, SIZE, OR COLOR.

CLASS 9—ELECTRICAL AND SCIENTIFIC APPARATUS

FOR DOWNLOADABLE SOFTWARE IN THE NATURE OF A MOBILE APPLICATION FOR NOTIFICATIONS, MESSAGING, SMS, MMS, E-MAIL, SOCIAL AND BUSINESS NETWORKING, AND VIRTUAL CALENDARS FOR INDIVIDUALS, ORGANIZATIONS, AND BUSINESSES FOR PURPOSES OF COMMUNICATION, COLLABORATION, ORGANIZATION, AND SOCIAL AND BUSINESS NETWORKING (U.S. CLS. 21, 23, 26, 36 AND 38).

CLASS 41—EDUCATION AND ENTERTAINMENT

FOR ON-LINE JOURNALS, NAMELY, A BLOG CONTAINING TEXT, GRAPHICS, AUDIO, AND VIDEO CLIPS FEATURING NEWS, INFORMATION, TIPS, AND COMMENTARY IN THE FIELD OF SOFTWARE APPLICATIONS FOR USE WITH MOBILE AND STATIONARY CONSUMER ELECTRONIC DEVICES, NAMELY, MOBILE PHONES, HANDHELD COMPUTERS, PORTABLE AND HANDHELD DIGITAL ELECTRONIC DEVICES, HANDHELD COMMUNICATION DEVICES, ELECTRONIC HANDHELD UNITS, TELEPHONES, SMARTPHONES, PERSONAL DIGITAL ASSISTANTS, COMPUTERS, COMPUTER NETWORKS, AND GLOBAL COMMUNICATION NETWORKS (U.S. CLS. 100, 101 AND 107).

CLASS 42—SCIENTIFIC AND COMPUTER SERVICES

FOR DESIGNING AND DEVELOPING SOFTWARE APPLICATIONS AND COMPONENTS FOR INDIVIDUALS AND BUSINESSES FOR USE WITH MOBILE AND STATIONERY CONSUMER ELECTRONIC DEVICES, NAMELY, MOBILE PHONES, HANDHELD COMPUTERS, PORTABLE AND HANDHELD DIGITAL ELECTRONIC DEVICES, HANDHELD COMMUNICATION DEVICES, ELECTRONIC HANDHELD UNITS, TELEPHONES, SMARTPHONES, PERSONAL DIGITAL ASSISTANTS, COMPUTERS, COMPUTER NETWORKS, AND GLOBAL COMMUNICATION NETWORKS (U.S. CLS. 100 AND 101).

Laurie Kaufman, Examining Attorney

SN 85-226,882. APPCONOMY, INC., AUSTIN, TX. FILED 1-26-2011.



SN 85-226,393. APPCONOMY, INC., AUSTIN, TX. FILED 1-26-2011.

APPCOMMERCE

THE MARK CONSISTS OF STANDARD CHARACTERS WITHOUT CLAIM TO ANY PARTICULAR FONT, STYLE, SIZE, OR COLOR.

CLASS 9—ELECTRICAL AND SCIENTIFIC APPARATUS

FOR DOWNLOADABLE SOFTWARE IN THE NATURE OF A MOBILE APPLICATION FOR NOTIFICATIONS, MESSAGING, SMS, MMS, E-MAIL, SOCIAL AND BUSINESS NETWORKING, AND VIRTUAL CALENDARS FOR INDIVIDUALS, ORGANIZATIONS, AND BUSINESSES FOR PURPOSES OF COMMUNICATION, COLLABORATION, ORGANIZATION, AND SOCIAL AND BUSINESS NETWORKING (U.S. CLS. 21, 23, 26, 36 AND 38).

CLASS 41—EDUCATION AND ENTERTAINMENT

FOR ON-LINE JOURNALS, NAMELY, A BLOG CONTAINING TEXT, GRAPHICS, AUDIO, AND VIDEO CLIPS FEATURING NEWS, INFORMATION, TIPS, AND COMMENTARY IN THE FIELD OF SOFTWARE APPLICATIONS FOR USE WITH MOBILE AND STATIONARY CONSUMER ELECTRONIC DEVICES, NAMELY, MOBILE PHONES, HANDHELD COMPUTERS, PORTABLE AND HANDHELD DIGITAL ELECTRONIC DEVICES, HANDHELD COMMUNICATION DEVICES, ELECTRONIC HANDHELD UNITS, TELEPHONES, SMARTPHONES, PERSONAL DIGITAL ASSISTANTS, COMPUTERS, COMPUTER NETWORKS, AND GLOBAL COMMUNICATION NETWORKS (U.S. CLS. 100, 101 AND 107).

CLASS 42—SCIENTIFIC AND COMPUTER SERVICES

FOR DESIGNING AND DEVELOPING SOFTWARE APPLICATIONS AND COMPONENTS FOR INDIVIDUALS AND BUSINESSES FOR USE WITH MOBILE AND STATIONERY CONSUMER ELECTRONIC DEVICES, NAMELY, MOBILE PHONES, HANDHELD COMPUTERS, PORTABLE AND HANDHELD DIGITAL ELECTRONIC DEVICES, HANDHELD COMMUNICATION DEVICES, ELECTRONIC HANDHELD UNITS, TELEPHONES, SMARTPHONES, PERSONAL DIGITAL ASSISTANTS, COMPUTERS, COMPUTER NETWORKS, AND GLOBAL COMMUNICATION NETWORKS (U.S. CLS. 100 AND 101).

Laurie Kaufman, Examining Attorney

THE MARK CONSISTS OF A STYLIZED LETTER "A".

CLASS 9—ELECTRICAL AND SCIENTIFIC APPARATUS

FOR DOWNLOADABLE SOFTWARE IN THE NATURE OF A MOBILE APPLICATION FOR NOTIFICATIONS, MESSAGING, SMS, MMS, E-MAIL, SOCIAL AND BUSINESS NETWORKING, AND VIRTUAL CALENDARS FOR INDIVIDUALS, ORGANIZATIONS, AND BUSINESSES FOR PURPOSES OF COMMUNICATION, COLLABORATION, ORGANIZATION, AND SOCIAL AND BUSINESS NETWORKING (U.S. CLS. 21, 23, 26, 36 AND 38).

CLASS 41—EDUCATION AND ENTERTAINMENT

FOR ON-LINE JOURNALS, NAMELY, A BLOG CONTAINING TEXT, GRAPHICS, AUDIO, AND VIDEO CLIPS FEATURING NEWS, INFORMATION, TIPS, AND COMMENTARY IN THE FIELD OF SOFTWARE APPLICATIONS FOR USE WITH MOBILE AND STATIONARY CONSUMER ELECTRONIC DEVICES, NAMELY, MOBILE PHONES, HANDHELD COMPUTERS, PORTABLE AND HANDHELD DIGITAL ELECTRONIC DEVICES, HANDHELD COMMUNICATION DEVICES, ELECTRONIC HANDHELD UNITS, TELEPHONES, SMARTPHONES, PERSONAL DIGITAL ASSISTANTS, COMPUTERS, COMPUTER NETWORKS, AND GLOBAL COMMUNICATION NETWORKS (U.S. CLS. 100, 101 AND 107).

CLASS 42—SCIENTIFIC AND COMPUTER SERVICES

FOR DESIGNING AND DEVELOPING SOFTWARE APPLICATIONS AND COMPONENTS FOR INDIVIDUALS AND BUSINESSES FOR USE WITH MOBILE AND STATIONERY CONSUMER ELECTRONIC DEVICES, NAMELY, MOBILE PHONES, HANDHELD COMPUTERS, PORTABLE AND HANDHELD DIGITAL ELECTRONIC DEVICES, HANDHELD COMMUNICATION DEVICES, ELECTRONIC HANDHELD UNITS, TELEPHONES, SMARTPHONES, PERSONAL DIGITAL ASSISTANTS, COMPUTERS, COMPUTER NETWORKS, AND GLOBAL COMMUNICATION NETWORKS (U.S. CLS. 100 AND 101).

Laurie Kaufman, Examining Attorney

SN 85-228,142. MGR DESIGN INTERNATIONAL, OAK PARK, CA. FILED 1-27-2011.

SN 85-230,402. KINETROL LTD., SURREY, ENGLAND, FILED 1-31-2011.

JULIA RAYMOND

Kinetrol

THE MARK CONSISTS OF STANDARD CHARACTERS WITHOUT CLAIM TO ANY PARTICULAR FONT, STYLE, SIZE, OR COLOR.

THE NAME "JULIA RAYMOND" IDENTIFIES A LIVING INDIVIDUAL WHOSE CONSENT IS OF RECORD.

CLASS 3—COSMETICS AND CLEANING PREPARATIONS

FOR AROMATIC POTPOURRI; INCENSE; POTPOURRI; SCENTED OILS; SCENTED ROOM SPRAYS; ROOM SCENT DIFFUSERS SOLD WITH REEDS AND SCENTED OILS AS A UNIT (U.S. CLS. 1, 4, 6, 50, 51 AND 52).

FIRST USE 6-0-2007; IN COMMERCE 6-0-2007.

CLASS 4—LUBRICANTS AND FUELS

FOR CANDLES; SCENTED CANDLES (U.S. CLS. 1, 6 AND 15).

FIRST USE 6-0-2007; IN COMMERCE 6-0-2007.

B. PARADEWELAI, EXAMINING ATTORNEY

THE MARK CONSISTS OF STANDARD CHARACTERS WITHOUT CLAIM TO ANY PARTICULAR FONT, STYLE, SIZE, OR COLOR.

OWNER OF U.S. REG. NOS. 2,490,085 AND 2,511,645.

CLASS 7—MACHINERY

FOR ROTARY VANE ACTUATORS, ROTARY DAMPERS AND HYDRAULIC POWER PACKS AND OVERRIDE GEAR BOXES FOR SAME (U.S. CLS. 13, 19, 21, 23, 31, 34 AND 35).

FIRST USE 12-31-1959; IN COMMERCE 6-3-1964.

CLASS 9—ELECTRICAL AND SCIENTIFIC APPARATUS

FOR CONTROL UNITS FOR ACTUATORS, NAMELY, ROTARY SPRING RETURNS, PNEUMATIC POSITIONERS, I/P CONVERTERS, ANGLE TRANSDUCERS, DIGITAL COMMUNICATIONS INTERFACES, POSITION INDICATORS, ELECTRONIC FLOW CONTROLLERS, SOLENOID VALVES, 180 DEGREE ANGLE CONVERTORS, OUTPUT ADAPTERS AND VISUAL POSITION MONITORS (U.S. CLS. 21, 23, 26, 36 AND 38).

FIRST USE 12-31-1959; IN COMMERCE 6-3-1964.

LINDA M. KING, EXAMINING ATTORNEY

SN 85-230,029. SMART KIDZ MEDIA, INC., CARSON CITY, NV. FILED 1-31-2011.

SN 85-230,895. CIGNA INTELLECTUAL PROPERTY, INC., CLAYMONT, DE. FILED 2-1-2011.

Bookmark Buddies

CIGNA GLOBAL HEALTH OPTIONS

THE MARK CONSISTS OF STANDARD CHARACTERS WITHOUT CLAIM TO ANY PARTICULAR FONT, STYLE, SIZE, OR COLOR.

NO CLAIM IS MADE TO THE EXCLUSIVE RIGHT TO USE "BOOKMARK" AS TO CLASS 16, APART FROM THE MARK AS SHOWN.

CLASS 16—PAPER GOODS AND PRINTED MATTER

FOR BOOK MARKERS; BOOKMARKERS; BOOKMARKS (U.S. CLS. 2, 5, 22, 23, 29, 37, 38 AND 50).

FIRST USE 6-1-2010; IN COMMERCE 6-1-2010.

CLASS 28—TOYS AND SPORTING GOODS

FOR PLUSH TOYS; STUFFED AND PLUSH TOYS; STUFFED TOY ANIMALS; TOY ANIMALS (U.S. CLS. 22, 23, 38 AND 50).

FIRST USE 6-1-2010; IN COMMERCE 6-1-2010.

MICHAEL ENGEL, EXAMINING ATTORNEY

THE MARK CONSISTS OF STANDARD CHARACTERS WITHOUT CLAIM TO ANY PARTICULAR FONT, STYLE, SIZE, OR COLOR.

OWNER OF U.S. REG. NOS. 1,270,224, 2,563,544 AND OTHERS.

NO CLAIM IS MADE TO THE EXCLUSIVE RIGHT TO USE "GLOBAL HEALTH OPTIONS", APART FROM THE MARK AS SHOWN.

CLASS 36—INSURANCE AND FINANCIAL

FOR INSURANCE SERVICES, NAMELY, INSURANCE ADMINISTRATION IN THE FIELDS OF MEDICAL, DENTAL, VISION, EVACUATION AND WELLNESS INSURANCE; INSURANCE SERVICES, NAMELY, UNDERWRITING IN THE FIELDS OF MEDICAL, DENTAL, VISION, EVACUATION AND WELLNESS INSURANCE; ADMINISTRATION OF EMPLOYEE BENEFIT PLANS CONCERNING HEALTH INSURANCE; INSURANCE SERVICES, NAMELY, UNDERWRITING, ISSUANCE AND ADMINISTRATION OF HEALTH, DENTAL, VISION, EVACUATION AND REPATRIATION INSURANCE FOR EXPATRIATES (U.S. CLS. 100, 101 AND 102).

CLASS 44—MEDICAL, BEAUTY AND AGRICULTURAL SERVICES

FOR HEALTH AND WELLNESS ASSESSMENT SERVICES, NAMELY, PROVIDING AN ONLINE INTERACTIVE HEALTH AND WELLNESS QUESTIONNAIRE TO BE USED TO EVALUATE AN INDIVIDUAL'S HEALTH HABITS AND LIFESTYLE, AND RECOMMEND IMPROVEMENTS; HEALTH AND WELLNESS COUNSELING AND CONSULTING SERVICES; HEALTH COACHING SERVICES, NAMELY, SELF-DIRECTED, ONLINE INTERACTIVE NUTRITIONAL, PHYSICAL ACTIVITY, SLEEP HABITS AND STRESS MANAGEMENT PROGRAMS (U.S. CLS. 100 AND 101).

JAY FLOWERS, EXAMINING ATTORNEY

SN 85-231,132. VYAPAR CAPITAL MARKET PARTNERS LLC, NEW YORK, NY. FILED 2-1-2011.

VOLMAX

THE MARK CONSISTS OF STANDARD CHARACTERS WITHOUT CLAIM TO ANY PARTICULAR FONT, STYLE, SIZE, OR COLOR.

CLASS 36—INSURANCE AND FINANCIAL

FOR GLOBAL FINANCIAL SERVICES IN THE NATURE OF AN ELECTRONIC MATCHING SERVICE FOR OVER THE COUNTER OR EXCHANGE TRADED DERIVATIVES INSTRUMENTS (U.S. CLS. 100, 101 AND 102).

FIRST USE 5-1-2010; IN COMMERCE 5-1-2010.

CLASS 38—COMMUNICATION

FOR TELECOMMUNICATIONS SERVICES, NAMELY, PROVIDING ACCESS TO SECURED ONLINE INTERFACE VIA THE INTERNET TO IDENTIFY, ANALYZE AND EFFECTUATE TRADES BETWEEN DEALERS (U.S. CLS. 100, 101 AND 104).

FIRST USE 5-1-2010; IN COMMERCE 5-1-2010.

LINDA E. BLOHM, EXAMINING ATTORNEY

SN 85-231,259. SHONK INVESTMENTS, LTD., AUSTIN, TX. FILED 2-1-2011.

HOLIDAYS CENTRAL

THE MARK CONSISTS OF STANDARD CHARACTERS WITHOUT CLAIM TO ANY PARTICULAR FONT, STYLE, SIZE, OR COLOR.

NO CLAIM IS MADE TO THE EXCLUSIVE RIGHT TO USE "HOLIDAYS", APART FROM THE MARK AS SHOWN.

CLASS 9—ELECTRICAL AND SCIENTIFIC APPARATUS

FOR DOWNLOADABLE SOFTWARE IN THE NATURE OF A MOBILE APPLICATION FOR PROVIDING INFORMATION IN THE FIELDS OF ENTERTAINMENT AND LEISURE, SHOPPING, RECIPES AND OBSERVED CALENDAR-BASED HOLIDAYS IN THE UNITED STATES (U.S. CLS. 21, 23, 26, 36 AND 38).

CLASS 35—ADVERTISING AND BUSINESS

FOR CONDUCTING PUBLIC OPINION POLLS; ADVERTISING AND DIRECTORY SERVICES, NAMELY, PROMOTING THE GOODS AND SERVICES OF OTHERS BY PROVIDING WEB LINKS TO THE RETAIL WEB SITES OF OTHERS; PROMOTING A WEBSITE FEATURING CONSUMER INFORMATION IN THE FIELDS OF HOME ENTERTAINMENT, RECIPES AND IDEAS FOR CELEBRATING OBSERVED CALENDAR-BASED HOLIDAYS IN THE UNITED STATES (U.S. CLS. 100, 101 AND 102).

CLASS 41—EDUCATION AND ENTERTAINMENT

FOR PROVIDING INFORMATION AND NEWS IN THE FIELD OF TEACHING METHODOLOGY AND EDUCATION; PROVIDING INFORMATION AND NEWS FOR THE ENTERTAINMENT OF CHILDREN; PROVIDING A WEBSITE WHERE USERS CAN POST RATINGS, REVIEWS AND RECOMMENDATIONS ON EVENTS AND ACTIVITIES IN THE FIELD OF ENTERTAINMENT, NAMELY, ENTERTAINMENT-RELATED ACTIVITIES CONCERNING OBSERVED CALENDAR-BASED HOLIDAYS IN THE UNITED STATES; PROVIDING MOBILE AND ONLINE INFORMATION RELATED TO SOCIAL ENTERTAINMENT EVENTS, PARTY PLANNING AND SPECIAL EVENTS FOR SOCIAL ENTERTAINMENT PURPOSES; PROVIDING NEWS AND INFORMATION IN THE FIELD OF ENTERTAINMENT-RELATED ACTIVITIES AND TRENDS CONCERNING OBSERVED CALENDAR-BASED HOLIDAYS IN THE UNITED STATES (U.S. CLS. 100, 101 AND 107).

CLASS 42—SCIENTIFIC AND COMPUTER SERVICES

FOR PROVIDING AN INTERACTIVE WEB SITE THAT ENABLES USERS TO ACCESS INFORMATION PERTAINING TO SPECIAL EVENTS FOR SOCIAL ENTERTAINMENT PURPOSES, RECIPES, AND SPECIAL EVENTS AND ACTIVITIES PERTAINING TO OBSERVED CALENDAR-BASED HOLIDAYS IN THE UNITED STATES; PROVIDING A WEB SITE FEATURING TEMPORARY USE OF NON-DOWNLOADABLE SOFTWARE FEATURING AN ONLINE COUNTDOWN CALENDAR FOR SPECIAL EVENTS, SPECIAL OCCASIONS, AND OBSERVED CALENDAR-BASED HOLIDAYS IN THE UNITED STATES (U.S. CLS. 100 AND 101).

CLASS 43—HOTEL AND RESTAURANT SERVICES

FOR PROVIDING A WEBSITE WHERE USERS CAN POST RATINGS, REVIEWS AND RECOMMENDATIONS ON RECIPES FOR FOOD APPRECIATION PURPOSES; PROVIDING MOBILE AND ONLINE INFORMATION IN THE NATURE OF A DATABASE IN THE FIELD OF RECIPES; PROVIDING NEWS AND INFORMATION IN THE FIELD OF RECIPES (U.S. CLS. 100 AND 101).

CLASS 45—PERSONAL AND LEGAL SERVICES

FOR ONLINE SOCIAL NETWORKING; PROVIDING ADVICE AND INFORMATION ON APPROPRIATE GIFTS FOR FAMILY, FRIENDS, SIGNIFICANT OTHERS AND CO-WORKERS (U.S. CLS. 100 AND 101).

MARC LEIPZIG, EXAMINING ATTORNEY

SN 85-231,455. GAMES PEOPLE PLAY, INC., BEAUMONT, TX. FILED 2-1-2011.

SN 85-231,954. TELEvisa, S.A. DE C.V., SANTA FE, MEXICO, FILED 2-2-2011.



OWNER OF MEXICO REG. NO. 1179189, DATED 7-20-2010, EXPIRES 7-20-2020.

OWNER OF MEXICO REG. NO. 1177318, DATED 7-20-2010, EXPIRES 7-20-2020.

THE NAME(S), PORTRAIT(S), AND/OR SIGNATURE(S) SHOWN IN THE MARK DOES NOT IDENTIFY A PARTICULAR LIVING INDIVIDUAL.

COLOR IS NOT CLAIMED AS A FEATURE OF THE MARK. THE MARK CONSISTS OF THE DESIGNATION "TERESA" FORMED BY VINES AND ACCOMPANIED BY A ROSE BUD DESIGN AT THE END OF THE LETTER "T" AND A ROSE PETAL DESIGN AT THE END OF THE LETTER "A".

CLASS 9—ELECTRICAL AND SCIENTIFIC APPARATUS

FOR PRE-RECORDED DIGITAL AND ELECTRONIC MEDIA, NAMELY, CDS AND DVDS FEATURING A SERIES OF FICTIONAL DRAMATIC TELEVISION SHOWS (U.S. CLS. 21, 23, 26, 36 AND 38).

CLASS 41—EDUCATION AND ENTERTAINMENT

FOR ONGOING DRAMATIC TELEVISION PROGRAM (U.S. CLS. 100, 101 AND 107).

JAMES A. RAUEN, EXAMINING ATTORNEY

OWNER OF U.S. REG. NO. 3,951,820. NO CLAIM IS MADE TO THE EXCLUSIVE RIGHT TO USE "GAMES", APART FROM THE MARK AS SHOWN.

THE COLOR(S) WHITE, BLUE AND ORANGE IS/ARE CLAIMED AS A FEATURE OF THE MARK.

THE MARK CONSISTS OF THE WORD "GAMES" IN WHITE UPPERCASE LETTERING INSIDE A BLUE RECTANGLE HAVING AN ARCED TOP AND BOTTOM AND WHITE AND BLUE BORDERS ABOVE A WHITE GOLF BALL HAVING BLUE SHADED DIMPLES; TO THE LEFT AND RIGHT OF THE BALL ARE ORANGE SPIKED RAYS; UNDER THE BALL ARE THE WORDS "PEOPLE PLAY" IN WHITE UPPERCASE LETTERING INSIDE A BLUE RECTANGLE HAVING WHITE AND BLUE BORDERS.

CLASS 35—ADVERTISING AND BUSINESS

FOR CUSTOMER SERVICES, NAMELY, RESPONDING TO CUSTOMERS INQUIRIES FOR OTHERS IN THE FIELD OF GOLF; RETAIL STORE AND ON-LINE RETAIL STORE SERVICES FEATURING GOLF EQUIPMENT, GOLF ACCESSORIES AND GOLF APPAREL (U.S. CLS. 100, 101 AND 102).

FIRST USE 1-1-1999; IN COMMERCE 1-1-1999.

CLASS 41—EDUCATION AND ENTERTAINMENT

FOR GOLF INSTRUCTION SERVICES; AND FITTING AND RE-FITTING OF GOLF CLUBS TO INDIVIDUAL USERS (U.S. CLS. 100, 101 AND 107).

FIRST USE 1-1-1999; IN COMMERCE 1-1-1999. MARC LEIPZIG, EXAMINING ATTORNEY

SN 85-232,380. ALUMA TOWER COMPANY, INC., VERO BEACH, FL. FILED 2-2-2011.

SCORPION

THE MARK CONSISTS OF STANDARD CHARACTERS WITHOUT CLAIM TO ANY PARTICULAR FONT, STYLE, SIZE, OR COLOR.

CLASS 6—METAL GOODS

FOR TRANSPORTABLE METAL CONSTRUCTIONS IN THE NATURE OF TRAILER MOUNTED COLLAPSIBLE MOBILE METAL TOWERS (U.S. CLS. 2, 12, 13, 14, 23, 25 AND 50).

FIRST USE 6-25-2009; IN COMMERCE 6-25-2009.

CLASS 9—ELECTRICAL AND SCIENTIFIC APPARATUS

FOR MOBILE TELECOMMUNICATION TOWERS (U.S. CLS. 21, 23, 26, 36 AND 38).
FIRST USE 6-25-2009; IN COMMERCE 6-25-2009.
NELSON SNYDER, EXAMINING ATTORNEY

SN 85-233,818. J.A. DEL RIO Y ASOCIADOS, S.C., GUADALAJARA, MEXICO, FILED 2-3-2011.

J.A. DEL RIO Y ASOCIADOS

SN 85-232,490. MOUNTAIN RESCUE ASSOCIATION, SAN DIEGO, CA. FILED 2-2-2011.



OWNER OF U.S. REG. NOS. 722,413 AND 1,158,662.
THE COLOR(S) BLUE AND WHITE IS/ARE CLAIMED AS A FEATURE OF THE MARK.
THE MARK CONSISTS OF A CIRCULAR DESIGN WITH THE WORDS "MOUNTAIN RESCUE" IN THE OUTER CIRCLE. THE WORDS ARE IN WHITE AND THE OUTER CIRCLE IS BLUE. INSIDE AN INNER CIRCLE IS A DEPICTION OF A MOUNTAIN IN BLUE WITH A WHITE CROSS WITHIN IT.
SEC. 2(F) AS TO "MOUNTAIN RESCUE".
THE 2(F) IN PART CLAIM IS RESTRICTED TO CLASS(ES) 41 AND 45.

CLASS 25—CLOTHING

FOR CLOTHING; NAMELY, T-SHIRTS, HATS, SWEATSHIRTS, POLO SHIRTS, LONG SLEEVE SHIRTS, JACKETS, PARKAS, VESTS, THERMAL UNDERWEAR AND SKI WEAR (U.S. CLS. 22 AND 39).
FIRST USE 0-0-1954; IN COMMERCE 0-0-1954.

CLASS 41—EDUCATION AND ENTERTAINMENT

FOR EDUCATIONAL SERVICES; NAMELY, CONDUCTING CLASSES, WORKSHOPS AND SEMINARS IN THE FIELD OF OUTDOOR SAFETY AND DISTRIBUTING COURSE MATERIALS IN CONNECTION THEREWITH; PUBLICATION OF BROCHURES, BOOKS AND PAPERS ON OUTDOOR SAFETY (U.S. CLS. 100, 101 AND 107).
FIRST USE 0-0-1963; IN COMMERCE 0-0-1963.

CLASS 45—PERSONAL AND LEGAL SERVICES

FOR PROVIDING SAFETY INFORMATION IN THE FIELD OF SEARCH, RESCUE, AND EVACUATION OF INJURED PERSONNEL IN MOUNTAINOUS TERRAIN, AND PROVIDING INFORMATION CONCERNING SAFETY RISKS IN THE BACK COUNTRY AND/OR AVALANCHE TERRAIN (U.S. CLS. 100 AND 101).
FIRST USE 8-11-1995; IN COMMERCE 8-11-1995.
KAREN K. BUSH, EXAMINING ATTORNEY

THE MARK CONSISTS OF STANDARD CHARACTERS WITHOUT CLAIM TO ANY PARTICULAR FONT, STYLE, SIZE, OR COLOR.

NO CLAIM IS MADE TO THE EXCLUSIVE RIGHT TO USE "Y ASOCIADOS", APART FROM THE MARK AS SHOWN.

THE NAME(S), PORTRAIT(S), AND/OR SIGNATURE(S) SHOWN IN THE MARK IDENTIFIES "JUAN ANTONIO DEL RIO", WHOSE CONSENT(S) TO REGISTER IS MADE OF RECORD.

THE ENGLISH TRANSLATION OF "Y ASOCIADOS" IN THE MARK IS "AND ASSOCIATES".

CLASS 35—ADVERTISING AND BUSINESS

FOR ACCOUNT AUDITING; ACCOUNTING SERVICES; FINANCIAL RECORDS MANAGEMENT; TAX AND TAXATION PLANNING, ADVICE, INFORMATION AND CONSULTANCY SERVICES (U.S. CLS. 100, 101 AND 102).
FIRST USE 7-18-1988; IN COMMERCE 7-18-1988.

CLASS 36—INSURANCE AND FINANCIAL

FOR FINANCIAL ADVICE AND CONSULTANCY SERVICES (U.S. CLS. 100, 101 AND 102).
FIRST USE 7-18-1988; IN COMMERCE 7-18-1988.
MELISSA VALLILLO, EXAMINING ATTORNEY

SN 85-234,394. CUTTER & BUCK INC., SEATTLE, WA. FILED 2-4-2011.



OWNER OF U.S. REG. NOS. 1,660,896 AND 2,311,321.
THE MARK CONSISTS OF THE LETTERS "C" AND "B" IN A STYLIZED FORM.

CLASS 9—ELECTRICAL AND SCIENTIFIC APPARATUS

FOR EYE GLASSES; SUN GLASSES; CARRYING CASES FOR USB (UNIVERSAL SERIAL BUS) FLASH DRIVES; COMPUTER STORAGE DEVICES, NAMELY, BLANK FLASH DRIVES; CARRYING CASES FOR CELL PHONES; MOUSEPADS; ELECTRONIC NOTE TAKERS IN THE NATURE OF POCKET COMPUTERS FOR NOTE-TAKING; CHARGER DISPLAY CASES, NAMELY, BATTERY CHARGERS ATTACHED TO CASES WITH DISPLAY PANELS (U.S. CLS. 21, 23, 26, 36 AND 38).

CLASS 14—JEWELRY

SN 85-234,586. VIA680 LLC, YOUNGSTOWN, OH. FILED 2-4-2011.

FOR JEWELRY; WATCHES; CLOCKS; TRAVEL CLOCKS; HOROLOGICAL AND CHRONOMETRIC INSTRUMENTS AND PARTS THEREOF; HOROLOGICAL AND CHRONOMETRIC INSTRUMENTS AND CASES THEREFOR; CLOCK CASES; KEY CHAINS OF PRECIOUS METAL (U.S. CLS. 2, 27, 28 AND 50).

CLASS 16—PAPER GOODS AND PRINTED MATTER

FOR PENS; PEN SETS COMPRISED OF PENS; PENCILS; WRITING INSTRUMENTS; BLOTTERS; LEATHER WRITING PADS; ZIPPERED PADFOLIOS; TRI-FOLD PADFOLIOS; NOTE PAD HOLDERS; STATIONERY; MEMO PADS; MEMO BOXES; PHOTO STORAGE BOXES; DESKTOP ORGANIZERS; PERSONAL ORGANIZERS; CALENDARS; FOLDERS; PASSPORT HOLDERS; LEATHER MONEY CLIPS; LEATHER PHOTO STORAGE BOXES (U.S. CLS. 2, 5, 22, 23, 29, 37, 38 AND 50).

CLASS 18—LEATHER GOODS

FOR TRUNKS; TRAVELING BAGS; ALL PURPOSE SPORT, CARRYON, DUFFEL, AND OVERNIGHT BAGS; LUGGAGE; UMBRELLAS; SHAVING BAGS SOLD EMPTY; PURSES; BRIEFCASES; BACKPACKS; WALLET; LEATHER KEY CHAINS; LEATHER LUGGAGE TAGS; SHOE BAGS FOR TRAVEL; LEATHER POUCHES; LEATHER TOTE BAGS FOR CARRYING WINE BOTTLES (U.S. CLS. 1, 2, 3, 22 AND 41).

THE MARK CONSISTS OF STANDARD CHARACTERS WITHOUT CLAIM TO ANY PARTICULAR FONT, STYLE, SIZE, OR COLOR.

CLASS 21—HOUSEWARES AND GLASS

FOR DRINKWARE, NAMELY, BEVERAGE GLASSWARE, CUPS, AND MUGS; KITCHEN CONTAINERS; CONTAINERS FOR HOUSEHOLD OR KITCHEN USE; CORK SCREWS; PLASTIC WARE FOR EVERYDAY USE, NAMELY, BOWLS, PLATES, AND CUPS; GLASSWARE FOR EVERYDAY USE, NAMELY, BOWLS, PLATES, AND CUPS; INSULATED CONTAINERS FOR FOOD OR BEVERAGES FOR DOMESTIC USE; LEATHER COASTERS (U.S. CLS. 2, 13, 23, 29, 30, 33, 40 AND 50).

CLASS 35—ADVERTISING AND BUSINESS

FOR BUSINESS CONSULTING SERVICES, NAMELY, PROVIDING BUSINESS ADVICE AND BUSINESS ASSISTANCE FOR THE CREATION AND ASSEMBLY OF INFORMATION TO BE DISSEMINATED TO TARGETED AUDIENCES VIA A COMPUTER NETWORK; BUSINESS DATA ANALYSIS, NAMELY, TABULATING AND ANALYZING FEEDBACK FROM TARGETED AUDIENCES TO WHOM CUSTOMER-ASSEMBLED INFORMATION IS DISSEMINATED VIA A COMPUTER NETWORK; BUSINESS ASSISTANCE SERVICES, NAMELY, UTILIZING FEEDBACK FROM TARGETED AUDIENCES TO PROVIDE ADVICE AND ASSISTANCE IN THE CREATION AND ASSEMBLY OF INFORMATION TO BE DISSEMINATED TO TARGETED AUDIENCES VIA A COMPUTER NETWORK (U.S. CLS. 100, 101 AND 102).

FIRST USE 9-30-2010; IN COMMERCE 9-30-2010.

CLASS 24—FABRICS

FOR TOWELS; GOLF TOWELS (U.S. CLS. 42 AND 50).

CLASS 38—COMMUNICATION

FOR TRANSMITTING CUSTOMER-ASSEMBLED INFORMATION VIA A COMPUTER NETWORK; INFORMATION TRANSMISSION VIA ELECTRONIC COMMUNICATIONS NETWORKS; PROVIDING ACCESS TO ELECTRONIC SITES FEATURING CUSTOMER-ASSEMBLED INFORMATION; INFORMATION TRANSMISSION VIA ELECTRONIC COMMUNICATIONS NETWORKS, NAMELY, DISSEMINATION OF CUSTOMER-ASSEMBLED INFORMATION TO A TARGETED AUDIENCE VIA A COMPUTER NETWORK (U.S. CLS. 100, 101 AND 104).

FIRST USE 9-30-2010; IN COMMERCE 9-30-2010.

CLASS 25—CLOTHING

FOR CLOTHING, NAMELY, SHIRTS, BLOUSES, JACKETS, COATS, SWEATERS, SWEATSHIRTS, PULL-OVERS, PANTS, SHORTS, SKIRTS, SKORTS, DRESSES, RAIN WEAR, VESTS, SWIMSUITS, BEACH COVERUPS, SOCKS, HATS, CAPS, GLOVES, SCARVES, AND BELTS; HEAD WEAR (U.S. CLS. 22 AND 39).

CLASS 39—TRANSPORTATION AND STORAGE

FOR PROVIDING A WEB SITE FOR THE ELECTRONIC STORAGE OF CUSTOMER-ASSEMBLED ELECTRONIC INFORMATION VIA A COMPUTER NETWORK; ELECTRONIC STORAGE OF CUSTOMER-ASSEMBLED ELECTRONIC INFORMATION VIA A COMPUTER NETWORK (U.S. CLS. 100 AND 105).

FIRST USE 9-30-2010; IN COMMERCE 9-30-2010.

CLASS 28—TOYS AND SPORTING GOODS

FOR DIVOT REPAIR TOOLS FOR GOLFERS; GOLF GLOVES; GOLF BAGS; GOLF ACCESSORY POUCHES (U.S. CLS. 22, 23, 38 AND 50).

WON TEAK OH, EXAMINING ATTORNEY

CLASS 42—SCIENTIFIC AND COMPUTER SERVICES

FOR SOFTWARE AS A SERVICE (SAAS) SERVICES FEATURING SOFTWARE FOR THE UPLOADING AND STORAGE OF CUSTOMER-ASSEMBLED ELECTRONIC INFORMATION IN THE NATURE RICH MEDIA CONTENT WHICH MAY INCLUDE DATA, PUBLICATIONS, DOCUMENTS, PHOTOGRAPHS AND IMAGES, VIDEOS, AUDIO FILES, QUESTIONNAIRES AND MESSAGES VIA A COMPUTER NETWORK, TRANSMITTING CUSTOMER-ASSEMBLED INFORMATION VIA A COMPUTER NETWORK, PROVIDING ACCESS TO ELECTRONIC SITES FEATURING CUSTOMER-ASSEMBLED INFORMATION, DISSEMINATION OF CUSTOMER-ASSEMBLED INFORMATION TO A TARGETED AUDIENCE VIA A COMPUTER NETWORK, UTILIZING FEEDBACK FROM TARGETED AUDIENCES TO PROVIDE ADVICE AND ASSISTANCE IN THE CREATION AND ASSEMBLY OF INFORMATION TO BE DISSEMINATED VIA SOFTWARE AS A SERVICE OVER A COMPUTER NETWORK; COMPUTER SOFTWARE CONSULTING SERVICES, NAMELY, PROVIDING ADVICE AND ASSISTANCE REGARDING USE OF SOFTWARE FOR THE CREATION AND ASSEMBLY OF INFORMATION TO BE DISSEMINATED TO TARGETED AUDIENCES VIA A COMPUTER NETWORK (U.S. CLS. 100 AND 101).

FIRST USE 9-30-2010; IN COMMERCE 9-30-2010.
APRIL HESIK, EXAMINING ATTORNEY

SN 85-234,595. VIA680 LLC, YOUNGSTOWN, OH. FILED 2-4-2011.



THE COLOR(S) LIME GREEN AND FOREST GREEN IS/ARE CLAIMED AS A FEATURE OF THE MARK.

THE MARK CONSISTS OF THE WORD "VIA" IN LOWER CASE LETTERS IN LIME GREEN AND THE NUMBERS "680" IN FOREST GREEN, WITH "680" PARTIALLY ENCLOSED IN A FOREST GREEN LOOP THAT ENDS IMMEDIATELY ABOVE AND BELOW THE CENTER OF THE "6".

CLASS 35—ADVERTISING AND BUSINESS

FOR BUSINESS CONSULTING SERVICES, NAMELY, PROVIDING BUSINESS ADVICE AND BUSINESS ASSISTANCE FOR THE CREATION AND ASSEMBLY OF INFORMATION TO BE DISSEMINATED TO TARGETED AUDIENCES VIA A COMPUTER NETWORK; BUSINESS DATA ANALYSIS, NAMELY, TABULATING AND ANALYZING FEEDBACK FROM TARGETED AUDIENCES TO WHOM CUSTOMER-ASSEMBLED INFORMATION IS DISSEMINATED VIA A COMPUTER NETWORK; BUSINESS ASSISTANCE SERVICES, NAMELY, UTILIZING FEEDBACK FROM TARGETED AUDIENCES TO PROVIDE ADVICE AND ASSISTANCE IN THE CREATION AND ASSEMBLY OF INFORMATION TO BE DISSEMINATED TO TARGETED AUDIENCES VIA A COMPUTER NETWORK (U.S. CLS. 100, 101 AND 102).

FIRST USE 10-6-2010; IN COMMERCE 10-6-2010.

CLASS 38—COMMUNICATION

FOR TRANSMITTING CUSTOMER-ASSEMBLED INFORMATION VIA A COMPUTER NETWORK; INFORMATION TRANSMISSION VIA ELECTRONIC COMMUNICATIONS NETWORKS; PROVIDING ACCESS TO ELECTRONIC SITES FEATURING CUSTOMER-ASSEMBLED INFORMATION; INFORMATION TRANSMISSION VIA ELECTRONIC COMMUNICATIONS NETWORKS, NAMELY, DISSEMINATION OF CUSTOMER-ASSEMBLED INFORMATION TO A TARGETED AUDIENCE VIA A COMPUTER NETWORK (U.S. CLS. 100, 101 AND 104).

FIRST USE 10-6-2010; IN COMMERCE 10-6-2010.

CLASS 39—TRANSPORTATION AND STORAGE

FOR PROVIDING A WEB SITE FOR THE ELECTRONIC STORAGE OF CUSTOMER-ASSEMBLED ELECTRONIC INFORMATION VIA A COMPUTER NETWORK; ELECTRONIC STORAGE OF CUSTOMER-ASSEMBLED ELECTRONIC INFORMATION VIA A COMPUTER NETWORK (U.S. CLS. 100 AND 105).

FIRST USE 10-6-2010; IN COMMERCE 10-6-2010.

CLASS 42—SCIENTIFIC AND COMPUTER SERVICES

FOR SOFTWARE AS A SERVICE (SAAS) SERVICES FEATURING SOFTWARE FOR THE UPLOADING AND STORAGE OF CUSTOMER-ASSEMBLED ELECTRONIC INFORMATION IN THE NATURE RICH MEDIA CONTENT WHICH MAY INCLUDE DATA, PUBLICATIONS, DOCUMENTS, PHOTOGRAPHS AND IMAGES, VIDEOS, AUDIO FILES, QUESTIONNAIRES AND MESSAGES VIA A COMPUTER NETWORK, TRANSMITTING CUSTOMER-ASSEMBLED INFORMATION VIA A COMPUTER NETWORK, PROVIDING ACCESS TO ELECTRONIC SITES FEATURING CUSTOMER-ASSEMBLED INFORMATION, DISSEMINATION OF CUSTOMER-ASSEMBLED INFORMATION TO A TARGETED AUDIENCE VIA A COMPUTER NETWORK, UTILIZING FEEDBACK FROM TARGETED AUDIENCES TO PROVIDE ADVICE AND ASSISTANCE IN THE CREATION AND ASSEMBLY OF INFORMATION TO BE DISSEMINATED VIA SOFTWARE AS A SERVICE OVER A COMPUTER NETWORK; COMPUTER SOFTWARE CONSULTING SERVICES, NAMELY, PROVIDING ADVICE AND ASSISTANCE REGARDING USE OF SOFTWARE FOR THE CREATION AND ASSEMBLY OF INFORMATION TO BE DISSEMINATED TO TARGETED AUDIENCES VIA A COMPUTER NETWORK (U.S. CLS. 100 AND 101).

FIRST USE 10-6-2010; IN COMMERCE 10-6-2010.
APRIL HESIK, EXAMINING ATTORNEY

SN 85-235,148. COCOVINA, INC., SUGAR LAND, TX. FILED 2-6-2011.



THE COLOR(S) GREEN AND BLACK IS/ARE CLAIMED AS A FEATURE OF THE MARK.

THE MARK CONSISTS OF LARGE CASE LETTER "C" WHEREIN LOWER DISTAL END CURVES TO FORM A COCONUT RESEMBLING A LOWER CASE LETTER "O", THE FOREGOING APPEARING IN GREEN AND BLACK.

NO CLAIM IS MADE TO THE EXCLUSIVE RIGHT TO USE "COMMUNITIES" OR "INSTITUTE", APART FROM THE MARK AS SHOWN.

CLASS 22—CORDAGE AND FIBERS

FOR COCONUT COIR FIBER (U.S. CLS. 1, 2, 7, 19, 22, 42 AND 50).

CLASS 31—NATURAL AGRICULTURAL PRODUCTS

FOR NON-FERTILIZING PLANT GROWTH MEDIUM DERIVED FROM COCONUT, NAMELY, COCOPEAT AND COIR PITH (U.S. CLS. 1 AND 46).

CLASS 37—CONSTRUCTION AND REPAIR

FOR PROCESSING OF AGRICULTURAL MATERIAL, NAMELY, COCONUTS (U.S. CLS. 100, 103 AND 106).
HELENE LIWINSKI, EXAMINING ATTORNEY

SN 85-235,153. COCOVINA, INC., SUGAR LAND, TX. FILED 2-6-2011.

COCOVINA

THE MARK CONSISTS OF STANDARD CHARACTERS WITHOUT CLAIM TO ANY PARTICULAR FONT, STYLE, SIZE, OR COLOR.

CLASS 22—CORDAGE AND FIBERS

FOR COCONUT COIR FIBER (U.S. CLS. 1, 2, 7, 19, 22, 42 AND 50).

CLASS 31—NATURAL AGRICULTURAL PRODUCTS

FOR NON-FERTILIZING PLANT GROWTH MEDIUM DERIVED FROM COCONUT, NAMELY, COCOPEAT AND COIR PITH (U.S. CLS. 1 AND 46).

CLASS 37—CONSTRUCTION AND REPAIR

FOR PROCESSING OF AGRICULTURAL MATERIAL, NAMELY, COCONUT, FOR COMMERCIAL AND INDUSTRIAL USE (U.S. CLS. 100, 103 AND 106).
HELENE LIWINSKI, EXAMINING ATTORNEY

SN 85-237,305. CISCO TECHNOLOGY, INC., SAN JOSE, CA. FILED 2-8-2011.

**SMART+CONNECTED
COMMUNITIES INSTITUTE**

THE MARK CONSISTS OF STANDARD CHARACTERS WITHOUT CLAIM TO ANY PARTICULAR FONT, STYLE, SIZE, OR COLOR.

CLASS 38—COMMUNICATION

FOR PROVISION OF ONLINE FORUMS FOR USERS FOR THE SHARING AND TRANSMISSION OF INFORMATION AND ELECTRONIC MEDIA CONCERNING ENVIRONMENTAL MATTERS; PROVIDING ON-LINE CHAT ROOMS AND ELECTRONIC BULLETIN BOARDS FOR TRANSMISSION OF MESSAGES AMONG USERS IN THE FIELD OF GENERAL INTEREST; PROVIDING AN ON-LINE FORUM FOR COMPANIES TO SHOW-CASE, DISPLAY, DEMONSTRATE AND PROMOTE NEW AND INNOVATIVE IDEAS, PRODUCTS AND SERVICES IN THE CONVENTION/MEETING MANAGEMENT ARENA; PROVIDING A VIDEO, AUDIO AND DOCUMENT SHARING PORTAL, NAMELY, STREAMING OF VIDEO MATERIAL, AUDIO MATERIAL AND DOCUMENT MATERIAL ON THE INTERNET; PROVIDING CHAT ROOMS AND ELECTRONIC BULLETIN BOARDS FOR THE TRANSMISSION OF MESSAGES, COMMENTS, DOCUMENTS AND MULTIMEDIA CONTENT AMONG USERS IN THE FIELDS OF URBAN PLANNING, INTELLIGENT COMMUNITIES, ENERGY CONSUMPTION, CONSERVATION AND MANAGEMENT, SUSTAINABILITY, HEALTHCARE, TRANSPORTATION, PUBLIC SAFETY AND TECHNOLOGY (U.S. CLS. 100, 101 AND 104).

FIRST USE 7-0-2010; IN COMMERCE 7-0-2010.

CLASS 41—EDUCATION AND ENTERTAINMENT

FOR EDUCATION SERVICES, NAMELY, PROVIDING LIVE AND ON-LINE SEMINARS AND WORKSHOPS IN THE FIELDS OF URBAN PLANNING, INTELLIGENT COMMUNITIES, ENERGY CONSUMPTION, CONSERVATION AND MANAGEMENT, SUSTAINABILITY, HEALTHCARE, TRANSPORTATION, PUBLIC SAFETY AND TECHNOLOGY; EDUCATIONAL SERVICES, NAMELY, DEVELOPING, ARRANGING, AND CONDUCTING EDUCATIONAL CONFERENCES AND PROGRAMS AND PROVIDING COURSES OF INSTRUCTION IN THE FIELDS OF URBAN PLANNING, INTELLIGENT COMMUNITIES, ENERGY CONSUMPTION, CONSERVATION AND MANAGEMENT, SUSTAINABILITY, HEALTHCARE, TRANSPORTATION, PUBLIC SAFETY AND TECHNOLOGY; ON-LINE JOURNALS, NAMELY, BLOGS IN THE FIELDS OF URBAN PLANNING, INTELLIGENT COMMUNITIES, ENERGY CONSUMPTION, CONSERVATION AND MANAGEMENT, SUSTAINABILITY, HEALTHCARE, TRANSPORTATION, PUBLIC SAFETY AND TECHNOLOGY; PROVIDING NEWSLETTERS VIA E-MAIL IN THE FIELDS OF URBAN PLANNING, INTELLIGENT COMMUNITIES, ENERGY CONSUMPTION, CONSERVATION AND MANAGEMENT, SUSTAINABILITY, HEALTHCARE, TRANSPORTATION, PUBLIC SAFETY AND TECHNOLOGY (U.S. CLS. 100, 101 AND 107).

FIRST USE 7-0-2010; IN COMMERCE 7-0-2010.

CLASS 42—SCIENTIFIC AND COMPUTER SERVICES

FOR PROVIDING A WEB SITE FEATURING TECHNOLOGY THAT ENABLES USERS TO SHARE, INDEX AND STORE CONTENT, ARTICLES, IMAGES AND OTHER INFORMATION RESOURCES IN ELECTRONIC FORM IN THE NATURE AND FIELDS OF URBAN PLANNING, INTELLIGENT COMMUNITIES, ENERGY CONSUMPTION, CONSERVATION AND MANAGEMENT, SUSTAINABILITY, HEALTHCARE, TRANSPORTATION, PUBLIC SAFETY AND TECHNOLOGY; PROVIDING A WEB SITE FEATURING TEMPORARY USE OF NON-DOWNLOADABLE SOFTWARE ALLOWING WEB SITE USERS TO UPLOAD, POST AND DISPLAY ONLINE VIDEOS FOR SHARING WITH OTHERS; PROVIDING WEB SITES FEATURING TECHNOLOGY THAT ENABLES USERS TO REQUEST AND RECORD IDEAS, SUGGESTIONS AND COMMENTS FROM OTHER USERS IN THE FIELDS OF URBAN PLANNING, INTELLIGENT COMMUNITIES, ENERGY CONSUMPTION, CONSERVATION AND MANAGEMENT, SUSTAINABILITY, HEALTHCARE, TRANSPORTATION, PUBLIC SAFETY AND TECHNOLOGY (U.S. CLS. 100 AND 101).

FIRST USE 7-0-2010; IN COMMERCE 7-0-2010.
TRICIA SONNEBORN, EXAMINING ATTORNEY

CLASS 41—EDUCATION AND ENTERTAINMENT

FOR EDUCATION SERVICES, NAMELY, PROVIDING LIVE AND ON-LINE SEMINARS AND WORKSHOPS IN THE FIELDS OF URBAN PLANNING, INTELLIGENT COMMUNITIES, ENERGY CONSUMPTION, CONSERVATION AND MANAGEMENT, SUSTAINABILITY, HEALTHCARE, TRANSPORTATION, PUBLIC SAFETY AND TECHNOLOGY; EDUCATIONAL SERVICES, NAMELY, DEVELOPING, ARRANGING, AND CONDUCTING EDUCATIONAL CONFERENCES AND PROGRAMS AND PROVIDING COURSES OF INSTRUCTION IN THE FIELDS OF URBAN PLANNING, INTELLIGENT COMMUNITIES, ENERGY CONSUMPTION, CONSERVATION AND MANAGEMENT, SUSTAINABILITY, HEALTHCARE, TRANSPORTATION, PUBLIC SAFETY AND TECHNOLOGY; ON-LINE JOURNALS, NAMELY, BLOGS IN THE FIELDS OF URBAN PLANNING, INTELLIGENT COMMUNITIES, ENERGY CONSUMPTION, CONSERVATION AND MANAGEMENT, SUSTAINABILITY, HEALTHCARE, TRANSPORTATION, PUBLIC SAFETY AND TECHNOLOGY; PROVIDING NEWSLETTERS VIA E-MAIL IN THE FIELDS OF URBAN PLANNING, INTELLIGENT COMMUNITIES, ENERGY CONSUMPTION, CONSERVATION AND MANAGEMENT, SUSTAINABILITY, HEALTHCARE, TRANSPORTATION, PUBLIC SAFETY AND TECHNOLOGY (U.S. CLS. 100, 101 AND 107).

FIRST USE 7-0-2010; IN COMMERCE 7-0-2010.

CLASS 42—SCIENTIFIC AND COMPUTER SERVICES

FOR PROVIDING A WEB SITE FEATURING TECHNOLOGY THAT ENABLES USERS TO SHARE, INDEX AND STORE CONTENT, ARTICLES, IMAGES AND OTHER INFORMATION RESOURCES IN ELECTRONIC FORM IN THE NATURE AND FIELDS OF URBAN PLANNING, INTELLIGENT COMMUNITIES, ENERGY CONSUMPTION, CONSERVATION AND MANAGEMENT, SUSTAINABILITY, HEALTHCARE, TRANSPORTATION, PUBLIC SAFETY AND TECHNOLOGY; PROVIDING A WEB SITE FEATURING TEMPORARY USE OF NON-DOWNLOADABLE SOFTWARE ALLOWING WEB SITE USERS TO UPLOAD, POST AND DISPLAY ONLINE VIDEOS FOR SHARING WITH OTHERS; PROVIDING WEB SITES FEATURING TECHNOLOGY THAT ENABLES USERS TO REQUEST AND RECORD IDEAS, SUGGESTIONS AND COMMENTS FROM OTHER USERS IN THE FIELDS OF URBAN PLANNING, INTELLIGENT COMMUNITIES, ENERGY CONSUMPTION, CONSERVATION AND MANAGEMENT, SUSTAINABILITY, HEALTHCARE, TRANSPORTATION, PUBLIC SAFETY AND TECHNOLOGY (U.S. CLS. 100 AND 101).

FIRST USE 7-0-2010; IN COMMERCE 7-0-2010.
TRICIA SONNEBORN, EXAMINING ATTORNEY

SN 85-237,315. CISCO TECHNOLOGY, INC., SAN JOSE, CA.
FILED 2-8-2011.

Smart+Connected **communities** Institute

NO CLAIM IS MADE TO THE EXCLUSIVE RIGHT TO USE "COMMUNITIES" OR "INSTITUTE", APART FROM THE MARK AS SHOWN.

THE COLOR(S) TEAL, GREEN, AND GREY IS/ARE CLAIMED AS A FEATURE OF THE MARK.

THE MARK CONSISTS OF A PLUS SIGN IN BETWEEN THE WORDS "SMART" AND "CONNECTED" ALL IN THE COLOR TEAL, FOLLOWED BY THE WORD "COMMUNITIES" IN GREEN WITH A TEAL OVERLAY ON THE "I"'S AND THE HORIZONTAL CROSS STROKE OF THE "T" APPEARING IN "COMMUNITIES" TO LOOK LIKE TWO STICK FIGURE PEOPLE, FOLLOWED BY THE WORD "INSTITUTE" IN GREY.

CLASS 38—COMMUNICATION

FOR PROVISION OF ONLINE FORUMS FOR USERS FOR THE SHARING AND TRANSMISSION OF INFORMATION AND ELECTRONIC MEDIA CONCERNING ENVIRONMENTAL MATTERS; PROVIDING ON-LINE CHAT ROOMS AND ELECTRONIC BULLETIN BOARDS FOR TRANSMISSION OF MESSAGES AMONG USERS IN THE FIELD OF GENERAL INTEREST; PROVIDING AN ON-LINE FORUM FOR COMPANIES TO SHOWCASE, DISPLAY, DEMONSTRATE AND PROMOTE NEW AND INNOVATIVE IDEAS, PRODUCTS AND SERVICES IN THE CONVENTION/MEETING MANAGEMENT ARENA; PROVIDING A VIDEO, AUDIO AND DOCUMENT SHARING PORTAL, NAMELY, STREAMING OF VIDEO MATERIAL, AUDIO MATERIAL AND DOCUMENT MATERIAL ON THE INTERNET; PROVIDING CHAT ROOMS AND ELECTRONIC BULLETIN BOARDS FOR THE TRANSMISSION OF MESSAGES, COMMENTS, DOCUMENTS AND MULTIMEDIA CONTENT AMONG USERS IN THE FIELDS OF URBAN PLANNING, INTELLIGENT COMMUNITIES, ENERGY CONSUMPTION, CONSERVATION AND MANAGEMENT, SUSTAINABILITY, HEALTHCARE, TRANSPORTATION, PUBLIC SAFETY AND TECHNOLOGY (U.S. CLS. 100, 101 AND 104).

FIRST USE 7-0-2010; IN COMMERCE 7-0-2010.

SN 85-237,390. BNY CONVERGEX GROUP, LLC, NEW YORK, NY. FILED 2-8-2011.

BLAZE

THE MARK CONSISTS OF STANDARD CHARACTERS WITHOUT CLAIM TO ANY PARTICULAR FONT, STYLE, SIZE, OR COLOR.

CLASS 9—ELECTRICAL AND SCIENTIFIC APPARATUS

FOR COMPUTER SOFTWARE FOR USE IN MANAGING AND EXECUTING SECURITIES TRANSACTIONS; COMPUTER SOFTWARE THAT PROVIDES WEB-BASED ACCESS TO FINANCIAL APPLICATIONS AND SERVICES THROUGH A WEB OPERATING SYSTEM OR PORTAL INTERFACE (U.S. CLS. 21, 23, 26, 36 AND 38).

SN 85-238,822. CHEN, JULIE T., SAN JOSE, CA. FILED 2-10-2011.

M.H.E.

CLASS 36—INSURANCE AND FINANCIAL

FOR FINANCIAL, INVESTMENT, AND SECURITIES SERVICES, NAMELY, FINANCIAL ANALYSIS AND SECURITIES TRADING SERVICES FOR OTHERS; SECURITIES TRADE ORDER MANAGEMENT SERVICES, NAMELY, ANALYZING SECURITIES PORTFOLIOS AND SECURITIES TRADES, CREATING, STAGING, AND ALLOCATING TO BROKERAGES TRADE ORDERS, RECEIVING TRADE EXECUTION DETAILS, AND EVALUATING TRADE EXECUTION PERFORMANCE; FINANCIAL SERVICES, NAMELY, INVESTMENT SECURITIES TRANSACTION SERVICES VIA THE INTERNET, COMPUTER-TO-COMPUTER INTERFACE, AND BY CONNECTIONS TO THE PROPRIETARY NETWORKS OF OTHER SERVICE PROVIDERS; ELECTRONIC FUNDS TRANSFER; PROVIDING AN INTERNET WEBSITE PORTAL IN THE FIELDS OF INVESTMENT SECURITIES AND SECURITIES TRANSACTIONS (U.S. CLS. 100, 101 AND 102).

THE MARK CONSISTS OF STANDARD CHARACTERS WITHOUT CLAIM TO ANY PARTICULAR FONT, STYLE, SIZE, OR COLOR.

CLASS 3—COSMETICS AND CLEANING PREPARATIONS

FOR NON-MEDICATED SKIN CARE PREPARATIONS; NON-MEDICATED ANTI-WRINKLE CREAMS; NON-MEDICATED SKIN CARE CREAMS, LOTIONS, AND MOISTURIZERS; SUNSCREEN CREAMS; AGE SPOT REDUCING CREAMS; NON-MEDICATED SKIN CARE PREPARATIONS TO INCREASE COLLAGEN PRODUCTION (U.S. CLS. 1, 4, 6, 50, 51 AND 52).

CLASS 42—SCIENTIFIC AND COMPUTER SERVICES

FOR PROVIDING TEMPORARY USE OF ONLINE NON-DOWNLOADABLE FINANCIAL SOFTWARE FOR MANAGING AND EXECUTING SECURITIES TRANSACTIONS (U.S. CLS. 100 AND 101).

EDWARD FENNESSY, EXAMINING ATTORNEY

CLASS 29—MEATS AND PROCESSED FOODS

FOR NUT-BASED SNACK FOODS; SNACK MIXES CONSISTING PRIMARILY OF PROCESSED NUTS, DEHYDRATED FRUIT, SEEDS, SOY-BASED SNACK, GRAINS AND CHOCOLATE; PROCESSED FRUIT-BASED FOOD BARS ALSO CONTAINING NUT, SEED, SOY-BASED SNACK, GRAINS AND CHOCOLATE (U.S. CL. 46).

WON TEAK OH, EXAMINING ATTORNEY

SN 85-238,024. INTERACTIVE WELLNESS, LLC, MIAMI BEACH, FL. FILED 2-9-2011.

SN 85-238,829. CHEN, JULIE T., SAN JOSE, CA. FILED 2-10-2011.

MILO HEALTH

MAKING HEALTHY EZ

THE MARK CONSISTS OF STANDARD CHARACTERS WITHOUT CLAIM TO ANY PARTICULAR FONT, STYLE, SIZE, OR COLOR.

NO CLAIM IS MADE TO THE EXCLUSIVE RIGHT TO USE "HEALTH", APART FROM THE MARK AS SHOWN.

THE MARK CONSISTS OF STANDARD CHARACTERS WITHOUT CLAIM TO ANY PARTICULAR FONT, STYLE, SIZE, OR COLOR.

CLASS 36—INSURANCE AND FINANCIAL

FOR PROVIDING INSURANCE CONSULTING SERVICES THROUGH AN INTERACTIVE, CUSTOMIZABLE WEBSITE (U.S. CLS. 100, 101 AND 102).

CLASS 3—COSMETICS AND CLEANING PREPARATIONS

FOR NON-MEDICATED SKIN CARE PREPARATIONS; NON-MEDICATED ANTI-WRINKLE CREAMS; NON-MEDICATED SKIN CARE CREAMS, LOTIONS, AND MOISTURIZERS; SUNSCREEN CREAMS; AGE SPOT REDUCING CREAMS; NON-MEDICATED SKIN CARE PREPARATIONS TO INCREASE COLLAGEN PRODUCTION (U.S. CLS. 1, 4, 6, 50, 51 AND 52).

CLASS 44—MEDICAL, BEAUTY AND AGRICULTURAL SERVICES

FOR HEALTH CARE SERVICES, NAMELY, PROVIDING EMPLOYEE WELLNESS PROGRAMS THROUGH AN INTERACTIVE, CUSTOMIZABLE WEBSITE THAT TRACKS EMPLOYEES' WELLNESS ACTIVITIES AND HEALTH INDICATORS AND THAT FEATURES INFORMATION ABOUT WELLNESS, HEALTH, EXERCISE AS IT RELATES TO OVERALL HEALTH AND WELLNESS, AND NUTRITION (U.S. CLS. 100 AND 101).

CHRISTINA SOBRAL, EXAMINING ATTORNEY

CLASS 29—MEATS AND PROCESSED FOODS

FOR NUT-BASED SNACK FOODS; SNACK MIXES CONSISTING PRIMARILY OF PROCESSED NUTS, DEHYDRATED FRUIT, SEEDS, SOY-BASED SNACK, GRAINS AND CHOCOLATE; PROCESSED FRUIT-BASED FOOD BARS ALSO CONTAINING NUT, SEED, SOY-BASED SNACK, GRAINS AND CHOCOLATE (U.S. CL. 46).

CLASS 44—MEDICAL, BEAUTY AND AGRICULTURAL SERVICES

FOR PROVIDING A WEBSITE FEATURING INFORMATION IN THE FIELD OF NUTRITION, DIET, WEIGHT MANAGEMENT, MIND AND BODY CONNECTION, MENTAL HEALTH, AND WELLNESS (U.S. CLS. 100 AND 101).

WON TEAK OH, EXAMINING ATTORNEY

SN 85-240,475. INTEGRAL SYSTEMS, INC., COLUMBIA, MD. FILED 2-11-2011.



NO CLAIM IS MADE TO THE EXCLUSIVE RIGHT TO USE "SYSTEMS", APART FROM THE MARK AS SHOWN.

THE MARK CONSISTS OF THE WORDS "INTEGRAL SYSTEMS" AND A SHARK FIN DESIGN ABOVE THE WORDS.

CLASS 37—CONSTRUCTION AND REPAIR

FOR INTEGRATED TECHNOLOGY SOLUTIONS FOR SATELLITE COMMUNICATIONS-INTERFACED SYSTEMS, NAMELY, INSTALLATION OF SATELLITE GROUND SYSTEMS FOR COMPUTER HARDWARE AND TELECOMMUNICATIONS HARDWARE FOR SATELLITE COMMAND AND CONTROL, DATA PROCESSING, SIMULATION, INTEGRATION AND TESTING, TRACKING APPLICATIONS, GROUND EQUIPMENT MONITORING AND CONTROL, FLIGHT SOFTWARE VALIDATION AND ANALYSIS; INSTALLATION AND MAINTENANCE OF COMPUTER HARDWARE FOR SATELLITE GROUND SYSTEMS (U.S. CLS. 100, 103 AND 106).

FIRST USE 0-0-1996; IN COMMERCE 0-0-1996.

CLASS 42—SCIENTIFIC AND COMPUTER SERVICES

FOR DESIGN FOR OTHERS OF COMPUTER HARDWARE AND SOFTWARE FOR SATELLITE GROUND SYSTEMS; INSTALLATION AND MAINTENANCE OF COMPUTER SOFTWARE FOR SATELLITE GROUND SYSTEMS (U.S. CLS. 100 AND 101).

FIRST USE 0-0-1996; IN COMMERCE 0-0-1996.

FLORENTINA BLANDU, EXAMINING ATTORNEY

SN 85-240,584. REALCME, INC., NEW YORK, NY. FILED 2-11-2011.

REALALIGNMENT

THE MARK CONSISTS OF STANDARD CHARACTERS WITHOUT CLAIM TO ANY PARTICULAR FONT, STYLE, SIZE, OR COLOR.

CLASS 35—ADVERTISING AND BUSINESS

FOR PROVIDING ON-LINE BUSINESS PLANNING, TRACKING, REPORTING, ANALYTICAL TOOLS, AND PERFORMANCE ANALYSIS FOR HEALTH CARE ORGANIZATIONS, HEALTH SYSTEMS, AND HEALTH CARE INSURERS (U.S. CLS. 100, 101 AND 102).

FIRST USE 1-14-2011; IN COMMERCE 1-14-2011.

CLASS 41—EDUCATION AND ENTERTAINMENT

FOR PROVIDING ON-LINE AND MOBILE INTERACTIVE HEALTHCARE EDUCATION SERVICES, NAMELY, PROVIDING LIVE AND ARCHIVED INTERACTIVE SEMINARS AND WORKSHOPS IN THE FIELD OF HEALTHCARE AND PROVIDING ON-LINE AND MOBILE STUDENT EDUCATIONAL COURSE TRACKING AND PROGRESS REPORTING FOR PROFESSIONAL DEVELOPMENT; PROVIDING CONTINUING MEDICAL EDUCATION COURSES; EDUCATIONAL COURSE MONITORING, NAMELY, TRACKING HEALTH PROFESSIONAL PERFORMANCE RELATING TO TRAINING AND CONTINUING MEDICAL EDUCATION (U.S. CLS. 100, 101 AND 107).

FIRST USE 1-14-2011; IN COMMERCE 1-14-2011.

CLASS 42—SCIENTIFIC AND COMPUTER SERVICES

FOR APPLICATION SERVICE PROVIDER FEATURING MEDICAL EDUCATION CONTENT AND SOFTWARE FOR USE IN DEVELOPING AND ANALYZING CONTENT IN THE FIELDS OF MEDICAL EDUCATION AND LEARNING MANAGEMENT (U.S. CLS. 100 AND 101).

FIRST USE 1-14-2011; IN COMMERCE 1-14-2011.

RAUL CORDOVA, EXAMINING ATTORNEY

SN 85-240,907. SYNERON MEDICAL LTD., YOKNEAM ILLIT, ISRAEL, FILED 2-12-2011.

eVoLastin

THE MARK CONSISTS OF STANDARD CHARACTERS WITHOUT CLAIM TO ANY PARTICULAR FONT, STYLE, SIZE, OR COLOR.

CLASS 10—MEDICAL APPARATUS

FOR MEDICAL DEVICES FOR NONSURGICAL COSMETIC TREATMENTS, NAMELY, AESTHETIC DEVICE UTILIZING RADIOFREQUENCY ENERGY FOR IMPROVEMENT OF SKIN TONE, LAXITY AND VOLUME (U.S. CLS. 26, 39 AND 44).

CLASS 44—MEDICAL, BEAUTY AND AGRICULTURAL SERVICES

FOR COSMETIC SKIN CARE SERVICES IN THE NATURE OF ENERGY BASED DERMAL REMODELING PROCEDURE FOR IMPROVEMENT OF SKIN TONE, LAXITY AND VOLUME (U.S. CLS. 100 AND 101).

ELIZABETH KAJUBI, EXAMINING ATTORNEY

SN 85-241,252. ESCALATION STUDIOS, LLC, DALLAS, TX.
FILED 2-14-2011.

SN 85-241,639. TWG SOLUTIONS, LLC, AUSTIN, TX. FILED
2-14-2011.

ETERNAL FATE

THE MARK CONSISTS OF STANDARD CHARACTERS WITHOUT CLAIM TO ANY PARTICULAR FONT, STYLE, SIZE, OR COLOR.

CLASS 9—ELECTRICAL AND SCIENTIFIC APPARATUS

FOR COMPUTER GAME SOFTWARE; COMPUTER GAME SOFTWARE FOR USE WITH COMPUTERS AND VIDEO GAME CONSOLES; COMPUTER GAME SOFTWARE AND RELATED INSTRUCTION MANUAL SOLD AS A UNIT; DOWNLOADABLE COMPUTER GAME SOFTWARE OFFERED VIA THE INTERNET AND WIRELESS DEVICES; COMPUTER GAME SOFTWARE FOR USE WITH MOBILE TELEPHONES; COMPUTER GAME SOFTWARE FOR USE WITH ON-LINE INTERACTIVE GAMES (U.S. CLS. 21, 23, 26, 36 AND 38).

CLASS 41—EDUCATION AND ENTERTAINMENT

FOR ENTERTAINMENT SERVICES, NAMELY, PROVIDING ON-LINE NON-DOWNLOADABLE INTERACTIVE COMPUTER GAMES VIA THE INTERNET AND WIRELESS DEVICES; MULTIMEDIA ENTERTAINMENT SOFTWARE PUBLISHING SERVICES, NAMELY, MULTIMEDIA PUBLISHING OF INTERACTIVE COMPUTER AND VIDEO GAME SOFTWARE FOR OTHERS TO USE FOR ENTERTAINMENT PURPOSES ONLY; PROVIDING ONLINE COMPUTER GAMES OFFERED VIA HAND-HELD COMPUTERS, MOBILE TELEPHONES AND WIRELESS DEVICES; PROVIDING ON-LINE NON-DOWNLOADABLE INTERACTIVE COMPUTER GAMES (U.S. CLS. 100, 101 AND 107).

ANDREW RHIM, EXAMINING ATTORNEY

SN 85-241,296. VITAKING, INC., BONITA SPRINGS, FL.
FILED 2-14-2011.

VITAKING

THE MARK CONSISTS OF STANDARD CHARACTERS WITHOUT CLAIM TO ANY PARTICULAR FONT, STYLE, SIZE, OR COLOR.

CLASS 5—PHARMACEUTICALS

FOR VITAMINS; HERBAL, NUTRITIONAL, AND DIETARY SUPPLEMENTS; VITAMIN SUPPLEMENTS (U.S. CLS. 6, 18, 44, 46, 51 AND 52).

CLASS 35—ADVERTISING AND BUSINESS

FOR RETAIL STORE SERVICES FEATURING VITAMINS, SUPPLEMENTS AND VITAMIN SUPPLEMENTS; ON-LINE RETAIL STORE SERVICES FEATURING VITAMINS, SUPPLEMENTS AND VITAMIN SUPPLEMENTS (U.S. CLS. 100, 101 AND 102).

CHRISTINA SOBRAL, EXAMINING ATTORNEY

TWG Plus

THE MARK CONSISTS OF STANDARD CHARACTERS WITHOUT CLAIM TO ANY PARTICULAR FONT, STYLE, SIZE, OR COLOR.

CLASS 35—ADVERTISING AND BUSINESS

FOR ADVERTISING AND MARKETING; BRANDING SERVICES, NAMELY, CONSULTING, DEVELOPMENT, MANAGEMENT AND MARKETING OF BRANDS FOR BUSINESSES; DESIGN OF ADVERTISING MATERIALS FOR OTHERS; MAILING LIST PREPARATION; DIRECT MAIL ADVERTISING SERVICES; INFORMATION, ADVISORY, CONSULTING, BUSINESS RESEARCH AND PLANNING SERVICES RELATING TO PUBLICITY, MARKETING COMMUNICATIONS, REPUTATION MANAGEMENT OR BUSINESS ADMINISTRATION, INCLUDING SUCH SERVICES PROVIDED ONLINE OR VIA THE INTERNET; PROVIDING ADVERTISING SERVICE TO DISTRIBUTE ADVERTISEMENTS FOR DISPLAY ON INTERNET, NAMELY, IN WEBSITES, SOCIAL CONVERSATIONS OVER THE INTERNET, E-MAILS, MICROBLOGS, BLOGS, ELECTRONIC MESSAGES, INSTANT MESSAGES, TEXT MESSAGES, MULTIMEDIA MESSAGES, SOCIAL NETWORKS, STATUS UPDATES, FORUMS, ELECTRONIC BULLETIN BOARDS; MARKET ANALYSIS; ADVERTISING SERVICES, NAMELY, CREATING CORPORATE LOGOS FOR OTHERS; ADVERTISING TEXT PUBLICATION SERVICES; BRANDING SERVICES, NAMELY, CONSULTING, DEVELOPMENT, MANAGEMENT AND MARKETING OF BRANDS FOR BUSINESSES; MARKET RESEARCH AND MARKET INTELLIGENCE SERVICES (U.S. CLS. 100, 101 AND 102).

FIRST USE 1-1-2011; IN COMMERCE 1-1-2011.

CLASS 38—COMMUNICATION

FOR ELECTRONIC MAIL SERVICES (U.S. CLS. 100, 101 AND 104).

FIRST USE 1-1-2011; IN COMMERCE 1-1-2011.

CLASS 41—EDUCATION AND ENTERTAINMENT

FOR SCRIPTWRITING SERVICES; VIDEOGRAPHY SERVICES (U.S. CLS. 100, 101 AND 107).

FIRST USE 1-1-2011; IN COMMERCE 1-1-2011.

CLASS 42—SCIENTIFIC AND COMPUTER SERVICES

FOR CUSTOMIZATION OF COMPUTER HARDWARE AND SOFTWARE; DESIGNING WEBSITES FOR ADVERTISING PURPOSES; COMPUTER SERVICES, NAMELY, SEARCH ENGINE OPTIMIZATION; WEBSITE DESIGN FOR OTHERS (U.S. CLS. 100 AND 101).

FIRST USE 1-1-2011; IN COMMERCE 1-1-2011.

JIM RINGLE, EXAMINING ATTORNEY

SN 85-241,740. CENTER FOR APPLIED RESEARCH, INC., PHILADELPHIA, PA. FILED 2-14-2011.

SN 85-241,974. EYELEVEL INTERACTIVE, LLC, GREENSBORO, GA. FILED 2-14-2011.

CFAR 

EYELEVEL

OWNER OF U.S. REG. NOS. 2,429,908 AND 2,469,646. THE MARK CONSISTS OF THE LETTERS "CFAR" IN STYLIZED FORM FOLLOWED BY THE DESIGN OF A SQUARE BROKEN BY A SINGLE NOT STRAIGHT LINE.

THE MARK CONSISTS OF STANDARD CHARACTERS WITHOUT CLAIM TO ANY PARTICULAR FONT, STYLE, SIZE, OR COLOR.

CLASS 35—ADVERTISING AND BUSINESS

FOR RESEARCH AND CONSULTING SERVICES IN THE FIELDS OF BUSINESS, COMMERCE AND ECONOMICS (U.S. CLS. 100, 101 AND 102).
FIRST USE 10-0-2000; IN COMMERCE 10-0-2000.

CLASS 41—EDUCATION AND ENTERTAINMENT

FOR EDUCATION AND TRAINING SEMINARS, CONFERENCES AND WORKSHOPS IN THE FIELDS OF BUSINESS, COMMERCE AND ECONOMICS (U.S. CLS. 100, 101 AND 107).
FIRST USE 10-0-2000; IN COMMERCE 10-0-2000.
ARETHA SOMERVILLE, EXAMINING ATTORNEY

SN 85-241,903. ABBOTT LABORATORIES, ABBOTT PARK, IL. FILED 2-14-2011.

THE NUTRITION AUTHORITY

THE MARK CONSISTS OF STANDARD CHARACTERS WITHOUT CLAIM TO ANY PARTICULAR FONT, STYLE, SIZE, OR COLOR.

NO CLAIM IS MADE TO THE EXCLUSIVE RIGHT TO USE "NUTRITION", APART FROM THE MARK AS SHOWN.

CLASS 5—PHARMACEUTICALS

FOR INFANT FORMULAS, NUTRITIONAL SUPPLEMENTS FOR INFANTS AND TODDLERS (U.S. CLS. 6, 18, 44, 46, 51 AND 52).

CLASS 16—PAPER GOODS AND PRINTED MATTER

FOR PRINTED MATERIALS IN THE NATURE OF EDUCATIONAL MATERIALS AND WRITTEN ARTICLES IN THE FIELD OF INFANT AND CHILDHOOD NUTRITION; AND INFORMATIONAL MATERIALS, NAMELY, BROCHURES, PAMPHLETS AND BOOKLETS IN THE FIELD OF INFANT AND CHILDHOOD NUTRITION (U.S. CLS. 2, 5, 22, 23, 29, 37, 38 AND 50).
ELIZABETH KAJUBI, EXAMINING ATTORNEY

CLASS 9—ELECTRICAL AND SCIENTIFIC APPARATUS

FOR APPARATUS FOR TRANSMISSION AND REPRODUCTION BY ELECTRONIC MEANS OF ADVERTISING TO INTERACTIVE ADVERTISING PANELS INCORPORATED INTO GARMENTS; COMPUTER PROGRAMS DOWNLOADABLE WITH ADVERTISING TO INTERACTIVE ADVERTISING PANELS INCORPORATED INTO GARMENTS; COMPUTER APPLICATION SOFTWARE FOR MOBILE PHONES, NAMELY, SOFTWARE FOR INTERACTIVE ADVERTISING PANELS ON GARMENTS; COMPUTER APPLICATION SOFTWARE FOR RETAIL MARKETING, NAMELY, SOFTWARE FOR INTERACTIVE ADVERTISING PANELS ON GARMENTS; COMPUTER GAME SOFTWARE FOR USE ON MOBILE AND CELLULAR PHONES; COMPUTER SOFTWARE TO ENABLE THE TRANSMISSION OF PHOTOGRAPHS TO MOBILE TELEPHONES; COMPUTER SOFTWARE, NAMELY, AN APPLICATION ALLOWING SALES AND FIELD SERVICE EMPLOYEES TO UPDATE AND RECEIVE DATA STORED IN AN ENTERPRISE'S COMPUTER DATABASES IN REAL TIME, USING A MOBILE DEVICE, WITH FULL TELEPHONY INTEGRATION WITH THE TELEPHONE AND/OR SOFTWARE FEATURES OF THE MOBILE DEVICE; COMPUTER SOFTWARE, NAMELY, ELECTRONIC FINANCIAL PLATFORM THAT ACCOMMODATES MULTIPLE TYPES OF PAYMENT AND DEBT TRANSACTIONS IN AN INTEGRATED MOBILE PHONE, PDA, AND WEB BASED ENVIRONMENT; COMPUTER SOFTWARE, NAMELY, SOFTWARE DEVELOPMENT TOOLS FOR THE CREATION OF MOBILE INTERNET APPLICATIONS AND CLIENT INTERFACES; DEVICES FOR HANDS-FREE USE OF MOBILE PHONES; DOWNLOADABLE GRAPHICS FOR MOBILE PHONES; DOWNLOADABLE IMAGES IN THE FIELD OF INTERACTIVE ADVERTISING PANELS ON GARMENTS FOR MOBILE PHONES; DOWNLOADABLE RING TONES AND GRAPHICS FOR MOBILE PHONES; DOWNLOADABLE RING TONES FOR MOBILE PHONES; DOWNLOADABLE SOFTWARE IN THE NATURE OF A MOBILE APPLICATION FOR INTERACTIVE ADVERTISING PANELS ON GARMENTS; ELECTRONIC CODING UNITS; ELECTRONIC EQUIPMENT FOR POINT-OF-SALES (POS) SYSTEMS, NAMELY, POINT-OF-SALE TERMINALS, BAR CODE READERS, OPTICAL READERS, ADVERTISEMENT DISPLAY MONITORS, KEYBOARDS, PRINTERS, SCANNERS, RADIO TRANSMITTERS, RADIO RECEIVERS, COMPUTER HARDWARE, AND COMPUTER OPERATING SOFTWARE; ENCODED ELECTRONIC CHIP CARDS FOR INTERACTIVE ADVERTISING PANELS ON GARMENTS (U.S. CLS. 21, 23, 26, 36 AND 38).

CLASS 25—CLOTHING

FOR CLOTHING, NAMELY, SHIRTS, JACKETS, VESTS, APRONS AND UNIFORMS FOR USE AS CARRIERS FOR INTERACTIVE ADVERTISING PANELS (U.S. CLS. 22 AND 39).

CLASS 35—ADVERTISING AND BUSINESS

FOR ELECTRONIC BILLBOARD ADVERTISING THROUGH INTERACTIVE ADVERTISING PANELS INCORPORATED INTO GARMENTS (U.S. CLS. 100, 101 AND 102).
SKYE YOUNG, EXAMINING ATTORNEY

SN 85-241,982. EYELEVEL INTERACTIVE, LLC, GREENSBORO, GA. FILED 2-14-2011.

EYELEVEL INTERACTIVE

THE MARK CONSISTS OF STANDARD CHARACTERS WITHOUT CLAIM TO ANY PARTICULAR FONT, STYLE, SIZE, OR COLOR.

NO CLAIM IS MADE TO THE EXCLUSIVE RIGHT TO USE "INTERACTIVE", APART FROM THE MARK AS SHOWN.

CLASS 9—ELECTRICAL AND SCIENTIFIC APPARATUS

FOR APPARATUS FOR TRANSMISSION AND REPRODUCTION BY ELECTRONIC MEANS OF ADVERTISING TO INTERACTIVE ADVERTISING PANELS INCORPORATED INTO GARMENTS; COMPUTER PROGRAMS DOWNLOADABLE WITH ADVERTISING TO INTERACTIVE ADVERTISING PANELS INCORPORATED INTO GARMENTS; COMPUTER APPLICATION SOFTWARE FOR MOBILE PHONES, NAMELY, SOFTWARE FOR INTERACTIVE ADVERTISING PANELS ON GARMENTS; COMPUTER APPLICATION SOFTWARE FOR RETAIL MARKETING, NAMELY, SOFTWARE FOR INTERACTIVE ADVERTISING PANELS ON GARMENTS; COMPUTER GAME SOFTWARE FOR USE ON MOBILE AND CELLULAR PHONES; COMPUTER SOFTWARE TO ENABLE THE TRANSMISSION OF PHOTOGRAPHS TO MOBILE TELEPHONES; COMPUTER SOFTWARE, NAMELY, AN APPLICATION ALLOWING SALES AND FIELD SERVICE EMPLOYEES TO UPDATE AND RECEIVE DATA STORED IN AN ENTERPRISE'S COMPUTER DATABASES IN REAL TIME, USING A MOBILE DEVICE, WITH FULL TELEPHONY INTEGRATION WITH THE TELEPHONE AND/OR SOFTWARE FEATURES OF THE MOBILE DEVICE; COMPUTER SOFTWARE, NAMELY, ELECTRONIC FINANCIAL PLATFORM THAT ACCOMMODATES MULTIPLE TYPES OF PAYMENT AND DEBT TRANSACTIONS IN AN INTEGRATED MOBILE PHONE, PDA, AND WEB BASED ENVIRONMENT; COMPUTER SOFTWARE, NAMELY, SOFTWARE DEVELOPMENT TOOLS FOR THE CREATION OF MOBILE INTERNET APPLICATIONS AND CLIENT INTERFACES; DEVICES FOR HANDS-FREE USE OF MOBILE PHONES; DOWNLOADABLE GRAPHICS FOR MOBILE PHONES; DOWNLOADABLE IMAGES IN THE FIELD OF INTERACTIVE ADVERTISING PANELS ON GARMENTS FOR MOBILE PHONES; DOWNLOADABLE RING TONES AND GRAPHICS FOR MOBILE PHONES; DOWNLOADABLE RING TONES FOR MOBILE PHONES; DOWNLOADABLE SOFTWARE IN THE NATURE OF A MOBILE APPLICATION FOR INTERACTIVE ADVERTISING PANELS ON GARMENTS; ELECTRONIC CODING UNITS; ELECTRONIC EQUIPMENT FOR POINT-OF-SALES (POS) SYSTEMS, NAMELY, POINT-OF-SALE TERMINALS, BAR CODE READERS, OPTICAL READERS, ADVERTISEMENT DISPLAY MONITORS, KEYBOARDS, PRINTERS, SCANNERS, RADIO TRANSMITTERS, RADIO RECEIVERS, COMPUTER HARDWARE, AND COMPUTER OPERATING SOFTWARE; ENCODED ELECTRONIC CHIP CARDS FOR INTERACTIVE ADVERTISING PANELS ON GARMENTS (U.S. CLS. 21, 23, 26, 36 AND 38).

CLASS 25—CLOTHING

FOR CLOTHING, NAMELY, SHIRTS, JACKETS, VESTS, APRONS AND UNIFORMS FOR USE AS CARRIERS FOR INTERACTIVE ADVERTISING PANELS (U.S. CLS. 22 AND 39).

CLASS 35—ADVERTISING AND BUSINESS

FOR ELECTRONIC BILLBOARD ADVERTISING THROUGH INTERACTIVE ADVERTISING PANELS INCORPORATED INTO GARMENTS (U.S. CLS. 100, 101 AND 102).

SKYE YOUNG, EXAMINING ATTORNEY

SN 85-242,425. 9 PLANET UNIVERSE INC., WEST HOLLYWOOD, CA. FILED 2-15-2011.



CLASS 3—COSMETICS AND CLEANING PREPARATIONS

FOR FRAGRANCES AND PERFUMERY (U.S. CLS. 1, 4, 6, 50, 51 AND 52).

FIRST USE 9-9-2009; IN COMMERCE 9-9-2009.

CLASS 14—JEWELRY

FOR JEWELRY, NAMELY, BRACELETS, BROOCHES, NECKLACES, PINS, RINGS AND WATCHES (U.S. CLS. 2, 27, 28 AND 50).

FIRST USE 9-9-2009; IN COMMERCE 9-9-2009.

CLASS 18—LEATHER GOODS

FOR BACKPACKS, BEACHBAGS, COSMETIC BAGS SOLD EMPTY, DUFFLE BAGS, GARMENT BAGS FOR TRAVEL, HANDBAGS, PURSES, SATCHELS, SCHOOL BAGS, SUITCASES, TOTE BAGS, AND WALLETS (U.S. CLS. 1, 2, 3, 22 AND 41).

FIRST USE 9-9-2009; IN COMMERCE 9-9-2009.

CLASS 25—CLOTHING

FOR CLOTHING ACCESSORIES, NAMELY, BANDANAS, BELTS, BLOUSES, GLOVES, SCARVES, SWEAT BANDS, SUSPENDERS AND TIES; CLOTHING, NAMELY, APRONS, BEACHWEAR, BLOUSES, BOTTOMS, DRESSES, FOOTWEAR, GYM SHORTS, GYM SUITS, JERSEYS, JUMPERS, JUMP SUITS, LOUNGEWEAR, PANTS, PULLOVERS, SHIRTS, SHORTS, SKIRTS, SLEEPWEAR, SUITS, SWEATERS, SWEAT PANTS, SWEAT SHIRTS, SWEAT SUITS, TANK TOPS, AND T-SHIRTS; UNDERWEAR; HEAD WEAR, NAMELY, CAPS, EAR MUFFS, HATS AND VISORS; OUTERWEAR, NAMELY, COATS, JACKETS, PARKAS, PONCHOS, SHAWLS, STOLE, VESTS, MITTENS, GLOVES AND SCARVES (U.S. CLS. 22 AND 39).

FIRST USE 9-9-2009; IN COMMERCE 9-9-2009.
MATTHEW KLINE, EXAMINING ATTORNEY

SN 85-242,715. GREENBRIER IA, INC., WHITE SULPHUR SPRING, WV. FILED 2-15-2011.

Greenbrier Presidential Care

THE MARK CONSISTS OF STANDARD CHARACTERS WITHOUT CLAIM TO ANY PARTICULAR FONT, STYLE, SIZE, OR COLOR.

OWNER OF U.S. REG. NOS. 1,482,046, 1,776,855 AND OTHERS.

CLASS 43—HOTEL AND RESTAURANT SERVICES

FOR HEALTH RESORT SERVICES, NAMELY, PROVIDING FOOD AND LODGING THAT SPECIALIZE IN PROMOTING PATRONS' GENERAL HEALTH AND WELL-BEING (U.S. CLS. 100 AND 101).

CLASS 44—MEDICAL, BEAUTY AND AGRICULTURAL SERVICES

FOR HEALTH CARE (U.S. CLS. 100 AND 101).
GIANCARLO CASTRO, EXAMINING ATTORNEY

SN 85-242,726. HARP HOME SERVICES, LLC, WEST BABYLON, NY. FILED 2-15-2011.



NO CLAIM IS MADE TO THE EXCLUSIVE RIGHT TO USE "HOME SERVICES, LLC", APART FROM THE MARK AS SHOWN.

THE MARK CONSISTS OF THE IMAGE OF AN UMBRELLA SHELTERING A HOUSE, WITH THE WORDS "HARP HOME SERVICES, LLC" SPANNING THE TOP OF THE UMBRELLA.

CLASS 35—ADVERTISING AND BUSINESS

FOR HOME WARRANTY SERVICES, NAMELY, ARRANGING FOR REPAIRS AND REPLACEMENT OF MAJOR HOME SYSTEMS, APPLIANCES AND PARTS THEREOF PROVIDED BY OTHERS PURSUANT TO SERVICE AGREEMENTS (U.S. CLS. 100, 101 AND 102).
FIRST USE 12-31-1979; IN COMMERCE 12-31-1979.

CLASS 37—CONSTRUCTION AND REPAIR

FOR ELECTRIC APPLIANCE INSTALLATION AND REPAIR (U.S. CLS. 100, 103 AND 106).
FIRST USE 12-31-1979; IN COMMERCE 12-31-1979.
ANTHONY RINKER, EXAMINING ATTORNEY

SN 85-242,830. NOVARTIS AG, BASEL, SWITZERLAND, FILED 2-15-2011.

HEALTHSIGNS

THE MARK CONSISTS OF STANDARD CHARACTERS WITHOUT CLAIM TO ANY PARTICULAR FONT, STYLE, SIZE, OR COLOR.

PRIORITY CLAIMED UNDER SEC. 44(D) ON SWITZERLAND APPLICATION NO. 59282/2010, FILED 9-3-2010, REG. NO. 604847, DATED 9-8-2010, EXPIRES 9-3-2020.

CLASS 5—PHARMACEUTICALS

FOR DIAGNOSTIC PREPARATIONS AND DIAGNOSTIC REAGENTS FOR MEDICAL USE; CLINICAL MEDICAL REAGENTS (U.S. CLS. 6, 18, 44, 46, 51 AND 52).

CLASS 9—ELECTRICAL AND SCIENTIFIC APPARATUS

FOR COMPUTER OPERATING SOFTWARE FOR USE IN APPARATUS FOR BLOOD TESTING; COMPUTER OPERATING SOFTWARE FOR USE IN APPARATUS FOR CLINICAL DIAGNOSTICS (U.S. CLS. 21, 23, 26, 36 AND 38).

CLASS 10—MEDICAL APPARATUS

FOR APPARATUS FOR BLOOD ANALYSIS; BLOOD TESTING APPARATUS; APPARATUS FOR CLINICAL DIAGNOSIS (U.S. CLS. 26, 39 AND 44).

CLASS 42—SCIENTIFIC AND COMPUTER SERVICES

FOR RESEARCH AND DEVELOPMENT OF TECHNOLOGY IN THE FIELD OF DIAGNOSTICS FOR MEDICAL AND CLINICAL USE (U.S. CLS. 100 AND 101).
STEVEN R. FINE, EXAMINING ATTORNEY

SN 85-242,865. STARTAL, INC., LOS ANGELES, CA. FILED 2-15-2011.



THE MARK CONSISTS OF A FIVE-POINT STAR WITHIN A STYLIZED LETTER "S".

CLASS 9—ELECTRICAL AND SCIENTIFIC APPARATUS

FOR COMPUTER SOFTWARE APPLICATIONS FOR USE ON WIRED AND WIRELESS MOBILE, HANDHELD, PORTABLE AND OTHER COMPUTER RELATED DEVICES, NAMELY, SOFTWARE THAT UTILIZES VARIOUS DATA TRANSMISSION TECHNOLOGIES VIA COMPUTER NETWORKS AND GLOBAL COMMUNICATION NETWORKS TO LINK AND SYNCHRONIZE END USERS ON A CENTRAL TECHNOLOGY PLATFORM OR PORTAL, WHICH WILL ENABLE END USERS TO ACQUIRE, CUSTOMIZE AND SHARE CONTENT FROM PRIVATE AND COMMERCIAL SOURCES, TO ADMINISTER REAL-TIME MESSAGING AND INTERACTIVE GAMING, AND TO STORE, SEARCH AND ACCESS PERSONAL AND PUBLIC DATA (U.S. CLS. 21, 23, 26, 36 AND 38).

CLASS 35—ADVERTISING AND BUSINESS

FOR MARKETING, ADVERTISING, MARKET RESEARCH AND PROMOTION SERVICES, NAMELY, PROMOTING THE GOODS AND SERVICES OF OTHERS VIA COMPUTER AND GLOBAL COMMUNICATION NETWORKS; ONLINE RETAIL STORE SERVICES FEATURING DOWNLOADABLE DIGITAL MULTI-MEDIA, NAMELY, PRERECORDED DIGITAL SOUND, VIDEO AND DATA RECORDINGS FEATURING MUSIC, GRAPHICS, IMAGES, PHOTOS, TEXT, MESSAGING, SEMINARS, WEBCASTS, VIDEO, STREAMING, SOUND EFFECTS, GAMES, COMEDY, DRAMA, ACTION, ADVENTURE AND ANIMATION (U.S. CLS. 100, 101 AND 102).

CLASS 42—SCIENTIFIC AND COMPUTER SERVICES

FOR COMPUTER SERVICES, NAMELY, PROVIDING TEMPORARY USE OF NON-DOWNLOADABLE SOFTWARE APPLICATIONS TO BE USED ON WIRED AND WIRELESS MOBILE, HANDHELD, PORTABLE AND OTHER COMPUTER RELATED DEVICES VIA COMPUTER NETWORKS AND GLOBAL COMMUNICATION NETWORKS TO ALLOW USERS TO REQUEST, CUSTOMIZE, SHARE AND RECEIVE CONTENT, TO CONDUCT REAL-TIME MESSAGING AND INTERACTIVE GAMING, TO ENGAGE IN SOCIAL MEDIA, AND TO ADMINISTER, RETRIEVE AND STORE DATABASE INFORMATION (U.S. CLS. 100 AND 101).

JAY FLOWERS, EXAMINING ATTORNEY

SN 85-243,039. FUSION LOGISTICS, INC., MIAMI, FL. FILED 2-15-2011.

FUSION LOGISTICS

THE MARK CONSISTS OF STANDARD CHARACTERS WITHOUT CLAIM TO ANY PARTICULAR FONT, STYLE, SIZE, OR COLOR.

NO CLAIM IS MADE TO THE EXCLUSIVE RIGHT TO USE "LOGISTICS", APART FROM THE MARK AS SHOWN.

CLASS 35—ADVERTISING AND BUSINESS

FOR THIRD PARTY LOGISTICS SERVICES, NAMELY, ARRANGING THE TRANSPORTATION OF GOODS FOR OTHERS; BUSINESS MANAGEMENT SERVICES, NAMELY, MANAGING LOGISTICS, REVERSE LOGISTICS, SUPPLY CHAIN SERVICES, SUPPLY CHAIN VISIBILITY AND SYNCHRONIZATION, SUPPLY AND DEMAND FORECASTING AND PRODUCT DISTRIBUTION PROCESSES FOR OTHERS; BUSINESS CONSULTING SERVICES RELATING TO LOGISTICS, REVERSE LOGISTICS, SUPPLY CHAIN, AND PRODUCTION SYSTEMS AND DISTRIBUTION SOLUTIONS (U.S. CLS. 100, 101 AND 102).

CLASS 39—TRANSPORTATION AND STORAGE

FOR BROKERAGE SERVICES, NAMELY, BROKERING AIR FREIGHT SHIPPING SERVICES, CARGO SHIP TRANSPORT SERVICES, AND PARCEL SHIPPING SERVICES (U.S. CLS. 100 AND 105).

MEGHAN REINHART, EXAMINING ATTORNEY

SN 85-243,337. CHIDI, HILARY, NEW YORK, NY. FILED 2-16-2011.

DAILY SPIN

THE MARK CONSISTS OF STANDARD CHARACTERS WITHOUT CLAIM TO ANY PARTICULAR FONT, STYLE, SIZE, OR COLOR.

NO CLAIM IS MADE TO THE EXCLUSIVE RIGHT TO USE "DAILY", APART FROM THE MARK AS SHOWN.

CLASS 9—ELECTRICAL AND SCIENTIFIC APPARATUS

FOR ELECTRONIC DOWNLOADABLE PUBLICATIONS, NAMELY, MAGAZINES AND ARTICLES FEATURING NEWS IN THE FIELD OF POLITICS AND CURRENT AFFAIRS (U.S. CLS. 21, 23, 26, 36 AND 38).

CLASS 16—PAPER GOODS AND PRINTED MATTER

FOR PRINTED PUBLICATIONS, NAMELY, MAGAZINES AND ARTICLES FEATURING NEWS IN THE FIELD OF POLITICS AND CURRENT AFFAIRS (U.S. CLS. 2, 5, 22, 23, 29, 37, 38 AND 50).

CLASS 41—EDUCATION AND ENTERTAINMENT

FOR PROVIDING ON-LINE NON-DOWNLOADABLE ELECTRONIC PUBLICATIONS, NAMELY, MAGAZINES, ARTICLES, AND BLOGS FEATURING NEWS IN THE FIELD OF POLITICS AND CURRENT AFFAIRS (U.S. CLS. 100, 101 AND 107).

BARBARA RUTLAND, EXAMINING ATTORNEY

SN 85-243,639. CROSS COUNTRY AUTOMOTIVE SERVICES, INC., MEDFORD, MA. FILED 2-16-2011.

AGERO

THE MARK CONSISTS OF STANDARD CHARACTERS WITHOUT CLAIM TO ANY PARTICULAR FONT, STYLE, SIZE, OR COLOR.

THE WORD "AGERO" HAS NO MEANING IN A FOREIGN LANGUAGE.

CLASS 9—ELECTRICAL AND SCIENTIFIC APPARATUS

FOR VEHICLE COMPUTER HARDWARE AND COMPUTER SOFTWARE FOR TRANSMITTING AND SHARING DATA AND INFORMATION RELATING TO VEHICLE DIAGNOSTICS, WEATHER, TRAFFIC, SOCIAL NETWORKING, MUSIC, RADIO STATIONS, ADVERTISING, ROADSIDE AND EMERGENCY SUPPORT SERVICES, NEWS AND INSURANCE CLAIMS NOTICES, FOR MAPPING AND NAVIGATION, FOR CONNECTING REMOTELY TO THE INTERNET, FOR WIRELESS CONTENT DELIVERY AND FOR REMOTELY STARTING VEHICLES (U.S. CLS. 21, 23, 26, 36 AND 38).

CLASS 35—ADVERTISING AND BUSINESS

FOR MANAGEMENT AND OPERATION OF TELEPHONE CALL CENTERS FOR OTHERS IN THE FIELD OF VEHICLE SUPPORT, VEHICLE INFORMATION AND VEHICLE EMERGENCY SERVICES; PROVIDING CONSUMER INFORMATION, TELEPHONE DIRECTORY INFORMATION AND REFERRALS TO VEHICLE DRIVERS ALL IN THE FIELD OF VEHICLE RECALLS, VEHICLE WARRANTY CLAIMS, VEHICLE DEALER LOCATIONS AND LOCATION-BASED VEHICLE MAINTENANCE AND VEHICLE ROADSIDE AND EMERGENCY SUPPORT SERVICES; CUSTOMER RELATIONSHIP MANAGEMENT FOR VEHICLE DEALERSHIPS REGARDING TOWING AND EMERGENCY ROADSIDE SERVICES; CONDUCTING BUSINESS AND MARKET RESEARCH SURVEYS, EVALUATION RELATING TO COMMERCIAL MATTERS AND STATISTICAL ANALYSIS SERVICES FOR BUSINESS PURPOSES FOR VEHICLE DEALERS; PROVIDING COMMERCIAL INFORMATION AND PRICE COMPARISON INFORMATION TO MOTORISTS REGARDING AVAILABLE AUTOMOTIVE DEALERS; LOCATING VEHICLES FOR COMMERCIAL PURPOSES IN THE FIELD OF EMERGENCY ROAD SIDE ASSISTANCE; PROVIDING CONSUMER PRODUCT INFORMATION BASED ON INFORMATION CONTAINED IN OWNER'S MANUALS TO MOTORISTS VIA TWO-WAY WIRELESS COMMUNICATION WITH REMOTE RESPONSE AND DATA CENTERS (U.S. CLS. 100, 101 AND 102).

CLASS 36—INSURANCE AND FINANCIAL

FOR PROVIDING FINANCIAL INFORMATION TO MOTORISTS REGARDING AVAILABLE AUTOMOTIVE DEALERS; WARRANTY CLAIMS ADMINISTRATIVE SERVICES, NAMELY, PROCESSING WARRANTY CLAIMS FOR MOTOR VEHICLES; PROVIDING EXTENDED WARRANTIES ON VEHICLES; INSURANCE CLAIMS PROCESSING; INSURANCE CLAIMS ADMINISTRATION (U.S. CLS. 100, 101 AND 102).

CLASS 37—CONSTRUCTION AND REPAIR

FOR EMERGENCY ROAD SIDE REPAIR SERVICES; EMERGENCY ROADSIDE ASSISTANCE SERVICES, NAMELY, RESPONDING TO CALLS FOR ROADSIDE ASSISTANCE, FLAT TIRE CHANGING, EMERGENCY FUEL SUPPLYING AND BATTERY JUMP STARTING; AUTOMOBILE CLUB CONSULTATION SERVICES, NAMELY, CONSULTATION IN THE FIELD OF EMERGENCY ROADSIDE ASSISTANCE SERVICES FOR MOTORISTS AND OWNERS OF MOTOR VEHICLES REGARDING EMERGENCY ROAD SIDE REPAIR SERVICES (U.S. CLS. 100, 103 AND 106).

CLASS 38—COMMUNICATION

FOR WIRELESS VEHICLE COMMUNICATION SERVICES, NAMELY, WIRELESS ELECTRONIC TRANSMISSION OF VOICE SIGNALS, DATA, FACSIMILES, IMAGES AND INFORMATION; VEHICLE COMMUNICATION SERVICES, NAMELY, TRANSMISSION OF VOICE, AUDIO, VISUAL IMAGES AND DATA BY TELECOMMUNICATIONS NETWORKS, WIRELESS COMMUNICATION NETWORKS, THE INTERNET, INFORMATION SERVICES NETWORKS AND DATA NETWORKS BETWEEN VEHICLES AND VEHICLE PASSENGERS AND REMOTE RESPONSE AND DATA CENTERS; WIRELESS ELECTRONIC TRANSMISSION OF VEHICLE DIAGNOSTIC INFORMATION, REAL-TIME DATA, INFORMATION AND VOICE SIGNALS; WIRELESS ELECTRONIC TRANSMISSION OF VEHICLE LOCATION INFORMATION, EMERGENCY ROADSIDE ASSISTANCE STATUS INFORMATION AND VOICE COMMUNICATION WITH PASSENGERS; SATELLITE POSITIONING SERVICES, NAMELY, SATELLITE COMMUNICATION AND TRANSMISSION SERVICES RELATING TO PRECISION VEHICLE POSITIONING AND VEHICLE NAVIGATION; TELEPHONE COMMUNICATION SYSTEM SERVICES, NAMELY, CELLULAR TELEPHONE TRANSMISSION SERVICES FOR MOTORIST LOCATION AND EMERGENCY ROADSIDE ASSISTANCE STATUS INFORMATION (U.S. CLS. 100, 101 AND 104).

CLASS 39—TRANSPORTATION AND STORAGE

FOR PROVIDING TRAFFIC, TRAVEL AND VEHICLE TOWING INFORMATION TO MOTORISTS REGARDING AVAILABLE AUTOMOTIVE DEALERS; PROVIDING RESCUE SERVICE INFORMATION REGARDING THE LOCATION OF EMERGENCY VEHICLES; EMERGENCY ROADSIDE AND ASSISTANCE SERVICES, NAMELY, VEHICLE TOWING; GPS NAVIGATION SERVICES; PROVIDING ROADSIDE AND IN-VEHICLE GPS NAVIGATION SERVICES TO MOTORISTS FROM REMOTE RESPONSE CENTERS VIA TWO-WAY WIRELESS COMMUNICATION; EMERGENCY ROADSIDE ASSISTANCE SERVICES, NAMELY, TOWING, WINCH-OUT AND KEY DELIVERY SERVICES; VEHICLE RENTAL SERVICES; TRANSPORTATION RESERVATION SERVICES; AUTOMOBILE CLUB CONSULTATION SERVICES, NAMELY, CONSULTATION IN THE FIELD OF EMERGENCY ROADSIDE ASSISTANCE SERVICES FOR MOTORISTS AND OWNERS OF MOTOR VEHICLES REGARDING AUTO AND TRUCK TOWING SERVICES; AUTOMOBILE CLUB TRAVEL SERVICES, NAMELY, ARRANGING TOURS, ORGANIZING TRIPS AND MAKING RESERVATIONS AND BOOKINGS FOR LAND TRANSPORTATION (U.S. CLS. 100 AND 105).

CLASS 45—PERSONAL AND LEGAL SERVICES

FOR EMERGENCY ROADSIDE ASSISTANCE SERVICES, NAMELY, OPENING OF LOCKS; SECURITY SERVICES FOR VEHICLES, NAMELY, PROVIDING PHYSICAL ACCESS TO VEHICLES VIA A REMOTE CALL-IN LOCKING DEVICE; AUTOMOBILE CLUB SERVICES, NAMELY, ACCIDENT INVESTIGATIONS AND ADVISORY AND INFORMATION SERVICES IN THE NATURE OF PREPARING AND PROVIDING REPORTS RELATING TO AUTOMOTIVE SAFETY (U.S. CLS. 100 AND 101).

DAVID YONTEF, EXAMINING ATTORNEY

SN 85-243,800. CROSS COUNTRY AUTOMOTIVE SERVICES, INC., MEDFORD, MA. FILED 2-16-2011.

7SPAN

THE MARK CONSISTS OF STANDARD CHARACTERS WITHOUT CLAIM TO ANY PARTICULAR FONT, STYLE, SIZE, OR COLOR.

CLASS 9—ELECTRICAL AND SCIENTIFIC APPARATUS

FOR VEHICLE COMPUTER HARDWARE AND COMPUTER SOFTWARE FOR TRANSMITTING AND SHARING DATA AND INFORMATION RELATING TO VEHICLE DIAGNOSTICS, WEATHER, TRAFFIC, SOCIAL NETWORKING, MUSIC, RADIO STATIONS, ADVERTISING, ROADSIDE AND EMERGENCY SUPPORT SERVICES, NEWS AND INSURANCE CLAIMS NOTICES, FOR CONNECTING REMOTELY TO THE INTERNET, FOR WIRELESS CONTENT DELIVERY AND FOR REMOTELY STARTING VEHICLES (U.S. CLS. 21, 23, 26, 36 AND 38).

CLASS 35—ADVERTISING AND BUSINESS

FOR MANAGEMENT AND OPERATION OF TELEPHONE CALL CENTERS FOR OTHERS IN THE FIELD OF VEHICLE SUPPORT, VEHICLE INFORMATION AND VEHICLE EMERGENCY SERVICES; PROVIDING CONSUMER INFORMATION, TELEPHONE DIRECTORY INFORMATION AND REFERRALS TO VEHICLE DRIVERS ALL IN THE FIELD OF VEHICLE RECALLS, VEHICLE WARRANTY CLAIMS, VEHICLE DEALER LOCATIONS AND LOCATION-BASED VEHICLE MAINTENANCE AND VEHICLE ROADSIDE AND EMERGENCY SUPPORT SERVICES; CUSTOMER RELATIONSHIP MANAGEMENT FOR VEHICLE DEALERSHIPS REGARDING TOWING AND EMERGENCY ROADSIDE SERVICES; CONDUCTING BUSINESS AND MARKET RESEARCH SURVEYS, EVALUATION RELATING TO COMMERCIAL MATTERS AND STATISTICAL ANALYSIS SERVICES FOR BUSINESS PURPOSES FOR VEHICLE DEALERS; PROVIDING COMMERCIAL INFORMATION AND PRICE COMPARISON INFORMATION TO MOTORISTS REGARDING AVAILABLE AUTOMOTIVE DEALERS; LOCATING VEHICLES FOR COMMERCIAL PURPOSES IN THE FIELD OF EMERGENCY ROAD SIDE ASSISTANCE; PROVIDING CONSUMER PRODUCT INFORMATION BASED ON INFORMATION CONTAINED IN OWNER'S MANUALS TO MOTORISTS VIA TWO-WAY WIRELESS COMMUNICATION WITH REMOTE RESPONSE AND DATA CENTERS (U.S. CLS. 100, 101 AND 102).

CLASS 36—INSURANCE AND FINANCIAL

FOR PROVIDING FINANCIAL INFORMATION TO MOTORISTS REGARDING AVAILABLE AUTOMOTIVE DEALERS; WARRANTY CLAIMS ADMINISTRATIVE SERVICES, NAMELY, PROCESSING WARRANTY CLAIMS FOR MOTOR VEHICLES; PROVIDING EXTENDED WARRANTIES ON VEHICLES; INSURANCE CLAIMS PROCESSING; INSURANCE CLAIMS ADMINISTRATION (U.S. CLS. 100, 101 AND 102).

CLASS 37—CONSTRUCTION AND REPAIR

FOR EMERGENCY ROAD SIDE REPAIR SERVICES; EMERGENCY ROADSIDE ASSISTANCE SERVICES, NAMELY, RESPONDING TO CALLS FOR ROADSIDE ASSISTANCE, FLAT TIRE CHANGING, EMERGENCY FUEL SUPPLYING AND BATTERY JUMP STARTING; AUTOMOBILE CLUB CONSULTATION SERVICES, NAMELY, CONSULTATION IN THE FIELD OF EMERGENCY ROADSIDE ASSISTANCE SERVICES FOR MOTORISTS AND OWNERS OF MOTOR VEHICLES REGARDING EMERGENCY ROAD SIDE REPAIR SERVICES (U.S. CLS. 100, 103 AND 106).

CLASS 38—COMMUNICATION

FOR WIRELESS VEHICLE COMMUNICATION SERVICES, NAMELY, WIRELESS ELECTRONIC TRANSMISSION OF VOICE SIGNALS, DATA, FACSIMILES, IMAGES AND INFORMATION; VEHICLE COMMUNICATION SERVICES, NAMELY, TRANSMISSION OF VOICE, AUDIO, VISUAL IMAGES AND DATA BY TELECOMMUNICATIONS NETWORKS, WIRELESS COMMUNICATION NETWORKS, THE INTERNET, INFORMATION SERVICES NETWORKS AND DATA NETWORKS BETWEEN VEHICLES AND VEHICLE PASSENGERS AND REMOTE RESPONSE AND DATA CENTERS; WIRELESS ELECTRONIC TRANSMISSION OF VEHICLE DIAGNOSTIC INFORMATION, REAL-TIME DATA, INFORMATION AND VOICE SIGNALS; WIRELESS ELECTRONIC TRANSMISSION OF VEHICLE LOCATION INFORMATION, EMERGENCY ROADSIDE ASSISTANCE STATUS INFORMATION AND VOICE COMMUNICATION WITH PASSENGERS; SATELLITE POSITIONING SERVICES, NAMELY, SATELLITE COMMUNICATION AND TRANSMISSION SERVICES RELATING TO PRECISION VEHICLE POSITIONING AND VEHICLE NAVIGATION; TELEPHONE COMMUNICATION SYSTEM SERVICES, NAMELY, CELLULAR TELEPHONE TRANSMISSION SERVICES FOR MOTORIST LOCATION AND EMERGENCY ROADSIDE ASSISTANCE STATUS INFORMATION (U.S. CLS. 100, 101 AND 104).

CLASS 39—TRANSPORTATION AND STORAGE

FOR PROVIDING TRAFFIC, TRAVEL AND VEHICLE TOWING INFORMATION TO MOTORISTS REGARDING AVAILABLE AUTOMOTIVE DEALERS; PROVIDING RESCUE SERVICE INFORMATION REGARDING THE LOCATION OF EMERGENCY VEHICLES; EMERGENCY ROADSIDE AND ASSISTANCE SERVICES, NAMELY, VEHICLE TOWING; GPS NAVIGATION SERVICES; PROVIDING ROADSIDE AND IN-VEHICLE GPS NAVIGATION SERVICES TO MOTORISTS FROM REMOTE RESPONSE CENTERS VIA TWO-WAY WIRELESS COMMUNICATION; EMERGENCY ROADSIDE ASSISTANCE SERVICES, NAMELY, TOWING, WINCH-OUT AND KEY DELIVERY SERVICES; VEHICLE RENTAL SERVICES; TRANSPORTATION RESERVATION SERVICES; AUTOMOBILE CLUB CONSULTATION SERVICES, NAMELY, CONSULTATION IN THE FIELD OF EMERGENCY ROADSIDE ASSISTANCE SERVICES FOR MOTORISTS AND OWNERS OF MOTOR VEHICLES REGARDING AUTO AND TRUCK TOWING SERVICES; AUTOMOBILE CLUB TRAVEL SERVICES, NAMELY, ARRANGING TOURS, ORGANIZING TRIPS AND MAKING RESERVATIONS AND BOOKINGS FOR LAND TRANSPORTATION (U.S. CLS. 100 AND 105).

CLASS 45—PERSONAL AND LEGAL SERVICES

FOR EMERGENCY ROADSIDE ASSISTANCE SERVICES, NAMELY, OPENING OF LOCKS; SECURITY SERVICES FOR VEHICLES, NAMELY, PROVIDING PHYSICAL ACCESS TO VEHICLES VIA A REMOTE CALL-IN LOCKING DEVICE; AUTOMOBILE CLUB SERVICES, NAMELY, ACCIDENT INVESTIGATIONS AND ADVISORY AND INFORMATION SERVICES IN THE NATURE OF PREPARING AND PROVIDING REPORTS RELATING TO AUTOMOTIVE SAFETY (U.S. CLS. 100 AND 101).

DAVID YONTEF, EXAMINING ATTORNEY

SN 85-243,836. CROSS COUNTRY AUTOMOTIVE SERVICES, INC., MEDFORD, MA. FILED 2-16-2011.

SPAN7

THE MARK CONSISTS OF STANDARD CHARACTERS WITHOUT CLAIM TO ANY PARTICULAR FONT, STYLE, SIZE, OR COLOR.

CLASS 9—ELECTRICAL AND SCIENTIFIC APPARATUS

FOR VEHICLE COMPUTER HARDWARE AND COMPUTER SOFTWARE FOR TRANSMITTING AND SHARING DATA AND INFORMATION RELATING TO VEHICLE DIAGNOSTICS, WEATHER, TRAFFIC, SOCIAL NETWORKING, MUSIC, RADIO STATIONS, ADVERTISING, ROADSIDE AND EMERGENCY SUPPORT SERVICES, NEWS AND INSURANCE CLAIMS NOTICES, FOR CONNECTING REMOTELY TO THE INTERNET, FOR WIRELESS CONTENT DELIVERY AND FOR REMOTELY STARTING VEHICLES (U.S. CLS. 21, 23, 26, 36 AND 38).

CLASS 35—ADVERTISING AND BUSINESS

FOR MANAGEMENT AND OPERATION OF TELEPHONE CALL CENTERS FOR OTHERS IN THE FIELD OF VEHICLE SUPPORT, VEHICLE INFORMATION AND VEHICLE EMERGENCY SERVICES; PROVIDING CONSUMER INFORMATION, TELEPHONE DIRECTORY INFORMATION AND REFERRALS TO VEHICLE DRIVERS ALL IN THE FIELD OF VEHICLE RECALLS, VEHICLE WARRANTY CLAIMS, VEHICLE DEALER LOCATIONS AND LOCATION-BASED VEHICLE MAINTENANCE AND VEHICLE ROADSIDE AND EMERGENCY SUPPORT SERVICES; CUSTOMER RELATIONSHIP MANAGEMENT FOR VEHICLE DEALERSHIPS REGARDING TOWING AND EMERGENCY ROADSIDE SERVICES; CONDUCTING BUSINESS AND MARKET RESEARCH SURVEYS, EVALUATION RELATING TO COMMERCIAL MATTERS AND STATISTICAL ANALYSIS SERVICES FOR BUSINESS PURPOSES FOR VEHICLE DEALERS; PROVIDING COMMERCIAL INFORMATION AND PRICE COMPARISON INFORMATION TO MOTORISTS REGARDING AVAILABLE AUTOMOTIVE DEALERS; LOCATING VEHICLES FOR COMMERCIAL PURPOSES IN THE FIELD OF EMERGENCY ROAD SIDE ASSISTANCE; PROVIDING CONSUMER PRODUCT INFORMATION BASED ON INFORMATION CONTAINED IN OWNER'S MANUALS TO MOTORISTS VIA TWO-WAY WIRELESS COMMUNICATION WITH REMOTE RESPONSE AND DATA CENTERS (U.S. CLS. 100, 101 AND 102).

CLASS 36—INSURANCE AND FINANCIAL

FOR PROVIDING FINANCIAL INFORMATION TO MOTORISTS REGARDING AVAILABLE AUTOMOTIVE DEALERS; WARRANTY CLAIMS ADMINISTRATIVE SERVICES, NAMELY, PROCESSING WARRANTY CLAIMS FOR MOTOR VEHICLES; PROVIDING EXTENDED WARRANTIES ON VEHICLES; INSURANCE CLAIMS PROCESSING; INSURANCE CLAIMS ADMINISTRATION (U.S. CLS. 100, 101 AND 102).

CLASS 37—CONSTRUCTION AND REPAIR

FOR EMERGENCY ROAD SIDE REPAIR SERVICES; EMERGENCY ROADSIDE ASSISTANCE SERVICES, NAMELY, RESPONDING TO CALLS FOR ROADSIDE ASSISTANCE, FLAT TIRE CHANGING, EMERGENCY FUEL SUPPLYING AND BATTERY JUMP STARTING; AUTOMOBILE CLUB CONSULTATION SERVICES, NAMELY, CONSULTATION IN THE FIELD OF EMERGENCY ROADSIDE ASSISTANCE SERVICES FOR MOTORISTS AND OWNERS OF MOTOR VEHICLES REGARDING EMERGENCY ROAD SIDE REPAIR SERVICES (U.S. CLS. 100, 103 AND 106).

CLASS 38—COMMUNICATION

FOR WIRELESS VEHICLE COMMUNICATION SERVICES, NAMELY, WIRELESS ELECTRONIC TRANSMISSION OF VOICE SIGNALS, DATA, FACSIMILES, IMAGES AND INFORMATION; VEHICLE COMMUNICATION SERVICES, NAMELY, TRANSMISSION OF VOICE, AUDIO, VISUAL IMAGES AND DATA BY TELECOMMUNICATIONS NETWORKS, WIRELESS COMMUNICATION NETWORKS, THE INTERNET, INFORMATION SERVICES NETWORKS AND DATA NETWORKS BETWEEN VEHICLES AND VEHICLE PASSENGERS AND REMOTE RESPONSE AND DATA CENTERS; WIRELESS ELECTRONIC TRANSMISSION OF VEHICLE DIAGNOSTIC INFORMATION, REAL-TIME DATA, INFORMATION AND VOICE SIGNALS; WIRELESS ELECTRONIC TRANSMISSION OF VEHICLE LOCATION INFORMATION, EMERGENCY ROADSIDE ASSISTANCE STATUS INFORMATION AND VOICE COMMUNICATION WITH PASSENGERS; SATELLITE POSITIONING SERVICES, NAMELY, SATELLITE COMMUNICATION AND TRANSMISSION SERVICES RELATING TO PRECISION VEHICLE POSITIONING AND VEHICLE NAVIGATION; TELEPHONE COMMUNICATION SYSTEM SERVICES, NAMELY, CELLULAR TELEPHONE TRANSMISSION SERVICES FOR MOTORIST LOCATION AND EMERGENCY ROADSIDE ASSISTANCE STATUS INFORMATION (U.S. CLS. 100, 101 AND 104).

CLASS 39—TRANSPORTATION AND STORAGE

FOR PROVIDING TRAFFIC, TRAVEL AND VEHICLE TOWING INFORMATION TO MOTORISTS REGARDING AVAILABLE AUTOMOTIVE DEALERS; PROVIDING RESCUE SERVICE INFORMATION REGARDING THE LOCATION OF EMERGENCY VEHICLES; EMERGENCY ROADSIDE AND ASSISTANCE SERVICES, NAMELY, VEHICLE TOWING; GPS NAVIGATION SERVICES; PROVIDING ROADSIDE AND IN-VEHICLE GPS NAVIGATION SERVICES TO MOTORISTS FROM REMOTE RESPONSE CENTERS VIA TWO-WAY WIRELESS COMMUNICATION; EMERGENCY ROADSIDE ASSISTANCE SERVICES, NAMELY, TOWING, WINCH-OUT AND KEY DELIVERY SERVICES; VEHICLE RENTAL SERVICES; TRANSPORTATION RESERVATION SERVICES; AUTOMOBILE CLUB CONSULTATION SERVICES, NAMELY, CONSULTATION IN THE FIELD OF EMERGENCY ROADSIDE ASSISTANCE SERVICES FOR MOTORISTS AND OWNERS OF MOTOR VEHICLES REGARDING AUTO AND TRUCK TOWING SERVICES; AUTOMOBILE CLUB TRAVEL SERVICES, NAMELY, ARRANGING TOURS, ORGANIZING TRIPS AND MAKING RESERVATIONS AND BOOKINGS FOR LAND TRANSPORTATION (U.S. CLS. 100 AND 105).

CLASS 45—PERSONAL AND LEGAL SERVICES

FOR EMERGENCY ROADSIDE ASSISTANCE SERVICES, NAMELY, OPENING OF LOCKS; SECURITY SERVICES FOR VEHICLES, NAMELY, PROVIDING PHYSICAL ACCESS TO VEHICLES VIA A REMOTE CALL-IN LOCKING DEVICE; AUTOMOBILE CLUB SERVICES, NAMELY, ACCIDENT INVESTIGATIONS AND ADVISORY AND INFORMATION SERVICES IN THE NATURE OF PREPARING AND PROVIDING REPORTS RELATING TO AUTOMOTIVE SAFETY (U.S. CLS. 100 AND 101).

DAVID YONTEF, EXAMINING ATTORNEY

SN 85-243,837. BREATHRESEARCH, INC, WALNUT CREEK, CA. FILED 2-16-2011.



OWNER OF U.S. REG. NO. 3,934,785.

THE COLOR(S) BLUE AND LIGHT BLUE IS/ARE CLAIMED AS A FEATURE OF THE MARK.

THE MARK CONSISTS OF THE STYLIZED WORDING "MYBREATH", WITH THE TERM "MY" APPEARING IN LIGHT BLUE AND THE TERM "BREATH" APPEARING IN BLUE. ABOVE THE WORDING APPEARS THE STYLIZED DESIGN OF A PERSON FROM HEAD TO WAIST WITH BOTH ARMS RAISED UP AND BENDING TO THE RIGHT, WITH A SHADOW OF THE DESIGN APPEARING TO THE RIGHT. THE TORSO AND ARMS APPEAR IN THE COLOR BLUE, THE SHADOW AND HEAD APPEAR IN LIGHT BLUE.

CLASS 9—ELECTRICAL AND SCIENTIFIC APPARATUS

FOR COMPUTER APPLICATION SOFTWARE FOR MOBILE PHONES, MOBILE DEVICES, IMBEDDED SYSTEMS, AND PERSONAL COMPUTERS, NAMELY, SOFTWARE FOR IDENTIFICATION, MEASUREMENT, ANALYSIS OF ACOUSTICAL RESPIRATION CHARACTERISTICS, FOR ACOUSTICAL MONITORING, FEEDBACK, DETECTION OF RESPIRATORY CONDITIONS, FOR DIAGNOSING OR TREATING RESPIRATORY CONDITIONS, FOR MEDICAL DEVICES FOR MONITORING RESPIRATORY EVENTS AND SYSTEM THAT TRANSMIT THE DATA THROUGH THE INTERNET, FOR MEDICAL PRODUCTS, NAMELY, BIOFEEDBACK SENSORS, FOR MEDICAL PRODUCTS, NAMELY, RESPIRATORY SENSORS, FOR PORTABLE MEDICAL DEVICES USED FOR BREATHING EXERCISES AND RESPIRATORY MUSCLE TRAINING, AND FOR HEALTH AND FITNESS FOR IMPROVING RESPIRATORY FUNCTIONS; COMPUTER HARDWARE AND PERIPHERAL DEVICES AND COMPUTER SOFTWARE FOR DATA COMMUNICATION AND TRANSLATING AND TRANSMITTING DATA SOLD THEREWITH; COMPUTER SOFTWARE THAT PROVIDES WEB-BASED ACCESS TO APPLICATIONS AND SERVICES THROUGH A WEB OPERATING SYSTEM OR PORTAL INTERFACE; MEDICAL SOFTWARE FOR IDENTIFICATION, MEASUREMENT, ANALYSIS OF ACOUSTICAL RESPIRATION CHARACTERISTICS, FOR ACOUSTICAL MONITORING, FEEDBACK, DETECTION OF RESPIRATORY CONDITIONS, FOR DIAGNOSING OR TREATING RESPIRATORY CONDITIONS, FOR MEDICAL DEVICES FOR MONITORING RESPIRATORY EVENTS AND SYSTEM THAT TRANSMIT THE DATA THROUGH THE INTERNET, FOR MEDICAL PRODUCTS, NAMELY, BIOFEEDBACK SENSORS, FOR MEDICAL PRODUCTS, NAMELY, RESPIRATORY SENSORS, FOR PORTABLE MEDICAL DEVICES USED FOR BREATHING EXERCISES AND RESPIRATORY MUSCLE TRAINING, AND FOR HEALTH AND FITNESS FOR IMPROVING RESPIRATORY FUNCTIONS (U.S. CLS. 21, 23, 26, 36 AND 38).

FIRST USE 3-1-2010; IN COMMERCE 7-21-2010.

CLASS 42—SCIENTIFIC AND COMPUTER SERVICES

FOR APPLICATION SERVICE PROVIDER (ASP) FEATURING SOFTWARE FOR IDENTIFICATION, MEASUREMENT, ANALYSIS OF ACOUSTICAL RESPIRATION CHARACTERISTICS, FOR ACOUSTICAL MONITORING, FEEDBACK, DETECTION OF RESPIRATORY CONDITIONS, FOR DIAGNOSING OR TREATING RESPIRATORY CONDITIONS, FOR MEDICAL DEVICES FOR MONITORING RESPIRATORY EVENTS AND SYSTEM THAT TRANSMIT THE DATA THROUGH THE INTERNET, FOR MEDICAL PRODUCTS, NAMELY, BIOFEEDBACK SENSORS, FOR MEDICAL PRODUCTS, NAMELY, RESPIRATORY SENSORS, FOR PORTABLE MEDICAL DEVICES USED FOR BREATHING EXERCISES AND RESPIRATORY MUSCLE TRAINING, AND FOR HEALTH AND FITNESS FOR IMPROVING RESPIRATORY FUNCTIONS; APPLICATION SERVICE PROVIDER FEATURING APPLICATION PROGRAMMING INTERFACE (API) SOFTWARE FOR ALLOWING DATA RETRIEVAL, UPLOAD, ACCESS AND MANAGEMENT; APPLICATION SERVICE PROVIDER, NAMELY, HOSTING, MANAGING, DEVELOPING, AND MAINTAINING APPLICATIONS, SOFTWARE, AND WEB SITES, IN THE FIELDS OF PERSONAL PRODUCTIVITY, WIRELESS COMMUNICATION, MOBILE INFORMATION ACCESS, AND REMOTE DATA MANAGEMENT FOR WIRELESS DELIVERY OF CONTENT TO HANDHELD COMPUTERS, LAPTOPS AND MOBILE ELECTRONIC DEVICES; SOFTWARE AS A SERVICE (SAAS) SERVICES FEATURING SOFTWARE FOR IDENTIFICATION, MEASUREMENT, ANALYSIS OF ACOUSTICAL RESPIRATION CHARACTERISTICS, FOR ACOUSTICAL MONITORING, FEEDBACK, DETECTION OF RESPIRATORY CONDITIONS, FOR DIAGNOSING OR TREATING RESPIRATORY CONDITIONS, FOR MEDICAL DEVICES FOR MONITORING RESPIRATORY EVENTS AND SYSTEM THAT TRANSMIT THE DATA THROUGH THE INTERNET, FOR MEDICAL PRODUCTS, NAMELY, BIOFEEDBACK SENSORS, FOR MEDICAL PRODUCTS, NAMELY, RESPIRATORY SENSORS, FOR PORTABLE MEDICAL DEVICES USED FOR BREATHING EXER-

CISES AND RESPIRATORY MUSCLE TRAINING, AND FOR HEALTH AND FITNESS FOR IMPROVING RESPIRATORY FUNCTIONS (U.S. CLS. 100 AND 101).

FIRST USE 3-1-2010; IN COMMERCE 7-21-2010.
LINDA E. BLOHM, EXAMINING ATTORNEY

SN 85-243,870. CROSS COUNTRY AUTOMOTIVE SERVICES, INC., MEDFORD, MA. FILED 2-16-2011.

VIANOVA

THE MARK CONSISTS OF STANDARD CHARACTERS WITHOUT CLAIM TO ANY PARTICULAR FONT, STYLE, SIZE, OR COLOR.

THE WORD "VIANOVA" HAS NO MEANING IN A FOREIGN LANGUAGE.

CLASS 9—ELECTRICAL AND SCIENTIFIC APPARATUS

FOR VEHICLE COMPUTER HARDWARE AND COMPUTER SOFTWARE FOR TRANSMITTING AND SHARING DATA AND INFORMATION RELATING TO VEHICLE DIAGNOSTICS, WEATHER, TRAFFIC, SOCIAL NETWORKING, MUSIC, RADIO STATIONS, ADVERTISING, ROADSIDE AND EMERGENCY SUPPORT SERVICES, NEWS AND INSURANCE CLAIMS NOTICES, FOR MAPPING AND NAVIGATION, FOR CONNECTING REMOTELY TO THE INTERNET, FOR WIRELESS CONTENT DELIVERY AND FOR REMOTELY STARTING VEHICLES (U.S. CLS. 21, 23, 26, 36 AND 38).

CLASS 35—ADVERTISING AND BUSINESS

FOR MANAGEMENT AND OPERATION OF TELEPHONE CALL CENTERS FOR OTHERS IN THE FIELD OF VEHICLE SUPPORT, VEHICLE INFORMATION AND VEHICLE EMERGENCY SERVICES; PROVIDING CONSUMER INFORMATION, TELEPHONE DIRECTORY INFORMATION AND REFERRALS TO VEHICLE DRIVERS ALL IN THE FIELD OF VEHICLE RECALLS, VEHICLE WARRANTY CLAIMS, VEHICLE DEALER LOCATIONS AND LOCATION-BASED VEHICLE MAINTENANCE AND VEHICLE ROADSIDE AND EMERGENCY SUPPORT SERVICES; CUSTOMER RELATIONSHIP MANAGEMENT FOR VEHICLE DEALERSHIPS REGARDING TOWING AND EMERGENCY ROADSIDE SERVICES; PROVIDING COMMERCIAL INFORMATION AND PRICE COMPARISON INFORMATION TO MOTORISTS REGARDING AVAILABLE AUTOMOTIVE DEALERS; LOCATING VEHICLES FOR COMMERCIAL PURPOSES IN THE FIELD OF EMERGENCY ROAD SIDE ASSISTANCE; PROVIDING CONSUMER PRODUCT INFORMATION BASED ON INFORMATION CONTAINED IN OWNER'S MANUALS TO MOTORISTS VIA TWO-WAY WIRELESS COMMUNICATION WITH REMOTE RESPONSE AND DATA CENTERS (U.S. CLS. 100, 101 AND 102).

CLASS 36—INSURANCE AND FINANCIAL

FOR PROVIDING FINANCIAL INFORMATION TO MOTORISTS REGARDING AVAILABLE AUTOMOTIVE DEALERS; WARRANTY CLAIMS ADMINISTRATIVE SERVICES, NAMELY, PROCESSING WARRANTY CLAIMS FOR MOTOR VEHICLES; PROVIDING EXTENDED WARRANTIES ON VEHICLES; INSURANCE CLAIMS PROCESSING; INSURANCE CLAIMS ADMINISTRATION (U.S. CLS. 100, 101 AND 102).

CLASS 37—CONSTRUCTION AND REPAIR

FOR EMERGENCY ROAD SIDE REPAIR SERVICES; EMERGENCY ROADSIDE ASSISTANCE SERVICES, NAMELY, RESPONDING TO CALLS FOR ROADSIDE ASSISTANCE, FLAT TIRE CHANGING, EMERGENCY FUEL SUPPLYING AND BATTERY JUMP STARTING; AUTOMOBILE CLUB CONSULTATION SERVICES, NAMELY, CONSULTATION IN THE FIELD OF EMERGENCY ROADSIDE ASSISTANCE SERVICES FOR MOTORISTS AND OWNERS OF MOTOR VEHICLES REGARDING EMERGENCY ROAD SIDE REPAIR SERVICES (U.S. CLS. 100, 103 AND 106).

CLASS 38—COMMUNICATION

FOR WIRELESS VEHICLE COMMUNICATION SERVICES, NAMELY, WIRELESS ELECTRONIC TRANSMISSION OF VOICE SIGNALS, DATA, FACSIMILES, IMAGES AND INFORMATION; VEHICLE COMMUNICATION SERVICES, NAMELY, TRANSMISSION OF VOICE, AUDIO, VISUAL IMAGES AND DATA BY TELECOMMUNICATIONS NETWORKS, WIRELESS COMMUNICATION NETWORKS, THE INTERNET, INFORMATION SERVICES NETWORKS AND DATA NETWORKS BETWEEN VEHICLES AND VEHICLE PASSENGERS AND REMOTE RESPONSE AND DATA CENTERS; WIRELESS ELECTRONIC TRANSMISSION OF VEHICLE DIAGNOSTIC INFORMATION, REAL-TIME DATA, INFORMATION AND VOICE SIGNALS; WIRELESS ELECTRONIC TRANSMISSION OF VEHICLE LOCATION INFORMATION, EMERGENCY ROADSIDE ASSISTANCE STATUS INFORMATION AND VOICE COMMUNICATION WITH PASSENGERS; SATELLITE POSITIONING SERVICES, NAMELY, SATELLITE COMMUNICATION AND TRANSMISSION SERVICES RELATING TO PRECISION VEHICLE POSITIONING AND VEHICLE NAVIGATION; TELEPHONE COMMUNICATION SYSTEM SERVICES, NAMELY, CELLULAR TELEPHONE TRANSMISSION SERVICES FOR MOTORIST LOCATION AND EMERGENCY ROADSIDE ASSISTANCE STATUS INFORMATION (U.S. CLS. 100, 101 AND 104).

CLASS 39—TRANSPORTATION AND STORAGE

FOR PROVIDING TRAFFIC, TRAVEL AND VEHICLE TOWING INFORMATION TO MOTORISTS REGARDING AVAILABLE AUTOMOTIVE DEALERS; PROVIDING RESCUE SERVICE INFORMATION REGARDING THE LOCATION OF EMERGENCY VEHICLES; EMERGENCY ROADSIDE AND ASSISTANCE SERVICES, NAMELY, VEHICLE TOWING; GPS NAVIGATION SERVICES; PROVIDING ROADSIDE AND IN-VEHICLE GPS NAVIGATION SERVICES TO MOTORISTS FROM REMOTE RESPONSE CENTERS VIA TWO-WAY WIRELESS COMMUNICATION; EMERGENCY ROADSIDE ASSISTANCE SERVICES, NAMELY, TOWING, WINCH-OUT AND KEY DELIVERY SERVICES; VEHICLE RENTAL SERVICES; TRANSPORTATION RESERVATION SERVICES; AUTOMOBILE CLUB CONSULTATION SERVICES, NAMELY, CONSULTATION IN THE FIELD OF EMERGENCY ROADSIDE ASSISTANCE SERVICES FOR MOTORISTS AND OWNERS OF MOTOR VEHICLES REGARDING AUTO AND TRUCK TOWING SERVICES; AUTOMOBILE CLUB TRAVEL SERVICES, NAMELY, ARRANGING TOURS, ORGANIZING TRIPS AND MAKING RESERVATIONS AND BOOKINGS FOR LAND TRANSPORTATION (U.S. CLS. 100 AND 105).

CLASS 45—PERSONAL AND LEGAL SERVICES

FOR EMERGENCY ROADSIDE ASSISTANCE SERVICES, NAMELY, OPENING OF LOCKS; SECURITY SERVICES FOR VEHICLES, NAMELY, PROVIDING PHYSICAL ACCESS TO VEHICLES VIA A REMOTE CALL-IN LOCKING DEVICE; AUTOMOBILE CLUB SERVICES, NAMELY, ACCIDENT INVESTIGATIONS AND ADVISORY AND INFORMATION SERVICES IN THE NATURE OF PREPARING AND PROVIDING REPORTS RELATING TO AUTOMOTIVE SAFETY (U.S. CLS. 100 AND 101).

DAVID YONTEF, EXAMINING ATTORNEY

SN 85-243,909. XIUS CORP., FORMERLY CELLULAR EXPRESS, INC., WOBURN, MA. FILED 2-16-2011.



OWNER OF U.S. REG. NOS. 2,879,511, 3,594,188 AND 3,629,948.

THE MARK CONSISTS OF CROSSED VERTICAL ARCED LINES FOLLOWED BY THE WORD "XIUS", ALL ABOVE THE WORDING "INNOVATE. LEAD."

CLASS 35—ADVERTISING AND BUSINESS

FOR DATA PROCESSING, ACCOUNT BILLING AND BUSINESS INFORMATION MANAGEMENT SERVICES PROVIDED TO WIRELESS COMMUNICATIONS CARRIERS AND THEIR SERVICE PROVIDERS AND OTHER BUSINESS PARTNERS; BUSINESS MANAGEMENT OF TELEPHONE COMMUNICATIONS NETWORKS, NAMELY, MANAGING TELEPHONE AND MOBILE COMMERCE SERVICES (U.S. CLS. 100, 101 AND 102).

FIRST USE 1-11-2011, THE MARK WAS FIRST USED ANYWHERE IN A DIFFERENT FORM OTHER THAN THAT SOUGHT TO BE REGISTERED AT LEAST AS EARLY AS 09/15/2000.; IN COMMERCE 1-11-2011, THE MARK WAS FIRST USED IN COMMERCE IN A DIFFERENT FORM OTHER THAN THAT SOUGHT TO BE REGISTERED AT LEAST AS EARLY AS 08/01/2003..

CLASS 36—INSURANCE AND FINANCIAL

FOR MERCHANT SERVICES, NAMELY, PAYMENT TRANSACTION PROCESSING SERVICES AND ELECTRONIC PAYMENT, NAMELY, ELECTRONIC PROCESSING AND TRANSMISSION OF BILL PAYMENT DATA, ALL FOR THE TELECOMMUNICATIONS INDUSTRY (U.S. CLS. 100, 101 AND 102).

FIRST USE 1-11-2011; IN COMMERCE 1-11-2011.

CLASS 42—SCIENTIFIC AND COMPUTER SERVICES

FOR APPLICATION SERVICE PROVIDER (ASP) FEATURING SOFTWARE FOR USE FOR DATA PROCESSING, ACCOUNT BILLING, CUSTOMER SERVICE AND FINANCIAL, E-COMMERCE AND TELECOMMUNICATION BILL TRANSACTION PROCESSING AND IN PERFORMING INFORMATION MANAGEMENT SERVICES FOR WIRELESS COMMUNICATIONS CARRIERS AND THEIR SERVICE PROVIDERS AND OTHER BUSINESS PARTNERS; COMPUTER SOFTWARE DEVELOPMENT SERVICES FOR OTHERS IN THE FIELD OF WIRELESS VOICE AND DATA TRANSMISSION AND MOBILE TRANSACTION PROCESSING (U.S. CLS. 100 AND 101).

FIRST USE 1-11-2011, THE MARK WAS FIRST USED ANYWHERE IN A DIFFERENT FORM OTHER THAN THAT SOUGHT TO BE REGISTERED AT LEAST AS EARLY AS 09/15/2000. ; IN COMMERCE 1-11-2011, THE MARK WAS FIRST USED IN COMMERCE IN A DIFFERENT FORM OTHER THAN THAT SOUGHT TO BE REGISTERED AT LEAST AS EARLY AS 08/01/2003..

ELISSA GARBER KON, EXAMINING ATTORNEY

SN 85-243,955. WONG, RYAN Y., BROOKLINE, MA. FILED 2-16-2011.

SN 85-243,971. PEACE FIRST, INC., BOSTON, MA. FILED 2-16-2011.

Heel-and-Toe

THE MARK CONSISTS OF STANDARD CHARACTERS WITHOUT CLAIM TO ANY PARTICULAR FONT, STYLE, SIZE, OR COLOR.

CLASS 18—LEATHER GOODS

FOR AUTOMOTIVE, MOTORSPORT AND RACING SECTOR ACCESSORIES AND APPAREL, NAMELY, ALL PURPOSE SPORT BAGS, ALL-PURPOSE ATHLETIC BAGS, ALL-PURPOSE CARRYING BAGS, ATHLETIC BAGS, BACKPACKS, BOOK BAGS, SPORTS BAGS, BUM BAGS, WALLETS AND HANDBAGS, BAGS AND HOLDALLS FOR SPORTS CLOTHING, CARRY-ALL BAGS, DUFFEL BAGS, DUFFEL BAGS FOR TRAVEL, DUFFLE BAGS, LUGGAGE, SPORT BAGS, SPORTS BAGS, TRAVEL BAGGAGE, TRAVEL BAGS, TRAVELING BAGS (U.S. CLS. 1, 2, 3, 22 AND 41).

CLASS 25—CLOTHING

FOR AUTOMOTIVE, MOTORSPORT AND RACING SECTOR ACCESSORIES AND APPAREL, NAMELY, SHIRTS, PANTS, JACKETS, FOOTWEAR, HATS AND CAPS, ATHLETIC UNIFORMS; BOXER SHORTS; CHILDREN'S AND INFANT'S APPAREL, NAMELY, JUMPERS, OVERALL SLEEPWEAR, PAJAMAS, ROMPERS AND ONE-PIECE GARMENTS; CLOTHING ITEMS, NAMELY, ADHESIVE POCKETS THAT MAY BE AFFIXED DIRECTLY TO THE BODY AS A DECORATIVE PIECE OF CLOTHING WITH UTILITY; CLOTHING ITEMS, NAMELY, ADHESIVE POCKETS THAT MAY BE AFFIXED DIRECTLY TO THE INSIDE OF CLOTHING FOR STORAGE AND SAFEKEEPING OF PERSONAL ITEMS; COATS; COLLARED SHIRTS; CREW NECK SWEATERS; FOOTWEAR; GLOVES; HATS; HEAD WEAR; HOODED PULLOVERS; HOODED SWEAT SHIRTS; HOODED SWEATSHIRTS; HOODIES; JACKETS; JEANS; LEGGINGS; LOAFERS; LONG-SLEEVED SHIRTS; LOUNGEWEAR; MEN'S SOCKS; MEN'S UNDERWEAR; NIGHTWEAR; PAJAMAS; RAIN WEAR; SCARFS; SCARVES; SCIENTIFIC AND TECHNOLOGICAL APPAREL, NAMELY, SHIRTS, PANTS, JACKETS, FOOTWEAR, HATS AND CAPS, UNIFORMS; SHIRTS; SHIRTS AND SHORT-SLEEVED SHIRTS; SHIRTS FOR INFANTS, BABIES, TODDLERS AND CHILDREN; SHOE COVERS FOR USE WHEN WEARING SHOES; SHOES; SHORTS; SHORT-SLEEVED OR LONG-SLEEVED T-SHIRTS; SHORT-SLEEVED SHIRTS; SLEEPWEAR; SOCKS; SPORT SHIRTS; SPORTS CAPS AND HATS; SPORTS JACKETS; SPORTS PANTS; SPORTS SHIRTS; SPORTS SHIRTS WITH SHORT SLEEVES; SWEAT JACKETS; SWEAT PANTS; SWEAT SHIRTS; SWEAT SHORTS; SWEATERS; SWEATPANTS; SWEATSHIRTS; SWIM WEAR; TEE SHIRTS; TIES; T-SHIRTS; UNDER GARMENTS; WATER REPELLING FOOTWEAR; WATERPROOF FOOTWEAR; WATERPROOF JACKETS AND PANTS; WEARABLE GARMENTS AND CLOTHING, NAMELY, SHIRTS; WIND RESISTANT JACKETS; WIND-JACKETS; WOMEN'S CLOTHING, NAMELY, SHIRTS, DRESSES, SKIRTS, BLOUSES; WOMEN'S SHOES; AND WOMEN'S UNDERWEAR (U.S. CLS. 22 AND 39).

KIMBERLY PERRY, EXAMINING ATTORNEY

PEACE FIRST PRIZE

THE MARK CONSISTS OF STANDARD CHARACTERS WITHOUT CLAIM TO ANY PARTICULAR FONT, STYLE, SIZE, OR COLOR.

OWNER OF U.S. REG. NOS. 3,870,125 AND 3,890,991.
NO CLAIM IS MADE TO THE EXCLUSIVE RIGHT TO USE "PRIZE", APART FROM THE MARK AS SHOWN.

CLASS 36—INSURANCE AND FINANCIAL

FOR CHARITABLE FUNDRAISING SERVICES AND FINANCIAL SPONSORSHIP OF AN AWARD FOR CHILDREN (U.S. CLS. 100, 101 AND 102).

CLASS 41—EDUCATION AND ENTERTAINMENT

FOR ENTERTAINMENT SERVICES, NAMELY, CONDUCTING A COMMUNITY SERVICE COMPETITION TO PROMOTE PEACE AND JUSTICE AND TO REWARD CHILDREN FOR THEIR INNOVATION AND INITIATIVE IN PROMOTING PEACE AND JUSTICE IN THEIR COMMUNITIES (U.S. CLS. 100, 101 AND 107).

SUNG IN, EXAMINING ATTORNEY

SN 85-243,977. FRANK ALGER REAL ESTATE GROUP, LLC, NEW YORK, NY. FILED 2-16-2011.

THE FARE GROUP

THE MARK CONSISTS OF STANDARD CHARACTERS WITHOUT CLAIM TO ANY PARTICULAR FONT, STYLE, SIZE, OR COLOR.

NO CLAIM IS MADE TO THE EXCLUSIVE RIGHT TO USE "GROUP", APART FROM THE MARK AS SHOWN.

CLASS 36—INSURANCE AND FINANCIAL

FOR REAL ESTATE BROKERAGE; REAL ESTATE MANAGEMENT SERVICES (U.S. CLS. 100, 101 AND 102).
FIRST USE 2-15-2011; IN COMMERCE 2-15-2011.

CLASS 37—CONSTRUCTION AND REPAIR

FOR REAL ESTATE DEVELOPMENT (U.S. CLS. 100, 103 AND 106).
FIRST USE 2-15-2011; IN COMMERCE 2-15-2011.
SUNG IN, EXAMINING ATTORNEY

SN 85-244,013. XLHEALTH CORPORATION, BALTIMORE, MD. FILED 2-16-2011.



OWNER OF U.S. REG. NO. 3,110,970.
THE COLOR(S) BLUE AND LIGHT BLUE IS/ARE CLAIMED AS A FEATURE OF THE MARK.
THE MARK CONSISTS OF THE WORD "XLHEALTH" IN BLUE WITH THE "L" IN LIGHT BLUE FOLLOWED BY THE WORDS "INFORM. EMPOWER. EXCEL." IN BLUE WITH A PERIOD AFTER EACH WORD.

CLASS 36—INSURANCE AND FINANCIAL

FOR PROVIDING HEALTHCARE INSURANCE UNDERWRITING AND ADMINISTRATION SERVICES FOR MEDICARE BENEFICIARIES (U.S. CLS. 100, 101 AND 102).

FIRST USE 2-9-2004; IN COMMERCE 2-9-2004.

CLASS 44—MEDICAL, BEAUTY AND AGRICULTURAL SERVICES

FOR PROVIDING HEALTHCARE SERVICES IN THE NATURE OF CARE MANAGEMENT AND DISEASE MANAGEMENT FOR MEMBERS (U.S. CLS. 100 AND 101).

FIRST USE 2-9-2004; IN COMMERCE 2-9-2004.

WILLIAM BRECKENFELD, EXAMINING ATTORNEY

SN 85-244,024. PAPANICOLAOU CORPS FOR CANCER RESEARCH, INC., DEERFIELD BEACH, FL. FILED 2-16-2011.

THE PAP CORPS

THE MARK CONSISTS OF STANDARD CHARACTERS WITHOUT CLAIM TO ANY PARTICULAR FONT, STYLE, SIZE, OR COLOR.

NO CLAIM IS MADE TO THE EXCLUSIVE RIGHT TO USE "CORPS", APART FROM THE MARK AS SHOWN.

CLASS 35—ADVERTISING AND BUSINESS

FOR ASSOCIATION SERVICES, NAMELY, PROMOTING THE PUBLIC INTEREST AND AWARENESS IN CANCER RESEARCH AND EDUCATION (U.S. CLS. 100, 101 AND 102).

FIRST USE 10-31-2010; IN COMMERCE 10-31-2010.

CLASS 36—INSURANCE AND FINANCIAL

FOR CHARITABLE FOUNDATION SERVICES, NAMELY, PROVIDING FUNDRAISING ACTIVITIES TO SUPPORT MEDICAL RESEARCH AND PROCEDURES FOR THOSE IN NEED; FINANCING MEDICAL RESEARCH OF OTHERS (U.S. CLS. 100, 101 AND 102).

FIRST USE 10-31-2010; IN COMMERCE 10-31-2010.

WILLIAM BRECKENFELD, EXAMINING ATTORNEY

SN 85-244,201. SCHOOL OF IMAGINATION, PLEASANTON, CA. FILED 2-16-2011.

School of Imagination

THE MARK CONSISTS OF STANDARD CHARACTERS WITHOUT CLAIM TO ANY PARTICULAR FONT, STYLE, SIZE, OR COLOR.

NO CLAIM IS MADE TO THE EXCLUSIVE RIGHT TO USE "SCHOOL", APART FROM THE MARK AS SHOWN.

CLASS 41—EDUCATION AND ENTERTAINMENT

FOR EDUCATIONAL PROGRAMS, NAMELY, PRE-SCHOOLS; PROVIDING INFORMATION IN THE FIELD OF LITERACY, READING, SIGN LANGUAGE, EDUCATION, TRAINING, EARLY CHILDHOOD INSTRUCTION AND TUTORING RELATED TO HEARING AND SPEECH DISABILITIES VIA THE INTERNET (U.S. CLS. 100, 101 AND 107).

FIRST USE 6-1-2005; IN COMMERCE 6-1-2005.

CLASS 44—MEDICAL, BEAUTY AND AGRICULTURAL SERVICES

FOR COGNITIVE THERAPY SERVICES; LISTENING THERAPY SERVICES; OCCUPATIONAL THERAPY SERVICES; SPEECH AND HEARING THERAPY; SPEECH PATHOLOGY THERAPY SERVICES; SPEECH THERAPY SERVICES (U.S. CLS. 100 AND 101).

FIRST USE 6-1-2005; IN COMMERCE 6-1-2005.

WILLIAM P. SHANAHAN, EXAMINING ATTORNEY

SN 85-244,267. YU, CHUNHONG, DBA GREEN LONG LIFE MING'S MARK INC., PHOENIX, AZ. FILED 2-16-2011.



NO CLAIM IS MADE TO THE EXCLUSIVE RIGHT TO USE "GREEN LONGLIFE", APART FROM THE MARK AS SHOWN.

THE COLOR(S) BRIGHT GREEN, DARK GREEN, AQUA, AND BLUE IS/ARE CLAIMED AS A FEATURE OF THE MARK.

THE MARK CONSISTS OF GLOBE WITH BRIGHT GREEN CONTINENTS AND AQUA OCEAN GRADIENT BRIGHT ON TOP AND WITH DARK BLUE AT THE BOTTOM. THE LETTERS "G", "R" ARE INSIDE THE GLOBE WITH THE LETTERS "E", "E", "N" COMPLETING THE WORD "GREEN". THE LETTERS "LONGLIFE" ARE ON THE LINE UNDER THE WORD "GREEN". ALL LETTERING IS DARK GREEN.

CLASS 9—ELECTRICAL AND SCIENTIFIC APPARATUS

FOR LIGHT DIODES; LIGHT EMITTING DIODE (LED) DISPLAYS; LIGHT EMITTING DIODES (LEDs); ALL OF THE AFOREMENTIONED GOODS BEING ENVIRONMENTALLY FRIENDLY (U.S. CLS. 21, 23, 26, 36 AND 38).

FIRST USE 11-15-2010; IN COMMERCE 12-15-2010.

CLASS 11—ENVIRONMENTAL CONTROL APPARATUS

FOR BACKUP LIGHTS FOR LAND VEHICLES; LED LIGHT BULBS; LIGHTS FOR VEHICLES; MINIATURE LIGHT BULBS; REAR LIGHTS FOR VEHICLES; RUNNING LIGHTS FOR LAND VEHICLES; RUNNING LIGHTS FOR RV, BOATS, TRUCK, TRAILER; TAIL LIGHTS FOR LAND VEHICLES; TAIL LIGHTS FOR VEHICLES; TRAILER LIGHTS FOR TRAILER, TRUCK, RV, BOAT; VEHICLE TURN-SIGNAL LIGHT BULBS; ALL OF THE AFOREMENTIONED GOODS BEING ENVIRONMENTALLY FRIENDLY (U.S. CLS. 13, 21, 23, 31 AND 34).

FIRST USE 11-15-2010; IN COMMERCE 12-15-2010.
KEVIN CORWIN, EXAMINING ATTORNEY

SN 85-244,348. YOGANATION, LLC, SANTA MONICA, CA. FILED 2-16-2011.

YOGANATION

THE MARK CONSISTS OF STANDARD CHARACTERS WITHOUT CLAIM TO ANY PARTICULAR FONT, STYLE, SIZE, OR COLOR.
OWNER OF U.S. REG. NO. 3,910,015.

CLASS 16—PAPER GOODS AND PRINTED MATTER

FOR EDUCATIONAL PUBLICATIONS, NAMELY, BOOKS, WORKBOOKS, INSTRUCTIONAL MANUALS, PRINTED CHARTS, PRINTED POSTERS, BROCHURES AND PAMPHLETS IN THE FIELDS OF YOGA, YOGA INSTRUCTION AND YOGA DEMONSTRATIONS; MAGAZINES IN THE FIELD OF YOGA, YOGA INSTRUCTION AND RELATED YOGA SUBJECT MATTER; NEWSLETTERS IN THE FIELD OF YOGA, YOGA INSTRUCTION AND RELATED YOGA SUBJECT MATTER (U.S. CLS. 2, 5, 22, 23, 29, 37, 38 AND 50).

FIRST USE 6-0-1996; IN COMMERCE 6-0-1996.

CLASS 41—EDUCATION AND ENTERTAINMENT

FOR ENTERTAINMENT SERVICES, NAMELY, PROVIDING A WEB SITE FEATURING PHOTOGRAPHIC, AUDIO, VIDEO AND PROSE PRESENTATIONS FEATURING YOGA, YOGA INSTRUCTION AND YOGA DEMONSTRATIONS; ON-LINE JOURNALS, NAMELY, BLOGS FEATURING YOGA, YOGA INSTRUCTION AND RELATED YOGA SUBJECT MATTER; PROVIDING A WEBSITE FEATURING BLOGS AND NON-DOWNLOADABLE PUBLICATIONS IN THE NATURE OF ARTICLES, WRITTEN INFORMATION, WRITTEN INTERVIEWS AND NON-DOWNLOADABLE INSTRUCTIONAL VIDEOS IN THE FIELD(S) OF YOGA, YOGA INSTRUCTION, YOGA DEMONSTRATIONS AND RELATED YOGA SUBJECT MATTER; PROVIDING ON-LINE MAGAZINES IN THE FIELD OF YOGA, YOGA INSTRUCTION AND RELATED YOGA SUBJECT MATTER; YOGA INSTRUCTION (U.S. CLS. 100, 101 AND 107).

FIRST USE 6-0-1996; IN COMMERCE 6-0-1996.
TINA MAI, EXAMINING ATTORNEY

SN 85-244,435. VALUMAX PROTECTIVE APPAREL INC., DBA VALUMAX PROTECTIVE APPAREL INC., ALLENTOWN, PA. FILED 2-16-2011.

Extra-Safe

THE MARK CONSISTS OF STANDARD CHARACTERS WITHOUT CLAIM TO ANY PARTICULAR FONT, STYLE, SIZE, OR COLOR.

CLASS 10—MEDICAL APPARATUS

FOR FACE MASKS FOR USE BY MEDICAL PERSONNEL (U.S. CLS. 26, 39 AND 44).

FIRST USE 7-17-2004; IN COMMERCE 7-17-2004.

CLASS 25—CLOTHING

FOR MEDICAL AND HOSPITAL APPAREL, NAMELY, LAB COATS, LAB JACKETS (U.S. CLS. 22 AND 39).

FIRST USE 7-17-2004; IN COMMERCE 7-17-2004.

CARYN GLASSER, EXAMINING ATTORNEY

SN 85-244,512. QUANTCAST CORPORATION, SAN FRANCISCO, CA. FILED 2-17-2011.

AUDIENCE DNA

THE MARK CONSISTS OF STANDARD CHARACTERS WITHOUT CLAIM TO ANY PARTICULAR FONT, STYLE, SIZE, OR COLOR.

NO CLAIM IS MADE TO THE EXCLUSIVE RIGHT TO USE "AUDIENCE", APART FROM THE MARK AS SHOWN.

CLASS 35—ADVERTISING AND BUSINESS

FOR ADVERTISING SERVICES, NAMELY, PLACEMENT AND DISSEMINATION OF ADVERTISING FOR OTHERS VIA AN ON-LINE COMMUNICATIONS NETWORK; BUSINESS MARKETING, PROMOTIONS, AND ADVERTISING CONSULTING SERVICES; PROVIDING ADVERTISING CAMPAIGN MANAGEMENT SERVICES IN THE NATURE OF TRACKING, ANALYZING, AND REPORTING ON CONSUMER DATA, DEMOGRAPHICS, AND CONSUMER BEHAVIORAL INFORMATION, COMPUTER NETWORK USE AND USERS FOR BUSINESS PURPOSES, AND CONSUMER RESPONSES TO ADVERTISEMENTS AND PROMOTIONAL MATERIALS; MANAGEMENT AND COMPILATION OF COMPUTERIZED DATABASES, NAMELY, CREATING AND MANAGING CUSTOMER LISTS AND CUSTOMER DATA IN A COMPUTER DATABASE FOR OTHERS; CONDUCTING MARKET RESEARCH AND CONSUMER RESEARCH; ADVERTISING AND ADVERTISEMENT SERVICES; ADVERTISING BY TRANSMISSION OF ONLINE PUBLICITY FOR THIRD PARTIES THROUGH ELECTRONIC COMMUNICATIONS NETWORKS; ADVERTISING VIA ELECTRONIC MEDIA AND SPECIFICALLY THE INTERNET; DISSEMINATION OF ADVERTISING FOR OTHERS VIA THE INTERNET; MEDIATION OF ADVERTISING; SERVICES TO DETERMINE THE AUDIENCE AFFECTED BY ADVERTISEMENTS (U.S. CLS. 100, 101 AND 102).

CLASS 42—SCIENTIFIC AND COMPUTER SERVICES

FOR PROVIDING ONLINE NON-DOWNLOADABLE SOFTWARE FOR TRACKING, MANAGING, AND OPTIMIZING ADVERTISING AND PROMOTIONAL CAMPAIGNS, AND CALCULATING RETURN ON INVESTMENT IN CONNECTION WITH THE SAME; PROVIDING ONLINE NON-DOWNLOADABLE SOFTWARE FOR TRACKING WEBSITE TRAFFIC, E-COMMERCE ACTIVITY, CUSTOMER LOYALTY, AND SALES CONVERSION RATES; PROVIDING ONLINE NON-DOWNLOADABLE SOFTWARE FOR MANAGING, COLLECTING, MONITORING AND ANALYZING WEB, BLOG AND OTHER ONLINE SITE TRAFFIC, USER PREFERENCES AND LINKS IN REAL TIME; DESIGN AND DEVELOPMENT SERVICES FOR OTHERS OF SOFTWARE FOR MANAGING, COLLECTING, MONITORING AND ANALYZING WEB, BLOG AND OTHER ONLINE SITE TRAFFIC, USER PREFERENCES AND LINKS; COMPUTER SERVICE, NAMELY, ACTING AS A SOFTWARE-AS-A-SERVICE PROVIDER (SAAS) IN THE FIELD OF DIGITAL MEDIA MEASUREMENT, WEBSITE AUDIENCE ANALYSIS AND ADVERTISING OPTIMIZATION TO HOST SOFTWARE THAT MANAGES, MONITORS, TRACKS, AND OPTIMIZES THE PERFORMANCE AND EFFECTIVENESS OF ONLINE AND OFFLINE MARKETING CAMPAIGNS; COMPUTER SERVICE, NAMELY, ACTING AS A SOFTWARE-AS-A-SERVICE PROVIDER (SAAS) IN THE FIELD OF WEB ANALYTICS TO HOST SOFTWARE THAT COLLECTS, MANAGES, INTEGRATES, ANALYZES, MONITORS, AND TRACKS THE PERFORMANCE OF WEBSITES THROUGH WEB USER BEHAVIOR (U.S. CLS. 100 AND 101).

JOHN E. MICHOS, EXAMINING ATTORNEY

SN 85-244,534. NO LIMIT, LLC, FARMINGTON, CT. FILED 2-17-2011.



OWNER OF U.S. REG. NOS. 3,145,005, 3,698,155 AND 3,698,312.

THE PORTRAIT OF PAUL NEWMAN IN THE MARK DOES NOT IDENTIFY A LIVING INDIVIDUAL.

THE MARK CONSISTS OF ARTISTIC RENDERING OF THE FACE OF PAUL NEWMAN.

CLASS 29—MEATS AND PROCESSED FOODS

FOR FROZEN ENTREES CONSISTING PRIMARILY OF MEAT, FISH, POULTRY OR VEGETABLES (U.S. CL. 46).

CLASS 30—STAPLE FOODS

FOR FROZEN ENTREES CONSISTING PRIMARILY OF PASTA OR RICE (U.S. CL. 46).
LINDA M. KING, EXAMINING ATTORNEY

SN 85-244,529. NO LIMIT, LLC, FARMINGTON, CT. FILED 2-17-2011.

NEWMAN'S OWN

THE MARK CONSISTS OF STANDARD CHARACTERS WITHOUT CLAIM TO ANY PARTICULAR FONT, STYLE, SIZE, OR COLOR.

OWNER OF U.S. REG. NOS. 1,280,046, 1,863,860 AND OTHERS.

THE NAME "NEWMAN" DOES NOT IDENTIFY A LIVING INDIVIDUAL.

CLASS 29—MEATS AND PROCESSED FOODS

FOR FROZEN ENTREES CONSISTING PRIMARILY OF MEAT, FISH, POULTRY OR VEGETABLES (U.S. CL. 46).

CLASS 30—STAPLE FOODS

FOR FROZEN ENTREES CONSISTING PRIMARILY OF PASTA OR RICE (U.S. CL. 46).
LINDA M. KING, EXAMINING ATTORNEY

SN 85-244,879. TECHNOLOGY AND ENTREPRENEURSHIP CENTER OF HOUSTON, INC., DBA HOUSTON TECHNOLOGY CENTER, HOUSTON, TX. FILED 2-17-2011.

Tech Champs

THE MARK CONSISTS OF STANDARD CHARACTERS WITHOUT CLAIM TO ANY PARTICULAR FONT, STYLE, SIZE, OR COLOR.

OWNER OF U.S. REG. NO. 3,536,440.
SEC. 2(F).

CLASS 35—ADVERTISING AND BUSINESS

FOR BUSINESS NETWORKING AND BUSINESS REFERRAL SERVICES, NAMELY, ASSISTING EMERGING BUSINESSES BY PROVIDING REFERRALS TO LEADING LEGAL, ACCOUNTING, ADVERTISING AND PUBLIC RELATIONS FIRMS CONSULTING ON A PRO BONO OR REDUCED FEE BASIS, AND TO VENTURE CAPITALISTS, INVESTORS AND MENTORS (U.S. CLS. 100, 101 AND 102).

FIRST USE 2-2-2004; IN COMMERCE 2-2-2004.

CLASS 41—EDUCATION AND ENTERTAINMENT

FOR EDUCATIONAL SERVICES, NAMELY, CONDUCTING CLASSES, SEMINARS, CONFERENCES, WORKSHOPS AND NETWORKING EVENTS IN THE FIELD OF GROWING EMERGING COMPANIES (U.S. CLS. 100, 101 AND 107).

FIRST USE 2-2-2004; IN COMMERCE 2-2-2004.
STEVEN JACKSON, EXAMINING ATTORNEY

SN 85-245,013. MAYER, SUSAN L., DBA 74 HARLEY STREET, OVERLAND PARK, KS. FILED 2-17-2011.

74 Harley Street

THE MARK CONSISTS OF STANDARD CHARACTERS WITHOUT CLAIM TO ANY PARTICULAR FONT, STYLE, SIZE, OR COLOR.

CLASS 14—JEWELRY

FOR BEADS, CRYSTALS AND SPARKLE EMBELLISHMENTS FOR USE IN THE MANUFACTURE OF JEWELRY, BODY JEWELRY, BRACELETS, BROOCHES, CAMEOS, CHARMS, SKELETON KEYS, COSTUME JEWELRY, HAIR JEWELRY AND HAIR CLIPS IN THE NATURE OF JEWELRY FOR USE IN THE HAIR, IMITATION JEWELRY, PEARLS, JEWELRY CHAINS, NECKLACES, DRESS CLIPS, EARRINGS AND VINTAGE EARRINGS, PINS BEING JEWELRY, AND RINGS BEING JEWELRY (U.S. CLS. 2, 27, 28 AND 50).

FIRST USE 11-5-2005; IN COMMERCE 11-5-2005.

CLASS 35—ADVERTISING AND BUSINESS

FOR MAIL ORDER SERVICES FEATURING JEWELRY; VENDING IN THE FIELD OF JEWELRY; ONLINE RETAIL STORE SERVICES FEATURING JEWELRY; VENDING IN THE FIELD OF JEWELRY AT SHOWS, AND AT HOMES, SCHOOLS AND BUSINESSES (U.S. CLS. 100, 101 AND 102).

FIRST USE 2-1-2010; IN COMMERCE 2-1-2010.
ODESSA BIBBINS, EXAMINING ATTORNEY

SN 85-245,021. C&S DISTRIBUTING, INC., GREENSBORO, NC. FILED 2-17-2011.

Yellow Rose

THE MARK CONSISTS OF STANDARD CHARACTERS WITHOUT CLAIM TO ANY PARTICULAR FONT, STYLE, SIZE, OR COLOR.

CLASS 3—COSMETICS AND CLEANING PREPARATIONS

FOR CLEANING PREPARATIONS FOR ADULT SEXUAL AIDS (U.S. CLS. 1, 4, 6, 50, 51 AND 52).

CLASS 10—MEDICAL APPARATUS

FOR ADULT SEXUAL AIDS, NAMELY, PENIS PUMPS, MASTURBATORS AND VIBRATORS (U.S. CLS. 26, 39 AND 44).

ZHALEH DELANEY, EXAMINING ATTORNEY

SN 85-245,050. RAINBOW INTERNATIONAL CARPET DYEING & CLEANING CO., WACO, TX. FILED 2-17-2011.

WE RESTORE, YOU RECOVER

THE MARK CONSISTS OF STANDARD CHARACTERS WITHOUT CLAIM TO ANY PARTICULAR FONT, STYLE, SIZE, OR COLOR.

CLASS 37—CONSTRUCTION AND REPAIR

FOR CARPET, UPHOLSTERY AND DRAPERY CLEANING, AND SPOT AND STAIN REMOVAL SERVICES, AIR-DUCT CLEANING SERVICES, DISASTER RESTORATION SERVICES, NAMELY, RESTORING BUILDING INTERIORS, CARPET AND FURNISHINGS DAMAGED BY FIRE, WATER, SMOKE AND OTHER DISASTERS; CARPET REPAIR SERVICES, COMMERCIAL AND RESIDENTIAL BUILDING CLEANING SERVICES; PROVIDING CARPET AND UPHOLSTERY DYEING, TINTING AND COLORIZING SERVICES (U.S. CLS. 100, 103 AND 106).

CLASS 40—MATERIAL TREATMENT

FOR CARPET, UPHOLSTERY AND DRAPERY ODOR REMOVAL SERVICES, MOLD INHIBITION SERVICES OF BUILDINGS AND THEIR CONTENTS (U.S. CLS. 100, 103 AND 106).

MORGAN WYNNE, EXAMINING ATTORNEY

SN 85-245,272. MEDI-DYNE HEALTHCARE PRODUCTS, LTD., COLLEYVILLE, TX. FILED 2-17-2011.

PROSTRETCH PLUS

THE MARK CONSISTS OF STANDARD CHARACTERS WITHOUT CLAIM TO ANY PARTICULAR FONT, STYLE, SIZE, OR COLOR.

OWNER OF U.S. REG. NOS. 1,645,088 AND 3,287,435.

CLASS 10—MEDICAL APPARATUS

FOR DEVICE FOR STRETCHING THE CALF MUSCLES, ACHILLES TENDON AND PLANTAR FASCIA OF THE LOWER HUMAN BODY FOR THERAPEUTIC AND PHYSICAL TRAINING FOR MEDICAL PURPOSES (U.S. CLS. 26, 39 AND 44).

CLASS 28—TOYS AND SPORTING GOODS

FOR DEVICE FOR STRETCHING THE CALF MUSCLES, ACHILLES TENDON AND PLANTAR FASCIA OF THE LOWER HUMAN BODY FOR PHYSICAL FITNESS TRAINING PURPOSES (U.S. CLS. 22, 23, 38 AND 50).

SANDRA BUJA, EXAMINING ATTORNEY

SN 85-245,388. AMPURE CAPITAL, LLC, DBA AMPURE CAPITAL, LOS ANGELES, CA. FILED 2-17-2011.

AMPURE CAPITAL

THE MARK CONSISTS OF STANDARD CHARACTERS WITHOUT CLAIM TO ANY PARTICULAR FONT, STYLE, SIZE, OR COLOR.

NO CLAIM IS MADE TO THE EXCLUSIVE RIGHT TO USE "CAPITAL", APART FROM THE MARK AS SHOWN.

CLASS 35—ADVERTISING AND BUSINESS

FOR ACQUISITION AND MERGER CONSULTATION; ADVERTISING AND MARKETING CONSULTANCY; ADVERTISING CONSULTATION; ADVICE IN THE FIELD OF BUSINESS MANAGEMENT AND MARKETING; ADVICE RELATING TO THE ORGANIZATION AND MANAGEMENT OF BUSINESS; ANALYZING AND COMPILING DATA FOR MEASURING THE PERFORMANCE OF FINANCIAL MARKETS; ASSISTANCE AND CONSULTANCY SERVICES IN THE FIELD OF BUSINESS MANAGEMENT OF COMPANIES IN THE ENERGY SECTOR; ASSISTANCE, ADVICE AND CONSULTANCY WITH REGARD TO BUSINESS PLANNING, BUSINESS ANALYSIS, BUSINESS MANAGEMENT AND BUSINESS ORGANIZATION RELATING TO PURCHASING FUNCTIONS; ASSISTANCE, ADVISORY SERVICES AND CONSULTANCY WITH REGARD TO BUSINESS PLANNING, BUSINESS ANALYSIS, BUSINESS MANAGEMENT, AND BUSINESS ORGANIZATION; ASSISTANCE, ADVISORY SERVICES AND CONSULTANCY WITH REGARD TO BUSINESS PLANNING, BUSINESS ANALYSIS, BUSINESS MANAGEMENT, AND BUSINESS ORGANIZATION RELATING TO MICRO CREDITS, MICRO FINANCE AND ENERGY PRODUCTS; ASSISTANCE, ADVISORY SERVICES AND CONSULTANCY WITH REGARD TO BUSINESS PLANNING, BUSINESS ANALYSIS, BUSINESS MANAGEMENT, BUSINESS ORGANIZATION, MARKETING AND CUSTOMER ANALYSIS; BUSINESS ACQUISITION AND MERGER CONSULTATION; BUSINESS ACQUISITIONS CONSULTATION; BUSINESS ADMINISTRATION CONSULTANCY; BUSINESS ADVICE AND ANALYSIS OF MARKETS; BUSINESS ADVICE AND COMMERCIAL INFORMATION; BUSINESS ADVICE AND INFORMATION RELATING TO LOANS, FINANCE AND CAPITAL; BUSINESS ADVISORY SERVICES, CONSULTANCY AND INFORMATION; BUSINESS CONSULTATION; BUSINESS CONSULTATION AND MANAGEMENT REGARDING MARKETING ACTIVITIES AND LAUNCHING OF NEW PRODUCTS; BUSINESS CONSULTATION IN THE FIELD OF MERGERS AND ACQUISITIONS, BUSINESS PLANS, GRANT PROPOSALS, FEASIBILITY AND MARKETING STUDIES FOR GREEN BUSINESSES AND START UPS; BUSINESS CONSULTATION SERVICES; BUSINESS CONSULTATION SERVICES TO ASSIST NON-PROFIT ORGANIZATIONS IN PLANNING, MANAGING, AND CONDUCTING FUNDRAISING ACTIVITIES VIA A GLOBAL COMPUTER NETWORK; BUSINESS CONSULTING AND ADVISORY SERVICES IN THE FIELD OF ENERGY EFFICIENCY; BUSINESS CONSULTING AND BUSINESS INFORMATION FOR ENTERPRISES; BUSINESS CONSULTING AND INFORMATION SERVICES; BUSINESS CONSULTING SERVICES IN THE FIELD OF MERGERS AND ACQUISITIONS, BUSINESS PLANS, GRANT PROPOSALS, FEASIBILITY AND MARKETING STUDIES FOR GREEN BUSINESSES AND START UPS; BUSINESS DEVELOPMENT CONSULTING SERVICES; BUSINESS FEASIBILITY STUDIES; BUSINESS MARKETING CONSULTING SERVICES; BUSINESS ORGANIZATION CONSULTING; BUSINESS ORGANIZATION AND MANAGEMENT CONSULTING; BUSINESS ORGANIZATION AND OPERATION CONSULTANCY; BUSINESS ORGANIZATION CONSULTING; BUSINESS ORGANIZATIONAL CONSULTATION; BUSINESS RESEARCH CONSULTATION; COLLECTION OF MARKET RESEARCH INFORMATION; COMMERCIAL FEASIBILITY STUDIES; COMPILING FINANCIAL, SECURITIES, STOCK EXCHANGE, TRADE AND QUOTE, INDEX

VALUE AND OTHER FINANCIAL MARKET INFORMATION FOR BUSINESS PURPOSES; COMPUTERIZED MARKET RESEARCH SERVICES; CONDUCTING BUSINESS AND MARKET RESEARCH SURVEYS; CONDUCTING FEASIBILITY STUDIES FOR BUSINESS PURPOSES; CONDUCTING MARKET SURVEYS; CONDUCTING MARKETING STUDIES; CONNECTING BUYERS AND SELLERS OF FINANCIAL ASSETS; CONSULTANCY AND ADVISORY SERVICES IN THE FIELD OF BUSINESS STRATEGY; CONSULTANCY SERVICES REGARDING BUSINESS STRATEGIES; CONSULTATION IN THE FIELD OF BUSINESS ACQUISITIONS; CONSULTATION SERVICES, NAMELY, CREATIVE AND STRATEGIC CONSULTATION REGARDING DEVELOPMENT AND PRODUCTION OF MARKETING CAMPAIGNS FOR OTHERS; CONSULTING SERVICES IN THE AREA OF SUSTAINABLE BUSINESS SOLUTIONS; ECONOMIC FEASIBILITY STUDIES; FINANCIAL INTERMEDIARY SERVICES, NAMELY, FACILITATING THE CHANNELING OF FUNDS BETWEEN LENDERS AND BORROWERS BY CONNECTING THOSE WITH A FINANCIAL SURPLUS WITH THOSE HAVING A FINANCIAL DEFICIT; MARKET ANALYSIS; MARKET ANALYSIS AND RESEARCH SERVICES; MARKET RESEARCH; MARKET RESEARCH AND BUSINESS ANALYSES; MARKET RESEARCH CONSULTATION; MARKET RESEARCH SERVICES; MARKET RESEARCH STUDIES; MARKET SEGMENTATION CONSULTATION; MARKET STUDY AND ANALYSIS OF MARKET STUDIES; MARKETING ANALYSIS SERVICES; MARKETING AND CONSULTING SERVICES IN THE FIELD OF PROMOTING AND TRACKING THE GOODS, SERVICES, AND BRANDS OF OTHERS THROUGH ALL PUBLIC COMMUNICATION MEANS, PARTICULARLY SPECIALIZING IN THE USE OF MOBILE, SOCIAL, AND PRINT MEDIA TO DRIVE CONSUMER INTEREST, ENGAGEMENT AND ACTION; MARKETING CONSULTATION IN THE FIELD OF MERGERS AND ACQUISITIONS, BUSINESS PLANS, GRANT PROPOSALS, FEASIBILITY AND MARKETING STUDIES FOR GREEN BUSINESSES AND START UPS; MARKETING CONSULTING; MARKETING CONSULTING SERVICES RELATING TO LONG-TERM BUSINESS STRATEGY DEVELOPMENT FOR NON-PROFIT ORGANIZATIONS; MARKETING PLAN DEVELOPMENT; MARKETING RESEARCH SERVICES; MARKETING SERVICES, NAMELY, CONSUMER MARKETING RESEARCH; NEW BUSINESS VENTURE DEVELOPMENT AND FORMATION CONSULTING SERVICES; PREPARING FINANCIAL REPORTS FOR OTHERS; PROFESSIONAL BUSINESS CONSULTATION; PROFESSIONAL BUSINESS CONSULTING; PROVIDING AND UPDATING A FINANCIAL INDEX OF SECURITIES VALUES AND CLASSIFICATION, ANALYSIS, AND REPORTING THEREOF; PROVIDING BUSINESS MANAGEMENT INFORMATION IN CONNECTION WITH CONSULTING AND ADVISORY SERVICES IN THE FIELD OF STRATEGIC PLANNING; WRITING OF GRANT PROPOSALS FOR NON-PROFIT ORGANIZATIONS, EDUCATIONAL INSTITUTIONS AND OTHER COMMUNITY ORGANIZATIONS (U.S. CLS. 100, 101 AND 102).

FIRST USE 11-23-2009; IN COMMERCE 11-23-2009.

CLASS 36—INSURANCE AND FINANCIAL

FOR ADVISORY SERVICES RELATING TO CREDIT AND DEBIT CONTROL, INVESTMENT, GRANTS AND FINANCING OF LOANS; CAPITAL INVESTMENT CONSULTING; CONSULTANCY CONCERNING FINANCING OF ENERGY PROJECTS; CONSULTANCY OF CAPITAL INVESTMENT; CORPORATE FINANCE SERVICES, NAMELY, CONSULTATION IN THE FIELD OF ASSET SALES; CORPORATE FINANCE SERVICES, NAMELY, CONSULTATION IN THE FIELD OF CAPITAL STRUCTURE; CREDIT AND FINANCIAL CONSULTATION; FINANCIAL ADVICE; FINANCIAL ADVICE AND CONSULTANCY SERVICES; FINANCIAL ADVISORY AND CONSULTANCY SERVICES; FINANCIAL AFFAIRS AND MONETARY AFFAIRS, NAMELY, FINANCIAL INFORMATION, MANAGEMENT AND ANALYSIS SERVICES; FINANCIAL ANALYSES; FINANCIAL ANALYSIS AND CONSULTATION; FINANCIAL ANALYSIS AND RESEARCH SERVICES; FINANCIAL CONSULTANCY; FINANCIAL CONSULTATION; FINANCIAL CONSULTATION IN THE FIELD OF RAISING DEBT AND EQUITY CAPITAL, GRANT PROPOSALS, HELPING INDIVIDUALS AND ENTITIES RAISE MONEY FOR GREEN BUSINESSES AND START UPS; FINANCIAL

CONSULTING; FINANCIAL CONSULTING AND ADVISING IN THE FIELD OF MERGERS AND ACQUISITIONS; FINANCIAL CONSULTING SERVICES, NAMELY, EXPERT ANALYSIS IN FINANCE; FINANCIAL INFORMATION; FINANCIAL INFORMATION AND ADVISORY SERVICES; FINANCIAL INFORMATION AND EVALUATIONS; FINANCIAL PLANNING; FINANCIAL PLANNING CONSULTATION; FINANCIAL RESEARCH; FINANCIAL RESEARCH AND INFORMATION SERVICES; FINANCIAL SERVICES, NAMELY, ASSISTING OTHERS WITH THE COMPLETION OF FINANCIAL TRANSACTIONS FOR STOCKS, BONDS, SECURITIES AND EQUITIES; FINANCIAL SERVICES, NAMELY, BUSINESS FUNDRAISING FOR OTHERS; FINANCIAL SERVICES, NAMELY, RAISING DEBT AND EQUITY CAPITAL FOR OTHERS; LEVERAGED BUY OUTS AND INVESTMENTS IN FINANCIALLY DISTRESSED OR UNDERPERFORMING COMPANIES; PRIVATE EQUITY CONSULTANT SERVICES; STRATEGIC CORPORATE FINANCIAL ADVISORY SERVICES; STRATEGIC FINANCIAL ADVISORY SERVICES; VENTURE CAPITAL ADVISORY SERVICES (U.S. CLS. 100, 101 AND 102).

FIRST USE 11-23-2009; IN COMMERCE 11-23-2009.
HOWARD SMIGA, EXAMINING ATTORNEY

SN 85-245,467. MARINUCCI LANDSCAPING, DBA MARINUCCI LANDSCAPING, WILLIAMSVILLE, NY. FILED 2-17-2011.

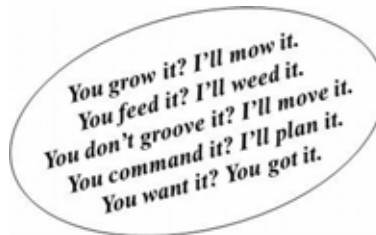

THE MARK CONSISTS OF THE WORDING, "YOU GROW IT? I'LL MOW IT. YOU FEED IT? I'LL WEED IT? YOU DON'T GROOVE IT? I'LL MOVE IT. YOU COMMAND IT? I'LL PLAN IT. YOU WANT IT? YOU GOT IT." ENCLOSED IN A TILTED OVAL, WHICH IS ALL IN BLACK-AND-WHITE.

CLASS 37—CONSTRUCTION AND REPAIR

FOR SNOW REMOVAL SERVICES (U.S. CLS. 100, 103 AND 106).

FIRST USE 1-1-2000; IN COMMERCE 3-1-2000.

CLASS 44—MEDICAL, BEAUTY AND AGRICULTURAL SERVICES

FOR LANDSCAPE DESIGN; LANDSCAPE GARDENING; LANDSCAPE GARDENING DESIGN FOR OTHERS; LAWN CARE; LAWN MOWING SERVICES (U.S. CLS. 100 AND 101).

FIRST USE 1-1-2000; IN COMMERCE 3-1-2000.
DAWN FELDMAN, EXAMINING ATTORNEY

SN 85-245,445. AERIOR, LTD., HOUSTON, TX. FILED 2-17-2011.

AERIOR

THE MARK CONSISTS OF STANDARD CHARACTERS WITHOUT CLAIM TO ANY PARTICULAR FONT, STYLE, SIZE, OR COLOR.

CLASS 37—CONSTRUCTION AND REPAIR

FOR INSTALLATION AND MAINTENANCE OF WIRELESS COMMUNICATION HARDWARE; INSTALLATION OF ANTENNA TOWERS (U.S. CLS. 100, 103 AND 106).

CLASS 42—SCIENTIFIC AND COMPUTER SERVICES

FOR TESTING FOR OTHERS IN THE FIELD OF WIRELESS COMMUNICATION HARDWARE AND SOFTWARE; INSTALLATION AND MAINTENANCE OF WIRELESS COMMUNICATION SOFTWARE; AND ENGINEERING DESIGN OF WIRELESS COMMUNICATION HARDWARE AND SOFTWARE FOR THE OPTIMIZATION OF THE PERFORMANCE OF ANTENNAE (U.S. CLS. 100 AND 101).

KATHERINE CHANG, EXAMINING ATTORNEY

SN 85-245,836. THE TRUSTEE OF THE ANSWER TRUST, CAMBRIDGE, MA. FILED 2-18-2011.

WAR IS STILL THE ANSWER

THE MARK CONSISTS OF STANDARD CHARACTERS WITHOUT CLAIM TO ANY PARTICULAR FONT, STYLE, SIZE, OR COLOR.

CLASS 16—PAPER GOODS AND PRINTED MATTER

FOR BUMPER STICKERS; PAPER BADGES; POSTERS (U.S. CLS. 2, 5, 22, 23, 29, 37, 38 AND 50).

CLASS 25—CLOTHING

FOR BASEBALL CAPS AND HATS; HOODED SWEATSHIRTS; SWEATSHIRTS; T-SHIRTS (U.S. CLS. 22 AND 39).

COLLEEN DOMBROW, EXAMINING ATTORNEY

SN 85-246,224. ROSALIE SCHULICK, DBA ROSIE'S WONDERS, BRATTLEBORO, VT. FILED 2-18-2011.

Rosie's Wonders

THE MARK CONSISTS OF STANDARD CHARACTERS WITHOUT CLAIM TO ANY PARTICULAR FONT, STYLE, SIZE, OR COLOR.
THE NAME "ROSIE" IDENTIFIES A LIVING INDIVIDUAL WHOSE CONSENT IS OF RECORD.

CLASS 14—JEWELRY

FOR JEWELRY (U.S. CLS. 2, 27, 28 AND 50).
FIRST USE 7-14-1995; IN COMMERCE 7-14-1995.

CLASS 16—PAPER GOODS AND PRINTED MATTER

FOR OCCASION CARDS (U.S. CLS. 2, 5, 22, 23, 29, 37, 38 AND 50).
FIRST USE 7-14-1995; IN COMMERCE 7-14-1995.

CLASS 25—CLOTHING

FOR SCARVES (U.S. CLS. 22 AND 39).
FIRST USE 7-14-1995; IN COMMERCE 7-14-1995.
ANDREA HACK, EXAMINING ATTORNEY

SN 85-246,232. VIRGIN AMERICA INC., BURLINGAME, CA.
FILED 2-18-2011.

BREATH OF FRESH AIRLINE

THE MARK CONSISTS OF STANDARD CHARACTERS WITHOUT CLAIM TO ANY PARTICULAR FONT, STYLE, SIZE, OR COLOR.

CLASS 39—TRANSPORTATION AND STORAGE

FOR AIR TRANSPORTATION; FREIGHT TRANSPORTATION SERVICES BY MEANS OF AIR, SHIP, TRUCK, AND RAIL; AIRPORT PASSENGER AND BAGGAGE CHECK-IN SERVICES; AIRPORT SERVICES, NAMELY, TICKETING AND BOARDING SERVICES; TRAVEL SERVICES, NAMELY, BOOKING SEATING ARRANGEMENTS FOR AIRLINE PASSENGERS; AIR TRANSPORTATION SERVICES FEATURING FREQUENT FLYER MILES AS A BONUS PROGRAM FOR FREQUENT AIR TRAVELERS; PROVIDING FLIGHT ARRIVAL AND DEPARTURE INFORMATION; AND TRANSPORTATION RESERVATION SERVICES (U.S. CLS. 100 AND 105).

CLASS 41—EDUCATION AND ENTERTAINMENT

FOR IN-FLIGHT ENTERTAINMENT SERVICES, NAMELY, PROVIDING PASSENGERS DURING AIR TRAVEL WITH ENTERTAINMENT SERVICES IN THE FORM OF MOVIES, RADIO, INDIVIDUALIZED MUSIC SELECTIONS, LIVE TELEVISION PROGRAMS, ACCESS TO ONLINE-READING MATERIAL, VIDEO GAMES, AND CHILDREN'S ON-LINE GAMES, ALL BY MEANS OF A PERSONAL COMPUTER ASSIGNED TO AN INDIVIDUAL PASSENGER FOR USE DURING AIR TRAVEL; ENTERTAINMENT SERVICES, NAMELY, PROVIDING MOVIES, RADIO, INDIVIDUALIZED MUSIC SELECTIONS, LIVE TELEVISION PROGRAMS, ACCESS TO ONLINE-READING MATERIAL, VIDEO GAMES, AND CHILDREN'S ON-LINE GAMES FOR USE BY AIRLINE PASSENGERS DURING FLIGHTS; ONBOARD IN-FLIGHT ENTERTAINMENT SERVICES, NAMELY, DISTRIBUTING MOVIES, TV PROGRAMS, RADIO AND AUDIO PROGRAMS, AND READING MATERIAL, AND PROVIDING TEMPORARY USE OF NON-DOWNLOADABLE INTERACTIVE SOFTWARE FOR PASSENGERS TO ACCESS VIDEO GAMES, MOVIES, TV PROGRAMS, RADIO AND AUDIO PROGRAMS, AND READING MATERIAL, ALL PROVIDED ON PERSONAL MONITORS FOR VIEWING THE SAME (U.S. CLS. 100, 101 AND 107).

CHRISTINA SOBRAL, EXAMINING ATTORNEY

SN 85-246,613. JIVE SOFTWARE, INC., PORTLAND, OR.
FILED 2-18-2011.

THE NEW WAY TO BUSINESS

THE MARK CONSISTS OF STANDARD CHARACTERS WITHOUT CLAIM TO ANY PARTICULAR FONT, STYLE, SIZE, OR COLOR.

NO CLAIM IS MADE TO THE EXCLUSIVE RIGHT TO USE "BUSINESS", APART FROM THE MARK AS SHOWN.

CLASS 9—ELECTRICAL AND SCIENTIFIC APPARATUS

FOR SOFTWARE FOR USE IN FACILITATING SOCIAL NETWORKING AMONG COMPUTER USERS WITHIN A BUSINESS ENTERPRISE AND AMONG A BUSINESS'S CONSUMERS; SOFTWARE FOR CONTROLLING AND MANAGING WEB SERVER APPLICATIONS IN THE FIELD OF ENTERPRISE COLLABORATION AND CONTENT CREATION; SOFTWARE FOR COMPREHENSIVE GROUP CHAT AND INSTANT MESSAGING IN CUSTOMER OR EMPLOYEE COMMUNITIES; SOFTWARE FOR SECURE SUPPORT OR SALES CONVERSATIONS WITH CUSTOMERS FROM A COMPANY'S WEBSITE; SOFTWARE FOR USE IN CREATING COMPUTER ONLINE COMMUNITIES; SOFTWARE FOR MONITORING SOCIAL NETWORKS (U.S. CLS. 21, 23, 26, 36 AND 38).

CLASS 35—ADVERTISING AND BUSINESS

FOR BUSINESS MANAGEMENT CONSULTATION SERVICES, NAMELY, ASSISTING IN THE DEVELOPMENT OF COLLABORATIVE EMPLOYEE AND PUBLIC COMMUNITIES, AND ADOPTION AND INTEGRATION OF EXISTING CORPORATE SYSTEMS WITH SOCIAL NETWORKING SOFTWARE (U.S. CLS. 100, 101 AND 102).

KIMBERLY PERRY, EXAMINING ATTORNEY

SN 85-246,772. PAMELA M. BLOSSOM, MATTESON, IL.
FILED 2-18-2011.

SN 85-247,234. ATI PROPERTIES, INC., ALBANY, OR. FILED
2-21-2011.

SOLID NEWS

425

THE MARK CONSISTS OF STANDARD CHARACTERS WITHOUT CLAIM TO ANY PARTICULAR FONT, STYLE, SIZE, OR COLOR.

NO CLAIM IS MADE TO THE EXCLUSIVE RIGHT TO USE "NEWS", APART FROM THE MARK AS SHOWN.

CLASS 16—PAPER GOODS AND PRINTED MATTER

FOR GENERAL FEATURE MAGAZINES; NEWSPAPERS (U.S. CLS. 2, 5, 22, 23, 29, 37, 38 AND 50).

CLASS 41—EDUCATION AND ENTERTAINMENT

FOR PROVIDING INFORMATION, NEWS AND COMMENTARY IN THE FIELD OF CURRENT EVENTS RELATING TO POLITICS, ENTERTAINMENT, SPORTS, COMEDY, BUSINESS, HEALTH, BEAUTY, LIFESTYLE, FASHION, FOOD, TECHNOLOGY, TRAVEL, SPIRITUALITY, SOCIAL ISSUES, EDUCATION, BOOKS, FINE ARTS, AND PERFORMING ARTS (U.S. CLS. 100, 101 AND 107).

REBECCA SMITH, EXAMINING ATTORNEY

SN 85-247,075. CRAIG TAYLOR, TORRANCE, CA. FILED 2-20-2011.

ROBUST QUAKERISK

THE MARK CONSISTS OF STANDARD CHARACTERS WITHOUT CLAIM TO ANY PARTICULAR FONT, STYLE, SIZE, OR COLOR.

NO CLAIM IS MADE TO THE EXCLUSIVE RIGHT TO USE "QUAKE RISK", APART FROM THE MARK AS SHOWN.

CLASS 9—ELECTRICAL AND SCIENTIFIC APPARATUS

FOR COMPUTER SOFTWARE FOR RISK CALCULATIONS RELATING TO EARTHQUAKES AND OTHER NATURAL HAZARDS; DOWNLOADABLE COMPUTER SOFTWARE FOR RISK CALCULATIONS RELATING TO EARTHQUAKES AND OTHER NATURAL HAZARDS (U.S. CLS. 21, 23, 26, 36 AND 38).

CLASS 42—SCIENTIFIC AND COMPUTER SERVICES

FOR APPLICATION SERVICE PROVIDER (ASP) FEATURING SOFTWARE FOR USE IN THE FIELD OF RISK CALCULATIONS RELATING TO EARTHQUAKES AND OTHER NATURAL HAZARDS (U.S. CLS. 100 AND 101).
ALYSSA STEEL, EXAMINING ATTORNEY

THE MARK CONSISTS OF STANDARD CHARACTERS WITHOUT CLAIM TO ANY PARTICULAR FONT, STYLE, SIZE, OR COLOR.

OWNER OF U.S. REG. NO. 3,225,635.

CLASS 9—ELECTRICAL AND SCIENTIFIC APPARATUS

FOR DOWNLOADABLE ELECTRONIC PUBLICATIONS IN THE NATURE OF BROCHURES, BOOKLETS, PAMPHLETS, PRESENTATION REPORTS, AND VISUALS IN THE NATURE OF PROMOTIONAL MATERIALS IN THE FIELD OF SPECIALTY METALS BUSINESS (U.S. CLS. 21, 23, 26, 36 AND 38).

CLASS 16—PAPER GOODS AND PRINTED MATTER

FOR PUBLICATIONS, NAMELY, BROCHURES, BOOKLETS, PAMPHLETS, PRINTED PRESENTATION REPORTS, AND PRINTED VISUALS IN THE NATURE OF PROMOTIONAL MATERIALS IN THE FIELD OF SPECIALTY METALS BUSINESS (U.S. CLS. 2, 5, 22, 23, 29, 37, 38 AND 50).

NELSON SNYDER, EXAMINING ATTORNEY

SN 85-247,289. LEADER'S HOLDING COMPANY, LARGO, FL. FILED 2-21-2011.

ISLAND WAY

THE MARK CONSISTS OF STANDARD CHARACTERS WITHOUT CLAIM TO ANY PARTICULAR FONT, STYLE, SIZE, OR COLOR.

OWNER OF U.S. REG. NO. 3,959,626.

CLASS 11—ENVIRONMENTAL CONTROL APPARATUS

FOR TABLE LAMPS, BUFFET LAMPS, FLOOR LAMPS AND SCONCES LIGHTING FIXTURES (U.S. CLS. 13, 21, 23, 31 AND 34).

FIRST USE 1-0-2011; IN COMMERCE 1-0-2011.

CLASS 21—HOUSEWARES AND GLASS

FOR DISHES, BOWLS, CUPS, PLATES, CANDLE HOLDERS AND NON-ELECTRIC WALL SCONCES (U.S. CLS. 2, 13, 23, 29, 30, 33, 40 AND 50).

FIRST USE 1-0-2011; IN COMMERCE 1-0-2011.

SALLY SHIH, EXAMINING ATTORNEY

SN 85-247,409. WESTERN PISTACHIO ASSOCIATION, FRESNO, CA. FILED 2-21-2011.



THE COLOR(S) LIGHT GREEN, DARK GREEN, GREEN, GOLD, BROWN, BLACK, WHITE, RED, BLUE AND SILVER IS/ARE CLAIMED AS A FEATURE OF THE MARK.

THE MARK CONSISTS OF A STYLIZED PISTACHIO WITH FACIAL FEATURES, ARMS, LEGS, GLOVE-SHAPED HANDS, TENNIS SHOE FEET, WEARING A CAPE SECURED AT THE NECK WITH A STAR, WITH HANDS ON HIPS; A LIGHT AND DARK GREEN AND GOLD COLORED PISTACHIO WITH GREEN LEGS, ARMS AND DARK GREEN EYE LIDS AND A GOLD OUTER SHELL AND GREEN BODY; FACIAL FEATURES INCLUDE EYES THAT ARE WHITE WITH BROWN IRISES AND BLACK PUPILS AND TOPPED WITH BLACK EYEBROWS, AND A BROAD SMILE WITH WHITE SQUARE TEETH; THE HANDS CONSIST OF WHITE GLOVES; FIGURE IS WEARING A RED, WHITE AND BLUE CAPE ATTACHED AT THE COLLAR WITH A SILVER STAR; THE FEET CONSIST OF BLACK RUNNING SHOES WITH GREEN STRIPES AND WHITE SOLES; AND WHITE SOCKS OVER THE TOP OF THE SHOE.

CLASS 25—CLOTHING

FOR CLOTHING, NAMELY, SHIRTS, PANTS, SKIRTS, DRESSES, SHORTS, GLOVES, SCARVES, HATS, HOODS, JACKETS, JERSEYS AND SOCKS (U.S. CLS. 22 AND 39).

CLASS 29—MEATS AND PROCESSED FOODS

FOR PROCESSED NUTS; ROASTED NUTS; SEASONED NUTS; SHELLED NUTS (U.S. CL. 46).

CLASS 35—ADVERTISING AND BUSINESS

FOR ASSOCIATION SERVICES, NAMELY, PROMOTING THE INTERESTS OF PISTACHIO GROWERS, PACKERS, PROCESSORS, AND PRODUCERS THROUGH COMMERCIAL ADVERTISEMENTS IN THE FORM OF TELEVISION, PRINT, FILM, MOTION PICTURE, AND ELECTRONIC MEDIA; ADVERTISING, PROMOTION, AND MARKETING SERVICES IN THE NATURE OF COMMERCIAL ADVERTISEMENTS IN THE FORM OF TELEVISION, PRINT, FILM, MOTION PICTURE AND ELECTRONIC MEDIA FOR THE PISTACHIO INDUSTRY, GROWERS, PACKERS, AND PROCESSORS AND FOR CONSUMERS OF PISTACHIO PRODUCTS; PRODUCT DEMONSTRATION AND BUSINESS MERCHANDISING DISPLAY SERVICES; BUSINESS CONSULTATION IN THE FIELD OF NUTRITION RESEARCH, AND PISTACHIO PRODUCT DEVELOPMENT; DISTRIBUTION AND DISSEMINATION OF ADVERTISING MATERIALS, NAMELY, DISTRIBUTION OF PRINTED ADVERTISING MATERIAL (U.S. CLS. 100, 101 AND 102).

LOURDES AYALA, EXAMINING ATTORNEY

SN 85-247,464. D3I TECHNOLOGIES LLC, CHICAGO, IL. FILED 2-21-2011.



OWNER OF U.S. REG. NO. 3,455,491.

NO CLAIM IS MADE TO THE EXCLUSIVE RIGHT TO USE "TECHNOLOGIES", APART FROM THE MARK AS SHOWN.

THE MARK CONSISTS OF THE LETTER "V" UNDERLINED AND THE WORDS "INCISENT TECHNOLOGIES" TO THE RIGHT OF THE "V" SEPARATED BY A VERTICAL LINE.

CLASS 35—ADVERTISING AND BUSINESS

FOR ADVERTISING SERVICES, NAMELY, PRODUCTION OF COMPUTER-GENERATED IMAGERY AND COMPUTER-GENERATED GRAPHICS FOR THE PRODUCTION OF CUSTOMIZED INTERNET ADVERTISING AND COMMERCIALS IN THE FIELD OF AUTOMOTIVE VEHICLES AND AUTOMOTIVE DEALERSHIPS; MANAGEMENT CONSULTING SERVICES TO BUSINESSES APPLYING ANALYTICS TO CREATE BUSINESS INTELLIGENCE TO OPTIMIZE BUSINESS PERFORMANCE; BUSINESS SERVICES, NAMELY, PROVIDING BUSINESS INFORMATION AND MARKETING DATA TO OTHERS; DATA PROCESSING SERVICES; COMPUTERIZED REAL-TIME AND DELAYED TRANSACTIONAL DATA MANAGEMENT SERVICES, NAMELY, SEARCHING, GATHERING, PROCESSING, ORGANIZING AND DISSEMINATING INFORMATION FOR OTHERS VIA A GLOBAL COMPUTER NETWORK (U.S. CLS. 100, 101 AND 102).

FIRST USE 6-6-2006; IN COMMERCE 7-6-2006.

CLASS 42—SCIENTIFIC AND COMPUTER SERVICES

FOR COMPUTER SOFTWARE CONSULTATION AND ADVISORY SERVICES IN THE FIELD OF BUSINESS INTELLIGENCE IN THE NATURE OF SOFTWARE DEVELOPMENT AND CUSTOMIZATION OF DATA STORAGE, RETRIEVAL, MANAGEMENT, ANALYSIS AND REPORTING, AND INTEGRATION OF DATA STRUCTURES (U.S. CLS. 100 AND 101).

FIRST USE 6-6-2006; IN COMMERCE 7-6-2006.

MATTHEW EINSTEIN, EXAMINING ATTORNEY

SN 85-247,633. FLANAGAN, MARY D., HANOVER, NH. FILED 2-21-2011.



THE COLOR(S) BLACK, WHITE, RED IS/ARE CLAIMED AS A FEATURE OF THE MARK.

THE MARK CONSISTS OF THE FOLLOWING: THE WORDS "POX SAVE THE PEOPLE" IN BLACK STYLIZED FONT ON A WHITE BACKGROUND WHERE THE CENTER OF THE LETTER "O" IN "POX" IS IN RED.

CLASS 9—ELECTRICAL AND SCIENTIFIC APPARATUS

FOR COMPUTER GAME PROGRAMMES; COMPUTER GAME PROGRAMMES DOWNLOADABLE VIA THE INTERNET; COMPUTER GAME PROGRAMS; COMPUTER GAME SOFTWARE; COMPUTER PROGRAMS FOR PRE-RECORDED GAMES; COMPUTER PROGRAMS FOR VIDEO AND COMPUTER GAMES; DOWNLOADABLE COMPUTER GAME PROGRAMS; DOWNLOADABLE COMPUTER GAME SOFTWARE VIA A GLOBAL COMPUTER NETWORK AND WIRELESS DEVICES; DOWNLOADABLE ELECTRONIC GAME PROGRAMS; ELECTRONIC GAME PROGRAMS; ELECTRONIC GAME SOFTWARE; ELECTRONIC GAME SOFTWARE FOR CELLULAR TELEPHONES; ELECTRONIC GAME SOFTWARE FOR HANDHELD ELECTRONIC DEVICES; INTERACTIVE GAME PROGRAMS; INTERACTIVE GAME SOFTWARE; INTERACTIVE MULTIMEDIA COMPUTER GAME PROGRAM; VIDEO AND COMPUTER GAME PROGRAMS (U.S. CLS. 21, 23, 26, 36 AND 38).

CLASS 28—TOYS AND SPORTING GOODS

FOR BOARD GAMES; EDUCATIONAL CARD GAMES; GAME CARDS (U.S. CLS. 22, 23, 38 AND 50).
ERNEST SHOSHO, EXAMINING ATTORNEY

SN 85-247,681. RUBBERMAID INCORPORATED, ATLANTA, GA. FILED 2-21-2011.

CUSTOM CLOSETS BY RUBBERMAID

THE MARK CONSISTS OF STANDARD CHARACTERS WITHOUT CLAIM TO ANY PARTICULAR FONT, STYLE, SIZE, OR COLOR.

NO CLAIM IS MADE TO THE EXCLUSIVE RIGHT TO USE "CUSTOM CLOSETS", APART FROM THE MARK AS SHOWN.

CLASS 37—CONSTRUCTION AND REPAIR

FOR INSTALLATION CONSULTATION IN THE FIELD OF CLOSETS AND OTHER STORAGE AREAS OF THE HOME (U.S. CLS. 100, 103 AND 106).

CLASS 42—SCIENTIFIC AND COMPUTER SERVICES

FOR CUSTOM DESIGN CONSULTATION IN THE FIELD OF CLOSETS AND OTHER STORAGE AREAS OF THE HOME (U.S. CLS. 100 AND 101).

CLASS 45—PERSONAL AND LEGAL SERVICES

FOR ORGANIZATIONAL CONSULTATION SERVICES FOR HOME OR PERSONAL PURPOSES, NAMELY, CONSULTING IN THE ORGANIZATION OF CLOSETS AND OTHER STORAGE AREAS OF THE HOME (U.S. CLS. 100 AND 101).
KAREN K. BUSH, EXAMINING ATTORNEY

SN 85-247,705. RUBBERMAID INCORPORATED, ATLANTA, GA. FILED 2-21-2011.

RUBBERMAID

THE MARK CONSISTS OF STANDARD CHARACTERS WITHOUT CLAIM TO ANY PARTICULAR FONT, STYLE, SIZE, OR COLOR.

CLASS 37—CONSTRUCTION AND REPAIR

FOR INSTALLATION CONSULTATION IN THE FIELD OF CLOSETS AND OTHER STORAGE AREAS OF THE HOME (U.S. CLS. 100, 103 AND 106).

CLASS 42—SCIENTIFIC AND COMPUTER SERVICES

FOR CUSTOM DESIGN CONSULTATION IN THE FIELD OF CLOSETS AND OTHER STORAGE AREAS OF THE HOME (U.S. CLS. 100 AND 101).

CLASS 45—PERSONAL AND LEGAL SERVICES

FOR ORGANIZATIONAL CONSULTATION SERVICES FOR HOME OR PERSONAL PURPOSES, NAMELY, CONSULTING IN THE ORGANIZATION OF CLOSETS AND OTHER STORAGE AREAS OF THE HOME (U.S. CLS. 100 AND 101).

KAREN K. BUSH, EXAMINING ATTORNEY

SN 85-247,980. H. J. HEINZ COMPANY, PITTSBURGH, PA. FILED 2-22-2011.



OWNER OF U.S. REG. NOS. 61,051, 1,122,910 AND 1,931,788.

THE MARK CONSISTS OF THE STYLIZED NUMBER "57" BESIDE "TH" IN BLOCK OVER THE WORDS "STREET" AND STYLIZED "GRILLE".

CLASS 29—MEATS AND PROCESSED FOODS

FOR FROZEN APPETIZERS, SNACKS AND HORS D'OEUVRES CONSISTING OF MEATS, POULTRY, FISH, SEAFOOD, POTATOES, FRUITS, VEGETABLES, MUSHROOMS, EGGS, AND CHEESE (U.S. CL. 46).

CLASS 30—STAPLE FOODS

FOR FROZEN APPETIZERS, SNACKS AND HORS D'OEUVRES CONSISTING OF BREAD, PASTRY, DOUGH OR RICE (U.S. CL. 46).

ALLISON HOLTZ, EXAMINING ATTORNEY

CLASS 45—PERSONAL AND LEGAL SERVICES

FOR ADVISORY SERVICES IN THE FIELD OF HOME SECURITY SYSTEMS; CONSULTANCY SERVICES IN THE FIELD OF HOME SECURITY; CONSULTATION SERVICES CONCERNING HOMELAND SAFETY AND SECURITY ISSUES; CONSULTING AND LEGAL SERVICES IN THE FIELD OF PRIVACY AND SECURITY LAWS, REGULATIONS, AND REQUIREMENTS; CONSULTING SERVICES IN THE FIELD OF HOMELAND SECURITY; CONSULTING SERVICES IN THE FIELD OF MAINTAINING THE SECURITY AND INTEGRITY OF DATABASES; CONSULTING SERVICES IN THE FIELD OF NATIONAL SECURITY; PROVIDING A WEB SITE FEATURING INFORMATION ON THE DEVELOPMENT OF PRIVACY, SECURITY AND DATA GOVERNANCE LAW; PROVIDING INFORMATION CONCERNING HOMELAND SAFETY AND SECURITY ISSUES; SECURITY CONSULTANCY; SECURITY INSPECTION SERVICES FOR OTHERS; SECURITY SERVICES, NAMELY, PROVIDING SECURITY ASSESSMENTS FOR BUSINESSES AND GOVERNMENTAL AGENCIES; SECURITY SERVICES, NAMELY, PROVIDING SECURITY ASSESSMENTS OF PHYSICAL LOCATIONS, INFORMATION SYSTEMS, AND WORKING ENVIRONMENTS (U.S. CLS. 100 AND 101).

FIRST USE 1-1-2000; IN COMMERCE 5-1-2000.
EDWARD NELSON, EXAMINING ATTORNEY

SN 85-248,076. ATSEC INFORMATION SECURITY CORPORATION, TA ATSEC, AUSTIN, TX. FILED 2-22-2011.

atsec

SN 85-248,162. D PET HOTELS, LLC, LOS ANGELES, CA. FILED 2-22-2011.

THE MARK CONSISTS OF STANDARD CHARACTERS WITHOUT CLAIM TO ANY PARTICULAR FONT, STYLE, SIZE, OR COLOR.

OWNER OF U.S. REG. NO. 3,070,552.

CLASS 42—SCIENTIFIC AND COMPUTER SERVICES

FOR ACCREDITATION SERVICES, NAMELY, DEVELOPING, EVALUATING, AND TESTING STANDARDS FOR INFORMATION SECURITY FOR THE PURPOSE OF ACCREDITATION; ACCREDITATION SERVICES, NAMELY, EVALUATING ORGANIZATIONS TO DETERMINE WHETHER THE ORGANIZATIONS CONFORM TO AN ESTABLISHED STANDARD; ACCREDITATION SERVICES, NAMELY, SETTING AND PROVIDING STANDARDS FOR INFORMATION SECURITY FOR THE PURPOSE OF ACCREDITATION; COMPUTER CONSULTATION IN THE FIELD OF COMPUTER SECURITY; COMPUTER SECURITY CONSULTANCY; COMPUTER SECURITY CONSULTANCY IN THE FIELD OF SCANNING AND PENETRATION TESTING OF COMPUTERS AND NETWORKS TO ASSESS INFORMATION SECURITY VULNERABILITY; CONSULTING IN THE FIELD OF INFORMATION TECHNOLOGY; DESIGN AND DEVELOPMENT OF ELECTRONIC DATA SECURITY SYSTEMS; DEVELOPING AND IMPLEMENTING CUSTOMIZED PLANS FOR IMPROVING COMPUTER SECURITY AND PREVENTING CRIMINAL ACTIVITY FOR BUSINESSES AND GOVERNMENTAL AGENCIES; DEVELOPMENT OF SECURITY SYSTEMS AND CONTINGENCY PLANNING FOR INFORMATION SYSTEMS; INFORMATION TECHNOLOGY CONSULTATION; MAINTENANCE OF COMPUTER SOFTWARE RELATING TO COMPUTER SECURITY AND PREVENTION OF COMPUTER RISKS; RESEARCH IN THE FIELD OF INTELLIGENCE AND SECURITY TECHNOLOGY; TESTING OF SECURITY SYSTEMS; UPDATING OF COMPUTER SOFTWARE RELATING TO COMPUTER SECURITY AND PREVENTION OF COMPUTER RISKS (U.S. CLS. 100 AND 101).

FIRST USE 1-1-2000; IN COMMERCE 5-1-2000.

D Pet Hotels Hollywood

THE MARK CONSISTS OF STANDARD CHARACTERS WITHOUT CLAIM TO ANY PARTICULAR FONT, STYLE, SIZE, OR COLOR.

OWNER OF U.S. REG. NO. 3,717,932.

NO CLAIM IS MADE TO THE EXCLUSIVE RIGHT TO USE "PET HOTELS HOLLYWOOD", APART FROM THE MARK AS SHOWN.

CLASS 43—HOTEL AND RESTAURANT SERVICES

FOR DOG HOTEL SERVICES; PET DAY CARE SERVICES (U.S. CLS. 100 AND 101).

FIRST USE 11-1-2008; IN COMMERCE 11-1-2008.

CLASS 44—MEDICAL, BEAUTY AND AGRICULTURAL SERVICES

FOR PET GROOMING SERVICES; VETERINARY DENTISTRY (U.S. CLS. 100 AND 101).

FIRST USE 11-1-2008; IN COMMERCE 11-1-2008.
JAMES LOVELACE, EXAMINING ATTORNEY

SN 85-248,345. EIC AGENCY, LLC, NEW YORK, NY. FILED 2-22-2011.

BOOYORK

THE MARK CONSISTS OF STANDARD CHARACTERS WITHOUT CLAIM TO ANY PARTICULAR FONT, STYLE, SIZE, OR COLOR.

THE WORDING "BOOYORK" HAS NO MEANING IN A FOREIGN LANGUAGE.

CLASS 35—ADVERTISING AND BUSINESS

FOR PROVIDING A WEBSITE FEATURING INFORMATION RELATED TO HALLOWEEN, NAMELY, FEATURING INFORMATION ABOUT RETAILERS AND ONLINE RETAILERS FEATURING HALLOWEEN SUPPLIES AND SERVICES; PROVIDING AN ON-LINE DIRECTORY OF HALLOWEEN-RELATED PARADES, EVENTS, RETAIL STORES, COSTUME STORES AND HAUNTED HOUSES, NAMELY, AN ONLINE COMMERCIAL INFORMATION DIRECTORY (U.S. CLS. 100, 101 AND 102).

FIRST USE 6-0-2009; IN COMMERCE 6-0-2009.

CLASS 41—EDUCATION AND ENTERTAINMENT

FOR PROVIDING A WEBSITE FEATURING INFORMATION RELATED TO HALLOWEEN, NAMELY, FEATURING INFORMATION ABOUT HALLOWEEN PARTIES AND PARADES AND AMUSEMENT ATTRACTIONS, AND HALLOWEEN COSTUME RENTALS; PROVIDING AN ON-LINE DIRECTORY OF HALLOWEEN-RELATED PARADES, EVENTS, RETAIL STORES, COSTUME STORES AND HAUNTED HOUSES, NAMELY, PROVIDING A DIRECTORY LISTING HALLOWEEN ENTERTAINMENT PARADES, EVENTS AND HAUNTED HOUSES (U.S. CLS. 100, 101 AND 107).

FIRST USE 6-0-2009; IN COMMERCE 6-0-2009.
APRIL ROACH, EXAMINING ATTORNEY

SN 85-248,366. HAREMLIK TEKSTIL URUNLERI SANAYI VE TICARET LIMITED SIRKETI, ISTANBUL, TURKEY, FILED 2-22-2011.



NO CLAIM IS MADE TO THE EXCLUSIVE RIGHT TO USE "ISTANBUL", APART FROM THE MARK AS SHOWN. THE COLOR(S) BLACK, RED, WHITE, AND GOLD IS/ ARE CLAIMED AS A FEATURE OF THE MARK.

THE MARK CONSISTS OF A DRAWING OF A TURKISH FEZ, RED IN COLOR WITH WHITE SIDES AND A BLACK FEATHER PROTRUDING FROM A GOLD BUCKLE, OVER THE WORD "HAREMLIQUE" IN WHITE STYLIZED FONT, WITH THE WORD "ISTANBUL" IN SMALLER GOLD STYLIZED FONT BELOW EVERYTHING, ALL THE FOREGOING APPEARING AGAINST A BLACK BACKGROUND.

THE WORDING "HAREMLIQUE" HAS NO MEANING IN A FOREIGN LANGUAGE.

CLASS 3—COSMETICS AND CLEANING PREPARATIONS

FOR ROOM FRAGRANCE, BATH SOAP, HAND SOAP (U.S. CLS. 1, 4, 6, 50, 51 AND 52).

CLASS 18—LEATHER GOODS

FOR MAKE-UP BAGS SOLD EMPTY; TRAVEL CASES FOR JEWELRY (U.S. CLS. 1, 2, 3, 22 AND 41).

CLASS 24—FABRICS

FOR BED SHEETS AND SHEET SETS, TOWELS MADE OF TEXTILE MATERIALS, TURKISH TOWELS, BATH TOWELS, FACE TOWELS OF TEXTILES, FACE TOWELS MADE OF TEXTILE MATERIALS, WASH CLOTHS, TOILE DE JOUY PRINTED SHEET SETS, WOVEN THROWS MADE OF CASHMERE; TABLE LINEN, NAMELY, NAPKINS AND PLACE MATS; PRINTED COTTON FABRICS (U.S. CLS. 42 AND 50).

CLASS 25—CLOTHING

FOR DRESSING GOWNS AND BATH ROBES; CAF-TANS (U.S. CLS. 22 AND 39).

CLASS 27—FLOOR COVERINGS

FOR BATH MATS (U.S. CLS. 19, 20, 37, 42 AND 50).

CLASS 35—ADVERTISING AND BUSINESS

FOR WHOLESALE AND RETAIL STORE SERVICES FEATURING CLOTHING, TEXTILES, COSMETICS; ON-LINE WHOLESALE AND RETAIL STORE SERVICES FEATURING CLOTHING, TEXTILES, AND COSMETICS (U.S. CLS. 100, 101 AND 102).

ANDREW LEASER, EXAMINING ATTORNEY

SN 85-248,403. ARGENTO SC BY SICURA INC., NEW YORK, NY. FILED 2-22-2011.



THE MARK CONSISTS OF THE WORD "ARTE" ABOVE THE WORD "DE" WHICH IS ABOVE THE WORD "CASA". THE THREE WORDS ARE LINED UP VERTICALLY. "ARTE" AND "CASA" ARE IN A LARGER FONT THAN "DE". THERE IS A LINE ON EITHER SIDE OF THE WORD "DE".

THE ENGLISH TRANSLATION OF "ARTE DE CASA" IN THE MARK IS "HOUSE ART".

CLASS 20—FURNITURE AND ARTICLES NOT OTHERWISE CLASSIFIED

FOR PICTURE FRAMES (U.S. CLS. 2, 13, 22, 25, 32 AND 50).

FIRST USE 1-1-2006; IN COMMERCE 1-1-2006.

CLASS 21—HOUSEWARES AND GLASS

FOR BOTTLE STOPPERS SPECIALLY ADAPTED FOR USE WITH WINE BOTTLES (U.S. CLS. 2, 13, 23, 29, 30, 33, 40 AND 50).

FIRST USE 1-1-2006; IN COMMERCE 1-1-2006.
GINA FINK, EXAMINING ATTORNEY

SN 85-248,479. CRYPTOLEX, INC., RANCHO MARAGE, CA.
FILED 2-22-2011.

SN 85-248,430. HAREMLIK TEKSTIL URUNLERI SANAYI VE TICARET LIMITED SIRKETI, ISTANBUL, TURKEY,
FILED 2-22-2011.



NO CLAIM IS MADE TO THE EXCLUSIVE RIGHT TO USE "TURKISH COFFEE" OR "ISTANBUL", APART FROM THE MARK AS SHOWN.

THE COLOR(S) BLACK, RED, WHITE, AND GOLD IS/ARE CLAIMED AS A FEATURE OF THE MARK.

THE MARK CONSISTS OF TURKISH FEZ, RED IN COLOR WITH WHITE SIDES AND A BLACK FEATHER PROTRUDING FROM A GOLD BUCKLE, OVER THE WORD "SELAMLIQUE" IN WHITE STYLIZED FONT, OVER THE WORDS "TURKISH COFFEE" IN WHITE STYLIZED FONT, WITH THE WORD "ISTANBUL" IN SMALLER GOLD STYLIZED FONT BELOW EVERYTHING, ALL THE FOREGOING APPEARING AGAINST A BLACK BACKGROUND.

THE WORDING "SELAMLIQUE" HAS NO MEANING IN A FOREIGN LANGUAGE.

CLASS 11—ENVIRONMENTAL CONTROL APPARATUS

FOR COFFEE MACHINES, NAMELY, ELECTRIC TURKISH COFFEE MAKERS (U.S. CLS. 13, 21, 23, 31 AND 34).

CLASS 21—HOUSEWARES AND GLASS

FOR COFFEE CUPS, NAMELY, CUPS FOR TURKISH COFFEE (U.S. CLS. 2, 13, 23, 29, 30, 33, 40 AND 50).

CLASS 30—STAPLE FOODS

FOR COFFEE, NAMELY, POWDERED TURKISH COFFEE, FLAVORED TURKISH COFFEE, TURKISH COFFEE CAPSULES CONTAINING COFFEE FOR BREWING FOR USE IN ELECTRIC COFFEE MAKERS (U.S. CL. 46).

CLASS 35—ADVERTISING AND BUSINESS

FOR WHOLESALE AND RETAIL STORE SERVICES FEATURING COFFEE BEVERAGES AND SMALL HOUSEHOLD APPLIANCES; ON-LINE WHOLESALE AND RETAIL STORE SERVICES FEATURING COFFEE BEVERAGES AND SMALL HOUSEHOLD APPLIANCES (U.S. CLS. 100, 101 AND 102).

ANDREW LEASER, EXAMINING ATTORNEY

MQRCO

THE MARK CONSISTS OF STANDARD CHARACTERS WITHOUT CLAIM TO ANY PARTICULAR FONT, STYLE, SIZE, OR COLOR.

CLASS 9—ELECTRICAL AND SCIENTIFIC APPARATUS

FOR COMPUTER HARDWARE AND SOFTWARE FOR PROVIDING COMMUNICATIONS FOR TELEPHONES FOR USE IN SECURITY, IDENTITY MANAGEMENT, ASSET MANAGEMENT, AND FINANCIAL TRANSACTIONS (U.S. CLS. 21, 23, 26, 36 AND 38).

CLASS 42—SCIENTIFIC AND COMPUTER SERVICES

FOR ONLINE SECURITY SERVICES, NAMELY, PROVIDING SECURITY AND ANONYMITY FOR ELECTRONICALLY TRANSMITTED ASSETS AND FINANCIAL TRANSACTIONS (U.S. CLS. 100 AND 101).

PAUL F. GAST, EXAMINING ATTORNEY

SN 85-248,542. 4K LAND AND CATTLE COMPANY, INC.,
FORT WORTH, TX. FILED 2-22-2011.

4K

THE MARK CONSISTS OF STANDARD CHARACTERS WITHOUT CLAIM TO ANY PARTICULAR FONT, STYLE, SIZE, OR COLOR.

CLASS 31—NATURAL AGRICULTURAL PRODUCTS

FOR LIVESTOCK (U.S. CLS. 1 AND 46).
FIRST USE 0-0-1989; IN COMMERCE 0-0-1989.

CLASS 41—EDUCATION AND ENTERTAINMENT

FOR RECREATIONAL SERVICES IN THE NATURE OF HUNTING EXCURSIONS AND HUNTING LEASES (U.S. CLS. 100, 101 AND 107).

FIRST USE 0-0-1996; IN COMMERCE 0-0-1996.
ARETHA SOMERVILLE, EXAMINING ATTORNEY

SN 85-248,730. LYONDELLBASELL INDUSTRIES HOLDINGS B.V., ROTTERDAM, NETHERLANDS, FILED 2-22-2011.

SN 85-249,053. MEER, SCOTT, VALLEY CENTER, CA. FILED 2-23-2011.

AMAZING CHEMISTRY

THE MARK CONSISTS OF STANDARD CHARACTERS WITHOUT CLAIM TO ANY PARTICULAR FONT, STYLE, SIZE, OR COLOR.

CLASS 1—CHEMICALS

FOR BASIC CHEMICALS AND BASIC PETROCHEMICALS, NAMELY, ACETIC ACID, METHANE CARBOXYLIC ACID, ETHANOIC ACID, METHANE CARBONYL AND ETHANOL, ALL FOR INDUSTRIAL USE; SOLVENTS FOR INDUSTRIAL USE; PROPYLENE OXIDE AND ITS DERIVATIVES, NAMELY, BUTANEDIOL, PROPYLENE GLYCOL, DEICING FLUIDS AND POLYOLS, ALL FOR INDUSTRIAL USE; STYRENE, BENZENE AND CHEMICAL AROMATIC COMPOUNDS, FOR INDUSTRIAL USE, POLYMERS, NAMELY, OLEFIN POLYMERS, OLEFIN COPOLYMERS AND COMPOSITIONS THEREOF, ALL FOR INDUSTRIAL USE; CATALYSTS FOR CHEMICAL PROCESSES; CHEMICAL ADDITIVES FOR FUELS (U.S. CLS. 1, 5, 6, 10, 26 AND 46).

CLASS 4—LUBRICANTS AND FUELS

FOR FUELS, NAMELY, GASOLINE, JET AIRCRAFT FUEL AND DIESEL; INDUSTRIAL LUBRICANTS, ALL PURPOSE LUBRICANTS; REFINED PETROLEUM PRODUCTS, NAMELY, FUELS AND LUBRICATING OILS; NON-CHEMICAL ADDITIVES FOR FUELS (U.S. CLS. 1, 6 AND 15).

JORDAN BAKER, EXAMINING ATTORNEY

SN 85-248,906. TEMPLE, KEVIN D., EL DORADO HILLS, CA. FILED 2-22-2011.

eNavigator

THE MARK CONSISTS OF STANDARD CHARACTERS WITHOUT CLAIM TO ANY PARTICULAR FONT, STYLE, SIZE, OR COLOR.

CLASS 35—ADVERTISING AND BUSINESS

FOR INFORMATION ABOUT SALES METHODS (U.S. CLS. 100, 101 AND 102).
FIRST USE 1-14-2008; IN COMMERCE 1-14-2008.

CLASS 41—EDUCATION AND ENTERTAINMENT

FOR PROVIDING ON-LINE TRAINING WORKSHOPS WITH TRAINING SIMULATIONS IN THE FIELD OF SALES (U.S. CLS. 100, 101 AND 107).
FIRST USE 1-14-2008; IN COMMERCE 1-14-2008.
WILLIAM VERHOSEK, EXAMINING ATTORNEY

DANS LE BAIN

THE MARK CONSISTS OF STANDARD CHARACTERS WITHOUT CLAIM TO ANY PARTICULAR FONT, STYLE, SIZE, OR COLOR.

NO CLAIM IS MADE TO THE EXCLUSIVE RIGHT TO USE "BAIN", APART FROM THE MARK AS SHOWN.

THE ENGLISH TRANSLATION OF "DANS LE BAIN" IS "IN THE BATH."

CLASS 3—COSMETICS AND CLEANING PREPARATIONS

FOR CLEANING PREPARATIONS, NAMELY, SOAP, LIQUID SOAP, BAR SOAP; MOISTURIZING PREPARATIONS FOR SKIN; SHAMPOOS; HAIR CONDITIONERS (U.S. CLS. 1, 4, 6, 50, 51 AND 52).

CLASS 4—LUBRICANTS AND FUELS

FOR CANDLES; PARAFFIN WAX; SOY WAX CANDLE (U.S. CLS. 1, 6 AND 15).

MICHAEL WIENER, EXAMINING ATTORNEY

SN 85-249,082. CONGRATS BOOKS INC., POMPANO BEACH, FL. FILED 2-23-2011.



THE COLOR(S) BLUE AND WHITE IS/ARE CLAIMED AS A FEATURE OF THE MARK.

THE MARK CONSISTS OF AN IMAGE OF TWO HANDS OVERLAPPING EACH OTHER APPEARING IN THE COLORS BLUE AND WHITE.

CLASS 9—ELECTRICAL AND SCIENTIFIC APPARATUS

FOR DOWNLOADABLE ELECTRONIC PUBLICATIONS IN THE NATURE OF BOOKS, WORKBOOKS, JOURNALS, MAGAZINES, MANUALS, AND AUDIO AND VIDEO RECORDINGS IN THE FIELD OF BUSINESS EDUCATION AND TRAINING; AUDIO AND VIDEO RECORDINGS FEATURING BUSINESS EDUCATION AND TRAINING (U.S. CLS. 21, 23, 26, 36 AND 38).

CLASS 41—EDUCATION AND ENTERTAINMENT

FOR BUSINESS EDUCATION AND TRAINING SERVICES, NAMELY, DEVELOPING AND FACILITATING CUSTOMIZED IN-COMPANY LEADERSHIP PROGRAMS, EMPLOYEE AND EXECUTIVE DEVELOPMENT PROGRAMS, EMPLOYEE COACHING AND TRAINING MATERIALS AND PROGRAMS, AND PROVIDING PUBLIC AND IN-COMPANY KEYNOTE PRESENTATIONS TO BUSINESS LEADERS (U.S. CLS. 100, 101 AND 107).

DAVID COLLIER, EXAMINING ATTORNEY

SN 85-249,100. PLAYGROUND PUPS, INC., NEW YORK, NY. FILED 2-23-2011.



SN 85-249,087. CONGRATS BOOKS INC., POMPANO BEACH, FL. FILED 2-23-2011.



THE COLOR(S) WHITE AND BLUE IS/ARE CLAIMED AS A FEATURE OF THE MARK.

THE MARK CONSISTS OF AN IMAGE OF TWO CLAPPING HANDS WITH ARMS THAT ARE COVERED WITH SLEEVES AND A CUFF LINK APPEARING ON A BLUE RECTANGULAR BACKGROUND BORDERED BY A WHITE AND BLUE BACKGROUND.

CLASS 16—PAPER GOODS AND PRINTED MATTER

FOR SERIES OF PUBLICATIONS, NAMELY, BOOKS, WORKBOOKS, TECHNICAL WORKBOOKS, JOURNALS, MAGAZINES, AND MANUALS IN THE FIELD OF CAREER DEVELOPMENT, EDUCATION, AND MOTIVATION (U.S. CLS. 2, 5, 22, 23, 29, 37, 38 AND 50).

CLASS 41—EDUCATION AND ENTERTAINMENT

FOR EDUCATION IN THE NATURE OF ON-LINE PUBLICATIONS IN THE FORM OF BOOKS, WORKBOOKS, JOURNALS, MAGAZINES, AND MANUALS, IN THE FIELDS OF CAREER DEVELOPMENT, EDUCATION AND MOTIVATION (U.S. CLS. 100, 101 AND 107).

DAVID COLLIER, EXAMINING ATTORNEY

NO CLAIM IS MADE TO THE EXCLUSIVE RIGHT TO USE "PUPS", APART FROM THE MARK AS SHOWN.

THE COLOR(S) YELLOW, BLACK AND WHITE IS/ARE CLAIMED AS A FEATURE OF THE MARK.

THE MARK CONSISTS OF A CIRCLE WITH AN IMAGE OF A BLACK AND WHITE SPOTTED DOG IN THE CENTER WITH WHITE IN THE BACKGROUND AND THE WORDS "PLAYGROUND PUPS" IN YELLOW INSIDE A BAND OF BLACK IN THE OUTER PORTION OF THE CIRCLE

CLASS 43—HOTEL AND RESTAURANT SERVICES

FOR DOG DAY CARE AND BOARDING SERVICES (U.S. CLS. 100 AND 101).

FIRST USE 4-1-2009; IN COMMERCE 4-1-2009.

CLASS 44—MEDICAL, BEAUTY AND AGRICULTURAL SERVICES

FOR DOG GROOMING SERVICES (U.S. CLS. 100 AND 101).

FIRST USE 4-1-2009; IN COMMERCE 4-1-2009.

ROBIN CHOSID, EXAMINING ATTORNEY

SN 85-249,148. WHITE KNIGHT ENGINEERED PRODUCTS, INC., CHARLOTTE, NC. FILED 2-23-2011.

Allergy Guardian

THE MARK CONSISTS OF STANDARD CHARACTERS WITHOUT CLAIM TO ANY PARTICULAR FONT, STYLE, SIZE, OR COLOR.

NO CLAIM IS MADE TO THE EXCLUSIVE RIGHT TO USE "ALLERGY", APART FROM THE MARK AS SHOWN.

CLASS 35—ADVERTISING AND BUSINESS

FOR MATERIALS SOURCING NAMELY, PROCUREMENT IN THE NATURE OF NON ALLERGENIC PRODUCTS FOR BEDDING FOR OTHERS; MATERIALS SOURCING, NAMELY, LOGISTICS MANAGEMENT IN THE FIELD OF NON ALLERGENIC PRODUCTS FOR BEDDING FOR OTHERS; MATERIALS SOURCING, NAMELY, BUSINESS CONSULTING SERVICES RELATING TO PRODUCT DISTRIBUTION, OPERATIONS MANAGEMENT SERVICES, LOGISTICS, REVERSE LOGISTICS, SUPPLY CHAIN, AND PRODUCTION SYSTEMS AND DISTRIBUTION SOLUTIONS, ALL PERTAINING TO ALLERGY CONTROL PRODUCTS FOR BEDDING; BUSINESS MARKETING SERVICES PERTAINING TO ALLERGY CONTROL PRODUCTS FOR BEDDING FOR OTHERS (U.S. CLS. 100, 101 AND 102).

CLASS 40—MATERIAL TREATMENT

FOR MANUFACTURE OF GENERAL PRODUCT LINES IN THE FIELD OF BEDDING TO THE ORDER AND SPECIFICATION OF OTHERS (U.S. CLS. 100, 103 AND 106).

CLASS 42—SCIENTIFIC AND COMPUTER SERVICES

FOR PRODUCT RESEARCH AND DEVELOPMENT; MATERIAL TESTING, ANALYSIS AND EVALUATION; DESIGNING OF WRAPPING MATERIALS AND PACKAGING DESIGN FOR OTHERS; QUALITY CONTROL FOR OTHERS (U.S. CLS. 100 AND 101).

DAVID TOOLEY, EXAMINING ATTORNEY

CLASS 39—TRANSPORTATION AND STORAGE

FOR WAREHOUSING SERVICES, NAMELY, STORAGE, DISTRIBUTION, PICK-UP, AND PACKING FOR SHIPMENT OF RECORDS AND DOCUMENTS FOR OTHERS; DOCUMENT STORAGE SERVICES; ELECTRONIC STORAGE OF FILES AND DOCUMENTS; PHYSICAL STORAGE OF ELECTRONICALLY-STORED DATA OR DOCUMENTS; STORAGE SERVICES FOR ARCHIVING DATABASES, IMAGES AND OTHER ELECTRONIC DATA; DOCUMENT DELIVERY SERVICES (U.S. CLS. 100 AND 105).

CLASS 42—SCIENTIFIC AND COMPUTER SERVICES

FOR ELECTRONIC RETRIEVAL SERVICES FOR FILES AND DOCUMENTS THAT ARE IN STORAGE, NAMELY, COMPUTERIZED FILE AND DOCUMENT RETRIEVAL SERVICES FOR OTHERS (U.S. CLS. 100 AND 101).

CHARLES L. JENKINS, EXAMINING ATTORNEY

SN 85-249,205. NORWEX HOLDING AS, LILLESTROM 2004, NORWAY, FILED 2-23-2011.

SN 85-249,203. RETRIEVEV FINANCING CORP., PEABODY, MA. FILED 2-23-2011.

FileLineACCESS
Retrievex Online Information Management

OWNER OF U.S. REG. NO. 3,670,186.
NO CLAIM IS MADE TO THE EXCLUSIVE RIGHT TO USE "ONLINE INFORMATION MANAGEMENT", APART FROM THE MARK AS SHOWN.

THE MARK CONSISTS OF THE WORD "FILELINE" TO THE LEFT OF A DIAMOND WITH THE WORD "ACCESS" TO THE RIGHT OF THE DIAMOND AND ABOVE THE WORDING "RETRIEVEX ONLINE INFORMATION MANAGEMENT".

CLASS 35—ADVERTISING AND BUSINESS

FOR ELECTRONIC MANAGEMENT OF FILES AND DOCUMENTS THAT ARE IN STORAGE, NAMELY, COMPUTERIZED FILE AND DOCUMENT MANAGEMENT SERVICES; BUSINESS AND FINANCIAL RECORDS MANAGEMENT SERVICES; RECORDS MANAGEMENT SERVICES, NAMELY, DOCUMENT INDEXING FOR OTHERS; INVENTORY MANAGEMENT AND CONTROL SERVICES FOR BUSINESS AND FINANCIAL RECORDS; MAINTENANCE OF BUSINESS RECORDS, NAMELY, INVENTORY MANAGEMENT AND CONTROL SERVICES OF BUSINESS RECORDS AND BUSINESS RECORDS IN THE NATURE OF VITAL RECORDS, COMPUTER DATA, FILMS, MASTER RECORDINGS, AND ARCHIVAL MATERIALS AND RECORDS (U.S. CLS. 100, 101 AND 102).



OWNER OF U.S. REG. NOS. 2,798,028 AND 3,964,282.
THE MARK CONSISTS OF A DROP OF LIQUID POSITIONED ABOVE A SERIES OF CONCENTRIC CIRCLES THAT FORM A WATER DROP WAVE.

CLASS 3—COSMETICS AND CLEANING PREPARATIONS

FOR ORGANIC LEG CREAM; ORGANIC FACE AND NECK GEL; ORGANIC HERBS SKIN CREAM; ORGANIC DAY SKIN CREAM; ORGANIC NIGHT SKIN CREAM; ORGANIC HAND CREAM (U.S. CLS. 1, 4, 6, 50, 51 AND 52).

FIRST USE 9-1-2007; IN COMMERCE 9-1-2007.

CLASS 21—HOUSEWARES AND GLASS

FOR EYEGLASS CLEANING CLOTHS (U.S. CLS. 2, 13, 23, 29, 30, 33, 40 AND 50).

FIRST USE 4-1-1999; IN COMMERCE 8-1-2000.
NATALIE POLZER, EXAMINING ATTORNEY

SN 85-249,335. WIRED 4 MISCHIEF, LLC, WEDDINGTON, NC. FILED 2-23-2011.



THE MARK CONSISTS OF THE WORDING "WIRED FOR MISCHIEF" IN STYLIZED FORM, WITH A HALO OVER "WIRED" AND A TAIL EXTENDING FROM THE "H" IN "MISCHIEF".

CLASS 16—PAPER GOODS AND PRINTED MATTER

FOR BUMPER STICKERS; GREETING CARDS; POSTERS; STATIONERY (U.S. CLS. 2, 5, 22, 23, 29, 37, 38 AND 50).

CLASS 18—LEATHER GOODS

FOR ANIMAL LEASHES; BACKPACKS; COLLARS FOR PETS; DOG LEASHES; GYM BAGS; LUGGAGE; MESSENGER BAGS; SPORTS BAGS; TOILETRY CASES SOLD EMPTY; TOTE BAGS; TRAVEL BAGS (U.S. CLS. 1, 2, 3, 22 AND 41).

CLASS 21—HOUSEWARES AND GLASS

FOR ALUMINUM WATER BOTTLES SOLD EMPTY; BOTTLES, SOLD EMPTY; MUGS; THERMAL INSULATED CONTAINERS FOR FOOD OR BEVERAGES (U.S. CLS. 2, 13, 23, 29, 30, 33, 40 AND 50).

CLASS 25—CLOTHING

FOR BANDANAS; CHILDREN'S AND INFANT'S APPAREL, NAMELY, JUMPERS, OVERALL SLEEPWEAR, PAJAMAS, ROMPERS AND ONE-PIECE GARMENTS; HATS; JACKETS; MITTENS; PAJAMAS; PANTS; SCARVES; SHIRTS; SHORTS; SOCKS; SUNDRESSES; SWEATSHIRTS; SWIMWEAR; T-SHIRTS; UNDERWEAR; WRAPS (U.S. CLS. 22 AND 39).

GEORGE LORENZO, EXAMINING ATTORNEY

SN 85-249,428. SIEMENS HEALTHCARE DIAGNOSTICS INC., DEERFIELD, IL. FILED 2-23-2011.

VISTA

THE MARK CONSISTS OF STANDARD CHARACTERS WITHOUT CLAIM TO ANY PARTICULAR FONT, STYLE, SIZE, OR COLOR.

OWNER OF U.S. REG. NOS. 1,536,203, 3,442,412 AND OTHERS.

CLASS 1—CHEMICALS

FOR DIAGNOSTIC REAGENTS FOR CLINICAL OR MEDICAL LABORATORY USE (U.S. CLS. 1, 5, 6, 10, 26 AND 46).

CLASS 5—PHARMACEUTICALS

FOR MEDICAL DIAGNOSTICS REAGENTS (U.S. CLS. 6, 18, 44, 46, 51 AND 52).

REBECCA SMITH, EXAMINING ATTORNEY

SN 85-249,470. 2228 PARK AVENUE, LLC, DBA PARK SOCIAL, MIAMI BEACH, FL. FILED 2-23-2011.

PARK SOCIAL

THE MARK CONSISTS OF STANDARD CHARACTERS WITHOUT CLAIM TO ANY PARTICULAR FONT, STYLE, SIZE, OR COLOR.

NO CLAIM IS MADE TO THE EXCLUSIVE RIGHT TO USE "SOCIAL", APART FROM THE MARK AS SHOWN.

CLASS 41—EDUCATION AND ENTERTAINMENT

FOR NIGHT CLUBS; SOCIAL CLUB SERVICES, NAMELY, ARRANGING, ORGANIZING, AND HOSTING SOCIAL EVENTS, GET-TOGETHERS, AND PARTIES FOR CLUB MEMBERS (U.S. CLS. 100, 101 AND 107).

CLASS 43—HOTEL AND RESTAURANT SERVICES

FOR RESTAURANT AND BAR SERVICES (U.S. CLS. 100 AND 101).

LEIGH CAROLINE CASE, EXAMINING ATTORNEY

SN 85-249,592. AMERICAN TEXTILE COMPANY, DUQUESNE, PA. FILED 2-23-2011.

TIMELESS ELEMENTS

THE MARK CONSISTS OF STANDARD CHARACTERS WITHOUT CLAIM TO ANY PARTICULAR FONT, STYLE, SIZE, OR COLOR.

CLASS 20—FURNITURE AND ARTICLES NOT OTHERWISE CLASSIFIED

FOR PILLOWS (U.S. CLS. 2, 13, 22, 25, 32 AND 50).

CLASS 24—FABRICS

FOR PILLOW COVERS, MATTRESS COVERS, BOX SPRING COVERS, MATTRESS PADS, BLANKETS, COMFORTERS AND SHEETS (U.S. CLS. 42 AND 50).

PATRICIA EVANKO, EXAMINING ATTORNEY

SN 85-249,596. CASKS & CORKS, LLC, SIOUX FALLS, SD.
FILED 2-23-2011.

SN 85-249,622. CASKS & CORKS, LLC, SIOUX FALLS, SD.
FILED 2-23-2011.

CASK & CORK

THE MARK CONSISTS OF STANDARD CHARACTERS WITHOUT CLAIM TO ANY PARTICULAR FONT, STYLE, SIZE, OR COLOR.

CLASS 35—ADVERTISING AND BUSINESS

FOR WHOLESALE DISTRIBUTORSHIPS FEATURING ALCOHOLIC AND NON-ALCOHOLIC BEVERAGES (U.S. CLS. 100, 101 AND 102).

FIRST USE 4-17-2008; IN COMMERCE 4-17-2008.

CLASS 39—TRANSPORTATION AND STORAGE

FOR PROVIDING WAREHOUSING AND TRANSPORT SERVICES BY TRUCK, VANS, MOTOR VEHICLES, AUTOMOBILES, AIR, RAIL, FREIGHT, SHIPS, AND THE LIKE, FOR ALCOHOLIC AND NON-ALCOHOLIC BEVERAGES (U.S. CLS. 100 AND 105).

FIRST USE 4-17-2008; IN COMMERCE 4-17-2008.
MICHAEL GAAFAR, EXAMINING ATTORNEY



NO CLAIM IS MADE TO THE EXCLUSIVE RIGHT TO USE "DISTRIBUTING", APART FROM THE MARK AS SHOWN.

THE MARK CONSISTS OF THE STYLIZED WORDING "CASK & CORK" SET ABOVE THE STYLIZED WORDING "DISTRIBUTING", ALL SET BELOW A DESIGN ELEMENT COMPRISED OF TWO OVERLAPPING "C" CHARACTERS FACING IN OPPOSITE DIRECTIONS, WITH AN ORNATE DESIGN ELEMENT COMPRISED OF CURVED LINES SET ON EITHER SIDE OF THE OVERLAPPING "C" CHARACTERS, ALL SET INSIDE A SHIELD OF A GENERALLY RECTANGULAR SHAPE.

CLASS 35—ADVERTISING AND BUSINESS

FOR WHOLESALE DISTRIBUTORSHIPS FEATURING ALCOHOLIC AND NON-ALCOHOLIC BEVERAGES (U.S. CLS. 100, 101 AND 102).

FIRST USE 4-17-2008; IN COMMERCE 4-17-2008.

CLASS 39—TRANSPORTATION AND STORAGE

FOR PROVIDING WAREHOUSING AND TRANSPORT SERVICES BY TRUCK, VANS, MOTOR VEHICLES, AUTOMOBILES, AIR, RAIL, FREIGHT, SHIPS, AND THE LIKE, FOR ALCOHOLIC AND NON-ALCOHOLIC BEVERAGES (U.S. CLS. 100 AND 105).

FIRST USE 4-17-2008; IN COMMERCE 4-17-2008.
MICHAEL GAAFAR, EXAMINING ATTORNEY

SN 85-249,620. 21ST CENTURY SYSTEMS, INC., OMAHA, NE. FILED 2-23-2011.

KAIMI

THE MARK CONSISTS OF STANDARD CHARACTERS WITHOUT CLAIM TO ANY PARTICULAR FONT, STYLE, SIZE, OR COLOR.

THE ENGLISH TRANSLATION OF "KAIMI" IN THE MARK IS "SEEKER".

CLASS 9—ELECTRICAL AND SCIENTIFIC APPARATUS

FOR COMPUTER SOFTWARE FOR CASINO FRAUD DETECTION, SURVEILLANCE, AND INVESTIGATION (U.S. CLS. 21, 23, 26, 36 AND 38).

FIRST USE 10-0-2009; IN COMMERCE 2-0-2010.

CLASS 42—SCIENTIFIC AND COMPUTER SERVICES

FOR CONSULTING SERVICES IN THE FIELD OF DESIGN, IMPLEMENTATION, USE AND SUPPORT OF COMPUTER SOFTWARE TOOLS FOR THE GAMING INDUSTRY (U.S. CLS. 100 AND 101).

FIRST USE 10-0-2009; IN COMMERCE 2-0-2010.
MICHAEL GAAFAR, EXAMINING ATTORNEY

SN 85-249,741. PRIACTA, INC., POWHATAN, VA. FILED 2-23-2011.



THE COLOR(S) BLUE AND GRAY IS/ARE CLAIMED AS A FEATURE OF THE MARK.

THE MARK CONSISTS OF A DIALOGUE BOX WITH A GRAY OUTLINE AND WHICH CONTAINS TWO GRAY CHECK MARKS AND TWO GRAY LINES. A PORTION OF A BLUE DIALOGUE BOX APPEARS ABOVE AND TO THE LEFT OF THE GRAY ONE, GIVING THE APPEARANCE OF THE GRAY ONE LAYING ON TOP OF THE BLUE ONE.

CLASS 9—ELECTRICAL AND SCIENTIFIC APPARATUS

FOR COMPUTER SOFTWARE FOR TASK AND PROJECT ASSIGNMENT, TRACKING, COORDINATION, AND FOLLOW-UP; COMPUTER SOFTWARE FOR TASK AND APPOINTMENT SCHEDULING; COMPUTER SOFTWARE FOR WORKFLOW COLLABORATION; COMPUTER SOFTWARE FOR WORK PERFORMANCE MONITORING; COMPUTER SOFTWARE FOR CREATING CALENDARS TO PROMOTE ORGANIZATIONAL EFFECTIVENESS; COMPUTER SOFTWARE FOR DELEGATION OF TASKS AND PROJECTS; COMPUTER SOFTWARE FOR CREATING AND DISTRIBUTING MEETING AGENDAS; AND COMPUTER SOFTWARE FOR USE IN ENGAGING IN SOCIAL NETWORKING (U.S. CLS. 21, 23, 26, 36 AND 38).

CLASS 9—ELECTRICAL AND SCIENTIFIC APPARATUS

FOR COMPUTER SOFTWARE FOR TASK AND PROJECT ASSIGNMENT, TRACKING, COORDINATION, AND FOLLOW-UP; COMPUTER SOFTWARE FOR TASK AND APPOINTMENT SCHEDULING; COMPUTER SOFTWARE FOR WORKFLOW COLLABORATION; COMPUTER SOFTWARE FOR WORK PERFORMANCE MONITORING; COMPUTER SOFTWARE FOR CREATING CALENDARS TO PROMOTE ORGANIZATIONAL EFFECTIVENESS; COMPUTER SOFTWARE FOR DELEGATION OF TASKS AND PROJECTS; COMPUTER SOFTWARE FOR CREATING AND DISTRIBUTING MEETING AGENDAS; AND COMPUTER SOFTWARE FOR USE IN ENGAGING IN SOCIAL NETWORKING (U.S. CLS. 21, 23, 26, 36 AND 38).

CLASS 42—SCIENTIFIC AND COMPUTER SERVICES

FOR SOFTWARE AS A SERVICE (SAAS) SERVICES FEATURING SOFTWARE FOR TASK AND PROJECT ASSIGNMENT, TRACKING, COORDINATION, AND FOLLOW-UP; SOFTWARE AS A SERVICE (SAAS) SERVICES FEATURING SOFTWARE FOR TASK AND APPOINTMENT SCHEDULING; SOFTWARE AS A SERVICE (SAAS) SERVICES FEATURING SOFTWARE FOR WORKFLOW COLLABORATION; SOFTWARE AS A SERVICE (SAAS) SERVICES FEATURING SOFTWARE FOR WORK PERFORMANCE MONITORING; SOFTWARE AS A SERVICE (SAAS) SERVICES FEATURING SOFTWARE FOR CREATING CALENDARS TO PROMOTE ORGANIZATIONAL EFFECTIVENESS; SOFTWARE AS A SERVICE (SAAS) SERVICES FEATURING SOFTWARE FOR DELEGATION OF TASKS AND PROJECTS; SOFTWARE AS A SERVICE (SAAS) SERVICES FEATURING SOFTWARE FOR CREATING AND DISTRIBUTING MEETING AGENDAS; AND SOFTWARE AS A SERVICE (SAAS) SERVICES FEATURING SOFTWARE FOR USE IN ENGAGING IN SOCIAL NETWORKING (U.S. CLS. 100 AND 101).

KATHERINE CHANG, EXAMINING ATTORNEY

CLASS 42—SCIENTIFIC AND COMPUTER SERVICES

FOR SOFTWARE AS A SERVICE (SAAS) SERVICES FEATURING SOFTWARE FOR TASK AND PROJECT ASSIGNMENT, TRACKING, COORDINATION, AND FOLLOW-UP; SOFTWARE AS A SERVICE (SAAS) SERVICES FEATURING SOFTWARE FOR TASK AND APPOINTMENT SCHEDULING; SOFTWARE AS A SERVICE (SAAS) SERVICES FEATURING SOFTWARE FOR WORKFLOW COLLABORATION; SOFTWARE AS A SERVICE (SAAS) SERVICES FEATURING SOFTWARE FOR WORK PERFORMANCE MONITORING; SOFTWARE AS A SERVICE (SAAS) SERVICES FEATURING SOFTWARE FOR CREATING CALENDARS TO PROMOTE ORGANIZATIONAL EFFECTIVENESS; SOFTWARE AS A SERVICE (SAAS) SERVICES FEATURING SOFTWARE FOR DELEGATION OF TASKS AND PROJECTS; SOFTWARE AS A SERVICE (SAAS) SERVICES FEATURING SOFTWARE FOR CREATING AND DISTRIBUTING MEETING AGENDAS; AND SOFTWARE AS A SERVICE (SAAS) SERVICES FEATURING SOFTWARE FOR USE IN ENGAGING IN SOCIAL NETWORKING (U.S. CLS. 100 AND 101).

KATHERINE CHANG, EXAMINING ATTORNEY

SN 85-249,752. PRIACTA, INC., POWHATAN, VA. FILED 2-23-2011.

SN 85-249,865. CADENCE SOFTWARE, LLC, EDEN PRAIRIE, MN. FILED 2-23-2011.



LittleBigERP

THE COLOR(S) BLUE AND WHITE IS/ARE CLAIMED AS A FEATURE OF THE MARK.

THE MARK CONSISTS OF A BLUE DIALOGUE BOX WITH A WHITE CHECK MARK APPEARING INSIDE THE BOX.

THE MARK CONSISTS OF STANDARD CHARACTERS WITHOUT CLAIM TO ANY PARTICULAR FONT, STYLE, SIZE, OR COLOR.

CLASS 9—ELECTRICAL AND SCIENTIFIC APPARATUS

FOR COMPUTER PROGRAMS AND SOFTWARE FOR MANUFACTURERS AND DISTRIBUTORS, NAMELY, ENTERPRISE SOFTWARE APPLICATIONS FOR COLLECTING, EDITING, ORGANIZING, MODIFYING, STORING AND SHARING DATA AND INFORMATION IN THE AREAS OF SUPPLIER MANAGEMENT, WAREHOUSING, DISTRIBUTION, LOGISTICS, CUSTOMER SERVICE, CUSTOMER-RELATIONSHIP MANAGEMENT, PRODUCT-LIFECYCLE MANAGEMENT, SUPPLIER-RELATIONSHIP MANAGEMENT, ORDER ENTRY, INVENTORY AND PRODUCTION PLANNING, PRODUCT DESIGN, PROCUREMENT ORDER MANAGEMENT, SUPPLY-CHAIN MANAGEMENT, ADMINISTRATION AND FORECASTING, SUPPORT SERVICES, SUPPLY-CHAIN COLLABORATION, DISTRIBUTION RESOURCE PLANNING, ELECTRONIC DATA INTERCHANGE, MANAGEMENT OF ACCOUNTS PAYABLE AND RECEIVABLE, ORDERING, INVOICING, SHIPPING CUSTOMER ORDERS, FIELD SERVICES, QUALITY MANAGEMENT, MANUFACTURING EXECUTION SYSTEMS, PRODUCT AND SALES-ORDER CONFIGURATION, AND ENTERPRISE RESOURCE PLANNING; COMPUTER PROGRAMS AND SOFTWARE THAT ALLOW USERS TO PERFORM BUSINESS TRANSACTIONS OVER THE INTERNET, NAMELY, ORDERING AND FULFILLING ORDERS FOR PRODUCTS, CREATING ON-LINE PRODUCT CATALOGS, TRACKING PRODUCT-ORDER STATUS AND MANAGING INFORMATION RELATING TO BUSINESS TRANSACTIONS (U.S. CLS. 21, 23, 26, 36 AND 38).

CLASS 42—SCIENTIFIC AND COMPUTER SERVICES

FOR COMPUTER PROGRAMMING AND SOFTWARE DESIGN; ADVISORY SERVICES IN THE FIELD OF PRODUCT DEVELOPMENT AND QUALITY IMPROVEMENT OF SOFTWARE; COMPUTER SOFTWARE CONSULTATION; COMPUTER SOFTWARE CONSULTANCY; COMPUTER SOFTWARE DEVELOPMENT; COMPUTER SOFTWARE DESIGN, COMPUTER PROGRAMMING, MAINTENANCE AND UPDATING OF COMPUTER SOFTWARE; COMPUTER SOFTWARE INSTALLATION AND MAINTENANCE; COMPUTER SOFTWARE RENTAL; CONSULTATION SERVICES IN THE FIELDS OF SELECTION, IMPLEMENTATION AND USE OF COMPUTER HARDWARE AND SOFTWARE SYSTEMS FOR OTHERS; CONSULTING SERVICES IN THE FIELD OF DESIGN, SELECTION, IMPLEMENTATION AND USE OF COMPUTER HARDWARE AND SOFTWARE SYSTEMS FOR OTHERS; CUSTOMIZED SOFTWARE DEVELOPMENT SERVICES; DESIGN AND DEVELOPMENT OF COMPUTER SOFTWARE; DESIGN, DEVELOPMENT AND IMPLEMENTATION OF SOFTWARE (U.S. CLS. 100 AND 101).
EMILY CHUO, EXAMINING ATTORNEY

SN 85-249,867. PREVEDERE LLC, COLUMBUS, OH. FILED 2-23-2011.

prevedere

THE MARK CONSISTS OF THE WORD "PREVEDERE" WITH A UNIQUE "V" THAT HAS AN ARROW POINTING UP AND AN ACCENT OVER THE NEXT TO LAST "E".
THE ENGLISH TRANSLATION OF "PREVEDERE" IN THE MARK IS "FORESIGHT".

CLASS 9—ELECTRICAL AND SCIENTIFIC APPARATUS

FOR DOWNLOADABLE COMPUTER SOFTWARE FOR ANALYTICS, REPORTING, CHARTING, AND GRAPHING DATA (U.S. CLS. 21, 23, 26, 36 AND 38).
FIRST USE 12-20-2010; IN COMMERCE 12-20-2010.

CLASS 42—SCIENTIFIC AND COMPUTER SERVICES

FOR COMPUTER SOFTWARE CONSULTING (U.S. CLS. 100 AND 101).
FIRST USE 12-20-2010; IN COMMERCE 12-20-2010.
EMILY CHUO, EXAMINING ATTORNEY

SN 85-250,089. TOLL, ROGER, WEST CALDWELL, NJ. FILED 2-23-2011.



TORO SACHELS

NO CLAIM IS MADE TO THE EXCLUSIVE RIGHT TO USE "SACHELS", APART FROM THE MARK AS SHOWN.
THE MARK CONSISTS OF A PARTICULAR DESIGN OF A BULL'S HEAD.

CLASS 18—LEATHER GOODS

FOR BRIEFCASES; LEATHER BAGS, SUITCASES AND WALLETS; LEATHER HANDBAGS; LEATHER PURSES; SACHELS (U.S. CLS. 1, 2, 3, 22 AND 41).

CLASS 35—ADVERTISING AND BUSINESS

FOR RETAIL STORE AND ON-LINE RETAIL STORE SERVICES FEATURING LEATHER GOODS, SACHELS, BAGS (U.S. CLS. 100, 101 AND 102).
DOMINICK J. SALEMI, EXAMINING ATTORNEY

SN 85-250,122. BURRELL STANLEY K., TRACY, CA. FILED 2-23-2011.

SEE HER FACE

THE MARK CONSISTS OF STANDARD CHARACTERS WITHOUT CLAIM TO ANY PARTICULAR FONT, STYLE, SIZE, OR COLOR.

CLASS 3—COSMETICS AND CLEANING PREPARATIONS

FOR BODY AND BEAUTY CARE COSMETICS (U.S. CLS. 1, 4, 6, 50, 51 AND 52).

CLASS 45—PERSONAL AND LEGAL SERVICES

FOR PERSONAL STYLIST SERVICES, NAMELY, EVALUATING THE PHYSICAL ATTRIBUTES, LIFESTYLE, AND FASHION STYLES OF OTHERS AND RECOMMENDING CLOTHING AND ACCESSORIES TO ACHIEVE THE PERSONAL IMAGE DESIRED BY THE CLIENT (U.S. CLS. 100 AND 101).
DEZMONA MIZELLE, EXAMINING ATTORNEY

CLASS 45—PERSONAL AND LEGAL SERVICES

FOR ALARM RESPONSE AND MONITORING SERVICES (U.S. CLS. 100 AND 101).
MAYUR VAGHANI, EXAMINING ATTORNEY

SN 85-250,125. JOAN M KELLY, LOUISVILLE, KY. FILED 2-23-2011.

SN 85-250,236. PIAGGIO & C. S.P.A., PONTEDERA (PISA), ITALY, FILED 2-24-2011.

ROAR

THE MARK CONSISTS OF STANDARD CHARACTERS WITHOUT CLAIM TO ANY PARTICULAR FONT, STYLE, SIZE, OR COLOR.

CLASS 41—EDUCATION AND ENTERTAINMENT

FOR ENTERTAINMENT AND EDUCATIONAL SERVICES, NAMELY, THE PRESENTATION OF SEMINARS, LECTURES, WORKSHOPS AND PANEL DISCUSSIONS, AND ONGOING TELEVISION AND RADIO TALK SHOWS ALL IN THE FIELD OF PUBLIC INTEREST CONCERNING HEALTH (U.S. CLS. 100, 101 AND 107).

CLASS 44—MEDICAL, BEAUTY AND AGRICULTURAL SERVICES

FOR PROVIDING HEALTHCARE INFORMATION (U.S. CLS. 100 AND 101).
DEZMONA MIZELLE, EXAMINING ATTORNEY



OWNER OF ERPN CMNTY TM OFC REG. NO. 1317130, DATED 1-16-2004, EXPIRES 9-21-2019.

OWNER OF U.S. REG. NOS. 1,929,118, 2,800,537 AND OTHERS.

THE MARK CONSISTS OF THE UNDERLINED WORD "VESPA" IN SCRIPT LETTERS.

THE ENGLISH TRANSLATION OF "VESPA" IN THE MARK IS "WASP".

SN 85-250,235. AMERICAN TOTAL PROTECTION, LLC, HAMDEN, CT. FILED 2-24-2011.



NO CLAIM IS MADE TO THE EXCLUSIVE RIGHT TO USE "AMERICAN" AND "PROTECTION", APART FROM THE MARK AS SHOWN.

THE MARK CONSISTS OF THE WORDS "AMERICAN TOTAL PROTECTION" WITH THE SECOND "A" IN "AMERICAN" REPLACED WITH THE LETTERS "ATP" WITHIN A SHIELD.

CLASS 37—CONSTRUCTION AND REPAIR

FOR INSTALLATION AND MAINTENANCE OF ALARM AND SECURITY SYSTEMS (U.S. CLS. 100, 103 AND 106).

CLASS 29—MEATS AND PROCESSED FOODS

FOR MEAT, FISH, POULTRY AND GAME; MEAT EXTRACTS; PRESERVED, DRIED AND COOKED FRUITS AND VEGETABLES; JELLIES, JAMS, FRUIT SAUCES EXCLUDING CRANBERRY AND APPLE SAUCES; EGGS, MILK; CHEESES; CREAM; DAIRY PRODUCTS, NAMELY, DAIRY-BASED CHOCOLATE FOOD BEVERAGES, DAIRY-BASED DIPS, DAIRY-BASED FOOD BEVERAGES; MARGARINE, MARGARINE SUBSTITUTES; SOUR CREAM, SOUR CREAM SUBSTITUTES; BUTTER, BUTTER SUBSTITUTES, PEANUT BUTTER; YOGURT; WHIPPING CREAM; EDIBLE OILS AND FATS (U.S. CL. 46).

CLASS 30—STAPLE FOODS

FOR COFFEE, TEA, COCOA, SUGAR, RICE, TAPIOCA, SAGO, ARTIFICIAL COFFEE; FLOUR AND PROCESSED CEREALS, BREAD, PASTY AND CONFECTIONERY CHIPS FOR BAKING; FLAVORED ICES; HONEY, TREACLE; YEAST, BAKING POWDER; SALT, MUSTARD; VINEGAR, SAUCES, CONDIMENTS, NAMELY, SALAD DRESSING, SPICES; CRANBERRY SAUCE; APPLESAUCE; AND ICE (U.S. CL. 46).

CLASS 32—LIGHT BEVERAGES

FOR COLAS; NON-ALCOHOLIC MALT BEVERAGES; SODA POP; SOFT DRINKS; NON-ALCOHOLIC PUNCH; SPORT DRINKS; TOMATO JUICE; VEGETABLE JUICE; NON-ALCOHOLIC AND DE-ALCOHOLIZED WINE; FRUIT DRINKS AND FRUIT JUICES; CONCENTRATES, SYRUPS OR POWDERS USED IN THE PREPARATION OF SOFT DRINKS (U.S. CLS. 45, 46 AND 48).

CLASS 33—WINES AND SPIRITS

FOR ALCOHOLIC BEVERAGES, NAMELY, PREPARED ALCOHOLIC COCKTAILS; AMONTILLADO; ANISETTE; APERITIF WINES; APERITIFS WITH DISTILLED ALCOHOLIC LIQUOR BASE; APERITIFS WITH A WINE BASE; ALCOHOLIC APERITIF BITTERS; AR-RACK; ALCOHOLIC BITTERS; CHERRY, FRENCH AND COOKING BRANDIES; BRANDY SPIRITS; CALVADOS; CHAMPAGNE; HARD CIDER; PREPARED WINE COCKTAIL; COGNAC; COOKING WINE; CORDIALS; CURA-CAO; DISTILLED SPIRITS OF RICE, CORN, BARLEY, FRUIT; EXTRACTS OF SPIRITUOUS LIQUORS; GIN; HERB LIQUEURS; KIRSCH; LIQUEURS; DISTILLED LIQUOR; MEAD; OUZO; PORT WINES; ALCOHOLIC PUNCH; WINE PUNCH; RUM; SAKE; SANGRIA; SCHNAPPS; SHERRY; TEQUILA; VERMOUTH; VODKA; WHISKEY; WINE, NAMELY, APERITIF, COOKING, FRUIT, RED, WHITE, ROSE, COOLERS, AND PUNCHES (U.S. CLS. 47 AND 49).

CLASS 35—ADVERTISING AND BUSINESS

FOR MANAGEMENT OF BARS, RESTAURANTS, HOTELS, DANCING SALOONS AND BALLROOMS, GYMNASIUMS, AND BEAUTY CENTERS FOR OTHERS (U.S. CLS. 100, 101 AND 102).

CLASS 43—HOTEL AND RESTAURANT SERVICES

FOR SERVICES RENDERED BY BUSINESS ENGAGED IN PREPARING FOODS AND DRINKS, NAMELY, CATERING SERVICES (U.S. CLS. 100 AND 101).
JOHN SCHUYLER YARD, EXAMINING ATTORNEY

SN 85-250,239. AMERICAN TOTAL PROTECTION, LLC, HAMDEN, CT. FILED 2-24-2011.



NO CLAIM IS MADE TO THE EXCLUSIVE RIGHT TO USE "AMERICAN" AND "PROTECTION, LLC", APART FROM THE MARK AS SHOWN.

THE MARK CONSISTS OF THE WORDS "ATP AMERICAN TOTAL PROTECTION, LLC" WITHIN A SHIELD.

CLASS 37—CONSTRUCTION AND REPAIR

FOR INSTALLATION AND MAINTENANCE OF ALARM AND SECURITY SYSTEMS (U.S. CLS. 100, 103 AND 106).

CLASS 45—PERSONAL AND LEGAL SERVICES

FOR ALARM RESPONSE AND MONITORING SERVICES (U.S. CLS. 100 AND 101).
MAYUR VAGHANI, EXAMINING ATTORNEY

SN 85-250,265. AVECTRA, INC., MCLEAN, VA. FILED 2-24-2011.

A-SCORE

THE MARK CONSISTS OF STANDARD CHARACTERS WITHOUT CLAIM TO ANY PARTICULAR FONT, STYLE, SIZE, OR COLOR.

CLASS 9—ELECTRICAL AND SCIENTIFIC APPARATUS

FOR COMPUTER SOFTWARE THAT GENERATES RANKINGS BASED ON ACTIVITIES OF ORGANIZATION MEMBERS AND DONORS, AND PROVIDES BUSINESS STRATEGY INFORMATION RELATING TO THE SAME (U.S. CLS. 21, 23, 26, 36 AND 38).

CLASS 42—SCIENTIFIC AND COMPUTER SERVICES

FOR COMPUTER SERVICES, NAMELY, PROVIDING AN ONLINE HOSTED PLATFORM THAT GENERATES RANKINGS BASED ON ACTIVITIES OF ORGANIZATION MEMBERS AND DONORS, AND PROVIDES BUSINESS STRATEGY INFORMATION RELATING TO THE SAME (U.S. CLS. 100 AND 101).
LINDA ESTRADA, EXAMINING ATTORNEY

SN 85-250,269. MARIA SNYDER INC., NEW YORK, NY. FILED 2-24-2011.



THE MARK CONSISTS OF A SHAPE INSPIRED BY THE SILHOUETTES OF TWO HUMAN HANDS EMBRACING THE GLOBE WITH THE WORDS ECOBRANDS WRITTEN ABOVE IT.

CLASS 18—LEATHER GOODS

FOR HANDBAGS; TOTE BAGS (U.S. CLS. 1, 2, 3, 22 AND 41).

CLASS 25—CLOTHING

FOR BELTS; BOTTOMS; SCARVES; SHOES; SKIRTS AND DRESSES; T-SHIRTS; TOPS (U.S. CLS. 22 AND 39).
CHRISTOPHER BUONGIORNO, EXAMINING ATTORNEY

SN 85-250,333. VOTEBLAST, INC., WEST HOLLYWOOD, CA.
FILED 2-24-2011.



THE COLOR(S) RED, YELLOW, GREEN AND BLUE IS/
ARE CLAIMED AS A FEATURE OF THE MARK.

THE MARK CONSISTS OF A RED FROWN FACE,
YELLOW NEUTRAL FACE, GREEN SMILEY FACE, AND
BLUE CIRCLE DESIGN WITH STARS. THE COLOR GRAY
APPEARS AS A SHADOW REFLECTION BEHIND THE
FACES AND CIRCLE IN THE MARK BUT IS NOT
CLAIMED AS A FEATURE OF THE MARK.

CLASS 35—ADVERTISING AND BUSINESS

FOR ADVERTISING, MARKETING AND PROMO-
TION SERVICES; MARKETING SERVICES, NAMELY,
PROMOTING THE GOODS AND SERVICES OF
OTHERS; BRAND IMAGERY CONSULTING SERVICES;
MARKET OPINION POLLING STUDIES; CONDUCTING
BUSINESS AND MARKET RESEARCH SURVEYS; PRO-
VIDING A SEARCHABLE WEBSITE FEATURING THE
GOODS AND SERVICES OF OTHER VENDORS; PRO-
VIDING A WEBSITE WHERE USERS CAN POST RAT-
INGS, REVIEWS AND RECOMMENDATIONS ON
PRODUCTS AND SERVICES FOR COMMERCIAL PUR-
POSES (U.S. CLS. 100, 101 AND 102).

CLASS 42—SCIENTIFIC AND COMPUTER SERVICES

FOR COMPUTER SERVICE, NAMELY, ACTING AS
AN APPLICATION SERVICE PROVIDER IN THE FIELD
OF INFORMATION MANAGEMENT TO HOST COMPU-
TER APPLICATION SOFTWARE FOR THE PURPOSE OF
DISPLAY, COLLECTION, EDITING, ORGANIZING,
MODIFYING, TRANSMISSION, STORAGE AND SHAR-
ING OF DATA AND INFORMATION IN THE FIELD OF
SURVEY AND OPINION SERVICES (U.S. CLS. 100 AND
101).

NATALIE POLZER, EXAMINING ATTORNEY

SN 85-250,389. VOTEBLAST, INC., WEST HOLLYWOOD, CA.
FILED 2-24-2011.

VOTEBLAST

THE MARK CONSISTS OF STANDARD CHARACTERS
WITHOUT CLAIM TO ANY PARTICULAR FONT, STYLE,
SIZE, OR COLOR.

CLASS 35—ADVERTISING AND BUSINESS

FOR ADVERTISING, MARKETING AND PROMO-
TION SERVICES; MARKETING SERVICES, NAMELY,
PROMOTING THE GOODS AND SERVICES OF
OTHERS; BRAND IMAGERY CONSULTING SERVICES;
MARKET OPINION POLLING STUDIES; CONDUCTING
BUSINESS AND MARKET RESEARCH SURVEYS; PRO-
VIDING A SEARCHABLE WEBSITE FEATURING THE
GOODS AND SERVICES OF OTHER VENDORS; PRO-
VIDING A WEBSITE WHERE USERS CAN POST RAT-
INGS, REVIEWS AND RECOMMENDATIONS ON
PRODUCTS AND SERVICES FOR COMMERCIAL PUR-
POSES (U.S. CLS. 100, 101 AND 102).

CLASS 42—SCIENTIFIC AND COMPUTER SERVICES

FOR COMPUTER SERVICE, NAMELY, ACTING AS
AN APPLICATION SERVICE PROVIDER IN THE FIELD
OF INFORMATION MANAGEMENT TO HOST COMPU-
TER APPLICATION SOFTWARE FOR THE PURPOSE OF
DISPLAY, COLLECTION, EDITING, ORGANIZING,
MODIFYING, TRANSMISSION, STORAGE AND SHAR-
ING OF DATA AND INFORMATION IN THE FIELD OF
SURVEY AND OPINION SERVICES (U.S. CLS. 100 AND
101).

NATALIE POLZER, EXAMINING ATTORNEY

SN 85-250,469. VOTEBLAST, INC., WEST HOLLYWOOD, CA.
FILED 2-24-2011.



THE MARK CONSISTS OF A FROWN FACE, NEUTRAL
FACE, SMILEY FACE, AND A CIRCLE DESIGN WITH
STARS.

CLASS 35—ADVERTISING AND BUSINESS

FOR ADVERTISING, MARKETING AND PROMO-
TION SERVICES; MARKETING SERVICES, NAMELY,
PROMOTING THE GOODS AND SERVICES OF
OTHERS; BRAND IMAGERY CONSULTING SERVICES;
MARKET OPINION POLLING STUDIES; CONDUCTING
BUSINESS AND MARKET RESEARCH SURVEYS; PRO-
VIDING A SEARCHABLE WEBSITE FEATURING THE
GOODS AND SERVICES OF OTHER VENDORS; PRO-
VIDING A WEBSITE WHERE USERS CAN POST RAT-
INGS, REVIEWS AND RECOMMENDATIONS ON
PRODUCTS AND SERVICES FOR COMMERCIAL PUR-
POSES (U.S. CLS. 100, 101 AND 102).

CLASS 42—SCIENTIFIC AND COMPUTER SERVICES

FOR COMPUTER SERVICE, NAMELY, ACTING AS
AN APPLICATION SERVICE PROVIDER IN THE FIELD
OF INFORMATION MANAGEMENT TO HOST COMPU-
TER APPLICATION SOFTWARE FOR THE PURPOSE OF
DISPLAY, COLLECTION, EDITING, ORGANIZING,
MODIFYING, TRANSMISSION, STORAGE AND SHAR-
ING OF DATA AND INFORMATION IN THE FIELD OF
SURVEY AND OPINION SERVICES (U.S. CLS. 100 AND
101).

NATALIE POLZER, EXAMINING ATTORNEY

SN 85-250,471. CRAFTJACK INC., CHICAGO, IL. FILED 2-24-2011.

SN 85-250,702. AMERICAN TEXTILE COMPANY, DUQUESNE, PA. FILED 2-24-2011.



THE COLOR(S) DARK GREY, LIGHT GREY, BLUE AND WHITE IS/ARE CLAIMED AS A FEATURE OF THE MARK. THE MARK CONSISTS OF HAMMER, SAW, PAINT BRUSH, WRENCH AND OUTLINE OF TOOLBOX ALL IN THE COLOR DARK GREY, WITH A HAND AND FOREARM IN THE COLOR BLUE, ALL BORDERED IN LIGHT GREY AND THE WORD "CRAFTJACK" IN THE COLOR BLUE APPEARS ON A WHITE BACKGROUND INSIDE THE OUTLINE OF THE TOOLBOX.

CLASS 37—CONSTRUCTION AND REPAIR

FOR BUILDING CONSTRUCTION INFORMATION; BUILDING CONSTRUCTION SERVICES; BUILDING CONSTRUCTION, REMODELING AND REPAIR; CONSTRUCTION CONSULTATION; CONSULTING IN THE FIELD OF BUILDING CONSTRUCTION; RESIDENTIAL AND BUILDING CONSTRUCTION CONSULTING (U.S. CLS. 100, 103 AND 106).

CLASS 42—SCIENTIFIC AND COMPUTER SERVICES

FOR PROVIDING A WEBSITE FEATURING TECHNOLOGY THAT ENABLES USERS TO SEEK BIDS FROM A NETWORK OF BUILDING AND CONSTRUCTION CONTRACTORS AND ACCESS AN ONLINE LEAD MANAGEMENT SERVICE (U.S. CLS. 100 AND 101).
JULIE WATSON, EXAMINING ATTORNEY

SN 85-250,677. AMERICAN TEXTILE COMPANY, DUQUESNE, PA. FILED 2-24-2011.



THE COLOR(S) BLUE, RED AND WHITE IS/ARE CLAIMED AS A FEATURE OF THE MARK. THE MARK CONSISTS OF THE LETTERS "PR" IN BLUE BLOCK TYPE FOLLOWED BY A RED CIRCLE WITH A WHITE CROSS THEREIN REPRESENTING THE LETTER "O" FOLLOWED BY THE LETTERS "CARE" IN BLUE BLOCK TYPE.

CLASS 20—FURNITURE AND ARTICLES NOT OTHERWISE CLASSIFIED

FOR PILLOWS (U.S. CLS. 2, 13, 22, 25, 32 AND 50).

CLASS 24—FABRICS

FOR PILLOW COVERS, MATTRESS COVERS, BOX SPRING COVERS, MATTRESS PADS, BLANKETS, COMFORTERS AND SHEETS (U.S. CLS. 42 AND 50).
PATRICIA EVANKO, EXAMINING ATTORNEY



THE COLOR(S) GREEN AND MAGENTA IS/ARE CLAIMED AS A FEATURE OF THE MARK.

THE MARK CONSISTS OF THE WORD "NATURES" IN GREEN SCRIPT TYPE, TO THE RIGHT OF THE WORD "NATURES," A FLOWER DESIGN IN MAGENTA, AND TO THE RIGHT OF THE FLOWER DESIGN THE WORD "HARMONY" IN GREEN SCRIPT TYPE.

CLASS 20—FURNITURE AND ARTICLES NOT OTHERWISE CLASSIFIED

FOR PILLOWS (U.S. CLS. 2, 13, 22, 25, 32 AND 50).

CLASS 24—FABRICS

FOR PILLOW COVERS, MATTRESS COVERS, BOX SPRING COVERS, MATTRESS PADS, BLANKETS, COMFORTERS AND SHEETS (U.S. CLS. 42 AND 50).
PATRICIA EVANKO, EXAMINING ATTORNEY

SN 85-250,720. AMERICAN TEXTILE COMPANY, DUQUESNE, PA. FILED 2-24-2011.



THE COLOR(S) GRAY, RED AND BLUE IS/ARE CLAIMED AS A FEATURE OF THE MARK.

THE MARK CONSISTS OF THE EXPRESSION "TEMP-A-TRUE" IN GRAY BLOCK TYPE ABOVE WHICH ARE TWO ARCULATE ARROWS, A LOWER ARROW IN RED FORMING A U-SHAPED CONFIGURATION, AND AN UPPER ARROW CONSISTING OF A BLUE INVERTED U-SHAPED CONFIGURATION WITH THE POINT OF THE BLUE ARROW POINTING TOWARD THE CENTER OF THE RED ARROW.

CLASS 20—FURNITURE AND ARTICLES NOT OTHERWISE CLASSIFIED

FOR PILLOWS (U.S. CLS. 2, 13, 22, 25, 32 AND 50).

CLASS 24—FABRICS

FOR PILLOW COVERS, MATTRESS COVERS, BOX SPRING COVERS, MATTRESS PADS, BLANKETS, COMFORTERS AND SHEETS (U.S. CLS. 42 AND 50).
PATRICIA EVANKO, EXAMINING ATTORNEY

SN 85-250,752. EBEVSOLUTIONS, LLC, FT. MYERS, FL.
FILED 2-24-2011.

SN 85-250,762. THE ARELI GROUP, LLC, BLOOMSBURY,
NJ. FILED 2-24-2011.

EBEVSEEKER

THE MARK CONSISTS OF STANDARD CHARACTERS WITHOUT CLAIM TO ANY PARTICULAR FONT, STYLE, SIZE, OR COLOR.

CLASS 9—ELECTRICAL AND SCIENTIFIC APPARATUS

FOR COMPUTER APPLICATION SOFTWARE FOR MOBILE PHONES, HANDHELD COMPUTERS, PERSONAL COMPUTERS AND WEBSITES, NAMELY, SOFTWARE THAT ALLOWS CONSUMERS TO REGISTER THEIR PREFERENCES FOR PRODUCTS AND BEVERAGES, LOCATIONS WHERE SUCH PRODUCTS AND BEVERAGES ARE SERVED, AND NOTIFICATIONS OF PROMOTIONS, DISCOUNTS, AND LOCATIONS FOR SUCH PRODUCTS AND BEVERAGES; DOWNLOADABLE SOFTWARE IN THE NATURE OF A MOBILE APPLICATION FOR SOFTWARE THAT ALLOWS CONSUMERS TO REGISTER THEIR PREFERENCES FOR PRODUCTS AND BEVERAGES, LOCATIONS WHERE SUCH PRODUCTS AND BEVERAGES ARE SERVED, AND NOTIFICATIONS OF PROMOTIONS, DISCOUNTS, AND LOCATIONS FOR SUCH PRODUCTS AND BEVERAGES (U.S. CLS. 21, 23, 26, 36 AND 38).

CLASS 35—ADVERTISING AND BUSINESS

FOR PROVIDING AN INTERNET WEBSITE PORTAL FEATURING PROMOTION AND ADVERTISING FOR CONSUMERS TO REGISTER THEIR PREFERENCES FOR PRODUCTS AND BEVERAGES, TO IDENTIFY LOCATIONS WHERE SUCH PRODUCTS AND BEVERAGES ARE SERVED, AND TO RECEIVE NOTIFICATIONS OF PROMOTIONS, DISCOUNTS, AND LOCATIONS FOR SUCH PRODUCTS AND BEVERAGES VIA EMAIL, TEXT, AND SOCIAL NETWORK SITES, UTILIZING A SOFTWARE APPLICATION WHEREBY CONSUMERS ARE ELIGIBLE TO RECEIVE PROMOTIONAL ITEMS CONSISTING OF COUPONS, DISCOUNTS OR SPECIAL OFFERINGS ON GOODS AND/OR SERVICE PROVIDED BY OTHERS; ADVERTISING SERVICES, NAMELY, PROMOTING THE BRANDS, GOODS AND SERVICES OF OTHERS (U.S. CLS. 100, 101 AND 102).

CLASS 42—SCIENTIFIC AND COMPUTER SERVICES

FOR PROVIDING AN ONLINE NON-DOWNLOADABLE INTERNET-BASED SYSTEM APPLICATION FEATURING TECHNOLOGY ENABLING USERS TO REGISTER THEIR PREFERENCES FOR PRODUCTS AND BEVERAGES, TO IDENTIFY LOCATIONS WHERE SUCH PRODUCTS AND BEVERAGES ARE SERVED, AND TO RECEIVE NOTIFICATIONS OF PROMOTIONS, DISCOUNTS, AND LOCATIONS FOR SUCH PRODUCTS AND BEVERAGES VIA EMAIL, TEXT, AND SOCIAL NETWORK SITES; PROVIDING A WEBSITE FEATURING NON-DOWNLOADABLE SOFTWARE FOR CONSUMERS TO REGISTER THEIR PREFERENCES FOR PRODUCTS AND BEVERAGES, TO IDENTIFY LOCATIONS WHERE SUCH PRODUCTS AND BEVERAGES ARE SERVED, AND TO RECEIVE NOTIFICATIONS OF PROMOTIONS, DISCOUNTS, AND LOCATIONS FOR SUCH PRODUCTS AND BEVERAGES VIA EMAIL, TEXT, AND SOCIAL NETWORK SITES (U.S. CLS. 100 AND 101).

ANGELA M. MICHELI, EXAMINING ATTORNEY

PROMOVERSE

THE MARK CONSISTS OF STANDARD CHARACTERS WITHOUT CLAIM TO ANY PARTICULAR FONT, STYLE, SIZE, OR COLOR.

CLASS 9—ELECTRICAL AND SCIENTIFIC APPARATUS

FOR COMPUTER SOFTWARE FOR USE IN DISTRIBUTING ADVERTISING AND PROMOTIONAL INFORMATION (U.S. CLS. 21, 23, 26, 36 AND 38).

CLASS 35—ADVERTISING AND BUSINESS

FOR ADVERTISING SERVICES (U.S. CLS. 100, 101 AND 102).
ANGELA M. MICHELI, EXAMINING ATTORNEY

SN 85-250,852. VON FLOTOW, ANDREAS H., HOOD RIVER,
OR. FILED 2-24-2011.

Hood Scientific

THE MARK CONSISTS OF STANDARD CHARACTERS WITHOUT CLAIM TO ANY PARTICULAR FONT, STYLE, SIZE, OR COLOR.

NO CLAIM IS MADE TO THE EXCLUSIVE RIGHT TO USE "SCIENTIFIC", APART FROM THE MARK AS SHOWN.

CLASS 9—ELECTRICAL AND SCIENTIFIC APPARATUS

FOR ELECTRONIC DIAGNOSTIC MONITOR THAT SENSES THE VIBRATION, POSITION, TIMING, AND SPEED OF TURBOMACHINERY (U.S. CLS. 21, 23, 26, 36 AND 38).

CLASS 42—SCIENTIFIC AND COMPUTER SERVICES

FOR TECHNICAL MONITORING SERVICES, NAMELY, ON-SITE TESTING AND ANALYSIS OF TURBOMACHINERY AND REPORTING THE TECHNICAL TESTING RESULTS (U.S. CLS. 100 AND 101).

BRIAN PINO, EXAMINING ATTORNEY

SN 85-250,856. THERMAL INDUSTRIES, INC., PITTSBURGH, PA. FILED 2-24-2011.

24 HOUR ROOM

THE MARK CONSISTS OF STANDARD CHARACTERS WITHOUT CLAIM TO ANY PARTICULAR FONT, STYLE, SIZE, OR COLOR.

NO CLAIM IS MADE TO THE EXCLUSIVE RIGHT TO USE "ROOM", APART FROM THE MARK AS SHOWN.

CLASS 6—METAL GOODS

FOR METALLIC WALL AND ROOF PANELS, SUPPORT BEAMS AND METALLIC HARDWARE, NAMELY, HINGES, HANDLES FOR WINDOWS AND DOORS AND LOCKS (U.S. CLS. 2, 12, 13, 14, 23, 25 AND 50).

FIRST USE 10-21-2009; IN COMMERCE 10-21-2009.

CLASS 19—NON-METALLIC BUILDING MATERIALS

FOR NON-METALLIC PATIO ENCLOSURES, NAMELY, WINDOW WALLS, ALL DOOR WALLS, DOORS, WINDOWS, WALL AND ROOF PANELS, SKYLIGHTS; NON-METAL WINDOWS, DOORS AND PARTS THEREOF PARTIALLY CONSTRUCTED OF VINYL (U.S. CLS. 1, 12, 33 AND 50).

FIRST USE 10-21-2009; IN COMMERCE 10-21-2009.

DOUGLAS LEE, EXAMINING ATTORNEY

SN 85-250,979. BRICKELL FINANCIAL SERVICES-MOTOR CLUB, INC., MIAMI, FL. FILED 2-24-2011.

LOCATEME

THE MARK CONSISTS OF STANDARD CHARACTERS WITHOUT CLAIM TO ANY PARTICULAR FONT, STYLE, SIZE, OR COLOR.

CLASS 37—CONSTRUCTION AND REPAIR

FOR EMERGENCY ROADSIDE REPAIR SERVICES; AUTOMOTIVE REPAIRS, NAMELY, EMERGENCY ROADSIDE ASSISTANCE SERVICES, NAMELY RESPONDING TO CALLS FOR ROADSIDE ASSISTANCE, FLAT TIRE CHANGING, EMERGENCY FUEL SUPPLYING AND BATTERY JUMP STARTING; WINDSHIELD REPAIR AND DENT REMOVAL (U.S. CLS. 100, 103 AND 106).

CLASS 39—TRANSPORTATION AND STORAGE

FOR EMERGENCY ROADSIDE ASSISTANCE SERVICES, NAMELY TOWING, WINCH-OUT AND KEY DELIVERY SERVICES (U.S. CLS. 100 AND 105).

CLASS 45—PERSONAL AND LEGAL SERVICES

FOR VEHICLE AND MOTORIST LOCATOR SERVICE USING GLOBAL POSITIONING SYSTEMS (GPS), CELLULAR TELECOMMUNICATIONS, AND LANDLINE TELEPHONE COMMUNICATIONS; EMERGENCY ROADSIDE ASSISTANCE SERVICES, NAMELY, OPENING OF LOCKS (U.S. CLS. 100 AND 101).

ROSELLE HERRERA, EXAMINING ATTORNEY

SN 85-250,993. AB DISTRIBUTING, LLC, BENTONVILLE, AR. FILED 2-24-2011.



OWNER OF U.S. REG. NOS. 3,505,104 AND 3,898,152.

NO CLAIM IS MADE TO THE EXCLUSIVE RIGHT TO USE "FARMS", APART FROM THE MARK AS SHOWN.

THE MARK CONSISTS OF THE WORDS "ARCADIA FARMS" WITH FLOWERS EXTENDING FROM THE FIRST "A" IN "ARCADIA".

CLASS 30—STAPLE FOODS

FOR TEA (U.S. CL. 46).

FIRST USE 5-31-2007; IN COMMERCE 5-31-2007.

CLASS 32—LIGHT BEVERAGES

FOR PUNCH; LEMONADE (U.S. CLS. 45, 46 AND 48).

FIRST USE 6-6-2010; IN COMMERCE 6-6-2010.

AMY KERTGATE, EXAMINING ATTORNEY

SN 85-251,046. HLT DOMESTIC IP LLC, MCLEAN, VA. FILED 2-24-2011.

DOUBLETREE CONNECT

THE MARK CONSISTS OF STANDARD CHARACTERS WITHOUT CLAIM TO ANY PARTICULAR FONT, STYLE, SIZE, OR COLOR.

OWNER OF U.S. REG. NOS. 1,094,809 AND 2,278,133.

CLASS 9—ELECTRICAL AND SCIENTIFIC APPARATUS

FOR DOWNLOADABLE ELECTRONIC NEWSLETTERS FEATURING HOTEL NEWS AND INFORMATION (U.S. CLS. 21, 23, 26, 36 AND 38).

CLASS 41—EDUCATION AND ENTERTAINMENT

FOR ONLINE ELECTRONIC NEWSLETTERS FEATURING HOTEL NEWS AND INFORMATION (U.S. CLS. 100, 101 AND 107).

ANGELA DUONG, EXAMINING ATTORNEY

SN 85-251,061. CUSTOMCALL DATA SYSTEMS, INC., MADISON, WI. FILED 2-24-2011.

SN 85-251,140. ROLAND E. WHEELER JR., WENATCHEE, WA. FILED 2-24-2011.

WEBTOP BPM

THE MARK CONSISTS OF STANDARD CHARACTERS WITHOUT CLAIM TO ANY PARTICULAR FONT, STYLE, SIZE, OR COLOR.

OWNER OF U.S. REG. NOS. 3,621,156 AND 3,621,158. SEC. 2(F).

CLASS 9—ELECTRICAL AND SCIENTIFIC APPARATUS

FOR COMPUTER SOFTWARE AND HARDWARE FOR USE IN CREATING, MAINTAINING AND MANAGING ACCOUNT MANAGEMENT SYSTEMS, OPERATIONAL SUPPORT SYSTEMS AND BILLING SYSTEMS BY CUSTOMERS AND COMPANIES IN THE TELECOMMUNICATIONS INDUSTRY (U.S. CLS. 21, 23, 26, 36 AND 38). FIRST USE 9-30-2005; IN COMMERCE 9-30-2005.

CLASS 42—SCIENTIFIC AND COMPUTER SERVICES

FOR APPLICATION SERVICE PROVIDER (ASP) FEATURING SOFTWARE FOR USE IN CREATING, MAINTAINING AND MANAGING ACCOUNT MANAGEMENT SYSTEMS, OPERATIONAL SUPPORT SYSTEMS AND BILLING SYSTEMS BY CUSTOMERS AND COMPANIES IN THE TELECOMMUNICATIONS INDUSTRY (U.S. CLS. 100 AND 101).

FIRST USE 9-30-2005; IN COMMERCE 9-30-2005. BRIAN NEVILLE, EXAMINING ATTORNEY

SN 85-251,063. ELITE GUDZ CORP., FARMINGDALE, NY. FILED 2-24-2011.



THE MARK CONSISTS OF THE STYLIZED TEXT "ELITE GUDZ" WITH THE WORD "GUDZ" UNDERLINED.

CLASS 16—PAPER GOODS AND PRINTED MATTER

FOR COMIC BOOKS (U.S. CLS. 2, 5, 22, 23, 29, 37, 38 AND 50). FIRST USE 7-18-2008; IN COMMERCE 7-18-2008.

CLASS 25—CLOTHING

FOR HATS; TEE SHIRTS (U.S. CLS. 22 AND 39). FIRST USE 7-18-2008; IN COMMERCE 7-18-2008. BRIAN NEVILLE, EXAMINING ATTORNEY

WHATILIKE

THE MARK CONSISTS OF STANDARD CHARACTERS WITHOUT CLAIM TO ANY PARTICULAR FONT, STYLE, SIZE, OR COLOR.

CLASS 35—ADVERTISING AND BUSINESS

FOR ONLINE SERVICES FOR CONNECTING SOCIAL NETWORK USERS WITH RETAILERS FOR THE PURPOSE OF OBTAINING LISTS OF A WIDE VARIETY OF CONSUMER PRODUCTS AND SERVICES SELECTED BY OTHERS, PROVIDING GIFT IDEAS, OFFERING ADVERTISING TO OTHERS, AND FACILITATING DISCOUNTED PURCHASES; ADVERTISING SERVICES, NAMELY, PROVIDING INFORMATION AS TO THE AVAILABILITY OF A WIDE VARIETY OF CONSUMER GOODS AND SERVICES FOR RENT OR PURCHASE; ADVICE AND INFORMATION ABOUT CUSTOMER SERVICES, PRODUCT MANAGEMENT, AND PRICES ON INTERNET SITES IN CONNECTION WITH PURCHASES MADE OVER THE INTERNET; COMMERCIAL EVALUATION AND RATING OF CONSUMER GOODS FOR OTHERS PRIOR TO PURCHASE; ONLINE MONITORING AND TRACKING FOR OTHERS OF PURCHASED CONSUMER GOODS AND SERVICES, ORDER FULFILLMENT, AND PACKAGE SHIPMENTS; ONLINE RETAIL STORE SERVICES FEATURING A WIDE VARIETY OF CONSUMER GOODS OF OTHERS; PROVIDING A WEBSITE FEATURING PRODUCT RATINGS OF A WIDE VARIETY OF CONSUMER GOODS OF OTHERS; PROVIDING A WEBSITE WHERE USERS CAN POST RATINGS, REVIEWS AND RECOMMENDATIONS ON A WIDE VARIETY OF CONSUMER PRODUCTS AND SERVICES FOR COMMERCIAL PURPOSES (U.S. CLS. 100, 101 AND 102).

CLASS 42—SCIENTIFIC AND COMPUTER SERVICES

FOR COMPUTER SERVICES IN THE NATURE OF CUSTOMIZED WEB PAGES FEATURING USER-DEFINED INFORMATION AND PERSONAL PROFILES; PROVIDING A WEBSITE THAT GIVES USERS THE ABILITY TO CREATE CUSTOMIZED WEB PAGES FEATURING USER-DEFINED PROFILES (U.S. CLS. 100 AND 101).

SEAN CROWLEY, EXAMINING ATTORNEY

SN 85-251,160. KERZNER INTERNATIONAL LIMITED, NASSAU, BAHAMAS, FILED 2-24-2011.

ONE & ONLY MOMENTS

THE MARK CONSISTS OF STANDARD CHARACTERS WITHOUT CLAIM TO ANY PARTICULAR FONT, STYLE, SIZE, OR COLOR.

OWNER OF U.S. REG. NOS. 2,889,998, 3,951,139 AND OTHERS.

CLASS 41—EDUCATION AND ENTERTAINMENT

FOR HEALTH CLUB SERVICES, NAMELY, PROVIDING INSTRUCTION AND EQUIPMENT IN THE FIELD OF PHYSICAL EXERCISE; PROVIDING SPORTS FACILITIES AND TENNIS COURT FACILITIES; ENTERTAINMENT IN THE NATURE OF GOLF AND TENNIS TOURNAMENTS; GOLF CLUB SERVICES; GOLF CADIE SERVICES (U.S. CLS. 100, 101 AND 107).

CLASS 43—HOTEL AND RESTAURANT SERVICES

FOR PROVIDING RESORT HOTELS AND LODGING SERVICES; RESTAURANT AND BAR SERVICES (U.S. CLS. 100 AND 101).

CLASS 44—MEDICAL, BEAUTY AND AGRICULTURAL SERVICES

FOR HEALTH SPA SERVICES, NAMELY, COSMETIC BODY CARE SERVICES; BEAUTY SALON SERVICES; MAKING RESERVATIONS AND BOOKINGS FOR OTHERS FOR TREATMENTS AT HEALTH SPAS AND BEAUTY SALONS (U.S. CLS. 100 AND 101).

BRENDAN REGAN, EXAMINING ATTORNEY

SN 85-251,165. ROLAND E. WHEELER JR., WENATCHEE, WA. FILED 2-24-2011.

YOUMIGHTLIKE

THE MARK CONSISTS OF STANDARD CHARACTERS WITHOUT CLAIM TO ANY PARTICULAR FONT, STYLE, SIZE, OR COLOR.

CLASS 35—ADVERTISING AND BUSINESS

FOR ONLINE SERVICES FOR CONNECTING SOCIAL NETWORK USERS WITH RETAILERS FOR THE PURPOSE OF OBTAINING LISTS OF A WIDE VARIETY OF CONSUMER PRODUCTS AND SERVICES SELECTED BY OTHERS, PROVIDING GIFT IDEAS, OFFERING ADVERTISING TO OTHERS, AND FACILITATING DISCOUNTED PURCHASES; ADVERTISING SERVICES, NAMELY, PROVIDING INFORMATION AS TO THE AVAILABILITY OF A WIDE VARIETY OF CONSUMER GOODS AND SERVICES FOR RENT OR PURCHASE; ADVICE AND INFORMATION ABOUT CUSTOMER SERVICES, PRODUCT MANAGEMENT, AND PRICES ON INTERNET SITES IN CONNECTION WITH PURCHASES MADE OVER THE INTERNET; COMMERCIAL EVALUATION AND RATING OF CONSUMER GOODS FOR OTHERS PRIOR TO PURCHASE; ONLINE MONITORING AND TRACKING FOR OTHERS OF PURCHASED CONSUMER GOODS AND SERVICES, ORDER FULFILLMENT, AND PACKAGE SHIPMENTS; ONLINE RETAIL STORE SERVICES FEATURING A WIDE VARIETY OF CONSUMER GOODS OF OTHERS; PROVIDING A WEBSITE FEATURING PRODUCT RATINGS OF A WIDE VARIETY OF CONSUMER GOODS OF OTHERS; PROVIDING A WEBSITE WHERE USERS CAN POST RATINGS, REVIEWS AND RECOMMENDATIONS ON A WIDE VARIETY OF CONSUMER PRODUCTS AND SERVICES FOR COMMERCIAL PURPOSES (U.S. CLS. 100, 101 AND 102).

CLASS 42—SCIENTIFIC AND COMPUTER SERVICES

FOR COMPUTER SERVICES IN THE NATURE OF CUSTOMIZED WEB PAGES FEATURING USER-DEFINED INFORMATION AND PERSONAL PROFILES PROVIDING A WEBSITE THAT GIVES USERS THE ABILITY TO CREATE CUSTOMIZED WEB PAGES FEATURING USER-DEFINED PROFILES (U.S. CLS. 100 AND 101).

SEAN CROWLEY, EXAMINING ATTORNEY

SN 85-251,184. ROLAND E. WHEELER JR., WENATCHEE, WA. FILED 2-24-2011.

DOYOULIKE

THE MARK CONSISTS OF STANDARD CHARACTERS WITHOUT CLAIM TO ANY PARTICULAR FONT, STYLE, SIZE, OR COLOR.

CLASS 35—ADVERTISING AND BUSINESS

FOR ONLINE SERVICES FOR CONNECTING SOCIAL NETWORK USERS WITH RETAILERS FOR THE PURPOSE OF OBTAINING LISTS OF A WIDE VARIETY OF CONSUMER PRODUCTS AND SERVICES SELECTED BY OTHERS, PROVIDING GIFT IDEAS, OFFERING ADVERTISING TO OTHERS, AND FACILITATING DISCOUNTED PURCHASES; ADVERTISING SERVICES, NAMELY, PROVIDING INFORMATION AS TO THE AVAILABILITY OF A WIDE VARIETY OF CONSUMER GOODS AND SERVICES FOR RENT OR PURCHASE; ADVICE AND INFORMATION ABOUT CUSTOMER SERVICES, PRODUCT MANAGEMENT, AND PRICES ON INTERNET SITES IN CONNECTION WITH PURCHASES MADE OVER THE INTERNET; COMMERCIAL EVALUATION AND RATING OF CONSUMER GOODS FOR OTHERS PRIOR TO PURCHASE; ONLINE MONITORING AND TRACKING FOR OTHERS OF PURCHASED CONSUMER GOODS AND SERVICES, ORDER FULFILLMENT, AND PACKAGE SHIPMENTS; ONLINE RETAIL STORE SERVICES FEATURING A WIDE VARIETY OF CONSUMER GOODS OF OTHERS; PROVIDING A WEBSITE FEATURING PRODUCT RATINGS OF A WIDE VARIETY OF CONSUMER GOODS OF OTHERS; PROVIDING A WEBSITE WHERE USERS CAN POST RATINGS, REVIEWS AND RECOMMENDATIONS ON A WIDE VARIETY OF CONSUMER PRODUCTS AND SERVICES FOR COMMERCIAL PURPOSES (U.S. CLS. 100, 101 AND 102).

CLASS 42—SCIENTIFIC AND COMPUTER SERVICES

FOR COMPUTER SERVICES IN THE NATURE OF CUSTOMIZED WEB PAGES FEATURING USER-DEFINED INFORMATION AND PERSONAL PROFILES PROVIDING A WEBSITE THAT GIVES USERS THE ABILITY TO CREATE CUSTOMIZED WEB PAGES FEATURING USER-DEFINED PROFILES (U.S. CLS. 100 AND 101).

SEAN CROWLEY, EXAMINING ATTORNEY

SN 85-251,185. KERZNER INTERNATIONAL LIMITED, NASSAU, BAHAMAS, FILED 2-24-2011.

SUMMER MOMENTS

THE MARK CONSISTS OF STANDARD CHARACTERS WITHOUT CLAIM TO ANY PARTICULAR FONT, STYLE, SIZE, OR COLOR.

CLASS 41—EDUCATION AND ENTERTAINMENT

FOR HEALTH CLUB SERVICES, NAMELY, PROVIDING INSTRUCTION AND EQUIPMENT IN THE FIELD OF PHYSICAL EXERCISE; PROVIDING SPORTS FACILITIES AND TENNIS COURT FACILITIES; ENTERTAINMENT IN THE NATURE OF GOLF AND TENNIS TOURNAMENTS; GOLF CLUB SERVICES; GOLF CADIE SERVICES (U.S. CLS. 100, 101 AND 107).

CLASS 43—HOTEL AND RESTAURANT SERVICES

FOR PROVIDING RESORT HOTELS AND LODGING SERVICES; RESTAURANT AND BAR SERVICES (U.S. CLS. 100 AND 101).

CLASS 44—MEDICAL, BEAUTY AND AGRICULTURAL SERVICES

FOR HEALTH SPA SERVICES, NAMELY, COSMETIC BODY CARE SERVICES; BEAUTY SALON SERVICES; MAKING RESERVATIONS AND BOOKINGS FOR OTHERS FOR TREATMENTS AT HEALTH SPAS AND BEAUTY SALONS (U.S. CLS. 100 AND 101).
BRENDAN REGAN, EXAMINING ATTORNEY

SN 85-251,206. ROLAND E. WHEELER JR., WENATCHEE, WA. FILED 2-24-2011.

URGONNALIKE

THE MARK CONSISTS OF STANDARD CHARACTERS WITHOUT CLAIM TO ANY PARTICULAR FONT, STYLE, SIZE, OR COLOR.

CLASS 35—ADVERTISING AND BUSINESS

FOR ONLINE SERVICES FOR CONNECTING SOCIAL NETWORK USERS WITH RETAILERS FOR THE PURPOSE OF OBTAINING LISTS OF A WIDE VARIETY OF CONSUMER PRODUCTS AND SERVICES SELECTED BY OTHERS, PROVIDING GIFT IDEAS, OFFERING ADVERTISING TO OTHERS, AND FACILITATING DISCOUNTED PURCHASES; ADVERTISING SERVICES, NAMELY, PROVIDING INFORMATION AS TO THE AVAILABILITY OF A WIDE VARIETY OF CONSUMER GOODS AND SERVICES FOR RENT OR PURCHASE; ADVICE AND INFORMATION ABOUT CUSTOMER SERVICES, PRODUCT MANAGEMENT, AND PRICES ON INTERNET SITES IN CONNECTION WITH PURCHASES MADE OVER THE INTERNET; COMMERCIAL EVALUATION AND RATING OF CONSUMER GOODS FOR OTHERS PRIOR TO PURCHASE; ONLINE MONITORING AND TRACKING FOR OTHERS OF PURCHASED CONSUMER GOODS AND SERVICES; ORDER FULFILLMENT, AND PACKAGE SHIPMENTS; ONLINE RETAIL STORE SERVICES FEATURING A WIDE VARIETY OF CONSUMER GOODS OF OTHERS; PROVIDING A WEBSITE FEATURING PRODUCT RATINGS OF A WIDE VARIETY OF CONSUMER GOODS OF OTHERS; PROVIDING A WEBSITE WHERE USERS CAN POST RATINGS, REVIEWS AND RECOMMENDATIONS ON A WIDE VARIETY OF CONSUMER PRODUCTS AND SERVICES FOR COMMERCIAL PURPOSES (U.S. CLS. 100, 101 AND 102).

CLASS 42—SCIENTIFIC AND COMPUTER SERVICES

FOR COMPUTER SERVICES IN THE NATURE OF CUSTOMIZED WEB PAGES FEATURING USER-DEFINED INFORMATION AND PERSONAL PROFILES; PROVIDING A WEBSITE THAT GIVES USERS THE ABILITY TO CREATE CUSTOMIZED WEB PAGES FEATURING USER-DEFINED PROFILES (U.S. CLS. 100 AND 101).
SEAN CROWLEY, EXAMINING ATTORNEY

SN 85-251,246. SWEET VALOR LLC, ENGLEWOOD, CO. FILED 2-24-2011.

BRAVIO

THE MARK CONSISTS OF STANDARD CHARACTERS WITHOUT CLAIM TO ANY PARTICULAR FONT, STYLE, SIZE, OR COLOR.

THE ENGLISH TRANSLATION OF "BRAVIO" IN THE MARK IS "FIERCE"; "FEROCITY".

CLASS 30—STAPLE FOODS

FOR CHOCOLATE; CHOCOLATE AND CHOCOLATES; CHOCOLATE BARS; CHOCOLATE CANDIES; CHOCOLATE CONFECTIONS; CHOCOLATE FOR CONFECTIONERY AND BREAD; CHOCOLATE TRUFFLES; CHOCOLATE-BASED READY-TO-EAT FOOD BARS; CHOCOLATES AND CHOCOLATE BASED READY TO EAT CANDIES AND SNACKS; CHOCOLATES CONTAINING NUTRIENTS; CONFECTIONERIES, NAMELY, SNACK FOODS, NAMELY, CHOCOLATE; FILLED CHOCOLATE; MILK CHOCOLATE; SNACK FOODS, NAMELY, CHOCOLATE-BASED SNACK FOODS (U.S. CL. 46).

CLASS 35—ADVERTISING AND BUSINESS

FOR ON-LINE WHOLESALE AND RETAIL STORE SERVICES FEATURING CHOCOLATE PRODUCTS AND CONFECTIONS, ALL WITH A PATRIOTIC THEME; ONLINE RETAIL SERVICES THROUGH DIRECT SOLICITATION BY SALESPERSONS DIRECTED TO END-USERS CONSISTING OF CHOCOLATE PRODUCTS AND CONFECTIONS, ALL WITH A PATRIOTIC THEME; PROMOTING AND SHOWCASING THE GOODS OF OTHERS IN THE FIELD OF CHOCOLATE CONFECTIONS, ALL WITH A PATRIOTIC THEME. BY MEANS OF AN ON-LINE SHOPPING SITE WITH LINKS TO THE RETAIL ADVERTISEMENTS OF OTHERS (U.S. CLS. 100, 101 AND 102).

ALEXANDER L. POWERS, EXAMINING ATTORNEY

SN 85-251,706. GROUP LOGIC, INC., ARLINGTON, VA. FILED 2-25-2011.

mobilEcho

THE MARK CONSISTS OF STANDARD CHARACTERS WITHOUT CLAIM TO ANY PARTICULAR FONT, STYLE, SIZE, OR COLOR.

SN 85-251,469. INTERNATIONAL ASSOCIATION FOR HEALTHCARE SECURITY AND SAFETY, INC., GLENDALE HEIGHTS, IL. FILED 2-25-2011.



OWNER OF U.S. REG. NOS. 1,830,733 AND 1,832,718. NO CLAIM IS MADE TO THE EXCLUSIVE RIGHT TO USE "INTERNATIONAL ASSOCIATION FOR HEALTHCARE SECURITY & SAFETY", APART FROM THE MARK AS SHOWN.

THE COLOR(S) BLUE, MAGENTA AND YELLOW IS/ARE CLAIMED AS A FEATURE OF THE MARK.

THE MARK CONSISTS OF THE LETTERS "IAHSS" IN MAGENTA OVER "INTERNATIONAL ASSOCIATION FOR HEALTHCARE SECURITY & SAFETY" IN YELLOW. ALL TO THE RIGHT OF A STYLISTIC DEPICTION OF A PORTION OF THE EARTH WITH THE CONTINENTS IN YELLOW, THE BODIES OF WATER IN BLUE AND A MAGENTA LINE CUTTING OFF THE LEFT PART OF THE GLOBE

CLASS 9—ELECTRICAL AND SCIENTIFIC APPARATUS

FOR COMPUTER PROGRAMS FOR USE IN TESTING KNOWLEDGE ABOUT HEALTHCARE SECURITY AND SAFETY ISSUES AND MAINTENANCE OF SECURITY AND SAFETY AT HEALTHCARE FACILITIES, AND USER MANUALS SOLD THEREWITH (U.S. CLS. 21, 23, 26, 36 AND 38).

CLASS 16—PAPER GOODS AND PRINTED MATTER

FOR JOURNALS, NEWSLETTERS, EDUCATIONAL AND INSTRUCTIONAL MANUALS, PRINTED TESTS, STUDY GUIDES AND PRINTED APPLICATIONS AND PRINTED DIRECTORIES FEATURING HEALTHCARE SECURITY AND SAFETY ISSUES (U.S. CLS. 2, 5, 22, 23, 29, 37, 38 AND 50).

CLASS 41—EDUCATION AND ENTERTAINMENT

FOR EDUCATIONAL SERVICES; NAMELY, CONDUCTING EDUCATIONAL PROGRAMS IN THE AREA OF HEALTHCARE SECURITY AND SAFETY (U.S. CLS. 100, 101 AND 107).

MICHAEL WEBSTER, EXAMINING ATTORNEY

CLASS 9—ELECTRICAL AND SCIENTIFIC APPARATUS

FOR COMPUTER SOFTWARE FOR BUSINESSES THAT ALLOWS USERS TO PERFORM ELECTRONIC BUSINESS TRANSACTIONS, COMMUNICATE WITH OTHER USERS, AND ACCESS AND EXCHANGE INFORMATION STORED ON A FILE SERVER VIA MOBILE DEVICES AND TABLET COMPUTERS (U.S. CLS. 21, 23, 26, 36 AND 38).

CLASS 42—SCIENTIFIC AND COMPUTER SERVICES

FOR WEB-BASED SOFTWARE SERVICES, NAMELY, SUBSCRIPTION-BASED APPLICATION SERVICE PROVIDER (ASP) FEATURING SOFTWARE FOR BUSINESSES THAT ALLOWS USERS TO PERFORM ELECTRONIC BUSINESS TRANSACTIONS, COMMUNICATE WITH OTHER USERS, AND ACCESS AND EXCHANGE INFORMATION STORED ON A FILE SERVER VIA MOBILE DEVICES AND TABLET COMPUTERS (U.S. CLS. 100 AND 101).

TINA MAI, EXAMINING ATTORNEY

SN 85-251,707. GROUP LOGIC, INC., ARLINGTON, VA. FILED 2-25-2011.

cloudEcho

THE MARK CONSISTS OF STANDARD CHARACTERS WITHOUT CLAIM TO ANY PARTICULAR FONT, STYLE, SIZE, OR COLOR.

CLASS 9—ELECTRICAL AND SCIENTIFIC APPARATUS

FOR COMPUTER SOFTWARE FOR BUSINESSES THAT ALLOWS USERS TO PERFORM ELECTRONIC BUSINESS TRANSACTIONS, COMMUNICATE WITH OTHER USERS, AND ACCESS AND EXCHANGE INFORMATION STORED ON A FILE SERVER VIA MOBILE DEVICES AND TABLET COMPUTERS (U.S. CLS. 21, 23, 26, 36 AND 38).

CLASS 42—SCIENTIFIC AND COMPUTER SERVICES

FOR WEB-BASED SOFTWARE SERVICES, NAMELY, SUBSCRIPTION-BASED APPLICATION SERVICE PROVIDER (ASP) FEATURING SOFTWARE FOR BUSINESSES THAT ALLOWS USERS TO PERFORM ELECTRONIC BUSINESS TRANSACTIONS, COMMUNICATE WITH OTHER USERS, AND ACCESS AND EXCHANGE INFORMATION STORED ON A FILE SERVER VIA MOBILE DEVICES AND TABLET COMPUTERS (U.S. CLS. 100 AND 101).

TINA MAI, EXAMINING ATTORNEY

SN 85-252,462. ARCH, ELIZABETH K., AKA LIZ ARCH, VENICE, CA. FILED 2-26-2011.



NO CLAIM IS MADE TO THE EXCLUSIVE RIGHT TO USE "YOGA", APART FROM THE MARK AS SHOWN.

THE NAME IN THE MARK REFERS TO A LIVING INDIVIDUAL WHOSE CONSENT IS OF RECORD.

THE COLOR(S) BLACK AND RED IS/ARE CLAIMED AS A FEATURE OF THE MARK.

THE MARK CONSISTS OF THE WORDING "PRIMAL YOGA WITH LIZ ARCH" IN BLACK WITH A STYLIZED LETTER "A" BOTH IN THE WORD "PRIMAL" AND THE WORD "YOGA". BETWEEN THE WORD "PRIMAL" AND "YOGA" IS A RED ABSTRACT AND ASIAN BRUSH STROKE INSPIRED DRAWING OF A FEMALE CHARACTER PERFORMING A ROUND KICK INSIDE OF A HALF-CIRCLE.

CLASS 25—CLOTHING

FOR CLOTHING, NAMELY, JACKETS AND T-SHIRTS (U.S. CLS. 22 AND 39).

FIRST USE 12-20-2009; IN COMMERCE 12-20-2009.

CLASS 41—EDUCATION AND ENTERTAINMENT

FOR YOGA INSTRUCTION, MARTIAL ARTS INSTRUCTION, MEDITATION INSTRUCTION, AND GROUP FITNESS INSTRUCTION (U.S. CLS. 100, 101 AND 107).

FIRST USE 12-20-2009; IN COMMERCE 12-20-2009.

PAUL F. GAST, EXAMINING ATTORNEY

SN 85-252,461. SUBURBAN SURVIVAL SKILLS, LLC, KANSAS CITY, MO. FILED 2-26-2011.

SUBURBAN SURVIVAL SKILLS

THE MARK CONSISTS OF STANDARD CHARACTERS WITHOUT CLAIM TO ANY PARTICULAR FONT, STYLE, SIZE, OR COLOR.

CLASS 9—ELECTRICAL AND SCIENTIFIC APPARATUS

FOR PRE-RECORDED ELECTRONIC AND DIGITAL MEDIA, NAMELY, CDS, CD-ROMS, DVDS, DOWNLOADABLE AUDIO FILES, DOWNLOADABLE VIDEO FILES, DOWNLOADABLE MULTIMEDIA FILES, DOWNLOADABLE PODCASTS, AND DOWNLOADABLE ELECTRONIC PUBLICATIONS IN THE NATURE OF ARTICLES, WORKBOOKS AND STUDY GUIDES, ALL IN THE FIELDS OF HEALTH, WELLNESS, PERSONAL EMPOWERMENT AND HAPPINESS, AND INTRAPERSONAL AND INTERPERSONAL RELATIONSHIP SKILLS (U.S. CLS. 21, 23, 26, 36 AND 38).

CLASS 16—PAPER GOODS AND PRINTED MATTER

FOR PRINTED MATERIALS, NAMELY, WORKBOOKS AND STUDY GUIDES IN THE FIELDS OF HEALTH, WELLNESS, PERSONAL EMPOWERMENT AND HAPPINESS, AND INTRAPERSONAL AND INTERPERSONAL RELATIONSHIP SKILLS (U.S. CLS. 2, 5, 22, 23, 29, 37, 38 AND 50).

CLASS 41—EDUCATION AND ENTERTAINMENT

FOR EDUCATIONAL SERVICES, NAMELY, WORKSHOPS AND SEMINARS IN THE FIELDS OF HEALTH, WELLNESS, PERSONAL EMPOWERMENT AND HAPPINESS, AND INTRAPERSONAL AND INTERPERSONAL RELATIONSHIP SKILLS (U.S. CLS. 100, 101 AND 107).

SAMUEL E. SHARPER JR., EXAMINING ATTORNEY

SN 85-252,563. LINEHAN, JESSICA A, DBA SALTY POND PUBLISHERS, EAST SANDWICH, MA. FILED 2-26-2011.

Salty Pond Publishers

THE MARK CONSISTS OF STANDARD CHARACTERS WITHOUT CLAIM TO ANY PARTICULAR FONT, STYLE, SIZE, OR COLOR.

NO CLAIM IS MADE TO THE EXCLUSIVE RIGHT TO USE "PUBLISHERS", APART FROM THE MARK AS SHOWN.

CLASS 9—ELECTRICAL AND SCIENTIFIC APPARATUS

FOR DIGITAL MUSIC DOWNLOADABLE FROM THE INTERNET; MUSICAL SOUND RECORDINGS (U.S. CLS. 21, 23, 26, 36 AND 38).

CLASS 16—PAPER GOODS AND PRINTED MATTER

FOR CHILDREN'S BOOKS; SERIES OF FICTION WORKS, NAMELY, NOVELS AND BOOKS (U.S. CLS. 2, 5, 22, 23, 29, 37, 38 AND 50).

TINA BROWN, EXAMINING ATTORNEY

SN 85-252,569. CEMATRIX (CANADA) INC., CALGARY, ALBERTA, CANADA, FILED 2-26-2011.

SN 85-252,853. ATTACKPOINT LLC, BETHESDA, MD, FILED 2-27-2011.

CEMATRIX

THE MARK CONSISTS OF STANDARD CHARACTERS WITHOUT CLAIM TO ANY PARTICULAR FONT, STYLE, SIZE, OR COLOR.

CLASS 7—MACHINERY

FOR MIXING, BLENDING, PUMPING AND EXPANSION MACHINES FOR THE PRODUCTION OF BUILDING MATERIALS, NAMELY, CELLULAR CONCRETE, CELLULAR MAGNESIUM AND CELLULAR GYPSUM (U.S. CLS. 13, 19, 21, 23, 31, 34 AND 35).

FIRST USE 5-10-1999; IN COMMERCE 6-1-2009.

CLASS 37—CONSTRUCTION AND REPAIR

FOR LEASING OF MIXING, BLENDING, PUMPING AND EXPANSION MACHINES FOR THE PRODUCTION OF BUILDING MATERIALS, NAMELY CELLULAR CONCRETE, CELLULAR MAGNESIUM OR CELLULAR GYPSUM (U.S. CLS. 100, 103 AND 106).

FIRST USE 5-10-1999; IN COMMERCE 6-1-2009.
PRISCILLA MILTON, EXAMINING ATTORNEY

SN 85-252,688. FERMAN, RANDALL, CHESTER, NJ. FILED 2-26-2011.

CHUM-N-DONE

THE MARK CONSISTS OF STANDARD CHARACTERS WITHOUT CLAIM TO ANY PARTICULAR FONT, STYLE, SIZE, OR COLOR.

CLASS 5—PHARMACEUTICALS

FOR ANIMAL FEED SUPPLEMENTS AND MICRONUTRIENT ANIMAL FEED, ALL FOR HUNTING, FISHING, AND ATTRACTING ANIMALS AND FOR USE IN ANIMAL FEEDERS, PLACEMENT DIRECTLY ON THE GROUND OR HUNG BY A ROPE-LIKE ITEM OR ATTACHED TO A TREE OR STRUCTURE USING FASTENING-LIKE DEVICES OR SCREW-LIKE DEVICES (U.S. CLS. 6, 18, 44, 46, 51 AND 52).

CLASS 28—TOYS AND SPORTING GOODS

FOR ANIMAL ATTRACTANTS, ALL FOR HUNTING, FISHING, AND ATTRACTING ANIMALS AND FOR USE IN ANIMAL FEEDERS, PLACEMENT DIRECTLY ON THE GROUND OR HUNG BY A ROPE-LIKE ITEM OR ATTACHED TO A TREE OR STRUCTURE USING FASTENING-LIKE DEVICES OR SCREW-LIKE DEVICES (U.S. CLS. 22, 23, 38 AND 50).

TINA MAI, EXAMINING ATTORNEY

ATTACKPOINT

THE MARK CONSISTS OF STANDARD CHARACTERS WITHOUT CLAIM TO ANY PARTICULAR FONT, STYLE, SIZE, OR COLOR.

CLASS 41—EDUCATION AND ENTERTAINMENT

FOR ON-LINE JOURNALS, NAMELY, BLOGS FEATURING USER-DEFINED CONTENT IN THE FIELD OF SPORTS TRAINING; PROVIDING A WEBSITE FEATURING ONLINE SPORTS TRAINING AND TRAINING ADVICE AND THE RECORDING OF TRAINING AND WORKOUTS (U.S. CLS. 100, 101 AND 107).

FIRST USE 4-3-2000; IN COMMERCE 4-3-2000.

CLASS 45—PERSONAL AND LEGAL SERVICES

FOR ONLINE SOCIAL NETWORKING SERVICES PROVIDED THROUGH A SPORTS COMMUNITY WEBSITE (U.S. CLS. 100 AND 101).

FIRST USE 4-3-2000; IN COMMERCE 4-3-2000.
MEGHAN REINHART, EXAMINING ATTORNEY

SN 85-252,900. MUSE, MICHAEL HAROLD, DBA MHMUSE STUDIOS, OSLO, NORWAY, FILED 2-28-2011.

happy to believe!

THE MARK CONSISTS OF STANDARD CHARACTERS WITHOUT CLAIM TO ANY PARTICULAR FONT, STYLE, SIZE, OR COLOR.

CLASS 9—ELECTRICAL AND SCIENTIFIC APPARATUS

FOR DECORATIVE MAGNETS; DECORATIVE REFRIGERATOR MAGNETS; REFRIGERATOR MAGNETS (U.S. CLS. 21, 23, 26, 36 AND 38).

CLASS 16—PAPER GOODS AND PRINTED MATTER

FOR 3D DECALS FOR USE ON ANY SURFACE; APPLIQUES IN THE FORM OF DECALS; BOOKMARKERS; BOOKMARKS; BUMPER STICKERS; CHILDREN'S WALL STICKERS AND MURALS; DECALS; DECORATIVE DECALS FOR VEHICLE WINDOWS; DECORATIVE STICKERS FOR HELMETS; MAGNETIC BUMPER STICKERS; STICKERS (U.S. CLS. 2, 5, 22, 23, 29, 37, 38 AND 50).

CLASS 25—CLOTHING

FOR SHIRTS; SHORT-SLEEVED OR LONG-SLEEVED T-SHIRTS (U.S. CLS. 22 AND 39).

DAVID TAYLOR, EXAMINING ATTORNEY

SN 85-253,003. AIMEE KESTENBERG, NEW YORK, NY.
FILED 2-28-2011.

JATALIKA

THE MARK CONSISTS OF STANDARD CHARACTERS WITHOUT CLAIM TO ANY PARTICULAR FONT, STYLE, SIZE, OR COLOR.

CLASS 9—ELECTRICAL AND SCIENTIFIC APPARATUS

FOR LAPTOP CARRYING CASES; CELL PHONE CASES; SUNGLASSES; PHONE CASES; EYEGLASS CASES (U.S. CLS. 21, 23, 26, 36 AND 38).

CLASS 14—JEWELRY

FOR JEWELRY (U.S. CLS. 2, 27, 28 AND 50).

CLASS 18—LEATHER GOODS

FOR HANDBAGS; POCKETBOOKS; LUGGAGE; UMBRELLAS; LEATHER KEY RINGS; WALLETS; BUSINESS CARD HOLDERS IN THE NATURE OF WALLETS AND CARD CASES; CHANGE PURSES; COSMETIC CASES SOLD EMPTY; TRAVEL CASES (U.S. CLS. 1, 2, 3, 22 AND 41).

CLASS 25—CLOTHING

FOR FOOTWEAR; BELTS; MILLINERY, NAMELY, FASCINATORS; SCARVES, HATS, BEANIES, ANKLE WARMERS, ARM WARMERS, NECK WARMERS, SHAWLS, TIES, GLOVES (U.S. CLS. 22 AND 39).
JOHN GARTNER, EXAMINING ATTORNEY

SN 85-253,061. SOSTRE ENTERPRISES, INC., MIAMI, FL.
FILED 2-28-2011.



THE MARK CONSISTS OF THE WORD "SYSTEM," IN A STYLIZED TYPEFACE, ABOVE THE WORD "PROTOCOLS," IN THE SAME TYPEFACE, WITH THE LETTER "T" IN THE WORD "PROTOCOLS" APPEARING IN THE FORM OF A CHRISTIAN CROSS, ALL APPEARING ABOVE AN ASTERISK DESIGN.

CLASS 16—PAPER GOODS AND PRINTED MATTER

FOR STICKERS (U.S. CLS. 2, 5, 22, 23, 29, 37, 38 AND 50).

CLASS 21—HOUSEWARES AND GLASS

FOR DRINKING VESSELS (U.S. CLS. 2, 13, 23, 29, 30, 33, 40 AND 50).

CLASS 25—CLOTHING

FOR HATS; SHIRTS; SHORTS (U.S. CLS. 22 AND 39).
DORITT L. CARROLL, EXAMINING ATTORNEY

SN 85-253,091. OLIVIER CHIABODO, ROUILLY, FRANCE.
FILED 2-28-2011.



THE COLOR(S) BLACK, ORANGE AND GRAY IS/ARE CLAIMED AS A FEATURE OF THE MARK.

THE MARK CONSISTS OF THE WORDS "SAVE YOUR LOGO" WITHIN A PARTIAL CIRCLE OPEN AT THE TOP ALL IN BLACK, WITH THE FIRST "O" IN LOGO BEING A STYLIZED REPRESENTATION OF THE EARTH IN ORANGE AND GRAY.

CLASS 25—CLOTHING

FOR CLOTHING, NAMELY, POLO SHIRTS, SHIRTS, T-SHIRTS, SWEATERS, JACKETS; HOSIERY; UNDERWEAR; BATHING SUITS; FOOTWEAR; SOCKS; SLIPPERS; CAPS AND HATS; BELTS; GLOVES; SCARVES (U.S. CLS. 22 AND 39).

CLASS 36—INSURANCE AND FINANCIAL

FOR CHARITABLE FUNDRAISING; FINANCIAL SPONSORSHIP OF SCIENTIFIC AND MEDICAL PROGRAMS FOR THE PRESERVATION OF BIODIVERSITY AND AGAINST THE DISAPPEARANCE OF SPECIES; FINANCING OF SCIENTIFIC AND MEDICAL PROGRAMS FOR THE PRESERVATION OF BIODIVERSITY AND AGAINST THE DISAPPEARANCE OF SPECIES; FINANCING OF INFORMATION AND TRAINING PROGRAMS FOR THE PRESERVATION OF BIODIVERSITY AND AGAINST THE DISAPPEARANCE OF SPECIES; ISSUE OF TOKENS OF VALUE (U.S. CLS. 100, 101 AND 102).

TAMARA FRAZIER, EXAMINING ATTORNEY

SN 85-253,166. ANDIS COMPANY, STURTEVANT, WI.
FILED 2-28-2011.

E.LOGICA

THE MARK CONSISTS OF STANDARD CHARACTERS WITHOUT CLAIM TO ANY PARTICULAR FONT, STYLE, SIZE, OR COLOR.

CLASS 8—HAND TOOLS

FOR ELECTRIC HAIR CLIPPERS AND TRIMMERS (U.S. CLS. 23, 28 AND 44).
FIRST USE 4-20-2010; IN COMMERCE 4-20-2010.

CLASS 9—ELECTRICAL AND SCIENTIFIC APPARATUS

FOR ELECTRIC HAIR STRAIGHTENER (U.S. CLS. 21, 23, 26, 36 AND 38).

CLASS 11—ENVIRONMENTAL CONTROL APPARATUS

FOR HAND-HELD ELECTRIC HAIR DRYERS (U.S. CLS. 13, 21, 23, 31 AND 34).
FIRST USE 10-7-2010; IN COMMERCE 10-7-2010.
CHERYL CLAYTON, EXAMINING ATTORNEY

CLASS 21—HOUSEWARES AND GLASS

FOR BEER JUGS; BEER MUGS; BEVERAGE GLASSWARE; CARAFES; CERAMIC FIGURINES; CERAMIC GRINDING BEADS FOR USE IN WET MILLING; CERAMIC PULLS FOR CABINETS, DRAWERS AND FURNITURE; CERAMIC SCULPTURES, VASES, VESSELS, BOWLS, PLATES AND POTS; CERAMIC TISSUE BOX COVERS; CLAY POTS; COASTERS NOT OF PAPER AND NOT BEING TABLE LINEN; COASTERS, NOT OF PAPER AND OTHER THAN TABLE LINEN; COFFEE CUPS, TEA CUPS AND MUGS; COFFEE MUGS; COOKIE JARS; CUPS; DECORATIVE CERAMIC TILES NOT FOR USE AS BUILDING MATERIALS; DRINKING CUPS AND SAUCERS; DRINKING GLASSES; DRINKING STEINS; DRINKING VESSELS; FOAM DRINK HOLDERS; GLASS BEVERAGEWARE; GLASS MUGS; HOLIDAY ORNAMENTS OF CERAMIC; LUNCH BOXES; LUNCH PAILS; MOSAIC ART TILES MADE OF GLASS AND CERAMIC; MOSAICS OF GLASS AND CERAMIC TILES, NOT FOR CONSTRUCTION; MUGS; PAPER AND PLASTIC CUPS; PLASTIC COASTERS; PLATES; PORCELAIN MUGS; PORTABLE BEVERAGE COOLERS; PORTABLE BEVERAGE DISPENSERS; PORTABLE COLDBOXES; PORTABLE ICE CHESTS FOR FOOD AND BEVERAGES; POTS; UPRIGHT SIGNBOARDS OF GLASS OR CERAMIC; VACUUM BOTTLES; WASHING CLOTHS (U.S. CLS. 2, 13, 23, 29, 30, 33, 40 AND 50).

SN 85-253,266. THE TRUSTEES OF EATON VANCE MANAGEMENT, BOSTON, MA. FILED 2-28-2011.

The New Nimble

THE MARK CONSISTS OF STANDARD CHARACTERS WITHOUT CLAIM TO ANY PARTICULAR FONT, STYLE, SIZE, OR COLOR.

CLASS 36—INSURANCE AND FINANCIAL

FOR FUND INVESTMENT AND ADVISORY SERVICES; INVESTMENT COUNSELING SERVICES; MANAGEMENT OF PORTFOLIOS COMPRISING SECURITIES; MUTUAL FUND DISTRIBUTION AND BROKERAGE SERVICES (U.S. CLS. 100, 101 AND 102).

CLASS 41—EDUCATION AND ENTERTAINMENT

FOR EDUCATIONAL SERVICES, NAMELY, CONDUCTING PROGRAMS IN THE FIELD OF FINANCIAL INVESTING FOR SECURITIES BROKER/DEALERS AND INVESTORS (U.S. CLS. 100, 101 AND 107).
ANGELA DUONG, EXAMINING ATTORNEY

CLASS 25—CLOTHING

FOR ANKLE SOCKS; APRONS; ATHLETIC APPAREL, NAMELY, SHIRTS, PANTS, JACKETS, FOOTWEAR, HATS AND CAPS, ATHLETIC UNIFORMS; ATHLETIC UNIFORMS; BABY BIBS NOT OF PAPER; BANDANAS; BASEBALL CAPS AND HATS; BASEBALL SHOES; BASKETBALL UNIFORMS; BASKETBALL SNEAKERS; BATHROBES; BEACH COVER-UPS; BERMUDA SHORTS; BIB OVERALLS; BLAZERS; BLOUSES; BODY SHIRTS; BOXER BRIEFS; BOXER SHORTS; BUTTON DOWN SHIRTS; CANVAS SHOES; CLAM DIGGERS; CLOTH BIBS; COATS; COATS FOR MEN AND WOMEN; COATS MADE OF COTTON; COATS OF DENIM; COLLARED SHIRTS; COVERALLS; CREEPERS; CREW NECK SWEATERS; CROP TOPS; DECK-SHOES; DENIM JACKETS; DO RAGS; DRESS SHIRTS; FLIP FLOPS; FOOTWEAR FOR MEN AND WOMEN; GLOVES; GOLF CAPS; GOLF PANTS, SHIRTS AND SKIRTS; GOLF SHIRTS; GOLF SHOES; GOLF SHORTS; GOLF TROUSERS; HALTER TOPS; HAT BANDS; HATS; HEAD SCARVES; HEAD WEAR; HEADBANDS; HEAVY COATS; HEAVY JACKETS; HOODED PULLOVERS; HOODED SWEAT SHIRTS; HOODS; INFANT WEAR; JACKETS; JEANS; KNEE HIGHS; KNICKERS; LEG WARMERS; LEGGINGS; LINGERIE; LONG JACKETS; LONG JOHNS; LONG SLEEVE PULLOVERS; LONG-SLEEVED SHIRTS; LOUNGEWEAR; MEN'S AND WOMEN'S JACKETS, COATS, TROUSERS, VESTS; MEN'S SOCKS; MEN'S UNDERWEAR; MINISKIRTS; MUSCLE TOPS; NECKERCHIEFS; NECKTIES; NECKWEAR; NEGLIGEEES; NIGHT GOWNS; NIGHT SHIRTS; NIGHTCAPS; NIGHTGOWNS; NIGHTTIES; NIGHTSHIRTS; NIGHTWEAR; OUTER JACKETS; OVER SHIRTS; OVERALLS; OVERCOATS; PAJAMAS; PANTIES; PANTS; PARKAS; PEACOATS; PEDAL PUSHERS; POLO KNIT TOPS; POLO SHIRTS; RAIN COATS; RAIN HATS; RAIN JACKETS; RAIN-PROOF JACKETS; RAINWEAR; REVERSIBLE JACKETS; ROBES; RUGBY SHIRTS; RUGBY SHORTS; SANDALS; SASHES; SCARFS; SCARVES; SHAWLS; SHIRTS; SHOES; SHORT-SLEEVED OR LONG-SLEEVED T-SHIRTS; SHORT-SLEEVED SHIRTS; SHORTS; SKIRTS; SKORTS; SLACKS; SLEEPWEAR; SLIPPERS; SMALL HATS; SMOCKS; SMOKING JACKETS; SNEAKERS; SOCKS; SPORT COATS; SPORT SHIRTS; SPORTS CAPS AND HATS; SPORTS JACKETS; SPORTS JERSEYS; SPORTS PANTS; SPORTS SHIRTS; STOCKINGS; SUIT COATS; SWEAT BANDS; SWEAT JACKETS; SWEAT PANTS; SWEAT SHIRTS; SWEAT SHORTS; SWEAT SUITS; T-SHIRTS; TANK TOPS; TEDDIES; TEE SHIRTS; THONGS; THONGS; TIES; TIGHTS; TOGAS; TROUSERS; TRUNKS; TUBE TOPS; TURTLE NECK SHIRTS; TURTLENECKS; UNDER GARMENTS; UNDERCLOTHES; UNDERPANTS; UNDERSHIRTS; UNDERSKIRTS; UNDERWEAR; UNIFORMS; VESTS; VISORS; WALKING SHORTS; WARM UP OUTFITS; WARM UP SUITS; WIND COATS; WIND PANTS; WIND RESISTANT JACKETS;

SN 85-253,333. BLOSSOM OLLIE PRODUCTIONS, LLC, CHEYENNE, WY. FILED 2-28-2011.



NO CLAIM IS MADE TO THE EXCLUSIVE RIGHT TO USE "BASEBALL", APART FROM THE MARK AS SHOWN. THE MARK CONSISTS OF THE WORDS "CHURCH OF" IN AN OUTLINED ARC SHAPE ABOVE A BASEBALL AND THE STYLIZED AND OUTLINED WORD "BASEBALL" UNDERLINED AND ON TOP OF THE BASEBALL.

WIND SHIRTS; WIND VESTS; WOMEN'S TOPS, NAMELY, CAMIS; WOMEN'S UNDERWEAR; WRIST BANDS (U.S. CLS. 22 AND 39).

REBECCA POVARCHUK, EXAMINING ATTORNEY

SN 85-253,395. CASSIUS MUSIC LLC, BOSTON, MA. FILED 2-28-2011.

TheTotallyWow

THE MARK CONSISTS OF STANDARD CHARACTERS WITHOUT CLAIM TO ANY PARTICULAR FONT, STYLE, SIZE, OR COLOR.

CLASS 9—ELECTRICAL AND SCIENTIFIC APPARATUS

FOR MUSICAL RECORDINGS (U.S. CLS. 21, 23, 26, 36 AND 38).

CLASS 41—EDUCATION AND ENTERTAINMENT

FOR LIVE PERFORMANCES BY A MUSICAL GROUP (U.S. CLS. 100, 101 AND 107).
CURTIS FRENCH, EXAMINING ATTORNEY

SN 85-253,410. KENT RECORD MANAGEMENT, INC., AKA KRM, GRAND RAPIDS, MI. FILED 2-28-2011.

V-ERMS

THE MARK CONSISTS OF STANDARD CHARACTERS WITHOUT CLAIM TO ANY PARTICULAR FONT, STYLE, SIZE, OR COLOR.

CLASS 35—ADVERTISING AND BUSINESS

FOR BUSINESS RECORDS MANAGEMENT; RECORDS MANAGEMENT SERVICES, NAMELY, DOCUMENT INDEXING FOR OTHERS (U.S. CLS. 100, 101 AND 102).

FIRST USE 12-1-2010; IN COMMERCE 12-1-2010.

CLASS 39—TRANSPORTATION AND STORAGE

FOR ELECTRONIC STORAGE OF FILES AND DOCUMENTS; STORAGE OF ELECTRONIC MEDIA, NAMELY, IMAGES, TEXT AND AUDIO DATA; STORAGE SERVICES FOR ARCHIVING DATABASES, IMAGES AND OTHER ELECTRONIC DATA; STORAGE SERVICES FOR ARCHIVING ELECTRONIC DATA (U.S. CLS. 100 AND 105).

FIRST USE 12-1-2010; IN COMMERCE 12-1-2010.
HANNO RITTNER, EXAMINING ATTORNEY

SN 85-253,495. CAN MANUFACTURERS INSTITUTE, INC., WASHINGTON, DC. FILED 2-28-2011.

THE GREAT AMERICAN CAN ROUNDUP

THE MARK CONSISTS OF STANDARD CHARACTERS WITHOUT CLAIM TO ANY PARTICULAR FONT, STYLE, SIZE, OR COLOR.

NO CLAIM IS MADE TO THE EXCLUSIVE RIGHT TO USE "CAN", APART FROM THE MARK AS SHOWN.

CLASS 35—ADVERTISING AND BUSINESS

FOR PROMOTING COMMUNITY RECYCLING SUSTAINABILITY BY SPONSORING RECYCLING EVENTS; PROMOTING PUBLIC AWARENESS OF THE NEED TO RECYCLE AND THE BENEFITS OF RECYCLING; ASSOCIATION SERVICES, NAMELY, PROMOTING THE INTERESTS OF CAN MANUFACTURERS AND THEIR SUPPLIERS; PROVIDING INFORMATION ON SUSTAINABILITY OF STEEL AND ALUMINUM AND PRODUCTS MADE OF THESE MATERIALS (U.S. CLS. 100, 101 AND 102).

CLASS 40—MATERIAL TREATMENT

FOR PROVIDING INFORMATION ABOUT THE IMPORTANCE OF RECYCLING; PROVIDING INFORMATION ABOUT STEEL AND ALUMINUM CAN RECYCLING AND THE SUSTAINABILITY BENEFITS OF RECYCLING (U.S. CLS. 100, 103 AND 106).

RUDY R. SINGLETON, EXAMINING ATTORNEY

SN 85-253,520. NURSEBANK AMERICA, LLC, BERWYN, PA. FILED 2-28-2011.



OWNER OF U.S. REG. NO. 3,969,570.

NO CLAIM IS MADE TO THE EXCLUSIVE RIGHT TO USE "COMPANIONS", APART FROM THE MARK AS SHOWN.

THE MARK CONSISTS OF THE WORDS "ANGEL COMPANIONS" UNDERNEATH AN IMAGE COMPRISING A CENTERED STYLIZED "V" AND A SMALLER STYLIZED "V" SET TO THE LEFT AND RIGHT OF THE CENTER "V", EACH "V" HAVING A CIRCLE INSET ABOVE THE JUNCTION OF EACH "V", A HALO ABOVE THE CIRCLE OF THE CENTER "V", AND ALL THREE VS SET UNDERNEATH AN OUTLINE OF A ROOF WITH A CHIMNEY ON THE RIGHT.

CLASS 37—CONSTRUCTION AND REPAIR

FOR LIGHT HOUSEKEEPING IN THE NATURE OF MAID SERVICES AND LAUNDRY SERVICES FOR MENTALLY AND PHYSICALLY CHALLENGED INDIVIDUALS (U.S. CLS. 100, 103 AND 106).

CLASS 43—HOTEL AND RESTAURANT SERVICES

FOR PREPARATION OF MEALS FOR MENTALLY AND PHYSICALLY CHALLENGED INDIVIDUALS (U.S. CLS. 100 AND 101).

SN 85-253,565. VINTON, JOHN R. KINGWOOD, TX. AND VINTON, MELODY R. KINGWOOD, TX. FILED 2-28-2011.

CLASS 45—PERSONAL AND LEGAL SERVICES

FOR IN-HOME SUPPORT SERVICES PROVIDED TO SENIOR PERSONS, NAMELY, GERIATRIC CARE MANAGEMENT SERVICES AND PERSONAL AFFAIRS MANAGEMENT SERVICES IN THE NATURE OF THE COORDINATION OF NECESSARY SERVICES AND CARE FOR OLDER INDIVIDUALS; PERSONAL CARE ASSISTANCE OF ACTIVITIES OF DAILY LIVING, SUCH AS BATHING, GROOMING AND PERSONAL MOBILITY FOR MENTALLY OR PHYSICALLY CHALLENGED PEOPLE; PROVIDING NON-MEDICAL PERSONAL ASSISTANT SERVICES FOR OTHERS IN THE NATURE OF PLANNING, ORGANIZING, COORDINATING, ARRANGING AND ASSISTING INDIVIDUALS IN THE PERFORMANCE OF DAILY TASKS (U.S. CLS. 100 AND 101).
BRIAN CALLAGHAN, EXAMINING ATTORNEY

Get Some Fitness

THE MARK CONSISTS OF STANDARD CHARACTERS WITHOUT CLAIM TO ANY PARTICULAR FONT, STYLE, SIZE, OR COLOR.

CLASS 28—TOYS AND SPORTING GOODS

FOR WEIGHT LIFTING GLOVES (U.S. CLS. 22, 23, 38 AND 50).

CLASS 35—ADVERTISING AND BUSINESS

FOR ON-LINE RETAIL STORE SERVICES FEATURING FITNESS CLOTHING AND GEAR (U.S. CLS. 100, 101 AND 102).
ROBIN CHOSID, EXAMINING ATTORNEY

SN 85-253,523. CHILD LIFE COUNCIL, ROCKVILLE, MD. FILED 2-28-2011.

SN 85-253,696. THE FOGUE, LLC, DBA BLAKE EVAN MUSIC, PARKER, CO. FILED 2-28-2011.

CHILD LIFE COUNCIL



THE MARK CONSISTS OF STANDARD CHARACTERS WITHOUT CLAIM TO ANY PARTICULAR FONT, STYLE, SIZE, OR COLOR.

OWNER OF U.S. REG. NO. 1,859,289.
NO CLAIM IS MADE TO THE EXCLUSIVE RIGHT TO USE "COUNCIL", APART FROM THE MARK AS SHOWN.
SEC. 2(F).

THE MARK CONSISTS OF THE STYLIZED LETTERS "BE", WITH ARROWS EMERGING FROM THE LEFT OF THE LETTER "B" AND RIGHT OF THE LETTER "E".

CLASS 35—ADVERTISING AND BUSINESS

FOR ASSOCIATION SERVICES; NAMELY, PROMOTING THE INTERESTS OF CHILD LIFE SPECIALISTS (U.S. CLS. 100, 101 AND 102).
FIRST USE 6-1-1982; IN COMMERCE 6-1-1982.

CLASS 9—ELECTRICAL AND SCIENTIFIC APPARATUS

FOR DIGITAL MEDIA, NAMELY, CDS, AUDIO FILES, MP3S AND VIDEOS FEATURING MUSIC (U.S. CLS. 21, 23, 26, 36 AND 38).
FIRST USE 6-0-2010; IN COMMERCE 6-0-2010.

CLASS 41—EDUCATION AND ENTERTAINMENT

FOR EDUCATIONAL SERVICES, NAMELY, CONDUCTING CLASSES, SEMINARS, AND WORKSHOPS IN THE FIELD OF CHILD LIFE (U.S. CLS. 100, 101 AND 107).
FIRST USE 6-1-1982; IN COMMERCE 6-1-1982.
MARK T. MULLEN, EXAMINING ATTORNEY

CLASS 41—EDUCATION AND ENTERTAINMENT

FOR ENTERTAINMENT SERVICES IN THE NATURE OF LIVE MUSICAL PERFORMANCES; MUSIC PRODUCTION SERVICES (U.S. CLS. 100, 101 AND 107).
FIRST USE 6-0-2010; IN COMMERCE 6-0-2010.
REBECCA POVARCHUK, EXAMINING ATTORNEY

SN 85-253,726. GREEN TOYS INCORPORATED, SAN FRANCISCO, CA. FILED 2-28-2011.

GREEN CLUB

THE MARK CONSISTS OF STANDARD CHARACTERS WITHOUT CLAIM TO ANY PARTICULAR FONT, STYLE, SIZE, OR COLOR.

NO CLAIM IS MADE TO THE EXCLUSIVE RIGHT TO USE "GREEN", APART FROM THE MARK AS SHOWN.

CLASS 8—HAND TOOLS

FOR TABLEWARE, NAMELY, KNIVES, FORKS AND SPOONS; MORTAR AND PESTLE; UTENSILS ADAPTED FOR FEEDING INFANTS AND TODDLERS, NAMELY, SPOONS (U.S. CLS. 23, 28 AND 44).

CLASS 10—MEDICAL APPARATUS

FOR BABY BOTTLES, CUPS ADAPTED FOR FEEDING BABIES AND TODDLERS (U.S. CLS. 26, 39 AND 44).

CLASS 21—HOUSEWARES AND GLASS

FOR DINNERWARE, NAMELY, PLATES, CUPS, SAUCERS, BOWLS, SERVING PLATTERS, SERVING TRAYS, DRINKING GLASSES, CARAFES, MUGS, CHOPSTICKS; SERVING LADLES, NON-ELECTRIC COOKING POTS AND PANS, COLANDERS, STRAINERS FOR HOUSEHOLD PURPOSES, HOUSEHOLD STORAGE CONTAINERS, LUNCH BOXES, LIDS FOR BOWLS AND CUPS, PITCHERS, SERVING TONGS, WHISKS, SLOTTED SPOONS, GRAVY BOATS, COOKING SKEWERS, SPOON RESTS, ROLLING PINS, BUTTER DISHES, SALT AND PEPPER SHAKERS, DISH DRYING RACKS, CUTTING BOARDS; DINNERWARE ADAPTED FOR FEEDING INFANTS AND TODDLERS, NAMELY, NON-METALLIC TRAYS, FOOD FLY CATCHERS, CHOP STICKS, SERVING TRAYS FOR BABY FOOD; HOUSEHOLD UTENSILS, NAMELY, SPATULAS (U.S. CLS. 2, 13, 23, 29, 30, 33, 40 AND 50).

CLASS 28—TOYS AND SPORTING GOODS

FOR TOYS, NAMELY, INFANT TOYS, ROLE PLAYING TOYS IN THE NATURE OF PLAY SETS FOR CHILDREN TO IMITATE REAL LIFE OCCUPATIONS, TOY BUILDING BLOCKS, TOY VEHICLES; TOY TEA SETS, TOY BAKEWARE AND COOKWARE, TOY SAND BUCKETS, TOY SAND SHOVELS, TOY SAND RAKES, SAND CASTLE MOLDS; TOY GARDENING SETS COMPRISING PLANTER TRAYS, PLANTER POTS, TROWELS, SOIL AND FLOWER AND PLANT SEEDS, ALL SOLD TOGETHER AS A UNIT; TOY FLYING DISCS; JUMP ROPES (U.S. CLS. 22, 23, 38 AND 50).

KAPIL BHANOT, EXAMINING ATTORNEY

SN 85-253,888. MGH HOLDINGS, LLC, HIGHLAND, UT. FILED 2-28-2011.

MYONATURAL

THE MARK CONSISTS OF STANDARD CHARACTERS WITHOUT CLAIM TO ANY PARTICULAR FONT, STYLE, SIZE, OR COLOR.

CLASS 5—PHARMACEUTICALS

FOR DIETARY SUPPLEMENTS; SPORTS CREAM FOR RELIEF OF PAIN; TOPICAL ANALGESIC CREAMS; TRANSDERMAL PATCHES FOR USE IN THE TREATMENT OF PAIN (U.S. CLS. 6, 18, 44, 46, 51 AND 52).

CLASS 10—MEDICAL APPARATUS

FOR CHEMICALLY ACTIVATED HOT AND/OR COLD COMPRESSES; THERAPEUTIC APPARATUS, NAMELY, CHEMICALLY ACTIVATED ANTI-CELLULITE WRAPS, ICE PACKS, COMPRESSES, AND COMPRESSION BANDAGES; THERAPEUTIC HOT AND COLD COMPRESSION WRAPS (U.S. CLS. 26, 39 AND 44).

ANNE FARRELL, EXAMINING ATTORNEY

SN 85-254,059. WE-DO ARCHITECTURE INCORPORATED, HERMOSA BEACH, CA. FILED 2-28-2011.

SOLZEBO

THE MARK CONSISTS OF STANDARD CHARACTERS WITHOUT CLAIM TO ANY PARTICULAR FONT, STYLE, SIZE, OR COLOR.

CLASS 6—METAL GOODS

FOR CARPORTS, PRIMARILY OF METAL (U.S. CLS. 2, 12, 13, 14, 23, 25 AND 50).

CLASS 19—NON-METALLIC BUILDING MATERIALS

FOR GAZEBOS, NOT PRIMARILY OF METAL (U.S. CLS. 1, 12, 33 AND 50).

CARRIE GENOVESE, EXAMINING ATTORNEY

SN 85-254,215. SMITH, STEVEN C., DADE CITY, FL. FILED 3-1-2011.

IT'S AMAZING!

THE MARK CONSISTS OF STANDARD CHARACTERS WITHOUT CLAIM TO ANY PARTICULAR FONT, STYLE, SIZE, OR COLOR.

CLASS 3—COSMETICS AND CLEANING PREPARATIONS

FOR ESSENTIAL OILS FOR PERSONAL USE (U.S. CLS. 1, 4, 6, 50, 51 AND 52).

FIRST USE 10-8-2010; IN COMMERCE 10-8-2010.

CLASS 5—PHARMACEUTICALS

FOR DIETARY AND NUTRITIONAL SUPPLEMENTS (U.S. CLS. 6, 18, 44, 46, 51 AND 52).

FIRST USE 10-8-2010; IN COMMERCE 10-8-2010.
DAVID COLLIER, EXAMINING ATTORNEY

SN 85-254,325. HESS CORPORATION, NEW YORK, NY.
FILED 3-1-2011.

THE POWER OF PARTNERSHIP

THE MARK CONSISTS OF STANDARD CHARACTERS WITHOUT CLAIM TO ANY PARTICULAR FONT, STYLE, SIZE, OR COLOR.

CLASS 4—LUBRICANTS AND FUELS

FOR GASOLINE, FUEL OIL, HEATING OIL, NATURAL GAS, MOTOR OIL (U.S. CLS. 1, 6 AND 15).

CLASS 35—ADVERTISING AND BUSINESS

FOR MARKETING OF ENERGY, NATURAL GAS, ELECTRICITY, MOTOR OIL, FUEL AND OIL; RETAIL CONVENIENCE STORE SERVICES; GAS STATION SERVICES, NAMELY, RETAIL GASOLINE SUPPLY SERVICES (U.S. CLS. 100, 101 AND 102).

CLASS 40—MATERIAL TREATMENT

FOR REFINING OF PETROLEUM PRODUCTS, MOTOR OIL, FUEL OIL, AND HEATING OIL; OIL AND GAS PRODUCTION SERVICES (U.S. CLS. 100, 103 AND 106).

CLASS 42—SCIENTIFIC AND COMPUTER SERVICES

FOR GAS AND OIL EXPLORATION SERVICES (U.S. CLS. 100 AND 101).
KEVON CHISOLM, EXAMINING ATTORNEY

SN 85-254,440. COLD SPRING SOLUTIONS INC., HUNTINGTON, NY. FILED 3-1-2011.

GETVIZIBLE

THE MARK CONSISTS OF STANDARD CHARACTERS WITHOUT CLAIM TO ANY PARTICULAR FONT, STYLE, SIZE, OR COLOR.

CLASS 35—ADVERTISING AND BUSINESS

FOR ADVERTISING AND MARKETING SERVICES PROVIDED BY MEANS OF INDIRECT METHODS OF MARKETING COMMUNICATIONS, NAMELY, SOCIAL MEDIA, SEARCH ENGINE MARKETING, INQUIRY MARKETING, INTERNET MARKETING, MOBILE MARKETING, BLOGGING AND OTHER FORMS OF PASSIVE, SHARABLE OR VIRAL COMMUNICATIONS CHANNELS; ADVERTISING THE SERVICES OF OTHERS VIA WEB PAGES OPTIMIZED FOR ONLINE SEARCH ENGINES; ON-LINE ADVERTISING AND MARKETING SERVICES; PROMOTING, ADVERTISING AND MARKETING OF THE BRANDS, PRODUCTS, SERVICES OR ONLINE WEBSITES OF INDIVIDUALS, BUSINESSES AND NONPROFIT ORGANIZATIONS; PROMOTING, ADVERTISING AND MARKETING OF THE ON-LINE WEB SITES OF OTHERS (U.S. CLS. 100, 101 AND 102).

FIRST USE 5-0-2010; IN COMMERCE 5-0-2010.

CLASS 42—SCIENTIFIC AND COMPUTER SERVICES

FOR COMPUTER SERVICES, NAMELY, SEARCH ENGINE OPTIMIZATION; CONSULTATION SERVICES IN THE FIELD OF SEARCH ENGINE OPTIMIZATION; CREATION, DESIGN, DEVELOPMENT AND MAINTENANCE OF WEB SITES FOR THIRD PARTIES (U.S. CLS. 100 AND 101).

FIRST USE 5-0-2010; IN COMMERCE 5-0-2010.

WARREN L. OLANDRIA, EXAMINING ATTORNEY

SN 85-254,452. MW LOGISTICS, LLC, DALLAS, TX. FILED 3-1-2011.

SMARTSOURCE

THE MARK CONSISTS OF STANDARD CHARACTERS WITHOUT CLAIM TO ANY PARTICULAR FONT, STYLE, SIZE, OR COLOR.

CLASS 35—ADVERTISING AND BUSINESS

FOR FREIGHT LOGISTICS MANAGEMENT AND TRANSPORTATION MANAGEMENT SERVICES, NAMELY, ARRANGING THE TRANSPORTATION OF GOODS FOR OTHERS; PROVIDING ELECTRONIC TRACKING OF FREIGHT INFORMATION TO OTHERS; COMPUTERIZED TRACKING AND TRACING OF PACKAGES IN TRANSIT (U.S. CLS. 100, 101 AND 102).

CLASS 42—SCIENTIFIC AND COMPUTER SERVICES

FOR PROVIDING TEMPORARY USE OF NON-DOWNLOADABLE COMPUTER SOFTWARE FOR TRACKING PACKAGES OVER COMPUTER NETWORKS, INTRANETS AND THE INTERNET (U.S. CLS. 100 AND 101).
WILLIAM P. SHANAHAN, EXAMINING ATTORNEY

SN 85-254,494. SPRINGS CREATIVE PRODUCTS GROUP, LLC, ROCK HILL, SC. FILED 3-1-2011.

PILLOWSKIN

THE MARK CONSISTS OF STANDARD CHARACTERS WITHOUT CLAIM TO ANY PARTICULAR FONT, STYLE, SIZE, OR COLOR.

CLASS 20—FURNITURE AND ARTICLES NOT OTHERWISE CLASSIFIED

FOR MATTRESSES AND PILLOWS (U.S. CLS. 2, 13, 22, 25, 32 AND 50).

CLASS 24—FABRICS

FOR MATTRESS COVERS; BED SHEETS; AND FABRIC FOR COVERING MATTRESSES, NAMELY, POLYESTER AND SPANDEX BLENDED FABRIC FOR USE AS A TEXTILE IN THE MANUFACTURE OF MATTRESSES, FABRICS FOR THE MANUFACTURE OF MATTRESSES AND FABRIC MATTRESS COVERS (U.S. CLS. 42 AND 50).

DAWN FELDMAN, EXAMINING ATTORNEY

SN 85-254,504. ANDIS COMPANY, STURTEVANT, WI. FILED 3-1-2011.

ANDIS

THE MARK CONSISTS OF STANDARD CHARACTERS WITHOUT CLAIM TO ANY PARTICULAR FONT, STYLE, SIZE, OR COLOR.

OWNER OF U.S. REG. NOS. 1,215,675, 3,669,258 AND OTHERS.

CLASS 9—ELECTRICAL AND SCIENTIFIC APPARATUS

FOR ELECTRIC IRONS (U.S. CLS. 21, 23, 26, 36 AND 38).

FIRST USE 12-17-2004; IN COMMERCE 12-17-2004.

CLASS 11—ENVIRONMENTAL CONTROL APPARATUS

FOR ELECTRIC COFFEE MAKERS (U.S. CLS. 13, 21, 23, 31 AND 34).

FIRST USE 4-26-2004; IN COMMERCE 4-26-2004.
CHERYL CLAYTON, EXAMINING ATTORNEY

SN 85-254,515. CHROMADEX, INC., IRVINE, CA. FILED 3-1-2011.



THE COLOR(S) BLACK AND RED IS/ARE CLAIMED AS A FEATURE OF THE MARK.

THE MARK CONSISTS OF AN INCOMPLETE OVAL WITH THE LEFT HALF OF THE OVAL BLACK AND THE RIGHT HALF OF THE OVAL RED.

CLASS 1—CHEMICALS

FOR CHEMICAL REAGENTS FOR NON-MEDICAL PURPOSES; CHEMICAL TEST KITS FOR ANALYTICAL MEASUREMENT OF RAW MATERIAL IDENTITY, POTENCY AND FORMULATION CONSISTENCY FOR LABORATORY OR RESEARCH USE; CHEMICALS FOR USE IN INDUSTRY AND SCIENCE; CHEMICALS FOR USE IN THE BIOCHEMICAL AND CHEMICAL INDUSTRY; ASSAYS FOR RESEARCH PURPOSES (U.S. CLS. 1, 5, 6, 10, 26 AND 46).

CLASS 42—SCIENTIFIC AND COMPUTER SERVICES

FOR CHEMICAL, BIOCHEMICAL, BIOLOGICAL AND BACTERIOLOGICAL RESEARCH AND ANALYSIS; CONSULTING IN THE FIELD OF PRODUCT DEVELOPMENT IN THE FIELD OF CHEMICALS; DEVELOPMENT AND ESTABLISHMENT OF TESTING SPECIFICATIONS AND PROCEDURES IN THE FIELD OF CHEMICALS; DEVELOPMENT AND TEST OF CHEMICAL PRODUCTION METHODS; DEVELOPMENT OF VOLUNTARY STANDARDS FOR CHEMICALS; EXECUTING OF CHEMICAL ANALYSES; INDUSTRIAL RESEARCH IN THE FIELD OF CHEMICALS; PHARMACEUTICAL RESEARCH AND DEVELOPMENT; PRODUCT RESEARCH AND DEVELOPMENT; RESEARCH AND DEVELOPMENT AND CONSULTATION RELATED THERETO IN THE FIELD OF CHEMICALS; TESTING OF RAW MATERIALS (U.S. CLS. 100 AND 101).

JAMES LOVELACE, EXAMINING ATTORNEY

SN 85-254,563. FROGGY'S FOG LLC, COLUMBIA, TN. FILED 3-1-2011.

FROGGY'S FOG

THE MARK CONSISTS OF STANDARD CHARACTERS WITHOUT CLAIM TO ANY PARTICULAR FONT, STYLE, SIZE, OR COLOR.

NO CLAIM IS MADE TO THE EXCLUSIVE RIGHT TO USE "FOG", APART FROM THE MARK AS SHOWN.

CLASS 1—CHEMICALS

FOR FLUID FOR USE WITH FOG MACHINES FOR GENERATING FOG, HAZE, THEATRICAL SNOW AND BUBBLES (U.S. CLS. 1, 5, 6, 10, 26 AND 46).

FIRST USE 3-0-2002; IN COMMERCE 3-0-2002.

CLASS 41—EDUCATION AND ENTERTAINMENT

FOR ENTERTAINMENT SERVICES, NAMELY PREPARATION OF SPECIAL EFFECTS AND PRODUCTION OF VISUAL EFFECTS FOR VIDEOS, DVDS, TELEVISION, AND FOR INTERNET WEB SITES (U.S. CLS. 100, 101 AND 107).

FIRST USE 0-0-2002; IN COMMERCE 0-0-2002.
JOSETTE BEVERLY, EXAMINING ATTORNEY

SN 85-254,589. FROGGY'S FOG LLC, COLUMBIA, TN. FILED 3-1-2011.



NO CLAIM IS MADE TO THE EXCLUSIVE RIGHT TO USE "FOG", APART FROM THE MARK AS SHOWN.

THE MARK CONSISTS OF A SLITHERING FROG DESIGN WITH THE STYLIZED WORDS "FROGGY'S FOG" BELOW THE SLITHERING FROG DESIGN.

CLASS 1—CHEMICALS

FOR FLUID FOR USE WITH FOG MACHINES FOR GENERATING FOG, HAZE, THEATRICAL SNOW AND BUBBLES (U.S. CLS. 1, 5, 6, 10, 26 AND 46). FIRST USE 3-0-2002; IN COMMERCE 3-0-2002.

CLASS 41—EDUCATION AND ENTERTAINMENT

FOR ENTERTAINMENT SERVICES, NAMELY PREPARATION OF SPECIAL EFFECTS AND PRODUCTION OF VISUAL EFFECTS FOR VIDEOS, DVDS, TELEVISION, AND FOR INTERNET WEB SITES (U.S. CLS. 100, 101 AND 107). FIRST USE 0-0-2002; IN COMMERCE 0-0-2002. JOSETTE BEVERLY, EXAMINING ATTORNEY

SN 85-254,762. KERZNER INTERNATIONAL LIMITED, NASSAU, BAHAMAS, FILED 3-1-2011.

LIVE THE MOMENT

THE MARK CONSISTS OF STANDARD CHARACTERS WITHOUT CLAIM TO ANY PARTICULAR FONT, STYLE, SIZE, OR COLOR.

CLASS 41—EDUCATION AND ENTERTAINMENT

FOR HEALTH CLUB SERVICES, NAMELY, PROVIDING INSTRUCTION AND EQUIPMENT IN THE FIELD OF PHYSICAL EXERCISE; PROVIDING SPORTS FACILITIES AND TENNIS COURT FACILITIES; ENTERTAINMENT IN THE NATURE OF GOLF AND TENNIS TOURNAMENTS; GOLF CLUB SERVICES; GOLF CADIE SERVICES (U.S. CLS. 100, 101 AND 107). FIRST USE 12-0-2002; IN COMMERCE 12-0-2002.

CLASS 43—HOTEL AND RESTAURANT SERVICES

FOR PROVIDING RESORT HOTELS AND LODGING SERVICES; RESTAURANT AND BAR SERVICES (U.S. CLS. 100 AND 101). FIRST USE 12-0-2002; IN COMMERCE 12-0-2002.

CLASS 44—MEDICAL, BEAUTY AND AGRICULTURAL SERVICES

FOR HEALTH SPA SERVICES, NAMELY, COSMETIC BODY CARE SERVICES; BEAUTY SALON SERVICES; MAKING RESERVATIONS AND BOOKINGS FOR OTHERS FOR TREATMENTS AT HEALTH SPAS AND BEAUTY SALONS (U.S. CLS. 100 AND 101). FIRST USE 12-0-2002; IN COMMERCE 12-0-2002. BRENDAN REGAN, EXAMINING ATTORNEY

SN 85-254,820. ENDER TECHNOLOGY CORPORATION, TORRANCE, CA. FILED 3-1-2011.

Ender Technology

THE MARK CONSISTS OF STANDARD CHARACTERS WITHOUT CLAIM TO ANY PARTICULAR FONT, STYLE, SIZE, OR COLOR.

NO CLAIM IS MADE TO THE EXCLUSIVE RIGHT TO USE "TECHNOLOGY", APART FROM THE MARK AS SHOWN.

CLASS 9—ELECTRICAL AND SCIENTIFIC APPARATUS

FOR COMPUTER SOFTWARE DEVELOPMENT TOOLS; WEB SITE DEVELOPMENT SOFTWARE (U.S. CLS. 21, 23, 26, 36 AND 38). FIRST USE 2-1-2000; IN COMMERCE 2-1-2000.

CLASS 42—SCIENTIFIC AND COMPUTER SERVICES

FOR COMPUTER SOFTWARE DEVELOPMENT; CONSULTING IN THE FIELD OF IT PROJECT MANAGEMENT; DESIGN, CREATION, HOSTING, MAINTENANCE OF WEBSITES FOR OTHERS; DESIGN, DEVELOPMENT AND IMPLEMENTATION OF SOFTWARE; DESIGNING, CREATING, MAINTAINING AND HOSTING ONLINE RETAIL AND ELECTRONIC COMMERCE WEBSITES FOR OTHERS; IT CONSULTING SERVICES; MAINTENANCE OF WEBSITES AND HOSTING ON-LINE WEB FACILITIES FOR OTHERS; PLANNING, DESIGN, DEVELOPMENT, MAINTENANCE AND OPTIMIZATION OF ONLINE WEBSITES FOR THIRD PARTIES; WEBSITE DESIGN AND DEVELOPMENT FOR OTHERS (U.S. CLS. 100 AND 101). FIRST USE 2-1-2000; IN COMMERCE 2-1-2000. MARGERY A. TIERNEY, EXAMINING ATTORNEY

SN 85-254,825. ENDER TECHNOLOGY CORPORATION, TORRANCE, CA. FILED 3-1-2011.

SN 85-254,840. BUILDERSCAPE, PLAIN CITY, OH. FILED 3-1-2011.

EnderTech

THE MARK CONSISTS OF STANDARD CHARACTERS WITHOUT CLAIM TO ANY PARTICULAR FONT, STYLE, SIZE, OR COLOR.

CLASS 9—ELECTRICAL AND SCIENTIFIC APPARATUS

FOR COMPUTER SOFTWARE DEVELOPMENT TOOLS; WEB SITE DEVELOPMENT SOFTWARE (U.S. CLS. 21, 23, 26, 36 AND 38).

FIRST USE 7-1-2002; IN COMMERCE 7-1-2002.

CLASS 42—SCIENTIFIC AND COMPUTER SERVICES

FOR COMPUTER SOFTWARE DEVELOPMENT; CONSULTING IN THE FIELD OF IT PROJECT MANAGEMENT; DESIGN, CREATION, HOSTING, MAINTENANCE OF WEBSITES FOR OTHERS; DESIGN, DEVELOPMENT AND IMPLEMENTATION OF SOFTWARE; DESIGNING, CREATING, MAINTAINING AND HOSTING ONLINE RETAIL AND ELECTRONIC COMMERCE WEBSITES FOR OTHERS; IT CONSULTING SERVICES; MAINTENANCE OF WEBSITES AND HOSTING ON-LINE WEB FACILITIES FOR OTHERS; PLANNING, DESIGN, DEVELOPMENT, MAINTENANCE AND OPTIMIZATION OF ONLINE WEBSITES FOR THIRD PARTIES; WEBSITE DESIGN AND DEVELOPMENT FOR OTHERS (U.S. CLS. 100 AND 101).

FIRST USE 7-1-2002; IN COMMERCE 7-1-2002.

MARGERY A. TIERNEY, EXAMINING ATTORNEY

SN 85-254,839. NEVER SUMMER INDUSTRIES, INC., DENVER, CO. FILED 3-1-2011.

NEVER SUMMER

THE MARK CONSISTS OF STANDARD CHARACTERS WITHOUT CLAIM TO ANY PARTICULAR FONT, STYLE, SIZE, OR COLOR.

OWNER OF U.S. REG. NO. 3,015,884.

CLASS 25—CLOTHING

FOR BEANIES; CAPS; HATS; HOODED PULLOVERS; HOODED SWEATSHIRTS; LONG-SLEEVED SHIRTS; PULLOVERS; SHIRTS; SWEATSHIRTS; T-SHIRTS (U.S. CLS. 22 AND 39).

FIRST USE 12-0-1991; IN COMMERCE 12-0-1991.

CLASS 28—TOYS AND SPORTING GOODS

FOR BAGS FOR SKATEBOARDS; BAGS SPECIALLY ADAPTED FOR SPORTS EQUIPMENT; LONGBOARD WHEELS; LONGBOARDS; SKATEBOARD DECKS; SKATEBOARD WHEELS; SKATEBOARDS; SNOWBOARD DECKS; SNOWBOARDS (U.S. CLS. 22, 23, 38 AND 50).

FIRST USE 12-0-1991; IN COMMERCE 12-0-1991.

MICHELLE DUBOIS, EXAMINING ATTORNEY

Builderscape

THE MARK CONSISTS OF STANDARD CHARACTERS WITHOUT CLAIM TO ANY PARTICULAR FONT, STYLE, SIZE, OR COLOR.

CLASS 37—CONSTRUCTION AND REPAIR

FOR BUILDING CONSTRUCTION AND REPAIR; CONSTRUCTING DECKS; CONSTRUCTING PORCHES; CONSTRUCTION AND INSTALLATION OF MASONRY WALLS AND STRUCTURES; CONSTRUCTION GRADING SERVICES; CONSTRUCTION OF BUILDINGS; CONSTRUCTION PROJECT MANAGEMENT SERVICES; GENERAL CONSTRUCTION CONTRACTING; INSTALLATION AND MAINTENANCE OF IRRIGATION SYSTEMS; IRRIGATION DEVICES INSTALLATION AND REPAIR; SNOW REMOVAL SERVICES (U.S. CLS. 100, 103 AND 106).

CLASS 44—MEDICAL, BEAUTY AND AGRICULTURAL SERVICES

FOR HORTICULTURAL PROCESSES AND TURF OR LAWN CARE SERVICES, NAMELY, PROVIDING PREPARATION AND DEVELOPMENT OF TURFGRASS AND/OR SOIL FOR PROVIDING AN ENVIRONMENT THAT ENCOURAGES IMPROVED GROWTH ATTRIBUTES; LANDSCAPE DESIGN; LAWN CARE; LAWN MOWING SERVICES (U.S. CLS. 100 AND 101).

HAI-LY LAM, EXAMINING ATTORNEY

SN 85-254,853. TRAPIT, INC., PALO ALTO, CA. FILED 3-1-2011.

Trapit

THE MARK CONSISTS OF STANDARD CHARACTERS WITHOUT CLAIM TO ANY PARTICULAR FONT, STYLE, SIZE, OR COLOR.

CLASS 9—ELECTRICAL AND SCIENTIFIC APPARATUS

FOR COMPUTER SEARCH ENGINE SOFTWARE (U.S. CLS. 21, 23, 26, 36 AND 38).

FIRST USE 7-0-2010; IN COMMERCE 8-0-2010.

CLASS 42—SCIENTIFIC AND COMPUTER SERVICES

FOR ADVANCED PRODUCT RESEARCH IN THE FIELD OF ARTIFICIAL INTELLIGENCE; PROVIDING A WEBSITE FEATURING A MEDIA AGGREGATOR AND SEARCH ENGINE FOR INTERNET CONTENT; PROVIDING CUSTOMIZED ON-LINE WEB PAGES AND DATA FEEDS FEATURING USER-DEFINED INFORMATION, WHICH INCLUDES BLOG POSTS, NEW MEDIA CONTENT, OTHER ON-LINE CONTENT, AND ON-LINE WEB LINKS TO OTHER WEBSITES (U.S. CLS. 100 AND 101).

FIRST USE 7-0-2010; IN COMMERCE 8-0-2010.

DORITT L. CARROLL, EXAMINING ATTORNEY

SN 85-254,878. STERLING INTERNATIONAL INC., SPOKANE, WA. FILED 3-1-2011.

ATTRACSTIK

THE MARK CONSISTS OF STANDARD CHARACTERS WITHOUT CLAIM TO ANY PARTICULAR FONT, STYLE, SIZE, OR COLOR.

CLASS 5—PHARMACEUTICALS

FOR INSECT ATTRACTANTS FOR USE IN PEST CONTROL (U.S. CLS. 6, 18, 44, 46, 51 AND 52).

CLASS 21—HOUSEWARES AND GLASS

FOR INSECT CONTROL TRAPS (U.S. CLS. 2, 13, 23, 29, 30, 33, 40 AND 50).

CLASS 37—CONSTRUCTION AND REPAIR

FOR INDUSTRIAL, COMMERCIAL, AND RESIDENTIAL PEST CONTROL SERVICES FOR OTHERS, NAMELY, THE SELECTION, IMPLEMENTATION, AND USE OF PEST CONTROL TECHNOLOGY; PROVIDING ON-LINE INFORMATION IN THE FIELD OF INDUSTRIAL, COMMERCIAL, AND RESIDENTIAL PEST CONTROL (U.S. CLS. 100, 103 AND 106).

CLASS 44—MEDICAL, BEAUTY AND AGRICULTURAL SERVICES

FOR AGRICULTURAL PEST CONTROL SERVICES FOR OTHERS, NAMELY, THE SELECTION, IMPLEMENTATION, AND USE OF PEST CONTROL TECHNOLOGY; PROVIDING ON-LINE INFORMATION IN THE FIELD OF AGRICULTURAL PEST CONTROL (U.S. CLS. 100 AND 101).

DAVID H. STINE, EXAMINING ATTORNEY

SN 85-254,935. NEVER SUMMER INDUSTRIES, INC., DENVER, CO. FILED 3-1-2011.



THE MARK CONSISTS OF A STYLIZED DRAWING OF AN EAGLE SURROUNDED BY FOUR ARC SHAPES THAT CREATE A CIRCLE AROUND THE EAGLE.

CLASS 25—CLOTHING

FOR BEANIES; CAPS; HATS; HOODED PULLOVERS; HOODED SWEATSHIRTS; LONG-SLEEVED SHIRTS; PULLOVERS; SHIRTS; SWEATSHIRTS; T-SHIRTS (U.S. CLS. 22 AND 39).

FIRST USE 7-0-2005; IN COMMERCE 7-0-2005.

CLASS 28—TOYS AND SPORTING GOODS

FOR BAGS FOR SKATEBOARDS; BAGS SPECIALLY ADAPTED FOR SPORTS EQUIPMENT; LONGBOARD WHEELS; LONGBOARDS; SKATEBOARD DECKS; SKATEBOARD WHEELS; SKATEBOARDS; SNOWBOARD DECKS; SNOWBOARDS (U.S. CLS. 22, 23, 38 AND 50).

FIRST USE 7-0-2005; IN COMMERCE 7-0-2005.

MICHELLE DUBOIS, EXAMINING ATTORNEY

SN 85-254,970. L'OREAL, PARIS, FRANCE, FILED 3-1-2011.

THE WORLD NEEDS BEAUTY

THE MARK CONSISTS OF STANDARD CHARACTERS WITHOUT CLAIM TO ANY PARTICULAR FONT, STYLE, SIZE, OR COLOR.

CLASS 3—COSMETICS AND CLEANING PREPARATIONS

FOR PERFUME, TOILET WATER; GELS, SALTS FOR THE BATH AND THE SHOWER NOT FOR MEDICAL PURPOSE; TOILET SOAPS, BODY DEODORANTS; COSMETICS, NAMELY, CREAMS, MILKS, LOTIONS, GELS AND POWDERS FOR THE FACE, THE BODY AND THE HANDS; NON-MEDICATED SUN CARE PREPARATIONS; MAKEUP PREPARATIONS; SHAMPOOS; GELS, SPRAYS, MOUSSES AND BALMS FOR HAIR STYLING AND HAIR CARE; HAIR LACQUERS; HAIR COLORING AND HAIR DECOLORANT PREPARATIONS; PERMANENT WAVING AND CURLING PREPARATIONS; ESSENTIAL OILS FOR PERSONAL USE (U.S. CLS. 1, 4, 6, 50, 51 AND 52).

CLASS 44—MEDICAL, BEAUTY AND AGRICULTURAL SERVICES

FOR COSMETIC BODY CARE SERVICES (U.S. CLS. 100 AND 101).

SIMON TENG, EXAMINING ATTORNEY

SN 85-254,994. WEATHERSTONE CHURCH, NEW BERLIN, WI. FILED 3-1-2011.

WEATHERSTONE

THE MARK CONSISTS OF STANDARD CHARACTERS WITHOUT CLAIM TO ANY PARTICULAR FONT, STYLE, SIZE, OR COLOR.

CLASS 41—EDUCATION AND ENTERTAINMENT

FOR RELIGIOUS INSTRUCTION SERVICES (U.S. CLS. 100, 101 AND 107).
FIRST USE 1-0-2011; IN COMMERCE 1-0-2011.

CLASS 45—PERSONAL AND LEGAL SERVICES

FOR CONDUCTING RELIGIOUS PRAYER SERVICES; RELIGIOUS AND SPIRITUAL SERVICES, NAMELY, PROVIDING GATHERINGS AND RETREATS TO DEVELOP AND ENHANCE THE SPIRITUAL LIVES OF INDIVIDUALS (U.S. CLS. 100 AND 101).
FIRST USE 1-0-2011; IN COMMERCE 1-0-2011.
KIMBERLY FRYE, EXAMINING ATTORNEY

SN 85-255,009. PATCHPAK, LLC, FORT WORTH, TX. FILED 3-1-2011.

PATCHPAK

THE MARK CONSISTS OF STANDARD CHARACTERS WITHOUT CLAIM TO ANY PARTICULAR FONT, STYLE, SIZE, OR COLOR.

CLASS 18—LEATHER GOODS

FOR BACKPACKS, BOOK BAGS, DUFFLE BAGS, MESSENGER BAGS, SHOULDER BAGS, SPORT BAGS, AND TOTE BAGS (U.S. CLS. 1, 2, 3, 22 AND 41).

CLASS 26—FANCY GOODS

FOR ORNAMENTAL CLOTH PATCHES; EMBROIDERED CLOTH PATCHES; FABRIC APPLIQUES (U.S. CLS. 37, 39, 40, 42 AND 50).
KAPIL BHANOT, EXAMINING ATTORNEY

SN 85-255,030. TED WILLIAMS FAMILY ENTERPRISES, LTD, HERNANDO, FL. FILED 3-1-2011.

TED WILLIAMS

THE MARK CONSISTS OF STANDARD CHARACTERS WITHOUT CLAIM TO ANY PARTICULAR FONT, STYLE, SIZE, OR COLOR.

THE NAME(S), PORTRAIT(S), AND/OR SIGNATURE(S) SHOWN IN THE MARK DOES NOT IDENTIFY A PARTICULAR LIVING INDIVIDUAL.

CLASS 9—ELECTRICAL AND SCIENTIFIC APPARATUS

FOR DIGITAL MATERIALS, NAMELY, DVDS AND DOWNLOADABLE VIDEO FILES FEATURING BASEBALL INSTRUCTION, INFORMATION ON BASEBALL AND INFORMATION ABOUT AND INTERVIEWS WITH BASEBALL PLAYERS; VIDEO TAPES FEATURING BASEBALL INSTRUCTION, INFORMATION ON BASEBALL AND INFORMATION ABOUT AND INTERVIEWS WITH BASEBALL PLAYERS (U.S. CLS. 21, 23, 26, 36 AND 38).

FIRST USE 10-8-1993; IN COMMERCE 10-8-1993.

CLASS 25—CLOTHING

FOR BASEBALL CAPS; BASEBALL UNIFORMS; HATS; SHIRTS; T-SHIRTS (U.S. CLS. 22 AND 39).
FIRST USE 1-0-1975; IN COMMERCE 1-0-1975.

CLASS 28—TOYS AND SPORTING GOODS

FOR BASEBALL BATS; BASEBALL GLOVES; BASEBALL MITTS; BASEBALLS (U.S. CLS. 22, 23, 38 AND 50).
FIRST USE 7-1-1997; IN COMMERCE 7-1-1997.

CLASS 41—EDUCATION AND ENTERTAINMENT

FOR BASEBALL CAMPS; ENTERTAINMENT IN THE NATURE OF YOUTH LEAGUE BASEBALL LEAGUES AND BASEBALL GAMES (U.S. CLS. 100, 101 AND 107).
FIRST USE 1-1-1997; IN COMMERCE 1-1-1997.
DANNEAN HETZEL, EXAMINING ATTORNEY

SN 85-255,031. PASTOR CAMPELLO, ANTONIA, 03201 ELCHE (ALICANTE), SPAIN, FILED 3-1-2011.

 CUPLE

OWNER OF ERPN CMNTY TM OFC REG. NO. 005944186, DATED 5-5-2008, EXPIRES 5-28-2017.

OWNER OF U.S. REG. NO. 2,937,950.
THE MARK CONSISTS OF THE WORD "CUPLE" AND A DESIGN OF INTERSECTING CURVED LINES.
THE ENGLISH TRANSLATION OF "CUPLE" IN THE MARK IS "POPULAR LYRICAL SONG".

CLASS 18—LEATHER GOODS

FOR HANDBAGS, PURSES, WALLETS (U.S. CLS. 1, 2, 3, 22 AND 41).

CLASS 25—CLOTHING

FOR FOOTWEAR, BELTS AND READY-MADE CLOTHING, NAMELY, SHIRTS, T-SHIRTS, TROUSERS, SHORTS, SKIRTS, PULLOVERS, SWEATERS, CARDIGANS, JACKETS, SWIMWEAR, COATS, ANORAKS, TIES, WRISTBANDS, SOCKS (U.S. CLS. 22 AND 39).

CLASS 35—ADVERTISING AND BUSINESS

FOR RETAIL STORE AND ON-LINE RETAIL STORE SERVICES FEATURING FOOTWEAR, HANDBAGS, BELTS, READY-MADE CLOTHING, HEADGEAR, AND FASHION ACCESSORIES, NAMELY, JEWELRY, PURSES, WALLETS, TIES, WRISTBANDS, SOCKS (U.S. CLS. 100, 101 AND 102).

DANNEAN HETZEL, EXAMINING ATTORNEY

SN 85-255,063. DEKKER MARKETING, SAN DIEGO, CA.
FILED 3-1-2011.

SN 85-255,159. A LOVELY DARE, INC, CUMMING, GA.
FILED 3-1-2011.

FROM THE BOAT TO THE PARTY

THE MARK CONSISTS OF STANDARD CHARACTERS WITHOUT CLAIM TO ANY PARTICULAR FONT, STYLE, SIZE, OR COLOR.

CLASS 25—CLOTHING

FOR JACKETS; PANTS; SHIRTS; SHOES (U.S. CLS. 22 AND 39).
FIRST USE 8-1-2010; IN COMMERCE 8-1-2010.

CLASS 35—ADVERTISING AND BUSINESS

FOR ON-LINE RETAIL STORE SERVICES FEATURING JACKETS, SHIRTS, PANTS, SHORTS, AND SHOES (U.S. CLS. 100, 101 AND 102).
FIRST USE 8-1-2010; IN COMMERCE 8-1-2010.
DEIRDRE ROBERTSON, EXAMINING ATTORNEY

SN 85-255,087. MY PINK VANITY, INC, GRAYSLAKE, IL.
FILED 3-1-2011.



NO CLAIM IS MADE TO THE EXCLUSIVE RIGHT TO USE "ESTABLISHED 2010", APART FROM THE MARK AS SHOWN.

THE COLOR(S) BLACK, PINK, AND AQUA IS/ARE CLAIMED AS A FEATURE OF THE MARK.

THE MARK CONSISTS OF THE WORDING "ESTABLISHED 2010" IS PINK, ALL LETTERS IN "MY PINK VANITY" (EXCEPT THE "P") ARE BLACK, THE LETTER P IN "MY PINK VANITY" IS PINK, THE WORDING "GLAMOUR ISN'T JUST A THING OF THE PAST..." IS ALL AQUA, THE STYLIZED VANITY MIRROR IMAGE CONSISTING OF AN OVAL AND SCROLLS IS BLACK.

CLASS 3—COSMETICS AND CLEANING PREPARATIONS

FOR BODY AND BEAUTY CARE COSMETICS (U.S. CLS. 1, 4, 6, 50, 51 AND 52).

CLASS 26—FANCY GOODS

FOR HAIR EXTENSIONS (U.S. CLS. 37, 39, 40, 42 AND 50).
FIRST USE 1-19-2010; IN COMMERCE 4-15-2010.
MATTHEW KLINE, EXAMINING ATTORNEY

Loveville

THE MARK CONSISTS OF STANDARD CHARACTERS WITHOUT CLAIM TO ANY PARTICULAR FONT, STYLE, SIZE, OR COLOR.

CLASS 41—EDUCATION AND ENTERTAINMENT

FOR PROVIDING A WEB-BASED SYSTEM AND ON-LINE PORTAL FOR CUSTOMERS TO PARTICIPATE IN ON-LINE GAMING, OPERATION AND COORDINATION OF GAME TOURNAMENTS, LEAGUES AND TOURS (U.S. CLS. 100, 101 AND 107).

CLASS 45—PERSONAL AND LEGAL SERVICES

FOR ON-LINE SOCIAL NETWORKING SERVICES (U.S. CLS. 100 AND 101).
JANICE L. MCMORROW, EXAMINING ATTORNEY

SN 85-255,249. POSTLETS LLC, BELMONT, CA. FILED 3-2-2011.

POSTLETS

THE MARK CONSISTS OF STANDARD CHARACTERS WITHOUT CLAIM TO ANY PARTICULAR FONT, STYLE, SIZE, OR COLOR.

CLASS 35—ADVERTISING AND BUSINESS

FOR DESIGN OF ADVERTISING MATERIALS FOR OTHERS; DESIGN OF INTERNET ADVERTISING; ON-LINE ADVERTISING AND MARKETING SERVICES; REAL ESTATE ADVERTISING SERVICES; REAL ESTATE MARKETING SERVICES, NAMELY, ON-LINE SERVICES FEATURING TOURS OF RESIDENTIAL AND COMMERCIAL REAL ESTATE (U.S. CLS. 100, 101 AND 102).
FIRST USE 5-7-2005; IN COMMERCE 5-7-2005.

CLASS 36—INSURANCE AND FINANCIAL

FOR CLASSIFIED REAL ESTATE LISTINGS OF APARTMENT RENTALS AND HOUSING RENTALS; PROVIDING REAL ESTATE LISTINGS AND REAL ESTATE INFORMATION VIA THE INTERNET; REAL ESTATE LISTING SERVICES FOR HOUSING RENTALS AND APARTMENT RENTALS (U.S. CLS. 100, 101 AND 102).
FIRST USE 5-7-2005; IN COMMERCE 5-7-2005.

CLASS 42—SCIENTIFIC AND COMPUTER SERVICES

FOR COMPUTER SERVICES, NAMELY, SEARCH ENGINE OPTIMIZATION; HOSTING OF DIGITAL CONTENT ON THE INTERNET; HOSTING OF WEB SITES; WEB SITE DESIGN; WEB SITE DEVELOPMENT FOR OTHERS (U.S. CLS. 100 AND 101).

FIRST USE 5-7-2005; IN COMMERCE 5-7-2005.
DOUGLAS LEE, EXAMINING ATTORNEY



SN 85-255,283. DIAGNOSTIC DEVICES, INC., CHARLOTTE, NC. FILED 3-2-2011.

AUTOCODE PRO

THE MARK CONSISTS OF STANDARD CHARACTERS WITHOUT CLAIM TO ANY PARTICULAR FONT, STYLE, SIZE, OR COLOR.

OWNER OF U.S. REG. NOS. 3,590,542 AND 3,590,585.

CLASS 5—PHARMACEUTICALS

FOR MEDICAL DIAGNOSTIC TEST STRIPS FOR DETERMINING THE LEVELS OF GLUCOSE IN BLOOD (U.S. CLS. 6, 18, 44, 46, 51 AND 52).

CLASS 10—MEDICAL APPARATUS

FOR BLOOD GLUCOSE METERS (U.S. CLS. 26, 39 AND 44).

JOSETTE BEVERLY, EXAMINING ATTORNEY



SN 85-255,469. MENTAL IMAGES GMBH, BERLIN, FED REP GERMANY, FILED 3-2-2011.

REALITY ISLAND

THE MARK CONSISTS OF STANDARD CHARACTERS WITHOUT CLAIM TO ANY PARTICULAR FONT, STYLE, SIZE, OR COLOR.

CLASS 41—EDUCATION AND ENTERTAINMENT

FOR EDUCATIONAL SERVICES, NAMELY, PROVIDING ON-LINE TRAINING IN THE FORM OF COURSES, SEMINARS, AND WORKSHOPS IN THE FIELDS OF USING SOFTWARE FOR DESIGNING INNOVATIVE VIRTUAL REALITY ENVIRONMENTS, DESIGNING COMPUTER GAMES AND VIRTUAL REALITY SOFTWARE AND COMPUTER GRAPHICS OPERATIONS AND IMAGE RENDERING, DIGITAL ANIMATION AND SPECIAL EFFECTS OF IMAGES; ENTERTAINMENT SERVICES, NAMELY, PROVIDING ON-LINE INTERACTIVE COMPUTER GAMES, ON-LINE INTERACTIVE VIRTUAL REALITY GAMES, ON-LINE COMPUTER GAMES, ON-LINE VIRTUAL REALITY GAMES, AND ON-LINE MULTI-PLAYER ELECTRONIC COMPUTER GAMES; ENTERTAINMENT SERVICES, NAMELY, PROVIDING AN ON-LINE COMPUTER GAME (U.S. CLS. 100, 101 AND 107).

CLASS 42—SCIENTIFIC AND COMPUTER SERVICES

FOR COMPUTER SERVICES, NAMELY, PROVIDING TEMPORARY USE OF ON-LINE, NON-DOWNLOADABLE SOFTWARE FOR DESIGNING INNOVATIVE VIRTUAL REALITY ENVIRONMENTS; COMPUTER SERVICES, NAMELY, PROVIDING AN ON-LINE COMPUTER DATABASE FEATURING COMPUTER SOFTWARE DESIGN INFORMATION REGARDING DESIGNING INNOVATIVE VIRTUAL REALITY ENVIRONMENTS; COMPUTER SERVICES, NAMELY, PROVIDING AN ON-LINE COMPUTER DATABASE IN THE FIELD OF THE DESIGN OF DIGITAL ANIMATION AND SPECIAL EFFECTS OF IMAGES; COMPUTER SERVICES, NAMELY, CREATING AN ONLINE COMMUNITY FOR REGISTERED USERS TO PARTICIPATE IN VIRTUAL ENVIRONMENTS AND TO SHOWCASE THEIR COMPUTER GRAPHICS AND IMAGE RENDERING, DIGITAL ANIMATION, AND SPECIAL EFFECTS IMAGES; COMPUTER SERVICES, NAMELY, HOSTING ON-LINE WEB FACILITIES FOR OTHERS FOR ORGANIZING AND CONDUCTING ONLINE MEETINGS, GATHERINGS, AND INTERACTIVE DISCUSSIONS; COMPUTER SERVICES IN THE NATURE OF CUSTOMIZED WEB PAGES FEATURING USER-DEFINED INFORMATION, PERSONAL PROFILES AND INFORMATION; COMPUTER SERVICES, NAMELY, HOSTING THE WEB SITES OF OTHERS ON A COMPUTER SERVER FOR A GLOBAL COMPUTER NETWORK; COMPUTER SERVICES, NAMELY, CREATING AND MAINTAINING WEB SITES FOR OTHERS (U.S. CLS. 100 AND 101).

SIMON TENG, EXAMINING ATTORNEY



SN 85-255,497. SPX CORPORATION, CHARLOTTE, NC. FILED 3-2-2011.

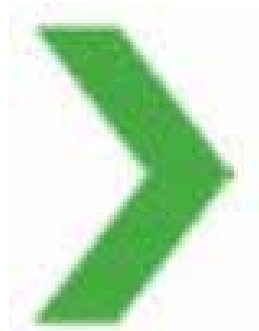

THE COLOR(S) GREEN IS/ARE CLAIMED AS A FEATURE OF THE MARK.
THE MARK CONSISTS OF A STYLIZED ARROW IN THE COLOR GREEN.

CLASS 7—MACHINERY

FOR HYDRAULIC JACKS; HYDRAULIC RAMS; POWER-OPERATED GEAR AND BEARING PULLERS; PNEUMATIC GREASE GUNS; VACUUM PUMPS; PORTABLE CABLE HOISTS; POWER-OPERATED PULLER FOR REMOVAL AND INSTALLATION OF GEARS, BEARING, WHEELS, PULLEYS, SLEEVES, SHAFTS AND OTHER FRICTION FITTED PARTS; SHOP CRANES; HYDRAULIC TRANSMISSION JACKS; CRAWLER TRACK HYDRAULIC PRESSES; HYDRAULICALLY POWERED CLAMPS FOR HOLDING WORK PIECES WHILE MANUFACTURING OPERATIONS ARE BEING PERFORMED THEREON, PORTABLE SELF-CONTAINED AIR/HYDRAULIC CIRCUIT CONTROL AND REGULATING VALVE ACTUATOR UNIT UTILIZED AS A CENTRAL POWER SOURCE FOR WORK CLAMPING DEVICES; POWER-OPERATED RACKS FOR GREASING AND REPAIRING VEHICLES; MOBILE HYDRAULIC VEHICLE JACKS; FLUID POWER PRODUCTS, NAMELY, ELECTRIC, PNEUMATIC AND ENGINE DRIVEN FLUID OPERATED PUMPS, MOTORS, CYLINDERS AND LINEAR ACTUATORS, RAMS, PRESSES, JACKS AND STRUCTURAL PARTS THEREFOR; POWER-OPERATED PORTABLE REFRIGERANT CHARGING STATION CONSISTING OF CONTROLS, GAUGES AND VALVES AND ASSOCIATED REFRIGERANT AND HOSES ALL SOLD AS A UNIT; POWER-OPERATED PORTABLE TORQUE CONVERTER NOT FOR LAND MACHINES AND AIR COOLER CLEANING MACHINE; ELECTRIC OIL FILTER CRUSHES; POWER-OPERATED HAND-HELD CRIMPERS; HYDRAULIC PUMPING UNITS; PORTABLE CABLE HOISTS; POWER-OPERATED PULLER FOR REMOVAL AND INSTALLATION OF GEARS, BEARINGS, WHEELS, PULLEYS, SLEEVES, SHAFTS AND OTHER FRICTION FITTED PARTS; SHOP CRANES, MACHINE PARTS, NAMELY, HYDRAULIC LOAD BEARING VALVES, HYDRAULIC CHECK VALVES, HYDRAULIC Y MANIFOLD, MULTIPLE PORT HYDRAULIC MANIFOLD BLOCKS; HYDRAULIC JACKS; HYDRAULIC TORQUE TENSIONERS; POWER-OPERATED VEHICLE PIECE SUPPORTING TOOLS FOR USE IN THE SERVICE AND REPAIR OF ENGINES, DRIVE TRAINS AND SUSPENSIONS; BRAKE DRUM AND SHOE FINISHING MACHINE; POWER-OPERATED UNITS FOR MOUNTING VEHICLE WHEELS AND TIRES; HYDRAULIC CONTROLS FOR PLOWING AND GRADING MACHINES; INDUSTRIAL MIXING MACHINE FOR MIXING ALL TYPES OF FLUIDS AND SOLIDS; TRANSMISSION OIL COOLER FLUSH AND FLOW TEST MACHINE; FUEL AND OIL FILTERS; FILTERS FOR INDUSTRIAL USE AS PARTS OF MACHINERY, NAMELY, LIQUID FILTERS, DRY GAS FILTERS, FILTER SEPARATORS, COALESCERS, CARBON BED FILTERS, VALVES BEING PARTS OF MACHINES, NAMELY, BUTTERFLY VALVES, BALL VALVES, GATE VALVES; POSITIVE DISPLACEMENT PUMPS; VACUUM PUMPS; HYDRAULIC HANDLERS FOR USE WITH PLOW AND GRADES CUTTING EDGE BLADES; INDUSTRIAL PUMPS, NAMELY, ROTARY PUMPS, SCREW PUMPS AND POSITIVE DISPLACEMENT PUMPS; PNEUMATIC AND ELECTRO-PNEUMATIC POSITIONERS; HEAT EXCHANGERS BEING PARTS OF MACHINES; GEAR PUMPS AND CENTRIFUGAL PUMPS FOR INDUSTRIAL PURPOSES; ELECTRIC, CENTRIFUGAL AND HYDRAULIC PUMPS FOR INDUSTRIAL PURPOSES (U.S. CLS. 13, 19, 21, 23, 31, 34 AND 35).

CLASS 9—ELECTRICAL AND SCIENTIFIC APPARATUS

FOR MACHINES AND GAUGES FOR TESTING INTERNAL COMBUSTION ENGINES, NAMELY, ELECTRICAL, IGNITION, TRANSMISSION, EXHAUST, CARBURETOR AND FUEL COMPRESSION TESTERS AND ANALYZERS; PRESSURE GAUGES; VEHICLE INJECTION NOZZLE TESTERS; OHM METERS, VOLT-METERS, CAPACITOR ANALYZERS, VOLT WATT METERS, VOLTAGE CONTINUITY TESTERS, VACUUM GAUGES, MANOMETERS; SAFETY GOGGLES; HYDRAULIC PRESSURE GAUGES; PINION ANGLE LEVEL GAUGES; HYDRAULIC IN-LINE PRESSURE TESTERS AND CONNECTOR ACCESSORIES THEREFOR; COMPUTERS, KEYBOARDS AND PRINTERS AND RELATED ACCESSORIES FOR CONTROLLED DIAGNOSTIC ANALYSIS OF VEHICLE ENGINES AND DRIVE TRAINS AND MANUALS FOR USE THEREWITH; DIESEL EN-

GINE TIMING METER; VEHICLE CHARGING SYSTEM ANALYZERS; ELECTRONIC IGNITION ANALYZERS; HYDRAULIC SYSTEM TESTING UNITS; COMPUTERIZED VEHICLE ENGINE ANALYZERS; HYDRAULIC/FLUID FLOW, PRESSURE AND TEMPERATURE TESTERS AND STRUCTURAL PARTS THEREFOR; SOLENOID VALVES; COMPUTER DATABASE SOFTWARE FOR SELECTING VEHICLE AND TOOL REPLACEMENT PARTS; ELECTRONIC BATTERY TESTERS; VACUUM GAUGES FOR REFRIGERATION SYSTEMS; CONTROL PANELS AND MANUALLY AND PYROMETRICALLY AND GALNOMETRICALLY CONTROLLED ELECTRIC SWITCHES RHEOSTATS, AND HEATING-CURRENT CONTROLLERS FOR REGULATING OR CONTROLLING THE TEMPERATURE OR OPERATING CONDITIONS OF ELECTRIC FURNACES, ELECTRIC OVENS, AND ELECTRIC HEAT-TREATING FURNACES; ELECTRIC FLOW METERS AND PRESSURE OR RATE OF FLOW CONTROLLERS, AND TELEMETERS; MECHANICAL FLOW METERS FOR RECORDING AND TOTALIZING WITH OR WITHOUT INDICATING MEANS; PNEUMATICALLY OPERATED REGULATOR TO VARY THE PASSAGE OF COMPRESSED AIR THROUGH A CONDUIT IN RESPONSE TO A CONTROLLED PRESSURE APPLIED THERETO; VOLTAGE AND CURRENT REGULATORS AND COMPENSATORS, BALLASTS AND REACTORS, ROTARY TYPE INTEGRATING FLOW METERS FOR STEAM, AIR AND GAS, AND ACCESSORIES THEREFOR, NAMELY, LIQUID GAUGE GLASS, REMOTE TOTALIZER, FLOW RATE INDICATOR, FLOW RATE RECORDER, FLOW DEMAND INDICATOR AND FLOW DEMAND RECORDER; VOLTAGE SENSING RELAYS, AND CURRENT SENSING RELAYS; LABORATORY MIXERS; DATA PROCESSING AND CONTROL SWITCHES AND RELAYS; MOISTURE DETECTING DEVICES FOR OIL QUENCH TANKS; ELECTRIC LINE VOLTAGE REGULATORS; ELECTRICAL AND ELECTRONIC EQUIPMENT, NAMELY, COILS, TRANSFORMERS, INDUCTORS AND REACTORS, ELECTRONIC RELAYS, SIGNAL GENERATORS, STATIC MAGNETIC VOLTAGE REGULATORS; ELECTROMECHANICAL DIAMETER CONTROL UNITS FOR CRYSTAL GROWING FURNACES; ELECTRICAL TRANSMISSION LINES, NAMELY, ELECTRONIC WAVEGUIDES FOR TRANSMISSION OF RADIO FREQUENCY ENERGY; ENERGY TRANSMISSION AND DISTRIBUTION EQUIPMENT, NAMELY, ELECTRICAL TRANSFORMERS, VOLTAGE SURGE ARRESTERS, TAP CHANGERS, AND PACKAGE SUBSTATIONS; AUTOMATIC VALVES, NAMELY, CONTROL VALVES, BALL VALVES, GLOBE VALVES, BUTTERFLY VALVES, PLUG VALVES, CHECK VALVES, ECCENTRIC VALVES, KNIFE GATE VALVES, GATE VALVES, ISOLATION VALVES, DIVERTER VALVES AND SLEEVE VALVES; CONTROL VALVES FOR REGULATING THE FLOW OF GASES AND LIQUIDS; AUTOMATIC VALVE ASSEMBLIES, CONSISTENCY TRANSMITTERS, SOLENOIDS, PNEUMATIC MOTION TRANSMITTERS, ELECTRIC TRANSFORMERS; ELECTRIC PNEUMATIC TRANSDUCERS, INDUSTRIAL VAPOR AND STEAM CONDITIONING VALVES, STRAINERS, AIR GAP DRAINS, AND/OR SETTERS; BOILER WATER REGULATORS; BOILER PRESSURE GOVERNORS; ELECTRONIC BLADE CONSISTENCY TRANSMITTERS FOR MEASURING LIQUID MIXTURES IN INDUSTRY; COMPUTER SOFTWARE FOR ASSISTING IN VALVE SYSTEMS AND IN SPECIFYING VALVE PRODUCTS; ELECTRONIC DIGITAL CONTROLLER FOR POSITIONING VALVES IN INDUSTRIAL EQUIPMENT, COMPUTER MONITOR AND SIGNAL CONDITIONERS FOR DIAGNOSING CONTROL VALVE PERFORMANCE; ELECTRONIC VALVE ACTUATORS; COAXIAL CABLE; HAND HELD COMPUTER FOR USE IN DETECTING LEAKS IN PRESSURIZED CABLES; ELECTRONIC VALIDATING AND REGISTERING BUS FARE BOXES; TICKET AND TOKEN VENDING MACHINES; REVENUE COLLECTION AND SECURITY EQUIPMENT, NAMELY, ELECTRONIC FARE COLLECTION, STORAGE AND COUNTING APPARATUS; PORTABLE DYNAMIC SIGNAL ANALYZERS FOR THE MEASUREMENT AND ANALYSIS OF AUDIO AND VIDEO SIGNALS; RAILROAD AND TRANSIT ELECTRIC HYDRAULIC CONTROL SWITCHES; UNDERWATER SAFETY LIGHTS TO DIRECT THE MOVEMENT OF FISH; ELECTRONIC LIGHTING CONTROLLERS AND POWER CONVERTERS; ELECTRONIC RECONNAISSANCE SYSTEMS COMPRISED OF ANTENNAS, COMPUTERS, MACHINE READABLE COMPUTER-PROGRAMS, DIRECTION FINDING RECEIVERS,

RADIO FREQUENCY DISTRIBUTION AND SWITCHING APPARATUS, SIGNAL ACQUISITION AND CLASSIFICATION APPARATUS; RADIO JAMMING APPARATUS; BROADCAST EQUIPMENT FOR WIRELESS TRANSMISSIONS, RADIO, AND TELEVISION, NAMELY, ANTENNAS AND STRUCTURAL AND ELECTRICAL COMPONENTS, PARTS AND ACCESSORIES THEREFOR, NAMELY, SWITCHING APPARATUS, DIPLEXERS, TOWERS, TRANSMISSION LINES AND CABLES, MATCHING UNITS AND CONTROL APPARATUS; ELECTRICAL FIBER-OPTIC COMMUNICATION TRANSMISSION LINES FOR AUDIO AND VIDEO SIGNAL TRANSMISSION; OPTICAL WAVEGUIDES; METALLIC WAVEGUIDE AND COAXIAL CABLE AND END-CONNECTORS; AIR FLOW SENSORS; THERMOSTATS; EMERGENCY WARNING LIGHTS, NAMELY, AVIATION OBSTRUCTION LIGHTING; SECURITY LIGHTING SYSTEMS; BEACON AND OBSTRUCTION WARNING SYSTEMS COMPRISED PRIMARILY OF POWER CONVERTER AND FLASH HEAD AND COMPONENT PARTS; HAND HELD COMPUTER FOR DETECTING LEAKS IN PRESSURIZED CABLES; WIRELESS DATA CARRIERS AND RECEIVERS FOR USE WITH VEHICLE DIAGNOSING AND MONITORING; COMPUTER HARDWARE AND SOFTWARE USED FOR RADIO SIGNAL INTERCEPT AND DIRECTION FINDING, RECEIVERS AND PROCESSORS FOR USE WITH SUCH SIGNAL PROCESSING SYSTEMS; WEIGHING SCALES; HEATING, COOLING AND HUMIDIFIED ENVIRONMENTAL CHAMBERS FOR RESEARCH, TESTING AND PRODUCTION; ELECTRIC ACTUATORS (U.S. CLS. 21, 23, 26, 36 AND 38).

CLASS 11—ENVIRONMENTAL CONTROL APPARATUS

FOR ELECTRIC HEAT-TREATING FURNACES; ELECTRIC HEATING UNITS FOR ELECTRIC FURNACES, ELECTRIC OVENS AND ELECTRIC HEAT-TREATING FURNACES; DEHYDRATORS FOR CONTINUOUS DRYING AND REMOVAL OF MOISTURE FROM COMPRESSED AIR; CRYSTAL GROWING FURNACES; FLUID HANDLING EQUIPMENT FOR PLUMBING USE, NAMELY, FLUID CONTROL VALVES; WATER COOLING TOWERS; INDUSTRIAL AIR CLEANERS; CABLE PRESSURIZATION UNITS COMPRISED PRIMARILY OF AIR DRYERS, COMPRESSORS, CENTRAL OFFICE MANIFOLDS, DISTRIBUTION MANIFOLDS, METERS AND PIPE FEED ACCESS PANELS, AND AIR PIPE CONNECTORS FOR USE IN FORCING DRY AIR INTO CABLES IN ORDER TO PROTECT THE CABLES FROM WATER DAMAGE; ELECTRIC DEHYDRATORS FOR CONTINUOUS DRYING AND REMOVAL OF MOISTURE FROM COMPRESSED AIR; AIR DRYER MONITORING AND CONTROL SYSTEMS COMPRISED PRIMARILY OF MOISTURE SEPARATORS, VALVES, STRAINERS, HEAT EXCHANGERS AND MOISTURE INDICATORS; COOLING TOWERS; VENTILATING FANS FOR INDUSTRIAL USE; PORTABLE ELECTRIC HEATERS; ELECTRIC WALL HEATERS FOR COMMERCIAL AND INDUSTRIAL USE; REFRIGERATED AIR DRYERS; SWITCHING VALVES FOR DESICCANT AIR DRYERS; ELECTRIC ROOM HEATERS; FANS AND VENTILATORS FOR ROOM VENTILATION; DESUPERHEATERS; AIRPORT LIGHTING SYSTEMS COMPRISED PRIMARILY OF LIGHTING UNITS, POWER CONVERTERS, INTERNAL CONTROLLERS AND SERIES CONTROLLERS (U.S. CLS. 13, 21, 23, 31 AND 34).

LINDA MICKLEBURGH, EXAMINING ATTORNEY

SN 85-255,504. SPX CORPORATION, CHARLOTTE, NC.
FILED 3-2-2011.



THE COLOR(S) GREEN IS/ARE CLAIMED AS A FEATURE OF THE MARK.

THE MARK CONSISTS OF A STYLIZED "X" IN THE COLOR GREEN.

CLASS 7—MACHINERY

FOR HYDRAULIC JACKS; HYDRAULIC RAMS; POWER-OPERATED GEAR AND BEARING PULLERS; PNEUMATIC GREASE GUNS; VACUUM PUMPS; PORTABLE CABLE HOISTS; POWER-OPERATED PULLER FOR REMOVAL AND INSTALLATION OF GEARS, BEARING, WHEELS, PULLEYS, SLEEVES, SHAFTS AND OTHER FRICTION FITTED PARTS; SHOP CRANES; HYDRAULIC TRANSMISSION JACKS; CRAWLER TRACK HYDRAULIC PRESSES; HYDRAULICALLY POWERED CLAMPS FOR HOLDING WORK PIECES WHILE MANUFACTURING OPERATIONS ARE BEING PERFORMED THEREON, PORTABLE SELF-CONTAINED AIR/HYDRAULIC CIRCUIT CONTROL AND REGULATING VALVE ACTUATOR UNIT UTILIZED AS A CENTRAL POWER SOURCE FOR WORK CLAMPING DEVICES; POWER-OPERATED RACKS FOR GREASING AND REPAIRING VEHICLES; MOBILE HYDRAULIC VEHICLE JACKS; FLUID POWER PRODUCTS, NAMELY, ELECTRIC, PNEUMATIC AND ENGINE DRIVEN FLUID OPERATED PUMPS, MOTORS, CYLINDERS AND LINEAR ACTUATORS, RAMS, PRESSES, JACKS AND STRUCTURAL PARTS THEREFOR; POWER-OPERATED PORTABLE REFRIGERANT CHARGING STATION CONSISTING OF CONTROLS, GAUGES AND VALVES AND ASSOCIATED REFRIGERANT AND HOSES ALL SOLD AS A UNIT; POWER-OPERATED PORTABLE TORQUE CONVERTER NOT FOR LAND MACHINES AND AIR COOLER CLEANING MACHINE; ELECTRIC OIL FILTER CRUSHES; POWER-OPERATED HAND-HELD CRIMPERS; HYDRAULIC PUMPING UNITS; PORTABLE CABLE HOISTS; POWER-OPERATED PULLER FOR REMOVAL AND INSTALLATION OF GEARS, BEARINGS, WHEELS, PULLEYS, SLEEVES, SHAFTS AND OTHER FRICTION FITTED PARTS; SHOP CRANES, MACHINE PARTS, NAMELY, HYDRAULIC LOAD BEARING VALVES, HYDRAULIC CHECK VALVES, HYDRAULIC Y MANIFOLD, MULTIPLE PORT HYDRAULIC MANIFOLD BLOCKS; HYDRAULIC JACKS; HYDRAULIC TORQUE TENSIONERS; POWER-OPERATED VEHICLE PIECE SUPPORTING TOOLS FOR USE IN THE SERVICE AND REPAIR OF ENGINES, DRIVE TRAINS AND SUSPENSIONS; BRAKE DRUM AND SHOE FINISHING MACHINE; POWER-OPERATED UNITS FOR MOUNTING VEHICLE WHEELS AND TIRES; HYDRAULIC CONTROLS FOR PLOWING AND GRADING MACHINES; INDUSTRIAL MIXING MACHINE FOR MIXING ALL TYPES OF FLUIDS AND SOLIDS; TRANSMISSION OIL COOLER FLUSH AND FLOW TEST MACHINE; FUEL AND OIL FILTERS; FILTERS FOR INDUSTRIAL USE AS PARTS OF MACHINERY, NAMELY, LIQUID FILTERS, DRY GAS FILTERS, FILTER SEPARATORS, COALESCERS, CARBON BED FILTERS, VALVES BEING PARTS OF MACHINES, NAMELY, BUTTERFLY VALVES, BALL VALVES, GATE VALVES; POSITIVE DISPLACEMENT PUMPS; VACUUM PUMPS; HYDRAULIC HANDLERS FOR USE WITH PLOW AND GRADES CUTTING EDGE BLADES; INDUSTRIAL PUMPS, NAMELY, ROTARY PUMPS, SCREW PUMPS AND

POSITIVE DISPLACEMENT PUMPS; PNEUMATIC AND ELECTRO-PNEUMATIC POSITIONERS; HEAT EXCHANGERS BEING PARTS OF MACHINES; GEAR PUMPS AND CENTRIFUGAL PUMPS FOR INDUSTRIAL PURPOSES; ELECTRIC, CENTRIFUGAL AND HYDRAULIC PUMPS FOR INDUSTRIAL PURPOSES (U.S. CLS. 13, 19, 21, 23, 31, 34 AND 35).

CLASS 9—ELECTRICAL AND SCIENTIFIC APPARATUS

FOR MACHINES AND GAUGES FOR TESTING INTERNAL COMBUSTION ENGINES, NAMELY, ELECTRICAL, IGNITION, TRANSMISSION, EXHAUST, CARBURETOR AND FUEL COMPRESSION TESTERS AND ANALYZERS; PRESSURE GAUGES; VEHICLE INJECTION NOZZLE TESTERS; OHM METERS, VOLTMETERS, CAPACITOR ANALYZERS, VOLT WATT METERS, VOLTAGE CONTINUITY TESTERS, VACUUM GAUGES, MANOMETERS; SAFETY GOGGLES; HYDRAULIC PRESSURE GAUGES; PINION ANGLE LEVEL GAUGES; HYDRAULIC IN-LINE PRESSURE TESTERS AND CONNECTOR ACCESSORIES THEREFOR; COMPUTERS, KEYBOARDS AND PRINTERS AND RELATED ACCESSORIES FOR CONTROLLED DIAGNOSTIC ANALYSIS OF VEHICLE ENGINES AND DRIVE TRAINS AND MANUALS FOR USE THEREWITH; DIESEL ENGINE TIMING METER; VEHICLE CHARGING SYSTEM ANALYZERS; ELECTRONIC IGNITION ANALYZERS; HYDRAULIC SYSTEM TESTING UNITS; COMPUTERIZED VEHICLE ENGINE ANALYZERS; HYDRAULIC/FLUID FLOW, PRESSURE AND TEMPERATURE TESTERS AND STRUCTURAL PARTS THEREFOR; SOLENOID VALVES; COMPUTER DATABASE SOFTWARE FOR SELECTING VEHICLE AND TOOL REPLACEMENT PARTS; ELECTRONIC BATTERY TESTERS; VACUUM GAUGES FOR REFRIGERATION SYSTEMS; CONTROL PANELS AND MANUALLY AND PYROMETRICALLY AND GALNOMETRICALLY CONTROLLED ELECTRIC SWITCHES RHEOSTATS, AND HEATING-CURRENT CONTROLLERS FOR REGULATING OR CONTROLLING THE TEMPERATURE OR OPERATING CONDITIONS OF ELECTRIC FURNACES, ELECTRIC OVENS, AND ELECTRIC HEAT-TREATING FURNACES; ELECTRIC FLOW METERS AND PRESSURE OR RATE OF FLOW CONTROLLERS, AND TELEMETERS; MECHANICAL FLOW METERS FOR RECORDING AND TOTALIZING WITH OR WITHOUT INDICATING MEANS; PNEUMATICALLY OPERATED REGULATOR TO VARY THE PASSAGE OF COMPRESSED AIR THROUGH A CONDUIT IN RESPONSE TO A CONTROLLED PRESSURE APPLIED THERETO; VOLTAGE AND CURRENT REGULATORS AND COMPENSATORS, BALLASTS AND REACTORS, ROTARY TYPE INTEGRATING FLOW METERS FOR STEAM, AIR AND GAS, AND ACCESSORIES THEREFOR, NAMELY, LIQUID GAUGE GLASS, REMOTE TOTALIZER, FLOW RATE INDICATOR, FLOW RATE RECORDER, FLOW DEMAND INDICATOR AND FLOW DEMAND RECORDER; VOLTAGE SENSING RELAYS, AND CURRENT SENSING RELAYS; LABORATORY MIXERS; DATA PROCESSING AND CONTROL SWITCHES AND RELAYS; MOISTURE DETECTING DEVICES FOR OIL QUENCH TANKS; ELECTRIC LINE VOLTAGE REGULATORS; ELECTRICAL AND ELECTRONIC EQUIPMENT, NAMELY, COILS, TRANSFORMERS, INDUCTORS AND REACTORS, ELECTRONIC RELAYS, SIGNAL GENERATORS, STATIC MAGNETIC VOLTAGE REGULATORS; ELECTROMECHANICAL DIAMETER CONTROL UNITS FOR CRYSTAL GROWING FURNACES; ELECTRICAL TRANSMISSION LINES, NAMELY, ELECTRONIC WAVEGUIDES FOR TRANSMISSION OF RADIO FREQUENCY ENERGY; ENERGY TRANSMISSION AND DISTRIBUTION EQUIPMENT, NAMELY, ELECTRICAL TRANSFORMERS, VOLTAGE SURGE ARRESTERS, TAP CHANGERS, AND PACKAGE SUBSTATIONS; AUTOMATIC VALVES, NAMELY, CONTROL VALVES, BALL VALVES, GLOBE VALVES, BUTTERFLY VALVES, PLUG VALVES, CHECK VALVES, ECCENTRIC VALVES, KNIFE GATE VALVES, GATE VALVES, ISOLATION VALVES, DIVERTER VALVES AND SLEEVE VALVES; CONTROL VALVES FOR REGULATING THE FLOW OF GASES AND LIQUIDS; AUTOMATIC VALVE ASSEMBLIES, CONSISTENCY TRANSMITTERS, SOLENOIDS, PNEUMATIC MOTION TRANSMITTERS, ELECTRIC TRANSFORMERS; ELECTRIC PNEUMATIC TRANSDUCERS, INDUSTRIAL VAPOR AND STEAM CONDITIONING VALVES,

STRAINERS, AIR GAP DRAINS, AND/OR SETTERS; BOILER WATER REGULATORS; BOILER PRESSURE GOVERNORS; ELECTRONIC BLADE CONSISTENCY TRANSMITTERS FOR MEASURING LIQUID MIXTURES IN INDUSTRY; COMPUTER SOFTWARE FOR ASSISTING IN VALVE SYSTEMS AND IN SPECIFYING VALVE PRODUCTS; ELECTRONIC DIGITAL CONTROLLER FOR POSITIONING VALVES IN INDUSTRIAL EQUIPMENT, COMPUTER MONITOR AND SIGNAL CONDITIONERS FOR DIAGNOSING CONTROL VALVE PERFORMANCE; ELECTRONIC VALVE ACTUATORS; COAXIAL CABLE; HAND HELD COMPUTER FOR USE IN DETECTING LEAKS IN PRESSURIZED CABLES; ELECTRONIC VALIDATING AND REGISTERING BUS FARE BOXES; TICKET AND TOKEN VENDING MACHINES; REVENUE COLLECTION AND SECURITY EQUIPMENT, NAMELY, ELECTRONIC FARE COLLECTION, STORAGE AND COUNTING APPARATUS; PORTABLE DYNAMIC SIGNAL ANALYZERS FOR THE MEASUREMENT AND ANALYSIS OF AUDIO AND VIDEO SIGNALS; RAILROAD AND TRANSIT ELECTRIC HYDRAULIC CONTROL SWITCHES; UNDERWATER SAFETY LIGHTS TO DIRECT THE MOVEMENT OF FISH; ELECTRONIC LIGHTING CONTROLLERS AND POWER CONVERTERS; ELECTRONIC RECONNAISSANCE SYSTEMS COMPRISED OF ANTENNAS, COMPUTERS, MACHINE READABLE COMPUTER-PROGRAMS, DIRECTION FINDING RECEIVERS, RADIO FREQUENCY DISTRIBUTION AND SWITCHING APPARATUS, SIGNAL ACQUISITION AND CLASSIFICATION APPARATUS; RADIO JAMMING APPARATUS; BROADCAST EQUIPMENT FOR WIRELESS TRANSMISSIONS, RADIO, AND TELEVISION, NAMELY, ANTENNAS AND STRUCTURAL AND ELECTRICAL COMPONENTS, PARTS AND ACCESSORIES THEREFOR, NAMELY, SWITCHING APPARATUS, DIPLEXERS, TOWERS, TRANSMISSION LINES AND CABLES, MATCHING UNITS AND CONTROL APPARATUS; ELECTRICAL FIBER-OPTIC COMMUNICATION TRANSMISSION LINES FOR AUDIO AND VIDEO SIGNAL TRANSMISSION; OPTICAL WAVEGUIDES; METALLIC WAVEGUIDE AND COAXIAL CABLE AND END-CONNECTORS; AIR FLOW SENSORS; THERMOSTATS; EMERGENCY WARNING LIGHTS, NAMELY, AVIATION OBSTRUCTION LIGHTING; SECURITY LIGHTING SYSTEMS; BEACON AND OBSTRUCTION WARNING SYSTEMS COMPRISED PRIMARILY OF POWER CONVERTER AND FLASH HEAD AND COMPONENT PARTS; HAND HELD COMPUTER FOR DETECTING LEAKS IN PRESSURIZED CABLES; WIRELESS DATA CARRIERS AND RECEIVERS FOR USE WITH VEHICLE DIAGNOSING AND MONITORING; COMPUTER HARDWARE AND SOFTWARE USED FOR RADIO SIGNAL INTERCEPT AND DIRECTION FINDING, RECEIVERS AND PROCESSORS FOR USE WITH SUCH SIGNAL PROCESSING SYSTEMS; WEIGHTING SCALES; HEATING, COOLING AND HUMIDIFIED ENVIRONMENTAL CHAMBERS FOR RESEARCH, TESTING AND PRODUCTION; ELECTRIC ACTUATORS (U.S. CLS. 21, 23, 26, 36 AND 38).

CLASS 11—ENVIRONMENTAL CONTROL APPARATUS

FOR ELECTRIC HEAT-TREATING FURNACES; ELECTRIC HEATING UNITS FOR ELECTRIC FURNACES, ELECTRIC OVENS AND ELECTRIC HEAT-TREATING FURNACES; DEHYDRATORS FOR CONTINUOUS DRYING AND REMOVAL OF MOISTURE FROM COMPRESSED AIR; CRYSTAL GROWING FURNACES; FLUID HANDLING EQUIPMENT FOR PLUMBING USE, NAMELY, FLUID CONTROL VALVES; WATER COOLING TOWERS; INDUSTRIAL AIR CLEANERS; CABLE PRESSURIZATION UNITS COMPRISED PRIMARILY OF AIR DRYERS, COMPRESSORS, CENTRAL OFFICE MANIFOLDS, DISTRIBUTION MANIFOLDS, METERS AND PIPE FEED ACCESS PANELS, AND AIR PIPE CONNECTORS FOR USE IN FORCING DRY AIR INTO CABLES IN ORDER TO PROTECT THE CABLES FROM WATER DAMAGE; ELECTRIC DEHYDRATORS FOR CONTINUOUS DRYING AND REMOVAL OF MOISTURE FROM COMPRESSED AIR; AIR DRYER MONITORING AND CONTROL SYSTEMS COMPRISED PRIMARILY OF MOISTURE SEPARATORS, VALVES, STRAINERS, HEAT EXCHANGERS

AND MOISTURE INDICATORS; COOLING TOWERS; VENTILATING FANS FOR INDUSTRIAL USE; PORTABLE ELECTRIC HEATERS; ELECTRIC WALL HEATERS FOR COMMERCIAL AND INDUSTRIAL USE; REFRIGERATED AIR DRYERS; SWITCHING VALVES FOR DESICCANT AIR DRYERS; ELECTRIC ROOM HEATERS; FANS AND VENTILATORS FOR ROOM VENTILATION; DESUPERHEATERS; AIRPORT LIGHTING SYSTEMS COMPRISED PRIMARILY OF LIGHTING UNITS, POWER CONVERTERS, INTERNAL CONTROLLERS AND SERIES CONTROLLERS (U.S. CLS. 13, 21, 23, 31 AND 34).

LINDA MICKLEBURGH, EXAMINING ATTORNEY

SN 85-255,811. YMFITNESS, NEW YORK, NY. FILED 3-2-2011.



THE MARK CONSISTS OF A STYLIZED LETTER "Y" WITHIN AND UNDERNEATH OF A STYLIZED LETTER "M," WHERE THE COMBINATION OF THE STYLIZED LETTERS "Y" AND "M" FORMS AN OVAL-LIKE SHAPE.

CLASS 25—CLOTHING

FOR FOOTWEAR; HEADWEAR; JACKETS; MUSCLE TOPS; PANTS; SHORTS; SOCKS; SWEATSHIRTS; T-SHIRTS; TANK TOPS; TIGHTS (U.S. CLS. 22 AND 39).

CLASS 41—EDUCATION AND ENTERTAINMENT

FOR PERSONAL FITNESS TRAINING SERVICES AND CONSULTANCY; PERSONAL TRAINER SERVICES; PHYSICAL FITNESS CONSULTATION; PHYSICAL FITNESS INSTRUCTION; PHYSICAL FITNESS TRAINING SERVICES (U.S. CLS. 100, 101 AND 107).

FIRST USE 12-29-2010; IN COMMERCE 1-14-2011.
MARK RADEMACHER, EXAMINING ATTORNEY

SN 85-255,825. VIAJES EL CORTE INGLES, S.A., MADRID, SPAIN, FILED 3-2-2011.



OWNER OF ERPN CMNTY TM OFC REG. NO. 009345761, DATED 12-29-2010, EXPIRES 9-1-2020.
THE COLOR(S) GREEN, BLACK AND WHITE IS/ARE CLAIMED AS A FEATURE OF THE MARK.

THE MARK CONSISTS OF THE WORD TRIPCRAISES WRITTEN IN GREEN LOWERCASE LETTERS FOLLOWED BY A CHILD DESIGN. THE DESIGN APPEARS IN GREEN COLOR. THE RIGHT EYE OF THE DESIGN IS BIGGER THAN THE LEFT EYE. BOTH EYES ARE WHITE AND HAVE A BLACK POINT INSIDE EACH EYE. THE DESIGN IS BEING OUTLINE AS THE WORDS IN COLOR GREEN.

CLASS 16—PAPER GOODS AND PRINTED MATTER

FOR MAGAZINES AND LEAFLETS FEATURING TRAVEL AND ACCOMMODATION (U.S. CLS. 2, 5, 22, 23, 29, 37, 38 AND 50).

CLASS 38—COMMUNICATION

FOR PROVIDING TELECOMMUNICATION CONNECTIONS TO GLOBAL COMPUTER NETWORK (U.S. CLS. 100, 101 AND 104).

CLASS 39—TRANSPORTATION AND STORAGE

FOR TRAVEL BOOKING AGENCY; TRAVEL AGENCY SERVICES, NAMELY, MAKING RESERVATIONS AND BOOKINGS FOR TRANSPORTATION (U.S. CLS. 100 AND 105).

VERNA BETH RIRIE, EXAMINING ATTORNEY

SN 85-255,848. APOTHECARY PRODUCTS, INC., BURNSVILLE, MN. FILED 3-2-2011.

Get the Most from Your Medication

THE MARK CONSISTS OF STANDARD CHARACTERS WITHOUT CLAIM TO ANY PARTICULAR FONT, STYLE, SIZE, OR COLOR.

CLASS 35—ADVERTISING AND BUSINESS

FOR ONLINE RETAIL AND WHOLESALE STORE AND MAIL ORDER CATALOG SERVICES FEATURING PHARMACEUTICAL AND PHARMACEUTICAL RELATED PRODUCTS (U.S. CLS. 100, 101 AND 102).

CLASS 44—MEDICAL, BEAUTY AND AGRICULTURAL SERVICES

FOR PROVIDING AN INFORMATIONAL WEBSITE FEATURING MEDICAL, HEALTH AND PHARMACEUTICAL INFORMATION (U.S. CLS. 100 AND 101).

FIRST USE 7-0-2010; IN COMMERCE 12-10-2010.
VERNA BETH RIRIE, EXAMINING ATTORNEY

SN 85-255,871. AND APPAREL, INC., LOS ANGELES, CA. FILED 3-2-2011.

SN 85-255,875. KARMALoop, INC., BOSTON, MA. FILED 3-2-2011.

KLIKIT

Good Work(s), Make a
Difference

THE MARK CONSISTS OF STANDARD CHARACTERS WITHOUT CLAIM TO ANY PARTICULAR FONT, STYLE, SIZE, OR COLOR.

CLASS 3—COSMETICS AND CLEANING PREPARATIONS

FOR BODY AND BEAUTY CARE COSMETICS; BODY SPRAYS; COSMETICS; HAIR SHAMPOOS AND CONDITIONERS; HAND SOAPS; LIP BALM; LOTIONS FOR COSMETIC PURPOSES; LOTIONS FOR FACE AND BODY CARE; PERFUMES; SOAPS FOR BODY CARE (U.S. CLS. 1, 4, 6, 50, 51 AND 52).

CLASS 4—LUBRICANTS AND FUELS

FOR CANDLES (U.S. CLS. 1, 6 AND 15).

CLASS 9—ELECTRICAL AND SCIENTIFIC APPARATUS

FOR CD CASES; CELL PHONE CASES; CELL PHONE COVERS; COMPUTER BAGS; COMPUTER CARRYING CASES; COMPUTER GAME CARTRIDGES AND DISCS; COMPUTER GAME PROGRAMS; COMPUTER GAME SOFTWARE; COMPUTER PERIPHERALS; DUST COVERS FOR COMPUTERS; HIGH PERFORMANCE COMPUTER HARDWARE WITH SPECIALIZED FEATURES FOR ENHANCED GAME PLAYING ABILITY; MOUSE PADS (U.S. CLS. 21, 23, 26, 36 AND 38).

CLASS 14—JEWELRY

FOR COSTUME JEWELRY; JEWELRY; WATCHES (U.S. CLS. 2, 27, 28 AND 50).

CLASS 18—LEATHER GOODS

FOR HANDBAGS; PET CLOTHING (U.S. CLS. 1, 2, 3, 22 AND 41).

CLASS 24—FABRICS

FOR BED BLANKETS; BED LINEN; BED SHEETS; BED SPREADS; BLANKET TROWS (U.S. CLS. 42 AND 50).

CLASS 25—CLOTHING

FOR BELTS; BLOUSES; COATS; COLLARED SHIRTS; DRESS SHIRTS; GYM SUITS; JOGGING OUTFITS; JOGGING SUITS; PANTS; POLO SHIRTS; SPORT SHIRTS; SPORTS BRAS; SPORTS PANTS; SPORTS SHIRTS; SWEAT SHIRTS; SWEATERS; SWIM SUITS; SWIM TRUNKS; T-SHIRTS; TANK-TOPS; TROUSERS; V-NECK SWEATERS; WOMEN'S CLOTHING, NAMELY, SHIRTS, DRESSES, SKIRTS, BLOUSES (U.S. CLS. 22 AND 39).
KEVIN DINALLO, EXAMINING ATTORNEY

THE MARK CONSISTS OF STANDARD CHARACTERS WITHOUT CLAIM TO ANY PARTICULAR FONT, STYLE, SIZE, OR COLOR.

CLASS 35—ADVERTISING AND BUSINESS

FOR ADVERTISING AND MARKETING; ADVERTISING AND MARKETING SERVICES, NAMELY, PROMOTING THE GOODS AND SERVICES OF OTHERS; PROMOTING THE GOODS AND SERVICES OF OTHERS THROUGH ONLINE INTERACTIVE VIDEOS (U.S. CLS. 100, 101 AND 102).

CLASS 42—SCIENTIFIC AND COMPUTER SERVICES

FOR DESIGN AND DEVELOPMENT OF INTERACTIVE VIDEOS; SOFTWARE AS A SERVICE, NAMELY, ONLINE NON-DOWNLOADABLE SOFTWARE FOR THE USE, DESIGN, AND DEVELOPMENT OF INTERACTIVE VIDEOS (U.S. CLS. 100 AND 101).

JAY FLOWERS, EXAMINING ATTORNEY

SN 85-255,918. CHICHILUNA LLC, FORT LAUDERDALE, FL. FILED 3-2-2011.

CHICHILUNA INDULGE YOUR PASSION

THE MARK CONSISTS OF STANDARD CHARACTERS WITHOUT CLAIM TO ANY PARTICULAR FONT, STYLE, SIZE, OR COLOR.

CLASS 14—JEWELRY

FOR WOMEN'S JEWELRY (U.S. CLS. 2, 27, 28 AND 50).

CLASS 25—CLOTHING

FOR WOMEN'S CLOTHING, NAMELY, SHIRTS, DRESSES, SKIRTS, BLOUSES (U.S. CLS. 22 AND 39).
ANDREA BUTLER, EXAMINING ATTORNEY

SN 85-255,928. SPORTSBLAST LLC, NORTHRIDGE, CA. FILED 3-2-2011.

SMOKE YOUR TIRES

THE MARK CONSISTS OF STANDARD CHARACTERS WITHOUT CLAIM TO ANY PARTICULAR FONT, STYLE, SIZE, OR COLOR.

CLASS 9—ELECTRICAL AND SCIENTIFIC APPARATUS

FOR COMPUTER GAME PROGRAMS; COMPUTER GAME SOFTWARE; DOWNLOADABLE COMPUTER GAME PROGRAMS; DOWNLOADABLE ELECTRONIC GAME PROGRAMS; ELECTRONIC GAME PROGRAMS; ELECTRONIC GAME SOFTWARE; ELECTRONIC GAME SOFTWARE FOR CELLULAR TELEPHONES; ELECTRONIC GAME SOFTWARE FOR HANDHELD ELECTRONIC DEVICES; ELECTRONIC GAME SOFTWARE FOR WIRELESS DEVICES; INTERACTIVE GAME PROGRAMS; INTERACTIVE GAME SOFTWARE; INTERACTIVE VIDEO GAME PROGRAMS; VIDEO GAME SOFTWARE (U.S. CLS. 21, 23, 26, 36 AND 38).

CLASS 41—EDUCATION AND ENTERTAINMENT

FOR ENTERTAINMENT SERVICES, NAMELY, PROVIDING AN ON-LINE COMPUTER GAME (U.S. CLS. 100, 101 AND 107).
JAMES A. RAUEN, EXAMINING ATTORNEY

SN 85-255,963. AEROCLAY INC, SOLON, OH. FILED 3-2-2011.

ClayPak

THE MARK CONSISTS OF STANDARD CHARACTERS WITHOUT CLAIM TO ANY PARTICULAR FONT, STYLE, SIZE, OR COLOR.

CLASS 17—RUBBER GOODS

FOR PACKAGING MATERIALS MADE FROM STONE-BASED PLASTIC SUBSTITUTES (U.S. CLS. 1, 5, 12, 13, 35 AND 50).

CLASS 39—TRANSPORTATION AND STORAGE

FOR PACKAGING AND PARCELLING OF GOODS FOR TRANSPORT PURPOSES, NAMELY, THE PACKING OF GOODS USING SUSTAINABLE OR BIODEGRADABLE PACKAGING AND SHIPPING MATERIALS (U.S. CLS. 100 AND 105).
THEODORE MCBRIDE, EXAMINING ATTORNEY

SN 85-255,992. AEROCLAY INC, SOLON, OH. FILED 3-2-2011.

LionPak

THE MARK CONSISTS OF STANDARD CHARACTERS WITHOUT CLAIM TO ANY PARTICULAR FONT, STYLE, SIZE, OR COLOR.

CLASS 17—RUBBER GOODS

FOR PACKAGING MATERIALS MADE FROM STONE-BASED PLASTIC SUBSTITUTES (U.S. CLS. 1, 5, 12, 13, 35 AND 50).

CLASS 39—TRANSPORTATION AND STORAGE

FOR PACKAGING AND PARCELLING OF GOODS FOR TRANSPORT PURPOSES, NAMELY, THE PACKING OF GOODS USING SUSTAINABLE OR BIODEGRADABLE PACKAGING AND SHIPPING MATERIALS (U.S. CLS. 100 AND 105).
THEODORE MCBRIDE, EXAMINING ATTORNEY

SN 85-256,064. DISCOVER FINANCIAL SERVICES, RIVERWOODS, IL. FILED 3-2-2011.

POSSIBILITIES

THE MARK CONSISTS OF STANDARD CHARACTERS WITHOUT CLAIM TO ANY PARTICULAR FONT, STYLE, SIZE, OR COLOR.

CLASS 9—ELECTRICAL AND SCIENTIFIC APPARATUS

FOR DOWNLOADABLE ELECTRONIC NEWSLETTERS DELIVERED VIA E-MAIL IN THE FIELDS OF PRE-PAID CARDS, BANKING AND BUSINESS FINANCIAL NEWS DIRECTED TOWARDS ISSUERS AND FINANCIAL INSTITUTIONS (U.S. CLS. 21, 23, 26, 36 AND 38).

CLASS 16—PAPER GOODS AND PRINTED MATTER

FOR PERIODICAL PUBLICATIONS, NAMELY, NEWSLETTERS IN THE FIELDS OF PRE-PAID CARDS, BANKING AND BUSINESS FINANCIAL NEWS DIRECTED TOWARDS ISSUERS AND FINANCIAL INSTITUTIONS (U.S. CLS. 2, 5, 22, 23, 29, 37, 38 AND 50).
CHARLES L. JENKINS, EXAMINING ATTORNEY

SN 85-256,136. THE GENERAL COUNSEL, LLC, IRVINE, CA. FILED 3-2-2011.

InnovaCounsel

THE MARK CONSISTS OF STANDARD CHARACTERS WITHOUT CLAIM TO ANY PARTICULAR FONT, STYLE, SIZE, OR COLOR.

CLASS 41—EDUCATION AND ENTERTAINMENT

FOR CONTINUING EDUCATION SERVICES, NAMELY, PROVIDING LIVE AND ON-LINE CONTINUING PROFESSIONAL EDUCATION SEMINARS IN THE FIELD OF LAW AND LEGAL SERVICES (U.S. CLS. 100, 101 AND 107).

CLASS 45—PERSONAL AND LEGAL SERVICES

FOR LEGAL DOCUMENT PREPARATION AND RESEARCH SERVICES FOR ATTORNEYS; LEGAL SERVICES; LITIGATION SERVICES; ON-SITE LEGAL SERVICES; PROVIDING AN ON-LINE INTERACTIVE DATABASE FEATURING LEGAL INFORMATION (U.S. CLS. 100 AND 101).

CHARLOTTE CORWIN, EXAMINING ATTORNEY

SN 85-256,296. WE FIRST, LOS ANGELES, CA. FILED 3-2-2011.



THE MARK CONSISTS OF A COMBINATION OF TWO WORDS: 'WE' AND 'FIRST'. THE 'WE' IS TREATED LIKE A STYLIZED INFINITY SYMBOL WITH THE LETTERS 'W' AND 'E' INTERWOVEN. THE "FIRST" IS WRITTEN IN CAPS BELOW.

CLASS 35—ADVERTISING AND BUSINESS

FOR ADVERTISING AND ADVERTISEMENT SERVICES; BUSINESS ADMINISTRATION AND MANAGEMENT; PROVIDING OFFICE FUNCTIONS (U.S. CLS. 100, 101 AND 102).

FIRST USE 2-1-2011; IN COMMERCE 2-1-2011.

CLASS 41—EDUCATION AND ENTERTAINMENT

FOR EDUCATIONAL SERVICES, NAMELY, CONDUCTING SEMINARS, WORKSHOPS, TRAINING, PUBLIC SPEAKING, AND CONFERENCES IN THE FIELD OF SOCIAL BRANDING, ADVERTISING, AND MARKETING AND DISTRIBUTION OF PRINTED MATERIALS IN CONNECTION THEREWITH IN HARD COPY OR ELECTRONIC FORMAT ON THE SAME TOPICS (U.S. CLS. 100, 101 AND 107).

FIRST USE 2-1-2011; IN COMMERCE 2-1-2011.

DOMINICK J. SALEMI, EXAMINING ATTORNEY

LITTLE GLASS MEN

THE MARK CONSISTS OF STANDARD CHARACTERS WITHOUT CLAIM TO ANY PARTICULAR FONT, STYLE, SIZE, OR COLOR.

CLASS 9—ELECTRICAL AND SCIENTIFIC APPARATUS

FOR AUDIO AND VIDEO RECORDINGS FEATURING MUSIC AND ARTISTIC PERFORMANCES; DIGITAL MUSIC DOWNLOADABLE FROM THE INTERNET; DOWNLOADABLE MUSICAL SOUND RECORDINGS; MUSICAL RECORDINGS (U.S. CLS. 21, 23, 26, 36 AND 38).

FIRST USE 2-18-2011; IN COMMERCE 2-26-2011.

CLASS 41—EDUCATION AND ENTERTAINMENT

FOR ENTERTAINMENT IN THE NATURE OF VISUAL AND AUDIO PERFORMANCES BY A MUSIC COMPOSER, PRODUCER, MUSICIAN AND PUBLISHER; ENTERTAINMENT SERVICES IN THE NATURE OF RECORDING, PRODUCTION AND POST-PRODUCTION SERVICES IN THE FIELD OF MUSIC; MUSIC COMPOSITION FOR OTHERS; MUSIC PRODUCTION SERVICES; PRODUCTION OF MUSICAL SOUND RECORDING (U.S. CLS. 100, 101 AND 107).

FIRST USE 2-18-2011; IN COMMERCE 2-26-2011.

ALLISON SCHRODY, EXAMINING ATTORNEY

SN 85-256,336. VANTAGEPOINT MANAGEMENT, INC., SAN BRUNO, CA. FILED 3-2-2011.

INNOVATION KNOWS NO BOUNDARIES

THE MARK CONSISTS OF STANDARD CHARACTERS WITHOUT CLAIM TO ANY PARTICULAR FONT, STYLE, SIZE, OR COLOR.

CLASS 35—ADVERTISING AND BUSINESS

FOR BUSINESS CONSULTATION; BUSINESS ACQUISITIONS AND MERGER CONSULTATION; BUSINESS MANAGEMENT CONSULTATION; BUSINESS PLANNING CONSULTATION; BUSINESS ORGANIZATIONAL CONSULTATION; BUSINESS OPERATIONS CONSULTATION; BUSINESS RECRUITING CONSULTATION; BUSINESS MARKETING CONSULTATION (U.S. CLS. 100, 101 AND 102).

CLASS 36—INSURANCE AND FINANCIAL

FOR INVESTMENT SERVICES IN THE FIELDS OF GROWTH CAPITAL, VENTURE CAPITAL, PRIVATE EQUITY AND PROJECT FINANCE, NAMELY, SOLICITATION OF CAPITAL FOR INVESTMENTS, EVALUATION OF FINANCIAL INVESTMENTS, OPERATION AND MANAGEMENT OF INVESTMENT FUNDS, AND INVESTMENT FUNDING, CONSULTATION, AND MANAGEMENT (U.S. CLS. 100, 101 AND 102).

ELI HELLMAN, EXAMINING ATTORNEY

CLASS 14—JEWELRY

FOR JEWELRY; TIMEPIECES AND CHRONOMETRIC INSTRUMENTS (U.S. CLS. 2, 27, 28 AND 50).

CLASS 25—CLOTHING

FOR COATS; DRESSES; FOOTWEAR; GLOVES; HEADWEAR; HOSIERY; JACKETS; LINGERIE; PANTS; RAINCOATS; SCARVES; SHIRTS; SKIRTS; SLEEPWEAR; TANK TOPS; UNDERGARMENTS (U.S. CLS. 22 AND 39).

JENNIFER VASQUEZ, EXAMINING ATTORNEY

SN 85-256,366. MITCHELL, NATE, LOS ANGELES, CA. FILED 3-2-2011.

SQUIBS

THE MARK CONSISTS OF STANDARD CHARACTERS WITHOUT CLAIM TO ANY PARTICULAR FONT, STYLE, SIZE, OR COLOR.

OWNER OF U.S. REG. NO. 3,723,423.

CLASS 16—PAPER GOODS AND PRINTED MATTER

FOR CHILDREN'S STORYBOOKS (U.S. CLS. 2, 5, 23, 29, 37, 38 AND 50).

CLASS 25—CLOTHING

FOR ATHLETIC APPAREL, NAMELY, SHIRTS, PANTS, JACKETS, FOOTWEAR, HATS AND CAPS, ATHLETIC UNIFORMS; CHILDREN'S AND INFANT'S APPAREL, NAMELY, JUMPERS, OVERALL SLEEPWEAR, PAJAMAS, ROMPERS AND ONE-PIECE GARMENTS; CHILDREN'S AND INFANTS' APPAREL TREATED WITH FIRE AND HEAT RETARDANTS, NAMELY, JUMPERS, OVERALL SLEEPWEAR, PAJAMAS, ROMPERS AND ONE-PIECE GARMENTS (U.S. CLS. 22 AND 39).

JASON TURNER, EXAMINING ATTORNEY

SN 85-256,374. ADDICTION NV, LLC, IRVINE, CA. FILED 3-2-2011.

ADDICTION·NV
cosmetics 

NO CLAIM IS MADE TO THE EXCLUSIVE RIGHT TO USE "COSMETICS" FOR INTERNATIONAL CLASS 3, APART FROM THE MARK AS SHOWN.

THE MARK CONSISTS OF THE CAPITALIZED WORDING "ADDICTION NV" WITH A DOT IN BETWEEN THE TWO WORDS AND ABOVE THE CURSIVE LOWERCASE LETTERING "COSMETICS". TO THE LEFT OF ALL THE WORDING IS A SILHOUETTE OF A WOMAN.

CLASS 3—COSMETICS AND CLEANING PREPARATIONS

FOR COSMETICS (U.S. CLS. 1, 4, 6, 50, 51 AND 52).

SN 85-256,407. VTECH ELECTRONICS NORTH AMERICA, LLC, ARLINGTON HEIGHTS, IL. FILED 3-3-2011.

MORE TO LOVE

THE MARK CONSISTS OF STANDARD CHARACTERS WITHOUT CLAIM TO ANY PARTICULAR FONT, STYLE, SIZE, OR COLOR.

CLASS 9—ELECTRICAL AND SCIENTIFIC APPARATUS

FOR AMUSEMENT APPARATUS AND GAMES ADAPTED FOR USE WITH TELEVISION RECEIVERS OR WITH VIDEO OR COMPUTER MONITORS; CAMERA CASES; CAMERAS; CHILDREN'S EDUCATIONAL SOFTWARE; COMPUTER GAME CARTRIDGES; COMPUTER GAME JOYSTICKS; COMPUTER GAME PROGRAMS; COMPUTER GAME SOFTWARE; ELECTRONIC GAME SOFTWARE FOR HANDHELD ELECTRONIC DEVICES; ELECTRONIC INTERACTIVE BOARD GAMES FOR USE WITH EXTERNAL MONITOR; HAND-HELD UNITS FOR PLAYING ELECTRONIC GAMES FOR USE WITH EXTERNAL DISPLAY SCREEN OR MONITOR; NOTEBOOK AND LAPTOP COMPUTERS; VIDEO GAME CARTRIDGES; VIDEO GAME CONSOLES FOR USE WITH AN EXTERNAL DISPLAY SCREEN OR MONITOR (U.S. CLS. 21, 23, 26, 36 AND 38).

CLASS 28—TOYS AND SPORTING GOODS

FOR BABY MULTIPLE ACTIVITY TOYS; BATH TOYS; BATTERY OPERATED ACTION TOYS; CHILDREN'S MULTIPLE ACTIVITY TOYS; CHILDREN'S MULTIPLE ACTIVITY TOYS SOLD AS A UNIT WITH PRINTED BOOKS; CRIB TOYS; ELECTRONIC ACTION TOYS; ELECTRONIC EDUCATIONAL GAME MACHINES FOR CHILDREN; ELECTRONIC GAMES FOR THE TEACHING OF CHILDREN; ELECTRONIC LEARNING TOYS; ELECTRONIC TOY VEHICLES; INFANT ACTION CRIB TOYS; INFANT DEVELOPMENT TOYS; INFANT TOYS; MUSICAL TOYS; PLUSH TOYS; PULL TOYS; TALKING TOYS (U.S. CLS. 22, 23, 38 AND 50).

REGINA DRUMMOND, EXAMINING ATTORNEY

SN 85-256,471. JEZEBEL, INC., MADRID, NM. FILED 3-3-2011.

SN 85-256,481. SCIUMBATO, DONNIE, PUEBLO, CO. FILED 3-3-2011.

JEZEBEL RADIANCE



THE MARK CONSISTS OF STANDARD CHARACTERS WITHOUT CLAIM TO ANY PARTICULAR FONT, STYLE, SIZE, OR COLOR.

CLASS 11—ENVIRONMENTAL CONTROL APPARATUS

FOR LAMPS, LAMP SHADES, LAMPSHADE HOLDERS (U.S. CLS. 13, 21, 23, 31 AND 34).
FIRST USE 1-1-2006; IN COMMERCE 1-23-2006.

CLASS 21—HOUSEWARES AND GLASS

FOR VASES, DISHES (U.S. CLS. 2, 13, 23, 29, 30, 33, 40 AND 50).
FIRST USE 1-1-2006; IN COMMERCE 1-23-2006.
COLLEEN KEARNEY, EXAMINING ATTORNEY

THE COLOR(S) BLACK, WHITE, ORANGE, YELLOW IS/ ARE CLAIMED AS A FEATURE OF THE MARK.

THE MARK CONSISTS OF A OVAL WITH A BLACK COLOR OUTLINE; WHEREIN THERE IS A FLYING GOOSE IN BLACK AND WHITE COLOR ON A ORANGE AND YELLOW BACKGROUND. THERE IS BACKWARD "G" INTERLOCKED WITH "G" IN A BLACK COLOR WITH WHITE OUTLINE UNDER GOOSE.

CLASS 13—FIREARMS

FOR SHOTGUNS AND PARTS THEREOF (U.S. CLS. 2 AND 9).

CLASS 16—PAPER GOODS AND PRINTED MATTER

FOR LETTERHEAD PAPER; PAPER STATIONERY; OFFICE STATIONERY; ENVELOPES (U.S. CLS. 2, 5, 22, 23, 29, 37, 38 AND 50).

CLASS 25—CLOTHING

FOR CLOTHING, NAMELY, TOPS, BOTTOMS, T-SHIRTS, HATS, COATS (U.S. CLS. 22 AND 39).

CLASS 28—TOYS AND SPORTING GOODS

FOR HUNTING BLINDS; HUNTING GAME CALLS (U.S. CLS. 22, 23, 38 AND 50).
THEODORE MCBRIDE, EXAMINING ATTORNEY

SN 85-256,475. LOWEY, KATHRYN, PLANO, TX. FILED 3-3-2011.

JUST COS YOU CAN DON'T MEAN YOU SHOULD.COM

THE MARK CONSISTS OF STANDARD CHARACTERS WITHOUT CLAIM TO ANY PARTICULAR FONT, STYLE, SIZE, OR COLOR.

CLASS 25—CLOTHING

FOR CLOTHING, NAMELY, TOPS, BOTTOMS, T-SHIRTS (U.S. CLS. 22 AND 39).

CLASS 41—EDUCATION AND ENTERTAINMENT

FOR PROVIDING A WEBSITE FOR ENTERTAINMENT PURPOSES WHERE USERS CAN VIEW AND POST STORIES, PHOTOS, VIDEOS, COMMENTS FEATURING HUMOROUS TOPICS (U.S. CLS. 100, 101 AND 107).
JOHN DALIER, EXAMINING ATTORNEY

SN 85-256,619. SOEX HOLDING USA, LLC, LOS ANGELES, CA. FILED 3-3-2011.

IT TAKES BLUE TO BE GREEN

THE MARK CONSISTS OF STANDARD CHARACTERS WITHOUT CLAIM TO ANY PARTICULAR FONT, STYLE, SIZE, OR COLOR.

CLASS 35—ADVERTISING AND BUSINESS

FOR DISTRIBUTORSHIP SERVICES IN THE FIELD OF NYLON FIBER, CARPET PADDING, AUTOMOTIVE INSULATION, MATTRESS PADDING, RESIDENTIAL AND COMMERCIAL WALL AND ATTIC INSULATION, ALL FROM RECYCLED TEXTILES, USED CLOTHING, SHOES, HOUSEHOLD GOODS AND TOYS, AND USED CARPETS; RETAIL STORE SERVICES FEATURING CLOTHING, SHOES, HOUSEHOLD GOODS AND TOYS; EXPORT AGENCY SERVICES FOR THE GOODS, NAMELY, CLOTHING, SHOES, HOUSEHOLD GOODS AND TOYS, OF OTHERS (U.S. CLS. 100, 101 AND 102).

FIRST USE 0-0-2008; IN COMMERCE 0-0-2008.

CLASS 37—CONSTRUCTION AND REPAIR

FOR RECYCLING SERVICES, NAMELY, COLLECTION, REMOVAL AND DISPOSAL OF USED CLOTHING, SHOES, HOUSEHOLD CLOTHING GOODS AND TOYS; AND TEXTILE RECYCLING, NAMELY, SORTING OF USED CLOTHING, SHOES, HOUSEHOLD GOODS AND TOYS FOR LATER DISTRIBUTION OR SHIPPING (U.S. CLS. 100, 103 AND 106).

FIRST USE 0-0-2008; IN COMMERCE 0-0-2008.

CLASS 40—MATERIAL TREATMENT

FOR RECYCLING (U.S. CLS. 100, 103 AND 106).

FIRST USE 0-0-2008; IN COMMERCE 0-0-2008.
DAVID HOFFMAN, EXAMINING ATTORNEY

SN 85-256,757. KESSEL MARKETING & VERTRIEBS GMBH, MOERFELDEN-WALLDORF, FED REP GERMANY, FILED 3-3-2011.

YCAP

THE MARK CONSISTS OF STANDARD CHARACTERS WITHOUT CLAIM TO ANY PARTICULAR FONT, STYLE, SIZE, OR COLOR.

CLASS 5—PHARMACEUTICALS

FOR SPERMICIDES, SPERMICIDAL GELS, CONTRACEPTIVE GELS (U.S. CLS. 6, 18, 44, 46, 51 AND 52).

CLASS 10—MEDICAL APPARATUS

FOR DIAPHRAGMS FOR CONTRACEPTION, CONTOURED CERVICAL BARRIERS FOR CONTRACEPTION (U.S. CLS. 26, 39 AND 44).

APRIL HESIK, EXAMINING ATTORNEY

SN 85-256,800. KESSEL MARKETING & VERTRIEBS GMBH, MOERFELDEN-WALLDORF, FED REP GERMANY, FILED 3-3-2011.

Y-CAP

THE MARK CONSISTS OF STANDARD CHARACTERS WITHOUT CLAIM TO ANY PARTICULAR FONT, STYLE, SIZE, OR COLOR.

CLASS 5—PHARMACEUTICALS

FOR SPERMICIDES, SPERMICIDAL GELS, CONTRACEPTIVE GELS (U.S. CLS. 6, 18, 44, 46, 51 AND 52).

CLASS 10—MEDICAL APPARATUS

FOR DIAPHRAGMS FOR CONTRACEPTION, CONTOURED CERVICAL BARRIERS FOR CONTRACEPTION (U.S. CLS. 26, 39 AND 44).

APRIL HESIK, EXAMINING ATTORNEY

SN 85-256,858. TECHNIKON LABORATORIES (PTY) LTD, ROBERTVILLE, GAUTENG, SOUTH AFRICA, FILED 3-3-2011.

ALTO 

THE MARK CONSISTS OF THE WORD "ALTO" APPEARING IN A ROUNDED STYLIZED FONT WITH A SUN DESIGN APPEARING IN THE RIGHT UPPER-HAND CORNER.

CLASS 3—COSMETICS AND CLEANING PREPARATIONS

FOR NON-MEDICATED SUNSCREEN AND SUN SCREENING PREPARATIONS (U.S. CLS. 1, 4, 6, 50, 51 AND 52).

CLASS 5—PHARMACEUTICALS

FOR MEDICATED SUNSCREEN AND SUN SCREENING PREPARATIONS (U.S. CLS. 6, 18, 44, 46, 51 AND 52).

TINA BROWN, EXAMINING ATTORNEY

SN 85-256,920. OLLEY GEAR, LLC, LOS ANGELES, CA, FILED 3-3-2011.



THE MARK CONSISTS OF THE WORD "OLLEY" IN STYLIZED FORM. THE LETTER "O" IN THE WORD "OLLEY" IS COMPROMISED OF TWO CONCENTRIC CIRCLES EACH WITH A SMALL BREAK IN THE UPPER RIGHT HAND SIDE, FROM WHICH EMERGES FROM THE OUTSIDE CIRCLE TWO STRAIGHT PARALLEL LINES MOVING OUTWARD, AND FROM THE INNER CIRCLE WHICH EMERGES TWO STRAIGHT PARALLEL LINES MOVING INWARD TOWARD THE CENTER OF THE INNER CIRCLE.

CLASS 9—ELECTRICAL AND SCIENTIFIC APPARATUS

FOR CRASH HELMETS; PROTECTIVE HELMETS; PROTECTIVE HELMETS FOR SPORTS (U.S. CLS. 21, 23, 26, 36 AND 38).

CLASS 18—LEATHER GOODS

FOR ALL PURPOSE SPORT BAGS; ALL-PURPOSE ATHLETIC BAGS; ALL-PURPOSE CARRYING BAGS; ATHLETIC BAGS; BACKPACKS, BOOK BAGS, SPORTS BAGS, BUM BAGS, WALLETS AND HANDBAGS; BAGS FOR CLIMBERS IN THE NATURE OF ALL-PURPOSE CARRYING BAGS; BAGS FOR SPORTS (U.S. CLS. 1, 2, 3, 22 AND 41).

SN 85-257,047. SAUNDERS ENTERPRISES, LLC, HENDERSON, NV. FILED 3-3-2011.

THE POWER OF KNOWING HOW
LIFE WORKS

THE MARK CONSISTS OF STANDARD CHARACTERS WITHOUT CLAIM TO ANY PARTICULAR FONT, STYLE, SIZE, OR COLOR.

CLASS 25—CLOTHING

FOR APPAREL FOR DANCERS, NAMELY, TEE SHIRTS, SWEATSHIRTS, PANTS, LEGGINGS, SHORTS AND JACKETS; BELTS; BELTS FOR CLOTHING; BODY SHIRTS; CLOTHING FOR ATHLETIC USE, NAMELY, PADDED ELBOW COMPRESSION SLEEVES BEING PART OF AN ATHLETIC GARMENT; CLOTHING FOR ATHLETIC USE, NAMELY, PADDED PANTS; CLOTHING FOR ATHLETIC USE, NAMELY, PADDED SHIRTS; CLOTHING FOR ATHLETIC USE, NAMELY, PADDED SHORTS; CLOTHING, NAMELY, ATHLETIC SLEEVES; GLOVES AS CLOTHING; GOLF SHIRTS; HEADBANDS FOR CLOTHING; HOODED SWEAT SHIRTS; HOODS; JACKETS; KNIT SHIRTS; OPEN-NECKED SHIRTS; SHIRTS; SHIRTS AND SHORT-SLEEVED SHIRTS; SHORT-SLEEVED SHIRTS; SNOWBOARD BOOTS; SNOWBOARD GLOVES; SNOWBOARD JACKETS; SNOWBOARD MITTENS; SNOWBOARD PANTS; SNOWBOARD TROUSERS; SPORTS SHIRTS; SPORTS SHIRTS WITH SHORT SLEEVES; SWEAT SHIRTS; T-SHIRTS; T-SHIRTS FOR MEN, WOMAN, AND CHILDREN; TOPS; WEARABLE GARMENTS AND CLOTHING, NAMELY, SHIRTS; WOMEN'S CLOTHING, NAMELY, SHIRTS, DRESSES, SKIRTS, BLOUSES (U.S. CLS. 22 AND 39).

CLASS 16—PAPER GOODS AND PRINTED MATTER

FOR SERIES OF NON-FICTION BOOKS IN THE FIELD OF SELF HELP AND PERSONAL AND BUSINESS DEVELOPMENT (U.S. CLS. 2, 5, 22, 23, 29, 37, 38 AND 50).

CLASS 41—EDUCATION AND ENTERTAINMENT

FOR EDUCATIONAL SERVICES, NAMELY, CONDUCTING LECTURES, WORKSHOPS AND SEMINARS IN THE FIELD OF SELF HELP AND PERSONAL AND BUSINESS DEVELOPMENT (U.S. CLS. 100, 101 AND 107).
JACLYN KIDWELL WALKER, EXAMINING ATTORNEY

CLASS 28—TOYS AND SPORTING GOODS

FOR BAGS ESPECIALLY DESIGNED FOR SURFBOARDS; BAGS FOR SKATEBOARDS; PADDLE SURFBOARDS; PROTECTIVE PADDING FOR SKATEBOARDING; PROTECTIVE PADDING FOR SNOWBOARDING; SKATEBOARD WHEELS; SKATEBOARDS; SNOWBOARDS; SURFBOARD CARRIER WORN ON THE BODY; SURFBOARDS (U.S. CLS. 22, 23, 38 AND 50).

DOMINIC J. FERRAIUOLO, EXAMINING ATTORNEY

SN 85-257,104. THIRTYTHINGS, LLC, HOBOKEN, NJ. FILED 3-3-2011.

SN 85-256,922. SARA LEE FOODS, LLC, DOWNERS GROVE, IL. FILED 3-3-2011.

FAN FAVORITES

THE MARK CONSISTS OF STANDARD CHARACTERS WITHOUT CLAIM TO ANY PARTICULAR FONT, STYLE, SIZE, OR COLOR.

CLASS 29—MEATS AND PROCESSED FOODS

FOR COOKED MEAT NAMELY, BEEF, PORK OR POULTRY; SNACK FOODS CONSISTING OF MEAT, CHEESE OR VEGETABLES (U.S. CL. 46).

CLASS 30—STAPLE FOODS

FOR SANDWICHES (U.S. CL. 46).
DOMINIC J. FERRAIUOLO, EXAMINING ATTORNEY

ILOVEAGOOD

THE MARK CONSISTS OF STANDARD CHARACTERS WITHOUT CLAIM TO ANY PARTICULAR FONT, STYLE, SIZE, OR COLOR.

CLASS 35—ADVERTISING AND BUSINESS

FOR RETAIL SHOP-AT-HOME PARTY SERVICES IN THE FIELD OF FASHION, HEALTH, AND BEAUTY CARE PRODUCTS (U.S. CLS. 100, 101 AND 102).

CLASS 42—SCIENTIFIC AND COMPUTER SERVICES

FOR COMPUTER SERVICES, NAMELY, CREATING AN ON-LINE COMMUNITY FOR REGISTERED USERS TO PARTICIPATE IN DISCUSSIONS, GET FEEDBACK FROM THEIR PEERS, FORM VIRTUAL COMMUNITIES, AND ENGAGE IN SOCIAL NETWORKING IN THE FIELD OF FASHION AND FASHION ACCESSORIES (U.S. CLS. 100 AND 101).
EDWARD NELSON, EXAMINING ATTORNEY

SN 85-257,129. IMPERVA, INC., REDWOOD SHORES, CA.
FILED 3-3-2011.



THE MARK CONSISTS OF A THREE-DIMENSIONAL CYLINDER SURROUNDED BY A SWIRL.

CLASS 9—ELECTRICAL AND SCIENTIFIC APPARATUS

FOR COMPUTER HARDWARE; EMBEDDED SOFTWARE SOLD AS AN INTEGRAL COMPONENT OF COMPUTER HARDWARE USED TO MONITOR, ANALYZE, MANAGE, ASSESS AND ANTICIPATE TRENDS, TROUBLESHOOT, RECORD, ENHANCE, AND THE MAINTAIN SECURITY OVER AND IN COMPUTER NETWORKS, COMPUTER APPLICATIONS, NETWORK DEVICES, NETWORK DEVICES, DATA STORAGE, AND TRANSFER OF DIGITAL DATA; COMPUTER SOFTWARE USED TO MONITOR, ANALYZE, MANAGE, ASSESS AND ANTICIPATE TRENDS, TROUBLESHOOT, RECORD, ENHANCE, AND THE MAINTAIN SECURITY OVER AND IN COMPUTER NETWORKS, COMPUTER APPLICATIONS, NETWORK DEVICES, NETWORK DEVICES, DATA STORAGE, AND TRANSFER OF DIGITAL DATA (U.S. CLS. 21, 23, 26, 36 AND 38).

FIRST USE 2-0-2004; IN COMMERCE 2-0-2004.

CLASS 42—SCIENTIFIC AND COMPUTER SERVICES

FOR TECHNICAL CONSULTING AND COMPUTER PROGRAMMING SERVICES TO MONITOR, ANALYZE, MANAGE, ASSESS AND ANTICIPATE TRENDS, TROUBLESHOOT, RECORD, ENHANCE, AND THE MAINTAIN SECURITY OVER AND IN COMPUTER NETWORKS, COMPUTER APPLICATIONS, NETWORK DEVICES, NETWORK DEVICES, DATA STORAGE, AND TRANSFER OF DIGITAL DATA; SERVICES FOR MAINTENANCE OF COMPUTER SOFTWARE (U.S. CLS. 100 AND 101).

FIRST USE 2-0-2004; IN COMMERCE 2-0-2004.
TASNEEM HUSSAIN, EXAMINING ATTORNEY

SN 85-257,134. TRUE, STEVEN, NEW WESTMINSTER, CANADA, FILED 3-3-2011.

ZALTANA

THE MARK CONSISTS OF STANDARD CHARACTERS WITHOUT CLAIM TO ANY PARTICULAR FONT, STYLE, SIZE, OR COLOR.

CLASS 20—FURNITURE AND ARTICLES NOT OTHERWISE CLASSIFIED

FOR AIR MATTRESSES FOR USE WHEN CAMPING; CAMPING FURNITURE; FURNITURE FOR CAMPING; INFLATABLE MATTRESSES FOR USE WHEN CAMPING; METAL FURNITURE AND FURNITURE FOR CAMPING; NON-METAL TENT PEGS; NON-METAL TENT STAKES; NONMETAL TENT POLES; SLEEPING BAGS (U.S. CLS. 2, 13, 22, 25, 32 AND 50).

FIRST USE 11-18-2010; IN COMMERCE 11-18-2010.

CLASS 22—CORDAGE AND FIBERS

FOR BED TENTS; RAIN FLIES FOR TENTS; TENT FLIES; TENTS; TENTS; TENTS FOR MOUNTAINEERING OR CAMPING (U.S. CLS. 1, 2, 7, 19, 22, 42 AND 50).

FIRST USE 11-18-2010; IN COMMERCE 11-18-2010.
SAMUEL E. SHARPER JR., EXAMINING ATTORNEY

SN 85-257,152. HUDSPETH, DONALD W., PHOENIX, AZ.
FILED 3-3-2011.

**"The Business of our Firm
is Business"**

THE MARK CONSISTS OF STANDARD CHARACTERS WITHOUT CLAIM TO ANY PARTICULAR FONT, STYLE, SIZE, OR COLOR.

CLASS 35—ADVERTISING AND BUSINESS

FOR BUSINESS CONSULTATION SERVICES, NAMELY, PROVIDING DIRECT AID IN THE OPERATIONS OR FUNCTIONS OF COMMERCIAL ENTERPRISES (U.S. CLS. 100, 101 AND 102).

FIRST USE 2-14-1995; IN COMMERCE 2-14-1995.

CLASS 45—PERSONAL AND LEGAL SERVICES

FOR LEGAL SERVICES (U.S. CLS. 100 AND 101).
FIRST USE 2-15-1995; IN COMMERCE 2-15-1995.
MARLENE BELL, EXAMINING ATTORNEY

SN 85-257,229. POSTINGSPLUS LLC, OYSTER BAY, NY.
FILED 3-3-2011.



THE MARK CONSISTS OF THE LOWER CASE LETTER "P" AND THE PLUS SYMBOL CONTAINED WITHIN TWO RECTANGULAR-SHAPED BOXES.

CLASS 35—ADVERTISING AND BUSINESS

FOR PROMOTING THE GOODS AND SERVICES OF OTHERS BY PROVIDING A WEB SITE FEATURING COUPONS, REBATES, PRICE-COMPARISON INFORMATION, PRODUCT REVIEWS, LINKS TO THE RETAIL WEB SITES OF OTHERS, AND DISCOUNT INFORMATION; PROVIDING NETWORKING OPPORTUNITIES FOR INDIVIDUALS SEEKING EMPLOYMENT (U.S. CLS. 100, 101 AND 102).

FIRST USE 12-16-2010; IN COMMERCE 12-16-2010.

CLASS 38—COMMUNICATION

FOR INTERNET RADIO SERVICES, NAMELY, TRANSMISSION OF AUDIO MATERIAL VIA THE INTERNET; PROVIDING E-MAIL SERVICES; PROVIDING ON-LINE CHAT ROOMS AND ELECTRONIC BULLETIN BOARDS FOR TRANSMISSION OF MESSAGES AMONG USERS IN THE FIELD OF GENERAL INTEREST; TRANSMISSION OF SOUND, VIDEO AND INFORMATION (U.S. CLS. 100, 101 AND 104).

FIRST USE 12-16-2010; IN COMMERCE 12-16-2010.

CLASS 45—PERSONAL AND LEGAL SERVICES

FOR INTERNET BASED SOCIAL NETWORKING, INTRODUCTION, AND DATING SERVICES; INTERNET-BASED SOCIAL NETWORKING SERVICES; PROVIDING A SOCIAL NETWORKING WEBSITE FOR ENTERTAINMENT PURPOSES (U.S. CLS. 100 AND 101).

FIRST USE 12-16-2010; IN COMMERCE 12-16-2010.
ANNE MADDEN, EXAMINING ATTORNEY

CLASS 35—ADVERTISING AND BUSINESS

FOR ADVERTISING AND MARKETING; BRANDING SERVICES, NAMELY, CONSULTING, DEVELOPMENT, MANAGEMENT AND MARKETING OF BRANDS FOR BUSINESSES; DESIGN OF ADVERTISING MATERIALS FOR OTHERS; MAILING LIST PREPARATION; DIRECT MAIL ADVERTISING SERVICES; INFORMATION, ADVISORY, CONSULTING, BUSINESS RESEARCH AND PLANNING SERVICES RELATING TO PUBLICITY, MARKETING COMMUNICATIONS, REPUTATION MANAGEMENT, OR BUSINESS ADMINISTRATION, INCLUDING SUCH SERVICES PROVIDED ONLINE OR VIA THE INTERNET; PROVIDING ADVERTISING SERVICE TO DISTRIBUTE ADVERTISEMENTS FOR DISPLAY ON INTERNET, NAMELY, IN WEBSITES, SOCIAL CONVERSATIONS OVER THE INTERNET, E-MAILS, MICROBLOGS, BLOGS, ELECTRONIC MESSAGES, INSTANT MESSAGES, TEXT MESSAGES, MULTIMEDIA MESSAGES, SOCIAL NETWORKS, STATUS UPDATES, FORUMS, ELECTRONIC BULLETIN BOARDS; MARKET ANALYSIS; ADVERTISING SERVICES, NAMELY, CREATING CORPORATE LOGOS FOR OTHERS; ADVERTISING TEXT PUBLICATION SERVICES; BRANDING SERVICES, NAMELY, CONSULTING, DEVELOPMENT, MANAGEMENT AND MARKETING OF BRANDS FOR BUSINESSES; MARKET RESEARCH AND MARKET INTELLIGENCE SERVICES (U.S. CLS. 100, 101 AND 102).

FIRST USE 1-1-2011; IN COMMERCE 1-1-2011.

CLASS 38—COMMUNICATION

FOR ELECTRONIC MAIL SERVICES (U.S. CLS. 100, 101 AND 104).

FIRST USE 1-1-2011; IN COMMERCE 1-1-2011.

CLASS 41—EDUCATION AND ENTERTAINMENT

FOR SCRIPTWRITING SERVICES; VIDEOGRAPHY SERVICES (U.S. CLS. 100, 101 AND 107).

FIRST USE 1-1-2011; IN COMMERCE 1-1-2011.

CLASS 42—SCIENTIFIC AND COMPUTER SERVICES

FOR CUSTOMIZATION OF COMPUTER HARDWARE AND SOFTWARE; DESIGNING WEBSITES FOR ADVERTISING PURPOSES; COMPUTER SERVICES, NAMELY, SEARCH ENGINE OPTIMIZATION; WEBSITE DESIGN FOR OTHERS (U.S. CLS. 100 AND 101).

FIRST USE 1-1-2011; IN COMMERCE 1-1-2011.

JIM RINGLE, EXAMINING ATTORNEY

SN 85-257,289. TWG SOLUTIONS, LLC, AUSTIN, TX. FILED 3-3-2011.



NO CLAIM IS MADE TO THE EXCLUSIVE RIGHT TO USE "MARKETING", APART FROM THE MARK AS SHOWN.

THE COLOR(S) WHITE, GREEN, AND BROWN IS/ARE CLAIMED AS A FEATURE OF THE MARK.

THE MARK CONSISTS OF THE TERM "TWG" IN WHITE SET AGAINST A GREEN BACKGROUND RECTANGLE WHICH IS NEXT TO A WHITE PLUS SYMBOL SET AGAINST A BROWN BACKGROUND CARRIER WITH AN OVERALL SQUARE SHAPE WITH TWO ROUNDED CORNERS; BENEATH APPEARS THE TERM "EDUCATED MARKETING" IN GREEN; THE BACKGROUND OF THE ENTIRE MARK IS WHITE.

SN 85-257,316. BENEFIT COSMETICS LLC, SAN FRANCISCO, CA. FILED 3-3-2011.

GLAMOURIETY

THE MARK CONSISTS OF STANDARD CHARACTERS WITHOUT CLAIM TO ANY PARTICULAR FONT, STYLE, SIZE, OR COLOR.

CLASS 3—COSMETICS AND CLEANING PREPARATIONS

FOR COSMETICS (U.S. CLS. 1, 4, 6, 50, 51 AND 52).

CLASS 18—LEATHER GOODS

FOR COSMETIC BAGS SOLD EMPTY (U.S. CLS. 1, 2, 3, 22 AND 41).

PAM WILLIS, EXAMINING ATTORNEY

SN 85-257,322. ALEX MAINE, LOS ANGELES, CA. FILED 3-3-2011.



THE MARK CONSISTS OF FIVE STRIPES COMING OFF TO THE LEFT OF THE STYLIZED TEXT "AM". THREE OF THE STRIPES ARE IN LINE WITH THE STYLIZED "AM" TEXT. THE BOTTOM TWO STRIPES RUN UNDERNEATH THE "AM" AND END IN LINE WITH THE "AM".

CLASS 9—ELECTRICAL AND SCIENTIFIC APPARATUS

FOR CASES FOR EYEGLASSES AND SUNGLASSES; SUNGLASSES (U.S. CLS. 21, 23, 26, 36 AND 38).

CLASS 14—JEWELRY

FOR CLOCKS; JEWELRY; WATCHES (U.S. CLS. 2, 27, 28 AND 50).

CLASS 18—LEATHER GOODS

FOR BACKPACKS; BOOK BAGS; BUM BAGS; HANDBAGS; SPORT BAGS; WALLETS (U.S. CLS. 1, 2, 3, 22 AND 41).

CLASS 25—CLOTHING

FOR ATHLETIC APPAREL, NAMELY, SHIRTS, PANTS, JACKETS, FOOTWEAR, HATS AND CAPS, ATHLETIC UNIFORMS; BELTS; COATS; FOOTWEAR; JACKETS; PANTS; SHORTS; SOCKS; SWEATERS; T-SHIRTS (U.S. CLS. 22 AND 39).

CLASS 35—ADVERTISING AND BUSINESS

FOR ON-LINE WHOLESALE AND RETAIL STORE SERVICES FEATURING CLOTHING AND ACCESSORIES (U.S. CLS. 100, 101 AND 102).
VIVIAN MICZNIK FIRST, EXAMINING ATTORNEY

SN 85-257,328. STANOJEVIC, DEJAN, DOWNEY, CA. FILED 3-3-2011.



THE STIPPLING IS FOR SHADING PURPOSES ONLY.

THE MARK CONSISTS OF A DONKEY WITH THE STYLIZED TEXT "RIDONKULOUS!".

CLASS 25—CLOTHING

FOR HATS; JEANS; SHORTS; SWEATERS; SWIMWEAR; T-SHIRTS (U.S. CLS. 22 AND 39).

CLASS 28—TOYS AND SPORTING GOODS

FOR PLUSH TOYS (U.S. CLS. 22, 23, 38 AND 50).

CLASS 41—EDUCATION AND ENTERTAINMENT

FOR ENTERTAINMENT SERVICES, NAMELY, THE PROVISION OF CONTINUING SEGMENTS FEATURING COMEDY DELIVERED BY TELEVISION, RADIO, SATELLITE, THE INTERNET (U.S. CLS. 100, 101 AND 107).
VIVIAN MICZNIK FIRST, EXAMINING ATTORNEY

SN 85-257,413. THE ARBOR SOCIETY, INC, OMAHA, NE. FILED 3-3-2011.



THE MARK CONSISTS OF A CIRCLE WITH A TREE IN THE MIDDLE. LEFT HALF OF TREE HAS LEAVES; RIGHT SIDE OF TREE IS DORMANT (NO LEAVES).

CLASS 40—MATERIAL TREATMENT

FOR CREMATION SERVICES (U.S. CLS. 100, 103 AND 106).
FIRST USE 3-31-2005; IN COMMERCE 3-31-2005.

CLASS 45—PERSONAL AND LEGAL SERVICES

FOR FUNERAL SERVICES ACCOMPANYING CREMATION (U.S. CLS. 100 AND 101).
FIRST USE 3-31-2005; IN COMMERCE 3-31-2005.
SUZANNE BLANE, EXAMINING ATTORNEY

SN 85-257,428. A HIGHER POSSIBILITY, SAN RAFAEL, CA. FILED 3-3-2011.

SN 85-257,511. HERB'N LIVING LLC, ST LOUIS, MO. FILED 3-3-2011.

THE SOULMATE EXPERIENCE

THE MARK CONSISTS OF STANDARD CHARACTERS WITHOUT CLAIM TO ANY PARTICULAR FONT, STYLE, SIZE, OR COLOR.

CLASS 16—PAPER GOODS AND PRINTED MATTER

FOR BOOKS IN THE FIELD OF RELATIONSHIPS (U.S. CLS. 2, 5, 22, 23, 29, 37, 38 AND 50).

CLASS 41—EDUCATION AND ENTERTAINMENT

FOR EDUCATION SERVICES, NAMELY, PROVIDING WORKSHOPS AND SEMINARS IN THE FIELD OF RELATIONSHIPS; PERSONAL COACHING SERVICES IN THE FIELD OF RELATIONSHIPS (U.S. CLS. 100, 101 AND 107).
WENDY GOODMAN, EXAMINING ATTORNEY



THE MARK CONSISTS OF AN IMAGE OF A STYLIZED FEATHER DUSTER.

CLASS 3—COSMETICS AND CLEANING PREPARATIONS

FOR CLEANING, WASHING AND POLISHING PREPARATIONS (U.S. CLS. 1, 4, 6, 50, 51 AND 52).
FIRST USE 7-15-2007; IN COMMERCE 7-15-2007.

CLASS 37—CONSTRUCTION AND REPAIR

FOR JANITORIAL SERVICES (U.S. CLS. 100, 103 AND 106).
FIRST USE 7-15-2007; IN COMMERCE 7-15-2007.
CURTIS FRENCH, EXAMINING ATTORNEY

SN 85-257,465. HEBREW HEROES, LLC, ENCINO, CA. FILED 3-3-2011.

HEBREW HEROES

THE MARK CONSISTS OF STANDARD CHARACTERS WITHOUT CLAIM TO ANY PARTICULAR FONT, STYLE, SIZE, OR COLOR.

CLASS 9—ELECTRICAL AND SCIENTIFIC APPARATUS

FOR ENTERTAINMENT SOFTWARE NAMELY SOFTWARE USED TO PROVIDE MULTIPLAYER ACCESS TO AN ONLINE GAME ENVIRONMENT (U.S. CLS. 21, 23, 26, 36 AND 38).

CLASS 41—EDUCATION AND ENTERTAINMENT

FOR ENTERTAINMENT SERVICES NAMELY PROVIDING ONLINE COMPUTER GAMES (U.S. CLS. 100, 101 AND 107).
JACQUELINE A. LAVINE, EXAMINING ATTORNEY

SN 85-257,532. ANDERSEN, KATHERINE, MIAMI BEACH, FL. FILED 3-3-2011.

CHANGE BEGINS WITH ONE

THE MARK CONSISTS OF STANDARD CHARACTERS WITHOUT CLAIM TO ANY PARTICULAR FONT, STYLE, SIZE, OR COLOR.

CLASS 35—ADVERTISING AND BUSINESS

FOR BUSINESS AND ORGANIZATIONAL MANAGEMENT CONSULTATION IN THE FIELD OF EXECUTIVE AND LEADERSHIP DEVELOPMENT; BUSINESS CONSULTING, MANAGEMENT, PLANNING AND SUPERVISION; BUSINESS LEADERSHIP DEVELOPMENT; BUSINESS MANAGEMENT CONSULTATION IN THE FIELD OF EXECUTIVE AND LEADERSHIP DEVELOPMENT; BUSINESS MANAGEMENT CONSULTING IN THE FIELD OF TEAM DEVELOPMENT (U.S. CLS. 100, 101 AND 102).
FIRST USE 1-31-2011; IN COMMERCE 1-31-2011.

CLASS 41—EDUCATION AND ENTERTAINMENT

FOR EDUCATION AND TRAINING SERVICES, NAMELY, PROVIDING CLASSES, SEMINARS, RETREATS, COACHING, AND WORKSHOPS IN THE AREAS OF BUSINESS LEADERSHIP, BUSINESS MANAGEMENT, EXECUTIVE LEADERSHIP AND DEVELOPMENT, TEAM LEADERSHIP AND DEVELOPMENT, ORGANIZATIONAL DEVELOPMENT, PERSONAL EMPOWERMENT, STRESS MANAGEMENT, HEALTH, WELL-BEING, AND MIND-BODY CONNECTION (U.S. CLS. 100, 101 AND 107).

FIRST USE 1-31-2011; IN COMMERCE 1-31-2011.
KARANENDRA S. CHHINA, EXAMINING ATTORNEY

SN 85-257,533. BENCHMADE KNIFE CO., INC., OREGON CITY, OR. FILED 3-3-2011.



OWNER OF U.S. REG. NOS. 1,932,859, 3,590,206 AND OTHERS.

THE MARK CONSISTS OF THE STYLIZED WORD "BENCHMADE" WITH THE LETTER "M" IN THE WORD OUTLINED IN A DESIGN OF A BUTTERFLY.

CLASS 8—HAND TOOLS

FOR KNIVES; HAND-OPERATED CUTTING TOOLS, NAMELY, SAFETY CUTTERS AND HOOKS; KNIFE SHEATHS; KNIFE SHARPENERS (U.S. CLS. 23, 28 AND 44).

FIRST USE 10-0-2003; IN COMMERCE 10-0-2003.

CLASS 16—PAPER GOODS AND PRINTED MATTER

FOR PENS (U.S. CLS. 2, 5, 22, 23, 29, 37, 38 AND 50).
FIRST USE 1-14-2008; IN COMMERCE 1-14-2008.

CLASS 25—CLOTHING

FOR HEADGEAR, NAMELY, HATS, CAPS AND BEANIES; T-SHIRTS; GOLF SHIRTS; DRESS SHIRTS; POLO SHIRTS; LONG-SLEEVED SHIRTS; SHORT-SLEEVED SHIRTS; HOODED SWEAT SHIRTS; FLEECE TOPS (U.S. CLS. 22 AND 39).

FIRST USE 10-0-2003; IN COMMERCE 10-0-2003.

CLASS 37—CONSTRUCTION AND REPAIR

FOR KNIFE SHARPENING (U.S. CLS. 100, 103 AND 106).

FIRST USE 10-0-2003; IN COMMERCE 10-0-2003.
DOMINIC FATHY, EXAMINING ATTORNEY

SN 85-257,553. MDU RESOURCES GROUP, INC., BISMARCK, ND. FILED 3-3-2011.

COMMITTED TO ZERO

THE MARK CONSISTS OF STANDARD CHARACTERS WITHOUT CLAIM TO ANY PARTICULAR FONT, STYLE, SIZE, OR COLOR.

OWNER OF U.S. REG. NO. 3,679,135.

CLASS 16—PAPER GOODS AND PRINTED MATTER

FOR MAGAZINES, MANUALS, BROCHURES, AND HOUSE ORGANS ALL FEATURING INFORMATION ON EMPLOYEE HEALTH AND SAFETY (U.S. CLS. 2, 5, 22, 23, 29, 37, 38 AND 50).

FIRST USE 1-22-2009; IN COMMERCE 1-22-2009.

CLASS 45—PERSONAL AND LEGAL SERVICES

FOR PROVIDING ONLINE INFORMATION ON WORKPLACE SAFETY FOR EMPLOYEES IN THE FIELDS OF NATURAL GAS, OIL AND ELECTRICITY (U.S. CLS. 100 AND 101).

FIRST USE 1-20-2009; IN COMMERCE 1-20-2009.
PATRICIA EVANKO, EXAMINING ATTORNEY

SN 85-257,681. SKINIT, INC., SAN DIEGO, CA. FILED 3-4-2011.

WHAT DO YOU SKIN FOR?

THE MARK CONSISTS OF STANDARD CHARACTERS WITHOUT CLAIM TO ANY PARTICULAR FONT, STYLE, SIZE, OR COLOR.

CLASS 9—ELECTRICAL AND SCIENTIFIC APPARATUS

FOR PRE-MADE AND CUSTOM-MADE VINYL AND PLASTIC SHELL COVERS FOR CELL PHONES, MP3 PLAYERS, LAPTOPS, COMPUTERS, PORTABLE GAME MACHINES, PORTABLE SATELLITE RADIOS, PERSONAL DIGITAL ASSISTANTS, REMOTE CONTROLS AND TELEVISION SATELLITE RECORDERS (U.S. CLS. 21, 23, 26, 36 AND 38).

CLASS 40—MATERIAL TREATMENT

FOR CUSTOM IMPRINTING OF CELL PHONES, MP3 PLAYERS, LAPTOPS, COMPUTERS, PORTABLE GAME MACHINES, PORTABLE SATELLITE RADIOS, PERSONAL DIGITAL ASSISTANTS, REMOTE CONTROLS, MEDICAL DEVICES, CAR AND TRUCK EXTERIORS, WALLPAPER, CAR DECORATIONS, AND TELEVISION SATELLITE RECORDERS WITH CUSTOM-MADE VINYL COVERS, AND ACCESSORIES (U.S. CLS. 100, 103 AND 106).

SUZANNE BLANE, EXAMINING ATTORNEY

SN 85-257,792. GLOBAL MARKETING RESOURCES, INC., DUNEDIN, FL. FILED 3-4-2011.

TIDBITS

THE MARK CONSISTS OF STANDARD CHARACTERS WITHOUT CLAIM TO ANY PARTICULAR FONT, STYLE, SIZE, OR COLOR.

CLASS 38—COMMUNICATION

FOR TELECOMMUNICATION SERVICES, NAMELY, PROVIDING ONLINE AND TELECOMMUNICATION FACILITIES FOR REAL-TIME INTERACTION BETWEEN AND AMONG USERS OF COMPUTERS, MOBILE AND HANDHELD COMPUTERS, AND WIRED AND WIRELESS COMMUNICATION DEVICES; ENABLING INDIVIDUALS TO SEND AND RECEIVE MESSAGES VIA EMAIL, INSTANT MESSAGING OR A WEBSITE ON THE INTERNET IN THE FIELD OF GENERAL INTEREST; PROVIDING ON-LINE CHAT ROOMS AND ELECTRONIC BULLETIN BOARDS FOR TRANSMISSION OF MESSAGES AMONG USERS IN THE FIELD OF GENERAL INTEREST; PROVIDING AN ONLINE COMMUNITY FORUM FOR REGISTERED USERS TO SHARE INFORMATION (U.S. CLS. 100, 101 AND 104).

SN 85-257,862. DAVID LINDSEY, INDIANAPOLIS, IN. FILED 3-4-2011.

CWAM

THE MARK CONSISTS OF STANDARD CHARACTERS WITHOUT CLAIM TO ANY PARTICULAR FONT, STYLE, SIZE, OR COLOR.

CLASS 45—PERSONAL AND LEGAL SERVICES

FOR PROVIDING A WEBSITE ON THE INTERNET FOR THE PURPOSE OF SOCIAL NETWORKING (U.S. CLS. 100 AND 101).
SUNG IN, EXAMINING ATTORNEY

CLASS 35—ADVERTISING AND BUSINESS

FOR CHARITABLE SERVICES, NAMELY, COORDINATION OF NON-MONETARY CONTRIBUTIONS TO CHARITIES AND NON-PROFITS (U.S. CLS. 100, 101 AND 102).
FIRST USE 12-13-2010; IN COMMERCE 12-13-2010.

CLASS 36—INSURANCE AND FINANCIAL

FOR ACCEPTING AND ADMINISTERING MONETARY CHARITABLE CONTRIBUTIONS (U.S. CLS. 100, 101 AND 102).
FIRST USE 12-13-2010; IN COMMERCE 12-13-2010.
PAUL MORENO, EXAMINING ATTORNEY

SN 85-257,830. ROYAL INDUSTRIES (THAILAND) PUBLIC COMPANY LIMITED, KRATHUMBAN SAMUTSAKORN, THAILAND, FILED 3-4-2011.

SN 85-257,872. ZODIAC WIZARD LLC, HOBE SOUND, FL. FILED 3-4-2011.



THE MARK CONSISTS OF THE IMAGE OF AN INFANT'S FACE WITHIN A STYLIZED LETTER "N", ARRANGED VERTICALLY ON TOP OF THE WORDING "NATURAL EXTENSION".

CLASS 18—LEATHER GOODS

FOR BACKPACKS; HIKING STICKS (U.S. CLS. 1, 2, 3, 22 AND 41).

CLASS 25—CLOTHING

FOR ATHLETIC FOOTWEAR; ATHLETIC SHOES; HOODED PULLOVERS; HOODED SWEATSHIRTS; JACKETS; SOCKS; SWEATSHIRTS; T-SHIRTS (U.S. CLS. 22 AND 39).
TINA MAI, EXAMINING ATTORNEY

CLASS 10—MEDICAL APPARATUS

FOR FEEDING BOTTLES; NIPPLES AND SPOUTS FOR BABY BOTTLES; CUPS ADAPTED FOR FEEDING BABIES AND CHILDREN (U.S. CLS. 26, 39 AND 44).

SN 85-257,882. DAVID LINDSEY, INDIANAPOLIS, IN. FILED 3-4-2011.

CLASS 21—HOUSEWARES AND GLASS

FOR DRINKING CUPS; TRAINING CUPS FOR BABIES AND CHILDREN; BOWLS; PLATES (U.S. CLS. 2, 13, 23, 29, 30, 33, 40 AND 50).
GISSELLE AGOSTO, EXAMINING ATTORNEY

Companies With A Mission

THE MARK CONSISTS OF STANDARD CHARACTERS WITHOUT CLAIM TO ANY PARTICULAR FONT, STYLE, SIZE, OR COLOR.

CLASS 35—ADVERTISING AND BUSINESS

SN 85-257,894. AGRADIS, INC., DOVER, DE. FILED 3-4-2011.

FOR CHARITABLE SERVICES, NAMELY, COORDINATION OF NON-MONETARY CONTRIBUTIONS TO CHARITIES AND NON-PROFITS (U.S. CLS. 100, 101 AND 102).

FIRST USE 12-13-2010; IN COMMERCE 12-13-2010.

CLASS 36—INSURANCE AND FINANCIAL

FOR ACCEPTING AND ADMINISTERING MONETARY CHARITABLE CONTRIBUTIONS (U.S. CLS. 100, 101 AND 102).

FIRST USE 12-13-2010; IN COMMERCE 12-13-2010.
PAUL MORENO, EXAMINING ATTORNEY

AGRADIS

SN 85-257,887. THE COLLEGE OF WILLIAM AND MARY IN VIRGINIA, WILLIAMSBURG, VA. FILED 3-4-2011.



OWNER OF U.S. REG. NO. 1,676,169.

THE COLOR(S) GREEN, GOLD, WHITE AND BEIGE IS/ARE CLAIMED AS A FEATURE OF THE MARK.

THE MARK CONSISTS OF A STANDING GRIFFIN, WITH ITS RIGHT ARM POINTED UPWARDS, AND WITH ITS ARMS, A PORTION OF ITS WINGS, AND A PATCH BEHIND THE EYE IN GREEN, THE HEAD AND CHEST IN WHITE, ITS BEAK AND A PORTION OF ITS WINGS IN GOLD AND ITS LEGS AND TAIL IN BEIGE, STANDING ABOVE THE WORD "TRIBE" IN STYLIZED SCRIPT, WITH THE WORD "TRIBE" IN GREEN LETTERS OUTLINED IN GOLD.

CLASS 16—PAPER GOODS AND PRINTED MATTER

FOR DECALS (U.S. CLS. 2, 5, 22, 23, 29, 37, 38 AND 50).
FIRST USE 4-30-2010; IN COMMERCE 4-30-2010.

CLASS 25—CLOTHING

FOR CLOTHING, NAMELY CAPS (U.S. CLS. 22 AND 39).

FIRST USE 4-30-2010; IN COMMERCE 4-30-2010.

CLASS 41—EDUCATION AND ENTERTAINMENT

FOR EDUCATIONAL SERVICES, NAMELY, PROVIDING COURSES OF INSTRUCTION AT THE COLLEGE LEVEL; ENTERTAINMENT SERVICES, NAMELY, ORGANIZING AND CONDUCTING COLLEGIATE SPORTING AND CULTURAL EVENTS (U.S. CLS. 100, 101 AND 107).

FIRST USE 4-30-2010; IN COMMERCE 4-30-2010.
JOHN E. MICHOS, EXAMINING ATTORNEY

THE MARK CONSISTS OF STANDARD CHARACTERS WITHOUT CLAIM TO ANY PARTICULAR FONT, STYLE, SIZE, OR COLOR.

CLASS 1—CHEMICALS

FOR ADJUVANTS FOR USE WITH OR TO REPLACE AGRICULTURAL CHEMICALS; GENES, MICROBES AND ENZYMES FOR AGRICULTURAL USE; FERTILIZERS FOR AGRICULTURAL USE; FOOD SUPPLEMENTS FOR AGRICULTURAL PRODUCTS AND OTHER PLANTS; PLANT GROWTH REGULATORS FOR AGRICULTURAL USE; SURFACTANTS FOR USE IN CONNECTION WITH AGRICULTURAL PESTICIDES; SOIL CONDITIONERS FOR AGRICULTURAL USE (U.S. CLS. 1, 5, 6, 10, 26 AND 46).

CLASS 5—PHARMACEUTICALS

FOR FERTILIZERS; HERBICIDES; SOIL-CONDITIONING CHEMICALS; PLANT GROWTH REGULATING PREPARATIONS; PLANT PROTECTION AGENTS FOR A PROPHYLACTIC NATURE; AGENTS TO PREVENT MILDEW; PREPARATIONS FOR ACTIVATING THE BIOLOGICAL RESISTANCE OF PLANTS AND SEEDLINGS AGAINST INSECTS, BACTERIA, FUNGAL DISEASES, PARASITES AND WEEDS; BIOCIDES FOR PROTECTING PLANTS AGAINST PLANT PATHOGENS, NAMELY, FUNGICIDES, NEMATICIDES, AND PARASITICIDES, ALL FOR AGRICULTURAL AND SCIENTIFIC USE; PREPARATIONS FOR THE TREATMENT OF DEFICIENCY DISEASES IN PLANTS; BIOPESTICIDES AND BIOFUNGICIDES, ALL FOR AGRICULTURAL AND SCIENTIFIC USE (U.S. CLS. 6, 18, 44, 46, 51 AND 52).

CLASS 31—NATURAL AGRICULTURAL PRODUCTS

FOR LIVE PLANTS WITH IMPROVED CHARACTERISTICS; SEEDS FOR AGRICULTURAL USE (U.S. CLS. 1 AND 46).

CLASS 42—SCIENTIFIC AND COMPUTER SERVICES

FOR SCIENTIFIC RESEARCH IN THE FIELDS OF AGRICULTURE, PLANT GENETICS, PLANT GROWTH, PLANT NUTRIENTS AND PLANT PESTS; RESEARCH IN THE FIELD OF CROP PLANT GENETICS; AGRICULTURAL RESEARCH, NAMELY, CONDUCTING STUDIES AND ANALYSIS IN THE FIELD OF AGRICULTURE; DEVELOPMENT OF INTELLECTUAL PROPERTY FOR THE COMMERCIALIZATION OF PRODUCTS IDENTIFIED BY SUCH RESEARCH (U.S. CLS. 100 AND 101).

JOHN E. MICHOS, EXAMINING ATTORNEY

SN 85-257,936. CHIEF OUTSIDERS, LLC, CYPRESS, TX.
FILED 3-4-2011.

SN 85-258,037. WÄRTSILÄ TECHNOLOGY OY AB, HELSINKI, FINLAND, FILED 3-4-2011.



THE MARK CONSISTS OF CIRCULAR DESIGN NEXT TO THE WORDS "CHIEF OUTSIDERS".

CLASS 35—ADVERTISING AND BUSINESS

FOR BUSINESS CONSULTING SERVICES IN THE FIELD OF EXECUTIVE MANAGEMENT (U.S. CLS. 100, 101 AND 102).
FIRST USE 8-1-2009; IN COMMERCE 8-1-2009.

CLASS 41—EDUCATION AND ENTERTAINMENT

FOR ON-LINE JOURNAL, NAMELY, BLOG FEATURING TOPICS OF INTEREST TO BUSINESS EXECUTIVES (U.S. CLS. 100, 101 AND 107).
FIRST USE 7-21-2010; IN COMMERCE 7-21-2010.
JAMES GRIFFIN, EXAMINING ATTORNEY

SN 85-257,941. CHIEF OUTSIDERS, LLC, CYPRESS, TX.
FILED 3-4-2011.

CHIEF OUTSIDERS

THE MARK CONSISTS OF STANDARD CHARACTERS WITHOUT CLAIM TO ANY PARTICULAR FONT, STYLE, SIZE, OR COLOR.

CLASS 35—ADVERTISING AND BUSINESS

FOR BUSINESS CONSULTING SERVICES IN THE FIELD OF EXECUTIVE MANAGEMENT (U.S. CLS. 100, 101 AND 102).
FIRST USE 8-1-2009; IN COMMERCE 8-1-2009.

CLASS 41—EDUCATION AND ENTERTAINMENT

FOR ON-LINE JOURNAL, NAMELY, BLOG FEATURING TOPICS OF INTEREST TO BUSINESS EXECUTIVES (U.S. CLS. 100, 101 AND 107).
FIRST USE 7-21-2010; IN COMMERCE 7-21-2010.
JAMES GRIFFIN, EXAMINING ATTORNEY

FLEXICYCLE

THE MARK CONSISTS OF STANDARD CHARACTERS WITHOUT CLAIM TO ANY PARTICULAR FONT, STYLE, SIZE, OR COLOR.

CLASS 7—MACHINERY

FOR MOTORS AND ENGINES NOT FOR USE WITH LAND VEHICLES, AND GENERATORS OF ELECTRICITY, ALL FOR USE IN POWER PLANTS, AND PARTS THEREFOR (U.S. CLS. 13, 19, 21, 23, 31, 34 AND 35).

CLASS 11—ENVIRONMENTAL CONTROL APPARATUS

FOR POWER PLANTS FOR PRODUCTION OF ELECTRICITY AND/OR HEAT (U.S. CLS. 13, 21, 23, 31 AND 34).
JAY FLOWERS, EXAMINING ATTORNEY

SN 85-258,274. CELAVIE BIOSCIENCES LLC, READING, PA.
FILED 3-4-2011.



NO CLAIM IS MADE TO THE EXCLUSIVE RIGHT TO USE "BIOSCIENCES", APART FROM THE MARK AS SHOWN.

THE MARK CONSISTS OF AN IMAGE OF A TREE WHERE A BRAIN SITS ATOP THE TRUNK. BELOW THE TREE IS THE WORD "CELAVIE" IN LARGE LETTERS AND BELOW "CELAVIE" IS THE WORD "BIOSCIENCES" IN SMALLER FONT.

CLASS 1—CHEMICALS

FOR BIOLOGICAL TISSUE, NAMELY, BLOOD, CELLS, UMBILICAL CORDS AND PLACENTAS FOR SCIENTIFIC AND MEDICAL RESEARCH USE (U.S. CLS. 1, 5, 6, 10, 26 AND 46).

CLASS 5—PHARMACEUTICALS

FOR DRUG DELIVERY AGENTS CONSISTING OF COMPOUNDS THAT FACILITATE DELIVERY OF A WIDE RANGE OF PHARMACEUTICALS; PHARMACEUTICAL PRODUCTS AND PREPARATIONS FOR TREATING NEUROLOGICAL CONDITIONS AND DISORDERS (U.S. CLS. 6, 18, 44, 51 AND 52).

CLASS 39—TRANSPORTATION AND STORAGE

FOR BIOMEDICAL SERVICES, NAMELY, THE STORAGE OF HUMAN CELLS FOR MEDICAL USE (U.S. CLS. 100 AND 105).

TRICIA SONNEBORN, EXAMINING ATTORNEY

SN 85-258,459. FLY BURGER TM, INC., WOODSTOCK, GA. FILED 3-4-2011.

Fly Burger

THE MARK CONSISTS OF STANDARD CHARACTERS WITHOUT CLAIM TO ANY PARTICULAR FONT, STYLE, SIZE, OR COLOR.

NO CLAIM IS MADE TO THE EXCLUSIVE RIGHT TO USE "BURGER", APART FROM THE MARK AS SHOWN.

CLASS 25—CLOTHING

FOR CLOTHING, NAMELY, SWEATERS, SHIRTS, T-SHIRTS, POLO SHIRTS, SWEATSHIRTS, VESTS, PANTS, SHORTS, SOCKS, JACKETS, EARMUFFS, SCARVES, GLOVES AND HEADGEAR, NAMELY, HATS, CAPS AND VISORS, AND HEADBANDS (U.S. CLS. 22 AND 39).

CLASS 43—HOTEL AND RESTAURANT SERVICES

FOR RESTAURANT SERVICES; FOOD AND BEVERAGE SERVICES, NAMELY, RESTAURANT SERVICES; CARRY-OUT AND EAT-IN FOOD SERVICES; CATERING SERVICES; PROVIDING INFORMATION VIA A GLOBAL NETWORK ABOUT RESTAURANT SERVICES (U.S. CLS. 100 AND 101).

SANDRA BUJA, EXAMINING ATTORNEY

SN 85-258,483. FLY BURGER TM, INC., WOODSTOCK, GA. FILED 3-4-2011.



THE MARK CONSISTS OF THE LETTERS "F" AND "L" FOLLOWED BY A ZIPPER UNZIPPED IN THE SHAPE OF A "Y".

CLASS 25—CLOTHING

FOR CLOTHING, NAMELY, SWEATERS, SHIRTS, T-SHIRTS, POLO SHIRTS, SWEATSHIRTS, VESTS, PANTS, SHORTS, SOCKS, JACKETS, EARMUFFS, SCARVES, GLOVES AND HEADGEAR, NAMELY, HATS, CAPS AND VISORS, AND HEADBANDS (U.S. CLS. 22 AND 39).

CLASS 43—HOTEL AND RESTAURANT SERVICES

FOR RESTAURANT SERVICES; FOOD AND BEVERAGE SERVICES, NAMELY, RESTAURANT SERVICES; CARRY-OUT AND EAT-IN FOOD SERVICES; CATERING SERVICES; PROVIDING INFORMATION VIA A GLOBAL NETWORK ABOUT RESTAURANT SERVICES (U.S. CLS. 100 AND 101).

SANDRA BUJA, EXAMINING ATTORNEY

SN 85-259,024. FRANCES, LAUREN, LOS ANGELES, CA. FILED 3-5-2011.

cupids inbox

THE MARK CONSISTS OF STANDARD CHARACTERS WITHOUT CLAIM TO ANY PARTICULAR FONT, STYLE, SIZE, OR COLOR.

CLASS 9—ELECTRICAL AND SCIENTIFIC APPARATUS

FOR DIGITAL MEDIA, NAMELY, CDS, DVDS, AND DOWNLOADABLE AUDIO FILES FEATURING ADVICE AND INFORMATION RELATING TO DATING, RELATIONSHIP, LOVE, AND ROMANCE; DOWNLOADABLE PODCASTS IN THE FIELD OF ADVICE AND INFORMATION RELATING TO DATING, RELATIONSHIP, LOVE, AND ROMANCE; ELECTRONIC PUBLICATIONS, NAMELY, BOOKS FEATURING ADVICE AND INFORMATION RELATING TO DATING, RELATIONSHIP, LOVE, AND ROMANCE RECORDED ON COMPUTER MEDIA (U.S. CLS. 21, 23, 26, 36 AND 38).

CLASS 41—EDUCATION AND ENTERTAINMENT

FOR ON-LINE JOURNALS, NAMELY, BLOGS FEATURING ADVICE AND INFORMATION ON DATING, RELATIONSHIPS, LOVE, AND ROMANCE; PROFESSIONAL COACHING SERVICES IN THE FIELD OF DATING, RELATIONSHIPS, LOVE, AND ROMANCE (U.S. CLS. 100, 101 AND 107).

CLASS 45—PERSONAL AND LEGAL SERVICES

FOR COMPUTER DATING SERVICES (U.S. CLS. 100 AND 101).

ANDREA K. NADELMAN, EXAMINING ATTORNEY

SN 85-259,514. INNOCOLL PHARMACEUTICALS LIMITED, CO. WESTMEATH, IRELAND, FILED 3-7-2011.

ZORPREVA

THE MARK CONSISTS OF STANDARD CHARACTERS WITHOUT CLAIM TO ANY PARTICULAR FONT, STYLE, SIZE, OR COLOR.

PRIORITY CLAIMED UNDER SEC. 44(D) ON ERPNCMNTY TM OFC APPLICATION NO. 9787599, FILED 3-4-2011.

CLASS 5—PHARMACEUTICALS

FOR SURGICAL DRESSINGS, NAMELY, COLLAGEN BASED HEMOSTATS USED TO CONTROL BLEEDING; HEMOSTATIC AGENTS (U.S. CLS. 6, 18, 44, 46, 51 AND 52).

SN 85-260,324. RABENOLD, JOSHUA, AMHERST, NY. AND VARGOVICH, MICHAEL, AMHERST, NY. FILED 3-7-2011.

CLASS 10—MEDICAL APPARATUS

FOR MEDICAL INSTRUMENTS, NAMELY, SURGICAL HEMOSTATS (U.S. CLS. 26, 39 AND 44).
TEJBIR SINGH, EXAMINING ATTORNEY

Avalon Landing

THE MARK CONSISTS OF STANDARD CHARACTERS WITHOUT CLAIM TO ANY PARTICULAR FONT, STYLE, SIZE, OR COLOR.

SN 85-259,909. ENGINEERS WITHOUT BORDERS-USA, BOULDER, CO. FILED 3-7-2011.

CLASS 9—ELECTRICAL AND SCIENTIFIC APPARATUS

FOR MUSICAL SOUND RECORDINGS (U.S. CLS. 21, 23, 26, 36 AND 38).

CLASS 41—EDUCATION AND ENTERTAINMENT

FOR ENTERTAINMENT IN THE NATURE OF VISUAL AND AUDIO PERFORMANCES BY MUSICAL BANDS; ENTERTAINMENT, NAMELY, LIVE PERFORMANCES BY A MUSICAL BAND (U.S. CLS. 100, 101 AND 107).
THOMAS MANOR, EXAMINING ATTORNEY

EWB-USA

THE MARK CONSISTS OF STANDARD CHARACTERS WITHOUT CLAIM TO ANY PARTICULAR FONT, STYLE, SIZE, OR COLOR.

OWNER OF U.S. REG. NO. 3,546,370.

SN 85-260,654. THUMB WORLD PRODUCTIONS LLC, NEW YORK, NY. FILED 3-8-2011.

CLASS 35—ADVERTISING AND BUSINESS

FOR ASSOCIATION SERVICES, NAMELY, PROMOTING THE INTERESTS OF PROFESSIONALS, FACULTY, AND STUDENTS IN THE FIELDS OF SCIENCE AND ENGINEERING; CONSULTING SERVICES RELATED TO THE ADMINISTRATIVE COORDINATION OF ORGANIZATIONS PROVIDING HUMANITARIAN ACTIVITIES OF INDIVIDUALS IMPLEMENTING SUSTAINABLE ENGINEERING PROJECTS IN DEVELOPING COMMUNITIES (U.S. CLS. 100, 101 AND 102).
FIRST USE 3-8-2001; IN COMMERCE 3-8-2001.

CLASS 41—EDUCATION AND ENTERTAINMENT

FOR EDUCATIONAL SERVICES, NAMELY, CONDUCTING CONFERENCES, SEMINARS, WEBINARS, AND WORKSHOPS IN THE FIELDS OF SCIENCE AND ENGINEERING (U.S. CLS. 100, 101 AND 107).
FIRST USE 3-8-2001; IN COMMERCE 3-8-2001.



THE MARK CONSISTS OF THE "@" SYMBOL WITH A THUMBS UP GESTURE IN THE CENTER.

CLASS 42—SCIENTIFIC AND COMPUTER SERVICES

FOR NON-PROFIT CIVIL AND ENVIRONMENTAL ENGINEERING SERVICES PROVIDED TO DEVELOPING COMMUNITIES, INVOLVING COLLEGE STUDENTS AND PROFESSIONALS (U.S. CLS. 100 AND 101).
FIRST USE 3-8-2001; IN COMMERCE 3-8-2001.
TEJBIR SINGH, EXAMINING ATTORNEY

CLASS 18—LEATHER GOODS

FOR HANDBAGS; PURSES; WALLETS; KEY CASES; GYM BAGS; SCHOOL BAGS; BOOK BAGS; TOTE BAGS; BACKPACKS; KNAPSACKS; SHOE BAGS FOR TRAVEL; LUGGAGE; CARRY-ON BAGS; SPORTS BAGS; DUFFEL BAGS; WRIST BAGS, NAMELY, WRIST MOUNTED CARRY ALL BAGS; WAIST POUCHES; FANNY PACKS; AND UMBRELLAS (U.S. CLS. 1, 2, 3, 22 AND 41).

CLASS 25—CLOTHING

FOR MEN'S, WOMEN'S AND CHILDREN'S CLOTHING, NAMELY, T-SHIRTS; SWEATSHIRTS; JEANS; SWEATPANTS; SHIRTS; PANTS; SWEATERS; UNDERWEAR; PANTIES; BRAS; UNDERSHIRTS; SLEEPWEAR; PAJAMAS; LINGERIE; ROBES; NIGHTGOWNS; JACKETS; RAINWEAR; RAINCOATS; SWIMWEAR; BATHING SUITS; BEACH COVER UPS; DRESSES; COATS; SHORTS; SUITS; TUXEDOS; TIES; BLOUSES; VESTS; JOGGING SUITS; GLOVES; SCARVES; MUFFLERS; HEADBANDS; SHOES; HATS; BELTS; SHAWLS; SCARVES; PONCHOS; SHOULDER WRAPS; SOCKS; STOCKINGS; HOSIERY; TIGHTS; LEGGINGS; AND LEOTARDS (U.S. CLS. 22 AND 39).

CLASS 35—ADVERTISING AND BUSINESS

FOR PROVIDING A WEBSITE FEATURING CONSUMER INFORMATION ABOUT GOODS IN CONNECTION WITH ON-GOING ANIMATED TELEVISION PROGRAMS AND TELEVISION PROGRAMS FOR CHILDREN; PROVIDING A WEBSITE FEATURING INFORMATION ABOUT GOODS OF OTHERS SOLD IN CONNECTION WITH ON-GOING ANIMATED TELEVISION PROGRAMS AND TELEVISION PROGRAMS FOR CHILDREN (U.S. CLS. 100, 101 AND 102).

CLASS 41—EDUCATION AND ENTERTAINMENT

FOR ENTERTAINMENT IN THE NATURE OF ON-GOING ANIMATED TELEVISION PROGRAMS AND TELEVISION PROGRAMS FOR CHILDREN; PROVIDING A WEBSITE FEATURING INFORMATION ABOUT CHILDREN'S TELEVISION PROGRAMS AND THE ANIMATED CHARACTERS ASSOCIATED THEREWITH (U.S. CLS. 100, 101 AND 107).

JESSICA FATHY, EXAMINING ATTORNEY

SN 85-260,778. 9 & DINE, LLC, BOCA RATON, FL. FILED 3-8-2011.



THE MARK CONSISTS OF THE LITERAL ELEMENTS "9 & DINE" WRITTEN IN A STYLIZED FORM WITH A SLIGHT CHECKED PATTERN WITHIN THE ELEMENTS WITH A FEW SPARKLES; THE "I" IN "DINE" CONTAINS A STYLIZED BALL WITH DIMPLES FOR THE DOT OF THE "I".

CLASS 18—LEATHER GOODS

FOR HANDBAGS (U.S. CLS. 1, 2, 3, 22 AND 41).

CLASS 25—CLOTHING

FOR CLOTHING, NAMELY, TOPS, BOTTOMS, MONEY BELTS, BELTS FOR CLOTHING, LEATHER TOPS, LEATHER BOTTOMS, COMBINATIONS, GLOVES, HATS, HEADBANDS, HOODS, JACKETS, JERSEYS, UNDERWEAR, ANTI-SWEAT UNDERWEAR (U.S. CLS. 22 AND 39).

CLASS 26—FANCY GOODS

FOR BROOCHES; BUCKLES OF PRECIOUS METAL; BUCKLES FOR CLOTHING; BELT BUCKLES; STRAP BUCKLES (U.S. CLS. 37, 39, 40, 42 AND 50).

LINDA E. BLOHM, EXAMINING ATTORNEY

SN 85-260,853. RAE, KAREN L., RIDGEFIELD, WA. FILED 3-8-2011.

GOOD ENOUGH NATION

THE MARK CONSISTS OF STANDARD CHARACTERS WITHOUT CLAIM TO ANY PARTICULAR FONT, STYLE, SIZE, OR COLOR.

OWNER OF U.S. REG. NO. 3,747,819.

CLASS 18—LEATHER GOODS

FOR ALL PURPOSE SPORT BAGS; ALL-PURPOSE ATHLETIC BAGS; ALL-PURPOSE CARRYING BAGS; ALL-PURPOSE REUSABLE CARRYING BAGS; ANIMAL GAME BAGS; BABY CARRYING BAGS; BACKPACKS, BOOK BAGS, SPORTS BAGS, BUM BAGS, WALLETS AND HANDBAGS; BAGS FOR CARRYING BABIES' ACCESSORIES; BARREL BAGS; BEACH BAGS; BILL-FOLDS; BOOK BAGS; BUM BAGS; CANVAS SHOPPING BAGS; CARRY-ALL BAGS; CARRY-ON BAGS; CHANGE PURSES; CHARM BAGS (OMAMORI-IRE); CLUTCH BAGS; CLUTCH PURSES; CLUTCHES; COIN PURSES; COSMETIC BAGS SOLD EMPTY; DIAPER BAGS; DUFFEL BAGS; DUFFEL BAGS FOR TRAVEL; DUFFLE BAGS; FLIGHT BAGS; GARMENT BAGS FOR TRAVEL; GARMENT BAGS FOR TRAVEL MADE OF LEATHER; GENERAL PURPOSE BAGS FOR CARRYING YOGA EQUIPMENT; GENERAL PURPOSE BAGS FOR HOLDING DANCE EQUIPMENT; GYM BAGS; HANDBAGS, PURSES AND WALLETS; HARD-SIDED AND SOFT-SIDED CARRY-ON BAGS AND GYM BAGS; HIKING BAGS; KEYCASES; LEATHER AND IMITATION LEATHER BAGS; LEATHER AND IMITATION LEATHER SPORT BAGS AND GENERAL PURPOSE TROLLEY BAGS; LEATHER BAGS AND WALLETS; LEATHER BAGS FOR MERCHANDISE PACKAGING; LEATHER BAGS, SUITCASES AND WALLETS; LEATHER PURSES; LEATHER SHOPPING BAGS; MAKE-UP BAGS SOLD EMPTY; MESSENGER BAGS; MILITARY DUFFLE BAGS, GARMENT BAGS FOR TRAVEL, TOTE BAGS, SHOULDER BAGS AND BACKPACKS; MULTI-PURPOSE PURSES; OVERNIGHT BAGS; OVERNIGHT CASES; POCKET WALLETS; POCKET-BOOKS; PURSE CHARMS; PURSES; PURSES AND WALLETS; REUSABLE SHOPPING BAGS; REUSABLE TEXTILE PRODUCE BAGS TO CARRY PRODUCE FROM GROCERY STORES AND FARMER'S MARKETS; SCHOOL BAGS; SCHOOL BOOK BAGS; SHOULDER BAGS; SLING BAGS; SMALL CLUTCH PURSES; SMALL PURSES; SPORT BAGS; SPORTS BAGS; TEXTILE SHOPPING BAGS; TOILETRY BAGS SOLD EMPTY; TOTE BAGS; TRAVEL BAGS; TRAVELING BAGS; TRAVELING BAGS (U.S. CLS. 1, 2, 3, 22 AND 41).

CLASS 25—CLOTHING

FOR APPAREL FOR DANCERS, NAMELY, TEE SHIRTS, SWEATSHIRTS, PANTS, LEGGINGS, SHORTS AND JACKETS; ATHLETIC APPAREL, NAMELY, SHIRTS, PANTS, JACKETS, FOOTWEAR, HATS AND CAPS, ATHLETIC UNIFORMS; BASEBALL CAPS; BASEBALL CAPS AND HATS; BELTS; BELTS FOR CLOTHING; BRIEFS; CAP VISORS; CAPRI PANTS; CAPS; CAPS WITH VISORS; CARGO PANTS; CHILDREN'S AND INFANT'S APPAREL, NAMELY, JUMPERS, OVERALL SLEEPWEAR, PAJAMAS, ROMPERS AND ONE-PIECE GARMENTS; CHILDREN'S AND INFANTS' APPAREL TREATED WITH FIRE AND HEAT RETARDANTS,

NAMELY, JUMPERS, OVERALL SLEEPWEAR, PAJAMAS, ROMPERS AND ONE-PIECE GARMENTS; CHILDREN'S AND INFANTS' CLOTH BIBS; CHILDREN'S HEADWEAR; CLOTH BIBS; FINISHED TEXTILE LININGS FOR GARMENTS; FOUNDATION GARMENTS; GLOVES FOR APPAREL; HEAD SCARVES; HEAD SWEATBANDS; HEAD WEAR; HEADBANDS AGAINST SWEATING; HEADBANDS FOR CLOTHING; HEADWEAR; HOODED SWEAT SHIRTS; HOODED SWEATSHIRTS; INFANT AND TODDLER ONE PIECE CLOTHING; INFANT WEAR; JACKETS; JEGGINGS, NAMELY, PANTS THAT ARE PARTIALLY JEANS AND PARTIALLY LEGGINGS; JOGGING PANTS; KNITTED CAPS; LADIES' UNDERWEAR; LEATHER BELTS; LEATHER HEADWEAR; LONG UNDERWEAR; MATERNITY SLEEPWEAR; MEN'S UNDERWEAR; MOISTURE-WICKING SPORTS BRAS; MOISTURE-WICKING SPORTS PANTS; MOISTURE-WICKING SPORTS SHIRTS; NIGHT SHIRTS; ONE PIECE GARMENT FOR INFANTS AND TODDLERS; ONE-PIECE GARMENTS FOR CHILDREN; RAIN WEAR; SHIRTS; SHIRTS AND SHORT-SLEEVED SHIRTS; SHIRTS FOR INFANTS, BABIES, TODDLERS AND CHILDREN; SHORT-SLEEVED OR LONG-SLEEVED T-SHIRTS; SHORT-SLEEVED SHIRTS; SKI WEAR; SKULLIES; SLEEP PANTS; SLEEP SHIRTS; SLEEPING GARMENTS; SLEEPWEAR; SLEEPWEAR TREATED WITH FIRE AND HEAT RETARDANTS; SPORT SHIRTS; SPORTS CAPS AND HATS; SPORTS SHIRTS; SPORTS SHIRTS WITH SHORT SLEEVES; STRETCH PANTS; SURF WEAR; SWEAT JACKETS; SWEAT PANTS; SWEAT SHIRTS; SWEAT SHORTS; SWEAT SUITS; SWEATPANTS; SWEATSHIRTS; SWIM WEAR; T-SHIRTS; TEE SHIRTS; TENNIS WEAR; THONGS; TOPS; TRACK JACKETS; TRACK PANTS; TRACK SUITS; UNDER GARMENTS; UNDERGARMENTS; UNDERWEAR; WATERPROOF JACKETS AND PANTS; WEARABLE GARMENTS AND CLOTHING, NAMELY, SHIRTS; WOMEN'S CLOTHING, NAMELY, SHIRTS, DRESSES, SKIRTS, BLOUSES; WOMEN'S UNDERWEAR; YOGA PANTS; YOGA SHIRTS (U.S. CLS. 22 AND 39).

ELLEN PERKINS, EXAMINING ATTORNEY

SN 85-261,760. MINUTEMAN PRESS INTERNATIONAL, INC., FARMINGDALE, NY. FILED 3-9-2011.

MINUTEMAN XPRESS

THE MARK CONSISTS OF STANDARD CHARACTERS WITHOUT CLAIM TO ANY PARTICULAR FONT, STYLE, SIZE, OR COLOR.

OWNER OF U.S. REG. NOS. 2,314,083 AND 3,304,742.

NO CLAIM IS MADE TO THE EXCLUSIVE RIGHT TO USE "EXPRESS", APART FROM THE MARK AS SHOWN.

CLASS 35—ADVERTISING AND BUSINESS

FOR COPYING OF DOCUMENTS FOR OTHERS (U.S. CLS. 100, 101 AND 102).

FIRST USE 10-18-2010; IN COMMERCE 10-18-2010.

CLASS 40—MATERIAL TREATMENT

FOR PRINTING SERVICES (U.S. CLS. 100, 103 AND 106).

FIRST USE 10-18-2010; IN COMMERCE 10-18-2010.

WENDY JUN, EXAMINING ATTORNEY

SN 85-261,010. INDULGE MEDIA GROUP LLC, COLORADO SPRINGS, CO. FILED 3-8-2011.

Welcome to the Power of U

THE MARK CONSISTS OF STANDARD CHARACTERS WITHOUT CLAIM TO ANY PARTICULAR FONT, STYLE, SIZE, OR COLOR.

CLASS 35—ADVERTISING AND BUSINESS

FOR CUSTOMER LOYALTY SERVICES AND CUSTOMER CLUB SERVICES, FOR COMMERCIAL, PROMOTIONAL AND/OR ADVERTISING PURPOSES; PROMOTING THE GOODS AND SERVICES OF OTHERS BY MEANS OF THE ISSUANCE OF LOYALTY REWARDS CARDS; PROVIDING A WEBSITE FOR USERS WITH SPECIFIC INFORMED RECOMMENDATIONS OF SPECIFIC CONSUMER PRODUCTS AND SERVICES VALIDATED BY THE USERS' INPUTTED PREFERENCES AND SOCIAL NETWORK (U.S. CLS. 100, 101 AND 102).

CLASS 36—INSURANCE AND FINANCIAL

FOR LOYALTY PROGRAM PAYMENT PROCESSING SERVICES (U.S. CLS. 100, 101 AND 102).

ANDREA K. NADELMAN, EXAMINING ATTORNEY

SN 85-261,869. NEXT ISSUE MEDIA, LLC, NEW YORK, NY. FILED 3-9-2011.

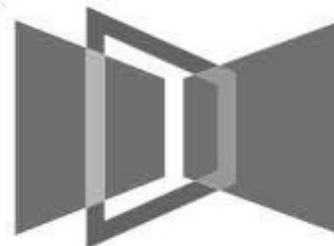

THE MARK CONSISTS OF A TRAPEZOID LINED UP PARALLEL TO ANOTHER TRAPEZOID WITH A TRAPEZOID OUTLINE OVERLAPPING THEM BOTH IN A PARALLEL FASHION.

CLASS 35—ADVERTISING AND BUSINESS

FOR ADVERTISING AND PUBLICITY SERVICES, NAMELY, PROMOTING THE GOODS, SERVICES, BRAND IDENTITY AND COMMERCIAL INFORMATION AND NEWS OF THIRD PARTIES THROUGH PRINT, AUDIO, VIDEO, DIGITAL AND ON-LINE MEDIA; ADVERTISING AND MARKETING SERVICES PROVIDED BY MEANS OF INDIRECT METHODS OF MARKETING COMMUNICATIONS, NAMELY, SOCIAL MEDIA, SEARCH ENGINE MARKETING, INQUIRY MARKETING, INTERNET MARKETING, MOBILE MARKETING, BLOGGING AND OTHER FORMS OF PASSIVE, SHARABLE OR VIRAL COMMUNICATIONS CHANNELS; ADVERTISING AND BUSINESS SERVICES, NAMELY, PROVIDING AN ONLINE WEBSITE WHERE ADVERTISERS, MARKETERS, AND CONTENT PROVIDERS CAN INTERACT WITH USERS FOR ADVERTISING AND PROMOTING KNOWLEDGE, PRODUCTS, AND SERVICES ON BEHALF OF THEMSELVES AND OTHERS; PROVIDING ADVERTISING SERVICES TO DISTRIBUTE ADVERTISEMENTS FOR DISPLAY ON THE INTERNET, NAMELY, IN WEBSITES, SOCIAL CONVERSATIONS OVER THE INTERNET, E-MAILS, MICROBLOGS, BLOGS, ELECTRONIC MESSAGES, INSTANT MESSAGES, TEXT MESSAGES, MULTIMEDIA MESSAGES, SOCIAL NETWORKS, STATUS UPDATES, FORUMS, ELECTRONIC BULLETIN BOARDS (U.S. CLS. 100, 101 AND 102).

CLASS 38—COMMUNICATION

FOR BROADCASTING SERVICES, NAMELY, TRANSMISSION OF ADVERTISING PROGRAMS AND MEDIA ADVERTISING COMMUNICATIONS VIA DIGITAL COMMUNICATIONS NETWORKS (U.S. CLS. 100, 101 AND 104).

CLASS 41—EDUCATION AND ENTERTAINMENT

FOR DIGITAL VIDEO, AUDIO, AND MULTIMEDIA PUBLISHING SERVICES (U.S. CLS. 100, 101 AND 107).
SHAUNIA CARLYLE, EXAMINING ATTORNEY

SN 85-262,143. MYASSIST, INC., STEVENS POINT, WI. FILED 3-9-2011.



THE MARK CONSISTS OF AN IMAGE OF A DESK BELL SET INSIDE A CIRCLE, WITH SHADING BEHIND THE BELL.

CLASS 42—SCIENTIFIC AND COMPUTER SERVICES

FOR PROVIDING INFORMATION AT THE SPECIFIC REQUEST OF END-USERS BY MEANS OF TELEPHONE OR GLOBAL COMPUTER NETWORKS (U.S. CLS. 100 AND 101).

CLASS 45—PERSONAL AND LEGAL SERVICES

FOR CONCIERGE SERVICES FOR OTHERS COMPRISING MAKING REQUESTED PERSONAL ARRANGEMENTS AND RESERVATIONS AND PROVIDING CUSTOMER-SPECIFIC INFORMATION TO MEET INDIVIDUAL NEEDS RENDERED TOGETHER IN A ONLINE ENVIRONMENT OR BY TELEPHONE (U.S. CLS. 100 AND 101).

JOHN SCHUYLER YARD, EXAMINING ATTORNEY

SN 85-262,503. MYASSIST, INC., STEVENS POINT, WI. FILED 3-9-2011.

IAYP

THE MARK CONSISTS OF STANDARD CHARACTERS WITHOUT CLAIM TO ANY PARTICULAR FONT, STYLE, SIZE, OR COLOR.

CLASS 42—SCIENTIFIC AND COMPUTER SERVICES

FOR PROVIDING INFORMATION AT THE SPECIFIC REQUEST OF END-USERS BY MEANS OF TELEPHONE OR GLOBAL COMPUTER NETWORKS (U.S. CLS. 100 AND 101).

CLASS 45—PERSONAL AND LEGAL SERVICES

FOR CONCIERGE SERVICES FOR OTHERS COMPRISING MAKING REQUESTED PERSONAL ARRANGEMENTS AND RESERVATIONS AND PROVIDING CUSTOMER-SPECIFIC INFORMATION TO MEET INDIVIDUAL NEEDS RENDERED TOGETHER IN A ONLINE ENVIRONMENT OR BY TELEPHONE (U.S. CLS. 100 AND 101).

JOHN SCHUYLER YARD, EXAMINING ATTORNEY

SN 85-262,525. MYASSIST, INC., STEVENS POINT, WI. FILED 3-9-2011.

INYP

THE MARK CONSISTS OF STANDARD CHARACTERS WITHOUT CLAIM TO ANY PARTICULAR FONT, STYLE, SIZE, OR COLOR.

CLASS 42—SCIENTIFIC AND COMPUTER SERVICES

FOR PROVIDING INFORMATION AT THE SPECIFIC REQUEST OF END-USERS BY MEANS OF TELEPHONE OR GLOBAL COMPUTER NETWORKS (U.S. CLS. 100 AND 101).

CLASS 45—PERSONAL AND LEGAL SERVICES

FOR CONCIERGE SERVICES FOR OTHERS COMPRISING MAKING REQUESTED PERSONAL ARRANGEMENTS AND RESERVATIONS AND PROVIDING CUSTOMER-SPECIFIC INFORMATION TO MEET INDIVIDUAL NEEDS RENDERED TOGETHER IN A ONLINE ENVIRONMENT OR BY TELEPHONE (U.S. CLS. 100 AND 101).

JOHN SCHUYLER YARD, EXAMINING ATTORNEY

SN 85-262,592. ANDERSON, JAMES MARTIN, GREENWOOD VILLAGE, CO. FILED 3-9-2011.

Middle Aged Fat Guys

THE MARK CONSISTS OF STANDARD CHARACTERS WITHOUT CLAIM TO ANY PARTICULAR FONT, STYLE, SIZE, OR COLOR.

CLASS 25—CLOTHING

FOR ATHLETIC APPAREL, NAMELY, SHIRTS, PANTS, JACKETS, FOOTWEAR, HATS AND CAPS, ATHLETIC UNIFORMS; CYCLING SHOES; CYCLING SHORTS; CYCLISTS' JERSEYS; GLOVES FOR APPAREL; JACKETS; JACKETS AND SOCKS; JERSEYS; LIGHT-REFLECTING JACKETS; RAIN JACKETS; RAINPROOF JACKETS; REVERSIBLE JACKETS; SHELL JACKETS; SLEEVED OR SLEEVELESS JACKETS; SLEEVELESS JERSEYS; SPORTS JERSEYS; WATERPROOF JACKETS AND PANTS; WIND RESISTANT JACKETS; WIND-JACKETS (U.S. CLS. 22 AND 39).

CLASS 39—TRANSPORTATION AND STORAGE

FOR ARRANGING, ORGANIZING, AND CONDUCTING CYCLING TOURS AND TRIPS (U.S. CLS. 100 AND 105).

SHAUNIA CARLYLE, EXAMINING ATTORNEY

SN 85-262,590. NEXT ISSUE MEDIA, LLC, NEW YORK, NY. FILED 3-9-2011.

NEXT ISSUE

THE MARK CONSISTS OF STANDARD CHARACTERS WITHOUT CLAIM TO ANY PARTICULAR FONT, STYLE, SIZE, OR COLOR.

CLASS 35—ADVERTISING AND BUSINESS

FOR ADVERTISING AND PUBLICITY SERVICES, NAMELY, PROMOTING THE GOODS, SERVICES, BRAND IDENTITY AND COMMERCIAL INFORMATION AND NEWS OF THIRD PARTIES THROUGH PRINT, AUDIO, VIDEO, DIGITAL AND ON-LINE MEDIA; ADVERTISING AND MARKETING SERVICES PROVIDED BY MEANS OF INDIRECT METHODS OF MARKETING COMMUNICATIONS, NAMELY, SOCIAL MEDIA, SEARCH ENGINE MARKETING, INQUIRY MARKETING, INTERNET MARKETING, MOBILE MARKETING, BLOGGING AND OTHER FORMS OF PASSIVE, SHARABLE OR VIRAL COMMUNICATIONS CHANNELS; ADVERTISING AND BUSINESS SERVICES, NAMELY, PROVIDING AN ONLINE WEBSITE WHERE ADVERTISERS, MARKETERS, AND CONTENT PROVIDERS CAN INTERACT WITH USERS FOR ADVERTISING AND PROMOTING KNOWLEDGE, PRODUCTS, AND SERVICES ON BEHALF OF THEMSELVES AND OTHERS; PROVIDING ADVERTISING SERVICES TO DISTRIBUTE ADVERTISEMENTS FOR DISPLAY ON THE INTERNET, NAMELY, IN WEBSITES, SOCIAL CONVERSATIONS OVER THE INTERNET, E-MAILS, MICROBLOGS, BLOGS, ELECTRONIC MESSAGES, INSTANT MESSAGES, TEXT MESSAGES, MULTIMEDIA MESSAGES, SOCIAL NETWORKS, STATUS UPDATES, FORUMS, ELECTRONIC BULLETIN BOARDS (U.S. CLS. 100, 101 AND 102).

CLASS 38—COMMUNICATION

FOR BROADCASTING SERVICES, NAMELY, TRANSMISSION OF ADVERTISING PROGRAMS AND MEDIA ADVERTISING COMMUNICATIONS VIA DIGITAL COMMUNICATIONS NETWORKS (U.S. CLS. 100, 101 AND 104).

CLASS 41—EDUCATION AND ENTERTAINMENT

FOR DIGITAL VIDEO, AUDIO, AND MULTIMEDIA PUBLISHING SERVICES (U.S. CLS. 100, 101 AND 107).

SHAUNIA CARLYLE, EXAMINING ATTORNEY

SN 85-263,315. NEC BIGLOBE, LTD., TOKYO, JAPAN, FILED 3-10-2011.

SMAPHO-MELODY

THE MARK CONSISTS OF STANDARD CHARACTERS WITHOUT CLAIM TO ANY PARTICULAR FONT, STYLE, SIZE, OR COLOR.

CLASS 9—ELECTRICAL AND SCIENTIFIC APPARATUS

FOR COMPUTER APPLICATION SOFTWARE FOR MOBILE PHONES, CELLULAR PHONES, SMART PHONES AND MOBILE HAND HELD DEVICES, NAMELY, COMPUTER SOFTWARE FOR SEARCHING, TRANSMITTING, SHARING, RECEIVING, DOWNLOADING, AND TRANSFERRING AUDIO, MUSIC AND VIDEO FILES (U.S. CLS. 21, 23, 26, 36 AND 38).

CLASS 35—ADVERTISING AND BUSINESS

FOR ON-LINE RETAIL STORE SERVICES FEATURING DOWNLOADABLE AUDIO, MUSIC AND VIDEO FILES PROVIDED VIA THE INTERNET AND OTHER COMPUTER AND ELECTRONIC COMMUNICATION NETWORKS (U.S. CLS. 100, 101 AND 102).

ANGELA DUONG, EXAMINING ATTORNEY

SN 85-263,529. PHARMACHEM LABORATORIES, INC., KEARNY, NJ. FILED 3-10-2011.



NO CLAIM IS MADE TO THE EXCLUSIVE RIGHT TO USE "TRAVEL" AND "ALL NATURAL REMEDIES FOR THE TRIP", APART FROM THE MARK AS SHOWN.

THE MARK CONSISTS OF A RECTANGULAR BOX CONTAINING AN IMAGE OF A DOCTOR HOLDING A MEDICAL BAG WITH A GREEK CROSS ON IT AND A STETHOSCOPE AROUND HIS NECK, WITH THE DOCTOR SHOWN FLYING IN THE SKY WITH CLOUDS OVER THE EARTH, WITH THE WORDS "TRAVEL DOCTOR" ON THE RIGHT AND THE WORDS "ALL NATURAL REMEDIES FOR THE TRIP" UNDERNEATH.

CLASS 3—COSMETICS AND CLEANING PREPARATIONS

FOR NATURAL COSMETIC PREPARATIONS FOR USE WHILE TRAVELLING (U.S. CLS. 1, 4, 6, 50, 51 AND 52).

CLASS 5—PHARMACEUTICALS

FOR NATURAL HEALTH PRODUCTS, NAMELY, NUTRITIONAL AND DIETARY SUPPLEMENTS, NON-PRESCRIPTION TOPICAL ANALGESIC CREAMS, AND NON-PRESCRIPTION MEDICINES, NAMELY ASPIRIN, ALL FOR USE WHILE TRAVELLING (U.S. CLS. 6, 18, 44, 46, 51 AND 52).

JENNIFER DIXON, EXAMINING ATTORNEY

SN 85-263,559. AFTON CHEMICAL CORPORATION, RICHMOND, VA. FILED 3-10-2011.

HITEC 11100

THE MARK CONSISTS OF STANDARD CHARACTERS WITHOUT CLAIM TO ANY PARTICULAR FONT, STYLE, SIZE, OR COLOR.

OWNER OF U.S. REG. NOS. 973,766, 1,504,472 AND 3,816,310.

CLASS 1—CHEMICALS

FOR CHEMICAL ADDITIVES FOR ENHANCING THE PERFORMANCE OF LUBRICATING OILS, GREASES AND INTERNAL COMBUSTION ENGINE FUELS; CHEMICAL ADDITIVES FOR FUEL TREATMENT; CHEMICAL ADDITIVES FOR OILS; CHEMICAL ADDITIVES FOR USE IN THE MANUFACTURE OF FUELS, OILS, LUBRICANTS AND HYDRAULIC FLUIDS; CHEMICAL ADDITIVES FOR USE WITH INTERNAL COMBUSTION ENGINE FUELS (U.S. CLS. 1, 5, 6, 10, 26 AND 46).

FIRST USE 8-25-2010; IN COMMERCE 8-25-2010.

CLASS 4—LUBRICANTS AND FUELS

FOR PETROLEUM PRODUCTS, NAMELY, PETROLEUM-BASED PETROLEUM SOLUBLE COMPOUNDS UTILIZED IN THE BLENDING OF MOTOR OILS, GEAR OILS AND INDUSTRIAL OILS (U.S. CLS. 1, 6 AND 15).

FIRST USE 8-25-2010; IN COMMERCE 8-25-2010.

MATTHEW MCDOWELL, EXAMINING ATTORNEY

SN 85-263,865. MAUER, JOSEPH PATRICK, CHICAGO, IL. FILED 3-10-2011.



THE MARK CONSISTS OF "7M" STYLIZED WITH BORDER.

CLASS 25—CLOTHING

FOR FOOTWEAR (U.S. CLS. 22 AND 39).

CLASS 41—EDUCATION AND ENTERTAINMENT

FOR ENTERTAINMENT IN THE NATURE OF COMPETITIONS IN THE FIELD OF BASEBALL; ENTERTAINMENT SERVICES, NAMELY, PERSONAL APPEARANCES OF A SPORTS CELEBRITY; PROVIDING A WEBSITE ON A GLOBAL COMPUTER NETWORK FEATURING INFORMATION ABOUT APPEARANCES, ACCOMPLISHMENTS, EXPLOITS, AND BIOGRAPHY OF A PROFESSIONAL BASEBALL PLAYER (U.S. CLS. 100, 101 AND 107).

WILLIAM BRECKENFELD, EXAMINING ATTORNEY

SN 85-264,906. SURDYK'S FLIGHTS, INC., MAPLE GROVE, MN. FILED 3-11-2011.



NO CLAIM IS MADE TO THE EXCLUSIVE RIGHT TO USE "WINE MARKET & BAR", APART FROM THE MARK AS SHOWN.

THE MARK CONSISTS OF THE DESIGN OF A WINE BOTTLE WITH WINGS CONTAINING A WINE GLASS AND THE WORDS "SURDYK'S FLIGHTS WINE MARKET & BAR".

CLASS 35—ADVERTISING AND BUSINESS

FOR RETAIL LIQUOR STORE SERVICES, RETAIL DELICATESSEN SERVICES (U.S. CLS. 100, 101 AND 102).

FIRST USE 7-24-2010; IN COMMERCE 7-24-2010.

CLASS 43—HOTEL AND RESTAURANT SERVICES

FOR BAR AND RESTAURANT SERVICES (U.S. CLS. 100 AND 101).
FIRST USE 7-24-2010; IN COMMERCE 7-24-2010.
LAURIE MAYES, EXAMINING ATTORNEY

SN 85-266,355. MYASSIST, INC., STEVENS POINT, WI.
FILED 3-14-2011.

GNYP

THE MARK CONSISTS OF STANDARD CHARACTERS WITHOUT CLAIM TO ANY PARTICULAR FONT, STYLE, SIZE, OR COLOR.

CLASS 42—SCIENTIFIC AND COMPUTER SERVICES

FOR PROVIDING INFORMATION AT THE SPECIFIC REQUEST OF END-USERS BY MEANS OF TELEPHONE OR GLOBAL COMPUTER NETWORKS (U.S. CLS. 100 AND 101).

CLASS 45—PERSONAL AND LEGAL SERVICES

FOR CONCIERGE SERVICES FOR OTHERS COMPRISING MAKING REQUESTED PERSONAL ARRANGEMENTS AND RESERVATIONS AND PROVIDING CUSTOMER-SPECIFIC INFORMATION TO MEET INDIVIDUAL NEEDS RENDERED TOGETHER IN A ONLINE ENVIRONMENT OR BY TELEPHONE (U.S. CLS. 100 AND 101).
JOHN SCHUYLER YARD, EXAMINING ATTORNEY

SN 85-267,059. MILLENNIUM RECYCLING, INC., SIOUX FALLS, SD. FILED 3-15-2011.

Ecomaniacs

THE MARK CONSISTS OF STANDARD CHARACTERS WITHOUT CLAIM TO ANY PARTICULAR FONT, STYLE, SIZE, OR COLOR.

CLASS 9—ELECTRICAL AND SCIENTIFIC APPARATUS

FOR ELECTRONIC DOWNLOADABLE PUBLICATIONS, NAMELY, MAGAZINES, NEWSLETTERS, BROCHURES AND PAMPHLETS ENCOURAGING RECYCLING (U.S. CLS. 21, 23, 26, 36 AND 38).

CLASS 16—PAPER GOODS AND PRINTED MATTER

FOR PROVIDING PRINTED MATERIALS IN THE NATURE OF MAGAZINES, NEWSLETTERS, BROCHURES AND PAMPHLETS ENCOURAGING RECYCLING (U.S. CLS. 2, 5, 22, 23, 29, 37, 38 AND 50).

CLASS 40—MATERIAL TREATMENT

FOR PROVIDING A WEBSITE FEATURING INFORMATION ENCOURAGING RECYCLING (U.S. CLS. 100, 103 AND 106).
MIDGE BUTLER, EXAMINING ATTORNEY

SN 85-269,620. AON CORPORATION, CHICAGO, IL. FILED 3-17-2011.

Aon 5

THE MARK CONSISTS OF STANDARD CHARACTERS WITHOUT CLAIM TO ANY PARTICULAR FONT, STYLE, SIZE, OR COLOR.

OWNER OF U.S. REG. NOS. 1,496,123, 3,254,615 AND OTHERS.

CLASS 35—ADVERTISING AND BUSINESS

FOR BUSINESS RISK ASSESSMENT SERVICES; BUSINESS RISK MANAGEMENT; HUMAN RESOURCE ANALYSIS AND CONSULTING SERVICES (U.S. CLS. 100, 101 AND 102).

CLASS 36—INSURANCE AND FINANCIAL

FOR CONSULTING AND INFORMATION CONCERNING INSURANCE; FINANCIAL ADVISORY AND CONSULTANCY SERVICES; FINANCIAL ANALYSES; FINANCIAL RESEARCH; FINANCIAL RISK MANAGEMENT; INSURANCE BROKERAGE (U.S. CLS. 100, 101 AND 102).
PRISCILLA MILTON, EXAMINING ATTORNEY

SN 85-269,622. GOLDMAN, SACHS & CO., NEW YORK, NY. FILED 3-17-2011.

REDI MAST

THE MARK CONSISTS OF STANDARD CHARACTERS WITHOUT CLAIM TO ANY PARTICULAR FONT, STYLE, SIZE, OR COLOR.

CLASS 35—ADVERTISING AND BUSINESS

FOR EXECUTION OF SECURITIES AND FUTURES TRADE ORDERS AND ROUTING OF SECURITIES AND FUTURES TRADE ORDERS, NAMELY, DIRECTING ORDERS FOR SECURITIES AND FUTURE TRADE ORDERS BY MEANS OF COMPUTER SOFTWARE WHICH AUTOMATICALLY DIRECTS TRADES TO THE BEST LOCATION FOR EXECUTING SUCH ORDERS AND PROVIDING ON-LINE FACILITIES FEATURING ROUTING OF SECURITIES AND FUTURES TRADER ORDERS, TRANSACTION ORDER ENTRY, ORDER DIRECTING AND ORDER CONFIRMATION SERVICES TO CUSTOMERS IN THE FIELD OF INVESTING (U.S. CLS. 100, 101 AND 102).

FIRST USE 2-3-2011; IN COMMERCE 2-3-2011.

CLASS 36—INSURANCE AND FINANCIAL

FOR FINANCIAL SERVICES, NAMELY, ELECTRONIC TRADING OF SECURITIES AND FUTURES; FINANCIAL PORTFOLIO MANAGEMENT SERVICES; INVESTMENT MANAGEMENT AND ADVISORY SERVICES; TRADING OF FINANCIAL SECURITIES AND FUTURES; FINANCIAL PLANNING SERVICES; MANAGEMENT OF FINANCIAL ACCOUNTS; TRADING OF SECURITIES AND FUTURES VIA AN ONLINE PLATFORM; FINANCIAL TRANSACTION AND PORTFOLIO INVESTMENT ADVISORY SERVICES; FINANCIAL RESEARCH SERVICES (U.S. CLS. 100, 101 AND 102).

FIRST USE 2-3-2011; IN COMMERCE 2-3-2011.
EMILY CHUO, EXAMINING ATTORNEY

SN 85-269,630. AON CORPORATION, CHICAGO, IL. FILED 3-17-2011.

Aon Five

THE MARK CONSISTS OF STANDARD CHARACTERS WITHOUT CLAIM TO ANY PARTICULAR FONT, STYLE, SIZE, OR COLOR.

OWNER OF U.S. REG. NOS. 1,496,123, 3,254,615 AND OTHERS.

CLASS 35—ADVERTISING AND BUSINESS

FOR BUSINESS RISK ASSESSMENT SERVICES; BUSINESS RISK MANAGEMENT; HUMAN RESOURCE ANALYSIS AND CONSULTING SERVICES (U.S. CLS. 100, 101 AND 102).

CLASS 36—INSURANCE AND FINANCIAL

FOR CONSULTING AND INFORMATION CONCERNING INSURANCE; FINANCIAL ADVISORY AND CONSULTANCY SERVICES; FINANCIAL ANALYSES; FINANCIAL RESEARCH; FINANCIAL RISK MANAGEMENT; INSURANCE BROKERAGE (U.S. CLS. 100, 101 AND 102).

PRISCILLA MILTON, EXAMINING ATTORNEY

SN 85-271,627. HALL INNOVATIONS, LLC, DBA PILLO1, MALIBU, CA. FILED 3-20-2011.

by Dr. Hall

THE MARK CONSISTS OF STANDARD CHARACTERS WITHOUT CLAIM TO ANY PARTICULAR FONT, STYLE, SIZE, OR COLOR.

THE NAME "DR. HALL" IDENTIFIES A LIVING INDIVIDUAL WHOSE CONSENT IS OF RECORD.

CLASS 10—MEDICAL APPARATUS

FOR CERVICAL PILLOWS FOR MEDICAL USE (U.S. CLS. 26, 39 AND 44).

FIRST USE 10-1-2008; IN COMMERCE 6-1-2009.

CLASS 20—FURNITURE AND ARTICLES NOT OTHERWISE CLASSIFIED

FOR BEDS, MATTRESSES, PILLOWS AND BOLSTERS (U.S. CLS. 2, 13, 22, 25, 32 AND 50).

FIRST USE 10-1-2008; IN COMMERCE 6-1-2009.

DORITT L. CARROLL, EXAMINING ATTORNEY

SN 85-274,376. EATING WELL, INC., CHARLOTTE, VT. FILED 3-23-2011.

EAT HEALTHY YOUR WAY

THE MARK CONSISTS OF STANDARD CHARACTERS WITHOUT CLAIM TO ANY PARTICULAR FONT, STYLE, SIZE, OR COLOR.

OWNER OF U.S. REG. NOS. 3,106,102 AND 3,953,831.

CLASS 16—PAPER GOODS AND PRINTED MATTER

FOR MAGAZINES IN THE FIELD OF FOOD, HEALTH, AND NUTRITION (U.S. CLS. 2, 5, 22, 23, 29, 37, 38 AND 50).

FIRST USE 9-30-2009; IN COMMERCE 9-30-2009.

CLASS 41—EDUCATION AND ENTERTAINMENT

FOR NON-DOWNLOADABLE ELECTRONIC MAGAZINE IN THE FIELD OF FOOD, HEALTH, AND NUTRITION (U.S. CLS. 100, 101 AND 107).

FIRST USE 8-31-2010; IN COMMERCE 8-31-2010.

CLASS 43—HOTEL AND RESTAURANT SERVICES

FOR PROVIDING A WEBSITE FEATURING INFORMATION IN THE FIELD OF FOOD, NAMELY, RECIPES AND COOKING INSTRUCTIONS (U.S. CLS. 100 AND 101).

FIRST USE 8-31-2010; IN COMMERCE 8-31-2010.

CLASS 44—MEDICAL, BEAUTY AND AGRICULTURAL SERVICES

FOR PROVIDING A WEBSITE FEATURING INFORMATION IN THE FIELD OF HEALTH, AND NUTRITION (U.S. CLS. 100 AND 101).

FIRST USE 8-31-2010; IN COMMERCE 8-31-2010.

BARBARA BROWN, EXAMINING ATTORNEY

SN 85-274,735. BATH & BODY WORKS BRAND MANAGEMENT, INC., REYNOLDSBURG, OH. FILED 3-23-2011.

A LITTLE R&R

THE MARK CONSISTS OF STANDARD CHARACTERS WITHOUT CLAIM TO ANY PARTICULAR FONT, STYLE, SIZE, OR COLOR.

CLASS 3—COSMETICS AND CLEANING PREPARATIONS

FOR ROOM FRAGRANCE REFILLS FOR NON-ELECTRIC AND ELECTRIC ROOM FRAGRANCE DISPENSERS, FRAGRANCES FOR AUTOMOBILES, ROOM FRAGRANCES, HOME FRAGRANCE OILS, FRAGRANCE REEDS, FRAGRANT ROOM SPRAY (U.S. CLS. 1, 4, 6, 50, 51 AND 52).

JENNY PARK, EXAMINING ATTORNEY

SN 85-275,107. HIDDEN VALUES, INC., DALLAS, TX. FILED 3-23-2011.

CLASS 4—LUBRICANTS AND FUELS

FOR CANDLES (U.S. CLS. 1, 6 AND 15).
JENNY PARK, EXAMINING ATTORNEY

SENIORS' OUT 'N ABOUT

SN 85-274,753. BATH & BODY WORKS BRAND MANAGEMENT, INC., REYNOLDSBURG, OH. FILED 3-23-2011.

THE MARK CONSISTS OF STANDARD CHARACTERS WITHOUT CLAIM TO ANY PARTICULAR FONT, STYLE, SIZE, OR COLOR.

NO CLAIM IS MADE TO THE EXCLUSIVE RIGHT TO USE "SENIORS'", APART FROM THE MARK AS SHOWN.

DIS-CONNECT

THE MARK CONSISTS OF STANDARD CHARACTERS WITHOUT CLAIM TO ANY PARTICULAR FONT, STYLE, SIZE, OR COLOR.

CLASS 16—PAPER GOODS AND PRINTED MATTER

FOR MAGAZINES FEATURING TOPICS PRIMARILY OF INTEREST TO ADULTS AGE 50 AND ABOVE (U.S. CLS. 2, 5, 22, 23, 29, 37, 38 AND 50).

CLASS 3—COSMETICS AND CLEANING PREPARATIONS

FOR ROOM FRAGRANCE REFILLS FOR NON-ELECTRIC AND ELECTRIC ROOM FRAGRANCE DISPENSERS, FRAGRANCES FOR AUTOMOBILES, ROOM FRAGRANCES, HOME FRAGRANCE OILS, FRAGRANCE REEDS, FRAGRANT ROOM SPRAY (U.S. CLS. 1, 4, 6, 50, 51 AND 52).

CLASS 41—EDUCATION AND ENTERTAINMENT

FOR PROVIDING ON-LINE MAGAZINES IN THE FIELD OF TOPICS PRIMARILY OF INTEREST TO ADULTS AGE 50 AND ABOVE (U.S. CLS. 100, 101 AND 107).

INGRID C. EULIN, EXAMINING ATTORNEY

CLASS 4—LUBRICANTS AND FUELS

FOR CANDLES (U.S. CLS. 1, 6 AND 15).
JENNY PARK, EXAMINING ATTORNEY

SN 85-278,274. NO LIMIT, LLC, FARMINGTON, CT. FILED 3-28-2011.

SN 85-274,768. BATH & BODY WORKS BRAND MANAGEMENT, INC., REYNOLDSBURG, OH. FILED 3-23-2011.

**CAN YOU FEEL THE LOVE**

THE MARK CONSISTS OF STANDARD CHARACTERS WITHOUT CLAIM TO ANY PARTICULAR FONT, STYLE, SIZE, OR COLOR.

OWNER OF U.S. REG. NOS. 1,280,046, 3,145,005 AND OTHERS.

NO CLAIM IS MADE TO THE EXCLUSIVE RIGHT TO USE "ALL PROFITS TO CHARITY", APART FROM THE MARK AS SHOWN.

THE NAME "NEWMAN" AND THE PORTRAIT OF PAUL NEWMAN DO NOT IDENTIFY A LIVING INDIVIDUAL.

THE MARK CONSISTS OF THE WORDS "NEWMAN'S OWN ALL PROFITS TO CHARITY" WITHIN A DOUBLE LINED ARCH ON TOP OF AN ARTISTIC RENDERING OF THE FACE OF PAUL NEWMAN.

CLASS 3—COSMETICS AND CLEANING PREPARATIONS

FOR ROOM FRAGRANCE REFILLS FOR NON-ELECTRIC AND ELECTRIC ROOM FRAGRANCE DISPENSERS, FRAGRANCES FOR AUTOMOBILES, ROOM FRAGRANCES, HOME FRAGRANCE OILS, FRAGRANCE REEDS, FRAGRANT ROOM SPRAY (U.S. CLS. 1, 4, 6, 50, 51 AND 52).

CLASS 29—MEATS AND PROCESSED FOODS

FOR FROZEN ENTREES CONSISTING PRIMARILY OF MEAT, FISH, POULTRY OR VEGETABLES (U.S. CL. 46).

CLASS 4—LUBRICANTS AND FUELS

FOR CANDLES (U.S. CLS. 1, 6 AND 15).

CLASS 30—STAPLE FOODS

FOR FROZEN ENTREES CONSISTING PRIMARILY OF PASTA OR RICE (U.S. CL. 46).
LINDA M. KING, EXAMINING ATTORNEY

SN 85-278,697. THE HEALTHY WEIGHT COMMITMENT FOUNDATION, WASHINGTON, DC. FILED 3-28-2011.

TOGETHER COUNTS

THE MARK CONSISTS OF STANDARD CHARACTERS WITHOUT CLAIM TO ANY PARTICULAR FONT, STYLE, SIZE, OR COLOR.

CLASS 16—PAPER GOODS AND PRINTED MATTER

FOR PRINTED NEWSLETTERS, REPORTS, FACT SHEETS AND TEACHING AND INSTRUCTIONAL MATERIALS REGARDING HEALTH, EXERCISE, NUTRITION AND WEIGHT LOSS (U.S. CLS. 2, 5, 22, 23, 29, 37, 38 AND 50).

CLASS 35—ADVERTISING AND BUSINESS

FOR ADVERTISING, MARKETING AND PROMOTION SERVICES AND PROMOTING PUBLIC AWARENESS OF HEALTH, EXERCISE, NUTRITION AND WEIGHT LOSS ISSUES, ALL ON BEHALF OF PRIVATE ORGANIZATIONS, AND PROVIDING ADVICE AND CONSULTING IN CONJUNCTION THEREWITH (U.S. CLS. 100, 101 AND 102).

CLASS 41—EDUCATION AND ENTERTAINMENT

FOR ONLINE ELECTRONIC PUBLISHING OF ARTICLES, BOOKS, FACT SHEETS AND PERIODICALS REGARDING HEALTH, EXERCISE, NUTRITION, WEIGHT LOSS AND RECREATION; PROVIDING INFORMATION ON PHYSICAL EXERCISE AND RECREATION (U.S. CLS. 100, 101 AND 107).

CLASS 44—MEDICAL, BEAUTY AND AGRICULTURAL SERVICES

FOR PROVIDING INFORMATION REGARDING HEALTH, NUTRITION AND WEIGHT LOSS (U.S. CLS. 100 AND 101).

IRA J. GOODSAD, EXAMINING ATTORNEY

SN 85-279,735. INTERACTIVE WELLNESS LLC, MIAMI BEACH, FL. FILED 3-29-2011.



THE MARK CONSISTS OF A LEAF DESIGN PLUS THE WORDS "MILO BRINGING HEALTH TO LIFE".

CLASS 36—INSURANCE AND FINANCIAL

FOR PROVIDING INSURANCE CONSULTING SERVICES THROUGH AN INTERACTIVE, CUSTOMIZABLE WEBSITE (U.S. CLS. 100, 101 AND 102).

CLASS 44—MEDICAL, BEAUTY AND AGRICULTURAL SERVICES

FOR HEALTH CARE SERVICES, NAMELY, PROVIDING EMPLOYEE WELLNESS PROGRAMS THROUGH AN INTERACTIVE, CUSTOMIZABLE WEBSITE THAT TRACKS EMPLOYEES' WELLNESS ACTIVITIES AND HEALTH INDICATORS AND THAT FEATURES INFORMATION ABOUT WELLNESS, HEALTH, EXERCISE AS IT RELATES TO OVERALL HEALTH AND WELLNESS, AND NUTRITION (U.S. CLS. 100 AND 101).

CHRISTINA SOBRAL, EXAMINING ATTORNEY

SN 85-280,786. COLLEGE CENTRAL NETWORK, INC., NEW YORK, NY. FILED 3-30-2011.

EMPLOYER CENTRAL

THE MARK CONSISTS OF STANDARD CHARACTERS WITHOUT CLAIM TO ANY PARTICULAR FONT, STYLE, SIZE, OR COLOR.

OWNER OF U.S. REG. NO. 3,791,942.

NO CLAIM IS MADE TO THE EXCLUSIVE RIGHT TO USE "EMPLOYER", APART FROM THE MARK AS SHOWN.

CLASS 35—ADVERTISING AND BUSINESS

FOR PROVIDING ONLINE JOB POSTING, RECRUITMENT GUIDANCE AND JOB PLACEMENT SERVICES VIA THE INTERNET; PROVIDING ONLINE INFORMATION IN THE FIELD OF PUBLIC POLICY ISSUES RELATED TO EMPLOYMENT (U.S. CLS. 100, 101 AND 102).

FIRST USE 12-22-1997; IN COMMERCE 12-22-1997.

CLASS 42—SCIENTIFIC AND COMPUTER SERVICES

FOR APPLICATION SERVICE PROVIDER (ASP) FEATURING SOFTWARE FOR USE IN JOB POSTING, JOB POSTING MANAGEMENT, AND MATCHING OF EMPLOYMENT OPPORTUNITIES WITH RESUMES AND CAREER PORTFOLIOS VIA THE INTERNET (U.S. CLS. 100 AND 101).

FIRST USE 12-22-1997; IN COMMERCE 12-22-1997.

DOUGLAS LEE, EXAMINING ATTORNEY

SN 85-284,063. GOLDMAN, SACHS & CO., NEW YORK, NY. FILED 4-1-2011.

NEW THINKING: BETTER TRADING

THE MARK CONSISTS OF STANDARD CHARACTERS WITHOUT CLAIM TO ANY PARTICULAR FONT, STYLE, SIZE, OR COLOR.

NO CLAIM IS MADE TO THE EXCLUSIVE RIGHT TO USE "BETTER TRADING", APART FROM THE MARK AS SHOWN.

CLASS 35—ADVERTISING AND BUSINESS

FOR DIRECTING ORDERS FOR TRADES OF FINANCIAL INSTRUMENTS, COMMODITIES, FOREIGN CURRENCIES, SECURITIES, SHARE OPTIONS, OTHER DERIVATIVE PRODUCTS, HEDGE FUNDS, AND MUTUAL FUNDS BY MEANS OF COMPUTER SOFTWARE WHICH AUTOMATICALLY DIRECTS TRADES TO THE BEST LOCATION FOR EXECUTING SUCH ORDERS; PROVIDING ON-LINE FACILITIES FEATURING TRANSACTION ORDER ENTRY, ORDER DIRECTING AND ORDER CONFIRMATION SERVICES TO CUSTOMERS IN THE FIELD OF INVESTING (U.S. CLS. 100, 101 AND 102).

CLASS 36—INSURANCE AND FINANCIAL

FOR FINANCIAL SERVICES, NAMELY, PROVIDING FINANCIAL INFORMATION IN THE NATURE OF MARKET AND QUOTATION INFORMATION FOR FOREIGN CURRENCIES AND FOREIGN CURRENCY EXCHANGE TRANSACTIONS; TRADING SUPPORT SERVICES IN THE FIELDS OF FOREIGN CURRENCIES AND FOREIGN CURRENCY EXCHANGE TRANSACTIONS, NAMELY, TRADE COMPARISON, COLLECTION, PROCESSING, TABULATION, DISTRIBUTION, NEGOTIATION, AND EXECUTION; CLASSIFICATION OF FOREIGN CURRENCIES AND FOREIGN CURRENCY EXCHANGE TRANSACTIONS; CREATION, DISTRIBUTION AND UPDATING FOREIGN CURRENCY VALUES AND PRICES; AUTOMATED FINANCIAL SERVICES, NAMELY, ONLINE BROKERAGE OF FOREIGN CURRENCIES AND CONDUCTING FOREIGN CURRENCY EXCHANGE TRANSACTIONS VIA A GLOBAL COMPUTER NETWORK; PROVIDING ONLINE ELECTRONIC COMPUTER DATABASES FEATURING FOREIGN CURRENCIES AND FOREIGN CURRENCY EXCHANGE TRANSACTIONS VIA A GLOBAL COMPUTER NETWORK; PROVIDING ONLINE ELECTRONIC COMPUTER DATABASES WHICH PROVIDE SUBSCRIBERS WITH TRADING INFORMATION CONCERNING FOREIGN CURRENCIES AND FOREIGN CURRENCY EXCHANGE TRANSACTIONS AND PROVIDE INSTITUTIONS AND INDIVIDUAL INVESTORS WITH AN AUTOMATIC NETWORK FOR TRADING IN FOREIGN CURRENCIES AND CONDUCTING FOREIGN CURRENCY EXCHANGE TRANSACTIONS; INVESTMENT OF FUNDS AND MUTUAL FUNDS FOR OTHERS; INVESTMENT FUNDS MANAGEMENT, DISTRIBUTION AND ADVISORY SERVICES; FINANCIAL SERVICES IN THE NATURE OF POOLED INVESTMENT FUNDS; PROVIDING FOR THE AUTOMATED TRADING OF COMMODITIES, SETTLEMENT SERVICES IN THE FIELD OF COMMODITIES TRADING, AND COMMODITIES CALCULATION SERVICES; PROVIDING FINANCIAL INFORMATION IN THE FIELD OF COMMODITIES; COMMODITIES INFORMATION SERVICES, NAMELY, MANAGING, TRACKING, AND REPORTING COMMODITIES PURCHASE AND SALE TRANSACTIONS; FINANCIAL ANALYSIS OF COMMODITIES TRADE TRANSACTIONS AND VALUES; FINANCIAL INFORMATION PROVIDED BY ELECTRONIC MEANS, NAMELY, PROVIDING ONLINE DATABASES WHICH PROVIDE ACCESS TO COMMODITIES TRADE ACCOUNT INFORMATION; FINANCIAL RESEARCH IN THE FIELD OF COMMODITIES; FINANCIAL CONSULTATION SERVICES, NAMELY, PROVIDING COMMODITIES FINANCIAL INFORMATION; FINANCIAL SERVICES, NAMELY, PROVIDING FOR THE ONLINE TRADING OF COMMODITIES; SECURITIES BROKERAGE SERVICES; ELECTRONIC TRADING OF SECURITIES AND FUTURES; FINANCIAL PORTFOLIO MANAGEMENT SERVICES; INVESTMENT MANAGEMENT AND ADVISORY SERVICES; TRADING OF FINANCIAL SECURITIES AND FUTURES; FINANCIAL PLANNING SERVICES; MANAGEMENT OF FINANCIAL ACCOUNTS; TRADING OF SECURITIES AND FUTURES VIA AN ONLINE PLATFORM; FINANCIAL TRANSACTION AND PORTFOLIO INVESTMENT ADVISORY SERVICES; FINANCIAL RESEARCH SERVICES; TRANSFER OF FINANCIAL ASSETS IN THE NATURE OF STOCKS, BONDS, SECURITIES, OTHER DERIVATIVE PRODUCTS, MU-

TUAL FUNDS, POOLED INVESTMENT FUNDS, HEDGE FUNDS, CASH ACCOUNTS, FOREIGN CURRENCY ACCOUNTS, FOREIGN CURRENCIES, COMMODITIES, RETIREMENT ACCOUNTS, AND REAL ESTATE INVESTMENTS; MANAGEMENT OF FINANCIAL ASSETS VIA AN ONLINE COMPUTER NETWORK; MANAGEMENT OF TRADING POSITIONS, NAMELY, MANAGEMENT OF BINDING COMMITMENTS TO BUY OR SELL A GIVEN AMOUNT OF FINANCIAL INSTRUMENTS VIA AN ONLINE COMPUTER NETWORK; PROVIDING FOR THE TRANSFER OF FINANCIAL ASSETS IN THE NATURE OF FINANCIAL INSTRUMENTS, STOCKS, BONDS, SECURITIES, SHARE OPTIONS, OTHER DERIVATIVE PRODUCTS, MUTUAL FUNDS, POOLED INVESTMENT FUNDS, HEDGE FUNDS, CASH ACCOUNTS, FOREIGN CURRENCY ACCOUNTS, FOREIGN CURRENCIES, COMMODITIES, RETIREMENT ACCOUNTS, AND REAL ESTATE INVESTMENTS AMONG VARIOUS PARTIES FOR THE PROTECTION OF SUCH FINANCIAL ASSETS VIA AN ONLINE COMPUTER NETWORK; MANAGEMENT OF FINANCIAL ASSETS; MANAGEMENT OF TRADING POSITIONS, NAMELY, MANAGEMENT OF BINDING COMMITMENTS TO BUY OR SELL A GIVEN AMOUNT OF FINANCIAL INSTRUMENTS (U.S. CLS. 100, 101 AND 102).

EMILY CHUO, EXAMINING ATTORNEY

SN 85-285,660. IGLOO PRODUCTS CORP., KATY, TX. FILED 4-4-2011.

IGLOO OUTDOORS

THE MARK CONSISTS OF STANDARD CHARACTERS WITHOUT CLAIM TO ANY PARTICULAR FONT, STYLE, SIZE, OR COLOR.

NO CLAIM IS MADE TO THE EXCLUSIVE RIGHT TO USE "OUTDOORS", APART FROM THE MARK AS SHOWN.

CLASS 18—LEATHER GOODS

FOR BACKPACKS (U.S. CLS. 1, 2, 3, 22 AND 41).

CLASS 20—FURNITURE AND ARTICLES NOT OTHERWISE CLASSIFIED

FOR CUSHIONS; OUTDOOR FURNITURE; SLEEPING BAG PADS; SLEEPING BAGS (U.S. CLS. 2, 13, 22, 25, 32 AND 50).

CLASS 22—CORDAGE AND FIBERS

FOR TENTS; TENTS FOR MOUNTAINEERING OR CAMPING (U.S. CLS. 1, 2, 7, 19, 22, 42 AND 50).

ANGELA DUONG, EXAMINING ATTORNEY

SN 85-286,125. HUHTAMAKI FINANCE B.V., 2132 HE HOOFDDORP, NETHERLANDS, FILED 4-5-2011.

WHOPPIN' RECIPES

THE MARK CONSISTS OF STANDARD CHARACTERS WITHOUT CLAIM TO ANY PARTICULAR FONT, STYLE, SIZE, OR COLOR.

OWNER OF U.S. REG. NOS. 965,678, 3,480,391 AND 3,613,728.

NO CLAIM IS MADE TO THE EXCLUSIVE RIGHT TO USE "RECIPES", APART FROM THE MARK AS SHOWN.

CLASS 16—PAPER GOODS AND PRINTED MATTER

FOR PRINTED RECIPES SOLD AS A COMPONENT OF FOOD PACKAGING (U.S. CLS. 2, 5, 22, 23, 29, 37, 38 AND 50).

FIRST USE 2-28-2007; IN COMMERCE 2-28-2007.

CLASS 30—STAPLE FOODS

FOR CANDY; CANDY PACKAGED WITH RECIPES (U.S. CL. 46).

FIRST USE 2-28-2007; IN COMMERCE 2-28-2007.

DAVID HOFFMAN, EXAMINING ATTORNEY

SN 85-286,800. SOCIETY OF GYNECOLOGIC ONCOLOGY, CHICAGO, IL. FILED 4-5-2011.



OWNER OF U.S. REG. NO. 2,904,507.
NO CLAIM IS MADE TO THE EXCLUSIVE RIGHT TO USE "SOCIETY OF GYNECOLOGIC ONCOLOGY", APART FROM THE MARK AS SHOWN.

THE MARK CONSISTS OF AN INCOMPLETE CIRCLE CONTAINING THE STYLIZED LETTERS "SGO" ABOVE THE STYLIZED WORDS "SOCIETY OF GYNECOLOGIC ONCOLOGY".

CLASS 35—ADVERTISING AND BUSINESS

FOR ASSOCIATION SERVICES, NAMELY, PROMOTING THE MEDICINE AND SCIENCE OF GYNECOLOGIC ONCOLOGY THROUGH APPROVING THE CARE OF WOMEN WITH GYNECOLOGIC CANCER, BY RAISING THE STANDARDS OF PRACTICE IN GYNECOLOGIC ONCOLOGY AND BY ENCOURAGING ON-GOING RESEARCH IN THE FIELD OF GYNECOLOGIC CANCER (U.S. CLS. 100, 101 AND 102).

CLASS 41—EDUCATION AND ENTERTAINMENT

FOR ARRANGING AND CONDUCTING EDUCATIONAL CONFERENCES RELATED TO GYNECOLOGIC ONCOLOGY AND WOMEN'S CANCER (U.S. CLS. 100, 101 AND 107).

JENNIFER MARTIN, EXAMINING ATTORNEY

SN 85-287,467. THUMB WORLD PRODUCTIONS LLC, NEW YORK, NY. FILED 4-6-2011.

THUMB GENERATION

THE MARK CONSISTS OF STANDARD CHARACTERS WITHOUT CLAIM TO ANY PARTICULAR FONT, STYLE, SIZE, OR COLOR.

OWNER OF U.S. REG. NOS. 3,278,049, 3,490,067 AND 3,551,730.

CLASS 25—CLOTHING

FOR MEN'S, WOMEN'S AND CHILDREN'S CLOTHING, NAMELY, JEANS, SWEATPANTS, SHIRTS, PANTS, SWEATERS, SHOES, UNDERWEAR, SLEEPWEAR, GLOVES, SCARVES, SOCKS, JACKETS (U.S. CLS. 22 AND 39).

CLASS 35—ADVERTISING AND BUSINESS

FOR RETAIL STORE SERVICES FEATURING CLOTHING AND CLOTHING ACCESSORIES, BOOKS, TOYS, GAMES, STATIONERY, CONSUMER ELECTRONICS, PRERECORDED CDS, VIDEOTAPES AND DVDS, VIDEO GAME CARTRIDGES, DISCS, SOFTWARE AND MACHINES, FOOD, FLOWERS, AND GENERAL CONSUMER MERCHANDISE (U.S. CLS. 100, 101 AND 102).

JESSICA FATHY, EXAMINING ATTORNEY

SN 85-287,516. WALGREEN CO., DEERFIELD, IL. FILED 4-6-2011.

PATRIOT

THE MARK CONSISTS OF STANDARD CHARACTERS WITHOUT CLAIM TO ANY PARTICULAR FONT, STYLE, SIZE, OR COLOR.

OWNER OF U.S. REG. NO. 3,633,538.

CLASS 3—COSMETICS AND CLEANING PREPARATIONS

FOR REEDS AND SCENTED OILS SOLD AS A UNIT FOR USE IN ROOM SCENT DIFFUSERS (U.S. CLS. 1, 4, 6, 50, 51 AND 52).

CLASS 4—LUBRICANTS AND FUELS

FOR TEALIGHT CANDLES (U.S. CLS. 1, 6 AND 15).

CLASS 5—PHARMACEUTICALS

FOR AIR FRESHENERS (U.S. CLS. 6, 18, 44, 46, 51 AND 52).

CLASS 11—ENVIRONMENTAL CONTROL APPARATUS

FOR ELECTRIC CANDLE WARMERS (U.S. CLS. 13, 21, 23, 31 AND 34).

CLASS 21—HOUSEWARES AND GLASS

FOR CANDLE HOLDERS (U.S. CLS. 2, 13, 23, 29, 30, 33, 40 AND 50).
WON TEAK OH, EXAMINING ATTORNEY

SN 85-288,894. WALGREEN CO., DEERFIELD, IL. FILED 4-7-2011.

CLASS 36—INSURANCE AND FINANCIAL

FOR ASSESSING INSURANCE CLAIMS; CONSULTING AND INFORMATION CONCERNING INSURANCE; FINANCIAL EVALUATION FOR INSURANCE PURPOSES; INSURANCE BROKERAGE; INSURANCE CLAIMS ADMINISTRATION; INSURANCE CONSULTANCY; INSURANCE SERVICES IN THE NATURE OF LOSS CONTROL MANAGEMENT FOR OTHERS (U.S. CLS. 100, 101 AND 102).

PRISCILLA MILTON, EXAMINING ATTORNEY

PLAYRIGHT

THE MARK CONSISTS OF STANDARD CHARACTERS WITHOUT CLAIM TO ANY PARTICULAR FONT, STYLE, SIZE, OR COLOR.
OWNER OF U.S. REG. NO. 2,738,679.

CLASS 14—JEWELRY

FOR JEWELRY (U.S. CLS. 2, 27, 28 AND 50).

CLASS 16—PAPER GOODS AND PRINTED MATTER

FOR CHALK; COLORING BOOKS (U.S. CLS. 2, 5, 22, 23, 29, 37, 38 AND 50).

CLASS 25—CLOTHING

FOR HALLOWEEN AND MASQUERADE COSTUMES (U.S. CLS. 22 AND 39).

CLASS 28—TOYS AND SPORTING GOODS

FOR SANDBOX TOYS; BATS FOR GAMES; ELECTRONIC ACTION TOYS; BALLOONS; BUBBLE MAKING WAND AND SOLUTION SETS; PUZZLES; TOY GUNS; TOY SQUIRT GUNS; DOLLS; STUFFED TOY ANIMALS; PLAYING CARDS AND CARD GAMES; EDUCATIONAL CARD GAMES (U.S. CLS. 22, 23, 38 AND 50).
WON TEAK OH, EXAMINING ATTORNEY

SN 85-299,086. AON CORPORATION, CHICAGO, IL. FILED 4-19-2011.

Aon Laser

THE MARK CONSISTS OF STANDARD CHARACTERS WITHOUT CLAIM TO ANY PARTICULAR FONT, STYLE, SIZE, OR COLOR.
OWNER OF U.S. REG. NOS. 1,496,123, 3,254,615 AND OTHERS.

CLASS 35—ADVERTISING AND BUSINESS

FOR INSURANCE CLAIMS AUDITING SERVICES; PROVIDING STATISTICAL EVALUATION OF INSURANCE CLAIMS PERFORMANCE MEASURES FOR OTHERS (U.S. CLS. 100, 101 AND 102).

EVERYWHERE I AM

SN 85-300,712. UNITED STATES POSTAL SERVICE, WASHINGTON, DC. FILED 4-21-2011.

THE MARK CONSISTS OF STANDARD CHARACTERS WITHOUT CLAIM TO ANY PARTICULAR FONT, STYLE, SIZE, OR COLOR.

CLASS 9—ELECTRICAL AND SCIENTIFIC APPARATUS

FOR DOWNLOADABLE SOFTWARE FOR USE IN MAILING, SHIPPING AND DELIVERY, FOR PERFORMING ELECTRONIC TRANSACTIONS RELATED TO COMPUTERIZED ON-LINE RETAIL STORE AND MAIL ORDER SERVICES IN THE FIELD OF POSTAGE STAMPS, PHILATELIC PRODUCTS, STATIONERY PRODUCTS AND GIFTS, FOR PERFORMING COMPUTERIZED TRACKING AND TRACING PACKAGES IN TRANSIT, FOR ENABLING THE PROVISION OF DIRECTORY INFORMATION REGARDING POSTAL LOCATIONS AND POSTAL CODES AND FOR ARRANGING PICK-UP, TRANSPORTATION, AND DELIVERY OF PACKAGES, LETTERS AND DOCUMENTS (U.S. CLS. 21, 23, 26, 36 AND 38).

CLASS 35—ADVERTISING AND BUSINESS

FOR SORTING, HANDLING, AND RECEIVING PACKAGES AND LETTERS AND PROVIDING INFORMATION CONCERNING THE SAME; COMPUTERIZED ON-LINE RETAIL STORE SERVICES IN THE FIELD OF POSTAGE STAMPS AND PHILATELIC PRODUCTS; COMPUTERIZED TRACKING AND TRACING OF PACKAGES IN TRANSIT AND PROVIDING INFORMATION CONCERNING THE SAME (U.S. CLS. 100, 101 AND 102).

CLASS 39—TRANSPORTATION AND STORAGE

FOR PICKUP, TRANSPORTATION, AND DELIVERY OF PACKAGES AND DOCUMENTS BY VARIOUS MODES OF TRANSPORTATION AND PROVIDING INFORMATION CONCERNING THE SAME (U.S. CLS. 100 AND 105).

JEFFERY COWARD, EXAMINING ATTORNEY

SN 85-300,978. GETWEAR LLP, EDINBURG, SCOTLAND, FILED 4-21-2011.

SN 85-306,190. A&E TELEVISION NETWORKS, LLC, NEW YORK, NY. FILED 4-27-2011.



THE MARK CONSISTS OF A STYLIZED LETTER "G" AS THE HANDLE OF SCISSORS.

CLASS 25—CLOTHING

FOR JEANS (U.S. CLS. 22 AND 39).

CLASS 35—ADVERTISING AND BUSINESS

FOR ON-LINE RETAIL STORE SERVICES FEATURING APPAREL; RETAIL CLOTHING STORES (U.S. CLS. 100, 101 AND 102).
TINA MAI, EXAMINING ATTORNEY

SN 85-300,991. GETWEAR LLP, EDINBURG, SCOTLAND, FILED 4-21-2011.

THE TRAGIC SIDE OF FAME

THE MARK CONSISTS OF STANDARD CHARACTERS WITHOUT CLAIM TO ANY PARTICULAR FONT, STYLE, SIZE, OR COLOR.

CLASS 9—ELECTRICAL AND SCIENTIFIC APPARATUS

FOR MULTIMEDIA GOODS, NAMELY, PRERECORDED DIGITAL VIDEO DISCS AND DVDS FEATURING SUBJECTS OF GENERAL HUMAN INTEREST; DIGITAL MEDIA, NAMELY, DOWNLOADABLE AUDIO AND VIDEO FILES FEATURING SUBJECTS OF GENERAL HUMAN INTEREST; DOWNLOADABLE WEBCASTS FEATURING SUBJECTS OF GENERAL HUMAN INTEREST (U.S. CLS. 21, 23, 26, 36 AND 38).

CLASS 41—EDUCATION AND ENTERTAINMENT

FOR ENTERTAINMENT SERVICES, NAMELY, A MULTIMEDIA PROGRAM SERIES FEATURING SUBJECTS OF GENERAL HUMAN INTEREST DISTRIBUTED VIA VARIOUS PLATFORMS ACROSS MULTIPLE FORMS OF TRANSMISSION MEDIA; ENTERTAINMENT SERVICES, NAMELY, AN ONGOING TELEVISION PROGRAM FEATURING SUBJECTS OF GENERAL HUMAN INTEREST; PROVIDING A WEBSITE FEATURING GENERAL HUMAN INTEREST INFORMATION FOR ENTERTAINMENT PURPOSES ONLY (U.S. CLS. 100, 101 AND 107).
MARCIE MILONE, EXAMINING ATTORNEY

SN 85-307,774. SEATTLE GENETICS, INC., BOTHELL, WA. FILED 4-28-2011.



THE MARK CONSISTS OF A STYLIZED LETTER "G" AS THE HANDLE OF SCISSORS AND THE WORD "GETWEAR".

CLASS 25—CLOTHING

FOR JEANS (U.S. CLS. 22 AND 39).

CLASS 35—ADVERTISING AND BUSINESS

FOR ON-LINE RETAIL STORE SERVICES FEATURING APPAREL; RETAIL CLOTHING STORES (U.S. CLS. 100, 101 AND 102).
TINA MAI, EXAMINING ATTORNEY



THE MARK CONSISTS OF A SINGLE, CONTINUOUS LOOPING LINE TWISTED TO FORM A TRI-LOBED THREE-DIMENSIONAL SHAPE, WITH A SPHERICAL ELEMENT SHOWN ABOVE AND BETWEEN THE TWO UPPER LOBES.

CLASS 5—PHARMACEUTICALS

FOR PHARMACEUTICAL PREPARATIONS FOR THE PREVENTION AND TREATMENT OF DISORDERS OF THE IMMUNE SYSTEM; PHARMACEUTICAL PREPARATIONS FOR THE TREATMENT OF CANCER; PHARMACEUTICAL PREPARATIONS FOR USE IN ONCOLOGY (U.S. CLS. 6, 18, 44, 46, 51 AND 52).

SN 85-308,284. ADP, INC., ROSELAND, NJ. FILED 4-29-2011.

LIGHTSPEEDNXT

THE MARK CONSISTS OF STANDARD CHARACTERS WITHOUT CLAIM TO ANY PARTICULAR FONT, STYLE, SIZE, OR COLOR.

CLASS 42—SCIENTIFIC AND COMPUTER SERVICES

FOR BIOTECHNOLOGY RESEARCH, NAMELY, PHARMACEUTICAL PRODUCT RESEARCH AND DEVELOPMENT OF DRUG THERAPIES AND DIAGNOSTIC TESTS FOR THE TREATMENT OF CANCER AND IMMUNOLOGICAL DISEASES (U.S. CLS. 100 AND 101).
RON FAIRBANKS, EXAMINING ATTORNEY

CLASS 9—ELECTRICAL AND SCIENTIFIC APPARATUS

FOR COMPUTER SOFTWARE FOR MANAGING PARTS INVENTORY, SALES, SERVICE, CUSTOMER RELATIONSHIP MANAGEMENT (CRM), ACCOUNTING AND DEALER PROFITABILITY IN THE POWERSPORTS AND MOTORCYCLE INDUSTRY, AND INSTRUCTION MANUALS SOLD THEREWITH; COMPUTER DATABASE MANAGEMENT SOFTWARE FOR USE IN PERSONALIZING THE CONTENT OF E-MAIL COMMUNICATIONS, AND INSTRUCTION MANUALS SOLD THEREWITH (U.S. CLS. 21, 23, 26, 36 AND 38).

SN 85-308,278. ADP, INC., ROSELAND, NJ. FILED 4-29-2011.

CLASS 42—SCIENTIFIC AND COMPUTER SERVICES

FOR COMPUTER SERVICES, NAMELY, PROVIDING A WEB-BASED SYSTEM AND ONLINE PORTAL FEATURING ON-LINE NON-DOWNLOADABLE SOFTWARE THAT ENABLES USERS TO MANAGE PARTS INVENTORY, SALES, SERVICE, CUSTOMER RELATIONSHIP MANAGEMENT (CRM), ACCOUNTING, AND DEALER PROFITABILITY IN THE POWERSPORTS AND MOTORCYCLE INDUSTRY (U.S. CLS. 100 AND 101).
ZACHARY BELLO, EXAMINING ATTORNEY

LIGHTSPEEDEVO

THE MARK CONSISTS OF STANDARD CHARACTERS WITHOUT CLAIM TO ANY PARTICULAR FONT, STYLE, SIZE, OR COLOR.

SN 85-309,031. METAL WIN, INC, TA UNICA, IRVINE, CA. FILED 4-30-2011.

CLASS 9—ELECTRICAL AND SCIENTIFIC APPARATUS

FOR COMPUTER SOFTWARE FOR MANAGING PARTS INVENTORY, SALES, SERVICE, CUSTOMER RELATIONSHIP MANAGEMENT (CRM), E-MAIL INTEGRATION, ACCOUNTING, RENTAL, MARINA AND BOAT STORAGE, AND DEALER PROFITABILITY IN THE MARINE AND RECREATIONAL VEHICLE INDUSTRY, AND INSTRUCTION MANUALS SOLD THEREWITH; COMPUTER DATABASE MANAGEMENT SOFTWARE FOR USE IN PERSONALIZING THE CONTENT OF E-MAIL COMMUNICATIONS, AND INSTRUCTION MANUALS SOLD THEREWITH (U.S. CLS. 21, 23, 26, 36 AND 38).



THE COLOR(S) BLACK, GRAY, AND BLUE IS/ARE CLAIMED AS A FEATURE OF THE MARK.

THE MARK CONSISTS OF "UNICA" IN BLACK, A DESIGN OF A HOUSE, PLATE, AND FORK IN BLUE, ALL PRINTED ON A GRAY BACKGROUND.

THE MARK DOES NOT HAVE ANY TRANSLATION.

CLASS 42—SCIENTIFIC AND COMPUTER SERVICES

FOR COMPUTER SERVICES, NAMELY, PROVIDING A WEB-BASED SYSTEM AND ONLINE PORTAL FEATURING ON-LINE NON-DOWNLOADABLE SOFTWARE THAT ENABLES USERS TO MANAGE PARTS INVENTORY, SALES, CUSTOMER RELATIONSHIP MANAGEMENT (CRM), E-MAIL, SERVICE, ACCOUNTING, RENTAL, MARINA AND BOAT STORAGE, AND DEALER PROFITABILITY IN THE MARINE AND RECREATIONAL VEHICLE INDUSTRY (U.S. CLS. 100 AND 101).
ZACHARY BELLO, EXAMINING ATTORNEY

CLASS 8—HAND TOOLS

FOR FLATWARE, NAMELY, KNIVES, FORKS, AND SPOONS (U.S. CLS. 23, 28 AND 44).

CLASS 21—HOUSEWARES AND GLASS

FOR CAMPING GRILLS AND NON-ELECTRIC COFFEE POTS (U.S. CLS. 2, 13, 23, 29, 30, 33, 40 AND 50).
PAUL F. GAST, EXAMINING ATTORNEY

SN 85-311,276. THE QUAKER OATS COMPANY, CHICAGO, IL. FILED 5-3-2011.

WELLO

THE MARK CONSISTS OF STANDARD CHARACTERS WITHOUT CLAIM TO ANY PARTICULAR FONT, STYLE, SIZE, OR COLOR.

CLASS 9—ELECTRICAL AND SCIENTIFIC APPARATUS

FOR ELECTRONIC HANDHELD DEVICES THAT CAN BE CARRIED OR WORN TO ASSIST PEOPLE IN TRACKING THEIR NUTRITIONAL INTAKE (U.S. CLS. 21, 23, 26, 36 AND 38).

CLASS 16—PAPER GOODS AND PRINTED MATTER

FOR PRINTED PAMPHLETS RELATED TO NUTRITIONAL GUIDANCE (U.S. CLS. 2, 5, 22, 23, 29, 37, 38 AND 50).

CLASS 41—EDUCATION AND ENTERTAINMENT

FOR EDUCATIONAL SERVICES, NAMELY, PROVIDING ONLINE INSTRUCTION IN THE FIELD OF NUTRITION VIA AN ONLINE WEBSITE (U.S. CLS. 100, 101 AND 107).

JANET LEE, EXAMINING ATTORNEY

SN 85-311,295. THE QUAKER OATS COMPANY, CHICAGO, IL. FILED 5-3-2011.



THE MARK CONSISTS OF THE WORD "WELLO" IN STYLIZED LETTERING WITH AN EXCLAMATION POINT IN PLACE OF THE SECOND "L".

CLASS 9—ELECTRICAL AND SCIENTIFIC APPARATUS

FOR ELECTRONIC HANDHELD DEVICES THAT CAN BE CARRIED OR WORN TO ASSIST PEOPLE IN TRACKING THEIR NUTRITIONAL INTAKE (U.S. CLS. 21, 23, 26, 36 AND 38).

CLASS 16—PAPER GOODS AND PRINTED MATTER

FOR PRINTED PAMPHLETS RELATED TO NUTRITIONAL GUIDANCE (U.S. CLS. 2, 5, 22, 23, 29, 37, 38 AND 50).

CLASS 41—EDUCATION AND ENTERTAINMENT

FOR EDUCATIONAL SERVICES, NAMELY, PROVIDING ONLINE INSTRUCTION IN THE FIELD OF NUTRITION VIA AN ONLINE WEBSITE (U.S. CLS. 100, 101 AND 107).

JANET LEE, EXAMINING ATTORNEY

SN 85-312,616. JOHNSON, ARRON, SONOMA, CA. FILED 5-4-2011.

Bad Ass V Twin

THE MARK CONSISTS OF STANDARD CHARACTERS WITHOUT CLAIM TO ANY PARTICULAR FONT, STYLE, SIZE, OR COLOR.

NO CLAIM IS MADE TO THE EXCLUSIVE RIGHT TO USE "V TWIN", APART FROM THE MARK AS SHOWN.

CLASS 37—CONSTRUCTION AND REPAIR

FOR REPAIR OF AMERICAN V TWIN MOTORCYCLES (U.S. CLS. 100, 103 AND 106).

CLASS 40—MATERIAL TREATMENT

FOR CUSTOM BUILDING OF AMERICAN V TWIN MOTORCYCLES (U.S. CLS. 100, 103 AND 106).

SANDRA BUJA, EXAMINING ATTORNEY

SN 85-318,279. SOUTHWESTERN/GREAT AMERICAN, INC., DBA THE SOUTHWESTERN COMPANY, NASHVILLE, TN. FILED 5-11-2011.



THE COLOR(S) LIGHT GREEN, DARK GREEN, ORANGE, BLUE, RED, AND PURPLE IS/ARE CLAIMED AS A FEATURE OF THE MARK.

THE MARK CONSISTS OF THE WORD "ADVANTAGE" IN LOWERCASE LETTERS, WITH THE LETTERS ON TOP OF EACH OTHER, THE "A"'S IN LIGHT GREEN, THE "D" IN ORANGE, THE "V AND "E" IN BLUE, THE "N" IN DARK GREEN, THE "T" IN RED, AND THE "G" IN PURPLE.

CLASS 9—ELECTRICAL AND SCIENTIFIC APPARATUS

FOR AUDIO BOOKS IN THE FIELD OF MATH, SCIENCE, HISTORY, COMPUTERS, TECHNOLOGY, BUSINESS, ECONOMICS, GOVERNMENT, LAW, SOCIOLOGY, POPULAR CULTURE, ENGLISH GRAMMAR, ENGLISH WRITING, FOREIGN LANGUAGES, ART, LITERATURE, CONTINENTS, COUNTRIES, STATES, GEOLOGY, GEOGRAPHY, ASTRONOMY, HEALTH, MEDICINE, ENVIRONMENT, ANIMALS, PLANTS, PEOPLE, LIFE AND PARENTING SKILLS, SELF- AND PERSONAL IMPROVEMENT, AND PERSONAL COACHING (U.S. CLS. 21, 23, 26, 36 AND 38).

CLASS 16—PAPER GOODS AND PRINTED MATTER

FOR BOOKS IN THE FIELD OF MATH, SCIENCE, HISTORY, COMPUTERS, TECHNOLOGY, BUSINESS, ECONOMICS, GOVERNMENT, LAW, SOCIOLOGY, POPULAR CULTURE, ENGLISH GRAMMAR, ENGLISH WRITING, FOREIGN LANGUAGES, ART, LITERATURE, CONTINENTS, COUNTRIES, STATES, GEOLOGY, GEOGRAPHY, ASTRONOMY, HEALTH, MEDICINE, ENVIRONMENT, ANIMALS, PLANTS, PEOPLE, LIFE AND PARENTING SKILLS, SELF- AND PERSONAL IMPROVEMENT, AND PERSONAL COACHING (U.S. CLS. 2, 5, 22, 23, 29, 37, 38 AND 50).

WILLIAM BRECKENFELD, EXAMINING ATTORNEY

SN 85-326,719. ESSEX & ORANGE, INC., SOMONAUK, IL. FILED 5-21-2011.

Our Girl Sarah

THE MARK CONSISTS OF STANDARD CHARACTERS WITHOUT CLAIM TO ANY PARTICULAR FONT, STYLE, SIZE, OR COLOR.

CLASS 25—CLOTHING

FOR APPAREL, NAMELY, SHIRTS, PANTS, JACKETS, FOOTWEAR, HATS AND/OR CAPS (U.S. CLS. 22 AND 39).

CLASS 28—TOYS AND SPORTING GOODS

FOR PLUSH DOLLS (U.S. CLS. 22, 23, 38 AND 50).
KAREN K. BUSH, EXAMINING ATTORNEY

SN 85-332,403. CONFORMAL SYSTEMS LLC, CHICAGO, IL. FILED 5-27-2011.

REAL SECURITY. REAL PRIVACY.

THE MARK CONSISTS OF STANDARD CHARACTERS WITHOUT CLAIM TO ANY PARTICULAR FONT, STYLE, SIZE, OR COLOR.

NO CLAIM IS MADE TO THE EXCLUSIVE RIGHT TO USE "SECURITY" AND "PRIVACY", APART FROM THE MARK AS SHOWN.

CLASS 9—ELECTRICAL AND SCIENTIFIC APPARATUS

FOR SOFTWARE FOR ELECTRONIC DATA STORAGE AND REMOTE DATA BACKUP (U.S. CLS. 21, 23, 26, 36 AND 38).

CLASS 39—TRANSPORTATION AND STORAGE

FOR ELECTRONIC STORAGE OF ELECTRONIC DATA (U.S. CLS. 100 AND 105).
JOHN HWANG, EXAMINING ATTORNEY

SN 85-975,244. ALANRIC FOOD DISBRITUBORS, INC., WEST DEPTFORD, NJ. FILED 12-10-2010.

FERRARA

THE MARK CONSISTS OF STANDARD CHARACTERS WITHOUT CLAIM TO ANY PARTICULAR FONT, STYLE, SIZE, OR COLOR.

OWNER OF U.S. REG. NOS. 1,454,501, 2,896,537 AND OTHERS.
SEC. 2(F).

CLASS 11—ENVIRONMENTAL CONTROL APPARATUS

FOR ELECTRIC PIZZELLE IRONS (U.S. CLS. 13, 21, 23, 31 AND 34).

CLASS 21—HOUSEWARES AND GLASS

FOR SERVING TRAYS AND SERVING PLATTERS (U.S. CLS. 2, 13, 23, 29, 30, 33, 40 AND 50).

CLASS 24—FABRICS

FOR KITCHEN LINENS AND KITCHEN TOWELS (U.S. CLS. 42 AND 50).

CLASS 25—CLOTHING

FOR APRONS (U.S. CLS. 22 AND 39).
COLLEEN DOMBROW, EXAMINING ATTORNEY

SN 85-975,349. ALANRIC FOOD DISTRIBUTORS, INC., WEST DEPTFORD, NJ. FILED 12-10-2010.

CENTO

THE MARK CONSISTS OF STANDARD CHARACTERS WITHOUT CLAIM TO ANY PARTICULAR FONT, STYLE, SIZE, OR COLOR.

OWNER OF U.S. REG. NOS. 2,591,109, 3,210,011 AND OTHERS.
THE ENGLISH TRANSLATION OF "CENTO" IN THE MARK IS "100".

**CLASS 11—ENVIRONMENTAL CONTROL AP-
PARATUS**

FOR PIZZELLE IRONS (U.S. CLS. 13, 21, 23, 31 AND 34).

CLASS 29—MEATS AND PROCESSED FOODS

FOR HAZELNUT SPREADS, BRUSCHETTA TOP-
PINGS, EXTRA VIRGIN OLIVE OIL, CHICKEN AND
BEEF STOCKS, CHICKEN AND BEEF BROTHS, TUNA
FISH IN A GLASS JAR, AND PREPARED AND EDIBLE
SALADS, EXCEPT MACARONI, RICE, AND PASTA
SALAD (U.S. CL. 46).

CLASS 30—STAPLE FOODS

FOR TORRONE NOUGAT, CANNOLI PASTRY
CREAM, CANNOLI SHELLS, PASTRIES, COOKIES,
CAKES, BISCOTTI, RISOTTO, ARBORIO RICE, CAR-
NAROLI RICE, PIZZA SAUCES, PESTO SAUCE IN A
GLASS JAR, PASTA, BREADSTICKS, ESPRESSO, COF-
FEE, ESPRESSO BEANS, COFFEE BEANS, COCOA
SPREAD, SPREAD CONTAINING CHOCOLATE AND
NUTS, BRUSCHETTA-TOPPED BREAD, PREPARED
AND EDIBLE SALADS OF MACARONI, PASTA AND
RICE, AND CANTUCCINI COOKIES (U.S. CL. 46).

CLASS 32—LIGHT BEVERAGES

FOR SYRUPS FOR BEVERAGES (U.S. CLS. 45, 46 AND
48).
GRETTA YAO, EXAMINING ATTORNEY

* * * * *

SECTION 2.— INTERNATIONAL CLASSIFICATION

The short titles associated below with the international class numbers are terms designed merely for quick identification and are not an official part of the international classification. The full names of international classes are given in section 6.1 of the trademark rules of practice.

The designation "U.S. Cl." appearing in this section refers to the U.S. class in effect prior to Sep. 1, 1973 rather than the international class which applies to applications filed on or after that date. For adoption of international classification see notice in the OFFICIAL GAZETTE of Jun. 26, 1973 (911 O.G. TM 210).

Application in one class

CLASS 1—CHEMICALS

SN 76-705,984. FORD, DON RICARDO, CLAREMONT, CA. FILED 1-13-2011.

CLASS 1—(Continued).

SN 77-882,457. RESIRENE, SOCIEDAD ANONIMA DE CAPITAL VARIABLE, TLAXCALA, MEXICO, FILED 11-30-2009.

MACH 3 ECO FUEL SAVER

THE MARK CONSISTS OF STANDARD CHARACTERS WITHOUT CLAIM TO ANY PARTICULAR FONT, STYLE, SIZE, OR COLOR.

NO CLAIM IS MADE TO THE EXCLUSIVE RIGHT TO USE "ECO FUEL SAVER", APART FROM THE MARK AS SHOWN.

FOR CHEMICAL FUEL ADDITIVE THAT INCREASES FUEL MILEAGE, REDUCES CARBON DIOXIDE, NITROGEN OXIDE, AND OTHER EMISSIONS RELATED TO THE BURNING OF FOSSIL FUELS INCLUDING GASOLINE, DIESEL, AND BIO FUEL; ALSO REDUCES THE OPACITY OF ENGINE EXHAUST AND INCREASES ENGINE PERFORMANCE (U.S. CLS. 1, 5, 6, 10, 26 AND 46).

JACQUELINE A. LAVINE, EXAMINING ATTORNEY

BIORENE

SN 77-715,199. ADVANCED NUTRIENTS LTD., ABBOTSFORD, CANADA, FILED 4-16-2009.

GRAND MASTER GROWER LEVEL

THE MARK CONSISTS OF STANDARD CHARACTERS WITHOUT CLAIM TO ANY PARTICULAR FONT, STYLE, SIZE, OR COLOR.

PRIORITY CLAIMED UNDER SEC. 44(D) ON CANADA APPLICATION NO. 1423747, FILED 12-23-2008, REG. NO. TMA797,134, DATED 5-10-2011, EXPIRES 5-10-2026.

NO CLAIM IS MADE TO THE EXCLUSIVE RIGHT TO USE "GROWER", APART FROM THE MARK AS SHOWN.

FOR PLANT NUTRIENTS, NAMELY, FERTILIZERS AND SOIL ADDITIVES (U.S. CLS. 1, 5, 6, 10, 26 AND 46).

RAUL CORDOVA, EXAMINING ATTORNEY

THE MARK CONSISTS OF STANDARD CHARACTERS WITHOUT CLAIM TO ANY PARTICULAR FONT, STYLE, SIZE, OR COLOR.

PRIORITY CLAIMED UNDER SEC. 44(D) ON MEXICO APPLICATION NO. 1021725, FILED 7-22-2009, REG. NO. 1157004, DATED 5-6-2010, EXPIRES 7-22-2019.

FOR UNPROCESSED ARTIFICIAL RESINS; HYBRID SYNTHETIC RESINS; BIODEGRADABLE SYNTHETIC RESINS; UNPROCESSED PLASTICS; CHEMICAL PREPARATIONS USED IN INDUSTRY (U.S. CLS. 1, 5, 6, 10, 26 AND 46).

KYLE PEETE, EXAMINING ATTORNEY

CLASS 1—(Continued).

SN 77-933,529. AIR PRODUCTS AND CHEMICALS, INC., ALLENTOWN, PA. FILED 2-11-2010.

Deposilk

THE MARK CONSISTS OF STANDARD CHARACTERS WITHOUT CLAIM TO ANY PARTICULAR FONT, STYLE, SIZE, OR COLOR.

THE WORDING "DEPOSILK" HAS NO MEANING IN A FOREIGN LANGUAGE.

FOR FILM FORMING POLYMERS FOR USE IN THE MANUFACTURE OF PERSONAL CARE PRODUCTS; POLYMERIC BASED THICKENER COMPOSITIONS AND TEMPERATURE SENSITIVE POLYMERS FOR USE IN THE MANUFACTURE OF PERSONAL CARE PRODUCTS, NAMELY, COSMETIC PRODUCTS; POLYMERS FOR USE AS DELIVERY AND SENSORY AGENTS IN THE FORM OF A SOLUTION, DISPERSION, EMULSION, POWDER, FLAKE, OR PASTILLE; POLYMERS FOR USE AS AN INGREDIENT IN THE MANUFACTURE OF DELIVERY AND SENSORY AGENTS FOR PERSONAL CARE PRODUCTS AND COSMETICS; CHEMICAL PRODUCTS, NAMELY, POLYMERIC ADDITIVES FOR USE IN THE MANUFACTURE OF PERSONAL CARE PRODUCTS; CHEMICAL ADDITIVES FOR USE IN THE MANUFACTURE OF PERSONAL CARE PRODUCTS AND COSMETICS (U.S. CLS. 1, 5, 6, 10, 26 AND 46).

MAYUR VAGHANI, EXAMINING ATTORNEY

SN 78-837,980. LABOPHARM, INC., LAVAL, QUEBEC, CANADA, FILED 3-15-2006.



PRIORITY CLAIMED UNDER SEC. 44(D) ON CANADA APPLICATION NO. 1289696, FILED 2-6-2006, REG. NO. TMA760408, DATED 2-23-2010, EXPIRES 2-23-2025.

OWNER OF U.S. REG. NO. 3,008,707.

FOR MODIFIED STARCH USED IN THE MANUFACTURE OF PHARMACEUTICAL PRODUCTS AS AN AGENT FOR CONTROLLED OR SUSTAINED RELEASE DRUG DELIVERY FOR ORAL AND PARENTERAL ADMINISTRATION (U.S. CLS. 1, 5, 6, 10, 26 AND 46).

GINA HAYES, EXAMINING ATTORNEY

CLASS 1—(Continued).

SN 79-080,522. GUANGZHOU TINCI MATERIALS TECHNOLOGY; CO., LTD., GUANGZHOU, CHINA, FILED 1-21-2010.



PRIORITY DATE OF 8-14-2009 IS CLAIMED.

OWNER OF INTERNATIONAL REGISTRATION 1033126 DATED 1-21-2010, EXPIRES 1-21-2020.

THE MARK CONSISTS OF THE WORD "TINCI" INSIDE A RECTANGLE; BELOW THAT IS A SMALLER RECTANGLE CONTAINING TWO CHINESE CHARACTERS.

THE ENGLISH TRANSLATION OF THE FOREIGN WORD (S) IN THE MARK IS: THE FIRST CHINESE CHARACTER CONTAINED IN THE MARK MEANS "THE SKY", THE SECOND CHARACTER MEANS "BESTOW, VOUCHSAFE"; THEY COULD BE TRANSLATED TO "THE SKY BESTOWS" IN COMBINATION.

THE TRANSLITERATION OF THE NON-LATIN CHARACTERS IN THE MARK IS: THE TWO CHINESE CHARACTERS CONTAINED IN THE MARK TRANSLITERATE INTO "TIAN CI".

FOR CHEMICAL SURFACTANT, NAMELY, CATIONIC SURFACTANTS AS RAW MATERIALS FOR USE IN THE MANUFACTURE OF INDUSTRIAL PRODUCTS, CONSUMER AND HOUSEHOLD PRODUCTS; CHEMICAL ADDITIVES FOR USE IN THE MANUFACTURE OF COSMETIC, PHARMACEUTICALS AND FOOD; WETTING AGENTS FOR USE IN THE MANUFACTURE OF COSMETICS; SILICON FLUIDS IN THE NATURE OF SILICON OIL; SILICONE, NAMELY, SILICONE RESINS AND SILICA GEL; FUNCTIONALIZED SILICONES FOR USE IN THE MANUFACTURE OF PERSONAL CARE AND COSMETIC COMPOSITIONS; CATIONIC CONDITIONER FOR INDUSTRIAL PURPOSE, NAMELY, FATTY-ACID BASED DIESEL AND GASOLINE FUEL CONDITIONERS AND CHEMICAL SOIL CONDITIONERS; CHEMICAL THICKENERS FOR USE IN THE MANUFACTURE OF COSMETICS; CATIONIC CONDITIONER FOR INDUSTRIAL PURPOSE, NAMELY, CATIONIC CHEMICAL CONDITIONERS FOR USE IN THE MANUFACTURE OF HAIR SHAMPOO; GLUTAMIC ACID BASED CONDITIONER AS RAW MATERIALS FOR USE IN THE MANUFACTURE OF COSMETICS; LIPIDS USED IN THE MANUFACTURE OF COSMETICS, BEVERAGES, FOOD PRODUCTS AND FOOD SUPPLEMENTS; EMOLLIENT USED AS AN INGREDIENT IN THE MANUFACTURE OF COSMETICS, TOILETRIES, AND PHARMACEUTICALS; CHEMICAL PRESERVATIVES, NAMELY, CHEMICAL PRESERVATIVES FOR USE IN MANUFACTURE OF SOAP AND VEGETABLE OIL; BOTANICAL EXTRACTS FOR USE IN MAKING COSMETICS; CHEMICAL PRESERVATIVES FOR USE IN THE PRODUCTION OF A WIDE VARIETY OF CHEMICALS; CHEMICAL OENOLOGICAL BACTERICIDE AS RAW MATERIALS FOR USE IN THE MANUFACTURE OF INDUSTRIAL PRODUCTS, CONSUMER AND HOUSEHOLD PRODUCTS; CHEMICAL ADDI-

CLASS 1—(Continued).

TIVES FOR USE IN THE MANUFACTURE OF COSMETICS; EMULSIFIERS FOR USE IN THE MANUFACTURE OF INDUSTRIAL PRODUCTS, CONSUMER AND HOUSEHOLD PRODUCTS; ACRYLATE COPOLYMER BEADS FOR USE IN MANUFACTURING; POLYMERS AND POLYMERIC ADDITIVES FOR USE IN THE MANUFACTURE OF PHARMACEUTICAL PREPARATIONS, MEDICAL DEVICES, PLASTICS, COSMETICS, PERSONAL CARE PRODUCTS; CARBOMER POLYMER BEADS FOR USE IN MANUFACTURING; INDUSTRIAL CHEMICAL ADDITIVES FOR USE IN THE MANUFACTURE OF FOODS, PHARMACEUTICALS AND COSMETICS; ELECTROLYTE FOR LITHIUM-ION BATTERY; LITHIUM SALT; CATHODE AND ANODE MATERIAL IN THE NATURE OF INDUSTRIAL CHEMICALS FOR LITHIUM-ION BATTERY, NAMELY, LITHIUM NICKEL OXIDE, LITHIUM IRON PHOSPHATE, COBALTATE LITHIUM, LITHIUM TITANATE, NATURAL GRAPHITE AND GRAPHITE IN RAW OR SEMI-FINISHED FORM FOR USE IN MANUFACTURING (U.S. CLS. 1, 5, 6, 10, 26 AND 46).

KATHERINE E. HALMEN, EXAMINING ATTORNEY

SN 79-084,959. DANISCO US INC., UNITED STATES, FILED 5-14-2010.

PROTEX

PRIORITY DATE OF 11-18-2009 IS CLAIMED.
OWNER OF INTERNATIONAL REGISTRATION 1044858 DATED 5-14-2010, EXPIRES 5-14-2020.

THE MARK CONSISTS OF STANDARD CHARACTERS WITHOUT CLAIM TO ANY PARTICULAR FONT STYLE, SIZE, OR COLOR.

FOR PROTEOLYTIC ENZYMES AND ENZYME PREPARATIONS FOR INDUSTRIAL USES, NAMELY, FOR USE IN THE PULP AND PAPER INDUSTRY, FISHMEAL PRODUCTION INDUSTRY, FISH STICKWATER PROCESSING INDUSTRY, CHONDROITIN SULFATE PRODUCTION INDUSTRY, HEPARIN PRODUCTION INDUSTRY, PROCESSING OF PLANT-DERIVED AND ANIMAL-DERIVED WASTE MATERIALS, YEAST PROCESSING INDUSTRY, INDUSTRIAL FERMENTATION INDUSTRY, SILVER RECOVERY FROM IMAGING FILM, WASTEWATER AND SLUDGE PROCESSING INDUSTRY, NONSOLVENT OILSEED PROCESSING INDUSTRY, CONTACT LENS CLEANING SOLUTION INDUSTRY, XANTHAN GUM PRODUCTION INDUSTRY, LEATHER PRODUCTION INDUSTRY, GELATIN PRODUCTION INDUSTRY, AND MEDICAL INSTRUMENT CLEANING FORMULATIONS INDUSTRY (U.S. CLS. 1, 5, 6, 10, 26 AND 46).

MARC LEIPZIG, EXAMINING ATTORNEY

CLASS 1—(Continued).

SN 79-092,046. POLYTEC PT GMBH, FED REP GERMANY, FILED 12-17-2010.



PRIORITY DATE OF 7-20-2010 IS CLAIMED.
OWNER OF INTERNATIONAL REGISTRATION 1063680 DATED 12-17-2010, EXPIRES 12-17-2020.

NO CLAIM IS MADE TO THE EXCLUSIVE RIGHT TO USE "POLYMERE TECHNOLOGIEN", APART FROM THE MARK AS SHOWN.

THE COLOR(S) ORANGE, WHITE, BLACK IS/ARE CLAIMED AS A FEATURE OF THE MARK.

THE MARK CONSISTS OF THE WORDING "POLYTEC PT POYMERE TECHNOLOGIEN" IN BLACK LETTERING TO THE RIGHT OF A BLACK CIRCLE WITH A HALF-EMPTY ERLLENMEYER FLASK; THE CIRCLE DESIGN AND WORDING, "POLYTEC PT" ARE ON A HORIZONTAL FIELD OF YELLOW TRISECTED BY TWO EQUIDISTANT WHITE LINES.

THE ENGLISH TRANSLATION OF "POLYMERE TECHNOLOGIEN" IN THE MARK IS "POLYMERIC TECHNOLOGIES".

FOR ADHESIVES USED IN INDUSTRY (U.S. CLS. 1, 5, 10, 26 AND 46).

GILBERT SWIFT, EXAMINING ATTORNEY

SN 79-094,785. ANGEL YEAST CO., LTD., CHINA, FILED 1-28-2011.



OWNER OF INTERNATIONAL REGISTRATION 1012460 DATED 8-20-2009, EXPIRES 8-20-2019.

OWNER OF U.S. REG. NO. 3,851,296.

FOR CHEMICAL SUBSTANCES FOR PRESERVING FOODSTUFFS; CHEMICALS USED IN FERMENTING WINE; OILS FOR THE PRESERVATION OF FOOD; MILK FERMENTS FOR CHEMICAL PURPOSES, NAMELY, MILK DERIVED FERMENTS FOR THE CHEMICAL PRESERVATION OF FOOD; ARTIFICIAL SWEETENERS BEING CHEMICAL PREPARATIONS; AGAR-AGAR; ENZYME PREPARATIONS FOR INDUSTRIAL PURPOSES, NAMELY, FOR USE IN THE ALCOHOL INDUSTRY, PHARMACEUTICAL INDUSTRY, FOOD INDUSTRY, FEED INDUSTRY; FERMENTS FOR CHEMICAL PURPOSES, NAMELY, BACTERIA FOR USE IN CHEMICAL MANUFACTURING (U.S. CLS. 1, 5, 6, 10, 26 AND 46).

APRIL ROACH, EXAMINING ATTORNEY

CLASS 1—(Continued).

SN 79-095,585. AES CHEMUNEX, FRANCE, FILED 3-8-2011.

IBISA

THE MARK CONSISTS OF STANDARD CHARACTERS WITHOUT CLAIM TO ANY PARTICULAR FONT, STYLE, SIZE, OR COLOR.

PRIORITY DATE OF 9-15-2010 IS CLAIMED. OWNER OF INTERNATIONAL REGISTRATION 1072593 DATED 3-8-2011, EXPIRES 3-8-2021.

FOR CHEMICALS USED IN INDUSTRY, SCIENCE AND PHOTOGRAPHY, AS WELL AS IN AGRICULTURE, HORTICULTURE AND FORESTRY (U.S. CLS. 1, 5, 6, 10, 26 AND 46).

NAKIA HENRY, EXAMINING ATTORNEY

SN 85-105,158. TECHNICAL RUBBER COMPANY, INC., JOHNSTOWN, OH. FILED 8-11-2010.

TRUFLEX/PANG

THE MARK CONSISTS OF STANDARD CHARACTERS WITHOUT CLAIM TO ANY PARTICULAR FONT, STYLE, SIZE, OR COLOR.

FOR VULCANIZING FLUIDS, TIRE PUNCTURE SEALANT, AND CHEMICALS AND SEALANTS FOR USE IN TIRE REPAIR, NAMELY, RUBBER AND LIQUID CEMENTS FOR REPAIRING TIRES, RUBBER AND LIQUID CEMENTS FOR RETREADING TIRES, CONTACT CEMENTS, RUBBER CEMENTS, VULCANIZING CEMENTS, AND ADHESIVES USED IN BONDING RUBBER (U.S. CLS. 1, 5, 6, 10, 26 AND 46).

FIRST USE 12-31-1974; IN COMMERCE 12-31-1974.

LINDA E. BLOHM, EXAMINING ATTORNEY

SN 85-110,056. MULTISORB TECHNOLOGIES, INC., BUFFALO, NY. FILED 8-18-2010.

INTELLISORB

THE MARK CONSISTS OF STANDARD CHARACTERS WITHOUT CLAIM TO ANY PARTICULAR FONT, STYLE, SIZE, OR COLOR.

FOR HUMECTANTS, CHEMICALS FOR ABSORBING OXYGEN, CHEMICALS FOR ABSORBING HYDROCARBON AND COMBINATIONS THEREOF IN THE FORM OF CANISTERS, SACHETS, LABELS, AND COMPRESSED TABLETS (U.S. CLS. 1, 5, 6, 10, 26 AND 46).

JOHN DALIER, EXAMINING ATTORNEY

CLASS 1—(Continued).

SN 85-155,111. NEO INTERNATIONAL CORP., BRIDGETOWN, BARBADOS, FILED 10-18-2010.



THE MARK CONSISTS OF A STYLIZED "N" DESIGN TO THE LEFT OF "NEO" IN STYLIZED FORM.

FOR RARE EARTHS, ZIRCONIUM CHLORIDE, GALLIUM, INDIUM AND RHENIUM (U.S. CLS. 1, 5, 6, 10, 26 AND 46).

KEVIN DINALLO, EXAMINING ATTORNEY

SN 85-155,122. NEO INTERNATIONAL CORP., BRIDGETOWN, BARBADOS, FILED 10-18-2010.

NEO POWDERS

THE MARK CONSISTS OF STANDARD CHARACTERS WITHOUT CLAIM TO ANY PARTICULAR FONT, STYLE, SIZE, OR COLOR.

NO CLAIM IS MADE TO THE EXCLUSIVE RIGHT TO USE "POWDERS", APART FROM THE MARK AS SHOWN.

FOR RARE EARTHS, ZIRCONIUM CHLORIDE, GALLIUM, INDIUM AND RHENIUM (U.S. CLS. 1, 5, 6, 10, 26 AND 46).

KEVIN DINALLO, EXAMINING ATTORNEY

SN 85-158,858. TECHNICAL RUBBER COMPANY, INC., JOHNSTOWN, OH. FILED 10-22-2010.

PANG INDUSTRIAL

THE MARK CONSISTS OF STANDARD CHARACTERS WITHOUT CLAIM TO ANY PARTICULAR FONT, STYLE, SIZE, OR COLOR.

NO CLAIM IS MADE TO THE EXCLUSIVE RIGHT TO USE "INDUSTRIAL", APART FROM THE MARK AS SHOWN.

FOR CONTACT CEMENT FOR USE ON SPLICING BELTS; CONTACT CEMENT FOR BONDING PVC AND POLYURETHANE; CHEMICAL ACTIVATOR FOR BONDING CEMENTS; CHEMICAL SOLVENT FOR USE TO CLEAN RUBBER, METAL AND OTHER SURFACES; ADHESIVE PRIMER USED TO COAT METAL PRODUCTS FOR BONDING RUBBER TO METAL; VULCANIZING FLUID TO BOND REPAIR PATCHES; VULCANIZING ADHESIVE CEMENT FOR HOT SPLICING HEAVY-DUTY CONVEYOR BELTS; AND TWO-PART SELF-VULCANIZING PUTTY FOR REPAIRING DAMAGED HEAVY-DUTY CONVEYOR BELTS (U.S. CLS. 1, 5, 6, 10, 26 AND 46).

LINDA E. BLOHM, EXAMINING ATTORNEY

CLASS 1—(Continued).

SN 85-168,154. MULTISORB TECHNOLOGIES, INC., BUFFALO, NY. FILED 11-3-2010.

FreshPlus

THE MARK CONSISTS OF STANDARD CHARACTERS WITHOUT CLAIM TO ANY PARTICULAR FONT, STYLE, SIZE, OR COLOR.

OWNER OF U.S. REG. NOS. 1,696,737, 3,824,706 AND OTHERS.

FOR CHEMICALS IN THE NATURE OF PLASTIC AND RESIN-BASED SORBENTS AND HUMECTANTS INCLUDING SORBENTS AND HUMECTANTS IN FILM, SHEET, AND CONTAINER FORM (U.S. CLS. 1, 5, 6, 10, 26 AND 46).

TARA PATE, EXAMINING ATTORNEY

CLASS 1—(Continued).

SN 85-216,633. BASTECH, LLC, JACKSONVILLE, FL. FILED 1-13-2011.

ECO FLOAT AID

THE MARK CONSISTS OF STANDARD CHARACTERS WITHOUT CLAIM TO ANY PARTICULAR FONT, STYLE, SIZE, OR COLOR.

NO CLAIM IS MADE TO THE EXCLUSIVE RIGHT TO USE "FLOAT AID", APART FROM THE MARK AS SHOWN.

FOR CHEMICAL PREPARATIONS FOR SELECTIVELY SEPARATING CALCIUM PHOSPHATE FROM SAND (U.S. CLS. 1, 5, 6, 10, 26 AND 46).

FIRST USE 1-25-2010; IN COMMERCE 6-2-2010.

KAREN BRACEY, EXAMINING ATTORNEY

SN 85-168,218. MULTISORB TECHNOLOGIES, INC., BUFFALO, NY. FILED 11-3-2010.

Fresh+

THE MARK CONSISTS OF STANDARD CHARACTERS WITHOUT CLAIM TO ANY PARTICULAR FONT, STYLE, SIZE, OR COLOR.

OWNER OF U.S. REG. NOS. 1,696,737, 3,824,706 AND OTHERS.

FOR CHEMICALS IN THE NATURE OF PLASTIC AND RESIN-BASED SORBENTS AND HUMECTANTS INCLUDING SORBENTS AND HUMECTANTS IN FILM, SHEET, AND CONTAINER FORM (U.S. CLS. 1, 5, 6, 10, 26 AND 46).

TARA PATE, EXAMINING ATTORNEY

SN 85-223,021. MIRAKLET, LLC, DELRAY BEACH, FL. FILED 1-21-2011.



Acquagen
Technology by Miraklet

FOR CHEMICAL PREPARATIONS FOR USE IN SOIL REMEDIATION, DRINKING WATER TREATMENT, MUNICIPAL AND INDUSTRIAL WASTEWATER TREATMENT (U.S. CLS. 1, 5, 6, 10, 26 AND 46).

FIRST USE 9-29-2010; IN COMMERCE 1-1-2011.

KATHERINE M. DUBRAY, EXAMINING ATTORNEY

SN 85-207,344. D & L DISTRIBUTION LLC, LANCASTER, PA. FILED 12-29-2010.

TURBO

THE MARK CONSISTS OF STANDARD CHARACTERS WITHOUT CLAIM TO ANY PARTICULAR FONT, STYLE, SIZE, OR COLOR.

FOR ADJUVANTS FOR USE WITH HERBICIDES; WATER CONDITIONERS FOR USE WITH HERBICIDES (U.S. CLS. 1, 5, 6, 10, 26 AND 46).

SUZANNE BLANE, EXAMINING ATTORNEY

SN 85-242,753. NANO-TEX, INC., OAKLAND, CA. FILED 2-15-2011.

AQUAPEL

THE MARK CONSISTS OF STANDARD CHARACTERS WITHOUT CLAIM TO ANY PARTICULAR FONT, STYLE, SIZE, OR COLOR.

FOR CHEMICALS FOR TREATMENT OF TEXTILE FIBERS, YARNS, FABRICS, SYNTHETIC TEXTILE MATERIALS, OR TEXTILE FINISHED GOODS (U.S. CLS. 1, 5, 6, 10, 26 AND 46).

ELLEN BURNS, EXAMINING ATTORNEY

CLASS 1—(Continued).

SN 85-243,427. U.S. AG, LLC, LUTHERSVILLE, GA. FILED 2-16-2011.

SUR TEC

THE MARK CONSISTS OF STANDARD CHARACTERS WITHOUT CLAIM TO ANY PARTICULAR FONT, STYLE, SIZE, OR COLOR.

FOR ADJUVANT FOR USE WITH AGRICULTURAL CHEMICALS (U.S. CLS. 1, 5, 6, 10, 26 AND 46).

FIRST USE 1-1-2002; IN COMMERCE 1-1-2002.

CHRISTINA SOBRAL, EXAMINING ATTORNEY

SN 85-243,678. MERCK KGAA, D - 64293 DARMSTADT, FED REP GERMANY, FILED 2-16-2011.

NOVACHOICE

THE MARK CONSISTS OF STANDARD CHARACTERS WITHOUT CLAIM TO ANY PARTICULAR FONT, STYLE, SIZE, OR COLOR.

FOR CHEMICAL REAGENTS FOR NON-MEDICAL PURPOSES, NAMELY, CHEMICALS REAGENTS FOR CELLULAR TRANSFECTION OF DNA AND RNA FOR SCIENTIFIC AND RESEARCH USE (U.S. CLS. 1, 5, 6, 10, 26 AND 46).

FIRST USE 4-13-2011; IN COMMERCE 4-13-2011.

SIMON TENG, EXAMINING ATTORNEY

SN 85-250,336. CLEAR LAM PACKAGING, INC., ELK GROVE VILLAGE, IL. FILED 2-24-2011.

RENU

THE MARK CONSISTS OF STANDARD CHARACTERS WITHOUT CLAIM TO ANY PARTICULAR FONT, STYLE, SIZE, OR COLOR.

FOR POLYMERS, BIOPOLYMERS, POLYMERIC ADDITIVES AND BIOPOLYMERIC ADDITIVES FOR USE IN THE MANUFACTURE OF INDUSTRIAL PRODUCTS, CONSUMER AND HOUSEHOLD PRODUCTS, SEALANTS OR PACKAGING (U.S. CLS. 1, 5, 6, 10, 26 AND 46).

FIRST USE 3-9-2010; IN COMMERCE 3-9-2010.

CHRISIE B. KING, EXAMINING ATTORNEY

CLASS 1—(Continued).

SN 85-250,523. CRITICAL CARE DIAGNOSTICS, INC., DBA CRITICAL DIAGNOSTICS, SAN DIEGO, CA. FILED 2-24-2011.



THE MARK CONSISTS OF A STYLIZED HEART DESIGN APPEARING ABOVE TWO CONCENTRIC CIRCLES.

FOR CLINICAL DIAGNOSTICS, NAMELY, DIAGNOSTIC REAGENTS FOR CLINICAL OR MEDICAL LABORATORY USE (U.S. CLS. 1, 5, 6, 10, 26 AND 46).

JILL PRATER, EXAMINING ATTORNEY

SN 85-251,760. NORTHWEST AGRICULTURAL PRODUCTS, INC., PASCO, WA. FILED 2-25-2011.



NO CLAIM IS MADE TO THE EXCLUSIVE RIGHT TO USE "NORTHWEST AGRI PRODUCTS", APART FROM THE MARK AS SHOWN.

THE MARK CONSISTS OF THE WORDING "NAP" ABOVE THE WORDING "NORTHWEST AGRI PRODUCTS". THE "A" IN "NAP" IS STYLIZED BY A CURVED LINE INTERSECTING THE "A". TO THE RIGHT OF THE WORDING "NAP" IS A DESIGN ELEMENT OF A CHEMICAL BEAKER. THE LITERAL AND DESIGN ELEMENTS ARE ON A SHADED BACKGROUND.

FOR FERTILIZERS FOR AGRICULTURAL USE (U.S. CLS. 1, 5, 6, 10, 26 AND 46).

FIRST USE 9-1-1989; IN COMMERCE 9-1-1989.

WENDY JUN, EXAMINING ATTORNEY

CLASS 1—(Continued).

SN 85-251,782. NORTHWEST AGRICULTURAL PRODUCTS, INC., PASCO, WA. FILED 2-25-2011.



OWNER OF U.S. REG. NOS. 3,913,507, 3,913,509 AND OTHERS.

THE MARK CONSISTS OF THE WORDING "STERICS". ABOVE THE WORDING IS A TRIANGULAR DESIGN WITH ONE CURVED SIDE.

FOR FERTILIZERS FOR AGRICULTURAL USE (U.S. CLS. 1, 5, 6, 10, 26 AND 46).

FIRST USE 3-15-2002; IN COMMERCE 3-15-2002.
WENDY JUN, EXAMINING ATTORNEY

CLASS 1—(Continued).

SN 85-255,533. GENEX LABS, INC., POMONA, CA. FILED 3-2-2011.

PREGNEXONE

THE MARK CONSISTS OF STANDARD CHARACTERS WITHOUT CLAIM TO ANY PARTICULAR FONT, STYLE, SIZE, OR COLOR.

FOR CHEMICAL ADDITIVES FOR USE IN THE MANUFACTURE OF NUTRITIONAL AND DIETARY SUPPLEMENTS; CHEMICALS FOR USE IN THE MANUFACTURE OF NUTRITIONAL AND DIETARY SUPPLEMENTS (U.S. CLS. 1, 5, 6, 10, 26 AND 46).

COURTNEY ALVAREZ, EXAMINING ATTORNEY

SN 85-252,447. SONNEBORN INC., MAHWAH, NJ. FILED 2-25-2011.

SONNEWARMIX

THE MARK CONSISTS OF STANDARD CHARACTERS WITHOUT CLAIM TO ANY PARTICULAR FONT, STYLE, SIZE, OR COLOR.

FOR CHEMICAL PRODUCTS, NAMELY, CHEMICAL ADMIXTURES USED TO IMPROVE THE PROPERTIES OF BITUMEN WHICH ACTS AS A BINDING AGENT FOR ASPHALT AND PRODUCTS USED IN THE ROOFING INDUSTRY (U.S. CLS. 1, 5, 6, 10, 26 AND 46).

FIRST USE 4-25-2010; IN COMMERCE 4-25-2010.
ANNE MADDEN, EXAMINING ATTORNEY

SN 85-257,753. SMARTGUARD, LLC, AUBURN HILLS, MI. FILED 3-4-2011.

SmartGuard

THE MARK CONSISTS OF STANDARD CHARACTERS WITHOUT CLAIM TO ANY PARTICULAR FONT, STYLE, SIZE, OR COLOR.

FOR SURFACE AND TEXTILE PROTECTANT IN THE NATURE OF A SPRAY-ON POLYMER FOR PROVIDING ANTIMICROBIAL PROTECTION FOR POROUS AND NON-POROUS SURFACES (U.S. CLS. 1, 5, 6, 10, 26 AND 46).

SCOTT BIBB, EXAMINING ATTORNEY

SN 85-253,382. TESSENDERLO KERLEY, INC., PHOENIX, AZ. FILED 2-28-2011.

K-ROW 23

THE MARK CONSISTS OF STANDARD CHARACTERS WITHOUT CLAIM TO ANY PARTICULAR FONT, STYLE, SIZE, OR COLOR.

NO CLAIM IS MADE TO THE EXCLUSIVE RIGHT TO USE "23", APART FROM THE MARK AS SHOWN.

FOR FERTILIZERS CONTAINING POTASSIUM; FERTILIZERS FOR AGRICULTURAL USE CONTAINING POTASSIUM (U.S. CLS. 1, 5, 6, 10, 26 AND 46).

TINA BROWN, EXAMINING ATTORNEY

SN 85-257,932. GRIGNARD COMPANY, LLC, RAHWAY, NJ. FILED 3-4-2011.

BUGFUEL

THE MARK CONSISTS OF STANDARD CHARACTERS WITHOUT CLAIM TO ANY PARTICULAR FONT, STYLE, SIZE, OR COLOR.

FOR CHEMICAL ADDITIVE FOR THE DENITRIFICATION OF WASTE WATER (U.S. CLS. 1, 5, 6, 10, 26 AND 46).

JAMES GRIFFIN, EXAMINING ATTORNEY

CLASS 1—(Continued).

SN 85-257,951. MIDTECH R & D, INC., FAIRMONT, MN.
FILED 3-4-2011.

FACTOR

THE MARK CONSISTS OF STANDARD CHARACTERS WITHOUT CLAIM TO ANY PARTICULAR FONT, STYLE, SIZE, OR COLOR.

FOR FERTILIZERS (U.S. CLS. 1, 5, 6, 10, 26 AND 46).
INGRID C. EULIN, EXAMINING ATTORNEY

SN 85-257,967. MIDTECH R & D, INC., FAIRMONT, MN.
FILED 3-4-2011.

R2G

THE MARK CONSISTS OF STANDARD CHARACTERS WITHOUT CLAIM TO ANY PARTICULAR FONT, STYLE, SIZE, OR COLOR.

FOR FERTILIZERS (U.S. CLS. 1, 5, 6, 10, 26 AND 46).
INGRID C. EULIN, EXAMINING ATTORNEY

SN 85-273,899. WILBUR-ELLIS COMPANY, SAN FRANCISCO, CA. FILED 3-22-2011.



OWNER OF U.S. REG. NO. 3,481,393.
THE COLOR(S) GREEN AND GOLD IS/ARE CLAIMED AS A FEATURE OF THE MARK.

THE MARK CONSISTS OF THE WORD "NDEMAND", WHERE THE "N" APPEARS IN GREEN WITH GOLD BORDER AND THE UPPER RIGHT PORTION OF THE "N" IS A GREEN LEAF WITH GOLD VEINS; THE LETTERS "DEMAND" ALL APPEAR IN GOLD WITH GREEN BORDERS; THE SAME FONT STYLE IS USED FOR ALL THE LETTERS, BUT THE FIRST "N" AND FIRST "D" ARE APPROXIMATELY 50% LARGER THAN THE OTHER LETTERS.

FOR FERTILIZERS (U.S. CLS. 1, 5, 6, 10, 26 AND 46).
FIRST USE 1-24-2011; IN COMMERCE 1-24-2011.
JESSICA A. POWERS, EXAMINING ATTORNEY

CLASS 2—PAINTS

SN 85-088,537. INDUSTRIAL FLOOR CORPORATION, JENKINTOWN, PA. FILED 7-20-2010.

POXEPLATE

THE MARK CONSISTS OF STANDARD CHARACTERS WITHOUT CLAIM TO ANY PARTICULAR FONT, STYLE, SIZE, OR COLOR.

FOR EPOXY COATING FOR USE ON CONCRETE INDUSTRIAL FLOORS (U.S. CLS. 6, 11 AND 16).
FIRST USE 3-9-1964; IN COMMERCE 9-22-1965.
JAMES A. RAUEN, EXAMINING ATTORNEY

SN 85-135,108. WANG, LIANG, ACWORTH, GA. AND TANG, PING, ACWORTH, GA. FILED 9-21-2010.

MIRACLE

THE MARK CONSISTS OF STANDARD CHARACTERS WITHOUT CLAIM TO ANY PARTICULAR FONT, STYLE, SIZE, OR COLOR.

FOR EXTERIOR SURFACE PROTECTIVE COATINGS (U.S. CLS. 6, 11 AND 16).
FIRST USE 1-12-2010; IN COMMERCE 1-12-2010.
ANNE FARRELL, EXAMINING ATTORNEY

SN 85-199,344. DUNCAN ENTERPRISES, AKA ILOVE-TOCREATE, FRESNO, CA. FILED 12-16-2010.

TULIP ONE-STEP DYE

THE MARK CONSISTS OF STANDARD CHARACTERS WITHOUT CLAIM TO ANY PARTICULAR FONT, STYLE, SIZE, OR COLOR.

OWNER OF U.S. REG. NOS. 2,458,179, 2,653,661 AND OTHERS.

NO CLAIM IS MADE TO THE EXCLUSIVE RIGHT TO USE "ONE-STEP DYE", APART FROM THE MARK AS SHOWN.

FOR PERMANENT FABRIC DYE, SPECIFICALLY FOR DYING CLOTHING, FABRICS AND TEXTILES (U.S. CLS. 6, 11 AND 16).

FIRST USE 3-25-2010; IN COMMERCE 3-25-2010.
STEVEN PEREZ, EXAMINING ATTORNEY

CLASS 2—(Continued).

SN 85-216,754. BONA AB, SE-200 21 MALMÖ, SWEDEN, FILED 1-13-2011.

BONA SPORTIVE 1K

THE MARK CONSISTS OF STANDARD CHARACTERS WITHOUT CLAIM TO ANY PARTICULAR FONT, STYLE, SIZE, OR COLOR.

OWNER OF U.S. REG. NOS. 1,640,991, 3,925,024 AND OTHERS.

NO CLAIM IS MADE TO THE EXCLUSIVE RIGHT TO USE "1K", APART FROM THE MARK AS SHOWN.

FOR COATING IN THE NATURE OF WOOD FLOOR FINISH (U.S. CLS. 6, 11 AND 16).

JULIE WATSON, EXAMINING ATTORNEY

SN 85-229,011. MICHELMAN, INC., CINCINNATI, OH. FILED 1-28-2011.

NATURESHIELD

THE MARK CONSISTS OF STANDARD CHARACTERS WITHOUT CLAIM TO ANY PARTICULAR FONT, STYLE, SIZE, OR COLOR.

FOR COATINGS FOR PAPERBOARD, PAPERBOARD PACKAGING AND PACKAGING CONTAINERS FOR IMPARTING OIL AND GREASE RESISTANCE, ADDING MOISTURE VAPOR RESISTANCE, OXYGEN BARRIER, AND WATER BARRIER (U.S. CLS. 6, 11 AND 16).

ESTHER A. BORSUK, EXAMINING ATTORNEY

SN 85-230,333. DUNCAN ENTERPRISES, DBA ILOVE-TOCREATE, FRESNO, CA. FILED 1-31-2011.

TULIP SUPERBIG ONE-STEP TIE-DYE KIT

THE MARK CONSISTS OF STANDARD CHARACTERS WITHOUT CLAIM TO ANY PARTICULAR FONT, STYLE, SIZE, OR COLOR.

OWNER OF U.S. REG. NOS. 3,896,737, 3,928,746 AND OTHERS.

NO CLAIM IS MADE TO THE EXCLUSIVE RIGHT TO USE "SUPERBIG ONE-STEP TIE-DYE KIT", APART FROM THE MARK AS SHOWN.

FOR TIE-DYE KITS COMPRISED PRIMARILY OF DYES, COLOR FIXERS, LATEX GLOVES AND RUBBER BANDS, SPECIFICALLY FOR DYING CLOTHING, FABRICS AND TEXTILES (U.S. CLS. 6, 11 AND 16).

FIRST USE 5-31-2008; IN COMMERCE 5-31-2008.
ELLEN B. AWRICH, EXAMINING ATTORNEY

CLASS 2—(Continued).

SN 85-236,588. SCOTT PAINT COMPANY, SARASOTA, FL. FILED 2-8-2011.



NO CLAIM IS MADE TO THE EXCLUSIVE RIGHT TO USE "PAINT", APART FROM THE MARK AS SHOWN.

THE MARK CONSISTS OF THE WORDING "SCOTT PAINT" IN A STYLIZED LETTER "S" DESIGN. THE STYLIZED LETTER "S" CURVES AROUND TWO OVALS. THE TERM "SCOTT" APPEARS IN THE TOP OVAL AND THE TERM "PAINT" APPEARS IN THE LOWER OVAL.

FOR EXTERIOR PAINT; INTERIOR PAINT; PAINT PRIMERS; PAINT SEALERS; PAINTS FOR ARCHITECTURAL USES (U.S. CLS. 6, 11 AND 16).

FIRST USE 9-0-1965; IN COMMERCE 9-0-1965.
MARLENE BELL, EXAMINING ATTORNEY

SN 85-241,271. THINK TRADING, INC., PALM BEACH GARDENS, FL. FILED 2-14-2011.

BLACK BUDDHA

THE MARK CONSISTS OF STANDARD CHARACTERS WITHOUT CLAIM TO ANY PARTICULAR FONT, STYLE, SIZE, OR COLOR.

NO CLAIM IS MADE TO THE EXCLUSIVE RIGHT TO USE "BLACK", APART FROM THE MARK AS SHOWN.

FOR TATTOO INKS (U.S. CLS. 6, 11 AND 16).
FIRST USE 12-1-2010; IN COMMERCE 12-1-2010.
CARRIE GENOVESE, EXAMINING ATTORNEY

CLASS 2—(Continued).

SN 85-248,320. RUPERT, GIBBONS & SPIDER, INC.,
HEALDSBURG, CA. FILED 2-22-2011.

JACQUARD

THE MARK CONSISTS OF STANDARD CHARACTERS
WITHOUT CLAIM TO ANY PARTICULAR FONT, STYLE,
SIZE, OR COLOR.

OWNER OF U.S. REG. NO. 2,114,175.
FOR ARTS AND CRAFTS SUPPLIES, NAMELY,
PAINTS, DYES AND PIGMENTS FOR SURFACE DE-
SIGN (U.S. CLS. 6, 11 AND 16).

FIRST USE 0-0-1985; IN COMMERCE 0-0-1985.
KHANH LE, EXAMINING ATTORNEY

CLASS 2—(Continued).

SN 85-253,411. THE VALSPAR CORPORATION, MINNEA-
POLIS, MN. FILED 2-28-2011.

THAT'S PRO.

THE MARK CONSISTS OF STANDARD CHARACTERS
WITHOUT CLAIM TO ANY PARTICULAR FONT, STYLE,
SIZE, OR COLOR.

FOR PAINTS; COATINGS IN THE NATURE OF WOOD
FINISHES (U.S. CLS. 6, 11 AND 16).

KEVIN CORWIN, EXAMINING ATTORNEY

SN 85-250,516. ULTRA DURABLE FLOOR TECHNOLOGIES
INC., ST. CLOUD, MN. FILED 2-24-2011.

EPIC

THE MARK CONSISTS OF STANDARD CHARACTERS
WITHOUT CLAIM TO ANY PARTICULAR FONT, STYLE,
SIZE, OR COLOR.

FOR POLYURETHANE COATINGS FOR FLOORS
(U.S. CLS. 6, 11 AND 16).

FIRST USE 10-26-2009; IN COMMERCE 10-26-2009.
JILL PRATER, EXAMINING ATTORNEY

SN 85-253,506. THE VALSPAR CORPORATION, MINNEA-
POLIS, MN. FILED 2-28-2011.

EXPRESS DECK

THE MARK CONSISTS OF STANDARD CHARACTERS
WITHOUT CLAIM TO ANY PARTICULAR FONT, STYLE,
SIZE, OR COLOR.

NO CLAIM IS MADE TO THE EXCLUSIVE RIGHT TO
USE "DECK", APART FROM THE MARK AS SHOWN.

FOR PAINTS, STAINS, AND COATINGS IN THE
NATURE OF WOOD FINISHES (U.S. CLS. 6, 11 AND 16).

KEVIN CORWIN, EXAMINING ATTORNEY

SN 85-252,393. WD-40 COMPANY, SAN DIEGO, CA. FILED 2-
25-2011.

MARKSMAN SPOUT

THE MARK CONSISTS OF STANDARD CHARACTERS
WITHOUT CLAIM TO ANY PARTICULAR FONT, STYLE,
SIZE, OR COLOR.

NO CLAIM IS MADE TO THE EXCLUSIVE RIGHT TO
USE "SPOUT", APART FROM THE MARK AS SHOWN.

FOR PROTECTIVE COATING FOR METALS FOR
CORROSION CONTROL (U.S. CLS. 6, 11 AND 16).

STEVEN R. FINE, EXAMINING ATTORNEY

SN 85-254,259. NANOSONIC, INC., BLACKSBURG, VA.
FILED 3-1-2011.

HYBRIDSHIELD

THE MARK CONSISTS OF STANDARD CHARACTERS
WITHOUT CLAIM TO ANY PARTICULAR FONT, STYLE,
SIZE, OR COLOR.

FOR ARCHITECTURAL PROTECTIVE COATINGS
(U.S. CLS. 6, 11 AND 16).

NATALIE POLZER, EXAMINING ATTORNEY

CLASS 2—(Continued).

SN 85-258,237. BONA AB, SE-200 21 MALMÖ, SWEDEN, FILED 3-4-2011.

BONA PACIFIC FILLER

THE MARK CONSISTS OF STANDARD CHARACTERS WITHOUT CLAIM TO ANY PARTICULAR FONT, STYLE, SIZE, OR COLOR.

OWNER OF U.S. REG. NOS. 1,640,991, 3,925,024 AND OTHERS.

NO CLAIM IS MADE TO THE EXCLUSIVE RIGHT TO USE "FILLER", APART FROM THE MARK AS SHOWN.

FOR COATINGS IN THE NATURE OF WOOD FLOOR FILLERS (U.S. CLS. 6, 11 AND 16).

FIRST USE 2-0-2000; IN COMMERCE 2-0-2000.

JULIE WATSON, EXAMINING ATTORNEY

CLASS 3—(Continued).

SN 76-703,817. BOSCIA, LLC, IRVINE, CA. FILED 7-19-2010.

BOSCIA B.B. CREAM BRILLIANT

THE MARK CONSISTS OF STANDARD CHARACTERS WITHOUT CLAIM TO ANY PARTICULAR FONT, STYLE, SIZE, OR COLOR.

NO CLAIM IS MADE TO THE EXCLUSIVE RIGHT TO USE "CREAM", APART FROM THE MARK AS SHOWN.

FOR CREAMS, NAMELY, CLEANSING CREAMS, COLD CREAMS, FOUNDATION CREAMS, HAND CREAMS, SUNBURN CREAMS, EYE CREAMS, LIP CREAMS; SKIN CARE AND BATH PRODUCTS, NAMELY, SUN BLOCK LOTIONS AND SPRAYS, SUNSCREEN LOTIONS AND SPRAYS, SELF-TANNING LOTIONS AND SPRAYS, MOISTURIZING LOTIONS AND SPRAYS, AFTER-SUN LOTIONS AND SPRAYS, BODY MASK LOTIONS AND SPRAYS, SKIN LOTIONS AND SPRAYS, SKIN REFINERS, PORE MATTIFIERS, HAIR LOTIONS AND SPRAYS, FACIAL LOTIONS AND SPRAYS, BODY LOTIONS AND SPRAYS, MOISTURIZERS AND TONERS, TINTED MOISTURIZERS, AFTER-BATH LOTIONS AND SPRAYS, COSMETIC MASKS, BODY MASKS, SKIN MASKS, SKIN MOISTURIZER MASKS, FACIAL MASKS, BEAUTY MASKS, FACIAL BEAUTY MASKS (U.S. CLS. 1, 4, 6, 50, 51 AND 52).

SIMON TENG, EXAMINING ATTORNEY

SN 77-381,833. MULCHANDANI, MANISH, DUBAI, UNITED ARAB EMIR., FILED 1-28-2008.

Playa'**CLASS 3—COSMETICS AND CLEANING PREPARATIONS**

SN 76-703,816. BOSCIA, LLC, IRVINE, CA. FILED 7-19-2010.

BOSCIA B.B. CREAM BRIGHT

THE MARK CONSISTS OF STANDARD CHARACTERS WITHOUT CLAIM TO ANY PARTICULAR FONT, STYLE, SIZE, OR COLOR.

NO CLAIM IS MADE TO THE EXCLUSIVE RIGHT TO USE "CREAM", APART FROM THE MARK AS SHOWN.

FOR CREAMS, NAMELY, CLEANSING CREAMS, COLD CREAMS, FOUNDATION CREAMS, HAND CREAMS, SUNBURN CREAMS, EYE CREAMS, LIP CREAMS; SKIN CARE AND BATH PRODUCTS, NAMELY, SUN BLOCK LOTIONS AND SPRAYS, SUNSCREEN LOTIONS AND SPRAYS, SELF-TANNING LOTIONS AND SPRAYS, MOISTURIZING LOTIONS AND SPRAYS, AFTER-SUN LOTIONS AND SPRAYS, BODY MASK LOTIONS AND SPRAYS, SKIN LOTIONS AND SPRAYS, SKIN REFINERS, PORE MATTIFIERS, HAIR LOTIONS AND SPRAYS, FACIAL LOTIONS AND SPRAYS, BODY LOTIONS AND SPRAYS, MOISTURIZERS AND TONERS, TINTED MOISTURIZERS, AFTER-BATH LOTIONS AND SPRAYS, COSMETIC MASKS, BODY MASKS, SKIN MASKS, SKIN MOISTURIZER MASKS, FACIAL MASKS, BEAUTY MASKS, FACIAL BEAUTY MASKS (U.S. CLS. 1, 4, 6, 50, 51 AND 52).

SIMON TENG, EXAMINING ATTORNEY

THE MARK CONSISTS OF STANDARD CHARACTERS WITHOUT CLAIM TO ANY PARTICULAR FONT, STYLE, SIZE, OR COLOR.

PRIORITY CLAIMED UNDER SEC. 44(D) ON UNITED KINGDOM APPLICATION NO. 2463453, FILED 8-1-2007, REG. NO. 2463453, DATED 8-1-2007, EXPIRES 8-1-2007.

FOR COSMETICS; DEODORANTS FOR PERSONAL USE (U.S. CLS. 1, 4, 6, 50, 51 AND 52).

CORY BOONE, EXAMINING ATTORNEY

SN 77-676,979. SIAMONS INTERNATIONAL INC., TORONTO, ONTARIO, CANADA, FILED 2-24-2009.

ECO-WASH

THE MARK CONSISTS OF STANDARD CHARACTERS WITHOUT CLAIM TO ANY PARTICULAR FONT, STYLE, SIZE, OR COLOR.

FOR CLEANING COMPOSITIONS FOR CLEANING EXTERIOR SURFACES (U.S. CLS. 1, 4, 6, 50, 51 AND 52).

ANGELA DUONG, EXAMINING ATTORNEY

CLASS 3—(Continued).

SN 77-721,823. SCHERING-PLOUGH HEALTHCARE PRODUCTS, INC., MEMPHIS, TN. FILED 4-24-2009.



OWNER OF U.S. REG. NOS. 512,484, 1,257,297 AND OTHERS.

NO CLAIM IS MADE TO THE EXCLUSIVE RIGHT TO USE "ODOR" OR "TRIPLE ACTION SYSTEM", APART FROM THE MARK AS SHOWN.

THE COLOR(S) YELLOW, GREEN, LIGHT GREEN, DARK GREEN, BLUE, DARK BLUE, SILVER, AND WHITE IS/ARE CLAIMED AS A FEATURE OF THE MARK.

THE MARK CONSISTS OF YELLOW TRADE DRESS FEATURING DIAGONAL WAVY BANDS IN THE ORDER OF GREEN, SILVER, YELLOW, SILVER, AND GREEN STARTING FROM THE TOP LEFT TO THE BOTTOM RIGHT, OF WHICH THE GREEN WAVY BANDS EACH CONSISTS OF A LIGHT GREEN AND DARK GREEN CIRCLE-SHAPED PATTERN; CONTAINED ON TOP OF THE WAVY BANDS IS "DR. SCHOLL'S" IN WHITE STYLED LETTERING OUTLINED IN SILVER WITH A YELLOW PERIOD IN THE FORM OF A SHADED SQUARE UNDER THE LETTER "R" IN "DR." ALL OF WHICH APPEARS IN A COMPLETELY DARK BLUE SHADED OVAL WITHIN A SILVER OVAL WITH A WHITE STARBURST DESIGN ON THE BOTTOM RIGHT OF THE SILVER OVAL; UNDER THIS THE TERM "ODOR DESTROYERS" APPEARS IN DARK BLUE LETTERING OUTLINED IN WHITE; UNDER THIS IS A BLUE RECTANGLE-SHAPED BAND; UNDER THIS A BLUE RECTANGLE-SHAPED BAND CONTAINING THE TERM "WITH 3X" IN WHITE LETTERING OUTLINED IN DARK BLUE WITH A WHITE BAND UNDERLINING "WITH", AND AFTER "3X", THE WORDS "TRIPLE ACTION SYSTEM" IN BLUE LETTERING APPEARS INSIDE A WHITE ARROW-LIKE DESIGN OUTLINED IN DARK BLUE, WITH THREE DARK BLUE VERTICAL LINES WITH WHITE BACKGROUND; AND UNDER THIS, ON THE LEFT SIDE, IS A BLUE VERTICAL LINE WITH THREE BLUE BOXES EACH CONTAINING WHITE "X" MARKS. THE DOTTED OUTLINES OF THE CONTAINER AND CAP FOR THE GOODS ARE INTENDED TO SHOW THE POSITION OF THE MARK AND ARE NOT CLAIMED AS A PART OR FEATURE OF THE MARK.

FOR NON-MEDICATED DEODORANT FOOT POWDER (U.S. CLS. 1, 4, 6, 50, 51 AND 52).

GRETCHEN ULRICH, EXAMINING ATTORNEY

CLASS 3—(Continued).

SN 77-791,886. L'OREAL, PARIS, FRANCE, FILED 7-29-2009.

DEPSEA HYDRABILITY

THE MARK CONSISTS OF STANDARD CHARACTERS WITHOUT CLAIM TO ANY PARTICULAR FONT, STYLE, SIZE, OR COLOR.

PRIORITY CLAIMED UNDER SEC. 44(D) ON FRANCE APPLICATION NO. 093627848, FILED 2-6-2009, REG. NO. 093627848, DATED 2-6-2009, EXPIRES 2-6-2019.

OWNER OF U.S. REG. NOS. 3,055,487, 3,596,722 AND OTHERS.

NO CLAIM IS MADE TO THE EXCLUSIVE RIGHT TO USE "HYDRABILITY", APART FROM THE MARK AS SHOWN.

FOR PERFUME, TOILET WATER; BATH AND SHOWER GELS AND SALTS NOT FOR MEDICAL PURPOSE; TOILET SOAPS, BODY DEODORANTS; COSMETICS, NAMELY, CREAMS, MILKS, LOTIONS, GELS AND POWDERS FOR THE FACE, THE BODY AND THE HANDS; NON-MEDICATED SUN CARE PREPARATIONS; MAKEUP PREPARATIONS; SHAMPOOS; PRODUCTS FOR HAIR STYLING AND HAIR CARE, NAMELY, GELS, SPRAYS, MOUSSES, BALMS, CREAM, NON-MEDICATED SERUMS, WAX AND LOTIONS; HAIR LACQUERS; HAIR COLOURING AND HAIR DECOLORANT PREPARATIONS; PERMANENT WAVING AND CURLING PREPARATIONS; ESSENTIAL OILS FOR PERSONAL USE (U.S. CLS. 1, 4, 6, 50, 51 AND 52).

BARNEY CHARLON, EXAMINING ATTORNEY

SN 77-923,885. GANDANG KALIKASAN, INC., QUEZON CITY, NCR, PHILIPPINES, FILED 1-29-2010.

HUMAN NATURE

THE MARK CONSISTS OF STANDARD CHARACTERS WITHOUT CLAIM TO ANY PARTICULAR FONT, STYLE, SIZE, OR COLOR.

FOR BODY BUTTER; BODY LOTION; BODY WASH; FACIAL CLEANSERS; FACIAL SCRUBS; FACIAL WASHES; HAIR CONDITIONER; HAND SOAPS; LIP BALM; PERFUME; SHAMPOOS; SKIN CLEANSERS; SKIN MOISTURIZER; SKIN TONERS (U.S. CLS. 1, 4, 6, 50, 51 AND 52).

FIRST USE 11-28-2008; IN COMMERCE 12-1-2008.

DAWN HAN, EXAMINING ATTORNEY

CLASS 3—(Continued).

SN 77-938,908. BORGHESE TRADEMARKS, INC., WILMINGTON, DE. FILED 2-18-2010.

BELLA COLORE MINERALI BY
BORGHESE

THE MARK CONSISTS OF STANDARD CHARACTERS WITHOUT CLAIM TO ANY PARTICULAR FONT, STYLE, SIZE, OR COLOR.

OWNER OF U.S. REG. NOS. 3,369,371, 3,703,691 AND OTHERS.

NO CLAIM IS MADE TO THE EXCLUSIVE RIGHT TO USE "COLORE MINERALI", APART FROM THE MARK AS SHOWN.

THE ENGLISH TRANSLATION OF "BELLA COLORE MINERALI" IS "BEAUTIFUL COLOR MINERAL" AND THE ENGLISH TRANSLATION OF "BORGHESE" IN THE MARK IS "MIDDLE-CLASS".

FOR BLUSH; COSMETIC PENCILS; COSMETICS AND MAKE-UP; EYE LINER; EYE PENCILS; EYE SHADOWS; EYEBROW COLORS; EYEBROW COSMETICS; EYES MAKE-UP; EYESHADOWS; FACE POWDER; FACIAL CONCEALER; LIP GLOSS; LIP LINER; LIPSTICK; MAKE-UP FOUNDATIONS; MASCARAS; ROUGES (U.S. CLS. 1, 4, 6, 50, 51 AND 52).

CHARLOTTE CORWIN, EXAMINING ATTORNEY

SN 78-271,427. HUNTER AMENITIES INTERNATIONAL LTD., BURLINGTON, CANADA, FILED 7-8-2003.



PRIORITY CLAIMED UNDER SEC. 44(D) ON CANADA APPLICATION NO. 1181110, FILED 6-17-2003.

NO CLAIM IS MADE TO THE EXCLUSIVE RIGHT TO USE "COLLECTION", APART FROM THE MARK AS SHOWN.

THE MARK CONSISTS OF DUCK FOOT PRINTS ABOVE AND BELOW A PICTURE OF A DUCK. THE WORDING "DUCKFEET COLLECTION" APPEARS BELOW THE DUCK AND THE FEET AT THE BOTTOM OF THE MARK APPEAR IN A RECTANGLE.

FOR MASSAGE OIL; SHAMPOO; LOTION, NAMELY, HAND LOTION, FOOT LOTION, AND BODY LOTION; LIP BALM, COCOA BUTTER FOR COSMETIC PURPOSES; NON-MEDICATED DIAPER RASH CREAM; SUN CARE LOTION; BODY WASH; BAR SOAPS; AND OILS, NAMELY, BABY OIL; BODY OIL, BATH OIL AND ESSENTIAL OILS FOR PERSONAL USE (U.S. CLS. 1, 4, 6, 50, 51 AND 52).

SANI KHOURI, EXAMINING ATTORNEY

CLASS 3—(Continued).

SN 79-051,399. COTY DEUTSCHLAND GMBH, MAINZ, FED REP GERMANY, FILED 2-20-2008.

PRESS TO PLAY

THE MARK CONSISTS OF STANDARD CHARACTERS WITHOUT CLAIM TO ANY PARTICULAR FONT, STYLE, SIZE, OR COLOR.

PRIORITY DATE OF 11-9-2007 IS CLAIMED.

OWNER OF INTERNATIONAL REGISTRATION 0957428 DATED 2-20-2008, EXPIRES 2-20-2018.

FOR SOAPS, PERFUMERY; ESSENTIAL OILS; COSMETICS; COSMETIC HAIR LOTIONS (U.S. CLS. 1, 4, 6, 50, 51 AND 52).

ANDREA HACK, EXAMINING ATTORNEY

SN 79-087,679. D'ORSAY PARIS SAS, FRANCE, FILED 9-9-2010.

INTRIGANTE

THE MARK CONSISTS OF STANDARD CHARACTERS WITHOUT CLAIM TO ANY PARTICULAR FONT, STYLE, SIZE, OR COLOR.

OWNER OF INTERNATIONAL REGISTRATION 1052049 DATED 9-9-2010, EXPIRES 9-9-2020.

THE ENGLISH TRANSLATION OF "INTRIGANTE" IN THE MARK IS "BEWITCHING".

FOR PERFUMES, EAU DE PARFUM, TOILET WATER, PERFUMED SOAPS, CREAMS AND MOISTURIZING MILKS FOR THE SKIN, SHOWER GELS, BATH SALTS AND BATH OILS, ROOM FRAGRANCES (U.S. CLS. 1, 4, 6, 50, 51 AND 52).

SUSAN RICHARDS, EXAMINING ATTORNEY

SN 79-089,565. FORDAYS CO., LTD., TOKYO 103-0025, JAPAN, FILED 7-14-2010.

For Days フォーデイズ

OWNER OF INTERNATIONAL REGISTRATION 1057155 DATED 7-14-2010, EXPIRES 7-14-2020.

OWNER OF U.S. REG. NOS. 3,734,411 AND 3,793,227.

THE MARK CONSISTS OF THE WORDING "FOR DAYS" IN STYLIZED FONT ABOVE ASIAN (JAPANESE) CHARACTERS.

THE TRANSLITERATION OF THE NON-LATIN CHARACTERS IN THE MARK IS "FODEIZU" AND THIS MEANS "FOR DAYS".

FOR ANTI-STATIC PREPARATIONS FOR HOUSEHOLD PURPOSES; DE-GREASING PREPARATIONS FOR HOUSEHOLD PURPOSES; RUST REMOVING PREPARATIONS; STAIN REMOVING BENZENE; FABRIC SOFTENERS FOR LAUNDRY USE; LAUNDRY BLEACH; ADHESIVES FOR AFFIXING FALSE HAIR; ADHESIVES FOR AFFIXING FALSE EYELASHES; LAUNDRY STARCH; SEAWEED GELATINE FOR LAUNDRY USE; PAINT STRIPPING PREPARATIONS; SHOE AND BOOT CREAM; SHOE BLACK; POLISHING PREPARATIONS; SOAPS AND DETERGENTS; DENTIFRICES; COSMETICS AND NON-MEDICATED TOILETRIES; PERFUMERY, FRAGRANCES AND INCENSES OTHER THAN PERFUMES USED AS COSMETICS AND TOILETRIES; ABRASIVE PAPER; ABRASIVE CLOTH; ABRASIVE SAND; ARTIFICIAL PUMICE STONE FOR PERSONAL USE; POLISHING PAPER; FALSE NAILS; FALSE EYELASHES (U.S. CLS. 1, 4, 6, 50, 51 AND 52).

DANIEL CAPSHAW, EXAMINING ATTORNEY

CLASS 3—(Continued).

SN 79-090,422. DA LIAN YA TU TOU ZI ZI XUN YOU XIAN GONG SI, DALIAN CITY; LIAONING PROVINCE, CHINA, FILED 11-25-2010.



OWNER OF INTERNATIONAL REGISTRATION 1059707 DATED 11-25-2010, EXPIRES 11-25-2020.

THE MARK CONSISTS OF A SHIELD WITH STARS AND A FEMALE SYMBOL IN THE BORDER. WITHIN THE SHIELD ARE A ZODIAC SYMBOL, A CIRCLE AND THE LETTER "B".

FOR HAIR LOTIONS; CAKES OF TOILET SOAP; FOAMING CLEANSERS FOR PERSONAL USE; ESSENTIAL OILS; PERFUMERY; COSMETICS; PERFUMES; DENTIFRICES; POTPOURRIS; COSMETICS FOR ANIMALS (U.S. CLS. 1, 4, 6, 50, 51 AND 52).

KATHERINE CHANG, EXAMINING ATTORNEY

CLASS 3—(Continued).

SN 79-090,424. DA LIAN YA TU TOU ZI ZI XUN YOU XIAN GONG SI, DALIAN CITY; LIAONING PROVINCE, CHINA, FILED 11-25-2010.



OWNER OF INTERNATIONAL REGISTRATION 1059709 DATED 11-25-2010, EXPIRES 11-25-2020.

THE MARK CONSISTS OF A SHIELD WITH STARS AND A MALE SYMBOL IN THE BORDER. WITHIN THE SHIELD ARE A ZODIAC SYMBOL, AN ARROW WITHIN A CIRCLE AND A CIRCLE IN THE FORM OF THE LETTER "O".

FOR HAIR LOTIONS; CAKES OF TOILET SOAP; FOAMING CLEANSERS FOR PERSONAL USE; ESSENTIAL OILS; PERFUMERY; COSMETICS; PERFUMES; DENTIFRICES; POTPOURRIS; COSMETICS FOR ANIMALS (U.S. CLS. 1, 4, 6, 50, 51 AND 52).

KATHERINE CHANG, EXAMINING ATTORNEY

SN 79-090,423. DA LIAN YA TU TOU ZI ZI XUN YOU XIAN GONG SI, DALIAN CITY; LIAONING PROVINCE, CHINA, FILED 11-25-2010.



OWNER OF INTERNATIONAL REGISTRATION 1059708 DATED 11-25-2010, EXPIRES 11-25-2020.

THE MARK CONSISTS OF A SHIELD WITH STARS AND A MALE SYMBOL IN THE BORDER. WITHIN THE SHIELD ARE A ZODIAC SYMBOL, AN ARROW WITHIN A CIRCLE AND THE LETTER "A".

FOR HAIR LOTIONS; CAKES OF TOILET SOAP; FOAMING CLEANSERS FOR PERSONAL USE; ESSENTIAL OILS; PERFUMERY; COSMETICS; PERFUMES; DENTIFRICES; POTPOURRIS; COSMETICS FOR ANIMALS (U.S. CLS. 1, 4, 6, 50, 51 AND 52).

KATHERINE CHANG, EXAMINING ATTORNEY

SN 79-090,425. DA LIAN YA TU TOU ZI ZI XUN YOU XIAN GONG SI, DALIAN CITY; LIAONING PROVINCE, CHINA, FILED 11-25-2010.



OWNER OF INTERNATIONAL REGISTRATION 1059710 DATED 11-25-2010, EXPIRES 11-25-2020.

THE MARK CONSISTS OF A SHIELD WITH STARS AND A MALE SYMBOL IN THE BORDER. WITHIN THE SHIELD ARE A ZODIAC SYMBOL, AN ARROW WITHIN A CIRCLE AND THE LETTERS "AB".

FOR HAIR LOTIONS; CAKES OF TOILET SOAP; FOAMING CLEANSERS FOR PERSONAL USE; ESSENTIAL OILS; PERFUMERY; COSMETICS; PERFUMES; DENTIFRICES; POTPOURRIS; COSMETICS FOR ANIMALS (U.S. CLS. 1, 4, 6, 50, 51 AND 52).

KATHERINE CHANG, EXAMINING ATTORNEY

CLASS 3—(Continued).

SN 79-090,426. DA LIAN YA TU TOU ZI ZI XUN YOU XIAN GONG SI, LIAONING PROVINCE, CHINA, FILED 11-25-2010.

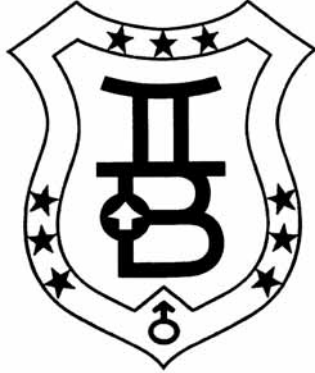

OWNER OF INTERNATIONAL REGISTRATION 1059711 DATED 11-25-2010, EXPIRES 11-25-2020.

THE MARK CONSISTS OF A STYLIZED SHIELD WITH THREE STARS WITHIN THE TOP, LEFT AND RIGHT BORDERS OF THE SHIELD, AND A MALE GENDER SYMBOL WITHIN THE BOTTOM BORDER. WITHIN THE SHIELD AT THE TOP IS AN ARROW IN A CIRCLE SUPERIMPOSED OVER TOP TO BOTTOM "II B".

FOR HAIR LOTIONS; CAKES OF TOILET SOAP; FOAMING CLEANSERS FOR PERSONAL USE; ESSENTIAL OILS; PERFUMERY; COSMETICS; PERFUMES; DENTIFRICES; POTPOURRIS; COSMETICS FOR ANIMALS (U.S. CLS. 1, 4, 6, 50, 51 AND 52).

LINDA MICKLEBURGH, EXAMINING ATTORNEY

CLASS 3—(Continued).

SN 79-090,650. DA LIAN YA TU TOU ZI ZI XUN YOU XIAN GONG SI, DALIAN CITY; LIAONING PROVINCE, CHINA, FILED 11-25-2010.



SN 79-090,427. DA LIAN YA TU TOU ZI ZI XUN YOU XIAN GONG SI, CHINA, FILED 11-25-2010.



OWNER OF INTERNATIONAL REGISTRATION 1059712 DATED 11-25-2010, EXPIRES 11-25-2020.

THE MARK CONSISTS OF A STYLIZED SHIELD WITH THREE STARS WITHIN THE TOP, LEFT AND RIGHT BORDERS OF THE SHIELD, AND A MALE GENDER SYMBOL WITHIN THE BOTTOM BORDER. WITHIN THE SHIELD AT THE TOP IS THE TAURUS ZODIAC SYMBOL WITH AN ARROW IN A CIRCLE IN THE MIDDLE, OVER A STYLIZED LETTER "A".

FOR HAIR LOTIONS; CAKES OF TOILET SOAP; FOAMING CLEANSERS FOR PERSONAL USE; ESSENTIAL OILS; PERFUMERY; COSMETICS; PERFUMES; DENTIFRICES; POTPOURRI; COSMETICS FOR ANIMALS (U.S. CLS. 1, 4, 6, 50, 51 AND 52).

LINDA MICKLEBURGH, EXAMINING ATTORNEY

OWNER OF INTERNATIONAL REGISTRATION 1060210 DATED 11-25-2010, EXPIRES 11-25-2020.

THE MARK CONSISTS OF A STYLIZED SHIELD WITH THREE STARS WITHIN THE TOP BORDER OF THE SHIELD, THREE STARS WITHIN THE LOWER LEFT AND RIGHT PORTIONS OF THE BORDER, AND A FEMALE GENDER SYMBOL WITHIN THE BOTTOM BORDER. WITHIN THE SHIELD AT THE TOP IS THE ZODIAC SYMBOL FOR SCORPIO ATOP THE LETTERS "AB" WITH A STYLIZED OVAL IN THE MIDDLE OF THE DESIGN.

FOR HAIR LOTIONS; CAKES OF TOILET SOAP; FOAMING CLEANSERS FOR PERSONAL USE; ESSENTIAL OILS; PERFUMERY; COSMETICS; PERFUMES; DENTIFRICES; POTPOURRI; COSMETICS FOR ANIMALS (U.S. CLS. 1, 4, 6, 50, 51 AND 52).

SCOTT BIBB, EXAMINING ATTORNEY

CLASS 3—(Continued).

SN 79-092,144. NETTWERK PRODUCTIONS PTY LTD, AUSTRALIA, FILED 11-25-2010.

AquaVerse

THE MARK CONSISTS OF STANDARD CHARACTERS WITHOUT CLAIM TO ANY PARTICULAR FONT, STYLE, SIZE, OR COLOR.

OWNER OF INTERNATIONAL REGISTRATION 1063961 DATED 11-25-2010, EXPIRES 11-25-2020.

FOR NON-MEDICATED SOAPS FOR PERSONAL USE; NON-MEDICATED TOILETRIES; NON-MEDICATED COSMETICS INCLUDING COSMETIC CREAMS; PERFUMES; ESSENTIAL OILS AND COSMETICS CONTAINING NATURAL EXTRACTS FROM HERBS AND OTHER NATURAL SUBSTANCES; SKIN MOISTURIZERS; MAKE-UP REMOVING PREPARATIONS; NAIL CARE PREPARATIONS; HAIR CARE PREPARATIONS, NAMELY, HAIR LOTIONS, HAIR SHAMPOOS AND HAIR CONDITIONERS; NAIL POLISH REMOVERS; SHAVING PREPARATIONS; LIQUID SOAPS; BATH PREPARATIONS, NAMELY, BATH OIL, BATH SALTS AND BATH AND SHOWER GELS; FACE, HAND AND BODY CREAMS; NON-MEDICATED SKIN CARE PREPARATIONS; SKIN PROTECTION PREPARATIONS, NAMELY, SUNSCREENS, AFTER SUN MOISTURIZERS AND COOLING BODY PREPARATIONS IN THE NATURE OF COOLING AFTER-SUN FACE AND BODY GEL AND CREAM, AND WATER IN ATOMIZED CONTAINERS USED TO PRODUCE A COOLING EFFECT; NON-MEDICATED MASSAGE PREPARATIONS, NAMELY, MASSAGE OILS, CREAMS AND LOTIONS; BABY CARE PRODUCTS, NAMELY, BABY TALCUM POWDER, LOTIONS, TEAR-LESS SHAMPOOS, SOAP-LESS CLEANSERS AND BABY OILS; BODY LOTIONS AND CLEANSERS, NAMELY, FACE AND BODY SCRUBS; FACIAL CARE PRODUCTS, NAMELY, FACE CARE LOTION, FACE CARE MOISTURIZER; COLOR COSMETICS FOR THE EYES, SKIN, LIPS AND EYEBROWS; MINERAL WATER SPRAYS, NAMELY, WATER SOLD IN ATOMIZED CONTAINERS TO BE USED FOR COSMETIC PURPOSES; WATER FOR COSMETIC USE, NAMELY, WATER SOLD IN ATOMIZED CONTAINERS TO BE USED FOR COSMETIC PURPOSES; WIPES IMPREGNATED WITH COSMETIC LOTION (U.S. CLS. 1, 4, 6, 50, 51 AND 52).

SUZANNE BLANE, EXAMINING ATTORNEY

SN 79-094,571. MERCK KGAA, FED REP GERMANY, FILED 2-5-2011.

DIABION

THE MARK CONSISTS OF STANDARD CHARACTERS WITHOUT CLAIM TO ANY PARTICULAR FONT, STYLE, SIZE, OR COLOR.

PRIORITY DATE OF 8-6-2010 IS CLAIMED. OWNER OF INTERNATIONAL REGISTRATION 1069671 DATED 2-5-2011, EXPIRES 2-5-2021.

OWNER OF U.S. REG. NO. 3,902,922. FOR CREAMS, NON-MEDICATED OINTMENTS, LOTIONS AND BODY OILS FOR COSMETIC USE (U.S. CLS. 1, 4, 6, 50, 51 AND 52).

SIMON TENG, EXAMINING ATTORNEY

CLASS 3—(Continued).

SN 85-012,028. JACQUI & DAVID, LLC, DORAL, FL. FILED 4-12-2010.



THE MARK CONSISTS OF THE LETTER "J" AND "D" IN CAPITAL CURSIVE STYLIZED FONT WITH "JACQUI & DAVID" UNDERNEATH IN CURSIVE STYLIZED FONT.

FOR BODY CREAMS; BODY BUTTER; BODY LOTIONS; BODY OILS; MASSAGE OIL; BODY POWDER; BODY SCRUB; BODY SPRAYS; BODY MISTS; BODY WASHES; FACE AND BODY CREAMS; SCENTED BODY LOTIONS AND CREAMS; SCENTED BODY SPRAY; SCENTED BODY MISTS; PERFUMED CREAMS; PERFUMED POWDER; PERFUMED SOAPS; PERFUMED TALCUM POWDER; PERFUMES; PERFUMING SACHETS; EAU DE PARFUM; MOISTURIZING CREAMS; EYE LINER; EYE MAKE-UP; EYE PENCILS; EYE SHADOWS; MASCARAS; LIP GLOSS; LIPSTICKS; LIP GLOSS PALATTE; LIP LINER; BLUSH; BATH BEADS; BATH GELS; SKIN CLEANSERS; BODY EXFOLIATING LOTION, WHIPPED HYDRATING LOTIONS FOR SKIN; FACIAL AND BODY MASKS; FOOT SCRUBS; NON-MEDICATED FOOT CREAMS; AFTERSHAVE; BLUSH; EYE SHADOW; COLOGNE; DEODORANT FOR PERSONAL USE; COSMETICS FOR HAIR, NAMELY, SHAMPOO, CONDITIONER, RELAXERS, DETANGLERS, NON-MEDICATED HAIR TREATMENTS, STYLING AND MOLDING GELS, OIL MOISTURIZERS, CHOLESTEROL HAIR CREAMS, SPRITZES, SETTING LOTIONS, HAIR POLISHERS, HAIR POMADES, HOT OIL TREATMENTS, LEAVE-IN TREATMENTS, FOAM WRAPS LOTIONS, AND BRAID SPRAYS; AND COSMETICS FOR SKIN CARE, NAMELY, ALFA-HYDROXY ACID CREAMS, BETA-HYDROXY ACID CREAMS, DEPILATORIES, RAZOR BUMP CREAM, NON-MEDICATED ACNE PREPARATIONS, STRETCH MARK CREAM, TONERS, CLEANSING CREAMS, FACIAL SCRUBS, CLARIFYING SKIN TREATMENT AND FADE CREAMS (U.S. CLS. 1, 4, 6, 50, 51 AND 52).

MICHAEL WEBSTER, EXAMINING ATTORNEY

CLASS 3—(Continued).

SN 85-015,889. AMOREPACIFIC CORPORATION, SEOUL, REPUBLIC OF KOREA, FILED 4-16-2010.

水律

PRIORITY CLAIMED UNDER SEC. 44(D) ON REPUBLIC OF KOREA APPLICATION NO. 2010-0014686, FILED 3-19-2010, REG. NO. 0866698, DATED 5-31-2011, EXPIRES 5-31-2021.

THE MARK CONSISTS OF TWO CHINESE CHARACTERS.

THE NON-LATIN CHARACTERS IN THE MARK TRANSLITERATE TO SU YUL AND THIS MEANS "WATER" AND "RULE", "LAW". THE COMBINATION OF THE TWO CHARACTERS BEARS NO MEANING, IN ENGLISH.

FOR SKIN LOTIONS; COSMETIC PREPARATIONS FOR SKIN CARE; EYE CREAMS; LIQUID FOUNDATIONS FOR COSMETIC PURPOSES; COSMETIC CREAMS; COSMETICS; HAIR SHAMPOOS; COSMETIC MILKS, NAMELY, MOISTURIZING ESSENCE IN THE NATURE OF MILKY LOTION; NON-MEDICATED SKIN CARE PREPARATIONS, NAMELY, FACIAL MIST; COSMETIC SOAPS; DENTIFRICES; ROOM FRAGRANCES (U.S. CLS. 1, 4, 6, 50, 51 AND 52).

TRICIA SONNEBORN, EXAMINING ATTORNEY

SN 85-017,715. WEBCAST MEDIA GROUP, INC., DBA BOCA COSMETICS GROUP, BOCA RATON, FL. FILED 4-19-2010.

THE MARK CONSISTS OF COMPOSED OF THE WORD "ZELO", SHOWING A STYLIZED "L" AND A HAIR STRAND CROSSING THE NAME IS/ARE CLAIMED AS A FEATURE OF THE MARK.

THE ENGLISH TRANSLATION OF "ZELO" IS "DILIGENT DEVOTION".

FOR SHAMPOOS; HAIR CONDITIONERS AND HAIR CARE PREPARATIONS, NAMELY, STRENGTHENING PREPARATIONS, NAMELY, KERATIN-DERIVED PREPARATIONS, HAIR STRAIGHTENING PREPARATIONS, BALMS, AND HAIR VOLUMIZING PREPARATIONS; HAIR COLOURING, PERMANENT WAVING AND CURLING PREPARATIONS (U.S. CLS. 1, 4, 6, 50, 51 AND 52). FIRST USE 2-1-2010; IN COMMERCE 2-1-2010.

TIMOTHY FINNEGAN, EXAMINING ATTORNEY

CLASS 3—(Continued).

SN 85-018,771. BEDROCK BRANDS, LP, DALLAS, TX. FILED 4-20-2010.

SHINOLA

THE MARK CONSISTS OF STANDARD CHARACTERS WITHOUT CLAIM TO ANY PARTICULAR FONT, STYLE, SIZE, OR COLOR.

THE NAME "SHINOLA" SHOWN IN THE MARK DOES NOT IDENTIFY A PARTICULAR LIVING INDIVIDUAL.

THE WORDING "SHINOLA" HAS NO MEANING IN A FOREIGN LANGUAGE.

FOR SHOE POLISH (U.S. CLS. 1, 4, 6, 50, 51 AND 52). CHARISMA HAMPTON, EXAMINING ATTORNEY

SN 85-042,384. UNILEVER SUPPLY CHAIN, INC., CLINTON, CT. FILED 5-19-2010.

OWNER OF U.S. REG. NOS. 2,902,403 AND 3,169,687. NO CLAIM IS MADE TO THE EXCLUSIVE RIGHT TO USE "KIDS", APART FROM THE MARK AS SHOWN.

THE COLOR(S) BLUE, WHITE AND GRAY IS/ARE CLAIMED AS A FEATURE OF THE MARK.

THE MARK CONSISTS OF A BLUE WAVE DESIGN WITH THE WORDS "SUAVE" AND "KIDS" IN WHITE LETTERS AND TWO WHITE AND GRAY WAVE DESIGNS SURROUNDING THE WORD "SUAVE". THE TERM "KIDS" IS OUTLINED IN BLUE.

FOR SOAPS; PERFUMERY; ESSENTIAL OILS; DEODORANTS AND ANTIPERSPIRANTS; NON-MEDICATED HAIR CARE PREPARATIONS; HAIR COLORANTS, HAIR DYES, HAIR LOTIONS, HAIR WAVING PREPARATIONS, HAIR SHAMPOOS, HAIR CONDITIONERS, HAIR SPRAYS, HAIR-WASHING POWDER, COSMETIC HAIR DRESSINGS, HAIR LACQUERS, HAIR MOUSSES, HAIR GLAZES, HAIR GELS, HAIR MOISTURIZING CREAMS, CONDITIONERS AND GELS; HAIR LIQUID, NAMELY, LIQUID MOISTURIZING TREATMENTS FOR HAIR; HAIR PRESERVATION TREATMENTS IN THE NATURE OF HAIR CONDITIONERS AND NON-MEDICATED HAIR SERUMS, HAIR DESICCATING TREATMENTS, NAMELY, HAIR TONIC AND HAIR CREAMS FOR USE IN REMOVING EXCESS OIL FROM THE HAIR, HAIR OILS, HAIR TONIC, HAIR CREAMS, NON-MEDICATED PREPARATIONS FOR THE BATH AND/OR SHOWER; NON-MEDICATED TOILET PREPARATIONS IN THE NATURE OF SOAP, TOILET WATER, TALCUM POWDER FOR TOILET USE; NON-MEDICATED SKIN CARE PREPARATIONS; COSMETICS (U.S. CLS. 1, 4, 6, 50, 51 AND 52).

Laurie Mayes, EXAMINING ATTORNEY

CLASS 3—(Continued).

SN 85-061,822. LANCOME PARFUMS ET BEAUTE & CIE, PARIS, FRANCE, FILED 6-14-2010.

EYE MIRACLE

THE MARK CONSISTS OF STANDARD CHARACTERS WITHOUT CLAIM TO ANY PARTICULAR FONT, STYLE, SIZE, OR COLOR.

PRIORITY CLAIMED UNDER SEC. 44(D) ON FRANCE APPLICATION NO. 093698702, FILED 12-15-2009, REG. NO. 093698702, DATED 12-15-2009, EXPIRES 12-15-2019.

NO CLAIM IS MADE TO THE EXCLUSIVE RIGHT TO USE "EYE", APART FROM THE MARK AS SHOWN.

FOR PERFUME; EAU DE TOILETTE; BATH AND SHOWER GELS AND SALTS NOT FOR MEDICAL PURPOSES; TOILET SOAPS; BODY DEODORANTS; COSMETICS, NAMELY, CREAMS, MILKS, LOTIONS, GELS AND POWDERS FOR THE FACE, BODY AND HANDS; NON-MEDICATED SUN CARE PREPARATIONS; MAKEUP PREPARATIONS; ESSENTIAL OILS FOR PERSONAL USE (U.S. CLS. 1, 4, 6, 50, 51 AND 52). FLORENTINA BLANDU, EXAMINING ATTORNEY

SN 85-065,312. BOTANI AUSTRALIA PTY LIMITED, BRUNSWICK VIC 3056, AUSTRALIA, FILED 6-17-2010.



THE MARK CONSISTS OF A LEAF AND THE WORD "BOTANI" WHICH IS PRONOUNCED VOH-TAH-NEE. THIS IS NOT A GREEK WORD BUT IS A COMBINATION OF GREEK ROMAN CHARACTERS.

THE WORDING "BOTANI" HAS NO MEANING IN A FOREIGN LANGUAGE.

FOR NON-MEDICATED TOILET PREPARATIONS; COSMETICS; NON-MEDICATED PREPARATIONS AND SUBSTANCES ALL FOR THE CARE OF THE SKIN, FACE, LIPS, BODY, HAIR AND SCALP; SKINCARE PRODUCTS, NAMELY, COSMETIC PREPARATIONS FOR THE SKIN, BODY AND BEAUTY CARE COSMETICS, FOOT SCRUBS, LIP BALM, LOTIONS FOR FACE AND BODY CARE, SKIN CREAMS, EXFOLIANT CREAMS, BODY OILS, AND HAND CREAM; NATURAL SKINCARE PRODUCTS, NAMELY, COSMETIC PREPARATIONS FOR THE SKIN, BODY AND BEAUTY CARE COSMETICS, FOOT SCRUBS, LIP BALM, LOTIONS FOR FACE AND BODY CARE, SKIN CREAMS, EXFOLIANT CREAMS, BODY OILS, AND HAND CREAM; SKINCARE PREPARATIONS; NON-MEDICATED NATURAL PREPARATIONS AND SUBSTANCES ALL FOR THE CARE OF THE SKIN, FACE, LIPS, BODY, HAIR AND SCALP; CREAMS AND LOTIONS FOR THE SKIN; NON-MEDICATED PREPARATIONS FOR TOPICAL TREATMENT OF SKIN DRYNESS, OILINESS, CHAPPING, BLEMISHES AND IRRITATIONS; NON-MEDICATED SKIN CARE AND TREATMENT PRODUCTS AND PREPARATIONS CONTAINING BOTANICAL EXTRACTS, NAMELY, SKIN CREAMS, SKIN

CLASS 3—(Continued).

LOTIONS, BODY OILS, AND LIP BALMS; SKIN CLEANSING, HYDRATING, MOISTURISING, PROTECTING, FRESHENING, SOFTENING, SOOTHING, FIRING AND TONING CREAMS, LOTIONS, GELS, BALMS, SERUMS, SCRUBS, WASHES, OILS AND MISTS; ESSENCES FOR SKIN CARE, NAMELY, PERFUMES FOR SKIN CARE AND MASSAGE OILS; SKIN EMOLLIENTS; MASSAGE PREPARATIONS, NAMELY, MASSAGE WAXES, MASSAGE OILS, CREAMS, AND MASSAGE LOTIONS; AFTER-SHAVE; DEODORANTS FOR PERSONAL USE; ANTIPERSPIRANTS FOR PERSONAL USE; SHAMPOOS AND CONDITIONERS; HAIR CARE PREPARATIONS; EXFOLIANTS FOR BODY, FACE, FEET, AND SKIN; SCRUBS; SALT SCRUBS FOR HANDS; FACIAL SCRUBS; BODY SCRUBS; FOOT SCRUBS; NON-MEDICATED BALMS FOR USE ON HAIR, SKIN, AND LIPS; HAIR BALMS; SKIN BALMS; LIP BALMS; FOOT BALMS; BODY LOTIONS; BODY WASHES; COSMETIC EYE TREATMENTS, NAMELY, EYE CREAM, EYE LOTION, AND EYE SERUM (U.S. CLS. 1, 4, 6, 50, 51 AND 52).

FIRST USE 10-20-2006; IN COMMERCE 10-20-2006. ARETHA SOMERVILLE, EXAMINING ATTORNEY

SN 85-068,930. GHC SYSTEMS INC., SASKATCHEWAN, CANADA, FILED 6-22-2010.

BASSU

THE MARK CONSISTS OF STANDARD CHARACTERS WITHOUT CLAIM TO ANY PARTICULAR FONT, STYLE, SIZE, OR COLOR.

PRIORITY CLAIMED UNDER SEC. 44(D) ON CANADA APPLICATION NO. 1,464,207, FILED 12-24-2009, REG. NO. TMA796,496, DATED 5-2-2011, EXPIRES 5-2-2026.

FOR SHAMPOO, CONDITIONER, HAIR STYLING PRODUCTS, NAMELY, PROTEIN HAIR REPAIR TONICS AND NON-MEDICATED HAIR TREATMENTS, HAIR SHINE AND GLOSS DROPS, HAIR SPRAY, HAIR SMOOTHING CREAM, HAIR STYLING GELS, PASTES, WAXES, POMADES AND CREAMS, NON-MEDICATED HAIR REPAIR TREATMENTS, MOUSSE FOR HAIR-STYLING, LOTIONS FOR HAIR, HAIR CURLING AND STRAIGHTENING CHEMICALS, HAIR RELAXERS, NON-MEDICATED FRIZZ REDUCTION TREATMENTS FOR HAIR, HAIR COLOR (U.S. CLS. 1, 4, 6, 50, 51 AND 52).

MATTHEW EINSTEIN, EXAMINING ATTORNEY

CLASS 3—(Continued).

SN 85-082,980. VENETO WHOLESALE, INC, MIAMI, FL.
FILED 7-13-2010.

VENETO FRAGRANCE

THE MARK CONSISTS OF STANDARD CHARACTERS WITHOUT CLAIM TO ANY PARTICULAR FONT, STYLE, SIZE, OR COLOR.

NO CLAIM IS MADE TO THE EXCLUSIVE RIGHT TO USE "FRAGRANCE", APART FROM THE MARK AS SHOWN.

FOR COSMETICS AND CLEANING PRODUCTS, NAMELY, PERFUMES, FLOWER PERFUMES, PERFUMES PREPARED FROM EXTRACTS OF FLOWERS AND OILS FOR PERFUMES AND SCENTS (U.S. CLS. 1, 4, 6, 50, 51 AND 52).

FIRST USE 1-1-2010; IN COMMERCE 1-1-2010.
TEJBIR SINGH, EXAMINING ATTORNEY

CLASS 3—(Continued).

SN 85-096,930. DEGIL SAFETY PRODUCTS (1989) INC.,
VAUGHAN, ONTARIO, CANADA, FILED 7-30-2010.



PRIORITY CLAIMED UNDER SEC. 44(D) ON CANADA APPLICATION NO. 1490244, FILED 7-27-2010, REG. NO. TMA797681, DATED 5-16-2011, EXPIRES 5-16-2026.

THE MARK CONSISTS OF A SUN AND CROCODILE FOR SUNSCREENS, NAMELY, LOTIONS, LIQUID SPRAYS AND SINGLE USE TOWELETTES; LIP BALMS (U.S. CLS. 1, 4, 6, 50, 51 AND 52).

FIRST USE 1-1-2005; IN COMMERCE 1-1-2005.
EMILY CARLSEN, EXAMINING ATTORNEY

SN 85-097,668. LONGEVITY FORMULAS INC., SCOTTSDALE, AZ. FILED 8-1-2010.

DermaTox

THE MARK CONSISTS OF STANDARD CHARACTERS WITHOUT CLAIM TO ANY PARTICULAR FONT, STYLE, SIZE, OR COLOR.

FOR COSMETIC PREPARATIONS FOR SKIN RENEWAL (U.S. CLS. 1, 4, 6, 50, 51 AND 52).

FIRST USE 9-1-2008; IN COMMERCE 9-1-2008.
KAELIE KUNG, EXAMINING ATTORNEY

SN 85-099,198. DUPONT TRADING LLC, HOUSTON, TX.
FILED 8-3-2010.

GMC JadeBlast

THE MARK CONSISTS OF STANDARD CHARACTERS WITHOUT CLAIM TO ANY PARTICULAR FONT, STYLE, SIZE, OR COLOR.

PRIORITY CLAIMED UNDER SEC. 44(D) ON AUSTRALIA APPLICATION NO. 1341129, FILED 1-15-2010, REG. NO. 1341129, DATED 1-15-2010, EXPIRES 1-15-2020.

FOR CLEANING, POLISHING, SCOURING AND ABRASIVE PREPARATIONS AND SUBSTANCES; INDUSTRIAL ABRASIVES FOR GRINDING, POLISHING, SANDBLASTING AND CUTTING; GARNETS AND JADE BLENDS FOR USE AS ABRASIVES; ALL OF THE FOREGOING COMPRISED IN WHOLE OR SUBSTANTIALLY IN PART OF JADE (U.S. CLS. 1, 4, 6, 50, 51 AND 52).

REBECCA GILBERT, EXAMINING ATTORNEY



THE COLOR(S) RED IS/ARE CLAIMED AS A FEATURE OF THE MARK.

THE MARK CONSISTS OF RED LETTERS CONSISTING OF A CAPITAL "R", LOWERCASE "E" WITH A CIRCUMFLEX ACCENT OVER IT, LOWERCASE "V" AND LOWERCASE "E".

THE ENGLISH TRANSLATION OF "REVE" IN THE MARK IS "DREAM".

FOR PERFUME (U.S. CLS. 1, 4, 6, 50, 51 AND 52).
FIRST USE 8-1-2008; IN COMMERCE 8-1-2008.
PAUL MORENO, EXAMINING ATTORNEY

CLASS 3—(Continued).

SN 85-100,411. AYUR CENTRE PTY LIMITED, SYDNEY, NSW, 2000., AUSTRALIA, FILED 8-4-2010.

AYURVÉ

THE MARK CONSISTS OF STANDARD CHARACTERS WITHOUT CLAIM TO ANY PARTICULAR FONT, STYLE, SIZE, OR COLOR.

FOR BODY CARE PRODUCTS AND SKIN CARE PREPARATIONS, NAMELY, BODY CREAMS, BODY OILS, BODY MILKS, BODY AND FOOT SCRUBS, ANTI-AGING CREAMS, MASSAGE CREAMS AND OILS, SKIN CREAM MASKS, NON-MEDICATED LIP BALM, SHAMPOO, HAIR CONDITIONERS, HAIR GELS, HAIR TONICS, HAIR MOUSSE, HAIR RINSE, TOOTHPASTE, MOUTHWASH, TOOTHPOWDER, SHOWER GELS, PERSONAL DEODORANTS, BREATH FRESHENERS, BODY SOAPS, FACIAL CLEANSERS, FACIAL CREAMS, FACIAL MASKS, FACIAL LOTIONS, FACIAL SERUMS, FACIAL TONERS, EYE CREAMS, EYE GEL, COSMETIC TANNING PREPARATIONS, SHAVING CREAM, SHAVING GEL, SHAVING SOAPS, COSMETICS, LIPSTICKS, LIP GLOSS, MASCARA, EYELINERS, EYE SHADOWS, CONCEALERS, MAKE-UP POWDERS, MAKE-UP FOUNDATION, ESSENTIAL OILS, AROMATIC PRODUCTS, NAMELY, PERFUME, BODY MISTS, AROMATHERAPY OILS (U.S. CLS. 1, 4, 6, 50, 51 AND 52).

LOURDES AYALA, EXAMINING ATTORNEY

SN 85-100,986. BELVEDERE INTERNATIONAL INC., MISSISSAUGA, ONTARIO, CANADA, FILED 8-5-2010.

JUST BE NATURAL

THE MARK CONSISTS OF STANDARD CHARACTERS WITHOUT CLAIM TO ANY PARTICULAR FONT, STYLE, SIZE, OR COLOR.

FOR HAIR CARE PRODUCTS, NAMELY, SHAMPOOS, CONDITIONERS, HAIR STYLING GELS, HAIRSPRAY, SPRITZING SOLUTION FOR HAIR STYLING, HAIR MOUSSE, POMADE, PUTTY, HAIR STYLING PASTE, STYLING COMPOUND IN STICK FORM, HAIR SERUM, LEAVE-IN HAIR GLOSSERS, BALMS, AND HAIR WAXES; BODY WASH; FOAM BATH; BUBBLE BATH; SKIN LOTIONS; SKIN MOISTURIZERS; BODY SCRUBS; AND LIQUID HAND AND BODY SOAP (U.S. CLS. 1, 4, 6, 50, 51 AND 52).

ELLEN BURNS, EXAMINING ATTORNEY

CLASS 3—(Continued).

SN 85-102,314. FUSION BRANDS INTERNATIONAL SRL, CHRIST CHURCH, BARBADOS, FILED 8-6-2010.

TRANSLUSCENT WATERS

THE MARK CONSISTS OF STANDARD CHARACTERS WITHOUT CLAIM TO ANY PARTICULAR FONT, STYLE, SIZE, OR COLOR.

FOR PERSONAL CARE PRODUCTS, NAMELY, FRAGRANCES, BATH AND BODY LOTIONS, BATH AND SHOWER GELS AND SKIN AND BODY CREAMS AND NON-MEDICATED SKIN CARE PREPARATIONS (U.S. CLS. 1, 4, 6, 50, 51 AND 52).

LINDA MICKLEBURGH, EXAMINING ATTORNEY

SN 85-103,177. FUSION BRANDS INTERNATIONAL SRL, CHRIST CHURCH, BARBADOS, FILED 8-9-2010.

GOTHIC AND LOLITA

THE MARK CONSISTS OF STANDARD CHARACTERS WITHOUT CLAIM TO ANY PARTICULAR FONT, STYLE, SIZE, OR COLOR.

FOR PERSONAL CARE PRODUCTS, NAMELY, COSMETICS, FRAGRANCES, BATH AND BODY LOTIONS, NON-MEDICATED SKIN CARE PREPARATIONS, AND NAIL POLISH (U.S. CLS. 1, 4, 6, 50, 51 AND 52).

LINDA MICKLEBURGH, EXAMINING ATTORNEY

SN 85-103,221. FUSION BRANDS INTERNATIONAL SRL, CHRIST CHURCH, BARBADOS, FILED 8-9-2010.

NUDITE INTENSE

THE MARK CONSISTS OF STANDARD CHARACTERS WITHOUT CLAIM TO ANY PARTICULAR FONT, STYLE, SIZE, OR COLOR.

THE ENGLISH TRANSLATION OF "NUDITE" IN THE MARK IS "NUDITY".

FOR PERSONAL CARE PRODUCTS, NAMELY, SOAPS, DEODORANTS, FRAGRANCES, BATH AND BODY LOTIONS, BATH AND SHOWER GELS AND SKIN AND BODY CREAMS AND NON-MEDICATED SKIN CARE PREPARATIONS (U.S. CLS. 1, 4, 6, 50, 51 AND 52).

LINDA MICKLEBURGH, EXAMINING ATTORNEY

CLASS 3—(Continued).

SN 85-105,161. MALONEY, TRACY, EAST HANOVER, NJ. FILED 8-11-2010.

HAPPY HOUR BY TRACY DIMARCO

THE MARK CONSISTS OF STANDARD CHARACTERS WITHOUT CLAIM TO ANY PARTICULAR FONT, STYLE, SIZE, OR COLOR.

THE NAME(S), PORTRAIT(S), AND/OR SIGNATURE(S) SHOWN IN THE MARK IDENTIFIES THE STAGE NAME OF "TRACY" MALONEY, WHOSE CONSENT(S) TO REGISTER IS MADE OF RECORD.

FOR COSMETICS; HAIR CARE PREPARATIONS (U.S. CLS. 1, 4, 6, 50, 51 AND 52).

MIDGE BUTLER, EXAMINING ATTORNEY

SN 85-116,476. DEBRIS, LLC, POMPANO BEACH, FL. FILED 8-26-2010.

debris

THE MARK CONSISTS OF STANDARD CHARACTERS WITHOUT CLAIM TO ANY PARTICULAR FONT, STYLE, SIZE, OR COLOR.

FOR COSMETIC PRODUCTS, NAMELY, EYE SHADOWS, FOUNDATIONS, EYE LINERS, MASCARA, EYEBROW COSMETICS IN THE NATURE OF POWDERS, LIP LINERS, LIPSTICK, LIP GLOSS, BLUSH POWDER, SKIN BRONZING POWDER, SKIN PRIMER, LIP PRIMER, CONCEALER, SELF-TANNING PREPARATIONS (U.S. CLS. 1, 4, 6, 50, 51 AND 52).

CARYN GLASSER, EXAMINING ATTORNEY

CLASS 3—(Continued).

SN 85-120,926. INTERNATIONAL HAIR COSMETICS LIMITED, ROMSEY, HAMPSHIRE, UNITED KINGDOM, FILED 9-1-2010.



PRIORITY CLAIMED UNDER SEC. 44(D) ON ERPN CMNTY TM OFC APPLICATION NO. 009249764, FILED 7-15-2010, REG. NO. 009249764, DATED 12-27-2010, EXPIRES 7-15-2020.

OWNER OF U.S. REG. NO. 3,769,708.

NO CLAIM IS MADE TO THE EXCLUSIVE RIGHT TO USE "ADVANCED HAIR THERAPY", APART FROM THE MARK AS SHOWN.

THE COLOR(S) BLACK, WHITE, AND PURPLE (PANTONE 7504) IS/ARE CLAIMED AS A FEATURE OF THE MARK.

THE MARK CONSISTS OF A FLOWER DESIGN IN PURPLE (PANTONE 7504) IN VARYING STRENGTHS ABOVE THE TERM "KITOKO" IN BLACK AND THE TERMS "ADVANCED HAIR THERAPY" IN PURPLE (PANTONE 7504). THE BACKGROUND IS IN WHITE.

THE ENGLISH TRANSLATION OF "KITOKO" IN THE MARK IS "BEAUTIFUL".

FOR NON-MEDICATED TOILET PREPARATIONS, NAMELY, HAIR COLOUR REMOVER; PREPARATIONS FOR THE CARE AND TREATMENT OF THE HAIR AND/OR SCALP, NAMELY, HAIR AND SCALP LOTIONS AND CREAMS; HAIR COSMETICS, NAMELY, HAIR DYE AND HAIR BLEACH; HAIR COLOURANTS; SHAMPOOS; CONDITIONERS; STYLING GELS, HAIR SPRAYS AND MOUSSES; ESSENTIAL OILS (U.S. CLS. 1, 4, 6, 50, 51 AND 52).

JAMES STEIN, EXAMINING ATTORNEY

SN 85-123,988. LONSTEIN, SHOSHANNA, NEW YORK, NY. FILED 9-7-2010.

SHOSHANNA

THE MARK CONSISTS OF STANDARD CHARACTERS WITHOUT CLAIM TO ANY PARTICULAR FONT, STYLE, SIZE, OR COLOR.

OWNER OF U.S. REG. NO. 2,256,096.

FOR COSMETICS; FACIAL MAKEUP, CONCEALERS, BLUSHERS, FACIAL POWDERS, FOUNDATION MAKEUP, EYE MAKEUP, EYE PENCILS, EYEBROW PENCILS, MASCARA, FALSE EYELASHES, FACE AND BODY GLITTER, COSMETIC COMPACTS, COSMETIC PENCILS, LIPSTICK, LIPSTICK CASES, LIPSTICK HOLDERS, LIP GLOSS, LIP POMADES, LIP PENCILS, MAKEUP REMOVERS, MAKEUP APPLICATORS IN THE NATURE OF COTTON SWABS FOR COSMETIC PURPOSES, EYE CREAMS, FACIAL CLEANSERS, TONERS, FACIAL EXFOLIANTS AND SCRUBS, FACIAL CREAMS, FACIAL MOISTURIZERS, FACIAL LOTIONS AND NON-MEDICATED FACIAL TREATMENTS IN THE NATURE OF FACIAL EMULSIONS, WRINKLE REMOVING SKIN CARE PREPARATIONS, NAIL

CLASS 3—(Continued).

POLISHES, NAIL POLISH BASE COAT, NAIL POLISH TOP COAT, NAIL STRENGTHENERS, NAIL HARDENERS, NAIL POLISH REMOVERS, NAIL CREAMS, CUTICLE REMOVING PREPARATIONS, NAIL TIPS, AND NAIL BUFFING PREPARATIONS; BEAUTY MILKS, SKIN MOISTURIZERS AND SKIN MOISTURIZER MASKS, SKIN CONDITIONERS, HAND CREAMS, MASSAGE OILS, ESSENTIAL OILS FOR PERSONAL USE, TALCUM POWDER, PERFUMED POWDERS, BATH BEADS, BATH CRYSTALS, BATH FOAM, BATH GELS, BATH OILS, BATH POWDERS, BATH SALTS, FACE WASH, SKIN CLEANSERS, SKIN HIGHLIGHTER, BODY SCRUBS, BODY FRAGRANCES, FRAGRANCES FOR PERSONAL USE, BODY AND HAND LOTIONS, BODY GELS, SHOWER GELS, BODY OILS, BODY POWDERS, BODY EXFOLIANTS, BODY MASKS, BODY MASK CREAMS AND LOTIONS, SHAVING PREPARATIONS, AFTER SHAVE LOTIONS, SHAVING BALM, SHAVING CREAM, SHAVING GEL, SKIN ABRASIVE PREPARATIONS, NON-MEDICATED SKIN CREAMS AND SKIN LOTIONS FOR RELIEVING RAZOR BURNS, NON-MEDICATED LIP CARE PREPARATIONS, LIP CREAM, SUNSCREEN PREPARATIONS, SUNTANNING PREPARATIONS AND AFTER-SUN LOTIONS; COSMETIC SUN-PROTECTING PREPARATIONS; SUN TAN OILS; SELF-TANNING PREPARATIONS, NAMELY, SELF TANNING MILK AND CREAM, ACCELERATED TANNING CREAM, SELF-TANNING LOTIONS, GELS AND SPRAYS; NON-MEDICATED OINTMENTS FOR THE TREATMENT OF SUNBURNS; NON-MEDICATED TOILETRIES; PERFUME, PERFUME OILS, COLOGNE, EAU DE TOILETTE, EAU DE PERFUME, EAU DE COLOGNE AND TOILETTE WATER; TOOTHPASTE, DEODORANT AND ANTIPERSPIRANT; COSMETIC SOAPS, PERFUMED SOAPS, LIQUID SOAPS, HAND, FACIAL AND BATH SOAPS, DEODORANT SOAPS, SHAVING SOAPS, SOAP POWDER, TOILET SOAPS, SOAPS FOR BODY CARE, AND SOAPS FOR PERSONAL USE; COSMETIC PADS, PRE-MOISTENED COSMETIC WIPES, PRE-MOISTENED COSMETIC TISSUES AND TOWELETTES; COTTON STICKS FOR COSMETIC PURPOSES; ALL PURPOSE COTTON SWABS FOR PERSONAL USE AND COSMETIC PURPOSES; NON-MEDICATED TOPICAL SKIN CREAMS, GELS, TONERS, AND LOTIONS; TOPICAL SKIN SPRAYS FOR COSMETIC PURPOSES; AROMATHERAPY CREAMS, LOTIONS AND OILS; HAIR CARE PRODUCTS, NAMELY, SHAMPOOS, CONDITIONERS, MOUSSE, GELS, FROSTS, CREAMS, RINSES, SPRAYS, HAIR COLOR, HAIR WAVING LOTION, PERMANENT WAVE PREPARATIONS, HAIR LIGHTENERS, HAIR DYES, HAIR EMOLLIENTS, HAIR MASCARA, HAIR POMADES, HAIR COLOR REMOVERS, HAIR RELAXING PREPARATIONS, HAIR STYLING PREPARATIONS, HAIR REMOVING CREAM, AND HAIR CARE PREPARATIONS; ASTRINGENTS FOR COSMETIC PURPOSES; BABY WIPES; DISPOSABLE WIPES IMPREGNATED WITH CHEMICALS OR COMPOUNDS FOR PERSONAL HYGIENE AND HOUSEHOLD USE; INCENSE; ROOM FRAGRANCES; FRAGRANCE EMITTING WICKS FOR ROOM FRAGRANCES; SACHETS; SACHET-LIKE EYE PILLOWS CONTAINING FRAGRANCES; SCENTED CERAMIC STONES; SCENTED LINEN SPRAYS AND SCENTED ROOM SPRAYS; SCENTED OILS USED TO PRODUCE AROMAS WHEN HEATED; SCENTED PINE CONES; POTPOURRI; AROMATHERAPY PILLOWS COMPRISING POTPOURRI IN FABRIC CONTAINERS (U.S. CLS. 1, 4, 6, 50, 51 AND 52).

KELLY BOULTON, EXAMINING ATTORNEY

CLASS 3—(Continued).

SN 85-138,795. JAMES THOMAS, HOUSTON, TX. FILED 9-27-2010.

Thomas Hair Internal System

THE MARK CONSISTS OF STANDARD CHARACTERS WITHOUT CLAIM TO ANY PARTICULAR FONT, STYLE, SIZE, OR COLOR.

NO CLAIM IS MADE TO THE EXCLUSIVE RIGHT TO USE "HAIR AND SYSTEM", APART FROM THE MARK AS SHOWN.

FOR HAIR SHAMPOO, CONDITIONER AND HAIR TREATMENT PRODUCTS, NAMELY, HAIR CARE CREAMS AND HAIR CARE LOTIONS (U.S. CLS. 1, 4, 6, 50, 51 AND 52).

FIRST USE 1-1-2008; IN COMMERCE 1-1-2008.

MARK T. MULLEN, EXAMINING ATTORNEY

SN 85-143,768. RON ROBINSON, INC., LOS ANGELES, CA. FILED 10-2-2010.

APOTHIA BY RON ROBINSON

THE MARK CONSISTS OF STANDARD CHARACTERS WITHOUT CLAIM TO ANY PARTICULAR FONT, STYLE, SIZE, OR COLOR.

THE NAME(S), PORTRAIT(S), AND/OR SIGNATURE(S) SHOWN IN THE MARK IDENTIFIES "RON ROBINSON", A LIVING PERSON, WHOSE CONSENT(S) TO REGISTER IS MADE OF RECORD.

FOR BATH GELS; BEAUTY CREAMS; BEAUTY GELS; BEAUTY SOAP; BODY CREAMS; BODY LOTION; COSMETICS IN GENERAL, INCLUDING PERFUMES; EAU DE PERFUME; HAIR GEL; LOTIONS FOR COSMETIC PURPOSES; PERFUME; SKIN AND BODY TOPICAL LOTIONS, CREAMS AND OILS FOR COSMETIC USE; SKIN MOISTURIZING GEL (U.S. CLS. 1, 4, 6, 50, 51 AND 52).

FIRST USE 12-14-1996; IN COMMERCE 12-14-1996.

DAVID I, EXAMINING ATTORNEY

CLASS 3—(Continued).

SN 85-143,778. PURARIZE, WATERFORD WORKS, NJ. FILED 10-2-2010.



THE COLOR(S) PURPLE AND GRAY IS/ARE CLAIMED AS A FEATURE OF THE MARK.

THE MARK CONSISTS OF THREE GRAY WATERWAVES WITH TWO GRAY WATER DROPS BETWEEN THE FIRST AND SECOND WATERWAVE ABOVE THE PURPLE "PURARIZE" WORD. "PURARIZE" IS IN BERKELEY ITALIC FONT.

FOR 3-IN-1 HAIR CONDITIONERS; 3-IN-1 HAIR SHAMPOOS; 3-IN-1 ORGANIC SOAP BARS FOR USE AS SOAP; SHAMPOO AND CONDITIONER; AFTER SHAVE LOTIONS; AFTER-SHAVE LOTIONS; AFTER-SUN LOTIONS; ALMOND SOAPS; ANTI-BACTERIAL SOAP; ANTIBACTERIAL SKIN SOAPS; ANTIBACTERIAL SOAP; AROMATIC BODY CARE PRODUCTS, NAMELY, BODY LOTION, SHOWER GEL, SHAMPOO, CONDITIONER, NON-MEDICATED LIP BALM, SOAP, BODY POLISH, BODY AND FOOT SCRUB AND NON-MEDICATED FOOT CREAM; AROMATIC PREPARATIONS, NAMELY, SKIN LOTION AND BODY SPRAY; BABY BUBBLE BATH; BABY HAIR CONDITIONER; BABY HAND SOAP; BABY LOTION; BAR SOAP; BATH AND SHOWER GELS AND SALTS NOT FOR MEDICAL PURPOSES; BATH BEADS; BATH CREAM; BATH CRYSTALS; BATH FIZZIES; BATH FLAKES; BATH FOAM; BATH FOAMS; BATH GEL; BATH GELS; BATH HERBS; BATH LOTION; BATH MILKS; BATH OIL; BATH OILS; BATH OILS AND BATH SALTS; BATH OILS FOR COSMETIC PURPOSES; BATH PEARLS; BATH POWDER; BATH SALTS; BATH SALTS; BATH SOAPS; BATH SOAPS IN LIQUID, SOLID OR GEL FORM; BATHING LOTIONS; BEAUTY CREAMS FOR BODY CARE; BEAUTY LOTIONS; BEAUTY SOAP; BODY AND BEAUTY CARE COSMETICS; BODY BUTTER; BODY CREAM; BODY CREAM SOAP; BODY CREAMS; BODY DEODORANTS; BODY EMULSIONS; BODY GLITTER; BODY LOTION; BODY LOTIONS; BODY MASK CREAM; BODY MASK LOTION; BODY MASKS; BODY MILK; BODY MILKS; BODY OIL; BODY OILS; BODY POWDER; BODY SCRUB; BODY SPLASH; BODY SPRAY USED AS A PERSONAL DEODORANT AND AS FRAGRANCE; BODY SPRAYS; BODY SPRAYS, NAMELY, WATER IN ATOMIZED CONTAINERS USED TO PRODUCE A COOLING EFFECT; BODY WASH; BUBBLE BATH; CAKES OF TOILET SOAP; CLOTHS OR TISSUES IMPREGNATED WITH A SKIN CLEANSER; COLOGNES, PERFUMES AND COSMETICS; CONCEALERS FOR SKIN, HAIR, BODY; CONDITIONERS; COSMETIC BATH SALTS; COSMETIC CREAMS FOR SKIN CARE; COSMETIC HAIR DRESSING PREPARATIONS; COSMETIC OLIVE OIL FOR THE FACE AND BODY; COSMETIC PREPARATIONS FOR BODY CARE; COSMETIC PREPARATIONS FOR PROTECTING THE SKIN FROM THE SUN'S RAYS; COSMETIC PREPARATIONS FOR SKIN CARE; COSMETIC PREPARATIONS FOR THE HAIR AND SCALP; COSMETIC PREPARATIONS, NAMELY, COSMETIC PREPARATIONS, NAMELY, SKIN BALMS; COSMETIC PRODUCTS IN THE FORM OF AEROSOLS FOR SKIN CARE; COSMETIC SKIN FRESHENERS; COSMETIC SOAPS; COSMETIC SUN MILK LOTIONS; COSMETIC SUNTAN LOTIONS; COSMETICS IN GENERAL, INCLUDING PERFUMES; COSMETICS IN THE FORM OF MILKS, LOTIONS AND EMULSIONS; CREAM SOAPS; DEODORANT SOAP; DEODORANTS FOR BODY CARE; DETERGENT SOAP; DISINFECTANT SOAPS; DISINFECTING PERFUMED SOAPS; EAU DE PERFUME; ESSENTIAL OILS AS PERFUME FOR LAUNDRY PURPOSES; EXFOLIANTS FOR SKIN, HAIR, BODY; EYE LOTIONS; FACE AND BODY BEAUTY CREAMS; FACE AND BODY CREAMS; FACE AND BODY GLITTER; FACE AND BODY LOTIONS; FACE AND BODY MILK; FACE MILK AND LOTIONS; FACIAL LOTION; FOAM BATH; FRAGRANCED BODY CARE PREPARATIONS, NAMELY, BODY SCRUBS AND SHOWER GELS; FRAGRANCED SKIN CARE

CLASS 3—(Continued).

PREPARATIONS, NAMELY, SKIN CLEANERS AND SKIN MOISTURIZERS; GEL FOR HAIR SCULPTING; GIFT BASKETS CONTAINING NON-MEDICATED BATH PREPARATIONS AND COSMETIC PREPARATIONS; GRANULATED SOAPS; HAIR BALSAM; HAIR CARE CREAMS; HAIR CARE KITS COMPRISING NON-MEDICATED HAIR CARE PREPARATIONS, NAMELY, HAIR SPRAY, SKIN CREAM, BODY LOTION; HAIR CARE LOTIONS; HAIR CARE PREPARATIONS; HAIR CARE PREPARATIONS CONSISTING OF ORGANIC COCONUT VIRGIN OIL AND COCONUT VIRGIN OIL; HAIR CARE PRODUCTS, NAMELY, HEAT PROTECTION SPRAYS; HAIR CLEANING PREPARATIONS; HAIR COLOR; HAIR COLORING; HAIR CONDITIONER; HAIR CONDITIONERS; HAIR CONDITIONERS FOR BABIES; HAIR CREAMS; HAIR CURLING PREPARATIONS; HAIR DRESSINGS FOR MEN; HAIR DRESSINGS FOR WOMEN; HAIR EMOLLIENTS; HAIR FIXERS; HAIR GEL; HAIR GEL AND HAIR MOUSSE; HAIR GELS; HAIR LOTION; HAIR LOTIONS; HAIR MASKS; HAIR MOUSSE; HAIR MOUSSES; HAIR NOURISHERS; HAIR OILS; HAIR POMADES; HAIR PRODUCTS, NAMELY, THICKENING CONTROL CREAMS; HAIR RINSES; HAIR RINSES; HAIR SHAMPOO; HAIR SHAMPOOS AND CONDITIONERS; HAIR SHEEN SPRAY; HAIR SPRAY; HAIR SPRAYS; HAIR SPRAYS AND HAIR GELS; HAIR STYLING GEL; HAIR STYLING PREPARATIONS; HAIR STYLING SPRAY; HAIR TONIC; HAIR TONICS; HAIR-WASHING POWDER; HAND LOTIONS; HAND SOAPS; HANDMADE SOAP BARS; LAUNDRY SOAP; LIQUID BATH SOAPS; LIQUID PERFUMES; LIQUID SOAP; LIQUID SOAP USED IN FOOT BATH; LIQUID SOAPS; LIQUID SOAPS FOR HANDS AND FACE; LIQUID SOAPS FOR HANDS, FACE AND BODY; LOOFAH SOAPS; LOTIONS FOR BEARDS; LOTIONS FOR CELLULITE REDUCTION; LOTIONS FOR COSMETIC PURPOSES; LOTIONS FOR FACE AND BODY CARE; LOTIONS FOR STRENGTHENING THE NAILS; LOTIONS FOR SKIN, HAIR, BODY; MAKE-UP FOR THE FACE AND BODY; MAKE-UP PREPARATIONS FOR THE FACE AND BODY; MAKE-UP REMOVING LOTIONS; MAKE-UP REMOVING MILK, GEL, LOTIONS AND CREAMS; MASSAGE LOTIONS; MEDICATED SOAP; MEDICATED SOAPS; MINERAL SALT IN THE NATURE OF BATH SALTS NOT FOR MEDICAL PURPOSES; MOISTURIZING PREPARATIONS FOR THE SKIN; MOISTURIZING SOLUTIONS FOR THE SKIN; MOUSSE FOR SKIN, HAIR, BODY; NATURAL COCOA BUTTER BASED PERSONAL CARE PRODUCTS, NAMELY, BODY LOTION, SHOWER GEL, SOAP, BODY POLISH, BODY AND FOOT SCRUB AND NON-MEDICATED SKIN CREAMS; NATURAL SOAP BARS; NATURALLY HANDMADE SOAP BARS; NON-MEDICATED BALMS FOR USE ON HAIR, SKIN, BODY; NON-MEDICATED BATH PREPARATIONS; NON-MEDICATED BATH SALTS; NON-MEDICATED BODY SOAKS; NON-MEDICATED BUBBLE BATH PREPARATIONS; NON-MEDICATED CLEANSERS FOR PERSONAL USE, NAMELY, SKIN CLEANERS, FACIAL CLEANSERS; NON-MEDICATED CLEANSERS, NAMELY, SKIN CLEANSERS AND FACIAL CLEANSERS; NON-MEDICATED COSMETIC SKIN CARE PREPARATIONS CONSISTING OF ORGANIC COCONUT VIRGIN OIL AND COCONUT VIRGIN OIL; NON-MEDICATED DIAPER RASH OINTMENTS AND LOTIONS; NON-MEDICATED FOOT LOTIONS; NON-MEDICATED HAIR RESTORATION LOTIONS; NON-MEDICATED HAIR SERUMS; NON-MEDICATED HAIR TREATMENT PREPARATIONS FOR COSMETIC PURPOSES; NON-MEDICATED HERBAL BODY CARE PRODUCTS, NAMELY, BODY OILS, SALVES, AND LIP BALMS; NON-MEDICATED PREPARATIONS ALL FOR THE CARE OF SKIN, HAIR AND SCALP; NON-MEDICATED SERUMS FOR USE ON BODY, SKIN, HAIR; NON-MEDICATED SKIN CARE CREAMS AND LOTIONS; NON-MEDICATED SKIN CARE PREPARATION, NAMELY, BODY MIST; NON-MEDICATED SKIN CARE PREPARATIONS; NON-MEDICATED SKIN CARE PREPARATIONS, NAMELY, CREAMS, LOTIONS, GELS, TONERS, CLEANERS AND PEELS; NON-MEDICATED SKIN CREAM FOR GENERAL SKIN RASH AND IRRITATION RESULTING FROM SKIN SHINGLES; NON-MEDICATED SKIN CREAMS; NON-MEDICATED STIMULATING LOTIONS FOR THE SKIN; OIL BATHS FOR HAIR CARE; OILS FOR HAIR CONDITIONING; OILS FOR PERFUMES AND SCENTS; ORGANIC SOAP BARS; PATCHES CONTAINING SUN SCREEN AND SUN

CLASS 3—(Continued).

BLOCK FOR USE ON THE SKIN; PERFUME; PERFUME OILS; PERFUME OILS FOR THE MANUFACTURE OF COSMETIC PREPARATIONS; PERFUMED CREAMS; PERFUMED EXTRACTS FOR TISSUES AND PERFUMES; PERFUMED SOAP; PERFUMED SOAPS; PERFUMED TALCUM POWDER; PERFUMES; PERFUMES AND COLOGNES; PERFUMES AND TOILET WATERS; PERFUMES FOR INDUSTRIAL PURPOSES; PERFUMES IN SOLID FORM; PERFUMES, AFTERSHAVES AND COLOGNES; PERFUMES, EAU DE COLOGNES AND AFTERSHAVES; PERFUMES, EAUX DE COLOGNE AND AFTERSHAVES; PERFUMING SACHETS; PET CARE KITS COMPRISING SHAMPOO, CONDITIONER, BODY SPRAY; POMADES FOR BODY, SKIN, HAIR; PREPARATIONS FOR SETTING HAIR; SACHETS FOR PERFUMING LINEN; SCENTED BODY LOTIONS AND CREAMS; SCENTED BODY SPRAY; SEAWATER-BASED SKIN CARE PREPARATIONS FOR SKIN RENEWAL; SHAVING LOTION; SHAVING LOTIONS; SHAVING SOAP; SHAVING SOAPS; SHOWER AND BATH FOAM; SHOWER AND BATH GEL; SKIN ABRASIVE PREPARATIONS; SKIN AND BODY TOPICAL LOTIONS, CREAMS AND OILS FOR COSMETIC USE; SKIN BRONZER; SKIN BRONZING CREAMS; SKIN CARE PREPARATION, NAMELY, BODY POLISH; SKIN CARE PREPARATIONS, NAMELY, BODY BALM; SKIN CARE PREPARATIONS, NAMELY, FRUIT ACID PEELS FOR SKIN; SKIN CARE PREPARATIONS, NAMELY, SKIN PEELS; SKIN CARE PRODUCTS, NAMELY, NON-MEDICATED SKIN SERUM; SKIN CLARIFIERS; SKIN CLEANSERS; SKIN CLEANSING CREAM; SKIN CLEANSING LOTION; SKIN CONDITIONERS; SKIN CONDITIONING CREAMS FOR COSMETIC PURPOSES; SKIN CREAM; SKIN CREAMS; SKIN CREAMS IN LIQUID AND IN SOLID FORM; SKIN CREAMS IN LIQUID AND SOLID; SKIN CREAMS IN LIQUID AND SOLID FORM; SKIN EMOLLIENTS; SKIN FRESHENERS; SKIN LIGHTENERS; SKIN LIGHTENING CREAMS; SKIN LOTION; SKIN LOTIONS; SKIN MASKS; SKIN MOISTURIZER; SKIN MOISTURIZER MASKS; SKIN MOISTURIZING GEL; SKIN POLISHING RICE BRAN (ARAI-NUKA); SKIN SOAP; SKIN TEXTURIZERS; SKIN TONERS; SKIN WHITENING CREAMS; SKIN WHITENING PREPARATIONS; SOAP IN THE FORM OF BATH TOYS; SOAP POWDER; SOAPS; SOAPS AND DETERGENTS; SOAPS FOR BODY CARE; SOAPS FOR HOUSEHOLD USE; SOAPS FOR PERSONAL USE; SOAPS FOR TOILET PURPOSES; STYLING CLAY FOR HAIR; STYLING FOAM FOR HAIR; STYLING LOTIONS; STYLING PASTE FOR HAIR; SUN CARE LOTIONS; SUN TAN LOTION; SUN-BLOCK LOTIONS; SUN-TANNING OILS AND LOTIONS; TISSUES IMPREGNATED WITH COSMETIC LOTIONS; TOILET SOAP; TOILET SOAPS; TONING LOTION, FOR THE FACE, BODY AND HANDS; TOPICAL SKIN SPRAYS FOR COSMETIC PURPOSES; WATERLESS SOAP; WIPES IMPREGNATED WITH A SKIN CLEANSER; WRINKLE REMOVING SKIN CARE PREPARATIONS (U.S. CLS. 1, 4, 6, 50, 51 AND 52).

EDWARD FENNESSY, EXAMINING ATTORNEY

CLASS 3—(Continued).

SN 85-149,062. PARAS PHARMACEUTICALS LIMITED, AHMEDABAD, INDIA, FILED 10-9-2010.



THE MARK CONSISTS OF THE STYLIZED WORDS "SET WET" WITH THE WORD "STYLE" BELOW.

FOR PERFUME-BASED PREPARATION, NAMELY, DEODORANTS FOR PERSONAL USE AND PERFUMED POWDERS (U.S. CLS. 1, 4, 6, 50, 51 AND 52).
APRIL HESIK, EXAMINING ATTORNEY

SN 85-152,236. SHAPIRO, GERRY M, EUGENE, OR. FILED 10-14-2010.

Hemp Balm

THE MARK CONSISTS OF STANDARD CHARACTERS WITHOUT CLAIM TO ANY PARTICULAR FONT, STYLE, SIZE, OR COLOR.

OWNER OF U.S. REG. NO. 2,993,518.
NO CLAIM IS MADE TO THE EXCLUSIVE RIGHT TO USE "BALM", APART FROM THE MARK AS SHOWN.
SEC. 2(F).

FOR LIP BALM CONTAINING HEMP SEED OIL (U.S. CLS. 1, 4, 6, 50, 51 AND 52).

FIRST USE 8-1-1994; IN COMMERCE 10-1-1994.
RICHARD WHITE, EXAMINING ATTORNEY

CLASS 3—(Continued).

SN 85-163,523. NAMASTE LABORATORIES, L.L.C., BLUE ISLAND, IL. FILED 10-28-2010.



NO CLAIM IS MADE TO THE EXCLUSIVE RIGHT TO USE "CARROT OIL", APART FROM THE MARK AS SHOWN.

THE COLOR(S) ORANGE AND GOLD IS/ARE CLAIMED AS A FEATURE OF THE MARK.

THE MARK CONSISTS OF THE STYLIZED WORDING "CARROT OIL" IN ORANGE LETTERING APPEARING OVER THE DESIGN OF A BUNCH OF SEVEN CARROTS IN THE COLOR ORANGE INSIDE OF A RECTANGLE BORDER IN THE COLOR GOLD.

FOR HAIR CREME (U.S. CLS. 1, 4, 6, 50, 51 AND 52).
AMY C. KEAN, EXAMINING ATTORNEY

SN 85-180,823. KITTY LIKES TO SCRATCH PRODUCTIONS, INC., LOS ANGELES, CA. FILED 11-19-2010.

LOVE OF YOUR LIFE

THE MARK CONSISTS OF STANDARD CHARACTERS WITHOUT CLAIM TO ANY PARTICULAR FONT, STYLE, SIZE, OR COLOR.

FOR COSMETICS, NAMELY, FRAGRANCES, PERFUMES, AND NON-MEDICATED FACE CARE PREPARATIONS (U.S. CLS. 1, 4, 6, 50, 51 AND 52).

BRIDGETT SMITH, EXAMINING ATTORNEY

SN 85-188,596. KATE SOMERVILLE SKIN CARE LLC, WEST HOLLYWOOD, CA. FILED 12-1-2010.

ILLUMIKATE

THE MARK CONSISTS OF STANDARD CHARACTERS WITHOUT CLAIM TO ANY PARTICULAR FONT, STYLE, SIZE, OR COLOR.

FOR FACIAL MOISTURIZERS; BODY LOTIONS; COSMETIC CREAMS; NON-MEDICATED SKINCARE PREPARATIONS (U.S. CLS. 1, 4, 6, 50, 51 AND 52).

GISELLE AGOSTO, EXAMINING ATTORNEY

CLASS 3—(Continued).

SN 85-194,782. AKG INNOVATIONS LLC, BEVERLY HILLS, CA. FILED 12-10-2010.

NU - LIP - KA

THE MARK CONSISTS OF STANDARD CHARACTERS WITHOUT CLAIM TO ANY PARTICULAR FONT, STYLE, SIZE, OR COLOR.

FOR ORAL CARE PRODUCTS, NAMELY LIP GLOSS, LIP BALM, COSMETIC PREPARATION USED TO MAKE LIPS APPEAR FULLER; TOOTHPASTE; MOUTHWASH; BREATH FRESHENERS, NAMELY DISSOLVABLE BREATH STRIPS, BREATH MINTS, CANDY AND GUM; COSMETIC TOOTH WHITENING PREPARATIONS; COSMETIC TOOTH STAIN REMOVING PREPARATIONS (U.S. CLS. 1, 4, 6, 50, 51 AND 52).

AISHA CLARKE, EXAMINING ATTORNEY

SN 85-194,786. AKG INNOVATIONS LLC, BEVERLY HILLS, CA. FILED 12-10-2010.

SMILE YOUNG

THE MARK CONSISTS OF STANDARD CHARACTERS WITHOUT CLAIM TO ANY PARTICULAR FONT, STYLE, SIZE, OR COLOR.

FOR ORAL CARE PRODUCTS, NAMELY LIP GLOSS, LIP BALM, COSMETIC PREPARATION USED TO MAKE LIPS APPEAR FULLER; TOOTHPASTE; MOUTHWASH; BREATH FRESHENERS, NAMELY DISSOLVABLE BREATH STRIPS, BREATH MINTS, CANDY AND GUM; COSMETIC TOOTH WHITENING PREPARATIONS; COSMETIC TOOTH STAIN REMOVING PREPARATIONS (U.S. CLS. 1, 4, 6, 50, 51 AND 52).

AISHA CLARKE, EXAMINING ATTORNEY

SN 85-194,868. ORLY INTERNATIONAL, INC., VAN NUYS, CA. FILED 12-10-2010.

**FASHION IS SEASONAL STYLE
IS FOREVER**

THE MARK CONSISTS OF STANDARD CHARACTERS WITHOUT CLAIM TO ANY PARTICULAR FONT, STYLE, SIZE, OR COLOR.

FOR COSMETICS, NAIL CARE PREPARATIONS, NON-MEDICATED SKIN CARE PREPARATIONS (U.S. CLS. 1, 4, 6, 50, 51 AND 52).

BRIAN CALLAGHAN, EXAMINING ATTORNEY

CLASS 3—(Continued).

SN 85-196,919. AIM STAR NETWORK CO., LTD., WATTANA BANGKOK 10110, THAILAND, FILED 12-13-2010.



The logo for BodySOFT features the word "BodySOFT" in a dark grey, sans-serif font. The letter "O" in "SOFT" is replaced by a lime green circle with a white outline, and the letter "S" is also in a lime green color.

THE COLOR(S) DARK GREY AND LIME GREEN IS/ARE CLAIMED AS A FEATURE OF THE MARK.

THE MARK CONSISTS OF THE WORDS "BODYSOFT" IN DARK GREY WITH THE SECOND "O" HAVING A SQUARED-OFF UPPER RIGHT CORNER AND A SMALLER LIME GREEN CIRCLE INSIDE. THE COLOR WHITE REPRESENTS TRANSPARENT AREAS AND IS NOT PART OF THE MARK.

FOR PERSONAL SKIN CARE PRODUCTS, NAMELY, CREAMS AND LOTIONS; BODY CARE AND CLEANSING PRODUCTS, NAMELY, BODY CARE COSMETICS, SOAPS FOR BODY CARE, SHOWER GEL, BODY POWDER, DEODORANT, SHAMPOO, CONDITIONER, AND NON-MEDICATED HAIR SERUM (U.S. CLS. 1, 4, 6, 50, 51 AND 52).

AISHA SALEM, EXAMINING ATTORNEY

SN 85-210,354. BONA AB, SE-200 21 MALMÖ, SWEDEN, FILED 1-4-2011.

BONA DEEP CLEAN SOLUTION

THE MARK CONSISTS OF STANDARD CHARACTERS WITHOUT CLAIM TO ANY PARTICULAR FONT, STYLE, SIZE, OR COLOR.

OWNER OF U.S. REG. NOS. 1,640,991, 3,457,098 AND OTHERS.

NO CLAIM IS MADE TO THE EXCLUSIVE RIGHT TO USE "DEEP CLEAN SOLUTION", APART FROM THE MARK AS SHOWN.

FOR WOOD FLOOR CLEANERS (U.S. CLS. 1, 4, 6, 50, 51 AND 52).

JULIE WATSON, EXAMINING ATTORNEY

CLASS 3—(Continued).

SN 85-215,454. WILKINSON, CHRIS, SANTA BARBARA, CA, FILED 1-11-2011.



The logo for AVASOL consists of the word "AVASOL" in a bold, black, serif font.

THE MARK CONSISTS OF STANDARD CHARACTERS WITHOUT CLAIM TO ANY PARTICULAR FONT, STYLE, SIZE, OR COLOR.

THE WORDING "AVASOL" HAS NO MEANING IN A FOREIGN LANGUAGE.

FOR AFTER-SUN MILKS; AROMATIC BODY CARE PRODUCTS, NAMELY, BODY LOTION, SHOWER GEL, CUTICLE CREAM, SHAMPOO, CONDITIONER, NON-MEDICATED LIP BALM, SOAP, BODY POLISH, BODY AND FOOT SCRUB AND NON-MEDICATED FOOT CREAM; ASTRINGENTS FOR COSMETIC PURPOSES; BAR SOAP; BATH SOAPS; BEAUTY SOAP; BODY AND BEAUTY CARE COSMETICS; BODY CREAM SOAP; CLEANSING CREAMS; COSMETIC CREAMS; COSMETIC CREAMS FOR SKIN CARE; COSMETIC HAND CREAMS; COSMETIC PREPARATIONS AGAINST SUNBURN; COSMETIC PREPARATIONS FOR BODY CARE; COSMETIC PREPARATIONS FOR PROTECTING THE SKIN FROM THE SUN'S RAYS; COSMETIC PREPARATIONS FOR SKIN RENEWAL; COSMETIC SOAPS; COSMETIC SUN MILK LOTIONS; COSMETIC SUN-PROTECTING PREPARATIONS; COSMETIC SUN-TANNING PREPARATIONS; COSMETIC SUNSCREEN PREPARATIONS; COSMETIC SUNTAN PREPARATIONS; COSMETICS; COSMETICS AND COSMETIC PREPARATIONS; CREAM SOAPS; HAND CLEANERS; HAND CLEANING GELS; HAND CLEANING PREPARATIONS; HAND CREAM; HAND CREAMS; HAND LOTIONS; HAND SOAPS; LIQUID BATH SOAPS; LIQUID SOAP; LIQUID SOAPS; LIQUID SOAPS FOR HANDS AND FACE; LIQUID SOAPS FOR HANDS, FACE AND BODY; LOTIONS FOR COSMETIC PURPOSES; MEDICATED SOAP; NATURAL COCOA BUTTER BASED PERSONAL CARE PRODUCTS, NAMELY, BODY LOTION, SHOWER GEL, SOAP, BODY POLISH, BODY AND FOOT SCRUB AND NON-MEDICATED SKIN CREAMS; NATURAL SOAP BARS; NATURALLY HANDMADE SOAP BARS; ORGANIC SOAP BARS; SHAVING SOAP; SKIN AND BODY TOPICAL LOTIONS, CREAMS AND OILS FOR COSMETIC USE; SKIN BRONZING CREAMS; SKIN CONDITIONING CREAMS FOR COSMETIC PURPOSES; SKIN SOAP; SOAPS; SOAPS FOR BODY CARE; SOAPS FOR PERSONAL USE; SUN BLOCK; SUN BLOCK PREPARATIONS; SUN CARE LOTIONS; SUN CREAMS; SUN SCREEN; SUN SCREEN PREPARATIONS; SUN-BLOCK LOTIONS; SUN-TANNING PREPARATIONS; SUNSCREEN CREAM; SUNSCREEN CREAMS; SUNTAN CREAMS; TANNING AND AFTER-SUN MILKS, GELS AND OILS; TONING LOTION, FOR THE FACE, BODY AND HANDS; WATERPROOF SUNSCREEN (U.S. CLS. 1, 4, 6, 50, 51 AND 52).

AISHA SALEM, EXAMINING ATTORNEY

CLASS 3—(Continued).

SN 85-219,080. SOUDABEH GHAEMI, RANCHO PALOS VERDES, CA. FILED 1-17-2011.

**Sudi's Lead Free Kohl
Powder Eyeliner - Sudi's
Sormehblackpowdereyeliner**

THE MARK CONSISTS OF STANDARD CHARACTERS WITHOUT CLAIM TO ANY PARTICULAR FONT, STYLE, SIZE, OR COLOR.

NO CLAIM IS MADE TO THE EXCLUSIVE RIGHT TO USE "LEAD FREE KOHL POWDER EYELINER" AND "SORMEHBLACKPOWDEREYELINER", APART FROM THE MARK AS SHOWN.

FOR LEAD FREE EYE LINER; LEAD FREE EYELINER; LEAD FREE EYELINERS (U.S. CLS. 1, 4, 6, 50, 51 AND 52).

FIRST USE 10-1-1982; IN COMMERCE 10-3-2009.
TARA PATE, EXAMINING ATTORNEY

SN 85-221,400. PURE & NATURAL COMPANY, SCOTTS-DALE, AZ. FILED 1-19-2011.

COMPLETE 3-IN-1

THE MARK CONSISTS OF STANDARD CHARACTERS WITHOUT CLAIM TO ANY PARTICULAR FONT, STYLE, SIZE, OR COLOR.

OWNER OF U.S. REG. NO. 3,674,774.

NO CLAIM IS MADE TO THE EXCLUSIVE RIGHT TO USE "3-IN-1", APART FROM THE MARK AS SHOWN.

FOR ANTI-STATIC DRYER SHEETS; FABRIC SOFTENERS; LAUNDRY DETERGENTS (U.S. CLS. 1, 4, 6, 50, 51 AND 52).

FIRST USE 4-21-2009; IN COMMERCE 4-21-2009.
DEBRA LEE, EXAMINING ATTORNEY

SN 85-226,885. GENG MAUD D., PLAINFIELD, MA. FILED 1-26-2011.

DANCING BARE

THE MARK CONSISTS OF STANDARD CHARACTERS WITHOUT CLAIM TO ANY PARTICULAR FONT, STYLE, SIZE, OR COLOR.

FOR BAR SOAPS, LIQUID SOAPS, BODY CLEANSERS (U.S. CLS. 1, 4, 6, 50, 51 AND 52).

FIRST USE 2-15-2010; IN COMMERCE 5-7-2010.
EDWARD FENNESSY, EXAMINING ATTORNEY

CLASS 3—(Continued).

SN 85-230,069. DUNCAN ENTERPRISES, DBA ILOVE-TOCREATE, FRESNO, CA. FILED 1-31-2011.

TULIP FABRIC COLOR REMOVER

THE MARK CONSISTS OF STANDARD CHARACTERS WITHOUT CLAIM TO ANY PARTICULAR FONT, STYLE, SIZE, OR COLOR.

OWNER OF U.S. REG. NOS. 3,896,737, 3,928,746 AND OTHERS.

NO CLAIM IS MADE TO THE EXCLUSIVE RIGHT TO USE "FABRIC COLOR REMOVER", APART FROM THE MARK AS SHOWN.

FOR FABRIC DYE REMOVER (U.S. CLS. 1, 4, 6, 50, 51 AND 52).

ELLEN B. AWRICH, EXAMINING ATTORNEY

SN 85-231,804. KING, BERNADETTE, OJAI, CA. FILED 2-1-2011.

OJAI SUGAR



All Natural Body Scrub

NO CLAIM IS MADE TO THE EXCLUSIVE RIGHT TO USE "OJAI SUGAR" AND "ALL NATURAL BODY SCRUB", APART FROM THE MARK AS SHOWN.

THE MARK CONSISTS OF AN ABSTRACT LEAF DESIGN AT THE CENTER. THE STYLIZED WORDING "OJAI SUGAR" APPEARS ABOVE THE LEAF DESIGN. THE STYLIZED WORDING "ALL NATURAL BODY SCRUB" APPEARS BELOW THE LEAF DESIGN.

FOR BODY SCRUB CONTAINING SUGAR (U.S. CLS. 1, 4, 6, 50, 51 AND 52).

FIRST USE 4-1-2010; IN COMMERCE 5-1-2010.
CIMMERIAN COLEMAN, EXAMINING ATTORNEY

SN 85-233,538. C2D INC., NEWPORT BEACH, CA. FILED 2-3-2011.

vault

THE MARK CONSISTS OF STANDARD CHARACTERS WITHOUT CLAIM TO ANY PARTICULAR FONT, STYLE, SIZE, OR COLOR.

OWNER OF U.S. REG. NO. 3,706,097.

FOR LIP GLOSS; MASCARA (U.S. CLS. 1, 4, 6, 50, 51 AND 52).

FIRST USE 8-1-2008; IN COMMERCE 2-1-2011.
MICHAEL ENGEL, EXAMINING ATTORNEY

CLASS 3—(Continued).

SN 85-234,184. WALGREEN CO., DEERFIELD, IL. FILED 2-4-2011.

NICE!

THE MARK CONSISTS OF STANDARD CHARACTERS WITHOUT CLAIM TO ANY PARTICULAR FONT, STYLE, SIZE, OR COLOR.

FOR BABY OIL; BAR SOAPS; LIQUID SOAPS; BODY WASH FOR HUMANS OR ANIMALS; ALL PURPOSE CLEANERS; DRAIN OPENERS; HOUSEHOLD CLEANERS; IMPREGNATED CLEANING CLOTHS; FURNITURE POLISHES; GLASS CLEANERS; PRE-MOISTENED COSMETIC TOWELETTES; FACIAL CLEANSERS; EYE CREAMS; MAKE-UP REMOVER; BODY DEODORANTS IN SPRAY FORM; NON-MEDICATED DOUCHES; BODY, FACIAL AND HAND LOTIONS; SHAVING LOTIONS; LAUNDRY BLEACH; LIQUID DISH DETERGENTS AND SOAPS; ANTI-STATIC DRYER SHEETS; STAIN REMOVERS; LAUNDRY STARCH (U.S. CLS. 1, 4, 6, 50, 51 AND 52).

JIM RINGLE, EXAMINING ATTORNEY

CLASS 3—(Continued).

SN 85-239,388. LOISAIDA LABS LLC, NEW YORK, NY. FILED 2-10-2011.

sweet bella

THE MARK CONSISTS OF STANDARD CHARACTERS WITHOUT CLAIM TO ANY PARTICULAR FONT, STYLE, SIZE, OR COLOR.

FOR BEAUTY CREAMS FOR BODY CARE; FACE AND BODY CREAMS; FRAGRANCED BODY CARE PREPARATIONS, NAMELY, SHOWER GELS, SOAPS, SCRUBS; HAIR CARE CREAMS; HAIR SHAMPOOS AND CONDITIONERS (U.S. CLS. 1, 4, 6, 50, 51 AND 52).

JOHN DALIER, EXAMINING ATTORNEY

SN 85-239,715. BIOTHERM, MONACO, MONACO, FILED 2-11-2011.

SN 85-238,580. VS. DIRTY, INC., WHITE BEAR LAKE, MN. FILED 2-10-2011.



THE COLOR(S) BLUE AND WHITE IS/ARE CLAIMED AS A FEATURE OF THE MARK.

THE MARK CONSISTS OF THE WORDS "VS. DIRTY" IN WHITE WITH A DESIGN OF A BLUE AND WHITE SHIELD WITH A DEPICTION OF A MICROSCOPE IN WHITE.

FOR CLEANING PREPARATIONS (U.S. CLS. 1, 4, 6, 50, 51 AND 52).

KEVIN DINALLO, EXAMINING ATTORNEY



OWNER OF U.S. REG. NOS. 1,151,377, 1,961,313 AND OTHERS.

THE COLOR(S) WHITE, SILVER, GRAY, AQUA, BLUE AND BLACK IS/ARE CLAIMED AS A FEATURE OF THE MARK.

THE MARK CONSISTS OF THE WORDING "BIOTHERM" FEATURED IN GRADATIONS OF WHITE, GRAY, SILVER AND BLACK, BELOW WHICH APPEARS A WAVY BAR DESIGN IN GRADATIONS OF BLACK, BLUE AND AQUA, AND BENEATH APPEARS THE WORDING, "AQUA ONE" IN GRAY. ALL FEATURED INSIDE A RECTANGLE CARRIER DEPICTED IN SILVER.

FOR COSMETICS, NAMELY, CREAMS, MILKS, LOTIONS, GELS AND POWDERS FOR THE FACE, THE BODY AND THE HANDS (U.S. CLS. 1, 4, 6, 50, 51 AND 52).

KELLY CHOE, EXAMINING ATTORNEY

CLASS 3—(Continued).

SN 85-242,322. AUGENBRAUN & ASSOCIATES, BRIDGE-PORT, CT. FILED 2-15-2011.

MA.NISH.MA.

THE MARK CONSISTS OF STANDARD CHARACTERS WITHOUT CLAIM TO ANY PARTICULAR FONT, STYLE, SIZE, OR COLOR.

THE ENGLISH TRANSLATION OF "MA NISHMA" IN THE MARK IS "HOW ARE YOU".

FOR COSMETICS; FRAGRANCES (U.S. CLS. 1, 4, 6, 50, 51 AND 52).

ANDREW RHIM, EXAMINING ATTORNEY

SN 85-242,918. EZ NAILS, INC., GARDEN GROVE, CA. FILED 2-15-2011.

GELLA

THE MARK CONSISTS OF STANDARD CHARACTERS WITHOUT CLAIM TO ANY PARTICULAR FONT, STYLE, SIZE, OR COLOR.

FOR NAIL POLISH (U.S. CLS. 1, 4, 6, 50, 51 AND 52).

FIRST USE 2-1-2011; IN COMMERCE 2-1-2011.

WON TEAK OH, EXAMINING ATTORNEY

SN 85-243,127. JORDAN, LARRY, SPRING VALLEY, CA. AND JORDAN, STEPHANIE, SPRING VALLEY, CA. FILED 2-15-2011.

21
Again

THE MARK CONSISTS OF THE NUMBER "21", OVER THE WORD "AGAIN", THE NUMBER "21" BEING OF EQUAL LENGTH AND PROPORTIONAL HEIGHT TO THE WORD "AGAIN", AND BOTH IN AN ART DECO-STYLE FONT.

FOR ANTI-AGING MOISTURIZER; FACIAL CREAMS; FACIAL EMULSIONS; FACIAL LOTION; FRAGRANCED FACIAL MOISTURIZER; SKIN MOISTURIZER (U.S. CLS. 1, 4, 6, 50, 51 AND 52).

FIRST USE 1-1-2011; IN COMMERCE 1-1-2011.

GRETTA YAO, EXAMINING ATTORNEY

CLASS 3—(Continued).

SN 85-245,179. E.T. BROWNE DRUG CO., INC., ENGLEWOOD CLIFFS, NJ. FILED 2-17-2011.

SUPER CONTROL EDGE HOLD

THE MARK CONSISTS OF STANDARD CHARACTERS WITHOUT CLAIM TO ANY PARTICULAR FONT, STYLE, SIZE, OR COLOR.

NO CLAIM IS MADE TO THE EXCLUSIVE RIGHT TO USE "CONTROL" AND "HOLD", APART FROM THE MARK AS SHOWN.

FOR HAIR STYLING PREPARATIONS (U.S. CLS. 1, 4, 6, 50, 51 AND 52).

PATRICIA EVANKO, EXAMINING ATTORNEY

SN 85-245,182. E.T. BROWNE DRUG CO., INC., ENGLEWOOD CLIFFS, NJ. FILED 2-17-2011.

**PALMER'S COCONUT OIL
FORMULA**

THE MARK CONSISTS OF STANDARD CHARACTERS WITHOUT CLAIM TO ANY PARTICULAR FONT, STYLE, SIZE, OR COLOR.

OWNER OF U.S. REG. NOS. 1,005,155, 3,927,173 AND OTHERS.

NO CLAIM IS MADE TO THE EXCLUSIVE RIGHT TO USE "COCONUT OIL FORMULA", APART FROM THE MARK AS SHOWN.

FOR HAIR CARE PREPARATIONS CONTAINING COCONUT OIL (U.S. CLS. 1, 4, 6, 50, 51 AND 52).

FIRST USE 2-6-1974; IN COMMERCE 2-6-1974.

PATRICIA EVANKO, EXAMINING ATTORNEY

SN 85-245,188. E.T. BROWNE DRUG CO., INC., ENGLEWOOD CLIFFS, NJ. FILED 2-17-2011.

**PALMER'S PRESSING OIL
FORMULA**

THE MARK CONSISTS OF STANDARD CHARACTERS WITHOUT CLAIM TO ANY PARTICULAR FONT, STYLE, SIZE, OR COLOR.

OWNER OF U.S. REG. NOS. 1,005,155, 3,922,745 AND OTHERS.

NO CLAIM IS MADE TO THE EXCLUSIVE RIGHT TO USE "PRESSING OIL FORMULA", APART FROM THE MARK AS SHOWN.

FOR HAIR CARE PREPARATIONS (U.S. CLS. 1, 4, 6, 50, 51 AND 52).

FIRST USE 0-0-1980; IN COMMERCE 0-0-1980.

PATRICIA EVANKO, EXAMINING ATTORNEY

CLASS 3—(Continued).

SN 85-245,191. E.T. BROWNE DRUG CO., INC., ENGLEWOOD CLIFFS, NJ. FILED 2-17-2011.

CLASS 3—(Continued).

SN 85-246,630. FL DAUERN RESEARCH, INC., PHOENIX, AZ. FILED 2-18-2011.

PALMER'S BERGAMOT FORMULA

DELIVERING GOODNESS

THE MARK CONSISTS OF STANDARD CHARACTERS WITHOUT CLAIM TO ANY PARTICULAR FONT, STYLE, SIZE, OR COLOR.

OWNER OF U.S. REG. NOS. 1,005,155, 3,672,986 AND OTHERS.

NO CLAIM IS MADE TO THE EXCLUSIVE RIGHT TO USE "BERGAMOT FORMULA", APART FROM THE MARK AS SHOWN.

FOR BERGAMOT-SCENTED HAIR CARE PREPARATIONS (U.S. CLS. 1, 4, 6, 50, 51 AND 52).

FIRST USE 0-0-1981; IN COMMERCE 0-0-1981.

PATRICIA EVANKO, EXAMINING ATTORNEY

THE MARK CONSISTS OF STANDARD CHARACTERS WITHOUT CLAIM TO ANY PARTICULAR FONT, STYLE, SIZE, OR COLOR.

FOR PERSONAL CARE PRODUCTS, NAMELY, HAND CREAM, SKIN MOISTURIZERS, SKIN AND HAIR CONDITIONERS, HAIR SHAMPOOS, LIQUID AND BAR HAND AND BODY SOAPS, BODY DEODORANTS, TOOTHPASTES, MOUTHWASHES; PERSONAL CARE PRODUCTS, NAMELY, FACIAL SCRUB, SKIN CLEANSING PADS, NAMELY, CLOTHS, PADS OR TISSUES IMPREGNATED WITH A SKIN CLEANSER, CLEANSING BODY WASH FOR HUMANS AND EYE CREAMS, ALL FOR TOPICAL USE AND NOT FOR INGESTION (U.S. CLS. 1, 4, 6, 50, 51 AND 52).

MICHAEL TANNER, EXAMINING ATTORNEY

SN 85-246,602. FL DAUERN RESEARCH, INC., PHOENIX, AZ. FILED 2-18-2011.

SN 85-247,099. MORRIS, DERRIK R. G., PHILADELPHIA, PA. FILED 2-20-2011.

POWERED BY WELLNESS

Bright Star for Men

THE MARK CONSISTS OF STANDARD CHARACTERS WITHOUT CLAIM TO ANY PARTICULAR FONT, STYLE, SIZE, OR COLOR.

FOR PERSONAL CARE PRODUCTS, NAMELY, HAND CREAM, SKIN MOISTURIZERS, SKIN AND HAIR CONDITIONERS, HAIR SHAMPOOS, LIQUID AND BAR HAND AND BODY SOAPS, BODY DEODORANTS, TOOTHPASTES, MOUTHWASHES; PERSONAL CARE PRODUCTS, NAMELY, FACIAL SCRUB, SKIN CLEANSING PADS, NAMELY, CLOTHS, PADS OR TISSUES IMPREGNATED WITH A SKIN CLEANSER, CLEANSING BODY WASH FOR HUMANS AND EYE CREAMS, ALL FOR TOPICAL USE AND NOT FOR INGESTION (U.S. CLS. 1, 4, 6, 50, 51 AND 52).

MICHAEL TANNER, EXAMINING ATTORNEY

THE MARK CONSISTS OF STANDARD CHARACTERS WITHOUT CLAIM TO ANY PARTICULAR FONT, STYLE, SIZE, OR COLOR.

NO CLAIM IS MADE TO THE EXCLUSIVE RIGHT TO USE "FOR MEN", APART FROM THE MARK AS SHOWN.

FOR SKIN LIGHTENERS (U.S. CLS. 1, 4, 6, 50, 51 AND 52).

SUNG IN, EXAMINING ATTORNEY

CLASS 3—(Continued).

SN 85-247,948. GRANT LLOYD BERRY, INC., ARMONK, NY. FILED 2-22-2011.

SYNCHRONOLOGY

THE MARK CONSISTS OF STANDARD CHARACTERS WITHOUT CLAIM TO ANY PARTICULAR FONT, STYLE, SIZE, OR COLOR.

FOR COSMETICS, NAMELY, EYE PENCILS, EYE LINER, EYE SHADOW, LIP PENCILS, LIP LINER, LIPSTICK, FACE MAKE UP, FOUNDATION, BLUSH, CONCEALER, PRESSED FACE POWDER, MASCARA, LIP GLOSS, NAIL ENAMEL; HAIR CARE PRODUCTS, NAMELY, SHAMPOO, CONDITIONER, HAIR COLOR; SKIN CARE PRODUCTS, NAMELY, FACE CREAMS, FACE GELS, FACE POWDERS, FACE MOISTURIZERS, EYE CREAMS, EYE GELS, EYE MOISTURIZERS, NON-MEDICATED LIP TREATMENT BALMS, NON-MEDICATED SKIN TREATMENT PREPARATIONS, NON-MEDICATED EYE TREATMENT CREAMS, ALL OVER BODY CREAMS, ALL OVER BODY GELS (U.S. CLS. 1, 4, 6, 50, 51 AND 52).

CHRISTINE MARTIN, EXAMINING ATTORNEY

SN 85-249,388. MAD BEAUTY LIMITED, EDGWARE, UNITED KINGDOM, FILED 2-23-2011.



NO CLAIM IS MADE TO THE EXCLUSIVE RIGHT TO USE "THE LIP GLOSS COMPANY", APART FROM THE MARK AS SHOWN.

THE COLOR(S) RED, WHITE, AND BLACK IS/ARE CLAIMED AS A FEATURE OF THE MARK.

THE MARK CONSISTS OF GRAPHIC DEPICTION OF HUMAN LIPS IN THE RED, OUTLINED IN BLACK AND HIGHLIGHTED IN WHITE ABOVE THE STYLIZED WORDS "THE LIP GLOSS" ON ONE LINE AND ON A SECOND LINE THE STYLIZED WORD "COMPANY" BELOW THE WORD "GLOSS".

FOR COSMETICS; LIP BALM; LIP CREAM; LIP GLOSS; LIP LINER; LIPSTICK; MAKE-UP PREPARATIONS; SKIN CREAMS; SKIN LOTIONS; SUN BLOCK (U.S. CLS. 1, 4, 6, 50, 51 AND 52).

WILLIAM VERHOSEK, EXAMINING ATTORNEY

CLASS 3—(Continued).

SN 85-249,545. PHILOSOPHY, INC., PHOENIX, AZ. FILED 2-23-2011.

PHILOSOPHY COLOR

THE MARK CONSISTS OF STANDARD CHARACTERS WITHOUT CLAIM TO ANY PARTICULAR FONT, STYLE, SIZE, OR COLOR.

OWNER OF U.S. REG. NOS. 2,016,208, 3,440,195 AND OTHERS.

NO CLAIM IS MADE TO THE EXCLUSIVE RIGHT TO USE "COLOR", APART FROM THE MARK AS SHOWN.

FOR COSMETIC PENCILS; COSMETICS AND MAKE-UP (U.S. CLS. 1, 4, 6, 50, 51 AND 52).

ALICIA COLLINS, EXAMINING ATTORNEY

SN 85-249,838. L'OREAL USA CREATIVE, INC., NEW YORK, NY. FILED 2-23-2011.

APOTHECARY FUSIONS

THE MARK CONSISTS OF STANDARD CHARACTERS WITHOUT CLAIM TO ANY PARTICULAR FONT, STYLE, SIZE, OR COLOR.

NO CLAIM IS MADE TO THE EXCLUSIVE RIGHT TO USE "APOTHECARY", APART FROM THE MARK AS SHOWN.

FOR FRAGRANCES AND PERFUMERY, EAU DE TOILETTE, FRAGRANCE MISTS, SCENTED BODY LOTIONS AND CREAMS, SCENTED OILS, SHOWER GELS, LIQUID SOAPS, BATH SOAPS, BODY LOTIONS AND CREAMS, BODY SCRUBS, BATH SALTS, BUBBLE BATH, BODY MISTS, AND NON-MEDICATED BATH PREPARATIONS (U.S. CLS. 1, 4, 6, 50, 51 AND 52).

EMILY CHUO, EXAMINING ATTORNEY

SN 85-250,437. MITCHELL GROUP USA LLC, MIAMI, FL. AND ISIS PHARMA GMBH, BRIG, SWITZERLAND, FILED 2-24-2011.

SENSILIA MOISTURE RESCUE

THE MARK CONSISTS OF STANDARD CHARACTERS WITHOUT CLAIM TO ANY PARTICULAR FONT, STYLE, SIZE, OR COLOR.

NO CLAIM IS MADE TO THE EXCLUSIVE RIGHT TO USE "MOISTURE", APART FROM THE MARK AS SHOWN.

FOR MOISTURIZING PREPARATIONS FOR THE SKIN; SKIN AND BODY TOPICAL LOTIONS, CREAMS AND OILS FOR COSMETIC USE; SKIN CONDITIONING CREAMS FOR COSMETIC PURPOSES; SKIN CREAM; SKIN LOTION; SKIN MOISTURIZER (U.S. CLS. 1, 4, 6, 50, 51 AND 52).

JOHN WILKE, EXAMINING ATTORNEY

CLASS 3—(Continued).

SN 85-250,688. L'OREAL USA CREATIVE, INC., NEW YORK, NY. FILED 2-24-2011.

COLOR IDOL

THE MARK CONSISTS OF STANDARD CHARACTERS WITHOUT CLAIM TO ANY PARTICULAR FONT, STYLE, SIZE, OR COLOR.

NO CLAIM IS MADE TO THE EXCLUSIVE RIGHT TO USE "COLOR", APART FROM THE MARK AS SHOWN. FOR HAIR COLOR (U.S. CLS. 1, 4, 6, 50, 51 AND 52). EMILY CHUO, EXAMINING ATTORNEY

SN 85-251,316. US MILK CORPORATION, WESTMINSTER, CA. FILED 2-24-2011.



NO CLAIM IS MADE TO THE EXCLUSIVE RIGHT TO USE "US MILK", APART FROM THE MARK AS SHOWN.

THE MARK CONSISTS OF A FLAG WITH THE STYLIZED TEXT "US MILK". FOR COSMETICS (U.S. CLS. 1, 4, 6, 50, 51 AND 52). CARYN GLASSER, EXAMINING ATTORNEY

SN 85-252,197. HICO, INC., ENCINO, CA. FILED 2-25-2011.

CELLUSPA

THE MARK CONSISTS OF STANDARD CHARACTERS WITHOUT CLAIM TO ANY PARTICULAR FONT, STYLE, SIZE, OR COLOR.

OWNER OF U.S. REG. NO. 3,962,045. FOR COSMETIC PRODUCTS, NAMELY, MOISTURIZERS; COSMETIC CREAMS, NAMELY, DAY BODY CREAMS, NIGHT CREAMS, EYE CREAMS, COSMETIC CREAMS FOR MEN AND WOMEN, HAND CREAMS, NON-MEDICATED FAT BURNING CREAMS, ENERGIZING CREAMS, COSMETIC GELS, NAMELY, MOISTURIZING GELS FOR THE FACE AND BODY, SHOWER AND BATH GELS, GELS FOR CELLULITE REDUCTION; LOTIONS FOR COSMETIC PURPOSES, NAMELY, HAND LOTION, FACIAL LOTION, HAIR LOTION, AND EYE LOTION (U.S. CLS. 1, 4, 6, 50, 51 AND 52). JAMES STEIN, EXAMINING ATTORNEY

CLASS 3—(Continued).

SN 85-252,398. WD-40 COMPANY, SAN DIEGO, CA. FILED 2-25-2011.

MARKSMAN SPOUT

THE MARK CONSISTS OF STANDARD CHARACTERS WITHOUT CLAIM TO ANY PARTICULAR FONT, STYLE, SIZE, OR COLOR.

NO CLAIM IS MADE TO THE EXCLUSIVE RIGHT TO USE "SPOUT", APART FROM THE MARK AS SHOWN. FOR CLEANING PREPARATION FOR USE ON METAL SURFACES (U.S. CLS. 1, 4, 6, 50, 51 AND 52). STEVEN R. FINE, EXAMINING ATTORNEY

SN 85-253,157. BATH & BODY WORKS BRAND MANAGEMENT, INC., REYNOLDSBURG, OH. FILED 2-28-2011.

PRETTY IN PREP

THE MARK CONSISTS OF STANDARD CHARACTERS WITHOUT CLAIM TO ANY PARTICULAR FONT, STYLE, SIZE, OR COLOR.

FOR PERSONAL CARE PRODUCTS, NAMELY, ANTI-BACTERIAL SKIN SOAPS, BATH BEADS, BATH CRYSTALS, BATH FOAMS, BATH GELS, BATH LOTION, BATH MILKS, BATH OILS FOR COSMETIC PURPOSES, BATH PEARLS, BATH SALTS, BATH SOAPS IN LIQUID, SOLID OR GEL FORM, BATHING LOTIONS, BODY CREAM SOAP, BODY CREAMS, BODY EMULSIONS, BODY LOTIONS, BODY MASKS, BODY MILKS, BODY MOISTURIZING MOUSSE, BODY OILS, BODY SCRUB, BODY MIST, BODY SPRAY USED AS A PERSONAL DEODORANT AND AS FRAGRANCE, BODY SPRAYS, NAMELY WATER IN ATOMIZED CONTAINERS USED TO PRODUCE A COOLING EFFECT, BODY WASHES, BUBBLE BATH, COLOGNE, COLOGNE WATER, CREAMS FOR CELLULITE REDUCTION, CREAM TO OIL BODY LOTION, DEPILATORIES, DEPILATORY CREAMS, EAU DE PARFUM, EAU DE TOILETTE, ESSENTIAL OILS FOR PERSONAL USE, FIRMLING BODY LOTION, HAIR SHAMPOO, HAIR CONDITIONERS, HAND CREAMS, HAND LOTIONS, HAND SOAPS, CUTICLE CREAM, CUTICLE CONDITIONERS, LIP BALM, LIP GLOSS, LIQUID BATH SOAPS, LIQUID SOAP, LIQUID SOAPS FOR HANDS, FACE AND BODY, LOTIONS FOR CELLULITE REDUCTION, LOTIONS FOR FACE AND BODY CARE, MOISTURIZING CREAMS, MOISTURIZING MILKS, PRE-SUNTANNING LOTIONS FOR THE BODY AND FACE, POST-SUNTANNING LOTIONS FOR THE BODY AND FACE, PERFUME, PERFUME OILS, FOOT SCRUBS, NON-MEDICATED FOOT CREAMS, NON-MEDICATED FOOT LOTIONS, PRE-SHAVE CREAMS, SCENTED BODY SPRAY, SHAVING BALM, SHAVING CREAMS, SHAVING FOAMS, SHAVING GELS, SHAVING LOTIONS, SHAVING MOUSSE, SHAVING PREPARATIONS, SHAVING SOAP, SHOWER AND BATH FOAM, SHOWER AND BATH GEL, SHOWER CREAMS, AND SHOWER GELS (U.S. CLS. 1, 4, 6, 50, 51 AND 52). JENNY PARK, EXAMINING ATTORNEY

CLASS 3—(Continued).

SN 85-253,235. WOLF, CARL, DBA ATLANTIC BEAUTY SALES, CHERRY HILL, NJ. FILED 2-28-2011.

CLASS 3—(Continued).

SN 85-253,287. TRADEMARK COSMETICS INC., RIVERSIDE, CA. FILED 2-28-2011.



LOTUS NAILS

NO CLAIM IS MADE TO THE EXCLUSIVE RIGHT TO USE "GREEN" OR "ORGANICS", APART FROM THE MARK AS SHOWN.

THE COLOR(S) BROWN, GREEN, AND WHITE IS/ARE CLAIMED AS A FEATURE OF THE MARK.

THE MARK CONSISTS OF THE WORDING "TRU GREEN" IN A STYLIZED GREEN FONT ON THE DESIGN OF SEVERAL GREEN TREES, SURROUNDED BY WHITE, AND ABOVE A SERIES OF DIAGONAL GREEN LINES. THE WORDING, TREES AND LINES ARE WITHIN TWO BROWN CONCENTRIC CIRCLES, WITH THE AREA BETWEEN THE CIRCLES APPEARING IN LIGHT BROWN, AND THE WORDING "ORGANICS" IN A BROWN STYLIZED FONT BENEATH THE INNERMOST CIRCLE.

FOR ORGANIC COSMETIC PREPARATIONS FOR BODY CARE; ORGANIC HAIR CARE PREPARATIONS CONSISTING OF ORGANIC COCONUT VIRGIN OIL AND COCONUT VIRGIN OIL; ORGANIC NON-MEDICATED COSMETIC SKIN CARE PREPARATIONS CONSISTING OF ORGANIC COCONUT VIRGIN OIL AND COCONUT VIRGIN OIL (U.S. CLS. 1, 4, 6, 50, 51 AND 52).
JAMES MACFARLANE, EXAMINING ATTORNEY

SN 85-253,407. TOWSE, DANIEL, NEW YORK, NY. FILED 2-28-2011.

THE MARK CONSISTS OF STANDARD CHARACTERS WITHOUT CLAIM TO ANY PARTICULAR FONT, STYLE, SIZE, OR COLOR.

NO CLAIM IS MADE TO THE EXCLUSIVE RIGHT TO USE "NAILS", APART FROM THE MARK AS SHOWN.

FOR ADHESIVES FOR ARTIFICIAL NAILS; COSMETIC PREPARATIONS FOR NAIL DRYING; FALSE NAILS; LOTIONS FOR STRENGTHENING THE NAILS; NAIL ART STICKERS; NAIL BUFFING PREPARATIONS; NAIL CARE KITS COMPRISING NAIL POLISH; NAIL CARE PREPARATIONS; NAIL CARE PREPARATIONS, NAMELY, NAIL SOFTENERS; NAIL CREAM; NAIL ENAMEL REMOVERS; NAIL ENAMELS; NAIL GEL; NAIL GLITTER; NAIL GROOMING PRODUCTS, NAMELY, TIPS, GLUE, LACQUER AND GLITTER; NAIL HARDENERS; NAIL POLISH; NAIL POLISH BASE COAT; NAIL POLISH PROTECTOR IN THE NATURE OF A THIN PLASTIC COVERING APPLIED TO NAILS; NAIL POLISH REMOVERS; NAIL POLISH TOP COAT; NAIL REPAIR PRODUCTS, NAMELY, NAIL WRAPS; NAIL STENCILS; NAIL STRENGTHENERS; NAIL TIPS; NAIL VARNISHES; NON-MEDICATED NAIL CARE PREPARATIONS (U.S. CLS. 1, 4, 6, 50, 51 AND 52).
KRISTIN CARLSON, EXAMINING ATTORNEY

Tools for men

THE MARK CONSISTS OF STANDARD CHARACTERS WITHOUT CLAIM TO ANY PARTICULAR FONT, STYLE, SIZE, OR COLOR.

NO CLAIM IS MADE TO THE EXCLUSIVE RIGHT TO USE "FOR MEN", APART FROM THE MARK AS SHOWN.

FOR AFTERSHAVE; BODY SPRAYS; COLOGNE; NON-MEDICATED TOILETRIES (U.S. CLS. 1, 4, 6, 50, 51 AND 52).
HANNO RITTNER, EXAMINING ATTORNEY

CLASS 3—(Continued).

SN 85-253,467. MY BEST FOR U, L.L.C, NEW YORK, NY.
FILED 2-28-2011.

ISRAEL'S MAGIC

THE MARK CONSISTS OF STANDARD CHARACTERS WITHOUT CLAIM TO ANY PARTICULAR FONT, STYLE, SIZE, OR COLOR.

FOR HAIR CARE AND HAIR TREATMENT PREPARATIONS, NAMELY, HAIR SHAMPOO, HAIR CONDITIONERS, HAIR OILS, NON-MEDICATED HAIR BALMS, HAIR CREAMS, HAIR RINSES, HAIR LOTIONS, HAIR GELS; SKIN CARE AND SKIN TREATMENT PREPARATIONS, NAMELY, SKIN CLEANSERS, SKIN LOTIONS, SKIN CREAMS, SKIN MASKS, NON-MEDICATED SKIN GELS, EXFOLIANTS, SKIN MOISTURIZERS, SKIN SOAPS, SKIN TONERS, FACIAL SCRUBS (U.S. CLS. 1, 4, 6, 50, 51 AND 52).

MAYUR VAGHANI, EXAMINING ATTORNEY

SN 85-253,471. MY BEST FOR U, L.L.C, NEW YORK, NY.
FILED 2-28-2011.

ISRAEL'S WONDER

THE MARK CONSISTS OF STANDARD CHARACTERS WITHOUT CLAIM TO ANY PARTICULAR FONT, STYLE, SIZE, OR COLOR.

FOR HAIR CARE AND HAIR TREATMENT PREPARATIONS, NAMELY, HAIR SHAMPOO, HAIR CONDITIONERS, HAIR OILS, NON-MEDICATED HAIR BALMS, HAIR CREAMS, HAIR RINSES, HAIR LOTIONS, HAIR GELS; SKIN CARE AND SKIN TREATMENT PREPARATIONS, NAMELY, SKIN CLEANSERS, SKIN LOTIONS, SKIN CREAMS, SKIN MASKS, NON-MEDICATED SKIN GELS, EXFOLIANTS, SKIN MOISTURIZERS, SKIN SOAPS, SKIN TONERS, FACIAL SCRUBS (U.S. CLS. 1, 4, 6, 50, 51 AND 52).

MAYUR VAGHANI, EXAMINING ATTORNEY

SN 85-253,905. THIRD DEGREE BURN, LLC, LOS ANGELES, CA. FILED 2-28-2011.

SEX RULES

THE MARK CONSISTS OF STANDARD CHARACTERS WITHOUT CLAIM TO ANY PARTICULAR FONT, STYLE, SIZE, OR COLOR.

FOR COSMETICS; PERFUME (U.S. CLS. 1, 4, 6, 50, 51 AND 52).

TIMOTHY FINNEGAN, EXAMINING ATTORNEY

CLASS 3—(Continued).

SN 85-254,047. COSMETICS WITHOUT SYNTHETICS, INC., DEWEY, AZ. FILED 2-28-2011.

Earth's Beauty

THE MARK CONSISTS OF STANDARD CHARACTERS WITHOUT CLAIM TO ANY PARTICULAR FONT, STYLE, SIZE, OR COLOR.

NO CLAIM IS MADE TO THE EXCLUSIVE RIGHT TO USE "BEAUTY", APART FROM THE MARK AS SHOWN.

FOR CONCEALERS; COSMETIC PENCILS; COSMETIC ROUGES; COSMETICS AND MAKE-UP (U.S. CLS. 1, 4, 6, 50, 51 AND 52).

FIRST USE 11-17-1999; IN COMMERCE 11-17-1999.

ANDREW RHIM, EXAMINING ATTORNEY

SN 85-254,186. GROSS, DENNIS, NEW YORK, NY. FILED 3-1-2011.

TRIFIX

THE MARK CONSISTS OF STANDARD CHARACTERS WITHOUT CLAIM TO ANY PARTICULAR FONT, STYLE, SIZE, OR COLOR.

FOR SKIN CARE PRODUCTS, NAMELY MOISTURIZERS (U.S. CLS. 1, 4, 6, 50, 51 AND 52).

HEATHER THOMPSON, EXAMINING ATTORNEY

SN 85-254,544. MARGARITAVILLE ENTERPRISES, LLC, PALM BEACH, FL. FILED 3-1-2011.

MARGARITAVILLE

THE MARK CONSISTS OF STANDARD CHARACTERS WITHOUT CLAIM TO ANY PARTICULAR FONT, STYLE, SIZE, OR COLOR.

OWNER OF U.S. REG. NOS. 1,642,132, 3,900,886 AND OTHERS.

FOR NON-MEDICATED SUN CARE PREPARATIONS; SUN TAN OIL; SUN TAN LOTION; SUN-TANNING PREPARATIONS; SUN SCREEN; SUN BLOCK; TANNING AND AFTER-SUN MILKS, GELS AND OILS; AFTER-SUN CREAMS; AFTER-SUN LOTIONS; COSMETIC PREPARATIONS AGAINST SUNBURN; COSMETIC PREPARATIONS FOR SKIN CARE; COSMETIC PREPARATIONS FOR BATH AND SHOWER; BATH SALTS; BATH OILS; SKIN SOAPS; SKIN LOTIONS; NON-MEDICATED SKIN GELS; COSMETIC CREAMS; SCENTED BODY SPRAY; NON-MEDICATED LIP BALM; COSMETICS AND MAKE-UP (U.S. CLS. 1, 4, 6, 50, 51 AND 52).

DAVID COLLIER, EXAMINING ATTORNEY

CLASS 3—(Continued).

SN 85-254,545. MARGARITAVILLE ENTERPRISES, LLC,
PALM BEACH, FL. FILED 3-1-2011.

PARROTHEAD

THE MARK CONSISTS OF STANDARD CHARACTERS WITHOUT CLAIM TO ANY PARTICULAR FONT, STYLE, SIZE, OR COLOR.

OWNER OF U.S. REG. NOS. 2,502,259, 3,193,090 AND OTHERS.

FOR NON-MEDICATED SUN CARE PREPARATIONS; SUN TAN OIL; SUN TAN LOTION; SUN-TANNING PREPARATIONS; SUN SCREEN; SUN BLOCK; TANNING AND AFTER-SUN MILKS, GELS AND OILS; AFTER-SUN CREAMS; AFTER-SUN LOTIONS; COSMETIC PREPARATIONS AGAINST SUNBURN; COSMETIC PREPARATIONS FOR SKIN CARE; COSMETIC PREPARATIONS FOR BATH AND SHOWER; BATH SALTS; BATH OILS; SKIN SOAPS; SKIN LOTIONS; NON-MEDICATED SKIN GELS; COSMETIC CREAMS; SCENTED BODY SPRAY; NON-MEDICATED LIP BALM; COSMETICS AND MAKE-UP (U.S. CLS. 1, 4, 6, 50, 51 AND 52).

DAVID COLLIER, EXAMINING ATTORNEY

CLASS 3—(Continued).

SN 85-254,914. FATBOYHAIR, LLC, NEW YORK, NY. FILED 3-1-2011.

fatboy

THE MARK CONSISTS OF STANDARD CHARACTERS WITHOUT CLAIM TO ANY PARTICULAR FONT, STYLE, SIZE, OR COLOR.

FOR HAIR STYLING PREPARATIONS; STYLING PASTE FOR HAIR (U.S. CLS. 1, 4, 6, 50, 51 AND 52).

FIRST USE 12-1-2009; IN COMMERCE 12-1-2009.

DEIRDRE ROBERTSON, EXAMINING ATTORNEY

SN 85-255,033. HADAVISION, L.L.C., LAS VEGAS, NV.
FILED 3-1-2011.

THE ORIGINAL I'VE GOT MY BACK

SN 85-254,622. KANGHYUN SUNG, TA VOGUE LASHES BY
SJ, LLC, ORADELL, NJ. FILED 3-1-2011.



THE MARK CONSISTS OF VOGUE IN SCRIPT WITH APOSTROPHE LIKE MARK OVER THE "E".

FOR FALSE EYELASHES (U.S. CLS. 1, 4, 6, 50, 51 AND 52).

PAUL MORENO, EXAMINING ATTORNEY

THE MARK CONSISTS OF STANDARD CHARACTERS WITHOUT CLAIM TO ANY PARTICULAR FONT, STYLE, SIZE, OR COLOR.

NO CLAIM IS MADE TO THE EXCLUSIVE RIGHT TO USE "THE ORIGINAL", APART FROM THE MARK AS SHOWN.

FOR BODY LOTION; BODY LOTIONS; COSMETIC SUNSCREEN PREPARATIONS; FACE AND BODY LOTIONS; FOAMS CONTAINING COSMETICS AND SUNSCREENS; LOTIONS FOR FACE AND BODY CARE; NON-MEDICATED SKIN CARE PREPARATIONS; NON-MEDICATED SKIN CREAMS; SUNSCREEN CREAM; SUNSCREEN CREAMS; WATERPROOF SUNSCREEN (U.S. CLS. 1, 4, 6, 50, 51 AND 52).

TOBY BULLOFF, EXAMINING ATTORNEY

SN 85-254,804. SMOKER'S ONLY, INC., CLINTON TWP., MI.
FILED 3-1-2011.

TSUNAMI

THE MARK CONSISTS OF STANDARD CHARACTERS WITHOUT CLAIM TO ANY PARTICULAR FONT, STYLE, SIZE, OR COLOR.

FOR INCENSE (U.S. CLS. 1, 4, 6, 50, 51 AND 52).

FIRST USE 11-1-2010; IN COMMERCE 12-28-2010.

BRIAN CALLAGHAN, EXAMINING ATTORNEY

SN 85-255,302. ORIGINS NATURAL RESOURCES, INC.,
NEW YORK, NY. FILED 3-2-2011.

MEGA BRIGHT

THE MARK CONSISTS OF STANDARD CHARACTERS WITHOUT CLAIM TO ANY PARTICULAR FONT, STYLE, SIZE, OR COLOR.

FOR NON-MEDICATED SKIN CARE PREPARATIONS (U.S. CLS. 1, 4, 6, 50, 51 AND 52).

LAURIE KAUFMAN, EXAMINING ATTORNEY

CLASS 3—(Continued).

SN 85-255,338. AUSTRALIAN GOLD, LLC, INDIANAPOLIS, IN. FILED 3-2-2011.

GRAPEFUL

THE MARK CONSISTS OF STANDARD CHARACTERS WITHOUT CLAIM TO ANY PARTICULAR FONT, STYLE, SIZE, OR COLOR.
FOR INDOOR AND OUTDOOR NON-MEDICATED SKIN TANNING PREPARATION (U.S. CLS. 1, 4, 6, 50, 51 AND 52).
JULIE GUTTADAURO, EXAMINING ATTORNEY

CLASS 3—(Continued).

SN 85-255,361. AUSTRALIAN GOLD, LLC, INDIANAPOLIS, IN. FILED 3-2-2011.

**HONEY, FACE FACTS ...
(YOU'RE UNBEELEEVABLE)**

THE MARK CONSISTS OF STANDARD CHARACTERS WITHOUT CLAIM TO ANY PARTICULAR FONT, STYLE, SIZE, OR COLOR.
FOR INDOOR AND OUTDOOR NON-MEDICATED SKIN TANNING PREPARATION (U.S. CLS. 1, 4, 6, 50, 51 AND 52).
JULIE GUTTADAURO, EXAMINING ATTORNEY

SN 85-255,345. AUSTRALIAN GOLD, LLC, INDIANAPOLIS, IN. FILED 3-2-2011.

PURITEA

THE MARK CONSISTS OF STANDARD CHARACTERS WITHOUT CLAIM TO ANY PARTICULAR FONT, STYLE, SIZE, OR COLOR.
FOR INDOOR AND OUTDOOR NON-MEDICATED SKIN TANNING PREPARATION (U.S. CLS. 1, 4, 6, 50, 51 AND 52).
JULIE GUTTADAURO, EXAMINING ATTORNEY

SN 85-255,369. AUSTRALIAN GOLD, LLC, INDIANAPOLIS, IN. FILED 3-2-2011.

**I MIST YOU...(DID YOU MIST
ME?)**

THE MARK CONSISTS OF STANDARD CHARACTERS WITHOUT CLAIM TO ANY PARTICULAR FONT, STYLE, SIZE, OR COLOR.
FOR INDOOR AND OUTDOOR NON-MEDICATED SKIN TANNING PREPARATION (U.S. CLS. 1, 4, 6, 50, 51 AND 52).
JULIE GUTTADAURO, EXAMINING ATTORNEY

SN 85-255,352. AUSTRALIAN GOLD, LLC, INDIANAPOLIS, IN. FILED 3-2-2011.

**(JUICED IN TIME TO...)
STEAL THE LIMELIGHT**

THE MARK CONSISTS OF STANDARD CHARACTERS WITHOUT CLAIM TO ANY PARTICULAR FONT, STYLE, SIZE, OR COLOR.
FOR INDOOR AND OUTDOOR NON-MEDICATED SKIN TANNING PREPARATION (U.S. CLS. 1, 4, 6, 50, 51 AND 52).
JULIE GUTTADAURO, EXAMINING ATTORNEY

SN 85-255,384. AUSTRALIAN GOLD, LLC, INDIANAPOLIS, IN. FILED 3-2-2011.

AT FIRST SIGHT

THE MARK CONSISTS OF STANDARD CHARACTERS WITHOUT CLAIM TO ANY PARTICULAR FONT, STYLE, SIZE, OR COLOR.
FOR INDOOR AND OUTDOOR NON-MEDICATED SKIN TANNING PREPARATION (U.S. CLS. 1, 4, 6, 50, 51 AND 52).
JULIE GUTTADAURO, EXAMINING ATTORNEY

CLASS 3—(Continued).

SN 85-255,391. AUSTRALIAN GOLD, LLC, INDIANAPOLIS, IN. FILED 3-2-2011.

LOVE, DS

THE MARK CONSISTS OF STANDARD CHARACTERS WITHOUT CLAIM TO ANY PARTICULAR FONT, STYLE, SIZE, OR COLOR.

FOR INDOOR AND OUTDOOR NON-MEDICATED SKIN TANNING PREPARATION (U.S. CLS. 1, 4, 6, 50, 51 AND 52).

JULIE GUTTADAURO, EXAMINING ATTORNEY

CLASS 3—(Continued).

SN 85-255,406. L'OREAL USA CREATIVE, INC., NEW YORK, NY. FILED 3-2-2011.

FIT FINDER

THE MARK CONSISTS OF STANDARD CHARACTERS WITHOUT CLAIM TO ANY PARTICULAR FONT, STYLE, SIZE, OR COLOR.

FOR COSMETICS AND A MAKEUP SHADE SELECTION SYSTEM COMPRISING PRIMARILY OF FOUNDATION MAKEUP, FACE POWDER, BLUSH, AND CONCEALER (U.S. CLS. 1, 4, 6, 50, 51 AND 52).

EMILY CHUO, EXAMINING ATTORNEY

SN 85-255,398. AUSTRALIAN GOLD, LLC, INDIANAPOLIS, IN. FILED 3-2-2011.

PURPLE REIGN

THE MARK CONSISTS OF STANDARD CHARACTERS WITHOUT CLAIM TO ANY PARTICULAR FONT, STYLE, SIZE, OR COLOR.

FOR INDOOR AND OUTDOOR NON-MEDICATED SKIN TANNING PREPARATION (U.S. CLS. 1, 4, 6, 50, 51 AND 52).

JULIE GUTTADAURO, EXAMINING ATTORNEY

SN 85-255,418. L'OREAL USA CREATIVE, INC., NEW YORK, NY. FILED 3-2-2011.

SUPERSTAY 10 STAIN GLOSS

THE MARK CONSISTS OF STANDARD CHARACTERS WITHOUT CLAIM TO ANY PARTICULAR FONT, STYLE, SIZE, OR COLOR.

OWNER OF U.S. REG. NOS. 3,131,107, 3,674,338 AND OTHERS.

NO CLAIM IS MADE TO THE EXCLUSIVE RIGHT TO USE "STAIN GLOSS", APART FROM THE MARK AS SHOWN.

FOR LIP COLOR (U.S. CLS. 1, 4, 6, 50, 51 AND 52).
EMILY CHUO, EXAMINING ATTORNEY

SN 85-255,401. L'OREAL USA CREATIVE, INC., NEW YORK, NY. FILED 3-2-2011.

SPACE PASTE

THE MARK CONSISTS OF STANDARD CHARACTERS WITHOUT CLAIM TO ANY PARTICULAR FONT, STYLE, SIZE, OR COLOR.

NO CLAIM IS MADE TO THE EXCLUSIVE RIGHT TO USE "PASTE", APART FROM THE MARK AS SHOWN.

FOR HAIR STYLING PREPARATION (U.S. CLS. 1, 4, 6, 50, 51 AND 52).

EMILY CHUO, EXAMINING ATTORNEY

SN 85-255,424. AUSTRALIAN GOLD, LLC, INDIANAPOLIS, IN. FILED 3-2-2011.

CAST IN COLOR

THE MARK CONSISTS OF STANDARD CHARACTERS WITHOUT CLAIM TO ANY PARTICULAR FONT, STYLE, SIZE, OR COLOR.

FOR INDOOR AND OUTDOOR NON-MEDICATED SKIN TANNING PREPARATION (U.S. CLS. 1, 4, 6, 50, 51 AND 52).

JOHN DWYER, EXAMINING ATTORNEY

CLASS 3—(Continued).

SN 85-255,432. AUSTRALIAN GOLD, LLC, INDIANAPOLIS, IN. FILED 3-2-2011.

POLISH ME PERFECT

THE MARK CONSISTS OF STANDARD CHARACTERS WITHOUT CLAIM TO ANY PARTICULAR FONT, STYLE, SIZE, OR COLOR.

FOR INDOOR AND OUTDOOR NON-MEDICATED SKIN TANNING PREPARATION (U.S. CLS. 1, 4, 6, 50, 51 AND 52).

JOHN DWYER, EXAMINING ATTORNEY

CLASS 3—(Continued).

SN 85-255,468. AUSTRALIAN GOLD, LLC, INDIANAPOLIS, IN. FILED 3-2-2011.

GLOW SCIENCE

THE MARK CONSISTS OF STANDARD CHARACTERS WITHOUT CLAIM TO ANY PARTICULAR FONT, STYLE, SIZE, OR COLOR.

FOR INDOOR AND OUTDOOR NON-MEDICATED SKIN TANNING PREPARATION (U.S. CLS. 1, 4, 6, 50, 51 AND 52).

JOHN DWYER, EXAMINING ATTORNEY

SN 85-255,441. AUSTRALIAN GOLD, LLC, INDIANAPOLIS, IN. FILED 3-2-2011.

BE ETERNAL

THE MARK CONSISTS OF STANDARD CHARACTERS WITHOUT CLAIM TO ANY PARTICULAR FONT, STYLE, SIZE, OR COLOR.

FOR INDOOR AND OUTDOOR NON-MEDICATED SKIN TANNING PREPARATION (U.S. CLS. 1, 4, 6, 50, 51 AND 52).

JOHN DWYER, EXAMINING ATTORNEY

SN 85-255,483. AUSTRALIAN GOLD, LLC, INDIANAPOLIS, IN. FILED 3-2-2011.

HD MILLIONAIRE

THE MARK CONSISTS OF STANDARD CHARACTERS WITHOUT CLAIM TO ANY PARTICULAR FONT, STYLE, SIZE, OR COLOR.

FOR INDOOR AND OUTDOOR NON-MEDICATED SKIN TANNING PREPARATION (U.S. CLS. 1, 4, 6, 50, 51 AND 52).

JOHN DWYER, EXAMINING ATTORNEY

SN 85-255,452. AUSTRALIAN GOLD, LLC, INDIANAPOLIS, IN. FILED 3-2-2011.

BARE SCIENCE

THE MARK CONSISTS OF STANDARD CHARACTERS WITHOUT CLAIM TO ANY PARTICULAR FONT, STYLE, SIZE, OR COLOR.

FOR INDOOR AND OUTDOOR NON-MEDICATED SKIN TANNING PREPARATION (U.S. CLS. 1, 4, 6, 50, 51 AND 52).

JOHN DWYER, EXAMINING ATTORNEY

SN 85-255,526. AUSTRALIAN GOLD, LLC, INDIANAPOLIS, IN. FILED 3-2-2011.

COLOR IQ

THE MARK CONSISTS OF STANDARD CHARACTERS WITHOUT CLAIM TO ANY PARTICULAR FONT, STYLE, SIZE, OR COLOR.

FOR INDOOR AND OUTDOOR NON-MEDICATED SKIN TANNING PREPARATION (U.S. CLS. 1, 4, 6, 50, 51 AND 52).

JULIE GUTTADAURO, EXAMINING ATTORNEY

CLASS 3—(Continued).

SN 85-255,549. LARD-TM, LLC, ENGLEWOOD, NJ. FILED 3-2-2011.

GLAMBITION

THE MARK CONSISTS OF STANDARD CHARACTERS WITHOUT CLAIM TO ANY PARTICULAR FONT, STYLE, SIZE, OR COLOR.
FOR COSMETICS (U.S. CLS. 1, 4, 6, 50, 51 AND 52).
JAMES LOVELACE, EXAMINING ATTORNEY

SN 85-255,947. AYA, INC., TOKYO, JAPAN, FILED 3-2-2011.

Scandal Queen

THE MARK CONSISTS OF STANDARD CHARACTERS WITHOUT CLAIM TO ANY PARTICULAR FONT, STYLE, SIZE, OR COLOR.
PRIORITY CLAIMED UNDER SEC. 44(D) ON JAPAN APPLICATION NO. 2010-070326, FILED 9-7-2010.
FOR COSMETICS (U.S. CLS. 1, 4, 6, 50, 51 AND 52).
FIRST USE 1-25-2011; IN COMMERCE 1-25-2011.
SEAN CROWLEY, EXAMINING ATTORNEY

SN 85-255,993. C7 GLOBAL, LLC, SAN JUAN, PUERTO RICO, FILED 3-2-2011.



THE COLOR(S) RED, YELLOW, BLACK AND WHITE IS/ ARE CLAIMED AS A FEATURE OF THE MARK.
THE MARK CONSISTS OF THE WHITE WORDS "ULTRA YEP YEP! NOW MY LAUNDRY IS FRESH & CLEAN!" WITH BLACK OUTLINING WITH A RED CIRCLE BEHIND "YEP" AND YELLOW BUBBLE LIKE DESIGNS AROUND AND WITHIN THE CIRCLE.
FOR DETERGENT SOAP; DETERGENTS FOR HOUSEHOLD USE; LAUNDRY DETERGENT; LAUNDRY DETERGENTS (U.S. CLS. 1, 4, 6, 50, 51 AND 52).
FIRST USE 2-4-2011; IN COMMERCE 2-4-2011.
VIVIAN MICZNIK FIRST, EXAMINING ATTORNEY

CLASS 3—(Continued).

SN 85-256,310. SWEETEREX LLC, DBA KINEVATIVE, SPRINGFIELD, MO. FILED 3-2-2011.

 **Dermapril-SP**

THE MARK CONSISTS OF THE WORDING "DERMAPRIL-SP" ADJACENT TO A PATTERN COMPRISED OF CONNECTED OCTAGONS
FOR ANTI-AGING CREAM (U.S. CLS. 1, 4, 6, 50, 51 AND 52).
RONALD MCMORROW, EXAMINING ATTORNEY

SN 85-256,402. OWEN, JACKIE, LAGUNA BEACH, CA. FILED 3-3-2011.

MAVERICKS

THE MARK CONSISTS OF STANDARD CHARACTERS WITHOUT CLAIM TO ANY PARTICULAR FONT, STYLE, SIZE, OR COLOR.
FOR COSMETICS AND MAKE-UP; NON-MEDICATED SKIN CARE PREPARATIONS; PERFUME; SUN CARE LOTIONS (U.S. CLS. 1, 4, 6, 50, 51 AND 52).
ELISSA GARBER KON, EXAMINING ATTORNEY

SN 85-256,605. GK WORLD HOLDING LLC, FORT LAUDERDALE, FL. FILED 3-3-2011.

NELOIR

THE MARK CONSISTS OF STANDARD CHARACTERS WITHOUT CLAIM TO ANY PARTICULAR FONT, STYLE, SIZE, OR COLOR.
FOR HAIR SHAMPOOS AND CONDITIONERS; HAIR STRAIGHTENING PREPARATIONS (U.S. CLS. 1, 4, 6, 50, 51 AND 52).
DARRYL SPRUILL, EXAMINING ATTORNEY

CLASS 3—(Continued).

SN 85-256,765. CLCM ASSOCIATES LLC, DBA VPI, CLIFTON, NJ. FILED 3-3-2011.

FORGET ABOUT THE FUTURE

THE MARK CONSISTS OF STANDARD CHARACTERS WITHOUT CLAIM TO ANY PARTICULAR FONT, STYLE, SIZE, OR COLOR.

FOR COSMETIC SKIN CARE PRODUCTS THAT ADDRESS AGING, NAMELY, CLEANSERS, TONICS, MOISTURIZERS, MASKS, EXFOLIATORS, FOUNDATIONS, PRIMERS, EYE GELS AND CREAMS AND CONCEALERS (U.S. CLS. 1, 4, 6, 50, 51 AND 52).
WILLIAM ROSSMAN, EXAMINING ATTORNEY

SN 85-256,803. CLCM ASSOCIATES LLC, DBA VPI, CLIFTON, NJ. FILED 3-3-2011.

REMAIN CALM

THE MARK CONSISTS OF STANDARD CHARACTERS WITHOUT CLAIM TO ANY PARTICULAR FONT, STYLE, SIZE, OR COLOR.

FOR SKIN CARE PRODUCTS FOR SENSITIVE SKIN PRONE TO REDNESS, IRRITATION AND INFLAMMATION, NAMELY, CLEANSERS, TONICS, MOISTURIZERS, MASKS, EXFOLIATORS, FOUNDATIONS, PRIMERS, EYE GELS AND CREAMS AND POWDERS (U.S. CLS. 1, 4, 6, 50, 51 AND 52).
WILLIAM ROSSMAN, EXAMINING ATTORNEY

SN 85-256,842. FOREST FINKELSTEIN, NEW YORK, NY. FILED 3-3-2011.

PowerFill

THE MARK CONSISTS OF STANDARD CHARACTERS WITHOUT CLAIM TO ANY PARTICULAR FONT, STYLE, SIZE, OR COLOR.

FOR CLEANING AND WASHING PREPARATIONS (U.S. CLS. 1, 4, 6, 50, 51 AND 52).
MARGARET POWER, EXAMINING ATTORNEY

CLASS 3—(Continued).

SN 85-256,923. UNDER THE WILLOW, LLC, CAMBRIDGE, MD. FILED 3-3-2011.

Cottage & Castle

THE MARK CONSISTS OF STANDARD CHARACTERS WITHOUT CLAIM TO ANY PARTICULAR FONT, STYLE, SIZE, OR COLOR.

FOR NATURAL HOUSEHOLD CLEANER (U.S. CLS. 1, 4, 6, 50, 51 AND 52).
FIRST USE 11-15-2009; IN COMMERCE 11-15-2009.
DOMINIC J. FERRAIUOLO, EXAMINING ATTORNEY

SN 85-257,028. CLCM ASSOCIATES LLC, DBA VPI, CLIFTON, NJ. FILED 3-3-2011.

**CHANGE THE WAY YOU SEE
GNIHTYREVE**

THE MARK CONSISTS OF STANDARD CHARACTERS WITHOUT CLAIM TO ANY PARTICULAR FONT, STYLE, SIZE, OR COLOR.

FOR COSMETICS, NAMELY, FACE POWDERS, POWDER EYESHADOW, POWDER BLUSH, CREAM EYESHADOW, FOUNDATIONS IN POWDER, CREAM, CREAM TO POWDER, LIQUID AND GEL FORMULATIONS, BROW POWDERS, CREAMS, WAXES AND PENCILS, FACE PRIMERS, HIGHLIGHTERS, AND CONCEALERS (U.S. CLS. 1, 4, 6, 50, 51 AND 52).
WILLIAM ROSSMAN, EXAMINING ATTORNEY

SN 85-257,042. YZY INC, MIAMI, FL. FILED 3-3-2011.

SETAI

THE MARK CONSISTS OF STANDARD CHARACTERS WITHOUT CLAIM TO ANY PARTICULAR FONT, STYLE, SIZE, OR COLOR.

FOR COLOGNES, PERFUMES AND COSMETICS; EAU DE TOILETTE AND EAU DE COLOGNE; PERFUMES, EAU DE COLOGNES AND AFTERSHAVES (U.S. CLS. 1, 4, 6, 50, 51 AND 52).
FIRST USE 12-15-2008; IN COMMERCE 6-10-2010.
JACLYN KIDWELL WALKER, EXAMINING ATTORNEY

CLASS 3—(Continued).

SN 85-257,095. RETAIL ROYALTY COMPANY, LAS VEGAS, NV. FILED 3-3-2011.

LAUGHING LIPS

THE MARK CONSISTS OF STANDARD CHARACTERS WITHOUT CLAIM TO ANY PARTICULAR FONT, STYLE, SIZE, OR COLOR.

NO CLAIM IS MADE TO THE EXCLUSIVE RIGHT TO USE "LIPS", APART FROM THE MARK AS SHOWN.

FOR LIP BALM; LIP GLOSS; LIPSTICK (U.S. CLS. 1, 4, 6, 50, 51 AND 52).

FONG HSU, EXAMINING ATTORNEY

SN 85-257,192. CLCM ASSOCIATES LLC, DBA VPI, CLIFTON, NJ. FILED 3-3-2011.

WHO CAN BETRAY THE SUN

THE MARK CONSISTS OF STANDARD CHARACTERS WITHOUT CLAIM TO ANY PARTICULAR FONT, STYLE, SIZE, OR COLOR.

FOR SUN SCREEN, SELF-TANNING PREPARATIONS, AFTER SUN CREAMS, AND COSMETICS WITH SUN SCREEN, NAMELY, FOUNDATION, FACE PRIMER, EYE PRIMER, LIP PRIMER AND FACE AND BODY CREAMS (U.S. CLS. 1, 4, 6, 50, 51 AND 52).

WILLIAM ROSSMAN, EXAMINING ATTORNEY

CLASS 3—(Continued).

SN 85-257,287. CHOWAIKI, ALBERTO, SAN DIEGO, CA. AND CHOWAIKI, RONDA LYN, SAN DIEGO, CA. FILED 3-3-2011.

RONDA'S CLOSET

THE MARK CONSISTS OF STANDARD CHARACTERS WITHOUT CLAIM TO ANY PARTICULAR FONT, STYLE, SIZE, OR COLOR.

FOR BABY BUBBLE BATH; BATH AND SHOWER GELS AND SALTS NOT FOR MEDICAL PURPOSES; BATH BEADS; BATH CREAM; BATH CRYSTALS; BATH FIZZIES; BATH FLAKES; BATH FOAM; BATH FOAMS; BATH GEL; BATH GELS; BATH HERBS; BATH LOTION; BATH MILKS; BATH OIL; BATH OILS; BATH OILS AND BATH SALTS; BATH OILS FOR COSMETIC PURPOSES; BATH PEARLS; BATH POWDER; BATH SALTS; BATH SALTS; BATH SOAPS; BATH SOAPS IN LIQUID, SOLID OR GEL FORM; BATHING LOTIONS; BODY AND BEAUTY CARE COSMETICS; BUBBLE BATH; COLOGNES, PERFUMES AND COSMETICS; COSMETIC BATH SALTS; COSMETIC CREAMS FOR SKIN CARE; COSMETIC HAND CREAMS; COSMETIC MASSAGE CREAMS; COSMETIC NOURISHING CREAMS; COSMETIC OILS; COSMETIC PREPARATIONS FOR BATH AND SHOWER; COSMETICS; COSMETICS AND COSMETIC PREPARATIONS; COSMETICS AND MAKE-UP; FOAM BATH; GIFT BASKETS CONTAINING NON-MEDICATED BATH PREPARATIONS AND COSMETIC PREPARATIONS; LIQUID BATH SOAPS; LIQUID SOAP USED IN FOOT BATH; MINERAL SALT IN THE NATURE OF BATH SALTS NOT FOR MEDICAL PURPOSES; NON-MEDICATED BATH PREPARATIONS; NON-MEDICATED BATH SALTS; NON-MEDICATED BUBBLE BATH PREPARATIONS; OIL BATHS FOR HAIR CARE; PRE-MOISTENED COSMETIC TOWELETES; PRE-MOISTENED COSMETIC WIPES; SCENTED BATHING SALTS; SHOWER AND BATH FOAM; SKIN AND BODY TOPICAL LOTIONS, CREAMS AND OILS FOR COSMETIC USE; SKIN CONDITIONING CREAMS FOR COSMETIC PURPOSES (U.S. CLS. 1, 4, 6, 50, 51 AND 52).

FIRST USE 1-1-2002; IN COMMERCE 1-1-2002.

ANNE MADDEN, EXAMINING ATTORNEY

SN 85-257,702. E I H DISTRIBUTING INC., MORGANTOWN, WV. FILED 3-4-2011.

SANZI

THE MARK CONSISTS OF STANDARD CHARACTERS WITHOUT CLAIM TO ANY PARTICULAR FONT, STYLE, SIZE, OR COLOR.

FOR (BASED ON USE IN COMMERCE) HAIR SHAMPOO(BASED ON INTENT TO USE) HAIR CONDITIONERS (U.S. CLS. 1, 4, 6, 50, 51 AND 52).

FIRST USE 11-23-2010; IN COMMERCE 12-3-2010.

ZACHARY BELLO, EXAMINING ATTORNEY

CLASS 3—(Continued).

SN 85-257,724. DE LA CRUZ G., JUAN A., SANTO DOMINGO, DOMINICAN REP, FILED 3-4-2011.



NO CLAIM IS MADE TO THE EXCLUSIVE RIGHT TO USE "LINE", APART FROM THE MARK AS SHOWN.

THE COLOR(S) RED, WHITE, GREEN IS/ARE CLAIMED AS A FEATURE OF THE MARK.

THE MARK CONSISTS OF THE WORD "VICTALIA", IN A STYLIZED RAISED WHITE FONT; WITH A WHITE ARC EXTENDING OFF THE TOP OF THE LEADING EDGE OF THE "V"; ATTACHING TO A STYLIZED GREEN LEAF, APPEARING BEHIND THE LETTERS, "I" AND "C"; WITH A WHITE UNDERLINE OF THE "VICTALIA" WORD, INTERRUPTED BY THE WORD "LINE", IN A WHITE, ITALICIZED, CURSIVE FONT ALL ON A RED BACKGROUND.

FOR COLORING PREPARATIONS FOR COSMETIC PURPOSES; COSMETIC CREAMS; HAIR COLOR REMOVERS; HAIR COLORANTS; HAIR CONDITIONERS; HAIR DYES; LOTIONS FOR COSMETIC PURPOSES; PERFUMES; SHAMPOOS (U.S. CLS. 1, 4, 6, 50, 51 AND 52).

KIMBERLY PERRY, EXAMINING ATTORNEY

SN 85-258,449. THERAPY SYSTEMS, INC., NASHVILLE, TN, FILED 3-4-2011.

duck call primer

THE MARK CONSISTS OF STANDARD CHARACTERS WITHOUT CLAIM TO ANY PARTICULAR FONT, STYLE, SIZE, OR COLOR.

NO CLAIM IS MADE TO THE EXCLUSIVE RIGHT TO USE "PRIMER", APART FROM THE MARK AS SHOWN.

FOR LIP BALM (U.S. CLS. 1, 4, 6, 50, 51 AND 52).

MARILYN IZZI, EXAMINING ATTORNEY

SN 85-258,613. JLMH CONCEPTS, INC., DALLAS, TX, FILED 3-4-2011.

In Reverse

THE MARK CONSISTS OF STANDARD CHARACTERS WITHOUT CLAIM TO ANY PARTICULAR FONT, STYLE, SIZE, OR COLOR.

FOR CLEANSING LOTIONS FOR FACIAL CLEANSING; BEAUTY SERUMS; EYE CREAMS; NON-MEDICATED BEAUTY TONICS TO LESSEN THE APPEARANCE OF AGE SPOTS AND SKIN DISCOLORATION (U.S. CLS. 1, 4, 6, 50, 51 AND 52).

Laurie Mayes, Examining Attorney

CLASS 3—(Continued).

SN 85-259,228. SIROT, ELLEN, MT. KISCO, NY, FILED 3-6-2011.

Eye Perfection

THE MARK CONSISTS OF STANDARD CHARACTERS WITHOUT CLAIM TO ANY PARTICULAR FONT, STYLE, SIZE, OR COLOR.

OWNER OF U.S. REG. NO. 3,677,595.

NO CLAIM IS MADE TO THE EXCLUSIVE RIGHT TO USE "EYE", APART FROM THE MARK AS SHOWN.

FOR BEAUTY CREAMS FOR BODY CARE; BODY AND BEAUTY CARE COSMETICS; COSMETIC CREAMS FOR SKIN CARE; COSMETIC PREPARATIONS FOR BODY CARE; COSMETIC PREPARATIONS FOR EYE LASHES; EYE COMPRESSES FOR COSMETIC PURPOSES; EYE CREAM; EYE GELS; EYE LINER; EYE LOTIONS; EYE MAKE-UP; EYE MAKE-UP REMOVER; EYE PENCILS; EYE SHADOW; EYE SHADOWS; EYE SHADOW; EYES MAKE-UP; EYES PENCILS; GEL EYE MASKS; GEL FOR EYES; SACHET-LIKE EYE PILLOWS CONTAINING FRAGRANCES; UNDER-EYE ENHANCERS; WRINKLE REMOVING SKIN CARE PREPARATIONS (U.S. CLS. 1, 4, 6, 50, 51 AND 52).

Wendy Jun, Examining Attorney

SN 85-260,622. L'OREAL USA CREATIVE, INC., NEW YORK, NY, FILED 3-8-2011.

CLEAN BREW

THE MARK CONSISTS OF STANDARD CHARACTERS WITHOUT CLAIM TO ANY PARTICULAR FONT, STYLE, SIZE, OR COLOR.

NO CLAIM IS MADE TO THE EXCLUSIVE RIGHT TO USE "CLEAN", APART FROM THE MARK AS SHOWN.

FOR HAIR CARE PREPARATIONS AND BODY WASH (U.S. CLS. 1, 4, 6, 50, 51 AND 52).

Emily Chuo, Examining Attorney

CLASS 3—(Continued).

SN 85-261,497. ZERRAN INTERNATIONAL CORPORATION, PACOIMA, CA. FILED 3-8-2011.

ZERRAN REALLISSE

THE MARK CONSISTS OF STANDARD CHARACTERS WITHOUT CLAIM TO ANY PARTICULAR FONT, STYLE, SIZE, OR COLOR.

OWNER OF U.S. REG. NOS. 1,819,635, 2,235,272 AND 3,454,748.

THE WORDING "ZERRAN REALLISSE" IS A COINED TERM AND HAS NO MEANING IN THE APPLICANT'S TRADE/INDUSTRY AND NO MEANING IN ANY FOREIGN LANGUAGE.

FOR HAIR CARE PREPARATIONS; HAIR SHAMPOOS AND CONDITIONERS (U.S. CLS. 1, 4, 6, 50, 51 AND 52). FIRST USE 1-30-2010; IN COMMERCE 1-30-2010. THOMAS MANOR, EXAMINING ATTORNEY

SN 85-261,931. PALMS FASHION, INC, NEW YORK, NY. FILED 3-9-2011.

LANELL

THE MARK CONSISTS OF STANDARD CHARACTERS WITHOUT CLAIM TO ANY PARTICULAR FONT, STYLE, SIZE, OR COLOR.

OWNER OF U.S. REG. NOS. 3,960,241 AND 3,963,911. FOR ADHESIVES FOR AFFIXING FALSE HAIR; GLUE REMOVERS (U.S. CLS. 1, 4, 6, 50, 51 AND 52). FIRST USE 9-25-2006; IN COMMERCE 9-25-2006. WENDY JUN, EXAMINING ATTORNEY

CLASS 3—(Continued).

SN 85-262,155. FIRST AMERICAN BRANDS, INC., NEW YORK, NY. FILED 3-9-2011.

BBNY
BESTBRANDNEWYORK

NO CLAIM IS MADE TO THE EXCLUSIVE RIGHT TO USE "BESTBRANDNEWYORK", APART FROM THE MARK AS SHOWN.

THE MARK CONSISTS OF "BBNY" ABOVE "BESTBRANDNEWYORK" IN A SMALLER TYPEFACE.

FOR COLOGNES, PERFUMES AND COSMETICS; COSMETICS IN GENERAL, INCLUDING PERFUMES; DISINFECTING PERFUMED SOAPS; EAU DE PERFUME; ESSENTIAL OILS AS PERFUME FOR LAUNDRY PURPOSES; LIQUID PERFUMES; OILS FOR PERFUMES AND SCENTS; PERFUME; PERFUME OILS; PERFUME OILS FOR THE MANUFACTURE OF COSMETIC PREPARATIONS; PERFUMED CREAMS; PERFUMED EXTRACTS FOR TISSUES AND PERFUMES; PERFUMED PASTE; PERFUMED POWDER; PERFUMED POWDERS; PERFUMED SOAP; PERFUMED SOAPS; PERFUMED TALCUM POWDER; PERFUMES; PERFUMES AND COLOGNES; PERFUMES AND TOILET WATERS; PERFUMES, AFTERSHAVES AND COLOGNES; PERFUMES, EAU DE COLOGNES AND AFTERSHAVES; PERFUMES, EAUX DE COLOGNE AND AFTERSHAVES; PERFUMING SACHETS (U.S. CLS. 1, 4, 6, 50, 51 AND 52). MATTHEW KLINE, EXAMINING ATTORNEY

SN 85-266,964. NEW VITALITY, FARMINGDALE, NY. FILED 3-15-2011.

Incredible Legs

THE MARK CONSISTS OF STANDARD CHARACTERS WITHOUT CLAIM TO ANY PARTICULAR FONT, STYLE, SIZE, OR COLOR.

NO CLAIM IS MADE TO THE EXCLUSIVE RIGHT TO USE "LEGS", APART FROM THE MARK AS SHOWN.

FOR CONCEALERS; COSMETIC PREPARATIONS; COSMETIC PREPARATIONS FOR SKIN CARE; COSMETIC PREPARATIONS FOR SKIN RENEWAL; NON-MEDICATED SKIN CARE CREAMS AND LOTIONS (U.S. CLS. 1, 4, 6, 50, 51 AND 52).

FIRST USE 4-15-2011; IN COMMERCE 4-15-2011. ELISSA GARBER KON, EXAMINING ATTORNEY

CLASS 3—(Continued).

SN 85-267,190. RETAIL ROYALTY COMPANY, LAS VEGAS, NV. FILED 3-15-2011.

CHEERFUL CHEEKS

THE MARK CONSISTS OF STANDARD CHARACTERS WITHOUT CLAIM TO ANY PARTICULAR FONT, STYLE, SIZE, OR COLOR.

NO CLAIM IS MADE TO THE EXCLUSIVE RIGHT TO USE "CHEEKS", APART FROM THE MARK AS SHOWN.

FOR COSMETICS, NAMELY, BLUSH (U.S. CLS. 1, 4, 6, 50, 51 AND 52).

FONG HSU, EXAMINING ATTORNEY

CLASS 3—(Continued).

SN 85-282,293. LANCOME PARFUMS ET BEAUTE & CIE, PARIS, FRANCE, FILED 3-31-2011.

MIRACLE EFFECT

THE MARK CONSISTS OF STANDARD CHARACTERS WITHOUT CLAIM TO ANY PARTICULAR FONT, STYLE, SIZE, OR COLOR.

OWNER OF U.S. REG. NOS. 2,584,294, 3,614,539 AND OTHERS.

FOR MAKEUP BASE, FOUNDATION MAKEUP (U.S. CLS. 1, 4, 6, 50, 51 AND 52).

EDWARD NELSON, EXAMINING ATTORNEY

SN 85-276,644. L'OREAL, PARIS, FRANCE, FILED 3-25-2011.

LUMI MAGIC

THE MARK CONSISTS OF STANDARD CHARACTERS WITHOUT CLAIM TO ANY PARTICULAR FONT, STYLE, SIZE, OR COLOR.

FOR MAKEUP PREPARATIONS (U.S. CLS. 1, 4, 6, 50, 51 AND 52).

SIMON TENG, EXAMINING ATTORNEY

SN 85-278,291. PHILOSOPHY, INC., PHOENIX, AZ. FILED 3-28-2011.

PHILOSOPHY BABY

THE MARK CONSISTS OF STANDARD CHARACTERS WITHOUT CLAIM TO ANY PARTICULAR FONT, STYLE, SIZE, OR COLOR.

OWNER OF U.S. REG. NOS. 2,016,208, 3,440,195 AND OTHERS.

NO CLAIM IS MADE TO THE EXCLUSIVE RIGHT TO USE "BABY", APART FROM THE MARK AS SHOWN.

FOR BABY HEAD-TO-TOE BODY WASH; NON-MEDICATED DIAPER CREAM; BABY BODY LOTION (U.S. CLS. 1, 4, 6, 50, 51 AND 52).

ALICIA COLLINS, EXAMINING ATTORNEY

SN 85-291,292. ALETHIA SKIN CARE LLC, ARDMORE, PA. FILED 4-11-2011.

SYMPHONY OF INGREDIENTS

THE MARK CONSISTS OF STANDARD CHARACTERS WITHOUT CLAIM TO ANY PARTICULAR FONT, STYLE, SIZE, OR COLOR.

FOR NON-MEDICATED SKIN CARE PREPARATIONS, NAMELY, CREAMS, LOTIONS, GELS, TONERS, CLEANSERS AND PEELS; HAIR CARE PRODUCTS, NAMELY, SHAMPOOS AND CONDITIONERS (U.S. CLS. 1, 4, 6, 50, 51 AND 52).

BARBARA GAYNOR, EXAMINING ATTORNEY

SN 85-291,362. L'OREAL, PARIS, FRANCE, FILED 4-11-2011.

EXPERT AT BEING A MAN

THE MARK CONSISTS OF STANDARD CHARACTERS WITHOUT CLAIM TO ANY PARTICULAR FONT, STYLE, SIZE, OR COLOR.

OWNER OF U.S. REG. NO. 3,233,924.

FOR NON-MEDICATED SKINCARE PREPARATIONS (U.S. CLS. 1, 4, 6, 50, 51 AND 52).

SIMON TENG, EXAMINING ATTORNEY

CLASS 3—(Continued).

SN 85-300,969. PROCTER & GAMBLE INTERNATIONAL OPERATIONS, S.A., PETIT-LANCY, SWITZERLAND, FILED 4-21-2011.

GHOST

THE MARK CONSISTS OF STANDARD CHARACTERS WITHOUT CLAIM TO ANY PARTICULAR FONT, STYLE, SIZE, OR COLOR.

OWNER OF SWITZERLAND REG. NO. 550438, DATED 9-21-2006, EXPIRES 8-10-2014.

FOR PERFUMES, PERFUME OILS, ESSENTIAL OILS, FRAGRANCES, COLOGNES, TOILET WATER, EAU DE COLOGNE, EAU DE PERFUME, SOAPS, BATH GEL, SHOWER GEL, BATH FOAMS, DEODORANTS FOR PERSONAL USE, SKIN CREAMS, BODY LOTION AND COSMETICS (U.S. CLS. 1, 4, 6, 50, 51 AND 52).
WENDY GOODMAN, EXAMINING ATTORNEY

SN 85-302,160. CONCEPT LABORATORIES, INC., CHICAGO, IL. FILED 4-22-2011.

EVENZA

THE MARK CONSISTS OF STANDARD CHARACTERS WITHOUT CLAIM TO ANY PARTICULAR FONT, STYLE, SIZE, OR COLOR.

THE WORDING "EVENZA" HAS NO MEANING IN A FOREIGN LANGUAGE.

FOR NON-MEDICATED SKIN CARE PREPARATIONS, NAMELY, LOTIONS, CREAMS, SERUMS AND LIQUIDS (U.S. CLS. 1, 4, 6, 50, 51 AND 52).

KIM MONINGHOFF, EXAMINING ATTORNEY

SN 85-310,561. GONZALEZ AND TAPANES FOODS, INC., MOONACHIE, NJ. FILED 5-3-2011.

CANDADO

THE MARK CONSISTS OF STANDARD CHARACTERS WITHOUT CLAIM TO ANY PARTICULAR FONT, STYLE, SIZE, OR COLOR.

THE ENGLISH TRANSLATION OF THE SPANISH WORD "CANDADO" IN THE MARK IS "PADLOCK".

FOR LAUNDRY DETERGENT (U.S. CLS. 1, 4, 6, 50, 51 AND 52).

JAMES MACFARLANE, EXAMINING ATTORNEY

CLASS 3—(Continued).

SN 85-311,838. AUSTRALIAN GOLD, LLC, INDIANAPOLIS, IN. FILED 5-4-2011.

RESTORED

THE MARK CONSISTS OF A STYLIZED VERSION OF THE WORD "RESTORED".

FOR NON-MEDICATED SKIN CARE PREPARATIONS (U.S. CLS. 1, 4, 6, 50, 51 AND 52).

JULIE GUTTADAURO, EXAMINING ATTORNEY

SN 85-330,218. LAURICE EL BADRY RAHME LTD. DBA LAURICE & CO., NEW YORK, NY. FILED 5-25-2011.

BOND NO. 9 HUDSON YARDS

THE MARK CONSISTS OF STANDARD CHARACTERS WITHOUT CLAIM TO ANY PARTICULAR FONT, STYLE, SIZE, OR COLOR.

OWNER OF U.S. REG. NOS. 2,742,675, 3,883,256 AND OTHERS.

FOR FRAGRANCES FOR PERSONAL USE, NAMELY, PERFUMES, COLOGNES, AND BODY SPRAYS; COSMETICS, NAMELY, NON-MEDICATED SKIN CARE PREPARATIONS, BODY CREAMS, SKIN LOTIONS, SKIN CLEANSERS, SKIN CREAMS, SKIN MOISTURIZERS, MAKEUP, LIPSTICK, FOUNDATION FACE POWDER, EYESHADOW, NAIL POLISH, MASCARA AND EYE PENCILS (U.S. CLS. 1, 4, 6, 50, 51 AND 52).

MAYUR VAGHANI, EXAMINING ATTORNEY

CLASS 4—LUBRICANTS AND FUELS

SN 77-467,541. THE COMFORT CANDLE COMPANY, L.C., COMFORT, TX. FILED 5-7-2008.

Comfort Candle Co.

NO CLAIM IS MADE TO THE EXCLUSIVE RIGHT TO USE "CANDLE CO.", APART FROM THE MARK AS SHOWN.

THE MARK CONSISTS OF THE LITERAL ELEMENT "COMFORT CANDLE CO." IN A STYLIZED FONT.

FOR CANDLES; SCENTED CANDLES (U.S. CLS. 1, 6 AND 15).

ANGELA DUONG, EXAMINING ATTORNEY

CLASS 4—(Continued).

SN 85-068,267. ENVIRACARBON INC, DAYTONA BEACH SHORES, FL. FILED 6-22-2010.

ENVIRACARBON

THE MARK CONSISTS OF STANDARD CHARACTERS WITHOUT CLAIM TO ANY PARTICULAR FONT, STYLE, SIZE, OR COLOR.

FOR BLENDED GREEN BIO-MASS FUEL MADE OF WOOD THAT LOOKS AND BURNS LIKE COAL BUT WITH NEGLIGIBLE ASH AND SULFUR CONTENT (U.S. CLS. 1, 6 AND 15).

FIRST USE 4-23-2010; IN COMMERCE 4-23-2010.
JACQUELINE A. LAVINE, EXAMINING ATTORNEY

CLASS 4—(Continued).

SN 85-252,401. WD-40 COMPANY, SAN DIEGO, CA. FILED 2-25-2011.

MARKSMAN SPOUT

THE MARK CONSISTS OF STANDARD CHARACTERS WITHOUT CLAIM TO ANY PARTICULAR FONT, STYLE, SIZE, OR COLOR.

NO CLAIM IS MADE TO THE EXCLUSIVE RIGHT TO USE "SPOUT", APART FROM THE MARK AS SHOWN.
FOR ALL-PURPOSE PENETRATING AND LUBRICATING OIL (U.S. CLS. 1, 6 AND 15).

STEVEN R. FINE, EXAMINING ATTORNEY

SN 85-248,165. LUVISI, CHRISTINA, PLEASANT HILL, CA. AND LUVISI, SCOTT, PLEASANT HILL, CA. FILED 2-22-2011.

Mystic Candles

THE MARK CONSISTS OF STANDARD CHARACTERS WITHOUT CLAIM TO ANY PARTICULAR FONT, STYLE, SIZE, OR COLOR.

NO CLAIM IS MADE TO THE EXCLUSIVE RIGHT TO USE "CANDLES", APART FROM THE MARK AS SHOWN.
FOR CANDLES (U.S. CLS. 1, 6 AND 15).

FIRST USE 6-1-2010; IN COMMERCE 6-1-2010.
JAMES LOVELACE, EXAMINING ATTORNEY

SN 85-253,359. KAMA CANDLES, INC., SAN DIEGO, CA. FILED 2-28-2011.

KAMA CANDLES

THE MARK CONSISTS OF STANDARD CHARACTERS WITHOUT CLAIM TO ANY PARTICULAR FONT, STYLE, SIZE, OR COLOR.

NO CLAIM IS MADE TO THE EXCLUSIVE RIGHT TO USE "CANDLES", APART FROM THE MARK AS SHOWN.
FOR CANDLES (U.S. CLS. 1, 6 AND 15).

FIRST USE 6-1-2009; IN COMMERCE 6-1-2009.
DOUGLAS LEE, EXAMINING ATTORNEY

SN 85-249,096. GREEN EARTH TECHNOLOGIES, INC., STAMFORD, CT. FILED 2-23-2011.

G-OIL

THE MARK CONSISTS OF STANDARD CHARACTERS WITHOUT CLAIM TO ANY PARTICULAR FONT, STYLE, SIZE, OR COLOR.

OWNER OF U.S. REG. NOS. 3,608,781 AND 3,612,243.
FOR LUBRICATING AND ENGINE OIL FOR WATER-CRAFTS (U.S. CLS. 1, 6 AND 15).

FIRST USE 11-1-2009; IN COMMERCE 11-1-2009.
SHAILA SETTLES, EXAMINING ATTORNEY

SN 85-257,130. LIFE PLUS STYLE LTD., NEW YORK, NY. FILED 3-3-2011.

trompe l'oeil

THE MARK CONSISTS OF STANDARD CHARACTERS WITHOUT CLAIM TO ANY PARTICULAR FONT, STYLE, SIZE, OR COLOR.

THE ENGLISH TRANSLATION OF "TROMPE L'OEIL" IN THE MARK IS "TO FOOL THE EYE".
FOR SCENTED CANDLES; TAPERS (U.S. CLS. 1, 6 AND 15).

FIRST USE 8-25-2010; IN COMMERCE 8-25-2010.
MARLENE BELL, EXAMINING ATTORNEY

CLASS 4—(Continued).

SN 85-257,865. DEEPHAVEN DESIGN, INC., BLOOMINGTON, MN. FILED 3-4-2011.

rareEARTH

THE MARK CONSISTS OF STANDARD CHARACTERS WITHOUT CLAIM TO ANY PARTICULAR FONT, STYLE, SIZE, OR COLOR.

FOR AROMATHERAPY FRAGRANCE CANDLES; CANDLES; PERFUMED CANDLES; SCENTED CANDLES (U.S. CLS. 1, 6 AND 15).

FIRST USE 0-0-2010; IN COMMERCE 0-0-2010.

MARIA-VICTORIA SUAREZ, EXAMINING ATTORNEY

CLASS 4—(Continued).

SN 85-306,376. MVP GROUP INTERNATIONAL, INC., CHARLESTON, SC. FILED 4-27-2011.

COZY COTTAGE

THE MARK CONSISTS OF STANDARD CHARACTERS WITHOUT CLAIM TO ANY PARTICULAR FONT, STYLE, SIZE, OR COLOR.

FOR CANDLES; SCENTED CANDLES (U.S. CLS. 1, 6 AND 15).

GEORGE LORENZO, EXAMINING ATTORNEY

SN 85-301,190. MVP GROUP INTERNATIONAL, INC., CHARLESTON, SC. FILED 4-21-2011.



THE MARK CONSISTS OF A FLAME SHAPE ABOVE A LETTER "W".

FOR CANDLES; SCENTED CANDLES (U.S. CLS. 1, 6 AND 15).

GEORGE LORENZO, EXAMINING ATTORNEY

CLASS 5—PHARMACEUTICALS

SN 76-703,943. S.T.D. PHARMACEUTICAL PRODUCTS LTD., HEREFORD HR4 OEL, ENGLAND, FILED 7-29-2010.



NO CLAIM IS MADE TO THE EXCLUSIVE RIGHT TO USE "3 1 %", APART FROM THE MARK AS SHOWN.

THE MARK CONSISTS OF THE STYLIZED WORDING "FIBRO-VEIN" ABOVE AN OVAL CONTAINING THE WORDING "3 1 %", WHERE THE SHADING INSIDE THE OVAL IS DARKER BEHIND "3 1" THAN IT IS BEHIND THE "%" SYMBOL. TO THE LEFT OF THE LETTER "F" IS A GRAPHIC OF FOUR CURVED LINES WITH VARYING DEGREES OF THICKNESS.

FOR INJECTABLE PHARMACEUTICAL PREPARATION FOR TREATING VARICOSE VEINS (U.S. CLS. 6, 18, 44, 46, 51 AND 52).

ALYSSA STEEL, EXAMINING ATTORNEY

SN 85-302,530. LIFE PLUS STYLE LTD., NEW YORK, NY. FILED 4-22-2011.

ANCIENT WATERS

THE MARK CONSISTS OF STANDARD CHARACTERS WITHOUT CLAIM TO ANY PARTICULAR FONT, STYLE, SIZE, OR COLOR.

FOR FRAGRANT WAX FOR USE IN POTPOURRI BURNERS; SCENTED CANDLES; TAPERS (U.S. CLS. 1, 6 AND 15).

FIRST USE 4-4-2011; IN COMMERCE 4-4-2011.

MARLENE BELL, EXAMINING ATTORNEY

SN 76-704,724. OLDE GRANDDAD INDUSTRIES, INC., KEARNY, NJ. FILED 9-29-2010.

BINACA BLAST

THE MARK CONSISTS OF STANDARD CHARACTERS WITHOUT CLAIM TO ANY PARTICULAR FONT, STYLE, SIZE, OR COLOR.

FOR FRAGRANCE PRODUCTS FOR LAND VEHICLES, AIRCRAFT, MARINE CRAFT, PERSONAL, COMMERCIAL, INDUSTRIAL AND HOME USE, NAMELY, AIR FRESHENERS FOR CARS, ROOMS AND HOUSEHOLDS (U.S. CLS. 6, 18, 44, 46, 51 AND 52).

DAVID I, EXAMINING ATTORNEY

CLASS 5—(Continued).

SN 76-705,249. MIRZA, ASMA, PISCATAWAY, NJ. FILED 11-8-2010.

MIZMAAR

THE MARK CONSISTS OF STANDARD CHARACTERS WITHOUT CLAIM TO ANY PARTICULAR FONT, STYLE, SIZE, OR COLOR.

FOR DIETARY AND NUTRITIONAL SUPPLEMENTS FOR PROVIDING AND MAINTAINING HEALTHY HAIR; NUTRITIONAL SUPPLEMENTS FOR MEDICAL USE; NUTRITIONAL ADDITIVES FOR MEDICAL PURPOSES USED IN FOOD PRODUCTS FOR HUMAN CONSUMPTION; NUTRITIONAL ADDITIVES FOR MEDICAL PURPOSES AND DIETARY SUPPLEMENTS FOR HUMAN CONSUMPTION FOR PROVIDING AND MAINTAINING HEALTHY HAIR; DIETARY AND NUTRITIONAL SUPPLEMENTS FOR STIMULATING HAIR GROWTH, AND PREVENTING HAIR LOSS; DIETARY AND NUTRITIONAL SUPPLEMENTS TO PREVENT AND REVERSE GRAYING HAIR (U.S. CLS. 6, 18, 44, 46, 51 AND 52).

JAMES GRIFFIN, EXAMINING ATTORNEY

CLASS 5—(Continued).

SN 77-184,560. SANOFI, PARIS, FRANCE, FILED 5-18-2007.

XUBIERT

THE MARK CONSISTS OF STANDARD CHARACTERS WITHOUT CLAIM TO ANY PARTICULAR FONT, STYLE, SIZE, OR COLOR.

PRIORITY CLAIMED UNDER SEC. 44(D) ON FRANCE APPLICATION NO. 06/3463759, FILED 11-20-2006, REG. NO. 06/3463759, DATED 11-20-2006, EXPIRES 11-20-2016.

FOR PHARMACEUTICAL PREPARATIONS FOR THE PREVENTION AND TREATMENT OF DISORDERS OF THE NERVOUS SYSTEM, THE IMMUNE SYSTEM, THE CARDIOVASCULAR SYSTEM, THE RESPIRATORY SYSTEM, THE MUSCULOSKELETAL SYSTEM, THE GENITOURINARY SYSTEM, FOR THE TREATMENT OF INFLAMMATORY DISORDERS, FOR USE IN DERMATOLOGY, IN ONCOLOGY, IN OPHTHALMOLOGY, FOR USE IN THE GASTROENTEROLOGICAL AREA AND THE PREVENTION AND TREATMENT OF OCULAR DISORDERS; PHARMACEUTICAL PREPARATIONS FOR THE TREATMENT OF SKIN DISORDERS, CANCER, AND EYE DISORDERS (U.S. CLS. 6, 18, 44, 46, 51 AND 52).

VERNA BETH RIRIE, EXAMINING ATTORNEY

SN 77-213,178. SQI DIAGNOSTICS SYSTEMS INC., TORONTO, ONTARIO, CANADA, FILED 6-22-2007.

SQID

SN 76-706,627. ESSEN NUTRITION CORP., ROMEOVILLE, IL. FILED 3-2-2011.

ISOPOWER

THE MARK CONSISTS OF STANDARD CHARACTERS WITHOUT CLAIM TO ANY PARTICULAR FONT, STYLE, SIZE, OR COLOR.

FOR DIETARY DRINK MIX FOR USE AS A MEAL REPLACEMENT; DIETARY SUPPLEMENTAL DRINKS (U.S. CLS. 6, 18, 44, 46, 51 AND 52).

CORY BOONE, EXAMINING ATTORNEY

THE MARK CONSISTS OF STANDARD CHARACTERS WITHOUT CLAIM TO ANY PARTICULAR FONT, STYLE, SIZE, OR COLOR.

PRIORITY CLAIMED UNDER SEC. 44(D) ON CANADA APPLICATION NO. 1.329,396, FILED 12-22-2006, REG. NO. TMA715,961, DATED 6-5-2008, EXPIRES 6-5-2023.

FOR ASSAY DEVICES FOR THE DETECTION AND QUANTIFICATION OF ANALYTES, NAMELY, MEDICAL DIAGNOSTIC IMMUNO-ASSAYS INVOLVING MICRO-ARRAYS AND THE BINDING OF ANTIBODIES WITH REPORTER LABELS TO ANTIGENS AND USED FOR PROTEOMIC TESTING AND ANTIBODY SCREENING, ALL UNRELATED TO THE MEASURE OF MAGNETIC FIELDS (U.S. CLS. 6, 18, 44, 46, 51 AND 52).

AISHA SALEM, EXAMINING ATTORNEY

CLASS 5—(Continued).

SN 77-353,914. FAIRFIELD CLINICAL TRIALS, LLC, WESTON, CT. FILED 12-17-2007.

MOTHER NURTURE

THE MARK CONSISTS OF STANDARD CHARACTERS WITHOUT CLAIM TO ANY PARTICULAR FONT, STYLE, SIZE, OR COLOR.

FOR NUTRITIONAL SUPPLEMENT FOR POST-PARTUM BREAST FEEDING WOMEN (U.S. CLS. 6, 18, 44, 46, 51 AND 52).

STEVEN R. FINE, EXAMINING ATTORNEY

SN 77-483,339. PACIFICPHARMA CORPORATION, SEOUL, REPUBLIC OF KOREA, FILED 5-26-2008.

ESTURA

THE MARK CONSISTS OF STANDARD CHARACTERS WITHOUT CLAIM TO ANY PARTICULAR FONT, STYLE, SIZE, OR COLOR.

OWNER OF REPUBLIC OF KOREA REG. NO. 40-0865638, DATED 5-23-2011, EXPIRES 5-23-2021.

FOR FOOD FOR BABIES; DIETETIC MILK SUGAR FOR MEDICAL USE; LACTEAL FLOUR FOR USE AS BABY FOOD; NUTRITIVE SUBSTANCES OF MICROORGANISMS FOR MEDICAL AND VETERINARY PURPOSES; FIRST AID KITS; FLY CATCHING PAPER; LINIMENT; PHARMACEUTICAL PREPARATIONS FOR SKIN CARE; ALLERGY MEDICATIONS; PHARMACEUTICAL SKIN LOTIONS; MEDICINAL PREPARATIONS FOR STIMULATING HAIR GROWTH; BALMS FOR MEDICAL PURPOSES; ANTIBIOTIC OINTMENTS; ANTI-INFLAMMATORY OINTMENTS; ANTI-ITCH OINTMENT; HEMORRHOIDAL OINTMENTS; MEDICATED DIAPER RASH OINTMENTS AND LOTIONS; VITAMIN PREPARATIONS; DIET PILLS; DIETETIC FOODS ADAPTED FOR MEDICAL USE; MEAL REPLACEMENT AND DIETARY SUPPLEMENT DRINK MIXES; STIMULATORY MEDICATIONS FOR USE IN WEIGHT REDUCTION PROGRAMS; THERAPEUTIC AGENTS FOR WEIGHT CONTROL AND APPETITE SUPPRESSION; PHARMACEUTICAL PREPARATIONS, NAMELY, APPETITE SUPPRESSANTS; MEDICINAL TEA; ANTI-PHLOGISTIC; POULTICES; MEDICATED COMPRESSES; PHARMACEUTICAL PREPARATIONS FOR TREATING DANDRUFF; SUNBURN PREPARATIONS FOR PHARMACEUTICAL PURPOSES; EYE PATCHES FOR MEDICAL PURPOSES; BANDAGES FOR SKIN WOUNDS; PLASTERS FOR MEDICAL PURPOSES; ANALGESICS; TOPICAL ANALGESICS; ANTI-INFLAMMATORY AND ANTIPYRETIC PREPARATIONS; PHARMACEUTICAL PREPARATIONS FOR USE IN THE TREATMENT OF EPIDERMAL DISEASES, DISEASES OF THE CENTRAL NERVOUS SYSTEM, DISEASES OF THE PERIPHERAL NERVOUS SYSTEM, ALLERGIC REACTIONS, AND TUMORS; ANTIBIOTICS; ANTISEPTICS; MEDICAL PLASTERS; PHARMACEUTICALS FOR THE TREATMENT OF RHEUMATOID ARTHRITIS; ANTI-INFLAMMATORY AGENTS; FEBRIFUGES; ADHESIVE BANDAGES; MEDICAL ADHESIVE TAPE; ADJUVANTS FOR MEDICAL PURPOSES; ANAESTHETICS; ANTISEPTIC COTTON; BANDAGES FOR DRESSINGS; CHEMICAL REAGENTS FOR MEDICAL PURPOSES; PHARMACEUTICAL PREPARATIONS FOR THE TREATMENT OF DERMATOSIS; CHEMICO-PHARMACEUTICAL PREPARATIONS FOR TREATMENT OF

CLASS 5—(Continued).

INFECTIOUS DISEASES, PAIN, IRRITATION, DRUG DEPENDENCY AND SUPPRESSION OF THE SYMPTOMS OF DRUG WITHDRAWAL, ANEMIA, CARDIOVASCULAR SYSTEM DISEASES, AND ASTHMA RELIEF AND COUGHS; PREPARATIONS FOR CLEANSING THE SKIN FOR MEDICAL USE; DIAGNOSTIC PREPARATIONS FOR MEDICAL PURPOSES; DIGESTIVES FOR PHARMACEUTICAL PURPOSES; FECAL ENZYME INHIBITING COMPOSITIONS USED AS AN INGREDIENT IN MEDICATED CREAMS, OINTMENTS AND LOTIONS; FERMENTS FOR PHARMACEUTICAL PURPOSES; HEMATOGEN; HEMOGLOBIN; HEADACHE TREATMENT PREPARATIONS; LOZENGES FOR PHARMACEUTICAL PURPOSES; NUTRITIVE SUBSTANCES OF MICROORGANISM CULTURES FOR MEDICAL AND VETERINARY USE; REAGENTS FOR MEDICAL OR VETERINARY PURPOSES; SEROTHERAPEUTIC MEDICINES; MEDICATED SERUMS FOR THE TREATMENT OF WOUNDS AND SKINCARE; SICCATIVES FOR MEDICAL PURPOSES; VACCINES; VERMIFUGES; APPETITE SUPPRESSANTS FOR MEDICAL PURPOSES; ADHESIVE BANDAGES; MEDICAL ADHESIVE TAPE; MEDICAL ADHESIVES FOR BINDING WOUNDS; BURN RELIEF MEDICATION; DRESSINGS FOR BURNS; FUNGICIDES; GERMICIDES; PHARMACEUTICAL PREPARATIONS FOR THE PREVENTION AND TREATMENT OF DISORDERS OF THE NERVOUS SYSTEM, THE IMMUNE SYSTEM, THE CARDIOVASCULAR SYSTEM, THE METABOLIC SYSTEM, THE RESPIRATORY SYSTEM, THE MUSCULO-SKELETAL SYSTEM, THE GENITOURINARY SYSTEM; PHARMACEUTICAL PREPARATIONS FOR THE TREATMENT OF INFLAMMATORY DISORDERS; PHARMACEUTICAL PREPARATIONS FOR USE IN DERMATOLOGY, ONCOLOGY, HEMATOLOGY AND IN TISSUE AND ORGAN TRANSPLANTATION, IN OPHTHALMOLOGY, AND FOR GASTROENTEROLOGICAL DISORDERS; PHARMACEUTICAL PREPARATIONS FOR THE PREVENTION AND TREATMENT OF OCULAR DISORDERS OR DISEASES; PHARMACEUTICAL PREPARATIONS FOR THE TREATMENT OF BACTERIA-BASED DISEASES; PHARMACEUTICAL PREPARATIONS FOR THE TREATMENT OF DIABETES; PHARMACEUTICAL PREPARATIONS, NAMELY, ANTI-INFECTIVE PREPARATIONS, ANTIVIRAL PREPARATIONS, ANTIBIOTICS, ANTIFUNGAL PREPARATIONS AND VACCINES (U.S. CLS. 6, 18, 44, 46, 51 AND 52).

KRISTIN CARLSON, EXAMINING ATTORNEY

CLASS 5—(Continued).

SN 77-639,606. GLAXO GROUP LIMITED, GREENFORD, MIDDLESEX, UNITED KINGDOM, FILED 12-24-2008.

JAVOLA

THE MARK CONSISTS OF STANDARD CHARACTERS WITHOUT CLAIM TO ANY PARTICULAR FONT, STYLE, SIZE, OR COLOR.

THE WORDING "JAVOLA" HAS NO MEANING IN A FOREIGN LANGUAGE.

FOR PHARMACEUTICAL PREPARATIONS AND SUBSTANCES FOR THE TREATMENT OF INFECTIOUS DISEASES, BLOOD DISORDERS, PAIN, INFLAMMATION, SEPSIS, ALOPECIA, OBESITY AND COGNITIVE DISORDERS; PHARMACEUTICAL PREPARATIONS AND SUBSTANCES FOR THE TREATMENT OF VIRAL, METABOLIC, ENDOCRINE, MUSCULOSKELETAL, CARDIOVASCULAR, CARDIOPULMONARY, GENITOURINARY, SEXUAL DYSFUNCTION, ONCOLOGICAL, HEPATOLOGICAL, OPHTHALMIC, RESPIRATORY, NEUROLOGICAL, GASTROINTESTINAL, HORMONAL, DERMATOLOGICAL, PSYCHIATRIC AND IMMUNE SYSTEM RELATED DISEASES AND DISORDERS; PHARMACEUTICAL PREPARATIONS AND SUBSTANCES FOR THE TREATMENT OF DAMAGED SKIN AND TISSUE; AND FOR VACCINES (U.S. CLS. 6, 18, 44, 46, 51 AND 52).

RICHARD WHITE, EXAMINING ATTORNEY

CLASS 5—(Continued).

SN 77-826,407. IDEALCLEANSE LLC, TARPON SPRINGS, FL. FILED 9-15-2009.

MAQUISLIM

THE MARK CONSISTS OF STANDARD CHARACTERS WITHOUT CLAIM TO ANY PARTICULAR FONT, STYLE, SIZE, OR COLOR.

FOR DIETARY AND NUTRITIONAL SUPPLEMENTS (U.S. CLS. 6, 18, 44, 46, 51 AND 52).

DAVID ELTON, EXAMINING ATTORNEY

SN 77-923,992. GANDANG KALIKASAN, INC., QUEZON CITY, NCR, PHILIPPINES, FILED 1-29-2010.

HUMAN NATURE

SN 77-790,705. SEIKAGAKU KOGYO KABUSHIKI KAISHA, DBA SEIKAGAKU CORPORATION, TOKYO, JAPAN, FILED 7-27-2009.

ARUSTAK

THE MARK CONSISTS OF STANDARD CHARACTERS WITHOUT CLAIM TO ANY PARTICULAR FONT, STYLE, SIZE, OR COLOR.

PRIORITY CLAIMED UNDER SEC. 44(D) ON JAPAN APPLICATION NO. 2009-056311, FILED 7-24-2009, REG. NO. 5382130, DATED 1-7-2011, EXPIRES 1-7-2021.

THE WORDING "ARUSTAK" HAS NO MEANING IN A FOREIGN LANGUAGE.

FOR PHARMACEUTICAL PRODUCTS IN GEL STATE FOR THE TREATMENT OF JOINT DISEASE; INJECTION SYRINGE CONTAINING CROSS-LINKED HYALURONIC ACID GEL FOR THE TREATMENT OF JOINT DISEASE (U.S. CLS. 6, 18, 44, 46, 51 AND 52).

KELLY CHOE, EXAMINING ATTORNEY

THE MARK CONSISTS OF STANDARD CHARACTERS WITHOUT CLAIM TO ANY PARTICULAR FONT, STYLE, SIZE, OR COLOR.

FOR ACNE MEDICATIONS; ACNE TREATMENT PREPARATIONS; ANTIBACTERIAL ALCOHOL SKIN SANITIZER GEL; ANTIBACTERIAL HAND LOTIONS; DIETARY AND NUTRITIONAL SUPPLEMENTS; DOUCHES; FOOD SUPPLEMENTS; HAND-SANITIZING PREPARATIONS; MEDICATED BABY OILS; MEDICATED BABY POWDERS; MEDICATED BATH PREPARATIONS; MEDICATED BATH SALTS; MEDICATED COSMETICS; MEDICATED DIAPER RASH OINTMENTS AND LOTIONS; MEDICATED HAIR CARE PREPARATIONS; MEDICATED HAIR SERUMS; MEDICATED HAND WASH; MEDICATED LIP BALM; MEDICATED LOTIONS FOR SKIN, FACE AND BODY; MEDICATED MAKE-UP; MEDICATED MOUTH CARE AND TREATMENT PREPARATIONS; MEDICATED SHAMPOO; MEDICATED SHAVING PREPARATIONS; MEDICATED SKIN CARE PREPARATIONS; MEDICATED SKIN CARE PREPARATIONS, NAMELY, CREAMS, LOTIONS, GELS, TONERS, CLEANERS AND PEELS; MEDICATED SUN CARE PREPARATIONS; MEDICATED SUNBURN LOTIONS; POWDERED NUTRITIONAL SUPPLEMENT DRINK MIX; SANITIZING WIPES; VAGINAL WASHES; VITAMINS (U.S. CLS. 6, 18, 44, 46, 51 AND 52).

DAWN HAN, EXAMINING ATTORNEY

CLASS 5—(Continued).

SN 77-942,854. INTEZYNE TECHNOLOGIES, INC., DBA INTEZYNE, TAMPA, FL. FILED 2-23-2010.

IVECT

THE MARK CONSISTS OF STANDARD CHARACTERS WITHOUT CLAIM TO ANY PARTICULAR FONT, STYLE, SIZE, OR COLOR.
FOR PHARMACEUTICAL PREPARATIONS, NAMELY, POLYMERS USED AS DRUG DELIVERY SYSTEMS (U.S. CLS. 6, 18, 44, 46, 51 AND 52).
KATHERINE CHANG, EXAMINING ATTORNEY

SN 77-950,383. HOLOGIC, INC., BEDFORD, MA. FILED 3-4-2010.

GESTIVA

THE MARK CONSISTS OF STANDARD CHARACTERS WITHOUT CLAIM TO ANY PARTICULAR FONT, STYLE, SIZE, OR COLOR.
FOR PHARMACEUTICAL PREPARATIONS FOR USE IN PATIENTS UNDERGOING GENDER REASSIGNMENT PROCEDURES; PHARMACEUTICAL PREPARATIONS FOR OBSTETRICS AND GYNECOLOGY, NAMELY, FOR THE TREATMENT OF MISCARRIAGE, PRETERM LABOR, PRETERM BIRTH, INFERTILITY, ABNORMALITIES AND COMPLICATIONS OF PREGNANCY AND ABNORMALITIES AND COMPLICATIONS OF LABOR AND DELIVERY, AND POSTPARTUM CONDITIONS (U.S. CLS. 6, 18, 44, 46, 51 AND 52).
JENNIFER VASQUEZ, EXAMINING ATTORNEY

CLASS 5—(Continued).

SN 77-953,759. MORRIA BIOPHARMACEUTICALS PLC, LONDON, UNITED KINGDOM, FILED 3-8-2010.

MORRIA

THE MARK CONSISTS OF STANDARD CHARACTERS WITHOUT CLAIM TO ANY PARTICULAR FONT, STYLE, SIZE, OR COLOR.
FOR PHARMACEUTICAL PRODUCTS AND PREPARATIONS FOR TREATING DISEASE, NAMELY, OBSTRUCTIVE RESPIRATORY DISEASE, ASTHMA, INFLAMMATORY AND ANTI-VIRAL DISEASES, COLITIS, CROHN'S DISEASE, CENTRAL NERVOUS SYSTEM INSULT, MULTIPLE SCLEROSIS, CONTACT DERMATITIS, PSORIASIS, CARDIOVASCULAR DISEASE, INVASIVE CELLULAR PROLIFERATIVE DISORDERS, ALLERGIC RHINITIS, CYSTIC FIBROSIS, INFLAMMATORY DISEASE OF THE SKIN, OPHTHALMOLOGIC DISEASES, HEMOLYTIC SYNDROMES, SEPSIS, ACUTE RESPIRATORY DISTRESS SYNDROME, TISSUE TRANSPLANT REJECTION SYNDROMES, AUTOIMMUNE DISEASE, VIRAL INFECTION, AND HYPERSENSITIVITY CONJUNCTIVITIS; PHARMACEUTICALS FOR USE AS A COATING FOR CARDIOVASCULAR STENTS AND OTHER STENTS; COATING TREATMENTS, NAMELY, PHARMACEUTICAL PREPARATIONS USED TO COAT DEVICES FOR THE PREVENTION OF INFLAMMATORY REACTIONS AS A RESULT OF INVASIVE PROCEDURES; ANTI-OXIDANTS SUPPLEMENTS; PHARMACEUTICAL PREPARATIONS, NAMELY, ANTI-INFLAMMATORIES AND ANALGESICS (U.S. CLS. 6, 18, 44, 46, 51 AND 52).
DAVID MILLER, EXAMINING ATTORNEY

SN 78-362,993. WHITCOMB CAPITAL, LLC, NEW CANAAN, CT. FILED 2-5-2004.

PACIFICAL

THE MARK CONSISTS OF STANDARD CHARACTERS WITHOUT CLAIM TO ANY PARTICULAR FONT, STYLE, SIZE, OR COLOR.
FOR DIETARY SUPPLEMENTS AND HEALTH CARE PRODUCTS, NAMELY, VITAMINS, NUTRITIONAL SUPPLEMENTS, HERBAL PRODUCTS, NAMELY, HERBAL SUPPLEMENTS AND MEDICINAL HERBAL EXTRACTS, FOOD SUPPLEMENTS AND NUTRITIONALLY FORTIFIED BEVERAGES (U.S. CLS. 6, 18, 44, 46, 51 AND 52).
MICHAEL LITZAU, EXAMINING ATTORNEY

CLASS 5—(Continued).

SN 79-076,721. BIOFUTURA PHARMA S.P.A., I-00040 POMEZIA (ROMA), ITALY, FILED 10-29-2009.

BIOFUTURA PHARMA

THE MARK CONSISTS OF STANDARD CHARACTERS WITHOUT CLAIM TO ANY PARTICULAR FONT, STYLE, SIZE, OR COLOR.

OWNER OF INTERNATIONAL REGISTRATION 1023180 DATED 10-29-2009, EXPIRES 10-29-2019.

NO CLAIM IS MADE TO THE EXCLUSIVE RIGHT TO USE "PHARMA", APART FROM THE MARK AS SHOWN. THE WORDING "BIOFUTURA" HAS NO MEANING IN A FOREIGN LANGUAGE.

FOR PHARMACEUTICAL PREPARATIONS FOR THE PREVENTION AND TREATMENT OF DISORDERS OF THE NERVOUS SYSTEM, THE IMMUNE SYSTEM, THE CARDIO-VASCULAR SYSTEM INCLUDING DIABETES AND METABOLIC DISEASES, THE RESPIRATORY SYSTEM, THE MUSCULOSKELETAL SYSTEM AND THE GENITOURINARY SYSTEM; PHARMACEUTICAL PREPARATIONS FOR THE TREATMENT OF INFLAMMATORY DISORDERS AND FOR USE IN DERMATOLOGY; PHARMACEUTICAL PREPARATIONS FOR USE IN HEMATOLOGY, IN ONCOLOGY, IN TRANSPLANTATION, IN OPHTHALMOLOGY AND FOR USE IN THE GASTROENTEROLOGICAL AREAS AND FOR USE IN THE PREVENTION AND TREATMENT OF OCULAR DISORDERS OR DISEASES; PHARMACEUTICAL PREPARATIONS, NAMELY, ANTI-INFECTION PREPARATIONS, PHARMACEUTICAL PREPARATIONS FOR THE TREATMENT OF BACTERIAL-BASES DISEASE, ANTIVIRAL PREPARATIONS, ANTIBIOTICS, ANTI-FUNGAL PREPARATIONS AND VACCINES (U.S. CLS. 6, 18, 44, 46, 51 AND 52).

BILL DAWE, EXAMINING ATTORNEY

SN 79-086,100. MONSIEUR HENRI NUMA MARCEL SCHILLER, FRANCE, FILED 7-9-2010.

RACEGEL

THE MARK CONSISTS OF STANDARD CHARACTERS WITHOUT CLAIM TO ANY PARTICULAR FONT, STYLE, SIZE, OR COLOR.

OWNER OF INTERNATIONAL REGISTRATION 1047744 DATED 7-9-2010, EXPIRES 7-9-2020.

FOR PHARMACEUTICAL PREPARATIONS FOR DENTAL USE, NAMELY, GINGIVAL PREPARATION GEL TO PREPARE THE SULCUS PRIOR TO IMPRESSION TAKING, SEATING RESTORATIONS AND CLASS II, II AND V RESTORATIONS AND TO CONTROL BLEEDING AND GINGIVAL OozING; SANITARY PREPARATIONS FOR DENTAL USE; PLASTERS FOR DENTAL PURPOSES; MATERIALS FOR DRESSINGS FOR DENTAL USE, MATERIALS FOR STOPPING TEETH AND FOR DENTAL IMPRESSIONS, DISINFECTANTS FOR DENTAL USE (U.S. CLS. 6, 18, 44, 46, 51 AND 52).

JAMES MACFARLANE, EXAMINING ATTORNEY

CLASS 5—(Continued).

SN 79-089,945. A.C.M. CRAWFORD, FRANCE, FILED 7-30-2010.

MOLUTREX

THE MARK CONSISTS OF STANDARD CHARACTERS WITHOUT CLAIM TO ANY PARTICULAR FONT, STYLE, SIZE, OR COLOR.

OWNER OF INTERNATIONAL REGISTRATION 1058172 DATED 7-30-2010, EXPIRES 7-30-2020.

FOR PHARMACEUTICAL PRODUCTS FOR THE TREATMENT OF VERRUCAE (U.S. CLS. 6, 18, 44, 46, 51 AND 52).

MICHAEL WIENER, EXAMINING ATTORNEY

SN 79-090,253. NOVARTIS AG, SWITZERLAND, FILED 11-18-2010.

FLUCELIC

THE MARK CONSISTS OF STANDARD CHARACTERS WITHOUT CLAIM TO ANY PARTICULAR FONT, STYLE, SIZE, OR COLOR.

PRIORITY DATE OF 8-3-2010 IS CLAIMED.

OWNER OF INTERNATIONAL REGISTRATION 1059126 DATED 11-18-2010, EXPIRES 11-18-2020.

OWNER OF U.S. REG. NOS. 3,890,355 AND 3,890,357.

THE WORDING "FLUCELIC" HAS NO MEANING IN A FOREIGN LANGUAGE.

FOR VACCINES FOR HUMAN USE (U.S. CLS. 6, 18, 44, 46, 51 AND 52).

MARLENE BELL, EXAMINING ATTORNEY

SN 79-095,854. PROFESSIONAL DIETETICS SRL, ITALY, FILED 2-18-2011.

MUCOSAMIN

THE MARK CONSISTS OF STANDARD CHARACTERS WITHOUT CLAIM TO ANY PARTICULAR FONT, STYLE, SIZE, OR COLOR.

OWNER OF INTERNATIONAL REGISTRATION 1073260 DATED 2-18-2011, EXPIRES 2-18-2021.

FOR MEDICAL DEVICES FOR CARE AND PROTECTION OF ORAL MUCOUS MEMBRANES (U.S. CLS. 6, 18, 44, 46, 51 AND 52).

ARETHA SOMERVILLE, EXAMINING ATTORNEY

CLASS 5—(Continued).

SN 79-096,232. PROFESSIONAL DIETETICS SRL, ITALY, FILED 2-18-2011.

RADIODERM

THE MARK CONSISTS OF STANDARD CHARACTERS WITHOUT CLAIM TO ANY PARTICULAR FONT, STYLE, SIZE, OR COLOR.

PRIORITY DATE OF 10-7-2010 IS CLAIMED. OWNER OF INTERNATIONAL REGISTRATION 1074079 DATED 2-18-2011, EXPIRES 2-18-2021.

FOR HYALURONIC ACID AND AMINO ACIDS BASED PHARMACEUTICAL PRODUCTS, FOR DERMATITIS CAUSED BY RADIOTHERAPY AND CHEMOTHERAPY (U.S. CLS. 6, 18, 44, 46, 51 AND 52).

ARETHA SOMERVILLE, EXAMINING ATTORNEY

CLASS 5—(Continued).

SN 85-041,354. BRAIN RESEARCH LABS, LLC, SPOKANE, WA. FILED 5-18-2010.

CERAPLEX

THE MARK CONSISTS OF STANDARD CHARACTERS WITHOUT CLAIM TO ANY PARTICULAR FONT, STYLE, SIZE, OR COLOR.

FOR DIETARY AND NUTRITIONAL SUPPLEMENTS (U.S. CLS. 6, 18, 44, 46, 51 AND 52).

FIRST USE 6-1-2005; IN COMMERCE 6-1-2005.

SKYE YOUNG, EXAMINING ATTORNEY

SN 79-097,457. PUNISH FIGHT GEAR PTY LTD, AUSTRALIA, FILED 12-9-2010.

PUNISH

THE MARK CONSISTS OF STANDARD CHARACTERS WITHOUT CLAIM TO ANY PARTICULAR FONT, STYLE, SIZE, OR COLOR.

PRIORITY DATE OF 10-14-2010 IS CLAIMED. OWNER OF INTERNATIONAL REGISTRATION 1077357 DATED 12-9-2010, EXPIRES 12-9-2020.

FOR NUTRITIONAL SUPPLEMENTS (U.S. CLS. 6, 18, 44, 46, 51 AND 52).

ANDREA HACK, EXAMINING ATTORNEY

SN 85-050,086. BOMAC VETS PLUS, INC., KNAPP, WI. FILED 5-28-2010.

NuLife

THE MARK CONSISTS OF STANDARD CHARACTERS WITHOUT CLAIM TO ANY PARTICULAR FONT, STYLE, SIZE, OR COLOR.

FOR DIETARY SUPPLEMENTS AND VETERINARY PREPARATIONS FOR ASSISTING IN MAINTENANCE OF HEALTH, ENERGY AND NUTRITIONAL WELLNESS, IN THE DIGESTIVE, IMMUNE, CIRCULATORY, INTEGUMENTARY, MUSCULO-SKELETAL AND REPRODUCTIVE SYSTEMS, IN THE HEALTH AND MAINTENANCE OF HOOVES, NAILS, HAIR, AND UDDER, AND IN THE TREATMENT OF INTESTINAL AND RESPIRATORY INFECTIONS AND POST SURGICAL INFECTIONS OF DOMESTIC ANIMALS AND LIVESTOCK (U.S. CLS. 6, 18, 44, 46, 51 AND 52).

KEVIN DINALLO, EXAMINING ATTORNEY

SN 85-025,008. JAYSON MICHAELS, LLC, NEW YORK, NY. FILED 4-28-2010.

Alift

THE MARK CONSISTS OF STANDARD CHARACTERS WITHOUT CLAIM TO ANY PARTICULAR FONT, STYLE, SIZE, OR COLOR.

FOR DIETARY SUPPLEMENT; VITAMIN, MINERAL AND ELECTROLYTE ENERGY ENHANCED CONCENTRATE USED IN THE PREPARATION OF CARBONATED AND NON-CARBONATED BEVERAGES (U.S. CLS. 6, 18, 44, 46, 51 AND 52).

FIRST USE 8-3-2010; IN COMMERCE 8-3-2010.

JEFF DEFORD, EXAMINING ATTORNEY

SN 85-069,659. NEXCYON PHARMACEUTICALS, INC., PENDLETON, IN. FILED 6-23-2010.

NEXCYON

THE MARK CONSISTS OF STANDARD CHARACTERS WITHOUT CLAIM TO ANY PARTICULAR FONT, STYLE, SIZE, OR COLOR.

OWNER OF AUSTRALIA REG. NO. 1352045, DATED 3-19-2010, EXPIRES 3-19-2020.

FOR VETERINARY PHARMACEUTICAL PREPARATIONS FOR THE THERAPEUTIC TREATMENT OF DISEASE AND PARASITES IN ANIMALS (U.S. CLS. 6, 18, 44, 46, 51 AND 52).

CHERYL CLAYTON, EXAMINING ATTORNEY

CLASS 5—(Continued).

SN 85-072,794. INVITE HEALTH, INC., NEW HYDE PARK, NY. FILED 6-28-2010.

POWERPLANT

THE MARK CONSISTS OF STANDARD CHARACTERS WITHOUT CLAIM TO ANY PARTICULAR FONT, STYLE, SIZE, OR COLOR.

FOR DIETARY SUPPLEMENTS (U.S. CLS. 6, 18, 44, 46, 51 AND 52).
DEBRA LEE, EXAMINING ATTORNEY

SN 85-084,955. INTELLIGENT AROMAS, LLC, SAVANNAH, GA. FILED 7-14-2010.

AROMACLENZ

THE MARK CONSISTS OF STANDARD CHARACTERS WITHOUT CLAIM TO ANY PARTICULAR FONT, STYLE, SIZE, OR COLOR.

FOR SPRAY ANTI-MICROBIAL SOLUTION IN A PERSONAL SIZE SPRAYER FOR USE ON CLOTHING, FABRICS AND HARD SURFACES, AND REFILLS THEREFORE (U.S. CLS. 6, 18, 44, 46, 51 AND 52).

FIRST USE 12-0-2007; IN COMMERCE 12-0-2007.
DEBRA LEE, EXAMINING ATTORNEY

SN 85-085,624. WARDWELL INTERNATIONAL, LLC, NORTHPORT, ME. FILED 7-15-2010.



Natural Woman

NO CLAIM IS MADE TO THE EXCLUSIVE RIGHT TO USE "NATURAL WOMAN", APART FROM THE MARK AS SHOWN.

THE MARK CONSISTS OF THE IMAGE OF A WOMAN CONTAINED IN A SHADED OVAL WITHIN A BROKEN OVAL, AND THE WORDS "NATURAL WOMAN".

FOR NATURAL DIETARY SUPPLEMENTS (U.S. CLS. 6, 18, 44, 46, 51 AND 52).
FIRST USE 6-29-2010; IN COMMERCE 6-29-2010.
DAVID C. REIHNER, EXAMINING ATTORNEY

CLASS 5—(Continued).

SN 85-089,483. INSTANTDX, LLC, GAITHERSBURG, MD. FILED 7-21-2010.

InstantDX

THE MARK CONSISTS OF STANDARD CHARACTERS WITHOUT CLAIM TO ANY PARTICULAR FONT, STYLE, SIZE, OR COLOR.

OWNER OF U.S. REG. NO. 3,250,993.

FOR RAPID IMMUNODIAGNOSTIC REAGENTS FOR MEDICAL USE FOR THE TESTING OF DISEASES OR BIOCHEMICAL STATUS FOR PROFESSIONAL MEDICAL OR CONSUMER USE; MEDICAL DIAGNOSTIC TEST STRIPS FOR TESTING BODY FLUIDS AND RELATED DEVICES SOLD AS A UNIT WITH THE TEST STRIPS, NAMELY, TEST STRIP READERS (U.S. CLS. 6, 18, 44, 46, 51 AND 52).
JULIE WATSON, EXAMINING ATTORNEY

SN 85-093,146. PRIMARY INVESTMENTS GROUP LIMITED, ROAD TOWN, TORTOLA, BR. VIRGIN ISLANDS, FILED 7-26-2010.

GREENS & GREENS PHYTO-FOOD
ENERGY

THE MARK CONSISTS OF STANDARD CHARACTERS WITHOUT CLAIM TO ANY PARTICULAR FONT, STYLE, SIZE, OR COLOR.

NO CLAIM IS MADE TO THE EXCLUSIVE RIGHT TO USE "PHYTO-FOOD" AND "ENERGY", APART FROM THE MARK AS SHOWN.

FOR SUPPLEMENTS IN THE NATURE OF DIETARY, FOOD, HERBAL, NUTRITIONAL, VITAMIN, MINERAL AND MULTI-VITAMIN AND MULTI-MINERAL SUPPLEMENTS, ALL CONTAINING PHYTOFOODS (U.S. CLS. 6, 18, 44, 46, 51 AND 52).

FIRST USE 7-26-2010; IN COMMERCE 7-26-2010.
RENEE SERVANCE, EXAMINING ATTORNEY

CLASS 5—(Continued).

SN 85-100,949. VITA ZAHNFABRIK H. RAUTER GMBH & CO. KG, SACKINGEN, FED REP GERMANY, FILED 8-5-2010.

VITABLOCS RealLife

OWNER OF FED REP GERMANY REG. NO. 302009019704, DATED 11-5-2009, EXPIRES 3-31-2019.

THE MARK CONSISTS OF THE WORDS "VITABLOCS" (IN ARIAL FONT AND IN UPPER CASE FORM) AND "REALLIFE" (ONE WORD WITH THE LETTERS "R" AND "L" IN UPPER CASE FORM).

FOR DENTAL CERAMIC COMPOSITIONS IN THE FORM OF BLOCKS FOR PREPARING CERAMIC RESTORATIONS (U.S. CLS. 6, 18, 44, 46, 51 AND 52).

TRACY FLETCHER, EXAMINING ATTORNEY

SN 85-101,549. MERZ AESTHETICS, INC., SAN MATEO, CA, FILED 8-5-2010.

QUADRINONE

THE MARK CONSISTS OF STANDARD CHARACTERS WITHOUT CLAIM TO ANY PARTICULAR FONT, STYLE, SIZE, OR COLOR.

THE WORD(S) "QUADRINONE" HAS NO MEANING IN A FOREIGN LANGUAGE.

FOR ANTI-INFLAMMATORIES; MEDICATED SKIN-CARE PREPARATIONS; ANTI-ITCH CREAM; 4-ETHOXYBENZALDEHYDE SOLD AS A COMPONENT OF MEDICATED LOTIONS, OINTMENTS AND CREAMS FOR TREATMENT OF INFLAMMATION, ITCHING, ECZEMA, ROSACEA, PSORIASIS AND THERMAL, CHEMICAL, UV AND IONIZING RADIATION BURNS; 4-ETHOXYBENZALDEHYDE SOLD AS A COMPONENT OF MEDICATED LOTIONS, OINTMENTS AND CREAMS FOR PREVENTION OF RADIATION BURNS; 4-ETHOXYBENZALDEHYDE SOLD AS A COMPONENT OF MEDICATED SUNBURN LOTIONS FOR REDUCING SKIN REDNESS AND IRRITATION; 4-ETHOXYBENZALDEHYDE SOLD AS A COMPONENT OF MEDICATED DANDRUFF PRODUCTS FOR REDUCING SKIN IRRITATION (U.S. CLS. 6, 18, 44, 46, 51 AND 52).

ELISSA GARBER KON, EXAMINING ATTORNEY

CLASS 5—(Continued).

SN 85-102,509. FLEAVAC, LLC, CARLSBAD, CA. FILED 8-7-2010.



OWNER OF U.S. REG. NO. 3,765,220.

THE COLOR(S) OLIVE GREEN, YELLOW, GREY, BLACK AND WHITE IS/ARE CLAIMED AS A FEATURE OF THE MARK.

THE MARK CONSISTS OF A BUG BEING SUCKED INTO A LARGE STYLIZED "V". THE BUG IS OLIVE GREEN WITH SHADES OF GREY AND BLACK AND WHITE EYES; THE STYLIZED "V" IS A MIXTURE OF YELLOW, GREY AND OLIVE GREEN; AND THE REMAINDER OF THE LETTERS "F", "L", "E", "A" AND "C" ARE WHITE INSIDE A BLACK BACKGROUND WITH A GREY BORDER.

FOR INSECTICIDES; PESTICIDES (U.S. CLS. 6, 18, 44, 46, 51 AND 52).

FIRST USE 11-1-2009; IN COMMERCE 11-1-2009.

NAPOLEON SHARMA, EXAMINING ATTORNEY

SN 85-106,388. FLACK'S BAKERVIEW KELP PRODUCTS INC., PRITCHARD, CANADA, FILED 8-12-2010.

ULTRA-KELP

THE MARK CONSISTS OF STANDARD CHARACTERS WITHOUT CLAIM TO ANY PARTICULAR FONT, STYLE, SIZE, OR COLOR.

FOR FOOD SUPPLEMENTS CONTAINING OR DERIVING FROM KELP FOR USE BY ANIMALS (U.S. CLS. 6, 18, 44, 46, 51 AND 52).

FIRST USE 4-9-1986; IN COMMERCE 10-7-1986.

MARCIE MILONE, EXAMINING ATTORNEY

SN 85-111,416. X-BODY, INC., DBA X-BODY BIOSCIENCES, WALTHAM, MA. FILED 8-19-2010.

X-BODY

THE MARK CONSISTS OF STANDARD CHARACTERS WITHOUT CLAIM TO ANY PARTICULAR FONT, STYLE, SIZE, OR COLOR.

FOR PHARMACEUTICALS, NAMELY, ANTIBODY AND PROTEIN THERAPEUTICS FOR THE TREATMENT OF NEOPLASTIC DISEASE, CANCER, INFLAMMATORY DISORDERS, INFECTIOUS DISEASE, METABOLIC DISEASE, AND GENETIC DISORDERS (U.S. CLS. 6, 18, 44, 46, 51 AND 52).

JACQUELINE A. LAVINE, EXAMINING ATTORNEY

CLASS 5—(Continued).

SN 85-112,450. MURRAY & POOL ENTERPRISES LTD., GIBRALTAR, UNITED KINGDOM, FILED 8-20-2010.

SICCAFORTE

THE MARK CONSISTS OF STANDARD CHARACTERS WITHOUT CLAIM TO ANY PARTICULAR FONT, STYLE, SIZE, OR COLOR.

PRIORITY CLAIMED UNDER SEC. 44(D) ON ERP CMNTY TM OFC APPLICATION NO. 008917239, FILED 3-1-2010.

THE WORDING "SICCAFORTE" HAS NO MEANING IN A FOREIGN LANGUAGE.

FOR PHARMACEUTICAL AND VETERINARY PREPARATIONS FOR TREATMENT OF DRY EYES; OPHTHALMOLOGICAL PREPARATIONS; MEDICINES FOR OPHTHALMOLOGICAL PURPOSES; EYE DROPS; EYE OINTMENTS, NAMELY, PHARMACEUTICAL PREPARATIONS FOR THE TREATMENT OF EYE DISEASES AND CONDITIONS; SANITARY PREPARATIONS FOR MEDICAL USE; DIETETIC SUBSTANCES ADAPTED FOR MEDICAL USE, NAMELY, DIETETIC BEVERAGES, DIETETIC FOODS AND DIETETIC SUGAR FOR MEDICAL USE; FOOD FOR BABIES; MEDICAL AND SURGICAL PLASTERS; DISINFECTANTS, NAMELY, ALL PURPOSE DISINFECTANTS; PREPARATIONS FOR DESTROYING VERMIN; FUNGICIDES, HERBICIDES (U.S. CLS. 6, 18, 44, 46, 51 AND 52).

KATHERINE CONNOLLY, EXAMINING ATTORNEY

SN 85-114,375. PUREBRANDS, LLC, BOCA RATON, FL. FILED 8-24-2010.

ACTIVATE YOUR ENERGY

THE MARK CONSISTS OF STANDARD CHARACTERS WITHOUT CLAIM TO ANY PARTICULAR FONT, STYLE, SIZE, OR COLOR.

FOR TRANSDERMAL DELIVERY PATCHES FOR USE IN ADMINISTERING NUTRITIONAL SUPPLEMENTS, DIETARY AND MINERAL SUPPLEMENTS AND VITAMINS (U.S. CLS. 6, 18, 44, 46, 51 AND 52).

LOURDES AYALA, EXAMINING ATTORNEY

CLASS 5—(Continued).

SN 85-114,553. HORIZON PHARMA USA, INC., NORTH-BROOK, IL. FILED 8-24-2010.

NURAY

THE MARK CONSISTS OF STANDARD CHARACTERS WITHOUT CLAIM TO ANY PARTICULAR FONT, STYLE, SIZE, OR COLOR.

THE WORDING "NURAY" HAS NO MEANING IN A FOREIGN LANGUAGE.

FOR PHARMACEUTICAL PREPARATIONS FOR HUMAN USE FOR THE TREATMENT OF INFLAMMATORY AND AUTOIMMUNE DISORDERS (U.S. CLS. 6, 18, 44, 46, 51 AND 52).

JERI J. FICKES, EXAMINING ATTORNEY

SN 85-114,557. HORIZON PHARMA USA, INC., NORTH-BROOK, IL. FILED 8-24-2010.

SURREXI

THE MARK CONSISTS OF STANDARD CHARACTERS WITHOUT CLAIM TO ANY PARTICULAR FONT, STYLE, SIZE, OR COLOR.

THE WORDING "SURREXI" HAS NO MEANING IN A FOREIGN LANGUAGE.

FOR PHARMACEUTICAL PREPARATIONS FOR HUMAN USE FOR THE TREATMENT OF INFLAMMATORY AND AUTOIMMUNE DISORDERS (U.S. CLS. 6, 18, 44, 46, 51 AND 52).

JERI J. FICKES, EXAMINING ATTORNEY

SN 85-114,560. HORIZON PHARMA USA, INC., NORTH-BROOK, IL. FILED 8-24-2010.

NYCIRCA

THE MARK CONSISTS OF STANDARD CHARACTERS WITHOUT CLAIM TO ANY PARTICULAR FONT, STYLE, SIZE, OR COLOR.

THE WORDING "NYCIRCA" HAS NO MEANING IN A FOREIGN LANGUAGE.

FOR PHARMACEUTICAL PREPARATIONS FOR HUMAN USE FOR THE TREATMENT OF INFLAMMATORY AND AUTOIMMUNE DISORDERS (U.S. CLS. 6, 18, 44, 46, 51 AND 52).

JERI J. FICKES, EXAMINING ATTORNEY

CLASS 5—(Continued).

SN 85-114,578. HORIZON PHARMA USA, INC., NORTH-BROOK, IL. FILED 8-24-2010.

ENRAY

THE MARK CONSISTS OF STANDARD CHARACTERS WITHOUT CLAIM TO ANY PARTICULAR FONT, STYLE, SIZE, OR COLOR.

THE WORDING "ENRAY" HAS NO MEANING IN A FOREIGN LANGUAGE.

FOR PHARMACEUTICAL PREPARATIONS FOR HUMAN USE FOR THE TREATMENT OF INFLAMMATORY AND AUTOIMMUNE DISORDERS (U.S. CLS. 6, 18, 44, 46, 51 AND 52).

JERI J. FICKES, EXAMINING ATTORNEY



SN 85-115,123. BIOCEPT, INC., SAN DIEGO, CA. FILED 8-25-2010.

ONCOCEE-BR

THE MARK CONSISTS OF STANDARD CHARACTERS WITHOUT CLAIM TO ANY PARTICULAR FONT, STYLE, SIZE, OR COLOR.

OWNER OF U.S. REG. NO. 3,326,287.

FOR DIAGNOSTIC TEST KITS COMPRISED OF REAGENTS AND ASSAYS FOR CANCER DETECTION; MEDICAL MOLECULAR DIAGNOSTIC ASSAYS FOR CANCER TESTING OF BIOLOGICAL FLUIDS OR TISSUES; MEDICAL DIAGNOSTIC REAGENTS; MEDICAL DIAGNOSTIC REAGENTS AND ASSAYS FOR TESTING OF BODY FLUIDS OR TISSUES; DIAGNOSTIC TESTS COMPRISED OF REAGENTS FOR MEDICAL USE; TESTS DESIGNED TO ISOLATE AND EXTRACT CELLS FOR GENETIC ANALYSIS COMPRISED OF REAGENTS FOR MEDICAL DIAGNOSTIC USE; AND PREDICTIVE DIAGNOSTIC TESTS USED IN THE ONCOLOGY FIELD COMPRISED OF MICRO FLUIDIC CHANNELS AND REAGENTS FOR CAPTURING CIRCULATING TUMOR CELLS FROM THE BLOOD, SPINAL FLUID OR URINE OF CANCER PATIENTS (U.S. CLS. 6, 18, 44, 46, 51 AND 52).

MARK T. MULLEN, EXAMINING ATTORNEY

CLASS 5—(Continued).

SN 85-115,124. BIOCEPT, INC., SAN DIEGO, CA. FILED 8-25-2010.

ONCOCEE-LU

THE MARK CONSISTS OF STANDARD CHARACTERS WITHOUT CLAIM TO ANY PARTICULAR FONT, STYLE, SIZE, OR COLOR.

OWNER OF U.S. REG. NO. 3,326,287.

FOR DIAGNOSTIC TEST KITS COMPRISED OF REAGENTS AND ASSAYS FOR CANCER DETECTION; MEDICAL MOLECULAR DIAGNOSTIC ASSAYS FOR CANCER TESTING AND TESTING OF BIOLOGICAL FLUIDS OR TISSUES; MEDICAL DIAGNOSTIC REAGENTS; MEDICAL DIAGNOSTIC REAGENTS AND ASSAYS FOR TESTING OF BODY FLUIDS OR TISSUES; DIAGNOSTIC TESTS COMPRISED OF REAGENTS FOR MEDICAL USE; TESTS DESIGNED TO ISOLATE AND EXTRACT CELLS FOR GENETIC ANALYSIS COMPRISED OF REAGENTS FOR MEDICAL DIAGNOSTIC USE; AND PREDICTIVE DIAGNOSTIC TESTS USED IN THE ONCOLOGY FIELD COMPRISED OF MICRO FLUIDIC CHANNELS AND REAGENTS FOR CAPTURING CIRCULATING TUMOR CELLS FROM THE BLOOD, SPINAL FLUID OR URINE OF CANCER PATIENTS (U.S. CLS. 6, 18, 44, 46, 51 AND 52).

MARK T. MULLEN, EXAMINING ATTORNEY



SN 85-115,125. BIOCEPT, INC., SAN DIEGO, CA. FILED 8-25-2010.

ONCOCEE-PR

THE MARK CONSISTS OF STANDARD CHARACTERS WITHOUT CLAIM TO ANY PARTICULAR FONT, STYLE, SIZE, OR COLOR.

OWNER OF U.S. REG. NO. 3,326,287.

FOR DIAGNOSTIC TEST KITS COMPRISED OF REAGENTS AND ASSAYS FOR CANCER DETECTION; MEDICAL MOLECULAR DIAGNOSTIC ASSAYS FOR CANCER TESTING OF BIOLOGICAL FLUIDS OR TISSUES; MEDICAL DIAGNOSTIC REAGENTS; MEDICAL DIAGNOSTIC REAGENTS AND ASSAYS FOR TESTING OF BODY FLUIDS OR TISSUES; DIAGNOSTIC TESTS COMPRISED OF REAGENTS FOR MEDICAL USE; TESTS DESIGNED TO ISOLATE AND EXTRACT CELLS FOR GENETIC ANALYSIS COMPRISED OF REAGENTS FOR MEDICAL DIAGNOSTIC USE; AND PREDICTIVE DIAGNOSTIC TESTS USED IN THE ONCOLOGY FIELD COMPRISED OF MICRO FLUIDIC CHANNELS AND REAGENTS FOR CAPTURING CIRCULATING TUMOR CELLS FROM THE BLOOD, SPINAL FLUID OR URINE OF CANCER PATIENTS (U.S. CLS. 6, 18, 44, 46, 51 AND 52).

MARK T. MULLEN, EXAMINING ATTORNEY

CLASS 5—(Continued).

SN 85-115,126. BIOCEPT, INC., SAN DIEGO, CA. FILED 8-25-2010.

ONCOCEE-CR

THE MARK CONSISTS OF STANDARD CHARACTERS WITHOUT CLAIM TO ANY PARTICULAR FONT, STYLE, SIZE, OR COLOR.

OWNER OF U.S. REG. NO. 3,326,287.

FOR DIAGNOSTIC TEST KITS COMPRISED OF REAGENTS AND ASSAYS FOR CANCER DETECTION; MEDICAL MOLECULAR DIAGNOSTIC ASSAYS FOR CANCER TESTING OF BIOLOGICAL FLUIDS OR TISSUES; MEDICAL DIAGNOSTIC REAGENTS; MEDICAL DIAGNOSTIC REAGENTS AND ASSAYS FOR TESTING OF BODY FLUIDS OR TISSUES; DIAGNOSTIC TESTS COMPRISED OF REAGENTS FOR MEDICAL USE; TESTS DESIGNED TO ISOLATE AND EXTRACT CELLS FOR GENETIC ANALYSIS COMPRISED OF REAGENTS FOR MEDICAL DIAGNOSTIC USE; AND PREDICTIVE DIAGNOSTIC TESTS USED IN THE ONCOLOGY FIELD COMPRISED OF MICRO FLUIDIC CHANNELS AND REAGENTS FOR CAPTURING CIRCULATING TUMOR CELLS FROM THE BLOOD, SPINAL FLUID OR URINE OF CANCER PATIENTS (U.S. CLS. 6, 18, 44, 46, 51 AND 52).

MARK T. MULLEN, EXAMINING ATTORNEY

CLASS 5—(Continued).

SN 85-115,998. BIOCEPT, INC., SAN DIEGO, CA. FILED 8-25-2010.

ONCOCEE-OV

THE MARK CONSISTS OF STANDARD CHARACTERS WITHOUT CLAIM TO ANY PARTICULAR FONT, STYLE, SIZE, OR COLOR.

OWNER OF U.S. REG. NO. 3,326,287.

THE WORDING "ONCOCEE" HAS NO MEANING IN A FOREIGN LANGUAGE.

FOR MEDICAL DIAGNOSTIC TEST KITS COMPRISED OF REAGENTS AND ASSAYS FOR CANCER DETECTION; MEDICAL DIAGNOSTIC REAGENTS AND ASSAYS FOR CANCER DETECTION; MEDICAL MOLECULAR DIAGNOSTIC ASSAYS FOR CANCER TESTING OF BLOOD AND BODILY FLUIDS; MEDICAL DIAGNOSTIC REAGENTS; MEDICAL DIAGNOSTIC REAGENTS AND ASSAYS FOR TESTING OF BODY FLUIDS OR TISSUES; DIAGNOSTIC TESTS COMPRISED OF REAGENTS FOR MEDICAL USE; TESTS DESIGNED TO ISOLATE AND EXTRACT CELLS FOR GENETIC ANALYSIS COMPRISED OF REAGENTS FOR MEDICAL DIAGNOSTIC USE; AND PREDICTIVE DIAGNOSTIC TESTS USED IN THE ONCOLOGY FIELD COMPRISED OF MICROFLUIDIC CHANNELS AND REAGENTS FOR CAPTURING CIRCULATING TUMOR CELLS FROM THE BLOOD, SPINAL FLUID OR URINE OF CANCER PATIENTS (U.S. CLS. 6, 18, 44, 46, 51 AND 52).

ELISSA GARBER KON, EXAMINING ATTORNEY

SN 85-115,995. BIOCEPT, INC., SAN DIEGO, CA. FILED 8-25-2010.

ONCOCEE-CE

THE MARK CONSISTS OF STANDARD CHARACTERS WITHOUT CLAIM TO ANY PARTICULAR FONT, STYLE, SIZE, OR COLOR.

OWNER OF U.S. REG. NO. 3,326,287.

FOR DIAGNOSTIC TEST KITS COMPRISED OF REAGENTS AND ASSAYS FOR CANCER DETECTION; MEDICAL MOLECULAR DIAGNOSTIC ASSAYS FOR CANCER TESTING OF BIOLOGICAL FLUIDS OR TISSUES; MEDICAL DIAGNOSTIC REAGENTS; MEDICAL DIAGNOSTIC REAGENTS AND ASSAYS FOR TESTING OF BODY FLUIDS OR TISSUES; DIAGNOSTIC TESTS COMPRISED OF REAGENTS FOR MEDICAL USE; TESTS DESIGNED TO ISOLATE AND EXTRACT CELLS FOR GENETIC ANALYSIS COMPRISED OF REAGENTS FOR MEDICAL DIAGNOSTIC USE; AND PREDICTIVE DIAGNOSTIC TESTS USED IN THE ONCOLOGY FIELD COMPRISED OF MICRO FLUIDIC CHANNELS AND REAGENTS FOR CAPTURING CIRCULATING TUMOR CELLS FROM THE BLOOD, SPINAL FLUID OR URINE OF CANCER PATIENTS (U.S. CLS. 6, 18, 44, 46, 51 AND 52).

MARK T. MULLEN, EXAMINING ATTORNEY

SN 85-116,000. BIOCEPT, INC., SAN DIEGO, CA. FILED 8-25-2010.

ONCOCEE-ME

THE MARK CONSISTS OF STANDARD CHARACTERS WITHOUT CLAIM TO ANY PARTICULAR FONT, STYLE, SIZE, OR COLOR.

OWNER OF U.S. REG. NO. 3,326,287.

THE WORDING "ONCOCEE" HAS NO MEANING IN A FOREIGN LANGUAGE.

FOR MEDICAL DIAGNOSTIC TEST KITS COMPRISED OF REAGENTS AND ASSAYS FOR CANCER DETECTION; MEDICAL DIAGNOSTIC REAGENTS AND ASSAYS FOR CANCER DETECTION; MEDICAL MOLECULAR DIAGNOSTIC ASSAYS FOR CANCER TESTING OF BLOOD AND BODILY FLUIDS; MEDICAL DIAGNOSTIC REAGENTS; MEDICAL DIAGNOSTIC REAGENTS AND ASSAYS FOR TESTING OF BODY FLUIDS OR TISSUES; DIAGNOSTIC TESTS COMPRISED OF REAGENTS FOR MEDICAL USE; TESTS DESIGNED TO ISOLATE AND EXTRACT CELLS FOR GENETIC ANALYSIS COMPRISED OF REAGENTS FOR MEDICAL DIAGNOSTIC USE; AND PREDICTIVE DIAGNOSTIC TESTS USED IN THE ONCOLOGY FIELD COMPRISED OF MICROFLUIDIC CHANNELS AND REAGENTS FOR CAPTURING CIRCULATING TUMOR CELLS FROM THE BLOOD, SPINAL FLUID OR URINE OF CANCER PATIENTS (U.S. CLS. 6, 18, 44, 46, 51 AND 52).

ELISSA GARBER KON, EXAMINING ATTORNEY

CLASS 5—(Continued).

SN 85-116,001. BIOCEPT, INC., SAN DIEGO, CA. FILED 8-25-2010.

ONCOCEE-RE

THE MARK CONSISTS OF STANDARD CHARACTERS WITHOUT CLAIM TO ANY PARTICULAR FONT, STYLE, SIZE, OR COLOR.

OWNER OF U.S. REG. NO. 3,326,287.
THE WORDING "ONCOCEE" HAS NO MEANING IN A FOREIGN LANGUAGE.

FOR MEDICAL DIAGNOSTIC TEST KITS COMPRISED OF REAGENTS AND ASSAYS FOR CANCER DETECTION; MEDICAL DIAGNOSTIC REAGENTS AND ASSAYS FOR CANCER DETECTION; MEDICAL MOLECULAR DIAGNOSTIC ASSAYS FOR CANCER TESTING OF BLOOD AND BODILY FLUIDS; MEDICAL DIAGNOSTIC REAGENTS; MEDICAL DIAGNOSTIC REAGENTS AND ASSAYS FOR TESTING OF BODY FLUIDS OR TISSUES; DIAGNOSTIC TESTS COMPRISED OF REAGENTS FOR MEDICAL USE; TESTS DESIGNED TO ISOLATE AND EXTRACT CELLS FOR GENETIC ANALYSIS COMPRISED OF REAGENTS FOR MEDICAL DIAGNOSTIC USE; AND PREDICTIVE DIAGNOSTIC TESTS USED IN THE ONCOLOGY FIELD COMPRISED OF MICROFLUIDIC CHANNELS AND REAGENTS FOR CAPTURING CIRCULATING TUMOR CELLS FROM THE BLOOD, SPINAL FLUID OR URINE OF CANCER PATIENTS (U.S. CLS. 6, 18, 44, 46, 51 AND 52).

ELISSA GARBER KON, EXAMINING ATTORNEY

SN 85-116,002. BIOCEPT, INC., SAN DIEGO, CA. FILED 8-25-2010.

ONCOCEE-LI

THE MARK CONSISTS OF STANDARD CHARACTERS WITHOUT CLAIM TO ANY PARTICULAR FONT, STYLE, SIZE, OR COLOR.

OWNER OF U.S. REG. NO. 3,326,287.
THE WORDING "ONCOCEE" HAS NO MEANING IN A FOREIGN LANGUAGE.

FOR MEDICAL DIAGNOSTIC TEST KITS COMPRISED OF REAGENTS AND ASSAYS FOR CANCER DETECTION; MEDICAL DIAGNOSTIC REAGENTS AND ASSAYS FOR CANCER DETECTION; MEDICAL MOLECULAR DIAGNOSTIC ASSAYS FOR CANCER TESTING OF BLOOD AND BODILY FLUIDS; MEDICAL DIAGNOSTIC REAGENTS; MEDICAL DIAGNOSTIC REAGENTS AND ASSAYS FOR TESTING OF BODY FLUIDS OR TISSUES; DIAGNOSTIC TESTS COMPRISED OF REAGENTS FOR MEDICAL USE; TESTS DESIGNED TO ISOLATE AND EXTRACT CELLS FOR GENETIC ANALYSIS COMPRISED OF REAGENTS FOR MEDICAL DIAGNOSTIC USE; AND PREDICTIVE DIAGNOSTIC TESTS USED IN THE ONCOLOGY FIELD COMPRISED OF MICROFLUIDIC CHANNELS AND REAGENTS FOR CAPTURING CIRCULATING TUMOR CELLS FROM THE BLOOD, SPINAL FLUID OR URINE OF CANCER PATIENTS (U.S. CLS. 6, 18, 44, 46, 51 AND 52).

ELISSA GARBER KON, EXAMINING ATTORNEY

CLASS 5—(Continued).

SN 85-116,004. BIOCEPT, INC., SAN DIEGO, CA. FILED 8-25-2010.

ONCOCEE-TE

THE MARK CONSISTS OF STANDARD CHARACTERS WITHOUT CLAIM TO ANY PARTICULAR FONT, STYLE, SIZE, OR COLOR.

OWNER OF U.S. REG. NO. 3,326,287.
THE WORDING "ONCOCEE" HAS NO MEANING IN A FOREIGN LANGUAGE.

FOR MEDICAL DIAGNOSTIC TEST KITS COMPRISED OF REAGENTS AND ASSAYS FOR CANCER DETECTION; MEDICAL DIAGNOSTIC REAGENTS AND ASSAYS FOR CANCER DETECTION; MEDICAL MOLECULAR DIAGNOSTIC ASSAYS FOR CANCER TESTING OF BLOOD AND BODILY FLUIDS; MEDICAL DIAGNOSTIC REAGENTS; MEDICAL DIAGNOSTIC REAGENTS AND ASSAYS FOR TESTING OF BODY FLUIDS OR TISSUES; DIAGNOSTIC TESTS COMPRISED OF REAGENTS FOR MEDICAL USE; TESTS DESIGNED TO ISOLATE AND EXTRACT CELLS FOR GENETIC ANALYSIS COMPRISED OF REAGENTS FOR MEDICAL DIAGNOSTIC USE; AND PREDICTIVE DIAGNOSTIC TESTS USED IN THE ONCOLOGY FIELD COMPRISED OF MICROFLUIDIC CHANNELS AND REAGENTS FOR CAPTURING CIRCULATING TUMOR CELLS FROM THE BLOOD, SPINAL FLUID OR URINE OF CANCER PATIENTS (U.S. CLS. 6, 18, 44, 46, 51 AND 52).

ELISSA GARBER KON, EXAMINING ATTORNEY

SN 85-116,005. BIOCEPT, INC., SAN DIEGO, CA. FILED 8-25-2010.

ONCOCEE-GI

THE MARK CONSISTS OF STANDARD CHARACTERS WITHOUT CLAIM TO ANY PARTICULAR FONT, STYLE, SIZE, OR COLOR.

OWNER OF U.S. REG. NO. 3,326,287.
FOR DIAGNOSTIC TEST KITS COMPRISED OF REAGENTS AND ASSAYS FOR CANCER DETECTION;

MEDICAL MOLECULAR DIAGNOSTIC ASSAYS FOR CANCER TESTING OF BIOLOGICAL FLUIDS OR TISSUES; MEDICAL DIAGNOSTIC REAGENTS; MEDICAL DIAGNOSTIC REAGENTS AND ASSAYS FOR TESTING OF BODY FLUIDS OR TISSUES; DIAGNOSTIC TESTS COMPRISED OF REAGENTS FOR MEDICAL USE; TESTS DESIGNED TO ISOLATE AND EXTRACT CELLS FOR GENETIC ANALYSIS COMPRISED OF REAGENTS FOR MEDICAL DIAGNOSTIC USE; AND PREDICTIVE DIAGNOSTIC TESTS USED IN THE ONCOLOGY FIELD COMPRISED OF MICRO FLUIDIC CHANNELS AND REAGENTS FOR CAPTURING CIRCULATING TUMOR CELLS FROM THE BLOOD, SPINAL FLUID OR URINE OF CANCER PATIENTS (U.S. CLS. 6, 18, 44, 46, 51 AND 52).

MARK T. MULLEN, EXAMINING ATTORNEY

CLASS 5—(Continued).

SN 85-116,012. ADVANCED NUTRITION SYSTEMS, LLC, GREENVILLE, SC. FILED 8-25-2010.



THE COLOR(S) GRAY, SKY BLUE IS/ARE CLAIMED AS A FEATURE OF THE MARK.

THE MARK CONSISTS OF THE LETTERS "ANS" IN GRAY. EACH LETTER IS OUTLINED WITH SKY BLUE COLOR. THE COLOR WHITE IS ONLY A BACKGROUND. FOR DIETARY AND NUTRITIONAL SUPPLEMENTS (U.S. CLS. 6, 18, 44, 46, 51 AND 52).

FIRST USE 12-1-2006; IN COMMERCE 12-1-2006.
SHAUNIA CARLYLE, EXAMINING ATTORNEY

SN 85-117,243. VIFOR (INTERNATIONAL) AG VIFOR (INTERNATIONAL) LTD. AND VIFOR (INTERNATIONAL) INC., 9014 ST. GALLEN, SWITZERLAND, FILED 8-27-2010.



THE MARK CONSISTS OF STANDARD CHARACTERS WITHOUT CLAIM TO ANY PARTICULAR FONT, STYLE, SIZE, OR COLOR.

OWNER OF SWITZERLAND REG. NO. 513745, DATED 8-27-2003, EXPIRES 8-7-2013.

OWNER OF U.S. REG. NO. 2,992,641.
FOR PREPARATIONS FOR THE TREATMENT OF IRON DEFICIENCY (U.S. CLS. 6, 18, 44, 46, 51 AND 52).
DAWN FELDMAN, EXAMINING ATTORNEY

SN 85-117,253. VIFOR (INTERNATIONAL) AG VIFOR (INTERNATIONAL) LTD. AND VIFOR (INTERNATIONAL) INC., 9014 ST. GALLEN, SWITZERLAND, FILED 8-27-2010.



THE MARK CONSISTS OF STANDARD CHARACTERS WITHOUT CLAIM TO ANY PARTICULAR FONT, STYLE, SIZE, OR COLOR.

OWNER OF SWITZERLAND REG. NO. 513747, DATED 8-27-2003, EXPIRES 8-7-2013.

OWNER OF U.S. REG. NO. 2,992,643.
FOR PREPARATIONS FOR THE TREATMENT OF IRON DEFICIENCY (U.S. CLS. 6, 18, 44, 46, 51 AND 52).
DAWN FELDMAN, EXAMINING ATTORNEY

CLASS 5—(Continued).

SN 85-120,248. PBI-GORDON CORPORATION, KANSAS CITY, MO. FILED 8-31-2010.



THE MARK CONSISTS OF STANDARD CHARACTERS WITHOUT CLAIM TO ANY PARTICULAR FONT, STYLE, SIZE, OR COLOR.

OWNER OF U.S. REG. NO. 684,682.
FOR VITAMIN-MINERAL FOOD SUPPLEMENT FOR ANIMALS (U.S. CLS. 6, 18, 44, 46, 51 AND 52).
TOBY BULLOFF, EXAMINING ATTORNEY

SN 85-122,710. RODRIGUEZ, CESAR, PROSPER, TX. FILED 9-3-2010.



THE MARK CONSISTS OF STANDARD CHARACTERS WITHOUT CLAIM TO ANY PARTICULAR FONT, STYLE, SIZE, OR COLOR.

FOR DIETARY SUPPLEMENTS FOR HUMAN CONSUMPTION (U.S. CLS. 6, 18, 44, 46, 51 AND 52).
CURTIS FRENCH, EXAMINING ATTORNEY

SN 85-126,148. XENOPORT, INC., SANTA CLARA, CA. FILED 9-9-2010.



THE MARK CONSISTS OF STANDARD CHARACTERS WITHOUT CLAIM TO ANY PARTICULAR FONT, STYLE, SIZE, OR COLOR.

THE WORD "BLEXATA" HAS NO MEANING IN A FOREIGN LANGUAGE.

FOR PHARMACEUTICAL PREPARATIONS FOR HUMAN USE FOR THE TREATMENT OF CENTRAL NERVOUS SYSTEM DISORDERS, GASTROINTESTINAL DISORDERS, HEMATOLOGICAL DISORDERS, AUTO-IMMUNE DISORDERS, GENETIC DISORDERS, INFLAMMATORY DISORDERS, DERMATOLOGICAL DISORDERS AND FOR THE TREATMENT OF PAIN (U.S. CLS. 6, 18, 44, 46, 51 AND 52).

KEVIN DINALLO, EXAMINING ATTORNEY

CLASS 5—(Continued).

SN 85-126,155. XENOPORT, INC., SANTA CLARA, CA.
FILED 9-9-2010.

CLASS 5—(Continued).

SN 85-126,246. XENOPORT, INC., SANTA CLARA, CA.
FILED 9-9-2010.

DREXEND

REFLESO

THE MARK CONSISTS OF STANDARD CHARACTERS WITHOUT CLAIM TO ANY PARTICULAR FONT, STYLE, SIZE, OR COLOR.

THE WORD "DREXEND" HAS NO MEANING IN A FOREIGN LANGUAGE.

FOR PHARMACEUTICAL PREPARATIONS FOR HUMAN USE FOR THE TREATMENT OF CENTRAL NERVOUS SYSTEM DISORDERS, GASTROINTESTINAL DISORDERS, HEMATOLOGICAL DISORDERS, AUTO-IMMUNE DISORDERS, GENETIC DISORDERS, INFLAMMATORY DISORDERS, DERMATOLOGICAL DISORDERS AND FOR THE TREATMENT OF PAIN (U.S. CLS. 6, 18, 44, 46, 51 AND 52).

KEVIN DINALLO, EXAMINING ATTORNEY

THE MARK CONSISTS OF STANDARD CHARACTERS WITHOUT CLAIM TO ANY PARTICULAR FONT, STYLE, SIZE, OR COLOR.

THE WORD "REFLESO" HAS NO MEANING IN A FOREIGN LANGUAGE.

FOR PHARMACEUTICAL PREPARATIONS FOR HUMAN USE FOR THE TREATMENT OF CENTRAL NERVOUS SYSTEM DISORDERS, GASTROINTESTINAL DISORDERS, HEMATOLOGICAL DISORDERS, AUTO-IMMUNE DISORDERS, GENETIC DISORDERS, INFLAMMATORY DISORDERS, DERMATOLOGICAL DISORDERS AND FOR THE TREATMENT OF PAIN (U.S. CLS. 6, 18, 44, 46, 51 AND 52).

KEVIN DINALLO, EXAMINING ATTORNEY

SN 85-126,240. XENOPORT, INC., SANTA CLARA, CA.
FILED 9-9-2010.

SN 85-126,261. XENOPORT, INC., SANTA CLARA, CA.
FILED 9-9-2010.

DURLUXA

RELTAUT

THE MARK CONSISTS OF STANDARD CHARACTERS WITHOUT CLAIM TO ANY PARTICULAR FONT, STYLE, SIZE, OR COLOR.

THE WORD "DURLUXA" HAS NO MEANING IN A FOREIGN LANGUAGE.

FOR PHARMACEUTICAL PREPARATIONS FOR HUMAN USE FOR THE TREATMENT OF CENTRAL NERVOUS SYSTEM DISORDERS, GASTROINTESTINAL DISORDERS, HEMATOLOGICAL DISORDERS, AUTO-IMMUNE DISORDERS, GENETIC DISORDERS, INFLAMMATORY DISORDERS, DERMATOLOGICAL DISORDERS AND FOR THE TREATMENT OF PAIN (U.S. CLS. 6, 18, 44, 46, 51 AND 52).

KEVIN DINALLO, EXAMINING ATTORNEY

THE MARK CONSISTS OF STANDARD CHARACTERS WITHOUT CLAIM TO ANY PARTICULAR FONT, STYLE, SIZE, OR COLOR.

THE WORD "RELTAUT" HAS NO MEANING IN A FOREIGN LANGUAGE.

FOR PHARMACEUTICAL PREPARATIONS FOR HUMAN USE FOR THE TREATMENT OF CENTRAL NERVOUS SYSTEM DISORDERS, GASTROINTESTINAL DISORDERS, HEMATOLOGICAL DISORDERS, AUTO-IMMUNE DISORDERS, GENETIC DISORDERS, INFLAMMATORY DISORDERS, DERMATOLOGICAL DISORDERS AND FOR THE TREATMENT OF PAIN (U.S. CLS. 6, 18, 44, 46, 51 AND 52).

KEVIN DINALLO, EXAMINING ATTORNEY

CLASS 5—(Continued).

SN 85-126,266. XENOPORT, INC., SANTA CLARA, CA.
FILED 9-9-2010.

CLASS 5—(Continued).

SN 85-126,308. XENOPORT, INC., SANTA CLARA, CA.
FILED 9-9-2010.

RIGLESO

TULESRA

THE MARK CONSISTS OF STANDARD CHARACTERS WITHOUT CLAIM TO ANY PARTICULAR FONT, STYLE, SIZE, OR COLOR.

THE WORD "RIGLESO" HAS NO MEANING IN A FOREIGN LANGUAGE.

FOR PHARMACEUTICAL PREPARATIONS FOR HUMAN USE FOR THE TREATMENT OF CENTRAL NERVOUS SYSTEM DISORDERS, GASTROINTESTINAL DISORDERS, HEMATOLOGICAL DISORDERS, AUTOIMMUNE DISORDERS, GENETIC DISORDERS, INFLAMMATORY DISORDERS, DERMATOLOGICAL DISORDERS AND FOR THE TREATMENT OF PAIN (U.S. CLS. 6, 18, 44, 46, 51 AND 52).

KEVIN DINALLO, EXAMINING ATTORNEY

THE MARK CONSISTS OF STANDARD CHARACTERS WITHOUT CLAIM TO ANY PARTICULAR FONT, STYLE, SIZE, OR COLOR.

THE WORD "TULESRA" HAS NO MEANING IN A FOREIGN LANGUAGE.

FOR PHARMACEUTICAL PREPARATIONS FOR HUMAN USE FOR THE TREATMENT OF CENTRAL NERVOUS SYSTEM DISORDERS, GASTROINTESTINAL DISORDERS, HEMATOLOGICAL DISORDERS, AUTOIMMUNE DISORDERS, GENETIC DISORDERS, INFLAMMATORY DISORDERS, DERMATOLOGICAL DISORDERS AND FOR THE TREATMENT OF PAIN (U.S. CLS. 6, 18, 44, 46, 51 AND 52).

KEVIN DINALLO, EXAMINING ATTORNEY

SN 85-126,303. XENOPORT, INC., SANTA CLARA, CA.
FILED 9-9-2010.

SN 85-126,318. XENOPORT, INC., SANTA CLARA, CA.
FILED 9-9-2010.

SUZINRO

ZURLEXO

THE MARK CONSISTS OF STANDARD CHARACTERS WITHOUT CLAIM TO ANY PARTICULAR FONT, STYLE, SIZE, OR COLOR.

THE WORD "SUZINRO" HAS NO MEANING IN A FOREIGN LANGUAGE.

FOR PHARMACEUTICAL PREPARATIONS FOR HUMAN USE FOR THE TREATMENT OF CENTRAL NERVOUS SYSTEM DISORDERS, GASTROINTESTINAL DISORDERS, HEMATOLOGICAL DISORDERS, AUTOIMMUNE DISORDERS, GENETIC DISORDERS, INFLAMMATORY DISORDERS, DERMATOLOGICAL DISORDERS AND FOR THE TREATMENT OF PAIN (U.S. CLS. 6, 18, 44, 46, 51 AND 52).

KEVIN DINALLO, EXAMINING ATTORNEY

THE MARK CONSISTS OF STANDARD CHARACTERS WITHOUT CLAIM TO ANY PARTICULAR FONT, STYLE, SIZE, OR COLOR.

THE WORD "ZURLEXO" HAS NO MEANING IN A FOREIGN LANGUAGE.

FOR PHARMACEUTICAL PREPARATIONS FOR HUMAN USE FOR THE TREATMENT OF CENTRAL NERVOUS SYSTEM DISORDERS, GASTROINTESTINAL DISORDERS, HEMATOLOGICAL DISORDERS, AUTOIMMUNE DISORDERS, GENETIC DISORDERS, INFLAMMATORY DISORDERS, DERMATOLOGICAL DISORDERS AND FOR THE TREATMENT OF PAIN (U.S. CLS. 6, 18, 44, 46, 51 AND 52).

KEVIN DINALLO, EXAMINING ATTORNEY

CLASS 5—(Continued).

SN 85-132,281. BIOCEPT, INC., SAN DIEGO, CA. FILED 9-17-2010.

ONCOCEE-BN

THE MARK CONSISTS OF STANDARD CHARACTERS WITHOUT CLAIM TO ANY PARTICULAR FONT, STYLE, SIZE, OR COLOR.

OWNER OF U.S. REG. NO. 3,326,287.
THE WORDING "ONCOCEE" HAS NO MEANING IN A FOREIGN LANGUAGE.

FOR MEDICAL DIAGNOSTIC TEST KITS COMPRISED OF REAGENTS AND ASSAYS FOR CANCER DETECTION; MEDICAL DIAGNOSTIC REAGENTS AND ASSAYS FOR CANCER DETECTION; MEDICAL MOLECULAR DIAGNOSTIC ASSAYS FOR CANCER TESTING OF BLOOD AND BODILY FLUIDS; MEDICAL DIAGNOSTIC REAGENTS; MEDICAL DIAGNOSTIC REAGENTS AND ASSAYS FOR TESTING OF BODY FLUIDS OR TISSUES; DIAGNOSTIC TESTS COMPRISED OF REAGENTS FOR MEDICAL USE; TESTS DESIGNED TO ISOLATE AND EXTRACT CELLS FOR GENETIC ANALYSIS COMPRISED OF REAGENTS FOR MEDICAL DIAGNOSTIC USE; AND PREDICTIVE DIAGNOSTIC TESTS USED IN THE ONCOLOGY FIELD COMPRISED OF MICROFLUIDIC CHANNELS AND REAGENTS FOR CAPTURING CIRCULATING TUMOR CELLS FROM THE BLOOD, SPINAL FLUID OR URINE OF CANCER PATIENTS (U.S. CLS. 6, 18, 44, 46, 51 AND 52).

ELISSA GARBER KON, EXAMINING ATTORNEY

SN 85-132,940. FORTUNE MEDICAL INSTRUMENT CORP., TAIPEI HSIEN, TAIWAN, FILED 9-19-2010.

Rystora

THE MARK CONSISTS OF STANDARD CHARACTERS WITHOUT CLAIM TO ANY PARTICULAR FONT, STYLE, SIZE, OR COLOR.

THE WORDING "RYSTORA" HAS NO MEANING IN A FOREIGN LANGUAGE.

FOR ADHESIVE TAPES FOR MEDICAL PURPOSES; MEDICAL DRESSINGS; ADHESIVE BANDAGES FOR SKIN WOUNDS (U.S. CLS. 6, 18, 44, 46, 51 AND 52).

DEBRA LEE, EXAMINING ATTORNEY

CLASS 5—(Continued).

SN 85-146,596. CATALYST BIOSCIENCES, INC., SOUTH SAN FRANCISCO, CA. FILED 10-6-2010.

ALTERASE

THE MARK CONSISTS OF STANDARD CHARACTERS WITHOUT CLAIM TO ANY PARTICULAR FONT, STYLE, SIZE, OR COLOR.

THE ENGLISH TRANSLATION OF "ALTERASE" IN THE MARK IS "ALTER, CHANGE".

FOR BIOCHEMICALS, NAMELY, FOR THE TREATMENT OF INFECTIOUS, AUTO-IMMUNE, CELL-PROLIFERATIVE, INFLAMMATORY, METABOLIC, CARDIOVASCULAR, RESPIRATORY, NEUROLOGICAL, AND MUSCULOSKELETAL DISORDERS AND DISEASES (U.S. CLS. 6, 18, 44, 46, 51 AND 52).

APRIL ROACH, EXAMINING ATTORNEY

SN 85-148,997. BARRATT, ALAN RICHARD, BARSTON, SOLIHULL, UNITED KINGDOM, FILED 10-9-2010.

DEVASTATOR

THE MARK CONSISTS OF STANDARD CHARACTERS WITHOUT CLAIM TO ANY PARTICULAR FONT, STYLE, SIZE, OR COLOR.

OWNER OF ERPN CMNTY TM OFC REG. NO. 009435124, DATED 2-28-2011, EXPIRES 10-9-2020.

FOR DIETARY AND NUTRITIONAL SUPPLEMENTS; DIETARY SUPPLEMENT DRINK MIXES; FOOD AND DIETARY SUPPLEMENTS FOR SPORTS AND PERFORMANCE ENHANCEMENT (U.S. CLS. 6, 18, 44, 46, 51 AND 52).

BRENDAN MCCAULEY, EXAMINING ATTORNEY

SN 85-149,060. PARAS PHARMACEUTICALS LIMITED, AHMEDABAD, INDIA, FILED 10-9-2010.



NO CLAIM IS MADE TO THE EXCLUSIVE RIGHT TO USE "JOINT PAIN RELIEVER", APART FROM THE MARK AS SHOWN.

THE MARK CONSISTS OF THE STYLIZED WORD "MOOV" WITH THE WORDS "JOINT PAIN RELIEVER" BELOW.

FOR PREPARATIONS FOR THE RELIEF OF PAIN (U.S. CLS. 6, 18, 44, 46, 51 AND 52).

APRIL HESIK, EXAMINING ATTORNEY

CLASS 5—(Continued).

SN 85-149,065. PARAS PHARMACEUTICALS LIMITED, AHMEDABAD, INDIA, FILED 10-9-2010.



NO CLAIM IS MADE TO THE EXCLUSIVE RIGHT TO USE "NEW", APART FROM THE MARK AS SHOWN.

THE MARK CONSISTS OF THE STYLIZED WORD "D'COLD" CONTAINED WITHIN A RECTANGLE AND THE STYLIZED WORD "NEW" LOCATED ABOVE THE UPPER LEFT CORNER OF THE RECTANGLE.

FOR MEDICATION PREPARATIONS FOR USE IN THE TREATMENT OF PAINFUL THROAT IRRITATION, COUGHS, CONGESTION, FEVER, AND PAIN (U.S. CLS. 6, 18, 44, 46, 51 AND 52).

APRIL HESIK, EXAMINING ATTORNEY

SN 85-158,350. NITRO US TRADEMARK LTD., OAKVILLE, ONTARIO, CANADA, FILED 10-21-2010.

SMART CASEIN

THE MARK CONSISTS OF STANDARD CHARACTERS WITHOUT CLAIM TO ANY PARTICULAR FONT, STYLE, SIZE, OR COLOR.

NO CLAIM IS MADE TO THE EXCLUSIVE RIGHT TO USE "CASEIN", APART FROM THE MARK AS SHOWN.

FOR DIETARY SUPPLEMENTS CONTAINING CASEIN (U.S. CLS. 6, 18, 44, 46, 51 AND 52).

DAWN HAN, EXAMINING ATTORNEY

SN 85-167,759. THE BALLARD GROUP, INC., CINCINNATI, OH. FILED 11-3-2010.

SALMATE

THE MARK CONSISTS OF STANDARD CHARACTERS WITHOUT CLAIM TO ANY PARTICULAR FONT, STYLE, SIZE, OR COLOR.

FOR FAT SUPPLEMENTS FOR ANIMALS (U.S. CLS. 6, 18, 44, 46, 51 AND 52).

FIRST USE 5-7-2003; IN COMMERCE 5-7-2003.

NAKWAMA ANKRAH, EXAMINING ATTORNEY

CLASS 5—(Continued).

SN 85-168,695. STANDARD HOMEOPATHIC COMPANY, LOS ANGELES, CA. FILED 11-3-2010.



OWNER OF U.S. REG. NOS. 2,172,207, 2,977,921 AND OTHERS.

THE COLOR(S) BROWN, BLUE, WHITE AND SILVER IS/ARE CLAIMED AS A FEATURE OF THE MARK.

THE MARK CONSISTS OF IN ITS UPPER PORTION, A BROWN BACKGROUND WITH A WHITE BURST ON A BROWN BACKGROUND. "HYLAND'S" APPEARS IN STYLIZED WHITE LETTERS IN A BLUE OVAL WITHIN A WHITE OUTLINE TO THE UPPER LEFT OF THE WHITE BURST. BELOW THE WHITE BURST ON A BROWN BACKGROUND IS A SILVER CURVING HORIZONTAL LINE. BENEATH THE SILVER CURVING HORIZONTAL LINE IS A BLUE FIELD.

FOR HOMEOPATHIC MEDICATIONS AND HOMEOPATHIC PHARMACEUTICALS FOR USE IN THE TREATMENT OF LEG, FOOT AND LOWER BACK CRAMPS AND PAIN, AND AIDING SLEEP (U.S. CLS. 6, 18, 44, 46, 51 AND 52).

FIRST USE 12-14-2009; IN COMMERCE 12-14-2009.

STEVEN JACKSON, EXAMINING ATTORNEY

SN 85-174,229. BETANCOURT SPORTS NUTRITION, LLC, MIAMI LAKES, FL. FILED 11-11-2010.

FULLDOSE

THE MARK CONSISTS OF STANDARD CHARACTERS WITHOUT CLAIM TO ANY PARTICULAR FONT, STYLE, SIZE, OR COLOR.

FOR DIETARY AND NUTRITIONAL SUPPLEMENTS; DIETARY AND NUTRITIONAL SUPPLEMENTS FOR ENDURANCE SPORTS; NUTRITIONAL SUPPLEMENT IN THE NATURE OF A NUTRIENT-DENSE, PROTEIN-BASED DRINK MIX; NUTRITIONAL SUPPLEMENTS FOR SPORTS (U.S. CLS. 6, 18, 44, 46, 51 AND 52).

CARYN GLASSER, EXAMINING ATTORNEY

CLASS 5—(Continued).

SN 85-175,114. ARES TRADING S.A., AUBONNE CH-1170, SWITZERLAND, FILED 11-11-2010.

SCIENAT

THE MARK CONSISTS OF STANDARD CHARACTERS WITHOUT CLAIM TO ANY PARTICULAR FONT, STYLE, SIZE, OR COLOR.

OWNER OF U.S. REG. NO. 3,447,978.

FOR PHARMACEUTICAL PREPARATIONS FOR HUMAN USE, NAMELY, PREPARATIONS FOR THE TREATMENT OF IMMUNOLOGICAL DISEASES AND DISORDERS, INFLAMMATORY DISEASES AND DISORDERS, ENDOCRINOLOGICAL DISEASES AND DISORDERS, METABOLIC DISEASES AND DISORDERS, RHEUMATOLOGICAL DISEASES AND DISORDERS, MUSCULO-SKELETAL DISEASES AND DISORDERS, ONCOLOGIC DISEASES AND DISORDERS, NEUROLOGICAL DISEASES AND DISORDERS (U.S. CLS. 6, 18, 44, 46, 51 AND 52).

DANIEL CAPSHAW, EXAMINING ATTORNEY

CLASS 5—(Continued).

SN 85-178,785. U.S. ANIMAL HEALTH, LLC, BRENTWOOD, NY, FILED 11-17-2010.

ARMOR GUARD

THE MARK CONSISTS OF STANDARD CHARACTERS WITHOUT CLAIM TO ANY PARTICULAR FONT, STYLE, SIZE, OR COLOR.

FOR PET CARE PREPARATIONS, NAMELY, PREPARATIONS FOR KILLING AND REPELLING FLEAS, TICKS, MOSQUITOES, LICE AND MITES (U.S. CLS. 6, 18, 44, 46, 51 AND 52).

KATHERINE STOIDES, EXAMINING ATTORNEY

SN 85-179,891. SEQUANA NATURALS, INC., ELIZABETH, CO. FILED 11-18-2010.

SEQUANA

THE MARK CONSISTS OF STANDARD CHARACTERS WITHOUT CLAIM TO ANY PARTICULAR FONT, STYLE, SIZE, OR COLOR.

FOR TOPICAL OILS, LOTIONS, CREAMS, AND SALVES MADE FROM NATURAL INGREDIENTS FOR THERAPEUTIC MUSCLE AND JOINT HEALTH (U.S. CLS. 6, 18, 44, 46, 51 AND 52).

FIRST USE 1-1-2010; IN COMMERCE 1-1-2010.

MARIA-VICTORIA SUAREZ, EXAMINING ATTORNEY

SN 85-175,117. ARES TRADING S.A., AUBONNE CH-1170, SWITZERLAND, FILED 11-11-2010.

WISOM

THE MARK CONSISTS OF STANDARD CHARACTERS WITHOUT CLAIM TO ANY PARTICULAR FONT, STYLE, SIZE, OR COLOR.

OWNER OF U.S. REG. NO. 3,447,979.

THE WORDING "WISOM" HAS NO MEANING IN A FOREIGN LANGUAGE.

FOR PHARMACEUTICAL PREPARATIONS FOR HUMAN USE, NAMELY PREPARATIONS FOR THE TREATMENT OF IMMUNOLOGICAL DISEASES AND DISORDERS, INFLAMMATORY DISEASES AND DISORDERS, ENDOCRINOLOGICAL DISEASES AND DISORDERS, METABOLIC DISEASES AND DISORDERS, RHEUMATOLOGICAL DISEASES AND DISORDERS, MUSCULO-SKELETAL DISEASES AND DISORDERS (U.S. CLS. 6, 18, 44, 46, 51 AND 52).

DANIEL CAPSHAW, EXAMINING ATTORNEY

SN 85-182,281. VAXART, INC., SAN FRANCISCO, CA. FILED 11-22-2010.

VAXART

THE MARK CONSISTS OF STANDARD CHARACTERS WITHOUT CLAIM TO ANY PARTICULAR FONT, STYLE, SIZE, OR COLOR.

FOR ORAL VACCINES FOR USE IN HUMANS (U.S. CLS. 6, 18, 44, 46, 51 AND 52).

FIRST USE 11-12-2010; IN COMMERCE 11-12-2010.

KELLY BOULTON, EXAMINING ATTORNEY

CLASS 5—(Continued).

SN 85-185,375. SUN PHARMACEUTICALS INDUSTRIES LTD, TA SUN PHARMACEUTICALS INDUSTRIES LTD, MUMBAI- 400093, INDIA, FILED 11-26-2010.

Bsure

THE MARK CONSISTS OF STANDARD CHARACTERS WITHOUT CLAIM TO ANY PARTICULAR FONT, STYLE, SIZE, OR COLOR.

FOR ORAL CONTRACEPTIVES; PHARMACEUTICAL PREPARATIONS IN THE NATURE OF AN EMERGENCY CONTRACEPTIVE ORAL PILL CONTAINING PROGESTIN (U.S. CLS. 6, 18, 44, 46, 51 AND 52).

KELLY CHOE, EXAMINING ATTORNEY

SN 85-187,509. SWEETWATER FARMS, INC., AQUA DULCE, CA. FILED 11-30-2010.

Hoof ReNu

THE MARK CONSISTS OF STANDARD CHARACTERS WITHOUT CLAIM TO ANY PARTICULAR FONT, STYLE, SIZE, OR COLOR.

NO CLAIM IS MADE TO THE EXCLUSIVE RIGHT TO USE "HOOF", APART FROM THE MARK AS SHOWN.

FOR FEED SUPPLEMENTS FOR HORSES (U.S. CLS. 6, 18, 44, 46, 51 AND 52).

ALICIA COLLINS, EXAMINING ATTORNEY

SN 85-194,138. DAIICHI SANKYO COMPANY, LIMITED, TOKYO, JAPAN, FILED 12-9-2010.

SELPATH

THE MARK CONSISTS OF STANDARD CHARACTERS WITHOUT CLAIM TO ANY PARTICULAR FONT, STYLE, SIZE, OR COLOR.

FOR PHARMACEUTICAL PREPARATIONS FOR THE TREATMENT AND PREVENTION OF CARDIOVASCULAR DISEASE, ATHEROSCLEROSIS, DIABETIC NEPHROPATHY, STROKE, HEART ATTACK, HYPERCHOLESTEROLEMIA, DYSLIPIDEMIA, ANEMIA, BLOOD DISORDERS, DIABETES, THYROID FUNCTION DISEASE, CANCER, ONCOLOGICAL DISEASE, METASTASIS, AUTOIMMUNE DISEASE, ALLERGY, BACTERIAL INFECTION, VIRAL INFECTION, FUNGAL INFECTION, INFLAMMATION, MUSCULOSKELETAL DISORDERS, PAIN, OSTEOPOROSIS, ALZHEIMER'S DISEASE, OBESITY, ANOREXIA, URINARY AND KIDNEY DISEASE, RESPIRATORY DISEASE, GASTROINTESTINAL DISEASE; VACCINES; DIAGNOSTIC REAGENTS AND CONTRAST MEDIA FOR MEDICAL USE (U.S. CLS. 6, 18, 44, 46, 51 AND 52).

ANGELA M. MICHELI, EXAMINING ATTORNEY

CLASS 5—(Continued).

SN 85-195,538. ANDERSON GLOBAL GROUP, LLC, IRVINE, CA. FILED 12-10-2010.

The logo for Trans-min AEP features the word "Trans-min" in a serif font above the word "AEP" in a large, bold, italicized sans-serif font. To the left of "AEP" are three small circles in blue, green, and red, followed by a horizontal line with a dot at its end.

NO CLAIM IS MADE TO THE EXCLUSIVE RIGHT TO USE "AEP", APART FROM THE MARK AS SHOWN.

THE COLOR(S) BLUE, GREEN, RED, WHITE, AND BLACK IS/ARE CLAIMED AS A FEATURE OF THE MARK.

THE MARK CONSISTS OF THE LETTERING "TRANS-MIN" AND "AEP" IN BLACK WITH BUBBLES APPEARING FROM LEFT TO RIGHT IN THE FOLLOWING COLORS: BLUE, GREEN, RED, BLUE AND WHITE WITH BLACK SHADOW, GREEN AND WHITE WITH A BLACK SHADOW, WHITE WITH A BLACK SHADOW, AND WHITE WITH A BLACK SHADOW.

FOR DIETARY AND NUTRITIONAL SUPPLEMENTS CONTAINING AEP (U.S. CLS. 6, 18, 44, 46, 51 AND 52).

HEATHER BIDDULPH, EXAMINING ATTORNEY

SN 85-196,911. AIM STAR NETWORK CO., LTD., WATTANA BANGKOK 10110, THAILAND, FILED 12-13-2010.

The logo for AG bloc features the letters "AG" in a large, bold, red sans-serif font. To the right of "AG" is a grey cluster of dots forming a stylized figure-eight shape. Below "AG" and the cluster is the word "bloc" in a smaller, bold, black sans-serif font.

THE COLOR(S) RED, LIGHT GREY, GREY AND BLACK IS/ARE CLAIMED AS A FEATURE OF THE MARK.

THE MARK CONSISTS OF LARGE UPPERCASE LETTERS "AG" IN RED, FOLLOWED BY THE WORD "BLOC" IN LOWER CASE LETTERS IN BLACK, WITH TWO LIGHT GREY FIGURE 8 FORMS ON A DIAGONAL AXIS AND A GREY FIGURE 8 FORM ON EACH SIDE ALL ABOVE THE WORD "BLOC".

FOR DIETARY SUPPLEMENT FOR WEIGHT MANAGEMENT (U.S. CLS. 6, 18, 44, 46, 51 AND 52).

AISHA SALEM, EXAMINING ATTORNEY

SN 85-197,222. WELLSPRING PHARMACEUTICAL CORPORATION, SARASOTA, FL. FILED 12-14-2010.

The logo for K+onserv features the letter "K" in a large, bold, black serif font, followed by a plus sign in superscript. To the right of the plus sign is the word "onserv" in a smaller, bold, black serif font.

THE MARK CONSISTS OF WORDING "KONSERV" WITH THE PLUS SYMBOL IN SUPERSCRIPIT PLACED AFTER CAPITAL "K".

FOR POTASSIUM SPARING DIURETICS (U.S. CLS. 6, 18, 44, 46, 51 AND 52).

RAMONA ORTIGA, EXAMINING ATTORNEY

CLASS 5—(Continued).

SN 85-202,198. BIOLARGO, INC., LA MIRADA, CA. FILED 12-20-2010.

Cleaner & Dryer = Safer & Healthier

THE MARK CONSISTS OF STANDARD CHARACTERS WITHOUT CLAIM TO ANY PARTICULAR FONT, STYLE, SIZE, OR COLOR.

FOR DISINFECTING AND DEODORIZING PREPARATIONS FOR FACILITIES, EQUIPMENT, BEDDING, STALLS, DIRT, DRAINS, PIPES, MOLD, DRAINAGE SYSTEMS ASSOCIATED WITH ANIMALS AND ANIMAL CARE (U.S. CLS. 6, 18, 44, 46, 51 AND 52).

FIRST USE 6-19-2009; IN COMMERCE 6-19-2009.
JENNIFER MARTIN, EXAMINING ATTORNEY

SN 85-202,227. BIOLARGO, INC., LA MIRADA, CA. FILED 12-20-2010.



THE MARK CONSISTS OF LETTERS "ONM" EN-CIRCLED.

FOR DISINFECTING AND DEODORIZING PREPARATIONS FOR FACILITIES, EQUIPMENT, BEDDING, STALLS, DIRT, DRAINS, PIPES, MOLD, DRAINAGE SYSTEMS ASSOCIATED WITH ANIMALS AND ANIMAL CARE (U.S. CLS. 6, 18, 44, 46, 51 AND 52).

FIRST USE 2-6-2009; IN COMMERCE 6-19-2009.
JENNIFER MARTIN, EXAMINING ATTORNEY

SN 85-208,930. DOW AGROSCIENCES LLC, INDIANAPOLIS, IN. FILED 1-3-2011.

ECOZOME

THE MARK CONSISTS OF STANDARD CHARACTERS WITHOUT CLAIM TO ANY PARTICULAR FONT, STYLE, SIZE, OR COLOR.

FOR PESTICIDES AND PREPARATIONS FOR DESTROYING VERMIN, NAMELY, HERBICIDES, INSECTICIDES AND FUNGICIDES FOR AGRICULTURE, HORTICULTURE, FORESTRY, TURF AND ORNAMENTAL, COMMERCIAL, INDUSTRIAL AND DOMESTIC USE (U.S. CLS. 6, 18, 44, 46, 51 AND 52).

ANDREA HACK, EXAMINING ATTORNEY

CLASS 5—(Continued).

SN 85-209,549. MOTHER'S CUPBOARD INC., DBA MOTHER'S CUPBOARD NUTRITION, SPOKANE VALLEY, WA. FILED 1-3-2011.

ManPower

THE MARK CONSISTS OF STANDARD CHARACTERS WITHOUT CLAIM TO ANY PARTICULAR FONT, STYLE, SIZE, OR COLOR.

FOR DIETARY AND NUTRITIONAL SUPPLEMENTS; DIETARY FOOD SUPPLEMENTS; DIETARY SUPPLEMENTS; DIETARY SUPPLEMENTS FOR HUMAN CONSUMPTION; FOOD SUPPLEMENTS; HEALTH FOOD SUPPLEMENTS; NATURAL SUPPLEMENTS FOR TREATING ERECTILE DYSFUNCTION; NUTRACEUTICALS FOR USE AS A DIETARY SUPPLEMENT; NUTRITIONAL SUPPLEMENTS (U.S. CLS. 6, 18, 44, 46, 51 AND 52).

FIRST USE 1-2-2010; IN COMMERCE 1-2-2010.
JULIE GUTTADAURO, EXAMINING ATTORNEY

SN 85-210,728. DEMPSEY, MARIA A., LEE'S SUMMIT, MO. FILED S.R. 1-5-2011; AM. P.R. 5-6-2011.

Muscle CPR

THE MARK CONSISTS OF STANDARD CHARACTERS WITHOUT CLAIM TO ANY PARTICULAR FONT, STYLE, SIZE, OR COLOR.

NO CLAIM IS MADE TO THE EXCLUSIVE RIGHT TO USE "MUSCLE", APART FROM THE MARK AS SHOWN.

FOR NUTRACEUTICALS FOR THE TREATMENT OF MUSCLE CRAMPS (U.S. CLS. 6, 18, 44, 46, 51 AND 52).

FIRST USE 12-20-2010; IN COMMERCE 12-20-2010.
LEIGH LOWRY, EXAMINING ATTORNEY

SN 85-215,033. MIRAKLET, LLC, DELRAY BEACH, FL. FILED 1-11-2011.



NO CLAIM IS MADE TO THE EXCLUSIVE RIGHT TO USE "TECHNOLOGY", APART FROM THE MARK AS SHOWN.

FOR BIOCIDES, GERMICIDES, BACTERICIDES, VIRUCIDES, FUNGICIDES, INSECTICIDES, PESTICIDES AND HERBICIDES (U.S. CLS. 6, 18, 44, 46, 51 AND 52).

FIRST USE 9-29-2010; IN COMMERCE 1-1-2011.

KATHERINE M. DUBRAY, EXAMINING ATTORNEY

CLASS 5—(Continued).

SN 85-215,144. MIRAKLET, LLC, DELRAY BEACH, FL. FILED 1-11-2011.



NO CLAIM IS MADE TO THE EXCLUSIVE RIGHT TO USE "TECHNOLOGY", APART FROM THE MARK AS SHOWN.

FOR INSECT EXTERMINATING AGENTS; INSECT REPELLENT AGENTS (U.S. CLS. 6, 18, 44, 46, 51 AND 52).

FIRST USE 9-29-2010; IN COMMERCE 1-1-2011.

KATHERINE M. DUBRAY, EXAMINING ATTORNEY

CLASS 5—(Continued).

SN 85-222,584. BLK BRANDS, LLC, NEW YORK, NY. FILED 1-20-2011.

blk.

THE MARK CONSISTS OF STANDARD CHARACTERS WITHOUT CLAIM TO ANY PARTICULAR FONT, STYLE, SIZE, OR COLOR.

FOR DIETARY SUPPLEMENTAL DRINKS IN THE NATURE OF VITAMIN AND MINERAL BEVERAGES; NUTRITIONALLY FORTIFIED WATER (U.S. CLS. 6, 18, 44, 46, 51 AND 52).

FIRST USE 1-14-2011; IN COMMERCE 1-19-2011.

BRENDAN REGAN, EXAMINING ATTORNEY

SN 85-216,829. MYDAILYDOSE, LLC, JERSEY CITY, NJ. FILED 1-13-2011.

MYDAILYDOSE

THE MARK CONSISTS OF STANDARD CHARACTERS WITHOUT CLAIM TO ANY PARTICULAR FONT, STYLE, SIZE, OR COLOR.

OWNER OF U.S. REG. NO. 2,956,187. FOR DIETARY SUPPLEMENTS (U.S. CLS. 6, 18, 44, 46, 51 AND 52).

FIRST USE 4-1-2001; IN COMMERCE 4-1-2001.

APRIL ROACH, EXAMINING ATTORNEY

SN 85-224,206. AMERICAN HEALTH FORMULATIONS, INC., EDGEWOOD, NY. FILED 1-24-2011.

AngleNutrition

THE MARK CONSISTS OF STANDARD CHARACTERS WITHOUT CLAIM TO ANY PARTICULAR FONT, STYLE, SIZE, OR COLOR.

FOR DIETARY SUPPLEMENTS (U.S. CLS. 6, 18, 44, 46, 51 AND 52).

KATHLEEN M. VANSTON, EXAMINING ATTORNEY

SN 85-219,237. SWEETWATER FARMS, INC., AQUA DULCE, CA. FILED 1-17-2011.

Sweetwater Nutrition

THE MARK CONSISTS OF STANDARD CHARACTERS WITHOUT CLAIM TO ANY PARTICULAR FONT, STYLE, SIZE, OR COLOR.

NO CLAIM IS MADE TO THE EXCLUSIVE RIGHT TO USE "NUTRITION", APART FROM THE MARK AS SHOWN.

FOR VITAMINS, DIETARY FOOD SUPPLEMENTS, AND FEED SUPPLEMENTS FOR ANIMALS (U.S. CLS. 6, 18, 44, 46, 51 AND 52).

ALICIA COLLINS, EXAMINING ATTORNEY

SN 85-229,446. 1ST PHORM LLC, ST LOUIS, MO. FILED 1-29-2011.

Anabolic Bridge

THE MARK CONSISTS OF STANDARD CHARACTERS WITHOUT CLAIM TO ANY PARTICULAR FONT, STYLE, SIZE, OR COLOR.

NO CLAIM IS MADE TO THE EXCLUSIVE RIGHT TO USE "ANABOLIC", APART FROM THE MARK AS SHOWN.

FOR DIETARY AND NUTRITIONAL SUPPLEMENTS WHICH SPEED UP THE ANABOLIC PROCESS (U.S. CLS. 6, 18, 44, 46, 51 AND 52).

FIRST USE 11-1-2010; IN COMMERCE 11-1-2010.

IRA J. GOODSID, EXAMINING ATTORNEY

CLASS 5—(Continued).

SN 85-232,940. UNIVERSITY OF FLORIDA RESEARCH FOUNDATION, INC., GAINESVILLE, FL. FILED 2-3-2011.

ENTERADE

THE MARK CONSISTS OF STANDARD CHARACTERS WITHOUT CLAIM TO ANY PARTICULAR FONT, STYLE, SIZE, OR COLOR.

FOR NUTRITIONALLY FORTIFIED BEVERAGES CONSISTING PRIMARILY OF AMINO ACIDS AND CARBOHYDRATES TO BE USED FOR TREATING PATIENTS WITH WELL-KNOWN DISEASE CONDITIONS AND AILMENTS BY WAY OF SUPPLYING EITHER AMINO ACIDS OR CARBOHYDRATES AS NEEDED AND SUITABLE TO THE PATIENTS WITH CERTAIN TYPES OF DISEASES (U.S. CLS. 6, 18, 44, 46, 51 AND 52).

TIMOTHY FINNEGAN, EXAMINING ATTORNEY



SN 85-233,446. ABBOTT LABORATORIES, ABBOTT PARK, IL. FILED 2-3-2011.

PEDIALYTE JUNIOR

THE MARK CONSISTS OF STANDARD CHARACTERS WITHOUT CLAIM TO ANY PARTICULAR FONT, STYLE, SIZE, OR COLOR.

OWNER OF U.S. REG. NO. 3,098,124.
NO CLAIM IS MADE TO THE EXCLUSIVE RIGHT TO USE "JUNIOR", APART FROM THE MARK AS SHOWN.
FOR ORAL ELECTROLYTE SOLUTION (U.S. CLS. 6, 18, 44, 46, 51 AND 52).
ELIZABETH KAJUBI, EXAMINING ATTORNEY



SN 85-233,459. ABBOTT LABORATORIES, ABBOTT PARK, IL. FILED 2-3-2011.

PEDIALYTE INFANT

THE MARK CONSISTS OF STANDARD CHARACTERS WITHOUT CLAIM TO ANY PARTICULAR FONT, STYLE, SIZE, OR COLOR.

OWNER OF U.S. REG. NO. 3,098,124.
NO CLAIM IS MADE TO THE EXCLUSIVE RIGHT TO USE "INFANT", APART FROM THE MARK AS SHOWN.
FOR ORAL ELECTROLYTE SOLUTION (U.S. CLS. 6, 18, 44, 46, 51 AND 52).
ELIZABETH KAJUBI, EXAMINING ATTORNEY

CLASS 5—(Continued).

SN 85-234,171. WALGREEN CO., DEERFIELD, IL. FILED 2-4-2011.

NICE!

THE MARK CONSISTS OF STANDARD CHARACTERS WITHOUT CLAIM TO ANY PARTICULAR FONT, STYLE, SIZE, OR COLOR.

FOR ELECTROLYTE DRINKS FOR MEDICAL PURPOSES; INFANT FORMULA; HAND SANITIZERS; ALL-PURPOSE DISINFECTANT SPRAYS; DISINFECTANT TOILET BOWL CLEANERS; MEDICAL DIAGNOSTIC TEST STRIPS FOR USE IN TESTING FOR URINARY TRACT INFECTION; MEDICATED DOUCHES; OVULATION TEST KITS; PERSONAL LUBRICANTS; PREGNANCY TEST KITS FOR HOME USE; SANITARY PADS AND NAPKINS; MEDICATED WIPES FOR THE TREATMENT OF ACNE (U.S. CLS. 6, 18, 44, 46, 51 AND 52).

JIM RINGLE, EXAMINING ATTORNEY



SN 85-236,585. WEIDER PUBLICATIONS, LLC, BOCA RATON, FL. FILED 2-8-2011.

FitPregnancy

OWNER OF U.S. REG. NOS. 1,994,180 AND 2,188,470.
THE MARK CONSISTS OF THE WORDS "FIT PREGNANCY".
FOR DIETARY AND NUTRITIONAL SUPPLEMENTS (U.S. CLS. 6, 18, 44, 46, 51 AND 52).
TEJBIR SINGH, EXAMINING ATTORNEY

CLASS 5—(Continued).

SN 85-237,917. GOLDEN BIOTECHNOLOGY CORPORATION, TAIPEI COUNTY 2514, TAIWAN, FILED 2-9-2011.



THE MARK CONSISTS OF A DESIGN OF A TEARDROP WITH A CHEVRON ABOVE IT. THERE ARE TWO SIMILAR TEARDROP AND CHEVRON DESIGNS BEHIND THE MAIN TEARDROP DESIGN.

FOR ADJUVANTS FOR MEDICAL PURPOSES; ANTI-ALLERGIC MEDICINES; ANTI-CANCER PREPARATIONS; MEDICINAL HERBAL EXTRACTS FOR MEDICAL PURPOSES; PHARMACEUTICAL AND MEDICINAL PREPARATIONS AND SUBSTANCES FOR THE PREVENTION AND TREATMENT OF DISORDERS OF THE NERVOUS SYSTEM, THE IMMUNE SYSTEM, THE CARDIO-VASCULAR SYSTEM, THE METABOLIC SYSTEM, THE RESPIRATORY SYSTEM, THE MUSCULO-SKELETAL SYSTEM, THE GENITOURINARY SYSTEM, FOR THE TREATMENT OF INFLAMMATORY DISORDERS, OCULAR DISORDERS, OR BONE DISEASES, FOR USE IN DERMATOLOGY, ONCOLOGY, HEMATOLOGY AND OPHTHALMOLOGY AND FOR GASTROENTEROLOGICAL DISORDERS OR LIVER AILMENTS; PHARMACEUTICAL AND MEDICINAL PREPARATIONS FOR THE TREATMENT OF BRAIN DISEASES OR DISORDERS AND AUTOIMMUNE DISEASES OR DISORDERS; DIETARY AND NUTRITIONAL SUPPLEMENTS FOR MEDICAL USE; DIETARY SUPPLEMENTS FOR TREATING FATIGUE OR LIVER SUPPORT; ANIMAL FEED ADDITIVE FOR USE AS A NUTRITIONAL SUPPLEMENT FOR MEDICAL PURPOSES; DIETARY SUPPLEMENTS FOR HUMAN CONSUMPTION OR FOR ANIMALS; NUTRITIONAL ADDITIVES FOR MEDICAL PURPOSES FOR USE IN FOODS FOR HUMAN CONSUMPTION OR FOR ANIMALS; ANIMAL FEED SUPPLEMENTS; DIETARY PET SUPPLEMENTS IN THE FORM OF PET TREATS; FUNGI PREPARATIONS FOR MEDICAL OR VETERINARY USE FOR TREATING DISORDERS OF THE NERVOUS SYSTEM, THE IMMUNE SYSTEM, THE CARDIO-VASCULAR SYSTEM, THE METABOLIC SYSTEM, THE RESPIRATORY SYSTEM, THE MUSCULO-SKELETAL SYSTEM, THE GENITOURINARY SYSTEM, FOR THE TREATMENT OF INFLAMMATORY DISORDERS, OCULAR DISORDERS, BRAIN DISEASES OR DISORDERS, AUTOIMMUNE DISEASES OR DISORDERS, OR BONE DISEASES, FOR USE IN DERMATOLOGY, ONCOLOGY, HEMATOLOGY AND OPHTHALMOLOGY AND FOR GASTROENTEROLOGICAL DISORDERS OR LIVER AILMENTS; PHARMACEUTICAL PREPARATIONS AND SUBSTANCES FOR VETERINARY PURPOSES FOR TREATING DISORDERS OF THE NERVOUS SYSTEM, THE IMMUNE SYSTEM, THE CARDIO-VASCULAR SYSTEM, THE METABOLIC SYSTEM, THE RESPIRATORY SYSTEM, THE MUSCULO-SKELETAL SYSTEM, THE GENITOURINARY SYSTEM, FOR THE TREATMENT OF INFLAMMATORY DISORDERS, OCULAR DISORDERS, BRAIN DISEASES OR DISORDERS, AUTOIMMUNE DISEASES OR DISORDERS, OR BONE DISEASES, FOR USE IN DERMATOLOGY, ONCOLOGY, HEMATOLOGY AND OPHTHALMOLOGY AND FOR GASTROENTEROLOGICAL DISORDERS OR LIVER AILMENTS; CHEMICAL PREPARATIONS FOR MEDICINAL PURPOSES FOR TREATING DISORDERS OF THE NERVOUS SYSTEM, THE IMMUNE SYSTEM, THE CARDIO-VASCULAR SYSTEM, THE METABOLIC SYSTEM, THE RESPIRA-

CLASS 5—(Continued).

TORY SYSTEM, THE MUSCULO-SKELETAL SYSTEM, THE GENITOURINARY SYSTEM, FOR THE TREATMENT OF INFLAMMATORY DISORDERS, OCULAR DISORDERS, BRAIN DISEASES OR DISORDERS, AUTOIMMUNE DISEASES OR DISORDERS, OR BONE DISEASES, FOR USE IN DERMATOLOGY, ONCOLOGY, HEMATOLOGY AND OPHTHALMOLOGY AND FOR GASTROENTEROLOGICAL DISORDERS OR LIVER AILMENTS; CARDIOVASCULAR PHARMACEUTICALS; CARDIOVASCULAR TREATMENT PREPARATIONS; PHARMACEUTICALS PREPARATIONS FOR THE TREATMENT OF KIDNEY DISEASES (U.S. CLS. 6, 18, 44, 46, 51 AND 52).

KAREN K. BUSH, EXAMINING ATTORNEY

SN 85-238,153. MARTHA STEWART LIVING OMNIMEDIA, INC., NEW YORK, NY. FILED 2-9-2011.

MARTHA STEWART

THE MARK CONSISTS OF STANDARD CHARACTERS WITHOUT CLAIM TO ANY PARTICULAR FONT, STYLE, SIZE, OR COLOR.

OWNER OF U.S. REG. NOS. 3,435,783, 3,709,397 AND OTHERS.

THE NAME(S), PORTRAIT(S), AND/OR SIGNATURE(S) SHOWN IN THE MARK IDENTIFIES "MARTHA STEWART", WHOSE CONSENT(S) TO REGISTER IS MADE OF RECORD.

FOR HEALTHY LIVING PRODUCTS, NAMELY, VITAMINS; HERBAL PRODUCTS, NAMELY, HERBAL DIETARY SUPPLEMENTS AND BOTANICAL SUPPLEMENTS; HOMEOPATHIC SUPPLEMENTS; EYE PILLOWS CONTAINING AROMATIC AND NON-AROMATIC SUBSTANCES FOR RELIEF FROM HEADACHES, INSOMNIA AND SINUS DISCOMFORT; SINUS PILLOWS CONTAINING AROMATIC AND NON-AROMATIC SUBSTANCES FOR RELIEF FROM HEADACHES, INSOMNIA AND SINUS DISCOMFORT; NATURAL PESTICIDES; ADHESIVE BANDAGES (U.S. CLS. 6, 18, 44, 46, 51 AND 52).

LINDA MICKLEBURGH, EXAMINING ATTORNEY

SN 85-238,817. CHEN, JULIE T., SAN JOSE, CA. FILED 2-10-2011.

M.H.E.

THE MARK CONSISTS OF STANDARD CHARACTERS WITHOUT CLAIM TO ANY PARTICULAR FONT, STYLE, SIZE, OR COLOR.

FOR VITAMINS; NUTRITIONAL SUPPLEMENTS; DIETARY SUPPLEMENTS; NUTRITIONAL FOOD BARS FOR USE AS A MEAL REPLACEMENT; MEAL REPLACEMENT BARS; DIETARY SUPPLEMENTS IN THE NATURE OF NUTRITIONAL BARS (U.S. CLS. 6, 18, 44, 46, 51 AND 52).

WON TEAK OH, EXAMINING ATTORNEY

CLASS 5—(Continued).

SN 85-238,824. CHEN, JULIE T., SAN JOSE, CA. FILED 2-10-2011.

MAKING HEALTHY EZ

THE MARK CONSISTS OF STANDARD CHARACTERS WITHOUT CLAIM TO ANY PARTICULAR FONT, STYLE, SIZE, OR COLOR.

FOR VITAMINS; NUTRITIONAL SUPPLEMENTS; DIETARY SUPPLEMENTS; NUTRITIONAL FOOD BARS FOR USE AS A MEAL REPLACEMENT; MEAL REPLACEMENT BARS; DIETARY SUPPLEMENTS IN THE NATURE OF NUTRITIONAL BARS (U.S. CLS. 6, 18, 44, 46, 51 AND 52).

WON TEAK OH, EXAMINING ATTORNEY

SN 85-239,517. MANZEN, LLC, LAS VEGAS, NV. FILED 2-10-2011.



OWNER OF U.S. REG. NOS. 3,159,491, 3,703,170 AND OTHERS.

THE MARK CONSISTS OF A BARCODE DESIGN WITH THE TEXT "XYIENCE" BELOW IT.

FOR DIETARY SUPPLEMENTS; NUTRITIONAL SUPPLEMENTS (U.S. CLS. 6, 18, 44, 46, 51 AND 52).

FIRST USE 5-20-2004; IN COMMERCE 5-20-2004.

RUSS HERMAN, EXAMINING ATTORNEY

SN 85-241,705. ENERGIQUE, INC, WOODBINE, IA. FILED 2-14-2011.



OWNER OF U.S. REG. NO. 2,566,389.

NO CLAIM IS MADE TO THE EXCLUSIVE RIGHT TO USE "NATURAL REMEDIES", APART FROM THE MARK AS SHOWN.

THE MARK CONSISTS OF THE WORD "ENERGIQUE" IN A STYLIZED ARC OVER AN EMBLEM CONSISTING OF STYLIZED LEAVES AND THE LETTER "E". THE WORDS "NATURAL REMEDIES" AND "FROM THE HEARTLAND" ARE CENTERED BENEATH THE EMBLEM DESIGN.

FOR DIETARY AND NUTRITIONAL SUPPLEMENTS CONTAINING HERBALS AND PLANTS USED TO STIMULATE THE BODY TO HEAL USING ENERGETIC PATTERNS; HOMEOPATHIC SUPPLEMENTS (U.S. CLS. 6, 18, 44, 46, 51 AND 52).

FIRST USE 1-17-2011; IN COMMERCE 1-17-2011.

PAULA MAHONEY, EXAMINING ATTORNEY

CLASS 5—(Continued).

SN 85-241,728. ENERGIQUE, INC, WOODBINE, IA. FILED 2-14-2011.



OWNER OF U.S. REG. NO. 2,566,389.

NO CLAIM IS MADE TO THE EXCLUSIVE RIGHT TO USE "SINCE 1987", APART FROM THE MARK AS SHOWN.

THE MARK CONSISTS OF THE WORD "ENERGIQUE" IN A STYLIZED ARC OVER AN EMBLEM CONSISTING OF STYLIZED LEAVES AND THE LETTER "E". THE EMBLEM IS CENTERED BETWEEN THE WORD "SINCE" AND "1987".

FOR DIETARY AND NUTRITIONAL SUPPLEMENTS CONTAINING HERBALS AND PLANTS USED TO STIMULATE THE BODY TO HEAL USING ENERGETIC PATTERNS; HOMEOPATHIC SUPPLEMENTS (U.S. CLS. 6, 18, 44, 46, 51 AND 52).

FIRST USE 1-17-2011; IN COMMERCE 1-17-2011.

PAULA MAHONEY, EXAMINING ATTORNEY

SN 85-241,746. ENERGIQUE, INC, WOODBINE, IA. FILED 2-14-2011.

NATURAL REMEDIES FROM THE HEARTLAND

THE MARK CONSISTS OF STANDARD CHARACTERS WITHOUT CLAIM TO ANY PARTICULAR FONT, STYLE, SIZE, OR COLOR.

NO CLAIM IS MADE TO THE EXCLUSIVE RIGHT TO USE "NATURAL REMEDIES", APART FROM THE MARK AS SHOWN.

FOR DIETARY AND NUTRITIONAL SUPPLEMENTS CONTAINING HERBALS AND PLANTS USED TO STIMULATE THE BODY TO HEAL USING ENERGETIC PATTERNS; HOMEOPATHIC SUPPLEMENTS (U.S. CLS. 6, 18, 44, 46, 51 AND 52).

FIRST USE 1-17-2011; IN COMMERCE 1-17-2011.

PAULA MAHONEY, EXAMINING ATTORNEY

SN 85-242,529. UNITED SUPPLIERS, INC., ELDORA, IA. FILED 2-15-2011.

Sentry Trifluralin 4EC

THE MARK CONSISTS OF STANDARD CHARACTERS WITHOUT CLAIM TO ANY PARTICULAR FONT, STYLE, SIZE, OR COLOR.

OWNER OF U.S. REG. NO. 2,377,235.

NO CLAIM IS MADE TO THE EXCLUSIVE RIGHT TO USE "TRIFLURALIN 4EC", APART FROM THE MARK AS SHOWN.

FOR HERBICIDES FOR AGRICULTURAL USE (U.S. CLS. 6, 18, 44, 46, 51 AND 52).

LEIGH CAROLINE CASE, EXAMINING ATTORNEY

CLASS 5—(Continued).

SN 85-242,837. PUREBRANDS, LLC, BOCA RATON, FL.
FILED 2-15-2011.

GET READY FOR THE GAME

THE MARK CONSISTS OF STANDARD CHARACTERS WITHOUT CLAIM TO ANY PARTICULAR FONT, STYLE, SIZE, OR COLOR.

FOR TRANSDERMAL AND TOPICAL PATCHES CONTAINING NUTRITIONAL SUPPLEMENTS, DIETARY SUPPLEMENTS, VITAMINS AND MINERALS SUPPLEMENTS (U.S. CLS. 6, 18, 44, 46, 51 AND 52).

TAMARA FRAZIER, EXAMINING ATTORNEY

SN 85-246,615. FL DAUERN RESEARCH, INC., PHOENIX, AZ. FILED 2-18-2011.

POWERED BY WELLNESS

THE MARK CONSISTS OF STANDARD CHARACTERS WITHOUT CLAIM TO ANY PARTICULAR FONT, STYLE, SIZE, OR COLOR.

FOR NUTRITIONAL SUPPLEMENTS, DIETARY SUPPLEMENTS, LIQUID DIETARY SUPPLEMENTS; NUTRITIONALLY FORTIFIED FRUIT-BASED BEVERAGES; WEIGHT LOSS PREPARATIONS, NAMELY, DIETARY AND NUTRITIONAL SUPPLEMENTS USED FOR WEIGHT LOSS; HERBAL SUPPLEMENTS, ENZYME FOOD SUPPLEMENTS, VITAMIN AND MINERAL SUPPLEMENTS (U.S. CLS. 6, 18, 44, 46, 51 AND 52).

MICHAEL TANNER, EXAMINING ATTORNEY

SN 85-246,631. FL DAUERN RESEARCH, INC., PHOENIX, AZ. FILED 2-18-2011.

DELIVERING GOODNESS

THE MARK CONSISTS OF STANDARD CHARACTERS WITHOUT CLAIM TO ANY PARTICULAR FONT, STYLE, SIZE, OR COLOR.

FOR NUTRITIONAL SUPPLEMENTS, DIETARY SUPPLEMENTS, LIQUID DIETARY SUPPLEMENTS; NUTRITIONALLY FORTIFIED FRUIT-BASED BEVERAGES; WEIGHT LOSS PREPARATIONS, NAMELY, DIETARY AND NUTRITIONAL SUPPLEMENTS USED FOR WEIGHT LOSS; HERBAL SUPPLEMENTS, ENZYME FOOD SUPPLEMENTS, VITAMIN AND MINERAL SUPPLEMENTS (U.S. CLS. 6, 18, 44, 46, 51 AND 52).

MICHAEL TANNER, EXAMINING ATTORNEY

CLASS 5—(Continued).

SN 85-246,723. PERSIMMON SCIENTIFIC, INC., LA JOLLA, CA. FILED 2-18-2011.

DermAmi

THE MARK CONSISTS OF STANDARD CHARACTERS WITHOUT CLAIM TO ANY PARTICULAR FONT, STYLE, SIZE, OR COLOR.

FOR INCONTINENCE GARMENTS, NAMELY, REMOVABLE CLOTHING LINERS MADE OF FABRIC, FABRIC PANTY LINERS, FABRIC BRIEF LINERS, FABRIC LINERS FOR DIAPERS AND INCONTINENCE BRIEFS (U.S. CLS. 6, 18, 44, 46, 51 AND 52).

FIRST USE 1-0-2011; IN COMMERCE 1-0-2011.

HOWARD B. LEVINE, EXAMINING ATTORNEY

SN 85-246,760. PERSIMMON SCIENTIFIC, INC., LA JOLLA, CA. FILED 2-18-2011.



OWNER OF U.S. REG. NO. 3,670,049.

THE MARK CONSISTS OF THE SHAPE OF A STYLIZED HEART FORMED BY THE OUTER LINES OF SCRIPT LETTERS "E" AND "P" AND THE STYLIZED SHAPE OF A WOMAN DEFINED BY THE INSIDE LOOP OF THE "P" HOLDING AN INFANT DEFINED BY THE INNER CURVES OF THE "E". THE SCRIPT LETTERS "IBI" ARE LOCATED BELOW AND TO THE RIGHT OF THE HEART SHAPE.

FOR FABRIC NURSING PADS; INCONTINENCE GARMENTS, NAMELY, REMOVABLE CLOTHING LINERS MADE OF FABRIC, FABRIC PANTY LINERS, FABRIC BRIEF LINERS, FABRIC LINERS FOR DIAPERS AND INCONTINENCE BRIEFS (U.S. CLS. 6, 18, 44, 46, 51 AND 52).

FIRST USE 12-0-2009; IN COMMERCE 12-0-2009.

HOWARD B. LEVINE, EXAMINING ATTORNEY

CLASS 5—(Continued).

SN 85-246,968. PURDUE PHARMACEUTICAL PRODUCTS L.P., STAMFORD, CT. FILED 2-19-2011.

RETURN TO SLEEP AGAIN

THE MARK CONSISTS OF STANDARD CHARACTERS WITHOUT CLAIM TO ANY PARTICULAR FONT, STYLE, SIZE, OR COLOR.

FOR PHARMACEUTICAL PREPARATIONS FOR THE TREATMENT OF SLEEP DISORDERS (U.S. CLS. 6, 18, 44, 46, 51 AND 52).

FONG HSU, EXAMINING ATTORNEY

SN 85-247,066. RUSS WEINZIMMER, MILFORD, NH. FILED 2-20-2011.

LipCrom

THE MARK CONSISTS OF STANDARD CHARACTERS WITHOUT CLAIM TO ANY PARTICULAR FONT, STYLE, SIZE, OR COLOR.

FOR PHARMACEUTICAL PREPARATIONS, NAMELY, TOPICAL PREPARATIONS FOR TREATMENT AND PREVENTION OF ORAL ALLERGY SYNDROME (U.S. CLS. 6, 18, 44, 46, 51 AND 52).

ALYSSA STEEL, EXAMINING ATTORNEY

SN 85-247,070. RUSS WEINZIMMER, MILFORD, NH. FILED 2-20-2011.

CromoLyp

THE MARK CONSISTS OF STANDARD CHARACTERS WITHOUT CLAIM TO ANY PARTICULAR FONT, STYLE, SIZE, OR COLOR.

FOR PHARMACEUTICAL PREPARATIONS, NAMELY, TOPICAL PREPARATIONS FOR TREATMENT AND PREVENTION OF ORAL ALLERGY SYNDROME (U.S. CLS. 6, 18, 44, 46, 51 AND 52).

ALYSSA STEEL, EXAMINING ATTORNEY

CLASS 5—(Continued).

SN 85-247,685. TRICORD PHARMACEUTICALS, LLC, TULSA, OK. FILED 2-21-2011.

LAVI

THE MARK CONSISTS OF STANDARD CHARACTERS WITHOUT CLAIM TO ANY PARTICULAR FONT, STYLE, SIZE, OR COLOR.

THE WORDING "LAVI" HAS NO MEANING IN A FOREIGN LANGUAGE.

FOR NON-MEDICATED NASAL SPRAY PREPARATIONS; NON-MEDICATED NASAL WASH PREPARATIONS; NON-MEDICATED NASAL RINSE PREPARATIONS; NON-MEDICATED NASAL IRRIGATION PREPARATIONS; NON-MEDICATED NASAL LAVAGE PREPARATIONS; NON-MEDICATED NASAL GEL PREPARATIONS; NON-MEDICATED NASAL OINTMENT PREPARATIONS; DRY INGREDIENTS FOR MAKING A NON-MEDICATED SALINE SOLUTION FOR SINUS AND NASAL IRRIGATION; CONCENTRATED INGREDIENTS IN THE NATURE OF SALT FOR MAKING A NON-MEDICATED SALINE SOLUTION FOR SINUS AND NASAL IRRIGATION; NON-MEDICATED EYE DROPS; NON-MEDICATED EYE WASHES; NON-MEDICATED EYE OINTMENT; NON-MEDICATED EAR DROPS; NON-MEDICATED EAR WASHES; NON-MEDICATED EAR OINTMENT; COTTON SWABS IMPREGNATED WITH NON-MEDICATED HOMEOPATHIC OR HYGIENIC PREPARATIONS FOR NASAL CLEANSING, EAR CLEANSING; NON-MEDICATED SUPPOSITORIES; NON-MEDICATED ENEMA PREPARATIONS; NON-MEDICATED VAGINAL WASHES (U.S. CLS. 6, 18, 44, 46, 51 AND 52).

HENRY S. ZAK, EXAMINING ATTORNEY

SN 85-248,328. TRACTOR SUPPLY CO. OF TEXAS, LP, BRENTWOOD, TN. FILED 2-22-2011.

RETRIEVER

THE MARK CONSISTS OF STANDARD CHARACTERS WITHOUT CLAIM TO ANY PARTICULAR FONT, STYLE, SIZE, OR COLOR.

OWNER OF U.S. REG. NOS. 1,826,539 AND 3,257,566. FOR MEDICATED FLEA AND TICK SHAMPOO FOR PETS; FLEA AND TICK REPELLENT AEROSOLS, PUMP SPRAYS, SHAMPOOS AND COLLARS (U.S. CLS. 6, 18, 44, 46, 51 AND 52).

SCOTT BIBB, EXAMINING ATTORNEY

CLASS 5—(Continued).

SN 85-248,641. TANYA ZUCKERBROT, BAY HARBOR, FL.
FILED 2-22-2011.

F-FACTOR KIDS

THE MARK CONSISTS OF STANDARD CHARACTERS WITHOUT CLAIM TO ANY PARTICULAR FONT, STYLE, SIZE, OR COLOR.

OWNER OF U.S. REG. NO. 3,370,707.

NO CLAIM IS MADE TO THE EXCLUSIVE RIGHT TO USE "KIDS", APART FROM THE MARK AS SHOWN.

FOR NUTRITIONAL FOOD BARS FOR USE AS A MEAL REPLACEMENT; VITAMIN SUPPLEMENTS (U.S. CLS. 6, 18, 44, 46, 51 AND 52).

NAKIA HENRY, EXAMINING ATTORNEY

SN 85-248,670. TANYA ZUCKERBROT, BAY HARBOR, FL.
FILED 2-22-2011.

F-FACTOR KIDZ

THE MARK CONSISTS OF STANDARD CHARACTERS WITHOUT CLAIM TO ANY PARTICULAR FONT, STYLE, SIZE, OR COLOR.

OWNER OF U.S. REG. NO. 3,370,707.

NO CLAIM IS MADE TO THE EXCLUSIVE RIGHT TO USE "KIDZ", APART FROM THE MARK AS SHOWN.

FOR NUTRITIONAL FOOD BARS FOR USE AS A MEAL REPLACEMENT; VITAMIN SUPPLEMENTS (U.S. CLS. 6, 18, 44, 46, 51 AND 52).

NAKIA HENRY, EXAMINING ATTORNEY

CLASS 5—(Continued).

SN 85-249,879. UNIVERSAL LIFE FORCE, INC., SHERMAN OAKS, CA. FILED 2-23-2011.

KARTZINEL HEALTH

THE MARK CONSISTS OF STANDARD CHARACTERS WITHOUT CLAIM TO ANY PARTICULAR FONT, STYLE, SIZE, OR COLOR.

NO CLAIM IS MADE TO THE EXCLUSIVE RIGHT TO USE "HEALTH", APART FROM THE MARK AS SHOWN.

THE NAME(S), PORTRAIT(S), AND/OR SIGNATURE(S) SHOWN IN THE MARK IDENTIFIES DR. JERRY "KARTZINEL", WHOSE CONSENT(S) TO REGISTER IS MADE OF RECORD.

FOR DIETARY FOOD, NAMELY, DIETARY FOOD SUPPLEMENTS; NUTRITIONAL, HERBAL, VITAMIN, MINERAL, AND HOMEOPATHIC SUPPLEMENTS AND NUTRACEUTICALS FOR USE AS A DIETARY SUPPLEMENT, IN POWDER, CAPSULE, TABLET, AND LIQUID FORM; DIETARY BEVERAGE SUPPLEMENTS FOR HUMAN CONSUMPTION IN LIQUID AND DRY MIX FORM FOR THERAPEUTIC PURPOSES; DIETARY FIBER AS AN ADDITIVE FOR FOOD PRODUCTS; DIETARY SUPPLEMENTAL DRINKS; ENZYME FOOD SUPPLEMENTS; HERBAL SUPPLEMENTS; NUTRACEUTICALS FOR USE AS A DIETARY SUPPLEMENT; NUTRITIONAL SUPPLEMENT IN THE NATURE OF A NUTRIENT-DENSE, PROTEIN-BASED DRINK MIX; PROTEIN SUPPLEMENTS; WEIGHT MANAGEMENT DIETARY SUPPLEMENTS, NAMELY, WEIGHT GAIN AND WEIGHT LOSS SUPPLEMENTS; NUTRITIONAL SUPPLEMENTS, NAMELY, MUSCLE BUILDING, GAINING, STRENGTHENING AND ENDURANCE SUPPLEMENTS; WEIGHT MANAGEMENT DIETARY SUPPLEMENTS, NAMELY, FAT LOSS SUPPLEMENTS; DIETARY SUPPLEMENTS AND HERBAL SUPPLEMENTS FOR PROMOTING THERMOGENIC EFFECT IN THE HUMAN BODY; DIETARY SUPPLEMENTS FOR PREVENTING WATER RETENTION; MEAL REPLACEMENT PRODUCTS, NAMELY, BARS, DRINKS, POWDERS, SHAKES, AND DRINK AND SHAKE MIXES; MINERAL SUPPLEMENTS AND HERBAL SUPPLEMENTS, FOR USE IN WEIGHT LOSS IN POWDER, CAPSULE, TABLET, AND LIQUID FORM; PREPARATIONS COMPRISED OF VITAMINS, MINERALS, AND MEDICINAL HERBS FOR USE IN WEIGHT LOSS, IN POWDER, CAPSULE, TABLET, AND LIQUID FORM; HERBAL, VITAMIN, MINERAL, AND HOMEOPATHIC SUPPLEMENTS FOR USE IN ELIMINATING TOXINS FROM THE INTESTINAL TRACT, DIGESTIVE TRACT, LUNGS, ORGANS, COLON, LIVER, KIDNEYS, LYMPHATIC SYSTEM, CELLULAR SYSTEM, CIRCULATORY SYSTEM, TISSUES, BLOOD, AND SKIN OF THE HUMAN BODY; HERBAL, VITAMIN, MINERAL, AND HOMEOPATHIC SUPPLEMENTS USED TO PURIFY THE BLOOD AND BODY OF HEAVY METALS, HERBAL, VITAMIN, MINERAL, AND HOMEOPATHIC SUPPLEMENTS USED TO CLEANSE, DETOXIFY, AND PROMOTE THE HEALTH OF THE INTESTINAL TRACT, DIGESTIVE TRACT, LUNGS, ORGANS, COLON, LIVER, KIDNEYS, LYMPHATIC SYSTEM, CELLULAR SYSTEM, CIRCULATORY SYSTEM, TISSUES, BLOOD, AND SKIN OF THE HUMAN BODY; HERBAL, VITAMIN, MINERAL, AND HOMEOPATHIC SUPPLEMENTS USED TO CLEANSE THE HUMAN BODY OF CANDIDA ALBICANS (U.S. CLS. 6, 18, 44, 46, 51 AND 52).

FIRST USE 2-1-2011; IN COMMERCE 2-1-2011.

ROBIN CHOSID, EXAMINING ATTORNEY

CLASS 5—(Continued).

SN 85-250,162. NUTRIENT SCIENCES, INC., PORT ST. LUCIE, FL. FILED 2-24-2011.

Liquid Pump

THE MARK CONSISTS OF STANDARD CHARACTERS WITHOUT CLAIM TO ANY PARTICULAR FONT, STYLE, SIZE, OR COLOR.

NO CLAIM IS MADE TO THE EXCLUSIVE RIGHT TO USE "LIQUID", APART FROM THE MARK AS SHOWN.

FOR DIETARY AND NUTRITIONAL SUPPLEMENTS (U.S. CLS. 6, 18, 44, 46, 51 AND 52).

FIRST USE 1-15-2009; IN COMMERCE 1-15-2009.
NELSON SNYDER, EXAMINING ATTORNEY

SN 85-250,167. JOYA, ABRAHAM, PORT JEFFERSON STA., NY. FILED 2-24-2011.

NUTRI-LIVING "OPTIMIZING YOUR WELL-BEING AND WEALTH"

THE MARK CONSISTS OF STANDARD CHARACTERS WITHOUT CLAIM TO ANY PARTICULAR FONT, STYLE, SIZE, OR COLOR.

FOR NUTRACEUTICALS FOR USE AS A DIETARY SUPPLEMENT; NUTRITIONAL AND DIETARY SUPPLEMENTS; HERBAL SUPPLEMENTS; VITAMINS (U.S. CLS. 6, 18, 44, 46, 51 AND 52).

MATTHEW EINSTEIN, EXAMINING ATTORNEY

SN 85-250,493. LUITPOLD PHARMACEUTICALS, INC., SHIRLEY, NY. FILED 2-24-2011.

REGENCY THERAPEUTICS

THE MARK CONSISTS OF STANDARD CHARACTERS WITHOUT CLAIM TO ANY PARTICULAR FONT, STYLE, SIZE, OR COLOR.

NO CLAIM IS MADE TO THE EXCLUSIVE RIGHT TO USE "THERAPEUTICS", APART FROM THE MARK AS SHOWN.

FOR PHARMACEUTICAL PREPARATIONS FOR THE TREATMENT OF PAIN (U.S. CLS. 6, 18, 44, 46, 51 AND 52).

LINDA LAVACHE, EXAMINING ATTORNEY

CLASS 5—(Continued).

SN 85-250,892. CLINICAL INNOVATIONS, LLC, MURRAY, UT. FILED 2-24-2011.

ROM Plus

THE MARK CONSISTS OF STANDARD CHARACTERS WITHOUT CLAIM TO ANY PARTICULAR FONT, STYLE, SIZE, OR COLOR.

FOR MEDICAL DIAGNOSTIC REAGENTS AND ASSAYS FOR TESTING OF BODY FLUIDS; MEDICAL DIAGNOSTIC TEST STRIPS FOR USE IN THE FIELD OF OBSTETRICS AND GYNECOLOGY FOR RUPTURE OF MEMBRANES (U.S. CLS. 6, 18, 44, 46, 51 AND 52).

MORGAN WYNNE, EXAMINING ATTORNEY

SN 85-251,681. GOLDEN BIOTECHNOLOGY CORPORATION, TAIPEI COUNTY 2514, TAIWAN, FILED 2-25-2011.

Pheodol

THE MARK CONSISTS OF STANDARD CHARACTERS WITHOUT CLAIM TO ANY PARTICULAR FONT, STYLE, SIZE, OR COLOR.

FOR ADJUVANTS FOR MEDICAL PURPOSES; ANTI-ALLERGIC MEDICINES; ANTI-CANCER PREPARATIONS; MEDICINAL HERBAL EXTRACTS FOR MEDICAL PURPOSES; PHARMACEUTICAL AND MEDICINAL PREPARATIONS AND SUBSTANCES FOR THE PREVENTION AND TREATMENT OF DISORDERS OF THE NERVOUS SYSTEM, THE IMMUNE SYSTEM, THE CARDIO-VASCULAR SYSTEM, THE METABOLIC SYSTEM, THE RESPIRATORY SYSTEM, THE MUSCULO-SKELETAL SYSTEM, THE GENITOURINARY SYSTEM, FOR THE TREATMENT OF INFLAMMATORY DISORDERS, OCULAR DISORDERS, OR BONE DISEASES, FOR USE IN DERMATOLOGY, ONCOLOGY, HEMATOLOGY AND OPHTHALMOLOGY AND FOR GASTROENTEROLOGICAL DISORDERS OR LIVER AILMENTS; PHARMACEUTICAL AND MEDICINAL PREPARATIONS FOR THE TREATMENT OF BRAIN DISEASES OR DISORDERS AND AUTOIMMUNE DISEASES OR DISORDERS; DIETARY AND NUTRITIONAL SUPPLEMENTS FOR MEDICAL USE; DIETARY SUPPLEMENTS FOR TREATING FATIGUE OR LIVER SUPPORT; ANIMAL FEED ADDITIVE FOR USE AS A NUTRITIONAL SUPPLEMENT FOR MEDICAL PURPOSES; DIETARY SUPPLEMENTS FOR HUMAN CONSUMPTION OR FOR ANIMALS; NUTRITIONAL ADDITIVES FOR MEDICAL PURPOSES FOR USE IN FOODS FOR HUMAN CONSUMPTION OR FOR ANIMALS; ANIMAL FEED SUPPLEMENTS; DIETARY PET SUPPLEMENTS IN THE FORM OF PET TREATS; FUNGI PREPARATIONS FOR MEDICAL OR VETERINARY USE FOR TREATING DISORDERS OF THE NERVOUS SYSTEM, THE IMMUNE SYSTEM, THE CARDIO-VASCULAR SYSTEM, THE METABOLIC SYSTEM, THE RESPIRATORY SYSTEM, THE MUSCULO-SKELETAL SYSTEM, THE GENITOURINARY SYSTEM, FOR THE TREATMENT OF INFLAMMATORY DISORDERS, OCULAR DISORDERS, BRAIN DISEASES OR DISORDERS, AUTOIMMUNE DISEASES OR DISORDERS, OR BONE DISEASES, FOR USE IN DERMATOLOGY, ONCOLOGY, HEMATOLOGY AND OPHTHALMOLOGY AND FOR GASTROENTEROLOGICAL DISORDERS OR LIVER AILMENTS; PHARMACEUTICAL PREPARATIONS AND SUBSTANCES FOR VETERINARY PURPOSES FOR TREATING DISORDERS OF THE NERVOUS SYSTEM, THE IMMUNE

CLASS 5—(Continued).

SYSTEM, THE CARDIO-VASCULAR SYSTEM, THE METABOLIC SYSTEM, THE RESPIRATORY SYSTEM, THE MUSCULO-SKELETAL SYSTEM, THE GENITOURINARY SYSTEM, FOR THE TREATMENT OF INFLAMMATORY DISORDERS, OCULAR DISORDERS, BRAIN DISEASES OR DISORDERS, AUTOIMMUNE DISEASES OR DISORDERS, OR BONE DISEASES, FOR USE IN DERMATOLOGY, ONCOLOGY, HEMATOLOGY AND OPHTHALMOLOGY AND FOR GASTROENTEROLOGICAL DISORDERS OR LIVER AILMENTS; CHEMICAL PREPARATIONS FOR MEDICINAL PURPOSES FOR TREATING DISORDERS OF THE NERVOUS SYSTEM, THE IMMUNE SYSTEM, THE CARDIO-VASCULAR SYSTEM, THE METABOLIC SYSTEM, THE RESPIRATORY SYSTEM, THE MUSCULO-SKELETAL SYSTEM, THE GENITOURINARY SYSTEM, FOR THE TREATMENT OF INFLAMMATORY DISORDERS, OCULAR DISORDERS, BRAIN DISEASES OR DISORDERS, AUTOIMMUNE DISEASES OR DISORDERS, OR BONE DISEASES, FOR USE IN DERMATOLOGY, ONCOLOGY, HEMATOLOGY AND OPHTHALMOLOGY AND FOR GASTROENTEROLOGICAL DISORDERS OR LIVER AILMENTS; CARDIOVASCULAR PHARMACEUTICALS; CARDIOVASCULAR TREATMENT PREPARATIONS; PHARMACEUTICALS PREPARATIONS FOR THE TREATMENT OF KIDNEY DISEASES (U.S. CLS. 6, 18, 44, 46, 51 AND 52).

KAREN K. BUSH, EXAMINING ATTORNEY

SN 85-252,615. CAR LABS, LLC., BAKERSFIELD, CA. FILED 2-26-2011.

BOOZE BURNER

THE MARK CONSISTS OF STANDARD CHARACTERS WITHOUT CLAIM TO ANY PARTICULAR FONT, STYLE, SIZE, OR COLOR.

NO CLAIM IS MADE TO THE EXCLUSIVE RIGHT TO USE "BOOZE", APART FROM THE MARK AS SHOWN.

FOR DIETARY SUPPLEMENTS (U.S. CLS. 6, 18, 44, 46, 51 AND 52).

FIRST USE 1-4-2011; IN COMMERCE 2-23-2011.
MAYUR VAGHANI, EXAMINING ATTORNEY

SN 85-252,829. NUTRA-C M&D LLC, LAUREL, MD. FILED 2-27-2011.

OsteoBlast-Plus

THE MARK CONSISTS OF STANDARD CHARACTERS WITHOUT CLAIM TO ANY PARTICULAR FONT, STYLE, SIZE, OR COLOR.

FOR NUTRACEUTICALS FOR USE AS A DIETARY SUPPLEMENT; NUTRACEUTICALS FOR USE AS A DIETARY SUPPLEMENT FOR BONE CELLS GROWTH (U.S. CLS. 6, 18, 44, 46, 51 AND 52).

MICHAEL GAFFAR, EXAMINING ATTORNEY

CLASS 5—(Continued).

SN 85-252,986. PROTICA INC., WHITEHALL, PA. FILED 2-28-2011.

Yes Whey

THE MARK CONSISTS OF STANDARD CHARACTERS WITHOUT CLAIM TO ANY PARTICULAR FONT, STYLE, SIZE, OR COLOR.

FOR DIETARY AND NUTRITIONAL SUPPLEMENTS CONTAINING WHEY (U.S. CLS. 6, 18, 44, 46, 51 AND 52).
JOHN GARTNER, EXAMINING ATTORNEY

SN 85-252,994. MED-RITE LABORATORIES LLC, DALLAS, TX. FILED 2-28-2011.

FIBO  **RITE**

THE COLOR(S) GRAY, BLUE, PURPLE, PINK, ORANGE, LIGHT GREEN AND GREEN IS/ARE CLAIMED AS A FEATURE OF THE MARK.

THE MARK CONSISTS OF THE LETTERS "FIBO" IN GRAY COLOR FOLLOWED BY A STAR WITH SIX POINTS. EACH POINT OF THE STAR IS A DIFFERENT COLOR, BEGINNING AT THE TOP AND GOING CLOCKWISE, THE COLORS OF EACH ARM ARE BLUE, PURPLE, PINK, ORANGE, LIGHT GREEN AND GREEN. THE LETTERS "RITE" FOLLOW THE STAR IN THE COLOR GRAY. THE COLOR WHITE IN THE MARK REPRESENTS BACKGROUND AND/OR TRANSPARENT AREAS, AND IS NOT PART OF THE MARK.

FOR DIETARY AND NUTRITIONAL SUPPLEMENTS (U.S. CLS. 6, 18, 44, 46, 51 AND 52).

FIRST USE 10-1-2010; IN COMMERCE 10-1-2010.

MARIA-VICTORIA SUAREZ, EXAMINING ATTORNEY

SN 85-253,114. HERITAGE PHARMACEUTICALS INC., EDISON, NJ. FILED 2-28-2011.

**VALUE DRIVEN
PHARMACEUTICALS**

THE MARK CONSISTS OF STANDARD CHARACTERS WITHOUT CLAIM TO ANY PARTICULAR FONT, STYLE, SIZE, OR COLOR.

NO CLAIM IS MADE TO THE EXCLUSIVE RIGHT TO USE "PHARMACEUTICALS", APART FROM THE MARK AS SHOWN.

FOR FULL LINE OF NEUROLOGICAL, CENTRAL NERVOUS SYSTEM, ANTI-INFLAMMATORY, CARDIOVASCULAR, RENAL, ANTI-MICROBIAL, ANTI-NEOPLASTIC, IMMUNOMODULATORY, HEMATOPOIETIC, ANTICOAGULANT, THROMBOLYTIC, ANTIPLATELET, ESTROGENIC, PROGESTIN, ANDROGEN, THYROID, ANTI-THYROID, OPHTHALMIC, HISTAMINE H2 RECEPTOR ANTAGONIST, PROTON PUMP ANTAGONIST, ANTI-EMETIC, ANTI-CONVULSANT, ANTI-ASTHMATIC AND ANTI-DIABETIC PHARMACEUTICAL PREPARATIONS (U.S. CLS. 6, 18, 44, 46, 51 AND 52).

STEVEN JACKSON, EXAMINING ATTORNEY

CLASS 5—(Continued).

SN 85-253,177. RAPTOR PHARMACEUTICAL, INC., NOVATO, CA. FILED 2-28-2011.

KESTRELA

THE MARK CONSISTS OF STANDARD CHARACTERS WITHOUT CLAIM TO ANY PARTICULAR FONT, STYLE, SIZE, OR COLOR.

FOR PHARMACEUTICAL PREPARATIONS FOR TREATING CYSTINOSIS AND NEPHROPATHIC CYSTINOSIS; PHARMACEUTICAL PREPARATIONS FOR TREATING NEUROLOGICAL DISEASES AND DISORDERS; PHARMACEUTICAL PREPARATIONS FOR TREATING KIDNEY DISORDERS; PHARMACEUTICAL PREPARATIONS FOR TREATING LIVER DISEASES AND DISORDERS; SUSTAINED RELEASE CYSTEAMINE (U.S. CLS. 6, 18, 44, 46, 51 AND 52).
MICHAEL WEBSTER, EXAMINING ATTORNEY



SN 85-253,335. ROSEN, HOWARD, DBA CCPI, MONTEREY, CA. FILED 2-28-2011.

PROLOGEL

THE MARK CONSISTS OF STANDARD CHARACTERS WITHOUT CLAIM TO ANY PARTICULAR FONT, STYLE, SIZE, OR COLOR.

THE WORDING "PROLOGEL" HAS NO MEANING IN A FOREIGN LANGUAGE.
FOR TOPICAL GEL FOR MEDICAL AND THERAPEUTIC USE, NAMELY, ULTRASOUND GEL (U.S. CLS. 6, 18, 44, 46, 51 AND 52).
GEORGE LORENZO, EXAMINING ATTORNEY



SN 85-253,465. PHYSICIAN'S SCIENCE & NATURE, INC., NEWPORT BEACH, CA. FILED 2-28-2011.

PROMOLAXIN

THE MARK CONSISTS OF STANDARD CHARACTERS WITHOUT CLAIM TO ANY PARTICULAR FONT, STYLE, SIZE, OR COLOR.

FOR LAXATIVES (U.S. CLS. 6, 18, 44, 46, 51 AND 52). FIRST USE 2-21-2011; IN COMMERCE 5-9-2011.
KAREN K. BUSH, EXAMINING ATTORNEY

CLASS 5—(Continued).

SN 85-254,126. INNUTRAGENIX LLC, MIAMI, FL. FILED 3-1-2011.

LIPOLINEX

THE MARK CONSISTS OF STANDARD CHARACTERS WITHOUT CLAIM TO ANY PARTICULAR FONT, STYLE, SIZE, OR COLOR.

FOR NUTRACEUTICALS FOR USE AS A DIETARY SUPPLEMENT (U.S. CLS. 6, 18, 44, 46, 51 AND 52).
DOMINIC FATHY, EXAMINING ATTORNEY

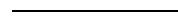

SN 85-254,190. GROSS, DENNIS, NEW YORK, NY. FILED 3-1-2011.

TRIFIX

THE MARK CONSISTS OF STANDARD CHARACTERS WITHOUT CLAIM TO ANY PARTICULAR FONT, STYLE, SIZE, OR COLOR.

FOR ACNE MEDICATIONS (U.S. CLS. 6, 18, 44, 46, 51 AND 52).
HEATHER THOMPSON, EXAMINING ATTORNEY

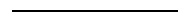

SN 85-254,273. THE REPUBLIC OF TEA, INC., NOVATO, CA. FILED 3-1-2011.

BE WELL GREEN

THE MARK CONSISTS OF STANDARD CHARACTERS WITHOUT CLAIM TO ANY PARTICULAR FONT, STYLE, SIZE, OR COLOR.

OWNER OF U.S. REG. NO. 3,269,578.
NO CLAIM IS MADE TO THE EXCLUSIVE RIGHT TO USE "GREEN", APART FROM THE MARK AS SHOWN.
FOR HERB TEAS FOR MEDICINAL PURPOSES (U.S. CLS. 6, 18, 44, 46, 51 AND 52).
IRA J. GOODSaid, EXAMINING ATTORNEY

CLASS 5—(Continued).

SN 85-254,383. JIMMY TEES INC, BURLINGTON, CANADA, FILED 3-1-2011.

REPRESENT FRESH FLAG

THE MARK CONSISTS OF STANDARD CHARACTERS WITHOUT CLAIM TO ANY PARTICULAR FONT, STYLE, SIZE, OR COLOR.
FOR AIR FRESHENERS, ABSORBENT BODIES IMPREGNATED WITH A PERFUMED AIR DEODORANT (U.S. CLS. 6, 18, 44, 46, 51 AND 52).
KATINA MISTER, EXAMINING ATTORNEY

SN 85-254,528. OPTICS LABORATORY, INC., EL MONTE, CA. FILED 3-1-2011.

OCUSAVE

THE MARK CONSISTS OF STANDARD CHARACTERS WITHOUT CLAIM TO ANY PARTICULAR FONT, STYLE, SIZE, OR COLOR.
FOR DIETARY AND NUTRITIONAL SUPPLEMENTS (U.S. CLS. 6, 18, 44, 46, 51 AND 52).
FIRST USE 2-1-2011; IN COMMERCE 2-1-2011.
DAVID COLLIER, EXAMINING ATTORNEY

SN 85-254,645. ARIAD PHARMACEUTICALS, INC., CAMBRIDGE, MA. FILED 3-1-2011.

XENRUTE

THE MARK CONSISTS OF STANDARD CHARACTERS WITHOUT CLAIM TO ANY PARTICULAR FONT, STYLE, SIZE, OR COLOR.
FOR PHARMACEUTICAL PREPARATIONS FOR USE IN ONCOLOGY (U.S. CLS. 6, 18, 44, 46, 51 AND 52).
SUNG IN, EXAMINING ATTORNEY

CLASS 5—(Continued).

SN 85-254,649. ARIAD PHARMACEUTICALS, INC., CAMBRIDGE, MA. FILED 3-1-2011.

JORATI

THE MARK CONSISTS OF STANDARD CHARACTERS WITHOUT CLAIM TO ANY PARTICULAR FONT, STYLE, SIZE, OR COLOR.
FOR PHARMACEUTICAL PREPARATIONS FOR USE IN ONCOLOGY (U.S. CLS. 6, 18, 44, 46, 51 AND 52).
SUNG IN, EXAMINING ATTORNEY

SN 85-254,659. ARIAD PHARMACEUTICALS, INC., CAMBRIDGE, MA. FILED 3-1-2011.

ICLUSIG

THE MARK CONSISTS OF STANDARD CHARACTERS WITHOUT CLAIM TO ANY PARTICULAR FONT, STYLE, SIZE, OR COLOR.
FOR PHARMACEUTICAL PREPARATIONS FOR USE IN ONCOLOGY (U.S. CLS. 6, 18, 44, 46, 51 AND 52).
SUNG IN, EXAMINING ATTORNEY

SN 85-254,669. ARIAD PHARMACEUTICALS, INC., CAMBRIDGE, MA. FILED 3-1-2011.

FYDEKLA

THE MARK CONSISTS OF STANDARD CHARACTERS WITHOUT CLAIM TO ANY PARTICULAR FONT, STYLE, SIZE, OR COLOR.
FOR PHARMACEUTICAL PREPARATIONS FOR USE IN ONCOLOGY (U.S. CLS. 6, 18, 44, 46, 51 AND 52).
SUNG IN, EXAMINING ATTORNEY

CLASS 5—(Continued).

SN 85-254,857. WYETH LLC, MADISON, NJ. FILED 3-1-2011.



THE MARK CONSISTS OF A DESIGN WITH FOUR OVERLAPPING LETTER "B" IN A CONCENTRIC PATTERN AND THE MARK "BOSULIF".
 FOR ONCOLOGY PHARMACEUTICAL PREPARATIONS (U.S. CLS. 6, 18, 44, 46, 51 AND 52).
 WILLIAM BRECKENFELD, EXAMINING ATTORNEY

CLASS 5—(Continued).

SN 85-255,048. CANFO NATURAL PRODUCTS, EL MONTE, CA. FILED 3-1-2011.



THE MARK CONSISTS OF STANDARD CHARACTERS WITHOUT CLAIM TO ANY PARTICULAR FONT, STYLE, SIZE, OR COLOR.
 FOR HERBAL SUPPLEMENTS (U.S. CLS. 6, 18, 44, 46, 51 AND 52).
 FIRST USE 12-27-2010; IN COMMERCE 2-28-2011.
 FRED CARL, EXAMINING ATTORNEY

SN 85-254,951. BIOPHARMGEN HOLDINGS INC., LA VERNE, CA. FILED 3-1-2011.



THE MARK CONSISTS OF STANDARD CHARACTERS WITHOUT CLAIM TO ANY PARTICULAR FONT, STYLE, SIZE, OR COLOR.
 FOR DIETARY SUPPLEMENTS FOR SUPPORTING BRAIN HEALTH IN THE FORM OF CAPSULES, TABLETS, EXTRACTS, POWDERS AND/OR LIQUIDS (U.S. CLS. 6, 18, 44, 46, 51 AND 52).
 NICHOLAS ALTREE, EXAMINING ATTORNEY

SN 85-255,059. CANFO NATURAL PRODUCTS, EL MONTE, CA. FILED 3-1-2011.



THE MARK CONSISTS OF STANDARD CHARACTERS WITHOUT CLAIM TO ANY PARTICULAR FONT, STYLE, SIZE, OR COLOR.
 FOR HERBAL SUPPLEMENTS (U.S. CLS. 6, 18, 44, 46, 51 AND 52).
 FIRST USE 12-27-2010; IN COMMERCE 2-28-2011.
 FRED CARL, EXAMINING ATTORNEY

SN 85-254,993. AIRSPENCER USA LLC, ALPINE, UT. FILED 3-1-2011.



THE MARK CONSISTS OF STANDARD CHARACTERS WITHOUT CLAIM TO ANY PARTICULAR FONT, STYLE, SIZE, OR COLOR.
 FOR AIR DEODORANT; AIR DEODORIZER; AIR FRESHENERS; AIR FRESHENERS AND AIR FRESHENING PREPARATIONS; AIR FRESHENING PREPARATIONS; REFILLS FOR AIR FRESHENERS (U.S. CLS. 6, 18, 44, 46, 51 AND 52).
 FIRST USE 8-7-2008; IN COMMERCE 9-28-2008.
 KIMBERLY FRYE, EXAMINING ATTORNEY

SN 85-255,069. CANFO NATURAL PRODUCTS, EL MONTE, CA. FILED 3-1-2011.



THE MARK CONSISTS OF STANDARD CHARACTERS WITHOUT CLAIM TO ANY PARTICULAR FONT, STYLE, SIZE, OR COLOR.
 FOR HERBAL SUPPLEMENTS (U.S. CLS. 6, 18, 44, 46, 51 AND 52).
 FIRST USE 12-27-2010; IN COMMERCE 2-28-2011.
 FRED CARL, EXAMINING ATTORNEY

CLASS 5—(Continued).

SN 85-255,075. CANFO NATURAL PRODUCTS, EL MONTE, CA. FILED 3-1-2011.

GlucoseShield

THE MARK CONSISTS OF STANDARD CHARACTERS WITHOUT CLAIM TO ANY PARTICULAR FONT, STYLE, SIZE, OR COLOR.

FOR HERBAL SUPPLEMENTS (U.S. CLS. 6, 18, 44, 46, 51 AND 52).

FIRST USE 12-27-2010; IN COMMERCE 2-28-2011.
FRED CARL, EXAMINING ATTORNEY

SN 85-255,078. CANFO NATURAL PRODUCTS, EL MONTE, CA. FILED 3-1-2011.

LungCare

THE MARK CONSISTS OF STANDARD CHARACTERS WITHOUT CLAIM TO ANY PARTICULAR FONT, STYLE, SIZE, OR COLOR.

FOR HERBAL SUPPLEMENTS (U.S. CLS. 6, 18, 44, 46, 51 AND 52).

FIRST USE 12-27-2010; IN COMMERCE 2-28-2011.
FRED CARL, EXAMINING ATTORNEY

SN 85-255,372. TRIARCO INDUSTRIES, INC., WAYNE, NJ. FILED 3-2-2011.

VITOSTEROL

THE MARK CONSISTS OF STANDARD CHARACTERS WITHOUT CLAIM TO ANY PARTICULAR FONT, STYLE, SIZE, OR COLOR.

FOR VITAMINS, MINERAL SUPPLEMENTS, NUTRITIONAL AND DIETARY SUPPLEMENTS (U.S. CLS. 6, 18, 44, 46, 51 AND 52).

MEGHAN REINHART, EXAMINING ATTORNEY

CLASS 5—(Continued).

SN 85-255,414. QUALITY OF LIFE LABORATORIES, INC., PURCHASE, NY. FILED 3-2-2011.

PEPTISOL

THE MARK CONSISTS OF STANDARD CHARACTERS WITHOUT CLAIM TO ANY PARTICULAR FONT, STYLE, SIZE, OR COLOR.

FOR DIETARY AND NUTRITIONAL SUPPLEMENTS (U.S. CLS. 6, 18, 44, 46, 51 AND 52).

KEVIN CORWIN, EXAMINING ATTORNEY

SN 85-255,448. CHEMTURA CORPORATION, MIDDLEBURY, CT. FILED 3-2-2011.

VIGILANT

THE MARK CONSISTS OF STANDARD CHARACTERS WITHOUT CLAIM TO ANY PARTICULAR FONT, STYLE, SIZE, OR COLOR.

OWNER OF U.S. REG. NO. 1,364,123.

FOR ACARACIDES, MITICIDES AND INSECTICIDES FOR AGRICULTURAL USE (U.S. CLS. 6, 18, 44, 46, 51 AND 52).

KATHLEEN LORENZO, EXAMINING ATTORNEY

SN 85-255,473. TAMMY BLAKESLEE, SUTTON, MA. FILED 3-2-2011.



THE MARK CONSISTS OF A HORSE DRAWN SURREY SITUATED ON AN ARROW WITH A BACKGROUND OF 2 CONCENTRIC OVALS WITH THE PHRASE "OLDE WORLD" ALIGNED IN THE TOP PORTION OF THE OUTER OVAL AND "FARMACY" ALIGNED IN THE BOTTOM PORTION OF THE OUTER CIRCLE.

FOR VETERINARY PREPARATIONS FOR HOMEOPATHIC TREATMENT OF ANIMALS, NAMELY INFECTIONS (U.S. CLS. 6, 18, 44, 46, 51 AND 52).

FIRST USE 2-0-2010; IN COMMERCE 7-0-2010.

BARBARA RUTLAND, EXAMINING ATTORNEY

CLASS 5—(Continued).

SN 85-255,734. KING'S INTERNATIONAL INVESTMENT GROUP, LLC, LOS ANGELES, CA. FILED 3-2-2011.

MR. PINK

THE MARK CONSISTS OF STANDARD CHARACTERS WITHOUT CLAIM TO ANY PARTICULAR FONT, STYLE, SIZE, OR COLOR.

FOR NUTRITIONALLY FORTIFIED BEVERAGES (U.S. CLS. 6, 18, 44, 46, 51 AND 52).

MIDGE BUTLER, EXAMINING ATTORNEY

SN 85-255,876. ARTHUR ANDREW MEDICAL, INC., SCOTTSDALE, AZ. FILED 3-2-2011.

ACID ARMOR

THE MARK CONSISTS OF STANDARD CHARACTERS WITHOUT CLAIM TO ANY PARTICULAR FONT, STYLE, SIZE, OR COLOR.

FOR NUTRITIONAL SUPPLEMENTS; DIETARY SUPPLEMENTS; CAPSULES SOLD EMPTY FOR PHARMACEUTICALS AND NUTRACEUTICALS (U.S. CLS. 6, 18, 44, 46, 51 AND 52).

JAY FLOWERS, EXAMINING ATTORNEY

SN 85-255,920. TOKU-E COMPANY, BELLINGHAM, WA. FILED 3-2-2011.

DE-PLASMA

THE MARK CONSISTS OF STANDARD CHARACTERS WITHOUT CLAIM TO ANY PARTICULAR FONT, STYLE, SIZE, OR COLOR.

FOR ANTIBIOTICS FOR SCIENTIFIC RESEARCH PURPOSES (U.S. CLS. 6, 18, 44, 46, 51 AND 52).

ANDREA BUTLER, EXAMINING ATTORNEY

CLASS 5—(Continued).

SN 85-255,971. PRIMARY INVESTMENTS GROUP LIMITED, ROAD TOWN, TORTOLA, BR. VIRGIN ISLANDS, FILED 3-2-2011.



THE MARK CONSISTS OF A SHAPE LIKE A SLIVER OF THE MOON WITH BEVELED INNER EDGE, WITH THREE LEAVES, ONE SMALL AND TWO LARGE WITH WATER DROPS ON THE TWO LARGE LEAVES, ATTACHED TO THE APPROXIMATE MIDDLE OF THE SLIVER.

FOR ORGANIC DIETARY SUPPLEMENTS; ORGANIC FOOD SUPPLEMENTS; ORGANIC HERBAL SUPPLEMENTS; ORGANIC NUTRITIONAL SUPPLEMENTS (U.S. CLS. 6, 18, 44, 46, 51 AND 52).

FIRST USE 7-8-2010; IN COMMERCE 7-8-2010.
CYNTHIA SLOAN, EXAMINING ATTORNEY

SN 85-256,162. KYOWA HAKKO BIO CO., LTD., TOKYO, JAPAN, FILED 3-2-2011.

SETRIA

THE MARK CONSISTS OF STANDARD CHARACTERS WITHOUT CLAIM TO ANY PARTICULAR FONT, STYLE, SIZE, OR COLOR.

OWNER OF U.S. REG. NO. 3,346,787.
FOR DIETARY SUPPLEMENTS (U.S. CLS. 6, 18, 44, 46, 51 AND 52).

NICHOLAS COLEMAN, EXAMINING ATTORNEY

SN 85-256,247. TURNER, NOEL A, ALISO VIEJO, CA. FILED 3-2-2011.

FREZZOR

THE MARK CONSISTS OF STANDARD CHARACTERS WITHOUT CLAIM TO ANY PARTICULAR FONT, STYLE, SIZE, OR COLOR.

FOR DIETARY AND NUTRITIONAL SUPPLEMENTS (U.S. CLS. 6, 18, 44, 46, 51 AND 52).

ESTHER A. BORSUK, EXAMINING ATTORNEY

CLASS 5—(Continued).

SN 85-256,521. GLAXOSMITHKLINE BIOLOGICALS S.A., RIXENSART, BELGIUM, FILED 3-3-2011.

HIBMENRIX

THE MARK CONSISTS OF STANDARD CHARACTERS WITHOUT CLAIM TO ANY PARTICULAR FONT, STYLE, SIZE, OR COLOR.
FOR VACCINES (U.S. CLS. 6, 18, 44, 46, 51 AND 52).
FLORENTINA BLANDU, EXAMINING ATTORNEY

SN 85-256,604. INTOCELL DISTRIBUTORS, LLC, BOCA RATON, FL. FILED 3-3-2011.

DYNASPORT EXTREME

THE MARK CONSISTS OF STANDARD CHARACTERS WITHOUT CLAIM TO ANY PARTICULAR FONT, STYLE, SIZE, OR COLOR.
FOR DIETARY AND NUTRITIONAL SUPPLEMENTS FOR PROMOTING IMPROVED ENERGY LEVELS AND PERFORMANCE (U.S. CLS. 6, 18, 44, 46, 51 AND 52).
SUSAN RICHARDS, EXAMINING ATTORNEY

SN 85-256,659. IMMUPHARMA AG, REINACH, SWITZERLAND, FILED 3-3-2011.

LUPUZOR

THE MARK CONSISTS OF STANDARD CHARACTERS WITHOUT CLAIM TO ANY PARTICULAR FONT, STYLE, SIZE, OR COLOR.
FOR PHARMACEUTICAL PREPARATIONS FOR THE TREATMENT OF IMMUNOLOGICAL DISORDERS (U.S. CLS. 6, 18, 44, 46, 51 AND 52).
CHERYL CLAYTON, EXAMINING ATTORNEY

CLASS 5—(Continued).

SN 85-256,827. SEATTLE GENETICS, INC., BOTHELL, WA. FILED 3-3-2011.

SEASPERA

THE MARK CONSISTS OF STANDARD CHARACTERS WITHOUT CLAIM TO ANY PARTICULAR FONT, STYLE, SIZE, OR COLOR.
FOR PHARMACEUTICAL PREPARATIONS FOR USE IN HUMANS, NAMELY, CHEMOTHERAPEUTICS; PHARMACEUTICAL PREPARATIONS FOR THE PREVENTION AND TREATMENT OF DISORDERS OF THE NERVOUS SYSTEM, THE IMMUNE SYSTEM, THE CARDIO-VASCULAR SYSTEM, THE METABOLIC SYSTEM, THE RESPIRATORY SYSTEM, THE MUSCULO-SKELETAL SYSTEM, AND THE GENITOURINARY SYSTEM; PHARMACEUTICAL PREPARATIONS FOR THE TREATMENT OF CANCER, AUTOIMMUNE DISEASES, AND INFLAMMATORY DISORDERS; PHARMACEUTICAL PREPARATIONS FOR USE IN DERMATOLOGY, ONCOLOGY, HEMATOLOGY, OPHTHALMOLOGY, GASTROENTEROLOGY, AND TISSUE AND ORGAN TRANSPLANTOLOGY (U.S. CLS. 6, 18, 44, 46, 51 AND 52).
RON FAIRBANKS, EXAMINING ATTORNEY

SN 85-256,840. SEATTLE GENETICS, INC., BOTHELL, WA. FILED 3-3-2011.

THERANTA

THE MARK CONSISTS OF STANDARD CHARACTERS WITHOUT CLAIM TO ANY PARTICULAR FONT, STYLE, SIZE, OR COLOR.
FOR PHARMACEUTICAL PREPARATIONS FOR USE IN HUMANS, NAMELY, CHEMOTHERAPEUTICS; PHARMACEUTICAL PREPARATIONS FOR THE PREVENTION AND TREATMENT OF DISORDERS OF THE NERVOUS SYSTEM, THE IMMUNE SYSTEM, THE CARDIO-VASCULAR SYSTEM, THE METABOLIC SYSTEM, THE RESPIRATORY SYSTEM, THE MUSCULO-SKELETAL SYSTEM, AND THE GENITOURINARY SYSTEM; PHARMACEUTICAL PREPARATIONS FOR THE TREATMENT OF CANCER, AUTOIMMUNE DISEASES, AND INFLAMMATORY DISORDERS; PHARMACEUTICAL PREPARATIONS FOR USE IN DERMATOLOGY, ONCOLOGY, HEMATOLOGY, OPHTHALMOLOGY, GASTROENTEROLOGY, AND TISSUE AND ORGAN TRANSPLANTOLOGY (U.S. CLS. 6, 18, 44, 46, 51 AND 52).
RON FAIRBANKS, EXAMINING ATTORNEY

CLASS 5—(Continued).

SN 85-256,846. SEATTLE GENETICS, INC., BOTHELL, WA.
FILED 3-3-2011.

ADCIMRI

THE MARK CONSISTS OF STANDARD CHARACTERS WITHOUT CLAIM TO ANY PARTICULAR FONT, STYLE, SIZE, OR COLOR.

FOR PHARMACEUTICAL PREPARATIONS FOR USE IN HUMANS, NAMELY, CHEMOTHERAPEUTICS; PHARMACEUTICAL PREPARATIONS FOR THE PREVENTION AND TREATMENT OF DISORDERS OF THE NERVOUS SYSTEM, THE IMMUNE SYSTEM, THE CARDIO-VASCULAR SYSTEM, THE METABOLIC SYSTEM, THE RESPIRATORY SYSTEM, THE MUSCULO-SKELETAL SYSTEM, AND THE GENITOURINARY SYSTEM; PHARMACEUTICAL PREPARATIONS FOR THE TREATMENT OF CANCER, AUTOIMMUNE DISEASES, AND INFLAMMATORY DISORDERS; PHARMACEUTICAL PREPARATIONS FOR USE IN DERMATOLOGY, ONCOLOGY, HEMATOLOGY, OPHTHALMOLOGY, GASTROENTEROLOGY, AND TISSUE AND ORGAN TRANSPLANTOLOGY (U.S. CLS. 6, 18, 44, 46, 51 AND 52).

RON FAIRBANKS, EXAMINING ATTORNEY

SN 85-257,155. BIOTIVIA LLC, NEW YORK, NY. FILED 3-3-2011.

TransMX

THE MARK CONSISTS OF STANDARD CHARACTERS WITHOUT CLAIM TO ANY PARTICULAR FONT, STYLE, SIZE, OR COLOR.

FOR DIETARY AND NUTRITIONAL SUPPLEMENTS (U.S. CLS. 6, 18, 44, 46, 51 AND 52).

HEATHER BIDDULPH, EXAMINING ATTORNEY

SN 85-257,169. BIOTIVIA LLC, NEW YORK, CA. FILED 3-3-2011.

PteroMX

THE MARK CONSISTS OF STANDARD CHARACTERS WITHOUT CLAIM TO ANY PARTICULAR FONT, STYLE, SIZE, OR COLOR.

FOR DIETARY AND NUTRITIONAL SUPPLEMENTS (U.S. CLS. 6, 18, 44, 46, 51 AND 52).

HEATHER BIDDULPH, EXAMINING ATTORNEY

CLASS 5—(Continued).

SN 85-257,246. SMARTGUARD, LLC, AUBURN HILLS, MI.
FILED 3-3-2011.

MoldGuard

THE MARK CONSISTS OF STANDARD CHARACTERS WITHOUT CLAIM TO ANY PARTICULAR FONT, STYLE, SIZE, OR COLOR.

FOR ANTIMICROBIAL COATINGS TO TREAT THE GROWTH OF MOLD, MILDEW, BACTERIA AND FUNGUS ON VARIOUS SURFACES (U.S. CLS. 6, 18, 44, 46, 51 AND 52).

SCOTT BIBB, EXAMINING ATTORNEY

SN 85-257,464. GR8LUBE, INC, BOCA RATON, FL. FILED 3-3-2011.

GR8LUBE

THE MARK CONSISTS OF STANDARD CHARACTERS WITHOUT CLAIM TO ANY PARTICULAR FONT, STYLE, SIZE, OR COLOR.

FOR PERSONAL SEXUAL LUBRICANTS (U.S. CLS. 6, 18, 44, 46, 51 AND 52).

FIRST USE 2-10-2010; IN COMMERCE 4-22-2010.

JACQUELINE A. LAVINE, EXAMINING ATTORNEY

SN 85-257,598. SARGENT, JOSHUA, PEORIA, AZ. FILED 3-3-2011.

LeetSTART

THE MARK CONSISTS OF STANDARD CHARACTERS WITHOUT CLAIM TO ANY PARTICULAR FONT, STYLE, SIZE, OR COLOR.

FOR NUTRITIONAL SUPPLEMENTS FOR INCREASING ENERGY, REFLEXES, AND OVERALL BRAIN FUNCTION (U.S. CLS. 6, 18, 44, 46, 51 AND 52).

WILLIAM BRECKENFELD, EXAMINING ATTORNEY

CLASS 5—(Continued).

SN 85-257,812. CH LABORATORIES, INC., GARDENA, CA.
FILED 3-4-2011.

SONERGY

THE MARK CONSISTS OF STANDARD CHARACTERS
WITHOUT CLAIM TO ANY PARTICULAR FONT, STYLE,
SIZE, OR COLOR.
FOR VITAMINS (U.S. CLS. 6, 18, 44, 46, 51 AND 52).
GISELLE AGOSTO, EXAMINING ATTORNEY

SN 85-257,898. HYDRO ONE, LLC., AUGUSTA, GA. FILED 3-
4-2011.

BÖDE

THE MARK CONSISTS OF STANDARD CHARACTERS
WITHOUT CLAIM TO ANY PARTICULAR FONT, STYLE,
SIZE, OR COLOR.
FOR NUTRITIONALLY FORTIFIED BEVERAGES
(U.S. CLS. 6, 18, 44, 46, 51 AND 52).
FIRST USE 4-1-2009; IN COMMERCE 5-1-2009.
LINDA E. BLOHM, EXAMINING ATTORNEY

SN 85-257,927. MDDYNAMIX, LLC, NORTH HAVEN, CT.
FILED 3-4-2011.

MDdynamix

THE MARK CONSISTS OF STANDARD CHARACTERS
WITHOUT CLAIM TO ANY PARTICULAR FONT, STYLE,
SIZE, OR COLOR.
FOR DIETARY SUPPLEMENTS; HEALTH FOOD SUP-
PLEMENTS; NUTRITIONAL SUPPLEMENTS; VITAMINS
(U.S. CLS. 6, 18, 44, 46, 51 AND 52).
FIRST USE 12-10-2010; IN COMMERCE 12-10-2010.
JAMES GRIFFIN, EXAMINING ATTORNEY

CLASS 5—(Continued).

SN 85-258,874. KAPLAN, JEFFREY, FORT LAUDERDALE,
FL. FILED 3-5-2011.

AFTATE

THE MARK CONSISTS OF STANDARD CHARACTERS
WITHOUT CLAIM TO ANY PARTICULAR FONT, STYLE,
SIZE, OR COLOR.
FOR FUNGAL MEDICATIONS (U.S. CLS. 6, 18, 44, 46,
51 AND 52).
JORDAN BAKER, EXAMINING ATTORNEY

SN 85-261,787. JOHNSON & JOHNSON, NEW BRUNSWICK,
NJ. FILED 3-9-2011.

ZEFIOR

THE MARK CONSISTS OF STANDARD CHARACTERS
WITHOUT CLAIM TO ANY PARTICULAR FONT, STYLE,
SIZE, OR COLOR.
FOR HUMAN PHARMACEUTICALS FOR THE
TREATMENT OF INFECTIOUS-RELATED DISEASE,
AUTO-IMMUNE AND INFLAMMATORY DISEASES,
CARDIOVASCULAR DISEASES, CENTRAL NERVOUS
SYSTEM DISEASES AND PAIN, DERMATOLOGIC DIS-
ORDERS, METABOLIC DISEASES, ANTI-VIRAL DIS-
EASES, ONCOLOGIC DISEASES, RESPIRATORY
DISEASES, OPHTHALMIC DISEASES, MUSCLE DYSTO-
NIAS, WRINKLES AND SMOOTH MUSCLE DISOR-
DERS, GASTRO-INTESTINAL DISEASES; HUMAN
PHARMACEUTICALS FOR USE AS HEMOSTATIC
AGENTS (U.S. CLS. 6, 18, 44, 46, 51 AND 52).
ELLEN PERKINS, EXAMINING ATTORNEY

SN 85-261,789. JOHNSON & JOHNSON, NEW BRUNSWICK,
NJ. FILED 3-9-2011.

TRINZON

THE MARK CONSISTS OF STANDARD CHARACTERS
WITHOUT CLAIM TO ANY PARTICULAR FONT, STYLE,
SIZE, OR COLOR.
FOR HUMAN PHARMACEUTICALS FOR THE
TREATMENT OF INFECTIOUS-RELATED DISEASE,
AUTO-IMMUNE AND INFLAMMATORY DISEASES,
CARDIOVASCULAR DISEASES, CENTRAL NERVOUS
SYSTEM DISEASES AND PAIN, DERMATOLOGIC DIS-
ORDERS, METABOLIC DISEASES, ANTI-VIRAL DIS-
EASES, ONCOLOGIC DISEASES, RESPIRATORY
DISEASES, OPHTHALMIC DISEASES, MUSCLE DYSTO-
NIAS, WRINKLES AND SMOOTH MUSCLE DISOR-
DERS, GASTRO-INTESTINAL DISEASES; HUMAN
PHARMACEUTICALS FOR USE AS HEMOSTATIC
AGENTS (U.S. CLS. 6, 18, 44, 46, 51 AND 52).
ELLEN PERKINS, EXAMINING ATTORNEY

CLASS 5—(Continued).

SN 85-261,793. JOHNSON & JOHNSON, NEW BRUNSWICK, NJ. FILED 3-9-2011.

PRILOGY

THE MARK CONSISTS OF STANDARD CHARACTERS WITHOUT CLAIM TO ANY PARTICULAR FONT, STYLE, SIZE, OR COLOR.

FOR HUMAN PHARMACEUTICALS FOR THE TREATMENT OF INFECTIOUS-RELATED DISEASE, AUTO-IMMUNE AND INFLAMMATORY DISEASES, CARDIOVASCULAR DISEASES, CENTRAL NERVOUS SYSTEM DISEASES AND PAIN, DERMATOLOGIC DISORDERS, METABOLIC DISEASES, ANTI-VIRAL DISEASES, ONCOLOGIC DISEASES, RESPIRATORY DISEASES, OPHTHALMIC DISEASES, MUSCLE DYSTONIAS, WRINKLES AND SMOOTH MUSCLE DISORDERS, GASTRO-INTESTINAL DISEASES; HUMAN PHARMACEUTICALS FOR USE AS HEMOSTATIC AGENTS (U.S. CLS. 6, 18, 44, 46, 51 AND 52).
ELLEN PERKINS, EXAMINING ATTORNEY

CLASS 5—(Continued).

SN 85-261,798. JOHNSON & JOHNSON, NEW BRUNSWICK, NJ. FILED 3-9-2011.

VERSAZEF

THE MARK CONSISTS OF STANDARD CHARACTERS WITHOUT CLAIM TO ANY PARTICULAR FONT, STYLE, SIZE, OR COLOR.

FOR HUMAN PHARMACEUTICALS FOR THE TREATMENT OF INFECTIOUS-RELATED DISEASE, AUTO-IMMUNE AND INFLAMMATORY DISEASES, CARDIOVASCULAR DISEASES, CENTRAL NERVOUS SYSTEM DISEASES AND PAIN, DERMATOLOGIC DISORDERS, METABOLIC DISEASES, ANTI-VIRAL DISEASES, ONCOLOGIC DISEASES, RESPIRATORY DISEASES, OPHTHALMIC DISEASES, MUSCLE DYSTONIAS, WRINKLES AND SMOOTH MUSCLE DISORDERS, GASTRO-INTESTINAL DISEASES; HUMAN PHARMACEUTICALS FOR USE AS HEMOSTATIC AGENTS (U.S. CLS. 6, 18, 44, 46, 51 AND 52).
ELLEN PERKINS, EXAMINING ATTORNEY

SN 85-261,796. JOHNSON & JOHNSON, NEW BRUNSWICK, NJ. FILED 3-9-2011.

BACRIDA

THE MARK CONSISTS OF STANDARD CHARACTERS WITHOUT CLAIM TO ANY PARTICULAR FONT, STYLE, SIZE, OR COLOR.

FOR HUMAN PHARMACEUTICALS FOR THE TREATMENT OF INFECTIOUS-RELATED DISEASE, AUTO-IMMUNE AND INFLAMMATORY DISEASES, CARDIOVASCULAR DISEASES, CENTRAL NERVOUS SYSTEM DISEASES AND PAIN, DERMATOLOGIC DISORDERS, METABOLIC DISEASES, ANTI-VIRAL DISEASES, ONCOLOGIC DISEASES, RESPIRATORY DISEASES, OPHTHALMIC DISEASES, MUSCLE DYSTONIAS, WRINKLES AND SMOOTH MUSCLE DISORDERS, GASTRO-INTESTINAL DISEASES; HUMAN PHARMACEUTICALS FOR USE AS HEMOSTATIC AGENTS (U.S. CLS. 6, 18, 44, 46, 51 AND 52).
ELLEN PERKINS, EXAMINING ATTORNEY

SN 85-261,801. JOHNSON & JOHNSON, NEW BRUNSWICK, NJ. FILED 3-9-2011.

KEVABAX

THE MARK CONSISTS OF STANDARD CHARACTERS WITHOUT CLAIM TO ANY PARTICULAR FONT, STYLE, SIZE, OR COLOR.

FOR HUMAN PHARMACEUTICALS FOR THE TREATMENT OF INFECTIOUS-RELATED DISEASE, AUTO-IMMUNE AND INFLAMMATORY DISEASES, CARDIOVASCULAR DISEASES, CENTRAL NERVOUS SYSTEM DISEASES AND PAIN, DERMATOLOGIC DISORDERS, METABOLIC DISEASES, ANTI-VIRAL DISEASES, ONCOLOGIC DISEASES, RESPIRATORY DISEASES, OPHTHALMIC DISEASES, MUSCLE DYSTONIAS, WRINKLES AND SMOOTH MUSCLE DISORDERS, GASTRO-INTESTINAL DISEASES; HUMAN PHARMACEUTICALS FOR USE AS HEMOSTATIC AGENTS (U.S. CLS. 6, 18, 44, 46, 51 AND 52).
ELLEN PERKINS, EXAMINING ATTORNEY

CLASS 5—(Continued).

SN 85-261,803. JOHNSON & JOHNSON, NEW BRUNSWICK, NJ. FILED 3-9-2011.

CRONTERA

THE MARK CONSISTS OF STANDARD CHARACTERS WITHOUT CLAIM TO ANY PARTICULAR FONT, STYLE, SIZE, OR COLOR.

FOR HUMAN PHARMACEUTICALS FOR THE TREATMENT OF INFECTIOUS-RELATED DISEASE, AUTO-IMMUNE AND INFLAMMATORY DISEASES, CARDIOVASCULAR DISEASES, CENTRAL NERVOUS SYSTEM DISEASES AND PAIN, DERMATOLOGIC DISORDERS, METABOLIC DISEASES, ANTI-VIRAL DISEASES, ONCOLOGIC DISEASES, RESPIRATORY DISEASES, OPHTHALMIC DISEASES, MUSCLE DYSTONIAS, WRINKLES AND SMOOTH MUSCLE DISORDERS, GASTRO-INTESTINAL DISEASES; HUMAN PHARMACEUTICALS FOR USE AS HEMOSTATIC AGENTS (U.S. CLS. 6, 18, 44, 46, 51 AND 52).
ELLEN PERKINS, EXAMINING ATTORNEY

CLASS 5—(Continued).

SN 85-261,806. JOHNSON & JOHNSON, NEW BRUNSWICK, NJ. FILED 3-9-2011.

AVENALE

THE MARK CONSISTS OF STANDARD CHARACTERS WITHOUT CLAIM TO ANY PARTICULAR FONT, STYLE, SIZE, OR COLOR.

FOR HUMAN PHARMACEUTICALS FOR THE TREATMENT OF INFECTIOUS-RELATED DISEASE, AUTO-IMMUNE AND INFLAMMATORY DISEASES, CARDIOVASCULAR DISEASES, CENTRAL NERVOUS SYSTEM DISEASES AND PAIN, DERMATOLOGIC DISORDERS, METABOLIC DISEASES, ANTI-VIRAL DISEASES, ONCOLOGIC DISEASES, RESPIRATORY DISEASES, OPHTHALMIC DISEASES, MUSCLE DYSTONIAS, WRINKLES AND SMOOTH MUSCLE DISORDERS, GASTRO-INTESTINAL DISEASES; HUMAN PHARMACEUTICALS FOR USE AS HEMOSTATIC AGENTS (U.S. CLS. 6, 18, 44, 46, 51 AND 52).
ELLEN PERKINS, EXAMINING ATTORNEY

SN 85-261,804. JOHNSON & JOHNSON, NEW BRUNSWICK, NJ. FILED 3-9-2011.

ACUTERA

THE MARK CONSISTS OF STANDARD CHARACTERS WITHOUT CLAIM TO ANY PARTICULAR FONT, STYLE, SIZE, OR COLOR.

FOR HUMAN PHARMACEUTICALS FOR THE TREATMENT OF INFECTIOUS-RELATED DISEASE, AUTO-IMMUNE AND INFLAMMATORY DISEASES, CARDIOVASCULAR DISEASES, CENTRAL NERVOUS SYSTEM DISEASES AND PAIN, DERMATOLOGIC DISORDERS, METABOLIC DISEASES, ANTI-VIRAL DISEASES, ONCOLOGIC DISEASES, RESPIRATORY DISEASES, OPHTHALMIC DISEASES, MUSCLE DYSTONIAS, WRINKLES AND SMOOTH MUSCLE DISORDERS, GASTRO-INTESTINAL DISEASES; HUMAN PHARMACEUTICALS FOR USE AS HEMOSTATIC AGENTS (U.S. CLS. 6, 18, 44, 46, 51 AND 52).
ELLEN PERKINS, EXAMINING ATTORNEY

SN 85-266,648. MONAVIE LLC, SOUTH JORDAN, UT. FILED 3-14-2011.



THE COLOR(S) ORANGE AND BLACK IS/ARE CLAIMED AS A FEATURE OF THE MARK.

THE MARK CONSISTS OF COLOR AND ITS PLACE-

CLASS 5—(Continued).

MENT ON A CONTAINER DESIGN. THE CONTAINER AND LID APPEAR IN THE COLOR BLACK. ON THE BODY OF THE CONTAINER APPEARS THE LETTERS "RVL" IN ORANGE, AND ON THE CONTAINER, BELOW THE LETTERS "RVL", APPEARS AN ORANGE RECTANGLE. THE SHAPE OF THE CONTAINER IS DISPLAYED BY DOTTED OR BROKEN LINES AND IS NOT CLAIMED AS A FEATURE OF THE MARK; THE BROKEN LINES SERVE ONLY TO INDICATE THE PLACEMENT OF THE MARK ON THE CONTAINER.

FOR DIETARY AND NUTRITIONAL SUPPLEMENTS; DIETARY AND NUTRITIONAL SUPPLEMENTS USED FOR WEIGHT LOSS; DIETARY DRINK MIX FOR USE AS A MEAL REPLACEMENT; DIETARY SUPPLEMENTS IN THE NATURE OF WEIGHT LOSS POWDERS; MEAL REPLACEMENT AND DIETARY SUPPLEMENT DRINK MIXES; MEAL REPLACEMENT POWDERS; MEAL REPLACEMENT SHAKES; NUTRITIONAL DRINK MIX FOR USE AS A MEAL REPLACEMENT; NUTRITIONAL DRINKS USED FOR MEAL REPLACEMENT; NUTRITIONAL SHAKES FOR USE AS A MEAL SUBSTITUTE; NUTRITIONAL SUPPLEMENT IN THE NATURE OF A NUTRIENT-DENSE, PROTEIN-BASED DRINK MIX; POWDERED FRUIT-FLAVORED DIETARY SUPPLEMENT DRINK MIX; POWDERED NUTRITIONAL SUPPLEMENT DRINK MIX; WEIGHT MANAGEMENT SUPPLEMENTS (U.S. CLS. 6, 18, 44, 46, 51 AND 52).

FIRST USE 1-5-2011; IN COMMERCE 1-5-2011.
ALEXANDER L. POWERS, EXAMINING ATTORNEY

CLASS 5—(Continued).

SN 85-270,613. GEOFFREY, LLC, WAYNE, NJ. FILED 3-18-2011.



THE MARK CONSISTS OF A BEAR HOLDING A SIPPY CUP.

FOR INFANT FORMULA (U.S. CLS. 6, 18, 44, 46, 51 AND 52).
KAELIE KUNG, EXAMINING ATTORNEY

SN 85-267,400. NOVARTIS AG, BASEL, SWITZERLAND, FILED 3-15-2011.



THE COLOR(S) RED, WHITE AND GRAY IS/ARE CLAIMED AS A FEATURE OF THE MARK.

THE MARK CONSISTS OF THREE OVERLAPPING TEARDROPS; THE LARGE AND SMALL TEARDROPS ARE RED AND THE MIDDLE TEARDROP IS GRAY AND WHITE; THE GRAY BACKGROUND IS NOT A FEATURE OF THE MARK.

FOR PHARMACEUTICAL PREPARATIONS FOR THE TREATMENT AND PREVENTION OF DISEASES AND DISORDERS OF THE CENTRAL NERVOUS SYSTEM, THE IMMUNE SYSTEM, THE CARDIOVASCULAR SYSTEM AND FOR USE IN ONCOLOGY; PHARMACEUTICAL PREPARATIONS FOR THE TREATMENT OF BLOOD AND BLOOD FORMING ORGANS (U.S. CLS. 6, 18, 44, 46, 51 AND 52).

PAM WILLIS, EXAMINING ATTORNEY

SN 85-272,346. PFIZER INC., NEW YORK, NY. FILED 3-21-2011.

CONTROLINE

THE MARK CONSISTS OF STANDARD CHARACTERS WITHOUT CLAIM TO ANY PARTICULAR FONT, STYLE, SIZE, OR COLOR.

FOR VETERINARY PREPARATIONS FOR THE PREVENTION AND TREATMENT OF OCULAR DISORDERS, ORAL DISEASES, DISORDERS OF THE NERVOUS SYSTEM, THE BLOOD AND IMMUNE SYSTEM, THE CARDIO-VASCULAR SYSTEM, THE RESPIRATORY SYSTEM, THE MUSCULOSKELETAL SYSTEM, THE DIGESTIVE SYSTEM, THE GENITOURINARY SYSTEM, AND THE REPRODUCTIVE SYSTEM; VETERINARY PREPARATIONS AND SUBSTANCES FOR THE TREATMENT AND PREVENTION OF INFECTIOUS DISEASES, OBESITY, BEHAVIORAL DISORDERS AND INFLAMMATORY DISORDERS; VETERINARY PREPARATIONS AND SUBSTANCES FOR USE IN DERMATOLOGY, ONCOLOGY, HEMATOLOGY, OPHTHALMOLOGY, AND GASTROENTEROLOGY; ANTI-INFECTION; ANTIVIRALS; ANTIBIOTICS; ANTIFUNGALS; ANTHELMINTICS; PARASITICIDES; ANALGESICS AND ANTI-ALLERGEN VETERINARY PREPARATIONS; ALL OF THE FOREGOING FOR FELINES, CANINES, BOVINES, PORCINES, EQUINES, RABBITS, POULTRY, GOATS AND SHEEP (U.S. CLS. 6, 18, 44, 46, 51 AND 52).

AMY HELLA, EXAMINING ATTORNEY

CLASS 5—(Continued).

SN 85-280,574. JULIE T. CHEN, SAN JOSE, CA. FILED 3-29-2011.



THE MARK CONSISTS OF A LEAF PETAL DESIGN PLUS THE WORDS "MAKING HEALTHY EZ".

FOR VITAMINS; NUTRITIONAL SUPPLEMENTS; DIETARY SUPPLEMENTS; NUTRITIONAL FOOD BARS FOR USE AS A MEAL REPLACEMENT; MEAL REPLACEMENT BARS; DIETARY SUPPLEMENTS IN THE NATURE OF NUTRITIONAL BARS (U.S. CLS. 6, 18, 44, 46, 51 AND 52).

WON TEAK OH, EXAMINING ATTORNEY

SN 85-282,731. WYETH LLC, MADISON, NJ. FILED 3-31-2011.

ADVIL TECHNATABS

THE MARK CONSISTS OF STANDARD CHARACTERS WITHOUT CLAIM TO ANY PARTICULAR FONT, STYLE, SIZE, OR COLOR.

OWNER OF U.S. REG. NOS. 1,298,347, 1,635,943 AND 1,942,746.

FOR ANALGESICS (U.S. CLS. 6, 18, 44, 46, 51 AND 52). WILLIAM BRECKENFELD, EXAMINING ATTORNEY

SN 85-282,734. WYETH LLC, MADISON, NJ. FILED 3-31-2011.

ADVIL ISOTABS

THE MARK CONSISTS OF STANDARD CHARACTERS WITHOUT CLAIM TO ANY PARTICULAR FONT, STYLE, SIZE, OR COLOR.

OWNER OF U.S. REG. NOS. 1,298,347, 1,635,943 AND 1,942,746.

FOR ANALGESICS (U.S. CLS. 6, 18, 44, 46, 51 AND 52). WILLIAM BRECKENFELD, EXAMINING ATTORNEY

CLASS 5—(Continued).

SN 85-282,741. WYETH LLC, MADISON, NJ. FILED 3-31-2011.

ADVIL PLUSTABS

THE MARK CONSISTS OF STANDARD CHARACTERS WITHOUT CLAIM TO ANY PARTICULAR FONT, STYLE, SIZE, OR COLOR.

OWNER OF U.S. REG. NOS. 1,298,347, 1,635,943 AND 1,942,746.

FOR ANALGESICS (U.S. CLS. 6, 18, 44, 46, 51 AND 52). WILLIAM BRECKENFELD, EXAMINING ATTORNEY

SN 85-283,566. WYETH LLC, MADISON, NJ. FILED 4-1-2011.

ADVIL ISOPLUS

THE MARK CONSISTS OF STANDARD CHARACTERS WITHOUT CLAIM TO ANY PARTICULAR FONT, STYLE, SIZE, OR COLOR.

OWNER OF U.S. REG. NOS. 1,298,347, 1,635,943 AND 1,942,746.

FOR ANALGESICS (U.S. CLS. 6, 18, 44, 46, 51 AND 52). WILLIAM BRECKENFELD, EXAMINING ATTORNEY

SN 85-283,569. WYETH LLC, MADISON, NJ. FILED 4-1-2011.

ADVIL ISOCAPS

THE MARK CONSISTS OF STANDARD CHARACTERS WITHOUT CLAIM TO ANY PARTICULAR FONT, STYLE, SIZE, OR COLOR.

OWNER OF U.S. REG. NOS. 1,298,347, 1,635,943 AND 1,942,746.

FOR ANALGESICS (U.S. CLS. 6, 18, 44, 46, 51 AND 52). WILLIAM BRECKENFELD, EXAMINING ATTORNEY

CLASS 5—(Continued).

SN 85-283,571. WYETH LLC, MADISON, NJ. FILED 4-1-2011.

ADVIL ISOGELS

THE MARK CONSISTS OF STANDARD CHARACTERS WITHOUT CLAIM TO ANY PARTICULAR FONT, STYLE, SIZE, OR COLOR.

OWNER OF U.S. REG. NOS. 1,298,347, 1,635,943 AND 1,942,746.

FOR ANALGESICS (U.S. CLS. 6, 18, 44, 46, 51 AND 52). WILLIAM BRECKENFELD, EXAMINING ATTORNEY

CLASS 5—(Continued).

SN 85-303,649. TRIARCO INDUSTRIES, INC., WAYNE, NJ. FILED 4-25-2011.

CRANTEIN

THE MARK CONSISTS OF STANDARD CHARACTERS WITHOUT CLAIM TO ANY PARTICULAR FONT, STYLE, SIZE, OR COLOR.

FOR VITAMINS, MINERAL SUPPLEMENTS, NUTRITIONAL AND DIETARY SUPPLEMENTS (U.S. CLS. 6, 18, 44, 46, 51 AND 52).

MEGHAN REINHART, EXAMINING ATTORNEY

SN 85-290,833. TRUE 2 BEAUTY, INC., COMMERCE, CA. FILED 4-8-2011.

LIBIGROW

THE MARK CONSISTS OF STANDARD CHARACTERS WITHOUT CLAIM TO ANY PARTICULAR FONT, STYLE, SIZE, OR COLOR.

OWNER OF U.S. REG. NO. 3,222,174. FOR HERBAL MALE ENHANCEMENT CAPSULES; HERBAL SUPPLEMENTS (U.S. CLS. 6, 18, 44, 46, 51 AND 52).

FIRST USE 2-1-2006; IN COMMERCE 2-1-2006. SETH A. RAPPAPORT, EXAMINING ATTORNEY

SN 85-307,761. SEATTLE GENETICS, INC., BOTHELL, WA. FILED 4-28-2011.



THE MARK CONSISTS OF A SINGLE, CONTINUOUS LOOPING LINE TWISTED TO FORM A TRI-LOBED THREE-DIMENSIONAL SHAPE, WITH A SPHERICAL ELEMENT SHOWN ABOVE AND BETWEEN THE TWO UPPER LOBES, FOLLOWED BY THE WORD "ADCETRIS".

FOR PHARMACEUTICAL PREPARATIONS FOR THE PREVENTION AND TREATMENT OF DISORDERS OF THE IMMUNE SYSTEM; PHARMACEUTICAL PREPARATIONS FOR THE TREATMENT OF CANCER; PHARMACEUTICAL PREPARATIONS FOR USE IN ONCOLOGY (U.S. CLS. 6, 18, 44, 46, 51 AND 52). RON FAIRBANKS, EXAMINING ATTORNEY

SN 85-303,542. THE PROCTER & GAMBLE COMPANY, CINCINNATI, OH. FILED 4-25-2011.

PEPTO-BISMOL TO-GO

THE MARK CONSISTS OF STANDARD CHARACTERS WITHOUT CLAIM TO ANY PARTICULAR FONT, STYLE, SIZE, OR COLOR.

OWNER OF U.S. REG. NOS. 224,933, 3,604,347 AND OTHERS.

FOR TREATMENT PREPARATIONS FOR GASTRO-INTESTINAL DISORDERS; TREATMENT PREPARATIONS TO SUPPORT GASTRO-INTESTINAL HEALTH (U.S. CLS. 6, 18, 44, 46, 51 AND 52). WENDY GOODMAN, EXAMINING ATTORNEY

SN 85-312,651. G&H BRANDS LLC, CALABASAS, CA. FILED 5-4-2011.

Make Love Longer

THE MARK CONSISTS OF STANDARD CHARACTERS WITHOUT CLAIM TO ANY PARTICULAR FONT, STYLE, SIZE, OR COLOR.

FOR PHARMACEUTICAL PREPARATIONS FOR THE TREATMENT AND PREVENTION OF PREMATURE EJACULATION (U.S. CLS. 6, 18, 44, 46, 51 AND 52). ROSELLE HERRERA, EXAMINING ATTORNEY

CLASS 5—(Continued).

SN 85-315,717. GENERAL NUTRITION INVESTMENT COMPANY, PHOENIX, AZ. FILED 5-9-2011.

CAT FRESH

THE MARK CONSISTS OF STANDARD CHARACTERS WITHOUT CLAIM TO ANY PARTICULAR FONT, STYLE, SIZE, OR COLOR.

NO CLAIM IS MADE TO THE EXCLUSIVE RIGHT TO USE "CAT", APART FROM THE MARK AS SHOWN.

FOR DIETARY SUPPLEMENTS FOR PETS (U.S. CLS. 6, 18, 44, 46, 51 AND 52).

ELISSA GARBER KON, EXAMINING ATTORNEY

CLASS 6—METAL GOODS

SN 77-955,895. GEORGIA INDUSTRIAL MAINTENANCE, INC., VALDOSTA, GA. FILED 3-10-2010.



NO CLAIM IS MADE TO THE EXCLUSIVE RIGHT TO USE "DESIGN", APART FROM THE MARK AS SHOWN.

THE MARK CONSISTS OF A GATE IN THE BACKGROUND WITH THE WORDS, "CHANGE ' N" ON THE LEFT SIDE OF THE SOLID PORTION OF SAID GATE AND THE WORDS, "TIMES DESIGN" ON THE RIGHT SIDE OF THE SOLID PORTION OF SAID GATE.

FOR METAL GATES AND DECORATIVE METAL PRODUCTS SOLD AS INTEGRAL COMPONENTS OF METAL GATES, NAMELY, METAL INSERTS DEPICTING NATURE, SPORTS TEAMS AND OTHER PERSONALIZED DESIGNS FABRICATED FROM STAINLESS STEEL AND OTHER METALS; ORNAMENTAL AND DECORATIVE MAILBOXES AND MAILBOX COVERS FABRICATED FROM STAINLESS STEEL AND OTHER METALS; DECORATIVE METAL PRODUCTS, NAMELY, METAL INSERTS FOR USE WITH MAILBOXES AND MAILBOX COVERS FOR ORNAMENTAL PURPOSES DEPICTING NATURE, SPORTS TEAMS AND OTHER PERSONALIZED DESIGNS FABRICATED FROM STAINLESS STEEL AND OTHER METALS (U.S. CLS. 2, 12, 13, 14, 23, 25 AND 50).

ALYSSA STEEL, EXAMINING ATTORNEY

SN 85-333,682. GENERAL NUTRITION INVESTMENT COMPANY, PHOENIX, AZ. FILED 5-31-2011.

GNC GENETIX

THE MARK CONSISTS OF STANDARD CHARACTERS WITHOUT CLAIM TO ANY PARTICULAR FONT, STYLE, SIZE, OR COLOR.

OWNER OF U.S. REG. NOS. 2,180,647, 3,429,065 AND OTHERS.

FOR DIETARY SUPPLEMENTS; MEAL REPLACEMENT AND DIETARY SUPPLEMENT DRINK MIXES; MEAL REPLACEMENT BARS; MEAL REPLACEMENT DRINKS; MEAL REPLACEMENT POWDERS; NUTRITIONAL DRINK MIX FOR USE AS A MEAL REPLACEMENT (U.S. CLS. 6, 18, 44, 46, 51 AND 52).

ELISSA GARBER KON, EXAMINING ATTORNEY

SN 77-958,965. STOCKTON PRODUCTS, NORTH LAS VEGAS, NV. FILED 3-15-2010.

SOLID GROUND

THE MARK CONSISTS OF STANDARD CHARACTERS WITHOUT CLAIM TO ANY PARTICULAR FONT, STYLE, SIZE, OR COLOR.

FOR METAL LATH AND PLASTER ACCESSORY PRODUCTS FOR BUILDING PURPOSES, NAMELY, METAL REVEAL MOLDINGS FOR USE IN LATH AND PLASTER, DRYWALL AND ACOUSTICAL CEILING APPLICATIONS; METAL STOPS FOR USE IN LATH AND PLASTER, DRYWALL AND ACOUSTICAL CEILING APPLICATIONS; METAL TRIM FOR USE IN LATH AND PLASTER, DRYWALL AND ACOUSTICAL CEILING APPLICATIONS; METAL CONTROL JOINTS FOR USE IN LATH AND PLASTER, DRYWALL AND ACOUSTICAL CEILING APPLICATIONS; METAL EXPANSION JOINTS FOR USE IN LATH AND PLASTER, DRYWALL AND ACOUSTICAL CEILING APPLICATIONS; METAL FOUNDATION WEEP SCREEDS FOR USE IN LATH AND PLASTER AND DRYWALL APPLICATIONS; AND METAL SHADOW MOLDINGS FOR USE IN PLASTER, DRYWALL AND ACOUSTICAL CEILING APPLICATIONS (U.S. CLS. 2, 12, 13, 14, 23, 25 AND 50).

DAVID MURRAY, EXAMINING ATTORNEY

CLASS 6—(Continued).

SN 79-076,343. WENZHOU HAITAN; MAGNETIC ELECTRICAL EQUIPMENT CO., LTD., CHINA, FILED 11-26-2009.



OWNER OF INTERNATIONAL REGISTRATION 1022123 DATED 11-26-2009, EXPIRES 11-26-2019.

THE MARK CONSISTS OF A DESIGN OF A CIRCLE CONNECTED TO AN ARC THAT GRADUALLY WIDENS AND THINS INTO THREE SEPARATE LINES TO THE RIGHT OF TWO CHINESE CHARACTERS, ALL ABOVE THE WORDING "HENGZHU".

THE ENGLISH TRANSLATION OF THE TERM "HENGZHU" IS "ETERNAL PEARL".

THE NON-LATIN CHARACTERS IN THE MARK TRANSLITERATE TO "HENGZHU". THE ENGLISH TRANSLATION OF "HENG" IN THE MARK IS "ETERNAL", AND "ZHU" IN THE MARK IS "PEARL".

FOR IRONMONGERY, NAMELY, RING BOLTS, SCREWS; DOOR HANDLES OF METAL; PEGS OF METAL; LATCH BARS OF METAL; METAL DOOR BOLTS; HINGES OF METAL; METAL SAFES; PROPS OF METAL, NAMELY, METAL CEILING SUPPORTS; BRANCHING PIPES OF METAL; FITTINGS OF METAL FOR FURNITURE (U.S. CLS. 2, 12, 13, 14, 23, 25 AND 50).
MARLENE BELL, EXAMINING ATTORNEY

SN 85-053,952. QUAD PERFORMANCE PRODUCTS, INC., BONNOTS MILL, MO. FILED 6-3-2010.

LIL' GRIZZ

THE MARK CONSISTS OF STANDARD CHARACTERS WITHOUT CLAIM TO ANY PARTICULAR FONT, STYLE, SIZE, OR COLOR.

FOR HUMANE ANIMAL TRAPS, NAMELY, WILD ANIMAL TRAPS (U.S. CLS. 2, 12, 13, 14, 23, 25 AND 50).
TARA PATE, EXAMINING ATTORNEY

SN 85-087,780. BRENNAN INDUSTRIES, INC., BEACHWOOD, OH. FILED 7-19-2010.

BI-LENE

THE MARK CONSISTS OF STANDARD CHARACTERS WITHOUT CLAIM TO ANY PARTICULAR FONT, STYLE, SIZE, OR COLOR.

FOR METAL HYDRAULIC FITTINGS AND ADAPTERS USED IN THE CONNECTION OF COMPONENTS OF HYDRAULIC SYSTEMS, EQUIPMENT AND MACHINERY (U.S. CLS. 2, 12, 13, 14, 23, 25 AND 50).
ASMAT KHAN, EXAMINING ATTORNEY

CLASS 6—(Continued).

SN 85-087,972. AVIBANK MANUFACTURING, INC., NORTH HOLLYWOOD, CA. FILED 7-19-2010.

BALL-LOCK

THE MARK CONSISTS OF STANDARD CHARACTERS WITHOUT CLAIM TO ANY PARTICULAR FONT, STYLE, SIZE, OR COLOR.

OWNER OF U.S. REG. NO. 2,006,168.
FOR METAL FASTENERS, NAMELY, QUICK RELEASE PINS (U.S. CLS. 2, 12, 13, 14, 23, 25 AND 50).
ANTHONY RINKER, EXAMINING ATTORNEY

SN 85-106,788. BRENNAN INDUSTRIES, INC., BEACHWOOD, OH. FILED 8-13-2010.

BRENNAN BLACK

THE MARK CONSISTS OF STANDARD CHARACTERS WITHOUT CLAIM TO ANY PARTICULAR FONT, STYLE, SIZE, OR COLOR.

THE NAME "BRENNAN BLACK" DOES NOT IDENTIFY A LIVING INDIVIDUAL.

FOR METAL HYDRAULIC FITTINGS AND ADAPTERS USED IN THE CONNECTION OF COMPONENTS OF HYDRAULIC SYSTEMS, EQUIPMENT AND MACHINERY (U.S. CLS. 2, 12, 13, 14, 23, 25 AND 50).
ASMAT KHAN, EXAMINING ATTORNEY

SN 85-111,530. CUSTOMETAL, S.A. DE C.V., MONTERREY, NUEVO LEON, MEXICO, FILED 8-19-2010.

CONSTRUFENCE

THE MARK CONSISTS OF STANDARD CHARACTERS WITHOUT CLAIM TO ANY PARTICULAR FONT, STYLE, SIZE, OR COLOR.

FOR PERMANENT AND TEMPORARY STEEL FENCE SYSTEMS COMPRISED OF CHAIN LINK FENCES, WIRE FENCES, METAL FENCE PANELS, FENCE POSTS, FENCE STANDS, FENCE BRACKETS AND FENCE GATES (U.S. CLS. 2, 12, 13, 14, 23, 25 AND 50).
ANTHONY RINKER, EXAMINING ATTORNEY

CLASS 6—(Continued).

SN 85-121,735. HAMPTON PRODUCTS INTERNATIONAL CORPORATION, FOOTHILL RANCH, CA. FILED 9-2-2010.



The logo for Wright Products features the word "Wright" in a large, stylized, cursive font. Below it, the word "PRODUCTS" is written in a smaller, bold, sans-serif font, underlined.

OWNER OF U.S. REG. NOS. 2,497,135, 2,613,811 AND OTHERS.

NO CLAIM IS MADE TO THE EXCLUSIVE RIGHT TO USE "PRODUCTS", APART FROM THE MARK AS SHOWN.

THE MARK CONSISTS OF THE STYLIZED WORD "WRIGHT" UNDERSCORED BY A HORIZONTAL LINE, BELOW WHICH IS THE WORD "PRODUCTS" IN CAPITALIZED BLOCK LETTERS.

SEC. 2(F).

FOR METAL DOOR HARDWARE, NAMELY, LATCHES, HANDLES, LOCKS, AND HINGES FOR STORM, SCREEN, AND PATIO DOORS (U.S. CLS. 2, 12, 13, 14, 23, 25 AND 50).

FIRST USE 12-1-2009; IN COMMERCE 12-1-2009.
KATHY DE JONGE, EXAMINING ATTORNEY

SN 85-141,636. NINGBO YONGXIANG COPPER PIPELINE CO., LTD., NINGBO, CHINA, FILED 9-30-2010.



The logo consists of the letters "H" and "I" in a bold, black, serif font. The "H" is on the left and the "I" is on the right, both standing upright and slightly separated.

THE MARK CONSISTS OF TWO VERTICAL PILLARS WHERE THE LEFT PILLAR HAS A HORIZONTAL PROTRUSION AT THE MIDDLE. THE PILLAR DESIGN FORMS THE LETTER "H".

FOR DRAIN PIPES MADE OF METAL; ELBOWS OF METAL FOR PIPES; MANUALLY OPERATED METAL VALVES; METAL AIR CONDITIONING DUCTS; METAL GUTTER PIPES; METAL JUNCTIONS FOR PIPES; METAL PENSTOCK PIPES; METAL PIPE COLLARS; PIPEWORK OF METAL INCLUDING THOSE FROM ALLOY STEEL AND TITANIUM; VENTILATING DUCTS OF METAL (U.S. CLS. 2, 12, 13, 14, 23, 25 AND 50).

FIRST USE 6-1-2005; IN COMMERCE 5-20-2008.
CURTIS FRENCH, EXAMINING ATTORNEY

CLASS 6—(Continued).

SN 85-182,594. MILLBROOK HUTTERIAN BRETHREN, INC., MITCHELL, SD. FILED 11-22-2010.

AMERICAN TRUCKBOXES

THE MARK CONSISTS OF STANDARD CHARACTERS WITHOUT CLAIM TO ANY PARTICULAR FONT, STYLE, SIZE, OR COLOR.

OWNER OF U.S. REG. NO. 2,953,866.

NO CLAIM IS MADE TO THE EXCLUSIVE RIGHT TO USE "TRUCKBOXES", APART FROM THE MARK AS SHOWN.

SEC. 2(F).

FOR METAL TOOL BOXES (U.S. CLS. 2, 12, 13, 14, 23, 25 AND 50).

FIRST USE 5-1-2004; IN COMMERCE 5-1-2004.

SALLY SHIH, EXAMINING ATTORNEY

SN 85-197,305. JON MICHAEL GULLETTE, GALVESTON, TX. FILED 12-14-2010.



The logo features a large, bold, black letter "X" on the left. To its right, the word "FORM" is written in a bold, black, sans-serif font.

NO CLAIM IS MADE TO THE EXCLUSIVE RIGHT TO USE "FORM", APART FROM THE MARK AS SHOWN.

THE MARK CONSISTS OF THE LETTER "X" HAVING ONE LEG LONGER THAN THE OTHER LEG, AND THE WORD "FORM" TO THE RIGHT OF THE "X".

FOR METAL FORMS FOR FORMING CONCRETE COLUMNS (U.S. CLS. 2, 12, 13, 14, 23, 25 AND 50).

JANICE L. MCMORROW, EXAMINING ATTORNEY

SN 85-213,839. UNISON HARDWARE, INC., SACRAMENTO, CA. FILED 1-10-2011.

Cologne

THE MARK CONSISTS OF STANDARD CHARACTERS WITHOUT CLAIM TO ANY PARTICULAR FONT, STYLE, SIZE, OR COLOR.

FOR METAL HANDLES FOR DOORS, NAMELY, DOOR HANDLES FOR INTERIOR ENTRY AND EXIT DOORS AND DOOR HANDLES FOR EXTERIOR ENTRY AND EXIT DOORS (U.S. CLS. 2, 12, 13, 14, 23, 25 AND 50).

FIRST USE 7-1-2005; IN COMMERCE 7-1-2005.

AMEEN IMAM, EXAMINING ATTORNEY

CLASS 6—(Continued).

SN 85-214,059. ATI PROPERTIES, INC., ALBANY, OR. FILED 1-10-2011.

ATI 334MO

THE MARK CONSISTS OF STANDARD CHARACTERS WITHOUT CLAIM TO ANY PARTICULAR FONT, STYLE, SIZE, OR COLOR.

OWNER OF U.S. REG. NOS. 2,949,136, 3,542,562 AND OTHERS.

FOR METAL IN MILL PRODUCT FORMS, NAMELY, SHEET AND STRIP MADE FROM STEEL ALLOYS (U.S. CLS. 2, 12, 13, 14, 23, 25 AND 50).

FIRST USE 11-4-2010; IN COMMERCE 11-4-2010.
NELSON SNYDER, EXAMINING ATTORNEY

SN 85-221,000. KYO-EI INDUSTRIAL CORPORATION, CHUO-KU, OSAKA, JAPAN, FILED 1-19-2011.

TUSKEY

THE MARK CONSISTS OF THE UPPER-CASE WORDING "TUSKEY" WITH THE BLOCKED LETTERS "TUS" IN COLOR WHITE AND THE BLOCKED LETTERS "KEY" IN COLOR BLACK. BETWEEN THE LETTERS "S" AND "K" A BLOCKED LINE DESIGN IN COLOR BLACK EXTENDS ACROSS THE LETTERS "KEY".

FOR WHEEL LOCK METAL NUTS FOR AUTOMOBILES (U.S. CLS. 2, 12, 13, 14, 23, 25 AND 50).
WON TEAK OH, EXAMINING ATTORNEY

SN 85-227,037. LINNEA, HILLSBORO, OR. FILED 1-26-2011.

Linnea

THE COLOR(S) BLUE AND GRAY IS/ARE CLAIMED AS A FEATURE OF THE MARK.

THE MARK CONSISTS OF THE WORDING "LINNEA" IN BLUE AND A GRAY HANDLE.

FOR DOOR STOPS OF METAL; HARDWARE, NAMELY, METAL BRACKETS FOR GENERAL USE; METAL BATHROOM HARDWARE, NAMELY, PULLS; METAL CLOTHES HOOKS; METAL HANDLES FOR DOORS, CABINETS, AND DRAWERS; METAL KNOBS; METAL LOCKS FOR DOORS AND CABINETS; METAL MAIL SLOTS; METAL PULLS FOR CABINETS AND DRAWERS; METAL SHOWER GRAB BARS (U.S. CLS. 2, 12, 13, 14, 23, 25 AND 50).

FIRST USE 2-28-2002; IN COMMERCE 5-31-2003.
GRETTA YAO, EXAMINING ATTORNEY

CLASS 6—(Continued).

SN 85-243,393. CRS HOLDINGS, INC., WILMINGTON, DE. FILED 2-16-2011.

TEMPER TOUGH

THE MARK CONSISTS OF STANDARD CHARACTERS WITHOUT CLAIM TO ANY PARTICULAR FONT, STYLE, SIZE, OR COLOR.

NO CLAIM IS MADE TO THE EXCLUSIVE RIGHT TO USE "TEMPER", APART FROM THE MARK AS SHOWN.

FOR METAL ALLOYS IN THE FORM OF WROUGHT PRODUCTS, NAMELY, BILLETS AND BARS (U.S. CLS. 2, 12, 13, 14, 23, 25 AND 50).

BENJAMIN OKEKE, EXAMINING ATTORNEY

SN 85-246,238. EXPANDER AMERICAS, INC., COTTONWOOD, AZ. FILED 2-18-2011.

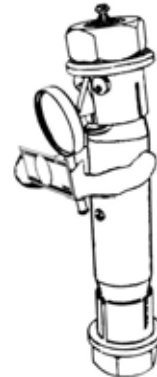

THE MARK CONSISTS OF A PIVOT PIN WITH HUMAN LIKE ATTRIBUTES HOLDING A MAGNIFYING GLASS AND A CURRENCY BILL.

FOR A PIN MADE FROM METAL THAT, WHILE ALLOWING ARTICULATING MOTION, SECURES TWO PARTS OF A WIDE VARIETY OF MACHINES SUCH AS A BACKHOLE, EXCAVATOR, BULL DOZER, AND HAUL TRUCK (U.S. CLS. 2, 12, 13, 14, 23, 25 AND 50).

JENNY PARK, EXAMINING ATTORNEY

CLASS 6—(Continued).

SN 85-246,546. COMMERCIAL METALS COMPANY, IRVING, TX. FILED 2-18-2011.



NO CLAIM IS MADE TO THE EXCLUSIVE RIGHT TO USE "PRODUCTS", APART FROM THE MARK AS SHOWN.

THE MARK CONSISTS OF THE WORDS "PERFORMANCE PRODUCTS" AND A HARD HAT DESIGN CONTAINED WITHIN A STYLIZED GLOBE.

FOR METAL WIRE AND STEEL PRODUCTS AND ACCESSORIES THEREFOR, NAMELY, WIRE, STEEL, TIE WIRE, BLACK ANNEALED BUNDLE WIRE, METAL BAR TIES, METAL BAR TIE TWISTERS, TIE WIRE REELS, STEEL STAKES, METAL SLAB BOLSTERS, METAL CONTINUOUS HIGH CHAIRS, METAL BAR SUPPORTS, NAILS, AND METAL REBAR CAPS (U.S. CLS. 2, 12, 13, 14, 23, 25 AND 50).

GRETTA YAO, EXAMINING ATTORNEY

SN 85-249,200. ROTARY DRILLING TOOLS USA, BEASLY, TX. FILED 2-23-2011.

WEAR KNOT

THE MARK CONSISTS OF STANDARD CHARACTERS WITHOUT CLAIM TO ANY PARTICULAR FONT, STYLE, SIZE, OR COLOR.

FOR PIPE, NAMELY, DRILL PIPE FOR USE IN DRILLING OPERATIONS (U.S. CLS. 2, 12, 13, 14, 23, 25 AND 50).

ODESSA BIBBINS, EXAMINING ATTORNEY

SN 85-254,529. PLATT, GREG, WINDBER, PA. FILED 3-1-2011.

H.A.M.

THE MARK CONSISTS OF STANDARD CHARACTERS WITHOUT CLAIM TO ANY PARTICULAR FONT, STYLE, SIZE, OR COLOR.

FOR METAL HOOKS FOR HANGING HUNTING EQUIPMENT (U.S. CLS. 2, 12, 13, 14, 23, 25 AND 50).

JEFFERY COWARD, EXAMINING ATTORNEY

CLASS 6—(Continued).

SN 85-254,557. HOOVER MATERIALS HANDLING GROUP, INC., HOUSTON, TX. FILED 3-1-2011.

LIQUITOTE

THE MARK CONSISTS OF STANDARD CHARACTERS WITHOUT CLAIM TO ANY PARTICULAR FONT, STYLE, SIZE, OR COLOR.

FOR METAL TANKS SOLD EMPTY FOR USE IN TRANSPORTING AND STORING LIQUID MATERIALS (U.S. CLS. 2, 12, 13, 14, 23, 25 AND 50).

FIRST USE 3-1-1988; IN COMMERCE 7-1-1988.

REBECCA EISINGER, EXAMINING ATTORNEY

SN 85-254,784. HORIZONS INCORPORATED, CLEVELAND, OH. FILED 3-1-2011.

DuraJet

THE MARK CONSISTS OF STANDARD CHARACTERS WITHOUT CLAIM TO ANY PARTICULAR FONT, STYLE, SIZE, OR COLOR.

FOR SUBSURFACE INK JET PRINTABLE ANODIZED ALUMINUM SHEETS THAT ALLOW THE IMAGE TO BE SEALED INSIDE THE ANODIZED LAYER (U.S. CLS. 2, 12, 13, 14, 23, 25 AND 50).

SUE LAWRENCE, EXAMINING ATTORNEY

SN 85-255,426. CORBIN RUSSWIN, INC., MONROE, NC. FILED 3-2-2011.

INSPIRE

THE MARK CONSISTS OF STANDARD CHARACTERS WITHOUT CLAIM TO ANY PARTICULAR FONT, STYLE, SIZE, OR COLOR.

FOR METAL DOOR LOCKS AND LEVERS; METAL LATCHES, METAL DOOR KNOBS; METAL ESCUTCHEONS FOR USE WITH LOCK SETS AND FOR USE ON DOORS; AND EXIT DEVICES COMPRISED OF METAL DOOR LATCHES, BARS AND PUSH PADS (U.S. CLS. 2, 12, 13, 14, 23, 25 AND 50).

FIRST USE 12-2-2010; IN COMMERCE 12-2-2010.

LINDA MICKLEBURGH, EXAMINING ATTORNEY

CLASS 6—(Continued).

SN 85-256,152. CANNON SAFE, INC., SAN BERNARDINO, CA. FILED 3-2-2011.

HOMEGUARD

THE MARK CONSISTS OF STANDARD CHARACTERS WITHOUT CLAIM TO ANY PARTICULAR FONT, STYLE, SIZE, OR COLOR.

FOR METAL CONTAINERS FOR STORING FIREARMS; METAL LOCKS FOR FIREARMS (U.S. CLS. 2, 12, 13, 14, 23, 25 AND 50).

KATHERINE STOIDES, EXAMINING ATTORNEY

SN 85-256,260. DOLE FOOD COMPANY, INC., WESTLAKE VILLAGE, CA. FILED 3-2-2011.



OWNER OF U.S. REG. NOS. 1,334,608, 1,494,440 AND 1,568,638.

THE COLOR(S) RED, YELLOW, AND BLUE IS/ARE CLAIMED AS A FEATURE OF THE MARK.

THE MARK CONSISTS OF THE WORD "DOLE" IN RED LETTERS WITH A YELLOW SUNBURST ENCAPSULATED IN THE LETTER "O" AND A BLUE BAR UNDER THE WORD AND EXTENDING THE LENGTH OF THE WORD. THE COLOR WHITE IS USED FOR BACKGROUND PURPOSES AND IS NOT A PART OF THE MARK.

FOR GENERAL PURPOSE METAL STORAGE CONTAINERS (U.S. CLS. 2, 12, 13, 14, 23, 25 AND 50).

DOMINICK J. SALEMI, EXAMINING ATTORNEY

SN 85-256,293. CONSOLIDATED FABRICATORS CORP., VAN NUYS, CA. FILED 3-2-2011.

CONFAB

THE MARK CONSISTS OF STANDARD CHARACTERS WITHOUT CLAIM TO ANY PARTICULAR FONT, STYLE, SIZE, OR COLOR.

FOR COMMERCIAL WASTE CONTAINERS OF METAL (U.S. CLS. 2, 12, 13, 14, 23, 25 AND 50).

DOMINICK J. SALEMI, EXAMINING ATTORNEY

CLASS 6—(Continued).

SN 85-257,833. PLATT, GREG, WINDBER, PA. FILED 3-4-2011.



NO CLAIM IS MADE TO THE EXCLUSIVE RIGHT TO USE "HUNTING ACCESSORY MANUFACTURERS LLC", APART FROM THE MARK AS SHOWN.

THE MARK CONSISTS OF ANTLERS SURROUNDING THE WORDING "HUNTING ACCESSORY MANUFACTURERS LLC", WITH A STYLIZED LINE OVER THE WORD "HUNTING" AND UNDER THE WORD "MANUFACTURERS". THE WORDING "WWW.HUNTAM.COM" IS UNDER THE TERM "LLC" SURROUNDED BY A BANNER.

FOR METAL HOOKS FOR HANGING HUNTING EQUIPMENT (U.S. CLS. 2, 12, 13, 14, 23, 25 AND 50).

JEFFERY COWARD, EXAMINING ATTORNEY

SN 85-258,386. PALADIN BRANDS GROUP, INC., CEDAR RAPIDS, IA. FILED 3-4-2011.

SHEAR JAW ARMOR

THE MARK CONSISTS OF STANDARD CHARACTERS WITHOUT CLAIM TO ANY PARTICULAR FONT, STYLE, SIZE, OR COLOR.

NO CLAIM IS MADE TO THE EXCLUSIVE RIGHT TO USE "SHEAR JAW", APART FROM THE MARK AS SHOWN.

FOR WEAR RESISTANT, METAL CLADDING FOR EXCAVATOR SHEARS (U.S. CLS. 2, 12, 13, 14, 23, 25 AND 50).

ZACHARY BELLO, EXAMINING ATTORNEY

SN 85-302,730. ALCAN PRODUCTS CORPORATION, CHICAGO, IL. FILED 4-22-2011.

GRAVITYGRIP

THE MARK CONSISTS OF STANDARD CHARACTERS WITHOUT CLAIM TO ANY PARTICULAR FONT, STYLE, SIZE, OR COLOR.

FOR CABLE CLAMPS OF METAL (U.S. CLS. 2, 12, 13, 14, 23, 25 AND 50).

KATHRYN COWARD, EXAMINING ATTORNEY

CLASS 6—(Continued).

SN 85-331,787. PARAMOUNT PICTURES CORPORATION, HOLLYWOOD, CA. FILED 5-26-2011.

WWZ

THE MARK CONSISTS OF STANDARD CHARACTERS WITHOUT CLAIM TO ANY PARTICULAR FONT, STYLE, SIZE, OR COLOR.

FOR BUSTS OF NON-PRECIOUS METAL; FIGURINES OF COMMON METAL; METAL KEY CHAINS; STATUES OF NON-PRECIOUS METAL (U.S. CLS. 2, 12, 13, 14, 23, 25 AND 50).

SUSAN RICHARDS, EXAMINING ATTORNEY

CLASS 7—(Continued).

SN 76-705,925. MERITool L.L.C., ELLICOTTVILLE, NY. FILED 1-7-2011.

STOUT TOOL

THE MARK CONSISTS OF STANDARD CHARACTERS WITHOUT CLAIM TO ANY PARTICULAR FONT, STYLE, SIZE, OR COLOR.

OWNER OF U.S. REG. NO. 2,954,837.
NO CLAIM IS MADE TO THE EXCLUSIVE RIGHT TO USE "TOOL", APART FROM THE MARK AS SHOWN.

FOR POWER OPERATED HAND TOOLS, NAMELY, BAND SAWS (U.S. CLS. 13, 19, 21, 23, 31, 34 AND 35).

CAROL SPILS, EXAMINING ATTORNEY

CLASS 7—MACHINERY

SN 76-701,197. AEROMIX SYSTEMS, INC., GOLDEN VALLEY, MN. FILED 1-14-2010.

AEROMIX IS YOUR SOLAR SOLUTION IN AERATION AND CIRCULATION

THE MARK CONSISTS OF STANDARD CHARACTERS WITHOUT CLAIM TO ANY PARTICULAR FONT, STYLE, SIZE, OR COLOR.

OWNER OF U.S. REG. NO. 1,912,420.
FOR WATER TREATMENT APPARATUS, NAMELY, AERATORS, ELECTRIC MOTORS FOR WATER TREATMENT MACHINES, PROPELLERS FOR WATER TREATMENT MACHINES, WATER TREATMENT MACHINE PARTS IN THE NATURE OF WATER PROPELLER BLADES, FLOATS, INTAKE CONES, AND DIFFUSION HEADS (U.S. CLS. 13, 19, 21, 23, 31, 34 AND 35).

ANDREW LEASER, EXAMINING ATTORNEY

THE MARK CONSISTS OF A STYLIZED LETTER "M" WITH BIRD WINGS.

FOR MACHINES AND MACHINE TOOLS FOR THE CUTTING AND FORMING OF MATERIALS (U.S. CLS. 13, 19, 21, 23, 31, 34 AND 35).

STEVEN R. FINE, EXAMINING ATTORNEY

SN 76-705,674. TEETER, MONTY J., ULYSSES, KS. FILED 12-13-2010.

THE MARK CONSISTS OF THE WORDING "SEE LEVEL" OVER A GRAPHIC REPRESENTATION OF WATER. THE TWO "E'S" IN "SEE" HAVE EYES AND EYEBROWS, AND THE "S" SERIFS ARE SHAPED AS FISHTAILS. THE WORDING "SEE LEVEL" ALSO APPEARS IN THE GRAPHIC OF THE WATER.

FOR LUBRICATION PUMP, NAMELY, WHEEL GEAR BOX LUBRICATOR FOR A CENTER PIVOT IRRIGATION SYSTEM (U.S. CLS. 13, 19, 21, 23, 31, 34 AND 35).

FIRST USE 4-1-1999; IN COMMERCE 4-1-1999.

ALYSSA STEEL, EXAMINING ATTORNEY

SN 77-771,072. BAY SHORE SYSTEMS, INC., RATHDRUM, ID. FILED 6-30-2009.

HIDRIL

THE MARK CONSISTS OF STANDARD CHARACTERS WITHOUT CLAIM TO ANY PARTICULAR FONT, STYLE, SIZE, OR COLOR.

FOR MOBILE EXCAVATION EQUIPMENT BOOM ATTACHMENTS FOR FOUNDATION DRILLING, NAMELY, EARTH AUGER AND DRILLING ATTACHMENTS. THE EXCAVATION EQUIPMENT BEING MOBILE EXCAVATION EQUIPMENT SUCH AS TRACK HOES, EXCAVATORS, AND/OR TRUCK RIGS. THE EXCAVATION EQUIPMENT IS USED TO PREPARE CONSTRUCTION SITES WITH SPECIFIC EMPHASIS ON THE EXCAVATION OF HOLES TYPICALLY USED TO RECEIVE CONCRETE WHEN PREPARING FOUNDATIONS (U.S. CLS. 13, 19, 21, 23, 31, 34 AND 35).

CURTIS FRENCH, EXAMINING ATTORNEY

CLASS 7—(Continued).

SN 77-911,781. BELANGER, INC., NORTHVILLE, MI. FILED 1-14-2010.

CLASS 7—(Continued).

SN 77-956,791. INTELLA LIFTPARTS, INC., HOLLAND, MI. FILED 3-11-2010.

ChemCycle

THE MARK CONSISTS OF STANDARD CHARACTERS WITHOUT CLAIM TO ANY PARTICULAR FONT, STYLE, SIZE, OR COLOR.

FOR PARTS FOR VEHICLE WASHING MACHINES, NAMELY, AUTOMOBILE TIRE DRESSING APPLICATORS (U.S. CLS. 13, 19, 21, 23, 31, 34 AND 35).

FIRST USE 9-19-2008; IN COMMERCE 9-24-2008.
JENNIFER MARTIN, EXAMINING ATTORNEY



SN 77-936,722. ARTEMIS RUBBER TECHNOLOGY, INC., LONGMONT, CO. FILED 2-16-2010.

Gummi-Jäger

THE MARK CONSISTS OF STANDARD CHARACTERS WITHOUT CLAIM TO ANY PARTICULAR FONT, STYLE, SIZE, OR COLOR.

THE TRANSLATION OF "GUMMI-JÄGER" IS RUBBER-HUNTER.

FOR DIFFUSERS AND WATER AERATORS USED IN MACHINES FOR WASTE WATER TREATMENT; ROUND-SHAPED SLOTTED AND HOSE-SHAPED SLOTTED ELASTOMERIC STRUCTURAL PARTS OF THE AFOREMENTIONED DIFFUSERS AND AERATORS, IN THE NATURE OF TUBES OR DISKS, AND SOLD AS A COMPONENT PART THEREOF; AND HOLDERS SPECIALLY ADAPTED FOR THE AFOREMENTIONED DIFFUSERS AND AERATORS AND SOLD AS A COMPONENT PART THEREOF (U.S. CLS. 13, 19, 21, 23, 31, 34 AND 35).

FIRST USE 1-6-2000; IN COMMERCE 1-6-2000.
ALYSSA STEEL, EXAMINING ATTORNEY

NO CLAIM IS MADE TO THE EXCLUSIVE RIGHT TO USE "LIFTPARTS INC", APART FROM THE MARK AS SHOWN.

THE MARK CONSISTS OF A FORKLIFT RAISING A BOX WITH THE WORDS "INTELLA" NEXT TO THE BOX AND "LIFTPARTS INC" APPEARING DIRECTLY BELOW THE WORDING "INTELLA".

FOR PRODUCTS AND COMPONENTS FOR USE ON FORKLIFT TRUCKS, NAMELY, MACHINE PARTS, NAMELY, BEARINGS AND BUSHINGS, BELTS FOR MACHINES, BELTS FOR ENGINES, CARBURETORS, OIL FILTERS FOR MOTORS AND ENGINES, AIR FILTERS FOR FORKLIFT MOTORS AND ENGINES, METAL ENGINE GASKETS FOR FORKLIFTS, AND GEARS FOR MACHINES; FORKLIFT ENGINE PARTS, NAMELY, CHARGE AIR COOLERS AND THEIR COMPONENT PARTS; FORKLIFT ENGINE PARTS, NAMELY, INTERCOOLERS, HYDRAULIC PUMPS, WATER PUMPS FOR USE IN MOTORS AND ENGINES, STARTERS FOR MOTORS AND ENGINES, ALTERNATORS, IGNITION WIRES FOR MOTOR FORKLIFTS, IGNITION DEVICES FOR MOTORS OF FORKLIFTS, IGNITION PARTS FOR INTERNAL COMBUSTION ENGINES, NAMELY, CAPS AND ROTORS, GEAR LEVER KNOBS FOR MACHINES, REGULATORS BEING PARTS OF MACHINES, ENGINE MUFFLERS, EXHAUST MUFFLERS FOR MOTORS, SPARK PLUGS, PRESSURE SWITCHES AS PARTS OF MACHINES; AND INTERNAL COMBUSTION ENGINES LAND VEHICLE PARTS, NAMELY, DISTRIBUTOR CAPS (U.S. CLS. 13, 19, 21, 23, 31, 34 AND 35).

FIRST USE 4-1-2007; IN COMMERCE 4-1-2007.
ERIN FALK, EXAMINING ATTORNEY

CLASS 7—(Continued).

SN 79-076,883. COMMERCIAL DIVING SERVICES PTY LTD, YALLAH NSW 2530, AUSTRALIA, FILED 10-26-2009.

HST

THE MARK CONSISTS OF STANDARD CHARACTERS WITHOUT CLAIM TO ANY PARTICULAR FONT, STYLE, SIZE, OR COLOR.

PRIORITY DATE OF 5-14-2009 IS CLAIMED.

OWNER OF INTERNATIONAL REGISTRATION 1023728 DATED 10-26-2009, EXPIRES 10-26-2019.

FOR MACHINES, NAMELY, MACHINES AND APPARATUS FOR OPERATING UNDERWATER, NAMELY, CLEANING AND ANTI-FOULING CLEANING MACHINES AND APPARATUS FOR UNDERWATER SURFACES; MACHINES AND APPARATUS FOR THE TREATMENT OF ANTI-FOULING PAINTS, NON-ANTI-FOULING PAINTS AND OF MARINE GROWTH ON UNDERWATER SURFACES INCLUDING SHIP'S HULLS IN PARTICULAR, NAMELY, NON-ABRASIVE BLAST CLEANING MACHINES FOR CLEANING SURFACES; FLUID FLOW DEVICES FOR USE WITH MACHINES AND APPARATUS, NAMELY, FLUID POWER COMPONENT KIT FOR MACHINE CONTROL COMPRISING PUMPS AND VALVES; FLUID FLOW MACHINES AND APPARATUS, NAMELY, CLEANING AND ANTI-FOULING CLEANING MACHINES AND APPARATUS FOR UNDERWATER SURFACES USING FLUIDS; FLUID HANDLING MACHINES AND APPARATUS, NAMELY, CLEANING AND ANTI-FOULING CLEANING MACHINES AND APPARATUS FOR UNDERWATER SURFACES USING FLUIDS; FLUID PUMPING INSTALLATIONS, NAMELY, FLUID PUMPING MACHINES; MACHINES AND APPARATUS FOR TRANSFERRING LIQUID MATERIALS, NAMELY, CLEANING AND ANTI-FOULING CLEANING MACHINES AND APPARATUS FOR UNDERWATER SURFACES; HEAT TRANSFER MACHINES AND APPARATUS, NAMELY, HEAT TRANSFER PRESSES; MACHINES AND APPARATUS INCLUDING THOSE UTILIZING HEAT AND STEAM FOR CLEANING SHIP'S HULLS AND OTHER UNDERWATER SURFACES, NAMELY, MACHINES FOR CLEANING SURFACES USING FLUIDS (U.S. CLS. 13, 19, 21, 23, 31, 34 AND 35).

CAROL SPILS, EXAMINING ATTORNEY

SN 79-083,920. EVG ENTWICKLUNGS- U. VERWERTUNGS-GESELLSCHAFT M.B.; H., AUSTRIA, FILED 5-3-2010.

POLYCAGE

THE MARK CONSISTS OF STANDARD CHARACTERS WITHOUT CLAIM TO ANY PARTICULAR FONT, STYLE, SIZE, OR COLOR.

PRIORITY DATE OF 2-16-2010 IS CLAIMED.

OWNER OF INTERNATIONAL REGISTRATION 1042537 DATED 5-3-2010, EXPIRES 5-3-2020.

FOR MACHINES FOR NON-CUTTING PROCESSING OF METALLIC WIRE, BARS OR STRIP MATERIAL, NAMELY, METALWORKING MACHINES; ELECTRIC WELDING MACHINES AND BENDING MACHINES FOR USE ON METALLIC WIRE, BARS OR STRIP MATERIAL FOR LONGITUDINAL AND TRANSVERSE EXTENDING CONCRETE REINFORCEMENT BARS, FOR THE FORMING OF PRISMATIC CONCRETE REINFORCEMENT ELEMENTS (U.S. CLS. 13, 19, 21, 23, 31, 34 AND 35).

LAURA HAMMEL, EXAMINING ATTORNEY

CLASS 7—(Continued).

SN 79-085,860. ZHEJIANG SHUANGNIAO MACHINERY CO., LTD., CHINA, FILED 7-14-2010.

TBM

OWNER OF INTERNATIONAL REGISTRATION 1047057 DATED 7-14-2010, EXPIRES 7-14-2020.

FOR LOADING AND UNLOADING MACHINES; HOISTS; CONVEYOR; HOISTING MACHINE; GAS-OPERATED WELDING MACHINES (U.S. CLS. 13, 19, 21, 23, 31, 34 AND 35).

KRISTINA MORRIS, EXAMINING ATTORNEY

SN 79-087,766. OPEM S.P.A., PARMA (PR), ITALY, FILED 7-14-2010.

OPEM

THE MARK CONSISTS OF STANDARD CHARACTERS WITHOUT CLAIM TO ANY PARTICULAR FONT, STYLE, SIZE, OR COLOR.

OWNER OF INTERNATIONAL REGISTRATION 0922628 DATED 4-3-2007, EXPIRES 4-3-2017.

THE WORDING "OPEM" HAS NO MEANING IN A FOREIGN LANGUAGE.

FOR PACKAGING MACHINES FOR FOOD (U.S. CLS. 13, 19, 21, 23, 31, 34 AND 35).

RONALD DELGIZZI, EXAMINING ATTORNEY

SN 79-088,319. INTRADIN (SHANGHAI) MACHINERY CO., LTD., CHINA, FILED 3-31-2010.



OWNER OF INTERNATIONAL REGISTRATION 1053813 DATED 3-31-2010, EXPIRES 3-31-2020.

THE MARK CONSISTS OF THE WORDING "HYDROWORKS" IN STYLIZED FONT WITHIN A SHADED QUADRILATERAL BACKGROUND WHICH IS DIVIDED SUCH THAT THE PORTION BEHIND THE ELEMENT "HYDRO" IS A DARKER SHADE THAN THAT BEHIND "WORKS".

FOR VALVES BEING PARTS OF MACHINES; HYDRAULIC CONTROLS FOR MACHINES AND ENGINES; HYDRAULIC VALVES AS PARTS OF MACHINES; PRESSURE ADJUSTING VALVES AS PARTS OF MACHINES; ELECTROMAGNETIC VALVES AS PARTS OF MACHINES; HYDRAULIC ELEMENTS OTHER THAN FOR VEHICLES, NAMELY, CYLINDERS FOR MOTORS AND ENGINES, CYLINDERS BEING PART OF MACHINES; HYDRAULIC COUPLINGS FOR MACHINES; HYDRAULIC DOOR OPENERS AND CLOSERS BEING PARTS OF MACHINES (U.S. CLS. 13, 19, 21, 23, 31, 34 AND 35).

STEVEN PEREZ, EXAMINING ATTORNEY

CLASS 7—(Continued).

SN 79-090,016. REDSTACK B.V., NETHERLANDS, FILED 7-22-2010.



PRIORITY DATE OF 3-25-2010 IS CLAIMED.
OWNER OF INTERNATIONAL REGISTRATION 1058374 DATED 7-22-2010, EXPIRES 7-22-2020.
NO CLAIM IS MADE TO THE EXCLUSIVE RIGHT TO USE "POWER", APART FROM THE MARK AS SHOWN.
THE COLOR(S) BLUE AND RED IS/ARE CLAIMED AS A FEATURE OF THE MARK.
THE MARK CONSISTS OF THE STYLIZED WORDING "RED" IN BLUE AND THE STYLIZED WORDING "POWER" IN RED AND SMALLER FONT AND UNDERLINED BY FOUR LINES, ALSO IN RED.
FOR POWER GENERATORS, NAMELY ELECTRICITY GENERATORS (U.S. CLS. 13, 19, 21, 23, 31, 34 AND 35).
MARILYN IZZI, EXAMINING ATTORNEY

SN 79-091,257. NINGBO HXYP ELEVATOR CO., LTD., 315800 ZHEJIANG, CHINA, FILED 10-8-2010.



PRIORITY DATE OF 6-12-2010 IS CLAIMED.
OWNER OF INTERNATIONAL REGISTRATION 1061693 DATED 10-8-2010, EXPIRES 10-8-2020.
THE MARK CONSISTS OF STYLED WORDING "HXYP" APPEARING TO THE RIGHT OF A RECTANGLE CONTAINING A STYLIZED CROSS WHOSE HORIZONTAL LINE ENDS IN A VERTICAL LINE EXTENDING UP AND DOWN ON BOTH SIDES WHICH TURNS INTO AN INCOMPLETE RECTANGLE.
FOR LIFTS, NAMELY, ELEVATORS; MOBILE ELEVATING OR LIFTING WORK PLATFORMS; ELEVATING OR LIFTING WORK PLATFORMS; ESCALATORS; MOVING STAIRCASES IN THE NATURE OF ESCALATORS; MECHANICAL RAILED LIFTING CONVEYORS; CONVEYING MACHINES, NAMELY, CONVEYORS; HOSTS; MATERIAL HANDLING MACHINES, NAMELY, PALLETIZERS, CASE ELEVATORS, AUTOMATIC PALLET DISPENSING MACHINES AND AUTOMATIC SLIP SHEET DISPENSING MACHINES (U.S. CLS. 13, 19, 21, 23, 31, 34 AND 35).
MICHAEL TANNER, EXAMINING ATTORNEY

CLASS 7—(Continued).

SN 79-092,639. SHIGIYA MACHINERY WORKS LTD., HIR-OSHIMA 721-0957, JAPAN, FILED 12-17-2010.



OWNER OF INTERNATIONAL REGISTRATION 1065327 DATED 12-17-2010, EXPIRES 12-17-2020.

THE WORDING "SHIGIYA" HAS NO MEANING IN A FOREIGN LANGUAGE.

FOR METALWORKING MACHINES, NAMELY, BENDING MACHINES, BORING MACHINES, BROACHING MACHINES, CUTTING MACHINES, DRILLING MACHINES, ELECTRO-CHEMICAL DISCHARGE MACHINE TOOLS FOR METALWORKING, GRINDING MACHINES, HONING MACHINES, LAPPING MACHINES, LATHES, MACHINING CENTERS, MECHANICAL PRESSES, MILLING MACHINES, PERFORATING MACHINES, PLANING MACHINES, ROLLING MILLS, SHAPING MACHINES, SHEARING MACHINES, SLOTTING MACHINES, THREADING MACHINES, TUBING MILLS; METALWORKING MACHINE TOOLS; MINING MACHINES AND APPARATUS, NAMELY, DRILLS FOR THE MINING INDUSTRY, BITS FOR MINING MACHINES; CONSTRUCTION MACHINES, NAMELY, EXCAVATING MACHINES, CONCRETE CONSTRUCTION MACHINES; LOADING-UNLOADING MACHINES AND APPARATUS; MACHINES AND INSTRUMENTS FOR FISHING, NAMELY, WIRE COILING MACHINES; CHEMICAL PROCESSING MACHINES AND APPARATUS, NAMELY, DISSOLVING MACHINES, EMULSIFYING MACHINES; TEXTILE MACHINES AND APPARATUS, NAMELY, TEXTILE SCUTCHING MACHINES, TEXTILE TENTERING MACHINES; FOOD OR BEVERAGE PROCESSING MACHINES AND APPARATUS, NAMELY, ELECTRIC FOOD CHOPPERS, ELECTRIC FOOD GRINDERS; LUMBERING, WOODWORKING, OR VENEER OR PLYWOOD MAKING MACHINES AND APPARATUS, NAMELY, SAW-TOOTH SETTING MACHINES, LUMBERING BAND SAWS; PULP MAKING, PAPER-MAKING OR PAPER-WORKING MACHINES AND APPARATUS, NAMELY, PULP REFINING MACHINES; PRINTING OR BOOKBINDING MACHINES; SEWING MACHINES; AGRICULTURAL MACHINES, NAMELY, CULTIVATORS, HARVESTERS; SHOE MAKING MACHINES; LEATHER TANNING MACHINES; TOBACCO PROCESSING MACHINES; GLASSWARE MANUFACTURING MACHINES; PAINTING MACHINES AND APPARATUS, NAMELY, PAINT SPRAYERS, PAINT SPRAY GUNS; PACKAGING MACHINES; WRAPPING MACHINES; POWER-OPERATED POTTERS' WHEELS; PLASTIC PROCESSING MACHINES AND APPARATUS, NAMELY, EXTRUSION MACHINES FOR PLASTIC, INJECTION PLASTIC MOLDING MACHINES; SEMICONDUCTOR MANUFACTURING MACHINES; MACHINES AND APPARATUS FOR MANUFACTURING RUBBER GOODS, NAMELY, RUBBER FORMING MACHINES, RUBBER MIXING MACHINES; STONE WORKING MACHINES; MECHANICAL PARKING SYSTEMS COMPRISED OF POWER-OPERATED LIFTS FOR MOVING, PARKING AND STORING LAND VEHICLES; VEHICLE WASHING INSTALLATIONS; FOOD MIXING MACHINES FOR COMMERCIAL USE; FOOD PEELING MACHINES AND SLICING MACHINES FOR COMMERCIAL USE, NAMELY, ELECTRIC FRUIT PEELERS, ELECTRIC VEGETABLE PEELERS; DISHWASHING MACHINES FOR INDUSTRIAL PURPOSES; ELECTRIC FOOD CUTTING, CHOPPING AND SLICING MACHINES FOR COMMERCIAL USE; ELECTRIC WAX-POLISHING MACHINES FOR INDUSTRIAL PURPOSES; VACUUM CLEANERS FOR INDUSTRIAL PURPOSES; LAWNMOWERS; ELECTRICALLY-OPERATED CURTAIN DRAWING DEVICES, NAMELY, POWER WINCHES; WASTE COMPACTING MACHINES; WASTE CRUSHING MACHINES (U.S. CLS. 13, 19, 21, 23, 31, 34 AND 35).
GILBERT SWIFT, EXAMINING ATTORNEY

CLASS 7—(Continued).

SN 79-096,834. NABELL CORPORATION, JAPAN, FILED 3-2-2011.

Bella-Armor

OWNER OF INTERNATIONAL REGISTRATION 1075570 DATED 3-2-2011, EXPIRES 3-2-2021.

FOR PARTS AND ACCESSORIES OF METALWORKING MACHINE TOOLS; PARTS AND ACCESSORIES OF SEMICONDUCTOR MANUFACTURING MACHINES AND SYSTEMS (U.S. CLS. 13, 19, 21, 23, 31, 34 AND 35).
KATINA MISTER, EXAMINING ATTORNEY

SN 85-002,271. SEARS BRANDS, LLC, HOFFMAN ESTATES, IL. FILED 3-30-2010.

360° POWERWASH

THE MARK CONSISTS OF STANDARD CHARACTERS WITHOUT CLAIM TO ANY PARTICULAR FONT, STYLE, SIZE, OR COLOR.

NO CLAIM IS MADE TO THE EXCLUSIVE RIGHT TO USE "POWERWASH", APART FROM THE MARK AS SHOWN.

FOR DISH WASHING MACHINES FEATURING A WASH ARM FOR THE WASH CYCLE (U.S. CLS. 13, 19, 21, 23, 31, 34 AND 35).

KIM MONINGHOFF, EXAMINING ATTORNEY

SN 85-023,011. KSIN LUXEMBOURG III, S.A.R.L., L-1628, LUXEMBOURG, FILED 4-26-2010.

MAGIC STEAM PRESS

THE MARK CONSISTS OF STANDARD CHARACTERS WITHOUT CLAIM TO ANY PARTICULAR FONT, STYLE, SIZE, OR COLOR.

NO CLAIM IS MADE TO THE EXCLUSIVE RIGHT TO USE "STEAM PRESS", APART FROM THE MARK AS SHOWN.

FOR ELECTRIC STEAM CLOTHING PRESSING MACHINES (U.S. CLS. 13, 19, 21, 23, 31, 34 AND 35).

LINDA MICKLEBURGH, EXAMINING ATTORNEY

CLASS 7—(Continued).

SN 85-047,642. RF ENGINE TECHNOLOGIES, LLC, SOUTHLAKE, TX. FILED 5-25-2010.

RF ENGINE TECHNOLOGIES

THE MARK CONSISTS OF STANDARD CHARACTERS WITHOUT CLAIM TO ANY PARTICULAR FONT, STYLE, SIZE, OR COLOR.

NO CLAIM IS MADE TO THE EXCLUSIVE RIGHT TO USE "ENGINE TECHNOLOGIES", APART FROM THE MARK AS SHOWN.

FOR ENHANCEMENT PARTS FOR INTERNAL COMBUSTION ENGINES, NAMELY, FUEL CATALYSTS (U.S. CLS. 13, 19, 21, 23, 31, 34 AND 35).

DOMINICK J. SALEMI, EXAMINING ATTORNEY

SN 85-064,956. ETTRIDGE DAVID WILLIAM, HOUSTON, TX. FILED 6-17-2010.

NRG Plus

THE MARK CONSISTS OF STANDARD CHARACTERS WITHOUT CLAIM TO ANY PARTICULAR FONT, STYLE, SIZE, OR COLOR.

NO CLAIM IS MADE TO THE EXCLUSIVE RIGHT TO USE "ENERGY", APART FROM THE MARK AS SHOWN.

FOR AIR TURBINES (U.S. CLS. 13, 19, 21, 23, 31, 34 AND 35).

THOMAS MANOR, EXAMINING ATTORNEY

SN 85-083,510. LASER SALES INC., LONDON, CANADA, FILED 7-13-2010.

PRO-KUT

THE MARK CONSISTS OF STANDARD CHARACTERS WITHOUT CLAIM TO ANY PARTICULAR FONT, STYLE, SIZE, OR COLOR.

FOR CHAINSAW PARTS AND ACCESSORIES, NAMELY, CHAINS FOR CHAIN SAWS IN THE NATURE OF SAW CHAINS (U.S. CLS. 13, 19, 21, 23, 31, 34 AND 35).

FIRST USE 12-29-2006; IN COMMERCE 12-29-2006.

ERIN FALK, EXAMINING ATTORNEY

CLASS 7—(Continued).

SN 85-090,783. FIBERIO TECHNOLOGY CORPORATION, EDINBURG, TX. FILED 7-22-2010.



THE MARK CONSISTS OF A STYLIZED DEPICTION OF AN ANGLED VORTEX COMPRISING A SERIES OF ARROWS ALONG APPROXIMATELY THE RIGHT AND TOP SIDE OF AN ELLIPSE, WITH A CURVED BAND ALONG THE LEFT SIDE OF THE ELLIPSE.

FOR CENTRIFUGAL FIBER MANUFACTURING MACHINES AND STRUCTURAL PARTS THEREFORE, NAMELY, CENTRIFUGAL FIBER PROCESSING CHAMBERS, FIBER COLLECTORS, NOZZLES USED WITH EQUIPMENT TO MAKE FIBERS, NEEDLES USED WITH EQUIPMENT TO MAKE FIBERS, SPINNERETS USED WITH EQUIPMENT TO MAKE FIBERS, NEEDLE HOLDERS USED WITH EQUIPMENT TO MAKE FIBERS, NOZZLE AND NEEDLE HOLDER SETS USED WITH EQUIPMENT TO MAKE FIBERS, AND HEATING ELEMENTS BEING MACHINE PARTS USED WITH EQUIPMENT TO MAKE FIBERS (U.S. CLS. 13, 19, 21, 23, 31, 34 AND 35).

MYRIAH HABEEB, EXAMINING ATTORNEY

CLASS 7—(Continued).

SN 85-105,355. PANASONIC CORPORATION OF NORTH AMERICA, SECAUCUS, NJ. FILED 8-11-2010.

Digital Cordless Tools

NO CLAIM IS MADE TO THE EXCLUSIVE RIGHT TO USE "DIGITAL CORDLESS TOOLS", APART FROM THE MARK AS SHOWN.

THE MARK CONSISTS OF THE WORDS "DIGITAL CORDLESS TOOLS". THE SECOND "O" IN THE WORD "TOOLS" LOOKS LIKE A GEAR, WHILE THE "L" IN THE WORD "TOOLS" LOOKS LIKE A DRILL BIT.

FOR CORDLESS POWER TOOLS, NAMELY, SCREWDRIVERS, DRILL-DRIVERS, HAMMERDRILL-DRIVERS, MULTI-IMPACT DRILL-DRIVERS, IMPACT DRIVERS, IMPACT WRENCHES, ROTARY HAMMERS, CIRCULAR SAWS, RECIPROCATING SAWS, AND JIG SAWS; KITS CONTAINING COMBINATIONS OF CORDLESS POWER TOOLS, NAMELY, DRILLS, HAMMER-DRILLS, CIRCULAR SAWS, RECIPROCATING SAWS, JIG SAWS, AND FLASHLIGHTS (U.S. CLS. 13, 19, 21, 23, 31, 34 AND 35).

FIRST USE 9-30-2009; IN COMMERCE 9-30-2009.
INGA ERVIN, EXAMINING ATTORNEY

SN 85-090,792. FIBERIO TECHNOLOGY CORPORATION, EDINBURG, TX. FILED 7-22-2010.

THE FORCE FOR NANOFIBERS

THE MARK CONSISTS OF STANDARD CHARACTERS WITHOUT CLAIM TO ANY PARTICULAR FONT, STYLE, SIZE, OR COLOR.

NO CLAIM IS MADE TO THE EXCLUSIVE RIGHT TO USE "NANOFIBERS", APART FROM THE MARK AS SHOWN.

FOR CENTRIFUGAL FIBER MANUFACTURING MACHINES AND STRUCTURAL PARTS THEREFORE, NAMELY, CENTRIFUGAL FIBER PROCESSING CHAMBERS, FIBER COLLECTORS, NOZZLES USED WITH EQUIPMENT TO MAKE FIBERS, NEEDLES USED WITH EQUIPMENT TO MAKE FIBERS, SPINNERETS USED WITH EQUIPMENT TO MAKE FIBERS, NEEDLE HOLDERS USED WITH EQUIPMENT TO MAKE FIBERS, NOZZLE AND NEEDLE HOLDER SETS USED WITH EQUIPMENT TO MAKE FIBERS, AND HEATING ELEMENTS BEING MACHINE PARTS USED WITH EQUIPMENT TO MAKE FIBERS (U.S. CLS. 13, 19, 21, 23, 31, 34 AND 35).

MYRIAH HABEEB, EXAMINING ATTORNEY

SN 85-110,960. ANDERSEN & ASSOCIATES, WIXOM, MI. FILED 8-19-2010.

ULTRABATCH

THE MARK CONSISTS OF STANDARD CHARACTERS WITHOUT CLAIM TO ANY PARTICULAR FONT, STYLE, SIZE, OR COLOR.

FOR CONVEYOR SYSTEM CONSISTING PRIMARILY OF CONVEYORS, INDIVIDUAL PACKAGE DISPLACEMENT BARS, PNEUMATIC VALVES AND CONTROLLERS, PACKAGE POSITION SENSORS, AND LOADING STATION DATA TERMINALS TO DIRECT PACKAGES INTO AND OUT OF LOADING STATIONS (U.S. CLS. 13, 19, 21, 23, 31, 34 AND 35).

FIRST USE 4-27-2010; IN COMMERCE 4-27-2010.
MICHAEL SOUDERS, EXAMINING ATTORNEY

CLASS 7—(Continued).

SN 85-119,344. WUXI SHUANGNIAO TECHNOLOGY INC., WUXI, JIANGSU, CHINA, FILED 8-31-2010.



THE MARK CONSISTS OF THE WORDING "SAMLIN" AND BEGIN WITH SPECIAL VERTICAL CROSSING TWO SQUARES.

FOR AIR CONDENSERS; AIR-COOLED CONDENSERS; AXIAL FAN CONDENSERS; BEARINGS, AS PARTS OF MACHINES; BELLOWS; CENTRIFUGAL FAN CONDENSERS; COMPRESSED AIR MACHINES; COMPRESSORS FOR MACHINES; COMPRESSORS FOR REFRIGERATORS; IGNITION PARTS FOR INTERNAL COMBUSTION ENGINES, NAMELY, CONDENSERS; LUBRICATING PUMPS; PUMPS AS PARTS OF MACHINES, MOTORS AND ENGINES; TURBOCHARGERS FOR MACHINES (U.S. CLS. 13, 19, 21, 23, 31, 34 AND 35).

FIRST USE 9-4-2003; IN COMMERCE 9-4-2003.
JASON TURNER, EXAMINING ATTORNEY

CLASS 7—(Continued).

SN 85-126,370. SMITH INTERNATIONAL, INC., HOUSTON, TX. FILED 9-9-2010.

POWER THAT LASTS

THE MARK CONSISTS OF STANDARD CHARACTERS WITHOUT CLAIM TO ANY PARTICULAR FONT, STYLE, SIZE, OR COLOR.

NO CLAIM IS MADE TO THE EXCLUSIVE RIGHT TO USE "POWER", APART FROM THE MARK AS SHOWN.

FOR OILFIELD MACHINES AND MACHINE PARTS, NAMELY, POWER SECTIONS FOR CONVERTING HYDRAULIC POWER TO MECHANICAL POWER FOR DRILLING; OILFIELD MACHINES AND MACHINE PARTS, NAMELY, ROTORS AND STATORS; OILFIELD MACHINE PARTS, NAMELY TUNGSTEN CARBIDE BEARINGS; OILFIELD MACHINES AND MACHINE PARTS, NAMELY, MOTORS FOR DRILLING MACHINES AND PARTS THEREFORE, NAMELY, POWER SECTIONS, ROTORS AND STATORS; OILFIELD MACHINES AND MACHINE PARTS, NAMELY, MUD MOTORS USED FOR OILFIELD DRILLING; OILFIELD MACHINES AND MACHINE PARTS, NAMELY, PROGRESSING CAVITY PUMPS (U.S. CLS. 13, 19, 21, 23, 31, 34 AND 35).

FIRST USE 12-1-2004; IN COMMERCE 12-1-2004.
ANDREA HACK, EXAMINING ATTORNEY

SN 85-122,065. COINAMATIC CANADA INC., MISSISSAUGA, ONTARIO, CANADA, FILED 9-2-2010.

SN 85-133,415. TCP INVESTMENTS, LLC, SAN DIEGO, CA. FILED 9-20-2010.

**TRITON WASHING MACHINE**

THE MARK CONSISTS OF STANDARD CHARACTERS WITHOUT CLAIM TO ANY PARTICULAR FONT, STYLE, SIZE, OR COLOR.

OWNER OF CANADA REG. NO. TMA545567, DATED 5-25-2001, EXPIRES 5-25-2016.

NO CLAIM IS MADE TO THE EXCLUSIVE RIGHT TO USE "WASHING MACHINE", APART FROM THE MARK AS SHOWN.

FOR COMMERCIAL AND INDUSTRIAL LAUNDRY WASHERS (U.S. CLS. 13, 19, 21, 23, 31, 34 AND 35).
DANNEAN HETZEL, EXAMINING ATTORNEY

NO CLAIM IS MADE TO THE EXCLUSIVE RIGHT TO USE "AIRBRUSH", APART FROM THE MARK AS SHOWN. THE COLOR(S) WHITE AND DEEP BLUE IS/ARE CLAIMED AS A FEATURE OF THE MARK.

THE MARK CONSISTS OF THE STYLIZED WORD "MASTER" IN DEEP BLUE SITS ABOVE A REPLICA OF ONE OF OUR AIRBRUSHES THAT IS IN DEEP BLUE. THE WORD "AIRBRUSH" IN WHITE SITS INSIDE THE HANDLE OF THE REPLICA AIRBRUSH. THERE IS ALSO A WHITE MINI REPLICA AIRBRUSH INSIDE OF THE DEEP BLUE REPLICA AIRBRUSH.

SEC. 2(F).

FOR AIR BRUSHES FOR APPLYING COLORING AND THE LIKE; AIR BRUSHES FOR APPLYING PAINT; PAINT SPRAY GUNS; SPRAY GUNS FOR PAINT; SPRAY GUNS FOR PAINTING (U.S. CLS. 13, 19, 21, 23, 31, 34 AND 35).

FIRST USE 8-17-2007; IN COMMERCE 8-17-2007.
CAROLYN CATALDO, EXAMINING ATTORNEY

CLASS 7—(Continued).

SN 85-138,959. PCS ENGINEERING, INC., DBA PM TECHNOLOGIES, OSSEO, MN. FILED 9-27-2010.



OWNER OF U.S. REG. NO. 2,811,783.
NO CLAIM IS MADE TO THE EXCLUSIVE RIGHT TO USE "3", APART FROM THE MARK AS SHOWN.
THE STIPPLING IS A FEATURE OF THE MARK AND DOES NOT INDICATE COLOR; THE STIPPLING IS FOR SHADING PURPOSES ONLY.

THE MARK CONSISTS OF THE LETTERS "P" AND "M" WITH THE NUMERAL "3" ELEVATED ABOVE AND TO THE RIGHT OF THE LETTERS. THESE ALPHA NUMERIC CHARACTERS ARE FLANKED AT THE TOP LEFT AND ON THE BOTTOM RIGHT BY A CRESCENT MOON. BELOW THIS ENTIRE GROUPING IS THE WORD "TECHNOLOGIES".

SEC. 2(F).

FOR MACHINES THAT UTILIZE A WATER RECIRCULATION PROCESS FOR CLEANING THREE-DIMENSIONAL MODELS PRODUCED BY RAPID PROTOTYPING MACHINES (U.S. CLS. 13, 19, 21, 23, 31, 34 AND 35).

FIRST USE 10-14-2002; IN COMMERCE 10-14-2002.
JACQUELINE A. LAVINE, EXAMINING ATTORNEY

SN 85-157,141. SMITH INTERNATIONAL, INC., HOUSTON, TX. FILED 10-20-2010.

DYNA-DRILL

THE MARK CONSISTS OF STANDARD CHARACTERS WITHOUT CLAIM TO ANY PARTICULAR FONT, STYLE, SIZE, OR COLOR.

OWNER OF U.S. REG. NOS. 1,222,384 AND 3,356,373.

FOR OILFIELD MACHINES AND MACHINE PARTS, NAMELY, POWER SECTIONS FOR CONVERTING HYDRAULIC POWER TO MECHANICAL POWER FOR DRILLING; OILFIELD MACHINES AND MACHINE PARTS, NAMELY, ROTORS AND STATORS; OILFIELD MACHINE PARTS, NAMELY, TUNGSTEN CARBIDE BEARINGS; OILFIELD MACHINES AND MACHINE PARTS, NAMELY, MOTORS FOR DRILLING MACHINES AND PARTS THEREFORE, NAMELY, POWER SECTIONS, ROTORS AND STATORS; OILFIELD MACHINES AND MACHINE PARTS, NAMELY, MUD MOTORS USED FOR OILFIELD DRILLING; OILFIELD MACHINES AND MACHINE PARTS, NAMELY, PROGRESSING CAVITY PUMPS (U.S. CLS. 13, 19, 21, 23, 31, 34 AND 35).

FIRST USE 12-1-1999; IN COMMERCE 12-1-1999.
ANDREA HACK, EXAMINING ATTORNEY

CLASS 7—(Continued).

SN 85-179,081. HP&T PRODUCTS, INC., HOUSTON, TX. FILED 11-17-2010.

HPT

THE MARK CONSISTS OF STANDARD CHARACTERS WITHOUT CLAIM TO ANY PARTICULAR FONT, STYLE, SIZE, OR COLOR.

FOR MACHINES AND PARTS OF MACHINES, NAMELY, MANUAL HYDRAULIC AND PNEUMATIC HIGH PRESSURE AND TEMPERATURE GATE VALVES AND ACTUATORS FOR THE OIL AND GAS INDUSTRY (U.S. CLS. 13, 19, 21, 23, 31, 34 AND 35).

FIRST USE 10-3-2001; IN COMMERCE 1-23-2002.
LINDA MICKLEBURGH, EXAMINING ATTORNEY

SN 85-206,687. GRAHAM ENGINEERING CORPORATION, YORK, PA. FILED 12-28-2010.

GRAHAM ENGINEERING

THE MARK CONSISTS OF STANDARD CHARACTERS WITHOUT CLAIM TO ANY PARTICULAR FONT, STYLE, SIZE, OR COLOR.

FOR MACHINES FOR PLASTICS WORKING, NAMELY, PLASTIC MOLDING MACHINES (U.S. CLS. 13, 19, 21, 23, 31, 34 AND 35).

FIRST USE 0-0-1973; IN COMMERCE 0-0-1973.
IRA J. GOODSAD, EXAMINING ATTORNEY

SN 85-216,676. DYNASEP LLC, NEWARK, NJ. FILED 1-13-2011.

AMBIDRI

THE MARK CONSISTS OF STANDARD CHARACTERS WITHOUT CLAIM TO ANY PARTICULAR FONT, STYLE, SIZE, OR COLOR.

THE WORDING "AMBIDRI" HAS NO MEANING IN A FOREIGN LANGUAGE.

FOR ELECTRONIC EQUIPMENT FOR USE IN THE EXTRACTION OF WATER, NUTRACEUTICALS, OIL AND OTHER COMPONENTS FROM BIOMASS (U.S. CLS. 13, 19, 21, 23, 31, 34 AND 35).

LAURA KOVALSKY, EXAMINING ATTORNEY

CLASS 7—(Continued).

SN 85-218,319. KEN'S PRODUCTION EQUIPMENT LOCATORS, INC., DBA KW INTERNATIONAL, HOUSTON, TX. FILED 1-14-2011.

CLASS 7—(Continued).

SN 85-230,776. SHIN-YAIN INDUSTRIAL CO., LTD., TAI-CHUNG, TAIWAN, FILED 2-1-2011.

SAND BANDIT

THE MARK CONSISTS OF STANDARD CHARACTERS WITHOUT CLAIM TO ANY PARTICULAR FONT, STYLE, SIZE, OR COLOR.

NO CLAIM IS MADE TO THE EXCLUSIVE RIGHT TO USE "SAND", APART FROM THE MARK AS SHOWN.

FOR INDUSTRIAL SEPARATORS FOR SEPARATING GASES FROM PARTICULATES (U.S. CLS. 13, 19, 21, 23, 31, 34 AND 35).

CHRIS WELLS, EXAMINING ATTORNEY

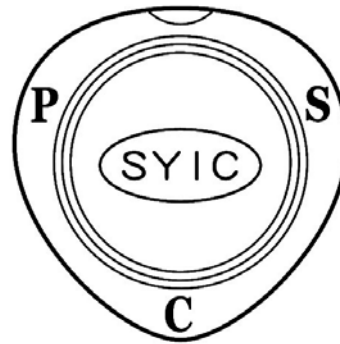

SN 85-230,763. SHIN-YAIN INDUSTRIAL CO., LTD., TAI-CHUNG, TAIWAN, FILED 1-31-2011.

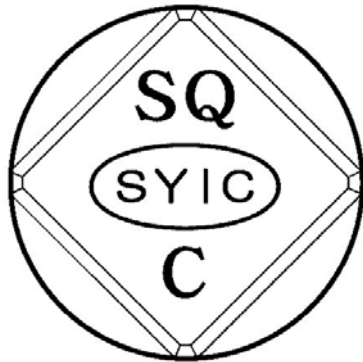

OWNER OF U.S. REG. NO. 2,420,542.

THE MARK CONSISTS OF A CIRCLE, A SQUARE FRAME EMBEDDED IN THE CIRCLE, AN ELLIPSE INSIDE THE SQUARE FRAME, THE WORD "SYIC" INSIDE THE ELLIPSE, AND THE LETTERS "SQ" ABOVE THE ELLIPSE AND THE LETTER "C" BELOW THE ELLIPSE.

FOR BLADES FOR POWER TOOLS; CHUCKS FOR POWER DRILLS; DRILL BITS FOR ROCK DRILLING; INSERTS FOR POWER-OPERATED BORING MACHINES, DRILLING MACHINES, LATHES, METALWORKING MACHINES, MILLING MACHINES; MACHINE PARTS, NAMELY, BLADES; MACHINE PARTS, NAMELY, TOOLHOLDERS FOR METALWORKING MACHINES; MACHINE TOOL HOLDERS; MACHINE TOOLS, NAMELY, MILLING CUTTERS AND GEAR CUTTERS; PARTS FOR BORING MACHINES, NAMELY, POWER OPERATED BORING CUTTERS AND BORING HEADS; POWER DRILL BITS; POWER TOOLS AND PARTS THEREFOR, NAMELY, COLLETS, LATHE CENTERS, MILLING CUTTER ARBORS, SPANNERS, TAPER ADAPTERS AND TAPPERS; SPRAYING MACHINES (U.S. CLS. 13, 19, 21, 23, 31, 34 AND 35).

FIRST USE 1-5-2011; IN COMMERCE 1-5-2011.

ODESSA BIBBINS, EXAMINING ATTORNEY

OWNER OF U.S. REG. NO. 2,420,542.

THE MARK CONSISTS OF A ROUNDED INVERTED TRIANGULAR SHAPE; THREE CONCENTRIC CIRCLES INSIDE THE INVERTED ROUNDED TRIANGULAR SHAPE; AN ELLIPSE INSIDE THE INNERMOST OF THE CIRCLES; THE WORD "SYIC" INSIDE THE ELLIPSE; THE LETTERS "S", "C" AND "P" SYMMETRICALLY ARRANGED AROUND THE OUTERMOST OF THE CIRCLES, WITH THE "S" AND "P" NEAR THE TOP AT THE SAME LEVEL AND THE "C" AT THE BOTTOM; AND A SHORT CONCAVE CURVE BRANCHING DOWNWARD FROM INSIDE OF THE TOP OF THE ROUNDED INVERTED TRIANGULAR SHAPE.

FOR BLADES FOR POWER TOOLS; CHUCKS FOR POWER DRILLS; DRILL BITS FOR ROCK DRILLING; INSERTS FOR POWER-OPERATED BORING MACHINES, DRILLING MACHINES, LATHES, METALWORKING MACHINES, MILLING MACHINES; MACHINE PARTS, NAMELY, BLADES; MACHINE PARTS, NAMELY, TOOLHOLDERS FOR METALWORKING MACHINES; MACHINE TOOL HOLDERS; MACHINE TOOLS, NAMELY, MILLING CUTTERS AND GEAR CUTTERS; PARTS FOR BORING MACHINES, NAMELY, POWER OPERATED BORING CUTTERS AND BORING HEADS; POWER DRILL BITS; POWER TOOLS AND PARTS THEREFOR, NAMELY, COLLETS, LATHE CENTERS, MILLING CUTTER ARBORS, SPANNERS, TAPER ADAPTERS AND TAPPERS; SPRAYING MACHINES (U.S. CLS. 13, 19, 21, 23, 31, 34 AND 35).

FIRST USE 1-5-2011; IN COMMERCE 1-5-2011.

ODESSA BIBBINS, EXAMINING ATTORNEY

CLASS 7—(Continued).

SN 85-233,504. SHENQ FANG YUAN TECHNOLOGY CO., LTD., TAICHUNG CITY, TAIWAN, FILED 2-3-2011.



NO CLAIM IS MADE TO THE EXCLUSIVE RIGHT TO USE "NEW TECH", APART FROM THE MARK AS SHOWN. THE MARK CONSISTS OF A GLOBE IN THE CENTER OF AN ELLIPTICAL TRACK WITH WORDING "NEW TECH" ON TOP OF THE GLOBE.

FOR BORING MACHINES, CUTTING MACHINES, CNC (COMPUTER NUMERICAL CONTROL) DOUBLE COLUMN HIGH SPEED MACHINING CENTERS, CNC (COMPUTER NUMERICAL CONTROL) 5 AXIS MACHINING CENTERS, DRILLING MACHINES, ENGRAVING MACHINES, GRINDING MACHINES FOR USE IN TURNING, MILLING, BALANCING, INSPECTION, GRINDING AND HONING PROCESSES, LATHES, METAL WORKING MACHINES, NAMELY, MACHINING CENTERS; MILLING MACHINES (U.S. CLS. 13, 19, 21, 23, 31, 34 AND 35).

JACQUELINE A. LAVINE, EXAMINING ATTORNEY

CLASS 7—(Continued).

SN 85-245,827. ONEIDA AIR SYSTEMS, INC., SYRACUSE, NY, FILED 2-18-2011.

ONEIDA AIR SYSTEMS

THE MARK CONSISTS OF STANDARD CHARACTERS WITHOUT CLAIM TO ANY PARTICULAR FONT, STYLE, SIZE, OR COLOR.

OWNER OF U.S. REG. NOS. 3,048,238 AND 3,048,239. NO CLAIM IS MADE TO THE EXCLUSIVE RIGHT TO USE "AIR SYSTEMS", APART FROM THE MARK AS SHOWN.

FOR DUST SEPARATION AND CONTAINMENT MACHINES AND DUST SEPARATORS THAT ATTACH TO WOODWORKING MACHINES, FLOOR SANDERS, AND WOOD EDGERS (U.S. CLS. 13, 19, 21, 23, 31, 34 AND 35). FIRST USE 5-0-1993; IN COMMERCE 5-0-1993.

KATHY DE JONGE, EXAMINING ATTORNEY

SN 85-244,030. BADGER AIR BRUSH CO., FRANKLIN PARK, IL, FILED 2-16-2011.

KING OF CAKES

THE MARK CONSISTS OF STANDARD CHARACTERS WITHOUT CLAIM TO ANY PARTICULAR FONT, STYLE, SIZE, OR COLOR.

NO CLAIM IS MADE TO THE EXCLUSIVE RIGHT TO USE "CAKES", APART FROM THE MARK AS SHOWN.

FOR AIR BRUSHES FOR APPLYING COLORING AND THE LIKE (U.S. CLS. 13, 19, 21, 23, 31, 34 AND 35).

WILLIAM BRECKENFELD, EXAMINING ATTORNEY

SN 85-249,776. JOY MM DELAWARE INC., WILMINGTON, DE, FILED 2-23-2011.

DYNACUT

THE MARK CONSISTS OF STANDARD CHARACTERS WITHOUT CLAIM TO ANY PARTICULAR FONT, STYLE, SIZE, OR COLOR.

FOR MINING EQUIPMENT, NAMELY, HARD ROCK CONTINUOUS MINERS (U.S. CLS. 13, 19, 21, 23, 31, 34 AND 35).

AMY C. KEAN, EXAMINING ATTORNEY

CLASS 7—(Continued).

SN 85-250,202. SUZHOU DELAN ENERGY TECHNOLOGY CO., LTD., SUZHOU,JIANGSUPROVINCE, CHINA, FILED 2-24-2011.



THE MARK CONSISTS OF A DESIGN CONSISTING OF THREE STYLIZED VERTICAL BARS OF VARIOUS SHAPES AND SIZES.

FOR AUTOMOBILE ENGINE VALVE COVERS; BACK PRESSURE VALVES AS PARTS OF MACHINES; BALL VALVES BEING PARTS OF MACHINES; CENTRIFUGAL GRINDING MACHINES; CENTRIFUGAL SEPARATORS; CENTRIFUGES; COMPRESSED AIR MACHINE COMPONENTS, NAMELY, CYLINDERS, VALVES AND AIR GRIPS; EMISSION REDUCTION UNITS FOR MOTORS AND ENGINES, NAMELY, EGR VALVES; EMISSION REDUCTION UNITS FOR MOTORS AND ENGINES, NAMELY, PCV VALVES; FLUID POWER COMPONENT KIT FOR MACHINE CONTROL COMPRISING PUMPS AND VALVES; GAS DIVERTERS CONSISTING OF A PUMP, STORAGE AND REFILLING TANK, PRE-HEATER, VAPORIZER, RECUPERATOR, CONDENSER AND VALVES; HYDRAULIC PUMPS AND MOTORS FOR HYDROSTATIC SYSTEMS, COMPRISED OF PUMPS, MOTORS, VALVES, SWITCHES, SENSORS AND ELECTRONIC CONTROLS, FOR HYDRAULIC DRIVES AND FORCE TRANSMISSION IN MACHINES, MACHINE TOOLS, GRINDING AND FOOD PROCESSING MACHINES AND IN OFF-ROAD-VEHICLES; HYDRAULIC VALVE ACTUATORS; METAL VALVES USED IN CLEANING MACHINES FOR GAS TURBINE AND COMBUSTION ENGINES; OIL CENTRIFUGES; PARTS FOR COMPRESSED-AIR TOOLS, NAMELY, BRAKES, FILTERS, HOSES, PIPES, COUPLINGS VALVES, SWITCHES, COMPRESSORS, CLAMPING TOOLS AND INJECTORS; PARTS FOR PNEUMATIC BLOW GUNS, NAMELY, INFLATOR TIPS, INFLATOR VALVES, VALVE ADAPTERS, NOZZLES, NIPPLES, COUPLERS, CONNECTORS AND PIVOTS; PARTS OF OILFIELD WELLHEAD MACHINES, NAMELY, GATE VALVES, BALL VALVES, CHECK VALVES, PLUG VALVES, GLOBE VALVES, CHOKE AND MANIFOLD INDUSTRIAL PUMPS, PUMP AND VALVE PARTS, PIPE FITTINGS AND FLANGES; PNEUMATIC VALVE ACTUATORS; PROPORTIONAL FLOW VALVES AS PARTS OF MACHINES; PUMP CONTROL VALVES; SERVO-VALVES; SPRAY PAINT SYSTEMS COMPRISED OF PUMPS, PUMP CONTROLLERS, NOZZLES, TUBING AND VALVES; THERMOSTATIC CONTROL VALVES FOR MACHINES; VALVES AS MACHINE COMPONENTS; VALVES BEING ENGINE PARTS FOR INTRODUCING FUEL-AIR MIXTURES INTO THE COMBUSTION CHAMBERS OF INTERNAL COMBUSTION ENGINES; VALVES BEING PARTS OF MACHINES; VALVES BEING PARTS OF MACHINES OPERATED PNEUMATICALLY AND BY AIR; VALVES BEING PARTS OF CENTRIFUGAL GRINDING MACHINES; VALVES FOR PUMPS; VEHICLE PARTS, NAMELY, POWER VALVE FOR CARBURETORS (U.S. CLS. 13, 19, 21, 23, 31, 34 AND 35).

FIRST USE 1-1-2005; IN COMMERCE 1-1-2005.

GIANCARLO CASTRO, EXAMINING ATTORNEY

CLASS 7—(Continued).

SN 85-250,341. UNIVERSAL SEWING SUPPLY, INC., ST. LOUIS, MO. FILED 2-24-2011.

ENDURO

THE MARK CONSISTS OF STANDARD CHARACTERS WITHOUT CLAIM TO ANY PARTICULAR FONT, STYLE, SIZE, OR COLOR.

FOR SERVO MOTORS FOR SEWING MACHINES (U.S. CLS. 13, 19, 21, 23, 31, 34 AND 35).

BARBARA A. GOLD, EXAMINING ATTORNEY

SN 85-252,088. INNOVATIVE AG TECHNOLOGIES, LLC, OREGON, MO. FILED 2-25-2011.

SPLIT-FLEX

THE MARK CONSISTS OF STANDARD CHARACTERS WITHOUT CLAIM TO ANY PARTICULAR FONT, STYLE, SIZE, OR COLOR.

FOR AGRICULTURAL MACHINERY, NAMELY HARVESTER HEADS (U.S. CLS. 13, 19, 21, 23, 31, 34 AND 35).

FIRST USE 9-13-2009; IN COMMERCE 9-13-2009.

MARTHA FROMM, EXAMINING ATTORNEY

SN 85-252,343. MCLAIN, MICHAEL, WARREN, IN. FILED 2-25-2011.

BIG GULP

THE MARK CONSISTS OF STANDARD CHARACTERS WITHOUT CLAIM TO ANY PARTICULAR FONT, STYLE, SIZE, OR COLOR.

FOR AIR-INTAKE FILTERS FOR AFTER-MARKET INSTALLATION OF AUTOMOTIVE ENGINES (U.S. CLS. 13, 19, 21, 23, 31, 34 AND 35).

FIRST USE 1-1-2011; IN COMMERCE 1-1-2011.

CHARISMA HAMPTON, EXAMINING ATTORNEY

CLASS 7—(Continued).

SN 85-253,064. ROBERT BOSCH TOOL CORPORATION,
MOUNT PROSPECT, IL. FILED 2-28-2011.



THE MARK CONSISTS OF THE LETTER "O" WITH
OCTOPUS LEGS AND STANDARD CHARACTERS "CTO".
FOR POWER TOOLS, NAMELY, SANDERS (U.S. CLS.
13, 19, 21, 23, 31, 34 AND 35).
FIRST USE 4-0-2006; IN COMMERCE 4-0-2006.
TASNEEM HUSSAIN, EXAMINING ATTORNEY

SN 85-253,436. ABSOLUTE INNOVATIONS, INC., OSCEOLA,
IN. FILED 2-28-2011.

ABI

THE MARK CONSISTS OF STANDARD CHARACTERS
WITHOUT CLAIM TO ANY PARTICULAR FONT, STYLE,
SIZE, OR COLOR.
OWNER OF U.S. REG. NOS. 3,722,950 AND 3,731,945.
FOR GROUND SURFACE TREATING MACHINES
FOR GRAVEL ROADS, LANDSCAPING, EQUINE ARE-
NAS, PASTURES, SEED BEDS, TRAILS, GARDENS,
FOOD PLOTS AND FIREBREAKS (U.S. CLS. 13, 19, 21,
23, 31, 34 AND 35).
FIRST USE 1-15-2008; IN COMMERCE 1-15-2008.
EDWARD NELSON, EXAMINING ATTORNEY

SN 85-253,477. ABSOLUTE INNOVATIONS, INC., OSCEOLA,
IN. FILED 2-28-2011.

ABI ATTACHMENTS

THE MARK CONSISTS OF STANDARD CHARACTERS
WITHOUT CLAIM TO ANY PARTICULAR FONT, STYLE,
SIZE, OR COLOR.
OWNER OF U.S. REG. NOS. 3,722,950 AND 3,731,945.
NO CLAIM IS MADE TO THE EXCLUSIVE RIGHT TO
USE "ATTACHMENTS", APART FROM THE MARK AS
SHOWN.
FOR GROUND SURFACE TREATING MACHINES
FOR GRAVEL ROADS, LANDSCAPING, EQUINE ARE-
NAS, PASTURES, SEED BEDS, TRAILS, GARDENS,
FOOD PLOTS AND FIREBREAKS (U.S. CLS. 13, 19, 21,
23, 31, 34 AND 35).
FIRST USE 1-15-2008; IN COMMERCE 1-15-2008.
EDWARD NELSON, EXAMINING ATTORNEY

CLASS 7—(Continued).

SN 85-253,795. KING KUTTER, INC., WINFIELD, AL. FILED
2-28-2011.

TAYLOR-WAY

THE MARK CONSISTS OF STANDARD CHARACTERS
WITHOUT CLAIM TO ANY PARTICULAR FONT, STYLE,
SIZE, OR COLOR.
OWNER OF U.S. REG. NO. 3,041,600.
FOR TRACTOR-TOWED GROUND-ENGAGING IM-
PLEMENTS, NAMELY, DISC PLOWS, DISC HARROWS,
DISC TILLER PLOWS, ROTARY TILLERS, SUBSOILER
PLOWS, REAR BLADES AND BOX BLADES; GRASS
CUTTERS (U.S. CLS. 13, 19, 21, 23, 31, 34 AND 35).
FIRST USE 12-31-1947; IN COMMERCE 12-31-1947.
CAROLYN CATALDO, EXAMINING ATTORNEY

SN 85-253,797. KING KUTTER, INC., WINFIELD, AL. FILED
2-28-2011.

TAYLOR PITTSBURGH

THE MARK CONSISTS OF STANDARD CHARACTERS
WITHOUT CLAIM TO ANY PARTICULAR FONT, STYLE,
SIZE, OR COLOR.
OWNER OF U.S. REG. NO. 3,041,600.
NO CLAIM IS MADE TO THE EXCLUSIVE RIGHT TO
USE "PITTSBURGH", APART FROM THE MARK AS
SHOWN.
FOR TRACTOR-TOWED GROUND-ENGAGING IM-
PLEMENTS, NAMELY, DISC PLOWS, DISC HARROWS,
DISC TILLER PLOWS, ROTARY TILLERS, SUBSOILER
PLOWS, REAR BLADES AND BOX BLADES; GRASS
CUTTERS (U.S. CLS. 13, 19, 21, 23, 31, 34 AND 35).
FIRST USE 12-31-1978; IN COMMERCE 12-31-1978.
CAROLYN CATALDO, EXAMINING ATTORNEY

CLASS 7—(Continued).

SN 85-254,249. S & P MULLEN ENTERPRISES, INC., OLDSMAR, FL. FILED 3-1-2011.

VIED

THE MARK CONSISTS OF STANDARD CHARACTERS WITHOUT CLAIM TO ANY PARTICULAR FONT, STYLE, SIZE, OR COLOR.

FOR MOTORCYCLE ENGINE PARTS, NAMELY, MODULAR COMPONENT SYSTEMS CONSISTING OF FUEL INJECTION MODULES AND ELECTRONIC FUEL INJECTION MODULES; AUTOMOTIVE PARTS, NAMELY, MODULAR COMPONENT SYSTEMS CONSISTING OF FUEL INJECTION MODULES AND ELECTRONIC FUEL INJECTION MODULES; VEHICLE ENGINE PARTS, NAMELY, MODULAR COMPONENT SYSTEMS CONSISTING OF FUEL INJECTION MODULES AND ELECTRONIC FUEL INJECTION MODULES; ENHANCEMENT PARTS FOR INTERNAL COMBUSTION ENGINES, NAMELY, ELECTRONIC AIR FUEL REGULATING DEVICES THAT ADJUST THE PERFORMANCE OF AN INTERNAL COMBUSTION ENGINE AND FUEL MIXTURE ENRICHMENT DEVICES IN THE NATURE OF FUEL INJECTORS (U.S. CLS. 13, 19, 21, 23, 31, 34 AND 35).

FIRST USE 5-14-2008; IN COMMERCE 5-14-2008.
SUZANNE BLANE, EXAMINING ATTORNEY

CLASS 7—(Continued).

SN 85-255,769. MARUYAMA U.S., INC., DENTON, TX. FILED 3-2-2011.



THE MARK CONSISTS OF A STYLIZED DEPICTION OF TWIN MOUNTAINS ON A CIRCULAR BACKGROUND.

FOR GAS-POWERED BLOWERS FOR LAWN DEBRIS; GAS-POWERED WEED AND GRASS STRING TRIMMERS; GAS-POWERED BRUSH CUTTERS; GAS-POWERED HEDGE TRIMMERS; GAS-POWERED SPRAYERS; GAS-POWERED LEAF BLOWERS; GAS-POWERED WATER PUMPS FOR USE IN IRRIGATION, DRAINAGE, SWIMMING POOLS AND LANDSCAPING; GAS-POWERED CHEMICAL PUMPS; GAS-POWERED ENGINES FOR GENERAL PURPOSES AND NOT FOR LAND VEHICLES, AND GAS-POWERED ENGINES FOR LAWN AND GARDEN MACHINERY; GAS-POWERED EDGERS; GAS-POWERED SPRAY PUMPS; GAS-POWERED THREE-IN-ONE SYSTEM THAT INCLUDES AN EDGER, A TRIMMER AND HEDGE TRIMMER; GAS-POWERED BRUSHCUTTER (U.S. CLS. 13, 19, 21, 23, 31, 34 AND 35).

FIRST USE 9-0-2010; IN COMMERCE 9-0-2010.
MIDGE BUTLER, EXAMINING ATTORNEY

SN 85-256,279. DOLE FOOD COMPANY, INC., WESTLAKE VILLAGE, CA. FILED 3-2-2011.

SN 85-254,595. DANA MOSMAN, BOULDER, CO. FILED 3-1-2011.

Trinator



OWNER OF U.S. REG. NOS. 1,334,608, 1,494,440 AND 1,568,638.

THE COLOR(S) RED, YELLOW, BLUE IS/ARE CLAIMED AS A FEATURE OF THE MARK.

THE MARK CONSISTS OF THE WORD "DOLE" IN RED LETTERS WITH A YELLOW SUNBURST ENCAPSULATED IN THE LETTER "O" AND A BLUE BAR UNDER THE WORD AND EXTENDING THE LENGTH OF THE WORD. THE COLOR WHITE IS USED FOR BACKGROUND PURPOSES AND IS NOT A PART OF THE MARK.

FOR ELECTRIC FOOD BLENDERS; ELECTRIC FOOD PROCESSORS; ELECTRIC JUICERS; ELECTRIC MIXERS FOR HOUSEHOLD PURPOSES (U.S. CLS. 13, 19, 21, 23, 31, 34 AND 35).

DOMINICK J. SALEMI, EXAMINING ATTORNEY

THE MARK CONSISTS OF STANDARD CHARACTERS WITHOUT CLAIM TO ANY PARTICULAR FONT, STYLE, SIZE, OR COLOR.

FOR AGRICULTURAL MACHINES, NAMELY, LEAF TRIMMERS CAPABLE OF HARVESTING AND PROCESSING VARIOUS PLANTS AND HERBS (U.S. CLS. 13, 19, 21, 23, 31, 34 AND 35).

MIDGE BUTLER, EXAMINING ATTORNEY

CLASS 7—(Continued).

SN 85-256,849. ALLTRA CORPORATION, DEWEY, OK.
FILED 3-3-2011.

ALLTRA

THE MARK CONSISTS OF STANDARD CHARACTERS WITHOUT CLAIM TO ANY PARTICULAR FONT, STYLE, SIZE, OR COLOR.

FOR SHAPE CUTTING MACHINES (U.S. CLS. 13, 19, 21, 23, 31, 34 AND 35).

FIRST USE 0-0-1992; IN COMMERCE 0-0-1992.
RON FAIRBANKS, EXAMINING ATTORNEY

CLASS 7—(Continued).

SN 85-311,554. ZODIAC POOL SYSTEMS, INC., MOORPARK, CA. FILED 5-3-2011.

BARACUDA M3

THE MARK CONSISTS OF STANDARD CHARACTERS WITHOUT CLAIM TO ANY PARTICULAR FONT, STYLE, SIZE, OR COLOR.

OWNER OF U.S. REG. NO. 1,505,584.

FOR SWIMMING POOL SPA AND CLEANING EQUIPMENT, NAMELY, SWEEPERS AND VACUUMS, AND PARTS THEREFOR (U.S. CLS. 13, 19, 21, 23, 31, 34 AND 35).

BRIAN NEVILLE, EXAMINING ATTORNEY

SN 85-257,443. QUINTON Q. QUISENBERRY, ROSEBURG, OR. FILED 3-3-2011.

QuiKone

THE MARK CONSISTS OF STANDARD CHARACTERS WITHOUT CLAIM TO ANY PARTICULAR FONT, STYLE, SIZE, OR COLOR.

FOR MACHINERY PARTS; NAMELY EARTH BORING AND DRILLING BITS (U.S. CLS. 13, 19, 21, 23, 31, 34 AND 35).

WENDY GOODMAN, EXAMINING ATTORNEY

SN 85-311,590. APPLIED MATERIALS, INC., SANTA CLARA, CA. FILED 5-3-2011.

CONFORMA

THE MARK CONSISTS OF STANDARD CHARACTERS WITHOUT CLAIM TO ANY PARTICULAR FONT, STYLE, SIZE, OR COLOR.

FOR EQUIPMENT AND MACHINES FOR THE PROCESSING, MANUFACTURE, AND PRODUCTION OF SEMICONDUCTOR SUBSTRATES, THIN FILMS, SILICON DISCS AND WAFERS, INCLUDING POLISHING, CLEANING, PROCESS MONITORING, AND SEMICONDUCTOR MEASURING EQUIPMENT (U.S. CLS. 13, 19, 21, 23, 31, 34 AND 35).

LAURIE KAUFMAN, EXAMINING ATTORNEY

SN 85-269,510. SAINT-GOBAIN ABRASIVES, INC., WORCESTER, MA. FILED 3-17-2011.

PARADIGM

THE MARK CONSISTS OF STANDARD CHARACTERS WITHOUT CLAIM TO ANY PARTICULAR FONT, STYLE, SIZE, OR COLOR.

FOR DIAMOND AND CUBIC BORON NITRIDE GRINDING WHEELS, STONES, AND FILES USED ON POWER-DRIVEN MACHINERY (U.S. CLS. 13, 19, 21, 23, 31, 34 AND 35).

KAPIL BHANOT, EXAMINING ATTORNEY

SN 85-313,400. PANASONIC CORPORATION OF NORTH AMERICA, SECAUCUS, NJ. FILED 5-5-2011.

JETTURN

THE MARK CONSISTS OF STANDARD CHARACTERS WITHOUT CLAIM TO ANY PARTICULAR FONT, STYLE, SIZE, OR COLOR.

FOR VACUUM CLEANERS (U.S. CLS. 13, 19, 21, 23, 31, 34 AND 35).

CARYN GLASSER, EXAMINING ATTORNEY

CLASS 8—HAND TOOLS

SN 76-706,384. PRODUCT STRATEGIES, INC., MAMARONECK, NY. FILED 2-11-2011.

RAZOR RX

THE MARK CONSISTS OF STANDARD CHARACTERS WITHOUT CLAIM TO ANY PARTICULAR FONT, STYLE, SIZE, OR COLOR.

NO CLAIM IS MADE TO THE EXCLUSIVE RIGHT TO USE "RAZOR", APART FROM THE MARK AS SHOWN.

FOR MANUALLY OPERATED SHARPENERS (U.S. CLS. 23, 28 AND 44).

CYNTHIA SLOAN, EXAMINING ATTORNEY

SN 79-079,950. EXEL INDUSTRIES, F-51200 EPERNAY, FRANCE, FILED 12-15-2009.

CP

THE MARK CONSISTS OF STANDARD CHARACTERS WITHOUT CLAIM TO ANY PARTICULAR FONT, STYLE, SIZE, OR COLOR.

PRIORITY DATE OF 6-29-2009 IS CLAIMED.

OWNER OF INTERNATIONAL REGISTRATION 1031577 DATED 12-15-2009, EXPIRES 12-15-2019.

FOR SMALL DEVICES FOR AGRICULTURAL PURPOSES, SPARE PARTS AND ACCESSORIES, NAMELY, HAND-OPERATED TOOLS AND INSTRUMENTS IN THE NATURE OF SPADES, FORKS AND DIBBLES, WITH THE EXCEPTION OF AND NOT INCLUDING PNEUMATIC IMPACT WRENCHES, SCREWDRIVERS, COMPRESSION TOOLS, NAMELY, AIR COMPRESSORS, HYDRAULIC AND PNEUMATIC RIVETERS, HYDRAULIC AND PNEUMATIC PRESSURE UNITS, AND HYDRAULIC AND PNEUMATIC PUNCHES, DRILLS, ABRASIVE TOOLS, NAMELY, PNEUMATIC DIE GRINDERS, ANGLE AND VERTICAL GRINDERS AND SANDERS, AND HORIZONTAL GRINDERS AND SANDERS, HAMMERS, DEMOLITION TOOLS, NAMELY, CONCRETE BREAKERS, SINKER DRILLS, CLAY DIGGERS AND SCALING HAMMERS, ROCK DRILLS, TAMPERS, VIBRATORS, PUMPS, HOISTS, BALANCERS AND WINCHES, STATIONARY MOTORS FOR USE WITH SCREW JACKS, STRAPPING MACHINERY, DOOR AND VALVE ACTUATORS, AND AGITATOR/MIXING EQUIPMENT AND AIR LINES, BUILDING MATERIALS, BUILDING SUPPLIES, CONSTRUCTION TOOLS, POWER TOOLS, NAMELY, TORQUED CONTROLLED WRENCHES, HIGH POWER AND STANDARD ELECTRIC SCREWDRIVERS, PISTOL GRIP NUTRUNNERS, IN-LINE NUTRUNNERS, ANGLE HEAD NUTRUNNERS, FIXTURE SPINDLES, SOCKETS, NAMELY, PNEUMATIC OPERATED SOCKET WRENCHES AND SOCKETS; HAND-OPERATED AGRICULTURAL IMPLEMENTS AND HAND-OPERATED HAND TOOLS FOR GARDENING IN THE NATURE OF HOES, GARDENING

CLASS 8—(Continued).

TROWELS, CULTIVATORS; APPLICATORS IN THE NATURE OF HAND-OPERATED SPRAYERS FOR INSECTICIDES, FUNGICIDES, HERBICIDES AND OTHER CHEMICAL, BIOLOGICAL AND PHYTOSANITARY PRODUCTS; HAND TOOLS, NAMELY, SPRAY GUNS FOR PAINTING, ENAMELING AND TREATING OF HERBICIDES, INSECTICIDES AND FUNGICIDES APPLICATIONS; NOZZLES FOR HANDHELD, HAND-OPERATED SPRAY GUNS; HAND-OPERATED SPRAY GUNS FOR PAINT; HAND-OPERATED HAND TOOLS AND IMPLEMENTS IN THE NATURE OF HAND OPERATED ATOMIZERS, VAPORIZERS, SPRAYERS, SPRAY GUNS FOR TREATING SURFACES BEFORE PAINTING; ABRASIVE WHEELS IN THE NATURE OF MANUALLY-OPERATED GRINDING WHEELS; HAND-HELD, HAND-OPERATED SPRAY GUNS FOR ELECTROSTATIC ENAMELING; HAND-HELD, HAND-OPERATED SPRAY GUNS FOR ELECTROSTATIC DUSTING; HAND-HELD, HAND-OPERATED SPRAY GUNS USED FOR LIQUID PAINT OR VARNISHES (U.S. CLS. 23, 28 AND 44).

TINA BROWN, EXAMINING ATTORNEY

SN 85-118,254. I-MERSION LLC, SCOTTSDALE, AZ. FILED 8-29-2010.

ELF

THE MARK CONSISTS OF STANDARD CHARACTERS WITHOUT CLAIM TO ANY PARTICULAR FONT, STYLE, SIZE, OR COLOR.

FOR HAND OPERATED TOOLS, NAMELY, MULTI-FUNCTION HAND TOOLS COMPRISED OF KNIVES, SCISSORS, PLIERS, MULTI-PURPOSE SHEARS, CAN AND BOTTLE OPENERS, CORKSCREWS, SCREWDRIVERS, FASTENER DRIVERS, FILES, PUNCHES, UTILITY KNIVES, WIRE CUTTERS, AND BOX CUTTERS; MULTI-PURPOSE POCKET KNIVES; MULTI-FUNCTION PERSONAL CARE TOOLS, NAMELY, TWEEZERS, NAIL CLIPPERS, AND FILES; MULTI-FUNCTION WINE TOOLS, NAMELY, CUTTERS FOR WINE BOTTLE FOIL; KITCHEN CUTLERY AND UTENSILS, NAMELY, KNIVES, FORKS AND SPOONS; KITCHEN TOOLS, NAMELY, HAND OPERATED KITCHEN APPLIANCES FOR SLICING, DICING, CHOPPING, GRATING, PEELING, BEATING, TURNING, MEASURING AND SERVING FOOD; AND CASES AND HOUSINGS IN THE NATURE OF SHEATHS FOR THE AFOREMENTIONED HAND OPERATED TOOLS, MULTI-FUNCTION HAND TOOLS AND CUTTING TOOL (U.S. CLS. 23, 28 AND 44).

BARBARA RUTLAND, EXAMINING ATTORNEY

CLASS 8—(Continued).

SN 85-143,506. RBS SHAVING, LLC, PLAINVIEW, NY. FILED 10-1-2010.

MARTELL BLADE BUDDY

THE MARK CONSISTS OF STANDARD CHARACTERS WITHOUT CLAIM TO ANY PARTICULAR FONT, STYLE, SIZE, OR COLOR.

NO CLAIM IS MADE TO THE EXCLUSIVE RIGHT TO USE "BLADE", APART FROM THE MARK AS SHOWN.

THE NAME(S), PORTRAIT(S), AND/OR SIGNATURE(S) SHOWN IN THE MARK IDENTIFIES CELSO E. "MARTELL", WHOSE CONSENT(S) TO REGISTER IS MADE OF RECORD.

FOR MANUALLY-OPERATED RAZOR BLADE SHARPENERS IN THE NATURE OF A SILICONE PAD USED TO SHARPEN OR STRAIGHTEN THE EDGE OF A RAZOR BLADE USED FOR SHAVING (U.S. CLS. 23, 28 AND 44).

KIMBERLY PERRY, EXAMINING ATTORNEY

SN 85-152,101. RBS SHAVING, LLC, PLAINVIEW, NY. FILED 10-13-2010.

JUST PUSH IT

THE MARK CONSISTS OF STANDARD CHARACTERS WITHOUT CLAIM TO ANY PARTICULAR FONT, STYLE, SIZE, OR COLOR.

FOR MANUALLY-OPERATED RAZOR BLADE SHARPENERS IN THE NATURE OF A SILICONE PAD USED TO SHARPEN OR STRAIGHTEN THE EDGE OF A RAZOR BLADE USED FOR SHAVING (U.S. CLS. 23, 28 AND 44).

KIMBERLY PERRY, EXAMINING ATTORNEY

SN 85-229,749. UNIWELD PRODUCTS, INC., FORT LAUDERDALE, FL. FILED 1-31-2011.

VAPOR VUE

THE MARK CONSISTS OF STANDARD CHARACTERS WITHOUT CLAIM TO ANY PARTICULAR FONT, STYLE, SIZE, OR COLOR.

NO CLAIM IS MADE TO THE EXCLUSIVE RIGHT TO USE "VAPOR", APART FROM THE MARK AS SHOWN.

FOR HAND OPERATED GAS VAPORIZERS (U.S. CLS. 23, 28 AND 44).

TINA MAI, EXAMINING ATTORNEY

CLASS 8—(Continued).

SN 85-230,873. UNIWELD PRODUCTS, INC., FORT LAUDERDALE, FL. FILED 2-1-2011.



NO CLAIM IS MADE TO THE EXCLUSIVE RIGHT TO USE "VAPOR", APART FROM THE MARK AS SHOWN.

THE COLOR(S) BLACK, WHITE AND BLUE IS/ARE CLAIMED AS A FEATURE OF THE MARK.

THE MARK CONSISTS OF THE WORD "VAPOR" OUTLINED IN BLACK WITH WHITE INTERIOR, FOLLOWED BY THE WORD "VUE" OUTLINED IN BLACK WITH WHITE INTERIOR, ALL LYING ON ITS SIDE WITH A CENTRALLY LOCATED PUPIL OF AN EYE INCLUDING A BLACK INNER CIRCLE OUTLINED IN WHITE WITH A SMALLER WHITE CIRCLE ON ITS OUTER EDGE, AND A CONCENTRIC BLUE CIRCLE ABOUT THE INNER BLACK CIRCLE.

FOR HAND OPERATED GAS VAPORIZERS (U.S. CLS. 23, 28 AND 44).

TINA MAI, EXAMINING ATTORNEY

SN 85-235,019. ELDORADO WALL COMPANY, INC., BOULDER, CO. FILED 2-5-2011.

ZIPSTOP

THE MARK CONSISTS OF STANDARD CHARACTERS WITHOUT CLAIM TO ANY PARTICULAR FONT, STYLE, SIZE, OR COLOR.

FOR HAND OPERATED BRAKES USED TO STOP, SLOW, OR LOWER AT A CONTROLLED SPEED PARTICIPANTS IN ACTIVITIES SUCH AS ZIP LINES AND CHALLENGE COURSES (U.S. CLS. 23, 28 AND 44).

DAWN FELDMAN, EXAMINING ATTORNEY

SN 85-248,281. TRACTOR SUPPLY CO. OF TEXAS, LP, BRENTWOOD, TN. FILED 2-22-2011.

RETRIEVER

THE MARK CONSISTS OF STANDARD CHARACTERS WITHOUT CLAIM TO ANY PARTICULAR FONT, STYLE, SIZE, OR COLOR.

FOR NAIL TRIMMERS AND NAIL FILES (U.S. CLS. 23, 28 AND 44).

SCOTT BIBB, EXAMINING ATTORNEY

CLASS 8—(Continued).

SN 85-248,420. DAVID H BROWN, VISTA, CA. FILED 2-22-2011.

OWNER OF U.S. REG. NO. 3,114,023.
THE MARK CONSISTS OF "UNIT" WITH STARS IN BETWEEN EACH LETTER.

FOR ALL-IN-ONE SKATEBOARD HAND TOOL COMPRISED OF A "T" HANDLE WITH SOCKET WRENCHES ON THE TIPS AND A COMBINATION ALLEN KEY AND SCREWDRIVER STORED IN THE HANDLE (U.S. CLS. 23, 28 AND 44).

ANDREW LEASER, EXAMINING ATTORNEY

CLASS 8—(Continued).

SN 85-254,347. MIX, RYAN, FOLEY, MN. FILED 3-1-2011.

ROLLERHOE

THE MARK CONSISTS OF STANDARD CHARACTERS WITHOUT CLAIM TO ANY PARTICULAR FONT, STYLE, SIZE, OR COLOR.

FOR HAND TOOLS, NAMELY, SOD CUTTERS, HOES (U.S. CLS. 23, 28 AND 44).

FIRST USE 1-25-2011; IN COMMERCE 1-25-2011.

LAKEISHA LEWIS, EXAMINING ATTORNEY

SN 85-251,040. NEVER WITHOUT LLC, POINT PLEASANT, NJ. FILED 2-24-2011.

The Rectifier

THE MARK CONSISTS OF STANDARD CHARACTERS WITHOUT CLAIM TO ANY PARTICULAR FONT, STYLE, SIZE, OR COLOR.

FOR HAND-OPERATED HUNTING TOOL DESIGNED TO REMOVE THE MATERIAL BETWEEN THE PELVIC REGION OF A DEER (U.S. CLS. 23, 28 AND 44).

KIMBERLY FRYE, EXAMINING ATTORNEY

SN 85-254,815. PROGRESSIVE INTERNATIONAL CORPORATION, KENT, WA. FILED 3-1-2011.

WEDGE AND POP

THE MARK CONSISTS OF STANDARD CHARACTERS WITHOUT CLAIM TO ANY PARTICULAR FONT, STYLE, SIZE, OR COLOR.

FOR APPLE CORERS (U.S. CLS. 23, 28 AND 44).

MARGERY A. TIERNEY, EXAMINING ATTORNEY

SN 85-253,152. PERFECT SCORE TECHNOLOGIES, LLC, RED OAK, TX. FILED S.R. 2-28-2011; AM. P.R. 6-2-2011.

Perfect Score

THE MARK CONSISTS OF STANDARD CHARACTERS WITHOUT CLAIM TO ANY PARTICULAR FONT, STYLE, SIZE, OR COLOR.

FOR GLASS CUTTERS (U.S. CLS. 23, 28 AND 44).

FIRST USE 1-1-1999; IN COMMERCE 1-1-1999.

TRICIA SONNEBORN, EXAMINING ATTORNEY

SN 85-255,808. LIFETIME BRANDS, INC., GARDEN CITY, NY. FILED 3-2-2011.

KIZMOS GET HAPPY

THE MARK CONSISTS OF STANDARD CHARACTERS WITHOUT CLAIM TO ANY PARTICULAR FONT, STYLE, SIZE, OR COLOR.

FOR CAN OPENERS; NON-ELECTRIC FRUIT PEELERS; NON-ELECTRIC VEGETABLE PEELERS; PIZZA CUTTERS; SPOONS (U.S. CLS. 23, 28 AND 44).

THEODORE MCBRIDE, EXAMINING ATTORNEY

CLASS 8—(Continued).

SN 85-255,845. LIFETIME BRANDS, INC., GARDEN CITY, NY. FILED 3-2-2011.

GET HAPPY

THE MARK CONSISTS OF STANDARD CHARACTERS WITHOUT CLAIM TO ANY PARTICULAR FONT, STYLE, SIZE, OR COLOR.

FOR CAN OPENERS; NON-ELECTRIC FRUIT PEELERS; NON-ELECTRIC VEGETABLE PEELERS; PIZZA CUTTERS; SPOONS (U.S. CLS. 23, 28 AND 44).
THEODORE MCBRIDE, EXAMINING ATTORNEY

CLASS 8—(Continued).

SN 85-256,759. MIX, RYAN, FOLEY, MN. FILED 3-3-2011.

sodkicker

THE MARK CONSISTS OF STANDARD CHARACTERS WITHOUT CLAIM TO ANY PARTICULAR FONT, STYLE, SIZE, OR COLOR.

FOR HAND TOOLS, NAMELY, SOD CUTTERS, HOES (U.S. CLS. 23, 28 AND 44).
FIRST USE 1-25-2011; IN COMMERCE 1-25-2011.
LAKEISHA LEWIS, EXAMINING ATTORNEY

SN 85-256,039. CARLISLE FOODSERVICE PRODUCTS, INCORPORATED, OKLAHOMA CITY, OK. FILED 3-2-2011.

BALSAM

THE MARK CONSISTS OF STANDARD CHARACTERS WITHOUT CLAIM TO ANY PARTICULAR FONT, STYLE, SIZE, OR COLOR.

FOR SILVERWARE, NAMELY, FORKS, SPOONS AND KNIVES THAT ARE MADE OF SILVER OR SILVER-PLATE (U.S. CLS. 23, 28 AND 44).
KATHERINE M. DUBRAY, EXAMINING ATTORNEY

CLASS 9—ELECTRICAL AND SCIENTIFIC APPARATUS

SN 76-402,767. R & R ACQUISITION ENTERPRISES, LLC, ST. LOUIS, MO. FILED 5-1-2002.



FOR COMPUTER HARDWARE FOR THE AUTOMATIC CONVERSION OF TELEFAX TO AN E-MAIL MESSAGE (U.S. CLS. 21, 23, 26, 36 AND 38).
BRIAN PINO, EXAMINING ATTORNEY

SN 85-256,300. DOLE FOOD COMPANY, INC., WESTLAKE VILLAGE, CA. FILED 3-2-2011.



OWNER OF U.S. REG. NOS. 1,334,608, 1,494,440 AND 1,568,638.

THE COLOR(S) RED, YELLOW, AND BLUE IS/ARE CLAIMED AS A FEATURE OF THE MARK.

THE MARK CONSISTS OF THE WORD "DOLE" IN RED LETTERS WITH A YELLOW SUNBURST ENCAPSULATED IN THE LETTER "O" AND A BLUE BAR UNDER THE WORD AND EXTENDING THE LENGTH OF THE WORD. THE COLOR WHITE IS USED AS BACKGROUND AND IS NOT A PART OF THE MARK.

FOR CUTLERY; HAND-OPERATED CHOPPERS (U.S. CLS. 23, 28 AND 44).

DOMINICK J. SALEMI, EXAMINING ATTORNEY

SN 76-619,225. JAY-Y ENTERPRISE CO., INC., POMONA, CA. FILED 11-2-2004.



OWNER OF U.S. REG. NO. 3,221,256.
FOR SUNGLASSES (U.S. CLS. 21, 23, 26, 36 AND 38).
FIRST USE 2-1-2002; IN COMMERCE 2-1-2002.
B. PARADEWELAI, EXAMINING ATTORNEY

CLASS 9—(Continued).

SN 76-701,509. BODY FX LLC, SAN DIEGO, CA. FILED 2-12-2010.

Body FX

THE MARK CONSISTS OF STANDARD CHARACTERS WITHOUT CLAIM TO ANY PARTICULAR FONT, STYLE, SIZE, OR COLOR.

FOR DVD CASES; DVDS FEATURING FITNESS MATERIAL, NAMELY, EXERCISE ROUTINES, FITNESS PROGRAMS (U.S. CLS. 21, 23, 26, 36 AND 38).

ALLISON HOLTZ, EXAMINING ATTORNEY

SN 76-702,928. SAKAR ACQUISITION, LLC, EDISON, NJ. FILED 5-13-2010.

SERIES 1

THE MARK CONSISTS OF STANDARD CHARACTERS WITHOUT CLAIM TO ANY PARTICULAR FONT, STYLE, SIZE, OR COLOR.

FOR BINOCULARS; CAMERA LENSES, BINOCULAR LENSES AND TELESCOPE LENSES (U.S. CLS. 21, 23, 26, 36 AND 38).

MARK RADEMACHER, EXAMINING ATTORNEY

SN 76-706,046. WHOLESALE VENTURE, INC., BROOKLYN, NY. FILED 1-19-2011.

HemingWeigh

THE MARK CONSISTS OF THE WORDING "HEMINGWEIGH" IN STYLIZED FONT.

FOR KITCHEN AND BATHROOM WEIGHING SCALES (U.S. CLS. 21, 23, 26, 36 AND 38).

FIRST USE 9-0-2010; IN COMMERCE 9-0-2010.

ROBERT STRUCK, EXAMINING ATTORNEY

CLASS 9—(Continued).

SN 76-706,391. BLUMBERGEXCELSIOR, INC., NEW YORK, NY. FILED 2-11-2011.

BLUMBERG ENTITY TRACKER BET

THE MARK CONSISTS OF STANDARD CHARACTERS WITHOUT CLAIM TO ANY PARTICULAR FONT, STYLE, SIZE, OR COLOR.

OWNER OF U.S. REG. NOS. 1,838,593, 2,708,847 AND OTHERS.

NO CLAIM IS MADE TO THE EXCLUSIVE RIGHT TO USE "ENTITY TRACKER", APART FROM THE MARK AS SHOWN.

FOR COMPUTER SOFTWARE FOR USE IN DOCUMENT MANAGEMENT AND PRODUCTION AND FOR USE IN DATABASE MANAGEMENT AND ELECTRONIC STORAGE OF DATA FOR BUSINESS ENTITIES (U.S. CLS. 21, 23, 26, 36 AND 38).

SEAN CROWLEY, EXAMINING ATTORNEY

SN 76-706,615. SOFT COMPUTER CONSULTANTS, INC., CLEARWATER, FL. FILED 2-28-2011.

SOFTPATHDX

THE MARK CONSISTS OF STANDARD CHARACTERS WITHOUT CLAIM TO ANY PARTICULAR FONT, STYLE, SIZE, OR COLOR.

OWNER OF U.S. REG. NOS. 2,238,971, 2,246,053 AND OTHERS.

FOR COMPUTER SOFTWARE PROGRAM THAT SUPPORTS DIAGNOSTIC PATHOLOGY LABORATORIES WITH PROCESSES OF HISTOLOGY, SLIDE STAINING, AND IMMUNOHISTOCHEMICAL STAINING THROUGH INTERPRETATION USING BOTH TEXTUAL AND DISCRETE RESULT REPORTING (U.S. CLS. 21, 23, 26, 36 AND 38).

FIRST USE 12-0-2008; IN COMMERCE 12-0-2008.

KIMBERLY FRYE, EXAMINING ATTORNEY

SN 76-706,676. TAXCONNECTIONS, INC., LA JOLLA, CA. FILED 3-7-2011.

RECEIPTKEEPER

THE MARK CONSISTS OF STANDARD CHARACTERS WITHOUT CLAIM TO ANY PARTICULAR FONT, STYLE, SIZE, OR COLOR.

FOR COMPUTER SOFTWARE FOR THE COLLECTION, EDITING, ORGANIZING, MODIFYING, BOOKMARKING, TRANSMISSION, STORAGE AND SHARING OF DATA AND INFORMATION IN THE FIELDS OF BUSINESS AND FINANCIAL TRANSACTIONS (U.S. CLS. 21, 23, 26, 36 AND 38).

LAURIE MAYES, EXAMINING ATTORNEY

CLASS 9—(Continued).

SN 76-706,992. UNIVERSAL LIGHTING TECHNOLOGIES, INC., NASHVILLE, TN. FILED 3-29-2011.



COLOR IS NOT CLAIMED AS A PART OF THE DESIGN. THE DESIGN CONSISTS OF THE STYLIZED WORD "EVERLINE" WITH THE "E", "E" AND "R" IN "EVER" BEING IN A MATCHING THICK UPPERCASE DARK STYLIZED FONT AND WITH THE "V" HAVING A STYLIZED THIN LEFT LINE STARTING AT THE TOP AND BECOMING THICK AT THE BOTTOM AND CONTINUING WITH THE THICK LINE UP THE RIGHT LINE TO COMPLETE THE "V". THE WORD "LINE" IS IN A THIN UPPERCASE FONT.

FOR LED LAMPS, LED CONTROLLERS, LED BALLASTS, AND LED MODULE (U.S. CLS. 21, 23, 26, 36 AND 38).

DAWN FELDMAN, EXAMINING ATTORNEY

SN 76-706,993. UNIVERSAL LIGHTING TECHNOLOGIES, INC., NASHVILLE, TN. FILED 3-29-2011.



THE MARK CONSISTS OF STANDARD CHARACTERS WITHOUT CLAIM TO ANY PARTICULAR FONT, STYLE, SIZE, OR COLOR.

FOR LED LAMPS, LED CONTROLLERS, LED BALLASTS, AND LED MODULE (U.S. CLS. 21, 23, 26, 36 AND 38).

DAWN FELDMAN, EXAMINING ATTORNEY

SN 77-046,774. TECHTIUM LTD., TEL AVIV, ISRAEL, FILED 11-17-2006.



THE MARK CONSISTS OF STANDARD CHARACTERS WITHOUT CLAIM TO ANY PARTICULAR FONT, STYLE, SIZE, OR COLOR.

FOR MIXED-SIGNAL SEMICONDUCTORS (U.S. CLS. 21, 23, 26, 36 AND 38).

CORY BOONE, EXAMINING ATTORNEY

CLASS 9—(Continued).

SN 77-057,623. RED LLAMA, INC., SEATTLE, WA. FILED 12-5-2006.



THE MARK CONSISTS OF STANDARD CHARACTERS WITHOUT CLAIM TO ANY PARTICULAR FONT, STYLE, SIZE, OR COLOR.

FOR SOFTWARE FOR USE IN TRAINING PERSONNEL TO USE MEDICAL EQUIPMENT, USING INTERACTIVE IMAGES AND MEDIA (U.S. CLS. 21, 23, 26, 36 AND 38).

FIRST USE 5-17-2004; IN COMMERCE 10-1-2006.

JOHN DWYER, EXAMINING ATTORNEY

SN 77-154,299. STEVE E. STONE, MACON, GA. FILED 4-11-2007.



THE MARK CONSISTS OF STANDARD CHARACTERS WITHOUT CLAIM TO ANY PARTICULAR FONT, STYLE, SIZE, OR COLOR.

FOR DISPOSABLE PROTECTIVE CLOTHING, NAMELY, COVERALLS, ONE PIECE WATER RESISTANT SUITS AND VESTS USED IN THE PLUMBING, HVAC, ELECTRICAL, PEST CONTROL AND CONTRACTING INDUSTRIES FOR USE IN DEALING WITH HAZARDOUS MATERIALS, DIRT AND WASTE (U.S. CLS. 21, 23, 26, 36 AND 38).

FIRST USE 9-1-2000; IN COMMERCE 9-1-2000.

TINA BROWN, EXAMINING ATTORNEY

CLASS 9—(Continued).

SN 77-392,978. DIRECTV, INC., EL SEGUNDO, CA. FILED 2-8-2008.

DIRECTVIEW

THE MARK CONSISTS OF STANDARD CHARACTERS WITHOUT CLAIM TO ANY PARTICULAR FONT, STYLE, SIZE, OR COLOR.

FOR ELECTRONIC DATABASES IN THE FIELDS OF TELEVISION PROGRAMMING AND TELEVISION ADVERTISING FEATURING INFORMATION COMPILED FROM MEDIA RESEARCH DEALING WITH DEMOGRAPHIC DATA AND MEDIA RATING INFORMATION REGARDING THE LISTENING, VIEWING AND USAGE HABITS OF SIGNAL RECEIVING AUDIENCES, ALL RECORDED ON COMPUTER MEDIA; ELECTRONIC DOWNLOADABLE PUBLICATIONS VIA THE INTERNET AND WIRELESS DEVICES, IN THE NATURE OF INFORMATIONAL REPORTS FOR USE BY ADVERTISERS IN MARKET RESEARCH AND ANALYSIS OF LISTENING, VIEWING AND USAGE HABITS OF SIGNAL RECEIVING AUDIENCES (U.S. CLS. 21, 23, 26, 36 AND 38).

RUSS HERMAN, EXAMINING ATTORNEY

CLASS 9—(Continued).

SN 77-669,719. LAVA LAMP RECORDS, LLC, SMYRNA, TN. FILED 2-12-2009.



NO CLAIM IS MADE TO THE EXCLUSIVE RIGHT TO USE "RECORDS", APART FROM THE MARK AS SHOWN. THE STIPPLING IS FOR SHADING PURPOSES ONLY.

THE MARK CONSISTS OF THE TEXT "LAVA LAMP" ABOVE THE TEXT "RECORDS" WITH A "LAVA LAMP" DESIGN WITH FOUR BUBBLES BESIDE THE WORD "LAMP" AND AN INCOMPLETE CIRCLE INTERSECTING THE "A" IN "LAVA", THE "E" IN "RECORDS" AND THE BASE OF THE "LAVA LAMP" DESIGN.

FOR DIGITAL MATERIALS, NAMELY, CDS, DOWNLOADABLE AUDIO FILES FEATURING MUSIC (U.S. CLS. 21, 23, 26, 36 AND 38).

FIRST USE 2-3-2009; IN COMMERCE 6-5-2009.
MARK SHINER, EXAMINING ATTORNEY

SN 77-421,153. TWENTIETH CENTURY FOX FILM CORPORATION, LOS ANGELES, CA. FILED 3-13-2008.

THE OMEN

THE MARK CONSISTS OF STANDARD CHARACTERS WITHOUT CLAIM TO ANY PARTICULAR FONT, STYLE, SIZE, OR COLOR.

FOR MOTION PICTURE FILMS FEATURING HORROR; PRE-RECORDED DVDS FEATURING HORROR; PRE-RECORDED CDS FEATURING HORROR AND MUSICAL PERFORMANCES; DOWNLOADABLE AUDIO AND VIDEO RECORDINGS FEATURING HORROR; DOWNLOADABLE MOTION PICTURES FEATURING HORROR; DOWNLOADABLE RING TONES, GRAPHICS, WALLPAPER, AND MUSIC VIA A GLOBAL COMPUTER NETWORK AND WIRELESS DEVICES; COMPUTER SCREEN SAVER SOFTWARE; VIDEO AND COMPUTER GAME SOFTWARE (U.S. CLS. 21, 23, 26, 36 AND 38).

SUSAN RICHARDS, EXAMINING ATTORNEY

SN 77-763,928. SPEAKERCRAFT, LLC, RIVERSIDE, CA. FILED 6-19-2009.

SPEAKERCRAFT NIRV

THE MARK CONSISTS OF STANDARD CHARACTERS WITHOUT CLAIM TO ANY PARTICULAR FONT, STYLE, SIZE, OR COLOR.

OWNER OF U.S. REG. NOS. 2,295,065, 3,095,367 AND 3,095,378.

FOR AUDIO AND VIDEO DISTRIBUTION SYSTEMS NOT ENDORSED BY MUSICAL ARTISTS AND NOT ASSOCIATED WITH PROMOTIONS RELATING TO MUSICAL ARTISTS, NAMELY, AUDIO/VIDEO DISTRIBUTION DEVICE AMPLIFIERS, AMPLIFIERS, AND MULTI-ZONE POWER CONTROLLERS; AUDIO SPEAKERS NOT ENDORSED BY MUSICAL ARTISTS AND NOT ASSOCIATED WITH PROMOTIONS RELATING TO MUSICAL ARTISTS (U.S. CLS. 21, 23, 26, 36 AND 38).

KATHERINE M. DUBRAY, EXAMINING ATTORNEY

CLASS 9—(Continued).

SN 77-764,114. CELLULAR SPECIALTIES, INC., MANCHESTER, NH. FILED 6-19-2009.

WIRELESS ENGINE

THE MARK CONSISTS OF STANDARD CHARACTERS WITHOUT CLAIM TO ANY PARTICULAR FONT, STYLE, SIZE, OR COLOR.

NO CLAIM IS MADE TO THE EXCLUSIVE RIGHT TO USE "WIRELESS", APART FROM THE MARK AS SHOWN. SEC. 2(F).

FOR DIGITAL WIRELESS SIGNAL REPEATER FOR USE WITHIN AN ENCLOSED STRUCTURE (U.S. CLS. 21, 23, 26, 36 AND 38).

FIRST USE 5-0-2006; IN COMMERCE 6-0-2006.
BERYL GARDNER, EXAMINING ATTORNEY

SN 77-802,234. KONICA MINOLTA BUSINESS TECHNOLOGIES, INC., TOKYO, JAPAN, FILED 8-11-2009.



OWNER OF U.S. REG. NOS. 3,075,546 AND 3,424,146.

NO CLAIM IS MADE TO THE EXCLUSIVE RIGHT TO USE "OP", "ARCHITECTURE", AND "PRINT SYSTEM", APART FROM THE MARK AS SHOWN.

THE COLOR(S) BLACK, WHITE, BLUE AND GRAY IS/ARE CLAIMED AS A FEATURE OF THE MARK.

THE MARK CONSISTS OF THREE BLUE SPHERES WITHIN A PARTIAL GRAY SPHERE WITH A BLUE INTERIOR. THE COLOR BLACK APPEARS AS SHADING FOR ALL FOUR SPHERES. THE WORDING "BIZHUB OP" IS IN WHITE ON THE OUTSIDE OF THE GRAY SPHERE. THE WHITE WORDING "BIZHUB ARCHITECTURE" IS ON ONE OF THE BLUE SPHERES. THE WHITE WORDING "BIZHUB EST" IS ON ANOTHER BLUE SPHERE. THE WHITE WORDING "EMPERON PRINT SYSTEM" IS ON THE THIRD BLUE SPHERE. THE COLOR WHITE ALSO APPEARS AS HIGHLIGHTING ON THE GRAY SPHERE AND IN THE BACKGROUND.

FOR PRINTERS, COPYING MACHINES, FACSIMILE MACHINES, SCANNERS, MULTIFUNCTIONAL PRODUCTS, NAMELY, MACHINES WHICH OFFER COPYING, FACSIMILE, PRINTING AND SCANNING FUNCTIONS; INTEGRATED CONTROL SYSTEM, NAMELY, SOFTWARE WHICH CONTROLS THE AFOREMENTIONED GOODS (U.S. CLS. 21, 23, 26, 36 AND 38).

KIM MONINGHOFF, EXAMINING ATTORNEY

CLASS 9—(Continued).

SN 77-810,057. SKY CATCHER COMMUNICATIONS, INC., SPINDALE, NC. FILED 8-21-2009.

ENCRYPTOKEY

THE MARK CONSISTS OF STANDARD CHARACTERS WITHOUT CLAIM TO ANY PARTICULAR FONT, STYLE, SIZE, OR COLOR.

FOR SECURITY SYSTEMS COMPRISING HARDWARE AND SOFTWARE FOR PROVIDING VIDEO SURVEILLANCE OPERATIONS OVER WIRELESS DEVICES AND NETWORKS, INCLUDING BIOMETRICALLY SECURED UNIVERSAL SERIAL BUS (USB) DEVICES (U.S. CLS. 21, 23, 26, 36 AND 38).

JOHN HWANG, EXAMINING ATTORNEY

SN 77-810,981. WILLIAM JONES, KIRKLAND, WA. FILED 8-24-2009.

iPlanz

THE MARK CONSISTS OF STANDARD CHARACTERS WITHOUT CLAIM TO ANY PARTICULAR FONT, STYLE, SIZE, OR COLOR.

FOR COMPUTER PROGRAMS FOR USING THE INTERNET AND THE WORLD WIDE WEB; COMPUTER SOFTWARE FOR APPLICATION AND DATABASE INTEGRATION (U.S. CLS. 21, 23, 26, 36 AND 38).

KEVIN CORWIN, EXAMINING ATTORNEY

SN 77-817,529. ARISTOCRAT TECHNOLOGIES AUSTRALIA PTY LTD., NORTH RYDE, NSW, AUSTRALIA, FILED 9-1-2009.

PLATINUM COLLECTION

THE MARK CONSISTS OF STANDARD CHARACTERS WITHOUT CLAIM TO ANY PARTICULAR FONT, STYLE, SIZE, OR COLOR.

PRIORITY CLAIMED UNDER SEC. 44(D) ON AUSTRALIA APPLICATION NO. 1288752, FILED 3-11-2009, REG. NO. 1288752, DATED 3-11-2009, EXPIRES 3-11-2019.

NO CLAIM IS MADE TO THE EXCLUSIVE RIGHT TO USE "COLLECTION", APART FROM THE MARK AS SHOWN.

FOR ELECTRONIC GAMING MACHINES, NAMELY, DEVICES WHICH ACCEPT A WAGER (U.S. CLS. 21, 23, 26, 36 AND 38).

NICHOLAS ALTREE, EXAMINING ATTORNEY

CLASS 9—(Continued).

SN 77-843,282. ONE PASS IMPLEMENTS INC., LANGBANK, SASKATCHEWAN, CANADA, FILED 10-7-2009.

SECTIONAL CONTROL

THE MARK CONSISTS OF STANDARD CHARACTERS WITHOUT CLAIM TO ANY PARTICULAR FONT, STYLE, SIZE, OR COLOR.

PRIORITY CLAIMED UNDER SEC. 44(D) ON CANADA APPLICATION NO. 1434827, FILED 4-16-2009, REG. NO. 789312, DATED 2-1-2011, EXPIRES 2-1-2026.

FOR ELECTRONIC SEEDING SENSOR CONTROLLED BY A GLOBAL POSITIONING SYSTEM IN AGRICULTURAL SEEDING EQUIPMENT (U.S. CLS. 21, 23, 26, 36 AND 38).

REBECCA EISINGER, EXAMINING ATTORNEY

SN 77-907,072. JASON GOODMAN, NEW YORK, NY. FILED 1-7-2010.

SCORPION

THE MARK CONSISTS OF STANDARD CHARACTERS WITHOUT CLAIM TO ANY PARTICULAR FONT, STYLE, SIZE, OR COLOR.

FOR COMPUTER PROGRAMS FOR USE IN HYPERLINKING DIGITIZED VIDEO AND AUDIO MEDIA TO A GLOBAL COMPUTER INFORMATION NETWORK; DECORATIVE MAGNETS; DECORATIVE SWITCH PLATE COVERS (U.S. CLS. 21, 23, 26, 36 AND 38).

MYRIAH HABEEB, EXAMINING ATTORNEY

SN 77-909,868. PERKINELMER HEALTH SCIENCES, INC., WALTHAM, MA. FILED S.R. 1-12-2010; AM. P.R. 1-12-2010.

BOBSOFT

THE MARK CONSISTS OF STANDARD CHARACTERS WITHOUT CLAIM TO ANY PARTICULAR FONT, STYLE, SIZE, OR COLOR.

PRIORITY CLAIMED UNDER SEC. 44(D) ON ERPNCMNTY TM OFC APPLICATION NO. 008433039, FILED 7-17-2009.

FOR COMPUTER SOFTWARE FOR DNA ANALYSIS; SOFTWARE IN THE FIELD OF DNA RESEARCH FOR ACQUISITION, ANALYSIS AND PROCESSING OF SCIENTIFIC, PHARMACEUTICAL, BIOLOGICAL, BIOTECHNOLOGICAL AND VETERINARY DATA (U.S. CLS. 21, 23, 26, 36 AND 38).

FIRST USE 1-12-2010; IN COMMERCE 1-12-2010.

TEJBIR SINGH, EXAMINING ATTORNEY

CLASS 9—(Continued).

SN 77-915,140. EASYNET (SEPERIA) LTD., HERZELIA PITUACH, ISRAEL, FILED 1-19-2010.



THE COLOR(S) GREEN AND GRAY IS/ARE CLAIMED AS A FEATURE OF THE MARK.

THE MARK CONSISTS OF A STYLIZED COMBINATION OF LETTERS SPELLING "SEPERIA" IN THE COLOR GREEN ACCOMPANIED BY FOUR (4) VERTICAL DOTS BEFORE THE WORD. THE UPPERMOST DOT IS GREEN AND THE REMAINING THREE DOTS ARE GRAY. THE GREEN DOT IS SLIGHTLY LARGER THAN THE GRAY DOTS.

FOR COMPUTER SOFTWARE FOR ACCESSING INFORMATION DIRECTORIES THAT MAY BE DOWNLOADED FROM THE GLOBAL COMPUTER NETWORK (U.S. CLS. 21, 23, 26, 36 AND 38).

FIRST USE 7-1-2005; IN COMMERCE 7-1-2005.

MARK SPARACINO, EXAMINING ATTORNEY

SN 77-921,367. DIBA INDUSTRIES INC., DANBURY, CT. FILED 1-27-2010.



OWNER OF U.S. REG. NO. 1,974,831.

THE MARK CONSISTS OF THE WORD "DIBA" AND DESIGN COMPRISED OF STYLIZED LETTER "D"'S AND A FLUID DROPLET.

FOR INDUSTRIAL AND MEDICAL LABORATORY EQUIPMENT FOR THE ANALYSIS AND PROCESSING OF FLUIDS, NAMELY, GLASS, PLASTIC AND METAL TUBES AND RECEPTACLES, FLEXIBLE AND RIGID PLASTIC AND METAL FITTINGS USED TO CONNECT TUBES, RECEPTACLES, PROBES, VALVES, PUMPS, HEATERS, MIXERS, GLASS, PLASTIC AND METAL FLUID SAMPLE AND DISPENSE PROBES, METERED FLUID PUMPS, AUTOMATIC AND MANUAL VALVES, FLUID MIXING TUBES AND COILS, FLUID HEATING AND COOLING TUBES AND COILS, FLUID FILTERS, ADAPTORS, SOLVENT BOTTLECAPS AND CHROMATOGRAPHY APPARATUS FOR LABORATORY USE (U.S. CLS. 21, 23, 26, 36 AND 38).

LINDA E. BLOHM, EXAMINING ATTORNEY

CLASS 9—(Continued).

SN 77-928,443. LG ELECTRONICS INC., SEOUL, REPUBLIC OF KOREA, FILED 2-4-2010.

Media Funtasia

THE MARK CONSISTS OF STANDARD CHARACTERS WITHOUT CLAIM TO ANY PARTICULAR FONT, STYLE, SIZE, OR COLOR.

PRIORITY CLAIMED UNDER SEC. 44(D) ON REPUBLIC OF KOREA APPLICATION NO. 40-2010-0002, FILED 1-15-2010, REG. NO. 0861674, DATED 4-19-2011, EXPIRES 4-19-2021.

NO CLAIM IS MADE TO THE EXCLUSIVE RIGHT TO USE "MEDIA", APART FROM THE MARK AS SHOWN.

FOR COMPUTER SOFTWARE FOR MOBILE PHONES, NAMELY, FOR MOBILE PHONE OPERATING SYSTEMS, SENDING AND RECEIVING INFORMATION AND TO PROVIDE WEB-BASED ACCESS TO APPLICATIONS, PRODUCTS AND SERVICES; COMPUTER SOFTWARE FOR TELEVISIONS, NAMELY, SOFTWARE FOR SETTING-UP AND CALIBRATING TELEVISIONS; COMPUTER SOFTWARE FOR PERSONAL COMPUTER MONITORS, NAMELY, SOFTWARE FOR SETTING-UP AND CALIBRATING PERSONAL COMPUTER MONITORS; LAPTOP COMPUTERS; COMPUTERS (U.S. CLS. 21, 23, 26, 36 AND 38).

TARA PATE, EXAMINING ATTORNEY

CLASS 9—(Continued).

SN 77-937,399. USH ENTERTAINMENT, INC., NEW YORK, NY, FILED 2-17-2010.

USH ENTERTAINMENT

THE MARK CONSISTS OF STANDARD CHARACTERS WITHOUT CLAIM TO ANY PARTICULAR FONT, STYLE, SIZE, OR COLOR.

NO CLAIM IS MADE TO THE EXCLUSIVE RIGHT TO USE "ENTERTAINMENT", APART FROM THE MARK AS SHOWN.

THE NAME "USH" IDENTIFIES A LIVING INDIVIDUAL WHOSE CONSENT IS OF RECORD.

FOR MOTION PICTURE FILMS FEATURING COMEDY, DRAMA, ACTION, ADVENTURE, SPORTS, MUSICAL PERFORMANCES, AND/OR ANIMATION; SOUND RECORDINGS, NAMELY, PRE-RECORDED PHONOGRAPH RECORDS, AUDIO TAPES, AUDIO-VIDEO TAPES, AUDIO VIDEO CASSETTES, AUDIO VIDEO DISCS, COMPACT DISCS, DIGITAL VERSATILE DISCS, FEATURING COMEDY, DRAMA, ACTION, ADVENTURE, SPORTS, MUSICAL PERFORMANCES, AND/OR ANIMATION AND MOVIES IN THE FIELDS OF COMEDY, DRAMA, ACTION, ADVENTURE, SPORTS, MUSICAL PERFORMANCES, AND/OR ANIMATION; COMPUTER INTERFACE BOARDS AND GRAPHICAL USER INTERFACE SOFTWARE FOR USE IN FACILITATING THE DELIVERY OF PRODUCTS AND SERVICES BY CABLE OR WIRELESS TRANSMISSION (U.S. CLS. 21, 23, 26, 36 AND 38).

SARA BENJAMIN, EXAMINING ATTORNEY

SN 77-937,391. USH ENTERTAINMENT, INC., NEW YORK, NY, FILED 2-17-2010.

USH

THE MARK CONSISTS OF STANDARD CHARACTERS WITHOUT CLAIM TO ANY PARTICULAR FONT, STYLE, SIZE, OR COLOR.

THE NAME "USH" IDENTIFIES A LIVING INDIVIDUAL WHOSE CONSENT IS OF RECORD.

FOR MOTION PICTURE FILMS FEATURING COMEDY, DRAMA, ACTION, ADVENTURE, SPORTS, MUSICAL PERFORMANCES, AND/OR ANIMATION; SOUND RECORDINGS, NAMELY, PRE-RECORDED PHONOGRAPH RECORDS, AUDIO TAPES, AUDIO-VIDEO TAPES, AUDIO VIDEO CASSETTES, AUDIO VIDEO DISCS, COMPACT DISCS, DIGITAL VERSATILE DISCS, FEATURING COMEDY, DRAMA, ACTION, ADVENTURE, SPORTS, MUSICAL PERFORMANCES, AND/OR ANIMATION AND MOVIES IN THE FIELDS OF COMEDY, DRAMA, ACTION, ADVENTURE, SPORTS, MUSICAL PERFORMANCES, AND/OR ANIMATION; COMPUTER INTERFACE BOARDS AND GRAPHICAL USER INTERFACE SOFTWARE FOR USE IN FACILITATING THE DELIVERY OF PRODUCTS AND SERVICES BY CABLE OR WIRELESS TRANSMISSION (U.S. CLS. 21, 23, 26, 36 AND 38).

SARA BENJAMIN, EXAMINING ATTORNEY

SN 77-938,967. BAE SYSTEMS INFORMATION AND ELECTRONIC SYSTEMS INTEGRATION INC., NASHUA, NH, FILED 2-18-2010.



THE MARK CONSISTS OF A RECTANGLE CONTAINING THE STYLIZED WORD "JESTER" WITH A JESTER HAT RESTING ON THE "J" AND A STARBURST OVER THE "ER," AS WELL AS NUMEROUS CIRCLES AND PARTIAL CIRCLES THROUGHOUT THE RECTANGLE.

FOR A HAND-HELD, AIRBORNE, OR VEHICLE-BASED, DIRECTION-FINDING DEVICE FOR GEOLOCATION COMPRISING A RADIO FREQUENCY EMITTER, AN ANTENNAE, A TRANSCEIVER, A USER INTERFACE ELECTROTECHNICAL AND ELECTRONIC DEVICE, AND A SWITCHING NETWORK, ALL FOR USE IN HOMELAND DEFENSE AND NATIONAL SECURITY APPLICATIONS (U.S. CLS. 21, 23, 26, 36 AND 38).

ROBIN MITTLER, EXAMINING ATTORNEY

CLASS 9—(Continued).

SN 77-941,863. SOUND RESOURCE MANAGEMENT GROUP, INC., OLYMPIA, WA. FILED 2-22-2010.

MEBCalc

THE MARK CONSISTS OF STANDARD CHARACTERS WITHOUT CLAIM TO ANY PARTICULAR FONT, STYLE, SIZE, OR COLOR.

FOR COMPUTER SOFTWARE FOR COMPUTING THE ENVIRONMENTAL FOOTPRINT OF WASTE MANAGEMENT SYSTEMS AND FEATURING THE COMPUTATION IN SPREADSHEET FORM (U.S. CLS. 21, 23, 26, 36 AND 38).

JULIE VEPPUMTHARA, EXAMINING ATTORNEY

CLASS 9—(Continued).

SN 77-957,596. SONY CORPORATION, TOKYO, JAPAN, FILED 3-12-2010.

Wireless Studio

THE MARK CONSISTS OF STANDARD CHARACTERS WITHOUT CLAIM TO ANY PARTICULAR FONT, STYLE, SIZE, OR COLOR.

NO CLAIM IS MADE TO THE EXCLUSIVE RIGHT TO USE "WIRELESS", APART FROM THE MARK AS SHOWN.

FOR APPLICATIONS SOFTWARE FOR DIGITAL WIRELESS MICROPHONE SYSTEMS (U.S. CLS. 21, 23, 26, 36 AND 38).

FIRST USE 4-30-2010; IN COMMERCE 4-30-2010.
DANIEL CAPSHAW, EXAMINING ATTORNEY

SN 77-954,247. ZEIKOS INC., NEW YORK, NY. FILED 3-9-2010.

SKULL BREAKER

THE MARK CONSISTS OF STANDARD CHARACTERS WITHOUT CLAIM TO ANY PARTICULAR FONT, STYLE, SIZE, OR COLOR.

FOR ADAPTER PLUGS; AUDIO HEADPHONES; AUDIO RECORDERS; AUDIO SPEAKERS; BATTERY CASES; BATTERY CHARGE DEVICES; BATTERY CHARGERS; BATTERY PACKS; CAMERAS; CARRYING CASES FOR CELL PHONES; CARRYING CASES FOR MOBILE COMPUTERS; CD PLAYERS; DIGITAL AUDIO PLAYERS; DIGITAL CAMERAS; EARPHONES AND HEADPHONES; FITTED PLASTIC FILMS KNOWN AS SKINS FOR COVERING AND PROVIDING A SCRATCH PROOF BARRIER OR PROTECTION FOR ELECTRONIC DEVICES, NAMELY, MP3 PLAYERS, MOBILE TELEPHONES, SMART TELEPHONES, DIGITAL CAMERAS, GLOBAL POSITIONING SYSTEMS AND PERSONAL DIGITAL ASSISTANTS; MOBILE RADIOS; MP3 PLAYERS; MP4 PLAYERS; PERSONAL STEREO; PROTECTIVE CARRYING CASES FOR PORTABLE MUSIC PLAYERS, NAMELY, MP3 PLAYERS; RADIO TRANSMITTERS; RADIOS; RADIOS INCORPORATING CLOCKS; SPECIALTY HOLSTER FOR CARRYING MP3 AND MP4 PLAYERS AND MOBILE PHONES, SMARTPHONES AND PDAS; STEREO AMPLIFIERS; STEREO CABLES; STEREO HEADPHONES; STEREO TUNERS; SUNGLASSES; USB (UNIVERSAL SERIAL BUS) HARDWARE; USB CABLES (U.S. CLS. 21, 23, 26, 36 AND 38).

FIRST USE 2-1-2010; IN COMMERCE 2-1-2010.
MARC LEIPZIG, EXAMINING ATTORNEY

SN 77-961,158. VIRTUAL COMPUTER, INC., WESTFORD, MA. FILED 3-17-2010.



NO CLAIM IS MADE TO THE EXCLUSIVE RIGHT TO USE "VIRTUAL COMPUTER", APART FROM THE MARK AS SHOWN.

THE MARK CONSISTS OF A STYLIZED LETTER "V" POSITIONED ON TOP OF A CIRCLE, SUCH DESIGN APPEARING TO THE LEFT OF "VIRTUAL COMPUTER".

FOR COMPUTER SOFTWARE USED TO DEVELOP COMPUTER SYSTEMS; COMPUTER SOFTWARE USED TO ANALYZE, OPTIMIZE AND ADMINISTER COMPUTING SYSTEMS, APPLICATIONS, MULTIPLE OPERATING SYSTEMS, COMPUTER HARDWARE, SEMICONDUCTORS, CENTRAL PROCESSING UNITS AND COMPUTER PERIPHERALS; COMPUTER SOFTWARE USED TO CREATE COMPUTER CODE IN APPLICATIONS; COMPUTER SOFTWARE USED TO MANAGE OTHER COMPUTER SOFTWARE BY PROVIDING WEB BASED ACCESS TO APPLICATIONS, FUNCTIONS AND SERVICES THROUGH A WEB OPERATING SYSTEM OR PORTAL INTERFACE; COMPUTER SOFTWARE USED TO MANAGE COMPUTER HARDWARE, SEMICONDUCTORS, CENTRAL PROCESSING UNITS AND COMPUTER PERIPHERALS BY DELIVERING TO ANOTHER COMPUTER SYSTEM SOFTWARE THAT PERFORMS MAINTENANCE, SECURITY, ADMINISTRATION AND SUPPORT FUNCTIONS BASED ON INSTRUCTIONS RECEIVED FROM ANOTHER COMPUTER SYSTEM (U.S. CLS. 21, 23, 26, 36 AND 38).

FIRST USE 11-0-2008; IN COMMERCE 11-0-2008.
MAYUR VAGHANI, EXAMINING ATTORNEY

CLASS 9—(Continued).

SN 77-964,076. QUADO MEDIA INC., SUNNYVALE, CA. FILED 3-20-2010.

QUADO

THE MARK CONSISTS OF STANDARD CHARACTERS WITHOUT CLAIM TO ANY PARTICULAR FONT, STYLE, SIZE, OR COLOR.

THE WORDING "QUADO" HAS NO MEANING IN A FOREIGN LANGUAGE.

FOR DIGITAL BOARD GAMES, NAMELY, ELECTRONIC INTERACTIVE BOARD GAMES FOR USE WITH EXTERNAL MONITORS (U.S. CLS. 21, 23, 26, 36 AND 38).

SUZANNE BLANE, EXAMINING ATTORNEY

SN 78-458,619. LESSLIE, JAMES, HOWARD BEACH, NY. FILED 7-29-2004.

Cowabunga

THE MARK CONSISTS OF STANDARD CHARACTERS WITHOUT CLAIM TO ANY PARTICULAR FONT, STYLE, SIZE, OR COLOR.

OWNER OF U.S. REG. NOS. 2,618,559, 2,640,094 AND OTHERS.

FOR MOTION PICTURE FILMS FEATURING COMEDY, DRAMA, ACTION, ADVENTURE AND ANIMATION; SHORT MOTION PICTURE FILMS FEATURING COMEDY, DRAMA, ACTION, ADVENTURE AND ANIMATION; PRERECORDED SHORT MOTION PICTURE FILM VIDEO CASSETTES FEATURING COMEDY, DRAMA, ACTION, ADVENTURE AND ANIMATION TO BE USED WITH HAND-HELD VIEWERS OR PROJECTORS; SERIES OF AUDIO CASSETTES AND COMPACT DISCS FEATURING SOUNDTRACKS, MUSIC OF CARTOON THEME SONGS AND OTHER MUSICAL SOUND RECORDINGS; PRERECORDED VINYL PHONOGRAPH RECORDS, AUDIO TAPES, VIDEO TAPES, AUDIO AND VIDEO CASSETTES, AUDIO AND VIDEO DISCS, AND DIGITAL VERSATILE DISCS FEATURING MUSIC, COMEDY, DRAMA, ACTION, ADVENTURE, AND ANIMATION; STEREO HEADPHONES; BATTERIES; CORDLESS TELEPHONES; HAND-HELD CALCULATORS; AUDIO TAPES FEATURING COMEDY, DRAMA, AC-

CLASS 9—(Continued).

TION, ADVENTURE AND ANIMATION AND CD PLAYERS; HAND-HELD KARAOKE PLAYERS, TELEPHONES AND RADIO PAGERS; VIDEO CASSETTE RECORDERS, DIGITAL AUDIO TAPE RECORDERS AND PLAYERS, ELECTRONIC DIARIES; RADIOS; PRERECORDED AUDIO TAPES AND BOOKLETS SOLD TOGETHER AS A UNIT FEATURING COMEDY, DRAMA, ACTION, ADVENTURE AND ANIMATION; COMPUTER PROGRAMS, NAMELY, SOFTWARE FOR LINKING DIGITIZED VIDEO AND AUDIO MEDIA TO A GLOBAL COMPUTER INFORMATION NETWORK; GAME EQUIPMENT, NAMELY, COMPUTER GAME SOFTWARE AND JOYSTICK SOLD AS A UNIT FOR PLAYING A PARLOR-TYPE COMPUTER GAME; VIDEO GAME INTERACTIVE CONTROLS, NAMELY, JOYSTICKS AND MOUSE PADS; DECORATIVE REFRIGERATOR MAGNETS FEATURING CARTOONS; ENCODED MAGNETIC CARDS, NAMELY, KEY CARDS, CALLING CARDS, CREDIT CARDS, DEBIT CARDS AND CASH CARDS; EYEGLASS CASES; SUNGLASS CASES (U.S. CLS. 21, 23, 26, 36 AND 38).

BARBARA GAYNOR, EXAMINING ATTORNEY

SN 78-854,440. REVEALITY SOFT LIMITED, NICOSIA, CYPRUS, FILED 4-5-2006.

WELL

THE MARK CONSISTS OF STANDARD CHARACTERS WITHOUT CLAIM TO ANY PARTICULAR FONT, STYLE, SIZE, OR COLOR.

OWNER OF ERPN CMNTY TM OFC REG. NO. 004975116, DATED 11-5-2007, EXPIRES 3-23-2016.

FOR READ ONLY MEMORY COMPACT DISCS CONTAINING COMPUTER GAMES, VIDEO GAMES, CARTOON MOVIES AND CINEMATIC MOVIES; COMPACT AUDIO AND VIDEO DISCS CONTAINING COMPUTER GAMES, VIDEO GAMES, CARTOON MOVIES, CINEMATIC MOVIES AND INFORMATION ABOUT COMPUTER GAMES, VIDEO GAMES, CARTOON MOVIES AND CINEMATIC MOVIES; VIDEO DISCS AND VIDEO TAPES CONTAINING COMPUTER GAMES, VIDEO GAMES, CARTOON MOVIES, CINEMATIC MOVIES AND INFORMATION ABOUT COMPUTER GAMES, VIDEO GAMES, CARTOON MOVIES AND CINEMATIC MOVIES; TEACHING APPARATUS, NAMELY, COMPUTER DISCS AND VIDEO DISCS CONTAINING CHILDREN'S EDUCATIONAL SOFTWARE FOR USE IN COMPUTER GAMES, INCLUDING ONLINE COMPUTER GAMES, VIDEO GAMES, CARTOON MOVIES AND CINEMATIC MOVIES; RECORD PLAYERS; DOWNLOADABLE ELECTRONIC PUBLICATIONS, NAMELY, MAGAZINES, JOURNALS, NEWSLETTERS, BROCHURES, LEAFLETS, PAMPHLETS IN THE FIELD OF COMPUTER GAMES, INCLUDING ONLINE COMPUTER GAMES, VIDEO GAMES, CARTOON MOVIES AND CINEMATIC MOVIES; SMART CARDS, NAMELY, BLANK INTEGRATED CIRCUIT CARDS; AUDIOVISUAL TEACHING APPARATUS, NAMELY, COMPUTER DISCS AND VIDEO DISCS CONTAINING CHILDREN'S EDUCATIONAL SOFTWARE FOR USE IN COMPUTER GAMES, INCLUDING ONLINE COMPUTER GAMES, VIDEO GAMES, CARTOON MOVIES AND CINEMATIC MOVIES; COMPUTER MEMORIES; COMPUTER PERIPHERAL DEVICES; INTEGRATED CIRCUIT CHIPS FOR USE IN CONNECTION WITH COMPUTER GAMES, INCLUDING ONLINE GAMES, VIDEO GAMES, CARTOON MOVIES AND CINEMATIC MOVIES; COMPUTERS; NOTEBOOK COMPUTERS (U.S. CLS. 21, 23, 26, 36 AND 38).

PAUL F. GAST, EXAMINING ATTORNEY

CLASS 9—(Continued).

SN 79-080,610. STEINER-OPTIK GMBH, 95448 BAYREUTH, FED REP GERMANY, FILED 3-19-2010.

STEINER

THE MARK CONSISTS OF STANDARD CHARACTERS WITHOUT CLAIM TO ANY PARTICULAR FONT, STYLE, SIZE, OR COLOR.

OWNER OF INTERNATIONAL REGISTRATION 0732069 DATED 3-18-2000, EXPIRES 3-18-2020.

OWNER OF U.S. REG. NOS. 2,665,199, 2,746,333 AND 3,253,981.

SEC. 2(F).

FOR BINOCULARS, TELESCOPES, AIMING TELESCOPES AND RANGE FINDERS (U.S. CLS. 21, 23, 26, 36 AND 38).

SANJEEV VOHRA, EXAMINING ATTORNEY

CLASS 9—(Continued).

SN 79-086,866. KAMURO OPTICAL CO., LTD, TOKYO 104-0061, JAPAN, FILED 8-12-2010.

KAMURO

OWNER OF INTERNATIONAL REGISTRATION 1049723 DATED 8-12-2010, EXPIRES 8-12-2020.

THE MARK CONSISTS OF THE WORDING "KAMURO" IN STYLIZED FONT.

THE WORDING "KAMURO" HAS NO MEANING IN A FOREIGN LANGUAGE.

FOR SPECTACLES; PARTS AND ACCESSORIES FOR SPECTACLES, NAMELY, LENSES, CASES, FRAMES, HINGES, BRIDGES, PADS, TEMPLES, HOLDERS, CHAINS, CORDS, STRAPS, PINCE-NEZ (U.S. CLS. 21, 23, 26, 36 AND 38).

SCOTT BIBB, EXAMINING ATTORNEY

SN 79-086,943. REDSTACK B.V., NETHERLANDS, FILED 7-22-2010.



PRIORITY DATE OF 3-22-2010 IS CLAIMED.

OWNER OF INTERNATIONAL REGISTRATION 1049977 DATED 7-22-2010, EXPIRES 7-22-2020.

NO CLAIM IS MADE TO THE EXCLUSIVE RIGHT TO USE "RED STACK", APART FROM THE MARK AS SHOWN.

THE COLOR(S) BLUE AND RED IS/ARE CLAIMED AS A FEATURE OF THE MARK.

THE MARK CONSISTS OF THE WORDING "RED" IN THE COLOR BLUE, THE WORDING "STACK" IN THE COLOR RED, UNDERNEATH THE WORDING "STACK" APPEARS FOUR HORIZONTAL LINES IN THE COLOR RED.

FOR POWER GENERATION PLANTS (U.S. CLS. 21, 23, 26, 36 AND 38).

JOSETTE BEVERLY, EXAMINING ATTORNEY

SN 79-083,136. X-RITE EUROPE GMBH, CH-8105 REGENSDORF, SWITZERLAND, FILED 5-11-2010.

CAPSURE

THE MARK CONSISTS OF STANDARD CHARACTERS WITHOUT CLAIM TO ANY PARTICULAR FONT, STYLE, SIZE, OR COLOR.

PRIORITY DATE OF 12-14-2009 IS CLAIMED.

OWNER OF INTERNATIONAL REGISTRATION 1040319 DATED 5-11-2010, EXPIRES 5-11-2020.

FOR SPECTROPHOTOMETERS, NAMELY, ELECTRONIC SPECTROPHOTOMETERS FOR USE BY DESIGN PROFESSIONALS, INTERIOR DECORATORS, FASHION DESIGNERS, GRAPHIC DESIGNERS, INDUSTRIAL DESIGNERS, CONTRACTORS, PAINT RETAILERS, PAINTERS, HOME FURNISHING RETAILERS, HANDYMEN, PRINTERS, PUBLISHERS AND CONSUMERS WITH DO-IT-YOURSELF PROJECTS TO MEASURE COLORS ON SURFACES AND MATERIALS AND TO MATCH THE MEASURED COLORS WITH ELECTRONICALLY STORED COLORS; COLORIMETERS FOR USE BY DESIGN PROFESSIONALS, INTERIOR DECORATORS, FASHION DESIGNERS, GRAPHIC DESIGNERS, INDUSTRIAL DESIGNERS, CONTRACTORS, PAINT RETAILERS, PAINTERS, HOME FURNISHING RETAILERS, HANDYMEN, PRINTERS, PUBLISHERS AND CONSUMERS WITH DO-IT-YOURSELF PROJECTS TO MEASURE COLORS ON SURFACES AND MATERIALS AND TO MATCH THE MEASURED COLORS WITH ELECTRONICALLY STORED COLORS; AND SOFTWARE FOR USE IN CONNECTION WITH SUCH SPECTROPHOTOMETERS AND COLORIMETERS (U.S. CLS. 21, 23, 26, 36 AND 38).

JAMES STEIN, EXAMINING ATTORNEY

SN 79-088,313. SHENZHEN 3NOD INVESTMENT MANAGEMENT CO., LTD., GUANGDONG, CHINA, FILED 8-19-2010.

TiN

OWNER OF INTERNATIONAL REGISTRATION 1053803 DATED 8-19-2010, EXPIRES 8-19-2020.

FOR COMPUTERS; NOTEBOOK COMPUTERS; COMPUTER KEYBOARDS; PERIPHERAL DEVICES, NAMELY, COMPUTERS; DATA PROCESSING EQUIPMENT, NAMELY, COMPUTER MOUSE; CABINETS FOR LOUDSPEAKERS; LOUDSPEAKERS; AUDIO AND VIDEO RECEIVERS; PERSONAL STEREO; HEADPHONES (U.S. CLS. 21, 23, 26, 36 AND 38).

HOWARD SMIGA, EXAMINING ATTORNEY

CLASS 9—(Continued).

SN 79-089,214. BOMAG GMBH, BOPPARD, FED REP GERMANY, FILED 8-20-2010.

BOSS

THE MARK CONSISTS OF STANDARD CHARACTERS WITHOUT CLAIM TO ANY PARTICULAR FONT, STYLE, SIZE, OR COLOR.

PRIORITY DATE OF 3-24-2010 IS CLAIMED.

OWNER OF INTERNATIONAL REGISTRATION 1056303 DATED 8-20-2010, EXPIRES 8-20-2020.

FOR SAFETY SYSTEMS TO PREVENT MACHINES FROM A PARTIAL OR COMPLETE RUNNING OVER PERSONS, COMPOSED OF TRANSMITTERS AND RECEIVERS OF ELECTROMAGNETIC WAVES, UNITS FOR CONTROLLING THE DRIVE OF THE MACHINE, PROGRAMS FOR PERFORMING A SELF-TEST OF THE MACHINE, FOR USE WITH CONSTRUCTION MACHINES, NAMELY, FOR MULTI-PURPOSE COMPACTORS, TRENCH ROLLER, ROAD ROLLER, VIBRATORY PLATE COMPACTORS, PAVER, LANDFILL COMPACTORS, ROAD MILLERS, NAMELY, A SYSTEM FOR MONITORING A SAFETY DISTANCE BETWEEN PERSONS AND THE MACHINE; PARTS AND FITTINGS FOR SUCH SYSTEM, NAMELY, TRANSMITTERS AND RECEIVERS OF ELECTROMAGNETIC WAVES, REMOTE CONTROL UNITS, TRANSPONDERS, TRANSCIEVERS AND ELECTRICAL CONTROLLERS; ALL THE AFOREMENTIONED NOT FOR AUDIO COMPONENTS IN THE FIELD OF ENTERTAINMENT ELECTRONICS (U.S. CLS. 21, 23, 26, 36 AND 38).
MARK T. MULLEN, EXAMINING ATTORNEY

SN 79-089,397. LOOK VISION SOCIÉTÉ À RESPONSABILITÉ LIMITÉE, FRANCE, FILED 10-11-2010.

OWNER OF INTERNATIONAL REGISTRATION 1056815 DATED 10-11-2010, EXPIRES 10-11-2020.

THE MARK CONSISTS OF THE STYLIZED WORDING "XENITH" WITH AN "X" APPEARING IN A CIRCLE DOTTING THE "I" IN "XENITH".

THE TRANSLITERATION OF THE NON-LATIN CHARACTERS IN THE MARK IS "XENITH".

FOR OPTICAL GOODS, NAMELY, FRAMES FOR SPECTACLES, SUNGLASSES, OPHTHALMIC LENSES, SPECTACLE CASES, CONTACT LENSES, OPTICAL LENSES (U.S. CLS. 21, 23, 26, 36 AND 38).
NAAKWAMA ANKRAH, EXAMINING ATTORNEY

CLASS 9—(Continued).

SN 79-090,145. INSTITUT PASTEUR KOREA, REPUBLIC OF KOREA, FILED 11-2-2010.

PHENOMICID

OWNER OF INTERNATIONAL REGISTRATION 1058758 DATED 11-2-2010, EXPIRES 11-2-2020.

THE MARK CONSISTS OF THE WORDING "PHENOMICID" IN STYLIZED FONT.

FOR COMPUTER SOFTWARE FOR USE IN ASSAYS DEVELOPMENT, DRUG RESEARCH AND DEVELOPMENT, AND BIOLOGICAL IMAGING, RECORDED, IN THE FIELD OF SCIENCE, MEDICINES, DRUGS, BIOLOGY, BIOTECHNOLOGY; COMPUTER SOFTWARE FOR USE IN IDENTIFYING DISEASE TARGETS, RECORDED, IN THE FIELD OF SCIENCE, MEDICINES, DRUGS, BIOLOGY, BIOTECHNOLOGY; COMPUTER PROGRAMS IN THE NATURE OF SOFTWARE FOR USE IN ASSAYS DEVELOPMENT, SEARCHING DISEASE TARGET AND IDENTIFYING DISEASE TARGETS THAT EXERT AN EFFECT OF INTEREST IN A LIVE DISEASE MODEL (U.S. CLS. 21, 23, 26, 36 AND 38).
ROBERT STRUCK, EXAMINING ATTORNEY

SN 79-091,342. VENDINOVA GROUP B.V., NETHERLANDS, FILED 11-22-2010.

soup·server
innovative vending solutions

OWNER OF INTERNATIONAL REGISTRATION 1061912 DATED 11-22-2010, EXPIRES 11-22-2020.

NO CLAIM IS MADE TO THE EXCLUSIVE RIGHT TO USE "SOUP SERVER" OR "VENDING", APART FROM THE MARK AS SHOWN.

THE MARK CONSISTS OF THE WORDING "SOUP-SERVER INNOVATIVE VENDING SOLUTIONS" IN STYLIZED FONT.

FOR VENDING MACHINES FOR THE PREPARATION AND DELIVERY OF WARM AND COLD DRINKS, IN PARTICULAR SOUPS (U.S. CLS. 21, 23, 26, 36 AND 38).
ROBERT STRUCK, EXAMINING ATTORNEY

SN 79-091,844. POINTGRAB LTD., ISRAEL, FILED 11-30-2010.

POINTGRAB

THE MARK CONSISTS OF STANDARD CHARACTERS WITHOUT CLAIM TO ANY PARTICULAR FONT, STYLE, SIZE, OR COLOR.

PRIORITY DATE OF 5-31-2010 IS CLAIMED.

OWNER OF INTERNATIONAL REGISTRATION 1063154 DATED 11-30-2010, EXPIRES 11-30-2020.

FOR COMPUTER SOFTWARE, DRIVERS, FIRMWARE AND HARDWARE FOR USE IN VIDEO PATTERN AND MOVEMENT RECOGNITION AND CONTROL TECHNOLOGY USED AS AN INPUT DEVICE FOR PERSONAL COMPUTERS, HOME APPLIANCES AND GAMING CONSOLES (U.S. CLS. 21, 23, 26, 36 AND 38).
DAVID HOFFMAN, EXAMINING ATTORNEY

CLASS 9—(Continued).

SN 79-093,331. FAR EAST CABLE CO., LTD., CHINA, FILED 1-18-2011.



OWNER OF INTERNATIONAL REGISTRATION 1067034 DATED 1-18-2011, EXPIRES 1-18-2021.

THE MARK CONSISTS OF CHINESE CHARACTERS LOCATED WITHIN A BROKEN CIRCLE.

THE FIRST CHINESE CHARACTER WHOSE TRANSLITERATION IS "WAN" MEANS "TEN THOUSAND"; THE SECOND CHINESE CHARACTER WHOSE TRANSLITERATION IS "NENG" MEANS "CAN"; THE THIRD CHINESE CHARACTER WHOSE TRANSLITERATION IS "DA" MEANS "REACH".

THE TRANSLITERATION OF THE NON-LATIN CHARACTERS IN THE MARK IS: WAN NENG DA.

FOR ELECTRIC WIRES; ELECTRIC CABLES (U.S. CLS. 21, 23, 26, 36 AND 38).

MARK RADEMACHER, EXAMINING ATTORNEY

SN 79-095,506. EOPLY NEW ENERGY TECHNOLOGY CO., LTD., CHINA, FILED 3-1-2011.



OWNER OF INTERNATIONAL REGISTRATION 1072314 DATED 3-1-2011, EXPIRES 3-1-2021.

THIS MARK IS COMBINATION OF DEVICE AND WORDS CONSISTING OF TWO ARCS, THE DEVICE LOOKS LIKE THE RISING SUN AND THE HORIZON BELOW THE DEVICE, THE WORD "EOPLY" IS PRESENTED HORIZONTALLY.

FOR SOLAR CELLS; BATTERIES; ACCUMULATOR JARS; BATTERIES FOR LIGHTING; BATTERY BOXES; HIGH-TENSION BATTERIES; BATTERY CHARGERS; GALVANIC CELLS; BATTERY PLATES; ACCUMULATOR BOXES (U.S. CLS. 21, 23, 26, 36 AND 38).

CARYN GLASSER, EXAMINING ATTORNEY

CLASS 9—(Continued).

SN 79-096,662. ESSILOR INTERNATIONAL (COMPAGNIE GENERALE D'OPTIQUE), FRANCE, FILED 3-3-2011.

ESSICOLOR

THE MARK CONSISTS OF STANDARD CHARACTERS WITHOUT CLAIM TO ANY PARTICULAR FONT, STYLE, SIZE, OR COLOR.

PRIORITY DATE OF 9-8-2010 IS CLAIMED.

OWNER OF INTERNATIONAL REGISTRATION 1075117 DATED 3-3-2011, EXPIRES 3-3-2021.

FOR OPHTHALMIC LENSES; SPECTACLE LENSES, INCLUDING ORGANIC GLASS LENSES, MINERAL LENSES, CORRECTIVE LENSES, SINGLE VISION LENSES, MULTIFOCAL LENSES, PROGRESSIVE LENSES, SUNGLASS LENSES, POLARIZED LENSES, TINTED LENSES, COLORED LENSES, LIGHT-SENSITIVE LENSES, PHOTOCROMIC LENSES, TREATED LENSES, COATED LENSES, ANTI-REFLECTIVE LENSES, SEMI-FINISHED LENSES; SPECTACLE LENSE BLANKS; SEMI-FINISHED SPECTACLE LENSE BLANKS; COATINGS FOR OPHTHALMIC LENSES; COATINGS FOR SPECTACLE LENSES; OPHTHALMIC LENSE CASES; SPECTACLE LENSE CASES (U.S. CLS. 21, 23, 26, 36 AND 38).

ALLISON HOLTZ, EXAMINING ATTORNEY

SN 79-097,031. LAZER SPORT N.V., BELGIUM, FILED 2-4-2011.

NUT'Z

THE MARK CONSISTS OF STANDARD CHARACTERS WITHOUT CLAIM TO ANY PARTICULAR FONT, STYLE, SIZE, OR COLOR.

PRIORITY DATE OF 8-31-2010 IS CLAIMED.

OWNER OF INTERNATIONAL REGISTRATION 1076183 DATED 2-4-2011, EXPIRES 2-4-2021.

FOR PROTECTIVE HELMETS; PROTECTIVE HELMETS FOR SPORTS; CLOTHING FOR PROTECTION AGAINST ACCIDENTS, IRRADIATION AND FIRE; SPECTACLES; SPECTACLE GLASSES; SPECTACLE CASES; SPECTACLE FRAMES; HEADPHONES; VEHICLE TRACKING DEVICES COMPRISING CELLULAR RADIO MODULES, COMPUTER SOFTWARE AND COMPUTER HARDWARE, SENSORS, TRANSMITTERS, RECEIVERS AND GLOBAL POSITIONING SATELLITE RECEIVERS, ALL FOR VEHICLE TRACKING, VEHICLE MONITORING AND ANTI-THEFT ALARM DEVICES FOR VEHICLES; NAVIGATIONAL INSTRUMENTS FOR VEHICLES (ON-BOARD COMPUTERS); NAVIGATION APPARATUS FOR VEHICLES (ON-BOARD COMPUTERS) (U.S. CLS. 21, 23, 26, 36 AND 38).

KELLEY WELLS, EXAMINING ATTORNEY

CLASS 9—(Continued).

SN 85-031,137. SAMSUNG ELECTRO-MECHANICS CO., LTD., SUWON-SI, KYUNGKI-DO, REPUBLIC OF KOREA, FILED 5-5-2010.

ENERGYCAP

THE MARK CONSISTS OF STANDARD CHARACTERS WITHOUT CLAIM TO ANY PARTICULAR FONT, STYLE, SIZE, OR COLOR.

PRIORITY CLAIMED UNDER SEC. 44(D) ON REPUBLIC OF KOREA APPLICATION NO. 2009-0063126, FILED 12-22-2009, REG. NO. 0860005, DATED 4-7-2011, EXPIRES 4-7-2021.

FOR CAPACITORS, ELECTRIC CAPACITORS, ELECTRIC DOUBLE LAYER CAPACITORS, ELECTROCHEMICAL CAPACITORS, ELECTRIC CAPACITORS FOR TELECOMMUNICATION APPARATUS, AND ELECTRIC ACCUMULATORS (U.S. CLS. 21, 23, 26, 36 AND 38).

RAMONA ORTIGA, EXAMINING ATTORNEY

SN 85-032,712. SPORTSMEDIA TECHNOLOGY CORPORATION, DURHAM, NC. FILED 5-7-2010.

ISO TRACK

THE MARK CONSISTS OF STANDARD CHARACTERS WITHOUT CLAIM TO ANY PARTICULAR FONT, STYLE, SIZE, OR COLOR.

NO CLAIM IS MADE TO THE EXCLUSIVE RIGHT TO USE "TRACK", APART FROM THE MARK AS SHOWN.

FOR COMPUTER HARDWARE AND COMPUTER SOFTWARE SYSTEM FOR TRACKING AND HIGHLIGHTING OBJECTS IN REAL TIME FROM A MOVING OR FIXED TELEVISION CAMERA (U.S. CLS. 21, 23, 26, 36 AND 38).

FIRST USE 4-11-2010; IN COMMERCE 4-11-2010.

AISHA SALEM, EXAMINING ATTORNEY

SN 85-037,130. GAMESTREAMER INC., SARASOTA, FL. FILED 5-12-2010.

PLATFORMZ

THE MARK CONSISTS OF STANDARD CHARACTERS WITHOUT CLAIM TO ANY PARTICULAR FONT, STYLE, SIZE, OR COLOR.

FOR COMPUTER GAME SOFTWARE DOWNLOADABLE FROM A GLOBAL COMPUTER NETWORK (U.S. CLS. 21, 23, 26, 36 AND 38).

SANJEEV VOHRA, EXAMINING ATTORNEY

CLASS 9—(Continued).

SN 85-041,684. VOXEO CORPORATION, ORLANDO, FL. FILED 5-18-2010.

MOHO

THE MARK CONSISTS OF STANDARD CHARACTERS WITHOUT CLAIM TO ANY PARTICULAR FONT, STYLE, SIZE, OR COLOR.

FOR DOWNLOADABLE COMPUTER SOFTWARE FOR FACILITATING DEVELOPMENT OF COMMUNICATIONS APPLICATIONS IN THE FIELD OF TELEPHONY (U.S. CLS. 21, 23, 26, 36 AND 38).

FIRST USE 5-5-2010; IN COMMERCE 5-5-2010.

LEIGH LOWRY, EXAMINING ATTORNEY

SN 85-050,056. SAMMY LEE ENTERPRISES, INC., BIRMINGHAM, AL. FILED 5-28-2010.



OWNER OF U.S. REG. NO. 3,823,435.

THE MARK CONSISTS OF A FISH IN THE MIDDLE OF A CIRCLE WITH A WATER SPLASH AND THE WORDS "TIGHT LINES" LISTED BELOW.

SEC. 2(F) AS TO "TIGHT LINES".

FOR AUDIO DISCS FEATURING FISHING INFORMATION; DOWNLOADABLE VIDEO RECORDINGS FEATURING FISHING; VIDEO DISCS FEATURING FISHING (U.S. CLS. 21, 23, 26, 36 AND 38).

FIRST USE 1-31-1998; IN COMMERCE 1-31-1998.

REGINA DRUMMOND, EXAMINING ATTORNEY

SN 85-050,140. FRONTLINE TEST EQUIPMENT, INC., CHARLOTTESVILLE, VA. FILED 5-28-2010.

BPA

THE MARK CONSISTS OF STANDARD CHARACTERS WITHOUT CLAIM TO ANY PARTICULAR FONT, STYLE, SIZE, OR COLOR.

FOR WIRELESS COMMUNICATION DEVICES, NAMELY, WIRELESS COMMUNICATION PROTOCOL TESTING APPARATUS TO TEST CONNECTIVITY AND INTEROPERABILITY OF WIRELESS COMMUNICATION DEVICES FOR VOICE, DATA, AND IMAGE TRANSMISSION AND SOFTWARE FOR ANALYZING WIRELESS COMMUNICATION PROTOCOLS (U.S. CLS. 21, 23, 26, 36 AND 38).

FIRST USE 12-5-2000; IN COMMERCE 12-5-2000.

NAKIA HENRY, EXAMINING ATTORNEY

CLASS 9—(Continued).

SN 85-055,047. OLD WORLD IMPORTS, INC., PALM BEACH, FL. FILED 6-4-2010.

IRIS APFEL

THE MARK CONSISTS OF STANDARD CHARACTERS WITHOUT CLAIM TO ANY PARTICULAR FONT, STYLE, SIZE, OR COLOR.

THE NAME(S), PORTRAIT(S), AND/OR SIGNATURE(S) SHOWN IN THE MARK IDENTIFIES "IRIS APFEL", WHOSE CONSENT(S) TO REGISTER IS MADE OF RECORD.

FOR OPTICAL EYEWEAR, NAMELY, SUNGLASSES, EYEFRAMES, AND RELATED ACCESSORIES, IN THE NATURE OF CORDS, CLIPS, CASES AND READERS (U.S. CLS. 21, 23, 26, 36 AND 38).

FLORENTINA BLANDU, EXAMINING ATTORNEY

CLASS 9—(Continued).

SN 85-068,042. KLH CONSULTING INCORPORATED, SANTA ROSA, CA. FILED 6-21-2010.

VINTEGRATE

THE MARK CONSISTS OF STANDARD CHARACTERS WITHOUT CLAIM TO ANY PARTICULAR FONT, STYLE, SIZE, OR COLOR.

FOR COMPUTER SOFTWARE FOR: ACCOUNTING; SUPPLY CHAIN PLANNING, EXECUTION AND MANAGEMENT; MARKETING AND SALES IN THE NATURE OF AN APPLICATION TO ORGANIZE MARKETING PLANS AND MANAGE MARKETING PROJECTS AND RESOURCES AND FOR USE IN AUTOMATING THE MARKETING AND SALES FUNCTIONS OF A BUSINESS; INVENTORY FOR DOCUMENTING AND TRACKING ASSETS, INVENTORY FORECASTING, INVENTORY MANAGEMENT, PURCHASING AND PLANNING INVENTORIES; MANAGEMENT OF E-COMMERCE TRANSACTIONS; DATA MANAGEMENT FOR WINE CLUBS AND DATA MANAGEMENT TO ASSIST WITH COMPLIANCE WITH WINE REGULATIONS (U.S. CLS. 21, 23, 26, 36 AND 38).

ANDREA K. NADELMAN, EXAMINING ATTORNEY

SN 85-060,097. RF INDUSTRIES PTY LTD, NORTH ROCKS, AUSTRALIA, FILED 6-10-2010.

DSPbR

THE MARK CONSISTS OF STANDARD CHARACTERS WITHOUT CLAIM TO ANY PARTICULAR FONT, STYLE, SIZE, OR COLOR.

PRIORITY CLAIMED UNDER SEC. 44(D) ON AUSTRALIA APPLICATION NO. 1364870, FILED 6-3-2010, REG. NO. 1364870, DATED 1-17-2011, EXPIRES 6-3-2020.

FOR CARRIER FREQUENCY REPEATERS; REPEATERS FOR PUBLIC SAFETY RADIO NETWORKS; RADIO FREQUENCY REPEATERS FOR USE IN DATA NETWORKING (U.S. CLS. 21, 23, 26, 36 AND 38).

FIRST USE 9-0-2010; IN COMMERCE 9-0-2010.

MARK PILARO, EXAMINING ATTORNEY

SN 85-075,019. MISTRAS GROUP, INC., PRINCETON JUNCTION, NJ. FILED 6-30-2010.

Pocket UT

THE MARK CONSISTS OF STANDARD CHARACTERS WITHOUT CLAIM TO ANY PARTICULAR FONT, STYLE, SIZE, OR COLOR.

NO CLAIM IS MADE TO THE EXCLUSIVE RIGHT TO USE "UT", APART FROM THE MARK AS SHOWN.

FOR BATTERY-OPERATED, HANDHELD ULTRASONIC TESTING DEVICE TO ACQUIRE FULL C-SCAN DATA WHEN CONDUCTING ON-SITE INSPECTIONS (U.S. CLS. 21, 23, 26, 36 AND 38).

FIRST USE 1-2-2006; IN COMMERCE 1-2-2006.

TEJBIR SINGH, EXAMINING ATTORNEY

CLASS 9—(Continued).

SN 85-076,152. SONIC SOLUTIONS, NOVATO, CA. FILED 7-1-2010.



THE MARK CONSISTS OF STYLIZED DRAWING OF AN INSECT WEARING AUDIO HEADPHONES.

FOR DOWNLOADABLE SOFTWARE FOR ACCESSING ELECTRONIC MEDIA OR INFORMATION OVER THE INTERNET OR OTHER COMMUNICATIONS NETWORK; DOWNLOADABLE SOFTWARE TO ENABLE USERS TO ACCESS PERSONAL MUSIC COLLECTIONS FROM ANY COMPUTER TO ANOTHER COMPUTER OR PORTABLE ELECTRONIC DEVICE; COMPUTER APPLICATION SOFTWARE FOR MOBILE PHONES AND PORTABLE ELECTRONIC DEVICES USED TO ACCESS ELECTRONIC MEDIA FROM ONE COMPUTER TO ANOTHER COMPUTER OR PORTABLE ELECTRONIC DEVICE; DOWNLOADABLE COMPUTER SOFTWARE FOR CREATING, ACCESSING AND SHARING MUSIC AND MEDIA PLAYLISTS (U.S. CLS. 21, 23, 26, 36 AND 38).

FIRST USE 12-31-2009; IN COMMERCE 12-31-2009.
KIMBERLY FRYE, EXAMINING ATTORNEY

CLASS 9—(Continued).

SN 85-078,124. HITACHI-LG DATA STORAGE KOREA, INC., SEOUL 153-803, REPUBLIC OF KOREA, FILED 7-6-2010.



THE MARK CONSISTS OF THE STYLIZED LETTERS AND SYMBOL "H:D" ABOVE THE STYLIZED WORDING "HYDRIVE" AND THE DESIGN OF AN OUTLINE OF AN INCOMPLETE OVAL BENEATH THE WORDING "HYDRIVE".

FOR COMPUTER HARDWARE (U.S. CLS. 21, 23, 26, 36 AND 38).

JAY BESCH, EXAMINING ATTORNEY



SN 85-083,879. YAP.TV, INC., LOS ALTOS, CA. FILED 7-13-2010.



THE MARK CONSISTS OF STANDARD CHARACTERS WITHOUT CLAIM TO ANY PARTICULAR FONT, STYLE, SIZE, OR COLOR.

FOR COMPUTER SOFTWARE FOR ENHANCING AND FACILITATING SOCIAL NETWORKING FOR TELEVISION VIEWERS; COMPUTER SOFTWARE THAT PROVIDES ON-SCREEN PROGRAMMING SCHEDULES AND LISTINGS FOR BROADCAST, CABLE AND SATELLITE TELEVISION; COMPUTER SOFTWARE FOR PROVIDING INTERACTIVE ACTIVITIES IN REAL TIME FOR TELEVISION VIEWERS, NAMELY, CONDUCTING USER-GENERATED POLLS, INTEGRATION WITH OTHER SOCIAL NETWORKING SITES AND CELEBRITY SITES, AND AUTOMATIC CHECK-IN TO BECOME INFORMED WHAT FRIENDS AND CELEBRITIES ARE WATCHING ON TELEVISION; ELECTRONIC PROGRAMMING GUIDE, NAMELY, PROVIDING AN ONLINE GUIDE FEATURING THE TRANSMISSION OF ON-SCREEN PROGRAMMING SCHEDULES AND LISTINGS FOR BROADCAST, CABLE AND SATELLITE TELEVISION (U.S. CLS. 21, 23, 26, 36 AND 38).

BILL DAWE, EXAMINING ATTORNEY

SN 85-078,117. HITACHI-LG DATA STORAGE KOREA, INC., SEOUL 153-803, REPUBLIC OF KOREA, FILED 7-6-2010.



THE MARK CONSISTS OF STANDARD CHARACTERS WITHOUT CLAIM TO ANY PARTICULAR FONT, STYLE, SIZE, OR COLOR.

FOR COMPUTER HARDWARE (U.S. CLS. 21, 23, 26, 36 AND 38).

JAY BESCH, EXAMINING ATTORNEY

CLASS 9—(Continued).

SN 85-084,726. COLIBRI SOLUTIONS LLC, NEW YORK, NY. FILED 7-14-2010.

RPM

THE MARK CONSISTS OF STANDARD CHARACTERS WITHOUT CLAIM TO ANY PARTICULAR FONT, STYLE, SIZE, OR COLOR.

FOR COMPUTER SOFTWARE FOR PROTOCOL AND FACILITIES MANAGEMENT FOR ANIMAL RESEARCH (U.S. CLS. 21, 23, 26, 36 AND 38).

FIRST USE 3-0-2010; IN COMMERCE 3-0-2010.
BRIDGETT SMITH, EXAMINING ATTORNEY

SN 85-085,022. NAPA PRODUCT SOLUTIONS, INC, FREMONT, CA. FILED 7-15-2010.

NAPA ACOUSTIC

THE MARK CONSISTS OF STANDARD CHARACTERS WITHOUT CLAIM TO ANY PARTICULAR FONT, STYLE, SIZE, OR COLOR.

NO CLAIM IS MADE TO THE EXCLUSIVE RIGHT TO USE "ACOUSTIC", APART FROM THE MARK AS SHOWN. FOR ELECTRICAL PRODUCTS, NAMELY, LOUD-SPEAKERS, AUDIO AMPLIFIER, VACUUM TUBE AUDIO AMPLIFIER, CD PLAYER, REFLECTIVE AND ABSORPTIVE ACOUSTIC PANELS FOR USE IN STEREO SPEAKER CABINETS, AC POWER LINE CONDITIONERS, AND AUDIO CABLES (U.S. CLS. 21, 23, 26, 36 AND 38).

FIRST USE 9-8-2009; IN COMMERCE 9-8-2009.
JOHN DWYER, EXAMINING ATTORNEY

SN 85-086,166. WPFY, INC., WILMINGTON, DE. FILED 7-16-2010.

COLOR-TRAK

THE MARK CONSISTS OF STANDARD CHARACTERS WITHOUT CLAIM TO ANY PARTICULAR FONT, STYLE, SIZE, OR COLOR.

FOR ELECTRIC CABLES (U.S. CLS. 21, 23, 26, 36 AND 38).

FIRST USE 6-0-2002; IN COMMERCE 6-0-2002.
ANNE FARRELL, EXAMINING ATTORNEY

CLASS 9—(Continued).

SN 85-086,610. JOLIECO, LLC, DANVILLE, CA. FILED 7-16-2010.

Smart Funnies

THE MARK CONSISTS OF STANDARD CHARACTERS WITHOUT CLAIM TO ANY PARTICULAR FONT, STYLE, SIZE, OR COLOR.

FOR DOWNLOADABLE ELECTRONIC PUBLICATIONS, NAMELY, BOOKS, E-BOOKS AND WORKBOOKS FEATURING MUSIC INSTRUCTION RECORDING ON COMPUTER MEDIA; COMPUTER APPLICATION SOFTWARE FOR MOBILE PHONES AND MOBILE DEVICES, NAMELY, EDUCATIONAL SOFTWARE FEATURING INSTRUCTION IN FINE ARTS, MATH, SCIENCE, WRITING, LANGUAGE ARTS, AND SOCIAL STUDIES (U.S. CLS. 21, 23, 26, 36 AND 38).

FIRST USE 6-1-2010; IN COMMERCE 6-1-2010.
RENEE SERVANCE, EXAMINING ATTORNEY

SN 85-087,708. OSBE S.R.L., MONCALIERI (TO), ITALY, FILED 7-19-2010.



NO CLAIM IS MADE TO THE EXCLUSIVE RIGHT TO USE "HELMETS", APART FROM THE MARK AS SHOWN.

THE MARK CONSISTS OF AN OVAL OPEN ON ITS ENDS WITH THE WORDS "HELMETS" IN SMALLER LETTERS UNDERNEATH THE LARGER LETTERS "OSBE" ALL IN THE MIDDLE OF THE OVAL.

FOR SPORTS HELMETS; SAFETY HELMETS; SECURITY HELMETS; CRASH HELMETS FOR MOTORCYCLES; INDUSTRIAL SAFETY HELMETS; MOTORCYCLE HELMETS; PROTECTIVE HELMETS (U.S. CLS. 21, 23, 26, 36 AND 38).

DOMINIC J. FERRAIUOLO, EXAMINING ATTORNEY

SN 85-088,232. HANCHETT ENTRY SYSTEMS, INC., PHOENIX, AZ. FILED 7-20-2010.

GENESIS

THE MARK CONSISTS OF STANDARD CHARACTERS WITHOUT CLAIM TO ANY PARTICULAR FONT, STYLE, SIZE, OR COLOR.

FOR DOOR ELECTRIC STRIKES (U.S. CLS. 21, 23, 26, 36 AND 38).

FIRST USE 0-0-2000; IN COMMERCE 0-0-2000.
MICHAEL GAAFAR, EXAMINING ATTORNEY

CLASS 9—(Continued).

SN 85-089,070. COLOR-LOGIC INC, WEST CHESTER, OH.
FILED 7-20-2010.



NO CLAIM IS MADE TO THE EXCLUSIVE RIGHT TO USE "COLOR" OR "SPECIAL EFFECTS FOR PRINT", APART FROM THE MARK AS SHOWN.

FOR COMPUTER APPLICATION SOFTWARE FOR INKJET DIGITAL PRINTING, OFFSET PRINTING, FLEXOGRAPHIC PRINTING, THERMAL TRANSFER PRINTING, XEROGRAPHIC, ELECTROINK, AND ALL FORMS OF PRINTING AND REPRODUCTION WITHIN THE MEDIUM OF METALLIC INK OR METALLIC SUBSTRATES IN THE FIELD OF GRAPHIC DESIGN, PRINTING, DIGITAL IMAGING (U.S. CLS. 21, 23, 26, 36 AND 38).

FIRST USE 3-14-2010; IN COMMERCE 3-15-2010.
MATTHEW KLINE, EXAMINING ATTORNEY

SN 85-092,495. POINT HORIZON INSTITUTE, RAVENDALE, CA. FILED 7-26-2010.

CLAIRVISION

THE MARK CONSISTS OF STANDARD CHARACTERS WITHOUT CLAIM TO ANY PARTICULAR FONT, STYLE, SIZE, OR COLOR.

OWNER OF U.S. REG. NOS. 1,848,357 AND 1,851,946.
FOR DVDS, CDS, CD-ROMS, CASSETTE TAPES, ELECTRONIC PUBLICATIONS, NAMELY, BOOKS, DOWNLOADABLE SOFTWARE FOR DOWNLOADING EDUCATIONAL COURSES ONLINE, ALL IN THE FIELDS OF CONSCIOUSNESS STUDIES, MEDITATION, SPIRITUALITY, RELIGION, ALTERNATIVE THERAPIES, NATURAL THERAPY, HEALING AND ENERGETIC MANAGEMENT TECHNIQUES, DEATH AND DYING AND GRIEF AND BEREAVEMENT MANAGEMENT, SPIRITUAL PHILOSOPHY, ASTROLOGY, ESOTERICISM, PSYCHOLOGY, PSYCHOTHERAPY, PERSONAL DEVELOPMENT, SELF-EXPLORATION AND SELF-TRANSFORMATION; DOWNLOADABLE MUSIC (U.S. CLS. 21, 23, 26, 36 AND 38).

ALEX KEAM, EXAMINING ATTORNEY

CLASS 9—(Continued).

SN 85-096,359. FEATHER FREE LLC, CARSON, CA. FILED 7-29-2010.

AVIHAZE

THE MARK CONSISTS OF STANDARD CHARACTERS WITHOUT CLAIM TO ANY PARTICULAR FONT, STYLE, SIZE, OR COLOR.

FOR ELECTROMECHANICAL DEVICE FOR DELIVERING AN AIRBORNE BIRD REPELLENT, FOR USE IN PEST CONTROL (U.S. CLS. 21, 23, 26, 36 AND 38).

FIRST USE 7-0-2008; IN COMMERCE 7-0-2008.
TASNEEM HUSSAIN, EXAMINING ATTORNEY

SN 85-100,501. EARTHQUAKE SOUND CORPORATION, HAYWARD, CA. FILED 8-4-2010.

3D MOTION

THE MARK CONSISTS OF STANDARD CHARACTERS WITHOUT CLAIM TO ANY PARTICULAR FONT, STYLE, SIZE, OR COLOR.

NO CLAIM IS MADE TO THE EXCLUSIVE RIGHT TO USE "MOTION", APART FROM THE MARK AS SHOWN.

FOR AMUSEMENT APPARATUS ADAPTED FOR USE WITH TELEVISION RECEIVERS OR WITH VIDEO OR COMPUTER MONITORS FOR GENERATING VIBRATION EFFECTS DURING VIDEO GAME PLAY AND VIEWING OF TELEVISION PROGRAMS AND MOVIES (U.S. CLS. 21, 23, 26, 36 AND 38).

FIRST USE 1-15-2010; IN COMMERCE 1-15-2010.
APRIL ROACH, EXAMINING ATTORNEY

SN 85-100,740. INSIGHT APPLICATIONS, LLC, CINCINNATI, OH. FILED 8-5-2010.

appMD

THE MARK CONSISTS OF STANDARD CHARACTERS WITHOUT CLAIM TO ANY PARTICULAR FONT, STYLE, SIZE, OR COLOR.

FOR COMPUTER APPLICATION SOFTWARE FOR MOBILE DEVICES, NAMELY, SOFTWARE WITH MOBILE AND INTERNET BASED APPLICATION FOR DELIVERING MEDICAL AND HEALTH-CARE INFORMATION IN THE NATURE OF QUESTIONS THAT PATIENTS SHOULD ASK DOCTORS DURING VISITS (U.S. CLS. 21, 23, 26, 36 AND 38).

FIRST USE 7-21-2010; IN COMMERCE 7-21-2010.
ANGELA M. MICHELI, EXAMINING ATTORNEY

CLASS 9—(Continued).

SN 85-100,836. CLIFFORD, LINDSEY J., RANCHO SANTA FE, CA. FILED 8-5-2010.



THE MARK CONSISTS OF AN ORNATE, SYMBOLIC CROSS ENCLOSED BY A DECORATIVE OVAL RESEMBLING A VERTICAL FISH.

FOR COMPUTER APPLICATION SOFTWARE FOR MOBILE PHONES FOR TRANSMITTING ELECTRONIC BOOKS, ARTICLES, COMMENTARY AND INFORMATION ABOUT RELIGION (U.S. CLS. 21, 23, 26, 36 AND 38).

ASMAT KHAN, EXAMINING ATTORNEY

SN 85-101,702. HORIBA JOBIN YVON INC., EDISON, NJ. FILED 8-6-2010.

DELTADIODE

THE MARK CONSISTS OF STANDARD CHARACTERS WITHOUT CLAIM TO ANY PARTICULAR FONT, STYLE, SIZE, OR COLOR.

FOR SCIENTIFIC APPARATUS AND INSTRUMENTS FOR OPTICAL ANALYSIS, NAMELY, SPECTROMETERS, PHOTOLUMINESCENCE AND FLUORESCENCE SPECTROMETERS. APPARATUS AND INSTRUMENTS FOR PHOTOLUMINESCENCE LIFE-TIME MEASUREMENT AND SPECTROGRAPHS; MICROSCOPES; SCANNERS; AND RELATED COMPONENTS THEREOF, NAMELY, LIGHT-CONDUCTING FILAMENTS, ELECTRIC POWER CABLES, INTERFACE BETWEEN ELECTRICAL POWER CONNECTORS, DIFFRACTION GRATING, OPTICAL LENSES, OPTICAL MIRRORS AND OPTICAL FILTERS; COMPUTER SOFTWARE FOR OPTICAL ANALYSIS AND DATA ACQUISITION AND PROCESSING FOR USE IN ASSOCIATION WITH SPECTROMETERS (U.S. CLS. 21, 23, 26, 36 AND 38).

MICHELLE DUBOIS, EXAMINING ATTORNEY

CLASS 9—(Continued).

SN 85-102,245. VALVE CORPORATION, BELLEVUE, WA. FILED 8-6-2010.

DOTA

THE MARK CONSISTS OF STANDARD CHARACTERS WITHOUT CLAIM TO ANY PARTICULAR FONT, STYLE, SIZE, OR COLOR.

FOR COMPUTER GAME SOFTWARE; ELECTRONIC GAME SOFTWARE; VIDEO GAME SOFTWARE (U.S. CLS. 21, 23, 26, 36 AND 38).

MICHAEL SOUDERS, EXAMINING ATTORNEY

SN 85-102,392. SANDISK CORPORATION, MILPITAS, CA. FILED 8-6-2010.

SANDISK IMAGEVAULT

THE MARK CONSISTS OF STANDARD CHARACTERS WITHOUT CLAIM TO ANY PARTICULAR FONT, STYLE, SIZE, OR COLOR.

OWNER OF U.S. REG. NOS. 2,036,202, 2,794,796 AND OTHERS.

FOR COMPUTER STORAGE DEVICES, NAMELY, USB FLASH DRIVES PRELOADED WITH DATA ARCHIVING SOFTWARE (U.S. CLS. 21, 23, 26, 36 AND 38).

LINDA ORNDORFF, EXAMINING ATTORNEY

SN 85-103,207. 31, INC., NEWCOMERSTOWN, OH. FILED 8-9-2010.

X^oTRA SEAL SMART SENSOR

OWNER OF U.S. REG. NOS. 2,188,672 AND 2,249,824.

NO CLAIM IS MADE TO THE EXCLUSIVE RIGHT TO USE "SEAL SMART SENSOR", APART FROM THE MARK AS SHOWN.

THE MARK CONSISTS OF THE WORDS "XTRA SEAL SMART SENSOR" WITH AN ELEVATED SMALL "O" BETWEEN THE LETTERS "X" AND "T" OF THE WORD "XTRA".

FOR TIRE PRESSURE SENSORS (U.S. CLS. 21, 23, 26, 36 AND 38).

EDWARD FENNESSY, EXAMINING ATTORNEY

CLASS 9—(Continued).

SN 85-103,220. PROGRESS SOFTWARE CORPORATION, BEDFORD, MA. FILED 8-9-2010.

FUSESOURCE

THE MARK CONSISTS OF STANDARD CHARACTERS WITHOUT CLAIM TO ANY PARTICULAR FONT, STYLE, SIZE, OR COLOR.

OWNER OF U.S. REG. NOS. 3,656,398, 3,656,401 AND OTHERS.

FOR COMPUTER PROGRAMS AND COMPUTER SOFTWARE FOR OPEN SOURCE ENTERPRISE MESSAGING; COMPUTER PROGRAMS AND COMPUTER SOFTWARE FOR SERVICE-ORIENTED ARCHITECTURES, NAMELY, COMPUTER PROGRAMS AND COMPUTER SOFTWARE FOR MANAGING, DEVELOPING, INTEGRATING, DEPLOYING AND MONITORING COMPUTER PROGRAMS AND COMPONENTS WITHIN AN ENVIRONMENT WHICH ALLOWS DISTRIBUTED SYSTEMS TO OPERATE; COMPUTER PROGRAMS AND COMPUTER SOFTWARE FOR DEVELOPING, INTEGRATING AND DEPLOYING COMPUTER PROGRAMS AND FOR THE INTEGRATION OF SOFTWARE APPLICATIONS AND SYSTEM COMPONENTS ACROSS DIFFERENT LANGUAGES, PLATFORMS AND NETWORKS, INCLUDING ACROSS GLOBAL COMPUTER NETWORKS (U.S. CLS. 21, 23, 26, 36 AND 38).

CHRISTOPHER BUONGIORNO, EXAMINING ATTORNEY

SN 85-103,252. 31, INC., NEWCOMERSTOWN, OH. FILED 8-9-2010.

X_oTRA SEAL ONE TO ONE SENSOR

OWNER OF U.S. REG. NOS. 2,188,672 AND 2,249,824. NO CLAIM IS MADE TO THE EXCLUSIVE RIGHT TO USE "SEAL" AND "SENSOR", APART FROM THE MARK AS SHOWN.

THE MARK CONSISTS OF THE WORDS "XTRA SEAL ONE TO ONE SENSOR" WITH AN ELEVATED SMALL "O" BETWEEN THE LETTERS "X" AND "T" OF THE WORD "XTRA".

FOR VEHICLE SAFETY EQUIPMENT, NAMELY, ELECTRONIC TIRE PRESSURE MONITORS (U.S. CLS. 21, 23, 26, 36 AND 38).

EDWARD FENNESSY, EXAMINING ATTORNEY

CLASS 9—(Continued).

SN 85-103,266. OLYMPUS MEDICAL SYSTEMS CORP., TOKYO, JAPAN, FILED 8-9-2010.

OLYBIE

THE MARK CONSISTS OF STANDARD CHARACTERS WITHOUT CLAIM TO ANY PARTICULAR FONT, STYLE, SIZE, OR COLOR.

FOR PDA (PERSONAL DIGITAL ASSISTANTS); PARTS AND ACCESSORIES THEREFOR, NAMELY, CRADLES FOR PORTABLE DEVICES, ALTERNATING CURRENT (AC) ADAPTERS, BATTERIES AND COMPUTER SOFTWARE FOR USE WITH MEDICAL PATIENT MONITORING EQUIPMENT FOR RECEIVING, PROCESSING AND DISPLAYING DATA; PDA (PERSONAL DIGITAL ASSISTANTS) AS USED IN THE MEDICAL FIELD; PARTS AND ACCESSORIES THEREFOR, NAMELY, CRADLES FOR PORTABLE DEVICES, ALTERNATING CURRENT (AC) ADAPTERS, BATTERIES AND COMPUTER SOFTWARE FOR USE WITH MEDICAL PATIENT MONITORING EQUIPMENT FOR RECEIVING, PROCESSING AND DISPLAYING DATA AS USED IN THE MEDICAL FIELD AND ALL OF THE FOREGOING SOLD AS A UNIT (U.S. CLS. 21, 23, 26, 36 AND 38).

JUDITH HELFMAN, EXAMINING ATTORNEY

SN 85-103,365. ZIPPY TECHNOLOGY CORP., HSIN-TIEN CITY, TAIWAN, FILED 8-9-2010.

Dancing Light

THE MARK CONSISTS OF STANDARD CHARACTERS WITHOUT CLAIM TO ANY PARTICULAR FONT, STYLE, SIZE, OR COLOR.

FOR COMPUTER KEYBOARDS; COMPUTER MOUSE; MOUSE PADS; REMOTE CONTROLS FOR RADIOS, TELEVISIONS AND STEREOS; COMPUTER NETWORK HUBS; COMPUTER CURSOR CONTROL DEVICES, NAMELY, DIGITIZER TABLETS; COMPUTER STANDS SPECIALLY DESIGNED FOR HOLDING A COMPUTER, NOTEBOOK, PRINTER AND ACCESSORIES (U.S. CLS. 21, 23, 26, 36 AND 38).

GINA FINK, EXAMINING ATTORNEY

CLASS 9—(Continued).

SN 85-103,566. GEBLER, KATHRYN, BELL CANYON, CA. FILED 8-9-2010.

THE COTTONTAIL CANDY CO.

THE MARK CONSISTS OF STANDARD CHARACTERS WITHOUT CLAIM TO ANY PARTICULAR FONT, STYLE, SIZE, OR COLOR.

NO CLAIM IS MADE TO THE EXCLUSIVE RIGHT TO USE "CANDY CO.", APART FROM THE MARK AS SHOWN. FOR COTTON CANDY VENDING MACHINES (U.S. CLS. 21, 23, 26, 36 AND 38).

TIMOTHY FINNEGAN, EXAMINING ATTORNEY

SN 85-104,040. THERMO PROCESS INSTRUMENTS, L.P., SUGAR LAND, TX. FILED 8-10-2010.

PRIMA

THE MARK CONSISTS OF STANDARD CHARACTERS WITHOUT CLAIM TO ANY PARTICULAR FONT, STYLE, SIZE, OR COLOR.

FOR SPECTROMETERS, NAMELY, MASS SPECTROMETERS (U.S. CLS. 21, 23, 26, 36 AND 38).

FIRST USE 12-31-1989; IN COMMERCE 12-31-1990.

PAULA MAHONEY, EXAMINING ATTORNEY

SN 85-104,178. BELKIN INTERNATIONAL, INC., PLAYA VISTA, CA. FILED 8-10-2010.

CONSERVE ADVISOR

THE MARK CONSISTS OF STANDARD CHARACTERS WITHOUT CLAIM TO ANY PARTICULAR FONT, STYLE, SIZE, OR COLOR.

FOR BUILDING SYSTEMS FOR DETERMINING ENERGY USAGE, NAMELY, DIGITAL MONITORS FOR MEASURING POWER CONSUMPTION AND POWER CONSUMPTION METERS (U.S. CLS. 21, 23, 26, 36 AND 38).

JEFFREY LOOK, EXAMINING ATTORNEY

CLASS 9—(Continued).

SN 85-105,070. JASCO PRODUCTS COMPANY LLC, OKLAHOMA CITY, OK. FILED 8-11-2010.

HD3 Tech

THE MARK CONSISTS OF STANDARD CHARACTERS WITHOUT CLAIM TO ANY PARTICULAR FONT, STYLE, SIZE, OR COLOR.

NO CLAIM IS MADE TO THE EXCLUSIVE RIGHT TO USE "TECH", APART FROM THE MARK AS SHOWN.

FOR ACCESSORY PRODUCTS FOR AUDIO-VIDEO DEVICES, NAMELY, SET TOP BOXES, COMPUTERS, MOBILE PHONES, ELECTRONIC PORTABLE DEVICES, NAMELY, AUDIO HEADPHONES AND HEADSETS FOR COMPUTERS, MICROPHONES, AUDIO SPEAKERS, COAX AND ELECTRIC CABLES, ANTENNAS, REMOTE CONTROLS FOR TELEVISIONS AND RECEIVERS, SIGNAL ENHANCING DEVICES, NAMELY, TRANSMITTERS OF ELECTRIC SIGNALS, BATTERIES, INPUT DEVICES FOR COMPUTERS, COMPUTER CAMERAS, NETWORK HUBS, ELECTRONIC CARD READERS, NETWORK ROUTERS, MOUSE PADS AND WRIST RESTS FOR USE WITH COMPUTERS, CASES AND MOUNTS FOR COMPUTERS, CAMERAS, MOBILE PHONES, SIGNAL SPLITTERS FOR ELECTRONIC APPARATUS, AUDIO AND VIDEO RECEIVERS, DIGITAL MEDIA STREAMING DEVICES, ELECTRIC SWITCH AND OUTLET WALL PLATES (U.S. CLS. 21, 23, 26, 36 AND 38).

DEIRDRE ROBERTSON, EXAMINING ATTORNEY

SN 85-106,041. ROTOLIGHT LIMITED, WIMBLEDON, LONDON, UNITED KINGDOM, FILED 8-12-2010.

ROTOLIGHT

THE MARK CONSISTS OF STANDARD CHARACTERS WITHOUT CLAIM TO ANY PARTICULAR FONT, STYLE, SIZE, OR COLOR.

FOR STILL CAMERAS; VIDEO CAMERAS; CINEMATIC FILM CAMERAS; PHOTOGRAPHIC FLASH LIGHTING APPARATUS, NAMELY, FLASH BULBS, PHOTOGRAPHIC FLASH UNITS AND RING FLASH UNITS; FLASH LAMPS; CAMERA AND VIDEO LIGHTING APPARATUS, NAMELY, LIGHTS FOR USE ON STILL CAMERAS, LIGHTS FOR USE ON VIDEO CAMERAS, STUDIO LIGHTS, BROADCAST LIGHTS, LIGHTS MOUNTED TO TRIPODS OR LIGHTING STANDS, RING LIGHTS AND FILL LIGHTS; POUCHES AND CASES FOR THE AFORESAID GOODS; PRE-RECORDED MAGNETIC DATA CARRIERS IN THE FIELD OF PHOTOGRAPHY, FLASH PHOTOGRAPHY, FILMING, PHOTOGRAPHIC LIGHTING AND VIDEO LIGHTING; COMPUTERS (U.S. CLS. 21, 23, 26, 36 AND 38).

MICHAEL KEATING, EXAMINING ATTORNEY

CLASS 9—(Continued).

SN 85-106,732. WHEELWRIGHT PARTNERS LLC, MORRIS PLAINS, NJ. FILED 8-13-2010.

CLASS 9—(Continued).

SN 85-107,012. ROAMING KEYBOARDS LLC., MILLBRAE, CA. FILED 8-13-2010.

Watch Your Six!

PADKITE

THE MARK CONSISTS OF STANDARD CHARACTERS WITHOUT CLAIM TO ANY PARTICULAR FONT, STYLE, SIZE, OR COLOR.

FOR SAFETY AND VISION SYSTEMS FOR MOTOR VEHICLES COMPRISED OF CAMERAS, MONITORS, AND ELECTRIC SENSORS FOR IMPROVING REAR VISIBILITY (U.S. CLS. 21, 23, 26, 36 AND 38).

CHRISTINA SOBRAL, EXAMINING ATTORNEY

THE MARK CONSISTS OF STANDARD CHARACTERS WITHOUT CLAIM TO ANY PARTICULAR FONT, STYLE, SIZE, OR COLOR.

FOR COMPUTER HARDWARE; COMPUTER PERIPHERALS; COMPUTER SOFTWARE PROGRAMS FOR PERSONAL INFORMATION MANAGEMENT, DATABASE MANAGEMENT SOFTWARE, ELECTRONIC MAIL AND MESSAGING SOFTWARE, PAGING SOFTWARE, DATABASE SYNCHRONIZATION SOFTWARE, COMPUTER PROGRAMS FOR ACCESSING, BROWSING AND SEARCHING ONLINE DATABASES, COMPUTER SOFTWARE AND FIRMWARE, NAMELY, OPERATING SYSTEM PROGRAMS, DATA SYNCHRONIZATION PROGRAMS, AND APPLICATION DEVELOPMENT COMPUTER SOFTWARE PROGRAMS FOR PERSONAL AND HANDHELD COMPUTERS; SOFTWARE FOR THE REDIRECTION OF MESSAGES, INTERNET E-MAIL, AND/OR OTHER DATA TO ONE OR MORE ELECTRONIC HANDHELD SERVICES FROM A DATA STORE OR ASSOCIATED WITH PERSONAL COMPUTER OR A SERVER; SOFTWARE FOR THE SYNCHRONIZATION OF DATA BETWEEN A REMOTE STATION OR DEVICE AND A FIXED OR REMOTE STATION OR DEVICE (U.S. CLS. 21, 23, 26, 36 AND 38).

FIRST USE 8-13-2010; IN COMMERCE 8-13-2010.
ANGELA DUONG, EXAMINING ATTORNEY

SN 85-106,736. WHEELWRIGHT PARTNERS LLC, MORRIS PLAINS, NJ. FILED 8-13-2010.

SN 85-107,126. JOE GIBBS RACING, INC., HUNTERSVILLE, NC. FILED 8-13-2010.



JOE GIBBS DRIVEN

THE MARK CONSISTS OF A RIDER ON A MOTORCYCLE DESIGN WITH THE LETTERS "WATCH YOUR SIX!" APPEARING UNDERNEATH THE DESIGN.

FOR SAFETY AND VISION SYSTEMS FOR MOTOR VEHICLES COMPRISED OF CAMERAS, MONITORS, AND ELECTRIC SENSORS FOR IMPROVING REAR VISIBILITY (U.S. CLS. 21, 23, 26, 36 AND 38).

CHRISTINA SOBRAL, EXAMINING ATTORNEY

THE MARK CONSISTS OF STANDARD CHARACTERS WITHOUT CLAIM TO ANY PARTICULAR FONT, STYLE, SIZE, OR COLOR.

OWNER OF U.S. REG. NOS. 1,851,538, 3,474,514 AND OTHERS.

THE NAME(S), PORTRAIT(S), AND/OR SIGNATURE(S) SHOWN IN THE MARK IDENTIFIES "JOE GIBBS", WHOSE CONSENT(S) TO REGISTER IS MADE OF RECORD.

FOR GPS NAVIGATION DEVICES (U.S. CLS. 21, 23, 26, 36 AND 38).

LINDA POWELL, EXAMINING ATTORNEY

CLASS 9—(Continued).

SN 85-107,312. AVANTEXT, INC., CONSHOHOCKEN, PA. FILED 8-13-2010.

Avantext...
sentinel

OWNER OF U.S. REG. NO. 3,443,940.
THE MARK CONSISTS OF THE WORD "AVANTEXT" WITH A TRIANGLE SERVING AS THE CROSS IN THE FIRST LETTER "A" FOLLOWED BY THREE DOTS ABOVE THE WORD "SENTINEL" WITH THE LAST DOT COMPRISING THE DOT FOR THE LETTER "I".

FOR COMPUTER SOFTWARE FEATURING REGULATORY INFORMATION REGARDING AIRWORTHINESS FOR THE AERONAUTICAL INDUSTRY AND AVIATORS (U.S. CLS. 21, 23, 26, 36 AND 38).

DORITT L. CARROLL, EXAMINING ATTORNEY

SN 85-107,683. NECTOSOFT INC., DBA NECTOSOFT INC., NEW ALBANY, OH. FILED 8-14-2010.

StickyDoo

THE MARK CONSISTS OF STANDARD CHARACTERS WITHOUT CLAIM TO ANY PARTICULAR FONT, STYLE, SIZE, OR COLOR.

FOR COMPUTER APPLICATION SOFTWARE FOR MOBILE PHONES, PORTABLE MEDIA PLAYERS, HANDHELD COMPUTERS, NAMELY, SOFTWARE FOR TASK MANAGEMENT AND FOR PROVIDING PERSONALIZED CONSUMER RESOURCES FOR SEARCHING, LOCATING, PROVIDING DIRECTIONS FOR THE PURCHASE, CONSUMPTION, AND USE OF A WIDE RANGE OF CONSUMER PRODUCTS, SERVICES AND INFORMATION OVER A GLOBAL COMMUNICATIONS NETWORK AND USING ANY CONNECTIVITY IN ANY FORMAT, NAMELY, MOBILE COMMUNICATION DEVICES, EMAIL, DESKTOP INTERNET, OR SOCIAL MEDIA CHANNELS; DOWNLOADABLE SOFTWARE IN THE NATURE OF A MOBILE APPLICATION FOR TASK MANAGEMENT AND FOR PROVIDING PERSONALIZED CONSUMER RESOURCES FOR SEARCHING, LOCATING, PROVIDING DIRECTIONS FOR THE PURCHASE, CONSUMPTION, AND USE OF A WIDE RANGE OF CONSUMER PRODUCTS, SERVICES AND INFORMATION OVER A GLOBAL COMMUNICATIONS NETWORK AND USING ANY CONNECTIVITY IN ANY FORMAT, NAMELY, MOBILE COMMUNICATION DEVICES, EMAIL, DESKTOP INTERNET, OR SOCIAL MEDIA CHANNELS (U.S. CLS. 21, 23, 26, 36 AND 38).

FIRST USE 3-1-2010; IN COMMERCE 8-14-2010.

MARGARET POWER, EXAMINING ATTORNEY

CLASS 9—(Continued).

SN 85-108,556. SAMSIN USA, LLC, MASON, OH. FILED 8-16-2010.

samsin

THE MARK CONSIST OF THE WORD "SAMSIN" WITH THE LETTER "I" AS A LEG OF THE LETTER "N".

THE WORD "SAMSIN" HAS NO MEANING IN A FOREIGN LANGUAGE.

FOR ELECTRICAL CABLES; CABLE ASSEMBLIES FOR USE WITH COMPUTERS, CELLULAR OR OTHER MOBILE PHONES, OR COMMUNICATIONS NETWORK TRANSCEIVERS, NAMELY, ELECTRICAL CABLES WITH AN OVERMOLDED CONNECTOR AND STRAIN RELIEF ON AN END THEREOF; BATTERY CHARGERS (U.S. CLS. 21, 23, 26, 36 AND 38).

KATHERINE STOIDES, EXAMINING ATTORNEY

SN 85-109,965. SARTORIUS AG, GOETTINGEN, FED REP GERMANY, FILED 8-18-2010.

ProRecipe XT

THE MARK CONSISTS OF STANDARD CHARACTERS WITHOUT CLAIM TO ANY PARTICULAR FONT, STYLE, SIZE, OR COLOR.

PRIORITY CLAIMED UNDER SEC. 44(D) ON ERPNCMNTY TM OFC APPLICATION NO. 008941007, FILED 3-10-2010, REG. NO. 008941007, DATED 9-27-2010, EXPIRES 3-10-2020.

NO CLAIM IS MADE TO THE EXCLUSIVE RIGHT TO USE "XT", APART FROM THE MARK AS SHOWN.

FOR SOFTWARE FOR ADMINISTERING AND MANAGING THE MANUALLY AND AUTOMATIC DISPENSING OF PRESCRIBED MIXTURES FOR USE IN THE PHARMACEUTICAL, FOOD AND COSMETIC INDUSTRIES (U.S. CLS. 21, 23, 26, 36 AND 38).

CARYN GLASSER, EXAMINING ATTORNEY

CLASS 9—(Continued).

SN 85-110,478. ANDERSEN & ASSOCIATES, WIXOM, MI.
FILED 8-18-2010.

ULTRAPICK

THE MARK CONSISTS OF STANDARD CHARACTERS WITHOUT CLAIM TO ANY PARTICULAR FONT, STYLE, SIZE, OR COLOR.

FOR COMPUTER SOFTWARE FOR CONTROLLING DELIVERY OF MULTIPLE PRODUCTS FROM A CONVEYOR CAROUSEL STORAGE SYSTEM TO A SELECTION STATION AND FOR PROVIDING TOUCH SCREEN CONTROLS AND COMMANDS TO DIRECT PRODUCTION DISPOSITION (U.S. CLS. 21, 23, 26, 36 AND 38).

MICHAEL SOUDERS, EXAMINING ATTORNEY

SN 85-113,288. IMAGINATION TECHNOLOGIES LTD.,
HERTFORDSHIRE WD4 8LZ, UNITED KINGDOM,
FILED 8-23-2010.

AVALON

THE MARK CONSISTS OF STANDARD CHARACTERS WITHOUT CLAIM TO ANY PARTICULAR FONT, STYLE, SIZE, OR COLOR.

OWNER OF ERPN CMNTY TM OFC REG. NO. 5799721,
DATED 1-31-2008, EXPIRES 1-31-2018.

FOR TELEVISION SETS; TELEVISION DECODING APPARATUS AND SET TOP BOXES, BEING RECEPTION EQUIPMENT FOR TELEVISIONS; SATELLITE TELEVISION RECEIVERS; VIDEO RECORDERS AND PLAYERS; DVD RECORDERS AND PLAYERS; PARTS AND FITTINGS FOR ALL THE AFORESAID GOODS (U.S. CLS. 21, 23, 26, 36 AND 38).

JILL PRATER, EXAMINING ATTORNEY

SN 85-113,767. DYK, JEFFREY O., AKA JEFF DYK, KATY,
TX. AND NIVEN, CHRISTOPHER J., AKA CHRIS NIVEN,
HOUSTON, TX. FILED 8-23-2010.

TOTAL ASSET MANAGER

THE MARK CONSISTS OF STANDARD CHARACTERS WITHOUT CLAIM TO ANY PARTICULAR FONT, STYLE, SIZE, OR COLOR.

NO CLAIM IS MADE TO THE EXCLUSIVE RIGHT TO USE "ASSET MANAGER", APART FROM THE MARK AS SHOWN.

FOR COMPUTER SOFTWARE TO FACILITATE MINING, DRILLING, AND PRODUCTION OF PETROLEUM AND NATURAL GAS (U.S. CLS. 21, 23, 26, 36 AND 38).

FIRST USE 1-1-2009; IN COMMERCE 1-1-2009.

JOHN DWYER, EXAMINING ATTORNEY

CLASS 9—(Continued).

SN 85-114,034. OVERTONE, INC., SAN FRANCISCO, CA.
FILED 8-23-2010.

open  mic

OWNER OF U.S. REG. NO. 3,785,731.

THE MARK CONSISTS OF THE WORDS "OPEN" AND "MIC" IN LOWER CASE LETTERS WITH THE TOP OF A MICROPHONE APPEARING BETWEEN THE TWO WORDS. FOR COMPUTER SOFTWARE FOR EXTRACTING, ORGANIZING AND ANALYZING TEXTUAL AND NUMERIC DATA AND INFORMATION FOR USE IN REPORTING ON DIRECT CUSTOMER FEEDBACK AND IN THE FIELD OF SOCIAL MEDIA CONTENTS AND OTHER INTERNET-BASED CONTENTS (U.S. CLS. 21, 23, 26, 36 AND 38).

FIRST USE 1-26-2009; IN COMMERCE 1-26-2009.

ELIZABETH KAJUBI, EXAMINING ATTORNEY

SN 85-114,716. B4 CONCEPTS, LLC, SHAWNEE, KS. FILED 8-24-2010.



NO CLAIM IS MADE TO THE EXCLUSIVE RIGHT TO USE "GARAGE STOP-FOB" AND "PARKING", APART FROM THE MARK AS SHOWN.

THE COLOR(S) BLACK, RED, BLUE IS/ARE CLAIMED AS A FEATURE OF THE MARK.

THE MARK CONSISTS OF RED STYLIZED LETTERS FOR THE WORDS "GARAGE STOP-FOB" WITH A BLUE BALL BELOW THE LETTER "P" WITH BLACK STYLIZED LETTERS FORMING A CURVE FOR THE WORDS "FOR PERFECT PARKING" WITH A BLACK LINE AND TWO BLACK OVALS FORMING THE SHAPE OF A CAR.

FOR GARAGE VEHICLE STOP INDICATORS, NAMELY, INDICATORS PLACED ON THE CEILING OF A GARAGE THAT HANG DOWN TO THE VEHICLE WINDSHIELD AND SIGNAL THE DRIVER WHEN TO STOP (U.S. CLS. 21, 23, 26, 36 AND 38).

TARA PATE, EXAMINING ATTORNEY

CLASS 9—(Continued).

SN 85-118,333. SECURUS TECHNOLOGIES, INC., DALLAS, TX. FILED 8-30-2010.

SECURUS

THE MARK CONSISTS OF STANDARD CHARACTERS WITHOUT CLAIM TO ANY PARTICULAR FONT, STYLE, SIZE, OR COLOR.

OWNER OF U.S. REG. NO. 3,169,198.
FOR DIGITAL RECORDERS AND COMPUTER HARDWARE FOR DATA STORAGE, FOR RECORDING, TRANSMISSION, PROCESSING AND REPRODUCTION OF SOUND, IMAGES OR DATA; SWITCHES AND ROUTERS FOR TRANSMISSION OF COMMUNICATIONS (U.S. CLS. 21, 23, 26, 36 AND 38).
CAROLYN CATALDO, EXAMINING ATTORNEY

CLASS 9—(Continued).

SN 85-118,654. GRADUS GROUP LLC, NEW YORK, NY. FILED 8-30-2010.

OBEN

THE MARK CONSISTS OF STANDARD CHARACTERS WITHOUT CLAIM TO ANY PARTICULAR FONT, STYLE, SIZE, OR COLOR.

THE ENGLISH TRANSLATION OF THE WORD "OBEN" IN THE MARK IS UP, ABOVE OR TOP.

FOR TRIPODS, MONOPODS, STANDS, SUPPORTS AND MOUNTS FOR PHOTO AND VIDEO CAMERAS; PARTS AND ACCESSORIES FOR PHOTO AND DIGITAL CAMERA TRIPODS, MONOPODS, SUPPORTS, STANDS, AND MOUNTS, NAMELY, STRAPS, HANDLES, AND CARRYING BAGS, ALL SPECIALLY ADAPTED FOR HOLDING TRIPODS, MONOPODS, STANDS, SUPPORTS AND MOUNTS FOR PHOTO AND VIDEO CAMERAS, AND PARTS AND ACCESSORIES THEREFOR, HEADS, LEGS, ATTACHMENT BRACKETS AND PLATES, SPREADERS, WHEELS, AND DOLLIES, ALL FOR TRIPODS, MONOPODS, STANDS, SUPPORTS AND MOUNTS FOR PHOTO AND VIDEO CAMERAS (U.S. CLS. 21, 23, 26, 36 AND 38).

EDWARD FENNESSY, EXAMINING ATTORNEY

SN 85-118,573. WEST CORPORATION, OMAHA, NE. FILED 8-30-2010.

TeleVox Sync

THE MARK CONSISTS OF STANDARD CHARACTERS WITHOUT CLAIM TO ANY PARTICULAR FONT, STYLE, SIZE, OR COLOR.

NO CLAIM IS MADE TO THE EXCLUSIVE RIGHT TO USE "SYNC", APART FROM THE MARK AS SHOWN.

FOR COMPUTER SOFTWARE FOR USE IN COMPUTER TELEPHONY SYSTEMS ALLOWING FOR TWO-WAY COMMUNICATIONS BETWEEN BUSINESSES AND THEIR CLIENTS VIA TRADITIONAL VOICE AND FAX COMMUNICATION LINES AND VIA COMMUNICATION LINES ON GLOBAL COMPUTER NETWORKS (U.S. CLS. 21, 23, 26, 36 AND 38).
BRIAN CALLAGHAN, EXAMINING ATTORNEY

SN 85-118,946. ALCOHOL COUNTERMEASURE SYSTEMS (INTERNATIONAL) INC., TORONTO, ONTARIO, CANADA, FILED 8-30-2010.

INTERVIEW

THE MARK CONSISTS OF STANDARD CHARACTERS WITHOUT CLAIM TO ANY PARTICULAR FONT, STYLE, SIZE, OR COLOR.

OWNER OF CANADA REG. NO. TMA788886, DATED 1-27-2011, EXPIRES 1-27-2026.

FOR WEB BROWSER SOFTWARE FOR PROVIDING SECURE ACCESS TO DATA COLLECTED FROM BREATH ALCOHOL INTERLOCK DEVICES AND FROM SERVICE CENTERS, THE SERVICE CENTERS BEING OF THE TYPE WHICH INSTALL, MAINTAIN AND COLLECT DATA FROM BREATH ALCOHOL IGNITION INTERLOCK DEVICES (U.S. CLS. 21, 23, 26, 36 AND 38).
BARBARA BROWN, EXAMINING ATTORNEY

CLASS 9—(Continued).

SN 85-119,774. NATHAN T ARENDT, DBA YOUR CABLE STORE, PARADISE, CA. FILED 8-31-2010.



NO CLAIM IS MADE TO THE EXCLUSIVE RIGHT TO USE "YOURCABLESTORE.COM", APART FROM THE MARK AS SHOWN.

THE COLOR(S) NAVY BLUE AND ORANGE IS/ARE CLAIMED AS A FEATURE OF THE MARK.

THE MARK CONSISTS OF "YOURCABLESTORE.COM" WITH "YOUR" IN NAVY BLUE, "CABLE" IN ORANGE, "STORE" IN NAVY BLUE, THE PERIOD IN ORANGE AND "COM" IN NAVY BLUE. THE "Y" HAS A TAIL THAT EXTENDS BELOW THE LETTERING TO THE RIGHT AND ENDS IN A CABLE CONNECTOR AT THE END OF THE LETTERING ALL APPEARING IN BLUE.

FOR COMPUTER CABLES (U.S. CLS. 21, 23, 26, 36 AND 38).

FIRST USE 3-2-2006; IN COMMERCE 3-2-2006.
JASON TURNER, EXAMINING ATTORNEY

CLASS 9—(Continued).

CASSETTE RECORDERS AND PLAYERS, COMPACT DISC PLAYERS, DIGITAL AUDIO TAPE RECORDERS AND PLAYERS; RADIOS; MOUSE PADS; EYEGLASSES, SUNGLASSES AND CASES THEREFOR; GAME EQUIPMENT SOLD AS A UNIT FOR PLAYING A PARLOR-TYPE COMPUTER GAME; VIDEO AND COMPUTER GAME PROGRAMS; VIDEO GAME CARTRIDGES AND CASSETTES; COMPUTER AND VIDEO GAMES WHICH ARE DESIGNED FOR HARDWARE PLATFORMS, NAMELY, GAME CONSOLES AND PERSONAL COMPUTERS; CD-ROM COMPUTER GAME DISCS AND COMPUTER PROGRAMS, NAMELY, SOFTWARE LINKING DIGITIZED VIDEO AND AUDIO MEDIA TO A GLOBAL COMPUTER INFORMATION NETWORK, CELLULAR TELEPHONE ACCESSORIES, NAMELY, HANDS-FREE ACCESSORIES, CELLULAR TELEPHONE COVERS AND CELLULAR TELEPHONE FACE COVERS; ENCODED MAGNETIC CARDS, NAMELY, PHONE CARDS, CREDIT CARDS, CASH CARDS, DEBIT CARDS AND MAGNETIC KEY CARDS; AND DECORATIVE MAGNETS (U.S. CLS. 21, 23, 26, 36 AND 38).

KATHRYN COWARD, EXAMINING ATTORNEY

SN 85-123,018. BROXBURN DRIVE LIMITED, SOUTHAMPTON, UNITED KINGDOM, FILED 9-3-2010.

SN 85-120,131. DC COMICS, NEW YORK, NY. FILED 8-31-2010.

SUPER POWERS

THE MARK CONSISTS OF STANDARD CHARACTERS WITHOUT CLAIM TO ANY PARTICULAR FONT, STYLE, SIZE, OR COLOR.

FOR MOTION PICTURE FILMS FEATURING COMEDY, DRAMA, ACTION, ADVENTURE AND/OR ANIMATION; AND MOTION PICTURE FILMS FOR BROADCAST ON TELEVISION FEATURING COMEDY, DRAMA, ACTION, ADVENTURE AND/OR ANIMATION; AUDIO TAPES, AUDIO-VIDEO TAPES, AUDIO VIDEO CASSETTES, AUDIO VIDEO DISCS, AND DIGITAL VERSATILE DISCS FEATURING MUSIC, COMEDY, DRAMA, ACTION, ADVENTURE, AND/OR ANIMATION; STEREO HEADPHONES; CORDLESS TELEPHONES; AUDIO CASSETTE AND CD PLAYERS; CD ROM COMPUTER GAME DISCS; TELEPHONE AND/OR RADIO PAGERS; SHORT MOTION PICTURE FILM CASSETTES FEATURING COMEDY, DRAMA, ACTION, ADVENTURE AND/OR ANIMATION TO BE USED WITH HAND-HELD VIEWERS OR PROJECTORS; VIDEO

one2onetracker

THE MARK CONSISTS OF STANDARD CHARACTERS WITHOUT CLAIM TO ANY PARTICULAR FONT, STYLE, SIZE, OR COLOR.

PRIORITY CLAIMED UNDER SEC. 44(D) ON UNITED KINGDOM APPLICATION NO. 2543487, FILED 3-31-2010, REG. NO. 2543487, DATED 7-30-2010, EXPIRES 3-31-2020.

FOR COMPUTER HARDWARE; COMPUTER SOFTWARE FOR USE IN THE FIELD OF HUMAN RESOURCES FOR TRACKING AND EVIDENCING PERSONAL, TEAM AND ORGANIZATIONAL PERFORMANCE, ACCESSING EMPLOYEE RECORDS, SETTING OBJECTIVES, REVIEWS, APPRAISALS, RECORDKEEPING AND ADMINISTRATION; COMPUTER SOFTWARE FOR USE IN THE FIELD OF PERSONNEL MANAGEMENT FOR TRACKING AND EVIDENCING PERSONAL, TEAM AND ORGANIZATIONAL PERFORMANCE, ACCESSING EMPLOYEE RECORDS, SETTING OBJECTIVES, REVIEWS, APPRAISALS, RECORDKEEPING AND ADMINISTRATION; COMPUTER SOFTWARE FOR USE IN THE FIELD OF BUSINESS MANAGEMENT FOR TRACKING AND EVIDENCING PERSONAL, TEAM AND ORGANIZATIONAL PERFORMANCE, ACCESSING EMPLOYEE RECORDS, SETTING OBJECTIVES, REVIEWS, APPRAISALS, RECORDKEEPING AND ADMINISTRATION (U.S. CLS. 21, 23, 26, 36 AND 38).

PAUL F. GAST, EXAMINING ATTORNEY

CLASS 9—(Continued).

SN 85-123,465. WINGS OF STEEL PRODUCTIONS, INC., NORTH HOLLYWOOD, CA. FILED 9-5-2010.

SAINTS & SINNERS

THE MARK CONSISTS OF STANDARD CHARACTERS WITHOUT CLAIM TO ANY PARTICULAR FONT, STYLE, SIZE, OR COLOR.

FOR LEATHER CASES DESIGNED SPECIFICALLY FOR SMART PHONES; AND LEATHER CASES DESIGNED SPECIFICALLY FOR TABLET COMPUTERS (U.S. CLS. 21, 23, 26, 36 AND 38).

CURTIS FRENCH, EXAMINING ATTORNEY

SN 85-125,169. THE REGENTS OF THE UNIVERSITY OF COLORADO, DENVER, CO. FILED 9-8-2010.

BIONET

THE MARK CONSISTS OF STANDARD CHARACTERS WITHOUT CLAIM TO ANY PARTICULAR FONT, STYLE, SIZE, OR COLOR.

FOR COMPUTER SOFTWARE FOR COMPUTERIZED CONTROL OF AUTOMATED SYSTEMS FOR DIGITAL DEVICES AND NETWORKS USED IN AEROSPACE VEHICLES (U.S. CLS. 21, 23, 26, 36 AND 38).

FIRST USE 2-0-2006; IN COMMERCE 5-1-2010.

NICHOLAS COLEMAN, EXAMINING ATTORNEY

SN 85-125,185. THE REGENTS OF THE UNIVERSITY OF COLORADO, DENVER, CO. FILED 9-8-2010.



THE MARK CONSISTS OF A CIRCLE WITH FOUR LINES RUNNING THROUGH IT.

FOR COMPUTER SOFTWARE FOR COMPUTERIZED CONTROL OF AUTOMATED SYSTEMS FOR DIGITAL DEVICES AND NETWORKS USED IN AEROSPACE VEHICLES (U.S. CLS. 21, 23, 26, 36 AND 38).

FIRST USE 7-0-2009; IN COMMERCE 5-0-2010.

NICHOLAS COLEMAN, EXAMINING ATTORNEY

CLASS 9—(Continued).

SN 85-130,114. MIRACLE RECREATION EQUIPMENT COMPANY, MONETT, MO. FILED 9-15-2010.

MIRACLETECH

THE MARK CONSISTS OF STANDARD CHARACTERS WITHOUT CLAIM TO ANY PARTICULAR FONT, STYLE, SIZE, OR COLOR.

OWNER OF U.S. REG. NOS. 841,174, 2,043,224 AND 2,988,973.

FOR PLAYGROUND SECURITY/MONITORING SYSTEM COMPRISED OF ONE OR MORE OF SECURITY LIGHTING, VIDEO MONITORING EQUIPMENT, AND AN ANTI-LOITERING AUDIO DEVICE, NAMELY, A SOUND GENERATOR (U.S. CLS. 21, 23, 26, 36 AND 38).

FIRST USE 4-6-2010; IN COMMERCE 4-6-2010.

SHAUNIA CARLYLE, EXAMINING ATTORNEY

SN 85-130,195. ACCESSDATA GROUP, LLC, LINDON, CA. FILED 9-15-2010.

AD Summation

THE MARK CONSISTS OF STANDARD CHARACTERS WITHOUT CLAIM TO ANY PARTICULAR FONT, STYLE, SIZE, OR COLOR.

OWNER OF U.S. REG. NOS. 1,363,032, 2,111,600 AND 2,917,523.

FOR COMPUTER SOFTWARE FOR ADMINISTRATION OF COMPUTER NETWORKS; COMPUTER SOFTWARE FOR APPLICATION AND DATABASE INTEGRATION; COMPUTER SOFTWARE FOR CREATING SEARCHABLE DATABASES OF INFORMATION AND DATA; COMPUTER SOFTWARE FOR PROCESSING DIGITAL IMAGES; COMPUTER SOFTWARE FOR THE COLLECTION, EDITING, ORGANIZING, MODIFYING, BOOK MARKING, TRANSMISSION, STORAGE AND SHARING OF DATA AND INFORMATION (U.S. CLS. 21, 23, 26, 36 AND 38).

FIRST USE 7-22-2010; IN COMMERCE 7-22-2010.

KATHERINE E. HALMEN, EXAMINING ATTORNEY

CLASS 9—(Continued).

SN 85-130,644. WOLVERT, TERRY DOUGLAS, WILSON-VILLE, OR. FILED S.R. 9-15-2010; AM. P.R. 5-26-2011.



NO CLAIM IS MADE TO THE EXCLUSIVE RIGHT TO USE "PRICING GATEWAY.COM", APART FROM THE MARK AS SHOWN.

THE COLOR(S) ORANGE, WHITE AND BLACK IS/ARE CLAIMED AS A FEATURE OF THE MARK.

THE MARK CONSISTS OF TWO DOCUMENTS THAT ARE TILTED TO THE RIGHT AT 45 DEGREES AND SEPARATED BY BLACK LINES SHOWING THE MOVEMENT OF INFORMATION. THE DOCUMENT ON THE LEFT IS ORANGE WITH A BLACK OUTLINE AND BLACK LINES REPRESENTING TEXT, AND THE DOCUMENT ON THE RIGHT IS WHITE WITH A BLACK OUTLINE AND BLACK LINES REPRESENTING TEXT. THE TEXT IN THE MARK IS BLACK. BELOW THE DOCUMENTS IS THE WORD "PRICING" AND BELOW THE WORD "PRICING" IS "GATEWAY.COM".

FOR COMPUTER SOFTWARE AND HARDWARE FOR UPLOAD, STORAGE, RETRIEVAL, DOWNLOAD, TRANSMISSION AND DELIVERY OF DIGITAL CONTENT (U.S. CLS. 21, 23, 26, 36 AND 38).

FIRST USE 11-1-2009; IN COMMERCE 11-1-2009.
EUGENIA MARTIN, EXAMINING ATTORNEY

CLASS 9—(Continued).

SN 85-137,869. JMASTM, LLC, MIAMI BEACH, FL. FILED 9-24-2010.

C1

THE MARK CONSISTS OF STANDARD CHARACTERS WITHOUT CLAIM TO ANY PARTICULAR FONT, STYLE, SIZE, OR COLOR.

PRIORITY CLAIMED UNDER SEC. 44(D) ON UNITED KINGDOM APPLICATION NO. 2543317, FILED 3-29-2010, REG. NO. 2543317, DATED 7-9-2010, EXPIRES 3-29-2020.

FOR ELECTRICALLY HEATED HAIR STYLING PRODUCTS AND HAIR STYLING APPARATUS, NAMELY, ELECTRIC IRONS FOR STYLING HAIR; ELECTRICALLY HEATED HAIR CURLING APPARATUS AND INSTRUMENTS, NAMELY, ELECTRIC HAIR CURLING IRONS; ELECTRICAL HAIR STRAIGHTENING IRONS; ELECTRIC HAIR CURLING TONGS; ELECTRICALLY HEATED HAIR WAVING APPARATUS, NAMELY, ELECTRIC IRONS FOR STYLING HAIR; ELECTRICALLY HEATED HAIR COMBS, ROLLERS, BRUSHES AND CURLING IRONS; HEATED ROLLER APPARATUS FOR HAIR, NAMELY, ELECTRIC HAIR ROLLERS; ELECTRICALLY HEATED APPLIANCES FOR CURLING AND STYLING HAIR, NAMELY, ELECTRIC HAND-HELD HAIR STYLING IRONS; ELECTRIC CRIMPING IRONS FOR THE HAIR; PARTS AND FITTINGS FOR THE AFORESAID GOODS (U.S. CLS. 21, 23, 26, 36 AND 38).

JILL PRATER, EXAMINING ATTORNEY

SN 85-140,807. EVERLAST WORLD'S BOXING HEADQUARTERS CORPORATION, NEW YORK, NY. FILED 9-29-2010.

EVERLAST

THE MARK CONSISTS OF STANDARD CHARACTERS WITHOUT CLAIM TO ANY PARTICULAR FONT, STYLE, SIZE, OR COLOR.

OWNER OF U.S. REG. NOS. 2,701,246, 3,133,391 AND OTHERS.

FOR EYEWEAR, NAMELY, EYEGLASSES, SUNGLASSES, EYEWEAR CASES; CHAINS FOR SPECTACLES AND FOR SUNGLASSES; STRINGS FOR EYEGLASSES; STRINGS FOR SUNGLASSES; EYEGLASS CORDS; SUNGLASS CORDS; COMPUTER APPLICATION SOFTWARE FOR MOBILE PHONES, PORTABLE MEDIA PLAYERS AND HANDHELD COMPUTERS, NAMELY, SOFTWARE FOR PURCHASING COMPUTER GAMES AND GENERAL MERCHANDISE, SOFTWARE FOR PARTICIPATION IN BUYER LOYALTY AND REWARD PROGRAMS BY ALLOWING USERS TO PLAY GAMES OFFERING PRIZES OF COUPONS, DISCOUNTS AND MERCHANDISE, INTERACTIVE MULTIMEDIA SOFTWARE FOR PROVIDING INFORMATION THROUGH THE INTEGRATION OF TEXT, AUDIO, GRAPHICS, STILL IMAGES AND MOVING PICTURES FOR THE CREATION AND MANAGEMENT OF INDIVIDUALIZED HEALTH, WELL-BEING, EXERCISE AND NUTRITION PROGRAMS AND BY CONNECTING USERS TO THE INTERNET (U.S. CLS. 21, 23, 26, 36 AND 38).

LESLIE RICHARDS, EXAMINING ATTORNEY

SN 85-133,852. AGS LLC, HENDERSON, NV. FILED 9-20-2010.

99 BOTTLES OF BEER ON THE WALL

THE MARK CONSISTS OF STANDARD CHARACTERS WITHOUT CLAIM TO ANY PARTICULAR FONT, STYLE, SIZE, OR COLOR.

FOR GAMING MACHINES; GAMING MACHINES THAT INCLUDE A BONUS FEATURE; GAMING MACHINES THAT INCLUDE A NETWORKED BONUSING SYSTEM; GAMING MACHINES THAT INCLUDE A PLAYER REWARDS PROGRAM; GAMING MACHINES, NAMELY, DEVICES THAT ACCEPT A WAGER; GAMING MACHINES, NAMELY, SLOT MACHINES AND VIDEO GAMING TERMINALS; AND MACHINES FOR PLAYING GAMES OF CHANCE (U.S. CLS. 21, 23, 26, 36 AND 38).

CARYN GLASSER, EXAMINING ATTORNEY

CLASS 9—(Continued).

SN 85-143,756. ACTIVISION TV, INC., FORMERLY AD MEDIA DISPLAYS, INC. AND ACTIVISION INC., NAPLES, FL. FILED 10-2-2010.

ACTIVISION.TV

THE MARK CONSISTS OF STANDARD CHARACTERS WITHOUT CLAIM TO ANY PARTICULAR FONT, STYLE, SIZE, OR COLOR.

FOR TELEVISIONS, MONITORS AND DISPLAY, NAMELY, LIQUID CRYSTAL DISPLAYS, LIGHT EMITTING DIODE DISPLAYS, AND PLASMA DISPLAYS AND COMPONENTS AND REPLACEMENT PARTS THEREFOR, NAMELY, FLAT PANEL DISPLAY SCREENS, STEREO AND TELEVISION TUNERS, CABLE TELEVISION RECEIVERS, MODEMS, DIGITAL SIGNAL WIRELESS RECEIVERS AND TRANSMITTERS, SATELLITE SIGNAL RECEIVERS AND TRANSMITTERS, WIRELESS SOUND AND VIDEO CARDS, COMPUTER MICRO PROCESSORS CONTROLLING THE OPERATION OF THE TELEVISION OR DISPLAY SET AS WELL AS ALLOWING INTERACTIVE USE OF THE FOREGOING, VIDEO MONITORS, PROGRAMMABLE TELEVISION AND DIGITAL VIDEO RECORDERS, AUDIO RECORDERS AND AUDIO-VIDEO RECORDERS, DVD-ROM DRIVES, VCRS, AUDIO SPEAKERS, AND AMPLIFIERS, ALL FOR SALE TO COMMERCIAL BUYERS IN THE HOSPITALITY, TRANSPORTATION, COMMERCIAL SERVICE, COMMERCIAL ENTERTAINMENT, INSTITUTIONAL, DISPLAY/SIGNAGE AND RETAIL MARKET CHANNELS AND NOT TO CONSUMERS GENERALLY; INTEGRATED COMPUTERIZED TELEVISIONS AND DISPLAYS CAPABLE OF OPERATING AS A TELEVISION, A DISPLAY AND A COMPUTER FOR SALE TO COMMERCIAL BUYERS IN THE HOSPITALITY, TRANSPORTATION, COMMERCIAL SERVICE, COMMERCIAL ENTERTAINMENT, INSTITUTIONAL, DISPLAY/SIGNAGE AND RETAIL MARKET CHANNELS AND NOT TO CONSUMERS GENERALLY; PROMOTIONAL DISPLAYS IN THE NATURE OF INTERACTIVE AND NON-INTERACTIVE COMPUTER KIOSKS COMPRISING COMPUTERS, COMPUTER HARDWARE, PERIPHERALS, AND COMPUTER OPERATING SOFTWARE FOR USE IN PROVIDING DIRECTORY AND OTHER TYPES OF INFORMATIONAL ASSISTANCE FOR OR IN RELATION TO A DEFINED GEOGRAPHIC AREA, A FACILITY, OR INDIVIDUAL SECTION OF A FACILITY AND IN PROVIDING MARKETING AND PROMOTIONAL ADVERTISEMENT OF GOODS AND SERVICES, WITH OR WITHOUT THE CAPABILITY OF PURCHASING SAID GOODS OR SERVICES AND WITH OR WITHOUT THE CAPABILITY OF DISPENSING THE PURCHASED GOODS OR SERVICES AND IN PROVIDING FINANCIAL TRANSACTIONS INCLUDING BANKING, MONEY EXCHANGE AND BILL PAYMENTS AND IN PROVIDING CONCIERGE SERVICES IN THE HOSPITALITY, TRANSPORTATION AND ENTERTAINMENT INDUSTRIES AND VENUES; COMPUTER SOFTWARE ENABLING THE OPERATION OF PROMOTIONAL DISPLAYS AND PERFORMANCE OF THEIR CAPABILITIES/FUNCTIONS; COMPONENTS AND REPLACEMENT COMPONENTS FOR COMPUTERIZED TELEVISIONS AND DISPLAYS AND PROMOTIONAL DISPLAYS, NAMELY, COMPUTERS PRE-CONFIGURED TO PERFORM THE INTENDED FUNCTIONS OF THE COMPUTERIZED TELEVISIONS AND DISPLAYS AND PROMOTIONAL DISPLAYS AND COMPUTERS PRE-CONFIGURED TO ACCEPT AND RESPOND TO ELECTRONIC SIGNALS FROM REMOTE LOCATIONS CONTAINING CONTENT TO BE DISPLAYED ON THE DISPLAY AS WELL AS THE TIMING AND/OR SEQUENCE OF THE DISPLAY OF SAID CONTENT (U.S. CLS. 21, 23, 26, 36 AND 38).

FIRST USE 6-18-2009; IN COMMERCE 6-18-2009.
ROSELLE HERRERA, EXAMINING ATTORNEY

CLASS 9—(Continued).

SN 85-143,883. TOUCHIT MEDIA GROUP, LLC, LAS VEGAS, NV. FILED 10-3-2010.



THE COLOR(S) BLACK, GREEN AND WHITE IS/ARE CLAIMED AS A FEATURE OF THE MARK.

THE MARK CONSISTS OF THE WORD "TOUCHIT" WITH THE FIRST FIVE LETTERS IN GREEN THE SECOND TWO WHITE WITH A BLACK THUMB PRINT OVER THE LAST TWO LETTERS.

FOR ELECTRONIC LCD ADVERTISEMENT DISPLAY UNIT WITH MULTI-NETWORKING (TCP/IP) CAPABILITIES (U.S. CLS. 21, 23, 26, 36 AND 38).

FIRST USE 10-1-2009; IN COMMERCE 10-1-2009.
GIANCARLO CASTRO, EXAMINING ATTORNEY

SN 85-146,099. CONTROLLED ENTRY DISTRIBUTORS, INC., SALT LAKE CITY, UT. FILED 10-6-2010.

MANGO

THE MARK CONSISTS OF STANDARD CHARACTERS WITHOUT CLAIM TO ANY PARTICULAR FONT, STYLE, SIZE, OR COLOR.

FOR ELECTRONICALLY ENCODED ACCESS CARDS FOR SECURED ENTRY (U.S. CLS. 21, 23, 26, 36 AND 38).
MARY CRAWFORD, EXAMINING ATTORNEY

SN 85-150,483. APPLE INDUSTRIES INC., BAYCHESTER, NY. FILED 10-12-2010.

Pix Place

THE MARK CONSISTS OF STANDARD CHARACTERS WITHOUT CLAIM TO ANY PARTICULAR FONT, STYLE, SIZE, OR COLOR.

NO CLAIM IS MADE TO THE EXCLUSIVE RIGHT TO USE "PIX", APART FROM THE MARK AS SHOWN.

FOR STAND ALONE PAY FOR USE INTERACTIVE PHOTO KIOSKS FOR CAPTURING, PRINTING AND UPLOADING DIGITAL AND PHOTOGRAPHIC IMAGES (U.S. CLS. 21, 23, 26, 36 AND 38).

BRIAN CALLAGHAN, EXAMINING ATTORNEY

CLASS 9—(Continued).

SN 85-151,151. J.D.RESEARCH, INC., ORANGE, CA. FILED 10-13-2010.

SHARK TECHNOLOGY

THE MARK CONSISTS OF STANDARD CHARACTERS WITHOUT CLAIM TO ANY PARTICULAR FONT, STYLE, SIZE, OR COLOR.

NO CLAIM IS MADE TO THE EXCLUSIVE RIGHT TO USE "TECHNOLOGY", APART FROM THE MARK AS SHOWN.

FOR POWER SUPPLIES USED FOR PERSONAL COMPUTERS THAT REQUIRE A LOW VOLTAGE POWER SOURCE (U.S. CLS. 21, 23, 26, 36 AND 38).

FIRST USE 1-10-2005; IN COMMERCE 8-4-2005.

JANICE L. MCMORROW, EXAMINING ATTORNEY

SN 85-152,142. PLANTRONICS, INC., SANTA CRUZ, CA. FILED 10-13-2010.

CLARITY PAL

THE MARK CONSISTS OF STANDARD CHARACTERS WITHOUT CLAIM TO ANY PARTICULAR FONT, STYLE, SIZE, OR COLOR.

OWNER OF U.S. REG. NOS. 1,581,278, 3,772,198 AND OTHERS.

FOR HANDHELD ELECTRONIC DEVICES, NAMELY, MOBILE PHONES FOR THE SENDING AND RECEIVING OF TELEPHONE CALLS AND ELECTRONIC MAIL (U.S. CLS. 21, 23, 26, 36 AND 38).

DAVID ELTON, EXAMINING ATTORNEY

SN 85-153,096. KHLONEY INC., WOODLAND HILLS, CA. FILED 10-14-2010.

HEY DOLL

THE MARK CONSISTS OF STANDARD CHARACTERS WITHOUT CLAIM TO ANY PARTICULAR FONT, STYLE, SIZE, OR COLOR.

FOR DOWNLOADABLE SOFTWARE APPLICATION FOR RINGTONES, RING BACKS AND MUSIC FOR SMART PHONES, MOBILE PHONES, PERSONAL DIGITAL ASSISTANTS AND OTHER COMMUNICATIONS DEVICES; DOWNLOADABLE RINGTONES (U.S. CLS. 21, 23, 26, 36 AND 38).

MATTHEW PAPPAS, EXAMINING ATTORNEY

CLASS 9—(Continued).

SN 85-153,701. TWENTIETH CENTURY FOX FILM CORPORATION, LOS ANGELES, CA. FILED 10-15-2010.



OWNER OF U.S. REG. NO. 3,861,823.

THE MARK CONSISTS OF THE STYLIZED WORD "ARCHER" TO THE RIGHT OF A SILHOUETTE OF A MAN HOLDING A GUN.

FOR PRE-RECORDED DVDS FEATURING COMEDY; PRE-RECORDED CDS FEATURING COMEDY AND MUSICAL PERFORMANCES; DOWNLOADABLE AUDIO AND VIDEO RECORDINGS FEATURING COMEDY; DOWNLOADABLE TELEVISION SHOWS AND VIDEO RECORDINGS FEATURING COMEDY; DOWNLOADABLE RING TONES, RING BACKS, GRAPHICS, WALLPAPER, ELECTRONIC GAMES AND MUSIC VIA A GLOBAL COMPUTER NETWORK AND WIRELESS DEVICES; COMPUTER SCREEN SAVER SOFTWARE; COMPUTER GAME AND VIDEO GAME SOFTWARE; MOUSEPADS; DECORATIVE MAGNETS (U.S. CLS. 21, 23, 26, 36 AND 38).

GINA FINK, EXAMINING ATTORNEY

SN 85-154,956. JOHNSON, JAY, BIRMINGHAM, AL. FILED 10-18-2010.



THE MARK CONSISTS OF STYLIZED U WITH SHADING.

FOR COMPUTER APPLICATION SOFTWARE FOR MOBILE PHONES, NAMELY, SOFTWARE FOR ELECTRONIC COMMERCE WEB APPLICATIONS; COMPUTER APPLICATION SOFTWARE FOR MOBILE PHONES AND HANDHELD COMPUTERS, NAMELY, SOFTWARE FOR ELECTRONIC COMMERCE WEB APPLICATIONS (U.S. CLS. 21, 23, 26, 36 AND 38).

JAMES A. RAUEN, EXAMINING ATTORNEY

CLASS 9—(Continued).

SN 85-157,401. SHENZHEN SUPER PERFECT OPTICS LIMITED, SHENZHEN, GUANGDONG, CHINA, FILED 10-20-2010.



THE COLOR(S) BLUE, PURPLE AND GRAY IS/ARE CLAIMED AS A FEATURE OF THE MARK.

THE MARK CONSISTS OF A STYLIZED LETTER "D", WHERE THE LEFT UPRIGHT PORTION OF THE MARK IS IN THE COLOR BLUE, THE TOP RIGHT ARC OF THE LETTER IS IN THE COLOR PURPLE, AND THE BOTTOM RIGHT PORTION IS IN THE COLOR GRAY.

FOR COMPUTERS; NOTEBOOK COMPUTERS; COMPUTER KEYBOARDS; COMPUTER MOUSE; COMPUTER GAME PROGRAMS; COMPUTER PROGRAMS FOR DOCUMENT MANAGEMENT; COMPUTER OPERATING PROGRAMS, RECORDED; COMPUTER GAME SOFTWARE; COMPUTER MONITORS; TELEVISION MONITORS; WALKIE-TALKIES; APPARATUS FOR ELECTRONIC GAMES, NAMELY, COMPUTER GAME CONSOLES, VIDEO GAME CONSOLES, VIDEO GAME MACHINES, HAND-HELD UNITS FOR PLAYING ELECTRONIC GAMES, AND VIDEO OUTPUT GAME MACHINE, ALL ADAPTED FOR USE WITH AN EXTERNAL DISPLAY SCREEN OR MONITOR; TELEVISION SETS; STEREOSCOPIES; ELECTRONIC CHIPS FOR THE MANUFACTURER OF INTEGRATED CIRCUITS (U.S. CLS. 21, 23, 26, 36 AND 38).

JAY BESCH, EXAMINING ATTORNEY

SN 85-160,010. INGRASYS TECHNOLOGY INC., TAOYUAN 33066, TAIWAN, FILED 10-25-2010.



THE MARK CONSISTS OF THE WORDING "IMEGE MAGIC IN VISION", WITH A CRESCENT DESIGN ABOVE TWO CIRCLES AND TWO CIRCLES IN THE LETTER "G".

FOR REMOTE CONTROL APPARATUS FOR DEVICES FOR MONITORING THE ENVIRONMENT; COMPUTER HARDWARE AND SOFTWARE SYSTEM FOR REMOTELY MONITORING ENVIRONMENTAL CONDITIONS AND CONTROLLING DEVICES WITHIN A BUILDING, FACILITY, GROUNDS, OR DESIGNATED SPATIAL AREA; DIGITAL VIDEO PLAYERS AND RECORDERS; NETWORK VIDEO PLAYERS AND RECORDERS; NETWORK CAMERAS; VIDEO SERVERS; VIDEO DECODERS; VIDEO BROADCAST SYSTEMS COMPRISED OF VIDEO PROCESSORS, VIDEO RECEIVERS, VIDEO SCREENS, VIDEO TRANSMISSION APPARATUS, VIDEO MONITORS, VIDEO CABLES, VIDEO CAMERAS, VIDEO CIRCUIT BOARDS, AND VIDEO DISPLAY CARDS; AND SOFTWARE FOR CONTROLLING THE OPERATION OF VIDEO PLAYERS (U.S. CLS. 21, 23, 26, 36 AND 38).

JUSTINE D. PARKER, EXAMINING ATTORNEY

CLASS 9—(Continued).

SN 85-160,454. MAZZARELLA MEDIA, LLC, SOUTHTON, CT. FILED 10-25-2010.

POTTY POWER

THE MARK CONSISTS OF STANDARD CHARACTERS WITHOUT CLAIM TO ANY PARTICULAR FONT, STYLE, SIZE, OR COLOR.

NO CLAIM IS MADE TO THE EXCLUSIVE RIGHT TO USE "POTTY", APART FROM THE MARK AS SHOWN.

FOR TOILET TRAINING DVDS AND VIDEOS (U.S. CLS. 21, 23, 26, 36 AND 38).

FIRST USE 11-30-2003; IN COMMERCE 11-30-2003.

ALICIA COLLINS, EXAMINING ATTORNEY

SN 85-160,757. BROCADE COMMUNICATIONS SYSTEMS, INC., SAN JOSE, CA. FILED 10-25-2010.

CLOUDPLEX

THE MARK CONSISTS OF STANDARD CHARACTERS WITHOUT CLAIM TO ANY PARTICULAR FONT, STYLE, SIZE, OR COLOR.

FOR COMPUTER SOFTWARE AND HARDWARE, NAMELY, SERVERS AND ROUTERS, USED TO CREATE AND MANAGE VIRTUALIZED DATA CENTERS AND COMPUTING INFRASTRUCTURES (U.S. CLS. 21, 23, 26, 36 AND 38).

ERIN FALK, EXAMINING ATTORNEY

CLASS 9—(Continued).

SN 85-166,689. BLUES DESTINY RECORDS, LLC, DBA BLUES DESTINY RECORDS, LLC, DESTIN, FL. FILED 11-1-2010.

Blues Destiny Records

THE MARK CONSISTS OF STANDARD CHARACTERS WITHOUT CLAIM TO ANY PARTICULAR FONT, STYLE, SIZE, OR COLOR.

NO CLAIM IS MADE TO THE EXCLUSIVE RIGHT TO USE "BLUES" AND "RECORDS", APART FROM THE MARK AS SHOWN.

FOR COMPACT DISCS FEATURING MUSIC; DIGITAL MUSIC DOWNLOADABLE FROM THE INTERNET; DIGITAL MUSIC SYSTEM THAT SYNCHRONIZES DIGITAL MUSIC FILES STORED ON A HOME UNIT AND A CAR UNIT; DOWNLOADABLE MP3 FILES AND MP3 RECORDINGS FEATURING MUSIC; DOWNLOADABLE MP3 FILES, MP3 RECORDINGS, ON-LINE DISCUSSION BOARDS, WEBCASTS, WEBINARS AND PODCASTS FEATURING MUSIC, AUDIO BOOKS IN THE FIELD OF MUSIC, AND NEWS BROADCASTS; DOWNLOADABLE MUSICAL SOUND RECORDINGS; DOWNLOADABLE RING TONES, GRAPHICS AND MUSIC VIA A GLOBAL COMPUTER NETWORK AND WIRELESS DEVICES (U.S. CLS. 21, 23, 26, 36 AND 38).

FIRST USE 1-1-2008; IN COMMERCE 1-1-2008.

ANNE E. GUSTASON, EXAMINING ATTORNEY

SN 85-167,501. TWISTED RECORDS, INC., NEW YORK, NY. FILED 11-2-2010.



THE MARK CONSISTS OF A STYLIZED BLACK AND WHITE TRIBAL FIGURE WITH HIS TONGUE STICKING OUT, ARMS UP, AND FEET SPREAD APART. THERE IS WHITE SPACE TO CREATE AN OPEN MOUTH. EACH HAND HAS THREE FINGERS POINTED IN THE AIR AND EACH FOOT HAS THREE TOES. THERE ARE FOUR SEPARATE CONCENTRIC CIRCLES ON HIS CHEST. IT IS INSPIRED BY ANCIENT IMAGES BUT NEWLY DRAWN AND CREATED.

FOR AUDIO RECORDINGS FEATURING MUSIC; COMPACT DISCS FEATURING MUSIC; DIGITAL MUSIC DOWNLOADABLE FROM THE INTERNET; DOWNLOADABLE MP3 FILES AND MP3 RECORDINGS FEATURING MUSIC; DOWNLOADABLE MUSICAL SOUND RECORDINGS; MUSICAL SOUND RECORDINGS; PHONOGRAPH RECORD SLEEVES; PHONOGRAPH RECORDS FEATURING MUSIC; PHONOGRAPH RECORDS FEATURING MUSIC; PLASTIC AND CARDBOARD CASES FOR STORING RECORD ALBUMS (U.S. CLS. 21, 23, 26, 36 AND 38).

FIRST USE 5-1-1991; IN COMMERCE 5-1-1991.

MARK RADEMACHER, EXAMINING ATTORNEY

CLASS 9—(Continued).

SN 85-173,246. AGATEC SAS, F-78600 MESNIL-LE-ROI, FRANCE, FILED 11-10-2010.

AGATEC

THE MARK CONSISTS OF STANDARD CHARACTERS WITHOUT CLAIM TO ANY PARTICULAR FONT, STYLE, SIZE, OR COLOR.

FOR LASER LEVELS, NAMELY, LASER LEVEL INDICATORS, LASER PLUMB LEVELS, LASER CARPENTER'S LEVELS; LASER POINTERS; LASER DEVICES, NAMELY, LASER MEASURING SYSTEMS; LASER DEVICES FOR PROJECTING A VISIBLE STRAIGHT LINE ON A WORK SURFACE FOR CONSTRUCTION PURPOSES; SURVEYING INSTRUMENTS (U.S. CLS. 21, 23, 26, 36 AND 38).

KATHERINE CHANG, EXAMINING ATTORNEY

SN 85-178,849. JACOB, DARON, BROOKLYN, NY. FILED 11-17-2010.



THE MARK CONSISTS OF THE STYLIZED TERM "SKINCARE", WITHIN BRACKETS WITH "SKIN" BEING UNDERLINED. UNDER THE TERM "CARE", THERE ARE THREE ICON DESIGNS, NAMELY, AN IMAGE OF A PHONE FALLING TO THE GROUND, AN IMAGE OF A DROP OF WATER APPROACHING A BODY OF WATER, AND THE THIRD IS AN IMAGE OF A FLAME.

FOR PRE-MADE AND CUSTOM-MADE COVERS FOR CELL PHONES, MP3 PLAYERS, LAPTOPS, COMPUTERS, PORTABLE SATELLITE RADIOS, PERSONAL DIGITAL ASSISTANTS, REMOTE CONTROLS, AND TELEVISION SATELLITE RECORDERS (U.S. CLS. 21, 23, 26, 36 AND 38).

FIRST USE 10-1-2009; IN COMMERCE 10-1-2009.

TRACY WHITTAKER-BROWN, EXAMINING ATTORNEY

CLASS 9—(Continued).

SN 85-182,096. GOLDEN PILOT LIMITED, ROAD TOWN, TORTOLA, BR.VIRGIN ISLANDS, FILED 11-22-2010.



OWNER OF U.S. REG. NO. 3,929,990.
THE MARK CONSISTS OF THE WORD "ECOTOTAL" WITH TWO LEAVES COMING OUT OF THE LETTER "O" WITH CHINESE CHARACTERS UNDER THE WORD "ECOTOTAL".

THE NON-LATIN CHARACTERS IN THE MARK TRANSLITERATE TO YUAN ZI RAN AND THIS MEANS "SOURCED OR COMES FROM THE NATURE" IN ENGLISH.

FOR ELECTRIC ACCUMULATORS; ELECTRIC BATTERIES; BATTERIES AND BATTERY PACKS; BATTERY ADAPTERS; BATTERY CASES; BATTERY CHARGERS; BATTERY TESTERS; GALVANIC BATTERIES; DRY CELLS (U.S. CLS. 21, 23, 26, 36 AND 38).

H. M. FISHER, EXAMINING ATTORNEY

SN 85-182,148. ELBIT SYSTEMS LTD., HAIFA, ISRAEL, FILED 11-22-2010.

SKEYE CITY

THE MARK CONSISTS OF STANDARD CHARACTERS WITHOUT CLAIM TO ANY PARTICULAR FONT, STYLE, SIZE, OR COLOR.

FOR SURVEILLANCE IMAGING SYSTEM COMPRISING PRIMARILY COMPUTER HARDWARE AND SOFTWARE FOR UBIQUITOUS SURVEILLANCE OF EVENTS AND ACTIVITIES ON A CONTINUOUS BASIS IN AREAS OF INTEREST; SURVEILLANCE IMAGING SYSTEM COMPRISING PRIMARILY COMPUTER HARDWARE AND SOFTWARE FOR USE WITH AN AIR VEHICLE AND COMPATIBLE WITH GROUND STATIONS (U.S. CLS. 21, 23, 26, 36 AND 38).

ELLEN BURNS, EXAMINING ATTORNEY

CLASS 9—(Continued).

SN 85-185,040. OUTFIT7 LTD., PREDDVOR, SLOVENIA, FILED 11-24-2010.

OUTFIT7

THE MARK CONSISTS OF STANDARD CHARACTERS WITHOUT CLAIM TO ANY PARTICULAR FONT, STYLE, SIZE, OR COLOR.

FOR COMPUTER GAME SOFTWARE AND ENTERTAINMENT SOFTWARE IN THE NATURE OF COMPUTER GAMES FOR USE ON MOBILE AND CELLULAR PHONES, HANDHELD COMPUTERS, COMPUTERS, VIDEO GAME CONSOLES, BOTH HANDHELD AND FREE STANDING, AND OTHER WIRELESS POS (POINT OF SERVICE) DEVICES; COMPUTER GAME SOFTWARE; APPLICATION DEVELOPMENT TOOL PROGRAMS FOR PERSONAL COMPUTERS AND/OR MOBILE DIGITAL ELECTRONIC DEVICES AND/OR HAND HELD COMPUTERS AND MOBILE TELEPHONES; COMPUTER GAME SOFTWARE FEATURING MUSIC AND MOTION PICTURE SOUNDTRACKS; COMPUTER GAME SOFTWARE AND DOWNLOADABLE DIGITAL FILES FEATURING ANIMATED CARTOONS; DOWNLOADABLE COMPUTER GAME SOFTWARE VIA A GLOBAL COMPUTER NETWORK AND WIRELESS POS (POINT OF SERVICE) DEVICES; DOWNLOADABLE COMPUTER GAME SOFTWARE FEATURING TOUCH AND VOICE CONTROL; DOWNLOADABLE SOFTWARE FOR DEVELOPING, DESIGNING, MODIFYING, RECORDING AND CUSTOMIZING SOUND AND SPEECH; DOWNLOADABLE SOFTWARE FOR DEVELOPING, DESIGNING, MODIFYING, RECORDING AND CUSTOMIZING VIDEO, COMPUTER AND ONLINE GAMES; DOWNLOADABLE COMPUTER GAME SOFTWARE FOR ELECTRONIC APPARATUS USING INTERACTIVE AND MULTIMEDIA FUNCTIONS; INTERACTIVE MULTIMEDIA COMPUTER GAME SOFTWARE PROGRAMS; COMPUTER GAME PROGRAMS FOR ENTERTAINMENT FEATURING CHARACTER RECOGNITION, VOICE RECOGNITION, TOUCH SENSITIVITY, LIGHT SENSITIVITY AND GRAVITY SENSITIVITY; SOFTWARE FOR ENABLING VIDEO COMPUTER AND ONLINE GAMES TO BE RUN ON MULTIPLE PLATFORMS; DOWNLOADABLE SOFTWARE FOR PLAYING VIDEO, COMPUTER AND ONLINE GAMES; SPEECH RECOGNITION SOFTWARE; TOUCH AND VOICE DRIVEN INTERACTIVE COMPUTER GAME SOFTWARE; VIDEO AND AUDIO GAMES, NAMELY, COMPUTER GAME PROGRAMS FEATURING INTERACTIVE VIDEO AND AUDIO CONTENT (U.S. CLS. 21, 23, 26, 36 AND 38).

LIEF MARTIN, EXAMINING ATTORNEY

CLASS 9—(Continued).

SN 85-185,053. OUTFIT7 LTD., PREDDVOR, SLOVENIA, FILED 11-24-2010.

CLASS 9—(Continued).

SN 85-185,360. AINSWORTH GAME TECHNOLOGY, NEW-INGTON, AUSTRALIA, FILED 11-25-2010.

Jackpot Central

TALKING BACTERIA

THE MARK CONSISTS OF STANDARD CHARACTERS WITHOUT CLAIM TO ANY PARTICULAR FONT, STYLE, SIZE, OR COLOR.

NO CLAIM IS MADE TO THE EXCLUSIVE RIGHT TO USE "JACKPOT", APART FROM THE MARK AS SHOWN.

FOR COMPUTER SOFTWARE AND FIRMWARE FOR GAMES OF CHANCE ON ANY COMPUTERIZED PLATFORM, INCLUDING DEDICATED GAMING CONSOLES, VIDEO BASED SLOT MACHINES, REEL BASED SLOT MACHINES, AND VIDEO LOTTERY TERMINALS (U.S. CLS. 21, 23, 26, 36 AND 38).

BILL DAWE, EXAMINING ATTORNEY

THE MARK CONSISTS OF STANDARD CHARACTERS WITHOUT CLAIM TO ANY PARTICULAR FONT, STYLE, SIZE, OR COLOR.

FOR COMPUTER GAME SOFTWARE AND ENTERTAINMENT SOFTWARE IN THE NATURE OF COMPUTER GAMES FOR USE ON MOBILE AND CELLULAR PHONES, HANDHELD COMPUTERS, COMPUTERS, VIDEO GAME CONSOLES, BOTH HANDHELD AND FREE STANDING, AND OTHER WIRELESS POS (POINT OF SERVICE) DEVICES; COMPUTER GAME SOFTWARE; APPLICATION DEVELOPMENT TOOL PROGRAMS FOR PERSONAL COMPUTERS AND/OR MOBILE DIGITAL ELECTRONIC DEVICES AND/OR HAND HELD COMPUTERS AND MOBILE TELEPHONES; COMPUTER GAME SOFTWARE FEATURING MUSIC AND MOTION PICTURE SOUNDTRACKS; COMPUTER GAME SOFTWARE AND DOWNLOADABLE DIGITAL FILES FEATURING ANIMATED CARTOONS; DOWNLOADABLE COMPUTER GAME SOFTWARE VIA A GLOBAL COMPUTER NETWORK AND WIRELESS POS (POINT OF SERVICE) DEVICES; DOWNLOADABLE COMPUTER GAME SOFTWARE FEATURING TOUCH AND VOICE CONTROL; DOWNLOADABLE SOFTWARE FOR DEVELOPING, DESIGNING, MODIFYING, RECORDING AND CUSTOMIZING SOUND AND SPEECH; DOWNLOADABLE SOFTWARE FOR DEVELOPING, DESIGNING, MODIFYING, RECORDING AND CUSTOMIZING VIDEO, COMPUTER AND ONLINE GAMES; DOWNLOADABLE COMPUTER GAME SOFTWARE FOR ELECTRONIC APPARATUS USING INTERACTIVE AND MULTIMEDIA FUNCTIONS; INTERACTIVE MULTIMEDIA COMPUTER GAME SOFTWARE PROGRAMS; COMPUTER GAME PROGRAMS FOR ENTERTAINMENT FEATURING CHARACTER RECOGNITION, VOICE RECOGNITION, TOUCH SENSITIVITY, LIGHT SENSITIVITY AND GRAVITY SENSITIVITY; SOFTWARE FOR ENABLING VIDEO COMPUTER AND ONLINE GAMES TO BE RUN ON MULTIPLE PLATFORMS; DOWNLOADABLE SOFTWARE FOR PLAYING VIDEO, COMPUTER AND ONLINE GAMES; SPEECH RECOGNITION SOFTWARE; TOUCH AND VOICE DRIVEN INTERACTIVE COMPUTER GAME SOFTWARE; VIDEO AND AUDIO GAMES, NAMELY, COMPUTER GAME PROGRAMS FEATURING INTERACTIVE VIDEO AND AUDIO CONTENT (U.S. CLS. 21, 23, 26, 36 AND 38).

LIEF MARTIN, EXAMINING ATTORNEY

SN 85-187,794. GUERCIO, JAMES W., BOULDER, CO. FILED 11-30-2010.

CARIBOU RANCH THE ART & CULTURE OF THE AMERICAN WEST

THE MARK CONSISTS OF STANDARD CHARACTERS WITHOUT CLAIM TO ANY PARTICULAR FONT, STYLE, SIZE, OR COLOR.

NO CLAIM IS MADE TO THE EXCLUSIVE RIGHT TO USE "THE ART & CULTURE OF THE AMERICAN WEST", APART FROM THE MARK AS SHOWN.

FOR MOTION PICTURE FILMS ABOUT AMERICAN ART, HISTORY AND CULTURE, VIDEO DISCS FEATURING AMERICAN ART, HISTORY AND CULTURE; DOWNLOADABLE ELECTRONIC MEDIA AND PUBLICATIONS, NAMELY, MAGAZINES AND BOOKS FEATURING AMERICAN ART, CULTURE AND TOPICS OF GENERAL INTEREST AND DOWNLOADABLE SOFTWARE IN THE NATURE OF AN APPLICATION FOR OBTAINING INFORMATION, COMMENTARY, AND TEXTUAL, AUDIO AND VISUAL CONTENT ABOUT AMERICAN ART, HISTORY, CULTURE AND TOPICS OF GENERAL INTEREST ON MOBILE AND STATIONARY CONSUMER ELECTRONIC DEVICES; DOWNLOADABLE SOUND RECORDINGS FEATURING MUSIC; DOWNLOADABLE VIDEO RECORDINGS FEATURING AMERICAN ART, HISTORY AND CULTURE (U.S. CLS. 21, 23, 26, 36 AND 38).

MARK T. MULLEN, EXAMINING ATTORNEY

CLASS 9—(Continued).

SN 85-189,124. OUTFIT7 LTD., PREDDVOR, SLOVENIA,
FILED 12-2-2010.

CLASS 9—(Continued).

SN 85-190,184. IMPLEN GMBH, 81829 MUENCHEN, FED
REP GERMANY, FILED 12-3-2010.

NANOPHOTOMETER

TALKING BACTERIA JOHN,
JOHN & JOHN

THE MARK CONSISTS OF STANDARD CHARACTERS
WITHOUT CLAIM TO ANY PARTICULAR FONT, STYLE,
SIZE, OR COLOR.

FOR SCIENTIFIC APPARATUS, NAMELY, SPECTRO-
PHOTOMETER FOR MEASURING RELATIVE DNA/
RNA AND PROTEIN (U.S. CLS. 21, 23, 26, 36 AND 38).

FIRST USE 4-25-2006; IN COMMERCE 8-28-2006.

JILL PRATER, EXAMINING ATTORNEY

THE MARK CONSISTS OF STANDARD CHARACTERS
WITHOUT CLAIM TO ANY PARTICULAR FONT, STYLE,
SIZE, OR COLOR.

PRIORITY CLAIMED UNDER SEC. 44(D) ON ERPN
CMNTY TM OFC APPLICATION NO. 009493826, FILED 11-
3-2010.

FOR COMPUTER GAME SOFTWARE AND ENTER-
TAINMENT SOFTWARE IN THE NATURE OF COMPU-
TER GAMES FOR USE ON MOBILE AND CELLULAR
PHONES, HANDHELD COMPUTERS, COMPUTERS, VI-
DEO GAME CONSOLES, BOTH HANDHELD AND FREE
STANDING, AND OTHER WIRELESS POS (POINT OF
SERVICE) DEVICES; COMPUTER GAME SOFTWARE;
APPLICATION DEVELOPMENT TOOL PROGRAMS FOR
PERSONAL COMPUTERS AND/OR MOBILE DIGITAL
ELECTRONIC DEVICES AND/OR HAND HELD COM-
PUTERS AND MOBILE TELEPHONES; COMPUTER
GAME SOFTWARE FEATURING MUSIC AND MOTION
PICTURE SOUNDTRACKS; COMPUTER GAME SOFT-
WARE AND DOWNLOADABLE DIGITAL FILES FEAT-
URING ANIMATED CARTOONS; DOWNLOADABLE
COMPUTER GAME SOFTWARE VIA A GLOBAL COM-
PUTER NETWORK AND WIRELESS POS (POINT OF
SERVICE) DEVICES; DOWNLOADABLE COMPUTER
GAME SOFTWARE FEATURING TOUCH AND VOICE
CONTROL; DOWNLOADABLE SOFTWARE FOR DE-
VELOPING, DESIGNING, MODIFYING, RECORDING
AND CUSTOMIZING SOUND AND SPEECH; DOWN-
LOADABLE SOFTWARE FOR DEVELOPING, DESIGN-
ING, MODIFYING, RECORDING AND CUSTOMIZING
VIDEO, COMPUTER AND ONLINE GAMES; DOWN-
LOADABLE COMPUTER GAME SOFTWARE FOR
ELECTRONIC APPARATUS USING INTERACTIVE
AND MULTIMEDIA FUNCTIONS; INTERACTIVE MUL-
TIMEDIA COMPUTER GAME SOFTWARE PROGRAMS;
COMPUTER GAME PROGRAMS FOR ENTERTAIN-
MENT FEATURING CHARACTER RECOGNITION,
VOICE RECOGNITION, TOUCH SENSITIVITY, LIGHT
SENSITIVITY AND GRAVITY SENSITIVITY; SOFT-
WARE FOR ENABLING VIDEO COMPUTER AND ON-
LINE GAMES TO BE RUN ON MULTIPLE PLATFORMS;
DOWNLOADABLE SOFTWARE FOR PLAYING VIDEO,
COMPUTER AND ONLINE GAMES; SPEECH RECOGN-
ITION SOFTWARE; TOUCH AND VOICE DRIVEN IN-
TERACTIVE COMPUTER GAME SOFTWARE; VIDEO
AND AUDIO GAMES, NAMELY, COMPUTER GAME
PROGRAMS FEATURING INTERACTIVE VIDEO AND
AUDIO CONTENT (U.S. CLS. 21, 23, 26, 36 AND 38).

LIEF MARTIN, EXAMINING ATTORNEY

SN 85-190,203. IMPLEN GMBH, 81829 MUENCHEN, FED
REP GERMANY, FILED 12-3-2010.

IMPLEN

THE MARK CONSISTS OF STANDARD CHARACTERS
WITHOUT CLAIM TO ANY PARTICULAR FONT, STYLE,
SIZE, OR COLOR.

FOR SCIENTIFIC APPARATUS, NAMELY, SPECTRO-
PHOTOMETER FOR MEASURING RELATIVE DNA/
RNA AND PROTEIN (U.S. CLS. 21, 23, 26, 36 AND 38).

FIRST USE 8-0-2003; IN COMMERCE 5-24-2005.

JILL PRATER, EXAMINING ATTORNEY

CLASS 9—(Continued).

SN 85-191,397. DOOBIC CO., LTD., SEOCHO GU, SEOUL, REPUBLIC OF KOREA, FILED 12-6-2010.



NO CLAIM IS MADE TO THE EXCLUSIVE RIGHT TO USE "COMPANY", APART FROM THE MARK AS SHOWN. THE COLOR(S) BLACK, WHITE AND ORANGE IS/ARE CLAIMED AS A FEATURE OF THE MARK.

THE MARK CONSISTS OF THE TERMS "SHADOW COMPANY" IN WHITE AGAINST A BLACK BACKGROUND AND APPEARING ABOVE THE TERMS "THE MERCENARY WAR" IN BLACK AND APPEARING AGAINST AN ORANGE BACKGROUND, WHEREIN A SILHOUETTE OF A SOLDIER IN BLACK APPEARS OVER THE LETTER "O" IN THE TERM "SHADOW".

FOR COMPUTER GAME PROGRAMS; COMPUTER SOFTWARE FOR GAMES; COMPUTER APPLICATION SOFTWARE FOR MOBILE PHONES FOR GAMES; VIRTUAL REALITY GAME SOFTWARE; SOFTWARE FOR PROCESSING IMAGES, GRAPHICS AND TEXT; COMPUTER PROGRAMS FOR PRE-RECORDED GAMES; RECORDED COMPUTER OPERATING PROGRAMS; RECORDED COMPUTER PROGRAMS FOR GAMES; DOWNLOADABLE COMPUTER SOFTWARE FOR GAMES; AND COMPUTER PROGRAMS FOR THE ENABLING OF ACCESS OR ENTRANCE CONTROL; ALL OF THE FOREGOING FOR USE WITH COMPUTER GAMES (U.S. CLS. 21, 23, 26, 36 AND 38).

ALICIA COLLINS, EXAMINING ATTORNEY

CLASS 9—(Continued).

SN 85-193,001. APPLE INDUSTRIES, INC., BAYCHESTER, NY, FILED 12-8-2010.

EZ PHOTO

THE MARK CONSISTS OF STANDARD CHARACTERS WITHOUT CLAIM TO ANY PARTICULAR FONT, STYLE, SIZE, OR COLOR.

NO CLAIM IS MADE TO THE EXCLUSIVE RIGHT TO USE "PHOTO", APART FROM THE MARK AS SHOWN.

FOR STAND ALONE PAY FOR USE INTERACTIVE PHOTO KIOSKS FOR CAPTURING, PRINTING AND UPLOADING DIGITAL AND PHOTOGRAPHIC IMAGES (U.S. CLS. 21, 23, 26, 36 AND 38).

SAIMA MAKHDOOM, EXAMINING ATTORNEY

SN 85-191,775. GLOCK, GASTON J., WIEN 1190, AUSTRIA, FILED 12-6-2010.



THE NAME "GASTON" IDENTIFIES A LIVING INDIVIDUAL WHOSE CONSENT IS OF RECORD.

THE COLOR(S) RED, BLACK, AND WHITE IS/ARE CLAIMED AS A FEATURE OF THE MARK.

THE MARK CONSISTS OF THE WORD "GASTON" IN BLACK AND INCORPORATES A WHITE "G" INSIDE A RED CIRCLE DESIGN LOGO, WHICH STANDS FOR THE LETTER "O" IN "GASTON".

FOR SPECIAL GLASSES FOR SHOOTING, HUNTING, AND SPORTS; PROTECTIVE GLASSES; SPORTS GLASSES; SUN GLASSES; BINOCULARS; PROTECTIVE EAR PLUGS (U.S. CLS. 21, 23, 26, 36 AND 38).

JANICE L. MCMORROW, EXAMINING ATTORNEY

SN 85-194,860. TAIWAN HURKU CO., LTD., TAICHUNG HSIEN, TAIWAN, FILED 12-10-2010.



THE MARK CONSISTS OF A STYLIZED DESIGN WITH THE WORD "TDF"; THE LETTER "T" IS SPLIT IN THE MIDDLE, FORMULATING AN UPSIDE DOWN LETTER "L", AND THE OTHER HALF OF THE LETTER IS CONJOINED WITH THE LETTER "D".

FOR TELEVISIONS, AUDIO SPEAKERS, LOUD SPEAKERS, MEGAPHONES, MICROPHONES, EARPHONES, RADIOS, AUDIO RECORDERS, CASSETTE PLAYERS, KARAOKE PLAYERS, COMPACT DISC PLAYERS, STEREO TUNERS, AUDIO MIXERS, LOUD-SPEAKER CABINETS, JUKE BOXES FOR COMPUTER AND FOR MUSIC, ECHO SOUNDERS DEVICE, AUDIO MIXERS, TV CAMERAS, TV MONITORS, AUDIO HEADPHONES (U.S. CLS. 21, 23, 26, 36 AND 38).

KEVON CHISOLM, EXAMINING ATTORNEY

CLASS 9—(Continued).

SN 85-196,403. SOLIANT CONSULTING INC., CHICAGO, IL. FILED 12-13-2010.



THE MARK CONSISTS OF THREE OVERLAPPING SQUARES OF 3 DIFFERENT SIZES WITH THE NAME "BORDS" UNDERNEATH THE SQUARES AND WITH THE LETTER "O" AS UNDERLINED AND SUPERSCRIPED. THE LARGEST SQUARE IS IN FRONT, THE SMALLEST SQUARE IS IN THE BACK LEFT AND THE SECOND LARGEST SQUARE IS IN THE BACK RIGHT.

FOR COMPUTER APPLICATION SOFTWARE FOR CREATIVELY ORGANIZING IDEAS AND THOUGHTS (U.S. CLS. 21, 23, 26, 36 AND 38).

FIRST USE 12-7-2010; IN COMMERCE 12-7-2010.
LESLEY LAMOTHE, EXAMINING ATTORNEY

CLASS 9—(Continued).

SN 85-196,855. SENAO INTERNATIONAL CO., LTD., HSIN-TIEN CITY, TAIWAN, FILED 12-13-2010.



THE COLOR(S) RED, BLACK AND WHITE IS/ARE CLAIMED AS A FEATURE OF THE MARK.

THE MARK CONSISTS OF THE WORDS "MEGA KING" IN STYLIZED PRINT IN RED WITH WHITE AND BLACK BORDERS IN BROKEN LINES AND A WHITE AMORPHOUS CONFIGURATION EXTENDING THROUGH THE LETTERS "N" AND "G" OF THE WORD "KING".

FOR BATTERY CHARGERS; BATTERIES; BATTERIES FOR FLASHLIGHT; SOLAR CELLS; WIRELESS EARPHONES; WIRELESS COMPUTER KEYBOARDS; PROTECTIVE FILMS FOR CELLULAR TELEPHONE SCREENS; COVERS FOR CELLULAR TELEPHONES MADE OF LEATHER OR SILICONE (U.S. CLS. 21, 23, 26, 36 AND 38).

B. PARADEWELAI, EXAMINING ATTORNEY

SN 85-196,848. SENAO INTERNATIONAL CO., LTD., HSIN-TIEN CITY, TAIWAN, FILED 12-13-2010.



THE MARK CONSISTS OF THE WORDS "MEGA KING" IN STYLIZED PRINT WITH AN AMORPHOUS CONFIGURATION EXTENDING THROUGH THE LETTERS "N" AND "G" OF THE WORD "KING".

FOR BATTERY CHARGERS; BATTERIES; BATTERIES FOR FLASHLIGHT; SOLAR CELLS; WIRELESS EARPHONES; WIRELESS COMPUTER KEYBOARDS; PROTECTIVE FILMS FOR CELLULAR TELEPHONE SCREENS; COVERS FOR CELLULAR TELEPHONES MADE OF LEATHER OR SILICONE (U.S. CLS. 21, 23, 26, 36 AND 38).

B. PARADEWELAI, EXAMINING ATTORNEY

SN 85-199,039. SILICON TURNKEY SOLUTIONS, INC., MILPITAS, CA. FILED 12-15-2010.

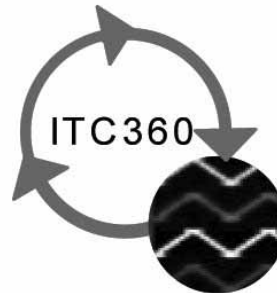

THE MARK CONSISTS OF A CIRCLE WITH THREE ARROWS WITH THE WORD "ITC360" IN THE CENTER WITH THE FIRST CIRCLE BEING INTERTWINED WITH A SECOND CIRCLE CONTAINING MULTIPLE PARALLEL LINES.

FOR ELECTRONIC RELIANCE TESTING EQUIPMENT FOR RELIANCE TESTING OF SEMI-CONDUCTORS, PROCESSORS, LEDS, LED MODULES, AND PRECISION THERMAL CONTROLLERS (U.S. CLS. 21, 23, 26, 36 AND 38).

NAPOLEON SHARMA, EXAMINING ATTORNEY

CLASS 9—(Continued).

SN 85-199,515. THE NOCO COMPANY, CLEVELAND, OH.
FILED 12-16-2010.

WICKED SMART

THE MARK CONSISTS OF STANDARD CHARACTERS WITHOUT CLAIM TO ANY PARTICULAR FONT, STYLE, SIZE, OR COLOR.

OWNER OF U.S. REG. NO. 3,835,896.

NO CLAIM IS MADE TO THE EXCLUSIVE RIGHT TO USE "SMART", APART FROM THE MARK AS SHOWN.

FOR BATTERY CHARGERS, SOLAR BATTERY CHARGERS, POWER INVERTERS, ELECTRIC POWER CONVERTERS, AND CHARGE CONTROLLERS (U.S. CLS. 21, 23, 26, 36 AND 38).

MICHAEL WIENER, EXAMINING ATTORNEY

SN 85-199,525. THE NOCO COMPANY, CLEVELAND, OH.
FILED 12-16-2010.

**NOW THAT'S SMART . . .
WICKED SMART!**

THE MARK CONSISTS OF STANDARD CHARACTERS WITHOUT CLAIM TO ANY PARTICULAR FONT, STYLE, SIZE, OR COLOR.

OWNER OF U.S. REG. NO. 3,835,896.

FOR BATTERY CHARGERS, SOLAR BATTERY CHARGERS, POWER INVERTERS, ELECTRIC POWER CONVERTERS, AND CHARGE CONTROLLERS (U.S. CLS. 21, 23, 26, 36 AND 38).

MICHAEL WIENER, EXAMINING ATTORNEY

CLASS 9—(Continued).

SN 85-199,653. WILLOW HOLDINGS, INC., NEW BERN, NC.
FILED 12-16-2010.

TRUTH IN LITERATURE

THE MARK CONSISTS OF STANDARD CHARACTERS WITHOUT CLAIM TO ANY PARTICULAR FONT, STYLE, SIZE, OR COLOR.

NO CLAIM IS MADE TO THE EXCLUSIVE RIGHT TO USE "LITERATURE", APART FROM THE MARK AS SHOWN.

FOR PRE-RECORDED VIDEO AND AUDIO CASSETTES, COMPACT DISCS, VIDEO DISCS, DVDS, AND RECORDED LASER DISCS FEATURING MIDDLE SCHOOL, HIGH SCHOOL AND UNIVERSITY-LEVEL EDUCATIONAL COURSE MATERIAL IN THE FIELD OF LITERATURE; COMPUTER SOFTWARE PROGRAMS FOR THE INTEGRATION OF TEXT, AUDIO, GRAPHICS, STILL IMAGES AND MOVING PICTURES INTO AN INTERACTIVE DELIVERY FOR MULTIMEDIA APPLICATIONS, PRE-RECORDED ON CD-ROMS AND COMPACT DISCS FEATURING MIDDLE SCHOOL, HIGH SCHOOL AND UNIVERSITY-LEVEL COURSE MATERIAL IN THE FIELD OF LITERATURE; DOWNLOADABLE ELECTRONIC PUBLICATIONS IN THE NATURE OF BOOKS, MAGAZINES, AND MANUALS FEATURING MIDDLE SCHOOL, HIGH SCHOOL, AND UNIVERSITY-LEVEL COURSE MATERIAL AND STUDY GUIDES IN THE FIELD OF LITERATURE, INCLUDING STUDENT EDITIONS FEATURING BASIC TEXT, PLOT ANALYSIS, CHARACTER LISTS, ANALYSIS OF MAJOR CHARACTERS, CHAPTER SUMMARIES, STUDY QUESTIONS AND ESSAY TOPICS; DOWNLOADABLE ELECTRONIC TEACHER MANUALS IN THE NATURE OF CUSTOMIZED HOMEWORK ASSIGNMENTS, TESTS, TEACHING AIDS AND MATERIALS (U.S. CLS. 21, 23, 26, 36 AND 38).

BRIAN NEVILLE, EXAMINING ATTORNEY

SN 85-200,828. HARDCANDY CASES, LLC, DANVILLE, CA.
FILED 12-17-2010.

Fanny Wang

THE MARK CONSISTS OF STANDARD CHARACTERS WITHOUT CLAIM TO ANY PARTICULAR FONT, STYLE, SIZE, OR COLOR.

THE NAME SHOWN IN THE MARK DOES NOT IDENTIFY A PARTICULAR LIVING INDIVIDUAL.

FOR PROTECTIVE CASES FOR SMARTPHONES AND CELLULAR PHONES; ACCESSORIES FOR ELECTRONIC DEVICES, NAMELY, HEADPHONES, DATA CABLES AND HEADPHONE SPLITTERS (U.S. CLS. 21, 23, 26, 36 AND 38).

FIRST USE 12-0-2010; IN COMMERCE 12-0-2010.

TINA BROWN, EXAMINING ATTORNEY

CLASS 9—(Continued).

SN 85-202,694. TAKE-TWO INTERACTIVE SOFTWARE, INC., NEW YORK, NY. FILED 12-21-2010.

RED DEAD REDEMPTION

THE MARK CONSISTS OF STANDARD CHARACTERS WITHOUT CLAIM TO ANY PARTICULAR FONT, STYLE, SIZE, OR COLOR.

OWNER OF U.S. REG. NO. 3,036,636.
FOR ANIMATED MOTION PICTURE FILMS FEATURING WESTERN THEMES (U.S. CLS. 21, 23, 26, 36 AND 38).

FIRST USE 10-19-2010; IN COMMERCE 10-19-2010.
MARK PILARO, EXAMINING ATTORNEY

SN 85-202,700. TAKE-TWO INTERACTIVE SOFTWARE, INC., NEW YORK, NY. FILED 12-21-2010.

ROCKSTAR FILMS

THE MARK CONSISTS OF STANDARD CHARACTERS WITHOUT CLAIM TO ANY PARTICULAR FONT, STYLE, SIZE, OR COLOR.

OWNER OF U.S. REG. NOS. 2,456,387, 3,905,775 AND OTHERS.

NO CLAIM IS MADE TO THE EXCLUSIVE RIGHT TO USE "FILMS", APART FROM THE MARK AS SHOWN.

FOR ANIMATED MOTION PICTURE FILMS FEATURING ENTERTAINMENT, NAMELY, ACTION, ADVENTURE, DRAMATIC, COMEDIC, CHILDREN'S AND DOCUMENTARY THEMES; PRE-RECORDED VIDEO DISCS AND OTHER PRE-RECORDED DIGITAL AND ELECTRONIC MEDIA IN THE FIELD OF LIVE ACTION PROGRAMS, MOTION PICTURES, OR ANIMATION FEATURING ENTERTAINMENT, NAMELY, ACTION, ADVENTURE, DRAMATIC, COMEDIC, CHILDREN'S AND DOCUMENTARY THEMES (U.S. CLS. 21, 23, 26, 36 AND 38).

FIRST USE 10-19-2010; IN COMMERCE 10-19-2010.
MARK PILARO, EXAMINING ATTORNEY

SN 85-205,638. GARZO, KENNETH ALAN, CAMPBELL, CA. FILED 12-25-2010.

Make a Face

THE MARK CONSISTS OF STANDARD CHARACTERS WITHOUT CLAIM TO ANY PARTICULAR FONT, STYLE, SIZE, OR COLOR.

FOR COMPUTER APPLICATION SOFTWARE FOR MOBILE PHONES AND DESKTOP COMPUTERS, NAMELY, SOFTWARE FOR CREATING GRAPHICS FACIAL DISPLAYS (U.S. CLS. 21, 23, 26, 36 AND 38).

FIRST USE 12-25-1990; IN COMMERCE 12-6-2009.
SUE LAWRENCE, EXAMINING ATTORNEY

CLASS 9—(Continued).

SN 85-206,017. M.P. ELECTRONICS, INC., APOPKA, FL. FILED 12-27-2010.

THE EXERCISER

THE MARK CONSISTS OF STANDARD CHARACTERS WITHOUT CLAIM TO ANY PARTICULAR FONT, STYLE, SIZE, OR COLOR.

FOR ELECTRIC RELAY THAT ALLOWS A SUMP PUMP TO TURN ON AND OFF PERIODICALLY (U.S. CLS. 21, 23, 26, 36 AND 38).

ALICIA COLLINS, EXAMINING ATTORNEY

SN 85-207,109. AMONIX, INC., SEAL BEACH, CA. FILED 12-29-2010.



OWNER OF U.S. REG. NOS. 3,549,262 AND 3,633,778.

THE MARK CONSISTS OF THE WORD "AMONIX" IN BLOCK LETTERING AND A SUN DESIGN APPEARING IN THE OPENING OF THE LETTER "O" IN THE WORD "AMONIX".

FOR APPARATUS FOR CONVERTING ELECTRONIC RADIATION TO ELECTRICAL ENERGY, NAMELY, PHOTOVOLTAIC SOLAR AND THERMAL MODULES AND SOLAR CELLS; SOLAR CELLS; PHOTOVOLTAIC CELLS; PHOTOVOLTAIC CELLS AND MODULES, INCLUDING A THERMAL COLLECTOR SOLD AS A UNIT (U.S. CLS. 21, 23, 26, 36 AND 38).

FIRST USE 6-0-2010; IN COMMERCE 6-0-2010.
TARA PATE, EXAMINING ATTORNEY

CLASS 9—(Continued).

SN 85-209,423. BRETT GILBERT PALACIO, DBA GATSBY, HESPERIA, CA. FILED S.R. 1-3-2011; AM. P.R. 5-31-2011.

Gatsby

THE MARK CONSISTS OF STANDARD CHARACTERS WITHOUT CLAIM TO ANY PARTICULAR FONT, STYLE, SIZE, OR COLOR.

FOR AUDIO AND VIDEO RECORDINGS FEATURING MUSIC AND ARTISTIC PERFORMANCES; AUDIO AND VIDEO RECORDINGS FEATURING MUSIC; AUDIO RECORDERS; AUDIO TAPES FEATURING MUSIC; COMPACT DISCS FEATURING MUSIC; DIGITAL MEDIA, NAMELY, PRE-RECORDED DVDS, DOWNLOADABLE AUDIO AND VIDEO RECORDINGS, AND CDS FEATURING AND PROMOTING MUSIC; DIGITAL MEDIA, NAMELY, PRE-RECORDED VIDEO CASSETTES, DIGITAL VIDEO DISCS, DIGITAL VERSATILE DISCS, DOWNLOADABLE AUDIO AND VIDEO RECORDINGS, DVDS, AND HIGH DEFINITION DIGITAL DISCS FEATURING MUSIC; DIGITAL MUSIC DOWNLOADABLE FROM THE INTERNET; DOWNLOADABLE MP3 FILES AND MP3 RECORDINGS FEATURING MUSIC; DOWNLOADABLE MUSICAL SOUND RECORDINGS; DOWNLOADABLE RING TONES, GRAPHICS AND MUSIC VIA A GLOBAL COMPUTER NETWORK AND WIRELESS DEVICES; DOWNLOADABLE VIDEO RECORDINGS FEATURING MUSIC; DOWNLOADABLE MUSIC RINGTONES, WAV AUDIO FILES, WMA AUDIO FILES, MP3 AUDIO FILES AND DIGITAL AUDIO FILES VIA THE INTERNET AND WIRELESS DEVICES; MUSICAL SOUND RECORDINGS; MUSICAL VIDEO RECORDINGS; PRE-RECORDED CDS FEATURING MUSIC; PRE-RECORDED CDS, VIDEO TAPES, LASER DISKS AND DVDS FEATURING MUSIC; PRE-RECORDED DIGITAL MEDIA FEATURING MUSIC; PRE-RECORDED DIGITAL VIDEO DISCS FEATURING MUSIC; PRE-RECORDED DVDS FEATURING MUSIC; PRE-RECORDED ELECTRONIC AND DIGITAL MEDIA FEATURING MUSIC; PRE-RECORDED ELECTRONIC MEDIA FEATURING MUSIC; PRE-RECORDED ELECTRONIC FLASH DRIVES FEATURING MUSIC; SERIES OF MUSICAL SOUND RECORDINGS; VINYL COVERS SPECIALLY ADAPTED FOR CELL PHONES, MP3 PLAYERS, LAPTOPS, COMPUTERS, PORTABLE SATELLITE RADIOS, PERSONAL DIGITAL ASSISTANTS, REMOTE CONTROLS, AND TELEVISION SATELLITE RECORDERS; VISUAL AND AUDIO RECORDINGS FEATURING MUSIC; VISUAL RECORDINGS AND AUDIOVISUAL RECORDINGS FEATURING MUSIC AND ANIMATION (U.S. CLS. 21, 23, 26, 36 AND 38).

FIRST USE 11-12-2010; IN COMMERCE 11-12-2010.

TINA BROWN, EXAMINING ATTORNEY

CLASS 9—(Continued).

SN 85-212,117. SANDRO BELLANI, 8106 ADLIKON, SWITZERLAND, FILED 1-6-2011.

PASS THE EXAM !!

THE MARK CONSISTS OF THE PHRASE "PASS THE EXAM !!!" WITH SPACE AFTER THE WORD "EXAM" AND OF FONT CARBON BLOCK (TRUETYPE).

FOR COMPUTER APPLICATION SOFTWARE FOR MOBILE AND HANDHELD COMPUTER DEVICES, NAMELY, SOFTWARE FOR FACILITATING STUDY AIDS FOR PROFESSIONAL OR EDUCATION EXAMINATIONS BY ALLOWING THE USER THE ABILITY TO ELECTRONICALLY CREATE THEIR OWN CUSTOMIZED SOFTWARE FLASHCARDS ON THE MOBILE DEVICE AND TO IMPLEMENT AUDIO, VIDEO, TEXT AND PICTURES WITHIN THE FLASHCARDS DESIGNED TO MAKE THE FLASHCARDS MORE INFORMATIVE AS A STUDY AID; COMPUTER SOFTWARE FOR CREATING USER-CUSTOMIZED ELECTRONIC FLASHCARD STUDY AIDS ON MOBILE AND HANDHELD COMPUTER DEVICES THAT MAY BE DOWNLOADED FROM A GLOBAL COMPUTER NETWORK; DOWNLOADABLE COMPUTER SOFTWARE FOR MOBILE AND HANDHELD COMPUTER DEVICES TO ALLOW THE USER TO CREATE USER-CUSTOMIZED ELECTRONIC FLASHCARD STUDY AIDS ON THE MOBILE OR HANDHELD COMPUTER DEVICE AS SOFTWARE THAT WILL RUN ON THAT DEVICE; DOWNLOADABLE SOFTWARE IN THE NATURE OF A MOBILE APPLICATION FOR MOBILE AND HANDHELD COMPUTER DEVICES THAT ALLOWS A USER TO CREATE THEIR OWN ELECTRONIC SOFTWARE EXAMINATION STUDY AID FLASHCARDS SOFTWARE APPLICATIONS (U.S. CLS. 21, 23, 26, 36 AND 38).

FIRST USE 12-3-2010; IN COMMERCE 12-3-2010.

EUGENIA MARTIN, EXAMINING ATTORNEY

SN 85-215,259. COLEMAN III, JESSE LEE, CHICAGO, IL. FILED 1-11-2011.

YUNG HOLLA

THE MARK CONSISTS OF STANDARD CHARACTERS WITHOUT CLAIM TO ANY PARTICULAR FONT, STYLE, SIZE, OR COLOR.

THE NAME(S), PORTRAIT(S), AND/OR SIGNATURE(S) SHOWN IN THE MARK IDENTIFIES JESSE LEE COLEMAN III, WHOSE CONSENT(S) TO REGISTER IS MADE OF RECORD.

FOR MUSICAL SOUND RECORDINGS; AUDIO-VISUAL RECORDINGS, NAMELY, COMPACT DISCS, TAPE CASSETTES, AUDIO CASSETTES, AUDIO TAPES, AUDIO DISCS, RECORDS, CD-ROMS, VIDEO TAPES, VIDEO CASSETTES, VIDEO DISCS, DVDS, DATS, AND LASER DISCS, ALL FEATURING MUSIC, DISC JOCKEYING AND SUBJECT MATTERS GENERALLY RELATED TO THE ENTERTAINMENT INDUSTRY, NAMELY, MUSIC, MOVIES, TELEVISION, GAMING, MUSIC VIDEOS, ATHLETICS, BIOGRAPHIES, DRAMA AND COMEDIES; DOWNLOADABLE VIDEO RECORDINGS FEATURING MUSIC; DOWNLOADABLE ELECTRONIC PUBLICATIONS IN THE NATURE OF BOOKS, BOOKLETS, MAGAZINES, JOURNALS, MANUALS, BROCHURES, LEAFLETS, PAMPHLETS AND NEWSLETTERS, ALL IN THE FIELDS OF MUSIC, DISC JOCKEYING AND SUBJECT MATTERS GENERALLY RELATED TO THE ENTERTAINMENT INDUSTRY, NAMELY, MUSIC, MOVIES, TELEVISION, GAMING, MUSIC VIDEOS, ATHLETICS, BIOGRAPHIES, DRAMA

CLASS 9—(Continued).

AND COMEDIES; ELECTRONIC PUBLICATIONS, NAMELY, BOOKS, BOOKLETS, MAGAZINES, JOURNALS, MANUALS, BROCHURES, LEAFLETS, PAMPHLETS AND NEWSLETTERS, ALL IN THE FIELDS OF MUSIC, DISC JOCKEYING AND SUBJECT MATTERS GENERALLY RELATED TO THE ENTERTAINMENT INDUSTRY, NAMELY, MUSIC, MOVIES, TELEVISION, GAMING, MUSIC VIDEOS, ATHLETICS, BIOGRAPHIES, DRAMA AND COMEDIES, ALL RECORDED ON CD-ROMS, DISKETTES, FLOPPY DISKS, VIDEO CASSETTES, AND MAGNETIC TAPES; MAGNETS; DECORATIVE MAGNETS; REFRIGERATOR MAGNETS; NOVELTY MAGNETS; MOUSE PADS; COMPACT DISC CASES; FITTED CASES FOR STORAGE AND TRANSPORTATION, NAMELY, CASES FOR COMPACT DISCS, AUDIO CASSETTES, VIDEO CASSETTES, CD-ROMS, HOME VIDEO GAMES, HOME VIDEO GAME ACCESSORIES, COMPUTERS, COMPUTER ACCESSORIES, CAMERAS, CAMCORDERS AND PORTABLE PHONES; COMPUTER CARRYING CASES; WRIST RESTS AND SUPPORTS FOR COMPUTER MOUSE USERS; WRIST RESTS FOR COMPUTER PRODUCTS; COMPUTER KEYBOARD WRIST PADS; COMPUTER GAME CARTRIDGES, CASSETTES, TAPES, DISCS, JOYSTICKS, PROGRAMS AND SOFTWARE; ELECTRONIC GAME PROGRAMS; VIDEO GAME CARTRIDGES, TAPE CASSETTES, DISCS, JOYSTICKS, PROGRAMS AND SOFTWARE, ELECTRONIC GAME PROGRAMS; ELECTRONIC GOODS, PLAYERS AND RECORDERS, NAMELY, AUDIO CASSETTE RECORDERS, AUDIO TAPE RECORDERS, COMPACT DISC RECORDERS, DIGITAL VIDEO RECORDERS, VIDEO TAPE RECORDERS, PHONOGRAPH PLAYERS, MP3 PLAYERS, DIGITAL AUDIO PLAYERS, DIGITAL VIDEO PLAYERS, PORTABLE MEDIA PLAYERS, AUDIO TAPE PLAYERS AND COMPACT DISC PLAYERS (U.S. CLS. 21, 23, 26, 36 AND 38).

FIRST USE 3-0-2010; IN COMMERCE 10-0-2010.
JILL C. ALT, EXAMINING ATTORNEY

SN 85-215,476. JESLINX, INC., MIAMI, FL. FILED 1-11-2011.

dCAB

THE MARK CONSISTS OF STANDARD CHARACTERS WITHOUT CLAIM TO ANY PARTICULAR FONT, STYLE, SIZE, OR COLOR.

FOR COMPUTER COMMUNICATIONS SOFTWARE TO ALLOW CUSTOMERS TO ACCESS BANK ACCOUNT INFORMATION AND TRANSACT BANK BUSINESS; COMPUTER E-COMMERCE SOFTWARE TO ALLOW USERS TO PERFORM ELECTRONIC BUSINESS TRANSACTIONS VIA A GLOBAL COMPUTER NETWORK; COMPUTER HARDWARE AND COMPUTER SOFTWARE FOR RETAIL INVENTORY MANAGEMENT, SOLD AS A UNIT; COMPUTER HARDWARE AND COMPUTER SOFTWARE PROGRAMS FOR THE INTEGRATION OF TEXT, AUDIO, GRAPHICS, STILL IMAGES AND MOVING PICTURES INTO AN INTERACTIVE DELIVERY FOR MULTIMEDIA APPLICATIONS; COMPUTER HARDWARE FOR WIRELESS CONTENT DELIVERY; COMPUTER PROGRAMS FOR CONNECTING REMOTELY TO COMPUTERS OR COMPUTER NETWORKS; COMPUTER PROGRAMS FOR SEARCHING REMOTELY FOR CONTENT ON COMPUTERS AND COMPUTER NETWORKS; COMPUTER PROGRAMS FOR SEARCHING THE CONTENTS OF COMPUTERS AND COMPUTER NETWORKS BY REMOTE CONTROL; COMPUTER PROGRAMS FOR USER INTERFACE DESIGN; COMPUTER PROGRAMS FOR USING THE INTERNET AND THE WORLD WIDE WEB; COMPUTER SOFTWARE THAT ASSISTS COMPUTERS IN DEPLOYING PARALLEL APPLICATIONS AND PERFORMING PARALLEL COMPUTATIONS; COMPUTER SOFTWARE THAT PROVIDES WEB-BASED AC-

CLASS 9—(Continued).

CESS TO APPLICATIONS AND SERVICES THROUGH A WEB OPERATING SYSTEM OR PORTAL INTERFACE; COMPUTER SOFTWARE TO AUTOMATE DATA WAREHOUSING; COMPUTER SOFTWARE, NAMELY, AN APPLICATION ALLOWING SALES AND FIELD SERVICE EMPLOYEES TO UPDATE AND RECEIVE DATA STORED IN AN ENTERPRISE'S COMPUTER DATABASES IN REAL TIME, USING A MOBILE DEVICE, WITH FULL TELEPHONY INTEGRATION WITH THE TELEPHONE AND/OR SOFTWARE FEATURES OF THE MOBILE DEVICE; COMPUTER SOFTWARE, NAMELY, ELECTRONIC FINANCIAL PLATFORM THAT ACCOMMODATES MULTIPLE TYPES OF PAYMENT AND DEBT TRANSACTIONS IN AN INTEGRATED MOBILE PHONE, PDA, AND WEB BASED ENVIRONMENT; COMPUTER TELEPHONY SOFTWARE; COMPUTER UTILITY PROGRAMS; CREDIT SCREENING SOFTWARE; DOWNLOADABLE ELECTRONIC DATA FILES AND DATABASES, NAMELY, BUSINESS AND TAX FORMS, FOR USE WITH COMPUTER SOFTWARE; WAN (WIDE AREA NETWORK) OPERATING SOFTWARE; COMMUNICATIONS SOFTWARE FOR CONNECTING USERS TO A CLOUD COMPUTING NETWORK, NAMELY, DATA TRANSMISSION BETWEEN CLOUD COMPUTING NETWORKS AND NON-CLOUD COMPUTING NETWORKS; COMPUTER APPLICATION SOFTWARE FOR MOBILE PHONES, NAMELY, COMPUTER SOFTWARE FOR FINANCIAL MANAGEMENT, CLIENT AND VENDOR MANAGEMENT, INVENTORY MANAGEMENT, PROJECT MANAGEMENT, EVENT MANAGEMENT, BUSINESS SERVICES MANAGEMENT, INCIDENT MANAGEMENT, EMPLOYEE MANAGEMENT, BUSINESS AGENCY MANAGEMENT, TEAM MANAGEMENT, RESOURCES MANAGEMENT, LOGISTICS MANAGEMENT, TIME REPORTING, BUSINESS INTELLIGENCE AND REPORTING; COMPUTER APPLICATION SOFTWARE FOR CORPORATE APPLICATIONS, NAMELY, COMPUTER SOFTWARE FOR FINANCIAL MANAGEMENT, CLIENT AND VENDOR MANAGEMENT, INVENTORY MANAGEMENT, PROJECT MANAGEMENT, EVENT MANAGEMENT, BUSINESS SERVICES MANAGEMENT, INCIDENT MANAGEMENT, EMPLOYEE MANAGEMENT, BUSINESS AGENCY MANAGEMENT, TEAM MANAGEMENT, RESOURCES MANAGEMENT, LOGISTICS MANAGEMENT, TIME REPORTING, BUSINESS INTELLIGENCE AND REPORTING; COMPUTER SOFTWARE FOR FINANCIAL MANAGEMENT, CLIENT AND VENDOR MANAGEMENT, INVENTORY MANAGEMENT, PROJECT MANAGEMENT, EVENT MANAGEMENT, BUSINESS SERVICES MANAGEMENT, INCIDENT MANAGEMENT, EMPLOYEE MANAGEMENT, BUSINESS AGENCY MANAGEMENT, TEAM MANAGEMENT, RESOURCES MANAGEMENT, LOGISTICS MANAGEMENT, TIME REPORTING, BUSINESS INTELLIGENCE AND REPORTING; COMPUTER PROGRAMS FOR CORPORATE APPLICATIONS FOR CLOUD AND MOBILE PLATFORMS, NAMELY, COMPUTER SOFTWARE FOR FINANCIAL MANAGEMENT, CLIENT AND VENDOR MANAGEMENT, INVENTORY MANAGEMENT, PROJECT MANAGEMENT, EVENT MANAGEMENT, BUSINESS SERVICES MANAGEMENT, INCIDENT MANAGEMENT, EMPLOYEE MANAGEMENT, BUSINESS AGENCY MANAGEMENT, TEAM MANAGEMENT, RESOURCES MANAGEMENT, LOGISTICS MANAGEMENT, TIME REPORTING, BUSINESS INTELLIGENCE AND REPORTING; COMPUTER SOFTWARE FOR BUSINESS CONTINUITY AND DISASTER RECOVERY, NAMELY, COMPUTER SOFTWARE FOR DATA RECOVERY AND DATA BACKUP USED FOR BUSINESS CONTINUITY AND DISASTER RECOVERY; COMPUTER SOFTWARE FOR CORPORATE AND BUSINESS APPLICATIONS THAT MAY BE DOWNLOADED FROM A GLOBAL COMPUTER NETWORK, NAMELY, COMPUTER SOFTWARE FOR FINANCIAL MANAGEMENT, CLIENT AND VENDOR MANAGEMENT, INVENTORY MANAGEMENT, PROJECT MANAGEMENT, EVENT MANAGEMENT, BUSINESS SERVICES MANAGEMENT, INCIDENT MANAGEMENT, EMPLOYEE MANAGEMENT, BUSINESS AGENCY MANAGEMENT, TEAM MANAGEMENT, RESOURCES MANAGEMENT, LOGISTICS MANAGEMENT, TIME REPORTING, BUSINESS INTELLIGENCE AND REPORTING; COMPUTER SOFTWARE PLATFORMS FOR INTERACTION WITH THE CLOUD AND MOBILE DEVICES, NAMELY, COMPUTER SOFTWARE FOR DATA TRANSMISSION BETWEEN CLOUD COMPUTING NETWORKS AND MOBILE DEVICES (U.S. CLS. 21, 23, 26, 36 AND 38).

FIRST USE 5-20-2009; IN COMMERCE 5-20-2009.
KIM SAITO, EXAMINING ATTORNEY

CLASS 9—(Continued).

SN 85-216,401. AINSWORTH GAME TECHNOLOGY, NEW-
INGTON, AUSTRALIA, FILED 1-12-2011.

Scatter Action

THE MARK CONSISTS OF STANDARD CHARACTERS WITHOUT CLAIM TO ANY PARTICULAR FONT, STYLE, SIZE, OR COLOR.

NO CLAIM IS MADE TO THE EXCLUSIVE RIGHT TO USE "SCATTER", APART FROM THE MARK AS SHOWN.

FOR COMPUTER SOFTWARE AND FIRMWARE FOR GAMES OF CHANCE ON ANY COMPUTERIZED PLATFORM, INCLUDING DEDICATED GAMING CONSOLES, VIDEO BASED SLOT MACHINES, REEL BASED SLOT MACHINES, AND VIDEO LOTTERY TERMINALS (U.S. CLS. 21, 23, 26, 36 AND 38).

KIMBERLY FRYE, EXAMINING ATTORNEY

CLASS 9—(Continued).

SN 85-219,409. AITKEN JEAN MARIE, SAN JOSE, CA. FILED 1-17-2011.

DRYER SHY

THE MARK CONSISTS OF STANDARD CHARACTERS WITHOUT CLAIM TO ANY PARTICULAR FONT, STYLE, SIZE, OR COLOR.

NO CLAIM IS MADE TO THE EXCLUSIVE RIGHT TO USE "DRYER", APART FROM THE MARK AS SHOWN.

FOR DECORATIVE MAGNETS (U.S. CLS. 21, 23, 26, 36 AND 38).

WON TEAK OH, EXAMINING ATTORNEY

SN 85-218,187. OWN LLC, LOS ANGELES, CA. FILED 1-14-2011.

THE COLOR(S) ORANGE, YELLOW, GREEN, LIGHT GREEN, PURPLE AND LIGHT PURPLE IS/ARE CLAIMED AS A FEATURE OF THE MARK.

THE MARK CONSISTS OF THE WORD "OWN" DEPICTED IN CAPITAL LETTERS WITH VARYING SHADES OF ORANGE FORMING "O" WITH YELLOW APPEARING IN THE CENTER; VARYING SHADES OF GREEN TO LIGHT GREEN FORMING "W" AND VARYING SHADES OF PURPLE TO LIGHT PURPLE FORMING "N" WITH A SHADOW UNDER EACH LETTER THAT IS DEPICTED IN THE SAME COLOR AS THE LETTER.

FOR PRERECORDED AUDIOVISUAL RECORDINGS, AUDIOTAPES, VIDEOTAPES, VIDEO DISCS, COMPACT DISCS, DVDS AND MULTIMEDIA SOFTWARE RECORDED ON CD-ROM, ALL FEATURING SUBJECTS OF GENERAL HUMAN INTEREST; ELECTRONIC LEARNING GAMES IN THE NATURE OF ELECTRONIC GAME SOFTWARE FOR EDUCATIONAL PURPOSES; VIDEO GAME DISCS; COMPUTER GAME DISCS; ELECTRONIC GAME PROGRAMS; DOWNLOADABLE RING TONES, GRAPHICS, RING BACKS, ANIMATED RINGERS, VIDEO RINGERS AND ANIMATED SCREENSAVERS VIA THE INTERNET AND WIRELESS DEVICES; DIGITAL MEDIA, NAMELY, DOWNLOADABLE PRERECORDED VIDEO CLIPS, PRERECORDED AUDIO CLIPS, TEXT AND GRAPHICS HELD IN ELECTRONIC PERSONAL COMPUTERS AND HANDHELD WIRELESS DEVICES, ALL FEATURING SUBJECTS OF GENERAL HUMAN INTEREST; SUNGLASSES (U.S. CLS. 21, 23, 26, 36 AND 38).

THOMAS MANOR, EXAMINING ATTORNEY

SN 85-222,274. GENERAL CABLE TECHNOLOGIES CORPORATION, HIGHLAND HEIGHTS, KY. FILED 1-20-2011.

THE MARK CONSISTS OF STANDARD CHARACTERS WITHOUT CLAIM TO ANY PARTICULAR FONT, STYLE, SIZE, OR COLOR.

OWNER OF U.S. REG. NOS. 3,122,875 AND 3,424,152. FOR RISER AND PLENUM COPPER ELECTRIC CABLES (U.S. CLS. 21, 23, 26, 36 AND 38).

TARA PATE, EXAMINING ATTORNEY

SN 85-222,975. AVKM, LLC, MINEOLA, TX. FILED 1-21-2011.

THE MARK CONSISTS OF THE STYLIZED LETTERS "KNOWLEDGEWALL".

FOR MULTIPLE PROJECTION DISPLAY SCREENS PROVIDING A SINGLE CONTINUOUS SCREEN SURFACE FOR USE WITH IMAGE SOURCE GENERATING PROJECTORS (U.S. CLS. 21, 23, 26, 36 AND 38).

TIMOTHY FINNEGAN, EXAMINING ATTORNEY

CLASS 9—(Continued).

SN 85-224,464. PRECIMETER SCIENTIFIC AB, 429 31 KUL-LAVIK, SWEDEN, FILED 1-24-2011.

PRECIMETER

THE MARK CONSISTS OF STANDARD CHARACTERS WITHOUT CLAIM TO ANY PARTICULAR FONT, STYLE, SIZE, OR COLOR.

FOR APPARATUS AND INSTRUMENTS, NAMELY, OPTICAL, INDUCTIVE AND CAPACITIVE SENSORS, ELECTRONIC ACTUATORS FOR CONTROLLING, REGULATING, MEASURING AND MONITORING LEVELS AND FLOW OF MOLTEN METAL; COMPUTER PROGRAMS FOR CONTROLLING, REGULATING, MEASURING AND MONITORING LEVELS AND FLOW OF MOLTEN METAL (U.S. CLS. 21, 23, 26, 36 AND 38).

KEVIN DINALLO, EXAMINING ATTORNEY

SN 85-224,967. SUPREME FICTION, MOUNTAIN VIEW, CA. FILED 1-24-2011.

SUPREME FICTION

THE MARK CONSISTS OF STANDARD CHARACTERS WITHOUT CLAIM TO ANY PARTICULAR FONT, STYLE, SIZE, OR COLOR.

FOR SOUND RECORDINGS FEATURING PERFORMANCES OF A MUSICAL ARTIST OR GROUP; VIDEO RECORDINGS FEATURING PERFORMANCES OF A MUSICAL ARTIST OR GROUP (U.S. CLS. 21, 23, 26, 36 AND 38).

FIRST USE 9-18-2007; IN COMMERCE 9-18-2007.
SUNG IN, EXAMINING ATTORNEY

CLASS 9—(Continued).

SN 85-225,825. WARING, DIANA LYNNE, LAKE STEVENS, WA. AND WARING, WILLIAM JAMES, LAKE STEVENS, WA. FILED 1-25-2011.

Education That's Relational

THE MARK CONSISTS OF STANDARD CHARACTERS WITHOUT CLAIM TO ANY PARTICULAR FONT, STYLE, SIZE, OR COLOR.

FOR CHILDREN'S EDUCATIONAL MUSIC CDS AND DVDS; CHILDREN'S EDUCATIONAL SOFTWARE; DIGITAL MATERIALS, NAMELY, DVDS, CD-ROMS AND DOWNLOADABLE LESSONS AND EDUCATIONAL MATERIALS FEATURING EDUCATIONAL MATERIALS FOR K-12 STUDENTS FEATURING INFORMATION AND CLASS LESSONS IN THE AREAS OF HISTORY, THEOLOGY, SOCIOLOGY AND RELATED SUBJECTS, AND EDUCATIONAL MATERIALS FOR TEACHERS AND HOMESCHOOL PARENTS IN THE AREAS OF TEACHING K-12 STUDENTS, HISTORY, THEOLOGY, SOCIOLOGY AND EDUCATIONAL METHODS; DIGITAL MEDIA, NAMELY, DVDS, CD-ROMS AND DOWNLOADABLE EDUCATIONAL MATERIALS FEATURING EDUCATIONAL MATERIALS FOR K-12 STUDENTS FEATURING INFORMATION AND CLASS LESSONS IN THE AREAS OF HISTORY, THEOLOGY, SOCIOLOGY AND RELATED SUBJECTS, AND EDUCATIONAL MATERIALS FOR TEACHERS AND HOMESCHOOL PARENTS IN THE AREAS OF TEACHING K-12 STUDENTS, HISTORY, THEOLOGY, SOCIOLOGY AND EDUCATIONAL METHODS; DVD FEATURING EDUCATIONAL MATERIALS FOR K-12 STUDENTS FEATURING INFORMATION AND CLASS LESSONS IN THE AREAS OF HISTORY, THEOLOGY, SOCIOLOGY AND RELATED SUBJECTS, AND EDUCATIONAL MATERIALS FOR TEACHERS AND HOMESCHOOL PARENTS IN THE AREAS OF TEACHING K-12 STUDENTS, HISTORY, THEOLOGY, SOCIOLOGY AND EDUCATIONAL METHODS; PRE-RECORDED DVDS FEATURING EDUCATIONAL MATERIALS FOR K-12 STUDENTS FEATURING INFORMATION AND CLASS LESSONS IN THE AREAS OF HISTORY, THEOLOGY, SOCIOLOGY AND RELATED SUBJECTS, AND EDUCATIONAL MATERIALS FOR TEACHERS AND HOMESCHOOL PARENTS IN THE AREAS OF TEACHING K-12 STUDENTS, HISTORY, THEOLOGY, SOCIOLOGY AND EDUCATIONAL METHODS (U.S. CLS. 21, 23, 26, 36 AND 38).

FIRST USE 1-10-2011; IN COMMERCE 1-10-2011.

TIMOTHY FINNEGAN, EXAMINING ATTORNEY

SN 85-228,305. NIX, GEOFFREY, MARIETTA, GA. AND SYKES, CHARLES DALLAS, MARIETTA, GA. FILED 1-27-2011.

Thank God i'm Married

THE MARK CONSISTS OF STANDARD CHARACTERS WITHOUT CLAIM TO ANY PARTICULAR FONT, STYLE, SIZE, OR COLOR.

FOR MAGNETS; MOUSE PADS (U.S. CLS. 21, 23, 26, 36 AND 38).

FIRST USE 11-1-2010; IN COMMERCE 12-1-2010.

MATTHEW MCDOWELL, EXAMINING ATTORNEY

CLASS 9—(Continued).

SN 85-229,458. DYNAGEN TECHNOLOGIES INCORPORATED, DARTMOUTH, NOVA SCOTIA, CANADA, FILED 1-29-2011.

RAPIDCORE

THE MARK CONSISTS OF STANDARD CHARACTERS WITHOUT CLAIM TO ANY PARTICULAR FONT, STYLE, SIZE, OR COLOR.

FOR COMPUTER SOFTWARE AND FIRMWARE FOR OPERATING SYSTEM PROGRAMS; COMPUTER SOFTWARE FOR MODELING AND SIMULATION OF CONTROL SYSTEMS; PROGRAMMABLE ELECTRONIC CONTROLLERS FOR ENGINE-POWERED MACHINERY AND ELECTRICAL POWER EQUIPMENT IN THE NATURE OF GENERATOR SETS, PUMPS, AIR COMPRESSORS, GAS COMPRESSORS, CHIPPERS, GRINDERS, CRUSHERS, IRRIGATION SETS, GROUND POWER UNITS, MARINE PROPULSION UNITS, LIGHT PLANTS, AUXILIARY POWER UNITS, OIL FIELD PUMPS, VEHICLES, TRUCKS, BUSES, LIFT TRUCKS, LOCOMOTIVES, BOATS, TRACTORS, DOZERS, LOADERS, CRANES, EXCAVATORS, GRADERS, HARVESTERS, PAVING UNITS, COMPACTORS, STEAM TURBINES, COMBUSTION TURBINES, POWER CONVERTERS, POWER INVERTERS, UNINTERRUPTIBLE POWER SUPPLIES, SOLAR POWER GENERATORS, WIND POWER GENERATORS, FUEL CELLS, HYDRO POWER GENERATORS, TIDAL POWER GENERATORS, WAVE POWER GENERATORS, HYDRAULIC POWER UNITS, TRANSFER SWITCHES, FREQUENCY CONVERTERS, PARALLELING SWITCHGEAR, SYNCHRONIZERS, PROTECTION RELAYS, MULTIFUNCTION RELAYS, ELECTRIC MOTORS, POWER LOAD MANAGERS, ELECTRIC METERS, AND PHASOR MEASUREMENT UNITS (U.S. CLS. 21, 23, 26, 36 AND 38).

COLLEEN KEARNEY, EXAMINING ATTORNEY

CLASS 9—(Continued).

SN 85-230,394. SHAFFER MANUFACTURING CORP., URBANA, OH. FILED 1-31-2011.

EagleEye

THE MARK CONSISTS OF STANDARD CHARACTERS WITHOUT CLAIM TO ANY PARTICULAR FONT, STYLE, SIZE, OR COLOR.

FOR MACHINE VISION SYSTEMS AND PARTS THEREOF, NAMELY, COMPUTER HARDWARE AND SOFTWARE FOR INSPECTING BAKERY PRODUCTS (U.S. CLS. 21, 23, 26, 36 AND 38).

CARRIE GENOVESE, EXAMINING ATTORNEY

SN 85-230,481. MAVERICK INDUSTRIES, PLANO, TX. FILED 1-31-2011.

CONNECT720

THE MARK CONSISTS OF STANDARD CHARACTERS WITHOUT CLAIM TO ANY PARTICULAR FONT, STYLE, SIZE, OR COLOR.

FOR COMMUNICATION SOFTWARE FOR PROVIDING ACCESS TO THE INTERNET (U.S. CLS. 21, 23, 26, 36 AND 38).

FIRST USE 1-5-2011; IN COMMERCE 1-5-2011.
JULIE WATSON, EXAMINING ATTORNEY

SN 85-229,630. FACE THE ACE LLC., AKA FACE THE ACE GAMES, LLC, GLEN ELLYN, IL. FILED 1-30-2011.

FACE THE ACE GAMES

THE MARK CONSISTS OF STANDARD CHARACTERS WITHOUT CLAIM TO ANY PARTICULAR FONT, STYLE, SIZE, OR COLOR.

NO CLAIM IS MADE TO THE EXCLUSIVE RIGHT TO USE "GAMES", APART FROM THE MARK AS SHOWN.

FOR GAME SOFTWARE (U.S. CLS. 21, 23, 26, 36 AND 38).

RONALD AIKENS, EXAMINING ATTORNEY

SN 85-230,830. SHAMIR OPTICAL INDUSTRY LTD., UPPER GALILEE 12135, ISRAEL, FILED 2-1-2011.

SPECTRUM PROPRIOCEPTION

THE MARK CONSISTS OF STANDARD CHARACTERS WITHOUT CLAIM TO ANY PARTICULAR FONT, STYLE, SIZE, OR COLOR.

NO CLAIM IS MADE TO THE EXCLUSIVE RIGHT TO USE "SPECTRUM", APART FROM THE MARK AS SHOWN.

FOR OPTICAL LENSES FOR SPECTACLES AND OPTICAL INSTRUMENTS SPECTACLES; CONTACT LENSES; CONTAINERS FOR OPTICAL LENSES, CONTACT LENSES AND SPECTACLES; CASES, HOLDERS, PARTS AND FITTINGS FOR THE AFOREMENTIONED GOODS; COMPUTER SOFTWARE FOR PRODUCTION OF OPTICAL LENSES (U.S. CLS. 21, 23, 26, 36 AND 38).

JENNIFER MARTIN, EXAMINING ATTORNEY

CLASS 9—(Continued).

SN 85-230,903. NEW RETAIL SOLUTIONS, LLC, NASHUA, NH. FILED 2-1-2011.

InSPIRE

THE MARK CONSISTS OF STANDARD CHARACTERS WITHOUT CLAIM TO ANY PARTICULAR FONT, STYLE, SIZE, OR COLOR.

FOR ELECTRONIC DEVICE TO CHARGE AND SECURE TABLET PCS (U.S. CLS. 21, 23, 26, 36 AND 38).

FIRST USE 8-10-2010; IN COMMERCE 8-10-2010.

JOHN HWANG, EXAMINING ATTORNEY

CLASS 9—(Continued).

SN 85-232,857. TURBO CHILLI PTY LTD, SYDNEY, AUSTRALIA, FILED 2-3-2011.

STICK SKATER

THE MARK CONSISTS OF STANDARD CHARACTERS WITHOUT CLAIM TO ANY PARTICULAR FONT, STYLE, SIZE, OR COLOR.

NO CLAIM IS MADE TO THE EXCLUSIVE RIGHT TO USE "SKATER", APART FROM THE MARK AS SHOWN.

FOR COMPUTER GAMES ENTERTAINMENT SOFTWARE; COMPUTER GAMES PROGRAMS; COMPUTER PROGRAMS FOR COMPUTER GAMES; PROGRAMS FOR USE WITH COMPUTER GAMES; COMPUTER PROGRAMS FOR VIDEO GAMES; PROGRAMMED VIDEO GAMES SOFTWARE; ELECTRONIC GAMES FOR HAND HELD DEVICES, MOBILE PHONES AND COMPUTERS INCLUDING LAPTOPS; ELECTRONIC ARCADE GAMES ADAPTED FOR USE WITH AN EXTERNAL DISPLAY SCREEN OR MONITOR (U.S. CLS. 21, 23, 26, 36 AND 38).

FIRST USE 4-16-2010; IN COMMERCE 4-16-2010.

JANICE L. MCMORROW, EXAMINING ATTORNEY

SN 85-231,565. SMITH, LARRY BRUCE, FT. MILL, SC. FILED 2-1-2011.

SN 85-233,071. SUTTON, RHONA, NEW YORK, NY. FILED 2-3-2011.

FLASHkaddy
FLASH-DRIVE ORGANIZER!

Rhona Sutton

NO CLAIM IS MADE TO THE EXCLUSIVE RIGHT TO USE "FLASH-DRIVE ORGANIZER", APART FROM THE MARK AS SHOWN.

THE COLOR(S) ORANGE, YELLOW, AND BLACK IS/ARE CLAIMED AS A FEATURE OF THE MARK.

THE MARK CONSISTS OF "FLASHKADDY" WITH ORANGE LETTERS, OUTLINED IN YELLOW, WITH BLACK SHADOW AND THE WORDS "FLASH-DRIVE ORGANIZER!" UNDERNEATH IN BLACK AND OUTLINED IN YELLOW.

FOR COMPUTER ACCESSORIES, NAMELY, CADDIES ESPECIALLY ADAPTED FOR HOLDING AND ORGANIZING FLASH DRIVES (U.S. CLS. 21, 23, 26, 36 AND 38).

CARYN GLASSER, EXAMINING ATTORNEY

OWNER OF U.S. REG. NOS. 3,710,914, 3,710,915 AND 3,710,917.

THE NAME(S), PORTRAIT(S), AND/OR SIGNATURE(S) SHOWN IN THE MARK IDENTIFIES "SUTTON, RHONA", WHOSE CONSENT(S) TO REGISTER IS MADE OF RECORD.

THE MARK CONSISTS OF THE STYLIZED WORDS "RHONA SUTTON".

FOR SUNGLASSES; NAMELY, CHILDREN'S SUNGLASSES (U.S. CLS. 21, 23, 26, 36 AND 38).

DOMINIC J. FERRAIUOLO, EXAMINING ATTORNEY

CLASS 9—(Continued).

SN 85-233,776. KLEIN ELECTRONICS, INC., ESCONDIDO, CA. FILED 2-3-2011.



NO CLAIM IS MADE TO THE EXCLUSIVE RIGHT TO USE "MIL SPEC", APART FROM THE MARK AS SHOWN. THE COLOR(S) RED AND BLUE IS/ARE CLAIMED AS A FEATURE OF THE MARK.

THE MARK CONSISTS OF A DEPICTION OF A BALD EAGLE'S HEAD IN BLUE WITH THE EAGLE LOOKING TO THE LEFT. ON BOTH SIDES OF THE EAGLE'S HEAD ARE SEVEN STARS IN BLUE. ON BOTH SIDES OF THE STARS ARE THREE HORIZONTAL RED STRIPES. UNDER THIS DESIGN ARE THE WORDS "MIL SPEC" IN BLUE.

FOR HIGH NOISE COMMUNICATIONS HEADSETS FOR USE WITH COMMUNICATION RADIOS, INTERCOM SYSTEMS, OR OTHER COMMUNICATIONS NETWORK TRANSCIVERS; HEADSETS WITH NOISE CONTROL, NOISE SUPPRESSION, IMPULSE NOISE SUPPRESSION AND INTELLIGENT ADAPTIVE HEARING PROTECTION CIRCUITRY TO FILTER, SUBDUCE OR CONTROL UNDESIRABLE NOISE OR SOUNDS AND TO ALLOW TWO-WAY COMMUNICATION IN NOISY AND STRESSFUL ENVIRONMENTS, AND NOT FOR MEDICAL PURPOSES; ELECTRONIC HEADSETS FOR USE WITH 2-WAY RADIOS IN THE FIELDS OF RACING, ATHLETICS, MANUFACTURING, CONSTRUCTION AND ENGINEERING, AND NOT FOR MEDICAL PURPOSES; ELECTRONIC NOISE SUPPRESSION HEADSETS FOR RACING, ATHLETICS, MANUFACTURING, CONSTRUCTION AND ENGINEERING, AND NOT FOR MEDICAL PURPOSES; ELECTRONIC NOISE SUPPRESSION HEADSETS FOR USE WITH 2-WAY RADIOS IN THE FIELDS OF RACING, ATHLETICS, MANUFACTURING, CONSTRUCTION AND ENGINEERING, AND NOT FOR MEDICAL PURPOSES; ELECTRONIC HEADSETS WITH INTELLIGENT ADAPTIVE HEARING PROTECTION CIRCUITRY FOR USE WITH 2-WAY RADIOS IN THE FIELDS OF RACING, ATHLETICS, MANUFACTURING, CONSTRUCTION AND ENGINEERING, AND NOT FOR MEDICAL PURPOSES; ELECTRONIC NOISE SUPPRESSION HEADSETS FOR RACING, ATHLETICS, MANUFACTURING, CONSTRUCTION AND ENGINEERING, AND NOT FOR MEDICAL USE; HEADSETS FOR TWO WAY RADIOS FOR USE IN HIGH NOISE ENVIRONMENTS, AND NOT FOR MEDICAL PURPOSES; NOISE REDUCTION HEADSETS FOR USE WITH 2-WAY RADIOS IN THE FIELDS OF RACING, ATHLETICS, MANUFACTURING, CONSTRUCTION AND ENGINEERING, AND NOT FOR MEDICAL PURPOSES; NOISE CANCELLATION HEADPHONES; TWO-WAY RADIO EARPIECES, LISTEN-ONLY EARPIECES; CELL PHONE ACCESSORIES, NAMELY, EARPIECES (U.S. CLS. 21, 23, 26, 36 AND 38).

B. PARADEWELAI, EXAMINING ATTORNEY

CLASS 9—(Continued).

SN 85-235,545. CTB, INC., MILFORD, IN. FILED 2-7-2011.



THE MARK CONSISTS OF A KERNEL OF CORN FROM WHICH IS SUSPENDED AN OPEN SOYBEAN POD SURROUNDING A STAND OF A SMALL GRAIN.

FOR ELECTRONIC METER FOR MEASURING THE MOISTURE CONTENT, TEMPERATURE, VOLUME AND/OR WEIGHT OF GRAINS, BEANS, SEEDS, RICE, LEGUMES, COFFEE, TEA AND/OR COCOA (U.S. CLS. 21, 23, 26, 36 AND 38).

FIRST USE 5-1-1983; IN COMMERCE 5-1-1983.

CHRISIE B. KING, EXAMINING ATTORNEY

SN 85-235,774. COLEMAN, LYNN DEE, TA AERIAL FABRIC AEROBATICS, LLC, DENVER, CO. FILED 2-7-2011.



OWNER OF U.S. REG. NO. 3,855,229.

NO CLAIM IS MADE TO THE EXCLUSIVE RIGHT TO USE "AERIAL FABRIC AEROBATICS", APART FROM THE MARK AS SHOWN.

THE COLOR(S) WHITE, GREY, BURGUNDY IS/ARE CLAIMED AS A FEATURE OF THE MARK.

THE MARK CONSISTS OF AN AERIAL AEROBAT IN SPLITS POSITION ON AERIAL FABRIC IN THE COLOR WHITE WITHIN A CIRCLE THAT IS IN THE COLOR GREY WHICH IS ABOVE THE WORDING "AERIAL FABRIC AEROBATICS" ALL IN LOWER CASE LETTERING; THE TERMS "AERIAL" AND "AEROBATICS" ARE IN THE COLOR WHITE AND THE TERM "FABRIC" IS IN THE COLOR GREY WITH A HORIZONTAL LINE BETWEEN THE TERMS "AERIAL FABRIC" AND "AEROBATICS" IN LIGHT BURGUNDY. ALL SUPERIMPOSED OVER A BURGUNDY BACKGROUND.

FOR PRE-RECORDED DVDS FEATURING CONDITIONING AND AERIAL INSTRUCTION DOING AERIAL AEROBATICS ON FABRIC (U.S. CLS. 21, 23, 26, 36 AND 38).

FIRST USE 10-10-2010; IN COMMERCE 10-10-2010.

BARBARA RUTLAND, EXAMINING ATTORNEY

CLASS 9—(Continued).

SN 85-236,616. GLOWZONE INC, BREA, CA. FILED S.R. 2-8-2011; AM. P.R. 5-17-2011.

MoonSkins

THE MARK CONSISTS OF STANDARD CHARACTERS WITHOUT CLAIM TO ANY PARTICULAR FONT, STYLE, SIZE, OR COLOR.

FOR CASES FOR MOBILE PHONES; CELL PHONE CASES; CELL PHONE COVERS (U.S. CLS. 21, 23, 26, 36 AND 38).

FIRST USE 2-18-2011; IN COMMERCE 3-1-2011.
DOMINIC J. FERRAIUOLO, EXAMINING ATTORNEY

SN 85-237,004. MCELROY MANUFACTURING, INC., TULSA, OK. FILED 2-8-2011.

THE COACH

THE MARK CONSISTS OF STANDARD CHARACTERS WITHOUT CLAIM TO ANY PARTICULAR FONT, STYLE, SIZE, OR COLOR.

FOR PIPE FUSION CONTROL AND DATA RECORDING MACHINE (U.S. CLS. 21, 23, 26, 36 AND 38).

FIRST USE 3-31-1998; IN COMMERCE 3-31-1998.
GINA HAYES, EXAMINING ATTORNEY

SN 85-238,539. LIMA, CLISLEY, SAN DIEGO, CA. FILED 2-10-2011.

AVA BRAZIL

THE MARK CONSISTS OF STANDARD CHARACTERS WITHOUT CLAIM TO ANY PARTICULAR FONT, STYLE, SIZE, OR COLOR.

NO CLAIM IS MADE TO THE EXCLUSIVE RIGHT TO USE "BRAZIL", APART FROM THE MARK AS SHOWN.

FOR SUNGLASSES (U.S. CLS. 21, 23, 26, 36 AND 38).
FIRST USE 8-1-2010; IN COMMERCE 10-1-2010.
RUSS HERMAN, EXAMINING ATTORNEY

CLASS 9—(Continued).

SN 85-238,803. TEACH N' KIDS LEARN, INC., DORAL, FL. FILED 2-10-2011.



OWNER OF U.S. REG. NOS. 3,947,296 AND 3,947,298.
NO CLAIM IS MADE TO THE EXCLUSIVE RIGHT TO USE "PROTOCOL" AND "CLASSROOM INSTRUCTIONAL IMPROVEMENT", APART FROM THE MARK AS SHOWN.

THE MARK CONSISTS OF THE LETTERS CI AND THE NUMBER 2 IN SUPERSCRIPIT ENCASED IN A SQUARE WITH A DIAMOND SITTING AT THE TOP OF AND INTERSECTING THE TOP LINE OF THE SQUARE AND A SHADOW OF THE SQUARE AND DIAMOND DIAGONALLY EXTENDING TO THE BOTTOM LEFT SIDE OF THE FIGURE. THE WORD PROTOCOL IS POSITIONED UNDERNEATH THE DESIGN AND THE WORDS CLASSROOM INSTRUCTIONAL IMPROVEMENT FOLLOW THE DESIGN TO THE RIGHT WITH THE WORD CLASSROOM ABOVE THE WORDS INSTRUCTIONAL IMPROVEMENT.

FOR COMPUTER APPLICATION SOFTWARE FOR HANDHELD DEVICES FOR USE IN PROVIDING FEEDBACK TO TEACHERS REGARDING CLASSROOM INSTRUCTION (U.S. CLS. 21, 23, 26, 36 AND 38).
BARBARA RUTLAND, EXAMINING ATTORNEY

SN 85-238,833. IRVINE SENSORS CORP., COSTA MESA, CA. FILED 2-10-2011.

VAULT-MM

THE MARK CONSISTS OF STANDARD CHARACTERS WITHOUT CLAIM TO ANY PARTICULAR FONT, STYLE, SIZE, OR COLOR.

FOR PORTABLE COMPUTER DATA STORAGE DEVICES, NAMELY, BLANK USB FLASH MEMORY DRIVES AND BLANK USB FLASH MEMORY DRIVES HAVING SECURITY ANTI-TAMPER FEATURES (U.S. CLS. 21, 23, 26, 36 AND 38).

FIRST USE 12-1-2009; IN COMMERCE 12-1-2009.
WON TEAK OH, EXAMINING ATTORNEY

CLASS 9—(Continued).

SN 85-239,783. PANNIN TECHNOLOGIES, MEMPHIS, TN.
FILED 2-11-2011.

PANNIN

THE MARK CONSISTS OF THE TERM "PANNIN" WITH A TRIANGLE REPRESENTING THE "A". THE TRIANGLE IS LINED IN THE LOWER RIGHT CORNER.

FOR POLICE AND EMERGENCY PERSONAL IN-CAR CAMERAS AND STATIONARY CAMERAS; LICENSE PLATE RECOGNITION (LPR) CAMERAS; COMPUTERS; DESKTOP COMPUTERS; LAPTOP COMPUTERS; COMPUTER SOFTWARE FOR LOCATING VEHICLES (U.S. CLS. 21, 23, 26, 36 AND 38).

FIRST USE 1-1-2009; IN COMMERCE 1-1-2009.
CAROLINE WOOD, EXAMINING ATTORNEY

CLASS 9—(Continued).

SN 85-241,961. WHITAKER HOUSE, NEW KENSINGTON, PA. FILED 2-14-2011.



SN 85-241,449. DEMAND WORKS COMPANY, WEST CHESTER, PA. FILED 2-14-2011.

PIVOT MAPS

THE MARK CONSISTS OF STANDARD CHARACTERS WITHOUT CLAIM TO ANY PARTICULAR FONT, STYLE, SIZE, OR COLOR.

OWNER OF U.S. REG. NOS. 3,434,690 AND 3,871,533.

NO CLAIM IS MADE TO THE EXCLUSIVE RIGHT TO USE "MAPS", APART FROM THE MARK AS SHOWN.

FOR COMPUTER SOFTWARE, NAMELY, COMPUTER PROGRAMS DESIGNED FOR ANALYZING BUSINESS OPERATIONS FOR SUPPLY CHAIN MANAGEMENT IN THE AREAS OF BUSINESS DEMAND AND SUPPLY PLANNING (U.S. CLS. 21, 23, 26, 36 AND 38).

FIRST USE 2-13-2011; IN COMMERCE 2-13-2011.
INGRID C. EULIN, EXAMINING ATTORNEY

SN 85-241,655. SUPPLY CHAIN CONSULTANTS, INC, WILMINGTON, DE. FILED 2-14-2011.

ARKIEVA

THE MARK CONSISTS OF STANDARD CHARACTERS WITHOUT CLAIM TO ANY PARTICULAR FONT, STYLE, SIZE, OR COLOR.

THE WORDING "ARKIEVA" HAS NO MEANING IN A FOREIGN LANGUAGE.

FOR COMPUTER SOFTWARE PROGRAMS FOR PROVIDING BUSINESS DECISION SUPPORT FOR FORECASTING, BUSINESS PLANNING, MANUFACTURING PLANNING, INVENTORY MANAGEMENT, DISTRIBUTION OF GOODS, FINANCIAL REPORTING, SALES AND OPERATIONS PLANNING, AND SCHEDULING OPERATIONS (U.S. CLS. 21, 23, 26, 36 AND 38).

DOUGLAS LEE, EXAMINING ATTORNEY

OWNER OF U.S. REG. NOS. 3,135,003 AND 3,936,462.
NO CLAIM IS MADE TO THE EXCLUSIVE RIGHT TO USE "AUDIO", APART FROM THE MARK AS SHOWN.

THE MARK CONSISTS OF THE WORDS "WHITAKER AUDIO" BENEATH A RECTANGLE THAT HAS HORIZONTAL STRIPES RUNNING THROUGH IT BUT NOT EXTENDING BEYOND ITS EDGES, AND A "W" STYLIZED AS A DOVE IN THE CENTER OF THE RECTANGLE AND SUPERIMPOSED ON THE STRIPES, WITH HEADPHONES SURROUNDING THE RECTANGLE ON THE TOP AND ON THE LEFT AND RIGHT SIDES.

FOR PRE-RECORDED CDS FEATURING BOOKS IN THE FIELD OF RELIGION (U.S. CLS. 21, 23, 26, 36 AND 38).

FIRST USE 8-30-2003; IN COMMERCE 9-30-2003.
ANGELA DUONG, EXAMINING ATTORNEY

CLASS 9—(Continued).

SN 85-242,049. IT-SOFT USA, INC., CHICAGO, IL. FILED 2-14-2011.



THE COLOR(S) LIGHT GREEN AND BLACK IS/ARE CLAIMED AS A FEATURE OF THE MARK.

THE MARK CONSISTS OF THE WORDING "FACTORY-SCRIBE" WHEREIN THE "FACTORY" PORTION IS IN BLACK AND THE "SCRIBE" PORTION IS IN LIGHT GREEN BELOW A DESIGN OF LIGHT GREEN SHEETS OF PAPER THAT GRADUALLY FADE FROM TOP TO BOTTOM.

FOR AN OPTICAL METROLOGY INSPECTION SYSTEM COMPRISED OF A LIGHT SOURCE, ONE OR MORE CAMERAS AND SENSORS IN COMMUNICATION WITH COMPUTER SOFTWARE AND HARDWARE; COMPUTER APPLICATION SOFTWARE FOR MOBILE PHONES, NAMELY, SOFTWARE FOR CONVERTING WRITTEN IMAGES INTO ELECTRONIC FORM; COMPUTER APPLICATION SOFTWARE FOR ELECTRONIC PENS AND OTHER WRITING DEVICES IN THE NATURE OF ELECTRONIC WRITING TABLETS, MAGNETIC PENS, NAMELY, SOFTWARE FOR CONVERTING WRITTEN IMAGES INTO ELECTRONIC FORM; COMPUTER CURSOR CONTROL DEVICES, NAMELY, LIGHT PENS; COMPUTER HARDWARE AND SOFTWARE FOR MEDICAL IMAGING APPARATUS; COMPUTER SOFTWARE AND HARDWARE FOR PROCESSING DIGITAL IMAGES, USE IN ELECTRONIC STORAGE OF DATA FOR USE WITH ELECTRONIC PENS AND OTHER WRITING DEVICES IN THE NATURE OF ELECTRONIC WRITING TABLETS, MAGNETIC PENS; COMPUTER SOFTWARE FOR ENCRYPTION; COMPUTER SOFTWARE FOR PROCESSING DIGITAL IMAGES; ELECTRONIC PENS; ELECTRONIC WRITING TABLETS; LIGHT PENS; MAGNETIC PENS; MAGNETO-OPTICAL PENS (U.S. CLS. 21, 23, 26, 36 AND 38).

HAI-LY LAM, EXAMINING ATTORNEY

SN 85-242,535. POWERFUL SIGNAL, LLC, HURRICANE, UT. FILED 2-15-2011.



NO CLAIM IS MADE TO THE EXCLUSIVE RIGHT TO USE "SIGNAL SOLUTIONS", APART FROM THE MARK AS SHOWN.

THE COLOR(S) BLUE, LIGHT BLUE, ORANGE AND WHITE IS/ARE CLAIMED AS A FEATURE OF THE MARK. THE MARK CONSISTS OF THE WORDING "POWERFUL SIGNAL" WITH POWERFUL IN BLUE LETTERING AND

CLASS 9—(Continued).

THE WORD SIGNAL IN ORANGE LETTERING WITH THE PHRASE "STRONGER SIGNAL SOLUTIONS" UNDER PORTIONS OF POWERFUL AND SIGNAL. THE PHRASE STRONGER SIGNAL SOLUTIONS IS IN THE SAME BLUE COLOR AS THE TERM POWERFUL. THE LEFT HAND PORTION OF THE MARK WHICH INCLUDES THE LETTERS "P, O, AND W" OF POWERFUL AND "S, T, R, AND O" OF STRONGER ARE SUPERIMPOSED OVER THE TOP OF WHAT ARE FASHIONED AS SOUND WAVES IN LIGHT BLUE EMANATING FROM THE "O" IN POWERFUL.

FOR AMPLIFIER FOR WIRELESS COMMUNICATIONS; ANTENNAS FOR WIRELESS COMMUNICATIONS APPARATUS; APPARATUS FOR WIRELESS TRANSMISSION OF ACOUSTIC INFORMATION; BROADBAND WIRELESS EQUIPMENT, NAMELY, TELECOMMUNICATIONS BASE STATION EQUIPMENT FOR CELLULAR AND FIXED NETWORKING AND COMMUNICATIONS APPLICATIONS; CONTINGENCY RESPONSE COMMUNICATION SYSTEM DESIGNED TO PROVIDE RADIO INTEROPERABILITY, STREAMING VIDEO, WIRELESS INTERNET, AND VOIP PHONE; DEVICES FOR WIRELESS RADIO TRANSMISSION; INDUSTRIAL WIRELESS POINT-TO-MULTIPOINT RADIO; INTEGRATED CIRCUITS AND INTEGRATED CIRCUIT CORES FOR USE IN WIRELESS COMMUNICATIONS AND WIRELESS COMMUNICATION EQUIPMENT AND APPARATUS AND DIGITAL SIGNAL PROCESSORS (DSP); MOBILE COMPUTING AND OPERATING PLATFORMS CONSISTING OF DATA TRANSCEIVERS, WIRELESS NETWORKS AND GATEWAYS FOR COLLECTION AND MANAGEMENT OF DATA; WIRELESS ADAPTERS USED TO LINK COMPUTERS TO A TELECOMMUNICATIONS NETWORK; WIRELESS COMMUNICATION DEVICES FOR VOICE, DATA OR IMAGE TRANSMISSION; WIRELESS CONTROLLER TO MONITOR AND CONTROL THE FUNCTIONING OF OTHER ELECTRONIC DEVICES; WIRELESS POS (POINT OF SERVICE) DEVICES (U.S. CLS. 21, 23, 26, 36 AND 38).

FIRST USE 10-23-2006; IN COMMERCE 10-23-2006.

NAKWAMA ANKRAH, EXAMINING ATTORNEY

SN 85-242,626. SEPTRONICS, INC., OCONOMOWOC, WI. FILED 2-15-2011.

SEPTRONICS

THE MARK CONSISTS OF STANDARD CHARACTERS WITHOUT CLAIM TO ANY PARTICULAR FONT, STYLE, SIZE, OR COLOR.

FOR ELECTRONIC EQUIPMENT, NAMELY, JUNCTION BOXES, PEDESTALS, NAMELY, CABINETS, HOUSING AND STRUCTURAL MOUNTING PARTS FOR ELECTRICAL APPARATUS AND INSTRUMENTS, ELECTRONIC SUMP PUMP CONTROLS, AUTOMATIC FLOAT SWITCHES AND CONTROL PANELS FOR THE WASTEWATER INDUSTRY (U.S. CLS. 21, 23, 26, 36 AND 38).

FIRST USE 11-26-1997; IN COMMERCE 11-26-1997.

KIMBERLY PERRY, EXAMINING ATTORNEY

CLASS 9—(Continued).

SN 85-242,738. COLLECTIVE BYTES, LLC, BAY HARBOR, FL. FILED 2-15-2011.

RHETI

THE MARK CONSISTS OF STANDARD CHARACTERS WITHOUT CLAIM TO ANY PARTICULAR FONT, STYLE, SIZE, OR COLOR.

FOR COMPUTER SOFTWARE DEVELOPMENT TOOLS (U.S. CLS. 21, 23, 26, 36 AND 38).

FIRST USE 2-6-2011; IN COMMERCE 2-6-2011.
ANNE FARRELL, EXAMINING ATTORNEY

SN 85-242,804. GENERAL CABLE TECHNOLOGIES CORPORATION, HIGHLAND HEIGHTS, KY. FILED 2-15-2011.



The logo for TactiCel features the word "TactiCel" in a bold, sans-serif font. The letter "i" is lowercase and has a dot that is a solid black circle. The letter "C" is uppercase and also has a dot that is a solid black circle.

THE MARK CONSISTS OF THE WORD "TACTICEL" IN STYLIZED LETTERING WITH A CIRCLE IN THE CENTER OF THE SECOND "C".

FOR ELECTRONIC WIRE AND CABLE PRODUCTS FOR USE WITH AUDIO AND VIDEO APPLICATIONS, NAMELY, VIDEO PRECISION COAXIAL BROADCAST CABLES, CONVENTIONAL VIDEO PRECISION COAXIAL CABLES, CONVENTIONAL COAXIAL CABLES, MASTER-ANTENNA TELEVISION/CLOSED-CIRCUIT TELEVISION (MATV/CCTV) COAXIAL CABLES, SPECIAL APPLICATION TRIAXIAL CABLES, CONVENTIONAL TRIAXIAL CABLES, AND CUSTOM CABLE ASSEMBLIES COMPRISED OF COMBINATIONS OF THE FOREGOING CABLES (U.S. CLS. 21, 23, 26, 36 AND 38).

TARA PATE, EXAMINING ATTORNEY

SN 85-243,487. WEXLER, JACOB, BLOOMFIELD HILLS, MI. FILED 2-16-2011.

SolidMaker

THE MARK CONSISTS OF STANDARD CHARACTERS WITHOUT CLAIM TO ANY PARTICULAR FONT, STYLE, SIZE, OR COLOR.

FOR COMPUTER PROGRAMS RECORDED ON DATA MEDIA (SOFTWARE) DESIGNED FOR USE IN CONSTRUCTION AND AUTOMATED MANUFACTURING (CAD/CAM) (U.S. CLS. 21, 23, 26, 36 AND 38).

FIRST USE 8-22-2006; IN COMMERCE 8-22-2006.
JANICE L. MCMORROW, EXAMINING ATTORNEY

CLASS 9—(Continued).

SN 85-243,713. FUJI BATTERIES INC., MAHWAH, NJ. FILED 2-16-2011.

ENVIROMAX

THE MARK CONSISTS OF STANDARD CHARACTERS WITHOUT CLAIM TO ANY PARTICULAR FONT, STYLE, SIZE, OR COLOR.

OWNER OF U.S. REG. NO. 3,828,862.
FOR BLANK USB FLASH DRIVES, FLASH MEMORY CARDS, MICRO SECURE DIGITAL MEMORY CARDS, BLANK MICRO FLASH DRIVES, BLANK COMPACT DISCS FOR SOUND OR VIDEO RECORDING, BLANK REWRITABLE COMPACT DISKS FOR SOUND OR VIDEO RECORDING, DIGITAL VIDEO RECORDER, REWRITABLE DIGITAL VIDEO RECORDERS, BLANK OPTICAL AND MAGNETO-OPTICAL DISCS FOR SOUND OR VIDEO RECORDING (U.S. CLS. 21, 23, 26, 36 AND 38).

FIRST USE 2-11-2011; IN COMMERCE 2-11-2011.
LAURIE KAUFMAN, EXAMINING ATTORNEY

SN 85-243,959. R.E.M./ATHENS, LTD., ATHENS, GA. FILED 2-16-2011.

R.E.M.

THE MARK CONSISTS OF STANDARD CHARACTERS WITHOUT CLAIM TO ANY PARTICULAR FONT, STYLE, SIZE, OR COLOR.

OWNER OF U.S. REG. NO. 1,247,934.
FOR CDS FEATURING MUSIC; DVDS FEATURING MUSIC VIDEOS, CONCERT FOOTAGE AND SPOKEN WORDS; DIGITAL MUSIC DOWNLOADABLE FROM THE INTERNET; DOWNLOADABLE MP3 FILES AND MP3 RECORDINGS FEATURING MUSIC AND SPOKEN WORDS; PHONOGRAPH RECORDS FEATURING MUSIC (U.S. CLS. 21, 23, 26, 36 AND 38).

FIRST USE 7-0-1981; IN COMMERCE 7-0-1981.
SUNG IN, EXAMINING ATTORNEY

CLASS 9—(Continued).

SN 85-244,124. MACRI, JOHN G., NEW HYDE PARK, NY. AND ROBBINS, PETER L., GREAT NECK, NY. FILED 2-16-2011.

QUICK2SAVE

THE MARK CONSISTS OF STANDARD CHARACTERS WITHOUT CLAIM TO ANY PARTICULAR FONT, STYLE, SIZE, OR COLOR.

FOR RESCUE APPARATUS, NAMELY, A PROJECTILE DELIVERY LAUNCHER USED TO THROW A LINE TO RESCUE A VICTIM OR TO DELIVER SUPPLIES IN EMERGENCY SITUATIONS (U.S. CLS. 21, 23, 26, 36 AND 38).

TRACY WHITTAKER-BROWN, EXAMINING ATTORNEY

CLASS 9—(Continued).

SN 85-245,215. TOM LAUNE, FRANKLIN, TN. FILED 2-17-2011.



NO CLAIM IS MADE TO THE EXCLUSIVE RIGHT TO USE "RECORDS", APART FROM THE MARK AS SHOWN.

THE MARK CONSISTS OF THE WORDING, "TAR & FEATHER RECORDS" EMBODIED IN A CIRCLE WITHIN A CIRCLE, INCLUDING TWO LIGHTNING BOLT IMAGES AND A STYLIZED LETTER "T" AND "F" COMBINATION VISUAL GRAPHIC IN THE CENTER CIRCLE, WITH THE TOP HALF OF THE OUTER CIRCLE CONTAINING BLACK FONT ON A WHITE BACKGROUND AND THE BOTTOM HALF OF THE OUTER CIRCLE CONTAINING WHITE FONT ON A BLACK BACKGROUND.

FOR AUDIO AND VIDEO RECORDINGS FEATURING MUSIC AND ARTISTIC PERFORMANCES (U.S. CLS. 21, 23, 26, 36 AND 38).

FIRST USE 5-11-2010; IN COMMERCE 9-17-2010.
PAM WILLIS, EXAMINING ATTORNEY

SN 85-244,317. ONG, ANH, LAS VEGAS, NV. AND MULLEN, ERIC, LAS VEGAS, NV. AND SENA, JARED, LAS VEGAS, NV. FILED 2-16-2011.

Cannapedia

THE MARK CONSISTS OF STANDARD CHARACTERS WITHOUT CLAIM TO ANY PARTICULAR FONT, STYLE, SIZE, OR COLOR.

FOR COMPUTER APPLICATION SOFTWARE FOR MOBILE PHONES, NAMELY, SOCIAL NETWORKING SOFTWARE FOR PEOPLE INTERESTED IN MEDICINAL HERBS (U.S. CLS. 21, 23, 26, 36 AND 38).

LINDSEY RUBIN, EXAMINING ATTORNEY

SN 85-245,599. CAERUSPOINT LLC, ORLANDO, FL. FILED 2-18-2011.

MAJOR DECISION

THE MARK CONSISTS OF STANDARD CHARACTERS WITHOUT CLAIM TO ANY PARTICULAR FONT, STYLE, SIZE, OR COLOR.

FOR DIGITAL MEDIA, NAMELY, DVDS, MOBILE APPLICATIONS AND DOWNLOADABLE AUDIOVISUAL FILES FEATURING A DOCUMENTARY SHOW FOCUSING ON VARIOUS JOBS, INDUSTRIES, AND CAREERS FOR HIGH SCHOOL STUDENTS, COLLEGE STUDENTS AND CAREER GUIDANCE COUNSELORS (U.S. CLS. 21, 23, 26, 36 AND 38).

MARLENE BELL, EXAMINING ATTORNEY

CLASS 9—(Continued).

SN 85-245,736. PHOENIX SOFTWARE INTERNATIONAL, INC., EL SEGUNDO, CA. FILED 2-18-2011.

ZHISR

THE MARK CONSISTS OF STANDARD CHARACTERS WITHOUT CLAIM TO ANY PARTICULAR FONT, STYLE, SIZE, OR COLOR.

FOR COMPUTER SOFTWARE, NAMELY, COMPUTER SOFTWARE WHICH PRODUCES ANALYTICAL REPORTS REVEALING BASIC STATISTICAL INFORMATION REGARDING COMPUTER SOFTWARE AND HARDWARE RESOURCES UTILIZATION, E.G., SPACE, AS WELL AS IN-DEPTH HOT SPOT ANALYSIS, NAMELY, IDENTIFICATION OF PROGRAMS UTILIZING EXCESSIVE HARDWARE RESOURCES (U.S. CLS. 21, 23, 26, 36 AND 38).

LINDA POWELL, EXAMINING ATTORNEY

SN 85-245,761. BAKER, ROBERT R, JR, GROSSE POINTE WOODS, MI. FILED 2-18-2011.

Anchor Flanker

THE MARK CONSISTS OF STANDARD CHARACTERS WITHOUT CLAIM TO ANY PARTICULAR FONT, STYLE, SIZE, OR COLOR.

NO CLAIM IS MADE TO THE EXCLUSIVE RIGHT TO USE "ANCHOR", APART FROM THE MARK AS SHOWN.

FOR MARKING AND SIGNALLING BUOYS (U.S. CLS. 21, 23, 26, 36 AND 38).

LESLEY LAMOTHE, EXAMINING ATTORNEY

SN 85-245,980. CONTROLDOCS.COM, DBA ICONTROLESI, DALLAS, TX. FILED 2-18-2011.

RECENSEO

THE MARK CONSISTS OF STANDARD CHARACTERS WITHOUT CLAIM TO ANY PARTICULAR FONT, STYLE, SIZE, OR COLOR.

FOR COMPUTER SOFTWARE USED TO ORGANIZE, SEARCH, HOST, REVIEW, PRODUCE, CONVERT, AND CLUSTER IMAGES AND ELECTRONICALLY STORED INFORMATION IN THE LEGAL INDUSTRY; SOFTWARE FOR DOCUMENT MINING, NAMELY, INDEXING, FILTERING, EMAIL THREADING, DUPLICATE AND NEAR DUPLICATE IDENTIFICATION, AND SUGGESTED REVIEW TAGGING, FOLDERING DURING THE COURSE OF MANAGED REVIEW (U.S. CLS. 21, 23, 26, 36 AND 38).

FIRST USE 2-4-2011; IN COMMERCE 2-4-2011.
ANGELA DUONG, EXAMINING ATTORNEY

CLASS 9—(Continued).

SN 85-246,074. THE PROMOTION MAN, DBA YODER'S MOBILE MARKETING, WASHINGTON, IN. FILED 2-18-2011.



NO CLAIM IS MADE TO THE EXCLUSIVE RIGHT TO USE "MEDIA", APART FROM THE MARK AS SHOWN.

THE COLOR(S) BLACK, WHITE, LIGHT BLUE AND DARK BLUE IS/ARE CLAIMED AS A FEATURE OF THE MARK.

THE MARK CONSISTS OF THE UNDERLINED WORDS "PRO" AND "MEDIA" WITH A DECORATIVE "X" BETWEEN THE WORDS AND RADIO WAVES EMANATING FROM THE LETTER "I" IN THE WORD "MEDIA" ALL WITHIN A RECTANGULAR BACKGROUND. THE COLOR WHITE APPEARS IN THE WORDS "PRO" AND "MEDIA" AND IN THE SHADING OF THE "X"; THE COLOR LIGHT BLUE APPEARS IN THE "X"; THE COLOR DARK BLUE APPEARS IN THE "X" AND IN THE SOUND WAVES; AND THE COLOR BLACK APPEARS IN THE MIDDLE OF THE "X" AND AS THE BACKGROUND COLOR.

FOR AD SERVER, NAMELY, A COMPUTER SERVER FOR STORING ADVERTISEMENTS AND DELIVERING ADVERTISEMENTS TO WEBSITES; ELECTRONIC ADVERTISEMENT AND MESSAGING DISPLAY UNIT WITH MULTI-NETWORKING (TCP/IP) CAPABILITIES AND REMOTE CONNECTIVITY (U.S. CLS. 21, 23, 26, 36 AND 38).

CARYN GLASSER, EXAMINING ATTORNEY

SN 85-246,425. WAHL INSTRUMENTS, INC., ASHEVILLE, NC. FILED 2-18-2011.

WAHL

THE MARK CONSISTS OF STANDARD CHARACTERS WITHOUT CLAIM TO ANY PARTICULAR FONT, STYLE, SIZE, OR COLOR.

FOR THERMAL IMAGING SYSTEMS; HAND-HELD AND FIXED INFRARED THERMOMETERS; THERMOMETERS NOT FOR MEDICAL USE; DIGITAL PROCESS THERMOMETERS; TEMPERATURE CALIBRATORS; CALIBRATION DEVICES FOR CALIBRATING TEMPERATURE, PRESSURE, VOLTAGE, CURRENT, RESISTANCE, AND FREQUENCY METERS AND SENSORS; BLACKBODY CALIBRATORS; TEST GAUGES FOR TEMPERATURE AND PRESSURE; TEMPERATURE RECORDING LABELS; RTD (RESISTANCE TEMPERATURE DETECTOR) AND THERMOCOUPLE SENSORS; ELECTRONIC DATA LOGGERS; OHMMETERS; AND GAS FLUE ANALYZERS; WIRELESS INSTRUMENTATION EQUIPMENT, NAMELY, PRESSURE SENSORS AND TEMPERATURE SENSORS; PRESSURE TRANSDUCERS FOR MONITORING AND TRANSMITTING PRESSURE DATA TO A CONTROL SOURCE (U.S. CLS. 21, 23, 26, 36 AND 38).

FIRST USE 0-0-1968; IN COMMERCE 0-0-1968.
AISHA CLARKE, EXAMINING ATTORNEY

CLASS 9—(Continued).

SN 85-246,597. LAVERA CREEK SOFTWARE LLC, AUSTIN, TX. FILED 2-18-2011.

Lavera Creek Software

THE MARK CONSISTS OF STANDARD CHARACTERS WITHOUT CLAIM TO ANY PARTICULAR FONT, STYLE, SIZE, OR COLOR.

NO CLAIM IS MADE TO THE EXCLUSIVE RIGHT TO USE "SOFTWARE", APART FROM THE MARK AS SHOWN.

FOR COMPUTER GAME SOFTWARE FOR MOBILE DEVICES; COMPUTER APPLICATION SOFTWARE FOR MOBILE DEVICES FOR LOCATING, ORGANIZING AND PLAYING MUSIC AND VIDEOS (U.S. CLS. 21, 23, 26, 36 AND 38).

IRA J. GOODSaid, EXAMINING ATTORNEY

SN 85-246,944. SCHUYLER, WILLIAM RANDOLPH, DBA WATER HEATER RESCUE, MARINA, CA. FILED 2-19-2011.



NO CLAIM IS MADE TO THE EXCLUSIVE RIGHT TO USE "WATER HEATER", APART FROM THE MARK AS SHOWN.

THE MARK CONSISTS OF A CIRCLE WITH A BAR ON TOP OF IT, BISECTING IT, WITH THE WHOLE CANTED UPWARD TO THE RIGHT. "WATER" IS DEPICTED ON THE UPPER INSIDE OF THE CIRCLE AND "HEATER" ON THE LOWER INSIDE, WITH "RESCUE" IN ITALICS DEPICTED IN THE BAR.

FOR WATER HEATER PARTS, NAMELY, KITS PRIMARILY CONSISTING OF SACRIFICIAL AND ELECTRIC ANODES TO EXTEND THE LIVES OF WATER HEATERS (U.S. CLS. 21, 23, 26, 36 AND 38).

FIRST USE 5-1-1998; IN COMMERCE 5-1-1998.

KALIE KUNG, EXAMINING ATTORNEY

CLASS 9—(Continued).

SN 85-247,172. MYOWNITGUY, INC., PHILADELPHIA, PA. FILED 2-21-2011.



THE COLOR(S) BLUE, GRAY AND LIME GREEN IS/ARE CLAIMED AS A FEATURE OF THE MARK.

THE MARK CONSISTS OF THE STRING "LOKADOT" IN BLUE LETTERING WITH PHONETIC SYMBOLS ABOVE THE VOWELS "O", "A" AND "O" TO SYMBOLIZE THEIR PRONUNCIATION AS LONG "O", SHORT "A", AND LONG "O". THE FIRST "O" IN "LOKADOT" IS GREEN, AND STYLIZED TO RESEMBLE AN EARBUD (THAT COMES STANDARD WITH AN APPLE IPHONE/IPOD/ITOUCH) AND IS EMBEDDED INSIDE A PUSHPIN DESIGN THAT ONE WOULD TYPICALLY SEE REPRESENTING A POINT OF INTEREST ON A MAP. AND UNDERNEATH THIS STYLIZED LETTER "O" IS A STYLIZED IMAGE OF A ROADMAP IN GREY. BENEATH "LOKADOT" IS OUR TAGLINE "WHAT LIFE SOUNDS LIKE." IN GREY.

THE WORDING "LOKADOT" HAS NO MEANING IN A FOREIGN LANGUAGE.

FOR COMPUTER APPLICATION SOFTWARE AND DOWNLOADABLE COMPUTER SOFTWARE FOR MOBILE PHONES, NAMELY, SOFTWARE FOR SERENDIPITOUSLY STREAMING CROWD-SOURCED AUDIO FILES TO LISTENERS BASED ON THEIR LOCATION, LISTENING PREFERENCES, AND NEARBY POINTS OF INTEREST (U.S. CLS. 21, 23, 26, 36 AND 38).

FIRST USE 9-1-2010; IN COMMERCE 2-14-2011.

KIMBERLY PERRY, EXAMINING ATTORNEY

SN 85-247,263. B&W TEK, INC., NEWARK, DE. FILED 2-21-2011.

i-trometer

THE MARK CONSISTS OF STANDARD CHARACTERS WITHOUT CLAIM TO ANY PARTICULAR FONT, STYLE, SIZE, OR COLOR.

FOR SCIENTIFIC APPARATUS, NAMELY, SPECTROMETERS AND PARTS AND FITTINGS THEREFOR (U.S. CLS. 21, 23, 26, 36 AND 38).

FIRST USE 8-1-2008; IN COMMERCE 8-1-2008.

MARGARET POWER, EXAMINING ATTORNEY

CLASS 9—(Continued).

SN 85-247,495. CAC OPTICAL, INC., LONG ISLAND CITY, NY. FILED 2-21-2011.



NO CLAIM IS MADE TO THE EXCLUSIVE RIGHT TO USE "EYEWEAR", APART FROM THE MARK AS SHOWN. THE MARK CONSISTS OF THE WORD "LAGHU" IN STYLIZED FONT ABOVE THE STYLIZED WORD "EYEWEAR".

THE WORD(S) "LAGHU" HAS NO MEANING IN A FOREIGN LANGUAGE.

FOR EYEWEAR, NAMELY, EYEGLASSES, EYEGLASS FRAMES, SUNGLASSES, AND SUNGLASS FRAMES (U.S. CLS. 21, 23, 26, 36 AND 38).

FIRST USE 3-8-2002; IN COMMERCE 3-8-2002.
ANDREW RHIM, EXAMINING ATTORNEY

CLASS 9—(Continued).

SN 85-247,930. OLIVER, TIMOTHY ANDREW, PERTH, AUSTRALIA, FILED 2-22-2011.



THE MARK CONSISTS OF STANDARD CHARACTERS WITHOUT CLAIM TO ANY PARTICULAR FONT, STYLE, SIZE, OR COLOR.

THE ENGLISH TRANSLATION OF "UBER" IN THE MARK IS "SUPER".

FOR COMPUTER GAME PROGRAMMES DOWNLOADABLE VIA THE INTERNET; COMPUTER GAME SOFTWARE FOR PERSONAL COMPUTERS AND HOME VIDEO GAME CONSOLES; COMPUTER GAME SOFTWARE FOR USE ON MOBILE AND CELLULAR PHONES; COMPUTER PROGRAMS FOR VIDEO AND COMPUTER GAMES (U.S. CLS. 21, 23, 26, 36 AND 38).

FIRST USE 7-17-2003; IN COMMERCE 3-15-2010.
KEVON CHISOLM, EXAMINING ATTORNEY

SN 85-247,532. PARK, BRIAN, CLIFTON, VA. FILED 2-21-2011.



THE MARK CONSISTS OF STANDARD CHARACTERS WITHOUT CLAIM TO ANY PARTICULAR FONT, STYLE, SIZE, OR COLOR.

NO CLAIM IS MADE TO THE EXCLUSIVE RIGHT TO USE "HOV HITCHHIKER", APART FROM THE MARK AS SHOWN.

FOR COMPUTER SOFTWARE PLATFORMS IN REAL TIME FOR LOCATING REGISTERED USERS IN A CHATROOM COMMUNITY AND CONNECTING THEM WITH OTHER USERS IN SPECIFIED GEOGRAPHICAL LOCATIONS FOR THE PURPOSES OF CARPOOLING AND COMMUTING WITH OTHER RIDERS (U.S. CLS. 21, 23, 26, 36 AND 38).

BERYL GARDNER, EXAMINING ATTORNEY

SN 85-248,116. JAZZ APPS MOBILE LLC, ROUND ROCK, TX. FILED 2-22-2011.



THE MARK CONSISTS OF STANDARD CHARACTERS WITHOUT CLAIM TO ANY PARTICULAR FONT, STYLE, SIZE, OR COLOR.

FOR COMPUTER APPLICATION SOFTWARE FOR MOBILE DEVICES, NAMELY, FOR THE PURPOSE OF TEACHING JAZZ IMPROVISATION AND MUSIC THEORY IN THE FIELD OF MUSIC EDUCATION (U.S. CLS. 21, 23, 26, 36 AND 38).

FIRST USE 1-26-2011; IN COMMERCE 2-19-2011.
MICHAEL SOUDERS, EXAMINING ATTORNEY

SN 85-247,679. IRVINE SENSORS CORP., COSTA MESA, CA. FILED 2-21-2011.



THE MARK CONSISTS OF STANDARD CHARACTERS WITHOUT CLAIM TO ANY PARTICULAR FONT, STYLE, SIZE, OR COLOR.

FOR PORTABLE COMPUTER DATA STORAGE DEVICES, NAMELY, BLANK USB FLASH MEMORY DRIVES AND BLANK USB FLASH MEMORY DRIVES HAVING SECURITY ANTI-TAMPER FEATURES (U.S. CLS. 21, 23, 26, 36 AND 38).

WON TEAK OH, EXAMINING ATTORNEY

SN 85-248,125. CLARK, RYAN, NINE MILE FALLS, WA. FILED 2-22-2011.



THE MARK CONSISTS OF STANDARD CHARACTERS WITHOUT CLAIM TO ANY PARTICULAR FONT, STYLE, SIZE, OR COLOR.

FOR WEAPON SIGHTING SYSTEM COMPRISED OF MULTI-LENS LASER POINTERS FOR THE PURPOSE OF MATCHING A KNOWN PATTERN OF SHOT (U.S. CLS. 21, 23, 26, 36 AND 38).

ALEX KEAM, EXAMINING ATTORNEY

CLASS 9—(Continued).

SN 85-248,223. NCH SOFTWARE, INC, GREENWOOD VIL-
LAGE, CO. FILED 2-22-2011.

Inventoria

THE MARK CONSISTS OF STANDARD CHARACTERS
WITHOUT CLAIM TO ANY PARTICULAR FONT, STYLE,
SIZE, OR COLOR.

THE ENGLISH TRANSLATION OF THE WORD "INVEN-
TORIA" IN THE MARK IS "INVENTORS".

FOR COMPUTER HARDWARE AND COMPUTER
SOFTWARE FOR RETAIL INVENTORY MANAGE-
MENT, SOLD AS A UNIT (U.S. CLS. 21, 23, 26, 36 AND
38).

FIRST USE 3-30-2009; IN COMMERCE 3-30-2009.
MAYUR VAGHANI, EXAMINING ATTORNEY

CLASS 9—(Continued).

SN 85-248,347. DRB SYSTEMS, INCORPORATED, AKRON,
OH. FILED 2-22-2011.

SOCIAL CIRCLE

THE MARK CONSISTS OF STANDARD CHARACTERS
WITHOUT CLAIM TO ANY PARTICULAR FONT, STYLE,
SIZE, OR COLOR.

FOR COMPUTER SOFTWARE FOR TRACKING CAR
WASH SERVICES FOR INDIVIDUALS AND OBTAINING
DISCOUNTS ON CAR WASH SERVICES; COMPUTER
PROGRAM APPLICATIONS FOR AUTOMATICALLY
POSTING MESSAGES ON WEB SITES REPORTING A
CAR WASH EVENT FOR A PARTICULAR USER AND
PROMOTING CAR WASH SERVICES (U.S. CLS. 21, 23,
26, 36 AND 38).

ALICE BENMAMAN, EXAMINING ATTORNEY

SN 85-248,245. IWAVE SICURA MEDIA INC., NEW YORK,
NY. FILED 2-22-2011.



THE MARK CONSISTS OF THE WORD "GRASS" ABOVE
THE WORD "ROOTS". THE "G" IN "GRASS" IS EXTENDED
DOWN AND PARALLEL WITH THE WORD "ROOTS". THE
"R" IN "GRASS" AND THE "R" IN "ROOTS" ARE LINKED
TOGETHER AND FORM AN INPUT PLUG TYPICALLY
USED WITH AUDIO DEVICES. THERE ARE TWO SMALL
LEAVES ABOVE THE LETTER "G".

FOR HEADPHONES, EARPHONES, EARBUDS, EAR-
PHONE CORDS, PROTECTIVE COVERS AND CASES
FOR CELLULAR PHONES AND PORTABLE MEDIA
PLAYERS (U.S. CLS. 21, 23, 26, 36 AND 38).

FIRST USE 1-1-2008; IN COMMERCE 1-1-2008.
ALICE BENMAMAN, EXAMINING ATTORNEY

SN 85-248,353. DRB SYSTEMS, INCORPORATED, AKRON,
OH. FILED 2-22-2011.

SOCIAL CIRCLE MODULE

THE MARK CONSISTS OF STANDARD CHARACTERS
WITHOUT CLAIM TO ANY PARTICULAR FONT, STYLE,
SIZE, OR COLOR.

NO CLAIM IS MADE TO THE EXCLUSIVE RIGHT TO
USE "MODULE", APART FROM THE MARK AS SHOWN.

FOR COMPUTER SOFTWARE FOR TRACKING CAR
WASH SERVICES FOR INDIVIDUALS AND OBTAINING
DISCOUNTS ON CAR WASH SERVICES; COMPUTER
PROGRAM APPLICATIONS FOR AUTOMATICALLY
POSTING MESSAGES ON WEB SITES REPORTING A
CAR WASH EVENT FOR A PARTICULAR USER AND
PROMOTING CAR WASH SERVICES (U.S. CLS. 21, 23,
26, 36 AND 38).

ALICE BENMAMAN, EXAMINING ATTORNEY

CLASS 9—(Continued).

SN 85-248,427. BUSINESS MEDIA SOLUTIONS, INC., DBA RUSSELL ASSOCIATES, LE SUEUR, MN. FILED 2-22-2011.



THE MARK CONSISTS OF A LARGE CHECKMARK WITH A LOWER CASE "I" POSITIONED ON THE CHECKMARK. THE LETTERS "NSPECTI" IN LOWER CASE, FOLLOWED BY "TRAC" IN UPPERCASE ARE POSITIONED TO THE RIGHT OF THE CHECKMARK. ALL TOGETHER, THE LETTERS SPELL "INSPECTITRAC".

FOR CUSTOMIZABLE SOFTWARE APPLICATION FOR USE IN INSPECTING PLANT FACILITIES AND EQUIPMENT THAT PRESENTS THE USER WITH A TOUCH SCREEN INDEX OF INSPECTIONS THAT HAVE BEEN PRE-PROGRAMMED FOR SPECIFIC PLANTS OR FACILITIES AND CREATES REPORTS OF SUCH INSPECTIONS (U.S. CLS. 21, 23, 26, 36 AND 38).
ANDREW LEASER, EXAMINING ATTORNEY

CLASS 9—(Continued).

SN 85-248,870. BAILEY, SKYLAR JAMES, BRONX, NY. FILED 2-22-2011.

Dreamable Music

THE MARK CONSISTS OF STANDARD CHARACTERS WITHOUT CLAIM TO ANY PARTICULAR FONT, STYLE, SIZE, OR COLOR.

NO CLAIM IS MADE TO THE EXCLUSIVE RIGHT TO USE "MUSIC", APART FROM THE MARK AS SHOWN.

FOR DIGITAL MATERIALS, NAMELY, CDS, DVDS, DOWNLOADABLE AUDIO FILES, AND DOWNLOADABLE ALBUMS IN THE NATURE OF DOWNLOADABLE AUDIO FILES FEATURING MUSIC (U.S. CLS. 21, 23, 26, 36 AND 38).

MICHAEL GAFFAR, EXAMINING ATTORNEY

SN 85-248,881. IOANNIS P. PARALIS, LYNNWOOD, WA. FILED 2-22-2011.

SN 85-248,556. RICE LAKE WEIGHING SYSTEMS, INC., RICE LAKE, WI. FILED 2-22-2011.

TICKETPRESS



NO CLAIM IS MADE TO THE EXCLUSIVE RIGHT TO USE "BINARY", APART FROM THE MARK AS SHOWN.

THE MARK CONSISTS OF TWELVE BLACK AND WHITE SQUARES ARRANGED IN TWO ROWS OF SIX SQUARES EACH. THE BLACK AND WHITE COLORS ALTERNATE BOTH VERTICALLY AND HORIZONTALLY IN A CHECKERBOARD PATTERN. INSIDE EACH SQUARE IS ONE LETTER TO FORM THE WORDS "CROSS BINARY" WHERE THE TOP RIGHT SQUARE REMAINS FULLY SHADED IN BLACK.

FOR COMPUTER APPLICATION SOFTWARE FOR MOBILE PHONES, NAMELY, SOFTWARE FOR CROSSWORD PUZZLES USING BINARY NUMBERS (U.S. CLS. 21, 23, 26, 36 AND 38).

CAROLINE WOOD, EXAMINING ATTORNEY

THE MARK CONSISTS OF STANDARD CHARACTERS WITHOUT CLAIM TO ANY PARTICULAR FONT, STYLE, SIZE, OR COLOR.

FOR PRINTER USED WITH MULTI-PART PAPER TO PRINT DATA FROM A SCALE, DIGITAL WEIGHT INDICATOR OR PERSONAL COMPUTER, USED IN CONJUNCTION WITH FOOD PROCESSING, MEDICAL DEVICE WEIGHING, MEDICAL PROCEDURE WEIGHING OF FLUIDS OR SOLIDS, SHIPPING/RECEIVING, MANUFACTURING, VEHICLE WEIGHING AND ALL-PURPOSE WEIGHING (U.S. CLS. 21, 23, 26, 36 AND 38).
JOHN DWYER, EXAMINING ATTORNEY

CLASS 9—(Continued).

SN 85-248,895. ADVANCED BUSINESS MACHINES, LINCOLN, RI. FILED 2-22-2011.

OFFICE PROVISIONS & PRINTOLOGY

THE MARK CONSISTS OF STANDARD CHARACTERS WITHOUT CLAIM TO ANY PARTICULAR FONT, STYLE, SIZE, OR COLOR.

NO CLAIM IS MADE TO THE EXCLUSIVE RIGHT TO USE "OFFICE PROVISIONS", APART FROM THE MARK AS SHOWN.

FOR FACSIMILE MACHINES; MULTIFUNCTION ELECTRONIC DEVICES FOR USE IN COPYING, PRINTING, SCANNING, VIDEO CAPTURING AND/OR TRANSMITTING DOCUMENTS AND IMAGES; PHOTOCOPY MACHINES; SCANNERS (U.S. CLS. 21, 23, 26, 36 AND 38).

WILLIAM VERHOSEK, EXAMINING ATTORNEY

SN 85-248,949. ECOSHOP HOLDING, LLC, BOTHELL, WA. FILED 2-22-2011.

CityAlerts Mobile Emergency Alert System

THE MARK CONSISTS OF STANDARD CHARACTERS WITHOUT CLAIM TO ANY PARTICULAR FONT, STYLE, SIZE, OR COLOR.

NO CLAIM IS MADE TO THE EXCLUSIVE RIGHT TO USE "MOBILE EMERGENCY ALERT SYSTEM", APART FROM THE MARK AS SHOWN.

FOR COMPUTER SOFTWARE FOR DELIVERING RAPID EMERGENCY ALERT NOTIFICATIONS TO A GEO-TARGETED AUDIENCE (U.S. CLS. 21, 23, 26, 36 AND 38).

FIRST USE 4-27-2006; IN COMMERCE 4-28-2006.
NAAKWAMA ANKRAH, EXAMINING ATTORNEY

SN 85-248,979. BARNES, TERENCE D, DBA MIND OVER MONEY, ALCOLU, SC. FILED 2-22-2011.

MIND OVER MONEY

THE MARK CONSISTS OF STANDARD CHARACTERS WITHOUT CLAIM TO ANY PARTICULAR FONT, STYLE, SIZE, OR COLOR.

FOR MUSICAL SOUND RECORDINGS (U.S. CLS. 21, 23, 26, 36 AND 38).

CIMMERIAN COLEMAN, EXAMINING ATTORNEY

CLASS 9—(Continued).

SN 85-249,030. PB&J PUBLISHING, LLC, MCLEAN, VA. FILED 2-23-2011.



NO CLAIM IS MADE TO THE EXCLUSIVE RIGHT TO USE "PUBLISHING", APART FROM THE MARK AS SHOWN.

FOR DOWNLOADABLE SOFTWARE IN THE NATURE OF A MOBILE APPLICATION FOR DISPLAYING AND PLAYING ELECTRONIC BOOKS, ENTERTAINMENT CONTENT, MUSIC, VIDEO CLIPS AND GRAPHICS (U.S. CLS. 21, 23, 26, 36 AND 38).

MARK RADEMACHER, EXAMINING ATTORNEY

SN 85-249,187. WAYANS, DAMON, NEW YORK, NY. FILED 2-23-2011.

RECUT

THE MARK CONSISTS OF STANDARD CHARACTERS WITHOUT CLAIM TO ANY PARTICULAR FONT, STYLE, SIZE, OR COLOR.

FOR COMPUTER APPLICATION SOFTWARE FOR MOBILE PHONES, NAMELY, SOFTWARE FOR DEVELOPING, DIRECTING AND FORMATING IMAGINARY ENTERTAINMENT SEGMENTS SUCH AS SKETCH COMEDIES AND COMPLEX MYSTERIES; COMPUTER GAME SOFTWARE DOWNLOADABLE FROM A GLOBAL COMPUTER NETWORK; COMPUTER GAME SOFTWARE FOR PERSONAL COMPUTERS AND HOME VIDEO GAME CONSOLES; COMPUTER GAME SOFTWARE FOR USE ON MOBILE AND CELLULAR PHONES; COMPUTER-GAMING SOFTWARE; DOWNLOADABLE ELECTRONIC GAME PROGRAMS; DOWNLOADABLE SOFTWARE IN THE NATURE OF A MOBILE APPLICATION FOR DEVELOPING, DIRECTING AND FORMATING IMAGINARY ENTERTAINMENT SEGMENTS SUCH AS SKETCH COMEDIES AND COMPLEX MYSTERIES (U.S. CLS. 21, 23, 26, 36 AND 38).

NICHOLAS ALTREE, EXAMINING ATTORNEY

CLASS 9—(Continued).

SN 85-249,222. WAYANS, DAMON, NEW YORK, NY. FILED 2-23-2011.



THE COLOR(S) BLACK, WHITE AND BLUE IS/ARE CLAIMED AS A FEATURE OF THE MARK.

THE MARK CONSISTS OF THE WORD "RE CUT" APPEARING IN BLACK WITH WHITE AND BLUE OUTLINES AND ALL LOWER CASE LETTERS EXCEPT FOR THE LETTER "C" WHICH APPEARS IN UPPER CASE. A PAIR OF SCISSORS IN WHITE WITH BLACK AND BLUE OUTLINES APPEARS ABOVE THE WORD "RE CUT" AFTER THE LETTER "C".

FOR COMPUTER APPLICATION SOFTWARE FOR MOBILE PHONES, NAMELY, SOFTWARE FOR DEVELOPING, DIRECTING AND FORMATING IMAGINARY ENTERTAINMENT SEGMENTS SUCH AS SKETCH COMEDIES AND COMPLEX MYSTERIES; COMPUTER GAME SOFTWARE DOWNLOADABLE FROM A GLOBAL COMPUTER NETWORK; COMPUTER GAME SOFTWARE FOR PERSONAL COMPUTERS AND HOME VIDEO GAME CONSOLES; COMPUTER GAME SOFTWARE FOR USE ON MOBILE AND CELLULAR PHONES; COMPUTER-GAMING SOFTWARE; DOWNLOADABLE ELECTRONIC GAME PROGRAMS; DOWNLOADABLE SOFTWARE IN THE NATURE OF A MOBILE APPLICATION FOR DEVELOPING, DIRECTING AND FORMATING IMAGINARY ENTERTAINMENT SEGMENTS SUCH AS SKETCH COMEDIES AND COMPLEX MYSTERIES (U.S. CLS. 21, 23, 26, 36 AND 38).

NICHOLAS ALTREE, EXAMINING ATTORNEY

SN 85-249,240. ELYNX TECHNOLOGIES, LLC, TULSA, OK. FILED 2-23-2011.



THE MARK CONSISTS OF A CIRCLE WITH THE LETTER "I", THE NUMBER "4", AND THE LETTER "D" IMPOSED OVER THE CIRCLE.

FOR COMPUTER HARDWARE AND SOFTWARE FOR USE IN DATA COLLECTION, ENERGY PRODUCTION, DATA RECORDING, PRODUCTION TRENDING, EQUIPMENT MONITORING AND USER ALERTS FOR THE ENERGY INDUSTRY (U.S. CLS. 21, 23, 26, 36 AND 38).

JOHN WILKE, EXAMINING ATTORNEY

CLASS 9—(Continued).

SN 85-249,331. SCG COMMUNICATIONS, LLC, TIMONIUM, MD. FILED 2-23-2011.

Wicked Obsessions

THE MARK CONSISTS OF STANDARD CHARACTERS WITHOUT CLAIM TO ANY PARTICULAR FONT, STYLE, SIZE, OR COLOR.

FOR DOWNLOADABLE ADULT-THEMED PHOTOGRAPHS AND VIDEOS (U.S. CLS. 21, 23, 26, 36 AND 38).
JAMES GRIFFIN, EXAMINING ATTORNEY

SN 85-249,347. ATMA CORE, LLC, HOUSTON, TX. FILED 2-23-2011.



THE MARK CONSISTS OF AN OVAL WITH A LINE DOWN THE CENTER IN THE TOP PORTION OF THE DESIGN AND AN ARROW FACING UP THAT INTERSECTS OVAL AND THE LINE OF THE OVAL. THE DESIGN ALSO REPRESENTS FANCIFUL BACK TO BACK LETTERS "RR".

FOR VIDEO GAME SOFTWARE (U.S. CLS. 21, 23, 26, 36 AND 38).

CHRISIE B. KING, EXAMINING ATTORNEY

SN 85-249,491. MUSTARD TREE INSTRUMENTS, LLC, RESEARCH TRIANGLE PARK, NC. FILED 2-23-2011.

Mustard Tree Instruments

THE MARK CONSISTS OF STANDARD CHARACTERS WITHOUT CLAIM TO ANY PARTICULAR FONT, STYLE, SIZE, OR COLOR.

NO CLAIM IS MADE TO THE EXCLUSIVE RIGHT TO USE "INSTRUMENTS", APART FROM THE MARK AS SHOWN.

FOR SCIENTIFIC APPARATUS, NAMELY, SPECTROMETERS AND PARTS AND FITTINGS THEREFOR (U.S. CLS. 21, 23, 26, 36 AND 38).

ANNE MADDEN, EXAMINING ATTORNEY

CLASS 9—(Continued).

SN 85-249,721. BARBARA HAUBRICH, DBA DEADLINE DIRECT, BAKERSFIELD, CA. FILED 2-23-2011.

DEADLINE DIRECT

THE MARK CONSISTS OF STANDARD CHARACTERS WITHOUT CLAIM TO ANY PARTICULAR FONT, STYLE, SIZE, OR COLOR.

NO CLAIM IS MADE TO THE EXCLUSIVE RIGHT TO USE "DEADLINE", APART FROM THE MARK AS SHOWN. FOR COMPUTER APPLICATION SOFTWARE FOR PERSONAL COMPUTERS, NAMELY, SOFTWARE FOR CALCULATING BUSINESS DEADLINES AND INTEGRATING THEM INTO A CALENDAR PROGRAM (U.S. CLS. 21, 23, 26, 36 AND 38).

FIRST USE 3-14-2011; IN COMMERCE 3-16-2011.
GILBERT SWIFT, EXAMINING ATTORNEY

CLASS 9—(Continued).

SN 85-249,831. SCHRADER ELECTRONICS, INC., SPRINGFIELD, TN. FILED 2-23-2011.

EZ-TIRE

THE MARK CONSISTS OF STANDARD CHARACTERS WITHOUT CLAIM TO ANY PARTICULAR FONT, STYLE, SIZE, OR COLOR.

FOR VEHICLE SAFETY EQUIPMENT, NAMELY, ELECTRONIC TIRE PRESSURE SENSORS; VEHICLE SAFETY EQUIPMENT, NAMELY, DIRECT TIRE PRESSURE MONITORING SYSTEM (TPMS) COMPRISING PRESSURE SENSORS EMBEDDED INSIDE EACH TIRE TO TRANSMIT DATA TO A DASHBOARD DISPLAY ALERTING DRIVERS TO TIRE PRESSURE ISSUES (U.S. CLS. 21, 23, 26, 36 AND 38).

EMILY CHUO, EXAMINING ATTORNEY

SN 85-249,738. AVENUE MEDIA LLC, NEW YORK, NY. FILED 2-23-2011.

AVENUE

THE MARK CONSISTS OF STANDARD CHARACTERS WITHOUT CLAIM TO ANY PARTICULAR FONT, STYLE, SIZE, OR COLOR.

FOR DOWNLOADABLE ELECTRONIC MAGAZINES FEATURING ARTS, REAL ESTATE, HOME FURNISHINGS AND DECOR, SOCIETY, CULTURAL AND LIFESTYLE TOPICS OF GENERAL INTEREST (U.S. CLS. 21, 23, 26, 36 AND 38).

FIRST USE 3-0-2007; IN COMMERCE 3-0-2007.
KATHERINE CHANG, EXAMINING ATTORNEY

SN 85-249,868. RAFI SAID, MANHASSET HILLS, NY. FILED 2-23-2011.



NO CLAIM IS MADE TO THE EXCLUSIVE RIGHT TO USE "SECURITY SYSTEMS", APART FROM THE MARK AS SHOWN.

THE MARK CONSISTS OF THE STYLIZED TEXT "PROCTOR SECURITY SYSTEMS" WITH AN ABSTRACT OVAL DESIGN.

FOR CLOSED CIRCUIT TV SYSTEMS FOR SECURITY AND SURVEILLANCE, NAMELY, CAMERAS, SWITCHERS, MONITORS, MICROPHONES, AND RECORDERS (U.S. CLS. 21, 23, 26, 36 AND 38).

EMILY CHUO, EXAMINING ATTORNEY

SN 85-249,743. ALL IN RECORDS, LLC, ATLANTA, GA. FILED 2-23-2011.

THE FARM INC. NASHVILLE, TN

THE MARK CONSISTS OF STANDARD CHARACTERS WITHOUT CLAIM TO ANY PARTICULAR FONT, STYLE, SIZE, OR COLOR.

NO CLAIM IS MADE TO THE EXCLUSIVE RIGHT TO USE "NASHVILLE, TN", APART FROM THE MARK AS SHOWN.

FOR MUSICAL SOUND RECORDINGS; AUDIOVISUAL RECORDINGS FEATURING MUSICAL ENTERTAINMENT (U.S. CLS. 21, 23, 26, 36 AND 38).

JANICE L. MCMORROW, EXAMINING ATTORNEY

SN 85-250,003. TOP-VOX CORPORATION, BARRINGTON, IL. FILED 2-23-2011.

BLUEMASTER

THE MARK CONSISTS OF STANDARD CHARACTERS WITHOUT CLAIM TO ANY PARTICULAR FONT, STYLE, SIZE, OR COLOR.

FOR HEADSETS FOR WIRELESS COMMUNICATION, NAMELY, FOR USE WITH VOICE-COMPATIBLE HANDHELD COMMUNICATION DEVICES AND COMPUTERS (U.S. CLS. 21, 23, 26, 36 AND 38).

FIRST USE 2-1-2011; IN COMMERCE 2-1-2011.

COURTNEY ALVAREZ, EXAMINING ATTORNEY

CLASS 9—(Continued).

SN 85-250,029. TAP WORLDWIDE, LLC, COMPTON, CA. FILED 2-23-2011.

CART ALLIANCE

THE MARK CONSISTS OF STANDARD CHARACTERS WITHOUT CLAIM TO ANY PARTICULAR FONT, STYLE, SIZE, OR COLOR.

FOR COMPUTER E-COMMERCE SOFTWARE TO ALLOW USERS TO PERFORM ELECTRONIC BUSINESS TRANSACTIONS VIA A GLOBAL COMPUTER NETWORK (U.S. CLS. 21, 23, 26, 36 AND 38).

ZHALEH DELANEY, EXAMINING ATTORNEY



SN 85-250,117. BURRELL STANLEY K., TRACY, CA. FILED 2-23-2011.

U CAN'T TOUCH THIS

THE MARK CONSISTS OF STANDARD CHARACTERS WITHOUT CLAIM TO ANY PARTICULAR FONT, STYLE, SIZE, OR COLOR.

FOR COMPUTER SCREENS (U.S. CLS. 21, 23, 26, 36 AND 38).

DEZMONA MIZELLE, EXAMINING ATTORNEY



SN 85-250,216. COMPULAB LTD., NESHER, ISRAEL, FILED 2-24-2011.

Intense-PC

THE MARK CONSISTS OF STANDARD CHARACTERS WITHOUT CLAIM TO ANY PARTICULAR FONT, STYLE, SIZE, OR COLOR.

FOR COMPUTER HARDWARE (U.S. CLS. 21, 23, 26, 36 AND 38).

KARANENDRA S. CHHINA, EXAMINING ATTORNEY

CLASS 9—(Continued).

SN 85-250,406. SRA INTERNATIONAL, INC., FAIRFAX, VA. FILED 2-24-2011.

One Vault Messenger

THE MARK CONSISTS OF STANDARD CHARACTERS WITHOUT CLAIM TO ANY PARTICULAR FONT, STYLE, SIZE, OR COLOR.

NO CLAIM IS MADE TO THE EXCLUSIVE RIGHT TO USE "MESSENGER", APART FROM THE MARK AS SHOWN.

FOR COMPUTER SOFTWARE PROVIDING SECURE MESSAGING BETWEEN MOBILE DEVICES (U.S. CLS. 21, 23, 26, 36 AND 38).

FIRST USE 2-1-2011; IN COMMERCE 2-15-2011.

BRENDAN MCCAULEY, EXAMINING ATTORNEY



SN 85-250,431. VOTEBLAST, INC., WEST HOLLYWOOD, CA. FILED 2-24-2011.



THE COLOR(S) RED, YELLOW, GREEN, AND BLUE IS/ ARE CLAIMED AS A FEATURE OF THE MARK.

THE MARK CONSISTS OF A RED FROWN FACE, YELLOW NEUTRAL FACE, GREEN SMILEY FACE, AND BLUE CIRCLE DESIGN WITH STARS. THE COLOR GRAY APPEARS AS A SHADOW REFLECTION BEHIND THE FACES AND CIRCLE IN THE MARK BUT IS NOT CLAIMED AS A FEATURE OF THE MARK.

FOR COMPUTER APPLICATION SOFTWARE FOR MOBILE DEVICES, NAMELY, SOFTWARE USED FOR THE DISPLAY, COLLECTION, EDITING, ORGANIZING, MODIFYING, TRANSMISSION, STORAGE AND SHARING OF DATA AND INFORMATION IN THE FIELD OF SURVEY AND OPINION SERVICES; COMPUTER SOFTWARE FOR THE DISPLAY, COLLECTION, EDITING, ORGANIZING, MODIFYING, TRANSMISSION, STORAGE AND SHARING OF DATA AND INFORMATION IN THE FIELD OF SURVEY AND OPINION SERVICES (U.S. CLS. 21, 23, 26, 36 AND 38).

NATALIE POLZER, EXAMINING ATTORNEY

CLASS 9—(Continued).

SN 85-250,500. FORTUNA LOGISTICS, LLC, ORLANDO, FL. FILED 2-24-2011.



NO CLAIM IS MADE TO THE EXCLUSIVE RIGHT TO USE ".COM", APART FROM THE MARK AS SHOWN.

THE COLOR(S) GREEN AND BLACK IS/ARE CLAIMED AS A FEATURE OF THE MARK.

THE MARK CONSISTS OF THE STYLIZED BLACK WORDING "XACT LINK .COM" WITH A STYLIZED "X" DESIGN. THERE IS A GREEN BROKEN OVAL THAT ENCOMPASSES THE "XACT LINK .COM" WORDING AND PART OF THE "X" DESIGN. THE "X" DESIGN IS GREEN AT THE LOWER RIGHT TAIL WITH LIGHTER GREEN INTERIOR BORDER AND BLACK OUTER BORDER. PROGRESSING UPWARD TOWARD THE BODY OF THE "X", THE "X" DESIGN INTERIOR GETS DARKER GREEN TURNING TO BLACK, BUT STILL RETAINING THE LIGHTER GREEN INTERIOR BORDER AND BLACK OUTER BORDER.

FOR COMPUTER PROGRAMS FOR MANAGING CONSTRUCTION PROJECTS, NAMELY, SALES, MARKETING, ACCOUNTING AND SCHEDULING INFORMATION (U.S. CLS. 21, 23, 26, 36 AND 38).

BRIAN PINO, EXAMINING ATTORNEY

SN 85-250,520. FIGURE 53, LLC, BALTIMORE, MD. FILED 2-24-2011.

QLAB

THE MARK CONSISTS OF STANDARD CHARACTERS WITHOUT CLAIM TO ANY PARTICULAR FONT, STYLE, SIZE, OR COLOR.

FOR DOWNLOADABLE COMPUTER SOFTWARE FOR CREATING MULTIMEDIA PRESENTATIONS FOR LIVE PERFORMANCES AND PRESENTATIONS (U.S. CLS. 21, 23, 26, 36 AND 38).

FIRST USE 12-30-2005; IN COMMERCE 12-30-2005.

JILL PRATER, EXAMINING ATTORNEY

CLASS 9—(Continued).

SN 85-250,522. DOMAINBASE INC., ONTARIO, CANADA, FILED 2-24-2011.

DOMAINBASE

THE MARK CONSISTS OF STANDARD CHARACTERS WITHOUT CLAIM TO ANY PARTICULAR FONT, STYLE, SIZE, OR COLOR.

FOR SOFTWARE FOR THE MANAGEMENT OF DOMAIN NAMES AND WEBSITES (U.S. CLS. 21, 23, 26, 36 AND 38).

FIRST USE 1-1-2000; IN COMMERCE 1-1-2000.

JILL PRATER, EXAMINING ATTORNEY

SN 85-250,692. 745 LLC, BOSTON, MA. FILED 2-24-2011.

BEAT POP

THE MARK CONSISTS OF STANDARD CHARACTERS WITHOUT CLAIM TO ANY PARTICULAR FONT, STYLE, SIZE, OR COLOR.

FOR COMPUTER GAME SOFTWARE; COMPUTER GAME SOFTWARE FOR MOBILE DEVICES; COMPUTER GAME SOFTWARE DOWNLOADABLE TO WIRELESS DEVICES; COMPUTER GAME SOFTWARE DOWNLOADABLE VIA A GLOBAL COMPUTER NETWORK (U.S. CLS. 21, 23, 26, 36 AND 38).

BRENDAN MCCAULEY, EXAMINING ATTORNEY

SN 85-250,795. MOLDEX-METRIC, INC., CULVER CITY, CA. FILED 2-24-2011.

AIRWAVE

THE MARK CONSISTS OF STANDARD CHARACTERS WITHOUT CLAIM TO ANY PARTICULAR FONT, STYLE, SIZE, OR COLOR.

FOR DISPOSABLE AND REUSABLE PROTECTIVE FILTER FACE MASKS (U.S. CLS. 21, 23, 26, 36 AND 38).

NAKWAMA ANKRAH, EXAMINING ATTORNEY

CLASS 9—(Continued).

SN 85-250,805. NCH SOFTWARE INC. GREENWOOD VIL-
LAGE, CO. FILED S.R. 2-24-2011; AM. P.R. 5-26-2011.

Debut

THE MARK CONSISTS OF STANDARD CHARACTERS WITHOUT CLAIM TO ANY PARTICULAR FONT, STYLE, SIZE, OR COLOR.

FOR COMPUTER SOFTWARE FOR CONTROLLING THE OPERATION OF AUDIO AND VIDEO DEVICES; COMPUTER SOFTWARE FOR PROCESSING DIGITAL IMAGES; COMPUTER SOFTWARE TO ENHANCE THE AUDIO-VISUAL CAPABILITIES OF MULTIMEDIA APPLICATIONS, NAMELY, FOR THE INTEGRATION OF TEXT, AUDIO, GRAPHICS, STILL IMAGES AND MOVING PICTURES (U.S. CLS. 21, 23, 26, 36 AND 38).

FIRST USE 4-18-2008; IN COMMERCE 4-18-2008.
JOHN E. MICHOS, EXAMINING ATTORNEY

CLASS 9—(Continued).

SN 85-251,208. TURBO CHILLI PTY LTD, SYDNEY, AUS-
TRALIA, FILED 2-24-2011.

STICK RIDER

THE MARK CONSISTS OF STANDARD CHARACTERS WITHOUT CLAIM TO ANY PARTICULAR FONT, STYLE, SIZE, OR COLOR.

FOR COMPUTER GAMES ENTERTAINMENT SOFTWARE; COMPUTER GAMES PROGRAMS; COMPUTER PROGRAMS FOR COMPUTER GAMES; PROGRAMS FOR USE WITH COMPUTER GAMES; COMPUTER PROGRAMS FOR VIDEO GAMES; PROGRAMMED VIDEO GAMES SOFTWARE; ELECTRONIC GAMES FOR HAND HELD DEVICES, MOBILE PHONES AND COMPUTERS INCLUDING LAPTOPS; ELECTRONIC ARCADE GAMES ADAPTED FOR USE WITH AN EXTERNAL DISPLAY SCREEN OR MONITOR (U.S. CLS. 21, 23, 26, 36 AND 38).

JANICE L. MCMORROW, EXAMINING ATTORNEY

SN 85-250,859. NCH SOFTWARE INC. GREENWOOD VIL-
LAGE, CO. FILED S.R. 2-24-2011; AM. P.R. 5-26-2011.

PhotoStage

THE MARK CONSISTS OF STANDARD CHARACTERS WITHOUT CLAIM TO ANY PARTICULAR FONT, STYLE, SIZE, OR COLOR.

FOR COMPUTER SOFTWARE FOR ORGANIZING AND VIEWING DIGITAL IMAGES AND PHOTOGRAPHS; COMPUTER SOFTWARE FOR PROCESSING DIGITAL IMAGES (U.S. CLS. 21, 23, 26, 36 AND 38).

FIRST USE 5-20-2008; IN COMMERCE 5-20-2008.
JOHN E. MICHOS, EXAMINING ATTORNEY

SN 85-251,294. NATHAN AMARAL INTERNATIONAL, INC.,
DIGHTON, MA. FILED 2-24-2011.

Nathan Amaral

THE MARK CONSISTS OF STANDARD CHARACTERS WITHOUT CLAIM TO ANY PARTICULAR FONT, STYLE, SIZE, OR COLOR.

THE NAME "NATHAN AMARAL" IDENTIFIES A LIVING INDIVIDUAL WHOSE CONSENT IS OF RECORD.

FOR AUDIO AND VIDEO RECORDINGS FEATURING PERSONAL IMPROVEMENT, FINANCIAL IMPROVEMENT, AND SALES TRAINING (U.S. CLS. 21, 23, 26, 36 AND 38).

FIRST USE 12-20-2010; IN COMMERCE 12-26-2010.
JACLYN KIDWELL WALKER, EXAMINING ATTORNEY

SN 85-250,953. FANDORA, INC., SAN ANTONIO, TX. FILED
2-24-2011.

FANDEMIC

THE MARK CONSISTS OF STANDARD CHARACTERS WITHOUT CLAIM TO ANY PARTICULAR FONT, STYLE, SIZE, OR COLOR.

FOR INTERACTIVE COMPUTER SOFTWARE APPLICATION FOR A MOBILE PHONE FOR PROVIDING PROMOTION OF BANDS AND MUSICIANS THROUGH PROVIDING INFORMATION, INCLUDING SCHEDULES AND LOCATIONS, FOR SUCH BANDS AND MUSICIANS (U.S. CLS. 21, 23, 26, 36 AND 38).

LINDA LAVACHE, EXAMINING ATTORNEY

SN 85-251,573. LEAD TECHNOLOGY CAPITAL MANAGE-
MENT, LLC, MIAMI, FL. FILED 2-25-2011.

JUST SYNC

THE MARK CONSISTS OF STANDARD CHARACTERS WITHOUT CLAIM TO ANY PARTICULAR FONT, STYLE, SIZE, OR COLOR.

FOR COMPUTER SEARCH ENGINE SOFTWARE; COMPUTER SOFTWARE FOR APPLICATIONS, DATABASES, AND ONLINE KEYWORD SEARCHES THAT INTEGRATE WITH OTHER EXISTING PROGRAMS; GRAPHICAL USER INTERFACE SOFTWARE, NAMELY TOOLBAR SOFTWARE FOR USE WITH SEARCH ENGINE SOFTWARE, WEBSITES AND APPLICATIONS (U.S. CLS. 21, 23, 26, 36 AND 38).

MICHELE SWAIN, EXAMINING ATTORNEY

CLASS 9—(Continued).

SN 85-251,685. O'BRIEN, GLENN, NEW YORK, NY. FILED 2-25-2011.

TV PARTY

THE MARK CONSISTS OF STANDARD CHARACTERS WITHOUT CLAIM TO ANY PARTICULAR FONT, STYLE, SIZE, OR COLOR.

NO CLAIM IS MADE TO THE EXCLUSIVE RIGHT TO USE "TV", APART FROM THE MARK AS SHOWN.

FOR VIDEO RECORDINGS FEATURING A VARIETY TELEVISION SHOW (U.S. CLS. 21, 23, 26, 36 AND 38).

FIRST USE 12-31-1986; IN COMMERCE 12-31-1986.

MAYUR VAGHANI, EXAMINING ATTORNEY

CLASS 9—(Continued).

SN 85-251,863. FLANNEL, GRAND RAPIDS, MI. FILED 2-25-2011.

Flannel Stories

THE MARK CONSISTS OF STANDARD CHARACTERS WITHOUT CLAIM TO ANY PARTICULAR FONT, STYLE, SIZE, OR COLOR.

OWNER OF U.S. REG. NO. 3,358,571.

NO CLAIM IS MADE TO THE EXCLUSIVE RIGHT TO USE "STORIES", APART FROM THE MARK AS SHOWN.

FOR DIGITAL MATERIALS, NAMELY, DVD'S, CD'S, DOWN-LOADABLE AUDIO FILES, AND DOWN-LOADABLE VIDEO FILES, FEATURING FULL-LENGTH AND SHORT FILES IN THE FIELD OF SPIRITUALITY (U.S. CLS. 21, 23, 26, 36 AND 38).

FIRST USE 1-31-2008; IN COMMERCE 1-31-2008.

FLORENTINA BLANDU, EXAMINING ATTORNEY

SN 85-251,726. ATAKAMA LABS INC., SAN FRANCISCO, CA. FILED 2-25-2011.

Little Cave Hero

THE MARK CONSISTS OF STANDARD CHARACTERS WITHOUT CLAIM TO ANY PARTICULAR FONT, STYLE, SIZE, OR COLOR.

FOR COMPUTER GAME SOFTWARE; COMPUTER GAME SOFTWARE DOWNLOADABLE FROM A GLOBAL COMPUTER NETWORK; COMPUTER GAME SOFTWARE FOR USE ON MOBILE AND CELLULAR PHONES; COMPUTER SOFTWARE FOR SOCIAL NETWORKING AND SHARING ELECTRONIC MEDIA AND INFORMATION AMONG FRIENDS AND VIRTUAL COMMUNITIES, THAT MAY BE DOWNLOADED FROM A GLOBAL COMPUTER NETWORK; DOWNLOADABLE COMPUTER GAME PROGRAMS; DOWNLOADABLE COMPUTER GAME SOFTWARE VIA A GLOBAL COMPUTER NETWORK AND WIRELESS DEVICES; INTERACTIVE GAME PROGRAMS; VIDEO GAME SOFTWARE (U.S. CLS. 21, 23, 26, 36 AND 38).

GRETTA YAO, EXAMINING ATTORNEY

SN 85-251,870. SAFILO USA, INC., PARSIPPANY, NJ. FILED 2-25-2011.

NOT JUST MORE LIGHT. MORE LIFE.

THE MARK CONSISTS OF STANDARD CHARACTERS WITHOUT CLAIM TO ANY PARTICULAR FONT, STYLE, SIZE, OR COLOR.

FOR EYEWEAR, NAMELY, EYEGLASSES, SUNGLASSES, SPORT GOGGLES, EYEGASS AND SUNGLASS LENSES AND EYEGLOSS CASES (U.S. CLS. 21, 23, 26, 36 AND 38).

JERI J. FICKES, EXAMINING ATTORNEY

CLASS 9—(Continued).

SN 85-252,098. VISITING NURSE SERVICE OF NEW YORK, NEW YORK, NY. FILED 2-25-2011.



OWNER OF U.S. REG. NOS. 3,296,361, 3,698,790 AND 3,809,137.

NO CLAIM IS MADE TO THE EXCLUSIVE RIGHT TO USE "VISITING NURSE SERVICE OF NEW YORK" OR "NY", APART FROM THE MARK AS SHOWN.

THE MARK CONSISTS OF THE WORDS "VISITING NURSE SERVICE OF NEW YORK" ARRANGED TO FORM A CIRCLE, INSIDE WHICH ARE THE LETTERS "VNSNY" OF WHICH THE LETTERS "VSN" APPEAR IN A DESIGN FORMED OF GEOMETRIC SHAPES.

FOR EMERGENCY NOTIFICATION SYSTEM COMPRISED OF A DATA PROCESSOR AND A USER INPUT DEVICE FOR CONNECTING THE DATA PROCESSOR TO AN EMERGENCY RESPONSE ENTITY THROUGH A COMMUNICATION NETWORK AND ALLOWING AUDIO AND DATA COMMUNICATION BETWEEN THE PROCESSOR AND THE ENTITY; EMERGENCY SIGNAL TRANSMITTERS; PERSONAL SECURITY ALARMS (U.S. CLS. 21, 23, 26, 36 AND 38).

FIRST USE 1-7-2011; IN COMMERCE 1-7-2011.
HANNO RITTNER, EXAMINING ATTORNEY

SN 85-252,185. CERCIS CONSULTING, LLC, GASTON, OR. FILED 2-25-2011.

CERCIS

THE MARK CONSISTS OF STANDARD CHARACTERS WITHOUT CLAIM TO ANY PARTICULAR FONT, STYLE, SIZE, OR COLOR.

OWNER OF U.S. REG. NO. 3,668,576.

FOR DOWNLOADABLE DATABASE AND GEOGRAPHIC INFORMATION DISPLAY SOFTWARE FOR USE IN THE FIELD OF SITE SELECTION PROJECT MANAGEMENT (U.S. CLS. 21, 23, 26, 36 AND 38).

JAMES GRIFFIN, EXAMINING ATTORNEY

CLASS 9—(Continued).

SN 85-252,349. PICOKINETIX, PORTLAND, OR. FILED 2-25-2011.

picokinetix

THE MARK CONSISTS OF STANDARD CHARACTERS WITHOUT CLAIM TO ANY PARTICULAR FONT, STYLE, SIZE, OR COLOR.

FOR ELECTRIC OR ELECTRONIC SENSORS FOR VIBRATION AND FREQUENCY; FIBER OPTIC INSTRUMENTS, NAMELY, SENSING DEVICE; PHOTOELECTRIC SENSORS (U.S. CLS. 21, 23, 26, 36 AND 38).

SHAUNIA CARLYLE, EXAMINING ATTORNEY

SN 85-252,537. ACCELEROTO, INC., HENDERSON, NV. FILED 2-26-2011.

Invasion Strike

THE MARK CONSISTS OF STANDARD CHARACTERS WITHOUT CLAIM TO ANY PARTICULAR FONT, STYLE, SIZE, OR COLOR.

FOR COMPUTER GAME PROGRAMS; COMPUTER GAME SOFTWARE; COMPUTER GAME SOFTWARE FOR PERSONAL COMPUTERS AND HOME VIDEO GAME CONSOLES; COMPUTER GAME SOFTWARE FOR USE ON MOBILE AND CELLULAR PHONES; DOWNLOADABLE COMPUTER GAME SOFTWARE VIA A GLOBAL COMPUTER NETWORK AND WIRELESS DEVICES (U.S. CLS. 21, 23, 26, 36 AND 38).

SKYE YOUNG, EXAMINING ATTORNEY

CLASS 9—(Continued).

SN 85-252,706. DATAVEIL TECHNOLOGIES PTY LTD, ELSTERNWICK, AUSTRALIA, FILED 2-26-2011.

Data Veil

THE MARK CONSISTS OF STANDARD CHARACTERS WITHOUT CLAIM TO ANY PARTICULAR FONT, STYLE, SIZE, OR COLOR.

OWNER OF AUSTRALIA REG. NO. 1370852, DATED 2-14-2011, EXPIRES 7-7-2020.

NO CLAIM IS MADE TO THE EXCLUSIVE RIGHT TO USE "DATA", APART FROM THE MARK AS SHOWN.

FOR COMMUNICATION SOFTWARE FOR PROVIDING ACCESS TO THE INTERNET; COMMUNICATIONS SOFTWARE FOR CONNECTING DATABASES AND COMPUTER DATA FILES; COMPILER SOFTWARE; COMPUTER APPLICATION SOFTWARE FOR OBFUSCATION, DISGUISE AND ENCRYPTION OF DATA, NAMELY, SOFTWARE FOR MANIPULATING STORED OR TRANSMITTED DATA; COMPUTER PROGRAMS FOR OBFUSCATION, DISGUISE AND ENCRYPTION OF DATA; COMPUTER SOFTWARE FOR ENCRYPTION; COMPUTER SOFTWARE FOR USE IN THE ENCRYPTION AND DECRYPTION OF DIGITAL FILES, INCLUDING AUDIO, VIDEO, TEXT, BINARY, STILL IMAGES, GRAPHICS AND MULTIMEDIA FILES; COMPUTER SOFTWARE FOR USE IN THE SAFEGUARDING OF DIGITAL FILES, INCLUDING AUDIO, VIDEO, TEXT, BINARY, STILL IMAGES, GRAPHICS AND MULTIMEDIA FILES; COMPUTER SOFTWARE FOR OBFUSCATION, DISGUISE AND ENCRYPTION OF DATA; COMPUTER SOFTWARE PLATFORMS FOR OBFUSCATION, DISGUISE AND ENCRYPTION OF DATA; COMPUTERS FOR USE IN DATA MANAGEMENT (U.S. CLS. 21, 23, 26, 36 AND 38).

Laurie Kaufman, Examining Attorney

SN 85-252,849. TIMO, PAUL V., RENTON, WA. FILED 2-27-2011.

Chance a Trance

THE MARK CONSISTS OF STANDARD CHARACTERS WITHOUT CLAIM TO ANY PARTICULAR FONT, STYLE, SIZE, OR COLOR.

FOR SOUND RECORDINGS FEATURING MUSIC; SOUND RECORDINGS FEATURING SELF-IMPROVEMENT (U.S. CLS. 21, 23, 26, 36 AND 38).

Meghan Reinhart, Examining Attorney

CLASS 9—(Continued).

SN 85-253,095. MILLER, TIMOTHY T., COLUMBUS, OH. FILED 2-28-2011.

CANNIBAL

THE MARK CONSISTS OF STANDARD CHARACTERS WITHOUT CLAIM TO ANY PARTICULAR FONT, STYLE, SIZE, OR COLOR.

FOR COMPUTER SOFTWARE FOR THE SAFEGUARDING OF CONFIDENTIAL INFORMATION (U.S. CLS. 21, 23, 26, 36 AND 38).

Tamara Frazier, Examining Attorney

SN 85-253,181. BIG BEAR IMPORT BROKERS, INC., DBA GLOW MACHINE LTD., SANTA BARBARA, CA. FILED 2-28-2011.

THE ORIGINAL GLOW MACHINE

THE MARK CONSISTS OF STANDARD CHARACTERS WITHOUT CLAIM TO ANY PARTICULAR FONT, STYLE, SIZE, OR COLOR.

NO CLAIM IS MADE TO THE EXCLUSIVE RIGHT TO USE "THE ORIGINAL" OR "MACHINE", APART FROM THE MARK AS SHOWN.

FOR VENDING MACHINES (U.S. CLS. 21, 23, 26, 36 AND 38).

First Use 2-28-2006; In Commerce 2-28-2006.

Cynthia Tripi, Examining Attorney

CLASS 9—(Continued).

SN 85-253,260. KEVIN GROSS, JAMESTOWN, CO. FILED 2-28-2011.



THE MARK CONSISTS OF A REPRESENTATION OF THE GLOBE IN THE FOREGROUND WITH MERIDIANS AND PARALLELS RUNNING THROUGH THE INTERIOR OF THE GLOBE. THE GLOBE IS ENCOMPASSED WITHIN A DESIGN OF THE OUTER PORTION OF A CAMERA LENS. IN THE BACKGROUND OF THE GLOBE IS THE DESIGN OF THE EYE OF THE CAMERA LENS.

FOR SOFTWARE PROGRAM FOR MANIPULATION OF PANORAMIC IMAGES IN A COMPUTER (U.S. CLS. 21, 23, 26, 36 AND 38).

FIRST USE 12-29-2010; IN COMMERCE 1-6-2011.
ANGELA DUONG, EXAMINING ATTORNEY

SN 85-253,288. TELEVOX SOFTWARE, INC., MOBILE, AL. FILED 2-28-2011.

ReachPay

THE MARK CONSISTS OF STANDARD CHARACTERS WITHOUT CLAIM TO ANY PARTICULAR FONT, STYLE, SIZE, OR COLOR.

FOR COMPUTER SOFTWARE FOR USE IN COMPUTER TELEPHONY SYSTEMS ALLOWING FOR TWO-WAY COMMUNICATIONS BETWEEN BUSINESSES AND THEIR CLIENTS VIA TRADITIONAL VOICE AND FACSIMILE COMMUNICATION LINES AND VIA COMMUNICATION LINES ON GLOBAL COMPUTER NETWORKS (U.S. CLS. 21, 23, 26, 36 AND 38).

DOMINIC FATHY, EXAMINING ATTORNEY

CLASS 9—(Continued).

SN 85-253,311. THE CARTOON NETWORK, INC., ATLANTA, GA. FILED 2-28-2011.

THE HEART, SHE HOLLER

THE MARK CONSISTS OF STANDARD CHARACTERS WITHOUT CLAIM TO ANY PARTICULAR FONT, STYLE, SIZE, OR COLOR.

FOR DVDS FEATURING ENTERTAINMENT, NAMELY, ANIMATION, COMEDY, ACTION AND ADVENTURE FOR YOUNG ADULTS; DOWNLOADABLE PRE-RECORDED VIDEO RECORDINGS FEATURING ANIMATION, COMEDY, ACTION AND ADVENTURE; DOWNLOADABLE MULTIMEDIA FILES CONTAINING TEXT AND GRAPHICS FEATURING ANIMATION, COMEDY, ACTION AND ADVENTURE (U.S. CLS. 21, 23, 26, 36 AND 38).

PAUL F. GAST, EXAMINING ATTORNEY

SN 85-253,372. ENVIRONTRONICS, INC., GRAND RAPIDS, MI. FILED 2-28-2011.

ENDURANCE

THE MARK CONSISTS OF STANDARD CHARACTERS WITHOUT CLAIM TO ANY PARTICULAR FONT, STYLE, SIZE, OR COLOR.

FOR ENVIRONMENTAL TEST EQUIPMENT FOR TESTING ITEMS IN SIMULATED ENVIRONMENTAL CONDITIONS; ENVIRONMENTAL TEST CHAMBER, NAMELY, TEMPERATURE AND HUMIDITY SIMULATION EQUIPMENT (U.S. CLS. 21, 23, 26, 36 AND 38).

FIRST USE 10-26-2010; IN COMMERCE 10-26-2010.
CURTIS FRENCH, EXAMINING ATTORNEY

SN 85-253,404. BECTON, DICKINSON AND COMPANY, FRANKLIN LAKES, NJ. FILED 2-28-2011.



OWNER OF U.S. REG. NOS. 1,367,436, 2,996,913 AND OTHERS.

THE MARK CONSISTS OF A SHADED CIRCLE CONTAINING A SUNBURST DESIGN AND A PARTIAL ARC DESIGN; NEXT TO THE SHADED CIRCLE ARE THE LETTERS "BD" AND THE WORD "FACJSJAZZ".

FOR LABORATORY INSTRUMENT, NAMELY FLOW CYTOMETER (U.S. CLS. 21, 23, 26, 36 AND 38).

HANNO RITTNER, EXAMINING ATTORNEY

CLASS 9—(Continued).

SN 85-253,419. E-TRANSIT, INC., BRIDGEPORT, PA. FILED 2-28-2011.

iPOS

THE MARK CONSISTS OF STANDARD CHARACTERS WITHOUT CLAIM TO ANY PARTICULAR FONT, STYLE, SIZE, OR COLOR.

FOR COMPUTER SOFTWARE FOR BUSINESS PURPOSES, NAMELY, VERIFYING THAT CASHIERS ARE PERFORMING THEIR JOB CORRECTLY AND HONESTLY (U.S. CLS. 21, 23, 26, 36 AND 38).

VERNA BETH RIRIE, EXAMINING ATTORNEY

SN 85-253,559. SONY COMPUTER ENTERTAINMENT AMERICA LLC, FOSTER CITY, CA. FILED 2-28-2011.

MOVE.ME

THE MARK CONSISTS OF STANDARD CHARACTERS WITHOUT CLAIM TO ANY PARTICULAR FONT, STYLE, SIZE, OR COLOR.

FOR COMPUTER SOFTWARE FOR RESEARCHERS, UNIVERSITY INSTRUCTORS, COLLEGE STUDENTS AND HOBBYISTS, NAMELY APPLICATION SERVER SOFTWARE THAT IS USED TO DELIVER SPECIFIC TELEMETRY DATA TO AN APPLICATION BEING DEVELOPED ON A CONNECTED PERSONAL COMPUTER OR OTHER INTERNET CONNECTED DEVICE (U.S. CLS. 21, 23, 26, 36 AND 38).

JOHN DWYER, EXAMINING ATTORNEY

SN 85-253,866. CENPAC INTERNATIONAL, DBA LAS VEGAS WORLD FAMOUS BRAND CENTER, LAS VEGAS, NV. FILED 2-28-2011.

CENPAC

THE COLOR(S) RED IS/ARE CLAIMED AS A FEATURE OF THE MARK.

THE MARK CONSISTS OF "CENPAC" IN RED.

FOR CAR NAVIGATION COMPUTERS; PERSONAL DIGITAL ASSISTANTS (PDA); PORTABLE AND HANDHELD DIGITAL ELECTRONIC DEVICES FOR RECORDING, ORGANIZING, TRANSMITTING, MANIPULATING, AND REVIEWING TEXT, DATA, IMAGE, AND AUDIO FILES (U.S. CLS. 21, 23, 26, 36 AND 38).

ANGELA DUONG, EXAMINING ATTORNEY

CLASS 9—(Continued).

SN 85-253,928. SCM TECHNOLOGIES, CLEVELAND, OH. FILED 2-28-2011.



NO CLAIM IS MADE TO THE EXCLUSIVE RIGHT TO USE "CELL", APART FROM THE MARK AS SHOWN.

THE MARK CONSISTS OF THE WORD "CELL SWITCH" WITH BROADCAST WAVES OVER THE TWO "LS" IN "CELL" AND NEXT TO TWO CURVED BANDS THAT GIVE THE IMPRESSION OF A "C" AND AN "S".

FOR CELLULAR PHONE MODULES THAT ACCEPT ANY STANDARD GSM SIM CARD THAT, WHEN THE MODULE IS ACTIVATED AND PROGRAMMED, CAN ACCEPT CELLULAR PHONE CALLS OR SMS MESSAGES TO PERFORM ANY NUMBER OF FUNCTIONS REMOTELY CONNECTED TO THE MODULES, WHILE ALSO MONITORING BOTH DIGITAL AND ANALOG INPUTS AND SIGNALS AND RELAYS THE STATUS OF THESE INPUTS VIA A SMS MESS (U.S. CLS. 21, 23, 26, 36 AND 38).

FRANK LATTUCA, EXAMINING ATTORNEY

SN 85-254,081. ALPHABLIP LLC, PALO ALTO, CA. FILED 2-28-2011.

BLIP

THE MARK CONSISTS OF STANDARD CHARACTERS WITHOUT CLAIM TO ANY PARTICULAR FONT, STYLE, SIZE, OR COLOR.

FOR COMPUTER APPLICATION SOFTWARE FOR MOBILE PHONES, NAMELY, SOFTWARE FOR DIAGNOSTIC MONITORING (U.S. CLS. 21, 23, 26, 36 AND 38).

KELLY BOULTON, EXAMINING ATTORNEY

SN 85-254,086. KONAMI GAMING, INC., LAS VEGAS, NV. FILED 2-28-2011.

BUBBLE STRIKE FRENZY

THE MARK CONSISTS OF STANDARD CHARACTERS WITHOUT CLAIM TO ANY PARTICULAR FONT, STYLE, SIZE, OR COLOR.

OWNER OF U.S. REG. NOS. 3,195,085 AND 3,636,329.

FOR ELECTRONIC GAME PROGRAMS; GAMING EQUIPMENT, NAMELY, SLOT MACHINES WITH OR WITHOUT VIDEO OUTPUT; GAMING MACHINES; MACHINES FOR PLAYING GAMES OF CHANCE; SLOT MACHINES (U.S. CLS. 21, 23, 26, 36 AND 38).

MARK PILARO, EXAMINING ATTORNEY

CLASS 9—(Continued).

SN 85-254,089. KONAMI GAMING, INC., LAS VEGAS, NV. FILED 2-28-2011.

LEGENDS OF PARADISE

THE MARK CONSISTS OF STANDARD CHARACTERS WITHOUT CLAIM TO ANY PARTICULAR FONT, STYLE, SIZE, OR COLOR.

OWNER OF U.S. REG. NOS. 3,140,283, 3,719,777 AND OTHERS.

FOR ELECTRONIC GAME PROGRAMS; GAMING EQUIPMENT, NAMELY, SLOT MACHINES WITH OR WITHOUT VIDEO OUTPUT; GAMING MACHINES; MACHINES FOR PLAYING GAMES OF CHANCE; SLOT MACHINES (U.S. CLS. 21, 23, 26, 36 AND 38).

MARK PILARO, EXAMINING ATTORNEY

SN 85-254,092. KONAMI GAMING, INC., LAS VEGAS, NV. FILED 2-28-2011.

BAND OF GYPSIES

THE MARK CONSISTS OF STANDARD CHARACTERS WITHOUT CLAIM TO ANY PARTICULAR FONT, STYLE, SIZE, OR COLOR.

OWNER OF U.S. REG. NO. 2,849,542.

FOR ELECTRONIC GAME PROGRAMS; GAMING EQUIPMENT, NAMELY, SLOT MACHINES WITH OR WITHOUT VIDEO OUTPUT; GAMING MACHINES; MACHINES FOR PLAYING GAMES OF CHANCE; SLOT MACHINES (U.S. CLS. 21, 23, 26, 36 AND 38).

MARK PILARO, EXAMINING ATTORNEY

SN 85-254,197. ABL SA, LUXEMBOURG, LUXEMBOURG, FILED 3-1-2011.

DEEPCHEK

THE MARK CONSISTS OF STANDARD CHARACTERS WITHOUT CLAIM TO ANY PARTICULAR FONT, STYLE, SIZE, OR COLOR.

FOR SOFTWARE FOR STORAGE, MANAGEMENT, ANALYSIS, AND SUBTYPING OF DNA SEQUENCES GENERATED BY DNA SEQUENCERS (U.S. CLS. 21, 23, 26, 36 AND 38).

ROBIN CHOSID, EXAMINING ATTORNEY

CLASS 9—(Continued).

SN 85-254,309. VIRTUAL-Q INC., HOUSTON, TX. FILED 3-1-2011.

RightOffice

THE MARK CONSISTS OF STANDARD CHARACTERS WITHOUT CLAIM TO ANY PARTICULAR FONT, STYLE, SIZE, OR COLOR.

FOR COMPUTER HARDWARE AND SOFTWARE FOR INTERCONNECTING, SECURING, CONTROLLING, OPERATING, AND ACCESSING LOCAL, WIDE, AND GLOBAL AREA NETWORKS, DATA CENTERS, AND NETWORK INFRASTRUCTURE; COMPUTER HARDWARE AND SOFTWARE FOR ROUTING, SWITCHING, TRANSMITTING, PROCESSING, FILTERING, SECURING, AND STORING DATA, VIDEO OR VOICE TRAFFIC, PACKETS, OR OTHER FORMS OF COMMUNICATIONS; COMPUTER HARDWARE AND CLOUD COMPUTING SOFTWARE FOR USE IN OR WITH NETWORKS AND DATA CENTERS PROVIDING A VIRTUALIZED DESKTOP AND SERVER COMPUTING ENVIRONMENT (U.S. CLS. 21, 23, 26, 36 AND 38).

FIRST USE 11-1-2010; IN COMMERCE 1-3-2011.

KATHERINE STOIDES, EXAMINING ATTORNEY

SN 85-254,358. HOPLITE ARMOUR LLC, NAPERVILLE, IL. FILED 3-1-2011.

LEGION ARMOUR

THE MARK CONSISTS OF STANDARD CHARACTERS WITHOUT CLAIM TO ANY PARTICULAR FONT, STYLE, SIZE, OR COLOR.

FOR PROTECTIVE SPORTS FACE-MASKS AND HELMETS, NAMELY, BASEBALL AND SOFTBALL FACE-MASKS AND HELMETS (U.S. CLS. 21, 23, 26, 36 AND 38).

KEVON CHISOLM, EXAMINING ATTORNEY

SN 85-254,381. CONCEPT ENGINEERING GMBH, 79111 FREIBURG, FED REP GERMANY, FILED 3-1-2011.

STARVISION

THE MARK CONSISTS OF STANDARD CHARACTERS WITHOUT CLAIM TO ANY PARTICULAR FONT, STYLE, SIZE, OR COLOR.

FOR COMPUTER SOFTWARE, NAMELY, SOFTWARE FOR GENERATING AND DISPLAYING SCHEMATIC REPRESENTATIONS OF ELECTRONIC CIRCUITS (U.S. CLS. 21, 23, 26, 36 AND 38).

KATINA MISTER, EXAMINING ATTORNEY

CLASS 9—(Continued).

SN 85-254,403. FREEDOM SCIENTIFIC, INC., ST. PETERSBURG, FL. FILED 3-1-2011.

GEM

THE MARK CONSISTS OF STANDARD CHARACTERS WITHOUT CLAIM TO ANY PARTICULAR FONT, STYLE, SIZE, OR COLOR.

FOR COMPUTER SOFTWARE FOR THE PRESENTATION, MANIPULATION AND CAPTURE OF VIDEO MAGNIFIER CAMERA DATA FOR USERS WITH LOW VISION (U.S. CLS. 21, 23, 26, 36 AND 38).

WARREN L. OLANDRIA, EXAMINING ATTORNEY

CLASS 9—(Continued).

SN 85-254,578. ARCANANETWORKS, INC., NEWARK, CA. FILED 3-1-2011.

ICFG

THE MARK CONSISTS OF STANDARD CHARACTERS WITHOUT CLAIM TO ANY PARTICULAR FONT, STYLE, SIZE, OR COLOR.

FOR COMPUTER SOFTWARE APPLICATION FOR DEPLOYING AND CONFIGURING NETWORK DEVICES FROM MOBILE PHONES (U.S. CLS. 21, 23, 26, 36 AND 38).

MIDGE BUTLER, EXAMINING ATTORNEY

SN 85-254,408. AVANTRA BIOSCIENCES CORPORATION, WOBURN, MA. FILED 3-1-2011.

QPDX

THE MARK CONSISTS OF STANDARD CHARACTERS WITHOUT CLAIM TO ANY PARTICULAR FONT, STYLE, SIZE, OR COLOR.

FOR BIO-CHIPS FOR RESEARCH OR SCIENTIFIC PURPOSES (U.S. CLS. 21, 23, 26, 36 AND 38).

FIRST USE 1-1-2011; IN COMMERCE 1-1-2011.

DAVID COLLIER, EXAMINING ATTORNEY

SN 85-254,733. E-FILLIATE, INC., RANCHO CORDOVA, CA. FILED 3-1-2011.

POWER BANDIT

THE MARK CONSISTS OF STANDARD CHARACTERS WITHOUT CLAIM TO ANY PARTICULAR FONT, STYLE, SIZE, OR COLOR.

NO CLAIM IS MADE TO THE EXCLUSIVE RIGHT TO USE "POWER", APART FROM THE MARK AS SHOWN.

FOR ELECTRIC CORDS FOR RECHARGING BATTERY POWERED ELECTRONIC DEVICES AND POWER CORDS FOR REMOVABLE ATTACHMENT TO ELECTRONIC DEVICES (U.S. CLS. 21, 23, 26, 36 AND 38).

JENNIFER MARTIN, EXAMINING ATTORNEY

SN 85-254,410. AVANTRA BIOSCIENCES CORPORATION, WOBURN, MA. FILED 3-1-2011.

ANGIOGENQX

THE MARK CONSISTS OF STANDARD CHARACTERS WITHOUT CLAIM TO ANY PARTICULAR FONT, STYLE, SIZE, OR COLOR.

FOR BIO-CHIPS FOR RESEARCH OR SCIENTIFIC PURPOSES (U.S. CLS. 21, 23, 26, 36 AND 38).

FIRST USE 1-1-2011; IN COMMERCE 1-1-2011.

DAVID COLLIER, EXAMINING ATTORNEY

SN 85-254,750. ABB INC., CARY, NC. FILED 3-1-2011.

SMARTRACK

THE MARK CONSISTS OF STANDARD CHARACTERS WITHOUT CLAIM TO ANY PARTICULAR FONT, STYLE, SIZE, OR COLOR.

FOR APPARATUS FOR MOVING ELECTRICAL DEVICES INTO AND OUT OF CONNECTION WITH CONDUCTORS IN SWITCHGEAR CABINET CELLS (U.S. CLS. 21, 23, 26, 36 AND 38).

ANNE MADDEN, EXAMINING ATTORNEY

CLASS 9—(Continued).

SN 85-254,798. PITTMAN, JERRY, SAUGERTIES, NY. FILED 3-1-2011.

FEAR IS DEAD

THE MARK CONSISTS OF STANDARD CHARACTERS WITHOUT CLAIM TO ANY PARTICULAR FONT, STYLE, SIZE, OR COLOR.

FOR DIGITAL MATERIALS, NAMELY, CDS, DVDS AND DOWNLOADABLE AUDIO FILES FEATURING ORIGINAL MUSICAL WORKS (U.S. CLS. 21, 23, 26, 36 AND 38).

BRENDAN MCCAULEY, EXAMINING ATTORNEY

CLASS 9—(Continued).

SN 85-255,190. ARECONT VISION, LLC, GLENDALE, CA. FILED 3-1-2011.

MegaBall

THE MARK CONSISTS OF STANDARD CHARACTERS WITHOUT CLAIM TO ANY PARTICULAR FONT, STYLE, SIZE, OR COLOR.

FOR SECURITY SURVEILLANCE CAMERA (U.S. CLS. 21, 23, 26, 36 AND 38).

BERYL GARDNER, EXAMINING ATTORNEY

SN 85-255,268. SPECTRA SONICS, LLC, LAYTON, UT. FILED 3-2-2011.



THE MARK CONSISTS OF A CIRCLE WITH TWO SINE WAVE SIGNALS REPRESENTING INPUT AND OUTPUT WAVEFORM AS SHOWN IN THE MARK.

FOR AUDIO AMPLIFIERS; APPARATUS FOR BROADCASTING, RECORDING, TRANSMISSION OR REPRODUCTION OF SOUND OR IMAGES (U.S. CLS. 21, 23, 26, 36 AND 38).

FIRST USE 1-1-1964; IN COMMERCE 1-1-1965.

MARK T. MULLEN, EXAMINING ATTORNEY

SN 85-254,836. SOURCEFIRE, INC., COLUMBIA, MD. FILED 3-1-2011.

IMMUNET

THE MARK CONSISTS OF STANDARD CHARACTERS WITHOUT CLAIM TO ANY PARTICULAR FONT, STYLE, SIZE, OR COLOR.

FOR COMPUTER ANTI-VIRUS SOFTWARE (U.S. CLS. 21, 23, 26, 36 AND 38).

FIRST USE 8-20-2009; IN COMMERCE 8-20-2009.

JASON TURNER, EXAMINING ATTORNEY

SN 85-254,837. GARMIN SWITZERLAND GMBH, SCHAFFHAUSEN, SWITZERLAND, FILED 3-1-2011.

MONTANA

THE MARK CONSISTS OF STANDARD CHARACTERS WITHOUT CLAIM TO ANY PARTICULAR FONT, STYLE, SIZE, OR COLOR.

FOR HANDHELD SATELLITE NAVIGATIONAL SYSTEM, NAMELY, A GLOBAL POSITIONING SYSTEM (GPS) (U.S. CLS. 21, 23, 26, 36 AND 38).

HAI-LY LAM, EXAMINING ATTORNEY

SN 85-255,314. VALSPRESSO, INC., MCLEAN, VA. FILED 3-2-2011.

WEALTHQUBE

THE MARK CONSISTS OF STANDARD CHARACTERS WITHOUT CLAIM TO ANY PARTICULAR FONT, STYLE, SIZE, OR COLOR.

FOR COMPUTER APPLICATION SOFTWARE FOR ASSESSING THE RISKS OF INVESTING IN PUBLICLY TRADED COMPANIES (U.S. CLS. 21, 23, 26, 36 AND 38).

SANDRA BUJA, EXAMINING ATTORNEY

CLASS 9—(Continued).

SN 85-255,386. TABIDACHI LLC, EUGENE, OR. FILED 3-2-2011.

NEWSEE

THE MARK CONSISTS OF STANDARD CHARACTERS WITHOUT CLAIM TO ANY PARTICULAR FONT, STYLE, SIZE, OR COLOR.

FOR COMPUTER APPLICATION SOFTWARE FOR USE WITH MOBILE PHONES, MOBILE PERSONAL COMPUTERS AND ELECTRONIC HANDHELD TERMINALS, NAMELY, SOFTWARE FOR FACILITATING ACCESS TO MEDIA ON MOBILE PLATFORMS THROUGH THE USE OF VOICE COMMANDS AND TEXT TO SPEECH (U.S. CLS. 21, 23, 26, 36 AND 38).
MORGAN WYNNE, EXAMINING ATTORNEY

SN 85-255,428. BLUE ORB, INC., FORMERLY KEYBOWL, INC., MAITLAND, FL. FILED 3-2-2011.

ORBITOUCH

THE MARK CONSISTS OF STANDARD CHARACTERS WITHOUT CLAIM TO ANY PARTICULAR FONT, STYLE, SIZE, OR COLOR.

FOR COMBINATION COMPUTER KEYBOARD AND MOUSE (U.S. CLS. 21, 23, 26, 36 AND 38).
FIRST USE 5-1-2001; IN COMMERCE 5-1-2001.
JOHN GARTNER, EXAMINING ATTORNEY

SN 85-255,463. MOTOROLA TRADEMARK HOLDINGS, LLC, LIBERTYVILLE, IL. FILED 3-2-2011.

IMPEL

THE MARK CONSISTS OF STANDARD CHARACTERS WITHOUT CLAIM TO ANY PARTICULAR FONT, STYLE, SIZE, OR COLOR.

FOR MOBILE PHONES, SMARTPHONES, AND ACCESSORIES THEREFOR, NAMELY BATTERY CHARGERS AND POWER ADAPTORS (U.S. CLS. 21, 23, 26, 36 AND 38).
BARBARA RUTLAND, EXAMINING ATTORNEY

CLASS 9—(Continued).

SN 85-255,667. STREAMING MEDIA CLOUD, INC., PORTLAND, OR. FILED 3-2-2011.

IPCopper

THE MARK CONSISTS OF STANDARD CHARACTERS WITHOUT CLAIM TO ANY PARTICULAR FONT, STYLE, SIZE, OR COLOR.

FOR ELECTRONIC DATA RECORDERS (U.S. CLS. 21, 23, 26, 36 AND 38).
FIRST USE 9-11-2010; IN COMMERCE 12-1-2010.
PAM WILLIS, EXAMINING ATTORNEY

SN 85-255,693. SHENZHEN NETCOM ELECTRONICS CO., LTD, SHENZHEN, CHINA, FILED 3-2-2011.

NBOX

THE MARK CONSISTS OF THE WORD NBOX IN STYLIZED BLOCK LETTERS.

THE WORDING NBOX HAS NO MEANING IN A FOREIGN LANGUAGE.

FOR AMUSEMENT APPARATUS ADAPTED FOR USE WITH AN EXTERNAL DISPLAY SCREEN OR MONITOR; AUTOMATIC VENDING MACHINES; BLANK CD-ROMS FOR SOUND OR VIDEO RECORDING; BLANK RECORDABLE CD-RS AND DVD-RS; BLANK SMART CARDS; CASH REGISTERS; COMPACT DISC PLAYERS; COMPUTER MEMORIES; COMPUTER MEMORY HARDWARE; COMPUTER PERIPHERAL EQUIPMENT; COMPUTERS; MULTIMEDIA PROJECTORS; PERSONAL STEREO (U.S. CLS. 21, 23, 26, 36 AND 38).
FIRST USE 1-1-2009; IN COMMERCE 3-1-2009.
BARBARA BROWN, EXAMINING ATTORNEY

SN 85-255,719. BOXX CORP., PORTLAND, OR. FILED 3-2-2011.

DRIVE

THE MARK CONSISTS OF STANDARD CHARACTERS WITHOUT CLAIM TO ANY PARTICULAR FONT, STYLE, SIZE, OR COLOR.

FOR ELECTRONIC CONTROLS FOR OPERATING AN ELECTRIC VEHICLE (U.S. CLS. 21, 23, 26, 36 AND 38).
BRIAN NEVILLE, EXAMINING ATTORNEY

CLASS 9—(Continued).

SN 85-255,725. PANOPTISOFT, LLC, DBA GEOLOQI.COM, PORTLAND, OR. FILED 3-2-2011.

Geonote

THE MARK CONSISTS OF STANDARD CHARACTERS WITHOUT CLAIM TO ANY PARTICULAR FONT, STYLE, SIZE, OR COLOR.

FOR COMPUTER SOFTWARE FOR VIRTUAL GEO-CACHING WITH OR WITHOUT OTHER USERS VIA THE INTERNET AND MOBILE DEVICES, AND FINDING, LOCATING, AND INTERACTING WITH OTHER USERS AND PLACES. THAT MAY BE DOWNLOADED FROM A GLOBAL COMPUTER NETWORK (U.S. CLS. 21, 23, 26, 36 AND 38).

FIRST USE 4-4-2010; IN COMMERCE 4-4-2010.
WILLIAM ROSSMAN, EXAMINING ATTORNEY

SN 85-255,776. AGILENT TECHNOLOGIES, INC., SANTA CLARA, CA. FILED 3-2-2011.

CrossLabs

THE MARK CONSISTS OF STANDARD CHARACTERS WITHOUT CLAIM TO ANY PARTICULAR FONT, STYLE, SIZE, OR COLOR.

FOR COMPUTER SOFTWARE PLATFORMS FOR DATA VISUALIZATION AND ANALYSIS, DATA AGGREGATION AND SEARCHING, AND COLLABORATIVE DATA EXCHANGE (U.S. CLS. 21, 23, 26, 36 AND 38).

WENDY GOODMAN, EXAMINING ATTORNEY

SN 85-255,777. SHENZHEN HIGHFOUND ELECTRONICS CO., LTD., SHENZHEN, CHINA, FILED 3-2-2011.

WINSEMI

THE MARK CONSISTS OF THE WORD WINSEMI IN STYLIZED LETTERS.

THE WORDING WINSEMI HAS NO MEANING IN A FOREIGN LANGUAGE.

FOR COMPUTER CHIPS; ELECTRIC CONDUCTORS; ELECTRIC CONTROL PANELS; ELECTRONIC CHIPS FOR THE MANUFACTURER OF INTEGRATED CIRCUITS; INTEGRATED CIRCUITS; LIGHTING BALLASTS; MICROCHIPS; PHOTOVOLTAIC CELLS; SEMI-CONDUCTORS; SILICON WAFERS; TRANSISTORS; VACUUM TUBES FOR RADIOS (U.S. CLS. 21, 23, 26, 36 AND 38).

WENDY GOODMAN, EXAMINING ATTORNEY

CLASS 9—(Continued).

SN 85-255,795. ACRISON, INC., MOONACHIE, NJ. FILED 3-2-2011.

ACRI-DATA

THE MARK CONSISTS OF STANDARD CHARACTERS WITHOUT CLAIM TO ANY PARTICULAR FONT, STYLE, SIZE, OR COLOR.

OWNER OF U.S. REG. NO. 1,158,803.
FOR COMPUTER SOFTWARE TO PERMIT REMOTE MONITORING AND CONTROLLING OF CONTINUOUS WEIGH FEEDERS FOR DRY SOLIDS AND LIQUIDS (U.S. CLS. 21, 23, 26, 36 AND 38).

FIRST USE 7-0-2005; IN COMMERCE 7-0-2005.
JENNY PARK, EXAMINING ATTORNEY

SN 85-255,829. LIFETIME BRANDS, INC., GARDEN CITY, NY. FILED 3-2-2011.

KIZMOS GET HAPPY

THE MARK CONSISTS OF STANDARD CHARACTERS WITHOUT CLAIM TO ANY PARTICULAR FONT, STYLE, SIZE, OR COLOR.

FOR MEASURING CUPS; MEASURING SPOONS (U.S. CLS. 21, 23, 26, 36 AND 38).

THEODORE MCBRIDE, EXAMINING ATTORNEY

SN 85-255,864. LIFETIME BRANDS, INC., GARDEN CITY, NY. FILED 3-2-2011.

GET HAPPY

THE MARK CONSISTS OF STANDARD CHARACTERS WITHOUT CLAIM TO ANY PARTICULAR FONT, STYLE, SIZE, OR COLOR.

FOR MEASURING CUPS; MEASURING SPOONS (U.S. CLS. 21, 23, 26, 36 AND 38).

THEODORE MCBRIDE, EXAMINING ATTORNEY

CLASS 9—(Continued).

SN 85-255,865. PASSTOUCH, LLC, SURF CITY, NC. FILED 3-2-2011.

PASSTOUCH

THE MARK CONSISTS OF STANDARD CHARACTERS WITHOUT CLAIM TO ANY PARTICULAR FONT, STYLE, SIZE, OR COLOR.

FOR COMPUTER SOFTWARE, NAMELY, GRAPHICAL INTERFACES FOR USER AUTHENTICATION AND IDENTIFICATION (U.S. CLS. 21, 23, 26, 36 AND 38).

KEVIN DINALLO, EXAMINING ATTORNEY

CLASS 9—(Continued).

SN 85-256,112. HALE PRODUCTS, INC., CONSHOHOCKEN, PA. FILED 3-2-2011.

ULTRAVIEW

THE MARK CONSISTS OF STANDARD CHARACTERS WITHOUT CLAIM TO ANY PARTICULAR FONT, STYLE, SIZE, OR COLOR.

FOR INSTRUMENT PANEL FOR HEAVY DUTY VEHICLES WHICH GRAPHICALLY DISPLAYS VEHICLE DATA AND INFORMATION ALONG WITH A CONTROL PANEL WHICH ALLOWS THE USER TO CONTROL FUNCTIONS OF THE VEHICLE (U.S. CLS. 21, 23, 26, 36 AND 38).

LINDA ORNDORFF, EXAMINING ATTORNEY

SN 85-255,874. PASSTOUCH, LLC, SURF CITY, NC. FILED 3-2-2011.



THE MARK CONSISTS OF AN ARRANGEMENT OF CURVES.

FOR COMPUTER SOFTWARE, NAMELY, GRAPHICAL INTERFACES FOR USER AUTHENTICATION AND IDENTIFICATION (U.S. CLS. 21, 23, 26, 36 AND 38).

KEVIN DINALLO, EXAMINING ATTORNEY

SN 85-256,135. MICROBIONETICS, LLC, ELDERSBURG, MD. FILED 3-2-2011.

MICROBIONETICS

THE MARK CONSISTS OF STANDARD CHARACTERS WITHOUT CLAIM TO ANY PARTICULAR FONT, STYLE, SIZE, OR COLOR.

FOR SCIENTIFIC APPARATUS AND INSTRUMENTS FOR DETECTING AND MEASURING BACTERIA AND BACTERIAL GROWTH (U.S. CLS. 21, 23, 26, 36 AND 38).

FIRST USE 3-5-2008; IN COMMERCE 3-5-2008.

MORGAN WYNNE, EXAMINING ATTORNEY

SN 85-256,025. EXCELLUS TECHNOLOGIES, INC., WATER-TOWN, SD. FILED 3-2-2011.

SAM II

THE MARK CONSISTS OF STANDARD CHARACTERS WITHOUT CLAIM TO ANY PARTICULAR FONT, STYLE, SIZE, OR COLOR.

OWNER OF U.S. REG. NO. 3,899,925.

FOR MEDICAL TEACHING MANNEQUINS (U.S. CLS. 21, 23, 26, 36 AND 38).

FIRST USE 12-31-2010; IN COMMERCE 12-31-2010.

ERIN FALK, EXAMINING ATTORNEY

SN 85-256,140. MICROBIONETICS, LLC, ELDERSBURG, MD. FILED 3-2-2011.

CULTURESTAT

THE MARK CONSISTS OF STANDARD CHARACTERS WITHOUT CLAIM TO ANY PARTICULAR FONT, STYLE, SIZE, OR COLOR.

FOR SCIENTIFIC APPARATUS AND INSTRUMENTS FOR DETECTING AND MEASURING BACTERIA AND BACTERIAL GROWTH (U.S. CLS. 21, 23, 26, 36 AND 38).

FIRST USE 3-5-2008; IN COMMERCE 3-5-2008.

MORGAN WYNNE, EXAMINING ATTORNEY

CLASS 9—(Continued).

SN 85-256,144. TA OPERATING LLC, WESTLAKE, OH. FILED 3-2-2011.

TruckSmart

THE MARK CONSISTS OF STANDARD CHARACTERS WITHOUT CLAIM TO ANY PARTICULAR FONT, STYLE, SIZE, OR COLOR.

FOR COMPUTER APPLICATION SOFTWARE FOR MOBILE PHONES, NAMELY, SOFTWARE FOR USE BY PROFESSIONAL DRIVERS IN THE MANAGEMENT OF REWARDS PROGRAMS, AMENITIES AND ROADSIDE AND MAINTENANCE SERVICES (U.S. CLS. 21, 23, 26, 36 AND 38).

FIRST USE 2-25-2011; IN COMMERCE 2-25-2011. MIDGE BUTLER, EXAMINING ATTORNEY

CLASS 9—(Continued).

SN 85-256,312. CORO LLC, RENO, NV. FILED 3-2-2011.



FOR COMPUTER APPLICATION SOFTWARE FOR MOBILE PHONES, NAMELY, SOFTWARE FOR SHARING FISH IMAGES AND INFORMATION RELATED TO FISHING (U.S. CLS. 21, 23, 26, 36 AND 38).

RONALD MCMORROW, EXAMINING ATTORNEY

SN 85-256,183. DISRUPTOR HOLDINGS, INC., LOS ANGELES, CA. FILED 3-2-2011.

DISRUPTOR

THE MARK CONSISTS OF STANDARD CHARACTERS WITHOUT CLAIM TO ANY PARTICULAR FONT, STYLE, SIZE, OR COLOR.

FOR INTERACTIVE VIDEO GAME SOFTWARE (U.S. CLS. 21, 23, 26, 36 AND 38).

KHANH LE, EXAMINING ATTORNEY

Hantton

THE MARK CONSISTS OF STYLIZED WORD HANTTON. FOR BATTERY BOXES; BATTERY CHARGERS; CURRENT RECTIFIERS; DISTRIBUTION BOXES FOR ELECTRICAL POWER; ELECTRIC CONVERTERS; GALVANIC BATTERIES; INVERTERS; PLATES FOR BATTERIES; SOLAR BATTERIES; SWITCHBOARDS (U.S. CLS. 21, 23, 26, 36 AND 38).

FIRST USE 11-5-2010; IN COMMERCE 11-5-2010. ASMAT KHAN, EXAMINING ATTORNEY

SN 85-256,242. BLUTRON GROUP, DALLAS, TX. FILED 3-2-2011.



THE MARK CONSISTS OF A CHARGER WITH TWO LEAFS COMING OUT OF THE CHARGER. TO THE RIGHT THERE IS THE STYLIZED TEXT "MSNCHARGER".

FOR CELL PHONE BATTERY CHARGERS (U.S. CLS. 21, 23, 26, 36 AND 38).

ESTHER A. BORSUK, EXAMINING ATTORNEY

SN 85-256,483. PS ENERGY GROUP, INC, ATLANTA, GA. FILED 3-3-2011.

ETRAC-ST

THE MARK CONSISTS OF STANDARD CHARACTERS WITHOUT CLAIM TO ANY PARTICULAR FONT, STYLE, SIZE, OR COLOR.

FOR COMPUTER SOFTWARE FOR STORM TRACKING (U.S. CLS. 21, 23, 26, 36 AND 38).

THEODORE MCBRIDE, EXAMINING ATTORNEY

CLASS 9—(Continued).

SN 85-256,520. WASHING SYSTEMS, LLC, CINCINNATI, OH. FILED 3-3-2011.

WASH-EYE

THE MARK CONSISTS OF STANDARD CHARACTERS WITHOUT CLAIM TO ANY PARTICULAR FONT, STYLE, SIZE, OR COLOR.

FOR COMPUTER SOFTWARE AND MANUALS THEREFORE DESIGNED TO MONITOR COMMERCIAL LAUNDRY FACILITIES (U.S. CLS. 21, 23, 26, 36 AND 38). FIRST USE 3-30-2009; IN COMMERCE 3-30-2009. FLORENTINA BLANDU, EXAMINING ATTORNEY

SN 85-256,522. MARCHFIVE LLC, WYNDMOOR, PA. FILED 3-3-2011.

SHUTDIGGITY

THE MARK CONSISTS OF STANDARD CHARACTERS WITHOUT CLAIM TO ANY PARTICULAR FONT, STYLE, SIZE, OR COLOR.

FOR PLAY-BACK DEVICE, NAMELY, AN APPARATUS FOR TRANSMISSION AND REPRODUCTION OF PRE-RECORDED SOUNDS (U.S. CLS. 21, 23, 26, 36 AND 38). FLORENTINA BLANDU, EXAMINING ATTORNEY

SN 85-256,561. LANDMARK GRAPHICS CORPORATION, HOUSTON, TX. FILED 3-3-2011.

ZETAANALYTICS

THE MARK CONSISTS OF STANDARD CHARACTERS WITHOUT CLAIM TO ANY PARTICULAR FONT, STYLE, SIZE, OR COLOR.

FOR COMPUTER SOFTWARE WHICH STREAMS LARGE VOLUMES OF DATA REAL-TIME INTO A DATA MANAGEMENT SYSTEM FOR STORAGE, RETRIEVAL AND ANALYSIS, ALL FOR USE IN THE EXPLORATION, DEVELOPMENT AND/OR PRODUCTION OF HYDROCARBONS AND OTHER MINERAL DEPOSITS (U.S. CLS. 21, 23, 26, 36 AND 38). JAMES STEIN, EXAMINING ATTORNEY

CLASS 9—(Continued).

SN 85-256,653. PHILADELPHIA INDUSTRIAL DEVELOPMENT CORPORATION, PHILADELPHIA, PA. FILED 3-3-2011.

P R T F O L

THE MARK CONSISTS OF THE LETTER "P" TO THE LEFT OF A SWIRL DESIGN FORMING THE LETTER "O" WITH THE LETTERS R, T, F, O, L TO THE RIGHT OF THE SWIRL DESIGN.

FOR COMPUTER SOFTWARE DESIGNED TO SUPPORT THE MANAGEMENT OF PROSPECTIVE ECONOMIC DEVELOPERS; COMPUTER SOFTWARE FOR ECONOMIC DEVELOPERS; COMPUTER SOFTWARE WITH A FULLY INTEGRATED CONTACT AND CLIENT MANAGEMENT SOFTWARE SYSTEM THAT TRACKS ECONOMIC DEVELOPMENT ACTIVITIES INCLUDING CREATING AND TRACKING CUSTOMIZED ACTIVITIES; COMPUTER SOFTWARE FOR USE IN THE SERVICING AND MANAGING OF LOANS (U.S. CLS. 21, 23, 26, 36 AND 38).

FIRST USE 4-1-2005; IN COMMERCE 4-1-2005. CAROLYN CATALDO, EXAMINING ATTORNEY

SN 85-256,678. WILOCITY, LTD., CAESAREA, ISRAEL, FILED 3-3-2011.

DockingZone

THE MARK CONSISTS OF STANDARD CHARACTERS WITHOUT CLAIM TO ANY PARTICULAR FONT, STYLE, SIZE, OR COLOR.

FOR COMPUTER CHIPSET FOR USE IN TRANSMITTING DATA TO AND FROM A CENTRAL PROCESSING UNIT; COMPUTER HARDWARE, NAMELY, WIRELESS ACCESS POINT (WAP) DEVICES; COMPUTER SOFTWARE FOR WIRELESS CONTENT DELIVERY; DEVICES FOR WIRELESS RADIO TRANSMISSION; HOME AND OFFICE AUTOMATION SYSTEMS COMPRISING WIRELESS AND WIRED CONTROLLERS, CONTROLLED DEVICES, AND SOFTWARE FOR LIGHTING, HVAC, SECURITY, SAFETY AND OTHER HOME AND OFFICE MONITORING AND CONTROL APPLICATIONS; INTEGRATED CIRCUITS AND INTEGRATED CIRCUIT CORES FOR USE IN WIRELESS COMMUNICATIONS AND WIRELESS COMMUNICATION EQUIPMENT AND APPARATUS AND DIGITAL SIGNAL PROCESSORS (DSP); WIRELESS COMPUTER PERIPHERALS; ELECTRONIC INTEGRATED CIRCUITS; CARDS WITH INTEGRATED CIRCUITS; COMMUNICATION HUBS; COMPUTER NETWORK HUBS, SWITCHES AND ROUTERS; GATEWAY ROUTERS IN THE NATURE OF COMPUTER CONTROL HARDWARE; WIRELESS COMPUTER CHIPSETS, NAMELY BROADBASE, MEDIUM ACCESS CONTROL (MAC) AND RADIO IC WIRELESS COMPUTER CHIPSETS FOR USE IN TRANSMITTING DATA TO AND FROM A CENTRAL PROCESSING UNIT FOR WIRELESS ACCESS TO COMPUTER PERIPHERALS; WIRELESS ADD-ON OR EMBEDDED NETWORK LAN (LOCAL AREA NETWORK) COMPUTER CARDS USED FOR FAST GIGA BITS PER SECOND TRANSMISSION OF DATA TO REPLACE CABLES FOR CONNECTING PORTABLE COMPUTER DEVICES TO COMPUTER NETWORKS (U.S. CLS. 21, 23, 26, 36 AND 38). KARANENDRA S. CHHINA, EXAMINING ATTORNEY

CLASS 9—(Continued).

SN 85-256,696. PHILADELPHIA INDUSTRIAL DEVELOPMENT CORPORATION, PHILADELPHIA, PA. FILED 3-3-2011.

Created on the Job. Proven
Every Day.

THE MARK CONSISTS OF STANDARD CHARACTERS WITHOUT CLAIM TO ANY PARTICULAR FONT, STYLE, SIZE, OR COLOR.

FOR COMPUTER SOFTWARE DESIGNED TO SUPPORT THE MANAGEMENT OF PROSPECTIVE ECONOMIC DEVELOPMENT TRANSACTIONS FOR ECONOMIC DEVELOPERS; COMPUTER SOFTWARE WITH A FULLY INTEGRATED CONTACT AND CLIENT MANAGEMENT SOFTWARE SYSTEM THAT TRACKS ECONOMIC DEVELOPMENT ACTIVITIES INCLUDING CREATING AND TRACKING CUSTOMIZED ACTIVITIES; COMPUTER SOFTWARE FOR USE IN THE SERVICING AND MANAGING OF LOANS (U.S. CLS. 21, 23, 26, 36 AND 38).

FIRST USE 4-1-2005; IN COMMERCE 4-1-2005.
CAROLYN CATALDO, EXAMINING ATTORNEY

SN 85-256,740. PHILADELPHIA INDUSTRIAL DEVELOPMENT CORPORATION, PHILADELPHIA, PA. FILED 3-3-2011.



THE MARK CONSISTS OF TWO SEMI-CIRCLES FORMING A SWIRL.

FOR COMPUTER SOFTWARE DESIGNED TO SUPPORT THE MANAGEMENT OF PROSPECTIVE ECONOMIC DEVELOPMENT TRANSACTIONS FOR ECONOMIC DEVELOPERS; COMPUTER SOFTWARE WITH A FULLY INTEGRATED CONTACT AND CLIENT MANAGEMENT SOFTWARE SYSTEM THAT TRACKS ECONOMIC DEVELOPMENT ACTIVITIES INCLUDING CREATING AND TRACKING CUSTOMIZED ACTIVITIES; COMPUTER SOFTWARE FOR USE IN THE SERVICING AND MANAGING OF LOANS (U.S. CLS. 21, 23, 26, 36 AND 38).

FIRST USE 4-1-2005; IN COMMERCE 4-1-2005.
CAROLYN CATALDO, EXAMINING ATTORNEY

CLASS 9—(Continued).

SN 85-256,769. BOHEMIA INTERACTIVE A.S., MNÍEK POD BRDY 25210, CZECH REPUBLIC, FILED 3-3-2011.

TAKE ON HELICOPTERS

THE MARK CONSISTS OF STANDARD CHARACTERS WITHOUT CLAIM TO ANY PARTICULAR FONT, STYLE, SIZE, OR COLOR.

FOR COMPUTER AND VIDEO GAME DISCS AND SOFTWARE; COMPUTER AND VIDEO GAME DISCS AND SOFTWARE FOR MULTI-PLAYER VIDEO GAMING VIA WORLDWIDE AND LOCAL COMPUTER NETWORKS; COMPUTER AND VIDEO GAME DISCS AND SOFTWARE FOR INTERACTIVE VIDEO GAMING; DOWNLOADABLE COMPUTER GAME AND VIDEO GAME SOFTWARE; DOWNLOADABLE COMPUTER AND VIDEO GAME SOFTWARE FOR MULTI-PLAYER VIDEO GAMING VIA WORLDWIDE AND LOCAL COMPUTER NETWORKS; DOWNLOADABLE SOFTWARE FOR PLAYING INTERACTIVE COMPUTER AND VIDEO GAMES; AND EACH OF THE FORGOING SOLD AS A UNIT WITH MANUALS (U.S. CLS. 21, 23, 26, 36 AND 38).
ZACHARY BELLO, EXAMINING ATTORNEY

SN 85-256,841. COLLEGE FITNESS, LLC, MAYFIELD VILLAGE, OH. FILED 3-3-2011.

YUMEE

THE MARK CONSISTS OF STANDARD CHARACTERS WITHOUT CLAIM TO ANY PARTICULAR FONT, STYLE, SIZE, OR COLOR.

FOR DOWNLOADABLE SOFTWARE IN THE NATURE OF A MOBILE APPLICATION FOR DETERMINING RESTAURANT AND MENU INFORMATION, IDENTIFYING RESTAURANT AND GROCERY OFFERINGS MEETING CERTAIN LOCATION AND HEALTHFULNESS CRITERIA, IDENTIFYING DIETARY INFORMATION FOR BRAND NAME AND GENERIC GROCERY STORE FOOD PRODUCTS, IDENTIFYING DIETARY INFORMATION FOR ALCOHOLIC AND NON-ALCOHOLIC BEVERAGES, FILTERING DATA WITHIN THE APPLICATION BY LOCATION AND DIETARY CHARACTERISTICS, TRACKING AND ANALYZING ONE'S DAILY CONSUMPTION AND HEALTHFULNESS OF FOOD AND BEVERAGE PRODUCTS, AND ENGAGING IN SOCIAL NETWORKING (U.S. CLS. 21, 23, 26, 36 AND 38).

ANDREA HACK, EXAMINING ATTORNEY

CLASS 9—(Continued).

SN 85-256,941. THINKGEEK, INC., FAIRFAX, VA. FILED 3-3-2011.

JOYSTICK-IT

THE MARK CONSISTS OF STANDARD CHARACTERS WITHOUT CLAIM TO ANY PARTICULAR FONT, STYLE, SIZE, OR COLOR.

FOR AMUSEMENT APPARATUS ADAPTED FOR USE WITH COMPUTER HARDWARE AND VIDEO OR COMPUTER MONITORS; VIDEO GAME JOYSTICKS (U.S. CLS. 21, 23, 26, 36 AND 38).

FIRST USE 1-5-2011; IN COMMERCE 1-5-2011.
DOMINIC J. FERRAIUOLO, EXAMINING ATTORNEY

SN 85-256,964. CEGEDIM, BOULOGNE-BILLAN COURT, FRANCE, FILED 3-3-2011.

ONCOWEB

THE MARK CONSISTS OF STANDARD CHARACTERS WITHOUT CLAIM TO ANY PARTICULAR FONT, STYLE, SIZE, OR COLOR.

FOR SOFTWARE FOR MANAGEMENT OF ONCOLOGY PATIENTS' FILES (U.S. CLS. 21, 23, 26, 36 AND 38).
DARRYL SPRUILL, EXAMINING ATTORNEY

SN 85-257,005. DAVID L. DURFEE, JR., FAIRVIEW, PA. FILED 3-3-2011.

CellSlinger

THE MARK CONSISTS OF STANDARD CHARACTERS WITHOUT CLAIM TO ANY PARTICULAR FONT, STYLE, SIZE, OR COLOR.

FOR CARRYING CASES FOR CELL PHONES; CELL PHONE BACKPLATES; CELL PHONE BATTERY CHARGERS; CELL PHONE BATTERY CHARGERS FOR USE IN VEHICLES; CELL PHONE CASES; CELL PHONE COVERS; CELL PHONE FACEPLATES; CELL PHONE HAVING LARGE KEYS AND NUMBERS THAT ASSIST USERS HAVING IMPAIRED VISION OR DEXTERITY; CELL PHONE STRAPS; CELL PHONES; COMPUTER APPLICATION SOFTWARE FOR MOBILE PHONES, NAMELY, SOFTWARE FOR SEARCHING THE WEB; HEAD-CLIP CELL PHONE HOLDERS; PROTECTIVE COVERS AND CASES FOR CELL PHONES, LAPTOPS AND PORTABLE MEDIA PLAYERS; VINYL COVERS SPECIALLY ADAPTED FOR CELL PHONES, MP3 PLAYERS, LAPTOPS, COMPUTERS, PORTABLE SATELLITE RADIOS, PERSONAL DIGITAL ASSISTANTS, REMOTE CONTROLS, AND TELEVISION SATELLITE RECORDERS (U.S. CLS. 21, 23, 26, 36 AND 38).
HEATHER THOMPSON, EXAMINING ATTORNEY

CLASS 9—(Continued).

SN 85-257,013. AETREX WORLDWIDE, INC., TEANECK, NJ. FILED 3-3-2011.

AETREX

THE MARK CONSISTS OF STANDARD CHARACTERS WITHOUT CLAIM TO ANY PARTICULAR FONT, STYLE, SIZE, OR COLOR.

OWNER OF U.S. REG. NO. 2,953,620.
FOR INTERACTIVE COMPUTER KIOSKS COMPRISING COMPUTERS, COMPUTER HARDWARE, COMPUTER PERIPHERALS AND COMPUTER OPERATING SOFTWARE FOR USE IN SCANNING AND ANALYZING THE FOOT, DISPLAYING DIGITAL FOOTPRINTS AND RECOMMENDING FOOTWEAR AND FOOT ORTHOTICS (U.S. CLS. 21, 23, 26, 36 AND 38).

FIRST USE 4-30-2002; IN COMMERCE 4-30-2002.
DAVID HOFFMAN, EXAMINING ATTORNEY

SN 85-257,021. ENERGY PLATFORMS, LLC, SHAKOPEE, MN. FILED 3-3-2011.

NEEDS

THE MARK CONSISTS OF STANDARD CHARACTERS WITHOUT CLAIM TO ANY PARTICULAR FONT, STYLE, SIZE, OR COLOR.

FOR COMPUTER SOFTWARE FOR USE IN ENERGY USAGE MANAGEMENT AND ANALYSIS (U.S. CLS. 21, 23, 26, 36 AND 38).

PATRICIA EVANKO, EXAMINING ATTORNEY

SN 85-257,023. ZYLOWARE CORPORATION, PORT CHESTER, NY. FILED 3-3-2011.

I-STAMP

THE MARK CONSISTS OF STANDARD CHARACTERS WITHOUT CLAIM TO ANY PARTICULAR FONT, STYLE, SIZE, OR COLOR.

FOR OPTICAL FRAMES (U.S. CLS. 21, 23, 26, 36 AND 38).

BARNEY CHARLON, EXAMINING ATTORNEY

CLASS 9—(Continued).

SN 85-257,238. MOTOROLA TRADEMARK HOLDINGS, LLC, LIBERTYVILLE, IL. FILED 3-3-2011.

MOTOROLA XOOM

THE MARK CONSISTS OF STANDARD CHARACTERS WITHOUT CLAIM TO ANY PARTICULAR FONT, STYLE, SIZE, OR COLOR.

FOR MOBILE COMPUTERS AND RELATED ACCESSORIES, NAMELY, MOBILE COMPUTER DOCKING STATIONS, CARRYING CASES FOR MOBILE COMPUTERS, PROTECTIVE COVERS FOR MOBILE COMPUTERS, PROTECTIVE OR DECORATIVE SKINS, NAMELY, FITTED OR PLASTIC FILMS KNOWN AS SKINS FOR COVERING AND PROTECTING MOBILE COMPUTERS, BATTERIES, POWER ADAPTORS, COMPUTER CABLES, CABLE CONNECTORS (U.S. CLS. 21, 23, 26, 36 AND 38).

FIRST USE 2-15-2011; IN COMMERCE 2-15-2011.
BARBARA RUTLAND, EXAMINING ATTORNEY

CLASS 9—(Continued).

SN 85-257,334. TURN-LUCKILY INTERNATIONAL, INC., DBA TOTAL TECHNOLOGIES, LTD., IRVINE, CA. FILED 3-3-2011.

Hi-PQ

THE MARK CONSISTS OF STANDARD CHARACTERS WITHOUT CLAIM TO ANY PARTICULAR FONT, STYLE, SIZE, OR COLOR.

OWNER OF U.S. REG. NO. 3,024,840.
SEC. 2(F).

FOR CONNECTION CABLES AND CONNECTION CABLE ADAPTORS (U.S. CLS. 21, 23, 26, 36 AND 38).

FIRST USE 10-6-2004; IN COMMERCE 10-6-2004.
KIM SAITO, EXAMINING ATTORNEY

SN 85-257,448. ACTIFIO, INC., WALTHAM, MA. FILED 3-3-2011.

ANYIT

THE MARK CONSISTS OF STANDARD CHARACTERS WITHOUT CLAIM TO ANY PARTICULAR FONT, STYLE, SIZE, OR COLOR.

FOR COMPUTER HARDWARE AND SOFTWARE FOR MANAGING NETWORK STORAGE AND NON-NETWORK STORAGE (U.S. CLS. 21, 23, 26, 36 AND 38).

WENDY GOODMAN, EXAMINING ATTORNEY

SN 85-257,294. CAANES, LLC, ALBUQUERQUE, NM. FILED 3-3-2011.

BAKE

SN 85-257,536. ACRO ASSOCIATES, INC., CONCORD, CA. FILED 3-3-2011.

Acrotouch

THE MARK CONSISTS OF STANDARD CHARACTERS WITHOUT CLAIM TO ANY PARTICULAR FONT, STYLE, SIZE, OR COLOR.

FOR COMPUTER SOFTWARE ALLOWING REAL-TIME MONITORING OF GLOBAL COMPUTER NETWORKS TO DETECT MALICIOUS CONTENT; SOFTWARE ALLOWING OPERATORS TO PERFORM ANALYSIS TO GAIN KNOWLEDGE, TOPOLOGY OF NETWORKS, HIDDEN NODES, THREATS, INTENT, AND CAPABILITIES; SOFTWARE THAT HAS CLUSTER AND INSTANCE BASED LEARNING TECHNIQUES INBUILT TO PREDICT ACTIVITIES INVOLVED WITH MALICIOUS NETWORKS (U.S. CLS. 21, 23, 26, 36 AND 38).

TOBY BULLOFF, EXAMINING ATTORNEY

THE MARK CONSISTS OF STANDARD CHARACTERS WITHOUT CLAIM TO ANY PARTICULAR FONT, STYLE, SIZE, OR COLOR.

FOR TOUCH PANELS (U.S. CLS. 21, 23, 26, 36 AND 38).
DOMINIC FATHY, EXAMINING ATTORNEY

CLASS 9—(Continued).

SN 85-257,768. PASSTOUCH, LLC, SURF CITY, NC. FILED 3-4-2011.



THE MARK CONSISTS OF CONTINUOUS SPIRALING CURVE.

FOR COMPUTER SOFTWARE, NAMELY, GRAPHICAL INTERFACES FOR USER AUTHENTICATION AND IDENTIFICATION (U.S. CLS. 21, 23, 26, 36 AND 38).

KEVIN DINALLO, EXAMINING ATTORNEY

CLASS 9—(Continued).

SN 85-257,937. JIANGSU HANTTON SOLAR CO.,LTD, ZHANGJIAGANG CITY, CHINA, FILED 3-4-2011.

THE MARK CONSISTS OF STYLIZED WORD HTT. FOR BATTERIES; BATTERY BOXES; BATTERY CHARGERS; CONVERTERS; DISTRIBUTION BOXES FOR ELECTRICAL POWER; ELECTRICAL DISTRIBUTION BOXES; INVERTERS; PLATES FOR BATTERIES; RECTIFIERS; SOLAR BATTERIES; SWITCHBOARDS (U.S. CLS. 21, 23, 26, 36 AND 38).

FIRST USE 12-11-2010, THE MARK WAS FIRST USED ANYWHERE IN A DIFFERENT FORM OTHER THAN THAT SOUGHT TO BE REGISTERED AT LEAST AS EARLY AS 12/11/2010; IN COMMERCE 12-11-2010, THE MARK WAS FIRST USED IN COMMERCE IN A DIFFERENT FORM OTHER THAN THAT SOUGHT TO BE REGISTERED AT LEAST AS EARLY AS 12/11/2010.

JAMES GRIFFIN, EXAMINING ATTORNEY

SN 85-257,863. E-STEP CONSULTING, INC., VESTAL, NY. FILED 3-4-2011.

Mobile University

THE MARK CONSISTS OF STANDARD CHARACTERS WITHOUT CLAIM TO ANY PARTICULAR FONT, STYLE, SIZE, OR COLOR.

FOR SOFTWARE APPLICATION DESIGNED FOR MOBILE DEVICES THAT PROVIDES THE ABILITY FOR THE VARIOUS CAMPUS COMMUNITY PERSONNEL (I.E. PROSPECTIVE STUDENTS, CURRENT STUDENTS, ALUMNI, FACULTY, STAFF AND OTHER EMPLOYEES) TO SEARCH FOR INFORMATION ABOUT COLLEGES AND UNIVERSITIES, COMMUNICATE WITH COLLEGES AND UNIVERSITIES, AND PROCESS TRANSACTIONAL DATA (U.S. CLS. 21, 23, 26, 36 AND 38).

MARIA-VICTORIA SUAREZ, EXAMINING ATTORNEY

SN 85-257,952. ADRIENNE RAHEB, NORTHRIDGE, CA. FILED 3-4-2011.

EARMAGINATION

THE MARK CONSISTS OF STANDARD CHARACTERS WITHOUT CLAIM TO ANY PARTICULAR FONT, STYLE, SIZE, OR COLOR.

FOR DIGITAL MATERIALS, NAMELY, PRE-RECORDED AUDIO AND VIDEO CASSETTES, DIGITAL VIDEO DISKS, DIGITAL VERSATILE DISKS, DOWNLOADABLE AUDIO AND VIDEO RECORDINGS, DVDS, CDS AND HIGH DEFINITION DIGITAL DISKS FEATURING EDUCATION AND EDUCATIONAL TESTING MATERIALS (U.S. CLS. 21, 23, 26, 36 AND 38).

ANNE MADDEN, EXAMINING ATTORNEY

CLASS 9—(Continued).

SN 85-259,787. XIRIS AUTOMATION INC., BURLINGTON, ONTARIO, CANADA, FILED 3-7-2011.

XIRIS

THE MARK CONSISTS OF STANDARD CHARACTERS WITHOUT CLAIM TO ANY PARTICULAR FONT, STYLE, SIZE, OR COLOR.

FOR OPTICAL INSPECTION AND GUIDANCE APPARATUS FOR INDUSTRIAL USES AND FACTORY AUTOMATION, NAMELY, SOFTWARE AND CAMERAS TO INTEGRATE OPTICAL INSPECTION APPARATUS WITH MANUFACTURING AND GENERAL INDUSTRIAL MACHINE OPERATIONS (U.S. CLS. 21, 23, 26, 36 AND 38).

FIRST USE 12-31-1995; IN COMMERCE 12-31-1995.
LINDA E. BLOHM, EXAMINING ATTORNEY

CLASS 9—(Continued).

SN 85-260,603. ASTRAL BUOYANCY COMPANY, ASHEVILLE, NC. FILED 3-8-2011.

ASTRAL

THE MARK CONSISTS OF STANDARD CHARACTERS WITHOUT CLAIM TO ANY PARTICULAR FONT, STYLE, SIZE, OR COLOR.

FOR LIFE JACKETS (U.S. CLS. 21, 23, 26, 36 AND 38).
FIRST USE 8-0-2002; IN COMMERCE 8-0-2002.
THOMAS MANOR, EXAMINING ATTORNEY

SN 85-260,970. CLIC GOGGLES, INC., CORTE MADERA, CA. FILED 3-8-2011.

SN 85-260,538. GAMELEARN, S.L., 28224 MADRID, SPAIN, FILED 3-8-2011.



VUNETIC

THE MARK CONSISTS OF STANDARD CHARACTERS WITHOUT CLAIM TO ANY PARTICULAR FONT, STYLE, SIZE, OR COLOR.

FOR EYEWEAR (U.S. CLS. 21, 23, 26, 36 AND 38).
DEZMONA MIZELLE, EXAMINING ATTORNEY

SN 85-262,441. FARM CREDIT SERVICES OF AMERICA, ACA, OMAHA, NE. FILED 3-9-2011.

PRIORITY CLAIMED UNDER SEC. 44(D) ON ERP N CMNTY TM OFC APPLICATION NO. 009554676, FILED 11-26-2010, REG. NO. 009554676, DATED 4-19-2011, EXPIRES 11-26-2020.

THE COLOR(S) BROWN, GREY, BLACK, BEIGE, OCHRE, ORANGE AND WHITE IS/ARE CLAIMED AS A FEATURE OF THE MARK.

THE MARK CONSISTS OF A CIRCLE ON A BLACK BACKGROUND. WITHIN THE CIRCLE ARE THREE CURVED LEGS HAVING BROWN AND WHITE SEGMENTS. WITHIN EACH CURVE IS A REPRESENTATION OF THE INTERNAL PARTS OF A STOPWATCH IN GREY, BEIGE, OCHRE AND ORANGE ON A BROWN BACKGROUND. THE WORD "TRISKELION" IN WHITE OVERLIES THE CIRCLE.

THE ENGLISH TRANSLATION OF "TRISKELION" IN THE MARK IS "THREE-LEGGED".

FOR INTERACTIVE VIDEO GAME PROGRAM FOR TRAINING IN BUSINESS MANAGEMENT, NAMELY, IN TIME MANAGEMENT AND PERSONAL PRODUCTIVITY (U.S. CLS. 21, 23, 26, 36 AND 38).

ZACHARY BELLO, EXAMINING ATTORNEY

VISUAL VALUATION

THE MARK CONSISTS OF STANDARD CHARACTERS WITHOUT CLAIM TO ANY PARTICULAR FONT, STYLE, SIZE, OR COLOR.

NO CLAIM IS MADE TO THE EXCLUSIVE RIGHT TO USE "VALUATION", APART FROM THE MARK AS SHOWN.

FOR COMPUTER SOFTWARE FEATURING COMPUTER DATABASES, REPORTS, AND OTHER INFORMATION AND BUSINESS UTILITIES AND TOOLS IN THE FIELD OF REAL ESTATE APPRAISAL (U.S. CLS. 21, 23, 26, 36 AND 38).

ALEXANDER L. POWERS, EXAMINING ATTORNEY

CLASS 9—(Continued).

SN 85-262,520. SPACETIME STUDIOS, INC., AUSTIN, TX.
FILED 3-9-2011.

Empire of Night

THE MARK CONSISTS OF STANDARD CHARACTERS WITHOUT CLAIM TO ANY PARTICULAR FONT, STYLE, SIZE, OR COLOR.

FOR COMPUTER GAME PROGRAMS; COMPUTER GAME SOFTWARE; COMPUTER GAME SOFTWARE DOWNLOADABLE FROM A GLOBAL COMPUTER NETWORK; COMPUTER GAME SOFTWARE FOR USE ON MOBILE AND CELLULAR PHONES; COMPUTER PROGRAMS FOR VIDEO AND COMPUTER GAMES; DOWNLOADABLE COMPUTER GAME PROGRAMS; DOWNLOADABLE COMPUTER GAME SOFTWARE VIA A GLOBAL COMPUTER NETWORK AND WIRELESS DEVICES; DOWNLOADABLE ELECTRONIC GAME PROGRAMS; ELECTRONIC GAME SOFTWARE FOR CELLULAR TELEPHONES; ELECTRONIC GAME SOFTWARE FOR HANDHELD ELECTRONIC DEVICES; ELECTRONIC GAME SOFTWARE FOR WIRELESS DEVICES; INTERACTIVE GAME PROGRAMS; INTERACTIVE GAME SOFTWARE; VIDEO AND COMPUTER GAME PROGRAMS (U.S. CLS. 21, 23, 26, 36 AND 38).
DEZMONA MIZELLE, EXAMINING ATTORNEY

SN 85-262,591. SPACETIME STUDIOS, INC., AUSTIN, TX.
FILED 3-9-2011.

Blood and Dust

THE MARK CONSISTS OF STANDARD CHARACTERS WITHOUT CLAIM TO ANY PARTICULAR FONT, STYLE, SIZE, OR COLOR.

FOR COMPUTER GAME PROGRAMS; COMPUTER GAME SOFTWARE; COMPUTER GAME SOFTWARE DOWNLOADABLE FROM A GLOBAL COMPUTER NETWORK; COMPUTER GAME SOFTWARE FOR USE ON MOBILE AND CELLULAR PHONES; COMPUTER PROGRAMS FOR VIDEO AND COMPUTER GAMES; DOWNLOADABLE COMPUTER GAME PROGRAMS; DOWNLOADABLE COMPUTER GAME SOFTWARE VIA A GLOBAL COMPUTER NETWORK AND WIRELESS DEVICES; DOWNLOADABLE ELECTRONIC GAME PROGRAMS; ELECTRONIC GAME SOFTWARE FOR CELLULAR TELEPHONES; ELECTRONIC GAME SOFTWARE FOR HANDHELD ELECTRONIC DEVICES; ELECTRONIC GAME SOFTWARE FOR WIRELESS DEVICES; INTERACTIVE GAME PROGRAMS; INTERACTIVE GAME SOFTWARE; VIDEO AND COMPUTER GAME PROGRAMS (U.S. CLS. 21, 23, 26, 36 AND 38).
DEZMONA MIZELLE, EXAMINING ATTORNEY

CLASS 9—(Continued).

SN 85-262,657. SPACETIME STUDIOS, INC., AUSTIN, TX.
FILED 3-9-2011.

BaD

THE MARK CONSISTS OF STANDARD CHARACTERS WITHOUT CLAIM TO ANY PARTICULAR FONT, STYLE, SIZE, OR COLOR.

FOR COMPUTER GAME PROGRAMS; COMPUTER GAME SOFTWARE; COMPUTER GAME SOFTWARE DOWNLOADABLE FROM A GLOBAL COMPUTER NETWORK; COMPUTER GAME SOFTWARE FOR USE ON MOBILE AND CELLULAR PHONES; COMPUTER PROGRAMS FOR VIDEO AND COMPUTER GAMES; DOWNLOADABLE COMPUTER GAME PROGRAMS; DOWNLOADABLE COMPUTER GAME SOFTWARE VIA A GLOBAL COMPUTER NETWORK AND WIRELESS DEVICES; DOWNLOADABLE ELECTRONIC GAME PROGRAMS; ELECTRONIC GAME SOFTWARE FOR CELLULAR TELEPHONES; ELECTRONIC GAME SOFTWARE FOR HANDHELD ELECTRONIC DEVICES; ELECTRONIC GAME SOFTWARE FOR WIRELESS DEVICES; INTERACTIVE GAME PROGRAMS; INTERACTIVE GAME SOFTWARE; VIDEO AND COMPUTER GAME PROGRAMS (U.S. CLS. 21, 23, 26, 36 AND 38).
DEZMONA MIZELLE, EXAMINING ATTORNEY

SN 85-264,845. JUST MOBILE LTD., TAICHUNG CITY 406,
TAIWAN, FILED 3-11-2011.

AluPen

THE MARK CONSISTS OF STANDARD CHARACTERS WITHOUT CLAIM TO ANY PARTICULAR FONT, STYLE, SIZE, OR COLOR.

THE WORDING "ALUPEN" HAS NO MEANING IN A FOREIGN LANGUAGE.

FOR COMPUTER STYLUS (U.S. CLS. 21, 23, 26, 36 AND 38).

FIRST USE 4-19-2010; IN COMMERCE 8-21-2010.
ELISSA GARBER KON, EXAMINING ATTORNEY

CLASS 9—(Continued).

SN 85-265,078. GOLDEN BOY PRODUCTS, LLC, CARSON CITY, NV. FILED 3-11-2011.

CLAVE AL INGLÉS

THE MARK CONSISTS OF STANDARD CHARACTERS WITHOUT CLAIM TO ANY PARTICULAR FONT, STYLE, SIZE, OR COLOR.

NO CLAIM IS MADE TO THE EXCLUSIVE RIGHT TO USE "INGLÉS", APART FROM THE MARK AS SHOWN.

THE ENGLISH TRANSLATION OF "CLAVE AL INGLÉS" IN THE MARK IS "KEY TO ENGLISH".

FOR COMPUTER APPLICATION SOFTWARE FOR MOBILE PHONES, PORTABLE MEDIA PLAYERS AND HANDHELD COMPUTERS, NAMELY, SOFTWARE FOR TEACHING ENGLISH LANGUAGE TO SPANISH SPEAKERS; DIGITAL MEDIA, NAMELY, PRE-RECORDED CDS, DVDS, DIGITAL VIDEO DISCS, DIGITAL VERSATILE DISCS, DOWNLOADABLE AUDIO AND VIDEO RECORDINGS, AND HIGH DEFINITION DIGITAL DISCS FEATURING ENGLISH LANGUAGE INSTRUCTION; DOWNLOADABLE MP3, MP4 AND MP5 FILES AND RECORDINGS FEATURING ENGLISH LANGUAGE INSTRUCTION; EDUCATIONAL SOFTWARE FEATURING INSTRUCTION IN ENGLISH LANGUAGE; PORTABLE MEDIA PLAYERS, NAMELY, MP3, MP4 AND MP5 PLAYERS PRE-LOADED WITH EDUCATIONAL SOFTWARE FEATURING INSTRUCTION IN ENGLISH LANGUAGE (U.S. CLS. 21, 23, 26, 36 AND 38).

TINA MAI, EXAMINING ATTORNEY

SN 85-265,115. FREIGHT SECURITY NET, AUSTIN, TX. FILED 3-11-2011.

FlightSmart

THE MARK CONSISTS OF STANDARD CHARACTERS WITHOUT CLAIM TO ANY PARTICULAR FONT, STYLE, SIZE, OR COLOR.

FOR COMPUTER HARDWARE AND SOFTWARE SYSTEM FOR REMOTELY MONITORING ENVIRONMENTAL CONDITIONS AND CONTROLLING DEVICES WITHIN A BUILDING, FACILITY, GROUNDS, OR DESIGNATED SPATIAL AREA; COMPUTER HARDWARE AND SOFTWARE SYSTEM FOR TRACKING PEOPLE, OBJECTS AND PETS USING GPS DATA ON A DEVICE ON THE TRACKED PEOPLE, OBJECTS AND PETS; VEHICLE LOCATOR AND RECOVERY DEVICE PROGRAMMED TO USE GLOBAL POSITIONING SYSTEMS (GPS) AND CELLULAR TELECOMMUNICATIONS; VEHICLE TRACKING DEVICES COMPRISED OF CELLULAR RADIO MODULES, COMPUTER SOFTWARE AND COMPUTER HARDWARE, SENSORS, TRANSMITTERS, RECEIVERS AND GLOBAL POSITIONING SATELLITE RECEIVERS, ALL FOR USE IN CONNECTION WITH VEHICLE TRACKING, VEHICLE MONITORING AND ANTI-THEFT VEHICLE ALARMS (U.S. CLS. 21, 23, 26, 36 AND 38).

H. M. FISHER, EXAMINING ATTORNEY

CLASS 9—(Continued).

SN 85-265,921. LOPEZ, MANUEL, AZUSA, CA. FILED 3-14-2011.

swivelhand360

THE MARK CONSISTS OF STANDARD CHARACTERS WITHOUT CLAIM TO ANY PARTICULAR FONT, STYLE, SIZE, OR COLOR.

FOR HAND HELD CASE HOLDER FOR COMPUTERS, HAVING A COMPUTER BACKSIDE AND COMPUTER DISPLAY SIDE THAT ALLOWS THE COMPUTER TO BE SECURELY HELD IN THE PALM OF THE OPERATOR'S HAND VIA A HAND STRAP, AND BE ROTATED THROUGH A PREFERABLY 360 DEGREES (U.S. CLS. 21, 23, 26, 36 AND 38).

MATTHEW KLINE, EXAMINING ATTORNEY

SN 85-266,115. TELEVOX SOFTWARE, INC., MOBILE, AL. FILED 3-14-2011.

EasyRemind

THE MARK CONSISTS OF STANDARD CHARACTERS WITHOUT CLAIM TO ANY PARTICULAR FONT, STYLE, SIZE, OR COLOR.

FOR COMPUTER SOFTWARE FOR USE IN COMPUTER TELEPHONY SYSTEMS ALLOWING FOR TWO-WAY COMMUNICATIONS BETWEEN BUSINESSES AND THEIR CLIENTS VIA TRADITIONAL VOICE AND FAX COMMUNICATION LINES AND ALSO VIA COMMUNICATION LINES ON GLOBAL COMPUTER NETWORKS (U.S. CLS. 21, 23, 26, 36 AND 38).

DOMINIC FATHY, EXAMINING ATTORNEY

SN 85-268,448. MERIAL LIMITED, HARLOW, ESSEX CM19 5QA, UNITED KINGDOM, FILED 3-16-2011.

FLEAMINDER

THE MARK CONSISTS OF STANDARD CHARACTERS WITHOUT CLAIM TO ANY PARTICULAR FONT, STYLE, SIZE, OR COLOR.

FOR ELECTRONIC PET TAG FOR REMINDING PET OWNERS TO ADMINISTER MEDICATION TO THEIR PETS (U.S. CLS. 21, 23, 26, 36 AND 38).

RAUL CORDOVA, EXAMINING ATTORNEY

CLASS 9—(Continued).

SN 85-268,475. MERIAL LIMITED, HARLOW, ESSEX CM19 5QA, UNITED KINGDOM, FILED 3-16-2011.

HEARTMINDER

THE MARK CONSISTS OF STANDARD CHARACTERS WITHOUT CLAIM TO ANY PARTICULAR FONT, STYLE, SIZE, OR COLOR.

FOR ELECTRONIC PET TAG FOR REMINDING PET OWNERS TO ADMINISTER MEDICATION TO THEIR PETS (U.S. CLS. 21, 23, 26, 36 AND 38).

RAUL CORDOVA, EXAMINING ATTORNEY

SN 85-269,104. PROMISE TECHNOLOGY, INC., MILPITAS, CA. FILED 3-17-2011.



THE MARK CONSISTS OF THE WORD "PEGASUS" WITH THE LETTER "P" APPEARING AS A STYLIZED WING.

FOR RAID-BASED HARD DRIVE BACKUP SYSTEMS (U.S. CLS. 21, 23, 26, 36 AND 38).

SAMUEL E. SHARPER JR., EXAMINING ATTORNEY

SN 85-269,356. AMI ENTERTAINMENT NETWORK, INC., BRISTOL, PA. FILED 3-17-2011.

MONKEY BASH

THE MARK CONSISTS OF STANDARD CHARACTERS WITHOUT CLAIM TO ANY PARTICULAR FONT, STYLE, SIZE, OR COLOR.

FOR COMPUTER AND ELECTRONIC GAME PROGRAMS; COMPUTER AND ELECTRONIC GAME SOFTWARE; DOWNLOADABLE ELECTRONIC GAMES VIA THE INTERNET AND WIRELESS DEVICES (U.S. CLS. 21, 23, 26, 36 AND 38).

FIRST USE 1-4-2009; IN COMMERCE 1-4-2009.
SKYE YOUNG, EXAMINING ATTORNEY

CLASS 9—(Continued).

SN 85-274,993. WEIDLINGER ASSOCIATES, INC., MOUNTAIN VIEW, CA. FILED 3-23-2011.

MediFlex

THE MARK CONSISTS OF STANDARD CHARACTERS WITHOUT CLAIM TO ANY PARTICULAR FONT, STYLE, SIZE, OR COLOR.

OWNER OF U.S. REG. NO. 3,569,003.

FOR GRAPHICAL USER INTERFACE BASED SIMULATION SOFTWARE TOOLS FOR HIGH FIDELITY MEDICAL ULTRASOUND IMAGING, THERAPEUTIC APPLICATIONS, AND HIGH INTENSITY FOCUSED ULTRASOUND SYSTEMS (U.S. CLS. 21, 23, 26, 36 AND 38).

AMY KERTGATE, EXAMINING ATTORNEY

SN 85-279,567. NAMCO BANDAI GAMES INC., SHINAGAWA-KU TOKYO, JAPAN, FILED 3-29-2011.

KATAMARI AMORE

THE MARK CONSISTS OF STANDARD CHARACTERS WITHOUT CLAIM TO ANY PARTICULAR FONT, STYLE, SIZE, OR COLOR.

OWNER OF U.S. REG. NOS. 3,077,193, 3,225,455 AND 3,283,430.

THE ENGLISH TRANSLATION OF "KATAMARI" IN THE MARK IS "SOLID" AND THE ENGLISH TRANSLATION OF THE "AMORE" IN THE MARKS IS "LOVE".

FOR COMPUTER GAME PROGRAMS; COMPUTER GAME PROGRAMS, CARTRIDGES, AND CASSETTES; COMPUTER GAME SOFTWARE; DOWNLOADABLE COMPUTER GAME PROGRAMS; DOWNLOADABLE COMPUTER GAME SOFTWARE VIA A GLOBAL COMPUTER NETWORK AND WIRELESS DEVICES; VIDEO GAME CARTRIDGES; VIDEO GAME DISCS; VIDEO GAME SOFTWARE (U.S. CLS. 21, 23, 26, 36 AND 38).

EDWARD FENNESSY, EXAMINING ATTORNEY

CLASS 9—(Continued).

SN 85-279,570. NAMCO BANDAI GAMES INC., SHINAGAWA-KU TOKYO, JAPAN, FILED 3-29-2011.

KATAMARI AMORE ROLLING WHOPPER

THE MARK CONSISTS OF STANDARD CHARACTERS WITHOUT CLAIM TO ANY PARTICULAR FONT, STYLE, SIZE, OR COLOR.

OWNER OF U.S. REG. NOS. 3,077,193, 3,225,455 AND 3,283,430.

THE ENGLISH TRANSLATION OF "KATAMARI" IN THE MARK IS "SOLID" AND THE ENGLISH TRANSLATION OF THE "AMORE" IN THE MARKS IS "LOVE".

FOR COMPUTER GAME PROGRAMS; COMPUTER GAME PROGRAMS, CARTRIDGES, AND CASSETTES; COMPUTER GAME SOFTWARE; DOWNLOADABLE COMPUTER GAME PROGRAMS; DOWNLOADABLE COMPUTER GAME SOFTWARE VIA A GLOBAL COMPUTER NETWORK AND WIRELESS DEVICES; VIDEO GAME CARTRIDGES; VIDEO GAME DISCS; VIDEO GAME SOFTWARE (U.S. CLS. 21, 23, 26, 36 AND 38).

EDWARD FENNESSY, EXAMINING ATTORNEY

CLASS 9—(Continued).

SN 85-280,932. XIUS CORP., FORMERLY CELLULAR EXPRESS, INC., WOBURN, MA. FILED 3-30-2011.

ACTIVE POSTER

THE MARK CONSISTS OF STANDARD CHARACTERS WITHOUT CLAIM TO ANY PARTICULAR FONT, STYLE, SIZE, OR COLOR.

NO CLAIM IS MADE TO THE EXCLUSIVE RIGHT TO USE "POSTER", APART FROM THE MARK AS SHOWN.

FOR ELECTRONIC INTERACTIVE DISPLAY BOARD IN THE NATURE OF PAPER OR PLASTIC LAMINATED DISPLAYS BOARDS; COMPUTER HARDWARE AND SOFTWARE THAT ENABLES NEAR FIELD COMMUNICATION CAPABILITY AND THAT FACILITATES COMMUNICATIONS BETWEEN ELECTRONIC INTERACTIVE DISPLAY BOARDS AND MOBILE DEVICES, FOR USE IN FACILITATING E-COMMERCE OR MOBILE COMMERCE TRANSACTIONS (U.S. CLS. 21, 23, 26, 36 AND 38).

ELISSA GARBER KON, EXAMINING ATTORNEY

SN 85-281,149. QUALCOMM INCORPORATED, SAN DIEGO, CA. FILED 3-30-2011.

SN 85-280,794. BEAR-ECO TECHNOLOGIES, LLC, BRISTOW, VA. FILED 3-30-2011.

Pirate Ph.D.

THE MARK CONSISTS OF STANDARD CHARACTERS WITHOUT CLAIM TO ANY PARTICULAR FONT, STYLE, SIZE, OR COLOR.

NO CLAIM IS MADE TO THE EXCLUSIVE RIGHT TO USE "PIRATE", APART FROM THE MARK AS SHOWN.

FOR CHILDREN'S EDUCATIONAL SOFTWARE (U.S. CLS. 21, 23, 26, 36 AND 38).

JORDAN BAKER, EXAMINING ATTORNEY



OWNER OF U.S. REG. NOS. 1,622,128, 3,720,881 AND OTHERS.

THE MARK CONSISTS OF A STYLIZED LETTER "Q" ON TOP OF THE WORDS "QUALCOMM" AND "POWERED" IN A VERTICAL STACK. THE COLORS BLACK, WHITE AND/OR GRAY REPRESENT BACKGROUND, OUTLINING, SHADING AND/OR TRANSPARENT AREAS AND ARE NOT PART OF THE MARK.

FOR INTEGRATED CIRCUITS AND MICROPROCESSORS (U.S. CLS. 21, 23, 26, 36 AND 38).

ROBERT C. CLARK JR., EXAMINING ATTORNEY

CLASS 9—(Continued).

SN 85-281,152. QUALCOMM INCORPORATED, SAN DIEGO, CA. FILED 3-30-2011.



OWNER OF U.S. REG. NOS. 1,622,128, 3,720,881 AND OTHERS.

THE MARK CONSISTS OF A STYLIZED LETTER "Q" NEXT TO THE WORDS "QUALCOMM" AND "POWERED". THE COLORS BLACK, WHITE AND/OR GRAY REPRESENT BACKGROUND, OUTLINING, SHADING AND/OR TRANSPARENT AREAS AND ARE NOT PART OF THE MARK.

FOR INTEGRATED CIRCUITS AND MICROPROCESSORS (U.S. CLS. 21, 23, 26, 36 AND 38).

ROBERT C. CLARK JR., EXAMINING ATTORNEY

SN 85-282,926. E-FILLIATE, INC., RANCHO CORDOVA, CA. FILED 3-31-2011.

TECH & GO

THE MARK CONSISTS OF STANDARD CHARACTERS WITHOUT CLAIM TO ANY PARTICULAR FONT, STYLE, SIZE, OR COLOR.

NO CLAIM IS MADE TO THE EXCLUSIVE RIGHT TO USE "TECH", APART FROM THE MARK AS SHOWN.

FOR USB CABLES, USB HUBS, ELECTRONIC CARD READERS, ELECTRIC PATCH CABLES, COMPUTER MICE, MOUSE PADS, KEYBOARDS; BATTERY CHARGERS, NAMELY, WALL CHARGERS, CAR CHARGERS, AND USB CHARGERS; AC/DC CONVERTERS, USB ADAPTERS, EARBUDS, HEADPHONES, AUDIO SPEAKERS; BLANK CDS AND DVDS; CD AND DVD CASES; FLASH MEDIA, NAMELY, FLASH MEMORY CARDS; POWER CABLES; AUDIO AND VIDEO CABLES AND ADAPTERS, BATTERIES AND BATTERY CHARGERS; MP3 PLAYERS AND SMART PHONE ACCESSORIES, NAMELY, HEADPHONES, SIGNAL SPLITTERS, SPEAKERS, ELECTRONIC CABLES FOR SYNCING AND CHARGING MP3 PLAYERS AND SMART PHONES, BATTERY CHARGERS, ELECTRONIC DOCKING STATIONS, ADAPTERS, USB CONVERTERS, AND AUDIO AND VIDEO CABLES; CASES, BAGS, STANDS, HOLDERS, BELT CLIPS, STRAPS, SCREEN PROTECTORS, STYLUS, SPECIALLY ADAPTED FOR HOLDING MP3 PLAYERS AND SMART PHONES; CAMERA ACCESSORIES, NAMELY, TRIPODS, BATTERY CHARGERS, ELECTRONIC CABLES FOR SYNCING AND CHARGING CAMERAS, USB ADAPTERS, STRAPS SPECIALLY ADAPTED FOR CAMERAS, AND ADAPTERS; CASES AND BAGS SPECIALLY ADAPTED FOR HOLDING CAMERAS (U.S. CLS. 21, 23, 26, 36 AND 38).

JENNIFER MARTIN, EXAMINING ATTORNEY

CLASS 9—(Continued).

SN 85-283,598. FLIR SYSTEMS, INC., WILSONVILLE, OR. FILED 4-1-2011.

VOYAGER

THE MARK CONSISTS OF STANDARD CHARACTERS WITHOUT CLAIM TO ANY PARTICULAR FONT, STYLE, SIZE, OR COLOR.

FOR ELECTROMAGNETIC IMAGING SYSTEMS COMPRISED OF INFRARED CAMERAS AND MOVEABLE MOUNTS; VISIBLE LIGHT IMAGERS FOR NON-MEDICAL PURPOSES; THERMAL IMAGERS FOR NON-MEDICAL PURPOSES; INFRARED IMAGERS FOR NON-MEDICAL PURPOSES (U.S. CLS. 21, 23, 26, 36 AND 38).

FIRST USE 12-0-2007; IN COMMERCE 12-0-2007.
STEVEN JACKSON, EXAMINING ATTORNEY

SN 85-283,640. PING IDENTITY CORPORATION, DENVER, CO. FILED 4-1-2011.

PINGONE

THE MARK CONSISTS OF STANDARD CHARACTERS WITHOUT CLAIM TO ANY PARTICULAR FONT, STYLE, SIZE, OR COLOR.

OWNER OF U.S. REG. NOS. 3,017,959, 3,336,775 AND OTHERS.

FOR DOWNLOADABLE COMPUTER SOFTWARE THAT FACILITATES IDENTITY FEDERATION IN THE FIELD OF DIGITAL SECURITY AND IDENTITY VERIFICATION (U.S. CLS. 21, 23, 26, 36 AND 38).

AMY HELLA, EXAMINING ATTORNEY

SN 85-285,589. URSA MAJOR MEDIA INCORPORATED, RENO, NV. FILED 4-4-2011.

Bollywood Fantastic

THE MARK CONSISTS OF STANDARD CHARACTERS WITHOUT CLAIM TO ANY PARTICULAR FONT, STYLE, SIZE, OR COLOR.

FOR VIDEO SLOT MACHINE (U.S. CLS. 21, 23, 26, 36 AND 38).

DOMINICK J. SALEMI, EXAMINING ATTORNEY

CLASS 9—(Continued).

SN 85-287,234. BEAR-ECO TECHNOLOGIES, LLC, BRISTOW, VA. FILED 4-5-2011.

Princess Ph.D.

THE MARK CONSISTS OF STANDARD CHARACTERS WITHOUT CLAIM TO ANY PARTICULAR FONT, STYLE, SIZE, OR COLOR.

NO CLAIM IS MADE TO THE EXCLUSIVE RIGHT TO USE "PRINCESS", APART FROM THE MARK AS SHOWN. FOR CHILDREN'S EDUCATIONAL SOFTWARE (U.S. CLS. 21, 23, 26, 36 AND 38).

FIRST USE 3-29-2011; IN COMMERCE 3-29-2011.
JORDAN BAKER, EXAMINING ATTORNEY

CLASS 9—(Continued).

SN 85-299,453. SMART MODULAR TECHNOLOGIES, INC., NEWARK, CA. FILED 4-20-2011.

SYSGUARD

THE MARK CONSISTS OF STANDARD CHARACTERS WITHOUT CLAIM TO ANY PARTICULAR FONT, STYLE, SIZE, OR COLOR.

FOR SOLID STATE DRIVES (U.S. CLS. 21, 23, 26, 36 AND 38).
WENDY GOODMAN, EXAMINING ATTORNEY

SN 85-291,439. THE CARTOON NETWORK, INC., ATLANTA, GA. FILED 4-11-2011.

BEN 10 OMNIVERSE

THE MARK CONSISTS OF STANDARD CHARACTERS WITHOUT CLAIM TO ANY PARTICULAR FONT, STYLE, SIZE, OR COLOR.

OWNER OF U.S. REG. NOS. 3,080,336, 3,819,704 AND OTHERS.

THE NAME IN THE MARK DOES NOT REFER TO A PARTICULAR LIVING INDIVIDUAL.

FOR AUDIO AND VIDEO RECORDINGS FEATURING ENTERTAINMENT FOR CHILDREN; INTERACTIVE VIDEO GAME PROGRAMS; VIDEO GAME CARTRIDGES AND DISCS; ELECTRONIC GAME PROGRAMS; COMPUTER GAME CARTRIDGES AND DISCS; DOWNLOADABLE PRE-RECORDED VIDEO RECORDINGS FEATURING ENTERTAINMENT FOR CHILDREN; SUNGLASSES AND PROTECTIVE HELMETS FOR SPORTS (U.S. CLS. 21, 23, 26, 36 AND 38).
PAUL F. GAST, EXAMINING ATTORNEY

SN 85-299,459. SMART MODULAR TECHNOLOGIES, INC., NEWARK, CA. FILED 4-20-2011.

CELLGUARD

THE MARK CONSISTS OF STANDARD CHARACTERS WITHOUT CLAIM TO ANY PARTICULAR FONT, STYLE, SIZE, OR COLOR.

FOR SOLID STATE DRIVES (U.S. CLS. 21, 23, 26, 36 AND 38).
WENDY GOODMAN, EXAMINING ATTORNEY

SN 85-299,450. SMART MODULAR TECHNOLOGIES, INC., NEWARK, CA. FILED 4-20-2011.

XCEEDIOPS

THE MARK CONSISTS OF STANDARD CHARACTERS WITHOUT CLAIM TO ANY PARTICULAR FONT, STYLE, SIZE, OR COLOR.

FOR SOLID STATE DRIVES (U.S. CLS. 21, 23, 26, 36 AND 38).
WENDY GOODMAN, EXAMINING ATTORNEY

SN 85-299,463. SMART MODULAR TECHNOLOGIES, INC., NEWARK, CA. FILED 4-20-2011.

ENDURAGUARD

THE MARK CONSISTS OF STANDARD CHARACTERS WITHOUT CLAIM TO ANY PARTICULAR FONT, STYLE, SIZE, OR COLOR.

FOR SOLID STATE DRIVES (U.S. CLS. 21, 23, 26, 36 AND 38).
WENDY GOODMAN, EXAMINING ATTORNEY

CLASS 9—(Continued).

SN 85-299,467. SMART MODULAR TECHNOLOGIES, INC.,
NEWARK, CA. FILED 4-20-2011.

SMARTGUARD

THE MARK CONSISTS OF STANDARD CHARACTERS
WITHOUT CLAIM TO ANY PARTICULAR FONT, STYLE,
SIZE, OR COLOR.
FOR SOLID STATE DRIVES (U.S. CLS. 21, 23, 26, 36
AND 38).
WENDY GOODMAN, EXAMINING ATTORNEY

CLASS 9—(Continued).

SN 85-299,476. SMART MODULAR TECHNOLOGIES, INC.,
NEWARK, CA. FILED 4-20-2011.

TESTGUARD

THE MARK CONSISTS OF STANDARD CHARACTERS
WITHOUT CLAIM TO ANY PARTICULAR FONT, STYLE,
SIZE, OR COLOR.
FOR SOLID STATE DRIVES (U.S. CLS. 21, 23, 26, 36
AND 38).
WENDY GOODMAN, EXAMINING ATTORNEY

SN 85-299,469. SMART MODULAR TECHNOLOGIES, INC.,
NEWARK, CA. FILED 4-20-2011.

INFOGUARD

THE MARK CONSISTS OF STANDARD CHARACTERS
WITHOUT CLAIM TO ANY PARTICULAR FONT, STYLE,
SIZE, OR COLOR.
FOR SOLID STATE DRIVES (U.S. CLS. 21, 23, 26, 36
AND 38).
WENDY GOODMAN, EXAMINING ATTORNEY

SN 85-299,477. SMART MODULAR TECHNOLOGIES, INC.,
NEWARK, CA. FILED 4-20-2011.

CRYPTOGUARD

THE MARK CONSISTS OF STANDARD CHARACTERS
WITHOUT CLAIM TO ANY PARTICULAR FONT, STYLE,
SIZE, OR COLOR.
FOR SOLID STATE DRIVES (U.S. CLS. 21, 23, 26, 36
AND 38).
WENDY GOODMAN, EXAMINING ATTORNEY

SN 85-299,474. SMART MODULAR TECHNOLOGIES, INC.,
NEWARK, CA. FILED 4-20-2011.

FAILGUARD

THE MARK CONSISTS OF STANDARD CHARACTERS
WITHOUT CLAIM TO ANY PARTICULAR FONT, STYLE,
SIZE, OR COLOR.
FOR SOLID STATE DRIVES (U.S. CLS. 21, 23, 26, 36
AND 38).
WENDY GOODMAN, EXAMINING ATTORNEY

SN 85-299,480. SMART MODULAR TECHNOLOGIES, INC.,
NEWARK, CA. FILED 4-20-2011.

VERIGUARD

THE MARK CONSISTS OF STANDARD CHARACTERS
WITHOUT CLAIM TO ANY PARTICULAR FONT, STYLE,
SIZE, OR COLOR.
FOR SOLID STATE DRIVES (U.S. CLS. 21, 23, 26, 36
AND 38).
WENDY GOODMAN, EXAMINING ATTORNEY

CLASS 9—(Continued).

SN 85-299,481. SMART MODULAR TECHNOLOGIES, INC., NEWARK, CA. FILED 4-20-2011.

HEALTHGUARD

THE MARK CONSISTS OF STANDARD CHARACTERS WITHOUT CLAIM TO ANY PARTICULAR FONT, STYLE, SIZE, OR COLOR.
FOR SOLID STATE DRIVES (U.S. CLS. 21, 23, 26, 36 AND 38).
WENDY GOODMAN, EXAMINING ATTORNEY

SN 85-299,482. SMART MODULAR TECHNOLOGIES, INC., NEWARK, CA. FILED 4-20-2011.

LIFEGUARD

THE MARK CONSISTS OF STANDARD CHARACTERS WITHOUT CLAIM TO ANY PARTICULAR FONT, STYLE, SIZE, OR COLOR.
FOR SOLID STATE DRIVES (U.S. CLS. 21, 23, 26, 36 AND 38).
WENDY GOODMAN, EXAMINING ATTORNEY

SN 85-299,483. SMART MODULAR TECHNOLOGIES, INC., NEWARK, CA. FILED 4-20-2011.

DRIVEGUARD

THE MARK CONSISTS OF STANDARD CHARACTERS WITHOUT CLAIM TO ANY PARTICULAR FONT, STYLE, SIZE, OR COLOR.
FOR SOLID STATE DRIVES (U.S. CLS. 21, 23, 26, 36 AND 38).
WENDY GOODMAN, EXAMINING ATTORNEY

CLASS 9—(Continued).

SN 85-301,027. GUIDEPOSTS A CHURCH CORPORATION, CARMEL, NY. FILED 4-21-2011.

TIME OUT FOR THE SPIRIT

THE MARK CONSISTS OF STANDARD CHARACTERS WITHOUT CLAIM TO ANY PARTICULAR FONT, STYLE, SIZE, OR COLOR.
FOR COMPUTER APPLICATION SOFTWARE FOR MOBILE PHONES, AND OTHER MOBILE DEVICES, NAMELY, SOFTWARE FOR THE TRANSMISSION OF DATA, SOUND AND GRAPHICS RELATING TO DEVOTIONAL AND INSPIRATIONAL MESSAGES AND CONTENT (U.S. CLS. 21, 23, 26, 36 AND 38).
STEVEN PEREZ, EXAMINING ATTORNEY

SN 85-301,263. ARECONT VISION, LLC, GLENDALE, CA. FILED 4-21-2011.

MegaVision

THE MARK CONSISTS OF STANDARD CHARACTERS WITHOUT CLAIM TO ANY PARTICULAR FONT, STYLE, SIZE, OR COLOR.
FOR SECURITY SURVEILLANCE CAMERA (U.S. CLS. 21, 23, 26, 36 AND 38).
BERYL GARDNER, EXAMINING ATTORNEY

SN 85-301,281. WEST CORPORATION, OMAHA, NE. FILED 4-21-2011.

SteadyLink

THE MARK CONSISTS OF STANDARD CHARACTERS WITHOUT CLAIM TO ANY PARTICULAR FONT, STYLE, SIZE, OR COLOR.
FOR NETWORK ROUTERS, NAMELY, PUBLIC SAFETY GRADE ROUTERS FOR PROVIDING SECURE REDUNDANT CONNECTIVITY BY LOAD-SHARING TRAFFIC OVER MULTIPLE INDEPENDENT TRANSPORT PATHS (U.S. CLS. 21, 23, 26, 36 AND 38).
SALLY SHIH, EXAMINING ATTORNEY

CLASS 9—(Continued).

SN 85-311,158. SAM ASH MUSIC CORPORATION, HICKSVILLE, NY. FILED 5-3-2011.

TOURTEK

THE MARK CONSISTS OF STANDARD CHARACTERS WITHOUT CLAIM TO ANY PARTICULAR FONT, STYLE, SIZE, OR COLOR.

OWNER OF U.S. REG. NO. 3,242,413.

FOR CABLES AND CONNECTORS FOR MICROPHONES, AUDIO SPEAKERS, AUDIO AMPLIFIERS AND MUSICAL INSTRUMENTS (U.S. CLS. 21, 23, 26, 36 AND 38).

FIRST USE 1-18-2006; IN COMMERCE 1-18-2006.

WILLIAM BRECKENFELD, EXAMINING ATTORNEY

SN 85-313,064. MPC INC., WILMINGTON, DE. FILED 5-5-2011.

FLEX-SENSE

THE MARK CONSISTS OF STANDARD CHARACTERS WITHOUT CLAIM TO ANY PARTICULAR FONT, STYLE, SIZE, OR COLOR.

FOR PARTICLE EMISSION SENSOR (U.S. CLS. 21, 23, 26, 36 AND 38).

FIRST USE 3-1-1996; IN COMMERCE 3-1-1996.

EMILY CHUO, EXAMINING ATTORNEY

SN 85-315,325. ALLI, ALLIANCE OF ACTION SPORTS, LLC, BURR RIDGE, IL. FILED 5-9-2011.

ALLI SPORTS

THE MARK CONSISTS OF STANDARD CHARACTERS WITHOUT CLAIM TO ANY PARTICULAR FONT, STYLE, SIZE, OR COLOR.

OWNER OF U.S. REG. NO. 3,908,921.

NO CLAIM IS MADE TO THE EXCLUSIVE RIGHT TO USE "SPORTS", APART FROM THE MARK AS SHOWN.

FOR INTERACTIVE ELECTRONIC PRODUCTS, NAMELY, VIDEO GAME PROGRAMS AND CARTRIDGES, AND COMPUTER GAME SOFTWARE AND CARTRIDGES; CELL PHONE ACCESSORIES, NAMELY, FACE PLATES AND CELL PHONE COVERS; PRE-RECORDED DVDS FEATURING A VARIETY OF SPORTING EVENTS AND COMPETITIONS; EYEWEAR, NAMELY, SUNGLASSES, SPORTS EYEWEAR AND PROTECTIVE EYEWEAR; SPORTS HELMETS (U.S. CLS. 21, 23, 26, 36 AND 38).

JOHN WILKE, EXAMINING ATTORNEY

CLASS 9—(Continued).

SN 85-315,355. ALLI, ALLIANCE OF ACTION SPORTS, LLC, BURR RIDGE, IL. FILED 5-9-2011.

ALLI ALLIANCE OF ACTION SPORTS

THE MARK CONSISTS OF STANDARD CHARACTERS WITHOUT CLAIM TO ANY PARTICULAR FONT, STYLE, SIZE, OR COLOR.

NO CLAIM IS MADE TO THE EXCLUSIVE RIGHT TO USE "ACTION SPORTS", APART FROM THE MARK AS SHOWN.

FOR INTERACTIVE ELECTRONIC PRODUCTS, NAMELY, VIDEO GAME PROGRAMS AND CARTRIDGES, AND COMPUTER GAME SOFTWARE AND CARTRIDGES; CELL PHONE ACCESSORIES, NAMELY, FACE PLATES AND CELL PHONE COVERS; PRE-RECORDED DVDS FEATURING A VARIETY OF SPORTING EVENTS AND COMPETITIONS; EYEWEAR, NAMELY, SUNGLASSES, SPORTS EYEWEAR AND PROTECTIVE EYEWEAR; SPORTS HELMETS (U.S. CLS. 21, 23, 26, 36 AND 38).

JOHN WILKE, EXAMINING ATTORNEY

SN 85-315,982. SAMSUNG ELECTRONICS CO., LTD., SUWON-SI, GYEONGGI-DO, REPUBLIC OF KOREA, FILED 5-9-2011.

SAMSUNG PROCLAIM

THE MARK CONSISTS OF STANDARD CHARACTERS WITHOUT CLAIM TO ANY PARTICULAR FONT, STYLE, SIZE, OR COLOR.

OWNER OF U.S. REG. NOS. 2,929,519, 3,503,660 AND OTHERS.

THE ENGLISH TRANSLATION OF "SAMSUNG" IN THE MARK IS "THREE STARS".

FOR MOBILE PHONES; SMARTPHONES (U.S. CLS. 21, 23, 26, 36 AND 38).

JULIE GUTTADAURO, EXAMINING ATTORNEY

SN 85-315,985. SAMSUNG ELECTRONICS CO., LTD., SUWON-SI, GYEONGGI-DO, REPUBLIC OF KOREA, FILED 5-9-2011.

SAMSUNG LEVITY

THE MARK CONSISTS OF STANDARD CHARACTERS WITHOUT CLAIM TO ANY PARTICULAR FONT, STYLE, SIZE, OR COLOR.

OWNER OF U.S. REG. NOS. 2,929,519, 3,503,660 AND OTHERS.

THE ENGLISH TRANSLATION OF "SAMSUNG" IN THE MARK IS "THREE STARS".

FOR MOBILE PHONES; SMARTPHONES (U.S. CLS. 21, 23, 26, 36 AND 38).

JULIE GUTTADAURO, EXAMINING ATTORNEY

CLASS 9—(Continued).

SN 85-315,989. SAMSUNG ELECTRONICS CO., LTD., SU-WON-SI, GYEONGGI-DO, REPUBLIC OF KOREA, FILED 5-9-2011.

SAMSUNG GENERIS

THE MARK CONSISTS OF STANDARD CHARACTERS WITHOUT CLAIM TO ANY PARTICULAR FONT, STYLE, SIZE, OR COLOR.

OWNER OF U.S. REG. NOS. 2,929,519, 3,503,660 AND OTHERS.

THE ENGLISH TRANSLATION OF "SAMSUNG" IN THE MARK IS "THREE STARS".

FOR MOBILE PHONES; SMARTPHONES (U.S. CLS. 21, 23, 26, 36 AND 38).

JULIE GUTTADAURO, EXAMINING ATTORNEY

CLASS 9—(Continued).

SN 85-317,675. SAMSUNG ELECTRONICS CO., LTD., SU-WON-SI, GYEONGGI-DO, REPUBLIC OF KOREA, FILED 5-11-2011.

SAMSUNG SAY N GO

THE MARK CONSISTS OF STANDARD CHARACTERS WITHOUT CLAIM TO ANY PARTICULAR FONT, STYLE, SIZE, OR COLOR.

OWNER OF U.S. REG. NOS. 2,882,774, 2,929,523 AND OTHERS.

THE ENGLISH TRANSLATION OF "SAMSUNG" IN THE MARK IS "THREE STARS".

FOR COMPUTER APPLICATION SOFTWARE FOR MOBILE PHONES AND TABLET COMPUTERS, NAMELY, SOFTWARE FOR USE IN VOICE RECOGNITION AND TRANSLATION (U.S. CLS. 21, 23, 26, 36 AND 38).

JULIE GUTTADAURO, EXAMINING ATTORNEY

SN 85-315,990. SAMSUNG ELECTRONICS CO., LTD., SU-WON-SI, GYEONGGI-DO, REPUBLIC OF KOREA, FILED 5-9-2011.

SAMSUNG GENERATE

THE MARK CONSISTS OF STANDARD CHARACTERS WITHOUT CLAIM TO ANY PARTICULAR FONT, STYLE, SIZE, OR COLOR.

OWNER OF U.S. REG. NOS. 2,929,519, 3,503,660 AND OTHERS.

THE ENGLISH TRANSLATION OF "SAMSUNG" IN THE MARK IS "THREE STARS".

FOR MOBILE PHONES; SMARTPHONES (U.S. CLS. 21, 23, 26, 36 AND 38).

JULIE GUTTADAURO, EXAMINING ATTORNEY

SN 85-319,729. SAMSUNG ELECTRONICS CO., LTD., SU-WON-SI, GYEONGGI-DO, REPUBLIC OF KOREA, FILED 5-12-2011.

GALAXY CHOICE

THE MARK CONSISTS OF STANDARD CHARACTERS WITHOUT CLAIM TO ANY PARTICULAR FONT, STYLE, SIZE, OR COLOR.

OWNER OF U.S. REG. NO. 3,905,843.

FOR COMPUTER APPLICATION SOFTWARE FOR MOBILE PHONES AND TABLET COMPUTERS, NAMELY, SOFTWARE THAT RECOMMENDS THE BEST APPLICATIONS FOR USE ON DEVICE (U.S. CLS. 21, 23, 26, 36 AND 38).

JULIE GUTTADAURO, EXAMINING ATTORNEY

SN 85-316,210. SAMSUNG ELECTRONICS CO., LTD., SU-WON-SI, GYEONGGI-DO, REPUBLIC OF KOREA, FILED 5-9-2011.

IT'S TIME TO TAB

THE MARK CONSISTS OF STANDARD CHARACTERS WITHOUT CLAIM TO ANY PARTICULAR FONT, STYLE, SIZE, OR COLOR.

FOR TABLET COMPUTER (U.S. CLS. 21, 23, 26, 36 AND 38).

JULIE GUTTADAURO, EXAMINING ATTORNEY

SN 85-319,746. SAMSUNG ELECTRONICS CO., LTD., SU-WON-SI, GYEONGGI-DO, REPUBLIC OF KOREA, FILED 5-12-2011.

SAMSUNG DENIM

THE MARK CONSISTS OF STANDARD CHARACTERS WITHOUT CLAIM TO ANY PARTICULAR FONT, STYLE, SIZE, OR COLOR.

OWNER OF U.S. REG. NOS. 2,929,519, 3,503,660 AND OTHERS.

THE ENGLISH TRANSLATION OF "SAMSUNG" IN THE MARK IS "THREE STARS".

FOR MOBILE PHONES; SMARTPHONES (U.S. CLS. 21, 23, 26, 36 AND 38).

JULIE GUTTADAURO, EXAMINING ATTORNEY

CLASS 10—MEDICAL APPARATUS

SN 76-705,270. JANICE P. MURRAY, ABINGTON, MA. FILED 11-8-2010.



NO CLAIM IS MADE TO THE EXCLUSIVE RIGHT TO USE "TRUNK TRAINER STRENGTHENING THRU THE SPINE", APART FROM THE MARK AS SHOWN.

THE COLOR(S) OFF WHITE, PURPLE, GRAY, GREEN AND BLACK IS/ARE CLAIMED AS A FEATURE OF THE MARK.

THE MARK CONSISTS OF AN OFF WHITE COLORED HUMAN SPINE OUTLINED IN BLACK AND A LIGHT GRAY ELEPHANT TRUNK NEXT TO THE SPINE WRAPPED WITH A GREEN VINE AND THREE PURPLE MORNING GLORY FLOWERS. THE WORDS "TRUNK TRAINER" ARE PRINTED IN BLACK CAPITAL LETTERS ALONG THE RIGHT SIDE OF THE ELEPHANT TRUNK IN A CURVED-CLOCKWISE-DOWNWARD DIRECTION. THE WORDS "STRENGTHENING THRU THE SPINE" ARE HAND PRINTED IN BLACK ON THE LEFT LOWER PORTION BELOW ONE OF THE MORNING GLORIES IN A CURVED-DOWNWARD-COUNTERCLOCKWISE DIRECTION.

FOR MANUALLY-OPERATED EXERCISE EQUIPMENT, NAMELY, FOR PHYSICAL REHABILITATION AND PHYSICAL THERAPY PURPOSES (U.S. CLS. 26, 39 AND 44).

FIRST USE 10-26-2009; IN COMMERCE 10-26-2009. VIVIAN MICZNIK FIRST, EXAMINING ATTORNEY

CLASS 10—(Continued).

SN 77-768,296. NEORAD AS, OSLO, NORWAY, FILED 6-25-2009.

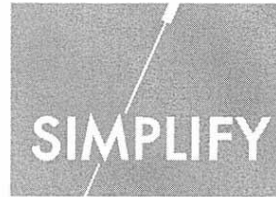

PRIORITY CLAIMED UNDER SEC. 44(D) ON NORWAY APPLICATION NO. 200904363, FILED 4-28-2009, REG. NO. 251644, DATED 6-30-2009, EXPIRES 6-30-2019.

THE MARK CONSISTS OF THE WORD "SIMPLIFY" WITH A LINE BISECTING IT INTO 2 SECTIONS ALL APPEARING ON A RECTANGLE.

FOR NEEDLE HOLDER FOR IMAGE GUIDED INTERVENTION PERFORMED BY RADIOLOGISTS (U.S. CLS. 26, 39 AND 44).

JESSICA FATHY, EXAMINING ATTORNEY

SN 77-785,997. LINVATEC CORPORATION, LARGO, FL. FILED 7-21-2009.

SURE SHOT

THE MARK CONSISTS OF STANDARD CHARACTERS WITHOUT CLAIM TO ANY PARTICULAR FONT, STYLE, SIZE, OR COLOR.

FOR SURGICAL INSTRUMENTS, NAMELY, SUTURE PASSING DEVICES FOR PASSING SUTURE THROUGH TISSUE (U.S. CLS. 26, 39 AND 44).

MEGHAN REINHART, EXAMINING ATTORNEY

SN 77-888,336. CROSSTEX INTERNATIONAL, INC., HAUPAUGE, NY. FILED 12-8-2009.

ULTRA

THE MARK CONSISTS OF STANDARD CHARACTERS WITHOUT CLAIM TO ANY PARTICULAR FONT, STYLE, SIZE, OR COLOR.

FOR SURGICAL FACE MASKS (U.S. CLS. 26, 39 AND 44).

FIRST USE 1-1-2005; IN COMMERCE 1-1-2005. KAPIL BHANOT, EXAMINING ATTORNEY

CLASS 10—(Continued).

SN 77-922,532. SI03, INC., CAPE GIRARDEAU, MO. FILED 1-28-2010.

METRIX

THE MARK CONSISTS OF STANDARD CHARACTERS WITHOUT CLAIM TO ANY PARTICULAR FONT, STYLE, SIZE, OR COLOR.

FOR ALARMS AND SENSORS TO BE WORN ON A PERSON WHILE EXERCISING FOR THE PURPOSE OF MONITORING HEART RATE; BODY-FAT MONITORS; DEVICES FOR MONITORING BLOOD GLUCOSE FOR MEDICAL PURPOSES; HEALTH MONITORING DEVICES, NAMELY, BLOOD PRESSURE MONITORS, THERMOMETERS AND PEDOMETERS; HEART MONITORS; HEART MONITORS TO BE WORN DURING EXERCISE; PATIENT MONITORING SENSORS AND ALARMS; PULSE RATE MONITORS; RESPIRATION MONITORS (U.S. CLS. 26, 39 AND 44).

ELIZABETH KAJUBI, EXAMINING ATTORNEY

SN 79-025,400. MAQUET S.A., FRANCE, FILED 4-7-2006.

MODUTEC

THE MARK CONSISTS OF STANDARD CHARACTERS WITHOUT CLAIM TO ANY PARTICULAR FONT, STYLE, SIZE, OR COLOR.

PRIORITY DATE OF 10-27-2005 IS CLAIMED.

OWNER OF INTERNATIONAL REGISTRATION 0889008 DATED 4-7-2006, EXPIRES 4-7-2016.

FOR CEILING SERVICE UNITS, DOME LIGHTS AND OPERATORY LIGHTING LAMPS FOR OPERATORY APPARATUS (U.S. CLS. 26, 39 AND 44).

ARETHA SOMERVILLE, EXAMINING ATTORNEY

SN 79-088,652. PROSTALUND OPERATIONS AB, SE-751 06 UPSALA, SWEDEN, FILED 5-19-2010.

CORETHERM

THE MARK CONSISTS OF STANDARD CHARACTERS WITHOUT CLAIM TO ANY PARTICULAR FONT, STYLE, SIZE, OR COLOR.

OWNER OF INTERNATIONAL REGISTRATION 1054735 DATED 5-19-2010, EXPIRES 5-19-2020.

OWNER OF U.S. REG. NO. 2,745,160.

FOR SURGICAL, MEDICAL, ODONTOLOGICAL AND VETERINARY APPARATUS AND INSTRUMENTS FOR UROLOGICAL SURGERY; MEDICAL APPARATUS AND INSTRUMENTS FOR UROLOGICAL TREATMENT AND FOR HEAT TREATMENT OF BODY TISSUE; CATHETERS, TREATMENT CATHETERS (U.S. CLS. 26, 39 AND 44).

MARLENE BELL, EXAMINING ATTORNEY

CLASS 10—(Continued).

SN 79-088,809. MAM BABYARTIKEL GESELLSCHAFT M.B.H., AUSTRIA, FILED 9-22-2010.

DENTOFLEX

THE MARK CONSISTS OF STANDARD CHARACTERS WITHOUT CLAIM TO ANY PARTICULAR FONT, STYLE, SIZE, OR COLOR.

PRIORITY DATE OF 4-6-2010 IS CLAIMED.

OWNER OF INTERNATIONAL REGISTRATION 1055149 DATED 9-22-2010, EXPIRES 9-22-2020.

FOR PACIFIERS AND TEATS FOR BABIES; PARTS AND FITTINGS OF THE AFORESAID GOODS, NAMELY, PACIFIER SHIELDS (U.S. CLS. 26, 39 AND 44).

DEBRA LEE, EXAMINING ATTORNEY

SN 79-092,652. WEN SONGXIA, CHINA, FILED 11-24-2010.

JIEAN 捷安

OWNER OF INTERNATIONAL REGISTRATION 1065359 DATED 11-24-2010, EXPIRES 11-24-2020.

THE MARK CONSISTS OF THE TERM "JIEAN" WITH THE DESIGN OF A HEART IN THE LETTER "A". TO THE RIGHT OF THIS TERM APPEARS TWO CHINESE CHARACTERS TRANSLITERATED AS "JIE AN".

THE ENGLISH TRANSLATION OF THE FOREIGN WORD(S) IN THE MARK IS: THE FIRST CHINESE CHARACTER WHOSE TRANSLITERATION IS "JIE" MEANS "NIMBLE", THE SECOND CHINESE CHARACTER WHOSE TRANSLITERATION IS "AN" MEANS "SAFE".

THE TRANSLITERATION OF THE NON-LATIN CHARACTERS IN THE MARK IS: JIE AN.

FOR ANAESTHETIC MASKS; ANAESTHETIC DELIVERY APPARATUS; CATHETERS; ANAESTHETIC INSTRUMENT BAGS FOR USE BY SURGEONS AND DOCTORS (U.S. CLS. 26, 39 AND 44).

MICHAEL WIENER, EXAMINING ATTORNEY

SN 79-095,449. THUASNE, FRANCE, FILED 3-3-2011.

GENUIMMO

THE MARK CONSISTS OF STANDARD CHARACTERS WITHOUT CLAIM TO ANY PARTICULAR FONT, STYLE, SIZE, OR COLOR.

OWNER OF INTERNATIONAL REGISTRATION 1072154 DATED 3-3-2011, EXPIRES 3-3-2021.

FOR PRESSURE AND RESTRAINT ARTICLES, NAMELY KNEE SUPPORTS, BELTS AND STRAPS, BRACES, FOR MEDICAL AND ORTHOPEDIC PURPOSES FOR SUPPORTING, HOLDING, IMMOBILISING, COMPRESSING AND STABILISING THE KNEE (U.S. CLS. 26, 39 AND 44).

ALLISON HOLTZ, EXAMINING ATTORNEY

CLASS 10—(Continued).

SN 85-012,425. DIABETIC SUPPLY OF SUNCOAST, DORADO, PUERTO RICO, FILED 4-13-2010.

Personal Patient Advocate

THE MARK CONSISTS OF STANDARD CHARACTERS WITHOUT CLAIM TO ANY PARTICULAR FONT, STYLE, SIZE, OR COLOR.

OWNER OF U.S. REG. NOS. 3,321,780, 3,321,781 AND 3,486,798.

NO CLAIM IS MADE TO THE EXCLUSIVE RIGHT TO USE "PERSONAL PATIENT", APART FROM THE MARK AS SHOWN.

FOR APPARATUS FOR BLOOD ANALYSIS; BLOOD GLUCOSE METER; BLOOD TESTING APPARATUS; DEVICES FOR MEASURING BLOOD SUGAR FOR MEDICAL PURPOSES; DEVICES FOR MONITORING BLOOD GLUCOSE FOR MEDICAL PURPOSES (U.S. CLS. 26, 39 AND 44).

HEATHER THOMPSON, EXAMINING ATTORNEY

SN 85-058,375. CORE 3D CENTRES LLP, DBA CORE 3D CENTRES, LAS VEGAS, NV. FILED 6-9-2010.

CORE 3d CENTRES

THE MARK CONSISTS OF STANDARD CHARACTERS WITHOUT CLAIM TO ANY PARTICULAR FONT, STYLE, SIZE, OR COLOR.

NO CLAIM IS MADE TO THE EXCLUSIVE RIGHT TO USE "3D CENTRES", APART FROM THE MARK AS SHOWN.

FOR DENTAL INSTRUMENTS, NAMELY, DENTAL MILLING MACHINES (U.S. CLS. 26, 39 AND 44).

FIRST USE 3-1-2010; IN COMMERCE 3-1-2010.
LOURDES AYALA, EXAMINING ATTORNEY

SN 85-098,630. MEINHOLD, MATTHIAS, NUREMBERG, FED REP GERMANY, FILED 8-3-2010.

tickSAFE

THE MARK CONSISTS OF STANDARD CHARACTERS WITHOUT CLAIM TO ANY PARTICULAR FONT, STYLE, SIZE, OR COLOR.

PRIORITY CLAIMED UNDER SEC. 44(D) ON ERPNCMNTY TM OFC APPLICATION NO. 009238775, FILED 7-12-2010, REG. NO. 009238775, DATED 12-24-2010, EXPIRES 7-12-2020.

FOR MEDICAL APPARATUS, NAMELY, TICK REMOVAL DEVICES (U.S. CLS. 26, 39 AND 44).

FIRST USE 7-1-2010; IN COMMERCE 7-1-2010.
LINDA M. KING, EXAMINING ATTORNEY

CLASS 10—(Continued).

SN 85-104,222. HYPNOZ THERAPEUTIC DEVICES, INC., SAN DIEGO, CA. FILED 8-10-2010.



The logo for HYPNOZ THERAPEUTIC DEVICES features the word "HYPNOZ" in a bold, sans-serif font. To the left of the "H" is a stylized graphic of a human head profile in profile, facing right. Below "HYPNOZ" is the text "THERAPEUTIC DEVICES" in a smaller, all-caps, sans-serif font.

OWNER OF U.S. REG. NO. 3,782,127.

NO CLAIM IS MADE TO THE EXCLUSIVE RIGHT TO USE "THERAPEUTIC DEVICES", APART FROM THE MARK AS SHOWN.

FOR SUPPORTS FOR JAWS FOR MEDICAL USE (U.S. CLS. 26, 39 AND 44).

FIRST USE 10-22-2008; IN COMMERCE 10-22-2008.
SIMON TENG, EXAMINING ATTORNEY

SN 85-104,318. SPECTRA MEDICAL DEVICES, INC., WILMINGTON, MA. FILED 8-10-2010.

SPECTRA MEDICAL DEVICES, INC.

THE MARK CONSISTS OF STANDARD CHARACTERS WITHOUT CLAIM TO ANY PARTICULAR FONT, STYLE, SIZE, OR COLOR.

NO CLAIM IS MADE TO THE EXCLUSIVE RIGHT TO USE "MEDICAL DEVICES, INC.", APART FROM THE MARK AS SHOWN.

FOR NEEDLES FOR MEDICAL USE, NAMELY, EPIDURAL NEEDLES, SPINAL NEEDLES, STRAIGHT AND NON-CORING HUBER AND CANNULA NEEDLES, GUIDE WIRE INTRODUCERS FOR RADIO FREQUENCY NEEDLES, CUSTOM NEEDLES (MADE TO CUSTOMER SPECIFICATION) AND COATED NEEDLES, GLASS AND PLASTIC LOSS OF RESISTANCE (LOR) SYRINGES; MEDICAL AND SURGICAL INSTRUMENTS, NAMELY, HYPODERMIC TUBING AND WIRE, BRASS AND STEEL METAL FITTINGS FOR NEEDLES; DISPOSABLE SCALPELS, BLADES AND SAFETY SCALPELS; SURGICAL INSTRUMENTS FOR DENTAL USE; SURGICAL SPONGE APPLICATORS; BIOHAZARD BAGS FOR MEDICAL WASTE AND SURGICAL PLASTIC RULERS (U.S. CLS. 26, 39 AND 44).

FIRST USE 7-1-1995; IN COMMERCE 7-1-1995.
ANGELA M. MICHELI, EXAMINING ATTORNEY

CLASS 10—(Continued).

SN 85-113,207. ARJO HOSPITAL EQUIPMENT AB, ESLOV, SWEDEN, FILED 8-23-2010.

STEDY

THE MARK CONSISTS OF STANDARD CHARACTERS WITHOUT CLAIM TO ANY PARTICULAR FONT, STYLE, SIZE, OR COLOR.

FOR DEVICES FOR LIFTING, HANDLING, AND TRANSPORTING PATIENTS, INVALIDS, AND DISABLED PERSONNEL, NAMELY, INVALID LIFTS, INVALID HOISTS, INVALID OVERHEAD CRANES, SLINGS, STRETCHERS; DEVICES FOR SUPPORTING PATIENTS, INVALIDS, AND DISABLED PERSONNEL FOR MEDICAL PURPOSES, NAMELY, STANDING AIDS AND SUPPORTS; DEVICES FOR ASSISTING IN PERSONAL HYGIENE OF PATIENTS, INVALIDS, AND DISABLED PERSONNEL, NAMELY, STRETCHERS FOR USE IN SHOWERS, BATHS, AND POOLS, AND FOR SECURING AND ALLOWING ACCESS TO PATIENTS, INVALIDS, AND DISABLED PERSONNEL DURING ASSISTED WASHING (U.S. CLS. 26, 39 AND 44).

PRISCILLA MILTON, EXAMINING ATTORNEY

SN 85-123,353. BILAUER ENTERPRISES, LLC, HOWELL, MI. FILED 9-4-2010.

Evac-Q-Sling

THE MARK CONSISTS OF STANDARD CHARACTERS WITHOUT CLAIM TO ANY PARTICULAR FONT, STYLE, SIZE, OR COLOR.

FOR STRETCHERS FOR PERSON TRANSPORT, NAMELY, A SLING CONSTRUCTED PRIMARILY OF FABRIC FOR SUPPORTING A PERSON INCLUDING A PERSON'S ARMS, WRISTS, LEGS AND ANY OTHER BODY PARTS, FOR USE AS AN EMERGENCY INVALID LIFTING AND EVACUATION DEVICE, AND FOR A PATIENT SAFETY RESTRAINT (U.S. CLS. 26, 39 AND 44).

FIRST USE 2-26-2009; IN COMMERCE 5-27-2009.

MARCIE MILONE, EXAMINING ATTORNEY

CLASS 10—(Continued).

SN 85-126,189. PHYSIO-CONTROL, INC., REDMOND, WA. FILED 9-9-2010.

TrueCPR

THE MARK CONSISTS OF STANDARD CHARACTERS WITHOUT CLAIM TO ANY PARTICULAR FONT, STYLE, SIZE, OR COLOR.

FOR MEDICAL APPARATUS AND INSTRUMENTS, NAMELY, APPARATUS FOR INDICATING CHEST COMPRESSION AND ANALYSIS APPARATUS FOR MEDICAL PURPOSES, NAMELY, APPARATUS FOR ANALYSIS RELATED TO DEFIBRILLATION (U.S. CLS. 26, 39 AND 44).

JEFFERY COWARD, EXAMINING ATTORNEY

SN 85-133,494. EMBRACE HEALTHCARE, LLC, NASHUA, NH. FILED 9-20-2010.



THE MARK CONSISTS OF THE TERMINOLOGY "COSMIC NEE-NOGGS" IN AN ARC ABOVE FANCIFUL SPACE ALIEN CHARACTERS IN A SPACE SETTING WITH A ROCKET.

FOR MEDICAL MASKS, NAMELY, FACE SHIELDS AND EYE SHIELDS (U.S. CLS. 26, 39 AND 44).

FIRST USE 5-1-2010; IN COMMERCE 5-1-2010.

CHARLES L. JENKINS, EXAMINING ATTORNEY

SN 85-139,804. MASIMO LABORATORIES, INC., IRVINE, CA. FILED 9-28-2010.

ZUNZUNCITO

THE MARK CONSISTS OF STANDARD CHARACTERS WITHOUT CLAIM TO ANY PARTICULAR FONT, STYLE, SIZE, OR COLOR.

FOR MEDICAL DEVICES, NAMELY, PATIENT MONITORS AND PATIENT SENSORS FOR MONITORING AND MEASURING BLOOD PROPERTIES OR RESPIRATORY EVENTS (U.S. CLS. 26, 39 AND 44).

DANIEL CAPSHAW, EXAMINING ATTORNEY

CLASS 10—(Continued).

SN 85-157,838. SALZMAN AG, ST. GALLEN, SWITZERLAND, FILED 10-21-2010.

Venopress

THE MARK CONSISTS OF STANDARD CHARACTERS WITHOUT CLAIM TO ANY PARTICULAR FONT, STYLE, SIZE, OR COLOR.

OWNER OF U.S. REG. NOS. 1,884,807 AND 1,942,283.
FOR MEDICAL COMPRESSION STOCKING FOR THE THIGH FOR SAPHENOUS VEIN ABLATION (U.S. CLS. 26, 39 AND 44).

BERYL GARDNER, EXAMINING ATTORNEY

CLASS 10—(Continued).

SN 85-162,339. WAG AND BARK ENTERPRISES, L.L.C., THE WOODLANDS, TX. FILED 10-27-2010.



NO CLAIM IS MADE TO THE EXCLUSIVE RIGHT TO USE "TICK FREE AMERICA", APART FROM THE MARK AS SHOWN.

THE COLOR(S) GREEN, DARK GREEN, LIGHT GREEN, YELLOW, AND WHITE IS/ARE CLAIMED AS A FEATURE OF THE MARK.

THE MARK CONSISTS OF THE WORDING "TICKZAPPER" WHERE THE LETTERS "TICK" "APPER" ARE GREEN AND OUTLINED IN DARK GREEN AND WHITE, AND THE LETTER "Z" IS YELLOW AND OUTLINED IN DARK GREEN AND WHITE, AND STYLIZED TO LOOK LIKE A LIGHTNING BOLT. THE WORDING "TICK FREE AMERICA" IS IN DARK GREEN AND OUTLINED IN WHITE. THE WORDING AND DESIGN APPEAR AGAINST A LIGHT GREEN RECTANGULAR BACKGROUND.

FOR HAND OPERATED REACHING DEVICES FOR PICKING UP AND REMOVING OBJECTS, NAMELY, TICKS (U.S. CLS. 26, 39 AND 44).

FIRST USE 5-1-2010; IN COMMERCE 5-1-2010.

RICHARD WHITE, EXAMINING ATTORNEY

SN 85-163,720. ULTRADENT PRODUCTS, INC., SOUTH JORDAN, UT. FILED 10-28-2010.

ARIOS

THE MARK CONSISTS OF STANDARD CHARACTERS WITHOUT CLAIM TO ANY PARTICULAR FONT, STYLE, SIZE, OR COLOR.

FOR ENDODONTIC INSTRUMENTS, NAMELY, DENTAL HANDPIECES (U.S. CLS. 26, 39 AND 44).

JOHN DALIER, EXAMINING ATTORNEY

SN 85-162,235. MEDTRONIC, INC., MINNEAPOLIS, MN. FILED 10-27-2010.

ENSURA DR MRI

THE MARK CONSISTS OF STANDARD CHARACTERS WITHOUT CLAIM TO ANY PARTICULAR FONT, STYLE, SIZE, OR COLOR.

NO CLAIM IS MADE TO THE EXCLUSIVE RIGHT TO USE "DR MRI", APART FROM THE MARK AS SHOWN.

THE WORDING "ENSURA" HAS NO MEANING IN A FOREIGN LANGUAGE.

FOR IMPLANTED CARDIAC DEVICES, NAMELY, PACEMAKERS AND COMPONENT PARTS AND FITTINGS THEREFOR (U.S. CLS. 26, 39 AND 44).

TINA BROWN, EXAMINING ATTORNEY

SN 85-172,472. MEDTRONIC, INC., MINNEAPOLIS, MN. FILED 11-9-2010.

CAPSURE SENSE MRI

THE MARK CONSISTS OF STANDARD CHARACTERS WITHOUT CLAIM TO ANY PARTICULAR FONT, STYLE, SIZE, OR COLOR.

OWNER OF U.S. REG. NOS. 1,454,090, 2,675,693 AND OTHERS.

NO CLAIM IS MADE TO THE EXCLUSIVE RIGHT TO USE "SENSE MRI", APART FROM THE MARK AS SHOWN.

FOR MEDICAL LEADS, NAMELY, CARDIAC PACING LEADS (U.S. CLS. 26, 39 AND 44).

TINA BROWN, EXAMINING ATTORNEY

CLASS 10—(Continued).

SN 85-185,980. GENERAL ELECTRIC COMPANY, SCHE-
NECTADY, NY. FILED 11-29-2010.

FLASHPAD

THE MARK CONSISTS OF STANDARD CHARACTERS
WITHOUT CLAIM TO ANY PARTICULAR FONT, STYLE,
SIZE, OR COLOR.

FOR WIRELESS DIGITAL DETECTOR, NAMELY, A
MEDICAL IMAGING DEVICE FOR USE WITH X-RAY
SYSTEMS (U.S. CLS. 26, 39 AND 44).
DAVID I, EXAMINING ATTORNEY

CLASS 10—(Continued).

SN 85-196,641. KEYSTONE DENTAL, INC., BURLINGTON,
MA. FILED 12-13-2010.

SURECONNECT

THE MARK CONSISTS OF STANDARD CHARACTERS
WITHOUT CLAIM TO ANY PARTICULAR FONT, STYLE,
SIZE, OR COLOR.

FOR STRUCTURAL CONNECTOR FOR DENTAL
ABUTMENTS AND DENTAL PROSTHETICS (U.S. CLS.
26, 39 AND 44).
FIRST USE 11-1-2010; IN COMMERCE 12-7-2010.
CORY BOONE, EXAMINING ATTORNEY

SN 85-191,323. DERMATOLOGIC LAB AND SUPPLY, INC.,
DBA DELASCO, COUNCIL BLUFFS, IA. FILED 12-6-2010.



OWNER OF U.S. REG. NOS. 1,406,622, 1,627,763 AND
1,664,921.

NO CLAIM IS MADE TO THE EXCLUSIVE RIGHT TO
USE "DERMATOLOGIC LAB AND SUPPLY INC", APART
FROM THE MARK AS SHOWN.

THE MARK CONSISTS OF A HALF GLOBE WITH
ORBITS FOLLOWING "DELASCO DERMATOLOGIC LAB
AND SUPPLY INC". THE LETTER "D" IN "DELASCO"
APPEARS WITHIN A BOX LIKE DESIGN.

FOR SURGICAL AND MEDICAL APPARATUS AND
INSTRUMENTS FOR USE IN GENERAL SURGERY (U.S.
CLS. 26, 39 AND 44).

FIRST USE 1-1-2010; IN COMMERCE 1-1-2010.
ELIZABETH KAJUBI, EXAMINING ATTORNEY

SN 85-203,107. POLY-MED, INC., ANDERSON, SC. FILED 12-
21-2010.

GLYCOPRENE

SN 85-194,999. 3088081 CANADA INC., QUEBEC, CANADA,
FILED 12-10-2010.

COREDISH

THE MARK CONSISTS OF STANDARD CHARACTERS
WITHOUT CLAIM TO ANY PARTICULAR FONT, STYLE,
SIZE, OR COLOR.

FOR MULTI-COMPARTMENT BIOPSY SPECIMEN
CONTAINER FOR USE IN THE MEDICAL FIELD (U.S.
CLS. 26, 39 AND 44).

BRIDGETT SMITH, EXAMINING ATTORNEY

THE MARK CONSISTS OF STANDARD CHARACTERS
WITHOUT CLAIM TO ANY PARTICULAR FONT, STYLE,
SIZE, OR COLOR.

OWNER OF U.S. REG. NOS. 2,952,831 AND 3,261,428.
FOR MEDICAL APPARATUS FOR USE IN SURGERY,
NAMELY, ABSORBABLE SURGICAL MESH; ABSORB-
ABLE MONOFILAMENT FOR MEDICAL USES,
NAMELY, FOR USE IN SUTURES AND LOCATION
MARKING DEVICES; MULTIFILAMENT FOR USE IN
SUTURES; INJECTION MOLDED ARTICLES FOR USE
IN SURGICAL STAPLES AND FASTENER DEVICES
(U.S. CLS. 26, 39 AND 44).

FIRST USE 4-1-2009; IN COMMERCE 4-1-2009.
ELIZABETH KAJUBI, EXAMINING ATTORNEY

CLASS 10—(Continued).

SN 85-205,754. BIOPROTECT LTD., LOD, ISRAEL, FILED 12-27-2010.

PROSPACE

THE MARK CONSISTS OF STANDARD CHARACTERS WITHOUT CLAIM TO ANY PARTICULAR FONT, STYLE, SIZE, OR COLOR.

FOR MEDICAL AND SURGICAL INSTRUMENTS, NAMELY, BALLOON IMPLANTS OF ARTIFICIAL MATERIALS, BLADDER IMPLANTS OF ARTIFICIAL MATERIALS, BIODEGRADABLE OR BIOABSORBABLE IMPLANTS OF ARTIFICIAL MATERIALS, BALLOON CATHETERS, EXPANDABLE AND/OR INFLATABLE TISSUE EXTRACTORS, EXPANDABLE AND/OR INFLATABLE TISSUE DISSECTORS, EXPANDABLE AND/OR INFLATABLE RADIATION SCREENING DEVICES, EXPANDABLE AND/OR INFLATABLE TISSUE DISPLACEMENT DEVICES, EXPANDABLE AND/OR INFLATABLE TISSUE SEPARATING DEVICES AND EXPANDABLE AND/OR INFLATABLE IMPLANT-TO-TISSUE FIXATORS; SURGICAL INSTRUMENT KITS CONTAINING BALLOON IMPLANTS OF ARTIFICIAL MATERIALS AND ACCESSORIES THEREOF, NAMELY, INTRODUCTION NEEDLES, ECOGENIC NEEDLES, HYDRO-DISSECTION INSTRUMENTS, EXTENSION TUBES, DILATORS, DELIVERY NEEDLES AND/OR SHEETHS; MEDICAL SYSTEMS AND DEVICES FOR INTRODUCING, DEPLOYING AND/OR CONTROLLING BALLOONS INSIDE A HUMAN BODY, NAMELY, MEDICAL NEEDLES, TROCARS, MEDICAL SYRINGES, MEDICAL DILATORS, EXTERNAL GUIDING TEMPLATES, IMPLANT FIXATORS, HANDHELD INTRODUCERS, AND HANDLES (U.S. CLS. 26, 39 AND 44).

ARETHA SOMERVILLE, EXAMINING ATTORNEY

SN 85-206,449. ALLEN MEDICAL SYSTEMS, INC., BATESVILLE, IN. FILED 12-28-2010.

EASY CATCHER

THE MARK CONSISTS OF STANDARD CHARACTERS WITHOUT CLAIM TO ANY PARTICULAR FONT, STYLE, SIZE, OR COLOR.

NO CLAIM IS MADE TO THE EXCLUSIVE RIGHT TO USE "CATCHER", APART FROM THE MARK AS SHOWN. FOR SURGICAL TABLE ACCESSORIES, NAMELY, FLUID CONTAINMENT APPARATUS (U.S. CLS. 26, 39 AND 44).

TIMOTHY FINNEGAN, EXAMINING ATTORNEY

CLASS 10—(Continued).

SN 85-214,528. SAFE INDEPENDENCE, LLC, SURPRISE, AZ. FILED 1-10-2011.



THE MARK CONSISTS OF THE WORDS "SECURE TRACKS" ABOVE THE WORDS "KEEPING RECOVERY ON TRACK" NEXT TO A STYLIZED FIGURE WITH AN "X" SYMBOLIZING THE BODY AND AN "O" SYMBOLIZING THE HEAD WITH A DIAGONAL LINE UNDERNEATH.

FOR MEDICAL APPARATUS, NAMELY, A PATIENT SUPPORT FRAME USED IN CONJUNCTION WITH A ROLLING TROLLEY AND OVERHEAD MONORAIL TRACK FOR USE IN REHABILITATION THERAPY (U.S. CLS. 26, 39 AND 44).

SUSAN RICHARDS, EXAMINING ATTORNEY

SN 85-219,553. PERMA LABORATORIES, LLC, RICHFIELD, OH. FILED 1-18-2011.

PROSOFT PROFESSIONAL DENTURE RELINER

THE MARK CONSISTS OF STANDARD CHARACTERS WITHOUT CLAIM TO ANY PARTICULAR FONT, STYLE, SIZE, OR COLOR.

NO CLAIM IS MADE TO THE EXCLUSIVE RIGHT TO USE "PROFESSIONAL DENTURE RELINER", APART FROM THE MARK AS SHOWN.

FOR PLASTIC MATERIAL FOR PRODUCING, RELINING AND REPAIR OF DENTAL PROSTHESES (U.S. CLS. 26, 39 AND 44).

FIRST USE 1-14-2011; IN COMMERCE 1-14-2011.

ANDREW LEASER, EXAMINING ATTORNEY

SN 85-231,489. ALTICOR INC., ADA, MI. FILED 2-1-2011.

CLEAR.NOW

THE MARK CONSISTS OF STANDARD CHARACTERS WITHOUT CLAIM TO ANY PARTICULAR FONT, STYLE, SIZE, OR COLOR.

OWNER OF U.S. REG. NOS. 3,064,432 AND 3,729,915. FOR MEDICAL APPARATUS, NAMELY, ELECTRIC HEATING DEVICES FOR CURATIVE TREATMENT, NAMELY, FOR THE TREATMENT OF ACNE AND SKIN BLEMISHES (U.S. CLS. 26, 39 AND 44).

TARA PATE, EXAMINING ATTORNEY

CLASS 10—(Continued).

SN 85-241,681. SPECTRA MEDICAL DEVICES, INC., WILMINGTON, MA. FILED 2-14-2011.

PORT GLIDE

THE MARK CONSISTS OF STANDARD CHARACTERS WITHOUT CLAIM TO ANY PARTICULAR FONT, STYLE, SIZE, OR COLOR.

NO CLAIM IS MADE TO THE EXCLUSIVE RIGHT TO USE "PORT", APART FROM THE MARK AS SHOWN.

FOR MEDICAL NEEDLES AND INTRODUCERS (U.S. CLS. 26, 39 AND 44).

JENNIFER VASQUEZ, EXAMINING ATTORNEY

SN 85-242,368. MEGO AFEK AC LTD., ISRAEL, FILED 2-15-2011.

LYMPHAPULSE

THE MARK CONSISTS OF STANDARD CHARACTERS WITHOUT CLAIM TO ANY PARTICULAR FONT, STYLE, SIZE, OR COLOR.

FOR COMPRESSION THERAPY APPARATUS, IN PARTICULAR FOR REDUCING SWELLING IN EXTREMITIES FOR AFTERCARE PURPOSES WITH REGARD TO LIPOSUCTION, FOR INCREASING MICROCIRCULATION AND ACCELERATING REGENERATION; ESTHETIC MASSAGE APPARATUS; VACUUM PUMPS FOR MEDICAL PURPOSES; PUMPS FOR MEDICAL PURPOSES, NAMELY, LYMPHEDEMA PUMPS; VIBROMASSAGE DEVICES (U.S. CLS. 26, 39 AND 44).

LAURA KOVALSKY, EXAMINING ATTORNEY

SN 85-243,715. JEFFREY LEE ROSENBLUM, M.D., EXTON, PA. FILED 2-16-2011.

EJACULOMETER

THE MARK CONSISTS OF STANDARD CHARACTERS WITHOUT CLAIM TO ANY PARTICULAR FONT, STYLE, SIZE, OR COLOR.

FOR MEDICAL DIAGNOSTIC DEVICE FOR TREATMENT OF MALE SEXUAL DYSFUNCTION, NAMELY, A DEVICE FOR MEASUREMENT OF THE FORCE OF EJACULATION (U.S. CLS. 26, 39 AND 44).

KATHLEEN LORENZO, EXAMINING ATTORNEY

CLASS 10—(Continued).

SN 85-247,511. PULSE TRACER TECHNOLOGIES INC, DBA BASIS, VANCOUVER, BC, CANADA, FILED 2-21-2011.

Lifescore

THE MARK CONSISTS OF STANDARD CHARACTERS WITHOUT CLAIM TO ANY PARTICULAR FONT, STYLE, SIZE, OR COLOR.

OWNER OF U.S. REG. NO. 3,821,284.

FOR ALARMS AND SENSORS TO BE WORN ON A PERSON WHILE EXERCISING FOR THE PURPOSE OF MONITORING HEART RATE; HEART MONITORS; HEART MONITORS TO BE WORN DURING EXERCISE; HEART RATE MONITORS; MEDICAL INSTRUMENTS FOR RECORDING HEART ACTIVITY; PULSE RATE MONITORS (U.S. CLS. 26, 39 AND 44).

MARTHA FROMM, EXAMINING ATTORNEY

SN 85-247,706. FIORE, JOHN W, DBA BODYLINE COMFORT SYSTEMS, JACKSONVILLE, FL. FILED 2-21-2011.

Relax-A-Neck

THE MARK CONSISTS OF STANDARD CHARACTERS WITHOUT CLAIM TO ANY PARTICULAR FONT, STYLE, SIZE, OR COLOR.

FOR CERVICAL PILLOWS FOR MEDICAL USE (U.S. CLS. 26, 39 AND 44).

KAREN K. BUSH, EXAMINING ATTORNEY

SN 85-248,369. MALLORY V. PROPHET, DETROIT, MI. FILED 2-22-2011.

THINK! CAPS BY THINK WEAR INC.

THE MARK CONSISTS OF STANDARD CHARACTERS WITHOUT CLAIM TO ANY PARTICULAR FONT, STYLE, SIZE, OR COLOR.

NO CLAIM IS MADE TO THE EXCLUSIVE RIGHT TO USE "INC.", APART FROM THE MARK AS SHOWN.

FOR CONDOMS (U.S. CLS. 26, 39 AND 44).

FIRST USE 3-10-2010; IN COMMERCE 3-10-2010.

KHANH LE, EXAMINING ATTORNEY

CLASS 10—(Continued).

SN 85-250,241. TRACTOR SUPPLY CO. OF TEXAS, LP, BRENTWOOD, TN. FILED 2-24-2011.

DUMOR

THE MARK CONSISTS OF STANDARD CHARACTERS WITHOUT CLAIM TO ANY PARTICULAR FONT, STYLE, SIZE, OR COLOR.

OWNER OF U.S. REG. NO. 1,471,155.

FOR ANIMAL CARE SUPPLIES, NAMELY, CALVING BOTTLES, INJECTION NEEDLES, SYRINGES, NIPPLES FOR FEEDING BOTTLES, CASTRATION BANDS (U.S. CLS. 26, 39 AND 44).

CHERYL CLAYTON, EXAMINING ATTORNEY

CLASS 10—(Continued).

SN 85-252,215. HICO, INC., ENCINO, CA. FILED 2-25-2011.

CELLUSPA

THE MARK CONSISTS OF STANDARD CHARACTERS WITHOUT CLAIM TO ANY PARTICULAR FONT, STYLE, SIZE, OR COLOR.

OWNER OF U.S. REG. NO. 3,962,045.

FOR MASSAGE APPLIANCES AND APPARATUS, NAMELY, ELECTRIC VIBRATING MASSAGERS (U.S. CLS. 26, 39 AND 44).

JAMES STEIN, EXAMINING ATTORNEY

SN 85-252,515. ACCURATE MANUFACTURING, INC., SWANSEA, SC. FILED 2-26-2011.

"Happy Healers"

THE MARK CONSISTS OF STANDARD CHARACTERS WITHOUT CLAIM TO ANY PARTICULAR FONT, STYLE, SIZE, OR COLOR.

NO CLAIM IS MADE TO THE EXCLUSIVE RIGHT TO USE "HEALERS", APART FROM THE MARK AS SHOWN.

FOR MEDICAL ICE PACKS (U.S. CLS. 26, 39 AND 44).

FIRST USE 8-1-2010; IN COMMERCE 1-1-2011.

H. M. FISHER, EXAMINING ATTORNEY

SN 85-250,929. BENTEC MEDICAL, INC., WOODLAND, CA. FILED 2-24-2011.



THE COLOR(S) BLUE AND WHITE IS/ARE CLAIMED AS A FEATURE OF THE MARK.

THE MARK CONSISTS OF THE WORD "BENTEC" IN SMALL WHITE LETTERS ABOVE THE NAME "DR. CLEAN" IN LARGE WHITE LETTERS WITH TWO WHITE WAVY LINES ABOVE THE LETTER "C" ALL WITHIN A WHITE CRESCENT AND ON A BLUE BACKGROUND.

FOR BLOOD COMPONENT SEPARATION APPARATUS FOR MEDICAL PURPOSES; MEDICAL APPARATUS AND INSTRUMENTS FOR USE IN SURGERY; MEDICAL TABLE SHEETS FOR EXAMINING TABLES AND OPERATING TABLES; SURGICAL AND MEDICAL APPARATUS AND INSTRUMENTS FOR USE IN GENERAL SURGERY; SURGICAL AND MEDICAL APPARATUS AND INSTRUMENTS FOR USE IN ORTHOPEDIC SURGERY; SURGICAL AND MEDICAL APPARATUS AND INSTRUMENTS FOR USE IN VASCULAR, CARDIAC, ELECTROPHYSIOLOGY SURGERY; SURGICAL APPARATUS AND INSTRUMENTS FOR MEDICAL, DENTAL OR VETERINARY USE; SURGICAL DEVICES AND INSTRUMENTS (U.S. CLS. 26, 39 AND 44).

FIRST USE 2-1-2011; IN COMMERCE 2-11-2011.

JOHN WILKE, EXAMINING ATTORNEY

SN 85-252,743. REA, RYAN, VENTURA, CA. FILED 2-27-2011.

NEUROMAP

THE MARK CONSISTS OF STANDARD CHARACTERS WITHOUT CLAIM TO ANY PARTICULAR FONT, STYLE, SIZE, OR COLOR.

FOR ELECTROTHERAPY DEVICES FOR PROVIDING TRANSCUTANEOUS ELECTRICAL NERVE STIMULATION, INFRARED HEAT AND COMPRESSION (U.S. CLS. 26, 39 AND 44).

MARTHA FROMM, EXAMINING ATTORNEY

CLASS 10—(Continued).

SN 85-253,469. BOSTON SCIENTIFIC SCIMED, INC., MAPLE GROVE, MN. FILED 2-28-2011.

ZGLIDE

THE MARK CONSISTS OF STANDARD CHARACTERS WITHOUT CLAIM TO ANY PARTICULAR FONT, STYLE, SIZE, OR COLOR.

FOR COATING SOLD AS AN INTEGRAL COMPONENT OF MEDICAL BALLOON CATHETERS (U.S. CLS. 26, 39 AND 44).

KAREN SEVERSON, EXAMINING ATTORNEY

CLASS 10—(Continued).

SN 85-254,229. ALLIANT HEALTHCARE PRODUCTS, RICHLAND, MI. FILED 3-1-2011.

Microsurge

THE MARK CONSISTS OF STANDARD CHARACTERS WITHOUT CLAIM TO ANY PARTICULAR FONT, STYLE, SIZE, OR COLOR.

FOR MEDICAL DEVICES, NAMELY, LAPAROSCOPIC SCISSORS, GRASPERS, DISSECTORS, TROCARS AND MINI SUTURE GUIDE (U.S. CLS. 26, 39 AND 44).

THOMAS MANOR, EXAMINING ATTORNEY

SN 85-253,483. TERUMO KABUSHIKI KAISHA, DBA TERUMO CORPORATION, SHIBUYA-KU, TOKYO, JAPAN, FILED 2-28-2011.

NAVICROSS

THE MARK CONSISTS OF STANDARD CHARACTERS WITHOUT CLAIM TO ANY PARTICULAR FONT, STYLE, SIZE, OR COLOR.

FOR MEDICAL AND SURGICAL CATHETERS (U.S. CLS. 26, 39 AND 44).

KELLY BOULTON, EXAMINING ATTORNEY

SN 85-254,341. U.S. ENDOSCOPY GROUP, INC., MENTOR, OH. FILED 3-1-2011.

INFINITY

THE MARK CONSISTS OF STANDARD CHARACTERS WITHOUT CLAIM TO ANY PARTICULAR FONT, STYLE, SIZE, OR COLOR.

FOR MEDICAL DEVICES, NAMELY, CYTOLOGY BRUSHES, SAMPLING BRUSHES, AND BILIARY DUCT SAMPLING TOOLS (U.S. CLS. 26, 39 AND 44).

PAM WILLIS, EXAMINING ATTORNEY

SN 85-254,163. GRAHAM, ROBERT WILLIAM, DAYTON, OH. FILED 3-1-2011.

Med4orce

THE MARK CONSISTS OF STANDARD CHARACTERS WITHOUT CLAIM TO ANY PARTICULAR FONT, STYLE, SIZE, OR COLOR.

FOR PATIENT SAFETY RESTRAINTS (U.S. CLS. 26, 39 AND 44).

WARREN L. OLANDRIA, EXAMINING ATTORNEY

SN 85-254,524. INNERSPACE MEDICAL, INC., TUSTIN, CA. FILED 3-1-2011.

FIREFLY

THE MARK CONSISTS OF STANDARD CHARACTERS WITHOUT CLAIM TO ANY PARTICULAR FONT, STYLE, SIZE, OR COLOR.

FOR MEDICAL DEVICES; NAMELY STYLET USED FOR VENTRICULAR CATHETER (U.S. CLS. 26, 39 AND 44).

DAVID H. STINE, EXAMINING ATTORNEY

CLASS 10—(Continued).

SN 85-254,569. DIAGNOSTIC DEVICES, INC., CHARLOTTE, NC. FILED 3-1-2011.

IQPUMP

THE MARK CONSISTS OF STANDARD CHARACTERS WITHOUT CLAIM TO ANY PARTICULAR FONT, STYLE, SIZE, OR COLOR.

FOR INSULIN INJECTORS SOLD EMPTY; INSULIN PUMPS; INSULIN DELIVERY DEVICES (U.S. CLS. 26, 39 AND 44).

JOSETTE BEVERLY, EXAMINING ATTORNEY

CLASS 10—(Continued).

SN 85-255,529. REVERSE MEDICAL CORPORATION, IRVINE, CA. FILED 3-2-2011.

REVERSE

THE MARK CONSISTS OF STANDARD CHARACTERS WITHOUT CLAIM TO ANY PARTICULAR FONT, STYLE, SIZE, OR COLOR.

FOR CATHETERS; MICROCATHETERS FOR INTRACRANIAL USE (U.S. CLS. 26, 39 AND 44).

TASNEEM HUSSAIN, EXAMINING ATTORNEY

SN 85-254,579. DIAGNOSTIC DEVICES, INC., CHARLOTTE, NC. FILED 3-1-2011.

IQPATCH

THE MARK CONSISTS OF STANDARD CHARACTERS WITHOUT CLAIM TO ANY PARTICULAR FONT, STYLE, SIZE, OR COLOR.

FOR INSULIN INJECTORS SOLD EMPTY; INSULIN PUMPS; INSULIN DELIVERY DEVICES (U.S. CLS. 26, 39 AND 44).

JOSETTE BEVERLY, EXAMINING ATTORNEY

SN 85-255,534. REVERSE MEDICAL CORPORATION, IRVINE, CA. FILED 3-2-2011.

REPORT

THE MARK CONSISTS OF STANDARD CHARACTERS WITHOUT CLAIM TO ANY PARTICULAR FONT, STYLE, SIZE, OR COLOR.

FOR GUIDE CATHETERS AND ASPIRATION CATHETERS (U.S. CLS. 26, 39 AND 44).

FIRST USE 5-25-2009; IN COMMERCE 5-25-2009.
TASNEEM HUSSAIN, EXAMINING ATTORNEY

SN 85-254,953. MIMOSA ACOUSTICS, INC., CHAMPAIGN, IL. FILED 3-1-2011.

Otostat

THE MARK CONSISTS OF STANDARD CHARACTERS WITHOUT CLAIM TO ANY PARTICULAR FONT, STYLE, SIZE, OR COLOR.

FOR MEDICAL TESTING DEVICES FOR MEASURING HEARING LOSS IN PATIENTS, NAMELY, AUDIOMETERS (U.S. CLS. 26, 39 AND 44).

LINDA ORNDORFF, EXAMINING ATTORNEY

SN 85-255,606. BOSTON SCIENTIFIC NEUROMODULATION CORPORATION, VALENCIA, CA. FILED 3-2-2011.

INFINION

THE MARK CONSISTS OF STANDARD CHARACTERS WITHOUT CLAIM TO ANY PARTICULAR FONT, STYLE, SIZE, OR COLOR.

FOR MEDICAL LEADS, NAMELY, PULSE GENERATOR LEADS (U.S. CLS. 26, 39 AND 44).

APRIL ROACH, EXAMINING ATTORNEY

CLASS 10—(Continued).

SN 85-256,770. ZOLL CIRCULATION, INC., SUNNYVALE, CA. FILED 3-3-2011.

FORTIUS

THE MARK CONSISTS OF STANDARD CHARACTERS WITHOUT CLAIM TO ANY PARTICULAR FONT, STYLE, SIZE, OR COLOR.
FOR MEDICAL CATHETERS (U.S. CLS. 26, 39 AND 44).
RAMONA ORTIGA, EXAMINING ATTORNEY



SN 85-256,955. CAREFUSION 2200, INC., SAN DIEGO, CA. FILED 3-3-2011.

ACCELERODESIS

THE MARK CONSISTS OF STANDARD CHARACTERS WITHOUT CLAIM TO ANY PARTICULAR FONT, STYLE, SIZE, OR COLOR.
FOR PLEURAL DRAINAGE CATHETER (U.S. CLS. 26, 39 AND 44).
ROSELLE HERRERA, EXAMINING ATTORNEY



SN 85-257,418. CARDIOGRIP IPH, INC., DBA ZONA HEALTH, BOISE, ID. FILED 3-3-2011.

ZONARX

THE MARK CONSISTS OF STANDARD CHARACTERS WITHOUT CLAIM TO ANY PARTICULAR FONT, STYLE, SIZE, OR COLOR.
FOR MEDICAL DEVICES USING ISOMETRIC RESISTANCE AND/OR BIOFEEDBACK FOR USE IN LOWERING BLOOD PRESSURE AND REDUCING THE RISKS ASSOCIATED WITH CARDIOVASCULAR DISEASES (U.S. CLS. 26, 39 AND 44).
STEVEN JACKSON, EXAMINING ATTORNEY

CLASS 10—(Continued).

SN 85-257,732. TELCARE, INC., BETHESDA, MD. FILED 3-4-2011.

Telcare BGM

THE MARK CONSISTS OF STANDARD CHARACTERS WITHOUT CLAIM TO ANY PARTICULAR FONT, STYLE, SIZE, OR COLOR.
FOR INTEGRATED HEALTH MONITORING SYSTEM COMPRISING WIRELESS ENABLED BLOOD GLUCOSE MONITORS AND SOFTWARE FOR TRANSMITTING, PROCESSING, RECEIVING AND DISPLAYING DATA VIA TELECOMMUNICATION AND GLOBAL COMPUTER NETWORKS FOR MEDICAL TREATMENT OF DIABETES AND PATIENT REMOTE USE (U.S. CLS. 26, 39 AND 44).
KIMBERLY PERRY, EXAMINING ATTORNEY



SN 85-257,743. THEKEN SPINE, LLC, AKRON, OH. FILED 3-4-2011.

CORAL

THE MARK CONSISTS OF STANDARD CHARACTERS WITHOUT CLAIM TO ANY PARTICULAR FONT, STYLE, SIZE, OR COLOR.
FOR MEDICAL DEVICES, NAMELY, SPINAL IMPLANTS COMPOSED OF ARTIFICIAL MATERIALS AND INSTRUMENTATION THEREFOR; MEDICAL DEVICES, NAMELY, PEDICLE SCREWS, CONNECTING RODS, CROSS CONNECTORS, SPINAL HOOKS, LOCKING SCREWS AND SURGICAL INSTRUMENTS FOR USE IN SPINAL SURGERY (U.S. CLS. 26, 39 AND 44).
FIRST USE 9-27-2004; IN COMMERCE 9-27-2004.
KIMBERLY PERRY, EXAMINING ATTORNEY



SN 85-257,856. ZHEJIANG KANGLIDI MEDICAL ARTICLES CO.,LTD, YUEQING, CHINA, FILED 3-4-2011.

STOMAPLAST

THE MARK CONSISTS OF STANDARD CHARACTERS WITHOUT CLAIM TO ANY PARTICULAR FONT, STYLE, SIZE, OR COLOR.
FOR MEDICAL DEVICES USED IN COLOSTOMY PROCEDURES TO COLLECT WASTE MATERIAL (U.S. CLS. 26, 39 AND 44).
MARIA-VICTORIA SUAREZ, EXAMINING ATTORNEY

CLASS 10—(Continued).

SN 85-259,038. DNB, INC., DBA MEDCORP INTERNATIONAL, LAGUNA HILLS, CA. FILED 3-5-2011.

TracHold

THE MARK CONSISTS OF STANDARD CHARACTERS WITHOUT CLAIM TO ANY PARTICULAR FONT, STYLE, SIZE, OR COLOR.

FOR MEDICAL INSTRUMENTS AND DEVICES, NAMELY, EXTERNAL FIXATORS (U.S. CLS. 26, 39 AND 44).

FIRST USE 12-10-2009; IN COMMERCE 1-1-2010.
LINDA E. BLOHM, EXAMINING ATTORNEY

SN 85-263,563. INCONTROL MEDICAL, LLC, BROOKFIELD, WI. FILED 3-10-2011.

INTONE

THE MARK CONSISTS OF STANDARD CHARACTERS WITHOUT CLAIM TO ANY PARTICULAR FONT, STYLE, SIZE, OR COLOR.

FOR MEDICAL DEVICES FOR THE TREATMENT OF INCONTINENCE, NAMELY, ELECTROTHERAPY AND BIOFEEDBACK DEVICES FOR STRENGTHENING PELVIC FLOOR MUSCLES (U.S. CLS. 26, 39 AND 44).

AMY HELLA, EXAMINING ATTORNEY

SN 85-273,003. BECTON, DICKINSON AND COMPANY, FRANKLIN LAKES, NJ. FILED 3-22-2011.



OWNER OF U.S. REG. NOS. 2,510,232, 2,996,913 AND OTHERS.

THE MARK CONSISTS OF A SHADED CIRCLE CONTAINING A SUNBURST DESIGN AND A PARTIAL ARC DESIGN; NEXT TO THE SHADED CIRCLE ARE THE LETTERS "BD" AND THE WORD "SOLUVIA".

FOR MEDICAL INJECTION SYSTEMS, NAMELY, SYRINGES AND INSTRUMENTS FOR INJECTIONS; MEDICAL SYRINGE HOLDERS; NEEDLES FOR MEDICAL USE (U.S. CLS. 26, 39 AND 44).

HANNO RITTNER, EXAMINING ATTORNEY

CLASS 10—(Continued).

SN 85-288,671. PROFOOT, INC., BROOKLYN, NY. FILED 4-7-2011.

TOEKINI

THE MARK CONSISTS OF STANDARD CHARACTERS WITHOUT CLAIM TO ANY PARTICULAR FONT, STYLE, SIZE, OR COLOR.

FOR ORTHOPEDIC CUSHIONS, NAMELY, BALL OF FOOT PROTECTORS (U.S. CLS. 26, 39 AND 44).

FIRST USE 11-30-2010; IN COMMERCE 11-30-2010.
LINDA M. KING, EXAMINING ATTORNEY

SN 85-310,825. GLOBUS MEDICAL, INC., AUDUBON, PA. FILED 5-3-2011.

FORGE

THE MARK CONSISTS OF STANDARD CHARACTERS WITHOUT CLAIM TO ANY PARTICULAR FONT, STYLE, SIZE, OR COLOR.

FOR SPINAL IMPLANTS AND MEDICAL INSTRUMENTS MADE FROM ARTIFICIAL MATERIALS FOR USE IN SPINE SURGERY (U.S. CLS. 26, 39 AND 44).

JOHN GARTNER, EXAMINING ATTORNEY

CLASS 11—ENVIRONMENTAL CONTROL APPARATUS

SN 76-701,320. INNOVAIR CORPORATION, MIAMI, FL. FILED 1-22-2010.



OWNER OF U.S. REG. NO. 3,002,993.
NO CLAIM IS MADE TO THE EXCLUSIVE RIGHT TO USE "MULTIZONE", APART FROM THE MARK AS SHOWN.

THE MARK CONSISTS OF A STYLIZED BAND APPEARING ABOVE THE STYLIZED WORD "MULTIZONE".

SEC. 2(F).
FOR AIR CONDITIONERS AND STRUCTURAL PARTS THEREFOR (U.S. CLS. 13, 21, 23, 31 AND 34).

FIRST USE 11-0-2004; IN COMMERCE 11-0-2004.
ELI HELLMAN, EXAMINING ATTORNEY

CLASS 11—(Continued).

SN 76-706,663. JEM STUDIO LIGHTING, INC., VAN NUYS, CA. FILED 3-7-2011.

JEM BALL

FOR LIGHTING FIXTURES FOR STUDIO (U.S. CLS. 13, 21, 23, 31 AND 34).
HEATHER SAPP, EXAMINING ATTORNEY

SN 76-706,664. JEM STUDIO LIGHTING, INC., VAN NUYS, CA. FILED 3-7-2011.

JEM STUDIO LIGHTING

NO CLAIM IS MADE TO THE EXCLUSIVE RIGHT TO USE "STUDIO LIGHTING", APART FROM THE MARK AS SHOWN.
FOR LIGHTING FIXTURES FOR STUDIO (U.S. CLS. 13, 21, 23, 31 AND 34).
FIRST USE 6-0-1997; IN COMMERCE 6-0-1997.
HEATHER SAPP, EXAMINING ATTORNEY

SN 77-392,895. INTENSE LIGHTING, LLC, ANAHEIM, CA. FILED 2-8-2008.

INFUZ

THE MARK CONSISTS OF STANDARD CHARACTERS WITHOUT CLAIM TO ANY PARTICULAR FONT, STYLE, SIZE, OR COLOR.
FOR ELECTRIC LIGHTING FIXTURES (U.S. CLS. 13, 21, 23, 31 AND 34).
RONALD DELGIZZI, EXAMINING ATTORNEY

SN 77-530,250. CRANE CO., TROOPER, PA. FILED 7-24-2008.

ACCU-SPRAY

THE MARK CONSISTS OF STANDARD CHARACTERS WITHOUT CLAIM TO ANY PARTICULAR FONT, STYLE, SIZE, OR COLOR.
FOR WATER DISTRIBUTION DEVICES FOR DEAERATORS AND FEED WATER HEATERS, NAMELY, SPRAY NOZZLES AND SPRAY VALVES (U.S. CLS. 13, 21, 23, 31 AND 34).
FIRST USE 0-0-1990; IN COMMERCE 0-0-1990.
JASON BLAIR, EXAMINING ATTORNEY

CLASS 11—(Continued).

SN 77-831,793. KOHLER CO., KOHLER, WI. FILED 9-22-2009.

SAN RAPHAEL

THE MARK CONSISTS OF STANDARD CHARACTERS WITHOUT CLAIM TO ANY PARTICULAR FONT, STYLE, SIZE, OR COLOR.
FOR TOILETS; TOILET TRIP LEVERS (U.S. CLS. 13, 21, 23, 31 AND 34).
FIRST USE 7-7-1981; IN COMMERCE 7-7-1981.
RONALD MCMORROW, EXAMINING ATTORNEY

SN 77-883,236. HOFSETH, KRISTIAN, DORAL, FL. FILED 12-1-2009.

EuroLamps

THE MARK CONSISTS OF STANDARD CHARACTERS WITHOUT CLAIM TO ANY PARTICULAR FONT, STYLE, SIZE, OR COLOR.
FOR ELECTRIC LAMPS; FLASHLIGHTS; HALOGEN LIGHT BULBS (U.S. CLS. 13, 21, 23, 31 AND 34).
FIRST USE 4-21-1994; IN COMMERCE 4-21-1994.
PRISCILLA MILTON, EXAMINING ATTORNEY

SN 77-916,145. LEC LIGHT EMITTING COMPUTERS INC., VICTORIA, B.C., CANADA, FILED 1-20-2010.

PLANT WHISPERER

THE MARK CONSISTS OF STANDARD CHARACTERS WITHOUT CLAIM TO ANY PARTICULAR FONT, STYLE, SIZE, OR COLOR.
NO CLAIM IS MADE TO THE EXCLUSIVE RIGHT TO USE "PLANT", APART FROM THE MARK AS SHOWN.
FOR COMPUTER CONTROLLED GROW LIGHTS FOR HORTICULTURE AND AGRICULTURE COMPRISING LIGHT EMITTING DIODE LIGHTING FIXTURES AND LAMPS (U.S. CLS. 13, 21, 23, 31 AND 34).
MATTHEW EINSTEIN, EXAMINING ATTORNEY

CLASS 11—(Continued).

SN 79-080,408. KNOG PTY LTD, AUSTRALIA, FILED 12-4-2009.

BOOMER

THE MARK CONSISTS OF STANDARD CHARACTERS WITHOUT CLAIM TO ANY PARTICULAR FONT, STYLE, SIZE, OR COLOR.

PRIORITY DATE OF 6-10-2009 IS CLAIMED.

OWNER OF INTERNATIONAL REGISTRATION 1032821 DATED 12-4-2009, EXPIRES 12-4-2019.

FOR BICYCLE LIGHTS (U.S. CLS. 13, 21, 23, 31 AND 34).

RON FAIRBANKS, EXAMINING ATTORNEY

CLASS 11—(Continued).

SN 79-081,670. I.C.I. CALDAIE S.P.A., ZEVIO FRAZIONE CAMPAGNOLA (VERONA), ITALY, FILED 1-22-2010.



PRIORITY DATE OF 9-16-2009 IS CLAIMED.
OWNER OF INTERNATIONAL REGISTRATION 1036239 DATED 1-22-2010, EXPIRES 1-22-2020.

NO CLAIM IS MADE TO THE EXCLUSIVE RIGHT TO USE "CALDAIE", APART FROM THE MARK AS SHOWN.

THE MARK CONSISTS OF A SIGN DEPICTING A STYLIZED SQUARE WITH ROUNDED CORNERS INSIDE WHICH THERE IS THE WORDING "ICI" IN FANCY CHARACTERS, ALL INSCRIBED WITHIN A STYLIZED SQUARE WITH ROUNDED CORNERS, OF A LARGER SIZE INSIDE WHICH THERE IS THE WORDING "CALDAIE" IN FANCY CHARACTERS.

THE ENGLISH TRANSLATION OF "CALDAIE" IN THE MARK IS BOILERS.

FOR HEATING BOILERS; GAS BOILERS; WALL-MOUNTED AND GROUND-BASED GAS, OIL, ELECTRIC AND HEATING BOILERS; BOILERS FOR HOT WATER PRODUCTION FOR DOMESTIC AND INDUSTRIAL USE; CONDENSING BOILERS; CONDENSING BOILER AND HEAT OR COOLING METERING MODULES FOR THE ACCOUNTING OF HEAT SOLD AS A UNIT; HEATING SYSTEMS FOR RESIDENTIAL AND COMMERCIAL BUILDINGS COMPOSED PRIMARILY OF BOILERS, VALVES, PIPES, MANIFOLDS, CONTROL PANEL, SWITCHES AND ELECTRICAL WIRE, ALL SOLD AS A UNIT; INDUSTRIAL AND HEATING BOILERS, OTHER THAN PARTS OF MACHINES; STEAM BOILERS, OTHER THAN PARTS OF MACHINES; FLUES FOR HEATING BOILERS; PIPES FOR HEATING BOILERS; HYDRONIC HEATERS; WATER HEATERS; GAS WATER HEATERS; WATER HEATERS FOR BATHS; CALORIFIERS; COOLERS; HEAT GENERATORS; STEAM GENERATORS; CENTRAL HEATING INSTALLATIONS CONSISTING OF BOILERS AND GAS, OIL BURNERS; EXPANSION TANKS FOR CENTRAL HEATING INSTALLATIONS; LEVEL CONTROLLING VALVES IN TANKS; THERMOSTATIC VALVES, AS PARTS OF HEATING INSTALLATIONS; HEATING INSTALLATIONS COMPRISING HOT WATER TANKS, PLATE HEAT EXCHANGER, SOLAR PANELS; WATER HEATING INSTALLATIONS, NAMELY, HEATING BOILERS, GAS WATER HEATERS, HOT WATER SPACE HEATING APPLIANCES FOR INDUSTRIAL PURPOSES; HEATING ELEMENTS; GAS AND OIL BURNERS; STEAM GENERATING INSTALLATIONS; HEAT EXCHANGERS, NOT BEING PARTS OF MACHINES; REGULATING ACCESSORIES FOR WATER AND GAS APPARATUS AND PIPES, NAMELY, PRESSURE SWITCHES AND FLOW SWITCHES (U.S. CLS. 13, 21, 23, 31 AND 34).

PRISCILLA MILTON, EXAMINING ATTORNEY

CLASS 11—(Continued).

SN 79-089,137. ULRICH MAURER, CH-8304 WALLISELLEN, SWITZERLAND, FILED 6-30-2010.

MABI-Frites

THE MARK CONSISTS OF STANDARD CHARACTERS WITHOUT CLAIM TO ANY PARTICULAR FONT, STYLE, SIZE, OR COLOR.

PRIORITY DATE OF 1-5-2010 IS CLAIMED.

OWNER OF INTERNATIONAL REGISTRATION 1056105 DATED 6-30-2010, EXPIRES 6-30-2020.

THE ENGLISH TRANSLATION OF "FRITES" IN THE MARK IS "FRENCH FRIES". THE WORDING "MABI" HAS NO MEANING IN A FOREIGN LANGUAGE.

FOR AUTOMATED ELECTRIC APPARATUS FOR REFRIGERATING AND COOKING FROZEN FRENCH FRIES (U.S. CLS. 13, 21, 23, 31 AND 34).

REBECCA POVARCHUK, EXAMINING ATTORNEY

CLASS 11—(Continued).

SN 79-094,876. JØTUL AS, NORWAY, FILED 10-11-2010.



PRIORITY DATE OF 9-21-2010 IS CLAIMED.
OWNER OF INTERNATIONAL REGISTRATION 1070497 DATED 10-11-2010, EXPIRES 10-11-2020.

THE MARK CONSISTS OF THE LETTERS "ILD" IN THE SHAPE OF A FLAME.

FOR FIREPLACES, FIREPLACE INSERTS IN THE NATURE OF STOVES AND SOLID FUEL BURNERS, WOOD-BURNING STOVES; AND FITTINGS FOR ALL THE FORESAID GOODS (U.S. CLS. 13, 21, 23, 31 AND 34).

SANI KHOURI, EXAMINING ATTORNEY

SN 79-089,362. MIDEKO PTY LTD, AUSTRALIA, FILED 2-15-2010.



OWNER OF INTERNATIONAL REGISTRATION 1056743 DATED 2-15-2010, EXPIRES 2-15-2020.

THE MARK CONSISTS OF A STYLIZED LETTER "M" LOGO WITHIN A CIRCULAR CARRIER DESIGN.

FOR INDUSTRIAL AIRBORNE PARTICULATE REDUCTION APPARATUS, NAMELY, FABRIC DUST COLLECTORS AND BAG HOUSES, AND PARTS THEREFOR, NAMELY, FILTERS, FILTER BAGS, BAG HOUSINGS AND CLOTH BAG FILTERS; INDUSTRIAL SCRUBBERS FOR REMOVING PARTICULATE MATTER FROM AIR, NAMELY, IMPINGEMENT BAFFLE PLATE SCRUBBERS AND VENTURI SCRUBBERS; INDUSTRIAL AIR POLLUTION CONTROL EQUIPMENT, APPARATUS AND INSTALLATIONS, NAMELY, GRAVEL BED FILTERS; INDUSTRIAL DUST SUPPRESSION APPARATUS AND INSTALLATIONS, NAMELY, PIVOT MOUNTED BAFFLE INTAKE FLAPS FOR SILOS, HOPPERS AND OTHER BULK STORAGE CONTAINERS; AIR FILTERING INSTALLATIONS FOR INDUSTRIAL USE; AIR FILTERS AND AIRBORNE DUST COLLECTORS FOR USE IN INDUSTRIAL APPLICATIONS IN THE CEMENT, CONCRETE, GRAIN, FEED, WHEAT, CHEMICAL, FERTILIZER, MINING, MINERAL AND ORE PROCESSING, TIMBER PROCESSING, PLASTER POWDER AND FLOUR INDUSTRIES AND IN SILO VENTING APPLICATIONS; GAS SCRUBBERS; GAS SCRUBBERS FEATURING VENTURI, IMPINGEMENT, BAFFLE PLATE, WET SCRUBBING APPARATUS (U.S. CLS. 13, 21, 23, 31 AND 34).

DAVID H. STINE, EXAMINING ATTORNEY

SN 79-096,536. RATIONAL AG, FED REP GERMANY, FILED 3-21-2011.

EPS

THE MARK CONSISTS OF STANDARD CHARACTERS WITHOUT CLAIM TO ANY PARTICULAR FONT, STYLE, SIZE, OR COLOR.

PRIORITY DATE OF 11-2-2010 IS CLAIMED.

OWNER OF INTERNATIONAL REGISTRATION 1074814 DATED 3-21-2011, EXPIRES 3-21-2021.

FOR COOKING AND STEAM GENERATING APPARATUS FOR THE TREATMENT AND PREPARATION OF FOOD IN COMMERCIAL KITCHENS, NAMELY ELECTRIC FOOD COOKERS, ELECTRIC FOOD STEAMERS, AND COOKING OVENS, ALL FOR COMMERCIAL USE AND SOLD AS A UNIT; GAS FOOD COOKERS, GAS FOOD STEAMERS AND COOKING OVENS, ALL FOR COMMERCIAL USE AND SOLD AS A UNIT; AND STRUCTURAL PARTS AND ACCESSORIES THEREFOR (U.S. CLS. 13, 21, 23, 31 AND 34).

NICHOLAS COLEMAN, EXAMINING ATTORNEY

CLASS 11—(Continued).

SN 79-096,911. STULZ GMBH, FED REP GERMANY, FILED 3-22-2011.

CyberRow

THE MARK CONSISTS OF STANDARD CHARACTERS WITHOUT CLAIM TO ANY PARTICULAR FONT, STYLE, SIZE, OR COLOR.

PRIORITY DATE OF 9-27-2010 IS CLAIMED. OWNER OF INTERNATIONAL REGISTRATION 1075821 DATED 3-22-2011, EXPIRES 3-22-2021. FOR PRECISION AIR CONDITIONING APPARATUS (U.S. CLS. 13, 21, 23, 31 AND 34). CHARISMA HAMPTON, EXAMINING ATTORNEY

CLASS 11—(Continued).

SN 85-114,147. NINGBO UTEC ELECTRIC CO., LTD., ZHEJIANG PROVINCE, CHINA, FILED 8-24-2010.



NO CLAIM IS MADE TO THE EXCLUSIVE RIGHT TO USE "LUX", APART FROM THE MARK AS SHOWN.

THE COLOR(S) GREY AND YELLOW IS/ARE CLAIMED AS A FEATURE OF THE MARK.

THE MARK CONSISTS OF THE GREY WORDS "LUTEC BY YAOHUA LUX" AND A GREY CIRCULAR BAND WITH A YELLOW ELLIPSE OVER THE UPPER RIGHT AREA.

THE WORDING "LUTEC" OR "YAOHUA" HAS NO MEANING IN A FOREIGN LANGUAGE.

FOR AQUARIUM LIGHTS; CEILING LIGHTS; DIVING LIGHTS; INCANDESCENT LAMPS; LAMP SHADES; LAMPS; LANTERNS; LIGHTING APPARATUS, NAMELY, LIGHTING INSTALLATIONS; LUMINOUS HOUSE NUMBERS; STREET LAMPS (U.S. CLS. 13, 21, 23, 31 AND 34).

JOHN DALIER, EXAMINING ATTORNEY

SN 85-130,705. U.S.TENDGE GROUP CO., LTD., STE.100 SACRAMENTO, CA. FILED 9-15-2010.

Tendge

THE MARK CONSISTS OF THE STYLIZED TERM "TENDGE".

THE WORDING "TENDGE" HAS NO MEANING IN A FOREIGN LANGUAGE.

FOR AQUARIUM FILTRATION APPARATUS; FILTERS FOR DRINKING WATER; SEWAGE PURIFICATION APPARATUS; SEWAGE PURIFICATION INSTALLATIONS; WATER COOLERS; WATER DESALINATION PLANTS; WATER FILTERS; WATER PURIFICATION INSTALLATIONS; WATER PURIFYING APPARATUS; WATER SOFTENING APPARATUS AND INSTALLATIONS (U.S. CLS. 13, 21, 23, 31 AND 34).

NELSON SNYDER, EXAMINING ATTORNEY

SN 85-018,813. STEVEN HANDELMAN, DBA STEVEN HANDELMAN STUDIOS, SANTA BARBARA, CA. FILED 4-20-2010.



NO CLAIM IS MADE TO THE EXCLUSIVE RIGHT TO USE "STUDIOS INC.", APART FROM THE MARK AS SHOWN.

THE MARK CONSISTS OF "STEVEN HANDELMAN STUDIOS INC".

FOR LIGHTING FIXTURES (U.S. CLS. 13, 21, 23, 31 AND 34).

FIRST USE 10-12-1973; IN COMMERCE 10-12-1973. GINA HAYES, EXAMINING ATTORNEY

SN 85-137,255. KOHLER CO., KOHLER, WI. FILED 9-24-2010.

QUICK-ATTACH

THE MARK CONSISTS OF STANDARD CHARACTERS WITHOUT CLAIM TO ANY PARTICULAR FONT, STYLE, SIZE, OR COLOR.

FOR TOILET SEATS (U.S. CLS. 13, 21, 23, 31 AND 34). REBECCA EISINGER, EXAMINING ATTORNEY

CLASS 11—(Continued).

SN 85-149,392. DIALIGHT CORPORATION, FARMINGDALE, NJ. FILED 10-11-2010.

VIGILANT

THE MARK CONSISTS OF STANDARD CHARACTERS WITHOUT CLAIM TO ANY PARTICULAR FONT, STYLE, SIZE, OR COLOR.

FOR LED (LIGHT EMITTING DIODE) LIGHTING FIXTURES AND LED LUMINAIRES ALL FOR COMMERCIAL AND INDUSTRIAL USE (U.S. CLS. 13, 21, 23, 31 AND 34).

BERYL GARDNER, EXAMINING ATTORNEY

SN 85-153,863. PENG, HUNG-HAI, TAICHUNG COUNTY, TAIWAN, FILED 10-15-2010.

SONERGY

THE MARK CONSISTS OF STANDARD CHARACTERS WITHOUT CLAIM TO ANY PARTICULAR FONT, STYLE, SIZE, OR COLOR.

FOR BATHTUBS, URINALS, SINKS, BIDETS, SHOWERS, FAUCETS, FAUCET AERATORS, TWIN-LEVEL FAUCETS, SINGLE-LEVEL FAUCETS, AND WATER FILTERS FOR USE WITH HOUSEHOLD FILTERING DEVICES; SOLAR LIGHT FIXTURES, NAMELY, INDOOR AND OUTDOOR SOLAR POWERED LIGHTING UNITS AND FIXTURES; SOLAR WATER HEATERS, SOLAR ENERGY RECEIVERS FOR HEATING SYSTEMS FOR RESIDENTIAL AND COMMERCIAL BUILDINGS, SOLAR ENERGY BASED AIR CONDITIONERS (U.S. CLS. 13, 21, 23, 31 AND 34).

FIRST USE 10-11-2010; IN COMMERCE 10-11-2010.
ALYSSA STEEL, EXAMINING ATTORNEY

CLASS 11—(Continued).

SN 85-194,963. MASTER BRANDS HK LIMITED, MARLBOROUGH, MA. FILED 12-10-2010.

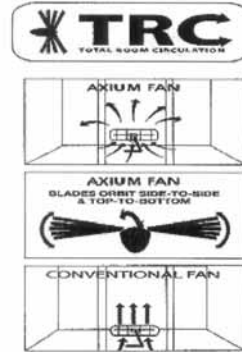

NO CLAIM IS MADE TO THE EXCLUSIVE RIGHT TO USE "ROOM CIRCULATION" OR "FAN" OR "BLADES ORBIT SIDE-TO-SIDE & TOP-TO-BOTTOM" OR "CONVENTIONAL FAN", APART FROM THE MARK AS SHOWN.

THE MARK CONSISTS OF THE WORDS "TRC TOTAL ROOM CIRCULATION" INSIDE AN ELONGATED OVAL WITH THE DESIGN OF FAN BLADES TO THE LEFT OF "TRC" AND THE LETTER "C" IN "TRC" CONTAINING ARROWS AT EACH END; BELOW THAT, THE WORDS "AXIUM FAN" INSIDE A RECTANGLE WITH ARROWS EMANATING FROM A SMALLER OVAL WITH CROSS PATCHING; A SECOND RECTANGLE BENEATH THAT WITH THE WORDS "AXIUM FAN BLADES ORBIT SIDE-TO-SIDE & TOP-TO-BOTTOM" AND DESIGN OF FAN BLADES AND ROTATIONAL ARROWS; AND THEN BELOW THAT THE WORDS "CONVENTIONAL FAN" INSIDE A THIRD RECTANGLE WITH ARROWS EMANATING FROM A SMALL OVAL HAVING CROSS PATCHING.

FOR ELECTRIC FANS (U.S. CLS. 13, 21, 23, 31 AND 34).

FIRST USE 6-15-2008; IN COMMERCE 3-15-2009.
JESSICA A. POWERS, EXAMINING ATTORNEY

SN 85-207,104. AMONIX, INC., SEAL BEACH, CA. FILED 12-29-2010.



OWNER OF U.S. REG. NOS. 3,549,262 AND 3,633,778.
THE MARK CONSISTS OF THE WORD "AMONIX" IN BLOCK LETTERING AND A SUN DESIGN APPEARING IN THE OPENING OF THE LETTER "O" IN THE WORD "AMONIX".

FOR SOLAR COLLECTORS AND SOLAR HEAT COLLECTION PANELS (U.S. CLS. 13, 21, 23, 31 AND 34).
FIRST USE 6-0-2010; IN COMMERCE 6-0-2010.
TARA PATE, EXAMINING ATTORNEY

CLASS 11—(Continued).

SN 85-215,394. AFEEL CORPORATION, DBA HUNTINGTON BRASS, CYPRESS, CA. FILED 1-11-2011.

HB

THE MARK CONSISTS OF STANDARD CHARACTERS WITHOUT CLAIM TO ANY PARTICULAR FONT, STYLE, SIZE, OR COLOR.

OWNER OF U.S. REG. NO. 2,819,313.

FOR PLUMBING FIXTURES AND HARDWARE, NAMELY, FAUCETS, TUB FILLERS, SHOWER SYSTEMS COMPOSED OF SHOWER HEAD, SHOWER CONTROL VALVES, SHOWER FLOW DIVERTERS, SHOWER SPRAYERS, SHOWER HANDLES AND SHOWER TRIMS; SHOWER CONTROL VALVES, SHOWER HEADS, SHOWER FLOW DIVERTERS, SHOWER HEAD WALL MOUNTS, SHOWER ARM, AND RELATED PLUMBING ACCESSORIES, NAMELY, FAUCET HANDLES, POP-UP DRAINS AND DRAINS (U.S. CLS. 13, 21, 23, 31 AND 34).

FIRST USE 7-1-2006; IN COMMERCE 7-1-2006.
LINDSEY RUBIN, EXAMINING ATTORNEY

SN 85-219,185. W.R. BRADLEY CO., LLC, DBA CDIMS, ARID-DRY, ARID-ICE, BRIGHTON, MI. FILED 1-17-2011.

Accelerated Desiccant Drying

THE MARK CONSISTS OF STANDARD CHARACTERS WITHOUT CLAIM TO ANY PARTICULAR FONT, STYLE, SIZE, OR COLOR.

NO CLAIM IS MADE TO THE EXCLUSIVE RIGHT TO USE "DESICCANT DRYING", APART FROM THE MARK AS SHOWN.

FOR INDUSTRIAL DRYERS FOR HEATING AND DEHUMIDIFYING (U.S. CLS. 13, 21, 23, 31 AND 34).

FIRST USE 1-7-2011; IN COMMERCE 1-7-2011.
NAAKWAMA ANKRAH, EXAMINING ATTORNEY

SN 85-226,801. GARDNER, MICHAEL C, DBA FUN FLUSHERS, LAS VEGAS, NV. FILED 1-26-2011.



NO CLAIM IS MADE TO THE EXCLUSIVE RIGHT TO USE "ORIGINAL" AND "FLUSHERS", APART FROM THE MARK AS SHOWN.

THE COLOR(S) RED, BLACK, ORANGE, YELLOW, BLUE, TAN, WHITE AND GRAY IS/ARE CLAIMED AS A FEATURE OF THE MARK.

THE MARK CONSISTS OF THE WORDS "THE ORIGI-

CLASS 11—(Continued).

NAL" IN THE SHAPE OF A SEMI CIRCLE ABOVE THE MAIN CHARACTER, THE LETTERS ARE OUTLINED IN BLACK, WHITE, AND THE LETTERS ARE RED ON THE TOP HALF AND THEY ARE ORANGE ON THE LOWER HALF. THERE IS A TAN HAND WITH WHITE FINGERNAILS WITH A BLACK OUTLINED WHITE CUFF ON THE LEFT SIDE OF THE MARK THAT IS POSITIONED WITH THE THUMB DOWN AND THE INDEX FINGER EXTENDED OUT IN A FLUSHING MANNER PUSHING THE HANDLE ON THE TOILET THAT SAYS "FUN FLUSHERS". THE HANDLE IS OUTLINED IN BLACK IN A RECTANGULAR SHAPE WITH ROUNDED CORNERS ENCOMPASSING THE WORDS "FUN FLUSHERS" THAT ARE OUTLINED IN BLACK WITH ORANGE LETTERING THERE IS GRAY IN BETWEEN THE BLACK OUTLINED LETTERS AND THE RECTANGULAR SHAPE. BEHIND THE HANDLE IS A RED "C" SHAPED CIRCLE THAT HAS A WHITE TOILET TANK ON A YELLOW BACKGROUND. THE TOILET TANK HAS A HAPPY FACE POSITIONED TO THE RIGHT OF THE HANDLE. THE EYES ARE LOOKING AT THE HANDLE WITH HAPPY EYEBROWS AND A SMILE ALL ARE BLACK WITH GRAY COLORING OUTSIDE THE PUPILS ON THE EYES. THERE ARE A TOTAL OF SIX DECORATIVE STARS WITHIN THE RED "C" SHAPED SEMI CIRCLE THAT OUTLINES THE TOILET TANK AND THE HANDLE, THE TOP TWO ARE ON THE RED "C" SHAPE AND THEY ARE BLUE AND YELLOW. THE OTHER FOUR ARE LOCATED IN PAIRS ON THE TANK TWO RED ABOVE THE "FUN FLUSHERS" HANDLE AND ONE BLUE AND ONE RED PLACED BELOW THE HANDLE. THERE IS ONE MOTION INDICATOR IN BLACK ON THE LOWER LEFT SIDE OF THE TOILET HANDLE INDICATING THE "FUN FLUSHERS" ARE BEING PUSHED BY THE HAND, THEREBY GIVING THE PICTURE A SENSE OF MOTION.

FOR PLASTIC HANDLES FOR TOILETS, NAMELY, FLUSH LEVERS (U.S. CLS. 13, 21, 23, 31 AND 34).
LAKEISHA LEWIS, EXAMINING ATTORNEY

SN 85-234,581. HACHIPA, INC., POWAY, CA. FILED 2-4-2011.

PerformaLUX

THE MARK CONSISTS OF STANDARD CHARACTERS WITHOUT CLAIM TO ANY PARTICULAR FONT, STYLE, SIZE, OR COLOR.

FOR ELECTRIC LIGHTING FIXTURES; LED (LIGHT EMITTING DIODE) LIGHTING FIXTURES; LED (LIGHT EMITTING DIODES) LIGHTING FIXTURES FOR USE IN DISPLAY, COMMERCIAL, INDUSTRIAL, RESIDENTIAL, AND ARCHITECTURAL ACCENT LIGHTING APPLICATIONS; LED LIGHTING FIXTURES FOR INDOOR AND OUTDOOR LIGHTING APPLICATIONS (U.S. CLS. 13, 21, 23, 31 AND 34).

FIRST USE 4-1-2010; IN COMMERCE 4-1-2010.

KARANENDRA S. CHHINA, EXAMINING ATTORNEY

CLASS 11—(Continued).

SN 85-238,377. DWT DEUTSCHE WASSERTECHNOLOGIEN GMBH, FRANKFURT, FED REP GERMANY, FILED 2-9-2011.

PRIO

THE MARK CONSISTS OF STANDARD CHARACTERS WITHOUT CLAIM TO ANY PARTICULAR FONT, STYLE, SIZE, OR COLOR.

THE WORDING "PRIO" HAS NO MEANING IN A FOREIGN LANGUAGE.

FOR PITCHERS SOLD EMPTY INCORPORATING WATER FILTERS; CARTRIDGES FOR PITCHERS INCORPORATING WATER FILTERS; ATTACHABLE TAP WATER FAUCET FILTERS; CARTRIDGES FOR ATTACHABLE TAP WATER FAUCET FILTERS; ATTACHABLE SHOWER HEAD WATER FILTERS; CARTRIDGES FOR ATTACHABLE SHOWER HEAD FILTERS; UNDER SINK TAP WATER FILTERS; CARTRIDGES FOR UNDER SINK TAP WATER FILTERS (U.S. CLS. 13, 21, 23, 31 AND 34).

BRENDAN REGAN, EXAMINING ATTORNEY

CLASS 11—(Continued).

SN 85-245,289. NEOPAC LIGHTING, LIMITED, KLN., HONG KONG, FILED 2-17-2011.

OWNER OF U.S. REG. NO. 3,419,128.

THE MARK CONSISTS OF A DIAMOND LIKE CONTOUR WITHIN A BROKEN LINE DIAMOND CONTOUR NEXT TO THE STYLIZED LETTERS "NEOPAC" WITH A HORIZONTAL LINE BAR PASSING THROUGH THE STYLIZED LETTERS "NEOPAC".

FOR BULBS, NAMELY, LIGHT BULBS, ELECTRIC LIGHT BULBS, AND HALOGEN LIGHT BULBS; LIGHTING, NAMELY, LIGHT BULBS, INFRARED LIGHTING FIXTURES, AND ELECTRIC NIGHT LIGHTS; FLUORESCENT LAMPS; FLASHLIGHTS; LAMPS FOR INTERNAL ILLUMINATION; LIGHTS FOR VEHICLES, NAMELY, AUTOMOTIVE LIGHT BULBS, MOTORCYCLE LIGHT BULBS, BRAKE LAMPS, VEHICLE HEADLIGHTS, VEHICLE TAILLIGHTS, VEHICLE SIDE LIGHTS, DIRECTION INDICATOR LIGHTS; BICYCLE LIGHTS, NAMELY, DYNAMO-POWERED LAMPS FOR BIKE, AND STOP INDICATOR LIGHTS; REFLECTORS FOR VEHICLES; ELECTRICAL LIGHT BULBS; LAMPS; FOG LAMPS (U.S. CLS. 13, 21, 23, 31 AND 34).

PAULA MAHONEY, EXAMINING ATTORNEY

SN 85-245,870. TILE REDI, LLC, CORAL SPRINGS, FL. FILED 2-18-2011.

BECAUSE YOU WONDER WHERE THE DRAIN IS

THE MARK CONSISTS OF STANDARD CHARACTERS WITHOUT CLAIM TO ANY PARTICULAR FONT, STYLE, SIZE, OR COLOR.

FOR PLUMBING FITTINGS, NAMELY, CHANNELS THROUGH WHICH LIQUID MAY RUN OFF, NAMELY, DRAINS (U.S. CLS. 13, 21, 23, 31 AND 34).

GRETTA YAO, EXAMINING ATTORNEY

SN 85-240,346. AMERICAN RECREATION PRODUCTS, INC., CHESTERFIELD, MO. FILED 2-11-2011.

KELTY

THE MARK CONSISTS OF STANDARD CHARACTERS WITHOUT CLAIM TO ANY PARTICULAR FONT, STYLE, SIZE, OR COLOR.

OWNER OF U.S. REG. NOS. 1,059,258, 1,294,302 AND OTHERS.

SEC. 2(F).

FOR LAMP WHOSE LIGHT CAN BE TURNED IN ALL DIRECTIONS; LAMPS FOR OUTDOOR USE; LANTERNS; LED LIGHT MACHINES; PORTABLE UTILITY LIGHTS (U.S. CLS. 13, 21, 23, 31 AND 34).

FIRST USE 6-30-2010; IN COMMERCE 6-30-2010.

CAROLYN CATALDO, EXAMINING ATTORNEY

SN 85-246,084. TILE REDI, LLC, CORAL SPRINGS, FL. FILED 2-18-2011.

BECAUSE YOU WONDER WHERE THE TRENCH IS

THE MARK CONSISTS OF STANDARD CHARACTERS WITHOUT CLAIM TO ANY PARTICULAR FONT, STYLE, SIZE, OR COLOR.

FOR PLUMBING FITTINGS, NAMELY, CHANNELS THROUGH WHICH LIQUID MAY RUN OFF, NAMELY, DRAINS (U.S. CLS. 13, 21, 23, 31 AND 34).

GRETTA YAO, EXAMINING ATTORNEY

CLASS 11—(Continued).

SN 85-249,387. AJAX TOCCO MAGNETHERMIC CORPORATION, WARREN, OH. FILED 2-23-2011.

PILLAR

THE MARK CONSISTS OF STANDARD CHARACTERS WITHOUT CLAIM TO ANY PARTICULAR FONT, STYLE, SIZE, OR COLOR.

OWNER OF U.S. REG. NO. 1,713,144.

FOR ELECTRICAL INDUCTION HEATING APPARATUS FOR THE INDUCTION HEATING OR MELTING OF METAL, AND ELECTRONIC PARTS THEREOF, NAMELY, CONTROLLERS, POWER SUPPLIES, CONVERTERS, INVERTERS, AND TRANSFORMERS (U.S. CLS. 13, 21, 23, 31 AND 34).

FIRST USE 2-0-1968; IN COMMERCE 2-0-1968.
BRIAN PINO, EXAMINING ATTORNEY

CLASS 11—(Continued).

SN 85-253,040. HENNY PENNY CORPORATION, EATON, OH. FILED 2-28-2011.

PRIMELT

THE MARK CONSISTS OF STANDARD CHARACTERS WITHOUT CLAIM TO ANY PARTICULAR FONT, STYLE, SIZE, OR COLOR.

FOR ELECTRIC AND GAS COMMERCIAL FOOD FRYERS, COMPONENTS FOR ELECTRIC AND GAS COMMERCIAL FRYERS, NAMELY, AN INTEGRATED, ON-BOARD MELTER, SPECIFICALLY ENGINEERED FOR LOW OIL VOLUME FRYERS, THAT CONVERTS SEMI-SOLID SHORTENING TO A CLEAR LIQUID AND MAINTAINS IT FOR REPLENISHMENT WITHOUT HOT SPLASH (U.S. CLS. 13, 21, 23, 31 AND 34).

MEGHAN REINHART, EXAMINING ATTORNEY

SN 85-250,842. COLUMBIA LIGHTING PROPERTIES, INC., WILMINGTON, DE. FILED 2-24-2011.

ALERA LIGHTING

THE MARK CONSISTS OF STANDARD CHARACTERS WITHOUT CLAIM TO ANY PARTICULAR FONT, STYLE, SIZE, OR COLOR.

NO CLAIM IS MADE TO THE EXCLUSIVE RIGHT TO USE "LIGHTING", APART FROM THE MARK AS SHOWN. FOR LIGHTING FIXTURES (U.S. CLS. 13, 21, 23, 31 AND 34).

FIRST USE 5-19-2000; IN COMMERCE 5-19-2000.
KHANH LE, EXAMINING ATTORNEY

SN 85-254,490. DAMON F. HENRY, FORT COLLINS, CO. FILED 3-1-2011.

Bar-Barianz

THE MARK CONSISTS OF STANDARD CHARACTERS WITHOUT CLAIM TO ANY PARTICULAR FONT, STYLE, SIZE, OR COLOR.

FOR BICYCLE LIGHTS (U.S. CLS. 13, 21, 23, 31 AND 34).

FIRST USE 3-5-2008; IN COMMERCE 3-5-2008.
HEATHER BIDDULPH, EXAMINING ATTORNEY

SN 85-251,017. IRH2O, LLC, WARREN, NJ. FILED 2-24-2011.



FOR AIR PURIFIERS; ELECTRIC AND BATTERY OPERATED AROMATHERAPY UNITS; HUMIDIFIERS (U.S. CLS. 13, 21, 23, 31 AND 34).

MARK RADEMACHER, EXAMINING ATTORNEY

SN 85-254,686. B-K LIGHTING, INC., MADERA, CA. FILED 3-1-2011.

ADJUST-E-LUME

THE MARK CONSISTS OF STANDARD CHARACTERS WITHOUT CLAIM TO ANY PARTICULAR FONT, STYLE, SIZE, OR COLOR.

FOR ELECTRIC LIGHTING FIXTURES (U.S. CLS. 13, 21, 23, 31 AND 34).

SUNG IN, EXAMINING ATTORNEY

CLASS 11—(Continued).

SN 85-255,812. IZUNAMI, INC., PORT WASHINGTON, NY. FILED 3-2-2011.

G6

THE MARK CONSISTS OF STANDARD CHARACTERS WITHOUT CLAIM TO ANY PARTICULAR FONT, STYLE, SIZE, OR COLOR.

FOR HAIR DRYERS (U.S. CLS. 13, 21, 23, 31 AND 34). MIDGE BUTLER, EXAMINING ATTORNEY

SN 85-256,072. NORDIC WATER PRODUCTS AB, FROLUNDA, SWEDEN, FILED 3-2-2011.

ZICKERT SHARK

THE MARK CONSISTS OF STANDARD CHARACTERS WITHOUT CLAIM TO ANY PARTICULAR FONT, STYLE, SIZE, OR COLOR.

FOR WATER AND WASTE TREATMENT EQUIPMENT FOR USE IN CLARIFICATION AND FILTRATION OF AND SLUDGE REMOVAL FROM WATER, WASTE WATER AND INDUSTRIAL WATER, NAMELY, GRANULAR BED FILTERS, PLATE CLARIFIERS, DISSOLVED AIR FLOTATION EQUIPMENT, FLOCCULATION MIXERS, CHEMICAL FEEDERS AND MIXERS, VACUUM SUCTION HEADERS, SURFACE SLUDGE AND SCUM SKIMMERS, SLUDGE SCRAPERS, SCREENS FOR SCREENING WASTE WATER, PRESSES FOR DEWATERING OF SLUDGE, CONVEYORS FOR TRANSPORTATION OF DEWATERED SLUDGE, WASTE WATER MIXERS, SLUDGE MIXERS, ODOR CONTROL UNITS, AERATORS, SLUDGE REMOVERS, FILTER MEDIA, ALL SOLD AS A UNIT (U.S. CLS. 13, 21, 23, 31 AND 34). JAY FLOWERS, EXAMINING ATTORNEY

CLASS 11—(Continued).

SN 85-256,292. DOLE FOOD COMPANY, INC., WESTLAKE VILLAGE, CA. FILED 3-2-2011.



OWNER OF U.S. REG. NOS. 1,334,608, 1,494,440 AND 1,568,638.

THE COLOR(S) RED, YELLOW, AND BLUE IS/ARE CLAIMED AS A FEATURE OF THE MARK.

THE MARK CONSISTS OF THE WORD "DOLE" IN RED LETTERS WITH A YELLOW SUNBURST ENCAPSULATED IN THE LETTER "O" AND A BLUE BAR UNDER THE WORD AND EXTENDING THE LENGTH OF THE WORD. THE COLOR WHITE IS USED AS BACKGROUND AND IS NOT A PART OF THE MARK.

FOR BARBECUES AND GRILLS; ELECTRIC YOGURT MAKERS (U.S. CLS. 13, 21, 23, 31 AND 34). DOMINICK J. SALEMI, EXAMINING ATTORNEY

SN 85-256,892. JACK'S TOOL SHED, LLC, MAYER, MN. FILED 3-3-2011.

ProMagnify

THE MARK CONSISTS OF STANDARD CHARACTERS WITHOUT CLAIM TO ANY PARTICULAR FONT, STYLE, SIZE, OR COLOR.

FOR ELECTRIC LAMPS; FLUORESCENT LAMPS; LAMPS; MAGNIFIER LAMPS (U.S. CLS. 13, 21, 23, 31 AND 34). ROBIN MITTLER, EXAMINING ATTORNEY

SN 85-256,906. O.C. WHITE CO., THORNDIKE, MA. FILED 3-3-2011.

ULTRAFLEX

THE MARK CONSISTS OF STANDARD CHARACTERS WITHOUT CLAIM TO ANY PARTICULAR FONT, STYLE, SIZE, OR COLOR.

OWNER OF U.S. REG. NO. 2,440,690. FOR ADJUSTABLE ELECTRIC LIGHTING FIXTURES (U.S. CLS. 13, 21, 23, 31 AND 34). FIRST USE 12-31-1965; IN COMMERCE 12-31-1965. DARRYL SPRUILL, EXAMINING ATTORNEY

CLASS 11—(Continued).

SN 85-256,958. O.C. WHITE CO., THORNDIKE, MA. FILED 3-3-2011.

UNIFLEX

THE MARK CONSISTS OF STANDARD CHARACTERS WITHOUT CLAIM TO ANY PARTICULAR FONT, STYLE, SIZE, OR COLOR.
 OWNER OF U.S. REG. NO. 2,435,361.
 FOR ADJUSTABLE ELECTRIC LIGHTING FIXTURES (U.S. CLS. 13, 21, 23, 31 AND 34).
 FIRST USE 12-31-1965; IN COMMERCE 12-31-1965.
 DARRYL SPRUILL, EXAMINING ATTORNEY

SN 85-257,209. STREAMLIGHT, INC., EAGLEVILLE, PA. FILED 3-3-2011.

PROTAC

THE MARK CONSISTS OF STANDARD CHARACTERS WITHOUT CLAIM TO ANY PARTICULAR FONT, STYLE, SIZE, OR COLOR.
 OWNER OF U.S. REG. NOS. 2,873,946 AND 3,648,492.
 FOR FLASHLIGHTS AND PARTS THEREFOR (U.S. CLS. 13, 21, 23, 31 AND 34).
 NICHOLAS ALTREE, EXAMINING ATTORNEY

SN 85-257,523. 1,4GROUP, INC., MERIDIAN, ID. FILED 3-3-2011.

E-FRESH

THE MARK CONSISTS OF STANDARD CHARACTERS WITHOUT CLAIM TO ANY PARTICULAR FONT, STYLE, SIZE, OR COLOR.
 FOR ELECTRIC THERMAL FOGGING MACHINES (U.S. CLS. 13, 21, 23, 31 AND 34).
 KELLY CHOE, EXAMINING ATTORNEY

CLASS 11—(Continued).

SN 85-257,922. CHRISTOPHER RITTER, BANGOR, ME. AND THOMAS RITTER, BANGOR, ME. FILED 3-4-2011.

SHOULDER

THE MARK CONSISTS OF STANDARD CHARACTERS WITHOUT CLAIM TO ANY PARTICULAR FONT, STYLE, SIZE, OR COLOR.
 FOR WEARABLE PORTABLE BATTERY-POWERED WORK LAMPS AND WORK LIGHTS AND PARTS AND FITTINGS THEREFOR (U.S. CLS. 13, 21, 23, 31 AND 34).
 INGA ERVIN, EXAMINING ATTORNEY

SN 85-332,180. SUNBEAM PRODUCTS, INC., BOCA RATON, FL. FILED 5-27-2011.



THE MARK CONSISTS OF THE LITERAL ELEMENT "AER" WHICH HAS A CIRCLE OF A LIGHT HUE TO THE TOP RIGHT OF THE LETTER "R" IN "AER" AND WITHIN THE CIRCLE IS THE NUMBER "1".
 FOR ELECTRICAL HOUSEHOLD APPLIANCES, NAMELY, AIR PURIFIERS AND HUMIDIFIERS; FILTERS FOR AIR PURIFIERS AND HUMIDIFIERS (U.S. CLS. 13, 21, 23, 31 AND 34).
 MORGAN WYNNE, EXAMINING ATTORNEY

SN 85-332,203. SUNBEAM PRODUCTS, INC., BOCA RATON, FL. FILED 5-27-2011.

aer1 filter series

THE MARK CONSISTS OF STANDARD CHARACTERS WITHOUT CLAIM TO ANY PARTICULAR FONT, STYLE, SIZE, OR COLOR.
 NO CLAIM IS MADE TO THE EXCLUSIVE RIGHT TO USE "FILTER SERIES", APART FROM THE MARK AS SHOWN.
 FOR ELECTRICAL HOUSEHOLD APPLIANCES, NAMELY, AIR PURIFIERS AND HUMIDIFIERS; FILTERS FOR AIR PURIFIERS AND HUMIDIFIERS (U.S. CLS. 13, 21, 23, 31 AND 34).
 MORGAN WYNNE, EXAMINING ATTORNEY

CLASS 11—(Continued).

SN 85-332,217. SUNBEAM PRODUCTS, INC., BOCA RATON, FL. FILED 5-27-2011.

aer1 ready

THE MARK CONSISTS OF STANDARD CHARACTERS WITHOUT CLAIM TO ANY PARTICULAR FONT, STYLE, SIZE, OR COLOR.

FOR ELECTRICAL HOUSEHOLD APPLIANCES, NAMELY, AIR PURIFIERS AND HUMIDIFIERS; FILTERS FOR AIR PURIFIERS AND HUMIDIFIERS (U.S. CLS. 13, 21, 23, 31 AND 34).

MORGAN WYNNE, EXAMINING ATTORNEY

SN 85-332,224. SUNBEAM PRODUCTS, INC., BOCA RATON, FL. FILED 5-27-2011.

aer1

THE MARK CONSISTS OF STANDARD CHARACTERS WITHOUT CLAIM TO ANY PARTICULAR FONT, STYLE, SIZE, OR COLOR.

FOR ELECTRICAL HOUSEHOLD APPLIANCES, NAMELY, AIR PURIFIERS AND HUMIDIFIERS; FILTERS FOR AIR PURIFIERS AND HUMIDIFIERS (U.S. CLS. 13, 21, 23, 31 AND 34).

MORGAN WYNNE, EXAMINING ATTORNEY

SN 85-332,264. SUNBEAM PRODUCTS, INC., BOCA RATON, FL. FILED 5-27-2011.

aer¹
ready

THE MARK CONSISTS OF THE LITERAL ELEMENT "AER1 READY" WITH A CIRCLE OF A LIGHT HUE AT THE TOP RIGHT OF THE LETTER "R" IN THE TERM "AER". WITHIN THE MIDDLE OF THE CIRCLE IS THE NUMBER "1". THE WORD "READY" IS ALSO LOCATED BELOW THE WORD "AER".

FOR ELECTRICAL HOUSEHOLD APPLIANCES, NAMELY, AIR PURIFIERS AND HUMIDIFIERS; FILTERS FOR AIR PURIFIERS AND HUMIDIFIERS (U.S. CLS. 13, 21, 23, 31 AND 34).

MORGAN WYNNE, EXAMINING ATTORNEY

CLASS 11—(Continued).

SN 85-332,278. SUNBEAM PRODUCTS, INC., BOCA RATON, FL. FILED 5-27-2011.

aer¹
filter series

NO CLAIM IS MADE TO THE EXCLUSIVE RIGHT TO USE "FILTER SERIES", APART FROM THE MARK AS SHOWN.

THE MARK CONSISTS OF FOUR HORIZONTALLY ARRANGED PARTIALLY OVERLAPPING CIRCLES OF THE SAME SIZE, WITH THE LEFT CIRCLE BEING OF THE DARKEST HUE AND THE RIGHT CIRCLE BEING OF THE LIGHTEST HUE, WITH ALL FOUR CIRCLES PRECEDING THE LITERAL ELEMENT "AER1 FILTER SERIES". THE TERM "AER" OF THE LITERAL ELEMENT IS DIRECTLY TO THE RIGHT OF THE FOUR CIRCLES. A CIRCLE OF A LIGHT HUE IS NEXT TO THE TOP RIGHT OF THE LETTER "R" IN THE TERM "AER". WITHIN THE MIDDLE OF THE CIRCLE IS THE NUMBER "1". THE WORDS "FILTER SERIES" ARE DIRECTLY UNDERNEATH THE WORD "AER" IN THE LITERAL ELEMENT.

FOR ELECTRICAL HOUSEHOLD APPLIANCES, NAMELY, AIR PURIFIERS AND HUMIDIFIERS; FILTERS FOR AIR PURIFIERS AND HUMIDIFIERS (U.S. CLS. 13, 21, 23, 31 AND 34).

MORGAN WYNNE, EXAMINING ATTORNEY

SN 85-332,294. SUNBEAM PRODUCTS, INC., BOCA RATON, FL. FILED 5-27-2011.

aer¹
filter series

NO CLAIM IS MADE TO THE EXCLUSIVE RIGHT TO USE "FILTER SERIES", APART FROM THE MARK AS SHOWN.

THE MARK CONSISTS OF THE LITERAL ELEMENT "AER1 FILTER SERIES" WITH A SHADED CIRCLE DIRECTLY AT THE TOP RIGHT OF THE LETTER "R" IN THE TERM "AER". WITHIN THE MIDDLE OF THE CIRCLE IS THE NUMBER "1". THE WORDS "FILTER SERIES" ARE OF A SMALLER FONT AND DIRECTLY UNDERNEATH THE TERM "AER".

FOR ELECTRICAL HOUSEHOLD APPLIANCES, NAMELY, AIR PURIFIERS AND HUMIDIFIERS; FILTERS FOR AIR PURIFIERS AND HUMIDIFIERS (U.S. CLS. 13, 21, 23, 31 AND 34).

MORGAN WYNNE, EXAMINING ATTORNEY

CLASS 12—VEHICLES

SN 77-925,242. MOBEX OF NORTH FLORIDA INC., JACKSONVILLE, FL. FILED 2-1-2010.



NO CLAIM IS MADE TO THE EXCLUSIVE RIGHT TO USE "INC.", APART FROM THE MARK AS SHOWN.

THE MARK CONSISTS OF THE STYLIZED WORD "MOBEX" WITH A WHEEL INSIDE THE LETTER "O" WITH HORIZONTAL LINES EXTENDING FROM THE WHEEL TOWARD THE LETTER "M", INDICATING MOTION AND QUICK MOVEMENT OF THE WHEEL, WITH THE WORD "INC." APPEARING UNDERNEATH THE LETTER "X".

FOR MOBILIZATION EQUIPMENT, NAMELY, JACK MOUNTED ON WHEELS FOR USE IN SECURING AND LIFTING STOCKED GONDOLAS AND RETAIL SHEL-VING UNITS IN RETAIL STORES AND WAREHOUSES; MOBILIZATION EQUIPMENT, NAMELY, JACK MOUNTED ON WHEELS FOR USE IN SECURING AND LIFTING STOCKED WAREHOUSE RACKING IN WAREHOUSES AND RETAIL STORES (U.S. CLS. 19, 21, 23, 31, 35 AND 44).

FIRST USE 4-1-2008; IN COMMERCE 4-1-2008.
JOSETTE BEVERLY, EXAMINING ATTORNEY

SN 77-965,436. MANUEL SAEZ LTD., L.I.C., NY. FILED 3-22-2010.

BROOKLYNESS

THE MARK CONSISTS OF STANDARD CHARACTERS WITHOUT CLAIM TO ANY PARTICULAR FONT, STYLE, SIZE, OR COLOR.

FOR BICYCLE AND BICYCLE ACCESSORIES, NAMELY, BICYCLE CHAINS, BICYCLE BELLS, BI-CYCLE GRIP TAPE; SCOOTERS; MOTORIZED SCOO-TERS; ELECTRIC MOTORIZED SKATEBOARDS; SADDLEBAGS FOR BICYCLES (U.S. CLS. 19, 21, 23, 31, 35 AND 44).

KATHERINE M. DUBRAY, EXAMINING ATTORNEY

SN 77-965,437. MANUEL SAEZ LTD., L.I.C., NY. FILED 3-22-2010.

BKLYNESS

THE MARK CONSISTS OF STANDARD CHARACTERS WITHOUT CLAIM TO ANY PARTICULAR FONT, STYLE, SIZE, OR COLOR.

FOR BICYCLE AND BICYCLE ACCESSORIES, NAMELY, BICYCLE CHAINS, BICYCLE BELLS, BI-CYCLE GRIP TAPE; SCOOTERS; MOTORIZED SCOO-TERS; ELECTRIC MOTORIZED SKATEBOARDS; SADDLEBAGS FOR BICYCLES (U.S. CLS. 19, 21, 23, 31, 35 AND 44).

KATHERINE M. DUBRAY, EXAMINING ATTORNEY

CLASS 12—(Continued).

SN 79-087,880. BAYERISCHE MOTOREN WERKE AKTIEN-GESELLSCHAFT, FED REP GERMANY, FILED 9-8-2010.

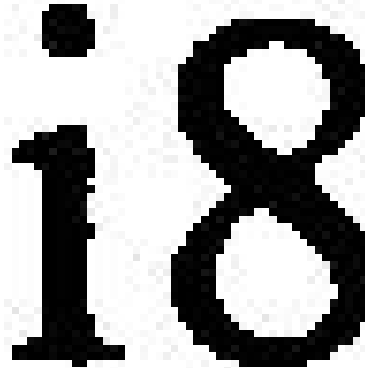

THE MARK CONSISTS OF STANDARD CHARACTERS WITHOUT CLAIM TO ANY PARTICULAR FONT, STYLE, SIZE, OR COLOR.

PRIORITY DATE OF 3-18-2010 IS CLAIMED.
OWNER OF INTERNATIONAL REGISTRATION 1052584 DATED 9-8-2010, EXPIRES 9-8-2020.

FOR LAND VEHICLES, NAMELY, HYBRID AUTO-MOBILES, AND STRUCTURAL PARTS THEREFOR (U.S. CLS. 19, 21, 23, 31, 35 AND 44).

STEVEN PEREZ, EXAMINING ATTORNEY

SN 79-087,888. BAYERISCHE MOTOREN WERKE AKTIEN-GESELLSCHAFT, FED REP GERMANY, FILED 9-8-2010.



THE MARK CONSISTS OF STANDARD CHARACTERS WITHOUT CLAIM TO ANY PARTICULAR FONT, STYLE, SIZE, OR COLOR.

PRIORITY DATE OF 3-18-2010 IS CLAIMED.
OWNER OF INTERNATIONAL REGISTRATION 1052594 DATED 9-8-2010, EXPIRES 9-8-2020.

FOR LAND VEHICLES, NAMELY, ELECTRIC AUTO-MOBILES, AND STRUCTURAL PARTS THEREFOR (U.S. CLS. 19, 21, 23, 31, 35 AND 44).

STEVEN PEREZ, EXAMINING ATTORNEY

CLASS 12—(Continued).

SN 79-087,890. BAYERISCHE MOTOREN WERKE AKTIEN-GESELLSCHAFT, FED REP GERMANY, FILED 9-8-2010.

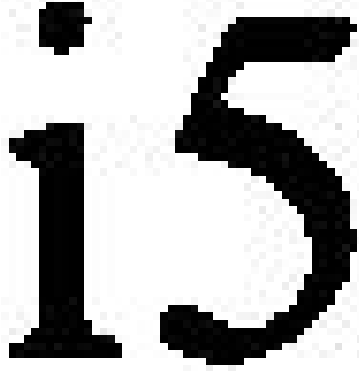

THE MARK CONSISTS OF STANDARD CHARACTERS WITHOUT CLAIM TO ANY PARTICULAR FONT, STYLE, SIZE, OR COLOR.

PRIORITY DATE OF 3-18-2010 IS CLAIMED.
OWNER OF INTERNATIONAL REGISTRATION 1052596 DATED 9-8-2010, EXPIRES 9-8-2020.

FOR LAND VEHICLES, NAMELY, ELECTRIC AUTOMOBILES, AS WELL AS HYBRID AUTOMOBILES POWERED BY ONE OR MORE ELECTRIC MOTORS AND AN INTERNAL COMBUSTION ENGINE, EXCLUDING INTERNAL COMBUSTION ENGINES WITH STRAIGHT-FIVE ENGINE CONFIGURATIONS; STRUCTURAL PARTS OF THE AFORESAID VEHICLES (U.S. CLS. 19, 21, 23, 31, 35 AND 44).

STEVEN PEREZ, EXAMINING ATTORNEY

CLASS 12—(Continued).

SN 79-088,115. BAYERISCHE MOTOREN WERKE AKTIEN-GESELLSCHAFT, FED REP GERMANY, FILED 9-8-2010.

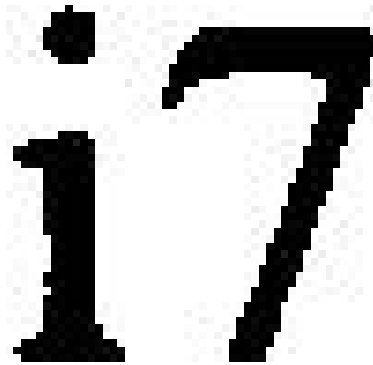

THE MARK CONSISTS OF STANDARD CHARACTERS WITHOUT CLAIM TO ANY PARTICULAR FONT, STYLE, SIZE, OR COLOR.

PRIORITY DATE OF 3-18-2010 IS CLAIMED.
OWNER OF INTERNATIONAL REGISTRATION 1053236 DATED 9-8-2010, EXPIRES 9-8-2020.

FOR LAND VEHICLES, NAMELY, ELECTRIC AND HYBRID AUTOMOBILES, AND STRUCTURAL PARTS THEREFOR (U.S. CLS. 19, 21, 23, 31, 35 AND 44).

STEVEN PEREZ, EXAMINING ATTORNEY

SN 79-087,891. BAYERISCHE MOTOREN WERKE AKTIEN-GESELLSCHAFT, FED REP GERMANY, FILED 9-8-2010.

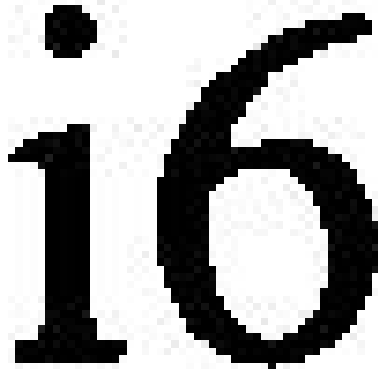

THE MARK CONSISTS OF STANDARD CHARACTERS WITHOUT CLAIM TO ANY PARTICULAR FONT, STYLE, SIZE, OR COLOR.

PRIORITY DATE OF 3-18-2010 IS CLAIMED.
OWNER OF INTERNATIONAL REGISTRATION 1052597 DATED 9-8-2010, EXPIRES 9-8-2020.

FOR LAND VEHICLES, NAMELY, ELECTRIC AUTOMOBILES, AS WELL AS HYBRID AUTOMOBILES POWERED BY ONE OR MORE ELECTRIC MOTORS AND AN INTERNAL COMBUSTION ENGINE, EXCLUDING INTERNAL COMBUSTION ENGINES WITH STRAIGHT-SIX ENGINE CONFIGURATIONS; STRUCTURAL PARTS OF THE AFORESAID VEHICLES (U.S. CLS. 19, 21, 23, 31, 35 AND 44).

STEVEN PEREZ, EXAMINING ATTORNEY

SN 79-093,259. GULF AGENCY COMPANY LIMITED, LIECHTENSTEIN, FILED 12-27-2010.



PRIORITY DATE OF 9-30-2010 IS CLAIMED.
OWNER OF INTERNATIONAL REGISTRATION 1066920 DATED 12-27-2010, EXPIRES 12-27-2020.

THE COLOR(S) BLUE, YELLOW, ORANGE AND WHITE IS/ARE CLAIMED AS A FEATURE OF THE MARK.

THE MARK CONSISTS OF THE WORDING "HULLWIPER". THE WORDING "HULL" IN BLUE AND WHITE, AND "WIPER" IN BLUE, IMPOSED UPON A YELLOW AND ORANGE DESIGN WITH A BLUE DESIGN ABOVE INSIDE A SQUARE

FOR MOTORIZED VEHICLES USED FOR CLEANING THE HULLS OF VESSELS; APPARATUS FOR LOCOMOTION BY LAND, AIR OR WATER (U.S. CLS. 19, 21, 31, 35 AND 44).

FRANK LATTUCA, EXAMINING ATTORNEY

CLASS 12—(Continued).

SN 79-097,204. BAYERISCHE MOTOREN WERKE AKTIEN-
GESELLSCHAFT, FED REP GERMANY, FILED 4-19-2011.

Paceman

THE MARK CONSISTS OF STANDARD CHARACTERS
WITHOUT CLAIM TO ANY PARTICULAR FONT, STYLE,
SIZE, OR COLOR.

PRIORITY DATE OF 12-8-2010 IS CLAIMED.
OWNER OF INTERNATIONAL REGISTRATION 1076669
DATED 4-19-2011, EXPIRES 4-19-2021.
FOR AUTOMOBILES (U.S. CLS. 19, 21, 23, 31, 35 AND
44).
NAKIA HENRY, EXAMINING ATTORNEY

CLASS 12—(Continued).

SN 85-094,427. DADS MACHINERY, LLC, SYRACUSE, IN.
FILED 7-28-2010.

SOLAR CRUISER

THE MARK CONSISTS OF STANDARD CHARACTERS
WITHOUT CLAIM TO ANY PARTICULAR FONT, STYLE,
SIZE, OR COLOR.

NO CLAIM IS MADE TO THE EXCLUSIVE RIGHT TO
USE "CRUISER", APART FROM THE MARK AS SHOWN.
FOR BOATS (U.S. CLS. 19, 21, 23, 31, 35 AND 44).
ESTHER A. BORSUK, EXAMINING ATTORNEY

SN 85-073,923. POLARIS INDUSTRIES INC., MEDINA, MN.
FILED 6-29-2010.

RZR

THE MARK CONSISTS OF STANDARD CHARACTERS
WITHOUT CLAIM TO ANY PARTICULAR FONT, STYLE,
SIZE, OR COLOR.

OWNER OF U.S. REG. NO. 3,509,238.
FOR ALL-TERRAIN UTILITY VEHICLES AND
STRUCTURAL PARTS THEREFOR (U.S. CLS. 19, 21, 23,
31, 35 AND 44).
FIRST USE 5-7-2007; IN COMMERCE 5-7-2007.
ALEX KEAM, EXAMINING ATTORNEY

SN 85-103,188. TRQSS, INC., TORONTO, ONTARIO, CANA-
DA, FILED 8-9-2010.

TRQSS

THE MARK CONSISTS OF STANDARD CHARACTERS
WITHOUT CLAIM TO ANY PARTICULAR FONT, STYLE,
SIZE, OR COLOR.

OWNER OF CANADA REG. NO. TMA798,657, DATED 5-
26-2011, EXPIRES 5-26-2026.
FOR SECURITY HARNESS FOR VEHICLE SEATS;
SAFETY BELTS FOR VEHICLE SEATS; SEAT BELTS
(U.S. CLS. 19, 21, 23, 31, 35 AND 44).
AISHA CLARKE, EXAMINING ATTORNEY

SN 85-094,426. DADS MACHINERY, LLC, SYRACUSE, IN.
FILED 7-28-2010.

QUIET STORM

THE MARK CONSISTS OF STANDARD CHARACTERS
WITHOUT CLAIM TO ANY PARTICULAR FONT, STYLE,
SIZE, OR COLOR.

FOR BOATS (U.S. CLS. 19, 21, 23, 31, 35 AND 44).
ESTHER A. BORSUK, EXAMINING ATTORNEY

SN 85-103,866. BRIDGESTONE CORPORATION, TOKYO,
JAPAN, FILED 8-10-2010.

R135

THE MARK CONSISTS OF STANDARD CHARACTERS
WITHOUT CLAIM TO ANY PARTICULAR FONT, STYLE,
SIZE, OR COLOR.

OWNER OF U.S. REG. NOS. 1,249,494 AND 3,018,562.
FOR TIRES FOR VEHICLES (U.S. CLS. 19, 21, 23, 31, 35
AND 44).
STEVEN R. FINE, EXAMINING ATTORNEY

CLASS 12—(Continued).

SN 85-105,145. TECHNICAL RUBBER COMPANY, INC., JOHNSTOWN, OH. FILED 8-11-2010.

TRUFLEX/PANG

THE MARK CONSISTS OF STANDARD CHARACTERS WITHOUT CLAIM TO ANY PARTICULAR FONT, STYLE, SIZE, OR COLOR.

FOR AUTOMOTIVE TIRE AND TUBE REPAIR MATERIALS, NAMELY, TUBE AND TIRE REPAIR KITS CONSISTING OF RUBBER INSERTS USED TO FILL NAIL HOLES OR OTHER INJURIES TO A TIRE, TIRE PATCHES, VULCANIZING LIQUID CEMENT AND ACTIVATOR USED TOGETHER TO ADHERE REPAIRS TO TIRE, INSERT TOOL TO ASSIST INSERTING NAIL-HOLE REPAIR INSERT, AND CARRYING CASE; PATCHES FOR TUBE AND TIRE REPAIRS; TUBELESS TIRE PUNCTURE REPAIR KITS CONSISTING OF RUBBER INSERTS TO FILL NAIL HOLES OR OTHER INJURIES TO A TIRE, TIRE PLUGS, TIRE PATCHES, LIQUID CEMENT AND ACTIVATOR USED TOGETHER TO ADHERE REPAIRS TO TIRE, INSERT TOOL TO ASSIST INSERTING NAIL-HOLE REPAIR INSERT, AND CARRYING CASE; QUICK PATCHES; BIAS PLY TIRE SECTION REPAIR UNITS, NAMELY, TIRE PATCHES AND VULCANIZING LIQUID CEMENT AND ACTIVATOR USED TOGETHER TO ADHERE REPAIRS TO TIRE; RADIAL TIRE NAIL HOLE REPAIR KITS, NAMELY, RUBBER INSERTS TO FILL NAIL HOLES OR OTHER INJURIES TO A TIRE, TIRE PLUGS, INSERT TOOLS, TIRE PATCHES, AND LIQUID CEMENT AND ACTIVATOR USED TOGETHER TO ADHERE REPAIRS TO TIRE; BIAS PLY TIRE REPAIR UNITS, NAMELY, RUBBER INSERTS TO FILL NAIL HOLES OR OTHER INJURIES TO A TIRE, TIRE PATCHES, LIQUID CEMENT AND ACTIVATOR USED TOGETHER TO ADHERE REPAIRS TO TIRE, AND INSERT TOOLS; RADIAL TIRE REPAIR UNITS, NAMELY, INSERTS TO FILL NAIL HOLES OR OTHER INJURIES TO A TIRE, TIRE PATCHES, LIQUID CEMENT AND ACTIVATOR USED TOGETHER TO ADHERE REPAIRS TO TIRE, AND INSERT TOOLS; AND SELF-VULCANIZING LIQUID CEMENT AND ACTIVATOR USED TOGETHER TO ADHERE REPAIRS TO TIRE (U.S. CLS. 19, 21, 23, 31, 35 AND 44).

FIRST USE 12-31-1974; IN COMMERCE 12-31-1974.
LINDA E. BLOHM, EXAMINING ATTORNEY

SN 85-107,313. HONDA MOTOR CO., LTD., MINATO-KU, TOKYO, JAPAN, FILED 8-13-2010.

I-SHIFT

THE MARK CONSISTS OF STANDARD CHARACTERS WITHOUT CLAIM TO ANY PARTICULAR FONT, STYLE, SIZE, OR COLOR.

FOR SHIFTING SYSTEMS, NAMELY, COMPUTER CONTROLLED TRANSMISSIONS FOR AUTOMOBILES (U.S. CLS. 19, 21, 23, 31, 35 AND 44).

CYNTHIA TRIPI, EXAMINING ATTORNEY

CLASS 12—(Continued).

SN 85-109,854. KOROKNAY, TOM, LEXINGTON, OH. FILED 8-17-2010.

LYMAN

THE MARK CONSISTS OF STANDARD CHARACTERS WITHOUT CLAIM TO ANY PARTICULAR FONT, STYLE, SIZE, OR COLOR.

OWNER OF U.S. REG. NOS. 2,420,177, 2,578,365 AND 2,902,748.

SEC. 2(F).

FOR BOATS (U.S. CLS. 19, 21, 23, 31, 35 AND 44).

JULIE WATSON, EXAMINING ATTORNEY

SN 85-138,430. TAG-THE ACCESSORY GROUP, INC., DBA TAG PRODUCT, PLACENTIA, CA. FILED 9-26-2010.



NO CLAIM IS MADE TO THE EXCLUSIVE RIGHT TO USE "FENDER FLARES", APART FROM THE MARK AS SHOWN.

THE MARK CONSISTS OF THE STYLIZED TERM "TRAILDRIVER" ABOVE A CIRCLE ENCLOSING A COWBOY FIGURE WITH THE TERM "FENDER FLARES" AT THE BOTTOM OF THE CIRCLE AND A ROPE ABOVE THE CIRCLE.

FOR AUTOMOBILE BUMPERS; LAND VEHICLE PARTS, NAMELY, FENDER FLARES; MOTOR VEHICLES, NAMELY, AUTOMOBILES, TRUCKS, VANS, SPORT UTILITY VEHICLES AND STRUCTURAL PARTS THEREFOR; STEPS FOR ATTACHMENT TO LAND VEHICLES (U.S. CLS. 19, 21, 23, 31, 35 AND 44).

FIRST USE 5-1-2010; IN COMMERCE 5-1-2010.

TINA MAI, EXAMINING ATTORNEY

CLASS 12—(Continued).

SN 85-159,285. SDR FABRICATIONS, INC., OCEANSIDE, CA.
FILED 10-22-2010.

BAJA WAGON

THE MARK CONSISTS OF STANDARD CHARACTERS WITHOUT CLAIM TO ANY PARTICULAR FONT, STYLE, SIZE, OR COLOR.

NO CLAIM IS MADE TO THE EXCLUSIVE RIGHT TO USE "WAGON", APART FROM THE MARK AS SHOWN.

FOR SMALL WAGONS FOR CHILDREN; VEHICLE SEAT CUSHIONS (U.S. CLS. 19, 21, 23, 31, 35 AND 44).

FIRST USE 10-1-2008; IN COMMERCE 10-1-2008.

RAUL CORDOVA, EXAMINING ATTORNEY

SN 85-171,622. FORD MOTOR COMPANY, DEARBORN, MI.
FILED 11-8-2010.

ACTIVE CITY STOP

THE MARK CONSISTS OF STANDARD CHARACTERS WITHOUT CLAIM TO ANY PARTICULAR FONT, STYLE, SIZE, OR COLOR.

NO CLAIM IS MADE TO THE EXCLUSIVE RIGHT TO USE "ACTIVE", APART FROM THE MARK AS SHOWN.

FOR ELECTRONIC BRAKING SYSTEMS FOR AUTOMOBILES (U.S. CLS. 19, 21, 23, 31, 35 AND 44).

MICHAEL KEATING, EXAMINING ATTORNEY

SN 85-172,425. WACO HOLDINGS INC., BATTLE CREEK, MI. FILED 11-9-2010.

WACO CLASSIC

THE MARK CONSISTS OF STANDARD CHARACTERS WITHOUT CLAIM TO ANY PARTICULAR FONT, STYLE, SIZE, OR COLOR.

NO CLAIM IS MADE TO THE EXCLUSIVE RIGHT TO USE "CLASSIC", APART FROM THE MARK AS SHOWN.

FOR AIRPLANES (U.S. CLS. 19, 21, 23, 31, 35 AND 44).
FIRST USE 12-0-1985; IN COMMERCE 12-0-1985.

SHAUNIA CARLYLE, EXAMINING ATTORNEY

CLASS 12—(Continued).

SN 85-189,250. MSI DEFENSE SOLUTIONS, LLC, MOORESVILLE, NC. FILED 12-2-2010.

HARB

THE MARK CONSISTS OF STANDARD CHARACTERS WITHOUT CLAIM TO ANY PARTICULAR FONT, STYLE, SIZE, OR COLOR.

FOR HYDRAULIC ANTI-ROLL SUSPENSION SYSTEM FOR A VEHICLE, NAMELY, AN AUTOMOBILE (U.S. CLS. 19, 21, 23, 31, 35 AND 44).

TIMOTHY FINNEGAN, EXAMINING ATTORNEY

SN 85-198,449. BRADLEY ELLMAN, OCEANSIDE, NY.
FILED 12-15-2010.

PLATE PARTNER

THE MARK CONSISTS OF STANDARD CHARACTERS WITHOUT CLAIM TO ANY PARTICULAR FONT, STYLE, SIZE, OR COLOR.

NO CLAIM IS MADE TO THE EXCLUSIVE RIGHT TO USE "PLATE", APART FROM THE MARK AS SHOWN.

FOR LICENSE PLATE HOLDERS (U.S. CLS. 19, 21, 23, 31, 35 AND 44).

TINA MAI, EXAMINING ATTORNEY

SN 85-222,684. PRAXIS WORKS, LLC, AKA PRAXIS WORKS, PRAXIS CYCLES, PRAXIS, APTOS, CA. FILED 1-20-2011.

LEVATIME

THE MARK CONSISTS OF STANDARD CHARACTERS WITHOUT CLAIM TO ANY PARTICULAR FONT, STYLE, SIZE, OR COLOR.

FOR BICYCLE CHAINS; BICYCLE GEARS; BICYCLE PARTS, NAMELY, CHANGE-SPEED GEARS; BICYCLE PARTS, NAMELY, DERAILLEURS; BICYCLE PARTS, NAMELY, DRIVE CHAINS; BICYCLE PARTS, NAMELY, DRIVE TRAINS; BICYCLE PARTS, NAMELY, GEAR WHEELS; BICYCLE PARTS, NAMELY, SPROCKETS (U.S. CLS. 19, 21, 23, 31, 35 AND 44).

FIRST USE 1-29-2011; IN COMMERCE 1-29-2011.

MARK SPARACINO, EXAMINING ATTORNEY

CLASS 12—(Continued).

SN 85-244,138. PEDEGO, LLC, IRVINE, CA. FILED 2-16-2011.

PEDEGO

THE MARK CONSISTS OF STANDARD CHARACTERS WITHOUT CLAIM TO ANY PARTICULAR FONT, STYLE, SIZE, OR COLOR.

OWNER OF U.S. REG. NO. 3,770,790.
FOR ELECTRIC-POWERED BICYCLES (U.S. CLS. 19, 21, 23, 31, 35 AND 44).
NICHOLAS ALTREE, EXAMINING ATTORNEY

SN 85-249,478. ALL RIGHT STEEL, LLC, CUSHING, OK. FILED 2-23-2011.

BALEJACK

THE MARK CONSISTS OF STANDARD CHARACTERS WITHOUT CLAIM TO ANY PARTICULAR FONT, STYLE, SIZE, OR COLOR.

FOR TRACTOR TOWED AGRICULTURAL IMPLEMENTS, NAMELY, HAY HAULING TRAILERS (U.S. CLS. 19, 21, 23, 31, 35 AND 44).
ALICE BENMAMAN, EXAMINING ATTORNEY

SN 85-249,498. UNIVERSAL BRANDING & MEDIA LLC, MILFORD, CT. FILED 2-23-2011.



THE MARK CONSISTS OF THE WORDS "LIL PRO" WRITTEN IN CURSIVE WITH A STAR BETWEEN THE WORDS "LIL" AND "PRO".

FOR BICYCLES (U.S. CLS. 19, 21, 23, 31, 35 AND 44).
FIRST USE 1-31-2011; IN COMMERCE 1-31-2011.
ANDREW RHIM, EXAMINING ATTORNEY

CLASS 12—(Continued).

SN 85-250,778. MOTORSPOT, INC., BONSALE, CA. FILED 2-24-2011.

TRUEWIRE

OWNER OF U.S. REG. NOS. 3,657,871, 3,657,993 AND OTHERS.

THE MARK CONSISTS OF THE STYLIZED WORDING "TRUEWIRE" WITH THREE HORIZONTAL BARS REPRESENTING THE FIRST LETTER "E".

FOR CAPS FOR WHEEL RIMS; HUB CAP COVERS; HUB CAPS; LAND VEHICLE PARTS, NAMELY, WHEELS; VEHICLE WHEEL RIMS; VEHICLE WHEEL RIMS AND STRUCTURAL PARTS THEREFOR; VEHICLE WHEELS; WHEEL HUBS FOR LAND VEHICLES FEATURING CHROME WIRE RIMS; WHEEL RIMS; WHEEL RIMS FOR MOTOR CARS (U.S. CLS. 19, 21, 23, 31, 35 AND 44).

NICHOLAS ALTREE, EXAMINING ATTORNEY

SN 85-250,883. ZHANG, QI LIN, JINSHA DIST., SHANGHAI, CHINA, FILED 2-24-2011.



NICONIA

THE MARK CONSISTS OF FOUR STYLIZED, CHINESE CHARACTERS, PRONOUNCED AS: NI KE NI YA - ABOVE THE WORD NICONIA.

THE WORDING NICONIA HAS NO MEANING IN A FOREIGN LANGUAGE.

THE NON-LATIN CHARACTERS IN THE MARK TRANSLITERATE TO NI KE NI YA AND THIS HAS NO MEANING IN A FOREIGN LANGUAGE.

FOR BICYCLES; ELECTRIC MOTORCYCLES; ELECTRIC VEHICLES, NAMELY, BICYCLES AND TRICYCLES; LAND VEHICLES, NAMELY, LOW-SPEED ELECTRIC VEHICLES; MOTORIZED PERSONAL MOBILITY SCOOTERS; THREE-WHEELED MOTOR VEHICLES; TRICYCLES; TWO-WHEELED MOTOR VEHICLES (U.S. CLS. 19, 21, 23, 31, 35 AND 44).

FIRST USE 12-24-2010; IN COMMERCE 12-24-2010.
EDWARD FENNESSY, EXAMINING ATTORNEY

CLASS 12—(Continued).

SN 85-251,641. HEINZ, RICHARD N, GLADSTONE, MI. FILED 2-25-2011.



NO CLAIM IS MADE TO THE EXCLUSIVE RIGHT TO USE "FUEL", APART FROM THE MARK AS SHOWN.

THE MARK CONSISTS OF OUTLINE OF UPPER PART OF SEMI TRUCK WITH TRAILER, INCLUDING EXHAUST PIPE, OVER LETTERING "FUEL SHIVERS" OVER SWOOSH MARK BEGINNING AS ONE THICK SEGMENT ON LEFT, GRADUALLY MORPHING IN THREE SMALLER SEGMENTS AS IT MOVES RIGHT ACROSS THE BOTTOM OF THE LOGO.

FOR AERO-DYNAMIC FAIRINGS FOR VEHICLES (U.S. CLS. 19, 21, 23, 31, 35 AND 44).

PAUL F. GAST, EXAMINING ATTORNEY

CLASS 12—(Continued).

SN 85-253,244. HINO JIDOSHA KABUSHIKI KAISHA, TA HINO MOTORS, LTD., HINO-SHI, TOKYO, JAPAN, FILED 2-28-2011.



NO CLAIM IS MADE TO THE EXCLUSIVE RIGHT TO USE "HYBRID", APART FROM THE MARK AS SHOWN.

THE MARK CONSISTS OF A STYLIZED PARALLELOGRAM WITHIN WHICH ARE THREE COLUMNS OF THREE STYLIZED SQUARES AND ONE COLUMN OF THREE STYLIZED DOTS, AND THE TERM "HYBRID"

FOR LAND VEHICLES AND STRUCTURAL PARTS THEREFOR; LUGGAGE CARRIERS FOR VEHICLES; TRUCK PARTS, NAMELY, A PREMIUM OUTFITTED TRUCK CAB; ENGINES AND MOTORS FOR LAND VEHICLES (U.S. CLS. 19, 21, 23, 31, 35 AND 44).

ANGELA DUONG, EXAMINING ATTORNEY

SN 85-253,087. TRACTOR SUPPLY CO. OF TEXAS, LP, BRENTWOOD, TN. FILED 2-28-2011.

TRAVELLER

THE MARK CONSISTS OF STANDARD CHARACTERS WITHOUT CLAIM TO ANY PARTICULAR FONT, STYLE, SIZE, OR COLOR.

OWNER OF U.S. REG. NOS. 756,067, 951,789 AND OTHERS.

FOR TRAILER HITCHES AND BALLS; TIRE TUBES FOR VEHICLES; METAL LOCKING DEVICE FOR TRAILER HITCH COUPLERS; INNER TUBES FOR PNEUMATIC TIRES; BED LINERS FOR TRUCKS (U.S. CLS. 19, 21, 23, 31, 35 AND 44).

ANGELA DUONG, EXAMINING ATTORNEY

SN 85-253,446. MARUI LTD, KOBE, HYOGO, JAPAN, FILED 2-28-2011.

COMPETITION III

THE MARK CONSISTS OF STANDARD CHARACTERS WITHOUT CLAIM TO ANY PARTICULAR FONT, STYLE, SIZE, OR COLOR.

OWNER OF U.S. REG. NO. 1,465,345.

NO CLAIM IS MADE TO THE EXCLUSIVE RIGHT TO USE "COMPETITION", APART FROM THE MARK AS SHOWN.

FOR BICYCLE TIRES (U.S. CLS. 19, 21, 23, 31, 35 AND 44).

FIRST USE 6-10-1980; IN COMMERCE 2-15-1981.

JAMES LOVELACE, EXAMINING ATTORNEY

SN 85-253,232. DYNACRAFT BSC, INC., AMERICAN CANYON, CA. FILED 2-28-2011.

ROOFTOP

THE MARK CONSISTS OF STANDARD CHARACTERS WITHOUT CLAIM TO ANY PARTICULAR FONT, STYLE, SIZE, OR COLOR.

FOR BICYCLES (U.S. CLS. 19, 21, 23, 31, 35 AND 44).

FIRST USE 2-0-2010; IN COMMERCE 2-0-2010.

ELLEN BURNS, EXAMINING ATTORNEY

SN 85-253,623. TRACTOR SUPPLY CO. OF TEXAS, LP, BRENTWOOD, TN. FILED 2-28-2011.

HUSKEE

THE MARK CONSISTS OF STANDARD CHARACTERS WITHOUT CLAIM TO ANY PARTICULAR FONT, STYLE, SIZE, OR COLOR.

OWNER OF U.S. REG. NOS. 1,183,496 AND 1,713,048.

FOR ATTACHMENTS FOR RIDING AND WALK BEHIND LAWN MOWERS, NAMELY, LEAF CATCHERS, GRASS CATCHERS, AND STRUCTURAL PARTS THEREOF (U.S. CLS. 19, 21, 23, 31, 35 AND 44).

KATHLEEN LORENZO, EXAMINING ATTORNEY

CLASS 12—(Continued).

SN 85-253,821. MISSION TRADING COMPANY INC., SACRAMENTO, CA. FILED 2-28-2011.

SAMEER

THE MARK CONSISTS OF STANDARD CHARACTERS WITHOUT CLAIM TO ANY PARTICULAR FONT, STYLE, SIZE, OR COLOR.

FOR STRUCTURAL PARTS FOR AUTOMOBILES; STRUCTURAL PARTS FOR TRUCKS (U.S. CLS. 19, 21, 23, 31, 35 AND 44).

FIRST USE 1-13-1997; IN COMMERCE 1-13-1997.
KYLE PEETE, EXAMINING ATTORNEY

CLASS 12—(Continued).

SN 85-254,618. CARRIAGE, INC., MILLERSBURG, IN. FILED 3-1-2011.

CARRIAGE

THE MARK CONSISTS OF STANDARD CHARACTERS WITHOUT CLAIM TO ANY PARTICULAR FONT, STYLE, SIZE, OR COLOR.

FOR TRAVEL TRAILERS AND FIFTH WHEEL TRAILERS (U.S. CLS. 19, 21, 23, 31, 35 AND 44).

FIRST USE 1-1-1968; IN COMMERCE 1-1-1968.
SUNG IN, EXAMINING ATTORNEY

SN 85-254,471. MISSION TRADING COMPANY INC., SACRAMENTO, CA. FILED 3-1-2011.

RONAK

THE MARK CONSISTS OF STANDARD CHARACTERS WITHOUT CLAIM TO ANY PARTICULAR FONT, STYLE, SIZE, OR COLOR.

FOR STRUCTURAL PARTS FOR AUTOMOBILES; STRUCTURAL PARTS FOR TRUCKS (U.S. CLS. 19, 21, 23, 31, 35 AND 44).

FIRST USE 1-22-1997; IN COMMERCE 1-22-1997.
DOMINIC FATHY, EXAMINING ATTORNEY

SN 85-254,765. TAP WORLDWIDE, LLC, COMPTON, CA. FILED 3-1-2011.

X20

THE MARK CONSISTS OF STANDARD CHARACTERS WITHOUT CLAIM TO ANY PARTICULAR FONT, STYLE, SIZE, OR COLOR.

FOR AUTOMOBILE AND TRUCK STRUCTURAL PARTS AND ACCESSORIES SPECIALLY ADAPTED FOR AUTOMOBILES AND TRUCKS, NAMELY, STRUCTURAL PARTS FOR AUTOMOBILES, WHEELS, WHEEL RIMS, TIRES, SHOCK ABSORBERS, SHOCK ABSORBER MOUNTS, SHOCK ABSORBER BRACKETS, PITMAN ARMS, STEERING ARMS, TIRE RODS, STEERING DAMPENERS, SUSPENSION SYSTEMS FOR AUTOMOBILES FEATURING REAR STABILIZER BARS, AUTOMOBILE AND TRUCK BODY PARTS IN THE NATURE OF SIDEBARS, BUMPERS, BRUSH GUARDS, GRILL GUARDS, AND FITTED BUMPER CAPS, ROLL BARS, INTERIOR CAB CAGES, SKID PLATES, LIGHT BARS, TOW BARS, TOW HITCHES, STEP PADS, CUSTOM VEHICLE GRILLES, SEATS, MOTORIZED TAILGATES, SPARE TIRE COVERS, TURN SIGNAL MOUNTING BRACKETS AS STRUCTURAL PARTS OF VEHICLES, FITTED LINERS FOR THE CARGO AREA OF VEHICLES, LOCKING LUG NUTS FOR VEHICLE WHEELS AND REPLACEMENT SOFT TOPS FOR VEHICLES; TRANSMISSIONS FOR LAND VEHICLES AND REPLACEMENT PARTS THEREOF; DRIVE TRAINS AND STRUCTURAL PARTS THEREFORE FOR LAND VEHICLES, NAMELY, CLUTCHES FOR LAND VEHICLES, RING AND PINION SETS COMPRISING PINION SEALS, PINION BEARINGS, GEARS AND GEAR RINGS, DRIVE SHAFTS FOR LAND VEHICLES AND DIFFERENTIALS FOR LAND VEHICLES; LAND VEHICLE PARTS, NAMELY, AXLES, AXLE SHAFTS, TRANSMISSION GEARS, AND INSTALLATION KITS FOR LAND VEHICLES COMPRISING TRANSMISSION SEALS, AXLE BEARINGS, AXLE SHAFTS, DRIVE SHAFTS, SLEEVES FOR AUTOMOTIVE STEERING SYSTEMS, SHIMS FOR AUTOMOTIVE BRAKES, LICENSE PLATE FASTENERS, AND LUG NUTS FOR VEHICLE WHEELS (U.S. CLS. 19, 21, 23, 31, 35 AND 44).

ZHALEH DELANEY, EXAMINING ATTORNEY

SN 85-254,575. CARRIAGE, INC., MILLERSBURG, IN. FILED 3-1-2011.

CARRI-LITE

THE MARK CONSISTS OF STANDARD CHARACTERS WITHOUT CLAIM TO ANY PARTICULAR FONT, STYLE, SIZE, OR COLOR.

FOR TRAVEL TRAILERS AND FIFTH WHEEL TRAILERS (U.S. CLS. 19, 21, 23, 31, 35 AND 44).

FIRST USE 1-1-1981; IN COMMERCE 1-1-1981.
SUNG IN, EXAMINING ATTORNEY

CLASS 12—(Continued).

SN 85-255,146. ACTIONWHEELS, MESA, AZ. FILED 3-1-2011.

Cycle Board

THE MARK CONSISTS OF STANDARD CHARACTERS WITHOUT CLAIM TO ANY PARTICULAR FONT, STYLE, SIZE, OR COLOR.

FOR SCOOTERS (U.S. CLS. 19, 21, 23, 31, 35 AND 44).
SUSAN LESLIE DUBOIS, EXAMINING ATTORNEY

CLASS 12—(Continued).

SN 85-256,824. BLUE-COLLAR PRODUCTS, INC., NEW LONDON, OH. FILED 3-3-2011.

RSPONDR

THE MARK CONSISTS OF STANDARD CHARACTERS WITHOUT CLAIM TO ANY PARTICULAR FONT, STYLE, SIZE, OR COLOR.

FOR TRAILER HITCHES AND UTILITY RING FOR TRAILER HITCHES (U.S. CLS. 19, 21, 23, 31, 35 AND 44).
MARGARET POWER, EXAMINING ATTORNEY

SN 85-256,102. PLAYER WHEEL GROUP, LTD., YOUNGSTOWN, OH. FILED 3-2-2011.

DYNASTY

THE MARK CONSISTS OF STANDARD CHARACTERS WITHOUT CLAIM TO ANY PARTICULAR FONT, STYLE, SIZE, OR COLOR.

FOR VEHICLE WHEELS (U.S. CLS. 19, 21, 23, 31, 35 AND 44).

FIRST USE 12-31-2007; IN COMMERCE 12-31-2007.
BRENDAN REGAN, EXAMINING ATTORNEY

SN 85-256,838. BLUE-COLLAR PRODUCTS, INC., NEW LONDON, OH. FILED 3-3-2011.

WHAT'S IN YOUR HITCH?

THE MARK CONSISTS OF STANDARD CHARACTERS WITHOUT CLAIM TO ANY PARTICULAR FONT, STYLE, SIZE, OR COLOR.

FOR TRAILER HITCHES AND UTILITY RING FOR TRAILER HITCHES (U.S. CLS. 19, 21, 23, 31, 35 AND 44).
MARGARET POWER, EXAMINING ATTORNEY

SN 85-256,225. TSAI, BETTY, ONTARIO, CA. FILED 3-2-2011.

FastBack

THE MARK CONSISTS OF STANDARD CHARACTERS WITHOUT CLAIM TO ANY PARTICULAR FONT, STYLE, SIZE, OR COLOR.

FOR BOOSTER SEATS FOR USE IN VEHICLES; CHILDREN'S CAR SEATS; CHILDREN'S SAFETY SEATS FOR CARS; CHILDREN'S SAFETY SEATS FOR VEHICLES (U.S. CLS. 19, 21, 23, 31, 35 AND 44).

ALLISON SCHRODY, EXAMINING ATTORNEY

SN 85-257,336. WORKS CONNECTION, INC., DBA WORKS CONNECTION, INC., DIAMOND SPRINGS, CA. FILED 3-3-2011.

WORKS CONNECTION

THE MARK CONSISTS OF STANDARD CHARACTERS WITHOUT CLAIM TO ANY PARTICULAR FONT, STYLE, SIZE, OR COLOR.

FOR MOTORCYCLE ACCESSORIES, NAMELY, RADIATOR BRACES, SKID PLATES, ENGINE GUARDS, FRAME GUARDS, REAR CALIPER GUARDS (U.S. CLS. 19, 21, 23, 31, 35 AND 44).

FIRST USE 1-1-1989; IN COMMERCE 1-1-1989.
CHRISTINA SOBRAL, EXAMINING ATTORNEY

CLASS 12—(Continued).

SN 85-259,384. JAYCO, INC., MIDDLEBURY, IN. FILED 3-7-2011.

STARFLYER

THE MARK CONSISTS OF STANDARD CHARACTERS WITHOUT CLAIM TO ANY PARTICULAR FONT, STYLE, SIZE, OR COLOR.

OWNER OF U.S. REG. NO. 1,183,677.
FOR FOLDING CAMPING TRAILERS (U.S. CLS. 19, 21, 23, 31, 35 AND 44).
CHRISTINA SOBRAL, EXAMINING ATTORNEY

CLASS 12—(Continued).

SN 85-267,032. DAYCO PRODUCTS, LLC, TULSA, OK. FILED 3-15-2011.



NO CLAIM IS MADE TO THE EXCLUSIVE RIGHT TO USE "BELT", APART FROM THE MARK AS SHOWN.

THE MARK CONSISTS OF THE WORDS "ELA BELT" INSIDE AN OBLONG WITH A ZIG ZAG LINE BETWEEN THE WORDS.

FOR TRANSMISSION BELTS FOR LAND VEHICLES (U.S. CLS. 19, 21, 23, 31, 35 AND 44).

FIRST USE 3-9-2011; IN COMMERCE 3-9-2011.
WON TEAK OH, EXAMINING ATTORNEY

SN 85-259,412. POLARIS INDUSTRIES INC., MEDINA, MN. FILED 3-7-2011.

PRO-CANVAS

THE MARK CONSISTS OF STANDARD CHARACTERS WITHOUT CLAIM TO ANY PARTICULAR FONT, STYLE, SIZE, OR COLOR.

FOR CABS FOR ALL-TERRAIN UTILITY VEHICLES (U.S. CLS. 19, 21, 23, 31, 35 AND 44).
CARYN GLASSER, EXAMINING ATTORNEY

SN 85-274,226. POLARIS INDUSTRIES INC., MEDINA, MN. FILED 3-23-2011.

SN 85-259,414. POLARIS INDUSTRIES INC., MEDINA, MN. FILED 3-7-2011.

ROULETTE**PRO-POLY**

THE MARK CONSISTS OF STANDARD CHARACTERS WITHOUT CLAIM TO ANY PARTICULAR FONT, STYLE, SIZE, OR COLOR.

FOR CABS FOR ALL-TERRAIN UTILITY VEHICLES (U.S. CLS. 19, 21, 23, 31, 35 AND 44).
CARYN GLASSER, EXAMINING ATTORNEY

THE MARK CONSISTS OF STANDARD CHARACTERS WITHOUT CLAIM TO ANY PARTICULAR FONT, STYLE, SIZE, OR COLOR.

FOR MOTORCYCLES AND STRUCTURAL PARTS THEREFOR (U.S. CLS. 19, 21, 23, 31, 35 AND 44).
CARYN GLASSER, EXAMINING ATTORNEY

CLASS 12—(Continued).

SN 85-286,635. TAP WORLDWIDE, LLC, COMPTON, CA.
FILED 4-5-2011.

CLASS 13—FIREARMS

SN 77-720,296. PHOENIX TECHNOLOGY, LTD., BURGAW,
NC. FILED 4-23-2009.

PHOENIX TECHNOLOGY**OFF ROAD DRIVEN**

THE MARK CONSISTS OF STANDARD CHARACTERS WITHOUT CLAIM TO ANY PARTICULAR FONT, STYLE, SIZE, OR COLOR.

NO CLAIM IS MADE TO THE EXCLUSIVE RIGHT TO USE "TECHNOLOGY", APART FROM THE MARK AS SHOWN.

FOR FIREARM ACCESSORIES, NAMELY, RECOIL SUPPRESSORS FOR FIREARMS (U.S. CLS. 2 AND 9).
SAIMA MAKHDOOM, EXAMINING ATTORNEY

THE MARK CONSISTS OF STANDARD CHARACTERS WITHOUT CLAIM TO ANY PARTICULAR FONT, STYLE, SIZE, OR COLOR.

NO CLAIM IS MADE TO THE EXCLUSIVE RIGHT TO USE "OFF ROAD", APART FROM THE MARK AS SHOWN.

FOR AUTOMOBILE AND TRUCK STRUCTURAL PARTS AND ACCESSORIES SPECIALLY ADAPTED FOR AUTOMOBILES AND TRUCKS, NAMELY, STRUCTURAL PARTS FOR AUTOMOBILES, WHEELS, WHEEL RIMS, TIRES, SHOCK ABSORBERS, SHOCK ABSORBER MOUNTS, SHOCK ABSORBER BRACKETS, PITMAN ARMS, STEERING ARMS, TIRE RODS, STEERING DAMPENERS, SUSPENSION SYSTEMS FOR AUTOMOBILES FEATURING REAR STABILIZER BARS, AUTOMOBILE AND TRUCK BODY PARTS IN THE NATURE OF SIDEBARS, BUMPERS, BRUSH GUARDS, GRILL GUARDS, AND FITTED BUMPER CAPS, ROLL BARS, INTERIOR CAB CAGES, SKID PLATES, LIGHT BARS, TOW BARS, TOW HITCHES, STEP PADS, CUSTOM VEHICLE GRILLES, SEATS, MOTORIZED TAILGATES, SPARE TIRE COVERS, TURN SIGNAL MOUNTING BRACKETS AS STRUCTURAL PARTS OF VEHICLES, FITTED LINERS FOR THE CARGO AREA OF VEHICLES, LOCKING LUG NUTS FOR VEHICLE WHEELS AND REPLACEMENT SOFT TOPS FOR VEHICLES; TRANSMISSIONS FOR LAND VEHICLES AND REPLACEMENT PARTS THEREOF; DRIVE TRAINS AND STRUCTURAL PARTS THEREFORE FOR LAND VEHICLES, NAMELY, CLUTCHES FOR LAND VEHICLES, RING AND PINION SETS COMPRISING PINION SEALS, PINION BEARINGS, GEARS AND GEAR RINGS, DRIVE SHAFTS FOR LAND VEHICLES AND DIFFERENTIALS FOR LAND VEHICLES; LAND VEHICLE PARTS, NAMELY, AXLES, AXLE SHAFTS, TRANSMISSION GEARS, AND INSTALLATION KITS FOR LAND VEHICLES COMPRISING TRANSMISSION SEALS, AXLE BEARINGS, AXLE SHAFTS, DRIVE SHAFTS, SLEEVES FOR AUTOMOTIVE STEERING SYSTEMS, SHIMS FOR AUTOMOTIVE BRAKES, LICENSE PLATE FASTENERS, AND LUG NUTS FOR VEHICLE WHEELS (U.S. CLS. 19, 21, 23, 31, 35 AND 44).

ZHALEH DELANEY, EXAMINING ATTORNEY

SN 79-083,127. HECKLER & KOCH GMBH, FED REP GERMANY, FILED 4-8-2010.

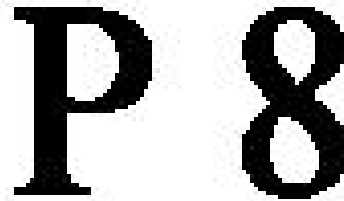

THE MARK CONSISTS OF STANDARD CHARACTERS WITHOUT CLAIM TO ANY PARTICULAR FONT, STYLE, SIZE, OR COLOR.

PRIORITY DATE OF 2-25-2010 IS CLAIMED.

OWNER OF INTERNATIONAL REGISTRATION 1040291 DATED 4-8-2010, EXPIRES 4-8-2020.

OWNER OF U.S. REG. NOS. 1,653,009, 3,587,432 AND OTHERS.

FOR FIREARMS; AIR PISTOLS BEING WEAPONS AND NOT TOYS; AIR GUNS BEING WEAPONS AND NOT TOYS; STUN GUNS; SOFT-AIR-WEAPONS, NAMELY, AIR GUNS AND PISTOLS NOT FOR RECREATIONAL USE; AMMUNITION AND PROJECTILES (U.S. CLS. 2 AND 9).

MYRIAH HABEEB, EXAMINING ATTORNEY

CLASS 13—(Continued).

SN 85-053,918. ALLIANCE ARMAMENT, LLC, BOONVILLE, IN. FILED 6-3-2010.



THE LINING IS FOR SHADING PURPOSES.
THE MARK CONSISTS OF A LOGO COMPRISED OF TWO LETTER "A'S, ONE RIGHT-SIDE UP, THE OTHER UPSIDE DOWN, TO THE LEFT AND RIGHT OF THE LETTERS ARE TWO STYLIZED FLAME DESIGNS, EACH FACING OUTWARD AWAY FROM THE LETTERS.
FOR FIREARMS (U.S. CLS. 2 AND 9).
FIRST USE 4-20-2007; IN COMMERCE 4-20-2007.
RUSS HERMAN, EXAMINING ATTORNEY

SN 85-111,238. GREENVILLE AMMO SUPPLY LLC, DBA GAS AMMO, TAYLORS, SC. FILED 8-19-2010.

BUY THE CLIP

THE MARK CONSISTS OF STANDARD CHARACTERS WITHOUT CLAIM TO ANY PARTICULAR FONT, STYLE, SIZE, OR COLOR.
NO CLAIM IS MADE TO THE EXCLUSIVE RIGHT TO USE "CLIP", APART FROM THE MARK AS SHOWN.
FOR SMALL ARMS AMMUNITION (U.S. CLS. 2 AND 9).
ANDREA HACK, EXAMINING ATTORNEY

SN 85-150,023. MAXAM DANTEX SOUTH AFRICA (PROPRIETARY) LIMITED, FLORIDA, GAUTENG, SOUTH AFRICA, FILED 10-11-2010.

SPLITEX

THE MARK CONSISTS OF STANDARD CHARACTERS WITHOUT CLAIM TO ANY PARTICULAR FONT, STYLE, SIZE, OR COLOR.
OWNER OF SOUTH AFRICA REG. NO. 1992/7857, DATED 9-18-1992, EXPIRES 9-18-2012.
FOR EXPLOSIVES, BLASTING EXPLOSIVES, BLASTING COMPOUNDS (U.S. CLS. 2 AND 9).
REBECCA EISINGER, EXAMINING ATTORNEY

CLASS 13—(Continued).

SN 85-248,153. MULLEN, DOUG, AUSTIN, TX. FILED 2-22-2011.

RAMP (Rapid Access Magazine Pod)

THE MARK CONSISTS OF STANDARD CHARACTERS WITHOUT CLAIM TO ANY PARTICULAR FONT, STYLE, SIZE, OR COLOR.
NO CLAIM IS MADE TO THE EXCLUSIVE RIGHT TO USE "RAPID ACCESS MAGAZINE POD", APART FROM THE MARK AS SHOWN.
FOR GUN BELT ATTACHMENT, NAMELY, PLASTIC CASE THAT HOLDS MAGAZINES FOR WEAPONS (U.S. CLS. 2 AND 9).
CHRISTINE MARTIN, EXAMINING ATTORNEY

SN 85-249,271. GEAR FOR GRUNTS, LLC, AUSTIN, TX. FILED 2-23-2011.

Gear 4 Grunts Tactical Innovation

THE MARK CONSISTS OF STANDARD CHARACTERS WITHOUT CLAIM TO ANY PARTICULAR FONT, STYLE, SIZE, OR COLOR.
NO CLAIM IS MADE TO THE EXCLUSIVE RIGHT TO USE "GEAR" AND "TACTICAL INNOVATION", APART FROM THE MARK AS SHOWN.
FOR GUN BELT ATTACHMENT, NAMELY, PLASTIC PIECE THAT HOLDS MAGAZINES FOR WEAPONS (U.S. CLS. 2 AND 9).
JULIE GUTTADAURO, EXAMINING ATTORNEY

CLASS 13—(Continued).

SN 85-250,081. STRIKE INDUSTRIES, SANTA ANA, CA. FILED 2-23-2011.

STRIKE INDUSTRIES

THE MARK CONSISTS OF STANDARD CHARACTERS WITHOUT CLAIM TO ANY PARTICULAR FONT, STYLE, SIZE, OR COLOR.

NO CLAIM IS MADE TO THE EXCLUSIVE RIGHT TO USE "INDUSTRIES", APART FROM THE MARK AS SHOWN.

FOR FIREARM ATTACHMENTS, NAMELY, MODULAR EXTERNAL RAIL SYSTEMS FOR ATTACHING ACCESSORIES TO FIREARMS; FIREARM ATTACHMENTS, NAMELY, MODULAR EXTERNAL RAIL SYSTEMS FOR FIREARMS; FIREARM ATTACHMENTS, NAMELY, MOUNTS FOR ATTACHING ACCESSORIES TO A FIREARM; FIREARM ATTACHMENTS, NAMELY, MOUNTS FOR ATTACHING ANCILLARY EQUIPMENT TO A FIREARM; FIREARM ATTACHMENTS, NAMELY, MOUNTS FOR ATTACHING GRIPS TO A FIREARM; FIREARM ATTACHMENTS, NAMELY, MOUNTS FOR ATTACHING GUN SIGHTS TO A FIREARM; FIREARM ATTACHMENTS, NAMELY, MOUNTS FOR ATTACHING LASER POINTING DEVICES TO A FIREARM; FIREARM ATTACHMENTS, NAMELY, MOUNTS FOR ATTACHING LIGHTS TO A FIREARM; FIREARM HAND GUARDS; FIREARM SIGHTS; FIREARM SLINGS; FORESIGHTS FOR FIREARMS; GUNSIGHTS FOR FIREARMS; NON-TELESCOPIC GUN SIGHTS FOR FIREARMS; SIGHTS, NAMELY, OPEN SIGHTS FOR USE ON FIREARMS; SLING STRAPS FOR FIREARMS; TRIPODS AND STANDS FOR FIREARMS (U.S. CLS. 2 AND 9).

FIRST USE 6-1-2010; IN COMMERCE 6-1-2010.
DOMINICK J. SALEMI, EXAMINING ATTORNEY

SN 85-266,465. NEW COLT HOLDING CORP., WEST HARTFORD, CT. FILED 3-14-2011.

CCR

THE MARK CONSISTS OF STANDARD CHARACTERS WITHOUT CLAIM TO ANY PARTICULAR FONT, STYLE, SIZE, OR COLOR.

FOR RIFLES AND PARTS THEREOF (U.S. CLS. 2 AND 9).

JILL C. ALT, EXAMINING ATTORNEY

CLASS 14—JEWELRY

SN 76-704,050. ROGACKI, ZENON A., NORTH HOLLYWOOD, CA. FILED 8-9-2010.



NO CLAIM IS MADE TO THE EXCLUSIVE RIGHT TO USE "IMPAIRED VISION ID", APART FROM THE MARK AS SHOWN.

THE MARK CONSISTS OF THE WORDING "TROPHY IMPAIRED VISION ID" WITH A STYLIZED REPRESENTATION OF AN EYE. THE TERMS "TROPHY" AND "VISION ID" ARE UNDERLINED AND THE MARK IS OUTLINED WITH A SQUARE BORDER.

FOR IDENTIFICATION BADGES OF PRECIOUS METAL FOR THE VISION IMPAIRED (U.S. CLS. 2, 27, 28 AND 50).

HEATHER THOMPSON, EXAMINING ATTORNEY

SN 76-706,650. ASSAEL INTERNATIONAL INC., NEW YORK, NY. FILED 3-4-2011.

**ASSAEL, THE MOST
MAGNIFICENT PEARLS IN THE
WORLD**

THE MARK CONSISTS OF STANDARD CHARACTERS WITHOUT CLAIM TO ANY PARTICULAR FONT, STYLE, SIZE, OR COLOR.

FOR RINGS, EARRINGS, NECKLACES, BRACELETS AND PENDANTS SET WITH PEARLS (U.S. CLS. 2, 27, 28 AND 50).

FIRST USE 1-17-2011; IN COMMERCE 1-17-2011.
ELI HELLMAN, EXAMINING ATTORNEY

CLASS 14—(Continued).

SN 77-663,101. EK SUCCESS, LTD., CLIFTON, NJ. FILED 2-4-2009.

Jolee's Jewels

THE MARK CONSISTS OF STANDARD CHARACTERS WITHOUT CLAIM TO ANY PARTICULAR FONT, STYLE, SIZE, OR COLOR.

OWNER OF U.S. REG. NOS. 2,758,913, 3,845,982 AND OTHERS.

NO CLAIM IS MADE TO THE EXCLUSIVE RIGHT TO USE "JEWELS", APART FROM THE MARK AS SHOWN.

FOR JEWELRY-MAKING COMPONENTS FOR USE IN JEWELRY-MAKING CRAFTS, NAMELY, GEMS AND METAL (U.S. CLS. 2, 27, 28 AND 50).

FRED CARL, EXAMINING ATTORNEY

CLASS 14—(Continued).

SN 77-930,299. SCOTT KAY, INC., TEANECK, NJ. FILED 2-8-2010.

UNION

THE MARK CONSISTS OF STANDARD CHARACTERS WITHOUT CLAIM TO ANY PARTICULAR FONT, STYLE, SIZE, OR COLOR.

FOR JEWELRY (U.S. CLS. 2, 27, 28 AND 50).
ALICIA COLLINS, EXAMINING ATTORNEY

SN 77-700,353. RICHLINE GROUP, INC., MOUNT VERNON, NY. FILED 3-26-2009.

SHADOWS

THE MARK CONSISTS OF STANDARD CHARACTERS WITHOUT CLAIM TO ANY PARTICULAR FONT, STYLE, SIZE, OR COLOR.

FOR JEWELRY (U.S. CLS. 2, 27, 28 AND 50).
ROBIN MITTLER, EXAMINING ATTORNEY

SN 78-778,761. DIVERSIFIED GLOBAL TECHNOLOGIES, LLC, WOONSOCKET, RI. FILED 12-21-2005.

RUNWAY STYLE

THE MARK CONSISTS OF STANDARD CHARACTERS WITHOUT CLAIM TO ANY PARTICULAR FONT, STYLE, SIZE, OR COLOR.

OWNER OF U.S. REG. NO. 3,636,845.
FOR BRACELETS ; COSTUME JEWELRY; JEWELRY; JEWELRY CHAINS; JEWELRY FOR THE HEAD; JEWELRY PINS FOR USE ON HATS; JEWELRY, NAMELY, AMULETS; JEWELRY, NAMELY, CROSSES; LAPEL PINS; PINS BEING JEWELRY; RINGS BEING JEWELRY (U.S. CLS. 2, 27, 28 AND 50).
KATINA MISTER, EXAMINING ATTORNEY

SN 77-771,924. RICHEMONT INTERNATIONAL S.A., VILARS-SUR-GLANE, SWITZERLAND, FILED 7-1-2009.

PHIDIAS

THE MARK CONSISTS OF STANDARD CHARACTERS WITHOUT CLAIM TO ANY PARTICULAR FONT, STYLE, SIZE, OR COLOR.

OWNER OF SWITZERLAND REG. NO. P-368911, DATED 12-21-1988, RENEWED AS REG. NO. P-368911, DATED 12-21-2008, EXPIRES 12-21-2018.

FOR NECKLACES, EARRINGS, BRACELETS, BROOCHES, RINGS, CUFF-LINKS; WATCHES, CHRONOMETERS, AND CLOCKS (U.S. CLS. 2, 27, 28 AND 50).
ANNE FARRELL, EXAMINING ATTORNEY

SN 79-086,465. INTERLEMO S.A., ECUBLENS, SWITZERLAND, FILED 7-6-2010.

PREDATOR

THE MARK CONSISTS OF STANDARD CHARACTERS WITHOUT CLAIM TO ANY PARTICULAR FONT, STYLE, SIZE, OR COLOR.

PRIORITY DATE OF 1-6-2010 IS CLAIMED.
OWNER OF INTERNATIONAL REGISTRATION 1048695 DATED 7-6-2010, EXPIRES 7-6-2020.

FOR JEWELRY, NAMELY, RINGS, EARRINGS, BRACELETS, CUFF LINKS, NECKLACES, BROOCHES, PENDANTS; PRECIOUS STONES; WATCHES, WRISTWATCHES, STRAPS FOR WATCHES, WATCH CASES, WATCH GLASSES, WINDERS, MOVEMENTS FOR WATCHES, BUCKLES FOR WATCH STRAPS, DIALS FOR WATCHES, GLASSES FOR WATCH CASES, CHRONOMETERS, CHRONOGRAPHS, CLOCKS, DIALS FOR CLOCKS, CASES AND BOXES INTENDED TO CONTAIN CLOCKS; PARTS FOR WATCHES, CLOCKS, CHRONOMETERS AND CHRONOGRAPHS (U.S. CLS. 2, 27, 28 AND 50).
SOPHIA S. KIM, EXAMINING ATTORNEY

CLASS 14—(Continued).

SN 79-091,904. ISABELLE LANGLOIS, PARIS, FRANCE, FILED 10-19-2010.



ISABELLE LANGLOIS
PARIS

OWNER OF INTERNATIONAL REGISTRATION 1063308 DATED 10-19-2010, EXPIRES 10-19-2020.

OWNER OF U.S. REG. NO. 2,667,903.

NO CLAIM IS MADE TO THE EXCLUSIVE RIGHT TO USE "PARIS", APART FROM THE MARK AS SHOWN.

THE NAME(S), PORTRAIT(S), AND/OR SIGNATURE(S) SHOWN IN THE MARK IDENTIFIES "ISABELLE LANGLOIS", WHOSE CONSENT(S) TO REGISTER IS MADE OF RECORD.

THE MARK CONSISTS OF "IL" IN STYLIZED FONT, WITH THE "I" AND "L" SHARING THE SAME VERTICAL LINE, ALL ABOVE THE WORDING "ISABELLE LANGLOIS", ABOVE THE WORDING "PARIS", ALL IN STYLIZED FONT.

FOR JEWELRY, STONES, NAMELY, SEMI-PRECIOUS STONES, NON-PRECIOUS STONES AND PRECIOUS STONES, PEARLS, WATCHES, ORNAMENTAL PINS, UNWROUGHT OR SEMI-WROUGHT PRECIOUS METALS (U.S. CLS. 2, 27, 28 AND 50).

KAREN SEVERSON, EXAMINING ATTORNEY

SN 79-093,018. KABUSHIKI KAISHA RYU KOUBOU, IWATE-GUN, IWATE 020-0585, JAPAN, FILED 1-4-2011.

流

OWNER OF INTERNATIONAL REGISTRATION 1066378 DATED 1-4-2011, EXPIRES 1-4-2021.

THE ENGLISH TRANSLATION OF THE FOREIGN WORD IN THE MARK IS "FLOW".

THE TRANSLITERATION OF THE NON-LATIN CHARACTERS IN THE MARK IS "RYU, NAGARE".

FOR KEY RINGS OF PRECIOUS METAL, NAMELY, TRINKETS OR FOBS; TROPHIES OF PRECIOUS METAL; COMMEMORATIVE MEDALS, PERSONAL ORNAMENTS OR PRECIOUS METALS; CLOCKS AND WATCHES (U.S. CLS. 2, 27, 28 AND 50).

JULIE WATSON, EXAMINING ATTORNEY

CLASS 14—(Continued).

SN 85-059,542. LORRAINE E. SCHWARTZ, INC., NEW YORK, NY. FILED 6-10-2010.

LORRAINE SCHWARTZ

THE MARK CONSISTS OF STANDARD CHARACTERS WITHOUT CLAIM TO ANY PARTICULAR FONT, STYLE, SIZE, OR COLOR.

THE NAME(S), PORTRAIT(S), AND/OR SIGNATURE(S) SHOWN IN THE MARK IDENTIFIES "LORRAINE SCHWARTZ", WHOSE CONSENT(S) TO REGISTER IS MADE OF RECORD.

FOR JEWELRY (U.S. CLS. 2, 27, 28 AND 50).

CHARLOTTE CORWIN, EXAMINING ATTORNEY

SN 85-082,117. BLUE RIVER, LLC, SAN FRANCISCO, CA. FILED 7-11-2010.

Night Ice

THE MARK CONSISTS OF STANDARD CHARACTERS WITHOUT CLAIM TO ANY PARTICULAR FONT, STYLE, SIZE, OR COLOR.

NO CLAIM IS MADE TO THE EXCLUSIVE RIGHT TO USE "ICE", APART FROM THE MARK AS SHOWN.

FOR COSTUME JEWELRY (U.S. CLS. 2, 27, 28 AND 50).

FIRST USE 6-1-2007; IN COMMERCE 10-31-2007.

RICHARD WHITE, EXAMINING ATTORNEY

SN 85-086,324. DARLING DESIGNS OF NEW YORK, LLC, BRONX, NY. FILED 7-16-2010.



NO CLAIM IS MADE TO THE EXCLUSIVE RIGHT TO USE "DESIGNS OF NEW YORK", APART FROM THE MARK AS SHOWN.

THE MARK CONSISTS OF THE STYLIZED WORD "DARLING" POSITIONED ABOVE AND PARTIALLY OVERLAPPING THE STYLIZED WORD "DESIGNS", WHICH IS POSITIONED ABOVE THE STYLIZED WORDS "OF NEW YORK". IN ADDITION, AN IMAGE OF A WOMAN AND CHILD HOLDING HANDS APPEARS AFTER THE WORD "DESIGNS", AND A BACKGROUND OF THE MARK CONSISTS OF A SHADED, DECORATIVE BORDER HAVING SCALLOPED, RUFFLED AND POINTED EDGES.

FOR JEWELRY (U.S. CLS. 2, 27, 28 AND 50).

SARA BENJAMIN, EXAMINING ATTORNEY

CLASS 14—(Continued).

SN 85-086,886. DIANNE MARIE JOHNSON, WHITMAN, MA. FILED 7-16-2010.

Angel Rosebeads

THE MARK CONSISTS OF STANDARD CHARACTERS WITHOUT CLAIM TO ANY PARTICULAR FONT, STYLE, SIZE, OR COLOR.

NO CLAIM IS MADE TO THE EXCLUSIVE RIGHT TO USE "ROSEBEADS", APART FROM THE MARK AS SHOWN.

FOR JEWELRY (U.S. CLS. 2, 27, 28 AND 50).
FIRST USE 6-1-2006; IN COMMERCE 6-1-2006.
BARBARA A. GOLD, EXAMINING ATTORNEY

CLASS 14—(Continued).

SN 85-115,580. MOORE, DAVID L., HOUSTON, TX. FILED 8-25-2010.

RING'S BEST FRIEND

THE MARK CONSISTS OF STANDARD CHARACTERS WITHOUT CLAIM TO ANY PARTICULAR FONT, STYLE, SIZE, OR COLOR.

NO CLAIM IS MADE TO THE EXCLUSIVE RIGHT TO USE "RING'S", APART FROM THE MARK AS SHOWN.

FOR JEWELRY ACCESSORIES, NAMELY, RETENTION DEVICES OR FLEXIBLE GUARDS, USED TO PROTECT JEWELRY AGAINST LOSS, TWISTING AND TURNING FOR THE PURPOSE OF MAKING A STANDARD RING STAY ON THE FINGER IF TOO LARGE (U.S. CLS. 2, 27, 28 AND 50).

SIMON TENG, EXAMINING ATTORNEY

SN 85-116,650. VELO BLING DESIGNS, LLC, LAKEWOOD, CO. FILED 8-26-2010.

Velo Bling Designs

THE MARK CONSISTS OF STANDARD CHARACTERS WITHOUT CLAIM TO ANY PARTICULAR FONT, STYLE, SIZE, OR COLOR.

NO CLAIM IS MADE TO THE EXCLUSIVE RIGHT TO USE "BLING DESIGNS", APART FROM THE MARK AS SHOWN.

THE ENGLISH TRANSLATION OF "VELO" IN THE MARK IS "BIKE".

FOR JEWELRY, JEWELRY HOLDER DISPLAY, AND CLOCKS MADE FROM BICYCLE AND MOTORCYCLE PARTS (U.S. CLS. 2, 27, 28 AND 50).

KHANH LE, EXAMINING ATTORNEY

SN 85-104,339. M.S.B.H. ALLIANCE, ANTWERP, BELGIUM, FILED 8-10-2010.

YOU SPARK

THE MARK CONSISTS OF STANDARD CHARACTERS WITHOUT CLAIM TO ANY PARTICULAR FONT, STYLE, SIZE, OR COLOR.

FOR JEWELRY; JEWELRY FINDINGS; GEMSTONE AND PRECIOUS STONES; SEMI-PRECIOUS STONES; PEARLS; OPALS; PLATINUM AND ITS ALLOYS; PRECIOUS METALS; CHARMS, CHOKERS, AND PENDANTS; LAPEL PINS; ORNAMENTAL LAPEL PINS; PINS BEING JEWELRY; BODY-PIERCING RINGS AND STUDS; EAR STUDS; EAR CLIPS; TIE PINS; TIE CLIPS; TIE BARS; TIE TACKS; TIE FASTENERS; BOLO TIES WITH PRECIOUS METAL TIPS; CUFF-LINKS; SHIRT STUDS; BADGES OF PRECIOUS METAL; COSTUME JEWELRY; JEWELRY CHAINS; JEWELRY PINS FOR USE ON HATS; HAT ORNAMENTS OF PRECIOUS METAL; HOLIDAY ORNAMENTS OF PRECIOUS METAL; JEWELRY BOXES AND CASES; KEY HOLDERS OF PRECIOUS METALS; KEY CHAINS OF PRECIOUS METAL; WATCHES; WATCH BRACELETS; WATCH ACCESSORIES, NAMELY, PARTS FOR WATCHES; WRISTWATCHES; POCKET WATCHES; STOP WATCHES; WATCH STRAPS AND BANDS; WATCH CHAINS AND FOBS; WATCH CASES; WATCH BOXES; CLOCKS; ALARM CLOCKS; CLOCKS INCORPORATING RADIOS; WALL CLOCKS; TIMEPIECES; BOXES FOR TIMEPIECES; FIGURINES, SCULPTURES, BUSTS, FIGURES, STATUES, AND STATUETTES, ALL OF THE FOREGOING OF PRECIOUS METAL (U.S. CLS. 2, 27, 28 AND 50).

JOHN DWYER, EXAMINING ATTORNEY

SN 85-116,992. HICKEN, WILLIAM M., MOUNT PLEASANT, SC. FILED 8-26-2010.



THE MARK CONSISTS OF STYLIZED LETTERS "YB" AND WINGS.

FOR JEWELRY (U.S. CLS. 2, 27, 28 AND 50).
ARETHA SOMERVILLE, EXAMINING ATTORNEY

CLASS 14—(Continued).

SN 85-136,128. NYBYE, LANCE S., SR., MR., VALLEY CENTER, CA. FILED 9-23-2010.

GREEN TREE JEWELRY

THE MARK CONSISTS OF STANDARD CHARACTERS WITHOUT CLAIM TO ANY PARTICULAR FONT, STYLE, SIZE, OR COLOR.

NO CLAIM IS MADE TO THE EXCLUSIVE RIGHT TO USE "JEWELRY", APART FROM THE MARK AS SHOWN. FOR JEWELRY (U.S. CLS. 2, 27, 28 AND 50).
 NAPOLEON SHARMA, EXAMINING ATTORNEY

SN 85-175,664. TURNBULL, ELIZABETH, JANE, DBA FERN'S FEEL GOODS, GRIGGSVILLE, IL. FILED 11-12-2010.

Fern's Feel-Goods

THE MARK CONSISTS OF STANDARD CHARACTERS WITHOUT CLAIM TO ANY PARTICULAR FONT, STYLE, SIZE, OR COLOR.

THE NAME "FERN" DOES NOT IDENTIFY A LIVING INDIVIDUAL.
 FOR CHARMS (U.S. CLS. 2, 27, 28 AND 50).
 FIRST USE 11-16-2010; IN COMMERCE 11-16-2010.
 INGA ERVIN, EXAMINING ATTORNEY

SN 85-188,826. MIA PEZZI, LLC, DBA TZEN, CHICAGO, IL. FILED 12-2-2010.

TZEN

THE MARK CONSISTS OF STANDARD CHARACTERS WITHOUT CLAIM TO ANY PARTICULAR FONT, STYLE, SIZE, OR COLOR.

SEC. 2(F).
 FOR BRACELETS; DIAMOND JEWELRY; EARRINGS; GEMSTONE JEWELRY; GOLD THREAD JEWELRY; JEWELRY; RINGS; WOMEN'S JEWELRY (U.S. CLS. 2, 27, 28 AND 50).
 FIRST USE 12-1-2008; IN COMMERCE 12-1-2008.
 DEIRDRE ROBERTSON, EXAMINING ATTORNEY

CLASS 14—(Continued).

SN 85-193,177. ANGELIQUE HELENE GLENNON, SANTA MONICA, CA. FILED 12-8-2010.

EcCeptical

THE MARK CONSISTS OF STANDARD CHARACTERS WITHOUT CLAIM TO ANY PARTICULAR FONT, STYLE, SIZE, OR COLOR.

FOR HANDCRAFTED WEARABLE ART IN THE NATURE OF JEWELRY (U.S. CLS. 2, 27, 28 AND 50).
 ERIN FALK, EXAMINING ATTORNEY

SN 85-193,948. WRISTWATCH.COM, LLC, MCALLEN, TX. FILED 12-9-2010.

HYDROLIX

THE MARK CONSISTS OF STANDARD CHARACTERS WITHOUT CLAIM TO ANY PARTICULAR FONT, STYLE, SIZE, OR COLOR.

FOR WATCHES (U.S. CLS. 2, 27, 28 AND 50).
 KEVIN CORWIN, EXAMINING ATTORNEY

SN 85-193,954. WRISTWATCH.COM, LLC, MCALLEN, TX. FILED 12-9-2010.

SWSTEEL

THE MARK CONSISTS OF STANDARD CHARACTERS WITHOUT CLAIM TO ANY PARTICULAR FONT, STYLE, SIZE, OR COLOR.

FOR WATCHES WHEREIN THE WATCHES' HOUSINGS ARE MADE OF A FORM OF STEEL (U.S. CLS. 2, 27, 28 AND 50).
 KEVIN CORWIN, EXAMINING ATTORNEY

CLASS 14—(Continued).

SN 85-214,560. MOCHINSKI, JACOB, DBA AIRCRAFT-KEEPERS, EVERETT, WA. FILED 1-11-2011.

jaggedfashion

THE MARK CONSISTS OF STANDARD CHARACTERS WITHOUT CLAIM TO ANY PARTICULAR FONT, STYLE, SIZE, OR COLOR.

FOR CHOKERS; NECKLACES (U.S. CLS. 2, 27, 28 AND 50).

ROSELLE HERRERA, EXAMINING ATTORNEY

CLASS 14—(Continued).

SN 85-233,687. LINDSEYMARIE SARL, GENEVA, SWITZERLAND, FILED 2-3-2011.

LINDSEY MARIE

THE MARK CONSISTS OF STANDARD CHARACTERS WITHOUT CLAIM TO ANY PARTICULAR FONT, STYLE, SIZE, OR COLOR.

THE NAME(S), PORTRAIT(S), AND/OR SIGNATURE(S) SHOWN IN THE MARK IDENTIFIES LINDSEY MARIE WENDLER, WHOSE CONSENT(S) TO REGISTER IS MADE OF RECORD.

FOR JEWELRY AND ACCESSORIES, NAMELY, JEWELRY ADORNMENTS CONSISTING OF GEMSTONES AND PEARLS (U.S. CLS. 2, 27, 28 AND 50).

FIRST USE 4-1-2006; IN COMMERCE 4-1-2006.
GISELLE AGOSTO, EXAMINING ATTORNEY

SN 85-239,927. ELBA JEWELRY INC, SAN DIMAS, CA. FILED 2-11-2011.

SN 85-231,333. TANEJA, GAURAV, DBA WEST COAST SILVER, CONCORD, CA. FILED 2-1-2011.

West Coast Silver

THE MARK CONSISTS OF STANDARD CHARACTERS WITHOUT CLAIM TO ANY PARTICULAR FONT, STYLE, SIZE, OR COLOR.

NO CLAIM IS MADE TO THE EXCLUSIVE RIGHT TO USE "SILVER", APART FROM THE MARK AS SHOWN.

FOR BRACELETS MADE IN WHOLE OR SIGNIFICANT PART OF SILVER; BROACHES MADE IN WHOLE OR SIGNIFICANT PART OF SILVER; BROOCHES MADE IN WHOLE OR SIGNIFICANT PART OF SILVER; CHARMS MADE IN WHOLE OR SIGNIFICANT PART OF SILVER; EARRINGS MADE IN WHOLE OR SIGNIFICANT PART OF SILVER; JEWEL PENDANTS MADE IN WHOLE OR SIGNIFICANT PART OF SILVER; JEWELRY CHAINS MADE IN WHOLE OR SIGNIFICANT PART OF SILVER; JEWELRY, MADE IN WHOLE OR SIGNIFICANT PART OF SILVER WITH STONE PENDANTS; PENDANTS MADE IN WHOLE OR SIGNIFICANT PART OF SILVER; RINGS MADE IN WHOLE OR SIGNIFICANT PART OF SILVER; WOMEN'S JEWELRY MADE IN WHOLE OR SIGNIFICANT PART OF SILVER; SILVER BRACELETS; SILVER BROACHES; SILVER BROOCHES; SILVER CHARMS; SILVER EARRINGS; JEWELLED SILVER PENDANTS; SILVER JEWELRY CHAINS; SILVER JEWELRY WITH STONE PENDANTS; SILVER PENDANTS; SILVER RINGS; WOMEN'S SILVER JEWELRY (U.S. CLS. 2, 27, 28 AND 50).

FIRST USE 1-1-2011; IN COMMERCE 1-1-2011.
JOHN DALIER, EXAMINING ATTORNEY

THE MARK CONSISTS OF STANDARD CHARACTERS WITHOUT CLAIM TO ANY PARTICULAR FONT, STYLE, SIZE, OR COLOR.

FOR JEWELRY MADE IN WHOLE OR PART OF GOLD (U.S. CLS. 2, 27, 28 AND 50).

DAVID I, EXAMINING ATTORNEY

SN 85-241,320. MG WORLDWIDE LLC, NEW YORK, NY. FILED 2-14-2011.



NO CLAIM IS MADE TO THE EXCLUSIVE RIGHT TO USE "925", APART FROM THE MARK AS SHOWN.

THE MARK CONSISTS OF THE LETTERS "MG" NESTLED IN A BRACKET DESIGN WITH THE NUMBERS "9 2 5" BELOW THE DESIGN.

FOR JEWELRY (U.S. CLS. 2, 27, 28 AND 50).
MARK SPARACINO, EXAMINING ATTORNEY

CLASS 14—(Continued).

SN 85-241,902. LANFORD, CYNTHIA WILLIS, HARLEM, GA. FILED 2-14-2011.

Gem Song

THE MARK CONSISTS OF STANDARD CHARACTERS WITHOUT CLAIM TO ANY PARTICULAR FONT, STYLE, SIZE, OR COLOR.

NO CLAIM IS MADE TO THE EXCLUSIVE RIGHT TO USE "GEM", APART FROM THE MARK AS SHOWN. FOR HAND-CRAFTED JEWELRY (U.S. CLS. 2, 27, 28 AND 50).

FIRST USE 3-1-2008; IN COMMERCE 8-28-2010.
PAUL MORENO, EXAMINING ATTORNEY

SN 85-246,616. REDD, WHITNEY, TEXARKANA, TX. FILED 2-18-2011.

Clay Horse Jewelry

THE MARK CONSISTS OF STANDARD CHARACTERS WITHOUT CLAIM TO ANY PARTICULAR FONT, STYLE, SIZE, OR COLOR.

NO CLAIM IS MADE TO THE EXCLUSIVE RIGHT TO USE "JEWELRY", APART FROM THE MARK AS SHOWN. FOR JEWELRY (U.S. CLS. 2, 27, 28 AND 50).

FIRST USE 8-1-2008; IN COMMERCE 8-1-2008.
CHARISMA HAMPTON, EXAMINING ATTORNEY

SN 85-247,514. ALMOD DIAMONDS LTD., NEW YORK, NY. FILED 2-21-2011.

Pure Mountain, Pure Tanzanite

THE MARK CONSISTS OF STANDARD CHARACTERS WITHOUT CLAIM TO ANY PARTICULAR FONT, STYLE, SIZE, OR COLOR.

NO CLAIM IS MADE TO THE EXCLUSIVE RIGHT TO USE "PURE TANZANITE", APART FROM THE MARK AS SHOWN.

FOR GEMSTONE JEWELRY, GEMSTONES, AND JEWELRY MADE IN WHOLE OR SIGNIFICANT PART OF TANZANITE (U.S. CLS. 2, 27, 28 AND 50).

FIRST USE 11-1-2010; IN COMMERCE 11-1-2010.
LESLIE RICHARDS, EXAMINING ATTORNEY

CLASS 14—(Continued).

SN 85-249,054. ENERGY FACTOR INC, TAMPA, FL. FILED 2-23-2011.

ENERGY FACTOR

THE MARK CONSISTS OF STANDARD CHARACTERS WITHOUT CLAIM TO ANY PARTICULAR FONT, STYLE, SIZE, OR COLOR.

NO CLAIM IS MADE TO THE EXCLUSIVE RIGHT TO USE "ENERGY", APART FROM THE MARK AS SHOWN.

FOR PRECIOUS METALS AND THEIR ALLOYS; RUBBER OR SILICON WRISTBANDS IN THE NATURE OF A BRACELET; METAL AND SILICONE NECKLACES; JEWELLERY (U.S. CLS. 2, 27, 28 AND 50).

MARTHA FROMM, EXAMINING ATTORNEY

SN 85-249,720. MILOR S.P.A., MILAN, ITALY, FILED 2-23-2011.

ULTRAGOLD

THE MARK CONSISTS OF STANDARD CHARACTERS WITHOUT CLAIM TO ANY PARTICULAR FONT, STYLE, SIZE, OR COLOR.

FOR GOLD JEWELRY (U.S. CLS. 2, 27, 28 AND 50).
GILBERT SWIFT, EXAMINING ATTORNEY

SN 85-249,730. BASE4 GROUP, INC., CARROLLTON, TX. FILED 2-23-2011.

SLAPLINX

THE MARK CONSISTS OF STANDARD CHARACTERS WITHOUT CLAIM TO ANY PARTICULAR FONT, STYLE, SIZE, OR COLOR.

FOR JEWELRY ACCESSORIES, NAMELY, ATTACHMENTS FOR SLAP BRACELETS (U.S. CLS. 2, 27, 28 AND 50).

FIRST USE 2-15-2011; IN COMMERCE 2-15-2011.
KATINA MISTER, EXAMINING ATTORNEY

CLASS 14—(Continued).

SN 85-249,757. DORA INTERNATIONAL INC, PINE BROOK, NJ. FILED 2-23-2011.

VENETIAN LACE

THE MARK CONSISTS OF STANDARD CHARACTERS WITHOUT CLAIM TO ANY PARTICULAR FONT, STYLE, SIZE, OR COLOR.

FOR JEWELRY (U.S. CLS. 2, 27, 28 AND 50).
FIRST USE 3-0-2010; IN COMMERCE 3-0-2010.
AMY C. KEAN, EXAMINING ATTORNEY

SN 85-250,145. JAN FELD, LLC, NEW YORK, NY. FILED 2-23-2011.

DAHLIA DIAMOND

THE MARK CONSISTS OF STANDARD CHARACTERS WITHOUT CLAIM TO ANY PARTICULAR FONT, STYLE, SIZE, OR COLOR.

NO CLAIM IS MADE TO THE EXCLUSIVE RIGHT TO USE "DIAMOND", APART FROM THE MARK AS SHOWN, FOR JEWELRY COMPRISED IN WHOLE OR IN PART OF DIAMONDS (U.S. CLS. 2, 27, 28 AND 50).
FIRST USE 9-0-2010; IN COMMERCE 9-0-2010.
CARYN GLASSER, EXAMINING ATTORNEY

SN 85-251,058. POWER UP BALANCE, AUSTIN, TX. FILED 2-24-2011.



THE MARK CONSISTS OF THE STYLIZED TEXT "PUB LIVE UP BE U".

FOR SILICONE WRISTBAND WITH TWO EMBEDDED HOLOGRAMS WHICH CONTAIN 7.8 HERTZ FREQUENCY THAT ALIGN THE BODIES NATURAL BIO ELECTRONIC CURRENT (U.S. CLS. 2, 27, 28 AND 50).
FIRST USE 12-10-2010; IN COMMERCE 12-10-2010.
BRIAN NEVILLE, EXAMINING ATTORNEY

CLASS 14—(Continued).

SN 85-254,370. AANYA INC., REGO PARK, NY. FILED 3-1-2011.



THE MARK CONSISTS OF A STYLIZED LETTER "A". FOR EARRINGS; JEWELRY (U.S. CLS. 2, 27, 28 AND 50).

FIRST USE 10-0-2010; IN COMMERCE 10-0-2010.
DOUGLAS LEE, EXAMINING ATTORNEY

SN 85-254,708. ROSY BLUE JEWELRY INC., NEW YORK, NY. FILED 3-1-2011.



THE MARK CONSISTS OF THE WORDS FOREVER BRILLIANT FOLLOWED BY THE WORDS TWICE THE LOVE UNDERNEATH AND AN IMAGE OF A STAR ABOVE ALL OF THE FOREGOING WORDING.

FOR JEWELRY; DIAMONDS; PRECIOUS AND SEMI PRECIOUS STONES (U.S. CLS. 2, 27, 28 AND 50).
SALLY SHIH, EXAMINING ATTORNEY

SN 85-254,852. PEKTEE INDUSTRIES, INC., WILLOW-BROOK, IL. FILED 3-1-2011.

PEKTEE

THE MARK CONSISTS OF STANDARD CHARACTERS WITHOUT CLAIM TO ANY PARTICULAR FONT, STYLE, SIZE, OR COLOR.

FOR BRACELETS (U.S. CLS. 2, 27, 28 AND 50).
MICHELLE DUBOIS, EXAMINING ATTORNEY

CLASS 14—(Continued).

SN 85-255,611. THE KEEP A BREAST FOUNDATION, CARLSBAD, CA. FILED 3-2-2011.

i♥boobies!

THE MARK CONSISTS OF A HEART WITH THE OUTLINE OF ANOTHER HEART SUPERIMPOSED ON TWO HALF CIRCLES REPRESENTING ABSTRACT BREASTS. THE HEART IS PRECEDED BY "I" AND FOLLOWED BY THE WORD "BOOBIES" WITH AN EXCLAMATION POINT. FOR BRACELETS (U.S. CLS. 2, 27, 28 AND 50). FIRST USE 5-15-2009; IN COMMERCE 5-15-2009. JOHN E. MICHOS, EXAMINING ATTORNEY

SN 85-256,007. FRIED, LIMOR, NYC, NY. FILED 3-2-2011.

MONOCHRON

THE MARK CONSISTS OF STANDARD CHARACTERS WITHOUT CLAIM TO ANY PARTICULAR FONT, STYLE, SIZE, OR COLOR. FOR CLOCKS AND PARTS THEREFOR (U.S. CLS. 2, 27, 28 AND 50). FIRST USE 2-28-2010; IN COMMERCE 2-28-2010. JEFFREY LOOK, EXAMINING ATTORNEY

SN 85-256,009. PRINCESS CRUISE LINES, LTD., SANTA CLARITA, CA. FILED 3-2-2011.

PRINCESS CHARMED KEEPSAKES

THE MARK CONSISTS OF STANDARD CHARACTERS WITHOUT CLAIM TO ANY PARTICULAR FONT, STYLE, SIZE, OR COLOR. NO CLAIM IS MADE TO THE EXCLUSIVE RIGHT TO USE "CHARMED KEEPSAKES", APART FROM THE MARK AS SHOWN. FOR CHARMS; JEWELRY (U.S. CLS. 2, 27, 28 AND 50). SAIMA MAKHDOOM, EXAMINING ATTORNEY

CLASS 14—(Continued).

SN 85-256,243. PENNYBANDZ LLC, COPPELL, TX. FILED 3-2-2011.

PENNYBANDZ

THE MARK CONSISTS OF STANDARD CHARACTERS WITHOUT CLAIM TO ANY PARTICULAR FONT, STYLE, SIZE, OR COLOR. FOR RUBBER OR SILICON WRISTBANDS IN THE NATURE OF A BRACELET (U.S. CLS. 2, 27, 28 AND 50). TASNEEM HUSSAIN, EXAMINING ATTORNEY

SN 85-256,280. CRAIG, JENNIFER, NAPLES, FL. FILED 3-2-2011.

I am grateful for...

THE MARK CONSISTS OF STANDARD CHARACTERS WITHOUT CLAIM TO ANY PARTICULAR FONT, STYLE, SIZE, OR COLOR. FOR JEWELRY (U.S. CLS. 2, 27, 28 AND 50). FIRST USE 10-1-2009; IN COMMERCE 11-1-2009. JOHN GARTNER, EXAMINING ATTORNEY

SN 85-256,779. GH INNOVATIONS LLC, MADISON, WI. FILED 3-3-2011.

RINGSKIN

THE MARK CONSISTS OF STANDARD CHARACTERS WITHOUT CLAIM TO ANY PARTICULAR FONT, STYLE, SIZE, OR COLOR. FOR RING PROTECTOR; GUARDS USED TO PROTECT JEWELRY AGAINST DAMAGE; RING PROTECTOR FOR GUARDING JEWELRY. RINGS AND/OR BANDS AGAINST DAMAGE AND/OR LOSS; FLEXIBLE HOOP FOR PARTIALLY ENCOMPASSING AN ENGAGEMENT OR FASHION RING (U.S. CLS. 2, 27, 28 AND 50). ZACHARY BELLO, EXAMINING ATTORNEY

CLASS 14—(Continued).

SN 85-257,131. SAMUEL AARON, INC., LONG ISLAND CITY, NY. FILED 3-3-2011.

LUCIANA

THE MARK CONSISTS OF STANDARD CHARACTERS WITHOUT CLAIM TO ANY PARTICULAR FONT, STYLE, SIZE, OR COLOR.

FOR JEWELRY (U.S. CLS. 2, 27, 28 AND 50).
MARLENE BELL, EXAMINING ATTORNEY

CLASS 14—(Continued).

SN 85-261,062. RAE, KAREN L., RIDGEFIELD, WA. FILED 3-8-2011.

GOOD ENOUGH NATION

SN 85-257,737. CAPITUS PTE LTD, SINGAPORE, SINGAPORE, FILED 3-4-2011.

Debauch

THE MARK CONSISTS OF STANDARD CHARACTERS WITHOUT CLAIM TO ANY PARTICULAR FONT, STYLE, SIZE, OR COLOR.

FOR BRACELETS; EARRINGS; JEWELLERY AND IMITATION JEWELLERY; NECKLACES; WATCHES (U.S. CLS. 2, 27, 28 AND 50).

KIMBERLY PERRY, EXAMINING ATTORNEY

THE MARK CONSISTS OF STANDARD CHARACTERS WITHOUT CLAIM TO ANY PARTICULAR FONT, STYLE, SIZE, OR COLOR.

OWNER OF U.S. REG. NO. 3,747,819.

FOR ANKLE BRACELETS; BANGLE BRACELETS; BEADS FOR USE IN THE MANUFACTURE OF JEWELRY; BODY-PIERCING RINGS; BRACELETS; BRACELETS; BROACHES; BROOCHES; CHARMS; CHARMS FOR COLLAR JEWELRY AND BRACELET; CHARMS IN PRECIOUS METALS OR COATED THEREWITH; CLIP EARRINGS; CLOCKS AND WATCHES; COSTUME JEWELRY; DIAMOND JEWELRY; DRESS WATCHES; EAR STUDS; EARRINGS; GEMSTONE JEWELRY; HAIR JEWELRY IN THE NATURE OF JEWELRY FOR USE IN THE HAIR; IDENTIFICATION BRACELETS; INEXPENSIVE NON-JEWELRY WATCHES; JEWELLERY AND WATCHES; JEWELLERY, CLOCKS AND WATCHES; JEWELRY; JEWELRY AND IMITATION JEWELRY; JEWELRY BROOCHES; JEWELRY CASES; JEWELRY CHAINS; JEWELRY FOR ATTACHMENT TO CLOTHING; JEWELRY FOR THE HEAD; JEWELRY WATCHES; JEWELRY, NAMELY, AMULETS; JEWELRY, NAMELY, ANKLETS; JEWELRY, NAMELY, DOG TAGS FOR WEAR BY HUMANS FOR DECORATIVE PURPOSES; KEY CHAINS AS JEWELLERY; KEY CHAINS OF PRECIOUS METAL; KEY HOLDERS OF PRECIOUS METALS; KEY RINGS OF PRECIOUS METAL; KEY RINGS OF PRECIOUS METALS; LAPEL PINS; LEATHER JEWELRY AND ACCESSORY BOXES; NECK CHAINS; NECKLACES; PET JEWELRY; PLASTIC BRACELETS IN THE NATURE OF JEWELRY; POCKET WATCHES; PRECIOUS STONES AND WATCHES; RINGS; RINGS BEING JEWELRY; RUBBER OR SILICON WRISTBANDS IN THE NATURE OF A BRACELET; SPORTS WATCHES; TIMEPIECES; TIMEPIECES AND CHRONOMETRIC INSTRUMENTS; WATCH BANDS; WATCH BANDS AND STRAPS; WATCH BOXES; WATCH BRACELETS; WATCH CASES; WATCHES; WATCHES AND CLOCKS; WATCHES AND JEWELLERY; WATCHES AND JEWELRY; WATCHES AND STRAPS FOR WATCHES; WATCHES FOR SPORTING USE; WATCHES, CLOCKS; WATCHES, CLOCKS, JEWELLERY AND IMITATION JEWELLERY; WATCHES, CLOCKS, JEWELRY AND IMITATION JEWELRY; WOMEN'S JEWELRY; WOMEN'S WATCHES; WRIST WATCHES (U.S. CLS. 2, 27, 28 AND 50).

ELLEN PERKINS, EXAMINING ATTORNEY

SN 85-259,076. THE OHIO STATE UNIVERSITY, COLUMBUS, OH. FILED 3-5-2011.

OSU

THE MARK CONSISTS OF STANDARD CHARACTERS WITHOUT CLAIM TO ANY PARTICULAR FONT, STYLE, SIZE, OR COLOR.

FOR BRACELETS; EARRINGS; PENDANTS (U.S. CLS. 2, 27, 28 AND 50).

FIRST USE 0-0-1975; IN COMMERCE 0-0-1975.

JEFFREY LOOK, EXAMINING ATTORNEY

CLASS 14—(Continued).

SN 85-263,828. HARAJUKU LOVERS, LLC, BEVERLY HILLS, CA. FILED 3-10-2011.

HARAJUKU MINI

THE MARK CONSISTS OF STANDARD CHARACTERS WITHOUT CLAIM TO ANY PARTICULAR FONT, STYLE, SIZE, OR COLOR.

OWNER OF U.S. REG. NOS. 3,562,719, 3,833,077 AND OTHERS.

FOR CHARMS, CLOCKS, JEWELRY, JEWELRY BOXES, TIARAS, WATCH CASES, WATCHES, WATCH BANDS, AND WATCH STRAPS (U.S. CLS. 2, 27, 28 AND 50).

INGRID C. EULIN, EXAMINING ATTORNEY

SN 85-295,752. LOS ANGELES GEM & JEWELRY DESIGN, INC., LOS ANGELES, CA. FILED 4-14-2011.

SILVER SPARKLE SHINE

THE MARK CONSISTS OF STANDARD CHARACTERS WITHOUT CLAIM TO ANY PARTICULAR FONT, STYLE, SIZE, OR COLOR.

NO CLAIM IS MADE TO THE EXCLUSIVE RIGHT TO USE "SILVER", APART FROM THE MARK AS SHOWN.

FOR BANGLES; BRACELETS; BROOCHES; CHARMS; CUFF LINKS AND TIE CLIPS; EARRINGS; HAIR JEWELRY IN THE NATURE OF JEWELRY FOR USE IN THE HAIR; JEWELRY; JEWELRY BOXES; JEWELRY CHAINS; JEWELRY, NAMELY, ANKLETS; LOCKETS; NECKLACES; PENDANTS; RINGS; TIE CLIPS; WATCHES; WOMEN'S JEWELRY AND ALL OF THE FOREGOING GOODS ARE MADE IN WHOLE OR IN PART OF SILVER (U.S. CLS. 2, 27, 28 AND 50).

EDWARD NELSON, EXAMINING ATTORNEY

SN 85-308,512. STANLEY CREATIONS, INC., MELROSE PARK, PA. FILED 4-29-2011.

BIRTHSTONE BABIES

THE MARK CONSISTS OF STANDARD CHARACTERS WITHOUT CLAIM TO ANY PARTICULAR FONT, STYLE, SIZE, OR COLOR.

NO CLAIM IS MADE TO THE EXCLUSIVE RIGHT TO USE "BIRTHSTONE", APART FROM THE MARK AS SHOWN.

FOR JEWELRY, NAMELY, CHARM PENDANTS (U.S. CLS. 2, 27, 28 AND 50).

FIRST USE 2-13-2006; IN COMMERCE 2-13-2006.

JUDITH HELFMAN, EXAMINING ATTORNEY

CLASS 14—(Continued).

SN 85-318,245. KATIE POP INC., NEW YORK, NY. FILED 5-11-2011.

KATIE POP

THE MARK CONSISTS OF STANDARD CHARACTERS WITHOUT CLAIM TO ANY PARTICULAR FONT, STYLE, SIZE, OR COLOR.

FOR JEWELRY; WATCHES (U.S. CLS. 2, 27, 28 AND 50).

RUDY R. SINGLETON, EXAMINING ATTORNEY

CLASS 15—MUSICAL INSTRUMENTS

SN 79-092,934. REINHARDT GMBH, FED REP GERMANY, FILED 1-26-2011.



PRIORITY DATE OF 8-3-2010 IS CLAIMED.
OWNER OF INTERNATIONAL REGISTRATION 1066136 DATED 1-26-2011, EXPIRES 1-26-2021.
FOR GUITARS; UKULELES (U.S. CLS. 2, 21 AND 36).
AISHA SALEM, EXAMINING ATTORNEY

SN 79-094,421. DACARBO AG, SWITZERLAND, FILED 2-18-2011.



PRIORITY DATE OF 2-9-2011 IS CLAIMED.
OWNER OF INTERNATIONAL REGISTRATION 1069337 DATED 2-18-2011, EXPIRES 2-18-2021.

THE MARK CONSISTS OF THE TERM "DACARBO" BROKEN INTO TWO WORDS WITH THE "DA" PORTION OVER THE "CARBO" PORTION. A LINE OF THREE DOTS EXTENDS DIAGONALLY FROM THE "A" IN "DA" UPWARDS TO A GROUP OF SIX LARGER DOTS, THEN CONNECTING TO NINE SMALLER DOTS.

FOR MUSICAL INSTRUMENTS (U.S. CLS. 2, 21 AND 36).

CURTIS FRENCH, EXAMINING ATTORNEY

CLASS 15—(Continued).

SN 85-106,188. PREMIER BUILDERS GUILD, LLC, PITTSBURGH, PA. FILED 8-12-2010.



THE MARK CONSISTS OF A LOWER CASE LETTER "B". THE NUMBER "3" APPEARS TO THE UPPER RIGHT EDGE OF THE LOWER CASE LETTER "B" AND APPEARS TO BE SLIGHTLY BEHIND THE LOWER CASE LETTER "B".
FOR GUITARS (U.S. CLS. 2, 21 AND 36).
FIRST USE 4-1-2006; IN COMMERCE 4-1-2006.
NICHOLAS COLEMAN, EXAMINING ATTORNEY

SN 85-173,831. LAWTON, JOASH, ROWVILLE, VICTORIA, AUSTRALIA, FILED 11-10-2010.

MULHOLLAND DRIVE

THE MARK CONSISTS OF STANDARD CHARACTERS WITHOUT CLAIM TO ANY PARTICULAR FONT, STYLE, SIZE, OR COLOR.
THE WORDING "MULHOLLAND" HAS NO MEANING IN A FOREIGN LANGUAGE.
FOR GUITAR PEDALS; MUSICAL ACCESSORIES, NAMELY, ELECTRONIC EFFECTS PEDALS FOR USE WITH MUSICAL INSTRUMENTS; MUSICAL ACCESSORIES, NAMELY, SOUND EFFECT PEDALS FOR MUSICAL INSTRUMENTS (U.S. CLS. 2, 21 AND 36).
CAROLYN CATALDO, EXAMINING ATTORNEY

CLASS 15—(Continued).

SN 85-226,332. MARSHALL AMPLIFICATION PLC, BUCKINGHAMSHIRE, UNITED KINGDOM, FILED 1-26-2011.



PRIORITY CLAIMED UNDER SEC. 44(D) ON ERP N CMNTY TM OFC APPLICATION NO. 9641432, FILED 1-5-2011, REG. NO. 9641432, DATED 5-18-2011, EXPIRES 1-5-2021.
OWNER OF U.S. REG. NO. 3,896,296.
THE MARK CONSISTS OF SUN DESIGN.
FOR MUSICAL INSTRUMENTS, CONGAS, BONGOS, DRUMS, PERCUSSION ACCESSORIES, NAMELY, SHAKERS, CABASAS, COWBELLS, TAMBOURINES, GANZAS, CAXIXI, GUIROS, BAR CHIMES, BLOCKS, HEADS; HAND PERCUSSION INSTRUMENTS; PERCUSSION INSTRUMENTS; PARTS AND FITTINGS FOR THE AFORESAID GOODS (U.S. CLS. 2, 21 AND 36).
DEZMONA MIZELLE, EXAMINING ATTORNEY

SN 85-235,129. U.E. CORP., RINGOES, NJ. FILED 2-6-2011.

SPOILER

THE MARK CONSISTS OF THE WORD "SPOILER" IN STYLIZED LETTERING.
FOR STRINGED INSTRUMENT PARTS, NAMELY, TAILPIECES, TAILPIECE ADAPTORS, BRIDGES, FINE TUNERS AND STRAP CONNECTORS (U.S. CLS. 2, 21 AND 36).
FIRST USE 11-18-2010; IN COMMERCE 11-18-2010.
MARK SPARACINO, EXAMINING ATTORNEY

SN 85-256,080. FRIED, LIMOR, DBA ADAFRUIT INDUSTRIES, NYC, NY. FILED 3-2-2011.

xØxbØx

THE MARK CONSISTS OF STANDARD CHARACTERS WITHOUT CLAIM TO ANY PARTICULAR FONT, STYLE, SIZE, OR COLOR.
FOR MUSIC SYNTHESIZERS (U.S. CLS. 2, 21 AND 36).
FIRST USE 1-31-2005; IN COMMERCE 1-31-2005.
JEFFREY LOOK, EXAMINING ATTORNEY

CLASS 15—(Continued).

SN 85-256,248. GONZALEZ, GALDINO, WILDOMAR, CA.
FILED 3-2-2011.

pasaye

THE MARK CONSISTS OF STANDARD CHARACTERS WITHOUT CLAIM TO ANY PARTICULAR FONT, STYLE, SIZE, OR COLOR.

FOR CASES FOR MUSICAL INSTRUMENTS; GUITAR PICKS; GUITAR STRAPS; GUITAR STRINGS; GUITARS (U.S. CLS. 2, 21 AND 36).

ESTHER A. BORSUK, EXAMINING ATTORNEY

SN 85-262,412. YU, QUINCY, RANCHO CUCAMONGA, CA.
FILED 3-9-2011.

TYCOON PERCUSSION

THE MARK CONSISTS OF STANDARD CHARACTERS WITHOUT CLAIM TO ANY PARTICULAR FONT, STYLE, SIZE, OR COLOR.

NO CLAIM IS MADE TO THE EXCLUSIVE RIGHT TO USE "PERCUSSION", APART FROM THE MARK AS SHOWN.

FOR PERCUSSION INSTRUMENTS (U.S. CLS. 2, 21 AND 36).

FIRST USE 5-3-2006; IN COMMERCE 6-1-2006.
AMY HELLA, EXAMINING ATTORNEY

CLASS 16—PAPER GOODS AND PRINTED MATTER

SN 76-705,874. DEEP CHANGE, INC, BELLAIRE, TX. FILED 1-3-2011.



deep change

Distinctive Results

THE MARK CONSISTS OF THE WORDING "DEEP CHANGE DISTINCTIVE RESULTS" AND DESIGN. THE WORDING "DEEP CHANGE" APPEARS ABOVE THE WORDING "DISTINCTIVE RESULTS". TO THE LEFT OF THE WORDING IS A FINGER PRINT.

FOR BOOKS, BOOKLETS, PAMPHLETS, NEWSLETTERS AND WORKBOOKS ALL ON A VARIETY OF TOPICS FEATURING EMOTIONAL WELLBEING, HAPPINESS, SPIRITUALITY, BALANCING SPIRITUAL AND WORK LIFE, THE ROLE OF SPIRITUALITY IN LEADERSHIP, MANAGEMENT, BUSINESS MANAGEMENT, WORKPLACE ENVIRONMENT DEVELOPMENT AND MANAGEMENT, HUMAN RESOURCES MANAGEMENT, INDIVIDUAL PERFORMANCE AND EFFECTIVENESS, TEAM PERFORMANCE AND EFFECTIVENESS, MOTIVATIONAL TOPICS, SELF-IMPROVEMENT TOPICS, OR A COMBINATION THEREOF (U.S. CLS. 2, 5, 22, 23, 29, 37, 38 AND 50).

MARLENE BELL, EXAMINING ATTORNEY

SN 76-706,739. NEVER FORGET PUBLISHING, INC., ALEDO, IL. FILED 3-8-2011.

A BOOK BY ME

THE MARK CONSISTS OF STANDARD CHARACTERS WITHOUT CLAIM TO ANY PARTICULAR FONT, STYLE, SIZE, OR COLOR.

FOR PRINTED MATTER, NAMELY, CHILDREN'S BOOKS AND BOOKMARKS (U.S. CLS. 2, 5, 22, 23, 29, 37, 38 AND 50).

FIRST USE 3-12-2006; IN COMMERCE 3-12-2006.
KATHERINE CONNOLLY, EXAMINING ATTORNEY

CLASS 16—(Continued).

SN 76-707,481. EH PUBLISHING, INC., FRAMINGHAM, MA. FILED 5-3-2011.



NO CLAIM IS MADE TO THE EXCLUSIVE RIGHT TO USE "ROBOTICS TRENDS", APART FROM THE MARK AS SHOWN.

THE MARK CONSISTS OF WORD "ROBOTICS" POSITIONED ABOVE THE WORD "TRENDS" WHERE BOTH WORDS ARE RIGHT JUSTIFIED. TO THE LEFT ARE THE LETTERS "R" AND "T" BOTH CONTAINED IN INDIVIDUAL CIRCLES.

FOR PRINTED SUBSCRIPTION PUBLICATION, NAMELY, NEWSLETTER FEATURING RESEARCH AND INSIGHTS INTO THE BUSINESS OF ROBOTICS (U.S. CLS. 2, 5, 22, 23, 29, 37, 38 AND 50).

FIRST USE 1-0-2009; IN COMMERCE 1-0-2009.
INGRID C. EULIN, EXAMINING ATTORNEY

SN 77-392,980. DIRECTV, INC., EL SEGUNDO, CA. FILED 2-8-2008.

DIRECTVIEW

THE MARK CONSISTS OF STANDARD CHARACTERS WITHOUT CLAIM TO ANY PARTICULAR FONT, STYLE, SIZE, OR COLOR.

FOR PRINTED REPORTS, MAGAZINE, NEWSLETTER PUBLICATIONS AND BOOKS, CONTAINING TELEVISION PROGRAMMING, MEDIA ADVERTISING AND MEDIA RESEARCH AND ANALYSIS DEALING WITH DEMOGRAPHIC INFORMATION, MEDIA RATING INFORMATION, INTERNET AND/OR COMPUTER USAGE INFORMATION, AND PRODUCT PURCHASE AND USAGE INFORMATION IN CONNECTION WITH THE LISTENING, VIEWING AND USAGE HABITS OF SIGNAL RECEIVING AUDIENCES, INTERNET USERS AND/OR COMPUTER USERS (U.S. CLS. 2, 5, 22, 23, 29, 37, 38 AND 50).

RUSS HERMAN, EXAMINING ATTORNEY

SN 77-782,183. RAO, MANOJ, EL SOBRANTE, CA. FILED 7-15-2009.

WMDS

THE MARK CONSISTS OF STANDARD CHARACTERS WITHOUT CLAIM TO ANY PARTICULAR FONT, STYLE, SIZE, OR COLOR.

PRIORITY CLAIMED UNDER SEC. 44(D) ON CANADA APPLICATION NO. 1441791, FILED 6-22-2009, REG. NO. TMA793470, DATED 3-21-2011, EXPIRES 3-21-2026.

FOR COMIC BOOKS (U.S. CLS. 2, 5, 22, 23, 29, 37, 38 AND 50).

DAWN HAN, EXAMINING ATTORNEY

CLASS 16—(Continued).

SN 77-785,911. TY LOKE, LLC, NEW YORK, NY. FILED 7-21-2009.

TYRA BANKS

THE MARK CONSISTS OF STANDARD CHARACTERS WITHOUT CLAIM TO ANY PARTICULAR FONT, STYLE, SIZE, OR COLOR.

THE NAME "TYRA BANKS" IDENTIFIES A LIVING INDIVIDUAL WHOSE CONSENT IS OF RECORD.

FOR PAPER PARTY PRODUCTS, NAMELY, PARTY FAVORS, PARTY BAGS, PARTY DECORATIONS; GIFT WRAPPING PAPER, PAPER BOWS AND RIBBONS FOR GIFT WRAP; PAPER RIBBONS; METALLIC GIFT WRAP AND GIFT WRAPPING PAPER; SCENTED PAPER DRAWER LINERS, SHELF PAPER, PLASTIC GIFT WRAP, PAPER BOXES AND PAPER DISPLAY BOXES, PAPER GIFT TAGS, PAPER FOR PACKAGING AND TISSUE PAPER; CORRUGATED PAPER, BOXES AND CONTAINERS; CORRUGATED RECORD STORAGE BOXES; PAPER CUTTERS; PRINTING PAPER, RECYCLED PAPER, ART PAPER, CRAFT PAPER, CREPE PAPER, TRACING PAPER, PAPER MACHE, PAPER MACHE FIGURINES, DRAWING PAPER, CONSTRUCTION PAPER, CORRUGATED PAPER, FLUORESCENT PAPER, ILLUSTRATION PAPER, LAMINATED PAPER, LINING PAPER, PAPER BABY BIBS, PAPER MAIL POUCHES, PAPER MATS, PAPER PILLOWCASES, PAPER NAPKINS, PAPER PLACE MATS, PAPER BOARDS, PAPER CAKE DECORATIONS, PAPER DOILIES, PAPER DROP CLOTHS, PAPER TABLE CLOTHS AND LINENS, PAPER TRAY COVERS, PAPER WASHCLOTHS, PAPER TOWELS, PARCHMENT PAPER AND WAX PAPER; PRINTED AND RELATED MATTER, NAMELY, POSTERS, CALENDARS, TEMPORARY TATTOOS, STICKERS, DECALS, IRON-ON OR PLASTIC TRANSFERS, BUMPER STICKERS, PAPER BAGS AND PAPER GIFT BAGS, FABRIC GIFT BAGS, NOTE CARDS, POSTCARDS, PICTURE POSTCARDS, GREETING CARDS, MUSICAL GREETING CARDS, PRINTED GREETING CARDS WITH ELECTRONIC INFORMATION STORED THEREIN, GIFT CARDS, OCCASION CARDS, SOCIAL NOTE CARDS, MOTIVATIONAL CARDS, CARDS BEARING UNIVERSAL GREETINGS, BLANK CARDS, BLANK NOTE CARDS, PLACE CARDS, BLANK AND PARTIALLY PRINTED CARDS, RECORD CARDS, SCORE CARDS, TRADING CARDS, SCRAPBOOKS, STATIONERY, NOTE PADS, NOTE PAPER, PAPER NOTE TABLETS, WRITING TABLETS, LOOSE LEAF PAPER, NOTEBOOKS, FOLDERS, FILE FOLDERS, STATIONERY FOLDERS, BOOKMARKS, PAPER PENNANTS, BINDERS, WRITING PAPER, ENVELOPES, APPOINTMENT BOOKS, ADDRESS BOOKS, DESK PADS AND PAPER TAGS; PAPER LABELS; PASSPORT CASES, PASSPORT COVERS, PASSPORT HOLDERS, PAPER HOLE PUNCHES, PERSONAL ORGANIZERS, DESK TOP ORGANIZERS, ORGANIZERS FOR STATIONERY USE AND STATIONERY-TYPE PORTFOLIOS, STATIONERY BOXES, PAPER FLAGS, MOUNTS FOR STAMPS, RUBBER STAMPS, RUBBER DOCUMENT STAMPS, STAMP ALBUMS, STAMP PAD INKS, STAMP PADS, SLEEVES FOR HOLDING AND PROTECTING STAMPS, PAPER BANNERS, HOLDERS FOR DESK ACCESSORIES, COASTERS MADE OF PAPER, LETTER OPENERS, LETTER TRAYS, LETTER RACKS, PENS, PENCILS, MARKERS, PEN AND PENCIL SETS, STICK MARKERS, ERASERS, DRAWING AND DRAFTING RULERS, PENCIL SHARPENERS, BOOK ENDS, BOOK COVERS, CHECKBOOK COVERS, BOOK HOLDERS, PHOTOGRAPH AND COIN ALBUMS; PHOTOGRAPH MOUNTS; PHOTOGRAPHIC OR ART MOUNTS; PHOTOGRAPHIC PRINTS; PHOTOGRAPHS; LITHOGRAPHS; DECORATIVE PAPER CENTERPIECES; DECORATIVE PENCIL-TOP ORNAMENTS; PICTURE BOOKS; PAPER AND CARDBOARD PICTURE MOUNTS; STORAGE CONTAINERS MADE OF PAPER; GLOBES; PAPER-WEIGHTS; PAPER CLIP HOLDERS; PRINTED PAPER SIGNS; PAPER EMBLEMS; PAPER IDENTIFICATION

CLASS 16—(Continued).

TAGS; PAPER NAME BADGES; PAPER ILLUSTRATION BOARDS; PAPER FLOWER POT COVERS; CLIP BOARDS; PAPER HANDKERCHIEFS; TOUR BOOKS AND FOLIOS; EVENT PROGRAMS AND SOUVENIR PROGRAMS CONCERNING MODELING AND FASHION SHOWS; MAGAZINES, LEAFLETS, JOURNALS, NEWSLETTERS, BOOKLETS, PAMPHLETS AND BROCHURES, ALL OF THE AFORESAID FEATURING LIFESTYLES, BEAUTY AND FASHION, MODELING, ENTERTAINING AND ENTERTAINMENT, MUSIC, THE ARTS, CULTURE AND POLITICS (U.S. CLS. 2, 5, 22, 23, 29, 37, 38 AND 50).

CHARLES L. JENKINS, EXAMINING ATTORNEY

CLASS 16—(Continued).

SN 77-937,406. USH ENTERTAINMENT, INC., NEW YORK, NY. FILED 2-17-2010.

USH ENTERTAINMENT

SN 77-837,684. MARKET STUDIES, LLC, SCOTTSDALE, AZ. FILED 9-29-2009.

SEQUENTIAL

THE MARK CONSISTS OF STANDARD CHARACTERS WITHOUT CLAIM TO ANY PARTICULAR FONT, STYLE, SIZE, OR COLOR.

FOR PUBLICATIONS, NAMELY, BOOKS, MAGAZINES, NEWSLETTERS, PRINTED TEACHING AND LECTURE MATERIALS AND PRINTED LECTURES ALL IN THE FIELD OF FINANCIAL MARKETS AND EXCHANGE TRADED COMMODITIES (U.S. CLS. 2, 5, 22, 23, 29, 37, 38 AND 50).

HEATHER BIDDULPH, EXAMINING ATTORNEY

THE MARK CONSISTS OF STANDARD CHARACTERS WITHOUT CLAIM TO ANY PARTICULAR FONT, STYLE, SIZE, OR COLOR.

NO CLAIM IS MADE TO THE EXCLUSIVE RIGHT TO USE "ENTERTAINMENT", APART FROM THE MARK AS SHOWN.

THE NAME "USH" IDENTIFIES A LIVING INDIVIDUAL WHOSE CONSENT IS OF RECORD.

FOR PAPER GOODS AND PRINTED MATTER, NAMELY, THE FOLLOWING— BOOKS FEATURING CONTENT IN THE FIELDS OF ENTERTAINMENT, NAMELY, COMEDY, SCREENPLAYS, DRAMA, ACTION, ADVENTURE, THE ARTS, FASHION, LIFESTYLES, TELEVISION, MOVIES, RADIO, SPORTS, MUSICAL PERFORMANCES, AND ANIMATION; MAGAZINES FEATURING CONTENT IN THE FIELDS OF ENTERTAINMENT, NAMELY, COMEDY, SCREENPLAYS, DRAMA, ACTION, ADVENTURE, THE ARTS, FASHION, LIFESTYLES, TELEVISION, MOVIES, RADIO, SPORTS, MUSICAL PERFORMANCES, AND ANIMATION; SONG BOOKS; SHEET MUSIC BOOKS; LITHOGRAPHS; POSTCARDS; BOOK COVERS, BOOK MARKS, CALENDARS; POSTERS; INSERTS FOR AUDIO AND/OR VISUAL MEDIA; GREETINGS CARDS; PRINTED TRANSFERS FOR EMBROIDERY OR FABRIC APPLIQUES; PRINTED PATTERNS FOR CLOTHING; MOUNTED AND UNMOUNTED PHOTOGRAPHS; HEAT TRANSFERS; STATIONERY, WRITING PAPER, ENVELOPES, NOTEBOOKS, DIARIES, NOTE CARDS, TRADING CARD (U.S. CLS. 2, 5, 22, 23, 29, 37, 38 AND 50).

SARA BENJAMIN, EXAMINING ATTORNEY

CLASS 16—(Continued).

SN 77-937,417. USH ENTERTAINMENT, INC., NEW YORK, NY. FILED 2-17-2010.

USH

THE MARK CONSISTS OF STANDARD CHARACTERS WITHOUT CLAIM TO ANY PARTICULAR FONT, STYLE, SIZE, OR COLOR.

THE NAME "USH" IDENTIFIES A LIVING INDIVIDUAL WHOSE CONSENT IS OF RECORD.

FOR PAPER GOODS AND PRINTED MATTER, NAMELY, THE FOLLOWING— BOOKS FEATURING CONTENT IN THE FIELDS OF ENTERTAINMENT, NAMELY, COMEDY, SCREENPLAYS, DRAMA, ACTION, ADVENTURE, THE ARTS, FASHION, LIFESTYLES, TELEVISION, MOVIES, RADIO, SPORTS, MUSICAL PERFORMANCES, AND ANIMATION; MAGAZINES FEATURING CONTENT IN THE FIELDS OF ENTERTAINMENT, NAMELY, COMEDY, SCREENPLAYS, DRAMA, ACTION, ADVENTURE, THE ARTS, FASHION, LIFESTYLES, TELEVISION, MOVIES, RADIO, SPORTS, MUSICAL PERFORMANCES, AND ANIMATION; SONG BOOKS; SHEET MUSIC BOOKS; LITHOGRAPHS; POSTCARDS; BOOK COVERS, BOOK MARKS, CALENDARS; POSTERS; INSERTS FOR AUDIO AND/OR VISUAL MEDIA; GREETINGS CARDS; PRINTED TRANSFERS FOR EMBROIDERY OR FABRIC APPLIQUES; PRINTED PATTERNS FOR CLOTHING; MOUNTED AND UNMOUNTED PHOTOGRAPHS; HEAT TRANSFERS; STATIONERY, WRITING PAPER, ENVELOPES, NOTEBOOKS, DIARIES, NOTE CARDS, TRADING CARD (U.S. CLS. 2, 5, 22, 23, 29, 37, 38 AND 50).

SARA BENJAMIN, EXAMINING ATTORNEY

SN 77-940,076. UNIFIED BUDDHIST CHURCH, INC., ESCONDIDO, CA. AND CHEUNG, LILIAN W. Y., WELLESLEY, MA. FILED 2-19-2010.

INEATING

THE MARK CONSISTS OF STANDARD CHARACTERS WITHOUT CLAIM TO ANY PARTICULAR FONT, STYLE, SIZE, OR COLOR.

FOR PRINTED MATTER, NAMELY, BOOKS IN THE FIELDS OF BUDDHISM, MEDITATION AND MINDFUL LIVING (U.S. CLS. 2, 5, 22, 23, 29, 37, 38 AND 50).

KATHERINE CONNOLLY, EXAMINING ATTORNEY

CLASS 16—(Continued).

SN 77-940,158. UNIFIED BUDDHIST CHURCH, INC., ESCONDIDO, CA. AND CHEUNG, LILIAN W. Y., WELLESLEY, MA. FILED 2-19-2010.

INMOVING

THE MARK CONSISTS OF STANDARD CHARACTERS WITHOUT CLAIM TO ANY PARTICULAR FONT, STYLE, SIZE, OR COLOR.

FOR PRINTED MATTER, NAMELY, BOOKS IN THE FIELDS OF BUDDHISM, MEDITATION AND MINDFUL LIVING (U.S. CLS. 2, 5, 22, 23, 29, 37, 38 AND 50).

KATHERINE CONNOLLY, EXAMINING ATTORNEY

SN 77-940,176. UNIFIED BUDDHIST CHURCH, INC., ESCONDIDO, CA. AND CHEUNG, LILIAN W. Y., WELLESLEY, MA. FILED 2-19-2010.

INBREATHING

THE MARK CONSISTS OF STANDARD CHARACTERS WITHOUT CLAIM TO ANY PARTICULAR FONT, STYLE, SIZE, OR COLOR.

FOR PRINTED MATTER, NAMELY, BOOKS IN THE FIELDS OF BUDDHISM, MEDITATION AND MINDFUL LIVING (U.S. CLS. 2, 5, 22, 23, 29, 37, 38 AND 50).

KATHERINE CONNOLLY, EXAMINING ATTORNEY

SN 77-947,785. MADARAS GALLERY, INC., TUCSON, AZ. FILED 3-1-2010.

PUPPY TANGO

THE MARK CONSISTS OF STANDARD CHARACTERS WITHOUT CLAIM TO ANY PARTICULAR FONT, STYLE, SIZE, OR COLOR.

NO CLAIM IS MADE TO THE EXCLUSIVE RIGHT TO USE "PUPPY", APART FROM THE MARK AS SHOWN.

FOR PAPER GOODS AND PRINTED MATTER, NAMELY, ARTWORK MADE FROM CUSTOM MANUFACTURED PAPER, POSTERS, POST CARDS, GREETING CARDS, PHOTOGRAPHS, PHOTOGRAPH ALBUMS, CALENDARS, PERSONAL ORGANIZERS, DIARIES, PENS, PENCILS, ERASERS, STATIONERY, BLANK PERSONAL JOURNALS, NOTEBOOKS, NOTE PADS, SKETCH PADS, PAPER BOOKMARKS, CHILDREN'S BOOKS, CHILDREN'S ACTIVITY BOOKS AND COLORING BOOKS, ARTS AND CRAFT PAINT KITS; PAPER PARTY GOODS, NAMELY, PAPER NAPKINS, PAPER PLACEMATS, PAPER TABLECLOTHS; TRADING CARDS (U.S. CLS. 2, 5, 22, 23, 29, 37, 38 AND 50).

NAKWAMA ANKRAH, EXAMINING ATTORNEY

CLASS 16—(Continued).

SN 77-955,124. PAUL S CAMPBELL, NEPTUNE BEACH, FL.
FILED 3-10-2010.

LIVE AS ONE

THE MARK CONSISTS OF STANDARD CHARACTERS WITHOUT CLAIM TO ANY PARTICULAR FONT, STYLE, SIZE, OR COLOR.

FOR STICKERS; PRINTED MATTER AND PUBLICATIONS, NAMELY, MAGAZINES IN THE FIELD OF GENERAL INTEREST; PHOTOGRAPHS; POSTERS (U.S. CLS. 2, 5, 22, 23, 29, 37, 38 AND 50).

DAVID COLLIER, EXAMINING ATTORNEY

SN 77-967,315. VIVINT, INC., PROVO, UT. FILED 3-24-2010.

PROTECTING FAMILIES

THE MARK CONSISTS OF STANDARD CHARACTERS WITHOUT CLAIM TO ANY PARTICULAR FONT, STYLE, SIZE, OR COLOR.

FOR WRITING IMPLEMENTS, PRINTED INSTRUCTIONAL MATERIALS, NAMELY, INSTRUCTION MANUALS, BOOKLETS, AND GUIDES ON THE TOPICS OF BUILDING AUTOMATION SYSTEMS AND SECURITY, TROUBLE AND EMERGENCY ALARM SYSTEMS; PRINTED PAPER SIGNS (U.S. CLS. 2, 5, 22, 23, 29, 37, 38 AND 50).

TIMOTHY FINNEGAN, EXAMINING ATTORNEY

CLASS 16—(Continued).

SN 77-968,626. MSC SERVICES CORP., MELVILLE, NY.
FILED 3-25-2010.

WORKSMART

THE MARK CONSISTS OF STANDARD CHARACTERS WITHOUT CLAIM TO ANY PARTICULAR FONT, STYLE, SIZE, OR COLOR.

FOR MARKING PRODUCTS, NAMELY, INK PADS, RUBBER STAMPS, DATE STAMPS, SELF-INKING INK STAMPS, PRE-INKED STAMP PADS, PAPER EMBOSERS, PRINTED PAPER SIGNS, PAPER BANNERS, INK ROLLERS FOR STAMP PADS, STENCILS, STENCIL MACHINES IN THE NATURE OF MIMEOGRAPHS, CHECK MARKING MACHINES FOR PREVENTING FRAUD, PRICE MARKERS IN THE NATURE OF LABEL PRINTING MACHINES, DRY-ERASE MARKING BOARDS, MARKERS, MARKING PENS, PENCILS, PENS, CHALK AND INDUSTRIAL MARKING PRODUCT, NAMELY, SOAPSTONE; LABELING PRODUCTS, NAMELY, PAPER LABELS, MARKING TABS, SLEEVE PROTECTORS IN THE NATURE OF DOCUMENT FOLDERS, ADHESIVE LABELS, OFFICE LABELING MACHINES, LABEL PRINTING MACHINES, FOLDERS, LABEL RIBBON TAPES; ADHESIVES FOR STATIONERY, OFFICE AND HOUSEHOLD USE, LAMINATING MACHINES AND LAMINATING POUCHES FOR USE THEREWITH (U.S. CLS. 2, 5, 22, 23, 29, 37, 38 AND 50).

JULIE WATSON, EXAMINING ATTORNEY

SN 78-345,357. DUGDILL, GERARD, NEW ELTHAM, LONDON, UNITED KINGDOM, FILED 12-24-2003.

PINK RIBBON

THE MARK CONSISTS OF STANDARD CHARACTERS WITHOUT CLAIM TO ANY PARTICULAR FONT, STYLE, SIZE, OR COLOR.

FOR MAGAZINES RELATING TO LIFESTYLE AND WOMEN'S HEALTH (U.S. CLS. 2, 5, 22, 23, 29, 37, 38 AND 50).

INGA ERVIN, EXAMINING ATTORNEY

CLASS 16—(Continued).

SN 79-087,167. HUIZHOU SHI YIKE HUAXUEGONGYE
YOUXIANGONGSI, CHINA, FILED 7-20-2010.



PRIORITY DATE OF 1-27-2010 IS CLAIMED.
OWNER OF INTERNATIONAL REGISTRATION 1050607
DATED 7-20-2010, EXPIRES 7-20-2020.
NO CLAIM IS MADE TO THE EXCLUSIVE RIGHT TO
USE "COMMON COLOR DESIGN SYSTEM", APART FROM
THE MARK AS SHOWN.

THE MARK CONSISTS OF THE STYLIZED LETTERS
"CCDS" WHERE THE SECOND "C" IN "CCDS" CONTAINS
A DESIGN THAT APPEARS AS MULTIPLE TRIANGLES
WITHIN A CIRCLE. THE WORDING "COMMON COLOR
DESIGN SYSTEM" APPEARS BELOW THE LETTERS "D" &
"S".

FOR COLOR ATLAS; SCRAPBOOKS; BOOKLETS IN
THE FIELD OF COLOR DESIGN SYSTEMS; CATALOGS
IN THE FIELD OF COLOR DESIGN SYSTEMS
SOFTWARE; PRINTED MATTER, NAMELY, HAND-
BOOKS OR MANUALS IN THE FIELD OF COLOR
DESIGN SYSTEMS; BOOKS IN THE FIELD OF COLOR
DESIGN SYSTEMS; PRINTED PUBLICATIONS,
NAMELY, BOOKS, HAND-OUTS, WORKBOOKS IN
THE FIELDS OF COLOR DESIGN SYSTEMS; PRINTED
PERIODICALS IN THE FIELD OF COLOR DESIGN
SYSTEMS; MODEL SPECIMEN FOR TEACHING, SPECI-
FICALLY, THREE MODELS FOR EDUCATIONAL PUR-
POSES (U.S. CLS. 2, 5, 22, 23, 29, 37, 38 AND 50).
CHERYL CLAYTON, EXAMINING ATTORNEY

SN 79-093,717. HAMELIN PAPERBRANDS LIMITED, SUP-
FOLK IP28 8WG, UNITED KINGDOM, FILED 1-26-2011.

BLACK N' RED

THE MARK CONSISTS OF STANDARD CHARACTERS
WITHOUT CLAIM TO ANY PARTICULAR FONT, STYLE,
SIZE, OR COLOR.

OWNER OF INTERNATIONAL REGISTRATION 1067504
DATED 1-26-2011, EXPIRES 1-26-2021.

FOR NOTE BOOKS; NOTE PADS (U.S. CLS. 2, 5, 22, 23,
29, 37, 38 AND 50).

AISHA SALEM, EXAMINING ATTORNEY

CLASS 16—(Continued).

SN 79-095,023. BORCH GMBH, 94051 HAUZENBERG, FED
REP GERMANY, FILED 8-31-2010.

Borch

THE MARK CONSISTS OF STANDARD CHARACTERS
WITHOUT CLAIM TO ANY PARTICULAR FONT, STYLE,
SIZE, OR COLOR.

PRIORITY DATE OF 6-23-2010 IS CLAIMED.
OWNER OF INTERNATIONAL REGISTRATION 1070881
DATED 8-31-2010, EXPIRES 8-31-2020.

SEC. 2(F).
FOR CARTOGRAPHIC PRODUCTS, NAMELY, ROAD
MAPS AND CITY MAPS (U.S. CLS. 2, 5, 22, 23, 29, 37, 38
AND 50).

DANIEL CAPSHAW, EXAMINING ATTORNEY

SN 85-007,813. THE AMEN CLINICS, INC., NEWPORT
BEACH, CA. FILED 4-6-2010.

CHANGE YOUR BRAIN CHANGE YOUR LIFE

THE MARK CONSISTS OF STANDARD CHARACTERS
WITHOUT CLAIM TO ANY PARTICULAR FONT, STYLE,
SIZE, OR COLOR.

FOR A SERIES OF PUBLICATIONS, NAMELY,
BOOKS, FLASH CARDS, AND WORKSHEETS IN THE
FIELD OF BRAIN FUNCTIONING AND OPTIMAL
IMPROVEMENT THROUGH THE USE OF SCIENTIFIC
AND MEDICAL RESEARCH (U.S. CLS. 2, 5, 22, 23, 29, 37,
38 AND 50).

MICHAEL WEBSTER, EXAMINING ATTORNEY

SN 85-015,434. ROJAS, IVAN, SANTA ANA, CA. FILED 4-16-
2010.

QUE PASO MAGAZINE

THE MARK CONSISTS OF STANDARD CHARACTERS
WITHOUT CLAIM TO ANY PARTICULAR FONT, STYLE,
SIZE, OR COLOR.

NO CLAIM IS MADE TO THE EXCLUSIVE RIGHT TO
USE "MAGAZINE", APART FROM THE MARK AS SHOWN.
THE ENGLISH TRANSLATION OF "QUE PASO" IN THE
MARK IS "WHAT HAPPENED".

FOR PAPER GOODS AND PRINTED MATERIAL,
NAMELY, PRINTED MATTER IN THE NATURE OF
MAGAZINES IN THE FIELDS OF ENTERTAINMENT
AND ADVERTISEMENT (U.S. CLS. 2, 5, 22, 23, 29, 37, 38
AND 50).

JANICE L. MCMORROW, EXAMINING ATTORNEY

CLASS 16—(Continued).

SN 85-015,443. ROJAS, IVAN, SANTA ANA, CA. FILED 4-16-2010.

QUE PASA MAGAZINE

THE MARK CONSISTS OF STANDARD CHARACTERS WITHOUT CLAIM TO ANY PARTICULAR FONT, STYLE, SIZE, OR COLOR.

NO CLAIM IS MADE TO THE EXCLUSIVE RIGHT TO USE "MAGAZINE", APART FROM THE MARK AS SHOWN. THE ENGLISH TRANSLATION OF "QUE PASA" IN THE MARK IS "WHAT IS HAPPENING".

FOR PAPER GOODS AND PRINTED MATERIAL, NAMELY, PRINTED MATTER IN THE NATURE OF MAGAZINES IN THE FIELDS OF ENTERTAINMENT AND ADVERTISEMENT (U.S. CLS. 2, 5, 22, 23, 29, 37, 38 AND 50).

JANICE L. MCMORROW, EXAMINING ATTORNEY

CLASS 16—(Continued).

SN 85-046,308. WOODGLEN PUBLISHING LLC, CALIFON, NJ. FILED 5-24-2010.

LITTLE VALLEY BOOKS

THE MARK CONSISTS OF STANDARD CHARACTERS WITHOUT CLAIM TO ANY PARTICULAR FONT, STYLE, SIZE, OR COLOR.

NO CLAIM IS MADE TO THE EXCLUSIVE RIGHT TO USE "BOOKS", APART FROM THE MARK AS SHOWN.

FOR PAPER GOODS AND PRINTED MATERIAL, NAMELY, CHILDREN'S BOOKS; PRINTED INSTRUCTIONAL AND TEACHING MATERIALS IN THE FIELDS OF CREATIVE WRITING, READING, AND MATH (U.S. CLS. 2, 5, 22, 23, 29, 37, 38 AND 50).

ALEX KEAM, EXAMINING ATTORNEY

SN 85-034,517. TOMBOW PENCIL CO., LTD., TOKYO, JAPAN, FILED 5-10-2010.

ERGO

THE MARK CONSISTS OF STANDARD CHARACTERS WITHOUT CLAIM TO ANY PARTICULAR FONT, STYLE, SIZE, OR COLOR.

FOR OFFICE, CRAFT AND STATIONERY SUPPLIES AND PRODUCTS, NAMELY, CORRECTING TAPE FOR TYPE, CORRECTING TAPE FOR TYPE DISPENSERS, ADHESIVE TAPE FOR STATIONERY OR HOUSEHOLD PURPOSES, AND ADHESIVE TAPE DISPENSERS (U.S. CLS. 2, 5, 22, 23, 29, 37, 38 AND 50).

TARA PATE, EXAMINING ATTORNEY

SN 85-049,902. KAT VON D, INC., WEST HOLLYWOOD, CA. FILED 5-27-2010.

KAT VON D

THE MARK CONSISTS OF STANDARD CHARACTERS WITHOUT CLAIM TO ANY PARTICULAR FONT, STYLE, SIZE, OR COLOR.

THE NAME(S), PORTRAIT(S), AND/OR SIGNATURE(S) SHOWN IN THE MARK IDENTIFIES "KAT VON D", WHOSE CONSENT(S) TO REGISTER IS MADE OF RECORD.

FOR (BASED ON INTENT TO USE) PAPER GOODS AND PRINTED MATTER, NAMELY, SERIES OF BOOKS IN THE FIELD OF TATTOOS; COMIC BOOKS AND MAGAZINES FEATURING COMIC STRIPS AND SCIENCE FICTION THEMES, STORIES AND CHARACTERS; COMIC BOOK REFERENCE GUIDE BOOKS; A SERIES OF FICTION BOOKS FEATURING STORIES ON COMIC STRIPS AND SCIENCE FICTION THEMES, STORIES AND CHARACTERS IN ILLUSTRATED FORMS; NOVELS FEATURING GRAPHICAL ILLUSTRATIONS; GRAPHIC NOVELS; NOVELS; PRINTED POSTCARDS; PICTURE POSTCARDS; COMIC POSTCARDS; POSTCARDS; TRADING CARDS AND PRINTED COLLECTORS' CARDS MADE PRIMARILY OF PAPER FEATURING COMIC BOOK, COMIC STRIP, CARTOON AND LIVE ACTION CHARACTERS; NOTEBOOKS; BINDERS; DECALS; PHOTOGRAPH AND SCRAPBOOK ALBUMS; GREETING CARDS; FOLDERS; DESK PADS; WRITING PADS; STATIONERY FOLDERS AND STATIONERY; PENS; PENCILS; ERASERS; VIDEO GAME STRATEGY MANUALS AND BOOKS; COMPUTER GAME INSTRUCTION MANUALS; PAPER TOWELS; PAPER STORAGE CONTAINERS; CHALK BOARDS FOR SCHOOL OR HOME USE; DRY ERASE WRITING BOARDS AND WRITING SURFACES; PAPER FLAGS; PAPER PENNANTS (BASED ON USE IN COMMERCE) POSTERS; CALENDARS; STICKERS, PHOTOGRAPHS (U.S. CLS. 2, 5, 22, 23, 29, 37, 38 AND 50).

FIRST USE 9-1-2005; IN COMMERCE 9-1-2005.

BARNEY CHARLON, EXAMINING ATTORNEY

SN 85-038,417. INTERPACK, INC., BERRYVILLE, AR. FILED 5-14-2010.

INTERSTAK

THE MARK CONSISTS OF STANDARD CHARACTERS WITHOUT CLAIM TO ANY PARTICULAR FONT, STYLE, SIZE, OR COLOR.

FOR PAPER GOODS, NAMELY, PAPER AND CARDBOARD; CORRUGATED PAPER PARTITIONS, CONTAINERS, BOXES, AND BOARDS (U.S. CLS. 2, 5, 22, 23, 29, 37, 38 AND 50).

ARETHA SOMERVILLE, EXAMINING ATTORNEY

CLASS 16—(Continued).

SN 85-063,907. WISSEL, PAUL M., SCOTTSDALE, AZ. FILED 6-16-2010.



NO CLAIM IS MADE TO THE EXCLUSIVE RIGHT TO USE "STANDARD OPERATING PROCEDURES", APART FROM THE MARK AS SHOWN.

THE COLOR(S) GREEN, BLACK, LIGHT GREY, DARK GREY, YELLOW, SKY BLUE, BLUE AND RED IS/ARE CLAIMED AS A FEATURE OF THE MARK.

THE MARK CONSISTS OF THE WORD "BIZSOPS"; WHEREIN "BIZ" IS WRITTEN IN GREEN COLOR WITH A BLACK SHADOW IN A SOUTHEAST POSITION AND THE LETTERS "S" AND "P" OF "SOPS" ARE FEATURED IN A BLACK AND THE LAST LETTER "S" IS IN GREEN COLOR. THE LETTER "O" IS REPRESENTED BY A COMPASS FACE FEATURING A DARK GREY OUTER RING WITH THE EXTERIOR TRACED IN BLACK AND A YELLOW INNER RING WITH FOUR DIAMOND SHAPED DIRECTIONAL POINTS PASSING THROUGH BOTH OF THESE TWO RINGS WITH THE LETTERS "N, W, S AND E" FEATURED IN A YELLOW AND BLACK LINES DIVIDE THE INNER YELLOW RING IN THE NORTHWEST, NORTHEAST, SOUTHWEST AND SOUTHEAST POSITIONS, THE INNER FACE FEATURES A CHECKERED SKY BLUE AND LIGHT GREY BACKGROUND WITH A WIDE RED AND GREY DIRECTIONAL NEEDLE POINTING NORTH WITH A BLACK RING AND A YELLOW PIN POSITIONED MIDWAY IN THE NEEDLE SEPARATING THE TWO COLORS OF RED AND GREY. ABOVE THE COMPASS IS AN ARCHING BLUE ROADWAY WITH A YELLOW DOTTED LINE BETWEEN THE NORTH AND EAST POINTS WITH THE WIDEST POINT OVER THE NORTH POINT. ABOVE THE ROADWAY AND COMPASS IS THE SLOGAN "GUIDING YOUR PEOPLE" IN A GREEN COLOR. OUTSIDE THE OUTER RING OF THE COMPASS THERE ARE FOUR RED SPIKES BEYOND THE DIRECTIONAL DIAMONDS OF N, W, S AND E EXTENDING INTO THE ROADWAY, THE LETTERS "S" AND "P" OF "SOPS" AND INTO THE UNDERLINING BANNER BELOW. THE UNDERLINING BANNER BELOW "BIZSOPS" IS BLACK WITH FOUR YELLOW RIVETS IN THE CORNERS AND EXTENDS THE FULL WIDTH OF THE WORD BIZSOPS. IN THIS BANNER ARE THE WORDS "STANDARD OPERATING PROCEDURES" IN A GREEN COLOR.

FOR PRINTED MATTER, NAMELY, JOURNALS FEATURING BUSINESS STANDARD OPERATING PROCEDURE INFORMATION; BUSINESS FORMS; PRINTED MATTER, NAMELY, BOOKS FEATURING BUSINESS STANDARD OPERATING PROCEDURES; PRINTED INSTRUCTIONAL AND TEACHING MATERIAL IN THE FIELD OF THE DEVELOPMENT OF STANDARD OPERATING PROCEDURES FOR BUSINESSES (U.S. CLS. 2, 5, 22, 23, 29, 37, 38 AND 50).

JENNIFER MARTIN, EXAMINING ATTORNEY

CLASS 16—(Continued).

SN 85-071,582. SIMON & SCHUSTER, INC., NEW YORK, NY. FILED 6-25-2010.

MISTER DOODLE

THE MARK CONSISTS OF STANDARD CHARACTERS WITHOUT CLAIM TO ANY PARTICULAR FONT, STYLE, SIZE, OR COLOR.

THE NAME(S), PORTRAIT(S), AND/OR SIGNATURE(S) SHOWN IN THE MARK DOES NOT IDENTIFY A PARTICULAR LIVING INDIVIDUAL.

FOR SERIES OF CHILDREN'S BOOKS (U.S. CLS. 2, 5, 22, 23, 29, 37, 38 AND 50).

MARK T. MULLEN, EXAMINING ATTORNEY

SN 85-092,905. HARD CANDY, LLC, HOLLYWOOD, FL. FILED 7-26-2010.



OWNER OF U.S. REG. NOS. 2,567,186, 3,695,602 AND OTHERS.

THE COLOR(S) BLACK, WHITE, PINK AND LIGHT PINK IS/ARE CLAIMED AS A FEATURE OF THE MARK.

THE MARK CONSISTS OF DESIGN OF A PINK HEART WITH LIGHT PINK SCROLLING, A WHITE BANNER OUTLINED IN BLACK, WRAPPING AROUND THE HEART, AND THE WORDING "HARD CANDY" IN BLACK ON THE BANNER.

FOR SCHOOL SUPPLY KITS CONTAINING VARIOUS COMBINATIONS OF SELECTED SCHOOL SUPPLIES, NAMELY, WRITING INSTRUMENTS, PENS, PENCILS, MECHANICAL PENCILS, ERASERS, MARKERS, CRAYONS, HIGHLIGHTERS, FOLDERS, NOTEBOOKS, PAPER, PROTRACTORS, PAPER CLIPS, PENCIL SHARPENERS, WRITING GRIPS, GLUE AND BOOK MARKS; PENS, PENCILS AND OTHER SCHOOL SUPPLIES, NAMELY, MECHANICAL PENCILS, ERASERS, MARKERS, CRAYONS, HIGHLIGHTERS, FOLDERS, NOTEBOOKS, PAPER, PROTRACTORS, PAPER CLIPS, PENCIL SHARPENERS, WRITING GRIPS, GLUE AND BOOK MARKS (U.S. CLS. 2, 5, 22, 23, 29, 37, 38 AND 50).

CARRIE GENOVESE, EXAMINING ATTORNEY

CLASS 16—(Continued).

SN 85-099,430. PAPERLIX NORTH AMERICA, INC., SANTA FE SPRINGS, CA. FILED 8-3-2010.

CATALINA

THE MARK CONSISTS OF STANDARD CHARACTERS WITHOUT CLAIM TO ANY PARTICULAR FONT, STYLE, SIZE, OR COLOR.

FOR RECYCLED CLAY-COATED AND NON-CLAY-COATED PAPERBOARDS FOR USE IN CARTONS AND INDUSTRIAL PACKAGING (U.S. CLS. 2, 5, 22, 23, 29, 37, 38 AND 50).

THEODORE MCBRIDE, EXAMINING ATTORNEY

CLASS 16—(Continued).

SN 85-100,596. SHABAZZ, VENUS, BROOKLYN, NY. FILED 8-5-2010.

BRINGING OUT NEW DESIGNERS

THE MARK CONSISTS OF STANDARD CHARACTERS WITHOUT CLAIM TO ANY PARTICULAR FONT, STYLE, SIZE, OR COLOR.

FOR PAPER GOODS AND PRINTED MATERIAL, NAMELY, PERIODICAL MAGAZINES FOR CONSUMERS OF ALL AGES IN THE FIELD OF FASHION (U.S. CLS. 2, 5, 22, 23, 29, 37, 38 AND 50).

NAAKWAMA ANKRAH, EXAMINING ATTORNEY

SN 85-100,361. LUBURICH, MONICA M., CHICAGO, IL. FILED 8-4-2010.

FINE PAPERS FOR THE WELL-HEELED

THE MARK CONSISTS OF STANDARD CHARACTERS WITHOUT CLAIM TO ANY PARTICULAR FONT, STYLE, SIZE, OR COLOR.

FOR PAPER PRODUCTS, NAMELY, GREETING CARDS, NOTE CARDS, ENVELOPES AND BOXES OF PAPER OR CARDBOARD PAPER (U.S. CLS. 2, 5, 22, 23, 29, 37, 38 AND 50).

FIRST USE 7-10-2009; IN COMMERCE 7-10-2009.

WILLIAM P. SHANAHAN, EXAMINING ATTORNEY

SN 85-102,908. ADVANTUS CORP., JACKSONVILLE, FL. FILED 8-9-2010.

Projections

THE MARK CONSISTS OF STANDARD CHARACTERS WITHOUT CLAIM TO ANY PARTICULAR FONT, STYLE, SIZE, OR COLOR.

FOR FILE FOLDERS; FILE POCKETS; FILE SORTERS; LETTER FILES; AND PAPER EXPANDING FILES (U.S. CLS. 2, 5, 22, 23, 29, 37, 38 AND 50).

FIRST USE 7-14-2010; IN COMMERCE 7-27-2010.

CHRIS WELLS, EXAMINING ATTORNEY

SN 85-100,373. LUBURICH, MONICA M., CHICAGO, IL. FILED 8-4-2010.

PERGIE

THE MARK CONSISTS OF STANDARD CHARACTERS WITHOUT CLAIM TO ANY PARTICULAR FONT, STYLE, SIZE, OR COLOR.

FOR PAPER PRODUCTS, NAMELY, GREETING CARDS, NOTE CARDS, ENVELOPES AND BOXES OF PAPER OR CARDBOARD PAPER (U.S. CLS. 2, 5, 22, 23, 29, 37, 38 AND 50).

WILLIAM P. SHANAHAN, EXAMINING ATTORNEY

SN 85-103,299. WOODARD, TRACY, DBA BODY COUNT NOVELS, CHICAGO, IL. AND TYSON, ROBERT, DBA BODY COUNT NOVELS, CHICAGO, IL. FILED 8-9-2010.

Pump Mistress

THE MARK CONSISTS OF STANDARD CHARACTERS WITHOUT CLAIM TO ANY PARTICULAR FONT, STYLE, SIZE, OR COLOR.

FOR SERIES OF FICTION WORKS, NAMELY, NOVELS AND BOOKS (U.S. CLS. 2, 5, 22, 23, 29, 37, 38 AND 50).

FIRST USE 7-19-2010; IN COMMERCE 7-19-2010.

FONG HSU, EXAMINING ATTORNEY

CLASS 16—(Continued).

SN 85-104,605. SUPER7 MEDIA, INC., SAN FRANCISCO, CA.
FILED 8-10-2010.

SUPER7

THE MARK CONSISTS OF STANDARD CHARACTERS WITHOUT CLAIM TO ANY PARTICULAR FONT, STYLE, SIZE, OR COLOR.

OWNER OF U.S. REG. NO. 3,079,331.
FOR PRINTED MATERIALS, NAMELY, BOOKS, COFFEE TABLE BOOKS, AND MAGAZINES ABOUT TOYS, ARTS, AND HANDICRAFTS; TRAVEL GUIDES; AND NOTEBOOKS (U.S. CLS. 2, 5, 22, 23, 29, 37, 38 AND 50).
FIRST USE 2-1-2007; IN COMMERCE 2-1-2007.
HOWARD B. LEVINE, EXAMINING ATTORNEY

SN 85-106,718. BATMEDIA PUBLISHING AND PRINTING CORP., SOUTH MIAMI, FL. FILED 8-13-2010.

SUNSET DRIVE MAGAZINE

THE MARK CONSISTS OF STANDARD CHARACTERS WITHOUT CLAIM TO ANY PARTICULAR FONT, STYLE, SIZE, OR COLOR.

NO CLAIM IS MADE TO THE EXCLUSIVE RIGHT TO USE "MAGAZINE", APART FROM THE MARK AS SHOWN.
FOR PAPER GOODS AND PRINTED MATERIAL, NAMELY, LIFE STYLE MAGAZINES (U.S. CLS. 2, 5, 22, 23, 29, 37, 38 AND 50).
LESLEY LAMOTHE, EXAMINING ATTORNEY

SN 85-106,939. SECURUS TECHNOLOGIES, INC., DALLAS, TX. FILED 8-13-2010.

THE MAGIC BOARD

THE MARK CONSISTS OF STANDARD CHARACTERS WITHOUT CLAIM TO ANY PARTICULAR FONT, STYLE, SIZE, OR COLOR.

NO CLAIM IS MADE TO THE EXCLUSIVE RIGHT TO USE "BOARD", APART FROM THE MARK AS SHOWN.
FOR MOUNTED POSTERS; POSTER BOARD; POSTERS; POSTERS MADE OF PAPER; PRINTED ADVERTISING BOARDS OF PAPER OR CARDBOARD; PRINTED CHARTS; PRINTED PAPER SIGNS; PRINTED VISUALS IN THE NATURE OF ACCOUNT SPECIFIC DATA, INFORMATION GRAPHICS AND PROMOTIONAL MATERIALS FOR USE IN ADVERTISING, MARKETING AND SALES (U.S. CLS. 2, 5, 22, 23, 29, 37, 38 AND 50).
CAROLYN CATALDO, EXAMINING ATTORNEY

CLASS 16—(Continued).

SN 85-110,931. INTELPROPLIST LLC, MACEDON, NY.
FILED 8-19-2010.

Flexible-Day

THE MARK CONSISTS OF STANDARD CHARACTERS WITHOUT CLAIM TO ANY PARTICULAR FONT, STYLE, SIZE, OR COLOR.

FOR DRY-ERASE WHITEBOARD CHARTMAKING SETS COMPRISED OF DRY-ERASE WHITEBOARDS, AND ITEMS USED THEREON, NAMELY, ADHESIVE TAPES, DRY-ERASE WRITE ON MAGNETIC STRIPS, DRY-ERASE PENS, ERASERS AND BOARD WIPES, PRESS -ON LETTER AND NUMBER SETS DESIGNED FOR USE ON DRY-ERASE WHITEBOARDS, MAGNETIC LETTER, NUMBER AND SYMBOL SETS DESIGNED FOR USE ON WHITEBOARDS AND CARD HOLDERS AND CARD INSERTS SPECIFICALLY DESIGNED FOR ATTACHING TO DRY ERASE WHITEBOARDS (U.S. CLS. 2, 5, 22, 23, 29, 37, 38 AND 50).

FIRST USE 12-23-2005; IN COMMERCE 12-29-2005.
COLLEEN KEARNEY, EXAMINING ATTORNEY

SN 85-118,371. INTELPROPLIST LLC, MACEDON, NY.
FILED 8-30-2010.

GiantQuarter

THE MARK CONSISTS OF STANDARD CHARACTERS WITHOUT CLAIM TO ANY PARTICULAR FONT, STYLE, SIZE, OR COLOR.

FOR DRY-ERASE WHITEBOARD CHARTMAKING SETS COMPRISED OF DRY-ERASE WHITEBOARDS, AND ITEMS USED THEREON, NAMELY, ADHESIVE TAPES, DRY-ERASE WRITE ON MAGNETIC STRIPS, DRY-ERASE PENS, ERASERS AND BOARD WIPES, PRESS -ON LETTER AND NUMBER SETS DESIGNED FOR USE ON DRY-ERASE WHITEBOARDS, MAGNETIC LETTER, NUMBER AND SYMBOL SETS DESIGNED FOR USE ON WHITEBOARDS AND CARD HOLDERS AND CARD INSERTS SPECIFICALLY DESIGNED FOR ATTACHING TO DRY ERASE WHITEBOARDS (U.S. CLS. 2, 5, 22, 23, 29, 37, 38 AND 50).

FIRST USE 3-1-2007; IN COMMERCE 4-17-2007.
COLLEEN KEARNEY, EXAMINING ATTORNEY

CLASS 16—(Continued).

SN 85-123,886. PATERSON, STUART WILLIAM, WELLSFORD, NEW ZEALAND, FILED 9-7-2010.



PRIORITY CLAIMED UNDER SEC. 44(D) ON NEW ZEALAND APPLICATION NO. 821100, FILED 3-17-2010, REG. NO. 821100, DATED 9-23-2010, EXPIRES 3-17-2020.

NO CLAIM IS MADE TO THE EXCLUSIVE RIGHT TO USE "HERD HEALTH MANAGEMENT SYSTEMS", APART FROM THE MARK AS SHOWN.

FOR ADHESIVE PATCHES TO BE PRINTED WITH AN INDIVIDUAL ANIMAL'S MEDICAL AND PERSONAL INFORMATION (U.S. CLS. 2, 5, 22, 23, 29, 37, 38 AND 50). SIMON TENG, EXAMINING ATTORNEY

CLASS 16—(Continued).

SN 85-124,993. PAPETERIES DE CLAIREFONTAINE, ETI-VAL CLAIREFONTAINE, FRANCE, FILED 9-8-2010.



PRIORITY CLAIMED UNDER SEC. 44(D) ON ERPN CMNTY TM OFC APPLICATION NO. 008977274, FILED 3-9-2010, REG. NO. 008977274, DATED 10-12-2010, EXPIRES 3-9-2020.

OWNER OF U.S. REG. NO. 3,228,065.

THE COLOR(S) BLUE AND WHITE IS/ARE CLAIMED AS A FEATURE OF THE MARK.

THE MARK CONSISTS OF A RECTANGLE WITH VARYING SHADES OF BLUE; THE TERM "CLAIREFONTAINE", IN WHITE LETTERING, IN THE LOWER RIGHT CORNER AND A DESIGN WITHIN A TRIANGLE APPEARING ABOVE THE TERM CLAIREFONTAINE. THE DESIGN WITHIN A TRIANGLE CONSISTS OF BLUE BACKGROUND AND WHITE SWIRLS MAKING AN ABSTRACT DESIGN OF A WOMAN AND A MOON IN WHITE.

FOR UNPROCESSED, SEMI-PROCESSED PAPER AND CARDBOARD FOR STATIONERY AND PRINTING PURPOSES; EXERCISE BOOKS, WRITING PADS, WRITING AND DRAWING BOOKS, COLORING BOOKS, PRINTING BLOCKS, NOTE BOOKS, DAILY PLANNERS; ENVELOPES, DOCUMENT PORTFOLIOS, DRAWING CARDS, GREETING CARDS, INVITATION CARDS, PLAIN POSTCARDS, VISITING CARDS, MAPS; BOOK-BINDING MATERIAL, FOLDERS FOR FILES, INNER FOLDERS, FLAP FOLDERS, PAPER EXPANDING FILES, FILE SEPARATORS, SQUARE CUT FOLDERS; PHOTOGRAPHS; PHOTOGRAPH ALBUMS; STATIONARY; STATIONERY ARTICLES FOR CREATIVE LEISURE PURPOSES, NAMELY, STICKERS, WRITING PAPER, GIFT WRAPPING PAPER, ORIGAMI PAPER, CREPE PAPER, TISSUE PAPER, CRAFT PAPER, GLASS PAPER, PRINTED PAPER, GREASEPROOF PAPER, RECYCLED PAPER, GRAPH PAPER, CORRUGATED CARDBOARD, DECORATIVE PHOTO CORNERS, DECORATIVE BORDERS FOR SCRAP BOOKING, POSTER, PAPER BAGS, BOXES OF PAPER AND CARDBOARD, PAPER RIBBON; ADHESIVES FOR STATIONERY OR HOUSEHOLD PURPOSES; NON-TEXTILE PAPER LABELS, ADHESIVE LABELS; ARTISTS' MATERIALS, NAMELY, BOOKS FOR SINGING AND FOR MUSIC, FINE ART PADS, SPIRAL DRAWING PADS, SKETCH PADS, CARDBOARDS, ART FOLDERS; WIREBOUND PADS; PAINTBRUSHES; TYPEWRITERS AND OFFICE

CLASS 16—(Continued).

REQUISITES EXCEPT FURNITURE, NAMELY, RUBBER ERASERS AND PEN CASES, ADHESIVE TAPE DISPENSERS, PAPER EMBOSSERS, PUNCHES, STAPLERS, STAPLE REMOVERS, UNGRADUATED RULERS, PAPER CLIPS, RUBBER BANDS, DIGITAL COLOR COPY PAPER; PRINTED INSTRUCTIONAL AND TEACHING MATERIALS, EXCLUDING APPARATUS, IN THE FIELD OF SCHOOL REPORTS, BLANK CLASS JOURNALS, SCHOOL DATE BOOKS; PRINTING TYPE; PRINTING BLOCKS; STATIONERY CLASSIFICATION ARTICLES, NAMELY, LOOSE-LEAF FILE FOLDERS, CARDBOARD CLASSIFICATION BOXES, CARRYING CASES MADE OF CARDBOARD, ELASTICATED FILING BOX FOR STORAGE OF BUSINESS AND PERSONAL RECORDS, ORGANIZER FILE FOLDERS, ELASTIC FOLDERS, ELASTIC PAPER EXPANDING FOLDERS, BINDERS, LEVER ARCH FILES, RING BINDER; STATIONERY ARTICLES FOR GRAPHIC ARTS AND ENGINEERING DRAWING, NAMELY, DRAWING PAPER, SKETCH BOOK, TRACING PAPER, CARBON PAPER (U.S. CLS. 2, 5, 22, 23, 29, 37, 38 AND 50).

HEATHER BIDDULPH, EXAMINING ATTORNEY

CLASS 16—(Continued).

SN 85-147,246. NURTURE, INC., NEW YORK, NY. FILED 10-7-2010.

HAPPYMAMA

THE MARK CONSISTS OF STANDARD CHARACTERS WITHOUT CLAIM TO ANY PARTICULAR FONT, STYLE, SIZE, OR COLOR.

FOR PREGNANCY BELLY CAST KITS, NAMELY, PLASTER IN THE NATURE OF ARTIST MATERIALS (U.S. CLS. 2, 5, 22, 23, 29, 37, 38 AND 50).

CHRISTINA SOBRAL, EXAMINING ATTORNEY

SN 85-129,227. BREAKFAST HOLDINGS, INC., NEW YORK, NY. FILED 9-14-2010.

FOODY FACE

THE MARK CONSISTS OF STANDARD CHARACTERS WITHOUT CLAIM TO ANY PARTICULAR FONT, STYLE, SIZE, OR COLOR.

NO CLAIM IS MADE TO THE EXCLUSIVE RIGHT TO USE "FOODY", APART FROM THE MARK AS SHOWN.

FOR A SERIES OF BOOKS ABOUT FOOD PREPARATION, FOOD PRESENTATION, AND RECIPES; GREETING CARDS (U.S. CLS. 2, 5, 22, 23, 29, 37, 38 AND 50).

LAURA HAMMEL, EXAMINING ATTORNEY

SN 85-153,345. PARMIGIANI FLEURIER SA, 2114 FLEURIER, SWITZERLAND, FILED 10-15-2010.

PARMIGIANI

SN 85-133,357. THE ZONDERVAN CORPORATION L.L.C., GRAND RAPIDS, MI. FILED 9-20-2010.

THE PRINCESS PARABLES

THE MARK CONSISTS OF STANDARD CHARACTERS WITHOUT CLAIM TO ANY PARTICULAR FONT, STYLE, SIZE, OR COLOR.

OWNER OF U.S. REG. NO. 2,428,228.

THE ENGLISH TRANSLATION OF "PARMIGIANI" IN THE MARK IS NATIVE OR INHABITANTS OF PARMA.

FOR WRITING INSTRUMENTS, PEN NIBS, PENS, PENCILS, BALLPOINT PENS, FOUNTAIN PENS, PAPERWEIGHTS, PAPER KNIVES, WRITING PADS, PEN CASES, MONEY CLIPS (U.S. CLS. 2, 5, 22, 23, 29, 37, 38 AND 50).

MARK PILARO, EXAMINING ATTORNEY

THE MARK CONSISTS OF STANDARD CHARACTERS WITHOUT CLAIM TO ANY PARTICULAR FONT, STYLE, SIZE, OR COLOR.

NO CLAIM IS MADE TO THE EXCLUSIVE RIGHT TO USE "PARABLES", APART FROM THE MARK AS SHOWN.

FOR A SERIES OF BOOKS FOR CHILDREN; BIBLES; BIBLE COVERS (U.S. CLS. 2, 5, 22, 23, 29, 37, 38 AND 50).

MELISSA VALLILLO, EXAMINING ATTORNEY

CLASS 16—(Continued).

SN 85-165,816. HAHNEMÜHLE FINEART GMBH, DASSEL, FED REP GERMANY, AND HARMAN TECHNOLOGY LTD, CHESHIRE WA16 7JL, UNITED KINGDOM, FILED 11-1-2010.



PRIORITY CLAIMED UNDER SEC. 44(D) ON FED REP GERMANY APPLICATION NO. 302010030060, FILED 5-21-2010, REG. NO. 302010030060, DATED 8-11-2010, EXPIRES 5-31-2020.

NO CLAIM IS MADE TO THE EXCLUSIVE RIGHT TO USE "PROFESSIONAL INKJET", APART FROM THE MARK AS SHOWN.

THE COLOR(S) WHITE, RED AND BLACK IS/ARE CLAIMED AS A FEATURE OF THE MARK.

THE MARK CONSISTS OF THE WORD "HARMAN", IN WHITE, THE WORD "PROFESSIONAL", IN RED, THE WORD "INKJET", OUTLINED IN RED, AND THE WORDS "BY HAHNEMUHLE", IN WHITE, ALL APPEARING ON A BLACK BACKGROUND.

THE ENGLISH TRANSLATION OF "HAHNEMÜHLE" IN THE MARK IS ROOSTER MILL.

FOR PAPER AND CARDBOARD, IN PARTICULAR DECKLE-EDGED PAPERS, DRAWING PAPERS, WRITING PAPERS, PRINTING PAPERS, DOCUMENT PAPERS, COLOURED PAPERS, FILTER PAPERS, INGRES PAPERS, PAPERS FOR PERSONAL STATIONERY, TICKET PAPERS, CARDBOARD CORRESPONDING TO THE AFORESAID PAPERS, AND SPECIAL PAPERS AND SPECIAL CARDBOARD, INCLUDING FOR ARTISTS AND MUSEUMS, CARDS AND ENVELOPES (U.S. CLS. 2, 5, 22, 23, 29, 37, 38 AND 50).

EVELYN BRADLEY, EXAMINING ATTORNEY

SN 85-171,313. HART SUPPLY COMPANY, INC., HINGHAM, MA. FILED 11-8-2010.

ROYALCOAT

THE MARK CONSISTS OF STANDARD CHARACTERS WITHOUT CLAIM TO ANY PARTICULAR FONT, STYLE, SIZE, OR COLOR.

FOR PRINTABLE MATERIAL, NAMELY, ROLL MEDIA, BANNERS, OVER LAMINATE, SIGNS, AND TRANSPARENT AND TRANSLUCENT FILM FOR USE WITH SOLVENT AND AQUEOUS PRINTING EQUIPMENT, FOR USE IN THE WIDE FORMAT DIGITAL PRINTING INDUSTRY (U.S. CLS. 2, 5, 22, 23, 29, 37, 38 AND 50).

STEVEN JACKSON, EXAMINING ATTORNEY

CLASS 16—(Continued).

SN 85-172,222. LEWIS, LORNA ALICIA, BATON ROUGE, LA. FILED 11-9-2010.

Take Along Teacher

THE MARK CONSISTS OF STANDARD CHARACTERS WITHOUT CLAIM TO ANY PARTICULAR FONT, STYLE, SIZE, OR COLOR.

FOR EDUCATIONAL KITS SOLD AS A UNIT IN THE FIELD OF READING, MATH, SCIENCE, SOCIAL STUDIES, STUDY SKILLS CONSISTING PRIMARILY OF EDUCATIONAL BOOKS, FLASH CARDS AND WORKSHEETS, AND ALSO INCLUDING AN EDUCATIONAL DVD (U.S. CLS. 2, 5, 22, 23, 29, 37, 38 AND 50).

GENE MACIOL, EXAMINING ATTORNEY

SN 85-175,302. PLANIT PRODUCTS LIMITED, TA TOAST-ABAGS, MALVERN, UNITED KINGDOM, FILED 11-12-2010.

toastabags

THE MARK CONSISTS OF STANDARD CHARACTERS WITHOUT CLAIM TO ANY PARTICULAR FONT, STYLE, SIZE, OR COLOR.

OWNER OF U.S. REG. NO. 3,378,460.

FOR APPARATUS FOR STEAMING AND COOKING, NAMELY, NON-STICK PLASTIC BAGS AND FLEXIBLE PAPER CONTAINERS FOR COOKING IN A TOASTER, OVEN OR MICROWAVE OVEN (U.S. CLS. 2, 5, 22, 23, 29, 37, 38 AND 50).

FIRST USE 1-1-2005; IN COMMERCE 1-6-2010.

MICHELLE DUBOIS, EXAMINING ATTORNEY

SN 85-185,776. TRALY (U.S.A.) INC., BOCA RATON, FL. FILED 11-28-2010.

FROMBIES

THE MARK CONSISTS OF STANDARD CHARACTERS WITHOUT CLAIM TO ANY PARTICULAR FONT, STYLE, SIZE, OR COLOR.

FOR ART PRINTS, PRINTED MATERIALS, NAMELY, POSTERS, COMIC BOOKS (U.S. CLS. 2, 5, 22, 23, 29, 37, 38 AND 50).

KRISTINA MORRIS, EXAMINING ATTORNEY

CLASS 16—(Continued).

SN 85-185,782. TRALY (U.S.A.) INC., BOCA RATON, FL. FILED 11-28-2010.

FROMBIE

THE MARK CONSISTS OF STANDARD CHARACTERS WITHOUT CLAIM TO ANY PARTICULAR FONT, STYLE, SIZE, OR COLOR.

FOR ART PRINTS, PRINTED MATERIALS, NAMELY, POSTERS, COMIC BOOKS (U.S. CLS. 2, 5, 22, 23, 29, 37, 38 AND 50).

KRISTINA MORRIS, EXAMINING ATTORNEY

SN 85-187,281. BOOMERATION GREETINGS LLC., COLLINGSWOOD, NJ. FILED 11-30-2010.



NO CLAIM IS MADE TO THE EXCLUSIVE RIGHT TO USE "GREETINGS" OR "GREETING CARDS", APART FROM THE MARK AS SHOWN.

FOR CARDS, NAMELY, GREETING CARDS, NOTE CARDS, AND BUSINESS CARDS (U.S. CLS. 2, 5, 22, 23, 29, 37, 38 AND 50).

MARK RADEMACHER, EXAMINING ATTORNEY

SN 85-187,792. GUERCIO, JAMES W., BOULDER, CO. FILED 11-30-2010.

CARIBOU RANCH THE ART & CULTURE OF THE AMERICAN WEST

THE MARK CONSISTS OF STANDARD CHARACTERS WITHOUT CLAIM TO ANY PARTICULAR FONT, STYLE, SIZE, OR COLOR.

NO CLAIM IS MADE TO THE EXCLUSIVE RIGHT TO USE "THE ART & CULTURE OF THE AMERICAN WEST", APART FROM THE MARK AS SHOWN.

FOR PRINTED PERIODICALS IN THE FIELD OF AMERICAN ART, HISTORY, CULTURE AND TOPICS OF GENERAL INTEREST; MAGAZINES FEATURING ART, CULTURE, AND TOPICS OF GENERAL INTEREST; LITHOGRAPHIC WORKS OF ART; POSTERS; CALENDARS; BOOKMARKS; WRITING INSTRUMENTS (U.S. CLS. 2, 5, 22, 23, 29, 37, 38 AND 50).

MARK T. MULLEN, EXAMINING ATTORNEY

CLASS 16—(Continued).

SN 85-192,544. RECOGNITION WORKS LLC, KIRKLAND, WA. FILED 12-7-2010.

RECOGNIZE THE MOMENT

THE MARK CONSISTS OF STANDARD CHARACTERS WITHOUT CLAIM TO ANY PARTICULAR FONT, STYLE, SIZE, OR COLOR.

FOR PACKAGED KIT COMPRISED PRIMARILY OF PRINTED CARDS AND POSTERS FEATURING QUOTATIONS, PRINTED CERTIFICATES, PRINTED FLYERS, PRINTED CARDS, PRINTED QUESTIONNAIRES AND PRINTED BROCHURES ALL FEATURING INFORMATION AND ADVICE REGARDING EMPLOYEE RECOGNITION AND ADHESIVE NOTE PADS, PENS, AND FLASHLIGHTS, BUSINESS CARD CASES, INSCRIBED NATURAL STONES, CHOCOLATES AND SUGAR COATED ALMONDS ALL SOLD IN THE SAME PACKAGE THEREWITH; BOXES OF CARDBOARD OR PAPER; PRINTED CARDS AND POSTERS FEATURING QUOTATIONS; PRINTED CERTIFICATES; PRINTED FLYERS, PRINTED CARDS, PRINTED QUESTIONNAIRES AND PRINTED BROCHURES ALL THE FOREGOING FEATURING INFORMATION AND ADVICE REGARDING EMPLOYEE RECOGNITION; ADHESIVE NOTE PADS; PENS (U.S. CLS. 2, 5, 22, 23, 29, 37, 38 AND 50).

BERYL GARDNER, EXAMINING ATTORNEY

SN 85-192,586. RECOGNITION WORKS LLC, KIRKLAND, WA. FILED 12-7-2010.



THE MARK CONSISTS OF "RW" STYLIZED FEATURING A SPEECH BUBBLE CONTAINING A STAR.

FOR PACKAGED KIT COMPRISED PRIMARILY OF PRINTED CARDS AND POSTERS FEATURING QUOTATIONS, PRINTED CERTIFICATES, PRINTED FLYERS, PRINTED CARDS, PRINTED QUESTIONNAIRES AND PRINTED BROCHURES ALL FEATURING INFORMATION AND ADVICE REGARDING EMPLOYEE RECOGNITION AND ADHESIVE NOTE PADS, PENS, AND FLASHLIGHTS, BUSINESS CARD CASES, INSCRIBED NATURAL STONES, CHOCOLATES AND SUGAR COATED ALMONDS ALL SOLD IN THE SAME PACKAGE THEREWITH; BOXES OF CARDBOARD OR PAPER; PRINTED CARDS AND POSTERS FEATURING QUOTATIONS; PRINTED CERTIFICATES; PRINTED FLYERS, PRINTED CARDS, PRINTED QUESTIONNAIRES AND PRINTED BROCHURES ALL THE FOREGOING FEATURING INFORMATION AND ADVICE REGARDING EMPLOYEE RECOGNITION; ADHESIVE NOTE PADS; PENS (U.S. CLS. 2, 5, 22, 23, 29, 37, 38 AND 50).

BERYL GARDNER, EXAMINING ATTORNEY

CLASS 16—(Continued).

SN 85-196,425. LIZARA FREEZONE N.V., ORANJESTAD, ARUBA, FILED 12-13-2010.

CLASS 16—(Continued).

SN 85-199,664. WILLOW HOLDINGS, INC., NEW BERN, NC, FILED 12-16-2010.



THE MARK CONSISTS OF THE LETTERS "NB" IN ON A SQUARE BACKGROUND WITH A HOOKMARK IN THE UPPER LEFT CORNER, FOLLOWED BY THE LETTERS "FRAME".

FOR CANVAS PANELS FOR ARTISTS (U.S. CLS. 2, 5, 22, 23, 29, 37, 38 AND 50).
MAYUR VAGHANI, EXAMINING ATTORNEY

TRUTH IN LITERATURE

SN 85-199,360. DAVID-GAINES, WENDY, MERRICK, NY, FILED 12-16-2010.

POCS

THE MARK CONSISTS OF STANDARD CHARACTERS WITHOUT CLAIM TO ANY PARTICULAR FONT, STYLE, SIZE, OR COLOR.

FOR PRINTED PUBLICATIONS, NAMELY, BROCHURES, BOOKLETS, TEACHING MATERIALS, WORKBOOKS, AND BOOKS IN THE FIELD OF PROVIDING ADVICE TO PARENTS OF COLLEGE STUDENTS; PRINTED MATTER, NAMELY, BOOKS, NEWSLETTERS, INFORMATIONAL PRESENTATION FOLDERS IN THE FIELD OF PROVIDING ADVICE TO PARENTS OF COLLEGE STUDENTS; PRINTED PUBLICATIONS, NAMELY, HAND-OUTS AND PRESENTATION FOLDERS IN THE FIELD OF PROVIDING ADVICE TO PARENTS OF COLLEGE STUDENTS; PRINTED LECTURES (U.S. CLS. 2, 5, 22, 23, 29, 37, 38 AND 50).

FIRST USE 9-17-2010; IN COMMERCE 11-6-2010.
JAY BESCH, EXAMINING ATTORNEY

THE MARK CONSISTS OF STANDARD CHARACTERS WITHOUT CLAIM TO ANY PARTICULAR FONT, STYLE, SIZE, OR COLOR.

NO CLAIM IS MADE TO THE EXCLUSIVE RIGHT TO USE "LITERATURE", APART FROM THE MARK AS SHOWN.

FOR PRINTED MATTER, NAMELY, INSTRUCTIONAL, EDUCATIONAL AND TEACHING MATERIAL IN THE FIELD OF MIDDLE SCHOOL, HIGH SCHOOL AND UNIVERSITY-LEVEL COURSE INSTRUCTION IN THE FIELD OF LITERATURE; BOOKS, BROCHURES AND PAMPHLETS IN THE FIELD OF LITERATURE; STUDY GUIDES IN THE FIELD OF LITERATURE, INCLUDING STUDENT EDITIONS FEATURING BASIC TEXT, PLOT ANALYSIS, CHARACTER LISTS, ANALYSIS OF MAJOR CHARACTERS, CHAPTER SUMMARIES AND ANALYSIS, STUDY QUESTIONS AND ESSAY TOPICS; TEACHER EDITIONS FEATURING ASSIGNMENTS AND ACTIVITIES, READING QUIZZES, ESSAY AND DISCUSSION QUESTIONS (U.S. CLS. 2, 5, 22, 23, 29, 37, 38 AND 50).

BRIAN NEVILLE, EXAMINING ATTORNEY

CLASS 16—(Continued).

SN 85-205,451. HIPPOCRATES UNIVERSITY, LAS VEGAS, NV. AND HRABAL, ANTONIN, LAS VEGAS, NV. FILED 12-23-2010.

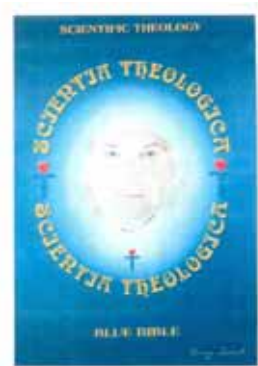

NO CLAIM IS MADE TO THE EXCLUSIVE RIGHT TO USE "SCIENTIFIC THEOLOGY", "SCIENTIA THEOLOGICA" OR "BLUE BIBLE", APART FROM THE MARK AS SHOWN.

THE NAME(S), PORTRAIT(S), AND/OR SIGNATURE(S) SHOWN IN THE MARK DOES NOT IDENTIFY A PARTICULAR LIVING INDIVIDUAL.

THE COLOR(S) BLUE, YELLOW, RED AND WHITE IS/ARE CLAIMED AS A FEATURE OF THE MARK.

THE MARK CONSISTS OF THE WORDING "SCIENTIFIC THEOLOGY", "SCIENTIA THEOLOGICA" AND "BLUE BIBLE" IN YELLOW WITH A MAN'S FACE APPEARING IN WHITE WITH BLUE EYES IN THE CENTER OF "SCIENTIA THEOLOGICA". THREE BLUE CROSSES WITH A RED HEART APPEAR ON EACH SIDE AND BENEATH THE MAN'S FACE. THE NAME "TONY SAINT" APPEARS IN THE LOWER RIGHT CORNER IN WHITE. THE BACKGROUND IS BLUE.

THE ENGLISH TRANSLATION OF "SCIENTIA THEOLOGICA" IN THE MARK IS "SCIENTIFIC THEOLOGY".

FOR RELIGIOUS BOOKS (U.S. CLS. 2, 5, 22, 23, 29, 37, 38 AND 50).

FIRST USE 12-10-2002; IN COMMERCE 12-10-2002.

TAMARA FRAZIER, EXAMINING ATTORNEY

CLASS 16—(Continued).

SN 85-210,765. DAVID-GAINES, WENDY, MERRICK, NY. FILED 1-5-2011.



THE MARK CONSISTS OF THE STYLIZED DEPICTION OF TWO HUMAN FORMS FORMED BY GEOMETRIC SHAPES, WHERE THE TALLER FORM IS BEHIND THE SHORTER FORM. THE TALLER FORM IS COMPRISED OF AN OUTLINE OF A CIRCLE FOR A HEAD, AN OUTLINE OF A TRIANGLE FOR A BODY AND TWO OUTLINES OF NARROW TRIANGLES FOR ARMS CONNECTED TO THE ARMS OF THE SMALLER FORM. THE SHORTER FORM IS COMPRISED OF A TRIANGULAR BODY, TRIANGULAR ARMS, A CIRCULAR HEAD AND A GRADUATION CAP.

FOR PRINTED PUBLICATIONS, NAMELY, BROCHURES, BOOKLETS, TEACHING MATERIALS, WORKBOOKS, AND BOOKS IN THE FIELD OF PROVIDING ADVICE TO PARENTS OF COLLEGE STUDENTS; PRINTED MATTER, NAMELY, BOOKS, NEWSLETTERS, INFORMATIONAL PRESENTATION FOLDERS IN THE FIELD OF PROVIDING ADVICE TO PARENTS OF COLLEGE STUDENTS; PRINTED PUBLICATIONS, NAMELY, HAND-OUTS AND PRESENTATION FOLDERS IN THE FIELD OF PROVIDING ADVICE TO PARENTS OF COLLEGE STUDENTS; PRINTED LECTURES (U.S. CLS. 2, 5, 22, 23, 29, 37, 38 AND 50).

FIRST USE 9-17-2010; IN COMMERCE 11-6-2010.

JAY BESCH, EXAMINING ATTORNEY

CLASS 16—(Continued).

SN 85-218,158. OWN LLC, LOS ANGELES, CA. FILED 1-14-2011.



THE COLOR(S) ORANGE, YELLOW, GREEN, LIGHT GREEN, PURPLE AND LIGHT PURPLE IS/ARE CLAIMED AS A FEATURE OF THE MARK.

THE MARK CONSISTS OF THE WORD "OWN" DEPICTED IN CAPITAL LETTERS WITH VARYING SHADES OF ORANGE FORMING "O" WITH YELLOW APPEARING IN THE CENTER; VARYING SHADES OF GREEN TO LIGHT GREEN FORMING "W" AND VARYING SHADES OF PURPLE TO LIGHT PURPLE FORMING "N" WITH A SHADOW UNDER EACH LETTER THAT IS DEPICTED IN THE SAME COLOR AS THE LETTER.

FOR BOOKS, MAGAZINES, NEWSLETTERS, INSTRUCTIONAL MANUALS AND PRINTED INSTRUCTIONAL TEACHING MATERIALS, ALL FEATURING SUBJECTS OF GENERAL HUMAN INTEREST; PHOTOGRAPHS; STATIONERY; ADHESIVES FOR STATIONERY OR HOUSEHOLD USES; ARTISTS' MATERIALS, NAMELY, ARTISTS' BRUSHES AND ARTISTS' PASTELS; PAINT BRUSHES; PLASTIC MATERIAL FOR PACKAGING, NAMELY, PLASTIC BAGS; PRINTERS' TYPE; PRINTING BLOCKS; POSTERS; POSTCARDS; NOTE CARDS; DESK TOP ORGANIZERS; DESK SETS; DESK PADS; BLOTTERS; PERSONAL ORGANIZERS; DIARIES; AGENDAS; PENS; PENCILS; PENCIL CASES; PEN CASES; DRAWING RULERS; BOOKMARKS; BOOK PLATES; BOOK COVERS; PAPER STATIONERY PORTFOLIOS; BINDERS; NOTEBOOKS; COLORING BOOKS; NOTE PADS; NON-ELECTRIC ERASERS; NON-ELECTRIC PENCIL SHARPENERS; STENCILS; STATIONERY LETTER AND WRITING PAPER HOLDERS; FILE FOLDERS; RUBBER STAMPS; BLACKBOARDS; PAPER BAGS; PLASTIC BAGS FOR GENERAL USE; WRAPPING PAPER; TRADING CARDS; CHILDREN'S ACTIVITY BOOKS; EDUCATIONAL ACTIVITY BOOKS IN FIELDS OF GENERAL HUMAN INTEREST; COMPOSITION BOOKS; STICKERS; DECALS; PAPER NAPKINS; PAPER TABLECLOTHS; PLACE MATS OF PAPER; CALENDARS; PAPER, INCLUDING WRITING PAPER, ART PAPER, CONSTRUCTION PAPER; ART AND CRAFTS PAINT KITS; ART PRINTS; COLOR PRINTS; LITHOGRAPHIC PRINTS; PHOTOGRAPHIC PRINTS; COMIC STRIPS; PAPER PARTY FAVORS; PAPER PARTY DECORATIONS; PAPER PARTY BAGS; MAPS (U.S. CLS. 2, 5, 22, 23, 29, 37, 38 AND 50).

THOMAS MANOR, EXAMINING ATTORNEY

CLASS 16—(Continued).

SN 85-220,123. RAT ROD MAGAZINE, PRINCETON, MN. FILED 1-18-2011.



NO CLAIM IS MADE TO THE EXCLUSIVE RIGHT TO USE "RAT ROD MAGAZINE", APART FROM THE MARK AS SHOWN.

THE COLOR(S) ORANGE IS/ARE CLAIMED AS A FEATURE OF THE MARK.

THE MARK CONSISTS OF THE STYLIZED TERMS "RAT ROD MAGAZINE" IN ORANGE WHERE THE "RAT ROD" HAS STYLIZED FLAMES IN ORANGE ON THE TOP AND THE WORDING "MAGAZINE" IS IN A SMALLER STYLIZED FONT BELOW; THE COLOR WHITE REPRESENTS BACKGROUND AND IS NOT PART OF THE MARK.

FOR MAGAZINES FEATURING AUTOMOBILES AND MODELS (U.S. CLS. 2, 5, 22, 23, 29, 37, 38 AND 50).

FIRST USE 3-0-2010; IN COMMERCE 3-0-2010.

TASNEEM HUSSAIN, EXAMINING ATTORNEY

CLASS 16—(Continued).

SN 85-220,426. NINTENDO OF AMERICA INC., REDMOND, WA. FILED 1-18-2011.

CLASS 16—(Continued).

SN 85-224,023. GREER, ROY, POMONA, CA. FILED 1-23-2011.

Romance by Rg2

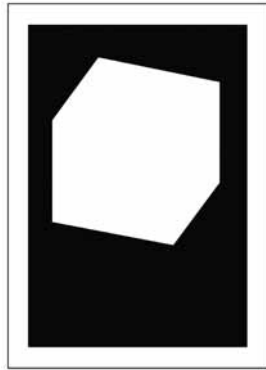

THE MARK CONSISTS OF STANDARD CHARACTERS WITHOUT CLAIM TO ANY PARTICULAR FONT, STYLE, SIZE, OR COLOR.

NO CLAIM IS MADE TO THE EXCLUSIVE RIGHT TO USE "ROMANCE", APART FROM THE MARK AS SHOWN. THE "RG2" IN THE MARK IDENTIFIES ROY GREER, A LIVING INDIVIDUAL WHOSE CONSENT IS OF RECORD.

FOR SERIES OF FICTION WORKS, NAMELY, NOVELS AND SHORT STORIES; GREETING CARDS (U.S. CLS. 2, 5, 22, 23, 29, 37, 38 AND 50).

WILLIAM VERHOSEK, EXAMINING ATTORNEY

SN 85-224,586. NINA GARGOVIC, CHICAGO, IL. FILED 1-24-2011.

THE MARK CONSISTS OF A HEXAGON CONTAINED WITHIN TWO RECTANGLES.

FOR PRINTED MATTER AND PUBLICATIONS, NAMELY, ADDRESS BOOKS; ARTISTS' BRUSHES; ARTISTS' PASTELS; ARTS AND CRAFTS PAINT KITS; BOOK COVERS; BOOKMARKS; BOOKPLATES; CALENDARS; CARDBOARD GIFT BOXES; CHILDREN'S BOOKS; COLORING BOOKS AND CHILDREN'S ACTIVITY BOOKS; COMIC BOOKS; CRAYONS; DECORATIVE FIGURES ATTACHABLE TO PENCILS; DRAWING RULERS; DRY ERASE WRITING BOARDS; ERASERS; FELT-TIP MARKERS; GIFT WRAPPING PAPER; GREETING CARDS; INVITATION CARDS; IRON-ON TRANSFERS; MAGAZINES, BOOKS, BOOKLETS, CATALOGS, MANUALS AND PAMPHLETS REGARDING VIDEO GAMES; MAGNETIC SLATE BOARDS FOR WRITING; MEMO BOARDS; MEMO PADS; NEWSPAPER CARTOONS; NOTEBOOKS; NOTEPADS; PAINTING SETS FOR ARTISTS; PAINTING SETS FOR CHILDREN; PAPER BANNERS; PAPER DECORATIONS MOUNTABLE ON DOORS; PAPER GIFT BAGS; PAPER NAPKINS; PAPER PARTY FAVORS; PAPER PARTY HATS; PAPER PLACEMATS; PAPER STAPLERS; UNFITTED PAPER TABLE COVERS; PAPERBACK BOOKS FOR CHILDREN; PENCIL BOXES WITH MAGNETIC CLOSURES; PENCIL SHARPENERS; PENCILS; PENS; PICTURE STORYBOOKS; NON-MAGNETICALLY ENCODED PRE-PAID PURCHASE CARDS FOR ALLOWING USERS TO TRANSFER FINANCIAL VALUE ON-LINE VIA RETAIL COMPUTER NETWORKS AND GIFT CARDS; POSTCARDS; POSTERS; MULTI-RING BINDERS; RUBBER STAMPS; SCORE BOOKS; SCRAPBOOKS; STAMP COLLECTOR BOOKS; SCRATCH PADS; STAPLERS IN THE NATURE OF OFFICE REQUISITES; STATIONERY; STATIONERY-TYPE PORTFOLIOS; STICKER ALBUMS; STICKERS; TRADING CARDS (U.S. CLS. 2, 5, 22, 23, 29, 37, 38 AND 50).

JANICE L. MCMORROW, EXAMINING ATTORNEY



THE COLOR(S) WHITE, BLACK, GREY, YELLOW, RED, PINK, BLUE, PURPLE, GREEN, PEACH, BROWN IS/ARE CLAIMED AS A FEATURE OF THE MARK.

THE MARK CONSISTS OF THE WORDING "I AM PRINCESS." IN WHITE STYLIZED FONT; ABOVE THIS WORDING IS A DESIGN OF A GIRL PRINCESS WITH A PEACH FACE; BLACK PUPILS, SMILING MOUTH, NOSE, EYEBROWS AND FACIAL ACCENTS; GREY HAIR; BLUE SHIRT, GREEN VEST, GREY PANTS WITH PURPLE STARS, BROWN SHOES, YELLOW CROWN WITH GREEN, PURPLE, BLUE, RED, AND PINK JEWELS AND A PINK HEART ON TOP OF THE HIGHEST PEAK OF THE CROWN; ALL OVER A BLUE BACKGROUND.

FOR STORY BOOKS (U.S. CLS. 2, 5, 22, 23, 29, 37, 38 AND 50).

BENJAMIN OKEKE, EXAMINING ATTORNEY

CLASS 16—(Continued).

SN 85-231,549. BALLOON KNOT, INC., WEST HOLLYWOOD, CA. FILED 2-1-2011.

TYLERISMS

THE MARK CONSISTS OF STANDARD CHARACTERS WITHOUT CLAIM TO ANY PARTICULAR FONT, STYLE, SIZE, OR COLOR.

FOR PAPER OR CARDBOARD ARTICLES AND PRINTED MATTER, NAMELY, POSTERS, DECALS, STATIONERY, MOUNTED AND UNMOUNTED PHOTOGRAPHS, BOOKS IN THE FIELD OF HUMOR, LIFESTYLE, FASHION, AUTOBIOGRAPHY, NEWSPAPERS, MAGAZINES IN THE FIELD OF HUMOR, LIFESTYLE, FASHION, BROCHURES IN THE FIELD OF HUMOR, LIFESTYLE, FASHION, COMIC BOOKS, CALENDARS, NOTEBOOKS, MEMO PADS, PENS, PENCILS, STICKERS, ERASERS, PENCIL SHARPENERS, PENCIL CASES, STAPLERS, WRITING PAPER, ENVELOPES, PAPER WEIGHTS, PAPER COASTERS, PAPER MATS, DRAWING RULERS, POSTCARDS AND TRADING CARDS (U.S. CLS. 2, 5, 22, 23, 29, 37, 38 AND 50).

TRACY CROSS, EXAMINING ATTORNEY

SN 85-232,624. BROWN PAPER TICKETS, LLC, SEATTLE, WA. FILED 2-2-2011.

BROWN PAPER TICKETS

THE MARK CONSISTS OF STANDARD CHARACTERS WITHOUT CLAIM TO ANY PARTICULAR FONT, STYLE, SIZE, OR COLOR.

OWNER OF U.S. REG. NO. 3,927,297.

NO CLAIM IS MADE TO THE EXCLUSIVE RIGHT TO USE "PAPER TICKETS", APART FROM THE MARK AS SHOWN.

SEC. 2(F).

FOR ENTRY TICKETS (U.S. CLS. 2, 5, 22, 23, 29, 37, 38 AND 50).

FIRST USE 1-1-2002; IN COMMERCE 1-1-2002.

MICHAEL TANNER, EXAMINING ATTORNEY

CLASS 16—(Continued).

SN 85-235,010. NUSSBAUM, ILISA SPITZER, WESTON, CT. FILED 2-5-2011.



NO CLAIM IS MADE TO THE EXCLUSIVE RIGHT TO USE "COOKING", "NUTRITION" AND "EDUCATION", APART FROM THE MARK AS SHOWN.

THE COLOR(S) LIGHT GREEN, GREEN, ORANGE AND BLACK IS/ARE CLAIMED AS A FEATURE OF THE MARK.

THE MARK CONSISTS OF THE LIGHT GREEN WORDING "COOKING CORPS" AND THE BLACK WORDING "NUTRITION. EDUCATION". THERE ARE TWO STYLIZED ORANGE CARROTS WITH GREEN TOPS ALL OUTLINED IN BLACK BETWEEN THE WORDING.

FOR EDUCATIONAL AND LEARNING PUBLICATIONS, NAMELY, BOOKLETS AND FLASH CARDS ON A VARIETY OF EDUCATIONAL DISCIPLINES IN PRE-SCHOOL THROUGH EIGHTH GRADE; EDUCATIONAL PUBLICATIONS, NAMELY, EDUCATIONAL LEARNING CARDS, FLASH CARDS, ACTIVITY CARDS, WORKBOOKS, TEXTBOOKS, ACTIVITY BOOKS, STORY BOOKS, PUZZLE BOOKS, PRINTED PUZZLES, TEACHER GUIDES, MANUALS, POSTERS AND EDUCATIONAL BOOKLETS IN THE FIELD OF NUTRITION; EDUCATIONAL PUBLICATIONS, NAMELY, TRAINING MANUALS IN THE FIELD OF NUTRITION; EDUCATIONAL PUBLICATIONS, NAMELY, HAND-OUTS IN THE FIELDS OF NUTRITION; PACKAGED KITS COMPRISING PRINTED INSTRUCTIONAL, EDUCATIONAL, AND TEACHING MATERIALS FOR EDUCATIONAL ACTIVITIES IN THE FIELD OF NUTRITION; PRINTED EDUCATIONAL MATERIALS IN THE FIELD OF NUTRITION (U.S. CLS. 2, 5, 22, 23, 29, 37, 38 AND 50).

FIRST USE 3-1-2010; IN COMMERCE 3-1-2010.

TOBY BULLOFF, EXAMINING ATTORNEY

SN 85-236,147. SHELTON, DANNY, WEST FRANKFORT, IL. AND LEWIS, YVONNE, WEST FRANKFORT, IL. FILED 2-7-2011.



NO CLAIM IS MADE TO THE EXCLUSIVE RIGHT TO USE "HISTORICAL TRADING CARDS", APART FROM THE MARK AS SHOWN.

THE MARK CONSISTS OF AN OUTLINED, STYLIZED ROUNDED-CORNER RECTANGLE CONTAINING THE WORDS, "DID YOU KNOW?" IN LARGE BOLD FONT ABOVE THE TERMS "HISTORICAL TRADING CARDS" IN A SMALL FONT.

FOR TRADING CARDS (U.S. CLS. 2, 5, 22, 23, 29, 37, 38 AND 50).

ANTHONY RINKER, EXAMINING ATTORNEY

CLASS 16—(Continued).

SN 85-237,145. WALGREEN CO., DEERFIELD, IL. FILED 2-8-2011.

NICE!

THE MARK CONSISTS OF STANDARD CHARACTERS WITHOUT CLAIM TO ANY PARTICULAR FONT, STYLE, SIZE, OR COLOR.

FOR PAPER NAPKINS; DISPOSABLE DIAPERS, FACIAL TISSUE; PLASTIC GARBAGE BAGS (U.S. CLS. 2, 5, 22, 23, 29, 37, 38 AND 50).

JIM RINGLE, EXAMINING ATTORNEY

CLASS 16—(Continued).

SN 85-242,128. HANS ROPERS, AKRON, OH. FILED 2-14-2011.

MAR NOVELTIES

THE MARK CONSISTS OF STANDARD CHARACTERS WITHOUT CLAIM TO ANY PARTICULAR FONT, STYLE, SIZE, OR COLOR.

NO CLAIM IS MADE TO THE EXCLUSIVE RIGHT TO USE "NOVELTIES", APART FROM THE MARK AS SHOWN.

FOR GIFT BOXES AND PRINTED CERTIFICATES ALL BEARING A SCREW-THEMED NOVELTY PHRASE (U.S. CLS. 2, 5, 22, 23, 29, 37, 38 AND 50).

DAVID HOFFMAN, EXAMINING ATTORNEY

SN 85-244,507. SANDERS, JUDITH ELLEN, AMHERST, MA. FILED 2-17-2011.

Coloring Creativity

THE MARK CONSISTS OF STANDARD CHARACTERS WITHOUT CLAIM TO ANY PARTICULAR FONT, STYLE, SIZE, OR COLOR.

NO CLAIM IS MADE TO THE EXCLUSIVE RIGHT TO USE "COLORING", APART FROM THE MARK AS SHOWN.

FOR A SERIES OF BOOKS AND WRITTEN ARTICLES IN THE FIELD OF ART, COLOR, DESIGN, AND CREATIVITY; A SERIES OF BOOKS, WRITTEN ARTICLES, HANDOUTS AND WORKSHEETS IN THE FIELD OF ART, COLOR, DESIGN, AND CREATIVITY; ADDRESS BOOKS; ADDRESS BOOKS AND DIARIES; ANNIVERSARY BOOKS; APPOINTMENT BOOKS; ART AND PHOTOGRAPH PORTFOLIO CASES; ART ETCHINGS; ART PADS; ART PAPER; ART PICTURES; ART PRINTS; ART PRINTS COMPRISED OF DIGITAL ILLUSTRATIONS ORIGINATING FROM PHOTOGRAPHS; ART PRINTS ON CANVAS; AUTOGRAPH BOOKS; BABY BOOKS; BIRTHDAY BOOKS; BLACKBOARDS AND SCRAP BOOKS; BLANK CARDS; BLANK JOURNAL BOOKS; BLANK JOURNALS; BLANK NOTE CARDS; BLANK PAPER NOTEBOOKS; BLANK WRITING JOURNALS; BOOK COVERS; BOOK ENDS; BOOK MARKERS; BOOK MARKS; BOOK PLATES; BOOKS IN THE FIELD OF ART, COLOR, DESIGN, AND CREATIVITY; CALENDAR DESK PADS; CALENDAR DESK STANDS; CALENDAR REFILLS; CALENDAR STANDS; CALENDARS; CALENDARS AND DIARIES; CARDS BEARING UNIVERSAL GREETINGS; CARDS, NAMELY, GREETING CARDS, NOTECARDS, POSTCARDS; CHILDREN'S ACTIVITY BOOKS; CHILDREN'S BOOKS; CHILDREN'S INTERACTIVE EDUCATIONAL BOOKS; CHILDREN'S STORYBOOKS; CHILDREN'S WALL STICKERS AND MURALS; CHILDREN'S ARTS AND CRAFTS PAPER KITS; CHRISTMAS CARDS; COFFEE TABLE BOOKS FEATURING ART, COLOR, DESIGN, AND CREATIVITY; COLOR PENCILS; COLOR PRINTS; COLORING BOOKS; COMPOSITION BOOKS; COOK BOOKS; CORRESPONDENCE CARDS; CUSTOMIZABLE JOURNAL BOOKS; DATE BOOKS; DESK CALENDARS; EDUCATIONAL AND LEARNING PUBLICATIONS, NAMELY, BOOKLETS AND FLASH CARDS ON A VARIETY OF EDUCATIONAL DISCIPLINES IN PRE-SCHOOL THROUGH EIGHTH GRADE; EDUCATIONAL BOOKS FEATURING ART, COLOR, DESIGN, AND CREATIVITY; EDUCATIONAL KITS SOLD AS A UNIT IN THE FIELD OF ART, COLOR, DESIGN, AND CREATIVITY CONSISTING PRIMARILY OF EDUCATIONAL BOOKS

SN 85-238,885. MEDSTUDY CORPORATION, COLORADO SPRINGS, CO. FILED 2-10-2011.

Core Scripts

THE MARK CONSISTS OF STANDARD CHARACTERS WITHOUT CLAIM TO ANY PARTICULAR FONT, STYLE, SIZE, OR COLOR.

FOR FLASH CARDS AND ANSWER BOOKS IN THE FIELD OF MEDICINE (U.S. CLS. 2, 5, 22, 23, 29, 37, 38 AND 50).

JAMES GRIFFIN, EXAMINING ATTORNEY

SN 85-239,576. JEFFREY S POMEROY, DBA OILMINDER-INC., HOPKINS, MI. FILED 2-10-2011.



THE MARK CONSISTS OF AN OIL CAN WITH A DROP OF OIL DRIPPING FROM THE SPOUT ON TO THE WORD "OILMINDER".

FOR ADHESIVE LABELS (U.S. CLS. 2, 5, 22, 23, 29, 37, 38 AND 50).

MARGERY A. TIERNEY, EXAMINING ATTORNEY

CLASS 16—(Continued).

AND ALSO INCLUDING DVDS AND T-SHIRTS; EDUCATIONAL KITS SOLD AS A UNIT IN THE FIELD OF ART, COLOR, DESIGN, AND CREATIVITY CONSISTING PRIMARILY OF EDUCATIONAL BOOKS, FLASH CARDS AND WORKSHEETS, AND ALSO INCLUDING AN EDUCATIONAL DVD; EDUCATIONAL PUBLICATIONS, NAMELY, BOOKS, HAND-OUTS, WORKBOOKS, JOURNALS, PLAYBOOKS, WORKSHEETS AND CARDS IN THE FIELD OF RIGHT-BRAIN FITNESS; EDUCATIONAL PUBLICATIONS, NAMELY, EDUCATIONAL LEARNING CARDS, FLASH CARDS, ACTIVITY CARDS, WORKBOOKS, TEXTBOOKS, ACTIVITY BOOKS, STORY BOOKS, PUZZLE BOOKS, PRINTED PUZZLES, TEACHER GUIDES, MANUALS, POSTERS AND EDUCATIONAL BOOKLETS IN THE FIELD OF ART, COLOR, DESIGN, AND CREATIVITY; ENGAGEMENT BOOKS; FLASH CARDS; FRAMED ART ETCHINGS; FRAMED ART PICTURES; FRAMED ART PRINTS; FRAMED GRAPHIC ART REPRODUCTIONS; FREE-STANDING AND WALL-MOUNTED PAPER AND CARDBOARD BOXES FOR DEPOSITING A WRITTEN MESSAGE OR PRAYER WISHING A LOVED ONE WELL, FOR USE IN HOSPITALS, ELDER CARE RESIDENCES, SCHOOLS, AND INSTITUTIONS FOR CHILDREN WITH SPECIAL NEEDS; GIFT BOOKS FEATURING ART, COLOR, DESIGN, AND CREATIVITY; GIFT CARDS; GIFT SETS CONSISTING OF A BOOK IN THE FIELD OF ART, COLOR, DESIGN, AND CREATIVITY AND ALSO INCLUDING A BLANKET; GRAPHIC ART REPRODUCTIONS; GRAPHIC FINE ART PRINTS; GREETING CARDS; GREETINGS CARDS AND POSTCARDS; GUEST BOOKS; HOLDERS SPECIALLY ADAPTED FOR HOLDING GREETING CARDS; HOLIDAY CARDS; INVITATION CARDS; LOG BOOKS; MANUSCRIPT BOOKS; MEMORANDUM BOOKS; MEMORY BOOKS; MOTIVATIONAL CARDS; MUSICAL GREETING CARDS; NOTE BOOKS; NOTE CARDS; NOTE CARDS THAT UNFOLD TO ACT AS WORKSHEETS FOR DAILY/MONTHLY PLANNERS, ORGANIZERS, CALENDARS, TO DO LISTS THAT RE-FOLD TO MAKE A CREDIT CARD SIZED ITEM THAT FITS NEATLY IN YOUR WALLET OR POCKET; NOTEBOOK DIVIDERS; NOTEBOOKS; NOVELTY IDENTIFICATION CARDS; OCCASION CARDS; PAINTING SETS FOR CHILDREN; PAPER BOXES FOR STORING GREETING CARDS; PAPER LETTERS AND NUMBER FOR USE IN MAKING NOTECARDS AND POSTERS; PAPER NOTEBOOKS; PERSONALIZED COLORING BOOKS FOR CHILDREN; PERSONALIZED WRITING JOURNALS; PICTURE BOOKS; PICTURE CARDS; PLACE CARDS; POCKET CALENDARS; POCKET MEMORANDUM BOOKS; POST CARDS; POSTCARDS AND GREETING CARDS; POSTER BOARD; POSTERS; POSTERS MADE OF PAPER; PRINTED ART REPRODUCTIONS; PRINTED CALENDARS; PRINTED CHILDREN'S COLORING PAGES; PRINTED GREETING CARDS WITH ELECTRONIC INFORMATION STORED THEREIN; PRINTED INFORMATIONAL CARDS IN THE FIELD OF ART, COLOR, DESIGN, AND CREATIVITY; PRINTED MATERIALS, NAMELY, NOVELS AND SERIES OF FICTION BOOKS AND SHORT STORIES FEATURING SCENES AND CHARACTERS BASED ON VIDEO GAMES; PRINTED MATTER, NAMELY, PAPER SIGNS, BOOKS, MANUALS, CURRICULUM, NEWSLETTERS, INFORMATIONAL CARDS AND BROCHURES IN THE FIELD OF ART, COLOR, DESIGN, AND CREATIVITY; PRINTED MUSIC BOOKS; PRINTED RECIPE CARDS; PROTECTIVE COVERS FOR BOOKS; PROTECTIVE COVERS FOR SHEETS OR PAPER AND PAGES OF BOOKS AND THE LIKE; PUBLICATIONS, NAMELY, BOOKS, STORYBOOKS, COLORING BOOKS IN THE FIELDS OF ART, COLOR, DESIGN, AND CREATIVITY; RECIPE BOOKS; SCHOOL WRITING BOOKS; SCRAP BOOKS; SERIES OF FICTION BOOKS; SERIES OF FICTION WORKS, NAMELY, NOVELS AND BOOKS; SERIES OF NON-FICTION BOOKS IN THE FIELD OF ART, COLOR, DESIGN, AND CREATIVITY; SKETCH BOOKS; SKETCH PADS; SKETCHES; SOCIAL NOTE CARDS; SPIRAL-BOUND NOTEBOOKS; STORY BOOKS; TALKING CHILDREN'S BOOKS; WALL CALENDARS; WIRE-BOUND NOTEBOOKS; WIREBOUND BOOKS; WRITING JOURNAL SHEETS (U.S. CLS. 2, 5, 22, 23, 29, 37, 38 AND 50).

JOHN E. MICHOS, EXAMINING ATTORNEY

CLASS 16—(Continued).

SN 85-245,074. SAKURA COLOR PRODUCTS CORPORATION, OSAKA-SHI, OSAKA-FU, JAPAN, FILED 2-17-2011.

PIGMA CALLIGRAPHER

THE MARK CONSISTS OF STANDARD CHARACTERS WITHOUT CLAIM TO ANY PARTICULAR FONT, STYLE, SIZE, OR COLOR.

OWNER OF U.S. REG. NOS. 1,278,932 AND 3,504,058.
NO CLAIM IS MADE TO THE EXCLUSIVE RIGHT TO USE "CALLIGRAPHER", APART FROM THE MARK AS SHOWN.

FOR WRITING INSTRUMENTS (U.S. CLS. 2, 5, 22, 23, 29, 37, 38 AND 50).

GINA HAYES, EXAMINING ATTORNEY

SN 85-245,947. STORK COMMUNICATIONS, LLC, HAMILTON, OH. FILED 2-18-2011.

THE BABY GUIDE AND KIDS TOO

THE MARK CONSISTS OF STANDARD CHARACTERS WITHOUT CLAIM TO ANY PARTICULAR FONT, STYLE, SIZE, OR COLOR.

NO CLAIM IS MADE TO THE EXCLUSIVE RIGHT TO USE "BABY GUIDE", APART FROM THE MARK AS SHOWN.

FOR MAGAZINES RELATING TO MATERNITY AND PARENTHOOD (U.S. CLS. 2, 5, 22, 23, 29, 37, 38 AND 50).

FIRST USE 6-30-2008; IN COMMERCE 6-30-2008.
CARYN GLASSER, EXAMINING ATTORNEY

CLASS 16—(Continued).

SN 85-246,357. SAKURA COLOR PRODUCTS CORPORATION, OSAKA-SHI, OSAKA-FU, JAPAN, FILED 2-18-2011.



OWNER OF U.S. REG. NOS. 1,278,932 AND 3,504,058.
NO CLAIM IS MADE TO THE EXCLUSIVE RIGHT TO USE "COLOR TECHNOLOGIES", APART FROM THE MARK AS SHOWN.

THE COLOR(S) PURPLE, RED, YELLOW, GREEN, BLUE, WHITE, AND BLACK IS/ARE CLAIMED AS A FEATURE OF THE MARK.

THE MARK CONSISTS OF THE WORDS "PIGMA COLOR TECHNOLOGIES" INSIDE A BLACK OVAL. "P" IN "PIGMA" IS IN PURPLE. "I" IN "PIGMA" IS IN RED. "G" IN "PIGMA" IS IN YELLOW. "M" IN "PIGMA" IS IN GREEN. "A" IN "PIGMA" IS IN BLUE. "COLOR TECHNOLOGIES" IS IN WHITE.

FOR WRITING INSTRUMENTS (U.S. CLS. 2, 5, 22, 23, 29, 37, 38 AND 50).

FIRST USE 4-0-2000; IN COMMERCE 4-0-2000.
GINA HAYES, EXAMINING ATTORNEY

SN 85-246,368. SAKURA COLOR PRODUCTS CORPORATION, OSAKA-SHI, OSAKA-FU, JAPAN, FILED 2-18-2011.

PEN-TOUCH CALLIGRAPHER

THE MARK CONSISTS OF STANDARD CHARACTERS WITHOUT CLAIM TO ANY PARTICULAR FONT, STYLE, SIZE, OR COLOR.

OWNER OF U.S. REG. NO. 1,278,933.

NO CLAIM IS MADE TO THE EXCLUSIVE RIGHT TO USE "CALLIGRAPHER", APART FROM THE MARK AS SHOWN.

FOR WRITING INSTRUMENTS (U.S. CLS. 2, 5, 22, 23, 29, 37, 38 AND 50).

FIRST USE 0-0-1995; IN COMMERCE 0-0-1995.
GINA HAYES, EXAMINING ATTORNEY

CLASS 16—(Continued).

SN 85-246,378. SAKURA COLOR PRODUCTS CORPORATION, OSAKA-SHI, OSAKA-FU, JAPAN, FILED 2-18-2011.

PIGMA GRAPHIC

THE MARK CONSISTS OF STANDARD CHARACTERS WITHOUT CLAIM TO ANY PARTICULAR FONT, STYLE, SIZE, OR COLOR.

OWNER OF U.S. REG. NOS. 1,278,932 AND 3,504,058.

NO CLAIM IS MADE TO THE EXCLUSIVE RIGHT TO USE "GRAPHIC", APART FROM THE MARK AS SHOWN.

FOR WRITING INSTRUMENTS (U.S. CLS. 2, 5, 22, 23, 29, 37, 38 AND 50).

FIRST USE 0-0-1991; IN COMMERCE 0-0-1991.

GINA HAYES, EXAMINING ATTORNEY

SN 85-246,398. SAKURA COLOR PRODUCTS CORPORATION, OSAKA-SHI, OSAKA-FU, JAPAN, FILED 2-18-2011.

PIGMA BRUSH

THE MARK CONSISTS OF STANDARD CHARACTERS WITHOUT CLAIM TO ANY PARTICULAR FONT, STYLE, SIZE, OR COLOR.

OWNER OF U.S. REG. NOS. 1,278,932 AND 3,504,058.

NO CLAIM IS MADE TO THE EXCLUSIVE RIGHT TO USE "BRUSH", APART FROM THE MARK AS SHOWN.

FOR WRITING INSTRUMENTS (U.S. CLS. 2, 5, 22, 23, 29, 37, 38 AND 50).

FIRST USE 0-0-1991; IN COMMERCE 0-0-1991.

GINA HAYES, EXAMINING ATTORNEY

SN 85-246,619. FL DAUERN RESEARCH, INC., PHOENIX, AZ. FILED 2-18-2011.

POWERED BY WELLNESS

THE MARK CONSISTS OF STANDARD CHARACTERS WITHOUT CLAIM TO ANY PARTICULAR FONT, STYLE, SIZE, OR COLOR.

FOR PRINTED NEWSLETTERS IN THE FIELDS OF PERSONAL CARE, NUTRITIONAL AND DIETARY SUPPLEMENTS, EXERCISE, NUTRITION, FITNESS AND WELLNESS; PRINTED INSTRUCTIONAL, EDUCATIONAL AND TEACHING MATERIALS IN THE FIELDS OF PERSONAL CARE, NUTRITIONAL AND DIETARY SUPPLEMENTS, EXERCISE, NUTRITION, FITNESS AND WELLNESS (U.S. CLS. 2, 5, 22, 23, 29, 37, 38 AND 50).

MICHAEL TANNER, EXAMINING ATTORNEY

CLASS 16—(Continued).

SN 85-246,633. FL DAUERN RESEARCH, INC., PHOENIX, AZ. FILED 2-18-2011.

DELIVERING GOODNESS

THE MARK CONSISTS OF STANDARD CHARACTERS WITHOUT CLAIM TO ANY PARTICULAR FONT, STYLE, SIZE, OR COLOR.

FOR PRINTED NEWSLETTERS IN THE FIELDS OF PERSONAL CARE, NUTRITIONAL AND DIETARY SUPPLEMENTS, EXERCISE, NUTRITION, FITNESS AND WELLNESS; PRINTED INSTRUCTIONAL, EDUCATIONAL AND TEACHING MATERIALS IN THE FIELDS OF PERSONAL CARE, NUTRITIONAL AND DIETARY SUPPLEMENTS, EXERCISE, NUTRITION, FITNESS AND WELLNESS (U.S. CLS. 2, 5, 22, 23, 29, 37, 38 AND 50).

MICHAEL TANNER, EXAMINING ATTORNEY

SN 85-249,453. EDITORIAL TELEVISA INTERNATIONAL, S.A., SANTA FE, MEXICO, FILED 2-23-2011.

TECH AND BITS

NO CLAIM IS MADE TO THE EXCLUSIVE RIGHT TO USE "TECH", APART FROM THE MARK AS SHOWN.

THE COLOR(S) BLACK AND ORANGE IS/ARE CLAIMED AS A FEATURE OF THE MARK.

THE MARK CONSISTS OF THE WORDS "TECH" AND "BITS" IN THE COLOR BLACK AND THE WORD "AND" WRITTEN IN A VERTICAL ORIENTATION IN THE COLOR ORANGE.

FOR MAGAZINE DEDICATED TO TECHNOLOGY AND LIFESTYLE IN LATIN AMERICA CONTAINING ARTICLES ON THE LATEST ADVANCES IN TECHNOLOGY (U.S. CLS. 2, 5, 22, 23, 29, 37, 38 AND 50).

ELLEN B. AWRICH, EXAMINING ATTORNEY

SN 85-249,949. DVM CONSULTANTS LLC, DBA DVM CONSULTANTS LLC, SYRACUSE, NY. FILED 2-23-2011.

Fun with Abby & Alyssa

THE MARK CONSISTS OF STANDARD CHARACTERS WITHOUT CLAIM TO ANY PARTICULAR FONT, STYLE, SIZE, OR COLOR.

FOR CHILDREN'S INTERACTIVE EDUCATIONAL BOOKS (U.S. CLS. 2, 5, 22, 23, 29, 37, 38 AND 50).

ASMAT KHAN, EXAMINING ATTORNEY

CLASS 16—(Continued).

SN 85-250,330. C7 GLOBAL, LLC, SAN JUAN, PUERTO RICO, FILED 2-24-2011.

SMART KITCHEN

THE MARK CONSISTS OF STANDARD CHARACTERS WITHOUT CLAIM TO ANY PARTICULAR FONT, STYLE, SIZE, OR COLOR.

NO CLAIM IS MADE TO THE EXCLUSIVE RIGHT TO USE "KITCHEN", APART FROM THE MARK AS SHOWN.

FOR DISPOSABLE NAPKINS; HAND TOWELS OF PAPER; NAPKIN PAPER; PAPER HAND-TOWELS; PAPER TOWELS (U.S. CLS. 2, 5, 22, 23, 29, 37, 38 AND 50).

FIRST USE 1-1-2008; IN COMMERCE 1-1-2008.

VIVIAN MICZNIK FIRST, EXAMINING ATTORNEY

SN 85-250,618. D.O.C. RESTAURANT GROUP, LLC, DBA A16 RESTAURANT AND WINE BAR, SAN FRANCISCO, CA. FILED 2-24-2011.

A16

THE MARK CONSISTS OF STANDARD CHARACTERS WITHOUT CLAIM TO ANY PARTICULAR FONT, STYLE, SIZE, OR COLOR.

OWNER OF U.S. REG. NOS. 3,182,393 AND 3,182,394.

FOR A SERIES OF BOOKS AND WRITTEN ARTICLES IN THE FIELD OF COOKING (U.S. CLS. 2, 5, 22, 23, 29, 37, 38 AND 50).

JASON BLAIR, EXAMINING ATTORNEY

SN 85-250,739. LASS, DEBRA, J, NEW YORK, NY. FILED 2-24-2011.

SOPHISTIBITCH

THE MARK CONSISTS OF STANDARD CHARACTERS WITHOUT CLAIM TO ANY PARTICULAR FONT, STYLE, SIZE, OR COLOR.

OWNER OF U.S. REG. NO. 3,088,257.

FOR CARTOON STRIPS, COMIC BOOKS, CALENDARS, DAILY PLANNERS, POSTERS, POSTCARDS, NOTEPADS, GREETING CARDS (U.S. CLS. 2, 5, 22, 23, 29, 37, 38 AND 50).

FIRST USE 9-10-2002; IN COMMERCE 2-15-2005.

JOHN HWANG, EXAMINING ATTORNEY

CLASS 16—(Continued).

SN 85-251,273. JENSEN, GRANT R, LAKESIDE, CA. FILED 2-24-2011.

Surprisingly Funny

THE MARK CONSISTS OF STANDARD CHARACTERS WITHOUT CLAIM TO ANY PARTICULAR FONT, STYLE, SIZE, OR COLOR.

FOR GREETINGS CARDS AND POSTCARDS (U.S. CLS. 2, 5, 22, 23, 29, 37, 38 AND 50).

TAMARA FRAZIER, EXAMINING ATTORNEY

SN 85-251,314. GUNDY, KARLETHA, ARLINGTON, TX. FILED 2-24-2011.



NO CLAIM IS MADE TO THE EXCLUSIVE RIGHT TO USE "SALUTATIONS", APART FROM THE MARK AS SHOWN.

THE MARK CONSISTS OF THE STYLIZED TEXT "SARCASTIC SALUTATIONS BECAUSE SOMETIMES, THINGS ARE BETTER LEFT UNSAID..." THERE IS A SMALL FACE WITH A FINGER OVER ITS MOUTH BETWEEN THE TWO LETTER "S"'S.

FOR GREETING CARDS; INVITATION CARDS; NOTEPADS; PENCILS; STATIONERY (U.S. CLS. 2, 5, 22, 23, 29, 37, 38 AND 50).

FIRST USE 9-15-2010; IN COMMERCE 10-1-2010.

KRISTIN CARLSON, EXAMINING ATTORNEY

SN 85-251,452. LIZ CLAIBORNE, INC., NEW YORK, NY. FILED 2-25-2011.

A PORTFOLIO OF BRANDS

THE MARK CONSISTS OF STANDARD CHARACTERS WITHOUT CLAIM TO ANY PARTICULAR FONT, STYLE, SIZE, OR COLOR.

FOR BUSINESS CARDS; CALENDARS; DESK PADS; ENVELOPES; ERASERS; LETTERHEAD PAPER; NOTE PADS; PAPER FOLDERS; PENCILS; PENS (U.S. CLS. 2, 5, 22, 23, 29, 37, 38 AND 50).

LINDA POWELL, EXAMINING ATTORNEY

CLASS 16—(Continued).

SN 85-251,667. SAZERAC NORTH AMERICA, INC., FRANKFORT, KY. FILED 2-25-2011.



OWNER OF U.S. REG. NOS. 683,398 AND 2,329,608.
THE MARK CONSISTS OF THE CAPITAL LETTER "B" IN A CIRCLE TO THE LEFT OF THE WORD "BARTON", WHICH IS IN ALL CAPS.

FOR PAPER PRODUCTS, NAMELY, PAPER NAPKINS, PRINTED PAPER SIGNS, PAPER BANNERS, STATIONERY, INFORMATIONAL BROCHURES IN THE FIELD OF WHISKEY PRODUCTION; PRINTED EDUCATION MATERIALS, WRITTEN ARTICLES, PRINTED PRESS AND NEWS RELEASES, AND PRINTED TOUR AND MUSEUM EXHIBIT GUIDES, ALL RELATING TO THE HISTORY OF AMERICAN WHISKEY AND THE PRODUCTION, BOTTLING AND DISTRIBUTION OF WHISKEY AND VODKA; POSTCARDS (U.S. CLS. 2, 5, 22, 23, 29, 37, 38 AND 50).

GRETTA YAO, EXAMINING ATTORNEY

SN 85-252,256. MILES DESIGN, LLC, TUSCON, AZ. FILED 2-25-2011.



NO CLAIM IS MADE TO THE EXCLUSIVE RIGHT TO USE "LABEL CO., INC", APART FROM THE MARK AS SHOWN.

THE MARK CONSISTS OF THE STYLIZED LETTERING, MILES LABEL CO., INC., THERE IS A ZIG ZAG OVER THE WORD MILES.

FOR ADHESIVE LABELS (U.S. CLS. 2, 5, 22, 23, 29, 37, 38 AND 50).

FIRST USE 2-0-1997; IN COMMERCE 2-0-1997.

ELLEN BURNS, EXAMINING ATTORNEY

SN 85-252,602. BIZOLUTION, LLC, KNOXVILLE, TN. FILED 2-26-2011.

HANGPACK

THE MARK CONSISTS OF STANDARD CHARACTERS WITHOUT CLAIM TO ANY PARTICULAR FONT, STYLE, SIZE, OR COLOR.

FOR COUPON BOOKS (U.S. CLS. 2, 5, 22, 23, 29, 37, 38 AND 50).

ANNE MADDEN, EXAMINING ATTORNEY

CLASS 16—(Continued).

SN 85-252,727. ELIZA MADA DALIAN, TA DALIAN SCHOOL FOR HEALTH AND CONSCIOUSNESS, VANCOUVER, BC, CANADA, FILED 2-27-2011.



OWNER OF U.S. REG. NO. 3,626,462.
 NO CLAIM IS MADE TO THE EXCLUSIVE RIGHT TO USE "METHOD", APART FROM THE MARK AS SHOWN.
 THE COLOR(S) BLACK, PURPLE, BLUE, AND WHITE IS/ARE CLAIMED AS A FEATURE OF THE MARK.
 THE MARK CONSISTS OF A DRAWING OF EIGHT FLOWER PETALS IN SHADES OF BLACK, PURPLE, BLUE, AND LIGHT BLUE POSITIONED AROUND A SMALL CENTRAL CIRCLE WITH LIGHT BLUE COLOR IN THE MIDDLE AND SHADES OF DARKER BLUE TOWARDS THE PERIPHERY; THE PETALS APPEAR TO MOVE COUNTER-CLOCKWISE; ALSO, THERE IS A CONCH SHELL DRAWING WHICH APPEARS TO COME OUT OF THE CENTRAL CIRCLE AND GOES OVER THE PETALS; THE CONCH SHELL DRAWING HAS A WHITE OUTLINE AND IS FILLED WITH PALE BLUE COLOR; ON TOP OF THE PETALS THERE ARE BLACK CAPITAL LETTERS "D A L I A N" WRITTEN IN A SEMI-CIRCLE; AT THE BOTTOM OF THE PETALS THERE ARE BLACK CAPITAL LETTERS "M E T H O D" WRITTEN IN A SEMI-CIRCLE.
 FOR EDUCATIONAL BOOKS FEATURING HOLISTIC HEALTH CARE FOCUSING ON SELF-HEALING; EDUCATIONAL KITS SOLD AS A UNIT IN THE FIELD OF HOLISTIC HEALTH CARE FOCUSING ON SELF-HEALING CONSISTING PRIMARILY OF BOOKS, PRINTED INSTRUCTIONAL MATERIALS, WORKSHEETS, PRINTED COURSE MATERIALS, AND ALSO INCLUDING DVDS, VIDEOS, AUDIO CDS; EDUCATIONAL PUBLICATIONS, NAMELY, TRAINING MANUALS IN THE FIELD OF HOLISTIC HEALTH CARE FOCUSING ON SELF-HEALING (U.S. CLS. 2, 5, 22, 23, 29, 37, 38 AND 50).
 FIRST USE 1-1-2010, THE MARK WAS FIRST USED ANYWHERE IN A DIFFERENT FORM OTHER THAN THAT SOUGHT TO BE REGISTERED AT LEAST AS EARLY AS 01/01/1998.; IN COMMERCE 1-1-2010, THE MARK WAS FIRST USED IN COMMERCE IN A DIFFERENT FORM OTHER THAN THAT SOUGHT TO BE REGISTERED AT LEAST AS EARLY AS 01/01/2010..
 DEIRDRE ROBERTSON, EXAMINING ATTORNEY

CLASS 16—(Continued).

SN 85-252,737. MUSE, MICHAEL HAROLD, DBA MHMUSE STUDIOS, OSLO, NORWAY, FILED 2-27-2011.



THE MARK CONSISTS OF A STYLIZED FISH SYMBOLIZING A RELIGIOUS BELIEF. INSIDE THE CENTRAL PORTION OF THE STYLIZED FISH IS A "HAPPY-FACE". BELOW THE STYLIZED FISH SYMBOL IS THE FOLLOWING PHRASE: "HAPPY TO BELIEVE!" PLEASE NOTE: THE EXCLAMATION POINT AT THE END OF HAPPY TO BELIEVE IS A PART OF THE DESIGN.
 FOR 3D DECALS FOR USE ON ANY SURFACE; APPLIQUES IN THE FORM OF DECALS; BUMPER STICKERS; CHILDREN'S WALL STICKERS AND MURALS; DECALS; DECORATIVE DECALS FOR VEHICLE WINDOWS; DECORATIVE STICKERS FOR HELMETS; STICKERS (U.S. CLS. 2, 5, 22, 23, 29, 37, 38 AND 50).
 DAVID TAYLOR, EXAMINING ATTORNEY

SN 85-252,811. PARTENIO, DAVID, A, SYOSSET, NY, FILED 2-27-2011.

The Men Commandments -----

THE MARK CONSISTS OF STANDARD CHARACTERS WITHOUT CLAIM TO ANY PARTICULAR FONT, STYLE, SIZE, OR COLOR.
 NO CLAIM IS MADE TO THE EXCLUSIVE RIGHT TO USE "MEN", APART FROM THE MARK AS SHOWN.
 FOR WEDDING BOOKS (U.S. CLS. 2, 5, 22, 23, 29, 37, 38 AND 50).
 DAVID YONTEF, EXAMINING ATTORNEY

SN 85-252,907. MUSE, MICHAEL HAROLD, DBA MHMUSE STUDIOS, OSLO, NORWAY, FILED 2-28-2011.

Happy Fish

THE MARK CONSISTS OF STANDARD CHARACTERS WITHOUT CLAIM TO ANY PARTICULAR FONT, STYLE, SIZE, OR COLOR.
 FOR 3D DECALS FOR USE ON ANY SURFACE; APPLIQUES IN THE FORM OF DECALS; BUMPER STICKERS; CHILDREN'S WALL STICKERS AND MURALS; DECALS; DECORATIVE DECALS FOR VEHICLE WINDOWS; DECORATIVE STICKERS FOR HELMETS; MAGNETIC BUMPER STICKERS; STICKERS (U.S. CLS. 2, 5, 22, 23, 29, 37, 38 AND 50).
 DAVID TAYLOR, EXAMINING ATTORNEY

CLASS 16—(Continued).

SN 85-253,271. GOOD NEWS PUBLISHERS, WHEATON, IL. FILED 2-28-2011.

CLASS 16—(Continued).

SN 85-254,191. DAVEY, ANNE, DBA ANNE DAVEY IMAGES, WEST LEBANON, NH. FILED 3-1-2011.

Trusted.

THE MARK CONSISTS OF STANDARD CHARACTERS WITHOUT CLAIM TO ANY PARTICULAR FONT, STYLE, SIZE, OR COLOR.
 FOR BIBLES (U.S. CLS. 2, 5, 22, 23, 29, 37, 38 AND 50).
 FIRST USE 2-28-2011; IN COMMERCE 2-28-2011.
 ALLISON SCHRODY, EXAMINING ATTORNEY



SN 85-253,275. 7191731 CANADA INC., HAMILTON, CANADA, FILED 2-28-2011.



OMNIDEGRADABLE

THE MARK CONSISTS OF STANDARD CHARACTERS WITHOUT CLAIM TO ANY PARTICULAR FONT, STYLE, SIZE, OR COLOR.
 FOR FOOD WRAPPING PLASTIC FILM FOR HOUSEHOLD USE; GARBAGE BAGS OF PLASTIC; GENERAL PURPOSE PLASTIC BAGS; MERCHANDISE BAGS; PLASTIC BAGS FOR PACKAGING; PLASTIC BAGS FOR PACKING; PLASTIC FILM NOT FOR COMMERCIAL OR INDUSTRIAL PURPOSES; PLASTIC FOOD STORAGE BAGS FOR HOUSEHOLD USE; PLASTIC GARBAGE BAGS; PLASTIC OR PAPER BAGS FOR HOUSEHOLD USE; PLASTIC OR PAPER BAGS FOR MERCHANDISE PACKAGING; RUBBISH BAGS MADE OF PAPER OR PLASTIC MATERIALS (U.S. CLS. 2, 5, 22, 23, 29, 37, 38 AND 50).
 CARYN GLASSER, EXAMINING ATTORNEY

THE MARK CONSISTS OF PROFILE VIEW OF A RAVEN WITH SPREAD WINGS ABOUT TO TAKE OFF FROM ITS PERCH ON AN HOURGLASS FILLED WITH SAND.
 FOR ART PICTURES; ART PRINTS; ART PRINTS COMPRISED OF DIGITAL ILLUSTRATIONS ORIGINATING FROM PHOTOGRAPHS; ART PRINTS ON CANVAS; BLANK CARDS; BLANK NOTE CARDS; BLANK OR PARTIALLY PRINTED POSTCARDS; CHRISTMAS CARDS; COLOR PRINTS; FRAMED ART PICTURES; FRAMED ART PRINTS; GICLEE PRINTS; GRAPHIC FINE ART PRINTS; GRAPHIC PRINTS AND REPRESENTATIONS; GREETINGS CARDS AND POSTCARDS; HOLIDAY CARDS; LITHOGRAPHIC PRINTS; NOTE CARDS; PHOTOGRAPHIC PRINTS; PRINTED CALENDARS (U.S. CLS. 2, 5, 22, 23, 29, 37, 38 AND 50).
 FIRST USE 6-1-2008; IN COMMERCE 6-1-2008.
 HEATHER THOMPSON, EXAMINING ATTORNEY

CLASS 16—(Continued).

SN 85-254,254. BUTLER, DAVID MARK, INDEPENDENCE, MO. FILED 3-1-2011.

...yell, No! Let's Go!

THE MARK CONSISTS OF STANDARD CHARACTERS WITHOUT CLAIM TO ANY PARTICULAR FONT, STYLE, SIZE, OR COLOR.

FOR A SERIES OF BOOKS AND WRITTEN ARTICLES IN THE FIELD OF DANGEROUS SITUATIONS, CHILD ABDUCTION, AND DRUG AWARENESS; A SERIES OF BOOKS, WRITTEN ARTICLES, HANDOUTS AND WORKSHEETS IN THE FIELD OF DANGEROUS SITUATIONS, CHILD ABDUCTION, AND DRUG AWARENESS; BOOK MARKS; BUMPER STICKERS; CHILDREN'S ACTIVITY BOOKS; CHILDREN'S BOOKS; CHILDREN'S INTERACTIVE EDUCATIONAL BOOKS; CHILDREN'S WALL STICKERS AND MURALS; CHILDREN'S ARTS AND CRAFTS PAPER KITS; COLORING BOOKS; EDUCATIONAL AND LEARNING PUBLICATIONS, NAMELY, BOOKLETS AND FLASH CARDS ON A VARIETY OF EDUCATIONAL DISCIPLINES IN PRE-SCHOOL THROUGH EIGHTH GRADE; EDUCATIONAL BOOKS FEATURING ELEMENTARY LEVEL MATH AND SCIENCE; EDUCATIONAL PUBLICATIONS, NAMELY, BOOKS, COLORING BOOKS IN THE FIELDS OF DANGEROUS SITUATIONS, CHILD ABDUCTION, AND DRUG AWARENESS; FLIP BOOKS; PERSONALIZED COLORING BOOKS FOR CHILDREN; PICTURE BOOKS; RELIGIOUS BOOKS; SCHOOL SUPPLY KITS CONTAINING VARIOUS COMBINATIONS OF SELECTED SCHOOL SUPPLIES, NAMELY, WRITING INSTRUMENTS, PENS, PENCILS, MECHANICAL PENCILS, ERASERS, MARKERS, CRAYONS, HIGHLIGHTER PENS, FOLDERS, NOTEBOOKS, PAPER, PROTRACTORS, PAPER CLIPS, PENCIL SHARPENERS, WRITING GRIPS, GLUE AND BOOK MARKS; STICKERS; STORY BOOKS; TALKING CHILDREN'S BOOKS (U.S. CLS. 2, 5, 22, 23, 29, 37, 38 AND 50).

SHAUNIA CARLYLE, EXAMINING ATTORNEY

SN 85-254,298. CASTINEIRAS COMPANIES, LLC, FARMINGTON, CT. FILED 3-1-2011.

LIVE YOUR IMAGINATION

THE MARK CONSISTS OF STANDARD CHARACTERS WITHOUT CLAIM TO ANY PARTICULAR FONT, STYLE, SIZE, OR COLOR.

FOR CUSTOMIZED POSTAGE STAMPS (U.S. CLS. 2, 5, 22, 23, 29, 37, 38 AND 50).

BRIAN CALLAGHAN, EXAMINING ATTORNEY

CLASS 16—(Continued).

SN 85-254,520. DOUBLE 19 PRODUCTIONS, LOS ANGELES, CA. FILED 3-1-2011.

Acting Outside The Box

THE MARK CONSISTS OF STANDARD CHARACTERS WITHOUT CLAIM TO ANY PARTICULAR FONT, STYLE, SIZE, OR COLOR.

FOR INSPIRATIONAL DECK OF CARDS (U.S. CLS. 2, 5, 22, 23, 29, 37, 38 AND 50).

FIRST USE 4-1-2004; IN COMMERCE 4-1-2004.
SUZANNE BLANE, EXAMINING ATTORNEY

SN 85-254,541. AMERICAN SOCIETY FOR BIOCHEMISTRY AND MOLECULAR BIOLOGY, BETHESDA, MD. FILED 3-1-2011.

JOURNAL OF BIOLOGICAL CHEMISTRY

THE MARK CONSISTS OF STANDARD CHARACTERS WITHOUT CLAIM TO ANY PARTICULAR FONT, STYLE, SIZE, OR COLOR.

NO CLAIM IS MADE TO THE EXCLUSIVE RIGHT TO USE "JOURNAL", APART FROM THE MARK AS SHOWN. SEC. 2(F).

FOR PRINTED MATERIALS, NAMELY, JOURNALS FEATURING ARTICLES IN THE FIELD OF SCIENCE (U.S. CLS. 2, 5, 22, 23, 29, 37, 38 AND 50).

FIRST USE 10-31-1905; IN COMMERCE 10-31-1905.
REBECCA EISINGER, EXAMINING ATTORNEY

SN 85-254,685. DUNCAN, DARLENE, ARCADIA, CA. FILED 3-1-2011.

Sing a Song of Love

THE MARK CONSISTS OF STANDARD CHARACTERS WITHOUT CLAIM TO ANY PARTICULAR FONT, STYLE, SIZE, OR COLOR.

FOR PRINTED EDUCATIONAL MATERIALS IN THE FIELD OF PSYCHOLOGY (U.S. CLS. 2, 5, 22, 23, 29, 37, 38 AND 50).

SUNG IN, EXAMINING ATTORNEY

CLASS 16—(Continued).

SN 85-254,764. WILSON SEELEY DESIGNS, LLC, FLORENCE, MT. FILED 3-1-2011.

NO! ON TEXT! OR YOU'LL BE
NEXT!

THE MARK CONSISTS OF STANDARD CHARACTERS WITHOUT CLAIM TO ANY PARTICULAR FONT, STYLE, SIZE, OR COLOR.

FOR BUMPER STICKERS; DECALS; MAGNETIC BUMPER STICKERS; STICKERS; STICKERS AND TRANSFERS (U.S. CLS. 2, 5, 22, 23, 29, 37, 38 AND 50).
SUE LAWRENCE, EXAMINING ATTORNEY

SN 85-254,770. CONVERD LLC, EAST LONGMEADOW, MA. FILED 3-1-2011.

EnviroScape Mural

THE MARK CONSISTS OF STANDARD CHARACTERS WITHOUT CLAIM TO ANY PARTICULAR FONT, STYLE, SIZE, OR COLOR.

NO CLAIM IS MADE TO THE EXCLUSIVE RIGHT TO USE "MURAL", APART FROM THE MARK AS SHOWN.

FOR MURALS; PAPER FOR USE IN MAKING SIGNS; PAPER FOR USE IN THE GRAPHIC ARTS INDUSTRY; PAPER FOR USE IN THE MANUFACTURE OF WALL-PAPER; PAPER STOCK; PAPER SUBSTRATES ONTO WHICH DIGITAL IMAGES ARE PRINTED; PAPERS FOR HOUSEHOLD AND INDUSTRIAL USE; PAPERS FOR USE IN THE GRAPHIC ARTS INDUSTRY; POSTERS; RECYCLED PAPER; REEL PAPER FOR PRINTERS; UNPRINTED PAPER; WOOD PULP PAPER (U.S. CLS. 2, 5, 22, 23, 29, 37, 38 AND 50).

FIRST USE 3-30-2010; IN COMMERCE 3-30-2010.
JEFF DEFORD, EXAMINING ATTORNEY

SN 85-254,814. COSMO CRICKET, NIBLEY, UT. FILED 3-1-2011.

Glübers

THE MARK CONSISTS OF STANDARD CHARACTERS WITHOUT CLAIM TO ANY PARTICULAR FONT, STYLE, SIZE, OR COLOR.

FOR ADHESIVE FOR CRAFT, STATIONERY, AND HOBBY USE (U.S. CLS. 2, 5, 22, 23, 29, 37, 38 AND 50).
FIRST USE 1-20-2011; IN COMMERCE 2-22-2011.
MARGERY A. TIERNEY, EXAMINING ATTORNEY

CLASS 16—(Continued).

SN 85-255,385. CEREPLAST, INC., HAWTHORNE, CA. FILED 3-2-2011.

BIOPAPER

THE MARK CONSISTS OF STANDARD CHARACTERS WITHOUT CLAIM TO ANY PARTICULAR FONT, STYLE, SIZE, OR COLOR.

FOR PAPER MADE FROM PLASTICS WITH RENEWABLE CONTENT (U.S. CLS. 2, 5, 22, 23, 29, 37, 38 AND 50).

MICHAEL SOUDERS, EXAMINING ATTORNEY

SN 85-255,499. ROUNDY, DR. CYNTHIA, LIVERPOOL, NY. FILED 3-2-2011.

DIRTY BOOTS ARE YOU KNEE
DEEP?

THE MARK CONSISTS OF STANDARD CHARACTERS WITHOUT CLAIM TO ANY PARTICULAR FONT, STYLE, SIZE, OR COLOR.

FOR BOOKS IN THE FIELD OF ORGANIZATIONAL LEADERSHIP AND ETHICS (U.S. CLS. 2, 5, 22, 23, 29, 37, 38 AND 50).

ERIN FALK, EXAMINING ATTORNEY

SN 85-255,710. DAVIS, DANIEL M., MERCER ISLAND, WA. FILED 3-2-2011.

Free Range Women

THE MARK CONSISTS OF STANDARD CHARACTERS WITHOUT CLAIM TO ANY PARTICULAR FONT, STYLE, SIZE, OR COLOR.

NO CLAIM IS MADE TO THE EXCLUSIVE RIGHT TO USE "WOMEN", APART FROM THE MARK AS SHOWN.

FOR CALENDAR DESK PADS; CALENDAR REFILLS; CALENDARS AND DIARIES; COMIC MAGAZINES; DESK CALENDARS; GENERAL FEATURE MAGAZINE IN THE FIELD OF WOMEN'S ISSUES; MAGAZINE DEPARTMENTS IN THE FIELD OF WOMEN'S ISSUES; MAGAZINE SECTIONS IN THE FIELD OF WOMEN'S ISSUES; MOUNTED AND UNMOUNTED PHOTOGRAPHS; PHOTOGRAPHS THAT HAVE BEEN COMPUTER MANIPULATED AND ENHANCED TO LOOK LIKE PAINTINGS; POCKET CALENDARS; PRINTED CALENDARS; TEAR-OFF CALENDARS; UNMOUNTED AND MOUNTED PHOTOGRAPHS; WALL CALENDARS (U.S. CLS. 2, 5, 22, 23, 29, 37, 38 AND 50).

TINA MAI, EXAMINING ATTORNEY

CLASS 16—(Continued).

SN 85-255,889. CRAIGMORE CREATIONS LLC, PORTLAND, OR. FILED 3-2-2011.

TERRA TEMPO

THE MARK CONSISTS OF STANDARD CHARACTERS WITHOUT CLAIM TO ANY PARTICULAR FONT, STYLE, SIZE, OR COLOR.

THE ENGLISH TRANSLATION OF TERRA TEMPO IN THE MARK IS EARTH TIME.

FOR SERIES OF GRAPHIC NOVELS; EDUCATIONAL PUBLICATIONS, NAMELY, WORKBOOKS IN THE FIELD OF NATURAL HISTORY; POSTERS; POSTCARDS (U.S. CLS. 2, 5, 22, 23, 29, 37, 38 AND 50).

KRISTINA MORRIS, EXAMINING ATTORNEY

SN 85-255,965. MARK MCBRIDE, BRONX, NY. FILED 3-2-2011.

BUILDING CHARACTER

THE MARK CONSISTS OF STANDARD CHARACTERS WITHOUT CLAIM TO ANY PARTICULAR FONT, STYLE, SIZE, OR COLOR.

FOR DRAWINGS; CARTOON PRINTS; ART PRINTS (U.S. CLS. 2, 5, 22, 23, 29, 37, 38 AND 50).

FIRST USE 12-10-2009; IN COMMERCE 12-10-2009.

ANDREA HACK, EXAMINING ATTORNEY

SN 85-256,324. WARMUS, EDWARD, HONOLULU, HI. FILED 3-2-2011.

Never Look Where They Point

THE MARK CONSISTS OF STANDARD CHARACTERS WITHOUT CLAIM TO ANY PARTICULAR FONT, STYLE, SIZE, OR COLOR.

FOR SERIES OF NON-FICTION BOOKS IN THE FIELD OF BUSINESS (U.S. CLS. 2, 5, 22, 23, 29, 37, 38 AND 50).

FIRST USE 1-1-2011; IN COMMERCE 1-1-2011.

KARANENDRA S. CHHINA, EXAMINING ATTORNEY

CLASS 16—(Continued).

SN 85-256,498. MARTINEZ, TOMAS MARIO, FRESNO, CA. FILED 3-3-2011.

MARS-1

THE MARK CONSISTS OF STANDARD CHARACTERS WITHOUT CLAIM TO ANY PARTICULAR FONT, STYLE, SIZE, OR COLOR.

FOR ART PAINTINGS (U.S. CLS. 2, 5, 22, 23, 29, 37, 38 AND 50).

FIRST USE 1-1-1994; IN COMMERCE 5-5-1994.

EVELYN BRADLEY, EXAMINING ATTORNEY

SN 85-256,633. TREASURE LEARNING SYSTEMS, LLC, DBA DISCIPLINLAND, FORT COLLINS, CO. FILED 3-3-2011.

Disciples for Life

THE MARK CONSISTS OF STANDARD CHARACTERS WITHOUT CLAIM TO ANY PARTICULAR FONT, STYLE, SIZE, OR COLOR.

FOR EDUCATIONAL PUBLICATIONS, NAMELY, EDUCATIONAL LEARNING CARDS, FLASH CARDS, ACTIVITY CARDS, WORKBOOKS, TEXTBOOKS, ACTIVITY BOOKS, STORY BOOKS, PUZZLE BOOKS, PRINTED PUZZLES, TEACHER GUIDES, MANUALS, POSTERS AND EDUCATIONAL BOOKLETS IN THE FIELD OF RELIGION (U.S. CLS. 2, 5, 22, 23, 29, 37, 38 AND 50).

FIRST USE 12-7-2009; IN COMMERCE 12-7-2009.

TASNEEM HUSSAIN, EXAMINING ATTORNEY

SN 85-256,933. CLEARWATER PAPER CORPORATION, SPOKANE, WA. FILED 3-3-2011.

SPILL AWAY

THE MARK CONSISTS OF STANDARD CHARACTERS WITHOUT CLAIM TO ANY PARTICULAR FONT, STYLE, SIZE, OR COLOR.

FOR PAPER TOWELS (U.S. CLS. 2, 5, 22, 23, 29, 37, 38 AND 50).

DOMINIC J. FERRAIUOLO, EXAMINING ATTORNEY

CLASS 16—(Continued).

SN 85-256,935. DIANNE DENGEL, ROCHESTER, NY. FILED 3-3-2011.

DIANNE DENGEL

THE MARK CONSISTS OF STANDARD CHARACTERS WITHOUT CLAIM TO ANY PARTICULAR FONT, STYLE, SIZE, OR COLOR.

THE NAME(S), PORTRAIT(S), AND/OR SIGNATURE(S) SHOWN IN THE MARK IDENTIFIES DIANNE DENGEL, WHOSE CONSENT(S) TO REGISTER IS MADE OF RECORD.

FOR ILLUSTRATIONS (U.S. CLS. 2, 5, 22, 23, 29, 37, 38 AND 50).

FIRST USE 0-0-1957; IN COMMERCE 12-0-1971.

DOMINIC J. FERRAIUOLO, EXAMINING ATTORNEY

CLASS 16—(Continued).

SN 85-257,154. LIFE PLUS STYLE LTD., NEW YORK, NY. FILED 3-3-2011.

TROMPE L'OEIL

THE MARK CONSISTS OF STANDARD CHARACTERS WITHOUT CLAIM TO ANY PARTICULAR FONT, STYLE, SIZE, OR COLOR.

THE ENGLISH TRANSLATION OF TROMPE L'OEIL IN THE MARK IS TO FOOL THE EYE.

FOR BLANK JOURNALS; MEMO PADS; NOTE CARDS; PEN AND PENCIL CASES; STATIONERY (U.S. CLS. 2, 5, 22, 23, 29, 37, 38 AND 50).

FIRST USE 1-5-2011; IN COMMERCE 1-5-2011.

MARLENE BELL, EXAMINING ATTORNEY

SN 85-257,060. JEFFREY ROSEN, AVENTURA, FL. FILED 3-3-2011.

TATWO

THE MARK CONSISTS OF STANDARD CHARACTERS WITHOUT CLAIM TO ANY PARTICULAR FONT, STYLE, SIZE, OR COLOR.

FOR TWO-SIDED MARKERS FOR TEMPORARY TATTOOS (U.S. CLS. 2, 5, 22, 23, 29, 37, 38 AND 50).

JACLYN KIDWELL WALKER, EXAMINING ATTORNEY

SN 85-257,444. A HIGHER POSSIBILITY, SAN RAFAEL, CA. FILED 3-3-2011.

CREATE THE LOVE OF YOUR LIFE - KEEP THE LIFE IN YOUR LOVE.

THE MARK CONSISTS OF STANDARD CHARACTERS WITHOUT CLAIM TO ANY PARTICULAR FONT, STYLE, SIZE, OR COLOR.

FOR BOOKS IN THE FIELD OF RELATIONSHIPS (U.S. CLS. 2, 5, 22, 23, 29, 37, 38 AND 50).

WENDY GOODMAN, EXAMINING ATTORNEY

SN 85-257,106. PIXLEY, JAMES W., ALPHARETTA, GA. FILED 3-3-2011.

MASCOT

THE MARK CONSISTS OF STANDARD CHARACTERS WITHOUT CLAIM TO ANY PARTICULAR FONT, STYLE, SIZE, OR COLOR.

FOR MAGAZINE FEATURING VINTAGE CARS (U.S. CLS. 2, 5, 22, 23, 29, 37, 38 AND 50).

LEIGH CAROLINE CASE, EXAMINING ATTORNEY

SN 85-257,622. WARGAMES FACTORY LLC, LONGMONT, CO. FILED 3-3-2011.

ALIEN SUNS

THE MARK CONSISTS OF STANDARD CHARACTERS WITHOUT CLAIM TO ANY PARTICULAR FONT, STYLE, SIZE, OR COLOR.

FOR ROLE PLAYING GAME MAGAZINES, BOOKS AND MANUALS; COMIC BOOKS; RULE BOOKS FOR PLAYING GAMES; PRINTED INSTRUCTIONAL MANUALS IN THE AREA OF HOBBY GAMES, SKIRMISH GAMES, WAR GAMES, TABLE TOP GAMES AND ROLE PLAYING GAMES (U.S. CLS. 2, 5, 22, 23, 29, 37, 38 AND 50).

TINA BROWN, EXAMINING ATTORNEY

CLASS 16—(Continued).

SN 85-257,664. SQUARE ONE CANVAS, LLC, DELTONA, FL. FILED 3-4-2011.



Your picture's starting place.

NO CLAIM IS MADE TO THE EXCLUSIVE RIGHT TO USE "CANVAS LLC", APART FROM THE MARK AS SHOWN.

THE COLOR(S) RED, GREY, DARK GREY, WHITE IS/ARE CLAIMED AS A FEATURE OF THE MARK.

THE MARK CONSISTS OF THE STYLIZED RED WORDING "SQUARE ONE CANVAS, LLC." APPEARING SUPERIMPOSED OVER A ROTATED CUBE, THAT APPEARS IN GREY AND DARK GREY OUTLINED IN WHITE. THE PHRASE "YOUR PICTURE'S STARTING PLACE." APPEARS IN RED BELOW.

FOR ART PRINTS; ART PRINTS COMPRISED OF DIGITAL ILLUSTRATIONS ORIGINATING FROM PHOTOGRAPHS; ART PRINTS ON CANVAS; CANVAS FOR PRINTING; GICLEE PRINTS (U.S. CLS. 2, 5, 22, 23, 29, 37, 38 AND 50).

FIRST USE 3-3-2011; IN COMMERCE 3-3-2011.
GISELLE AGOSTO, EXAMINING ATTORNEY

CLASS 16—(Continued).

SN 85-260,322. MCCREA, DARREN J., DBA SPOKAMSTERDAM, SPOKANE, WA. FILED 3-7-2011.

Spokamsterdam

THE MARK CONSISTS OF STANDARD CHARACTERS WITHOUT CLAIM TO ANY PARTICULAR FONT, STYLE, SIZE, OR COLOR.

FOR PACKAGED KITS COMPRISING PRINTED INSTRUCTIONAL, EDUCATIONAL, AND TEACHING MATERIALS FOR EDUCATIONAL ACTIVITIES IN THE FIELD OF AGRICULTURE (U.S. CLS. 2, 5, 22, 23, 29, 37, 38 AND 50).

THOMAS MANOR, EXAMINING ATTORNEY

SN 85-263,488. REDCAMPER, INC., DENVER, CO. FILED 3-10-2011.



OWNER OF U.S. REG. NO. 3,422,570.

THE COLOR(S) RED AND WHITE IS/ARE CLAIMED AS A FEATURE OF THE MARK.

THE MARK CONSISTS OF AN ILLUSTRATION OF A RED CAMPER TRAILER FOLLOWED BY THE WORD "REDCAMPER" WITH THE WORD "RED" IN RED AND THE WORD "CAMPER" IN WHITE WITH A RED OUTLINE.

FOR GREETING CARDS (U.S. CLS. 2, 5, 22, 23, 29, 37, 38 AND 50).

FIRST USE 8-1-2009; IN COMMERCE 8-1-2009.

DANIEL CAPSHAW, EXAMINING ATTORNEY

SN 85-260,258. TUCKER, MELODY CLAIRE, ALDERWOOD MANOR, WA. FILED 3-7-2011.

NOSE-TO-TOES

THE MARK CONSISTS OF STANDARD CHARACTERS WITHOUT CLAIM TO ANY PARTICULAR FONT, STYLE, SIZE, OR COLOR.

FOR MONTHLY NEWSLETTER IN THE FIELD OF ANIMALS (U.S. CLS. 2, 5, 22, 23, 29, 37, 38 AND 50).

FIRST USE 6-1-1996; IN COMMERCE 6-1-1996.

HEATHER THOMPSON, EXAMINING ATTORNEY

SN 85-264,750. TODD DOMKE, CANTON, MA. AND JUDAH DOMKE, SOUTHPORT, CT. FILED 3-11-2011.

PSYCH-OUT

THE MARK CONSISTS OF STANDARD CHARACTERS WITHOUT CLAIM TO ANY PARTICULAR FONT, STYLE, SIZE, OR COLOR.

FOR SERIES OF NON-FICTION BOOKS IN THE FIELDS OF COMEDY, SPORTS, RECREATION, ENTERTAINMENT, EDUCATION, PARENTING, BUSINESS, POLITICS AND RELATIONSHIPS (U.S. CLS. 2, 5, 22, 23, 29, 37, 38 AND 50).

TASNEEM HUSSAIN, EXAMINING ATTORNEY

CLASS 16—(Continued).

SN 85-268,652. WOLTERS KLUWER HEALTH, INC., PHILADELPHIA, PA. FILED 3-16-2011.

ADVANCES IN NURSING SCIENCE

THE MARK CONSISTS OF STANDARD CHARACTERS WITHOUT CLAIM TO ANY PARTICULAR FONT, STYLE, SIZE, OR COLOR.
 OWNER OF U.S. REG. NO. 1,149,344.
 SEC. 2(F).
 FOR JOURNAL CONCERNING NURSING SCIENCE (U.S. CLS. 2, 5, 22, 23, 29, 37, 38 AND 50).
 FIRST USE 0-0-1978; IN COMMERCE 0-0-1978.
 SHAUNIA CARLYLE, EXAMINING ATTORNEY

SN 85-280,208. SPC RESOURCES, INC., HARTSVILLE, SC. FILED 3-29-2011.

SEALTAB

THE MARK CONSISTS OF STANDARD CHARACTERS WITHOUT CLAIM TO ANY PARTICULAR FONT, STYLE, SIZE, OR COLOR.
 FOR BAGS OR POUCHES MADE OF FLEXIBLE PLASTIC LAMINATE COMPOSITE FILMS FOR USE IN THE PACKAGING OF FOOD PRODUCTS, HOUSEHOLD PRODUCTS AND PERSONAL CARE PRODUCTS (U.S. CLS. 2, 5, 22, 23, 29, 37, 38 AND 50).
 ELLEN PERKINS, EXAMINING ATTORNEY

SN 85-281,136. JULIE T. CHEN, SAN JOSE, CA. FILED 3-30-2011.



THE COLOR(S) BLUE, TURQUOISE, GREEN, ORANGE, AND YELLOW IS/ARE CLAIMED AS A FEATURE OF THE MARK.
 THE MARK CONSISTS OF A LEAF PETAL WITH THE COLORS ORANGE, YELLOW, GREEN AND TURQUOISE DESIGN PLUS THE WORDS "MAKING HEALTHY EZ" IN BLUE.
 FOR BOOKS IN THE FIELD OF HEALTH, NUTRITION, DIET, WEIGHT MANAGEMENT, MIND AND BODY CONNECTION, MENTAL HEALTH, AND WELLNESS (U.S. CLS. 2, 5, 22, 23, 29, 37, 38 AND 50).
 WON TEAK OH, EXAMINING ATTORNEY

CLASS 16—(Continued).

SN 85-291,440. THE CARTOON NETWORK, INC., ATLANTA, GA. FILED 4-11-2011.

BEN 10 OMNIVERSE

THE MARK CONSISTS OF STANDARD CHARACTERS WITHOUT CLAIM TO ANY PARTICULAR FONT, STYLE, SIZE, OR COLOR.
 OWNER OF U.S. REG. NOS. 3,080,336, 3,819,704 AND OTHERS.
 THE NAME IN THE MARK DOES NOT REFER TO A PARTICULAR LIVING INDIVIDUAL.
 FOR PAPER PARTY DECORATIONS; CHILDREN'S BOOKS; STATIONERY; WRITING IMPLEMENTS, STICKERS, POSTERS AND CALENDARS (U.S. CLS. 2, 5, 22, 23, 29, 37, 38 AND 50).
 PAUL F. GAST, EXAMINING ATTORNEY

SN 85-300,295. LIFE PLUS STYLE LTD., NEW YORK, NY. FILED 4-20-2011.

UNTITLED

THE MARK CONSISTS OF STANDARD CHARACTERS WITHOUT CLAIM TO ANY PARTICULAR FONT, STYLE, SIZE, OR COLOR.
 FOR BLANK JOURNALS; MEMO PADS; NOTE CARDS; PEN AND PENCIL CASES; STATIONERY (U.S. CLS. 2, 5, 22, 23, 29, 37, 38 AND 50).
 FIRST USE 12-8-2010; IN COMMERCE 12-8-2010.
 MARLENE BELL, EXAMINING ATTORNEY

SN 85-300,328. LIFE PLUS STYLE LTD., NEW YORK, NY. FILED 4-20-2011.

LIFE IN COLOR

THE MARK CONSISTS OF STANDARD CHARACTERS WITHOUT CLAIM TO ANY PARTICULAR FONT, STYLE, SIZE, OR COLOR.
 FOR BLANK JOURNALS; MEMO PADS; NOTE CARDS; PEN AND PENCIL CASES; STATIONERY (U.S. CLS. 2, 5, 22, 23, 29, 37, 38 AND 50).
 FIRST USE 12-8-2010; IN COMMERCE 12-8-2010.
 MARLENE BELL, EXAMINING ATTORNEY

CLASS 16—(Continued).

SN 85-300,380. ZUFFA, LLC, LAS VEGAS, NV. FILED 4-20-2011.

UFC

THE MARK CONSISTS OF STANDARD CHARACTERS WITHOUT CLAIM TO ANY PARTICULAR FONT, STYLE, SIZE, OR COLOR.

OWNER OF U.S. REG. NOS. 2,706,754, 3,004,864 AND OTHERS.

FOR ADDRESS BOOKS; PHOTOGRAPH ALBUMS; APPOINTMENT BOOKS; ARTS AND CRAFT PAINT KITS; AUTOGRAPH BOOKS; BABY BOOKS; PAPER PARTY BAGS; BINDERS; BOOKENDS; BOOKMARKS; PAPER GIFT WRAP BOWS; PAPER CAKE DECORATIONS; GIFT CARDS; GREETING CARDS; CARTOON STRIPS; DECORATIVE PAPER CENTERPIECES; CHALK; CHILDREN'S ACTIVITY BOOKS; MODELING CLAY; PAPER TABLE CLOTHS; COLORING BOOKS; COMIC STRIPS; COMIC BOOKS; PAPER PARTY DECORATIONS; DIARIES; GIFT WRAPPING PAPER; PAPER NAPKINS; ENTERTAINMENT NEWSPAPERS; PAPER SHOPPING BAGS (U.S. CLS. 2, 5, 22, 23, 29, 37, 38 AND 50).

ROBIN CHOSID, EXAMINING ATTORNEY

CLASS 16—(Continued).

SN 85-315,336. ALLI, ALLIANCE OF ACTION SPORTS, LLC, BURR RIDGE, IL. FILED 5-9-2011.

ALLI SPORTS

THE MARK CONSISTS OF STANDARD CHARACTERS WITHOUT CLAIM TO ANY PARTICULAR FONT, STYLE, SIZE, OR COLOR.

OWNER OF U.S. REG. NO. 3,908,921.

NO CLAIM IS MADE TO THE EXCLUSIVE RIGHT TO USE "SPORTS", APART FROM THE MARK AS SHOWN.

FOR PRINTED MATERIALS, NAMELY, CALENDARS, POSTERS, STICKERS, AUTOGRAPH BOOKS, AND EVENT PROGRAMS; SCHOOL SUPPLIES, NAMELY, FOLDERS AND BOUND NOTEBOOKS (U.S. CLS. 2, 5, 22, 23, 29, 37, 38 AND 50).

JOHN WILKE, EXAMINING ATTORNEY

SN 85-320,782. BROWN PAPER TICKETS, LLC, DBA BROWN PAPER TICKETS, SEATTLE, WA. FILED 5-13-2011.



SN 85-307,421. CARSON-DELLOSA PUBLISHING, LLC, GREENSBORO, NC. FILED 4-28-2011.

SPECTRUM

THE MARK CONSISTS OF STANDARD CHARACTERS WITHOUT CLAIM TO ANY PARTICULAR FONT, STYLE, SIZE, OR COLOR.

FOR PRINTED MATERIALS, NAMELY, WORKBOOKS FOR CHILDREN IN THE FIELDS OF BASIC EARLY CHILDHOOD CONCEPTS, MATHEMATICS, READING COMPREHENSION, VOCABULARY, SPELLING, PHONICS, WRITING, TEST PRACTICE AND PREPARATION, GEOGRAPHY, LANGUAGE ARTS AND SCIENCE, AND LEARNING FLASHCARDS FOR CHILDREN IN THE FIELDS OF BASIC EARLY CHILDHOOD CONCEPTS AND MATHEMATICS (U.S. CLS. 2, 5, 22, 23, 29, 37, 38 AND 50).

FIRST USE 12-31-1997; IN COMMERCE 12-31-1997.
EDWARD NELSON, EXAMINING ATTORNEY

OWNER OF U.S. REG. NO. 3,927,297.

NO CLAIM IS MADE TO THE EXCLUSIVE RIGHT TO USE "PAPER TICKETS", APART FROM THE MARK AS SHOWN.

THE COLOR(S) BROWN, BLUE, ORANGE, AND WHITE IS/ARE CLAIMED AS A FEATURE OF THE MARK.

THE MARK CONSISTS OF STYLIZED WORDING "BROWN PAPER TICKETS" AS WELL AS THE DEPICTION OF THREE SEPARATE STYLIZED TICKET STUBS ARRANGED IN A HORIZONTAL LINE. THE COLOR WHITE APPEARS IN THE WORDING "BROWN PAPER TICKETS". THE COLOR BROWN APPEARS ON THE LEFT TICKET STUB THAT SURROUNDS THE WORD "BROWN". THE COLOR BLUE APPEARS ON THE MIDDLE TICKET STUB THAT SURROUNDS THE WORD "PAPER". THE COLOR ORANGE APPEARS ON THE RIGHT TICKET STUB THAT SURROUNDS THE WORD "TICKETS".

SEC. 2(F) AS TO "BROWN PAPER TICKETS".

FOR ENTRY TICKETS; PRINTED TICKETS; TICKET STOCK (U.S. CLS. 2, 5, 22, 23, 29, 37, 38 AND 50).

FIRST USE 1-1-2000; IN COMMERCE 1-1-2000.
MICHAEL TANNER, EXAMINING ATTORNEY

CLASS 17—RUBBER GOODS

SN 76-706,307. ACCUMETRIC, LLC, ELIZABETHTOWN, KY.
FILED 2-7-2011.

MEGALOC

THE MARK CONSISTS OF STANDARD CHARACTERS WITHOUT CLAIM TO ANY PARTICULAR FONT, STYLE, SIZE, OR COLOR.

OWNER OF U.S. REG. NO. 1,873,495.

FOR PIPE JOINT SEALANTS, NAMELY, MULTIPURPOSE THREAD SEALANTS FOR PLASTIC AND METAL THREADS FOR USE IN THE PLUMBING INDUSTRY (U.S. CLS. 1, 5, 12, 13, 35 AND 50).

FIRST USE 3-31-1999; IN COMMERCE 3-31-1999.

GINA FINK, EXAMINING ATTORNEY

CLASS 17—(Continued).

SN 79-088,118. WUHAN KINGBULL ECONOMIC DEVELOPMENT CO., LTD., HUBEI, CHINA, FILED 8-11-2010.



KINGBULL

OWNER OF INTERNATIONAL REGISTRATION 1053242 DATED 8-11-2010, EXPIRES 8-11-2020.

THE MARK CONSISTS OF A HIGHLY STYLIZED DESIGN OF A BULL HEAD AND THE WORD "KINGBULL".

FOR PLASTIC PLUMBING PIPES AND TUBES; PLASTIC COMPOSITE MATERIAL IN THE FORM OF BOARDS, RODS, AND BARS FOR USE IN MANUFACTURING; COUPLINGS, NOT OF METAL, FOR PLUMBING PIPES; PIPE JACKETS, NOT OF METAL FOR USE WITH PLUMBING PIPES; JOINT PACKING FOR PLUMBING PIPES (U.S. CLS. 1, 5, 12, 13, 35 AND 50).

CURTIS FRENCH, EXAMINING ATTORNEY

SN 85-061,898. ADVANCED THERMAL PRODUCTS, INC., IRVINE, CA. FILED 6-14-2010.



THE MARK CONSISTS OF AN ARROW CURVING AROUND TO THE RIGHT, FORMING A SEMICIRCLE, WITH THE TERM "ATP".

FOR INSULATION BLANKETS FOR INDUSTRIAL MACHINERY, INDUSTRIAL, FORESTRY, MINING AND AGRICULTURAL HEAVY EQUIPMENT, LAND VEHICLES, AIRCRAFT, SHIPS, BOATS AND MARINE VEHICLES; INSULATING MATERIAL, NAMELY, UNFITTED COVERS FOR INDUSTRIAL MACHINERY, INDUSTRIAL, FORESTRY, MINING AND AGRICULTURAL HEAVY EQUIPMENT, LAND VEHICLES, AIRCRAFT, SHIPS, BOATS AND MARINE VEHICLES; HEAT SHIELDS FOR FIRE PREVENTION FOR INDUSTRIAL MACHINERY, INDUSTRIAL, FORESTRY, MINING AND AGRICULTURAL HEAVY EQUIPMENT, LAND VEHICLES, AIRCRAFT, SHIPS, BOATS AND MARINE VEHICLES (U.S. CLS. 1, 5, 12, 13, 35 AND 50).

FIRST USE 2-0-1995; IN COMMERCE 2-0-1995.

KIM SAITO, EXAMINING ATTORNEY

SN 77-214,893. INVIBIO LIMITED, LANCASHIRE, UNITED KINGDOM, FILED 6-25-2007.

PEEK-OPTIMA

THE MARK CONSISTS OF STANDARD CHARACTERS WITHOUT CLAIM TO ANY PARTICULAR FONT, STYLE, SIZE, OR COLOR.

OWNER OF ERPN CMNTY TM OFC REG. NO. 001087592, DATED 7-26-2000, EXPIRES 2-22-2019.

OWNER OF U.S. REG. NO. 2,592,032.

FOR PLASTICS FOR USE IN MANUFACTURE OF GOODS OTHER THAN PACKAGING MATERIALS, NAMELY, PLASTICS IN THE FORM OF BARS, BLOCKS, PELLETS, RODS, GRANULES, SHEETS AND TUBES FOR USE IN MANUFACTURING, PLASTICS IN SEMI-FINISHED FORM FOR USE IN MANUFACTURE OF GOODS OTHER THAN PACKAGING MATERIALS, NAMELY, PLASTICS IN THE FORM OF BARS, BLOCKS, PELLETS, RODS, GRANULES, SHEETS AND TUBES ALL FOR USE IN MANUFACTURE (U.S. CLS. 1, 5, 12, 13, 35 AND 50).

JAMES LOVELACE, EXAMINING ATTORNEY

CLASS 17—(Continued).

SN 85-091,642. KRATON POLYMERS U.S. LLC, HOUSTON, TX. FILED 7-23-2010.

CARIFLEX

THE MARK CONSISTS OF STANDARD CHARACTERS WITHOUT CLAIM TO ANY PARTICULAR FONT, STYLE, SIZE, OR COLOR.

FOR RUBBER AND RUBBER LATEX FOR USE IN MANUFACTURING IN A WIDE VARIETY OF INDUSTRIES NOT FOR USE IN MANUFACTURING IMPACT RESISTANT ARMOR AND SHIELDING GOODS, EQUIPMENT AND MATERIALS USED FOR BALLISTIC PROTECTION AND PROTECTION FROM PROJECTILES (U.S. CLS. 1, 5, 12, 13, 35 AND 50).

TRACY WHITTAKER-BROWN, EXAMINING ATTORNEY

CLASS 17—(Continued).

SN 85-158,877. TECHNICAL RUBBER COMPANY, INC., JOHNSTOWN, OH. FILED 10-22-2010.

PANG INDUSTRIAL

THE MARK CONSISTS OF STANDARD CHARACTERS WITHOUT CLAIM TO ANY PARTICULAR FONT, STYLE, SIZE, OR COLOR.

NO CLAIM IS MADE TO THE EXCLUSIVE RIGHT TO USE "INDUSTRIAL", APART FROM THE MARK AS SHOWN.

FOR INDUSTRIAL RUBBER PRODUCTS, NAMELY, RUBBER LINING TO COVER METAL CHUTES AND INSIDE METAL TANKS FOR PROTECTION AGAINST GRAVEL, COAL, ORE AND SLURRY; RUBBER SHEETING CHUTE LINING AND PULLEY LAGGING; RUBBER COVERING FOR DRIVEN AND NON DRIVEN PULLEYS ALL FOR USE IN THE FURTHER MANUFACTURE OF DRIVE PULLEYS FOR INDUSTRIAL CONVEYOR BELTS; RUBBER SHEETING USED FOR SPLICES AND REPLACING BELT COVERS; RUBBER REPAIR STRIPS TO COVER AND PROTECT SURFACES; RUBBER SHEETING USED FOR SKIRT BOARDS; REPAIR STRIPS MADE OF NON-METAL FABRIC FOR THE REPAIR OF HEAVY DUTY CONVEYOR BELTS (U.S. CLS. 1, 5, 12, 13, 35 AND 50).

LINDA E. BLOHM, EXAMINING ATTORNEY

SN 85-109,271. SCAPA NORTH AMERICA INC., WINDSOR, CT. FILED 8-17-2010.

Polyflex

THE MARK CONSISTS OF STANDARD CHARACTERS WITHOUT CLAIM TO ANY PARTICULAR FONT, STYLE, SIZE, OR COLOR.

OWNER OF U.S. REG. NO. 2,149,788.

FOR WATERPROOF PRESSURE SENSITIVE ADHESIVE TAPE FOR INDUSTRIAL AND COMMERCIAL USE (U.S. CLS. 1, 5, 12, 13, 35 AND 50).

FIRST USE 8-11-2009; IN COMMERCE 8-11-2009.

WENDY JUN, EXAMINING ATTORNEY

SN 85-198,927. LANUZA, CRAIG S., VENTURA, CA. FILED 12-15-2010.

MAGTACK

THE MARK CONSISTS OF STANDARD CHARACTERS WITHOUT CLAIM TO ANY PARTICULAR FONT, STYLE, SIZE, OR COLOR.

FOR LAMINATE FOIL CONSISTING PRIMARILY OF PLASTIC WITH OR WITHOUT A METAL LAYER FOR APPLICATION TO A SUBSTRATE (U.S. CLS. 1, 5, 12, 13, 35 AND 50).

FIRST USE 1-1-2002; IN COMMERCE 1-1-2002.

MARY ROSSMAN, EXAMINING ATTORNEY

CLASS 17—(Continued).

SN 85-250,822. THE GARLAND COMPANY, INC., CLEVELAND, OH. FILED 2-24-2011.

TUFF-STUFF

THE MARK CONSISTS OF STANDARD CHARACTERS WITHOUT CLAIM TO ANY PARTICULAR FONT, STYLE, SIZE, OR COLOR.

FOR POLYMER SEALANT AND BONDING AGENT FOR USE IN SEALING AND BONDING EXPANSION AND CONTROL JOINTS, REGLETS, PRECAST PANELS, TILTUP WALLS, METAL CURTAIN WALLS, COPINGS, WINDOW AND DOOR PERIMETERS, PANEL BEDDING AND GLAZING DETAILS; POLYURETHANE SEALANT AND BONDING AGENT FOR USE IN SEALING AND BONDING EXPANSION AND CONTROL JOINTS, REGLETS, PRECAST PANELS, TILTUP WALLS, METAL CURTAIN WALLS, COPINGS, WINDOW AND DOOR PERIMETERS, PANEL BEDDING AND GLAZING DETAILS (U.S. CLS. 1, 5, 12, 13, 35 AND 50).

FIRST USE 2-1-2011; IN COMMERCE 2-1-2011.
DAWN FELDMAN, EXAMINING ATTORNEY

SN 85-251,626. ROGERS CORPORATION, ROGERS, CT. FILED 2-25-2011.

THINSTIK

THE MARK CONSISTS OF STANDARD CHARACTERS WITHOUT CLAIM TO ANY PARTICULAR FONT, STYLE, SIZE, OR COLOR.

FOR URETHANE FOAMS FEATURING AN ADHESIVE LAYER OR LAYERS, FOR USE IN ELECTRONIC DEVICES FOR GASKETING, SEALING, FILLING VARIABLE GAPS, CUSHIONING, IMPACT, VIBRATION, AND ACOUSTICAL DAMPING (U.S. CLS. 1, 5, 12, 13, 35 AND 50).

BARBARA RUTLAND, EXAMINING ATTORNEY

SN 85-252,972. HANITA COATINGS RCA LTD., HANITA, ISRAEL, FILED 2-28-2011.

DURASHIELD

THE MARK CONSISTS OF STANDARD CHARACTERS WITHOUT CLAIM TO ANY PARTICULAR FONT, STYLE, SIZE, OR COLOR.

FOR LAMINATED FILM IN ROLL FORMAT FOR PHOTOVOLTAIC PANEL ENCAPSULATION TO PROVIDE ELECTRICAL INSULATION, MECHANICAL STRENGTH AND BARRIER FROM GAS PERMEATION AND UV RADIANT (U.S. CLS. 1, 5, 12, 13, 35 AND 50).

KATHERINE M. DUBRAY, EXAMINING ATTORNEY

CLASS 17—(Continued).

SN 85-254,567. HENRY COMPANY CANADA, INC., SCARBOROUGH, ONTARIO, CANADA, FILED 3-1-2011.

BlueskinVP

THE MARK CONSISTS OF STANDARD CHARACTERS WITHOUT CLAIM TO ANY PARTICULAR FONT, STYLE, SIZE, OR COLOR.

OWNER OF U.S. REG. NO. 1,568,993.
FOR SYNTHETIC NON-WOVEN BARRIER MATERIAL IN THE NATURE OF SHEETS OF PLASTIC FABRIC USED AS A PROTECTIVE AND ISOLATIVE BARRIER IN BUILDING CONSTRUCTION (U.S. CLS. 1, 5, 12, 13, 35 AND 50).

FIRST USE 8-0-2009; IN COMMERCE 8-0-2009.
PAM WILLIS, EXAMINING ATTORNEY

SN 85-254,945. IZOMAKS YALITIM VE ENDUSTRI SANAYI TICARET ANONIM SIRKETI, CERKEZKOY - TEKIRDAG, TURKEY, FILED 3-1-2011.



THE COLOR(S) LIGHT BLUE IS/ARE CLAIMED AS A FEATURE OF THE MARK.

THE MARK CONSISTS OF THE TERM "POLIONE" IN LIGHT BLUE, STYLIZED LETTERING.

FOR CONSTRUCTION MATERIALS, NAMELY, A NONMETAL SUB-FLOOR MEMBRANE FOR RESIDENTIAL AND COMMERCIAL SOUNDPROOFING USE; INSULATING WATER PROOFING MEMBRANES; WATER PROOFING MEMBRANES FOR FOUNDATIONS OF BUILDINGS; WEATHERIZING MEMBRANES AND VAPOR BARRIERS (U.S. CLS. 1, 5, 12, 13, 35 AND 50).

SIMON TENG, EXAMINING ATTORNEY

SN 85-256,873. TORAY FILM KAKOH KABUSHIKI KAISHA, TA TORAY ADVANCED FILM CO., LTD., 3-CHOME CHUO-KU, TOKYO, JAPAN, FILED 3-3-2011.

Torettec

THE MARK CONSISTS OF STANDARD CHARACTERS WITHOUT CLAIM TO ANY PARTICULAR FONT, STYLE, SIZE, OR COLOR.

FOR PLASTIC FILM FOR COMMERCIAL AND INDUSTRIAL USE; ADHESIVE PLASTIC FILM FOR INDUSTRIAL AND COMMERCIAL USE (U.S. CLS. 1, 5, 12, 13, 35 AND 50).

FIRST USE 10-0-1989; IN COMMERCE 7-0-1998.
JUDITH HELFMAN, EXAMINING ATTORNEY

CLASS 17—(Continued).

SN 85-273,437. SPC RESOURCES, INC., HARTSVILLE, SC. FILED 3-22-2011.

SEALTAB

THE MARK CONSISTS OF STANDARD CHARACTERS WITHOUT CLAIM TO ANY PARTICULAR FONT, STYLE, SIZE, OR COLOR.

FOR PLASTIC FLEXIBLE PACKAGING FILM SOLD IN BULK TO INDUSTRIAL AND COMMERCIAL MANUFACTURERS (U.S. CLS. 1, 5, 12, 13, 35 AND 50). ELLEN PERKINS, EXAMINING ATTORNEY

CLASS 18—LEATHER GOODS

SN 77-079,168. PEI LICENSING, INC., MIAMI, FL. FILED 1-9-2007.

LAUNDRY BY DESIGN

THE MARK CONSISTS OF STANDARD CHARACTERS WITHOUT CLAIM TO ANY PARTICULAR FONT, STYLE, SIZE, OR COLOR.

OWNER OF U.S. REG. NOS. 3,083,904 AND 3,122,190. FOR BACKPACKS; BRIEFCASES; CLUTCHES; COSMETIC CASES SOLD EMPTY; CREDIT CARD CASES; HANDBAGS; KEY CASES; LUGGAGE; PURSES; SPORTS BAGS; UMBRELLAS; WALLETS (U.S. CLS. 1, 2, 3, 22 AND 41).

JAMES LOVELACE, EXAMINING ATTORNEY

SN 77-556,086. VINTAGE BEBE, LLC, JEFFERSONVILLE, IN. FILED 8-26-2008.

Z Sling

THE MARK CONSISTS OF STANDARD CHARACTERS WITHOUT CLAIM TO ANY PARTICULAR FONT, STYLE, SIZE, OR COLOR.

NO CLAIM IS MADE TO THE EXCLUSIVE RIGHT TO USE "SLING", APART FROM THE MARK AS SHOWN.

FOR SLINGS FOR CARRYING INFANTS (U.S. CLS. 1, 2, 3, 22 AND 41).

FIRST USE 2-16-2008; IN COMMERCE 2-16-2008. KATINA MISTER, EXAMINING ATTORNEY

CLASS 18—(Continued).

SN 78-446,607. NUDIE PTY. LTD., EASTGARDENS, AUSTRALIA, FILED 7-6-2004.

NUDIE

THE MARK CONSISTS OF STANDARD CHARACTERS WITHOUT CLAIM TO ANY PARTICULAR FONT, STYLE, SIZE, OR COLOR.

FOR BAGS, NAMELY, DUFFEL BAGS AND CARRY ALL BAGS; BACKPACKS; FANNY PACKS, HAVERSACKS AND SATCHELS; VALISES, SUITCASES, GARMENT BAGS AND TRUNKS; PURSES, WALLETS, HANDBAGS, BRIEFCASES, AND KEY CASES; UMBRELLAS AND PARASOLS AND COVERS THEREFORE (U.S. CLS. 1, 2, 3, 22 AND 41).

PRISCILLA MILTON, EXAMINING ATTORNEY

SN 79-092,152. XIAMEN CITY SPARK IMP. & EXP. CO., LTD., SIMING, XIAMEN; FUJIAN, CHINA, FILED 1-4-2011.



OWNER OF INTERNATIONAL REGISTRATION 1063991 DATED 1-4-2011, EXPIRES 1-4-2021.

THE MARK CONSISTS OF A CIRCLE DESIGN SPLIT INTO FOUR QUADRANTS BY A GREEK CROSS. THREE OF THE QUADRANTS ARE FILLED IN AND THE FOURTH IS EMPTY.

FOR IMITATION LEATHER; ANIMAL SKINS, NAMELY, MOLESKIN; UMBRELLAS, SCHOOL SATCHELS; VALISES; POCKET WALLETS; BRIEFCASES; BACKPACKS; LEATHER LEASHES; LEATHER SHOULDER BELTS (U.S. CLS. 1, 2, 3, 22 AND 41).

MATTHEW MCDOWELL, EXAMINING ATTORNEY

CLASS 18—(Continued).

SN 79-093,017. VALENTINO S.P.A., I-20121 MILANO, ITALY, FILED 12-9-2010.

ROCKSTUD

THE MARK CONSISTS OF STANDARD CHARACTERS WITHOUT CLAIM TO ANY PARTICULAR FONT, STYLE, SIZE, OR COLOR.

PRIORITY DATE OF 6-28-2010 IS CLAIMED. OWNER OF INTERNATIONAL REGISTRATION 1066376 DATED 12-9-2010, EXPIRES 12-9-2020.

FOR LEATHER AND IMITATIONS OF LEATHER, HANDBAGS, WALLETS, LUGGAGE, ATTACHE CASES, TOTE BAGS, BRIEFCASES, SPORTS BAGS, TRAVELING TRUNKS, CARRY-ON BAGS, SHOULDER BAGS, GARMENT BAGS FOR TRAVELLING, KEY CASES, UMBRELLAS, PARASOLS, WALKING STICKS, WHIPS, HARNESES, SADDLERY (U.S. CLS. 1, 2, 3, 22 AND 41). PATRICIA EVANKO, EXAMINING ATTORNEY



SN 79-095,920. GABOL, S.L., E-46113MONCADA (VALENCIA), SPAIN, FILED 2-23-2011.

GABOL

OWNER OF INTERNATIONAL REGISTRATION 0569019 DATED 3-10-1991, EXPIRES 3-10-2021.

FOR TRAVELING BAGS, SPORTS BAGS, WOMEN'S HANDBAGS, POCKET WALLETS, BRIEFCASES, SUITCASES, COIN PURSES (U.S. CLS. 1, 2, 3, 22 AND 41). DAVID HOFFMAN, EXAMINING ATTORNEY



SN 85-085,446. L & LEUNG HANDBAGS MFY. LTD., NEW TERRITORIES, HONG KONG, FILED 7-15-2010.

envy

THE MARK CONSISTS OF STANDARD CHARACTERS WITHOUT CLAIM TO ANY PARTICULAR FONT, STYLE, SIZE, OR COLOR.

FOR HANDBAGS (U.S. CLS. 1, 2, 3, 22 AND 41). MARK SHINER, EXAMINING ATTORNEY

CLASS 18—(Continued).

SN 85-093,464. CELLURA, ASHLEY, ROCHESTER, NY. AND SULLIVAN ELIZA, ROCHESTER, NY. FILED 7-27-2010.

EVEN ODD

THE MARK CONSISTS OF STANDARD CHARACTERS WITHOUT CLAIM TO ANY PARTICULAR FONT, STYLE, SIZE, OR COLOR.

FOR CARRY-ALL BAGS; HANDBAGS, PURSES AND WALLETS; HOBO BAGS; MESSENGER BAGS; MULTI-PURPOSE PURSES; PURSES; PURSES AND WALLETS; REUSABLE SHOPPING BAGS; SHOULDER BAGS; SLING BAGS; TOTE BAGS (U.S. CLS. 1, 2, 3, 22 AND 41).

FIRST USE 4-30-2009; IN COMMERCE 5-7-2010. DEBRA LEE, EXAMINING ATTORNEY



SN 85-097,943. BACIK, JOHN ANDREW, SCOTTSDALE, AZ. FILED 8-2-2010.

FLEXX

THE MARK CONSISTS OF STANDARD CHARACTERS WITHOUT CLAIM TO ANY PARTICULAR FONT, STYLE, SIZE, OR COLOR.

FOR MARKET UMBRELLAS; BEACH UMBRELLAS; OUTDOOR UMBRELLAS; PATIO UMBRELLAS; TABLE UMBRELLAS; DECK UMBRELLAS; UMBRELLAS SUPPORTED BY UMBRELLA STANDS, ALL OF THE FOREGOING BEING WIND-RESISTANT COMMERCIAL GRADE UMBRELLAS, NOT FOR HAND-HELD USE (U.S. CLS. 1, 2, 3, 22 AND 41).

FIRST USE 7-30-2010; IN COMMERCE 7-30-2010. TRICIA SONNEBORN, EXAMINING ATTORNEY

CLASS 18—(Continued).

SN 85-102,380. SAN FRANCISCO SOCIETY FOR THE PREVENTION OF CRUELTY TO ANIMALS, SAN FRANCISCO, CA. FILED 8-6-2010.

ECO-DOG

THE MARK CONSISTS OF STANDARD CHARACTERS WITHOUT CLAIM TO ANY PARTICULAR FONT, STYLE, SIZE, OR COLOR.

FOR ANIMAL LEASHES; DOG APPAREL; DOG CLOTHING; DOG COATS; DOG COLLARS; DOG COLLARS AND LEADS; DOG LEASHES; DOG PARKAS; DOG SHOES; LEASHES FOR ANIMALS; NECKWEAR FOR DOGS; PET ACCESSORIES, NAMELY, SPECIALLY DESIGNED CANVAS, VINYL OR LEATHER BAGS ATTACHED TO ANIMAL LEASHES FOR HOLDING SMALL ITEMS SUCH AS KEYS, CREDIT CARDS, MONEY OR DISPOSABLE BAGS FOR DISPOSING OF PET WASTE; PET PRODUCTS, NAMELY, PET RESTRAINING DEVICES CONSISTING OF LEASHES, COLLARS, HARNESSES, RESTRAINING STRAPS, AND LEASHES WITH LOCKING DEVICES; PET TAGS SPECIALLY ADAPTED FOR ATTACHING TO PET LEASHES OR COLLARS; RAWHIDE CHEWS FOR DOGS (U.S. CLS. 1, 2, 3, 22 AND 41).

LINDA MICKLEBURGH, EXAMINING ATTORNEY

SN 85-114,059. ABLE PLANET, INCORPORATED, WHEAT RIDGE, CO. FILED 8-23-2010.

EXTREME

THE MARK CONSISTS OF STANDARD CHARACTERS WITHOUT CLAIM TO ANY PARTICULAR FONT, STYLE, SIZE, OR COLOR.

FOR ALL PURPOSE BAGS, NAMELY, SPORTS, ATHLETIC, CARRY-ALL, DUFFLE, GYM, HIKING, MESH SHOPPING AND TOTE BAGS; BACKPACKS; POUCHES AND BAGS SOLD EMPTY FOR ATTACHMENT TO BACKPACKS; SACK PACKS, NAMELY, DRAWSTRING BAGS USED AS BACKPACKS; SOUVENIR BAGS; TRAVEL BAGS (U.S. CLS. 1, 2, 3, 22 AND 41).

ARETHA SOMERVILLE, EXAMINING ATTORNEY

SN 85-116,966. HICKEN, WILLIAM M., MOUNT PLEASANT, SC. FILED 8-26-2010.



THE MARK CONSISTS OF STYLIZED LETTERS "YB" AND WINGS.

FOR HANDBAGS; POCKETBOOKS (U.S. CLS. 1, 2, 3, 22 AND 41).

ARETHA SOMERVILLE, EXAMINING ATTORNEY

CLASS 18—(Continued).

SN 85-117,937. RELIANCE BRAND, LLC, MONTEBELLO, CA. FILED 8-27-2010.

S.Y.L.K.

THE MARK CONSISTS OF THE STYLIZED LETTER "S" FOLLOWED BY A PERIOD, FOLLOWED BY A STYLIZED LETTER "Y", FOLLOWED BY A PERIOD, FOLLOWED BY A STYLIZED LETTER "L" FOLLOWED BY A PERIOD, FOLLOWED BY A STYLIZED LETTER "K" FOLLOWED BY A PERIOD.

FOR WALLETS; PURSES; POCKETBOOKS; HANDBAGS; SHOULDER BAGS; CLUTCH BAGS; TOTE BAGS; BOOK BAGS; BUSINESS, CREDIT AND NAME CARD CASES; KEY CASES; COSMETIC CASES SOLD EMPTY; TOILETRY CASES SOLD EMPTY; DUFFEL BAGS; UMBRELLAS; BACKPACKS; VANITY CASES SOLD EMPTY; TRAVELLING BAGS (U.S. CLS. 1, 2, 3, 22 AND 41).

CHERYL CLAYTON, EXAMINING ATTORNEY

SN 85-125,614. INTEUS INTERNATIONAL, NORWOOD, NJ. FILED 9-9-2010.

YASMAÚRA

THE MARK CONSISTS OF STANDARD CHARACTERS WITHOUT CLAIM TO ANY PARTICULAR FONT, STYLE, SIZE, OR COLOR.

FOR ALL-PURPOSE CARRYING BAGS; HANDBAGS, POCKETBOOKS, SHOULDER BAGS, CLUTCH PURSES, CREDIT CARD CASES, KEY CASES, PURSES, SHOPPING BAGS MADE OF LEATHER, POUCHES OF LEATHER OR TEXTILE, TOTE BAGS, TRAVEL BAGS, COSMETIC BAGS SOLD EMPTY, BACKPACKS, DUFFLE BAGS, SLING BAGS, OVERNIGHT BAGS, OVERNIGHT CASES, WEEKENDER BAGS, CARRY-ON BAGS, ATTACHE CASES, SATCHELS, BELT BAGS, WALLETS, UMBRELLAS (U.S. CLS. 1, 2, 3, 22 AND 41).

ALEXANDER L. POWERS, EXAMINING ATTORNEY

CLASS 18—(Continued).

SN 85-185,951. INTEUS INTERNATIONAL, NORWOOD, NJ. FILED 11-29-2010.



NO CLAIM IS MADE TO THE EXCLUSIVE RIGHT TO USE "USA", APART FROM THE MARK AS SHOWN.

THE MARK CONSISTS OF THE MARK "IEOLUS" IS LOCATED ABOVE THE TERM "USA" AND A DESIGN OF TWO STANDING SEMI-ARCED ARCHES IN A SHIELD DESIGN.

FOR ALL-PURPOSE CARRYING BAGS; HANDBAGS, POCKETBOOKS, SHOULDER BAGS, CLUTCH PURSES, CREDIT CARD CASES, KEY CASES, PURSES, SHOPPING BAGS MADE OF LEATHER, POUCHES OF LEATHER OR TEXTILE, TOTE BAGS, TRAVEL BAGS, COSMETIC BAGS SOLD EMPTY, BACKPACKS, DUFFLE BAGS, SLING BAGS, OVERNIGHT BAGS, OVERNIGHT CASES, WEEKENDER BAGS, CARRY-ON BAGS, AT-TACHÉ CASES, SATCHELS, BELT BAGS, WALLETS, UMBRELLAS (U.S. CLS. 1, 2, 3, 22 AND 41).

ALEXANDER L. POWERS, EXAMINING ATTORNEY

SN 85-191,780. GLOCK, GASTON J., WIEN 1190, AUSTRIA, FILED 12-6-2010.



THE NAME "GASTON" IDENTIFIES A LIVING INDIVIDUAL WHOSE CONSENT IS OF RECORD.

THE COLOR(S) RED, BLACK, AND WHITE IS/ARE CLAIMED AS A FEATURE OF THE MARK.

THE MARK CONSISTS OF THE WORD "GASTON" IN BLACK AND INCORPORATES A WHITE "G" INSIDE A RED CIRCLE DESIGN LOGO, WHICH STANDS FOR THE LETTER "O" IN "GASTON".

FOR SPORTS BAGS; ATHLETIC BAGS; BACK PACKS; RUCK SACKS; TRAVEL BAGS; DUFFLE BAGS (U.S. CLS. 1, 2, 3, 22 AND 41).

JANICE L. MCMORROW, EXAMINING ATTORNEY

CLASS 18—(Continued).

SN 85-191,801. GLOCK, GASTON J., WIEN 1190, AUSTRIA, FILED 12-7-2010.



THE COLOR(S) RED AND WHITE IS/ARE CLAIMED AS A FEATURE OF THE MARK.

THE MARK CONSISTS OF A WHITE "G" INSIDE A RED CIRCLE DESIGN LOGO.

FOR SPORTS BAGS; ATHLETIC BAGS; BACK PACKS; RUCK SACKS; TRAVEL BAGS; DUFFLE BAGS (U.S. CLS. 1, 2, 3, 22 AND 41).

JANICE L. MCMORROW, EXAMINING ATTORNEY

SN 85-235,358. MENGDI WU, NEW YORK, NY. FILED 2-7-2011.

mengdi3wu

THE MARK CONSISTS OF STANDARD CHARACTERS WITHOUT CLAIM TO ANY PARTICULAR FONT, STYLE, SIZE, OR COLOR.

THE NAME(S), PORTRAIT(S), AND/OR SIGNATURE(S) SHOWN IN THE MARK IDENTIFIES MENGDI, WHOSE CONSENT(S) TO REGISTER IS MADE OF RECORD.

FOR ALL PURPOSE SPORT BAGS; ALL-PURPOSE ATHLETIC BAGS; ALL-PURPOSE CARRYING BAGS; ALL-PURPOSE REUSABLE CARRYING BAGS; ATHLETIC BAGS; BAGS FOR SPORTS; CANVAS SHOPPING BAGS; LEATHER SHOPPING BAGS; TEXTILE SHOPPING BAGS; TOTE BAGS (U.S. CLS. 1, 2, 3, 22 AND 41).

FIRST USE 8-1-2010; IN COMMERCE 8-1-2010. NAPOLEON SHARMA, EXAMINING ATTORNEY

SN 85-235,786. VALENTINA DOMINGUEZ, INCORPORATED, DBA SHAWNA DOMINGUEZ, INDIANAPOLIS, IN. FILED 2-7-2011.

Shawna Dominguez

THE MARK CONSISTS OF STANDARD CHARACTERS WITHOUT CLAIM TO ANY PARTICULAR FONT, STYLE, SIZE, OR COLOR.

THE NAME SHAWNA DOMINGUEZ IDENTIFIES A LIVING INDIVIDUAL WHOSE CONSENT IS OF RECORD.

FOR BACKPACKS; BOOK BAGS, SPORTS BAGS, BUM BAGS, WALLETS AND HANDBAGS (U.S. CLS. 1, 2, 3, 22 AND 41).

THEODORE MCBRIDE, EXAMINING ATTORNEY

CLASS 18—(Continued).

SN 85-246,019. COLLECTIONS 2000 INC., CARLSBAD, CA. FILED 2-18-2011.

THE NAME "KALAH ROSE" DOES NOT IDENTIFY A LIVING INDIVIDUAL.

THE MARK CONSISTS OF THE WORDING "KALAH ROSE" IN STYLIZED FORM.

FOR CLUTCH PURSES; HANDBAGS; PURSES AND WALLETS (U.S. CLS. 1, 2, 3, 22 AND 41).

JORDAN BAKER, EXAMINING ATTORNEY

CLASS 18—(Continued).

SN 85-255,263. STEPHEN LONGO, KINGS PARK, NY. FILED 3-2-2011.

Hands Free! Doody Free!

THE MARK CONSISTS OF STANDARD CHARACTERS WITHOUT CLAIM TO ANY PARTICULAR FONT, STYLE, SIZE, OR COLOR.

FOR DOG LEASH ATTACHMENTS, NAMELY, PLASTIC HOLDING DEVICES FOR ATTACHING AND DETACHING ITEMS FROM THE LEASH (U.S. CLS. 1, 2, 3, 22 AND 41).

PAUL MORENO, EXAMINING ATTORNEY

SN 85-254,407. LIANG, CELIA H, PATERSON, NJ. FILED 3-1-2011.

Dirty Laundry

THE MARK CONSISTS OF STANDARD CHARACTERS WITHOUT CLAIM TO ANY PARTICULAR FONT, STYLE, SIZE, OR COLOR.

FOR LUGGAGE (U.S. CLS. 1, 2, 3, 22 AND 41).

PAM WILLIS, EXAMINING ATTORNEY

SN 85-255,688. COOPER, JAYNE MELISSA, STEVENSON RANCH, CA. FILED 3-2-2011.

JUST JAYNE

THE MARK CONSISTS OF STANDARD CHARACTERS WITHOUT CLAIM TO ANY PARTICULAR FONT, STYLE, SIZE, OR COLOR.

THE NAME SHOWN IN THE MARK IDENTIFIES JAYNE COOPER, WHOSE CONSENT TO REGISTER IS MADE OF RECORD.

FOR ALL-PURPOSE SPORT BAGS; TOTE BAGS; ALL-PURPOSE CARRYING BAGS; ATHLETIC BAGS; BEACH BAGS; GYM BAGS (U.S. CLS. 1, 2, 3, 22 AND 41).

JOHN WILKE, EXAMINING ATTORNEY

SN 85-254,864. JB & CO. INT. LTD., GUANGZHOU 510858, CHINA, FILED 3-1-2011.

SHOULDER CHIC

THE MARK CONSISTS OF STANDARD CHARACTERS WITHOUT CLAIM TO ANY PARTICULAR FONT, STYLE, SIZE, OR COLOR.

FOR GOODS MADE OF LEATHER OR IMITATIONS OF LEATHER, NAMELY, SHOULDER BAGS, HANDBAGS, BABY BACKPACKS, ATHLETIC BAGS, BEACH BAGS, ATTACHE CASES, ALL PURPOSE SPORTS BAGS, BOOK BAGS, CARRY-ON BAGS, CLUTCH BAGS, TOTE BAGS, TRAVEL BAGS, GARMENT BAGS FOR TRAVEL, BRIEFCASES, CHANGE PURSES, COIN PURSES, FANNY PACKS, KEY CASES, KNAPSACKS, LUGGAGE, POCKETBOOKS, BRIEFCASE-TYPE PORTFOLIOS, DRAWSTRING POUCHES, FELT POUCHES, PURSES, VALISES, WALLETS (U.S. CLS. 1, 2, 3, 22 AND 41).

MICHAEL WIENER, EXAMINING ATTORNEY

SN 85-289,433. ALLSTAR MARKETING GROUP, LLC, HAWTHORNE, NY. FILED 4-7-2011.

HAPPY WRAP

THE MARK CONSISTS OF STANDARD CHARACTERS WITHOUT CLAIM TO ANY PARTICULAR FONT, STYLE, SIZE, OR COLOR.

NO CLAIM IS MADE TO THE EXCLUSIVE RIGHT TO USE "WRAP", APART FROM THE MARK AS SHOWN.

FOR PET CLOTHING (U.S. CLS. 1, 2, 3, 22 AND 41).

JULIE GUTTADAURO, EXAMINING ATTORNEY

CLASS 18—(Continued).

SN 85-305,328. RONALD STACEY KING, BEVERLY HILLS, CA. FILED 4-26-2011.

2BIG 2STRONG 2FAST 2GOOD

THE MARK CONSISTS OF STANDARD CHARACTERS WITHOUT CLAIM TO ANY PARTICULAR FONT, STYLE, SIZE, OR COLOR.

FOR ATHLETIC BAGS, OVERNIGHT BAGS, UMBRELLAS, BACKPACKS, DUFFEL BAGS, TOTE BAGS, LUGGAGE, LUGGAGE TAGS, BILLFOLDS, WALLETS, BRIEFCASES, BOOK BAGS, ALL PURPOSE SPORTS BAGS, GYM BAGS, PURSES, FANNY PACKS, WAIST PACKS, GARMENT BAGS FOR TRAVEL, HANDBAGS, KEY CASES, KNAPSACKS, SUITCASES, TOILETRY CASES SOLD EMPTY AND TRUNKS FOR TRAVELING (U.S. CLS. 1, 2, 3, 22 AND 41).

KEVIN CORWIN, EXAMINING ATTORNEY

SN 85-315,337. ALLI, ALLIANCE OF ACTION SPORTS, LLC, BURR RIDGE, IL. FILED 5-9-2011.

ALLI SPORTS

THE MARK CONSISTS OF STANDARD CHARACTERS WITHOUT CLAIM TO ANY PARTICULAR FONT, STYLE, SIZE, OR COLOR.

NO CLAIM IS MADE TO THE EXCLUSIVE RIGHT TO USE "SPORTS", APART FROM THE MARK AS SHOWN.

FOR BAGS, NAMELY, BACKPACKS (U.S. CLS. 1, 2, 3, 22 AND 41).

JOHN WILKE, EXAMINING ATTORNEY

SN 85-315,350. ALLI, ALLIANCE OF ACTION SPORTS, LLC, BURR RIDGE, IL. FILED 5-9-2011.

ALLI ALLIANCE OF ACTION SPORTS

THE MARK CONSISTS OF STANDARD CHARACTERS WITHOUT CLAIM TO ANY PARTICULAR FONT, STYLE, SIZE, OR COLOR.

OWNER OF U.S. REG. NO. 3,908,921.

NO CLAIM IS MADE TO THE EXCLUSIVE RIGHT TO USE "ACTION SPORTS", APART FROM THE MARK AS SHOWN.

FOR BAGS, NAMELY, BACKPACKS (U.S. CLS. 1, 2, 3, 22 AND 41).

JOHN WILKE, EXAMINING ATTORNEY

CLASS 19—NON-METALLIC BUILDING MATERIALS

SN 85-002,325. DECOUSTICS LIMITED, WOODBRIDGE, ONTARIO, CANADA, FILED 3-30-2010.



PRIORITY CLAIMED UNDER SEC. 44(D) ON CANADA APPLICATION NO. 1455444, FILED 10-15-2009, REG. NO. TMA798,162, DATED 5-20-2011, EXPIRES 5-20-2026.

THE MARK CONSISTS OF A CAPITAL LETTER "G" SURROUNDED BY A CIRCLE. THE CIRCLE HAS A LEAF SPROUTING FROM THE UPPER RIGHT SECTION.

FOR WALL TILES, CEILING TILES AND PANELS NOT OF METAL, AND WALL PANELS NOT OF METAL (U.S. CLS. 1, 12, 33 AND 50).

KARANENDRA S. CHHINA, EXAMINING ATTORNEY

SN 85-085,479. DOORMASTERS, INC., RED DEER, ALBERTA, CANADA, FILED 7-15-2010.

SUNSHINE DOOR

THE MARK CONSISTS OF STANDARD CHARACTERS WITHOUT CLAIM TO ANY PARTICULAR FONT, STYLE, SIZE, OR COLOR.

NO CLAIM IS MADE TO THE EXCLUSIVE RIGHT TO USE "DOOR", APART FROM THE MARK AS SHOWN.

FOR NON-METAL GARAGE DOORS (U.S. CLS. 1, 12, 33 AND 50).

FIRST USE 10-0-2001; IN COMMERCE 10-0-2001.

DAVID C. REIHNER, EXAMINING ATTORNEY

SN 85-087,455. CARISELLA, J. V., BATON ROUGE, LA. FILED 7-19-2010.

NEOSUPERSLURRY

THE MARK CONSISTS OF STANDARD CHARACTERS WITHOUT CLAIM TO ANY PARTICULAR FONT, STYLE, SIZE, OR COLOR.

FOR CEMENT MIXES FOR USE IN OIL AND GAS DRILLING OPERATIONS (U.S. CLS. 1, 12, 33 AND 50).

CIMMERIAN COLEMAN, EXAMINING ATTORNEY

CLASS 19—(Continued).

SN 85-097,078. CBC (AMERICA) CORP., COMMACK, NY.
FILED 7-30-2010.

UNICA

THE MARK CONSISTS OF STANDARD CHARACTERS WITHOUT CLAIM TO ANY PARTICULAR FONT, STYLE, SIZE, OR COLOR.

THE ENGLISH TRANSLATION OF "UNICA" IN THE MARK IS "UNIQUE".

FOR FLOORING, NAMELY, STONE TILES (U.S. CLS. 1, 12, 33 AND 50).

FIRST USE 11-30-2009; IN COMMERCE 11-30-2009.
ANTHONY RINKER, EXAMINING ATTORNEY

SN 85-100,958. MCINTYRE TILE COMPANY, INC., HEALDSBURG, CA. FILED 8-5-2010.

STREAMLINE BY MCINTYRE

THE MARK CONSISTS OF STANDARD CHARACTERS WITHOUT CLAIM TO ANY PARTICULAR FONT, STYLE, SIZE, OR COLOR.

FOR CERAMIC TILES (U.S. CLS. 1, 12, 33 AND 50).
FIRST USE 11-9-2009; IN COMMERCE 11-9-2009.
DAVID ELTON, EXAMINING ATTORNEY

SN 85-107,842. CUSTOM BUILDING PRODUCTS, INC., SEAL BEACH, CA. FILED 8-15-2010.

MULTI-BOND

THE MARK CONSISTS OF STANDARD CHARACTERS WITHOUT CLAIM TO ANY PARTICULAR FONT, STYLE, SIZE, OR COLOR.

FOR MORTARS, THIN-SET MORTARS (U.S. CLS. 1, 12, 33 AND 50).
FIRST USE 9-0-1989; IN COMMERCE 9-0-1989.
MELISSA VALLILLO, EXAMINING ATTORNEY

CLASS 19—(Continued).

SN 85-177,724. LAKE STATES LUMBER, INC., AITKIN, MN.
FILED 11-16-2010.



NO CLAIM IS MADE TO THE EXCLUSIVE RIGHT TO USE "WHISTLER" AND "PREMIUM WESTERN RED CEDAR WP4 PANELING", APART FROM THE MARK AS SHOWN.

THE MARK CONSISTS OF A MOUNTAIN RANGE WITH ABSTRACT TREES. WHISTLER IN ALL CAPITALS WITH PREMIUM WESTERN RED CEDAR WP4 PANELING CENTERED UNDERNEATH.

FOR WESTERN RED CEDAR WOOD PANNELLING (U.S. CLS. 1, 12, 33 AND 50).

FIRST USE 10-11-2010; IN COMMERCE 10-11-2010.
B. PARADEWELAI, EXAMINING ATTORNEY

SN 85-216,712. SEAMAN CORPORATION, WOOSTER, OH.
FILED 1-13-2011.

WRAPID

THE MARK CONSISTS OF STANDARD CHARACTERS WITHOUT CLAIM TO ANY PARTICULAR FONT, STYLE, SIZE, OR COLOR.

FOR ROOFING FABRICS, NAMELY, COATED FABRICS FORMED AS A BOOT TO BE RECEIVED AROUND A ROOF PENETRATION AND TO BE ATTACHED TO THE EXISTING ROOF COVERING (U.S. CLS. 1, 12, 33 AND 50).

TARA PATE, EXAMINING ATTORNEY

SN 85-224,961. MAJESKA & ASSOCIATES, TULSA, OK.
FILED 1-24-2011.

Lynx

THE MARK CONSISTS OF STANDARD CHARACTERS WITHOUT CLAIM TO ANY PARTICULAR FONT, STYLE, SIZE, OR COLOR.

FOR COLD-POUR CRACK FILLING, NAMELY, ASPHALT PAVING COMPOSITIONS USED FOR ASPHALT PAVING (U.S. CLS. 1, 12, 33 AND 50).

ASMAT KHAN, EXAMINING ATTORNEY

CLASS 19—(Continued).

SN 85-240,801. PERGO (EUROPE) AB, TRELLEBORG, SWEDEN, FILED 2-12-2011.

PERMAMAX

THE MARK CONSISTS OF STANDARD CHARACTERS WITHOUT CLAIM TO ANY PARTICULAR FONT, STYLE, SIZE, OR COLOR.

FOR PROTECTIVE, WEAR-RESISTANT OVERLAY BONDED ONTO AND SOLD AS A FEATURE OF LAMINATE FLOORING (U.S. CLS. 1, 12, 33 AND 50).
KIMBERLY FRYE, EXAMINING ATTORNEY

CLASS 19—(Continued).

SN 85-249,235. VESUVIUS CRUCIBLE COMPANY, PITTSBURGH, PA. FILED 2-23-2011.

THERMO GUN

THE MARK CONSISTS OF STANDARD CHARACTERS WITHOUT CLAIM TO ANY PARTICULAR FONT, STYLE, SIZE, OR COLOR.

FOR REFRACTORY RAMMING MIXES (U.S. CLS. 1, 12, 33 AND 50).
FIRST USE 12-31-1985; IN COMMERCE 12-31-1985.
SEAN CROWLEY, EXAMINING ATTORNEY

SN 85-245,287. GUARDIAN INDUSTRIES CORP., AUBURN HILLS, MI. FILED 2-17-2011.

MIDNIGHTGRAY

THE MARK CONSISTS OF STANDARD CHARACTERS WITHOUT CLAIM TO ANY PARTICULAR FONT, STYLE, SIZE, OR COLOR.

OWNER OF U.S. REG. NO. 3,901,046.
FOR GLASS PANELS AND SHEETS FOR USE IN BUILDINGS (U.S. CLS. 1, 12, 33 AND 50).
ERNEST SHOSHO, EXAMINING ATTORNEY

SN 85-250,690. GLASSCRAFT DOOR I, LP, DBA GLASSCRAFT DOOR COMPANY, HOUSTON, TX. FILED 2-24-2011.

Cantania

THE MARK CONSISTS OF STANDARD CHARACTERS WITHOUT CLAIM TO ANY PARTICULAR FONT, STYLE, SIZE, OR COLOR.

THE WORDING "CANTANIA" HAS NO MEANING IN A FOREIGN LANGUAGE.
FOR INSULATED GLASS (U.S. CLS. 1, 12, 33 AND 50).
FIRST USE 9-7-2010; IN COMMERCE 9-7-2010.
DEZMONA MIZELLE, EXAMINING ATTORNEY

SN 85-246,049. JI, JIANBIN, NEW YORK, NY. FILED 2-18-2011.



THE COLOR(S) WHITE, DARK GREEN, LIGHT GREEN, GREEN AND GRAY IS/ARE CLAIMED AS A FEATURE OF THE MARK.

THE MARK CONSISTS OF THE DESIGN OF A MULBERRY TREE IN THE COLORS LIGHT GREEN WITH DARK GREEN LEAVES AND SHADING IN THE COLOR WHITE FEATURED TO THE LEFT OF THE WORKING "DESIGN FOR THE FUTURE" WHERE THE WORD "DESIGN" IS FEATURED UNDERNEATH THE LEAVES OF THE TREE. THE WORDING "DESIGN FOR THE" APPEAR IN THE COLOR GRAY AND "FUTURE" APPEARS IN THE COLOR GREEN.

FOR BUILDING GLASS; BUILDING MATERIALS, NAMELY, NON-METAL COUNTERTOPS FOR FURTHER INSTALLATION; DECORATIVE GLASS; GLASS PANELS FOR BUILDING CONSTRUCTION PURPOSES; GLASS PANES; GLASS TILES; NON-METAL DOOR PANELS; WALL PANELS NOT OF METAL; WINDOW GLASS (U.S. CLS. 1, 12, 33 AND 50).
CHARISMA HAMPTON, EXAMINING ATTORNEY

SN 85-250,718. GLASSCRAFT DOOR I, LP, DBA GLASSCRAFT DOOR COMPANY, HOUSTON, TX. FILED 2-24-2011.

Novara

THE MARK CONSISTS OF STANDARD CHARACTERS WITHOUT CLAIM TO ANY PARTICULAR FONT, STYLE, SIZE, OR COLOR.

THE WORDING "NOVARA" HAS NO MEANING IN A FOREIGN LANGUAGE.
FOR INSULATED GLASS (U.S. CLS. 1, 12, 33 AND 50).
FIRST USE 9-7-2010; IN COMMERCE 9-7-2010.
DEZMONA MIZELLE, EXAMINING ATTORNEY

CLASS 19—(Continued).

SN 85-250,767. GLASSCRAFT DOOR I, LP, DBA GLASS-CRAFT DOOR COMPANY, HOUSTON, TX. FILED 2-24-2011.

Genoa

THE MARK CONSISTS OF STANDARD CHARACTERS WITHOUT CLAIM TO ANY PARTICULAR FONT, STYLE, SIZE, OR COLOR.

THE WORDING "GENOA" HAS NO MEANING IN A FOREIGN LANGUAGE.

FOR INSULATED GLASS (U.S. CLS. 1, 12, 33 AND 50).
FIRST USE 9-7-2010; IN COMMERCE 9-7-2010.

DEZMONA MIZELLE, EXAMINING ATTORNEY

SN 85-251,847. GEOPRO, INC., ELKTON, SD. FILED 2-25-2011.

Thermal Grout Lite

THE MARK CONSISTS OF STANDARD CHARACTERS WITHOUT CLAIM TO ANY PARTICULAR FONT, STYLE, SIZE, OR COLOR.

NO CLAIM IS MADE TO THE EXCLUSIVE RIGHT TO USE "THERMAL GROUT", APART FROM THE MARK AS SHOWN.

FOR GROUT, NAMELY, GROUT USED TO SEAL AND PROVIDE THERMAL CONDUCTIVITY FOR IN GROUND SOURCE HEAT LOOPS THAT USE THE EARTH TO HEAT AND COOL (U.S. CLS. 1, 12, 33 AND 50).

FIRST USE 0-0-1999; IN COMMERCE 0-0-1999.
LINDA POWELL, EXAMINING ATTORNEY

SN 85-252,036. GEOPRO, INC., ELKTON, SD. FILED 2-25-2011.

Thermal Grout Select

THE MARK CONSISTS OF STANDARD CHARACTERS WITHOUT CLAIM TO ANY PARTICULAR FONT, STYLE, SIZE, OR COLOR.

NO CLAIM IS MADE TO THE EXCLUSIVE RIGHT TO USE "THERMAL GROUT", APART FROM THE MARK AS SHOWN.

FOR GROUT, NAMELY, GROUT USED TO SEAL AND PROVIDE THERMAL CONDUCTIVITY FOR IN GROUND SOURCE HEAT LOOPS THAT USE THE EARTH TO HEAT AND COOL (U.S. CLS. 1, 12, 33 AND 50).

FIRST USE 0-0-1999; IN COMMERCE 0-0-1999.
LINDA POWELL, EXAMINING ATTORNEY

CLASS 19—(Continued).

SN 85-252,067. LOUISIANA-PACIFIC CORPORATION, NASHVILLE, TN. FILED 2-25-2011.

SILVERSIDE

THE MARK CONSISTS OF STANDARD CHARACTERS WITHOUT CLAIM TO ANY PARTICULAR FONT, STYLE, SIZE, OR COLOR.

FOR BUILDING MATERIALS, NAMELY, PANELS MADE PRIMARILY OF WOOD (U.S. CLS. 1, 12, 33 AND 50).

MARTHA FROMM, EXAMINING ATTORNEY

SN 85-252,089. LOUISIANA-PACIFIC CORPORATION, NASHVILLE, TN. FILED 2-25-2011.

SILVERCREST

THE MARK CONSISTS OF STANDARD CHARACTERS WITHOUT CLAIM TO ANY PARTICULAR FONT, STYLE, SIZE, OR COLOR.

FOR BUILDING MATERIALS, NAMELY, PANELS MADE PRIMARILY OF WOOD (U.S. CLS. 1, 12, 33 AND 50).

MARTHA FROMM, EXAMINING ATTORNEY

SN 85-252,121. GEOPRO, INC., ELKTON, SD. FILED 2-25-2011.

GeoPro

THE MARK CONSISTS OF STANDARD CHARACTERS WITHOUT CLAIM TO ANY PARTICULAR FONT, STYLE, SIZE, OR COLOR.

FOR GROUT, NAMELY, GROUT USED TO SEAL AND PROVIDE THERMAL CONDUCTIVITY FOR IN GROUND SOURCE HEAT LOOPS THAT USE THE EARTH TO HEAT AND COOL (U.S. CLS. 1, 12, 33 AND 50).

FIRST USE 0-0-1995; IN COMMERCE 0-0-1995.
LINDA POWELL, EXAMINING ATTORNEY

CLASS 19—(Continued).

SN 85-253,552. GEOPRO, INC., ELKTON, SD. FILED 2-28-2011.

TG Lite

THE MARK CONSISTS OF STANDARD CHARACTERS WITHOUT CLAIM TO ANY PARTICULAR FONT, STYLE, SIZE, OR COLOR.

FOR GROUT, NAMELY, GROUT USED TO SEAL AND PROVIDE THERMAL CONDUCTIVITY FOR IN GROUND SOURCE HEAT LOOPS THAT USE THE EARTH TO HEAT AND COOL (U.S. CLS. 1, 12, 33 AND 50).

LINDA POWELL, EXAMINING ATTORNEY

SN 85-253,649. GEOPRO, INC., ELKTON, SD. FILED 2-28-2011.

TG Select

THE MARK CONSISTS OF STANDARD CHARACTERS WITHOUT CLAIM TO ANY PARTICULAR FONT, STYLE, SIZE, OR COLOR.

FOR GROUT, NAMELY, GROUT USED TO SEAL AND PROVIDE THERMAL CONDUCTIVITY FOR IN GROUND SOURCE HEAT LOOPS THAT USE THE EARTH TO HEAT AND COOL (U.S. CLS. 1, 12, 33 AND 50).

LINDA POWELL, EXAMINING ATTORNEY

SN 85-253,729. GEOPRO, INC., ELKTON, SD. FILED 2-28-2011.

BH20

THE MARK CONSISTS OF STANDARD CHARACTERS WITHOUT CLAIM TO ANY PARTICULAR FONT, STYLE, SIZE, OR COLOR.

FOR GROUT, NAMELY, GROUT USED TO SEAL AND PROVIDE THERMAL CONDUCTIVITY FOR IN GROUND SOURCE HEAT LOOPS THAT USE THE EARTH TO HEAT AND COOL (U.S. CLS. 1, 12, 33 AND 50).

LINDA POWELL, EXAMINING ATTORNEY

CLASS 19—(Continued).

SN 85-255,610. STATICWORX, INC., WATERTOWN, MA. FILED 3-2-2011.

GROUNDSAFE

THE MARK CONSISTS OF STANDARD CHARACTERS WITHOUT CLAIM TO ANY PARTICULAR FONT, STYLE, SIZE, OR COLOR.

FOR VINYL FLOORING, RUBBER FLOORING, AND EPOXY FLOORING (U.S. CLS. 1, 12, 33 AND 50).

JOHN E. MICHOS, EXAMINING ATTORNEY

SN 85-256,263. PERGO (EUROPE) AB, TRELLEBORG, SWEDEN, FILED 3-2-2011.

PERGO XP - XTREME PERFORMANCE

THE MARK CONSISTS OF STANDARD CHARACTERS WITHOUT CLAIM TO ANY PARTICULAR FONT, STYLE, SIZE, OR COLOR.

OWNER OF U.S. REG. NOS. 1,693,204, 3,147,660 AND OTHERS.

FOR FLOORING, NAMELY, WOOD, THERMOSETTING LAMINATE, THERMOSETTING LAMINATE BONDED TO A BASE OF PARTICLE BOARD OR FIBERBOARD AND PARTICLE BOARD OR FIBERBOARD PROVIDED WITH A DECORATIVE SURFACE OR COATING (U.S. CLS. 1, 12, 33 AND 50).

KIMBERLY FRYE, EXAMINING ATTORNEY

SN 85-256,895. EVERSTONE INTERNATIONAL PTY. LTD., SYDNEY, AUSTRALIA, FILED 3-3-2011.

EVERQUARTZ

THE MARK CONSISTS OF STANDARD CHARACTERS WITHOUT CLAIM TO ANY PARTICULAR FONT, STYLE, SIZE, OR COLOR.

FOR PORCELAIN TILES FOR APPLICATION TO FLOORS AND WALLS (U.S. CLS. 1, 12, 33 AND 50).

FIRST USE 3-1-2011; IN COMMERCE 3-1-2011.

PAUL MORENO, EXAMINING ATTORNEY

CLASS 19—(Continued).

SN 85-257,911. MOULURES M.G. INC., SAINTE-MARIE, QUEBEC, CANADA, FILED 3-4-2011.

EZE-O'GEE

THE MARK CONSISTS OF STANDARD CHARACTERS WITHOUT CLAIM TO ANY PARTICULAR FONT, STYLE, SIZE, OR COLOR.

OWNER OF CANADA REG. NO. TMA790,294, DATED 2-10-2011, EXPIRES 2-10-2026.

FOR DECORATIVE WOOD AND MDF (MEDIUM DENSITY FIBERBOARD) MOULDINGS (U.S. CLS. 1, 12, 33 AND 50).

B. PARADEWELAI, EXAMINING ATTORNEY

SN 85-288,657. HENRY COMPANY CANADA, INC., SCARBOROUGH, ONTARIO, CANADA, FILED 4-7-2011.

EAVEGUARD

THE MARK CONSISTS OF STANDARD CHARACTERS WITHOUT CLAIM TO ANY PARTICULAR FONT, STYLE, SIZE, OR COLOR.

FOR ROOFING UNDERLAYMENT (U.S. CLS. 1, 12, 33 AND 50).

FIRST USE 1-0-1986; IN COMMERCE 1-0-1986.
PAM WILLIS, EXAMINING ATTORNEY

CLASS 20—FURNITURE AND ARTICLES NOT OTHERWISE CLASSIFIED

SN 76-706,431. MURRAY J. CHRISTOPHER, PAINESVILLE, OH. FILED 2-16-2011.

TAGYOURDUCKS

THE MARK CONSISTS OF STANDARD CHARACTERS WITHOUT CLAIM TO ANY PARTICULAR FONT, STYLE, SIZE, OR COLOR.

FOR PLASTIC IDENTIFICATION TAGS (U.S. CLS. 2, 13, 22, 25, 32 AND 50).

FIRST USE 1-31-2011; IN COMMERCE 1-31-2011.
DANIEL CAPSHAW, EXAMINING ATTORNEY

CLASS 20—(Continued).

SN 77-812,038. HANDY STORE FIXTURES, DBA GONDOLA CITY, NEWARK, NJ. FILED 8-25-2009.



THE COLOR(S) BLUE AND ORANGE IS/ARE CLAIMED AS A FEATURE OF THE MARK.

THE MARK CONSISTS OF THE WORD "GONDOLA" IN BLUE TEXT, THE LETTER "L" IN "GONDOLA" USING A ARTWORK IMAGE OF A BUILDING ACTING LIKE THE LETTER "L". THE WORD "CITY" UNDERNEATH THE WORD "GONDOLA" IN ORANGE ITALIC. THE RIGHT OF THE "GONDOLA CITY" TEXT IS ARTWORK OF A "GONDOLA" ORANGE WITH BLUE HIGHLIGHTS".

FOR METAL SHELVING; SHELVES; SHELVES FOR STORAGE; SHELVING; SHELVING AND COMPONENT PARTS THEREOF, NAMELY, SHELVES AND BRACKETS SOLD AS A UNIT (U.S. CLS. 2, 13, 22, 25, 32 AND 50).
FRANK LATTUCA, EXAMINING ATTORNEY

SN 77-921,812. STEELCASE INC., GRAND RAPIDS, MI. FILED 1-27-2010.

SONATA

THE MARK CONSISTS OF STANDARD CHARACTERS WITHOUT CLAIM TO ANY PARTICULAR FONT, STYLE, SIZE, OR COLOR.

FOR FURNITURE FOR HEALTHCARE ENVIRONMENTS, NAMELY, SEATING, CABINETS, WARDROBES, SHELVING, NON-METAL STORAGE UNITS FOR MEDICAL RECORDS AND MEDICAL SUPPLIES (U.S. CLS. 2, 13, 22, 25, 32 AND 50).

FIRST USE 11-29-2008; IN COMMERCE 11-29-2008.
JULIE VEPPUMTHARA, EXAMINING ATTORNEY

CLASS 20—(Continued).

SN 77-921,989. SUMMIT ENTERTAINMENT, LLC, SANTA MONICA, CA. FILED 1-28-2010.

ECLIPSE

THE MARK CONSISTS OF STANDARD CHARACTERS WITHOUT CLAIM TO ANY PARTICULAR FONT, STYLE, SIZE, OR COLOR.

FOR BULLETIN BOARDS, DECORATIVE WALL PLAQUES OF PLASTIC, DECORATIVE WALL PLAQUES OF WOOD, NON-METAL DOG TAGS, PICTURE FRAMES, PILLOWS, PLASTIC BANNERS, PLASTIC BOXES, PLASTIC NOVELTY LICENSE PLATES, WOOD BOXES; AND VINYL APPLIQUES FOR ATTACHMENT TO WINDOWS, MIRRORS AND OTHER SOLID SURFACES (U.S. CLS. 2, 13, 22, 25, 32 AND 50).

LESLIE RICHARDS, EXAMINING ATTORNEY

CLASS 20—(Continued).

SN 85-020,744. TIME'S UP, INC., LAS VEGAS, NV. FILED 4-22-2010.

VISUALLY STUNNING CUSTOM CUPS

THE MARK CONSISTS OF STANDARD CHARACTERS WITHOUT CLAIM TO ANY PARTICULAR FONT, STYLE, SIZE, OR COLOR.

NO CLAIM IS MADE TO THE EXCLUSIVE RIGHT TO USE "CUSTOM CUPS", APART FROM THE MARK AS SHOWN.

FOR PLASTIC STORAGE CONTAINERS FOR COMMERCIAL AND INDUSTRIAL USE (U.S. CLS. 2, 13, 22, 25, 32 AND 50).

FIRST USE 3-1-2007; IN COMMERCE 3-1-2007.

DOMINIC J. FERRAIUOLO, EXAMINING ATTORNEY

SN 79-087,560. OPINION CIATTI S.R.L., ITALY, FILED 7-30-2010.

OPINION CIATTI

THE MARK CONSISTS OF STANDARD CHARACTERS WITHOUT CLAIM TO ANY PARTICULAR FONT, STYLE, SIZE, OR COLOR.

PRIORITY DATE OF 7-26-2010 IS CLAIMED.

OWNER OF INTERNATIONAL REGISTRATION 1051696 DATED 7-30-2010, EXPIRES 7-30-2020.

THE WORDING "CIATTI" HAS NO MEANING IN A FOREIGN LANGUAGE.

FOR FURNITURE, MIRRORS (U.S. CLS. 2, 13, 22, 25, 32 AND 50).

MYRIAH HABEEB, EXAMINING ATTORNEY

SN 85-117,958. SINOMAX USA INC, HOUSTON, TX. FILED 8-27-2010.

pureFOAM

THE MARK CONSISTS OF "PURE" WITH THE SPECIAL CHARACTER CALLED AN UMLAUT APPEARING "Ü", CREATED IN LOWER CASE FONT OF BOLD, WITH ACCOMPANYING WORD "FOAM" IN ALL CAPITALIZATION AND OF THIN FONT.

FOR BEDS, MATTRESSES, PILLOWS AND BOLSTERS; MATTRESS TOPPERS; MATTRESSES AND PILLOWS (U.S. CLS. 2, 13, 22, 25, 32 AND 50).

FIRST USE 7-21-2010; IN COMMERCE 8-6-2010.

SALLY SHIH, EXAMINING ATTORNEY

SN 79-095,287. WILKHahn WILKENING + HAHNE GMBH + CO. KG, FED REP GERMANY, FILED 3-2-2011.

Graph

THE MARK CONSISTS OF STANDARD CHARACTERS WITHOUT CLAIM TO ANY PARTICULAR FONT, STYLE, SIZE, OR COLOR.

PRIORITY DATE OF 9-2-2010 IS CLAIMED.

OWNER OF INTERNATIONAL REGISTRATION 1071729 DATED 3-2-2011, EXPIRES 3-2-2021.

FOR FURNITURE (U.S. CLS. 2, 13, 22, 25, 32 AND 50).

GRETTA YAO, EXAMINING ATTORNEY

SN 85-130,246. BATESVILLE SERVICES, INC., BATESVILLE, IN. FILED 9-15-2010.

WESTON

THE MARK CONSISTS OF STANDARD CHARACTERS WITHOUT CLAIM TO ANY PARTICULAR FONT, STYLE, SIZE, OR COLOR.

SEC. 2(F).

FOR CASKETS (U.S. CLS. 2, 13, 22, 25, 32 AND 50).

FIRST USE 6-1-2004; IN COMMERCE 6-1-2004.

ANN E. SAPPENFIELD, EXAMINING ATTORNEY

CLASS 20—(Continued).

SN 85-131,433. CHAUTAUQUA INSTITUTION, CHAUTAUQUA, NY. FILED 9-16-2010.



OWNER OF U.S. REG. NOS. 1,705,022, 2,380,660 AND OTHERS.

THE MARK CONSISTS OF THE STYLIZED WORDING "CHAUTAUQUA INSTITUTION" UNDERNEATH THE DESIGN OF A BELL TOWER ENCLOSED IN AN OVAL.

SEC. 2(F) AS TO "CHAUTAUQUA".
FOR SEAT CUSHIONS (U.S. CLS. 2, 13, 22, 25, 32 AND 50).

FIRST USE 1-31-1991; IN COMMERCE 1-31-1991.
MAUREEN DALL, EXAMINING ATTORNEY

SN 85-141,560. LESLIE M MITCHELL, MONTPELIER, OH. FILED 9-29-2010.

Dead Stop

THE MARK CONSISTS OF STANDARD CHARACTERS WITHOUT CLAIM TO ANY PARTICULAR FONT, STYLE, SIZE, OR COLOR.

FOR DOOR STOPS OF PLASTIC (U.S. CLS. 2, 13, 22, 25, 32 AND 50).

FIRST USE 9-10-2010; IN COMMERCE 9-10-2010.
EDWARD FENNESSY, EXAMINING ATTORNEY

SN 85-160,979. MAXCHIEF INVESTMENTS, LTD., GUANGDONG, CHINA, FILED 10-26-2010.

MAXCHIEF

THE MARK CONSISTS OF STANDARD CHARACTERS WITHOUT CLAIM TO ANY PARTICULAR FONT, STYLE, SIZE, OR COLOR.

FOR FURNITURE MADE OF PLASTIC FOR RESIDENTIAL AND COMMERCIAL PURPOSES (U.S. CLS. 2, 13, 22, 25, 32 AND 50).

FIRST USE 10-1-2001; IN COMMERCE 10-1-2001.
MICHAEL SOUDERS, EXAMINING ATTORNEY

CLASS 20—(Continued).

SN 85-162,539. STARWOVE PTY LTD, CONDON QLD 4815, AUSTRALIA, FILED 10-27-2010.

CUDDLE FISH

THE MARK CONSISTS OF STANDARD CHARACTERS WITHOUT CLAIM TO ANY PARTICULAR FONT, STYLE, SIZE, OR COLOR.

PRIORITY CLAIMED UNDER SEC. 44(D) ON AUSTRALIA APPLICATION NO. 1355861, FILED 4-27-2010, REG. NO. 1355861, DATED 4-27-2010, EXPIRES 4-27-2020.

FOR COTS; BEDDING FOR COTS OTHER THAN BED LINEN, NAMELY, PILLOWS, PLASTIC FASTENERS FOR HOLDING BED SHEETS AND LINENS IN PLACE; NURSERY COTS; SAFETY COTS; CRIBS; BEDDING EXCEPT LINEN, NAMELY, PILLOWS, PLASTIC FASTENERS FOR HOLDING BED SHEETS AND LINENS IN PLACE; ADJUSTABLE BEDS; BEDS; ELECTRICALLY OPERATED ADJUSTABLE BEDS NOT FOR MEDICAL PURPOSES; FURNITURE FOR THE BEDROOM; HOSPITAL BEDS (U.S. CLS. 2, 13, 22, 25, 32 AND 50).
SUSAN STIGLITZ, EXAMINING ATTORNEY

SN 85-167,812. STEPHEN SCHILLER, NAPLES, FL. FILED 11-3-2010.

OM SHANTI

THE MARK CONSISTS OF STANDARD CHARACTERS WITHOUT CLAIM TO ANY PARTICULAR FONT, STYLE, SIZE, OR COLOR.

THE ENGLISH TRANSLATION OF "SHANTI" IN THE MARK IS "PEACE".

FOR INDOOR PREMIUM BEDDING, NAMELY, MATTRESSES, BOX SPRINGS AND MATTRESS FOUNDATIONS FOR USE IN INDOOR SLEEPING AREAS (U.S. CLS. 2, 13, 22, 25, 32 AND 50).

FIRST USE 10-30-2010; IN COMMERCE 10-30-2010.
ROBERT C. CLARK JR., EXAMINING ATTORNEY

SN 85-179,473. FELSEN, MICHAEL, SANTA ANA, CA. FILED 11-17-2010.

ISG Hospitality

THE MARK CONSISTS OF STANDARD CHARACTERS WITHOUT CLAIM TO ANY PARTICULAR FONT, STYLE, SIZE, OR COLOR.

NO CLAIM IS MADE TO THE EXCLUSIVE RIGHT TO USE "HOSPITALITY", APART FROM THE MARK AS SHOWN.

FOR ARMOIRES; BEDS; CHAIRS; DESKS; FURNITURE, NAMELY, DRESSERS; MIRRORS; SOFAS; TABLES (U.S. CLS. 2, 13, 22, 25, 32 AND 50).

ALICIA COLLINS, EXAMINING ATTORNEY

CLASS 20—(Continued).

SN 85-200,176. TWIN STAR INTERNATIONAL, INC., DEL-
RAY BEACH, FL. FILED 12-17-2010.

ANTIQUA

THE MARK CONSISTS OF STANDARD CHARACTERS WITHOUT CLAIM TO ANY PARTICULAR FONT, STYLE, SIZE, OR COLOR.

OWNER OF U.S. REG. NO. 3,915,350.
THE ENGLISH TRANSLATION OF "ANTIQUA" IN THE MARK IS "OLD".

SEC. 2(F).
FOR CABINETRY FOR THE HOME; KITCHEN CABINETS, BATHROOM VANITIES, MEDICINE CABINETS AND BATHROOM ACCESSORIES, NAMELY, MIRRORS, AND SHELVES (U.S. CLS. 2, 13, 22, 25, 32 AND 50).

FIRST USE 11-14-2005; IN COMMERCE 11-14-2005.
DARRYL SPRUILL, EXAMINING ATTORNEY

CLASS 20—(Continued).

SN 85-205,563. VERSIA, INC., PHOENIX, AZ. FILED 12-24-2010.



THE COLOR(S) GREEN, WHITE, BLACK AND GRAY IS/ARE CLAIMED AS A FEATURE OF THE MARK.

THE MARK CONSISTS OF A GREEN AND WHITE PIXELATED APPLE WITH A BLACK STEM AND A GRAY SHADOW BELOW THE APPLE.

FOR FURNITURE; RESIDENTIAL AND COMMERCIAL FURNITURE; CUSTOM FURNITURE; CABINETS; FURNITURE PARTS; FURNITURE, NAMELY, WALL UNITS; OFFICE FURNITURE; FILING CABINETS; OFFICE TABLES; HIGH DENSITY MOBILE FILING AND STORAGE SHELVING; TABLES; COMPACTABLE ROLLING SHELVING FOR FILING AND STORAGE; SHELVING; SHELVING FOR LOCKERS (U.S. CLS. 2, 13, 22, 25, 32 AND 50).

JACQUELINE A. LAVINE, EXAMINING ATTORNEY

SN 85-205,556. VERSIA, INC., PHOENIX, AZ. FILED 12-24-2010.

versatile to the core

THE MARK CONSISTS OF STANDARD CHARACTERS WITHOUT CLAIM TO ANY PARTICULAR FONT, STYLE, SIZE, OR COLOR.

FOR FURNITURE; RESIDENTIAL AND COMMERCIAL FURNITURE; CUSTOM FURNITURE; CABINETS; FURNITURE PARTS; FURNITURE, NAMELY, WALL UNITS; OFFICE FURNITURE; FILING CABINETS; OFFICE TABLES; HIGH DENSITY MOBILE FILING AND STORAGE SHELVING; TABLES; COMPACTABLE ROLLING SHELVING FOR FILING AND STORAGE; SHELVING; SHELVING FOR LOCKERS (U.S. CLS. 2, 13, 22, 25, 32 AND 50).

JACQUELINE A. LAVINE, EXAMINING ATTORNEY

SN 85-205,567. VERSIA, INC., PHOENIX, AZ. FILED 12-24-2010.



THE COLOR(S) GREEN, WHITE AND GRAY IS/ARE CLAIMED AS A FEATURE OF THE MARK.

THE MARK CONSISTS OF A WHITE LETTER "V" ON A PIXELATED GREEN SUBSTANTIALLY-TRAPEZOIDAL BACKGROUND WITH A GRAY SHADOW AT THE BOTTOM.

FOR FURNITURE; RESIDENTIAL AND COMMERCIAL FURNITURE; CUSTOM FURNITURE; CABINETS; FURNITURE PARTS; FURNITURE, NAMELY, WALL UNITS; OFFICE FURNITURE; FILING CABINETS; OFFICE TABLES; HIGH DENSITY MOBILE FILING AND STORAGE SHELVING; TABLES; COMPACTABLE ROLLING SHELVING FOR FILING AND STORAGE; SHELVING; SHELVING FOR LOCKERS (U.S. CLS. 2, 13, 22, 25, 32 AND 50).

JACQUELINE A. LAVINE, EXAMINING ATTORNEY

CLASS 20—(Continued).

SN 85-213,902. FUSION SPECIALTIES, INC., BROOMFIELD, CO. FILED 1-10-2011.

G-FLEX

THE MARK CONSISTS OF STANDARD CHARACTERS WITHOUT CLAIM TO ANY PARTICULAR FONT, STYLE, SIZE, OR COLOR.

FOR MANNEQUINS AND PARTS THEREFOR (U.S. CLS. 2, 13, 22, 25, 32 AND 50).
GINA HAYES, EXAMINING ATTORNEY

CLASS 20—(Continued).

SN 85-224,831. ROBERN INC., BRISTOL, PA. FILED 1-24-2011.

TVID

THE MARK CONSISTS OF STANDARD CHARACTERS WITHOUT CLAIM TO ANY PARTICULAR FONT, STYLE, SIZE, OR COLOR.

FOR BATHROOM CABINETS; BATHROOM MIRRORS (U.S. CLS. 2, 13, 22, 25, 32 AND 50).
ODESSA BIBBINS, EXAMINING ATTORNEY

SN 85-216,614. EVRIHOLDER PRODUCTS LLC, ANAHEIM, CA. FILED 1-13-2011.

MAGNET-MATES

THE MARK CONSISTS OF STANDARD CHARACTERS WITHOUT CLAIM TO ANY PARTICULAR FONT, STYLE, SIZE, OR COLOR.

FOR PLASTIC CLIPS FOR SEALING BAGS WITH AN INTEGRATED MAGNET AND WRITEABLE SURFACE (U.S. CLS. 2, 13, 22, 25, 32 AND 50).
KAREN BRACEY, EXAMINING ATTORNEY

SN 85-238,343. GRAND HOTEL LLC, MACKINAC ISLAND, MI. FILED 2-9-2011.

Grand Hotel Touch of Softness

THE MARK CONSISTS OF STANDARD CHARACTERS WITHOUT CLAIM TO ANY PARTICULAR FONT, STYLE, SIZE, OR COLOR.

NO CLAIM IS MADE TO THE EXCLUSIVE RIGHT TO USE "HOTEL", APART FROM THE MARK AS SHOWN. FOR MATTRESSES (U.S. CLS. 2, 13, 22, 25, 32 AND 50). FIRST USE 1-28-2011; IN COMMERCE 1-28-2011.
KIM SAITO, EXAMINING ATTORNEY

SN 85-219,093. AZER SCIENTIFIC INC. FORMERLY EVER SCIENTIFIC, MORGANTOWN, PA. FILED 1-17-2011.

FlyLock

THE MARK CONSISTS OF STANDARD CHARACTERS WITHOUT CLAIM TO ANY PARTICULAR FONT, STYLE, SIZE, OR COLOR.

FOR NON-METAL AND NON-PAPER CLOSURES FOR DROSOPHILA BOTTLES AND VIALS FOR USE IN RESEARCH LABS (U.S. CLS. 2, 13, 22, 25, 32 AND 50). FIRST USE 11-1-2010; IN COMMERCE 11-1-2010.
LEIGH LOWRY, EXAMINING ATTORNEY

SN 85-242,644. ENGLANDER SLEEP PRODUCTS, L.L.C., OLIVE BRANCH, MS. FILED 2-15-2011.

HEALTH WEDGE

THE MARK CONSISTS OF STANDARD CHARACTERS WITHOUT CLAIM TO ANY PARTICULAR FONT, STYLE, SIZE, OR COLOR.

NO CLAIM IS MADE TO THE EXCLUSIVE RIGHT TO USE "WEDGE", APART FROM THE MARK AS SHOWN. FOR MATTRESSES AND FOUNDATIONS (U.S. CLS. 2, 13, 22, 25, 32 AND 50). FIRST USE 1-24-2011; IN COMMERCE 1-24-2011.
PAUL E. FAHRENKOPF, EXAMINING ATTORNEY

CLASS 20—(Continued).

SN 85-246,542. FREDMAN BROS. FURNITURE COMPANY, INC., ST. LOUIS, MO. FILED 2-18-2011.



NO CLAIM IS MADE TO THE EXCLUSIVE RIGHT TO USE "SPACE SAVER", APART FROM THE MARK AS SHOWN.

THE MARK CONSISTS OF "SPACE SAVER" AND A STYLIZED "S" WITH TWO ARROWS.
FOR BED BASES (U.S. CLS. 2, 13, 22, 25, 32 AND 50).
APRIL HESIK, EXAMINING ATTORNEY

SN 85-248,188. TRACTOR SUPPLY CO. OF TEXAS, LP, BRENTWOOD, TN. FILED 2-22-2011.

RETRIEVER

THE MARK CONSISTS OF STANDARD CHARACTERS WITHOUT CLAIM TO ANY PARTICULAR FONT, STYLE, SIZE, OR COLOR.

OWNER OF U.S. REG. NOS. 1,826,539 AND 3,257,566.
FOR BEDS AND PILLOWS FOR HOUSEHOLD PETS (U.S. CLS. 2, 13, 22, 25, 32 AND 50).
SCOTT BIBB, EXAMINING ATTORNEY

SN 85-249,193. PEACOCK ALLEY, INC., DALLAS, TX. FILED 2-23-2011.

DREAM AT HOME PEACOCK ALLEY

THE MARK CONSISTS OF STANDARD CHARACTERS WITHOUT CLAIM TO ANY PARTICULAR FONT, STYLE, SIZE, OR COLOR.

OWNER OF U.S. REG. NOS. 2,152,148 AND 3,288,922.
FOR BEDS FOR HOUSEHOLD PETS, PET CUSHIONS, PET FURNITURE, PILLOWS FOR HOUSEHOLD PETS (U.S. CLS. 2, 13, 22, 25, 32 AND 50).
GRETTA YAO, EXAMINING ATTORNEY

CLASS 20—(Continued).

SN 85-249,265. ZONK DESIGNS, INC., CHATTANOOGA, TN. FILED 2-23-2011.

U-FLEX

THE MARK CONSISTS OF STANDARD CHARACTERS WITHOUT CLAIM TO ANY PARTICULAR FONT, STYLE, SIZE, OR COLOR.

FOR MATERNITY PILLOWS; MATTRESSES AND PILLOWS (U.S. CLS. 2, 13, 22, 25, 32 AND 50).
KAREN K. BUSH, EXAMINING ATTORNEY

SN 85-249,828. ENPRESS, L.L.C., EASTLAKE, OH. FILED 2-23-2011.



THE MARK CONSISTS OF THE LETTERS "E", "F", "T" IN WHICH THE MIDDLE HORIZONTAL PORTION OF THE "E" AND THE LOWER HORIZONTAL PORTION OF THE "F" ARE FORMED BY A PAIR OF CURVED ADJACENT CONNECTING LINES, ABOVE THE WORD "INSIDE", WHICH IS ABOVE THE WORD "EFTINSIDE.COM", ALL CONTAINED WITHIN A HORIZONTAL OVAL.

FOR NON-METAL FLUID STORAGE TANKS, NAMELY, THERMOPLASTIC PRESSURE VESSELS (U.S. CLS. 2, 13, 22, 25, 32 AND 50).
CIMMERIAN COLEMAN, EXAMINING ATTORNEY

SN 85-249,845. ENPRESS, L.L.C., EASTLAKE, OH. FILED 2-23-2011.

EFT INSIDE

THE MARK CONSISTS OF STANDARD CHARACTERS WITHOUT CLAIM TO ANY PARTICULAR FONT, STYLE, SIZE, OR COLOR.

FOR NON-METAL FLUID STORAGE TANKS, NAMELY, THERMOPLASTIC PRESSURE VESSELS (U.S. CLS. 2, 13, 22, 25, 32 AND 50).
CIMMERIAN COLEMAN, EXAMINING ATTORNEY

CLASS 20—(Continued).

SN 85-249,886. ENPRESS, L.L.C., EASTLAKE, OH. FILED 2-23-2011.



THE MARK CONSISTS OF THE WORD "VORTECH" ABOVE THE WORD "INSIDE" BOTH EXTENDING ACROSS AN OPEN CENTRAL PORTION OF A CIRCULAR RING HAVING SIX SPOKES RADIATING OUTWARDLY AS IF THE RING WAS ROTATING IN A COUNTER-CLOCKWISE DIRECTION.

FOR NON-METAL FLUID STORAGE TANKS, NAMELY, THERMOPLASTIC PRESSURE VESSELS (U.S. CLS. 2, 13, 22, 25, 32 AND 50).

FIRST USE 8-6-2007; IN COMMERCE 8-6-2007.
CIMMERIAN COLEMAN, EXAMINING ATTORNEY

SN 85-249,902. ENPRESS, L.L.C., EASTLAKE, OH. FILED 2-23-2011.

VORTECH INSIDE

THE MARK CONSISTS OF STANDARD CHARACTERS WITHOUT CLAIM TO ANY PARTICULAR FONT, STYLE, SIZE, OR COLOR.

FOR NON-METAL FLUID STORAGE TANKS, NAMELY, THERMOPLASTIC PRESSURE VESSELS (U.S. CLS. 2, 13, 22, 25, 32 AND 50).

FIRST USE 8-6-2007; IN COMMERCE 8-6-2007.
CIMMERIAN COLEMAN, EXAMINING ATTORNEY

CLASS 20—(Continued).

SN 85-250,033. E. S. KLUFT & COMPANY, LLC, RANCHO CUCAMONGA, CA. FILED 2-23-2011.

MADELEINE BED

THE MARK CONSISTS OF STANDARD CHARACTERS WITHOUT CLAIM TO ANY PARTICULAR FONT, STYLE, SIZE, OR COLOR.

NO CLAIM IS MADE TO THE EXCLUSIVE RIGHT TO USE "BED", APART FROM THE MARK AS SHOWN.

FOR MATTRESSES AND MATTRESS FOUNDATIONS (U.S. CLS. 2, 13, 22, 25, 32 AND 50).

FIRST USE 1-24-2011; IN COMMERCE 1-24-2011.
KIMBERLY FRYE, EXAMINING ATTORNEY

SN 85-250,367. ROLLFORM OF JAMESTOWN, INC., DBA PRECISION LOCKER COMPANY, JAMESTOWN, NY. FILED 2-24-2011.

Small Lockers Big Solutions

THE MARK CONSISTS OF STANDARD CHARACTERS WITHOUT CLAIM TO ANY PARTICULAR FONT, STYLE, SIZE, OR COLOR.

NO CLAIM IS MADE TO THE EXCLUSIVE RIGHT TO USE "SMALL LOCKERS", APART FROM THE MARK AS SHOWN.

FOR LOCKERS (U.S. CLS. 2, 13, 22, 25, 32 AND 50).

FIRST USE 3-23-2010; IN COMMERCE 3-23-2010.
DOUGLAS LEE, EXAMINING ATTORNEY

SN 85-250,368. SUCCESSFUL TOGETHER, ST SIMONS IS, GA. FILED 2-24-2011.

SWITCHSCREENS

THE MARK CONSISTS OF STANDARD CHARACTERS WITHOUT CLAIM TO ANY PARTICULAR FONT, STYLE, SIZE, OR COLOR.

FOR ROOM DIVIDERS (U.S. CLS. 2, 13, 22, 25, 32 AND 50).

FIRST USE 10-1-2010; IN COMMERCE 1-15-2011.
HOWARD B. LEVINE, EXAMINING ATTORNEY

CLASS 20—(Continued).

SN 85-251,218. FRANK SCHOOLEY CABINETS, INC., MA-
TLACHA, FL. FILED 2-24-2011.

TERRA PEG

THE MARK CONSISTS OF STANDARD CHARACTERS
WITHOUT CLAIM TO ANY PARTICULAR FONT, STYLE,
SIZE, OR COLOR.

NO CLAIM IS MADE TO THE EXCLUSIVE RIGHT TO
USE "PEG", APART FROM THE MARK AS SHOWN.

FOR FURNITURE; FURNITURE FOR HOUSE, OF-
FICE AND GARDEN; FURNITURE MADE FROM
WOOD OR SUBSTITUTES FOR WOOD (U.S. CLS. 2, 13,
22, 25, 32 AND 50).

FIRST USE 1-16-2011; IN COMMERCE 1-16-2011.
KIMBERLY PERRY, EXAMINING ATTORNEY

CLASS 20—(Continued).

SN 85-253,225. MAXI-LIFT, INC., DALLAS, TX. FILED 2-28-
2011.

MIGHTY-MAX

THE MARK CONSISTS OF STANDARD CHARACTERS
WITHOUT CLAIM TO ANY PARTICULAR FONT, STYLE,
SIZE, OR COLOR.

OWNER OF U.S. REG. NOS. 2,785,047 AND 2,803,639.
FOR PLASTIC LIVESTOCK FEED CONTAINERS (U.S.
CLS. 2, 13, 22, 25, 32 AND 50).

FIRST USE 8-0-2006; IN COMMERCE 8-0-2006.
CHERYL CLAYTON, EXAMINING ATTORNEY

SN 85-251,796. BOON, INC., CHANDLER, AZ. FILED 2-25-
2011.

FLAIR

THE MARK CONSISTS OF STANDARD CHARACTERS
WITHOUT CLAIM TO ANY PARTICULAR FONT, STYLE,
SIZE, OR COLOR.

FOR HIGH CHAIRS (U.S. CLS. 2, 13, 22, 25, 32 AND 50).
FIRST USE 5-29-2007; IN COMMERCE 5-29-2007.
KELLY CHOE, EXAMINING ATTORNEY

SN 85-252,006. BUTTERFLY SAFETY PRODUCTS LLC,
BUFFALO, NY. FILED 2-25-2011.

Butterfly Smoke Seal

THE MARK CONSISTS OF STANDARD CHARACTERS
WITHOUT CLAIM TO ANY PARTICULAR FONT, STYLE,
SIZE, OR COLOR.

NO CLAIM IS MADE TO THE EXCLUSIVE RIGHT TO
USE "SMOKE SEAL", APART FROM THE MARK AS
SHOWN.

FOR SMOKE GUARDS, NAMELY, A STUFFED TEX-
TILE TUBE SMOKE STOPPERS FOR DOORS TO PRE-
VENT THE PASSAGE OF SMOKE (U.S. CLS. 2, 13, 22, 25,
32 AND 50).

MAYUR VAGHANI, EXAMINING ATTORNEY

SN 85-253,584. INMARK, INC., AUSTELL, GA. FILED 2-28-
2011.

InTemp

THE MARK CONSISTS OF STANDARD CHARACTERS
WITHOUT CLAIM TO ANY PARTICULAR FONT, STYLE,
SIZE, OR COLOR.

FOR NON-METAL AND NON-PAPER INSULATED
SHIPPING CONTAINERS FOR TRANSPORTING FRO-
ZEN AND REFRIGERATED MATERIALS (U.S. CLS. 2,
13, 22, 25, 32 AND 50).

PAUL MORENO, EXAMINING ATTORNEY

SN 85-253,861. BORGREN THOMAS M, DULUTH, MN.
FILED 2-28-2011.

Boner Bee Gone

THE MARK CONSISTS OF STANDARD CHARACTERS
WITHOUT CLAIM TO ANY PARTICULAR FONT, STYLE,
SIZE, OR COLOR.

FOR NOVELTY GOODS IN THE NATURE OF A
PLACEBO SPRAY USED TO ALTER ONE'S REACTION
TO A SITUATION (U.S. CLS. 2, 13, 22, 25, 32 AND 50).

MIDGE BUTLER, EXAMINING ATTORNEY

CLASS 20—(Continued).

SN 85-254,201. WINCO BEDDING USA, LLC, CORSICANA, TX. FILED 3-1-2011.

SLEEP FOR TOMORROW

THE MARK CONSISTS OF STANDARD CHARACTERS WITHOUT CLAIM TO ANY PARTICULAR FONT, STYLE, SIZE, OR COLOR.
 FOR MATTRESSES, BOXSPRINGS, MATTRESS TOPPERS, PILLOWS (U.S. CLS. 2, 13, 22, 25, 32 AND 50).
 FIRST USE 2-1-2011; IN COMMERCE 2-1-2011.
 THOMAS MANOR, EXAMINING ATTORNEY

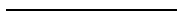

SN 85-254,293. VYMAC CORPORATION, AKA VERLO FACTORY MATTRESS STORES, FORT ATKINSON, WI. FILED 3-1-2011.

CRAFTED COMFORT FOR LIFE

THE MARK CONSISTS OF STANDARD CHARACTERS WITHOUT CLAIM TO ANY PARTICULAR FONT, STYLE, SIZE, OR COLOR.
 OWNER OF U.S. REG. NO. 1,603,797.
 FOR MATTRESSES (U.S. CLS. 2, 13, 22, 25, 32 AND 50).
 MIDGE BUTLER, EXAMINING ATTORNEY



SN 85-254,989. OWEN G. DUNN CO., INC., NEW BERN, NC. FILED 3-1-2011.

VersaSign

THE MARK CONSISTS OF STANDARD CHARACTERS WITHOUT CLAIM TO ANY PARTICULAR FONT, STYLE, SIZE, OR COLOR.
 FOR NON-METAL HOLDERS FOR SIGNS, NAMELY, A MOLDED PLASTIC SIGN SYSTEM COMPRISED OF A BASE, THREE COLUMNS, AND A CAP FOR HOLDING A STANDARD SIGN BLANK (U.S. CLS. 2, 13, 22, 25, 32 AND 50).
 KIMBERLY FRYE, EXAMINING ATTORNEY

CLASS 20—(Continued).

SN 85-255,444. ARGINGTON, INC., BROOKLYN, NY. FILED 3-2-2011.



THE COLOR(S) ORANGE BLUE IS/ARE CLAIMED AS A FEATURE OF THE MARK.
 THE MARK CONSISTS OF SOLID ORANGE RECTANGULAR ELEMENT WITH STYLISTIC BORDER WITH THE COMPANY NAME "ARGINGTON" WRITTEN IN BLUE.
 FOR FURNITURE (U.S. CLS. 2, 13, 22, 25, 32 AND 50).
 FIRST USE 7-1-2003; IN COMMERCE 7-1-2003.
 ROBIN CHOSID, EXAMINING ATTORNEY



SN 85-255,732. J. SQUARED, INC., DBA UNIVERSITY LOFT COMPANY, GREENFIELD, IN. FILED 3-2-2011.

MAKERS OF COOL

THE MARK CONSISTS OF STANDARD CHARACTERS WITHOUT CLAIM TO ANY PARTICULAR FONT, STYLE, SIZE, OR COLOR.
 FOR FURNITURE (U.S. CLS. 2, 13, 22, 25, 32 AND 50).
 FIRST USE 9-17-2010; IN COMMERCE 9-17-2010.
 JENNY PARK, EXAMINING ATTORNEY



SN 85-255,779. LIFETIME BRANDS, INC., GARDEN CITY, NY. FILED 3-2-2011.

KIZMOS GET HAPPY

THE MARK CONSISTS OF STANDARD CHARACTERS WITHOUT CLAIM TO ANY PARTICULAR FONT, STYLE, SIZE, OR COLOR.
 FOR PLASTIC CLIPS FOR SEALING BAGS (U.S. CLS. 2, 13, 22, 25, 32 AND 50).
 THEODORE MCBRIDE, EXAMINING ATTORNEY

CLASS 20—(Continued).

SN 85-255,786. BUSHONG, ELIZABETH, C., DBA LIZ BUSHONG, JOHNSON CITY, TN. FILED 3-2-2011.

SASSYSCAPES

THE MARK CONSISTS OF STANDARD CHARACTERS WITHOUT CLAIM TO ANY PARTICULAR FONT, STYLE, SIZE, OR COLOR.
FOR DINING ROOM TABLES; DISPLAY TABLES (U.S. CLS. 2, 13, 22, 25, 32 AND 50).
JAMES MACFARLANE, EXAMINING ATTORNEY

SN 85-255,836. LIFETIME BRANDS, INC., GARDEN CITY, NY. FILED 3-2-2011.

GET HAPPY

THE MARK CONSISTS OF STANDARD CHARACTERS WITHOUT CLAIM TO ANY PARTICULAR FONT, STYLE, SIZE, OR COLOR.
FOR PLASTIC CLIPS FOR SEALING BAGS (U.S. CLS. 2, 13, 22, 25, 32 AND 50).
THEODORE MCBRIDE, EXAMINING ATTORNEY

SN 85-255,961. 360 AND THE ONE DEGREES INC., GARDEN CITY, NY. FILED 3-2-2011.

DESKWISE

THE MARK CONSISTS OF STANDARD CHARACTERS WITHOUT CLAIM TO ANY PARTICULAR FONT, STYLE, SIZE, OR COLOR.
FOR DESKS, PORTABLE DESKS, WRITING DESKS, COMPUTER DESKS, READING DESKS, DRAFTING DESKS, ARTIST'S DESKS (U.S. CLS. 2, 13, 22, 25, 32 AND 50).
ODESSA BIBBINS, EXAMINING ATTORNEY

CLASS 20—(Continued).

SN 85-256,686. SANTNER, DEAN, DBA DEAN SANTNER DESIGN, ALAMEDA, CA. FILED 3-3-2011.

MRW

THE MARK CONSISTS OF STANDARD CHARACTERS WITHOUT CLAIM TO ANY PARTICULAR FONT, STYLE, SIZE, OR COLOR.
FOR FURNITURE (U.S. CLS. 2, 13, 22, 25, 32 AND 50).
KATHERINE M. DUBRAY, EXAMINING ATTORNEY

SN 85-257,006. DANIEL BENCHETRIT, LAVAL, CANADA, FILED 3-3-2011.

SUNFIBER

THE MARK CONSISTS OF STANDARD CHARACTERS WITHOUT CLAIM TO ANY PARTICULAR FONT, STYLE, SIZE, OR COLOR.
FOR OUTDOOR FURNITURE (U.S. CLS. 2, 13, 22, 25, 32 AND 50).
HEATHER THOMPSON, EXAMINING ATTORNEY

SN 85-257,363. WESTERN INDUSTRIES, INC., WINFIELD, KS. FILED 3-3-2011.

**BUILT TO USE EVERY DAY,
NOT JUST TO STORE AWAY**

THE MARK CONSISTS OF STANDARD CHARACTERS WITHOUT CLAIM TO ANY PARTICULAR FONT, STYLE, SIZE, OR COLOR.
FOR STORAGE AND ORGANIZATION SYSTEMS FOR LAWN AND GARDEN EQUIPMENT, HOUSEHOLD AND GARAGE EQUIPMENT, CAMPING AND HIKING EQUIPMENT, HUNTING AND SPORTING EQUIPMENT, AND CONSTRUCTION AND CONTRACTOR EQUIPMENT, COMPRISING SHELVES, CABINETS, DRAWERS, BASKETS, STORAGE HOOKS, STORAGE BINS, STORAGE CONTAINERS, STORAGE LOCKERS, CUPBOARDS, TOTES, SOLD AS A UNIT (U.S. CLS. 2, 13, 22, 25, 32 AND 50).
HAI-LY LAM, EXAMINING ATTORNEY

CLASS 20—(Continued).

SN 85-257,740. INFLATE CO., INC., TUSTIN, CA. FILED 3-4-2011.

SKYFLATABLES

THE MARK CONSISTS OF STANDARD CHARACTERS WITHOUT CLAIM TO ANY PARTICULAR FONT, STYLE, SIZE, OR COLOR.

FOR INFLATABLE PUBLICITY OBJECTS (U.S. CLS. 2, 13, 22, 25, 32 AND 50).

FIRST USE 2-23-2011; IN COMMERCE 2-23-2011.
KIMBERLY PERRY, EXAMINING ATTORNEY

SN 85-260,667. ASTRAL BUOYANCY COMPANY, ASHEVILLE, NC. FILED 3-8-2011.

ASTRAL

THE MARK CONSISTS OF STANDARD CHARACTERS WITHOUT CLAIM TO ANY PARTICULAR FONT, STYLE, SIZE, OR COLOR.

FOR DOG BEDS (U.S. CLS. 2, 13, 22, 25, 32 AND 50).

FIRST USE 8-0-2008; IN COMMERCE 8-0-2008.
THOMAS MANOR, EXAMINING ATTORNEY

SN 85-263,540. SCHIFFMAYER SALES & ENGINEERING L.L.C., ALGONQUIN, IL. FILED 3-10-2011.

TASKET

THE MARK CONSISTS OF STANDARD CHARACTERS WITHOUT CLAIM TO ANY PARTICULAR FONT, STYLE, SIZE, OR COLOR.

FOR FOLDABLE PLASTIC CRATES (U.S. CLS. 2, 13, 22, 25, 32 AND 50).

FIRST USE 11-24-1992; IN COMMERCE 11-24-1992.
ELISSA GARBER KON, EXAMINING ATTORNEY

CLASS 20—(Continued).

SN 85-263,836. HARAJUKU LOVERS, LLC, BEVERLY HILLS, CA. FILED 3-10-2011.

HARAJUKU MINI

THE MARK CONSISTS OF STANDARD CHARACTERS WITHOUT CLAIM TO ANY PARTICULAR FONT, STYLE, SIZE, OR COLOR.

OWNER OF U.S. REG. NOS. 3,562,719, 3,833,077 AND OTHERS.

FOR BABY BOUNCERS, BABY CHANGING MATS, BASSINETS, BEACH CHAIRS, FURNITURE, CORKBOARDS, DECORATIVE MOBILES, GIFT PACKAGE DECORATIONS MADE OF PLASTIC, HANDHELD MIRRORS, PARTY ORNAMENTS OF PLASTIC, PILLOWS, PICTURE FRAMES, PLASTIC KEY CHAINS, PLASTIC NOVELTY LICENSE PLATE FRAMES, PLAYPENS, STATUETTES OF PLASTIC OR WOOD, SOFT SCULPTURE WALL DECORATIONS, AND SLEEPING BAGS (U.S. CLS. 2, 13, 22, 25, 32 AND 50).

INGRID C. EULIN, EXAMINING ATTORNEY

SN 85-274,398. AS IP HOLDCO, LLC, PISCATAWAY, NJ. FILED 3-23-2011.

QUICKSPIN

THE MARK CONSISTS OF STANDARD CHARACTERS WITHOUT CLAIM TO ANY PARTICULAR FONT, STYLE, SIZE, OR COLOR.

FOR PLASTIC NUT USED TO CONNECT PLUMBING FITTINGS (U.S. CLS. 2, 13, 22, 25, 32 AND 50).

FIRST USE 1-1-2010; IN COMMERCE 1-1-2010.
RAUL CORDOVA, EXAMINING ATTORNEY

SN 85-276,963. BOON, INC., CHANDLER, AZ. FILED 3-25-2011.

STASH

THE MARK CONSISTS OF STANDARD CHARACTERS WITHOUT CLAIM TO ANY PARTICULAR FONT, STYLE, SIZE, OR COLOR.

FOR STORAGE COMPARTMENTS IN THE NATURE OF WALL MOUNTED AND COUNTERTOP SHELVING UNITS (U.S. CLS. 2, 13, 22, 25, 32 AND 50).

FIRST USE 8-21-2009; IN COMMERCE 8-21-2009.
FLORENTINA BLANDU, EXAMINING ATTORNEY

CLASS 20—(Continued).

SN 85-278,045. DIEBOLD, INCORPORATED, NORTH CANTON, OH. FILED 3-27-2011.

**DIEBOLD ACCENT FURNITURE
DESIGN**

THE MARK CONSISTS OF STANDARD CHARACTERS WITHOUT CLAIM TO ANY PARTICULAR FONT, STYLE, SIZE, OR COLOR.

NO CLAIM IS MADE TO THE EXCLUSIVE RIGHT TO USE "FURNITURE DESIGN", APART FROM THE MARK AS SHOWN.

FOR MODULAR COUNTERS FOR FINANCIAL INSTITUTIONS (U.S. CLS. 2, 13, 22, 25, 32 AND 50).

JANICE L. MCMORROW, EXAMINING ATTORNEY

CLASS 21—HOUSEWARES AND GLASS

SN 76-702,947. ROBIN HABER, HIGHLAND PARK, IL. AND WILLIAM HABER, HIGHLAND PARK, IL. FILED 5-14-2010.

SQUEEZE CLOTH

THE MARK CONSISTS OF STANDARD CHARACTERS WITHOUT CLAIM TO ANY PARTICULAR FONT, STYLE, SIZE, OR COLOR.

FOR HOUSEHOLD UTENSILS, NAMELY, A FLEXIBLE MAT-SHAPED MULTI-FUNCTION KITCHEN TOOL USED FOR STRAINING, REMOVING LIQUIDS, SIFTING, WRAPPING FOODS FOR POACHING (U.S. CLS. 2, 13, 23, 29, 30, 33, 40 AND 50).

TRACY WHITTAKER-BROWN, EXAMINING ATTORNEY

SN 77-949,654. IDEAVILLAGE PRODUCTS CORP., WAYNE, NJ. FILED 3-3-2010.

SHOEDINI

THE MARK CONSISTS OF STANDARD CHARACTERS WITHOUT CLAIM TO ANY PARTICULAR FONT, STYLE, SIZE, OR COLOR.

FOR SHOE HORNS (U.S. CLS. 2, 13, 23, 29, 30, 33, 40 AND 50).

FIRST USE 12-31-2009; IN COMMERCE 12-31-2009.

JOHN SCHUYLER YARD, EXAMINING ATTORNEY

CLASS 21—(Continued).

SN 79-057,950. JIANGSU PROVINCE YIXING; PAINTED-POTTERY CRAFTWORK FACTORY, YIXING; JIANGSU, CHINA. FILED 6-5-2008.



OWNER OF INTERNATIONAL REGISTRATION 0974815 DATED 6-5-2008. EXPIRES 6-5-2018.

THE MARK CONSISTS OF NON-LATIN CHARACTERS WHICH TRANSLITERATE TO "YI CUI", A LATIN CHARACTER "Y" AND A ELLIPTIC CIRCLE AROUND ALL THE CHARACTERS.

THE NON-LATIN CHARACTERS IN THE MARK TRANSLITERATE TO "YI CUI", AND "YI" MEANS "ART" AND "CUI" MEANS "ASSEMBLE" IN ENGLISH.

FOR GLAZE-COLOURED POTTERY, NAMELY, WINE BOTTLES SOLD EMPTY; VASES; POTS; EARTHEN POTS; TEA SETS (U.S. CLS. 2, 13, 23, 29, 30, 33, 40 AND 50).

PAUL MORENO, EXAMINING ATTORNEY

SN 85-003,971. DERMER, DAVID, NORTHBROOK, IL. FILED 4-1-2010.

THREESUMS

THE MARK CONSISTS OF STANDARD CHARACTERS WITHOUT CLAIM TO ANY PARTICULAR FONT, STYLE, SIZE, OR COLOR.

FOR BEVERAGE GLASSWARE; MUGS; SNIFFERS; CHAMPAGNE FLUTES; DRINKING GLASSES; GLASS JARS AND BOWLS; BAR ACCESSORIES, NAMELY, COCKTAIL SHAKERS, CORK OR GLASS WINE STOPPERS, CORKSCREWS, COASTERS NOT OF PAPER AND NOT BEING TABLE LINEN, BOTTLE OPENERS, MIXING GLASSES, LIQUID DISPENSERS, NAMELY, BEVERAGE DISPENSERS AND COCKTAIL STIRRERS (U.S. CLS. 2, 13, 23, 29, 30, 33, 40 AND 50).

KIMBERLY PERRY, EXAMINING ATTORNEY

CLASS 21—(Continued).

SN 85-031,674. CRYSTALWARE, BROOKLYN, NY. FILED 5-6-2010.

Sterex

THE MARK CONSISTS OF STANDARD CHARACTERS WITHOUT CLAIM TO ANY PARTICULAR FONT, STYLE, SIZE, OR COLOR.

FOR DISPOSABLE GLOVES FOR HOME USE; DISPOSABLE LATEX AND NITRILE GLOVES FOR GENERAL USE; DISPOSABLE PLASTIC GLOVES FOR USE IN THE FOOD SERVICE INDUSTRY (U.S. CLS. 2, 13, 23, 29, 30, 33, 40 AND 50).

FIRST USE 1-1-2004; IN COMMERCE 1-1-2004.
KATHERINE CHANG, EXAMINING ATTORNEY

SN 85-059,742. KIM, SOON JIN, KWANAK-GU, SEOUL, REPUBLIC OF KOREA, AND NOLBOO CO., LTD., SEOUL, REPUBLIC OF KOREA, FILED 6-10-2010.

BARBETZ

THE MARK CONSISTS OF STANDARD CHARACTERS WITHOUT CLAIM TO ANY PARTICULAR FONT, STYLE, SIZE, OR COLOR.

PRIORITY CLAIMED UNDER SEC. 44(D) ON REPUBLIC OF KOREA APPLICATION NO. 40-2010-0005, FILED 2-2-2010, REG. NO. 859353, DATED 4-1-2011, EXPIRES 4-1-2021.

OWNER OF U.S. REG. NOS. 3,365,641 AND 3,369,205.

THE WORDING "BARBETZ" HAS NO MEANING IN A FOREIGN LANGUAGE.

FOR COOKING POTS; JUGS; FRYING PANS; BASINS; BEER MUGS; MUGS; BASINS; TANKARDS; BEVERAGEWARE, NAMELY, LIQUEUR SETS; DISHES; DRINKING GLASSES; CUPS OF PAPER OR PLASTIC; CUPS; MESS-TINS; NAPKIN-HOLDERS; SCOOPS; THERMALLY INSULATED CONTAINERS FOR FOOD; TOOTHPICKS; TRAYS, NOT OF PRECIOUS METAL; CHOPSTICKS; HOUSEHOLD UTENSILS, NAMELY SPATULAS; LAZY SUSANS; BUCKETS; INSULATED FLASKS; CONTAINERS FOR HOUSEHOLD OR KITCHEN USE; NON-ELECTRIC TEA POTS; COFFEE SERVICES NOT OF PRECIOUS METAL; CRUETS; BASTING SPOONS, FOR KITCHEN USE (U.S. CLS. 2, 13, 23, 29, 30, 33, 40 AND 50).

ALLISON SCHRODY, EXAMINING ATTORNEY

CLASS 21—(Continued).

SN 85-083,547. EMSAR, INC., STRATFORD, CT. FILED 7-13-2010.

ESSENCIA

THE MARK CONSISTS OF STANDARD CHARACTERS WITHOUT CLAIM TO ANY PARTICULAR FONT, STYLE, SIZE, OR COLOR.

FOR MANUALLY-OPERATED NON-PRESSURIZED SPRAY SYSTEMS, NAMELY, FINE MIST SPRAYERS AND ATOMIZERS FOR ATTACHMENT TO CONTAINERS, SOLD EMPTY, FOR PERSONAL CARE AND HOUSEHOLD USE; MANUALLY-OPERATED NON-PRESSURIZED PUMP DISPENSERS FOR USE IN DISPENSING LIQUIDS FOR ATTACHMENT TO CONTAINERS, SOLD EMPTY, FOR PERSONAL CARE AND HOUSEHOLD USE (U.S. CLS. 2, 13, 23, 29, 30, 33, 40 AND 50).

SARA BENJAMIN, EXAMINING ATTORNEY

SN 85-091,574. CISCO SALES CORPORATION, TORRANCE, CA. FILED 7-23-2010.

Digi-Piggy

THE MARK CONSISTS OF STANDARD CHARACTERS WITHOUT CLAIM TO ANY PARTICULAR FONT, STYLE, SIZE, OR COLOR.

FOR NON-METAL DIGITAL COIN BANK (U.S. CLS. 2, 13, 23, 29, 30, 33, 40 AND 50).

SUNG IN, EXAMINING ATTORNEY

SN 85-102,207. H. E. ASSOCIATES, YORKVILLE, IL. FILED 8-6-2010.

Tomato Tender



NO CLAIM IS MADE TO THE EXCLUSIVE RIGHT TO USE "TOMATO", APART FROM THE MARK AS SHOWN.

THE STIPPLING IS FOR SHADING PURPOSES ONLY.

THE MARK CONSISTS OF THE LANGUAGE "TOMATO TENDER" INSIDE A RECTANGLE AND BELOW THE RECTANGLE ARE TWO HANDS HOLDING A TOMATO.

FOR PLANTING POT, SUCH AS A SELF-WATERING POT FOR GROWING TOMATOES (U.S. CLS. 2, 13, 23, 29, 30, 33, 40 AND 50).

LAURIE MAYES, EXAMINING ATTORNEY

CLASS 21—(Continued).

SN 85-105,538. C. WONDER LLC, NEW YORK, NY. FILED 8-11-2010.

C. WONDER

THE MARK CONSISTS OF STANDARD CHARACTERS WITHOUT CLAIM TO ANY PARTICULAR FONT, STYLE, SIZE, OR COLOR.

FOR HOUSEHOLD UTENSILS, NAMELY, GRATERS, SPATULAS, SIEVES, STRAINERS, TURNERS, KITCHEN TONGS, AND WHISKS; COOKWARE, NAMELY, POTS AND PANS; BAKEWARE; BEVERAGE GLASSWARE; CANDLE HOLDERS; SERVING TRAYS (U.S. CLS. 2, 13, 23, 29, 30, 33, 40 AND 50).

FLORENTINA BLANDU, EXAMINING ATTORNEY

SN 85-107,020. EVERLAST WORLD'S BOXING HEADQUARTERS CORPORATION, NEW YORK, NY. FILED 8-13-2010.



OWNER OF U.S. REG. NOS. 3,517,682, 3,606,812 AND 3,772,066.

THE MARK CONSISTS OF THE LETTER "E" SLANTED TO THE LEFT.

FOR FIGURINES MADE OUT OF FIBERGLASS, CHINA, CRYSTAL, EARTHENWARE, GLASS OR PORCELAIN; MINIATURE FIGURES OF CHINA, CRYSTAL, EARTHENWARE, GLASS OR PORCELAIN; GIFTWARE ARTICLES AND WORKS OF ART, ALL MADE OF BONE CHINA, CHINA CRYSTAL, EARTHENWARE, GLASS, PORCELAIN OR TERRACOTTA, NAMELY, FIGURINES AND SCULPTURES; LUNCHBOXES; THERMAL INSULATED WRAP FOR CANS TO KEEP THE CONTENTS COLD OR HOT; COOL BAGS, NAMELY, THERMAL INSULATED BAGS FOR FOOD OR BEVERAGES; THERMAL INSULATED CONTAINERS FOR FOOD OR BEVERAGES (U.S. CLS. 2, 13, 23, 29, 30, 33, 40 AND 50).

LESLIE RICHARDS, EXAMINING ATTORNEY

CLASS 21—(Continued).

SN 85-115,834. WAL-MART STORES, INC., BENTONVILLE, AR. FILED 8-25-2010.



NO CLAIM IS MADE TO THE EXCLUSIVE RIGHT TO USE "SUPERIOR BROWNING GREAT TASTE EASY CLEAN UP", APART FROM THE MARK AS SHOWN.

THE MARK CONSISTS OF THE WORDS "TRIPLE PERFORMANCE GRID" SURROUNDED BY THE WORDS "SUPERIOR BROWNING" AND "GREAT TASTE" AND "EASY CLEAN UP".

FOR BAKEWARE; COOKWARE FOR USE IN MICROWAVE OVENS; COOKWARE, NAMELY, POTS AND PANS; COOKWARE, NAMELY, ROASTING PANS; COOKWARE, NAMELY, STEAMERS (U.S. CLS. 2, 13, 23, 29, 30, 33, 40 AND 50).

KEVON CHISOLM, EXAMINING ATTORNEY

SN 85-119,468. C & F FOODS COMPANY, INC., SYOSSET, NY. FILED 8-31-2010.



THE MARK CONSISTS OF AN ILLUSTRATION OF A MEDITERRANEAN STYLE HOUSE HAVING DOORS AND WINDOWS.

SEC. 2(F). FOR DRINKING CUPS (U.S. CLS. 2, 13, 23, 29, 30, 33, 40 AND 50).

FIRST USE 1-17-2005; IN COMMERCE 1-17-2005.

TIMOTHY FINNEGAN, EXAMINING ATTORNEY

CLASS 21—(Continued).

SN 85-186,300. DEER PARK IRON WORKS, LLC, DBA DEER PARK IRONWORKS, REISTERSTOWN, MD. FILED 11-29-2010.

Deer Park Ironworks

THE MARK CONSISTS OF STANDARD CHARACTERS WITHOUT CLAIM TO ANY PARTICULAR FONT, STYLE, SIZE, OR COLOR.

NO CLAIM IS MADE TO THE EXCLUSIVE RIGHT TO USE "IRONWORKS", APART FROM THE MARK AS SHOWN.

SEC. 2(F).

FOR OUTDOOR WROUGHT IRON PLANTERS FOR FLOWERS AND PLANTS FOR HOME AND GARDEN USE (U.S. CLS. 2, 13, 23, 29, 30, 33, 40 AND 50).

FIRST USE 1-1-2000; IN COMMERCE 1-1-2000.

JEAN IM, EXAMINING ATTORNEY

SN 85-201,914. ARC WARE, LAS VEGAS, NV. FILED 12-20-2010.

SWIH

THE MARK CONSISTS OF STANDARD CHARACTERS WITHOUT CLAIM TO ANY PARTICULAR FONT, STYLE, SIZE, OR COLOR.

OWNER OF U.S. REG. NO. 3,884,234.

FOR BOTTLE HOLDER THAT MAY SERVE AS A BODY COOLER WHEN THE BOTTLES ARE COOL (U.S. CLS. 2, 13, 23, 29, 30, 33, 40 AND 50).

FIRST USE 5-28-2010; IN COMMERCE 5-28-2010.

RENEE MCCRAY, EXAMINING ATTORNEY

SN 85-212,523. LIFETIME BRANDS, INC., GARDEN CITY, NY. FILED 1-7-2011.

RED ORLEANS

THE MARK CONSISTS OF STANDARD CHARACTERS WITHOUT CLAIM TO ANY PARTICULAR FONT, STYLE, SIZE, OR COLOR.

NO CLAIM IS MADE TO THE EXCLUSIVE RIGHT TO USE "RED", APART FROM THE MARK AS SHOWN.

FOR DINNERWARE (U.S. CLS. 2, 13, 23, 29, 30, 33, 40 AND 50).

ALICIA COLLINS, EXAMINING ATTORNEY

CLASS 21—(Continued).

SN 85-212,527. LIFETIME BRANDS, INC., GARDEN CITY, NY. FILED 1-7-2011.

PASHA GOLD

THE MARK CONSISTS OF STANDARD CHARACTERS WITHOUT CLAIM TO ANY PARTICULAR FONT, STYLE, SIZE, OR COLOR.

NO CLAIM IS MADE TO THE EXCLUSIVE RIGHT TO USE "GOLD", APART FROM THE MARK AS SHOWN.

FOR DINNERWARE (U.S. CLS. 2, 13, 23, 29, 30, 33, 40 AND 50).

ALICIA COLLINS, EXAMINING ATTORNEY

SN 85-213,677. YAUW LIEN ELECTRICAL MANUFACTURING COMPANY LIMITED, KOWLOON, HONG KONG, FILED 1-10-2011.

ALPHA TOOL

THE MARK CONSISTS OF STANDARD CHARACTERS WITHOUT CLAIM TO ANY PARTICULAR FONT, STYLE, SIZE, OR COLOR.

OWNER OF HONG KONG REG. NO. 300440388, DATED 6-17-2005, EXPIRES 6-16-2015.

OWNER OF U.S. REG. NO. 3,795,449.

NO CLAIM IS MADE TO THE EXCLUSIVE RIGHT TO USE "TOOL", APART FROM THE MARK AS SHOWN.

FOR COMBS; LARGE-TOOTHED COMBS FOR THE HAIR; ELECTRIC HAIR COMBS; BRUSHES FOR PETS; COSMETIC NAIL BRUSHES; BRUSHES FOR WASHING FOOTWEAR; SHOE BRUSHES; ELECTRIC PET BRUSHES; ELECTRIC TOOTH BRUSHES; MAKE-UP BRUSHES; EYEBROW BRUSHES; SHAVING BRUSHES; STANDS FOR SHAVING BRUSHES; SHAVING BRUSH STANDS; COSMETIC BRUSHES FOR CHEEKS; COSMETIC EYE SHADOW BRUSH; COSMETIC EYELASH BRUSH; BRUSH SHOE WARE, NAMELY, BRUSHES FOR SHOES; ELECTRIC TOOLS FOR BRUSHING SHOES, NAMELY, SHOE BRUSHES (U.S. CLS. 2, 13, 23, 29, 30, 33, 40 AND 50).

MAUREEN DALL, EXAMINING ATTORNEY

SN 85-214,843. HERCULES CHEMICAL COMPANY, INC., PASSAIC, NJ. FILED 1-11-2011.

EXTENDA-SPOUT

THE MARK CONSISTS OF STANDARD CHARACTERS WITHOUT CLAIM TO ANY PARTICULAR FONT, STYLE, SIZE, OR COLOR.

FOR PLASTIC TELESCOPING NOZZLE SOLD AS AN INTEGRAL COMPONENT OF LUBRICATING OIL BOTTLES (U.S. CLS. 2, 13, 23, 29, 30, 33, 40 AND 50).

FIRST USE 3-12-1979; IN COMMERCE 3-12-1979.

ANGELA M. MICHELI, EXAMINING ATTORNEY

CLASS 21—(Continued).

SN 85-216,771. MOUNTAIN GLASS ARTS INC., ASHEVILLE, NC. FILED 1-13-2011.

AccuGrind

THE MARK CONSISTS OF STANDARD CHARACTERS WITHOUT CLAIM TO ANY PARTICULAR FONT, STYLE, SIZE, OR COLOR.

FOR GLASSBLOWING PRODUCTS IN THE NATURE OF GLASS RODS AND GLASS PIPES, NOT FOR BUILDING AND NOT FOR SCIENTIFIC PURPOSES (U.S. CLS. 2, 13, 23, 29, 30, 33, 40 AND 50).

FIRST USE 12-1-2010; IN COMMERCE 12-1-2010.
MARC LEIPZIG, EXAMINING ATTORNEY

CLASS 21—(Continued).

SN 85-226,174. NOVA LEE, LOS ALTOS, CA. FILED 1-26-2011.

HicCup

THE MARK CONSISTS OF STANDARD CHARACTERS WITHOUT CLAIM TO ANY PARTICULAR FONT, STYLE, SIZE, OR COLOR.

FOR COLLAPSIBLE REUSABLE DRINKING CUP (U.S. CLS. 2, 13, 23, 29, 30, 33, 40 AND 50).

FIRST USE 1-1-2011; IN COMMERCE 1-1-2011.
FONG HSU, EXAMINING ATTORNEY

SN 85-225,176. ALICE INK, INC., DELRAY BEACH, FL. FILED 1-25-2011.

PURELAST

THE MARK CONSISTS OF STANDARD CHARACTERS WITHOUT CLAIM TO ANY PARTICULAR FONT, STYLE, SIZE, OR COLOR.

FOR CUTTING BOARDS; MIXING CUPS IN THE NATURE OF PREP CUPS AND PINCH CUPS; MIXING BOWLS (U.S. CLS. 2, 13, 23, 29, 30, 33, 40 AND 50).

HENRY S. ZAK, EXAMINING ATTORNEY

SN 85-225,978. NIKMEL, INC., MANHATTAN BEACH, CA. FILED 1-25-2011.

NIK MELLER COLLECTION

THE MARK CONSISTS OF STANDARD CHARACTERS WITHOUT CLAIM TO ANY PARTICULAR FONT, STYLE, SIZE, OR COLOR.

NO CLAIM IS MADE TO THE EXCLUSIVE RIGHT TO USE "COLLECTION", APART FROM THE MARK AS SHOWN.

THE NAME(S), PORTRAIT(S), AND/OR SIGNATURE(S) SHOWN IN THE MARK IDENTIFIES NIKOLAUS MELLER, WHOSE CONSENT(S) TO REGISTER IS MADE OF RECORD.

FOR STATUES OF GLASS OR CRYSTAL (U.S. CLS. 2, 13, 23, 29, 30, 33, 40 AND 50).

FIRST USE 1-1-2009; IN COMMERCE 1-1-2009.
JACLYN KIDWELL WALKER, EXAMINING ATTORNEY

SN 85-234,621. WALGREEN CO., DEERFIELD, IL. FILED 2-4-2011.

NICE!

THE MARK CONSISTS OF STANDARD CHARACTERS WITHOUT CLAIM TO ANY PARTICULAR FONT, STYLE, SIZE, OR COLOR.

FOR BATH SPONGES; CLEANING SPONGES; PAPER AND PLASTIC CUPS; PAPER AND PLASTIC PLATES; PAPER CUPS; DISPOSABLE GLOVES FOR HOME USE; PRE-MOISTENED TOWELETTES FOR CLEANING (U.S. CLS. 2, 13, 23, 29, 30, 33, 40 AND 50).

JIM RINGLE, EXAMINING ATTORNEY

SN 85-235,409. JAMISON, WILL C., CARSON, CA. FILED S.R. 2-7-2011; AM. P.R. 5-19-2011.

STEAMWAVE PRO

THE MARK CONSISTS OF STANDARD CHARACTERS WITHOUT CLAIM TO ANY PARTICULAR FONT, STYLE, SIZE, OR COLOR.

NO CLAIM IS MADE TO THE EXCLUSIVE RIGHT TO USE "PRO", APART FROM THE MARK AS SHOWN.

FOR COOKING STEAMERS (U.S. CLS. 2, 13, 23, 29, 30, 33, 40 AND 50).

PRISCILLA MILTON, EXAMINING ATTORNEY

CLASS 21—(Continued).

SN 85-242,719. GREEN HOME SHIELD, LLLP, DEERFIELD BEACH, FL. FILED 2-15-2011.

BED BUG SLASHER

THE MARK CONSISTS OF STANDARD CHARACTERS WITHOUT CLAIM TO ANY PARTICULAR FONT, STYLE, SIZE, OR COLOR.

NO CLAIM IS MADE TO THE EXCLUSIVE RIGHT TO USE "BED BUG", APART FROM THE MARK AS SHOWN.

FOR ARTHROPOD TRAPS (U.S. CLS. 2, 13, 23, 29, 30, 33, 40 AND 50).

GIANCARLO CASTRO, EXAMINING ATTORNEY

SN 85-243,305. RUSSELL CORA, EVANSTON, IL. FILED 2-16-2011.

FAN FLASK

THE MARK CONSISTS OF STANDARD CHARACTERS WITHOUT CLAIM TO ANY PARTICULAR FONT, STYLE, SIZE, OR COLOR.

NO CLAIM IS MADE TO THE EXCLUSIVE RIGHT TO USE "FLASK", APART FROM THE MARK AS SHOWN.

FOR FLASKS (U.S. CLS. 2, 13, 23, 29, 30, 33, 40 AND 50).

PATRICIA EVANKO, EXAMINING ATTORNEY

SN 85-243,780. FREUND'S FARM, INC., EAST CANAAN, CT. FILED 2-16-2011.

COWPOTS

THE MARK CONSISTS OF STANDARD CHARACTERS WITHOUT CLAIM TO ANY PARTICULAR FONT, STYLE, SIZE, OR COLOR.

FOR BIODEGRADABLE PLANTING CONTAINERS MADE FROM COMPOSTED MANURE (U.S. CLS. 2, 13, 23, 29, 30, 33, 40 AND 50).

FIRST USE 1-1-2005; IN COMMERCE 1-1-2005.

KIMBERLY FRYE, EXAMINING ATTORNEY

CLASS 21—(Continued).

SN 85-244,965. DR FRESH INC., BUENA PARK, CA. FILED 2-17-2011.

Dr Fresh Velocity

THE MARK CONSISTS OF STANDARD CHARACTERS WITHOUT CLAIM TO ANY PARTICULAR FONT, STYLE, SIZE, OR COLOR.

OWNER OF U.S. REG. NOS. 2,648,137, 3,451,981 AND OTHERS.

THE NAME "DR FRESH VELOCITY" OR "DR FRESH" DOES NOT IDENTIFY A LIVING INDIVIDUAL.

FOR COMPACTS CONTAINING DENTAL FLOSS AND ALSO INCLUDING LIP GLOSS; DENTAL CARE KIT COMPRISING TOOTHBRUSHES AND FLOSS; DENTAL FLOSS; DENTAL FLOSS DISPENSERS; ELECTRIC TOOTHBRUSHES; ELECTRICAL TOOTHBRUSHES; HOME DENTAL CARE PRODUCTS FOR DOGS AND CATS, NAMELY, TOOTHBRUSH; MANUAL TOOTHBRUSHES; ORAL CARE KIT COMPRISING TOOTHBRUSHES AND FLOSS; TOOTHBRUSH CASES; TOOTHBRUSH HOLDERS; TOOTHBRUSHES; TOOTHBRUSHES (U.S. CLS. 2, 13, 23, 29, 30, 33, 40 AND 50).

FIRST USE 2-20-2003; IN COMMERCE 2-20-2003.

CURTIS FRENCH, EXAMINING ATTORNEY

SN 85-249,204. PEACOCK ALLEY, INC., DALLAS, TX. FILED 2-23-2011.

DREAM AT HOME PEACOCK ALLEY

THE MARK CONSISTS OF STANDARD CHARACTERS WITHOUT CLAIM TO ANY PARTICULAR FONT, STYLE, SIZE, OR COLOR.

OWNER OF U.S. REG. NOS. 2,152,148 AND 3,288,922.

FOR TOWEL BAR, TOWEL RAIL, TOOTH BRUSH HOLDER (U.S. CLS. 2, 13, 23, 29, 30, 33, 40 AND 50).

GRETTA YAO, EXAMINING ATTORNEY

SN 85-249,716. GRANT III, WILLIAM C., PHOENIX, AZ. FILED 2-23-2011.

Bug Nabit

THE MARK CONSISTS OF STANDARD CHARACTERS WITHOUT CLAIM TO ANY PARTICULAR FONT, STYLE, SIZE, OR COLOR.

NO CLAIM IS MADE TO THE EXCLUSIVE RIGHT TO USE "BUG", APART FROM THE MARK AS SHOWN.

FOR FLY CATCHERS; FLY TRAPS; INSECT TRAPS (U.S. CLS. 2, 13, 23, 29, 30, 33, 40 AND 50).

GILBERT SWIFT, EXAMINING ATTORNEY

CLASS 21—(Continued).

SN 85-249,901. VLAHOS, STEPHANIE A, PALM DESERT, CA.
FILED 2-23-2011.

Totally Trivet

THE MARK CONSISTS OF STANDARD CHARACTERS WITHOUT CLAIM TO ANY PARTICULAR FONT, STYLE, SIZE, OR COLOR.

NO CLAIM IS MADE TO THE EXCLUSIVE RIGHT TO USE "TRIVET", APART FROM THE MARK AS SHOWN.

FOR NAPKIN HOLDERS (U.S. CLS. 2, 13, 23, 29, 30, 33, 40 AND 50).

CIMMERIAN COLEMAN, EXAMINING ATTORNEY

SN 85-249,908. VLAHOS, STEPHANIE A, PALM DESERT, CA.
FILED 2-23-2011.

Napkin Mate

THE MARK CONSISTS OF STANDARD CHARACTERS WITHOUT CLAIM TO ANY PARTICULAR FONT, STYLE, SIZE, OR COLOR.

NO CLAIM IS MADE TO THE EXCLUSIVE RIGHT TO USE "NAPKIN", APART FROM THE MARK AS SHOWN.

FOR NAPKIN HOLDERS (U.S. CLS. 2, 13, 23, 29, 30, 33, 40 AND 50).

CIMMERIAN COLEMAN, EXAMINING ATTORNEY

SN 85-250,610. TRAXLER MICHAEL, NORTH HOLLYWOOD, CA. FILED 2-24-2011.



NO CLAIM IS MADE TO THE EXCLUSIVE RIGHT TO USE "SPOUT", APART FROM THE MARK AS SHOWN.

THE MARK CONSISTS OF THE LETTER "V" AND THE WORD "SPOUT," WHICH IS ACROSS THE LENGTH OF THE LETTER "V".

FOR FUNNELS; POURING SPOUTS FOR HOUSEHOLD USE (U.S. CLS. 2, 13, 23, 29, 30, 33, 40 AND 50).

FIRST USE 6-22-2010; IN COMMERCE 2-17-2011.

JANET LEE, EXAMINING ATTORNEY

CLASS 21—(Continued).

SN 85-251,676. SAZERAC NORTH AMERICA, INC., FRANKFORT, KY. FILED 2-25-2011.



THE MARK CONSISTS OF THE CAPITAL LETTER "B" IN A CIRCLE TO THE LEFT OF THE WORD "BARTON", WHICH IS IN ALL CAPS.

FOR GLASSWARE, NAMELY, BEVERAGE GLASSES, AND SHOT GLASSES; DRINKING FLASKS; REUSABLE PLASTIC WATER BOTTLES SOLD EMPTY; REUSABLE METAL WATER BOTTLES SOLD EMPTY; PAPER AND PLASTIC PLATES AND PAPER AND PLASTIC CUPS (U.S. CLS. 2, 13, 23, 29, 30, 33, 40 AND 50).

GRETTA YAO, EXAMINING ATTORNEY

SN 85-251,865. BOON, INC., CHANDLER, AZ. FILED 2-25-2011.

CATCH BOWL

THE MARK CONSISTS OF STANDARD CHARACTERS WITHOUT CLAIM TO ANY PARTICULAR FONT, STYLE, SIZE, OR COLOR.

NO CLAIM IS MADE TO THE EXCLUSIVE RIGHT TO USE "BOWL", APART FROM THE MARK AS SHOWN.

FOR BOWLS (U.S. CLS. 2, 13, 23, 29, 30, 33, 40 AND 50).

FIRST USE 11-13-2007; IN COMMERCE 11-13-2007.

FLORENTINA BLANDU, EXAMINING ATTORNEY

SN 85-252,270. SAM, RICHARD, ROSEMEAD, CA. FILED 2-25-2011.

CLASSIC BARE

THE MARK CONSISTS OF STANDARD CHARACTERS WITHOUT CLAIM TO ANY PARTICULAR FONT, STYLE, SIZE, OR COLOR.

FOR COSMETIC BRUSHES (U.S. CLS. 2, 13, 23, 29, 30, 33, 40 AND 50).

ELLEN BURNS, EXAMINING ATTORNEY

CLASS 21—(Continued).

SN 85-254,128. R&G MANUFACTURING INC, MILWAUKEE, WI. FILED 3-1-2011.

BLENDERBLASTER

THE MARK CONSISTS OF STANDARD CHARACTERS WITHOUT CLAIM TO ANY PARTICULAR FONT, STYLE, SIZE, OR COLOR.

FOR NON-ELECTRIC FOOD BLENDERS (U.S. CLS. 2, 13, 23, 29, 30, 33, 40 AND 50).

FIRST USE 11-14-2001; IN COMMERCE 11-14-2001.
STEVEN R. FINE, EXAMINING ATTORNEY

SN 85-254,499. HELEN OF TROY LIMITED, ST. MICHAEL, BARBADOS, FILED 3-1-2011.

Groundskeeper

THE MARK CONSISTS OF STANDARD CHARACTERS WITHOUT CLAIM TO ANY PARTICULAR FONT, STYLE, SIZE, OR COLOR.

FOR NON-ELECTRIC COFFEE MAKERS (U.S. CLS. 2, 13, 23, 29, 30, 33, 40 AND 50).

DAWN FELDMAN, EXAMINING ATTORNEY

SN 85-254,801. YEELES, MICHELE, BOSTON, MA. FILED 3-1-2011.

Ginger

THE MARK CONSISTS OF STANDARD CHARACTERS WITHOUT CLAIM TO ANY PARTICULAR FONT, STYLE, SIZE, OR COLOR.

FOR BEAKERS, NAMELY, WIDE-MOUTHED DRINKING CUPS FOR HOUSEHOLD USE; BOWLS; BUTTER DISHES; BUTTER-DISH AND CHEESE-DISH COVERS; COFFEE CUPS; COFFEE CUPS, TEA CUPS AND MUGS; COFFEE MUGS; COMMEMORATIVE PLATES; CROCKERY, NAMELY, POTS, DISHES, DRINKING CUPS AND SAUCERS, BOWLS, SERVING BOWLS AND TRAYS; CUPS; CUPS AND MUGS; DECORATIVE PLATES; DEMITASSE SETS COMPRISED OF CUPS AND SAUCERS; DEMITASSE SETS COMPRISED OF CUPS, SAUCERS AND STIRRING SPOONS SOLD AS A UNIT; DESSERT PLATES; DINNERWARE, NAMELY, PLATES, BOWLS, CUPS, SAUCERS, PLATTERS, DISHES, TRAYS; DISH COVERS; DISHES; DISHES AND PLATES; DRINKING CUPS; DRINKING CUPS AND SAUCERS; DRINKING CUPS FOR BABIES AND CHILDREN AND PARTS AND FITTINGS THEREFOR, NAMELY, CUPS FOR BABIES AND CHILDREN SOLD AS A UNIT WITH VALVES AND

CLASS 21—(Continued).

LIDS; DRINKING CUPS FOR CHILDREN AND PARTS AND FITTINGS THEREFOR, NAMELY, DRINKING CUPS FOR CHILDREN SOLD AS A UNIT WITH NON-INSULATED LIDS; DRINKING CUPS FOR INFANTS AND PARTS AND FITTINGS THEREFOR, NAMELY, VALVES AND LIDS SOLD AS A UNIT; EGG CUPS; EGG CUPS; FLOWER VASES AND BOWLS; FRUIT BOWLS; INSULATING SLEEVE HOLDER FOR BEVERAGE CUPS; JAPANESE RICE BOWLS (CHAWAN); JAPANESE STYLE PERSONAL DINING TRAYS OR STANDS (ZEN); JAPANESE STYLE SOUP SERVING BOWLS (WAN); MEAL TRAYS; MIXING BOWLS; MIXING CUPS; MUGS; NON-METALLIC TRAYS; PAPER AND PLASTIC CUPS; PEPPER POTS, SUGAR BOWLS AND SALT SHAKERS; PET FEEDING AND DRINKING BOWLS; PET FEEDING DISHES; PLASTIC CUPS; PLASTIC PLATES; SAKE CUPS; SALAD BOWLS; SAUCERS; SERVING BOWLS (HACHI); SERVING DISHES; SERVING PLATTERS; SERVING TRAYS; SHALLOW BOWLS; SOAP DISHES; SUGAR BOWLS; TRAINING CUPS FOR BABIES AND CHILDREN (U.S. CLS. 2, 13, 23, 29, 30, 33, 40 AND 50).
TOBY BULLOFF, EXAMINING ATTORNEY

SN 85-254,892. FRINGE COSMETICS, LLC, PALM BEACH GARDENS, FL. FILED 3-1-2011.

Versi

THE MARK CONSISTS OF STANDARD CHARACTERS WITHOUT CLAIM TO ANY PARTICULAR FONT, STYLE, SIZE, OR COLOR.

FOR HAIR BRUSHES, HAIR COMBS (U.S. CLS. 2, 13, 23, 29, 30, 33, 40 AND 50).

FIRST USE 7-20-2009; IN COMMERCE 12-1-2009.
GENE MACIOL, EXAMINING ATTORNEY

SN 85-254,893. HOME BOX OFFICE, INC., NEW YORK, NY. FILED 3-1-2011.

STRIKE BACK

THE MARK CONSISTS OF STANDARD CHARACTERS WITHOUT CLAIM TO ANY PARTICULAR FONT, STYLE, SIZE, OR COLOR.

FOR MUGS, DRINKING GLASSES, SHOT GLASSES, DISHES, PLATES, BOWLS, CUPS, SAUCERS AND TRAYS MADE OF GLASSWARE, PORCELAIN, CERAMIC OR EARTHENWARE; BARWARE, NAMELY, DECANTERS, WINE BUCKETS, BOTTLE OPENERS, WINE OPENERS, COOLERS FOR WINE, COASTERS NOT OF PAPER AND OTHER THAN TABLE LINEN, DRINKING FLASKS; NON-ELECTRIC COFFEE POTS, COFFEE STIRRERS AND NON-ELECTRIC COFFEE GRINDERS; PORCELAIN FIGURINES; HOUSEHOLD UTENSILS, NAMELY, GRATERS, SPATULAS AND ROLLING PINS; CONTAINERS FOR HOUSEHOLD OR KITCHEN USE (U.S. CLS. 2, 13, 23, 29, 30, 33, 40 AND 50).
JACLYN KIDWELL WALKER, EXAMINING ATTORNEY

CLASS 21—(Continued).

SN 85-255,816. LOGOMARK, INC., TUSTIN, CA. FILED 3-2-2011.

PËRKA

THE MARK CONSISTS OF STANDARD CHARACTERS WITHOUT CLAIM TO ANY PARTICULAR FONT, STYLE, SIZE, OR COLOR.

FOR MUGS (U.S. CLS. 2, 13, 23, 29, 30, 33, 40 AND 50).
LINDA M. KING, EXAMINING ATTORNEY

SN 85-255,972. LIFETIME BRANDS, INC., GARDEN CITY, NY. FILED 3-2-2011.

GET HAPPY

THE MARK CONSISTS OF STANDARD CHARACTERS WITHOUT CLAIM TO ANY PARTICULAR FONT, STYLE, SIZE, OR COLOR.

FOR BOTTLE OPENERS; CLEANING BRUSHES FOR HOUSEHOLD USE; COASTERS, NOT OF PAPER AND OTHER THAN TABLE LINEN; COLANDERS; HOUSEHOLD UTENSILS, NAMELY, TURNERS, SPATULAS AND SPOONULAS; ICE CREAM SCOOPS; MIXING BOWLS; SALT AND PEPPER SHAKERS; SLOTTED SPOONS; SPONGE HOLDERS (U.S. CLS. 2, 13, 23, 29, 30, 33, 40 AND 50).

THEODORE MCBRIDE, EXAMINING ATTORNEY

SN 85-255,980. LIFETIME BRANDS, INC., GARDEN CITY, NY. FILED 3-2-2011.

KIZMOS GET HAPPY

THE MARK CONSISTS OF STANDARD CHARACTERS WITHOUT CLAIM TO ANY PARTICULAR FONT, STYLE, SIZE, OR COLOR.

FOR BOTTLE OPENERS; CLEANING BRUSHES FOR HOUSEHOLD USE; COASTERS, NOT OF PAPER AND OTHER THAN TABLE LINEN; COLANDERS; HOUSEHOLD UTENSILS, NAMELY, TURNERS, SPATULAS AND SPOONULAS; ICE CREAM SCOOPS; MIXING BOWLS; SALT AND PEPPER SHAKERS; SLOTTED SPOONS; SPONGE HOLDERS (U.S. CLS. 2, 13, 23, 29, 30, 33, 40 AND 50).

THEODORE MCBRIDE, EXAMINING ATTORNEY

CLASS 21—(Continued).

SN 85-257,026. NEW THERMO-SERV, LTD., DALLAS, TX. FILED 3-3-2011.



THE MARK CONSISTS OF A LEAF AND TWIG CAMOUFLAGE DESIGN.

FOR CUPS AND MUGS (U.S. CLS. 2, 13, 23, 29, 30, 33, 40 AND 50).
CYNTHIA SLOAN, EXAMINING ATTORNEY

SN 85-257,113. SALTZ, MOIRA, ENGLEWOOD, CO. FILED 3-3-2011.

No-Tox

THE MARK CONSISTS OF STANDARD CHARACTERS WITHOUT CLAIM TO ANY PARTICULAR FONT, STYLE, SIZE, OR COLOR.

FOR CUPS; CUPS, NOT OF PRECIOUS METAL; DRINKING CUPS; DRINKING CUPS FOR BABIES AND CHILDREN AND PARTS AND FITTINGS THEREFOR, NAMELY, CUPS FOR BABIES AND CHILDREN SOLD AS A UNIT WITH VALVES AND LIDS; DRINKING CUPS FOR INFANTS AND PARTS AND FITTINGS THEREFOR, NAMELY, VALVES AND LIDS SOLD AS A UNIT (U.S. CLS. 2, 13, 23, 29, 30, 33, 40 AND 50).

NELSON SNYDER, EXAMINING ATTORNEY

SN 85-257,138. PENTASTAR AVIATION, LLC, WATERFORD, MI. FILED 3-3-2011.

THERMASTAR

OWNER OF U.S. REG. NOS. 2,974,552 AND 3,024,574.

THE MARK CONSISTS OF THE WORD THERMASTAR WITH THE DESIGN OF A STAR AROUND THE FIRST LETTER "A," AND A CURVED LINE THROUGH THE "A" AND THE STAR.

FOR INSULATED CONTAINERS DESIGNED TO TRANSPORT FOOD AND BEVERAGES (U.S. CLS. 2, 13, 23, 29, 30, 33, 40 AND 50).

JENNY PARK, EXAMINING ATTORNEY

CLASS 21—(Continued).

SN 85-257,222. PACTIV CORPORATION, LAKE FOREST, IL. FILED 3-3-2011.

VIBRANTS

THE MARK CONSISTS OF STANDARD CHARACTERS WITHOUT CLAIM TO ANY PARTICULAR FONT, STYLE, SIZE, OR COLOR.

FOR PLASTIC DISPOSABLE CUPS (U.S. CLS. 2, 13, 23, 29, 30, 33, 40 AND 50).

FIRST USE 4-0-2002; IN COMMERCE 4-0-2002.

MARK PILARO, EXAMINING ATTORNEY

SN 85-263,837. HARAJUKU LOVERS, LLC, BEVERLY HILLS, CA. FILED 3-10-2011.

HARAJUKU MINI

THE MARK CONSISTS OF STANDARD CHARACTERS WITHOUT CLAIM TO ANY PARTICULAR FONT, STYLE, SIZE, OR COLOR.

OWNER OF U.S. REG. NOS. 3,562,719, 3,833,077 AND OTHERS.

FOR BEVERAGEWARE, BABY BATH TUBS, BOTTLE OPENERS, CANDY BOXES, COMBS, COMPACTS SOLD EMPTY, COOKIE JARS, DECORATIVE PLATES, DINNERWARE, FOAM DRINK HOLDERS, HAIR BRUSHES, LUNCH BOXES, PAPER PLATES, PAPER CUPS, PLASTIC COASTERS, PLASTIC PLATES, PLASTIC CUPS, PORTABLE COOLERS, SALT AND PEPPER SHAKERS, AND TOOTHBRUSHES; AND FIGURES MADE OF EARTHWARE, GLASS OR PORCELAIN (U.S. CLS. 2, 13, 23, 29, 30, 33, 40 AND 50).

INGRID C. EULIN, EXAMINING ATTORNEY

SN 85-265,009. TRAIL DESIGNS, LLC, YOSEMITE NATIONAL PARK, CA. FILED 3-11-2011.

VARI-VENT

THE MARK CONSISTS OF STANDARD CHARACTERS WITHOUT CLAIM TO ANY PARTICULAR FONT, STYLE, SIZE, OR COLOR.

FOR WINDSCREENS FOR PORTABLE COOKING KITS (U.S. CLS. 2, 13, 23, 29, 30, 33, 40 AND 50).

FIRST USE 1-11-2006; IN COMMERCE 7-4-2006.

ZACHARY BELLO, EXAMINING ATTORNEY

CLASS 21—(Continued).

SN 85-276,769. BOON, INC., CHANDLER, AZ. FILED 3-25-2011.

GRASS

THE MARK CONSISTS OF STANDARD CHARACTERS WITHOUT CLAIM TO ANY PARTICULAR FONT, STYLE, SIZE, OR COLOR.

FOR DRYING RACKS FOR BABY PRODUCTS IN THE NATURE OF DISHES, BABY BOTTLES, PACIFIERS, UTENSILS, CUPS AND THE LIKE (U.S. CLS. 2, 13, 23, 29, 30, 33, 40 AND 50).

FIRST USE 11-20-2009; IN COMMERCE 11-20-2009.

FLORENTINA BLANDU, EXAMINING ATTORNEY

SN 85-285,690. IGLOO PRODUCTS CORP., KATY, TX. FILED 4-4-2011.

IGLOO OUTDOORS

THE MARK CONSISTS OF STANDARD CHARACTERS WITHOUT CLAIM TO ANY PARTICULAR FONT, STYLE, SIZE, OR COLOR.

NO CLAIM IS MADE TO THE EXCLUSIVE RIGHT TO USE "OUTDOORS", APART FROM THE MARK AS SHOWN.

FOR PORTABLE CONTAINERS FOR ICE, FOOD, AND BEVERAGES (U.S. CLS. 2, 13, 23, 29, 30, 33, 40 AND 50).

ANGELA DUONG, EXAMINING ATTORNEY

SN 85-308,794. GK WORLD HOLDING LLC, FORT LAUDERDALE, FL. FILED 4-29-2011.



OWNER OF U.S. REG. NOS. 3,831,714, 3,831,928 AND OTHERS.

NO CLAIM IS MADE TO THE EXCLUSIVE RIGHT TO USE "KERATIN", APART FROM THE MARK AS SHOWN.

THE MARK CONSISTS OF THE STYLIZED LETTERS "GK" IN A CIRCLE NEXT TO THE WORDS "GLOBAL KERATIN".

FOR HAIR BRUSHES (U.S. CLS. 2, 13, 23, 29, 30, 33, 40 AND 50).

FIRST USE 3-31-2010; IN COMMERCE 3-31-2010.

DARRYL SPRUILL, EXAMINING ATTORNEY

CLASS 21—(Continued).

SN 85-975,293. DUVETTE INC., NEW YORK, NY. FILED 7-27-2010.

DUVETTE

THE MARK CONSISTS OF STANDARD CHARACTERS WITHOUT CLAIM TO ANY PARTICULAR FONT, STYLE, SIZE, OR COLOR.

FOR TEXTILE AND FABRIC STORAGE CONTAINERS FOR HOUSEHOLD USE (U.S. CLS. 2, 13, 23, 29, 30, 33, 40 AND 50).

KAREN K. BUSH, EXAMINING ATTORNEY

CLASS 22—CORDAGE AND FIBERS

SN 78-715,030. CRAILAR FIBER TECHNOLOGIES INC., VANCOUVER, BC, CANADA, FILED 9-16-2005.

CRAILAR

THE MARK CONSISTS OF STANDARD CHARACTERS WITHOUT CLAIM TO ANY PARTICULAR FONT, STYLE, SIZE, OR COLOR.

PRIORITY CLAIMED UNDER SEC. 44(D) ON CANADA APPLICATION NO. TMA796212, FILED 9-16-2005, REG. NO. TMA796,212, DATED 4-26-2011, EXPIRES 4-26-2026.

FOR NATURALLY-DERIVED FIBER, FOR USE IN PRODUCTS NORMALLY MADE WITH COTTON FIBERS, SYNTHETIC FIBERS OR GLASS FIBERS SUCH AS CORDAGE, TEXTILE, YARN, AUTOMOBILE TIRE CORD, PLASTIC REINFORCING, FABRICS, YARNS, ROPES, LOOSE FIBER, WEAVES, KNITS, CLOTHING, CARPET (U.S. CLS. 1, 2, 7, 19, 22, 42 AND 50).

FIRST USE 3-0-2011; IN COMMERCE 5-6-2011.
ANDREW LEASER, EXAMINING ATTORNEY

SN 85-119,103. CJD LLC, NEW YORK, NY. FILED 8-30-2010.

LIVE TANGLE-FREE

THE MARK CONSISTS OF STANDARD CHARACTERS WITHOUT CLAIM TO ANY PARTICULAR FONT, STYLE, SIZE, OR COLOR.

NO CLAIM IS MADE TO THE EXCLUSIVE RIGHT TO USE "TANGLE-FREE", APART FROM THE MARK AS SHOWN.

FOR ALL-PURPOSE STRAPS FOR MANAGING AND SECURING ALL TYPES OF CORDS AND CABLES (U.S. CLS. 1, 2, 7, 19, 22, 42 AND 50).

SHAUNIA CARLYLE, EXAMINING ATTORNEY

CLASS 22—(Continued).

SN 85-127,293. PACTEC, INC., CLINTON, LA. FILED 9-10-2010.

WEATHERZIP

THE MARK CONSISTS OF STANDARD CHARACTERS WITHOUT CLAIM TO ANY PARTICULAR FONT, STYLE, SIZE, OR COLOR.

FOR WEATHER RESISTANT FLEXIBLE SHEETING ENCLOSURES FOR STORAGE AND TRANSPORTATION OF CONSTRUCTION MATERIALS (U.S. CLS. 1, 2, 7, 19, 22, 42 AND 50).

JACQUELINE A. LAVINE, EXAMINING ATTORNEY

SN 85-178,323. GIANOTTI LUIS FRANCISCO, DBA LG SAILS, SAN DIEGO, CA. FILED 11-16-2010.



NO CLAIM IS MADE TO THE EXCLUSIVE RIGHT TO USE "SAILS", APART FROM THE MARK AS SHOWN.

THE COLOR(S) WHITE AND RED IS/ARE CLAIMED AS A FEATURE OF THE MARK.

THE MARK CONSISTS OF TWO RED CIRCLES, ENCLOSING A ROUND RED TRIANGLE SAIL, WITH THE WHITE WORDING "SAILS" ON IT AND A ROUND PEAR RED SHAPED FORM, WITH THE WHITE "LG" LETTERS INSIDE; NO CLAIM TO THE BACKGROUND COLOR.

FOR MARINE SAILS AND SAIL HANDLING SYSTEMS COMPRISING LINES AND FITTINGS SOLD AS A UNIT (U.S. CLS. 1, 2, 7, 19, 22, 42 AND 50).

FIRST USE 3-12-2010; IN COMMERCE 3-12-2010.

NAKIA HENRY, EXAMINING ATTORNEY

CLASS 22—(Continued).

SN 85-196,209. XANOFI, INC., RALEIGH, NC. FILED 12-13-2010.

XANOSHEAR

THE MARK CONSISTS OF STANDARD CHARACTERS WITHOUT CLAIM TO ANY PARTICULAR FONT, STYLE, SIZE, OR COLOR.

FOR POLYMERIC, COMPOSITE AND CO-POLYMER NANOFIBERS, NAMELY, NON-WOVEN POLYMERIC NANOFIBERS FOR CONVERSION INTO A VARIETY OF INDUSTRIAL AND CONSUMER GOODS; GLASS NANOFIBERS FOR TEXTILE USE FOR USE IN THE FIELDS OF MEDICINE, TEXTILES AND ENERGY; RAW TEXTILE NANOFIBERS FOR USE IN THE FIELDS OF MEDICINE, TEXTILES AND ENERGY (U.S. CLS. 1, 2, 7, 19, 22, 42 AND 50).

FIRST USE 12-3-2010; IN COMMERCE 12-3-2010.
MEGHAN REINHART, EXAMINING ATTORNEY

SN 85-196,352. TAIAN ROPE NET PLASTIC CO., LTD., TAIAN, CHINA, FILED 12-13-2010.

ROPEKIN

THE MARK CONSISTS OF THE WORD "ROPEKIN", WHERE A GLOBE WITH MERIDIANS AND PARALLEL LINES STANDS FOR THE LETTER "O" IN THE WORD.

FOR ROPES (U.S. CLS. 1, 2, 7, 19, 22, 42 AND 50).
FIRST USE 0-0-2007; IN COMMERCE 0-0-2007.
GISELLE AGOSTO, EXAMINING ATTORNEY

SN 85-204,217. E3 DESIGN LLC, HAYDEN LAKE, ID. FILED 12-22-2010.

LYNX Hooks

THE MARK CONSISTS OF STANDARD CHARACTERS WITHOUT CLAIM TO ANY PARTICULAR FONT, STYLE, SIZE, OR COLOR.

NO CLAIM IS MADE TO THE EXCLUSIVE RIGHT TO USE "HOOKS", APART FROM THE MARK AS SHOWN.

FOR NON-METAL TIE DOWNS WHICH MAY BE CONNECTED TOGETHER IN DIFFERENT LENGTHS AND CONFIGURATIONS (U.S. CLS. 1, 2, 7, 19, 22, 42 AND 50).

STEVEN PEREZ, EXAMINING ATTORNEY

CLASS 22—(Continued).

SN 85-248,259. OLAM INTERNATIONAL LIMITED COMPANY SINGAPORE, SINGAPORE, SINGAPORE, FILED 2-22-2011.

OLAM

OWNER OF U.S. REG. NO. 3,114,474.
THE MARK CONSISTS OF THE WORD "OLAM" IN STYLIZED LETTERS.

FOR COTTON FIBERS; RAW COTTON (U.S. CLS. 1, 2, 7, 19, 22, 42 AND 50).

FIRST USE 12-31-2007; IN COMMERCE 12-31-2007.
JEFF DEFORD, EXAMINING ATTORNEY

SN 85-258,990. J.L.WILSON, LLC, DBA J.L.WILSON, LLC, OCEAN PINES, MD. FILED 3-5-2011.

Beach Um

NO CLAIM IS MADE TO THE EXCLUSIVE RIGHT TO USE "BEACH", APART FROM THE MARK AS SHOWN.

THE MARK CONSISTS OF THE WORDING "BEACH UM" IN STYLIZED LETTERING.

FOR TENTS (U.S. CLS. 1, 2, 7, 19, 22, 42 AND 50).
FIRST USE 12-12-2010; IN COMMERCE 2-28-2011.
FRED CARL, EXAMINING ATTORNEY

SN 85-288,512. JAB DISTRIBUTORS, LLC, DBA PROTECT-A-BED, NORTHBROOK, IL. FILED 4-7-2011.

BEDBUGANATOR

THE MARK CONSISTS OF STANDARD CHARACTERS WITHOUT CLAIM TO ANY PARTICULAR FONT, STYLE, SIZE, OR COLOR.

FOR SEALABLE PLASTIC BAGS FOR USE IN CONNECTION WITH FUMIGATION (U.S. CLS. 1, 2, 7, 19, 22, 42 AND 50).

WILLIAM VERHOSEK, EXAMINING ATTORNEY

CLASS 22—(Continued).

SN 85-288,513. JAB DISTRIBUTORS, LLC, DBA PROTECT-A-BED, NORTHBROOK, IL. FILED 4-7-2011.

BUGANATOR

THE MARK CONSISTS OF STANDARD CHARACTERS WITHOUT CLAIM TO ANY PARTICULAR FONT, STYLE, SIZE, OR COLOR.

FOR SEALABLE PLASTIC BAGS FOR USE IN CONNECTION WITH FUMIGATION (U.S. CLS. 1, 2, 7, 19, 22, 42 AND 50).

WILLIAM VERHOSEK, EXAMINING ATTORNEY

CLASS 23—(Continued).

SN 85-246,216. BERROCO, INC., NORTH SMITHFIELD, RI. FILED 2-18-2011.

BERROCO VOYAGE

THE MARK CONSISTS OF STANDARD CHARACTERS WITHOUT CLAIM TO ANY PARTICULAR FONT, STYLE, SIZE, OR COLOR.

OWNER OF U.S. REG. NOS. 1,597,403 AND 3,327,742. FOR YARN FOR HAND-KNITTING, SOLD IN SPECIALTY YARN SHOPS (U.S. CL. 43).

KHANH LE, EXAMINING ATTORNEY

CLASS 23—YARNS AND THREADS

SN 79-088,632. AMANN NÄHGARNE GMBH & CO. KG, 86199 AUGSBURG, FED REP GERMANY, FILED 7-23-2010.

Strongbond

THE MARK CONSISTS OF STANDARD CHARACTERS WITHOUT CLAIM TO ANY PARTICULAR FONT, STYLE, SIZE, OR COLOR.

OWNER OF INTERNATIONAL REGISTRATION 1054671 DATED 7-23-2010, EXPIRES 7-23-2020.

FOR THREADS AND YARNS FOR TEXTILE USE, NAMELY, THREADS AND TWISTED YARNS, YARNS SPUN OR NOT SPUN, UNPROCESSED OR DYED, MADE OF NATURAL AND SYNTHETIC MATERIAL; YARNS FOR TEXTILE USE IN THE NATURE OF YARNS FOR THE MANUFACTURING OF NON-WOVEN FABRIC, NAMELY, SEWING THREAD AND YARN (U.S. CL. 43).

SUZANNE BLANE, EXAMINING ATTORNEY

SN 85-246,219. BERROCO, INC., NORTH SMITHFIELD, RI. FILED 2-18-2011.

BERROCO LINK

THE MARK CONSISTS OF STANDARD CHARACTERS WITHOUT CLAIM TO ANY PARTICULAR FONT, STYLE, SIZE, OR COLOR.

OWNER OF U.S. REG. NOS. 1,597,403 AND 3,327,742. FOR YARN FOR HAND-KNITTING, SOLD IN SPECIALTY YARN SHOPS (U.S. CL. 43).

KHANH LE, EXAMINING ATTORNEY

SN 85-246,214. BERROCO, INC., NORTH SMITHFIELD, RI. FILED 2-18-2011.

BERROCO BOBOLI

THE MARK CONSISTS OF STANDARD CHARACTERS WITHOUT CLAIM TO ANY PARTICULAR FONT, STYLE, SIZE, OR COLOR.

OWNER OF U.S. REG. NOS. 1,597,403, 3,327,742 AND OTHERS.

FOR YARN FOR HAND-KNITTING, SOLD IN SPECIALTY YARN SHOPS (U.S. CL. 43).

KHANH LE, EXAMINING ATTORNEY

SN 85-246,222. BERROCO, INC., NORTH SMITHFIELD, RI. FILED 2-18-2011.

BERROCO SOUFFLÉ

THE MARK CONSISTS OF STANDARD CHARACTERS WITHOUT CLAIM TO ANY PARTICULAR FONT, STYLE, SIZE, OR COLOR.

OWNER OF U.S. REG. NOS. 1,597,403, 3,327,742 AND OTHERS.

FOR YARN (U.S. CL. 43).

KHANH LE, EXAMINING ATTORNEY

CLASS 23—(Continued).

SN 85-252,684. DR KELLER HOLDINGS LLC, SALT LAKE CITY, UT. FILED 2-26-2011.

Kitty-Rabbit Kreations

THE MARK CONSISTS OF STANDARD CHARACTERS WITHOUT CLAIM TO ANY PARTICULAR FONT, STYLE, SIZE, OR COLOR.

NO CLAIM IS MADE TO THE EXCLUSIVE RIGHT TO USE "CREATIONS", APART FROM THE MARK AS SHOWN.

FOR KNITTING YARN (U.S. CL. 43).
DAVID TOOLEY, EXAMINING ATTORNEY

CLASS 24—(Continued).

SN 77-943,483. BALLY RIBBON MILLS, INC., BALLY, PA. FILED 2-24-2010.

The Fabric of America

THE MARK CONSISTS OF STANDARD CHARACTERS WITHOUT CLAIM TO ANY PARTICULAR FONT, STYLE, SIZE, OR COLOR.

FOR NARROW WOVEN FABRICS (U.S. CLS. 42 AND 50).

TARA PATE, EXAMINING ATTORNEY

SN 85-071,678. DAWN RAE MANCUSO, JACKSONVILLE BEACH, FL. FILED 6-25-2010.



NO CLAIM IS MADE TO THE EXCLUSIVE RIGHT TO USE "CHANGE TOWEL", APART FROM THE MARK AS SHOWN.

THE COLOR(S) BLACK, RED AND GREY IS/ARE CLAIMED AS A FEATURE OF THE MARK.

THE MARK CONSISTS OF THE WORDING "THE NO PEEK CHANGE TOWEL" WITH "THE" IN SMALL BLACK LETTERING OVER THE "N" OF THE WORD "NO" WHICH IS ALSO IN BLACK. THE "O" IS RED WITH A DIAGONAL RED SLASH. THE WORD "PEEK" IS IN GREY AND BELOW IT ARE THE WORDS "CHANGE TOWEL" IN SMALLER RED LETTERING. THE COLOR WHITE IS USED FOR BACKGROUND ONLY AND IS NOT CLAIMED AS A FEATURE OF THE MARK.

FOR TOWELS THAT MAY BE WORN AS A DRESS OR SIMILAR GARMENT FOR THE PURPOSE OF MAINTAINING PRIVACY WHILE CHANGING CLOTHES IN PUBLIC (U.S. CLS. 42 AND 50).

FIRST USE 4-1-2009; IN COMMERCE 1-1-2010.
MATTHEW MCDOWELL, EXAMINING ATTORNEY

CLASS 24—FABRICS

SN 77-464,003. KAPPA ALPHA ORDER, LEXINGTON, VA. FILED 5-2-2008.



OWNER OF U.S. REG. NO. 2,387,271.
THE COLOR(S) CRIMSON, WHITE AND GOLD IS/ARE CLAIMED AS A FEATURE OF THE MARK.

THE MARK CONSISTS OF A DESIGN FOR A FLAG CONTAINING A WHITE SHIELD TOWARD THE CENTER BEARING THE CRIMSON-COLORED GREEK ALPHABET LETTERS "K" (KAPPA) AND "A" (ALPHA) ABOVE A CRIMSON-COLORED GREEK CROSS WITH A CRIMSON-COLORED BACKGROUND TO THE LEFT OF THE SHIELD AND A GOLD COLORED BACKGROUND TO THE RIGHT OF THE SHIELD.

SEC. 2(F).
FOR FABRIC FLAGS (U.S. CLS. 42 AND 50).
FIRST USE 0-0-1967; IN COMMERCE 0-0-1967.
HEATHER THOMPSON, EXAMINING ATTORNEY

SN 85-081,547. MONTEREY, INC., JANESVILLE, WI. FILED 7-9-2010.

THE SECRET'S IN THE WOOL

THE MARK CONSISTS OF STANDARD CHARACTERS WITHOUT CLAIM TO ANY PARTICULAR FONT, STYLE, SIZE, OR COLOR.

FOR HIGH PILE OIL ABSORPTION FABRIC IN THE NATURE OF PILE FABRIC MADE FROM WOOL, PILE FABRIC CONTAINING WOOL FOR USE IN THE MANUFACTURE OF PAINT ROLLERS AND WAX APPLICATORS, WASHING MITTS AND BUFFING PADS FOR MOTOR VEHICLES, BOATS AND FURNITURE, BLANKETS, COMFORTERS AND BEDDING (U.S. CLS. 42 AND 50).

HEATHER THOMPSON, EXAMINING ATTORNEY

CLASS 24—(Continued).

SN 85-089,716. CAPRICE AUSTRALIA PTY LTD, DANDE-
NONG S. VICTORIA, AUSTRALIA, FILED 7-21-2010.

PRELUDE

THE MARK CONSISTS OF STANDARD CHARACTERS WITHOUT CLAIM TO ANY PARTICULAR FONT, STYLE, SIZE, OR COLOR.

OWNER OF AUSTRALIA REG. NO. 723431, DATED 12-6-1996, EXPIRES 12-6-2016.

FOR TEXTILE AND TEXTILE GOODS IN THIS CLASS, NAMELY, TEXTILES AND TEXTILE GOODS FOR USE ON OFFICE SCREENS, PARTITIONS, WALLS, WORK STATIONS, RECEPTION WALLS AND PUBLIC AREAS; FABRICS AND MATERIALS INCLUDING FABRICS FOR USE ON OFFICE SCREENS, PARTITIONS, WALLS, WORKSTATIONS, RECEPTION WALLS AND PUBLIC AREAS; UPHOLSTERY FABRICS; DECORATIVE SURFACING FABRICS; FABRICS FOR USE IN AUTOMOBILES, TRUCKS, BUSES, BOATS; FILTERING MATERIALS OF NON-WOVEN TEXTILE; NON-WOVEN TEXTILE FOR SURFACING APPLICATIONS; FABRICS COMPOSED OF POLYESTER AND NYLON (U.S. CLS. 42 AND 50).

KATINA MISTER, EXAMINING ATTORNEY

SN 85-107,109. DIVATEX HOME FASHION, INC., NEW YORK, NY. FILED 8-13-2010.

DXL

THE MARK CONSISTS OF STANDARD CHARACTERS WITHOUT CLAIM TO ANY PARTICULAR FONT, STYLE, SIZE, OR COLOR.

FOR BEDDING, NAMELY, BLANKETS, THROWS, COMFORTERS, QUILTS, COVERLETS, DUVET COVERS, SHEETS, PILLOW CASES AND SHAMS; WINDOW TREATMENTS, NAMELY, FABRIC TAILORED VALANCES, WINDOW SCARVES, CURTAINS, SWAGS, AND SHEERS; SHOWER CURTAINS, TOWELS (U.S. CLS. 42 AND 50).

MATTHEW PAPPAS, EXAMINING ATTORNEY

SN 85-204,351. TAMARA MCKENZIE, LOGANVILLE, GA. FILED 12-22-2010.

Baby Berrie

THE MARK CONSISTS OF STANDARD CHARACTERS WITHOUT CLAIM TO ANY PARTICULAR FONT, STYLE, SIZE, OR COLOR.

NO CLAIM IS MADE TO THE EXCLUSIVE RIGHT TO USE "BABY", APART FROM THE MARK AS SHOWN.

FOR BURP CLOTH WITH CLOTH BIB FEATURE (U.S. CLS. 42 AND 50).

SOPHIA S. KIM, EXAMINING ATTORNEY

CLASS 24—(Continued).

SN 85-216,879. SILVER GUARDION, LLC, BATESVILLE, IN. FILED 1-13-2011.

TRINITY SILVER GUARDION

THE MARK CONSISTS OF STANDARD CHARACTERS WITHOUT CLAIM TO ANY PARTICULAR FONT, STYLE, SIZE, OR COLOR.

FOR BED COVERS; MATTRESS COVERS; COVERS FOR HOSPITAL BEDS AND NURSING HOME BEDS (U.S. CLS. 42 AND 50).

STEVEN JACKSON, EXAMINING ATTORNEY

SN 85-229,570. PARADISE CREEK MARKETING LIMITED, ROAD TOWN, BR. VIRGIN ISLANDS, FILED 1-30-2011.

MOLORI FABRIC

THE MARK CONSISTS OF STANDARD CHARACTERS WITHOUT CLAIM TO ANY PARTICULAR FONT, STYLE, SIZE, OR COLOR.

OWNER OF U.S. REG. NO. 3,738,902.

NO CLAIM IS MADE TO THE EXCLUSIVE RIGHT TO USE "FABRIC", APART FROM THE MARK AS SHOWN.

THE WORDING "MOLORI" HAS NO MEANING IN A FOREIGN LANGUAGE.

FOR BATH LINEN; BEACH TOWELS; BED LINEN; BLANKET THROWS; CHENILLE FABRIC; CHIFFON FABRIC; CLOTH PENNANTS; CURTAINS; CUSHION COVERS; FABRIC CASCADES; FABRICS FOR TEXTILE USE; FABRICS THAT MAY OR MAY NOT HAVE PRINTED PATTERNS AND DESIGNS THEREON FOR USE IN TEXTILE APPLICATIONS, NAMELY, THE MANUFACTURE OF APPAREL, UPHOLSTERY; SIGNAGE, FLAGS, BANNERS AND WALLPAPER; HOUSEHOLD LINEN; KITCHEN LINEN; QUILTS; TABLE LINEN; TEXTILE HANG TAGS; TEXTILE WALL HANGINGS (U.S. CLS. 42 AND 50).

BENJAMIN OKEKE, EXAMINING ATTORNEY

SN 85-234,027. M.M. EXPORTS (INDIA), FARIDABAD, INDIA, FILED 2-4-2011.



THE MARK CONSISTS OF A STYLIZED DEPICTION OF THE TERM "GUDI" OVER THE WEB ADDRESS "WWW.GUDI.NET".

THE WORDING "GUDI" HAS NO MEANING IN A FOREIGN LANGUAGE.

FOR TEXTILE FABRICS FOR USE IN THE MANUFACTURE OF GARMENTS, BAGS, JACKETS, GLOVES, AND APPAREL (U.S. CLS. 42 AND 50).

JANICE L. MCMORROW, EXAMINING ATTORNEY

CLASS 24—(Continued).

SN 85-235,993. WALGREEN CO., DEERFIELD, IL. FILED 2-7-2011.

NICE!

THE MARK CONSISTS OF STANDARD CHARACTERS WITHOUT CLAIM TO ANY PARTICULAR FONT, STYLE, SIZE, OR COLOR.
FOR PLASTIC TABLE COVERS; BED BLANKETS; THROWS (U.S. CLS. 42 AND 50).
JIM RINGLE, EXAMINING ATTORNEY

SN 85-243,553. JAMES, DANIELLE, GILROY, CA. FILED 2-16-2011.

Piaget's Blanket

THE MARK CONSISTS OF STANDARD CHARACTERS WITHOUT CLAIM TO ANY PARTICULAR FONT, STYLE, SIZE, OR COLOR.
NO CLAIM IS MADE TO THE EXCLUSIVE RIGHT TO USE "BLANKET", APART FROM THE MARK AS SHOWN.
THE NAME "PIAGET" DOES NOT IDENTIFY A LIVING INDIVIDUAL.
FOR CHILDREN'S BLANKETS (U.S. CLS. 42 AND 50).
LINDA M. KING, EXAMINING ATTORNEY

SN 85-247,950. REEVES, SEABREN, DBA BITZY BABY, LLC, BRUNSWICK, ME. AND REEVES, WHITNEY, DBA BITZY BABY, LLC, BRUNSWICK, ME. FILED 2-22-2011.

Bitzy Bumper

THE MARK CONSISTS OF STANDARD CHARACTERS WITHOUT CLAIM TO ANY PARTICULAR FONT, STYLE, SIZE, OR COLOR.
NO CLAIM IS MADE TO THE EXCLUSIVE RIGHT TO USE "BUMPER", APART FROM THE MARK AS SHOWN.
FOR BABY BEDDING, NAMELY, BUNDLE BAGS, SWADDLING BLANKETS, CRIB BUMPERS, FITTED CRIB SHEETS, CRIB SKIRTS, CRIB BLANKETS, AND DIAPER CHANGING PAD COVERS NOT OF PAPER; CRIB BUMPER PADS; CRIB BUMPERS (U.S. CLS. 42 AND 50).
ANDREW LEASER, EXAMINING ATTORNEY

CLASS 24—(Continued).

SN 85-247,984. REEVES, SEABREN, DBA BITZY BABY, LLC, BRUNSWICK, ME. AND REEVES, WHITNEY, DBA BITZY BABY, LLC, BRUNSWICK, ME. FILED 2-22-2011.

Bitzy Baby

THE MARK CONSISTS OF STANDARD CHARACTERS WITHOUT CLAIM TO ANY PARTICULAR FONT, STYLE, SIZE, OR COLOR.
NO CLAIM IS MADE TO THE EXCLUSIVE RIGHT TO USE "BABY", APART FROM THE MARK AS SHOWN.
FOR BABY BEDDING, NAMELY, BUNDLE BAGS, SWADDLING BLANKETS, CRIB BUMPERS, FITTED CRIB SHEETS, CRIB SKIRTS, CRIB BLANKETS, AND DIAPER CHANGING PAD COVERS NOT OF PAPER; CRIB BUMPER PADS; CRIB BUMPERS (U.S. CLS. 42 AND 50).
ANDREW LEASER, EXAMINING ATTORNEY

SN 85-248,421. REEVES, SEABREN, DBA BITZY BABY, LLC, BRUNSWICK, ME. AND REEVES, WHITNEY, DBA BITZY BABY, LLC, BRUNSWICK, ME. FILED 2-22-2011.



NO CLAIM IS MADE TO THE EXCLUSIVE RIGHT TO USE "BABY", APART FROM THE MARK AS SHOWN.
THE MARK CONSISTS OF A STYLIZED BABY TUCKED INTO A BLANKET, BELOW WHICH APPEARS THE STYLIZED WORD "BITZY", AND BELOW "BITZY" APPEARS THE STYLIZED WORD "BABY".
FOR BABY BEDDING, NAMELY, BUNDLE BAGS, SWADDLING BLANKETS, CRIB BUMPERS, FITTED CRIB SHEETS, CRIB SKIRTS, CRIB BLANKETS, AND DIAPER CHANGING PAD COVERS NOT OF PAPER; CRIB BUMPER PADS; CRIB BUMPERS (U.S. CLS. 42 AND 50).
ANDREW LEASER, EXAMINING ATTORNEY

CLASS 24—(Continued).

SN 85-249,346. SALLY RAMIREZ, SAN ANTONIO, TX.
FILED 2-23-2011.



NO CLAIM IS MADE TO THE EXCLUSIVE RIGHT TO USE "STADIUM SEAT SAVER", APART FROM THE MARK AS SHOWN.

THE MARK CONSISTS OF THE STYLIZED WORDING "STADIUM SEAT SAVER" SET ABOVE THE STYLIZED WORDING "MARK YOUR TERRITORY", WITH THE TERMS "STADIUM" AND "SAVER" SET INSIDE GEOMETRIC DESIGNS OF A GENERALLY RECTANGULAR SHAPE WITH STYLIZED DEPICTIONS OF KNOTS PLACED ON THE OUTER EDGES OF THE RECTANGULAR GEOMETRIC DESIGNS.

FOR UNFITTED SEAT COVERS OF TEXTILE (U.S. CLS. 42 AND 50).

MICHAEL GAAFAR, EXAMINING ATTORNEY

SN 85-250,801. THE GARLAND COMPANY, INC., CLEVELAND, OH. FILED 2-24-2011.

ULTI-MAT

THE MARK CONSISTS OF STANDARD CHARACTERS WITHOUT CLAIM TO ANY PARTICULAR FONT, STYLE, SIZE, OR COLOR.

FOR REINFORCING FABRIC AND MAT USED IN ROOFING AND CONSTRUCTION APPLICATIONS (U.S. CLS. 42 AND 50).

FIRST USE 2-1-2011; IN COMMERCE 2-1-2011.
DAWN FELDMAN, EXAMINING ATTORNEY

SN 85-253,190. FIRST QUALITY NONWOVENS, INC., GREAT NECK, NY. FILED 2-28-2011.

SILKSPUN+

THE MARK CONSISTS OF STANDARD CHARACTERS WITHOUT CLAIM TO ANY PARTICULAR FONT, STYLE, SIZE, OR COLOR.

FOR NON-WOVEN FABRIC (U.S. CLS. 42 AND 50).
RONALD AIKENS, EXAMINING ATTORNEY

CLASS 24—(Continued).

SN 85-253,543. DOWN RIGHT LTD., BROOKLYN, NY.
FILED 2-28-2011.



OWNER OF U.S. REG. NOS. 1,854,679 AND 3,153,988.

THE MARK CONSISTS OF A FIGURE OF A BED WITH A PILLOW AND THE LETTERS PM BELOW AND THE WORDS BY DOWNRIGHT BELOW THAT.

FOR BED BLANKETS; COMFORTERS; QUILTS (U.S. CLS. 42 AND 50).

FIRST USE 2-23-2011; IN COMMERCE 2-23-2011.

LINDA M. KING, EXAMINING ATTORNEY

SN 85-253,675. DST LLC, SAN MARCOS, CA. FILED 2-28-2011.

DIRTYSEXTOWEL

THE MARK CONSISTS OF STANDARD CHARACTERS WITHOUT CLAIM TO ANY PARTICULAR FONT, STYLE, SIZE, OR COLOR.

FOR BATH TOWELS; TOWELS (U.S. CLS. 42 AND 50).
KATHLEEN LORENZO, EXAMINING ATTORNEY

SN 85-255,340. SPRINGS CREATIVE PRODUCTS GROUP, LLC, ROCK HILL, SC. FILED 3-2-2011.

FLUIDSTRETCH

THE MARK CONSISTS OF STANDARD CHARACTERS WITHOUT CLAIM TO ANY PARTICULAR FONT, STYLE, SIZE, OR COLOR.

FOR MATTRESS COVERS; BED SHEETS; AND FABRIC FOR COVERING MATTRESSES, NAMELY, POLYESTER AND SPANDEX BLENDED FABRIC FOR USE AS A TEXTILE IN THE MANUFACTURE OF MATTRESSES, FABRICS FOR THE MANUFACTURE OF MATTRESSES AND FABRIC MATTRESS COVERS (U.S. CLS. 42 AND 50).

DAWN FELDMAN, EXAMINING ATTORNEY

CLASS 24—(Continued).

SN 85-255,987. RAMOS, MARIO, GLENDALE, CA. FILED 3-2-2011.

IBUDYOU.COM

THE MARK CONSISTS OF STANDARD CHARACTERS WITHOUT CLAIM TO ANY PARTICULAR FONT, STYLE, SIZE, OR COLOR.

FOR PILLOWCASES (U.S. CLS. 42 AND 50).
FIRST USE 7-1-2008; IN COMMERCE 7-1-2008.
SCOTT BIBB, EXAMINING ATTORNEY

CLASS 24—(Continued).

SN 85-257,690. DE LEEON, JUAN, KEY WEST, FL. FILED 3-4-2011.

TOWEL-CICLE

THE MARK CONSISTS OF STANDARD CHARACTERS WITHOUT CLAIM TO ANY PARTICULAR FONT, STYLE, SIZE, OR COLOR.

FOR COTTON AND VELOUR TOWELS DESIGNED TO BE USED FROZEN AND ROLLED TO REFRESH PEOPLE WALKING IN THE HEAT (U.S. CLS. 42 AND 50).
JUSTINE D. PARKER, EXAMINING ATTORNEY

SN 85-256,446. GRT DEVELOPMENT PTY LTD, SYDNEY, AUSTRALIA, FILED 3-3-2011.

SPEED - TECH

THE MARK CONSISTS OF STANDARD CHARACTERS WITHOUT CLAIM TO ANY PARTICULAR FONT, STYLE, SIZE, OR COLOR.

FOR FABRICS FOR TEXTILE USE; FABRICS FOR THE USE TO MINIMIZE WIND RESISTANCE AND FRICTION, INCREASING SPEED AND EFFICIENCY DURING SPORTS OR MOTION ACTIVITIES (U.S. CLS. 42 AND 50).

LAKEISHA LEWIS, EXAMINING ATTORNEY

SN 85-259,180. LEVITAN, BRENDA LYNN, DBA QUICK DRAPES INC., LAWRENCE, NY. FILED 3-6-2011.

Quick Drapes

THE MARK CONSISTS OF STANDARD CHARACTERS WITHOUT CLAIM TO ANY PARTICULAR FONT, STYLE, SIZE, OR COLOR.

NO CLAIM IS MADE TO THE EXCLUSIVE RIGHT TO USE "DRAPES", APART FROM THE MARK AS SHOWN.

FOR CURTAINS (U.S. CLS. 42 AND 50).
WENDY JUN, EXAMINING ATTORNEY

SN 85-256,560. MUCHE, JUDY A., COLLEGEVILLE, PA. FILED 3-3-2011.

No Calorie Candy with all the Comfort

THE MARK CONSISTS OF STANDARD CHARACTERS WITHOUT CLAIM TO ANY PARTICULAR FONT, STYLE, SIZE, OR COLOR.

FOR QUILTS (U.S. CLS. 42 AND 50).
FIRST USE 9-1-2010; IN COMMERCE 9-1-2010.
DAVID HOFFMAN, EXAMINING ATTORNEY

SN 85-262,646. WORKSVILLE, LLC, ENGLEWOOD, CO. FILED 3-9-2011.

Grandia Comforter

THE MARK CONSISTS OF STANDARD CHARACTERS WITHOUT CLAIM TO ANY PARTICULAR FONT, STYLE, SIZE, OR COLOR.

NO CLAIM IS MADE TO THE EXCLUSIVE RIGHT TO USE "COMFORTER", APART FROM THE MARK AS SHOWN.

FOR COMFORTERS (U.S. CLS. 42 AND 50).
FIRST USE 12-10-2010; IN COMMERCE 12-10-2010.
DEZMONA MIZELLE, EXAMINING ATTORNEY

CLASS 24—(Continued).

SN 85-263,839. HARAJUKU LOVERS, LLC, BEVERLY HILLS, CA. FILED 3-10-2011.

HARAJUKU MINI

THE MARK CONSISTS OF STANDARD CHARACTERS WITHOUT CLAIM TO ANY PARTICULAR FONT, STYLE, SIZE, OR COLOR.

OWNER OF U.S. REG. NOS. 3,562,719, 3,833,077 AND OTHERS.

FOR BATH LINEN, BED LINEN, TABLE LINEN, KITCHEN LINEN, CRIB BUMPERS, CRIB CANOPIES, CURTAINS AND HANDKERCHIEFS (U.S. CLS. 42 AND 50).

INGRID C. EULIN, EXAMINING ATTORNEY

CLASS 25—(Continued).

SN 76-705,960. HOGAN, KIRSTEN, CHARLOTTE, NC. FILED 1-10-2011.



NO CLAIM IS MADE TO THE EXCLUSIVE RIGHT TO USE "NODA", APART FROM THE MARK AS SHOWN.

THE MARK CONSISTS OF THE WORDING "I NODA" IN LOWERCASE LETTERING WRITTEN ON TWO LINES. A HEART DESIGN APPEARS TO THE RIGHT OF THE LETTER "I".

FOR CLOTHING, NAMELY, SHIRTS, HATS, AND SWEATSHIRTS (U.S. CLS. 22 AND 39).

FIRST USE 8-1-2005; IN COMMERCE 10-1-2010.

H. M. FISHER, EXAMINING ATTORNEY

CLASS 25—CLOTHING

SN 76-693,916. GOTTA PEA, LLC, MECHANICSBURG, PA. FILED 10-28-2008.

SLEEPEA

THE MARK CONSISTS OF STANDARD CHARACTERS WITHOUT CLAIM TO ANY PARTICULAR FONT, STYLE, SIZE, OR COLOR.

FOR CLOTHING, NAMELY, T-SHIRTS, LONG-SLEEVE T-SHIRTS, POLO SHIRTS, VESTS, TANK TOPS, SWEATERS, JUMPERS, HOODED TOPS, SHIRTS, JACKETS, PANTS, JEANS, TROUSERS, DRESSES, SKIRTS, BLOUSES, FROCKS, BOOTS, SHOES, SPORTS SHOES, SLIPPERS, SANDALS; FOOTWEAR, HEADGEAR, NAMELY, BASEBALL CAPS, CLOTHING CAPS, HATS, BEANIES, SKULL CAPS, BERETS, HEADBANDS (U.S. CLS. 22 AND 39).

AMY KERTGATE, EXAMINING ATTORNEY

SN 77-194,745. WRIGHT, SUZETTE, CHICAGO, IL. FILED 5-31-2007.

SPIRITUALITEES

SN 76-704,183. BATES, LINDA, VALENCIA, CA. FILED 8-20-2010.

GONE ROGUE

THE MARK CONSISTS OF STANDARD CHARACTERS WITHOUT CLAIM TO ANY PARTICULAR FONT, STYLE, SIZE, OR COLOR.

FOR MEN'S AND WOMEN'S APPAREL, NAMELY, SHIRTS (U.S. CLS. 22 AND 39).

KAREN SEVERSON, EXAMINING ATTORNEY

THE MARK CONSISTS OF STANDARD CHARACTERS WITHOUT CLAIM TO ANY PARTICULAR FONT, STYLE, SIZE, OR COLOR.

FOR BATHROBES; BELTS; BOTTOMS; CLOTH DIAPERS; COATS; DRESSES; FOOTWEAR; FOUL WEATHER GEAR; GLOVES; HEAD WEAR; INFANT WEAR; JACKETS; NECKWEAR; PANTS; SHIRTS; SHORTS; SKIRTS; SLEEPING GARMENTS; SOCKS AND STOCKINGS; SUITS; SWEATERS; SWIM WEAR; TOPS; T-SHIRTS; UNDER GARMENTS (U.S. CLS. 22 AND 39).

JOHN E. MICHOS, EXAMINING ATTORNEY

CLASS 25—(Continued).

SN 77-483,046. ENTREPRENEURIAL VENTURES CAPITAL CO., PITTSBURGH, PA. FILED 5-24-2008.

WHET ME

THE MARK CONSISTS OF STANDARD CHARACTERS WITHOUT CLAIM TO ANY PARTICULAR FONT, STYLE, SIZE, OR COLOR.

OWNER OF U.S. REG. NOS. 3,541,668, 3,570,752 AND 3,577,812.

FOR CLOTHING, NAMELY, SHIRTS, PANTS, HEADWEAR, UNDERWEAR, BASEBALL CAPS, GOLF SHIRTS, GYM SHORTS, JOGGING PANTS, SPORT SHIRTS, SPORTS JERSEYS, SPORTS SHIRTS, SPORTS SHIRTS WITH SHORT SLEEVES, TANK-TOPS, T-SHIRTS, WALKING SHORTS, WRIST BANDS (U.S. CLS. 22 AND 39).

FIRST USE 8-18-2008; IN COMMERCE 8-18-2008.
MARGARET POWER, EXAMINING ATTORNEY

SN 77-527,178. GARMENT GROUP, INC., LOS ANGELES, CA. FILED 7-21-2008.

VANNUCCI

THE MARK CONSISTS OF STANDARD CHARACTERS WITHOUT CLAIM TO ANY PARTICULAR FONT, STYLE, SIZE, OR COLOR.

SEC. 2(F).

FOR SOCKS (U.S. CLS. 22 AND 39).

FIRST USE 12-18-1989; IN COMMERCE 12-18-1989.

DOMINIC J. FERRAIUOLO, EXAMINING ATTORNEY

SN 77-567,829. MOLONEY, KEVIN, SHARON, MA. FILED 9-11-2008.

CREEP

THE MARK CONSISTS OF STANDARD CHARACTERS WITHOUT CLAIM TO ANY PARTICULAR FONT, STYLE, SIZE, OR COLOR.

FOR CLOTHING, NAMELY, T-SHIRTS, POLO SHIRTS, BUTTON DOWN SHIRTS, SHIRTS, SHORTS, PANTS, JACKETS, CAPS, HATS, VISORS, SOCKS, SHOES, SNEAKERS, SWEAT SHIRTS, SWEAT PANTS (U.S. CLS. 22 AND 39).

MICHAEL LITZAU, EXAMINING ATTORNEY

CLASS 25—(Continued).

SN 77-576,172. WELCOME, JOSEPH L., LAFAYETTE, LA. FILED 9-23-2008.

Lucrative Apparel

THE MARK CONSISTS OF STANDARD CHARACTERS WITHOUT CLAIM TO ANY PARTICULAR FONT, STYLE, SIZE, OR COLOR.

NO CLAIM IS MADE TO THE EXCLUSIVE RIGHT TO USE "APPAREL", APART FROM THE MARK AS SHOWN.

FOR ATHLETIC APPAREL, NAMELY, SHIRTS, PANTS, JACKETS, FOOTWEAR, HATS AND CAPS, ATHLETIC UNIFORMS; HOODED SWEAT SHIRTS; LONG-SLEEVED SHIRTS; SHIRTS; SHORT-SLEEVED OR LONG-SLEEVED T-SHIRTS; SHORT-SLEEVED SHIRTS; SPORT SHIRTS; SPORTS SHIRTS WITH SHORT SLEEVES; SWEAT SHIRTS; T-SHIRTS; TEE SHIRTS (U.S. CLS. 22 AND 39).

LAURIE KAUFMAN, EXAMINING ATTORNEY

SN 77-754,665. LOPEZ JIMENEZ, DOMINGO HECTOR, TEHUACAN, PUEBLA, MEXICO, FILED 6-8-2009.



OWNER OF MEXICO REG. NO. 389163, DATED 11-28-1990, EXPIRES 7-4-2015.

NO CLAIM IS MADE TO THE EXCLUSIVE RIGHT TO USE "INDUSTRIAS AND S.A. DE C.V. CICEG 4687 CORTE AND PIEL VACUNO FORRO: PORCINO SUELA", APART FROM THE MARK AS SHOWN.

THE COLOR(S) ORANGE, YELLOW, PURPLE IS/ARE CLAIMED AS A FEATURE OF THE MARK.

THE MARK CONSISTS OF AN OVAL WITH MOSTLY ORANGE COLOR FADING TO YELLOW TOWARD THE TOP CENTER. THE STYLIZED WORD "FABY" IN PURPLE APPEARS IN CURSIVE IN THE OVAL AND THE WORDING "INDUSTRIAS FABY S.A. DE C.V. CICEG 4687 CORTE: PIEL VACUNO FORRO: PORCINO SUELA: SINT", ALSO IN PURPLE.

THE WORDING "CORTE: PIEL VACUNO FORRO: PORCINO SUELA: SINT" IN THE MARK TRANSLATES AS "CUFFING: BOVINE LEATHER LINING: PORCINE SOLES".

FOR SHOES AND SANDALS MADE WITH LEATHER (U.S. CLS. 22 AND 39).

KEVON CHISOLM, EXAMINING ATTORNEY

CLASS 25—(Continued).

SN 77-807,219. PEPPER GATE FOOTWEAR, INC., POMONA, CA. FILED 8-18-2009.



NO CLAIM IS MADE TO THE EXCLUSIVE RIGHT TO USE "LITE", APART FROM THE MARK AS SHOWN.

THE MARK CONSISTS OF LARGE SIZE LETTERS "PG" TO THE LEFT OF MEDIUM SIZE WAVY LETTERS "LITE" AND SMALL SIZE LETTERS "BY PEPPER GATE" UNDERNEATH "LITE".

FOR SHOES (U.S. CLS. 22 AND 39).
FIRST USE 2-10-1999; IN COMMERCE 2-10-1999.
PAM WILLIS, EXAMINING ATTORNEY

CLASS 25—(Continued).

SN 77-838,529. JONES SODA CO. (USA), INC., SEATTLE, WA. FILED 9-30-2009.

JONES SODA CO.

THE MARK CONSISTS OF STANDARD CHARACTERS WITHOUT CLAIM TO ANY PARTICULAR FONT, STYLE, SIZE, OR COLOR.

OWNER OF U.S. REG. NOS. 2,118,528 AND 2,839,363.
NO CLAIM IS MADE TO THE EXCLUSIVE RIGHT TO USE "CO.", APART FROM THE MARK AS SHOWN.

FOR APPAREL, NAMELY, T-SHIRTS, TANK TOPS, SWEATSHIRTS, POLO SHIRTS, JACKETS, TRACK JACKETS, WIND RESISTANT JACKETS, HATS, CAPS, BANDANAS (U.S. CLS. 22 AND 39).
RONALD DELGIZZI, EXAMINING ATTORNEY

SN 77-809,693. U.K. INC., DBA KONJO INDUSTRIES, SAN FRANCISCO, CA. FILED 8-21-2009.

CHOKESKILL

THE MARK CONSISTS OF STANDARD CHARACTERS WITHOUT CLAIM TO ANY PARTICULAR FONT, STYLE, SIZE, OR COLOR.

FOR ATHLETIC APPAREL, NAMELY, SHIRTS, PANTS, JACKETS, FOOTWEAR, HATS AND CAPS, ATHLETIC UNIFORMS (U.S. CLS. 22 AND 39).

FIRST USE 9-1-2008; IN COMMERCE 9-1-2008.
ANDREA HACK, EXAMINING ATTORNEY

SN 77-916,840. MUSCLES BY SARA, LLC, DBA REAL WOMEN HAVE MUSCLES, BEND, OR. FILED 1-21-2010.

Live the Beauty of Being Strong

THE MARK CONSISTS OF STANDARD CHARACTERS WITHOUT CLAIM TO ANY PARTICULAR FONT, STYLE, SIZE, OR COLOR.

FOR WEARABLE GARMENTS AND CLOTHING, NAMELY, SHIRTS (U.S. CLS. 22 AND 39).

FIRST USE 1-4-2010; IN COMMERCE 1-4-2010.
TIMOTHY FINNEGAN, EXAMINING ATTORNEY

SN 77-810,428. JOSH BAIRD, DBA IZNUTHIN APPAREL, DISCOVERY BAY, CA. FILED 8-21-2009.

IZNUTHIN

THE MARK CONSISTS OF STANDARD CHARACTERS WITHOUT CLAIM TO ANY PARTICULAR FONT, STYLE, SIZE, OR COLOR.

FOR CLOTHING FOR MEN, WOMEN, CHILDREN, AND INFANTS, NAMELY, SHIRTS, TOPS, T-SHIRTS, POLO SHIRTS, PANTS, JEANS, SKIRTS, SHORTS, LINGERIE, UNDERGARMENTS, SLEEPWEAR, ROBES, BATHROBES, BELTS, GLOVES, SHOES, BOOTS, SLIPPERS, FOOTWEAR, SOCKS, HATS, CAPS, BANDANA, HEADWEAR, COATS, JACKETS, PARKAS, RAINWEAR, SWEATERS, SWEATSHIRTS, BATHING SUITS, BODY SUITS; ATHLETIC APPAREL, NAMELY, ATHLETIC SHIRTS, PANTS, JACKETS, ATHLETIC UNIFORMS; ATHLETIC FOOTWEAR (U.S. CLS. 22 AND 39).

SANI KHOURI, EXAMINING ATTORNEY

SN 77-940,360. CAMPBELL, PAUL S, NEPTUNE BEACH, FL. FILED 2-19-2010.

LIVE AS ONE

THE MARK CONSISTS OF STANDARD CHARACTERS WITHOUT CLAIM TO ANY PARTICULAR FONT, STYLE, SIZE, OR COLOR.

FOR CLOTHING, NAMELY, TOPS, BOTTOMS, PANTS, SHIRTS, KNIT SHIRTS, BLOUSES, T-SHIRTS, JERSEYS, PULLOVERS, TANK TOPS; SPORT SHIRTS, POLO SHIRTS, SWEATERS, SHORTS; SWIMWEAR; SURF WEAR; HEADWEAR (U.S. CLS. 22 AND 39).

DAVID COLLIER, EXAMINING ATTORNEY

CLASS 25—(Continued).

SN 77-945,888. CHOI, TAE YI, ARCADIA, CA. FILED 2-26-2010.

TRUTH AND LIES

THE MARK CONSISTS OF STANDARD CHARACTERS WITHOUT CLAIM TO ANY PARTICULAR FONT, STYLE, SIZE, OR COLOR.

FOR SHORT-SLEEVED OR LONG-SLEEVED T-SHIRTS; T-SHIRTS (U.S. CLS. 22 AND 39).
FIRST USE 2-5-2007; IN COMMERCE 2-5-2007.
LINDSEY RUBIN, EXAMINING ATTORNEY

SN 77-951,740. ALEXANDER JULIAN, INC., RIDGEFIELD, CT. FILED 3-5-2010.

SouthernStyle

THE MARK CONSISTS OF STANDARD CHARACTERS WITHOUT CLAIM TO ANY PARTICULAR FONT, STYLE, SIZE, OR COLOR.

FOR CLOTHING AND ACCESSORIES, NAMELY, SUITS, SPORTS COATS, PANTS, TIES, SHIRTS, SWEATERS, JACKETS, SOCKS AND HOSIERY AND BELTS (U.S. CLS. 22 AND 39).

ELIZABETH HUGHITT, EXAMINING ATTORNEY

SN 77-981,346. ZYNGA GAME NETWORK INC., SAN FRANCISCO, CA. FILED 3-26-2010.

Mafia Wars

THE MARK CONSISTS OF THE WORDS "MAFIA WARS" WITH SHADING AROUND THE EDGES TO SUGGEST A RAISED SURFACE.

FOR CLOTHING, NAMELY, T-SHIRTS, SWEATSHIRTS, HOODED PULLOVERS, TANK TOPS, FOOTWEAR, SOCKS, JACKETS, BUTTON DOWN SHIRTS, POLO SHIRTS, DRESSES, SKIRTS, JEANS, SHORTS, SWEATPANTS, NECKTIES, APRONS, BELTS, GLOVES, JERSEYS, BASEBALL CAPS AND HATS, AND HEADWEAR (U.S. CLS. 22 AND 39).

BRIAN CALLAGHAN, EXAMINING ATTORNEY

CLASS 25—(Continued).

SN 79-006,127. ARENA DISTRIBUTION S.A., SWITZERLAND, FILED 9-9-2004.



PRIORITY DATE OF 6-10-2004 IS CLAIMED.
OWNER OF INTERNATIONAL REGISTRATION 0835407 DATED 9-9-2004. EXPIRES 9-9-2014.

THE COLOR(S) YELLOW, GRAY, BLACK, AND WHITE IS/ARE CLAIMED AS A FEATURE OF THE MARK.

THE COLOR YELLOW APPEARS IN THE STYLIZED "X" AND THE WORDING "XTREME"; THE COLOR GRAY APPEARS IN THE OUTLINE OF THE POLYGON DESIGN ELEMENT AND THE LETTER "X"; THE COLOR WHITE APPEARS IN THE WORDING "POWER", THE BACKGROUND OF THE DESIGN ELEMENT AND HIGHLIGHTS ON THE LETTER "X"; THE COLOR BLACK APPEARS IN THE WORDING "SKIN" AND IN THE OUTLINE OF THE LETTER "X" AND THE WORDING "XTREME".

FOR BATHING SUITS, BATHING TRUNKS, SWIMSUITS (U.S. CLS. 22 AND 39).

LEIGH LOWRY, EXAMINING ATTORNEY

SN 79-080,240. KWON KYEONG HAE, SEOUL, REPUBLIC OF KOREA, FILED 1-8-2010.



OWNER OF INTERNATIONAL REGISTRATION 1032342 DATED 1-8-2010. EXPIRES 1-8-2020.

THE MARK CONSISTS OF A STYLIZED BUTTERFLY DESIGN WHEREIN THE WINGS ARE DEPICTED AS THE LETTERS, "N" AND "B".

FOR MONEY BELTS; GALOSHES; SHOES; SPORTS SHOES FOR GOLF, BASKETBALL, RUGBY, VOLLEYBALL, BOXING, BOWLING, GYMNASIAC, CYCLING, TRACK AND FIELD, FIELD HOCKEY AND HANDBALL; SHOE SOLES; INSOLES; HEEL PIECES FOR SHOES AND BOOTS; HEELS; BATH SANDALS; BATH SLIPPERS; MULES; BALLET SLIPPERS; BALLET SHOES; BOOTS; BOOTS FOR SPORTS, NAMELY, CLIMBING, MOUNTAINEERING, MOTORCYCLIST, SKI AND HORSE-RIDING BOOTS; BOOT PARTS, NAMELY, UPPERS; SABOTS; SANDALS; SANDAL-CLOGS; SLIPPERS; INNER SOLES; WELTS FOR BOOTS; NON-SLIPPING DEVICES FOR BOOTS, NAMELY, INSERTS; TIPS FOR FOOTWEAR; IRON FITTINGS FOR BOOTS; BASEBALL SHOES; ESPARTO FABRIC SHOES AND SANDALS; OVERSHOES; FOOTBALL BOOTS AND STUDS FOR FOOTBALL BOOTS; TENNIS SHOES; KENDO OUTFITS; CYCLISTS' CLOTHING, NAMELY, SHIRTS AND SHORTS; WET SUITS FOR WATER-SKIING FOR PROFESSIONAL PLAYER; JUMPSUITS FOR SPORTS; RIDING COATS; SPORTS ANORAK; SPORTS WEAR FOR EXCLUSIVE USE FOR SPORTS, NAMELY, SHIRTS, SHORTS, SPORTS JERSEY, BREECHES, HATS, UNIFORM AND OVERUNIFORM FOR HORSEBACK RIDING, PROFESSIONAL ICE HOCKEY, BASEBALL, PROFESSIONAL GYMNASIAC, PROFESSIONAL SOCCER, TENNIS, BADMINTON, BASKETBALL, FENCING AND PROFESSIONAL HANDBALL; JUDO SUITS;

CLASS 25—(Continued).

TAEKWONDO UNIFORMS; MASQUERADE COSTUMES; CLOTHING OF LEATHER, NAMELY, TROUSERS, SUITS AND PANTS; GABARDINE CLOTHING, NAMELY, SHIRTS AND PANTS; OUTER CLOTHING, NAMELY, JACKETS AND COATS; GOLF WEAR, NAMELY, TROUSERS, SKIRTS, JUMPERS, SHIRTS AND VESTS; SCHOOL UNIFORMS; GREATCOATS; KIMONOS; READY-MADE CLOTHING FOR FISHING, NAMELY, TROUSERS, JACKETS AND VESTS; DRESSES; DRESS SUITS; RAIN COATS; LIVERIES; MORNING COATS; STUFF JACKETS; FUR COATS AND JACKETS; MANTLES; WIND RESISTANT JACKETS AND VESTS; SHORTS; TROUSERS FOR SWEATING; RAINPROOF JACKETS; BLAZERS; BLOUSON; SARIS; SAFARIS SUITS; LADIES PANTS; SUITS; SNOWBOARD PANTS; SNOWBOARD JACKETS; SNOWBOARDING SUITS; SMOKING JACKETS; SMOCKS; SKIRTS; SPORTS JACKETS; SKATEBOARD PANTS; SKATEBOARD SUITS; SKATING OUTFITS; SKI JACKETS; SKI WEAR; SKI PANTS; SLACKS; LAYETTES; CHILDREN'S CLOTHING, NAMELY, SHIRT; TROUSERS; CEREMONIAL DRESSES; OVERALL; OVERCOATS; OVER-TROUSERS; SUIT JACKETS; WEDDING GOWNS; INFANTS' CLOTHING, NAMELY, SHIRT AND PANTS; CLOTHING OF IMITATIONS OF LEATHER, NAMELY, SHIRT; WORK UNIFORMS; JUMPERS; PAPER CLOTHING, NAMELY, PAPER HATS; CHASUBLES; BLUE JEANS; COVERALLS; CAPE; TUXEDO; TENNIS SUITS; TENNIS SKIRTS; TOGAS; TUNIC; TWIN SETS; PARKAS; PANTS; TRENCH COATS; PELISSES; GIRDLES; NIGHTGOWNS; BUTTON-FRONT ALOHA SHIRTS; SINGLET; NEGLIGEE; KNICKERS; DRESSING GOWNS; SWEAT SUITS; SWEAT-ABSORBENT UNDERCLOTHING, NAMELY, UNDERWEAR; ROMPERS; CLOTHING FOR WEAR IN WRESTLING GAMES; LEOTARDS; MANTILLAS; HOSIERY; BATHROBES; BODICES; BOXER SHORTS; SHORTSLEEVED OR LONG-SLEEVED T-SHIRTS; DETACHABLE COLLARS; BRASSIERES; BLOUSES; BEACHWEAR; SHOWER CAPS; SHIRT YOKES; SHIRTS; SHIRT FRONTS; UNDERWEAR; UNDERSHIRTS; UNDERSKIRTS; BATHING CAPS; BATHING SUITS; CHEMISETTES; CHEMISES; SWEATERS; SWEAT SHIRTS; SWEAT PANTS; SLIPS; ATHLETIC UNIFORMS; UNITARDS; SLEEPING GARMENTS; JERSEYS; JOGGING PANTS; JOGGING SUITS; VESTS; JERKINS; CARDIGANS; COLLARS; COLLAR PROTECTORS; CUFFS; CAMISOLES; CORSETS; CORSELETS; COMBINATION UNDERWEAR, NAMELY, BODY-SUIT; TANK TOPS; TEDDIES; TRACK SUITS; TRAINING WEAR, NAMELY, TRAINING SUITS; PAJAMAS; PANTIES; PANTYHOSE; PETTICOATS; PULL-OVER; FINISHED TEXTILE LININGS FOR GARMENTS; BOW TIES; NECKERCHIEFS; NECKTIES; LEG WARMERS; LEGGINGS; HEADBANDS; MUFFS; FUR STOLE; MUFFLERS; BANDANAS; ANKLE SOCKS; WINTER GLOVES; KOREAN STYLE SOCKS; MITTENS; VEILS; BOAS; BIBS NOT OF PAPER; SERAPES; SHAWLS; WRIST BANDS; SHOULDER WRAPS; WIMPLES; MANIPLES; SLEEP MASKS; SWEATBANDS; SCARFS; STOCKINGS; HEEL PIECES FOR STOCKINGS IN THE NATURE OF HEEL INSERTS; ASCOTS; SOCKS; POCKET SQUARES; APRONS; DRESS SHIELDS; CHILDREN'S HEADWEAR; BABIES' DIAPERS OF TEXTILE; SASHES FOR WEAR; POCKETS FOR CLOTHING; GLOVES OF CLOTH; TEXTILE DIAPERS; CRAVATES; TIGHTS; PAREOS; PELERINES; LEATHER HEADWEAR; CAPS; SUN VISORS; FUR HATS; BERETS; MITERS, NAMELY, HATS; WOOLLY HATS; HOODS; CAPS WITH VISORS; TURBANS; SKULL CAPS; TOP HAT; GARTERS; GAITER STRAPS; SUSPENDER BELTS FOR MEN; TROUSER STRAPS; STOCKING SUSPENDERS; SOCK SUSPENDERS; SUSPENDER BELTS FOR WOMEN; SUSPENDERS; BELTS; WINTER MASKS, NAMELY, SKI MASKS; KOREAN STYLE ANKLE BANDS (DAENIM); KOREAN STYLE TRADITIONAL CLOTHES, NAMELY, TWO-PIECE DRESS (HANBOK); KOREAN STYLE TRADITIONAL HATS; NIGHTCAPS; KOREAN STYLE TRADITIONAL WINTER CAPS (NANBAWI); KNITTED CAPS; KOREAN STYLE HEADBANDS MADE OF HORSEHAIR (MANGGON) (U.S. CLS. 22 AND 39).

KELLY CHOE, EXAMINING ATTORNEY

CLASS 25—(Continued).

SN 79-083,838. MÜHLBAUER HUT UND MODE GMBH & CO KG, AUSTRIA, FILED 2-8-2010.

PRIORITY DATE OF 2-8-2010 IS CLAIMED. OWNER OF INTERNATIONAL REGISTRATION 1042280 DATED 2-8-2010, EXPIRES 2-8-2020.

THE NAME(S), PORTRAIT(S), AND/OR SIGNATURE(S) SHOWN IN THE MARK DOES NOT IDENTIFY A PARTICULAR LIVING INDIVIDUAL.

THE MARK CONSISTS OF THE WORDING "MÜHLBAUER" IN STYLIZED FONT.

SEC. 2(F).

FOR CLOTHING, NAMELY, SHIRTS, PANTS, COATS, DRESSES; FOOTWEAR; HEADGEAR, NAMELY, HATS, BEANIES AND CAPS (U.S. CLS. 22 AND 39).

NATALIE POLZER, EXAMINING ATTORNEY

SN 79-084,596. SHANGHAI ZHENGSHANG INDUSTRIAL CO., LTD, CHINA, FILED 4-12-2010.

OWNER OF INTERNATIONAL REGISTRATION 1044049 DATED 4-12-2010, EXPIRES 4-12-2020.

THE WORDING "JUSTYLE" HAS NO MEANING IN A FOREIGN LANGUAGE.

FOR CLOTHING, NAMELY, SHIRTS, SWEATSHIRTS, SHOES, HATS, SOCKS, TIES, BELTS, CHILDREN'S PANTS AND SHIRTS, KNIT SHIRTS AND SWEATERS (U.S. CLS. 22 AND 39).

SUSAN LESLIE DUBOIS, EXAMINING ATTORNEY

SN 79-088,207. GUANGZHOU ZENGCHENG GUANGYIN GARMENT CO., LTD, 511338 GUANGZHOU, CHINA, FILED 8-2-2010.

THE MARK CONSISTS OF STANDARD CHARACTERS WITHOUT CLAIM TO ANY PARTICULAR FONT, STYLE, SIZE, OR COLOR.

PRIORITY DATE OF 5-26-2010 IS CLAIMED.

OWNER OF INTERNATIONAL REGISTRATION 1053501 DATED 8-2-2010, EXPIRES 8-2-2020.

FOR JEANS; SHIRTS; TROUSERS; COATS; KNIT SHIRTS; LEATHER COATS; LEATHER PANTS; JACKETS; FROCKS; OVERCOATS; SURCOATS BEING OUTER COATS; COATS OF IMITATION LEATHER; PANTS OF IMITATION LEATHER; T-SHIRTS; DUST COATS; LAYETTE; BATHING SUITS; RUNNING SHOES; SHOES; HATS; HOSIERY; GLOVES BEING CLOTHING; NECKTIES; SCARFS; GIRDLES; BELTS BEING CLOTHING (U.S. CLS. 22 AND 39).

EVELYN BRADLEY, EXAMINING ATTORNEY

CLASS 25—(Continued).

SN 79-088,404. GUANGZHOU ZENGCHENG GUANGYIN GARMENT CO., LTD, GUANGZHOU, CHINA, FILED 8-2-2010.

Better in Blue

THE MARK CONSISTS OF STANDARD CHARACTERS WITHOUT CLAIM TO ANY PARTICULAR FONT, STYLE, SIZE, OR COLOR.

PRIORITY DATE OF 4-9-2010 IS CLAIMED.

OWNER OF INTERNATIONAL REGISTRATION 1054126 DATED 8-2-2010, EXPIRES 8-2-2020.

NO CLAIM IS MADE TO THE EXCLUSIVE RIGHT TO USE "BLUE", APART FROM THE MARK AS SHOWN.

FOR JEANS; SHIRTS; TROUSERS; COATS; KNIT SHIRTS; KNIT SKIRTS; LEATHER COATS; LEATHER PANTS; JACKETS; FROCKS; OVERCOATS; SURCOATS BEING OUTER COATS; COATS OF IMITATION LEATHER; PANTS OF IMITATION LEATHER; T-SHIRTS; DUST COATS; LAYETTES; BATHING SUITS; RUNNING SHOES; SHOES; HATS; HOSIERY; GLOVES BEING CLOTHING; NECKTIES; SCARFS; GIRDLES; BELTS BEING CLOTHING (U.S. CLS. 22 AND 39).

EVELYN BRADLEY, EXAMINING ATTORNEY

SN 79-088,978. MATTHIAS-KARIM AVICE, FRANCE, AND MARTIN SCHLEMMER, FRANCE, FILED 5-18-2010.

AFREECA

OWNER OF INTERNATIONAL REGISTRATION 1055639 DATED 5-18-2010, EXPIRES 5-18-2020.

THE WORDING "AFREECA" HAS NO MEANING IN A FOREIGN LANGUAGE.

FOR CLOTHING, NAMELY, TEE-SHIRTS, SWEAT-SHIRTS, PANTS, SHORTS, SWEATSUITS, DRESSES, SKIRTS, TUNICS, TANK TOPS, JACKETS, SHIRTS, BELTS, SCARVES, FOULARDS, GLOVES, NECKTIES, HOSIERY, UNDERWEAR, SOCKS; FOOTWEAR; HEADGEAR, NAMELY, CAPS, HATS; LEATHER AND IMITATION LEATHER CLOTHING IN THE NATURE OF JACKETS, LEATHER HATS; SLIPPERS; BEACH, SKI OR SPORTS FOOTWEAR (U.S. CLS. 22 AND 39).

SAIMA MAKHDOOM, EXAMINING ATTORNEY

SN 79-089,534. MAMMOTH CO., LTD., JAPAN, FILED 10-13-2010.

CUNE

OWNER OF INTERNATIONAL REGISTRATION 1057078 DATED 10-13-2010, EXPIRES 10-13-2020.

THE MARK CONSISTS OF THE WORDING "CUNE", TO THE LEFT OF THE WORDING IS A CIRCLE WHICH CONTAINS A SMALLER SEMI CIRCLE FACING LEFT.

THE WORDING "CUNE" HAS NO MEANING IN A FOREIGN LANGUAGE.

FOR CLOTHING, NAMELY, JEANS, PANTS, JACKETS, OVERCOATS, SWEATERS, VESTS, BLOUSES, SHIRTS, PAJAMAS, BATH ROBES, UNDERWEAR AND T-SHIRTS; GARTERS; SOCK SUSPENDERS; WAISTBANDS; BELTS FOR CLOTHING; SHOES AND BOOTS, BUT EXCLUDING SHOE DOWELS, SHOE PEGS, SHOE HANDLES, HOBNAILED AND SHOE PROTECTIVE METAL MEMBERS; MASQUERADE COSTUMES; SPORTS SHIRTS, SPORTS JACKETS (U.S. CLS. 22 AND 39).

LINDA MICKLEBURGH, EXAMINING ATTORNEY

CLASS 25—(Continued).

SN 79-093,324. SHANTOU CHUANHAI GARMENT CO.,LTD, SHANTOU CITY, GUANGDONG PROVINCE, CHINA, FILED 1-4-2011.



OWNER OF INTERNATIONAL REGISTRATION 1067026 DATED 1-4-2011, EXPIRES 1-4-2021.

THE MARK CONSISTS OF A QUADRILATERAL CONTAINING ONE RONDURE AND TWO IRREGULAR CURVES ABOVE THE STYLIZED WORDING "CHUANHAI".

"CHUANHAI" HAS NO MEANING IN A FOREIGN LANGUAGE.

FOR DRESSES; UNDERCLOTHING; UNDERPANTS; BRASSIERES; SHOES; HOSIERY; HATS; GLOVES; SCARFS; LEATHER BELT (U.S. CLS. 22 AND 39).

KIM SAITO, EXAMINING ATTORNEY

SN 85-020,971. LADINES, MICHELE, YONKERS, NY. FILED 4-22-2010.



THE COLOR(S) RED, WHITE AND BLACK IS/ARE CLAIMED AS A FEATURE OF THE MARK.

THE MARK CONSISTS OF THE WORD "CHELEMI" IN BLACK TEXT LOCATED IN THE CENTER OF FOUR JOINED WHITE CIRCLES SHAPED LIKE A FOUR PETAL FLOWER THEN CENTERED IN THE MIDDLE OF ONE LARGE RED CIRCLE.

THE WORDING "CHELEMI" HAS NO MEANING IN A FOREIGN LANGUAGE.

FOR CLOTHING, NAMELY, MEDICAL UNIFORMS, T-SHIRTS, JACKETS, PANTS, SKIRTS (U.S. CLS. 22 AND 39).

SARA BENJAMIN, EXAMINING ATTORNEY

CLASS 25—(Continued).

SN 85-032,008. DE LA TORRE, ERIC, LOS ANGELES, CA. AND TREJO, ADRIAN, LOS ANGELES, CA. AND OLORTEGUI, HENRY, LOS ANGELES, CA. AND AGUIRRE, ERIC, LOS ANGELES, CA. FILED 5-6-2010.

PURO PARI

THE MARK CONSISTS OF STANDARD CHARACTERS WITHOUT CLAIM TO ANY PARTICULAR FONT, STYLE, SIZE, OR COLOR.

OWNER OF U.S. REG. NO. 3,500,913.
THE ENGLISH TRANSLATION OF "PURO PARI" IN THE MARK IS "PURE EQUALS".
FOR T-SHIRTS (U.S. CLS. 22 AND 39).
FIRST USE 11-13-2004; IN COMMERCE 3-4-2007.
KHANH LE, EXAMINING ATTORNEY

CLASS 25—(Continued).

SN 85-055,001. CHARLIE WATSON, DBA CHARLIE WATTS WEAR, VALLEY STREAM, NY. FILED 6-4-2010.

C W CHARLIE WATT

THE MARK CONSISTS OF STANDARD CHARACTERS WITHOUT CLAIM TO ANY PARTICULAR FONT, STYLE, SIZE, OR COLOR.

THE NAME(S), PORTRAIT(S), AND/OR SIGNATURE(S) SHOWN IN THE MARK IDENTIFIES CHARLIE WATSON, WHOSE CONSENT(S) TO REGISTER IS MADE OF RECORD.

FOR ATHLETIC APPAREL, NAMELY, SHIRTS, PANTS, JACKET, FOOTWEAR, HATS AND CAPS, ATHLETIC UNIFORMS (U.S. CLS. 22 AND 39).
FIRST USE 5-15-2010; IN COMMERCE 5-15-2010.
KATINA MISTER, EXAMINING ATTORNEY

SN 85-042,159. CLARK, STEPHEN MARTIN, BALI, INDONESIA. AND VON LAWNER, DAMON, BALI, INDONESIA. FILED 5-19-2010.



PRIORITY CLAIMED UNDER SEC. 44(D) ON UNITED KINGDOM APPLICATION NO. 2548372, FILED 5-19-2010, REG. NO. 2548372, DATED 8-27-2010, EXPIRES 5-19-2020.

NO CLAIM IS MADE TO THE EXCLUSIVE RIGHT TO USE "FONDE EN 2010", APART FROM THE MARK AS SHOWN.

THE MARK CONSISTS OF A DIAMOND ON TOP OF THE HANDLE OF A SWORD, THE LETTERS "R" AND "C" IN A STYLIZED FONT INTERTWINED WITH THE BLADE OF THE SWORD, THE WORD "FONDE" TO THE LEFT OF THE SWORD AND THE WORDS "EN 2010" TO THE RIGHT OF THE SWORD.

THE ENGLISH TRANSLATION OF "FONDE EN" IN THE MARK IS ESTABLISHED IN.

FOR ARTICLES OF CLOTHING, NAMELY, SKIRTS, SHIRTS, SHORTS, SWEAT PANTS, JACKETS, PANTS, JEANS, OVERALLS, BLOUSES, DRESSES, SWEATERS, VESTS, T-SHIRTS, SWEATSHIRTS, SWIMWEAR, SCARVES, UNDERWEAR, SOCKS, SLEEPWEAR; FOOTWEAR; HEADGEAR, NAMELY, HATS, CAPS, HEADBANDS, VISORS, AND BEANIES (U.S. CLS. 22 AND 39).
ROBERT C. CLARK JR., EXAMINING ATTORNEY

SN 85-092,294. S. CARTER ENTERPRISES, LLC, NEW YORK, NY. FILED 7-25-2010.

ALL BLACK EVERYTHING

THE MARK CONSISTS OF STANDARD CHARACTERS WITHOUT CLAIM TO ANY PARTICULAR FONT, STYLE, SIZE, OR COLOR.

NO CLAIM IS MADE TO THE EXCLUSIVE RIGHT TO USE "ALL BLACK", APART FROM THE MARK AS SHOWN.

FOR BUTTON DOWN SHIRTS; COATS FOR MEN AND WOMEN; COLLARED SHIRTS; CUSTOM MADE TO MEASURE SUITS FOR MEN AND WOMEN; DRESS SHIRTS; FOOTWEAR; FOOTWEAR FOR MEN; FOOTWEAR FOR MEN AND WOMEN; FOOTWEAR FOR WOMEN; FOOTWEAR NOT FOR SPORTS; GLOVES AS CLOTHING; GOLF SHIRTS; HEADBANDS FOR CLOTHING; HOODED SWEAT SHIRTS; HOODS; JACKETS; JERSEYS; KNIT SHIRTS; LEATHER BELTS; LONG-SLEEVED SHIRTS; MEN'S AND WOMEN'S JACKETS, COATS, TROUSERS, VESTS; MEN'S SUITS, WOMEN'S SUITS; POCKET SQUARES; POLO SHIRTS; SHIRTS AND SHORT-SLEEVED SHIRTS; SPORTS SHIRTS; SPORTS SHIRTS WITH SHORT SLEEVES; T-SHIRTS; TIES; TURTLE NECK SHIRTS; WEARABLE GARMENTS AND CLOTHING, NAMELY, SHIRTS; WOMEN'S HATS AND HOODS; WOMEN'S SHOES; WOMEN'S TOPS, NAMELY, CAMIS; WOMEN'S UNDERWEAR (U.S. CLS. 22 AND 39).
NATALIE POLZER, EXAMINING ATTORNEY

CLASS 25—(Continued).

SN 85-093,413. GOULET, DEREK, PORT ROYAL, SC. FILED 7-27-2010.

CLASS 25—(Continued).

SN 85-099,663. ROCKET BALL, LTD, HOUSTON, TX. FILED 8-4-2010.

PALM LIFE

THE MARK CONSISTS OF STANDARD CHARACTERS WITHOUT CLAIM TO ANY PARTICULAR FONT, STYLE, SIZE, OR COLOR.

FOR CLOTHING PRODUCTS, NAMELY, CAPS, SHIRTS, T-SHIRTS, UNDERWEAR, SOCKS, PANTS, SWEATERS, JACKETS, SHOES, SANDALS, BATHING SUITS, BERMUDA SHORTS, WALKING SHORTS, WET SUITS, SWIM TRUNKS, CAPS WITH VISORS, VISORS, FLEECE PULLOVERS, SWEAT SHIRTS, SURF WEAR, BRIEFS, BOXER BRIEFS, PANTIES, WIND RESISTANT JACKETS FOR CONSUMERS (U.S. CLS. 22 AND 39).

FIRST USE 7-17-2010; IN COMMERCE 7-17-2010.
HOWARD FRIEDMAN, EXAMINING ATTORNEY



SN 85-096,085. WLR CONE MILLS IP, INC., GREENSBORO, NC. FILED 7-29-2010.

CONE

THE MARK CONSISTS OF STANDARD CHARACTERS WITHOUT CLAIM TO ANY PARTICULAR FONT, STYLE, SIZE, OR COLOR.

OWNER OF U.S. REG. NOS. 2,306,233, 3,687,474 AND 3,723,781.

FOR FABRICS SOLD AS AN INTEGRAL COMPONENT OF CLOTHING, NAMELY, JEANS, SHIRTS, JACKETS AND APRONS; CLOTHING, NAMELY, JEANS, SHIRTS, JACKETS AND APRONS (U.S. CLS. 22 AND 39).

FIRST USE 10-0-2005; IN COMMERCE 10-0-2005.
GRETTA YAO, EXAMINING ATTORNEY

OWNER OF U.S. REG. NO. 2,371,485.

NO CLAIM IS MADE TO THE EXCLUSIVE RIGHT TO USE "DENVER", APART FROM THE MARK AS SHOWN.

THE MARK CONSISTS OF CARICATURE OF A ROCKET BOUNCING A BASKETBALL, WITH MOUNTAIN AND THE WORDS "DENVER" AND "ROCKETS" ENCIRCLING.

FOR CLOTHING, NAMELY, HOSIERY, FOOTWEAR, BASKETBALL SHOES, BASKETBALL SNEAKERS, T-SHIRTS, SHIRTS, POLO SHIRTS, SWEATSHIRTS, SWEATPANTS, PANTS, TANK TOPS, JERSEYS, SHORTS, PAJAMAS, SPORT SHIRTS, RUGBY SHIRTS, SWEATERS, BELTS, TIES, NIGHTSHIRTS, HATS, CAPS, VISORS, WARM-UP SUITS, WARM-UP PANTS, WARM-UP TOPS/SHOOTING SHIRTS, JACKETS, WIND RESISTANT JACKETS, PARKAS, COATS, BABY BIBS NOT OF PAPER, HEAD BANDS, WRIST BANDS, APRONS, UNDERGARMENTS, BOXER SHORTS, SLACKS, EAR MUFFS, GLOVES, MITTENS, SCARVES, WOVEN AND KNIT SHIRTS, JERSEY DRESSES, DRESSES, CHEERLEADING DRESSES AND UNIFORMS, SWIM WEAR, BATHING SUITS, SWIMSUITS, BIKINIS, TANKINIS, SWIM TRUNKS, BATHING TRUNKS, BOARD SHORTS, WET SUITS, BEACH COVER-UPS, BATHING SUIT COVER-UPS, BATHING SUIT WRAPS, SANDALS, BEACH SANDALS, BEACH HATS, SUN VISORS, SWIM CAPS, BATHING CAPS, NOVELTY HEADWEAR WITH ATTACHED WIGS (U.S. CLS. 22 AND 39).

CHRISTINA SOBRAL, EXAMINING ATTORNEY

CLASS 25—(Continued).

SN 85-099,842. RAIDER JEAN, L.L.C., HOUSTON, TX. FILED 8-4-2010.

ALLAN RAIDER JEAN COMPANY

THE MARK CONSISTS OF STANDARD CHARACTERS WITHOUT CLAIM TO ANY PARTICULAR FONT, STYLE, SIZE, OR COLOR.

NO CLAIM IS MADE TO THE EXCLUSIVE RIGHT TO USE "JEAN COMPANY", APART FROM THE MARK AS SHOWN.

THE NAME(S), PORTRAIT(S), AND/OR SIGNATURE(S) SHOWN IN THE MARK IDENTIFIES "ALLAN RAIDER", WHOSE CONSENT(S) TO REGISTER IS MADE OF RECORD.

FOR MEN'S AND CHILDREN'S CLOTHING, NAMELY, JEANS, PANTS, SHORTS, KNIT SHIRTS, WOVEN SHIRTS, T-SHIRTS, FLEECE TOPS, SWEATERS, SWEAT SHIRTS, SWEAT SUITS, JACKETS, COATS AND BELTS (U.S. CLS. 22 AND 39).

RONALD AIKENS, EXAMINING ATTORNEY



SN 85-101,191. RAIDER JEAN, L.L.C., HOUSTON, TX. FILED 8-5-2010.



NO CLAIM IS MADE TO THE EXCLUSIVE RIGHT TO USE "JEAN COMPANY", APART FROM THE MARK AS SHOWN.

THE NAME(S), PORTRAIT(S), AND/OR SIGNATURE(S) SHOWN IN THE MARK IDENTIFIES "ALLAN RAIDER", WHOSE CONSENT(S) TO REGISTER IS MADE OF RECORD.

THE MARK CONSISTS OF THE WORDS "ALLAN RAIDER" POSITIONED ABOVE THE WORDS "JEAN COMPANY", ALL APPEARING IN CAPITAL LETTERS WITH THE OUTLINE OF A STAR APPEARING IN THE BACKGROUND.

FOR MEN'S AND CHILDREN'S CLOTHING, NAMELY, JEANS, PANTS, SHORTS, KNIT SHIRTS, WOVEN SHIRTS, T-SHIRTS, FLEECE TOPS, SWEATERS, SWEAT SHIRTS, SWEAT SUITS, JACKETS, COATS AND BELTS (U.S. CLS. 22 AND 39).

RONALD AIKENS, EXAMINING ATTORNEY

CLASS 25—(Continued).

SN 85-101,379. WORKERS FOR FREEDOM USA, INC., ENCINO, CA. FILED 8-5-2010.

PERMIT

THE MARK CONSISTS OF STANDARD CHARACTERS WITHOUT CLAIM TO ANY PARTICULAR FONT, STYLE, SIZE, OR COLOR.

FOR CLOTHING, NAMELY, DRESSES, BLOUSES, SHIRTS, TOPS, T-SHIRTS, SWEATERS, JERSEYS, SKIRTS, JEANS, TROUSERS, SHORTS, JACKETS, COATS, OVERCOATS, RAINCOATS, SUITS, NECKTIES, SCARVES, GLOVES (U.S. CLS. 22 AND 39).

RON FAIRBANKS, EXAMINING ATTORNEY



SN 85-103,296. MARC B. EDWARDS, NORTH HOLLYWOOD, CA. FILED 8-9-2010.

BLSD

THE MARK CONSISTS OF STANDARD CHARACTERS WITHOUT CLAIM TO ANY PARTICULAR FONT, STYLE, SIZE, OR COLOR.

FOR T-SHIRTS (U.S. CLS. 22 AND 39).

FIRST USE 8-9-2010; IN COMMERCE 8-9-2010.

MATTHEW PAPPAS, EXAMINING ATTORNEY



SN 85-103,393. HOUR LABEL, INC., SANTA FE SPRINGS, CA. FILED 8-9-2010.



THE MARK CONSISTS OF THE WORDS "HOUR" AND "LABEL" FOLLOWED BY A DOT WITH BARS RADIATING FROM IT, REPRESENTING A CLOCK FACE.

FOR SHOES; CLOTHING, NAMELY, PANTS, JEANS, SHORTS, T-SHIRTS, SWEAT SHIRTS, HOODED SWEAT SHIRTS, PULLOVER, JACKETS, BUTTON UP SHIRTS, SOCKS, BELTS, CAPS (U.S. CLS. 22 AND 39).

B. PARADEWELAI, EXAMINING ATTORNEY

CLASS 25—(Continued).

SN 85-105,210. WENG HUACONG, FUJIANG., CHINA, FILED 8-11-2010.



THE MARK CONSISTS OF A STYLIZED DESIGN OF A BICYCLE, APPEARING UNDERNEATH IS THE WORDING "YILI", WHICH FEATURES TWO HEARTS OF THE LETTER "I" IN THE WORD "YILI" AND AN ARROW GOING THROUGH THE HEARTS AND THE LETTER "L".

THE WORDING "YILI" HAS NO MEANING IN A FOREIGN LANGUAGE.

FOR CLOTHING, NAMELY, BELTS, CAPS, COATS, SHOES, HATS, GLOVES, SKI GLOVES, GOLF CAPS, GOLF JACKETS, GOLF PANTS, GOLF RAIN COATS, GOLF SHIRTS, GOLF SHOES, GOLF SOCKS, GOLF VESTS, JACKETS, JEANS, KNIT SWEATERS, KNIT SHIRTS, PANTS, RAIN COATS, SHIRTS, SKIRTS, SLEEPERS, SOCCER SHOES, SOCKS, ATHLETIC UNIFORMS, SPORTS SHIRTS, STOCKINGS, SUITS, SHOES, SWIMSUIT, T-SHIRTS, TANK-TOPS, TIES UNDERWEAR, UNIFORMS, SPORT FOOTWEAR, NAMELY, BASKETBALL SHOES, GOLF CLEATS, BASEBALL CAPS, AND WRIST BANDS (U.S. CLS. 22 AND 39).

FIRST USE 12-10-2009; IN COMMERCE 2-6-2010.
JAY FLOWERS, EXAMINING ATTORNEY

SN 85-106,317. BONNEY, TABI, WASHINGTON D.C., DC. FILED 8-12-2010.



THE MARK CONSISTS OF THE WORDING "BONNEY RUNWAY". "BONNEY" IS WRITTEN SO THAT IT IS READ FROM LEFT TO RIGHT. "RUNWAY" IS WRITTEN REVERSED AND BACKWARDS. THE TWO YS IN "BONNEY" AND "RUNWAY" MEET IN THE MIDDLE SO THERE ARE TWO YS.

FOR JEANS; SHIRTS (U.S. CLS. 22 AND 39).
FIRST USE 1-1-2003; IN COMMERCE 1-1-2003.
JANICE KIM, EXAMINING ATTORNEY

CLASS 25—(Continued).

SN 85-107,393. MIM, LLC, DBA MARIJUANA IS MEDICINE, LLC, CARMICHAEL, CA. FILED 8-13-2010.

Marijuana is Medicine

THE MARK CONSISTS OF STANDARD CHARACTERS WITHOUT CLAIM TO ANY PARTICULAR FONT, STYLE, SIZE, OR COLOR.

FOR HATS; HOODED SWEAT SHIRTS; KNIT SHIRTS; LONG-SLEEVED SHIRTS; SHIRTS; SHIRTS AND SHORT-SLEEVED SHIRTS; SHORT-SLEEVED OR LONG-SLEEVED T-SHIRTS; SHORT-SLEEVED SHIRTS; SWEAT SHIRTS; T-SHIRTS; TEE SHIRTS (U.S. CLS. 22 AND 39).

FIRST USE 8-13-2010; IN COMMERCE 8-13-2010.
KATINA MISTER, EXAMINING ATTORNEY

SN 85-107,429. B CHIC FASHION AND STYLE, REDWOOD SHORES, CA. FILED 8-13-2010.



NO CLAIM IS MADE TO THE EXCLUSIVE RIGHT TO USE "FASHIONS", APART FROM THE MARK AS SHOWN.

THE MARK CONSISTS OF A CIRCLE WITH THE LETTER "B" AND THE STYLIZED TEXT "B CHIC FASHIONS".

FOR BELTS; BIKINIS; DRESSES; JACKETS; PANTS; SHIRTS; SHOES; SHORTS (U.S. CLS. 22 AND 39).
CHRIS WELLS, EXAMINING ATTORNEY

SN 85-107,934. ALLYOGA LLC, NEW YORK, NY. FILED 8-16-2010.



NO CLAIM IS MADE TO THE EXCLUSIVE RIGHT TO USE "DESIGNER YOGAWEAR", APART FROM THE MARK AS SHOWN.

THE MARK CONSISTS OF A CONTEMPORARY OUTLINE OF AN INDIVIDUAL IN THE SEATED YOGA POSE WITH LEGS FOLDED; THE WORDS "PHAT BUDDHA" NEXT TO THE OUTLINE AND THE WORDS "DESIGNER YOGAWEAR" UNDERNEATH.

FOR CLOTHING, NAMELY, PANTS, SHIRTS, SHORTS, SKIRTS, DRESSES, UNDERGARMENTS, SOCKS (U.S. CLS. 22 AND 39).

FIRST USE 3-1-2008; IN COMMERCE 3-1-2008.
BENJAMIN OKEKE, EXAMINING ATTORNEY

CLASS 25—(Continued).

SN 85-108,042. STATUS SNOWBOARDS, LLC, VERNON, NJ. FILED 8-16-2010.

STATUS SNOWBOARDS

THE MARK CONSISTS OF STANDARD CHARACTERS WITHOUT CLAIM TO ANY PARTICULAR FONT, STYLE, SIZE, OR COLOR.

NO CLAIM IS MADE TO THE EXCLUSIVE RIGHT TO USE "SNOWBOARDS", APART FROM THE MARK AS SHOWN.

FOR TEE SHIRTS, HOODED SWEAT SHIRTS, HATS, BASEBALL CAPS, SKI JACKETS, SNOWBOARD JACKETS, SKI PANTS, SNOWBOARD PANTS, SOCKS, SKI GLOVES AND SNOWBOARD GLOVES, ALL OF THE FOREGOING SPECIFICALLY EXCLUDING SUSPENDERS (U.S. CLS. 22 AND 39).

BRENDAN MCCAULEY, EXAMINING ATTORNEY

CLASS 25—(Continued).

SN 85-108,850. WOJCIK, ABRAM, GAINESVILLE, FL. FILED 8-17-2010.

FARFUTURE CLOTHING

THE MARK CONSISTS OF STANDARD CHARACTERS WITHOUT CLAIM TO ANY PARTICULAR FONT, STYLE, SIZE, OR COLOR.

NO CLAIM IS MADE TO THE EXCLUSIVE RIGHT TO USE "CLOTHING", APART FROM THE MARK AS SHOWN.

FOR CLOTHING PRODUCTS, NAMELY, T-SHIRTS, JACKETS, SHOES, SHORTS, HOODED SWEATSHIRTS, JEANS, CAPS, AND HATS (U.S. CLS. 22 AND 39).

KATINA MISTER, EXAMINING ATTORNEY

SN 85-108,191. GUERRERO, MARTHA, CHICAGO, IL. FILED 8-16-2010.

"A" Couture

THE MARK CONSISTS OF STANDARD CHARACTERS WITHOUT CLAIM TO ANY PARTICULAR FONT, STYLE, SIZE, OR COLOR.

NO CLAIM IS MADE TO THE EXCLUSIVE RIGHT TO USE "COUTURE", APART FROM THE MARK AS SHOWN.

FOR CLOTHING, NAMELY, WOMEN'S ATHLETIC TOPS WITH BUILT-IN BRAS, BRAS, UNDERSHIRTS, UNDERWEAR, TANK TOPS, CAMISOLES AND SLIPS (U.S. CLS. 22 AND 39).

REGINA DRUMMOND, EXAMINING ATTORNEY

SN 85-109,372. TOMMY BAHAMA GROUP, INC., ATLANTA, GA. FILED 8-17-2010.

Another Tranquil Day in Paradise

THE MARK CONSISTS OF STANDARD CHARACTERS WITHOUT CLAIM TO ANY PARTICULAR FONT, STYLE, SIZE, OR COLOR.

FOR SHIRTS (U.S. CLS. 22 AND 39).

APRIL ROACH, EXAMINING ATTORNEY

SN 85-108,839. O'SULLIVAN, KATHLEEN, COTTEKILL, NY. FILED 8-17-2010.

KATWISE

THE MARK CONSISTS OF STANDARD CHARACTERS WITHOUT CLAIM TO ANY PARTICULAR FONT, STYLE, SIZE, OR COLOR.

FOR CLOTHING PRODUCTS, NAMELY, GLOVES, HATS, HEADBANDS, HOODS, JACKETS, KNITWEAR IN THE NATURE OF SHIRTS, SWEATERS; OUTER-CLOTHING IN THE NATURE OF COATS, VESTS, JACKETS, SCARVES, HEADWEAR; READY-MADE CLOTHING IN THE NATURE OF SHIRTS, PANTS, SHORTS, STUFF JACKETS (U.S. CLS. 22 AND 39).

FIRST USE 2-22-1994; IN COMMERCE 6-9-2006.

MARK RADEMACHER, EXAMINING ATTORNEY

SN 85-109,744. JOSHUA CREEM, DBA CYCLOSPORTIF, PORTLAND, OR. FILED 8-17-2010.

CYCLOSPORTIF

THE MARK CONSISTS OF STANDARD CHARACTERS WITHOUT CLAIM TO ANY PARTICULAR FONT, STYLE, SIZE, OR COLOR.

FOR CYCLING-THEMED APPAREL, NAMELY, JERSEYS, SHORTS, BIB SHORTS, TIGHTS, AND JACKETS (U.S. CLS. 22 AND 39).

FIRST USE 8-1-2007; IN COMMERCE 8-1-2007.

EVELYN BRADLEY, EXAMINING ATTORNEY

CLASS 25—(Continued).

SN 85-109,955. JAMES, TYRELL, BROOKLYN, NY. AND PALACIO, ROBERTO, BROOKLYN, NY. FILED 8-18-2010.

FIRE CRY

THE MARK CONSISTS OF STANDARD CHARACTERS WITHOUT CLAIM TO ANY PARTICULAR FONT, STYLE, SIZE, OR COLOR.

FOR APRONS, BELTS, SUSPENDERS, BRACES FOR CLOTHING, LEATHER CLOTHING, NAMELY, JACKETS, BELTS, COATS, PANTS, SKIRTS, HEADWEAR; COLLARS, CORSETS, CYCLISTS' CLOTHING, NAMELY, SHIRTS, PANTS, TOPS, BOTTOMS, UNDERWEAR, NAMELY, DRAWERS, EAR MUFFS, FUR COATS AND JACKETS, GLOVES, HATS, HEADBANDS, HOODS, JACKETS, JERSEYS, KNITWEAR, NAMELY, SHIRTS, PANTS, TOPS, BOTTOMS, LAYETTES, FINISHED TEXTILE LININGS FOR GARMENTS, MONEY BELTS, FINISHED TEXTILE READY-MADE LININGS FOR GARMENTS, WRISTBANDS (U.S. CLS. 22 AND 39).
AISHA SALEM, EXAMINING ATTORNEY

SN 85-110,186. TAHARI A.S.L. LLC, MILLBURN, NJ. FILED 8-18-2010.

SOHO TAHARI LEVINE

THE MARK CONSISTS OF STANDARD CHARACTERS WITHOUT CLAIM TO ANY PARTICULAR FONT, STYLE, SIZE, OR COLOR.

OWNER OF U.S. REG. NOS. 2,866,297, 3,205,348 AND OTHERS.

NO CLAIM IS MADE TO THE EXCLUSIVE RIGHT TO USE "SOHO", APART FROM THE MARK AS SHOWN.

"TAHARI" IDENTIFIES A LIVING INDIVIDUAL WHOSE CONSENT TO THIS APPLICATION IS OF RECORD. "LEVINE" IDENTIFIES A LIVING INDIVIDUAL WHOSE CONSENT TO THIS APPLICATION IS OF RECORD. "SOHO" DOES NOT IDENTIFY A PARTICULAR LIVING INDIVIDUAL.

FOR APPAREL, NAMELY, SUITS, BLOUSES, KNIT TOPS, SKIRTS, JACKETS, PANTS, DRESSES, SWEATERS, JUMPSUITS, SHIRTS, CAMISOLES, VESTS, BUSTIERS, SLEEPWEAR, LINGERIE, JEANS, BODY SUITS, T-SHIRTS, BATHING SUITS, STOCKINGS, UNDERWEAR, OVERCOATS, COATS, RAINCOATS, BELTS, HATS, CAPS, GLOVES, MITTENS AND SCARVES; FOOTWEAR (U.S. CLS. 22 AND 39).
JAMES STEIN, EXAMINING ATTORNEY

CLASS 25—(Continued).

SN 85-111,402. MCGEE, HEATHER, KENOSHA, WI. FILED 8-19-2010.



NO CLAIM IS MADE TO THE EXCLUSIVE RIGHT TO USE "SOCK", APART FROM THE MARK AS SHOWN.

THE COLOR(S) PINK, WHITE, BLUE AND BLACK IS/ARE CLAIMED AS A FEATURE OF THE MARK.

THE MARK CONSISTS OF THE STYLIZED WORDING "SOCK GRAMS" IN BLACK, IN THE SHAPE OF AN ARCH, OVER A DESIGN OF AN ENVELOPE WITH BLACK EDGES AND BORDERS AND A WHITE BACKGROUND WITH A PINK HEART DESIGN OUTLINED IN BLACK AT THE CLOSURE, WITH TWO STYLIZED SOCKS ONE OVER THE OTHER OUTLINED IN BLACK TO THE RIGHT SIDE OF THE ENVELOPE. THE TOP SOCK WITH BLUE DOTS, BLUE AND WHITE BACKGROUND AND PINK HEEL AND TOE, AND THE BOTTOM SOCK WITH PINK AND WHITE STRIPES WITH BLUE HEEL AND TOE.

FOR ADULT NOVELTY GAG CLOTHING ITEM, NAMELY, SOCKS; ANKLE SOCKS; ANKLETS; SLIPPER SOCKS; SOCKS; SOCKS AND STOCKINGS (U.S. CLS. 22 AND 39).

FIRST USE 3-30-2010; IN COMMERCE 3-30-2010.

DOMINIC J. FERRAIUOLO, EXAMINING ATTORNEY

SN 85-111,561. GEOFFREY BEENE, LLC, NEW YORK, NY. FILED 8-19-2010.

GEOFFREY BEENE GIVES BACK

THE MARK CONSISTS OF STANDARD CHARACTERS WITHOUT CLAIM TO ANY PARTICULAR FONT, STYLE, SIZE, OR COLOR.

OWNER OF U.S. REG. NOS. 899,265, 3,779,484 AND OTHERS.

THE NAME(S), PORTRAIT(S), AND/OR SIGNATURE(S) SHOWN IN THE MARK DOES NOT IDENTIFY A PARTICULAR LIVING INDIVIDUAL.

FOR HATS (U.S. CLS. 22 AND 39).

ANDREA K. NADELMAN, EXAMINING ATTORNEY

CLASS 25—(Continued).

SN 85-114,562. HOLLY-DALE SHAPIRO, DBA HOLLY-DALE SHAPIRO, NEW YORK, NY. FILED 8-24-2010.

PoshGoLosh

THE MARK CONSISTS OF STANDARD CHARACTERS WITHOUT CLAIM TO ANY PARTICULAR FONT, STYLE, SIZE, OR COLOR.
FOR GALOSHES (U.S. CLS. 22 AND 39).
VERNA BETH RIRIE, EXAMINING ATTORNEY

SN 85-117,024. HICKEN, WILLIAM M., MOUNT PLEASANT, SC. FILED 8-26-2010.



THE MARK CONSISTS OF STYLIZED LETTERS "YB" AND WINGS.
FOR CLOTHING, NAMELY MEN'S AND WOMEN'S SHIRTS, PANTS, UNDERWEAR, SCARVES AND HATS (U.S. CLS. 22 AND 39).
ARETHA SOMERVILLE, EXAMINING ATTORNEY

SN 85-119,082. REED, EVERETT, BRONX, NY. FILED 8-30-2010.



THE MARK CONSISTS OF A PICTURE OF A SIDE PROFILE OF A CHARACTER'S FACE WITH ONE EYE AND A NOSE. HE IS WEARING A CHAIN.
FOR HATS; HOODED SWEAT SHIRTS; SHIRTS; T-SHIRTS (U.S. CLS. 22 AND 39).
FIRST USE 1-1-2003; IN COMMERCE 2-1-2007.
KATHLEEN M. VANSTON, EXAMINING ATTORNEY

CLASS 25—(Continued).

SN 85-120,450. OUYANG JINGLUN, JINGAN DIS., SHANGHAI, CHINA, FILED 9-1-2010.



THE MARK CONSISTS OF AN OUTER TRIANGLE WITH CURVED SIDES AND AN INNER TRIANGULAR SHAPE WITH TWO SAILS WITHIN.
FOR COATS; GIRDLES; HATS; HOSIERY; SHOES; TROUSERS (U.S. CLS. 22 AND 39).
FIRST USE 7-1-2010; IN COMMERCE 7-1-2010.
CYNTHIA SLOAN, EXAMINING ATTORNEY

SN 85-122,332. TRUEWAY CORPORATION, TAOYUAN, TAIWAN, FILED 9-2-2010.



PRIORITY CLAIMED UNDER SEC. 44(D) ON TAIWAN APPLICATION NO. 99021283, FILED 5-6-2010, REG. NO. 1441950, DATED 12-1-2010, EXPIRES 11-30-2020.
THE MARK CONSISTS OF TEXT "TAKODA" UNDER A MOUNTAIN DESIGN, AND THE TEXT AND THE DESIGN ARE IN THE CENTER OF A TRIANGLE LINE BORDER.
FOR WORK CLOTHES, NAMELY, WORKING OVERALLS AND UNIFORMS; CASUAL CLOTHES, NAMELY, TEE SHIRTS AND POLO SHIRTS; AEROBICS CLOTHING, NAMELY, GYM SUITS, GYM PANTS, YOGA SUITS AND YOGA PANTS; SPORTSWEAR, NAMELY, SPORTS SHIRTS, SPORTS JERSEYS AND SPORTS JACKETS; CLOTHING, NAMELY, SHIRTS AND TEE SHIRTS; WATER SKIING APPAREL, NAMELY, WET SUITS; SPORT SHOES, NAMELY, ATHLETIC FOOTWEAR, TENNIS SHOES; BRAS; SWIMSUITS; SWIM TRUNKS; BEACHWEAR; VESTS; UNDERWEAR; COATS; SCARVES; SPORTS CAPS; SWIMMING CAPS; EARMUFFS; AND GLOVES (U.S. CLS. 22 AND 39).
PAM WILLIS, EXAMINING ATTORNEY

CLASS 25—(Continued).

SN 85-122,341. TRUEWAY CORPORATION, TAOYUAN, TAIWAN, FILED 9-2-2010.



THE MARK CONSISTS OF TEXT "TAKODA" ON LEFT SIDE OF A MOUNTAIN DESIGN.

FOR WORK CLOTHES, NAMELY, WORKING OVERALLS AND UNIFORMS; CASUAL CLOTHES, NAMELY, TEE SHIRTS AND POLO SHIRTS; AEROBICS CLOTHING, NAMELY, GYM SUITS, GYM PANTS, YOGA SUITS AND YOGA PANTS; SPORTSWEAR, NAMELY, SPORTS SHIRTS, SPORTS JERSEYS AND SPORTS JACKETS; CLOTHING, NAMELY, SHIRTS AND TEE SHIRTS; WATER SKIING APPAREL, NAMELY, WET SUITS; SPORT SHOES, NAMELY, ATHLETIC FOOTWEAR, TENNIS SHOES; SWIMSUITS; SWIM TRUNKS; BEACHWEAR; VESTS; UNDERWEAR; COATS; SCARVES; SPORTS CAPS; SWIMMING CAPS; AND GLOVES (U.S. CLS. 22 AND 39).

FIRST USE 4-20-2010; IN COMMERCE 11-15-2010.
PAM WILLIS, EXAMINING ATTORNEY

SN 85-124,503. EXHALE ENTERPRISES, INC., NEW YORK, NY. FILED 9-7-2010.

EXHALE

THE MARK CONSISTS OF STANDARD CHARACTERS WITHOUT CLAIM TO ANY PARTICULAR FONT, STYLE, SIZE, OR COLOR.

OWNER OF U.S. REG. NOS. 2,818,315, 3,309,027 AND 3,375,867.

FOR EXERCISE CLOTHING, NAMELY, GRIP SOCKS, YOGA PANTS, YOGA SHIRTS, SPORTS BRAS, RUNNING SUITS; HEADWEAR; HEADBANDS; FOOTWEAR; CLOTHING, NAMELY, SHIRTS, TEE SHIRTS, TANK TOPS, SHORTS, PANTS, JACKETS, SWEATSHIRTS, SOCKS, GLOVES; SWIMWEAR (U.S. CLS. 22 AND 39).

NATALIE POLZER, EXAMINING ATTORNEY

SN 85-126,514. FRONZIE, LLC, LENEXA, KS. FILED 9-10-2010.

DRY DUDZ

THE MARK CONSISTS OF STANDARD CHARACTERS WITHOUT CLAIM TO ANY PARTICULAR FONT, STYLE, SIZE, OR COLOR.

FOR SWIM WEAR, NAMELY, BOARD SHORTS AND BOARD SHORT LINERS MADE OF FABRIC; SWIMMING SHORTS AND SWIMMING SHORTS LINERS MADE OF FABRIC (U.S. CLS. 22 AND 39).

WILLIAM ROSSMAN, EXAMINING ATTORNEY

CLASS 25—(Continued).

SN 85-129,886. KHAM PRODUCTS INCORPORATED, SNELLVILLE, GA. FILED 9-15-2010.

By KHAM

THE MARK CONSISTS OF STANDARD CHARACTERS WITHOUT CLAIM TO ANY PARTICULAR FONT, STYLE, SIZE, OR COLOR.

THE NAME(S), PORTRAIT(S), AND/OR SIGNATURE(S) SHOWN IN THE MARK DOES NOT IDENTIFY A PARTICULAR LIVING INDIVIDUAL.

FOR ATHLETIC APPAREL, NAMELY, SHIRTS, PANTS, JACKETS, FOOTWEAR, HATS AND CAPS, ATHLETIC UNIFORMS (U.S. CLS. 22 AND 39).

HEATHER THOMPSON, EXAMINING ATTORNEY

SN 85-134,975. MORETT, CARLOS ANAYA, GUADALAJARA, JALISCO, MEXICO, FILED 9-21-2010.

ARTICHOKE'S HEART

THE MARK CONSISTS OF STANDARD CHARACTERS WITHOUT CLAIM TO ANY PARTICULAR FONT, STYLE, SIZE, OR COLOR.

FOR CLOTHING, NAMELY, SHIRTS, PANTS, SHORTS, JACKETS, HATS, CAPS (U.S. CLS. 22 AND 39).

LAURIE MAYES, EXAMINING ATTORNEY

CLASS 25—(Continued).

SN 85-134,984. MORETT, CARLOS ANAYA, GUADALAJARA, JALISCO, MEXICO, FILED 9-21-2010.



THE MARK CONSISTS OF THE DESIGN OF AN ARTICHOKE SURROUNDED WITH THE STYLIZED TERMS "ARTICHOKE'S HEART RESTAURANT" ENCIRCLING THE ARTICHOKE WITH A SMALL SOLID CIRCLE TO THE LEFT OF THE ARTICHOKE AND ANOTHER TO THE RIGHT OF THE ARTICHOKE. BLACK, WHITE AND GRAY ARE NOT CLAIMED AS A FEATURE OF THE MARK BUT MERELY REPRESENT BACKGROUND, OUTLINING, SHADING AND/OR TRANSPARENT AREAS AND ARE NOT PART OF THE MARK.

FOR CLOTHING, NAMELY, SHIRTS, PANTS, SHORTS, JACKETS, HATS, CAPS (U.S. CLS. 22 AND 39).
LAURIE MAYES, EXAMINING ATTORNEY

SN 85-145,420. PFF ENTERTAINMENT, LLC, NEW YORK, NY. FILED 10-5-2010.

Please laugh responsibly

THE MARK CONSISTS OF STANDARD CHARACTERS WITHOUT CLAIM TO ANY PARTICULAR FONT, STYLE, SIZE, OR COLOR.

FOR T-SHIRTS (U.S. CLS. 22 AND 39).
FIRST USE 9-1-2010; IN COMMERCE 9-1-2010.
GRETTA YAO, EXAMINING ATTORNEY

CLASS 25—(Continued).

SN 85-147,887. VOLZ, MEGAN, GREENSBORO, NC. FILED 10-7-2010.



THE MARK CONSISTS OF A PANDA HEAD WITH TWO BAMBOO STICKS CROSSED BEHIND IT. BELOW THERE IS THE STYLIZED TEXT "BAMBOOHEAD".

FOR HATS, JACKETS, SWEAT SHIRTS, T-SHIRTS, TANK TOPS, AND UNDERWEAR COMPRISED IN WHOLE OR IN PART OF BAMBOO (U.S. CLS. 22 AND 39).

FIRST USE 10-13-2009; IN COMMERCE 10-13-2009.
DEZMONA MIZELLE, EXAMINING ATTORNEY

SN 85-151,150. GARO KASSABIAN MD, INC., A PROFESSIONAL CORP., BEVERLY HILLS, CA. FILED 10-12-2010.

BEAUTY WHILE YOU

THE MARK CONSISTS OF STANDARD CHARACTERS WITHOUT CLAIM TO ANY PARTICULAR FONT, STYLE, SIZE, OR COLOR.

FOR SHAPEWEAR GARMENTS, NAMELY, CAMISOLE TOPS AND CAPRI LEGGINGS BELOW THE KNEE; ACTIVEWEAR GARMENTS, NAMELY, SPORTS BRAS; AND SLEEPING GARMENTS (U.S. CLS. 22 AND 39).

FIRST USE 10-1-2010; IN COMMERCE 10-1-2010.
EDWARD NELSON, EXAMINING ATTORNEY

SN 85-153,276. ZAINASHEFF, JAMIL, ELK GROVE, CA. FILED 10-15-2010.

BREW STRONG

THE MARK CONSISTS OF STANDARD CHARACTERS WITHOUT CLAIM TO ANY PARTICULAR FONT, STYLE, SIZE, OR COLOR.

FOR CLOTHING, NAMELY, HATS, JACKETS, SWEAT SHIRTS, T-SHIRTS (U.S. CLS. 22 AND 39).

FIRST USE 9-10-2006; IN COMMERCE 10-10-2006.
RONALD MCMORROW, EXAMINING ATTORNEY

CLASS 25—(Continued).

SN 85-153,557. GILLZ, LLC, LAKE LAND, FL. FILED 10-15-2010.



THE MARK CONSISTS OF A SHAPED FISH HEAD DRAWN WITHIN A BROKEN ROUND CIRCLE. BELOW THERE IS THE STYLIZED TEXT "BREATHELKEAFISH".

FOR CLOTHING, NAMELY, T-SHIRTS, LONG SLEEVE SHIRTS, TURTLE NECKS, MOCK TURTLE NECKS, HATS, SHORTS, SHIRTS, LEGGINGS, SOCKS, JERSEYS, PANTS, HEADWEAR, UNDER WEAR, TANK TOPS, WRISTBANDS, HEADBANDS, SHOES, RAIN SUITS, GLOVES, JACKETS, CAPS, SWEAT SHIRTS, PULLOVERS, BRA, MULTIPURPOSE WRAPS MADE OF TEXTILES FOR USE AS DECORATIVE HEADWEAR, LEG BANDS, MOISTURE WICKING SHIRTS (U.S. CLS. 22 AND 39).

FIRST USE 5-25-2009; IN COMMERCE 5-25-2009.
BRENDAN REGAN, EXAMINING ATTORNEY

SN 85-155,539. PNINATORNAI USA LLC, DOVER, DE. FILED 10-18-2010.

PERLA D. BY PNINA TORNAI

THE MARK CONSISTS OF STANDARD CHARACTERS WITHOUT CLAIM TO ANY PARTICULAR FONT, STYLE, SIZE, OR COLOR.

OWNER OF U.S. REG. NO. 3,315,690.
THE NAME(S), PORTRAIT(S), AND/OR SIGNATURE(S) SHOWN IN THE MARK IDENTIFIES "PNINA TORNAI", WHOSE CONSENT(S) TO REGISTER IS MADE OF RECORD.

FOR DRESSES, BRIDAL DRESSES AND EVENING DRESSES (U.S. CLS. 22 AND 39).

DAWN HAN, EXAMINING ATTORNEY

CLASS 25—(Continued).

SN 85-162,839. URBANIAK, LORRAINE, COLORADO SPRINGS, CO. FILED 10-27-2010.

CHICKS PLAY SPORTS

THE MARK CONSISTS OF STANDARD CHARACTERS WITHOUT CLAIM TO ANY PARTICULAR FONT, STYLE, SIZE, OR COLOR.

FOR HOODED SWEATSHIRTS; SHIRTS; SHORTS; SWEAT PANTS; T-SHIRTS; TANK TOPS (U.S. CLS. 22 AND 39).

FIRST USE 8-9-2010; IN COMMERCE 9-23-2010.
RONALD MCMORROW, EXAMINING ATTORNEY

SN 85-163,718. ANGELS NEW YORK US, INC, HOLLIS, NY. FILED 10-28-2010.

Trumpfit

THE MARK CONSISTS OF STANDARD CHARACTERS WITHOUT CLAIM TO ANY PARTICULAR FONT, STYLE, SIZE, OR COLOR.

FOR FOOTWEAR; INFANT AND TODDLER ONE PIECE CLOTHING; INFANTS' SHOES AND BOOTS (U.S. CLS. 22 AND 39).

FIRST USE 3-15-2010; IN COMMERCE 3-15-2010.
JENNIFER VASQUEZ, EXAMINING ATTORNEY

SN 85-166,055. IP HOLDINGS UNLTD LLC, NEW YORK, NY. FILED 11-1-2010.

XSC

THE MARK CONSISTS OF STANDARD CHARACTERS WITHOUT CLAIM TO ANY PARTICULAR FONT, STYLE, SIZE, OR COLOR.

FOR COATS; FOOTWEAR; GLOVES; HATS; JACKETS; JEANS; PANTS; SHIRTS; SOCKS; UNDERWEAR (U.S. CLS. 22 AND 39).

JANICE KIM, EXAMINING ATTORNEY

CLASS 25—(Continued).

SN 85-166,171. LULULEMON ATHLETICA CANADA INC., VANCOUVER, BC, CANADA, FILED 11-1-2010.

SET-MY-PONYTAIL-FREE

THE MARK CONSISTS OF STANDARD CHARACTERS WITHOUT CLAIM TO ANY PARTICULAR FONT, STYLE, SIZE, OR COLOR.

PRIORITY CLAIMED UNDER SEC. 44(D) ON CANADA APPLICATION NO. 1479646, FILED 5-4-2010, REG. NO. TMA794136, DATED 3-29-2011, EXPIRES 3-29-2026.

FOR CLOTHING, NAMELY, HOODED SWEAT-SHIRTS, JACKETS AND COATS; HEADWEAR, NAMELY, HATS AND CAPS (U.S. CLS. 22 AND 39).

ANGELA DUONG, EXAMINING ATTORNEY

SN 85-168,114. ROBINSON OUTDOOR PRODUCTS, LLC, CANNON FALLS, MN. FILED 11-3-2010.

TREE SPIDER

THE MARK CONSISTS OF STANDARD CHARACTERS WITHOUT CLAIM TO ANY PARTICULAR FONT, STYLE, SIZE, OR COLOR.

FOR HUNTING CLOTHING AND CAMOUFLAGE CLOTHING, NAMELY, JACKETS AND VESTS FOR USE WITH SAFETY AND SUPPORT DEVICES (U.S. CLS. 22 AND 39).

DORITT L. CARROLL, EXAMINING ATTORNEY

SN 85-169,931. A'NUE LIGNE, INC., MIAMI, FL. FILED 11-5-2010.

A'NUE LIGNE

THE MARK CONSISTS OF STANDARD CHARACTERS WITHOUT CLAIM TO ANY PARTICULAR FONT, STYLE, SIZE, OR COLOR.

NO CLAIM IS MADE TO THE EXCLUSIVE RIGHT TO USE "LIGNE", APART FROM THE MARK AS SHOWN.

THE ENGLISH TRANSLATION OF "LIGNE" IN THE MARK IS "LINE."

FOR CLOTHING, NAMELY, TOPS, BOTTOMS, PANTS, SKIRTS, JACKETS, BODYSUITS (U.S. CLS. 22 AND 39).

FIRST USE 3-0-1991; IN COMMERCE 3-0-1991.
KEVON CHISOLM, EXAMINING ATTORNEY

CLASS 25—(Continued).

SN 85-176,317. FISHNOODLE INDUSTRIES LLC, SAINT LOUIS, MO. FILED 11-14-2010.



THE MARK CONSISTS OF THE WORDS "BRIGHT" AND "STAR" IN LOWER CASE LETTERS. ABOVE THE WORDS THERE IS A 5 POINT STAR, SHIFTED SLIGHTLY OFF-CENTER AND TILTED. WITHIN THAT STAR, THERE IS ANOTHER 5 POINT STAR THAT IS SMALLER IN SCALE AND LIGHTER IN SHADING.

FOR INFANT CLOTH DIAPERS; INFANT DIAPER COVERS; INSERTS SPECIALLY ADAPTED FOR CLOTH DIAPERS MADE OF BAMBOO; INSERTS SPECIALLY ADAPTED FOR CLOTH DIAPERS MADE OF HEMP; INSERTS SPECIALLY ADAPTED FOR CLOTH DIAPERS MADE OF MICROFIBER; NON-DISPOSABLE CLOTH TRAINING PANTS (U.S. CLS. 22 AND 39).

FIRST USE 10-1-2010; IN COMMERCE 11-1-2010.

BILL DAWE, EXAMINING ATTORNEY

SN 85-182,020. DAVIS, TALITHA C, CHARLES TOWN, WV. FILED 11-22-2010.



FOR ATHLETIC APPAREL, NAMELY, SHIRTS, PANTS, JACKETS, FOOTWEAR, HATS AND CAPS, ATHLETIC UNIFORMS; DENIMS; DRESSES; EVENING DRESSES; SHORT-SLEEVED OR LONG-SLEEVED T-SHIRTS; SKIRTS; SKIRTS AND DRESSES; T-SHIRTS (U.S. CLS. 22 AND 39).

MARK SPARACINO, EXAMINING ATTORNEY

CLASS 25—(Continued).

SN 85-184,037. LITTLE PEOPLES CLOTHING LINE, MIAMI, FL. FILED 11-23-2010.



NO CLAIM IS MADE TO THE EXCLUSIVE RIGHT TO USE "FOR DWARF", APART FROM THE MARK AS SHOWN.

THE STIPPLING IS FOR SHADING PURPOSES ONLY.

THE MARK CONSISTS OF A STYLIZED DESIGN OF THE TEXT "LC LEGEND CHILD FOR DWARF". THE LETTERS "LC" ARE ENCLOSED IN AN OVAL. THERE IS ALSO TWO LINES.

FOR BELTS; BOXER BRIEFS; BOXER SHORTS; DRESSES; HATS; HOODED SWEAT SHIRTS; JACKETS; JEANS; SKIRTS; SNEAKERS; SOCKS; T-SHIRTS; TANK TOPS (U.S. CLS. 22 AND 39).

FIRST USE 6-8-2006; IN COMMERCE 7-24-2007.

ARETHA SOMERVILLE, EXAMINING ATTORNEY

SN 85-188,483. WELLS ENTERPRISES, INC., LE MARS, IA. FILED 12-1-2010.



OWNER OF U.S. REG. NOS. 1,039,931 AND 1,127,938. THE MARK CONSISTS OF THE STYLIZED DEPICTION OF A FROZEN CONFECTION IN THE SHAPE OF A 6 FIN ROCKET OR MISSILE ON A STICK. THE TWO HORIZONTAL LINES IN THE BODY OF THE MARK DELINEATE DIFFERENT SEGMENTS ON THE MARK.

FOR CLOTHING, NAMELY, T-SHIRTS (U.S. CLS. 22 AND 39).

FIRST USE 5-13-1997; IN COMMERCE 5-13-1997.

BRIAN PINO, EXAMINING ATTORNEY

CLASS 25—(Continued).

SN 85-191,786. GLOCK, GASTON J., WIEN 1190, AUSTRIA, FILED 12-6-2010.



THE NAME "GASTON" IDENTIFIES A LIVING INDIVIDUAL WHOSE CONSENT IS OF RECORD.

THE COLOR(S) RED, BLACK, AND WHITE IS/ARE CLAIMED AS A FEATURE OF THE MARK.

THE MARK CONSISTS OF THE WORD "GASTON" IN BLACK AND INCORPORATES A WHITE "G" INSIDE A RED CIRCLE DESIGN LOGO, WHICH STANDS FOR THE LETTER "O" IN "GASTON".

FOR SPORTSWEAR, SHOOTING AND HUNTING APPAREL, NAMELY, SHIRTS, JACKETS, TROUSERS, PANTS, SHOES, BOOTS, SOCKS, CAPS, HATS, KNITTED HATS, BEANIES, HEADBANDS, SHAWLS, HEAD-SCARVES, SCARVES, GLOVES, HAND-WARMERS, UNDERGARMENTS, VESTS, PULLOVERS, AND EAR MUFFS (U.S. CLS. 22 AND 39).

JANICE L. MCMORROW, EXAMINING ATTORNEY

SN 85-191,804. GLOCK, GASTON J., WIEN 1190, AUSTRIA, FILED 12-7-2010.



THE COLOR(S) RED AND WHITE IS/ARE CLAIMED AS A FEATURE OF THE MARK.

THE MARK CONSISTS OF A WHITE "G" INSIDE A RED CIRCLE DESIGN LOGO.

FOR SPORTSWEAR, SHOOTING AND HUNTING APPAREL, NAMELY, SHIRTS, JACKETS, TROUSERS, PANTS, SHOES, BOOTS, SOCKS, CAPS, HATS, KNITTED HATS, BEANIES, HEADBANDS, SHAWLS, HEAD-SCARVES, SCARVES, GLOVES, HAND-WARMERS, UNDERGARMENTS, VESTS, PULLOVERS, AND EAR MUFFS (U.S. CLS. 22 AND 39).

JANICE L. MCMORROW, EXAMINING ATTORNEY

CLASS 25—(Continued).

SN 85-191,886. THE VERMONT TEDDY BEAR COMPANY, INC., SHELBURNE, VT. FILED 12-7-2010.

CLASS 25—(Continued).

SN 85-194,953. EVEDEN LIMITED, KETTERING, UNITED KINGDOM, FILED 12-10-2010.

Performance sleepwear to
help you fall asleep ...
and stay asleep

THE MARK CONSISTS OF STANDARD CHARACTERS WITHOUT CLAIM TO ANY PARTICULAR FONT, STYLE, SIZE, OR COLOR.

NO CLAIM IS MADE TO THE EXCLUSIVE RIGHT TO USE "PERFORMANCE SLEEPWEAR", APART FROM THE MARK AS SHOWN.

FOR LOUNGEWEAR (U.S. CLS. 22 AND 39).
HOWARD B. LEVINE, EXAMINING ATTORNEY

ELOMI CURVE

SN 85-192,289. FLOP HAPPY LLC, POTTSTOWN, PA. FILED 12-7-2010.



THE MARK CONSISTS OF A FOOTPRINT THAT HAS A HAND DRAWN SMILING FACE CONSISTING OF TWO EYES AND SMILE.

FOR FLIP FLOPS (U.S. CLS. 22 AND 39).
FIRST USE 3-28-2010; IN COMMERCE 8-31-2010.
EVELYN BRADLEY, EXAMINING ATTORNEY

THE MARK CONSISTS OF STANDARD CHARACTERS WITHOUT CLAIM TO ANY PARTICULAR FONT, STYLE, SIZE, OR COLOR.

PRIORITY CLAIMED UNDER SEC. 44(D) ON ERP N CMNTY TM OFC APPLICATION NO. 9586249, FILED 12-9-2010.

OWNER OF ERP N CMNTY TM OFC REG. NO. 9586249, DATED 5-20-2011, EXPIRES 9-12-2020.

OWNER OF U.S. REG. NO. 3,852,465.
FOR CLOTHING, NAMELY, SWIMWEAR; BEACHWEAR; SOCKS, TIGHTS; AND UNDERCLOTHING, NAMELY, PANTYHOSE, STOCKINGS, LINGERIE (U.S. CLS. 22 AND 39).

NATALIE POLZER, EXAMINING ATTORNEY

CLASS 25—(Continued).

SN 85-195,818. CHAMBERS, JASON JEROME, AKA CHAMBERS, PALMDALE, CA. FILED 12-11-2010.



THE COLOR(S) BLACK, LIGHT GRAY AND GRAY IS/ARE CLAIMED AS A FEATURE OF THE MARK.

THE MARK CONSISTS OF THE WORDING "PROS" IN STYLIZED BLACK FONT APPEARING ABOVE THE WORDING "BETTER MY GAME." IN BLACK FONT, ALL ON A LIGHT GRAY BACKGROUND WITH A JAGGED EDGE SEPARATING THE GRAY PEBBLED QUADRILATERAL SHAPE AT THE BOTTOM FROM THE LIGHT GRAY BACKGROUND.

FOR APPAREL FOR DANCERS, NAMELY, TEE SHIRTS, SWEATSHIRTS, PANTS, LEGGINGS, SHORTS AND JACKETS; ATHLETIC APPAREL, NAMELY, SHIRTS, PANTS, JACKETS, FOOTWEAR, HATS AND CAPS, ATHLETIC UNIFORMS; ATHLETIC FOOTWEAR; ATHLETIC UNIFORMS; BASEBALL CAPS AND HATS; BASEBALL UNIFORMS; BEACH FOOTWEAR; CAMOUFLAGE PANTS; CLOTHING FOR ATHLETIC USE, NAMELY, PADDED PANTS; FLIP FLOPS; FOOTWEAR; FOOTWEAR FOR MEN; FOOTWEAR FOR MEN AND WOMEN; FOOTWEAR FOR TRACK AND FIELD ATHLETICS; FOOTWEAR FOR WOMEN; GOLF PANTS, SHIRTS AND SKIRTS; GYM PANTS; HAT BANDS; HATS; JOGGING PANTS; LEATHER HATS; LEATHER PANTS; LEG SHIELDING DEVICE, ATTACHABLE TO AND DETACHABLE FROM A PERSON'S PANTS, COMPRISED OF PADDING TO SHIELD THE LEGS FROM FLYING DEBRIS WHEN MOWING WITH A STRING TRIMMER; MOISTURE-WICKING SPORTS PANTS; NON-DISPOSABLE CLOTH TRAINING PANTS; PANTS; PERSPIRATION ABSORBENT STRAP TO BE USED IN THE BILL OF A HAT; RAIN HATS; SCIENTIFIC AND TECHNOLOGICAL APPAREL, NAMELY, SHIRTS, PANTS, JACKETS, FOOTWEAR, HATS AND CAPS, UNIFORMS; SNOW PANTS; SNOWBOARD PANTS; SOLES FOR FOOTWEAR; SPORTS CAPS AND HATS; SPORTS OVER UNIFORMS; SPORTS PANTS; STRETCH PANTS; SWEAT PANTS; TRACK PANTS; TRAVEL CLOTHING CONTAINED IN A PACKAGE COMPRISING REVERSIBLE JACKETS, PANTS, SKIRTS, TOPS AND A BELT OR SCARF; UNIFORMS; WATERPROOF JACKETS AND PANTS; WIND PANTS; WOMEN'S HATS AND HOODS; YOGA PANTS (U.S. CLS. 22 AND 39).

JULIE VEPPUMTHARA, EXAMINING ATTORNEY

SN 85-199,938. JAMES D. AXE, DBA AXE ENTERPRISES, MISSOULA, MT. FILED 12-16-2010.

Slightly Lifted

THE MARK CONSISTS OF STANDARD CHARACTERS WITHOUT CLAIM TO ANY PARTICULAR FONT, STYLE, SIZE, OR COLOR.

FOR SHIRTS, PANTS, SHOES, SWEAT SHIRTS, SWEAT PANTS, COATS, HATS (U.S. CLS. 22 AND 39).

CHARLOTTE CORWIN, EXAMINING ATTORNEY

CLASS 25—(Continued).

SN 85-203,853. CLUB HOUSE CREATIONS, INC., NEW YORK, NY. FILED 12-22-2010.



THE COLOR(S) DARK GREEN, LIME GREEN, YELLOW, MAGENTA, WHITE, BLACK, AND SILVER IS/ARE CLAIMED AS A FEATURE OF THE MARK.

THE MARK CONSISTS OF A STYLIZED BUG. THE COLOR DARK GREEN APPEARS IN THE LEGS AND BOTTOM OF THE BUG. THE COLOR LIME GREEN APPEARS IN UPPER PORTION AND ARMS OF THE BODY AND THE GLASS AND STRAW. THE COLOR YELLOW APPEARS AS THE LIQUID IN THE GLASS AND THE LEMON SLICE. THE COLOR MAGENTA APPEARS IN THE TONGUE AND THE DOTS AND STRAP OF THE BOW TIE. THE COLOR WHITE APPEARS IN THE BOW TIE AND IN THE EYES OF THE BUG AND IN THE WINGS. THE COLOR BLACK APPEARS IN THE OUTLINE OF THE WINGS, OUTLINE OF THE BUG, BACKGROUND OF THE MOUTH, ANTENNAS, EYES, AND EYEBROWS. THE COLOR SILVER APPEARS IN THE EYES.

FOR CHILDREN'S APPAREL, NAMELY, T-SHIRTS, PANTS, AND TOPS; CHILDREN'S SHOES (U.S. CLS. 22 AND 39).

DANNEAN HETZEL, EXAMINING ATTORNEY

SN 85-211,911. OMAR M. TREVINO, SAN ANTONIO, TX. FILED 1-6-2011.



NO CLAIM IS MADE TO THE EXCLUSIVE RIGHT TO USE "SAN ANTONIO LOGO DESIGN", APART FROM THE MARK AS SHOWN.

THE MARK CONSISTS OF THE LETTERS "SA" WITHIN A CIRCULAR BORDER THAT CONTAINS A DESIGN OF TWO LINES AND A CIRCLE AND THE WORDING "SAN ANTONIO LOGO DESIGN & ARTISTRY".

FOR BASEBALL CAPS AND HATS; SHIRTS (U.S. CLS. 22 AND 39).

FIRST USE 11-10-2009; IN COMMERCE 12-21-2010.

LINDA M. KING, EXAMINING ATTORNEY

CLASS 25—(Continued).

SN 85-214,062. CAGE HERO, LLC, PEMBROKE PINES, FL. FILED 1-10-2011.



THE MARK CONSISTS OF THE TERM "CAGEHERO" IN STYLIZED TEXT WITH AN IRREGULAR SHAPED POLYGON SURROUNDING THE LETTERS "GEHE".

FOR CLOTHING AND ATHLETIC APPAREL, NAMELY SHIRTS, PANTS, JACKETS, FOOTWEAR, HATS AND CAPS, ATHLETIC UNIFORMS, PANTIES, SHORTS, BRIEFS, SHORT-SLEEVED OR LONG-SLEEVED T-SHIRTS, SPORT SHIRTS, SWEATSHIRTS; HATS, NAMELY BASEBALL CAPS, WOOLLY HATS; RASHGUARDS; FOOTWEAR (U.S. CLS. 22 AND 39).

FIRST USE 4-17-2010; IN COMMERCE 4-17-2010.
ALLISON SCHRODY, EXAMINING ATTORNEY

SN 85-214,639. HENDERSON AQUATICS, INC., MILLVILLE, NJ. FILED 1-11-2011.

MICROPRENE 2

THE MARK CONSISTS OF STANDARD CHARACTERS WITHOUT CLAIM TO ANY PARTICULAR FONT, STYLE, SIZE, OR COLOR.

FOR ELASTOMERIC MATERIAL SOLD AS A COMPONENT OF WATERSPORTS APPAREL, NAMELY, WETSUITS, BOOTS AND HOODS (U.S. CLS. 22 AND 39).
STEVEN PEREZ, EXAMINING ATTORNEY

SN 85-215,680. SULLIVAN, ERIC, OCALA, FL. FILED 1-12-2011.

Sweet Magnolia Clothing Company

THE MARK CONSISTS OF STANDARD CHARACTERS WITHOUT CLAIM TO ANY PARTICULAR FONT, STYLE, SIZE, OR COLOR.

NO CLAIM IS MADE TO THE EXCLUSIVE RIGHT TO USE "CLOTHING COMPANY", APART FROM THE MARK AS SHOWN.

FOR BELTS; HATS; JACKETS; PANTS; SHIRTS (U.S. CLS. 22 AND 39).

RUDY R. SINGLETON, EXAMINING ATTORNEY

CLASS 25—(Continued).

SN 85-215,774. JULIUS ZORN, INC., CUYAHOGA FALLS, OH. FILED 1-12-2011.

NATURALLY SHEER

THE MARK CONSISTS OF STANDARD CHARACTERS WITHOUT CLAIM TO ANY PARTICULAR FONT, STYLE, SIZE, OR COLOR.

NO CLAIM IS MADE TO THE EXCLUSIVE RIGHT TO USE "SHEER", APART FROM THE MARK AS SHOWN.

FOR HOSIERY (U.S. CLS. 22 AND 39).

FIRST USE 5-3-2011; IN COMMERCE 5-3-2011.

REGINA DRUMMOND, EXAMINING ATTORNEY

SN 85-216,509. SHANGHAI HAMPSHEER GARMENTS CO., LTD., SHANGHAI CITY, CHINA, FILED 1-13-2011.



NO CLAIM IS MADE TO THE EXCLUSIVE RIGHT TO USE THE NON-LATIN CHARACTERS THAT TRANSLITERATE TO "BU", APART FROM THE MARK AS SHOWN.

THE MARK CONSISTS OF THE STYLIZED WORD "HAMPSHEER" AND 3 CHINESE CHARACTERS ABOVE THE CHARACTERS "AMPSHEER".

THE WORDING HAMPSHEER HAS NO MEANING IN A FOREIGN LANGUAGE.

THE NON-LATIN CHARACTERS IN THE MARK TRANSLITERATE TO HAN; BU; SHI AND THIS MEANS COLD; CLOTH; OFFICIAL CAREER IN ENGLISH.

FOR DOWN JACKETS; JACKETS; KNIT TOPS; OVERALLS; SKIRTS; SUITS; TOPCOATS; UNDERWEAR; UNIFORMS; WIND RESISTANT JACKETS (U.S. CLS. 22 AND 39).

DANIEL CAPSHAW, EXAMINING ATTORNEY

SN 85-217,929. FAUGHT, DONNIE, VALENCIA, CA. FILED 1-14-2011.

Dirty*Nasty*I Love You

THE MARK CONSISTS OF STANDARD CHARACTERS WITHOUT CLAIM TO ANY PARTICULAR FONT, STYLE, SIZE, OR COLOR.

FOR CLOTHING, NAMELY, HATS, TOPS, T-SHIRTS, BUTTON DOWN SHIRTS, BOTTOMS; PANTS, SHORTS, JACKETS, SWEATSHIRTS, AND SCARVES (U.S. CLS. 22 AND 39).

DAWN FELDMAN, EXAMINING ATTORNEY

CLASS 25—(Continued).

SN 85-218,038. OWN LLC, LOS ANGELES, CA. FILED 1-14-2011.



THE COLOR(S) ORANGE, YELLOW, GREEN, LIGHT GREEN, PURPLE AND LIGHT PURPLE IS/ARE CLAIMED AS A FEATURE OF THE MARK.

THE MARK CONSISTS OF THE WORD "OWN" DEPICTED IN CAPITAL LETTERS WITH VARYING SHADES OF ORANGE FORMING "O" WITH YELLOW APPEARING IN THE CENTER; VARYING SHADES OF GREEN TO LIGHT GREEN FORMING "W" AND VARYING SHADES OF PURPLE TO LIGHT PURPLE FORMING "N" WITH A SHADOW UNDER EACH LETTER THAT IS DEPICTED IN THE SAME COLOR AS THE LETTER.

FOR CLOTHING, NAMELY, SHIRTS, PANTS, SHORTS, SKIRTS, SKORTS, DRESSES, TOPS, BOTTOMS, OVERALLS, FOUL WEATHER GEAR, RAINWEAR, JACKETS, COATS, PONCHOS, SWEATERS, SWEAT SHIRTS, SWEAT PANTS, SWEAT JACKETS, SWEAT SUITS, TRACKSUITS, T-SHIRTS, JERSEYS, PULL-OVERS, LOUNGEWEAR, SOCKS, HOSIERY, UNDERGARMENTS, PAJAMAS, ROBES, NIGHTWEAR, SLEEPWEAR, SLEEP MASKS, GLOVES, MITTENS, SCARVES, BEACHWEAR, SWIMWEAR, BABY TOPS, BABY BOTTOMS, BABY BIBS NOT OF PAPER, BATH-ROBES, BELTS, NECKWEAR AND SUSPENDERS; HEADWEAR; FOOTWEAR (U.S. CLS. 22 AND 39).

THOMAS MANOR, EXAMINING ATTORNEY

SN 85-218,169. D.P.I. IMPORTS INC., BAY SHORE, NY. FILED 1-14-2011.



NO CLAIM IS MADE TO THE EXCLUSIVE RIGHT TO USE "HEAT", APART FROM THE MARK AS SHOWN. THE MARK CONSISTS OF A FIRST RECTANGLE IN

CLASS 25—(Continued).

WHICH THE TERM "32°" IS CENTERED, WITH A SECOND RECTANGLE TO THE IMMEDIATE RIGHT OF THE FIRST RECTANGLE AND A THIRD RECTANGLE TO THE IMMEDIATE RIGHT OF THE SECOND RECTANGLE, WHICH HAS THE WORD "DEGREES" CENTERED IN THE THIRD RECTANGLE SUCH THAT THE WORD "DEGREES" IS PERPENDICULAR TO THE TERM "32°" AND THE LETTER "D" IS CLOSEST TO THE TOP OF THE MARK, AND WITH THE TERM "HEAT" CENTERED BELOW THE THREE RECTANGLES.

FOR CLOTHING, NAMELY, COATS, JACKETS, BELTS, GLOVES, HATS, CAPS, HOSIERY, JEANS, SWEAT SUITS, SWEATSHIRTS, SWEAT PANTS, NECKWEAR, PANTS, PARKAS, PONCHOS, SWEATERS, RAINCOATS, PAJAMAS, ROBES, SHIRTS, SOCKS, SHORT SUITS, SWIMSUITS, T-SHIRTS, UNDERWEAR, SCARVES, AND VESTS; FOOTWEAR (U.S. CLS. 22 AND 39).

FIRST USE 8-30-2010; IN COMMERCE 8-30-2010. SAMUEL E. SHARPER JR., EXAMINING ATTORNEY

SN 85-219,882. DC LICENSING LLC, GREENWICH, CT. FILED 1-18-2011.

LINCS DC & CO. GOLF

THE MARK CONSISTS OF STANDARD CHARACTERS WITHOUT CLAIM TO ANY PARTICULAR FONT, STYLE, SIZE, OR COLOR.

OWNER OF U.S. REG. NO. 3,177,569.

NO CLAIM IS MADE TO THE EXCLUSIVE RIGHT TO USE "CO. GOLF", APART FROM THE MARK AS SHOWN. FOR CLOTHING, NAMELY, TROUSERS, SLACKS, PANTS, DRESS SHIRTS, POLO SHIRTS, SWEAT PANTS, SWEATSHIRTS, PULLOVERS, TOPS, JACKETS, SHORTS, T-SHIRTS, SWEATERS, COATS, HATS, CAPS AND VESTS (U.S. CLS. 22 AND 39).

JOHN DALIER, EXAMINING ATTORNEY

SN 85-222,581. REGAN METOYER, DBA RICHARD BUENO, LOS ANGELES, CA. FILED 1-20-2011.

Richard Bueno

THE MARK CONSISTS OF STANDARD CHARACTERS WITHOUT CLAIM TO ANY PARTICULAR FONT, STYLE, SIZE, OR COLOR.

THE TERM "RICHARD BUENO" DOES NOT IDENTIFY A LIVING INDIVIDUAL.

THE ENGLISH TRANSLATION OF "BUENO" IN THE MARK IS "GOOD".

FOR T-SHIRTS (U.S. CLS. 22 AND 39).

FIRST USE 1-1-2011; IN COMMERCE 1-1-2011.

AMY HELLA, EXAMINING ATTORNEY

CLASS 25—(Continued).

SN 85-224,698. VELOCITY, LLC, EVERETT, MA. FILED 1-24-2011.

MARATHON MONDAY

THE MARK CONSISTS OF STANDARD CHARACTERS WITHOUT CLAIM TO ANY PARTICULAR FONT, STYLE, SIZE, OR COLOR.

FOR CLOTHING, NAMELY, TOPS, BOTTOMS, HEADWEAR, SWEATSHIRTS, SWEAT PANTS, JACKETS, PULLOVERS, CAPS, HATS, SOCKS (U.S. CLS. 22 AND 39).

FIRST USE 4-7-2011; IN COMMERCE 4-11-2011.
CHRIS WELLS, EXAMINING ATTORNEY

CLASS 25—(Continued).

SN 85-227,440. WHOLESALE SCREEN PRINTING OF NAPLES, INC., NAPLES, FL. FILED 1-27-2011.



NO CLAIM IS MADE TO THE EXCLUSIVE RIGHT TO USE "COLLEGE" OR "SPORTS", APART FROM THE MARK AS SHOWN.

THE MARK CONSISTS OF THE WORDS "COLLEGE REPUBLIC" AROUND A SEAPLANE THAT IS IN FRONT OF TWO PALM TREES AND A LINED SUN. UNDERNEATH IS A WOOD SIGN THAT CONTAINS THE WORDS "BY FRONT ROW SPORTS".

FOR HOODED SWEATSHIRTS; SHORT-SLEEVED OR LONG-SLEEVED T-SHIRTS; SWEATSHIRTS; T-SHIRTS (U.S. CLS. 22 AND 39).

FIRST USE 1-0-2011; IN COMMERCE 1-0-2011.
JESSICA A. POWERS, EXAMINING ATTORNEY

SN 85-226,300. FASHION SEAL CORPORATION, LAS VEGAS, NV. FILED 1-26-2011.



THE COLOR(S) PALE GREEN, AND BLUE IS/ARE CLAIMED AS A FEATURE OF THE MARK.

THE MARK CONSISTS OF THE LITERAL ELEMENT "EVERYBODY MEDIA" WITH THE LITERAL ELEMENT "EVERY" LOCATED ON THE BOTTOM LEFTHAND SIDE IN SCRIPT IN PALE GREEN GRADUATED COLORING FROM LIGHTER AT THE TOP TO DARKER AT THE BOTTOM; THE LITERAL ELEMENT "BODY" LOCATED TO THE RIGHT OF THE LITERAL ELEMENT "EVERY", WITH THE "Y" IN "EVERY" SLIGHTLY OVERLAPPING THE BEGINNING OF THE "B" IN "BODY", THE "B" "D" AND "Y" OF THE LITERAL ELEMENT "BODY" IN BLOCK LETTERS IN BLUE GRADUATED COLORING FROM LIGHTER AT THE TOP TO DARKER AT THE BOTTOM, AND THE "O" IN "BODY" REPRESENTED AS A SERIES OF LIGHT AND DARK PALE GREEN AND BLUE THIN SWIRLING ARCS ENCASING A LARGE, THICK SWIRL OF BLUE; AND THE LITERAL ELEMENT "MEDIA" LOCATED ON THE UPPER RIGHTHAND SIDE IN SCRIPT IN PALE GREEN GRADUATED COLORING FROM LIGHTER AT THE TOP TO DARKER AT THE BOTTOM AND DIRECTLY OVER THE "DY" IN "BODY".

FOR CLOTHING, NAMELY, SHIRTS, APRONS AND VESTS, ALL HAVING A CHANGEABLE MESSAGE PORTION FOR USE BY SERVICE AND PRODUCT PROVIDERS AS A CHANGEABLE ADVERTISING DISPLAY (U.S. CLS. 22 AND 39).

ANDREA HACK, EXAMINING ATTORNEY

SN 85-227,839. RHE HATCO, INC., GARLAND, TX. FILED 1-27-2011.

RANCHO ESTANCIA

THE MARK CONSISTS OF STANDARD CHARACTERS WITHOUT CLAIM TO ANY PARTICULAR FONT, STYLE, SIZE, OR COLOR.

THE ENGLISH TRANSLATION OF "RANCHO ESTANCIA" IN THE MARK IS "RANCH STAY".

FOR CLOTHING, NAMELY, SHIRTS, SHORTS, PANTS, TOPS, T-SHIRTS AND HEADWEAR, NAMELY, HATS AND CAPS (U.S. CLS. 22 AND 39).

GENE MACIOL, EXAMINING ATTORNEY

CLASS 25—(Continued).

SN 85-228,855. BCK DESIGNS, LLC, ATLANTA, GA. FILED 1-28-2011.

RUFFS & CUFFS

THE MARK CONSISTS OF STANDARD CHARACTERS WITHOUT CLAIM TO ANY PARTICULAR FONT, STYLE, SIZE, OR COLOR.

NO CLAIM IS MADE TO THE EXCLUSIVE RIGHT TO USE "CUFFS", APART FROM THE MARK AS SHOWN.

FOR CLOTHING, NAMELY, NECKWEAR, AND WRIST WEAR, NAMELY, SHIRT CUFFS AND BLOUSE CUFFS (U.S. CLS. 22 AND 39).

FIRST USE 1-19-2011; IN COMMERCE 1-19-2011.
PAUL F. GAST, EXAMINING ATTORNEY

SN 85-230,842. FEIYI ZHU, NEW YORK, NY. FILED 2-1-2011.

SIGMA

THE MARK CONSISTS OF STANDARD CHARACTERS WITHOUT CLAIM TO ANY PARTICULAR FONT, STYLE, SIZE, OR COLOR.

FOR (BASED ON USE IN COMMERCE) JEANS; SHIRTS; SHORTS(BASED ON INTENT TO USE) BELTS; BLAZERS; CARGO PANTS; COATS; JACKETS; KNIT SHIRTS; KNIT TOPS; PANTS; SUITS; SWEATERS; T-SHIRTS; TROUSERS; VESTS (U.S. CLS. 22 AND 39).

FIRST USE 9-28-2010; IN COMMERCE 9-28-2010.
PAULA MAHONEY, EXAMINING ATTORNEY

SN 85-233,828. TAHITI BEACHCOMBER, S.A., TAHITI, FRENCH POLYNESIA, FILED 2-3-2011.

TETIAROA

THE MARK CONSISTS OF STANDARD CHARACTERS WITHOUT CLAIM TO ANY PARTICULAR FONT, STYLE, SIZE, OR COLOR.

FOR CLOTHING, NAMELY, TOPS, BOTTOMS, NECKWEAR, UNDERWEAR, SLEEPWEAR, SOCKS, GLOVES, KIMONOS, AND OUTERWEAR, NAMELY, SWEATSHIRTS, JACKETS, SWEATERS, COATS, AND PARKAS; HEADWEAR; ROBES; AND SLIPPERS (U.S. CLS. 22 AND 39).

THEODORE MCBRIDE, EXAMINING ATTORNEY

CLASS 25—(Continued).

SN 85-234,553. DENISE M TAMS, CLEARFIELD, UT. FILED 2-4-2011.



THE MARK CONSISTS OF THE STYLIZED WORDING "DT RIDER". BOTH "R" LETTERS HAVE A TOP SWIRL LINE COMING OFF THE LETTERS-WITH THE FIRST LETTER "R" GRAPHIC GLIDING INTO THE FIRST LETTER "D". THE "D" LETTERS, THE "I" LETTER AND THE "T" LETTER ALL HAVE DROPPED DESIGN GRAPHICS THAT REPRESENT DRIPPING AND SPLATTERED LIQUIDS. ALL LETTERS HAVE SPLATTER GRAPHICS IN EACH LETTER.

FOR BASEBALL CAPS AND HATS; CAMOUFLAGE PANTS; CAPRI PANTS; CARGO PANTS; DENIMS; DRESS PANTS; GOLF PANTS, SHIRTS AND SKIRTS; GYM PANTS; HAT BANDS; HATS; HATS FOR INFANTS, BABIES, TODDLERS AND CHILDREN; HUNTING PANTS; JOGGING PANTS; LOUNGE PANTS; PARTY HATS; RAIN HATS; SHORT-SLEEVED OR LONG-SLEEVED T-SHIRTS; SLEEP PANTS; SMALL HATS; SNOW PANTS; SNOWBOARD PANTS; SPORTS CAPS AND HATS; SPORTS PANTS; SWEAT PANTS; T-SHIRTS; WOMEN'S HATS AND HOODS; WOOLLY HATS; YOGA PANTS (U.S. CLS. 22 AND 39).

JENNIFER VASQUEZ, EXAMINING ATTORNEY

SN 85-236,126. MOVE ON - COMPONENTES E CALÇADO, SA, ESMORIZ, PORTUGAL, FILED 2-7-2011.

MOVE ON

THE MARK CONSISTS OF STANDARD CHARACTERS WITHOUT CLAIM TO ANY PARTICULAR FONT, STYLE, SIZE, OR COLOR.

FOR CLOTHING, NAMELY, SHIRTS, PANTS, JACKETS, FOOTWEAR AND HEADWEAR (U.S. CLS. 22 AND 39).

RONALD MCMORROW, EXAMINING ATTORNEY

CLASS 25—(Continued).

SN 85-236,591. GLOBAL CONCEPTS LIMITED, INC., DBA GLOBAL TV CONCEPTS, LTD., DEERFIELD BEACH, FL. FILED 2-8-2011.

EZ SLIMMERZ

THE MARK CONSISTS OF STANDARD CHARACTERS WITHOUT CLAIM TO ANY PARTICULAR FONT, STYLE, SIZE, OR COLOR.

FOR CLOTHING, NAMELY, GARMENTS IN THE NATURE OF UNDERGARMENTS, UNDERWEAR, PANTS, SHORTS, TIGHTS, SHAPEWEAR, NAMELY, GIRDLES, LEOTARDS, LEGGINGS AND TIGHT-FITTING FOUNDATION GARMENTS, AND PANTYHOSE; CLOTHING, NAMELY, GARMENTS IN THE NATURE OF UNDERGARMENTS, UNDERWEAR, PANTS, SHORTS, TIGHTS, SHAPEWEAR, NAMELY, GIRDLES, LEOTARDS, LEGGINGS AND TIGHT-FITTING FOUNDATION GARMENTS, AND PANTYHOSE FOR IMPROVING THE TONE AND FIRMNESS OF SKIN AND FOR CELLULITE CONTROL; CLOTHING, NAMELY, GARMENTS IN THE NATURE OF UNDERGARMENTS, UNDERWEAR, PANTS, SHORTS, TIGHTS, SHAPEWEAR, NAMELY, GIRDLES, LEOTARDS, LEGGINGS AND TIGHT-FITTING FOUNDATION GARMENTS, AND PANTYHOSE CONTAINING TIME RELEASED MICRO CAPSULES THAT BREAK OPEN AS THEY ARE WORN FOR MOISTURIZING AND SMOOTHING THE LOOK OF SKIN (U.S. CLS. 22 AND 39).

FIRST USE 5-1-2010; IN COMMERCE 5-1-2010.
MARLENE BELL, EXAMINING ATTORNEY

SN 85-237,302. ADIACIAS APPAREL, LLC, SCOTTSDALE, AZ. FILED 2-8-2011.

Mary Jane Smokewear

THE MARK CONSISTS OF STANDARD CHARACTERS WITHOUT CLAIM TO ANY PARTICULAR FONT, STYLE, SIZE, OR COLOR.

THE NAME(S), PORTRAIT(S), AND/OR SIGNATURE(S) SHOWN IN THE MARK DOES NOT IDENTIFY A PARTICULAR LIVING INDIVIDUAL.

FOR BASEBALL CAPS; HOODED SWEATSHIRTS; SWEATSHIRTS; T-SHIRTS (U.S. CLS. 22 AND 39).

FIRST USE 9-1-2009; IN COMMERCE 9-1-2009.
NAAKWAMA ANKRAH, EXAMINING ATTORNEY

CLASS 25—(Continued).

SN 85-237,439. STABINSCH, SUSAN, PEMBROKE, MA. FILED 2-9-2011.

SALONJACKETSBY SUSAN

THE MARK CONSISTS OF STANDARD CHARACTERS WITHOUT CLAIM TO ANY PARTICULAR FONT, STYLE, SIZE, OR COLOR.

THE NAME(S), PORTRAIT(S), AND/OR SIGNATURE(S) SHOWN IN THE MARK IDENTIFIES "SUSAN", WHOSE CONSENT(S) TO REGISTER IS MADE OF RECORD.

FOR SALON UNIFORMS (U.S. CLS. 22 AND 39).
GISELLE AGOSTO, EXAMINING ATTORNEY

SN 85-239,510. ACTIVISION PUBLISHING, INC., SANTA MONICA, DE. FILED 2-10-2011.

SKYLANDERS SPYRO'S ADVENTURE

THE MARK CONSISTS OF STANDARD CHARACTERS WITHOUT CLAIM TO ANY PARTICULAR FONT, STYLE, SIZE, OR COLOR.

OWNER OF U.S. REG. NOS. 2,997,313, 3,704,341 AND OTHERS.

FOR CLOTHING, NAMELY, BASEBALL CAPS, HATS, BEANIES, PAJAMAS, SLEEP PANTS, T-SHIRTS, WRIST BANDS, SOCKS, BATHROBES, SLIPPERS, SWIMWEAR, SWEAT SHIRTS, JACKETS, PANTS, SHIRTS, UNDERWEAR, COSTUMES FOR USE IN CHILDREN'S DRESS UP PLAY, HALLOWEEN COSTUMES, SHOES (U.S. CLS. 22 AND 39).

DOMINICK J. SALEMI, EXAMINING ATTORNEY

SN 85-240,529. TWO LEFT FEET BRANDS, LLC, LOS ANGELES, CA. FILED 2-11-2011.

hook + ALBERT

THE MARK CONSISTS OF STANDARD CHARACTERS WITHOUT CLAIM TO ANY PARTICULAR FONT, STYLE, SIZE, OR COLOR.

THE NAME(S), PORTRAIT(S), AND/OR SIGNATURE(S) SHOWN IN THE MARK DOES NOT IDENTIFY A PARTICULAR LIVING INDIVIDUAL.

FOR HOSIERY; MEN'S DRESS SOCKS; MEN'S SOCKS; NECKTIES; POCKET KERCHIEFS; POCKET SQUARES; SOCKS; SOCKS AND STOCKINGS (U.S. CLS. 22 AND 39).

JULIE VEPPUMTHARA, EXAMINING ATTORNEY

CLASS 25—(Continued).

SN 85-240,798. THOMPSON, DENNIS K, DBA TRUCE & SANCTUARY GANG AND DRUG FREE KIDS & TEENS STOP BULLYING, LAUREL, MD. FILED 2-11-2011.

Truce &
Sanctuary
Gang and Drug
Free
Kids & Teens
Stop Bullying

THE MARK CONSISTS OF STANDARD CHARACTERS WITHOUT CLAIM TO ANY PARTICULAR FONT, STYLE, SIZE, OR COLOR.

FOR ATHLETIC APPAREL, NAMELY, SHIRTS, PANTS, JACKETS, FOOTWEAR, HATS AND CAPS, ATHLETIC UNIFORMS (U.S. CLS. 22 AND 39).
GINA HAYES, EXAMINING ATTORNEY

SN 85-242,319. RENAISSANCE IMPORTS, INC, MATTHEWS, NC. FILED 2-15-2011.



NO CLAIM IS MADE TO THE EXCLUSIVE RIGHT TO USE "RIDING", APART FROM THE MARK AS SHOWN.

THE MARK CONSISTS OF A STYLIZED HORSE UNDERSCORED WITH A BROKEN HORIZONTAL LINE, WHICH IS UNDERSCORED BY THE PHRASE "THE RIDING CLUB"; THE BROKEN LINE COMPRISING A CIRCULAR BULLET AND LINEAR HORIZONTAL SEGMENTS ON EITHER SIDE OF THE BULLET.

FOR FOOTWEAR (U.S. CLS. 22 AND 39).
ELLEN B. AWRICH, EXAMINING ATTORNEY

SN 85-242,590. FME JEANS, LLC, LOS ANGELES, CA. FILED 2-15-2011.

FME

THE MARK CONSISTS OF STANDARD CHARACTERS WITHOUT CLAIM TO ANY PARTICULAR FONT, STYLE, SIZE, OR COLOR.

FOR APPAREL, NAMELY, JEANS, PANTS, SHORTS, SKIRTS, SHIRTS, CAMISOLES, UNDERGARMENTS (U.S. CLS. 22 AND 39).

TAMARA FRAZIER, EXAMINING ATTORNEY

CLASS 25—(Continued).

SN 85-242,978. HLADKY, JEFFREY, WALLINGFORD, CT. FILED 2-15-2011.



EVEREST ISLES
EVEREST ISLES

THE MARK CONSISTS OF A LOGO DEPICTING MOUNT EVEREST WITH A REFLECTIVE MIRROR IMAGE BELOW IT AS TO SYMBOLIZE IT BEING SURROUNDED BY WATER WITH THE WORDS "EVEREST ISLES" FACING EACH OTHER.

FOR BATHING SUITS (U.S. CLS. 22 AND 39).
CHARLES L. JENKINS, EXAMINING ATTORNEY

SN 85-243,614. KOPS, STEVEN, WEST ORANGE, NJ. FILED 2-16-2011.

TENET

THE MARK CONSISTS OF STANDARD CHARACTERS WITHOUT CLAIM TO ANY PARTICULAR FONT, STYLE, SIZE, OR COLOR.

FOR ATHLETIC APPAREL, NAMELY, SHIRTS, PANTS, JACKETS, FOOTWEAR, HATS AND CAPS, ATHLETIC UNIFORMS (U.S. CLS. 22 AND 39).

FLORENTINA BLANDU, EXAMINING ATTORNEY

SN 85-244,779. SUE LONDON INCORPORATED, NEW YORK, NY. FILED 2-17-2011.

Sue Londonuit

THE MARK CONSISTS OF STANDARD CHARACTERS WITHOUT CLAIM TO ANY PARTICULAR FONT, STYLE, SIZE, OR COLOR.

OWNER OF U.S. REG. NOS. 3,250,349 AND 3,300,029.
THE NAME "SUE LONDONUIT" DOES NOT IDENTIFY A LIVING INDIVIDUAL.

FOR FOOTWEAR; LEATHER SLIPPERS; SLIPPERS (U.S. CLS. 22 AND 39).

FIRST USE 4-3-2008; IN COMMERCE 4-3-2008.
AMY KERTGATE, EXAMINING ATTORNEY

CLASS 25—(Continued).

SN 85-244,846. GUMZ FARMS, LLC, MORGANFIELD, KY. FILED 2-17-2011.



NO CLAIM IS MADE TO THE EXCLUSIVE RIGHT TO USE "WEAR", APART FROM THE MARK AS SHOWN.

THE COLOR(S) BROWN AND GRAY IS/ARE CLAIMED AS A FEATURE OF THE MARK.

THE MARK CONSISTS OF THE STYLIZED WORDS "STUD WEAR" IN BROWN, UNDERLINED WITH BROWN DOTS AND ON EITHER SIDE THERE ARE TWO GRAY HORSESHOES WITH BROWN DOTS. THE LETTER "U" IN THE TERM "STUD" FEATURES A BROWN HORSESHOE WITH DOTS.

FOR HATS; JACKETS; SWEATSHIRTS; T-SHIRTS; VESTS (U.S. CLS. 22 AND 39).

FLORENTINA BLANDU, EXAMINING ATTORNEY

SN 85-245,175. BREEDING, JUDY K, MONROE, VA. FILED 2-17-2011.



THE MARK CONSISTS OF A MONKEY SITTING WITH HIS BACK FACING, AND THE WORDS "BELLY MONKEY" DOWN THE TAIL.

FOR T-SHIRTS FOR WOMEN, BABIES, AND CHILDREN (U.S. CLS. 22 AND 39).

FIRST USE 11-25-2010; IN COMMERCE 1-15-2011.

FONG HSU, EXAMINING ATTORNEY

CLASS 25—(Continued).

SN 85-245,609. HOLMES, LUEMISHER, BROOKLYN, NY. FILED 2-18-2011.

TTRINITY COUTURE

THE MARK CONSISTS OF STANDARD CHARACTERS WITHOUT CLAIM TO ANY PARTICULAR FONT, STYLE, SIZE, OR COLOR.

NO CLAIM IS MADE TO THE EXCLUSIVE RIGHT TO USE "COUTURE", APART FROM THE MARK AS SHOWN.

FOR CLOTHING, NAMELY, TOPS, BOTTOMS, BERMUDA SHORTS; BLOUSES; BODY SHIRTS; BOMBER JACKETS; BUTTON-FRONT ALOHA SHIRTS; CAMOUFLAGE JACKETS; CAMOUFLAGE PANTS; CAPRI PANTS; CARGO PANTS; DENIM JACKETS; DENIMS; DRESS SHIRTS; DRESS SUITS; FUR COATS AND JACKETS; FUR HATS; FUR JACKETS; HAT BANDS; HATS; HEAVY JACKETS; JACKET LINERS; JACKETS; JEANS; JOGGING PANTS; JOGGING SUITS; LADIES' SUITS; LEATHER JACKETS; LEATHER PANTS; LEISURE SUITS; LONG JACKETS; LONG-SLEEVED SHIRTS; MEN'S SUITS; MEN'S SUITS, WOMEN'S SUITS; OPEN-NECKED SHIRTS; OVER SHIRTS; PANTS; POLO SHIRTS; RUGBY SHIRTS; RUGBY SHORTS; SHIRT FRONTS; SHIRT YOKES; SHIRTS; SHORT-SLEEVED SHIRTS; SHIRTS FOR SUITS; SHORT SETS; SHORT TROUSERS; SHORT-SLEEVED OR LONG-SLEEVED T-SHIRTS; SHORT-SLEEVED SHIRTS; SHORTS; SKIRT SUITS; SKIRTS; DRESSES; SLEEVED OR SLEEVELESS JACKETS; SMALL HATS; STRETCH PANTS; SUEDE JACKETS; SUIT COATS; SUITS; SWEAT JACKETS; SWEAT PANTS; SWEAT SHORTS; SWEAT SUITS; T-SHIRTS; TRACK PANTS; TRACK SUITS; VESTED SUITS; WARM UP SUITS; WIND PANTS; WOMEN'S HATS AND HOODS, SHOES, BOOTS, SNEAKERS, SANDALS (U.S. CLS. 22 AND 39).

MARLENE BELL, EXAMINING ATTORNEY

SN 85-245,878. MATTEO GOTTARDI, NEW YORK, NY. FILED 2-18-2011.

WRK

THE MARK CONSISTS OF STANDARD CHARACTERS WITHOUT CLAIM TO ANY PARTICULAR FONT, STYLE, SIZE, OR COLOR.

OWNER OF U.S. REG. NO. 3,950,254.

FOR MEN'S AND WOMEN'S CLOTHING, NAMELY, COATS, JACKETS, BLAZERS, PANTS, SKIRTS, DRESSES, T-SHIRTS, SWEATSHIRTS, SWEATERS, BELTS, UNDERWEAR; HEADWEAR, NAMELY, HATS AND CAPS (U.S. CLS. 22 AND 39).

ROBERT C. CLARK JR., EXAMINING ATTORNEY

CLASS 25—(Continued).

SN 85-245,964. FABCO INTERNATIONAL INC, LA JOLLA, CA. FILED 2-18-2011.

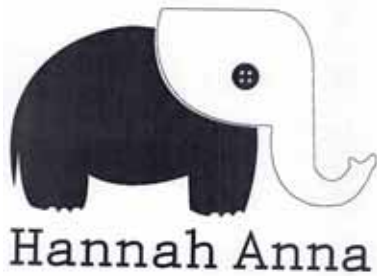

THE NAME(S), PORTRAIT(S), AND/OR SIGNATURE(S) SHOWN IN THE MARK DOES NOT IDENTIFY A PARTICULAR LIVING INDIVIDUAL.

THE MARK CONSISTS OF AN ELEPHANT ABOVE THE TEXT "HANNAH ANNA", AND THE EYE OF THE ELEPHANT IS A BUTTON.

FOR CLOTHING, NAMELY, FOOTWEAR, HEADBANDS, APRONS, CAPES, SHOES, BOOTS, T-SHIRTS, JEANS, SWEATERS, UNDERWEAR, HATS, CAPS, BEANIES, BELTS, TUTUS, CLOTH BIBS, AND PLASTIC BABY BIB (U.S. CLS. 22 AND 39).

FIRST USE 6-1-2006; IN COMMERCE 7-15-2006.
BARNEY CHARLON, EXAMINING ATTORNEY

SN 85-246,026. CLASSIC KNITS, INC., IRVINE, CA. FILED 2-18-2011.

Jolie & Grace

THE MARK CONSISTS OF STANDARD CHARACTERS WITHOUT CLAIM TO ANY PARTICULAR FONT, STYLE, SIZE, OR COLOR.

FOR CLOTHING FOR MEN, WOMEN AND CHILDREN, NAMELY, BLOUSES, SWEATERS, CARDIGANS, JACKETS, COATS, VESTS, SKIRTS, PANTS, SHIRTS, TOPS, SHELLS, DRESSES, GOWNS, SHAWLS, NECKWEAR, MANTLES, OVERCOATS, SHORTS, MUFFLERS, PONCHOS, BOMBER JACKETS, SHRUGS, STOLEES, CAPES, SCARVES, WRAPS, PASHMINAS, CLOAKS, WEARABLE BLANKETS IN THE NATURE OF BLANKETS WITH SLEEVES, LEGGINGS, BELTS, HATS AND GLOVES (U.S. CLS. 22 AND 39).

TINA L. SNAPP, EXAMINING ATTORNEY

CLASS 25—(Continued).

SN 85-246,042. PATTERSON BRUCE A, DBA CAMEO COLLECTIONS, EATON, IN. FILED 2-18-2011.

Cameo Lingerie

THE MARK CONSISTS OF STANDARD CHARACTERS WITHOUT CLAIM TO ANY PARTICULAR FONT, STYLE, SIZE, OR COLOR.

NO CLAIM IS MADE TO THE EXCLUSIVE RIGHT TO USE "LINGERIE", APART FROM THE MARK AS SHOWN, FOR LINGERIE (U.S. CLS. 22 AND 39).

FIRST USE 6-1-1995; IN COMMERCE 6-1-1995.
ALICIA COLLINS, EXAMINING ATTORNEY

SN 85-246,496. CONTRERAS, JESSE, MERCEDES, TX. FILED 2-18-2011.

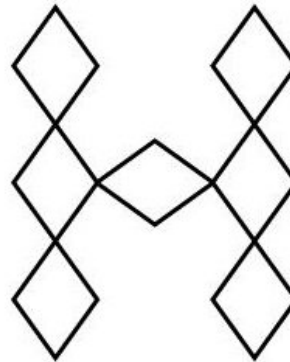

THE MARK CONSISTS OF A STYLIZED "H" COMPRISED OF SEVEN DIAMOND SHAPES.

FOR MEN'S, WOMEN'S, CHILDREN'S AND BABIES' CLOTHING, NAMELY, CAPS, HATS, VISORS, BEANIES, SHIRTS, T-SHIRTS, COATS, FABRIC BELTS, LEATHER BELTS, FLEECE PULLOVERS, SWEATERS, JACKETS, JEANS, PANTS, TROUSERS, OVERALLS, JERSEYS, SWEAT PANTS, SWEATSHIRTS, TANK TOPS, SHORTS, SWIM SUITS, TRUNKS, BANDANAS, SHOES, SANDALS, FOOTWEAR, THERMAL UNDERWEAR, UNDERWEAR, BRAS, SOCKS, NIGHT GOWNS, PAJAMAS, PANTIES, BATHROBES, CAPRI PANTS, YOGA PANTS, DRESSES, SKIRTS, BLOUSES, SCARVES, POLO SHIRTS, SPORTS BRAS, LEOTARDS, TIGHTS, LEGGINGS, BRIEFS, BOXER SHORTS, GLOVES, PONCHOS, VESTS, JUMP SUITS, RAIN COATS, WIND SHIRTS, TURTLENECKS, SWEATBANDS, WRISTBANDS, SNEAKERS, BIBS NOT OF PAPER, SNAP CROTCH T-SHIRTS, ROMPERS (U.S. CLS. 22 AND 39).

FIRST USE 2-7-2011; IN COMMERCE 2-7-2011.
JAY BESCH, EXAMINING ATTORNEY

CLASS 25—(Continued).

SN 85-246,738. MOTHER LLC, LOS ANGELES, CA. FILED 2-18-2011.

CLASS 25—(Continued).

SN 85-247,029. DIETMAR SZYMENDERA, VENLO, NETHERLANDS, FILED 2-20-2011.

MOTHER DENIM WERKS

THE MARK CONSISTS OF STANDARD CHARACTERS WITHOUT CLAIM TO ANY PARTICULAR FONT, STYLE, SIZE, OR COLOR.

NO CLAIM IS MADE TO THE EXCLUSIVE RIGHT TO USE "DENIM", APART FROM THE MARK AS SHOWN.

FOR CLOTHING MADE OF DENIM, NAMELY, TOPS, BOTTOMS, PANTS, JEANS, SHIRTS, T-SHIRTS, SWEAT-SHIRTS, SHORTS, DRESSES, SKIRTS, BLOUSES, HATS, JACKETS, COATS AND FOOTWEAR (U.S. CLS. 22 AND 39).

PATRICIA EVANKO, EXAMINING ATTORNEY

Certified Gangster

SN 85-246,789. DEATHTOUCH INC., ROGUE RIVER, OR. FILED 2-18-2011.

Deathtouch Inc.

THE MARK CONSISTS OF STANDARD CHARACTERS WITHOUT CLAIM TO ANY PARTICULAR FONT, STYLE, SIZE, OR COLOR.

NO CLAIM IS MADE TO THE EXCLUSIVE RIGHT TO USE "INC.", APART FROM THE MARK AS SHOWN.

FOR (BASED ON USE IN COMMERCE) T-SHIRTS; TOPS(BASED ON INTENT TO USE) ATHLETIC APPAREL, NAMELY, SHIRTS, PANTS, JACKETS, FOOTWEAR, HATS AND CAPS, ATHLETIC UNIFORMS; ATHLETIC SHOES; BALLOON PANTS; BANDANAS; BELTS FOR CLOTHING; BOXER SHORTS; BOXING SHORTS; CAMOUFLAGE PANTS; CAPRI PANTS; CARGO PANTS; CLOTHING FOR ATHLETIC USE, NAMELY, PADDED PANTS; CLOTHING FOR ATHLETIC USE, NAMELY, PADDED SHIRTS; CLOTHING FOR ATHLETIC USE, NAMELY, PADDED SHORTS; CLOTHING FOR WEAR IN JUDO PRACTICES; CLOTHING FOR WEAR IN WRESTLING GAMES; GLOVES AS CLOTHING; GYM PANTS; GYM SHORTS; HATS; HEADBANDS FOR CLOTHING; HOODS; JACKETS; JERSEYS; JOGGING PANTS; LOUNGE PANTS; PANTS; SANDALS AND BEACH SHOES; SCARVES; SOCKS AND STOCKINGS; SWEAT PANTS; TRACK PANTS; WATERPROOF JACKETS AND PANTS; WEARABLE GARMENTS AND CLOTHING, NAMELY, SHIRTS; WOMEN'S CLOTHING, NAMELY, SHIRTS, DRESSES, SKIRTS, BLOUSES; WRIST BANDS (U.S. CLS. 22 AND 39).

FIRST USE 12-27-2010; IN COMMERCE 12-27-2010.
MICHAEL TANNER, EXAMINING ATTORNEY

THE MARK CONSISTS OF STANDARD CHARACTERS WITHOUT CLAIM TO ANY PARTICULAR FONT, STYLE, SIZE, OR COLOR.

PRIORITY CLAIMED UNDER SEC. 44(D) ON FED REP GERMANY APPLICATION NO. 302011002851, FILED 1-19-2011.

FOR (BASED ON USE IN COMMERCE) ATHLETIC APPAREL, NAMELY, SHIRTS, PANTS, JACKETS, FOOTWEAR, HATS AND CAPS, ATHLETIC UNIFORMS; CHILDREN'S AND INFANT'S APPAREL, NAMELY, JUMPERS, OVERALL SLEEPWEAR, PAJAMAS, ROMPERS AND ONE-PIECE GARMENTS; COATS FOR MEN AND WOMEN; DISPOSABLE UNDERWEAR; EYESHADES; FOOTWEAR; FOOTWEAR FOR MEN; FOOTWEAR FOR MEN AND WOMEN; HATS; HEADWEAR; JACKETS; MEN'S AND WOMEN'S JACKETS, COATS, TROUSERS, VESTS; MEN'S SUITS, WOMEN'S SUITS; PANTS; SHIRTS; SHOES; SWEAT SHIRTS; T-SHIRTS; UNDERWEAR; WOMEN'S CLOTHING, NAMELY, SHIRTS, DRESSES, SKIRTS, BLOUSES (BASED ON 44(D) PRIORITY APPLICATION) ATHLETIC APPAREL, NAMELY, SHIRTS, PANTS, JACKETS, FOOTWEAR, HATS AND CAPS, ATHLETIC UNIFORMS; CHILDREN'S AND INFANT'S APPAREL, NAMELY, JUMPERS, OVERALL SLEEPWEAR, PAJAMAS, ROMPERS AND ONE-PIECE GARMENTS; COATS FOR MEN AND WOMEN; DISPOSABLE UNDERWEAR; EYESHADES; FOOTWEAR; FOOTWEAR FOR MEN; FOOTWEAR FOR MEN AND WOMEN; HATS; HEADWEAR; JACKETS; MEN'S AND WOMEN'S JACKETS, COATS, TROUSERS, VESTS; MEN'S SUITS, WOMEN'S SUITS; PANTS; SHIRTS; SHOES; SWEAT SHIRTS; T-SHIRTS; UNDERWEAR; WOMEN'S CLOTHING, NAMELY, SHIRTS, DRESSES, SKIRTS, BLOUSES (U.S. CLS. 22 AND 39).

FIRST USE 0-0-2006; IN COMMERCE 0-0-2010.
TINA L. SNAPP, EXAMINING ATTORNEY

CLASS 25—(Continued).

SN 85-247,087. ESSA, IBRAHIM M, CHERRY HILL, NJ. FILED 2-20-2011.

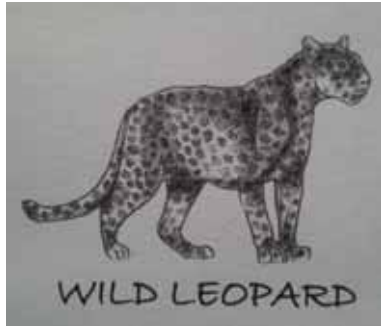

THE STIPPLING IS FOR SHADING PURPOSES. THE MARK CONSISTS OF A GRAPHIC OF A SPOTTED LEOPARD STANDING WITH ITS TAIL IN A LOW POSITION. THE WORDING "WILD LEOPARD" IS LOCATED UNDERNEATH THE ANIMAL. THE RECTANGULAR SHAPE OF THE BACKGROUND IS NOT CLAIMED AS A FEATURE OF THE MARK.

FOR BERMUDA SHORTS; BIB SHORTS; BOARD SHORTS; BOXER SHORTS; BOXING SHORTS; CAPRI PANTS; CARGO PANTS; CYCLING SHORTS; DENIM JACKETS; DENIMS; DOWN JACKETS; DRESS PANTS; FISHERMEN'S JACKETS; FISHING SHIRTS; FLEECE SHORTS; GOLF PANTS, SHIRTS AND SKIRTS; GOLF SHIRTS; GOLF SHORTS; GYM PANTS; GYM SHORTS; HEADBANDS AGAINST SWEATING; HEAVY JACKETS; HOODED SWEAT SHIRTS; JACKET LINERS; JACKETS; JACKETS AND SOCKS; JOGGING PANTS; KNIT JACKETS; KNIT SHIRTS; LEATHER JACKETS; LEATHER PANTS; LEATHER SHIRTS; LIGHT-REFLECTING JACKETS; LONG JACKETS; LONG-SLEEVED SHIRTS; MEN'S AND WOMEN'S JACKETS, COATS, TROUSERS, VESTS; MOISTURE-WICKING SPORTS SHIRTS; MOTORCYCLE JACKETS; NIGHT SHIRTS; OPEN-NECKED SHIRTS; OUTER JACKETS; OVER SHIRTS; PADDED JACKETS; PADDING JACKETS; PANTIES, SHORTS AND BRIEFS; PANTS; POLO SHIRTS; RAIN JACKETS; RAINPROOF JACKETS; REVERSIBLE JACKETS; SHIRT FRONTS; SHIRTS AND SHORT-SLEEVED SHIRTS; SHIRTS FOR INFANTS, BABIES, TODDLERS AND CHILDREN; SHIRTS FOR SUITS; SHORT-SLEEVED OR LONG-SLEEVED T-SHIRTS; SHORT-SLEEVED SHIRTS; SHORTS; SLEEP PANTS; SLEEP SHIRTS; SLEEVED OR SLEEVELESS JACKETS; SNOW PANTS; SNOWBOARD JACKETS; SNOWBOARD PANTS; SPORT SHIRTS; SPORTS JACKETS; SPORTS PANTS; SPORTS SHIRTS; SPORTS SHIRTS WITH SHORT SLEEVES; STRETCH PANTS; SUEDE JACKETS; SWEAT BANDS; SWEAT JACKETS; SWEAT PANTS; SWEAT SHIRTS; SWEAT SHORTS; SWEAT SUITS; T-SHIRTS; TEE SHIRTS; TRACK JACKETS; TRACK PANTS; TURTLE NECK SHIRTS; WALKING SHORTS; WATERPROOF JACKETS AND PANTS; WIND PANTS; WIND RESISTANT JACKETS; WIND-JACKETS (U.S. CLS. 22 AND 39).

FIRST USE 2-18-2011; IN COMMERCE 2-19-2011.
ALYSSA STEEL, EXAMINING ATTORNEY

CLASS 25—(Continued).

SN 85-247,760. WILLIAM VEASY, LOS ANGELES, CA. FILED 2-21-2011.



NO CLAIM IS MADE TO THE EXCLUSIVE RIGHT TO USE A PICTORIAL REPRESENTATION OF A FOOTBALL HELMET, APART FROM THE MARK AS SHOWN.

THE MARK CONSISTS OF THE LETTER "V" AND THE LETTER "Z" ARE STYLIZED AND RELATED INTO ONE; THE BOTTOM OF THE LETTER "Z" ANGLES DOWN AND IS ELONGATED; THE TERM "DOME" IS WRITTEN ON THE FRONT OF THE LETTER "Z" BOTTOM; A STYLIZED HELMET IS PARTIALLY COVERING THE LETTER "Z".

FOR CLOTHING, NAMELY, T-SHIRTS AND HATS (U.S. CLS. 22 AND 39).

KAPIL BHANOT, EXAMINING ATTORNEY

SN 85-248,040. RESTIVO, ANTHONY E, LISBON, CT. FILED 2-22-2011.



NO CLAIM IS MADE TO THE EXCLUSIVE RIGHT TO USE "CREATIONS", APART FROM THE MARK AS SHOWN.

THE COLOR(S) BLUE, RED, AND YELLOW IS/ARE CLAIMED AS A FEATURE OF THE MARK.

THE MARK CONSISTS OF A FIRST BLOCK "C" IN BLUE AND THE SCRIPT "OLOR" IS IN RED AND IS DIRECTLY AFTER THE "C". THE BLOCK "B" IN THE MIDDLE IS YELLOW AND THE SCRIPT "LIND" IS BLUE AND WITHIN THE LOWER HALF OF THE BLOCK LETTER "B". THE SECOND BLOCK "O" IS BACKWARDS AND IN RED, FOLLOWING THE SCRIPT "REATIONS", WHICH IS WRITTEN IN YELLOW.

FOR HATS; HOODED SWEATSHIRTS; JACKETS; MEN'S SOCKS; POLO SHIRTS; SOCKS; SWEATSHIRTS; T-SHIRTS; WOMEN'S UNDERWEAR (U.S. CLS. 22 AND 39).

MARGERY A. TIERNEY, EXAMINING ATTORNEY

CLASS 25—(Continued).

SN 85-248,232. KLEIN, MARK, HENRY, IL. FILED 2-22-2011.



THE MARK CONSISTS OF THE STYLIZED WORDING "DERBYTEES.COM" WITHIN A ROUND-EDGED RECTANGLE.

FOR CLOTHING, NAMELY, SHIRTS, T-SHIRTS, POLO SHIRTS, TOPS, TANK TOPS, VESTS, SWEATERS, SWEAT SHIRTS, HOODED SWEAT SHIRTS, JERSEYS, JACKETS, WIND RESISTANT JACKETS, WATER RESISTANT JACKETS, WIND RESISTANT PANTS, WARM-UP SUITS, PULLOVERS, COATS, SHORTS, PANTS, BELTS, WRISTBANDS, SOCKS, GLOVES, SCARVES, LEGGINGS; HEADWEAR, NAMELY, CAPS, HATS, VISORS, STOCKING CAPS, BEANIES AND HEADBANDS; FOOTWEAR; INFANT AND TODDLER CLOTHING, NAMELY, SHIRTS, HATS, SOCKS AND ONE PIECE GARMENTS (U.S. CLS. 22 AND 39).

FIRST USE 1-21-2003; IN COMMERCE 5-24-2003.
LAURA KOVALSKY, EXAMINING ATTORNEY

SN 85-248,244. ITS 90 PERCENT INC, CALABASAS, CA. FILED 2-22-2011.



THE MARK CONSISTS OF TWO CIRCLES ONE INSIDE THE OTHER WITH THE NUMBER "90" IN THE CENTER, BETWEEN THE CIRCLES AT THE TOP APPEARS THE STYLIZED WORD "PERCENT" AND AT THE BOTTOM THE STYLIZED WORD "MENTAL" AND ON THE LEFT AND RIGHT SIDES A SINGLE DOT.

FOR HATS; HEADBANDS; T-SHIRTS; VISORS; WRISTBANDS (U.S. CLS. 22 AND 39).
FIRST USE 11-26-2010; IN COMMERCE 11-26-2010.
JEFF DEFORD, EXAMINING ATTORNEY

CLASS 25—(Continued).

SN 85-248,912. TIFFAN, LAURIE, ROYERSFORD, PA. FILED 2-22-2011.

Umzie

THE MARK CONSISTS OF STANDARD CHARACTERS WITHOUT CLAIM TO ANY PARTICULAR FONT, STYLE, SIZE, OR COLOR.

THE NAME "UMZIE" DOES NOT IDENTIFY A LIVING INDIVIDUAL.

THE WORDING "UMZIE" HAS NO MEANING IN A FOREIGN LANGUAGE.

FOR RUBBER RING USED TO TIGHTEN SHIRTS AND BLOUSES TO OBTAIN A BETTER FIT, SPECIALLY DESIGNED FOR USE WITH SHIRTS AND BLOUSES (U.S. CLS. 22 AND 39).

JAMES MACFARLANE, EXAMINING ATTORNEY

SN 85-249,095. OMAR KURI CHAPUR, MERIDA, YUCATAN, MEXICO, FILED 2-23-2011.

THE PATH TO YOUR DREAMS

THE MARK CONSISTS OF STANDARD CHARACTERS WITHOUT CLAIM TO ANY PARTICULAR FONT, STYLE, SIZE, OR COLOR.

FOR SLEEP PANTS, TOPS, PANTS, T-SHIRTS, TUNICS; WOMEN'S TOPS, NAMELY, CAMIS; TANK TOPS, NIGHTGOWNS, GOWNS, WRAPS, DRESSES, LOUNGEWEAR, JACKETS, SHORTS, BOXER BRIEFS, BOXER SHORTS, LEGGINGS, ROBES, SKIRTS, SWEATERS, HOODED SWEATSHIRTS, BABY DOLL PAJAMAS, PAJAMAS, BRAS, PANTIES, BUSTIERS, HOSIERY, GARTER BELTS, CHEMISES, WAIST CINCHERS, SLIPPERS, BOOTIES, SANDALS, CAPS, HATS AND SCARVES (U.S. CLS. 22 AND 39).

DAVID COLLIER, EXAMINING ATTORNEY

SN 85-249,328. AC, LAS VEGAS, NV. FILED 2-23-2011.

Urban Layers

THE MARK CONSISTS OF STANDARD CHARACTERS WITHOUT CLAIM TO ANY PARTICULAR FONT, STYLE, SIZE, OR COLOR.

NO CLAIM IS MADE TO THE EXCLUSIVE RIGHT TO USE "URBAN", APART FROM THE MARK AS SHOWN.

FOR BELTS; HATS; HOODED SWEAT SHIRTS; JACKETS; PANTS; SHIRTS; SOCKS; T-SHIRTS (U.S. CLS. 22 AND 39).

JAMES GRIFFIN, EXAMINING ATTORNEY

CLASS 25—(Continued).

SN 85-249,374. RUBIE'S COSTUME CO., INC., RICHMOND HILL, NY. FILED 2-23-2011.

HEROS AND HOMBRES BY SECRET WISHES

THE MARK CONSISTS OF STANDARD CHARACTERS WITHOUT CLAIM TO ANY PARTICULAR FONT, STYLE, SIZE, OR COLOR.

OWNER OF U.S. REG. NOS. 3,107,884, 3,603,356 AND 3,603,361.

FOR HALLOWEEN COSTUMES AND MASKS SOLD IN CONNECTION THEREWITH; MASQUERADE COSTUMES AND MASKS SOLD IN CONNECTION THEREWITH (U.S. CLS. 22 AND 39).

JIM RINGLE, EXAMINING ATTORNEY

SN 85-249,825. LIFE LINE, NEW YORK, NY. FILED 2-23-2011.



NO CLAIM IS MADE TO THE EXCLUSIVE RIGHT TO USE "CLOTHING" AND "FASHION", APART FROM THE MARK AS SHOWN.

THE MARK CONSISTS OF THE WORDS "LIFE LINE" IN STYLIZED FONT CENTERED ABOVE THE STYLIZED WORD "CLOTHING". CENTERED BELOW THE WORD "CLOTHING" ARE THE WORDS "BRINGING FASHION BACK 2 LIFE" IN STYLIZED FONT. ABOVE THE DESCRIBED WORDS IS A DRAWING CONSISTING OF AN OUTLINED CIRCLE WITH A HORIZONTAL BISECTING LINE RESEMBLING ECG WAVE TRACING AND THE LETTERS "B.C." ON THE LEFT AND "A.D." ON THE RIGHT BOTH IN STYLIZED FONT.

FOR FOOTWEAR; HEADWEAR; JACKETS; PANTS; SHIRTS (U.S. CLS. 22 AND 39).

FIRST USE 12-28-2002; IN COMMERCE 12-28-2002.
SEAN CROWLEY, EXAMINING ATTORNEY

SN 85-249,873. LINDE, STACEY L., LAS VEGAS, NV. FILED 2-23-2011.

Teeny Wingkini

THE MARK CONSISTS OF STANDARD CHARACTERS WITHOUT CLAIM TO ANY PARTICULAR FONT, STYLE, SIZE, OR COLOR.

FOR CHILDREN'S SWIMWEAR FEATURING WATERPROOF WINGS AS AN ACCESSORY (U.S. CLS. 22 AND 39).

EMILY CHUO, EXAMINING ATTORNEY

CLASS 25—(Continued).

SN 85-250,059. LEG AVENUE, INC., CITY OF INUDSTRY, CA. FILED 2-23-2011.

ADVENTURELAND COSTUMES

THE MARK CONSISTS OF STANDARD CHARACTERS WITHOUT CLAIM TO ANY PARTICULAR FONT, STYLE, SIZE, OR COLOR.

NO CLAIM IS MADE TO THE EXCLUSIVE RIGHT TO USE "COSTUMES", APART FROM THE MARK AS SHOWN.

FOR HALLOWEEN COSTUMES AND MASKS SOLD IN CONNECTION THEREWITH (U.S. CLS. 22 AND 39).

LINDA POWELL, EXAMINING ATTORNEY

SN 85-250,090. JUANA'S INC., DBA JUANA'S PAGODAS AND SAILORS' GRILL, NAVARRE BEACH, FL. FILED 2-23-2011.

Juana's Pagodas and Sailor's Grill

THE MARK CONSISTS OF STANDARD CHARACTERS WITHOUT CLAIM TO ANY PARTICULAR FONT, STYLE, SIZE, OR COLOR.

NO CLAIM IS MADE TO THE EXCLUSIVE RIGHT TO USE "GRILL", APART FROM THE MARK AS SHOWN.

FOR SHORT-SLEEVED OR LONG-SLEEVED T-SHIRTS; T-SHIRTS; T-SHIRTS FOR RE-SALE (U.S. CLS. 22 AND 39).

FIRST USE 7-1-1989; IN COMMERCE 7-1-1989.

DOMINICK J. SALEMI, EXAMINING ATTORNEY

SN 85-250,218. NORMAN, HOLLEY, FONTANA, CA. FILED 2-24-2011.

SHOW UP!

THE MARK CONSISTS OF STANDARD CHARACTERS WITHOUT CLAIM TO ANY PARTICULAR FONT, STYLE, SIZE, OR COLOR.

FOR CLOTHING, NAMELY, TOPS, BOTTOMS, SHIRTS, TANK TOPS (U.S. CLS. 22 AND 39).

KARANENDRA S. CHHINA, EXAMINING ATTORNEY

CLASS 25—(Continued).

SN 85-250,361. HMB, LLC, SEATTLE, WA. FILED 2-24-2011.

HMB

THE MARK CONSISTS OF STANDARD CHARACTERS WITHOUT CLAIM TO ANY PARTICULAR FONT, STYLE, SIZE, OR COLOR.

FOR MEN'S, WOMEN'S AND CHILDREN'S APPAREL, NAMELY, TOPS, BOTTOMS, SPORTSWEAR, NAMELY, COLLARED SHIRTS, T-SHIRTS, POLO SHIRTS, HOODED SWEATSHIRTS, VESTS, SLACKS, SHORTS, AND ROMPERS, ACTIVEWEAR, NAMELY, T-SHIRTS, SWEAT SHIRTS, POLO SHIRTS, TANK TOPS, SPORT BRAS, HOODED SWEATSHIRTS, SWEAT PANTS, SWEAT SHORTS, COMPRESSION SHORTS, TURTLE AND MOCK TURTLE-NECK SHIRTS, AND ROMPERS, OUTERWEAR, NAMELY, JACKETS, VESTS, AND HOODED SWEATSHIRTS, UNDERWEAR, AEROBIC-WEAR, NAMELY, T-SHIRTS, TANK TOPS, SPORTS BRAS, SHORTS, PANTS, LEGGINGS, AND LEOTARDS, AND UNIFORMS (U.S. CLS. 22 AND 39).
BRIAN CALLAGHAN, EXAMINING ATTORNEY

SN 85-250,402. HMB, LLC, SEATTLE, WA. FILED 2-24-2011.



THE MARK CONSISTS OF A DESIGN INCLUDING THE STYLIZED LETTERS "H", "M", "B" POSITIONED IN A BOTTLE.

FOR MEN'S, WOMEN'S AND CHILDREN'S APPAREL, NAMELY, TOPS, BOTTOMS, SPORTSWEAR, NAMELY, COLLARED SHIRTS, T-SHIRTS, POLO SHIRTS, HOODED SWEATSHIRTS, VESTS, SLACKS, SHORTS, AND ROMPERS, ACTIVEWEAR, NAMELY, T-SHIRTS, SWEAT SHIRTS, POLO SHIRTS, TANK TOPS, SPORT BRAS, HOODED SWEATSHIRTS, SWEAT PANTS, SWEAT SHORTS, COMPRESSION SHORTS, TURTLE AND MOCK TURTLE-NECK SHIRTS, AND ROMPERS, OUTERWEAR, NAMELY, JACKETS, VESTS, AND HOODED SWEATSHIRTS, UNDERWEAR, AEROBIC-WEAR, NAMELY, T-SHIRTS, TANK TOPS, SPORTS BRAS, SHORTS, PANTS, LEGGINGS, AND LEOTARDS, AND UNIFORMS (U.S. CLS. 22 AND 39).
BRIAN CALLAGHAN, EXAMINING ATTORNEY

CLASS 25—(Continued).

SN 85-250,426. HMB, LLC, SEATTLE, WA. FILED 2-24-2011.

HOWMANYBOTTLES?

THE MARK CONSISTS OF STANDARD CHARACTERS WITHOUT CLAIM TO ANY PARTICULAR FONT, STYLE, SIZE, OR COLOR.

FOR MEN'S, WOMEN'S AND CHILDREN'S APPAREL, NAMELY, TOPS, BOTTOMS, SPORTSWEAR, NAMELY, COLLARED SHIRTS, T-SHIRTS, POLO SHIRTS, HOODED SWEATSHIRTS, VESTS, SLACKS, SHORTS, AND ROMPERS, ACTIVEWEAR, NAMELY, T-SHIRTS, SWEAT SHIRTS, POLO SHIRTS, TANK TOPS, SPORT BRAS, HOODED SWEATSHIRTS, SWEAT PANTS, SWEAT SHORTS, COMPRESSION SHORTS, TURTLE AND MOCK TURTLE-NECK SHIRTS, AND ROMPERS, OUTERWEAR, NAMELY, JACKETS, VESTS, AND HOODED SWEATSHIRTS, UNDERWEAR, AEROBIC-WEAR, NAMELY, T-SHIRTS, TANK TOPS, SPORTS BRAS, SHORTS, PANTS, LEGGINGS, AND LEOTARDS, AND UNIFORMS (U.S. CLS. 22 AND 39).
BRIAN CALLAGHAN, EXAMINING ATTORNEY

SN 85-250,512. PHILIP SCOTT, INC. DBA PHILIP B, INC., WESTLAKE VILLAGE, CA. FILED 2-24-2011.

THE WEATHERWITCH

THE MARK CONSISTS OF STANDARD CHARACTERS WITHOUT CLAIM TO ANY PARTICULAR FONT, STYLE, SIZE, OR COLOR.

FOR HOODS (U.S. CLS. 22 AND 39).
JILL PRATER, EXAMINING ATTORNEY

SN 85-250,637. ME TOO LLC, NEW YORK, NY. FILED 2-24-2011.

MTNY ME TOO NEW YORK

THE MARK CONSISTS OF STANDARD CHARACTERS WITHOUT CLAIM TO ANY PARTICULAR FONT, STYLE, SIZE, OR COLOR.

OWNER OF U.S. REG. NO. 3,757,658.
NO CLAIM IS MADE TO THE EXCLUSIVE RIGHT TO USE "NEW YORK", APART FROM THE MARK AS SHOWN.
FOR WOMEN'S AND CHILDREN'S FOOTWEAR (U.S. CLS. 22 AND 39).
FIRST USE 12-1-2005; IN COMMERCE 12-1-2005.
JASON BLAIR, EXAMINING ATTORNEY

CLASS 25—(Continued).

SN 85-250,954. CHRIS HUNTER ENTERPRISES, INC., DOUGLASVILLE, GA. FILED 2-24-2011.

REAL ATHLETES

THE MARK CONSISTS OF STANDARD CHARACTERS WITHOUT CLAIM TO ANY PARTICULAR FONT, STYLE, SIZE, OR COLOR.

NO CLAIM IS MADE TO THE EXCLUSIVE RIGHT TO USE "ATHLETES", APART FROM THE MARK AS SHOWN. FOR GYM SHORTS; HATS; HOODED SWEATSHIRTS; SHORT-SLEEVED OR LONG-SLEEVED T-SHIRTS; SHORTS; SWEATSHIRTS; T-SHIRTS (U.S. CLS. 22 AND 39).

TOBY BULLOFF, EXAMINING ATTORNEY

SN 85-251,400. LIVE 2 SHRED, LLC, ALLENDALE, NJ. FILED 2-25-2011.

Live To Shred

THE MARK CONSISTS OF STANDARD CHARACTERS WITHOUT CLAIM TO ANY PARTICULAR FONT, STYLE, SIZE, OR COLOR.

FOR ATHLETIC APPAREL, NAMELY, SHIRTS, PANTS, JACKETS, FOOTWEAR, HATS AND CAPS, ATHLETIC UNIFORMS; HOODED SWEAT SHIRTS; HOODED SWEATSHIRTS; HOODED SWEATSHIRTS FOR ACTION SPORTS; T-SHIRTS; T-SHIRTS FOR ACTION SPORTS (U.S. CLS. 22 AND 39).

ELLEN BURNS, EXAMINING ATTORNEY

CLASS 25—(Continued).

SN 85-251,466. COUNTER BALANCE CLOTHING, SAN RAMON, CA. FILED 2-25-2011.



THE MARK CONSISTS OF THE STYLIZED LETTERS "CB".

FOR ATHLETIC FOOTWEAR; ATHLETIC SHOES; ATHLETIC UNIFORMS; BANDANAS; BASEBALL CAPS; BASKETBALL SNEAKERS; BATH SLIPPERS; BATHING SUITS; BATHING TRUNKS; BATHROBES; BEACHWEAR; BEANIES; BELTS; BERETS; BERMUDA SHORTS; BLAZERS; BOOTS; BOTTOMS; BOW TIES; BOXER BRIEFS; BOXER SHORTS; CAMP SHIRTS; CAP VISORS; CAPS; CHEMISES; COATS; COATS OF DENIM; DENIM JACKETS; DENIMS; DO RAGS; DOWN JACKETS; DRESS SHIRTS; DRESS SUITS; DRESSES; DUNGAREES; FLEECE PULLOVERS; FLEECE SHORTS; FLIP FLOPS; FOOTWEAR; GLOVES; GOLF SHIRTS; GYM SHORTS; GYM SUITS; HALTER TOPS; HAT BANDS; HATS; HEAD SCARVES; HEAD SWEATBANDS; HEAD WEAR; HEADBANDS; HEAVY JACKETS; HOODS; INFANTWEAR; JACKETS; JEANS; JERSEYS; JOGGING OUTFITS; JUMPERS; JUMPSUITS; KNIT SHIRTS; KNITTED CAPS; LEATHER BELTS; LEATHER COATS; LEATHER HEADWEAR; LEATHER JACKETS; LIGHT-REFLECTING JACKETS; LINGERIE; LOUNGEWEAR; MEN'S AND WOMEN'S JACKETS, COATS, TROUSERS, VESTS; MITTENS; MOCK TURTLE-NECK SWEATERS; NECK BANDS; NECKWEAR; NIGHT SHIRTS; NIGHTWEAR; OPEN-NECKED SHIRTS; OVER COATS; PAJAMAS; PANTIES; PANTS; PARKAS; POLO SHIRTS; PULLOVERS; QUILTED VESTS; RAIN COATS; RAINWEAR; ROBES; SANDALS; SCARVES; SHAWLS; SHIRTS; SHIRTS; SHOES; SHORT-SLEEVED OR LONG-SLEEVED T-SHIRTS; SHORT-SLEEVED SHIRTS; SHORTS; SHRUGS; SKI WEAR; SKIRTS; SLACKS; SLEEPWEAR; SLIPPERS; SNEAKERS; SNOWBOARD BOOTS; SNOWBOARD GLOVES; SNOWBOARD PANTS; SOCKS; SPORT COATS; SPORT SHIRTS; SPORTS JACKETS; SPORTS SHIRTS; SPORTS SHIRTS WITH SHORT SLEEVES; STOLE; SUEDE JACKETS; SUITS; SURF WEAR; SUSPENDERS; SWEAT BANDS; SWEAT PANTS; SWEAT SHIRTS; SWEAT SHORTS; SWEAT SUITS; SWEATERS; SWIM WEAR; T-SHIRTS; TANK TOPS; THERMAL UNDERWEAR; TIES; TOP COATS; TOPS; TRAINING SUITS; TRUNKS; TURTLENECK SWEATERS; TURTLENECKS; UNDER GARMENTS; UNDERPANTS; UNDERSHIRTS; UNDERWEAR; VESTS; WARM UP SUITS; WATER-PROOF JACKETS AND PANTS; WIND RESISTANT JACKETS; WOOLLY HATS; WRAPS; WRISTBANDS (U.S. CLS. 22 AND 39).

FIRST USE 4-1-2008; IN COMMERCE 6-16-2008.

CIMMERIAN COLEMAN, EXAMINING ATTORNEY

CLASS 25—(Continued).

SN 85-251,714. FORTUNE DYNAMIC INC., CITY OF INDUSTRY, CA. FILED 2-25-2011.

HAPPY SODA

THE MARK CONSISTS OF STANDARD CHARACTERS WITHOUT CLAIM TO ANY PARTICULAR FONT, STYLE, SIZE, OR COLOR.

OWNER OF U.S. REG. NOS. 2,331,057, 2,931,439 AND 3,531,885.

FOR FOOTWEAR (U.S. CLS. 22 AND 39).

MATTHEW MCDOWELL, EXAMINING ATTORNEY

SN 85-251,744. FORTUNE DYNAMIC INC., CITY OF INDUSTRY, CA. FILED 2-25-2011.



OWNER OF U.S. REG. NOS. 2,331,057, 2,931,439 AND 3,531,885.

THE MARK CONSISTS OF THE WORD "SODA" INSIDE A PARTIAL OVAL LOOP DESIGN, AND THE WORD "HAPPY" POSITIONED ON THE LOOP.

FOR FOOTWEAR (U.S. CLS. 22 AND 39).

MATTHEW MCDOWELL, EXAMINING ATTORNEY

SN 85-251,814. DALVAFOX S.A., MONTEVIDEO, URUGUAY, FILED 2-25-2011.



OWNER OF URUGUAY REG. NO. 334237, DATED 2-20-2002, EXPIRES 2-20-2012.

THE MARK CONSISTS OF AN ASTERISK BELOW WHICH APPEARS THE WORD "AKIABARA" IN STYLIZED LETTERS.

THE WORDING "AKIABARA" HAS NO MEANING IN A FOREIGN LANGUAGE.

FOR BELTS; CARDIGANS; COATS; DRESSES; JACKETS; OVERCOATS; PARKAS; RAINCOATS; SHIRTS; SHORTS; SKIRTS; SLIPPERS; SOCKS; SWEATERS; SWIMSUITS; T-SHIRTS; TOPS (U.S. CLS. 22 AND 39).

NANCY CLARKE, EXAMINING ATTORNEY

CLASS 25—(Continued).

SN 85-251,934. MIXM, INC, ANAHEIM HILLS, CA. FILED 2-25-2011.



NO CLAIM IS MADE TO THE EXCLUSIVE RIGHT TO USE "VISOR BANDS", APART FROM THE MARK AS SHOWN.

THE MARK CONSISTS OF THE TEXT "MIXM" WHERE THE "X" IS REPRESENTED BY FOUR VISORS FORMING A PINWHEEL SHAPE AND THE TEXT "VISOR BANDS" IS CENTERED UNDERNEATH THE TEXT "MIXM".

FOR VISOR BANDS (U.S. CLS. 22 AND 39).

GINA HAYES, EXAMINING ATTORNEY

SN 85-252,131. THOMPSON, MILTON B., SEWELL, NJ. FILED 2-25-2011.

RELAX STEP THROW

THE MARK CONSISTS OF STANDARD CHARACTERS WITHOUT CLAIM TO ANY PARTICULAR FONT, STYLE, SIZE, OR COLOR.

FOR CLOTHING, NAMELY, SHIRTS, T-SHIRTS, POLO SHIRTS, TANK TOPS, BASEBALL SHIRTS, GOLF SHIRTS, BLOUSES, SHORTS, SWEATSHIRTS, SWEATPANTS, SWEATERS, BASEBALL PANTS, JACKETS, WIND-RESISTANT JACKETS, HATS, CAPS, BEANIES, SUNVISORS, BANDANAS, WRIST BANDS, SHOES, SNEAKERS, AND BASEBALL SHOES (U.S. CLS. 22 AND 39).

KEVIN DINALLO, EXAMINING ATTORNEY

SN 85-252,149. SEAN MURPHY, BELLEROSE, NY. FILED 2-25-2011.

THE PHANTOM LIFE

THE MARK CONSISTS OF STANDARD CHARACTERS WITHOUT CLAIM TO ANY PARTICULAR FONT, STYLE, SIZE, OR COLOR.

FOR CLOTHING, NAMELY, T-SHIRTS, SHIRTS, SWEATSHIRTS, HATS (U.S. CLS. 22 AND 39).

EUGENIA MARTIN, EXAMINING ATTORNEY

CLASS 25—(Continued).

SN 85-252,170. SEAN MURPHY, BELLEROSE, NY. FILED 2-25-2011.



THE MARK CONSISTS OF A SQUARE-FACED DESIGN OF A STYLIZED PHANTOM.
 FOR CLOTHING, NAMELY, T-SHIRTS, SHIRTS, SWEATSHIRTS, HATS (U.S. CLS. 22 AND 39).
 EUGENIA MARTIN, EXAMINING ATTORNEY

CLASS 25—(Continued).

SN 85-252,262. A.E.R.S. INC., LOS ANGELES, CA. FILED 2-25-2011.



THE STIPLING IS A FEATURE OF THE MARK AND DOES NOT INDICATE COLOR.

THE MARK CONSISTS OF THE WORD "CAVIAR". UNDERNEATH THE WORD "CAVIAR" IS A CIRCLE AND INSIDE THAT CIRCLE IS ANOTHER CIRCLE. INSIDE THE INNER CIRCLE IS THE WORD "CAVIAR" WHEREIN THE "C" IS CAPITALIZED AND THE REMAINING LETTERS "AVIAR" ARE WITHIN THE "C". THE WORD "DREMES" APPEARS BENEATH THE WORD "CAVIAR" WHEREIN THE "D" INTERSECTS THE LOWER PORTION OF THE "C" IN "CAVIAR". BENEATH THE OUTER CIRCLE IS THE WORD "DREMES".

FOR MEN'S AND BOY'S WEARING APPAREL, NAMELY, T-SHIRTS, SWEATSHIRTS, TANK TOPS, WOVEN SHIRTS, SWEATERS, CARDIGANS, VESTS, JACKETS, PANTS, SWEATPANTS, JEANS, SHORTS, HATS, CAPS, COATS, SCARVES, NECKERCHIEFS, NECK BANDS, WRIST BANDS, HEAD BANDS, GLOVES, BELTS, PAJAMAS, SHOES, SOCKS, UNDERWEAR, SWIM WEAR, AND TRUNKS; AND WOMEN'S AND GIRL'S WEARING APPAREL, NAMELY, T-SHIRTS, SWEATSHIRTS, TANK TOPS, WOVEN SHIRTS, SWEATERS, CARDIGANS, VESTS, JACKETS, PANTS, SWEATPANTS, JEANS, SHORTS, HATS, CAPS, COATS, BELTS, SCARVES, NECKERCHIEFS, NECK BANDS, WRIST BANDS, HEAD BANDS, GLOVES, PAJAMAS, SHOES, SOCKS, UNDERWEAR, FOUNDATION GARMENTS, PANTYHOSE, TEDDIES, BRAS, SKIRTS, DRESSES, BLOUSES, SWIM WEAR, AND BIKINIS (U.S. CLS. 22 AND 39).

ELLEN BURNS, EXAMINING ATTORNEY

SN 85-252,274. HAGHANI, VAFA, IRVINE, CA. FILED 2-25-2011.



THE MARK CONSISTS OF THE STYLIZED TEXT "OCEAN FACTOR" AND A DESIGN OF TWO HORIZONTAL RECTANGLES WITH CIRCULAR CURVES ON THE LEFT HAND SIDE, WHICH ARE ON TOP OF EACH BUT NOT TOUCHING AND THE RIGHT SIDE OF BOTH RECTANGLES IS ANGLED.

FOR BOARD SHORTS; COATS; JACKETS; JERSEYS; LONG-SLEEVED SHIRTS; PARKAS; SHIRTS; SHORT-SLEEVED SHIRTS; SHORTS; SWEAT SHIRTS; T-SHIRTS; TANK TOPS; TOPS (U.S. CLS. 22 AND 39).

FIRST USE 4-12-2010; IN COMMERCE 4-12-2010.

ELLEN BURNS, EXAMINING ATTORNEY

CLASS 25—(Continued).

SN 85-252,283. KC COLLECTIONS, LLC, NEW YORK, NY. FILED 2-25-2011.



NO CLAIM IS MADE TO THE EXCLUSIVE RIGHT TO USE "COLLECTIONS", APART FROM THE MARK AS SHOWN.

THE MARK CONSISTS OF THE STYLIZED LETTERS "KC" ABOVE THE WORD "COLLECTIONS" WHICH IS ALSO IN STYLIZED LETTERING. TO THE RIGHT OF THE LETTERS "KC" AND ABOVE THE WORD "COLLECTIONS" IS A LINE DRAWING OF THE SUN.

FOR COATS; JACKETS; PANTS; VESTS (U.S. CLS. 22 AND 39).

FIRST USE 6-0-2010; IN COMMERCE 6-0-2010.
MICHAEL GAAFAR, EXAMINING ATTORNEY

CLASS 25—(Continued).

SN 85-252,408. MILLS, JAMES, COLUMBUS, OH. FILED 2-25-2011.



THE MARK CONSISTS OF A STYLIZED DESIGN OF TWO HANDS GIVING A THUMBS UP AND THUMBS DOWN GESTURE INSIDE OF A CIRCLE.

FOR BELTS; FOOTWEAR; HATS; JACKETS; PANTS; SHIRTS; SHORTS (U.S. CLS. 22 AND 39).

FIRST USE 4-1-2010; IN COMMERCE 4-1-2010.
KHANH LE, EXAMINING ATTORNEY

SN 85-252,355. JLD REAL ESTATE, GLENWOOD, IL. FILED 2-25-2011.



THE MARK CONSISTS OF A LARGE LETTER "C" DISPLAYED WITH TWO WINGS, ONE AT EACH OPENING OF THE LETTER, WITH EACH WING HAVING FOUR TIPS THAT FACE OUTWARD, AND BELOW THE LETTER "C" IS THE WORD "GREEN" IN LOWER CASE LETTERS.

FOR BANDANAS; BELTS; BOXER SHORTS; COATS; FOOTWEAR; GLOVES; HEADWEAR; HOSIERY; JACKETS; LINGERIE; PANTS; SCARVES; SHIRTS; SOCKS; SWEATSHIRTS; T-SHIRTS; TIES; UNDERWEAR (U.S. CLS. 22 AND 39).

FIRST USE 1-6-2006; IN COMMERCE 3-10-2006.
JUDITH HELFMAN, EXAMINING ATTORNEY

SN 85-252,523. SOUTHERN TEXTILE NETWORK, LIMA, PERU, FILED 2-26-2011.

OUT OF PERU

THE MARK CONSISTS OF STANDARD CHARACTERS WITHOUT CLAIM TO ANY PARTICULAR FONT, STYLE, SIZE, OR COLOR.

NO CLAIM IS MADE TO THE EXCLUSIVE RIGHT TO USE "PERU", APART FROM THE MARK AS SHOWN.

FOR HOODED SWEATSHIRTS FOR MEN AND WOMEN; JACKETS; JERSEYS; MEN'S AND WOMEN'S JACKETS; COATS; TROUSERS; VESTS; MUFFLERS; SWEATSHIRTS FOR MEN AND WOMEN; T-SHIRTS FOR MEN AND WOMEN; TRAVEL CLOTHING CONTAINED IN A PACKAGE COMPRISING REVERSIBLE JACKETS, PANTS, SKIRTS, TOPS AND A BELT OR SCARF; WEARABLE GARMENTS AND CLOTHING, NAMELY, SHIRTS; WOMEN'S CLOTHING, NAMELY, SHIRTS, DRESSES, SKIRTS, BLOUSES; WRAPS (U.S. CLS. 22 AND 39).

MAYUR VAGHANI, EXAMINING ATTORNEY

CLASS 25—(Continued).

SN 85-252,785. STACEY S. CRUMMETT, HOLLISTER, CA.
FILED 2-27-2011.

Be Now for the evolved

THE MARK CONSISTS OF STANDARD CHARACTERS WITHOUT CLAIM TO ANY PARTICULAR FONT, STYLE, SIZE, OR COLOR.

FOR HATS; HOODED SWEAT SHIRTS; PANTS; SHIRTS; SHIRTS AND SHORT-SLEEVED SHIRTS; SHIRTS FOR INFANTS, BABIES, TODDLERS AND CHILDREN; SLEEP SHIRTS; SWEAT SHIRTS; T-SHIRTS; WEARABLE GARMENTS AND CLOTHING, NAMELY, SHIRTS; WOMEN'S CLOTHING, NAMELY, SHIRTS, DRESSES, SKIRTS, BLOUSES (U.S. CLS. 22 AND 39).

CAROLINE WOOD, EXAMINING ATTORNEY

SN 85-252,828. GAUNTLET WEAR, SEATTLE, WA. FILED 2-27-2011.

Gauntlet Wear

THE MARK CONSISTS OF STANDARD CHARACTERS WITHOUT CLAIM TO ANY PARTICULAR FONT, STYLE, SIZE, OR COLOR.

NO CLAIM IS MADE TO THE EXCLUSIVE RIGHT TO USE "WEAR", APART FROM THE MARK AS SHOWN.

FOR CLOTHING, NAMELY, ARM WARMERS; CLOTHING, NAMELY, KNEE WARMERS (U.S. CLS. 22 AND 39).

CHRISTINE MARTIN, EXAMINING ATTORNEY

SN 85-252,854. COLDWORLD ENTERPRISES, LOS ANGELES, CA. FILED 2-27-2011.

LEAGUE ME

THE MARK CONSISTS OF STANDARD CHARACTERS WITHOUT CLAIM TO ANY PARTICULAR FONT, STYLE, SIZE, OR COLOR.

FOR SHIRTS; SPORTS CAPS AND HATS; SWEAT SHIRTS (U.S. CLS. 22 AND 39).

MEGHAN REINHART, EXAMINING ATTORNEY

CLASS 25—(Continued).

SN 85-252,918. HOBE, MAEGAN, BLOCK ISLAND, RI.
FILED 2-28-2011.

FISH THE WORLD

THE MARK CONSISTS OF STANDARD CHARACTERS WITHOUT CLAIM TO ANY PARTICULAR FONT, STYLE, SIZE, OR COLOR.

FOR CLOTHING NAMELY, PRINTED AND EMBROIDERED T-SHIRTS, HATS, SWEATSHIRTS AND ACCESSORIES (U.S. CLS. 22 AND 39).

FIRST USE 5-1-2009; IN COMMERCE 6-1-2009.

HENRY S. ZAK, EXAMINING ATTORNEY

SN 85-252,920. SHAFIZ, AAZAM, LAGUNA NIGUEL, CA.
FILED 2-28-2011.

VIRJEAN

THE MARK CONSISTS OF STANDARD CHARACTERS WITHOUT CLAIM TO ANY PARTICULAR FONT, STYLE, SIZE, OR COLOR.

FOR CLOTHING, NAMELY, TOPS, BOTTOMS, JEANS, PANTS, SKIRTS, JACKETS, SHIRTS, UNDERWEAR, AND UNDER GARMENTS (U.S. CLS. 22 AND 39).

HENRY S. ZAK, EXAMINING ATTORNEY

SN 85-253,108. ARM THE ANIMALS LLC, PASADENA, CA.
FILED 2-28-2011.



THE MARK CONSISTS OF THE STYLIZED TEXT "ARM THE ANIMALS ATA" AND A DESIGN IN THE SHAPE OF A GORILLA HOLDING A RIFLE OVER HIS HEAD.

FOR BEANIES; HATS; SWEATSHIRTS; T-SHIRTS (U.S. CLS. 22 AND 39).

FIRST USE 10-1-2009; IN COMMERCE 8-1-2010.

JOHN GARTNER, EXAMINING ATTORNEY

CLASS 25—(Continued).

SN 85-253,156. TALKTOTHEWING.COM, LLC, LEXINGTON, SC. FILED 2-28-2011.



THE MARK CONSISTS OF AN OUTLINE OF AN OWL TURNED SLIGHTLY TO ITS LEFT WITH ITS EYES CUT TO ITS RIGHT.

FOR HATS; JACKETS; SWEATSHIRTS; T-SHIRTS (U.S. CLS. 22 AND 39).

TRICIA SONNEBORN, EXAMINING ATTORNEY

SN 85-253,187. PATRICIA M. CHARETTE, BEVERLY, MA. FILED 2-28-2011.

WACKO WESTIE

THE MARK CONSISTS OF STANDARD CHARACTERS WITHOUT CLAIM TO ANY PARTICULAR FONT, STYLE, SIZE, OR COLOR.

FOR MITTENS MODIFIED TO COVER THE HAND AND AN ANIMAL LEASH HANDLE OR OTHER LOOP (U.S. CLS. 22 AND 39).

BARBARA BROWN, EXAMINING ATTORNEY

SN 85-253,479. SWEET APPAREL LLC, DBA ENVAE, LOS ANGELES, CA. FILED 2-28-2011.

ENVAE

THE MARK CONSISTS OF STANDARD CHARACTERS WITHOUT CLAIM TO ANY PARTICULAR FONT, STYLE, SIZE, OR COLOR.

FOR APPAREL, NAMELY, SHIRTS, T-SHIRTS, SWEATSHIRTS, DRESSES, SKIRTS, PANTS, SHORTS, SWEATPANTS, JEANS, SOCKS, HEADWEAR, BLOUSES (U.S. CLS. 22 AND 39).

FIRST USE 11-10-2007; IN COMMERCE 1-1-2008.
KELLY BOULTON, EXAMINING ATTORNEY

CLASS 25—(Continued).

SN 85-253,484. TODDCO, LLC, SEVERNA PARK, MD. FILED 2-28-2011.

Todd's DIRT

THE MARK CONSISTS OF STANDARD CHARACTERS WITHOUT CLAIM TO ANY PARTICULAR FONT, STYLE, SIZE, OR COLOR.

OWNER OF U.S. REG. NO. 3,481,882.

FOR APRONS; T-SHIRTS (U.S. CLS. 22 AND 39).

FIRST USE 9-1-2007; IN COMMERCE 9-6-2007.

KELLY BOULTON, EXAMINING ATTORNEY

SN 85-253,509. 360SWEATER COMPANY, LLC, SANTA MONICA, CA. FILED 2-28-2011.

360JEANS

THE MARK CONSISTS OF STANDARD CHARACTERS WITHOUT CLAIM TO ANY PARTICULAR FONT, STYLE, SIZE, OR COLOR.

OWNER OF U.S. REG. NOS. 3,848,802, 3,848,834 AND 3,854,758.

FOR BOTTOMS; DRESSES; JACKETS; LEGGINGS; PANTS; SCARVES; SHIRTS; SKIRTS; SWEATERS; TOPS (U.S. CLS. 22 AND 39).

GRETCHEN ULRICH, EXAMINING ATTORNEY

SN 85-253,555. RICHARDS, TYRAN L, FAIRFIELD, CA. FILED 2-28-2011.

HIGHLIGHTED GIRL

THE MARK CONSISTS OF STANDARD CHARACTERS WITHOUT CLAIM TO ANY PARTICULAR FONT, STYLE, SIZE, OR COLOR.

NO CLAIM IS MADE TO THE EXCLUSIVE RIGHT TO USE "GIRL", APART FROM THE MARK AS SHOWN.

FOR BLAZERS; DENIMS; HOODED SWEATSHIRTS; SCARFS; SHIRTS; SKIRTS AND DRESSES; SWEAT JACKETS; SWEAT PANTS; T-SHIRTS; TANK TOPS; VESTS; WAIST BELTS (U.S. CLS. 22 AND 39).

ANDREW LEASER, EXAMINING ATTORNEY

CLASS 25—(Continued).

SN 85-253,610. KATY POP INC., NEW YORK, NY. FILED 2-28-2011.

KATIE POP

THE MARK CONSISTS OF STANDARD CHARACTERS WITHOUT CLAIM TO ANY PARTICULAR FONT, STYLE, SIZE, OR COLOR.

FOR WEARING APPAREL, NAMELY, MEN'S, WOMEN'S AND CHILDREN'S JEANS, T-SHIRTS, SHORTS, SWEAT PANTS, SWEAT SHIRTS, UNDERWEAR, SOCKS; FOOTWEAR (U.S. CLS. 22 AND 39).

RUDY R. SINGLETON, EXAMINING ATTORNEY

SN 85-253,614. KATY POP INC., NEW YORK, NY. FILED 2-28-2011.

MY LITTLE LADY

THE MARK CONSISTS OF STANDARD CHARACTERS WITHOUT CLAIM TO ANY PARTICULAR FONT, STYLE, SIZE, OR COLOR.

FOR WEARING APPAREL, NAMELY, MEN'S, WOMEN'S AND CHILDREN'S JEANS, T-SHIRTS, SHORTS, SWEAT PANTS, SWEAT SHIRTS, UNDERWEAR, SOCKS; FOOTWEAR (U.S. CLS. 22 AND 39).

RUDY R. SINGLETON, EXAMINING ATTORNEY

SN 85-253,889. CATHERINE ANN BLIZZARD, PARK HILL, OK. FILED 2-28-2011.

X ZONE XCELLENTLY XTREME

THE MARK CONSISTS OF STANDARD CHARACTERS WITHOUT CLAIM TO ANY PARTICULAR FONT, STYLE, SIZE, OR COLOR.

FOR ATHLETIC APPAREL, NAMELY, SHIRTS, PANTS, JACKETS, FOOTWEAR, HATS AND CAPS, ATHLETIC UNIFORMS; CAPS WITH VISORS; HEADGEAR, NAMELY, HATS, CAPS, VISORS, CAPS WITH VISOR; PANTS; SHIRTS AND SHORT-SLEEVED SHIRTS; SHORT-SLEEVED OR LONG-SLEEVED T-SHIRTS (U.S. CLS. 22 AND 39).

ANNE FARRELL, EXAMINING ATTORNEY

CLASS 25—(Continued).

SN 85-253,890. R.N'OVATE, INC., LOS ANGELES, CA. FILED 2-28-2011.

CLOVER CANYON

THE MARK CONSISTS OF STANDARD CHARACTERS WITHOUT CLAIM TO ANY PARTICULAR FONT, STYLE, SIZE, OR COLOR.

FOR CLOTHING, NAMELY, TOPS, BOTTOMS, SHIRTS, PANTS, SWEATERS, HEADWEAR, SHORTS, SWIMWEAR, LINGERIE, UNDERWEAR, JACKETS, COATS, WRAPS, DRESSES, SKIRTS, SCARVES, FOOTWEAR (U.S. CLS. 22 AND 39).

ANNE FARRELL, EXAMINING ATTORNEY

SN 85-253,950. BRAWLEY, BARRY ALLEN, TROUTMAN, NC. FILED 2-28-2011.

it happens

THE MARK CONSISTS OF THE STYLIZED WORDING "IT HAPPENS 2 YOU" IN WHICH THE "2" IS PLACED IN THE WORDING "IT" AND THE "YOU" IS PLACED IN THE WORDING "HAPPENS".

FOR JACKETS; SHIRTS (U.S. CLS. 22 AND 39); TIMOTHY FINNEGAN, EXAMINING ATTORNEY

SN 85-253,983. STEWART, LAWRENCE DARNELL, DBA FIVE LIONS ENTERTAINMENT, RESEDA, CA. FILED 2-28-2011.

AIJI

THE MARK CONSISTS OF STANDARD CHARACTERS WITHOUT CLAIM TO ANY PARTICULAR FONT, STYLE, SIZE, OR COLOR.

FOR ATHLETIC APPAREL, NAMELY, SHIRTS, PANTS, JACKETS, FOOTWEAR, HATS AND CAPS, ATHLETIC UNIFORMS (U.S. CLS. 22 AND 39).

JOHN E. MICHOS, EXAMINING ATTORNEY

CLASS 25—(Continued).

SN 85-254,162. PERRY, MICHAEL, CHICAGO, IL. AND M. WATTS, CHIQUITA, RICHTON PARK, IL. FILED 3-1-2011.

NEOSWEAT

THE MARK CONSISTS OF STANDARD CHARACTERS WITHOUT CLAIM TO ANY PARTICULAR FONT, STYLE, SIZE, OR COLOR.

FOR SPORTSWEAR FOR MEN, WOMEN AND CHILDREN, NAMELY T-SHIRTS, LONG-SLEEVE SHIRTS, SHORT SLEEVE SHIRTS, V-NECK SHIRTS, ROUND NECK SHIRTS, SWEATSHIRTS, HOODED SWEATSHIRTS, CROP TOPS, TUBE TOPS, SHORTS, PULL-OVERS, JUMPSUITS, PANTS, TIGHTS, TANK SHIRTS, TIE-UP TOPS, CAPRIS, CAPRI LEGGINGS, RAZER BACK TANKS AND BRA, SPORTS BRAS, SHIRTS, AND EXERCISE APPAREL, NAMELY TIGHTS, BODYSUITS, SHORTS, T-SHIRTS, ATHLETIC SHOES, SOCKS, VESTS, BELTS, HATS, BEANIES, GLOVES, HEAD BANDS (U.S. CLS. 22 AND 39).

SAIMA MAKHDOOM, EXAMINING ATTORNEY

SN 85-254,182. OLDAKER, MERRITT, MISSION VIEJO, CA. FILED 3-1-2011.

SIMPLE MINDED

THE MARK CONSISTS OF STANDARD CHARACTERS WITHOUT CLAIM TO ANY PARTICULAR FONT, STYLE, SIZE, OR COLOR.

FOR CLOTHING, NAMELY, PANTS, JACKETS, SWEAT SHIRTS, HATS, T-SHIRTS, SHOES, SOCKS, SHORTS, SLACKS, GLOVES, DRESS SHIRTS (U.S. CLS. 22 AND 39).

HEATHER THOMPSON, EXAMINING ATTORNEY

SN 85-254,359. LEYLA MORRIS, KAILUA-KONA, HI. FILED 3-1-2011.

Run Now, Die Later.

THE MARK CONSISTS OF STANDARD CHARACTERS WITHOUT CLAIM TO ANY PARTICULAR FONT, STYLE, SIZE, OR COLOR.

FOR SHORT-SLEEVED OR LONG-SLEEVED T-SHIRTS; T-SHIRTS (U.S. CLS. 22 AND 39).

KEVON CHISOLM, EXAMINING ATTORNEY

CLASS 25—(Continued).

SN 85-254,415. CSC PROPERTY MANAGEMENT, FORT COLLINS, CO. FILED 3-1-2011.

Bring Your Own Weather

THE MARK CONSISTS OF STANDARD CHARACTERS WITHOUT CLAIM TO ANY PARTICULAR FONT, STYLE, SIZE, OR COLOR.

FOR HATS; HOODED SWEAT SHIRTS; HOODED SWEATSHIRTS; PANTS; PULLOVERS; SHIRTS; SHORT-SLEEVED OR LONG-SLEEVED T-SHIRTS; SHORTS; SWEAT SHIRTS; SWEATERS; SWEATSHIRTS; T-SHIRTS (U.S. CLS. 22 AND 39).

DAVID COLLIER, EXAMINING ATTORNEY

SN 85-254,426. TENNIS KARMA, LLC., DALLAS, TX. FILED 3-1-2011.



NO CLAIM IS MADE TO THE EXCLUSIVE RIGHT TO USE "TENNIS", APART FROM THE MARK AS SHOWN.

THE COLOR(S) PURPLE AND GREEN IS/ARE CLAIMED AS A FEATURE OF THE MARK.

THE MARK CONSISTS OF THE WORDING TENNIS KARMA IN PURPLE STYLIZED FONT AND A DESIGN OF A YIN AND YANG SYMBOL IN THE COLOR OF GREEN, THE TWO DOTS WITHIN THE YIN AND YANG SYMBOL ARE IN THE COLOR OF PURPLE, THE COLOR WHITE IN THE DRAWING REPRESENTS BACKGROUND AND IS NOT PART OF THE MARK.

FOR TENNIS DRESSES; TENNIS SHOES; TENNIS WEAR (U.S. CLS. 22 AND 39).

WILLIAM P. SHANAHAN, EXAMINING ATTORNEY

CLASS 25—(Continued).

SN 85-254,451. KIM ALLEN, FEDERAL WAY, WA. FILED 3-1-2011.

snotrocker

THE MARK CONSISTS OF STANDARD CHARACTERS WITHOUT CLAIM TO ANY PARTICULAR FONT, STYLE, SIZE, OR COLOR.

FOR CAPS; HATS; SHORT-SLEEVED OR LONG-SLEEVED T-SHIRTS; T-SHIRTS (U.S. CLS. 22 AND 39).
WILLIAM P. SHANAHAN, EXAMINING ATTORNEY

SN 85-254,486. HIGHTOWER, RANDALL, DBA BIBLICALLY CORRECT, FARMINGTON, CT. FILED 3-1-2011.



Not, Politically Correct

NO CLAIM IS MADE TO THE EXCLUSIVE RIGHT TO USE "FOR GOD SO LOVED THE WORLD THAT HE GAVE HIS ONE & ONLY SON, THAT WHOEVER BELIEVES IN HIM SHALL NOT PERISH BUT HAVE ETERNAL LIFE", APART FROM THE MARK AS SHOWN.

THE COLOR(S) RED AND BLACK IS/ARE CLAIMED AS A FEATURE OF THE MARK.

THE MARK CONSISTS OF THE WORD "BIBLICALLY"

CLASS 25—(Continued).

ARCHED ABOVE AN OPEN BIBLE AND "CORRECT" ARCHED BELOW IT, ALL IN BLACK. THE WORDING "NOT", IN RED, AND "POLITICALLY CORRECT", IN BLACK, APPEAR UNDER THE WORD "CORRECT". THE BIBLE IS OPEN TO A PAGE WITH THE WORDS "FOR GOD SO LOVED THE WORLD THAT HE GAVE HIS ONE & ONLY SON, THAT WHOEVER BELIEVES IN HIM SHALL NOT PERISH BUT HAVE ETERNAL LIFE". WITH THE LETTER "Z" ON THE SECOND PAGE AND HORIZONTAL LINES DEPICTING WORDS, ALL IN BLACK.

FOR APPAREL FOR DANCERS, NAMELY, TEE SHIRTS, SWEATSHIRTS, PANTS, LEGGINGS, SHORTS AND JACKETS; ATHLETIC APPAREL, NAMELY, SHIRTS, PANTS, JACKETS, FOOTWEAR, HATS AND CAPS, ATHLETIC UNIFORMS; BUTTON DOWN SHIRTS; COLLARED SHIRTS; GOLF SHIRTS; HOODED SWEAT SHIRTS; KNIT SHIRTS; LONG-SLEEVED SHIRTS; MOISTURE-WICKING SPORTS SHIRTS; NIGHT SHIRTS; POLO SHIRTS; RUGBY SHIRTS; SCIENTIFIC AND TECHNOLOGICAL APPAREL, NAMELY, SHIRTS, PANTS, JACKETS, FOOTWEAR, HATS AND CAPS, UNIFORMS; SHIRTS; SHIRTS AND SHORT-SLEEVED SHIRTS; SHIRTS FOR INFANTS, BABIES, TODDLERS AND CHILDREN; SHORT-SLEEVED OR LONG-SLEEVED T-SHIRTS; SHORT-SLEEVED SHIRTS; SLEEP SHIRTS; SPORT SHIRTS; SPORTS SHIRTS WITH SHORT SLEEVES; SWEAT SHIRTS; T-SHIRTS; TEE SHIRTS; TURTLE NECK SHIRTS; WEARABLE GARMENTS AND CLOTHING, NAMELY, SHIRTS; WIND SHIRTS (U.S. CLS. 22 AND 39).

ELISSA GARBER KON, EXAMINING ATTORNEY

SN 85-254,689. CRAIG MORGAN GREER, NASHVILLE, TN. FILED 3-1-2011.

Corn Star

THE MARK CONSISTS OF STANDARD CHARACTERS WITHOUT CLAIM TO ANY PARTICULAR FONT, STYLE, SIZE, OR COLOR.

FOR HATS; UNDERWEAR; WEARABLE GARMENTS AND CLOTHING, NAMELY, SHIRTS (U.S. CLS. 22 AND 39).

SUNG IN, EXAMINING ATTORNEY

SN 85-254,718. SIXTH RULE, LLC, BROOKLYN, NY. FILED 3-1-2011.

JOOJOS

THE MARK CONSISTS OF THE STYLIZED TEXT "JOOJOS" WITH DOTS THAT ARE AN ABSTRACTION OF CARTOON-LIKE EYES.

FOR FOOTWEAR FOR INFANTS, TODDLERS, AND KIDS, NAMELY, SHOES AND SOCKS (U.S. CLS. 22 AND 39).

MELISSA VALLILLO, EXAMINING ATTORNEY

CLASS 25—(Continued).

SN 85-254,828. PURPOSELY CHOSEN, INC., PALM SPRINGS, CA. FILED 3-1-2011.

Purposely Chosen

THE MARK CONSISTS OF STANDARD CHARACTERS WITHOUT CLAIM TO ANY PARTICULAR FONT, STYLE, SIZE, OR COLOR.

FOR MEN'S, WOMEN'S AND CHILDREN'S CLOTHING, NAMELY, SHIRTS, T-SHIRTS, JACKETS, COATS, SWEATERS, CARDIGAN SWEATERS, SWEATER VESTS, BLAZERS, DRESS SHIRTS, SNAP CROTCH SHIRTS, BODYSUITS, ROMPERS, PANTIES, DRESSES, GLOVES, MITTENS, SKIRTS, BLOUSES, FABRIC BELTS, LEATHER BELTS, CAPS, HATS, VISORS, BEANIES, PULLOVERS, JEANS, PANTS, TROUSERS, POLO SHIRTS, SWEAT PANTS, SWEATSHIRTS, SWEAT SUITS, TANK TOPS, SHORTS, SWIM SUITS, TRUNKS, BANDANAS, SHOES, SANDALS, FLIP FLOPS, BOOTS, FOOTWEAR, THERMAL UNDERWEAR, SOCKS, NIGHT GOWNS, PAJAMAS, WIND SHIRTS, PONCHOS, VESTS, PARKAS, BOXER SHORTS, BRIEFS, UNDERWEAR, BRAS, YOGA PANTS, BATHROBES, JERSEYS, BIBS, CAPRI PANTS, WRAPS, SCARVES, SHAWLS, NECK TIES (U.S. CLS. 22 AND 39).

FIRST USE 1-31-2011; IN COMMERCE 1-31-2011.
MARGERY A. TIERNEY, EXAMINING ATTORNEY

SN 85-254,838. FIERCELY LOYAL MERCHANDISE COMPANY, LLC, MALIBU, CA. FILED 3-1-2011.

FIERCELY LOYAL

THE MARK CONSISTS OF STANDARD CHARACTERS WITHOUT CLAIM TO ANY PARTICULAR FONT, STYLE, SIZE, OR COLOR.

FOR TOPS; BOTTOMS; DRESSES; JACKETS; HEADWEAR (U.S. CLS. 22 AND 39).

MARK RADEMACHER, EXAMINING ATTORNEY

CLASS 25—(Continued).

SN 85-254,890. LUDWICK, MATTHEW, BURBANK, CA. FILED 3-1-2011.

Moto Meccanica

THE MARK CONSISTS OF STANDARD CHARACTERS WITHOUT CLAIM TO ANY PARTICULAR FONT, STYLE, SIZE, OR COLOR.

THE ENGLISH TRANSLATION OF MOTO MECCANICA IN THE MARK IS MECHANICAL MOTORCYCLE.

FOR CLOTHING, NAMELY, LONG AND SHORT SLEEVE T-SHIRTS, LONG AND SHORT SLEEVE SHIRTS, GOLF SHIRTS, WORK SHIRTS, V-NECK T-SHIRTS, HALTER TOPS, JERSEYS, TANK TOPS, COATS, DENIM JACKETS, HOODED JACKETS, VARSITY JACKETS, SPORTS JACKETS, FLEECE JACKETS, MOTORCYCLE JACKETS, GLOVES, FLEECE PULLOVERS, FLEECE VESTS, SWEATSHIRTS, PANTS, INFANT JUMPERS, INFANT ONE-PIECE PLAYWEAR, TRACK SUITS, WIND SUITS, WARM UP SUITS, RUNNING SHORTS, SWIMWEAR, UNDERGARMENTS, UNDERWEAR, BOXER SHORTS, SOCKS, LOUNGE PANTS, PAJAMAS, TIES, BELTS, HEADWEAR AND FOOTWEAR (U.S. CLS. 22 AND 39).

GENE MACIOL, EXAMINING ATTORNEY

SN 85-254,919. LUNSFORD, EDWIN, NORTH PALM BEACH, FL. FILED 3-1-2011.

SHREDNECK

THE MARK CONSISTS OF STANDARD CHARACTERS WITHOUT CLAIM TO ANY PARTICULAR FONT, STYLE, SIZE, OR COLOR.

FOR CLOTHING, NAMELY, TOPS, BOTTOMS, TEE-SHIRTS, JEANS, SINGLETS, SHORTS, PANTS, TROUSERS, SHIRTS, SUITS, SKIRTS, SWIMSUITS, SWIM WEAR, WET SUITS, BEACH WEAR, SURFWEAR, SARONGS, JACKETS, JUMPERS, SWEATERS, COATS, PARKAS, PULLOVERS, JERSEYS, HEAD BANDS, BANDANAS, MONEY BELTS; FOOTWEAR; HEADGEAR, NAMELY, HATS, CAPS, SUN VISORS, SWIMMING CAPS, BEANIES, AND SKULL CAPS (U.S. CLS. 22 AND 39).

MICHELLE DUBOIS, EXAMINING ATTORNEY

CLASS 25—(Continued).

SN 85-254,944. UNITED STATES POLO ASSOCIATION, LEXINGTON, KY. FILED 3-1-2011.

BEFORE FASHION, POLO WAS A
SPORT

THE MARK CONSISTS OF STANDARD CHARACTERS WITHOUT CLAIM TO ANY PARTICULAR FONT, STYLE, SIZE, OR COLOR.

FOR CLOTHING, NAMELY, TOPS, BOTTOMS, COATS, JACKETS, TIES, BELTS, HEADWEAR, FOOTWEAR, SWIMWEAR, SWEAT PANTS, SHORTS, SHIRTS (U.S. CLS. 22 AND 39).

SCOTT BIBB, EXAMINING ATTORNEY

SN 85-255,040. BAJA'D OUT CLOTHING COMPANY, LLC, TUCSON, AZ. FILED 3-1-2011.



THE MARK CONSISTS OF THE STYLIZED WORDS BAJA'D OUT WITH A LARGE CAPITAL O ELEMENT IN THE "OUT" FEATURE. A MOTORIZED BOAT WITH TRAILING WAKE IS DEPICTED PARTIALLY EXTENDING INTO THE LARGE CAPITAL O.

FOR CLOTHING, NAMELY, T-SHIRTS (U.S. CLS. 22 AND 39).

HOWARD B. LEVINE, EXAMINING ATTORNEY

CLASS 25—(Continued).

SN 85-255,088. CASNER, JOSHUA, UPLAND, CA. FILED 3-1-2011.



NO CLAIM IS MADE TO THE EXCLUSIVE RIGHT TO USE "CLOTHING", APART FROM THE MARK AS SHOWN.

THE MARK CONSISTS OF A HIGHLY STYLIZED, CIRCULAR-SHAPED LETTER "A" INSIDE TWO BARS THAT GO INTO A BREAK AT THE TOP LEFT AND THE BOTTOM RIGHT, ALL OVER THE STYLIZED WORDING "ASEITY CLOTHING".

FOR BELTS; HATS; HOODED SWEAT SHIRTS; PANTS; SHIRTS; SHORTS; SWIM WEAR; T-SHIRTS (U.S. CLS. 22 AND 39).

JEFFERY COWARD, EXAMINING ATTORNEY

SN 85-255,101. J.T. DESIGN STUDIO, INC., LOS ANGELES, CA. FILED 3-1-2011.

NINE 3 TWO

THE MARK CONSISTS OF STANDARD CHARACTERS WITHOUT CLAIM TO ANY PARTICULAR FONT, STYLE, SIZE, OR COLOR.

FOR CAMP SHIRTS; CAPS; DRESS SHIRTS; DRESSES; FOOTWEAR; HEADWEAR; JACKETS; JERSEYS; KNIT SHIRTS; KNIT TOPS; LONG-SLEEVED SHIRTS; PANTS; SHIRTS; SPORT SHIRTS; T-SHIRTS; TOPS; WOMEN'S CLOTHING, NAMELY, SHIRTS, DRESSES, SKIRTS, BLOUSES (U.S. CLS. 22 AND 39).

CHRISTINE MARTIN, EXAMINING ATTORNEY

CLASS 25—(Continued).

SN 85-255,236. PERNIA, PATRICK, SAN JOSE, CA. FILED 3-2-2011.



THE MARK CONSISTS OF AN EAGLE WITH WINGS FULLY SPREAD, A SHIELD ON ITS CHEST, AND A PAIR OF CRISS-CROSSING GOLF CLUBS ON THE SHIELD.

FOR SWEATERS, BLAZERS, SHIRTS, POLO SHIRTS, DRESS SHIRTS, TURTLE NECK SHIRTS, TEE-SHIRTS, SWEATSHIRTS, KNIT SHIRTS, JACKETS, PARKAS, TROUSERS, SHORTS, BERMUDA SHORTS, TRACK SUIT TROUSERS, TRACK SUITS, SKIRTS, DRESSES, BEACHWEAR, SOCKS, WRIST BANDS, HEAD BANDS, SCARVES, HEADWEAR, HATS, GOLF CAPS, NECKWEAR, GLOVES, UNDERWEAR, FOOTWEAR (U.S. CLS. 22 AND 39).

FIRST USE 3-3-2011; IN COMMERCE 4-10-2011.
GEOFFREY FOSDICK, EXAMINING ATTORNEY

SN 85-255,310. SARAYEV, NIKITA, BROOKLYN, NY. FILED 3-2-2011.

KESIV

THE MARK CONSISTS OF STANDARD CHARACTERS WITHOUT CLAIM TO ANY PARTICULAR FONT, STYLE, SIZE, OR COLOR.

THE ENGLISH TRANSLATION OF KESIV IN THE MARK IS MONEY.

FOR SHIRTS, T-SHIRTS, SWEATERS, SWEATSHIRTS, HEADGEAR NAMELY HATS, PANTS AND SHORTS (U.S. CLS. 22 AND 39).

ZACHARY BELLO, EXAMINING ATTORNEY

SN 85-255,422. BENNETT, JOHN DAVID, WEST MELBOURNE, FL. FILED 3-2-2011.

Lapping Box

THE MARK CONSISTS OF STANDARD CHARACTERS WITHOUT CLAIM TO ANY PARTICULAR FONT, STYLE, SIZE, OR COLOR.

FOR CLOTHING, NAMELY, T-SHIRTS, SWEATSHIRTS, SPORT SHIRTS, SHORTS, UNDERSHORTS BEING BOXER SHORTS, BRIEFS, PANTIES, AND UNDERWEAR, AND HATS (U.S. CLS. 22 AND 39).

JACLYN KIDWELL WALKER, EXAMINING ATTORNEY

CLASS 25—(Continued).

SN 85-255,487. CHANG, WILLIAM, TEMPLE CITY, CA. FILED 3-2-2011.

whoever brings home the
bacon gets to do the
spankin'

THE MARK CONSISTS OF STANDARD CHARACTERS WITHOUT CLAIM TO ANY PARTICULAR FONT, STYLE, SIZE, OR COLOR.

FOR T-SHIRTS (U.S. CLS. 22 AND 39).
MATTHEW KLINE, EXAMINING ATTORNEY

SN 85-255,591. RITUAL ACTIVEWEAR, LLC, SAN FRANCISCO, CA. FILED 3-2-2011.

ANONYA

THE MARK CONSISTS OF STANDARD CHARACTERS WITHOUT CLAIM TO ANY PARTICULAR FONT, STYLE, SIZE, OR COLOR.

THE NAME(S), PORTRAIT(S), AND/OR SIGNATURE(S) SHOWN IN THE MARK DOES NOT IDENTIFY A PARTICULAR LIVING INDIVIDUAL.

FOR BEANIES; BRAS; DRESSES; HATS; HEADBANDS; JACKETS; LEOTARDS; LONG-SLEEVED SHIRTS; PANTS; PULLOVERS; SCARVES; SHIRTS; SHORTS; SKIRTS; SOCKS; SPORTS BRA; SWEATSHIRTS; T-SHIRTS; TUNICS; UNITARDS; WOMEN'S ATHLETIC TOPS WITH BUILT-IN BRAS (U.S. CLS. 22 AND 39).

HANNO RITTNER, EXAMINING ATTORNEY

SN 85-255,639. SHIRK, THOMAS L. II, BLACK HAWK, CO. AND BARTHOLOMEW, WILLIAM J., AUSTIN, TX. FILED 3-2-2011.

Evil Eve

THE MARK CONSISTS OF STANDARD CHARACTERS WITHOUT CLAIM TO ANY PARTICULAR FONT, STYLE, SIZE, OR COLOR.

FOR ATHLETIC APPAREL, NAMELY, SHIRTS, PANTS, JACKETS, FOOTWEAR, HATS AND CAPS, ATHLETIC UNIFORMS (U.S. CLS. 22 AND 39).

WENDY GOODMAN, EXAMINING ATTORNEY

CLASS 25—(Continued).

SN 85-255,672. COOPER, JAYNE MELISSA, STEVENSON RANCH, CA. FILED 3-2-2011.

JUST JAYNE

THE MARK CONSISTS OF STANDARD CHARACTERS WITHOUT CLAIM TO ANY PARTICULAR FONT, STYLE, SIZE, OR COLOR.

THE NAME SHOWN IN THE MARK IDENTIFIES JAYNE COOPER, WHOSE CONSENT TO REGISTER IS MADE OF RECORD.

FOR CLOTHING, NAMELY, BATHING SUITS, BATHING TRUNKS, SWIM SUITS, SWIM TRUNKS, COVER-UPS, BEACHWEAR, BIKINIS, SHORTS, T-SHIRTS, SHOES, SANDALS, FLIP FLOPS, THONGS, SLIPPERS, SCARVES, SARONGS, T-SHIRTS, SHIRTS, SHORTS, BOARDSHORTS, PANTS, SWEATSHIRTS, HOODED SWEATSHIRTS, DRESSES, HATS, CAPS, VISORS, TANK TOPS, JACKETS, AND SKIRTS (U.S. CLS. 22 AND 39).

JOHN WILKE, EXAMINING ATTORNEY

CLASS 25—(Continued).

SN 85-255,747. SHIRK, THOMAS L. II, BLACK HAWK, CO. AND BARTHOLOMEW, WILLIAM J., AUSTIN, TX. FILED 3-2-2011.

Rednek Romeo

THE MARK CONSISTS OF STANDARD CHARACTERS WITHOUT CLAIM TO ANY PARTICULAR FONT, STYLE, SIZE, OR COLOR.

FOR ATHLETIC APPAREL, NAMELY, SHIRTS, PANTS, JACKETS, FOOTWEAR, HATS AND CAPS, ATHLETIC UNIFORMS (U.S. CLS. 22 AND 39).

WENDY GOODMAN, EXAMINING ATTORNEY

SN 85-255,766. CLEATSKINS INC., ENCINITAS, CA. FILED 3-2-2011.

Boatskins

THE MARK CONSISTS OF STANDARD CHARACTERS WITHOUT CLAIM TO ANY PARTICULAR FONT, STYLE, SIZE, OR COLOR.

FOR ATHLETIC APPAREL, NAMELY, SHIRTS, PANTS, JACKETS, FOOTWEAR, HATS AND CAPS, ATHLETIC UNIFORMS; ATHLETIC FOOTWEAR; BEACH FOOTWEAR; FOOTWEAR; NON-SLIP SOLES FOR FOOTWEAR; SOLES FOR FOOTWEAR; WATER-PROOF FOOTWEAR (U.S. CLS. 22 AND 39).

TRACY FLETCHER, EXAMINING ATTORNEY

SN 85-255,775. BORINI, MIKE, NORTHFIELD, NJ. FILED 3-2-2011.



THE COLOR(S) WHITE, GRAY AND BLACK IS/ARE CLAIMED AS A FEATURE OF THE MARK.

THE MARK CONSISTS OF THE WORDING "SPRAWL 'N' BRAWL", WRITTEN IN BLOCK LETTERING. THE COMMON LETTERING "RAWL" IS UTILIZED IN THE SPELLING OF BOTH WORDS. THE "SP" OF THE WORD "SPRAWL" AND THE "B" OF THE WORD "BRAWL" ARE ONE HALF OF THE SIZE OF THE "RAWL" AND THE "P" AND "B" ARE STACKED VERTICALLY. THE WORDS "SPRAWL" AND "BRAWL" ARE IN WHITE COLOR AND "N" IS IN GREY COLOR. ALL OF THE WORDING IS SHOWN AGAINST A BLACK BACKGROUND. SUPERIMPOSED OVER THE WORDING IS A GRAY CHAIN LINK FENCE.

FOR T-SHIRTS, HATS, SHORTS, SWEATSHIRTS (U.S. CLS. 22 AND 39).

BRENDAN MCCAULEY, EXAMINING ATTORNEY

SN 85-255,718. MCCOMBS, JAMES TIMOTHY, DBA DOG ASK DOG TELL, BIRMINGHAM, AL. FILED 3-2-2011.

Dog Ask Dog Tell

THE MARK CONSISTS OF STANDARD CHARACTERS WITHOUT CLAIM TO ANY PARTICULAR FONT, STYLE, SIZE, OR COLOR.

FOR T-SHIRTS (U.S. CLS. 22 AND 39).

FIRST USE 1-19-2011; IN COMMERCE 1-19-2011.

BRIAN NEVILLE, EXAMINING ATTORNEY

SN 85-255,738. CLEATSKINS INC., ENCINITAS, CA. FILED 3-2-2011.

Yachtskins

THE MARK CONSISTS OF STANDARD CHARACTERS WITHOUT CLAIM TO ANY PARTICULAR FONT, STYLE, SIZE, OR COLOR.

FOR ATHLETIC APPAREL, NAMELY, SHIRTS, PANTS, JACKETS, FOOTWEAR, HATS AND CAPS, ATHLETIC UNIFORMS; BEACH FOOTWEAR; FOOTWEAR (U.S. CLS. 22 AND 39).

TRACY FLETCHER, EXAMINING ATTORNEY

CLASS 25—(Continued).

SN 85-255,922. WHITFILL, CLIFFORD M., LONG BEACH, CA. FILED 3-2-2011.

RACE BOMB

THE MARK CONSISTS OF STANDARD CHARACTERS WITHOUT CLAIM TO ANY PARTICULAR FONT, STYLE, SIZE, OR COLOR.

FOR CLOTHING GOODS, NAMELY, SHIRTS, T-SHIRTS, SWEAT SHIRTS, VISORS, HATS, SOCKS, PANTS, AND JACKETS (U.S. CLS. 22 AND 39).

FIRST USE 1-30-2011; IN COMMERCE 1-30-2011.
ANDREA BUTLER, EXAMINING ATTORNEY

SN 85-256,110. PERRICONE, NICHOLAS V., MERIDEN, CT. FILED 3-2-2011.

VANILLA HIGH

THE MARK CONSISTS OF STANDARD CHARACTERS WITHOUT CLAIM TO ANY PARTICULAR FONT, STYLE, SIZE, OR COLOR.

FOR BLOUSES; COATS; DRESSES; FLEECE PULL-OVERS; FLEECE TOPS; FLEECE VESTS; GLOVES; HATS; JACKETS; JEANS; LEG-WARMERS; LEGGINGS; PANTS; SCARVES; SHIRTS; SHORTS; SKIRTS; SOCKS AND STOCKINGS; SWEATERS; SWEATPANTS; SWEAT-SHIRTS; SWIMSUITS; T-SHIRTS; TOPS (U.S. CLS. 22 AND 39).

JIM RINGLE, EXAMINING ATTORNEY

SN 85-256,187. ACHATI MARKETING, INC., MIAMI, FL. FILED 3-2-2011.

BEING SEXY

THE MARK CONSISTS OF STANDARD CHARACTERS WITHOUT CLAIM TO ANY PARTICULAR FONT, STYLE, SIZE, OR COLOR.

FOR BATHING SUITS; BODY SHAPERS; JEANS; LADIES' UNDERWEAR; LINGERIE; SHAPEWEAR, NAMELY, GIRDLES; SHIRTS; UNDERWEAR; WOMEN'S CLOTHING, NAMELY, SHIRTS, DRESSES, SKIRTS, BLOUSES (U.S. CLS. 22 AND 39).

COLLEEN DOMBROW, EXAMINING ATTORNEY

CLASS 25—(Continued).

SN 85-256,261. J. VALENTINE, INC., PARAMOUNT, CA. FILED 3-2-2011.

Faux Fur or No Fur

THE MARK CONSISTS OF STANDARD CHARACTERS WITHOUT CLAIM TO ANY PARTICULAR FONT, STYLE, SIZE, OR COLOR.

FOR HALLOWEEN COSTUMES; T-SHIRTS (U.S. CLS. 22 AND 39).

KIM SAITO, EXAMINING ATTORNEY

SN 85-256,306. EKUIITY LIFESTYLE INC., SAN LUIS OBISPO, CA. FILED 3-2-2011.

SOCIAL EKUIITY

THE MARK CONSISTS OF STANDARD CHARACTERS WITHOUT CLAIM TO ANY PARTICULAR FONT, STYLE, SIZE, OR COLOR.

FOR LONG SLEEVE PULLOVERS; PANTS; SPORT SHIRTS; SPORTS CAPS AND HATS; SWEAT SHIRTS; T-SHIRTS (U.S. CLS. 22 AND 39).

RONALD MCMORROW, EXAMINING ATTORNEY

SN 85-256,309. EKUIITY LIFESTYLE INC., SAN LUIS OBISPO, CA. FILED 3-2-2011.



THE MARK CONSISTS OF TWO LINES WHICH CONVERGE, CREATING THE IMPRESSION OF A DIRECTIONAL ARROW, WITHIN AN OUTLINED SHIELD.

FOR LONG SLEEVE PULLOVERS; PANTS; SPORT SHIRTS; SPORTS CAPS AND HATS; SWEAT SHIRTS; T-SHIRTS (U.S. CLS. 22 AND 39).

RONALD MCMORROW, EXAMINING ATTORNEY

CLASS 25—(Continued).

SN 85-256,332. CALVIN HAMMOCK, DAVENPORT, IA. FILED 3-2-2011.

It's Money In The Building

THE MARK CONSISTS OF STANDARD CHARACTERS WITHOUT CLAIM TO ANY PARTICULAR FONT, STYLE, SIZE, OR COLOR.

FOR CLOTHING, NAMELY, SHIRTS, JACKETS, PANTS, JEANS, HATS, AND SHOES (U.S. CLS. 22 AND 39).

JAMES STEIN, EXAMINING ATTORNEY

SN 85-256,412. RYAN, KYLE, TORRANCE, CA. FILED 3-3-2011.

UNEMPLOYED WINNER

THE MARK CONSISTS OF STANDARD CHARACTERS WITHOUT CLAIM TO ANY PARTICULAR FONT, STYLE, SIZE, OR COLOR.

FOR CLOTHING, NAMELY, SHIRTS, SWEAT SHIRTS, HOODED T-SHIRTS, TANK TOPS, HATS AND THERMAL INNER WEAR (U.S. CLS. 22 AND 39).

KATHY DE JONGE, EXAMINING ATTORNEY

SN 85-256,420. FLOWERS, ALBERT, CRESTVIEW, FL. FILED 3-3-2011.

PLATINUM JUNGLE

THE MARK CONSISTS OF STANDARD CHARACTERS WITHOUT CLAIM TO ANY PARTICULAR FONT, STYLE, SIZE, OR COLOR.

FOR CLOTHING, NAMELY, T-SHIRTS, SHORTS, PANTS, SWEATSHIRTS, HOODED SWEATSHIRTS, BELTS FOR CLOTHING, SHOES, HATS (U.S. CLS. 22 AND 39).

KELLEY WELLS, EXAMINING ATTORNEY

CLASS 25—(Continued).

SN 85-256,427. PALACIOS, ALVIN, SAN DIMAS, CA. FILED 3-3-2011.

MURKED

THE MARK CONSISTS OF STANDARD CHARACTERS WITHOUT CLAIM TO ANY PARTICULAR FONT, STYLE, SIZE, OR COLOR.

FOR CLOTHING, NAMELY, T-SHIRTS, CAPS, HOODED PULLOVERS, HOODED SWEATSHIRTS, SWEATSHIRTS, JACKETS, TANK TOPS, SHORTS, PANTS, BANDANAS, SOCKS, HATS, HEAD WEAR (U.S. CLS. 22 AND 39).

JOHN KELLY, EXAMINING ATTORNEY

SN 85-256,435. STRIKEFORCE BOWLING LLC, BROADVIEW, IL. FILED 3-3-2011.

SLIDES OUT OF THE BOX

THE MARK CONSISTS OF STANDARD CHARACTERS WITHOUT CLAIM TO ANY PARTICULAR FONT, STYLE, SIZE, OR COLOR.

FOR BOWLING SHOES (U.S. CLS. 22 AND 39).

MARGARET POWER, EXAMINING ATTORNEY

SN 85-256,476. ROBINSON, ARTHUR, PHILADELPHIA, PA. FILED 3-3-2011.

THE STRONGEST MUSCLE IN
YOUR BODY IS YOUR BRAIN. YOU
MUST ENHANCE AND ENRICH
YOUR LIFE TO PROSPER

THE MARK CONSISTS OF STANDARD CHARACTERS WITHOUT CLAIM TO ANY PARTICULAR FONT, STYLE, SIZE, OR COLOR.

FOR CLOTHING, NAMELY, TOPS, BOTTOMS, T-SHIRTS (U.S. CLS. 22 AND 39).

JOHN DALIER, EXAMINING ATTORNEY

CLASS 25—(Continued).

SN 85-256,535. SFD ENTERPRISES LLC, FARMINGTON HILLS, MI. FILED 3-3-2011.

GO FIT

THE MARK CONSISTS OF STANDARD CHARACTERS WITHOUT CLAIM TO ANY PARTICULAR FONT, STYLE, SIZE, OR COLOR.
FOR ATHLETIC FOOTWEAR (U.S. CLS. 22 AND 39).
WENDY GOODMAN, EXAMINING ATTORNEY

SN 85-256,567. O'NEILL, TIMOTHY, PHILADELPHIA, PA. FILED 3-3-2011.

URBAN ILL

THE MARK CONSISTS OF STANDARD CHARACTERS WITHOUT CLAIM TO ANY PARTICULAR FONT, STYLE, SIZE, OR COLOR.
FOR BOW TIES; NECKTIES; SCARFS; T-SHIRTS (U.S. CLS. 22 AND 39).
FIRST USE 2-26-2011; IN COMMERCE 2-26-2011.
HAI-LY LAM, EXAMINING ATTORNEY

SN 85-256,814. OKA CO., LTD., KAINAN-SHI, WAKAYAMA, JAPAN, FILED 3-3-2011.

AQUARUN

THE MARK CONSISTS OF STANDARD CHARACTERS WITHOUT CLAIM TO ANY PARTICULAR FONT, STYLE, SIZE, OR COLOR.
FOR STOCKINGS, NAMELY ANTI-SLIP STOCKINGS FOR USE IN WATER EXERCISE; ATHLETIC SHOES, NAMELY TRAINING SHOES FOR USE IN WATER EXERCISE (U.S. CLS. 22 AND 39).
CHARISMA HAMPTON, EXAMINING ATTORNEY

CLASS 25—(Continued).

SN 85-257,069. MORENO, DANIEL, MURRIETA, CA. FILED 3-3-2011.

Nothing To Lose

THE MARK CONSISTS OF STANDARD CHARACTERS WITHOUT CLAIM TO ANY PARTICULAR FONT, STYLE, SIZE, OR COLOR.
FOR CLOTHING, NAMELY, T-SHIRTS, HATS, HOODED SWEAT SHIRTS, SHOES, UNDERGARMENTS, PANTS, SHORTS, TANK TOPS, SWIM SUITS, JACKETS, BELTS (U.S. CLS. 22 AND 39).
FIRST USE 4-20-2008; IN COMMERCE 12-8-2010.
JAMES GRIFFIN, EXAMINING ATTORNEY

SN 85-257,070. CRMM, LLC, SAN FRANCISCO, CA. FILED 3-3-2011.



THE MARK CONSISTS OF THE WORD "LUGGERZ" INSIDE SIX SIDED, FILLED BOX.
FOR PANTS (U.S. CLS. 22 AND 39).
JAMES GRIFFIN, EXAMINING ATTORNEY

SN 85-257,126. PROVO BEACH RESORT, LLC, PROVO, UT. FILED 3-3-2011.



THE COLOR(S) RED, WHITE, OFF-WHITE, PINK, ORANGE, BROWN, GRAY, BLACK, AND BLUE IS/ARE CLAIMED AS A FEATURE OF THE MARK.
THE MARK CONSISTS OF AN IMAGE OF AN ICE CREAM CONE WITH A CHERRY IN DIFFERENT SHADES OF RED ON TOP OF A DOLIP OF CREAM IN WHITE AND GRAY ON TOP OF A SCOOP OF ICE CREAM IN DIFFER-

CLASS 25—(Continued).

ENT SHADES OF PINK AND ORANGE, WHICH SITS IN A WAFFLE CONE IN DIFFERENT SHADES OF BROWN WITH RECTANGULAR SHAPES IN BLACK ON THE CONE'S SURFACE. AN IMAGE OF A LABEL IS DISPLAYED ON THE FACE OF THE CONE IN RED, OFF-WHITE AND BLUE HORIZONTAL SECTIONS AND THE WORDS "I LIKE" IN OFF-WHITE ON TOP WITH A RED BACKGROUND, THE WORD "IKE'S" IN BLUE ON AN OFF-WHITE BACKGROUND AND THE WORD "CREAM" IN OFF-WHITE WITH A BLUE BACKGROUND.

FOR HATS AND T-SHIRTS (U.S. CLS. 22 AND 39).
EDWARD FENNESSY, EXAMINING ATTORNEY

CLASS 25—(Continued).

SN 85-257,318. JIM MARSHALL PHOTOGRAPHY LLC, SAN FRANCISCO, CA. FILED 3-3-2011.

JIM MARSHALL

SN 85-257,216. FAYETTE COUNTY NAACP, DBA FAYETTE COUNTY YOUTH COUNCIL NAACP, FAYETTEVILLE, GA. FILED 3-3-2011.

I'M NOT A TEXT-A-HOLIC

THE MARK CONSISTS OF STANDARD CHARACTERS WITHOUT CLAIM TO ANY PARTICULAR FONT, STYLE, SIZE, OR COLOR.

THE NAME "JIM MARSHALL" DOES NOT IDENTIFY A LIVING INDIVIDUAL.

FOR CLOTHING, NAMELY, T-SHIRTS (U.S. CLS. 22 AND 39).

FIRST USE 9-0-2010; IN COMMERCE 9-0-2010.
JORDAN BAKER, EXAMINING ATTORNEY

THE MARK CONSISTS OF STANDARD CHARACTERS WITHOUT CLAIM TO ANY PARTICULAR FONT, STYLE, SIZE, OR COLOR.

FOR ATHLETIC APPAREL, NAMELY, SHIRTS, PANTS, JACKETS, FOOTWEAR, HATS AND CAPS, ATHLETIC UNIFORMS; GOLF PANTS, SHIRTS AND SKIRTS; HOODED SWEAT SHIRTS; KNIT SHIRTS; OPEN-NECKED SHIRTS; POLO SHIRTS; SHORT-SLEEVED OR LONG-SLEEVED T-SHIRTS; TURTLE NECK SHIRTS; WEARABLE GARMENTS AND CLOTHING, NAMELY, SHIRTS; WRISTBANDS (U.S. CLS. 22 AND 39).

CHARLES L. JENKINS, EXAMINING ATTORNEY

SN 85-257,396. YOBROWEAR LLC, DENVER, PA. FILED 3-3-2011.



SN 85-257,279. BASIC FASHION WEAR INC., LOS ANGELES, CA. FILED 3-3-2011.

MISSSHOP

THE MARK CONSISTS OF STANDARD CHARACTERS WITHOUT CLAIM TO ANY PARTICULAR FONT, STYLE, SIZE, OR COLOR.

FOR WOMEN'S CLOTHING, NAMELY, SHIRTS, DRESSES, SKIRTS, BLOUSES (U.S. CLS. 22 AND 39).

FIRST USE 11-1-2009; IN COMMERCE 11-1-2009.
DAWN HAN, EXAMINING ATTORNEY

THE MARK CONSISTS OF SILHOUETTES OF TWO INDIVIDUALS JUMPING AND HIGHFIVING.

FOR BUTTON DOWN SHIRTS; PINNIES IN THE NATURE OF SCRIMMAGE VESTS FOR USE IN SPORTS; POLO SHIRTS; SHORTS; SWEATSHIRTS; T-SHIRTS (U.S. CLS. 22 AND 39).

RENEE MCCRAY, EXAMINING ATTORNEY

CLASS 25—(Continued).

SN 85-257,506. GROFF, CALEB D., BEAVERTON, OR. FILED 3-3-2011.



THE MARK CONSISTS OF A STYLIZED LETTER E IN LOWERCASE.
FOR HATS; PANTS; SHIRTS; T-SHIRTS (U.S. CLS. 22 AND 39).
WANDA KAY PRICE, EXAMINING ATTORNEY

SN 85-257,518. H. RUSH, LLC, DALLAS, TX. FILED 3-3-2011.



THE MARK CONSISTS OF A LOWER-CASE "H" ENCIRCLED BY FOUR TRIANGLES CURVED FROM BASE TO TIP IN A 90 DEGREE ARC AND ARRAYED END-TO-END TO FORM A CIRCLE.
FOR ATHLETIC APPAREL, NAMELY, SHIRTS, PANTS, JACKETS, FOOTWEAR, HATS AND CAPS, ATHLETIC UNIFORMS; SHORTS; SKIRTS AND DRESSES; TENNIS DRESSES; TENNIS SHOES; TENNIS WEAR (U.S. CLS. 22 AND 39).
FIRST USE 9-15-2010; IN COMMERCE 9-15-2010.
CURTIS FRENCH, EXAMINING ATTORNEY

CLASS 25—(Continued).

SN 85-257,554. EVOLUTIONARY APPAREL, INC., EL MONTE, CA. FILED 3-3-2011.

MOD MODÈLE

THE MARK CONSISTS OF STANDARD CHARACTERS WITHOUT CLAIM TO ANY PARTICULAR FONT, STYLE, SIZE, OR COLOR.
OWNER OF U.S. REG. NO. 3,908,748.
THE ENGLISH TRANSLATION OF THE WORD "MODÈLE" IN THE MARK IS "MODEL".
FOR PANTS, JACKETS, KNIT TOPS (U.S. CLS. 22 AND 39).
FIRST USE 8-1-2010; IN COMMERCE 8-1-2010.
PATRICIA EVANKO, EXAMINING ATTORNEY

SN 85-257,599. FARLEY BOYLE, LITTLE SILVER, NJ. FILED 3-3-2011.

Squirtini Bikini

THE MARK CONSISTS OF STANDARD CHARACTERS WITHOUT CLAIM TO ANY PARTICULAR FONT, STYLE, SIZE, OR COLOR.
NO CLAIM IS MADE TO THE EXCLUSIVE RIGHT TO USE "BIKINI", APART FROM THE MARK AS SHOWN.
FOR BATHING SUITS; BEACH COVER-UPS; BEACH FOOTWEAR; BOARD SHORTS; FOOTWEAR; HEADWEAR; SHORTS; SURF WEAR; SWEAT JACKETS; SWEAT PANTS; SWEAT SHIRTS; SWIM SUITS; SWIMWEAR; T-SHIRTS; TANK-TOPS (U.S. CLS. 22 AND 39).
WILLIAM BRECKENFELD, EXAMINING ATTORNEY

SN 85-257,634. COOKE RONALD H., AKA DIRTY FIGHT BIZZNESS, CHINO, CA. FILED 3-3-2011.

DIRTY FIGHT BIZZNESS DFB

THE MARK CONSISTS OF STANDARD CHARACTERS WITHOUT CLAIM TO ANY PARTICULAR FONT, STYLE, SIZE, OR COLOR.
FOR ATHLETIC APPAREL, NAMELY, SHIRTS, PANTS, JACKETS, FOOTWEAR, HATS AND CAPS, ATHLETIC UNIFORMS; ATHLETIC FOOTWEAR; ATHLETIC SHOES; ATHLETIC TIGHTS; ATHLETIC UNIFORMS; CLOTHING, NAMELY, ATHLETIC SLEEVES; HOODED SWEATSHIRTS; MARTIAL ARTS UNIFORMS; MARTIAL ARTS UNIFORMS, NAMELY, GIS; MIXED MARTIAL ARTS SUITS; SHORT-SLEEVED OR LONG-SLEEVED T-SHIRTS; SPORTS CAPS AND HATS; SPORTS JACKETS; SPORTS PANTS; SPORTS VESTS; SWEATSHIRTS; T-SHIRTS (U.S. CLS. 22 AND 39).
BARBARA GAYNOR, EXAMINING ATTORNEY

CLASS 25—(Continued).

SN 85-257,849. GOLD DEER DRESS INDUSTRIAL CO., LTD.,
TAIPEI, TAIWAN, FILED 3-4-2011.



THE COLOR(S) VIOLET AND RED IS/ARE CLAIMED AS
A FEATURE OF THE MARK.

THE MARK CONSISTS OF STYLIZED WORDING "ROSE-
MAID" IN COLOR VIOLET WITH A ROSE IN COLOR RED
GROWING UPWARD FROM THE LETTER "E".

FOR APRONS; BATHING COSTUMES; BATHING
SUITS; BATHROBES; BELTS; BIBS NOT OF PAPER;
BRASSIERES; CHILDREN'S AND INFANT'S APPAREL,
NAMELY, JUMPERS, OVERALL SLEEPWEAR, PAJA-
MAS, ROMPERS AND ONE-PIECE GARMENTS; COATS;
GIRDLES; GLOVES; HATS; JERSEYS; LADIES' SUITS;
LADIES' UNDERWEAR; LEOTARDS; MATERNITY
BRAS; MATERNITY LINGERIE; MATERNITY SLEEP-
WEAR; NECKERCHIEFS; NIGHTDRESSES; NIGHT-
GOWNS; PAJAMAS; PANTS; PANTYHOSE; SCARVES;
SHAWLS; SHIRTS; SHOES; SILK SCARVES; SKIRTS;
SOCKS; SUITS; SWEAT SUITS; SWEATERS; SWIMSUITS;
UNDERWEAR; VESTS (U.S. CLS. 22 AND 39).

FIRST USE 1-1-2011; IN COMMERCE 1-1-2011.

MARIA-VICTORIA SUAREZ, EXAMINING ATTORNEY

SN 85-257,934. B & D GARMENTS, L.L.C., LAFAYETTE, LA.
FILED 3-4-2011.

DUCKS IN A ROW CAMO

THE MARK CONSISTS OF STANDARD CHARACTERS
WITHOUT CLAIM TO ANY PARTICULAR FONT, STYLE,
SIZE, OR COLOR.

NO CLAIM IS MADE TO THE EXCLUSIVE RIGHT TO
USE "CAMO", APART FROM THE MARK AS SHOWN.

FOR CLOTHING, NAMELY SHIRTS, JACKETS, TIES,
T-SHIRTS, SHORTS, PANTS, SWEAT SHIRTS, HATS
AND CAPS (U.S. CLS. 22 AND 39).

FIRST USE 12-7-2001; IN COMMERCE 12-7-2001.

JAMES GRIFFIN, EXAMINING ATTORNEY

CLASS 25—(Continued).

SN 85-258,635. MY GIRL DRESS INC., LOS ANGELES, CA.
FILED 3-4-2011.

URBAN 1972

THE MARK CONSISTS OF STANDARD CHARACTERS
WITHOUT CLAIM TO ANY PARTICULAR FONT, STYLE,
SIZE, OR COLOR.

NO CLAIM IS MADE TO THE EXCLUSIVE RIGHT TO
USE "1972", APART FROM THE MARK AS SHOWN.

FOR PANTS; SHIRTS; SKIRTS AND DRESSES (U.S.
CLS. 22 AND 39).

FIRST USE 8-1-2004; IN COMMERCE 8-1-2004.

ARETHA SOMERVILLE, EXAMINING ATTORNEY

SN 85-258,696. MY GIRL DRESS INC., LOS ANGELES, CA.
FILED 3-4-2011.

MY GIRL DRESS

THE MARK CONSISTS OF STANDARD CHARACTERS
WITHOUT CLAIM TO ANY PARTICULAR FONT, STYLE,
SIZE, OR COLOR.

NO CLAIM IS MADE TO THE EXCLUSIVE RIGHT TO
USE "DRESS", APART FROM THE MARK AS SHOWN.

FOR DRESSES (U.S. CLS. 22 AND 39).

FIRST USE 1-8-2004; IN COMMERCE 1-8-2004.

ARETHA SOMERVILLE, EXAMINING ATTORNEY

SN 85-259,171. MONEYWORKS, INC., CHICAGO, IL. FILED
3-6-2011.

GODAHOLIC

THE MARK CONSISTS OF STANDARD CHARACTERS
WITHOUT CLAIM TO ANY PARTICULAR FONT, STYLE,
SIZE, OR COLOR.

FOR CLOTHING, NAMELY, JACKETS, OVERCOATS,
SWEATERS, T-SHIRTS, SHIRTS, PANTS, CAPS,
SCARVES, BELTS, AND SHOES (U.S. CLS. 22 AND 39).

SANI KHOURI, EXAMINING ATTORNEY

CLASS 25—(Continued).

SN 85-259,182. MONEYWORKS, INC., CHICAGO, IL. FILED 3-6-2011.

God Overcomes Discrimination

THE MARK CONSISTS OF STANDARD CHARACTERS WITHOUT CLAIM TO ANY PARTICULAR FONT, STYLE, SIZE, OR COLOR.

FOR CLOTHING, NAMELY, JACKETS, OVERCOATS, SWEATERS, T-SHIRTS, SHIRTS, PANTS, CAPS, SCARVES, BELTS, AND SHOES (U.S. CLS. 22 AND 39).
SANI KHOURI, EXAMINING ATTORNEY

SN 85-261,309. DOUGLAS, JESSE P., HIDDEN HILLS, CA. FILED 3-8-2011.

ONESKATER

THE MARK CONSISTS OF STANDARD CHARACTERS WITHOUT CLAIM TO ANY PARTICULAR FONT, STYLE, SIZE, OR COLOR.

FOR SHIRTS (U.S. CLS. 22 AND 39).
FIRST USE 3-6-2011; IN COMMERCE 3-6-2011.
GIANCARLO CASTRO, EXAMINING ATTORNEY

SN 85-261,427. ELLIE CLOTHING, INC, LOS ANGELES, CA. FILED 3-8-2011.

A&RO

THE MARK CONSISTS OF STANDARD CHARACTERS WITHOUT CLAIM TO ANY PARTICULAR FONT, STYLE, SIZE, OR COLOR.

FOR CLOTHING, NAMELY, JACKETS, WOVEN JACKETS, KNIT JACKETS, VESTS, PANTS, SHORTS, SKIRTS, KNIT SKIRTS, ROMPERS, KNIT SKIRTS, TOPS, T-SHIRTS, SHIRTS, SWEATSHIRTS, WOVEN BLOUSES, KNIT BLOUSES, WOVEN DRESSES, SWEATER DRESSES, JERSEY DRESSES, EVENING DRESSES, GOWNS, PANTS, JEANS, DENIM JACKETS, DENIM JUMPERS, SWEATERS, CARDIGANS, PULL OVERS, JUMPERS, LEATHER VESTS, LEATHER JACKETS, FUR COATS (U.S. CLS. 22 AND 39).
GIANCARLO CASTRO, EXAMINING ATTORNEY

CLASS 25—(Continued).

SN 85-261,495. MANISCALCO, ANTHONY, STATEN ISLAND, NY. FILED 3-8-2011.

Retrain Your Brain to Feel No Pain

THE MARK CONSISTS OF STANDARD CHARACTERS WITHOUT CLAIM TO ANY PARTICULAR FONT, STYLE, SIZE, OR COLOR.

FOR T-SHIRTS (U.S. CLS. 22 AND 39).
THOMAS MANOR, EXAMINING ATTORNEY

SN 85-262,368. DOUBLE M STUDIO, LLC, FOXBORO, MA. FILED 3-9-2011.



NO CLAIM IS MADE TO THE EXCLUSIVE RIGHT TO USE "COMFORT SYSTEM", APART FROM THE MARK AS SHOWN.

THE COLOR(S) WHITE, BLACK, BLUE, GREEN AND RED IS/ARE CLAIMED AS A FEATURE OF THE MARK.

THE MARK CONSISTS OF A BLACK RECTANGULAR BACKGROUND CONTAINING THE WORDING "COMMUTER COMFORT SYSTEM" IN WHITE. THE LETTERS "C", "O" AND "M" ARE INSIDE BLUE CIRCLES. THE LETTERS "F", "O", "R" AND "T" ARE INSIDE GREEN CIRCLES. THE LETTERS "S", "Y", "S", "T", "E", AND "M" ARE IN RED CIRCLES.

FOR FOOTWEAR CUSHIONING COMPONENTS, NAMELY, CUSHION INSERTS FOR SHOES PRIMARILY FOR NON-ORTHOPEDIC PURPOSES (U.S. CLS. 22 AND 39).

LINDA E. BLOHM, EXAMINING ATTORNEY

CLASS 25—(Continued).

SN 85-262,702. LEONARD MINGOIA, HUNTINGTON BEACH, CA. FILED 3-9-2011.



THE COLOR(S) TAN, BLACK, BLUE-GREEN, BROWN, BLUE, WHITE AND YELLOW IS/ARE CLAIMED AS A FEATURE OF THE MARK.

THE MARK CONSISTS OF A STANDING SURF BOARD IN THE COLOR BROWN WITH TAN AND BLACK STRIPES, TAN RUDDER AND BLACK OUTLINE ON A TAN BEACH OUTLINED IN BLACK WITH BLUE WATER AND A LIGHT BLUE WAVE OUTLINED IN WHITE WITH A SETTING SUN IN YELLOW AGAINST A BLUE-GREEN SKY BACKGROUND AND FLYING BIRDS IN BLACK ALL WITHIN AN OVAL CARRIER IN BLACK OUTLINE AND THE WORDS "GOTAWOODY.NET" IN BLACK AT THE BOTTOM OF THE OVAL.

FOR SHORT-SLEEVED OR LONG-SLEEVED T-SHIRTS; T-SHIRTS (U.S. CLS. 22 AND 39).
WILLIAM VERHOSEK, EXAMINING ATTORNEY

SN 85-264,069. CHRISTOPHER J. WILSON, CHICAGO, IL. FILED 3-10-2011.

Throw Strikes

THE MARK CONSISTS OF STANDARD CHARACTERS WITHOUT CLAIM TO ANY PARTICULAR FONT, STYLE, SIZE, OR COLOR.

FOR BASEBALL CAPS AND HATS; SWEATSHIRTS (U.S. CLS. 22 AND 39).
ALICIA COLLINS, EXAMINING ATTORNEY

CLASS 25—(Continued).

SN 85-266,429. PENILLA, RAPHAEL, LA VERNE, CA. FILED 3-14-2011.



THE MARK CONSISTS OF AN IMPOSSIBLE TRIANGLE WITH A CLOUD AND A LIGHTING BOLT.
FOR SHIRTS (U.S. CLS. 22 AND 39).
FIRST USE 1-25-2011; IN COMMERCE 2-14-2011.
ELISSA GARBER KON, EXAMINING ATTORNEY

SN 85-267,033. KATE SPADE LLC, NEW YORK, NY. FILED 3-15-2011.

LIVE COLORFULLY

THE MARK CONSISTS OF STANDARD CHARACTERS WITHOUT CLAIM TO ANY PARTICULAR FONT, STYLE, SIZE, OR COLOR.

FOR PANTS; SWEATERS; TOPS (U.S. CLS. 22 AND 39).
FIRST USE 9-0-2009; IN COMMERCE 9-0-2009.
JENNIFER MARTIN, EXAMINING ATTORNEY

SN 85-267,294. FENCHAK, GEROGETTE, HESPERIA, CA. FILED 3-15-2011.

RIVER GIRL

THE MARK CONSISTS OF STANDARD CHARACTERS WITHOUT CLAIM TO ANY PARTICULAR FONT, STYLE, SIZE, OR COLOR.

NO CLAIM IS MADE TO THE EXCLUSIVE RIGHT TO USE "GIRL", APART FROM THE MARK AS SHOWN.

FOR CLOTHING FOR GIRLS, NAMELY, HATS, JACKETS, SHORTS, SWEATSHIRTS, T-SHIRTS, AND TANK TOPS (U.S. CLS. 22 AND 39).

ALEXANDER L. POWERS, EXAMINING ATTORNEY

CLASS 25—(Continued).

SN 85-267,455. ELLIE CLOTHING, INC, LOS ANGELES, CA. FILED 3-15-2011.

Atro by Ellie

THE MARK CONSISTS OF STANDARD CHARACTERS WITHOUT CLAIM TO ANY PARTICULAR FONT, STYLE, SIZE, OR COLOR.

FOR CLOTHING, NAMELY, JACKETS, WOVEN JACKETS, KNIT JACKETS, VESTS, PANTS, SHORTS, SKIRTS, KNIT SKIRTS, ROMPERS, KNIT SKIRTS, TOPS, T-SHIRTS, SHIRTS, SWEATSHIRTS, WOVEN BLOUSES, KNIT BLOUSES, WOVEN DRESSES, SWEATER DRESSES, JERSEY DRESSES, EVENING DRESSES, GOWNS, PANTS, JEANS, DENIM JACKETS, DENIM JUMPERS, SWEATERS, CARDIGANS, PULL OVERS, JUMPERS, LEATHER VESTS, LEATHER JACKETS, FUR COATS (U.S. CLS. 22 AND 39).

GIANCARLO CASTRO, EXAMINING ATTORNEY

SN 85-267,815. YFY, LLC, CRYSTAL LAKE, IL. FILED 3-15-2011.

YUMZ GOURMET FROZEN YOGURT

THE MARK CONSISTS OF STANDARD CHARACTERS WITHOUT CLAIM TO ANY PARTICULAR FONT, STYLE, SIZE, OR COLOR.

OWNER OF U.S. REG. NO. 3,935,658.
FOR (BASED ON USE IN COMMERCE) T-SHIRTS; TOPS(BASED ON INTENT TO USE) HATS; HEADWEAR (U.S. CLS. 22 AND 39).

FIRST USE 2-24-2010; IN COMMERCE 11-25-2010.
SANI KHOURI, EXAMINING ATTORNEY

SN 85-267,837. YFY, LLC, CRYSTAL LAKE, IL. FILED 3-15-2011.



OWNER OF U.S. REG. NO. 3,935,658.

THE MARK CONSISTS OF A RECTANGULAR SHAPE ENCLOSING THE DESIGN OF SOFT-SERVE FROZEN YOGURT WITH THE END OF A SPOON STICKING OUT OF IT AND THE STYLIZED TEXT "YUMZ GOURMET FROZEN YOGURT" TO THE RIGHT OF THE DESIGN.

FOR (BASED ON INTENT TO USE) HATS; HEADWEAR; (BASED ON USE IN COMMERCE) T-SHIRTS; TOPS (U.S. CLS. 22 AND 39).

FIRST USE 2-24-2010; IN COMMERCE 11-25-2010.
SANI KHOURI, EXAMINING ATTORNEY

CLASS 25—(Continued).

SN 85-281,689. RHE HATCO, INC., GARLAND, TX. FILED 3-30-2011.

RANCHO ESTANCIA

THE MARK CONSISTS OF THE WORDS "RANCHO ESTANCIA" WITH A CROSS WITHIN A CIRCLE DESIGN BETWEEN "RANCHO" AND "ESTANCIA".

THE ENGLISH TRANSLATION OF "RANCHO ESTANCIA" IN THE MARK IS "RANCH STAY".

FOR CLOTHING, NAMELY, SHIRTS, SHORTS, PANTS, TOPS, T-SHIRTS AND HEADWEAR, NAMELY, HATS AND CAPS (U.S. CLS. 22 AND 39).

GENE MACIOL, EXAMINING ATTORNEY

SN 85-283,465. FERMAN, RANDALL, CHESTER, NJ. FILED 4-1-2011.

SKY WEAR

THE MARK CONSISTS OF STANDARD CHARACTERS WITHOUT CLAIM TO ANY PARTICULAR FONT, STYLE, SIZE, OR COLOR.

NO CLAIM IS MADE TO THE EXCLUSIVE RIGHT TO USE "WEAR", APART FROM THE MARK AS SHOWN.

FOR CAMOUFLAGE AND NON CAMOUFLAGE CLOTHING, NAMELY, HATS, CLOTH BIBS, OVERALLS, GLOVES, VESTS, SCARVES, PANTS, JUMP SUITS, BOOTS, SHOES, JACKETS, SHIRTS, KNIT FACE MASKS, SHOE AND BOOT COVERS FOR USE WHEN WEARING SHOES OR BOOTS (U.S. CLS. 22 AND 39).

TINA MAI, EXAMINING ATTORNEY

CLASS 25—(Continued).

SN 85-305,329. RONALD STACEY KING, BEVERLY HILLS, CA. FILED 4-26-2011.

2BIG 2STRONG 2FAST 2GOOD

THE MARK CONSISTS OF STANDARD CHARACTERS WITHOUT CLAIM TO ANY PARTICULAR FONT, STYLE, SIZE, OR COLOR.

FOR CLOTHING, NAMELY, HOSIERY, FOOTWEAR, BASKETBALL SHOES, BASKETBALL SNEAKERS, T-SHIRTS, SHIRTS, POLO SHIRTS, SWEATSHIRTS, SWEATPANTS, PANTS, TANK TOPS, JERSEYS, SHORTS, PAJAMAS, SPORT SHIRTS, RUGBY SHIRTS, SWEATERS, BELTS, TIES, NIGHTSHIRTS, HATS, CAPS, VISORS, WARM-UP SUITS, WARM-UP PANTS, WARM-UP TOPS/SHOOTING SHIRTS, JACKETS, WIND RESISTANT JACKETS, PARKAS, COATS, HEAD BANDS, WRIST BANDS, APRONS, UNDERGARMENTS, BOXER SHORTS, SLACKS, CAPS, EAR MUFFS, GLOVES, MITTENS, SCARVES, WOVEN AND KNIT SHIRTS, JERSEY DRESSES, DRESSES, SWIM WEAR, BATHING SUITS, SWIMSUITS, BIKINIS, TANKINIS, SWIM TRUNKS, BATHING TRUNKS, BOARD SHORTS, WET SUITS, BEACH COVER-UPS, BATHING SUIT COVER-UPS, BATHING SUIT WRAPS, SANDALS, BEACH SANDALS, BEACH HATS, SUN VISORS, SWIM CAPS, BATHING CAPS (U.S. CLS. 22 AND 39).

KEVIN CORWIN, EXAMINING ATTORNEY

SN 85-313,056. PIERCE, DAWN, FAIRFIELD, CA. AND PIERCE, SKYLER, FAIRFIELD, CA. FILED 5-5-2011.

Headstrong Fight Gear

THE MARK CONSISTS OF STANDARD CHARACTERS WITHOUT CLAIM TO ANY PARTICULAR FONT, STYLE, SIZE, OR COLOR.

NO CLAIM IS MADE TO THE EXCLUSIVE RIGHT TO USE "FIGHT GEAR", APART FROM THE MARK AS SHOWN.

FOR BEANIES; BELTS; HATS; PANTS; SHIRTS; SHORTS; SWEAT SHIRTS (U.S. CLS. 22 AND 39).

KATHERINE CONNOLLY, EXAMINING ATTORNEY

SN 85-313,427. WISHFULS LLC, PARADISE VALLEY, AZ. FILED 5-5-2011.

BE KIND PEOPLE

THE MARK CONSISTS OF STANDARD CHARACTERS WITHOUT CLAIM TO ANY PARTICULAR FONT, STYLE, SIZE, OR COLOR.

FOR CLOTHING, NAMELY, T-SHIRTS (U.S. CLS. 22 AND 39).

FIRST USE 4-16-2011; IN COMMERCE 4-16-2011.

COLLEEN DOMBROW, EXAMINING ATTORNEY

CLASS 25—(Continued).

SN 85-315,339. ALLI, ALLIANCE OF ACTION SPORTS, LLC, BURR RIDGE, IL. FILED 5-9-2011.

ALLI SPORTS

THE MARK CONSISTS OF STANDARD CHARACTERS WITHOUT CLAIM TO ANY PARTICULAR FONT, STYLE, SIZE, OR COLOR.

OWNER OF U.S. REG. NO. 3,908,921.

NO CLAIM IS MADE TO THE EXCLUSIVE RIGHT TO USE "SPORTS", APART FROM THE MARK AS SHOWN.

FOR CLOTHING, NAMELY, SHIRTS, SWEATSHIRTS, JACKETS, GLOVES, PANTS, SHORTS, FOOTWEAR AND HEADWEAR (U.S. CLS. 22 AND 39).

JOHN WILKE, EXAMINING ATTORNEY

SN 85-315,346. ALLI, ALLIANCE OF ACTION SPORTS, LLC, BURR RIDGE, IL. FILED 5-9-2011.

ALLI ALLIANCE OF ACTION SPORTS

THE MARK CONSISTS OF STANDARD CHARACTERS WITHOUT CLAIM TO ANY PARTICULAR FONT, STYLE, SIZE, OR COLOR.

OWNER OF U.S. REG. NO. 3,908,921.

NO CLAIM IS MADE TO THE EXCLUSIVE RIGHT TO USE "ACTION SPORTS", APART FROM THE MARK AS SHOWN.

FOR CLOTHING, NAMELY, SHIRTS, JACKETS, PANTS, SHORTS, FOOTWEAR AND HEADWEAR (U.S. CLS. 22 AND 39).

JOHN WILKE, EXAMINING ATTORNEY

SN 85-315,832. SHIJIAZHANG QINKE CLOTHING CO., LTD., HEBEI PROVINCE, CHINA, FILED 5-9-2011.



NO CLAIM IS MADE TO THE EXCLUSIVE RIGHT TO USE "BABY", APART FROM THE MARK AS SHOWN.

THE MARK CONSISTS OF THE STYLIZED WORDS "BABY FRIEND".

FOR BABY BIBS NOT OF PAPER; BABY LAYETTES FOR CLOTHING; COATS; FOOTWEAR; GLOVES; HATS; HATS FOR INFANTS, BABIES, TODDLERS AND CHILDREN; HOSIERY; INFANT CLOTH DIAPERS; INFANT WEAR; INFANTS' TROUSERS; SHAWLS; SHIRTS FOR INFANTS, BABIES, TODDLERS AND CHILDREN; WOMEN'S CLOTHING, NAMELY, SHIRTS, DRESSES, SKIRTS, BLOUSES (U.S. CLS. 22 AND 39).

FIRST USE 3-20-2008; IN COMMERCE 3-20-2008.

ARETHA SOMERVILLE, EXAMINING ATTORNEY

CLASS 25—(Continued).

SN 85-319,336. SCHAENGOLD, PHILLIP S, SAVANNAH, GA. FILED 5-12-2011.

TRIPETIA

THE MARK CONSISTS OF STANDARD CHARACTERS WITHOUT CLAIM TO ANY PARTICULAR FONT, STYLE, SIZE, OR COLOR.

FOR MEN'S, WOMEN'S AND CHILDREN CLOTHING, NAMELY, SWEATSHIRTS, SHIRTS, JEANS, JACKETS, COATS, SWEATPANTS, SUITS, HATS, HEADBANDS, VISORS, CAPS, BLOUSES, DRESSES, SHOES, SNEAKERS, BOOTS, WRISTBANDS, SOCKS, T-SHIRTS, BELTS, UNDERGARMENTS, NECKTIES, DRESS SHIRTS, COLLARED SHIRTS, RUGBY SHIRTS, KNIT SHIRTS, SHORTS, RAINWEAR, PAJAMAS, SLEEPWEAR, FOOTWEAR AND SANDALS (U.S. CLS. 22 AND 39).

REBECCA SMITH, EXAMINING ATTORNEY

CLASS 25—(Continued).

SN 85-331,780. PARAMOUNT PICTURES CORPORATION, HOLLYWOOD, CA. FILED 5-26-2011.

WWZ

THE MARK CONSISTS OF STANDARD CHARACTERS WITHOUT CLAIM TO ANY PARTICULAR FONT, STYLE, SIZE, OR COLOR.

FOR APPAREL, NAMELY, T-SHIRTS, SWEATSHIRTS, BOXER SHORTS, SLEEPWEAR, JACKETS, AND HEADWEAR; HALLOWEEN COSTUMES AND MASKS SOLD IN CONNECTION THEREWITH (U.S. CLS. 22 AND 39).

SUSAN RICHARDS, EXAMINING ATTORNEY

CLASS 26—FANCY GOODS

SN 76-706,669. VBS ONLINE, INC., MILWAUKEE, WI. FILED 3-7-2011.

DELILAH

THE MARK CONSISTS OF STANDARD CHARACTERS WITHOUT CLAIM TO ANY PARTICULAR FONT, STYLE, SIZE, OR COLOR.

FOR WIGS, HAIRPIECES, AND ADD-IN AND ADD-ON HAIR ACCESSORIES CONSTRUCTED PRIMARILY OF SYNTHETIC AND/OR HUMAN HAIR (U.S. CLS. 37, 39, 40, 42 AND 50).

MICHAEL TANNER, EXAMINING ATTORNEY

SN 85-329,115. ROSALIE MATUS, SAN BERNARDINO, CA. AND FELIX NEGRETE, SAN BERNARDINO, CA. FILED 5-24-2011.



NO CLAIM IS MADE TO THE EXCLUSIVE RIGHT TO USE "NATIVE AMERICAN", APART FROM THE MARK AS SHOWN.

THE MARK CONSISTS OF THE STYLIZED WORDING "HALFBLOOD" CENTERED ABOVE THE STYLIZED WORDING "NATIVE AMERICAN". AROUND THE WORDS IS AN INCOMPLETE CIRCLE WITH AN OPENING AT THE BOTTOM. TWO PAIRS OF FEATHERS HANG DOWNWARD FROM THE BOTTOM OF THE CIRCLE, ONE TO THE LEFT AND ONE TO THE RIGHT. THE BASES OF THE FEATHERS ARE COVERED BY A CIRCULAR BADGE CONTAINING AN ARROWHEAD.

FOR HATS, BEANIES, SHIRTS, T-SHIRTS, SWEATSHIRTS, HOODED SWEATSHIRTS, TANK TOPS AND TOPS FOR MEN, WOMEN AND CHILDREN, MADE OR PROVIDED BY NATIVE AMERICANS (U.S. CLS. 22 AND 39).

FIRST USE 5-1-2011; IN COMMERCE 5-1-2011.
KATHY DE JONGE, EXAMINING ATTORNEY

SN 85-100,876. HEAVEN, CRAIG MICHAEL, CARDIFF, UNITED KINGDOM, FILED 8-5-2010.

BOBBYGLAM

THE MARK CONSISTS OF STANDARD CHARACTERS WITHOUT CLAIM TO ANY PARTICULAR FONT, STYLE, SIZE, OR COLOR.

OWNER OF UNITED KINGDOM REG. NO. 2538403, DATED 6-18-2010, EXPIRES 2-5-2020.

THE NAME "BOBBYGLAM" DOES NOT IDENTIFY A LIVING INDIVIDUAL.

FOR HAIR EXTENSIONS; WIGS, HAIRPIECES, AND ADD-IN AND ADD-ON HAIR ACCESSORIES CONSTRUCTED PRIMARILY OF SYNTHETIC AND/OR HUMAN HAIR (U.S. CLS. 37, 39, 40, 42 AND 50).

CYNTHIA TRIPI, EXAMINING ATTORNEY

CLASS 26—(Continued).

SN 85-169,628. SC LICENSING CORP, WEST BRIDGE-WATER, MA. FILED 11-4-2010.

Travelite Wigs

THE MARK CONSISTS OF STANDARD CHARACTERS WITHOUT CLAIM TO ANY PARTICULAR FONT, STYLE, SIZE, OR COLOR.

NO CLAIM IS MADE TO THE EXCLUSIVE RIGHT TO USE "WIGS", APART FROM THE MARK AS SHOWN.

FOR WIGS (U.S. CLS. 37, 39, 40, 42 AND 50).

FIRST USE 1-20-2011; IN COMMERCE 1-20-2011.

TINA MAI, EXAMINING ATTORNEY

SN 85-181,748. ZOOM ZIPPER CORPORATION, DONG-GUAN, CHINA, FILED 11-19-2010.

ZOOM

THE MARK CONSISTS OF STANDARD CHARACTERS WITHOUT CLAIM TO ANY PARTICULAR FONT, STYLE, SIZE, OR COLOR.

FOR CLOTHING FASTENERS, NAMELY, SNAP BUTTONS; CLOTHING FASTENERS, NAMELY, SNAP HOOKS; CLOTHING FASTENERS, NAMELY, STUD BUTTONS; CLOTHING HOOKS; FASTENERS FOR SHOES AND BOOTS; HOOK AND LOOP FASTENERS FOR USE IN THE MANUFACTURE OF CLOTHING AND SHOES; METAL FASTENERS FOR SHOES AND BOOTS; ZIP FASTENERS; ZIPPER FASTENERS; ZIPPERS (U.S. CLS. 37, 39, 40, 42 AND 50).

WENDY GOODMAN, EXAMINING ATTORNEY

SN 85-200,547. RUSINQUE, JOPHER, SUNNY ISLES, FL. FILED 12-17-2010.



NO CLAIM IS MADE TO THE EXCLUSIVE RIGHT TO USE "LACEUPS", APART FROM THE MARK AS SHOWN.

THE COLOR(S) BLACK, WHITE, PURPLE, AND LIGHT PURPLE IS/ARE CLAIMED AS A FEATURE OF THE MARK.

THE MARK CONSISTS OF A BLACK HIGH HEELED BOOT, WITH WHITE SHADOWING AND DESIGNS ON THE BOOT, OVERLAPPING A LIGHT PURPLE CURSIVE "L" AND LIGHT PURPLE CURSIVE "U" WITH THE WORD "LACEUPS" IN PURPLE CENTERED BELOW THE LETTERS "LU" AND THE BOOT.

FOR FOOTWEAR ACCESSORY, NAMELY, SHOE LACES, SHOE BUCKLES, SHOE ORNAMENTS NOT OF PRECIOUS METAL (U.S. CLS. 37, 39, 40, 42 AND 50).

TINA BROWN, EXAMINING ATTORNEY

CLASS 26—(Continued).

SN 85-233,187. ELLEN L. HOLDER, WOODINVILLE, WA. FILED 2-3-2011.

CLEVER CRAFT TOOLS

THE MARK CONSISTS OF STANDARD CHARACTERS WITHOUT CLAIM TO ANY PARTICULAR FONT, STYLE, SIZE, OR COLOR.

NO CLAIM IS MADE TO THE EXCLUSIVE RIGHT TO USE "CRAFT TOOLS", APART FROM THE MARK AS SHOWN.

FOR FREE MOTION QUILTING DISKS, NAMELY, A SEWING AND STITCHING AID IN THE SHAPE OF DISKS THAT ARE USED TO ASSIST IN QUILTING (U.S. CLS. 37, 39, 40, 42 AND 50).

FIRST USE 7-1-2010; IN COMMERCE 1-21-2011.

ANDREW RHIM, EXAMINING ATTORNEY

SN 85-235,577. QWIK TRESS ENTERPRISES LLC, EVANSTON, IL. FILED 2-7-2011.

THE MARK CONSISTS OF TWO WORDS "FLEXI" AND "STRAND" SEPARATED BY A HYPHEN. THE FIRST LETTER OF EACH WORD IS CAPITALIZED. THE "I" AT THE END OF THE WORD "FLEXI" IS DOTTED WITH A SWIRL AND THE COMBINED WORD SITS UPON AND FOLLOWS THE SHAPE OF A WAVY BAND, WHICH UNDERLINES THE WORDS AND COMPLETES THE LOGO DESIGN.

FOR WIGS, HAIRPIECES, AND ADD-IN AND ADD-ON HAIR ACCESSORIES CONSTRUCTED PRIMARILY OF SYNTHETIC AND/OR HUMAN HAIR (U.S. CLS. 37, 39, 40, 42 AND 50).

FIRST USE 2-1-2003; IN COMMERCE 2-10-2003.

SOPHIA S. KIM, EXAMINING ATTORNEY

CLASS 26—(Continued).

SN 85-246,689. CLARK, KIMBERLY LANE, DBA PERSNICKETY BABY, VISALIA, CA. FILED 2-18-2011.

Persnickety Baby

THE MARK CONSISTS OF STANDARD CHARACTERS WITHOUT CLAIM TO ANY PARTICULAR FONT, STYLE, SIZE, OR COLOR.

NO CLAIM IS MADE TO THE EXCLUSIVE RIGHT TO USE "BABY", APART FROM THE MARK AS SHOWN.

FOR HAIR BOWS; HAIR CLIPS (U.S. CLS. 37, 39, 40, 42 AND 50).

FIRST USE 3-1-2009; IN COMMERCE 3-1-2009.
ELLEN B. AWRICH, EXAMINING ATTORNEY

CLASS 27—FLOOR COVERINGS

SN 85-250,168. SYNTHETIC GRASS WAREHOUSE, INC., ANAHEIM, CA. FILED 2-24-2011.

EVERLAST ARTIFICIAL GRASS

THE MARK CONSISTS OF STANDARD CHARACTERS WITHOUT CLAIM TO ANY PARTICULAR FONT, STYLE, SIZE, OR COLOR.

NO CLAIM IS MADE TO THE EXCLUSIVE RIGHT TO USE "ARTIFICIAL GRASS", APART FROM THE MARK AS SHOWN.

FOR SYNTHETIC GRASS (U.S. CLS. 19, 20, 37, 42 AND 50).

JAMES MACFARLANE, EXAMINING ATTORNEY

SN 85-255,817. MODEL MODEL HAIR FASHION, INC., COLLEGE POINT, NY. FILED 3-2-2011.

SPLASH

THE MARK CONSISTS OF STANDARD CHARACTERS WITHOUT CLAIM TO ANY PARTICULAR FONT, STYLE, SIZE, OR COLOR.

FOR HAIR PRODUCTS, NAMELY, HAIR PIECES, HAIR EXTENSIONS, WIGS AND PONYTAIL HAIR PIECES (U.S. CLS. 37, 39, 40, 42 AND 50).

EDWARD FENNESSY, EXAMINING ATTORNEY

SN 85-253,385. O'BRIEN, CAROL A, DBA CLEANICITY, AUSTIN, TX. FILED 2-28-2011.

Stikitty

THE MARK CONSISTS OF THE WORD "STIKITTY" IN STYLIZED FONT WHERE A PAW PRINT APPEARS ABOVE EACH LETTER "I".

FOR ADHESIVE COATED CONTAMINATION CONTROL FLOOR MAT MADE OF POLYPROPYLENE THAT CAPTURES PARTICULATES (U.S. CLS. 19, 20, 37, 42 AND 50).

FIRST USE 2-25-2011; IN COMMERCE 2-25-2011.
TINA BROWN, EXAMINING ATTORNEY

SN 85-305,011. PIATKOWSKI, ROBERT, WHEATON, IL. FILED 4-26-2011.

MISTLETOKE

THE MARK CONSISTS OF STANDARD CHARACTERS WITHOUT CLAIM TO ANY PARTICULAR FONT, STYLE, SIZE, OR COLOR.

OWNER OF U.S. REG. NO. 3,631,170.
FOR NOVELTY ITEM, NAMELY, DECORATIVE HANGING MARIJUANA PLANT LEAVES MADE OF SILK (U.S. CLS. 37, 39, 40, 42 AND 50).

LINDSEY RUBIN, EXAMINING ATTORNEY

SN 85-257,870. STARK CARPET CORP., NEW YORK, NY. FILED 3-4-2011.

DARIUS

THE MARK CONSISTS OF STANDARD CHARACTERS WITHOUT CLAIM TO ANY PARTICULAR FONT, STYLE, SIZE, OR COLOR.

OWNER OF U.S. REG. NO. 1,924,231.
FOR FLOOR COVERINGS, NAMELY, AREA RUGS, CARPETS, CARPETING, BROADLOOM CARPETING, RUGS, FLOOR MATS AND FLOOR MATS FOR VEHICLES (U.S. CLS. 19, 20, 37, 42 AND 50).

FIRST USE 7-1-1993; IN COMMERCE 9-1-1993.
APRIL HESIK, EXAMINING ATTORNEY

CLASS 27—(Continued).

SN 85-263,161. MURATORI, MARIE A, DBA MIA MURATORI, WILMINGTON, DE. FILED 3-10-2011.

MIA MURATORI

THE MARK CONSISTS OF STANDARD CHARACTERS WITHOUT CLAIM TO ANY PARTICULAR FONT, STYLE, SIZE, OR COLOR.

THE NAME(S), PORTRAIT(S), AND/OR SIGNATURE(S) SHOWN IN THE MARK IDENTIFIES "MIA MURATORI", WHOSE CONSENT(S) TO REGISTER IS MADE OF RECORD.

THE ENGLISH TRANSLATION OF "MURATORI" IN THE MARK IS "MASON".

FOR RUGS (U.S. CLS. 19, 20, 37, 42 AND 50).
FIRST USE 6-1-1960; IN COMMERCE 1-1-1994.
MAYUR VAGHANI, EXAMINING ATTORNEY

CLASS 28—(Continued).

SN 76-706,719. DUCKETT FISHING LLC, DEMOPOLIS, AL. FILED 3-9-2011.

Micro Magic

THE MARK CONSISTS OF STANDARD CHARACTERS WITHOUT CLAIM TO ANY PARTICULAR FONT, STYLE, SIZE, OR COLOR.

FOR FISHING RODS (U.S. CLS. 22, 23, 38 AND 50).
FIRST USE 12-24-2009; IN COMMERCE 12-24-2009.
CARYN GLASSER, EXAMINING ATTORNEY

SN 77-442,417. JEN GROOVER DESIGNS, LLC, BROOMALL, PA. FILED 4-8-2008.

LEADERGIRLZ**CLASS 28—TOYS AND SPORTING GOODS**

SN 76-028,537. K & M INTERNATIONAL, INC., TWINSBURG, OH. FILED 4-17-2000.

WILD GUARDIANS

THE MARK CONSISTS OF STANDARD CHARACTERS WITHOUT CLAIM TO ANY PARTICULAR FONT, STYLE, SIZE, OR COLOR.

FOR DOLLS, DOLL ACCESSORIES, DOLL CLOTHING, DOLL COSTUMES, DOLL HOUSE FURNISHINGS, DOLL HOUSES (U.S. CLS. 22, 23, 38 AND 50).
JAY BESCH, EXAMINING ATTORNEY

FOR PLUSH TOYS (U.S. CLS. 22, 23, 38 AND 50).
JENNIFER DIXON, EXAMINING ATTORNEY

SN 77-827,204. MATTEL, INC., EL SEGUNDO, CA. FILED 9-15-2009.

SN 76-706,675. JAMES, ROBERT, JAMES, COCOA, FL. FILED 3-7-2011.

VIDEO GIRL**Smart Bench For Dumbbells**

THE MARK CONSISTS OF STANDARD CHARACTERS WITHOUT CLAIM TO ANY PARTICULAR FONT, STYLE, SIZE, OR COLOR.

FOR FITNESS EQUIPMENT, NAMELY, WEIGHT LIFTING BENCHES SPECIFICALLY ENGINEERED FOR HOLDING DUMBBELLS (U.S. CLS. 22, 23, 38 AND 50).

FIRST USE 2-26-2008; IN COMMERCE 2-26-2008.
JAY BESCH, EXAMINING ATTORNEY

THE MARK CONSISTS OF STANDARD CHARACTERS WITHOUT CLAIM TO ANY PARTICULAR FONT, STYLE, SIZE, OR COLOR.

NO CLAIM IS MADE TO THE EXCLUSIVE RIGHT TO USE "GIRL", APART FROM THE MARK AS SHOWN.
FOR TOYS, GAMES AND PLAYTHINGS, NAMELY, DOLLS, DOLL CLOTHING AND DOLL ACCESSORIES (U.S. CLS. 22, 23, 38 AND 50).

FIRST USE 3-30-2010; IN COMMERCE 3-30-2010.
LEIGH LOWRY, EXAMINING ATTORNEY

CLASS 28—(Continued).

SN 77-862,968. DJB HOLDING LLC, CHEVY CHASE, MD.
FILED 11-2-2009.

BABY GIRL "B" ELEGANCE

THE MARK CONSISTS OF STANDARD CHARACTERS WITHOUT CLAIM TO ANY PARTICULAR FONT, STYLE, SIZE, OR COLOR.

FOR TOYS AND PLAYTHINGS, NAMELY, ACTION SKILL GAMES; ACTION FIGURES AND ACCESSORIES THEREFOR; BOARD GAMES; CARD GAMES; CHILDREN'S MULTIPLE ACTIVITY TOYS; BADMINTON SETS; SPORTS EQUIPMENT, NAMELY, WALKING POLES; BALLOONS; BASKETBALLS; BATH TOYS; BASEBALLS; BEACH BALLS; BEAN BAGS, BEAN BAG DOLLS; TOY BUILDING BLOCKS; BOWLING BALLS; BUBBLE MAKING WANDS AND SOLUTION SETS; CHESS SETS; CHILDREN'S PLAY COSMETICS; CHRISTMAS STOCKINGS; CHRISTMAS TREE DECORATIONS; COLLECTIBLE TOY FIGURES; CRIB MOBILES; CRIB TOYS; DISC TOSS TOYS; DOLLS; DOLL CLOTHING; DOLL ACCESSORIES; DOLL PLAYSETS; ELECTRIC ACTION TOYS; EQUIPMENT SOLD AS A UNIT FOR PLAYING CARD GAMES; FISHING TACKLE; GOLF BALLS; GOLF GLOVES; GOLF BALL MARKERS; HANDHELD UNIT FOR PLAYING ELECTRONIC GAMES OTHER THAN THOSE ADAPTED FOR USE WITH AN EXTERNAL DISPLAY SCREEN OR MONITOR; HOCKEY PUCKS; INFLATABLE TOYS; JIGSAW PUZZLES; JUMP ROPES; KITES; MAGIC TRICKS; MARBLES; MANIPULATIVE GAMES; MECHANICAL TOYS; MUSIC BOX TOYS; MUSICAL TOYS; PARLOR GAMES; PARTY FAVORS IN THE NATURE OF SMALL TOYS; PARTY GAMES; PLAYING CARDS; PLUSH TOYS; PUPPETS; ROLLER SKATES; RUBBER BALLS; SKATEBOARDS; SOCCER BALLS; SPINNING TOPS; SQUEEZE TOYS; STUFFED TOYS; TABLE TENNIS TABLES; TARGET GAMES; TEDDY BEARS; TENNIS BALLS; TOY ACTION FIGURES; TOY BUCKET AND SHOVEL SETS; TOY MOBILES; TOY VEHICLES; TOY SCOOTERS; TOY CARS; TOY MODEL HOBBYCRAFT KITS; TOY FIGURES; TOY BANKS; TOY TRUCKS; TOY WATCHES; WIND UPS TOYS; YO-YOS (U.S. CLS. 22, 23, 38 AND 50).

NICHOLAS COLEMAN, EXAMINING ATTORNEY

SN 77-933,318. JOSEPH BERTO, WHITE CITY, OR. FILED 2-11-2010.

AB-STIK

THE MARK CONSISTS OF STANDARD CHARACTERS WITHOUT CLAIM TO ANY PARTICULAR FONT, STYLE, SIZE, OR COLOR.

FOR EXERCISE DEVICES, NAMELY, MANUALLY OPERATED EXERCISE EQUIPMENT (U.S. CLS. 22, 23, 38 AND 50).

DAVID ELTON, EXAMINING ATTORNEY

CLASS 28—(Continued).

SN 77-947,793. MADARAS GALLERY, INC., TUCSON, AZ.
FILED 3-1-2010.

PUPPY TANGO

THE MARK CONSISTS OF STANDARD CHARACTERS WITHOUT CLAIM TO ANY PARTICULAR FONT, STYLE, SIZE, OR COLOR.

NO CLAIM IS MADE TO THE EXCLUSIVE RIGHT TO USE "PUPPY", APART FROM THE MARK AS SHOWN.

FOR TOYS, GAMES, AND PLAYTHINGS, NAMELY, STUFFED AND PLUSH TOYS, SNOW GLOBES, PLAYING CARDS; TOY BANKS, POP-UP TOYS, BEAN-FILLED TOYS, MECHANICAL PLUSH TOYS, DOG TOYS, CAT TOYS, LATEX BALLOONS, HEAD BOBBING TOY FIGURES, ACTION FIGURES AND ACCESSORIES THEREFOR, TOY FIGURINES, TOY FIGURES EMITTING SOUNDS AND MUSIC, CHRISTMAS TREE ORNAMENTS; CHRISTMAS DECORATIONS IN THE NATURE OF ARTIFICIAL GARLANDS, TREE SKIRTS; CHRISTMAS STOCKINGS FOR CHILDREN EMITTING SOUNDS AND MUSIC, MUSIC BOX TOYS, FINGER PUPPETS, BOARD GAMES, PUZZLES, INFLATABLE TOYS, PLASTIC SQUEEZE TOYS, TOY BALLS, NAMELY, PLAYGROUND BALLS, TOY GLIDERS, PADDLE BALLS, TOY PLAY LIGHT WANDS, YO-YO'S, FLYING DISCS, TOY DOLLS, INFLATABLE TOY DOLLS, IN-LINE SKATES, ICE SKATES, SNOW BOARDS, SKATEBOARDS, SWIM TOYS, NAMELY, SWIM BOARDS FOR RECREATIONAL USE, SWIM FINS, SWIM FLOATS FOR RECREATIONAL USE, WATER WING SWIM AIDS FOR RECREATIONAL USE; TOY VEHICLES, CHILDREN'S HOBBY CRAFT KITS FOR THE PURPOSE OF MAKING STUFFED ANIMALS, CHRISTMAS TREE DECORATIONS (U.S. CLS. 22, 23, 38 AND 50).

NAAKWAMA ANKRAH, EXAMINING ATTORNEY

SN 77-962,945. UBISOFT ENTERTAINMENT, RENNES, FRANCE, FILED 3-19-2010.

MIGHT & MAGIC

THE MARK CONSISTS OF STANDARD CHARACTERS WITHOUT CLAIM TO ANY PARTICULAR FONT, STYLE, SIZE, OR COLOR.

OWNER OF U.S. REG. NOS. 1,479,759, 3,451,464 AND OTHERS.

FOR TOYS AND PLAYTHINGS, NAMELY, DOLLS, TOY ACTION FIGURES, PLUSH TOYS AND ACCESSORIES THEREOF, PLAYSETS FOR DOLLS AND TOY ACTION FIGURES, TOY VEHICLES AND HAND HELD UNITS FOR PLAYING ELECTRONIC GAMES OTHER THAN THOSE ADAPTED FOR USE WITH AN EXTERNAL DISPLAY SCREEN OR MONITOR (U.S. CLS. 22, 23, 38 AND 50).

PAUL F. GAST, EXAMINING ATTORNEY

CLASS 28—(Continued).

SN 78-287,147. MATTEL, INC., EL SEGUNDO, CA. FILED 8-13-2003.

INCREDIBLE CRASH DUMMIES

FOR TOYS, GAMES AND PLAYTHINGS, NAMELY, TOY FIGURES AND ACCESSORIES THEREFOR, TOY VEHICLES AND ACCESSORIES THEREFOR, TOY FIGURE PLAYSETS AND ACCESSORIES THEREFOR, TOY VEHICLE PLAYSETS AND ACCESSORIES THEREFOR (U.S. CLS. 22, 23, 38 AND 50).

RON FAIRBANKS, EXAMINING ATTORNEY

SN 79-080,382. MODERN STAR INTERNATIONAL PTY LIMITED, BROOKVALE, AUSTRALIA, FILED 1-28-2010.



OWNER OF INTERNATIONAL REGISTRATION 1032792 DATED 1-28-2010, EXPIRES 1-28-2020.

NO CLAIM IS MADE TO THE EXCLUSIVE RIGHT TO USE "PLAY", APART FROM THE MARK AS SHOWN.

THE COLOR(S) WHITE, RED AND BLUE IS/ARE CLAIMED AS A FEATURE OF THE MARK.

THE MARK CONSISTS OF THE WORD "BASIC PLAY" WITH A DRAWING OF THE HEADS OF A BOY AND A GIRL WITHIN AN ABSTRACT SHAPED BACKGROUND. THE COLOR RED APPEARS IN THE TEXT AND AS THE OUTLINE OF THE TEXT, AS THE HAIR AND FEATURES OF THE BOY AND GIRL, AND PART OF THE OUTLINE OF THE BACKGROUND; THE COLOR BLUE APPEARS AS THE BACKGROUND, AND THE COLOR WHITE APPEARS AS THE INSIDE BORDER OF PART OF THE BACKGROUND, AS PART OF THE OUTLINE OF THE LETTERS "BASIC PLAY" AND THE FACES OF THE BOY AND GIRL.

FOR CHILDREN'S TOYS, NAMELY, CHILDREN'S MULTIPLE ACTIVITY TOYS, PLASTIC CHARACTER TOYS, POP UP TOYS; EDUCATIONAL PLAYTHINGS, NAMELY, EDUCATIONAL CARD GAMES, ELECTRIC EDUCATIONAL TOY USED TO DEMONSTRATE ALTERNATIVE ENERGY SOURCES; EDUCATIONAL TOYS, NAMELY, ELECTRONIC LEARNING TOYS; ACTION TOYS, NAMELY, MECHANICAL ACTION TOYS, LEVER ACTION TOYS, ELECTRONIC ACTION TOYS, BATTERY OPERATED ACTION TOYS; CONSTRUCTION TOYS; CRAFT TOYS SOLD IN KIT FORM, NAMELY, TOY MODEL HOBBY CRAFT KITS, SCALE MODEL KITS; PLASTIC TOYS, NAMELY, PLASTIC CHARACTER TOYS, PLASTIC TOY HOOPS, MODELED PLASTIC TOY FIGURINES; TOYS, NAMELY, STUFFED TOYS, BENDABLE TOYS, FLYING SAUCERS, FANTASY CHARACTER TOYS; HOBBY CRAFT KITS COMPRISED OF UNASSEMBLED PARTS FOR CONSTRUCTING TOY VEHICLES AND TOY MODEL VEHICLES (U.S. CLS. 22, 23, 38 AND 50).

CARYN GLASSER, EXAMINING ATTORNEY

CLASS 28—(Continued).

SN 79-091,609. KREATIVNI DOGADAJI D.O.O., HR-10000 ZAGREB, CROATIA, FILED 9-14-2010.



PRIORITY DATE OF 5-12-2010 IS CLAIMED. OWNER OF INTERNATIONAL REGISTRATION 1062463 DATED 9-14-2010, EXPIRES 9-14-2020.

THE COLOR(S) ORANGE, YELLOW AND BLACK IS/ARE CLAIMED AS A FEATURE OF THE MARK.

THE MARK CONSISTS OF THE WORDING "DRINKOPOLY" IN ORANGE OUTLINED IN BLACK, AND ABOVE APPEARS TWO STYLIZED HUMAN FIGURES IN YELLOW OUTLINED IN BLACK; THE COLOR WHITE IS NOT PART OF THE MARK AND REPRESENTS TRANSPARENT BACKGROUND.

FOR GAMES AND TOYS, NAMELY, BOARD GAMES (U.S. CLS. 22, 23, 38 AND 50).

KELLY CHOE, EXAMINING ATTORNEY

SN 85-088,495. TRUE TEMPER SPORTS, INC., MEMPHIS, TN. FILED 7-20-2010.

DG SPINNER

THE MARK CONSISTS OF STANDARD CHARACTERS WITHOUT CLAIM TO ANY PARTICULAR FONT, STYLE, SIZE, OR COLOR.

OWNER OF U.S. REG. NO. 2,508,169. FOR GOLF CLUB SHAFTS (U.S. CLS. 22, 23, 38 AND 50).

ALEXANDER L. POWERS, EXAMINING ATTORNEY

SN 85-090,610. INDIAN INDUSTRIES, INC., EVANSVILLE, IN. FILED 7-22-2010.

TENNIZ

THE MARK CONSISTS OF STANDARD CHARACTERS WITHOUT CLAIM TO ANY PARTICULAR FONT, STYLE, SIZE, OR COLOR.

FOR EQUIPMENT SOLD AS A UNIT FOR PLAYING A PORTABLE NET GAME WITH RACQUETS AND PLAYING PIECES; NETS FOR GAMES; GAME RACQUETS; GAME PLAYING PIECES (U.S. CLS. 22, 23, 38 AND 50).

DAWN FELDMAN, EXAMINING ATTORNEY

CLASS 28—(Continued).

SN 85-096,778. JOYSWAY HOBBY (HK) LIMITED, NEW TERRITORIES, HONG KONG, FILED 7-30-2010.



OWNER OF HONG KONG REG. NO. 301388250, DATED 7-20-2009, EXPIRES 7-20-2019.

NO CLAIM IS MADE TO THE EXCLUSIVE RIGHT TO USE "HOBBY", APART FROM THE MARK AS SHOWN.

THE MARK CONSISTS OF STYLIZED LETTERS "RC HOBBY WORLD" ABOVE STYLIZED LETTERS "JOYSWAY" IN A PATTERNED RECTANGLE.

FOR CHILDREN'S MULTIPLE ACTIVITY TOYS, ACTION SKILL GAMES; MODEL TOY VEHICLES; TOY MODEL HOBBYCRAFT KITS; REMOTE CONTROL TOYS, NAMELY, CARS, RACE CARS, AIRPLANES, BOATS; RADIO CONTROLLED TOY VEHICLES; REMOTE CONTROLLED TOY VEHICLES; TOY AIRPLANES; TOY HELICOPTERS; TOY LOCOMOTIVES; RADIO-CONTROLLED TOY VEHICLES, TOY AIRPLANES, TOY HELICOPTERS AND TOY LOCOMOTIVES (U.S. CLS. 22, 23, 38 AND 50).

SKYE YOUNG, EXAMINING ATTORNEY

SN 85-100,598. CAI DEFENG, CHENGHAI, GUANGDONG, CHINA, FILED 8-5-2010.



THE MARK CONSISTS OF STYLIZED WORD "MINGMING".

FOR CHILDREN'S MULTIPLE ACTIVITY TOYS; DOLL CLOTHING; DOLL HOUSES; DOLLS; DOLLS' FEEDING BOTTLES; DOLLS' ROOMS; ELECTRONIC LEARNING TOYS; PLUSH TOYS; RADIO CONTROLLED TOY VEHICLES; TOY BUILDINGS AND ACCESSORIES THEREFOR; TOY VEHICLES (U.S. CLS. 22, 23, 38 AND 50).

FIRST USE 3-17-2008; IN COMMERCE 3-17-2008. NAAKWAMA ANKRAH, EXAMINING ATTORNEY

CLASS 28—(Continued).

SN 85-105,970. FUNTASTIC, HOUSTON, TX. FILED 8-12-2010.



THE COLOR(S) YELLOW, ORANGE, WHITE, BLUE, BLACK IS/ARE CLAIMED AS A FEATURE OF THE MARK.

THE MARK CONSISTS OF A BLUE BACKGROUND ENCIRCLED WITH YELLOW AND ORANGE STRIPES. "SQUIRT" IS WHITE IN COLOR. THE "A" AND "NATOR" IS YELLOW IN COLOR. THE LETTERING IS OUTLINED IN BLACK.

FOR TOY GUNS; WATER SQUIRTING TOYS; WATER TOYS (U.S. CLS. 22, 23, 38 AND 50).

FIRST USE 6-15-2010; IN COMMERCE 6-18-2010. JAY FLOWERS, EXAMINING ATTORNEY

SN 85-106,782. BUILD A DREAM PLAYHOUSES, LLC, GATES MILLS, OH. FILED 8-13-2010.

Dream Machine

THE MARK CONSISTS OF STANDARD CHARACTERS WITHOUT CLAIM TO ANY PARTICULAR FONT, STYLE, SIZE, OR COLOR.

FOR CARDBOARD PLAY STRUCTURES, NAMELY, CORRUGATED CARDBOARD PLAY STRUCTURES IN THE FORM OF VEHICLES, NAMELY, AUTOMOBILES, CARS, TRUCKS, AND BOATS; CORRUGATED CARDBOARD PLAY STRUCTURES IN THE FORM OF VEHICLES AND ACCESSORIES THEREFOR (U.S. CLS. 22, 23, 38 AND 50).

JANICE KIM, EXAMINING ATTORNEY

SN 85-106,785. BUILD A DREAM PLAYHOUSES, LLC, GATES MILLS, OH. FILED 8-13-2010.

Imagine Wagon

THE MARK CONSISTS OF STANDARD CHARACTERS WITHOUT CLAIM TO ANY PARTICULAR FONT, STYLE, SIZE, OR COLOR.

NO CLAIM IS MADE TO THE EXCLUSIVE RIGHT TO USE "WAGON", APART FROM THE MARK AS SHOWN.

FOR CARDBOARD PLAY STRUCTURES, NAMELY, CORRUGATED CARDBOARD PLAY STRUCTURES IN THE FORM OF VEHICLES, NAMELY, TRUCKS, CAMPER, AMBULANCES, BUSES, CARS AND BOATS; CORRUGATED CARDBOARD PLAY STRUCTURES IN THE FORM OF VEHICLES AND ACCESSORIES THEREFOR (U.S. CLS. 22, 23, 38 AND 50).

JANICE KIM, EXAMINING ATTORNEY

CLASS 28—(Continued).

SN 85-113,576. SPORTSGUARD, LLC, AKA SPORTSGUARD, EAST BRUNSWICK, NJ. FILED 8-23-2010.

**SPORTS GUARD PROTECTION
WHERE YOU NEED IT**

THE MARK CONSISTS OF STANDARD CHARACTERS WITHOUT CLAIM TO ANY PARTICULAR FONT, STYLE, SIZE, OR COLOR.

NO CLAIM IS MADE TO THE EXCLUSIVE RIGHT TO USE "SPORTS GUARD" AND "PROTECTION", APART FROM THE MARK AS SHOWN.

FOR ATHLETIC PROTECTIVE PADS FOR HEAD, CHEST, AND WRIST (U.S. CLS. 22, 23, 38 AND 50).

FIRST USE 11-20-2007; IN COMMERCE 11-20-2007.

JANICE KIM, EXAMINING ATTORNEY

SN 85-113,703. SPORTSGUARD, LLC, AKA SPORTSGUARD, EAST BRUNSWICK, NJ. FILED 8-23-2010.

X GRIP

THE MARK CONSISTS OF STANDARD CHARACTERS WITHOUT CLAIM TO ANY PARTICULAR FONT, STYLE, SIZE, OR COLOR.

NO CLAIM IS MADE TO THE EXCLUSIVE RIGHT TO USE "GRIP", APART FROM THE MARK AS SHOWN.

FOR GRIP TAPES FOR BASEBALL BATS (U.S. CLS. 22, 23, 38 AND 50).

FIRST USE 11-20-2007; IN COMMERCE 11-20-2007.

JANICE KIM, EXAMINING ATTORNEY

SN 85-116,520. JONES JR., THOMAS O., PLYMOUTH MEETING, PA. FILED 8-26-2010.

AlignmentSquare

THE MARK CONSISTS OF STANDARD CHARACTERS WITHOUT CLAIM TO ANY PARTICULAR FONT, STYLE, SIZE, OR COLOR.

FOR GOLF APPARATUS, NAMELY, A PRACTICE AND TEACHING AID TO HELP WITH PROPER STANCE, ALIGNMENT AND BALL POSITIONING (U.S. CLS. 22, 23, 38 AND 50).

KATHRYN COWARD, EXAMINING ATTORNEY

CLASS 28—(Continued).

SN 85-120,097. DC COMICS, NEW YORK, NY. FILED 8-31-2010.

SUPER POWERS

THE MARK CONSISTS OF STANDARD CHARACTERS WITHOUT CLAIM TO ANY PARTICULAR FONT, STYLE, SIZE, OR COLOR.

FOR TOYS AND SPORTING GOODS, INCLUDING GAMES AND PLAYTHINGS, NAMELY, ACTION FIGURES AND ACCESSORIES THEREFOR; PLUSH TOYS; BALLOONS; BATHTUB TOYS; RIDE-ON TOYS; EQUIPMENT SOLD AS A UNIT FOR PLAYING CARD GAMES; TOY VEHICLES; DOLLS; FLYING DISCS; ELECTRONIC HAND-HELD GAME UNIT OTHER THAN THOSE ADAPTED FOR USE WITH AN EXTERNAL DISPLAY SCREEN OR MONITOR; GAME EQUIPMENT SOLD AS A UNIT FOR PLAYING A BOARD GAME, A CARD GAME, A MANIPULATIVE GAME, A PARLOR GAME AND AN ACTION TYPE TARGET GAME; STAND ALONE VIDEO OUTPUT GAME MACHINES; JIGSAW AND MANIPULATIVE PUZZLES; PAPER FACE MASKS; SKATEBOARDS; ICE SKATES; WATER SQUIRTING TOYS; BALLS, NAMELY, PLAYGROUND BALLS, SOCCER BALLS, BASEBALLS, BASKETBALLS; BASEBALL GLOVES; SWIMMING FLOATS FOR RECREATIONAL USE; KICKBOARD FLOTATION DEVICES FOR RECREATIONAL USE; SURFBOARDS; SWIM BOARDS FOR RECREATIONAL USE; SWIM FINS; TOY BAKEWARE AND TOY COOKWARE; TOY BANKS; TOY SNOW GLOBES; PAPER PARTY HATS; AND CHRISTMAS TREE ORNAMENTS (U.S. CLS. 22, 23, 38 AND 50).

KATHRYN COWARD, EXAMINING ATTORNEY

SN 85-124,335. LISA FRANK, INC., DBA LISA FRANK COMPANY, TUCSON, AZ. FILED 9-7-2010.

RAINBOW MAJESTY

THE MARK CONSISTS OF STANDARD CHARACTERS WITHOUT CLAIM TO ANY PARTICULAR FONT, STYLE, SIZE, OR COLOR.

OWNER OF U.S. REG. NOS. 3,424,529 AND 3,425,755.
FOR HOBBY CRAFT KITS COMPRISING TWO OR MORE OF THE FOLLOWING ITEMS: BEADS, SEQUINS, YARN, FABRIC, GLITTER, STRING, CARDBOARD, WAX, SAND, AND GLUE, FOR THE PURPOSE OF DECORATING TOY KEY CHAINS, BEANBAG TOYS, PICTURE FRAMES, SWITCH-PLATE COVERS, ROOM DECORATIONS, WINDOW HANGINGS, SIMULATED STAINED GLASS, AND FOR DECORATING CANDLES, SAND ART CREATIONS, CLOTHING, AND TOY BOXES (U.S. CLS. 22, 23, 38 AND 50).

MARC LEIPZIG, EXAMINING ATTORNEY

CLASS 28—(Continued).

SN 85-133,985. SHEEPSKIN DIRECT, INC., NEW CARLISLE, OH. FILED 9-20-2010.



NO CLAIM IS MADE TO THE EXCLUSIVE RIGHT TO USE "KOALA", APART FROM THE MARK AS SHOWN.

THE MARK CONSISTS OF A PICTURE OF KOALAS WITH THE WORDS MY KOALA AND HEART SYMBOLS. FOR PLUSH TOYS; STUFFED TOY BEARS (U.S. CLS. 22, 23, 38 AND 50).

FIRST USE 3-1-2010; IN COMMERCE 3-1-2010.
EUGENIA MARTIN, EXAMINING ATTORNEY

SN 85-141,877. MATTEL, INC., EL SEGUNDO, CA. FILED 9-30-2010.

GLIMMER

THE MARK CONSISTS OF STANDARD CHARACTERS WITHOUT CLAIM TO ANY PARTICULAR FONT, STYLE, SIZE, OR COLOR.

OWNER OF U.S. REG. NOS. 3,103,393, 3,472,942 AND 3,877,962.

FOR TOY ACTION FIGURES AND ACCESSORIES THEREFOR (U.S. CLS. 22, 23, 38 AND 50).

JESSICA A. POWERS, EXAMINING ATTORNEY

SN 85-162,354. CREATE! PRESS, INC., CARLSBAD, CA. FILED 10-27-2010.

CREATE-A-STORY

THE MARK CONSISTS OF STANDARD CHARACTERS WITHOUT CLAIM TO ANY PARTICULAR FONT, STYLE, SIZE, OR COLOR.

SEC. 2(F).

FOR BOARD GAMES (U.S. CLS. 22, 23, 38 AND 50).

FIRST USE 11-1-1999; IN COMMERCE 11-1-1999.

BERYL GARDNER, EXAMINING ATTORNEY

CLASS 28—(Continued).

SN 85-170,135. RAGDOLL WORLDWIDE LTD., BUCKINGHAMSHIRE, UNITED KINGDOM, FILED 11-5-2010.



OWNER OF U.S. REG. NO. 2,722,510.

THE MARK CONSISTS OF A STYLIZED SHIELD WITH THE WORD "BRUM" ON TOP WITH A STYLIZED RECTANGLE SURROUNDING THE WORD "BRUM" WITH A SMALLER STYLIZED RECTANGLE UNDERNEATH.

FOR TOYS, GAMES AND PLAYTHINGS, NAMELY, STUFFED TOYS, PLUSH TOYS, INFLATABLE BATH AND POOL TOYS, FLOATING PLASTIC BATH TOYS, PULL STRING TOYS, PLAY FIGURES, PLUSH TOYS WITH ELECTRONIC COMPONENTS, DOLLS, DOLL CLOTHING, DOLL ACCESSORIES, ACTION FIGURES, JIGSAW PUZZLES, INFANTS' RATTLES, MUSICAL TOYS; BOARD GAMES, TOY BUILDING BLOCKS, BALLOONS AND PLAYGROUND BALLS (U.S. CLS. 22, 23, 38 AND 50).

JAMES LOVELACE, EXAMINING ATTORNEY

SN 85-185,046. OUTFIT7 LTD., PREDDVOR, SLOVENIA, FILED 11-24-2010.

OUTFIT7

THE MARK CONSISTS OF STANDARD CHARACTERS WITHOUT CLAIM TO ANY PARTICULAR FONT, STYLE, SIZE, OR COLOR.

FOR TOYS, GAMES AND PLAYTHINGS, NAMELY, BATTERY OPERATED ACTION TOYS, PLUSH TOYS, CARD GAMES, BOARD GAMES, PARTY GAMES, AND ROLE PLAYING GAMES; DOLLS DESIGNED TO RESEMBLE COMPUTER GAME CHARACTERS; INTERACTIVE AUDIO VISUAL GAMES ON COMPUTER HARDWARE PLATFORMS, NAMELY, ELECTRONIC GAMES OTHER THAN THOSE ADAPTED FOR USE WITH TELEVISION RECEIVERS; HANDHELD COMPUTER GAME EQUIPMENT, NAMELY, HAND-HELD GAMES WITH LIQUID CRYSTAL DISPLAYS AND HAND-HELD UNITS FOR PLAYING ELECTRONIC GAMES OTHER THAN THOSE ADAPTED FOR USE WITH AN EXTERNAL DISPLAY SCREEN OR MONITOR; HOME VIDEO GAME MACHINES AND HAND-HELD VIDEO GAME MACHINES, NAMELY, HAND-HELD GAMES WITH LIQUID CRYSTAL DISPLAYS AND HAND-HELD UNITS FOR PLAYING ELECTRONIC GAMES OTHER THAN THOSE ADAPTED FOR USE WITH AN EXTERNAL DISPLAY SCREEN OR MONITOR; TALKING TOYS; TOY FIGURES; TALKING TOY FIGURES; PLAYTHINGS, NAMELY, BATTERY OPERATED ACTION TOYS, PLUSH TOYS, CARD GAMES, BOARD GAMES, PARTY GAMES, AND ROLE PLAYING GAMES FEATURING CHARACTERS FROM COMPUTER GAMES (U.S. CLS. 22, 23, 38 AND 50).

LIEF MARTIN, EXAMINING ATTORNEY

CLASS 28—(Continued).

SN 85-185,058. OUTFIT7 LTD., PREDDVOR, SLOVENIA,
FILED 11-24-2010.

TALKING BACTERIA

THE MARK CONSISTS OF STANDARD CHARACTERS WITHOUT CLAIM TO ANY PARTICULAR FONT, STYLE, SIZE, OR COLOR.

FOR TOYS, GAMES AND PLAYTHINGS, NAMELY, BATTERY OPERATED ACTION TOYS, PLUSH TOYS, CARD GAMES, BOARD GAMES, PARTY GAMES, AND ROLE PLAYING GAMES; DOLLS DESIGNED TO RESEMBLE COMPUTER GAME CHARACTERS; INTERACTIVE AUDIO VISUAL GAMES ON COMPUTER HARDWARE PLATFORMS, NAMELY, ELECTRONIC GAMES OTHER THAN THOSE ADAPTED FOR USE WITH TELEVISION RECEIVERS; HANDHELD COMPUTER GAME EQUIPMENT, NAMELY, HAND-HELD GAMES WITH LIQUID CRYSTAL DISPLAYS AND HAND-HELD UNITS FOR PLAYING ELECTRONIC GAMES OTHER THAN THOSE ADAPTED FOR USE WITH AN EXTERNAL DISPLAY SCREEN OR MONITOR; HOME VIDEO GAME MACHINES AND HAND-HELD VIDEO GAME MACHINES, NAMELY, HAND-HELD GAMES WITH LIQUID CRYSTAL DISPLAYS AND HAND-HELD UNITS FOR PLAYING ELECTRONIC GAMES OTHER THAN THOSE ADAPTED FOR USE WITH AN EXTERNAL DISPLAY SCREEN OR MONITOR; TALKING TOYS; TOY FIGURES; TALKING TOY FIGURES; PLAYTHINGS, NAMELY, BATTERY OPERATED ACTION TOYS, PLUSH TOYS, CARD GAMES, BOARD GAMES, PARTY GAMES, AND ROLE PLAYING GAMES FEATURING CHARACTERS FROM COMPUTER GAMES (U.S. CLS. 22, 23, 38 AND 50).

LIEF MARTIN, EXAMINING ATTORNEY

CLASS 28—(Continued).

SN 85-189,129. OUTFIT7 LTD., PREDDVOR, SLOVENIA,
FILED 12-2-2010.

TALKING BACTERIA JOHN,
JOHN & JOHN

THE MARK CONSISTS OF STANDARD CHARACTERS WITHOUT CLAIM TO ANY PARTICULAR FONT, STYLE, SIZE, OR COLOR.

PRIORITY CLAIMED UNDER SEC. 44(D) ON ERPN CMNTY TM OFC APPLICATION NO. 009493826, FILED 11-3-2010.

FOR TOYS, GAMES AND PLAYTHINGS, NAMELY, BATTERY OPERATED ACTION TOYS, PLUSH TOYS, CARD GAMES, BOARD GAMES, PARTY GAMES, AND ROLE PLAYING GAMES; DOLLS DESIGNED TO RESEMBLE COMPUTER GAME CHARACTERS; INTERACTIVE AUDIO VISUAL GAMES ON COMPUTER HARDWARE PLATFORMS, NAMELY, ELECTRONIC GAMES OTHER THAN THOSE ADAPTED FOR USE WITH TELEVISION RECEIVERS; HANDHELD COMPUTER GAME EQUIPMENT, NAMELY, HAND-HELD GAMES WITH LIQUID CRYSTAL DISPLAYS AND HAND-HELD UNITS FOR PLAYING ELECTRONIC GAMES OTHER THAN THOSE ADAPTED FOR USE WITH AN EXTERNAL DISPLAY SCREEN OR MONITOR; HOME VIDEO GAME MACHINES AND HAND-HELD VIDEO GAME MACHINES, NAMELY, HAND-HELD GAMES WITH LIQUID CRYSTAL DISPLAYS AND HAND-HELD UNITS FOR PLAYING ELECTRONIC GAMES OTHER THAN THOSE ADAPTED FOR USE WITH AN EXTERNAL DISPLAY SCREEN OR MONITOR; TALKING TOYS; TOY FIGURES; TALKING TOY FIGURES; PLAYTHINGS, NAMELY, BATTERY OPERATED ACTION TOYS, PLUSH TOYS, CARD GAMES, BOARD GAMES, PARTY GAMES, AND ROLE PLAYING GAMES FEATURING CHARACTERS FROM COMPUTER GAMES (U.S. CLS. 22, 23, 38 AND 50).

LIEF MARTIN, EXAMINING ATTORNEY

SN 85-191,790. GLOCK, GASTON J., WIEN 1190, AUSTRIA,
FILED 12-6-2010.

gaston 

THE NAME "GASTON" IDENTIFIES A LIVING INDIVIDUAL WHOSE CONSENT IS OF RECORD.

THE COLOR(S) RED, BLACK, AND WHITE IS/ARE CLAIMED AS A FEATURE OF THE MARK.

THE MARK CONSISTS OF THE WORD "GASTON" IN BLACK AND INCORPORATES A WHITE "G" INSIDE A RED CIRCLE DESIGN LOGO, WHICH STANDS FOR THE LETTER "O" IN "GASTON".

FOR EQUIPMENT FOR SHOOTING, HUNTING, AND SPORTS, NAMELY, FIREARM TARGETS, HUNTING STANDS, CLAY PIGEON/COCK TRAPS, DUCK CAROUSELS, PIGEON CAROUSELS (U.S. CLS. 22, 23, 38 AND 50).

JANICE L. MCMORROW, EXAMINING ATTORNEY

CLASS 28—(Continued).

SN 85-191,805. GLOCK, GASTON J., WIEN 1190, AUSTRIA, FILED 12-7-2010.



THE COLOR(S) RED AND WHITE IS/ARE CLAIMED AS A FEATURE OF THE MARK.

THE MARK CONSISTS OF A WHITE "G" INSIDE A RED CIRCLE DESIGN LOGO.

FOR EQUIPMENT FOR SHOOTING, HUNTING, AND SPORTS, NAMELY, FIREARM TARGETS, HUNTING STANDS, CLAY PIGEON/COCK TRAPS, DUCK CAROUSELS, PIGEON CAROUSELS (U.S. CLS. 22, 23, 38 AND 50).

JANICE L. MCMORROW, EXAMINING ATTORNEY

CLASS 28—(Continued).

SN 85-208,173. TARGET BRANDS, INC., MINNEAPOLIS, MN. FILED 12-30-2010.

FIRST FROST

THE MARK CONSISTS OF STANDARD CHARACTERS WITHOUT CLAIM TO ANY PARTICULAR FONT, STYLE, SIZE, OR COLOR.

FOR ARTIFICIAL CHRISTMAS GARLAND AND WREATHS; CHRISTMAS TREE ORNAMENTS AND DECORATIONS (U.S. CLS. 22, 23, 38 AND 50).

FIRST USE 11-1-2009; IN COMMERCE 11-1-2009.
CHRISTINA SOBRAL, EXAMINING ATTORNEY

SN 85-195,712. ENGLUND, JIM, BELLEVUE, WA. FILED 12-10-2010.



NO CLAIM IS MADE TO THE EXCLUSIVE RIGHT TO USE "PROHAMMER BATS", APART FROM THE MARK AS SHOWN.

THE COLOR(S) RED AND BLUE IS/ARE CLAIMED AS A FEATURE OF THE MARK.

THE MARK CONSISTS OF A THOR-LIKE IMAGE HOLDING A BAT IN BLUE FOLLOWED BY THE STYLIZED WORDING "PROHAMMER" IN CAPS, FOLLOWED BY THE VERTICALLY POSITIONED WORD "BATS". ALSO IN CAPS. THE COLOR RED APPEARS IN THE TERM "PRO" AND IN THE RECTANGLE DESIGN BEHIND THE THOR-LIKE IMAGE. THE COLOR BLUE APPEARS IN THE TERMS "HAMMER" AND "BATS" AND OUTLINING THE RECTANGLE DESIGN ENCOMPASSING THE WORDING AND DESIGNS IN THE MARK. THE COLOR WHITE APPEARS AS BACKGROUND IN THE MARK AND IS NOT CLAIMED AS A FEATURE OF THE MARK.

FOR BASEBALL BATS CUSTOMIZED FOR TRAINING PURPOSES (U.S. CLS. 22, 23, 38 AND 50).

FIRST USE 10-15-2008; IN COMMERCE 10-15-2008.
NATALIE POLZER, EXAMINING ATTORNEY

SN 85-208,189. TARGET BRANDS, INC., MINNEAPOLIS, MN. FILED 12-30-2010.

BIRCHWOOD CHALET

THE MARK CONSISTS OF STANDARD CHARACTERS WITHOUT CLAIM TO ANY PARTICULAR FONT, STYLE, SIZE, OR COLOR.

FOR ARTIFICIAL CHRISTMAS GARLAND AND WREATHS; CHRISTMAS TREE ORNAMENTS AND DECORATIONS (U.S. CLS. 22, 23, 38 AND 50).

FIRST USE 11-1-2008; IN COMMERCE 11-1-2008.
CHRISTINA SOBRAL, EXAMINING ATTORNEY

CLASS 28—(Continued).

SN 85-218,137. OWN LLC, LOS ANGELES, CA. FILED 1-14-2011.



THE COLOR(S) ORANGE, YELLOW, GREEN, LIGHT GREEN, PURPLE AND LIGHT PURPLE IS/ARE CLAIMED AS A FEATURE OF THE MARK.

THE MARK CONSISTS OF THE WORD "OWN" DEPICTED IN CAPITAL LETTERS WITH VARYING SHADES OF ORANGE FORMING "O" WITH YELLOW APPEARING IN THE CENTER; VARYING SHADES OF GREEN TO LIGHT GREEN FORMING "W" AND VARYING SHADES OF PURPLE TO LIGHT PURPLE FORMING "N" WITH A SHADOW UNDER EACH LETTER THAT IS DEPICTED IN THE SAME COLOR AS THE LETTER.

FOR GAMES, TOYS AND PLAYTHINGS, NAMELY, ACTION SKILL GAMES; ACTION TARGET GAMES; AMUSEMENT GAME MACHINES; ARCADE GAMES; BABY MULTIPLE ACTIVITY TOYS; BASKETBALL TABLE TOP GAMES; BATH TOYS; BEAN BAGS; BENDABLE TOYS; BILLIARD GAME PLAYING EQUIPMENT; BINGO GAME PLAYING EQUIPMENT; BOARD GAMES; BOBBLE HEAD DOLLS; BUBBLE MAKING WAND AND SOLUTION SETS; BUILDING GAMES; CASES FOR PLAY ACCESSORIES; CHILDREN'S MULTIPLE ACTIVITY TOYS; CHILDREN'S MULTIPLE ACTIVITY TABLES; CHILDREN'S PLAY COSMETICS; CHILDREN'S ART ACTIVITY TOYS NOT INCLUDING ARTS AND CRAFTS CLAY KITS OR PAINT KITS; COLLECTIBLE TOY FIGURES; CONSTRUCTION TOYS; COSTUME MASKS; CRIB MOBILES; CRIB TOYS; ELECTRIC ACTION TOYS; ELECTRONIC EDUCATIONAL GAME MACHINES FOR CHILDREN; ELECTRONIC LEARNING TOYS; ELECTRONIC TOY VEHICLES; NON-ELECTRONIC TOY VEHICLES; PUPPETS; INFANT TOYS; INFANT RATTLES; JIGSAW AND MANIPULATIVE PUZZLES; JUGGLING EQUIPMENT; KALEIDOSCOPIES; KITES; MAGIC TRICKS; MARBLES; MEMORY GAMES; MOBILES FOR CHILDREN; SCALE MODEL VEHICLES; MUSICAL TOYS; PAPER AIRPLANES; PARLOR GAMES; PARTY GAMES; PINBALL-TYPE GAMES; PLAY BALLOONS; PLAY WANDS; PLUSH TOYS; PULL TOYS; PUSH TOYS; RIDE-ON TOYS; ROCKING HORSES; SANDBOX TOYS; SNOW GLOBES; SPINNING TOPS; SQUEEZE TOYS; STACKING TOYS; TALKING TOYS; WIND-UP TOYS; TOY BANKS; TOY BUTTERFLY NETS; TOY MODELING DOUGH; CARD GAMES; TOY MODEL HOBBY CRAFT KITS; SOFT SCULPTURE TOYS; PUZZLES; TOY ACTION FIGURES AND ACCESSORIES THEREFOR; PLAY FIGURES; DOLLS AND ACCESSORIES AND PLAYSETS THEREFOR; YO-YOS; GYMNASTICS AND SPORTING ARTICLES NOT INCLUDED IN OTHER CLASSES, NAMELY, GYMNASTIC APPARATUS; BALLS FOR GAMES; SPORT BALLS; EXERCISE BALLS; BASKETBALL GAME PLAYING EQUIPMENT IN THE NATURE OF BASKETBALLS, HOOPS, NETS AND BACKBOARDS; SOCCER GAME PLAYING EQUIPMENT IN THE NATURE OF BALLS, NETS AND GOALS; BASEBALL GAME PLAYING EQUIPMENT IN THE NATURE OF BASEBALLS, BATS, BASES AND MITTS; BADMINTON GAME PLAYING EQUIPMENT IN THE NATURE OF RACKETS, SHUTTLECOCKS, POLES AND NETS; HOCKEY GAME PLAYING EQUIPMENT IN THE NATURE OF HOCKEY STICKS, PUCKS, NETS AND GOALS; DART GAME PLAYING EQUIPMENT IN THE NATURE OF DARTS AND DARTBOARDS; FOOTBALL GAME PLAYING EQUIPMENT IN THE NATURE OF FOOTBALLS AND GOALPOSTS; TABLE TENNIS GAME PLAYING EQUIPMENT IN THE NATURE OF PADDLES, TABLE TENNIS BALLS, TABLE TENNIS TABLES AND NETS; TENNIS GAME PLAYING EQUIPMENT IN THE NATURE OF TENNIS BALLS, RACKETS AND NETS; GOLF GAME

CLASS 28—(Continued).

PLAYING EQUIPMENT IN THE NATURE OF GOLF CLUBS, GOLF BALLS, TEES, DIVOT REPAIR TOOLS; VOLLEYBALL GAME PLAYING EQUIPMENT IN THE NATURE OF VOLLEYBALLS, POLES AND NETS; CASES SPECIALLY ADAPTED FOR SPORTS EQUIPMENT; CROQUET SETS; DISC TOSS TOYS; ICE SKATES; IN-LINE SKATES; ROLLER SKATES; JUMP ROPES; JUNGLE GYMS; NETBALLS; NETS FOR BALL GAMES; NETS FOR SPORTS; PADDLE BALL GAMES; PERSONAL EXERCISE MATS; YOGA MATS; PLAY SWIMMING POOLS; PLAY TENTS; SANDBOXES; PLAYGROUND SLIDES; SWING SETS; SEE-SAWS; SKATEBOARDS; SKIPPING ROPES; SLEDS FOR USE IN DOWNHILL AMUSEMENT RIDES; TRAMPOLINES; DECORATIONS FOR CHRISTMAS TREES; PET TOYS; AND PLAYING CARDS (U.S. CLS. 22, 23, 38 AND 50).
THOMAS MANOR, EXAMINING ATTORNEY

SN 85-218,795. SHIMANO INC., SAKAI CITY, OSAKA, JAPAN, FILED 1-16-2011.

MICRO MODULE

THE MARK CONSISTS OF STANDARD CHARACTERS WITHOUT CLAIM TO ANY PARTICULAR FONT, STYLE, SIZE, OR COLOR.

PRIORITY CLAIMED UNDER SEC. 44(D) ON JAPAN APPLICATION NO. 2010-093645, FILED 12-2-2010, REG. NO. 5397643, DATED 3-11-2011, EXPIRES 3-11-2021.

NO CLAIM IS MADE TO THE EXCLUSIVE RIGHT TO USE "MICRO", APART FROM THE MARK AS SHOWN.

FOR FISHING TACKLE (U.S. CLS. 22, 23, 38 AND 50).
NICHOLAS ALTREE, EXAMINING ATTORNEY

SN 85-219,069. WORLD SPORTS PRODUCTS, INC., ST. GEORGE, UT. FILED 1-17-2011.

Perfect Pitch

THE MARK CONSISTS OF STANDARD CHARACTERS WITHOUT CLAIM TO ANY PARTICULAR FONT, STYLE, SIZE, OR COLOR.

NO CLAIM IS MADE TO THE EXCLUSIVE RIGHT TO USE "PITCH", APART FROM THE MARK AS SHOWN.

FOR SPORTS TRAINING APPARATUS, NAMELY, PITCHING MACHINES (U.S. CLS. 22, 23, 38 AND 50).

RUSS HERMAN, EXAMINING ATTORNEY

CLASS 28—(Continued).

SN 85-220,422. NINTENDO OF AMERICA INC., REDMOND, WA. FILED 1-18-2011.

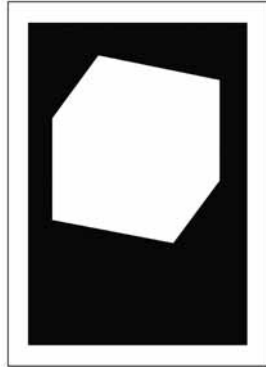

THE MARK CONSISTS OF A HEXAGON CONTAINED WITHIN TWO RECTANGLES.

FOR CARRYING CASES FOR HAND-HELD VIDEO GAME SYSTEMS; ELECTRONIC GAME EQUIPMENT WITH A WATCH FUNCTION; HAND-HELD GAME MACHINES WITH LIQUID CRYSTAL DISPLAYS; HAND-HELD GAME APPARATUS WITH LIQUID CRYSTAL DISPLAYS AND PARTS AND FITTINGS THEREFOR, NAMELY, POWER SUPPLIES, TRANSFORMERS, CABLES AND BATTERY CHARGERS, ALL SOLD AS A UNIT; HAND-HELD UNITS FOR PLAYING ELECTRONIC GAMES; HAND-HELD UNITS FOR PLAYING VIDEO GAMES NOT FOR USE WITH AN EXTERNAL DISPLAY SCREEN; PROTECTIVE WRAPS AND SKINS SPECIFICALLY DESIGNED FOR HAND-HELD UNITS FOR PLAYING VIDEO GAMES; PROTECTIVE FILMS FOR LIQUID CRYSTAL DISPLAY OF HAND-HELD GAMES; PROTECTIVE FILMS SPECIFICALLY DESIGNED FOR THE LIQUID CRYSTAL DISPLAY OF HAND-HELD GAME MACHINES; TOY KEY CHAINS WITH AND WITHOUT SOUND DEVICES; TRADING CARD GAMES; PLAYING CARDS; AND GAME CARDS (U.S. CLS. 22, 23, 38 AND 50).

JANICE L. MCMORROW, EXAMINING ATTORNEY

CLASS 28—(Continued).

SN 85-226,753. EST, LLC, WINNSBORO, LA. FILED 1-26-2011.



OWNER OF U.S. REG. NO. 2,841,442.

NO CLAIM IS MADE TO THE EXCLUSIVE RIGHT TO USE "DEER" AND "DEER ATTRACTANT", APART FROM THE MARK AS SHOWN.

THE MARK CONSISTS OF THE WORDS "C'MERE DEER" IN STYLIZED FORM WITH THE WORDS "THE REVOLUTIONARY DEER ATTRACTANT" IN STYLIZED FORM BELOW THEM. RISING BETWEEN THE LAST LETTER "E" OF "C'MERE" AND THE INITIAL LETTER "D" OF "DEER" THERE IS THE UPPER TORSO OF DEER.

FOR DEER ATTRACTANTS (U.S. CLS. 22, 23, 38 AND 50).

RAMONA ORTIGA, EXAMINING ATTORNEY

SN 85-224,409. GRISWELL, ANDREA M., STONE MOUNTAIN, GA. FILED 1-24-2011.

BOPEE BUDDIES

THE MARK CONSISTS OF STANDARD CHARACTERS WITHOUT CLAIM TO ANY PARTICULAR FONT, STYLE, SIZE, OR COLOR.

FOR TOYS, NAMELY, PLUSH DOLLS (U.S. CLS. 22, 23, 38 AND 50).

NAAKWAMA ANKRAH, EXAMINING ATTORNEY

SN 85-226,941. BRYANT, CHRIS, ALBANY, OR. FILED 1-26-2011.

Barefoot Boards

THE MARK CONSISTS OF STANDARD CHARACTERS WITHOUT CLAIM TO ANY PARTICULAR FONT, STYLE, SIZE, OR COLOR.

NO CLAIM IS MADE TO THE EXCLUSIVE RIGHT TO USE "BOARDS", APART FROM THE MARK AS SHOWN.

FOR BODY BOARDS; PADDLE SURFBOARDS; STAND-UP SURF PADDLES; SURFBOARD WAX; SURFBOARDS (U.S. CLS. 22, 23, 38 AND 50).

FIRST USE 1-22-2011; IN COMMERCE 1-22-2011.

ELIZABETH KAJUBI, EXAMINING ATTORNEY

CLASS 28—(Continued).

SN 85-231,038. THREE IN ONE TRANNING CUE BALL, HAMDEN, CT. FILED 2-1-2011.



THE MARK CONSISTS OF THE STYLIZED NUMBERS AND WORD "3 IN 1" INSIDE A TRIANGLE WITH ROUNDED CORNERS.

FOR BILLIARD BALLS (U.S. CLS. 22, 23, 38 AND 50). SALLY SHIH, EXAMINING ATTORNEY

SN 85-231,900. NEXT INNING, INC., TOPEKA, KS. FILED 2-2-2011.

Dugout Manager

THE MARK CONSISTS OF STANDARD CHARACTERS WITHOUT CLAIM TO ANY PARTICULAR FONT, STYLE, SIZE, OR COLOR.

NO CLAIM IS MADE TO THE EXCLUSIVE RIGHT TO USE "DUGOUT", APART FROM THE MARK AS SHOWN.

FOR BASEBALL AND SOFTBALL BAT RACKS; SOFTBALL BAT RACKS; STORAGE RACKS FOR ATHLETIC EQUIPMENT (U.S. CLS. 22, 23, 38 AND 50).

FIRST USE 2-15-2010; IN COMMERCE 2-15-2010. BARBARA A. GOLD, EXAMINING ATTORNEY

SN 85-237,996. ATTACK PRODUCTS, LLC, CHICAGO, IL. FILED 2-9-2011.

THE CHOICE OF ATHLETES

THE MARK CONSISTS OF STANDARD CHARACTERS WITHOUT CLAIM TO ANY PARTICULAR FONT, STYLE, SIZE, OR COLOR.

NO CLAIM IS MADE TO THE EXCLUSIVE RIGHT TO USE "ATHLETES", APART FROM THE MARK AS SHOWN.

FOR ARM BAND FOR AIDING BASKETBALL PLAYER'S SHOOTING TECHNIQUE AND CONTROL; FINGER PLACEMENT DEVICE FOR AIDING BASKETBALL PLAYER'S SHOOTING TECHNIQUE AND CONTROL (U.S. CLS. 22, 23, 38 AND 50).

KEVIN CORWIN, EXAMINING ATTORNEY

CLASS 28—(Continued).

SN 85-240,311. FREMANTLE MEDIA NORTH AMERICA, INC., BURBANK, CA. FILED 2-11-2011.

IDOL PROM

THE MARK CONSISTS OF STANDARD CHARACTERS WITHOUT CLAIM TO ANY PARTICULAR FONT, STYLE, SIZE, OR COLOR.

NO CLAIM IS MADE TO THE EXCLUSIVE RIGHT TO USE "PROM", APART FROM THE MARK AS SHOWN.

FOR BALLOONS, TOY FIGURES, CHILDREN'S PARTY GAMES, PINATAS, AND PARTY FAVORS IN THE NATURE OF SMALL TOYS, NOISEMAKERS, BLOWOUT AND PARTY HATS; DRESS-UP ACCESSORIES AND ROLE-PLAY PROPS, NAMELY, COSTUME AND TOY MASKS, TOY SPURS, TOY HELMETS, TOY HAND-CUFFS, TOY HOLSTERS, TOY EYE PATCHES NOT FOR MEDICAL USE, TOY JEWELRY, TOY WEAPONS, TOY SCEPTERS, TOY WALKING STAFFS, TOY WANDS, TOY MEDALLIONS, TOY TIARAS, TOY GUNS, TOY SWORDS, FAKE GLASSES, TOY MAKEUP, TOY FINGERNAILS, TOY WEAPONS, TOY HELMETS, PLAY HOUSES, PLAY TENTS (U.S. CLS. 22, 23, 38 AND 50).

JOHN WILKE, EXAMINING ATTORNEY

SN 85-242,186. MITCHELL, MICHAEL, NASHUA, NH. FILED 2-15-2011.



THE COLOR(S) BLUE, YELLOW, BLACK AND WHITE IS/ ARE CLAIMED AS A FEATURE OF THE MARK.

THE MARK CONSISTS OF A STYLIZED YIN-YANG DESIGN WHEREIN THE WHITE HALF IS DRAWN TO RESEMBLE A WHITE BIRD'S WING; A JAGGED PATTERN OF SCALES IS SUPERIMPOSED ON IT WITH A YELLOW REPTILIAN EYE AT ITS CENTER. THE BLACK HALF IS A DARK, ABSTRACT DESIGN; A WHITE STARBURST IS SUPERIMPOSED ON IT WITH A BLUE FEMININE EYE AT ITS CENTER AS SHOWN IN THE MARK. THE COLOR GRAY INDICATES SHADING AND IS NOT CLAIMED AS PART OF THE MARK.

FOR FANTASY AND ROLE PLAYING GAMES, NAMELY, PARLOR GAMES, TRADING CARD GAMES, BOARD GAMES, CARD GAMES, FANTASY ROLE PLAYING GAMES, COLLECTIBLE TOY ACTION FIGURES AND ACCESSORIES FOR USE THEREWITH; COLLECTIBLE TOY FIGURES; DICE; GAME BOARDS; GAME PIECES (U.S. CLS. 22, 23, 38 AND 50).

CAROLINE WOOD, EXAMINING ATTORNEY

CLASS 28—(Continued).

SN 85-244,943. MULTIPET INTERNATIONAL, INC., MOON-ACHIE, NJ. FILED 2-17-2011.

Woofie Cushion

THE MARK CONSISTS OF STANDARD CHARACTERS WITHOUT CLAIM TO ANY PARTICULAR FONT, STYLE, SIZE, OR COLOR.
 NO CLAIM IS MADE TO THE EXCLUSIVE RIGHT TO USE "CUSHION", APART FROM THE MARK AS SHOWN.
 FOR PET TOYS (U.S. CLS. 22, 23, 38 AND 50).
 BENJAMIN OKEKE, EXAMINING ATTORNEY

SN 85-245,062. BATTAT INCORPORATED, PLATTSBURGH, NY. FILED 2-17-2011.

OUR GENERATION OUTFITTERS

THE MARK CONSISTS OF STANDARD CHARACTERS WITHOUT CLAIM TO ANY PARTICULAR FONT, STYLE, SIZE, OR COLOR.
 OWNER OF U.S. REG. NOS. 2,483,148 AND 2,795,544.
 NO CLAIM IS MADE TO THE EXCLUSIVE RIGHT TO USE "OUTFITTERS", APART FROM THE MARK AS SHOWN.
 FOR DOLL ACCESSORIES; DOLL CLOTHING; DOLL FURNITURE; DOLL HOUSE FURNISHINGS; DOLLS (U.S. CLS. 22, 23, 38 AND 50).
 WILLIAM P. SHANAHAN, EXAMINING ATTORNEY

SN 85-246,430. ARIZONA MANUFACTURING & EMBROIDERY, INC., TEMPE, AZ. FILED 2-18-2011.

REVERB

THE MARK CONSISTS OF STANDARD CHARACTERS WITHOUT CLAIM TO ANY PARTICULAR FONT, STYLE, SIZE, OR COLOR.
 FOR COVERS FOR GOLF CLUBS; FITTED HEAD COVERS FOR GOLF CLUBS; GOLF CLUB COVERS; HEAD COVERS FOR GOLF CLUBS (U.S. CLS. 22, 23, 38 AND 50).
 AISHA CLARKE, EXAMINING ATTORNEY

CLASS 28—(Continued).

SN 85-248,728. PREMIER PET PRODUCTS, LLC, MID-LOTHIAN, VA. FILED 2-22-2011.

PLAYTIME FOR A LIFETIME

THE MARK CONSISTS OF STANDARD CHARACTERS WITHOUT CLAIM TO ANY PARTICULAR FONT, STYLE, SIZE, OR COLOR.
 FOR PET TOYS (U.S. CLS. 22, 23, 38 AND 50).
 FONG HSU, EXAMINING ATTORNEY

SN 85-248,864. MOFFAT, NATHANIEL, BETHESDA, MD. FILED 2-22-2011.

Writer's Stack

THE MARK CONSISTS OF STANDARD CHARACTERS WITHOUT CLAIM TO ANY PARTICULAR FONT, STYLE, SIZE, OR COLOR.
 NO CLAIM IS MADE TO THE EXCLUSIVE RIGHT TO USE "WRITER'S", APART FROM THE MARK AS SHOWN.
 FOR PLAYING CARDS, NAMELY, INSPIRATION-BOOSTING PLAYING CARDS FOR WRITERS (U.S. CLS. 22, 23, 38 AND 50).
 MICHAEL GAAFAR, EXAMINING ATTORNEY

SN 85-250,153. 227, LLC, PORTLAND, OR. FILED 2-24-2011.

SUPERIO

THE MARK CONSISTS OF STANDARD CHARACTERS WITHOUT CLAIM TO ANY PARTICULAR FONT, STYLE, SIZE, OR COLOR.
 FOR COVERS FOR GOLF CLUBS; FITTED HEAD COVERS FOR GOLF CLUBS; GOLF ACCESSORY POUCHES; GOLF ACCESSORY, NAMELY, SUPPORT FOR HOLDING A GOLF CLUB; GOLF BAGS; GOLF BAGS WITH OR WITHOUT WHEELS; GOLF CLUB BAGS; GOLF CLUB COVERS; GOLF CLUB HOLDERS FOR USE ON A DRIVING RANGE OR GOLF COURSE; GOLF CLUB SHAFTS; GOLF PUTTER COVERS; HEAD COVERS FOR GOLF CLUBS; TENNIS RACQUETS, BASEBALL BATS, CRICKET BATS, GOLF CLUBS AND HOCKEY STICKS (U.S. CLS. 22, 23, 38 AND 50).
 FIRST USE 0-0-2008; IN COMMERCE 0-0-2010.
 NELSON SNYDER, EXAMINING ATTORNEY

CLASS 28—(Continued).

SN 85-251,651. BOON, INC., CHANDLER, AZ. FILED 2-25-2011.

FLI

THE MARK CONSISTS OF STANDARD CHARACTERS WITHOUT CLAIM TO ANY PARTICULAR FONT, STYLE, SIZE, OR COLOR.

FOR MOBILES FOR CHILDREN (U.S. CLS. 22, 23, 38 AND 50).

FIRST USE 10-6-2009; IN COMMERCE 10-6-2009.
KELLY CHOE, EXAMINING ATTORNEY

SN 85-252,538. JOHN L. WEIL, BEACHWOOD, OH. FILED 2-26-2011.

SOLVE AND SMILE

THE MARK CONSISTS OF STANDARD CHARACTERS WITHOUT CLAIM TO ANY PARTICULAR FONT, STYLE, SIZE, OR COLOR.

FOR PUZZLE GAMES (U.S. CLS. 22, 23, 38 AND 50).
FIRST USE 11-16-2010; IN COMMERCE 1-24-2011.
SKYE YOUNG, EXAMINING ATTORNEY

SN 85-252,617. CREWS JR., JOHN WILLIAM, SALEM, VA. FILED 2-26-2011.

MISSILE BAITS

THE MARK CONSISTS OF STANDARD CHARACTERS WITHOUT CLAIM TO ANY PARTICULAR FONT, STYLE, SIZE, OR COLOR.

NO CLAIM IS MADE TO THE EXCLUSIVE RIGHT TO USE "BAITS", APART FROM THE MARK AS SHOWN.

FOR ARTIFICIAL FISHING LURES (U.S. CLS. 22, 23, 38 AND 50).

FLORENTINA BLANDU, EXAMINING ATTORNEY

CLASS 28—(Continued).

SN 85-253,331. MARKY SPARKY, INC., ESCONDIDO, NY. FILED 2-28-2011.

ANIMAILS

THE MARK CONSISTS OF STANDARD CHARACTERS WITHOUT CLAIM TO ANY PARTICULAR FONT, STYLE, SIZE, OR COLOR.

FOR INFLATABLE RIDE-ON TOYS (U.S. CLS. 22, 23, 38 AND 50).

LINDA ESTRADA, EXAMINING ATTORNEY

SN 85-254,176. TARGETT, JAMES AND MARIA, QUEENSLAND, AUSTRALIA, FILED 3-1-2011.

Success Power Of The Mind

THE MARK CONSISTS OF STANDARD CHARACTERS WITHOUT CLAIM TO ANY PARTICULAR FONT, STYLE, SIZE, OR COLOR.

FOR CARD GAMES (U.S. CLS. 22, 23, 38 AND 50).
WARREN L. OLANDRIA, EXAMINING ATTORNEY

SN 85-254,329. LAVIGNE, BRUCE A, WATERBURY, CT. FILED 3-1-2011.



NO CLAIM IS MADE TO THE EXCLUSIVE RIGHT TO USE "SENSOR SYSTEM", APART FROM THE MARK AS SHOWN.

THE MARK CONSISTS OF THE WORDING "STRIKE-MATE" IN STYLIZED LETTERING DEPICTED ABOVE THE WORDING "SENSOR SYSTEM" WITHIN A HORIZONTAL RECTANGULAR BORDER, ALL SUPERIMPOSED OVER A DESIGN OF A TIP-UP.

FOR BITE SENSORS (U.S. CLS. 22, 23, 38 AND 50).
KATHERINE STOIDES, EXAMINING ATTORNEY

CLASS 28—(Continued).

SN 85-254,550. MARSHALL, WALLY, GARLAND, TX. FILED 3-1-2011.

TROLL-TECH

THE MARK CONSISTS OF STANDARD CHARACTERS WITHOUT CLAIM TO ANY PARTICULAR FONT, STYLE, SIZE, OR COLOR.

FOR FISHING LURES, FISHING TACKLE, AND FISHING ACCESSORIES, NAMELY, RODS, REELS, HOOKS, JIGS, FLOATS, SINKERS, WEIGHTS, AND LINE (U.S. CLS. 22, 23, 38 AND 50).

FIRST USE 11-25-2010; IN COMMERCE 11-25-2010.
REBECCA EISINGER, EXAMINING ATTORNEY

CLASS 28—(Continued).

SN 85-254,918. PEKTEE INDUSTRIES, INC., WILLOW-BROOK, IL. FILED 3-1-2011.

PEKTEE

THE MARK CONSISTS OF STANDARD CHARACTERS WITHOUT CLAIM TO ANY PARTICULAR FONT, STYLE, SIZE, OR COLOR.

FOR TOYS, NAMELY BEADS ARRANGED ON A CORD FOR HANDHELD PLAY (U.S. CLS. 22, 23, 38 AND 50).

MICHELLE DUBOIS, EXAMINING ATTORNEY

SN 85-254,582. DOUGLAS C RUBEL, ASHEVILLE, AZ. FILED 3-1-2011.

Towers of Power

THE MARK CONSISTS OF STANDARD CHARACTERS WITHOUT CLAIM TO ANY PARTICULAR FONT, STYLE, SIZE, OR COLOR.

FOR BUILDING GAMES; MANIPULATIVE GAMES (U.S. CLS. 22, 23, 38 AND 50).

FIRST USE 1-1-2011; IN COMMERCE 1-1-2011.
JOSETTE BEVERLY, EXAMINING ATTORNEY

SN 85-254,921. PEKTEE INDUSTRIES, INC., WILLOW-BROOK, IL. FILED 3-1-2011.

WARRIOR

THE MARK CONSISTS OF STANDARD CHARACTERS WITHOUT CLAIM TO ANY PARTICULAR FONT, STYLE, SIZE, OR COLOR.

FOR TOYS, NAMELY BEADS ARRANGED ON A CORD FOR HANDHELD PLAY (U.S. CLS. 22, 23, 38 AND 50).

MICHELLE DUBOIS, EXAMINING ATTORNEY

SN 85-254,844. THE KONG COMPANY, GOLDEN, CO. FILED 3-1-2011.

BUBBY

THE MARK CONSISTS OF STANDARD CHARACTERS WITHOUT CLAIM TO ANY PARTICULAR FONT, STYLE, SIZE, OR COLOR.

FOR PET TOYS (U.S. CLS. 22, 23, 38 AND 50).
GENE MACIOL, EXAMINING ATTORNEY

SN 85-255,062. FROST PRODUCTIONS LLC, LOS ANGELES, CA. FILED 3-1-2011.

X MARKS THE SPOT

THE MARK CONSISTS OF STANDARD CHARACTERS WITHOUT CLAIM TO ANY PARTICULAR FONT, STYLE, SIZE, OR COLOR.

FOR DISPOSABLE TICKET SETS FOR PLAYING GAMES OF CHANCE; LOTTERY TICKETS; SCRATCH CARDS FOR PLAYING LOTTERY GAMES (U.S. CLS. 22, 23, 38 AND 50).

FIRST USE 8-26-2010; IN COMMERCE 9-2-2010.
CHRISTINE MARTIN, EXAMINING ATTORNEY

CLASS 28—(Continued).

SN 85-255,118. BEG, HIMAD, LEONIA, NJ. FILED 3-1-2011.

Froogy the Frog

THE MARK CONSISTS OF STANDARD CHARACTERS WITHOUT CLAIM TO ANY PARTICULAR FONT, STYLE, SIZE, OR COLOR.

NO CLAIM IS MADE TO THE EXCLUSIVE RIGHT TO USE "FROG", APART FROM THE MARK AS SHOWN.

FOR TOYS, NAMELY, STUFFED ANIMALS, RUBBER FIGURES, BATHTUB TOYS, AND PLASTIC FIGURES (U.S. CLS. 22, 23, 38 AND 50).

MATTHEW KLINE, EXAMINING ATTORNEY

CLASS 28—(Continued).

SN 85-255,886. COMPETITIVE ACTION SPORTS, L.L.C., EDMOND, OK. FILED 3-2-2011.

THE TUG WATER SLUG

THE MARK CONSISTS OF STANDARD CHARACTERS WITHOUT CLAIM TO ANY PARTICULAR FONT, STYLE, SIZE, OR COLOR.

FOR EXERCISE EQUIPMENT, NAMELY, RESISTIVE EXERCISE APPARATUS FOR STRENGTHENING AND CONDITIONING INDIVIDUALS (U.S. CLS. 22, 23, 38 AND 50).

KATHERINE STOIDES, EXAMINING ATTORNEY

SN 85-255,847. SENARIO LLC, WOODSTOCK, IL. FILED 3-2-2011.

Gunk

THE MARK CONSISTS OF STANDARD CHARACTERS WITHOUT CLAIM TO ANY PARTICULAR FONT, STYLE, SIZE, OR COLOR.

FOR REMOTE CONTROL TOYS, NAMELY, ROBOTS (U.S. CLS. 22, 23, 38 AND 50).

FIRST USE 1-1-2010; IN COMMERCE 10-10-2010.

BILL DAWE, EXAMINING ATTORNEY

SN 85-255,878. SENARIO LLC, WOODSTOCK, IL. FILED 3-2-2011.

Gek

THE MARK CONSISTS OF STANDARD CHARACTERS WITHOUT CLAIM TO ANY PARTICULAR FONT, STYLE, SIZE, OR COLOR.

FOR REMOTE CONTROL TOYS, NAMELY, ROBOTS (U.S. CLS. 22, 23, 38 AND 50).

FIRST USE 1-1-2010; IN COMMERCE 10-10-2010.

BILL DAWE, EXAMINING ATTORNEY

SN 85-256,375. MITCHELL, NATE, LOS ANGELES, CA. FILED 3-2-2011.

SQUIB KID

THE MARK CONSISTS OF STANDARD CHARACTERS WITHOUT CLAIM TO ANY PARTICULAR FONT, STYLE, SIZE, OR COLOR.

OWNER OF U.S. REG. NO. 3,723,423.

NO CLAIM IS MADE TO THE EXCLUSIVE RIGHT TO USE "KID", APART FROM THE MARK AS SHOWN.

FOR ACTION FIGURE TOYS; ATTACHABLE, WEARABLE, MAGNETIC TOY FIGURINES; BATHTUB TOYS; BATTERY OPERATED ACTION TOYS; BENDABLE TOYS; CHILDREN'S MULTIPLE ACTIVITY TOYS; COLLECTABLE TOY FIGURES; CONSTRUCTION TOYS; DECORATIVE TOY MOBILES AND PLUSH TOYS FOR CHILDREN MADE OF FELT; ELECTRIC ACTION TOYS; ELECTRONIC ACTION TOYS; ELECTRONIC NOVELTY TOYS, NAMELY, TOYS THAT ELECTRONICALLY RECORD, PLAY BACK, AND DISTORT OR MANIPULATE VOICES AND SOUNDS; ELECTRONIC TOY VEHICLES; FANTASY CHARACTER TOYS; INFLATABLE TOYS; LEVER ACTION TOYS; MECHANICAL ACTION TOYS; MECHANICAL TOYS; MODELED PLASTIC TOY FIGURINES; MOLDED TOY FIGURES; PLASTIC CHARACTER TOYS; PLUSH TOYS; POSITIONABLE TOY FIGURES; RADIO CONTROLLED TOY VEHICLES; SOFT SCULPTURE PLUSH TOYS; SOFT SCULPTURE TOYS; SQUEEZE TOYS; STUFFED AND PLUSH TOYS; STUFFED TOYS; TALKING TOYS; TOY ACTION FIGURES; TOY ACTION FIGURES AND ACCESSORIES THEREFOR; TOY FIGURES; TOY ROBOTS; TOY WATCHES; WATER SQUIRTING TOYS; WATER TOYS; WIND-UP TOYS; WIND-UP WALKING TOYS (U.S. CLS. 22, 23, 38 AND 50).

JASON TURNER, EXAMINING ATTORNEY

CLASS 28—(Continued).

SN 85-256,390. MITCHELL, NATE, LOS ANGELES, CA. FILED 3-2-2011.

A-DRIVE

THE MARK CONSISTS OF STANDARD CHARACTERS WITHOUT CLAIM TO ANY PARTICULAR FONT, STYLE, SIZE, OR COLOR.

FOR ACTION FIGURE TOYS; BATHTUB TOYS; BATTERY OPERATED ACTION TOYS; BENDABLE TOYS; ELECTRIC ACTION TOYS; ELECTRONIC ACTION TOYS; ELECTRONIC NOVELTY TOYS, NAMELY, TOYS THAT ELECTRONICALLY RECORD, PLAY BACK, AND DISTORT OR MANIPULATE VOICES AND SOUNDS; FANTASY CHARACTER TOYS; INFLATABLE TOYS; MECHANICAL ACTION TOYS; MECHANICAL TOYS; MODELED PLASTIC TOY FIGURINES; MOLDED TOY FIGURES; PLASTIC CHARACTER TOYS; PLUSH TOYS; SCALE MODEL KITS; SOFT SCULPTURE PLUSH TOYS; SOFT SCULPTURE TOYS; SQUEEZABLE SQUEAKING TOYS; STUFFED AND PLUSH TOYS; STUFFED TOYS; TALKING TOYS; TOY ACTION FIGURES; TOY ACTION FIGURES AND ACCESSORIES THEREFOR; TOY CLOCKS AND WATCHES; TOY FIGURES; TOY MODEL HOBBYCRAFT KITS; TOY ROBOTS; TOY WATCHES; TOY, NAMELY, BATTERY-POWERED COMPUTER GAME WITH LCD SCREEN WHICH FEATURES ANIMATION AND SOUND EFFECTS; TRANSFORMING ROBOTIC TOYS; WATER SQUIRTING TOYS; WATER TOYS; WIND-UP TOYS (U.S. CLS. 22, 23, 38 AND 50).

JASON TURNER, EXAMINING ATTORNEY

SN 85-256,394. MITCHELL, NATE, LOS ANGELES, CA. FILED 3-2-2011.

B-SIDE

THE MARK CONSISTS OF STANDARD CHARACTERS WITHOUT CLAIM TO ANY PARTICULAR FONT, STYLE, SIZE, OR COLOR.

FOR ACTION FIGURE TOYS; BATHTUB TOYS; BATTERY OPERATED ACTION TOYS; BENDABLE TOYS; ELECTRIC ACTION TOYS; ELECTRONIC ACTION TOYS; ELECTRONIC NOVELTY TOYS, NAMELY, TOYS THAT ELECTRONICALLY RECORD, PLAY BACK, AND DISTORT OR MANIPULATE VOICES AND SOUNDS; FANTASY CHARACTER TOYS; INFLATABLE TOYS; MECHANICAL ACTION TOYS; MECHANICAL TOYS; PLASTIC CHARACTER TOYS; PLUSH TOYS; POSITIONABLE TOY FIGURES; SOFT SCULPTURE PLUSH TOYS; SOFT SCULPTURE TOYS; SQUEEZABLE SQUEAKING TOYS; STUFFED AND PLUSH TOYS; STUFFED TOYS; TALKING TOYS; TOY ACTION FIGURES; TOY ACTION FIGURES AND ACCESSORIES THEREFOR; TOY FIGURES; TOY MODEL HOBBYCRAFT KITS; TOY ROBOTS; TOY WATCHES; TOY, NAMELY, BATTERY-POWERED COMPUTER GAME WITH LCD SCREEN WHICH FEATURES ANIMATION AND SOUND EFFECTS; TRANSFORMING ROBOTIC TOYS; WATER SQUIRTING TOYS; WATER TOYS; WIND-UP TOYS (U.S. CLS. 22, 23, 38 AND 50).

JASON TURNER, EXAMINING ATTORNEY

CLASS 28—(Continued).

SN 85-256,724. MATTEL, INC., EL SEGUNDO, CA. FILED 3-3-2011.

LUNAR BLASTER

THE MARK CONSISTS OF STANDARD CHARACTERS WITHOUT CLAIM TO ANY PARTICULAR FONT, STYLE, SIZE, OR COLOR.

FOR TOY ACTION FIGURES AND ACCESSORIES THEREFOR (U.S. CLS. 22, 23, 38 AND 50).

RON FAIRBANKS, EXAMINING ATTORNEY

SN 85-256,733. MATTEL, INC., EL SEGUNDO, CA. FILED 3-3-2011.

ALIEN MINDREADERS

THE MARK CONSISTS OF STANDARD CHARACTERS WITHOUT CLAIM TO ANY PARTICULAR FONT, STYLE, SIZE, OR COLOR.

FOR TOY ACTION FIGURES AND ACCESSORIES THEREFOR (U.S. CLS. 22, 23, 38 AND 50).

RON FAIRBANKS, EXAMINING ATTORNEY

SN 85-256,735. MATTEL, INC., EL SEGUNDO, CA. FILED 3-3-2011.

FROZEN FELONS

THE MARK CONSISTS OF STANDARD CHARACTERS WITHOUT CLAIM TO ANY PARTICULAR FONT, STYLE, SIZE, OR COLOR.

FOR TOY ACTION FIGURES AND ACCESSORIES THEREFOR (U.S. CLS. 22, 23, 38 AND 50).

RON FAIRBANKS, EXAMINING ATTORNEY

CLASS 28—(Continued).

SN 85-256,737. MATTEL, INC., EL SEGUNDO, CA. FILED 3-3-2011.

**HEADLESS HEADMISTRESS
BLOODGOOD**

THE MARK CONSISTS OF STANDARD CHARACTERS WITHOUT CLAIM TO ANY PARTICULAR FONT, STYLE, SIZE, OR COLOR.

FOR DOLLS, DOLL CLOTHING AND DOLL ACCESSORIES (U.S. CLS. 22, 23, 38 AND 50).

RON FAIRBANKS, EXAMINING ATTORNEY

SN 85-256,751. MATTEL, INC., EL SEGUNDO, CA. FILED 3-3-2011.

PRINCESS AND THE POTTY

THE MARK CONSISTS OF STANDARD CHARACTERS WITHOUT CLAIM TO ANY PARTICULAR FONT, STYLE, SIZE, OR COLOR.

FOR DOLLS, DOLL CLOTHING AND DOLL ACCESSORIES (U.S. CLS. 22, 23, 38 AND 50).

RON FAIRBANKS, EXAMINING ATTORNEY

SN 85-257,722. AGRILIFE PROTEIN SOLUTIONS, WATER-PROOF, LA. FILED 3-4-2011.

The Good Stuff

THE MARK CONSISTS OF STANDARD CHARACTERS WITHOUT CLAIM TO ANY PARTICULAR FONT, STYLE, SIZE, OR COLOR.

FOR FEED GRADE ATTRACTANT FOR WHITETAIL DEER, ELK, AND OTHER RUMINANT GAME ANIMALS (U.S. CLS. 22, 23, 38 AND 50).

MICHAEL SOUDERS, EXAMINING ATTORNEY

CLASS 28—(Continued).

SN 85-257,877. BONGIORNO, JOSEPH D., NAHANT, MA. FILED 3-4-2011.

Cosmic ConneXion

THE MARK CONSISTS OF STANDARD CHARACTERS WITHOUT CLAIM TO ANY PARTICULAR FONT, STYLE, SIZE, OR COLOR.

FOR CARD GAMES; EDUCATIONAL CARD GAMES; GAME CARDS; MEMORY GAMES; PARTY GAMES; PLAYING CARDS AND CARD GAMES (U.S. CLS. 22, 23, 38 AND 50).

CHARISMA HAMPTON, EXAMINING ATTORNEY

SN 85-259,946. BATTAT INCORPORATED, PLATTSBURGH, NY. FILED 3-7-2011.

og outfitters

THE MARK CONSISTS OF STANDARD CHARACTERS WITHOUT CLAIM TO ANY PARTICULAR FONT, STYLE, SIZE, OR COLOR.

FOR DOLL ACCESSORIES; DOLL CLOTHING; DOLL FURNITURE; DOLL HOUSE FURNISHINGS; DOLLS (U.S. CLS. 22, 23, 38 AND 50).

WILLIAM P. SHANAHAN, EXAMINING ATTORNEY

SN 85-260,198. QUIGLESS, KIRK, AKA QUIGLESS INNOVATIONS, ST. LOUIS, MO. FILED 3-7-2011.



THE MARK CONSISTS OF INTERCONNECTED "B" WITHIN A "G".

FOR ATHLETIC EQUIPMENT, NAMELY, MOUTH GUARDS (U.S. CLS. 22, 23, 38 AND 50).

FIRST USE 6-15-2010; IN COMMERCE 1-31-2011.

CHARLOTTE CORWIN, EXAMINING ATTORNEY

CLASS 28—(Continued).

SN 85-261,437. HADRON INDUSTRIES, INC., BIG BEAR LAKE, CA. FILED 3-8-2011.

///ECHELON

THE MARK CONSISTS OF THE STYLIZED WORD "ECHELON".
FOR SNOWBOARDS (U.S. CLS. 22, 23, 38 AND 50).
GIANCARLO CASTRO, EXAMINING ATTORNEY

SN 85-262,222. EASTMAN OUTDOORS, INC., FLUSHING, MI. FILED 3-9-2011.

BioSync³

THE MARK CONSISTS OF THE WORD "BIOSYNC" WITH THE LETTERS "B" AND "S" CAPITALIZED AND THE NUMBER "3" IN SUPERSCRIPT IMMEDIATELY AFTER IT.
FOR CROSSBOWS (U.S. CLS. 22, 23, 38 AND 50).
SANI KHOURI, EXAMINING ATTORNEY

SN 85-262,402. TOM'S TACKLE, INC., BAUDETTE, MN. FILED 3-9-2011.

HBJ(Charmer)

THE MARK CONSISTS OF STANDARD CHARACTERS WITHOUT CLAIM TO ANY PARTICULAR FONT, STYLE, SIZE, OR COLOR.
FOR FISHING TACKLE (U.S. CLS. 22, 23, 38 AND 50).
FIRST USE 3-16-2011; IN COMMERCE 3-16-2011.
LINDA ORNDORFF, EXAMINING ATTORNEY

SN 85-268,266. EASTMAN OUTDOORS, INC., FLUSHING, MI. FILED 3-16-2011.

LA FEMME DANGEREUSE

THE MARK CONSISTS OF STANDARD CHARACTERS WITHOUT CLAIM TO ANY PARTICULAR FONT, STYLE, SIZE, OR COLOR.
THE ENGLISH TRANSLATION OF "LA FEMME DANGEREUSE" IN THE MARK IS "THE DANGEROUS WOMAN".
FOR ARROWS (U.S. CLS. 22, 23, 38 AND 50).
SANI KHOURI, EXAMINING ATTORNEY

CLASS 28—(Continued).

SN 85-269,946. TY INC., WESTMONT, IL. FILED 3-17-2011.

PRAY FOR JAPAN

THE MARK CONSISTS OF STANDARD CHARACTERS WITHOUT CLAIM TO ANY PARTICULAR FONT, STYLE, SIZE, OR COLOR.

NO CLAIM IS MADE TO THE EXCLUSIVE RIGHT TO USE "JAPAN", APART FROM THE MARK AS SHOWN.
FOR BEAN BAG DOLLS; DOLLS; PLUSH DOLLS; PLUSH TOYS; SOFT SCULPTURE DOLLS; SOFT SCULPTURE PLUSH TOYS; STUFFED AND PLUSH TOYS; STUFFED DOLLS AND ANIMALS; STUFFED TOY ANIMALS; STUFFED TOYS (U.S. CLS. 22, 23, 38 AND 50).

SANDRA BUJA, EXAMINING ATTORNEY

SN 85-270,689. TY INC., WESTMONT, IL. FILED 3-18-2011.

HOPE FOR JAPAN

THE MARK CONSISTS OF STANDARD CHARACTERS WITHOUT CLAIM TO ANY PARTICULAR FONT, STYLE, SIZE, OR COLOR.

NO CLAIM IS MADE TO THE EXCLUSIVE RIGHT TO USE "JAPAN", APART FROM THE MARK AS SHOWN.
FOR BEAN BAG DOLLS; DOLLS; PLUSH DOLLS; PLUSH TOYS; SOFT SCULPTURE DOLLS; SOFT SCULPTURE PLUSH TOYS; STUFFED AND PLUSH TOYS; STUFFED DOLLS AND ANIMALS; STUFFED TOY ANIMALS; STUFFED TOYS (U.S. CLS. 22, 23, 38 AND 50).

SANDRA BUJA, EXAMINING ATTORNEY

SN 85-275,443. TY INC., WESTMONT, IL. FILED 3-24-2011.

I LOVE JAPAN

THE MARK CONSISTS OF STANDARD CHARACTERS WITHOUT CLAIM TO ANY PARTICULAR FONT, STYLE, SIZE, OR COLOR.

NO CLAIM IS MADE TO THE EXCLUSIVE RIGHT TO USE "JAPAN", APART FROM THE MARK AS SHOWN.
FOR BEAN BAG DOLLS; DOLLS; PLUSH DOLLS; PLUSH TOYS; SOFT SCULPTURE DOLLS; SOFT SCULPTURE PLUSH TOYS; STUFFED AND PLUSH TOYS; STUFFED DOLLS AND ANIMALS; STUFFED TOY ANIMALS; STUFFED TOYS (U.S. CLS. 22, 23, 38 AND 50).

SANDRA BUJA, EXAMINING ATTORNEY

CLASS 28—(Continued).

SN 85-276,156. BATTAT INCORPORATED, PLATTSBURGH, NY. FILED 3-24-2011.

ABC BLOCK PARTY

THE MARK CONSISTS OF STANDARD CHARACTERS WITHOUT CLAIM TO ANY PARTICULAR FONT, STYLE, SIZE, OR COLOR.

NO CLAIM IS MADE TO THE EXCLUSIVE RIGHT TO USE "ABC BLOCK", APART FROM THE MARK AS SHOWN.

FOR STACKING TOYS; TOY BUILDING BLOCKS (U.S. CLS. 22, 23, 38 AND 50).

WILLIAM P. SHANAHAN, EXAMINING ATTORNEY

SN 85-303,635. BAY TEK GAMES, INC., PULASKI, WI. FILED 4-25-2011.

GOAL RUSH

THE MARK CONSISTS OF STANDARD CHARACTERS WITHOUT CLAIM TO ANY PARTICULAR FONT, STYLE, SIZE, OR COLOR.

FOR REDEMPTION-TYPE SOCCER THEMED ALLEY BOWLER ARCADE GAMES (U.S. CLS. 22, 23, 38 AND 50).

DAVID ELTON, EXAMINING ATTORNEY

SN 85-303,659. BAY TEK GAMES, INC., PULASKI, WI. FILED 4-25-2011.

WACKY SHACK

THE MARK CONSISTS OF STANDARD CHARACTERS WITHOUT CLAIM TO ANY PARTICULAR FONT, STYLE, SIZE, OR COLOR.

FOR REDEMPTION-TYPE ARCADE GAMES (U.S. CLS. 22, 23, 38 AND 50).

DAVID ELTON, EXAMINING ATTORNEY

CLASS 28—(Continued).

SN 85-304,004. TOY STATE INDUSTRIAL LTD., TSIMSHAT-SUI, KOWLOON, HONG KONG, FILED 4-25-2011.

REVEALZ

THE MARK CONSISTS OF STANDARD CHARACTERS WITHOUT CLAIM TO ANY PARTICULAR FONT, STYLE, SIZE, OR COLOR.

FOR TOY VEHICLES (U.S. CLS. 22, 23, 38 AND 50).

KELLY BOULTON, EXAMINING ATTORNEY

SN 85-304,007. TOY STATE INDUSTRIAL LTD., TSIMSHAT-SUI, KOWLOON, HONG KONG, FILED 4-25-2011.

BEAT MAKERZ

THE MARK CONSISTS OF STANDARD CHARACTERS WITHOUT CLAIM TO ANY PARTICULAR FONT, STYLE, SIZE, OR COLOR.

FOR TOY VEHICLES (U.S. CLS. 22, 23, 38 AND 50).

KELLY BOULTON, EXAMINING ATTORNEY

SN 85-312,935. TRISTAR PRODUCTS, INC., FAIRFIELD, NJ. FILED 5-5-2011.

PANTHER

THE MARK CONSISTS OF STANDARD CHARACTERS WITHOUT CLAIM TO ANY PARTICULAR FONT, STYLE, SIZE, OR COLOR.

FOR ELLIPTICAL EXERCISE MACHINES (U.S. CLS. 22, 23, 38 AND 50).

ELI HELLMAN, EXAMINING ATTORNEY

CLASS 28—(Continued).

SN 85-315,340. ALLI, ALLIANCE OF ACTION SPORTS, LLC,
BURR RIDGE, IL. FILED 5-9-2011.

ALLI SPORTS

THE MARK CONSISTS OF STANDARD CHARACTERS WITHOUT CLAIM TO ANY PARTICULAR FONT, STYLE, SIZE, OR COLOR.

OWNER OF U.S. REG. NO. 3,908,921.

NO CLAIM IS MADE TO THE EXCLUSIVE RIGHT TO USE "SPORTS", APART FROM THE MARK AS SHOWN.

FOR TOYS, PLAYTHINGS AND SPORTING ARTICLES AND GOODS, NAMELY, SKATEBOARDS AND BOARD GAMES; ATHLETIC PROTECTIVE PADS, NAMELY, KNEE PADS, ELBOW PADS AND WRIST GUARDS (U.S. CLS. 22, 23, 38 AND 50).

JOHN WILKE, EXAMINING ATTORNEY

CLASS 29—MEATS AND PROCESSED FOODS

SN 77-217,658. TOOBRO NY, LLC, HEWLETT NECK, NY.
FILED 6-28-2007.

SN 85-315,341. ALLI, ALLIANCE OF ACTION SPORTS, LLC,
BURR RIDGE, IL. FILED 5-9-2011.

**ALLI ALLIANCE OF ACTION
SPORTS**

THE MARK CONSISTS OF STANDARD CHARACTERS WITHOUT CLAIM TO ANY PARTICULAR FONT, STYLE, SIZE, OR COLOR.

OWNER OF U.S. REG. NO. 3,908,921.

NO CLAIM IS MADE TO THE EXCLUSIVE RIGHT TO USE "ACTION SPORTS", APART FROM THE MARK AS SHOWN.

FOR TOYS, PLAYTHINGS AND SPORTING ARTICLES AND GOODS, NAMELY, SKATEBOARDS AND BOARD GAMES; ATHLETIC PROTECTIVE PADS, NAMELY, KNEE PADS, ELBOW PADS AND WRIST GUARDS (U.S. CLS. 22, 23, 38 AND 50).

JOHN WILKE, EXAMINING ATTORNEY

MY BABY

SN 85-331,801. PARAMOUNT PICTURES CORPORATION,
HOLLYWOOD, CA. FILED 5-26-2011.

WWZ

THE MARK CONSISTS OF STANDARD CHARACTERS WITHOUT CLAIM TO ANY PARTICULAR FONT, STYLE, SIZE, OR COLOR.

FOR ACTION FIGURES AND ACCESSORIES THEREFOR; BOARD GAMES; MODELED PLASTIC TOY FIGURINES; TOY MODEL HOBBYCRAFT KITS (U.S. CLS. 22, 23, 38 AND 50).

SUSAN RICHARDS, EXAMINING ATTORNEY

THE MARK CONSISTS OF STANDARD CHARACTERS WITHOUT CLAIM TO ANY PARTICULAR FONT, STYLE, SIZE, OR COLOR.

NO CLAIM IS MADE TO THE EXCLUSIVE RIGHT TO USE "BABY", APART FROM THE MARK AS SHOWN.

FOR KOSHER YOGURT FOR BABIES AND CHILDREN, EXCLUDING FROZEN CONFECTIONS, ICE CREAM, ICE MILK, AND FROZEN YOGURT (U.S. CL. 46).

FIRST USE 4-0-2007; IN COMMERCE 4-0-2007.
DAWN FELDMAN, EXAMINING ATTORNEY

CLASS 29—(Continued).

SN 77-926,842. DELTA FOODS S.A., 14565 AGHIOS STEFANOS ATTICA, GREECE, FILED 2-3-2010.



THE NAME SHOWN IN THE MARK DOES NOT IDENTIFY A PARTICULAR LIVING INDIVIDUAL.

THE COLOR(S) BLACK, BROWN, RED, BLUE, WHITE, YELLOW AND ORANGE IS/ARE CLAIMED AS A FEATURE OF THE MARK.

THE MARK CONSISTS OF A BLUE TRIANGLE CONTAINING A WOMAN CARRYING A BUCKET AND A BUSH IN WHITE; THREE BROKEN HORIZONTAL LINES IN RED; THE WORD "DELTA" IN RED ALL ON A WHITE RECTANGLE; THE WORD "MILKO" IN BROWN IN A VERTICAL POSITION WITH WHITE DOTS IN THE LETTER "O", OUTLINED IN WHITE WITH RED, ORANGE, YELLOW, AND BLUE HIGHLIGHTS, AND A YELLOW TRIANGLE ALL OF THE FOREGOING AGAINST A BLACK BACKGROUND.

THE WORDING "MILKO" HAS NO MEANING IN A FOREIGN LANGUAGE.

FOR DAIRY PRODUCTS, EXCLUDING ICE CREAM, ICE MILK AND FROZEN YOGURT; DAIRY-BASED BEVERAGES, DAIRY BASED FOOD BEVERAGES, DAIRY DESSERTS, DAIRY BASED DIPS, DAIRY BASED SPREADS, MILK AND MILK PRODUCTS, EXCLUDING ICE CREAM, ICE MILK AND FROZEN YOGURT; CHOCOLATE MILK, MILK-BASED ENERGY DRINKS, MILK POWDER, MILK BEVERAGES CONTAINING FRUITS, FLAVORED DAIRY BASED BEVERAGES, MILK AND CREAM MIXTURE FOR COFFEE, MILK BASED BEVERAGE CONTAINING COFFEE, YOGURT, YOGURT DRINKS, YOGURT BASED BEVERAGES, YOGURT WITH FRUITS, YOGURT WITH CEREALS, NAMELY, YOGURT CONTAINING CEREAL, CHEESE AND CHEESE PRODUCTS, NAMELY, CHEESE POWDER, CHEESE SPREADS, CREAM CHEESE, CREAM, CREAM FRAICHE, CREAM POWDER, WHIPPED CREAM, BUTTER (U.S. CL. 46).

DAVID C. REIHNER, EXAMINING ATTORNEY

CLASS 29—(Continued).

SN 77-926,863. DELTA FOODS S.A., 14565 AGHIOS STEFANOS ATTICA, GREECE, FILED 2-3-2010.



THE COLOR(S) PURPLE, RED, BLUE AND WHITE IS/ARE CLAIMED AS A FEATURE OF THE MARK.

THE MARK CONSISTS OF A BLUE TRIANGLE CONTAINING A WOMAN CARRYING A BUCKET AND A BUSH IN WHITE; THREE BROKEN HORIZONTAL LINES IN RED; THE WORD "DELTA" IN RED ALL ON A WHITE RECTANGLE; A PURPLE OVAL CONTAINING THE WORD "VITALINE" IN WHITE WITH A BLUE SHADOW, AND THE OVAL CONTAINED IN A BROKEN WHITE OVAL WITH A BLUE BORDER.

FOR DAIRY PRODUCTS, EXCLUDING ICE CREAM, ICE MILK AND FROZEN YOGURT; DAIRY-BASED BEVERAGES, DAIRY BASED FOOD BEVERAGES, DAIRY DESSERTS, DAIRY BASED DIPS, DAIRY BASED SPREADS, MILK AND MILK PRODUCTS, EXCLUDING ICE CREAM, ICE MILK AND FROZEN YOGURT; CHOCOLATE MILK, MILK-BASED ENERGY DRINKS, MILK POWDER, MILK BEVERAGES CONTAINING FRUITS, FLAVORED DAIRY BASED BEVERAGES, MILK AND CREAM MIXTURE FOR COFFEE, MILK BASED BEVERAGE CONTAINING COFFEE, YOGURT, YOGURT DRINKS, YOGURT BASED BEVERAGES, YOGURT WITH FRUITS, YOGURT WITH CEREALS, NAMELY, YOGURT CONTAINING CEREAL, CHEESE AND CHEESE PRODUCTS, NAMELY, CHEESE POWDER, CHEESE SPREADS, CREAM CHEESE, CREAM, CREAM FRAICHE, CREAM POWDER, WHIPPED CREAM, BUTTER (U.S. CL. 46).

DAVID C. REIHNER, EXAMINING ATTORNEY

CLASS 29—(Continued).

SN 77-926,996. DELTA FOODS S.A., 14565 AGHIOS STEFANOS ATTICA, GREECE, FILED 2-3-2010.

DELTA Vitaline

THE MARK CONSISTS OF STANDARD CHARACTERS WITHOUT CLAIM TO ANY PARTICULAR FONT, STYLE, SIZE, OR COLOR.

FOR DAIRY PRODUCTS, EXCLUDING ICE CREAM, ICE MILK AND FROZEN YOGURT; DAIRY-BASED BEVERAGES, DAIRY BASED FOOD BEVERAGES, DAIRY DESSERTS, DAIRY BASED DIPS, DAIRY BASED SPREADS, MILK AND MILK PRODUCTS, EXCLUDING ICE CREAM, ICE MILK AND FROZEN YOGURT; CHOCOLATE MILK, MILK-BASED ENERGY DRINKS, MILK POWDER, MILK BEVERAGES CONTAINING FRUITS, FLAVORED DAIRY BASED BEVERAGES, MILK AND CREAM MIXTURE FOR COFFEE, MILK BASED BEVERAGE CONTAINING COFFEE, YOGURT, YOGURT DRINKS, YOGURT BASED BEVERAGES, YOGURT WITH FRUITS, YOGURT WITH CEREALS, NAMELY, YOGURT CONTAINING CEREAL, CHEESE AND CHEESE PRODUCTS, NAMELY, CHEESE POWDER, CHEESE SPREADS, CREAM CHEESE, CREAM, CREAM FRAICHE, CREAM POWDER, WHIPPED CREAM, BUTTER (U.S. CL. 46).

DAVID C. REIHNER, EXAMINING ATTORNEY

SN 79-080,048. ASSOCIAZIONE NAZIONALE; ALLEVATORI DELLA RAZZA BRUNA, BUSSOLENGO (VERONA), ITALY, FILED 12-22-2009.



OWNER OF INTERNATIONAL REGISTRATION 1031833 DATED 12-22-2009, EXPIRES 12-22-2019.

NO CLAIM IS MADE TO THE EXCLUSIVE RIGHT TO USE "BRUNA", APART FROM THE MARK AS SHOWN.

THE COLOR(S) BLUE, RED AND WHITE IS/ARE CLAIMED AS A FEATURE OF THE MARK.

THE MARK CONSISTS OF A WHITE CONTAINER OF

CLASS 29—(Continued).

MILK AGAINST A BLUE SHADED SHADOW, WITH A BLUE LABEL PARTIALLY AFFIXED TO THE WHITE CONTAINER; THE BLUE LABEL BEARS THE WORDING "DISOLA BRUNA" IN THE COLOR WHITE, WITH THE WORDING "DISOLA" ABOVE THE WORDING "BRUNA"; THE MILK CONTAINER IS WITHIN A WELL-DEFINED CIRCLE HAVING A RED BACKGROUND AND WHITE AND BLUE OUTLINE, SURROUNDING WHICH IS ANOTHER CIRCLE IN THE COLOR RED WITH BLUE SHADING AND AN IRREGULAR OUTLINE.

THE ENGLISH TRANSLATION OF "DISOLA BRUNA" IN THE MARK IS ONLY BROWN.

FOR MILK AND MILK PRODUCTS EXCLUDING ICE CREAM, ICE MILK AND FROZEN YOGURT (U.S. CL. 46).

SUZANNE BLANE, EXAMINING ATTORNEY

SN 79-083,555. MINISTERO DELLE POLITICHE AGRICOLE, ALIMENTARI E FORESTALI - DIPARTIMENTO DELLE POLITICHE COMPETITIVE DEL MONDO RURALE E DELLA QUALITA' - DIREZIONE GENERALE PER LO SVILUPPO AGROALIMENTARE, LA QUALITA' E LA TUTELA DEL CONSUMATORE, ROMA, ITALY, FILED 4-23-2010.

SALAME D'OCA DI MORTARA

THE MARK CONSISTS OF STANDARD CHARACTERS WITHOUT CLAIM TO ANY PARTICULAR FONT, STYLE, SIZE, OR COLOR.

PRIORITY DATE OF 2-12-2010 IS CLAIMED.

OWNER OF INTERNATIONAL REGISTRATION 1041433 DATED 4-23-2010, EXPIRES 4-23-2020.

NO CLAIM IS MADE TO THE EXCLUSIVE RIGHT TO USE "SALAME D'OCA", APART FROM THE MARK AS SHOWN.

THE ENGLISH TRANSLATION OF "SALAME D'OCA DI MORTARA" IN THE MARK IS "GOOSE SALAMI FROM MORTARA".

THE CERTIFICATION MARK, AS INTENDED TO BE USED BY PERSONS AUTHORIZED BY THE CERTIFIER, IS INTENDED TO CERTIFY THAT THE GOODS PROVIDED ORIGINATE IN THE GEOGRAPHICALLY DISTINCTIVE AREA OF THE COMMUNES COMPRISING THE LOMELINA, (INCLUDING MORTARA), A SPECIFIC AREA IN THE PAVIA PROVINCE OF LOMBARDY REGION OF ITALY, AND THAT THE PREPARATION, PRODUCTION, AND/OR PROCESSING OF THE GOODS TAKE PLACE ACCORDING TO THE STANDARD OF RECORD.

FOR SALAMI (U.S. CL. 46).

KAREN M. STRYZ, EXAMINING ATTORNEY

SN 79-083,559. MINISTERO DELLE POLITICHE AGRICOLE, ALIMENTARI E FORESTALI - DIPARTIMENTO DELLE POLITICHE COMPETITIVE DEL MONDO RURALE E DELLA QUALITA' - DIREZIONE GENERALE PER LO SVILUPPO AGROALIMENTARE, LA QUALITA' E LA TUTELA DEL CONSUMATORE, ROMA, ITALY, FILED 4-23-2010.

VALDEMONE

THE MARK CONSISTS OF STANDARD CHARACTERS WITHOUT CLAIM TO ANY PARTICULAR FONT, STYLE, SIZE, OR COLOR.

PRIORITY DATE OF 2-12-2010 IS CLAIMED.

OWNER OF INTERNATIONAL REGISTRATION 1041433 DATED 4-23-2010, EXPIRES 4-23-2020.

THE CERTIFICATION MARK, AS INTENDED TO BE USED BY THE CERTIFIER, IS INTENDED TO CERTIFY THAT THE GOODS PROVIDED ORIGINATE IN THE

CLASS 29—(Continued).

WHOLE OF PROVINCE OF MESSINA (SICILY REGION) WITH THE EXCEPTION OF THE MUNICIPALITIES OF FLORESTA, MOIO ALCANTARA AND MALVAGNA IN ITALY (VALDEMONE REFERS TO AN ADMINISTRATIVE AND FINANCIAL TERRITORIAL SUBDIVISION WHICH EXISTED IN NORTHEASTERN SICILY FROM MIDDLE AGES UNTIL 1812), AND THAT THE PREPARATION, PRODUCTION, AND/OR PROCESSING OF THE GOODS TAKE PLACE ACCORDING TO THE STANDARD OF RECORD.

FOR EXTRA VIRGIN OLIVE OIL (U.S. CL. 46).
KAREN M. STRYZ, EXAMINING ATTORNEY

CLASS 29—(Continued).

SN 79-084,261. NORRMEJERIER EKONOMISK FÖRENING, SWEDEN, FILED 6-9-2010.



SN 79-083,563. MINISTERO DELLE POLITICHE AGRICOLE, ALIMENTARI E FORESTALI - DIPARTIMENTO DELLE POLITICHE COMPETITIVE DEL MONDO RURALE E DELLA QUALITA' - DIREZIONE GENERALE PER LO SVILUPPO AGROALIMENTARE, LA QUALITA' E LA TUTELA DEL CONSUMATORE, ROMA, ITALY, FILED 4-23-2010.

PRIORITY DATE OF 12-10-2009 IS CLAIMED.
OWNER OF INTERNATIONAL REGISTRATION 1043285 DATED 6-9-2010, EXPIRES 6-9-2020.

OWNER OF U.S. REG. NOS. 3,032,635, 3,032,636 AND 3,488,931.

THE COLOR(S) BLACK, WHITE AND GOLD IS/ARE CLAIMED AS A FEATURE OF THE MARK.

THE MARK CONSISTS OF THE TEXT "VÄSTERBOTTENSOST" IN BLACK, THE LETTER "W" IS IN BLACK AND WHITE, THE CROWN DESIGN IS IN BLACK AND WHITE, ALL AGAINST A GOLDEN BACKGROUND WITHIN TWO CIRCLES OUTLINED IN BLACK.

THE ENGLISH TRANSLATION OF "VÄSTERBOTTENSOST" IN THE MARK IS VÄSTERBOTTEN CHEESE.

SEC. 2(F) AS TO "VÄSTERBOTTENSOST".
FOR CHEESE ORIGINATING FROM THE VÄSTERBOTTEN REGION OF SWEDEN (U.S. CL. 46).
MARTHA FROMM, EXAMINING ATTORNEY

VALLE D'AOSTA JAMBON DE BOSSES

SN 85-090,808. WE DEAL, INC., DBA CALIFORNIA HEALTHY HARVEST, EMPIRE, CA. FILED 7-22-2010.

THE MARK CONSISTS OF STANDARD CHARACTERS WITHOUT CLAIM TO ANY PARTICULAR FONT, STYLE, SIZE, OR COLOR.

PRIORITY DATE OF 2-12-2010 IS CLAIMED.
OWNER OF INTERNATIONAL REGISTRATION 1041441 DATED 4-23-2010, EXPIRES 4-23-2020.

NO CLAIM IS MADE TO THE EXCLUSIVE RIGHT TO USE "JAMBON", APART FROM THE MARK AS SHOWN.

THE ENGLISH TRANSLATION OF "VALLE D'AOSTA JAMBON DE BOSSES" IN THE MARK IS "AOSTA VALLEY HAM FROM BOSSES".

THE CERTIFICATION MARK, AS INTENDED TO BE USED BY PERSONS AUTHORIZED BY THE CERTIFIER, IS INTENDED TO CERTIFY THAT THE GOODS PROVIDED ORIGINATE IN THE AREA OF THE COMMUNE OF SAINT-RHEMY-EN-BOSSES (ELEV. 1600 M, 21 KM NORTHWEST OF AOSTA) IN ITALY, AND THAT THE PREPARATION, PRODUCTION, AND/OR PROCESSING OF THE GOODS TAKE PLACE ACCORDING TO THE STANDARD OF RECORD.

FOR AGED DRY-CURED PROSCIUTTO (U.S. CL. 46).
KAREN M. STRYZ, EXAMINING ATTORNEY

California Healthy Harvest

THE MARK CONSISTS OF STANDARD CHARACTERS WITHOUT CLAIM TO ANY PARTICULAR FONT, STYLE, SIZE, OR COLOR.

NO CLAIM IS MADE TO THE EXCLUSIVE RIGHT TO USE "CALIFORNIA HEALTHY", APART FROM THE MARK AS SHOWN.

FOR CANNED FOOD, NAMELY, CANNED FRUIT AND VEGETABLES; PROCESSED NUTS; AND TRAIL MIX CONSISTING PRIMARILY OF PROCESSED NUTS, SEEDS, DRIED FRUIT AND ALSO CONTAINING CHOCOLATE (U.S. CL. 46).

FIRST USE 1-1-1997; IN COMMERCE 1-1-1997.
MARILYN IZZI, EXAMINING ATTORNEY

CLASS 29—(Continued).

SN 85-108,632. LUBERSKI, INC., DBA HIDDEN VILLA RANCH, FULLERTON, CA. FILED 8-16-2010.

Nest Fresh

THE MARK CONSISTS OF STANDARD CHARACTERS WITHOUT CLAIM TO ANY PARTICULAR FONT, STYLE, SIZE, OR COLOR.

NO CLAIM IS MADE TO THE EXCLUSIVE RIGHT TO USE "FRESH", APART FROM THE MARK AS SHOWN.

FOR SHELL EGGS (U.S. CL. 46).

FIRST USE 5-1-1992; IN COMMERCE 7-1-1997.

DOMINICK J. SALEMI, EXAMINING ATTORNEY

CLASS 29—(Continued).

SN 85-114,687. TOPCO ASSOCIATES, LLC, SKOKIE, IL. FILED 8-24-2010.

STEAMIN' EASY SINGLES

THE MARK CONSISTS OF STANDARD CHARACTERS WITHOUT CLAIM TO ANY PARTICULAR FONT, STYLE, SIZE, OR COLOR.

OWNER OF U.S. REG. NO. 3,402,520.

NO CLAIM IS MADE TO THE EXCLUSIVE RIGHT TO USE "STEAMING" AND "SINGLES", APART FROM THE MARK AS SHOWN.

FOR PROCESSED FROZEN VEGETABLES AND FROZEN VEGETABLE BLENDS IN MICROWAVABLE BAGS WHICH ALLOW VEGETABLES TO STEAM WITHIN THE BAG (U.S. CL. 46).

SUE LAWRENCE, EXAMINING ATTORNEY

SN 85-124,195. GRANDE CHEESE COMPANY, BROWNSVILLE, WI. FILED 9-7-2010.

ITALIAN BLENDS

OWNER OF U.S. REG. NOS. 2,825,286, 2,933,201 AND OTHERS.

NO CLAIM IS MADE TO THE EXCLUSIVE RIGHT TO USE "ITALIAN BLENDS", APART FROM THE MARK AS SHOWN.

THE MARK CONSISTS OF THE WORDS "ITALIAN BLENDS" IN A CURVED SCRIPT.

SEC. 2(F).

FOR CHEESE (U.S. CL. 46).

FIRST USE 8-17-2010, THE MARK WAS FIRST USED ANYWHERE IN A DIFFERENT FORM OTHER THAN THAT SOUGHT TO BE REGISTERED AT LEAST AS EARLY AS 08/24/1984; IN COMMERCE 8-17-2010, THE MARK WAS FIRST USED IN COMMERCE IN A DIFFERENT FORM OTHER THAN THAT SOUGHT TO BE REGISTERED AT LEAST AS EARLY AS 08/24/1984.

TRICIA SONNEBORN, EXAMINING ATTORNEY

SN 85-108,826. LUBERSKI, INC., DBA HIDDEN VILLA RANCH, FULLERTON, CA. FILED 8-17-2010.



NO CLAIM IS MADE TO THE EXCLUSIVE RIGHT TO USE "COLORADO", APART FROM THE MARK AS SHOWN.

THE COLOR(S) CREAM, GREEN, AND OLIVE GREEN IS/ ARE CLAIMED AS A FEATURE OF THE MARK.

THE MARK CONSISTS OF THE WORDS "COLORADO" AND "NATURAL" IN STYLIZED LETTERS AND IN A CREAM COLOR. THE WORDS "COLORADO" AND "NATURAL" HAVE OLIVE GREEN SHADING OUTLINING THE WORDS. THE WORDS "COLORADO" AND "NATURAL" ARE SET ON A GREEN BACKGROUND. THE WORD "COLORADO" IS SLIGHTLY ARCHED AND SET ABOVE THE WORD "NATURAL".

FOR SHELL EGGS AND LIQUID EGGS (U.S. CL. 46).

FIRST USE 4-0-2007; IN COMMERCE 4-0-2007.

DOMINICK J. SALEMI, EXAMINING ATTORNEY

SN 85-126,946. WILLAMETTE EGG FARMS, CANBY, OR. FILED 9-10-2010.

Willamette Foods

THE MARK CONSISTS OF STANDARD CHARACTERS WITHOUT CLAIM TO ANY PARTICULAR FONT, STYLE, SIZE, OR COLOR.

NO CLAIM IS MADE TO THE EXCLUSIVE RIGHT TO USE "FOODS", APART FROM THE MARK AS SHOWN.

SEC. 2(F).

FOR EGGS (U.S. CL. 46).

FIRST USE 6-4-1997; IN COMMERCE 6-4-1997.

JERI J. FICKES, EXAMINING ATTORNEY

CLASS 29—(Continued).

SN 85-154,230. CANNONE INDUSTRIE ALIMENTARI GLI ANTIPASTI - S.R.L., CERIGNOLA (FG), ITALY, FILED 10-15-2010.



NO CLAIM IS MADE TO THE EXCLUSIVE RIGHT TO USE "FINE FOOD", APART FROM THE MARK AS SHOWN.

THE MARK CONSISTS OF THE DESIGN OF A TREE FORMED BY LITTLE HEARTS. A FORK COMES OUT OF THE TREE AS ITS STEM, BELOW THIS DESIGN ARE THE WORDS "PETROLLA FINEFOOD", ALL IN STYLIZED LETTERS ONE PLACED ABOVE THE OTHER, THE WORD "FINEFOOD" IS IN SMALLER SIZE.

FOR MEAT, FISH, POULTRY AND GAME; MEAT EXTRACTS; PRESERVED, FROZEN, DRIED AND COOKED FRUITS AND VEGETABLES; JELLIES, JAMS, COMPOTES; EGGS, MILK; EDIBLE OILS AND FATS; VEGETABLES PRESERVED IN OIL; PICKLED VEGETABLES; PICKLED OLIVES (U.S. CL. 46).

ELI HELLMAN, EXAMINING ATTORNEY

SN 85-195,373. UPLANDS CHEESE, INC., DODGEVILLE, WI. FILED 12-10-2010.

RUSH CREEK RESERVE

THE MARK CONSISTS OF STANDARD CHARACTERS WITHOUT CLAIM TO ANY PARTICULAR FONT, STYLE, SIZE, OR COLOR.

NO CLAIM IS MADE TO THE EXCLUSIVE RIGHT TO USE "RESERVE", APART FROM THE MARK AS SHOWN.

FOR CHEESE (U.S. CL. 46).
FIRST USE 10-5-2010; IN COMMERCE 10-5-2010.
GINA FINK, EXAMINING ATTORNEY

CLASS 29—(Continued).

SN 85-209,807. OLEVANO IMPORTERS LLC, WILMINGTON, DE. FILED 1-4-2011.

OLEVANO

THE MARK CONSISTS OF STANDARD CHARACTERS WITHOUT CLAIM TO ANY PARTICULAR FONT, STYLE, SIZE, OR COLOR.

OWNER OF U.S. REG. NO. 2,916,828.

SEC. 2(F).

FOR FIRST COLD PRESS EXTRA VIRGIN OLIVE OIL, EXTRA VIRGIN OLIVE OIL AND OLIVE OIL (U.S. CL. 46).

FIRST USE 1-20-2003; IN COMMERCE 6-9-2003.

MATTHEW MCDOWELL, EXAMINING ATTORNEY

SN 85-213,164. COPPER RIVER SEAFOODS, ANCHORAGE, AK. FILED 1-7-2011.

Taste the Wild, Taste the Difference!

THE MARK CONSISTS OF STANDARD CHARACTERS WITHOUT CLAIM TO ANY PARTICULAR FONT, STYLE, SIZE, OR COLOR.

OWNER OF U.S. REG. NO. 3,563,924.

FOR SEAFOOD, NAMELY, SALMON, COD, HALIBUT, ROCKFISH, ROCKSOLE, KING CRAB AND PRAWNS (U.S. CL. 46).

FIRST USE 1-1-2009; IN COMMERCE 1-1-2009.

NANCY CLARKE, EXAMINING ATTORNEY

SN 85-213,462. GRILLED CHEESE & CO LLC, CATONSVILLE, MD. FILED 1-8-2011.

Crabby Dip

THE MARK CONSISTS OF STANDARD CHARACTERS WITHOUT CLAIM TO ANY PARTICULAR FONT, STYLE, SIZE, OR COLOR.

NO CLAIM IS MADE TO THE EXCLUSIVE RIGHT TO USE "DIP", APART FROM THE MARK AS SHOWN.

FOR DAIRY-BASED DIPS; DIPS; PREPARED ENTREES CONSISTING PRIMARILY OF SEAFOOD (U.S. CL. 46).

FIRST USE 11-1-2010; IN COMMERCE 11-1-2010.

CARYN GLASSER, EXAMINING ATTORNEY

CLASS 29—(Continued).

SN 85-213,712. BUSHLAND PRODUCTS PTY LTD, TA PANAMEX PACIFIC, AUCKLAND, NEW ZEALAND, FILED 1-10-2011.

I'APANA

THE MARK CONSISTS OF STANDARD CHARACTERS WITHOUT CLAIM TO ANY PARTICULAR FONT, STYLE, SIZE, OR COLOR.

THE WORD "I'APANA" HAS NO MEANING IN A FOREIGN LANGUAGE.

FOR SEAFOOD; MEAT AND POULTRY IN FRESH AND PROCESSED FORM; PROCESSED FRUIT AND VEGETABLES (U.S. CL. 46).

FIRST USE 11-30-2009; IN COMMERCE 11-30-2009.
GEOFFREY FOSDICK, EXAMINING ATTORNEY

SN 85-218,960. JTM PROVISIONS COMPANY, INC., HARRISON, OH. FILED 1-17-2011.

J.T.M. UNMEATABLE

THE MARK CONSISTS OF STANDARD CHARACTERS WITHOUT CLAIM TO ANY PARTICULAR FONT, STYLE, SIZE, OR COLOR.

OWNER OF U.S. REG. NOS. 3,412,464, 3,499,649 AND 3,839,585.

FOR FROZEN, PREPARED OR PACKAGED VEGETARIAN BASED ENTREES, CONSISTING OF CHILI WITH BEANS, TACO STYLE FILLING, PASTA/SPAGHETTI STYLE SAUCE, AND BURRITO FILLING (U.S. CL. 46).

CAROLINE WOOD, EXAMINING ATTORNEY

SN 85-228,754. CONAGRA FOODS MEXICO, S.A. DE C.V., IRAPUATO, GUANAJUATO, MEXICO, FILED 1-28-2011.



THE MARK CONSISTS OF THREE BELLS WITH THE IMAGE OF A FIELD ON EACH SIDE OF THE BELLS. THERE IS A LINE THAT CONNECTS THE RIGHT BELL TO THE LEFT BELL THAT REPRESENTS A SUNSET AND THERE ARE ALSO IMAGES OF BUSHES PLACED IN BOTH FIELDS. THE WORD "EL" IS PLACED IN THE TOP PORTION OF THE MIDDLE BELL AND THE OUTLINED WORD "CAMPANARIO" IS PLACED UNDERNEATH THE BELLS AND FIELD IMAGE.

THE ENGLISH TRANSLATION OF "CAMPANARIO" IN THE MARK IS "BELL TOWER".

FOR PROCESSED VEGETABLES (U.S. CL. 46).
ANNE MADDEN, EXAMINING ATTORNEY

CLASS 29—(Continued).

SN 85-229,207. BEST CHICAGO MEAT COMPANY, LLC, CHICAGO, IL. FILED 1-28-2011.

TASTE CHICAGO'S BEST

THE MARK CONSISTS OF STANDARD CHARACTERS WITHOUT CLAIM TO ANY PARTICULAR FONT, STYLE, SIZE, OR COLOR.

NO CLAIM IS MADE TO THE EXCLUSIVE RIGHT TO USE "CHICAGO'S BEST", APART FROM THE MARK AS SHOWN.

FOR MEAT (U.S. CL. 46).
SHAILA SETTLES, EXAMINING ATTORNEY

SN 85-232,579. MIDLAND DISTRIBUTION, INC., BLUE ISLAND, IL. FILED 2-2-2011.



THE COLOR(S) RED, BLUE, AND WHITE IS/ARE CLAIMED AS A FEATURE OF THE MARK.

THE MARK CONSISTS OF A RED-RIMMED, WHITE RECTANGLE WITH THE WORD "BALADNA" IN LARGE BLUE, STYLIZED LETTERS ACROSS THE CENTER, OVERLINED IN RED, UNDERLINED IN BLUE, ALL AGAINST A WHITE BACKDROP.

THE ENGLISH TRANSLATION OF "BALADNA" IN THE MARK IS "OUR LAND".

FOR DRIED BEANS; DRIED LENTILS; PREPARED COCONUT; PREPARED NUTS; PROCESSED BEANS; PROCESSED CHICKPEAS; PROCESSED EDIBLE SEEDS; PROCESSED NUTS; SHELLED NUTS; SNACK MIX CONSISTING OF PRIMARILY OF PROCESSED NUTS, SEEDS, DRIED FRUIT AND ALSO INCLUDING CHOCOLATE (U.S. CL. 46).

FIRST USE 3-3-1998; IN COMMERCE 3-3-1998.
JILL C. ALT, EXAMINING ATTORNEY

CLASS 29—(Continued).

SN 85-235,364. GANADEROS PRODUCTORES DE LECHE PURA, S.A. DE C.V., CUAUTITLAN IZCALLI, MEXICO, FILED 2-7-2011.

ALPURA FRUTAL

THE MARK CONSISTS OF STANDARD CHARACTERS WITHOUT CLAIM TO ANY PARTICULAR FONT, STYLE, SIZE, OR COLOR.

OWNER OF MEXICO REG. NO. 818261, DATED 1-22-2004, EXPIRES 12-8-2013.

OWNER OF U.S. REG. NOS. 2,123,203, 3,646,953 AND 3,646,957.

NO CLAIM IS MADE TO THE EXCLUSIVE RIGHT TO USE "FRUTAL", APART FROM THE MARK AS SHOWN.

THE ENGLISH TRANSLATION OF "FRUTAL" IN THE MARK IS "FRUIT-BEARING". THE WORDING "ALPURA" HAS NO MEANING IN A FOREIGN LANGUAGE.

FOR MILK-BASED BEVERAGES CONTAINING FRUIT AND FRUIT JUICE (U.S. CL. 46).

ELISSA GARBER KON, EXAMINING ATTORNEY

CLASS 29—(Continued).

SN 85-239,093. MIDLAND DISTRIBUTION, INC., BLUE ISLAND, IL. FILED 2-10-2011.



OWNER OF U.S. REG. NO. 2,941,783.

THE COLOR(S) GREEN AND RED IS/ARE CLAIMED AS A FEATURE OF THE MARK.

THE MARK CONSISTS OF THE WORD "ZDAN", WITH THE STYLIZED, CAPITAL LETTER "Z" IN GREEN WITH A CENTER STRIPE OF RED AND A SMALL GREEN CROWN RESTING ON ITS TOP HORIZONTAL; THE LETTERS "DAN" APPEAR IN STYLIZED, GREEN LOWER-CASE PRINT OUTLINED IN RED. THE LETTER "Z" IS ELONGATED ON THE BOTTOM, UNDERLINING THE LETTERS "DAN".

THE WORDING "ZDAN" HAS NO MEANING IN A FOREIGN LANGUAGE.

FOR CHEESE; CREAM; DAIRY PRODUCTS EXCLUDING ICE CREAM, ICE MILK AND FROZEN YOGURT; DAIRY-BASED FOOD BEVERAGES; FROZEN VEGETABLES; MILK; MILK PRODUCTS EXCLUDING ICE CREAM, ICE MILK AND FROZEN YOGURT; YOGURT (U.S. CL. 46).

FIRST USE 11-30-2002; IN COMMERCE 11-30-2002.

JILL C. ALT, EXAMINING ATTORNEY

SN 85-237,175. WALGREEN CO., DEERFIELD, IL. FILED 2-8-2011.

NICE!

THE MARK CONSISTS OF STANDARD CHARACTERS WITHOUT CLAIM TO ANY PARTICULAR FONT, STYLE, SIZE, OR COLOR.

FOR PROCESSED FRUIT-BASED FOOD BARS, NAMELY, FIG BARS; BUTTER; CREAM CHEESE; WHIPPED CREAM; CHEESE; PACKAGED MEALS CONSISTING PRIMARILY OF MEAT; MEATS; SALADS EXCEPT MACARONI, RICE, AND PASTA SALAD; PROCESSED POTATOES; DRIED FRUIT; PROCESSED NUTS; CANDIED NUTS; JERKY; SNACK MIX CONSISTING OF DEHYDRATED FRUIT AND PROCESSED NUTS; POTATO-BASED SNACK FOODS (U.S. CL. 46).

JIM RINGLE, EXAMINING ATTORNEY

SN 85-242,737. MARINE FISH & SEAFOOD COMPANY, INC., WILMINGTON, DE. FILED 2-15-2011.



NO CLAIM IS MADE TO THE EXCLUSIVE RIGHT TO USE "GOURMET", APART FROM THE MARK AS SHOWN.

THE MARK CONSISTS OF THE WORDS "CAPE GOURMET" IN BLACK SCRIPT LETTERS ON A WHITE RECTANGULAR BACKGROUND WITH PART OF A SHIP'S WHEEL VISIBLE BEHIND THE WORDS "CAPE GOURMET" ON THE WHITE RECTANGULAR BACKGROUND WITHIN DIAMOND SHAPED LINES ALL OF WHICH ARE ENCLOSED WITHIN A RECTANGULAR SHAPED BORDER WITH THE POINTS OF THE DIAMOND PROTRUDING BEYOND THE RECTANGULAR SHAPED BORDER.

FOR FISH AND SEAFOOD (U.S. CL. 46).

FIRST USE 6-0-1997; IN COMMERCE 6-0-1997.

ANTHONY RINKER, EXAMINING ATTORNEY

CLASS 29—(Continued).

SN 85-246,525. ROSINSKI, LEONARD D, COLUMBIA, SC.
FILED 2-18-2011.

Gordon's Potato Chips

THE MARK CONSISTS OF STANDARD CHARACTERS WITHOUT CLAIM TO ANY PARTICULAR FONT, STYLE, SIZE, OR COLOR.

NO CLAIM IS MADE TO THE EXCLUSIVE RIGHT TO USE "POTATO CHIPS", APART FROM THE MARK AS SHOWN.

FOR POTATO CHIPS (U.S. CL. 46).
EDWARD FENNESSY, EXAMINING ATTORNEY

SN 85-246,765. PRAIRIE GROVE FARMS OF IOWA, LLC,
SIOUX CENTER, IA. FILED 2-18-2011.

**GREAT TASTE WITHOUT THE
WORRY**

THE MARK CONSISTS OF STANDARD CHARACTERS WITHOUT CLAIM TO ANY PARTICULAR FONT, STYLE, SIZE, OR COLOR.

FOR (BASED ON SECTION 1(B)) EGGS; PREPACKAGED MEALS CONSISTING PRIMARILY OF MEAT, FISH, POULTRY OR VEGETABLES; FROZEN, PREPARED OR PACKAGED READY-TO-EAT MEALS CONSISTING PRIMARILY OF MEAT, FISH, POULTRY OR VEGETABLES; MEAT-BASED SNACK FOODS; CHEESE; (BASED ON SECTION 1(A)) FRESH, FROZEN AND PROCESSED MEATS; BEEF; POULTRY; PORK; PROCESSED LAMB; LUNCHEON MEATS (U.S. CL. 46).

FIRST USE 1-31-2009; IN COMMERCE 1-31-2009.
AMY HELLA, EXAMINING ATTORNEY

SN 85-247,004. BEATRICE COMPANIES INC, LAUGHLIN,
NV. FILED 2-19-2011.

Beatrice

THE MARK CONSISTS OF STANDARD CHARACTERS WITHOUT CLAIM TO ANY PARTICULAR FONT, STYLE, SIZE, OR COLOR.

OWNER OF U.S. REG. NO. 3,423,821.
FOR DAIRY PRODUCTS EXCLUDING ICE CREAM, ICE MILK AND FROZEN YOGURT; FROZEN PACKAGED ENTREES CONSISTING PRIMARILY OF MEAT, FISH, POULTRY OR VEGETABLES (U.S. CL. 46).
FIRST USE 4-13-2007; IN COMMERCE 4-13-2007.
BRIAN CALLAGHAN, EXAMINING ATTORNEY

CLASS 29—(Continued).

SN 85-247,385. LIU, HUA, IRVINE, CA. FILED 2-21-2011.



NO CLAIM IS MADE TO THE EXCLUSIVE RIGHT TO USE "GRASS CHICKEN", APART FROM THE MARK AS SHOWN.

THE COLOR(S) WHITE, GREEN, RED AND BLACK IS/ARE CLAIMED AS A FEATURE OF THE MARK.

THE MARK CONSISTS OF A ROOSTER HEAD AND A HEN HEAD APPEARING OUT FROM THE GRASS ALL CONTAINED IN AN OVAL DESIGN WITH THE WORDS "GRASS CHICKEN" APPEARING IN AN ARC AT THE TOP AND A FIVE-POINTED, SOLID STAR APPEARING EACH AT THE BEGINNING AND ENDING OF THE WORDS; THE WORDS AND HEADS APPEAR IN WHITE; THE ROOSTER'S COCKSCOMB AND WATTLE APPEAR IN RED; THE OUTLINE OF THE WORDS, THE PERIMETER OF THE OVAL, THE STARS, THE GRASS, THE OUTLINE OF THE ROOSTER AND HEN HEADS AND FEATURES THEREOF APPEAR IN BLACK.

FOR POULTRY (U.S. CL. 46).
ALEXANDER L. POWERS, EXAMINING ATTORNEY

SN 85-248,610. SEAFOOD AMERICA LLC, WARMINSTER,
PA. FILED 2-22-2011.

TAPAS TONITE

THE MARK CONSISTS OF STANDARD CHARACTERS WITHOUT CLAIM TO ANY PARTICULAR FONT, STYLE, SIZE, OR COLOR.

NO CLAIM IS MADE TO THE EXCLUSIVE RIGHT TO USE "TAPAS", APART FROM THE MARK AS SHOWN.
FOR SEAFOOD (U.S. CL. 46).
CARYN GLASSER, EXAMINING ATTORNEY

CLASS 29—(Continued).

SN 85-248,658. TANYA ZUCKERBROT, BAY HARBOR, FL.
FILED 2-22-2011.

F-FACTOR KIDS

THE MARK CONSISTS OF STANDARD CHARACTERS WITHOUT CLAIM TO ANY PARTICULAR FONT, STYLE, SIZE, OR COLOR.

OWNER OF U.S. REG. NO. 3,370,707.

NO CLAIM IS MADE TO THE EXCLUSIVE RIGHT TO USE "KIDS", APART FROM THE MARK AS SHOWN.

FOR CHEESE; FROZEN PRE-PACKAGED ENTREES CONSISTING PRIMARILY OF SEAFOOD; FRUIT CHIPS; POTATO CHIPS; VEGETABLE CHIPS; YOGURTS; FROZEN MEALS CONSISTING PRIMARILY OF MEAT, FISH, POULTRY OR VEGETABLES (U.S. CL. 46).

NAKIA HENRY, EXAMINING ATTORNEY

SN 85-248,665. TANYA ZUCKERBROT, BAY HARBOR, FL.
FILED 2-22-2011.

F-FACTOR KIDZ

THE MARK CONSISTS OF STANDARD CHARACTERS WITHOUT CLAIM TO ANY PARTICULAR FONT, STYLE, SIZE, OR COLOR.

OWNER OF U.S. REG. NO. 3,370,707.

NO CLAIM IS MADE TO THE EXCLUSIVE RIGHT TO USE "KIDZ", APART FROM THE MARK AS SHOWN.

FOR CHEESE; FROZEN PRE-PACKAGED ENTREES CONSISTING PRIMARILY OF SEAFOOD; FRUIT CHIPS; POTATO CHIPS; VEGETABLE CHIPS; YOGURTS; FROZEN MEALS CONSISTING PRIMARILY OF MEAT, FISH, POULTRY OR VEGETABLES (U.S. CL. 46).

NAKIA HENRY, EXAMINING ATTORNEY

SN 85-248,867. JEFF FOXWORTHY, SHERMAN OAKS, CA.
FILED 2-22-2011.

FOXWORTHY FARMS

THE MARK CONSISTS OF STANDARD CHARACTERS WITHOUT CLAIM TO ANY PARTICULAR FONT, STYLE, SIZE, OR COLOR.

OWNER OF U.S. REG. NOS. 3,228,903, 3,448,354 AND OTHERS.

NO CLAIM IS MADE TO THE EXCLUSIVE RIGHT TO USE "FARMS", APART FROM THE MARK AS SHOWN.

FOR MEAT AND PROCESSED FOODS, NAMELY, BEEF AND HAM JERKY, SAUSAGES AND BACON (U.S. CL. 46).

JOHN E. MICHOS, EXAMINING ATTORNEY

CLASS 29—(Continued).

SN 85-252,993. KFC CORPORATION, LOUISVILLE, KY.
FILED 2-28-2011.

TURN SUNDAYS INTO FUN DAYS

THE MARK CONSISTS OF STANDARD CHARACTERS WITHOUT CLAIM TO ANY PARTICULAR FONT, STYLE, SIZE, OR COLOR.

FOR COMBINATION MEAL CONSISTING PRIMARILY OF COOKED CHICKEN WITH COLE SLAW, COOKED VEGETABLES, VEGETABLE SALADS, MACARONI AND CHEESE, WEDGED OR MASHED POTATOES AND GRAVY, BISCUITS OR BREAD, SOFT DRINK AND/OR DESSERT FOR CONSUMPTION ON OR OFF THE PREMISES (U.S. CL. 46).

MARIA-VICTORIA SUAREZ, EXAMINING ATTORNEY

SN 85-253,228. ALAN STOPPER, ALBUQUERQUE, NM.
FILED 2-28-2011.

FRUIT OF PEACE

THE MARK CONSISTS OF STANDARD CHARACTERS WITHOUT CLAIM TO ANY PARTICULAR FONT, STYLE, SIZE, OR COLOR.

FOR OLIVE OIL (U.S. CL. 46).

JULIE VEPPUMTHARA, EXAMINING ATTORNEY

SN 85-253,442. AGROINDUSTRIAL SURFRUT LIMITADA,
SANTIAGO, CHILE, FILED 2-28-2011.

WE KNOW APPLES

THE MARK CONSISTS OF STANDARD CHARACTERS WITHOUT CLAIM TO ANY PARTICULAR FONT, STYLE, SIZE, OR COLOR.

FOR FRUIT-BASED SNACK FOOD (U.S. CL. 46).

KRISTIN CARLSON, EXAMINING ATTORNEY

CLASS 29—(Continued).

SN 85-253,535. ZACKY FARMS, LLC, FRESNO, CA. FILED 2-28-2011.

THE WESTERNER

THE MARK CONSISTS OF STANDARD CHARACTERS WITHOUT CLAIM TO ANY PARTICULAR FONT, STYLE, SIZE, OR COLOR.
FOR POULTRY (U.S. CL. 46).
ANDREW LEASER, EXAMINING ATTORNEY

SN 85-254,425. YOU AND ME FOODS LLC, NAPA, CA. FILED 3-1-2011.

Mourad's Moroccan

THE MARK CONSISTS OF STANDARD CHARACTERS WITHOUT CLAIM TO ANY PARTICULAR FONT, STYLE, SIZE, OR COLOR.
NO CLAIM IS MADE TO THE EXCLUSIVE RIGHT TO USE "MOROCCAN", APART FROM THE MARK AS SHOWN.
FOR VEGETABLE-BASED SPREADS (U.S. CL. 46).
WILLIAM P. SHANAHAN, EXAMINING ATTORNEY

SN 85-254,704. ENTRUST, SAN JOSE, CA. FILED 3-1-2011.



THE MARK CONSISTS OF THE STYLIZED TEXT "ENTRUST" ENCLOSED IN A FRAME.
FOR POWDERED MILK (U.S. CL. 46).
JULIE WATSON, EXAMINING ATTORNEY

CLASS 29—(Continued).

SN 85-255,042. KIND, LLC, NEW YORK, NY. FILED 3-1-2011.

FILL UP WITHOUT FILLING OUT

THE MARK CONSISTS OF STANDARD CHARACTERS WITHOUT CLAIM TO ANY PARTICULAR FONT, STYLE, SIZE, OR COLOR.
FOR HEALTHY SNACKS, NAMELY, NUT AND SEED BASED SNACK BARS; PROCESSED FRUIT AND NUT BASED FOOD BARS, NUT BASED SNACK FOOD BARS, FRUIT BASED SNACK FOOD BARS ALSO CONTAINING NUTS, GRAINS, CEREALS AND DRIED FRUIT (U.S. CL. 46).
FIRST USE 1-20-2011; IN COMMERCE 2-15-2011.
BENJAMIN OKEKE, EXAMINING ATTORNEY

SN 85-255,054. BETTY LOU'S, INC., MCMINNVILLE, OR. FILED 3-1-2011.

**Just Great Organic
Powdered Peanut Butter**

THE MARK CONSISTS OF STANDARD CHARACTERS WITHOUT CLAIM TO ANY PARTICULAR FONT, STYLE, SIZE, OR COLOR.
OWNER OF U.S. REG. NO. 3,380,283.
NO CLAIM IS MADE TO THE EXCLUSIVE RIGHT TO USE "ORGANIC POWDERED PEANUT BUTTER", APART FROM THE MARK AS SHOWN.
FOR ORGANIC PEANUT FLOUR FOR USE IN MAKING ORGANIC PEANUT SPREADS OR PEANUT BUTTER (U.S. CL. 46).
MICHAEL TANNER, EXAMINING ATTORNEY

SN 85-256,380. GUANGDONG WISDON NUTRITION TECHNOLOGY CO., LTD, GUANGDONG PROVINCE, CHINA, FILED 3-2-2011.

WISDOM

THE MARK CONSISTS OF STANDARD CHARACTERS WITHOUT CLAIM TO ANY PARTICULAR FONT, STYLE, SIZE, OR COLOR.
FOR EDIBLE FATS; FRUIT JELLIES; FRUIT SALADS; HAM; JAMS; JELLIES FOR FOOD; MILK POWDER; POWDERED EGGS; PREPARED NUTS; PROCESSED ALGAE FOR HUMAN CONSUMPTION; PROCESSED FISH; PROTEINS BEING FOODSTUFFS FOR HUMAN CONSUMPTION; SOYBEAN MILK; TINNED FISH; TINNED FRUITS; TINNED MEAT; TINNED VEGETABLES; TOASTED LAVAR; YOGHURT (U.S. CL. 46).
JESSICA FATHY, EXAMINING ATTORNEY

CLASS 29—(Continued).

SN 85-256,648. OMEGA PROTEIN, INC., HOUSTON, TX.
FILED 3-3-2011.

MAHIMI

THE MARK CONSISTS OF STANDARD CHARACTERS
WITHOUT CLAIM TO ANY PARTICULAR FONT, STYLE,
SIZE, OR COLOR.

FOR SEAFOOD, FRESH, FROZEN OR CANNED (U.S.
CL. 46).

KATHERINE M. DUBRAY, EXAMINING ATTORNEY

SN 85-256,683. OMEGA PROTEIN, INC., HOUSTON, TX.
FILED 3-3-2011.

FINARI

THE MARK CONSISTS OF STANDARD CHARACTERS
WITHOUT CLAIM TO ANY PARTICULAR FONT, STYLE,
SIZE, OR COLOR.

FOR SEAFOOD, FRESH, FROZEN OR CANNED (U.S.
CL. 46).

KATHERINE M. DUBRAY, EXAMINING ATTORNEY

SN 85-257,601. SUPERFRUIT NUTRITION LLC, WOLVER-
INE LAKE, MI. FILED 3-3-2011.

That's It.

THE MARK CONSISTS OF STANDARD CHARACTERS
WITHOUT CLAIM TO ANY PARTICULAR FONT, STYLE,
SIZE, OR COLOR.

FOR DEHYDRATED FRUIT SNACKS (U.S. CL. 46).
FIRST USE 3-3-2011; IN COMMERCE 3-3-2011.

WILLIAM BRECKENFELD, EXAMINING ATTORNEY

CLASS 29—(Continued).

SN 85-257,774. DANIEL HOOPER, SANTA FE SPRINGS, CA.
FILED 3-4-2011.



THE MARK CONSISTS OF "HOOPER'S" SUPERIMPOSED
OVER CONCENTRIC CIRCLES.

FOR PICKLES (U.S. CL. 46).

FIRST USE 3-1-2010; IN COMMERCE 2-11-2011.

MIDGE BUTLER, EXAMINING ATTORNEY

SN 85-257,784. LION ROCK LICENSING CORP., GRAND
RAPIDS, MI. FILED 3-4-2011.

QUIK-CREATIONS

THE MARK CONSISTS OF STANDARD CHARACTERS
WITHOUT CLAIM TO ANY PARTICULAR FONT, STYLE,
SIZE, OR COLOR.

FOR BUTTER-BASED SAUCES; CLARIFIED BUTTER;
BUTTER SHEETS (U.S. CL. 46).

SALLY SHIH, EXAMINING ATTORNEY

SN 85-257,914. SHAMROCK FOODS COMPANY, PHOENIX,
AZ. FILED 3-4-2011.

GOLD CANYON

THE MARK CONSISTS OF STANDARD CHARACTERS
WITHOUT CLAIM TO ANY PARTICULAR FONT, STYLE,
SIZE, OR COLOR.

FOR MEAT, NAMELY, PORK (U.S. CL. 46).

ANNE MADDEN, EXAMINING ATTORNEY

CLASS 29—(Continued).

SN 85-257,917. SHAMROCK FOODS COMPANY, PHOENIX, AZ. FILED 3-4-2011.

REGAL CREST FARMS. WHERE FRESHNESS COMES NATURALLY.

THE MARK CONSISTS OF STANDARD CHARACTERS WITHOUT CLAIM TO ANY PARTICULAR FONT, STYLE, SIZE, OR COLOR.
FOR MEAT, NAMELY, POULTRY (U.S. CL. 46).
ANNE MADDEN, EXAMINING ATTORNEY

SN 85-263,475. TRAN'S FAMILY, INC., SAN GABRIEL, CA. FILED 3-10-2011.

DOUBLE COW

THE MARK CONSISTS OF STANDARD CHARACTERS WITHOUT CLAIM TO ANY PARTICULAR FONT, STYLE, SIZE, OR COLOR.
FOR CANNED MILK (U.S. CL. 46).
DANIEL CAPSHAW, EXAMINING ATTORNEY

SN 85-278,321. NO LIMIT, LLC, FARMINGTON, CT. FILED 3-28-2011.



OWNER OF U.S. REG. NOS. 1,280,046, 3,145,005 AND OTHERS.

THE NAME "NEWMAN" AND THE PORTRAIT OF PAUL NEWMAN DO NOT IDENTIFY A LIVING INDIVIDUAL.

THE MARK CONSISTS OF THE WORDS "NEWMAN'S OWN" WITHIN A DOUBLE LINED ARCH ON TOP OF AN ARTISTIC RENDERING OF THE FACE OF PAUL NEWMAN.

FOR SALAD DRESSING (U.S. CL. 46).
FIRST USE 3-31-2010; IN COMMERCE 3-31-2010.
LINDA M. KING, EXAMINING ATTORNEY

CLASS 29—(Continued).

SN 85-283,487. PROTICA INC., WHITEHALL, PA. FILED 4-1-2011.

PURIVA

THE MARK CONSISTS OF STANDARD CHARACTERS WITHOUT CLAIM TO ANY PARTICULAR FONT, STYLE, SIZE, OR COLOR.
FOR YOGURT (U.S. CL. 46).
JOHN GARTNER, EXAMINING ATTORNEY

SN 85-300,700. SUGAR FOODS CORPORATION, NEW YORK, NY. FILED 4-21-2011.

THE BETTER DIP

THE MARK CONSISTS OF STANDARD CHARACTERS WITHOUT CLAIM TO ANY PARTICULAR FONT, STYLE, SIZE, OR COLOR.
NO CLAIM IS MADE TO THE EXCLUSIVE RIGHT TO USE "DIP", APART FROM THE MARK AS SHOWN.
FOR DIP MIXES; DIPS; SNACK DIPS (U.S. CL. 46).
DANNEAN HETZEL, EXAMINING ATTORNEY

SN 85-308,655. PINNACLE FOODS GROUP LLC, MOUNTAIN LAKES, NJ. FILED 4-29-2011.

VLASIC

THE MARK CONSISTS OF STANDARD CHARACTERS WITHOUT CLAIM TO ANY PARTICULAR FONT, STYLE, SIZE, OR COLOR.

OWNER OF U.S. REG. NOS. 699,512, 3,880,180 AND OTHERS.

FOR POTATO CHIPS; PROCESSED SUNFLOWER SEEDS (U.S. CL. 46).
FIRST USE 0-0-2009; IN COMMERCE 0-0-2009.
JOHN GARTNER, EXAMINING ATTORNEY

CLASS 29—(Continued).

SN 85-308,665. PINNACLE FOODS GROUP LLC, MOUNTAIN LAKES, NJ. FILED 4-29-2011.

OPEN PIT

THE MARK CONSISTS OF STANDARD CHARACTERS WITHOUT CLAIM TO ANY PARTICULAR FONT, STYLE, SIZE, OR COLOR.

OWNER OF U.S. REG. NO. 701,940.
FOR POTATO CHIPS (U.S. CL. 46).
FIRST USE 0-0-2004; IN COMMERCE 0-0-2004.
JOHN GARTNER, EXAMINING ATTORNEY

CLASS 30—(Continued).

SN 76-706,574. XAN CONFECTIONS, INC., IRVINE, CA. FILED 2-28-2011.

COCOHEART

THE MARK CONSISTS OF STANDARD CHARACTERS WITHOUT CLAIM TO ANY PARTICULAR FONT, STYLE, SIZE, OR COLOR.

FOR CANDIES, NAMELY, CHOCOLATES AND CHOCOLATES INFUSED WITH NUTRITIONAL SUPPLEMENTS (U.S. CL. 46).
FIRST USE 1-16-2011; IN COMMERCE 1-16-2011.
REBECCA GILBERT, EXAMINING ATTORNEY

CLASS 30—STAPLE FOODS

SN 76-703,721. CASSANO'S INC., DAYTON, OH. FILED 7-9-2010.

ALL EDGE

THE MARK CONSISTS OF STANDARD CHARACTERS WITHOUT CLAIM TO ANY PARTICULAR FONT, STYLE, SIZE, OR COLOR.

NO CLAIM IS MADE TO THE EXCLUSIVE RIGHT TO USE "EDGE", APART FROM THE MARK AS SHOWN.

FOR FOOD PRODUCTS FOR CONSUMPTION ON OR OFF THE PREMISES, NAMELY, AN ANNULAR PIZZA (U.S. CL. 46).

FIRST USE 7-1-2010; IN COMMERCE 7-1-2010.
STEVEN R. FINE, EXAMINING ATTORNEY

SN 76-706,577. XAN CONFECTIONS, INC., IRVINE, CA. FILED 2-28-2011.

COCOBRAIN

THE MARK CONSISTS OF STANDARD CHARACTERS WITHOUT CLAIM TO ANY PARTICULAR FONT, STYLE, SIZE, OR COLOR.

FOR CANDIES, NAMELY, CHOCOLATES AND CHOCOLATES INFUSED WITH NUTRITIONAL SUPPLEMENTS (U.S. CL. 46).

FIRST USE 1-16-2011; IN COMMERCE 1-16-2011.
REBECCA GILBERT, EXAMINING ATTORNEY

SN 76-704,425. L A D BAKERS, LLC, DBA LORRAINE'S LITTLE TASTE OF HEAVEN, NEWBURGH, NY. FILED 9-9-2010.

AMERICA'S FREEDOM CUPS

THE MARK CONSISTS OF STANDARD CHARACTERS WITHOUT CLAIM TO ANY PARTICULAR FONT, STYLE, SIZE, OR COLOR.

NO CLAIM IS MADE TO THE EXCLUSIVE RIGHT TO USE "AMERICA'S", APART FROM THE MARK AS SHOWN.

FOR CUPCAKES; MUFFINS; PEANUT BUTTER CUPS; COOKIES FEATURING A CUPCAKE; CUPCAKES IN THE NATURE OF PATRIOTIC SHAPES; BAKERY GOODS; PASTRIES; CAKES; PIES; CHEESECAKES; COOKIES; COOKIE BARS; BREADS; AND PUDDINGS FEATURING A CUPCAKE (U.S. CL. 46).

FIRST USE 12-21-2007; IN COMMERCE 12-21-2007.
REGINA DRUMMOND, EXAMINING ATTORNEY

SN 76-706,579. XAN CONFECTIONS, INC., IRVINE, CA. FILED 2-28-2011.

UN-BITCH YOURSELF

THE MARK CONSISTS OF STANDARD CHARACTERS WITHOUT CLAIM TO ANY PARTICULAR FONT, STYLE, SIZE, OR COLOR.

FOR CANDIES, NAMELY, CHOCOLATES AND CHOCOLATES INFUSED WITH NUTRITIONAL SUPPLEMENTS (U.S. CL. 46).

FIRST USE 1-16-2011; IN COMMERCE 1-16-2011.
REBECCA GILBERT, EXAMINING ATTORNEY

CLASS 30—(Continued).

SN 76-706,638. LIVEBROOK LTD, THORNHILL, ONTARIO, CANADA, FILED 3-3-2011.

SWEET BROOK

THE MARK CONSISTS OF STANDARD CHARACTERS WITHOUT CLAIM TO ANY PARTICULAR FONT, STYLE, SIZE, OR COLOR.

NO CLAIM IS MADE TO THE EXCLUSIVE RIGHT TO USE "SWEET", APART FROM THE MARK AS SHOWN.

FOR FOOD FLAVOURINGS (U.S. CL. 46).

MICHAEL WIENER, EXAMINING ATTORNEY

CLASS 30—(Continued).

SN 79-089,552. MARIAGE FRÈRES, FRANCE, FILED 4-12-2010.

BIRTHDAY TEA

THE MARK CONSISTS OF STANDARD CHARACTERS WITHOUT CLAIM TO ANY PARTICULAR FONT, STYLE, SIZE, OR COLOR.

OWNER OF INTERNATIONAL REGISTRATION 1057122 DATED 4-12-2010, EXPIRES 4-12-2020.

NO CLAIM IS MADE TO THE EXCLUSIVE RIGHT TO USE "TEA", APART FROM THE MARK AS SHOWN.

FOR TEAS; TEA-BASED BEVERAGES; EDIBLES FLOUR AND PREPARATIONS MADE FROM CEREALS, NAMELY, BISCUITS, TARTS, CAKES MADE WITH CEREALS, BREAD, PASTRY AND FROZEN CONFECTIONARY, EDIBLE ICES (U.S. CL. 46).

WILLIAM ROSSMAN, EXAMINING ATTORNEY

SN 77-898,807. AHOLD LICENSING SARL, GENEVA, SWITZERLAND, FILED 12-22-2009.

FIBER SELECT

THE MARK CONSISTS OF STANDARD CHARACTERS WITHOUT CLAIM TO ANY PARTICULAR FONT, STYLE, SIZE, OR COLOR.

NO CLAIM IS MADE TO THE EXCLUSIVE RIGHT TO USE "FIBER", APART FROM THE MARK AS SHOWN.

SEC. 2(F).

FOR BREAKFAST CEREALS; READY TO EAT, CEREAL DERIVED FOOD BARS (U.S. CL. 46).

FIRST USE 12-31-2006; IN COMMERCE 12-31-2006.

MARTHA FROMM, EXAMINING ATTORNEY

SN 79-091,048. SOLTREE INC., REPUBLIC OF KOREA, FILED 11-30-2010.

SN 79-083,561. MINISTERO DELLE POLITICHE AGRICOLE, ALIMENTARI E FORESTALI - DIPARTIMENTO DELLE POLITICHE COMPETITIVE DEL MONDO RURALE E DELLA QUALITA' - DIREZIONE GENERALE PER LO SVILUPPO AGROALIMENTARE, LA QUALITA' E LA TUTELA DEL CONSUMATORE, ROMA, ITALY, FILED 4-23-2010.

ZAFFERANO DI SAN GIMIGNANO

THE MARK CONSISTS OF STANDARD CHARACTERS WITHOUT CLAIM TO ANY PARTICULAR FONT, STYLE, SIZE, OR COLOR.

PRIORITY DATE OF 2-12-2010 IS CLAIMED.

OWNER OF INTERNATIONAL REGISTRATION 1041439 DATED 4-23-2010, EXPIRES 4-23-2020.

NO CLAIM IS MADE TO THE EXCLUSIVE RIGHT TO USE "ZAFFERANO", APART FROM THE MARK AS SHOWN.

THE ENGLISH TRANSLATION OF "ZAFFERANO DI SAN GIMIGNANO" IN THE MARK IS "SAFFRON FROM SAN GIMIGNANO".

THE CERTIFICATION MARK, AS INTENDED TO BE USED BY PERSONS AUTHORIZED BY THE CERTIFIER, IS INTENDED TO CERTIFY THAT THE GOODS PROVIDED ORIGINATE IN THE TERRITORY OF THE MUNICIPALITY OF SAN GIMIGNANO (SI) IN ITALY, AND THAT THE PREPARATION, PRODUCTION, AND/OR PROCESSING OF THE GOODS TAKE PLACE ACCORDING TO THE STANDARD OF RECORD.

FOR SAFFRON FOR USE AS A FOOD SEASONING (U.S. CL. 46).

KAREN M. STRYZ, EXAMINING ATTORNEY

SOLTtree

OWNER OF INTERNATIONAL REGISTRATION 1061249 DATED 11-30-2010, EXPIRES 11-30-2020.

THE MARK CONSISTS OF THE STYLIZED WORDING "SOLTREE".

FOR EDIBLE SALT; COOKING SALT; CELERY SALT; TABLE SALT MIXED WITH SESAME SEEDS; SEA WATER FOR COOKING; SALT FOR PRESERVING FOODSTUFFS (U.S. CL. 46).

NAPOLEON SHARMA, EXAMINING ATTORNEY

CLASS 30—(Continued).

SN 79-091,179. MILANI S.P.A., ITALY, FILED 9-24-2010.



PRIORITY DATE OF 6-18-2010 IS CLAIMED.
OWNER OF INTERNATIONAL REGISTRATION 1061440
DATED 9-24-2010, EXPIRES 9-24-2020.

NO CLAIM IS MADE TO THE EXCLUSIVE RIGHT TO
USE "CAFFÉ", APART FROM THE MARK AS SHOWN.

THE MARK CONSISTS OF A SHADED SQUARE TILTED
ON ONE OF ITS CORNERS, WITH AN UNSHADED
BORDER INSIDE THE TILTED SQUARE, CONTAINING
THE UNSHADED WORDING "CAFFÉ" IN ALL CAPS,
WITH THE UNSHADED WORDING, "MILANI" IN LAR-
GER CAPS BELOW, WITH AN UNSHADED COFFEE-
MAKER WITH A HANDLE BELOW "MILANI".

THE ENGLISH TRANSLATION OF "CAFFÉ" IN THE
MARK IS "COFFEE".

FOR COFFEE; UNROASTED AND ROASTED COFFEE,
COFFEE AND COFFEE BEANS; COFFEE BLENDS,
NAMELY, BEVERAGES WITH A COFFEE BASE, DECAFFEINATED COFFEE AND COFFEE EXTRACTS USED
AS A FLAVORING; COFFEE FLAVORINGS; NON-ALCOHOLIC COFFEE DRINKS, NAMELY, ICED COFFEE,
GREEN COFFEE; FREEZE-DRIED COFFEE AND INSTANT COFFEE IN SPRAY OR AGGLOMERATED
FORM; CAKE DOUGH; PASTA; CANDY; TEA; COCOA;
SUGAR; RICE; TAPIOCA; ARTIFICIAL COFFEE;
FLOURS, NAMELY, FLOUR FOR FOOD EXCLUDING
NUT FLOURS; CEREAL PREPARATIONS, NAMELY,
CEREAL BASED SNACK FOOD; BREAD; COOKIES;
CAKES; PASTRIES; SUGAR-COATED ALMONDS; EDIBLE ICES; HONEY; TREACLE; PEPPER; VINEGAR;
SPICES; ICE FOR REFRESHMENT; BEVERAGES MADE
WITH COFFEE, COCOA AND CHOCOLATE (U.S. CL. 46).

ODESSA BIBBINS, EXAMINING ATTORNEY

CLASS 30—(Continued).

SN 79-092,221. SUZHOU SHENNONGGEN HEALTH PRODUCTS CO., LTD., HUBEI PROVINCE, CHINA, FILED 7-20-2010.



OWNER OF INTERNATIONAL REGISTRATION 1064127
DATED 7-20-2010, EXPIRES 7-20-2020.

THE COLOR(S) GREEN, WHITE, YELLOW, BLACK AND
BROWN IS/ARE CLAIMED AS A FEATURE OF THE
MARK.

THE MARK CONSISTS OF THE BUST OF A LEGENDARY
GOD OF FARMING, WITH THE FACE IN BROWN
AND THE HAIR, MUSTACHE AND BEARD IN BROWN.
THE EYES OUTSIDE OF THE PUPILS APPEAR IN WHITE.
A ROOT APPEARS BELOW THE BUST IN BLACK AND
BROWN. ON THE BOTTOM LINE OF THE TRIANGLE
APPEAR THREE YELLOW SQUARES, EACH WITH A
BLACK CHINESE CHARACTER IN IT. THE MARK INCLUDES
A GREEN TRIANGLE AS A BACKGROUND CARRIER.
THE TRANSLITERATION OF THE CHINESE CHARACTERS
IS SHEN NONG GEN.

THE ENGLISH TRANSLATION OF THE FOREIGN
WORD(S) IN THE MARK IS: THE FIRST CHARACTER
MEANS GOD; THE SECOND CHARACTER MEANS FARMING;
THE THIRD CHARACTER MEANS ROOT; THE COMBINATION
OF THE CHARACTERS MEANS THE ROOT OF LEGENDARY
GOD OF FARMING.

THE NON-LATIN CHARACTERS IN THE MARK TRANSLITERATE
TO SHEN NONG GEN, AND THIS MEANS GOD, FARMING,
AND ROOT IN ENGLISH.

FOR ROYAL JELLY FOR HUMAN CONSUMPTION AND NOT FOR
MEDICAL PURPOSES; SPIRULINA USED FOR FOOD PURPOSES
AND NOT FOR MEDICAL PURPOSES; COFFEE SUBSTITUTES
CONSISTING OF VEGETAL PREPARATIONS; TEA SUBSTITUTES;
ARTIFICIAL COFFEE (U.S. CL. 46).

MICHAEL WIENER, EXAMINING ATTORNEY

CLASS 30—(Continued).

SN 79-093,472. LUIGI FORCINITI, MONACO, FILED 10-28-2010.



PRIORITY DATE OF 9-15-2010 IS CLAIMED.
 OWNER OF INTERNATIONAL REGISTRATION 1067274 DATED 10-28-2010, EXPIRES 10-28-2020.
 THE MARK CONSISTS OF THE WORD "ZELOS" IN STYLIZED FORM SUPERIMPOSED OVER A SCROLLED LEAF BACKGROUND DESIGN.
 FOR COFFEE, TEA, COCOA, SUGAR, RICE, TAPIOCA, SAGO, ARTIFICIAL COFFEE; FLOUR AND PREPARATIONS MADE FROM CEREALS, NAMELY, PASTA, BREAD, AND PASTRY; HONEY, TREACLE; YEAST, BAKING-POWDER; SALT, MUSTARD; VINEGAR, SAUCES; AND SPICES (U.S. CL. 46).
 DAVID H. STINE, EXAMINING ATTORNEY

SN 79-096,039. MIKO N.V., BELGIUM, FILED 2-10-2011.



OWNER OF INTERNATIONAL REGISTRATION 1073657 DATED 2-10-2011, EXPIRES 2-10-2021.
 NO CLAIM IS MADE TO THE EXCLUSIVE RIGHT TO USE "PURO", APART FROM THE MARK AS SHOWN.
 THE COLOR(S) BROWN, GREEN AND WHITE IS/ARE CLAIMED AS A FEATURE OF THE MARK.
 THE MARK CONSISTS OF THE WORD "PURO" IN UPPERCASE LETTERS, WITH THE LETTERS "PUR" IN GREEN AND THE LETTER "O" IN BROWN, TO THE LEFT OF WHICH APPEARS A BROWN COFFEE BEAN, BELOW AND TO THE RIGHT OF WHICH APPEARS A GREEN AND WHITE LEAF.
 THE ENGLISH TRANSLATION OF "PURO" IN THE MARK IS "PURE".
 FOR COFFEE; COFFEE EXTRACTS, ARTIFICIAL COFFEE, COFFEE TABLETS (U.S. CL. 46).
 EDWARD FENNESSY, EXAMINING ATTORNEY

CLASS 30—(Continued).

SN 85-013,579. JACOB CHRISTIAN WERNER JEBSEN, 6200 AABENRAA, DENMARK, FILED 4-14-2010.

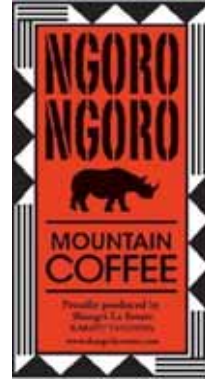

PRIORITY CLAIMED UNDER SEC. 44(D) ON ERPN CMNTY TM OFC APPLICATION NO. 008707184, FILED 11-24-2009, REG. NO. 008707184, DATED 7-5-2010, EXPIRES 11-24-2019.
 NO CLAIM IS MADE TO THE EXCLUSIVE RIGHT TO USE "NGORO NGORO", "MOUNTAIN COFFEE", "PROUDLY PRODUCED BY", "ESTATE" AND "KARATU TANZANIA", APART FROM THE MARK AS SHOWN.
 THE COLOR(S) RED, BLACK AND WHITE IS/ARE CLAIMED AS A FEATURE OF THE MARK.
 THE MARK CONSISTS OF THE WORDS "NGORO NGORO MOUNTAIN COFFEE PROUDLY PRODUCED BY SHANGRI-LA ESTATE KARATU TANZANIA WWW.SHANGRI-LA-ESTATE.COM" APPEARING IN THE COLOR BLACK ON A RED BACKGROUND WITHIN A RECTANGLE. A DESIGN OF A RHINOCEROS IN THE COLOR BLACK ALSO APPEARS WITHIN THE RECTANGLE BELOW THE WORDS "NGORO NGORO". THE BORDER OF THE RECTANGLE CONSISTS OF GEOMETRIC SHAPES APPEARING IN BLACK AND WHITE.
 FOR COFFEE (U.S. CL. 46).
 MATTHEW EINSTEIN, EXAMINING ATTORNEY

SN 85-040,509. NATIONAL COMMUNITY CHURCH, WASHINGTON, DC. FILED 5-17-2010.

EBENEZERS

THE MARK CONSISTS OF STANDARD CHARACTERS WITHOUT CLAIM TO ANY PARTICULAR FONT, STYLE, SIZE, OR COLOR.
 FOR PREPARED COFFEE AND COFFEE-BASED BEVERAGES; COFFEE; COFFEE BEANS; GROUND COFFEE BEANS (U.S. CL. 46).
 FIRST USE 3-15-2006; IN COMMERCE 3-15-2006.
 IRA J. GOODSaid, EXAMINING ATTORNEY

CLASS 30—(Continued).

SN 85-061,907. KING CAR FOOD INDUSTRIAL CO., LTD.,
TAIPEI, TAIWAN, FILED 6-14-2010.



PRIORITY CLAIMED UNDER SEC. 44(D) ON TAIWAN
APPLICATION NO. 099025629, FILED 5-28-2010, REG. NO.
01447141, DATED 1-1-2011, EXPIRES 12-31-2020.

THE MARK CONSISTS OF STYLIZED WORDING
"GREENTIME".

FOR TEA; TEA-BASED BEVERAGE; HOT CHOCOLATE;
COCOA; COFFEE; BISCUITS; BREAD; CAKES;
INSTANT PREPARED NOODLE; INSTANT PREPARED
RICE; RICE PORRIDGE; CONFECTIONERY, NAMELY,
CANDY; PASTRY; MACARONI; CORN CHIPS; OAT-
MEAL; STEAMED BUNS; STEAMED DUMPLINGS;
CHEWING GUMS; CANDIES WITH COFFEE FLAVOUR;
HERBAL TEA, NAMELY, LOSHEN FOR FOOD PURPOSES
(U.S. CL. 46).

JOHN DWYER, EXAMINING ATTORNEY

SN 85-064,354. GERRIT J. VERBURG CO., FENTON, MI.
FILED 6-16-2010.

BROADWAY ROLLS

THE MARK CONSISTS OF STANDARD CHARACTERS
WITHOUT CLAIM TO ANY PARTICULAR FONT, STYLE,
SIZE, OR COLOR.

NO CLAIM IS MADE TO THE EXCLUSIVE RIGHT TO
USE "ROLLS", APART FROM THE MARK AS SHOWN.

FOR CANDY (U.S. CL. 46).

FIRST USE 11-2-2009; IN COMMERCE 11-2-2009.

TARA PATE, EXAMINING ATTORNEY

CLASS 30—(Continued).

SN 85-070,045. KING CAR FOOD INDUSTRIAL CO., LTD.,
TAIPEI, TAIWAN, FILED 6-23-2010.



PRIORITY CLAIMED UNDER SEC. 44(D) ON TAIWAN
APPLICATION NO. 099028327, FILED 6-11-2010, REG. NO.
01455892, DATED 3-16-2011, EXPIRES 3-15-2020.

OWNER OF U.S. REG. NO. 1,371,559.

THE MARK CONSISTS OF A DESIGN OF A MAN IN A
SUIT HOLDING A CUP ABOVE THE LETTERS "MR.
BROWN", ALL INSIDE OF A SEMI-CIRCLE OUTLINE.

FOR BISCUITS, BREAD, CAKES, INSTANT PREPARED
NOODLES, INSTANT PREPARED RICE, PORRIDGE,
CONFECTIONERY, NAMELY, CANDY,
PASTRY, CORN CHIPS, CHEWING GUM, HOT CHOCOLATE,
COCOA, COFFEE BASED BEVERAGES; TEA,
BLACK TEA, TEA-BASED BEVERAGES CONTAINING
MILK, OOLONG TEA-BASED BEVERAGES, LEMON
TEA-BASED BEVERAGES, TEA-BASED BEVERAGES
CONTAINING POWDERED MILK, POWDERED OOLONG
TEA-BASED BEVERAGES, POWDERED LEMON
TEA-BASED BEVERAGES, HAW TEA BEING HERBAL
TEA FOR FOOD PURPOSES, HERB TEA FOR FOOD
PURPOSES (U.S. CL. 46).

JOHN DWYER, EXAMINING ATTORNEY

SN 85-086,676. TOPCO HOLDINGS, INC., SKOKIE, IL. FILED
7-16-2010.

COUNTY FAIR CORN

THE MARK CONSISTS OF STANDARD CHARACTERS
WITHOUT CLAIM TO ANY PARTICULAR FONT, STYLE,
SIZE, OR COLOR.

NO CLAIM IS MADE TO THE EXCLUSIVE RIGHT TO
USE "CORN", APART FROM THE MARK AS SHOWN.

FOR FROZEN CORN (U.S. CL. 46).

SANJEEV VOHRA, EXAMINING ATTORNEY

CLASS 30—(Continued).

SN 85-090,088. CAFE DEL PACIFICO, S.A. DE C.V., HERMOSILLO, SONORA CP, MEXICO, FILED 7-21-2010.



OWNER OF U.S. REG. NOS. 3,507,165, 3,762,211 AND OTHERS.

THE COLOR(S) BROWN AND GREEN IS/ARE CLAIMED AS A FEATURE OF THE MARK.

THE MARK CONSISTS OF A BROWN STYLIZED FOUR-LEAF CLOVER TO THE RIGHT OF WHICH IS THE WORD "CAFFENIO" IN BROWN STYLIZED LETTERS, BELOW WHICH IS THE WORD "ARTISANO" WHERE "ARTI" IS IN BROWN STYLIZED LETTERS AND "SANO" IS IN GREEN STYLIZED LETTERS, UNDERNEATH IS A BROWN BASKET CONTAINING BROWN MATERIAL, HELD BY TWO HANDS IN BROWN, AND FLANKED BY TWO BOUGHS CONSISTING OF GREEN LEAVES AND GREEN FLOWERS.

THE WORDING "CAFFENIO ARTISANO" HAS NO MEANING IN A FOREIGN LANGUAGE.

FOR COFFEE AND TEA (U.S. CL. 46).
MARC LEIPZIG, EXAMINING ATTORNEY

CLASS 30—(Continued).

SN 85-104,255. YUMMANAM, INC., FORT LAUDERDALE, FL. FILED 8-10-2010.



NO CLAIM IS MADE TO THE EXCLUSIVE RIGHT TO USE "BAKE SHOP", APART FROM THE MARK AS SHOWN. THE NAME(S), PORTRAIT(S), AND/OR SIGNATURE(S) SHOWN IN THE MARK DOES NOT IDENTIFY A PARTICULAR LIVING INDIVIDUAL.

THE MARK CONSISTS OF A HEAD SHOT OF A FEMALE WITH THE WORDING "YUMMANAM" APPEARING ABOVE THE IMAGE AND THE WORDING "DANISH GIRL'S BAKE SHOP" APPEARING BELOW THE IMAGE.

FOR CAKES; COOKIES; MUFFINS (U.S. CL. 46).
MARC LEIPZIG, EXAMINING ATTORNEY

SN 85-098,474. HERSHEY CHOCOLATE & CONFECTIONERY CORPORATION, WHEAT RIDGE, CO. FILED 8-2-2010.



OWNER OF U.S. REG. NOS. 54,041, 1,367,943 AND OTHERS.

THE STIPPLING IS FOR SHADING PURPOSES ONLY.

THE MARK CONSISTS OF THE CONFIGURATION OF A CANDY BAR IN THE SHAPE OF A RECTANGLE HAVING A FLAT BOTTOM, CONVEX TOP AND ARCHED VERTICAL ENDS WITH THE LETTERS "HERSHEY'S" ON THE TOP CURVED SURFACE.

SEC. 2(F).

FOR CANDY; CHOCOLATE (U.S. CL. 46).

FIRST USE 0-0-1962, THE MARK WAS FIRST USED ANYWHERE IN A DIFFERENT FORM OTHER THAN THAT SOUGHT TO BE REGISTERED AT LEAST AS EARLY AS 00/00/1932; IN COMMERCE 0-0-1962, THE MARK WAS FIRST USED IN COMMERCE IN A DIFFERENT FORM OTHER THAN THAT SOUGHT TO BE REGISTERED AT LEAST AS EARLY AS 00/00/1932.

MARK PILARO, EXAMINING ATTORNEY

SN 85-106,753. NATURAL SWEET VENTURES, LLC, SUGAR LAND, TX. FILED 8-13-2010.



THE MARK CONSISTS OF STANDARD CHARACTERS WITHOUT CLAIM TO ANY PARTICULAR FONT, STYLE, SIZE, OR COLOR.

OWNER OF U.S. REG. NO. 3,884,373.

NO CLAIM IS MADE TO THE EXCLUSIVE RIGHT TO USE "STEVIA", APART FROM THE MARK AS SHOWN.

FOR NATURAL SWEETENER; FLAVOR ENHANCER USED IN FOOD AND BEVERAGE PRODUCTS (U.S. CL. 46).

BARBARA BROWN, EXAMINING ATTORNEY

CLASS 30—(Continued).

SN 85-106,897. PERFECT FOOD MANUFACTURING (M) SDN. BHD., MELAKA, MALAYSIA, FILED 8-13-2010.



THE MARK CONSISTS OF A FANCIFUL DESIGN OF A GIRL WITH BOWS IN HER HAIR AND PONY TAILS.

FOR FLOUR AND PREPARATIONS MADE FROM CEREALS, NAMELY, CEREAL-BASED SNACK FOODS AND READY TO EAT CEREAL DERIVED FOOD BARS; BISCUITS, CAKES, CRACKERS, BISCUITS MADE FROM CEREALS, CRACKERS MADE FROM CEREALS, CHOCOLATE PRODUCTS, NAMELY, CHOCOLATE BISCUITS, CHOCOLATE COOKIES AND CHOCOLATE WAFERS, CHOCOLATE-CHIP COOKIES, CHOCOLATE CREAM FILLED BISCUITS, CHOCOLATE CREAM FILLED COOKIES AND CHOCOLATE CREAM FILLED WAFERS, CHOCOLATE FLAVORED BISCUITS, CHOCOLATE FLAVORED COOKIES AND CHOCOLATE FLAVORED WAFERS, CHOCOLATE-COATED PRODUCTS, NAMELY, CHOCOLATE-COATED WAFERS, CHOCOLATE-COATED WAFFLES, CHOCOLATE-COATED BISCUITS AND CHOCOLATE-COATED COOKIES, COOKIES, WAFFLES, WAFERS (U.S. CL. 46).

ASMAT KHAN, EXAMINING ATTORNEY

SN 85-109,655. MICHAEL A. DEFILIPPO, NEW YORK, NY. FILED 8-17-2010.

PASTA PAZZO

THE MARK CONSISTS OF STANDARD CHARACTERS WITHOUT CLAIM TO ANY PARTICULAR FONT, STYLE, SIZE, OR COLOR.

NO CLAIM IS MADE TO THE EXCLUSIVE RIGHT TO USE "PASTA", APART FROM THE MARK AS SHOWN.

THE ENGLISH TRANSLATION OF "PAZZO" IN THE MARK IS "CRAZY".

FOR GLUTEN-FREE PASTA; PREPARED FOOD KITS CONSISTING PRIMARILY OF GLUTEN-FREE PASTA INCLUDING SAUCES OR SEASONING READY FOR COOKING AND ASSEMBLY AS A MEAL; PREPARED PACKAGED MEALS CONSISTING PRIMARILY OF GLUTEN-FREE PASTA (U.S. CL. 46).

PAUL MORENO, EXAMINING ATTORNEY

CLASS 30—(Continued).

SN 85-112,045. VISTA BRANDS LLC, EDEN PRAIRIE, MN. FILED 8-20-2010.

FRUIKIE

THE MARK CONSISTS OF STANDARD CHARACTERS WITHOUT CLAIM TO ANY PARTICULAR FONT, STYLE, SIZE, OR COLOR.

FOR COOKIES (U.S. CL. 46).

KEVIN DINALLO, EXAMINING ATTORNEY

SN 85-112,049. VISTA BRANDS LLC, EDEN PRAIRIE, MN. FILED 8-20-2010.

FRUIKIES

THE MARK CONSISTS OF STANDARD CHARACTERS WITHOUT CLAIM TO ANY PARTICULAR FONT, STYLE, SIZE, OR COLOR.

FOR COOKIES (U.S. CL. 46).

KEVIN DINALLO, EXAMINING ATTORNEY

SN 85-134,180. PIZZA INN, INC., THE COLONY, TX. FILED 9-21-2010.

INNWRAPS

THE MARK CONSISTS OF STANDARD CHARACTERS WITHOUT CLAIM TO ANY PARTICULAR FONT, STYLE, SIZE, OR COLOR.

FOR SANDWICHES; SANDWICH WRAPS; CALZONES; DOUGH-BASED WRAPPER FILLED WITH ONE OR MORE OF MEAT, VEGETABLES, CHEESE AND SAUCE (U.S. CL. 46).

KATHLEEN LORENZO, EXAMINING ATTORNEY

CLASS 30—(Continued).

SN 85-134,181. PIZZA INN, INC., THE COLONY, TX. FILED 9-21-2010.

INN WRAPS

THE MARK CONSISTS OF STANDARD CHARACTERS WITHOUT CLAIM TO ANY PARTICULAR FONT, STYLE, SIZE, OR COLOR.

NO CLAIM IS MADE TO THE EXCLUSIVE RIGHT TO USE "WRAPS", APART FROM THE MARK AS SHOWN.

FOR SANDWICHES, SANDWICH WRAPS, CALZONES, DOUGH-BASED WRAPPER FILLED WITH ONE OR MORE OF MEAT, VEGETABLES, CHEESE AND SAUCE (U.S. CL. 46).

KATHLEEN LORENZO, EXAMINING ATTORNEY

CLASS 30—(Continued).

SN 85-145,306. THE PILLSBURY COMPANY, LLC, MINNEAPOLIS, MN. FILED 10-5-2010.

DECADENT & DELICIOUS

THE MARK CONSISTS OF STANDARD CHARACTERS WITHOUT CLAIM TO ANY PARTICULAR FONT, STYLE, SIZE, OR COLOR.

NO CLAIM IS MADE TO THE EXCLUSIVE RIGHT TO USE "DELICIOUS", APART FROM THE MARK AS SHOWN.

FOR FOOD PRODUCTS, NAMELY, REFRIGERATED BAKERY GOODS AND PASTRIES (U.S. CL. 46).

FIRST USE 5-31-2010; IN COMMERCE 5-31-2010.
CAROLYN CATALDO, EXAMINING ATTORNEY

SN 85-141,681. JACQUELINE'S WHOLESALE BAKERY, INC., AKA JACQUELINE'S GOURMET COOKIES, SALEM, MA. FILED 9-30-2010.

JACQUELINE'S GOURMET COOKIES

THE MARK CONSISTS OF STANDARD CHARACTERS WITHOUT CLAIM TO ANY PARTICULAR FONT, STYLE, SIZE, OR COLOR.

NO CLAIM IS MADE TO THE EXCLUSIVE RIGHT TO USE "GOURMET COOKIES", APART FROM THE MARK AS SHOWN.

THE NAME "JACQUELINE" IDENTIFIES A LIVING INDIVIDUAL WHOSE CONSENT IS OF RECORD.

FOR FRESH AND FROZEN DOUGHS FOR BAKERY PRODUCTS (U.S. CL. 46).

FIRST USE 12-31-1996; IN COMMERCE 12-31-1996.
DORITT L. CARROLL, EXAMINING ATTORNEY

SN 85-147,203. WHITEWAVE SERVICES, INC., DALLAS, TX. FILED 10-7-2010.



SN 85-141,714. YOGURTLAND FRANCHISING, INC., ANAHEIM, CA. FILED 9-30-2010.

YULETIDE YUMMINESS

THE MARK CONSISTS OF STANDARD CHARACTERS WITHOUT CLAIM TO ANY PARTICULAR FONT, STYLE, SIZE, OR COLOR.

FOR FROZEN YOGURT SOLD ONLY IN YOGURTLAND FRANCHISE STORES (U.S. CL. 46).

SANJEEV VOHRA, EXAMINING ATTORNEY

OWNER OF U.S. REG. NOS. 1,975,824, 3,741,012 AND OTHERS.

NO CLAIM IS MADE TO THE EXCLUSIVE RIGHT TO USE "NATURAL", APART FROM THE MARK AS SHOWN.

THE MARK CONSISTS OF A LEAPING COW IN FRONT OF A GLOBE, TOGETHER WITH THE WORD "HORIZON" UNDERLINED BY AN ARCHED LINE AND THE WORD "NATURAL". THE DESIGN ELEMENTS AND WORDING ARE ON A SHADED BACKGROUND THAT HAS A CURVED BOTTOM.

FOR FROZEN YOGURT; ICE CREAM; ICE MILK (U.S. CL. 46).

DOMINIC FATHY, EXAMINING ATTORNEY

CLASS 30—(Continued).

SN 85-160,225. LOCKWOOD, RANDALL S, PORTLAND, MI.
FILED 10-25-2010.



NO CLAIM IS MADE TO THE EXCLUSIVE RIGHT TO USE "SAUCE", APART FROM THE MARK AS SHOWN.
THE MARK CONSISTS OF THE WORDING "SAUCE GONE WILD" INSIDE A STYLIZED BOX.
FOR CHICKEN WING SAUCE (U.S. CL. 46).
FIRST USE 6-1-2010; IN COMMERCE 10-15-2010.
KEVON CHISOLM, EXAMINING ATTORNEY

SN 85-168,331. GLOBAL GARLIC, INC., MIRAMAR, FL.
FILED S.R. 11-3-2010; AM. P.R. 3-8-2011.

SEMITA MAZORCA

THE MARK CONSISTS OF STANDARD CHARACTERS WITHOUT CLAIM TO ANY PARTICULAR FONT, STYLE, SIZE, OR COLOR.

NO CLAIM IS MADE TO THE EXCLUSIVE RIGHT TO USE "SEMITA", APART FROM THE MARK AS SHOWN.

THE ENGLISH TRANSLATION OF THE WORD "SEMITA MAZORCA" IN THE MARK IS "BREAD" AND "EAR OF CORN".

FOR BREAD (U.S. CL. 46).
FIRST USE 12-31-2002; IN COMMERCE 12-31-2002.
BILL DAWE, EXAMINING ATTORNEY

CLASS 30—(Continued).

SN 85-171,970. LAVA FOODS, LLC, HOUSTON, TX. FILED 11-8-2010.

CHILICHASER

THE MARK CONSISTS OF STANDARD CHARACTERS WITHOUT CLAIM TO ANY PARTICULAR FONT, STYLE, SIZE, OR COLOR.

FOR SALSAS, HOT SAUCES, BARBECUE SAUCES, COOKING SAUCES, SEASONINGS, SPICES, KETCHUP, MAYONNAISE, PROCESSED CEREAL, RICE-BASED AND WHEAT-BASED SNACK FOODS, TORTILLA CHIPS, CORN CHIPS, AND POPCORN (U.S. CL. 46).

FIRST USE 3-15-2001; IN COMMERCE 8-15-2001.
ALYSSA STEEL, EXAMINING ATTORNEY

SN 85-182,321. GOINS, BRENDA, CLEVELAND, OH. FILED 11-22-2010.

Gracie G's Desserts

THE MARK CONSISTS OF STANDARD CHARACTERS WITHOUT CLAIM TO ANY PARTICULAR FONT, STYLE, SIZE, OR COLOR.

NO CLAIM IS MADE TO THE EXCLUSIVE RIGHT TO USE "DESSERTS", APART FROM THE MARK AS SHOWN.

THE NAME(S), PORTRAIT(S), AND/OR SIGNATURE(S) SHOWN IN THE MARK IDENTIFIES GRACE M. GOINS, WHOSE CONSENT(S) TO REGISTER IS MADE OF RECORD.

FOR BAKERY GOODS; CAKES; CUP CAKES; PIES (U.S. CL. 46).

SIMON TENG, EXAMINING ATTORNEY

SN 85-194,013. GRUPO BIMBO, S.A. B. DE C.V., MEXICO CITY, MEXICO, FILED 12-9-2010.



NO CLAIM IS MADE TO THE EXCLUSIVE RIGHT TO USE "LOW FAT", APART FROM THE MARK AS SHOWN.

THE MARK CONSISTS OF AN IMAGE OF A SALTED BAGEL PERSON GIVING THE THUMBS-UP SIGN AND WEARING A BANNER WITH THE WORDS "LOW FAT".

FOR BAKERY PRODUCTS (U.S. CL. 46).
JEFF DEFORD, EXAMINING ATTORNEY

CLASS 30—(Continued).

SN 85-194,537. GRUPO BIMBO, S.A. B. DE C.V., MEXICO CITY, MEXICO, FILED 12-9-2010.



NO CLAIM IS MADE TO THE EXCLUSIVE RIGHT TO USE "PEANUT BUTTER", "MUSTARD" AND "JAM", APART FROM THE MARK AS SHOWN.

THE MARK CONSISTS OF PERSONALIZED CONDIMENT CHARACTERS IN THE FORM OF A PIECE OF SWISS CHEESE, A LETTUCE LEAF, A JAR OF "PEANUT BUTTER", A JAR OF "MUSTARD" AND A JAR OF "JAM", ALL STANDING IN A GROUP.

FOR BAKERY PRODUCTS (U.S. CL. 46).
JEFF DEFORD, EXAMINING ATTORNEY

CLASS 30—(Continued).

SN 85-200,566. GRUPO BIMBO, S.A. B. DE C.V., MEXICO CITY, MEXICO, FILED 12-17-2010.

MOLI CREMAS

THE MARK CONSISTS OF STANDARD CHARACTERS WITHOUT CLAIM TO ANY PARTICULAR FONT, STYLE, SIZE, OR COLOR.

OWNER OF U.S. REG. NO. 3,884,152.

NO CLAIM IS MADE TO THE EXCLUSIVE RIGHT TO USE "CREMAS", APART FROM THE MARK AS SHOWN. THE ENGLISH TRANSLATION OF "CREMAS" IN THE MARK IS "CREAMS".

FOR COOKIES (U.S. CL. 46).
JEFF DEFORD, EXAMINING ATTORNEY

SN 85-205,218. RANDAZZO'S CAKES AND PASTRIES, INC., METAIRIE, LA, LA. FILED 12-23-2010.

Manny Randazzo King Cakes

THE MARK CONSISTS OF STANDARD CHARACTERS WITHOUT CLAIM TO ANY PARTICULAR FONT, STYLE, SIZE, OR COLOR.

NO CLAIM IS MADE TO THE EXCLUSIVE RIGHT TO USE "KING CAKES", APART FROM THE MARK AS SHOWN.

THE NAME(S), PORTRAIT(S), AND/OR SIGNATURE(S) SHOWN IN THE MARK IDENTIFIES "MANNY RANDAZZO", WHOSE CONSENT(S) TO REGISTER IS MADE OF RECORD.

FOR CAKES; PASTRIES (U.S. CL. 46).
FIRST USE 12-15-1994; IN COMMERCE 12-15-1994.
SAMUEL E. SHARPER JR., EXAMINING ATTORNEY

SN 85-195,415. MENIN, VERONICA, MIAMI, FL. FILED 12-10-2010.

Peace A' Cake

THE MARK CONSISTS OF STANDARD CHARACTERS WITHOUT CLAIM TO ANY PARTICULAR FONT, STYLE, SIZE, OR COLOR.

FOR VEGAN CAKES (U.S. CL. 46).
FIRST USE 4-1-2009; IN COMMERCE 4-1-2009.
KEVIN CORWIN, EXAMINING ATTORNEY

SN 85-200,442. GRUPO BIMBO, S.A. B. DE C.V., MEXICO CITY, MEXICO, FILED 12-17-2010.

MOLI CLUB

THE MARK CONSISTS OF STANDARD CHARACTERS WITHOUT CLAIM TO ANY PARTICULAR FONT, STYLE, SIZE, OR COLOR.

OWNER OF U.S. REG. NO. 3,884,152.
FOR COOKIES (U.S. CL. 46).
JEFF DEFORD, EXAMINING ATTORNEY

SN 85-208,337. HOME EPICUREAN LLC, TOMBALL, TX. FILED 12-30-2010.

Dinner De-Constructed

THE MARK CONSISTS OF STANDARD CHARACTERS WITHOUT CLAIM TO ANY PARTICULAR FONT, STYLE, SIZE, OR COLOR.

FOR COOKING SAUCES (U.S. CL. 46).
FIRST USE 11-23-2010; IN COMMERCE 11-23-2010.
JENNIFER MARTIN, EXAMINING ATTORNEY

CLASS 30—(Continued).

SN 85-212,616. SICILIANO, FRED, VENTURA, CA. FILED 1-7-2011.

God Bless You Tea

THE MARK CONSISTS OF STANDARD CHARACTERS WITHOUT CLAIM TO ANY PARTICULAR FONT, STYLE, SIZE, OR COLOR.

NO CLAIM IS MADE TO THE EXCLUSIVE RIGHT TO USE "TEA", APART FROM THE MARK AS SHOWN.

FOR TEA (U.S. CL. 46).

FIRST USE 1-1-1989; IN COMMERCE 1-1-1989.
FRANK LATTUCA, EXAMINING ATTORNEY

CLASS 30—(Continued).

SN 85-224,930. OFF THE FARM FOODS, INC., SAN LUIS OBISPO, CA. FILED 1-24-2011.

OFF THE FARM

THE MARK CONSISTS OF STANDARD CHARACTERS WITHOUT CLAIM TO ANY PARTICULAR FONT, STYLE, SIZE, OR COLOR.

NO CLAIM IS MADE TO THE EXCLUSIVE RIGHT TO USE "FARM", APART FROM THE MARK AS SHOWN.

FOR GRANOLA-BASED SNACK BARS, GRANOLA, BREAKFAST CEREALS, UNPROCESSED CEREALS, CEREAL BASED SNACK FOOD, PROCESSED GRAINS, GRAIN-BASED SNACK FOOD, CEREAL BASED ENERGY BARS (U.S. CL. 46).

FIRST USE 2-1-2009; IN COMMERCE 5-1-2009.

NAKWAMA ANKRAH, EXAMINING ATTORNEY

SN 85-218,447. PERFECT ENDINGS, LLC, NAPA, CA. FILED 1-14-2011.

Perfect Endings

THE MARK CONSISTS OF STANDARD CHARACTERS WITHOUT CLAIM TO ANY PARTICULAR FONT, STYLE, SIZE, OR COLOR.

FOR BAKERY PRODUCTS, NAMELY, SWEET BAKERY GOODS (U.S. CL. 46).

FIRST USE 1-1-1994; IN COMMERCE 1-1-1994.

MICHELLE DUBOIS, EXAMINING ATTORNEY

SN 85-225,997. HAMMOND'S CANDIES SINCE 1920 II, LLC, DENVER, CO. FILED 1-25-2011.

SN 85-222,223. PUNJANA LIMITED, BELFAST, NORTHERN IRELAND, FILED 1-20-2011.

PUNJANA

THE MARK CONSISTS OF STANDARD CHARACTERS WITHOUT CLAIM TO ANY PARTICULAR FONT, STYLE, SIZE, OR COLOR.

OWNER OF UNITED KINGDOM REG. NO. 674434, DATED 11-15-2007, EXPIRES 10-12-2017.

THE WORDING "PUNJANA" HAS NO MEANING IN A FOREIGN LANGUAGE.

FOR TEA, TEA BASED BEVERAGES (U.S. CL. 46).

ALYSSA STEEL, EXAMINING ATTORNEY

McCRAW'S

THE MARK CONSISTS OF STANDARD CHARACTERS WITHOUT CLAIM TO ANY PARTICULAR FONT, STYLE, SIZE, OR COLOR.

SEC. 2(F).

FOR CANDY (U.S. CL. 46).

FIRST USE 1-7-1994; IN COMMERCE 1-7-1994.

STEVEN PEREZ, EXAMINING ATTORNEY

CLASS 30—(Continued).

SN 85-229,120. HONEYBLAZE LLC, RIVERVIEW, FL. FILED 1-28-2011.



NO CLAIM IS MADE TO THE EXCLUSIVE RIGHT TO USE "ORIGINAL", APART FROM THE MARK AS SHOWN.

THE MARK CONSISTS OF A BUFFALO WITH FLAMES RISING FROM THE TOP. A BUMBLE BEE STINGING THE BUFFALO FROM BEHIND. THE NAME "HONEYBLAZE" WITH FLAMES RISING FROM THE TOP CURVED OVER THE TOP OF THE BUFFALO AND THE WORD "ORIGINAL" WITH FLAMES RISING FROM THE TOP BELOW THE BUFFALO.

FOR CONDIMENT, NAMELY, PEPPER SAUCE (U.S. CL. 46).

FIRST USE 6-6-2010; IN COMMERCE 12-23-2010.
CAROLYN CATALDO, EXAMINING ATTORNEY

SN 85-229,276. O-SO HEALTHY FOODS, LLC, NEWPORT BEACH, CA. FILED 1-28-2011.

LOVE 2B SLIM

THE MARK CONSISTS OF STANDARD CHARACTERS WITHOUT CLAIM TO ANY PARTICULAR FONT, STYLE, SIZE, OR COLOR.

FOR FOODS NOT FOR TREATMENT OF A MEDICAL CONDITION, NAMELY, CHOCOLATE AND GRAIN BASED FOOD BARS, TEAS, AND SHAKES, ALL FOR WEIGHT LOSS PURPOSES (U.S. CL. 46).

Laurie Kaufman, Examining Attorney

CLASS 30—(Continued).

SN 85-229,290. O-SO HEALTHY FOODS, LLC, NEWPORT BEACH, CA. FILED 1-28-2011.

SLIM AT LAST

THE MARK CONSISTS OF STANDARD CHARACTERS WITHOUT CLAIM TO ANY PARTICULAR FONT, STYLE, SIZE, OR COLOR.

FOR FOODS NOT FOR TREATMENT OF A MEDICAL CONDITION, NAMELY, CHOCOLATE AND GRAIN BASED FOOD BARS, TEAS, AND SHAKES, ALL FOR WEIGHT LOSS PURPOSES (U.S. CL. 46).

Laurie Kaufman, Examining Attorney

SN 85-235,593. GOLD MEDAL PRODUCTS CO., CINCINNATI, OH. FILED 2-7-2011.

MONSTER MUSHROOM POPCORN

THE MARK CONSISTS OF STANDARD CHARACTERS WITHOUT CLAIM TO ANY PARTICULAR FONT, STYLE, SIZE, OR COLOR.

NO CLAIM IS MADE TO THE EXCLUSIVE RIGHT TO USE "MUSHROOM POPCORN", APART FROM THE MARK AS SHOWN.

FOR UNPOPPED POPCORN KERNELS (U.S. CL. 46).

FIRST USE 11-19-2007; IN COMMERCE 11-19-2007.

Jason Blair, Examining Attorney

SN 85-236,011. WALGREEN CO., DEERFIELD, IL. FILED 2-7-2011.

NICE!

THE MARK CONSISTS OF STANDARD CHARACTERS WITHOUT CLAIM TO ANY PARTICULAR FONT, STYLE, SIZE, OR COLOR.

FOR BROWNIES; MUFFINS; DANISHES; BAKING SODA; SUGAR SUBSTITUTE; BUNS; CHOCOLATE COVERED PEANUTS; COFFEE; CHEESECAKE; SANDWICHES; BURRITOS; PIZZA; QUESADILLAS; HONEY; ICE CREAM, SHERBET; RICE; POPCORN; YOGURT COVERED PRETZELS; PRETZELS; SALSA; GREEN TEA; SANDWICH WRAPS; SNACK MIX CONSISTING PRIMARILY OF CRACKERS, PRETZELS AND/OR POPPED POPCORN (U.S. CL. 46).

Jim Ringle, Examining Attorney

CLASS 30—(Continued).

SN 85-236,218. SEVEN STAR TRADING, INC., SKOKIE, IL. FILED 2-7-2011.

LAZZAT

THE MARK CONSISTS OF STANDARD CHARACTERS WITHOUT CLAIM TO ANY PARTICULAR FONT, STYLE, SIZE, OR COLOR.

FOR SPICES (U.S. CL. 46).
FIRST USE 8-31-2002; IN COMMERCE 8-31-2002.
JEFFERY COWARD, EXAMINING ATTORNEY

SN 85-237,602. PRICE, ANNIE B., DBA ANN'S SNACK BAR, DECATUR, GA. FILED 2-9-2011.

GHETTO BURGER

THE MARK CONSISTS OF STANDARD CHARACTERS WITHOUT CLAIM TO ANY PARTICULAR FONT, STYLE, SIZE, OR COLOR.

OWNER OF U.S. REG. NO. 3,885,003.
NO CLAIM IS MADE TO THE EXCLUSIVE RIGHT TO USE "BURGER", APART FROM THE MARK AS SHOWN.
FOR CHEESEBURGER SANDWICHES; HAMBURGER SANDWICHES; SANDWICHES; SANDWICHES, NAMELY, HAMBURGERS FOR CONSUMPTION ON OR OFF THE PREMISES (U.S. CL. 46).
FIRST USE 11-30-1993; IN COMMERCE 11-30-1993.
MATTHEW PAPPAS, EXAMINING ATTORNEY

SN 85-237,710. GOUVEA'S & PURITY FOODS, INC., HONOLULU, HI. FILED 2-9-2011.

HAWAIIAN BRAND PIGGY PUPS

THE MARK CONSISTS OF STANDARD CHARACTERS WITHOUT CLAIM TO ANY PARTICULAR FONT, STYLE, SIZE, OR COLOR.

NO CLAIM IS MADE TO THE EXCLUSIVE RIGHT TO USE "HAWAIIAN BRAND" OR "PUPS", APART FROM THE MARK AS SHOWN.
FOR SAUSAGES WRAPPED IN BREAD (U.S. CL. 46).
ANNE MADDEN, EXAMINING ATTORNEY

CLASS 30—(Continued).

SN 85-241,725. BATTER UP LLC, MIAMI, FL. FILED 2-14-2011.

THE PIPING GOURMETS

THE MARK CONSISTS OF STANDARD CHARACTERS WITHOUT CLAIM TO ANY PARTICULAR FONT, STYLE, SIZE, OR COLOR.

FOR BAKERY GOODS; PRE-MIXED, UNBAKED INGREDIENTS FOR BAKERY GOODS, NAMELY, MIXES FOR BAKERY GOODS SOLD PRE-PACKAGED TO CONSUMERS; BATTER FOR BAKERY GOODS; PRE-MIXED, UNBAKED INGREDIENTS FOR BAKERY GOODS, NAMELY, MIXES FOR BAKERY GOODS SOLD PRE-PACKAGED IN INDIVIDUAL FREEZER-GRADE DISPOSABLE PASTRY BAGS (U.S. CL. 46).
MICHAEL KEATING, EXAMINING ATTORNEY

SN 85-241,777. BATTER UP LLC, MIAMI, FL. FILED 2-14-2011.



THE MARK CONSISTS OF THE WORDS "THE PIPING GOURMETS" WRITTEN IN SCRIPT INSIDE A CIRCLE SURROUND BY A SCALLOPED RING. A DRAWING OF A PASTRY BAG IS LOCATED IN THE UPPER RIGHT QUADRANT OF THE CIRCLE, WITH THE TIP OF THE PASTRY BAG LOCATED AT THE END OF THE LETTER "G" IN "PIPING", AND WITH THE END OF THE PASTRY BAG LOCATED OUTSIDE OF THE CIRCLE.

FOR BAKERY GOODS; PRE-MIXED, UNBAKED INGREDIENTS FOR BAKERY GOODS, NAMELY, MIXES FOR BAKERY GOODS SOLD PRE-PACKAGED TO CONSUMERS; BATTER FOR BAKERY GOODS; PRE-MIXED, UNBAKED INGREDIENTS FOR BAKERY GOODS, NAMELY, MIXES FOR BAKERY GOODS SOLD PRE-PACKAGED IN INDIVIDUAL FREEZER-GRADE DISPOSABLE PASTRY BAGS (U.S. CL. 46).
MICHAEL KEATING, EXAMINING ATTORNEY

CLASS 30—(Continued).

SN 85-242,438. ASTRO POPS, LLC, IRVINE, CA. FILED 2-15-2011.



OWNER OF U.S. REG. NO. 922,460.
NO CLAIM IS MADE TO THE EXCLUSIVE RIGHT TO USE "POP" AND "ORIGINAL", APART FROM THE MARK AS SHOWN.

THE MARK CONSISTS OF THE WORDS "ASTRO POP" APPEARING ABOVE THE WORD "ORIGINAL", WITHIN AN OVAL BACKGROUND. THERE ARE 2 BROKEN INTERSECTING OVALS ENVELOPING THE OVAL BACKGROUND.

FOR CANDY; LOLLIPOPS (U.S. CL. 46).
B. PARADEWELAI, EXAMINING ATTORNEY

SN 85-243,012. HEARTHESIDE FOOD SOLUTIONS, LLC, DOWNERS GROVE, IL. FILED 2-15-2011.

SNACK ALONGS

THE MARK CONSISTS OF STANDARD CHARACTERS WITHOUT CLAIM TO ANY PARTICULAR FONT, STYLE, SIZE, OR COLOR.

NO CLAIM IS MADE TO THE EXCLUSIVE RIGHT TO USE "SNACK", APART FROM THE MARK AS SHOWN.

FOR BAGEL CHIPS; BAKERY GOODS, NAMELY, GRANOLA; BAKERY PRODUCTS, NAMELY, SWEET BAKERY GOODS; BISCOTTI; BREAKFAST CEREALS; CANDY COATED POPCORN; CEREAL BASED ENERGY BARS; CEREAL-BASED SNACK FOODS; CHEESE FLAVORED PUFFED CORN SNACKS; CHEESE FLAVORED SNACKS, NAMELY, CHEESE CURLS; CHEESE FLAVORED SNACKS, NAMELY, PUFFED CHEESE BALLS; CHEESE-FLAVORED CORN SNACKS; CHOCOLATE COVERED POPCORN; CHOCOLATE COVERED PRETZELS; CORN CHIPS; CORN CURLS; CORN FLAKES; CORN-BASED SNACK FOODS; CRACKER AND CHEESE COMBINATIONS; CRACKERS; EXTRUDED CORN SNACKS; EXTRUDED WHEAT SNACKS; GLAZED POPCORN; GRAIN-BASED BEVERAGES; GRAIN-BASED FOOD BARS ALSO CONTAINING DRIED FRUITS; GRAIN-BASED FOOD BEVERAGES; GRAIN-BASED SNACK FOODS; GRANOLA; GRANOLA SNACKS; GRANOLA-BASED SNACK BARS; MULTI-GRAIN-BASED SNACK FOODS; PITA CHIPS; POPCORN; PUFFED CORN SNACKS; READY TO EAT, CEREAL DERIVED FOOD BARS; READY-TO-EAT CEREALS; RICE-BASED SNACK FOODS; SNACK FOOD CHEWS MADE PRIMARILY FROM BROWN RICE SYRUP; SNACK FOODS, NAMELY, CHOCOLATE-BASED SNACK FOODS; SNACK MIX CONSISTING PRIMARILY OF CRACKERS, PRETZELS AND/OR POPPED POPCORN; WHEAT-BASED SNACK FOODS; YOGURT-COVERED PRETZELS (U.S. CL. 46).

DAWN FELDMAN, EXAMINING ATTORNEY

CLASS 30—(Continued).

SN 85-243,896. PK OVERSEAS PVT. LTD., KAROLBAGH, NEW DELHI, INDIA, FILED 2-16-2011.

INDIA SALAAM

THE MARK CONSISTS OF STANDARD CHARACTERS WITHOUT CLAIM TO ANY PARTICULAR FONT, STYLE, SIZE, OR COLOR.

NO CLAIM IS MADE TO THE EXCLUSIVE RIGHT TO USE "INDIA", APART FROM THE MARK AS SHOWN.

THE ENGLISH TRANSLATION OF "SALAAM" IN THE MARK IS GREETINGS.

FOR PROCESSED CEREALS; READY-TO-EAT CEREALS; RICE; SPICES (U.S. CL. 46).

FIRST USE 0-0-1985; IN COMMERCE 2-0-2011.
LINDA ORNDORFF, EXAMINING ATTORNEY

SN 85-244,219. SUNNY HILLS DELIGHTS INC., NANTOU CITY, TAIWAN, FILED 2-16-2011.

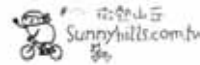

THE MARK CONSISTS OF AN ILLUSTRATION OF A FIGURE ON A BIKE WITH A SMALL ANIMAL FOLLOWING BEHIND WITH THE WORDS "SUNNYHILLS.COM.TW" ABOVE THE ANIMAL AND CHINESE CHARACTERS ABOVE THE WORDS "SUNNYHILLS.COM.TW".

THE NON-LATIN CHARACTERS IN THE MARK TRANSLITERATE TO WEI RE SHAN QUI AND THIS MEANS SLIGHT HOT HILLS IN ENGLISH.

FOR BISCUITS, BREAD, CAKES, COOKIES, HONEY, ICE CREAM, MACAROONS, PASTRIES, PEANUT BUTTER, PEANUT BUTTER CONFECTIONERY CHIPS, TARTS, TEA (U.S. CL. 46).

DOMINICK J. SALEMI, EXAMINING ATTORNEY

CLASS 30—(Continued).

SN 85-245,783. T.K. FOODS, LLC, RATHDRUM, ID. FILED 2-18-2011.



NO CLAIM IS MADE TO THE EXCLUSIVE RIGHT TO USE "HOME STYLE SALSA", APART FROM THE MARK AS SHOWN.

THE COLOR(S) RED, ORANGE, GREEN, BLACK, WHITE, YELLOW, BROWN, AND BLUE IS/ARE CLAIMED AS A FEATURE OF THE MARK.

THE MARK CONSISTS OF THE STYLIZED WORDS "LOS BANDITOS" IN RED AND "HOME STYLE SALSA" IN GREEN. IN BETWEEN THE STYLIZED WORDS IS A BLACK CIRCLE FILLED WITH A BLUE BACKGROUND AND BLUE TREES. ON TOP OF THE BACKGROUND ARE TWO ANIMATED PEPPERS. THE PEPPER ON THE LEFT APPEARS IN RED WITH GREEN HAIR, YELLOW ARMS AND LEGS AND WHITE HANDS. THE RED PEPPER IS WEARING AN ORANGE, GREEN AND RED HAT, BLACK SUNGLASSES, YELLOW SHOES, AND WHITE SOCKS. THE PEPPER ON THE RIGHT APPEARS IN GREEN WITH GREEN ARMS AND LEGS AND A WHITE GLOVED HAND. THE GREEN PEPPER IS WEARING AN ORANGE, GREEN AND RED HAT, BLACK SUNGLASSES, ORANGE SHOES, AND WHITE SOCKS. THE TWO PEPPERS ARE SITTING ON TOP OF A BROWN MOOSE WITH YELLOW ANTLERS AND GREEN, BLACK AND WHITE EYES, ON WHICH IS DRAPED A BLANKET IN RED, GREEN, YELLOW, BLACK AND WHITE.

THE ENGLISH TRANSLATION OF "LOS BANDITOS" IN THE MARK IS "THE BANDITS".

FOR SALSA (U.S. CL. 46).

EDWARD FENNESSY, EXAMINING ATTORNEY

SN 85-246,454. PIZZA STOP, INC., LIBERTYVILLE, IL. FILED 2-18-2011.

PIZZA STOP

THE MARK CONSISTS OF STANDARD CHARACTERS WITHOUT CLAIM TO ANY PARTICULAR FONT, STYLE, SIZE, OR COLOR.

NO CLAIM IS MADE TO THE EXCLUSIVE RIGHT TO USE "PIZZA", APART FROM THE MARK AS SHOWN.

FOR PIZZA (U.S. CL. 46).

NANCY CLARKE, EXAMINING ATTORNEY

CLASS 30—(Continued).

SN 85-246,893. WESTWOOD FOODS LLC, TAMPA, FL. FILED 2-19-2011.



NO CLAIM IS MADE TO THE EXCLUSIVE RIGHT TO USE "FLORIDA", APART FROM THE MARK AS SHOWN.

THE COLOR(S) RED, BLACK, GREEN, YELLOW, WHITE, ORANGE, AND BLUE IS/ARE CLAIMED AS A FEATURE OF THE MARK.

THE MARK CONSISTS OF TWO RED PEPPERS WITH BLACK SHADING AND GREEN STEMS SET AGAINST A YELLOW HORIZON WITH THE SUN RAYS IN WHITE AND THREE BLACK PALM TREES; YELLOW AND ORANGE FLAMES APPEAR BELOW THE PEPPERS; A BLUE CIRCLE ENCOMPASSES THE DESIGN WITH THE WORDS "FLAVORS OF FLORIDA" IN WHITE WITH THREE YELLOW STARS ON THE LEFT AND THREE YELLOW STARS ON THE RIGHT; A THIN RED CIRCLE ENCASES THE BLUE CIRCLE.

FOR SAUCES (U.S. CL. 46).

FIRST USE 8-15-2010; IN COMMERCE 2-17-2011.

ASMAT KHAN, EXAMINING ATTORNEY

SN 85-247,933. BALL, TROYLYN W., ASHEVILLE, NC. FILED 2-22-2011.

Crooked Creek Corn

THE MARK CONSISTS OF STANDARD CHARACTERS WITHOUT CLAIM TO ANY PARTICULAR FONT, STYLE, SIZE, OR COLOR.

NO CLAIM IS MADE TO THE EXCLUSIVE RIGHT TO USE "CORN", APART FROM THE MARK AS SHOWN.

FOR CORN MEAL (U.S. CL. 46).

KEVON CHISOLM, EXAMINING ATTORNEY

CLASS 30—(Continued).

SN 85-249,185. WOLFSON, HARRIS P, NICASIO, CA. FILED 2-23-2011.

PIECOTTI

THE MARK CONSISTS OF STANDARD CHARACTERS WITHOUT CLAIM TO ANY PARTICULAR FONT, STYLE, SIZE, OR COLOR.

THE WORDING "PIECOTTI" HAS NO MEANING IN A FOREIGN LANGUAGE.

FOR CHOCOLATE COVERED COOKIES; COOKIE DOUGH; COOKIE MIXES; COOKIES; COOKIES AND CRACKERS; FOOD PACKAGE COMBINATIONS CONSISTING PRIMARILY OF BREAD, CRACKERS AND/OR COOKIES; FROZEN COOKIE DOUGH; VEGAN COOKIES (U.S. CL. 46).

AISHA SALEM, EXAMINING ATTORNEY

CLASS 30—(Continued).

SN 85-249,661. JO SNOW, INC., CHICAGO, IL. FILED 2-23-2011.

JO SNOW SYRUPS

THE MARK CONSISTS OF STANDARD CHARACTERS WITHOUT CLAIM TO ANY PARTICULAR FONT, STYLE, SIZE, OR COLOR.

NO CLAIM IS MADE TO THE EXCLUSIVE RIGHT TO USE "SYRUPS", APART FROM THE MARK AS SHOWN.

THE NAME(S), PORTRAIT(S), AND/OR SIGNATURE(S) SHOWN IN THE MARK DOES NOT IDENTIFY A PARTICULAR LIVING INDIVIDUAL.

FOR FLAVORING SYRUP (U.S. CL. 46).

FIRST USE 10-20-2010; IN COMMERCE 10-20-2010.

MARY CRAWFORD, EXAMINING ATTORNEY

SN 85-250,043. ARGUETA, JACQUELINE, NEW YORK, NY. FILED 2-23-2011.

SN 85-249,641. JO SNOW, INC., CHICAGO, IL. FILED 2-23-2011.



THE NAME(S), PORTRAIT(S), AND/OR SIGNATURE(S) SHOWN IN THE MARK DOES NOT IDENTIFY A PARTICULAR LIVING INDIVIDUAL.

THE MARK CONSISTS OF THE STYLIZED WORDS "JO SNOW" ABOVE AN UPSIDE DOWN ICE CREAM CONE CONTAINED IN A BEVERAGE CUP.

FOR FLAVORING SYRUP (U.S. CL. 46).

FIRST USE 10-20-2010; IN COMMERCE 10-20-2010.

MARY CRAWFORD, EXAMINING ATTORNEY



NO CLAIM IS MADE TO THE EXCLUSIVE RIGHT TO USE "JAVA FARMS" AND "COFFEE COMPANY", APART FROM THE MARK AS SHOWN.

THE MARK CONSISTS OF THE WORDS "JAVA FARMS COFFEE COMPANY" WITHIN FOUR CONCENTRIC OVALS. THE WORDING "JAVA FARMS" APPEARS IN THE UPPER PERIMETER OF THE DESIGN. THE WORDING "COFFEE COMPANY" APPEARS IN THE LOWER PERIMETER OF THE DESIGN. IN THE FOREGROUND OF THE CENTER OVAL APPEARS A STYLIZED DRAWING OF A COFFEE CUP WITH SWIRLING STEAM RISING ABOVE THE CUP. ON EACH SIDE OF THE CUP ARE STYLIZED PLANT LEAVES WITH COFFEE BEANS THAT EXTEND AND BREAK THE BORDERS OF THE OTHER CONCENTRIC OVALS. IN THE BACKGROUND OF THE CENTER OVAL, BEHIND THE CUP AND LEAVES, APPEARS A MOUNTAIN LANDSCAPE.

FOR COFFEE; COFFEE BEANS; GREEN COFFEE; GROUND COFFEE BEANS; ROASTED COFFEE BEANS (U.S. CL. 46).

CHRISTOPHER BUONGIORNO, EXAMINING ATTORNEY

CLASS 30—(Continued).

SN 85-250,268. CHECKERS DRIVE-IN RESTAURANTS, INC., TAMPA, FL. FILED 2-24-2011.

ZILLA COMBOS

THE MARK CONSISTS OF STANDARD CHARACTERS WITHOUT CLAIM TO ANY PARTICULAR FONT, STYLE, SIZE, OR COLOR.

NO CLAIM IS MADE TO THE EXCLUSIVE RIGHT TO USE "COMBOS", APART FROM THE MARK AS SHOWN.

FOR PREPARED MEAL CONSISTING PRIMARILY OF A SANDWICH WITH FRENCH FRIES AND A DRINK (U.S. CL. 46).

FIRST USE 2-17-2011; IN COMMERCE 2-17-2011.
WON TEAK OH, EXAMINING ATTORNEY

CLASS 30—(Continued).

SN 85-251,330. AKI WEST INTERACTIVE LLC NEVADA, LAS VEGAS, NV. FILED 2-24-2011.

SUNLINE BRANDS

THE MARK CONSISTS OF STANDARD CHARACTERS WITHOUT CLAIM TO ANY PARTICULAR FONT, STYLE, SIZE, OR COLOR.

NO CLAIM IS MADE TO THE EXCLUSIVE RIGHT TO USE "BRANDS", APART FROM THE MARK AS SHOWN.

FOR CANDY (U.S. CL. 46).

MICHAEL WIENER, EXAMINING ATTORNEY

SN 85-251,080. LPB, LLC, DBA TOKIE'S, RICHMOND, VA. FILED 2-24-2011.

Tokie's All Natural

THE MARK CONSISTS OF STANDARD CHARACTERS WITHOUT CLAIM TO ANY PARTICULAR FONT, STYLE, SIZE, OR COLOR.

NO CLAIM IS MADE TO THE EXCLUSIVE RIGHT TO USE "ALL NATURAL", APART FROM THE MARK AS SHOWN.

FOR MIXES FOR MAKING BAKING BATTERS MADE FROM ALL NATURAL INGREDIENTS (U.S. CL. 46).

FIRST USE 1-0-2004; IN COMMERCE 1-0-2004.
MICHAEL WIENER, EXAMINING ATTORNEY

SN 85-252,188. DIGITAL DOWNLOAD, INC., NEW YORK, NY. FILED 2-25-2011.

ZOOM-ZOOM

THE MARK CONSISTS OF STANDARD CHARACTERS WITHOUT CLAIM TO ANY PARTICULAR FONT, STYLE, SIZE, OR COLOR.

FOR CHEWING GUM AND CANDY (U.S. CL. 46).

TIMOTHY FINNEGAN, EXAMINING ATTORNEY

SN 85-251,326. AKI WEST INTERACTIVE LLC NEVADA, LAS VEGAS, NV. FILED 2-24-2011.

SUNMARK BRANDS

THE MARK CONSISTS OF STANDARD CHARACTERS WITHOUT CLAIM TO ANY PARTICULAR FONT, STYLE, SIZE, OR COLOR.

NO CLAIM IS MADE TO THE EXCLUSIVE RIGHT TO USE "BRANDS", APART FROM THE MARK AS SHOWN.

FOR CANDY (U.S. CL. 46).

MICHAEL WIENER, EXAMINING ATTORNEY

SN 85-253,185. MELLOS PARTNERS, LLC, DBA MELLOS PEANUT COMPANY, CHICAGO, IL. FILED 2-28-2011.

Big Mel's

THE MARK CONSISTS OF STANDARD CHARACTERS WITHOUT CLAIM TO ANY PARTICULAR FONT, STYLE, SIZE, OR COLOR.

FOR CARAMEL POPCORN; FLAVOR-COATED POPPED POPCORN; GLAZED POPCORN; POPCORN; POPPED POPCORN; PROCESSED POPCORN (U.S. CL. 46).

BARBARA BROWN, EXAMINING ATTORNEY

CLASS 30—(Continued).

SN 85-253,478. KRAFT FOODS GLOBAL BRANDS LLC, NORTHFIELD, IL. FILED 2-28-2011.

FLAVOR YOU CAN FEEL OOMPH
YOU CAN TASTE

THE MARK CONSISTS OF STANDARD CHARACTERS WITHOUT CLAIM TO ANY PARTICULAR FONT, STYLE, SIZE, OR COLOR.
FOR CHEWING GUM (U.S. CL. 46).
KELLY BOULTON, EXAMINING ATTORNEY

SN 85-253,574. KO CATERING AND PIES, LLC, SOUTH BOSTON, MA. FILED 2-28-2011.

KO PIES

THE MARK CONSISTS OF STANDARD CHARACTERS WITHOUT CLAIM TO ANY PARTICULAR FONT, STYLE, SIZE, OR COLOR.
NO CLAIM IS MADE TO THE EXCLUSIVE RIGHT TO USE "PIES", APART FROM THE MARK AS SHOWN.
FOR PREPARED FOODS, NAMELY, MEAT AND VEGETARIAN PIES (U.S. CL. 46).
CHRISTINE MARTIN, EXAMINING ATTORNEY

SN 85-253,770. PACIFIC PUFFS, LLC, SAN FRANCISCO, CA. FILED 2-28-2011.

PACIFIC PUFFS

THE MARK CONSISTS OF STANDARD CHARACTERS WITHOUT CLAIM TO ANY PARTICULAR FONT, STYLE, SIZE, OR COLOR.
NO CLAIM IS MADE TO THE EXCLUSIVE RIGHT TO USE "PUFFS", APART FROM THE MARK AS SHOWN.
FOR BAKERY GOODS, NAMELY, CREAM PUFFS (U.S. CL. 46).
FIRST USE 5-1-2009; IN COMMERCE 5-1-2009.
DAVID H. STINE, EXAMINING ATTORNEY

CLASS 30—(Continued).

SN 85-253,772. JONES, DAHLIA LENAY, DBA JONES, DAHLIA LENAY, TAMPA, FL. FILED 2-28-2011.

Sweet Tooth Pastry

THE MARK CONSISTS OF STANDARD CHARACTERS WITHOUT CLAIM TO ANY PARTICULAR FONT, STYLE, SIZE, OR COLOR.
NO CLAIM IS MADE TO THE EXCLUSIVE RIGHT TO USE "PASTRY", APART FROM THE MARK AS SHOWN.
FOR BUTTERCREAM FILLINGS FOR CAKES; CAKE FROSTING; CAKE ICING; CAKE MIXES; CAKES; CUP CAKES; ICED CAKES (U.S. CL. 46).
FIRST USE 12-9-2010; IN COMMERCE 1-16-2011.
LINDA MICKLEBURGH, EXAMINING ATTORNEY

SN 85-253,807. SEOUL SHIK POOM, INC., DBA SEOUL TRADING USA CO., ENGLEWOOD, NJ. FILED 2-28-2011.

HONG MU DAN

THE MARK CONSISTS OF STANDARD CHARACTERS WITHOUT CLAIM TO ANY PARTICULAR FONT, STYLE, SIZE, OR COLOR.
THE ENGLISH TRANSLATION OF "HONG MU DAN" IN THE MARK IS "RED PEONY".
FOR RICE (U.S. CL. 46).
CAROLYN CATALDO, EXAMINING ATTORNEY

SN 85-253,940. LEON, RYAN, TAMPA, FL. FILED 2-28-2011.

Seoul Sauce

THE MARK CONSISTS OF STANDARD CHARACTERS WITHOUT CLAIM TO ANY PARTICULAR FONT, STYLE, SIZE, OR COLOR.
NO CLAIM IS MADE TO THE EXCLUSIVE RIGHT TO USE "SAUCE", APART FROM THE MARK AS SHOWN.
FOR BARBECUE SAUCE; MARINADES (U.S. CL. 46).
JOHN WILKE, EXAMINING ATTORNEY

CLASS 30—(Continued).

SN 85-254,196. DONUTZ GONUTZ, INC., ROSLYN HEIGHTS, NY. FILED 3-1-2011.

DONUTZ GONUTZ

THE MARK CONSISTS OF STANDARD CHARACTERS WITHOUT CLAIM TO ANY PARTICULAR FONT, STYLE, SIZE, OR COLOR.

NO CLAIM IS MADE TO THE EXCLUSIVE RIGHT TO USE "DONUTS", APART FROM THE MARK AS SHOWN.

FOR BAGELS; CAKES; COOKIES; CUP CAKES; DONUTS; MUFFINS; PASTRY (U.S. CL. 46).

FIRST USE 2-24-2011; IN COMMERCE 2-24-2011.

TRACY WHITTAKER-BROWN, EXAMINING ATTORNEY

SN 85-254,247. GRUMA CORPORATION, IRVING, TX. FILED 3-1-2011.

MISSION

THE MARK CONSISTS OF STANDARD CHARACTERS WITHOUT CLAIM TO ANY PARTICULAR FONT, STYLE, SIZE, OR COLOR.

OWNER OF U.S. REG. NOS. 1,216,032, 3,897,072 AND OTHERS.

FOR TACO KITS CONSISTING OF TACO SHELLS, TACO SAUCE AND SEASONING; WRAP KITS CONSISTING OF TORTILLAS, DRESSING AND SEASONING (U.S. CL. 46).

FIRST USE 2-0-2011; IN COMMERCE 2-0-2011.

WILLIAM P. SHANAHAN, EXAMINING ATTORNEY

SN 85-254,260. KMCH NATURAL FOODS, INC., VOLO, IL. FILED 3-1-2011.

MOTHER'S CUPBOARD

THE MARK CONSISTS OF STANDARD CHARACTERS WITHOUT CLAIM TO ANY PARTICULAR FONT, STYLE, SIZE, OR COLOR.

OWNER OF U.S. REG. NOS. 3,541,649 AND 3,757,197.

FOR REFRIGERATED COOKIE DOUGH (U.S. CL. 46).

FIRST USE 2-0-2011; IN COMMERCE 2-0-2011.

WILLIAM BRECKENFELD, EXAMINING ATTORNEY

CLASS 30—(Continued).

SN 85-254,263. GRUMA CORPORATION, IRVING, TX. FILED 3-1-2011.



OWNER OF U.S. REG. NOS. 1,216,032, 3,897,072 AND OTHERS.

THE MARK CONSISTS OF THE WORD "MISSION" IN RECTANGLE DESIGN; BELOW THE RECTANGLE CONTAINING THE WORD "MISSION" IS A BANNER DESIGN STARTING FROM UNDERNEATH THE LEFT HAND CORNER OF THE RECTANGLE AND EXTENDING BEYOND THE RIGHT HAND CORNER OF THE RECTANGLE; ABOVE THE RECTANGLE IS AN ARCH DESIGN CONTAINING A BELL IN AN OPENING WITH A FLOWER-LIKE DESIGN ON EITHER SIDE OF THE OPENING; THE WORDS "THE AUTHENTIC TRADITION" ARE ACROSS THE UPPER PORTION OF THE ARCH DESIGN.

FOR TACO KITS CONSISTING OF TACO SHELLS, TACO SAUCE AND SEASONING; WRAP KITS CONSISTING OF TORTILLAS, DRESSING AND SEASONING (U.S. CL. 46).

FIRST USE 2-0-2011; IN COMMERCE 2-0-2011.

WILLIAM P. SHANAHAN, EXAMINING ATTORNEY

SN 85-254,324. LUDLOW CREATIONS, LLC, DBA FLEURIR; HAND GROWN CHOCOLATES, HARTFIELD, VA. FILED 3-1-2011.



NO CLAIM IS MADE TO THE EXCLUSIVE RIGHT TO USE "CHOCOLATES", APART FROM THE MARK AS SHOWN.

THE MARK CONSISTS OF A RECTANGLE BOX DIVIDED INTO TWO PARTS. THE LEFT HAND SIDE OF THE RECTANGLE BOX HAS A FLOWER INSIDE OF IT. THE RIGHT HAND SIDE OF THE RECTANGLE BOX INCLUDES THE WORDS "FLEURIR" OVER THE WORDS "HAND GROWN CHOCOLATES". THE WORD "FLEURIR" IS LARGER THAN "HAND GROWN CHOCOLATES". THE LETTER "I" IN "FLEURIR" HAS A LEAF AS THE DOT FOR THE "I".

THE ENGLISH TRANSLATION OF "FLEURIR" IN THE MARK IS "TO FLOWER".

FOR CHOCOLATE BARS; CHOCOLATE CONFECTIONS (U.S. CL. 46).

FIRST USE 2-9-2009; IN COMMERCE 2-9-2009.

KATHERINE STOIDES, EXAMINING ATTORNEY

CLASS 30—(Continued).

SN 85-254,354. HIATT JR. ADEN DALE, COLORADO SPRINGS, CO. FILED 3-1-2011.

ICE-OFF

THE MARK CONSISTS OF STANDARD CHARACTERS WITHOUT CLAIM TO ANY PARTICULAR FONT, STYLE, SIZE, OR COLOR.

FOR WATER ICE (U.S. CL. 46).
KEVON CHISOLM, EXAMINING ATTORNEY

SN 85-254,698. BENJAMIN FLOWERS, JR., LADSON, SC. AND ALBERTHA S. FLOWERS, LADSON, SC. FILED 3-1-2011.

MS. BEE'S LIFE EVERLASTING
HERBAL TEA

THE MARK CONSISTS OF STANDARD CHARACTERS WITHOUT CLAIM TO ANY PARTICULAR FONT, STYLE, SIZE, OR COLOR.

NO CLAIM IS MADE TO THE EXCLUSIVE RIGHT TO USE "HERBAL TEA", APART FROM THE MARK AS SHOWN.

THE NAME "MS. BEE" DOES NOT IDENTIFY A LIVING INDIVIDUAL.

FOR HERBAL TEA (U.S. CL. 46).
LAURIE KAUFMAN, EXAMINING ATTORNEY

SN 85-254,783. ZHANGZHOU GUANGZHAOREN TEA CO., LTD., FUJIAN, CHINA, FILED 3-1-2011.

光照人

3H-SENDER

THE MARK CONSISTS OF THE WORDING "3H-SENDER" BENEATH THREE CHINESE CHARACTERS.

THE NON-LATIN CHARACTERS IN THE MARK TRANSLITERATE TO GUANG ZHAO REN AND THIS HAS NO MEANING IN A FOREIGN LANGUAGE.

FOR COFFEE; TEA; SUGAR; CONFECTIONERY MADE OF SUGAR; HONEY; WHEAT FLOUR FOR FOOD; SAUCES; SEASONINGS; YEAST; FOOD FLAVORINGS; COFFEE SUBSTITUTES (ARTIFICIAL COFFEE OR VEGETABLE PREPARATIONS FOR USE AS COFFEE); TEA-BASED BEVERAGES (U.S. CL. 46).
RICHARD WHITE, EXAMINING ATTORNEY

CLASS 30—(Continued).

SN 85-255,617. TIME BANDITS, LLC, CHICAGO, IL. FILED 3-2-2011.

WINTER FORMAL

THE MARK CONSISTS OF STANDARD CHARACTERS WITHOUT CLAIM TO ANY PARTICULAR FONT, STYLE, SIZE, OR COLOR.

FOR ESPRESSO BASED DRINKS (U.S. CL. 46).
FIRST USE 11-25-2010; IN COMMERCE 11-25-2010.
JOHN E. MICHOS, EXAMINING ATTORNEY

SN 85-255,658. KING'S INTERNATIONAL INVESTMENT GROUP, LLC, LOS ANGELES, CA. FILED 3-2-2011.

MR. PINK

THE MARK CONSISTS OF STANDARD CHARACTERS WITHOUT CLAIM TO ANY PARTICULAR FONT, STYLE, SIZE, OR COLOR.

FOR TEA; ICED TEA; SPARKLING ICED TEA (U.S. CL. 46).
MIDGE BUTLER, EXAMINING ATTORNEY

SN 85-255,733. AROUND THE GRILL, LLC, MEDINA, MN. FILED 3-2-2011.

FIELDER'S CHOICE

THE MARK CONSISTS OF STANDARD CHARACTERS WITHOUT CLAIM TO ANY PARTICULAR FONT, STYLE, SIZE, OR COLOR.

FOR BARBEQUE SAUCE (U.S. CL. 46).
JENNY PARK, EXAMINING ATTORNEY

CLASS 30—(Continued).

SN 85-256,082. NAPCO, INC., BATAVIA, IL. FILED 3-2-2011.

PAPANICHOLAS

THE MARK CONSISTS OF STANDARD CHARACTERS WITHOUT CLAIM TO ANY PARTICULAR FONT, STYLE, SIZE, OR COLOR.

OWNER OF U.S. REG. NOS. 1,681,340, 3,593,161 AND OTHERS.

FOR INSTANT COCOA MIX FOR MAKING HOT CHOCOLATE AND COCOA DRINKS (U.S. CL. 46).

FIRST USE 11-3-2009; IN COMMERCE 11-3-2009.

JULIE WATSON, EXAMINING ATTORNEY

CLASS 30—(Continued).

SN 85-256,138. NAPCO, INC., BATAVIA, IL. FILED 3-2-2011.

WHAT HOT COCOA IS SUPPOSED TO BE!

THE MARK CONSISTS OF STANDARD CHARACTERS WITHOUT CLAIM TO ANY PARTICULAR FONT, STYLE, SIZE, OR COLOR.

FOR COCOA MIX FOR MAKING COCOA (U.S. CL. 46).

JULIE WATSON, EXAMINING ATTORNEY

SN 85-256,105. NAPCO, INC., BATAVIA, IL. FILED 3-2-2011.

*Nicholas A.
Papanicholas*

OWNER OF U.S. REG. NO. 1,602,620.

THE NAME(S), PORTRAIT(S), AND/OR SIGNATURE(S) SHOWN IN THE MARK DOES NOT IDENTIFY A PARTICULAR LIVING INDIVIDUAL.

THE MARK CONSISTS OF "NICHOLAS A. PAPANICHOLAS" IN SCRIPT.

FOR INSTANT COCOA MIX FOR MAKING HOT CHOCOLATE AND COCOA DRINKS (U.S. CL. 46).

JULIE WATSON, EXAMINING ATTORNEY

SN 85-256,145. NAPCO, INC., BATAVIA, IL. FILED 3-2-2011.

AN INDULGENT CHOCOLATE EXPERIENCE!

THE MARK CONSISTS OF STANDARD CHARACTERS WITHOUT CLAIM TO ANY PARTICULAR FONT, STYLE, SIZE, OR COLOR.

FOR INSTANT COCOA MIX FOR MAKING HOT CHOCOLATE AND COCOA DRINKS (U.S. CL. 46).

JULIE WATSON, EXAMINING ATTORNEY

SN 85-256,130. NAPCO, INC., BATAVIA, IL. FILED 3-2-2011.

PAPA NICK'S

THE MARK CONSISTS OF STANDARD CHARACTERS WITHOUT CLAIM TO ANY PARTICULAR FONT, STYLE, SIZE, OR COLOR.

OWNER OF U.S. REG. NOS. 3,290,583 AND 3,684,548.

THE NAME(S), PORTRAIT(S), AND/OR SIGNATURE(S) SHOWN IN THE MARK DOES NOT IDENTIFY A PARTICULAR LIVING INDIVIDUAL.

FOR INSTANT COCOA MIX FOR MAKING HOT CHOCOLATE AND COCOA DRINKS (U.S. CL. 46).

JULIE WATSON, EXAMINING ATTORNEY

SN 85-256,388. JOSE M. GONZALEZ, VERNON, CA. FILED 3-2-2011.

LADY SLIM

THE MARK CONSISTS OF STANDARD CHARACTERS WITHOUT CLAIM TO ANY PARTICULAR FONT, STYLE, SIZE, OR COLOR.

FOR DRIED PROCESSED HERBS AND TEA SOLD LOOSE OR BAGGED FOR INDIVIDUAL SERVING (U.S. CL. 46).

ASMAT KHAN, EXAMINING ATTORNEY

CLASS 30—(Continued).

SN 85-257,190. CONNIE FAY, NORTH VANCOUVER, BC, CANADA, FILED 3-3-2011.

TRAIL PUCKS

THE MARK CONSISTS OF STANDARD CHARACTERS WITHOUT CLAIM TO ANY PARTICULAR FONT, STYLE, SIZE, OR COLOR.

FOR SNACK FOOD, NAMELY, COOKIES; BREAK-FAST CEREALS; CEREAL-BASED SNACK FOODS (U.S. CL. 46).

SUZANNE BLANE, EXAMINING ATTORNEY

SN 85-257,490. LT OVERSEAS NORTH AMERICA, INC., IRVINE, CA. FILED 3-3-2011.

ROYAL TOP TEA

THE MARK CONSISTS OF STANDARD CHARACTERS WITHOUT CLAIM TO ANY PARTICULAR FONT, STYLE, SIZE, OR COLOR.

OWNER OF U.S. REG. NOS. 1,683,914, 2,342,491 AND OTHERS.

NO CLAIM IS MADE TO THE EXCLUSIVE RIGHT TO USE "TEA", APART FROM THE MARK AS SHOWN.

FOR LOOSE TEA AND TEA BAGS (U.S. CL. 46).

WANDA KAY PRICE, EXAMINING ATTORNEY

SN 85-257,525. GOURMET KITCHENS, INC, CHICAGO, IL. FILED 3-3-2011.

SLIM GOURMET

THE MARK CONSISTS OF STANDARD CHARACTERS WITHOUT CLAIM TO ANY PARTICULAR FONT, STYLE, SIZE, OR COLOR.

NO CLAIM IS MADE TO THE EXCLUSIVE RIGHT TO USE "GOURMET", APART FROM THE MARK AS SHOWN.

FOR PREPARED FOODS, NAMELY, ENTREES CONSISTING PRIMARILY OF PASTA OR RICE WITH MEATS AND VEGETABLES (U.S. CL. 46).

FIRST USE 1-19-2011; IN COMMERCE 1-19-2011.

KELLY CHOE, EXAMINING ATTORNEY

CLASS 30—(Continued).

SN 85-260,063. KOBIKAYA LLC, ENCINO, CA. FILED 3-7-2011.



THE COLOR(S) BLACK, WHITE, YELLOW, MUSTARD YELLOW, CHOCOLATE BROWN IS/ARE CLAIMED AS A FEATURE OF THE MARK.

THE MARK CONSISTS OF A RECTANGLE BOX CONTAINING WHITE SPACE, OUTLINED IN BLACK WITH THE NAME "KOBIKAYA" INSIDE. "KOBI" IS BLACK, "KAYA" IS MUSTARD YELLOW. THE RECTANGLE BOX OVERLAYS A BLACK OUTLINED CIRCLE WITH A WHITE BORDER. THE TOP OF THE WHITE BORDER CONTAINS THE CURVED AND STYLIZED WORDS "NO TIME FOR SLEEPING" AND THE BOTTOM OF THE WHITE BORDER CONTAINS THE CURVED AND STYLIZED WORDS "WAKE UP, MY FRIEND AND GO SMARTER!" ALL IN CAPITAL LETTERS. INSIDE THE WHITE BORDER IS ANOTHER CIRCLE THAT CONSISTS OF STYLIZED SWIRLS OF YELLOW AND MUSTARD YELLOW ON THE TOP HALF AND CHOCOLATE BROWN ON THE BOTTOM HALF. A STYLIZED CHARACTER IS POSITIONED ON THE BOTTOM HALF OF THE COLORED PORTION OF THE CIRCLE, FACING TO THE RIGHT AS IF RUNNING. THE CHARACTER CONSISTS OF A SQUARE BODY OUTLINED IN BLACK AND CONTAINING WHITE SPACE WITH A STYLIZED BLACK EYE AND HALF A MOUTH FASHIONED INTO A SMILE, AND BLACK STICK FIGURE LEGS AND ARMS PROTRUDING FROM THE BODY. THE TOP OF THE CHARACTER CONSISTS OF A MUSTARD YELLOW BRAIN WITH 8 SMALL CIRCLES INSIDE AND A YELLOW SUNBURST WITH BLACK LINES EMANATING FROM THE TOP HALF OF THE BRAIN.

FOR BEVERAGES MADE OF COFFEE; BEVERAGES WITH A COFFEE BASE; COCOA BEVERAGES WITH MILK; COCOA-BASED BEVERAGES; COFFEE; COFFEE BASED BEVERAGES; COFFEE BEVERAGES WITH MILK; COFFEE FLAVORED SYRUP USED IN MAKING FOOD BEVERAGES; COFFEE-BASED BEVERAGE CONTAINING MILK; COFFEE-BASED BEVERAGES; ICED COFFEE; PREPARED COCOA AND COCOA-BASED BEVERAGES; PREPARED COFFEE AND COFFEE-BASED BEVERAGES (U.S. CL. 46).

REBECCA SMITH, EXAMINING ATTORNEY

CLASS 30—(Continued).

SN 85-263,029. GO TROPPO, INC., BROOKLINE, MA. FILED 3-10-2011.

STONERIFFIC

THE MARK CONSISTS OF STANDARD CHARACTERS WITHOUT CLAIM TO ANY PARTICULAR FONT, STYLE, SIZE, OR COLOR.

FOR ICE CREAM; FROZEN YOGURT; ICE CREAM DESSERTS AND FROZEN CONFECTIONS; ICE CREAM PIZZA; CHOCOLATES; BAKERY GOODS; HOT FUDGE; CANDY; CARAMEL; BUTTERSCOTCH; AND FUDGE (U.S. CL. 46).

LESLIE RICHARDS, EXAMINING ATTORNEY

SN 85-263,042. GO TROPPO, INC., BROOKLINE, MA. FILED 3-10-2011.

ICE CREAM THAT ROCKS

THE MARK CONSISTS OF STANDARD CHARACTERS WITHOUT CLAIM TO ANY PARTICULAR FONT, STYLE, SIZE, OR COLOR.

FOR ICE CREAM; FROZEN YOGURT; ICE CREAM DESSERTS AND FROZEN CONFECTIONS; ICE CREAM PIZZA; CHOCOLATES; BAKERY GOODS; HOT FUDGE; CANDY; CARAMEL; BUTTERSCOTCH; AND FUDGE (U.S. CL. 46).

LESLIE RICHARDS, EXAMINING ATTORNEY

SN 85-263,329. RALCORP HOLDINGS, INC., ST. LOUIS, MO. FILED 3-10-2011.

HOME FAVORITES

THE MARK CONSISTS OF STANDARD CHARACTERS WITHOUT CLAIM TO ANY PARTICULAR FONT, STYLE, SIZE, OR COLOR.

FOR BREAKFAST CEREALS; OATMEAL (U.S. CL. 46).

SANI KHOURI, EXAMINING ATTORNEY

CLASS 30—(Continued).

SN 85-263,487. TRAN'S FAMILY, INC., SAN GABRIEL, CA. FILED 3-10-2011.

MONTCAFE

THE MARK CONSISTS OF STANDARD CHARACTERS WITHOUT CLAIM TO ANY PARTICULAR FONT, STYLE, SIZE, OR COLOR.

FOR COFFEE BEVERAGES (U.S. CL. 46).
DANIEL CAPSHAW, EXAMINING ATTORNEY

SN 85-267,285. KOBIKAYA LLC, ENCINO, CA. FILED 3-15-2011.

Kobikaya

THE MARK CONSISTS OF STANDARD CHARACTERS WITHOUT CLAIM TO ANY PARTICULAR FONT, STYLE, SIZE, OR COLOR.

FOR BEVERAGES MADE OF COFFEE; BEVERAGES WITH A COFFEE BASE; COCOA BEVERAGES WITH MILK; COCOA-BASED BEVERAGES; COFFEE; COFFEE BASED BEVERAGES; COFFEE BEVERAGES WITH MILK; COFFEE FLAVORED SYRUP USED IN MAKING FOOD BEVERAGES; COFFEE-BASED BEVERAGE CONTAINING MILK; ICED COFFEE; PREPARED COCOA AND COCOA-BASED BEVERAGES; PREPARED COFFEE AND COFFEE-BASED BEVERAGES (U.S. CL. 46).

REBECCA SMITH, EXAMINING ATTORNEY

SN 85-278,302. NO LIMIT, LLC, FARMINGTON, CT. FILED 3-28-2011.



OWNER OF U.S. REG. NOS. 1,280,046, 3,145,005 AND OTHERS.

NO CLAIM IS MADE TO THE EXCLUSIVE RIGHT TO USE "ALL PROFITS TO CHARITY", APART FROM THE MARK AS SHOWN.

THE NAME "NEWMAN" AND THE PORTRAIT OF PAUL NEWMAN DO NOT IDENTIFY A LIVING INDIVIDUAL.

THE MARK CONSISTS OF THE WORDS "NEWMAN'S OWN ALL PROFITS TO CHARITY" WITHIN A DOUBLE LINED ARCH ON TOP OF AN ARTISTIC RENDERING OF THE FACE OF PAUL NEWMAN.

FOR SPAGHETTI SAUCE; BREAKFAST CEREAL; PIZZA (U.S. CL. 46).

FIRST USE 12-31-1993; IN COMMERCE 12-31-1993.

LINDA M. KING, EXAMINING ATTORNEY

CLASS 30—(Continued).

SN 85-278,348. NO LIMIT, LLC, FARMINGTON, CT. FILED 3-28-2011.



OWNER OF U.S. REG. NOS. 1,280,046, 3,145,005 AND OTHERS.

NO CLAIM IS MADE TO THE EXCLUSIVE RIGHT TO USE "ALL PROFITS TO CHARITY", APART FROM THE MARK AS SHOWN.

THE NAME "NEWMAN" AND THE PORTRAIT OF PAUL NEWMAN DO NOT IDENTIFY A LIVING INDIVIDUAL.

THE MARK CONSISTS OF THE WORDS "NEWMAN'S OWN ALL PROFITS TO CHARITY" WITHIN A SOMBRERO HAT ON TOP OF AN ARTISTIC RENDERING OF THE FACE OF PAUL NEWMAN WITH A MUSTACHE.

FOR SALSA (U.S. CL. 46).

FIRST USE 6-30-1993; IN COMMERCE 6-30-1993.
LINDA M. KING, EXAMINING ATTORNEY

SN 85-287,832. MARGARITAVILLE ENTERPRISES, LLC, PALM BEACH, FL. FILED 4-6-2011.

MARGARITAVILLE

THE MARK CONSISTS OF STANDARD CHARACTERS WITHOUT CLAIM TO ANY PARTICULAR FONT, STYLE, SIZE, OR COLOR.

OWNER OF U.S. REG. NOS. 3,002,011, 3,879,759 AND OTHERS.

FOR WHOLE BEAN COFFEE AND GROUND COFFEE (U.S. CL. 46).

DAVID COLLIER, EXAMINING ATTORNEY

SN 85-300,702. SUGAR FOODS CORPORATION, NEW YORK, NY. FILED 4-21-2011.

THE BETTER SALSA

THE MARK CONSISTS OF STANDARD CHARACTERS WITHOUT CLAIM TO ANY PARTICULAR FONT, STYLE, SIZE, OR COLOR.

NO CLAIM IS MADE TO THE EXCLUSIVE RIGHT TO USE "SALSA", APART FROM THE MARK AS SHOWN.

FOR SALSA (U.S. CL. 46).

DANNEAN HETZEL, EXAMINING ATTORNEY

CLASS 30—(Continued).

SN 85-300,914. GRUMA CORPORATION, IRVING, TX. FILED 4-21-2011.

DOGARITO

THE MARK CONSISTS OF STANDARD CHARACTERS WITHOUT CLAIM TO ANY PARTICULAR FONT, STYLE, SIZE, OR COLOR.

FOR TORTILLAS; TORTILLA PRODUCTS, NAMELY, WRAPS (U.S. CL. 46).

WILLIAM P. SHANAHAN, EXAMINING ATTORNEY

SN 85-311,054. WM. WRIGLEY JR. COMPANY, CHICAGO, IL. FILED 5-3-2011.

JUICY TROPICAL

THE MARK CONSISTS OF STANDARD CHARACTERS WITHOUT CLAIM TO ANY PARTICULAR FONT, STYLE, SIZE, OR COLOR.

OWNER OF U.S. REG. NOS. 105,032, 2,836,550 AND OTHERS.

FOR CHEWING GUM (U.S. CL. 46).

ANNE E. GUSTASON, EXAMINING ATTORNEY

CLASS 31—NATURAL AGRICULTURAL PRODUCTS

SN 77-696,465. MASTRONARDI PRODUCE LTD., SANTA BARBARA, CA. FILED 3-22-2009.

THE LITTLE FRENCH TOMATO COMPANY

THE MARK CONSISTS OF STANDARD CHARACTERS WITHOUT CLAIM TO ANY PARTICULAR FONT, STYLE, SIZE, OR COLOR.

PRIORITY CLAIMED UNDER SEC. 44(D) ON CANADA APPLICATION NO. 1430616, FILED 3-11-2009, REG. NO. TMA798091, DATED 5-20-2011, EXPIRES 5-20-2026.

NO CLAIM IS MADE TO THE EXCLUSIVE RIGHT TO USE "FRENCH TOMATO COMPANY", APART FROM THE MARK AS SHOWN.

FOR RAW AND UNPROCESSED VEGETABLES; FRESH, RAW AND UNPROCESSED HYDROPONIC VEGETABLES; FRESH VEGETABLES; FRESH TOMATOES; RAW TOMATOES; UNPROCESSED TOMATOES (U.S. CLS. 1 AND 46).

FIRST USE 4-30-2009; IN COMMERCE 4-30-2009.

CHRIS WELLS, EXAMINING ATTORNEY

CLASS 31—(Continued).

SN 77-866,331. SCOTT CAMERON AND JANNICE LAI A PARTNERSHIP ALSO DOING BUSINESS AS FRENCH COLONY FARMS, DBA FRENCH COLONY FARMS, BURNABY, BC, CANADA, FILED 11-5-2009.

MESCLUN 21

THE MARK CONSISTS OF STANDARD CHARACTERS WITHOUT CLAIM TO ANY PARTICULAR FONT, STYLE, SIZE, OR COLOR.

PRIORITY CLAIMED UNDER SEC. 44(D) ON CANADA APPLICATION NO. 1437086, FILED 5-5-2009, REG. NO. TMA774,382, DATED 8-12-2010, EXPIRES 8-12-2025.

NO CLAIM IS MADE TO THE EXCLUSIVE RIGHT TO USE "MESCLUN", APART FROM THE MARK AS SHOWN. FOR FRESH FRUIT AND VEGETABLES (U.S. CLS. 1 AND 46).

RAUL CORDOVA, EXAMINING ATTORNEY

CLASS 31—(Continued).

SN 85-012,729. DEL MONTE CORPORATION, SAN FRANCISCO, CA. FILED 4-13-2010.



OWNER OF U.S. REG. NOS. 2,770,488 AND 2,833,430. THE STIPPLING IS A FEATURE OF THE MARK AND DOES NOT INDICATE COLOR.

THE MARK CONSISTS OF THE CONFIGURATION OF A PET FOOD PRODUCT IN A THREE-DIMENSIONAL FORM WHICH HAS TWO BANDS THAT ARE TWISTED TOGETHER.

SEC. 2(F).

FOR PET FOOD (U.S. CLS. 1 AND 46).

FIRST USE 4-30-2001; IN COMMERCE 4-30-2001.

TRACY CROSS, EXAMINING ATTORNEY

SN 85-075,923. ERASMO SERNA, SAN ANTONIO, TX. FILED 7-1-2010.

SN 78-942,678. MASTRONARDI PRODUCE LTD., SANTA BARBARA, CA. FILED 8-1-2006.

SERIOUSLY SWEET TOMATOES

THE MARK CONSISTS OF STANDARD CHARACTERS WITHOUT CLAIM TO ANY PARTICULAR FONT, STYLE, SIZE, OR COLOR.

PRIORITY CLAIMED UNDER SEC. 44(D) ON CANADA APPLICATION NO. 1308946, FILED 7-13-2006, REG. NO. TMA798339, DATED 5-25-2011, EXPIRES 5-25-2026.

NO CLAIM IS MADE TO THE EXCLUSIVE RIGHT TO USE "SERIOUSLY SWEET TOMATOES", APART FROM THE MARK AS SHOWN.

FOR FRESH TOMATOES; RAW TOMATOES; UNPROCESSED TOMATOES (U.S. CLS. 1 AND 46).

FIRST USE 3-31-2006; IN COMMERCE 3-31-2006.

PATRICIA EVANKO, EXAMINING ATTORNEY



NO CLAIM IS MADE TO THE EXCLUSIVE RIGHT TO USE "APPETIZER GOURMET PET FOOD SPRITZER", "DINNER LUNCH BREAKFAST" AND "DRY DOG FOOD", APART FROM THE MARK AS SHOWN.

THE MARK CONSISTS OF THE WORDS "A-PET-TIZER GOURMET PET FOOD SPRITZER" WHICH IS BEING SPRAYED IN THE AIR ENCLOSED BY A CLOUD BY A DOG WHO IS HOLDING ONTO A FLAG POLE AND STANDING ON THREE DOG BOWLS THAT SAY: "DINNER", "LUNCH", AND "BREAKFAST". THE SECOND DOG IS POURING OUT THE DOG FOOD FROM A BAG LABELED "DRY DOG FOOD" ONTO THE GROUND. THE DOGHOUSE IS IN THE BACKGROUND.

FOR DOG FOOD; PET FOOD (U.S. CLS. 1 AND 46).

FIRST USE 4-30-2010; IN COMMERCE 4-30-2010.

EMILY CHUO, EXAMINING ATTORNEY

CLASS 31—(Continued).

SN 85-117,600. PETROL INC., CORNELIUS, NC. FILED 8-27-2010.

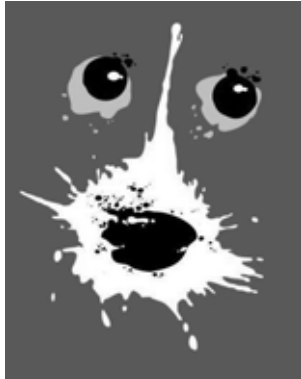

THE MARK CONSISTS OF A GRAPHIC ILLUSTRATING PORTIONS OF A DOG'S FACE INCLUDING THE DOG'S EYES AND NOSE AGAINST A SOLID BACKGROUND. FOR PET BEVERAGES (U.S. CLS. 1 AND 46). FIRST USE 12-1-2009; IN COMMERCE 12-1-2009. JANICE KIM, EXAMINING ATTORNEY

CLASS 31—(Continued).

SN 85-144,060. SY KATZ PRODUCE, INC., BOONE, NC. FILED 10-4-2010.



NO CLAIM IS MADE TO THE EXCLUSIVE RIGHT TO USE "SOUTHERN" AND "PRODUCE, INC" AND "BOONE, NORTH CAROLINA", APART FROM THE MARK AS SHOWN.

THE MARK CONSISTS OF A STAR AND SUNSET DEVICE WITH THE WORDING "SOUTHERN STAR" ABOVE THE STAR.

FOR FRESH FRUITS AND VEGETABLES, EXCLUDING ARTICHOKES (U.S. CLS. 1 AND 46).

FIRST USE 1-1-1995; IN COMMERCE 1-1-1995. JAY FLOWERS, EXAMINING ATTORNEY

SN 85-194,410. HORTECH, INC., SPRING LAKE, MI. FILED 12-9-2010.

BLUE BLUSH

THE MARK CONSISTS OF STANDARD CHARACTERS WITHOUT CLAIM TO ANY PARTICULAR FONT, STYLE, SIZE, OR COLOR.

FOR LIVING PLANTS, NAMELY, PLANTS OF THE SEDUM VARIETY (U.S. CLS. 1 AND 46).

FIRST USE 12-5-2010; IN COMMERCE 12-5-2010. SANI KHOURI, EXAMINING ATTORNEY

SN 85-118,918. THE HIGGINS GROUP CORP., MIAMI, FL. FILED 8-30-2010.

SPICE MARKET

THE MARK CONSISTS OF STANDARD CHARACTERS WITHOUT CLAIM TO ANY PARTICULAR FONT, STYLE, SIZE, OR COLOR.

NO CLAIM IS MADE TO THE EXCLUSIVE RIGHT TO USE "SPICE", APART FROM THE MARK AS SHOWN.

FOR PET FOOD, NAMELY, BIRD FOOD (U.S. CLS. 1 AND 46).

FIRST USE 8-6-2010; IN COMMERCE 8-6-2010. TRACY WHITTAKER-BROWN, EXAMINING ATTORNEY

SN 85-194,425. HORTECH, INC., SPRING LAKE, MI. FILED 12-9-2010.

BLUE DAWN

THE MARK CONSISTS OF STANDARD CHARACTERS WITHOUT CLAIM TO ANY PARTICULAR FONT, STYLE, SIZE, OR COLOR.

FOR LIVING PLANTS, NAMELY, PLANTS OF THE SEDUM VARIETY (U.S. CLS. 1 AND 46).

FIRST USE 12-5-2010; IN COMMERCE 12-5-2010. SANI KHOURI, EXAMINING ATTORNEY

CLASS 31—(Continued).

SN 85-194,434. HORTECH, INC., SPRING LAKE, MI. FILED
12-9-2010.

BLUE MAGIC

THE MARK CONSISTS OF STANDARD CHARACTERS
WITHOUT CLAIM TO ANY PARTICULAR FONT, STYLE,
SIZE, OR COLOR.

FOR LIVING PLANTS, NAMELY, PLANTS OF THE
SEDUM VARIETY (U.S. CLS. 1 AND 46).

FIRST USE 12-5-2010; IN COMMERCE 12-5-2010.
SANI KHOURI, EXAMINING ATTORNEY

SN 85-194,467. HORTECH, INC., SPRING LAKE, MI. FILED
12-9-2010.

SEDUM REFLEXUM DARK SPRUCE

THE MARK CONSISTS OF STANDARD CHARACTERS
WITHOUT CLAIM TO ANY PARTICULAR FONT, STYLE,
SIZE, OR COLOR.

NO CLAIM IS MADE TO THE EXCLUSIVE RIGHT TO
USE "SEDUM REFLEXUM", APART FROM THE MARK AS
SHOWN.

FOR LIVING PLANTS, NAMELY, PLANTS OF THE
SEDUM VARIETY (U.S. CLS. 1 AND 46).

FIRST USE 12-5-2010; IN COMMERCE 12-5-2010.
SANI KHOURI, EXAMINING ATTORNEY

SN 85-194,847. HORTECH, INC., SPRING LAKE, MI. FILED
12-10-2010.

SEDUM REFLEXUM GREEN SPRUCE

THE MARK CONSISTS OF STANDARD CHARACTERS
WITHOUT CLAIM TO ANY PARTICULAR FONT, STYLE,
SIZE, OR COLOR.

NO CLAIM IS MADE TO THE EXCLUSIVE RIGHT TO
USE "SEDUM REFLEXUM GREEN", APART FROM THE
MARK AS SHOWN.

FOR LIVING PLANTS, NAMELY, PLANTS OF THE
SEDUM VARIETY (U.S. CLS. 1 AND 46).

FIRST USE 12-5-2010; IN COMMERCE 12-5-2010.
SANI KHOURI, EXAMINING ATTORNEY

CLASS 31—(Continued).

SN 85-194,854. HORTECH, INC., SPRING LAKE, MI. FILED
12-10-2010.

SEDUM REFLEXUM GREEN TWIST

THE MARK CONSISTS OF STANDARD CHARACTERS
WITHOUT CLAIM TO ANY PARTICULAR FONT, STYLE,
SIZE, OR COLOR.

NO CLAIM IS MADE TO THE EXCLUSIVE RIGHT TO
USE "SEDUM REFLEXUM GREEN", APART FROM THE
MARK AS SHOWN.

FOR LIVING PLANTS, NAMELY, PLANTS OF THE
SEDUM VARIETY (U.S. CLS. 1 AND 46).

FIRST USE 12-5-2010; IN COMMERCE 12-5-2010.
SANI KHOURI, EXAMINING ATTORNEY

SN 85-194,875. HORTECH, INC., SPRING LAKE, MI. FILED
12-10-2010.

LIME TWIST

THE MARK CONSISTS OF STANDARD CHARACTERS
WITHOUT CLAIM TO ANY PARTICULAR FONT, STYLE,
SIZE, OR COLOR.

NO CLAIM IS MADE TO THE EXCLUSIVE RIGHT TO
USE "LIME", APART FROM THE MARK AS SHOWN.

FOR LIVING PLANTS, NAMELY, PLANTS OF THE
SEDUM VARIETY (U.S. CLS. 1 AND 46).

FIRST USE 12-5-2010; IN COMMERCE 12-5-2010.
SANI KHOURI, EXAMINING ATTORNEY

SN 85-217,268. SUN GRO HORTICULTURE CANADA LTD.,
SEBA BEACH, CANADA, FILED 1-13-2011.

TerraSoft

THE MARK CONSISTS OF STANDARD CHARACTERS
WITHOUT CLAIM TO ANY PARTICULAR FONT, STYLE,
SIZE, OR COLOR.

FOR FARM STALL BEDDING, HORSE BEDDING
AND PET BEDDING MADE OF PEAT (U.S. CLS. 1
AND 46).

JAMES GRIFFIN, EXAMINING ATTORNEY

CLASS 31—(Continued).

SN 85-229,625. PMS SOLUTIONS, LLC, NEWPORT NEWS, VA. FILED 1-30-2011.



NO CLAIM IS MADE TO THE EXCLUSIVE RIGHT TO USE THE UNIVERSAL PROHIBITION SYMBOL, APART FROM THE MARK AS SHOWN.

THE COLOR(S) BLACK AND RED IS/ARE CLAIMED AS A FEATURE OF THE MARK.

THE MARK CONSISTS OF A BLACK FOOTPRINT SURROUNDED BY A RED CIRCLE WITH A SLASH THROUGH IT. THE COLOR WHITE REPRESENTS BACKGROUND, OUTLINING, SHADING AND/OR TRANSPARENT AREAS AND IS NOT PART OF THE MARK.

FOR PINE SEEDS (U.S. CLS. 1 AND 46).
FIRST USE 1-23-2011; IN COMMERCE 1-23-2011.
MATTHEW PAPPAS, EXAMINING ATTORNEY

SN 85-237,791. WESTERN WONDER, LLC, SANTA FE, NM. FILED 2-9-2011.

WESTERN WONDER

THE MARK CONSISTS OF STANDARD CHARACTERS WITHOUT CLAIM TO ANY PARTICULAR FONT, STYLE, SIZE, OR COLOR.

FOR SOWING SEEDS (U.S. CLS. 1 AND 46).
FIRST USE 11-20-2010; IN COMMERCE 11-20-2010.
NAPOLEON SHARMA, EXAMINING ATTORNEY

SN 85-237,989. AMERINOVA PROPERTIES, LLC, BONSALE, CA. FILED 2-9-2011.

ROCKETTE

THE MARK CONSISTS OF STANDARD CHARACTERS WITHOUT CLAIM TO ANY PARTICULAR FONT, STYLE, SIZE, OR COLOR.

FOR LIVE PLANTS (U.S. CLS. 1 AND 46).
NICHOLAS ALTREE, EXAMINING ATTORNEY

CLASS 31—(Continued).

SN 85-242,282. STEYER ENTERPRISES, LTD., TIFFIN, OH. FILED 2-15-2011.

HORIZON GENETICS

THE MARK CONSISTS OF STANDARD CHARACTERS WITHOUT CLAIM TO ANY PARTICULAR FONT, STYLE, SIZE, OR COLOR.

NO CLAIM IS MADE TO THE EXCLUSIVE RIGHT TO USE "GENETICS", APART FROM THE MARK AS SHOWN. FOR AGRICULTURAL SEEDS (U.S. CLS. 1 AND 46).
FIRST USE 0-0-2000; IN COMMERCE 0-0-2000.
JAY FLOWERS, EXAMINING ATTORNEY

SN 85-247,751. HAITAI, INC., MONTEBELLO, CA. FILED 2-21-2011.

HAETAE

THE MARK CONSISTS OF STANDARD CHARACTERS WITHOUT CLAIM TO ANY PARTICULAR FONT, STYLE, SIZE, OR COLOR.

THE ENGLISH TRANSLATION OF "HAETAE" IN THE MARK IS "SLOKE".

FOR UNPROCESSED GRAINS, NAMELY, BARLEY; UNPROCESSED BEANS; UNPROCESSED RED BEANS; AND FRESH PEAS (U.S. CLS. 1 AND 46).
FIRST USE 1-15-2009; IN COMMERCE 1-15-2009.
MEGHAN REINHART, EXAMINING ATTORNEY

SN 85-247,764. LOFFREDO GARDENS, INC., DBA LOFFREDO FRESH PRODUCE CO., INC., DES MOINES, IA. FILED 2-21-2011.

Hwy 28 Farms

THE MARK CONSISTS OF STANDARD CHARACTERS WITHOUT CLAIM TO ANY PARTICULAR FONT, STYLE, SIZE, OR COLOR.

NO CLAIM IS MADE TO THE EXCLUSIVE RIGHT TO USE "FARMS", APART FROM THE MARK AS SHOWN.

FOR FRESH-CUT FRUITS AND VEGETABLES (U.S. CLS. 1 AND 46).
BRENDAN REGAN, EXAMINING ATTORNEY

CLASS 31—(Continued).

SN 85-248,555. MOONLIGHT PACKING CORPORATION, REEDLEY, CA. FILED 2-22-2011.

CHANGING THE WORLD, ONE
FRUIT AT A TIME...

THE MARK CONSISTS OF STANDARD CHARACTERS WITHOUT CLAIM TO ANY PARTICULAR FONT, STYLE, SIZE, OR COLOR.

FOR FRESH FRUIT (U.S. CLS. 1 AND 46).
ARETHA SOMERVILLE, EXAMINING ATTORNEY

SN 85-249,133. PERFORMANCE PET PRODUCTS, LLC, FAIRMONT, MN. FILED 2-23-2011.

SPRING NATURALS

THE MARK CONSISTS OF STANDARD CHARACTERS WITHOUT CLAIM TO ANY PARTICULAR FONT, STYLE, SIZE, OR COLOR.

NO CLAIM IS MADE TO THE EXCLUSIVE RIGHT TO USE "NATURALS", APART FROM THE MARK AS SHOWN. FOR PET FOOD; PET TREATS (U.S. CLS. 1 AND 46).
MICHAEL SOUDERS, EXAMINING ATTORNEY

SN 85-249,351. MANN PACKING CO., INC., SALINAS, CA. FILED 2-23-2011.

MANN'S ARCADIAN HARVEST

THE MARK CONSISTS OF STANDARD CHARACTERS WITHOUT CLAIM TO ANY PARTICULAR FONT, STYLE, SIZE, OR COLOR.

OWNER OF U.S. REG. NOS. 987,992, 1,733,413 AND 2,019,037.

FOR FRESH VEGETABLES, NAMELY, LETTUCE (U.S. CLS. 1 AND 46).

KATHY DE JONGE, EXAMINING ATTORNEY

CLASS 31—(Continued).

SN 85-250,325. JAMES GREENHOUSES, COLBERT, GA. FILED 2-24-2011.

POTLUCK

THE MARK CONSISTS OF STANDARD CHARACTERS WITHOUT CLAIM TO ANY PARTICULAR FONT, STYLE, SIZE, OR COLOR.

FOR LIVE ANNUAL FLOWER PLANTS; LIVE FLOWERING PLANTS; LIVE PLANTS; LIVE PLANTS, NAMELY, DAYLILIES, ORNAMENTAL GRASSES, FLOWERING SHRUBS, VEGETABLE PLANTS AND PERENNIALS; LIVE SHRUBS; LIVING PLANTS; NATURAL PLANTS AND FLOWERS; SHRUBS (U.S. CLS. 1 AND 46).

MATTHEW MCDOWELL, EXAMINING ATTORNEY

SN 85-252,297. SHEFFIELD, SHEILA, LOCKE, NY. FILED 2-25-2011.



NO CLAIM IS MADE TO THE EXCLUSIVE RIGHT TO USE "TREE" AND "INC.", APART FROM THE MARK AS SHOWN.

THE MARK CONSISTS OF A DESIGN OF A TREE TO THE RIGHT OF WHICH IS LOCATED THE WORDING "TREE" BELOW BOTH OF WHICH IS LOCATED THE WORDING "BEGINNINGS" BELOW WHICH IS LOCATED THE WORDING "INC."

FOR PLANT SEEDS AND AGRICULTURAL SEEDS (U.S. CLS. 1 AND 46).

FIRST USE 11-1-1992; IN COMMERCE 1-1-1993.

NAPOLEON SHARMA, EXAMINING ATTORNEY

SN 85-253,443. SUPERNATURALS GRAFTED VEGETABLES LLC, VISTA, CA. FILED 2-28-2011.

MIGHTY 'MATO

THE MARK CONSISTS OF STANDARD CHARACTERS WITHOUT CLAIM TO ANY PARTICULAR FONT, STYLE, SIZE, OR COLOR.

FOR LIVE PLANTS, NAMELY GRAFTED VEGETABLE PLANTS (U.S. CLS. 1 AND 46).

JULIE VEPPUMTHARA, EXAMINING ATTORNEY

CLASS 31—(Continued).

SN 85-254,566. BLUEBIRD GRAIN FARMS LLC, WINTHROP, WA. FILED 3-1-2011.

EINKA

THE MARK CONSISTS OF STANDARD CHARACTERS WITHOUT CLAIM TO ANY PARTICULAR FONT, STYLE, SIZE, OR COLOR.

FOR UNPROCESSED CEREAL GRAIN, NAMELY, EINKORN BEING TRITICUM MONOCOCCUM (U.S. CLS. 1 AND 46).

DANIEL CAPSHAW, EXAMINING ATTORNEY

CLASS 31—(Continued).

SN 85-256,313. SHELLINGTON, JAMIE, HATBORO, PA. AND WARD, KRISTEN, HATBORO, PA. FILED 3-2-2011.

CremePups

THE MARK CONSISTS OF STANDARD CHARACTERS WITHOUT CLAIM TO ANY PARTICULAR FONT, STYLE, SIZE, OR COLOR.

FOR FROZEN TREATS FOR DOGS SOLD IN A VARIETY OF FLAVORS (U.S. CLS. 1 AND 46).

RONALD MCMORROW, EXAMINING ATTORNEY

SN 85-254,742. BLUEBIRD GRAIN FARMS LLC, WINTHROP, WA. FILED 3-1-2011.



THE COLOR(S) BLUE, BLACK, WHITE AND YELLOW-BROWN IS/ARE CLAIMED AS A FEATURE OF THE MARK.

THE MARK CONSISTS OF A BLUE BIRD WITH BLACK AND WHITE DETAILS PERCHED ON A BLACK WHEAT STALK AGAINST A YELLOW-BROWN SQUARE BACKGROUND WITH A BLACK BORDER.

FOR UNPROCESSED GRAINS FOR EATING (U.S. CLS. 1 AND 46).

FIRST USE 2-2-2006; IN COMMERCE 2-2-2006.
DANIEL CAPSHAW, EXAMINING ATTORNEY

SN 85-256,555. CHURCH & DWIGHT CO., INC., PRINCETON, NJ. FILED 3-3-2011.

ULTRA LAST

THE MARK CONSISTS OF STANDARD CHARACTERS WITHOUT CLAIM TO ANY PARTICULAR FONT, STYLE, SIZE, OR COLOR.

FOR CAT LITTER (U.S. CLS. 1 AND 46).
ANGELA DUONG, EXAMINING ATTORNEY

SN 85-256,977. C7 GLOBAL, LLC, SAN JUAN, PUERTO RICO, FILED 3-3-2011.



NO CLAIM IS MADE TO THE EXCLUSIVE RIGHT TO USE "DOG", APART FROM THE MARK AS SHOWN.

THE COLOR(S) BLACK, TWO SHADES OF BLUE, AND WHITE IS/ARE CLAIMED AS A FEATURE OF THE MARK.

THE MARK CONSISTS OF THE WORD "DOG CAN" IN WHITE AND BLACK AND OUTLINED IN BLUE, WITH A SHADED BLUE CIRCLE BEHIND AND FOUR ARCHED BLUE DOTS ABOVE.

FOR DOG FOOD; FOOD FOR ANIMALS (U.S. CLS. 1 AND 46).

FIRST USE 3-1-2011; IN COMMERCE 3-1-2011.
VIVIAN MICZNIK FIRST, EXAMINING ATTORNEY

SN 85-255,323. COLUMBIA SEEDS, LLC, CORVALLIS, OR. FILED 3-2-2011.

defender

THE MARK CONSISTS OF STANDARD CHARACTERS WITHOUT CLAIM TO ANY PARTICULAR FONT, STYLE, SIZE, OR COLOR.

FOR GRASS SEEDS (U.S. CLS. 1 AND 46).
FIRST USE 2-1-2006; IN COMMERCE 2-1-2006.
JASON TURNER, EXAMINING ATTORNEY

CLASS 31—(Continued).

SN 85-257,815. SMITH BROS., INC., MEDINA, OH. FILED 3-4-2011.

TIMBER RIDGE

THE MARK CONSISTS OF STANDARD CHARACTERS WITHOUT CLAIM TO ANY PARTICULAR FONT, STYLE, SIZE, OR COLOR.
FOR MULCH (U.S. CLS. 1 AND 46).
RENEE MCCRAY, EXAMINING ATTORNEY

SN 85-269,420. KAPLAN, JEFFREY, FORT LAUDERDALE, FL. FILED 3-17-2011.

PUSS' N BOOTS

THE MARK CONSISTS OF STANDARD CHARACTERS WITHOUT CLAIM TO ANY PARTICULAR FONT, STYLE, SIZE, OR COLOR.
FOR CAT FOOD (U.S. CLS. 1 AND 46).
JORDAN BAKER, EXAMINING ATTORNEY

SN 85-275,099. NATURAL PACK, INC., SANTA BARBARA, CA. FILED 3-23-2011.

PROFAUNA

THE MARK CONSISTS OF STANDARD CHARACTERS WITHOUT CLAIM TO ANY PARTICULAR FONT, STYLE, SIZE, OR COLOR.

FOR VEGETABLE FIBERS, AGRICULTURAL MATERIAL OR BYPRODUCTS, NAMELY, COCONUT FIBER, SPHAGNUM AND OTHER MOSSES, KAPOK FIBER, COTTON FIBER, SEED HUSK, NUT SHELLS, CORN COB, TO BE USED AS ANIMAL, LIVESTOCK AND PET BEDDING AND AS NESTING MATERIAL FOR SMALL ANIMALS AND PETS; LITTER FOR DOMESTIC ANIMALS (U.S. CLS. 1 AND 46).

FIRST USE 12-27-2009; IN COMMERCE 12-27-2009.
CHRIS WELLS, EXAMINING ATTORNEY

CLASS 32—LIGHT BEVERAGES

SN 76-702,244. MENDEZ, ALBERT, NEW VERNON, NJ. FILED 3-26-2010.



NO CLAIM IS MADE TO THE EXCLUSIVE RIGHT TO USE "FRUIT JUICE", APART FROM THE MARK AS SHOWN.

THE MARK CONSISTS OF THE WORDING "JOGI FRUIT JUICE", WITH THE LETTER "O" IN "JOGI" REPRESENTED BY AN APPLE. THE WORDS "FRUIT JUICE" APPEAR UNDER THE LETTER "JO" IN "JOGI". THE WORDING AND APPLE DESIGN APPEAR ABOVE A CURVED LINE. THE WORDING "JOGI" HAS NO MEANING IN A FOREIGN LANGUAGE.

FOR FRUIT JUICES AND NECTARS (U.S. CLS. 45, 46 AND 48).

FONG HSU, EXAMINING ATTORNEY

SN 77-782,544. HANSEN BEVERAGE COMPANY, CORONA, CA. FILED 7-16-2009.

HAMMER M X-PRESSO MONSTER

THE MARK CONSISTS OF STANDARD CHARACTERS WITHOUT CLAIM TO ANY PARTICULAR FONT, STYLE, SIZE, OR COLOR.

OWNER OF U.S. REG. NOS. 3,044,314, 3,044,315 AND 3,057,061.

NO CLAIM IS MADE TO THE EXCLUSIVE RIGHT TO USE "ESPRESSO", APART FROM THE MARK AS SHOWN.

FOR NON-ALCOHOLIC BEVERAGES, NAMELY, ENERGY DRINKS FLAVORED WITH COFFEE AND ENHANCED WITH VITAMINS, MINERALS, NUTRIENTS, AMINO ACIDS AND/OR HERBS, EXCLUDING PERISHABLE BEVERAGE PRODUCTS THAT CONTAIN FRUIT JUICE OR SOY (U.S. CLS. 45, 46 AND 48).

FIRST USE 6-26-2009; IN COMMERCE 6-26-2009.
TINA BROWN, EXAMINING ATTORNEY

CLASS 32—(Continued).

SN 77-840,855. MELLOW BEVERAGE CO., LLC, ASPEN, CO. FILED 10-3-2009.

MELLOW

THE MARK CONSISTS OF STANDARD CHARACTERS WITHOUT CLAIM TO ANY PARTICULAR FONT, STYLE, SIZE, OR COLOR.

OWNER OF U.S. REG. NO. 3,757,909.
FOR FLAVORED WATERS; FRUIT JUICES AND FRUIT DRINKS; MIXED FRUIT JUICE (U.S. CLS. 45, 46 AND 48).

FIRST USE 8-14-2009; IN COMMERCE 8-14-2009.
ELIZABETH HUGHITT, EXAMINING ATTORNEY



SN 77-877,099. KO-OH-LA, WILMINGTON, NC. FILED 11-20-2009.

KO-OH-LA

THE MARK CONSISTS OF STANDARD CHARACTERS WITHOUT CLAIM TO ANY PARTICULAR FONT, STYLE, SIZE, OR COLOR.

FOR NON-ALCOHOLIC BEVERAGES NAMELY CARBONATED BEVERAGES (U.S. CLS. 45, 46 AND 48).
BRIAN CALLAGHAN, EXAMINING ATTORNEY



SN 78-461,598. VIFILFELL HF, REYKJAVIK, ICELAND, FILED 8-4-2004.

Vífilfell Viking

THE MARK CONSISTS OF STANDARD CHARACTERS WITHOUT CLAIM TO ANY PARTICULAR FONT, STYLE, SIZE, OR COLOR.

FOR BEER (U.S. CLS. 45, 46 AND 48).
STEVEN JACKSON, EXAMINING ATTORNEY

CLASS 32—(Continued).

SN 79-058,185. BROUWERIJ VAN HONSEBROUCK, BESLOTEN VENNOOTSCHAP; MET; BEPERKTE AANSPRAKELIJKHEID, B-8770 INGELMUNSTER, BELGIUM, FILED 8-7-2008.

KASTEEL

THE MARK CONSISTS OF STANDARD CHARACTERS WITHOUT CLAIM TO ANY PARTICULAR FONT, STYLE, SIZE, OR COLOR.

PRIORITY DATE OF 3-5-2008 IS CLAIMED.
OWNER OF INTERNATIONAL REGISTRATION 0975634 DATED 8-7-2008, EXPIRES 8-7-2018.

THE ENGLISH TRANSLATION OF "KASTEEL" IN THE MARK IS "CASTLE".

FOR BEERS, ALES (U.S. CLS. 45, 46 AND 48).
ALLISON HOLTZ, EXAMINING ATTORNEY



SN 79-058,186. BROUWERIJ VAN HONSEBROUCK, BESLOTEN VENNOOTSCHAP; MET; BEPERKTE AANSPRAKELIJKHEID, B-8770 INGELMUNSTER, BELGIUM, FILED 8-7-2008.



PRIORITY DATE OF 3-5-2008 IS CLAIMED.
OWNER OF INTERNATIONAL REGISTRATION 0975635 DATED 8-7-2008, EXPIRES 8-7-2018.

THE MARK CONSISTS OF THE WORD "KASTEEL" SUPERIMPOSED ON A BANNER DESIGN.

THE ENGLISH TRANSLATION OF "KASTEEL" IN THE MARK IS "CASTLE".

FOR BEERS, ALES (U.S. CLS. 45, 46 AND 48).
ALLISON HOLTZ, EXAMINING ATTORNEY

CLASS 32—(Continued).

SN 85-093,971. HANSEN BEVERAGE COMPANY, CORONA, CA. FILED 7-27-2010.



THE MARK CONSISTS OF A CLAW FORMING A HIGHLY STYLIZED LETTER "M", WITH A SUPERScript NUMERAL "3" TO THE RIGHT.

FOR NON-ALCOHOLIC BEVERAGES, NAMELY, CARBONATED ENERGY DRINKS AND SPORTS DRINKS (U.S. CLS. 45, 46 AND 48).

LEIGH LOWRY, EXAMINING ATTORNEY

SN 85-097,314. THE R.S. LIPMAN COMPANY, NASHVILLE, TN. FILED 7-30-2010.

Hap & Harry's

THE MARK CONSISTS OF STANDARD CHARACTERS WITHOUT CLAIM TO ANY PARTICULAR FONT, STYLE, SIZE, OR COLOR.

FOR BEER (U.S. CLS. 45, 46 AND 48).

JEFFREY LOOK, EXAMINING ATTORNEY

SN 85-107,563. BIG ROCK BREWERY LIMITED PARTNER-SHIP, CALGARY, ALBERTA, CANADA, FILED 8-13-2010.

GOPHER

THE MARK CONSISTS OF STANDARD CHARACTERS WITHOUT CLAIM TO ANY PARTICULAR FONT, STYLE, SIZE, OR COLOR.

PRIORITY CLAIMED UNDER SEC. 44(D) ON CANADA APPLICATION NO. 1469835, FILED 2-17-2010, REG. NO. TMA785443, DATED 12-20-2010, EXPIRES 12-20-2025.

FOR BREWED ALCOHOLIC BEVERAGES, NAMELY, BEER (U.S. CLS. 45, 46 AND 48).

DAVID I, EXAMINING ATTORNEY

CLASS 32—(Continued).

SN 85-108,756. VERNON STUBER, GUEMLIGEN, SWITZERLAND, FILED 8-16-2010.

CRIKEY

THE MARK CONSISTS OF STANDARD CHARACTERS WITHOUT CLAIM TO ANY PARTICULAR FONT, STYLE, SIZE, OR COLOR.

FOR ALCOHOL-FREE BEERS; BEER; BEER, ALE AND LAGER; BEER, ALE, LAGER, STOUT AND PORTER; BEER-BASED COOLERS; BEERS (U.S. CLS. 45, 46 AND 48).

DAVID I, EXAMINING ATTORNEY

SN 85-111,936. AGB TAPOUT LLC, TORONTO, ONTARIO, FILED 8-20-2010.

STAY IN THE FIGHT

THE MARK CONSISTS OF STANDARD CHARACTERS WITHOUT CLAIM TO ANY PARTICULAR FONT, STYLE, SIZE, OR COLOR.

FOR ENERGY DRINKS; SPORTS DRINKS, NAMELY, ENERGY DRINKS (U.S. CLS. 45, 46 AND 48).

TINA MAI, EXAMINING ATTORNEY

SN 85-121,529. CITRUS WORLD, INC., LAKE WALES, FL. FILED 9-2-2010.

FLORIDA'S NATURAL VINTAGE

THE MARK CONSISTS OF STANDARD CHARACTERS WITHOUT CLAIM TO ANY PARTICULAR FONT, STYLE, SIZE, OR COLOR.

OWNER OF U.S. REG. NOS. 1,745,985, 3,101,253 AND OTHERS.

SEC. 2(F) AS TO "FLORIDA'S NATURAL".

FOR FRUIT DRINKS AND FRUIT JUICES (U.S. CLS. 45, 46 AND 48).

ALLISON SCHRODY, EXAMINING ATTORNEY

CLASS 32—(Continued).

SN 85-124,502. KRATECH INC, PORT CHARLOTTE, FL.
FILED 9-7-2010.

COCO BUZZ

THE MARK CONSISTS OF STANDARD CHARACTERS WITHOUT CLAIM TO ANY PARTICULAR FONT, STYLE, SIZE, OR COLOR.

NO CLAIM IS MADE TO THE EXCLUSIVE RIGHT TO USE "COCO", APART FROM THE MARK AS SHOWN.

FOR NON ALCOHOLIC BEVERAGES, NAMELY, COCONUT-BASED NON ALCOHOLIC BEVERAGES (U.S. CLS. 45, 46 AND 48).

NATALIE POLZER, EXAMINING ATTORNEY

SN 85-124,504. KRATECH INC, PORT CHARLOTTE, FL.
FILED 9-7-2010.

COCO MOCHO

THE MARK CONSISTS OF STANDARD CHARACTERS WITHOUT CLAIM TO ANY PARTICULAR FONT, STYLE, SIZE, OR COLOR.

NO CLAIM IS MADE TO THE EXCLUSIVE RIGHT TO USE "COCO", APART FROM THE MARK AS SHOWN.

FOR NON ALCOHOLIC BEVERAGES, NAMELY, COCONUT-BASED NON ALCOHOLIC BEVERAGES (U.S. CLS. 45, 46 AND 48).

NATALIE POLZER, EXAMINING ATTORNEY

SN 85-131,025. MARLOWE, GEORGE, MARINA DEL REY,
CA. FILED 9-16-2010.

**TEST TAKER...IT'S ALMOST
LIKE CHEATING**

THE MARK CONSISTS OF STANDARD CHARACTERS WITHOUT CLAIM TO ANY PARTICULAR FONT, STYLE, SIZE, OR COLOR.

FOR ENERGY DRINKS (U.S. CLS. 45, 46 AND 48).

JILL C. ALT, EXAMINING ATTORNEY

CLASS 32—(Continued).

SN 85-169,767. BIG ISLAND FOOD COMPANY LLC, HAWAII.
HI. FILED 11-4-2010.

BIG ISLAND BAMBOO

THE MARK CONSISTS OF STANDARD CHARACTERS WITHOUT CLAIM TO ANY PARTICULAR FONT, STYLE, SIZE, OR COLOR.

OWNER OF U.S. REG. NO. 3,869,674.

NO CLAIM IS MADE TO THE EXCLUSIVE RIGHT TO USE "BIG ISLAND", APART FROM THE MARK AS SHOWN.

FOR NON-ALCOHOLIC COCKTAIL MIXES (U.S. CLS. 45, 46 AND 48).

FIRST USE 5-1-2010; IN COMMERCE 5-1-2010.

CHRIS WELLS, EXAMINING ATTORNEY

SN 85-184,361. PURETECH WATERS OF AMERICA, LLC,
GLASTONBURY, CT. FILED 11-24-2010.

Whale Water

THE MARK CONSISTS OF STANDARD CHARACTERS WITHOUT CLAIM TO ANY PARTICULAR FONT, STYLE, SIZE, OR COLOR.

NO CLAIM IS MADE TO THE EXCLUSIVE RIGHT TO USE "WATER", APART FROM THE MARK AS SHOWN.

FOR DRINKING WATER; DRINKING WATER, NAMELY, BOTTLED WATER, ENERGY WATER, AND MINERAL WATER (U.S. CLS. 45, 46 AND 48).

TARA PATE, EXAMINING ATTORNEY

SN 85-192,619. DIFCOM LA CAVE DES PERES SOCIÉTÉ ANONYME A CONSEIL D'ADMINISTRATION, VILLENEUVE D'ASCQ, FRANCE, FILED 12-7-2010.



OWNER OF FRANCE REG. NO. 103793630, DATED 12-28-2010, EXPIRES 12-28-2020.

THE COLOR(S) PINK, BLACK, GOLD, WHITE, SILVER, BLUE AND LIGHT BLUE IS/ARE CLAIMED AS A FEATURE OF THE MARK.

THE MARK CONSISTS OF AN ABSTRACT DESIGN OF A

CLASS 32—(Continued).

PINK PIG OUTLINED IN BLACK DRINKING GOLD BEER WITH WHITE FOAM OUT OF A MUG OUTLINED IN BLACK ALL SITUATED DIRECTLY ABOVE A SILVER BANNER OUTLINED IN BLACK WITH THE TERM "RINCE COCHON" IN BLACK, STYLIZED LETTERING WITHIN THE BANNER. BRANCHES OF BLACK WHEAT PROTRUDE FROM THE TOP OF THE BANNER DESIGN. THE BACKGROUND IS IN BLUE NEAR THE BOTTOM PORTION OF THE MARK AND BLENDS INTO LIGHT BLUE AT THE TOP PORTION OF THE MARK. DROPLETS OF WATER ALSO APPEAR IN THE BACKGROUND. THE MARK IS CONTAINED IN A SQUARE CARRIER WITH ROUNDED EDGES.

THE ENGLISH TRANSLATION OF "RINCE COCHON" IN THE MARK IS "RINSED PIG".

FOR BEERS; MINERAL AND SPARKLING WATERS; NON-ALCOHOLIC BEVERAGES, NAMELY, CARBONATED BEVERAGES, FRUIT FLAVORED DRINKS, AND PREPARATIONS FOR MAKING SAID BEVERAGES; FRUIT DRINKS AND FRUIT JUICES; SYRUPS FOR BEVERAGES (U.S. CLS. 45, 46 AND 48).

JOHN SCHUYLER YARD, EXAMINING ATTORNEY

SN 85-241,971. VANCE CASTLEMAN, MINOT, ND. FILED 2-14-2011.

Three Forks Ale

THE MARK CONSISTS OF STANDARD CHARACTERS WITHOUT CLAIM TO ANY PARTICULAR FONT, STYLE, SIZE, OR COLOR.

NO CLAIM IS MADE TO THE EXCLUSIVE RIGHT TO USE "ALE", APART FROM THE MARK AS SHOWN.

FOR BEER, ALE, LAGER, STOUT, PORTER, SHANDY; FLAVORED BEERS (U.S. CLS. 45, 46 AND 48).

CHARISMA HAMPTON, EXAMINING ATTORNEY

SN 85-243,244. GREENBEE GLOBAL, LLC, TRABUCO CANYON, CA. FILED 2-15-2011.



THE COLOR(S) PURPLE, GREEN, BLACK IS/ARE CLAIMED AS A FEATURE OF THE MARK.

THE MARK CONSISTS OF A PURPLE RECTANGLE WITH THE STYLIZED WORDING "MAQ" IN BLACK IN THE CENTER AND SUPER IMPOSED OVER A STYLIZED GREEN NUMERAL "1" WITH A BLACK A BORDER.

FOR ENERGY DRINKS (U.S. CLS. 45, 46 AND 48).

FIRST USE 10-2-2010; IN COMMERCE 10-2-2010.

JEFF DEFORD, EXAMINING ATTORNEY

CLASS 32—(Continued).

SN 85-245,394. BLUE SKY NATURAL BEVERAGE CO., CORONA, CA. FILED 2-17-2011.

BLUE SKY RECOVER ENERGY

THE MARK CONSISTS OF STANDARD CHARACTERS WITHOUT CLAIM TO ANY PARTICULAR FONT, STYLE, SIZE, OR COLOR.

OWNER OF U.S. REG. NOS. 2,214,762, 3,053,402 AND 3,474,039.

NO CLAIM IS MADE TO THE EXCLUSIVE RIGHT TO USE "ENERGY", APART FROM THE MARK AS SHOWN.

FOR NON-ALCOHOLIC BEVERAGES WITH TEA FLAVOR, NON-ALCOHOLIC BEVERAGES WITH TEA AND LEMONADE FLAVOR, SOFT DRINKS, ENERGY DRINKS, SPORTS DRINKS, ALL ENHANCED WITH VITAMINS, MINERALS, NUTRIENT, AMINO ACIDS AND/OR HERBS (U.S. CLS. 45, 46 AND 48).

EVELYN BRADLEY, EXAMINING ATTORNEY

SN 85-245,615. ELAN FOODS INC, FRESNO, CA. FILED 2-18-2011.

MIGHTY FRESH

THE MARK CONSISTS OF STANDARD CHARACTERS WITHOUT CLAIM TO ANY PARTICULAR FONT, STYLE, SIZE, OR COLOR.

NO CLAIM IS MADE TO THE EXCLUSIVE RIGHT TO USE "FRESH", APART FROM THE MARK AS SHOWN.

FOR BEERS AND NONALCOHOLIC DRINKS, NAMELY, FRUIT JUICE, FRUIT JUICE CONCENTRATES, CARBONATED BEVERAGES, AND NON-CARBONATED BEVERAGES, NAMELY, FRUIT DRINKS (U.S. CLS. 45, 46 AND 48).

MARLENE BELL, EXAMINING ATTORNEY

SN 85-246,041. OLIVINO, LLC, WOODLAND, CA. FILED 2-18-2011.

OLIVINO

THE MARK CONSISTS OF STANDARD CHARACTERS WITHOUT CLAIM TO ANY PARTICULAR FONT, STYLE, SIZE, OR COLOR.

FOR SPORTS DRINKS; SOFT DRINKS; POWDERS USED IN PREPARATION OF SPORTS DRINKS; NON-ALCOHOLIC FRUIT BASED BEVERAGES AND VEGETABLE DRINKS (U.S. CLS. 45, 46 AND 48).

NICHOLAS ALTREE, EXAMINING ATTORNEY

CLASS 32—(Continued).

SN 85-246,064. VATAN INTERNATIONAL, ARTESIA, CA.
FILED 2-18-2011.

CLASS 32—(Continued).

SN 85-246,256. LIFESTYLE BRANDS, LLC, ATLANTA, GA.
FILED 2-18-2011.

**Cool 2 Be American**

THE MARK CONSISTS OF STANDARD CHARACTERS WITHOUT CLAIM TO ANY PARTICULAR FONT, STYLE, SIZE, OR COLOR.

OWNER OF U.S. REG. NO. 3,835,785.

FOR BEER; BEER, ALE AND LAGER; BEER-BASED COOLERS; BEERS; BOTTLED DRINKING WATER; DRINKING WATER; DRINKING WATER WITH VITAMINS; FRUIT JUICE; FRUIT JUICES; FRUIT JUICES AND FRUIT DRINKS; MIXED FRUIT JUICE; NON-ALCOHOLIC BEVERAGES CONTAINING FRUIT JUICES; NON-ALCOHOLIC FRUIT JUICE BEVERAGES; PURIFIED BOTTLED DRINKING WATER (U.S. CLS. 45, 46 AND 48).

MARCIE MILONE, EXAMINING ATTORNEY

SN 85-246,623. FL DAUERN RESEARCH, INC., PHOENIX, AZ. FILED 2-18-2011.

NO CLAIM IS MADE TO THE EXCLUSIVE RIGHT TO USE "AYURVEDA", APART FROM THE MARK AS SHOWN.

THE COLOR(S) GREEN, YELLOW, DARK GREEN, LIGHT GREEN, WHITE, ORANGE, LIGHT YELLOW, BLACK IS/ARE CLAIMED AS A FEATURE OF THE MARK.

THE MARK CONSISTS OF A CIRCULAR DESIGN, THE CIRCULAR DESIGN FEATURES A BLACK BORDER, WITHIN THE CIRCULAR DESIGN IS AN ADDITIONAL CIRCLE WITH A GREEN BORDER, DIRECTLY BETWEEN THE CIRCLE WITH THE BLACK BORDER AND THE INNER CIRCLE WITH THE GREEN BORDER AND IN THE UPPER PORTION OF THE MARK IS THE WORDING "BASIC AYURVEDA" IN STYLIZED FONT AND IN THE COLOR OF A DARK GREEN, THE BACKGROUND COLOR BEHIND THE WORDING "BASIC AYURVEDA" IS IN THE COLOR OF A LIGHT GREEN, BETWEEN THE CIRCLE WITH THE BLACK BORDER AND THE INNER CIRCLE WITH THE GREEN BORDER OF THE MARK AND SEPARATING THE BOTTOM PORTION FROM THE UPPER PORTION ARE TWO HORIZONTAL LINES IN THE COLOR OF GREEN, THE BOTTOM PORTION OF THE MARK BETWEEN THE CIRCLE WITH THE BLACK BORDER AND THE INNER CIRCLE FEATURES A DESIGN OF A VINE IN THE COLOR OF DARK GREEN AND THE BACKGROUND IS IN THE COLOR OF YELLOW, THE INNER CIRCLE FEATURES A DESIGN THAT DEPICTS HUMAN HANDS IN THE COLOR OF GREEN WITH A BORDER IN THE COLOR OF WHITE HOLDING A SUN IN THE COLOR OF YELLOW AND FADES TO ORANGE, THE BACKGROUND OF THE INNER CIRCLE IS IN THE COLOR OF WHITE AND FADES TO A LIGHT YELLOW, BELOW THE CIRCLE WITH THE BLACK BORDER AND IN THE BOTTOM PORTION OF THE MARK IS THE WORDING "THE SCIENCE OF PURE HERBS" IN STYLIZED FONT AND IN THE COLOR OF BLACK.

FOR ALOE VERA JUICES; FRUIT JUICES; HERBAL JUICES; NON-ALCOHOLIC BEVERAGES CONTAINING FRUIT JUICES; NON-ALCOHOLIC FRUIT JUICE BEVERAGES (U.S. CLS. 45, 46 AND 48).

FIRST USE 11-1-2009; IN COMMERCE 11-1-2009.

HANNO RITTNER, EXAMINING ATTORNEY

POWERED BY WELLNESS

THE MARK CONSISTS OF STANDARD CHARACTERS WITHOUT CLAIM TO ANY PARTICULAR FONT, STYLE, SIZE, OR COLOR.

FOR FRUIT-BASED BEVERAGES; SPORTS DRINKS (U.S. CLS. 45, 46 AND 48).

MICHAEL TANNER, EXAMINING ATTORNEY

SN 85-246,635. FL DAUERN RESEARCH, INC., PHOENIX, AZ. FILED 2-18-2011.

DELIVERING GOODNESS

THE MARK CONSISTS OF STANDARD CHARACTERS WITHOUT CLAIM TO ANY PARTICULAR FONT, STYLE, SIZE, OR COLOR.

FOR FRUIT-BASED BEVERAGES; SPORTS DRINKS (U.S. CLS. 45, 46 AND 48).

MICHAEL TANNER, EXAMINING ATTORNEY

CLASS 32—(Continued).

SN 85-246,643. BROOKLYN BREW SHOP, LLC, BROOKLYN, NY. FILED 2-18-2011.

Brooklyn Brew Shop

THE MARK CONSISTS OF STANDARD CHARACTERS WITHOUT CLAIM TO ANY PARTICULAR FONT, STYLE, SIZE, OR COLOR.

NO CLAIM IS MADE TO THE EXCLUSIVE RIGHT TO USE "BROOKLYN BREW", APART FROM THE MARK AS SHOWN.

FOR BEER MAKING KIT (U.S. CLS. 45, 46 AND 48).
FIRST USE 3-25-2009; IN COMMERCE 3-25-2009.
JOHN DWYER, EXAMINING ATTORNEY

SN 85-247,307. T-D INNOVATIONS, APPLETON, WI. FILED 2-21-2011.

FUSION ENERGY DRINK

THE MARK CONSISTS OF STANDARD CHARACTERS WITHOUT CLAIM TO ANY PARTICULAR FONT, STYLE, SIZE, OR COLOR.

NO CLAIM IS MADE TO THE EXCLUSIVE RIGHT TO USE "ENERGY DRINK", APART FROM THE MARK AS SHOWN.

FOR NON-ALCOHOLIC BEVERAGES, NAMELY, CARBONATED CITRUS FLAVORED BEVERAGES (U.S. CLS. 45, 46 AND 48).
LINDA M. KING, EXAMINING ATTORNEY

SN 85-248,876. KRUPKA, RYAN, CAMARILLO, CA. FILED 2-22-2011.

Ale Hole Brew

THE MARK CONSISTS OF STANDARD CHARACTERS WITHOUT CLAIM TO ANY PARTICULAR FONT, STYLE, SIZE, OR COLOR.

NO CLAIM IS MADE TO THE EXCLUSIVE RIGHT TO USE "BREW", APART FROM THE MARK AS SHOWN.
FOR BEER (U.S. CLS. 45, 46 AND 48).
CAROLINE WOOD, EXAMINING ATTORNEY

CLASS 32—(Continued).

SN 85-249,422. BERNS, DAVID CRAIG, WOODLAND HILLS, CA. AND MATLOW, JACOB, WOODLAND HILLS, CA. FILED 2-23-2011.

Because U Deserve What Each Individual Should Enjoy Regularly

THE MARK CONSISTS OF STANDARD CHARACTERS WITHOUT CLAIM TO ANY PARTICULAR FONT, STYLE, SIZE, OR COLOR.

FOR ALCOHOL-FREE BEERS; BEER; ALE AND LAGER; BEER, ALE AND PORTER; BEER, ALE, LAGER, STOUT AND PORTER; BEER, ALE, LAGER, STOUT, PORTER, SHANDY; BEER-BASED COOLERS; BEERS; BLACK BEER; BREWED MALT-BASED ALCOHOLIC BEVERAGE IN THE NATURE OF A BEER; DE-ALCOHOLISED BEER; FLAVORED BEERS; GINGER BEER; IMITATION BEER; MALT BEER; MALT EXTRACTS FOR MAKING BEER; MALT LIQUOR; NON-ALCOHOLIC BEER; PALE BEER; PORTER (U.S. CLS. 45, 46 AND 48).

EUGENIA MARTIN, EXAMINING ATTORNEY

SN 85-250,248. ABBEY BEVERAGE COMPANY LLC, ABIQUIU, NM. FILED 2-24-2011.

monks' wit

THE MARK CONSISTS OF STANDARD CHARACTERS WITHOUT CLAIM TO ANY PARTICULAR FONT, STYLE, SIZE, OR COLOR.

OWNER OF U.S. REG. NO. 3,056,340.
NO CLAIM IS MADE TO THE EXCLUSIVE RIGHT TO USE "WIT", APART FROM THE MARK AS SHOWN.
SEC. 2(F) AS TO "MONKS".
FOR BEER (U.S. CLS. 45, 46 AND 48).
FIRST USE 9-1-2010; IN COMMERCE 9-21-2010.
ANGELA DUONG, EXAMINING ATTORNEY

CLASS 32—(Continued).

SN 85-251,397. ROGERS, BRUCE A., HAVERTOWN, PA. FILED 2-25-2011.

Cake

THE MARK CONSISTS OF STANDARD CHARACTERS WITHOUT CLAIM TO ANY PARTICULAR FONT, STYLE, SIZE, OR COLOR.

FOR BEAUTY BEVERAGES, NAMELY, FRUIT JUICES AND ENERGY DRINKS CONTAINING NUTRITIONAL SUPPLEMENTS; BOTTLED WATER; DRINKING WATERS; FROZEN FRUIT BEVERAGES; FRUIT BEVERAGES; FRUIT DRINKS AND FRUIT JUICES; FRUIT-BASED BEVERAGES; HERBAL JUICES; ICED FRUIT BEVERAGES; NON-ALCOHOLIC BEVERAGES CONTAINING FRUIT JUICES; PREPARATIONS FOR MAKING BEVERAGES, NAMELY, SMOOTHIES; PREPARED ENTREES CONSISTING OF FRUIT DRINKS AND FRUIT JUICES, FRUIT-BASED BEVERAGES, NON-ALCOHOLIC BEVERAGES CONTAINING FRUIT JUICES, NON-ALCOHOLIC FRUIT EXTRACTS USED IN THE PREPARATION OF BEVERAGES, NON-ALCOHOLIC FRUIT JUICE BEVERAGES, VEGETABLE JUICES, VEGETABLE-FRUIT JUICES AND SMOOTHIES; SMOOTHIES; SMOOTHIES CONTAINING GRAINS AND OATS; VEGETABLE DRINKS; VEGETABLE JUICE; VEGETABLE JUICES; VEGETABLE-FRUIT JUICES; WATER BEVERAGES (U.S. CLS. 45, 46 AND 48).

ELLEN BURNS, EXAMINING ATTORNEY

SN 85-254,230. AVANA INTERNATIONAL CORPORATION, PARK RIDGE, IL. FILED 3-1-2011.

GEN3

THE MARK CONSISTS OF STANDARD CHARACTERS WITHOUT CLAIM TO ANY PARTICULAR FONT, STYLE, SIZE, OR COLOR.

FOR DRINKING WATER WITH VITAMINS; DRINKING WATERS; ENERGY DRINKS; FROZEN CARBONATED BEVERAGES; FRUIT BEVERAGES; FRUIT DRINKS; FRUIT DRINKS AND FRUIT JUICES; FRUIT FLAVORED DRINKS; FRUIT JUICE; FRUIT-BASED BEVERAGES; FRUIT-FLAVORED BEVERAGES; FRUIT-FLAVOURED BEVERAGES; GRAPE JUICE BEVERAGES; ICED FRUIT BEVERAGES; NON-ALCOHOLIC DRINKS, NAMELY, ENERGY SHOTS; POP; SODA POPS; SOFT DRINKS; SOFT DRINKS FLAVORED WITH TEA; SPORTS DRINKS; SPORTS DRINKS, NAMELY, ENERGY DRINKS (U.S. CLS. 45, 46 AND 48).

THOMAS MANOR, EXAMINING ATTORNEY

CLASS 32—(Continued).

SN 85-254,418. UBATUBA BEVERAGE COMPANY, LLC, SANDY, UT. FILED 3-1-2011.

UBATUBA

THE MARK CONSISTS OF STANDARD CHARACTERS WITHOUT CLAIM TO ANY PARTICULAR FONT, STYLE, SIZE, OR COLOR.

FOR NON ALCOHOLIC CARBONATED AND NON CARBONATED BEVERAGES (U.S. CLS. 45, 46 AND 48).

DAVID COLLIER, EXAMINING ATTORNEY

SN 85-254,948. NUTRITION53, INC., LAFAYETTE, CA. FILED 3-1-2011.

CHANGING THE WORLD ONE SMOOTHIE AT A TIME

THE MARK CONSISTS OF STANDARD CHARACTERS WITHOUT CLAIM TO ANY PARTICULAR FONT, STYLE, SIZE, OR COLOR.

FOR SMOOTHIES CONTAINING NUTRITIONAL SUPPLEMENTS; SMOOTHIES CONTAINING GRAINS AND OATS; SMOOTHIES CONTAINING FRUIT AND FRUIT EXTRACTS (U.S. CLS. 45, 46 AND 48).

KHANH LE, EXAMINING ATTORNEY

SN 85-255,150. LEAF, JEFFREY, VENICE, CA. FILED 3-1-2011.

MYLKMAN

THE MARK CONSISTS OF STANDARD CHARACTERS WITHOUT CLAIM TO ANY PARTICULAR FONT, STYLE, SIZE, OR COLOR.

FOR COCONUT-BASED BEVERAGES; MILK OF ALMONDS FOR BEVERAGE (U.S. CLS. 45, 46 AND 48).

EDWARD NELSON, EXAMINING ATTORNEY

CLASS 32—(Continued).

SN 85-255,550. IV SCIENCE, LLC, DBA GREEN & CO., BUFFALO, NY. FILED 3-2-2011.

Pure1

THE MARK CONSISTS OF THE STYLIZED WORDING "PURE1".
FOR NON-ALCOHOLIC COCKTAIL MIXES (U.S. CLS. 45, 46 AND 48).
JAMES LOVELACE, EXAMINING ATTORNEY

SN 85-255,737. PEPSICO, INC., PURCHASE, NY. FILED 3-2-2011.

NOTHING REFRESHES LIKE A
DIET PEPSI

THE MARK CONSISTS OF STANDARD CHARACTERS WITHOUT CLAIM TO ANY PARTICULAR FONT, STYLE, SIZE, OR COLOR.
OWNER OF U.S. REG. NOS. 824,149, 824,152 AND OTHERS.
NO CLAIM IS MADE TO THE EXCLUSIVE RIGHT TO USE "DIET", APART FROM THE MARK AS SHOWN.
FOR SOFT DRINKS (U.S. CLS. 45, 46 AND 48).
ODESSA BIBBINS, EXAMINING ATTORNEY

SN 85-256,679. LBI BRANDS, INC., VANCOUVER, CANADA, FILED 3-3-2011.

DARKBLUE

THE MARK CONSISTS OF STANDARD CHARACTERS WITHOUT CLAIM TO ANY PARTICULAR FONT, STYLE, SIZE, OR COLOR.
OWNER OF U.S. REG. NOS. 3,181,832, 3,317,104 AND 3,555,237.
FOR NON-ALCOHOLIC BEVERAGES CONTAINING FRUIT JUICES (U.S. CLS. 45, 46 AND 48).
SUSAN RICHARDS, EXAMINING ATTORNEY

CLASS 32—(Continued).

SN 85-256,884. BLITZINGER LLC, SOUTH PALM BEACH, FL. FILED 3-3-2011.

BLITZINGER

THE MARK CONSISTS OF STANDARD CHARACTERS WITHOUT CLAIM TO ANY PARTICULAR FONT, STYLE, SIZE, OR COLOR.
FOR BEER (U.S. CLS. 45, 46 AND 48).
CHRISIE B. KING, EXAMINING ATTORNEY

SN 85-257,196. WAIAKEA INVESTMENTS, LLC, SANTA BARBARA, CA. FILED 3-3-2011.

Bottled With Mother Earth
In Mind

THE MARK CONSISTS OF STANDARD CHARACTERS WITHOUT CLAIM TO ANY PARTICULAR FONT, STYLE, SIZE, OR COLOR.
FOR BOTTLED WATER (U.S. CLS. 45, 46 AND 48).
ANDREW RHIM, EXAMINING ATTORNEY

SN 85-257,637. HELE MAI LLC, WILMINGTON, DE. FILED 3-3-2011.

PANIOLO

THE MARK CONSISTS OF STANDARD CHARACTERS WITHOUT CLAIM TO ANY PARTICULAR FONT, STYLE, SIZE, OR COLOR.

THE ENGLISH TRANSLATION OF "PANIOLO" IN THE MARK IS "HAWAIIAN COWBOY".

FOR BEER; NON-ALCOHOLIC BEER; ENERGY DRINKS; NON-ALCOHOLIC DRINKS AND BEVERAGES, NAMELY, MINERAL AND AERATED WATERS, FRUIT DRINKS, FRUIT JUICES, FRUIT NECTARS, VEGETABLE DRINKS, VEGETABLE JUICES, ISOTONIC BEVERAGES, WHEY DRINKS, AND SOFT DRINKS; WATER BEING BEVERAGES, NAMELY, BOTTLED WATER AND TABLE WATER; DRINKING WATER WITH VITAMINS; DRINKING WATER ENHANCED WITH MINERALS OR ANTIOXIDANTS; SYRUPS AND OTHER PREPARATIONS FOR MAKING BEVERAGES, NAMELY, FRUIT JUICES, FRUIT DRINKS, VEGETABLE JUICES, VEGETABLE DRINKS, ISOTONIC BEVERAGES, WHEY DRINKS, AND SOFT DRINKS; NON-ALCOHOLIC FRUIT EXTRACTS USED IN THE PREPARATION OF BEVERAGES; FROZEN FRUIT-BASED BEVERAGES; NON-ALCOHOLIC FRUIT JUICE BEVERAGES; POWDERS FOR USE IN THE PREPARATION OF SOFT DRINKS; ESSENCES FOR MAKING NON-ALCOHOLIC BEVERAGES; NON-ALCOHOLIC FRUIT EXTRACTS USED IN THE PREPARATION OF BEVERAGES (U.S. CLS. 45, 46 AND 48).

GRETCHEN ULRICH, EXAMINING ATTORNEY

CLASS 33—WINES AND SPIRITS

SN 76-657,529. GUY ANDERSON WINES LTD., SOMERSET, ENGLAND, FILED 3-30-2006.



THE ENGLISH TRANSLATION OF THE WORD "ROJO" IS "RED".
FOR WINES (U.S. CLS. 47 AND 49).
FIRST USE 5-8-2006; IN COMMERCE 5-8-2006.
SIMON TENG, EXAMINING ATTORNEY

SN 77-374,323. BESO APPAREL, LLC, ASTORIA, NY. FILED 1-17-2008.

BESO

THE MARK CONSISTS OF STANDARD CHARACTERS WITHOUT CLAIM TO ANY PARTICULAR FONT, STYLE, SIZE, OR COLOR.
OWNER OF U.S. REG. NOS. 3,693,387 AND 3,703,605.
THE ENGLISH TRANSLATION OF "BESO" IS "KISS", "PECK", "LOVE", "OSCULATION", "LAP", "BUMP", "COLLISION".
FOR WINES, LIQUEURS AND SPIRITS (U.S. CLS. 47 AND 49).
KATHY DE JONGE, EXAMINING ATTORNEY

SN 77-780,089. ROCKBARE PTY LTD, MELBOURNE, VICTORIA, AUSTRALIA, FILED 7-13-2009.

ROCKBARE MOJO

THE MARK CONSISTS OF STANDARD CHARACTERS WITHOUT CLAIM TO ANY PARTICULAR FONT, STYLE, SIZE, OR COLOR.
OWNER OF U.S. REG. NOS. 2,718,646 AND 3,591,235.
FOR WINES (U.S. CLS. 47 AND 49).
BARBARA GAYNOR, EXAMINING ATTORNEY

CLASS 33—(Continued).

SN 77-840,349. POSITSIOON OÜ, TALLINN, ESTONIA, FILED 10-2-2009.

WOOL

THE MARK CONSISTS OF STANDARD CHARACTERS WITHOUT CLAIM TO ANY PARTICULAR FONT, STYLE, SIZE, OR COLOR.
PRIORITY CLAIMED UNDER SEC. 44(D) ON ESTONIA APPLICATION NO. M200900381, FILED 4-2-2009, REG. NO. 48145, DATED 3-7-2011, EXPIRES 3-7-2021.
FOR ALCOHOLIC BEVERAGES EXCEPT BEERS; ALCOHOLIC BITTERS; BRANDY; FRUIT WINE; GIN; GRAPE WINE; PORT WINES; RUM; SHERRY; SPARKLING FRUIT WINE; SPARKLING GRAPE WINE; SPIRITS; TEQUILA; VERMOUTH; VODKA; WHISKY (U.S. CLS. 47 AND 49).
JUDITH HELFMAN, EXAMINING ATTORNEY

SN 79-066,164. BODEGAS VIRGEN DEL AGUILA., SDAD. COOP., SPAIN, FILED 10-7-2008.



PRIORITY DATE OF 7-27-2008 IS CLAIMED.
OWNER OF INTERNATIONAL REGISTRATION 0995718 DATED 10-7-2008, EXPIRES 10-7-2018.
THE MARK CONSISTS OF THE SILHOUETTE OF A WILD BOAR WALKING ON THE GROUND WITH THE WORDING "AGOSTÓN" UNDERNEATH.
THE WORDING "AGOSTON" HAS NO MEANING IN A FOREIGN LANGUAGE.
FOR ALCOHOLIC BEVERAGES EXCEPT BEERS (U.S. CLS. 47 AND 49).
SUE LAWRENCE, EXAMINING ATTORNEY

SN 79-086,356. "TARPAN" FABRYKA LIKIERÓW SP. Z O.O., POLAND, FILED 7-1-2010.

tarpan

THE MARK CONSISTS OF STANDARD CHARACTERS WITHOUT CLAIM TO ANY PARTICULAR FONT, STYLE, SIZE, OR COLOR.
OWNER OF INTERNATIONAL REGISTRATION 0792168 DATED 7-25-2002, EXPIRES 7-25-2012.
FOR ALCOHOLIC BEVERAGES NAMELY, VODKAS AND LIQUORS (U.S. CLS. 47 AND 49).
JESSICA FATHY, EXAMINING ATTORNEY

CLASS 33—(Continued).

SN 79-086,380. BLACK FOREST DISTILLERS GMBH, FED REP GERMANY, FILED 7-29-2010.

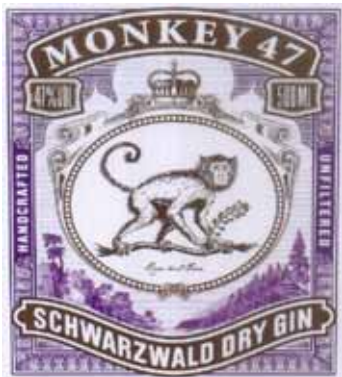

PRIORITY DATE OF 2-3-2010 IS CLAIMED.

OWNER OF INTERNATIONAL REGISTRATION 1048458 DATED 7-29-2010, EXPIRES 7-29-2020.

NO CLAIM IS MADE TO THE EXCLUSIVE RIGHT TO USE "47", "47%VOL", "500 ML", "HANDCRAFTED", "UNFILTERED", "DRY GIN", APART FROM THE MARK AS SHOWN.

THE COLOR(S) WHITE, DARK BROWN AND PURPLE IS/ ARE CLAIMED AS A FEATURE OF THE MARK.

THE MARK CONSISTS OF THE FOLLOWING: A LABEL FOR A LIQUOR BOTTLE WITH THE WORDING "MONKEY 47" IN A LARGE DARK BROWN AND WHITE BANNER ACROSS THE TOP OF THE LABEL. ON THE SIDES OF THE BANNER ALSO IN DARK BROWN AND WHITE ARE THE TERMS "47%VOL" AND "500ML." IN THE BACKGROUND OF THE LABEL IN PURPLE ARE A VARIETY OF DESIGNS THAT MAKE UP THE PERIMETER OF THE LABEL. ON THE LEFT SIDE OF THE LABEL IS THE WORD "HANDCRAFTED" IN WHITE ON A PURPLE BACKGROUND AND ON THE RIGHT SIDE OF THE LABEL IS THE WORD "UNFILTERED" IN WHITE ON A PURPLE BACKGROUND. THE WORDING "SCHWARZWALD DRY GIN" APPEARS IN A BANNER AT THE BOTTOM OF THE LABEL IN DARK BROWN AND WHITE. THE WORDING "RARE BUT TRUE" APPEARS BELOW THE BRANCH ON WHICH THE MONKEY IS STANDING. ABOVE THE BOTTOM BANNER IN PURPLE IS THE DESIGN OF A RIVER WITH TREES ALONG EACH SIDE OF THE RIVERBANK. ABOVE THE RIVER AND TREES IS AN OVAL WITH SMALL CIRCLES FORMING THE INSIDE DESIGN OF THE OVAL. THE TOP OF THE OVAL CONTAINS SCROLLS AND A CROWN. ON THE INSIDE OF THE OVAL IS THE PICTURE OF A MONKEY ON A TREE BRANCH. THE DESIGN ELEMENTS ABOVE THE RIVERBANK IN PURPLE ARE ALL IN BROWN WITH WHITE IN THE BACKGROUND.

THE ENGLISH TRANSLATION OF "SCHWARZWALD" IS BLACK FOREST.

FOR ALCOHOLIC BEVERAGES, NAMELY, GIN (U.S. CLS. 47 AND 49).

DAWN FELDMAN, EXAMINING ATTORNEY

SN 79-086,496. PIERRE LAFOREST GMBH, 65187 WIESBADEN, FED REP GERMANY, FILED 8-5-2010.

Fleur d'Amour

THE MARK CONSISTS OF STANDARD CHARACTERS WITHOUT CLAIM TO ANY PARTICULAR FONT, STYLE, SIZE, OR COLOR.

OWNER OF INTERNATIONAL REGISTRATION 1048793 DATED 8-5-2010, EXPIRES 8-5-2020.

THE ENGLISH TRANSLATION OF "FLEUR D'AMOUR" IN THE MARK IS "FLOWER OF LOVE".

FOR ALCOHOLIC BEVERAGES EXCEPT BEER (U.S. CLS. 47 AND 49).

FLORENTINA BLANDU, EXAMINING ATTORNEY

CLASS 33—(Continued).

SN 79-087,920. MIONETTO S.P.A., ITALY, FILED 8-11-2010.

sergio

OWNER OF INTERNATIONAL REGISTRATION 1052666 DATED 8-11-2010, EXPIRES 8-11-2020.

THE MARK "SERGIO" (FIGURATIVE) CONSISTS OF THE WORD "SERGIO" WRITTEN IN FANCY TYPEWRITE. FOR SPARKLING WINES (U.S. CLS. 47 AND 49).

CURTIS FRENCH, EXAMINING ATTORNEY

SN 79-092,331. CELLER LAGRAVERA, S.L.U., SPAIN, FILED 1-5-2011.



OWNER OF INTERNATIONAL REGISTRATION 1064400 DATED 1-5-2011, EXPIRES 1-5-2021.

THE MARK CONSISTS OF THE WORDING "LALTRE" IN STYLIZED LETTERING APPEARING TWICE INSIDE OF A SHADED RECTANGULAR CARRIER. THE WORDING APPEARS CENTERED AND HORIZONTALLY ALIGNED IN SCRIPT LETTERING AT THE TOP OF THE CARRIER AND AGAIN IN VERTICALLY ALIGNED BLOCK CAPITAL LETTERS BENEATH THE HORIZONTAL PRESENTATION OF THE WORDING.

THE WORDING "LALTRE" HAS NO MEANING IN A FOREIGN LANGUAGE.

FOR ALCOHOLIC BEVERAGES EXCEPT BEER (U.S. CLS. 47 AND 49).

DEBRA LEE, EXAMINING ATTORNEY

CLASS 33—(Continued).

SN 79-093,504. IPPONGI KUBOHONTEN CO., LTD., JAPAN, FILED 11-2-2010.

般若刀

OWNER OF INTERNATIONAL REGISTRATION 1067345 DATED 11-2-2010, EXPIRES 11-2-2020.

THE MARK CONSISTS OF STYLIZED JAPANESE CHARACTERS.

THE NON-LATIN CHARACTERS IN THE MARK TRANSLITERATE TO HANNYATOU AND THIS HAS NO MEANING IN A FOREIGN LANGUAGE.

FOR JAPANESE LIQUOR FLAVORED WITH JAPANESE PLUM EXTRACTS (U.S. CLS. 47 AND 49). DANIEL CAPSHAW, EXAMINING ATTORNEY

CLASS 33—(Continued).

SN 79-095,029. MANFREDI ALDO & C. - AZIENDA VITIVINICOLA CANTINE CASTELVECCHIO - PATRIZI - CANTINA TORRALTA - AZIENDA AGRICOLA BRICCO ROSSO - GI-EMME - S.A.S. (SIGLABILE MANFREDI ALDO & C. S.A.S.), ITALY, FILED 1-25-2011.

TIBALINI

THE MARK CONSISTS OF STANDARD CHARACTERS WITHOUT CLAIM TO ANY PARTICULAR FONT, STYLE, SIZE, OR COLOR.

OWNER OF INTERNATIONAL REGISTRATION 1070904 DATED 1-25-2011, EXPIRES 1-25-2021.

FOR ALCOHOLIC BEVERAGES EXCEPT BEERS (U.S. CLS. 47 AND 49).

JULIE VEPPUMTHARA, EXAMINING ATTORNEY

SN 79-094,920. JIANGSU BEN GANG INVESTMENT CO., LTD., CHINA, FILED 3-4-2011.

國
心

OWNER OF INTERNATIONAL REGISTRATION 1070612 DATED 3-4-2011, EXPIRES 3-4-2021.

THE CHINESE CHARACTER GUO MEANS NATION, COUNTRY, OR STATE IN ENGLISH, WHILE THE CHINESE CHARACTER XIN MEANS HEART IN ENGLISH. WHEN USED IN COMBINATION, THE CHARACTERS GUO XIN HAVE NO MEANING.

THE TRANSLITERATION OF THE CHINESE CHARACTERS IN THE MARK IS GUO XIN.

FOR PEPPERMINT LIQUEURS; ARAK; ALCOHOLIC COCKTAIL MIXES; WINE; BRANDY; SAKE; RICE ALCOHOL; VODKA; BUBBLING WINE; YELLOW WINE (U.S. CLS. 47 AND 49).

ELI HELLMAN, EXAMINING ATTORNEY

SN 79-095,759. AZ. AGR. LE RUINE DI FURIA EROS E LUCIO, I-37029 SAN PIETRO IN CARIANO (VR), ITALY, FILED 2-23-2011.

LAZZARONE

THE MARK CONSISTS OF STANDARD CHARACTERS WITHOUT CLAIM TO ANY PARTICULAR FONT, STYLE, SIZE, OR COLOR.

OWNER OF INTERNATIONAL REGISTRATION 1072969 DATED 2-23-2011, EXPIRES 2-23-2021.

FOR ALCOHOLIC BEVERAGES, EXCEPT BEER (U.S. CLS. 47 AND 49).

DAVID HOFFMAN, EXAMINING ATTORNEY

SN 79-096,955. SAKURAMASAMUNE CO., LTD, JAPAN, FILED 3-2-2011.

飛鯉
たきこい

OWNER OF INTERNATIONAL REGISTRATION 1075985 DATED 3-2-2011, EXPIRES 3-2-2021.

THE ENGLISH TRANSLATION OF THE FOREIGN WORD(S) IN THE MARK IS: CARP ASCENDS A WATERFALL.

THE TRANSLITERATION OF THE NON-LATIN CHARACTERS IN THE MARK IS: TAKIKOI.

FOR JAPANESE LIQUORS; SAKE; WESTERN LIQUORS; ALCOHOLIC FRUIT BEVERAGES; CHINESE LIQUORS; FLAVORED LIQUORS (U.S. CLS. 47 AND 49).

ASMAT KHAN, EXAMINING ATTORNEY

SN 79-094,975. SOCIETE CIVILE IMMOBILIERE DE L'ABBAYE DE FONTFROIDE, FRANCE, FILED 3-3-2011.

ABBAYE DE FONTFROIDE

THE MARK CONSISTS OF STANDARD CHARACTERS WITHOUT CLAIM TO ANY PARTICULAR FONT, STYLE, SIZE, OR COLOR.

OWNER OF INTERNATIONAL REGISTRATION 1070739 DATED 3-3-2011, EXPIRES 3-3-2021.

THE ENGLISH TRANSLATION OF THE FOREIGN WORD(S) IN THE MARK IS: ABBEY OF FONTFROIDE.

FOR WINES WITH APPELLATION OF ORIGIN (U.S. CLS. 47 AND 49).

MICHAEL WIENER, EXAMINING ATTORNEY

CLASS 33—(Continued).

SN 85-013,453. FRANK H. BARTHOLOMEW FOUNDATION, SONOMA, CA. FILED 4-14-2010.

BARTHOLOMEW PARK WINERY

THE MARK CONSISTS OF STANDARD CHARACTERS WITHOUT CLAIM TO ANY PARTICULAR FONT, STYLE, SIZE, OR COLOR.

NO CLAIM IS MADE TO THE EXCLUSIVE RIGHT TO USE "WINERY", APART FROM THE MARK AS SHOWN.

FOR WINE (U.S. CLS. 47 AND 49).
FIRST USE 0-0-1994; IN COMMERCE 0-0-1994.
LAURA HAMMEL, EXAMINING ATTORNEY

SN 85-059,776. KIM, SOON JIN, KWANAK-GU, SEOUL, REPUBLIC OF KOREA, AND NOLBOO CO., LTD., SEOUL, REPUBLIC OF KOREA, FILED 6-10-2010.

BARBETZ

THE MARK CONSISTS OF STANDARD CHARACTERS WITHOUT CLAIM TO ANY PARTICULAR FONT, STYLE, SIZE, OR COLOR.

PRIORITY CLAIMED UNDER SEC. 44(D) ON REPUBLIC OF KOREA APPLICATION NO. 40-2010-0005, FILED 2-2-2010, REG. NO. 859323, DATED 4-1-2011, EXPIRES 4-1-2021.

OWNER OF U.S. REG. NOS. 3,365,641 AND 3,369,205.

THE WORDING "BARBETZ" HAS NO MEANING IN A FOREIGN LANGUAGE.

FOR SOJU, NAMELY, KOREAN DISTILLED LIQUOR; RICE ALCOHOL; SAKE; UNREFINED RICE WINE; RUM; VODKA; BRANDY; ALCOHOLIC BEVERAGES CONTAINING FRUIT; WHISKEY; DISTILLED BEVERAGES, NAMELY, DISTILLED SPIRITS; WINE; ALCOHOLIC FRUIT EXTRACTS (U.S. CLS. 47 AND 49).

ALLISON SCHRODY, EXAMINING ATTORNEY

SN 85-085,241. CASTELL DEL REMEI, S.L., CASTELL DEL REMEI, SPAIN, FILED 7-15-2010.

SICORIS

THE MARK CONSISTS OF STANDARD CHARACTERS WITHOUT CLAIM TO ANY PARTICULAR FONT, STYLE, SIZE, OR COLOR.

OWNER OF ERPN CMNTY TM OFC REG. NO. 9248493, DATED 11-30-2010, EXPIRES 7-15-2020.

THE WORDING "SICORIS" HAS NO MEANING IN A FOREIGN LANGUAGE.

FOR ALCOHOLIC BEVERAGES EXCEPT BEERS (U.S. CLS. 47 AND 49).

MAYUR VAGHANI, EXAMINING ATTORNEY

CLASS 33—(Continued).

SN 85-094,164. SMITH & HOOK WINERY, INC., SOLEDAD, CA. FILED 7-27-2010.

TOUR DE CALIFORNIA

THE MARK CONSISTS OF STANDARD CHARACTERS WITHOUT CLAIM TO ANY PARTICULAR FONT, STYLE, SIZE, OR COLOR.

NO CLAIM IS MADE TO THE EXCLUSIVE RIGHT TO USE "CALIFORNIA", APART FROM THE MARK AS SHOWN.

THE ENGLISH TRANSLATION OF "TOUR DE CALIFORNIA" IN THE MARK IS "TOUR OF CALIFORNIA".

FOR WINE (U.S. CLS. 47 AND 49).
MYRIAH HABEEB, EXAMINING ATTORNEY

SN 85-097,968. PERNOD RICARD USA, LLC, PURCHASE, NY. FILED 8-2-2010.



OWNER OF U.S. REG. NOS. 1,374,134, 3,393,773 AND 3,816,881.

NO CLAIM IS MADE TO THE EXCLUSIVE RIGHT TO USE "COCKTAILS", APART FROM THE MARK AS SHOWN.

THE COLOR(S) BROWN, ORANGE, AND WHITE IS/ARE CLAIMED AS A FEATURE OF THE MARK.

THE MARK CONSISTS OF THE BROWN WORD "MALIBU" ABOVE TWO BROWN AND WHITE COCONUT TREES IN FRONT OF AN ORANGE SUN ABOVE THE BROWN WORD "COCKTAILS".

FOR ALCOHOLIC BEVERAGES EXCEPT BEERS (U.S. CLS. 47 AND 49).

CAROLINE WOOD, EXAMINING ATTORNEY

CLASS 33—(Continued).

SN 85-100,568. ARTEVINO LLC, NEW YORK, NY. FILED 8-5-2010.



THE MARK CONSISTS OF THE STYLIZED WORDING "WHITE ASS", WITH THE EARS AND TAIL OF A DONKEY OR ASS FORMING PART OF THE LETTER "A" IN "ASS".
FOR ALCOHOLIC BEVERAGES EXCEPT BEERS; WINE (U.S. CLS. 47 AND 49).
ZACHARY BELLO, EXAMINING ATTORNEY

SN 85-103,303. THE MORLET SELECTION, INCORPORATED, ST. HELENA, CA. FILED 8-9-2010.

MORLET FAMILY ESTATE

THE MARK CONSISTS OF STANDARD CHARACTERS WITHOUT CLAIM TO ANY PARTICULAR FONT, STYLE, SIZE, OR COLOR.
NO CLAIM IS MADE TO THE EXCLUSIVE RIGHT TO USE "FAMILY ESTATE", APART FROM THE MARK AS SHOWN.
FOR ALCOHOLIC BEVERAGES EXCEPT BEERS (U.S. CLS. 47 AND 49).
RUSS HERMAN, EXAMINING ATTORNEY

SN 85-110,549. AGRICOLA Y FORESTAL ARCO IRIS S.A., LAS CONDES, SANTIAGO,, CHILE, FILED 8-18-2010.

ALWA ANAKENA

THE MARK CONSISTS OF STANDARD CHARACTERS WITHOUT CLAIM TO ANY PARTICULAR FONT, STYLE, SIZE, OR COLOR.
OWNER OF U.S. REG. NOS. 2,453,647, 2,523,030 AND 3,811,764.
THE ENGLISH TRANSLATION OF "ALWA" IN THE MARK IS DAWN. "ANAKENA" IS A NATIVE WORD IN THE RAPA NUI LANGUAGE SPOKEN ON EASTER ISLAND, AND REFERS TO A BEACH LOCATED ON EASTER ISLAND.
FOR WINES (U.S. CLS. 47 AND 49).
JUDITH HELFMAN, EXAMINING ATTORNEY

CLASS 33—(Continued).

SN 85-110,557. AGRICOLA Y FORESTAL ARCO IRIS S.A., LAS CONDES, SANTIAGO,, CHILE, FILED 8-18-2010.

MAYNI ANAKENA

THE MARK CONSISTS OF STANDARD CHARACTERS WITHOUT CLAIM TO ANY PARTICULAR FONT, STYLE, SIZE, OR COLOR.
OWNER OF U.S. REG. NOS. 2,453,647, 2,523,030 AND 3,811,764.
THE ENGLISH TRANSLATION OF "MAYNI" IN THE MARK IS ONE. "ANAKENA" IS A WORD DERIVED FROM THE LANGUAGE RAPA NUI, WITHOUT KNOWN SPANISH OR ENGLISH TRANSLATION. THE WORD REFERS TO A BEACH LOCATED ON EASTER ISLAND.
FOR WINES (U.S. CLS. 47 AND 49).
JUDITH HELFMAN, EXAMINING ATTORNEY

SN 85-112,695. LES CAVES HENRI DE RICHEMERE SOCIETE COOPERATIVE AGRICOLE AGDE-MARSEILLAN, MARSEILLAN, FRANCE, FILED 8-20-2010.

TERRE ET MER

THE MARK CONSISTS OF STANDARD CHARACTERS WITHOUT CLAIM TO ANY PARTICULAR FONT, STYLE, SIZE, OR COLOR.
THE ENGLISH TRANSLATION OF "TERRE ET MER" IN THE MARK IS "LAND & SEA".
FOR ALCOHOLIC BEVERAGES EXCEPT BEERS; HARD CIDERS; LIQUEURS AND SPIRITS; WINE; SPIRIT BEVERAGES; ALCOHOLIC EXTRACTS; ALCOHOLIC ESSENCES (U.S. CLS. 47 AND 49).
RUSS HERMAN, EXAMINING ATTORNEY

SN 85-118,479. FELDMAN, ZACHARY, NEW YORK, NY. FILED 8-30-2010.

GET BITT SLAPPED

THE MARK CONSISTS OF STANDARD CHARACTERS WITHOUT CLAIM TO ANY PARTICULAR FONT, STYLE, SIZE, OR COLOR.
FOR ALCOHOLIC BEVERAGES, NAMELY, ALCOHOLIC BITTERS (U.S. CLS. 47 AND 49).
FIRST USE 8-10-2010; IN COMMERCE 8-10-2010.
ROBIN CHOSID, EXAMINING ATTORNEY

CLASS 33—(Continued).

SN 85-128,873. CHILLIXER, LLC, ATLANTA, GA. FILED 9-14-2010.

CAYRUM

THE MARK CONSISTS OF STANDARD CHARACTERS WITHOUT CLAIM TO ANY PARTICULAR FONT, STYLE, SIZE, OR COLOR.

FOR RUM (U.S. CLS. 47 AND 49).

FIRST USE 10-10-2010; IN COMMERCE 10-10-2010.

KELLY BOULTON, EXAMINING ATTORNEY

CLASS 33—(Continued).

SN 85-134,978. MORETT, CARLOS ANAYA, GUADALAJARA, JALISCO, MEXICO, FILED 9-21-2010.



THE MARK CONSISTS OF THE DESIGN OF AN ARTICHOKE SURROUNDED WITH THE STYLIZED TERMS "ARTICHOKE'S HEART RESTAURANT" ENCIRCLING THE ARTICHOKE WITH A SMALL SOLID CIRCLE TO THE LEFT OF THE ARTICHOKE AND ANOTHER TO THE RIGHT OF THE ARTICHOKE. BLACK, WHITE AND GRAY ARE NOT CLAIMED AS A FEATURE OF THE MARK BUT MERELY REPRESENT BACKGROUND, OUTLINING, SHADING AND/OR TRANSPARENT AREAS AND ARE NOT PART OF THE MARK.

FOR SPIRITS; WINE (U.S. CLS. 47 AND 49).

LAURIE MAYES, EXAMINING ATTORNEY

SN 85-132,308. BO HAE BREWERY CO., LTD., CHOLLANAM-DO, REPUBLIC OF KOREA, FILED 9-17-2010.

KIM SATGAT
김삿갓

OWNER OF REPUBLIC OF KOREA REG. NO. 0384956, DATED 12-2-1997, EXPIRES 12-2-2017.

THE NAME "KIM SAGAT" DOES NOT IDENTIFY A LIVING INDIVIDUAL.

THE MARK CONSISTS OF THE WORDS "KIM SATGAT" UNDERLINED ABOVE KOREAN CHARACTERS WHICH TRANSLITERATE TO "KIM SATGAT".

THE WORDING "KIM SATGAT" HAS NO MEANING IN A FOREIGN LANGUAGE.

THE NON-LATIN CHARACTERS IN THE MARK TRANSLITERATE TO "KIM SATGAT" AND THIS HAS NO MEANING IN A FOREIGN LANGUAGE.

FOR SOJU, NAMELY, A KOREAN DISTILLED LIQUOR; SAKE; YAG-JU, NAMELY, REFINED RICE WINE; HARD CIDER; CHINESE LIQUEURS, NAMELY, CHINESE KAOLYANGJU; FLAVORED TONIC LIQUORS; WINE (U.S. CLS. 47 AND 49).

SETH A. RAPPAPORT, EXAMINING ATTORNEY

SN 85-138,012. AMBROGIO E GIOVANNI FOLONARI TENUTE SOCIETÀ AGRICOLA A RESPONSABILITÀ LIMITATA, 50022 GREVE IN CHIANTI, ITALY, FILED 9-24-2010.



THE COLOR(S) BLACK, WHITE, BEIGE, GRAY, RED, GOLD AND BLUE IS/ARE CLAIMED AS A FEATURE OF THE MARK.

THE MARK CONSISTS OF A BEIGE RECTANGLE ON WHICH APPEAR A GOLD AND RED CROWN WITH BLACK DETAILS, A GOLD SHIELD WITH BLACK DETAILS AND WHITE AND BLACK STRIPES, AND A SECOND INNER SHIELD WITH BLACK DETAILS. THE TOP HALF OF THE INNER SHIELD IS GOLD AND FEATURES THREE RED TOWERS AND A BLACK AND WHITE ELEPHANT. THE BOTTOM HALF OF THE INNER SHIELD IS BLUE AND FEATURES THREE GOLD HORSES. GOLD AND WHITE RIBBONS EXTEND FROM EACH SIDE OF THE OUTER SHIELD. BENEATH THE SHIELD IS THE GRAY WORDING "POGGIO REALE" WITH WHITE AND GRAY SHADOWS.

THE ENGLISH TRANSLATION OF "POGGIO REALE" IN THE MARK IS "ROYAL HILL".

FOR WINES (U.S. CLS. 47 AND 49).

MARTHA FROMM, EXAMINING ATTORNEY

CLASS 33—(Continued).

SN 85-140,985. CRILLON IMPORTERS, LTD., PARAMUS, NJ.
FILED 9-29-2010.

GRAN TABLA

THE MARK CONSISTS OF STANDARD CHARACTERS WITHOUT CLAIM TO ANY PARTICULAR FONT, STYLE, SIZE, OR COLOR.

THE ENGLISH TRANSLATION OF "GRAN TABLA" IN THE MARK IS "LARGE TABLE".

FOR ALCOHOLIC BEVERAGES, NAMELY, ORANGE LIQUEUR (U.S. CLS. 47 AND 49).

SHAUNIA CARLYLE, EXAMINING ATTORNEY

CLASS 33—(Continued).

SN 85-194,627. SANTICO GROUP, LLC, SANTA ROSA, CA.
FILED 12-9-2010.

ALMA DE ORO

THE MARK CONSISTS OF STANDARD CHARACTERS WITHOUT CLAIM TO ANY PARTICULAR FONT, STYLE, SIZE, OR COLOR.

THE ENGLISH TRANSLATION OF "ALMA DE ORO" IN THE MARK IS "GOLD SOUL".

FOR TEQUILA (U.S. CLS. 47 AND 49).

NELSON SNYDER, EXAMINING ATTORNEY

SN 85-204,311. MATTHEW RORICK WINES, INC., NAPA, CA. FILED S.R. 12-22-2010; AM. P.R. 4-27-2011.

SN 85-148,757. MANOS NEGRAS S.A., MENDOZA, ARGENTINA, FILED 10-8-2010.



THE MARK CONSISTS OF THE STYLIZED WORDS "MANOS NEGRAS", WITH THE WORD "MANOS" APPEARING ABOVE THE WORD "NEGRAS".

THE ENGLISH TRANSLATION OF "MANOS NEGRAS" IN THE MARK IS "DIRTY HANDS".

FOR WINE (U.S. CLS. 47 AND 49).

NATALIE POLZER, EXAMINING ATTORNEY

Dexter Lake



THE NAME "DEXTER LAKE" DOES NOT IDENTIFY A LIVING INDIVIDUAL.

THE MARK CONSISTS OF A STYLIZED HANDLEBAR MUSTACHE AND THE WORDS "DEXTER LAKE".

FOR GRAPE WINE (U.S. CLS. 47 AND 49).

FIRST USE 10-19-2009; IN COMMERCE 10-19-2009.

MARK T. MULLEN, EXAMINING ATTORNEY

SN 85-176,955. VINA CONO SUR S.A., LAS CONDES, SANTIAGO, CHILE, FILED 11-15-2010.

ISLA NEGRA

THE MARK CONSISTS OF STANDARD CHARACTERS WITHOUT CLAIM TO ANY PARTICULAR FONT, STYLE, SIZE, OR COLOR.

THE ENGLISH TRANSLATION OF "ISLA NEGRA" IN THE MARK IS BLACK ISLAND.

FOR WINE (U.S. CLS. 47 AND 49).

FIRST USE 2-2-2003; IN COMMERCE 2-2-2003.

ANDREA HACK, EXAMINING ATTORNEY

SN 85-215,749. MARK ANTHONY PROPERTIES LTD., VANCOUVER, BC, CANADA, FILED 1-12-2011.



OWNER OF U.S. REG. NOS. 2,532,186, 2,720,573 AND 3,104,024.

NO CLAIM IS MADE TO THE EXCLUSIVE RIGHT TO USE "FAMILY ESTATE", APART FROM THE MARK AS SHOWN.

THE MARK CONSISTS OF THE WORDS "MISSION HILL", STACKED OVER THE WORDS "FAMILY ESTATE", IN STYLIZED FONTS. A PELICAN DESIGN APPEARS OVER THE LITERAL ELEMENT "MISSION HILL". A RECTANGULAR BORDER OUTLINES THE MARK.

FOR WINES (U.S. CLS. 47 AND 49).

FIRST USE 8-21-2007; IN COMMERCE 8-21-2007.

BARBARA BROWN, EXAMINING ATTORNEY

CLASS 33—(Continued).

SN 85-217,351. GREAT DOMAINS & ESTATES, LLC, WILLIAMSVILLE, NY. FILED 1-13-2011.

SIMPLY DELICIOUS

THE MARK CONSISTS OF STANDARD CHARACTERS WITHOUT CLAIM TO ANY PARTICULAR FONT, STYLE, SIZE, OR COLOR.

NO CLAIM IS MADE TO THE EXCLUSIVE RIGHT TO USE "DELICIOUS", APART FROM THE MARK AS SHOWN. FOR ALCOHOLIC BEVERAGES EXCEPT BEERS (U.S. CLS. 47 AND 49).

TARA PATE, EXAMINING ATTORNEY

SN 85-221,247. YOCHA DEHE WINTUN NATION, BROOKS, CA. FILED 1-19-2011.



THE MARK CONSISTS OF A PAW PRINT IN A SEAL. FOR WINE (U.S. CLS. 47 AND 49).
KATHY DE JONGE, EXAMINING ATTORNEY

SN 85-227,716. EL AFAN SPIRITS COMPANY, EL PASO, TX. FILED 1-27-2011.



THE MARK CONSISTS OF THE STYLIZED TERMS "EL AFAN" ABOVE A DESIGN ELEMENT FEATURING 7 RAYS ON THE OUTSIDE AND 6 RAYS ON THE INSIDE.

THE ENGLISH TRANSLATION OF "EL AFAN" IN THE MARK IS "DESIRE".

FOR TEQUILA (U.S. CLS. 47 AND 49).
FIRST USE 12-0-2010; IN COMMERCE 12-0-2010.
LOURDES AYALA, EXAMINING ATTORNEY

CLASS 33—(Continued).

SN 85-237,926. BERGSTROM WINES LLC, NEWBERG, OR. FILED 2-9-2011.



OWNER OF U.S. REG. NO. 3,539,688.
THE MARK CONSISTS OF A CREST DESIGN WITH THE WORDS "BERGSTROM - DE LANCELLOTTI" ON A BANNER AT THE TOP.

FOR WINE (U.S. CLS. 47 AND 49).
FIRST USE 0-0-2000; IN COMMERCE 0-0-2000.
PAM WILLIS, EXAMINING ATTORNEY

SN 85-242,296. CASSATA-SONOMA, LLC, PALOS PARK, IL. FILED 2-15-2011.

**Utopium Cassata-Sonoma
Vineyards**

THE MARK CONSISTS OF STANDARD CHARACTERS WITHOUT CLAIM TO ANY PARTICULAR FONT, STYLE, SIZE, OR COLOR.

NO CLAIM IS MADE TO THE EXCLUSIVE RIGHT TO USE "VINEYARDS", APART FROM THE MARK AS SHOWN.

FOR WINES PRODUCED FROM GRAPES GROWN IN SONOMA COUNTY (U.S. CLS. 47 AND 49).
KIMBERLY FRYE, EXAMINING ATTORNEY

CLASS 33—(Continued).

SN 85-243,231. NEIMENGGU AOCHUN WINE INDUSTRY CO., LTD., NEIMENGGU, CHINA, FILED 2-15-2011.

養身道酒

NO CLAIM IS MADE TO THE EXCLUSIVE RIGHT TO USE THE NON-LATIN CHARACTER THAT MEANS "ALCOHOL", APART FROM THE MARK AS SHOWN.

THE MARK CONSISTS OF STYLIZED CHINESE CHARACTERS.

THE ENGLISH TRANSLATION OF YANG SHEN DAO JIU IN THE MARK IS MAINTAIN BODY METHOD ALCOHOL.

THE NON-LATIN CHARACTERS IN THE MARK TRANSLITERATE TO YANG SHEN DAO JIU AND THIS MEANS MAINTAIN BODY METHOD ALCOHOL IN ENGLISH.

FOR ARRACK; BRANDY; DISTILLED SPIRITS; LIQUEURS; SAKE; SPIRITS; SPIRITS AND LIQUEURS; WINE; WINE-BASED BEVERAGE, NAMELY, PIQUETTE (U.S. CLS. 47 AND 49).

FIRST USE 3-20-2009; IN COMMERCE 3-20-2009.
JEFF DEFORD, EXAMINING ATTORNEY

CLASS 33—(Continued).

SN 85-244,917. FERNANDO MORA TORRIJO, ZARAGOZA, SPAIN, FILED 2-17-2011.



THE COLOR(S) WHITE AND GRAY IS/ARE CLAIMED AS A FEATURE OF THE MARK.

THE MARK CONSISTS OF A GRAY HEART WITH A WHITE INTERIOR. EXTENDING FROM THE TOP OF THE HEART IS A CURLY LINE IN GRAY AND WHITE, AND BENEATH THE HEART IS THE WORDING "LATIDOS DE VINO" IN GRAY.

THE ENGLISH TRANSLATION OF "LATIDOS DE VINO" IN THE MARK IS "BEATS OF WINE".

FOR ALCOHOLIC BEVERAGES EXCEPT BEERS (U.S. CLS. 47 AND 49).
MARTHA FROMM, EXAMINING ATTORNEY

SN 85-243,631. NAVARRE CELLARS LTD., DBA HARD ROW TO HOE VINEYARDS, CHELAN, WA. FILED 2-16-2011.

SN 85-249,957. J FILIPPI VINTAGE COMPANY, DBA JOSEPH FILIPPI WINERY, RANCHO CUCAMONGA, CA. FILED 2-23-2011.

After Noon Delight

Summer Sunset Red

THE MARK CONSISTS OF STANDARD CHARACTERS WITHOUT CLAIM TO ANY PARTICULAR FONT, STYLE, SIZE, OR COLOR.

FOR GRAPE WINE; RED WINE; RED WINES; STILL WINES; SWEET WINES; TABLE WINES; WHITE WINE; WINE; WINES (U.S. CLS. 47 AND 49).

FIRST USE 2-14-2011; IN COMMERCE 2-14-2011.
GEORGE LORENZO, EXAMINING ATTORNEY

THE MARK CONSISTS OF STANDARD CHARACTERS WITHOUT CLAIM TO ANY PARTICULAR FONT, STYLE, SIZE, OR COLOR.

NO CLAIM IS MADE TO THE EXCLUSIVE RIGHT TO USE "RED", APART FROM THE MARK AS SHOWN.

FOR GRAPE WINE; RED WINE; RED WINES; STILL WINES; TABLE WINES; WINE; WINES; WINES DERIVED FROM GRAPES GROWN IN CALIFORNIA, LABELED AND ADVERTISED IN COMPLIANCE WITH FEDERAL LAWS FOR TAX AND TRADE BUREAU (U.S. CLS. 47 AND 49).

FIRST USE 12-2-2009; IN COMMERCE 1-1-2010.
BARBARA RUTLAND, EXAMINING ATTORNEY

CLASS 33—(Continued).

SN 85-250,009. TONELLA, STEVE, SEBASTOPOL, CA. FILED 2-23-2011.

LA MALCONTENTA

THE MARK CONSISTS OF STANDARD CHARACTERS WITHOUT CLAIM TO ANY PARTICULAR FONT, STYLE, SIZE, OR COLOR.

THE ENGLISH TRANSLATION OF "LA MALCONTENTA" IN THE MARK IS "THE DISCONTENTED".

FOR WINES (U.S. CLS. 47 AND 49).

DAVID TOOLEY, EXAMINING ATTORNEY

CLASS 33—(Continued).

SN 85-252,172. PRECEPT BRANDS LLC, SEATTLE, WA. FILED 2-25-2011.

CONFECTIONER'S CHOCOLATE

THE MARK CONSISTS OF STANDARD CHARACTERS WITHOUT CLAIM TO ANY PARTICULAR FONT, STYLE, SIZE, OR COLOR.

NO CLAIM IS MADE TO THE EXCLUSIVE RIGHT TO USE "CHOCOLATE", APART FROM THE MARK AS SHOWN.

FOR WINE (U.S. CLS. 47 AND 49).

TOBY BULLOFF, EXAMINING ATTORNEY

SN 85-251,757. LES GRANDS CHAIS DE FRANCE S.A.S., PETERSBACH, FRANCE, FILED 2-25-2011.

CHAISE LONGUE

THE MARK CONSISTS OF STANDARD CHARACTERS WITHOUT CLAIM TO ANY PARTICULAR FONT, STYLE, SIZE, OR COLOR.

FOR WINES, SPARKLING WINES, SPIRITS AND LIQUORS (U.S. CLS. 47 AND 49).

GIANCARLO CASTRO, EXAMINING ATTORNEY

SN 85-252,179. PRECEPT BRANDS LLC, SEATTLE, WA. FILED 2-25-2011.

CHOCOLATE SHOP CRÈME DE COCOA

THE MARK CONSISTS OF STANDARD CHARACTERS WITHOUT CLAIM TO ANY PARTICULAR FONT, STYLE, SIZE, OR COLOR.

NO CLAIM IS MADE TO THE EXCLUSIVE RIGHT TO USE "CHOCOLATE" AND "CRÈME DE COCOA", APART FROM THE MARK AS SHOWN.

FOR WINE (U.S. CLS. 47 AND 49).

TOBY BULLOFF, EXAMINING ATTORNEY

SN 85-251,943. WEST BAY ESTATES, LLC, CHANDLER, AZ. FILED 2-25-2011.

Lake Effect Wines

THE MARK CONSISTS OF STANDARD CHARACTERS WITHOUT CLAIM TO ANY PARTICULAR FONT, STYLE, SIZE, OR COLOR.

NO CLAIM IS MADE TO THE EXCLUSIVE RIGHT TO USE "WINES", APART FROM THE MARK AS SHOWN.

FOR WINES (U.S. CLS. 47 AND 49).

MAYUR VAGHANI, EXAMINING ATTORNEY

SN 85-252,763. CAPITAL BRANDS, LLC., HENDERSON, NV. FILED 2-27-2011.

RODDY REDNECK

THE MARK CONSISTS OF STANDARD CHARACTERS WITHOUT CLAIM TO ANY PARTICULAR FONT, STYLE, SIZE, OR COLOR.

THE NAME "RODDY REDNECK" DOES NOT IDENTIFY A LIVING INDIVIDUAL.

FOR DISTILLED SPIRITS (U.S. CLS. 47 AND 49).

MARIA-VICTORIA SUAREZ, EXAMINING ATTORNEY

CLASS 33—(Continued).

SN 85-253,256. PANEBIANCO LLC, NEW YORK, NY. FILED 2-28-2011.

RAPET

THE MARK CONSISTS OF STANDARD CHARACTERS WITHOUT CLAIM TO ANY PARTICULAR FONT, STYLE, SIZE, OR COLOR.
OWNER OF U.S. REG. NO. 2,977,812.
FOR WINE (U.S. CLS. 47 AND 49).
FIRST USE 3-1-2005; IN COMMERCE 3-1-2005.
GENE MACIOL, EXAMINING ATTORNEY

CLASS 33—(Continued).

SN 85-254,648. WINEBOW, INC., MONTVALE, NJ. FILED 3-1-2011.

UNDERCURRENT

THE MARK CONSISTS OF STANDARD CHARACTERS WITHOUT CLAIM TO ANY PARTICULAR FONT, STYLE, SIZE, OR COLOR.
FOR WINE (U.S. CLS. 47 AND 49).
KALIE KUNG, EXAMINING ATTORNEY

SN 85-254,777. VIÑEDOS EMILIANA S.A., SANTIAGO, CHILE. FILED 3-1-2011.

SN 85-253,425. JACK JOHN INVESTMENTS, INC., PASA ROBLES, CA. FILED 2-28-2011.



THE MARK CONSISTS OF AN UNCLOSED CIRCULAR DESIGN WITH THE WORD "MALSTRIA" IN THE CENTER OF THE CIRCLE AND WITH THE SAME WORD "MALSTRIA" UPSIDE DOWN UNDER "MALSTRIA".
FOR WINES (U.S. CLS. 47 AND 49).
HEATHER SAPP, EXAMINING ATTORNEY

O BY EMILIANA

THE MARK CONSISTS OF STANDARD CHARACTERS WITHOUT CLAIM TO ANY PARTICULAR FONT, STYLE, SIZE, OR COLOR.
THE WORDING "EMILIANA" HAS NO MEANING IN A FOREIGN LANGUAGE.
FOR ALCOHOLIC BEVERAGES, NAMELY, GIN, VODKA, AND BRANDY SPIRITS; WINES (U.S. CLS. 47 AND 49).
DANIEL CAPSHAW, EXAMINING ATTORNEY

SN 85-254,972. CASTLE BRANDS INC., NEW YORK, NY. FILED 3-1-2011.

SN 85-254,335. PARAMOUNT DISTILLERS, INC., CLEVELAND, OH. FILED 3-1-2011.

COLONIAL CLUB

THE MARK CONSISTS OF STANDARD CHARACTERS WITHOUT CLAIM TO ANY PARTICULAR FONT, STYLE, SIZE, OR COLOR.
FOR ALCOHOLIC BEVERAGES EXCLUDING BEER (U.S. CLS. 47 AND 49).
FIRST USE 6-1-1953; IN COMMERCE 6-1-1953.
JULIE GUTTADAURO, EXAMINING ATTORNEY

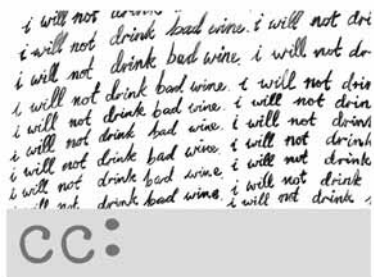

THE MARK CONSISTS OF THE WORDS "I WILL NOT DRINK BAD WINE" IN REPETITION AND IN LOWER CASE SCRIPT WITH THE LETTERS "CC" AND A COLON ALL APPEARING ON A LABEL.
FOR WINE (U.S. CLS. 47 AND 49).
FIRST USE 8-25-2010; IN COMMERCE 8-25-2010.
DANNEAN HETZEL, EXAMINING ATTORNEY

CLASS 33—(Continued).

SN 85-254,992. CASTLE BRANDS INC., NEW YORK, NY. FILED 3-1-2011.

I WILL NOT DRINK BAD WINE

THE MARK CONSISTS OF STANDARD CHARACTERS WITHOUT CLAIM TO ANY PARTICULAR FONT, STYLE, SIZE, OR COLOR.

FOR WINE (U.S. CLS. 47 AND 49).
FIRST USE 8-25-2010; IN COMMERCE 8-25-2010.
DANNEAN HETZEL, EXAMINING ATTORNEY

CLASS 33—(Continued).

SN 85-255,478. IV SCIENCE, LLC, DBA GREEN & CO., BUFFALO, NY. FILED 3-2-2011.

Pure1

THE MARK CONSISTS OF THE STYLIZED WORDING "PURE1".

FOR ALCOHOLIC COCKTAIL MIXES (U.S. CLS. 47 AND 49).
JAMES LOVELACE, EXAMINING ATTORNEY

SN 85-255,027. CASTLE BRANDS INC., NEW YORK, NY. FILED 3-1-2011.

BETTS & SCHOLL

THE MARK CONSISTS OF STANDARD CHARACTERS WITHOUT CLAIM TO ANY PARTICULAR FONT, STYLE, SIZE, OR COLOR.

FOR WINE (U.S. CLS. 47 AND 49).
FIRST USE 6-1-2004; IN COMMERCE 6-1-2004.
DANNEAN HETZEL, EXAMINING ATTORNEY

SN 85-255,552. BLACK ICE BEVERAGES, LLC, WEST BLOOMFIELD, MI. FILED 3-2-2011.

SEX ICE

THE MARK CONSISTS OF STANDARD CHARACTERS WITHOUT CLAIM TO ANY PARTICULAR FONT, STYLE, SIZE, OR COLOR.

FOR ALCOHOLIC BEVERAGES, NAMELY, FROZEN ALCOHOLIC COCKTAIL MIXES (U.S. CLS. 47 AND 49).
JAMES LOVELACE, EXAMINING ATTORNEY

SN 85-255,037. PIERCE, SEAN, LAS VEGAS, NV. FILED 3-1-2011.

STALT

THE MARK CONSISTS OF STANDARD CHARACTERS WITHOUT CLAIM TO ANY PARTICULAR FONT, STYLE, SIZE, OR COLOR.

FOR FLAVORED BREWED MALT BEVERAGE; ALCOHOLIC BEVERAGES EXCEPT BEERS; ALCOHOLIC MIXED BEVERAGES EXCEPT BEERS (U.S. CLS. 47 AND 49).

FIRST USE 1-12-2010; IN COMMERCE 9-15-2010.
GENE MACIOL, EXAMINING ATTORNEY

SN 85-256,015. ZUCCARDI, JOSÉ ALBERTO, MAIPU, MENDOZA PROV, ARGENTINA, FILED 3-2-2011.

fuZion
ALTA

THE MARK CONSISTS OF "FUZION ALTA" IN A STYLIZED FONT.

THE WORDING "FUZION" HAS NO MEANING IN A FOREIGN LANGUAGE.

THE ENGLISH TRANSLATION OF THE WORD "ALTA" IN THE MARK IS HIGH.

FOR WINE (U.S. CLS. 47 AND 49).
WILLIAM ROSSMAN, EXAMINING ATTORNEY

CLASS 33—(Continued).

SN 85-256,029. AURORA VINEYARDS, INC., CALISTOGA, CA. FILED 3-2-2011.

CLASS 33—(Continued).

SN 85-256,492. VILUKO VINEYARDS INC, SAN FRANCISCO, CA. FILED 3-3-2011.

KINGS ROW

VILUKO

THE MARK CONSISTS OF STANDARD CHARACTERS WITHOUT CLAIM TO ANY PARTICULAR FONT, STYLE, SIZE, OR COLOR.
FOR WINE (U.S. CLS. 47 AND 49).
KHANH LE, EXAMINING ATTORNEY

THE MARK CONSISTS OF STANDARD CHARACTERS WITHOUT CLAIM TO ANY PARTICULAR FONT, STYLE, SIZE, OR COLOR.
FOR WINES (U.S. CLS. 47 AND 49).
KATHRYN COWARD, EXAMINING ATTORNEY

SN 85-256,061. KAUTZ VINEYARDS, INC, DBA IRONSTONE VINEYARDS, MURPHY'S, CA. FILED 3-2-2011.

SN 85-256,635. DENNIS HILL, HEALDSBURG, CA. FILED 3-3-2011.

STONE VALLEY

RUMPELSTILTSKIN

THE MARK CONSISTS OF STANDARD CHARACTERS WITHOUT CLAIM TO ANY PARTICULAR FONT, STYLE, SIZE, OR COLOR.
FOR WINE (U.S. CLS. 47 AND 49).
FIRST USE 12-31-2006; IN COMMERCE 12-31-2006.
JORDAN BAKER, EXAMINING ATTORNEY

THE MARK CONSISTS OF STANDARD CHARACTERS WITHOUT CLAIM TO ANY PARTICULAR FONT, STYLE, SIZE, OR COLOR.
FOR WINES (U.S. CLS. 47 AND 49).
COLLEEN DOMBROW, EXAMINING ATTORNEY

SN 85-256,170. TERREDIVINO, LLC, SANTA BARBARA, CA. FILED 3-2-2011.

SN 85-257,112. GLJR WINE LLC, NAPA, CA. FILED 3-3-2011.

RARUS

G&G WINES

THE MARK CONSISTS OF STANDARD CHARACTERS WITHOUT CLAIM TO ANY PARTICULAR FONT, STYLE, SIZE, OR COLOR.
THE WORDING "RARUS" HAS NO MEANING IN A FOREIGN LANGUAGE.
FOR WINE; WINES (U.S. CLS. 47 AND 49).
JORDAN BAKER, EXAMINING ATTORNEY

THE MARK CONSISTS OF STANDARD CHARACTERS WITHOUT CLAIM TO ANY PARTICULAR FONT, STYLE, SIZE, OR COLOR.
NO CLAIM IS MADE TO THE EXCLUSIVE RIGHT TO USE "WINES", APART FROM THE MARK AS SHOWN.
FOR WINE (U.S. CLS. 47 AND 49).
NELSON SNYDER, EXAMINING ATTORNEY

CLASS 33—(Continued).

SN 85-257,297. SPIRITS MARQUE ONE LLC, NEW YORK, NY. FILED 3-3-2011.

MISTER SVEDKA

THE MARK CONSISTS OF STANDARD CHARACTERS WITHOUT CLAIM TO ANY PARTICULAR FONT, STYLE, SIZE, OR COLOR.

OWNER OF U.S. REG. NOS. 2,126,196, 3,483,861 AND OTHERS.

FOR DISTILLED SPIRITS (U.S. CLS. 47 AND 49).
KATHERINE CHANG, EXAMINING ATTORNEY



SN 85-257,342. JULIAN ENRIQUE CAVAGNARO, MAIPU, MENDOZA, ARGENTINA. FILED 3-3-2011.



THE MARK CONSISTS OF A HOUSE OVER THE MARK "CAVAGNARO".

FOR WINES (U.S. CLS. 47 AND 49).
FIRST USE 0-0-2007; IN COMMERCE 0-0-2007.
DANNEAN HETZEL, EXAMINING ATTORNEY



SN 85-257,969. SONS OF LIBERTY SPIRITS COMPANY, NARRAGANSETT, RI. FILED 3-4-2011.

Loyal Nine

THE MARK CONSISTS OF STANDARD CHARACTERS WITHOUT CLAIM TO ANY PARTICULAR FONT, STYLE, SIZE, OR COLOR.

FOR SPIRITS; VODKA (U.S. CLS. 47 AND 49).
MELISSA VALLILLO, EXAMINING ATTORNEY

CLASS 33—(Continued).

SN 85-259,317. BUSINESSB, RAMAT-GAN, ISRAEL, FILED 3-7-2011.

ILUSIÓN

THE COLOR(S) BLACK AND BROWN IS/ARE CLAIMED AS A FEATURE OF THE MARK.

THE MARK CONSISTS OF WORD "ILUSION" WHEREIN THERE IS ACCENT ABOVE THE LETTER "S" AND THE LETTER "O" IS IN TWO PARTS, THE UPPER ONE IS IN BLACK COLOR AND THE LOWER ONE IS IN BROWN COLOR AND THE LETTERS "ILUSIN" IS IN BLACK COLOR WITH BROWN OUTLINE AS SHOWN IN THE MARK.

THE ENGLISH TRANSLATION OF "ILUSION" IN THE MARK IS ILLUSION.

FOR ALCOHOLIC BEVERAGES EXCEPT BEERS; TEQUILA (U.S. CLS. 47 AND 49).
TASNEEM HUSSAIN, EXAMINING ATTORNEY



SN 85-262,030. MERCER WINE ESTATES, LLC, PROSSER, WA. FILED 3-9-2011.

MERCER

THE MARK CONSISTS OF STANDARD CHARACTERS WITHOUT CLAIM TO ANY PARTICULAR FONT, STYLE, SIZE, OR COLOR.

OWNER OF U.S. REG. NO. 3,528,762.
FOR WINE (U.S. CLS. 47 AND 49).
FIRST USE 1-28-2008; IN COMMERCE 1-28-2008.
SANI KHOURI, EXAMINING ATTORNEY



SN 85-310,943. E. & J. GALLO WINERY, MODESTO, CA. FILED 5-3-2011.

SWEETER BY THE DOZEN

THE MARK CONSISTS OF STANDARD CHARACTERS WITHOUT CLAIM TO ANY PARTICULAR FONT, STYLE, SIZE, OR COLOR.

FOR WINES (U.S. CLS. 47 AND 49).
NORA BUCHANAN WILL, EXAMINING ATTORNEY

CLASS 33—(Continued).

SN 85-311,851. INTERCONTINENTAL PACKAGING CO., ST. PAUL, MN. FILED 5-4-2011.

BABAROSA

THE MARK CONSISTS OF STANDARD CHARACTERS WITHOUT CLAIM TO ANY PARTICULAR FONT, STYLE, SIZE, OR COLOR.

THE WORDING "BABAROSA" HAS NO MEANING IN A FOREIGN LANGUAGE.

FOR ALCOHOLIC BEVERAGES EXCEPT BEERS (U.S. CLS. 47 AND 49).

ALEXANDER L. POWERS, EXAMINING ATTORNEY

CLASS 34—(Continued).

SN 77-335,416. DAVIDOFF & CIE SA, GENÈVE, SWITZERLAND, FILED 11-21-2007.

MILLENNIUM

THE MARK CONSISTS OF STANDARD CHARACTERS WITHOUT CLAIM TO ANY PARTICULAR FONT, STYLE, SIZE, OR COLOR.

FOR CIGARS WITH A WEIGHT OF AT LEAST FIVE GRAMS PER PIECE (U.S. CLS. 2, 8, 9 AND 17).

FIRST USE 9-11-2000; IN COMMERCE 9-11-2000.

KARANENDRA S. CHHINA, EXAMINING ATTORNEY

SN 85-315,817. INTERCONTINENTAL PACKAGING CO., ST. PAUL, MN. FILED 5-9-2011.

SONNENBAND

THE MARK CONSISTS OF STANDARD CHARACTERS WITHOUT CLAIM TO ANY PARTICULAR FONT, STYLE, SIZE, OR COLOR.

THE ENGLISH TRANSLATION OF "SONNENBAND" IN THE MARK IS "SUN RAYS".

FOR ALCOHOLIC BEVERAGES EXCEPT BEERS (U.S. CLS. 47 AND 49).

ALEXANDER L. POWERS, EXAMINING ATTORNEY

SN 77-335,423. DAVIDOFF & CIE SA, GENÈVE, SWITZERLAND, FILED 11-21-2007.

MILLENNIUM BLEND

THE MARK CONSISTS OF STANDARD CHARACTERS WITHOUT CLAIM TO ANY PARTICULAR FONT, STYLE, SIZE, OR COLOR.

NO CLAIM IS MADE TO THE EXCLUSIVE RIGHT TO USE "BLEND", APART FROM THE MARK AS SHOWN.

FOR CIGARS WITH A WEIGHT OF AT LEAST FIVE GRAMS PER PIECE (U.S. CLS. 2, 8, 9 AND 17).

FIRST USE 8-20-2001; IN COMMERCE 8-20-2001.

KARANENDRA S. CHHINA, EXAMINING ATTORNEY

CLASS 34—SMOKERS' ARTICLES

SN 76-706,404. RICHARD P. MELOGRANO, GARDENA, CA. FILED 2-14-2011.

EMBUR LITE

THE MARK CONSISTS OF STANDARD CHARACTERS WITHOUT CLAIM TO ANY PARTICULAR FONT, STYLE, SIZE, OR COLOR.

NO CLAIM IS MADE TO THE EXCLUSIVE RIGHT TO USE "LITE", APART FROM THE MARK AS SHOWN.

FOR FLAMELESS TOBACCO LIGHTER (U.S. CLS. 2, 8, 9 AND 17).

KRISTINA MORRIS, EXAMINING ATTORNEY

SN 77-957,943. INTERNATIONAL ODDITIES, INC., ROLLING HILLS, CA. FILED 3-12-2010.

DELUXE DUTCH

THE MARK CONSISTS OF STANDARD CHARACTERS WITHOUT CLAIM TO ANY PARTICULAR FONT, STYLE, SIZE, OR COLOR.

NO CLAIM IS MADE TO THE EXCLUSIVE RIGHT TO USE "DELUXE", APART FROM THE MARK AS SHOWN.

FOR HERBS FOR SMOKING; CIGARETTE CASES; LIGHTERS FOR SMOKERS NOT OF PRECIOUS METAL NOT FOR AUTOMOBILES; CIGARETTE ROLLING PAPERS; CIGARETTE ROLLING MACHINES; MATCH BOXES (U.S. CLS. 2, 8, 9 AND 17).

HEATHER THOMPSON, EXAMINING ATTORNEY

CLASS 34—(Continued).

SN 79-081,594. GALLAHER LIMITED, UNITED KINGDOM, FILED 3-17-2010.

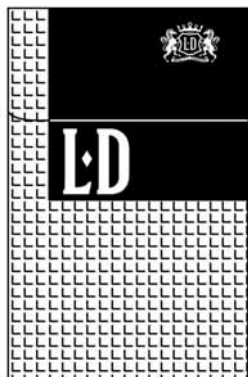

PRIORITY DATE OF 12-7-2009 IS CLAIMED.
OWNER OF INTERNATIONAL REGISTRATION 1036011 DATED 3-17-2010, EXPIRES 3-17-2020.
OWNER OF U.S. REG. NO. 3,704,340.
NO CLAIM IS MADE TO THE EXCLUSIVE RIGHT TO USE "QUALITY TOBACCO", APART FROM THE MARK AS SHOWN.

THE MARK CONSISTS OF A DESIGN OF THE DISTINCTIVE PACKAGING FOR THE GOODS. THERE IS A SQUARE AT THE TOP RIGHT HAND SIDE OF THE PACKAGING WITH A DESIGN FEATURE AT THE TOP RIGHT CORNER AND THE LETTERS "L D" AT THE BOTTOM LEFT HAND CORNER OF THE SQUARE. THE DESIGN FEATURE CONSISTS OF THE LETTERS "LD" WITHIN A SHIELD COMPRISED OF TWO STYLIZED HORSES FLANKING A SHIELD AND TOPPED BY A CROWN, A BANNER AT THE BOTTOM OF THE SHIELD DESIGN CONTAINS THE WORDING "QUALITY TOBACCO". IN ADDITION, THE LETTERS "L D" APPEAR IN STYLIZED LETTERING AT THE BOTTOM LEFT HAND CORNER OF THE SQUARE WITH A SMALL DIAMOND CENTERED BETWEEN THE LETTERS "L" AND "D". THE REMAINING BACKGROUND OF THE PACKAGING IS COVERED IN SMALL SQUARES. THE DOTTED LINES APPEARING AROUND THE PERIMETER OF THE DESIGN REPRESENT THE SHAPE OF A CIGARETTE BOX. A QUARTER OF THE WAY DOWN THE DESIGN APPEARS A HORIZONTAL LINE WHICH REPRESENTS THE FLIP TOP OF THE BOX.

FOR RAW AND MANUFACTURED TOBACCO, SMOKING TOBACCO, PIPE TOBACCO, HAND-ROLLED TOBACCO, CHEWING TOBACCO; CIGARETTES, CIGARS, CIGARILLOS; SNUFF; MOIST TOBACCO POWDER, NAMELY, SNUF; CIGARETTE PAPER, CIGARETTE TUBES; SMOKERS' ARTICLES, NAMELY, CIGARETTE PAPER, CIGARETTE FILTERS, CIGARETTE CASES NOT OF PRECIOUS METAL; CIGARETTE HOLDERS NOT OF PRECIOUS METAL; LIGHTERS FOR SMOKERS; MATCHES (U.S. CLS. 2, 8, 9 AND 17).

RONALD AIKENS, EXAMINING ATTORNEY

CLASS 34—(Continued).

SN 85-195,495. JESSEE, ROBERT, HEMET, CA. FILED 12-10-2010.

Vapors It's Pure Lifestyle

THE MARK CONSISTS OF STANDARD CHARACTERS WITHOUT CLAIM TO ANY PARTICULAR FONT, STYLE, SIZE, OR COLOR.

NO CLAIM IS MADE TO THE EXCLUSIVE RIGHT TO USE "VAPORS", APART FROM THE MARK AS SHOWN, FOR ELECTRONIC CIGARETTES (U.S. CLS. 2, 8, 9 AND 17).

GRETCHEN ULRICH, EXAMINING ATTORNEY

SN 85-251,616. YELLOWSTONE TOBACCO CO., LLC, FRANKIE, WY. FILED 2-25-2011.

BIG BAG

THE MARK CONSISTS OF STANDARD CHARACTERS WITHOUT CLAIM TO ANY PARTICULAR FONT, STYLE, SIZE, OR COLOR.

FOR CIGARETTE PAPER; CIGARETTE PAPERS; CIGARETTE ROLLING MACHINES; CIGARETTE ROLLING PAPERS; CIGARETTE TUBES; CIGARETTES (U.S. CLS. 2, 8, 9 AND 17).

FIRST USE 2-4-2010; IN COMMERCE 2-10-2010.

FRED CARL, EXAMINING ATTORNEY

SN 85-256,006. K. HANSOTIA & CO., INC., MIAMI, FL. FILED 3-2-2011.

UGLY STIXS

THE MARK CONSISTS OF STANDARD CHARACTERS WITHOUT CLAIM TO ANY PARTICULAR FONT, STYLE, SIZE, OR COLOR.

FOR CIGARS, TOBACCO, CIGARETTES, CIGARILLOS; TOBACCO PRODUCTS, NAMELY, ROLLING PAPERS AND STUBS; ARTICLES FOR SMOKERS NOT OF PRECIOUS METAL, NAMELY, CIGAR LIGHTERS, CIGARETTE LIGHTERS, CIGAR CASES, CIGARETTE CASES, CIGAR CUTTERS, CIGAR HOLDERS, CIGARETTE HOLDERS, CIGAR TUBES; ROLL YOUR OWN TOBACCO (U.S. CLS. 2, 8, 9 AND 17).

HANNO RITTNER, EXAMINING ATTORNEY

CLASS 34—(Continued).

SN 85-256,774. BRUNETTI, GIANNI, MIAMI, FL. AND PINTO, MIGUEL, MIAMI, FL. FILED 3-3-2011.

MERC

THE MARK CONSISTS OF STANDARD CHARACTERS WITHOUT CLAIM TO ANY PARTICULAR FONT, STYLE, SIZE, OR COLOR.

FOR CIGARS (U.S. CLS. 2, 8, 9 AND 17).
FIRST USE 8-31-2010; IN COMMERCE 1-15-2011.
RAMONA ORTIGA, EXAMINING ATTORNEY

CLASS 34—(Continued).

SN 85-301,742. AKRUM ALRAHIB, COMMERCE, CA. FILED 4-21-2011.

Cali Green

THE MARK CONSISTS OF STANDARD CHARACTERS WITHOUT CLAIM TO ANY PARTICULAR FONT, STYLE, SIZE, OR COLOR.

NO CLAIM IS MADE TO THE EXCLUSIVE RIGHT TO USE "CALI", APART FROM THE MARK AS SHOWN.

FOR CIGAR BOXES; CIGAR BOXES NOT OF PRECIOUS METAL; CIGAR CASES; CIGAR CUTTERS; CIGAR HOLDERS; CIGAR LIGHTERS; CIGARS; TOBACCO, CIGARS AND CIGARETTES (U.S. CLS. 2, 8, 9 AND 17).
SANDRA BUJA, EXAMINING ATTORNEY

SN 85-256,930. CIGARS INTERNATIONAL, INC., BETHLEHEM, PA. FILED 3-3-2011.

GENERAL GRANT

THE MARK CONSISTS OF STANDARD CHARACTERS WITHOUT CLAIM TO ANY PARTICULAR FONT, STYLE, SIZE, OR COLOR.

FOR CIGARS (U.S. CLS. 2, 8, 9 AND 17).
DOMINIC J. FERRAUOLO, EXAMINING ATTORNEY

SN 85-301,747. AKRUM ALRAHIB, COMMERCE, CA. FILED 4-21-2011.

Keep it on the Hush

THE MARK CONSISTS OF STANDARD CHARACTERS WITHOUT CLAIM TO ANY PARTICULAR FONT, STYLE, SIZE, OR COLOR.

FOR CIGAR AND CIGARETTE BOXES; CIGAR AND CIGARETTE BOXES NOT OF PRECIOUS METAL; CIGAR BOXES; CIGAR BOXES NOT OF PRECIOUS METAL; CIGAR CASES; CIGAR CUTTERS; CIGAR HOLDERS; CIGAR LIGHTERS; CIGAR TUBES; CIGARS (U.S. CLS. 2, 8, 9 AND 17).
SANDRA BUJA, EXAMINING ATTORNEY

SN 85-257,000. SMOKE INN, LLC, WEST PALM BEACH, FL. FILED 3-3-2011.

KAOS

THE MARK CONSISTS OF STANDARD CHARACTERS WITHOUT CLAIM TO ANY PARTICULAR FONT, STYLE, SIZE, OR COLOR.

FOR CIGARS (U.S. CLS. 2, 8, 9 AND 17).
HEATHER THOMPSON, EXAMINING ATTORNEY

SN 85-309,713. AKRUM ALRAHIB, COMMERCE, CA. FILED 5-2-2011.

HoodWraps Labels

THE MARK CONSISTS OF STANDARD CHARACTERS WITHOUT CLAIM TO ANY PARTICULAR FONT, STYLE, SIZE, OR COLOR.

FOR CIGAR BOXES; CIGAR CUTTERS; CIGAR HOLDERS; CIGARS (U.S. CLS. 2, 8, 9 AND 17).
SANDRA BUJA, EXAMINING ATTORNEY

CLASS 35—(Continued).**SERVICE MARKS****CLASS 35—ADVERTISING AND BUSINESS**

SN 76-702,957. FORREST DORSETT, DBA DORSETT SPORTS MARKETING, PASADENA, CA. FILED 5-14-2010.



NO CLAIM IS MADE TO THE EXCLUSIVE RIGHT TO USE "SPORTS", APART FROM THE MARK AS SHOWN.

THE MARK CONSISTS OF THE WORDING "DORSETT SPORTS" ADJACENT TO A STAR DESIGN SUPERIMPOSED ON A SINGLE LETTER "D".

FOR SERVICES FOR SHAPING THE IMAGE OF ACTIVE OR RETIRED PROFESSIONAL ATHLETES, NAMELY, BRAND DEVELOPMENT FOR INDIVIDUAL CLIENTS AND DEVELOPING AND EXECUTING INTEGRATED MARKETING CAMPAIGNS FOR OTHERS, SERVICES FOR SHAPING THE IMAGE OF ACTIVE AND/OR RETIRED PROFESSIONAL ATHLETES, NAMELY, IMAGE MANAGEMENT BEING PUBLIC RELATIONS FOR FURTHER SHAPING ATHLETE'S BRAND; CRISIS MANAGEMENT SERVICES, NAMELY, PUBLIC RELATIONS SERVICES DURING TIMES OF CRISIS (U.S. CLS. 100, 101 AND 102).

FIRST USE 10-9-2009; IN COMMERCE 10-9-2009.
RUDY R. SINGLETON, EXAMINING ATTORNEY

SN 76-705,531. INGRAM INDUSTRIES INC., NASHVILLE, TN. FILED 12-1-2010.



OWNER OF U.S. REG. NO. 2,363,732.
THE COLOR(S) GREEN, BLACK, GRAY AND WHITE IS/ ARE CLAIMED AS A FEATURE OF THE MARK.

THE MARK CONSISTS OF THE IMAGE OF A STYLIZED LEAF WITH A SPINE RUNNING NEARLY THE LENGTH OF THE LEAF, SAID LEAF INSIDE A GREEN DISK. THE WORDS "SPRING ARBOR" APPEAR TO THE RIGHT OF THE STYLIZED LEAF AND DISC DESIGN. THE COLOR GREEN APPEARS IN THE DISC AND IN THE SPINE OF THE LEAF. THE COLOR BLACK APPEARS IN THE WORD "SPRING". THE COLOR GRAY APPEARS IN THE WORD "ARBOR". THE COLOR WHITE APPEARS IN THE BODY OF THE STYLIZED LEAF.

FOR WHOLESALE DISTRIBUTORSHIP SERVICES IN THE FIELD OF BOOKS, BIBLES, RECORDED VIDEOS, AUDIO AND MUSIC, CARDS AND GIFTS (U.S. CLS. 100, 101 AND 102).

FIRST USE 8-1-2010; IN COMMERCE 8-1-2010.
NANCY CLARKE, EXAMINING ATTORNEY

CLASS 35—(Continued).

SN 76-706,068. NEW YORK WATER BAGEL COMPANY, TOMS RIVER, NJ. FILED 1-19-2011.



NO CLAIM IS MADE TO THE EXCLUSIVE RIGHT TO USE "NEW YORK WATER BAGEL COMPANY", APART FROM THE MARK AS SHOWN.

THE DESIGN CONSISTS OF A HORIZONTAL PIPE ENDING WITH A SPIGOT POURING THREE DROPS WHICH SUCCESSIVELY FORM INTO THE SHAPE OF A BAGEL. ABOVE THE PIPE ARE THE WORDS "NEW YORK WATER", ARRANGED HORIZONTALLY, AND BELOW THE PIPE IS THE WORD "BAGEL" ABOVE THE WORD "COMPANY". "BAGEL" APPEARS IN THE LARGEST TYPEFACE.

FOR RETAIL AND TAKE-OUT BAKERY SHOP FEATURING BAGELS CONTAINING WATER FROM NEW YORK AND RELATED FOOD AND BEVERAGE PRODUCTS AND BAKED GOODS CONTAINING WATER FROM NEW YORK (U.S. CLS. 100, 101 AND 102).

FIRST USE 7-1-2009; IN COMMERCE 7-1-2009.
ROBERT STRUCK, EXAMINING ATTORNEY

SN 76-706,656. RENEWED VISIONS, INC., DALLAS, TX. FILED 3-7-2011.

TAOVEO

THE MARK CONSISTS OF STANDARD CHARACTERS WITHOUT CLAIM TO ANY PARTICULAR FONT, STYLE, SIZE, OR COLOR.

FOR ONLINE RETAIL STORE SERVICES FEATURING OPTICAL EYEWEAR (U.S. CLS. 100, 101 AND 102).
JACQUELINE A. LAVINE, EXAMINING ATTORNEY

SN 76-706,677. TAXCONNECTIONS, INC., LA JOLLA, CA. FILED 3-7-2011.

TAXCONNECTIONS

THE MARK CONSISTS OF STANDARD CHARACTERS WITHOUT CLAIM TO ANY PARTICULAR FONT, STYLE, SIZE, OR COLOR.

FOR ONLINE BUSINESS NETWORKING SERVICES (U.S. CLS. 100, 101 AND 102).
LAURIE MAYES, EXAMINING ATTORNEY

CLASS 35—(Continued).

SN 77-058,934. IDEAL MARKETING, INC., CHICAGO, IL. FILED 12-7-2006.



NO CLAIM IS MADE TO THE EXCLUSIVE RIGHT TO USE "BEVERAGE NETWORK", APART FROM THE MARK AS SHOWN.

THE COLOR(S) RED, ORANGE, YELLOW, BLACK, AND WHITE IS/ARE CLAIMED AS A FEATURE OF THE MARK. THE MARK CONSISTS OF AN ARRAY OF BOTTLES. BELOW THE BOTTLES ARE THE WORDS "IDEAL" AND "BEVERAGE NETWORK" IN AN OUTLINED SHAPE. THE COLOR RED APPEARS IN THE SECOND AND FOURTH BOTTLE DESIGN, THE COLOR ORANGE APPEARS IN THE THIRD AND SIXTH BOTTLE DESIGN, THE COLOR YELLOW APPEARS IN THE FIRST AND FIFTH BOTTLE DESIGN, THE COLOR WHITE APPEARS ON EACH BOTTLE AS A MEANS OF SHOWING THEIR CONTOURS, AND THE COLOR BLACK APPEARS IN THE TEXT "IDEAL BEVERAGE NETWORK".

FOR BUSINESS MANAGEMENT AND MARKETING CONSULTING SERVICES FOR ALCOHOLIC BEVERAGE MANUFACTURERS AND RETAILERS, IN THE FIELD OF RETAIL ALCOHOLIC BEVERAGE SALES (U.S. CLS. 100, 101 AND 102).

LAURA HAMMEL, EXAMINING ATTORNEY

SN 77-058,940. IDEAL MARKETING, INC., CHICAGO, IL. FILED 12-7-2006.



NO CLAIM IS MADE TO THE EXCLUSIVE RIGHT TO USE "BEVERAGE MART", APART FROM THE MARK AS SHOWN.

THE COLOR(S) RED, ORANGE, YELLOW, BLACK, AND WHITE IS/ARE CLAIMED AS A FEATURE OF THE MARK. THE MARK CONSISTS OF AN ARRAY OF BOTTLES. BELOW THE BOTTLES ARE THE WORDS "IDEAL" AND "BEVERAGE MART" IN AN OUTLINED SHAPE. THE COLOR RED APPEARS IN THE SECOND AND FOURTH BOTTLE DESIGN AND IN THE TRANSPARENT PORTIONS OF THE THIRD AND FOURTH BOTTLE DESIGN, AND IN THE WORDING "IDEAL"; THE COLOR ORANGE APPEARS IN THE THIRD AND SIXTH BOTTLE DESIGN, IN THE

CLASS 35—(Continued).

TRANSPARENT PORTIONS OF THE FIFTH BOTTLE DESIGN, AND IN THE WORDING "BEVERAGE MART"; THE COLOR YELLOW APPEARS IN THE FIRST AND FIFTH BOTTLE DESIGN, AND IN THE TRANSPARENT PORTIONS OF THE SECOND BOTTLE DESIGN; THE COLOR BLACK APPEARS AS THE OUTLINE AROUND THE WORDS; THE COLOR WHITE APPEARS ON EACH OF THE BOTTLE NECKS AS A MEANS OF SHOWING THEIR CONTOURS AND BEHIND THE TEXT "IDEAL" AND "BEVERAGE MART".

FOR BUSINESS MANAGEMENT AND MARKETING CONSULTING SERVICES FOR ALCOHOLIC BEVERAGE MANUFACTURERS AND RETAILERS (U.S. CLS. 100, 101 AND 102).

LAURA HAMMEL, EXAMINING ATTORNEY

SN 77-211,068. INTERNATIONAL DATA GROUP, INC., FRAMINGHAM, MA. FILED 6-20-2007.

IDG MARKET FUSION

THE MARK CONSISTS OF STANDARD CHARACTERS WITHOUT CLAIM TO ANY PARTICULAR FONT, STYLE, SIZE, OR COLOR.

OWNER OF U.S. REG. NOS. 3,822,380, 3,861,645 AND OTHERS.

NO CLAIM IS MADE TO THE EXCLUSIVE RIGHT TO USE "MARKET", APART FROM THE MARK AS SHOWN.

FOR BUSINESS AND MARKETING CONSULTATION AND MARKET RESEARCH SERVICES; PROVIDING A WEBSITE FEATURING BUSINESS INFORMATION (U.S. CLS. 100, 101 AND 102).

LAURIE MAYES, EXAMINING ATTORNEY

SN 77-296,377. CONSTRUCTION SOFTWARE TECHNOLOGIES, INC., CINCINNATI, OH. FILED 10-4-2007.

SUPPLYLINK

THE MARK CONSISTS OF STANDARD CHARACTERS WITHOUT CLAIM TO ANY PARTICULAR FONT, STYLE, SIZE, OR COLOR.

FOR ONLINE BUSINESS NETWORKING SERVICES FOR CONNECTING SUPPLIERS, CONTRACTORS, AND CUSTOMERS IN THE CONSTRUCTION INDUSTRY, AND PROVIDING TARGETED ONLINE MARKETING AND ADVERTISING SERVICES FOR OTHERS IN THE CONSTRUCTION FIELD (U.S. CLS. 100, 101 AND 102).

FIRST USE 1-10-2006; IN COMMERCE 1-10-2006.
TASNEEM HUSSAIN, EXAMINING ATTORNEY

CLASS 35—(Continued).

SN 77-392,982. DIRECTV, INC., EL SEGUNDO, CA. FILED 2-8-2008.

CLASS 35—(Continued).

SN 77-611,351. SOLAR PROTECTIVE FACTORY, INC., MADISON, WI. FILED 11-10-2008.

SPF

DIRECTVIEW

THE MARK CONSISTS OF STANDARD CHARACTERS WITHOUT CLAIM TO ANY PARTICULAR FONT, STYLE, SIZE, OR COLOR.

OWNER OF U.S. REG. NO. 1,770,817.
FOR ON-LINE RETAIL STORE SERVICES FEATURING SUN PROTECTIVE CLOTHING (U.S. CLS. 100, 101 AND 102).

FIRST USE 12-0-2003; IN COMMERCE 12-0-2003.
STEVEN R. FINE, EXAMINING ATTORNEY

THE MARK CONSISTS OF STANDARD CHARACTERS WITHOUT CLAIM TO ANY PARTICULAR FONT, STYLE, SIZE, OR COLOR.

FOR MARKET RESEARCH SERVICES; DEMOGRAPHIC AND CONSUMER RESEARCH SERVICES; PROVIDING MARKET RESEARCH AND CONSUMER RESEARCH AND CONSULTING SERVICES, NAMELY, CONDUCTING AND ANALYZING CONSUMER SURVEYS AND ADVERTISING AND MARKETING STUDIES; COMPILING DATA AND INFORMATION AND PROVIDING ANALYSIS IN THE FIELD OF CONSUMER VIEWING AND USAGE HABITS AND BEHAVIOR AND ISSUING REPORTS IN CONNECTION THEREWITH; CONDUCTING AND ANALYZING DEMOGRAPHIC DATA REGARDING POPULATION AND HOUSEHOLD TRENDS FOR COMMERCIAL ADVERTISING PURPOSES; COLLECTING AND ANALYZING DEMOGRAPHIC INFORMATION AND STATISTICS AND ISSUING STATISTICAL REPORTS IN CONNECTION THEREWITH; CONDUCTING CONSUMER OPINION RESEARCH AND PUBLIC OPINION POLLING SERVICES; MEDIA RESEARCH SERVICES, NAMELY, MARKET RESEARCH SERVICES RELATING TO BROADCASTING AND NARROWCASTING OF MEDIA ADVERTISING FOR BUSINESSES; MEDIA RATING SERVICES IN CONNECTION WITH OVER-THE-AIR BROADCAST AND CABLE RATINGS INCLUDING THE TRANSMISSION, RECEPTION AND/OR CONTENT OF SIGNALS DELIVERED BY BROADCAST, SATELLITE, CABLE, AND GLOBAL COMPUTER NETWORKS; CONDUCTING MEDIA RESEARCH DEALING WITH SIGNAL RECEIVING AUDIENCE DEMOGRAPHICS AND BEHAVIOR, AND THE LISTENING, VIEWING, AND USAGE HABITS OF SIGNAL RECEIVING AUDIENCES REGARDING THE USE OF DVR PLAYBACK, HIGH DEFINITION TELEVISION, VIDEO-ON-DEMAND, INTERACTIVE NETWORK RESEARCH SERVICES AND ELECTRONIC PROGRAM GUIDES BY BOTH COMPUTER NETWORK USERS AND INTERNET USERS; PROVIDING ONLINE COMPUTER DATABASES FEATURING MARKETING INFORMATION DEALING WITH BROADCAST ADVERTISING, CABLE TELEVISION RATINGS, SIGNAL RECEIVING AUDIENCE DEMOGRAPHICS AND BEHAVIOR, AND ACCESS AND USAGE BEHAVIOR OF USERS OF GLOBAL COMPUTER NETWORKS AND GLOBAL COMPUTER NETWORK BROWSERS (U.S. CLS. 100, 101 AND 102).

RUSS HERMAN, EXAMINING ATTORNEY

SN 77-622,959. SARE, CHRISTINE, WOODLAND HILLS, CA. FILED 11-26-2008.

CHRIS SARE INTERNATIONAL

THE MARK CONSISTS OF STANDARD CHARACTERS WITHOUT CLAIM TO ANY PARTICULAR FONT, STYLE, SIZE, OR COLOR.

NO CLAIM IS MADE TO THE EXCLUSIVE RIGHT TO USE "INTERNATIONAL", APART FROM THE MARK AS SHOWN.

THE NAME(S), PORTRAIT(S), AND/OR SIGNATURE(S) SHOWN IN THE MARK IDENTIFIES "CHRIS SARE", WHOSE CONSENT(S) TO REGISTER IS MADE OF RECORD.

FOR MODELING SERVICES FOR ADVERTISING OR SALES PROMOTION (U.S. CLS. 100, 101 AND 102).
MICHAEL KEATING, EXAMINING ATTORNEY

CLASS 35—(Continued).

SN 77-713,092. WINKLE BV, DEIL, NETHERLANDS, FILED 4-14-2009.

WINKLE

THE MARK CONSISTS OF STANDARD CHARACTERS WITHOUT CLAIM TO ANY PARTICULAR FONT, STYLE, SIZE, OR COLOR.

PRIORITY CLAIMED UNDER SEC. 44(D) ON ERPN CMNTY TM OFC APPLICATION NO. 8119802, FILED 2-23-2009, REG. NO. 008119802, DATED 12-3-2009, EXPIRES 2-23-2019.

THE ENGLISH TRANSLATION OF "WINKLE" IN THE MARK IS THE VERB "TO DRAW OUT BY FORCE" AND IT IS THE NAME OF AN EDIBLE MOLLUSK.

FOR STATISTICAL EVALUATIONS OF MARKETING DATA; ADVERTISING AND BUSINESS MANAGEMENT CONSULTANCY; ADVERTISING AND BUSINESS SERVICES, NAMELY, SECURING AIRTIME ON ALL FORMS OF MEDIA COMMUNICATIONS STATIONS, SYSTEMS, NETWORKS, AND SERVICES FOR THE PURPOSE OF PROMOTING THE GOODS AND SERVICES OF OTHERS; ADVERTISING AND COMMERCIAL INFORMATION SERVICES, VIA THE INTERNET; ADVERTISING AND DIRECTORY SERVICES, NAMELY, PROMOTING THE SERVICES OF OTHERS BY PROVIDING A WEB PAGE FEATURING LINKS TO THE WEBSITES OF OTHERS; ADVERTISING AND MARKETING; ADVERTISING AND MARKETING SERVICES, NAMELY, PROMOTING THE GOODS AND SERVICES OF OTHERS; ADVERTISING AND PROMOTION SERVICES AND RELATED CONSULTING; ADVERTISING AND PROMOTIONAL SERVICES; ADVERTISING AND PUBLICITY SERVICES; ADVERTISING AND PUBLICITY SERVICES, NAMELY, PROMOTING THE GOODS, SERVICES, BRAND IDENTITY AND COMMERCIAL INFORMATION AND NEWS OF THIRD PARTIES THROUGH PRINT, AUDIO, VIDEO, DIGITAL AND ON-LINE MEDIUM; ADVERTISING BY TRANSMISSION OF ON-LINE PUBLICITY FOR THIRD PARTIES THROUGH ELECTRONIC COMMUNICATIONS NETWORKS; ADVERTISING CONSULTATION; ADVERTISING PARTICULARLY SERVICES FOR THE PROMOTION OF GOODS; ADVERTISING SERVICES; ADVERTISING SERVICES, NAMELY, CREATING CORPORATE AND BRAND IDENTITY FOR OTHERS; ADVERTISING SERVICES, NAMELY, CREATING CORPORATE LOGOS FOR OTHERS; ADVERTISING SERVICES, NAMELY, PROMOTING AND MARKETING THE GOODS AND SERVICES OF OTHERS THROUGH ALL PUBLIC COMMUNICATION MEANS; ADVERTISING THROUGH ALL PUBLIC COMMUNICATION MEANS; ADVERTISING VIA ELECTRONIC MEDIA AND SPECIFICALLY THE INTERNET; ADVERTISING, MARKETING AND PROMOTING THE GOODS AND SERVICES OF OTHERS USING KIOSKS; ADVERTISING, MARKETING AND PROMOTION SERVICES; ADVERTISING, PROMOTION AND MARKETING SERVICES IN THE NATURE OF E-MAIL BLAST CAMPAIGNS FOR OTHERS; ADVICE AND INFORMATION ABOUT CUSTOMER SERVICES AND PRODUCT MANAGEMENT AND PRICES ON INTERNET SITES IN CONNECTION WITH PURCHASES MADE OVER THE INTERNET; ADVICE IN THE FIELD OF BUSINESS MANAGEMENT AND MARKETING; ADVICE ON THE ANALYSIS OF CONSUMER BUYING HABITS AND NEEDS PROVIDED WITH THE HELP OF SENSORY, QUALITY AND QUANTITY-RELATED DATA; ADVICE RELATING TO THE ORGANISATION AND MANAGEMENT OF BUSINESS; ADVISORY SERVICES RELATING TO BUSINESS MANAGEMENT AND BUSINESS OPERATIONS; ARRANGING AND CONDUCTING BUSINESS CONFERENCES; ARRANGING AND CONDUCTING MARKETING PROMOTIONAL EVENTS FOR OTHERS; ARRANGING AND CONDUCTING OF FAIRS AND

CLASS 35—(Continued).

EXHIBITIONS FOR BUSINESS AND ADVERTISING PURPOSES; ASSISTANCE IN MANAGEMENT OF BUSINESS ACTIVITIES; ASSISTANCE WITH BUSINESS MANAGEMENT AND PLANNING; ASSISTANCE, ADVISORY SERVICES AND CONSULTANCY WITH REGARD TO BUSINESS PLANNING, BUSINESS ANALYSIS, BUSINESS MANAGEMENT, AND BUSINESS ORGANIZATION; ASSISTANCE, ADVISORY SERVICES AND CONSULTANCY WITH REGARD TO BUSINESS PLANNING, BUSINESS ANALYSIS, BUSINESS MANAGEMENT, BUSINESS ORGANIZATION, MARKETING AND CUSTOMER ANALYSIS; BRANDING SERVICES, NAMELY, CONSULTING, DEVELOPMENT, MANAGEMENT AND MARKETING OF BRANDS FOR BUSINESSES; BUSINESS ADVICE AND ANALYSIS OF MARKETS; BUSINESS ADVICE AND COMMERCIAL INFORMATION; BUSINESS ADVICE AND INFORMATION; BUSINESS ADVICE, INQUIRIES OR INFORMATION; BUSINESS ADVISORY SERVICES, CONSULTANCY AND INFORMATION; BUSINESS CONSULTATION; BUSINESS CONSULTATION AND MANAGEMENT REGARDING MARKETING ACTIVITIES AND LAUNCHING OF NEW PRODUCTS; BUSINESS CONSULTATION SERVICES; BUSINESS CONSULTING AND BUSINESS INFORMATION FOR ENTERPRISES; BUSINESS CONSULTING AND INFORMATION SERVICES; BUSINESS CONSULTING SERVICES, NAMELY, PROVIDING ASSISTANCE IN DEVELOPMENT OF BUSINESS STRATEGIES AND CREATIVE IDEATION; BUSINESS CONSULTING, INQUIRIES OR INFORMATION; BUSINESS CONSULTING, MANAGEMENT, PLANNING AND SUPERVISION; BUSINESS EFFICIENCY ADVICE; BUSINESS ENQUIRIES AND INVESTIGATIONS; BUSINESS INFORMATION AND INQUIRIES; BUSINESS INFORMATION MANAGEMENT; BUSINESS INFORMATION MANAGEMENT, NAMELY, ELECTRONIC REPORTING OF BUSINESS INFORMATION, BUSINESS ANALYTICS, NAMELY, BUSINESS INVESTIGATIONS, EVALUATIONS, EXPERT APPRAISALS, INFORMATION AND RESEARCH, TRADE SPEND BUSINESS MANAGEMENT; BUSINESS MANAGEMENT; BUSINESS MANAGEMENT AND ADVICE; BUSINESS MANAGEMENT AND CONSULTATION; BUSINESS MANAGEMENT CONSULTANCY AND ADVISORY SERVICES; BUSINESS MANAGEMENT CONSULTANCY AS WELL AS DEVELOPMENT OF PROCESSES FOR THE ANALYSIS AND THE IMPLEMENTATION OF STRATEGY PLANS AND MANAGEMENT PROJECTS; BUSINESS MANAGEMENT CONSULTANCY SERVICES; BUSINESS MANAGEMENT CONSULTATION; BUSINESS MANAGEMENT CONSULTING; BUSINESS MANAGEMENT CONSULTING AND ADVISORY SERVICES; BUSINESS MANAGEMENT CONSULTING WITH RELATION TO STRATEGY, MARKETING, PRODUCTION, PERSONNEL AND RETAIL SALE MATTERS; BUSINESS MANAGEMENT CONSULTING WITH RELATION TO STRATEGY, MARKETING, SALES, OPERATION, PRODUCT DESIGN PARTICULARLY SPECIALIZING IN THE USE OF ANALYTIC AND STATISTIC MODELS FOR THE UNDERSTANDING AND PREDICTING OF CONSUMERS, BUSINESSES, AND MARKET TRENDS AND ACTIONS; BUSINESS MANAGEMENT PLANNING; BUSINESS MARKETING AND DIRECT MAIL CONSULTING SERVICES; BUSINESS MARKETING CONSULTING SERVICES; BUSINESS MARKETING SERVICES; BUSINESS ORGANISATION CONSULTING; BUSINESS ORGANIZATION ADVICE; BUSINESS ORGANIZATION AND MANAGEMENT CONSULTING; BUSINESS ORGANIZATION AND OPERATION CONSULTANCY; BUSINESS ORGANIZATION CONSULTING; BUSINESS ORGANIZATIONAL CONSULTATION; BUSINESS PLANNING; BUSINESS RESEARCH; BUSINESS RESEARCH AND SURVEYS; BUSINESS RESEARCH CONSULTATION; BUSINESS RESEARCH SERVICES, NAMELY, PROVIDING ANALYSIS OF RETAIL DATA ON SPECIFIC BUSINESS LOCATIONS; BUSINESS RESEARCH USING FOCUS GROUPS; BUSINESS RISK MANAGEMENT; BUSINESS RISK MANAGEMENT CONSULTATION; BUSINESS TO BUSINESS DIRECT MARKETING SERVICES; COMMERCIAL INFORMATION AGENCIES; COMPILATION AND PROVISION OF TRADE AND BUSINESS PRICE AND STATISTICAL INFORMATION; COMPILATION OF ADVERTISEMENTS FOR USE AS WEB PAGES ON THE INTERNET; CONDUCTING BUSINESS AND MARKET RESEARCH SURVEYS; CONDUCTING BUSINESS RESEARCH AND SURVEYS;

CLASS 35—(Continued).

CONDUCTING MARKETING STUDIES; CONDUCTING ON-LINE BUSINESS MANAGEMENT RESEARCH SURVEYS; CONSULTANCY SERVICES REGARDING BUSINESS STRATEGIES; CONSULTATION SERVICES IN THE FIELD OF COMPANY, BUSINESS SECTOR AND INDUSTRY DATA AND RESEARCH; CONSULTING IN THE FIELDS OF BUSINESS ORGANIZATION AND MANAGEMENT; CONSULTING SERVICES IN THE AREA OF SUSTAINABLE BUSINESS SOLUTIONS; CONSULTING SERVICES IN THE FIELD OF MARKETING OF EDUCATIONAL TRAINING; COOPERATIVE ADVERTISING AND MARKETING; COOPERATIVE ADVERTISING AND MARKETING SERVICES BY WAY OF SOLICITATION, CUSTOMER SERVICE AND PROVIDING MARKETING INFORMATION VIA WEB SITES ON A GLOBAL COMPUTER NETWORK; CREATING AND UPDATING ADVERTISING MATERIAL; CREATION OF MARKETING TOOLS DESIGNED TO INCREASE A CLIENT COMPANY'S KNOWLEDGE OF CUSTOMER NEEDS, AND ITS COMPETITORS' PRODUCTS AND SERVICES, PRICING, ADVERTISING STRATEGY AND SALES STRATEGY; CREATIVE MARKETING DESIGN SERVICES; DESIGN OF ADVERTISING FLYERS FOR OTHERS; DESIGN OF ADVERTISING MATERIALS FOR OTHERS; DESIGN OF INTERNET ADVERTISING; DEVELOPING PROMOTIONAL CAMPAIGNS FOR BUSINESS; DEVELOPMENT OF MARKETING STRATEGIES AND CONCEPTS; DEVELOPMENT, OPERATION AND ADMINISTRATION OF DIGITAL SIGNAGE SYSTEMS AND DIGITAL ADVERTISING SYSTEMS FOR OTHERS, NAMELY, PROVIDING ADVERTISING SPACE BY ELECTRONIC MEANS AND GLOBAL COMPUTER INFORMATION NETWORKS; DIRECT MAIL ADVERTISING; DIRECT MARKETING ADVERTISING FOR OTHERS; DIRECT MARKETING CONSULTING SERVICES; DIRECT MARKETING SERVICES; DISPLAYING ADVERTISEMENTS FOR OTHERS; DISSEMINATION OF ADVERTISEMENTS; DISSEMINATION OF ADVERTISEMENTS AND OF ADVERTISING MATERIAL; DISSEMINATION OF ADVERTISING FOR OTHERS VIA AN ON-LINE COMMUNICATIONS NETWORK ON THE INTERNET; DISSEMINATION OF ADVERTISING FOR OTHERS VIA THE INTERNET; DISSEMINATION OF ADVERTISING MATERIAL; DISSEMINATION OF ADVERTISING MATTER; DISSEMINATION OF ADVERTISING, SCHEDULING AND MANAGING OF TRAINING COURSES AND PROGRAMS FOR OTHERS VIA A GLOBAL COMPUTER NETWORK; DISTRIBUTION AND DISSEMINATION OF ADVERTISING MATERIALS; DISTRIBUTION OF ADVERTISEMENTS AND COMMERCIAL ANNOUNCEMENTS; DISTRIBUTION OF ADVERTISING MAIL AND OF ADVERTISING SUPPLEMENTS ATTACHED TO REGULAR EDITIONS; ELECTRONIC BILLBOARD ADVERTISING; ELECTRONIC COMMERCE SERVICES, NAMELY, PROVIDING INFORMATION ABOUT PRODUCTS VIA TELECOMMUNICATION NETWORKS FOR ADVERTISING AND SALES PURPOSES; EXPERT EVALUATIONS AND REPORTS RELATING TO BUSINESS MATTERS; GENERAL BUSINESS MERCHANDISING SERVICES, NAMELY, MARKETING; IMPLEMENTATION AND FOLLOW-UP OF ADVICE IN THE FIELDS OF MARKETING; INFORMATION AND DATA COMPILING AND ANALYZING RELATING TO BUSINESS MANAGEMENT; INFORMATION IN BUSINESS MATTERS; INFORMATION OR ENQUIRIES ON BUSINESS AND MARKETING; INFORMATION SERVICES RELATING TO BUSINESS MATTERS; INFORMATION, ADVISORY AND CONSULTANCY SERVICES RELATING TO BUSINESS AND MANAGEMENT OR BUSINESS ADMINISTRATION, INCLUDING SUCH SERVICES PROVIDED ON LINE OR VIA THE INTERNET; INTERNET ADVERTISING SERVICES; ISSUING AND UPDATING OF ADVERTISING TEXTS; LAYOUT SERVICES FOR ADVERTISING PURPOSES; MARKET ANALYSIS; MARKET ANALYSIS AND RESEARCH SERVICES; MARKET MANIPULATION, RESEARCH AND ANALYSIS, WHETHER OR NOT VIA THE INTERNET; MARKET OPINION POLLING STUDIES; MARKET REPORTS AND STUDIES; MARKET RESEARCH; MARKET RESEARCH AND MARKET INTELLIGENCE SERVICES; MARKET RESEARCH CONSULTATION; MARKET RESEARCH SERVICES; MARKET RESEARCH STUDIES; MARKET SEGMENTATION CONSULTATION; MARKET STUDY AND ANALYSIS OF MARKET STUDIES; MARKETING ANALYSIS SERVICES; MARKETING AND BRANDING SERVICES, NAMELY, PERFORMING CONSUMER IN-

CLASS 35—(Continued).

SIGHT AND BRAND STRATEGY OF COMPANY LOGOS; MARKETING CONSULTING; MARKETING PLAN DEVELOPMENT; MARKETING SERVICES, NAMELY, CONDUCTING CONSUMER TRACKING BEHAVIOR RESEARCH AND CONSUMER TREND ANALYSIS; MARKETING SERVICES, NAMELY, CONSUMER MARKETING RESEARCH; MARKETING SERVICES, NAMELY, PROVIDING INFORMATIONAL WEB PAGES DESIGNED TO GENERATE SALES TRAFFIC VIA HYPERLINKS TO OTHER WEB SITES; MARKETING, ADVERTISING, AND PROMOTING THE RETAIL GOODS AND SERVICES OF OTHERS TO WIRELESS ELECTRONIC DEVICES; MARKETING, PROMOTIONAL AND ADVERTISING SERVICES PROVIDED BY MOBILE TELEPHONE CONNECTIONS; MEDIA BUYING ADVICE, NAMELY, ADVISING THE CLIENT HOW MUCH MEDIA TIME, AND AT WHAT TIMES THE CLIENT SHOULD BE PURCHASING ADVERTISING; MEDIA PLANNING, NAMELY, ADVISING THE CLIENT ON THE CORRECT TIMES AND STATIONS TO ADVERTISE BASED ON MEDIA ANALYSIS OF THE MARKET FOR THAT MEDIA; MEDIA PRODUCTION LOCATION SCOUTING SERVICES FOR ADVERTISING PURPOSES; MULTI-LEVEL MARKETING BUSINESS SERVICES; ON-LINE ADVERTISING AND MARKETING SERVICES; ON-LINE ADVERTISING ON COMPUTER COMMUNICATION NETWORKS; ON-LINE BUSINESS RESEARCH SERVICE THAT ALLOWS THE USER TO ANALYZE OPINION TRENDS CONTAINED IN DOCUMENTS ON THE INTERNET; PLACING ADVERTISEMENTS FOR OTHERS; PLANNING AND CONDUCTING OF TRADE FAIRS, EXHIBITIONS AND PRESENTATIONS FOR ECONOMIC OR ADVERTISING PURPOSES; PREPARATION AND REALIZATION OF MEDIA AND ADVERTISING PLANS AND CONCEPTS; PREPARATION OF CUSTOM ADVERTISEMENTS FOR OTHERS; PREPARATION OF CUSTOM OR NON-CUSTOM ADVERTISING FOR BUSINESSES FOR DISSEMINATION VIA THE WEB, CD OR DVD FOR OPTIONAL UPLOAD OR DOWNLOAD TO A COMPUTER; PREPARING ADVERTISEMENTS FOR OTHERS; PREPARING AND PLACING ADVERTISEMENTS FOR OTHERS; PREPARING AND PLACING OF ADVERTISEMENTS; PREPARING AND PLACING OUTDOOR ADVERTISEMENTS FOR OTHERS; PREPARING AUDIOVISUAL PRESENTATIONS FOR USE IN ADVERTISING; PREPARING BUSINESS REPORTS; PREPARING SPEECHES AND ORAL PRESENTATIONS FOR OTHERS FOR USE IN ADVERTISING; PRODUCTION OF ADVERTISING MATTER AND COMMERCIALS; PROFESSIONAL BUSINESS CONSULTATION; PROFESSIONAL BUSINESS CONSULTING; PROMOTING THE GOODS AND SERVICES OF OTHERS BY DISTRIBUTING ADVERTISING MATERIALS THROUGH A VARIETY OF METHODS; PROMOTING THE GOODS AND SERVICES OF OTHERS BY PREPARING AND PLACING ADVERTISEMENTS IN AN ELECTRONIC MAGAZINE ACCESSED THROUGH A GLOBAL COMPUTER NETWORK; PROMOTING, ADVERTISING AND MARKETING OF THE ON-LINE WEB SITES OF OTHERS; PROMOTION AND MARKETING SERVICES AND RELATED CONSULTING; PROMOTION, ADVERTISING AND MARKETING OF ON-LINE WEBSITES; PROMOTIONAL MARKETING AND REPRESENTATION SERVICES FOR SALES TO THE PUBLIC SECTOR; PROMOTIONAL SERVICES, NAMELY, DISTRIBUTION OF ADVERTISING FLYERS, COUPONS, CATALOGS AND PROMOTIONAL ITEMS OF OTHERS; PROVIDING ADVERTISING SERVICES; PROVIDING AND RENTAL OF ADVERTISING SPACE ON THE INTERNET; PROVIDING BUSINESS INTELLIGENCE SERVICES; PROVIDING BUSINESS MARKETING INFORMATION; PROVIDING INFORMATION IN THE FIELD OF MARKETING AND ON-LINE MARKETING MEDIA VIA THE INTERNET; PROVIDING INFORMATION IN THE FIELDS OF BUSINESS INNOVATION PROCESS, BUSINESS MANAGEMENT AND BUSINESS OPPORTUNITIES; PROVIDING MARKETING AND PROMOTION OF SPECIAL EVENTS; PROVIDING ON-LINE BUSINESS MANAGEMENT SERVICES INCLUDING ACCOUNTING, MARKETING, BUSINESS PROJECT MANAGEMENT, AND BUSINESS DEVELOPMENT; PROVIDING PROMOTIONAL MARKETING SERVICES TO BUSINESSES IN THE BROADBAND AND MEDIA INDUSTRIES; PROVIDING PUBLIC SECTOR BUSINESS

CLASS 35—(Continued).

AND MARKET INTELLIGENCE; PROVIDING PUBLIC SECTOR GO-TO-MARKET ADVICE AND STRATEGIES; PROVIDING SPACE AT A WEB SITE FOR THE ADVERTISEMENT OF THE GOODS AND SERVICES OF OTHERS; PROVIDING STATISTICAL INFORMATION; PROVISION OF ADVERTISING SPACE BY ELECTRONIC MEANS AND GLOBAL INFORMATION NETWORKS; PROVISION OF SPACE ON WEBSITES FOR ADVERTISING GOODS AND SERVICES; STATISTICAL ANALYSIS AND REPORTING SERVICES FOR BUSINESS PURPOSES; STATISTICAL EVALUATIONS OF MARKETING DATA (U.S. CLS. 100, 101 AND 102).
DAVID C. REIHNER, EXAMINING ATTORNEY

SN 77-762,775. COMPASS GROUP, INC., CINCINNATI, OH.
FILED 6-18-2009.

COMPASS CLINICAL CONSULTING

THE MARK CONSISTS OF STANDARD CHARACTERS WITHOUT CLAIM TO ANY PARTICULAR FONT, STYLE, SIZE, OR COLOR.

NO CLAIM IS MADE TO THE EXCLUSIVE RIGHT TO USE "CLINICAL CONSULTING", APART FROM THE MARK AS SHOWN.

FOR HOSPITAL MANAGEMENT CONSULTING SERVICES AND HOSPITAL ADMINISTRATION CONSULTING SERVICES (U.S. CLS. 100, 101 AND 102).

FIRST USE 3-30-2009; IN COMMERCE 3-30-2009.
CHARLOTTE CORWIN, EXAMINING ATTORNEY

SN 77-768,545. COMPASS GROUP, INC., CINCINNATI, OH.
FILED 6-25-2009.

COMPASS DATAWORKS

THE MARK CONSISTS OF STANDARD CHARACTERS WITHOUT CLAIM TO ANY PARTICULAR FONT, STYLE, SIZE, OR COLOR.

FOR HOSPITAL MANAGEMENT ADVISORY SERVICES AND HOSPITAL ADMINISTRATION CONSULTING SERVICES FOR IMPROVED CLINICAL AND FINANCIAL PERFORMANCE EMPLOYING AN INTEGRATED ANALYTICAL REPORTING SYSTEM TO ANALYZE OPERATIONAL PATTERNS AND MAKE DECISIONS LEADING TO COST-SAVINGS OPPORTUNITIES AND OPERATIONAL SUSTAINABILITY (U.S. CLS. 100, 101 AND 102).

FIRST USE 3-30-2009; IN COMMERCE 3-30-2009.
CHARLOTTE CORWIN, EXAMINING ATTORNEY

CLASS 35—(Continued).

SN 77-797,251. COMPASS GROUP, INC., CINCINNATI, OH.
FILED 8-5-2009.

COMPASS GROUP INC.

THE MARK CONSISTS OF STANDARD CHARACTERS WITHOUT CLAIM TO ANY PARTICULAR FONT, STYLE, SIZE, OR COLOR.

NO CLAIM IS MADE TO THE EXCLUSIVE RIGHT TO USE "GROUP INC.", APART FROM THE MARK AS SHOWN.

FOR HOSPITAL MANAGEMENT CONSULTING SERVICES AND HOSPITAL ADMINISTRATION CONSULTING SERVICES (U.S. CLS. 100, 101 AND 102).

FIRST USE 3-16-1988; IN COMMERCE 3-16-1988.

CHARLOTTE CORWIN, EXAMINING ATTORNEY

SN 77-846,156. BIZGREET, INC., AUSTIN, TX. FILED 10-11-2009.

BizGreet

THE MARK CONSISTS OF STANDARD CHARACTERS WITHOUT CLAIM TO ANY PARTICULAR FONT, STYLE, SIZE, OR COLOR.

FOR ADVERTISING VIA ELECTRONIC MEDIA AND SPECIFICALLY THE INTERNET (U.S. CLS. 100, 101 AND 102).

FIRST USE 6-23-2008; IN COMMERCE 6-23-2008.

JULIE VEPPUMTHARA, EXAMINING ATTORNEY

SN 77-848,752. THE UNIVERSITY OF KANSAS HOSPITAL AUTHORITY, WESTWOOD, KS. FILED 10-14-2009.

MISSYS' BOUTIQUE

THE MARK CONSISTS OF STANDARD CHARACTERS WITHOUT CLAIM TO ANY PARTICULAR FONT, STYLE, SIZE, OR COLOR.

NO CLAIM IS MADE TO THE EXCLUSIVE RIGHT TO USE "BOUTIQUE", APART FROM THE MARK AS SHOWN.

FOR RETAIL STORE SERVICES FEATURING CLOTHING, COSMETICS, JEWELRY, WIGS, HATS, BRAS, UNDERGARMENTS, BREAST FORMS, HEAD COVERINGS, SKIN PROTECTIVE ITEMS, LYMPHEDEMA THERAPY ITEMS, CANES, EYE PATCHES, OSTOMY CARE ITEMS, PILLOWS, BOOKS, TAPES, THERAPEUTIC PRODUCTS, AND PERSONAL HYGIENE PRODUCTS FOR CANCER PATIENTS AND SURVIVORS (U.S. CLS. 100, 101 AND 102).

JACLYN KIDWELL WALKER, EXAMINING ATTORNEY

CLASS 35—(Continued).

SN 77-874,509. MAKING IDEAS VISIBLE LLC, DULUTH, GA. FILED 11-17-2009.

Making Ideas Visible

THE MARK CONSISTS OF STANDARD CHARACTERS WITHOUT CLAIM TO ANY PARTICULAR FONT, STYLE, SIZE, OR COLOR.

FOR BUSINESS CONSULTING SERVICES, NAMELY, PROVIDING ASSISTANCE IN DEVELOPMENT OF BUSINESS STRATEGIES AND CREATIVE IDEATION (U.S. CLS. 100, 101 AND 102).

FIRST USE 11-1-2007; IN COMMERCE 11-1-2007.
KATHRYN COWARD, EXAMINING ATTORNEY

SN 77-894,674. CENTRAL OHIO PAINTBALL, INC., COLUMBUS, OH. FILED 12-16-2009.

Paintball Discounters

THE MARK CONSISTS OF STANDARD CHARACTERS WITHOUT CLAIM TO ANY PARTICULAR FONT, STYLE, SIZE, OR COLOR.

OWNER OF U.S. REG. NO. 2,805,985.

NO CLAIM IS MADE TO THE EXCLUSIVE RIGHT TO USE "DISCOUNTERS", APART FROM THE MARK AS SHOWN.

SEC. 2(F).

FOR RETAIL STORE SERVICES FEATURING A WIDE VARIETY OF GAME EQUIPMENT, NAMELY, PAINTBALL RELATED ITEMS (U.S. CLS. 100, 101 AND 102).

FIRST USE 10-6-1999; IN COMMERCE 10-6-1999.
ANN E. SAPPENFIELD, EXAMINING ATTORNEY

SN 77-895,974. REPPIFY LLC, SAN FRANCISCO, CA. FILED 12-17-2009.

REPPIFY

THE MARK CONSISTS OF STANDARD CHARACTERS WITHOUT CLAIM TO ANY PARTICULAR FONT, STYLE, SIZE, OR COLOR.

THE WORDING "REPPIFY" HAS NO MEANING IN A FOREIGN LANGUAGE.

FOR MARKET RESEARCH AND MARKET INTELLIGENCE SERVICES; BUSINESS CONSULTATION AND MARKET RESEARCH SERVICES IN THE NATURE OF A WEBSITE THAT RATES THE SOCIAL AND BUSINESS REPUTATION OF INDIVIDUALS BY ASSIGNING A NUMERIC SCORE, AND THAT PROVIDES BUSINESSES WITH DATA ABOUT INDIVIDUALS' ONLINE SOCIAL AND BUSINESS REPUTATIONS IN ORDER TO FACILITATE SAFE ONLINE COMMERCIAL TRANSACTIONS AND TARGETED MARKETING (U.S. CLS. 100, 101 AND 102).

JAMES STEIN, EXAMINING ATTORNEY

CLASS 35—(Continued).

SN 77-899,764. THE DECOR CORPORATION PTY. LTD., SCORESBY, VICTORIA 3179, AUSTRALIA, FILED 12-23-2009.

DECOR

THE MARK CONSISTS OF STANDARD CHARACTERS WITHOUT CLAIM TO ANY PARTICULAR FONT, STYLE, SIZE, OR COLOR.

FOR BUSINESS CONSULTATION AND MANAGEMENT REGARDING MARKET ACTIVITIES AND LAUNCHING OF NEW PRODUCTS IN THE FIELD OF COMMERCIAL AND DOMESTIC UTILITARIAN PLASTIC AND GLASS PRODUCTS; BUSINESS MARKETING SERVICES IN THE FIELD OF COMMERCIAL AND DOMESTIC UTILITARIAN PLASTIC AND GLASS PRODUCTS; PRODUCT MERCHANDISING IN THE FIELD OF COMMERCIAL AND DOMESTIC UTILITARIAN PLASTIC AND GLASS PRODUCTS; PREPARING AND PUBLISHING ADVERTISING MATERIALS AND BUSINESS SALES SUPPORT MATERIALS, NAMELY, PRICE-LISTS, CATALOGUES, DISPLAY CARDS, POSTERS PRINTED ADVERTISEMENTS AND SALES AIDS IN THE FIELD OF COMMERCIAL AND DOMESTIC UTILITARIAN PLASTIC AND GLASS PRODUCTS, EXCLUDING ALL SUCH ACTIVITIES AND SERVICES WITH RESPECT TO PLASTIC AND GLASS PRODUCTS USED AS DECORATION AND ORNAMENTATION (U.S. CLS. 100, 101 AND 102).

KELLEY WELLS, EXAMINING ATTORNEY

SN 77-901,011. STARCREST PRODUCTS OF CALIFORNIA, INC., PERRIS, CA. FILED 12-25-2009.

ALDENS

THE MARK CONSISTS OF STANDARD CHARACTERS WITHOUT CLAIM TO ANY PARTICULAR FONT, STYLE, SIZE, OR COLOR.

FOR FACSIMILE, PHONE, CATALOG, MAIL ORDER, AND ON-LINE ORDERING SERVICES FEATURING GENERAL MERCHANDISE; RETAIL STORE SERVICES AND ONLINE RETAIL STORE SERVICES FEATURING GENERAL MERCHANDISE; INTERACTIVE RETAIL STORE SERVICES PROVIDED VIA COMPUTER, TELEVISION AND THE INTERNET, FEATURING GENERAL MERCHANDISE; MAIL ORDER CATALOG SERVICES FEATURING GENERAL MERCHANDISE (U.S. CLS. 100, 101 AND 102).

LEIGH LOWRY, EXAMINING ATTORNEY

CLASS 35—(Continued).

SN 77-916,302. RADIUS GMR LLC, NEW YORK, NY. FILED 1-20-2010.



NO CLAIM IS MADE TO THE EXCLUSIVE RIGHT TO USE "GLOBAL MARKET RESEARCH", APART FROM THE MARK AS SHOWN.

THE MARK CONSISTS OF THE WORD "RADIUS" IN LOWERCASE LETTERING WITH THE LETTER "D" HAVING AN EXTENDED STEM AND THE WORDING "GLOBAL MARKET RESEARCH" IN ALL CAPITAL LETTERS IN SMALLER TYPE ABOVE THE "IUS" IN "RADIUS".

FOR MARKET RESEARCH, NAMELY, MARKET RESEARCH UTILIZING TOOLS THAT MEASURE BRAND EQUITY, CUSTOMER SATISFACTION, POSITIONING, PRICE, DEVELOPMENT PROCESS, AND OPTIMIZATION, IN THE AREAS OF STRATEGIC STUDIES, DEVELOPMENT OR OPTIMIZATION USING CHOICE MODELING, CUSTOMER AND EMPLOYEE SATISFACTION MEASUREMENT, AND BRAND AND ADVERTISING TRACKING, ALL PRIMARILY IN THE FIELDS OF MEDIA AND COMMUNICATIONS, TELECOMMUNICATIONS, CONSUMER PRODUCTS, FINANCIAL SERVICES, NON-ALCOHOLIC AND ALCOHOLIC BEVERAGES, FOOD SERVICES, FOOD PRODUCTS, CONSUMER PACKAGED GOODS, TECHNOLOGY, UTILITIES AND PHARMACEUTICALS (U.S. CLS. 100, 101 AND 102).

FIRST USE 1-19-2010; IN COMMERCE 1-19-2010.
ANTHONY RINKER, EXAMINING ATTORNEY

CLASS 35—(Continued).

SN 77-929,233. J. KNIPPER AND COMPANY, INC., LAKEWOOD, NJ. FILED 2-5-2010.



OWNER OF U.S. REG. NOS. 2,280,661 AND 2,282,683. THE COLOR(S) RED AND BLUE IS/ARE CLAIMED AS A FEATURE OF THE MARK.

THE MARK CONSISTS OF THE WORD "KNIPPER" IN BLUE STYLIZED LETTERING, UNDERLINED BY TWO RED LINES.

FOR DIRECT MARKETING AND MAIL ADVERTISING SERVICES; ORDER FULFILLMENT SERVICES IN THE NATURE OF SAMPLE DISTRIBUTION SERVICES PROVIDED TO PATIENTS; PRODUCT RECALL SERVICES, NAMELY, PROVIDING PRODUCT INFORMATION TO POTENTIALLY AFFECTED DISTRIBUTORS, PHARMACIES AND CONSUMERS USING PAST AND CURRENT DISTRIBUTION RECORDS; DISTRIBUTION OF PRODUCT MATERIALS FOR SALES REPRESENTATIVES; BUSINESS CONSULTATION SERVICES IN THE FIELD OF REGULATION COMPLIANCE; COMPILATION AND MANAGEMENT OF PATIENT AND PHYSICIAN DATABASES, AND BUSINESS SUPPORT SERVICES, NAMELY, BUSINESS CONSULTING FOR PHARMACEUTICAL SALES REPRESENTATIVES, ALL AFOREMENTIONED SERVICES ALSO PROVIDED ONLINE AND IN THE FIELD OF HEALTHCARE (U.S. CLS. 100, 101 AND 102).

FIRST USE 0-0-1986; IN COMMERCE 0-0-1986.
SEAN CROWLEY, EXAMINING ATTORNEY

SN 77-921,972. TRINITY SALES AND MARKETING, INC., EATON RAPIDS, MI. FILED 1-28-2010.

TOURNAMENT EDGE

THE MARK CONSISTS OF STANDARD CHARACTERS WITHOUT CLAIM TO ANY PARTICULAR FONT, STYLE, SIZE, OR COLOR.

FOR MARINE WARRANTY SERVICES, NAMELY, ARRANGING FOR REPAIRS AND REPLACEMENT OF BOATS AND PARTS THEREOF PROVIDED BY OTHERS PURSUANT TO SERVICE AGREEMENTS (U.S. CLS. 100, 101 AND 102).

FIRST USE 10-1-2009; IN COMMERCE 10-1-2009.
MORGAN WYNNE, EXAMINING ATTORNEY

SN 77-932,670. BUREAU OF JEWISH EDUCATION OF GREATER LOS ANGELES, LOS ANGELES, CA. FILED 2-10-2010.

BJE

THE MARK CONSISTS OF STANDARD CHARACTERS WITHOUT CLAIM TO ANY PARTICULAR FONT, STYLE, SIZE, OR COLOR.

FOR ASSOCIATION SERVICES, NAMELY, PROMOTING THE VALUE OF JEWISH EDUCATION AND THE BENEFITS OF PARTICIPATION IN JEWISH EDUCATION (U.S. CLS. 100, 101 AND 102).

FIRST USE 9-0-2009; IN COMMERCE 9-0-2009.
ELIZABETH HUGHITT, EXAMINING ATTORNEY

CLASS 35—(Continued).

SN 77-943,966. EMBARKONS, INC., PALO ALTO, CA. FILED 2-24-2010.

EMBARKONS

THE MARK CONSISTS OF STANDARD CHARACTERS WITHOUT CLAIM TO ANY PARTICULAR FONT, STYLE, SIZE, OR COLOR.

FOR PROVIDING A WEB SITE FOR CONNECTING WEB APPLICATION DEVELOPERS WITH BUYERS AND DISTRIBUTORS (U.S. CLS. 100, 101 AND 102).
JOHN DALIER, EXAMINING ATTORNEY

SN 77-949,593. THE BANK OF NEW YORK MELLON CORPORATION, NEW YORK, NY. FILED 3-3-2010.

I-BID ADVANTAGE

THE MARK CONSISTS OF STANDARD CHARACTERS WITHOUT CLAIM TO ANY PARTICULAR FONT, STYLE, SIZE, OR COLOR.

NO CLAIM IS MADE TO THE EXCLUSIVE RIGHT TO USE "I-BID", APART FROM THE MARK AS SHOWN.

FOR AUCTIONING OF FINANCIAL SECURITIES OF OTHERS VIA A GLOBAL COMPUTER NETWORK (U.S. CLS. 100, 101 AND 102).

KELLEY WELLS, EXAMINING ATTORNEY

SN 77-957,789. AMERICAN SCHOOLS FOUNDATION ALLIANCE, CHICAGO, IL. FILED 3-12-2010.

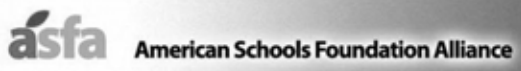

NO CLAIM IS MADE TO THE EXCLUSIVE RIGHT TO USE "AMERICAN SCHOOLS FOUNDATION ALLIANCE", APART FROM THE MARK AS SHOWN.

THE MARK CONSISTS OF THE LETTERS "ASFA" WITH A LEAF ABOVE THE LETTER "A" NEXT TO THE WORDS "AMERICAN SCHOOLS FOUNDATION ALLIANCE".

FOR ASSOCIATION SERVICES, NAMELY, PROMOTING THE INTERESTS OF MEMBERS THROUGH PROVIDING RESOURCES, TOOLS AND GUIDANCE FOR PUBLIC SCHOOL FOUNDATIONS (U.S. CLS. 100, 101 AND 102).

FIRST USE 10-0-2009; IN COMMERCE 10-0-2009.
CHRISIE B. KING, EXAMINING ATTORNEY

CLASS 35—(Continued).

SN 77-966,036. POLAR MUSIC INTERNATIONAL AB, STOCKHOLM, SWEDEN, FILED 3-23-2010.

ABBA

THE MARK CONSISTS OF STANDARD CHARACTERS WITHOUT CLAIM TO ANY PARTICULAR FONT, STYLE, SIZE, OR COLOR.

OWNER OF U.S. REG. NOS. 1,072,394, 3,389,319 AND OTHERS.

FOR DISTRIBUTORSHIP OF MUSIC RECORDINGS; DISTRIBUTORSHIPS IN THE FIELD OF MUSICAL SOUND RECORDINGS AND VIDEO RECORDINGS; ADVERTISING AND PROMOTION SERVICES AND RELATED CONSULTING SERVICES; ADVERTISING AND PUBLICITY SERVICES; ASSOCIATION SERVICES, NAMELY, PROMOTING THE INTERESTS OF MUSICIANS, SINGERS, SONGWRITERS, MUSICAL PERFORMERS AND ARTISTS; COMPUTERIZED ON-LINE ORDERING FEATURING GENERAL MERCHANDISE AND GENERAL CONSUMER GOODS; COMPUTERIZED ON-LINE ORDERING SERVICES IN THE FIELD OF MUSIC; COMPUTERIZED ONLINE RETAIL STORE SERVICES IN THE FIELD OF MUSIC; COMPUTERIZED ON-LINE GIFT ORDERING SERVICES WHICH MATCHES THE GIFT GIVER'S REQUIREMENTS WITH THE GIFT RECIPIENT'S WANTS AND NEEDS; CONDUCTING AN ON-LINE TRADESHOW EXHIBITION, IN THE FIELD OF MUSIC, MUSICAL CONCERTS AND VIDEOS; MAIL ORDER CATALOG SERVICES FEATURING CD'S, CASSETTES, DVD'S FEATURING MUSIC AND MUSIC-RELATED ENTERTAINMENT AND CLOTHING; ON-LINE RETAIL STORE SERVICES FEATURING DOWNLOADABLE PRE-RECORDED MUSIC AND AUDIO-VISUAL CONTENT FEATURING MUSIC AND MUSIC-RELATED ENTERTAINMENT, CLOTHING, AND GENERAL MERCHANDISE; ORGANIZATION OF PROMOTIONS USING AUDIO-VISUAL MEDIA; PREPARING AUDIO-VISUAL DISPLAYS IN THE FIELD OF MUSIC; PREPARING AUDIO VISUAL PRESENTATIONS FOR USE IN ADVERTISING; ARRANGING AND CONDUCTING TRADE SHOW EXHIBITIONS IN THE FIELD OF MUSIC AND ENTERTAINMENT; ARRANGING AND CONDUCTING FAIRS AND EXHIBITIONS FOR BUSINESS AND ADVERTISING PURPOSES; PROMOTING AND CONDUCTING TRADE SHOWS IN THE FIELD OF MUSIC; PROMOTING THE CONCERTS OF OTHERS; PROMOTING THE GOODS AND SERVICES OF OTHERS BY ARRANGING FOR SPONSORS TO AFFILIATE THEIR GOODS AND SERVICES WITH CONCERTS AND MUSICAL EVENTS; PROMOTING THE GOODS OF OTHERS BY PREPARING AND PLACING ADVERTISEMENTS IN AN ELECTRONIC MAGAZINE ACCESSED THROUGH A GLOBAL COMPUTER NETWORK. PROVIDING INFORMATION ABOUT THE GOODS AND SERVICES OF OTHERS VIA A GLOBAL COMPUTER NETWORK; RETAIL STORE SERVICES AVAILABLE THROUGH COMPUTER COMMUNICATIONS AND INTERACTIVE TELEVISION FEATURING CD'S, CASSETTES, DVD'S, VIDEOCASSETTES AND GENERAL CONSUMER MERCHANDISE; AND SUBSCRIPTIONS TO BOOKS, REVIEWS, NEWSPAPERS OR COMIC BOOKS (U.S. CLS. 100, 101 AND 102).

MICHAEL WEBSTER, EXAMINING ATTORNEY

CLASS 35—(Continued).

SN 77-966,836. BAE SYSTEMS INFORMATION AND ELECTRONIC SYSTEMS INTEGRATION INC., NASHUA, NH. FILED 3-24-2010.

**KEEPING THE WARFIGHTER
READY**

THE MARK CONSISTS OF STANDARD CHARACTERS WITHOUT CLAIM TO ANY PARTICULAR FONT, STYLE, SIZE, OR COLOR.

FOR LOGISTICS MANAGEMENT IN THE FIELD OF NATIONAL SECURITY, NAMELY, ORGANIZATION OF PRODUCT SUPPORT SERVICES FOR FIELDING AND MAINTAINING THE READINESS AND OPERATIONAL CAPABILITY OF WEAPON SYSTEMS, SUBSYSTEMS, AND SUPPORT SYSTEMS (U.S. CLS. 100, 101 AND 102).
ROBIN MITTLER, EXAMINING ATTORNEY

CLASS 35—(Continued).

SN 79-092,392. CONG TY LIEN DOANH NUOI VA PHAT TRIEN KHI VIET NAM, DONG NAI, VIETNAM, FILED 10-27-2010.



OWNER OF INTERNATIONAL REGISTRATION 1064592 DATED 10-27-2010, EXPIRES 10-27-2020.

THE TRADEMARK COMPRISES A STYLIZED CHARACTER "V" PUT IN ITS SHADOW WHICH LOOKS LIKE A TRIANGLE. ON THE LEFT OF "V" CHARACTER IS THE WORD "NAFO" AND ON THE RIGHT OF "V" CHARACTER IS THE WORD "NAFOVANNY".

THE WORD(S) "NAFO" AND "NAFOVANNY" HAVE NO MEANING IN A FOREIGN LANGUAGE.

FOR IMPORT-EXPORT AGENCIES IN THE FIELD OF MONKEYS; PROCUREMENT SERVICES, NAMELY, PURCHASING MONKEYS FOR RE-SALE TO OTHERS; WHOLESALE AND RETAIL STORE SERVICES FEATURING MONKEYS (U.S. CLS. 100, 101 AND 102).
KAREN SEVERSON, EXAMINING ATTORNEY

SN 79-094,123. START TODAY CO., LTD., CHIBA 261-7116, JAPAN, FILED 7-30-2010.

ZOZORESORT

THE MARK CONSISTS OF STANDARD CHARACTERS WITHOUT CLAIM TO ANY PARTICULAR FONT, STYLE, SIZE, OR COLOR.

PRIORITY DATE OF 7-28-2010 IS CLAIMED.

OWNER OF INTERNATIONAL REGISTRATION 1068591 DATED 7-30-2010, EXPIRES 7-30-2020.

FOR ADVERTISING ON THE INTERNET FOR OTHERS; ADVERTISING FOR OTHERS BY ELECTRONIC MAIL; ADVERTISING AND PUBLICITY SERVICES; PROVIDING ADVERTISING AND MARKETING INFORMATION RELATING TO ADVERTISEMENTS AND PROMOTIONAL MATERIALS INSERTED INTO NEWSPAPERS, PERIODICALS AND MAGAZINES; PROVIDING OF ADVERTISING SPACES ON THE INTERNET, NAMELY, PROVIDING AND RENTAL OF ADVERTISING SPACE ON THE INTERNET, PROVIDING SPACE AT A WEBSITE FOR THE ADVERTISEMENT OF THE GOODS AND SERVICES OF OTHERS; ORGANIZATION OF EXHIBITIONS FOR COMMERCIAL OR ADVERTISING PURPOSES ON THE INTERNET; ORGANIZATION OF EXHIBITIONS FOR COMMERCIAL OR ADVERTISING PURPOSES; SALES PROMOTION THROUGH CUSTOMER LOYALTY PROGRAMS FOR OTHERS, NAMELY, CUSTOMER LOYALTY SERVICES AND CUSTOMER CLUB SERVICES, FOR COMMERCIAL, PROMOTIONAL AND/OR ADVERTISING PURPOSES; BUSINESS MANAGEMENT CONSULTATION AND BUSINESS CONSULTATION; MARKETING RESEARCH SERVICES; BUSINESS CONSULTATION FOR PROVIDERS OF ON-LINE RETAIL STORE SERVICES ON THE INTERNET; PROVISION OF MARKET RESEARCH INFORMATION; PROVIDING INFORMATION RELATING TO BUSINESS AND MANAGEMENT AND BUSINESS ADMINISTRATION; ADVISORY AND CONSULTANCY SERVICES RELATING TO BUSINESS AND MANAGEMENT AND BUSINESS ADMINISTRATION; BUSINESS INFORMATION AND INQUIRIES; ADVISORY AND CONSULTATION SERVICES RELATING TO SALES PROMOTION; PROVIDING IN-

SN 77-967,928. JAIME ROGELIO CARRILLO LOMELI, GUADALAJARA, JALISCO., MEXICO, AND RODRIGO PADILLA NAVARRO, GUADALAJARA, JALISCO., MEXICO, FILED 3-24-2010.

FOLGOM

PRIORITY CLAIMED UNDER SEC. 44(D) ON MEXICO APPLICATION NO. 1071305, FILED 3-2-2010, REG. NO. 1211285, DATED 4-12-2011, EXPIRES 3-2-2020.

THE MARK CONSISTS OF THE TERM "FOLGOM" IN STYLIZED LETTERING.

THE WORDING "FOLGOM" HAS NO MEANING IN A FOREIGN LANGUAGE.

FOR ADVERTISING, BUSINESS MANAGEMENT, COMMERCIAL ADMINISTRATION OF THE LICENSING OF THE GOODS AND SERVICES OF OTHERS (U.S. CLS. 100, 101 AND 102).

PAULA MAHONEY, EXAMINING ATTORNEY

CLASS 35—(Continued).

FORMATION ON REQUESTS, REVIEWS AND RECOMMENDATIONS OF CONSUMERS, NAMELY, PROVIDING A WEB SITE WHERE USERS CAN POST RATINGS, REVIEWS AND RECOMMENDATIONS ON PRODUCTS AND SERVICES FOR COMMERCIAL PURPOSES; PROVIDING INFORMATION CONCERNING COMMERCIAL SALES; PRESENTATION OF GOODS ON COMMUNICATION MEDIA FOR RETAIL PURPOSES; COMMERCIAL INFORMATION AND ADVICE FOR CONSUMERS; PROVIDING INFORMATION CONCERNING COMMERCIAL SALES OFFERED AND ORDERED BY TELECOMMUNICATION AND BY ELECTRONIC MEANS; PROVIDING INFORMATION CONCERNING COMMERCIAL SALES BY MEANS OF COMPUTER; PROVIDING BUSINESS INFORMATION RELATING TO RANKINGS ON SALES; PROVIDING INFORMATION RELATING TO RETAIL STORES VIA THE GLOBAL COMPUTER NETWORK, NAMELY, PROVIDING BUSINESS INFORMATION RELATING TO RETAIL STORES, AND PROMOTING THE GOODS AND SERVICES OF OTHERS BY PROVIDING A WEBSITE FEATURING COUPONS, REBATES, PRICE-COMPARISON INFORMATION, PRODUCT REVIEWS, LINKS TO THE RETAIL WEBSITES OF OTHERS, AND DISCOUNT INFORMATION; PROVIDING INFORMATION RELATING TO RETAIL STORES, NAMELY, PROVIDING BUSINESS INFORMATION RELATING TO RETAIL STORES, AND PROMOTING THE GOODS AND SERVICES OF OTHERS BY PROVIDING A WEBSITE FEATURING COUPONS, REBATES, PRICE-COMPARISON INFORMATION, PRODUCT REVIEWS, LINKS TO THE RETAIL WEBSITES OF OTHERS, AND DISCOUNT INFORMATION; BUSINESS MANAGEMENT OF HOTELS; EMPLOYMENT AGENCIES; AUCTIONEERING; MEDIATION AND CONCLUSION OF COMMERCIAL TRANSACTIONS FOR OTHERS; MEDIATION AND CONCLUSION OF COMMERCIAL TRANSACTIONS BY TELECOMMUNICATION AND BY ELECTRONIC MEANS FOR OTHERS; ARRANGING OF BUYING AND SELLING CONTRACTS FOR THIRD PARTIES; ARRANGING OF BUYING AND SELLING CONTRACTS VIA THE INTERNET FOR THIRD PARTIES; IMPORT AND EXPORT AGENCIES; PROVISION OF INFORMATION RELATING TO IMPORT AND EXPORT AGENCIES; ARRANGING NEWSPAPER SUBSCRIPTIONS FOR OTHERS; SHORTHAND SERVICES; TRANSCRIPTION, NAMELY, CONFERENCE CALL TRANSCRIPTION SERVICES, MEDICAL TRANSCRIPTION SERVICES, MESSAGE TRANSCRIPTION SERVICES, STENOGRAPHIC TRANSCRIPTION SERVICES; DOCUMENT REPRODUCTION; PROVIDING OFFICE FUNCTIONS PRIMARILY IN THE NATURE OF FILING DOCUMENTS OR MAGNETIC TAPES; COMPUTERIZED FILE MANAGEMENT; COMPILATION AND SYSTEMIZATION OF INFORMATION INTO COMPUTER DATABASES; WORD PROCESSING; RECEPTION SERVICES FOR VISITORS IN BUILDINGS, NAMELY, ORGANIZATION FOR A THIRD PARTY OF TELEPHONE WELCOMING SERVICES AND OF TELEPHONE RECEPTIONIST SERVICES; PUBLICITY MATERIAL RENTAL; RENTAL OF TYPEWRITERS AND COPYING MACHINES; PROVIDING EMPLOYMENT INFORMATION; RENTAL OF VENDING MACHINES; DATA SEARCH IN COMPUTER FILES FOR OTHERS, NAMELY, COLLECTION AND SYSTEMIZATION OF INFORMATION INTO COMPUTER DATABASES, COMPUTERIZED DATABASE MANAGEMENT, DATA PROCESSING SERVICES, AND PROVIDING AN ON-LINE SEARCHABLE DATABASE FEATURING BUSINESS INFORMATION AND BUSINESS CONTACTS; RETAIL AND WHOLESALE STORE SERVICES FEATURING WOVEN FABRICS AND BEDDINGS, CLOTHING, HEADGEAR, FOOTWEAR, BAGS AND POUCHES, TRUNKS, PERSONAL ARTICLES, COMBS, FACE TOWELS OF TEXTILE, HANDKERCHIEFS OF TEXTILE, TOWELS OF TEXTILE, HAND-HELD FLAT FANS, STOCKING SUSPENDERS, SOCK SUSPENDERS, SUSPENDERS FOR CLOTHING, EXPANDING BANDS FOR HOLDING SLEEVES, BELTS, ORNAMENTS IN THE NATURE OF JEWELRY, EARRINGS, NECKLACES, RINGS, BRACELETS, CHAINS IN THE NATURE OF JEWELRY, CHARMS IN THE NATURE OF JEWELRY, KEY RINGS, KEY FOBS, BADGES FOR WEAR NOT OF PRECIOUS METAL, BUCKLES FOR CLOTHING NOT OF PRECIOUS METAL, BROOCHES FOR CLOTHING NOT OF PRECIOUS METAL, JAPANESE BUCKLES TO BIND A BROAD BELT OF KIMONOS, BONNET PINS NOT OF PRECIOUS METAL, ORNAMENTAL EMBLEMS ATTACHABLE ON CLOTHING, BRASSARDS, HOODS

CLASS 35—(Continued).

FOR CLOTHING, HAIR BANDS, BUTTONS, FALSE NAILS, FALSE EYELASHES, SHAVING UTENSILS CASES, PEDICURE SETS, EYELASH CURLERS, MANICURE SETS, EAR PICKS, TOILET CASES, COSMETIC UTENSILS, FALSE BEARDS, ORNAMENTAL BEARDS, ORNAMENTAL MOUSTACHES, HAND IMPLEMENTS FOR HAIR CURLERS, UMBRELLAS, FERRULES OF METAL FOR WALKING STICKS, CANES, METAL PARTS OF CANES AND WALKING-STICKS, WALKING STICK HANDLES, FOODS AND BEVERAGES, LIQUOR, MEAT, SEA FOOD, VEGETABLES AND FRUITS, CONFECTIONERY, BREAD AND BUNS, RICE AND CEREALS, MILK, CARBONATED DRINKS, REFRESHING BEVERAGES, NONALCOHOLIC FRUIT JUICE BEVERAGES, TEA, COFFEE, COCOA, PROCESSED FOOD, TWO WHEELED MOTOR VEHICLES, BICYCLES, FURNITURE, JOINERY FITTINGS, TATAMI MATS, BABY OILS, TEETHING RINGS, BABIES' BOTTLES, BABY CARRIAGES, BABIES' DIAPERS OF PAPER, ELECTRICAL MACHINERY AND APPARATUS, LIGHTING APPARATUS, HOUSEHOLD ELECTROTHERMIC APPLIANCES, BLADED AND POINTED HAND TOOLS, HAND TOOLS, HARDWARE, KITCHEN EQUIPMENT, HOUSEHOLD AND KITCHEN UTENSILS AND CONTAINERS, CLEANING TOOLS AND WASHING UTENSILS, PHARMACEUTICAL PREPARATIONS, VETERINARY AND SANITARY PREPARATIONS AND MEDICAL SUPPLIES, COSMETICS, TOILETRIES, DENTIFRICES, SOAPS AND DETERGENTS, AGRICULTURAL MACHINES, AGRICULTURAL IMPLEMENTS AND SUPPLIES, NATURAL FLOWERS AND TREES, PRINTED MATTER, PAPER AND STATIONERY, SPORTS GOODS, TOYS, DOLLS, GAME MACHINES AND APPARATUS, MUSICAL INSTRUMENTS AND RECORDS, PRE-RECORDED DVDS, CLOCKS, WATCHES AND SPECTACLES, EYEGLASSES AND GOGGLES, TOBACCO, SMOKERS' ARTICLES, CHAINS FOR DOGS, CLOTHING FOR PETS, BEDS FOR HOUSEHOLD PETS, DOG KENNELS, NESTING BOXES FOR SMALL BIRDS, FEEDING VESSELS FOR PETS, BRUSHES FOR PETS, CHEWING GOODS FOR PET DOGS, INDOOR AQUARIA AND THEIR FITTINGS, BIRD CAGES, BIRD BATHS, TOYS FOR DOMESTIC PETS, FOODS FOR PETS, UNWROUGHT AND SEMI-WROUGHT PRECIOUS STONES AND THEIR IMITATIONS (U.S. CLS. 100, 101 AND 102).

JAY BESCH, EXAMINING ATTORNEY

SN 79-094,478. BIJOU BRIGITTE MODISCHE ACCESSOIRES AG, FED REP GERMANY, FILED 1-28-2011.



Senso di Donna

PRIORITY DATE OF 10-9-2010 IS CLAIMED.
OWNER OF INTERNATIONAL REGISTRATION 1069490 DATED 1-28-2011, EXPIRES 1-28-2021.

OWNER OF U.S. REG. NOS. 3,133,352 AND 3,502,027.
THE MARK CONSISTS OF THE WORDING "SENSO DI DONNA" BELOW A LION HEAD DESIGN AND AN ARC. THE ENGLISH TRANSLATION OF "SENSO DI DONNA" IN THE MARK IS "MEANING OF A WOMAN".

FOR RETAIL STORE SERVICES IN THE FIELDS OF SPECTACLE FRAMES, SUNGLASSES, JEWELLER'S WARES, JEWELLERY, PRECIOUS STONES, CLOCKS AND CHRONOMETERS, PRINTED MATTER, GOODS MADE OF LEATHER AND IMITATION LEATHER, LARGE AND SMALL SUITCASES, UMBRELLAS, PARASOLS AND WALKING STICKS, COSMETIC MIRRORS, COMBS AND SPONGES, BRUSHES, WOVEN FABRICS AND TEXTILE GOODS, BEDSPREADS AND TABLECLOTHS, CLOTHING, FOOTWEAR, HEADGEAR, LACE AND EMBROIDERY, RIBBONS AND LACES, BUTTONS, HOOKS AND EYES, NEEDLES, HAIR ORNAMENTS, HAIR RIBBONS, HAIR CLIPS, HAIR PINS, ARTIFICIAL FLOWERS (U.S. CLS. 100, 101 AND 102).

MATTHEW EINSTEIN, EXAMINING ATTORNEY

CLASS 35—(Continued).

SN 79-095,260. BIJOU BRIGITTE MODISCHE ACCESSOIRES AG, FED REP GERMANY, FILED 1-28-2011.

Bijou Brigitte

THE MARK CONSISTS OF STANDARD CHARACTERS WITHOUT CLAIM TO ANY PARTICULAR FONT, STYLE, SIZE, OR COLOR.

PRIORITY DATE OF 10-9-2010 IS CLAIMED.

OWNER OF INTERNATIONAL REGISTRATION 1071628 DATED 1-28-2011, EXPIRES 1-28-2021.

OWNER OF U.S. REG. NOS. 3,142,386, 3,725,800 AND OTHERS.

NO CLAIM IS MADE TO THE EXCLUSIVE RIGHT TO USE "BIJOU", APART FROM THE MARK AS SHOWN.

FOR RETAIL STORE SERVICES IN THE FIELDS OF SPECTACLE FRAMES, SUNGLASSES, JEWELLER'S WARES, JEWELLERY, PRECIOUS STONES, CLOCKS AND CHRONOMETERS, PRINTED MATTER, GOODS MADE OF LEATHER AND IMITATION LEATHER, LARGE AND SMALL SUITCASES, UMBRELLAS, PARASOLS AND WALKING STICKS, COSMETIC MIRRORS, COMBS AND SPONGES, BRUSHES, WOVEN FABRICS AND TEXTILE GOODS, BEDSPREADS AND TABLE-CLOTHS, CLOTHING, FOOTWEAR, HEADGEAR, LACE AND EMBROIDERY, RIBBONS AND LACES, BUTTONS, HOOKS AND EYES, NEEDLES, HAIR ORNAMENTS, HAIR RIBBONS, HAIR CLIPS, HAIR PINS, ARTIFICIAL FLOWERS (U.S. CLS. 100, 101 AND 102).

MATTHEW EINSTEIN, EXAMINING ATTORNEY

SN 79-095,261. BIJOU BRIGITTE MODISCHE ACCESSOIRES AG, FED REP GERMANY, FILED 1-28-2011.



PRIORITY DATE OF 10-9-2010 IS CLAIMED.
OWNER OF INTERNATIONAL REGISTRATION 1071629 DATED 1-28-2011, EXPIRES 1-28-2021.

OWNER OF U.S. REG. NOS. 3,142,386, 3,725,800 AND OTHERS.

NO CLAIM IS MADE TO THE EXCLUSIVE RIGHT TO USE "BIJOU", APART FROM THE MARK AS SHOWN.

THE MARK CONSISTS OF THE WORDING "BIJOU BRIGITTE" INSIDE A CLOUD DESIGN.

FOR RETAIL STORE SERVICES IN THE FIELDS OF SPECTACLE FRAMES, SUNGLASSES, JEWELLER'S WARES, JEWELLERY, PRECIOUS STONES, CLOCKS AND CHRONOMETERS, PRINTED MATTER, GOODS MADE OF LEATHER AND IMITATION LEATHER, LARGE AND SMALL SUITCASES, UMBRELLAS, PARASOLS AND WALKING STICKS, COSMETIC MIRRORS, COMBS AND SPONGES, BRUSHES, WOVEN FABRICS AND TEXTILE GOODS, BEDSPREADS AND TABLE-CLOTHS, CLOTHING, FOOTWEAR, HEADGEAR, LACE AND EMBROIDERY, RIBBONS AND LACES, BUTTONS, HOOKS AND EYES, NEEDLES, HAIR ORNAMENTS, HAIR RIBBONS, HAIR CLIPS, HAIR PINS, ARTIFICIAL FLOWERS (U.S. CLS. 100, 101 AND 102).

MATTHEW EINSTEIN, EXAMINING ATTORNEY

CLASS 35—(Continued).

SN 79-095,262. BIJOU BRIGITTE MODISCHE ACCESSOIRES AG, FED REP GERMANY, FILED 2-23-2011.

Senso die Donna

THE MARK CONSISTS OF STANDARD CHARACTERS WITHOUT CLAIM TO ANY PARTICULAR FONT, STYLE, SIZE, OR COLOR.

PRIORITY DATE OF 10-9-2010 IS CLAIMED.

OWNER OF INTERNATIONAL REGISTRATION 1071630 DATED 2-23-2011, EXPIRES 2-23-2021.

OWNER OF U.S. REG. NOS. 3,133,352 AND 3,502,027.

THE ENGLISH TRANSLATION OF "SENSO DIE DONNA" IN THE MARK IS "MEANING OF A WOMAN".

FOR RETAIL STORE SERVICES IN THE FIELDS OF SPECTACLE FRAMES, SUNGLASSES, JEWELLER'S WARES, JEWELLERY, PRECIOUS STONES, CLOCKS AND CHRONOMETERS, PRINTED MATTER, GOODS MADE OF LEATHER AND IMITATION LEATHER, LARGE AND SMALL SUITCASES, UMBRELLAS, PARASOLS AND WALKING STICKS, COSMETIC MIRRORS, COMBS AND SPONGES, BRUSHES, WOVEN FABRICS AND TEXTILE GOODS, BEDSPREADS AND TABLE-CLOTHS, CLOTHING, FOOTWEAR, HEADGEAR, LACE AND EMBROIDERY, RIBBONS AND LACES, BUTTONS, HOOKS AND EYES, NEEDLES, HAIR ORNAMENTS, HAIR RIBBONS, HAIR CLIPS, HAIR PINS, ARTIFICIAL FLOWERS (U.S. CLS. 100, 101 AND 102).

MATTHEW EINSTEIN, EXAMINING ATTORNEY

SN 85-027,185. FLORIDA GUN CENTER, INC., HIALEAH, FL. FILED 4-30-2010.

FLORIDA GUN CENTER

THE MARK CONSISTS OF STANDARD CHARACTERS WITHOUT CLAIM TO ANY PARTICULAR FONT, STYLE, SIZE, OR COLOR.

NO CLAIM IS MADE TO THE EXCLUSIVE RIGHT TO USE "GUN CENTER", APART FROM THE MARK AS SHOWN.

SEC. 2(F).

FOR RETAIL STORE SERVICES FEATURING FIREARMS, FIREARMS ACCESSORIES, TACTICAL CLOTHING, AND AMMUNITION (U.S. CLS. 100, 101 AND 102). FIRST USE 2-1-1984; IN COMMERCE 2-1-1984.

DEBRA LEE, EXAMINING ATTORNEY

CLASS 35—(Continued).

SN 85-027,774. ABCSP, INC., DBA ALWAYS BEST CARE SENIOR SERVICES, ROSEVILLE, CA. FILED 4-30-2010.

Always Best Care Senior Services

THE MARK CONSISTS OF STANDARD CHARACTERS WITHOUT CLAIM TO ANY PARTICULAR FONT, STYLE, SIZE, OR COLOR.

OWNER OF U.S. REG. NOS. 3,390,095 AND 3,563,168.

NO CLAIM IS MADE TO THE EXCLUSIVE RIGHT TO USE "BEST CARE SENIOR SERVICES", APART FROM THE MARK AS SHOWN.

FOR EMPLOYMENT AGENCY SERVICES, NAMELY, TEMPORARY PLACEMENT OF IN-HOME, NON-MEDICAL, HEALTH CARE PROVIDERS; FRANCHISE SERVICES, NAMELY, OFFERING BUSINESS MANAGEMENT ASSISTANCE IN THE ESTABLISHMENT AND OPERATION OF EMPLOYEE PLACEMENT SERVICE FOR IN-HOME, NON MEDICAL, HEALTH CARE BUSINESS (U.S. CLS. 100, 101 AND 102).

FIRST USE 1-1-1996; IN COMMERCE 1-1-1996.

BILL DAWE, EXAMINING ATTORNEY

SN 85-028,269. MODISH MARKETING, YORBA LINDA, CA. FILED 5-2-2010.

Modish

THE MARK CONSISTS OF STANDARD CHARACTERS WITHOUT CLAIM TO ANY PARTICULAR FONT, STYLE, SIZE, OR COLOR.

FOR CREATIVE MARKETING DESIGN SERVICES (U.S. CLS. 100, 101 AND 102).

FIRST USE 7-1-2007; IN COMMERCE 7-1-2007.

DORITT L. CARROLL, EXAMINING ATTORNEY

SN 85-038,023. SALAS O'BRIEN ENGINEERS, INC., DBA SALAS O'BRIEN, SAN JOSE, CA. FILED 5-13-2010.

CARBON SCOUT

THE MARK CONSISTS OF STANDARD CHARACTERS WITHOUT CLAIM TO ANY PARTICULAR FONT, STYLE, SIZE, OR COLOR.

NO CLAIM IS MADE TO THE EXCLUSIVE RIGHT TO USE "CARBON", APART FROM THE MARK AS SHOWN.

FOR CONSULTING SERVICES IN THE FIELD OF ENERGY USAGE AND MANAGEMENT AND ENERGY EFFICIENCY (U.S. CLS. 100, 101 AND 102).

ELLEN BURNS, EXAMINING ATTORNEY

CLASS 35—(Continued).

SN 85-044,600. DON VACCARO, DBA PRIMETIX, VERNON, CT. FILED 5-21-2010.

PrimeTix

THE COLOR(S) BLUE AND GREEN IS/ARE CLAIMED AS A FEATURE OF THE MARK.

THE MARK CONSISTS OF THE STYLIZED WORDING "PRIMETIX" WITH THE LETTERS "P" AND "T" AS UPPER-CASE LETTERS AND THE REMAINING LETTERS IN LOWERCASE. THE "PRIME" PORTION IS IN BLUE AND THE "TIX" PORTION IS IN GREEN. THE UPPER HALF OF THE LETTERS IS SLIGHTLY DARKER THAN THE BOTTOM HALF.

FOR ENTERTAINMENT ADMISSION VENUE CONTROL SERVICES, NAMELY, THE REMOTE VERIFICATION OF TICKET VALIDITY UPON PRESENTATION OF TICKETS AT AN ENTERTAINMENT VENUE; MANAGEMENT OF EVENT TICKETING FOR OTHERS; PROCUREMENT, NAMELY, PURCHASING TICKETS TO ENTERTAINMENT EVENTS FOR OTHERS (U.S. CLS. 100, 101 AND 102).

KELLEY WELLS, EXAMINING ATTORNEY

SN 85-052,245. DIAZ JR., PEDRO, LYNN, MA. FILED 6-1-2010.



NO CLAIM IS MADE TO THE EXCLUSIVE RIGHT TO USE "PROMOTIONS", APART FROM THE MARK AS SHOWN.

THE STIPPLING IS FOR SHADING PURPOSES ONLY.

THE MARK CONSISTS OF AN OVAL CONTAINING THE WORDING "JUPREY PROMOTIONS". "PROMOTIONS" IS WRITTEN BELOW THE LETTERS "UPRE" OF THE WORD "JUPREY". BELOW THE "JU" OF THE WORD "JUPREY" IS AN AUDIO SYMBOL WITH TWO BOLTS PROJECTING OUTWARD FROM IT. THERE IS A CURVED LINE ABOVE THE WORDING "JUPREY" EXTENDING FROM THE "J" OF THE WORD "JUPREY" TO THE "Y" OF THE WORD "JUPREY". THERE IS A CURVED LINE BELOW THE WORD "PROMOTIONS" AND THE "Y" IN THE WORD "JUPREY" THAT EXTENDS FROM THE "P" IN "PROMOTIONS" TO THE "Y" IN "JUPREY". BELOW THE "PRO" IN THE WORD "PROMOTIONS" ARE FOUR STARS. THE STARS DECREASE IN SIZE AS THEY PROCEED LEFT. TO THE RIGHT OF THE WORD "JUPREY" ARE FOUR STARS. THE STARS DECREASE IN SIZE AS THEY PROCEED DOWNWARD.

FOR PROMOTING THE GOODS AND SERVICES OF OTHERS BY ADVERTISING THROUGH VARIOUS MEDIA OUTLETS (U.S. CLS. 100, 101 AND 102).

JOHN DALIER, EXAMINING ATTORNEY

CLASS 35—(Continued).

SN 85-052,926. STEPHANIE PHILLIPS, LANTANA, TX.
FILED 6-2-2010.

Crafty Steals

THE MARK CONSISTS OF STANDARD CHARACTERS WITHOUT CLAIM TO ANY PARTICULAR FONT, STYLE, SIZE, OR COLOR.

FOR ON-LINE RETAIL STORE FEATURING ARTS AND CRAFTS (U.S. CLS. 100, 101 AND 102).

FIRST USE 6-15-2009; IN COMMERCE 6-15-2009.
WENDY GOODMAN, EXAMINING ATTORNEY

CLASS 35—(Continued).

SN 85-067,600. RUBY CLOVER NEW YORK LLC, DBA
CLOVER NEW YORK, NEW YORK, NY. FILED 6-21-2010.

CLOVER New York

THE MARK CONSISTS OF STANDARD CHARACTERS WITHOUT CLAIM TO ANY PARTICULAR FONT, STYLE, SIZE, OR COLOR.

NO CLAIM IS MADE TO THE EXCLUSIVE RIGHT TO USE "NEW YORK", APART FROM THE MARK AS SHOWN.

FOR ON-LINE RETAIL STORE SERVICES FEATURING CHILDREN'S CLOTHING (U.S. CLS. 100, 101 AND 102).

FIRST USE 9-13-2009; IN COMMERCE 9-13-2009.
ROBERT STRUCK, EXAMINING ATTORNEY

SN 85-053,040. CLASSICS DU JOUR, DBA LIBOW UNLIMITED, INC., NEW YORK, NY. FILED 6-2-2010.



OWNER OF U.S. REG. NO. 3,916,614.
THE COLOR(S) RED, WHITE, GREY IS/ARE CLAIMED AS A FEATURE OF THE MARK.

THE MARK CONSISTS OF THE WORDING "CLASSICS" IN RED WITH WHITE STREAKS AND THE WORDS "DU JOUR" IN GREY WITH STREAKS OF BLACK.

THE ENGLISH TRANSLATION OF "DU JOUR" IN THE MARK IS "OF THE DAY".

FOR PROMOTION AND MARKETING SERVICES AND RELATED CONSULTING (U.S. CLS. 100, 101 AND 102).

FIRST USE 4-8-2009; IN COMMERCE 4-8-2009.
NAAKWAMA ANKRAH, EXAMINING ATTORNEY

SN 85-069,553. DONNA MICHELE BAXTER, PITTSBURGH, PA. FILED 6-23-2010.

SOUL PITT

THE MARK CONSISTS OF STANDARD CHARACTERS WITHOUT CLAIM TO ANY PARTICULAR FONT, STYLE, SIZE, OR COLOR.

FOR ADVERTISING SERVICES; PROMOTION SERVICES; PLACING ADVERTISEMENTS FOR OTHERS; PUBLIC RELATION SERVICES; MEDIA SERVICES; NAMELY, MEDIA PRODUCTION LOCATION SCOUTING SERVICES FOR ADVERTISING PURPOSES; CONSULTING SERVICES IN THE FIELD OF MARKETING; ELECTRONIC NEWSLETTER AND EMAIL BLASTS (U.S. CLS. 100, 101 AND 102).

ARETHA SOMERVILLE, EXAMINING ATTORNEY

SN 85-060,955. ANTIBUS SCALES & SYSTEMS, INC., FORT WAYNE, IN. FILED 6-11-2010.



NO CLAIM IS MADE TO THE EXCLUSIVE RIGHT TO USE "BARCODE GEAR.COM", APART FROM THE MARK AS SHOWN.

THE MARK CONSISTS OF CONCENTRIC DIAMOND SHAPED FIGURES AND STYLIZED "BARCODEGEAR.COM".

FOR ONLINE RETAIL STORE SERVICES FEATURING BARCODE SCANNERS, BARCODE PRINTERS, MOBILE TERMINALS, ACCESS POINTS, RFID LABELS, RFID READERS AND RELATED OPERATING SOFTWARE; VALUE-ADDED RESELLER SERVICES, NAMELY, DISTRIBUTORSHIP SERVICES FEATURING BARCODE SCANNERS, BARCODE PRINTERS, MOBILE TERMINALS, ACCESS POINTS, RFID LABELS, RFID READERS AND RELATED OPERATING SOFTWARE (U.S. CLS. 100, 101 AND 102).

FIRST USE 5-31-2010; IN COMMERCE 5-31-2010.
CHRISTINE COOPER, EXAMINING ATTORNEY

SN 85-074,525. 21ST CENTURY EDGE, INC., KANSAS CITY, MO. FILED 6-30-2010.

THE KEYS TO GETTING PAID

THE MARK CONSISTS OF STANDARD CHARACTERS WITHOUT CLAIM TO ANY PARTICULAR FONT, STYLE, SIZE, OR COLOR.

FOR PROVIDING INFORMATION REGARDING BUSINESS MANAGEMENT IN THE FIELD OF HEALTH-CARE (U.S. CLS. 100, 101 AND 102).

FIRST USE 3-0-2004; IN COMMERCE 3-0-2004.
RAMONA ORTIGA, EXAMINING ATTORNEY

CLASS 35—(Continued).

SN 85-079,473. QUESTCARE MEDICAL SERVICES, P.A., DALLAS, TX. FILED 7-7-2010.

QUESTCARE DOCASSIST

THE MARK CONSISTS OF STANDARD CHARACTERS WITHOUT CLAIM TO ANY PARTICULAR FONT, STYLE, SIZE, OR COLOR.

OWNER OF U.S. REG. NOS. 2,364,219 AND 3,708,432. FOR PROVIDING MEDICAL DICTATION AND MEDICAL TRANSCRIPTION SERVICES, NAMELY, MAKING NOTES IN MEDICAL RECORDS AS DICTATED BY PHYSICIANS, CONCERNING PHYSICIANS' EXAMINATIONS OF PATIENTS (U.S. CLS. 100, 101 AND 102). JULIE VEPPIUMTHARA, EXAMINING ATTORNEY

CLASS 35—(Continued).

SN 85-084,746. BFAD, INC., CULVER CITY, CA. FILED 7-14-2010.

BICYCLE FOR A DAY

THE MARK CONSISTS OF STANDARD CHARACTERS WITHOUT CLAIM TO ANY PARTICULAR FONT, STYLE, SIZE, OR COLOR.

FOR PROMOTING PUBLIC AWARENESS OF HEALTH AND ENVIRONMENTAL ISSUES AND INITIATIVES (U.S. CLS. 100, 101 AND 102). FIRST USE 8-0-2006; IN COMMERCE 8-0-2006. MICHELE SWAIN, EXAMINING ATTORNEY

SN 85-082,152. HEALTHMEDIA, INC., ANN ARBOR, MI. FILED 7-12-2010.

HEALTHMEDIA CAPTIVATE

THE MARK CONSISTS OF STANDARD CHARACTERS WITHOUT CLAIM TO ANY PARTICULAR FONT, STYLE, SIZE, OR COLOR.

OWNER OF U.S. REG. NOS. 2,276,506 AND 2,577,770. FOR PROVIDING CUSTOMER SUPPORT SERVICES, NAMELY, PROVIDING BUSINESS ADVICE AND BUSINESS ASSISTANCE TO INCREASE PARTICIPATION AND ENGAGEMENT IN PROGRAMS IN THE FIELDS OF WELLNESS, HEALTH PROMOTION, PREVENTATIVE HEALTH CARE, DISEASE MANAGEMENT, BEHAVIOR CHANGE AND HEALTH RISK ASSESSMENT (U.S. CLS. 100, 101 AND 102). LINDA LAVACHE, EXAMINING ATTORNEY

SN 85-085,085. TECHNICAL ENERGY PERFORMANCE GROUP, LLC, BYRON CENTER, MI. FILED 7-15-2010.

RIGHTFIT

THE MARK CONSISTS OF STANDARD CHARACTERS WITHOUT CLAIM TO ANY PARTICULAR FONT, STYLE, SIZE, OR COLOR.

FOR DESIGN AND IMPLEMENTATION OF ENERGY SAVINGS PROGRAMS, NAMELY, ENERGY AUDIT, CONSULTATION IN THE FIELD OF ENERGY EFFICIENCY, AND ENERGY USAGE MANAGEMENT (U.S. CLS. 100, 101 AND 102). FIRST USE 7-0-2009; IN COMMERCE 4-0-2010. JENNY PARK, EXAMINING ATTORNEY

SN 85-084,352. BOOZBUCKS, LLC, OYSTER BAY, NY. FILED 7-14-2010.

Booz-on

THE MARK CONSISTS OF STANDARD CHARACTERS WITHOUT CLAIM TO ANY PARTICULAR FONT, STYLE, SIZE, OR COLOR.

FOR ISSUING GIFT CERTIFICATES WHICH MAY THEN BE REDEEMED FOR GOODS OR SERVICES; PROMOTING THE GOODS AND SERVICES OF OTHERS THROUGH THE ISSUANCE OF GIFT CERTIFICATES VIA THE INTERNET THAT MAY BE REDEEMED FROM PARTICIPATING THIRD-PARTY MERCHANTS (U.S. CLS. 100, 101 AND 102). DAVID H. STINE, EXAMINING ATTORNEY

SN 85-085,087. TECHNICAL ENERGY PERFORMANCE GROUP, LLC, BYRON CENTER, MI. FILED 7-15-2010.

TEPG

THE MARK CONSISTS OF STANDARD CHARACTERS WITHOUT CLAIM TO ANY PARTICULAR FONT, STYLE, SIZE, OR COLOR.

FOR DESIGN AND IMPLEMENTATION OF ENERGY SAVINGS PROGRAMS, NAMELY, ENERGY AUDIT, CONSULTATION IN THE FIELD OF ENERGY EFFICIENCY, AND ENERGY USAGE MANAGEMENT (U.S. CLS. 100, 101 AND 102). FIRST USE 5-0-2007; IN COMMERCE 4-0-2010. JENNY PARK, EXAMINING ATTORNEY

CLASS 35—(Continued).

SN 85-089,201. SPAFINDER, INC., NEW YORK, NY. FILED 7-21-2010.



OWNER OF U.S. REG. NOS. 2,111,806, 3,272,044 AND OTHERS.

NO CLAIM IS MADE TO THE EXCLUSIVE RIGHT TO USE "SPA" AND "DEAL DAYS", APART FROM THE MARK AS SHOWN.

THE COLOR(S) RED, GRAY AND WHITE IS/ARE CLAIMED AS A FEATURE OF THE MARK.

THE MARK CONSISTS OF THE STYLIZED WORD "SPAFINDER" IN GRAY APPEARING ABOVE THE STYLIZED WORDS "DEAL" IN RED AND "SPA" IN WHITE ON A RED TAG DESIGN THAT IS HANGING FROM THE LETTER "L" BY A GRAY STRING LOOPED AROUND THE TOP OF THE LETTER, FOLLOWED BY THE STYLIZED WORD "DAYS" IN RED.

FOR PROMOTING THE GOODS AND SERVICES OF HEALTH SPAS, MEDICAL SPAS, DAY SPAS, BEAUTY SALONS, RESORTS, AND HOTELS, NAMELY, ORGANIZING PROMOTIONAL BUSINESS TO BUSINESS AND CONSUMER EVENTS FEATURING DISCOUNTS AND SPECIAL OFFERS FOR THE GOODS AND SERVICES OF OTHERS; PROMOTING THE GOODS AND SERVICES OF HEALTH SPAS, MEDICAL SPAS, DAY SPAS, BEAUTY SALONS, RESORTS, AND HOTELS, NAMELY, PROVIDING A WEB SITE FEATURING INFORMATION ON DISCOUNTS AND SPECIAL OFFERS FOR THE GOODS AND SERVICES OF OTHERS; ARRANGING AND CONDUCTING MARKETING PROMOTIONAL EVENTS FOR OTHERS (U.S. CLS. 100, 101 AND 102).

FIRST USE 12-21-2009; IN COMMERCE 12-21-2009.

BARBARA A. GOLD, EXAMINING ATTORNEY

SN 85-089,958. BIG BANG MANAGEMENT LLC, PLAINVIEW, NY. FILED 7-21-2010.

PLAYERNET

THE MARK CONSISTS OF STANDARD CHARACTERS WITHOUT CLAIM TO ANY PARTICULAR FONT, STYLE, SIZE, OR COLOR.

FOR BUSINESS NETWORKING PROVIDED THROUGH A SPORTS WEBSITE; ADVERTISING AND PUBLICITY SERVICES, NAMELY, PROMOTING THE GOODS, SERVICES, BRAND IDENTITY AND COMMERCIAL INFORMATION AND NEWS OF ATHLETES, PROVIDED THROUGH A SPORTS WEBSITE; CREATIVE MARKETING DESIGN SERVICES PROVIDED THROUGH A SPORTS WEBSITE; ONLINE RETAIL STORE SERVICES FEATURING ATHLETIC GEAR AND SPORTS MEMORABILIA PROVIDED THROUGH A SPORTS WEBSITE (U.S. CLS. 100, 101 AND 102).

FIRST USE 10-1-2009; IN COMMERCE 2-1-2010.

LINDA M. KING, EXAMINING ATTORNEY

CLASS 35—(Continued).

SN 85-090,831. MARKET PROBE, INC., MILWAUKEE, WI. FILED 7-22-2010.

SHARE⁺

THE MARK CONSISTS OF THE UNDERLINED STYLIZED TEXT "SHARE" FOLLOWED BY A SUPERSCRIPED PLUS SYMBOL.

FOR BUSINESS CONSULTING SERVICES IN THE FIELD OF MARKETING AND CUSTOMER ANALYSIS (U.S. CLS. 100, 101 AND 102).

ADA HAN, EXAMINING ATTORNEY

SN 85-091,157. CONTROL4 CORPORATION, SALT LAKE CITY, UT. FILED 7-22-2010.

4STORE

THE MARK CONSISTS OF STANDARD CHARACTERS WITHOUT CLAIM TO ANY PARTICULAR FONT, STYLE, SIZE, OR COLOR.

FOR ADVERTISING SERVICES; MARKETING SERVICES (U.S. CLS. 100, 101 AND 102).

LINDA MICKLEBURGH, EXAMINING ATTORNEY

SN 85-091,241. SPAFINDER, INC., NEW YORK, NY. FILED 7-23-2010.

SPAFINDER DEAL DAYS

THE MARK CONSISTS OF STANDARD CHARACTERS WITHOUT CLAIM TO ANY PARTICULAR FONT, STYLE, SIZE, OR COLOR.

OWNER OF U.S. REG. NOS. 2,111,806, 3,272,044 AND OTHERS.

NO CLAIM IS MADE TO THE EXCLUSIVE RIGHT TO USE "DEAL DAYS", APART FROM THE MARK AS SHOWN.

FOR PROMOTING THE GOODS AND SERVICES OF HEALTH SPAS, MEDICAL SPAS, DAY SPAS, BEAUTY SALONS, RESORTS, AND HOTELS, NAMELY, ORGANIZING PROMOTIONAL BUSINESS TO BUSINESS AND CONSUMER EVENTS FEATURING DISCOUNTS AND SPECIAL OFFERS FOR THE GOODS AND SERVICES OF OTHERS; PROMOTING THE GOODS AND SERVICES OF HEALTH SPAS, MEDICAL SPAS, DAY SPAS, BEAUTY SALONS, RESORTS, AND HOTELS, NAMELY, PROVIDING A WEB SITE FEATURING INFORMATION ON DISCOUNTS AND SPECIAL OFFERS FOR THE GOODS AND SERVICES OF OTHERS; ARRANGING AND CONDUCTING MARKETING PROMOTIONAL EVENTS FOR OTHERS (U.S. CLS. 100, 101 AND 102).

FIRST USE 12-21-2009; IN COMMERCE 12-21-2009.

BARBARA A. GOLD, EXAMINING ATTORNEY

CLASS 35—(Continued).

SN 85-092,693. D'NITIATIVES, LLC, WASHINGTON, DC. FILED 7-26-2010.

D'NITIATIVES LLC

THE MARK CONSISTS OF STANDARD CHARACTERS WITHOUT CLAIM TO ANY PARTICULAR FONT, STYLE, SIZE, OR COLOR.

NO CLAIM IS MADE TO THE EXCLUSIVE RIGHT TO USE "LLC", APART FROM THE MARK AS SHOWN.

FOR BUSINESS CONSULTATION SERVICES TO ASSIST NONPROFIT ORGANIZATIONS, GRANTMAKERS, PUBLIC AGENCIES, AND PUBLIC-PRIVATE PARTNERSHIPS IN THE FIELD OF MARKETING, STRATEGIC PLANNING, TRAINING, CAMPAIGN PLANNING, CONSTITUENT ENGAGEMENT, INITIATIVE AND PROJECT DEVELOPMENT AND IMPLEMENTATION, RESEARCH, FUNDRAISING, BUSINESS MANAGEMENT, BUSINESS MEETING PLANNING, AND PLAN, PROPOSAL, REPORT AND PAPER WRITING (U.S. CLS. 100, 101 AND 102).

ANNE FARRELL, EXAMINING ATTORNEY

CLASS 35—(Continued).

SN 85-094,023. SIGNATURE STYLES, LLC, NEW YORK, NY. FILED 7-27-2010.

SPIEGEL SIGNATURE ESTATE

THE MARK CONSISTS OF STANDARD CHARACTERS WITHOUT CLAIM TO ANY PARTICULAR FONT, STYLE, SIZE, OR COLOR.

OWNER OF U.S. REG. NOS. 3,444,214 AND 3,702,383.

FOR ON-LINE RETAIL STORE SERVICES FEATURING HANDBAGS, JEWELRY, CLOTHING AND ACCESSORIES (U.S. CLS. 100, 101 AND 102).

TIMOTHY FINNEGAN, EXAMINING ATTORNEY

SN 85-094,632. BURRELLE'S INFORMATION SERVICES, LLC, LIVINGSTON, NJ. FILED 7-28-2010.

BURRELLESLUCE WORKFLOW

THE MARK CONSISTS OF STANDARD CHARACTERS WITHOUT CLAIM TO ANY PARTICULAR FONT, STYLE, SIZE, OR COLOR.

OWNER OF U.S. REG. NOS. 3,070,359, 3,169,569 AND OTHERS.

FOR MEDIA MONITORING SERVICES, NAMELY, MONITORING PRINT MEDIA, TELEVISION, RADIO, AND OTHER MEDIA FOR CUSTOMER-SPECIFIED TOPICS, GATHERING RELEVANT CONTENT ON THOSE TOPICS, AND PROVIDING DOCUMENTATION AND ANALYSIS OF THAT MEDIA CONTENT TO OTHERS FOR BUSINESS PURPOSES; BUSINESS INFORMATION SERVICES, NAMELY, DISTRIBUTION OF CLIPPINGS AND BROADCAST SUMMARIES FROM MEDIA AND ELECTRONIC BROADCAST MEDIA, INCLUDING NEWS SERVICES, TELEVISION, RADIO, ELECTRONIC PUBLICATIONS AND COMMUNICATIONS VIA A GLOBAL COMPUTER NETWORK, AND ANALYSES OF CLIPPINGS AND BROADCAST TRANSCRIPTS RELATING TO ADVERTISING, EDITORIAL SLANT, NUMBER OF MESSAGE MENTIONS, CIRCULATION AND CONTENT (U.S. CLS. 100, 101 AND 102).

GRETTA YAO, EXAMINING ATTORNEY

SN 85-093,424. DELL INC., ROUND ROCK, TX. FILED 7-27-2010.

SOCIAL NET ADVOCACY

THE MARK CONSISTS OF STANDARD CHARACTERS WITHOUT CLAIM TO ANY PARTICULAR FONT, STYLE, SIZE, OR COLOR.

NO CLAIM IS MADE TO THE EXCLUSIVE RIGHT TO USE "SOCIAL NET", APART FROM THE MARK AS SHOWN.

FOR MARKET RESEARCH SERVICES; SOCIAL MEDIA MEASUREMENT SYSTEM TO ASSESS CUSTOMER FEEDBACK, NAMELY, SERVICES FOR ANALYZING CONSUMER IMPRESSIONS ON SOCIAL MEDIA ABOUT PRODUCTS AND SERVICES, AND PROVISION OF REPORTS AND ANALYSES ABOUT CUSTOMER COMMENTARY ON SOCIAL MEDIA REGARDING PRODUCTS AND SERVICES OFFERED BY OTHERS (U.S. CLS. 100, 101 AND 102).

TRICIA SONNEBORN, EXAMINING ATTORNEY

CLASS 35—(Continued).

SN 85-098,736. CITIZENS FOR RESTORING AMERICA'S FINANCIAL FUTURE, INC., ATLANTA, GA. FILED 8-3-2010.



NO CLAIM IS MADE TO THE EXCLUSIVE RIGHT TO USE "SOLUTION", APART FROM THE MARK AS SHOWN. THE COLOR(S) RED, WHITE AND BLUE IS/ARE CLAIMED AS A FEATURE OF THE MARK.

THE MARK CONSISTS OF THE WORDS "ONE CENT SOLUTION" IN THE COLORS BLUE AND RED WITH THE DEPICTION OF A SIDE PROFILE OF ABRAHAM LINCOLN IN RED TO THE LEFT OF THE WORDS ON A WHITE BACKGROUND IN A PARTIAL CIRCLE WITH A BLUE CIRCLE SURROUNDING THE WHITE CIRCLE AND HAVING TEN WHITE STARS. A PARTIAL RED LINE SURROUNDS THE BLUE CIRCLE. THERE ARE TWO RED WAVES UNDERNEATH THE WORDS WITH THE TOP WAVE CUTTING OFF THE BOTTOM OF THE CIRCLE.

FOR PROVIDING A WEBSITE FEATURING INFORMATION ABOUT POLITICAL ISSUES, NAMELY, THE NEED TO REDUCE GOVERNMENT SPENDING AND THE NATIONAL DEBT (U.S. CLS. 100, 101 AND 102).

JOHN DALIER, EXAMINING ATTORNEY

CLASS 35—(Continued).

SN 85-099,710. VIDEOEGG, INC., SAN FRANCISCO, CA. FILED 8-4-2010.

ADFRAMES SPARK

THE MARK CONSISTS OF STANDARD CHARACTERS WITHOUT CLAIM TO ANY PARTICULAR FONT, STYLE, SIZE, OR COLOR.

OWNER OF U.S. REG. NO. 3,652,081.

FOR ADVERTISING SERVICES, NAMELY, THE DISSEMINATION OF ADVERTISING FOR OTHERS THROUGH DIGITAL AND ONLINE MEDIA, CREATION AND DESIGN OF ADVERTISING MATERIAL FOR OTHERS, AND TRACKING FOR OTHERS OF VIEWERSHIP OF SUCH ADVERTISING (U.S. CLS. 100, 101 AND 102).

WILLIAM P. SHANAHAN, EXAMINING ATTORNEY

SN 85-100,424. MORELLO-SYOR, LISA, LITTLETON, CO. FILED 8-4-2010.



NO CLAIM IS MADE TO THE EXCLUSIVE RIGHT TO USE "MILITARY PJS", APART FROM THE MARK AS SHOWN.

THE COLOR(S) BLACK, WHITE, GRAY, BLUE, AND RED IS/ARE CLAIMED AS A FEATURE OF THE MARK.

THE MARK CONSISTS OF THE ARTISTIC RENDERING OF A MILITARY DOG TAG IN BLACK AND GRAY WITH A WHITE AND GRAY CHAIN. ON THE FACE OF THE FOREMENTIONED ARTISTIC RENDERING IS THE ARTISTIC RENDERING OF A SHIELD IN WHITE AND GRAY WITH A HALF BLUE INTERIOR CONTAINING THREE STARS IN WHITE AND BLUE AND A HALF RED AND WHITE STRIPED INTERIOR. TO THE RIGHT OF THE ARTISTIC RENDERING OF THE SHIELD ARE THE STYLIZED LETTERS "MP" IN GRAY AND WHITE SURROUNDED BY BLUE. BELOW THE STYLIZED LETTERS "MP" ARE THE STYLIZED WORDS "MILITARY PJS" IN WHITE WITH A BLACK SHADOW.

FOR RETAIL STORE AND ON-LINE RETAIL STORE SERVICES FEATURING CLOTHING, SLEEPWEAR, LOUNGEWEAR, BATH LINENS, BED LINENS, TOYS AND GENERAL CONSUMER MERCHANDISE (U.S. CLS. 100, 101 AND 102).

CHARLES L. JENKINS, EXAMINING ATTORNEY

SN 85-099,304. MOTION RECRUITMENT PARTNERS, INC., BOSTON, MA. FILED 8-3-2010.

MOTION RECRUITMENT PARTNERS

THE MARK CONSISTS OF STANDARD CHARACTERS WITHOUT CLAIM TO ANY PARTICULAR FONT, STYLE, SIZE, OR COLOR.

NO CLAIM IS MADE TO THE EXCLUSIVE RIGHT TO USE "RECRUITMENT" OR "PARTNERS", APART FROM THE MARK AS SHOWN.

FOR EMPLOYMENT PLACEMENT SERVICES; EMPLOYMENT RECRUITING AND COUNSELING SERVICES; RECRUITMENT OUTSOURCING SERVICES (U.S. CLS. 100, 101 AND 102).

MATTHEW PAPPAS, EXAMINING ATTORNEY

CLASS 35—(Continued).

SN 85-100,832. SONY ELECTRONICS INC., SAN DIEGO, CA. FILED 8-5-2010.

EYE ON EDUCATION

THE MARK CONSISTS OF STANDARD CHARACTERS WITHOUT CLAIM TO ANY PARTICULAR FONT, STYLE, SIZE, OR COLOR.

NO CLAIM IS MADE TO THE EXCLUSIVE RIGHT TO USE "EDUCATION", APART FROM THE MARK AS SHOWN.

FOR CUSTOMER LOYALTY SERVICES, NAMELY, ADMINISTERING A CUSTOMER BONUS INCENTIVE PROGRAM TO EDUCATIONAL INSTITUTIONS FOR COMMERCIAL, PROMOTIONAL AND/OR ADVERTISING PURPOSES FEATURING CONSUMER ELECTRONICS, NAMELY, DISPLAYS, PROJECTORS, PRO AUDIO CAMCORDERS, STUDIO CAMERAS AND SECURITY SYSTEMS (U.S. CLS. 100, 101 AND 102).

FIRST USE 11-1-2007; IN COMMERCE 11-1-2007.
ALYSSA STEEL, EXAMINING ATTORNEY

CLASS 35—(Continued).

SN 85-101,721. HUDSON VALLEY ECONOMIC DEVELOPMENT CORPORATION, NEW WINDSOR, NY. FILED 8-6-2010.



NO CLAIM IS MADE TO THE EXCLUSIVE RIGHT TO USE "NY", APART FROM THE MARK AS SHOWN.

THE COLOR(S) BLACK, BLUE AND GREEN IS/ARE CLAIMED AS A FEATURE OF THE MARK.

THE MARK CONSISTS OF THE WORDS "NY BIOHUD VALLEY" WITH BUBBLES COMING OUT OF THE LETTER "U". THE WORDS "NY" AND "VALLEY" ARE THE COLOR BLACK. THE LETTERS "BIO" AND THE BUBBLES ARE BLUE AND THE LETTERS "HUD" ARE GREEN.

FOR ECONOMIC DEVELOPMENT SERVICES, NAMELY, PROMOTION AND MARKETING OF THE HUDSON VALLEY, NEW YORK REGION AS A BIOTECHNOLOGY BUSINESS CENTER AND PLACE TO LOCATE BIOTECHNOLOGY BUSINESSES, ECONOMIC BUSINESS OUTREACH TO ATTRACT BIOTECHNOLOGY INDUSTRY BUSINESSES, NAMELY, PROMOTING PRIVATE AND GOVERNMENT FUNDING OF SUCH BUSINESSES; MARKETING AND ADVERTISING SERVICES; ASSOCIATION SERVICES, NAMELY, PROMOTING THE INTERESTS OF BIOTECHNOLOGY COMPANIES THROUGH POLITICS, EDUCATION, PUBLIC RELATIONS AND MARKETING (U.S. CLS. 100, 101 AND 102).

MICHELLE DUBOIS, EXAMINING ATTORNEY

SN 85-101,274. MAVEN GIRL MEDIA, TEMECULA, CA. FILED 8-5-2010.

The Secret to Success is Support

THE MARK CONSISTS OF STANDARD CHARACTERS WITHOUT CLAIM TO ANY PARTICULAR FONT, STYLE, SIZE, OR COLOR.

FOR ARRANGING AND CONDUCTING BUSINESS CONFERENCES; PROMOTING, MARKETING AND INCREASING ON-LINE TRAFFIC OF THE BLOGS OF OTHERS BY PROVIDING HYPERTEXT LINKS TO WEBSITES OF OTHERS FEATURING BLOGS ABOUT WOMEN'S ISSUES (U.S. CLS. 100, 101 AND 102).

FIRST USE 7-20-2008; IN COMMERCE 7-20-2008.
JULIE WATSON, EXAMINING ATTORNEY

SN 85-101,896. WESTPORT BUSINESS SOLUTIONS, LLC., WESTPORT, CT. FILED 8-6-2010.

ENRICHED SOLUTION

THE MARK CONSISTS OF STANDARD CHARACTERS WITHOUT CLAIM TO ANY PARTICULAR FONT, STYLE, SIZE, OR COLOR.

NO CLAIM IS MADE TO THE EXCLUSIVE RIGHT TO USE "SOLUTION", APART FROM THE MARK AS SHOWN.

FOR BUSINESS SERVICES, NAMELY, BUSINESS MANAGEMENT SERVICES; BUSINESS CONSULTING SERVICES; BUSINESS MANAGEMENT CONSULTING SERVICES; ACCOUNTING SERVICES; BUSINESS AUDITING SERVICES; BUSINESS HUMAN RESOURCE SERVICES; BUSINESS MARKETING SERVICES; GENERAL BUSINESS NETWORKING REFERRAL SERVICES, NAMELY, PROMOTING THE GOODS AND SERVICES OF OTHERS BY PASSING BUSINESS LEAD AND REFERRALS AMONG GROUP MEMBERS (U.S. CLS. 100, 101 AND 102).

FIRST USE 7-26-2010; IN COMMERCE 7-26-2010.
ESTHER A. BORSUK, EXAMINING ATTORNEY

CLASS 35—(Continued).

SN 85-103,301. SYNTHETIC SCENTS, LTD., FENTON, MI. FILED 8-9-2010.

MAKE BUCKS HUNT YOU

THE MARK CONSISTS OF STANDARD CHARACTERS WITHOUT CLAIM TO ANY PARTICULAR FONT, STYLE, SIZE, OR COLOR.

NO CLAIM IS MADE TO THE EXCLUSIVE RIGHT TO USE "BUCKS", APART FROM THE MARK AS SHOWN.

FOR WHOLESALE AND RETAIL STORE SERVICES FEATURING SYNTHETIC HUNTING SCENTS AND SCENT ELIMINATORS (U.S. CLS. 100, 101 AND 102).

FIRST USE 8-9-2010; IN COMMERCE 8-9-2010.
RUSS HERMAN, EXAMINING ATTORNEY

SN 85-103,818. DINERS CLUB INTERNATIONAL, RIVERWOODS, IL. FILED 8-10-2010.

DINERS CLUB PRIVILEGES

THE MARK CONSISTS OF STANDARD CHARACTERS WITHOUT CLAIM TO ANY PARTICULAR FONT, STYLE, SIZE, OR COLOR.

OWNER OF U.S. REG. NOS. 828,013, 2,658,760 AND OTHERS.

FOR CREDIT CARD USER LOYALTY AND REWARD PROGRAMS, NAMELY, CREDIT CARD CUSTOMER LOYALTY SERVICES FOR PROMOTIONAL PURPOSES (U.S. CLS. 100, 101 AND 102).

MAUREEN DALL, EXAMINING ATTORNEY

CLASS 35—(Continued).

SN 85-104,356. GREEN DESIGN EXPO LLC, SCARSDALE, NY. FILED 8-10-2010.



NO CLAIM IS MADE TO THE EXCLUSIVE RIGHT TO USE "GREEN DESIGN EXPO", APART FROM THE MARK AS SHOWN.

THE COLOR(S) GREEN AND BLACK IS/ARE CLAIMED AS A FEATURE OF THE MARK.

THE MARK CONSISTS OF THE WORDS "GREEN DESIGN" IN GREEN AND THE WORD "EXPO" IN BLACK BUT ONE OF THE LINES OF THE "X" IS GREEN AS WELL AS A LEAF DESIGN IN GREEN.

FOR RETAIL STORES FEATURING ENVIRONMENTALLY CORRECT PRODUCTS FOR THE HOME (U.S. CLS. 100, 101 AND 102).

JANICE L. MCMORROW, EXAMINING ATTORNEY

SN 85-105,328. SQUAD INC., TARRYTOWN, NY. FILED 8-11-2010.

NETCOSTS

THE MARK CONSISTS OF STANDARD CHARACTERS WITHOUT CLAIM TO ANY PARTICULAR FONT, STYLE, SIZE, OR COLOR.

SEC. 2(F).

FOR COST ANALYSIS SERVICES, NAMELY, REAL COST ASSESSMENT AND COST FORECASTING SERVICES FOR NETWORK, CABLE AND SYNDICATION TELEVISION (U.S. CLS. 100, 101 AND 102).

FIRST USE 2-11-2004; IN COMMERCE 2-11-2004.
KELLY BOULTON, EXAMINING ATTORNEY

CLASS 35—(Continued).

SN 85-107,581. HERDELL, JEFFREY, HIDDEN VALLEY LAKE, CA. FILED 8-13-2010.

VERSZ

THE MARK CONSISTS OF STANDARD CHARACTERS WITHOUT CLAIM TO ANY PARTICULAR FONT, STYLE, SIZE, OR COLOR.

FOR PROVIDING A WEBSITE THAT ALLOWS USERS TO DISCUSS, REVIEW, RATE, COMMENT, VOTE AND SUBMIT COMPARISONS ABOUT PRODUCTS AND SERVICES (U.S. CLS. 100, 101 AND 102).

FIRST USE 3-12-2010; IN COMMERCE 3-12-2010.
RONALD AIKENS, EXAMINING ATTORNEY

SN 85-109,489. CONNECT CONCEPTS, LLC, STUDIO CITY, CA. FILED 8-17-2010.

BOOMER HOTTIE

THE MARK CONSISTS OF STANDARD CHARACTERS WITHOUT CLAIM TO ANY PARTICULAR FONT, STYLE, SIZE, OR COLOR.

FOR PUBLIC ADVOCACY TO PROMOTE AWARENESS OF THE IMPORTANCE OF ACTIVE AND ENGAGED LIFESTYLES FOR WOMEN (U.S. CLS. 100, 101 AND 102).

DAVID C. REIHNER, EXAMINING ATTORNEY

SN 85-109,653. DOMESTIC ENVIRONMENTAL ALTERNATIVES, INC., MURPHYS, CA. FILED 8-17-2010.

BATHROOM MACHINERIES

THE MARK CONSISTS OF STANDARD CHARACTERS WITHOUT CLAIM TO ANY PARTICULAR FONT, STYLE, SIZE, OR COLOR.

OWNER OF U.S. REG. NO. 2,393,226.

SEC. 2(F).

FOR CATALOG ORDERING SERVICE FEATURING BOOKS, CLOTHING, AND SPECIALTY FIREFIGHTING EQUIPMENT AS WELL AS PLUMBING, LIGHTING, HARDWARE, KITCHEN PRODUCTS, AND ANTIQUE AND REPRODUCTION PLUMBING, LIGHTING, HARDWARE, AND KITCHEN PRODUCTS; ELECTRONIC CATALOG SERVICES FEATURING BOOKS, CLOTHING, AND SPECIALTY FIREFIGHTING EQUIPMENT AS WELL AS PLUMBING, LIGHTING, HARDWARE, KITCHEN PRODUCTS, AND ANTIQUE AND REPRODUCTION PLUMBING, LIGHTING, HARDWARE, AND KITCHEN PRODUCTS; MAIL ORDER CATALOG SERVICES FEATURING BOOKS, CLOTHING, AND SPECIALTY FIREFIGHTING EQUIPMENT AS WELL AS PLUMBING, LIGHTING, HARDWARE, KITCHEN PRODUCTS, AND ANTIQUE AND REPRODUCTION PLUMBING, LIGHTING, HARDWARE, AND KITCHEN

CLASS 35—(Continued).

PRODUCTS; ON-LINE RETAIL STORE SERVICES FEATURING BOOKS, CLOTHING, AND SPECIALTY FIREFIGHTING EQUIPMENT AS WELL AS PLUMBING, LIGHTING, HARDWARE, KITCHEN PRODUCTS, AND ANTIQUE AND REPRODUCTION PLUMBING, LIGHTING, HARDWARE, AND KITCHEN PRODUCTS; ON-LINE WHOLESALE AND RETAIL STORE SERVICES FEATURING BOOKS, CLOTHING, AND SPECIALTY FIREFIGHTING EQUIPMENT AS WELL AS PLUMBING, LIGHTING, HARDWARE, AND KITCHEN PRODUCTS; ANTIQUE AND REPRODUCTION PLUMBING, LIGHTING, HARDWARE, AND KITCHEN PRODUCTS; RETAIL SHOPS FEATURING BOOKS, CLOTHING, AND SPECIALTY FIREFIGHTING EQUIPMENT AS WELL AS PLUMBING, LIGHTING, HARDWARE, AND KITCHEN PRODUCTS; AND ANTIQUE AND REPRODUCTION PLUMBING, LIGHTING, HARDWARE, AND KITCHEN PRODUCTS; RETAIL STORE AND ON-LINE RETAIL STORE SERVICES FEATURING BOOKS, CLOTHING, AND SPECIALTY FIREFIGHTING EQUIPMENT AS WELL AS PLUMBING, LIGHTING, HARDWARE, AND KITCHEN PRODUCTS; WHOLESALE AND RETAIL STORE SERVICES FEATURING BOOKS, CLOTHING, AND SPECIALTY FIREFIGHTING EQUIPMENT AS WELL AS PLUMBING, LIGHTING, HARDWARE, AND KITCHEN PRODUCTS; WHOLESALE STORE SERVICES FEATURING BOOKS, CLOTHING, AND SPECIALTY FIREFIGHTING EQUIPMENT AS WELL AS PLUMBING, LIGHTING, HARDWARE, AND KITCHEN PRODUCTS; WHOLESALE STORES FEATURING BOOKS, CLOTHING, AND SPECIALTY FIREFIGHTING EQUIPMENT AS WELL AS PLUMBING, LIGHTING, HARDWARE, AND KITCHEN PRODUCTS; WHOLESALE AND RETAIL STORE SERVICES FEATURING BOOKS, CLOTHING, AND SPECIALTY FIREFIGHTING EQUIPMENT AS WELL AS PLUMBING, LIGHTING, HARDWARE, AND KITCHEN PRODUCTS (U.S. CLS. 100, 101 AND 102).

FIRST USE 1-1-1983; IN COMMERCE 1-1-1984.
MARK SHINER, EXAMINING ATTORNEY

CLASS 35—(Continued).

SN 85-110,003. SOCIETY FOR PEDIATRIC SEDATION, INC., RICHMOND, VA. FILED 8-18-2010.



NO CLAIM IS MADE TO THE EXCLUSIVE RIGHT TO USE "SOCIETY FOR PEDIATRIC SEDATION" AND "SAFE AND SOUND", APART FROM THE MARK AS SHOWN.

THE MARK CONSISTS OF AN IMAGE OF A CHILD RESTING IN THE HORIZONTAL POSITION WITH AN ARC EXTENDING FROM ABOVE THE CHILD'S HEAD TO BEHIND THE CHILD'S HEAD, WITH THE LETTERS "SPS" ABOVE A HORIZONTAL LINE AND BELOW THE IMAGE OF THE CHILD AND THE ARC. BELOW THE HORIZONTAL LINE ARE THE WORDS "SOCIETY FOR PEDIATRIC SEDATION SAFE AND SOUND".

FOR ASSOCIATION SERVICES, NAMELY, PROMOTING THE INTERESTS OF PEDIATRIC SEDATION HEALTH CARE PROVIDERS; BUSINESS SERVICES, NAMELY, FORMULATION AND PROMOTION OF BEST PRACTICES FOR PEDIATRIC SEDATION CARE (U.S. CLS. 100, 101 AND 102).

FIRST USE 1-15-2008; IN COMMERCE 1-15-2008.
LINDA ESTRADA, EXAMINING ATTORNEY

SN 85-110,144. TREASURE ISLAND FOODS, INC., CHICAGO, IL. FILED 8-18-2010.

TREASURE ISLAND

THE MARK CONSISTS OF STANDARD CHARACTERS WITHOUT CLAIM TO ANY PARTICULAR FONT, STYLE, SIZE, OR COLOR.

FOR RETAIL GROCERY STORES (U.S. CLS. 100, 101 AND 102).

FIRST USE 5-0-1963; IN COMMERCE 5-0-1963.
MICHAEL ENGEL, EXAMINING ATTORNEY

CLASS 35—(Continued).

SN 85-112,172. RUELALA, INC., BOSTON, MA. FILED 8-20-2010.

THE BARGAIN ALERT!

THE MARK CONSISTS OF STANDARD CHARACTERS WITHOUT CLAIM TO ANY PARTICULAR FONT, STYLE, SIZE, OR COLOR.

SEC. 2(F).

FOR PROMOTING THE GOODS AND SERVICES OF OTHERS BY PROVIDING NOTIFICATION ABOUT DISCOUNTS ON THE GOODS AND SERVICES OF OTHERS VIA ELECTRONIC COMMUNICATION NETWORKS (U.S. CLS. 100, 101 AND 102).

FIRST USE 11-30-2001; IN COMMERCE 12-1-2001.

PAM WILLIS, EXAMINING ATTORNEY

SN 85-113,496. ESCAPEMAKER.COM INC., BROOKLYN, NY. FILED 8-23-2010.

ESCAPEMAKER.COM MAKE YOUR ESCAPE THROUGH THE NET

THE MARK CONSISTS OF STANDARD CHARACTERS WITHOUT CLAIM TO ANY PARTICULAR FONT, STYLE, SIZE, OR COLOR.

FOR ADVERTISING AND DIRECTORY SERVICES, NAMELY, PROMOTING THE SERVICES OF OTHERS BY PROVIDING A WEB PAGE FEATURING LINKS TO THE WEBSITES OF OTHERS (U.S. CLS. 100, 101 AND 102).

FIRST USE 9-13-2000, THE MARK WAS FIRST USED ANYWHERE IN A DIFFERENT FORM OTHER THAN THAT SOUGHT TO BE REGISTERED AT LEAST AS EARLY AS 09/13/2000.; IN COMMERCE 9-13-2000, THE MARK WAS FIRST USED IN COMMERCE IN A DIFFERENT FORM OTHER THAN THAT SOUGHT TO BE REGISTERED AT LEAST AS EARLY AS 09/13/2000..

CHRISTINA SOBRAL, EXAMINING ATTORNEY

SN 85-113,989. BOYETTE, BRIAN, MESA, AZ. FILED 8-23-2010.

Avior Group

THE MARK CONSISTS OF STANDARD CHARACTERS WITHOUT CLAIM TO ANY PARTICULAR FONT, STYLE, SIZE, OR COLOR.

NO CLAIM IS MADE TO THE EXCLUSIVE RIGHT TO USE "GROUP", APART FROM THE MARK AS SHOWN.

FOR ASSISTANCE, ADVISORY SERVICES AND CONSULTANCY WITH REGARD TO BUSINESS PLANNING, BUSINESS ANALYSIS, BUSINESS MANAGEMENT, BUSINESS ORGANIZATION, MARKETING AND CUSTOMER ANALYSIS (U.S. CLS. 100, 101 AND 102).

FIRST USE 6-23-2003; IN COMMERCE 6-23-2003.

KARANENDRA S. CHHINA, EXAMINING ATTORNEY

CLASS 35—(Continued).

SN 85-114,316. HEWITSON, ANDREW, SAN CLEMENTE, CA. FILED 8-24-2010.

AVANT WELLNESS

THE MARK CONSISTS OF STANDARD CHARACTERS WITHOUT CLAIM TO ANY PARTICULAR FONT, STYLE, SIZE, OR COLOR.

NO CLAIM IS MADE TO THE EXCLUSIVE RIGHT TO USE "WELLNESS", APART FROM THE MARK AS SHOWN. FOR DISTRIBUTORSHIP SERVICES IN THE FIELD OF WELLNESS PRODUCTS (U.S. CLS. 100, 101 AND 102). CHRISTINA SOBRAL, EXAMINING ATTORNEY

SN 85-114,585. LATIN FRANCHISES CORP, PORT ST LUCIE, FL. FILED 8-24-2010.



NO CLAIM IS MADE TO THE EXCLUSIVE RIGHT TO USE "CENTRO LATINO", APART FROM THE MARK AS SHOWN.

THE COLOR(S) GREEN, YELLOW IS/ARE CLAIMED AS A FEATURE OF THE MARK.

THE MARK CONSISTS OF THE STYLIZED WORD "INTAX" IN GREEN WITH THE LETTER "X" SHADOWED IN YELLOW. BENEATH THE WORD "INTAX" IS THE WORDING "CENTRO LATINO" IN GREEN.

THE ENGLISH TRANSLATION OF "CENTRO LATINO" IN THE MARK IS "LATIN CENTER".

FOR INCOME TAX CONSULTATION; INCOME TAX PREPARATION; TAX FILING SERVICES; TAX PREPARATION (U.S. CLS. 100, 101 AND 102).

STEVEN JACKSON, EXAMINING ATTORNEY

SN 85-114,638. CRYSTAL ART IMPORTS, INC., COLUMBUS, OH. FILED 8-24-2010.

SHANNON

THE MARK CONSISTS OF STANDARD CHARACTERS WITHOUT CLAIM TO ANY PARTICULAR FONT, STYLE, SIZE, OR COLOR.

OWNER OF U.S. REG. NO. 1,510,085.

FOR CATALOG ORDERING SERVICE FEATURING CRYSTAL; ON-LINE RETAIL STORE SERVICES FEATURING CRYSTAL (U.S. CLS. 100, 101 AND 102).

FIRST USE 0-0-1976; IN COMMERCE 0-0-1976.

KARANENDRA S. CHHINA, EXAMINING ATTORNEY

CLASS 35—(Continued).

SN 85-116,212. HAWK, CHARLES W., DBA THE GEORGIA PIT, VINCENT, AL. FILED 8-26-2010.

The Georgia Pit

THE MARK CONSISTS OF STANDARD CHARACTERS WITHOUT CLAIM TO ANY PARTICULAR FONT, STYLE, SIZE, OR COLOR.

FOR MOBILE STREET VENDOR SERVICES FEATURING FOOD AND DRINK (U.S. CLS. 100, 101 AND 102).

FIRST USE 10-31-2009; IN COMMERCE 10-31-2009.

DAVID TAYLOR, EXAMINING ATTORNEY

SN 85-118,058. POLADORA LLC, CHICAGO, IL. FILED 8-28-2010.

Many gifts... One site.

THE MARK CONSISTS OF STANDARD CHARACTERS WITHOUT CLAIM TO ANY PARTICULAR FONT, STYLE, SIZE, OR COLOR.

FOR GIFT REGISTRY SERVICES (U.S. CLS. 100, 101 AND 102).

FIRST USE 7-27-2010; IN COMMERCE 7-27-2010.

JOHN DWYER, EXAMINING ATTORNEY

SN 85-118,528. KALALOU, INC., JACKSON, MS. FILED 8-30-2010.

AT WEST END

THE MARK CONSISTS OF STANDARD CHARACTERS WITHOUT CLAIM TO ANY PARTICULAR FONT, STYLE, SIZE, OR COLOR.

FOR MAIL ORDER SERVICES FEATURING HOME AND GARDEN FURNISHINGS, GIFTS AND ACCESSORIES; ON-LINE RETAIL STORE SERVICES FEATURING HOME AND GARDEN FURNISHINGS, GIFTS AND ACCESSORIES (U.S. CLS. 100, 101 AND 102).

FIRST USE 4-1-2006; IN COMMERCE 4-1-2006.

ROBIN CHOSID, EXAMINING ATTORNEY

CLASS 35—(Continued).

SN 85-121,066. EAGLE HOSPITAL PHYSICIANS, LLC, ATLANTA, GA. FILED 9-1-2010.

EHP

THE MARK CONSISTS OF STANDARD CHARACTERS WITHOUT CLAIM TO ANY PARTICULAR FONT, STYLE, SIZE, OR COLOR.

OWNER OF U.S. REG. NOS. 2,894,248 AND 3,291,775.

FOR HOSPITAL MANAGEMENT, BUSINESS MANAGEMENT OF PHYSICIAN PRACTICES, BUSINESS MANAGEMENT OF MANAGED CARE ORGANIZATIONS; ADMINISTRATIVE SUPPORT SERVICES PROVIDED TO HOSPITALS, PHYSICIAN PRACTICES AND MANAGED CARE ORGANIZATIONS, NAMELY, BUSINESS PLANNING AND PHYSICIAN RECRUITMENT (U.S. CLS. 100, 101 AND 102).

KAPIL BHANOT, EXAMINING ATTORNEY

SN 85-122,851. HUNTINGS MY LIFE, L.L.C., ODEBOLT, IA. FILED 9-3-2010.

HUNTING IS MY LIFE

THE MARK CONSISTS OF STANDARD CHARACTERS WITHOUT CLAIM TO ANY PARTICULAR FONT, STYLE, SIZE, OR COLOR.

NO CLAIM IS MADE TO THE EXCLUSIVE RIGHT TO USE "HUNTING", APART FROM THE MARK AS SHOWN.

FOR ON-LINE RETAIL STORE SERVICES FEATURING CLOTHING, APPAREL, COFFEE AND GIFTS (U.S. CLS. 100, 101 AND 102).

DEZMONA MIZELLE, EXAMINING ATTORNEY

SN 85-125,873. KINGDOM INVESTMENTS INTERNATIONAL, BEND, OR. FILED 9-9-2010.

OPERATION RANSOM

THE MARK CONSISTS OF STANDARD CHARACTERS WITHOUT CLAIM TO ANY PARTICULAR FONT, STYLE, SIZE, OR COLOR.

FOR CHARITABLE SERVICES, NAMELY, ORGANIZING AND DEVELOPING PROJECTS THAT AIM TO IMPROVE THE LIVES OF UNDERPRIVILEGED AND IMPOVERISHED PEOPLE AND VICTIMS OF SEXUAL EXPLOITATION AND GENDER-BASED VIOLENCE, ORGANIZING AND DEVELOPING PROJECTS THAT AIM TO PROMOTE GLOBAL AWARENESS ABOUT HUMAN TRAFFICKING AND THE COMMERCIAL SEX INDUSTRY, PROVIDING EMPLOYMENT COUNSELING SERVICES FOR THOSE LIVING IN POVERTY IN THE AREAS OF PREPARING FOR, OBTAINING, MAINTAINING AND ADVANCING IN EMPLOYMENT OPPORTUNITIES (U.S. CLS. 100, 101 AND 102).

KATHERINE STOIDES, EXAMINING ATTORNEY

CLASS 35—(Continued).

SN 85-126,792. ICE CREAM FACTORIA, LLC, WOOD RIDGE, NJ. FILED 9-10-2010.



NO CLAIM IS MADE TO THE EXCLUSIVE RIGHT TO USE "ICE CREAM FACTORIA", APART FROM THE MARK AS SHOWN.

THE MARK CONSISTS OF THE STYLIZED WORDS "ICE CREAM FACTORIA", AN IMAGE OF AN CONE WITH A SCOOP OF ICE CREAM ABOVE. A CHERRY ON TOP OF THE ICE CREAM.

THE ENGLISH TRANSLATION OF "FACTORIA" IN THE MARK IS "FACTORY".

FOR RETAIL STORE SERVICES FEATURING FROZEN DESSERTS AND CONFECTIONERY (U.S. CLS. 100, 101 AND 102).

ADA HAN, EXAMINING ATTORNEY

SN 85-130,158. MR. NICE GUYS MERCHANDISING, INC., WAITE PARK, MN. FILED 9-15-2010.

Mr. Nice Guys

THE MARK CONSISTS OF STANDARD CHARACTERS WITHOUT CLAIM TO ANY PARTICULAR FONT, STYLE, SIZE, OR COLOR.

FOR RETAIL STORES FEATURING TOBACCO HAND PIPES, TOBACCO WATER PIPES, TOBACCO PIPE CLEANERS, GLASS TOBACCO SMOKING PIPES, CHILLUMS, BUBBLERS, SPOONS, SMOKING PIPES, SIDE CARS, HERB GRINDERS, DIGITAL SCALES, GLASS JARS, GLASS PIPE CASES, TOBACCO SMOKING PIPE ACCESSORIES, DISC GOLF DISCS, DISC GOLF BAGS, DISC GOLF ACCESSORIES, ARTWORK, CIGARETTE ROLLING PAPERS, CIGAR ROLLING PAPERS, LIGHTERS, HOOKAHS, HOOKAH ACCESSORIES, AND GLASS PIPE PARTS (U.S. CLS. 100, 101 AND 102).

FIRST USE 7-31-2010; IN COMMERCE 7-31-2010.
PRISCILLA MILTON, EXAMINING ATTORNEY

CLASS 35—(Continued).

SN 85-131,412. PREFERRED OFFICE NETWORK, LLC, AUSTIN, TX. FILED 9-16-2010.



OWNER OF U.S. REG. NO. 3,167,255.
NO CLAIM IS MADE TO THE EXCLUSIVE RIGHT TO USE "PREFERRED OFFICE NETWORK", APART FROM THE MARK AS SHOWN.

THE MARK CONSISTS OF BLACK DOTS CONNECTED BY LINES AND THE WORDS "PREFERRED OFFICE NETWORK".

FOR REFERRALS IN THE FIELD OF OFFICE SPACE (U.S. CLS. 100, 101 AND 102).

ANNE E. GUSTASON, EXAMINING ATTORNEY

CLASS 35—(Continued).

SN 85-135,161. TRUELIGHT, LLC, BOSTON, MA. FILED 9-22-2010.

TRUELIGHT ENERGY

THE MARK CONSISTS OF STANDARD CHARACTERS WITHOUT CLAIM TO ANY PARTICULAR FONT, STYLE, SIZE, OR COLOR.

NO CLAIM IS MADE TO THE EXCLUSIVE RIGHT TO USE "ENERGY", APART FROM THE MARK AS SHOWN.

FOR ASSET MANAGEMENT SERVICES, NAMELY, AUCTIONING, LIQUIDATING AND REMARKETING ENERGY, RENEWABLE ENERGY AND ENERGY GENERATION ASSETS OF OTHERS (U.S. CLS. 100, 101 AND 102).

JULIE VEPPUMTHARA, EXAMINING ATTORNEY

SN 85-135,968. SRG ENTERPRISES, INC., PEMBROKE, MA. FILED 9-22-2010.

ITZAPARTY

THE MARK CONSISTS OF STANDARD CHARACTERS WITHOUT CLAIM TO ANY PARTICULAR FONT, STYLE, SIZE, OR COLOR.

FOR WHOLESALE AND RETAIL STORE SERVICES AND ON-LINE RETAIL AND WHOLESALE STORE SERVICES FEATURING GIFTS, CARDS, PARTY SUPPLIES, NOVELTIES AND PARTY EQUIPMENT RENTAL (U.S. CLS. 100, 101 AND 102).

FIRST USE 9-26-1996; IN COMMERCE 9-26-1996.

FRANK LATTUCA, EXAMINING ATTORNEY

SN 85-132,468. MR. NICE GUYS MERCHANDISING, INC., WAITE PARK, MN. FILED 9-17-2010.



THE COLOR(S) BLACK AND WHITE IS/ARE CLAIMED AS A FEATURE OF THE MARK.

THE MARK CONSISTS OF THE WORD "MR. NICE GUYS" IN BOLD WHITE LETTERS WITH A BLACK OUTLINE. TO THE LEFT OF THE WORDS IS A DESIGN WHICH FEATURES A SMILEY FACE CONSISTING OF A CIRCLE OUTLINED IN BLACK AND FILLED WITH THE COLOR WHITE. THE CIRCLE CONTAINS TWO BLACK EYES WHICH CONSIST OF HORIZONTAL BLACK LINES AND A BLACK SMILE.

FOR RETAIL STORES FEATURING TOBACCO HAND PIPES, TOBACCO WATER PIPES, TOBACCO PIPE CLEANERS, GLASS TOBACCO SMOKING PIPES, CHILLUMS, BUBBLERS, SPOONS, SMOKING PIPES, SIDE CARS, HERB GRINDERS, DIGITAL SCALES, GLASS JARS, GLASS PIPE CASES, TOBACCO SMOKING PIPE ACCESSORIES, DISC GOLF DISCS, DISC GOLF BAGS, DISC GOLF ACCESSORIES, ARTWORK, CIGARETTE ROLLING PAPERS, CIGAR ROLLING PAPERS, LIGHTERS, HOOKAHS, HOOKAH ACCESSORIES, AND GLASS PIPE PARTS (U.S. CLS. 100, 101 AND 102).

FIRST USE 7-31-2010; IN COMMERCE 7-31-2010.

PRISCILLA MILTON, EXAMINING ATTORNEY

SN 85-137,540. MUSEUM TOWER, LP, DALLAS, TX. FILED 9-24-2010.

MT

THE MARK CONSISTS OF STANDARD CHARACTERS WITHOUT CLAIM TO ANY PARTICULAR FONT, STYLE, SIZE, OR COLOR.

FOR REAL ESTATE SERVICES, NAMELY, CONDOMINIUM SALES MANAGEMENT (U.S. CLS. 100, 101 AND 102).

FIRST USE 4-1-2007; IN COMMERCE 6-0-2007.

KRISTINA MORRIS, EXAMINING ATTORNEY

CLASS 35—(Continued).

SN 85-138,042. KOBREN, SPENCER, CALABASAS, CA.
FILED 9-24-2010.

INTERNATIONAL ALLIANCE OF
HAIR RESTORATION SURGEONS

THE MARK CONSISTS OF STANDARD CHARACTERS
WITHOUT CLAIM TO ANY PARTICULAR FONT, STYLE,
SIZE, OR COLOR.

NO CLAIM IS MADE TO THE EXCLUSIVE RIGHT TO
USE "ALLIANCE OF HAIR RESTORATION SURGEONS",
APART FROM THE MARK AS SHOWN.

SEC. 2(F).

FOR ASSOCIATION SERVICES, NAMELY, PROMOT-
ING THE INTERESTS OF MEMBERS OF AN ASSOCIA-
TION OF DOCTORS (U.S. CLS. 100, 101 AND 102).

FIRST USE 3-30-1998; IN COMMERCE 3-30-1998.
B. PARADEWELAI, EXAMINING ATTORNEY

SN 85-139,024. MUSEUM TOWER, LP, DALLAS, TX. FILED
9-27-2010.

LIVE FOR THE ARTS

THE MARK CONSISTS OF STANDARD CHARACTERS
WITHOUT CLAIM TO ANY PARTICULAR FONT, STYLE,
SIZE, OR COLOR.

FOR REAL ESTATE SERVICES, NAMELY, CONDO-
MINIUM SALES MANAGEMENT (U.S. CLS. 100, 101
AND 102).

FIRST USE 6-0-2007; IN COMMERCE 6-0-2007.
KRISTINA MORRIS, EXAMINING ATTORNEY

SN 85-139,645. GRUPO ACTINVER, S.A. DE C.V., SANTA FE,
MEXICO, FILED 9-28-2010.

ACTINVER

THE MARK CONSISTS OF STANDARD CHARACTERS
WITHOUT CLAIM TO ANY PARTICULAR FONT, STYLE,
SIZE, OR COLOR.

OWNER OF MEXICO REG. NO. 1012045, DATED 11-20-
2007, EXPIRES 10-9-2016.

FOR PUBLICITY CONSULTATION; BUSINESS MAN-
AGEMENT; BUSINESS ADMINISTRATION; PROVID-
ING OFFICE FUNCTIONS (U.S. CLS. 100, 101 AND 102).

RONALD MCMORROW, EXAMINING ATTORNEY

CLASS 35—(Continued).

SN 85-140,068. MUSICIAN'S FRIEND, INC., MEDFORD, OR.
FILED 9-28-2010.

WWBW.COM

THE MARK CONSISTS OF STANDARD CHARACTERS
WITHOUT CLAIM TO ANY PARTICULAR FONT, STYLE,
SIZE, OR COLOR.

FOR ONLINE RETAIL STORE SERVICES FEATUR-
ING MUSICAL INSTRUMENTS, SHEET MUSIC, MUSIC
BOOKS, SOFTWARE FEATURING MUSIC INSTRUC-
TION, FOR USE IN TEACHING MUSIC, FOR USE IN
WRITING MUSIC, FOR USE IN PRODUCING MUSIC,
FOR USE IN COMPOSING MUSIC, FOR USE IN MAS-
TERING MUSIC, FOR USE IN RECORDING MUSIC
AND FOR USE IN MUSICAL APPLICATIONS, MUSICAL
INSTRUMENT ACCESSORIES, AND MUSICAL EQUIP-
MENT (U.S. CLS. 100, 101 AND 102).

MARY CRAWFORD, EXAMINING ATTORNEY

SN 85-141,382. ROWAN, WILLIAM, SAN JOSE, CA. FILED 9-
29-2010.

BRIEF SPACE

THE MARK CONSISTS OF STANDARD CHARACTERS
WITHOUT CLAIM TO ANY PARTICULAR FONT, STYLE,
SIZE, OR COLOR.

NO CLAIM IS MADE TO THE EXCLUSIVE RIGHT TO
USE "SPACE", APART FROM THE MARK AS SHOWN.

FOR ART GALLERY SERVICES; RETAIL STORE
SERVICES FEATURING CLOTHING, ART, TOYS AND
SPEAKERS; PROVIDING FACILITIES FOR BUSINESS
MEETINGS; PROVIDING FACILITIES FOR TRADE EX-
HIBITIONS (U.S. CLS. 100, 101 AND 102).

ROBERT C. CLARK JR., EXAMINING ATTORNEY

CLASS 35—(Continued).

SN 85-143,191. RIGBERG, GLENN, BEVERLY HILLS, CA.
FILED 10-1-2010.



THE COLOR(S) BROWN AND BLUE IS/ARE CLAIMED AS A FEATURE OF THE MARK.

THE MARK CONSISTS OF TWO HORIZONTAL BLUE LINES AND A VERTICAL BROWN LINE FORMING THE LETTER "I" WITHIN A CIRCLE OUTLINED IN BROWN ABOVE THE STYLIZED WORD "INPHENATE". THE LETTERS "NPHENATE" ARE BLUE. THE LETTER "I" OF "INPHENATE" HAS BLUE HORIZONTAL LINES AND A BROWN VERTICAL LINE. THE COLOR WHITE IN THE CIRCLE IS BACKGROUND COLOR AND NOT A FEATURE OF THE MARK.

FOR MANAGEMENT OF PERFORMING ARTISTS; TALENT AGENCIES; TALENT AGENCY SERVICES (U.S. CLS. 100, 101 AND 102).

FIRST USE 6-1-2010; IN COMMERCE 6-1-2010.
MARY BOAGNI, EXAMINING ATTORNEY

SN 85-144,142. TSA STORES, INC., ENGLEWOOD, CO.
FILED 10-4-2010.

ALL THINGS SPORTING GOOD

THE MARK CONSISTS OF STANDARD CHARACTERS WITHOUT CLAIM TO ANY PARTICULAR FONT, STYLE, SIZE, OR COLOR.

FOR RETAIL SPORTING GOODS STORES (U.S. CLS. 100, 101 AND 102).

CYNTHIA TRIPI, EXAMINING ATTORNEY

CLASS 35—(Continued).

SN 85-145,679. PB MICROSAVINGS, BEVERLY HILLS, CA.
FILED 10-5-2010.

PB MICROSAVINGS

THE MARK CONSISTS OF STANDARD CHARACTERS WITHOUT CLAIM TO ANY PARTICULAR FONT, STYLE, SIZE, OR COLOR.

NO CLAIM IS MADE TO THE EXCLUSIVE RIGHT TO USE "MICROSAVINGS", APART FROM THE MARK AS SHOWN.

FOR DATA PROCESSING SERVICES IN THE FIELD OF CHECK, CREDIT, DEBIT, STORED VALUE AND ELECTRONIC BENEFITS TRANSFER CARD TRANSACTIONS AND PAYMENTS; SERVICES FOR MERCHANTS FOR COMMERCIAL, PROMOTIONAL AND/OR ADVERTISING PURPOSES, NAMELY, CONDUCTING INCENTIVE AWARD PROGRAMS TO PROMOTE THE SALE OF PRODUCTS AND SERVICES OF OTHERS; PROMOTING THE SALE OF THE GOODS AND SERVICES OF OTHERS THROUGH THE DISTRIBUTION AND PROCESSING OF ELECTRONIC COUPONS ISSUED OVER A GLOBAL COMPUTER NETWORK; PROVIDING AN ON-LINE INTERACTIVE DATABASE CONTAINING COMMERCIAL BUSINESS INFORMATION REGARDING CONSUMERS, NAMELY, COMMERCIAL FINANCIAL TRANSACTION DATA, CONSUMER DATA AND CUSTOMER DATA; PROCESSING OF CUSTOMER DISCOUNTS AND REWARDS VIA WIRELESS PROXIMITY PAYMENT DEVICES AND MAGNETICALLY ENCODED CARDS (U.S. CLS. 100, 101 AND 102).

CHARLES L. JENKINS, EXAMINING ATTORNEY

SN 85-145,737. PB MICROSAVINGS, BEVERLY HILLS, CA.
FILED 10-5-2010.



NO CLAIM IS MADE TO THE EXCLUSIVE RIGHT TO USE "MICROSAVINGS", APART FROM THE MARK AS SHOWN.

THE COLOR(S) RED, BLACK AND GREY IS/ARE CLAIMED AS A FEATURE OF THE MARK.

THE MARK CONSISTS OF INCLUDE A RED "P" A BLACK "B" AND THE WORD "MICROSAVINGS" IN GREY.

FOR DATA PROCESSING SERVICES IN THE FIELD OF CHECK, CREDIT, DEBIT, STORED VALUE AND ELECTRONIC BENEFITS TRANSFER CARD TRANSACTIONS AND PAYMENTS; SERVICES FOR MERCHANTS FOR COMMERCIAL, PROMOTIONAL AND/OR ADVERTISING PURPOSES, NAMELY, CONDUCTING INCENTIVE AWARD PROGRAMS TO PROMOTE THE SALE OF PRODUCTS AND SERVICES OF OTHERS; PROMOTING THE SALE OF THE GOODS AND SERVICES OF OTHERS THROUGH THE DISTRIBUTION AND PROCESSING OF ELECTRONIC COUPONS ISSUED OVER A GLOBAL COMPUTER NETWORK; PROVIDING AN ON-LINE INTERACTIVE DATABASE CONTAINING COMMERCIAL BUSINESS INFORMATION REGARDING CONSUMERS, NAMELY, COMMERCIAL FINANCIAL TRANSACTION DATA, CONSUMER DATA AND CUSTOMER DATA; PROCESSING OF CUSTOMER DISCOUNTS AND REWARDS VIA WIRELESS PROXIMITY PAYMENT DEVICES AND MAGNETICALLY ENCODED CARDS (U.S. CLS. 100, 101 AND 102).

CHARLES L. JENKINS, EXAMINING ATTORNEY

CLASS 35—(Continued).

SN 85-145,746. PB MICROSAVINGS, BEVERLY HILLS, CA. FILED 10-5-2010.



NO CLAIM IS MADE TO THE EXCLUSIVE RIGHT TO USE "MIRCOSAVINGS", APART FROM THE MARK AS SHOWN.

THE COLOR(S) RED, BLACK AND GREY IS/ARE CLAIMED AS A FEATURE OF THE MARK.

THE MARK CONSISTS OF A GREY CLAM SHELL ENCOMPASSING A RED "P" A BLACK "B" AND THE WORD "MICROSAVINGS" IN GREY, UNDERNEATH THE "PB".

FOR DATA PROCESSING SERVICES IN THE FIELD OF CHECK, CREDIT, DEBIT, STORED VALUE AND ELECTRONIC BENEFITS TRANSFER CARD TRANSACTIONS AND PAYMENTS; SERVICES FOR MERCHANTS FOR COMMERCIAL, PROMOTIONAL AND/OR ADVERTISING PURPOSES, NAMELY, CONDUCTING INCENTIVE AWARD PROGRAMS TO PROMOTE THE SALE OF PRODUCTS AND SERVICES OF OTHERS; PROMOTING THE SALE OF THE GOODS AND SERVICES OF OTHERS THROUGH THE DISTRIBUTION AND PROCESSING OF ELECTRONIC COUPONS ISSUED OVER A GLOBAL COMPUTER NETWORK; PROVIDING AN ON-LINE INTERACTIVE DATABASE CONTAINING COMMERCIAL BUSINESS INFORMATION REGARDING CONSUMERS, NAMELY, COMMERCIAL FINANCIAL TRANSACTION DATA, CONSUMER DATA AND CUSTOMER DATA; PROCESSING OF CUSTOMER DISCOUNTS AND REWARDS VIA WIRELESS PROXIMITY PAYMENT DEVICES AND MAGNETICALLY ENCODED CARDS (U.S. CLS. 100, 101 AND 102).

CHARLES L. JENKINS, EXAMINING ATTORNEY

SN 85-146,514. THE BANK OF NEW YORK MELLON CORPORATION, NEW YORK, NY. FILED 10-6-2010.

BNY MELLON ONCORE

THE MARK CONSISTS OF STANDARD CHARACTERS WITHOUT CLAIM TO ANY PARTICULAR FONT, STYLE, SIZE, OR COLOR.

OWNER OF U.S. REG. NOS. 3,585,488, 3,811,443 AND 3,866,559.

FOR OUTSOURCING IN THE FIELD OF FINANCIAL ASSET SUPPORT SERVICES (U.S. CLS. 100, 101 AND 102).

FRANK LATTUCA, EXAMINING ATTORNEY

CLASS 35—(Continued).

SN 85-148,851. 44SPECIAL LLC, DUPONT, WA. FILED 10-8-2010.



NO CLAIM IS MADE TO THE EXCLUSIVE RIGHT TO USE "44 SPECIAL", APART FROM THE MARK AS SHOWN.

THE MARK CONSISTS OF A SINGLE ACTION REVOLVER WITH THE STYLIZED TEXT "44SPECIAL".

FOR RETAIL STORE AND ON-LINE RETAIL STORE SERVICES FEATURING FIREARMS, FIREARM ACCESSORIES, AND GUN AMMUNITION (U.S. CLS. 100, 101 AND 102).

HANNO RITTNER, EXAMINING ATTORNEY

SN 85-154,286. QUANTAFIABLE LLC, HORTONVILLE, NY. FILED 10-15-2010.

facedata

THE MARK CONSISTS OF STANDARD CHARACTERS WITHOUT CLAIM TO ANY PARTICULAR FONT, STYLE, SIZE, OR COLOR.

FOR BUSINESS RESEARCH (U.S. CLS. 100, 101 AND 102).

BILL DAWE, EXAMINING ATTORNEY

SN 85-155,675. ELECTRONICS EXPO LLC, WAYNE, NJ. FILED 10-19-2010.

ELECTRONICSEXPO.COM

THE MARK CONSISTS OF STANDARD CHARACTERS WITHOUT CLAIM TO ANY PARTICULAR FONT, STYLE, SIZE, OR COLOR.

OWNER OF U.S. REG. NO. 3,869,484.

SEC. 2(F).

FOR ONLINE RETAIL STORE SERVICES IN THE FIELD OF CONSUMER ELECTRONICS (U.S. CLS. 100, 101 AND 102).

FIRST USE 4-2-2010; IN COMMERCE 4-2-2010.

JOSETTE BEVERLY, EXAMINING ATTORNEY

CLASS 35—(Continued).

SN 85-155,917. IDEFY, LLC, SANTA MONICA, CA. FILED 10-19-2010.



THE STIPPLING IS FOR SHADING PURPOSES ONLY. THE MARK CONSISTS OF CIRCLES ASCENDING AND DESCENDING IN CIRCUMFERENCE NEXT TO BUSINESS NAME: "IDEFY".

FOR ADVERTISING AND INVOICING OF BUSINESS SERVICES; SOURCING SERVICES FOR THIRD PARTIES, NAMELY, OUTSOURCING IN THE FIELD GIFT COLLECTIBLES (U.S. CLS. 100, 101 AND 102).

FIRST USE 9-1-2010; IN COMMERCE 9-1-2010.
ANNE MADDEN, EXAMINING ATTORNEY

SN 85-157,162. ALPINE SEARCH ASSOCIATES, DBA BETTERSELL SOLUTIONS, NEWTON, MA. FILED 10-20-2010.

Sales Summits

THE MARK CONSISTS OF STANDARD CHARACTERS WITHOUT CLAIM TO ANY PARTICULAR FONT, STYLE, SIZE, OR COLOR.

NO CLAIM IS MADE TO THE EXCLUSIVE RIGHT TO USE "SALES", APART FROM THE MARK AS SHOWN.

FOR ASSISTANCE, ADVISORY SERVICES AND CONSULTANCY WITH REGARD TO BUSINESS PLANNING, BUSINESS ANALYSIS, BUSINESS MANAGEMENT, AND BUSINESS ORGANIZATION (U.S. CLS. 100, 101 AND 102).

FIRST USE 5-15-2009; IN COMMERCE 5-15-2009.
JAY FLOWERS, EXAMINING ATTORNEY

SN 85-159,281. DAVID NEWMAN FISHER, SAN FRANCISCO, CA. FILED 10-22-2010.

FEET RELIEF

THE MARK CONSISTS OF STANDARD CHARACTERS WITHOUT CLAIM TO ANY PARTICULAR FONT, STYLE, SIZE, OR COLOR.

SEC. 2(F).

FOR RETAIL STORE SERVICES IN THE FIELD OF CORRECTIVE FOOT AND TOE SPLINTS, SPREADERS AND PADS, ARCH SUPPORTS, FOOT BEDS, FOOT PAD, SHOE INSERTS AND INSOLES; INTERNET BASED RETAIL STORE SERVICES IN THE FIELD OF CORRECTIVE FOOT AND TOE SPLINTS, SPREADERS AND PADS, ARCH SUPPORTS, FOOT BEDS, FOOT PAD, SHOE INSERTS AND INSOLES (U.S. CLS. 100, 101 AND 102).

FIRST USE 10-0-1997; IN COMMERCE 10-0-1997.
RAUL CORDOVA, EXAMINING ATTORNEY

CLASS 35—(Continued).

SN 85-162,119. ENOVA FINANCIAL HOLDINGS LLC, CHICAGO, IL. FILED 10-27-2010.



OWNER OF U.S. REG. NO. 3,883,811.

THE COLOR(S) LIGHT BLUE AND DARK BLUE IS/ARE CLAIMED AS A FEATURE OF THE MARK.

THE MARK CONSISTS OF THREE LIGHT BLUE CURVED BANDS. THE TOP BAND CURVES DOWNWARD TO THE LEFT, WHILE THE MIDDLE BAND CURVES UPWARD AND EXTENDS OUT TO THE RIGHT. THE BOTTOM BAND APPEARS DIRECTLY BENEATH THE TOP AND MIDDLE BAND AND IS SLIGHTLY NARROWER. IT CURVES UPWARD TO THE RIGHT. THE WORD "ENOVA" IN DARK BLUE AND THE WORD "FINANCIAL" IN LIGHT BLUE APPEAR IN LOWER CASE CHARACTERS TO THE RIGHT OF THE CURVED BANDS.

FOR ADMINISTRATION OF BUSINESS PAYROLL FOR OTHERS; ADVERTISING SERVICES, NAMELY, PROMOTING THE GIFT CARDS OF OTHERS; ON-LINE LAYAWAY SERVICES FOR RETAIL MERCHANDISE; ON-LINE RETAIL STORE SERVICES FEATURING A WIDE VARIETY OF CONSUMER GOODS OF OTHERS; ON-LINE RETAIL STORE SERVICES FEATURING A WIDE VARIETY OF CONSUMER GOODS OF OTHERS THAT MAY BE PURCHASED ON A LAYAWAY BASIS; PAYROLL ADMINISTRATION AND MANAGEMENT SERVICES; PAYROLL PREPARATION; PAYROLL PROCESSING SERVICES; PROMOTIONAL SERVICES, NAMELY, PROMOTING THE GOODS OF OTHERS BY MEANS OF PROVIDING ONLINE GIFT CARDS; PROVIDING INCENTIVE AWARD PROGRAMS FOR CUSTOMERS AND EMPLOYEES THROUGH THE DISTRIBUTION OF PREPAID STORED VALUE CARDS FOR THE PURPOSE OF PROMOTING AND REWARDING LOYALTY; RETAIL JEWELRY STORES; SCRAP DEALERSHIPS; WHOLESALE AND RETAIL STORE SERVICES FEATURING JEWELRY (U.S. CLS. 100, 101 AND 102).

ESTHER A. BORSUK, EXAMINING ATTORNEY

SN 85-163,217. WIZLY TECHNOLOGIES, COLOMBES, FRANCE, FILED 10-28-2010.

wizme

THE MARK CONSISTS OF STANDARD CHARACTERS WITHOUT CLAIM TO ANY PARTICULAR FONT, STYLE, SIZE, OR COLOR.

FOR PROVIDING A WEB SITE WHERE USERS CAN POST RATINGS, REVIEWS AND RECOMMENDATIONS ON PRODUCTS AND SERVICES FOR COMMERCIAL PURPOSES (U.S. CLS. 100, 101 AND 102).

GISELLE AGOSTO, EXAMINING ATTORNEY

CLASS 35—(Continued).

SN 85-164,890. AUDIBERT, ALICE, OAKLAND, CA. FILED 10-29-2010.

AGENT A

THE MARK CONSISTS OF STANDARD CHARACTERS WITHOUT CLAIM TO ANY PARTICULAR FONT, STYLE, SIZE, OR COLOR.

THE NAME(S), PORTRAIT(S), AND/OR SIGNATURE(S) SHOWN IN THE MARK IDENTIFIES THE STAGE NAME OF ALICE AUDIBERT, WHOSE CONSENT(S) TO REGISTER IS MADE OF RECORD.

FOR ART GALLERY SERVICES (U.S. CLS. 100, 101 AND 102).

ANDREW RHIM, EXAMINING ATTORNEY

SN 85-168,364. QUALITY SOFTWARE SERVICES, INC., COLUMBIA, MD. FILED 11-3-2010.



NO CLAIM IS MADE TO THE EXCLUSIVE RIGHT TO USE "HEALTH", APART FROM THE MARK AS SHOWN.

THE COLOR(S) BLACK, WHITE, RED, GREEN, BLUE, AND YELLOW IS/ARE CLAIMED AS A FEATURE OF THE MARK.

THE MARK CONSISTS OF THE WORDS "HEALTH IT" WRITTEN IN THE COLOR BLACK AND APPEARING NEXT TO A SERIES OF FOUR OVERLAPPING TRIANGLES IN THE COLORS RED, GREEN, BLUE, AND YELLOW, WITH A WHITE PLUS SYMBOL IN THE CENTER OF THE SERIES OF FOUR OVERLAPPING TRIANGLES.

FOR BUSINESS SERVICES, NAMELY, BUSINESS MANAGEMENT SERVICES TO HELP ORGANIZATIONS ACHIEVE AND MAINTAIN HIPAA (HEALTH INSURANCE PORTABILITY AND ACCOUNTABILITY ACT) COMPLIANCE (U.S. CLS. 100, 101 AND 102).

FIRST USE 8-1-2010; IN COMMERCE 8-1-2010.
RICHARD WHITE, EXAMINING ATTORNEY

CLASS 35—(Continued).

SN 85-172,486. WILLILUCI LLC, DBA TAXPLACE, DEER-FIELD BEACH, FL. FILED 11-9-2010.



THE COLOR(S) WHITE, BLACK, RED, BLUE AND GREEN IS/ARE CLAIMED AS A FEATURE OF THE MARK. THE MARK CONSISTS OF FOUR BLOCKS OF THE LETTER "T"'S EACH IN A DIFFERENT COLOR OF BLACK, RED, BLUE AND GREEN AND OUTLINED IN THE COLOR WHITE WITH THE WORDS "TAXPLACE" BELOW IN THE COLOR BLACK.

FOR ACCOUNTING SERVICES; INCOME TAX CONSULTATION; INCOME TAX PREPARATION (U.S. CLS. 100, 101 AND 102).

FIRST USE 10-18-2004; IN COMMERCE 12-16-2009.
MICHAEL WEBSTER, EXAMINING ATTORNEY

SN 85-172,616. TBS DATA, LLC, PLYMOUTH MEETING, PA. FILED 11-9-2010.

BUY MORE CONTACTS

THE MARK CONSISTS OF STANDARD CHARACTERS WITHOUT CLAIM TO ANY PARTICULAR FONT, STYLE, SIZE, OR COLOR.

NO CLAIM IS MADE TO THE EXCLUSIVE RIGHT TO USE "CONTACTS", APART FROM THE MARK AS SHOWN. FOR ON-LINE RETAIL STORE SERVICES FEATURING CONTACT LENS, EYECARE PRODUCTS AND EYECARE AND OPTICAL ACCESSORIES (U.S. CLS. 100, 101 AND 102).

FIRST USE 4-12-2010; IN COMMERCE 4-12-2010.
BRIAN NEVILLE, EXAMINING ATTORNEY

CLASS 35—(Continued).

SN 85-172,996. AIM STAR NETWORK CO., LTD., WATTANA BANGKOK 10110, THAILAND, FILED 11-9-2010.



NO CLAIM IS MADE TO THE EXCLUSIVE RIGHT TO USE "NETWORK", APART FROM THE MARK AS SHOWN. THE MARK CONSISTS OF THE WORDS "AIM STAR" ABOVE THE WORD "NETWORK" TO THE LEFT A V ARRANGEMENT OF FIVE SMALL STARS POINTING TO A LARGER STAR TO THE RIGHT WITH AN ANGULAR V WEDGE CUTOUT, ALL ABOVE THE WORDS "WHERE HAPPINESS COMES TRUE".

FOR WHOLESALE STORE SERVICES FEATURING NUTRITIONAL SUPPLEMENTS, PERSONAL CARE PRODUCTS, COSMETICS, HOME CARE PRODUCTS, AND PERSONAL CARE PRODUCTS; WHOLESALE DISTRIBUTORSHIPS IN THE FIELD OF NUTRITIONAL SUPPLEMENTS, PERSONAL CARE PRODUCTS, COSMETICS, HOME CARE PRODUCTS, AND PERSONAL CARE PRODUCTS; COMPUTERIZED ONLINE WHOLESALE STORE SERVICES FEATURING NUTRITIONAL SUPPLEMENTS, PERSONAL CARE PRODUCTS, COSMETICS, HOME CARE PRODUCTS, AND PERSONAL CARE PRODUCTS; COMPUTERIZED ONLINE WHOLESALE DISTRIBUTORSHIPS IN THE FIELD OF NUTRITIONAL SUPPLEMENTS, PERSONAL CARE PRODUCTS, COSMETICS, HOME CARE PRODUCTS, AND PERSONAL CARE PRODUCTS; BUSINESS CONSULTATION IN THE NATURE OF RENDERING ASSISTANCE TO OTHERS IN CONNECTION WITH THE ESTABLISHMENT AND OPERATION OF DISTRIBUTORSHIPS; ASSOCIATION SERVICES, NAMELY, PROMOTING THE INTERESTS OF INDEPENDENT BUSINESS OWNERS (U.S. CLS. 100, 101 AND 102).

AISHA SALEM, EXAMINING ATTORNEY

SN 85-173,848. CASTLE MEGASTORE GROUP, INC., TEMPE, AZ. FILED 11-10-2010.



OWNER OF U.S. REG. NOS. 3,639,371 AND 3,879,678. NO CLAIM IS MADE TO THE EXCLUSIVE RIGHT TO USE "MEGASTORE", APART FROM THE MARK AS SHOWN.

THE MARK CONSISTS OF A CROWN WITH THE STYLIZED TEXT "CASTLE MEGASTORE".

FOR RETAIL STORE AND ON-LINE RETAIL STORE SERVICES FEATURING LINGERIE, ADULT SEXUAL STIMULATION AIDS, DVDS, TOYS, LUBRICANTS, CONDOMS, NOVELTY GIFTS, AND GAMES (U.S. CLS. 100, 101 AND 102).

FIRST USE 11-4-2010; IN COMMERCE 11-4-2010.
LAURIE MAYES, EXAMINING ATTORNEY

CLASS 35—(Continued).

SN 85-175,266. NISSAN JIDOSHA KABUSHIKI KAISHA, TA NISSAN MOTOR CO., LTD., YOKOHAMA-SHI, KANAGAWA, JAPAN, FILED 11-12-2010.

INFINITI CONNECTION

THE MARK CONSISTS OF STANDARD CHARACTERS WITHOUT CLAIM TO ANY PARTICULAR FONT, STYLE, SIZE, OR COLOR.

FOR MOBILE INFORMATION SERVICES, NAMELY, PROVIDING PRICE-COMPARISON INFORMATION IN THE FIELD OF GASOLINE (U.S. CLS. 100, 101 AND 102).
NICHOLAS ALTREE, EXAMINING ATTORNEY

SN 85-175,521. MYERS SERVICES, INC., BEDFORD, TX. FILED 11-12-2010.

Eco Aware

THE MARK CONSISTS OF STANDARD CHARACTERS WITHOUT CLAIM TO ANY PARTICULAR FONT, STYLE, SIZE, OR COLOR.

NO CLAIM IS MADE TO THE EXCLUSIVE RIGHT TO USE "ECO", APART FROM THE MARK AS SHOWN.

FOR PROMOTING PUBLIC AWARENESS OF THE NEED FOR ENVIRONMENTAL AWARENESS IN THE PEST CONTROL INDUSTRY (U.S. CLS. 100, 101 AND 102).

SUNG IN, EXAMINING ATTORNEY

SN 85-179,461. PAPAYA, INC., ASHLAND, OR. FILED 11-17-2010.

PAPAYA!

THE MARK CONSISTS OF STANDARD CHARACTERS WITHOUT CLAIM TO ANY PARTICULAR FONT, STYLE, SIZE, OR COLOR.

OWNER OF U.S. REG. NO. 3,456,645.
FOR RETAIL STORES FEATURING STATIONERY, CARDS AND GIFTS (U.S. CLS. 100, 101 AND 102).
JOHN HWANG, EXAMINING ATTORNEY

CLASS 35—(Continued).

SN 85-181,071. INTEGRATED SUPPLY NETWORK, INC., LAKELAND, FL. FILED 11-19-2010.



NO CLAIM IS MADE TO THE EXCLUSIVE RIGHT TO USE "EXPO", APART FROM THE MARK AS SHOWN. THE MARK CONSISTS OF THE WORDS "TOOL DEALER EXPO" WITH THE LETTER "R" OF "DEALER" IN THE DESIGN OF AN IMPACT WRENCH.

SEC. 2(F).
FOR TRADE SHOW EXHIBITIONS IN THE FIELD OF AUTOMOTIVE TOOLS AND EQUIPMENT (U.S. CLS. 100, 101 AND 102).
FIRST USE 6-30-2005; IN COMMERCE 6-30-2005.
KHANH LE, EXAMINING ATTORNEY

SN 85-184,576. SCHWARTZ, MICHAEL J., MIAMI, FL. FILED 11-24-2010.



THE COLOR(S) ORANGE, GRAY, LIGHT GRAY, AND WHITE IS/ARE CLAIMED AS A FEATURE OF THE MARK. THE MARK CONSISTS OF A PENTAGON IN GRAY INDICATING A BASEBALL BASE, WHICH IS COLORED IN LIGHT GRAY. INSIDE THE PENTAGON ARE TWO ORANGE SEMICIRCLES, EACH BISECTED WITH A GRAY LINE, INDICATING HALVES OF BASKETBALLS. IN THE MIDDLE, THERE ARE A SERIES OF WHITE LINES RESEMBLING THE LACES OF A FOOTBALL.
FOR MANAGEMENT AND AGENCY REPRESENTATION OF PROFESSIONAL ATHLETES (U.S. CLS. 100, 101 AND 102).
JANET LEE, EXAMINING ATTORNEY

CLASS 35—(Continued).

SN 85-187,423. DENTAL IDEA LAB LLC, NEWTON, MA. FILED 11-30-2010.



THE MARK CONSISTS OF LOOKING UP AT THE TOP OF A COLUMN.
FOR ADVERTISING AND MARKETING CONSULTANCY WITH REGARD TO MARKETING OF PROFESSIONAL DENTAL SERVICES PROVIDED BY A PROFESSIONAL ACADEMY COMPOSED OF DENTISTS AND DENTAL LABORATORY ORGANIZATIONS AND PROVIDING WRITTEN TRAINING MATERIAL REGARDING ADVERTISING AND MARKETING THEREWITH (U.S. CLS. 100, 101 AND 102).
FIRST USE 11-5-2010; IN COMMERCE 11-5-2010.
NAPOLEON SHARMA, EXAMINING ATTORNEY

SN 85-189,525. KARA FASHION, DBA THE KARA, DALLAS, TX. FILED 12-2-2010.

THE KARA

THE MARK CONSISTS OF STANDARD CHARACTERS WITHOUT CLAIM TO ANY PARTICULAR FONT, STYLE, SIZE, OR COLOR.
FOR WHOLESALE AND RETAIL STORE SERVICES AND ON-LINE RETAIL AND WHOLESALE STORE SERVICES FEATURING LADIES APPAREL (U.S. CLS. 100, 101 AND 102).
FIRST USE 12-1-2010; IN COMMERCE 12-1-2010.
CHRISTINE MARTIN, EXAMINING ATTORNEY

CLASS 35—(Continued).

SN 85-191,350. OURBIZPOST LTD., TORONTO, CANADA, FILED 12-6-2010.

OURBIZPOST

THE MARK CONSISTS OF STANDARD CHARACTERS WITHOUT CLAIM TO ANY PARTICULAR FONT, STYLE, SIZE, OR COLOR.

PRIORITY CLAIMED UNDER SEC. 44(D) ON CANADA APPLICATION NO. 1505460, FILED 11-25-2010.

FOR CLASSIFIED ADVERTISING SERVICES; PROVIDING AN INTERNET WEB SITE FOR CLASSIFIED ADVERTISING RELEVANT TO BUSINESS AND INDUSTRY; PROVIDING AN ON-LINE SEARCHABLE DATABASE FEATURING CLASSIFIED AD LISTINGS AND EMPLOYMENT OPPORTUNITIES; PROVIDING A WEB SITE WHERE USERS CAN POST ITEMS AND SERVICES FOR SALE THROUGH ON-LINE CLASSIFIED ADVERTISEMENTS; PROVIDING AN INTERNET WEB SITE FOR CLASSIFIED ADVERTISING FOR OTHERS TO BUY, LEASE AND SELL GOODS, BUY AND SELL BUSINESSES, LEASE AND OFFER REAL ESTATE AND OFFICE SPACE, AND OFFER AND OBTAIN SERVICES AND EMPLOYMENT; ADVERTISING AND DIRECTORY SERVICES, NAMELY, PROMOTING THE SERVICES OF OTHERS BY PROVIDING A WEB PAGE FEATURING LINKS TO THE WEBSITES OF OTHERS; DISSEMINATION OF ADVERTISING FOR OTHERS VIA AN INTERNET WEB SITE; ON-LINE BUSINESS NETWORKING SERVICES (U.S. CLS. 100, 101 AND 102).

GINA FINK, EXAMINING ATTORNEY

SN 85-191,543. MIXLINX INC., AURORA, CANADA, FILED 12-6-2010.



THE COLOR(S) WHITE, GREEN AND GREY IS/ARE CLAIMED AS A FEATURE OF THE MARK.

THE MARK CONSISTS OF THE LETTERS "MIXLINX" WITH THE SECOND "X" BEING IN THE FORM OF A GEOMETRIC FIGURE OF TWO CIRCLES INTERSECTING TO FORM THE LETTER "X" IN A PERSPECTIVE ORIENTATION WITH THE FRONT OF THE CIRCLES BEING A SOLID GREEN COLOR AND THE REAR OF THE CIRCLES BEING STRIPED IN ALTERNATING GREEN AND WHITE STRIPES. THE WORD "MIXLINX" IS WRITTEN IN GREY.

FOR PROMOTING, ADVERTISING AND MARKETING THE GOODS AND SERVICES OF OTHERS THROUGH ON-LINE ORDERING AND CATALOGING OF THOSE GOODS AND SERVICES; PROMOTING THE GOODS AND SERVICES OF OTHERS BY PROVIDING A WEB SITE FEATURING COUPONS, LOYALTY PROGRAMS, REBATES, PRICE-COMPARISON INFORMATION, PRODUCT REVIEWS, LINKS TO THE RETAIL WEB SITES OF OTHERS, AND DISCOUNT INFORMATION; ON-LINE ADVERTISING AND MARKETING SERVICES; SALES VOLUME TRACKING FOR OTHERS, NAMELY, FOR THE EXPENDITURE OF MONIES MADE THROUGH THE USE OF WEBSITES FOR MEMBERS; ON-LINE RETAIL STORE SERVICES AND RETAIL DISCOUNT STORE SERVICES IN THE FIELDS OF APPAREL AND ACCESSORIES, AUTOMOTIVE PARTS AND ACCESSORIES, TOYS, BOOKS, MUSIC, VIDEO,

CLASS 35—(Continued).

COMPUTER AND ELECTRONICS, AND SPORTING GOODS; RETAIL DEPARTMENT STORES; ON-LINE RETAIL STORE SERVICES AND RETAIL DISCOUNT STORE SERVICES FEATURING TICKETS FOR ENTERTAINMENT, NAMELY, AMUSEMENT PARKS, MOVIES, THEATERS AND SHOWS; ON-LINE RETAIL STORE SERVICES AND RETAIL DISCOUNT STORE SERVICES FEATURING FLOWERS AND GIFTS, FOOD AND DRUG, HEALTH AND BEAUTY, HOME FURNISHING AND IMPROVEMENT, JEWELRY, AND OFFICE SUPPLIES; ON-LINE NON-APPAREL SPECIALTY RETAIL STORE SERVICES FEATURING PET SUPPLIES; ON-LINE RETAIL STORE SERVICES AND RETAIL DISCOUNT STORE SERVICES FEATURING MUSIC RELATED MERCHANDISE AND MUSICAL INSTRUMENTS; ON-LINE RETAIL STORE SERVICES AND RETAIL DISCOUNT STORE SERVICES FEATURING HOBBY CRAFT SUPPLIES; ON-LINE RETAIL STORE SERVICES AND RETAIL DISCOUNT STORE SERVICES FEATURING TELECOMMUNICATIONS PRODUCTS INCLUDING WIRELESS PRODUCTS AND SERVICES INCLUDING WIRELESS HANDHELD DEVICES AND SERVICE PLANS, HOME TELEPHONE PRODUCTS AND SERVICE PLANS, AND CABLE ACCESS PRODUCTS AND SERVICE PLANS (U.S. CLS. 100, 101 AND 102).

INGA ERVIN, EXAMINING ATTORNEY

SN 85-192,102. KIERSTEN PILAR MILLER, NEW YORK, NY, FILED 12-7-2010.

THE MILK BAR

THE MARK CONSISTS OF STANDARD CHARACTERS WITHOUT CLAIM TO ANY PARTICULAR FONT, STYLE, SIZE, OR COLOR.

FOR RETAIL STORE SERVICES FEATURING MATERNITY CLOTHING, CLOTHING FOR NURSING MOTHERS, AND INFANT NURSING ACCESSORIES (U.S. CLS. 100, 101 AND 102).

ELLEN PERKINS, EXAMINING ATTORNEY

CLASS 35—(Continued).

SN 85-194,407. SPOTON, INC., SAN RAFAEL, CA. FILED 12-9-2010.

SPOTON

THE MARK CONSISTS OF STANDARD CHARACTERS WITHOUT CLAIM TO ANY PARTICULAR FONT, STYLE, SIZE, OR COLOR.

FOR BUSINESS MONITORING AND CONSULTING SERVICES, NAMELY, TRACKING WEBSITES AND APPLICATIONS OF OTHERS THROUGH ON-LINE SOCIAL NETWORKING SITES AND MOBILE NETWORK ACCESSIBLE DEVICES TO PROVIDE ADVERTISING STRATEGY, INSIGHT, MARKETING, SALES, OPERATION, AND PRODUCT DESIGN INFORMATION, PARTICULARLY SPECIALIZING IN THE USE OF ANALYTIC AND STRATEGIC MODELS FOR THE UNDERSTANDING AND PREDICTING OF CONSUMER, BUSINESS, AND MARKET TRENDS AND ACTIONS; PROMOTING THE GOODS AND SERVICES OF OTHERS THROUGH ON-LINE SOCIAL NETWORKING SITES AND MOBILE NETWORK ACCESSIBLE DEVICES TO DISTRIBUTE COUPONS AND ADVERTISING MATERIALS; MAINTAINING CONSUMER INCENTIVE DATA AND INFORMATION FOR OTHERS (U.S. CLS. 100, 101 AND 102).

HOWARD SMIGA, EXAMINING ATTORNEY

CLASS 35—(Continued).

SN 85-194,914. SAN DIEGO MILITARY OUTREACH MINISTRIES, LA JOLLA, CA. FILED 12-10-2010.

San Diego Military Outreach Ministries

THE MARK CONSISTS OF STANDARD CHARACTERS WITHOUT CLAIM TO ANY PARTICULAR FONT, STYLE, SIZE, OR COLOR.

NO CLAIM IS MADE TO THE EXCLUSIVE RIGHT TO USE "MILITARY OUTREACH MINISTRIES", APART FROM THE MARK AS SHOWN.

SEC. 2(F).

FOR CHARITABLE SERVICES, NAMELY, ORGANIZING AND CONDUCTING VOLUNTEER PROGRAMS AND COMMUNITY SERVICE PROJECTS AIMED AT INCREASING SUPPORT AND MORALE OF FAMILIES OF CURRENT MEMBERS OF THE U.S. MILITARY (U.S. CLS. 100, 101 AND 102).

FIRST USE 7-1-2005; IN COMMERCE 11-1-2005.

ERIN FALK, EXAMINING ATTORNEY

SN 85-194,415. SPOTON, INC., SAN RAFAEL, CA. FILED 12-9-2010.

WHERE SOCIAL MEDIA MEETS LOYALTY

THE MARK CONSISTS OF STANDARD CHARACTERS WITHOUT CLAIM TO ANY PARTICULAR FONT, STYLE, SIZE, OR COLOR.

FOR BUSINESS MONITORING AND CONSULTING SERVICES, NAMELY, TRACKING WEBSITES AND APPLICATIONS OF OTHERS THROUGH ON-LINE SOCIAL NETWORKING SITES AND MOBILE NETWORK ACCESSIBLE DEVICES TO PROVIDE ADVERTISING STRATEGY, INSIGHT, MARKETING, SALES, OPERATION, AND PRODUCT DESIGN INFORMATION, PARTICULARLY SPECIALIZING IN THE USE OF ANALYTIC AND STRATEGIC MODELS FOR THE UNDERSTANDING AND PREDICTING OF CONSUMER, BUSINESS, AND MARKET TRENDS AND ACTIONS; PROMOTING THE GOODS AND SERVICES OF OTHERS THROUGH ON-LINE SOCIAL NETWORKING SITES AND MOBILE NETWORK ACCESSIBLE DEVICES TO DISTRIBUTE COUPONS AND ADVERTISING MATERIALS; MAINTAINING CONSUMER INCENTIVE DATA AND INFORMATION FOR OTHERS (U.S. CLS. 100, 101 AND 102).

HOWARD SMIGA, EXAMINING ATTORNEY

SN 85-198,856. RATESPECIAL LLC, PASADENA, CA. FILED 12-15-2010.

SCOREDIRECT

THE MARK CONSISTS OF STANDARD CHARACTERS WITHOUT CLAIM TO ANY PARTICULAR FONT, STYLE, SIZE, OR COLOR.

FOR CONSUMER CREDIT SERVICES, NAMELY, MONITORING CONSUMER CREDIT REPORTS AND PROVIDING AN ALERT AS TO ANY CHANGES THEREIN, PROVIDED BY BOTH ELECTRONIC AND NON-ELECTRONIC MEANS; PROVIDING CONSUMER CREDIT REPORT MONITORING INFORMATION VIA THE INTERNET; LOST, MISPLACED AND STOLEN CREDIT, DEBIT AND ATM CARD REGISTRATION SERVICES (U.S. CLS. 100, 101 AND 102).

ANN E. SAPPENFIELD, EXAMINING ATTORNEY

CLASS 35—(Continued).

SN 85-199,258. WHAT'S ON 4 LTD, TADLEY, UNITED KINGDOM, FILED 12-16-2010.



OWNER OF UNITED KINGDOM REG. NO. 2553315, DATED 7-19-2010, EXPIRES 7-19-2020.

THE COLOR(S) RED, BLUE, YELLOW AND WHITE IS/ARE CLAIMED AS A FEATURE OF THE MARK.

THE MARK CONSISTS OF THE FOLLOWING: THE WORDING "WHAT'S ON" IN THE COLOR RED FORMS THE TOP ARC OF AN INCOMPLETE CIRCLE AND THE WORDING "LITTLE ONES" IN THE COLOR BLUE FORMS THE BOTTOM ARC OF THE INCOMPLETE CIRCLE, WITH A YELLOW AMORPHOUS SHAPE IN THE CENTER OF THE CIRCLE AND THE NUMERAL "4" IN THE COLOR WHITE IN THE CENTER OF THE YELLOW SHAPE.

FOR ON-LINE ADVERTISING TO PROMOTE THE SERVICES OF ACTIVITY PROVIDERS OF CLASSES, GROUPS AND CLUBS FOR BABIES, TODDLERS AND PRE-SCHOOL CHILDREN (U.S. CLS. 100, 101 AND 102).
SUZANNE BLANE, EXAMINING ATTORNEY

SN 85-200,506. CHRIS EVANS, KANSAS CITY, MO. FILED 12-17-2010.

YOU'RE WELCOME

THE MARK CONSISTS OF STANDARD CHARACTERS WITHOUT CLAIM TO ANY PARTICULAR FONT, STYLE, SIZE, OR COLOR.

FOR BUSINESS CONSULTING AND ADVISORY SERVICES IN THE FIELDS OF PRODUCT DESIGN, PRODUCT DEVELOPMENT, PRODUCT BRANDING, AND PRODUCT MARKETING (U.S. CLS. 100, 101 AND 102).
NAPOLEON SHARMA, EXAMINING ATTORNEY

CLASS 35—(Continued).

SN 85-200,803. ASSOCIATION OF MUSIC PRODUCERS, INC., NEW YORK, NY. FILED 12-17-2010.

ASSOCIATION OF MUSIC PRODUCERS

THE MARK CONSISTS OF STANDARD CHARACTERS WITHOUT CLAIM TO ANY PARTICULAR FONT, STYLE, SIZE, OR COLOR.

NO CLAIM IS MADE TO THE EXCLUSIVE RIGHT TO USE "ASSOCIATION", APART FROM THE MARK AS SHOWN.

SEC. 2(F).
FOR ASSOCIATION SERVICES, NAMELY, PROMOTING THE INTERESTS OF MUSIC AND SOUND PRODUCERS (U.S. CLS. 100, 101 AND 102).

FIRST USE 8-4-1998; IN COMMERCE 8-4-1998.
ALLISON SCHRODY, EXAMINING ATTORNEY

SN 85-206,032. LEE, WON SEOK, MONTROSE, CA. FILED 12-27-2010.

MAUYA

THE MARK CONSISTS OF STANDARD CHARACTERS WITHOUT CLAIM TO ANY PARTICULAR FONT, STYLE, SIZE, OR COLOR.

THE WORDING "MAUYA" HAS NO MEANING IN A FOREIGN LANGUAGE.

FOR RETAIL GIFT SHOPS (U.S. CLS. 100, 101 AND 102).

FIRST USE 11-30-2010; IN COMMERCE 11-30-2010.
SANJEEV VOHRA, EXAMINING ATTORNEY

SN 85-207,223. META PHARMACEUTICAL SERVICES, BLUE BELL, PA. FILED 12-29-2010.

WRITERESPONSE

THE MARK CONSISTS OF STANDARD CHARACTERS WITHOUT CLAIM TO ANY PARTICULAR FONT, STYLE, SIZE, OR COLOR.

FOR BUSINESS MARKETING SERVICES, NAMELY, A RESPONSIVE MARKETING PROGRAM THAT PROVIDES MARKETING INSIGHT INTO NEWLY LAUNCHED BRANDS, CLIENTS, AND COMPETITORS IN THE PHARMACEUTICAL INDUSTRY, INCLUDING BUT NOT LIMITED TO DETAILED TRACKING OF PHARMACEUTICAL PRESCRIPTION PATTERNS (U.S. CLS. 100, 101 AND 102).

TARA PATE, EXAMINING ATTORNEY

CLASS 35—(Continued).

SN 85-207,243. GOLDEN OPPORTUNITY INC., KEASBEY, NJ. FILED 12-29-2010.



THE MARK CONSISTS OF THE WORD "GOLDEN" IN LARGE, DARK CAPITAL LETTERS. THE "O" IS STYLIZED IN A SOMEWHAT WIDER FASHION, WITH A SLIMMER OUTER LINE THAN THE OTHER LETTERS. AN "S" CURVE SLICES THROUGH THE WORD VERTICALLY, THE DARK LOWER HALF OF THE "S" CURVES UNDER THE WORD FROM "G" TO "L" THEN EMERGES UP FROM THE "D" AND CURVES UP AND AROUND TO LIGHT ON THE FINAL "N."

FOR WHOLESALE DISTRIBUTORSHIP AND RETAIL STORE SERVICES IN THE FIELD OF HOME APPLIANCES, NAMELY, CONSUMER APPLIANCES, NAMELY, AIR CONDITIONERS, WASHERS, DRYERS, REFRIGERATORS, FREEZERS AND SMALL ELECTRIC APPLIANCES; WHOLESALE ORDERING SERVICES IN THE FIELD OF HOME CONSUMER APPLIANCES (U.S. CLS. 100, 101 AND 102).

FIRST USE 8-13-2009; IN COMMERCE 8-13-2009.
JILL C. ALT, EXAMINING ATTORNEY

SN 85-207,430. HARTMAN, BRADY, CHAMBERS, ALTA-MONTE SPRINGS, FL. FILED 12-29-2010.

ATEGRA

THE MARK CONSISTS OF STANDARD CHARACTERS WITHOUT CLAIM TO ANY PARTICULAR FONT, STYLE, SIZE, OR COLOR.

FOR BUSINESS SERVICES, NAMELY, PROCURING QUALIFIED AND CREDENTIALLED THIRD-PARTY EXPERTS, PROFESSIONALS AND OTHER QUALIFIED PERSONNEL, AND DOCUMENTATION AND INFORMATION ALL ON BEHALF OF OTHERS; CONSULTANCY OF PERSONNEL RECRUITMENT; HUMAN RESOURCES SERVICES, NAMELY, PERSONNEL SELECTION FOR OTHERS; JOB AND PERSONNEL PLACEMENT; MEDICAL PERSONNEL RECRUITMENT SERVICES AND CONSULTATION RELATED THERETO; PERSONNEL CONSULTANCY; PERSONNEL MANAGEMENT; PERSONNEL MANAGEMENT CONSULTATION; PERSONNEL MANAGEMENT CONSULTING; PERSONNEL PLACEMENT; PERSONNEL PLACEMENT AND RECRUITMENT; PERSONNEL RECRUITMENT SERVICES AND EMPLOYMENT AGENCIES; TEMPORARY PERSONNEL SERVICES (U.S. CLS. 100, 101 AND 102).

FIRST USE 8-26-1993; IN COMMERCE 8-26-1993.
TRACY FLETCHER, EXAMINING ATTORNEY

CLASS 35—(Continued).

SN 85-208,576. CONSULTNETWORK, LIVINGSTON, NJ. FILED 12-31-2010.

consultnetwork

THE MARK CONSISTS OF STANDARD CHARACTERS WITHOUT CLAIM TO ANY PARTICULAR FONT, STYLE, SIZE, OR COLOR.

FOR HUMAN RESOURCES CONSULTANCY (U.S. CLS. 100, 101 AND 102).

FIRST USE 5-1-2008; IN COMMERCE 5-1-2008.
PRISCILLA MILTON, EXAMINING ATTORNEY

SN 85-208,586. CONSULTNETWORK, LIVINGSTON, NJ. FILED 12-31-2010.

xtreme recruiting. xpect the unexpected.

THE MARK CONSISTS OF STANDARD CHARACTERS WITHOUT CLAIM TO ANY PARTICULAR FONT, STYLE, SIZE, OR COLOR.

NO CLAIM IS MADE TO THE EXCLUSIVE RIGHT TO USE "RECRUITING", APART FROM THE MARK AS SHOWN.

FOR HUMAN RESOURCES CONSULTANCY (U.S. CLS. 100, 101 AND 102).

FIRST USE 10-1-2010; IN COMMERCE 10-1-2010.
PRISCILLA MILTON, EXAMINING ATTORNEY

SN 85-211,644. SEA CLIFF VENTURES INC., BELIZE CITY, BELIZE, FILED 1-6-2011.

IHOOKUPCASH

THE MARK CONSISTS OF STANDARD CHARACTERS WITHOUT CLAIM TO ANY PARTICULAR FONT, STYLE, SIZE, OR COLOR.

FOR PROMOTING THE GOODS AND SERVICES OF OTHERS VIA A GLOBAL COMPUTER NETWORK THROUGH ONLINE CONTESTS AND INCENTIVE AWARD PROGRAMS TO PROMOTE THE SALE OF PRODUCTS AND SERVICES OF OTHERS; PROMOTING THE GOODS AND SERVICES OF OTHERS BY PROVIDING HYPERTEXT LINKS TO THE WEB SITES OF OTHERS; PROMOTING THE SALE OF GOODS AND SERVICES OF OTHERS THROUGH ELECTRONIC PROMOTIONS; INCENTIVE AWARD PROGRAMS TO PROMOTE THE SALE OF PRODUCTS AND SERVICES OF OTHERS; PROVIDING INCENTIVE AWARD PROGRAMS FOR CUSTOMERS THROUGH THE ISSUANCE AND PROCESSING OF LOYALTY COUPONS OR LOYALTY POINTS FOR FREQUENT USE OF PARTICIPATING BUSINESSES (U.S. CLS. 100, 101 AND 102).

ROBIN CHOSID, EXAMINING ATTORNEY

CLASS 35—(Continued).

SN 85-211,648. SEA CLIFF VENTURES INC., BELIZE CITY, BELIZE, FILED 1-6-2011.

HOOKUPCASH

THE MARK CONSISTS OF STANDARD CHARACTERS WITHOUT CLAIM TO ANY PARTICULAR FONT, STYLE, SIZE, OR COLOR.

FOR PROMOTING THE GOODS AND SERVICES OF OTHERS VIA A GLOBAL COMPUTER NETWORK THROUGH ONLINE CONTESTS AND INCENTIVE AWARD PROGRAMS TO PROMOTE THE SALE OF PRODUCTS AND SERVICES OF OTHERS; PROMOTING THE GOODS AND SERVICES OF OTHERS BY PROVIDING HYPERTEXT LINKS TO THE WEB SITES OF OTHERS; PROMOTING THE SALE OF GOODS AND SERVICES OF OTHERS THROUGH ELECTRONIC PROMOTIONS; INCENTIVE AWARD PROGRAMS TO PROMOTE THE SALE OF PRODUCTS AND SERVICES OF OTHERS; PROVIDING INCENTIVE AWARD PROGRAMS FOR CUSTOMERS THROUGH THE ISSUANCE AND PROCESSING OF LOYALTY COUPONS OR LOYALTY POINTS FOR FREQUENT USE OF PARTICIPATING BUSINESSES (U.S. CLS. 100, 101 AND 102).
ROBIN CHOSID, EXAMINING ATTORNEY

SN 85-211,649. SEA CLIFF VENTURES INC., BELIZE CITY, BELIZE, FILED 1-6-2011.

TANGOCASH

THE MARK CONSISTS OF STANDARD CHARACTERS WITHOUT CLAIM TO ANY PARTICULAR FONT, STYLE, SIZE, OR COLOR.

FOR PROMOTING THE GOODS AND SERVICES OF OTHERS VIA A GLOBAL COMPUTER NETWORK THROUGH ONLINE CONTESTS AND INCENTIVE AWARD PROGRAMS TO PROMOTE THE SALE OF PRODUCTS AND SERVICES OF OTHERS; PROMOTING THE GOODS AND SERVICES OF OTHERS BY PROVIDING HYPERTEXT LINKS TO THE WEB SITES OF OTHERS; PROMOTING THE SALE OF GOODS AND SERVICES OF OTHERS THROUGH ELECTRONIC PROMOTIONS; INCENTIVE AWARD PROGRAMS TO PROMOTE THE SALE OF PRODUCTS AND SERVICES OF OTHERS; PROVIDING INCENTIVE AWARD PROGRAMS FOR CUSTOMERS THROUGH THE ISSUANCE AND PROCESSING OF LOYALTY COUPONS OR LOYALTY POINTS FOR FREQUENT USE OF PARTICIPATING BUSINESSES (U.S. CLS. 100, 101 AND 102).
ROBIN CHOSID, EXAMINING ATTORNEY

CLASS 35—(Continued).

SN 85-213,769. D B K ENTERPRISES, INC., INDEPENDENCE, MO. FILED 1-10-2011.

THE SILVER CRAZE

THE MARK CONSISTS OF STANDARD CHARACTERS WITHOUT CLAIM TO ANY PARTICULAR FONT, STYLE, SIZE, OR COLOR.

NO CLAIM IS MADE TO THE EXCLUSIVE RIGHT TO USE "SILVER", APART FROM THE MARK AS SHOWN.

FOR ON-LINE RETAIL STORE SERVICES FEATURING SILVER JEWELRY AND ACCESSORIES (U.S. CLS. 100, 101 AND 102).

BRIAN PINO, EXAMINING ATTORNEY

SN 85-214,274. BENCHMARK SOLUTIONS HOLDINGS INC., NEW YORK, NY. FILED 1-10-2011.

MARKET CALIBRATED FRAMEWORK

THE MARK CONSISTS OF STANDARD CHARACTERS WITHOUT CLAIM TO ANY PARTICULAR FONT, STYLE, SIZE, OR COLOR.

NO CLAIM IS MADE TO THE EXCLUSIVE RIGHT TO USE "MARKET", APART FROM THE MARK AS SHOWN.

FOR FINANCIAL SERVICES, NAMELY, ANALYZING MARKET DATA AND PRICING ANALYTICS SERVICES FOR MEASURING THE PERFORMANCE OF FINANCIAL MARKETS FOR ASSET CLASSES WITHIN THE CAPITAL MARKETS, INCLUDING FIXED INCOME PRODUCTS (U.S. CLS. 100, 101 AND 102).

ARETHA SOMERVILLE, EXAMINING ATTORNEY

SN 85-214,299. U-HAUL INTERNATIONAL, INC., PHOENIX, AZ. FILED 1-10-2011.

U SHARE

THE MARK CONSISTS OF STANDARD CHARACTERS WITHOUT CLAIM TO ANY PARTICULAR FONT, STYLE, SIZE, OR COLOR.

OWNER OF U.S. REG. NOS. 746,034, 3,648,101 AND OTHERS.

NO CLAIM IS MADE TO THE EXCLUSIVE RIGHT TO USE "SHARE", APART FROM THE MARK AS SHOWN.

FOR PROVIDING FACILITIES FOR CONSUMERS TO USE IN TRADING, SWAPPING AND EXCHANGING USED HOUSEHOLD AND SPORTING GOODS, FURNITURE AND CLOTHING WITH OTHERS (U.S. CLS. 100, 101 AND 102).

FIRST USE 6-1-2008; IN COMMERCE 6-1-2008.

MARTHA FROMM, EXAMINING ATTORNEY

CLASS 35—(Continued).

SN 85-214,394. COMMUNITY PHARMACY PRESCRIPTION NETWORK, LLC, BRAIDWOOD, IL. FILED 1-10-2011.



NO CLAIM IS MADE TO THE EXCLUSIVE RIGHT TO USE "COMMUNITY PHARMACY PRESCRIPTION NETWORK", APART FROM THE MARK AS SHOWN.

THE MARK CONSISTS OF A MORTAR WITH A COILED SERPENT DESIGN AND PORTIONS OF LITERAL ELEMENT "CPRxN COMMUNITY PHARMACY PRESCRIPTION NETWORK" TO THE RIGHT OF THE DESIGN AND UNDERNEATH.

FOR ADMINISTERING PHARMACY REIMBURSEMENT PROGRAMS AND SERVICES; SUPPLYING PRESCRIPTION DRUGS TO HEALTH PLAN PARTICIPANTS FOR THE FUNDING ORGANIZATIONS; RETAIL PHARMACY SERVICES (U.S. CLS. 100, 101 AND 102).

TAMARA FRAZIER, EXAMINING ATTORNEY

CLASS 35—(Continued).

SN 85-215,147. U.S. STRUCTURES, INC., RICHMOND, VA. FILED 1-11-2011.

ARCHADECK OUTDOOR LIVING

THE MARK CONSISTS OF STANDARD CHARACTERS WITHOUT CLAIM TO ANY PARTICULAR FONT, STYLE, SIZE, OR COLOR.

OWNER OF U.S. REG. NOS. 1,328,943, 1,405,836 AND 1,621,227.

NO CLAIM IS MADE TO THE EXCLUSIVE RIGHT TO USE "OUTDOOR LIVING", APART FROM THE MARK AS SHOWN.

FOR ONLINE RETAIL STORE SERVICES, RETAIL STORE SERVICES AND RETAIL SERVICES THROUGH DIRECT SOLICITATION BY SALESPERSONS DIRECTED TO END-USERS, ALL FEATURING OUTDOOR FURNITURE, ORNAMENTAL FOUNTAINS, OUTDOOR LIGHTING FIXTURES, PORTABLE FIREPLACES, FIREPLACES AND OTHER HOME DÉCOR FOR OUTDOOR SPACES (U.S. CLS. 100, 101 AND 102).

KATHERINE M. DUBRAY, EXAMINING ATTORNEY

SN 85-214,887. AMERICAN SPORTS IMAGES, WORCESTER, MA. FILED 1-11-2011.



NO CLAIM IS MADE TO THE EXCLUSIVE RIGHT TO USE "AMERICAN SPORTS IMAGES", APART FROM THE MARK AS SHOWN.

THE COLOR(S) RED, WHITE, BLUE IS/ARE CLAIMED AS A FEATURE OF THE MARK.

THE MARK CONSISTS OF THE WORDING "AMERICAN" IN STYLIZED FONT, ALL CAPITAL LETTERS, THE COLOR BLUE, AND A THIN BLUE BORDER AROUND THE WORDING, THE LETTER "A" IN THE "AMERICAN" WORDING HAS A RED STAR BEHIND IT WITH WHITE BORDER AND THEN A BLUE BORDER BEHIND THE WHITE BORDER, BELOW THE WORDING "AMERICAN" APPEARS THE WORDING "SPORTS IMAGES" IN THICK WHITE STYLIZED FONT WITH A THIN BLUE BORDER, BELOW THE "SPORTS IMAGES" WORDING APPEARS THREE RED LINES WITH A RED STAR ON THE RIGHT END OF THE THREE RED LINES.

FOR MATCHING CONSUMERS OF SPORTS AND NON-SPORTS MEMORABILIA WITH SELLERS OF SPORTS AND NON-SPORTS MEMORABILIA; PROVIDING AUCTION SERVICES TO CHARITABLE AND OTHER ORGANIZATIONS; RETAIL AND WHOLESALE STORE SERVICES AND ONLINE RETAIL AND WHOLESALE STORE SERVICES ALL FEATURING SPORTS AND NON-SPORTS MEMORABILIA; ARRANGING AND CONDUCTING MARKETING PROMOTIONAL EVENTS FOR COMPANIES AND ORGANIZATIONS (U.S. CLS. 100, 101 AND 102).

FIRST USE 1-10-2008; IN COMMERCE 7-1-2008.
ROBIN CHOSID, EXAMINING ATTORNEY

SN 85-215,382. IPROTEST, LLC, RICHMOND, TX. FILED 1-11-2011.



THE COLOR(S) RED, WHITE AND BLACK IS/ARE CLAIMED AS A FEATURE OF THE MARK.

THE MARK CONSISTS OF THE COLOR RED APPEARING IN THE LOWERCASE LETTER "I" AND THE COLOR BLACK APPEARING IN THE TERM "PROTEST" ADJACENT TO SAID LETTER "I". THE DOT OF THE LOWERCASE "I" IS IN THE FORM OF A RED OUTLINED CIRCLE ENCASING A BLACK HOUSE FIGURE THEREIN. THE BACKGROUND IN THE CIRCLE IS WHITE AND THE MARK APPEARS AGAINST A WHITE BACKGROUND.

FOR PROVIDING INFORMATION IN THE FIELD OF PROPERTY TAX ASSESSMENT TO REAL PROPERTY OWNERS TO ASSIST THEM IN ELIMINATING PROPERTY TAX ASSESSMENT ERRORS AND TO AVOID PROPERTY TAX OVER-PAYMENTS (U.S. CLS. 100, 101 AND 102).

FIRST USE 4-23-2010; IN COMMERCE 4-23-2010.
JILL PRATER, EXAMINING ATTORNEY

CLASS 35—(Continued).

SN 85-215,745. MATTHEWS, CRAIG, DBA ARTISAN GEMS BOUTIQUE, FOUNTAIN VALLEY, CA. FILED 1-12-2011.

I-SHOP THE OUTLET

THE MARK CONSISTS OF STANDARD CHARACTERS WITHOUT CLAIM TO ANY PARTICULAR FONT, STYLE, SIZE, OR COLOR.

NO CLAIM IS MADE TO THE EXCLUSIVE RIGHT TO USE "OUTLET", APART FROM THE MARK AS SHOWN.

FOR ONLINE RETAIL STORE SERVICES, NAMELY, ONLINE OUTLET FEATURING HOME FURNISHINGS, WOMEN'S APPAREL, HANDBAGS, WOMEN'S FASHION ACCESSORIES, WOMEN'S FOOTWEAR, JEWELRY, WATCHES, BEAUTY PRODUCTS, MEN'S FOOTWEAR, MEN'S FASHION ACCESSORIES (U.S. CLS. 100, 101 AND 102).

FIRST USE 8-28-2010; IN COMMERCE 8-28-2010.
FRANK LATTUCA, EXAMINING ATTORNEY

CLASS 35—(Continued).

SN 85-216,529. TAZ TAX INC., FARMINGDALE, NY. FILED 1-13-2011.



THE MARK CONSISTS OF THE LETTER "P" IN CAPITAL WITH, FOLLOWED BY THE LETTER "A" IN CAPITAL LETTER WITH, THE LETTER "S" IN CAPITAL AND, THE LETTER "T" IN CAPITAL, FOLLOWED BY THE LETTER "Y" IN CAPITAL, FOLLOWED BY THE LETTER "E" IN CAPITAL, FOLLOWED BY THE LETTER "A", IN CAPITAL AND, FOLLOWED BY THE LETTER "R" IN CAPITAL, FOLLOWED BY THE LETTER "T" IN CAPITAL, FOLLOWED BY THE LETTER "A", IN CAPITAL AND, FOLLOWED BY THE LETTER "X" IN CAPITAL.

SEC. 2(F).
FOR INCOME TAX PREPARATION (U.S. CLS. 100, 101 AND 102).

FIRST USE 5-19-2006; IN COMMERCE 5-28-2006.
CARRIE GENOVESE, EXAMINING ATTORNEY

SN 85-216,392. MEXICO FOODS, LLC, HOUSTON, TX. FILED 1-12-2011.



THE COLOR(S) RED AND WHITE IS/ARE CLAIMED AS A FEATURE OF THE MARK.

THE MARK CONSISTS OF A HORIZONTAL RED BANNER WITH TWO FOLDS ON EACH SIDE AND THE WORDS "DE LA" IN CAPITALIZED LETTERS ON THE FIRST LINE AND THE WORD "HACIENDA" IN CAPITALIZED LETTERS AND LARGER FONT AT THE BOTTOM. THE COMBINATION OF WORDS "DE LA HACIENDA" APPEAR ON THE CENTER OF THE BANNER IN WHITE.

THE ENGLISH TRANSLATION OF "DE LA HACIENDA" IN THE MARK IS "FROM THE RANCH".

FOR WHOLESALE FOOD DISTRIBUTORSHIP SERVICES (U.S. CLS. 100, 101 AND 102).

ANNE FARRELL, EXAMINING ATTORNEY

SN 85-217,486. ACE METRIX, INC., LOS ANGELES, CA. FILED 1-13-2011.

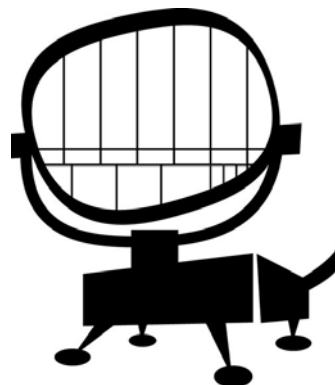

THE MARK CONSISTS OF A ROBOTIC DOG. FOR ADVERTISING AND MARKETING SERVICES, NAMELY, STANDARDIZED TESTING IN THE FIELD OF ADVERTISING EFFECTIVENESS (U.S. CLS. 100, 101 AND 102).

WENDY JUN, EXAMINING ATTORNEY

CLASS 35—(Continued).

SN 85-218,845. KOREANePAGE LLC, NEW YORK, NY.
FILED 1-16-2011.

KOREANePAGE

THE MARK CONSISTS OF STANDARD CHARACTERS WITHOUT CLAIM TO ANY PARTICULAR FONT, STYLE, SIZE, OR COLOR.

FOR ADVERTISING AND MARKETING; ADVERTISING AND MARKETING SERVICES PROVIDED BY MEANS OF INDIRECT METHODS OF MARKETING COMMUNICATIONS, NAMELY, SOCIAL MEDIA, SEARCH ENGINE MARKETING, INQUIRY MARKETING, INTERNET MARKETING, MOBILE MARKETING, BLOGGING AND OTHER FORMS OF PASSIVE, SHARABLE OR VIRAL COMMUNICATIONS CHANNELS; ADVERTISING AND MARKETING SERVICES, NAMELY, PROMOTING THE GOODS AND SERVICES OF OTHERS; ADVERTISING SERVICES, NAMELY, PROMOTING AND MARKETING THE GOODS AND SERVICES OF OTHERS IN THE FIELD OF UPSCALE CHOICES SUCH AS CULTURAL EVENTS, RESTAURANTS, SHOPPING, AND TRAVEL VIA PRINT AND ELECTRONIC MEDIA; ADVERTISING SERVICES, PUBLIC RELATIONS AND MARKETING SERVICES, NAMELY, PROMOTING AND MARKETING THE GOODS AND SERVICES OF OTHERS THROUGH ALL PUBLIC COMMUNICATION MEANS; ADVERTISING, MARKETING AND PROMOTION SERVICES; ADVERTISING, MARKETING AND PROMOTION SERVICES, NAMELY, PROMOTING THE GOODS AND SERVICES OF OTHERS BY PROVIDING CUSTOMIZED EXHIBITS (U.S. CLS. 100, 101 AND 102).

FIRST USE 1-4-2011; IN COMMERCE 1-4-2011.
DANNEAN HETZEL, EXAMINING ATTORNEY

SN 85-219,377. MEXICO FOODS, LLC, HOUSTON, TX.
FILED 1-17-2011.

Donde Compra Nuestra Gente

THE MARK CONSISTS OF STANDARD CHARACTERS WITHOUT CLAIM TO ANY PARTICULAR FONT, STYLE, SIZE, OR COLOR.

THE ENGLISH TRANSLATION OF "DONDE COMPRA NUESTRA GENTE" IN THE MARK IS "WHERE OUR PEOPLE SHOP".
FOR RETAIL GROCERY STORES (U.S. CLS. 100, 101 AND 102).

FIRST USE 1-1-2011; IN COMMERCE 1-1-2011.
ANNE FARRELL, EXAMINING ATTORNEY

CLASS 35—(Continued).

SN 85-220,869. PADOW'S DELI, INC., GLEN ALLEN, VA.
FILED 1-19-2011.

HAM HEADQUARTERS

THE MARK CONSISTS OF STANDARD CHARACTERS WITHOUT CLAIM TO ANY PARTICULAR FONT, STYLE, SIZE, OR COLOR.

NO CLAIM IS MADE TO THE EXCLUSIVE RIGHT TO USE "HAM", APART FROM THE MARK AS SHOWN.

FOR RETAIL STORE SERVICES FEATURING FOOD, NAMELY, HAMS AND DELI ITEMS (U.S. CLS. 100, 101 AND 102).

FIRST USE 12-31-2003; IN COMMERCE 12-31-2003.
ROBERT C. CLARK JR., EXAMINING ATTORNEY

SN 85-222,519. SPARK NETWORKS USA, LLC, BEVERLY HILLS, CA. FILED 1-20-2011.

JPICKS

THE MARK CONSISTS OF STANDARD CHARACTERS WITHOUT CLAIM TO ANY PARTICULAR FONT, STYLE, SIZE, OR COLOR.

THE WORDING "JPICKS" HAS NO MEANING IN A FOREIGN LANGUAGE.

FOR PROMOTING THE GOODS AND SERVICES OF OTHERS BY PROVIDING AN INTERACTIVE WEBSITE FEATURING COUPONS, REBATES, PRODUCT REVIEWS, DISCOUNTS AND PROMOTIONAL OFFERS OF OTHER BUSINESSES (U.S. CLS. 100, 101 AND 102).

FIRST USE 2-7-2011; IN COMMERCE 2-7-2011.
RONALD DELGIZZI, EXAMINING ATTORNEY

SN 85-226,209. EVANS, CHRISTIAN E., DBA EVANS ALLIANCE, LLC, SPARTA, NJ. FILED 1-26-2011.

**STEM - Strategic Targeted
Email Marketing**

THE MARK CONSISTS OF STANDARD CHARACTERS WITHOUT CLAIM TO ANY PARTICULAR FONT, STYLE, SIZE, OR COLOR.

NO CLAIM IS MADE TO THE EXCLUSIVE RIGHT TO USE "STRATEGIC TARGETED EMAIL MARKETING", APART FROM THE MARK AS SHOWN.

FOR PROVIDING ADVERTISING SERVICE TO DISTRIBUTE ADVERTISEMENTS FOR DISPLAY ON INTERNET, NAMELY, IN WEBSITES, SOCIAL CONVERSATIONS OVER THE INTERNET, E-MAILS, MICROBLOGS, BLOGS, ELECTRONIC MESSAGES, INSTANT MESSAGES, TEXT MESSAGES, MULTIMEDIA MESSAGES, SOCIAL NETWORKS, STATUS UPDATES, FORUMS, ELECTRONIC BULLETIN BOARDS (U.S. CLS. 100, 101 AND 102).

FIRST USE 9-12-2008; IN COMMERCE 10-21-2008.
NATALIE POLZER, EXAMINING ATTORNEY

CLASS 35—(Continued).

SN 85-226,311. FASHION SEAL CORPORATION, LAS VEGAS, NV. FILED 1-26-2011.



NO CLAIM IS MADE TO THE EXCLUSIVE RIGHT TO USE "MEDIA", APART FROM THE MARK AS SHOWN. THE COLOR(S) PALE GREEN, AND BLUE IS/ARE CLAIMED AS A FEATURE OF THE MARK.

THE MARK CONSISTS OF THE LITERAL ELEMENT "EVERYBODY MEDIA" WITH THE LITERAL ELEMENT "EVERY" LOCATED ON THE BOTTOM LEFTHAND SIDE IN SCRIPT IN PALE GREEN GRADUATED COLORING FROM LIGHTER AT THE TOP TO DARKER AT THE BOTTOM; THE LITERAL ELEMENT "BODY" LOCATED TO THE RIGHT OF THE LITERAL ELEMENT "EVERY", WITH THE "Y" IN "EVERY" SLIGHTLY OVERLAPPING THE BEGINNING OF THE "B" IN "BODY". THE "B" "D" AND "Y" OF THE LITERAL ELEMENT "BODY" IN BLOCK LETTERS IN BLUE GRADUATED COLORING FROM LIGHTER AT THE TOP TO DARKER AT THE BOTTOM, AND THE "O" IN "BODY" REPRESENTED AS A SERIES OF LIGHT AND DARK PALE GREEN AND BLUE THIN SWIRLING ARCS ENCASING A LARGE, THICK SWIRL OF BLUE; AND THE LITERAL ELEMENT "MEDIA" LOCATED ON THE UPPER RIGHTHAND SIDE IN SCRIPT IN PALE GREEN GRADUATED COLORING FROM LIGHTER AT THE TOP TO DARKER AT THE BOTTOM AND DIRECTLY OVER THE "DY" IN "BODY".

FOR CATALOG ORDERING SERVICES FEATURING CLOTHING WITH CHANGEABLE MESSAGING FOR USE BY SERVICE AND PRODUCT PROVIDERS AS A CHANGEABLE ADVERTISING DISPLAY, AND ADVERTISING SERVICES EMPLOYING CLOTHING WITH CHANGEABLE MESSAGING (U.S. CLS. 100, 101 AND 102).

ANDREA HACK, EXAMINING ATTORNEY

SN 85-226,322. CUSTOMER MATTERS CONSULTING, LLC, ARLINGTON, VA. FILED 1-26-2011.

Insights for Impact

THE MARK CONSISTS OF STANDARD CHARACTERS WITHOUT CLAIM TO ANY PARTICULAR FONT, STYLE, SIZE, OR COLOR.

FOR BUSINESS MANAGEMENT CONSULTING SERVICES RELATING TO BUSINESS STRATEGY, ORGANIZATION PERFORMANCE, RESEARCH AND RESEARCH DESIGN, BUSINESS RELATED POLICY AREAS, IMPROVEMENT OF SHORT-TERM BUSINESS PERFORMANCE, MARKETING, MANUFACTURING AND DISTRIBUTION MANPOWER DEVELOPMENT, PLANNING AND CONTROL, MANAGEMENT INFORMATION AND INFORMATION TECHNOLOGY, ALL IN THE FIELDS OF AEROSPACE AND DEFENSE, ELECTRONICS, TELECOMMUNICATIONS, AUTOMOTIVE, PACKAGED GOODS, MEDIA, PHARMACEUTICALS AND MEDICAL PRODUCTS, RETAIL, ENERGY, BANKING, SECURITIES, HEALTHCARE, INSURANCE AND TRANSPORTATION, GOVERNMENT CONTRACTING, GEOANALYTICS (U.S. CLS. 100, 101 AND 102).

AMY KERTGATE, EXAMINING ATTORNEY

CLASS 35—(Continued).

SN 85-227,738. BACKBEAT INDUSTRIES, LLC, SEATTLE, WA. FILED 1-27-2011.

BACKBEAT INDUSTRIES

THE MARK CONSISTS OF STANDARD CHARACTERS WITHOUT CLAIM TO ANY PARTICULAR FONT, STYLE, SIZE, OR COLOR.

NO CLAIM IS MADE TO THE EXCLUSIVE RIGHT TO USE "INDUSTRIES", APART FROM THE MARK AS SHOWN.

FOR ADVERTIZING AND MARKETING SERVICES, NAMELY, FOR THIRD PARTY MUSIC, TELEVISION, THEATRICAL AND FILM COMPANIES AND OTHER MEDIA ENTITIES (U.S. CLS. 100, 101 AND 102).

TINA L. SNAPP, EXAMINING ATTORNEY

SN 85-228,918. QUIBIDS HOLDINGS LLC, OKLAHOMA CITY, OK. FILED 1-28-2011.

QBar

THE MARK CONSISTS OF STANDARD CHARACTERS WITHOUT CLAIM TO ANY PARTICULAR FONT, STYLE, SIZE, OR COLOR.

OWNER OF U.S. REG. NO. 3,870,521.

FOR ON-LINE AUCTION SERVICES; PROVIDING AN INTERACTIVE WEBSITE CONCERNING NOTIFICATIONS OF CHANGES IN THE STATUS OF ON-LINE AUCTION ITEMS (U.S. CLS. 100, 101 AND 102).

FIRST USE 1-0-2011; IN COMMERCE 1-0-2011.

CAROLINE WOOD, EXAMINING ATTORNEY

SN 85-229,841. SOUTHEASTERN NETWORK AND PRINTING SYSTEMS, INC., DBA HOLON SOLUTIONS, ROSWELL, GA. FILED 1-31-2011.

CollaborNet

THE MARK CONSISTS OF STANDARD CHARACTERS WITHOUT CLAIM TO ANY PARTICULAR FONT, STYLE, SIZE, OR COLOR.

FOR PROMOTING THE EXCHANGE OF INFORMATION AND RESOURCES WITHIN THE SCIENTIFIC RESEARCH AND MEDICAL COMMUNITIES TO ACHIEVE ADVANCES IN THE FIELD OF HEALTHCARE (U.S. CLS. 100, 101 AND 102).

FIRST USE 1-15-2011; IN COMMERCE 1-20-2011.

JOHN HWANG, EXAMINING ATTORNEY

CLASS 35—(Continued).

SN 85-230,000. VON BRUENING, DONNA M., SAVANNAH, GA. FILED 1-31-2011.



NO CLAIM IS MADE TO THE EXCLUSIVE RIGHT TO USE "SAVANNAH WEDDING PROFESSIONALS", APART FROM THE MARK AS SHOWN.

THE MARK CONSISTS OF THE STYLIZED LETTERS "SWP" ON TOP OF THE WORDS "SAVANNAH WEDDING PROFESSIONALS" WHICH ARE ENCLOSED WITH TWO STYLIZED FLOURISH DESIGNS.

FOR ADVERTISING AND MARKETING SERVICES, NAMELY, PROMOTING THE GOODS AND SERVICES OF OTHERS (U.S. CLS. 100, 101 AND 102).

FIRST USE 7-9-2007; IN COMMERCE 7-9-2007.

PRISCILLA MILTON, EXAMINING ATTORNEY

SN 85-230,312. INTRIGO SYSTEMS, INC., PLEASANTON, CA. FILED 1-31-2011.

iSemi

THE MARK CONSISTS OF STANDARD CHARACTERS WITHOUT CLAIM TO ANY PARTICULAR FONT, STYLE, SIZE, OR COLOR.

FOR BUSINESS ADVISORY SERVICES, CONSULTANCY AND INFORMATION; BUSINESS CONSULTATION; BUSINESS CONSULTATION SERVICES; BUSINESS CONSULTATION SERVICES IN THE FIELDS OF SUPPLY CHAIN ANALYSIS, REGULATION COMPLIANCE AND COUNTERFEIT DETECTION; BUSINESS CONSULTING AND BUSINESS INFORMATION FOR ENTERPRISES; BUSINESS CONSULTING AND INFORMATION SERVICES; BUSINESS CONSULTING IN THE CONSUMER PRODUCTS INDUSTRY; BUSINESS CONSULTING SERVICES FOR THE CONCRETE INDUSTRY; BUSINESS CONSULTING SERVICES RELATING TO PRODUCT DISTRIBUTION, OPERATIONS MANAGEMENT SERVICES, LOGISTICS, REVERSE LOGISTICS, SUPPLY CHAIN, AND PRODUCTION SYSTEMS AND DISTRIBUTION SOLUTIONS; BUSINESS MANAGEMENT AND CONSULTATION; BUSINESS MANAGEMENT AND ENTERPRISE ORGANIZATION CONSULTANCY; BUSINESS MANAGEMENT CONSULTANCY AND ADVISORY SERVICES; BUSINESS MANAGEMENT CONSULTANCY SERVICES; BUSINESS MANAGEMENT CONSULTATION; BUSINESS MANAGEMENT CONSULTING; BUSINESS MANAGEMENT CONSULTING AND ADVISORY SERVICES; BUSINESS RISK MANAGEMENT CONSULTATION (U.S. CLS. 100, 101 AND 102).

FIRST USE 1-1-2011; IN COMMERCE 1-1-2011.

HEATHER SAPP, EXAMINING ATTORNEY

CLASS 35—(Continued).

SN 85-230,581. METAGENICS, INC., SAN CLEMENTE, CA. FILED 1-31-2011.

Perfect Office

THE MARK CONSISTS OF STANDARD CHARACTERS WITHOUT CLAIM TO ANY PARTICULAR FONT, STYLE, SIZE, OR COLOR.

NO CLAIM IS MADE TO THE EXCLUSIVE RIGHT TO USE "OFFICE", APART FROM THE MARK AS SHOWN.

FOR BRANDING SERVICES, NAMELY, CONSULTING, DEVELOPMENT, MANAGEMENT AND MARKETING OF BRANDS FOR BUSINESSES; PROVIDING ADVERTISING, MARKETING AND PROMOTIONAL SERVICES FOR HEALTH CARE PRACTITIONERS; ADVERTISING AND PUBLICITY SERVICES, NAMELY, PROMOTING THE GOODS, SERVICES, BRAND IDENTITY AND COMMERCIAL INFORMATION AND NEWS OF THIRD PARTIES THROUGH PRINT, AUDIO, VIDEO, DIGITAL AND ON-LINE MEDIUM; ADVICE IN THE FIELD OF BUSINESS MANAGEMENT AND MARKETING (U.S. CLS. 100, 101 AND 102).

INGRID C. EULIN, EXAMINING ATTORNEY

SN 85-230,593. NASTY ART PRODUCTIONS, INC., NEW YORK, NY. FILED 1-31-2011.

NAUGHTY ART

THE MARK CONSISTS OF STANDARD CHARACTERS WITHOUT CLAIM TO ANY PARTICULAR FONT, STYLE, SIZE, OR COLOR.

OWNER OF U.S. REG. NO. 3,085,943.

NO CLAIM IS MADE TO THE EXCLUSIVE RIGHT TO USE "ART", APART FROM THE MARK AS SHOWN.

FOR ON-LINE RETAIL STORE SERVICES FEATURING PRINTS, POSTERS, DVDS, BOOKS, ORIGINAL WORKS OF ART AND DOWNLOADABLE AND STREAMING IMAGES AND VIDEO (U.S. CLS. 100, 101 AND 102).

FIRST USE 10-12-2005; IN COMMERCE 10-12-2005.

ZACHARY BELLO, EXAMINING ATTORNEY

CLASS 35—(Continued).

SN 85-230,889. STROKIN, LLC, CHASKA, MN. FILED 2-1-2011.

HEARTLAND AMERICA

THE MARK CONSISTS OF STANDARD CHARACTERS WITHOUT CLAIM TO ANY PARTICULAR FONT, STYLE, SIZE, OR COLOR.

OWNER OF U.S. REG. NO. 1,686,859.

NO CLAIM IS MADE TO THE EXCLUSIVE RIGHT TO USE "AMERICA", APART FROM THE MARK AS SHOWN.

FOR ONLINE RETAIL STORE SERVICES, DIRECT MAIL RETAIL STORE SERVICES, MAIL ORDER CATALOG SERVICES IN THE FIELD OF GENERAL DURABLE AND NON-DURABLE MERCHANDISE OF OTHERS (U.S. CLS. 100, 101 AND 102).

STEVEN JACKSON, EXAMINING ATTORNEY

SN 85-230,920. BUZZ RECORDS LLC, WILLIAMSVILLE, NY. FILED 2-1-2011.

Buzz Records

THE MARK CONSISTS OF STANDARD CHARACTERS WITHOUT CLAIM TO ANY PARTICULAR FONT, STYLE, SIZE, OR COLOR.

NO CLAIM IS MADE TO THE EXCLUSIVE RIGHT TO USE "RECORDS", APART FROM THE MARK AS SHOWN.

FOR ENTERTAINMENT MARKETING SERVICES, NAMELY, MARKETING, PROMOTION AND ADVERTISING FOR INDEPENDENT RECORDING ARTISTS (U.S. CLS. 100, 101 AND 102).

SUSAN LESLIE DUBOIS, EXAMINING ATTORNEY

CLASS 35—(Continued).

SN 85-231,135. F & F FINE WINES INTERNATIONAL, INC., DBA ETHICA WINES, ENGLEWOOD CLIFFS, NJ. FILED 2-1-2011.

NO CLAIM IS MADE TO THE EXCLUSIVE RIGHT TO USE "ESSENZA DEL VINO", APART FROM THE MARK AS SHOWN.

THE MARK CONSISTS OF THE TERM "ETHICA" IN OVERSIZED, STYLIZED FORM, WITH THE TERM "ETHICA" OVERLINED ON THE TOP FROM THE "H" IN "ETHICA" THROUGH THE "A", AND UNDERLINED ON THE BOTTOM FROM THE "T" IN "ETHIC" THROUGH THE "A", WITH A SLANTED VERTICAL LINE CONNECTING THE TWO LINES BETWEEN THE "I" AND THE "C" IN "ETHICA", AND BENEATH THE UNDERLINE ARE DEPICTED THE WORDS IN SMALLER TYPE "ESSENZA DEL VINO".

THE ENGLISH TRANSLATION OF "ESSENZA DEL VINO" IN THE MARK IS THE ESSENCE OF WINE.

FOR ADVERTISING AND MARKETING SERVICES, NAMELY, PROMOTING THE GOODS AND SERVICES OF OTHERS; IMPORT AGENCY SERVICES IN THE FIELD OF WINES; INDEPENDENT SALES REPRESENTATIVES IN THE FIELD OF WINES (U.S. CLS. 100, 101 AND 102).

FIRST USE 3-3-2009; IN COMMERCE 3-3-2009.

KIMBERLY PERRY, EXAMINING ATTORNEY

SN 85-231,308. ACXIOM CORPORATION, LITTLE ROCK, AR. FILED 2-1-2011.

ACXIOM INTELLIGENT LEADS

THE MARK CONSISTS OF STANDARD CHARACTERS WITHOUT CLAIM TO ANY PARTICULAR FONT, STYLE, SIZE, OR COLOR.

OWNER OF U.S. REG. NOS. 1,907,571, 3,472,367 AND OTHERS.

NO CLAIM IS MADE TO THE EXCLUSIVE RIGHT TO USE "INTELLIGENT LEADS", APART FROM THE MARK AS SHOWN.

FOR COMMERCIAL INFORMATION AGENCIES, NAMELY, PROVIDING MARKETING LISTS OF POTENTIAL CONSUMERS AND RELATED CONSUMER DEMOGRAPHIC DATA TO OTHERS (U.S. CLS. 100, 101 AND 102).

FIRST USE 2-24-2010; IN COMMERCE 2-24-2010.

ALICIA COLLINS, EXAMINING ATTORNEY

CLASS 35—(Continued).

SN 85-231,985. SEMPRIS, LLC, MINNEAPOLIS, MN. FILED 2-2-2011.

SEMPRIS

THE MARK CONSISTS OF STANDARD CHARACTERS WITHOUT CLAIM TO ANY PARTICULAR FONT, STYLE, SIZE, OR COLOR.

FOR CONSUMER MEMBERSHIP PROGRAMS TO ENABLE PARTICIPANTS TO OBTAIN INFORMATION, REVIEWS, ASSESSMENTS, DISCOUNTS, SAVINGS AND REBATES ON GOODS AND SERVICES THROUGH USE OF A DISCOUNT MEMBERSHIP CARD FOR CONSUMER MERCHANDISE; ADMINISTRATION, MANAGEMENT AND OPERATION OF CONSUMER MEMBERSHIP PROGRAMS; MEMBERSHIP CLUB SERVICES PROVIDING DISCOUNTS AND PROCESSING REBATES FOR THE GOODS AND SERVICES OF OTHERS; CUSTOMER RELATIONSHIP MARKETING SERVICES; CUSTOMER RELATIONSHIP MANAGEMENT SERVICES; MARKETING SERVICES, NAMELY, DESIGNING, MAINTAINING, MODIFYING AND OPERATING CUSTOMER RELATIONSHIP MANAGEMENT PROGRAMS INTENDED TO PROMOTE CUSTOMER RETENTION AND INCREASE CUSTOMER LEVEL PROFIT; ADVERTISING SERVICES; PROMOTIONAL SERVICES; ADVERTISING, MARKETING AND PROMOTIONAL CONSULTING SERVICES; ADVERTISING, PROMOTION, AND MARKETING SERVICES IN THE NATURE OF DESIGNING, ADMINISTERING, IMPLEMENTING, MANAGING AND OPERATING MEMBERSHIP AND CUSTOMER LOYALTY PROGRAMS FOR OTHERS; CUSTOMER LOYALTY SERVICES AND CUSTOMER CLUB SERVICES, FOR COMMERCIAL, PROMOTIONAL AND ADVERTISING PURPOSES; ADMINISTRATION OF A CONSUMER LOYALTY PROGRAM TO PROMOTE THE GOODS AND SERVICES OF OTHERS; AND ARRANGING AND CONDUCTING MARKETING PROMOTIONAL EVENTS FOR OTHERS; BUYING CLUB SERVICES; PROMOTING THE GOODS AND SERVICES OF OTHERS THROUGH THE DISTRIBUTION OF COUPONS AND DISCOUNT OFFERS, NAMELY, DISCOUNT COUPONS, ON-LINE DISCOUNT COUPON CODES, AND PURCHASE-ACTIVATED DISCOUNT BENEFITS, NAMELY, GIFT CARDS, STORED VALUE GIFT CARDS, REBATES, GIFTS, GIVE-AWAYS, DISCOUNTED PURCHASES, SHIPPING AND HANDLING CHARGE WAIVERS, REFUNDS TO THE PURCHASER'S ACCOUNT THROUGH THIRD PARTY PAYMENT PROCESSORS (U.S. CLS. 100, 101 AND 102).

FRANK LATTUCA, EXAMINING ATTORNEY

CLASS 35—(Continued).

SN 85-232,033. SEMPRIS, LLC, MINNEAPOLIS, MN. FILED 2-2-2011.

SEMPRIS

THE COLOR(S) GREEN IS/ARE CLAIMED AS A FEATURE OF THE MARK.

THE MARK CONSISTS OF THE WORD "SEMPRIS" IN STYLIZED AND CAPITALIZED GREEN LETTERING.

FOR CONSUMER MEMBERSHIP PROGRAMS TO ENABLE PARTICIPANTS TO OBTAIN INFORMATION, REVIEWS, ASSESSMENTS, DISCOUNTS, SAVINGS AND REBATES ON GOODS AND SERVICES THROUGH USE OF A DISCOUNT MEMBERSHIP CARD FOR CONSUMER MERCHANDISE; ADMINISTRATION, MANAGEMENT AND OPERATION OF CONSUMER MEMBERSHIP PROGRAMS; MEMBERSHIP CLUB SERVICES PROVIDING DISCOUNTS AND PROCESSING REBATES FOR THE GOODS AND SERVICES OF OTHERS; CUSTOMER RELATIONSHIP MARKETING SERVICES; CUSTOMER RELATIONSHIP MANAGEMENT SERVICES; MARKETING SERVICES, NAMELY, DESIGNING, MAINTAINING, MODIFYING AND OPERATING CUSTOMER RELATIONSHIP MANAGEMENT PROGRAMS INTENDED TO PROMOTE CUSTOMER RETENTION AND INCREASE CUSTOMER LEVEL PROFIT; ADVERTISING SERVICES; PROMOTIONAL SERVICES; ADVERTISING, MARKETING AND PROMOTIONAL CONSULTING SERVICES; ADVERTISING, PROMOTION, AND MARKETING SERVICES IN THE NATURE OF DESIGNING, ADMINISTERING, IMPLEMENTING, MANAGING AND OPERATING MEMBERSHIP AND CUSTOMER LOYALTY PROGRAMS FOR OTHERS; CUSTOMER LOYALTY SERVICES AND CUSTOMER CLUB SERVICES, FOR COMMERCIAL, PROMOTIONAL AND ADVERTISING PURPOSES; ADMINISTRATION OF A CONSUMER LOYALTY PROGRAM TO PROMOTE THE GOODS AND SERVICES OF OTHERS; AND ARRANGING AND CONDUCTING MARKETING PROMOTIONAL EVENTS FOR OTHERS; BUYING CLUB SERVICES; PROMOTING THE GOODS AND SERVICES OF OTHERS THROUGH THE DISTRIBUTION OF COUPONS AND DISCOUNT OFFERS, NAMELY, DISCOUNT COUPONS, ON-LINE DISCOUNT COUPON CODES, AND PURCHASE-ACTIVATED DISCOUNT BENEFITS, NAMELY, GIFT CARDS, STORED VALUE GIFT CARDS, REBATES, GIFTS, GIVE-AWAYS, DISCOUNTED PURCHASES, SHIPPING AND HANDLING CHARGE WAIVERS, REFUNDS TO THE PURCHASER'S ACCOUNT THROUGH THIRD PARTY PAYMENT PROCESSORS (U.S. CLS. 100, 101 AND 102).

FRANK LATTUCA, EXAMINING ATTORNEY

CLASS 35—(Continued).

SN 85-232,052. SEMPRIS, LLC, MINNEAPOLIS, MN. FILED 2-2-2011.

SEMPRIS

THE MARK CONSISTS OF THE WORD "SEMPRIS" IN STYLIZED AND CAPITALIZED LETTERING.

FOR CONSUMER MEMBERSHIP PROGRAMS TO ENABLE PARTICIPANTS TO OBTAIN INFORMATION, REVIEWS, ASSESSMENTS, DISCOUNTS, SAVINGS AND REBATES ON GOODS AND SERVICES THROUGH USE OF A DISCOUNT MEMBERSHIP CARD FOR CONSUMER MERCHANDISE; ADMINISTRATION, MANAGEMENT AND OPERATION OF CONSUMER MEMBERSHIP PROGRAMS; MEMBERSHIP CLUB SERVICES PROVIDING DISCOUNTS AND PROCESSING REBATES FOR THE GOODS AND SERVICES OF OTHERS; CUSTOMER RELATIONSHIP MARKETING SERVICES; CUSTOMER RELATIONSHIP MANAGEMENT SERVICES; MARKETING SERVICES, NAMELY, DESIGNING, MAINTAINING, MODIFYING AND OPERATING CUSTOMER RELATIONSHIP MANAGEMENT PROGRAMS INTENDED TO PROMOTE CUSTOMER RETENTION AND INCREASE CUSTOMER LEVEL PROFIT; ADVERTISING SERVICES; PROMOTIONAL SERVICES; ADVERTISING, MARKETING AND PROMOTIONAL CONSULTING SERVICES; ADVERTISING, PROMOTION, AND MARKETING SERVICES IN THE NATURE OF DESIGNING, ADMINISTERING, IMPLEMENTING, MANAGING AND OPERATING MEMBERSHIP AND CUSTOMER LOYALTY PROGRAMS FOR OTHERS; CUSTOMER LOYALTY SERVICES AND CUSTOMER CLUB SERVICES, FOR COMMERCIAL, PROMOTIONAL AND ADVERTISING PURPOSES; ADMINISTRATION OF A CONSUMER LOYALTY PROGRAM TO PROMOTE THE GOODS AND SERVICES OF OTHERS; AND ARRANGING AND CONDUCTING MARKETING PROMOTIONAL EVENTS FOR OTHERS; BUYING CLUB SERVICES; PROMOTING THE GOODS AND SERVICES OF OTHERS THROUGH THE DISTRIBUTION OF COUPONS AND DISCOUNT OFFERS, NAMELY, DISCOUNT COUPONS, ON-LINE DISCOUNT COUPON CODES, AND PURCHASE-ACTIVATED DISCOUNT BENEFITS, NAMELY, GIFT CARDS, STORED VALUE GIFT CARDS, REBATES, GIFTS, GIVE-AWAYS, DISCOUNTED PURCHASES, SHIPPING AND HANDLING CHARGE WAIVERS, REFUNDS TO THE PURCHASER'S ACCOUNT THROUGH THIRD PARTY PAYMENT PROCESSORS (U.S. CLS. 100, 101 AND 102).

FRANK LATTUCA, EXAMINING ATTORNEY

CLASS 35—(Continued).

SN 85-232,243. COOL CLUB COM LLC, BATON ROUGE, LA. FILED 2-2-2011.



THE STIPPLING IS FOR SHADING PURPOSES ONLY. THE MARK CONSISTS OF AN IMAGE OF THE EARTH WITH PARTIAL CONTINENTS AND A SMILING FACE WITH SUNGLASSES ON IT. BELOW THE IMAGE IS THE TERM "WWW.COOLCLUBWORLD.COM".

FOR CLUB SERVICES, NAMELY, PROMOTING THE INTERESTS OF INDIVIDUAL MEMBERS BY ALLOWING THEM TO SHARE POSITIVE ACTIVITIES AND EXPERIENCES WITH FAMILY AND FRIENDS, AND PEOPLE WITH THE SAME CHURCH AFFILIATIONS AND MILITARY BACKGROUND (U.S. CLS. 100, 101 AND 102).

FIRST USE 6-30-2010; IN COMMERCE 7-3-2010.
SUSAN LESLIE DUBOIS, EXAMINING ATTORNEY

SN 85-232,314. AMERICAN STOCK TRANSFER & TRUST COMPANY, LLC, BROOKLYN, NY. FILED 2-2-2011.

PHOENIX ADVISORY PARTNERS

THE MARK CONSISTS OF STANDARD CHARACTERS WITHOUT CLAIM TO ANY PARTICULAR FONT, STYLE, SIZE, OR COLOR.

NO CLAIM IS MADE TO THE EXCLUSIVE RIGHT TO USE "ADVISORY PARTNERS", APART FROM THE MARK AS SHOWN.

FOR BUSINESS CONSULTING AND ADVISORY SERVICES IN THE FIELD OF CORPORATE GOVERNANCE, PROXY SOLICITATION, AND INFORMATION AGENCY (U.S. CLS. 100, 101 AND 102).

FIRST USE 7-0-2010; IN COMMERCE 7-0-2010.
KELLY BOULTON, EXAMINING ATTORNEY

CLASS 35—(Continued).

SN 85-232,318. AMERICAN STOCK TRANSFER & TRUST COMPANY, LLC, BROOKLYN, NY. FILED 2-2-2011.



NO CLAIM IS MADE TO THE EXCLUSIVE RIGHT TO USE "ADVISORY PARTNERS", APART FROM THE MARK AS SHOWN.

THE MARK CONSISTS OF A RECTANGLE WITH THREE SECTIONS, A SQUARE ON THE LEFT SIDE AND TWO HORIZONTAL STACKED RECTANGLES ON THE RIGHT. THE STYLIZED WORD "PHOENIX" IS IN THE UPPER RECTANGLE, THE STYLIZED WORDING "ADVISORY PARTNERS" IS IN THE LOWER SHADED RECTANGLE AND A DRAWING OF A "PHOENIX" RISING FROM FLAMES IS IN THE SQUARE.

FOR BUSINESS CONSULTING AND ADVISORY SERVICES IN THE FIELD OF CORPORATE GOVERNANCE, PROXY SOLICITATION, AND INFORMATION AGENCY (U.S. CLS. 100, 101 AND 102).

FIRST USE 7-0-2010; IN COMMERCE 7-0-2010.
KELLY BOULTON, EXAMINING ATTORNEY

SN 85-233,393. OPENONWARD, LLC, BALTIMORE, MD. FILED 2-3-2011.

OPENONWARD

THE MARK CONSISTS OF STANDARD CHARACTERS WITHOUT CLAIM TO ANY PARTICULAR FONT, STYLE, SIZE, OR COLOR.

FOR ADVERTISING AND ADVERTISEMENT SERVICES; ADVERTISING AND COMMERCIAL INFORMATION SERVICES, VIA THE INTERNET; ADVERTISING AND DIRECTORY SERVICES, NAMELY, PROMOTING THE SERVICES OF OTHERS BY PROVIDING A WEB PAGE FEATURING LINKS TO THE WEBSITES OF OTHERS; ADVERTISING BY TRANSMISSION OF ON-LINE PUBLICITY FOR THIRD PARTIES THROUGH ELECTRONIC COMMUNICATIONS NETWORKS; ADVERTISING SERVICES, NAMELY, PROMOTING AND MARKETING THE GOODS AND SERVICES OF OTHERS IN THE FIELD OF SCIENCE VIA PRINT AND ELECTRONIC MEDIA; ADVERTISING VIA ELECTRONIC MEDIA AND SPECIFICALLY THE INTERNET; DISSEMINATION OF ADVERTISING FOR OTHERS VIA THE INTERNET; MARKETING, ADVERTISING AND PROMOTING THE GOODS AND SERVICES OF OTHERS IN THE FIELD OF SCIENCE, NAMELY, PROVIDING INFORMATION VIA MAIL AND ELECTRONIC MAIL; MARKETING, ADVERTISING, AND PROMOTING THE RETAIL GOODS AND SERVICES OF OTHERS TO

CLASS 35—(Continued).

WIRELESS ELECTRONIC DEVICES; ON-LINE ADVERTISING SERVICES FOR OTHERS; PROMOTING THE GOODS AND SERVICES OF OTHERS BY DISTRIBUTING ADVERTISING MATERIALS THROUGH A VARIETY OF METHODS; PROMOTING THE GOODS AND SERVICES OF OTHERS BY MEANS OF DISTRIBUTING ADVERTISING ON THE INTERNET; PROMOTING, ADVERTISING AND MARKETING OF THE ON-LINE WEB SITES OF OTHERS; PROVIDING A SEARCHABLE ON-LINE ADVERTISING WEBSITE AND GUIDE FEATURING THE GOODS AND SERVICES OF OTHER VENDORS VIA THE INTERNET; PROVIDING A WEB SITE AT WHICH SCIENTISTS AND THOSE INTERESTED IN SCIENCE CAN POST PROMOTIONAL PROFILES AND RESPOND TO ADVERTISEMENTS FOR THEIR SERVICES; PROVIDING A WEB SITE THAT ENABLES USERS TO POST ITEMS FOR SALE THROUGH ON-LINE CLASSIFIED ADVERTISEMENTS; PROVIDING CONSUMER INFORMATION SERVICES AND MAKING REFERRALS IN THE FIELD OF SCIENCE (U.S. CLS. 100, 101 AND 102).

KELLY CHOE, EXAMINING ATTORNEY

SN 85-233,771. LINDSEYMARIE SARL, GENEVA, SWITZERLAND, FILED 2-3-2011.

LindseyMarie

THE MARK CONSISTS OF STANDARD CHARACTERS WITHOUT CLAIM TO ANY PARTICULAR FONT, STYLE, SIZE, OR COLOR.

THE NAME(S), PORTRAIT(S), AND/OR SIGNATURE(S) SHOWN IN THE MARK IDENTIFIES LINDSEY MARIE WENDLER, WHOSE CONSENT(S) TO REGISTER IS MADE OF RECORD.

FOR RETAIL STORES FEATURING JEWELRY AND ACCESSORIES (U.S. CLS. 100, 101 AND 102).

GISELLE AGOSTO, EXAMINING ATTORNEY

SN 85-233,788. LINDSEYMARIE SARL, GENEVA, SWITZERLAND, FILED 2-3-2011.



THE NAME(S), PORTRAIT(S), AND/OR SIGNATURE(S) SHOWN IN THE MARK IDENTIFIES LINDSEY MARIE WENDLER, WHOSE CONSENT(S) TO REGISTER IS MADE OF RECORD.

THE MARK CONSISTS OF A SCRIPTED LITERAL ELEMENT, THE TERM "LINDSEY MARIE" WITH TWO BUTTERFLY DESIGN ELEMENTS OVER THE LITERAL ELEMENT AND ONE BUTTERFLY DESIGN BELOW THE LITERAL ELEMENT.

FOR RETAIL STORES FEATURING JEWELRY AND ACCESSORIES (U.S. CLS. 100, 101 AND 102).

GISELLE AGOSTO, EXAMINING ATTORNEY

CLASS 35—(Continued).

SN 85-234,515. WALCHLE, JONATHAN, DBA LABOR STAFFING, INC., ALPHARETTA, GA. FILED 2-4-2011.

LS

THE MARK CONSISTS OF STANDARD CHARACTERS WITHOUT CLAIM TO ANY PARTICULAR FONT, STYLE, SIZE, OR COLOR.

FOR EMPLOYMENT AGENCY SERVICES, NAMELY, FILLING THE TEMPORARY AND PERMANENT STAFFING NEEDS OF BUSINESSES; EMPLOYMENT AGENCY SERVICES, NAMELY, TEMPORARY AND PERMANENT PLACEMENT OF HEALTH CARE PROFESSIONALS; EMPLOYMENT AGENCY SERVICES, NAMELY, TEMPORARY PLACEMENT OF CHILD CARE PROVIDERS; EMPLOYMENT HIRING, RECRUITING, PLACEMENT, STAFFING AND CAREER NETWORKING SERVICES; EMPLOYMENT RECRUITING AND STAFFING SERVICES PROVIDED VIA TEXT MESSAGING; EMPLOYMENT STAFFING CONSULTATION SERVICES; EMPLOYMENT STAFFING IN THE FIELD OF NAMELY HOSPITALITY, WAREHOUSING, GENERAL LABOR, JANITORIAL CLEANING, HOSPITAL WORKERS AND ALL LIGHT INDUSTRIAL WORKERS; PROFESSIONAL STAFFING AND RECRUITING SERVICES; PROVIDING AN EMPLOYER WITH CANDIDATES OR POTENTIAL EMPLOYEES TO FILL TEMPORARY, CONTRACT AND PERMANENT POSITIONS; STRATEGIC SOURCING, NAMELY, STAFFING IN THE FIELD OF ENGINEERING; TEMPORARY EMPLOYMENT AGENCIES; TEMPORARY PERSONNEL SERVICES (U.S. CLS. 100, 101 AND 102).

FIRST USE 5-14-1999; IN COMMERCE 5-14-1999.
CAROLINE WOOD, EXAMINING ATTORNEY

SN 85-235,813. COLEMAN, LYNN DEE, TA AERIAL FABRIC ACROBATICS, LLC, DENVER, CO. FILED 2-7-2011.



OWNER OF U.S. REG. NO. 3,855,229.
NO CLAIM IS MADE TO THE EXCLUSIVE RIGHT TO USE "AERIAL FABRIC ACROBATICS", APART FROM THE MARK AS SHOWN.

THE COLOR(S) WHITE, GREY AND BURGUNDY IS/ARE CLAIMED AS A FEATURE OF THE MARK.

THE MARK CONSISTS OF AN AERIAL ACROBAT IN

CLASS 35—(Continued).

SPLITS POSITION ON AERIAL FABRIC IN THE COLOR WHITE WITHIN A CIRCLE THAT IS IN THE COLOR GREY WHICH IS ABOVE THE WORDING "AERIAL FABRIC ACROBATICS" ALL IN LOWER CASE LETTERING; THE TERMS "AERIAL" AND "ACROBATICS" ARE IN THE COLOR WHITE AND THE TERM "FABRIC" IS IN THE COLOR GREY WITH A HORIZONTAL LINE BETWEEN THE TERMS "AERIAL FABRIC" AND "ACROBATICS" IN LIGHT BURGUNDY, ALL SUPERIMPOSED OVER A BURGUNDY BACKGROUND.

FOR RETAIL STORE AND ON-LINE RETAIL STORE SERVICES FEATURING PRE-RECORDED INSTRUCTIONAL DVDS AND EQUIPMENT FOR USE DOING AERIAL ACROBATICS ON FABRIC. HOOP, TRAPEZE, AERIAL HAMMOCK, YOGA HAMMOCK, NET, CORDE LISSE, AND BUNGEE (U.S. CLS. 100, 101 AND 102).

FIRST USE 10-10-2010; IN COMMERCE 10-10-2010.
BARBARA RUTLAND, EXAMINING ATTORNEY

SN 85-235,893. TRACY IGWE, DBA KINIKAN, LAKEWOOD, CA. FILED 2-7-2011.

Kinikan

THE MARK CONSISTS OF STANDARD CHARACTERS WITHOUT CLAIM TO ANY PARTICULAR FONT, STYLE, SIZE, OR COLOR.

FOR RETAIL STORE AND ON-LINE RETAIL STORE SERVICES FEATURING CLOTHING AND FASHION ACCESSORIES, NAMELY, JEWELRY, BELTS, SHOES, HATS, SCARVES, AND HANDBAGS (U.S. CLS. 100, 101 AND 102).

FIRST USE 1-30-2011; IN COMMERCE 1-30-2011.
INGA ERVIN, EXAMINING ATTORNEY

SN 85-236,168. DR. SEUSS ENTERPRISES, L.P., LA JOLLA, CA. FILED 2-7-2011.

LORAX

THE MARK CONSISTS OF STANDARD CHARACTERS WITHOUT CLAIM TO ANY PARTICULAR FONT, STYLE, SIZE, OR COLOR.

OWNER OF U.S. REG. NOS. 2,072,896, 3,786,205 AND OTHERS.

FOR BUSINESS CONSULTING SERVICES IN THE FIELD OF GREEN BUILDING, OBTAINING GREEN BUILDING CERTIFICATION, ENVIRONMENTAL SUSTAINABILITY; BUSINESS SERVICES, NAMELY, COORDINATION AND ADMINISTRATION OF THE GREEN BUILDING CERTIFICATION PROCESS FROM INCEPTION THROUGH CERTIFICATION FOR OTHERS (U.S. CLS. 100, 101 AND 102).

FIRST USE 6-0-2003; IN COMMERCE 6-0-2003.
WANDA KAY PRICE, EXAMINING ATTORNEY

CLASS 35—(Continued).

SN 85-237,288. HAGAN, ALICIA, MARIETTA, GA. FILED 2-8-2011.

Atlanta Moms

THE MARK CONSISTS OF STANDARD CHARACTERS WITHOUT CLAIM TO ANY PARTICULAR FONT, STYLE, SIZE, OR COLOR.

NO CLAIM IS MADE TO THE EXCLUSIVE RIGHT TO USE "ATLANTA", APART FROM THE MARK AS SHOWN.

FOR PROVIDING AN ON-LINE ADVERTISING WEBSITE AND GUIDE FEATURING THE GOODS AND SERVICES OF OTHER VENDORS VIA THE INTERNET (U.S. CLS. 100, 101 AND 102).

FIRST USE 10-26-2001; IN COMMERCE 7-15-2002.

KIMBERLY PERRY, EXAMINING ATTORNEY

CLASS 35—(Continued).

SN 85-238,958. RECELLULAR, INC., ANN ARBOR, MI. FILED 2-10-2011.

RECELLULARTOO

THE MARK CONSISTS OF STANDARD CHARACTERS WITHOUT CLAIM TO ANY PARTICULAR FONT, STYLE, SIZE, OR COLOR.

OWNER OF U.S. REG. NOS. 3,290,425 AND 3,401,022.

FOR ON-LINE RETAIL STORE SERVICES FEATURING MOBILE TELEPHONE, MOBILE COMMUNICATION DEVICES AND OTHER CONSUMER ELECTRONIC DEVICES (U.S. CLS. 100, 101 AND 102).

FIRST USE 9-11-2001; IN COMMERCE 9-11-2001.

DANNEAN HETZEL, EXAMINING ATTORNEY

SN 85-237,309. DINIUS, MICHAEL, DBA PERFORMANCE MANAGEMENT CONSULTING, LLC, RICHLAND, WA. FILED 2-8-2011.

earning employee excellence

THE MARK CONSISTS OF STANDARD CHARACTERS WITHOUT CLAIM TO ANY PARTICULAR FONT, STYLE, SIZE, OR COLOR.

NO CLAIM IS MADE TO THE EXCLUSIVE RIGHT TO USE "EMPLOYEE", APART FROM THE MARK AS SHOWN.

FOR CONSULTING SERVICES IN THE FIELDS OF BUSINESS MANAGEMENT, HUMAN RESOURCES, AND BUSINESS ORGANIZATIONAL DESIGN (U.S. CLS. 100, 101 AND 102).

NAAKWAMA ANKRAH, EXAMINING ATTORNEY

SN 85-238,398. CONCIERGE AUCTIONS LLC, NEW YORK, NY. FILED 2-9-2011.

CONCIERGE AUCTIONS

THE MARK CONSISTS OF STANDARD CHARACTERS WITHOUT CLAIM TO ANY PARTICULAR FONT, STYLE, SIZE, OR COLOR.

NO CLAIM IS MADE TO THE EXCLUSIVE RIGHT TO USE "AUCTIONS", APART FROM THE MARK AS SHOWN.

FOR ON-LINE AUCTION SERVICES; ARRANGING AND CONDUCTING AUCTIONS; AUCTION ADVERTISING AND MARKETING SERVICES; REAL ESTATE AUCTIONS; ARRANGING AND CONDUCTING REAL ESTATE AUCTIONS; REAL ESTATE AUCTION ADVERTISING AND MARKETING (U.S. CLS. 100, 101 AND 102).

FIRST USE 4-30-2008; IN COMMERCE 4-30-2008.

CHARLOTTE CORWIN, EXAMINING ATTORNEY

SN 85-239,046. THE 3/50 PROJECT LLC, GOLDEN VALLEY, MN. FILED 2-10-2011.

THE 3/50 PROJECT

THE MARK CONSISTS OF STANDARD CHARACTERS WITHOUT CLAIM TO ANY PARTICULAR FONT, STYLE, SIZE, OR COLOR.

NO CLAIM IS MADE TO THE EXCLUSIVE RIGHT TO USE "PROJECT", APART FROM THE MARK AS SHOWN.

FOR DESIGN AND DISTRIBUTION OF ADVERTISING FLYERS FOR OTHERS; ADVERTISING AND PROMOTIONAL SERVICES; ADVERTISING AND MARKETING SERVICES, NAMELY, PROMOTING THE GOODS AND SERVICES OF OTHERS; DEVELOPING PROMOTIONAL CAMPAIGNS FOR BUSINESSES; PREPARING PROMOTIONAL AND MERCHANDISING MATERIAL FOR OTHERS; PROMOTIONAL SERVICES, NAMELY, GUERRILLA MARKETING SERVICES; PROVIDING A WEBSITE FEATURING INFORMATION ON SHOPPING LOCAL AND SUPPORTING LOCAL BUSINESSES; ADMINISTRATION OF A PROGRAM TO PROMOTE THE SUPPORT OF LOCAL BUSINESSES; PROMOTING PUBLIC AWARENESS OF THE IMPORTANCE AND IMPACT OF SUPPORTING LOCAL BUSINESSES; ON-LINE RETAIL STORE SERVICES FEATURING A WIDE VARIETY OF CONSUMER GOODS (U.S. CLS. 100, 101 AND 102).

SANI KHOURI, EXAMINING ATTORNEY

SN 85-239,376. BRANDBUDDEE.COM, DBA BRANDBUDDEE.COM, BELLEVUE, WA. FILED 2-10-2011.

 The logo for brandbuddee features the word "brandbuddee" in a lowercase, sans-serif font. The letters "brand" are blue, "bud" is green, and "dee" is orange. A small orange arc is positioned below the "d" in "bud".

THE COLOR(S) GREEN, BLUE, AND ORANGE IS/ARE CLAIMED AS A FEATURE OF THE MARK.

THE MARK CONSISTS OF ORANGE HALF CIRCLE

CLASS 35—(Continued).

CONSISTING OF THE SMILE FORMED BY THE "D" AND THE "B" CONNECTED IN THE MIDDLE OF THE WORD "BRANDBUDDEE". THE WORD "BRANDBUDDEE" IS A UNIQUE SPELLING TO IDENTIFY THE BRAND AND IS ALL LOWER CASE. THE GREEN AND BLUE COLORS DOMINATE THE COLOR SCHEME FOR THE LOGO AND ARE REPRESENTED AS SUCH ACROSS THE SITE. "BRAND" IS RECOGNIZED BY A BLUE COLOR FORMAT AND "BUDDEE" IS RECOGNIZED BY A GREEN COLOR FORMAT.

FOR ADVERTISING AND MARKETING SERVICES; ADVERTISING AND MARKETING SERVICES PROVIDED BY MEANS OF INDIRECT METHODS OF MARKETING COMMUNICATIONS, NAMELY, SOCIAL MEDIA; ONLINE ADVERTISEMENTS; DIGITAL MARKETING SERVICES, NAMELY, PROMOTING THE GOODS AND SERVICES OF OTHERS (U.S. CLS. 100, 101 AND 102).

ANGELA DUONG, EXAMINING ATTORNEY

CLASS 35—(Continued).

SN 85-240,485. OPENONWARD, LLC, BALTIMORE, MD. FILED 2-11-2011.

WIKIFORMULATION

SN 85-239,801. HAAG, GLENDA JEAN, DBA DOODLEBUG KIDS, FT WORTH, TX. FILED 2-11-2011.



NO CLAIM IS MADE TO THE EXCLUSIVE RIGHT TO USE "KIDS", APART FROM THE MARK AS SHOWN.

THE COLOR(S) GREEN, BLUE, RED, YELLOW, BLACK, WHITE IS/ARE CLAIMED AS A FEATURE OF THE MARK.

THE MARK CONSISTS OF IN "DOODLEBUG KIDS" THE LETTERS AND COLORS ARE AS FOLLOWS THE "D" IS GREEN UPPER CASE, THE "O" S ARE LADY BUGS RED WITH BLACK DOTS BLACK HEAD AND ANTENNAS, THE "DLE" IS LOWER CASE GREEN, THE BUG IS LOWER CASE BLUE, THE LETTERS IN "KIDS" ARE RED AND THE "K" IS UPPER CASE THE "IDS" ARE LOWER CASE. THE DOT ABOVE THE "I" IS A BEE WITH YELLOW BODY BLACK STRIPES WHITE WINGS.

FOR RETAIL CHILDRENS CLOTHING STORE (U.S. CLS. 100, 101 AND 102).

FIRST USE 11-17-2010; IN COMMERCE 11-17-2010.

ELIZABETH KAJUBI, EXAMINING ATTORNEY

THE MARK CONSISTS OF STANDARD CHARACTERS WITHOUT CLAIM TO ANY PARTICULAR FONT, STYLE, SIZE, OR COLOR.

FOR ADVERTISING AND ADVERTISEMENT SERVICES; ADVERTISING AND COMMERCIAL INFORMATION SERVICES, VIA THE INTERNET; ADVERTISING AND DIRECTORY SERVICES, NAMELY, PROMOTING THE SERVICES OF OTHERS BY PROVIDING A WEB PAGE FEATURING LINKS TO THE WEBSITES OF OTHERS; ADVERTISING BY TRANSMISSION OF ON-LINE PUBLICITY FOR THIRD PARTIES THROUGH ELECTRONIC COMMUNICATIONS NETWORKS; ADVERTISING SERVICES, NAMELY, PROMOTING AND MARKETING THE GOODS AND SERVICES OF OTHERS IN THE FIELD OF SCIENCE VIA PRINT AND ELECTRONIC MEDIA; ADVERTISING VIA ELECTRONIC MEDIA AND SPECIFICALLY THE INTERNET; DISSEMINATION OF ADVERTISING FOR OTHERS VIA THE INTERNET; MARKETING, ADVERTISING AND PROMOTING THE GOODS AND SERVICES OF OTHERS IN THE FIELD OF SCIENCE, NAMELY, PROVIDING INFORMATION VIA MAIL AND ELECTRONIC MAIL; MARKETING, ADVERTISING, AND PROMOTING THE RETAIL GOODS AND SERVICES OF OTHERS TO WIRELESS ELECTRONIC DEVICES; ON-LINE ADVERTISING SERVICES FOR OTHERS; PROMOTING THE GOODS AND SERVICES OF OTHERS BY DISTRIBUTING ADVERTISING MATERIALS THROUGH A VARIETY OF METHODS; PROMOTING THE GOODS AND SERVICES OF OTHERS BY MEANS OF DISTRIBUTING ADVERTISING ON THE INTERNET; PROMOTING, ADVERTISING AND MARKETING OF THE ON-LINE WEB SITES OF OTHERS; PROVIDING A SEARCHABLE ON-LINE ADVERTISING WEBSITE AND GUIDE FEATURING THE GOODS AND SERVICES OF OTHER VENDORS VIA THE INTERNET; PROVIDING A WEB SITE AT WHICH SCIENTISTS AND THOSE INTERESTED IN SCIENCE CAN POST PROMOTIONAL PROFILES AND RESPOND TO ADVERTISEMENTS FOR THEIR SERVICES; PROVIDING A WEB SITE THAT ENABLES USERS TO POST ITEMS FOR SALE THROUGH ON-LINE CLASSIFIED ADVERTISEMENT; PROVIDING CONSUMER INFORMATION SERVICES AND MAKING REFERRALS IN THE FIELD OF SCIENCE (U.S. CLS. 100, 101 AND 102).

KELLY CHOE, EXAMINING ATTORNEY

CLASS 35—(Continued).

SN 85-240,563. BENCHMARK SOLUTIONS HOLDINGS INC., NEW YORK, NY. FILED 2-11-2011.



NO CLAIM IS MADE TO THE EXCLUSIVE RIGHT TO USE "CAPITAL MARKETS", APART FROM THE MARK AS SHOWN.

THE COLOR(S) PURPLE IS/ARE CLAIMED AS A FEATURE OF THE MARK.

THE MARK CONSISTS OF A PURPLE GLOBE DESIGN COMPOSED OF "X" AND LINE SHAPES. THE WORDS "ENLIGHTENING THE CAPITAL MARKETS" ARE PURPLE BELOW THE WORD "BENCHMARK". THE COLORS BLACK AND WHITE REPRESENT BACKGROUND, OUTLINING AND SHADING AND ARE NOT PART OF THE MARK.

FOR FINANCIAL SERVICES, NAMELY, ANALYZING MARKET DATA AND PRICING ANALYTICS SERVICES FOR MEASURING THE PERFORMANCE OF FINANCIAL MARKETS FOR ASSET CLASSES WITHIN THE CAPITAL MARKETS, INCLUDING FIXED INCOME PRODUCTS (U.S. CLS. 100, 101 AND 102).

ARETHA SOMERVILLE, EXAMINING ATTORNEY

SN 85-240,740. BROADSPRING, INC., IRVINE, CA. FILED 2-11-2011.

ADVERTORIAL DONE RIGHT

THE MARK CONSISTS OF STANDARD CHARACTERS WITHOUT CLAIM TO ANY PARTICULAR FONT, STYLE, SIZE, OR COLOR.

NO CLAIM IS MADE TO THE EXCLUSIVE RIGHT TO USE "ADVERTORIAL", APART FROM THE MARK AS SHOWN.

FOR ADVERTISING SERVICES; INTERNET ADVERTISING SERVICES (U.S. CLS. 100, 101 AND 102).

SAIMA MAKHDOOM, EXAMINING ATTORNEY

SN 85-241,111. BARRETT, ANDREW L., NEW CITY, NY. FILED 2-13-2011.

**The better you know us
The better you'll feel**

THE MARK CONSISTS OF STANDARD CHARACTERS WITHOUT CLAIM TO ANY PARTICULAR FONT, STYLE, SIZE, OR COLOR.

FOR INSTITUTIONAL RETAIL PHARMACY SERVICES; MAIL ORDER PHARMACY SERVICES; PHARMACEUTICAL SERVICES, NAMELY, PROCESSING ONLINE AND TELEPHONE PRESCRIPTION ORDERS IN RETAIL AND CENTRAL FILL PHARMACIES; RETAIL PHARMACY SERVICES (U.S. CLS. 100, 101 AND 102).

FIRST USE 2-11-2011; IN COMMERCE 2-11-2011.
RICHARD WHITE, EXAMINING ATTORNEY

CLASS 35—(Continued).

SN 85-241,340. LOS ANGELES PORT POLICE ASSOCIATION, INC., SAN PEDRO, CA. FILED 2-14-2011.



NO CLAIM IS MADE TO THE EXCLUSIVE RIGHT TO USE "PORT POLICE ASSOCIATION" AND "ILWU 65", APART FROM THE MARK AS SHOWN.

THE MARK CONSISTS OF A SHIELD WITH A CIRCULAR LIFE RING IN THE CENTER CONTAINING A BOAT AND WAVES. THERE IS A RIBBON AT THE TOP AND AT THE BOTTOM. THE STYLIZED TEXT "ILWU 65 LOS ANGELES PORT POLICE ASSOCIATION LAPPA" APPEARS ON THE RIBBON.

SEC. 2(F) AS TO "LOS ANGELES PORT POLICE ASSOCIATION".

FOR ASSOCIATION SERVICES, NAMELY, PROMOTING THE INTERESTS OF POLICE OFFICERS (U.S. CLS. 100, 101 AND 102).

FIRST USE 0-0-1992; IN COMMERCE 0-0-1992.
JOHN E. MICHOS, EXAMINING ATTORNEY

SN 85-241,597. CLASSY KIDS CONSIGNMENT LLC, NOKESVILLE, VA. FILED 2-14-2011.



NO CLAIM IS MADE TO THE EXCLUSIVE RIGHT TO USE "CONSIGNMENT", APART FROM THE MARK AS SHOWN.

THE COLOR(S) WHITE, TAN AND BROWN IS/ARE CLAIMED AS A FEATURE OF THE MARK.

THE MARK CONSISTS OF A BROWN, TAN, AND WHITE STYLIZED ROCKING HORSE ABOVE A TAN BACKGROUND CARRIER WHICH IS OUTLINED IN WHITE AND BROWN AND CARRYING THE TERM "CLASSY KIDS" IN BROWN AND UNDERLINED IN BROWN ABOVE THE TERM "CONSIGNMENT" IN BROWN. THE BACKGROUND OF THE ENTIRE MARK IS WHITE.

SEC. 2(F) AS TO "KIDS CONSIGNMENT".

FOR ON-LINE RETAIL CONSIGNMENT STORES FEATURING CHILDREN'S APPAREL; RETAIL CONSIGNMENT STORES FEATURING CHILDREN'S APPAREL (U.S. CLS. 100, 101 AND 102).

FIRST USE 3-0-2005; IN COMMERCE 3-0-2005.
JIM RINGLE, EXAMINING ATTORNEY

CLASS 35—(Continued).

SN 85-241,926. ULINE, INC., PLEASANT PRAIRIE, WI. FILED 2-14-2011.

ULINE.COM

THE MARK CONSISTS OF STANDARD CHARACTERS WITHOUT CLAIM TO ANY PARTICULAR FONT, STYLE, SIZE, OR COLOR.

OWNER OF U.S. REG. NOS. 2,165,496, 3,316,683 AND 3,316,687.

FOR ONLINE WHOLESALE AND RETAIL STORE SERVICES FEATURING PACKAGING AND SHIPPING SUPPLIES, FACILITY MAINTENANCE SUPPLIES, JANITORIAL SUPPLIES, INDUSTRIAL SUPPLIES, MATERIAL HANDLING SUPPLIES, SAFETY SUPPLIES AND WAREHOUSING SUPPLIES (U.S. CLS. 100, 101 AND 102).

FIRST USE 12-28-1996; IN COMMERCE 12-28-1996.
PRISCILLA MILTON, EXAMINING ATTORNEY

CLASS 35—(Continued).

SN 85-243,584. JOY OF A CHILD, FOX RIVER GROVE, IL. FILED 2-16-2011.

Joy of a Child

THE MARK CONSISTS OF STANDARD CHARACTERS WITHOUT CLAIM TO ANY PARTICULAR FONT, STYLE, SIZE, OR COLOR.

NO CLAIM IS MADE TO THE EXCLUSIVE RIGHT TO USE "CHILD", APART FROM THE MARK AS SHOWN.

FOR CHRISTIAN-BASED CHARITABLE SERVICES, NAMELY, ORGANIZING AND DEVELOPING PROJECTS THAT AIM TO IMPROVE THE LIVES OF UNDERPRIVILEGED AND IMPOVERISHED CHILDREN AND YOUTH (U.S. CLS. 100, 101 AND 102).

FIRST USE 4-16-2010; IN COMMERCE 4-16-2010.
CHRISIE B. KING, EXAMINING ATTORNEY

SN 85-241,964. MY SOCIAL PRACTICE, SALT LAKE CITY, UT. FILED 2-14-2011.

MY SOCIAL PRACTICE

THE MARK CONSISTS OF STANDARD CHARACTERS WITHOUT CLAIM TO ANY PARTICULAR FONT, STYLE, SIZE, OR COLOR.

NO CLAIM IS MADE TO THE EXCLUSIVE RIGHT TO USE "SOCIAL", APART FROM THE MARK AS SHOWN.

FOR PROVIDING SOCIAL MEDIA MARKETING SERVICE TO CREATE AND DISTRIBUTE MARKETING MATERIAL, ADVERTISEMENTS, AND PROMOTIONS FOR DISPLAY AND USE ON INTERNET, NAMELY, IN WEBSITES, SOCIAL CONVERSATIONS OVER THE INTERNET, E-MAILS, MICROBLOGS, BLOGS, ELECTRONIC MESSAGES, INSTANT MESSAGES, TEXT MESSAGES, MULTIMEDIA MESSAGES, SOCIAL NETWORKS, FORUMS, AND ELECTRONIC BULLETIN BOARDS (U.S. CLS. 100, 101 AND 102).

FIRST USE 2-4-2011; IN COMMERCE 2-4-2011.
ANGELA DUONG, EXAMINING ATTORNEY

SN 85-243,749. TRIPPO, INC., FORT WRIGHT, KY. FILED 2-16-2011.

TRIPPO

THE MARK CONSISTS OF STANDARD CHARACTERS WITHOUT CLAIM TO ANY PARTICULAR FONT, STYLE, SIZE, OR COLOR.

THE WORDING "TRIPPO" HAS NO MEANING IN A FOREIGN LANGUAGE.

FOR PROMOTING THE GOODS AND SERVICES OF OTHERS BY PROVIDING A WEBSITE FEATURING CONSUMER INFORMATION ABOUT DISCOUNTED PACKAGE DEALS IN THE FIELDS OF TRAVEL, LODGING, DINING AND ENTERTAINMENT, COUPONS, REBATES, PRICE-COMPARISON INFORMATION, PRODUCT AND SERVICE REVIEWS, LINKS TO THE RETAIL WEB SITES OF OTHERS, AND DISCOUNT INFORMATION (U.S. CLS. 100, 101 AND 102).

ELISSA GARBER KON, EXAMINING ATTORNEY

CLASS 35—(Continued).

SN 85-243,796. TEXAS AND SOUTHWESTERN CATTLE RAISERS ASSOCIATION, INC., FORT WORTH, TX. FILED 2-16-2011.

TEXAS AND SOUTHWESTERN
CATTLE RAISERS ASSOCIATION

THE MARK CONSISTS OF STANDARD CHARACTERS WITHOUT CLAIM TO ANY PARTICULAR FONT, STYLE, SIZE, OR COLOR.

OWNER OF U.S. REG. NO. 1,866,089.

NO CLAIM IS MADE TO THE EXCLUSIVE RIGHT TO USE "CATTLE RAISERS ASSOCIATION", APART FROM THE MARK AS SHOWN.

SEC. 2(F).

FOR ASSOCIATION SERVICES, NAMELY, PROMOTING THE INTERESTS OF CATTLE RAISERS (U.S. CLS. 100, 101 AND 102).

FIRST USE 3-0-1940; IN COMMERCE 3-0-1940.

JORDAN BAKER, EXAMINING ATTORNEY

SN 85-243,919. FOUR CORNERS INTERNATIONAL VENTURES, LLC, YARMOUTHPORT, MA. FILED 2-16-2011.

JUST PICKED

THE MARK CONSISTS OF STANDARD CHARACTERS WITHOUT CLAIM TO ANY PARTICULAR FONT, STYLE, SIZE, OR COLOR.

FOR RETAIL STORE SERVICES FEATURING A WIDE VARIETY OF CONSUMER GOODS, INCLUDING BUT NOT LIMITED TO, CANDLES, PAPER SHOPPING BAGS, PAPER STATIONERY, ENVELOPES, GIFT WRAPPING PAPER, WOVEN BASKETS, ROCKING CHAIRS, ARTIFICIAL FLOWERS, CHRISTMAS TREE ORNAMENTS AND DECORATIONS, CHRISTMAS TREE LIGHTS, ROCKING HORSES, STUFFED ANIMALS, TOYS, BRASSWARE, FLATWARE, CUTLERY, HARDWARE, GARDEN TOOLS, ELECTRIC LAMPS, OIL LAMPS, PAPER BOWS, PAPER GOODS, BOOKS, SCHOOL SUPPLIES, PHOTOGRAPH ALBUMS, NON-METALLIC BASKETS, PICTURE FRAMES, WALL MIRRORS, WALL PLAQUES, COOKWARE, CANDLESTICKS OF NON-PRECIOUS METAL, DINNERWARE, CRYSTAL, EARTHENWARE AND GLASS MUGS, WASTEPAPER BASKETS, PORCELAIN FIGURINES, CUTTING BOARDS, PAPER PLATES, SPRINKLERS, HOSE NOZZLES, TEXTILE WALL HANGINGS, KITCHEN, BATHROOM AND BEACH TOWELS, TEXTILE TABLE LINEN, CANDY, COOKIES, CRACKERS, COFFEE, TEA, SPICES, STATIONERY PRODUCTS, BATH SOAPS, BATH SALTS, SHOWER GELS, BATH GELS, SHAMPOOS, CONDITIONERS, BODY OILS, BODY LOTIONS, LAMP OILS, METAL BASKETS, FIREPLACE SCREENS, AIR CONDITIONERS, WARMING TRAYS, ELECTRIC BLANKETS, ELECTRIC COOKING UTENSILS, GIFT BAGS, GIFT WRAPS, PHOTO ALBUMS, PAPER TOWELS, BEACH UMBRELLAS, METAL FURNITURE, WOOD FURNITURE, METAL/GLASS FURNITURE, INDOOR FURNITURE, OUTDOOR FURNITURE, PICTURE FRAMES, BEDDING, KITCHEN UTENSILS, GLASSWARE, DISHWARE, WICKER BASKETS, WOOD BASKETS, CLOTH BASKETS, STRAW BASKETS, BATH ACCESSORIES, ROPES, STRING, TENTS, BED SHEETS, BED COVERS, BLANKETS, T-SHIRTS, SANDALS, SNEAKERS, RIBBONS, RUGS, MATS AND MATCHES (U.S. CLS. 100, 101 AND 102).

JOHN GARTNER, EXAMINING ATTORNEY

CLASS 35—(Continued).

SN 85-244,193. TODD BAKER, DBA DIRTY CATZ CLUB, CHICAGO, IL. FILED 2-16-2011.



NO CLAIM IS MADE TO THE EXCLUSIVE RIGHT TO USE "CLUB", APART FROM THE MARK AS SHOWN.

THE MARK CONSISTS OF A PICTURE OF A MAN IN A CIRCLE OUTLINE WITH A TOP HAT ON WITH A CIGARETTE IN HIS MOUTH WITH A SINGLE SMOKE FLAME SHOOTING UPWARD FROM THE CIGARETTE WITH THE LETTERS "DIRTY CATZ CLUB" UNDERNEATH THE PICTURE OF THE MAN IN THE CIRCLE.

FOR ON-LINE RETAIL STORE SERVICES FEATURING ADULT-THEMED MERCHANDISE (U.S. CLS. 100, 101 AND 102).

HOWARD SMIGA, EXAMINING ATTORNEY

SN 85-244,205. RANI FOODS LP, HOUSTON, TX. FILED 2-16-2011.

RANI'S WORLD FOODS

THE MARK CONSISTS OF STANDARD CHARACTERS WITHOUT CLAIM TO ANY PARTICULAR FONT, STYLE, SIZE, OR COLOR.

NO CLAIM IS MADE TO THE EXCLUSIVE RIGHT TO USE "WORLD FOODS", APART FROM THE MARK AS SHOWN.

THE ENGLISH TRANSLATION OF "RANI" IN THE MARK IS "QUEEN".

FOR RETAIL GROCERY STORE SERVICES AND ON-LINE RETAIL GROCERY STORE SERVICES (U.S. CLS. 100, 101 AND 102).

FIRST USE 6-5-2009; IN COMMERCE 6-5-2009.

WILLIAM P. SHANAHAN, EXAMINING ATTORNEY

CLASS 35—(Continued).

SN 85-244,271. KMC SOFTWARE, INC., FT. LAUDERDALE, FL. FILED 2-16-2011.

MICRO-REFERENCE

THE MARK CONSISTS OF STANDARD CHARACTERS WITHOUT CLAIM TO ANY PARTICULAR FONT, STYLE, SIZE, OR COLOR.

FOR EMPLOYMENT AGENCY SERVICES; EMPLOYMENT COUNSELING, HIRING, RECRUITING, PLACEMENT, STAFFING AND CAREER NETWORKING SERVICES; EMPLOYMENT SERVICES, NAMELY, PROVIDING A WEB SITE WITH ONLINE VIDEO, AUDIO AND TEXTUAL INTERVIEWING APPLICATIONS TO SUPPORT RECRUITING, ADMISSIONS, AND GENERAL CANDIDATE SCREENING PROCESSES; PROVIDING A WEB SITE WHERE USERS CAN POST RATINGS, REVIEWS AND RECOMMENDATIONS ON EMPLOYERS AND EMPLOYEES AND PLACES OF EMPLOYMENT FOR USE BY EMPLOYEES, EMPLOYERS, BUSINESS OWNERS, AND CONSUMERS; PROVIDING AN ON-LINE SEARCHABLE DATABASE FEATURING EMPLOYMENT OPPORTUNITIES AND CONTENT ABOUT EMPLOYMENT; PROVIDING NETWORKING OPPORTUNITIES FOR INDIVIDUALS SEEKING EMPLOYMENT; PROVIDING ON-LINE EMPLOYMENT PLACEMENT SERVICES, NAMELY, MATCHING RESUMES AND POTENTIAL EMPLOYERS VIA A GLOBAL COMPUTER NETWORK; PROVIDING ON-LINE INTERACTIVE EMPLOYMENT COUNSELING AND RECRUITMENT SERVICES; VENDOR-ON-PREMISE SERVICES, NAMELY, THE ADMINISTRATION OF THE EMPLOYMENT PROCESS ON-SITE, INCLUDING RESUME REVIEW AND CHECKING, EMPLOYMENT APPLICATION ACQUISITION, ADVERTISING FOR RECRUITMENT, CONDUCT OF INTERVIEWS, AND REFERENCE CHECKING (U.S. CLS. 100, 101 AND 102).

KEVIN CORWIN, EXAMINING ATTORNEY

CLASS 35—(Continued).

SN 85-244,272. KMC SOFTWARE, INC., FT. LAUDERDALE, FL. FILED 2-16-2011.

UNRABBLE

THE MARK CONSISTS OF STANDARD CHARACTERS WITHOUT CLAIM TO ANY PARTICULAR FONT, STYLE, SIZE, OR COLOR.

FOR EMPLOYMENT AGENCY SERVICES; EMPLOYMENT COUNSELING, HIRING, RECRUITING, PLACEMENT, STAFFING AND CAREER NETWORKING SERVICES; EMPLOYMENT SERVICES, NAMELY, PROVIDING A WEB SITE WITH ONLINE VIDEO, AUDIO AND TEXTUAL INTERVIEWING APPLICATIONS TO SUPPORT RECRUITING, ADMISSIONS, AND GENERAL CANDIDATE SCREENING PROCESSES; PROVIDING A WEB SITE WHERE USERS CAN POST RATINGS, REVIEWS AND RECOMMENDATIONS ON EMPLOYERS AND EMPLOYEES AND PLACES OF EMPLOYMENT FOR USE BY EMPLOYEES, EMPLOYERS, BUSINESS OWNERS, AND CONSUMERS; PROVIDING AN ON-LINE SEARCHABLE DATABASE FEATURING EMPLOYMENT OPPORTUNITIES AND CONTENT ABOUT EMPLOYMENT; PROVIDING NETWORKING OPPORTUNITIES FOR INDIVIDUALS SEEKING EMPLOYMENT; PROVIDING ON-LINE EMPLOYMENT PLACEMENT SERVICES, NAMELY, MATCHING RESUMES AND POTENTIAL EMPLOYERS VIA A GLOBAL COMPUTER NETWORK; PROVIDING ON-LINE INTERACTIVE EMPLOYMENT COUNSELING AND RECRUITMENT SERVICES; VENDOR-ON-PREMISE SERVICES, NAMELY, THE ADMINISTRATION OF THE EMPLOYMENT PROCESS ON-SITE, INCLUDING RESUME REVIEW AND CHECKING, EMPLOYMENT APPLICATION ACQUISITION, ADVERTISING FOR RECRUITMENT, CONDUCT OF INTERVIEWS, AND REFERENCE CHECKING (U.S. CLS. 100, 101 AND 102).

KEVIN CORWIN, EXAMINING ATTORNEY

SN 85-244,792. TRAIAD LC, ATLANTA, GA. FILED 2-17-2011.



NO CLAIM IS MADE TO THE EXCLUSIVE RIGHT TO USE "TRADE AD", APART FROM THE MARK AS SHOWN.

THE COLOR(S) GREEN AND BLACK IS/ARE CLAIMED AS A FEATURE OF THE MARK.

THE MARK CONSISTS OF THE STYLIZED WORDING "TRAIAD" WITH "TRAI" APPEARING IN BLACK AND "AD" APPEARING IN GREEN, AND WITH A GREEN LEFT-POINTING ARROW APPEARING ABOVE THE LETTER "T" IN "TRAI" AND A BLACK RIGHT-POINTING ARROW APPEARING BELOW THE LETTER "D" IN "AD".

FOR ON-LINE AUCTION SERVICES (U.S. CLS. 100, 101 AND 102).

FIRST USE 2-15-2010; IN COMMERCE 2-15-2010.

AMY KERTGATE, EXAMINING ATTORNEY

CLASS 35—(Continued).

SN 85-245,144. CAROL E. RIDOLPHI, DBA CER IMAGE CONSULTING LLC, SUMMIT, NJ. FILED 2-17-2011.

Steps to Style

THE MARK CONSISTS OF STANDARD CHARACTERS WITHOUT CLAIM TO ANY PARTICULAR FONT, STYLE, SIZE, OR COLOR.

NO CLAIM IS MADE TO THE EXCLUSIVE RIGHT TO USE "STYLE", APART FROM THE MARK AS SHOWN.

FOR CORPORATE IMAGE CONSULTING SERVICES (U.S. CLS. 100, 101 AND 102).

STEVEN R. FINE, EXAMINING ATTORNEY

SN 85-245,156. MEALMOBS, INC., GREENPOINT, NY. FILED 2-17-2011.



NO CLAIM IS MADE TO THE EXCLUSIVE RIGHT TO USE "MEAL", APART FROM THE MARK AS SHOWN.

THE COLOR(S) WHITE, RED, YELLOW AND ORANGE IS/ARE CLAIMED AS A FEATURE OF THE MARK.

THE MARK CONSISTS OF THE WORDS "MEAL" AND "MOBS" IN WHITE ON EITHER SIDE OF A PERSON IN YELLOW HOLDING A FORK AND KNIFE. BEHIND THE WORDS "MEAL MOBS" ARE MOBS OF PEOPLE IN ORANGE, HOLDING FORKS. THE ENTIRE MARK APPEARS ON A RED BACKGROUND.

FOR ADVERTISING SERVICES, NAMELY, PROMOTING AND MARKETING THE GOODS AND SERVICES OF OTHERS IN THE FIELD OF UPSCALE CHOICES SUCH AS CULTURAL EVENTS, RESTAURANTS, SHOPPING, AND TRAVEL VIA PRINT AND ELECTRONIC MEDIA (U.S. CLS. 100, 101 AND 102).

FIRST USE 2-1-2011; IN COMMERCE 2-1-2011.

JAMES GRIFFIN, EXAMINING ATTORNEY

CLASS 35—(Continued).

SN 85-245,490. GSENSE INC., BRIARCLIFF MANOR, NY. FILED 2-17-2011.

Diet Exchange

THE MARK CONSISTS OF STANDARD CHARACTERS WITHOUT CLAIM TO ANY PARTICULAR FONT, STYLE, SIZE, OR COLOR.

NO CLAIM IS MADE TO THE EXCLUSIVE RIGHT TO USE "DIET", APART FROM THE MARK AS SHOWN.

FOR AD SERVING, NAMELY, PLACING ADVERTISEMENTS ON WEBSITES FOR OTHERS USING SPECIALIZED COMPUTER SOFTWARE; ADVERTISEMENT AND PUBLICITY SERVICES BY TELEVISION, RADIO, MAIL; ADVERTISEMENT FOR OTHERS ON THE INTERNET; ADVERTISEMENT HOARDING RENTAL; ADVERTISEMENT VIA MOBILE PHONE NETWORKS; ADVERTISING AGENCIES; ADVERTISING AGENCIES PROVIDING THE STRATEGY, DESIGN AND EXECUTION OF PROGRAMS TO PROMOTE BUSINESSES IN THE FOOD AND FOODSERVICE INDUSTRIES; ADVERTISING AGENCIES, NAMELY, PROMOTING THE GOODS AND SERVICES OF OTHERS; ADVERTISING AGENCIES, NAMELY, PROMOTING HEALTH PRODUCTS THROUGH THE DISTRIBUTION OF PRINTED AND AUDIO PROMOTIONAL MATERIALS AND BY RENDERING SALES PROMOTION ADVICE; ADVERTISING AGENCY SPECIALIZING IN THE DESIGN AND EXECUTION OF WORD OF MOUTH, VIRAL, BUZZ AND EXPERIENTIAL MARKETING PROGRAMS; ADVERTISING AND ADVERTISEMENT SERVICES; ADVERTISING AND BUSINESS ADVICE RELATING TO TELEMATICS SERVICES; ADVERTISING AND BUSINESS MANAGEMENT CONSULTANCY; ADVERTISING AND BUSINESS SERVICES, NAMELY, PROVIDING AN ONLINE WEBSITE WHERE ADVERTISERS, MARKETERS, AND CONTENT PROVIDERS CAN INTERACT WITH USERS FOR ADVERTISING, BRANDING, AND PROMOTING KNOWLEDGE, PRODUCTS, AND SERVICES, AND TRADESHOWS, ON BEHALF OF THEMSELVES AND OTHERS, AND FOR EVALUATING AND RATING THE SAME, ALL THE FOREGOING RELEVANT TO HUMAN ACTIVITIES AFFECTING CLIMATE CHANGE AND RELATED FIELDS; ADVERTISING AND BUSINESS SERVICES, NAMELY, SECURING AIRTIME ON ALL FORMS OF MEDIA COMMUNICATIONS STATIONS, SYSTEMS, NETWORKS, AND SERVICES FOR THE PURPOSE OF PROMOTING THE GOODS AND SERVICES OF OTHERS; ADVERTISING AND COMMERCIAL INFORMATION SERVICES, VIA THE INTERNET; ADVERTISING AND DIRECTORY SERVICES, NAMELY, PROMOTING THE SERVICES OF OTHERS BY PROVIDING A WEB PAGE FEATURING LINKS TO THE WEBSITES OF OTHERS; ADVERTISING AND MARKETING; ADVERTISING AND MARKETING CONSULTANCY; ADVERTISING AND MARKETING SERVICES PROVIDED BY MEANS OF INDIRECT METHODS OF MARKETING COMMUNICATIONS, NAMELY, SOCIAL MEDIA, SEARCH ENGINE MARKETING, INQUIRY MARKETING, INTERNET MARKETING, MOBILE MARKETING, BLOGGING AND OTHER FORMS OF PASSIVE, SHARABLE OR VIRAL COMMUNICATIONS CHANNELS; ADVERTISING AND MARKETING SERVICES, NAMELY, PROMOTING THE GOODS AND SERVICES OF OTHERS; ADVERTISING AND PROMOTING THE GOODS AND SERVICES OF A VISUAL ARTIST; ADVERTISING AND PROMOTION SERVICES AND RELATED CONSULTING; ADVERTISING AND PROMOTIONAL SERVICES; ADVERTISING AND PUBLICITY SERVICES; ADVERTISING AND PUBLICITY SERVICES, NAMELY, PROMOTING THE GOODS, SERVICES, BRAND IDENTITY AND COMMERCIAL INFORMATION AND NEWS OF THIRD PARTIES THROUGH PRINT, AUDIO, VIDEO, DIGITAL AND ONLINE MEDIUM; ADVERTISING BUSINESS ESPECIALLY IN THE FIELD OF TELEMATIC AND TELEPHONE NETWORKS; ADVERTISING BY TRANSMISSION OF ON-LINE PUBLICITY FOR THIRD PARTIES THROUGH ELECTRONIC COMMUNICA-

CLASS 35—(Continued).

TIONS NETWORKS; ADVERTISING CONSULTATION; ADVERTISING COPYWRITING; ADVERTISING FLYER DISTRIBUTION; ADVERTISING IN PERIODICALS, BROCHURES AND NEWSPAPERS; ADVERTISING IN THE POPULAR AND PROFESSIONAL PRESS; ADVERTISING OF COMMERCIAL OR RESIDENTIAL REAL ESTATE; ADVERTISING OF THE PUBLISHED TEXTS OF OTHERS; ADVERTISING ON THE INTERNET FOR OTHERS; ADVERTISING PARTICULARLY SERVICES FOR THE PROMOTION OF GOODS; ADVERTISING RELATING TO PHARMACEUTICAL PRODUCTS AND IN-VIVO IMAGING PRODUCTS; ADVERTISING RELATING TO TRANSPORT AND DELIVERY; ADVERTISING SERVICES; ADVERTISING SERVICES FOR PROMOTING THE BROKERAGE OF STOCKS AND OTHER SECURITIES; ADVERTISING SERVICES OF A RADIO AND TELEVISION ADVERTISING AGENCY; ADVERTISING SERVICES RELATING TO SANDWICHES; ADVERTISING SERVICES, FOR THIRD PARTIES, IN CONNECTION WITH THE COMMERCIALIZATION AND SALE OF PERFUMERY AND COSMETIC ARTICLES, PRODUCTS FOR HOUSEHOLD PURPOSES, OPTICAL PRODUCTS, CLOCKS AND TIMEPIECES, JEWELLERY, FURNISHING ARTICLES; ADVERTISING SERVICES, NAMELY, COST-PER-ACTION ON-LINE ADVERTISING; ADVERTISING SERVICES, NAMELY, CREATING CORPORATE AND BRAND IDENTITY FOR OTHERS; ADVERTISING SERVICES, NAMELY, CREATING CORPORATE LOGOS FOR OTHERS; ADVERTISING SERVICES, NAMELY, CREATING PROMOTIONAL MURALS AND PAINTING SIGNS AND WALLS ADVERTISING THE GOODS AND SERVICES OF OTHERS; ADVERTISING SERVICES, NAMELY, PRODUCTION OF SPECIAL EFFECTS INCLUDING MODEL-MAKING SERVICES, COMPUTER-GENERATED IMAGERY AND COMPUTER-GENERATED GRAPHICS FOR THE PRODUCTION OF COMMERCIALS; ADVERTISING SERVICES, NAMELY, PROMOTING AND MARKETING THE GOODS AND SERVICES OF OTHERS IN THE FIELD OF UPSCALE CHOICES SUCH AS CULTURAL EVENTS, RESTAURANTS, SHOPPING, AND TRAVEL VIA PRINT AND ELECTRONIC MEDIA; ADVERTISING SERVICES, NAMELY, PROMOTING AND MARKETING THE GOODS AND SERVICES OF OTHERS THROUGH ALL PUBLIC COMMUNICATION MEANS; ADVERTISING SERVICES, NAMELY, PROMOTING CAR DEALERSHIPS OF OTHERS; ADVERTISING SERVICES, NAMELY, PROMOTING PROPERTIES FOR SALE BY OWNER VIA THE INTERNET; ADVERTISING SERVICES, NAMELY, PROMOTING THE BOOKS OF OTHERS IN THE FIELD OF LAW BY MEANS OF NEWS AND REVIEWS REGARDING SAME; ADVERTISING SERVICES, NAMELY, PROMOTING THE BRANDS, GOODS AND SERVICES OF OTHERS; ADVERTISING SERVICES, NAMELY, PROMOTING THE FOOD AND WINE OF OTHERS; ADVERTISING SERVICES, NAMELY, PROMOTING THE GIFT CARDS OF OTHERS; ADVERTISING SERVICES, NAMELY, PROMOTING THE POWER SPORTS DEALERSHIPS OF OTHERS; ADVERTISING SERVICES, NAMELY, PROMOTING THE SANDWICHES OF OTHERS; ADVERTISING SERVICES, NAMELY, PROVIDING A WEBSITE FOR THE PROMOTION OF THE BOOKS OF OTHERS IN THE FIELD OF LAW, INCLUDING NEWS AND REVIEWS REGARDING SAME; ADVERTISING SERVICES, NAMELY, PROVIDING ADVERTISING SPACE IN A PERIODICAL; ADVERTISING SERVICES, NAMELY, PROVIDING INFORMATION AS TO THE AVAILABILITY OF INFORMATIONAL PRODUCTS FOR RENT OR PURCHASE; ADVERTISING SERVICES, PUBLIC RELATIONS AND MARKETING SERVICES, NAMELY, PROMOTING AND MARKETING THE GOODS AND SERVICES OF OTHERS THROUGH ALL PUBLIC COMMUNICATION MEANS; ADVERTISING TEXT PUBLICATION SERVICES; ADVERTISING THE SERVICES OF OTHERS VIA WEB PAGES OPTIMIZED FOR ONLINE SEARCH ENGINES; ADVERTISING THROUGH ALL PUBLIC COMMUNICATION MEANS; ADVERTISING VIA ELECTRONIC MEDIA AND SPECIFICALLY THE INTERNET; ADVERTISING, INCLUDING ON-LINE ADVERTISING ON A COMPUTER NETWORK; ADVERTISING, INCLUDING PROMOTION OF PRODUCTS AND SERVICES OF THIRD PARTIES THROUGH SPONSORING ARRANGEMENTS AND LICENSE AGREEMENTS RELATING TO INTERNATIONAL SPORTS EVENTS; ADVERTISING,

CLASS 35—(Continued).

INCLUDING PROMOTION RELATING TO THE SALE OF ARTICLES AND SERVICES FOR THIRD PARTIES BY THE TRANSMISSION OF ADVERTISING MATERIAL AND THE DISSEMINATION OF ADVERTISING MESSAGES ON COMPUTER NETWORKS; ADVERTISING, MARKETING AND PROMOTING THE GOODS AND SERVICES OF OTHERS USING KIOSKS; ADVERTISING, MARKETING AND PROMOTION SERVICES; ADVERTISING, MARKETING AND PROMOTION SERVICES, NAMELY, PROMOTING THE GOODS AND SERVICES OF OTHERS BY PROVIDING CUSTOMIZED EXHIBITS; ADVERTISING, MARKETING AND PROMOTIONAL SERVICES FOR AUTOMOTIVE DEALERSHIPS; ADVERTISING, MARKETING AND PROMOTIONAL SERVICES FOR LIGHT AND HEAVY EQUIPMENT DEALERSHIPS; ADVERTISING, MARKETING AND PROMOTIONAL SERVICES FOR THE DONATION OF HUMAN BLOOD THAT EXACTLY MATCHES THE BLOOD TYPE OF INDIVIDUALS NEEDING TRANSFUSIONS; ADVERTISING, MARKETING AND PROMOTIONAL SERVICES RELATED TO ALL INDUSTRIES FOR THE PURPOSE OF FACILITATING NETWORKING AND SOCIALIZING OPPORTUNITIES FOR BUSINESS PURPOSES; ADVERTISING, PROMOTION AND MARKETING SERVICES BASED ON CONSUMER CREDIT REPORTS AND SCORES OF OTHERS; ADVERTISING, PROMOTION AND MARKETING SERVICES IN THE NATURE OF E-MAIL BLAST CAMPAIGNS FOR OTHERS; AGENCIES FOR ADVERTISING TIME AND SPACE; ANALYSIS OF ADVERTISING RESPONSE; ARRANGING AND CONDUCTING OF FAIRS AND EXHIBITIONS FOR BUSINESS AND ADVERTISING PURPOSES; ARRANGING AND CONDUCTING SPECIAL EVENTS FOR COMMERCIAL, PROMOTIONAL OR ADVERTISING PURPOSES; BANNER ADVERTISING; BUSINESS MANAGEMENT AND CONSULTING SERVICES FOR THE HEALTH CARE INDUSTRY, NAMELY, CUSTOMER SERVICE, ACCOUNTING SERVICES, AND WEB-BASED ADVERTISING AND MARKETING SERVICES; BUSINESS SERVICES, NAMELY, TRACKING AND MONITORING OF CALLS FOR OTHERS IN RESPONSE TO ADVERTISING ADS; CINEMA ADVERTISING; CLASSIFIED ADVERTISING SERVICES; COMPILATION OF ADVERTISEMENTS FOR USE AS WEB PAGES ON THE INTERNET; COMPILATION, PRODUCTION AND DISSEMINATION OF ADVERTISING MATTER; CONDUCTING, ARRANGING AND ORGANIZING TRADE SHOWS AND TRADE FAIRS FOR COMMERCIAL AND ADVERTISING PURPOSES; CONSUMER LOYALTY SERVICES FOR COMMERCIAL, PROMOTIONAL, AND/OR ADVERTISING PURPOSES, NAMELY, ADMINISTRATION OF FREQUENT FLYER PROGRAM THAT ALLOWS MEMBERS TO REDEEM MILES FOR POINTS OR AWARDS OFFERED BY OTHER LOYALTY PROGRAMS; COOPERATIVE ADVERTISING AND MARKETING; COOPERATIVE ADVERTISING AND MARKETING SERVICES BY WAY OF SOLICITATION, CUSTOMER SERVICE AND PROVIDING MARKETING INFORMATION VIA WEB SITES ON A GLOBAL COMPUTER NETWORK; COOPERATIVE ADVERTISING AND MARKETING SERVICES, NAMELY, OFFERING DISCOUNTS TO CLIENTS THROUGH THE JOINT PARTICIPATION OF MEMBER BEAUTY SALONS.; CREATING AND UPDATING ADVERTISING MATERIAL; CREATION OF MARKETING TOOLS DESIGNED TO INCREASE A CLIENT COMPANY'S KNOWLEDGE OF CUSTOMER NEEDS, AND ITS COMPETITORS' PRODUCTS AND SERVICES, PRICING, ADVERTISING STRATEGY AND SALES STRATEGY; CUSTOMER LOYALTY SERVICES AND CUSTOMER CLUB SERVICES, FOR COMMERCIAL, PROMOTIONAL AND/OR ADVERTISING PURPOSES; DESIGN OF ADVERTISING BROCHURES FOR OTHERS; DESIGN OF ADVERTISING FLYERS FOR OTHERS; DESIGN OF ADVERTISING MATERIALS FOR OTHERS; DESIGN OF INTERNET ADVERTISING; DEVELOPING ADVERTISING CAMPAIGNS FOR OTHERS GEARED TOWARD ENVIRONMENTAL ISSUES; DEVELOPMENT, OPERATION AND ADMINISTRATION OF DIGITAL SIGNAGE SYSTEMS AND DIGITAL ADVERTISING SYSTEMS FOR OTHERS, NAMELY, PROVIDING ADVERTISING SPACE BY ELECTRONIC MEANS AND GLOBAL COMPUTER INFORMATION NETWORKS; DIRECT MAIL ADVERTISING SERVICES; DIRECT MARKETING ADVERTISING FOR OTHERS; DISPLAYING ADVERTISEMENTS FOR OTHERS; DISSEMINATION OF ADVERTISEMENTS; DISSEMINATION OF ADVERTISEMENTS

CLASS 35—(Continued).

AND OF ADVERTISING MATERIAL; DISSEMINATION OF ADVERTISING FOR OTHERS VIA AN ON-LINE COMMUNICATIONS NETWORK ON THE INTERNET; DISSEMINATION OF ADVERTISING FOR OTHERS VIA PUBLIC AND PRIVATE WIRELESS NETWORKS FOR DISPLAY ON MOBILE DEVICES; DISSEMINATION OF ADVERTISING FOR OTHERS VIA THE INTERNET; DISSEMINATION OF ADVERTISING MATERIAL; DISSEMINATION OF ADVERTISING MATTER; DISSEMINATION OF ADVERTISING, SCHEDULING AND MANAGING OF TRAINING COURSES AND PROGRAMS FOR OTHERS VIA A GLOBAL COMPUTER NETWORK; DISSEMINATION SERVICES OF ADVERTISEMENT MATTER; DISTRIBUTION AND DISSEMINATION OF ADVERTISING MATERIALS; DISTRIBUTION OF ADVERTISEMENTS AND COMMERCIAL ANNOUNCEMENTS; DISTRIBUTION OF ADVERTISING MAIL AND OF ADVERTISING SUPPLEMENTS ATTACHED TO REGULAR EDITIONS; DISTRIBUTION OF ADVERTISING MATERIAL; DISTRIBUTION OF ADVERTISING MATERIALS; DISTRIBUTION OF PRODUCTS FOR ADVERTISING PURPOSES; ELECTRONIC BILLBOARD ADVERTISING; ELECTRONIC COMMERCE SERVICES, NAMELY, PROVIDING INFORMATION ABOUT PRODUCTS VIA TELECOMMUNICATION NETWORKS FOR ADVERTISING AND SALES PURPOSES; ENTERTAINMENT MARKETING SERVICES, NAMELY, MARKETING, PROMOTION AND ADVERTISING FOR INDEPENDENT RECORDING ARTISTS; ENTERTAINMENT MARKETING SERVICES, NAMELY, MARKETING, PROMOTION AND ADVERTISING FOR RECORDING AND PERFORMING ARTISTS; EVENT PLANNING AND MANAGEMENT FOR MARKETING, BRANDING, PROMOTING OR ADVERTISING THE GOODS AND SERVICES OF OTHERS; INTERNATIONAL BUSINESS CONSULTING SERVICES RELATING TO MERCHANDISE TRADING, HUMAN RESOURCE INTERCHANGE, MANAGEMENT SUPPORT, MARKETING, ADVERTISING, PROMOTION, AND DOMESTIC AND INTERNATIONAL MARKET RESEARCH AND DEVELOPMENT; INTERNET ADVERTISING SERVICES; ISSUING AND UPDATING OF ADVERTISING TEXTS; LAYOUT SERVICES FOR ADVERTISING PURPOSES; MANAGEMENT OF ADVERTISING THROUGH A COMMAND AND CONTROL CENTER FOR BOTH MOVIE THEATRE ON-SCREEN ADVERTISING AND OVER THE INTERNET; MARKETING AND ADVERTISING SERVICES FOR AUTOMOBILE DEALERSHIPS; MARKETING, ADVERTISING AND PROMOTING THE GOODS AND SERVICES OF OTHERS IN THE FIELD OF TRAVEL AND TOURISM, NAMELY, PROVIDING INFORMATION VIA MAIL AND ELECTRONIC MAIL; MARKETING, ADVERTISING, AND PROMOTING THE RETAIL GOODS AND SERVICES OF OTHERS TO WIRELESS ELECTRONIC DEVICES; MARKETING, PROMOTIONAL AND ADVERTISING SERVICES PROVIDED BY MOBILE TELEPHONE CONNECTIONS; MEDIA BUYING ADVICE, NAMELY, ADVISING THE CLIENT HOW MUCH MEDIA TIME, AND AT WHAT TIMES THE CLIENT SHOULD BE PURCHASING ADVERTISING; MEDIA PLANNING, NAMELY, ADVISING THE CLIENT ON THE CORRECT TIMES AND STATIONS TO ADVERTISE BASED ON MEDIA ANALYSIS OF THE MARKET FOR THAT MEDIA; MEDIA PRODUCTION LOCATION SCOUTING SERVICES FOR ADVERTISING PURPOSES; MEDIATION OF ADVERTISING; MODELING FOR ADVERTISING OR SALES PROMOTION; MODELING SERVICES FOR ADVERTISING OR SALES PROMOTION; MUSIC SELECTION SERVICES FOR USE IN ADVERTISING; ON-LINE ADVERTISING AND MARKETING SERVICES; ON-LINE ADVERTISING ON COMPUTER COMMUNICATION NETWORKS; ON-LINE ADVERTISING ON COMPUTER NETWORKS; ON-LINE ADVERTISING SERVICES FOR OTHERS; ONLINE ADVERTISEMENTS; ONLINE ADVERTISING AND PROMOTIONAL SERVICES; ONLINE ADVERTISING VIA A COMPUTER COMMUNICATIONS NETWORK; ORGANISATION AND HOLDING OF FAIRS FOR COMMERCIAL OR ADVERTISING PURPOSES; ORGANISATION OF EXHIBITIONS AND EVENTS FOR COMMERCIAL OR ADVERTISING PURPOSES; ORGANISATION OF EXHIBITIONS FOR COMMERCIAL OR ADVERTISING PURPOSES; ORGANISING EXHIBITIONS FOR COMMERCIAL OR ADVERTISING PURPOSES; ORGANIZATION OF EVENTS, EXHIBITIONS, FAIRS AND SHOWS FOR COMMERCIAL, PROMOTIONAL AND ADVERTISING

CLASS 35—(Continued).

ING PURPOSES; ORGANIZATION OF EXHIBITIONS FOR COMMERCIAL OR ADVERTISING PURPOSES; ORGANIZATION OF FAIRS AND EXHIBITIONS FOR COMMERCIAL AND ADVERTISING PURPOSES; ORGANIZATION OF FAIRS FOR COMMERCIAL AND ADVERTISING PURPOSES; ORGANIZING BUSINESS EXPOSITIONS FOR HEALTH PRODUCTS; ORGANIZING EXHIBITIONS FOR COMMERCIAL OR ADVERTISING PURPOSES; OUT-OF-HOME ADVERTISING SERVICES, NAMELY, RENTAL OF ADVERTISING SPACE, AND PREPARING AND PLACING ADVERTISEMENTS FOR OTHERS; PAY PER CLICK (PPC) ADVERTISING MANAGEMENT SERVICES; PLACING ADVERTISEMENTS FOR OTHERS; PLANNING AND CONDUCTING OF TRADE FAIRS, EXHIBITIONS AND PRESENTATIONS FOR ECONOMIC OR ADVERTISING PURPOSES; PREPARATION AND REALIZATION OF MEDIA AND ADVERTISING PLANS AND CONCEPTS; PREPARATION OF CUSTOM ADVERTISEMENTS FOR OTHERS; PREPARATION OF CUSTOM OR NON-CUSTOM ADVERTISING FOR BUSINESSES FOR DISSEMINATION VIA THE WEB, CD OR DVD FOR OPTIONAL UPLOAD OR DOWNLOAD TO A COMPUTER; PREPARING ADVERTISEMENTS FOR OTHERS; PREPARING ADVERTISEMENTS FOR OTHERS, NAMELY, PREPARING VIDEO ADVERTISING AND PROMOTIONAL VIDEOS FOR COMMERCIAL USE VIA THE INTERNET AND TELEVISION, DIGITAL CABLE AND VIDEO-ON-DEMAND OR DOWNLOAD; PREPARING AND PLACING ADVERTISEMENTS FOR OTHERS; PREPARING AND PLACING OF ADVERTISEMENTS; PREPARING AND PLACING OUTDOOR ADVERTISEMENTS FOR OTHERS; PREPARING AUDIOVISUAL PRESENTATIONS FOR USE IN ADVERTISING; PREPARING SPEECHES AND ORAL PRESENTATIONS FOR OTHERS FOR USE IN ADVERTISING; PROCESSING TELEPHONE INQUIRIES REGARDING ADVERTISED GOODS AND SERVICES; PRODUCTION OF ADVERTISING MATTER AND COMMERCIALS; PRODUCTION OF FILM AND TELEVISION ADVERTISING; PROMOTING AND MARKETING THE GOODS AND SERVICES OF OTHERS BY DISTRIBUTING ADVERTISING MATERIAL, COUPONS AND DISCOUNT OFFERS VIA TEXT MESSAGES; PROMOTING AND SHOWCASING THE GOODS OF OTHERS IN THE FIELD OF HEALTH PRODUCTS BY MEANS OF AN ON-LINE SHOPPING SITE WITH LINKS TO THE RETAIL ADVERTISEMENTS OF OTHERS; PROMOTING THE GOODS AND SERVICES OF OTHERS BY DISTRIBUTING ADVERTISING MATERIALS THROUGH A VARIETY OF METHODS; PROMOTING THE GOODS AND SERVICES OF OTHERS BY MEANS OF DISTRIBUTING ADVERTISING ON THE INTERNET; PROMOTING THE GOODS AND SERVICES OF OTHERS BY PREPARING AND PLACING ADVERTISEMENTS IN AN ELECTRONIC MAGAZINE ACCESSED THROUGH A GLOBAL COMPUTER NETWORK; PROMOTING, ADVERTISING AND MARKETING OF THE BRANDS, PRODUCTS, SERVICES OR ONLINE WEBSITES OF INDIVIDUALS, BUSINESSES AND NONPROFIT ORGANIZATIONS; PROMOTING, ADVERTISING AND MARKETING OF THE ON-LINE WEB SITES OF OTHERS; PROMOTING, ADVERTISING AND MARKETING THE ON-LINE DATABASES AND ELECTRONIC PUBLICATIONS OF OTHERS; PROMOTION, ADVERTISING AND MARKETING OF ON-LINE WEBSITES; PROMOTIONAL SERVICES, NAMELY, DISTRIBUTION OF ADVERTISING FLYERS, COUPONS, CATALOGS AND PROMOTIONAL ITEMS OF OTHERS; PROVIDING A SEARCHABLE ON-LINE ADVERTISING WEBSITE AND GUIDE FEATURING THE GOODS AND SERVICES OF OTHER VENDORS VIA THE INTERNET; PROVIDING A SEARCHABLE ONLINE ADVERTISING GUIDE FEATURING THE GOODS AND SERVICES OF ONLINE VENDORS; PROVIDING A SEARCHABLE ONLINE ADVERTISING GUIDE FEATURING THE GOODS AND SERVICES OF OTHER ON-LINE VENDORS ON THE INTERNET; PROVIDING A SEARCHABLE ONLINE ADVERTISING WEBSITE AND INFORMATIONAL GUIDE FEATURING THE GOODS AND SERVICES OF OTHER VENDORS VIA THE INTERNET IN THE FIELD OF HEALTH PRODUCTS; PROVIDING A WEB SITE AT WHICH FITNESS PROFESSIONALS AND FACILITIES CAN POST PROMOTIONAL PROFILES AND RESPOND TO ADVERTISEMENTS FOR THEIR SERVICES; PROVIDING A WEB SITE WHERE USERS CAN POST ITEMS FOR SALE THROUGH ON-LINE CLASSIFIED ADVERTISEMENTS; PROVIDING A WEB SITE WHICH FEA-

CLASS 35—(Continued).

TURES ADVERTISEMENTS FOR THE GOODS AND SERVICES OF OTHERS ON A GLOBAL COMPUTER NETWORK; PROVIDING ADVERTISING AND ADVERTISEMENT SERVICES; PROVIDING ADVERTISING SERVICE TO DISTRIBUTE ADVERTISEMENTS FOR DISPLAY ON INTERNET, NAMELY, IN WEBSITES, SOCIAL CONVERSATIONS OVER THE INTERNET, E-MAILS, MICROBLOGS, BLOGS, ELECTRONIC MESSAGES, INSTANT MESSAGES, TEXT MESSAGES, MULTIMEDIA MESSAGES, SOCIAL NETWORKS, STATUS UPDATES, FORUMS, ELECTRONIC BULLETIN BOARDS; PROVIDING ADVERTISING SERVICES; PROVIDING ADVERTISING SERVICES USING 3D AND ANIMATION DESIGNS; PROVIDING ADVERTISING SPACE IN PERIODICALS, NEWSPAPERS AND MAGAZINES; PROVIDING ADVERTISING SPACE ON BILLBOARDS AND IN KIOSKS; PROVIDING ADVERTISING SPACE ON FREE-STANDING VISUAL ADVERTISING SYSTEMS FEATURING THE GOODS AND SERVICES OF OTHERS; PROVIDING ADVERTISING, MARKETING AND PROMOTIONAL SERVICES FOR THE PHARMACEUTICAL AND MEDICAL INDUSTRY; PROVIDING ADVERTISING, MARKETING AND PROMOTIONAL SERVICES FOR THE PHARMACEUTICAL AND MEDICAL PRODUCTS OF OTHERS; PROVIDING ADVERTISING, MARKETING AND PROMOTIONAL SERVICES, NAMELY, DEVELOPMENT OF ADVERTISING CAMPAIGNS FOR THE HEALTH INDUSTRY; PROVIDING ADVERTISING, MARKETING AND PROMOTIONAL SERVICES, NAMELY, DEVELOPMENT OF ADVERTISING CAMPAIGNS PROVIDED THROUGH CABLE TELEVISION BROADCAST, WEB CASTS, RADIO BROADCASTS, NEWSPAPERS, MAGAZINES, ONLINE BANNERS, OUTDOOR BILLBOARDS, WILD POSTINGS, BUS AND SUBWAY ADS; PROVIDING AN INTERNET WEB SITE FOR CLASSIFIED ADVERTISING TO BUY AND SELL UKRAINIAN RELATED WARES, ART, ANTIQUES, BOOKS, EMBROIDERY, COSTUMES, COLLECTIBLES, INSTRUMENTS, MEMORABILIA AND OTHER ONE-OF-A-KIND ITEMS; PROVIDING AN INTERNET WEB SITE TO ADVERTISE SERVICES OF INTEREST TO THE UKRAINIAN COMMUNITY IN THE UNITED STATES OF AMERICA AND CANADA AND TO ADVERTISE SERVICES PROVIDED BY INDIVIDUALS OF UKRAINIAN ORIGIN; PROVIDING AN INTERNET WEBSITE PORTAL FEATURING PROMOTION AND ADVERTISING FOR HOME SERVICE PROVIDERS AND PRODUCT MANUFACTURERS; PROVIDING AN ONLINE DIRECTORY INFORMATION SERVICE FEATURING INFORMATION REGARDING VEHICLES IN THE NATURE OF CLASSIFIED ADVERTISEMENTS; PROVIDING AND RENTAL OF ADVERTISING SPACE ON THE INTERNET; PROVIDING ONLINE BUSINESS INFORMATION OF OTHERS, NAMELY, ADVERTISEMENTS OR SOLICITATIONS; PROVIDING SPACE AT A WEB SITE FOR THE ADVERTISEMENT OF THE GOODS AND SERVICES OF OTHERS; PROVIDING TELEVISION ADVERTISING FOR OTHERS; PROVISION OF ADVERTISING SPACE BY ELECTRONIC MEANS AND GLOBAL INFORMATION NETWORKS; PROVISION OF SPACE ON WEBSITES FOR ADVERTISING GOODS AND SERVICES; PUBLIC RELATIONS, ADVERTISING AND MARKETING SERVICES FOR THE TOURISM AND CONVENTION INDUSTRY, NAMELY, ORGANIZING AND HOSTING SITE INSPECTIONS AND FAMILIARIZATION TOURS FOR WHOLESALE, TOUR OPERATORS, TRAVEL AGENTS, MEETING AND INCENTIVE TRAVEL PLANNERS AND TRAVEL MEDIA; PUBLISHING OF ADVERTISING TEXTS; REAL ESTATE ADVERTISING SERVICES; RECRUITMENT ADVERTISEMENT SERVICES, NAMELY, POSTING OF CLINICAL TRIAL NOTICES FOR THE PURPOSE OF RECRUITING PATIENTS FOR PARTICIPATION IN CLINICAL TRIALS FOR THE TESTING OF DRUGS; RENTAL OF ADVERTISEMENT SPACE AND ADVERTISING MATERIAL; RENTAL OF ADVERTISING SPACE; RENTAL OF ADVERTISING SPACE ON WEB SITES; RENTAL OF SIGNS FOR ADVERTISING PURPOSES; RENTING OF ADVERTISING SPACES; SERVICES OF ADVERTISING AGENCIES; SERVICES TO DETERMINE THE AUDIENCE AFFECTED BY ADVERTISEMENTS; SPECIAL EVENT PLANNING FOR COMMERCIAL, PROMOTIONAL OR

CLASS 35—(Continued).

ADVERTISING PURPOSES; SPECIALTY MERCHANDISING SERVICES, NAMELY, PROMOTING THE GOODS AND SERVICES OF OTHERS THROUGH THE DISTRIBUTION OF CUSTOMIZED ADVERTISING MATERIALS, NAMELY, PENS AND CATALOGS; TELEVISION ADVERTISING AGENCIES; VENDOR-ON-PREMISE SERVICES, NAMELY, THE ADMINISTRATION OF THE EMPLOYMENT PROCESS ON-SITE, INCLUDING RESUME REVIEW AND CHECKING, EMPLOYMENT APPLICATION ACQUISITION, ADVERTISING FOR RECRUITMENT, CONDUCT OF INTERVIEWS, AND REFERENCE CHECKING (U.S. CLS. 100, 101 AND 102).
DEBRA LEE, EXAMINING ATTORNEY

SN 85-245,508. GSENSE INC., BRIARCLIFF MANOR, NY.
FILED 2-17-2011.

License Anything

THE MARK CONSISTS OF STANDARD CHARACTERS WITHOUT CLAIM TO ANY PARTICULAR FONT, STYLE, SIZE, OR COLOR.

OWNER OF U.S. REG. NO. 3,790,012.

NO CLAIM IS MADE TO THE EXCLUSIVE RIGHT TO USE "LICENSE", APART FROM THE MARK AS SHOWN.

FOR AD SERVING, NAMELY, PLACING ADVERTISEMENTS ON WEBSITES FOR OTHERS USING SPECIALIZED COMPUTER SOFTWARE; ADVERTISEMENT AND PUBLICITY SERVICES BY TELEVISION, RADIO, MAIL; ADVERTISEMENT FOR OTHERS ON THE INTERNET; ADVERTISEMENT HOARDING RENTAL; ADVERTISEMENT VIA MOBILE PHONE NETWORKS; ADVERTISING AGENCIES; ADVERTISING AGENCIES PROVIDING THE STRATEGY, DESIGN AND EXECUTION OF PROGRAMS TO PROMOTE BUSINESSES IN THE FOOD AND FOODSERVICE INDUSTRIES; ADVERTISING AGENCIES, NAMELY, PROMOTING THE GOODS AND SERVICES OF OTHERS; ADVERTISING AGENCY SPECIALIZING IN THE DESIGN AND EXECUTION OF WORD OF MOUTH, VIRAL, BUZZ AND EXPERIENTIAL MARKETING PROGRAMS; ADVERTISING AND ADVERTISEMENT SERVICES; ADVERTISING AND BUSINESS ADVICE RELATING TO TELEMATICS SERVICES; ADVERTISING AND BUSINESS MANAGEMENT CONSULTANCY; ADVERTISING AND BUSINESS SERVICES, NAMELY, PROVIDING AN ONLINE WEBSITE WHERE ADVERTISERS, MARKETERS, AND CONTENT PROVIDERS CAN INTERACT WITH USERS FOR ADVERTISING, BRANDING, AND PROMOTING KNOWLEDGE, PRODUCTS, AND SERVICES, AND TRADESHOWS, ON BEHALF OF THEMSELVES AND OTHERS, AND FOR EVALUATING AND RATING THE SAME, ALL THE FOREGOING RELEVANT TO HUMAN ACTIVITIES AFFECTING CLIMATE CHANGE AND RELATED FIELDS; ADVERTISING AND BUSINESS SERVICES, NAMELY, SECURING AIRTIME ON ALL FORMS OF MEDIA COMMUNICATIONS STATIONS, SYSTEMS, NETWORKS, AND SERVICES FOR THE PURPOSE OF PROMOTING THE GOODS AND SERVICES OF OTHERS; ADVERTISING AND COMMERCIAL INFORMATION SERVICES, VIA THE INTERNET; ADVERTISING AND DIRECTORY SERVICES, NAMELY, PROMOTING THE SERVICES OF OTHERS BY PROVIDING A WEB PAGE FEATURING LINKS TO THE WEBSITES OF OTHERS; ADVERTISING AND MARKETING; ADVERTISING AND MARKETING CONSULTANCY; ADVERTISING AND MARKETING SERVICES PROVIDED BY MEANS OF INDIRECT METHODS OF MARKETING COMMUNICATIONS, NAMELY, SOCIAL MEDIA, SEARCH ENGINE MARKETING, INQUIRY MARKETING, INTERNET MARKETING, MOBILE MARKETING, BLOGGING AND OTHER FORMS OF PASSIVE, SHARABLE OR VIRAL COMMUNICATIONS CHANNELS; ADVERTISING AND MARKETING SERVICES, NAMELY, PROMOTING THE

CLASS 35—(Continued).

GOODS AND SERVICES OF OTHERS; ADVERTISING AND PROMOTING THE GOODS AND SERVICES OF A VISUAL ARTIST; ADVERTISING AND PROMOTION SERVICES AND RELATED CONSULTING; ADVERTISING AND PROMOTIONAL SERVICES; ADVERTISING AND PUBLICITY SERVICES; ADVERTISING AND PUBLICITY SERVICES, NAMELY, PROMOTING THE GOODS, SERVICES, BRAND IDENTITY AND COMMERCIAL INFORMATION AND NEWS OF THIRD PARTIES THROUGH PRINT, AUDIO, VIDEO, DIGITAL AND ON-LINE MEDIUM; ADVERTISING BUSINESS ESPECIALLY IN THE FIELD OF TELEMATIC AND TELEPHONE NETWORKS; ADVERTISING BY TRANSMISSION OF ON-LINE PUBLICITY FOR THIRD PARTIES THROUGH ELECTRONIC COMMUNICATIONS NETWORKS; ADVERTISING CONSULTATION; ADVERTISING COPYWRITING; ADVERTISING FLYER DISTRIBUTION; ADVERTISING IN PERIODICALS, BROCHURES AND NEWSPAPERS; ADVERTISING IN THE POPULAR AND PROFESSIONAL PRESS; ADVERTISING OF COMMERCIAL OR RESIDENTIAL REAL ESTATE; ADVERTISING OF THE PUBLISHED TEXTS OF OTHERS; ADVERTISING ON THE INTERNET FOR OTHERS; ADVERTISING PARTICULARLY SERVICES FOR THE PROMOTION OF GOODS; ADVERTISING RELATING TO PHARMACEUTICAL PRODUCTS AND IN-VIVO IMAGING PRODUCTS; ADVERTISING RELATING TO TRANSPORT AND DELIVERY; ADVERTISING SERVICES; ADVERTISING SERVICES FOR PROMOTING THE BROKERAGE OF STOCKS AND OTHER SECURITIES; ADVERTISING SERVICES OF A RADIO AND TELEVISION ADVERTISING AGENCY; ADVERTISING SERVICES RELATING TO SANDWICHES; ADVERTISING SERVICES, FOR THIRD PARTIES, IN CONNECTION WITH THE COMMERCIALIZATION AND SALE OF PERFUMERY AND COSMETIC ARTICLES, PRODUCTS FOR HOUSEHOLD PURPOSES, OPTICAL PRODUCTS, CLOCKS AND TIMEPIECES, JEWELLERY, FURNISHING ARTICLES; ADVERTISING SERVICES, NAMELY, COST-PER-ACTION ON-LINE ADVERTISING; ADVERTISING SERVICES, NAMELY, CREATING CORPORATE AND BRAND IDENTITY FOR OTHERS; ADVERTISING SERVICES, NAMELY, CREATING CORPORATE LOGOS FOR OTHERS; ADVERTISING SERVICES, NAMELY, CREATING PROMOTIONAL MURALS AND PAINTING SIGNS AND WALLS ADVERTISING THE GOODS AND SERVICES OF OTHERS; ADVERTISING SERVICES, NAMELY, PRODUCTION OF SPECIAL EFFECTS INCLUDING MODEL-MAKING SERVICES, COMPUTER-GENERATED IMAGERY AND COMPUTER-GENERATED GRAPHICS FOR THE PRODUCTION OF COMMERCIALS; ADVERTISING SERVICES, NAMELY, PROMOTING AND MARKETING THE GOODS AND SERVICES OF OTHERS IN THE FIELD OF UPSCALE CHOICES SUCH AS CULTURAL EVENTS, RESTAURANTS, SHOPPING, AND TRAVEL VIA PRINT AND ELECTRONIC MEDIA; ADVERTISING SERVICES, NAMELY, PROMOTING AND MARKETING THE GOODS AND SERVICES OF OTHERS THROUGH ALL PUBLIC COMMUNICATION MEANS; ADVERTISING SERVICES, NAMELY, PROMOTING CAR DEALERSHIPS OF OTHERS; ADVERTISING SERVICES, NAMELY, PROMOTING PROPERTIES FOR SALE BY OWNER VIA THE INTERNET; ADVERTISING SERVICES, NAMELY, PROMOTING THE BOOKS OF OTHERS IN THE FIELD OF LAW BY MEANS OF NEWS AND REVIEWS REGARDING SAME; ADVERTISING SERVICES, NAMELY, PROMOTING THE BRANDS, GOODS AND SERVICES OF OTHERS; ADVERTISING SERVICES, NAMELY, PROMOTING THE FOOD AND WINE OF OTHERS; ADVERTISING SERVICES, NAMELY, PROMOTING THE GIFT CARDS OF OTHERS; ADVERTISING SERVICES, NAMELY, PROMOTING THE POWER SPORTS DEALERSHIPS OF OTHERS; ADVERTISING SERVICES, NAMELY, PROMOTING THE SANDWICHES OF OTHERS; ADVERTISING SERVICES, NAMELY, PROVIDING A WEBSITE FOR THE PROMOTION OF THE BOOKS OF OTHERS IN THE FIELD OF LAW, INCLUDING NEWS AND REVIEWS REGARDING SAME; ADVERTISING SERVICES, NAMELY, PROVIDING ADVERTISING SPACE IN A PERIODICAL; ADVERTISING SERVICES, NAMELY, PROVIDING INFORMATION AS TO THE AVAILABILITY OF MULTIMEDIA PRODUCTS FOR RENT OR PURCHASE; ADVERTISING SERVICES, PUBLIC RELATIONS AND MARKETING SERVICES,

CLASS 35—(Continued).

NAMELY, PROMOTING AND MARKETING THE GOODS AND SERVICES OF OTHERS THROUGH ALL PUBLIC COMMUNICATION MEANS; ADVERTISING TEXT PUBLICATION SERVICES; ADVERTISING THE SERVICES OF OTHERS VIA WEB PAGES OPTIMIZED FOR ONLINE SEARCH ENGINES; ADVERTISING THROUGH ALL PUBLIC COMMUNICATION MEANS; ADVERTISING VIA ELECTRONIC MEDIA AND SPECIFICALLY THE INTERNET; ADVERTISING, INCLUDING ON-LINE ADVERTISING ON A COMPUTER NETWORK; ADVERTISING, INCLUDING PROMOTION OF PRODUCTS AND SERVICES OF THIRD PARTIES THROUGH SPONSORING ARRANGEMENTS AND LICENSE AGREEMENTS RELATING TO INTERNATIONAL SPORTS EVENTS; ADVERTISING, INCLUDING PROMOTION RELATING TO THE SALE OF ARTICLES AND SERVICES FOR THIRD PARTIES BY THE TRANSMISSION OF ADVERTISING MATERIAL AND THE DISSEMINATION OF ADVERTISING MESSAGES ON COMPUTER NETWORKS; ADVERTISING, MARKETING AND PROMOTING THE GOODS AND SERVICES OF OTHERS USING KIOSKS; ADVERTISING, MARKETING AND PROMOTION SERVICES; ADVERTISING, MARKETING AND PROMOTION SERVICES, NAMELY, PROMOTING THE GOODS AND SERVICES OF OTHERS BY PROVIDING CUSTOMIZED EXHIBITS; ADVERTISING, MARKETING AND PROMOTIONAL SERVICES FOR AUTOMOTIVE DEALERSHIPS; ADVERTISING, MARKETING AND PROMOTIONAL SERVICES FOR LIGHT AND HEAVY EQUIPMENT DEALERSHIPS; ADVERTISING, MARKETING AND PROMOTIONAL SERVICES FOR THE DONATION OF HUMAN BLOOD THAT EXACTLY MATCHES THE BLOOD TYPE OF INDIVIDUALS NEEDING TRANSFUSIONS; ADVERTISING, MARKETING AND PROMOTIONAL SERVICES RELATED TO ALL INDUSTRIES FOR THE PURPOSE OF FACILITATING NETWORKING AND SOCIALIZING OPPORTUNITIES FOR BUSINESS PURPOSES; ADVERTISING, PROMOTION AND MARKETING SERVICES BASED ON CONSUMER CREDIT REPORTS AND SCORES OF OTHERS; ADVERTISING, PROMOTION AND MARKETING SERVICES IN THE NATURE OF E-MAIL BLAST CAMPAIGNS FOR OTHERS; ADVERTISING, PROMOTION, AND MARKETING SERVICES IN THE NATURE OF VIRAL MARKETING PROGRAM FOR WEB AND MOBILE PHONE USERS; AGENCIES FOR ADVERTISING TIME AND SPACE; ANALYSIS OF ADVERTISING RESPONSE; ARRANGING AND CONDUCTING OF FAIRS AND EXHIBITIONS FOR BUSINESS AND ADVERTISING PURPOSES; ARRANGING AND CONDUCTING SPECIAL EVENTS FOR COMMERCIAL, PROMOTIONAL OR ADVERTISING PURPOSES; BANNER ADVERTISING; BUSINESS MANAGEMENT AND CONSULTING SERVICES FOR THE HEALTH CARE INDUSTRY, NAMELY, CUSTOMER SERVICE, ACCOUNTING SERVICES, AND WEB-BASED ADVERTISING AND MARKETING SERVICES; BUSINESS SERVICES, NAMELY, TRACKING AND MONITORING OF CALLS FOR OTHERS IN RESPONSE TO ADVERTISING ADS; CINEMA ADVERTISING; CLASSIFIED ADVERTISING SERVICES; COMPILATION OF ADVERTISEMENTS FOR USE AS WEB PAGES ON THE INTERNET; COMPILATION, PRODUCTION AND DISSEMINATION OF ADVERTISING MATTER; CONDUCTING, ARRANGING AND ORGANIZING TRADE SHOWS AND TRADE FAIRS FOR COMMERCIAL AND ADVERTISING PURPOSES; CONSUMER LOYALTY SERVICES FOR COMMERCIAL, PROMOTIONAL, AND/OR ADVERTISING PURPOSES, NAMELY, ADMINISTRATION OF FREQUENT FLYER PROGRAM THAT ALLOWS MEMBERS TO REDEEM MILES FOR POINTS OR AWARDS OFFERED BY OTHER LOYALTY PROGRAMS; COOPERATIVE ADVERTISING AND MARKETING; COOPERATIVE ADVERTISING AND MARKETING SERVICES BY WAY OF SOLICITATION, CUSTOMER SERVICE AND PROVIDING MARKETING INFORMATION VIA WEB SITES ON A GLOBAL COMPUTER NETWORK; COOPERATIVE ADVERTISING AND MARKETING SERVICES, NAMELY, OFFERING DISCOUNTS TO CLIENTS THROUGH THE JOINT PARTICIPATION OF MEMBER BEAUTY SALONS.; CREATING AND UPDATING ADVERTISING MATERIAL; CREATION OF MARKETING TOOLS DESIGNED TO INCREASE A CLIENT COMPANY'S KNOWLEDGE OF CUSTOMER NEEDS, AND ITS COMPETITORS' PRODUCTS AND SERVICES, PRICING, ADVERTISING STRATEGY AND SALES STRATEGY;

CLASS 35—(Continued).

CUSTOMER LOYALTY SERVICES AND CUSTOMER CLUB SERVICES, FOR COMMERCIAL, PROMOTIONAL AND/OR ADVERTISING PURPOSES; DESIGN OF ADVERTISING BROCHURES FOR OTHERS; DESIGN OF ADVERTISING FLYERS FOR OTHERS; DESIGN OF ADVERTISING MATERIALS FOR OTHERS; DESIGN OF INTERNET ADVERTISING; DEVELOPING ADVERTISING CAMPAIGNS FOR OTHERS GEARED TOWARD ENVIRONMENTAL ISSUES; DEVELOPMENT, OPERATION AND ADMINISTRATION OF DIGITAL SIGNAGE SYSTEMS AND DIGITAL ADVERTISING SYSTEMS FOR OTHERS, NAMELY, PROVIDING ADVERTISING SPACE BY ELECTRONIC MEANS AND GLOBAL COMPUTER INFORMATION NETWORKS; DIRECT MAIL ADVERTISING SERVICES; DIRECT MARKETING ADVERTISING FOR OTHERS; DISPLAYING ADVERTISEMENTS FOR OTHERS; DISSEMINATION OF ADVERTISEMENTS; DISSEMINATION OF ADVERTISEMENTS AND OF ADVERTISING MATERIAL; DISSEMINATION OF ADVERTISING FOR OTHERS VIA AN ON-LINE COMMUNICATIONS NETWORK ON THE INTERNET; DISSEMINATION OF ADVERTISING FOR OTHERS VIA PUBLIC AND PRIVATE WIRELESS NETWORKS FOR DISPLAY ON MOBILE DEVICES; DISSEMINATION OF ADVERTISING FOR OTHERS VIA THE INTERNET; DISSEMINATION OF ADVERTISING MATERIAL; DISSEMINATION OF ADVERTISING MATTER; DISSEMINATION OF ADVERTISING, SCHEDULING AND MANAGING OF TRAINING COURSES AND PROGRAMS FOR OTHERS VIA A GLOBAL COMPUTER NETWORK; DISSEMINATION SERVICES OF ADVERTISEMENT MATTER; DISTRIBUTION AND DISSEMINATION OF ADVERTISING MATERIALS; DISTRIBUTION OF ADVERTISEMENTS AND COMMERCIAL ANNOUNCEMENTS; DISTRIBUTION OF ADVERTISING MAIL AND OF ADVERTISING SUPPLEMENTS ATTACHED TO REGULAR EDITIONS; DISTRIBUTION OF ADVERTISING MATERIAL; DISTRIBUTION OF ADVERTISING MATERIALS; DISTRIBUTION OF PRODUCTS FOR ADVERTISING PURPOSES; ELECTRONIC BILLBOARD ADVERTISING; ELECTRONIC COMMERCE SERVICES, NAMELY, PROVIDING INFORMATION ABOUT PRODUCTS VIA TELECOMMUNICATION NETWORKS FOR ADVERTISING AND SALES PURPOSES; ENTERTAINMENT MARKETING SERVICES, NAMELY, MARKETING, PROMOTION AND ADVERTISING FOR INDEPENDENT RECORDING ARTISTS; ENTERTAINMENT MARKETING SERVICES, NAMELY, MARKETING, PROMOTION AND ADVERTISING FOR RECORDING AND PERFORMING ARTISTS; EVENT PLANNING AND MANAGEMENT FOR MARKETING, BRANDING, PROMOTING OR ADVERTISING THE GOODS AND SERVICES OF OTHERS; INTERNATIONAL BUSINESS CONSULTING SERVICES RELATING TO MERCHANDISE TRADING, HUMAN RESOURCE INTERCHANGE, MANAGEMENT SUPPORT, MARKETING, ADVERTISING, PROMOTION, AND DOMESTIC AND INTERNATIONAL MARKET RESEARCH AND DEVELOPMENT; INTERNET ADVERTISING SERVICES; ISSUING AND UPDATING OF ADVERTISING TEXTS; LAYOUT SERVICES FOR ADVERTISING PURPOSES; MANAGEMENT OF ADVERTISING THROUGH A COMMAND AND CONTROL CENTER FOR BOTH MOVIE THEATRE ON-SCREEN ADVERTISING AND OVER THE INTERNET; MARKETING AND ADVERTISING SERVICES FOR AUTOMOBILE DEALERSHIPS; MARKETING, ADVERTISING AND PROMOTING THE GOODS AND SERVICES OF OTHERS IN THE FIELD OF TRAVEL AND TOURISM, NAMELY, PROVIDING INFORMATION VIA MAIL AND ELECTRONIC MAIL; MARKETING, ADVERTISING, AND PROMOTING THE RETAIL GOODS AND SERVICES OF OTHERS TO WIRELESS ELECTRONIC DEVICES; MARKETING, PROMOTIONAL AND ADVERTISING SERVICES PROVIDED BY MOBILE TELEPHONE CONNECTIONS; MEDIA BUYING ADVICE, NAMELY, ADVISING THE CLIENT HOW MUCH MEDIA TIME, AND AT WHAT TIMES THE CLIENT SHOULD BE PURCHASING ADVERTISING; MEDIA PLANNING, NAMELY, ADVISING THE CLIENT ON THE CORRECT TIMES AND STATIONS TO ADVERTISE BASED ON MEDIA ANALYSIS OF THE MARKET FOR THAT MEDIA; MEDIA PRODUCTION LOCATION SCOUTING SERVICES FOR ADVERTISING PURPOSES; MEDIATION OF ADVERTISING; MODELING FOR ADVERTISING OR SALES PROMOTION; MODELING SERVICES FOR ADVERTISING OR SALES PROMOTION; MUSIC

CLASS 35—(Continued).

SELECTION SERVICES FOR USE IN ADVERTISING; ON-LINE ADVERTISING AND MARKETING SERVICES; ON-LINE ADVERTISING ON COMPUTER COMMUNICATION NETWORKS; ON-LINE ADVERTISING ON COMPUTER NETWORKS; ON-LINE ADVERTISING SERVICES FOR OTHERS; ONLINE ADVERTISEMENTS; ONLINE ADVERTISING AND PROMOTIONAL SERVICES; ONLINE ADVERTISING VIA A COMPUTER COMMUNICATIONS NETWORK; ORGANISATION AND HOLDING OF FAIRS FOR COMMERCIAL OR ADVERTISING PURPOSES; ORGANISATION OF EXHIBITIONS AND EVENTS FOR COMMERCIAL OR ADVERTISING PURPOSES; ORGANISATION OF EXHIBITIONS FOR COMMERCIAL OR ADVERTISING PURPOSES; ORGANISING EXHIBITIONS FOR COMMERCIAL OR ADVERTISING PURPOSES; ORGANIZATION OF EVENTS, EXHIBITIONS, FAIRS AND SHOWS FOR COMMERCIAL, PROMOTIONAL AND ADVERTISING PURPOSES; ORGANIZATION OF EXHIBITIONS FOR COMMERCIAL OR ADVERTISING PURPOSES; ORGANIZATION OF FAIRS AND EXHIBITIONS FOR COMMERCIAL AND ADVERTISING PURPOSES; ORGANIZATION OF FAIRS FOR COMMERCIAL AND ADVERTISING PURPOSES; ORGANIZING BUSINESS EXPOSITIONS FOR ADVERTISING PRODUCTS; ORGANIZING EXHIBITIONS FOR COMMERCIAL OR ADVERTISING PURPOSES; ORGANIZING EXHIBITIONS FOR ADVERTISING PRODUCTS; OUT-OF-HOME ADVERTISING SERVICES, NAMELY, RENTAL OF ADVERTISING SPACE, AND PREPARING AND PLACING ADVERTISEMENTS FOR OTHERS; PAY PER CLICK (PPC) ADVERTISING MANAGEMENT SERVICES; PLACING ADVERTISEMENTS FOR OTHERS; PLANNING AND CONDUCTING OF TRADE FAIRS, EXHIBITIONS AND PRESENTATIONS FOR ECONOMIC OR ADVERTISING PURPOSES; PREPARATION AND REALIZATION OF MEDIA AND ADVERTISING PLANS AND CONCEPTS; PREPARATION OF CUSTOM ADVERTISEMENTS FOR OTHERS; PREPARATION OF CUSTOM OR NON-CUSTOM ADVERTISING FOR BUSINESSES FOR DISSEMINATION VIA THE WEB, CD OR DVD FOR OPTIONAL UPLOAD OR DOWNLOAD TO A COMPUTER; PREPARING ADVERTISEMENTS FOR OTHERS; PREPARING ADVERTISEMENTS FOR OTHERS, NAMELY, PREPARING VIDEO ADVERTISING AND PROMOTIONAL VIDEOS FOR COMMERCIAL USE VIA THE INTERNET AND TELEVISION, DIGITAL CABLE AND VIDEO-ON-DEMAND OR DOWNLOAD; PREPARING AND PLACING ADVERTISEMENTS FOR OTHERS; PREPARING AND PLACING OF ADVERTISEMENTS; PREPARING AND PLACING OUTDOOR ADVERTISEMENTS FOR OTHERS; PREPARING AUDIOVISUAL PRESENTATIONS FOR USE IN ADVERTISING; PREPARING SPEECHES AND ORAL PRESENTATIONS FOR OTHERS FOR USE IN ADVERTISING; PROCESSING TELEPHONE INQUIRIES REGARDING ADVERTISED GOODS AND SERVICES; PRODUCTION OF ADVERTISING MATTER AND COMMERCIALS; PRODUCTION OF FILM AND TELEVISION ADVERTISING; PROMOTING AND MARKETING THE GOODS AND SERVICES OF OTHERS BY DISTRIBUTING ADVERTISING MATERIAL, COUPONS AND DISCOUNT OFFERS VIA TEXT MESSAGES; PROMOTING AND SHOWCASING THE GOODS OF OTHERS IN THE FIELD OF ENTERTAINMENT BY MEANS OF AN ON-LINE SHOPPING SITE WITH LINKS TO THE RETAIL ADVERTISEMENTS OF OTHERS; PROMOTING THE GOODS AND SERVICES OF OTHERS BY DISTRIBUTING ADVERTISING MATERIALS THROUGH A VARIETY OF METHODS; PROMOTING THE GOODS AND SERVICES OF OTHERS BY MEANS OF DISTRIBUTING ADVERTISING ON THE INTERNET; PROMOTING THE GOODS AND SERVICES OF OTHERS BY PREPARING AND PLACING ADVERTISEMENTS IN AN ELECTRONIC MAGAZINE ACCESSED THROUGH A GLOBAL COMPUTER NETWORK; PROMOTING, ADVERTISING AND MARKETING OF THE BRANDS, PRODUCTS, SERVICES OR ONLINE WEBSITES OF INDIVIDUALS, BUSINESSES AND NONPROFIT ORGANIZATIONS; PROMOTING, ADVERTISING AND MARKETING OF THE ON-LINE WEB SITES OF OTHERS; PROMOTING, ADVERTISING AND MARKETING THE ON-LINE DATABASES AND ELECTRONIC PUBLICATIONS OF OTHERS; PROMOTION, ADVERTISING AND MARKETING OF ON-LINE WEBSITES; PROMOTIONAL SERVICES, NAMELY, DISTRIBUTION OF ADVERTISING FLYERS, COUPONS, CATALOGS AND PROMOTIONAL ITEMS OF OTHERS;

CLASS 35—(Continued).

PROVIDING A SEARCHABLE ON-LINE ADVERTISING WEBSITE AND GUIDE FEATURING THE GOODS AND SERVICES OF OTHER VENDORS VIA THE INTERNET; PROVIDING A SEARCHABLE ONLINE ADVERTISING GUIDE FEATURING THE GOODS AND SERVICES OF ONLINE VENDORS; PROVIDING A SEARCHABLE ONLINE ADVERTISING GUIDE FEATURING THE GOODS AND SERVICES OF OTHER VENDORS ON THE INTERNET; PROVIDING A SEARCHABLE ONLINE ADVERTISING WEBSITE AND INFORMATIONAL GUIDE FEATURING THE GOODS AND SERVICES OF OTHER VENDORS VIA THE INTERNET IN THE FIELD OF ENTERTAINMENT; PROVIDING A WEB SITE AT WHICH FITNESS PROFESSIONALS AND FACILITIES CAN POST PROMOTIONAL PROFILES AND RESPOND TO ADVERTISEMENTS FOR THEIR SERVICES; PROVIDING A WEB SITE WHERE USERS CAN POST ITEMS FOR SALE THROUGH ON-LINE CLASSIFIED ADVERTISEMENTS; PROVIDING A WEB SITE WHICH FEATURES ADVERTISEMENTS FOR THE GOODS AND SERVICES OF OTHERS ON A GLOBAL COMPUTER NETWORK; PROVIDING ADVERTISING AND ADVERTISEMENT SERVICES; PROVIDING ADVERTISING SERVICE TO DISTRIBUTE ADVERTISEMENTS FOR DISPLAY ON INTERNET, NAMELY, IN WEBSITES, SOCIAL CONVERSATIONS OVER THE INTERNET, E-MAILS, MICROBLOGS, BLOGS, ELECTRONIC MESSAGES, INSTANT MESSAGES, TEXT MESSAGES, MULTIMEDIA MESSAGES, SOCIAL NETWORKS, STATUS UPDATES, FORUMS, ELECTRONIC BULLETIN BOARDS; PROVIDING ADVERTISING SERVICES; PROVIDING ADVERTISING SERVICES USING 3D AND ANIMATION DESIGNS; PROVIDING ADVERTISING SPACE IN PERIODICALS, NEWSPAPERS AND MAGAZINES; PROVIDING ADVERTISING SPACE ON BILLBOARDS AND IN KIOSKS; PROVIDING ADVERTISING SPACE ON FREE-STANDING VISUAL ADVERTISING SYSTEMS FEATURING THE GOODS AND SERVICES OF OTHERS; PROVIDING ADVERTISING, MARKETING AND PROMOTIONAL SERVICES FOR THE PHARMACEUTICAL AND MEDICAL INDUSTRY; PROVIDING ADVERTISING, MARKETING AND PROMOTIONAL SERVICES FOR THE PHARMACEUTICAL AND MEDICAL PRODUCTS OF OTHERS; PROVIDING ADVERTISING, MARKETING AND PROMOTIONAL SERVICES, NAMELY, DEVELOPMENT OF ADVERTISING CAMPAIGNS FOR ONLINE USERS; PROVIDING ADVERTISING, MARKETING AND PROMOTIONAL SERVICES, NAMELY, DEVELOPMENT OF ADVERTISING CAMPAIGNS PROVIDED THROUGH CABLE TELEVISION BROADCAST, WEB CASTS, RADIO BROADCASTS, NEWSPAPERS, MAGAZINES, ONLINE BANNERS, OUTDOOR BILLBOARDS, WILD POSTINGS, BUS AND SUBWAY ADS; PROVIDING AN INTERNET WEB SITE FOR CLASSIFIED ADVERTISING TO BUY AND SELL UKRAINIAN RELATED WARES, ART, ANTIQUES, BOOKS, EMBROIDERY, COSTUMES, COLLECTIBLES, INSTRUMENTS, MEMORABILIA AND OTHER ONE-OF-A-KIND ITEMS; PROVIDING AN INTERNET WEB SITE TO ADVERTISE SERVICES OF INTEREST TO THE UKRAINIAN COMMUNITY IN THE UNITED STATES OF AMERICA AND CANADA AND TO ADVERTISE SERVICES PROVIDED BY INDIVIDUALS OF UKRAINIAN ORIGIN; PROVIDING AN INTERNET WEBSITE PORTAL FEATURING PROMOTION AND ADVERTISING FOR HOME SERVICE PROVIDERS AND PRODUCT MANUFACTURERS; PROVIDING AN ONLINE DIRECTORY INFORMATION SERVICE FEATURING INFORMATION REGARDING VEHICLES IN THE NATURE OF CLASSIFIED ADVERTISEMENTS; PROVIDING AND RENTAL OF ADVERTISING SPACE ON THE INTERNET; PROVIDING ONLINE BUSINESS INFORMATION OF OTHERS, NAMELY, ADVERTISEMENTS OR SOLICITATIONS; PROVIDING SPACE AT A WEB SITE FOR THE ADVERTISEMENT OF THE GOODS AND SERVICES OF OTHERS; PROVIDING TELEVISION ADVERTISING FOR OTHERS; PROVISION OF ADVERTISING SPACE BY ELECTRONIC MEANS AND GLOBAL INFORMATION NETWORKS; PROVISION OF SPACE ON WEBSITES FOR ADVERTISING GOODS AND SERVICES; PUBLIC RELATIONS, ADVERTISING AND MARKETING SERVICES FOR THE TOURISM AND CONVENTION INDUSTRY, NAMELY, ORGANIZING AND HOSTING SITE INSPECTIONS AND FAMILIARIZATION TOURS FOR WHOLESALERS, TOUR OPERATORS, TRAVEL AGENTS, MEETING AND INCENTIVE

CLASS 35—(Continued).

TRAVEL PLANNERS AND TRAVEL MEDIA; PUBLISHING OF ADVERTISING TEXTS; REAL ESTATE ADVERTISING SERVICES; RECRUITMENT ADVERTISEMENT SERVICES, NAMELY, POSTING OF CLINICAL TRIAL NOTICES FOR THE PURPOSE OF RECRUITING PATIENTS FOR PARTICIPATION IN CLINICAL TRIALS FOR THE TESTING OF DRUGS; RENTAL OF ADVERTISEMENT SPACE AND ADVERTISING MATERIAL; RENTAL OF ADVERTISING SPACE; RENTAL OF ADVERTISING SPACE ON WEB SITES; RENTAL OF SIGNS FOR ADVERTISING PURPOSES; RENTING OF ADVERTISING SPACES; SERVICES OF ADVERTISING AGENCIES; SERVICES TO DETERMINE THE AUDIENCE AFFECTED BY ADVERTISEMENTS; SPECIAL EVENT PLANNING FOR COMMERCIAL, PROMOTIONAL OR ADVERTISING PURPOSES; SPECIALTY MERCHANDISING SERVICES, NAMELY, PROMOTING THE GOODS AND SERVICES OF OTHERS THROUGH THE DISTRIBUTION OF CUSTOMIZED ADVERTISING MATERIALS, NAMELY, PENS AND CATALOGS; TELEVISION ADVERTISING AGENCIES; VENDOR-ON-PREMISE SERVICES, NAMELY, THE ADMINISTRATION OF THE EMPLOYMENT PROCESS ON-SITE, INCLUDING RESUME REVIEW AND CHECKING, EMPLOYMENT APPLICATION ACQUISITION, ADVERTISING FOR RECRUITMENT, CONDUCT OF INTERVIEWS, AND REFERENCE CHECKING (U.S. CLS. 100, 101 AND 102).
DEBRA LEE, EXAMINING ATTORNEY

SN 85-245,712. RED LEAF ROI, LLC, AUSTIN, TX. FILED 2-18-2011.

BLINX

THE MARK CONSISTS OF STANDARD CHARACTERS WITHOUT CLAIM TO ANY PARTICULAR FONT, STYLE, SIZE, OR COLOR.

FOR ADVERTISING SERVICES, NAMELY ELECTRONIC BUSINESS CARD SERVICES (U.S. CLS. 100, 101 AND 102).

FIRST USE 12-20-2010; IN COMMERCE 12-20-2010.
DAVID ELTON, EXAMINING ATTORNEY

SN 85-245,733. FEDERAL HOME LOAN MORTGAGE CORPORATION, MCLEAN, VA. FILED 2-18-2011.

FMHPI

THE MARK CONSISTS OF STANDARD CHARACTERS WITHOUT CLAIM TO ANY PARTICULAR FONT, STYLE, SIZE, OR COLOR.

FOR DEVELOPMENT OF FINANCIAL INDICES TO TRACK RESIDENTIAL REAL ESTATE PRICES (U.S. CLS. 100, 101 AND 102).

LINDA POWELL, EXAMINING ATTORNEY

CLASS 35—(Continued).

SN 85-246,076. REED ELSEVIER PROPERTIES INC., WILMINGTON, DE. FILED 2-18-2011.



NO CLAIM IS MADE TO THE EXCLUSIVE RIGHT TO USE "EXECUTIVES CLUB", APART FROM THE MARK AS SHOWN.

THE MARK CONSISTS OF THE WORDS "EXECUTIVES CLUB" WITH A STYLIZED "E" AND "C" WITH A IMAGE OF A MALE GOLFER SWINGING A GOLF CLUB.

FOR ORGANIZING AND CONDUCTING TRADE SHOWS, BUSINESS CONFERENCES AND BUSINESS MEETINGS IN THE FIELD OF GOLF (U.S. CLS. 100, 101 AND 102).

WILLIAM P. SHANAHAN, EXAMINING ATTORNEY

CLASS 35—(Continued).

NATURE OF DESIGNING, ADMINISTERING, IMPLEMENTING, MANAGING AND OPERATING MEMBERSHIP AND CUSTOMER LOYALTY PROGRAMS FOR OTHERS; CUSTOMER LOYALTY SERVICES AND CUSTOMER CLUB SERVICES, FOR COMMERCIAL, PROMOTIONAL AND ADVERTISING PURPOSES; ADMINISTRATION OF A CONSUMER LOYALTY PROGRAM TO PROMOTE THE GOODS AND SERVICES OF OTHERS; AND ARRANGING AND CONDUCTING MARKETING PROMOTIONAL EVENTS FOR OTHERS; BUYING CLUB SERVICES; PROMOTING THE GOODS AND SERVICES OF OTHERS THROUGH THE DISTRIBUTION OF COUPONS AND DISCOUNT OFFERS, NAMELY, DISCOUNT COUPONS, ON-LINE DISCOUNT COUPON CODES, AND PURCHASE-ACTIVATED DISCOUNT BENEFITS, NAMELY, GIFT CARDS, STORED VALUE GIFT CARDS, REBATES, GIFTS, GIVE-AWAYS, DISCOUNTED PURCHASES, SHIPPING AND HANDLING CHARGE WAIVERS, REFUNDS TO THE PURCHASER'S ACCOUNT THROUGH THIRD PARTY PAYMENT PROCESSORS (U.S. CLS. 100, 101 AND 102).
FRANK LATTUCA, EXAMINING ATTORNEY

SN 85-246,352. SEMPRIS, LLC, MINNEAPOLIS, MN. FILED 2-18-2011.

SN 85-246,350. SEMPRIS, LLC, MINNEAPOLIS, MN. FILED 2-18-2011.

SEMPRIS Innovators at
enhancing customer
profitability

SEMPRIS
Innovators at enhancing customer profitability

THE MARK CONSISTS OF STANDARD CHARACTERS WITHOUT CLAIM TO ANY PARTICULAR FONT, STYLE, SIZE, OR COLOR.

FOR CONSUMER MEMBERSHIP PROGRAMS TO ENABLE PARTICIPANTS TO OBTAIN INFORMATION, REVIEWS, ASSESSMENTS, DISCOUNTS, SAVINGS AND REBATES ON GOODS AND SERVICES THROUGH USE OF A DISCOUNT MEMBERSHIP CARD FOR CONSUMER MERCHANDISE; ADMINISTRATION, MANAGEMENT AND OPERATION OF CONSUMER MEMBERSHIP PROGRAMS; MEMBERSHIP CLUB SERVICES PROVIDING DISCOUNTS AND PROCESSING REBATES FOR THE GOODS AND SERVICES OF OTHERS; CUSTOMER RELATIONSHIP MARKETING SERVICES; CUSTOMER RELATIONSHIP MANAGEMENT SERVICES; MARKETING SERVICES, NAMELY, DESIGNING, MAINTAINING, MODIFYING AND OPERATING CUSTOMER RELATIONSHIP MANAGEMENT PROGRAMS INTENDED TO PROMOTE CUSTOMER RETENTION AND INCREASE CUSTOMER LEVEL PROFIT; ADVERTISING SERVICES; PROMOTIONAL SERVICES; ADVERTISING, MARKETING AND PROMOTIONAL CONSULTING SERVICES; ADVERTISING, PROMOTION, AND MARKETING SERVICES IN THE

THE COLOR(S) DARK GREEN AND LIGHT GREEN IS/ ARE CLAIMED AS A FEATURE OF THE MARK.

THE MARK CONSISTS OF THE WORDS "SEMPRIS" IN STYLIZED AND CAPITALIZED DARK GREEN LETTERING ABOVE THE WORDS "INNOVATORS AT ENHANCING CUSTOMER PROFITABILITY" IN LIGHT GREEN LETTERING.

FOR CONSUMER MEMBERSHIP PROGRAMS TO ENABLE PARTICIPANTS TO OBTAIN INFORMATION, REVIEWS, ASSESSMENTS, DISCOUNTS, SAVINGS AND REBATES ON GOODS AND SERVICES THROUGH USE OF A DISCOUNT MEMBERSHIP CARD FOR CONSUMER MERCHANDISE; ADMINISTRATION, MANAGEMENT AND OPERATION OF CONSUMER MEMBERSHIP PROGRAMS; MEMBERSHIP CLUB SERVICES PROVIDING DISCOUNTS AND PROCESSING REBATES FOR THE GOODS AND SERVICES OF OTHERS; CUSTOMER RELATIONSHIP MARKETING SERVICES; CUSTOMER RELATIONSHIP MANAGEMENT SERVICES; MARKETING SERVICES, NAMELY, DESIGNING, MAINTAINING, MODIFYING AND OPERATING CUSTOMER RELATIONSHIP MANAGEMENT PROGRAMS INTENDED TO PROMOTE CUSTOMER RETENTION AND INCREASE CUSTOMER LEVEL PROFIT; ADVERTISING SERVICES; PROMOTIONAL SERVICES; ADVERTISING, MARKETING AND PROMOTIONAL CONSULTING SERVICES; ADVERTISING, PROMOTION, AND MARKETING SERVICES IN THE

CLASS 35—(Continued).

NATURE OF DESIGNING, ADMINISTERING, IMPLEMENTING, MANAGING AND OPERATING MEMBERSHIP AND CUSTOMER LOYALTY PROGRAMS FOR OTHERS; CUSTOMER LOYALTY SERVICES AND CUSTOMER CLUB SERVICES, FOR COMMERCIAL, PROMOTIONAL AND ADVERTISING PURPOSES; ADMINISTRATION OF A CONSUMER LOYALTY PROGRAM TO PROMOTE THE GOODS AND SERVICES OF OTHERS; AND ARRANGING AND CONDUCTING MARKETING PROMOTIONAL EVENTS FOR OTHERS; BUYING CLUB SERVICES; PROMOTING THE GOODS AND SERVICES OF OTHERS THROUGH THE DISTRIBUTION OF COUPONS AND DISCOUNT OFFERS, NAMELY, DISCOUNT COUPONS, ON-LINE DISCOUNT COUPON CODES, AND PURCHASE-ACTIVATED DISCOUNT BENEFITS, NAMELY, GIFT CARDS, STORED VALUE GIFT CARDS, REBATES, GIFTS, GIVE-AWAYS, DISCOUNTED PURCHASES, SHIPPING AND HANDLING CHARGE WAIVERS, REFUNDS TO THE PURCHASER'S ACCOUNT THROUGH THIRD PARTY PAYMENT PROCESSORS (U.S. CLS. 100, 101 AND 102).
FRANK LATTUCA, EXAMINING ATTORNEY

CLASS 35—(Continued).

NATURE OF DESIGNING, ADMINISTERING, IMPLEMENTING, MANAGING AND OPERATING MEMBERSHIP AND CUSTOMER LOYALTY PROGRAMS FOR OTHERS; CUSTOMER LOYALTY SERVICES AND CUSTOMER CLUB SERVICES, FOR COMMERCIAL, PROMOTIONAL AND ADVERTISING PURPOSES; ADMINISTRATION OF A CONSUMER LOYALTY PROGRAM TO PROMOTE THE GOODS AND SERVICES OF OTHERS; AND ARRANGING AND CONDUCTING MARKETING PROMOTIONAL EVENTS FOR OTHERS; BUYING CLUB SERVICES; PROMOTING THE GOODS AND SERVICES OF OTHERS THROUGH THE DISTRIBUTION OF COUPONS AND DISCOUNT OFFERS, NAMELY, DISCOUNT COUPONS, ON-LINE DISCOUNT COUPON CODES, AND PURCHASE-ACTIVATED DISCOUNT BENEFITS, NAMELY, GIFT CARDS, STORED VALUE GIFT CARDS, REBATES, GIFTS, GIVE-AWAYS, DISCOUNTED PURCHASES, SHIPPING AND HANDLING CHARGE WAIVERS, REFUNDS TO THE PURCHASER'S ACCOUNT THROUGH THIRD PARTY PAYMENT PROCESSORS (U.S. CLS. 100, 101 AND 102).
FRANK LATTUCA, EXAMINING ATTORNEY

SN 85-246,358. SEMPRIS, LLC, MINNEAPOLIS, MN. FILED 2-18-2011.

SN 85-246,360. SEMPRIS, LLC, MINNEAPOLIS, MN. FILED 2-18-2011.

SEMPRIS The Upsell Leader



SEMPRIS
The Upsell Leader

THE MARK CONSISTS OF STANDARD CHARACTERS WITHOUT CLAIM TO ANY PARTICULAR FONT, STYLE, SIZE, OR COLOR.

NO CLAIM IS MADE TO THE EXCLUSIVE RIGHT TO USE "UPSELL", APART FROM THE MARK AS SHOWN.

FOR CONSUMER MEMBERSHIP PROGRAMS TO ENABLE PARTICIPANTS TO OBTAIN INFORMATION, REVIEWS, ASSESSMENTS, DISCOUNTS, SAVINGS AND REBATES ON GOODS AND SERVICES THROUGH USE OF A DISCOUNT MEMBERSHIP CARD FOR CONSUMER MERCHANDISE; ADMINISTRATION, MANAGEMENT AND OPERATION OF CONSUMER MEMBERSHIP PROGRAMS; MEMBERSHIP CLUB SERVICES PROVIDING DISCOUNTS AND PROCESSING REBATES FOR THE GOODS AND SERVICES OF OTHERS; CUSTOMER RELATIONSHIP MARKETING SERVICES; CUSTOMER RELATIONSHIP MANAGEMENT SERVICES; MARKETING SERVICES, NAMELY, DESIGNING, MAINTAINING, MODIFYING AND OPERATING CUSTOMER RELATIONSHIP MANAGEMENT PROGRAMS INTENDED TO PROMOTE CUSTOMER RETENTION AND INCREASE CUSTOMER LEVEL PROFIT; ADVERTISING SERVICES; PROMOTIONAL SERVICES; ADVERTISING, MARKETING AND PROMOTIONAL CONSULTING SERVICES; ADVERTISING, PROMOTION, AND MARKETING SERVICES IN THE

NO CLAIM IS MADE TO THE EXCLUSIVE RIGHT TO USE "UPSELL", APART FROM THE MARK AS SHOWN.

THE COLOR(S) DARK GREEN AND LIGHT GREEN IS/ARE CLAIMED AS A FEATURE OF THE MARK.

THE MARK CONSISTS OF THE WORDS "SEMPRIS" IN STYLIZED AND CAPITALIZED DARK GREEN LETTERING ABOVE THE WORDS "THE UPSSELL LEADER" IN LIGHT GREEN LETTERING.

FOR CONSUMER MEMBERSHIP PROGRAMS TO ENABLE PARTICIPANTS TO OBTAIN INFORMATION, REVIEWS, ASSESSMENTS, DISCOUNTS, SAVINGS AND REBATES ON GOODS AND SERVICES THROUGH USE OF A DISCOUNT MEMBERSHIP CARD FOR CONSUMER MERCHANDISE; ADMINISTRATION, MANAGEMENT AND OPERATION OF CONSUMER MEMBERSHIP PROGRAMS; MEMBERSHIP CLUB SERVICES PROVIDING DISCOUNTS AND PROCESSING REBATES FOR THE GOODS AND SERVICES OF OTHERS; CUSTOMER RELATIONSHIP MARKETING SERVICES; CUSTOMER RELATIONSHIP MANAGEMENT SERVICES; MARKETING SERVICES, NAMELY, DESIGNING, MAINTAINING, MODIFYING AND OPERATING CUSTOMER RELATIONSHIP MANAGEMENT PROGRAMS INTENDED TO PROMOTE CUSTOMER RETENTION AND INCREASE CUSTOMER LEVEL PROFIT; ADVERTISING SERVICES; PROMOTIONAL SERVICES; ADVERTISING, MARKETING AND PROMOTIONAL CONSULTING SERVICES; ADVERTISING, PROMOTION, AND MARKETING SERVICES IN THE

CLASS 35—(Continued).

NATURE OF DESIGNING, ADMINISTERING, IMPLEMENTING, MANAGING AND OPERATING MEMBERSHIP AND CUSTOMER LOYALTY PROGRAMS FOR OTHERS; CUSTOMER LOYALTY SERVICES AND CUSTOMER CLUB SERVICES, FOR COMMERCIAL, PROMOTIONAL AND ADVERTISING PURPOSES; ADMINISTRATION OF A CONSUMER LOYALTY PROGRAM TO PROMOTE THE GOODS AND SERVICES OF OTHERS; AND ARRANGING AND CONDUCTING MARKETING PROMOTIONAL EVENTS FOR OTHERS; BUYING CLUB SERVICES; PROMOTING THE GOODS AND SERVICES OF OTHERS THROUGH THE DISTRIBUTION OF COUPONS AND DISCOUNT OFFERS, NAMELY, DISCOUNT COUPONS, ON-LINE DISCOUNT COUPON CODES, AND PURCHASE-ACTIVATED DISCOUNT BENEFITS, NAMELY, GIFT CARDS, STORED VALUE GIFT CARDS, REBATES, GIFTS, GIVE-AWAYS, DISCOUNTED PURCHASES, SHIPPING AND HANDLING CHARGE WAIVERS, REFUNDS TO THE PURCHASER'S ACCOUNT THROUGH THIRD PARTY PAYMENT PROCESSORS (U.S. CLS. 100, 101 AND 102).
FRANK LATTUCA, EXAMINING ATTORNEY

SN 85-246,478. THE CAMERA EXCHANGE, INC., SAN ANTONIO, TX. FILED 2-18-2011.



NO CLAIM IS MADE TO THE EXCLUSIVE RIGHT TO USE "CAMERA" AND "INC", APART FROM THE MARK AS SHOWN.

THE MARK CONSISTS OF IMAGE OF A CAMERA WITH THE WORDS "THE CAMERA EXCHANGE INC". THEREON.

FOR RETAIL STORE SERVICES FEATURING PHOTOGRAPHIC AND VIDEO EQUIPMENT AND RELATED ACCESSORIES (U.S. CLS. 100, 101 AND 102).

FIRST USE 12-31-1975; IN COMMERCE 12-31-1975.
JASON TURNER, EXAMINING ATTORNEY

SN 85-246,627. BIBBES-RICHARDSON, RAGE, SAN DIEGO, CA. FILED 2-18-2011.

Operation Smoke Free

THE MARK CONSISTS OF STANDARD CHARACTERS WITHOUT CLAIM TO ANY PARTICULAR FONT, STYLE, SIZE, OR COLOR.

NO CLAIM IS MADE TO THE EXCLUSIVE RIGHT TO USE "SMOKE FREE", APART FROM THE MARK AS SHOWN.

FOR PROMOTING, ADVERTISING AND MARKETING OF THE BRANDS, PRODUCTS, SERVICES OR ONLINE WEBSITES OF INDIVIDUALS, BUSINESSES AND NONPROFIT ORGANIZATIONS (U.S. CLS. 100, 101 AND 102).

LAURIE KAUFMAN, EXAMINING ATTORNEY

CLASS 35—(Continued).

SN 85-246,819. PRAIRIE GROVE FARMS OF IOWA, LLC, SIOUX CENTER, IA. FILED 2-18-2011.



OWNER OF U.S. REG. NO. 3,129,375.

NO CLAIM IS MADE TO THE EXCLUSIVE RIGHT TO USE "FARMS", APART FROM THE MARK AS SHOWN.

THE MARK CONSISTS OF A BARN WITH A SUN AND A FIELD WITH A PARTIAL CIRCLE OVER THE SUN AND FIELD, OVER A BANNER CONTAINING THE TERM "PRAIRIE GROVE" WITH THE WORD "FARMS" SUPERIMPOSED.

FOR RETAIL AND ONLINE RETAIL STORE SERVICES FEATURING FRESH, FROZEN AND PROCESSED MEATS, LUNCHEON MEATS, BEEF, POULTRY, PORK, LAMB, EGGS, CHEESE, DAIRY PRODUCTS, READY-TO-EAT MEALS, PREPACKAGED MEALS, CONDIMENTS, SPICES, SAUCES, RUBS, SEASONINGS, MARINADES, MEAT-BASED SNACKS, AND COOKBOOKS; FOOD KIOSK SERVICES (U.S. CLS. 100, 101 AND 102).

AMY HELLA, EXAMINING ATTORNEY

SN 85-246,821. PRAIRIE GROVE FARMS OF IOWA, LLC, SIOUX CENTER, IA. FILED 2-18-2011.

GREAT TASTE WITHOUT THE WORRY

THE MARK CONSISTS OF STANDARD CHARACTERS WITHOUT CLAIM TO ANY PARTICULAR FONT, STYLE, SIZE, OR COLOR.

FOR RETAIL AND ONLINE RETAIL STORE SERVICES FEATURING FRESH, FROZEN AND PROCESSED MEATS, LUNCHEON MEATS, BEEF, POULTRY, PORK, LAMB, EGGS, CHEESE, DAIRY PRODUCTS, READY-TO-EAT MEALS, PREPACKAGED MEALS, CONDIMENTS, SPICES, SAUCES, RUBS, SEASONINGS, MARINADES, MEAT-BASED SNACKS, AND COOKBOOKS; FOOD KIOSK SERVICES (U.S. CLS. 100, 101 AND 102).

AMY HELLA, EXAMINING ATTORNEY

CLASS 35—(Continued).

SN 85-247,443. PAM RODGERS INTERIORS, INC., DBA BEDDING MART, CONWAY, AR. FILED 2-21-2011.

good sleep is priceless...
we make it affordable!

THE MARK CONSISTS OF STANDARD CHARACTERS WITHOUT CLAIM TO ANY PARTICULAR FONT, STYLE, SIZE, OR COLOR.

FOR RETAIL STORE SERVICES FEATURING MATTRESSES, PILLOWS, MATTRESS PROTECTORS, BED FRAMES, AND ADJUSTABLE BED BASES (U.S. CLS. 100, 101 AND 102).

FIRST USE 8-1-2005; IN COMMERCE 3-1-2006.
INGA ERVIN, EXAMINING ATTORNEY

CLASS 35—(Continued).

SN 85-247,675. MADJ, INC., PHOENIX, AZ. FILED 2-21-2011.

LODI

THE MARK CONSISTS OF STANDARD CHARACTERS WITHOUT CLAIM TO ANY PARTICULAR FONT, STYLE, SIZE, OR COLOR.

OWNER OF U.S. REG. NO. 3,138,416.
FOR RETAIL STORE SERVICES FEATURING DOORS, GARAGE FLOORS, GARAGE CABINETS, SOLAR ENERGY SYSTEMS AND ALTERNATIVE ENERGY PRODUCTS FOR RESIDENTIAL AND COMMERCIAL USE (U.S. CLS. 100, 101 AND 102).

FIRST USE 2-21-2011; IN COMMERCE 2-21-2011.
HENRY S. ZAK, EXAMINING ATTORNEY

SN 85-247,701. WAL-MART STORES, INC., BENTONVILLE, AR. FILED 2-21-2011.

WALMART EXPRESS

THE MARK CONSISTS OF STANDARD CHARACTERS WITHOUT CLAIM TO ANY PARTICULAR FONT, STYLE, SIZE, OR COLOR.

NO CLAIM IS MADE TO THE EXCLUSIVE RIGHT TO USE "EXPRESS", APART FROM THE MARK AS SHOWN.
FOR RETAIL STORE SERVICES FEATURING A WIDE VARIETY OF CONSUMER GOODS OF OTHERS (U.S. CLS. 100, 101 AND 102).

SAMUEL E. SHARPER JR., EXAMINING ATTORNEY

SN 85-247,710. HUSONG, RICK, LOS ANGELES, CA. FILED 2-21-2011.

Ideas Alive

THE MARK CONSISTS OF STANDARD CHARACTERS WITHOUT CLAIM TO ANY PARTICULAR FONT, STYLE, SIZE, OR COLOR.

NO CLAIM IS MADE TO THE EXCLUSIVE RIGHT TO USE "IDEAS", APART FROM THE MARK AS SHOWN.
FOR ADVERTISING AND MARKETING CONSULTANCY (U.S. CLS. 100, 101 AND 102).

KAREN K. BUSH, EXAMINING ATTORNEY

SN 85-247,645. RUNDAISY LLC, HENDERSONVILLE, TN. FILED 2-21-2011.



THE COLOR(S) RED, BLACK, PINK, BLUE, PEACH, GRAY, YELLOW, GREEN AND WHITE IS/ARE CLAIMED AS A FEATURE OF THE MARK.

THE MARK CONSISTS OF A FIGURE OF A WOMAN BEARING FLOWERS, HER HAIR IS RED, HER EYES ARE BLACK, HER LIPS ARE PINK, HER DRESS IS BLUE, HER STOCKINGS ARE GRAY, HER SHOES ARE YELLOW, HER SKIN IS PEACH AND THE FLOWERS ARE WHITE AND YELLOW WITH GREEN STEMS.

FOR PROMOTING THE GOODS AND SERVICES OF OTHERS BY PROVIDING A WEBSITE FEATURING COUPONS, REBATES, PRICE-COMPARISON INFORMATION, PRODUCT REVIEWS, LINKS TO THE RETAIL WEBSITES OF OTHERS, AND DISCOUNT INFORMATION (U.S. CLS. 100, 101 AND 102).

FIRST USE 10-25-2010; IN COMMERCE 10-25-2010.
KATHLEEN LORENZO, EXAMINING ATTORNEY

CLASS 35—(Continued).

SN 85-247,767. LEXIMA, JEANOSE, WASHINGTON, DC. FILED 2-21-2011.

Women on Change (Womenonchange.org).

THE MARK CONSISTS OF STANDARD CHARACTERS WITHOUT CLAIM TO ANY PARTICULAR FONT, STYLE, SIZE, OR COLOR.

FOR CHARITABLE SERVICES, NAMELY, ORGANIZING AND DEVELOPING PROJECTS THAT AIM TO IMPROVE THE LIVES OF UNDERPRIVILEGED AND IMPOVERISHED PEOPLE (U.S. CLS. 100, 101 AND 102).
MORGAN WYNNE, EXAMINING ATTORNEY

SN 85-247,833. CALFOLOGY, INC., WINDSOR, CO. FILED 2-22-2011.

Official Sponsor of Calf Health

THE MARK CONSISTS OF STANDARD CHARACTERS WITHOUT CLAIM TO ANY PARTICULAR FONT, STYLE, SIZE, OR COLOR.

NO CLAIM IS MADE TO THE EXCLUSIVE RIGHT TO USE "CALF HEALTH", APART FROM THE MARK AS SHOWN.

FOR ADVERTISING AND ADVERTISEMENT SERVICES; ADVERTISING AND BUSINESS SERVICES, NAMELY, PROVIDING AN ONLINE WEBSITE WHERE ADVERTISERS, MARKETERS, AND CONTENT PROVIDERS CAN INTERACT WITH USERS FOR ADVERTISING, BRANDING, AND PROMOTING KNOWLEDGE, PRODUCTS, AND SERVICES, AND TRADE SHOWS, ON BEHALF OF THEMSELVES AND OTHERS, AND FOR EVALUATING AND RATING THE SAME, ALL THE FOREGOING RELEVANT TO HUMAN ACTIVITIES AFFECTING CLIMATE CHANGE AND RELATED FIELDS; ADVERTISING AND MARKETING SERVICES PROVIDED BY MEANS OF INDIRECT METHODS OF MARKETING COMMUNICATIONS, NAMELY, SOCIAL MEDIA, SEARCH ENGINE MARKETING, INQUIRY MARKETING, INTERNET MARKETING, MOBILE MARKETING, BLOGGING AND OTHER FORMS OF PASSIVE, SHARABLE OR VIRAL COMMUNICATIONS CHANNELS; ADVERTISING AND MARKETING SERVICES, NAMELY, PROMOTING THE GOODS AND SERVICES OF OTHERS; ADVERTISING IN PERIODICALS, BROCHURES AND NEWSPAPERS; ADVERTISING ON THE INTERNET FOR OTHERS; ADVERTISING PARTICULARLY SERVICES FOR THE PROMOTION OF GOODS; ADVERTISING SERVICES, NAMELY, PROMOTING THE BRANDS, GOODS AND SERVICES OF OTHERS; COMPUTER SERVICES, NAMELY, PROVIDING CONSUMER INFORMATION IN THE FIELD OF ANIMALS AND PETS RELATING TO PET PRODUCTS, PET TREATS AND PET TOYS; DISSEMINATION OF ADVERTISING MATTER; MANAGEMENT AND BUSINESS CONSULTING SERVICES IN THE FIELD OF BOVINE HUSBANDRY AND VETERINARY; ON-LINE ADVERTISING AND MARKETING SERVICES; ORGANIZATION OF EVENTS, EXHIBITIONS, FAIRS AND SHOWS FOR COMMERCIAL, PROMOTIONAL AND ADVERTISING PURPOSES; PLANNING AND CONDUCTING OF TRADE FAIRS, EXHIBITIONS AND PRE-

CLASS 35—(Continued).

SENTATIONS FOR ECONOMIC OR ADVERTISING PURPOSES; PROMOTING AND SHOWCASING THE GOODS OF OTHERS IN THE FIELD OF ANIMAL HUSBANDRY AND AGRICULTURE BY MEANS OF AN ON-LINE SHOPPING SITE WITH LINKS TO THE RETAIL ADVERTISEMENTS OF OTHERS PROMOTING THE GOODS AND SERVICES OF THOSE IN THE BEEF AND DAIRY CALF INDUSTRIES THROUGH ON-LINE ORDERING AND CATALOGING OF THOSE GOODS AND SERVICES; PROMOTING, ADVERTISING AND MARKETING OF THE BRANDS, PRODUCTS, SERVICES OR ONLINE WEBSITES OF INDIVIDUALS, BUSINESSES AND NONPROFIT ORGANIZATIONS; PROVIDING A SEARCHABLE ON-LINE ADVERTISING WEBSITE AND GUIDE FEATURING THE GOODS AND SERVICES OF OTHER VENDORS VIA THE INTERNET; PROVIDING A SEARCHABLE ONLINE ADVERTISING WEBSITE AND INFORMATIONAL GUIDE FEATURING THE GOODS AND SERVICES OF OTHER VENDORS VIA THE INTERNET IN THE FIELD OF ANIMAL HUSBANDRY AND AGRICULTURE (U.S. CLS. 100, 101 AND 102).

FIRST USE 2-1-2011; IN COMMERCE 2-1-2011.
LAURA KOVALSKY, EXAMINING ATTORNEY

SN 85-247,957. FULTON, STEPHEN C., MACON, GA. FILED 2-22-2011.

F.A.D.D.

THE MARK CONSISTS OF STANDARD CHARACTERS WITHOUT CLAIM TO ANY PARTICULAR FONT, STYLE, SIZE, OR COLOR.

FOR PROMOTING PUBLIC AWARENESS OF THE DANGERS OF DRIVING WHILE BEING DROWSY AND THE NEED TO PROVIDE SUPPORT FOR THOSE WHO HAVE BEEN VICTIMIZED (U.S. CLS. 100, 101 AND 102).

FIRST USE 1-10-2010; IN COMMERCE 1-10-2010.
MARK T. MULLEN, EXAMINING ATTORNEY

CLASS 35—(Continued).

SN 85-248,089. LOVE LABELS, PLANT CITY, FL. FILED 2-22-2011.



THE COLOR(S) PINK AND BROWN IS/ARE CLAIMED AS A FEATURE OF THE MARK.

THE MARK CONSISTS OF PINK-COLORED STYLIZED TEXT "LOVE" FOLLOWED BY BROWN-COLORED STYLIZED TEXT "LABELS". POSITIONED ABOVE THE "LOVE LABELS" TEXT, A PINK-COLORED HORIZONTALLY-ORIENTED STYLIZED/CURSIVE "L" CONTIGUOUS WITH AND PARTIALLY OVERLAPPING A BROWN-COLORED HORIZONTALLY-ORIENTED STYLIZED/CURSIVE "L" WHEREIN THE CONTIGUOUS "L"'S HAVE THE APPEARANCE OF A PAIR OF OVERLAPPING HEARTS.

FOR ON-LINE AUCTION SERVICES; ON-LINE AUCTIONEERING SERVICES VIA THE INTERNET (U.S. CLS. 100, 101 AND 102).

CARRIE GENOVESE, EXAMINING ATTORNEY

CLASS 35—(Continued).

SN 85-248,187. THORNBERG & FORESTER, NEW YORK, NY. FILED 2-22-2011.

Design is Law

THE MARK CONSISTS OF STANDARD CHARACTERS WITHOUT CLAIM TO ANY PARTICULAR FONT, STYLE, SIZE, OR COLOR.

NO CLAIM IS MADE TO THE EXCLUSIVE RIGHT TO USE "DESIGN", APART FROM THE MARK AS SHOWN.

FOR ADVERTISING SERVICES, NAMELY, PRODUCTION OF SPECIAL EFFECTS INCLUDING MODEL-MAKING SERVICES, COMPUTER-GENERATED IMAGERY AND COMPUTER-GENERATED GRAPHICS FOR THE PRODUCTION OF COMMERCIALS; BUSINESS CARD DESIGN SERVICES; CREATIVE MARKETING DESIGN SERVICES; DESIGN OF ADVERTISING MATERIALS FOR OTHERS; PROVIDING ADVERTISING SERVICES USING 3D AND ANIMATION DESIGNS; PROVIDING ADVERTISING, MARKETING AND PROMOTIONAL SERVICES, NAMELY, DEVELOPMENT OF ADVERTISING CAMPAIGNS FOR TELEVISION (U.S. CLS. 100, 101 AND 102).

FIRST USE 1-1-2011; IN COMMERCE 1-1-2011.

KATHY DE JONGE, EXAMINING ATTORNEY

SN 85-248,186. JONES-STAATS LOGISTICS, LLC, DALLAS, TX. FILED 2-22-2011.



NO CLAIM IS MADE TO THE EXCLUSIVE RIGHT TO USE "LOGISTICS", APART FROM THE MARK AS SHOWN.

THE MARK CONSISTS OF THE STYLIZED TEXT "JSL JONES-STAATS LOGISTICS".

FOR TRANSPORTATION LOGISTICS SERVICES, NAMELY, ARRANGING THE TRANSPORTATION OF GOODS FOR OTHERS (U.S. CLS. 100, 101 AND 102).

KATHY DE JONGE, EXAMINING ATTORNEY

SN 85-248,266. MEDICAL MEDIA SOLUTIONS, INC, CHERY HILL, NJ. FILED 2-22-2011.

Strategic Medical Media Network

THE MARK CONSISTS OF STANDARD CHARACTERS WITHOUT CLAIM TO ANY PARTICULAR FONT, STYLE, SIZE, OR COLOR.

NO CLAIM IS MADE TO THE EXCLUSIVE RIGHT TO USE "MEDICAL MEDIA NETWORK", APART FROM THE MARK AS SHOWN.

FOR DEVELOPMENT, OPERATION AND ADMINISTRATION OF DIGITAL SIGNAGE SYSTEMS AND DIGITAL ADVERTISING SYSTEMS FOR OTHERS, NAMELY, PROVIDING ADVERTISING SPACE BY ELECTRONIC MEANS AND GLOBAL COMPUTER INFORMATION NETWORKS (U.S. CLS. 100, 101 AND 102).

FIRST USE 12-1-2010; IN COMMERCE 12-1-2010.

JEFF DEFORD, EXAMINING ATTORNEY

CLASS 35—(Continued).

SN 85-248,423. ESQUARED MEETINGS AND EVENTS, LLC, ORLANDO, FL. FILED 2-22-2011.

Esquared Meetings & Events

THE MARK CONSISTS OF STANDARD CHARACTERS WITHOUT CLAIM TO ANY PARTICULAR FONT, STYLE, SIZE, OR COLOR.

NO CLAIM IS MADE TO THE EXCLUSIVE RIGHT TO USE "MEETINGS" OR "EVENTS", APART FROM THE MARK AS SHOWN.

FOR BUSINESS MEETING PLANNING (U.S. CLS. 100, 101 AND 102).

ANDREW LEASER, EXAMINING ATTORNEY

SN 85-248,435. TRELIANT RISK ADVISORS, LLC, WASHINGTON, DC. FILED 2-22-2011.

FIERA

THE MARK CONSISTS OF STANDARD CHARACTERS WITHOUT CLAIM TO ANY PARTICULAR FONT, STYLE, SIZE, OR COLOR.

THE ENGLISH TRANSLATION OF THE MARK IS "FAIR".

FOR ANALYZING AND COMPILING DATA FOR ASSESSING THE ENTERPRISE RISK PROFILE OF FINANCIAL COMPANIES, INSTITUTIONS AND FINANCIAL PRODUCTS SUCH AS LOAN PORTFOLIOS (U.S. CLS. 100, 101 AND 102).

ANDREW LEASER, EXAMINING ATTORNEY

SN 85-248,451. EXHIBIT WORKS, INC., DBA EWI WORLDWIDE, LIVONIA, MI. FILED 2-22-2011.



an ewi worldwide company

OWNER OF U.S. REG. NO. 3,954,135.

NO CLAIM IS MADE TO THE EXCLUSIVE RIGHT TO USE "SHOW SERVICES" AND "WORLDWIDE COMPANY", APART FROM THE MARK AS SHOWN.

THE COLOR(S) GRAY AND ORANGE IS/ARE CLAIMED AS A FEATURE OF THE MARK.

THE MARK CONSISTS OF THE WORDS "TANARI SHOW SERVICES" IN LOWERCASE GRAY COLORED LETTERS,

CLASS 35—(Continued).

WITH THE "I" IN THE WORD "TANARI" DOTTED WITH AN ORANGE RECTANGLE, AND THE WORDS "SHOW SERVICES" IN SMALLER LOWERCASE GRAY COLORED LETTERS POSITIONED IMMEDIATELY BELOW THE WORD "TANARI", TOGETHER THE WORDS "TANARI" AND "SHOW SERVICES" ARE WITHIN A PARTIALLY-OPENED GRAY SQUARE BORDER AND POSITIONED IMMEDIATELY BELOW THE PARTIALLY-OPENED GRAY SQUARE BORDER ARE THE WORDS "AN EWI WORLDWIDE COMPANY" IN GRAY COLORED LETTERS.

FOR ADVERTISING, MARKETING AND PROMOTION SERVICES, NAMELY, PROMOTING THE GOODS AND SERVICES OF OTHERS BY PROVIDING CUSTOMIZED EXHIBITS (U.S. CLS. 100, 101 AND 102).

APRIL ROACH, EXAMINING ATTORNEY

SN 85-248,491. HILLTOP TEA, INC., NEW PROVIDENCE, NJ. FILED 2-22-2011.

TEAPH.D

THE MARK CONSISTS OF STANDARD CHARACTERS WITHOUT CLAIM TO ANY PARTICULAR FONT, STYLE, SIZE, OR COLOR.

FOR PROVIDING CONSUMER INFORMATION ABOUT FOOD PRODUCTS (U.S. CLS. 100, 101 AND 102).

MARK PILARO, EXAMINING ATTORNEY

SN 85-248,615. ALFA CORPORATION, MONTGOMERY, AL. FILED 2-22-2011.

MY ALFA

THE MARK CONSISTS OF STANDARD CHARACTERS WITHOUT CLAIM TO ANY PARTICULAR FONT, STYLE, SIZE, OR COLOR.

OWNER OF U.S. REG. NOS. 2,671,861, 3,656,202 AND OTHERS.

FOR ONLINE COMPUTER SERVICES PROVIDING CUSTOMER INFORMATION IN THE FIELDS OF INSURANCE AND ANNUITY ADMINISTRATION, EVALUATION, PROCESSING AND CLAIMS ADMINISTRATION AND PROCESSING (U.S. CLS. 100, 101 AND 102).

FIRST USE 4-0-2009; IN COMMERCE 8-0-2010.

MARK RADEMACHER, EXAMINING ATTORNEY

CLASS 35—(Continued).

SN 85-248,620. COAST CRANE COMPANY, SEATTLE, WA.
FILED 2-22-2011.

COAST CRANE COMPANY

THE MARK CONSISTS OF STANDARD CHARACTERS WITHOUT CLAIM TO ANY PARTICULAR FONT, STYLE, SIZE, OR COLOR.

NO CLAIM IS MADE TO THE EXCLUSIVE RIGHT TO USE "CRANE COMPANY", APART FROM THE MARK AS SHOWN.

FOR RESELLER SERVICES, NAMELY, DISTRIBUTORSHIP SERVICES IN THE FIELD OF CRANES (U.S. CLS. 100, 101 AND 102).

FIRST USE 12-31-1984; IN COMMERCE 12-31-1984.
NAKIA HENRY, EXAMINING ATTORNEY

SN 85-248,633. MONTY THOMPSON, WOODY CREEK, CO.
FILED 2-22-2011.

Double Dunk

THE MARK CONSISTS OF STANDARD CHARACTERS WITHOUT CLAIM TO ANY PARTICULAR FONT, STYLE, SIZE, OR COLOR.

FOR ADVERTISING, MARKETING AND PROMOTION SERVICES (U.S. CLS. 100, 101 AND 102).

JOHN KELLY, EXAMINING ATTORNEY

SN 85-248,852. IDEALGOLFER LLC, IRVING, TX. FILED 2-22-2011.

IDEALGOLFER

THE MARK CONSISTS OF STANDARD CHARACTERS WITHOUT CLAIM TO ANY PARTICULAR FONT, STYLE, SIZE, OR COLOR.

FOR PROMOTING THE GOODS AND SERVICES OF OTHERS BY PROVIDING A WEBSITE FEATURING COUPONS, REBATES, PRODUCT REVIEWS AND LINKS TO RETAIL WEBSITES OF OTHERS (U.S. CLS. 100, 101 AND 102).

FIRST USE 11-1-2010; IN COMMERCE 11-1-2010.
REBECCA EISINGER, EXAMINING ATTORNEY

CLASS 35—(Continued).

SN 85-249,038. ABDELHAG, FAHED, LAKEWOOD, OH.
AND ABDELHAQ, YAZED, LAKEWOOD, OH. AND
ABDELHAQ, ZIAD, LAKEWOOD, OH. FILED 2-23-2011.

KRUSH EXCLUSIVE

THE MARK CONSISTS OF STANDARD CHARACTERS WITHOUT CLAIM TO ANY PARTICULAR FONT, STYLE, SIZE, OR COLOR.

NO CLAIM IS MADE TO THE EXCLUSIVE RIGHT TO USE "EXCLUSIVE", APART FROM THE MARK AS SHOWN. FOR RETAIL CLOTHING STORES (U.S. CLS. 100, 101 AND 102).

FIRST USE 0-0-2002; IN COMMERCE 0-0-2002.

JAMES MACFARLANE, EXAMINING ATTORNEY

SN 85-249,153. BOBCAR INC., NEW YORK, NY. FILED 2-23-2011.

**BOBCAR MOBILE BEAUTY
BOUTIQUE**

THE MARK CONSISTS OF STANDARD CHARACTERS WITHOUT CLAIM TO ANY PARTICULAR FONT, STYLE, SIZE, OR COLOR.

NO CLAIM IS MADE TO THE EXCLUSIVE RIGHT TO USE "MOBILE BEAUTY BOUTIQUE", APART FROM THE MARK AS SHOWN.

FOR ADVERTISING SERVICES, NAMELY, PROVIDING ADVERTISING ON AND IN VEHICLES; PROVIDING A MOBILE DEMONSTRATION SHOWROOM ON AND IN VEHICLES FOR ADVERTISING THE GOODS OF OTHERS IN THE FIELDS OF COSMETICS, FRAGRANCES, BEAUTY AIDS, PERSONAL CARE PRODUCTS, BATH, BODY AND BEAUTY CARE PRODUCTS; RETAIL STORE SERVICES IN THE NATURE OF BOUTIQUES ON AND IN VEHICLES FEATURING COSMETICS, FRAGRANCES, BEAUTY AIDS, PERSONAL CARE PRODUCTS, BATH, BODY AND BEAUTY CARE PRODUCTS (U.S. CLS. 100, 101 AND 102).

KAREN SEVERSON, EXAMINING ATTORNEY

CLASS 35—(Continued).

SN 85-249,318. EMOTIONAL BRANDING ALLIANCE, LLC, NEW YORK, NY. FILED 2-23-2011.

SOCIAL VOICE

THE MARK CONSISTS OF STANDARD CHARACTERS WITHOUT CLAIM TO ANY PARTICULAR FONT, STYLE, SIZE, OR COLOR.

NO CLAIM IS MADE TO THE EXCLUSIVE RIGHT TO USE "SOCIAL", APART FROM THE MARK AS SHOWN.

FOR BRAND MARKETING AND CONSULTING SERVICES, NAMELY, BRAND CONCEPT CREATION, BRAND DESIGN, BRAND MARKETING AND COMMUNICATION, AND GO-TO-MARKET IMPLEMENTATION, UTILIZING BRANDED CONSUMER ENGAGEMENT, NEUROSCIENCE, SOCIO-CULTURAL, MARKET TREND AND CORPORATE SOCIAL RESPONSIBILITY BASED MARKET RESEARCH (U.S. CLS. 100, 101 AND 102).

JAMES GRIFFIN, EXAMINING ATTORNEY

SN 85-249,360. PHIL BERGER, RIVERDALE, NY. FILED 2-23-2011.



THE COLOR(S) BLUE, ORANGE AND WHITE IS/ARE CLAIMED AS A FEATURE OF THE MARK.

THE MARK CONSISTS OF THE STYLIZED WORDS "I AM TALENT", WITH A MICROPHONE FORMING THE LETTER "I", AND A CORD CURVING BENEATH THE MICROPHONE AND UNDER THE WORD "AM". THE BOTTOM OF THE MICROPHONE, THE MICROPHONE CORD AND "TALENT" ARE BLUE. THE TOP OF THE MICROPHONE IS ORANGE AND WHITE. THE WORD "AM" IS ORANGE.

FOR AN INTERACTIVE WEB SITE FOR USERS TO REVIEW AND RATE INTERNET CONTENT, PEOPLE, COMPANIES, PRODUCTS AND/OR SERVICES UTILIZING A SOFTWARE APPLICATION TO AWARD POINTS WHEREBY WEB SITE USERS ARE ELIGIBLE TO EXCHANGE POINTS EARNED FOR PROMOTIONAL ITEMS CONSISTING OF COUPONS, REBATES, DISCOUNTS OR SPECIAL OFFERINGS ON GOODS AND/OR SERVICE PROVIDED BY WEB SITE SPONSORS (U.S. CLS. 100, 101 AND 102).

IRA J. GOODSaid, EXAMINING ATTORNEY

CLASS 35—(Continued).

SN 85-249,632. LIFESTYLE VESTED, INC., CARSON CITY, NV. FILED 2-23-2011.

WE BUY SEXY HOUSES

THE MARK CONSISTS OF STANDARD CHARACTERS WITHOUT CLAIM TO ANY PARTICULAR FONT, STYLE, SIZE, OR COLOR.

NO CLAIM IS MADE TO THE EXCLUSIVE RIGHT TO USE "WE BUY" OR "HOUSES", APART FROM THE MARK AS SHOWN.

FOR PROVIDING MARKETING SOLUTIONS FOR REAL ESTATE PROFESSIONALS (U.S. CLS. 100, 101 AND 102).

FIRST USE 2-23-2011; IN COMMERCE 2-23-2011.

KATHERINE CHANG, EXAMINING ATTORNEY

SN 85-249,733. INNOVID, NEW YORK, NY. FILED 2-23-2011.

iRoll Apps

THE MARK CONSISTS OF STANDARD CHARACTERS WITHOUT CLAIM TO ANY PARTICULAR FONT, STYLE, SIZE, OR COLOR.

OWNER OF U.S. REG. NO. 3,847,429.

NO CLAIM IS MADE TO THE EXCLUSIVE RIGHT TO USE "APPS", APART FROM THE MARK AS SHOWN.

FOR PROVIDING INTERACTIVE DYNAMIC VIDEO ADVERTISING FOR DISPLAY ON PERSONAL COMPUTERS, MOBILE TELEPHONES AND TELEVISION (U.S. CLS. 100, 101 AND 102).

FIRST USE 4-4-2011; IN COMMERCE 4-4-2011.

JANICE L. MCMORROW, EXAMINING ATTORNEY

SN 85-250,079. BLUE MOON PARTS, LLC, MIDLAND, TX. FILED 2-23-2011.



NO CLAIM IS MADE TO THE EXCLUSIVE RIGHT TO USE "PARTS", APART FROM THE MARK AS SHOWN.

THE MARK CONSISTS OF STYLIZED WORDING WITH A MOON AND LINE. THE WORDS "BLUE MOON" ARE ABOVE THE LINE. THE WORD "PARTS" IS BELOW THE LINE.

FOR RETAIL STORE SERVICES FEATURING LAWNMOWER PARTS AND EQUIPMENT (U.S. CLS. 100, 101 AND 102).

DOMINICK J. SALEMI, EXAMINING ATTORNEY

CLASS 35—(Continued).

SN 85-250,110. WITHERITE, RODNEY, WEST MILTON, PA.
FILED 2-23-2011.



NO CLAIM IS MADE TO THE EXCLUSIVE RIGHT TO USE "MC", APART FROM THE MARK AS SHOWN.

THE MARK CONSISTS OF A SHIELD WITH A KNIGHT HOLDING A SWORD AND THE STYLIZED TEXT "LE MC". ON THE TOP THERE IS THE STYLIZED TEXT "BLUE ORDER".

FOR CLUB SERVICES, NAMELY, PROMOTING THE INTERESTS OF MOTORCYCLE ENTHUSIASTS (U.S. CLS. 100, 101 AND 102).

DOMINICK J. SALEMI, EXAMINING ATTORNEY

CLASS 35—(Continued).

SN 85-250,285. MEDIACY INC., BROOKLYN, NY. FILED 2-24-2011.

MEDIACY

THE MARK CONSISTS OF STANDARD CHARACTERS WITHOUT CLAIM TO ANY PARTICULAR FONT, STYLE, SIZE, OR COLOR.

FOR ADVERTISING AGENCIES PROVIDING THE STRATEGY, DESIGN AND EXECUTION OF PROGRAMS TO PROMOTE BUSINESSES; ADVERTISING AND COMMERCIAL INFORMATION SERVICES, VIA THE INTERNET; ADVERTISING SERVICES, NAMELY, ADVERTISING, PROMOTING, AND MARKETING THE BRANDS, GOODS AND SERVICES OF OTHERS; GENERAL BUSINESS MERCHANDISING SERVICES, NAMELY, MARKETING; PROMOTING THE GOODS AND SERVICES OF OTHERS BY MEANS OF WORD-OF-MOUTH AND NONTRADITIONAL MARKETING PROGRAMS; SPECIALTY MERCHANDISING SERVICES, NAMELY, PROMOTING THE GOODS AND SERVICES OF OTHERS THROUGH THE DISTRIBUTION OF CUSTOMIZED ADVERTISING MATERIALS, NAMELY, PET RELATED GOODS (U.S. CLS. 100, 101 AND 102).

FIRST USE 6-20-2009; IN COMMERCE 6-20-2009.
KRISTIN CARLSON, EXAMINING ATTORNEY

SN 85-250,130. FLG ENTERPRISES LLC, ARLINGTON, VA.
FILED 2-23-2011.

The Bulletproof Consumer

THE MARK CONSISTS OF STANDARD CHARACTERS WITHOUT CLAIM TO ANY PARTICULAR FONT, STYLE, SIZE, OR COLOR.

FOR BUSINESS CONSULTING SERVICES IN THE FIELD OF FINANCIAL LITERACY (U.S. CLS. 100, 101 AND 102).

JOHN WILKE, EXAMINING ATTORNEY

SN 85-250,355. FRANK UNDERWOOD, JR., ALEXANDRIA, VA. FILED 2-24-2011.

CREATIONS2THEBEAT

THE MARK CONSISTS OF STANDARD CHARACTERS WITHOUT CLAIM TO ANY PARTICULAR FONT, STYLE, SIZE, OR COLOR.

FOR COMMISSIONING OF WORKS OF ART; ONLINE ART GALLERIES; PROMOTING THE GRAPHIC ARTS DESIGN SERVICES OF OTHERS BY MEANS OF A WEBSITE FEATURING GRAPHIC ARTWORK SUBMITTED BY GRAPHIC ART DESIGNERS (U.S. CLS. 100, 101 AND 102).

BARBARA A. GOLD, EXAMINING ATTORNEY

CLASS 35—(Continued).

SN 85-250,533. MORRIS, SEAN W., TOPANGA, CA. FILED 2-24-2011.

REBEL FORM

THE MARK CONSISTS OF STANDARD CHARACTERS WITHOUT CLAIM TO ANY PARTICULAR FONT, STYLE, SIZE, OR COLOR.

FOR ON-LINE RETAIL STORE SERVICES FEATURING POSTERS, APPAREL, BOOKS; ON-LINE RETAIL STORE SERVICES FEATURING DOWNLOADABLE PRE-RECORDED MUSIC, CD'S, MP3'S, AND VIDEO; ON-LINE RETAIL STORE SERVICES FEATURING A WIDE VARIETY OF CONSUMER GOODS OF OTHERS; PROMOTING GRAPHIC (COMMUNICATION) ARTS AND DESIGN SERVICES OF OTHERS VIA A WEBSITE FEATURING GRAPHIC ARTWORK, PACKAGE DESIGN, LOGOS, WEB DESIGN, INTERIOR DESIGN, PRODUCT DESIGN, ILLUSTRATION, PHOTOGRAPHY, DIGITAL ART, TYPOGRAPHY, FURNITURE DESIGN, LIGHTING DESIGN, ERGONOMIC CHAIRS, ERGONOMIC ACCESSORIES, AND ENVIRONMENTAL GRAPHICS, SUBMITTED BY VARIOUS ARTISTS AND DESIGNERS (U.S. CLS. 100, 101 AND 102).
LAKEISHA LEWIS, EXAMINING ATTORNEY

CLASS 35—(Continued).

SN 85-250,847. COME OUT WITH PRIDE, INC., ORLANDO, FL. FILED 2-24-2011.

Come Out with Pride Orlando

THE MARK CONSISTS OF STANDARD CHARACTERS WITHOUT CLAIM TO ANY PARTICULAR FONT, STYLE, SIZE, OR COLOR.

NO CLAIM IS MADE TO THE EXCLUSIVE RIGHT TO USE "ORLANDO", APART FROM THE MARK AS SHOWN. FOR ARRANGING AND CONDUCTING SPECIAL EVENTS FOR COMMERCIAL, PROMOTIONAL OR ADVERTISING PURPOSES (U.S. CLS. 100, 101 AND 102).
FIRST USE 1-1-2006; IN COMMERCE 1-1-2006.
MATTHEW KLINE, EXAMINING ATTORNEY

SN 85-250,651. HALL & PARTNERS USA LLC, NEW YORK, NY. FILED 2-24-2011.

Hall & Partners

THE MARK CONSISTS OF STANDARD CHARACTERS WITHOUT CLAIM TO ANY PARTICULAR FONT, STYLE, SIZE, OR COLOR.

NO CLAIM IS MADE TO THE EXCLUSIVE RIGHT TO USE "PARTNERS", APART FROM THE MARK AS SHOWN.

FOR CONSULTING SERVICES IN THE FIELD OF BRAND CREATION, BRAND DEVELOPMENT AND BRAND MARKETING; MARKET RESEARCH AND ANALYSIS IN THE FIELD OF ADVERTISING COMMUNICATIONS, CREATIVE STRATEGIES, AND BRAND CREATION, BRAND DEVELOPMENT AND BRAND MARKETING; CONDUCTING MARKETING SURVEYS AND STUDIES RELATING TO ADVERTISING COMMUNICATIONS, CREATIVE STRATEGIES, AND BRAND MARKETING; ADVERTISING SERVICES; DIRECT MARKETING AND ADVERTISING; DIGITAL AND INTERNET MARKETING AND ADVERTISING (U.S. CLS. 100, 101 AND 102).

FIRST USE 1-23-1996; IN COMMERCE 1-23-1996.
MARK SHINER, EXAMINING ATTORNEY

SN 85-250,862. OPPORTUNITY BUYS, INC., INDIANAPOLIS, IN. FILED 2-24-2011.

OPPORTUNITY BUYS, INC.

THE MARK CONSISTS OF STANDARD CHARACTERS WITHOUT CLAIM TO ANY PARTICULAR FONT, STYLE, SIZE, OR COLOR.

NO CLAIM IS MADE TO THE EXCLUSIVE RIGHT TO USE "INC.", APART FROM THE MARK AS SHOWN.

FOR WHOLESALE AND RETAIL STORE SERVICES FEATURING GENERAL MERCHANDISE (U.S. CLS. 100, 101 AND 102).

FIRST USE 6-6-1994; IN COMMERCE 6-6-1994.
JOHN HWANG, EXAMINING ATTORNEY

CLASS 35—(Continued).

SN 85-250,875. O.C. TANNER COMPANY, SALT LAKE CITY, UT. FILED 2-24-2011.

IAPPRECIATE

THE MARK CONSISTS OF STANDARD CHARACTERS WITHOUT CLAIM TO ANY PARTICULAR FONT, STYLE, SIZE, OR COLOR.

OWNER OF U.S. REG. NOS. 3,595,651, 3,709,205 AND OTHERS.

FOR CREATION OF RECOGNITION AND INCENTIVE AWARD PROGRAMS FOR OTHERS, NAMELY, EMPLOYEE ACHIEVEMENT, PRODUCTIVITY, PERFORMANCE, SALES, SERVICE, CUSTOMER SATISFACTION, QUALITY, SAFETY, RETIREMENT, EVENT, AND OTHER RECOGNITION AND INCENTIVE AWARD PROGRAMS WITH AWARDS OF FINE JEWELRY, RINGS, WATCHES, CORPORATE EMBLEMS, AND SYMBOLS, WRITING INSTRUMENTS, ACTIVE AND SPORTS ACCESSORIES, CLOCKS, ELECTRONICS, OFFICE ACCESSORIES, CRYSTAL, HOME ACCESSORIES, PLAQUES, AND OTHER FINE GIFTS, MERCHANDISE, CASH, TRAVEL, AND OTHER AWARDS AND INCENTIVES; ADMINISTRATION OF RECOGNITION AND INCENTIVE AWARD PROGRAMS FOR OTHERS TO PROMOTE JOB SAFETY, QUALITY, PRODUCTIVITY, PERFORMANCE, SALES, SERVICE, AND CUSTOMER SATISFACTION; RETAIL STORES FEATURING FINE JEWELRY, RINGS, WATCHES, CORPORATE EMBLEMS AND SYMBOLS, WRITING INSTRUMENTS, ACTIVE AND SPORTS ACCESSORIES, CLOCKS, ELECTRONICS, OFFICE ACCESSORIES, CRYSTAL, HOME ACCESSORIES, AND PLAQUES (U.S. CLS. 100, 101 AND 102).

KHANH LE, EXAMINING ATTORNEY

SN 85-250,927. AGAIN AUTO PARTS LLC, CHICAGO, IL. FILED 2-24-2011.

AGAIN AUTO PARTS

THE MARK CONSISTS OF STANDARD CHARACTERS WITHOUT CLAIM TO ANY PARTICULAR FONT, STYLE, SIZE, OR COLOR.

NO CLAIM IS MADE TO THE EXCLUSIVE RIGHT TO USE "AUTO PARTS", APART FROM THE MARK AS SHOWN.

FOR RETAIL STORE SERVICES FEATURING USED AUTO PARTS (U.S. CLS. 100, 101 AND 102).

FIRST USE 12-2-2010; IN COMMERCE 12-2-2010.
JOHN WILKE, EXAMINING ATTORNEY

CLASS 35—(Continued).

SN 85-250,941. OPTIMUM WEB MARKETING, INC., MANHATTAN, MT. FILED 2-24-2011.

GENERATION WEB

THE MARK CONSISTS OF STANDARD CHARACTERS WITHOUT CLAIM TO ANY PARTICULAR FONT, STYLE, SIZE, OR COLOR.

NO CLAIM IS MADE TO THE EXCLUSIVE RIGHT TO USE "WEB", APART FROM THE MARK AS SHOWN.

FOR ON-LINE INTERNET ADVERTISING AND MARKETING SERVICES; SOCIAL MEDIA STRATEGY AND MARKETING CONSULTANCY (U.S. CLS. 100, 101 AND 102).

JOHN WILKE, EXAMINING ATTORNEY

SN 85-251,008. RAPID SHIPPING, LLC, OMAHA, NE. FILED 2-24-2011.



NO CLAIM IS MADE TO THE EXCLUSIVE RIGHT TO USE "SHIPPING", APART FROM THE MARK AS SHOWN.

THE MARK CONSISTS OF A STYLIZED "R", WITH THE BOTTOM PORTION OF THE "R" STYLIZED TO APPEAR LIKE A WING; THE WORDS "RAPID SHIPPING" CENTERED UNDERNEATH THE STYLIZED "R".

FOR ORDER FULFILLMENT SERVICES, NAMELY, RECEIVING AND FILLING OF PURCHASE ORDERS FOR WAREHOUSE INVENTORY FOR THIRD PARTIES (U.S. CLS. 100, 101 AND 102).

FIRST USE 2-1-2011; IN COMMERCE 2-1-2011.
DANNEAN HETZEL, EXAMINING ATTORNEY

SN 85-251,012. BGR, LLC, SHERIDAN, WY. FILED 2-24-2011.



NO CLAIM IS MADE TO THE EXCLUSIVE RIGHT TO USE "NEWS", APART FROM THE MARK AS SHOWN.

THE MARK CONSISTS OF THE STYLIZED TEXT "NNB NEWS NATION BREWING" WITH TWO STARS ON THE LETTER "B".

FOR PROVIDING AN INTERNET WEBSITE FEATURING NEWS AND INFORMATION IN THE FIELD OF NATIONAL AND INTERNATIONAL POLITICS (U.S. CLS. 100, 101 AND 102).

FIRST USE 1-6-2011; IN COMMERCE 1-6-2011.
MARK PILARO, EXAMINING ATTORNEY

CLASS 35—(Continued).

SN 85-251,038. DRIVERSTUWILLIAMS INC., LONG BEACH, CA. FILED 2-24-2011.

DRIVERS tu, williams inc

THE MARK CONSISTS OF STANDARD CHARACTERS WITHOUT CLAIM TO ANY PARTICULAR FONT, STYLE, SIZE, OR COLOR.

NO CLAIM IS MADE TO THE EXCLUSIVE RIGHT TO USE "INC", APART FROM THE MARK AS SHOWN.

FOR BOOKKEEPING; TAX ADVISORY SERVICES; TAX FILING SERVICES (U.S. CLS. 100, 101 AND 102).

FIRST USE 1-10-2005; IN COMMERCE 1-10-2005.
KIMBERLY FRYE, EXAMINING ATTORNEY

SN 85-251,119. MADE U LOOK PROMOTIONS L.L.C., EAST HARTFORD, CT. AND BALLOON INNOVATIONS LLC, WHEAT RIDGE, CO. FILED 2-24-2011.

BALLOON BOBBER

THE MARK CONSISTS OF STANDARD CHARACTERS WITHOUT CLAIM TO ANY PARTICULAR FONT, STYLE, SIZE, OR COLOR.

NO CLAIM IS MADE TO THE EXCLUSIVE RIGHT TO USE "BALLOON", APART FROM THE MARK AS SHOWN.

FOR ADVERTISING AND ADVERTISEMENT SERVICES; ON-LINE RETAIL STORE SERVICES FEATURING ADVERTISING BALLOONS AND THE DISPLAY ASSEMBLY ASSOCIATED THEREWITH (U.S. CLS. 100, 101 AND 102).

FIRST USE 7-31-2007; IN COMMERCE 7-31-2007.
MICHAEL WIENER, EXAMINING ATTORNEY

SN 85-251,146. BENCHMARK SOLUTIONS HOLDINGS INC., NEW YORK, NY. FILED 2-24-2011.

PRICE INSPECTOR

THE MARK CONSISTS OF STANDARD CHARACTERS WITHOUT CLAIM TO ANY PARTICULAR FONT, STYLE, SIZE, OR COLOR.

NO CLAIM IS MADE TO THE EXCLUSIVE RIGHT TO USE "PRICE", APART FROM THE MARK AS SHOWN.

FOR FINANCIAL SERVICES, NAMELY, ANALYZING MARKET DATA AND PRICING ANALYTICS SERVICES FOR MEASURING THE PERFORMANCE OF FINANCIAL MARKETS FOR ASSET CLASSES WITHIN THE CAPITAL MARKETS, INCLUDING FIXED INCOME PRODUCTS (U.S. CLS. 100, 101 AND 102).

ARETHA SOMERVILLE, EXAMINING ATTORNEY

CLASS 35—(Continued).

SN 85-251,157. BENCHMARK SOLUTIONS HOLDINGS INC., NEW YORK, NY. FILED 2-24-2011.

BMARK

THE MARK CONSISTS OF STANDARD CHARACTERS WITHOUT CLAIM TO ANY PARTICULAR FONT, STYLE, SIZE, OR COLOR.

FOR FINANCIAL SERVICES, NAMELY, ANALYZING MARKET DATA AND PRICING ANALYTICS SERVICES FOR MEASURING THE PERFORMANCE OF FINANCIAL MARKETS FOR ASSET CLASSES WITHIN THE CAPITAL MARKETS, INCLUDING FIXED INCOME PRODUCTS (U.S. CLS. 100, 101 AND 102).

ARETHA SOMERVILLE, EXAMINING ATTORNEY

SN 85-251,220. TARGETSAFETY.COM, INC., SAN DIEGO, CA. FILED 2-24-2011.



OWNER OF U.S. REG. NO. 3,844,401.

THE MARK CONSISTS OF LOWER CASE LETTERING "PREVENTIONLINK" WITH THE LETTERS "LINK" BEING IN A WIDER FONT, AND A STYLIZED ROUND TARGET WITH THREE RINGS TO THE RIGHT OF THE WORD WITH THE OUTER TWO RINGS NOT BEING CLOSED COMPLETELY AS THE TWO RINGS INTERSECT WITH THE "K" IN "PREVENTIONLINK".

FOR BUSINESS RISK MANAGEMENT; BUSINESS RISK MANAGEMENT CONSULTATION; INTERACTIVE RECORD KEEPING SERVICES FOR USE IN RISK MANAGEMENT AND REGULATORY COMPLIANCE REQUIREMENTS; PROMOTING THE GOODS AND SERVICES OF OTHERS BY PROVIDING HYPERTEXT LINKS TO THE WEB SITES OF OTHERS; PROMOTING A COMMUNITY-DRIVEN WEB SITE FEATURING USER-SUBMITTED CONTENT IN THE NATURE OF DOCUMENTS AND INTERACTIVE MATERIALS DESIGNED TO MEET THE NEEDS OF OTHER COMMUNITY MEMBERS TO REDUCE THE COST OF RISK, ALLOWING FOR MEMBER-TO-MEMBER COMMUNICATION, RATING OF CONTENT, ACCESS TO SOLUTIONS FROM THIRD PARTIES, AND OTHER SERVICES UNIQUE TO ORGANIZATIONS THAT RETAIN RISK, NAMELY, WEB MEETING TOOLS, MEMBERSHIP ROSTERS, FILES STORAGE, EVENT MANAGEMENT, ANNOUNCEMENTS, AND PERIODIC, AUTOMATED TARGETED EMAILS WITH RELEVANT INFORMATION AND CONTENT; WORKPLACE CERTIFICATION SERVICES, NAMELY, ASSIGNING AND DOCUMENTING SPECIFIC TASKS TO MAINTAIN COMPLIANCE WITH STATE AND FEDERAL REGULATIONS AND ORGANIZATIONAL POLICIES (U.S. CLS. 100, 101 AND 102).

LINDA POWELL, EXAMINING ATTORNEY

CLASS 35—(Continued).

SN 85-251,302. A&O SOCIETY NETWORKING, QUEENS, NY. FILED 2-24-2011.



NO CLAIM IS MADE TO THE EXCLUSIVE RIGHT TO USE "NETWORKING", APART FROM THE MARK AS SHOWN.

THE MARK CONSISTS OF A 9-POINT CROWN WITH THE WORDING "A&O SOCIETY NETWORKING" INSIDE ON THE BOTTOM PART OF CROWN AND THE "O" IN "A&O" DEPICTING THE PLANET EARTH.

FOR BUSINESS MANAGEMENT CONSULTING WITH RELATION TO STRATEGY, MARKETING, SALES, OPERATION, PRODUCT DESIGN PARTICULARLY SPECIALIZING IN THE USE OF ANALYTIC AND STATISTIC MODELS FOR THE UNDERSTANDING AND PREDICTING OF CONSUMERS, BUSINESSES, AND MARKET TRENDS AND ACTIONS (U.S. CLS. 100, 101 AND 102).

FIRST USE 7-1-2010; IN COMMERCE 8-1-2010.
CARYN GLASSER, EXAMINING ATTORNEY

SN 85-251,308. SENIOR MOMENTS, LLC, MONROE, NJ. FILED 2-24-2011.

A HANDBOOK OF DAILY LIVING
FOR SENIORS

THE MARK CONSISTS OF STANDARD CHARACTERS WITHOUT CLAIM TO ANY PARTICULAR FONT, STYLE, SIZE, OR COLOR.

NO CLAIM IS MADE TO THE EXCLUSIVE RIGHT TO USE "HANDBOOK" AND "FOR SENIORS", APART FROM THE MARK AS SHOWN.

FOR ADVERTISING SERVICES, NAMELY, PROMOTING THE BRANDS, GOODS AND SERVICES OF OTHERS (U.S. CLS. 100, 101 AND 102).

FIRST USE 12-1-2010; IN COMMERCE 12-1-2010.
CHRISTINE COOPER, EXAMINING ATTORNEY

CLASS 35—(Continued).

SN 85-251,511. HISPANIC BRIDGE, GOLDEN VALLEY, MN. FILED 2-25-2011.

Hispanic Bridge

THE MARK CONSISTS OF STANDARD CHARACTERS WITHOUT CLAIM TO ANY PARTICULAR FONT, STYLE, SIZE, OR COLOR.

NO CLAIM IS MADE TO THE EXCLUSIVE RIGHT TO USE "HISPANIC", APART FROM THE MARK AS SHOWN.

FOR PROVIDING ADVERTISING, MARKETING AND PROMOTIONAL SERVICES, NAMELY, DEVELOPMENT OF ADVERTISING CAMPAIGNS FOR PRINT (U.S. CLS. 100, 101 AND 102).

FIRST USE 9-6-2007; IN COMMERCE 9-6-2007.
ELLEN PERKINS, EXAMINING ATTORNEY

SN 85-251,513. CARDINAL BUSINESS SOLUTIONS, LLC, BIG CANOE, GA. FILED 2-25-2011.

FRANCHISE ASAP

THE MARK CONSISTS OF STANDARD CHARACTERS WITHOUT CLAIM TO ANY PARTICULAR FONT, STYLE, SIZE, OR COLOR.

NO CLAIM IS MADE TO THE EXCLUSIVE RIGHT TO USE "FRANCHISE", APART FROM THE MARK AS SHOWN.

FOR ADVICE IN THE RUNNING OF ESTABLISHMENTS AS FRANCHISES (U.S. CLS. 100, 101 AND 102).

FIRST USE 6-24-2008; IN COMMERCE 6-24-2008.
LINDA MICKLEBURGH, EXAMINING ATTORNEY

SN 85-251,633. MAVERICK BUYER, LLC, SCOTTSDALE, AZ. FILED 2-25-2011.

Maverick Buyer

THE MARK CONSISTS OF STANDARD CHARACTERS WITHOUT CLAIM TO ANY PARTICULAR FONT, STYLE, SIZE, OR COLOR.

NO CLAIM IS MADE TO THE EXCLUSIVE RIGHT TO USE "BUYER", APART FROM THE MARK AS SHOWN.

FOR PROMOTING THE GOODS AND SERVICES OF OTHERS BY PROVIDING A WEBSITE FEATURING COUPONS, REBATES, PRICE-COMPARISON INFORMATION, PRODUCT REVIEWS, LINKS TO THE RETAIL WEBSITES OF OTHERS, AND DISCOUNT INFORMATION (U.S. CLS. 100, 101 AND 102).

FIRST USE 1-20-2011; IN COMMERCE 2-7-2011.
ANDREA HACK, EXAMINING ATTORNEY

CLASS 35—(Continued).

SN 85-251,688. SAZERAC NORTH AMERICA, INC., FRANKFORT, KY. FILED 2-25-2011.



OWNER OF U.S. REG. NOS. 683,398 AND 2,329,608.
THE MARK CONSISTS OF THE CAPITAL LETTER "B" IN A CIRCLE TO THE LEFT OF THE WORD "BARTON", WHICH IS IN ALL CAPS.

FOR RETAIL GIFT SHOPS AND ON-LINE RETAIL STORE SERVICES FEATURING CLOTHING, BOOKS, BEVERAGE GLASSWARE, AND A WIDE VARIETY OF CONSUMER GOODS RELATED TO WHISKEY AND WHISKEY DISTILLERIES (U.S. CLS. 100, 101 AND 102).
GRETTA YAO, EXAMINING ATTORNEY

SN 85-251,821. SHOE SHOW, INC., CONCORD, NC. FILED 2-25-2011.

SHOEBILEE

THE MARK CONSISTS OF STANDARD CHARACTERS WITHOUT CLAIM TO ANY PARTICULAR FONT, STYLE, SIZE, OR COLOR.

FOR RETAIL STORE SERVICES FEATURING SHOES (U.S. CLS. 100, 101 AND 102).

FIRST USE 10-31-2003; IN COMMERCE 10-31-2003.
EVELYN BRADLEY, EXAMINING ATTORNEY

SN 85-251,858. PREVENTA INC., BAIE D'URFE, QUEBEC, CANADA, FILED 2-25-2011.



THE MARK CONSISTS OF THE WORD "PREVENTA" WITH THE WORDS "FROM RISK TO VALUE" SHOWN UNDERNEATH "PREVENTA", BEGINNING UNDER THE SECOND "E" IN PREVENTA; THREE SETS OF FIVE CIRCLES, EACH FORMING AN UPSIDE DOWN "V", WHICH TOGETHER FORMS AN ARROW POINTING UPWARD TO THE RIGHT, WITH THE BOTTOM OF THE ARROW STARTING ABOVE THE LAST LETTER OF "PREVENTA".

FOR BUSINESS RISK MANAGEMENT CONSULTATION (U.S. CLS. 100, 101 AND 102).

FIRST USE 2-1-2010; IN COMMERCE 2-1-2010.
GRETCHEN ULRICH, EXAMINING ATTORNEY

CLASS 35—(Continued).

SN 85-251,902. GREEN B.E.A.N. INDIANA, LLC, DBA GREEN B.E.A.N. DELIVERY, INDIANAPOLIS, IN. FILED 2-25-2011.

GREEN B.E.A.N. DELIVERY

THE MARK CONSISTS OF STANDARD CHARACTERS WITHOUT CLAIM TO ANY PARTICULAR FONT, STYLE, SIZE, OR COLOR.

NO CLAIM IS MADE TO THE EXCLUSIVE RIGHT TO USE "DELIVERY", APART FROM THE MARK AS SHOWN. FOR RETAIL GROCERY SERVICES; AND, FOOD DISTRIBUTORSHIP SERVICES (U.S. CLS. 100, 101 AND 102).

FIRST USE 9-7-2010; IN COMMERCE 9-7-2010.
H. M. FISHER, EXAMINING ATTORNEY

SN 85-252,064. THE GREATER BOSTON FOOD BANK, INC., BOSTON, MA. FILED 2-25-2011.

EVERYONE HAS A ROLE

THE MARK CONSISTS OF STANDARD CHARACTERS WITHOUT CLAIM TO ANY PARTICULAR FONT, STYLE, SIZE, OR COLOR.

FOR CHARITABLE SERVICES, NAMELY, COORDINATION OF THE PROCUREMENT AND DISTRIBUTION OF FOOD DONATIONS FROM MANUFACTURERS, WHOLESALERS, DISTRIBUTORS, RETAILERS, CORPORATIONS, COMPANIES AND INDIVIDUALS TO ORGANIZATIONS AND RELIEF EFFORTS PROVIDING FOOD TO NEEDY PEOPLE (U.S. CLS. 100, 101 AND 102).

INGA ERVIN, EXAMINING ATTORNEY

SN 85-252,146. PALDY, MATTHEW G., NEW YORK, NY. FILED 2-25-2011.

Massage Next

THE MARK CONSISTS OF STANDARD CHARACTERS WITHOUT CLAIM TO ANY PARTICULAR FONT, STYLE, SIZE, OR COLOR.

NO CLAIM IS MADE TO THE EXCLUSIVE RIGHT TO USE "MASSAGE", APART FROM THE MARK AS SHOWN. FOR PROVIDING A SEARCHABLE WEBSITE FEATURING THE GOODS AND SERVICES OF OTHER VENDORS (U.S. CLS. 100, 101 AND 102).

FIRST USE 2-15-2011; IN COMMERCE 2-22-2011.
BRIAN CALLAGHAN, EXAMINING ATTORNEY

CLASS 35—(Continued).

SN 85-252,161. ATHLETE ALLY, INC., ANNANDALE, NJ.
FILED 2-25-2011.

ATHLETE ALLY

THE MARK CONSISTS OF STANDARD CHARACTERS WITHOUT CLAIM TO ANY PARTICULAR FONT, STYLE, SIZE, OR COLOR.

NO CLAIM IS MADE TO THE EXCLUSIVE RIGHT TO USE "ATHLETE", APART FROM THE MARK AS SHOWN.

FOR ADVOCACY SERVICES AND SOCIAL MEDIA CAMPAIGNS TARGETED TO ATHLETES, COACHES, SPORTS FANS AND SPORTS PARTICIPANTS TO PROMOTE RESPECT FOR ALL MEMBERS OF THEIR COMMUNITIES REGARDLESS OF SEXUAL ORIENTATION OR GENDER IDENTITY (U.S. CLS. 100, 101 AND 102).

FIRST USE 12-20-2010; IN COMMERCE 12-20-2010.
JOHN HWANG, EXAMINING ATTORNEY

SN 85-252,230. THE GEREN GROUP, LLC, ST. LOUIS, MO.
FILED 2-25-2011.

COSMO FIREWORKS

THE MARK CONSISTS OF STANDARD CHARACTERS WITHOUT CLAIM TO ANY PARTICULAR FONT, STYLE, SIZE, OR COLOR.

NO CLAIM IS MADE TO THE EXCLUSIVE RIGHT TO USE "FIREWORKS", APART FROM THE MARK AS SHOWN.

FOR ON-LINE RETAIL STORE SERVICES FEATURING CONSUMER FIREWORKS; RETAIL STORE SERVICES FEATURING CONSUMER FIREWORKS (U.S. CLS. 100, 101 AND 102).

FIRST USE 9-23-2010; IN COMMERCE 10-11-2010.
JAMES GRIFFIN, EXAMINING ATTORNEY

SN 85-252,381. GRABOW, JAMES, NEWPORT BEACH, CA.
FILED 2-25-2011.

INNOVATIVE PREPAID SOLUTIONS

THE MARK CONSISTS OF STANDARD CHARACTERS WITHOUT CLAIM TO ANY PARTICULAR FONT, STYLE, SIZE, OR COLOR.

NO CLAIM IS MADE TO THE EXCLUSIVE RIGHT TO USE "PREPAID SOLUTIONS", APART FROM THE MARK AS SHOWN.

FOR BUSINESS SERVICES, NAMELY, MARKETING, PROGRAM MANAGEMENT AND CONSULTING SERVICES FOR OPEN-LOOP AND CLOSED-LOOP PREPAID FINANCIAL PRODUCTS AND SERVICES (U.S. CLS. 100, 101 AND 102).

FIRST USE 10-26-2010; IN COMMERCE 10-26-2010.
TOBY BULLOFF, EXAMINING ATTORNEY

CLASS 35—(Continued).

SN 85-252,429. FARYAB, FARID, BEVERLY HILLS, CA.
FILED 2-25-2011.



NO CLAIM IS MADE TO THE EXCLUSIVE RIGHT TO USE "ACCOUNTING GROUP", APART FROM THE MARK AS SHOWN.

THE MARK CONSISTS OF A STYLIZED GLOBE ON A SQUARED BACKGROUND TO THE LEFT, AND THE TEXT "WORLD ACCOUNTING GROUP" IN A STACKED FORMATION TO THE RIGHT, WITH "ACCOUNTING" ON A RECTANGULAR BACKGROUND.

FOR ACCOUNTING SERVICES; BUSINESS STRATEGIC PLANNING SERVICES; PAYROLL PREPARATION; TAX AND TAXATION PLANNING, ADVICE, INFORMATION AND CONSULTANCY SERVICES; TAX PREPARATION (U.S. CLS. 100, 101 AND 102).

FIRST USE 10-15-2003; IN COMMERCE 10-15-2003.
CHRISTINA SOBRAL, EXAMINING ATTORNEY

SN 85-252,484. DELTA PI RHO FRATERNITY, INC., HO-BART, IN. FILED 2-26-2011.

DELTA PI RHO

THE MARK CONSISTS OF STANDARD CHARACTERS WITHOUT CLAIM TO ANY PARTICULAR FONT, STYLE, SIZE, OR COLOR.

FOR ASSOCIATION SERVICES IN THE NATURE OF A FRATERNITY, NAMELY, PROMOTING THE INTERESTS OF THE MEMBERS THEREOF (U.S. CLS. 100, 101 AND 102).

FIRST USE 12-4-2004; IN COMMERCE 12-4-2004.
BRENDAN REGAN, EXAMINING ATTORNEY

CLASS 35—(Continued).

SN 85-252,716. ECOLOGICAL BABIES LLC, TALLAHASSEE, FL. FILED 2-26-2011.



NO CLAIM IS MADE TO THE EXCLUSIVE RIGHT TO USE "ECOLOGICAL BABIES", APART FROM THE MARK AS SHOWN.

THE MARK CONSISTS OF THE WORDING "ECOLOGICAL BABIES" IN A STYLIZED FONT, WITH THE FIRST "L" IN "ECOLOGICAL" APPEARING AS A BAMBOO PLANT, ALL TO THE LEFT OF A BABY CARRIAGE WITH EARTH AS THE BASKET AND FLOWERS IN THE MIDDLE OF THE WHEELS.

FOR RETAIL STORE SERVICES FEATURING DIAPERS, BABY CARRIERS, AND NATURAL PARENTING PRODUCTS AND ACCESSORIES (U.S. CLS. 100, 101 AND 102).

FIRST USE 7-15-2008; IN COMMERCE 9-30-2008.
JAMES MACFARLANE, EXAMINING ATTORNEY

SN 85-252,786. TRANSCEND MEDIA LLC, GREENACRES, FL. FILED 2-27-2011.

DirectKinex

THE MARK CONSISTS OF STANDARD CHARACTERS WITHOUT CLAIM TO ANY PARTICULAR FONT, STYLE, SIZE, OR COLOR.

FOR AD SERVING, NAMELY, PLACING ADVERTISEMENTS ON WEBSITES FOR OTHERS USING SPECIALIZED COMPUTER SOFTWARE (U.S. CLS. 100, 101 AND 102).

CAROLINE WOOD, EXAMINING ATTORNEY

CLASS 35—(Continued).

SN 85-252,908. WINERYINFO, LLC, SAN CARLOS, CA. FILED 2-28-2011.



NO CLAIM IS MADE TO THE EXCLUSIVE RIGHT TO USE "WINERY INFO", APART FROM THE MARK AS SHOWN.

THE COLOR(S) BLACK AND RED IS/ARE CLAIMED AS A FEATURE OF THE MARK.

THE MARK CONSISTS OF A COMBINATION OF THE WORDS "WINERY" AND "INFO". THE CHARACTERS IN THE WORD "WINERY" ARE IN BLACK, BLOCK NON-ITALICIZED TEXT, WITH THE EXCEPTION OF THE LETTER "I" IN "WINERY", WHICH IS A LARGE, ITALIC "I", RED IN COLOR. THE WORD "INFO" IS IN RED ITALICS. THE "I" IN "INFO" IS LARGE, AND IS SHARED WITH THE "I" IN "WINERY". THE REST OF THE CHARACTERS IN THE WORD "INFO", NAMELY, "N", "F", AND "O", ARE BELOW AND UNDER THE RIGHT SIDE OF THE WORD "WINERY".

FOR PROMOTING THE GOODS AND SERVICES OF OTHERS BY PROVIDING A WEBSITE FEATURING COUPONS, REBATES, PRICE-COMPARISON INFORMATION, PRODUCT REVIEWS, LINKS TO THE RETAIL WEBSITES OF OTHERS, AND DISCOUNT INFORMATION (U.S. CLS. 100, 101 AND 102).

FIRST USE 2-25-2011; IN COMMERCE 2-25-2011.
KATHRYN COWARD, EXAMINING ATTORNEY

SN 85-253,011. THE VINTAGE TWIN LLC, ANN ARBOR, MI. FILED 2-28-2011.

THE VINTAGE TWIN

THE MARK CONSISTS OF STANDARD CHARACTERS WITHOUT CLAIM TO ANY PARTICULAR FONT, STYLE, SIZE, OR COLOR.

NO CLAIM IS MADE TO THE EXCLUSIVE RIGHT TO USE "VINTAGE", APART FROM THE MARK AS SHOWN.

FOR RETAIL STORES FEATURING CLOTHING, JEWELRY AND ACCESSORIES; ONLINE RETAIL STORE FEATURING CLOTHING, JEWELRY AND ACCESSORIES (U.S. CLS. 100, 101 AND 102).

FIRST USE 8-0-2009; IN COMMERCE 3-0-2010.
ALEX KEAM, EXAMINING ATTORNEY

CLASS 35—(Continued).

SN 85-253,113. ILLINOIS AGRICULTURAL ASSOCIATION, BLOOMINGTON, IL. FILED 2-28-2011.

ADOPT-A-LEGISLATOR

THE MARK CONSISTS OF STANDARD CHARACTERS WITHOUT CLAIM TO ANY PARTICULAR FONT, STYLE, SIZE, OR COLOR.

FOR ASSOCIATION SERVICES, NAMELY, PROMOTING THE INTERESTS OF FARMERS; LOBBYING SERVICES, NAMELY, PROMOTING THE INTERESTS OF FARMERS IN THE FIELDS OF LEGISLATION AND REGULATION (U.S. CLS. 100, 101 AND 102).

FIRST USE 12-1-1999; IN COMMERCE 12-1-1999.
TINA BROWN, EXAMINING ATTORNEY

SN 85-253,205. BOSS INTERNATIONAL, LLC, DURHAM, NC. FILED 2-28-2011.



THE MARK CONSISTS OF THE WORDING "BOSS BE YOUR OWN SUCCESS STORY" IN STYLIZED FONT, THE WORD "BOSS" IS IN THE UPPER PORTION OF THE MARK AND IN LARGER STYLIZED FONT, WITHIN THE CHARACTER "O" IN THE WORD "BOSS" IS A DESIGN OF A BOOK AND DIRECTLY BELOW THE WORD "BOSS" IS THE WORDING "BE YOUR OWN SUCCESS STORY" IN SMALLER STYLIZED FONT.

FOR BUSINESS MANAGEMENT PLANNING; BUSINESS NETWORKING; BUSINESS ORGANIZATION ADVICE; BUSINESS ORGANIZATION AND MANAGEMENT CONSULTANCY INCLUDING PERSONNEL MANAGEMENT; BUSINESS ORGANIZATION AND MANAGEMENT CONSULTING; BUSINESS ORGANIZATION AND OPERATION CONSULTANCY; BUSINESS ORGANIZATION CONSULTING; BUSINESS PLANNING; BUSINESS STRATEGIC PLANNING SERVICES; BUSINESS STRATEGY DEVELOPMENT SERVICES; BUSINESS SUCCESSION PLANNING (U.S. CLS. 100, 101 AND 102).

RONALD AIKENS, EXAMINING ATTORNEY

SN 85-253,243. RAM MANAGEMENT GROUP, INC., BEACHWOOD, OH. FILED 2-28-2011.



NO CLAIM IS MADE TO THE EXCLUSIVE RIGHT TO USE "SALES & OPERATIONS PLANNING", APART FROM THE MARK AS SHOWN.

THE COLOR(S) GREEN, YELLOW, GREY AND BLACK IS/ARE CLAIMED AS A FEATURE OF THE MARK.

THE MARK CONSISTS OF THE STYLIZED WORDING

CLASS 35—(Continued).

"SNOP SALES & OPERATIONS PLANNING" IN LETTERS THAT GRADUATE IN COLOR FROM YELLOW TO GREEN AND THAT HAVE GRAY AND BLACK SHADING GIVING THE LETTERS A THREE-DIMENSIONAL APPEARANCE, AND A DESIGN COMPRISED OF THREE OVERLAPPING CIRCLES, WITH ONE CIRCLE ON THE TOP AND TWO CIRCLES ON THE BOTTOM, WITH EACH OF THE CIRCLES APPEARING IN A DIFFERENT SHADE OF GREEN AND WITH DIFFERENT SHADES OF GREEN APPEARING WHERE THE CIRCLES OVERLAP.

THE WORDING "SNOP" HAS NO MEANING IN A FOREIGN LANGUAGE.

FOR BUSINESS NETWORKING; BUSINESS SERVICES, NAMELY, PROVIDING COMPUTER DATABASES REGARDING THE PURCHASE AND SALE OF A WIDE VARIETY OF PRODUCTS AND SERVICES OF OTHERS; DISSEMINATION OF ADVERTISING FOR OTHERS VIA AN ON-LINE COMMUNICATIONS NETWORK ON THE INTERNET; GENERAL BUSINESS NETWORKING REFERRAL SERVICES, NAMELY, PROMOTING THE GOODS AND SERVICES OF OTHERS BY PASSING BUSINESS LEADS AND REFERRALS AMONG GROUP MEMBERS (U.S. CLS. 100, 101 AND 102).

FIRST USE 2-18-2009; IN COMMERCE 2-18-2009.
CYNTHIA TRIPI, EXAMINING ATTORNEY

SN 85-253,276. TSA STORES, INC., ENGLEWOOD, CO. FILED 2-28-2011.

SHARE THE GOOD

THE MARK CONSISTS OF STANDARD CHARACTERS WITHOUT CLAIM TO ANY PARTICULAR FONT, STYLE, SIZE, OR COLOR.

FOR RETAIL SPORTING GOODS STORES (U.S. CLS. 100, 101 AND 102).

TINA MAI, EXAMINING ATTORNEY

SN 85-253,279. TSA STORES, INC., ENGLEWOOD, CO. FILED 2-28-2011.

'SPORT YOUR TEAM

THE MARK CONSISTS OF STANDARD CHARACTERS WITHOUT CLAIM TO ANY PARTICULAR FONT, STYLE, SIZE, OR COLOR.

FOR RETAIL SPORTING GOODS STORES (U.S. CLS. 100, 101 AND 102).

TINA MAI, EXAMINING ATTORNEY

CLASS 35—(Continued).

SN 85-253,337. LIVE NATION ENTERTAINMENT, INC., BEVERLY HILLS, CA. FILED 2-28-2011.

FAN NETWORK

THE MARK CONSISTS OF STANDARD CHARACTERS WITHOUT CLAIM TO ANY PARTICULAR FONT, STYLE, SIZE, OR COLOR.

FOR ADVERTISING SERVICES (U.S. CLS. 100, 101 AND 102).

HAI-LY LAM, EXAMINING ATTORNEY

SN 85-253,347. KENTON COUNTY AIRPORT BOARD, DBA CINCINNATI/NORTHERN KENTUCKY INTERNATIONAL AIRPORT, CINCINNATI, OH. FILED 2-28-2011.

CVGFIRST ADVANTAGE

THE MARK CONSISTS OF STANDARD CHARACTERS WITHOUT CLAIM TO ANY PARTICULAR FONT, STYLE, SIZE, OR COLOR.

OWNER OF U.S. REG. NOS. 2,985,794, 3,114,581 AND OTHERS.

FOR CUSTOMER LOYALTY SERVICES AND CUSTOMER CLUB SERVICES, FOR COMMERCIAL, PROMOTIONAL AND/OR ADVERTISING PURPOSES (U.S. CLS. 100, 101 AND 102).

FIRST USE 9-13-2010; IN COMMERCE 9-13-2010.
WILLIAM VERHOSEK, EXAMINING ATTORNEY

SN 85-253,414. ACXIOM CORPORATION, LITTLE ROCK, AR. FILED 2-28-2011.

ACXIOM ADDRESSABLE ADVERTISING

THE MARK CONSISTS OF STANDARD CHARACTERS WITHOUT CLAIM TO ANY PARTICULAR FONT, STYLE, SIZE, OR COLOR.

OWNER OF U.S. REG. NOS. 1,907,571, 3,472,367 AND OTHERS.

NO CLAIM IS MADE TO THE EXCLUSIVE RIGHT TO USE "ADDRESSABLE ADVERTISING", APART FROM THE MARK AS SHOWN.

FOR MARKETING AND ADVERTISING SERVICES IN THE NATURE OF PROVIDING WEBSITE, MOBILE AND TV PUBLISHERS AND ON-LINE, MOBILE AND TV ADVERTISING NETWORKS WITH NON-PERSONALLY IDENTIFIABLE INFORMATION CONCERNING ON-LINE, MOBILE AND TV CUSTOMERS FOR THE PURPOSE OF TARGETED ADVERTISING (U.S. CLS. 100, 101 AND 102).

ALICIA COLLINS, EXAMINING ATTORNEY

CLASS 35—(Continued).

SN 85-253,426. KENTON COUNTY AIRPORT BOARD, DBA CINCINNATI/NORTHERN KENTUCKY INTERNATIONAL AIRPORT, CINCINNATI, OH. FILED 2-28-2011.

CVGFIRST

THE MARK CONSISTS OF STANDARD CHARACTERS WITHOUT CLAIM TO ANY PARTICULAR FONT, STYLE, SIZE, OR COLOR.

FOR CUSTOMER LOYALTY SERVICES AND CUSTOMER CLUB SERVICES, FOR COMMERCIAL, PROMOTIONAL AND/OR ADVERTISING PURPOSES (U.S. CLS. 100, 101 AND 102).

FIRST USE 9-13-2010; IN COMMERCE 9-13-2010.
WILLIAM VERHOSEK, EXAMINING ATTORNEY

SN 85-253,472. HOLSTED MARKETING INC., NEW YORK, NY. FILED 2-28-2011.

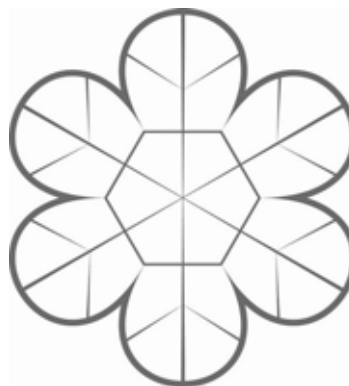

THE MARK CONSISTS OF STYLIZED SIX PETAL FLOWER.

FOR COMPUTERIZED ONLINE ORDERING SERVICES IN THE FIELD OF JEWELRY AND FASHION ACCESSORIES (U.S. CLS. 100, 101 AND 102).

FIRST USE 12-10-2010; IN COMMERCE 12-10-2010.
JENNY PARK, EXAMINING ATTORNEY

CLASS 35—(Continued).

SN 85-253,505. MATCOR, INC., DOYLESTOWN, PA. FILED 2-28-2011.

MPORT

THE MARK CONSISTS OF STANDARD CHARACTERS WITHOUT CLAIM TO ANY PARTICULAR FONT, STYLE, SIZE, OR COLOR.

FOR PROVIDING A WEB-BASED SYSTEM AND ON-LINE PORTALS FOR PROJECT MANAGEMENT FOR CLIENTS IN THE CORROSION INDUSTRY TO RECEIVE PROJECT STATUS UPDATES, TRACK PROJECTS, ACCESS DOCUMENTS, GENERATE REPORTS, AND PROVIDE FEEDBACK; PROVIDING AN ON-LINE COMPUTER DATABASE FOR ACCESS TO DOCUMENTS, NAMELY, PROPOSALS, CONTRACTS, STATUS REPORTS, ORDERS, DRAWINGS, AND DIAGRAMS FOR PROJECT MANAGEMENT IN THE CORROSION INDUSTRY; PROVIDING A SECURED ACCESS DATABASE VIA THE INTERNET THROUGH WHICH DOCUMENTS AND IMAGES CAN BE VIEWED AND PRINTED FOR PROJECT MANAGEMENT IN THE CORROSION INDUSTRY (U.S. CLS. 100, 101 AND 102).

DOUGLAS LEE, EXAMINING ATTORNEY

SN 85-253,514. MATCOR, INC., DOYLESTOWN, PA. FILED 2-28-2011.

THE MARK CONSISTS OF THE TERM "MPORT" IN LOWER CASE LETTERS EXCEPT FOR A CAPITAL LETTER "P" AND A FANCIFUL LETTER "O" THAT CONSISTS OF A SPHERE DIVIDED BY THREE CURVED PARALLEL LINES.

FOR PROVIDING A WEB-BASED SYSTEM AND ON-LINE PORTALS FOR PROJECT MANAGEMENT FOR CLIENTS IN THE CORROSION INDUSTRY TO RECEIVE PROJECT STATUS UPDATES, TRACK PROJECTS, ACCESS DOCUMENTS, GENERATE REPORTS, AND PROVIDE FEEDBACK; PROVIDING AN ON-LINE COMPUTER DATABASE FOR ACCESS TO DOCUMENTS, NAMELY, PROPOSALS, CONTRACTS, STATUS REPORTS, ORDERS, DRAWINGS, AND DIAGRAMS FOR PROJECT MANAGEMENT IN THE CORROSION INDUSTRY; PROVIDING A SECURED ACCESS DATABASE VIA THE INTERNET THROUGH WHICH DOCUMENTS AND IMAGES CAN BE VIEWED AND PRINTED FOR PROJECT MANAGEMENT IN THE CORROSION INDUSTRY (U.S. CLS. 100, 101 AND 102).

DOUGLAS LEE, EXAMINING ATTORNEY

CLASS 35—(Continued).

SN 85-253,587. INLAND PEDORTHIC SERVICES, RIVERSIDE, CA. FILED 2-28-2011.

LUCKY FEET

THE MARK CONSISTS OF STANDARD CHARACTERS WITHOUT CLAIM TO ANY PARTICULAR FONT, STYLE, SIZE, OR COLOR.

NO CLAIM IS MADE TO THE EXCLUSIVE RIGHT TO USE "FEET", APART FROM THE MARK AS SHOWN.

FOR ON-LINE RETAIL STORE SERVICES FEATURING FOOTWEAR, SHOES, FOOT LOTIONS, ORTHOTICS, SHOE LACES, SOCKS AND ARCH SUPPORTS; RETAIL STORE SERVICES FEATURING FOOTWEAR, SHOES, FOOT LOTIONS, ORTHOTICS, SHOE LACES, SOCKS AND ARCH SUPPORTS (U.S. CLS. 100, 101 AND 102).

SETH A. RAPPAPORT, EXAMINING ATTORNEY

SN 85-253,589. CDJ CONSULTING, LLC, KENT, OH. FILED 2-28-2011.

BARC

THE MARK CONSISTS OF STANDARD CHARACTERS WITHOUT CLAIM TO ANY PARTICULAR FONT, STYLE, SIZE, OR COLOR.

FOR PROVIDING BUSINESS CONSULTATION SERVICES UTILIZING COMPUTER SOFTWARE FOR CALCULATING AND DETERMINING BUSINESS OPERATING COSTS WITHIN SPECIFIED MUNICIPALITIES, COUNTIES, STATES OR GEOGRAPHIC REGIONS (U.S. CLS. 100, 101 AND 102).

MARILYN IZZI, EXAMINING ATTORNEY

SN 85-253,667. BNP MEDIA, INC., TROY, MI. FILED 2-28-2011.

CERAMIC INDUSTRY

THE MARK CONSISTS OF STANDARD CHARACTERS WITHOUT CLAIM TO ANY PARTICULAR FONT, STYLE, SIZE, OR COLOR.

OWNER OF U.S. REG. NOS. 1,638,386 AND 1,640,462. SEC. 2(F).

FOR PROVIDING INFORMATION AND NEWS IN THE FIELD OF BUSINESS AS IT PERTAINS TO THE CERAMIC AND GLASS MANUFACTURING INDUSTRIES VIA THE INTERNET (U.S. CLS. 100, 101 AND 102).

FIRST USE 4-28-1999; IN COMMERCE 4-28-1999. MICHAEL TANNER, EXAMINING ATTORNEY

CLASS 35—(Continued).

SN 85-253,718. FENTON DOWNTOWN DEVELOPMENT AUTHORITY, FENTON, MI. FILED 2-28-2011.

BE CLOSER

THE MARK CONSISTS OF STANDARD CHARACTERS WITHOUT CLAIM TO ANY PARTICULAR FONT, STYLE, SIZE, OR COLOR.

FOR PROMOTING THE ECONOMIC DEVELOPMENT IN THE CITY OF FENTON, MICHIGAN (U.S. CLS. 100, 101 AND 102).

FIRST USE 1-1-2011; IN COMMERCE 1-1-2011.
CHARISMA HAMPTON, EXAMINING ATTORNEY

SN 85-253,751. LEMONS-SHILLINGBURG, JACQUELYN, TOMBALL, TX. AND LEMONS-CAMPBELL, LORI, TOMBALL, TX. FILED 2-28-2011.



THE MARK CONSISTS OF A SLANTED "L" AND A BAR FORMING A TRIANGLE OR DELTA IMAGE BIFURCATED BY A SEMI-CIRCLE.

FOR ARRANGING AND CONDUCTING AUCTIONS; PROVIDING ON-LINE AUCTION SERVICES (U.S. CLS. 100, 101 AND 102).

FIRST USE 9-29-2009; IN COMMERCE 9-29-2009.
ASMAT KHAN, EXAMINING ATTORNEY

SN 85-253,818. MOSSY SIDE, SEATTLE, WA. FILED 2-28-2011.

INTEREST ENGINE

THE MARK CONSISTS OF STANDARD CHARACTERS WITHOUT CLAIM TO ANY PARTICULAR FONT, STYLE, SIZE, OR COLOR.

FOR DIRECT MARKETING; MARKET RESEARCH (U.S. CLS. 100, 101 AND 102).

FIRST USE 3-29-2009; IN COMMERCE 3-29-2009.
KYLE PEETE, EXAMINING ATTORNEY

CLASS 35—(Continued).

SN 85-253,990. BRAINSMATCH CORPORATION, NEW YORK, NY. FILED 2-28-2011.

BRAINSMATCH

NO CLAIM IS MADE TO THE EXCLUSIVE RIGHT TO USE "BRAIN", APART FROM THE MARK AS SHOWN.

THE MARK CONSISTS OF A STYLIZED DRAWING OF SCALED LINE OF PEOPLE AND TWO WORDS RUN TOGETHER "BRAINS" AND "MATCH".

FOR EMPLOYMENT HIRING, RECRUITING, PLACEMENT, STAFFING AND CAREER NETWORKING SERVICES; EMPLOYMENT SERVICES, NAMELY, PROVIDING A WEB SITE WITH ONLINE VIDEO, AUDIO AND TEXTUAL INTERVIEWING APPLICATIONS TO SUPPORT RECRUITING, ADMISSIONS, AND GENERAL CANDIDATE SCREENING PROCESSES; PROVIDING AN ON-LINE SEARCHABLE DATABASE FEATURING EMPLOYMENT OPPORTUNITIES AND CONTENT ABOUT EMPLOYMENT; PROVIDING ON-LINE EMPLOYMENT PLACEMENT SERVICES, NAMELY, MATCHING RESUMES AND POTENTIAL EMPLOYERS VIA A GLOBAL COMPUTER NETWORK; PROVIDING ONLINE DATABASES FEATURING INFORMATION RELATING TO EMPLOYERS AND EMPLOYEES AND PLACES OF EMPLOYMENT; TESTING TO DETERMINE EMPLOYMENT SKILLS; TESTING TO DETERMINE JOB COMPETENCY; TESTING TO DETERMINE PROFESSIONAL COMPETENCY (U.S. CLS. 100, 101 AND 102).

JOHN E. MICHOS, EXAMINING ATTORNEY

SN 85-254,195. POPULUS GROUP, LLC, SOUTHFIELD, MI. FILED 3-1-2011.

IWMF

THE MARK CONSISTS OF STANDARD CHARACTERS WITHOUT CLAIM TO ANY PARTICULAR FONT, STYLE, SIZE, OR COLOR.

FOR BUSINESS CONSULTATION IN THE FIELD OF TEMPORARY AND PERMANENT PERSONNEL RECRUITMENT AND PLACEMENT; BUSINESS MANAGEMENT CONSULTING; CONSULTING SERVICES IN THE FIELD OF HUMAN RESOURCES DEVELOPMENT, NAMELY, FOR THE PROMOTION OF EMPLOYEE RETENTION, CAREER GROWTH, AND INCREASED PRODUCTIVITY FOR EMPLOYEES AND EMPLOYERS; EMPLOYMENT AGENCY SERVICES, NAMELY, FILLING THE TEMPORARY AND PERMANENT STAFFING NEEDS OF BUSINESSES; EMPLOYMENT HIRING, RECRUITING, PLACEMENT, STAFFING AND CAREER NETWORKING SERVICES; HUMAN CAPITAL MANAGEMENT OUTSOURCING SERVICES; HUMAN RESOURCES MANAGEMENT; PERSONNEL MANAGEMENT; PERSONNEL PLACEMENT AND RECRUITMENT; TEMPORARY PERSONNEL SERVICES (U.S. CLS. 100, 101 AND 102).

FIRST USE 12-7-2010; IN COMMERCE 12-7-2010.
LAKEISHA LEWIS, EXAMINING ATTORNEY

CLASS 35—(Continued).

SN 85-254,226. MIXED GREENS, LLC, NEW YORK, NY.
FILED 3-1-2011.

MIXED GREENS

THE MARK CONSISTS OF STANDARD CHARACTERS WITHOUT CLAIM TO ANY PARTICULAR FONT, STYLE, SIZE, OR COLOR.

FOR ART GALLERY SERVICES (U.S. CLS. 100, 101 AND 102).

FIRST USE 11-18-1991; IN COMMERCE 11-18-1991.
PAUL MORENO, EXAMINING ATTORNEY

CLASS 35—(Continued).

SN 85-254,372. RHOADS, RYAN D., HONEYBROOK, PA.
FILED 3-1-2011.

unherd

THE MARK CONSISTS OF STANDARD CHARACTERS WITHOUT CLAIM TO ANY PARTICULAR FONT, STYLE, SIZE, OR COLOR.

FOR RETAIL STORE SERVICES FEATURING ART-WORK AND ART SUPPLIES (U.S. CLS. 100, 101 AND 102).

DOUGLAS LEE, EXAMINING ATTORNEY

SN 85-254,233. FARGOPAGES, LLC, MOORHEAD, MN.
FILED 3-1-2011.

SaveCoin

THE MARK CONSISTS OF STANDARD CHARACTERS WITHOUT CLAIM TO ANY PARTICULAR FONT, STYLE, SIZE, OR COLOR.

FOR PROMOTING THE GOODS OF OTHERS, NAMELY, PROVIDING COUPONS, REBATES AND VOUCHERS FOR THE GOODS OF OTHERS (U.S. CLS. 100, 101 AND 102).

FIRST USE 1-1-2011; IN COMMERCE 1-1-2011.
GRETCHEN ULRICH, EXAMINING ATTORNEY

SN 85-254,392. GREEN COURTE PARTNERS, LLC, LAKE FOREST, IL. FILED 3-1-2011.

PINE CONE

THE MARK CONSISTS OF STANDARD CHARACTERS WITHOUT CLAIM TO ANY PARTICULAR FONT, STYLE, SIZE, OR COLOR.

FOR RETAIL STORES FEATURING CHRISTMAS-THEMED GOODS (U.S. CLS. 100, 101 AND 102).

MARILYN IZZI, EXAMINING ATTORNEY

SN 85-254,250. STANLEY COHEN, BROOKLYN, NY. FILED 3-1-2011.

SOURCE IT

THE MARK CONSISTS OF STANDARD CHARACTERS WITHOUT CLAIM TO ANY PARTICULAR FONT, STYLE, SIZE, OR COLOR.

FOR IMPORT AGENCY SERVICES IN THE FIELD OF APPAREL (U.S. CLS. 100, 101 AND 102).

MIDGE BUTLER, EXAMINING ATTORNEY

SN 85-254,406. DAKO MANAGEMENT COMPANY, LLC, PRESCOTT, AZ. FILED 3-1-2011.

DAKO'S Fuel for Thought

THE MARK CONSISTS OF STANDARD CHARACTERS WITHOUT CLAIM TO ANY PARTICULAR FONT, STYLE, SIZE, OR COLOR.

FOR CONSULTING IN THE FIELD OF SALES METHODS, SALES MANAGEMENT, AND SALES IMPROVEMENT (U.S. CLS. 100, 101 AND 102).

FIRST USE 2-14-2009; IN COMMERCE 2-14-2009.
PAM WILLIS, EXAMINING ATTORNEY

CLASS 35—(Continued).

SN 85-254,421. DENNIS SALES COMPANY, RAYMOND, WA. FILED 3-1-2011.



THE MARK CONSISTS OF A DUCK WEARING A HAT AND BOOTS.

FOR RETAIL APPAREL STORES; RETAIL AUTOMOBILE PARTS AND ACCESSORIES STORES; RETAIL CLOTHING STORES; RETAIL DEPARTMENT STORES; RETAIL DISCOUNT STORE SERVICES IN THE FIELD OF GENERAL CONSUMER MERCHANDISE; RETAIL LAWN, GARDEN AND NURSERY STORES; RETAIL SPORTING GOODS STORES; RETAIL STORE SERVICES FEATURING A WIDE VARIETY OF CONSUMER GOODS OF OTHERS; RETAIL STORE SERVICES IN THE FIELD OF HOME APPLIANCES THAT CAN BE PURCHASED UNDER A RENT-TO-OWN CONTRACT (U.S. CLS. 100, 101 AND 102).

FIRST USE 4-1-1972; IN COMMERCE 4-1-1972.
JAMES A. RAUEN, EXAMINING ATTORNEY

SN 85-254,441. WELCH, GORDON, FOSTER, BARTLESVILLE, OK. FILED 3-1-2011.

Focus On Success

THE MARK CONSISTS OF STANDARD CHARACTERS WITHOUT CLAIM TO ANY PARTICULAR FONT, STYLE, SIZE, OR COLOR.

FOR CONSULTING SERVICES IN BUSINESS LEADERSHIP DEVELOPMENT AND BUSINESS MANAGEMENT (U.S. CLS. 100, 101 AND 102).

MIDGE BUTLER, EXAMINING ATTORNEY

CLASS 35—(Continued).

SN 85-254,497. BALAM ESCAPE, MIAMI BEACH, FL. FILED 3-1-2011.

The future state of green is blue

THE MARK CONSISTS OF STANDARD CHARACTERS WITHOUT CLAIM TO ANY PARTICULAR FONT, STYLE, SIZE, OR COLOR.

FOR PROMOTING THE INTERESTS OF PEOPLE CONCERNED WITH HEALTH, COMMUNITY AND ENVIRONMENTAL SUSTAINABILITY ISSUES (U.S. CLS. 100, 101 AND 102).

FIRST USE 9-1-2010; IN COMMERCE 9-1-2010.
DAWN FELDMAN, EXAMINING ATTORNEY

SN 85-254,601. JAGUAR CARS LIMITED, COVENTRY, UNITED KINGDOM, FILED 3-1-2011.

DRIVE IT FORWARD

THE MARK CONSISTS OF STANDARD CHARACTERS WITHOUT CLAIM TO ANY PARTICULAR FONT, STYLE, SIZE, OR COLOR.

FOR ADVERTISING AND PROMOTIONAL SERVICES FOR OTHERS RELATING TO MOTOR VEHICLES (U.S. CLS. 100, 101 AND 102).

KATHERINE STOIDES, EXAMINING ATTORNEY

SN 85-254,678. BRUCETON FARM SERVICE, INC., MORGANTOWN, WV. FILED 3-1-2011.

BFS

THE MARK CONSISTS OF STANDARD CHARACTERS WITHOUT CLAIM TO ANY PARTICULAR FONT, STYLE, SIZE, OR COLOR.

FOR RETAIL CONVENIENCE STORES (U.S. CLS. 100, 101 AND 102).

FIRST USE 2-9-2011; IN COMMERCE 2-9-2011.
KEVIN DINALLO, EXAMINING ATTORNEY

CLASS 35—(Continued).

SN 85-254,737. BRUCETON FARM SERVICE, INC., MORGANTOWN, WV. FILED 3-1-2011.



THE COLOR(S) RED AND WHITE IS/ARE CLAIMED AS A FEATURE OF THE MARK.

THE MARK CONSISTS OF THE LETTERS "BFS" IN RED BESIDE A RED CIRCLE WITH AN OFFSET WHITE CIRCLE INSIDE THE RED CIRCLE AND WHITE LINES PROJECTING OUT FROM THE WHITE CIRCLE.

FOR RETAIL CONVENIENCE STORES (U.S. CLS. 100, 101 AND 102).

FIRST USE 2-9-2011; IN COMMERCE 2-9-2011.
KEVIN DINALLO, EXAMINING ATTORNEY

CLASS 35—(Continued).

SN 85-254,929. LSN, INC., ATLANTA, GA. FILED 3-1-2011.

MOGIFT, GIFT CARDS MADE EASY

THE MARK CONSISTS OF STANDARD CHARACTERS WITHOUT CLAIM TO ANY PARTICULAR FONT, STYLE, SIZE, OR COLOR.

FOR ADVERTISING THE GOODS AND SERVICES OF OTHERS VIA WIRELESS DEVICES WITH ADVERTISEMENTS FEATURING PERSONALIZED GIFT CARDS THAT MAY BE REDEEMED BY THE USER (U.S. CLS. 100, 101 AND 102).

MICHELLE DUBOIS, EXAMINING ATTORNEY

SN 85-254,767. WELCH & ASSOCIATES, L.L.C., KANSAS CITY, MO. FILED 3-1-2011.

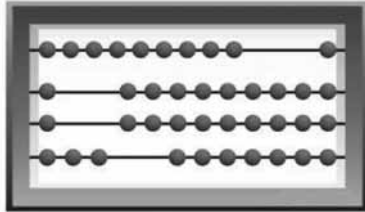

THE MARK CONSISTS OF A STYLIZED ABACUS.

FOR ACCOUNTING SERVICES; FORENSIC ACCOUNTING SERVICES; BUSINESS AND ACCOUNT AUDITING SERVICES; BUSINESS CONSULTING, MANAGEMENT, PLANNING, INVESTIGATION AND SUPERVISION; ADMINISTRATION OF BUSINESS PAYROLL FOR OTHERS; BOOKKEEPING; CORPORATE BUSINESS PLANNING; GENERAL FINANCIAL LEDGER AND FINANCIAL STATEMENT PREPARATION AND ANALYSIS SERVICES; TAX SERVICES, NAMELY, TAX ADVISORY, PREPARATION, PLANNING, CONSULTING, ACCOUNTING, COMPLIANCE, AND FILING SERVICES (U.S. CLS. 100, 101 AND 102).

FIRST USE 12-9-2010; IN COMMERCE 12-9-2010.
MARK RADEMACHER, EXAMINING ATTORNEY

SN 85-254,942. CSC BRANDS LP, CAMDEN, NJ. FILED 3-1-2011.

HELP HUNGER DISAPPEAR

THE MARK CONSISTS OF STANDARD CHARACTERS WITHOUT CLAIM TO ANY PARTICULAR FONT, STYLE, SIZE, OR COLOR.

FOR CHARITABLE SERVICES, NAMELY, COORDINATION OF THE PROCUREMENT AND DISTRIBUTION OF FOOD DONATIONS TO ORGANIZATIONS PROVIDING FOOD TO NEEDY PEOPLE (U.S. CLS. 100, 101 AND 102).

MICHELLE DUBOIS, EXAMINING ATTORNEY

SN 85-254,922. QUETOS, INC, SAN FRANCISCO, CA. FILED 3-1-2011.

masalaminds

THE MARK CONSISTS OF STANDARD CHARACTERS WITHOUT CLAIM TO ANY PARTICULAR FONT, STYLE, SIZE, OR COLOR.

FOR PROVIDING A WEB SITE WHERE USERS CAN POST RATINGS, REVIEWS AND RECOMMENDATIONS ON PRODUCTS AND SERVICES FOR COMMERCIAL PURPOSES (U.S. CLS. 100, 101 AND 102).

MICHELLE DUBOIS, EXAMINING ATTORNEY

SN 85-254,949. MILLER DESIGN, INC., DBA XCEL PARTNERS, INC., NEW ULM, TX. FILED 3-1-2011.

PEOPLE MAKE THE DIFFERENCE

THE MARK CONSISTS OF STANDARD CHARACTERS WITHOUT CLAIM TO ANY PARTICULAR FONT, STYLE, SIZE, OR COLOR.

FOR MANAGEMENT AND BUSINESS CONSULTING SERVICES IN THE FIELD OF OIL AND GAS DRILLING, EXPLORATION, AND PRODUCTION (U.S. CLS. 100, 101 AND 102).

FIRST USE 2-1-2010; IN COMMERCE 2-1-2010.
SIMON TENG, EXAMINING ATTORNEY

CLASS 35—(Continued).

SN 85-254,966. EDISON WATSON LLC, DOVER, DE. FILED 3-1-2011.

EDISON WATSON

THE MARK CONSISTS OF STANDARD CHARACTERS WITHOUT CLAIM TO ANY PARTICULAR FONT, STYLE, SIZE, OR COLOR.

THE NAME "EDISON WATSON" DOES NOT IDENTIFY A LIVING INDIVIDUAL.

FOR BUSINESS CONSULTATION SERVICES; BUSINESS CONSULTING IN THE CONSUMER PRODUCTS INDUSTRY; BUSINESS CONSULTING SERVICES, NAMELY, PROVIDING ASSISTANCE IN DEVELOPMENT OF BUSINESS STRATEGIES AND CREATIVE IDEATION; BUSINESS CONSULTING, MANAGEMENT, PLANNING AND SUPERVISION; BUSINESS MANAGEMENT CONSULTING; NEW BUSINESS VENTURE DEVELOPMENT AND FORMATION CONSULTING SERVICES; PROFESSIONAL BUSINESS CONSULTING (U.S. CLS. 100, 101 AND 102).

ANDREA HACK, EXAMINING ATTORNEY

CLASS 35—(Continued).

SN 85-254,996. LOCALITE INC., DBA LOCALITE, SEATTLE, WA. FILED 3-1-2011.

Localite

THE MARK CONSISTS OF STANDARD CHARACTERS WITHOUT CLAIM TO ANY PARTICULAR FONT, STYLE, SIZE, OR COLOR.

FOR MARKETING, ADVERTISING, AND PROMOTING THE RETAIL GOODS AND SERVICES OF OTHERS TO WIRELESS ELECTRONIC DEVICES; ONLINE ADVERTISING AND PROMOTIONAL SERVICES; ONLINE SERVICE FOR CONNECTING SOCIAL NETWORK USERS WITH RETAILERS FOR THE PURPOSE OF FACILITATING DISCOUNTED PURCHASES (U.S. CLS. 100, 101 AND 102).

KIMBERLY FRYE, EXAMINING ATTORNEY

SN 85-255,002. LOPEZ, MANUEL, WASHINGTON, DC. FILED 3-1-2011.

SN 85-254,995. LOPEZ, MANUEL, WASHINGTON, DC. FILED 3-1-2011.

RESILIENT POINT



THE MARK CONSISTS OF STANDARD CHARACTERS WITHOUT CLAIM TO ANY PARTICULAR FONT, STYLE, SIZE, OR COLOR.

FOR BUSINESS CONSULTANCY; BUSINESS MANAGEMENT AND ORGANIZATION CONSULTANCY; BUSINESS CONSULTING SERVICES, NAMELY, PROVIDING A TURN-KEY BUSINESS SOLUTION FOR REVIEWING PRODUCTS AND SERVICES, PLANNING DOCUMENTATION AND WORKFLOW, HIRING TECHNICAL WRITERS, MANAGING PROJECTS FOR BUSINESS PURPOSES, TRACKING USER SATISFACTION, AND RUNNING USABILITY STUDIES FOR BUSINESS PURPOSES (U.S. CLS. 100, 101 AND 102).

MATTHEW KLINE, EXAMINING ATTORNEY

THE MARK CONSISTS OF THE LITERAL ELEMENTS "RESILIENT POINT" WITH A IMAGE OF A FACE OF EAGLE TO THE LEFT OF IT AS SHOWN IN THE MARK.

FOR BUSINESS CONSULTANCY; BUSINESS MANAGEMENT AND ORGANIZATION CONSULTANCY; BUSINESS CONSULTING SERVICES, NAMELY, PROVIDING A TURN-KEY BUSINESS SOLUTION FOR REVIEWING PRODUCTS AND SERVICES, PLANNING DOCUMENTATION AND WORKFLOW, HIRING TECHNICAL WRITERS, MANAGING PROJECTS FOR BUSINESS PURPOSES, TRACKING USER SATISFACTION, AND RUNNING USABILITY STUDIES FOR BUSINESS PURPOSES (U.S. CLS. 100, 101 AND 102).

MATTHEW KLINE, EXAMINING ATTORNEY

CLASS 35—(Continued).

SN 85-255,141. CONTACT WELLNESS FOUNDATION, PORTLAND, OR. FILED 3-1-2011.

FAMILY TRUSTCO

THE MARK CONSISTS OF STANDARD CHARACTERS WITHOUT CLAIM TO ANY PARTICULAR FONT, STYLE, SIZE, OR COLOR.

FOR PROMOTING PUBLIC AWARENESS OF THE NEED FOR WELLNESS, PHYSICAL FITNESS, HEALTHY DIETS, AND HEALTHY LIFESTYLES TO AVOID OBESITY, DIABETES, STROKE, HEART ATTACKS AND OTHER CHRONIC DISEASES (U.S. CLS. 100, 101 AND 102).

INGRID C. EULIN, EXAMINING ATTORNEY

SN 85-255,177. ILOUNGE, IRVINE, CA. FILED 3-1-2011.

iLounge Pavilion

THE MARK CONSISTS OF STANDARD CHARACTERS WITHOUT CLAIM TO ANY PARTICULAR FONT, STYLE, SIZE, OR COLOR.

NO CLAIM IS MADE TO THE EXCLUSIVE RIGHT TO USE "PAVILION", APART FROM THE MARK AS SHOWN. FOR ARRANGING AND CONDUCTING TRADE SHOW EXHIBITIONS IN THE FIELD OF CONSUMER ELECTRONICS (U.S. CLS. 100, 101 AND 102).

FIRST USE 1-21-2009; IN COMMERCE 1-21-2009.
HOWARD B. LEVINE, EXAMINING ATTORNEY

CLASS 35—(Continued).

SN 85-255,255. KEENWAY (HK) ENTERPRISE LIMITED, NORTH POINT, HONG KONG, HONG KONG, FILED 3-2-2011.



THE MARK CONSISTS OF THE WORD "MYECODESK", ALL IN A STYLIZED FONT, WITH A SMALL BRANCH OF THREE LEAVES SPROUTING FROM THE TOP OF THE LETTER "O" IN THE MIDDLE OF THE WORD.

FOR ADVERTISING SERVICES, NAMELY, PROVIDING INFORMATION AS TO THE AVAILABILITY OF OFFICE SPACE AND/OR DESK SPACE FOR RENT OR PURCHASE; BUSINESS ADMINISTRATION AND MANAGEMENT; BUSINESS ADMINISTRATION AND OFFICE WORK; BUSINESS ADMINISTRATION ASSISTANCE; BUSINESS ASSISTANCE, MANAGEMENT AND INFORMATION SERVICES; BUSINESS OPERATION, BUSINESS ADMINISTRATION AND OFFICE FUNCTIONS; COMPUTERISED OFFICE MANAGEMENT; LEASING OF OFFICE EQUIPMENT; OFFICE ADMINISTRATION SERVICES; ONLINE ADVERTISEMENTS; ONLINE ADVERTISING VIA A COMPUTER COMMUNICATIONS NETWORK; PROVIDING A WEB SITE THAT FEATURES AN ON-LINE MARKET FOR USERS TO LIST OFFERED OR WANTED PERSONAL AND BUSINESS ASSETS AND SKILLS FOR HIRE, RENT, SALE OR AUCTION TRANSACTED ON THE BASIS OF PREDEFINED PERFORMANCE AND CLOSING TERMS AND CONDITIONS; PROVIDING A WEBSITE WHERE OWNERS CAN POST ITEMS AND SERVICES AVAILABLE FOR RENT BY OTHERS; PROVIDING OFFICE FUNCTIONS; PROVIDING ORGANIZING SERVICES FOR INDIVIDUALS AT HOME, IN HOME OFFICES AND IN BUSINESS OFFICES, THAT PROVIDES HELP WITH TIME AND PAPER MANAGEMENT (U.S. CLS. 100, 101 AND 102).

FIRST USE 1-24-2011; IN COMMERCE 1-24-2011.
DOUGLAS LEE, EXAMINING ATTORNEY

SN 85-255,308. CLINOVATIONS, LLC, WASHINGTON, DC. FILED 3-2-2011.



THE MARK CONSISTS OF THE WORDING "CLINOVATIONS" IN LOWER CASE LETTERS ADJACENT TO A CROSS DESIGN. THE CROSS DESIGN IS SURROUNDED BY FOUR CURVED ARCH SHAPES. THE CROSS WILL NOT APPEAR IN THE COLOR RED.

FOR BUSINESS AND MANAGEMENT CONSULTING SERVICES IN THE FIELD OF HEALTHCARE (U.S. CLS. 100, 101 AND 102).

FIRST USE 12-0-2007; IN COMMERCE 12-0-2007.
ZACHARY BELLO, EXAMINING ATTORNEY

CLASS 35—(Continued).

SN 85-255,596. LADIES & DAMES, INC., MYRTLE BEACH, SC. FILED 3-2-2011.



THE MARK CONSISTS OF THE WORDS "TOO..QT" IN STYLIZED LETTERING WITH THE LETTERS "QT" IN LARGER AND DARKER LETTERING PARTIALLY SUPERIMPOSED OVER "TOO..".

FOR RETAIL STORE AND ON-LINE RETAIL STORE SERVICES FEATURING WOMEN'S APPAREL (U.S. CLS. 100, 101 AND 102).

FIRST USE 2-3-2006; IN COMMERCE 2-3-2006.
TINA BROWN, EXAMINING ATTORNEY

SN 85-255,640. CALIFORNIA AVOCADO COMMISSION, IRVINE, CA. FILED 3-2-2011.

Avo Babies

THE MARK CONSISTS OF STANDARD CHARACTERS WITHOUT CLAIM TO ANY PARTICULAR FONT, STYLE, SIZE, OR COLOR.

NO CLAIM IS MADE TO THE EXCLUSIVE RIGHT TO USE "BABIES", APART FROM THE MARK AS SHOWN.

FOR ASSOCIATION SERVICES, NAMELY, PROMOTING THE INTERESTS OF CALIFORNIA AVOCADO GROWERS (U.S. CLS. 100, 101 AND 102).

FIRST USE 2-1-2011; IN COMMERCE 2-1-2011.
B. PARADEWELAI, EXAMINING ATTORNEY

SN 85-255,807. BPI BRAND MARKETING SOLUTIONS, INC., NEPTUNE, NJ. FILED 3-2-2011.

Congreenient

THE MARK CONSISTS OF STANDARD CHARACTERS WITHOUT CLAIM TO ANY PARTICULAR FONT, STYLE, SIZE, OR COLOR.

FOR ADVERTISING AGENCY SPECIALIZING IN THE DESIGN AND EXECUTION OF WORD OF MOUTH, VIRAL, BUZZ AND EXPERIENTIAL MARKETING PROGRAMS; ADVERTISING AND BUSINESS SERVICES, NAMELY, PROVIDING AN ONLINE WEBSITE WHERE ADVERTISERS, MARKETERS, AND CONTENT PROVIDERS CAN INTERACT WITH USERS FOR ADVERTISING, BRANDING, AND PROMOTING KNOWLEDGE, PRODUCTS, AND SERVICES, AND TRADESHOWS, ON BEHALF OF THEMSELVES AND OTHERS, AND FOR EVALUATING AND RATING THE SAME, ALL THE FOREGOING RELEVANT TO HUMAN ACTIVITIES AFFECTING CLIMATE CHANGE AND RELATED

CLASS 35—(Continued).

FIELDS; ADVERTISING AND MARKETING; ADVERTISING AND MARKETING CONSULTANCY; ADVERTISING AND MARKETING SERVICES PROVIDED BY MEANS OF INDIRECT METHODS OF MARKETING COMMUNICATIONS, NAMELY, SOCIAL MEDIA, SEARCH ENGINE MARKETING, INQUIRY MARKETING, INTERNET MARKETING, MOBILE MARKETING, BLOGGING AND OTHER FORMS OF PASSIVE, SHARABLE OR VIRAL COMMUNICATIONS CHANNELS; ADVERTISING AND MARKETING SERVICES, NAMELY, PROMOTING THE GOODS AND SERVICES OF OTHERS; ADVERTISING SERVICES, NAMELY, PROMOTING AND MARKETING THE GOODS AND SERVICES OF OTHERS IN THE FIELD OF UPSCALE CHOICES SUCH AS CULTURAL EVENTS, RESTAURANTS, SHOPPING, AND TRAVEL VIA PRINT AND ELECTRONIC MEDIA; ADVERTISING SERVICES, NAMELY, PROMOTING AND MARKETING THE GOODS AND SERVICES OF OTHERS THROUGH ALL PUBLIC COMMUNICATION MEANS; ADVERTISING SERVICES, PUBLIC RELATIONS AND MARKETING SERVICES, NAMELY, PROMOTING AND MARKETING THE GOODS AND SERVICES OF OTHERS THROUGH ALL PUBLIC COMMUNICATION MEANS; ADVERTISING, MARKETING AND PROMOTING THE GOODS AND SERVICES OF OTHERS USING KIOSKS; ADVERTISING, MARKETING AND PROMOTION SERVICES; ADVERTISING, MARKETING AND PROMOTION SERVICES, NAMELY, PROMOTING THE GOODS AND SERVICES OF OTHERS BY PROVIDING CUSTOMIZED EXHIBITS; ADVERTISING, MARKETING AND PROMOTIONAL SERVICES RELATED TO ALL INDUSTRIES FOR THE PURPOSE OF FACILITATING NETWORKING AND SOCIALIZING OPPORTUNITIES FOR BUSINESS PURPOSES; ARRANGING AND CONDUCTING MARKETING PROMOTIONAL EVENTS FOR OTHERS; ASSISTANCE, ADVISORY SERVICES AND CONSULTANCY WITH REGARD TO BUSINESS PLANNING, BUSINESS ANALYSIS, BUSINESS MANAGEMENT, BUSINESS ORGANIZATION, MARKETING AND CUSTOMER ANALYSIS; BRANDING SERVICES, NAMELY, CONSULTING, DEVELOPMENT, MANAGEMENT AND MARKETING OF BRANDS FOR BUSINESSES; BUSINESS CONSULTATION AND MANAGEMENT REGARDING MARKETING ACTIVITIES AND LAUNCHING OF NEW PRODUCTS; BUSINESS MANAGEMENT CONSULTING WITH RELATION TO STRATEGY, MARKETING, PRODUCTION, PERSONNEL AND RETAIL SALE MATTERS; BUSINESS MARKETING SERVICES; BUSINESS TO BUSINESS DIRECT MARKETING SERVICES; CONSULTING SERVICES IN THE FIELD OF INTERNET MARKETING; CREATIVE MARKETING DESIGN SERVICES; DEVELOPMENT OF MARKETING STRATEGIES AND CONCEPTS; DEVELOPMENT OF MARKETING STRATEGIES, CONCEPTS AND TACTICS, NAMELY, AUDIENCE DEVELOPMENT, BRAND AWARENESS, CUSTOMER RELATIONS, ONLINE COMMUNITY BUILDING AND DIGITAL WORD OF MOUTH COMMUNICATIONS; DEVELOPMENT OF MARKETING STRATEGIES, CONCEPTS AND TACTICS, NAMELY, AUDIENCE DEVELOPMENT, BRAND AWARENESS, ONLINE COMMUNITY BUILDING AND DIGITAL WORD OF MOUTH COMMUNICATIONS; DIRECT MARKETING; DIRECT MARKETING ADVERTISING FOR OTHERS; DIRECT MARKETING CONSULTING SERVICES; GENERAL BUSINESS MERCHANDISING SERVICES, NAMELY, MARKETING; IMPLEMENTATION AND FOLLOW-UP OF ADVICE IN THE FIELDS OF MARKETING; INFORMATION OR ENQUIRIES ON BUSINESS AND MARKETING; INFORMATION, ADVISORY, CONSULTING, BUSINESS RESEARCH AND PLANNING SERVICES RELATING TO PUBLICITY, MARKETING COMMUNICATIONS, REPUTATION MANAGEMENT OR BUSINESS ADMINISTRATION, INCLUDING SUCH SERVICES PROVIDED ONLINE OR VIA THE INTERNET; MARKETING CONSULTING; MARKETING CONSULTING SERVICES RELATING TO LONG-TERM BUSINESS STRATEGY DEVELOPMENT FOR NON-PROFIT ORGANIZATIONS; MARKETING PLAN DEVELOPMENT; ON-LINE ADVERTISING AND MARKETING SERVICES; PROMOTING AND MARKETING THE GOODS AND SERVICES OF OTHERS BY DISTRIBUTING ADVERTISING MATERIAL, COUPONS AND DISCOUNT OFFERS VIA TEXT MESSAGES; PROMOTING THE GOODS AND SERVICES OF OTHERS BY MEANS OF WORD-OF-MOUTH AND NONTRADITIONAL MARKETING PROGRAMS; PRO-

CLASS 35—(Continued).

MOTING, ADVERTISING AND MARKETING OF THE BRANDS, PRODUCTS, SERVICES OR ONLINE WEBSITES OF INDIVIDUALS, BUSINESSES AND NONPROFIT ORGANIZATIONS; PROMOTING, ADVERTISING AND MARKETING OF THE ON-LINE WEB SITES OF OTHERS; PROMOTING, ADVERTISING AND MARKETING THE ON-LINE DATABASES AND ELECTRONIC PUBLICATIONS OF OTHERS; PROMOTING, MARKETING AND ADVERTISING THE BRANDS AND GOODS OF OTHERS RELATED TO ALL INDUSTRIES, THROUGH ALL PUBLIC AND PRIVATE COMMUNICATION MEANS, NAMELY, PROMOTING THE BRANDS AND GOODS OF OTHERS MADE IN THE UNITED STATES; PROMOTION AND MARKETING SERVICES AND RELATED CONSULTING; PROMOTION, ADVERTISING AND MARKETING OF ON-LINE WEBSITES; PROMOTIONAL SERVICES, NAMELY, GUERRILLA MARKETING SERVICES; PROVIDING ADVERTISING, MARKETING AND PROMOTIONAL SERVICES, NAMELY, DEVELOPMENT OF ADVERTISING CAMPAIGNS PROVIDED THROUGH CABLE TELEVISION BROADCAST, WEB CASTS, RADIO BROADCASTS, NEWSPAPERS, MAGAZINES, ONLINE BANNERS, OUTDOOR BILLBOARDS, WILD POSTINGS, BUS AND SUBWAY ADS; PROVIDING BUSINESS MARKETING INFORMATION; PROVIDING INFORMATION IN THE FIELD OF MARKETING AND ON-LINE MARKETING MEDIA VIA THE INTERNET; PROVIDING MARKETING AND PROMOTION OF SPECIAL EVENTS; PROVIDING MARKETING SOLUTIONS FOR ALL BUSINESS; PROVIDING ONLINE BUSINESS MANAGEMENT SERVICES INCLUDING ACCOUNTING, MARKETING, BUSINESS PROJECT MANAGEMENT, AND BUSINESS DEVELOPMENT; PROVIDING PROMOTIONAL MARKETING SERVICES TO BUSINESSES IN THE BROADBAND AND MEDIA INDUSTRIES (U.S. CLS. 100, 101 AND 102).
EDWARD FENNESSY, EXAMINING ATTORNEY

SN 85-255,910. PORTLAND ENERGY CONSERVATION, INC., PORTLAND, OR. FILED 3-2-2011.

AIRCARE PLUS

THE MARK CONSISTS OF STANDARD CHARACTERS WITHOUT CLAIM TO ANY PARTICULAR FONT, STYLE, SIZE, OR COLOR.
FOR CONSULTATION IN THE FIELD OF HVAC ENERGY EFFICIENCY (U.S. CLS. 100, 101 AND 102).
FIRST USE 12-31-2002; IN COMMERCE 12-31-2002.
GINA FINK, EXAMINING ATTORNEY

SN 85-255,949. STREEETCARSHOPS.COM, LLC, PRAIRIEVILLE, LA. FILED 3-2-2011.

REWARDS FOR LIVING LOCALLY

THE MARK CONSISTS OF STANDARD CHARACTERS WITHOUT CLAIM TO ANY PARTICULAR FONT, STYLE, SIZE, OR COLOR.
FOR ADVERTISING AND MARKETING SERVICES, NAMELY, PROMOTING THE GOODS AND SERVICES OF OTHERS (U.S. CLS. 100, 101 AND 102).
LAURIE MAYES, EXAMINING ATTORNEY

CLASS 35—(Continued).

SN 85-256,127. VIVA LA BID, LLC, HOUSTON, TX. FILED 3-2-2011.

Viva La Bid

THE MARK CONSISTS OF STANDARD CHARACTERS WITHOUT CLAIM TO ANY PARTICULAR FONT, STYLE, SIZE, OR COLOR.
FOR AUCTIONING VIA TELECOMMUNICATION NETWORKS (U.S. CLS. 100, 101 AND 102).
CHARLOTTE CORWIN, EXAMINING ATTORNEY

SN 85-256,128. TUNECORE, INC., BROOKLYN, NY. FILED 3-2-2011.

SELL YOUR MUSIC, NOT YOUR SOUL

THE MARK CONSISTS OF STANDARD CHARACTERS WITHOUT CLAIM TO ANY PARTICULAR FONT, STYLE, SIZE, OR COLOR.
FOR ON-LINE DISTRIBUTORSHIP SERVICES IN THE FIELD OF DOWNLOADABLE PRE-RECORDED MUSICAL WORKS; COMMERCIAL ADMINISTRATION OF THE LICENSING OF PRE-RECORDED MUSICAL WORKS OF OTHERS (U.S. CLS. 100, 101 AND 102).
FIRST USE 1-20-2006; IN COMMERCE 1-20-2006.
CHARLOTTE CORWIN, EXAMINING ATTORNEY

SN 85-256,164. WISCONSIN EMERGENCY MEDICAL TECHNICIANS ASSOCIATION, INC., DBA WISCONSIN EMS ASSOCIATION, WIND LAKE, WI. FILED 3-2-2011.

RATEMYEMSSPEAKER

THE MARK CONSISTS OF STANDARD CHARACTERS WITHOUT CLAIM TO ANY PARTICULAR FONT, STYLE, SIZE, OR COLOR.
FOR ADVERTISING AND MARKETING SERVICES, NAMELY, PROMOTING THE GOODS AND SERVICES OF OTHERS; PROVIDING A SEARCHABLE ONLINE ADVERTISING WEBSITE AND INFORMATIONAL GUIDE FEATURING THE GOODS AND SERVICES OF OTHER VENDORS VIA THE INTERNET IN THE FIELD OF EMERGENCY MEDICAL SERVICES SPEAKER SERVICES; PROVIDING AN ON-LINE COMPUTER DATABASE FEATURING TRADE INFORMATION IN THE FIELD OF EMS SPEAKERS AND AUDIENCE REVIEWS OF PAST PRESENTATIONS (U.S. CLS. 100, 101 AND 102).
ESTHER A. BORSUK, EXAMINING ATTORNEY

CLASS 35—(Continued).

SN 85-256,200. BNP MEDIA, INC., TROY, MI. FILED 3-2-2011.

CERAMIC INDUSTRY

THE MARK CONSISTS OF STANDARD CHARACTERS WITHOUT CLAIM TO ANY PARTICULAR FONT, STYLE, SIZE, OR COLOR.

OWNER OF U.S. REG. NOS. 1,638,386 AND 1,640,462. SEC. 2(F).

FOR ON-LINE BUYERS GUIDE SERVICE PROVIDING INFORMATION IN THE FIELD OF THE CERAMIC, GLASS, AND BRICK MANUFACTURING INDUSTRIES (U.S. CLS. 100, 101 AND 102).

FIRST USE 6-0-2001; IN COMMERCE 6-0-2001.
MICHAEL TANNER, EXAMINING ATTORNEY

SN 85-256,284. QUILTIQUE LLC, HENDERSON, NV. FILED 3-2-2011.

QUILTIQUE

THE MARK CONSISTS OF STANDARD CHARACTERS WITHOUT CLAIM TO ANY PARTICULAR FONT, STYLE, SIZE, OR COLOR.

OWNER OF U.S. REG. NO. 3,343,481.

FOR RETAIL STORE SERVICES FEATURING FABRIC, SEWING AND QUILTING NOTIONS, BOOKS, PATTERNS, QUILT KITS, EMBROIDERY SUPPLIES, SEWING MACHINES, SEWING CABINETS AND SOFTWARE (U.S. CLS. 100, 101 AND 102).

FIRST USE 1-1-2003; IN COMMERCE 4-12-2003.
STEVEN JACKSON, EXAMINING ATTORNEY

SN 85-256,305. LEHMAN, AMANDA, MYRTLE BANK, AUSTRALIA, FILED 3-2-2011.

search, register, protect

THE MARK CONSISTS OF STANDARD CHARACTERS WITHOUT CLAIM TO ANY PARTICULAR FONT, STYLE, SIZE, OR COLOR.

FOR ON-LINE BUSINESS DIRECTORIES FEATURING BUSINESSES, BRANDS, AND PEOPLE (U.S. CLS. 100, 101 AND 102).

DOMINICK J. SALEMI, EXAMINING ATTORNEY

CLASS 35—(Continued).

SN 85-256,393. TEXTEDGE, INC., COLUMBUS, MN. FILED 3-2-2011.

TEXTEDGE

THE MARK CONSISTS OF STANDARD CHARACTERS WITHOUT CLAIM TO ANY PARTICULAR FONT, STYLE, SIZE, OR COLOR.

FOR PROMOTING AND MARKETING THE GOODS AND SERVICES OF OTHERS BY DISTRIBUTING ADVERTISING MATERIAL, COUPONS AND DISCOUNT OFFERS VIA TEXT MESSAGES; PROMOTING THE GOODS OF OTHERS, NAMELY, PROVIDING COUPONS, REBATES AND VOUCHERS FOR THE GOODS OF OTHERS; PROMOTIONAL SERVICES, NAMELY, PROMOTING THE GOODS OF OTHERS BY MEANS OF PROVIDING ONLINE COUPONS (U.S. CLS. 100, 101 AND 102).

JENNIFER VASQUEZ, EXAMINING ATTORNEY

SN 85-256,411. TEXTEDGE, INC., COLUMBUS, MN. FILED 3-3-2011.



NO CLAIM IS MADE TO THE EXCLUSIVE RIGHT TO USE "TEXT", APART FROM THE MARK AS SHOWN.

THE MARK CONSISTS OF THE WORD MARK "TEXT EDGE" WITHIN A RECTANGLE WITH ROUNDED CORNERS.

FOR PROMOTING AND MARKETING THE GOODS AND SERVICES OF OTHERS BY DISTRIBUTING ADVERTISING MATERIAL, COUPONS AND DISCOUNT OFFERS VIA TEXT MESSAGES; PROMOTING THE GOODS OF OTHERS, NAMELY, PROVIDING COUPONS, REBATES AND VOUCHERS FOR THE GOODS OF OTHERS; PROMOTIONAL SERVICES, NAMELY, PROMOTING THE GOODS OF OTHERS BY MEANS OF PROVIDING ONLINE COUPONS (U.S. CLS. 100, 101 AND 102).

JENNIFER VASQUEZ, EXAMINING ATTORNEY

CLASS 35—(Continued).

SN 85-256,461. MORALES, DANIELLA, VILLAGE OF PALMETTO BA, FL. FILED 3-3-2011.

ARTSENAL

THE MARK CONSISTS OF STANDARD CHARACTERS WITHOUT CLAIM TO ANY PARTICULAR FONT, STYLE, SIZE, OR COLOR.

FOR PROMOTING THE GRAPHIC ARTS DESIGN SERVICES OF OTHERS BY MEANS OF A WEBSITE FEATURING GRAPHIC ARTWORK SUBMITTED BY GRAPHIC ART DESIGNERS; PROMOTIONAL SERVICES, NAMELY, PROVIDING A WEBSITE AT WHICH ARTISTS CAN SHOWCASE THEIR TALENTS VIA AN ONLINE PORTFOLIO; ON-LINE RETAIL STORE SERVICES FEATURING ARTS AND CRAFTS, POP ART DESIGN, PHOTOGRAPHY, SCRAPBOOKING, HAND-CRAFTS AND DIGITAL DESIGNS (U.S. CLS. 100, 101 AND 102).

FIRST USE 10-1-2009; IN COMMERCE 11-1-2009.
JOHN KELLY, EXAMINING ATTORNEY

SN 85-256,472. CLEMENTS, LINDA, MERMAID WATERS, AUSTRALIA, FILED 3-3-2011.

PLATINUMHD PROPVID

THE MARK CONSISTS OF STANDARD CHARACTERS WITHOUT CLAIM TO ANY PARTICULAR FONT, STYLE, SIZE, OR COLOR.

FOR REAL ESTATE ADVERTISING SERVICES; REAL ESTATE AUCTIONS; REAL ESTATE SALES MANAGEMENT (U.S. CLS. 100, 101 AND 102).

COLLEEN KEARNEY, EXAMINING ATTORNEY

SN 85-256,474. OPEN END INVESTMENTS, MESA, AZ. FILED 3-3-2011.

THE ORCHARD

THE MARK CONSISTS OF STANDARD CHARACTERS WITHOUT CLAIM TO ANY PARTICULAR FONT, STYLE, SIZE, OR COLOR.

FOR RETAIL STORE FEATURING USED COMPUTERS, LAPTOPS, AND HANDHELD ELECTRONICS (U.S. CLS. 100, 101 AND 102).

FIRST USE 1-13-2010; IN COMMERCE 9-15-2010.
JOHN DALIER, EXAMINING ATTORNEY

CLASS 35—(Continued).

SN 85-256,488. YACHTING PROMOTIONS, INC., FORT LAUDERDALE, FL. FILED 3-3-2011.

BOATQUEST.COM

THE MARK CONSISTS OF STANDARD CHARACTERS WITHOUT CLAIM TO ANY PARTICULAR FONT, STYLE, SIZE, OR COLOR.

FOR PROVIDING ADVERTISING LISTINGS VIA A GLOBAL COMPUTER NETWORK RELATING TO MARINE VESSELS; PROVIDING AN ON-LINE SEARCHABLE DATABASE FEATURING CLASSIFIED AD LISTINGS FOR MARINE VESSELS AND MARINE GEAR AND EQUIPMENT, INFORMATION CONCERNING VALUATION OF MARINE VESSELS, MARINE VESSEL DEALERS, CHARTERS, AND SERVICE PROVIDERS, AS WELL AS GENERAL MARINE INDUSTRY NEWS; ADVERTISING ON THE INTERNET FOR OTHERS; ADVERTISING SERVICES, NAMELY, PROMOTING MARINE VESSELS FOR SALE BY BROKERS, DEALERS, AND BY OWNERS VIA THE INTERNET (U.S. CLS. 100, 101 AND 102).

FIRST USE 6-3-2003; IN COMMERCE 6-3-2003.
COLLEEN KEARNEY, EXAMINING ATTORNEY

SN 85-256,553. ADJECTOR, LLP, FORT LEE, NJ. FILED 3-3-2011.

ADjector

THE MARK CONSISTS OF STANDARD CHARACTERS WITHOUT CLAIM TO ANY PARTICULAR FONT, STYLE, SIZE, OR COLOR.

FOR DISSEMINATION OF ADVERTISING FOR OTHERS VIA THE INTERNET; ON-LINE ADVERTISING AND MARKETING SERVICES; ON-LINE ADVERTISING ON COMPUTER COMMUNICATION NETWORKS; PROMOTING, ADVERTISING AND MARKETING OF THE ON-LINE WEB SITES OF OTHERS (U.S. CLS. 100, 101 AND 102).

FIRST USE 2-0-2010; IN COMMERCE 3-0-2010.
MAYUR VAGHANI, EXAMINING ATTORNEY

CLASS 35—(Continued).

SN 85-256,747. NEIL D. BERLANT, LOS ANGELES, CA. FILED 3-3-2011.

Profiting From Water

THE MARK CONSISTS OF STANDARD CHARACTERS WITHOUT CLAIM TO ANY PARTICULAR FONT, STYLE, SIZE, OR COLOR.

FOR ACQUISITION AND MERGER CONSULTATION; ARRANGING AND CONDUCTING BUSINESS CONFERENCES; BUSINESS ACQUISITIONS CONSULTATION; PREPARATION OF REPORTS RELATING TO FINANCE AND INVESTMENTS (U.S. CLS. 100, 101 AND 102).
LINDA POWELL, EXAMINING ATTORNEY

SN 85-256,905. PHUNWARE, INC., AUSTIN, TX. FILED 3-3-2011.

PHUNDEALS

THE MARK CONSISTS OF STANDARD CHARACTERS WITHOUT CLAIM TO ANY PARTICULAR FONT, STYLE, SIZE, OR COLOR.

FOR PROMOTING THE GOODS AND SERVICES OF OTHERS BY PROVIDING SOFTWARE APPLICATIONS AND A WEBSITE FEATURING COUPONS, REBATES, PRICE-COMPARISON INFORMATION, PRODUCT REVIEWS, LINKS TO THE RETAIL WEBSITES OF OTHERS, AND DISCOUNT INFORMATION (U.S. CLS. 100, 101 AND 102).

ROBIN MITTLER, EXAMINING ATTORNEY

SN 85-257,011. ENERGY PLATFORMS, LLC, SHAKOPEE, MN. FILED 3-3-2011.

NEEDS

THE MARK CONSISTS OF STANDARD CHARACTERS WITHOUT CLAIM TO ANY PARTICULAR FONT, STYLE, SIZE, OR COLOR.

FOR CONSULTING SERVICES IN THE FIELD OF ENERGY USAGE MANAGEMENT AND ENERGY EFFICIENCY; ENERGY USAGE MANAGEMENT INFORMATION SERVICES (U.S. CLS. 100, 101 AND 102).
PATRICIA EVANKO, EXAMINING ATTORNEY

CLASS 35—(Continued).

SN 85-257,034. ROCKET FUEL INC., REDWOOD SHORES, CA. FILED 3-3-2011.

Campaigns run better on Rocket Fuel.

THE MARK CONSISTS OF STANDARD CHARACTERS WITHOUT CLAIM TO ANY PARTICULAR FONT, STYLE, SIZE, OR COLOR.

FOR ADVERTISEMENT FOR OTHERS ON THE INTERNET; ADVERTISEMENT VIA MOBILE PHONE NETWORKS; ADVERTISING AND ADVERTISEMENT SERVICES; ADVERTISING ON THE INTERNET FOR OTHERS; ADVERTISING VIA ELECTRONIC MEDIA AND SPECIFICALLY THE INTERNET; ANALYSIS OF ADVERTISING RESPONSE; DISPLAYING ADVERTISEMENTS FOR OTHERS; DISSEMINATION OF ADVERTISING FOR OTHERS VIA THE INTERNET (U.S. CLS. 100, 101 AND 102).

FIRST USE 6-1-2010; IN COMMERCE 6-1-2010.
EUGENIA MARTIN, EXAMINING ATTORNEY

SN 85-257,053. EDITION 01 LLC, GREAT NECK, NY. FILED 3-3-2011.

EDITION 01

THE MARK CONSISTS OF STANDARD CHARACTERS WITHOUT CLAIM TO ANY PARTICULAR FONT, STYLE, SIZE, OR COLOR.

FOR ON-LINE RETAIL STORE SERVICES FEATURING APPAREL, ACCESSORIES, AND FURNITURE; RETAIL STORE SERVICES FEATURING APPAREL, ACCESSORIES, AND FURNITURE (U.S. CLS. 100, 101 AND 102).
JACLYN KIDWELL WALKER, EXAMINING ATTORNEY

CLASS 35—(Continued).

SN 85-257,056. SANTA MONICA CONVENTION & VISITORS BUREAU, SANTA MONICA, CA. FILED 3-3-2011.



THE MARK CONSISTS OF THE NAME "CALIFORNIA'S MOST" ABOVE THE NAME "CELEBRATED BEACH CITY". ABOVE THE WORDING IS A STYLIZED SILHOUETTE DESIGN INCLUDING, FROM LEFT TO RIGHT, PALM TREES, BUILDING, FERRIS WHEEL, PALM TREES, ARCHED ENTRYWAY, PALM TREES AND BUILDING.

FOR ASSOCIATION SERVICES, NAMELY, PROMOTING THE BUSINESS INTERESTS OF MEMBERS OF THE HOTEL, RESTAURANT, RECREATION, THEATER, MUSEUM AND RETAIL SHOP INDUSTRIES; PROMOTING PUBLIC AWARENESS OF COMMUNITY AND CIVIC EVENTS, CULTURE AND THE ARTS; PROVIDING BUSINESS INFORMATION REGARDING BUSINESS DEVELOPMENTS IN THE SANTA MONICA, CALIFORNIA AREA VIA A WORLD WIDE WEB WEBSITE; PUBLIC RELATIONS; PUBLICITY SERVICES, NAMELY, PROMOTING THE GOODS AND SERVICES OF OTHERS VIA DISTRIBUTION AND DISSEMINATION OF ADVERTISING MATERIALS; CONVENTION AND VISITORS BUREAU SERVICES, NAMELY, PROMOTING BUSINESS, TOURISM AND CONVENTIONS IN THE SANTA MONICA, CALIFORNIA AREA; PROVIDING AN ONLINE DIRECTORY INFORMATION SERVICE FEATURING LISTINGS FOR RESTAURANTS AND OTHER FOOD ESTABLISHMENTS, FARMERS' MARKETS, SCHOOLS AND COLLEGES, SHOPPING MALLS AND OTHER SHOPPING VENUES, AND TOUR COMPANIES; AND CHAMBER OF COMMERCE SERVICES, NAMELY, PROMOTING BUSINESS AND TOURISM IN THE SANTA MONICA AND WESTERN AREAS OF LOS ANGELES COUNTY, CALIFORNIA (U.S. CLS. 100, 101 AND 102).

LEIGH CAROLINE CASE, EXAMINING ATTORNEY

SN 85-257,256. PINNACLE ENTERTAINMENT, INC., LAS VEGAS, NV. FILED 3-3-2011.



NO CLAIM IS MADE TO THE EXCLUSIVE RIGHT TO USE "DOWNS" AND "RACEBOOK", APART FROM THE MARK AS SHOWN.

THE MARK CONSISTS OF THE WORDS "RIVER DOWNS" IN STYLIZED FORM CENTERED OVER A SOLID LINE WHICH IS CENTERED OVER THE STYLIZED WORD "RACEBOOK" WHICH IS CENTERED OVER A SOLID LINE.

FOR RETAIL GIFT SHOPS; RETAIL STORE SERVICES FEATURING CLOTHING AND SOUVENIRS (U.S. CLS. 100, 101 AND 102).

JULIE GUTTADAURO, EXAMINING ATTORNEY

CLASS 35—(Continued).

SN 85-257,282. ABILITY CONNECTION TEXAS, DALLAS, TX. FILED 3-3-2011.



THE MARK CONSISTS OF A STYLIZED PARTIAL IMAGE OF A STICK FIGURE IN A WHEELCHAIR ON A DARK RECTANGULAR BACKGROUND.

FOR ASSOCIATION SERVICES, NAMELY, PROMOTING THE INTERESTS OF PEOPLE WITH DISABILITIES (U.S. CLS. 100, 101 AND 102).

FIRST USE 2-9-2011; IN COMMERCE 2-9-2011.

SEAN CROWLEY, EXAMINING ATTORNEY

SN 85-257,345. ANTHONY G. MARREN, PROVO, UT. FILED 3-3-2011.

OPERATION JUST ONE CAN

THE MARK CONSISTS OF STANDARD CHARACTERS WITHOUT CLAIM TO ANY PARTICULAR FONT, STYLE, SIZE, OR COLOR.

FOR CHARITABLE SERVICES, NAMELY, COORDINATION OF NON-MONETARY CONTRIBUTIONS TO CHARITIES AND NON-PROFITS; CHARITABLE SERVICES, NAMELY, ORGANIZING AND DEVELOPING PROJECTS THAT AIM TO IMPROVE THE LIVES OF UNDERPRIVILEGED AND IMPOVERISHED PEOPLE; MARKETING SERVICES, NAMELY, PROMOTIONAL SERVICES IN THE FIELD OF PLANNED-GIVING FOR NON-PROFIT AND CHARITABLE ORGANIZATIONS; PROMOTING THE CHARITABLE SERVICES OF OTHERS, NAMELY, PROVIDING INDIVIDUALS WITH INFORMATION FOR THE PURPOSE OF MAKING DONATIONS TO CHARITIES (U.S. CLS. 100, 101 AND 102).

FIRST USE 5-1-2009; IN COMMERCE 5-1-2009.

DANNEAN HETZEL, EXAMINING ATTORNEY

CLASS 35—(Continued).

SN 85-257,399. GOLD STANDARD SECURITY INC., CHICAGO, IL. FILED 3-3-2011.

COP-MEDICS

THE MARK CONSISTS OF STANDARD CHARACTERS WITHOUT CLAIM TO ANY PARTICULAR FONT, STYLE, SIZE, OR COLOR.

FOR EMPLOYMENT STAFFING IN THE FIELD OF DUAL TRAINED POLICE OFFICERS AND PARAMEDICS FOR EVENTS AND EXECUTIVE PROTECTION (U.S. CLS. 100, 101 AND 102).

RENEE MCCRAY, EXAMINING ATTORNEY

SN 85-257,468. CHECKMARK, INC., FORT COLLINS, CO. FILED 3-3-2011.

CHECKMARK

THE MARK CONSISTS OF STANDARD CHARACTERS WITHOUT CLAIM TO ANY PARTICULAR FONT, STYLE, SIZE, OR COLOR.

OWNER OF U.S. REG. NO. 3,784,547. FOR PAYROLL PROCESSING SERVICES (U.S. CLS. 100, 101 AND 102).

WENDY JUN, EXAMINING ATTORNEY

SN 85-257,653. LAKE BUSINESS DEVELOPMENT CORPORATION, FORT COLLINS, CO. FILED 3-4-2011.

TRANSTRATA

THE MARK CONSISTS OF STANDARD CHARACTERS WITHOUT CLAIM TO ANY PARTICULAR FONT, STYLE, SIZE, OR COLOR.

FOR BUSINESS CONSULTATION IN THE FIELD OF EARLY AND MIDDLE GROWTH STAGE PRIVATELY HELD ENTERPRISES IN THE NATURE OF CREATING DEVELOPMENT PLANS FOR ADVANTAGEOUS LEVERAGING; AND BUSINESS CONSULTATION IN THE FIELDS OF INTERNAL AND EXTERNAL OPERATIONS, HUMAN RESOURCES, FINANCIAL RESOURCES, ORGANIZATIONAL STRUCTURE, ORGANIZATIONAL CULTURE, PRODUCT MIX, PRODUCT SUPPORT SERVICES MIX, AND BUSINESS SYSTEMS AND PROCESSES, ALL TO ACCELERATE THE INCREASE IN ENTERPRISE VALUE (U.S. CLS. 100, 101 AND 102).

FIRST USE 5-20-2010; IN COMMERCE 5-20-2010. ALEX KEAM, EXAMINING ATTORNEY

CLASS 35—(Continued).

SN 85-257,665. JUNG, STEVEN, SOLANA BEACH, CA. FILED 3-4-2011.

KARTMOB

THE MARK CONSISTS OF STANDARD CHARACTERS WITHOUT CLAIM TO ANY PARTICULAR FONT, STYLE, SIZE, OR COLOR.

FOR PROMOTING THE GOODS AND SERVICES OF OTHERS BY PROVIDING A WEBSITE FEATURING DISCOUNT VOUCHERS, REBATES, PRICE-COMPARISON INFORMATION, PRODUCT REVIEWS, LINKS TO THE RETAIL WEBSITES OF OTHERS, AND DISCOUNT INFORMATION (U.S. CLS. 100, 101 AND 102).

ALEX KEAM, EXAMINING ATTORNEY

SN 85-257,765. SHANE'S INSPIRATION, VAN NUYS, CA. FILED 3-4-2011.

TOGETHER WE PLAY

THE MARK CONSISTS OF STANDARD CHARACTERS WITHOUT CLAIM TO ANY PARTICULAR FONT, STYLE, SIZE, OR COLOR.

FOR PROMOTING THE CONSTRUCTION AND UTILIZATION OF PLAYGROUNDS DESIGNED FOR CHILDREN OF ALL ABILITY LEVELS BY MEANS OF A CONTEST (U.S. CLS. 100, 101 AND 102).

MARGERY A. TIERNEY, EXAMINING ATTORNEY

SN 85-257,921. BATALION IMPORTS, LLC, BOCA RATON, FL. FILED 3-4-2011.

BATALION IMPORTS, LLC

THE MARK CONSISTS OF STANDARD CHARACTERS WITHOUT CLAIM TO ANY PARTICULAR FONT, STYLE, SIZE, OR COLOR.

NO CLAIM IS MADE TO THE EXCLUSIVE RIGHT TO USE "IMPORTS, LLC", APART FROM THE MARK AS SHOWN.

FOR WHOLESALE DISTRIBUTORSHIPS FEATURING LIGHTING FIXTURES, LAMPS, FURNITURE AND DECORATIVE ACCESSORIES (U.S. CLS. 100, 101 AND 102).

JAMES GRIFFIN, EXAMINING ATTORNEY

CLASS 35—(Continued).

SN 85-258,032. I GOLF LIKE A GIRL, LLC, FORT WORTH, TX. FILED 3-4-2011.



THE COLOR(S) WHITE, BLACK, BLUE, GREEN, YELLOW, TAN AND GRAY IS/ARE CLAIMED AS A FEATURE OF THE MARK.

THE MARK CONSISTS OF FEMALE GOLFER OUTLINED IN BLACK WITH BLUE EYES, WHITE SMILE, YELLOW HAIR IN A PONYTAIL WITH A WHITE HAIR BAND, WEARING A WHITE AND GRAY HAT, BLACK SHIRT, WHITE AND GRAY SKIRT, WHITE SHOES, WHITE AND GRAY GLOVES ON HANDS, SKIN IS TAN; SHE IS STANDING WITH HER RIGHT HAND ON HER HIP AND LEFT HAND HOLDING A BLACK GOLF CLUB OVER HER LEFT SHOULDER. TWO GRAY CURVED LINES THAT GRADUALLY FADE EXTEND FROM THE EDGE OF THE SKIRT TO THE GOLFER'S RIGHT ARM. THE GOLFER IS SUPERIMPOSED ON THE LEFT EDGE OF AN OVAL. THE OVAL IS GREEN, FADING TO YELLOW IN THE CENTER, AND OUTLINED IN BLACK. INSIDE THE OVAL IT THE WORDING "I GOLF LIKE A GIRL" IN WHITE OUTLINED IN BLACK, WITH THE LETTER "O" IN "GOLF" STYLIZED TO LOOK LIKE A GOLF BALL. THERE IS A WHITE GOLF HOLE WITH A BLACK FLAGSTICK AND WHITE FLAG ABOVE THE LETTER "L" IN "GIRL" AND TWO BLACK CURVED LINES THAT BEING NEAR THE LEFT CENTER EDGE OF THE OVAL AND CURVE UNDER THE LETTERS "LI" IN "LIKE" AND INTERSECT THE "O" IN "GOLF".

FOR ON-LINE RETAIL STORE SERVICES FEATURING GOLF ACCESSORIES AND APPAREL (U.S. CLS. 100, 101 AND 102).

ANDREA K. NADELMAN, EXAMINING ATTORNEY

SN 85-258,568. YOOMAX SOLUTIONS PTY LTD, TASMANIA 7310, AUSTRALIA, FILED 3-4-2011.

ASTARICKS

THE MARK CONSISTS OF STANDARD CHARACTERS WITHOUT CLAIM TO ANY PARTICULAR FONT, STYLE, SIZE, OR COLOR.

FOR ADVERTISING SERVICES; ADVERTISING SERVICES INCLUDING CLASSIFIED ADVERTISEMENT SERVICES PROVIDED ONLINE PROMOTING THE SERVICES AND GOODS OF ADVERTISERS; ADVERTISING SERVICES RELATING TO THE PROVISION AND PROMOTION OF BUSINESS DIRECTORIES; PROVIDING AND OPERATING ONLINE MARKETPLACES FOR SELLERS AND BUYERS OF GOODS AND SERVICES; PROVIDING A SEARCHABLE ONLINE ADVERTISING GUIDE, FEATURING, THE GOODS AND SERVICES OF ONLINE VENDORS (U.S. CLS. 100, 101 AND 102).

JOHN KELLY, EXAMINING ATTORNEY

CLASS 35—(Continued).

SN 85-259,324. GOODWILL INDUSTRIES INTERNATIONAL INC, ROCKVILLE, MD. FILED 3-7-2011.

GOODWILL CARS TO WORK

THE MARK CONSISTS OF STANDARD CHARACTERS WITHOUT CLAIM TO ANY PARTICULAR FONT, STYLE, SIZE, OR COLOR.

OWNER OF U.S. REG. NOS. 1,592,248, 3,024,951 AND OTHERS.

FOR CHARITABLE SERVICES, NAMELY, FINANCIALLY ASSISTING PEOPLE WITH DISABILITIES AND OTHER DISADVANTAGING CONDITIONS TO OBTAIN THROUGH PURCHASE PERSONAL MOTOR VEHICLES FOR TRANSPORTATION (U.S. CLS. 100, 101 AND 102).

THOMAS MANOR, EXAMINING ATTORNEY

SN 85-259,664. AMERICAN NURSES ASSOCIATION, SILVER SPRING, MD. FILED 3-7-2011.



NO CLAIM IS MADE TO THE EXCLUSIVE RIGHT TO USE "NURSES", APART FROM THE MARK AS SHOWN.

THE COLOR(S) PURPLE, GREEN, AND BLUE IS/ARE CLAIMED AS A FEATURE OF THE MARK.

THE MARK CONSISTS OF WORDING, ALL OF WHICH IS PRESENTED IN STYLIZED FONT, AND A STYLIZED DEPICTION OF TWO HANDS SHAKING. "NURSES" IS PURPLE AND SITUATED ABOVE "TRUSTED TO" WHICH IS GREEN AND IS SITUATED ABOVE THE TERM "CARE". THE "C" AND "R" ARE PURPLE AND THE "A" AND "E" ARE BLUE. THE HAND DESIGN IS SITUATED TO THE RIGHT OF THE WORDING AND IS COMPRISED OF A HORIZONTALLY AND VERTICALLY ORIENTED HAND. THE HORIZONTALLY SITUATED HAND IS GREEN AND THE VERTICALLY ORIENTED HAND IS PURPLE.

FOR ASSOCIATION SERVICES, NAMELY, PROMOTING THE INTERESTS OF THE NURSING PROFESSION (U.S. CLS. 100, 101 AND 102).

FIRST USE 1-13-2011; IN COMMERCE 1-13-2011.

GRETCHEN ULRICH, EXAMINING ATTORNEY

CLASS 35—(Continued).

SN 85-259,869. THE TRUSTEES OF INDIANA UNIVERSITY, BLOOMINGTON, IN. FILED 3-7-2011.

NSSE

THE MARK CONSISTS OF STANDARD CHARACTERS WITHOUT CLAIM TO ANY PARTICULAR FONT, STYLE, SIZE, OR COLOR.

FOR EDUCATIONAL RESEARCH, NAMELY, CONDUCTING AN ANNUAL EDUCATIONAL SURVEY FOR COLLEGE STUDENTS AT THE UNDERGRADUATE LEVEL; PROVIDING EDUCATIONAL INFORMATION, NAMELY, AN ANNUAL EDUCATIONAL SURVEY FOR COLLEGE STUDENTS AT THE UNDERGRADUATE LEVEL; AND CONSULTING IN THE FIELD OF EDUCATION (U.S. CLS. 100, 101 AND 102).

FIRST USE 1-1-1999; IN COMMERCE 1-1-1999.
DANIEL CAPSHAW, EXAMINING ATTORNEY

CLASS 35—(Continued).

SN 85-261,738. WHITMAN HOLDING ENTERPRISES, INC., GRANVILLE, OH. FILED 3-9-2011.

WHIT'S FROZEN CUSTARD

THE MARK CONSISTS OF STANDARD CHARACTERS WITHOUT CLAIM TO ANY PARTICULAR FONT, STYLE, SIZE, OR COLOR.

OWNER OF U.S. REG. NO. 3,636,003.

NO CLAIM IS MADE TO THE EXCLUSIVE RIGHT TO USE "FROZEN CUSTARD", APART FROM THE MARK AS SHOWN.

FOR RETAIL STORE SERVICES FEATURING FROZEN CUSTARD (U.S. CLS. 100, 101 AND 102).

FIRST USE 3-0-2003; IN COMMERCE 3-0-2008.
DANIEL CAPSHAW, EXAMINING ATTORNEY

SN 85-259,974. SUPERVALU INC., EDEN PRAIRIE, MN. FILED 3-7-2011.

HELPING AMERICA EAT WELL

THE MARK CONSISTS OF STANDARD CHARACTERS WITHOUT CLAIM TO ANY PARTICULAR FONT, STYLE, SIZE, OR COLOR.

FOR RETAIL GROCERY STORE SERVICES (U.S. CLS. 100, 101 AND 102).
REBECCA SMITH, EXAMINING ATTORNEY

SN 85-260,320. ELECTRONIC ENTERTAINMENT DESIGN AND RESEARCH, DBA EEDAR, CARLSBAD, CA. FILED 3-7-2011.

CONTEXT IS EVERYTHING

THE MARK CONSISTS OF STANDARD CHARACTERS WITHOUT CLAIM TO ANY PARTICULAR FONT, STYLE, SIZE, OR COLOR.

FOR ANALYSIS OF MARKET RESEARCH DATA AND STATISTICS (U.S. CLS. 100, 101 AND 102).
THOMAS MANOR, EXAMINING ATTORNEY

SN 85-262,857. SHAWN L. ROBINSON, DBA WORLD WIDE WINNING CONNECTIONS, SAN LEANDRO, CA. FILED 3-9-2011.



THE COLOR(S) NAVY BLUE AND SKY BLUE ACCENTS IS/ARE CLAIMED AS A FEATURE OF THE MARK.

THE MARK CONSISTS OF THE LANGUAGE "WORLD WIDE WINNING CONNECTIONS" WHERE THE "C" IS LARGE AND ITS END FORMS A PLUG AND WHERE THE "O"'S IN "CONNECTIONS" ARE A SKY BLUE PICTURE OF AN A/C OUTLET WITH A BIG "S" AT THE END WITH A LINE GOING THROUGH THE CENTER OF THE LOGO. THE LETTERS "NNECTI-N" ARE IN NAVY BLUE. "WORLD WIDE WINNING" IS IN NAVY BLUE. THE LINE UNDER "WORLD WIDE WINNING" IS IN SKY BLUE. THE "C" AND PLUG DESIGN IS IN NAVY BLUE WITH ITS SHADOW IN SKY BLUE. THE "S" IS IN SKY BLUE AND THE OUTLETS ARE IN SKY BLUE.

FOR ADVERTISING, MARKETING AND PROMOTIONAL SERVICES RELATED TO ALL INDUSTRIES FOR THE PURPOSE OF FACILITATING NETWORKING AND SOCIALIZING OPPORTUNITIES FOR BUSINESS PURPOSES; BUSINESS MANAGEMENT CONSULTING WITH RELATION TO STRATEGY, MARKETING, SALES, OPERATION, PRODUCT DESIGN PARTICULARLY SPECIALIZING IN THE USE OF ANALYTIC AND STATISTIC MODELS FOR THE UNDERSTANDING AND PREDICTING OF CONSUMERS, BUSINESSES, AND MARKET TRENDS AND ACTIONS (U.S. CLS. 100, 101 AND 102).

Laurie Mayes, Examining Attorney

CLASS 35—(Continued).

SN 85-263,331. SYLVESTER, LEONNA, HEMPSTEAD, NY. FILED 3-10-2011.



THE COLOR(S) BLUE AND BLACK IS/ARE CLAIMED AS A FEATURE OF THE MARK.
 THE MARK CONSISTS OF A SILHOUETTE OF A BOY'S FACE APPEARING IN BLACK AND OUTLINED IN BLUE AND WEARING BLUE SPECTACLES.
 FOR BUSINESS CONSULTING AND INFORMATION SERVICES (U.S. CLS. 100, 101 AND 102).
 KHANH LE, EXAMINING ATTORNEY

SN 85-263,452. SCHAENGOLD, PHILLIP S, SAVANNAH, GA. FILED 3-10-2011.

TRIPETIA

THE MARK CONSISTS OF STANDARD CHARACTERS WITHOUT CLAIM TO ANY PARTICULAR FONT, STYLE, SIZE, OR COLOR.
 FOR PROVIDING A WEB SITE FEATURING BUSINESS INFORMATION IN THE FORM OF AUDIO AND VIDEO INTERVIEWS, TRANSCRIPTS AND OTHER EDUCATIONAL MATERIALS (U.S. CLS. 100, 101 AND 102).
 REBECCA SMITH, EXAMINING ATTORNEY

SN 85-263,693. CLUB MONACO CORP, TORONTO, CANADA, FILED 3-10-2011.

CLUB MONACO STUDIO

THE MARK CONSISTS OF STANDARD CHARACTERS WITHOUT CLAIM TO ANY PARTICULAR FONT, STYLE, SIZE, OR COLOR.
 OWNER OF U.S. REG. NOS. 3,641,709, 3,904,614 AND OTHERS.
 NO CLAIM IS MADE TO THE EXCLUSIVE RIGHT TO USE "STUDIO", APART FROM THE MARK AS SHOWN.
 FOR RETAIL STORE SERVICES FEATURING APPAREL, FASHION ACCESSORIES AND HOME FURNISHINGS (U.S. CLS. 100, 101 AND 102).
 HOWARD SMIGA, EXAMINING ATTORNEY

CLASS 35—(Continued).

SN 85-263,890. THEBESTDISH LLC, HOUSTON, TX. FILED 3-10-2011.

THEBESTDISH

THE MARK CONSISTS OF STANDARD CHARACTERS WITHOUT CLAIM TO ANY PARTICULAR FONT, STYLE, SIZE, OR COLOR.
 FOR PROVIDING AN ONLINE, INTERACTIVE WEBSITE WHERE USERS CAN POST RATINGS, REVIEWS AND RECOMMENDATIONS ON RESTAURANTS, FOOD ESTABLISHMENTS, MOBILE FOOD ESTABLISHMENTS, BED AND BREAKFASTS, INNS, LODGES, MARKETS, FOOD, FOOD ITEMS, MENU ITEMS, LIQUOR, BEER AND WINE FOR COMMERCIAL PURPOSES; PROVIDING INFORMATION, NAMELY, COMPILATIONS, RATINGS, REVIEWS, REFERRALS, RECOMMENDATIONS, SCORING AND RANKINGS RELATING TO THE AFOREMENTIONED RESTAURANTS, FOOD ESTABLISHMENTS, MOBILE FOOD ESTABLISHMENTS, BED AND BREAKFASTS, INNS, LODGES, MARKETS, FOOD, FOOD ITEMS, MENU ITEMS, LIQUOR, BEER AND WINE (U.S. CLS. 100, 101 AND 102).
 FIRST USE 4-29-2009; IN COMMERCE 7-1-2010.
 KARANENDRA S. CHHINA, EXAMINING ATTORNEY

SN 85-264,467. ACADEMIC YEAR ABROAD, INC., ROSLINDALE, MA. FILED 3-11-2011.



THE MARK CONSISTS OF THE THREE UPPER CASE LETTERS "AYA" ARRANGED STYLISTICALLY IN A BORDERED CIRCLE.
 FOR ADMINISTERING STUDY ABROAD PROGRAMS FOR AMERICAN COLLEGE AND UNIVERSITY STUDENTS (U.S. CLS. 100, 101 AND 102).
 FIRST USE 2-25-2011; IN COMMERCE 2-25-2011.
 ALEXANDER L. POWERS, EXAMINING ATTORNEY

CLASS 35—(Continued).

SN 85-264,784. LOANSTACKER LLC, KNOXVILLE, TN.
FILED 3-11-2011.

LOANSTACKER

THE MARK CONSISTS OF STANDARD CHARACTERS WITHOUT CLAIM TO ANY PARTICULAR FONT, STYLE, SIZE, OR COLOR.

FOR COMPILING OF INFORMATION INTO COMPUTER DATABASES (U.S. CLS. 100, 101 AND 102).

ROBIN CHOSID, EXAMINING ATTORNEY

SN 85-264,804. STRONG-BRIDGE, LLC, SEATTLE, WA.
FILED 3-11-2011.



OWNER OF U.S. REG. NOS. 3,650,261 AND 3,663,105.
THE MARK CONSISTS OF THE WORDS "STRONG-BRIDGE" ABOVE THE WORDS "INSIGHT. INTEGRITY. IMPACT." WITH TWO NARROWING ARCHES BEGINNING ABOVE THE WORD "STRONG" AND ENDING ABOVE THE WORD "BRIDGE".

FOR MANAGEMENT AND BUSINESS CONSULTING SERVICES IN THE FIELDS OF PROGRAM AND PROJECT LEADERSHIP, CUSTOMER EXPERIENCE, STRATEGY REALIZATION, SOLUTION ARCHITECTURE AND PROCESS AND OPERATIONAL EFFICIENCIES (U.S. CLS. 100, 101 AND 102).

FIRST USE 1-29-2011; IN COMMERCE 1-29-2011.

CHRISTINE COOPER, EXAMINING ATTORNEY

SN 85-265,400. MONGOOSE ON THE LOOSE, INC, EL DORADO HILLS, CA. FILED 3-12-2011.

Purple Unions

THE MARK CONSISTS OF STANDARD CHARACTERS WITHOUT CLAIM TO ANY PARTICULAR FONT, STYLE, SIZE, OR COLOR.

FOR ADVERTISING AND DIRECTORY SERVICES, NAMELY, PROMOTING THE SERVICES OF OTHERS BY PROVIDING A WEB PAGE FEATURING LINKS TO THE WEBSITES OF OTHERS; ON-LINE BUSINESS DIRECTORIES FEATURING WEDDING VENDORS; PROVIDING AN ON-LINE DIRECTORY INFORMATION SERVICE FEATURING INFORMATION REGARDING WEDDING VENDORS; PROVIDING ON-LINE DIRECTORY INFORMATION SERVICES ALSO FEATURING HYPERLINKS TO OTHER WEB SITES (U.S. CLS. 100, 101 AND 102).

FIRST USE 7-1-2003; IN COMMERCE 7-1-2003.

WENDY JUN, EXAMINING ATTORNEY

CLASS 35—(Continued).

SN 85-266,229. SPICOLA, VINCENT P, DBA CARRIAGE CREEK OF NORTH MANLIUS LLC, KIRKVILLE, NY.
FILED 3-14-2011.

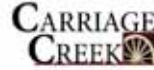

THE COLOR(S) BLACK, BARN RED AND TAN IS/ARE CLAIMED AS A FEATURE OF THE MARK.

THE MARK CONSISTS OF THE WORDS "CARRIAGE AND CREEK" IN BLACK LETTERING IN THE FONT PALATINO LINOTYPE. A BARN RED LINE UNDERLINES THE WORD "CREEK" AND ALSO FRAMES A PICTURE OF A TAN WAGON WHEEL WITH A BLACK BACKGROUND.

FOR RETAIL GIFT SHOPS (U.S. CLS. 100, 101 AND 102).

FIRST USE 8-1-2010; IN COMMERCE 2-12-2011.

LINDA ESTRADA, EXAMINING ATTORNEY

SN 85-266,437. OPPORTUNITY BUYS, INC., INDIANAPOLIS, IN. FILED 3-14-2011.

OBI IMPORT

THE MARK CONSISTS OF STANDARD CHARACTERS WITHOUT CLAIM TO ANY PARTICULAR FONT, STYLE, SIZE, OR COLOR.

NO CLAIM IS MADE TO THE EXCLUSIVE RIGHT TO USE "IMPORT", APART FROM THE MARK AS SHOWN.

FOR WHOLESALE AND RETAIL STORE SERVICES FEATURING GENERAL MERCHANDISE (U.S. CLS. 100, 101 AND 102).

FIRST USE 6-6-1994; IN COMMERCE 6-6-1994.

JOHN HWANG, EXAMINING ATTORNEY

SN 85-266,941. LIVE OAK PRESS, INC., COLUMBIA, SC.
FILED 3-15-2011.

OWN A PIECE OF THE SPORTING CLASSICS LIFE

THE MARK CONSISTS OF STANDARD CHARACTERS WITHOUT CLAIM TO ANY PARTICULAR FONT, STYLE, SIZE, OR COLOR.

OWNER OF U.S. REG. NO. 2,320,448.

FOR REAL ESTATE ADVERTISING SERVICES (U.S. CLS. 100, 101 AND 102).

FIRST USE 12-28-2010; IN COMMERCE 12-28-2010.

TASNEEM HUSSAIN, EXAMINING ATTORNEY

CLASS 35—(Continued).

SN 85-267,828. YFY, LLC, CRYSTAL LAKE, IL. FILED 3-15-2011.

YUMZ GOURMET FROZEN YOGURT

THE MARK CONSISTS OF STANDARD CHARACTERS WITHOUT CLAIM TO ANY PARTICULAR FONT, STYLE, SIZE, OR COLOR.

OWNER OF U.S. REG. NO. 3,935,658.

NO CLAIM IS MADE TO THE EXCLUSIVE RIGHT TO USE "GOURMET FROZEN YOGURT", APART FROM THE MARK AS SHOWN.

FOR (BASED ON USE IN COMMERCE) CUSTOMER LOYALTY SERVICES AND CUSTOMER CLUB SERVICES, FOR COMMERCIAL, PROMOTIONAL AND/OR ADVERTISING PURPOSES; RETAIL STORE SERVICES FEATURING FROZEN YOGURT, DESSERTS AND APPAREL (BASED ON INTENT TO USE) FRANCHISE SERVICES, NAMELY, OFFERING BUSINESS MANAGEMENT ASSISTANCE IN THE ESTABLISHMENT AND OPERATION OF FROZEN YOGURT SHOP AND RETAIL STORE FEATURING FROZEN YOGURT, DESSERTS, APPAREL AND HEADWEAR; RETAIL STORE SERVICES FEATURING HEADWEAR (U.S. CLS. 100, 101 AND 102).

FIRST USE 2-24-2010; IN COMMERCE 11-25-2010.
SANI KHOURI, EXAMINING ATTORNEY

SN 85-267,850. YFY, LLC, CRYSTAL LAKE, IL. FILED 3-15-2011.



OWNER OF U.S. REG. NO. 3,935,658.
NO CLAIM IS MADE TO THE EXCLUSIVE RIGHT TO USE "GOURMET FROZEN YOGURT", APART FROM THE MARK AS SHOWN.

THE MARK CONSISTS OF A RECTANGULAR SHAPE ENCLOSING THE DESIGN OF SOFT-SERVE FROZEN YOGURT WITH THE END OF A SPOON STICKING OUT OF IT AND THE STYLIZED TEXT "YUMZ GOURMET FROZEN YOGURT" TO THE RIGHT OF THE DESIGN.

FOR (BASED ON USE IN COMMERCE) CUSTOMER LOYALTY SERVICES AND CUSTOMER CLUB SERVICES, FOR COMMERCIAL, PROMOTIONAL AND/OR ADVERTISING PURPOSES; RETAIL STORE SERVICES FEATURING FROZEN YOGURT, DESSERTS AND APPAREL (BASED ON INTENT TO USE) FRANCHISE SERVICES, NAMELY, OFFERING BUSINESS MANAGEMENT ASSISTANCE IN THE ESTABLISHMENT AND OPERATION OF FROZEN YOGURT SHOP AND RETAIL STORE FEATURING FROZEN YOGURT, DESSERTS, APPAREL AND HEADWEAR; RETAIL STORE SERVICES FEATURING HEADWEAR (U.S. CLS. 100, 101 AND 102).

FIRST USE 2-24-2010; IN COMMERCE 11-25-2010.
SANI KHOURI, EXAMINING ATTORNEY

CLASS 35—(Continued).

SN 85-269,554. STAPLES THE OFFICE SUPERSTORE, LLC., FRAMINGHAM, MA. FILED 3-17-2011.



OWNER OF U.S. REG. NOS. 1,438,390, 3,385,468 AND OTHERS.

NO CLAIM IS MADE TO THE EXCLUSIVE RIGHT TO USE "INDUSTRIAL", APART FROM THE MARK AS SHOWN.

THE MARK CONSISTS OF THE STYLIZED WORD "STAPLES" IN A RECTANGLE TO THE TOP LEFT OF THE WORD "INDUSTRIAL".

FOR MAIL ORDER CATALOG SERVICES, AND COMPUTERIZED ONLINE RETAIL STORE SERVICES FEATURING INDUSTRIAL AND RETAIL PACKAGING AND SHIPPING PRODUCTS, NAMELY, CORRUGATED BOXES, POLYETHYLENE BAGS, PROTECTIVE PACKAGING, BIN STORAGE, JANITORIAL AND SANITATION PRODUCTS, WAREHOUSE SUPPLIES, TAPE, LABELS, MAILERS, RETAIL SHOPPING BAGS AND RELATED PACKAGING AND SHIPPING SUPPLIES (U.S. CLS. 100, 101 AND 102).

FIRST USE 4-0-2007; IN COMMERCE 4-0-2007.
GIANCARLO CASTRO, EXAMINING ATTORNEY

SN 85-272,989. CVS PHARMACY, INC., WOONSOCKET, RI. FILED 3-22-2011.

MY CVS

THE MARK CONSISTS OF STANDARD CHARACTERS WITHOUT CLAIM TO ANY PARTICULAR FONT, STYLE, SIZE, OR COLOR.

OWNER OF U.S. REG. NOS. 919,941, 3,776,243 AND OTHERS.

FOR RETAIL STORE SERVICES, NAMELY, PHARMACY, RETAIL DRUG STORE AND GENERAL MERCHANDISE STORE SERVICES, PROVIDED VIA APPLICANT'S STORES AND VIA THE INTERNET (U.S. CLS. 100, 101 AND 102).

CARRIE GENOVESE, EXAMINING ATTORNEY

CLASS 35—(Continued).

SN 85-272,990. CVS PHARMACY, INC., WOONSOCKET, RI. FILED 3-22-2011.

MY CVS PHARMACY

THE MARK CONSISTS OF STANDARD CHARACTERS WITHOUT CLAIM TO ANY PARTICULAR FONT, STYLE, SIZE, OR COLOR.

OWNER OF U.S. REG. NOS. 919,941, 3,211,443 AND OTHERS.

NO CLAIM IS MADE TO THE EXCLUSIVE RIGHT TO USE "PHARMACY", APART FROM THE MARK AS SHOWN.

FOR RETAIL STORE SERVICES, NAMELY, PHARMACY, RETAIL DRUG STORE AND GENERAL MERCHANDISE STORE SERVICES, PROVIDED VIA APPLICANT'S STORES AND VIA THE INTERNET (U.S. CLS. 100, 101 AND 102).

CARRIE GENOVESE, EXAMINING ATTORNEY



SN 85-279,401. SUPERVALU INC., EDEN PRAIRIE, MN. FILED 3-29-2011.

PLENTY FRESH FOR PLENTY LESS

THE MARK CONSISTS OF STANDARD CHARACTERS WITHOUT CLAIM TO ANY PARTICULAR FONT, STYLE, SIZE, OR COLOR.

FOR RETAIL GROCERY STORE SERVICES (U.S. CLS. 100, 101 AND 102).

REBECCA SMITH, EXAMINING ATTORNEY



SN 85-287,975. SUPERVALU INC., EDEN PRAIRIE, MN. FILED 4-6-2011.

FARM STAND FRESH

THE MARK CONSISTS OF STANDARD CHARACTERS WITHOUT CLAIM TO ANY PARTICULAR FONT, STYLE, SIZE, OR COLOR.

OWNER OF U.S. REG. NOS. 848,743 AND 2,499,262.

NO CLAIM IS MADE TO THE EXCLUSIVE RIGHT TO USE "FRESH", APART FROM THE MARK AS SHOWN.

FOR RETAIL GROCERY STORE SERVICES (U.S. CLS. 100, 101 AND 102).

REBECCA SMITH, EXAMINING ATTORNEY

CLASS 35—(Continued).

SN 85-288,508. SUPERVALU INC., EDEN PRAIRIE, MN. FILED 4-7-2011.

TALK ABOUT FRESH

THE MARK CONSISTS OF STANDARD CHARACTERS WITHOUT CLAIM TO ANY PARTICULAR FONT, STYLE, SIZE, OR COLOR.

FOR RETAIL GROCERY STORE SERVICES (U.S. CLS. 100, 101 AND 102).

REBECCA SMITH, EXAMINING ATTORNEY



SN 85-300,150. HOPE FOR HEALING: SILENT NO MORE, INCORPORATED, FAIRMONT, WV. FILED 4-20-2011.

Hope for Healing: Silent No More

THE MARK CONSISTS OF STANDARD CHARACTERS WITHOUT CLAIM TO ANY PARTICULAR FONT, STYLE, SIZE, OR COLOR.

FOR PROMOTING PUBLIC AWARENESS OF SEXUAL ABUSE AND PREVENTION (U.S. CLS. 100, 101 AND 102). FIRST USE 4-15-2011; IN COMMERCE 4-15-2011.

DARRYL SPRUILL, EXAMINING ATTORNEY



SN 85-301,013. AHOLD LICENSING SARL, GENEVA, SWITZERLAND, FILED 4-21-2011.



OWNER OF U.S. REG. NOS. 1,078,672, 3,685,164 AND OTHERS.

THE COLOR(S) YELLOW, GREEN AND RED IS/ARE CLAIMED AS A FEATURE OF THE MARK.

THE MARK CONSISTS OF A GREEN STEM BEARING TWO GREEN LEAVES, HELD BY A STYLIZED YELLOW HAND WHICH IN TURN APPEARS ABOVE THE WORD "GIANT" IN RED.

FOR SUPERMARKETS (U.S. CLS. 100, 101 AND 102).

KAREN BRACEY, EXAMINING ATTORNEY

CLASS 35—(Continued).

SN 85-301,014. AHOLD LICENSING SARL, GENEVA, SWITZERLAND, FILED 4-21-2011.



OWNER OF U.S. REG. NOS. 1,108,978, 2,544,584 AND OTHERS.

THE COLOR(S) YELLOW, GREEN AND RED IS/ARE CLAIMED AS A FEATURE OF THE MARK.

THE MARK CONSISTS OF A GREEN STEM BEARING TWO GREEN LEAVES, HELD BY A STYLIZED YELLOW HAND WHICH IN TURN APPEARS ABOVE THE WORD "MARTIN'S" IN RED.

FOR SUPERMARKETS (U.S. CLS. 100, 101 AND 102).
KAREN BRACEY, EXAMINING ATTORNEY

CLASS 35—(Continued).

SN 85-307,350. J. WALTER THOMPSON COMPANY, NEW YORK, NY. FILED 4-28-2011.



NO CLAIM IS MADE TO THE EXCLUSIVE RIGHT TO USE "PLACE", APART FROM THE MARK AS SHOWN.

THE MARK CONSISTS OF THE WORD "JILL'S" ON A SOFA AND THE WORD "PLACE" NEXT TO THE SOFA.

FOR CONDUCTING MARKET RESEARCH AND ANALYSIS IN THE FIELD OF CONSUMER BEHAVIOR, ATTITUDES, HABITS, AND PURCHASING OF PRODUCTS AND SERVICES, VIA AN ONLINE PLATFORM AND SESSIONS; PROVIDING AN INTERNET WEBSITE FOR THE PURPOSE OF CONDUCTING MARKET RESEARCH AND ANALYSIS IN THE FIELD OF CONSUMER BEHAVIOR, ATTITUDES, HABITS, AND PURCHASING OF PRODUCTS AND SERVICES (U.S. CLS. 100, 101 AND 102).

JENNY PARK, EXAMINING ATTORNEY

SN 85-317,281. WHEELER, KEN, BAKERSFIELD, CA. FILED 5-10-2011.

SN 85-303,257. GIBSON GUITAR CORP., NASHVILLE, TN. FILED 4-25-2011.



THE MARK CONSISTS OF STANDARD CHARACTERS WITHOUT CLAIM TO ANY PARTICULAR FONT, STYLE, SIZE, OR COLOR.

OWNER OF U.S. REG. NO. 1,543,093.
FOR DISTRIBUTORSHIP SERVICES IN THE FIELD OF MUSICAL INSTRUMENTS (U.S. CLS. 100, 101 AND 102).

KAREN K. BUSH, EXAMINING ATTORNEY

"When you finally get serious...it's where you'll shop"

THE MARK CONSISTS OF STANDARD CHARACTERS WITHOUT CLAIM TO ANY PARTICULAR FONT, STYLE, SIZE, OR COLOR.

FOR RETAIL STORE SERVICES FEATURING FITNESS EQUIPMENT AND NUTRITIONAL SUPPLEMENTS, NAMELY, EXERCISE TREADMILLS, ELLIPTICAL EXERCISE MACHINES, EXERCISE WEIGHTS, STATIONARY EXERCISE BICYCLES, DUMBBELLS, WEIGHT ROOM FLOORING, WEIGHT LIFTING BENCHES, EXERCISE ROWING MACHINES, EXERCISE WEIGHT RACKS, SPORTS DRINKS AND DIETARY SUPPLEMENTS (U.S. CLS. 100, 101 AND 102).

FIRST USE 1-0-1992; IN COMMERCE 1-0-1992.

DAVID YONTEF, EXAMINING ATTORNEY

CLASS 36—INSURANCE AND FINANCIAL

SN 76-704,690. QUALIFIED PLAN IN A BOX, LLC, FORT WAYNE, IN. FILED 9-27-2010.

Qualified Plan in a Box

THE MARK CONSISTS OF STANDARD CHARACTERS WITHOUT CLAIM TO ANY PARTICULAR FONT, STYLE, SIZE, OR COLOR.

NO CLAIM IS MADE TO THE EXCLUSIVE RIGHT TO USE "QUALIFIED PLAN", APART FROM THE MARK AS SHOWN.

FOR FINANCIAL ADVISORY, NAMELY, QUALIFIED PLAN TURNKEY ASSET MANAGEMENT SERVICES FOR COORDINATING AND COMPLETING THE REQUIRED FORMS NEEDED TO ESTABLISH OPEN INVESTMENT AND RETIREMENT QUALIFIED PLANS (U.S. CLS. 100, 101 AND 102).

FIRST USE 8-1-2010; IN COMMERCE 9-1-2010.

WILLIAM VERHOSEK, EXAMINING ATTORNEY

SN 76-706,706. NATIONAL WESTERN LIFE INSURANCE COMPANY, AUSTIN, TX. FILED 3-9-2011.

NWL IMPACT 7S

THE MARK CONSISTS OF STANDARD CHARACTERS WITHOUT CLAIM TO ANY PARTICULAR FONT, STYLE, SIZE, OR COLOR.

OWNER OF U.S. REG. NOS. 2,589,454, 2,744,049 AND OTHERS.

FOR ANNUITY UNDERWRITING SERVICES (U.S. CLS. 100, 101 AND 102).

APRIL HESIK, EXAMINING ATTORNEY

SN 76-706,707. NATIONAL WESTERN LIFE INSURANCE COMPANY, AUSTIN, TX. FILED 3-9-2011.

NWL IMPACT 10

THE MARK CONSISTS OF STANDARD CHARACTERS WITHOUT CLAIM TO ANY PARTICULAR FONT, STYLE, SIZE, OR COLOR.

OWNER OF U.S. REG. NOS. 2,589,454, 2,744,049 AND OTHERS.

FOR ANNUITY UNDERWRITING SERVICES (U.S. CLS. 100, 101 AND 102).

APRIL HESIK, EXAMINING ATTORNEY

CLASS 36—(Continued).

SN 76-706,708. NATIONAL WESTERN LIFE INSURANCE COMPANY, AUSTIN, TX. FILED 3-9-2011.

NWL IMPACT 7

THE MARK CONSISTS OF STANDARD CHARACTERS WITHOUT CLAIM TO ANY PARTICULAR FONT, STYLE, SIZE, OR COLOR.

OWNER OF U.S. REG. NOS. 2,589,454, 2,744,049 AND OTHERS.

FOR ANNUITY UNDERWRITING SERVICES (U.S. CLS. 100, 101 AND 102).

APRIL HESIK, EXAMINING ATTORNEY

SN 77-200,486. LATINO INTERACTIVE NETWORK, INC., NEW YORK, NY. FILED 6-7-2007.

MIO TV

THE MARK CONSISTS OF STANDARD CHARACTERS WITHOUT CLAIM TO ANY PARTICULAR FONT, STYLE, SIZE, OR COLOR.

NO CLAIM IS MADE TO THE EXCLUSIVE RIGHT TO USE "TV", APART FROM THE MARK AS SHOWN.

THE FOREIGN WORDING IN THE MARK TRANSLATES INTO ENGLISH AS "MY" OR "MINE".

FOR ELECTRONIC COMMERCE PAYMENT SERVICES, NAMELY, ESTABLISHING FUNDED ACCOUNTS USED TO PURCHASE GOODS AND SERVICES ON THE INTERNET (U.S. CLS. 100, 101 AND 102).

CARRIE GENOVESE, EXAMINING ATTORNEY

SN 77-394,379. BB&T CORPORATION, WINSTON-SALEM, NC. FILED 2-12-2008.

VAULT360

THE MARK CONSISTS OF STANDARD CHARACTERS WITHOUT CLAIM TO ANY PARTICULAR FONT, STYLE, SIZE, OR COLOR.

FOR BANKING AND FINANCIAL SERVICES, NAMELY, LOANS, LETTERS OF CREDIT, AND RESERVABLES FINANCING (U.S. CLS. 100, 101 AND 102).

MARK RADEMACHER, EXAMINING ATTORNEY

CLASS 36—(Continued).

SN 77-771,136. ELEKTRA TRADING & CONSULTING GROUP, S.A. DE C.V., MEXICO CITY, MEXICO, FILED 6-30-2009.



OWNER OF U.S. REG. NO. 3,103,544.
NO CLAIM IS MADE TO THE EXCLUSIVE RIGHT TO USE "MONEY TRANSFER", APART FROM THE MARK AS SHOWN.

THE COLOR(S) GREEN AND WHITE IS/ARE CLAIMED AS A FEATURE OF THE MARK.

THE MARK CONSISTS OF A GREEN BOX, OUTLINING THE MARK "DINERO EXPRESS MONEY TRANSFER", WHICH IS IN GREEN. THE COLOR WHITE APPEARS IN THE BACKGROUND OF THE BOX.

THE ENGLISH TRANSLATION OF "DINERO" IN THE MARK IS "MONEY".

SEC. 2(F).
FOR FINANCIAL SERVICES, NAMELY, ELECTRONIC TRANSFER OF FUNDS, AND MONEY TRANSFER SERVICES (U.S. CLS. 100, 101 AND 102).

FIRST USE 10-8-2010; IN COMMERCE 10-8-2010.
DEZMONA MIZELLE, EXAMINING ATTORNEY

SN 77-905,856. UNITED STATES CAPITAL CORPORATION, CRYSTAL LAKE, IL. FILED 1-6-2010.

**UNITED STATES CAPITAL
CORPORATION**

THE MARK CONSISTS OF STANDARD CHARACTERS WITHOUT CLAIM TO ANY PARTICULAR FONT, STYLE, SIZE, OR COLOR.

OWNER OF U.S. REG. NO. 3,866,711.
NO CLAIM IS MADE TO THE EXCLUSIVE RIGHT TO USE "CORPORATION", APART FROM THE MARK AS SHOWN.

SEC. 2(F) AS TO "UNITED STATES CAPITAL".
FOR FINANCING SERVICES; LEASE-PURCHASE FINANCING; LOAN FINANCING; AND EQUIPMENT LEASE FINANCING (U.S. CLS. 100, 101 AND 102).
REGINA DRUMMOND, EXAMINING ATTORNEY

CLASS 36—(Continued).

SN 77-918,852. CENTURY RESOURCES, INC., COLUMBUS, OH. FILED 1-24-2010.

Century Resources

THE MARK CONSISTS OF STANDARD CHARACTERS WITHOUT CLAIM TO ANY PARTICULAR FONT, STYLE, SIZE, OR COLOR.

NO CLAIM IS MADE TO THE EXCLUSIVE RIGHT TO USE "RESOURCES", APART FROM THE MARK AS SHOWN.

FOR CHARITABLE FUND RAISING SERVICES; FUNDRAISING SERVICES, NAMELY, ORGANIZING FUNDRAISERS FOR SCHOOLS AND OTHER GROUPS (U.S. CLS. 100, 101 AND 102).

FIRST USE 6-19-1978; IN COMMERCE 6-19-1978.
MICHAEL GAAFAR, EXAMINING ATTORNEY

SN 77-939,670. JPMORGAN CHASE & CO., NEW YORK, NY. FILED 2-19-2010.

INK CAPITAL

THE MARK CONSISTS OF STANDARD CHARACTERS WITHOUT CLAIM TO ANY PARTICULAR FONT, STYLE, SIZE, OR COLOR.

OWNER OF U.S. REG. NOS. 3,788,330, 3,788,472 AND 3,794,332.

NO CLAIM IS MADE TO THE EXCLUSIVE RIGHT TO USE "CAPITAL", APART FROM THE MARK AS SHOWN.
FOR CREDIT CARD SERVICES (U.S. CLS. 100, 101 AND 102).

FIRST USE 11-14-2009; IN COMMERCE 11-14-2009.
FONG HSU, EXAMINING ATTORNEY

SN 77-939,696. JPMORGAN CHASE & CO., NEW YORK, NY. FILED 2-19-2010.

INK PLUS

THE MARK CONSISTS OF STANDARD CHARACTERS WITHOUT CLAIM TO ANY PARTICULAR FONT, STYLE, SIZE, OR COLOR.

OWNER OF U.S. REG. NOS. 3,788,330, 3,788,472 AND 3,794,332.

FOR CREDIT CARD SERVICES (U.S. CLS. 100, 101 AND 102).

FIRST USE 5-21-2009; IN COMMERCE 5-21-2009.
FONG HSU, EXAMINING ATTORNEY

CLASS 36—(Continued).

SN 77-939,709. JPMORGAN CHASE & CO., NEW YORK, NY.
FILED 2-19-2010.

INK CASH

THE MARK CONSISTS OF STANDARD CHARACTERS WITHOUT CLAIM TO ANY PARTICULAR FONT, STYLE, SIZE, OR COLOR.

OWNER OF U.S. REG. NOS. 3,788,330, 3,788,472 AND 3,794,332.

NO CLAIM IS MADE TO THE EXCLUSIVE RIGHT TO USE "CASH", APART FROM THE MARK AS SHOWN.

FOR CREDIT CARD SERVICES (U.S. CLS. 100, 101 AND 102).

FIRST USE 9-21-2009; IN COMMERCE 9-21-2009.
FONG HSU, EXAMINING ATTORNEY

SN 77-940,947. JVL VENTURES, LLC, LITTLE ROCK, AR.
FILED 2-21-2010.

VENDI

THE MARK CONSISTS OF STANDARD CHARACTERS WITHOUT CLAIM TO ANY PARTICULAR FONT, STYLE, SIZE, OR COLOR.

THE ENGLISH TRANSLATION OF "VENDI" IN THE MARK IS "YOU SELL".

FOR PROVIDING FINANCIAL SERVICES VIA WIRELESS NETWORK, GLOBAL COMPUTER NETWORK AND MOBILE TELECOMMUNICATIONS DEVICES, NAMELY, BANKING, CREDIT, DEBIT AND STORED VALUE PAYMENTS SYSTEMS; SECURE ELECTRONIC CASH TRANSACTIONS; FINANCIAL TRANSACTION SERVICES, NAMELY, PROVIDING SECURE COMMERCIAL TRANSACTIONS AND PAYMENT OPTIONS; DISSEMINATION OF FINANCIAL INFORMATION VIA A GLOBAL COMPUTER NETWORK, WIRELESS NETWORK, MOBILE COMMUNICATION DEVICE (U.S. CLS. 100, 101 AND 102).

FRED CARL, EXAMINING ATTORNEY

CLASS 36—(Continued).

SN 77-944,681. KRILOGY FINANCIAL, LLC, AKA GSG ADVISORS, SAINT LOUIS, MO. FILED 2-25-2010.



NO CLAIM IS MADE TO THE EXCLUSIVE RIGHT TO USE "FINANCIAL", APART FROM THE MARK AS SHOWN.

THE COLOR(S) LIGHT BLUE, DARK BLUE, LIGHT ORANGE AND DARK ORANGE IS/ARE CLAIMED AS A FEATURE OF THE MARK.

THE MARK CONSISTS OF THE WORD "KRILOGY" AND THE LINE ABOVE THE WORDS APPEAR IN DARK BLUE. THE TWO DUAL LINED AND INTERTWINED RINGS APPEAR IN LIGHT BLUE, DARK BLUE, LIGHT ORANGE AND DARK ORANGE. THE WORD "FINANCIAL" APPEARS IN DARK ORANGE.

FOR FINANCIAL ADVICE; FINANCIAL ADVICE AND CONSULTANCY SERVICES; FINANCIAL AND INVESTMENT SERVICES, NAMELY, MANAGEMENT AND BROKERAGE IN THE FIELDS OF STOCKS, BONDS, OPTIONS, COMMODITIES, FUTURES AND OTHER SECURITIES, AND THE INVESTMENT OF FUNDS OF OTHERS; FINANCIAL ASSET MANAGEMENT; FINANCIAL CONSULTANCY; FINANCIAL CONSULTANCY AND INSURANCE CONSULTANCY (U.S. CLS. 100, 101 AND 102).

FIRST USE 9-1-2009; IN COMMERCE 9-1-2009.
KHANH LE, EXAMINING ATTORNEY

SN 77-959,658. UTICA MUTUAL INSURANCE COMPANY, DBA UTICA NATIONAL INSURANCE GROUP, NEW HARTFORD, NY. FILED 3-16-2010.

COMMERCIAL INSURANCE ESSENTIALS

THE MARK CONSISTS OF STANDARD CHARACTERS WITHOUT CLAIM TO ANY PARTICULAR FONT, STYLE, SIZE, OR COLOR.

NO CLAIM IS MADE TO THE EXCLUSIVE RIGHT TO USE "COMMERCIAL INSURANCE", APART FROM THE MARK AS SHOWN.

FOR INSURANCE SERVICES, NAMELY, PROPERTY AND CASUALTY INSURANCE UNDERWRITING AND INSURANCE RISK MANAGEMENT SERVICES FOR COMMERCIAL POLICY-HOLDERS (U.S. CLS. 100, 101 AND 102).

FIRST USE 12-0-2009; IN COMMERCE 12-0-2009.
DAVID MURRAY, EXAMINING ATTORNEY

CLASS 36—(Continued).

SN 77-965,688. OKLAHOMA TURNPIKE AUTHORITY, OKLAHOMA CITY, OK. FILED 3-23-2010.

PIKEPASS

THE MARK CONSISTS OF STANDARD CHARACTERS WITHOUT CLAIM TO ANY PARTICULAR FONT, STYLE, SIZE, OR COLOR.

OWNER OF U.S. REG. NO. 2,639,028.
SEC. 2(F).

FOR ELECTRONIC TOLL COLLECTION AND TOLL BILL PAYMENT PROCESSING SERVICES FOR HIGHWAYS; ELECTRONIC TOLL COLLECTION AND TOLL BILL PAYMENT PROCESSING SERVICES FOR PARKING LOTS (U.S. CLS. 100, 101 AND 102).

FIRST USE 1-1-1991; IN COMMERCE 1-1-1991.
SUZANNE BLANE, EXAMINING ATTORNEY

SN 79-066,090. NEOVIA FINANCIAL PLC, DOUGLAS ISLE OF MAN, UNITED KINGDOM, FILED 1-2-2009.



The logo for NEOVIA FINANCIAL features a stylized 'N' inside a square with a star-like shape on the left side. To the right of this icon, the word 'NEOVIA' is written in a large, bold, sans-serif font, and the word 'FINANCIAL' is written below it in a smaller, spaced-out, sans-serif font.

PRIORITY DATE OF 10-2-2008 IS CLAIMED.
OWNER OF INTERNATIONAL REGISTRATION 0995541
DATED 1-2-2009, EXPIRES 1-2-2019.

NO CLAIM IS MADE TO THE EXCLUSIVE RIGHT TO USE "FINANCIAL", APART FROM THE MARK AS SHOWN.

THE MARK CONSISTS OF THE STYLIZED WORD "NEOVIA" OVER THE STYLIZED WORD "FINANCIAL", WITH A GRAPHIC DEPICTION OF A BOX WITH THE LETTER "N" TO THE LEFT.

FOR E-WALLET ACCOUNT SERVICES, NAMELY, THE PROVISION OF ONLINE ELECTRONIC MONEY ACCOUNTS AND SERVICES FOR CONSUMERS AND ONLINE MERCHANTS WHEREBY CONSUMERS FUND THEIR ONLINE CASH ACCOUNTS AND CONSUMERS AND ONLINE MERCHANTS AND BUSINESSES SEND AND RECEIVE PAYMENTS AND REMITTANCES OVER THE INTERNET; DEBIT CARD SERVICES; PRE-PAID PURCHASE CARD SERVICES, NAMELY, PROCESSING ELECTRONIC PAYMENTS MADE THROUGH PREPAID CARDS; PAYMENT PROCESSING SERVICES, NAMELY, CASH CARD, CREDIT CARD AND DEBIT CARD TRANSACTION PROCESSING SERVICES; FOREIGN EXCHANGE CARD SERVICES; PAYMENT AND CREDIT CARD PROCESSING SERVICES FOR THE UTILIZATION OF VIRTUAL, NAMELY, ONLINE ELECTRONIC ONE-TIME-USE ONLY CARDS, NAMELY, PRE-PAID CARDS, CASH CARDS, CREDIT CARDS, AND DEBIT CARDS; FOREIGN EXCHANGE CARDS; ELECTRONIC PAYMENT, NAMELY, ELECTRONIC PROCESSING AND TRANSMISSION OF BILL PAYMENT DATA; PRE-PAID PURCHASE CARD SERVICES, NAMELY, PROCESSING ELECTRONIC PAYMENTS MADE THROUGH PREPAID CARDS; PAYMENT PROCESSING SERVICES, NAMELY, CASH CARD, CREDIT CARD AND DEBIT CARD TRANSACTION PROCESSING SERVICES; FOREIGN EXCHANGE CARD SERVICES, PAYROLL CARD SERVICES, GIFT CARD SERVICES, TRAVEL CARD SERVICES, FOREIGN EXCHANGE CARD SERVICES, REMITTANCE CARD SERVICES; CURRENCY EXCHANGE SERVICES; BANKING SERVICES; SAVINGS SERVICES, NAMELY, PROVIDING SAVINGS ACCOUNTS; FINANCIAL LENDING SERVICES; INVESTMENT SERVICES, NAMELY, RECEIVING FUNDS FROM CLIENTS AND PURCHASING

CLASS 36—(Continued).

INVESTMENT PRODUCTS ON THEIR BEHALF, PROVIDING CLIENTS WITH INVESTMENT ACCOUNT SERVICES; MAINTAINING ESCROW ACCOUNTS FOR INVESTMENT PURPOSES; PROVIDING CREDIT AGENCY SERVICES FOR BUSINESSES AND INDIVIDUALS; ACCEPTANCE OF SAVINGS DEPOSITS, NAMELY, RECEIVING AND HOLDING FUNDS IN A CONSUMER SAVINGS ACCOUNT AND OPERATING SAVINGS ACCOUNTS FOR CLIENTS; CURRENCY REMITTANCE, NAMELY, RECEIVING FUNDS FROM A CLIENT AND MAKING THEM AVAILABLE TO ANOTHER PERSON AT ANOTHER LOCATION AT THE CLIENT'S DIRECTION ALL IN A SECURE ENVIRONMENT; MONEY EXCHANGING; FOREIGN EXCHANGE TRANSACTIONS, CURRENCY EXCHANGE SERVICES; PAYMENT AND CREDIT CARD PROCESSING SERVICES FOR THE UTILIZATION OF VIRTUAL, NAMELY, ONLINE AND ELECTRONIC CARDS FOR THE AFOREMENTIONED PAYMENT PROCESSING, NAMELY, PRE-PAID CARD PURCHASE PAYMENT PROCESSING, CASH CARD, CREDIT CARD AND DEBIT CARD PAYMENT PROCESSING, FOREIGN EXCHANGE CARD CREDIT PROCESSING AND ONLINE PAYMENT PROCESSING; CARD SERVICES, NAMELY, PROCESSING THE ELECTRONIC PAYMENTS OF PAYROLL CARDS, NAMELY, CARDS FOR USE IN PURCHASING GOODS AND SERVICES AT THE POINT OF SALE AND FROM ONLINE INTERNET BUSINESSES WHICH CARDS ARE CONNECTED TO AN ONLINE CASH ACCOUNT INTO WHICH PAYROLL PAYMENTS ARE DEPOSITED, OF PREPAID CARDS, NAMELY, CARDS CONNECTED TO AN ONLINE CASH ACCOUNT INTO WHICH FUNDS FROM VARIOUS SOURCES ARE DEPOSITED OR TRANSFERRED, USE FOR PURCHASING GOODS AND SERVICES AT POINT OF SALE AND ONLINE, OF GIFT CARDS, NAMELY, CARDS USED BY MERCHANTS AS GIFT CERTIFICATES TO BE REDEEMED BY THE RECIPIENT, OF TRAVEL CARDS, NAMELY, CARDS THAT CAN BE PRE-FUNDED TO BE USED IN DIFFERENT COUNTRIES AND WITH DIFFERENT CURRENCIES, OF FOREIGN EXCHANGE CARDS, NAMELY, CARDS USED TO ACCESS AND FACILITATE THE USE OF FOREIGN CURRENCY, OF REMITTANCE CARDS, NAMELY, CARDS USED TO ACCESS FUNDS DEPOSITED INTO AN ACCOUNT BY THIRD PARTIES IN FOREIGN COUNTRIES, OF CREDIT CARDS, OF CASH CARDS, NAMELY, PRE-PAID CREDIT CARDS, OF PAYMENT CARDS, NAMELY, CREDIT CARDS, PREPAID CARDS AND DEBIT CARDS (U.S. CLS. 100, 101 AND 102).

MARIAM MAHMOUDI, EXAMINING ATTORNEY

SN 79-092,145. REGINE SIXT KINDERHILFE E.V., FED REP GERMANY, FILED 11-29-2010.

DRYING LITTLE TEARS

THE MARK CONSISTS OF STANDARD CHARACTERS WITHOUT CLAIM TO ANY PARTICULAR FONT, STYLE, SIZE, OR COLOR.

PRIORITY DATE OF 6-1-2010 IS CLAIMED.

OWNER OF INTERNATIONAL REGISTRATION 1063965
DATED 11-29-2010, EXPIRES 11-29-2020.

FOR CHARITABLE FUND RAISING, IN PARTICULAR FOR SUPPORTING POOR CHILDREN (U.S. CLS. 100, 101 AND 102).

TASNEEM HUSSAIN, EXAMINING ATTORNEY

CLASS 36—(Continued).

SN 79-096,297. ACNOVER, S.L., SPAIN, FILED 3-3-2011.



OWNER OF INTERNATIONAL REGISTRATION 1074212 DATED 3-3-2011, EXPIRES 3-3-2021.

THE COLOR(S) ORANGE IS/ARE CLAIMED AS A FEATURE OF THE MARK.

THE MARK CONSISTS OF ORANGE LETTERS "A", "N" AND "W" JOINED TOGETHER AT THEIR ENDS.

FOR INSURANCE SERVICES, NAMELY, INSURANCE AGENCIES, INSURANCE ADMINISTRATION, INFORMATION AND CONSULTANCY, INSURANCE UNDERWRITING SERVICES FOR ALL TYPES OF INSURANCE (U.S. CLS. 100, 101 AND 102).

ALLISON HOLTZ, EXAMINING ATTORNEY

CLASS 36—(Continued).

SN 85-049,417. PENLAND LEGACY ADVISORS LLC, CHARLOTTE, NC. FILED 5-27-2010.

PENLAND LEGACY ADVISORS

THE MARK CONSISTS OF STANDARD CHARACTERS WITHOUT CLAIM TO ANY PARTICULAR FONT, STYLE, SIZE, OR COLOR.

NO CLAIM IS MADE TO THE EXCLUSIVE RIGHT TO USE "LEGACY ADVISORS", APART FROM THE MARK AS SHOWN.

FOR FINANCIAL PLANNING AND INVESTMENT ADVISORY SERVICES (U.S. CLS. 100, 101 AND 102).

KELLY CHOE, EXAMINING ATTORNEY

SN 85-008,323. CONNOR'S HEROES FOUNDATION, MIDLOTHIAN, VA. FILED 4-7-2010.

CONNOR'S HEROES

THE MARK CONSISTS OF STANDARD CHARACTERS WITHOUT CLAIM TO ANY PARTICULAR FONT, STYLE, SIZE, OR COLOR.

THE NAME "CONNOR" IN THE MARK IDENTIFIES "CONNOR" GOODWIN, A LIVING INDIVIDUAL WHOSE CONSENT IS OF RECORD.

FOR CHARITABLE SERVICES, NAMELY, PROVIDING FINANCIAL ASSISTANCE TO CHILDREN WHO HAVE BEEN RECENTLY DIAGNOSED WITH CANCER AND THEIR FAMILIES (U.S. CLS. 100, 101 AND 102).

FIRST USE 6-30-2006; IN COMMERCE 6-30-2006.

JAMES GRIFFIN, EXAMINING ATTORNEY

SN 85-080,286. DONAY BV, DBA DONAY, AMERSFOORT, NETHERLANDS, FILED 7-8-2010.



PRIORITY CLAIMED UNDER SEC. 44(D) ON NETHERLANDS APPLICATION NO. 1196704, FILED 2-8-2010.

THE COLOR(S) AZUR BLUE IS/ARE CLAIMED AS A FEATURE OF THE MARK.

THE MARK CONSISTS OF THE BLUE STYLIZED WORDING "DONAY".

FOR ON-LINE ESCROW SERVICE FOR EXCHANGE OF SERVICES (U.S. CLS. 100, 101 AND 102).

CIMMERIAN COLEMAN, EXAMINING ATTORNEY

SN 85-041,679. OPTCAPITAL, LLC, CHARLOTTE, NC. FILED 5-18-2010.

Fund Alignment Right

THE MARK CONSISTS OF STANDARD CHARACTERS WITHOUT CLAIM TO ANY PARTICULAR FONT, STYLE, SIZE, OR COLOR.

OWNER OF U.S. REG. NO. 2,996,972.

NO CLAIM IS MADE TO THE EXCLUSIVE RIGHT TO USE "FUND ALIGNMENT", APART FROM THE MARK AS SHOWN.

FOR ADMINISTRATION OF EMPLOYEE BENEFIT PLANS CONCERNING INSURANCE AND FINANCE (U.S. CLS. 100, 101 AND 102).

FIRST USE 5-17-2010; IN COMMERCE 5-17-2010.

KATHRYN COWARD, EXAMINING ATTORNEY

SN 85-087,494. STRATEGIC ADVISORS, LLC, CLIVE, IA. FILED 7-19-2010.

INVEST WITHOUT FEAR

THE MARK CONSISTS OF STANDARD CHARACTERS WITHOUT CLAIM TO ANY PARTICULAR FONT, STYLE, SIZE, OR COLOR.

NO CLAIM IS MADE TO THE EXCLUSIVE RIGHT TO USE "INVEST", APART FROM THE MARK AS SHOWN.

FOR INVESTMENT ADVISORY SERVICES (U.S. CLS. 100, 101 AND 102).

CIMMERIAN COLEMAN, EXAMINING ATTORNEY

CLASS 36—(Continued).

SN 85-089,096. BOSCHUNG USA LLC, TULSA, OK. FILED 7-20-2010.



THE MARK CONSISTS OF A CURVED ARROW AND LINE WITH AN EXTERIOR OF A WORLD MAP REPRESENTATION AND THE WORDING "ABODEGLOBE" TO THE RIGHT OF THE ARROW.

FOR REAL ESTATE LISTING; REAL ESTATE LISTING SERVICES, NAMELY, PROVIDING AN ONLINE DATABASE LISTING RESIDENTIAL REAL ESTATE IN THE UNITED STATES; REAL ESTATE BROKERAGE SERVICES (U.S. CLS. 100, 101 AND 102).

JESSICA FATHY, EXAMINING ATTORNEY

CLASS 36—(Continued).

SN 85-091,430. INDEPENDENT HEALTH ASSOCIATION, INC., WILLIAMSVILLE, NY. FILED 7-23-2010.

**INDEPENDENT HEALTH'S
MEDICARE FAMILY CHOICE**

THE MARK CONSISTS OF STANDARD CHARACTERS WITHOUT CLAIM TO ANY PARTICULAR FONT, STYLE, SIZE, OR COLOR.

OWNER OF U.S. REG. NOS. 2,938,669, 3,745,083 AND OTHERS.

NO CLAIM IS MADE TO THE EXCLUSIVE RIGHT TO USE "HEALTH'S MEDICARE", APART FROM THE MARK AS SHOWN.

FOR ADMINISTRATION OF PRE-PAID HEALTH CARE PLANS IN THE NATURE OF A PREFERRED PROVIDER ORGANIZATION FOR MEDICARE-ELIGIBLE PARTICIPANTS RESIDING IN A NURSING FACILITY (U.S. CLS. 100, 101 AND 102).

FIRST USE 10-1-2009; IN COMMERCE 10-1-2009.
ROBERT STRUCK, EXAMINING ATTORNEY

SN 85-089,170. DAVID & GOLIATH LLC, EL SEGUNDO, CA. FILED 7-21-2010.

BRAVE

THE MARK CONSISTS OF THE WORDING "BRAVE" IN STYLIZED FONT WITH THE LETTERS "AVE" COMBINED. FOR CHARITABLE FUND RAISING SERVICES; PROVIDING EDUCATIONAL SCHOLARSHIPS (U.S. CLS. 100, 101 AND 102).

LAKEISHA LEWIS, EXAMINING ATTORNEY

SN 85-093,289. DOLORES C. HUERTA FOUNDATION, BAKERSFIELD, CA. FILED 7-26-2010.

WEAVING MOVEMENTS TOGETHER

THE MARK CONSISTS OF STANDARD CHARACTERS WITHOUT CLAIM TO ANY PARTICULAR FONT, STYLE, SIZE, OR COLOR.

FOR CHARITABLE FUND RAISING SERVICES, NAMELY, ORGANIZING AND PRODUCING COMMUNITY, LOCAL, REGIONAL, NATIONAL AND INTERNATIONAL EVENTS, CONCERTS, FESTIVALS, AND ACTIVITIES THAT RAISE FUNDS FOR PROGRAMS THAT SUPPORT SUSTAINABLE COMMUNITIES, EQUALITY, CIVIL RIGHTS, FEMINISM, PEACE, SOCIAL JUSTICE, OR ECONOMIC JUSTICE (U.S. CLS. 100, 101 AND 102).

FIRST USE 7-1-2010; IN COMMERCE 7-1-2010.
AMY KERTGATE, EXAMINING ATTORNEY

CLASS 36—(Continued).

SN 85-094,864. INTELLIPAYMENT LLC, NEW YORK, NY. FILED 7-28-2010.



THE MARK CONSISTS OF THE LETTERS "INTELLIPAYMENT" WITH A CAR ON A ROAD CURVING ABOVE THEM.

FOR PERIODIC LOAN REPAYMENT SERVICES (U.S. CLS. 100, 101 AND 102).

FIRST USE 8-0-2006; IN COMMERCE 8-0-2006.

WANDA KAY PRICE, EXAMINING ATTORNEY

SN 85-096,617. DOMESTIC BANK, CRANSTON, RI. FILED 7-30-2010.

ADMIRALS BANK

THE MARK CONSISTS OF STANDARD CHARACTERS WITHOUT CLAIM TO ANY PARTICULAR FONT, STYLE, SIZE, OR COLOR.

NO CLAIM IS MADE TO THE EXCLUSIVE RIGHT TO USE "BANK", APART FROM THE MARK AS SHOWN.

FOR FINANCIAL SERVICES, NAMELY, BANKING SERVICES; INTERNET AND ONLINE BANKING SERVICES; PERSONAL AND COMMERCIAL BANKING SERVICES; CHECKING ACCOUNT SERVICES; SAVINGS ACCOUNT SERVICES; DIRECT DEPOSIT SERVICES; DEPOSIT SERVICES IN THE NATURE OF ACCEPTANCE OF DEPOSITS; SAFETY DEPOSIT BOX SERVICES; FINANCIAL TRANSACTION SERVICES, NAMELY, CERTIFICATES OF DEPOSIT; ONLINE BANKING; ONLINE BILL PAYMENT SERVICES; MONEY WIRE TRANSFER SERVICES; AUTOMATED TELLER MACHINE SERVICES; ELECTRONIC FUNDS TRANSFER SERVICES; CERTIFIED CHECK SERVICES; PROVIDING BANK ACCOUNT INFORMATION BY TELEPHONE, INTERNET OR ELECTRONIC MEANS; DEBIT CARD SERVICES; CONSUMER AND COMMERCIAL LENDING SERVICES, NAMELY, PROVIDING, ACQUIRING AND SERVICING COMMERCIAL AND RESIDENTIAL MORTGAGE LOANS (INCLUDING REFINANCINGS), CONSTRUCTION LOANS, HOME IMPROVEMENT LOANS, CAR LOANS, HOME EQUITY LOANS, ISSUING LETTERS OF CREDIT (U.S. CLS. 100, 101 AND 102).

RENEE MCCRAY, EXAMINING ATTORNEY

CLASS 36—(Continued).

SN 85-105,486. GLOBAL LEISURE PARTNERS LLP, LONDON, UNITED KINGDOM, FILED 8-11-2010.

GLOBAL LEISURE CAPITAL PARTNERS

THE MARK CONSISTS OF STANDARD CHARACTERS WITHOUT CLAIM TO ANY PARTICULAR FONT, STYLE, SIZE, OR COLOR.

NO CLAIM IS MADE TO THE EXCLUSIVE RIGHT TO USE "CAPITAL PARTNERS", APART FROM THE MARK AS SHOWN.

SEC. 2(F).

FOR CAPITAL INVESTMENT SERVICES; EQUITY CAPITAL INVESTMENT; FINANCIAL INVESTMENT IN THE FIELD OF CASINOS AND GAMING, LODGING AND HOSPITALITY, RETAILING AND LIFESTYLE, CONSUMER MEDIA AND ENTERTAINMENT, TRAVEL AND TOURISM, AND HEALTH AND FITNESS; INVESTMENT OF FUNDS FOR OTHERS; AND INVESTMENT SERVICES, NAMELY, ASSET ACQUISITION, CONSULTATION, DEVELOPMENT AND MANAGEMENT SERVICES; ALL OF THE FOREGOING SERVICES BEING PROVIDED IN CONNECTION WITH THE LEISURE INDUSTRY (U.S. CLS. 100, 101 AND 102).

FIRST USE 0-0-2005; IN COMMERCE 0-0-2005.

LINDA ORNDORFF, EXAMINING ATTORNEY

SN 85-108,626. PRUDENT MAN ANALYSIS, INC., NAPERVILLE, IL. FILED 8-16-2010.



OWNER OF U.S. REG. NOS. 3,516,548, 3,723,873 AND OTHERS.

THE MARK CONSISTS OF A COLUMN DESIGN ON A BLACK BACKGROUND WITH THE INITIALISM "PMA" IMMEDIATELY TO THE RIGHT OF SAID DESIGN.

FOR INVESTMENT BROKERAGE, FINANCIAL AND INVESTMENT BANKING SERVICES, FINANCIAL AND INVESTMENT COUNSELING SERVICES, ALL OF THE FOREGOING FOR PUBLIC FINANCE, INSURANCE COOPERATIVE AND PENSION FUND CUSTOMERS AND SPECIFICALLY EXCLUDING SMALL BUSINESS CUSTOMERS AND RETAIL OR INDIVIDUAL CONSUMER CUSTOMERS (U.S. CLS. 100, 101 AND 102).

FIRST USE 10-31-2009; IN COMMERCE 10-31-2009.

DOMINICK J. SALEMI, EXAMINING ATTORNEY

CLASS 36—(Continued).

SN 85-112,114. FORT KNOX FINANCIAL SERVICES CORPORATION, LOUISVILLE, KY. FILED 8-20-2010.

Fee Advantage

THE MARK CONSISTS OF STANDARD CHARACTERS WITHOUT CLAIM TO ANY PARTICULAR FONT, STYLE, SIZE, OR COLOR.

NO CLAIM IS MADE TO THE EXCLUSIVE RIGHT TO USE "FEE", APART FROM THE MARK AS SHOWN.

FOR BILL PAYMENT SERVICES (U.S. CLS. 100, 101 AND 102).

FIRST USE 8-10-2010; IN COMMERCE 8-10-2010.

JIM RINGLE, EXAMINING ATTORNEY

SN 85-114,892. CLOW, DARRELL, WALNUT CREEK, CA. AND YOUNG, ELAINE, WALNUT CREEK, CA. FILED 8-24-2010.

EAST BAY PROPERTY PROS

THE MARK CONSISTS OF STANDARD CHARACTERS WITHOUT CLAIM TO ANY PARTICULAR FONT, STYLE, SIZE, OR COLOR.

NO CLAIM IS MADE TO THE EXCLUSIVE RIGHT TO USE "EAST BAY PROPERTY", APART FROM THE MARK AS SHOWN.

FOR REAL ESTATE BROKERAGE OF RESIDENTIAL, COMMERCIAL AND INDUSTRIAL PROPERTY AND LAND; REAL ESTATE LISTINGS OF RESIDENTIAL, COMMERCIAL AND INDUSTRIAL PROPERTY AND LAND; REAL ESTATE AGENCIES FOR RESIDENTIAL, COMMERCIAL AND INDUSTRIAL PROPERTY AND LAND (U.S. CLS. 100, 101 AND 102).

FIRST USE 7-4-2009; IN COMMERCE 7-4-2009.

KRISTIN CARLSON, EXAMINING ATTORNEY

CLASS 36—(Continued).

SN 85-116,273. AEQUOR HOMES, INC., ISELIN, NJ. FILED 8-26-2010.



NO CLAIM IS MADE TO THE EXCLUSIVE RIGHT TO USE "HOMES", APART FROM THE MARK AS SHOWN.

THE MARK CONSISTS OF THE OUTLINE OF A HOUSE OVER THE WORDS "AEQUOR" AND "HOMES" IN WHICH THE VERTICAL SEGMENT OF THE LETTER "H" IN THE WORD "HOMES" COMPRISES PART OF THE HOUSE.

THE ENGLISH TRANSLATION OF "AEQUOR" IN THE MARK IS "OCEAN".

FOR COMMERCIAL AND RESIDENTIAL REAL ESTATE AGENCY SERVICES; REAL ESTATE MANAGEMENT SERVICES OF RESIDENTIAL AND COMMERCIAL REAL ESTATE (U.S. CLS. 100, 101 AND 102).

FIRST USE 4-25-2005; IN COMMERCE 4-25-2005.

JENNY PARK, EXAMINING ATTORNEY

SN 85-122,367. RIVERA KENNEDY, ENRIQUE, SAN YSIDRO, CA. FILED 9-2-2010.

SEGUROS SIN FRONTERA

THE MARK CONSISTS OF STANDARD CHARACTERS WITHOUT CLAIM TO ANY PARTICULAR FONT, STYLE, SIZE, OR COLOR.

NO CLAIM IS MADE TO THE EXCLUSIVE RIGHT TO USE "SEGUROS", APART FROM THE MARK AS SHOWN.

THE ENGLISH TRANSLATION OF THE WORDS "SEGUROS SIN FRONTERA" IN THE MARK IS INSURANCE WITHOUT A BORDER.

FOR SELLING INSURANCE UNDERWRITTEN BY OTHERS THAT INSURE DRIVERS AND THEIR AUTOMOBILES WHILE THEY DRIVE IN A FOREIGN COUNTRY (U.S. CLS. 100, 101 AND 102).

LINDA POWELL, EXAMINING ATTORNEY

CLASS 36—(Continued).

SN 85-122,643. CHINATRUST COMMERCIAL BANK, LTD.,
TAIPEI, TAIWAN, FILED 9-3-2010.



OWNER OF U.S. REG. NOS. 2,762,230, 3,788,149 AND OTHERS.

NO CLAIM IS MADE TO THE EXCLUSIVE RIGHT TO USE THE NON-LATIN CHARACTERS THAT TRANSLITERATE TO ZHONG GUO XIN TUO, APART FROM THE MARK AS SHOWN.

THE COLOR(S) RED, GREEN AND WHITE IS/ARE CLAIMED AS A FEATURE OF THE MARK.

THE MARK CONSISTS OF THE FOUR CHINESE CHARACTERS IN GREEN ABOVE THE WORDING "CTCB" ALSO IN GREEN, UNDER A RED CIRCLE WITH THE WORDING "WE ARE FAMILY" IN WHITE AND A PAIR OF BRACKETS IN GREEN.

THE NON-LATIN CHARACTERS IN THE MARK TRANSLITERATE TO ZHONG GUO XIN TUO AND THIS MEANS CHINA TRUST IN ENGLISH.

FOR BANKING SERVICES; CAPITAL INVESTMENT; CREDIT CARD SERVICES; MONETARY EXCHANGE; BILL PAYMENT SERVICES; COMMERCIAL LENDING AND LOAN SERVICES; FINANCIAL INVESTMENT PLANNING SERVICES; REAL ESTATE BROKERAGE; REAL ESTATE TRUSTEE SERVICES; INSURANCE SERVICES, NAMELY, INSURANCE BROKERAGE, COMMERCIAL INSURANCE UNDERWRITING IN THE FIELD OF PROPERTY AND CASUALTY; SECURITIES SERVICES, NAMELY, STOCK BROKERAGE AND ADVISORY SERVICES; SAFE DEPOSIT BOX SERVICES FOR VALUABLES (U.S. CLS. 100, 101 AND 102).

CYNTHIA SLOAN, EXAMINING ATTORNEY

CLASS 36—(Continued).

SN 85-126,855. MOLECULAR SECURITIES INC., NEW YORK, NY. FILED 9-10-2010.



THE MARK CONSISTS OF FIVE SMEARED DOTS SURROUNDING AND IN THE CENTER OF AN "X", FOR FINANCIAL ADVISORY SERVICES IN THE FIELD OF MERGERS AND ACQUISITIONS (U.S. CLS. 100, 101 AND 102).

FIRST USE 7-1-2001; IN COMMERCE 7-1-2001.

ALYSSA STEEL, EXAMINING ATTORNEY

SN 85-126,866. MOLECULAR SECURITIES INC., NEW YORK, NY. FILED 9-10-2010.

MOLECULAR SECURITIES

THE MARK CONSISTS OF STANDARD CHARACTERS WITHOUT CLAIM TO ANY PARTICULAR FONT, STYLE, SIZE, OR COLOR.

NO CLAIM IS MADE TO THE EXCLUSIVE RIGHT TO USE "SECURITIES", APART FROM THE MARK AS SHOWN.

FOR FINANCIAL ADVISORY SERVICES IN THE FIELD OF MERGERS AND ACQUISITIONS (U.S. CLS. 100, 101 AND 102).

FIRST USE 7-1-2001; IN COMMERCE 7-1-2001.

ALYSSA STEEL, EXAMINING ATTORNEY

CLASS 36—(Continued).

SN 85-133,446. THE SCHOLARSHIP ORGANIZATION NETWORK, TAMPA, FL. FILED 9-20-2010.



NO CLAIM IS MADE TO THE EXCLUSIVE RIGHT TO USE "SCHOLARSHIP ORGANIZATION NETWORK", APART FROM THE MARK AS SHOWN.

THE MARK CONSISTS OF WORD "THE" ON TOP OF "SCHOLARSHIP" WHICH IS ON TOP OF "ORGANIZATION NETWORK". NEXT TO THE WORD "SCHOLARSHIP" IS A DRAWING OF CHILDREN HOLDING HANDS.

FOR FINANCIAL ADMINISTRATION OF SCHOLARSHIP PROGRAMS; PROVIDING EDUCATIONAL SCHOLARSHIPS (U.S. CLS. 100, 101 AND 102).

SHAUNIA CARLYLE, EXAMINING ATTORNEY



SN 85-135,094. TSUNAMI CAPITAL GROUP, INC., TORRANCE, CA. FILED 9-21-2010.

BrandRite

THE MARK CONSISTS OF STANDARD CHARACTERS WITHOUT CLAIM TO ANY PARTICULAR FONT, STYLE, SIZE, OR COLOR.

FOR ADVISING OTHERS CONCERNING INVESTMENTS IN INTELLECTUAL PROPERTY ASSETS AND INTANGIBLE BUSINESS ASSETS, BOTH DIRECTLY AND INDIRECTLY THROUGH OTHER ENTITIES (U.S. CLS. 100, 101 AND 102).

FIRST USE 0-0-2001; IN COMMERCE 0-0-2001.
ODESSA BIBBINS, EXAMINING ATTORNEY



SN 85-135,164. TRUELIGHT, LLC, BOSTON, MA. FILED 9-22-2010.

TRUELIGHT PARTNERS

THE MARK CONSISTS OF STANDARD CHARACTERS WITHOUT CLAIM TO ANY PARTICULAR FONT, STYLE, SIZE, OR COLOR.

NO CLAIM IS MADE TO THE EXCLUSIVE RIGHT TO USE "PARTNERS", APART FROM THE MARK AS SHOWN.

FOR SERVICES OF PROVIDING AND ACQUIRING FUNDING FOR RENEWABLE GENERATION ASSETS AND PROJECTS OF OTHERS, NAMELY, SOURCING INVESTMENT CAPITAL, RAISING PRIVATE EQUITY, AND FINANCIAL MANAGEMENT RELATING TO FUNDING SERVICES (U.S. CLS. 100, 101 AND 102).

JULIE VEPPUMTHARA, EXAMINING ATTORNEY

CLASS 36—(Continued).

SN 85-138,314. TSUNAMI CAPITAL GROUP, INC., TORRANCE, CA. FILED 9-25-2010.

BrandRight

THE MARK CONSISTS OF STANDARD CHARACTERS WITHOUT CLAIM TO ANY PARTICULAR FONT, STYLE, SIZE, OR COLOR.

FOR ADVISING OTHERS CONCERNING INVESTMENTS IN INTELLECTUAL PROPERTY ASSETS AND INTANGIBLE BUSINESS ASSETS, BOTH DIRECTLY AND INDIRECTLY THROUGH OTHER ENTITIES (U.S. CLS. 100, 101 AND 102).

FIRST USE 3-1-2010; IN COMMERCE 3-1-2010.
ODESSA BIBBINS, EXAMINING ATTORNEY



SN 85-139,699. GRUPO ACTINVER, S.A. DE C.V., SANTA FE, MEXICO, FILED 9-28-2010.

ACTINVER

THE MARK CONSISTS OF STANDARD CHARACTERS WITHOUT CLAIM TO ANY PARTICULAR FONT, STYLE, SIZE, OR COLOR.

OWNER OF MEXICO REG. NO. 1036111, DATED 4-23-2008, EXPIRES 10-9-2016.

FOR INSURANCE BROKERAGE; FINANCIAL MATTERS, NAMELY, FINANCIAL ADVICE, INSURANCE UNDERWRITING SERVICES FOR ALL TYPES OF INSURANCE, INVESTMENT MANAGEMENT AND ADVISORY SERVICES, MUTUAL FUND INVESTMENT SERVICES, PRIVATE EQUITY INVESTMENT SERVICES, VENTURE CAPITAL INVESTMENT SERVICES, FINANCIAL PLANNING SERVICES FOR OTHERS, INVESTMENT BANKING SERVICES, SECURITIES BROKERAGE SERVICES; MONETARY MATTERS, NAMELY, MONETARY EXCHANGE; REAL ESTATE MATTERS, NAMELY, REAL ESTATE VALUATIONS, REAL ESTATE INVESTMENT MANAGEMENT, REAL ESTATE APPRAISAL SERVICES, AND REAL ESTATE BROKERAGE SERVICES (U.S. CLS. 100, 101 AND 102).

RONALD MCMORROW, EXAMINING ATTORNEY

CLASS 36—(Continued).

SN 85-157,551. COINSTAR, INC., BELLEVUE, WA. FILED 10-20-2010.



OWNER OF U.S. REG. NO. 3,622,169.
THE COLOR(S) GREEN IS/ARE CLAIMED AS A FEATURE OF THE MARK.

THE MARK CONSISTS OF THE COLOR GREEN IN WHICH GREEN IS APPLIED TO THE EXTERIOR OF A KIOSK USED TO PROVIDE THE SERVICES. THE DOTTED LINES OUTLINING THE SHAPE OF THE KIOSK INDICATE THE PLACEMENT OF THE MARK ON THE KIOSK USED TO PROVIDE THE SERVICES AND ARE NOT PART OF THE MARK.

SEC. 2(F).

FOR COIN REDEMPTION SERVICES, NAMELY, COIN COUNTING, SORTING AND CONVERTING SERVICES; FINANCIAL SERVICES, NAMELY, PROVIDING KIOSKS WHICH CONVERT COINS INTO VOUCHERS REDEEMABLE FOR CASH, PREPAID CARDS, GIFT CARDS, OR STORED VALUE CARDS, AND THAT ISSUE COUPONS OFFERING DISCOUNTS TO SHOPPERS; FINANCIAL SERVICES, NAMELY, CHARITABLE FUND RAISING SERVICES THROUGH PROVIDING AUTOMATED KIOSKS TO PROCESS COINS THAT HAVE BEEN DONATED TO CIVIC AND NOT-FOR-PROFIT ORGANIZATIONS; ACCEPTING AND ADMINISTERING MONETARY CHARITABLE CONTRIBUTIONS PROVIDED THROUGH SELF-SERVICE KIOSKS PROVIDING KIOSKS THAT ACCEPT MONETARY CHARITABLE CONTRIBUTIONS; COIN CONVERSION AND COIN SORTING SERVICES; PROVIDING KIOSKS FOR COIN CONVERSION AND COIN SORTING; SELF-SERVICE KIOSKS FOR COIN CONVERSION AND COIN SORTING; FINANCIAL SERVICES, NAMELY, ISSUING AUTOMATED TELLER MACHINE (ATM) CARDS, GIFT CARDS, DEBIT CARDS, OTHER NON-CREDIT CARDS REDEEMABLE FOR GOODS AND SERVICES, STORED VALUE CARDS, CASH CARDS, PREPAID LONG DISTANCE CARDS, PREPAID WIRELESS CARDS, AND PREPAID INTERNET CARDS; INTERACTIVE GIFT CARD SERVICES, NAMELY, PROVIDING A SERVICE WHICH PROVIDES CONSUMERS WITH INFORMATION ABOUT THIRD PARTIES' GIFT CARDS, ALLOWS CONSUMERS TO PURCHASE THIRD PARTIES' GIFT CARDS, AND ALLOWS CONSUMERS TO RELOAD GIFT CARD BALANCES; BANKING SERVICES, NAMELY, PROVIDING AUTOMATED KIOSKS IN BANKS FOR PROCESSING COINS REDEEMABLE FOR CASH AND ISSUING CASH CARDS; CHECK CASHING SERVICES; PAYROLL CARD SERVICES, NAMELY, BILL PAYMENT SERVICES AND PAYROLL PAYMENT SERVICES, CHECKING AND SAVINGS ACCOUNT BALANCE SERVICES, VOUCHER SERVICES, NAMELY, ISSUING VOUCHERS FOR OTHERS REDEEMABLE FOR DISCOUNTS ON GOODS; FINANCIAL SERVICES, NAMELY, REDEEMING VOUCHERS FOR CASH; FINANCIAL SERVICES, NAMELY, ACCEPTING DEPOSITS TO FINANCIAL ACCOUNTS FROM COIN FROM KIOSKS; FINANCIAL SERVICES, NAMELY, BILL PAYMENT SERVICES (U.S. CLS. 100, 101 AND 102).

FIRST USE 3-31-2002; IN COMMERCE 3-31-2002.
TASNEEM HUSSAIN, EXAMINING ATTORNEY

CLASS 36—(Continued).

SN 85-157,719. AVIATOR FUND MANAGEMENT, L.P., GREENWICH, CT. FILED 10-21-2010.

AVIATOR FUND MANAGEMENT, LP

THE MARK CONSISTS OF STANDARD CHARACTERS WITHOUT CLAIM TO ANY PARTICULAR FONT, STYLE, SIZE, OR COLOR.

NO CLAIM IS MADE TO THE EXCLUSIVE RIGHT TO USE "FUND MANAGEMENT, LP", APART FROM THE MARK AS SHOWN.

FOR FINANCIAL SERVICES, NAMELY, INVESTMENT MANAGEMENT SERVICES, INVESTMENT ADVISORY SERVICES AND ASSET MANAGEMENT SERVICES (U.S. CLS. 100, 101 AND 102).

FIRST USE 7-1-2003; IN COMMERCE 7-1-2003.
CURTIS FRENCH, EXAMINING ATTORNEY

SN 85-160,053. RANGEMARK FINANCIAL SERVICES, INC., GREENWICH, CT. FILED 10-25-2010.

RANGEMARK

THE MARK CONSISTS OF STANDARD CHARACTERS WITHOUT CLAIM TO ANY PARTICULAR FONT, STYLE, SIZE, OR COLOR.

FOR SECURITIES BROKERAGE AND INVESTMENT BANKING SERVICES (U.S. CLS. 100, 101 AND 102).

FIRST USE 9-9-2009; IN COMMERCE 9-9-2009.
ROBERT C. CLARK JR., EXAMINING ATTORNEY

SN 85-164,887. TGM ASSOCIATES L.P., NEW YORK, NY. FILED 10-29-2010.

The Focused Resource for
Apartment Investors

THE MARK CONSISTS OF STANDARD CHARACTERS WITHOUT CLAIM TO ANY PARTICULAR FONT, STYLE, SIZE, OR COLOR.

NO CLAIM IS MADE TO THE EXCLUSIVE RIGHT TO USE "RESOURCE FOR APARTMENT INVESTORS", APART FROM THE MARK AS SHOWN.

FOR ACQUISITION OF MULTI-FAMILY HOUSING ON BEHALF OF INVESTOR CLIENTS; REAL ESTATE SERVICES, NAMELY, PROVISION OF COMMERCIAL AND RENTAL PROPERTY MANAGEMENT SERVICES TO INVESTOR CLIENTS (U.S. CLS. 100, 101 AND 102).

FIRST USE 7-1-1991; IN COMMERCE 7-1-1991.
SHAUNIA CARLYLE, EXAMINING ATTORNEY

CLASS 36—(Continued).

SN 85-186,944. ASKINS REALTY GROUP, LLC, MCKINNEY, TX. FILED S.R. 11-30-2010; AM. P.R. 6-3-2011.

ARG

THE MARK CONSISTS OF STANDARD CHARACTERS WITHOUT CLAIM TO ANY PARTICULAR FONT, STYLE, SIZE, OR COLOR.

FOR LEASE OF REAL ESTATE; LEASING OF REAL ESTATE; REAL ESTATE AGENCIES; REAL ESTATE BROKERAGE; REAL ESTATE LISTING; REAL ESTATE LISTING SERVICES FOR HOUSING RENTALS AND APARTMENT RENTALS; REAL ESTATE MULTIPLE LISTING SERVICES; REAL ESTATE RENTAL SERVICES, NAMELY, RENTAL OF RESIDENTIAL HOUSING (U.S. CLS. 100, 101 AND 102).

FIRST USE 7-29-2004; IN COMMERCE 7-29-2004.
STEVEN JACKSON, EXAMINING ATTORNEY

SN 85-190,195. HELP OUR MILITARY HEROES INC., EASTON, CT. FILED 12-3-2010.



THE MARK CONSISTS OF A CIRCLE WITH A HOUSE INSIDE AND STAR INSIDE OF HOUSE WRAPPED BY A 3/4 LAUREL WREATH WITH "HELP OUR MILITARY HEROES" BENEATH AND BAR WITH STARS BENEATH LETTERS.

FOR CHARITABLE FUNDRAISING FOR MILITARY SERVICE MEMBERS AND THEIR FAMILIES (U.S. CLS. 100, 101 AND 102).

FIRST USE 1-1-2010; IN COMMERCE 1-1-2010.
JILL PRATER, EXAMINING ATTORNEY

CLASS 36—(Continued).

SN 85-191,545. MC21 CORPORATION, CAGUAS, PUERTO RICO, FILED 12-6-2010.

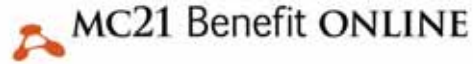

OWNER OF U.S. REG. NO. 3,698,440.
NO CLAIM IS MADE TO THE EXCLUSIVE RIGHT TO USE "BENEFIT ONLINE", APART FROM THE MARK AS SHOWN.

THE COLOR(S) ORANGE AND BLACK IS/ARE CLAIMED AS A FEATURE OF THE MARK.

THE MARK CONSISTS OF THE WORDS "MC21 BENEFIT ONLINE". TO THE LEFT OF "MC21", AND SLIGHTLY BELOW IT, IS A TRIANGULAR DESIGN CONSISTING OF THREE LARGE DOTS CONNECTED BY THREE LINES. THE COLOR ORANGE APPEARS IN THE DESIGN OF THREE DOTS. THE COLOR BLACK APPEARS IN THE WORDING.

FOR PHARMACY BENEFIT MANAGEMENT SERVICES (U.S. CLS. 100, 101 AND 102).
DORITT L. CARROLL, EXAMINING ATTORNEY

SN 85-192,280. RADIANT CHARITY CORPORATION, ALPHARETTA, GA. FILED 12-7-2010.

SPRINT FOR CANCER

THE MARK CONSISTS OF STANDARD CHARACTERS WITHOUT CLAIM TO ANY PARTICULAR FONT, STYLE, SIZE, OR COLOR.

SEC. 2(F).
FOR CHARITABLE FUNDRAISING SERVICES BY MEANS OF RUNNING AND WALKING EVENTS (U.S. CLS. 100, 101 AND 102).

FIRST USE 0-0-2005; IN COMMERCE 0-0-2005.
HOWARD SMIGA, EXAMINING ATTORNEY

SN 85-196,927. AIM STAR NETWORK CO., LTD., WATTANA BANGKOK 10110, THAILAND, FILED 12-13-2010.

STARMATCHING

THE MARK CONSISTS OF STANDARD CHARACTERS WITHOUT CLAIM TO ANY PARTICULAR FONT, STYLE, SIZE, OR COLOR.

FOR PROVIDING A COMPENSATION PROGRAM FOR OWNERS AND OPERATORS OF DISTRIBUTORSHIPS, NAMELY, PAYMENT PROCESSING SERVICES FOR COMPENSATION PROGRAMS BASED UPON SALES VOLUME (U.S. CLS. 100, 101 AND 102).

AISHA SALEM, EXAMINING ATTORNEY

CLASS 36—(Continued).

SN 85-203,361. NEUBERGER BERMAN MANAGEMENT LLC, NEW YORK, NY. FILED 12-21-2010.

NEUBERGER BERMAN MULTI-CAP OPPORTUNITIES FUND

THE MARK CONSISTS OF STANDARD CHARACTERS WITHOUT CLAIM TO ANY PARTICULAR FONT, STYLE, SIZE, OR COLOR.

OWNER OF U.S. REG. NO. 1,959,844.

NO CLAIM IS MADE TO THE EXCLUSIVE RIGHT TO USE "MULTI-CAP OPPORTUNITIES FUND", APART FROM THE MARK AS SHOWN.

FOR INVESTMENT ADVISORY AND MUTUAL FUND SERVICES, NAMELY, SPONSORING MUTUAL FUNDS, PROVIDING ADMINISTRATION AND SHAREHOLDER SERVICES TO MUTUAL FUNDS, DISTRIBUTING MUTUAL FUND SHARES AND MANAGING FUNDS, STOCKS AND BONDS AND OTHER INVESTMENTS FOR INSTITUTIONS AND THE GENERAL PUBLIC (U.S. CLS. 100, 101 AND 102).

FIRST USE 12-21-2009; IN COMMERCE 12-21-2009.
HEATHER SAPP, EXAMINING ATTORNEY

SN 85-203,510. CALAMOS HOLDINGS LLC, NAPERVILLE, IL. FILED 12-22-2010.

CALAMOS GROWTHWORKS

THE MARK CONSISTS OF STANDARD CHARACTERS WITHOUT CLAIM TO ANY PARTICULAR FONT, STYLE, SIZE, OR COLOR.

OWNER OF U.S. REG. NOS. 2,065,205, 2,662,667 AND 3,384,727.

FOR FINANCIAL ADVICE; FINANCIAL ANALYSES; FINANCIAL ANALYSIS AND CONSULTATION; FINANCIAL ASSET MANAGEMENT; FINANCIAL CONSULTING; FINANCIAL INVESTMENT IN THE FIELD OF SECURITIES; FINANCIAL PORTFOLIO MANAGEMENT; INVESTMENT SERVICES, NAMELY, INVESTMENT CONSULTATION, INVESTMENT OF FUNDS FOR OTHERS, AND INVESTMENT MANAGEMENT (U.S. CLS. 100, 101 AND 102).

EDWARD FENNESSY, EXAMINING ATTORNEY

SN 85-204,393. BUYERMLS, LLC, OAKS, PA. FILED 12-22-2010.

KEEP BUYERS AND COMMISSIONS IN-HOUSE

THE MARK CONSISTS OF STANDARD CHARACTERS WITHOUT CLAIM TO ANY PARTICULAR FONT, STYLE, SIZE, OR COLOR.

FOR PROVIDING INFORMATION IN THE FIELD OF REAL ESTATE VIA THE INTERNET (U.S. CLS. 100, 101 AND 102).

JAMES MACFARLANE, EXAMINING ATTORNEY

CLASS 36—(Continued).

SN 85-205,216. BMG MONEY, INC., MIAMI, FL. FILED 12-23-2010.



NO CLAIM IS MADE TO THE EXCLUSIVE RIGHT TO USE "LOANS", APART FROM THE MARK AS SHOWN.

THE MARK CONSISTS OF THE WORDING "LOANS AT WORK" INSIDE TWO QUADRILATERALS THAT REPRESENT A STREET SIGN.

FOR CONSUMER LENDING (U.S. CLS. 100, 101 AND 102).

AMY HELLA, EXAMINING ATTORNEY

SN 85-205,225. BMG MONEY, INC., MIAMI, FL. FILED 12-23-2010.



NO CLAIM IS MADE TO THE EXCLUSIVE RIGHT TO USE "LOANS", "PRESENTED BY" AND "MONEY", APART FROM THE MARK AS SHOWN.

THE MARK CONSISTS OF THE WORDING "LOANS AT WORK" INSIDE TWO QUADRILATERALS THAT REPRESENT A STREET SIGN. TO THE LOWER RIGHT OF THE SIGN IS THE WORDING "PRESENTED BY: BMG MONEY".

FOR CONSUMER LENDING (U.S. CLS. 100, 101 AND 102).

AMY HELLA, EXAMINING ATTORNEY

CLASS 36—(Continued).

SN 85-205,500. COMMUTER CHECK SERVICES CORPORATION, WATERTOWN, MA. FILED 12-24-2010.

COMMUTER CHECK DIRECT

THE MARK CONSISTS OF STANDARD CHARACTERS WITHOUT CLAIM TO ANY PARTICULAR FONT, STYLE, SIZE, OR COLOR.

OWNER OF U.S. REG. NOS. 2,465,014, 3,890,984 AND OTHERS.

NO CLAIM IS MADE TO THE EXCLUSIVE RIGHT TO USE "DIRECT", APART FROM THE MARK AS SHOWN. SEC. 2(F) AS TO "COMMUTER CHECK".

FOR TRAVEL VOUCHER SERVICES, NAMELY, PROVIDING VOUCHERS FOR PAYMENT OF TRANSPORTATION AND PARKING EXPENSES; ISSUING STORED VALUE CARDS FOR USE BY COMMUTERS TO PAY TRANSPORTATION AND PARKING EXPENSES; ADMINISTRATION OF EMPLOYEE BENEFIT PLANS PROVIDING FOR PAYMENT OF TRANSPORTATION AND PARKING EXPENSES (U.S. CLS. 100, 101 AND 102).

FIRST USE 1-0-2007; IN COMMERCE 1-0-2007.
DANIEL CAPSHAW, EXAMINING ATTORNEY

SN 85-205,501. COMMUTER CHECK SERVICES CORPORATION, WATERTOWN, MA. FILED 12-24-2010.

COMMUTER CHECK ECO

THE MARK CONSISTS OF STANDARD CHARACTERS WITHOUT CLAIM TO ANY PARTICULAR FONT, STYLE, SIZE, OR COLOR.

OWNER OF U.S. REG. NOS. 2,465,014, 3,890,984 AND OTHERS.

NO CLAIM IS MADE TO THE EXCLUSIVE RIGHT TO USE "ECO", APART FROM THE MARK AS SHOWN. SEC. 2(F) AS TO "COMMUTER CHECK".

FOR TRAVEL VOUCHER SERVICES, NAMELY, PROVIDING VOUCHERS FOR PAYMENT OF TRANSPORTATION AND PARKING EXPENSES; ISSUING STORED VALUE CARDS FOR USE BY COMMUTERS TO PAY TRANSPORTATION AND PARKING EXPENSES; ADMINISTRATION OF EMPLOYEE BENEFIT PLANS PROVIDING FOR PAYMENT OF TRANSPORTATION AND PARKING EXPENSES (U.S. CLS. 100, 101 AND 102).

FIRST USE 1-0-2010; IN COMMERCE 1-0-2010.
DANIEL CAPSHAW, EXAMINING ATTORNEY

CLASS 36—(Continued).

SN 85-209,006. THOMPSON INSURANCE ENTERPRISES, LLC, KENNESAW, GA. FILED 1-3-2011.



NO CLAIM IS MADE TO THE EXCLUSIVE RIGHT TO USE "INSURANCE ENTERPRISES, LLC", APART FROM THE MARK AS SHOWN.

THE COLOR(S) BLUE AND TEAL IS/ARE CLAIMED AS A FEATURE OF THE MARK.

THE MARK CONSISTS OF THE WORD "THOMCO" IN BLUE ABOVE THE WORDS "THOMPSON INSURANCE ENTERPRISES, LLC" IN TEAL, ALL APPEARING TO THE RIGHT OF A LOGO CONSISTING OF A BLUE CIRCLE WITH TRANSPARENT CENTER ENCLOSED BY A PARTIAL TEAL CIRCLE ENCLOSED BY A PARTIAL BLUE CIRCLE; ALL OF THE CIRCLES ARE SEPARATED BY TRANSPARENT AREAS; THE COLOR WHITE IN THE MARK REPRESENTS TRANSPARENT AREAS AND IS NOT A PART OF THE MARK.

FOR INSURANCE SERVICES, NAMELY, PROVIDING PROPERTY AND CASUALTY INSURANCE (U.S. CLS. 100, 101 AND 102).

FIRST USE 2-1-2006; IN COMMERCE 2-1-2006.
HEATHER BIDDULPH, EXAMINING ATTORNEY

SN 85-220,412. ROLLING RIVER DAY SCHOOL AND CAMP INC., EAST ROCKAWAY, NY. FILED 1-18-2011.

The Campmates Program

THE MARK CONSISTS OF STANDARD CHARACTERS WITHOUT CLAIM TO ANY PARTICULAR FONT, STYLE, SIZE, OR COLOR.

NO CLAIM IS MADE TO THE EXCLUSIVE RIGHT TO USE "PROGRAM", APART FROM THE MARK AS SHOWN.

FOR CHARITABLE FUNDRAISING SERVICES, NAMELY, PROVIDING A PROGRAM THAT RAISES FUNDS TO SUPPORT ELIGIBLE CHILDREN UP TO THE AGE OF 13 WHO WOULD LIKE TO ATTEND SUMMER CAMP, FACILITATED THROUGH ANNUAL FEES DONATED BY PARTICIPATING BUSINESSES GIVEN TOWARDS THE CAMP TUITION OF THE SELECTED CHILD (U.S. CLS. 100, 101 AND 102).

FIRST USE 3-1-2010; IN COMMERCE 5-11-2010.
TARA PATE, EXAMINING ATTORNEY

CLASS 36—(Continued).

SN 85-221,225. CREATIVE MARKETING ASSOCIATES, INC., KANSAS CITY, MO. FILED 1-19-2011.

HAPPY DIVORCE GIFT CARD

THE MARK CONSISTS OF STANDARD CHARACTERS WITHOUT CLAIM TO ANY PARTICULAR FONT, STYLE, SIZE, OR COLOR.

NO CLAIM IS MADE TO THE EXCLUSIVE RIGHT TO USE "GIFT CARD", APART FROM THE MARK AS SHOWN.

FOR STORED VALUE CARD SERVICES, NAMELY, PROVIDING PURCHASE AUTHORIZATIONS, AND/OR ELECTRONIC CERTIFICATES, AND/OR STORED VALUE CARDS FOR CELEBRATING THE DISSOLUTION OF A MARRIAGE (U.S. CLS. 100, 101 AND 102).

REBECCA EISINGER, EXAMINING ATTORNEY

CLASS 36—(Continued).

SN 85-228,133. WESTCHESTER BANK HOLDING CORPORATION, YONKERS, NY. FILED 1-27-2011.



The Westchester Bank

SN 85-225,428. ONEBEACON INSURANCE COMPANY, CANTON, MA. FILED 1-25-2011.



OWNER OF U.S. REG. NOS. 3,619,458 AND 3,619,459.
NO CLAIM IS MADE TO THE EXCLUSIVE RIGHT TO USE "INSURANCE GROUP", APART FROM THE MARK AS SHOWN.

THE MARK CONSISTS OF A CIRCLE DESIGN WITHIN WHICH IS A DEPICTION OF A LIGHT HOUSE, WITH THE WORDING "ONEBEACON" BELOW WHICH IS THE WORDING "INSURANCE GROUP".

FOR INSURANCE UNDERWRITING IN THE FIELD OF PROPERTY, CASUALTY, ACCIDENT, LIABILITY, HEALTH, REINSURANCE, AND SURETY; INSURANCE AGENCY SERVICES (U.S. CLS. 100, 101 AND 102).

FIRST USE 12-1-2010; IN COMMERCE 12-1-2010.
CHRISTINA SOBRAL, EXAMINING ATTORNEY

OWNER OF U.S. REG. NO. 3,521,648.

NO CLAIM IS MADE TO THE EXCLUSIVE RIGHT TO USE "THE WESTCHESTER BANK", APART FROM THE MARK AS SHOWN.

THE COLOR(S) RED AND BLACK IS/ARE CLAIMED AS A FEATURE OF THE MARK.

THE MARK CONSISTS OF THE WORDING "THE WESTCHESTER BANK" IN BLACK, IN STYLIZED TYPE. TO THE LEFT OF THE WORDING IS A DESIGN OF A SQUARE CONSISTING OF FOUR RED LETTERS "W".

FOR BANKING AND FINANCIAL SERVICES, NAMELY, BANKING SERVICES, PERSONAL AND COMMERCIAL BANKING SERVICES, CHECKING ACCOUNT SERVICES, SAVINGS ACCOUNT SERVICES, DEPOSIT SERVICES, SAFETY DEPOSIT BOX SERVICES, ONLINE BANKING, ONLINE BILL PAYMENT SERVICES, WIRE TRANSFER SERVICES, AUTOMATED TELLER MACHINE SERVICES, ELECTRONIC FUNDS TRANSFER SERVICES, CREDIT CARD AND DEBIT CARD SERVICES, INVESTMENT BANKING SERVICES, MORTGAGE AND LENDING SERVICES, REAL ESTATE FINANCING SERVICES, FINANCIAL PLANNING AND ANALYSIS, FINANCIAL ADVISORY SERVICES, FINANCIAL MANAGEMENT SERVICES, FINANCIAL MANAGEMENT, NAMELY, ASSET MANAGEMENT, INVESTMENT MANAGEMENT, INVESTMENT CONSULTATION, FUND INVESTMENT SERVICES, INVESTMENT BROKERAGE SERVICES, MONEY MARKET ACCOUNT SERVICES, MUTUAL FUND ADMINISTRATION AND BROKERAGE SERVICES; TRUST SERVICES, NAMELY, INVESTMENT AND TRUST COMPANY SERVICES; FIDUCIARY SERVICES, NAMELY, TRUST AND ESTATE PLAN CONSULTATION, ESTATE SETTLEMENT; TRUST, ESTATE AND INVESTMENT CUSTODY, ADMINISTRATION, RECORD KEEPING AND REPORTING SERVICES, NAMELY, SAFEKEEPING, INVESTING AND MANAGING ASSETS, EXECUTING AND SETTLING SECURITIES TRADES, CORPORATE FINANCIAL ACTION REPORTING AND MANAGEMENT, FINANCIAL TRANSACTION PROCESSING, BILL PAYMENT, TRACKING AND REPORTING FINANCIAL ACCOUNT, ASSET AND FINANCIAL TRANSACTION INFORMATION, ONLINE FINANCIAL ACCOUNT SERVICES; PROVIDING INFORMATION IN THE FIELDS OF BANKING, FINANCE, INVESTMENTS, ASSET MANAGEMENT, AND FINANCIAL PLANNING (U.S. CLS. 100, 101 AND 102).

FIRST USE 12-1-2008; IN COMMERCE 12-1-2008.
HEATHER BIDDULPH, EXAMINING ATTORNEY

SN 85-227,999. AVEN CORPORATION, TEMECULA, CA. FILED 1-27-2011.

NETT-GROSS GROUP

THE MARK CONSISTS OF STANDARD CHARACTERS WITHOUT CLAIM TO ANY PARTICULAR FONT, STYLE, SIZE, OR COLOR.

NO CLAIM IS MADE TO THE EXCLUSIVE RIGHT TO USE "GROUP", APART FROM THE MARK AS SHOWN.

FOR REAL ESTATE MANAGEMENT SERVICES (U.S. CLS. 100, 101 AND 102).

SAIMA MAKHDOOM, EXAMINING ATTORNEY

CLASS 36—(Continued).

SN 85-228,373. STOKES, JOHN, DBA JOHN STOKES FINANCIAL, NEWPORT BEACH, CA. FILED 1-28-2011.

Your Financial Compass for
Life

THE MARK CONSISTS OF STANDARD CHARACTERS WITHOUT CLAIM TO ANY PARTICULAR FONT, STYLE, SIZE, OR COLOR.

FOR FINANCIAL ADMINISTRATION OF RETIREMENT PLANS; FINANCIAL ADMINISTRATION OF STOCK EXCHANGE TRADING OF SHARES AND OTHER FINANCIAL SECURITIES IN FINANCIAL MARKETS; FINANCIAL ADVICE; FINANCIAL ADVICE AND CONSULTANCY SERVICES; FINANCIAL ADVISORY AND CONSULTANCY SERVICES; FINANCIAL ANALYSIS AND CONSULTATION; FINANCIAL AND INVESTMENT SERVICES, NAMELY, MANAGEMENT AND BROKERAGE IN THE FIELDS OF STOCKS, BONDS, OPTIONS, COMMODITIES, FUTURES AND OTHER SECURITIES, AND THE INVESTMENT OF FUNDS OF OTHERS; FINANCIAL ASSET MANAGEMENT; FINANCIAL CONSULTING; FINANCIAL PLANNING AND INVESTMENT ADVISORY SERVICES; FINANCIAL PLANNING FOR RETIREMENT (U.S. CLS. 100, 101 AND 102).

SUSAN LESLIE DUBOIS, EXAMINING ATTORNEY

SN 85-231,859. BANK OF AMERICA CORPORATION, CHARLOTTE, NC. FILED 2-1-2011.

TRADE PRO

THE MARK CONSISTS OF STANDARD CHARACTERS WITHOUT CLAIM TO ANY PARTICULAR FONT, STYLE, SIZE, OR COLOR.

NO CLAIM IS MADE TO THE EXCLUSIVE RIGHT TO USE "TRADE", APART FROM THE MARK AS SHOWN.

FOR BANKING AND RELATED FINANCIAL SERVICES, NAMELY, PROVIDING FOREIGN TRADE TRANSACTION INITIATION AND FINANCIAL INFORMATION TO CUSTOMERS RELATED TO IMPORT AND EXPORT TRADE TRANSACTIONS, LETTER OF CREDIT ACTIVITIES, AND OTHER FINANCIAL INFORMATION RELATED TO TRADE (U.S. CLS. 100, 101 AND 102).

LAURIE KAUFMAN, EXAMINING ATTORNEY

CLASS 36—(Continued).

SN 85-233,388. TRACK DATA CORPORATION, BROOKLYN, NY. FILED 2-3-2011.

MYTRACK EDGE

THE MARK CONSISTS OF STANDARD CHARACTERS WITHOUT CLAIM TO ANY PARTICULAR FONT, STYLE, SIZE, OR COLOR.

OWNER OF U.S. REG. NOS. 1,562,780 AND 1,841,035.

FOR FINANCIAL ADMINISTRATION OF STOCK EXCHANGE TRADING OF SHARES AND OTHER FINANCIAL SECURITIES IN FINANCIAL MARKETS (U.S. CLS. 100, 101 AND 102).

FIRST USE 0-0-1998; IN COMMERCE 0-0-1998.

KIM SAITO, EXAMINING ATTORNEY

SN 85-233,427. TRACK DATA CORPORATION, BROOKLYN, NY. FILED 2-3-2011.

MYTRACKPRO

THE MARK CONSISTS OF STANDARD CHARACTERS WITHOUT CLAIM TO ANY PARTICULAR FONT, STYLE, SIZE, OR COLOR.

OWNER OF U.S. REG. NOS. 1,562,780 AND 1,841,035.

FOR FINANCIAL ADMINISTRATION OF STOCK EXCHANGE TRADING OF SHARES AND OTHER FINANCIAL SECURITIES IN FINANCIAL MARKETS (U.S. CLS. 100, 101 AND 102).

FIRST USE 0-0-2008; IN COMMERCE 0-0-2008.

KIM SAITO, EXAMINING ATTORNEY

SN 85-233,576. TRACK DATA CORPORATION, BROOKLYN, NY. FILED 2-3-2011.

OPTRACK

THE MARK CONSISTS OF STANDARD CHARACTERS WITHOUT CLAIM TO ANY PARTICULAR FONT, STYLE, SIZE, OR COLOR.

OWNER OF U.S. REG. NOS. 1,562,780 AND 1,841,035.

FOR PROVIDING STOCK MARKET INFORMATION (U.S. CLS. 100, 101 AND 102).

FIRST USE 0-0-1981; IN COMMERCE 0-0-1981.

KIM SAITO, EXAMINING ATTORNEY

CLASS 36—(Continued).

SN 85-234,972. HMG RESOURCES LLC, NAPERVILLE, IL.
FILED 2-5-2011.

ACTACARE

THE MARK CONSISTS OF STANDARD CHARACTERS WITHOUT CLAIM TO ANY PARTICULAR FONT, STYLE, SIZE, OR COLOR.

FOR ADMINISTRATION OF EMPLOYEE BENEFIT PLANS CONCERNING INSURANCE AND FINANCE; ORGANIZING AND ADMINISTERING HEALTH CARE PLANS AND WELLNESS PLANS FOR OTHERS; ORGANIZING AND ADMINISTERING PREVENTATIVE HEALTH CARE PLANS FOR OTHERS; ORGANIZING AND ADMINISTERING LIFE INSURANCE AND DISABILITY PLANS FOR OTHERS; ADMINISTRATION OF SELF INSURED HEALTH PLANS OF OTHERS (U.S. CLS. 100, 101 AND 102).

FIRST USE 1-4-2011; IN COMMERCE 1-5-2011.
JAMES GRIFFIN, EXAMINING ATTORNEY

SN 85-235,691. HMVP PARTNERS, LCC, ORLANDO, FL.
FILED 2-7-2011.

BRINGING AMERICA HOME

THE MARK CONSISTS OF STANDARD CHARACTERS WITHOUT CLAIM TO ANY PARTICULAR FONT, STYLE, SIZE, OR COLOR.

FOR REAL ESTATE VALUATION SERVICES; REAL ESTATE PRICE PROTECTION SERVICES, NAMELY, OFFERING FINANCIAL MITIGATION FOR A DECLINE IN REAL ESTATE VALUE (U.S. CLS. 100, 101 AND 102).
ZACHARY BELLO, EXAMINING ATTORNEY

CLASS 36—(Continued).

SN 85-239,150. GREENBELT HOMES, INCORPORATED,
AKA GHI, GREENBELT, MD. FILED 2-10-2011.



NO CLAIM IS MADE TO THE EXCLUSIVE RIGHT TO USE "GREENBELT HOMES, INC.", APART FROM THE MARK AS SHOWN.

THE COLOR(S) GREEN AND WHITE IS/ARE CLAIMED AS A FEATURE OF THE MARK.

THE MARK CONSISTS OF A GREEN RECTANGULAR LOGO WITH ROUNDED CORNERS, WITH THE STYLIZED INITIALS "GHI" IN GREEN AND WHITE AT THE CENTER, WITH FOUR GREEN LEAVES SPROUTING FROM THE TOP OF THE LETTER "I"; THE RECTANGLE IS SURROUNDED BY A GREEN AND WHITE BORDER, THEN THE STYLIZED WORDS "GREENBELT HOMES INC" AND "THE COOPERATIVE COMMUNITY" IN GREEN SURROUND THE OUTSIDE OF THE LOGO.

FOR REAL ESTATE SERVICES, NAMELY, PROPERTY MANAGEMENT SERVICES FOR A RESIDENTIAL HOUSING COOPERATIVE (U.S. CLS. 100, 101 AND 102).
FIRST USE 2-1-1980; IN COMMERCE 2-1-1980.

JULIE GUTTADAURO, EXAMINING ATTORNEY

SN 85-239,833. KARL BUHL CONSULTING, LLC D/B/A
NAVOCATE, TAMPA, FL. FILED 2-11-2011.

NAVOCATE

THE MARK CONSISTS OF STANDARD CHARACTERS WITHOUT CLAIM TO ANY PARTICULAR FONT, STYLE, SIZE, OR COLOR.

FOR FINANCIAL SERVICES, NAMELY, FINANCIAL CONSULTING AND ADVISING IN THE FIELD OF SALES AND ACQUISITIONS OF BUSINESSES (U.S. CLS. 100, 101 AND 102).

FIRST USE 9-1-2010; IN COMMERCE 9-1-2010.

ELIZABETH KAJUBI, EXAMINING ATTORNEY

CLASS 36—(Continued).

SN 85-240,656. HARRIS FREEMAN FOUNDATION, ANAHEIM, CA. FILED 2-11-2011.



NO CLAIM IS MADE TO THE EXCLUSIVE RIGHT TO USE "FOUNDATION", APART FROM THE MARK AS SHOWN.

THE NAME(S), PORTRAIT(S), AND/OR SIGNATURE(S) SHOWN IN THE MARK DOES NOT IDENTIFY A PARTICULAR LIVING INDIVIDUAL.

THE MARK CONSISTS OF A TREE WITH THE SUN RISING IN THE BACKGROUND, ALL OF WHICH IS SURROUNDED BY AN OCTAGONAL BORDER. TO THE RIGHT IS THE WORDING "HARRIS FREEMAN", AND BELOW THAT WORDING IS THE WORD "FOUNDATION".

FOR PHILANTHROPIC SERVICES CONCERNING MONETARY DONATIONS (U.S. CLS. 100, 101 AND 102). FIRST USE 8-9-2010; IN COMMERCE 8-9-2010. JENNIFER MARTIN, EXAMINING ATTORNEY

CLASS 36—(Continued).

SN 85-242,349. THE ROYAL BANK OF SCOTLAND GROUP PLC, EDINBURGH, SCOTLAND, FILED 2-15-2011.



OWNER OF U.S. REG. NOS. 3,147,574, 3,198,052 AND OTHERS.

NO CLAIM IS MADE TO THE EXCLUSIVE RIGHT TO USE "AMERICA", APART FROM THE MARK AS SHOWN.

THE MARK CONSISTS OF THE WORDS "RBS AMERICA" IN STYLIZED TYPE. TO THE LEFT APPEARS A DESIGN CONSISTING OF A STYLIZED DEPICTION OF A DAISY.

FOR BANKING SERVICES; MONETARY TRANSFER SERVICES; ELECTRONIC BILL PAYMENT SERVICES; AUTOMATED BANKING SERVICES; HOME BANKING, NAMELY, BANKING SERVICES ACCESSED VIA A PERSONAL COMPUTER AND A GLOBAL COMPUTER NETWORK CONNECTION; INTERNET BANKING; SAVINGS SERVICES, NAMELY, PROVIDING SAVINGS ACCOUNTS AND CREDIT REBUILDER SAVINGS ACCOUNTS; CREDIT CARD, DEBIT CARD, CHARGE CARD, CASH CARD AND BANK CARD SERVICES; CASH MANAGEMENT; SAFE DEPOSIT BOX SERVICES; FINANCIAL CLEARING HOUSE SERVICES FOR BANKERS; ACCOUNT PAYABLE DEBITING SERVICES; MAINTAINING ESCROW ACCOUNTS FOR INVESTMENTS; REAL ESTATE ESCROW ACCOUNTS; CHECK CASHING SERVICES; CREDIT BROKERAGE SERVICES; AUTOMATIC CASH DISPENSING SERVICES, NAMELY, AUTOMATIC TELLER MACHINE SERVICES; INSURANCE SERVICES, NAMELY, INSURANCE BROKERAGE AND AGENCY SERVICES IN THE FIELD OF CREDIT INSURANCE, LIFE INSURANCE, HOME INSURANCE AND MEDICAL INSURANCE; FINANCING OF LOANS; PROVIDING LOANS SECURED BY COMMERCIAL PAPER; FINANCIAL INVESTMENT SERVICES IN THE FIELDS OF INVESTMENT SECURITIES AND CERTIFICATES OF DEPOSIT; CAPITAL INVESTMENT SERVICES; FINANCIAL MANAGEMENT SERVICES; PROVIDING BROKERS AND AGENTS TO BUY AND SELL BONDS AND SECURITIES FOR OTHERS; BROKERAGE AND AGENCY SERVICES IN THE FIELD OF BONDS AND SECURITIES; FINANCIAL CONSULTATION SERVICES; INVESTMENT ADVICE; FINANCIAL GUARANTEES AND SURETY SERVICES; PROVIDING FINANCIAL ANALYSIS AND REPORTS IN THE FIELD OF FINANCIAL INFORMATION; FINANCIAL INFORMATION PROCESSING; FINANCIAL INFORMATION PROVIDED VIA ELECTRONIC MEANS; FINANCIAL RESEARCH SERVICES; FINANCING SERVICES AND SECURING FUNDS FOR OTHERS; FINANCIAL ADVISORY SERVICES; BROKERAGE IN THE FIELD OF FINANCIAL INFORMATION AND CREDIT INFORMATION FOR OTHERS; ADMINISTRATION OF FINANCIAL AFFAIRS, NAMELY, PROVIDING PORTFOLIO MANAGEMENT SERVICES TO OTHERS; COMPUTERIZED FINANCIAL SERVICES, NAMELY, ONLINE BANK ACCOUNTS, ONLINE SECURITIES TRADING AND ELECTRONIC MONETARY PAYMENTS, NAMELY, ELECTRONIC PROCESSING AND TRANSMISSION OF BILL PAYMENT DATA; ADVICE AND INQUIRIES REGARDING CREDIT; ISSUING LETTERS OF CREDIT; PROVIDING CREDIT AGENCY SERVICES FOR BUSINESSES AND INDIVIDUALS; ACCEPTANCE OF SAVINGS DEPOSITS; DISCOUNT OF BILLS AND NOTES, NAMELY, DISCOUNT BROKERAGE SERVICES; DOMESTIC CURRENCY REMITTANCE; FINANCIAL LIABILITY GUARANTEE SERVICES; BILL PAYMENT SERVICES; MORTGAGING OF SECURITIES FOR OTHERS; ACQUISITION AND TRANSFER OF MONETARY CLAIMS; TRUSTESHIP OF MONEY; BROKERAGE OF FUTURES CONTRACTS; MONEY EXCHANGE, FOREIGN EXCHANGE TRANSACTIONS, CURRENCY EXCHANGE SERVICES, TRAVELERS' CHECK ISSUANCE, REPLACEMENT, AND REDEMPTION; ISSUANCE OF LETTERS OF CREDIT; SECURITIES TRADING; BROKERAGE OF INDEX FUTURES, SECURITIES OPTIONS AND OVERSEAS MAR-

SN 85-241,306. 108 ANGEL PROJECT LLC, FALMOUTH, ME. FILED 2-14-2011.

108 ANGELS

THE MARK CONSISTS OF STANDARD CHARACTERS WITHOUT CLAIM TO ANY PARTICULAR FONT, STYLE, SIZE, OR COLOR.

FOR CHARITABLE FUNDRAISING SERVICES BY MEANS OF ART EXHIBITIONS AND SELLING ART TO RAISE FUNDS; CHARITABLE FUNDRAISING SERVICES BY MEANS OF CONDUCTING ART EXHIBITIONS, CULTURAL EXHIBITIONS AND AUCTIONING OFF THE EXHIBITION PIECES (U.S. CLS. 100, 101 AND 102).

FIRST USE 3-21-2010; IN COMMERCE 3-21-2010. MARILYN IZZI, EXAMINING ATTORNEY

SN 85-242,288. APSON CAPITAL, GRAND CAYMAN, KY1-1104, CAYMAN ISLANDS, FILED 2-15-2011.

APSON CAPITAL

THE MARK CONSISTS OF STANDARD CHARACTERS WITHOUT CLAIM TO ANY PARTICULAR FONT, STYLE, SIZE, OR COLOR.

NO CLAIM IS MADE TO THE EXCLUSIVE RIGHT TO USE "CAPITAL", APART FROM THE MARK AS SHOWN.

FOR FINANCIAL SERVICES, NAMELY, ASSET MANAGEMENT SERVICES, INVESTMENT MANAGEMENT SERVICES AND INVESTMENT ADVISORY SERVICES (U.S. CLS. 100, 101 AND 102).

KIMBERLY FRYE, EXAMINING ATTORNEY

CLASS 36—(Continued).

KET SECURITIES FUTURES; UNDERWRITING SECURITIES; SECURITIES BROKERAGE SERVICES; PROCESSING SUBSCRIPTIONS AND OFFERINGS OF SECURITIES; PROVIDING STOCK MARKET INFORMATION; LIFE INSURANCE BROKERAGE, LIFE INSURANCE UNDERWRITING, AND INSURANCE ACTUARIAL SERVICES; MORTGAGE LENDING SERVICES; FINANCIAL SPONSORSHIP OF SPORTS, SPORTS TEAMS AND SPORTING EVENTS; FINANCIAL ADVISORY, CONSULTANCY AND INFORMATION SERVICES RELATING TO ALL OF THE AFORESAID SERVICES (U.S. CLS. 100, 101 AND 102).

MARK SPARACINO, EXAMINING ATTORNEY

SN 85-242,927. ATTAIN CAPITAL MANAGEMENT, LLC, CHICAGO, IL. FILED 2-15-2011.

Attain Capital Management

THE MARK CONSISTS OF STANDARD CHARACTERS WITHOUT CLAIM TO ANY PARTICULAR FONT, STYLE, SIZE, OR COLOR.

NO CLAIM IS MADE TO THE EXCLUSIVE RIGHT TO USE "CAPITAL MANAGEMENT", APART FROM THE MARK AS SHOWN.

FOR FINANCIAL SERVICES, NAMELY, COMMODITY TRADING AND MANAGED FUTURES ADVISORY AND MANAGEMENT SERVICES (U.S. CLS. 100, 101 AND 102). FIRST USE 8-1-2002; IN COMMERCE 8-1-2002.

PAUL MORENO, EXAMINING ATTORNEY

SN 85-243,249. THE GHROW FOUNDATION, INC., COLUMBIA, MD. FILED 2-15-2011.



NO CLAIM IS MADE TO THE EXCLUSIVE RIGHT TO USE "FOUNDATION", APART FROM THE MARK AS SHOWN.

THE MARK CONSISTS OF THE WORDING "THE GHROW FOUNDATION" WITH A LEAF DESIGN ABOVE THE LETTER "O" IN "GHROW".

THE WORDING "GHROW" HAS NO MEANING IN A FOREIGN LANGUAGE.

FOR CHARITABLE FOUNDATION SERVICES, NAMELY, PROVIDING FUNDRAISING ACTIVITIES, FUNDING, SCHOLARSHIPS AND/OR FINANCIAL ASSISTANCE FOR PRIVATE EDUCATION (U.S. CLS. 100, 101 AND 102).

FIRST USE 4-1-2010; IN COMMERCE 4-1-2010.

JEFF DEFORD, EXAMINING ATTORNEY

CLASS 36—(Continued).

SN 85-243,581. CHELSEA MORGAN SECURITIES, INC., DBA CHELSEA FINANCIAL SERVICES, STATEN ISLAND, NY. FILED 2-16-2011.

Chelsea Financial Services

THE MARK CONSISTS OF STANDARD CHARACTERS WITHOUT CLAIM TO ANY PARTICULAR FONT, STYLE, SIZE, OR COLOR.

NO CLAIM IS MADE TO THE EXCLUSIVE RIGHT TO USE "FINANCIAL SERVICES", APART FROM THE MARK AS SHOWN.

SEC. 2(F).

FOR FULL SERVICE STOCK BROKERAGE AND FINANCIAL CONSULTING (U.S. CLS. 100, 101 AND 102). FIRST USE 9-27-2000; IN COMMERCE 10-18-2000.

FLORENTINA BLANDU, EXAMINING ATTORNEY

SN 85-243,645. MARCH OF DIMES FOUNDATION, WHITE PLAINS, NY. FILED 2-16-2011.

RUN FOR BABIES

THE MARK CONSISTS OF STANDARD CHARACTERS WITHOUT CLAIM TO ANY PARTICULAR FONT, STYLE, SIZE, OR COLOR.

OWNER OF U.S. REG. NOS. 2,383,031, 3,683,922 AND OTHERS.

NO CLAIM IS MADE TO THE EXCLUSIVE RIGHT TO USE "RUN", APART FROM THE MARK AS SHOWN.

FOR CHARITABLE FUNDRAISING (U.S. CLS. 100, 101 AND 102).

MARY CRAWFORD, EXAMINING ATTORNEY

SN 85-243,685. PENTAIR RESIDENTIAL FILTRATION, LLC, GOLDEN VALLEY, MN. FILED 2-16-2011.

AQUAFIRST FUNDING

THE MARK CONSISTS OF STANDARD CHARACTERS WITHOUT CLAIM TO ANY PARTICULAR FONT, STYLE, SIZE, OR COLOR.

NO CLAIM IS MADE TO THE EXCLUSIVE RIGHT TO USE "FUNDING", APART FROM THE MARK AS SHOWN.

FOR CREDIT CARD SERVICES AND FINANCING SERVICES FOR THE PURCHASE OF WATER TREATMENT EQUIPMENT (U.S. CLS. 100, 101 AND 102).

STEVEN JACKSON, EXAMINING ATTORNEY

CLASS 36—(Continued).

SN 85-243,735. 2600 SOUTHSIDE ASSOCIATES, L.P., PITTSBURGH, PA. FILED 2-16-2011.

THE BRIX AT 26

THE MARK CONSISTS OF STANDARD CHARACTERS WITHOUT CLAIM TO ANY PARTICULAR FONT, STYLE, SIZE, OR COLOR.

FOR RENTAL OF APARTMENTS IN AN APARTMENT COMMUNITY (U.S. CLS. 100, 101 AND 102).

SCOTT BIBB, EXAMINING ATTORNEY



SN 85-244,579. THE MONEY SOURCE, INC., MELVILLE, NY. FILED 2-17-2011.



THE COLOR(S) GREEN AND WHITE IS/ARE CLAIMED AS A FEATURE OF THE MARK.

THE MARK CONSISTS OF A GREEN CIRCLE BISECTED HORIZONTALLY BY A WHITE LINE AND OUTLINED IN WHITE. THE WHITE OUTLINE IS IN TURN OUTLINED IN GREEN. IN THE TOP HALF OF THE GREEN CIRCLE IS THE WORD "JUST" IN WHITE, AND IN THE BOTTOM HALF IS THE WORDING "SAY NO" ALSO IN WHITE.

FOR MORTGAGE LOAN BROKERAGE SERVICES (U.S. CLS. 100, 101 AND 102).

FIRST USE 2-17-2011; IN COMMERCE 2-17-2011. KATHERINE CHANG, EXAMINING ATTORNEY

CLASS 36—(Continued).

SN 85-246,252. BCS FINANCIAL CORPORATION, OAKBROOK TERRACE, IL. FILED 2-18-2011.



NO CLAIM IS MADE TO THE EXCLUSIVE RIGHT TO USE "LIFE INSURANCE COMPANY", APART FROM THE MARK AS SHOWN.

THE MARK CONSISTS OF "4 EVER LIFE INSURANCE COMPANY", A VERTICAL LINE TO THE LEFT, AND DEPICTIONS OF THE ARABIC NUMERAL FOUR ARRANGED IN A DIAMOND SHAPE TO THE LEFT OF THE VERTICAL LINE.

FOR UNDERWRITING LIFE AND HEALTH INSURANCE, AND INSURANCE BROKERAGE SERVICES (U.S. CLS. 100, 101 AND 102).

WON TEAK OH, EXAMINING ATTORNEY



SN 85-247,272. SAFE AUTO INSURANCE COMPANY, COLUMBUS, OH. FILED 2-21-2011.

1 888 SAFEAUTO

THE MARK CONSISTS OF STANDARD CHARACTERS WITHOUT CLAIM TO ANY PARTICULAR FONT, STYLE, SIZE, OR COLOR.

OWNER OF U.S. REG. NOS. 1,828,559, 3,368,948 AND OTHERS.

NO CLAIM IS MADE TO THE EXCLUSIVE RIGHT TO USE "1 888", APART FROM THE MARK AS SHOWN.

FOR INSURANCE BROKERAGE SERVICES, NAMELY, PROVIDING LAND VEHICLE INSURANCE; INSURANCE UNDERWRITING AND ADMINISTRATION SERVICES IN THE FIELD OF LAND VEHICLE INSURANCE (U.S. CLS. 100, 101 AND 102).

FIRST USE 1-3-2011; IN COMMERCE 1-3-2011. MICHAEL GAFFAR, EXAMINING ATTORNEY

CLASS 36—(Continued).

SN 85-247,622. WYOMING VALLEY HEALTH & EDUCATION FOUNDATION, WILKES-BARRE, PA. FILED 2-21-2011.



NO CLAIM IS MADE TO THE EXCLUSIVE RIGHT TO USE "PARTNERSHIP" AND "FOUNDATION FOR A GREATER WYOMING VALLEY", APART FROM THE MARK AS SHOWN.

THE COLOR(S) RED, GREEN, BLACK, BROWN AND GRAY IS/ARE CLAIMED AS A FEATURE OF THE MARK.

THE MARK CONSISTS OF A STYLIZED APPLE TREE HAVING A BROWN TRUNK AND BRANCHES, GREEN LEAVES, AND RED APPLES TO THE RIGHT OF THE WORDS "THE APPLESEED PARTNERSHIP" AND "FOUNDATION FOR A GREATER WYOMING VALLEY". THE WORDING "THE" AND "FOUNDATION FOR A GREATER WYOMING VALLEY" APPEARS IN GRAY LETTERS, THE WORDING "APPLESEED" APPEARS IN RED LETTERS, AND THE WORD "PARTNERSHIP" APPEARS IN BLACK LETTERS.

FOR CHARITABLE FOUNDATION SERVICES, NAMELY, PROVIDING FUND RAISING ACTIVITIES AND FINANCIAL ASSISTANCE TO INDIVIDUALS AND ORGANIZATIONS TO SUPPORT THE PROVISION OF HEALTH CARE SERVICES TO THE UNINSURED, AND PROGRAMS WHICH ADVANCE PUBLIC HEALTH CARE EDUCATION (U.S. CLS. 100, 101 AND 102).

DEBRA LEE, EXAMINING ATTORNEY

SN 85-247,641. WYOMING VALLEY HEALTH & EDUCATION FOUNDATION, WILKES-BARRE, PA. FILED 2-21-2011.



THE COLOR(S) RED, GREEN, AND BROWN IS/ARE CLAIMED AS A FEATURE OF THE MARK.

THE MARK CONSISTS OF A STYLIZED APPLE TREE HAVING A BROWN TRUNK AND BRANCHES, GREEN LEAVES, AND RED APPLES.

FOR CHARITABLE FOUNDATION SERVICES, NAMELY, PROVIDING FUND RAISING ACTIVITIES AND FINANCIAL ASSISTANCE TO INDIVIDUALS AND ORGANIZATIONS TO SUPPORT THE PROVISION OF HEALTH CARE SERVICES TO THE UNINSURED, AND PROGRAMS WHICH ADVANCE PUBLIC HEALTH CARE EDUCATION (U.S. CLS. 100, 101 AND 102).

DEBRA LEE, EXAMINING ATTORNEY

CLASS 36—(Continued).

SN 85-247,928. SYNOVUS BANK, COLUMBUS, GA. FILED 2-22-2011.

THE BANK OF NASHVILLE

THE MARK CONSISTS OF STANDARD CHARACTERS WITHOUT CLAIM TO ANY PARTICULAR FONT, STYLE, SIZE, OR COLOR.

OWNER OF U.S. REG. NO. 1,594,769.

NO CLAIM IS MADE TO THE EXCLUSIVE RIGHT TO USE "THE BANK", APART FROM THE MARK AS SHOWN. SEC. 2(F).

FOR COMMERCIAL BANKING SERVICES FEATURING DEPOSIT, LOAN AND TRUST SERVICES (U.S. CLS. 100, 101 AND 102).

FIRST USE 7-10-1989; IN COMMERCE 7-10-1989.

KEVON CHISOLM, EXAMINING ATTORNEY

SN 85-249,135. THE AXEL GROUP LLC, ROSWELL, GA. FILED 2-23-2011.

MEDXpress

THE MARK CONSISTS OF STANDARD CHARACTERS WITHOUT CLAIM TO ANY PARTICULAR FONT, STYLE, SIZE, OR COLOR.

FOR LENDING SERVICES, NAMELY, PROVIDING SECURED AND UNSECURED LOANS TO MEDICAL PROFESSIONALS (U.S. CLS. 100, 101 AND 102).

SHAILA SETTLES, EXAMINING ATTORNEY

SN 85-249,253. PACIFIC RESERVE INC, SCOTTSDALE, AZ. FILED 2-23-2011.

Pacific Reserve, Inc.

THE MARK CONSISTS OF STANDARD CHARACTERS WITHOUT CLAIM TO ANY PARTICULAR FONT, STYLE, SIZE, OR COLOR.

NO CLAIM IS MADE TO THE EXCLUSIVE RIGHT TO USE "RESERVE, INC.", APART FROM THE MARK AS SHOWN.

FOR INSURANCE BROKERAGE (U.S. CLS. 100, 101 AND 102).

FIRST USE 5-20-1986; IN COMMERCE 5-20-1986.

KAREN K. BUSH, EXAMINING ATTORNEY

CLASS 36—(Continued).

SN 85-249,261. LEGACY MARKETING GROUP, PETALUMA, CA. FILED 2-23-2011.

CommandMark

THE MARK CONSISTS OF STANDARD CHARACTERS WITHOUT CLAIM TO ANY PARTICULAR FONT, STYLE, SIZE, OR COLOR.

FOR DISTRIBUTION OF A FIXED INDEXED DEFERRED ANNUITY OFFERING A CHOICE OF UNIQUE CREDITING RATE OPTIONS, VESTING PREMIUM BONUS OPTIONS, AND A COMPETITIVE INCOME RIDER AS A SINGLE-PREMIUM PRODUCT WITH A 10-YEAR SURRENDER CHARGE SCHEDULE (U.S. CLS. 100, 101 AND 102).

KAREN K. BUSH, EXAMINING ATTORNEY

SN 85-249,309. SECURITY GROUP, INC., SPARTANBURG, SC. FILED 2-23-2011.



THE COLOR(S) RED AND BLUE IS/ARE CLAIMED AS A FEATURE OF THE MARK.

THE MARK CONSISTS OF AN OVAL THAT IS COLORED BLUE IN THE TOP HALF AND RED IN THE BOTTOM HALF WITH INSERTED TRIANGLES AND A RECTANGLE WITH TWO ROUNDED CORNERS. WHEREBY A LETTER "P" IS CREATED IN THE MIDDLE OF THE OVAL, AND UNDER THE OVAL ARE BLUE CAPITAL LETTERS "PFS" UNDERLINED WITH A RED BAR. THE COLOR WHITE REPRESENTS BACKGROUND AND/OR TRANSPARENT AREAS AND IS NOT PART OF THE MARK.

FOR AUTOMOTIVE FINANCING FOR CONSUMERS BY PURCHASING MOTOR VEHICLE RETAIL INSTALLMENT SALES CONTRACTS FROM AUTOMOBILE DEALERS; CREDIT AND LOAN SERVICES (U.S. CLS. 100, 101 AND 102).

FIRST USE 9-30-2007; IN COMMERCE 9-30-2007.
JAMES GRIFFIN, EXAMINING ATTORNEY

CLASS 36—(Continued).

SN 85-249,365. HEMINGWAY WEALTH MANAGEMENT, LLC, MINNEAPOLIS, MN. FILED 2-23-2011.



OWNER OF U.S. REG. NO. 3,949,566.

NO CLAIM IS MADE TO THE EXCLUSIVE RIGHT TO USE "WEALTH MANAGEMENT", APART FROM THE MARK AS SHOWN.

THE MARK CONSISTS OF A CIRCLE WITH AN EMBEDDED "H" ABOVE THE PHRASE "HEMINGWAY WEALTH MANAGEMENT".

FOR FINANCIAL ADVICE, ANALYSIS, PLANNING, AND CONSULTING SERVICES; FINANCIAL INVESTMENT BROKERAGE SERVICES; INVESTMENT ADVISORY SERVICES (U.S. CLS. 100, 101 AND 102).

FIRST USE 6-10-2010; IN COMMERCE 6-10-2010.
LAURIE KAUFMAN, EXAMINING ATTORNEY

SN 85-249,367. MICHAEL DELAGRANGE, GRANTS PASS, OR. FILED 2-23-2011.

INSURANCE LOUNGE

THE MARK CONSISTS OF STANDARD CHARACTERS WITHOUT CLAIM TO ANY PARTICULAR FONT, STYLE, SIZE, OR COLOR.

NO CLAIM IS MADE TO THE EXCLUSIVE RIGHT TO USE "INSURANCE", APART FROM THE MARK AS SHOWN.

FOR INSURANCE SERVICES, NAMELY, BROKERAGE, ADMINISTRATION, AND UNDERWRITING OF PROPERTY, CASUALTY, AUTO, HOME, LIFE, INDIVIDUAL HEALTH, DISABILITY, LONG TERM CARE, MEDICARE, INVESTMENT, AND RETIREMENT INSURANCE PRODUCTS (U.S. CLS. 100, 101 AND 102).

LAURIE KAUFMAN, EXAMINING ATTORNEY

CLASS 36—(Continued).

SN 85-249,571. CITIZENS FINANCIAL GROUP, INC., PROVIDENCE, RI. FILED 2-23-2011.

CITIZENS YOUTH SAVINGS

THE MARK CONSISTS OF STANDARD CHARACTERS WITHOUT CLAIM TO ANY PARTICULAR FONT, STYLE, SIZE, OR COLOR.

OWNER OF U.S. REG. NOS. 2,482,203, 2,668,486 AND OTHERS.

NO CLAIM IS MADE TO THE EXCLUSIVE RIGHT TO USE "YOUTH SAVINGS", APART FROM THE MARK AS SHOWN.

FOR BANKING (U.S. CLS. 100, 101 AND 102).
CURTIS FRENCH, EXAMINING ATTORNEY

SN 85-249,601. CITIZENS FINANCIAL GROUP, INC., PROVIDENCE, RI. FILED 2-23-2011.

CHARTER ONE YOUTH SAVINGS

THE MARK CONSISTS OF STANDARD CHARACTERS WITHOUT CLAIM TO ANY PARTICULAR FONT, STYLE, SIZE, OR COLOR.

OWNER OF U.S. REG. NOS. 1,748,834, 2,450,402 AND OTHERS.

NO CLAIM IS MADE TO THE EXCLUSIVE RIGHT TO USE "YOUTH SAVINGS", APART FROM THE MARK AS SHOWN.

FOR BANKING (U.S. CLS. 100, 101 AND 102).
CURTIS FRENCH, EXAMINING ATTORNEY

SN 85-249,818. DEFRANCESCO, MICHAEL, BEAR CREEK, PA. AND HOOVER, ADAM, BEAR CREEK, PA. FILED 2-23-2011.

THE FUNDING

NO CLAIM IS MADE TO THE EXCLUSIVE RIGHT TO USE "FUNDING", APART FROM THE MARK AS SHOWN.

THE MARK CONSISTS OF THE WORDS "THE FUNDING ZONE" WITH A LIGHTNING BOLT TYPE LINE IN THE MIDDLE. ON THE LINE THERE IS A DIAMOND SHAPE WITH THE INITIALS "FZ" IN MIDDLE OF DIAMOND.

FOR FUNDRAISING SERVICES, NAMELY, ORGANIZING FUNDRAISERS FOR SCHOOLS AND OTHER GROUPS (U.S. CLS. 100, 101 AND 102).

FIRST USE 8-1-2010; IN COMMERCE 8-1-2010.
JAMES A. RAUEN, EXAMINING ATTORNEY

CLASS 36—(Continued).

SN 85-249,835. CARTER, MICHAEL, SUFFERN, NY. FILED 2-23-2011.

Firstdue Financial

THE MARK CONSISTS OF STANDARD CHARACTERS WITHOUT CLAIM TO ANY PARTICULAR FONT, STYLE, SIZE, OR COLOR.

NO CLAIM IS MADE TO THE EXCLUSIVE RIGHT TO USE "FINANCIAL", APART FROM THE MARK AS SHOWN.

FOR FINANCIAL ADMINISTRATION OF RETIREMENT PLANS; FINANCIAL CONSULTANCY AND INSURANCE CONSULTANCY; FINANCIAL INVESTMENT BROKERAGE (U.S. CLS. 100, 101 AND 102).
EMILY CHUO, EXAMINING ATTORNEY

SN 85-249,940. NETWORTH REALTY USA, LLC, HOUSTON, TX. FILED 2-23-2011.

NETWORTH REALTY

THE MARK CONSISTS OF STANDARD CHARACTERS WITHOUT CLAIM TO ANY PARTICULAR FONT, STYLE, SIZE, OR COLOR.

NO CLAIM IS MADE TO THE EXCLUSIVE RIGHT TO USE "REALTY", APART FROM THE MARK AS SHOWN.

FOR REAL ESTATE INVESTMENT SERVICES (U.S. CLS. 100, 101 AND 102).
TINA MAI, EXAMINING ATTORNEY

SN 85-250,189. DAY, ROBBIE, BRENTWOOD, TN. FILED 2-24-2011.

EXODUS FINANCIAL PARTNERS

THE MARK CONSISTS OF STANDARD CHARACTERS WITHOUT CLAIM TO ANY PARTICULAR FONT, STYLE, SIZE, OR COLOR.

NO CLAIM IS MADE TO THE EXCLUSIVE RIGHT TO USE "FINANCIAL PARTNERS", APART FROM THE MARK AS SHOWN.

FOR INSURANCE AND FINANCIAL INFORMATION AND CONSULTANCY SERVICES (U.S. CLS. 100, 101 AND 102).

MICHAEL WIENER, EXAMINING ATTORNEY

CLASS 36—(Continued).

SN 85-250,200. CREDIT ALLIANCE GROUP, INC., DALLAS, TX. FILED 2-24-2011.

CREDIT ALLIANCE GROUP

THE MARK CONSISTS OF STANDARD CHARACTERS WITHOUT CLAIM TO ANY PARTICULAR FONT, STYLE, SIZE, OR COLOR.

NO CLAIM IS MADE TO THE EXCLUSIVE RIGHT TO USE "CREDIT" AND "GROUP", APART FROM THE MARK AS SHOWN.

FOR FINANCIAL SERVICES, NAMELY, DEBT RESOLUTION SERVICES IN THE NATURE OF DEBT SETTLEMENT AND ELIMINATION; DEBT MANAGEMENT CONSULTATION; DEBT RECOVERY AND COLLECTION AGENCIES (U.S. CLS. 100, 101 AND 102).

FIRST USE 1-1-2005; IN COMMERCE 1-17-2006.
MAYUR VAGHANI, EXAMINING ATTORNEY

SN 85-250,206. CREDIT ALLIANCE GROUP, INC., DALLAS, TX. FILED 2-24-2011.



NO CLAIM IS MADE TO THE EXCLUSIVE RIGHT TO USE "CREDIT" AND "GROUP", APART FROM THE MARK AS SHOWN.

THE COLOR(S) BLACK AND ORANGE IS/ARE CLAIMED AS A FEATURE OF THE MARK.

THE MARK CONSISTS OF THE WORDS "CREDIT ALLIANCE GROUP" ARRANGED IN A VERTICAL CONFIGURATION IN BLACK COLOR AND THE DOT OF LETTER "I" OF THE WORD "CREDIT" DEPICTED AS AN ORANGE FLOWER.

FOR FINANCIAL SERVICES, NAMELY, DEBT RESOLUTION SERVICES IN THE NATURE OF DEBT SETTLEMENT AND ELIMINATION; DEBT MANAGEMENT CONSULTATION; DEBT RECOVERY AND COLLECTION AGENCIES (U.S. CLS. 100, 101 AND 102).

FIRST USE 1-1-2005; IN COMMERCE 1-17-2006.
MAYUR VAGHANI, EXAMINING ATTORNEY

CLASS 36—(Continued).

SN 85-250,715. CONGRESSIONAL COMMERCIAL, LLC, TAKOMA PARK, MD. FILED 2-24-2011.



NO CLAIM IS MADE TO THE EXCLUSIVE RIGHT TO USE "COMMERCIAL", APART FROM THE MARK AS SHOWN.

THE MARK CONSISTS OF THE TEXT "CONGRESSIONAL COMMERCIAL" AND HAS TWO SILO/CONE DESIGNS TO THE LEFT OF THE TEXT.

FOR LEASING OF REAL ESTATE; REAL ESTATE ACQUISITION SERVICES; REAL ESTATE BROKERAGE; REAL ESTATE INVESTMENT SERVICES (U.S. CLS. 100, 101 AND 102).

FIRST USE 8-1-2007; IN COMMERCE 8-1-2007.
ALEXANDER L. POWERS, EXAMINING ATTORNEY

SN 85-250,722. 24/7 REAL ESTATE, INC., WOODRIDGE, IL. FILED 2-24-2011.



NO CLAIM IS MADE TO THE EXCLUSIVE RIGHT TO USE "24 7 REAL ESTATE", APART FROM THE MARK AS SHOWN.

THE MARK CONSISTS OF THE STYLIZED NUMBERS "24" AND "7" IN A SOLD CIRCULAR CARRIER. THERE IS A CRESCENT OF DIFFERENT SHADING IN THE UPPER RIGHT PORTION OF THE CIRCLE BEHIND THE "7". THE STYLIZED WORDS "REAL ESTATE" ARE RIGHT OF THE CIRCLE.

FOR REAL ESTATE AGENCIES (U.S. CLS. 100, 101 AND 102).

FIRST USE 4-0-2002; IN COMMERCE 4-0-2002.
ALEXANDER L. POWERS, EXAMINING ATTORNEY

SN 85-251,101. GENEROUS ART, LLC, AUSTIN, TX. FILED 2-24-2011.

Generous Art

THE MARK CONSISTS OF STANDARD CHARACTERS WITHOUT CLAIM TO ANY PARTICULAR FONT, STYLE, SIZE, OR COLOR.

NO CLAIM IS MADE TO THE EXCLUSIVE RIGHT TO USE "ART", APART FROM THE MARK AS SHOWN.

FOR CHARITABLE FUNDRAISING SERVICES BY MEANS OF SELLING ARTWORK TO RAISE FUNDS FOR NON-PROFIT ORGANIZATIONS (U.S. CLS. 100, 101 AND 102).

MARK RADEMACHER, EXAMINING ATTORNEY

CLASS 36—(Continued).

SN 85-251,296. FBR WEALTH MANAGEMENT, TIGARD, OR. FILED 2-24-2011.

Cascadia Wealth Management

THE MARK CONSISTS OF STANDARD CHARACTERS WITHOUT CLAIM TO ANY PARTICULAR FONT, STYLE, SIZE, OR COLOR.

NO CLAIM IS MADE TO THE EXCLUSIVE RIGHT TO USE "WEALTH MANAGEMENT", APART FROM THE MARK AS SHOWN.

FOR ESTATE PLANNING; FINANCIAL PLANNING; FINANCIAL PLANNING FOR RETIREMENT; FINANCIAL SERVICES, NAMELY, WEALTH MANAGEMENT SERVICES; INVESTMENT MANAGEMENT (U.S. CLS. 100, 101 AND 102).

JACLYN KIDWELL WALKER, EXAMINING ATTORNEY

SN 85-252,030. SOUNDEXCHANGE, INC., WASHINGTON, DC. FILED 2-25-2011.

GET PLAYED. GET PAID.

THE MARK CONSISTS OF STANDARD CHARACTERS WITHOUT CLAIM TO ANY PARTICULAR FONT, STYLE, SIZE, OR COLOR.

FOR COLLECTION AND DISTRIBUTION OF ROYALTIES RELATING TO ELECTRONIC TRANSMISSION AND DISTRIBUTION OF COPYRIGHTED MUSIC AND SOUND RECORDINGS (U.S. CLS. 100, 101 AND 102).

FIRST USE 3-0-2007; IN COMMERCE 3-0-2007.

WILLIAM ROSSMAN, EXAMINING ATTORNEY

SN 85-252,265. ADES, BRIAN, LOS ANGELES, CA. FILED 2-25-2011.

**To make good decisions you
need good information**

THE MARK CONSISTS OF STANDARD CHARACTERS WITHOUT CLAIM TO ANY PARTICULAR FONT, STYLE, SIZE, OR COLOR.

FOR RESIDENTIAL REAL ESTATE AGENCY SERVICES (U.S. CLS. 100, 101 AND 102).

FIRST USE 1-1-2010; IN COMMERCE 1-1-2010.

ELLEN BURNS, EXAMINING ATTORNEY

CLASS 36—(Continued).

SN 85-252,434. ARMOUR KANKAKEE CREDIT UNION, BRADLEY, IL. FILED 2-25-2011.

FIELDSTONE CREDIT UNION

THE MARK CONSISTS OF STANDARD CHARACTERS WITHOUT CLAIM TO ANY PARTICULAR FONT, STYLE, SIZE, OR COLOR.

NO CLAIM IS MADE TO THE EXCLUSIVE RIGHT TO USE "CREDIT UNION", APART FROM THE MARK AS SHOWN.

FOR CREDIT UNION SERVICES (U.S. CLS. 100, 101 AND 102).

KATHERINE CHANG, EXAMINING ATTORNEY

SN 85-252,453. PACIFIC WEALTH ADVISORS LLC, PALO ALTO, CA. FILED 2-25-2011.

Pacific Wealth Advisors

THE MARK CONSISTS OF STANDARD CHARACTERS WITHOUT CLAIM TO ANY PARTICULAR FONT, STYLE, SIZE, OR COLOR.

NO CLAIM IS MADE TO THE EXCLUSIVE RIGHT TO USE "WEALTH ADVISORS", APART FROM THE MARK AS SHOWN.

FOR FINANCIAL PLANNING AND INVESTMENT ADVISORY SERVICES; FINANCIAL SERVICES, NAMELY, COORDINATION, WITHIN A SINGLE ACCOUNT, OF AN INVESTMENT PORTFOLIO'S MAINTENANCE, TRADING, REBALANCING, AND TAX MANAGEMENT NEEDS; FINANCIAL SERVICES, NAMELY, INVESTMENT ADVICE, INVESTMENT MANAGEMENT, INVESTMENT CONSULTATION AND INVESTMENT OF FUNDS FOR OTHERS, INCLUDING PRIVATE AND PUBLIC EQUITY AND DEBT INVESTMENT SERVICES; INSURANCE INFORMATION AND CONSULTANCY; INVESTMENT MANAGEMENT; PROVIDING INFORMATION AND ADVICE IN THE FIELD OF FINANCE, FINANCIAL INVESTMENTS, FINANCIAL VALUATIONS, AND THE FINANCIAL ASPECTS OF RETIREMENT (U.S. CLS. 100, 101 AND 102).

FIRST USE 12-1-2007; IN COMMERCE 12-1-2007.

ANNE MADDEN, EXAMINING ATTORNEY

CLASS 36—(Continued).

SN 85-252,683. MILLER, TODD, CULVER CITY, CA. FILED 2-26-2011.

MTI REAL ESTATE

THE MARK CONSISTS OF STANDARD CHARACTERS WITHOUT CLAIM TO ANY PARTICULAR FONT, STYLE, SIZE, OR COLOR.

NO CLAIM IS MADE TO THE EXCLUSIVE RIGHT TO USE "REAL ESTATE", APART FROM THE MARK AS SHOWN.

FOR REAL ESTATE BROKERAGE (U.S. CLS. 100, 101 AND 102).

FIRST USE 8-26-2010; IN COMMERCE 8-26-2010.
CHRISTINE MARTIN, EXAMINING ATTORNEY

CLASS 36—(Continued).

SN 85-253,077. BOUVIER BECKWITH & LENNOX, INC., W. HARTFORD, CT. FILED 2-28-2011.



NO CLAIM IS MADE TO THE EXCLUSIVE RIGHT TO USE "INSURANCE", APART FROM THE MARK AS SHOWN.

THE MARK CONSISTS OF THE STYLIZED LETTER "B" IN A CIRCLE OVER THE WORD "BOUVIER" WHICH IS OVER THE WORD "INSURANCE", WITH THE WORD "INSURANCE" UNDERLINED.

FOR INSURANCE UNDERWRITING AND ADMINISTRATIVE SERVICES IN THE FIELDS OF PROPERTY, COMMERCIAL, CASUALTY, PERSONAL, LIFE AND HEALTH INSURANCE (U.S. CLS. 100, 101 AND 102).

FIRST USE 12-21-2010; IN COMMERCE 12-21-2010.
LINDA E. BLOHM, EXAMINING ATTORNEY

SN 85-253,916. BARRETT, DANIEL, TIBURON, CA. FILED 2-28-2011.

PACIFIC PRECIOUS METALS

SN 85-253,054. THE TRUST COMPANY OF KANSAS, WICHITA, KS. FILED 2-28-2011.

The Trust Company of Kansas

THE MARK CONSISTS OF STANDARD CHARACTERS WITHOUT CLAIM TO ANY PARTICULAR FONT, STYLE, SIZE, OR COLOR.

NO CLAIM IS MADE TO THE EXCLUSIVE RIGHT TO USE "PRECIOUS METALS", APART FROM THE MARK AS SHOWN.

FOR PROVIDING MONETARY EXCHANGE SERVICES, NAMELY, EXCHANGING GOLD, PLATINUM AND SILVER OF OTHERS FOR CASH (U.S. CLS. 100, 101 AND 102).

FIRST USE 6-10-2010; IN COMMERCE 7-1-2010.
SIMON TENG, EXAMINING ATTORNEY

SN 85-254,205. UNITED SERVICES AUTOMOBILE ASSOCIATION, SAN ANTONIO, TX. FILED 3-1-2011.

LOAN@HOME

THE MARK CONSISTS OF STANDARD CHARACTERS WITHOUT CLAIM TO ANY PARTICULAR FONT, STYLE, SIZE, OR COLOR.

NO CLAIM IS MADE TO THE EXCLUSIVE RIGHT TO USE "TRUST COMPANY", APART FROM THE MARK AS SHOWN.

SEC. 2(F).

FOR TRUST SERVICES, NAMELY, INVESTMENT AND TRUST COMPANY SERVICES (U.S. CLS. 100, 101 AND 102).

FIRST USE 5-21-1990; IN COMMERCE 5-21-1990.
SETH A. RAPPAPORT, EXAMINING ATTORNEY

THE MARK CONSISTS OF STANDARD CHARACTERS WITHOUT CLAIM TO ANY PARTICULAR FONT, STYLE, SIZE, OR COLOR.

FOR BANKING AND FINANCING SERVICES (U.S. CLS. 100, 101 AND 102).

DANNEAN HETZEL, EXAMINING ATTORNEY

CLASS 36—(Continued).

SN 85-254,376. OPUS BANK, IRVINE, CA. FILED 3-1-2011.



THE MARK CONSISTS OF A STYLIZED HEAD, SHOULDERS AND ARM HOLDING A BATON.

FOR COMMERCIAL BUSINESS BANKING SERVICES; PRIVATE BANKING AND WEALTH MANAGEMENT, PERSONAL AND BUSINESS BANKING SERVICES; FULL SERVICE BANKING; ON-LINE BANKING SERVICES AND ELECTRONIC BANKING VIA A GLOBAL COMPUTER NETWORK; TELEPHONE BANKING SERVICES; BANKING SERVICES PROVIDED BY MOBILE TELEPHONE CONNECTIONS; ATM BANKING SERVICES; COMMERCIAL AND COMMERCIAL REAL ESTATE INCOME PROPERTY FINANCING; RESIDENTIAL AND MULTIFAMILY LENDING AND LOAN PROCESSING SERVICES; FINANCIAL LOAN CONSULTATION; FINANCIAL SERVICES RENDERED IN CONNECTION WITH THE ISSUANCE, RECEIPT AND TRANSFER OF LINES OF CREDIT, NAMELY, LOAN PROCESSING SERVICES; SMALL BUSINESS ADMINISTRATION ("SBA") LENDING PROGRAMS, NAMELY, PROVIDING SMALL BUSINESS LOANS; SBA PREFERRED LENDER PROGRAMS, NAMELY, PROVIDING SMALL BUSINESS LOANS; BANKING SERVICES FEATURING THE PROVISION OF CERTIFICATES OF DEPOSIT; ELECTRONIC FUNDS TRANSFER; PROVIDING ELECTRONIC PROCESSING OF ELECTRONIC FUNDS TRANSFER, ACH, CREDIT CARD, DEBIT CARD, ELECTRONIC CHECK AND ELECTRONIC PAYMENTS; PROVIDING ELECTRONIC PROCESSING OF ELECTRONIC CHECK PAYMENTS, NAMELY, REMOTE CAPTURE TO REMOTELY CAPTURE, CLEAR, AND POST A CHECK BILL PAYMENT TRANSACTION; SAFE DEPOSIT BOX SERVICES; CHECKING ACCOUNT SERVICES; SAVINGS ACCOUNT SERVICES; FINANCIAL ADMINISTRATION OF RETIREMENT PLANS; INDIVIDUAL RETIREMENT ACCOUNT SERVICES; FINANCIAL PLANNING FOR RETIREMENT; DEBIT CARD SERVICES; ISSUING OF TRAVELERS' CHECKS; AND FINANCIAL SERVICES FOR THE PURCHASE OF SAVINGS BONDS (U.S. CLS. 100, 101 AND 102).

FIRST USE 10-1-2010; IN COMMERCE 10-1-2010.
DOUGLAS LEE, EXAMINING ATTORNEY

CLASS 36—(Continued).

SN 85-254,455. AMERICAN EXPRESS MARKETING & DEVELOPMENT CORP., NEW YORK, NY. FILED 3-1-2011.

BLUE FAMILY

THE MARK CONSISTS OF STANDARD CHARACTERS WITHOUT CLAIM TO ANY PARTICULAR FONT, STYLE, SIZE, OR COLOR.

OWNER OF U.S. REG. NOS. 2,645,207, 2,779,690 AND 3,881,545.

FOR CREDIT CARD SERVICES (U.S. CLS. 100, 101 AND 102).

KIMBERLY PERRY, EXAMINING ATTORNEY

SN 85-254,469. AMERICAN EXPRESS MARKETING & DEVELOPMENT CORP., NEW YORK, NY. FILED 3-1-2011.

BLUE SUITE

THE MARK CONSISTS OF STANDARD CHARACTERS WITHOUT CLAIM TO ANY PARTICULAR FONT, STYLE, SIZE, OR COLOR.

OWNER OF U.S. REG. NOS. 2,645,207, 2,779,690 AND 3,881,545.

FOR CREDIT CARD SERVICES (U.S. CLS. 100, 101 AND 102).

FIRST USE 5-1-2011; IN COMMERCE 5-1-2011.

KIMBERLY PERRY, EXAMINING ATTORNEY

SN 85-254,665. CREATAIVE COWORKING LLC, EVANSTON, IL. FILED 3-1-2011.

YOUR OFFICE HOME

THE MARK CONSISTS OF STANDARD CHARACTERS WITHOUT CLAIM TO ANY PARTICULAR FONT, STYLE, SIZE, OR COLOR.

FOR RENTAL OF OFFICE SPACE (U.S. CLS. 100, 101 AND 102).

PAUL MORENO, EXAMINING ATTORNEY

CLASS 36—(Continued).

SN 85-254,711. W. BROWN & ASSOCIATES INSURANCE SERVICES, IRVINE, CA. FILED 3-1-2011.

Flight Line Plus

THE MARK CONSISTS OF STANDARD CHARACTERS WITHOUT CLAIM TO ANY PARTICULAR FONT, STYLE, SIZE, OR COLOR.

FOR INSURANCE SERVICES, NAMELY, UNDERWRITING, ISSUANCE AND ADMINISTRATION OF AVIATION INSURANCE POLICIES (U.S. CLS. 100, 101 AND 102).

FIRST USE 3-18-2008; IN COMMERCE 4-15-2010.
TINA BROWN, EXAMINING ATTORNEY

CLASS 36—(Continued).

SN 85-255,015. EDISON WATSON LLC, DOVER, DE. FILED 3-1-2011.

EDISON WATSON

THE MARK CONSISTS OF STANDARD CHARACTERS WITHOUT CLAIM TO ANY PARTICULAR FONT, STYLE, SIZE, OR COLOR.

THE NAME "EDISON WATSON" DOES NOT IDENTIFY A LIVING INDIVIDUAL.

FOR INVESTMENT ADVICE; INVESTMENT ADVISORY SERVICES; INVESTMENT CONSULTANCY; INVESTMENT CONSULTATION; INVESTMENT MANAGEMENT SERVICES IN THE FIELD OF ACQUIRING JOINT VENTURES; INVESTMENT SERVICES, NAMELY, ASSET ACQUISITION, CONSULTATION, DEVELOPMENT AND MANAGEMENT SERVICES (U.S. CLS. 100, 101 AND 102).

ANDREA HACK, EXAMINING ATTORNEY

SN 85-255,045. PHILANTHROPIC VENTURES FOUNDATION, OAKLAND, CA. FILED 3-1-2011.

PHILANTHROPIC VENTURES FOUNDATION

THE MARK CONSISTS OF STANDARD CHARACTERS WITHOUT CLAIM TO ANY PARTICULAR FONT, STYLE, SIZE, OR COLOR.

OWNER OF U.S. REG. NO. 2,551,360.

NO CLAIM IS MADE TO THE EXCLUSIVE RIGHT TO USE "FOUNDATION", APART FROM THE MARK AS SHOWN.

SEC. 2(F).

FOR PHILANTHROPIC SERVICES CONCERNING MONETARY DONATIONS AND GRANTS (U.S. CLS. 100, 101 AND 102).

FIRST USE 1-30-1991; IN COMMERCE 1-30-1991.
BENJAMIN OKEKE, EXAMINING ATTORNEY

SN 85-254,936. FARASH FOUNDATION HOLDINGS, LLC, ROCHESTER, NY. FILED 3-1-2011.



THE MARK CONSISTS OF THE VERTICAL OUTLINE OF A FLAME WITH A SEMICIRCLE ON AN ANGLE UNDERNEATH THE FLAME.

FOR CHARITABLE FOUNDATION SERVICES, NAMELY, PROVIDING FINANCIAL SUPPORT TO TAX EXEMPT ORGANIZATIONS THAT PROMOTE COMMUNITY SERVICE, EDUCATION, ENTREPRENEURSHIP, OR RELIGION; CHARITABLE FOUNDATION SERVICES, NAMELY, PROVIDING GRANTS TO TAX EXEMPT ORGANIZATIONS THAT PROMOTE COMMUNITY SERVICE, EDUCATION, ENTREPRENEURSHIP, OR RELIGION (U.S. CLS. 100, 101 AND 102).

FIRST USE 3-1-2011; IN COMMERCE 3-1-2011.
MICHELLE DUBOIS, EXAMINING ATTORNEY

SN 85-255,064. FOCUS ON CHILDREN NOW, INC., RESEDA, CA. FILED 3-1-2011.

FOCUS ON CHILDREN NOW

THE MARK CONSISTS OF STANDARD CHARACTERS WITHOUT CLAIM TO ANY PARTICULAR FONT, STYLE, SIZE, OR COLOR.

FOR CHARITABLE FUNDRAISING SERVICES (U.S. CLS. 100, 101 AND 102).

FIRST USE 10-0-2005; IN COMMERCE 3-0-2007.
DEIRDRE ROBERTSON, EXAMINING ATTORNEY

CLASS 36—(Continued).

SN 85-255,332. ALEX'S LEMONADE STAND FOUNDATION, WYNNWOOD, PA. FILED 3-2-2011.



THE MARK CONSISTS OF A GIRL HOLDING A CUP OF LEMONADE.
FOR CHARITABLE SERVICES, NAMELY FUND RAISING FOR MEDICAL TREATMENT AND RESEARCH (U.S. CLS. 100, 101 AND 102).
FIRST USE 3-0-2004; IN COMMERCE 3-0-2004.
KYLE PEETE, EXAMINING ATTORNEY

SN 85-255,346. ALEX'S LEMONADE STAND FOUNDATION, WYNNWOOD, PA. FILED 3-2-2011.

FIGHTING CHILDHOOD CANCER,
ONE CUP AT A TIME.

THE MARK CONSISTS OF STANDARD CHARACTERS WITHOUT CLAIM TO ANY PARTICULAR FONT, STYLE, SIZE, OR COLOR.
FOR CHARITABLE SERVICES, NAMELY FUND RAISING FOR MEDICAL TREATMENT AND RESEARCH (U.S. CLS. 100, 101 AND 102).
FIRST USE 4-0-2004; IN COMMERCE 4-0-2004.
KYLE PEETE, EXAMINING ATTORNEY

SN 85-255,670. FLAGSHIP SERVICES GROUP, INC., ENGLEWOOD, CO. FILED 3-2-2011.

FLAGSHIP

THE MARK CONSISTS OF STANDARD CHARACTERS WITHOUT CLAIM TO ANY PARTICULAR FONT, STYLE, SIZE, OR COLOR.
FOR INSURANCE CONSULTING SERVICES IN THE FIELD OF MEDICARE COMPLIANCE (U.S. CLS. 100, 101 AND 102).
FIRST USE 12-6-2010; IN COMMERCE 12-6-2010.
CARRIE GENOVESE, EXAMINING ATTORNEY

CLASS 36—(Continued).

SN 85-255,686. FLAGSHIP SERVICES GROUP, INC., ENGLEWOOD, CO. FILED 3-2-2011.



THE MARK CONSISTS OF THREE TRIANGULAR SHAPES FORMING THE IMAGE OF A SAILBOAT.
FOR INSURANCE CONSULTING SERVICES IN THE FIELD OF MEDICARE COMPLIANCE (U.S. CLS. 100, 101 AND 102).
FIRST USE 12-16-2010; IN COMMERCE 12-16-2010.
CARRIE GENOVESE, EXAMINING ATTORNEY

SN 85-255,745. WESTERN NATIONAL MUTUAL INSURANCE COMPANY, MINNESOTA, MN. FILED 3-2-2011.

THE PROOF IS IN THE
PARTNERSHIP

THE MARK CONSISTS OF STANDARD CHARACTERS WITHOUT CLAIM TO ANY PARTICULAR FONT, STYLE, SIZE, OR COLOR.
FOR INSURANCE UNDERWRITING FOR ALL TYPES OF INSURANCE (U.S. CLS. 100, 101 AND 102).
NICHOLAS ALTREE, EXAMINING ATTORNEY

SN 85-255,790. PROMERE CAPITAL MANAGEMENT LLC, BOSTON, MA. FILED 3-2-2011.

PROMERE

THE MARK CONSISTS OF STANDARD CHARACTERS WITHOUT CLAIM TO ANY PARTICULAR FONT, STYLE, SIZE, OR COLOR.
FOR FINANCIAL MANAGEMENT, NAMELY, INVESTMENT MANAGEMENT, INVESTMENT ADVICE, INVESTMENT CONSULTATION AND INVESTMENT OF FUNDS FOR OTHERS (U.S. CLS. 100, 101 AND 102).
JEAN IM, EXAMINING ATTORNEY

CLASS 36—(Continued).

SN 85-256,086. SILVER BRACELETS, INC., ORLANDO, FL. FILED 3-2-2011.



THE MARK CONSISTS OF A SOLID UNDER CAPITALIZED LETTER E WHICH INCLUDES A SOLID HORIZONTAL CROSS BAR WHICH INCLUDES THE WORDS "EARL'S COURT" IN ALL CAPITALIZED LETTERS.

FOR REAL ESTATE MANAGEMENT SERVICES, NAMELY, LEASING AND MANAGEMENT OF FOOD COURTS FOR OTHERS (U.S. CLS. 100, 101 AND 102).

JEFFREY LOOK, EXAMINING ATTORNEY

SN 85-256,159. RASIN CORP., CHICAGO, IL. FILED 3-2-2011.

FLOWERSIDE CREATIONS

THE MARK CONSISTS OF STANDARD CHARACTERS WITHOUT CLAIM TO ANY PARTICULAR FONT, STYLE, SIZE, OR COLOR.

FOR FINANCIAL INVESTMENT IN THE FIELD OF ENTERTAINMENT, INCLUDING FILMS, ART, AND LITERATURE (U.S. CLS. 100, 101 AND 102).

NICHOLAS COLEMAN, EXAMINING ATTORNEY

SN 85-256,182. BILL MANSY, JAMUL, CA. FILED 3-2-2011.

RATE RABBIT

THE MARK CONSISTS OF STANDARD CHARACTERS WITHOUT CLAIM TO ANY PARTICULAR FONT, STYLE, SIZE, OR COLOR.

NO CLAIM IS MADE TO THE EXCLUSIVE RIGHT TO USE "RATE", APART FROM THE MARK AS SHOWN.

FOR FINANCIAL EXCHANGE SERVICES, FEATURING THE PROVIDING OF MORTGAGE AND PRICING INFORMATION TO MORTGAGE ORIGINATORS, MORTGAGE LENDERS, MORTGAGE BANKERS, MORTGAGE BROKERS, BANKS, CREDIT UNIONS, AND CONSUMERS, AND ON-LINE FINANCIAL EXCHANGE SERVICES FEATURING THE PROVIDING OF MORTGAGE INFORMATION, PRICING INFORMATION, AND AGGREGATED LOAN PRICING (U.S. CLS. 100, 101 AND 102).

JORDAN BAKER, EXAMINING ATTORNEY

CLASS 36—(Continued).

SN 85-256,278. CITY AND COUNTY OF SAN FRANCISCO, SAN FRANCISCO, CA. FILED 3-2-2011.

Kindergarten to College

THE MARK CONSISTS OF STANDARD CHARACTERS WITHOUT CLAIM TO ANY PARTICULAR FONT, STYLE, SIZE, OR COLOR.

FOR ADMINISTRATION OF SAVINGS ACCOUNTS (U.S. CLS. 100, 101 AND 102).

FIRST USE 7-1-2010; IN COMMERCE 1-15-2011.

DOMINICK J. SALEMI, EXAMINING ATTORNEY

SN 85-256,291. CITY AND COUNTY OF SAN FRANCISCO, SAN FRANCISCO, CA. FILED 3-2-2011.

Save Steady. Dream Huge.

THE MARK CONSISTS OF STANDARD CHARACTERS WITHOUT CLAIM TO ANY PARTICULAR FONT, STYLE, SIZE, OR COLOR.

FOR ADMINISTRATION OF SAVINGS ACCOUNTS (U.S. CLS. 100, 101 AND 102).

FIRST USE 1-15-2011; IN COMMERCE 1-15-2011.

DOMINICK J. SALEMI, EXAMINING ATTORNEY

SN 85-256,395. CAIRN CAPITAL GROUP LIMITED, LONDON, GREAT BRITAIN, FILED 3-2-2011.



THE COLOR(S) GREY AND BLUE IS/ARE CLAIMED AS A FEATURE OF THE MARK.

THE MARK CONSISTS OF A DARK BLUE TRIANGLE ENCLOSED WITHIN A LARGE GREY LETTER "C".

FOR FINANCIAL SERVICES, NAMELY, INVESTMENT ADVISORY SERVICES, INVESTMENT MANAGEMENT SERVICES, ASSET MANAGEMENT SERVICES, FINANCIAL RESTRUCTURING SERVICES AND FINANCIAL INVESTMENT BROKERAGE (U.S. CLS. 100, 101 AND 102).

FIRST USE 2-0-2004; IN COMMERCE 2-0-2004.

JAMES MACFARLANE, EXAMINING ATTORNEY

CLASS 36—(Continued).

SN 85-256,565. CARROLL COMMUNITY BANK, SYKESVILLE, MD. FILED 3-3-2011.



THE COLOR(S) GREEN AND BLUE IS/ARE CLAIMED AS A FEATURE OF THE MARK.

THE MARK CONSISTS OF THREE ARCS OF VARYING SIZES, SEPARATED AT THE TOP AND CONNECTED AT THE BOTTOM, THE FIRST BEING THE SMALLEST, THE SECOND BEING LARGEST AND THE THIRD SIZED BETWEEN THE FIRST TWO. ALL THREE ARCS ARE GREEN AT THE TOP, FADING TO BLUE AT THE BOTTOM.

FOR BANKING SERVICES (U.S. CLS. 100, 101 AND 102).

FIRST USE 8-31-2010; IN COMMERCE 8-31-2010.
JENNIFER VASQUEZ, EXAMINING ATTORNEY

SN 85-256,596. CDOC, INC., CARMEL, IN. FILED 3-3-2011.

WASHINGTON NATIONAL PROGRESSIONS

THE MARK CONSISTS OF STANDARD CHARACTERS WITHOUT CLAIM TO ANY PARTICULAR FONT, STYLE, SIZE, OR COLOR.

OWNER OF U.S. REG. NOS. 3,263,912, 3,263,914 AND OTHERS.

FOR INSURANCE SERVICES, NAMELY, UNDERWRITING AND ADMINISTERING INSURANCE IN THE FIELD OF LIFE INSURANCE (U.S. CLS. 100, 101 AND 102).

MATTHEW KLINE, EXAMINING ATTORNEY

SN 85-256,628. NATIONAL LIFE INSURANCE COMPANY, MONTPELIER, VT. FILED 3-3-2011.

LIFECHANGERS

THE MARK CONSISTS OF STANDARD CHARACTERS WITHOUT CLAIM TO ANY PARTICULAR FONT, STYLE, SIZE, OR COLOR.

FOR ISSUANCE AND ADMINISTRATION OF ANNUITIES (U.S. CLS. 100, 101 AND 102).

CHERYL CLAYTON, EXAMINING ATTORNEY

CLASS 36—(Continued).

SN 85-256,654. ZIA BARKATULLAH, GARY, IN. FILED 3-3-2011.

EXTRACARE

THE MARK CONSISTS OF STANDARD CHARACTERS WITHOUT CLAIM TO ANY PARTICULAR FONT, STYLE, SIZE, OR COLOR.

FOR PROVIDING WARRANTIES ON GOODS MANUFACTURED BY OTHERS, NAMELY, DENTAL, AUDIOLOGICAL AND PODIATRIC APPLIANCES AND PROSTHETICS (U.S. CLS. 100, 101 AND 102).

CHERYL CLAYTON, EXAMINING ATTORNEY

SN 85-257,037. SKY ONE FEDERAL CREDIT UNION, HAWTHORNE, CA. FILED 3-3-2011.

OWNER OF U.S. REG. NO. 3,794,529.

NO CLAIM IS MADE TO THE EXCLUSIVE RIGHT TO USE "MOBILE", APART FROM THE MARK AS SHOWN.

THE MARK CONSISTS OF A LOWER CASE "i" FOLLOWED BY AN UPPER CASE "S" FOR THE WORD, "ISKY", AS WELL AS A CURVED LINE RUNNING THROUGH THE LETTERS SPELLING "MOBILE" WITH A TRIANGLE DESIGN/STYLIZED AIRCRAFT POSITIONED TO THE UPPER RIGHT.

FOR PROVIDING BANKING SERVICES VIA A GLOBAL COMPUTER NETWORK AND TELEPHONE, NAMELY, CONDUCTING TRANSACTIONS AND PROVIDING INFORMATION IN THE FIELD OF INDIVIDUAL AND INVESTMENT ACCOUNTS (U.S. CLS. 100, 101 AND 102).

FIRST USE 4-1-2010; IN COMMERCE 4-1-2010.
KAREN SEVERSON, EXAMINING ATTORNEY

CLASS 36—(Continued).

SN 85-257,173. WELLS FARGO & COMPANY, MINNEAPOLIS, MN. FILED 3-3-2011.

CLASS 36—(Continued).

SN 85-257,301. ABILITY CONNECTION TEXAS, DALLAS, TX. FILED 3-3-2011.

INDEPENDENCE, SIMPLIFIED



THE MARK CONSISTS OF A STYLIZED PARTIAL IMAGE OF A STICK FIGURE IN A WHEELCHAIR ON A DARK RECTANGULAR BACKGROUND.

FOR CHARITABLE FUNDRAISING SERVICES (U.S. CLS. 100, 101 AND 102).

FIRST USE 2-9-2011; IN COMMERCE 2-9-2011.
SEAN CROWLEY, EXAMINING ATTORNEY

THE MARK CONSISTS OF STANDARD CHARACTERS WITHOUT CLAIM TO ANY PARTICULAR FONT, STYLE, SIZE, OR COLOR.

FOR FINANCIAL AND INVESTMENT SERVICES, NAMELY, BROKERAGE SERVICES IN THE FIELDS OF STOCKS, BONDS, OPTIONS, MUTUAL FUNDS, COMMODITIES, FUTURES, AND OTHER SECURITIES; PROPRIETARY TRADING SERVICES, NAMELY, FUND INVESTMENT SERVICES FEATURING THE TRADING OF AN ACCOUNT HOLDER'S SECURITIES ACCORDING TO PREVIOUSLY ESTABLISHED CRITERIA IN ORDER TO MAINTAIN A PREDETERMINED LEVEL OF PAYMENTS TO THE ACCOUNT HOLDER; INVESTMENT BANKING SERVICES; SECURITIES BROKERAGE; EQUITY CAPITAL INVESTMENT SERVICES; PRIVATE PLACEMENTS OF HEDGE FUNDS, PRIVATE EQUITY FUNDS, SECURITIES AND DERIVATIVES FOR OTHERS; INVESTMENT OF FUNDS FOR OTHERS; SECURITIES TRADING AND INVESTING SERVICES FOR OTHERS VIA THE INTERNET; INVESTMENT ADVISORY SERVICES; INVESTMENT CONSULTATION SERVICES; INVESTMENT MANAGEMENT SERVICES; PROVIDING INFORMATION AND ADVICE IN THE FIELD OF FINANCE, FINANCIAL INVESTMENTS, FINANCIAL VALUATIONS, AND THE FINANCIAL ASPECTS OF RETIREMENT THROUGH A GLOBAL COMPUTER NETWORK; FINANCIAL PLANNING; CASH MANAGEMENT ACCOUNT SERVICES; PROVIDING FINANCIAL PORTFOLIO MANAGEMENT SERVICES; PROVIDING AN INTERACTIVE ONLINE COMPUTER DATABASE IN THE FIELD OF FINANCIAL PORTFOLIO MANAGEMENT, FINANCIAL DECISION MAKING, INVESTMENT RESEARCH, MONITORING INVESTMENT VALUE AND PERFORMANCE OF INVESTMENTS, ANALYZING INVESTMENT PERFORMANCE, EVALUATING ASSET ALLOCATION, RISK TOLERANCE, FINANCIAL ALTERNATIVE PLANS, AND INVESTMENT TIME FRAMES (U.S. CLS. 100, 101 AND 102).

HEATHER BIDDULPH, EXAMINING ATTORNEY

SN 85-257,826. FIVE BROTHERS MORTGAGE COMPANY SERVICES AND SECURING, INC., WARREN, MI. FILED 3-4-2011.

CLAIMSYS

THE MARK CONSISTS OF STANDARD CHARACTERS WITHOUT CLAIM TO ANY PARTICULAR FONT, STYLE, SIZE, OR COLOR.

FOR AUTOMATED PROCESSING AND MANAGEMENT OF CONVEYANCE HOUSING AND URBAN DEVELOPEMENT (HUD) MORTGAGE INSURANCE CLAIMS PROVIDED ON A GLOBAL COMPUTER NETWORK (U.S. CLS. 100, 101 AND 102).

FIRST USE 5-1-2010; IN COMMERCE 5-1-2010.
AISHA SALEM, EXAMINING ATTORNEY

CLASS 36—(Continued).

SN 85-257,875. LAWRENCE D. MOORE, STATEN ISLAND, NY. FILED 3-4-2011.

LEGACPA

THE MARK CONSISTS OF STANDARD CHARACTERS WITHOUT CLAIM TO ANY PARTICULAR FONT, STYLE, SIZE, OR COLOR.

FOR FINANCIAL SERVICES, NAMELY, WEALTH MANAGEMENT SERVICES; FINANCIAL EVALUATION FOR INSURANCE PURPOSES; FINANCIAL SERVICES, NAMELY, PROVIDING AN INVESTMENT OPTION AVAILABLE FOR VARIABLE AND INDEXED ANNUITIES AND LIFE INSURANCE PRODUCTS (U.S. CLS. 100, 101 AND 102).

KAPIL BHANOT, EXAMINING ATTORNEY

CLASS 36—(Continued).

SN 85-262,111. ARBELLA MUTUAL INSURANCE COMPANY, QUINCY, MA. FILED 3-9-2011.



OWNER OF U.S. REG. NOS. 3,342,565, 3,354,854 AND OTHERS.

NO CLAIM IS MADE TO THE EXCLUSIVE RIGHT TO USE "HOME & AUTO", APART FROM THE MARK AS SHOWN.

THE MARK CONSISTS OF DESIGN OF A HOUSE WITH AN ATTACHED GARAGE AND CAR INSIDE THE GARAGE WITH THE WORDS "CHAMBER HOME & AUTO @ WORK FROM ARBELLA".

FOR INSURANCE SERVICES, NAMELY, INSURANCE UNDERWRITING IN THE FIELDS OF AUTOMOBILE, ACCIDENT, LIABILITY, HOMEOWNERS, PROPERTY, FIRE, BURGLARY, ROBBERY AND THEFT; AND INSURANCE BROKERAGE AND AGENCY SERVICES (U.S. CLS. 100, 101 AND 102).

FIRST USE 10-0-2010; IN COMMERCE 10-0-2010.

FLORENTINA BLANDU, EXAMINING ATTORNEY

SN 85-262,166. PIPER AIRCRAFT, INC., VERO BEACH, FL. FILED 3-9-2011.

READY, SET, FLY

SN 85-257,966. PURSE OF HOPE, INC., ELBURN, IL. FILED 3-4-2011.

Purse of Hope

THE MARK CONSISTS OF STANDARD CHARACTERS WITHOUT CLAIM TO ANY PARTICULAR FONT, STYLE, SIZE, OR COLOR.

FOR FINANCIAL SERVICES, NAMELY, FUNDING AIRPLANE FLIGHT INSTRUCTION IN CONNECTION WITH THE PURCHASE OF A NEW AIRPLANE (U.S. CLS. 100, 101 AND 102).

LINDA E. BLOHM, EXAMINING ATTORNEY

SN 85-263,123. BB&T CORPORATION, WINSTON-SALEM, NC. FILED 3-10-2011.

BB&T VANTAGE

THE MARK CONSISTS OF STANDARD CHARACTERS WITHOUT CLAIM TO ANY PARTICULAR FONT, STYLE, SIZE, OR COLOR.

FOR ACCEPTING AND ADMINISTERING MONETARY CHARITABLE CONTRIBUTIONS; CHARITABLE FUNDRAISING SERVICES BY MEANS OF SELLING T-SHIRTS, JEWELRY AND MUGS TO RAISE FUNDS FOR HUMAN TRAFFICKING VICTIMS; CHARITABLE SERVICES, NAMELY, ORGANIZING FUNDRAISING SERVICES AND EVENTS TO RAISE FUNDS IN THE FIELD OF HUMAN TRAFFICKING (U.S. CLS. 100, 101 AND 102).

FIRST USE 7-1-2007; IN COMMERCE 3-1-2008.

INGRID C. EULIN, EXAMINING ATTORNEY

THE MARK CONSISTS OF STANDARD CHARACTERS WITHOUT CLAIM TO ANY PARTICULAR FONT, STYLE, SIZE, OR COLOR.

OWNER OF U.S. REG. NOS. 3,091,256, 3,337,198 AND OTHERS.

FOR BANKING AND RELATED FINANCIAL SERVICES, NAMELY, CHECKING, DEBIT AND CREDIT CARD SERVICES (U.S. CLS. 100, 101 AND 102).

FLORENTINA BLANDU, EXAMINING ATTORNEY

CLASS 36—(Continued).

SN 85-263,126. BB&T CORPORATION, WINSTON-SALEM, NC. FILED 3-10-2011.

BB&T WEALTH VANTAGE

THE MARK CONSISTS OF STANDARD CHARACTERS WITHOUT CLAIM TO ANY PARTICULAR FONT, STYLE, SIZE, OR COLOR.

OWNER OF U.S. REG. NOS. 3,091,256, 3,337,198 AND OTHERS.

NO CLAIM IS MADE TO THE EXCLUSIVE RIGHT TO USE "WEALTH", APART FROM THE MARK AS SHOWN.

FOR BANKING AND RELATED FINANCIAL SERVICES, NAMELY, CHECKING, DEBIT AND CREDIT CARD SERVICES (U.S. CLS. 100, 101 AND 102).

FLORENTINA BLANDU, EXAMINING ATTORNEY

SN 85-263,129. BB&T CORPORATION, WINSTON-SALEM, NC. FILED 3-10-2011.

BB&T PRIVATE VANTAGE

THE MARK CONSISTS OF STANDARD CHARACTERS WITHOUT CLAIM TO ANY PARTICULAR FONT, STYLE, SIZE, OR COLOR.

OWNER OF U.S. REG. NOS. 3,091,256, 3,337,198 AND OTHERS.

NO CLAIM IS MADE TO THE EXCLUSIVE RIGHT TO USE "PRIVATE", APART FROM THE MARK AS SHOWN.

FOR BANKING AND RELATED FINANCIAL SERVICES, NAMELY, CHECKING, DEBIT AND CREDIT CARD SERVICES (U.S. CLS. 100, 101 AND 102).

FLORENTINA BLANDU, EXAMINING ATTORNEY

SN 85-263,135. BB&T CORPORATION, WINSTON-SALEM, NC. FILED 3-10-2011.

BB&T PREFERRED VANTAGE

THE MARK CONSISTS OF STANDARD CHARACTERS WITHOUT CLAIM TO ANY PARTICULAR FONT, STYLE, SIZE, OR COLOR.

OWNER OF U.S. REG. NOS. 3,091,256, 3,337,198 AND OTHERS.

NO CLAIM IS MADE TO THE EXCLUSIVE RIGHT TO USE "PREFERRED", APART FROM THE MARK AS SHOWN.

FOR BANKING AND RELATED FINANCIAL SERVICES, NAMELY, CHECKING, DEBIT AND CREDIT CARD SERVICES (U.S. CLS. 100, 101 AND 102).

FLORENTINA BLANDU, EXAMINING ATTORNEY

CLASS 36—(Continued).

SN 85-266,232. ABBOTT, ELIZABETH AYN, FORT MYERS, FL. FILED 3-14-2011.



THE MARK CONSISTS OF A GIFT BOX DESIGN OVER THE STYLIZED LITERAL ELEMENT OF THE MARK "GIFTERCLUB".

FOR CREDIT CARD AND DEBIT CARD SERVICES; PROVIDING ELECTRONIC PROCESSING OF ELECTRONIC FUNDS TRANSFER, ACH, CREDIT CARD, DEBIT CARD, ELECTRONIC CHECK AND ELECTRONIC PAYMENTS (U.S. CLS. 100, 101 AND 102).

KYLE PEETE, EXAMINING ATTORNEY

SN 85-279,968. CLASSIC BICYCLE RACING LLC, DENVER, CO. FILED 3-29-2011.



THE COLOR(S) RED, ORANGE, YELLOW, WHITE, GREEN, AND PURPLE IS/ARE CLAIMED AS A FEATURE OF THE MARK.

THE MARK CONSISTS OF A RED, ORANGE AND YELLOW SUN BEHIND THE WHITE SILHOUETTE OF A CYCLIST ALL OVER STYLIZED LITERAL ELEMENTS WITH "SPOKES" IN GREEN, "OF" IN YELLOW, AND "CHANGE" IN PURPLE.

FOR CHARITABLE FUNDRAISING (U.S. CLS. 100, 101 AND 102).

LURIE KAUFMAN, EXAMINING ATTORNEY

SN 85-313,003. ONEXONE FOUNDATION, MONTREAL, QUEBEC, CANADA, FILED 5-5-2011.

ONEUP

THE MARK CONSISTS OF STANDARD CHARACTERS WITHOUT CLAIM TO ANY PARTICULAR FONT, STYLE, SIZE, OR COLOR.

FOR CHARITABLE FUNDRAISING (U.S. CLS. 100, 101 AND 102).

TAMARA FRAZIER, EXAMINING ATTORNEY

CLASS 37—CONSTRUCTION AND REPAIR

CLASS 37—(Continued).

SN 76-705,924. ARTERIORS, NATICK, MA. FILED 1-6-2011.

SN 85-038,810. CHINOOK SYSTEMS INC., COCOA BEACH, FL. FILED 5-14-2010.

ARTERIORS

THE MARK CONSISTS OF STANDARD CHARACTERS WITHOUT CLAIM TO ANY PARTICULAR FONT, STYLE, SIZE, OR COLOR.

FOR PAINTING SERVICES (U.S. CLS. 100, 103 AND 106).

FIRST USE 9-25-1994; IN COMMERCE 9-25-1994.
LINDA M. KING, EXAMINING ATTORNEY



SN 85-001,337. PROFESSIONAL CARPET & UPHOLSTERY CARE, INC., MARIETTA, GA. FILED 3-29-2010.

PRO CARPET

THE MARK CONSISTS OF THE "P" TOUCHING THE "R" IN "PRO"; "PRO" IS CAPITALIZED, BUT "P" IS LARGER THAN "RO", AND THE "C" IS LARGER THAN "ARPET" IN THE CAPITALIZED "CARPET".

SEC. 2(F).
FOR AIR DUCT CLEANING SERVICES; CARPET CLEANING; CLEANING OF UPHOLSTERY AND TILE (U.S. CLS. 100, 103 AND 106).

FIRST USE 12-1-1993; IN COMMERCE 12-1-1993.
BARBARA BROWN, EXAMINING ATTORNEY

NO CLAIM IS MADE TO THE EXCLUSIVE RIGHT TO USE "SYSTEMS INC.", APART FROM THE MARK AS SHOWN.

THE MARK CONSISTS OF STYLIZED LETTERS "C" AND "S" WITH A STAR DESIGN APPEARING AT THE TIP OF THE LETTER S ABOVE THE WORDS "CHINOOK SYSTEMS INC."

FOR BUILDING COMMISSIONING SERVICES IN THE NATURE OF NEW CONSTRUCTION AND RENOVATION OF EXISTING BUILDINGS (U.S. CLS. 100, 103 AND 106).

FIRST USE 1-22-2004; IN COMMERCE 2-2-2004.
C. DIONNE CLYBURN, EXAMINING ATTORNEY

SN 85-002,723. PARKSIDE CAPITAL LAND FUND, LTD., HOUSTON, TX. FILED 3-31-2010.

Parkside Capital

THE MARK CONSISTS OF STANDARD CHARACTERS WITHOUT CLAIM TO ANY PARTICULAR FONT, STYLE, SIZE, OR COLOR.

NO CLAIM IS MADE TO THE EXCLUSIVE RIGHT TO USE "CAPITAL", APART FROM THE MARK AS SHOWN.

FOR LAND DEVELOPMENT SERVICES, NAMELY, PLANNING AND LAYING OUT OF COMMERCIAL COMMUNITIES (U.S. CLS. 100, 103 AND 106).

ANDREW LEASER, EXAMINING ATTORNEY



THE MARK CONSISTS OF A UNIVERSAL BIOHAZARD SYMBOL WITH OUTSPREAD WINGS FORMING A STYLIZED DESIGN.

FOR BUILDING CONSTRUCTION, REMODELING AND REPAIR; CLEANING OF BUILDINGS AND VEHICLES HAVING BLOOD BORNE PATHOGENS AND BIOHAZARDOUS WASTE; CRIME SCENE CLEAN-UP SERVICES; ENVIRONMENTAL REMEDIATION SERVICES, NAMELY, WASTE DISPOSAL; HAZARDOUS WASTE DISPOSAL SERVICES (U.S. CLS. 100, 103 AND 106).

FIRST USE 2-5-2010; IN COMMERCE 3-2-2010.
JENNIFER MARTIN, EXAMINING ATTORNEY

CLASS 37—(Continued).

SN 85-100,096. CALLOWAY CLEANING & RESTORATION, INC., CINCINNATI, OH. FILED 8-4-2010.



NO CLAIM IS MADE TO THE EXCLUSIVE RIGHT TO USE "CLEANING & RESTORATION", APART FROM THE MARK AS SHOWN.

THE MARK CONSISTS OF THE LITERAL ELEMENT "CALLOWAY CLEANING & RESTORATION HELP IS JUST A CALL-O-WAY." WITH AN INVERTED SWOOSH IN BETWEEN THE WORDING "HELP IS JUST A CALL-O-WAY." AND "CALLOWAY CLEANING & RESTORATION".

FOR PROPERTY RESTORATION SERVICES IN THE NATURE OF RESTORATION, RECOVERY, DEMOLITION, CLEANING, WASTE DISPOSAL, AND RECONSTRUCTION OF COMMERCIAL, INDUSTRIAL, AND RESIDENTIAL BUILDINGS AND PERSONAL PROPERTY AND EQUIPMENT, NAMELY, FURNITURE, APPLIANCES, AUTOMOBILES, CLOTHING, MISCELLANEOUS HOUSEHOLD ITEMS, AND AUTOMOBILES DAMAGED BY FIRE, SMOKE, WIND, WATER, MOLD, POLLUTANTS, NATURAL DISASTERS, ENVIRONMENTAL DISASTERS AND OTHER CAUSES; MOLD AND ASBESTOS ASSESSMENT AND REMOVAL; COMMERCIAL, INDUSTRIAL, AND RESIDENTIAL BUILDING RESTORATION AND RECONSTRUCTION AND GENERAL CONSTRUCTIONS CONTRACTING THEREFORE (U.S. CLS. 100, 103 AND 106).

ALLISON SCHRODY, EXAMINING ATTORNEY

CLASS 37—(Continued).

SN 85-108,955. HIGHTOWER, MARC W., ROUND ROCK, TX. FILED 8-17-2010.



NO CLAIM IS MADE TO THE EXCLUSIVE RIGHT TO USE "ROOFING", APART FROM THE MARK AS SHOWN.

THE MARK CONSISTS OF THE WORDS "THE ROOFING EDGE" WITH TWO TRIANGLES ABOVE THE WORDING.

FOR CONSTRUCTION CONSULTANCY (U.S. CLS. 100, 103 AND 106).

FIRST USE 6-17-2010; IN COMMERCE 6-17-2010.

FRANK LATTUCA, EXAMINING ATTORNEY

SN 85-104,358. CRITTER CONTROL, INC., TRAVERSE CITY, MI. FILED 8-10-2010.



BIRD PATROL

THE MARK CONSISTS OF STANDARD CHARACTERS WITHOUT CLAIM TO ANY PARTICULAR FONT, STYLE, SIZE, OR COLOR.

NO CLAIM IS MADE TO THE EXCLUSIVE RIGHT TO USE "BIRD", APART FROM THE MARK AS SHOWN.

SEC. 2(F).

FOR ANIMAL CONTROL SERVICES, NAMELY, LARGE BIRD CONTROL, CAPTURING, AND TRAPPING; AND REMOVING BIRDS FROM RESIDENTIAL AND COMMERCIAL BUILDINGS (U.S. CLS. 100, 103 AND 106).

FIRST USE 12-31-2002; IN COMMERCE 12-31-2002.

TINA L. SNAPP, EXAMINING ATTORNEY

NO CLAIM IS MADE TO THE EXCLUSIVE RIGHT TO USE "RENOVATIONS", APART FROM THE MARK AS SHOWN.

THE MARK CONSISTS OF THE IMAGE OF AN OWL SITTING ON A CURVED LINE SITUATED OVER THE WORDING "LIFEWISE RENOVATIONS".

FOR RENOVATION IN THE FIELD OF HOUSES BY SKILLED AND QUALIFIED NURSES AND/OR THERAPISTS TO PROVIDE RECOMMENDATIONS FOR STRUCTURAL MODIFICATIONS THAT WILL PROMOTE PATIENT SAFETY AND ACCOMMODATE SPECIFIC HEALTH CONDITIONS AND CHANGING PHYSICAL ABILITIES; REMODELING OF THE HOME IN ACCORDANCE WITH THE RECOMMENDATIONS OF SKILLED AND QUALIFIED NURSES AND/OR THERAPISTS TO PROMOTE PATIENT SAFETY AND ACCOMMODATE SPECIFIC HEALTH CONDITIONS AND CHANGING PHYSICAL ABILITIES (U.S. CLS. 100, 103 AND 106).

FIRST USE 5-1-2010; IN COMMERCE 5-1-2010.

KAPIL BHANOT, EXAMINING ATTORNEY

CLASS 37—(Continued).

SN 85-178,188. MYERS SERVICES, INC., BEDFORD, TX.
FILED 11-16-2010.

No More Birds

THE MARK CONSISTS OF STANDARD CHARACTERS WITHOUT CLAIM TO ANY PARTICULAR FONT, STYLE, SIZE, OR COLOR.

NO CLAIM IS MADE TO THE EXCLUSIVE RIGHT TO USE "BIRDS", APART FROM THE MARK AS SHOWN.

FOR ANIMAL CONTROL SERVICES, NAMELY, BIRD CONTROL AND EXCLUSION (U.S. CLS. 100, 103 AND 106).

SUNG IN, EXAMINING ATTORNEY

CLASS 37—(Continued).

SN 85-222,669. NEXUS ENERGYHOMES, ANNAPOLIS, MD.
FILED 1-20-2011.



THE MARK CONSISTS OF A HOUSE WITH A SUNBURST IN THE UPPER HEMISPHERE BEHIND HOUSE AND LINEAR FORMATION OF DOTS RADIATING FROM THE CENTER OF THE HOUSE OUTWARD IN THE LOWER HEMISPHERE.

FOR CONSTRUCTION SERVICES, NAMELY, BUILDING OF ENERGY EFFICIENT HOMES (U.S. CLS. 100, 103 AND 106).

FIRST USE 8-15-2010; IN COMMERCE 8-15-2010.
ALICE BENMAMAN, EXAMINING ATTORNEY

SN 85-193,160. BRAD STEINMETZ, BOULDER, CO. FILED
12-8-2010.



NO CLAIM IS MADE TO THE EXCLUSIVE RIGHT TO USE "THERMAL CLEAN", APART FROM THE MARK AS SHOWN.

THE MARK CONSISTS OF A STYLIZED DRAWING OF A FLAME BESIDE THE WORDS "THERMAL CLEAN" IN A STYLIZED FONT.

FOR PEST CONTROL AND EXTERMINATION; BED BUG ERADICATION SERVICES (U.S. CLS. 100, 103 AND 106).

FIRST USE 1-0-2011; IN COMMERCE 1-0-2011.
TRACY WHITTAKER-BROWN, EXAMINING ATTORNEY

SN 85-234,434. DRY BASEMENT, INC., KANSAS CITY, MO.
FILED 2-4-2011.

DRY BASEMENT

SN 85-195,304. SHEVICK, DAVID ABRAHAM, SAN RAFAEL, CA. FILED 12-10-2010.

tanknot

THE MARK CONSISTS OF STANDARD CHARACTERS WITHOUT CLAIM TO ANY PARTICULAR FONT, STYLE, SIZE, OR COLOR.

FOR INSTALLATION AND REPLACEMENT SERVICE FOR WATER HEATERS (U.S. CLS. 100, 103 AND 106).

FIRST USE 12-1-2006; IN COMMERCE 12-1-2006.
JOHN SCHUYLER YARD, EXAMINING ATTORNEY

THE MARK CONSISTS OF STANDARD CHARACTERS WITHOUT CLAIM TO ANY PARTICULAR FONT, STYLE, SIZE, OR COLOR.

OWNER OF U.S. REG. NO. 1,158,386.

NO CLAIM IS MADE TO THE EXCLUSIVE RIGHT TO USE "BASEMENT", APART FROM THE MARK AS SHOWN. SEC. 2(F).

FOR WATERPROOFING OF BASEMENTS, FOUNDATION REPAIR SERVICES, BASEMENT REFINISHING SERVICES, AND PLUMBING SERVICES (U.S. CLS. 100, 103 AND 106).

FIRST USE 2-13-1975; IN COMMERCE 2-13-1975.
DOMINICK J. SALEMI, EXAMINING ATTORNEY

CLASS 37—(Continued).

SN 85-235,390. GYM DOOR REPAIR, INC., GREAT RIVER, NY. FILED 2-7-2011.



NO CLAIM IS MADE TO THE EXCLUSIVE RIGHT TO USE "GYM DOOR REPAIRS, INC.", APART FROM THE MARK AS SHOWN.

THE MARK CONSISTS OF AN IMAGE OF A SLIDING MECHANISM WITH A BACKGROUND OF A SKY SURROUNDED BY THE WORDS "GYM DOOR REPAIRS, INC."

FOR INSTALLATION, MAINTENANCE AND REPAIR SERVICES FOR ELECTRICALLY OPERATED, FOLDING, OPERABLE WALL SYSTEMS AND WALL PANEL SAFETY SYSTEMS (U.S. CLS. 100, 103 AND 106).

FIRST USE 1-0-2001; IN COMMERCE 1-0-2001.
DOMINICK J. SALEMI, EXAMINING ATTORNEY

CLASS 37—(Continued).

SN 85-241,557. GREEN IRON CLEANERS, LLC, GILBERT, AZ. FILED 2-14-2011.



NO CLAIM IS MADE TO THE EXCLUSIVE RIGHT TO USE "GREEN" AND "CLEANERS", APART FROM THE MARK AS SHOWN.

THE COLOR(S) GREEN, BLACK AND WHITE IS/ARE CLAIMED AS A FEATURE OF THE MARK.

THE MARK CONSISTS OF THE WORDS "GREEN IRON CLEANERS" WITH THE WORDS "GREEN" AND "IRON" APPEARING IN GREEN, THE LETTERS "C", "L", "E", "N", "E", "R", AND "S" IN "CLEANERS" APPEARING IN BLACK, AND WITH THE LETTER "A" IN "CLEANERS" BEING DEPICTED AS A GREEN STYLIZED IRON FACE WITH WHITE STEAM HOLES AT THE TOP AND A WHITE GROWING PLANT AT THE BOTTOM. THE MARK APPEARS ON A TRANSPARENT BACKGROUND.

FOR CLOTH LAUNDRY; CLOTHING LAUNDRY; FABRIC LAUNDRY; LAUNDRY SERVICES; ALL OF THE FOREGOING SERVICES FEATURING ENVIRONMENTALLY FRIENDLY CLEANING AGENTS AND PROCESSES (U.S. CLS. 100, 103 AND 106).

AMY KERTGATE, EXAMINING ATTORNEY

SN 85-236,607. WASH & ROLL, LLC, RALEIGH, NC. FILED 2-8-2011.

WASH & ROLL

THE MARK CONSISTS OF STANDARD CHARACTERS WITHOUT CLAIM TO ANY PARTICULAR FONT, STYLE, SIZE, OR COLOR.

NO CLAIM IS MADE TO THE EXCLUSIVE RIGHT TO USE "WASH", APART FROM THE MARK AS SHOWN.

FOR CAR WASH SERVICES (U.S. CLS. 100, 103 AND 106).

MARLENE BELL, EXAMINING ATTORNEY

SN 85-244,238. CORSCO, INC., DBA MRS. CLEAN, MILL CREEK, WA. FILED 2-16-2011.

HONEST TO GOODNESS CLEAN

THE MARK CONSISTS OF STANDARD CHARACTERS WITHOUT CLAIM TO ANY PARTICULAR FONT, STYLE, SIZE, OR COLOR.

NO CLAIM IS MADE TO THE EXCLUSIVE RIGHT TO USE "CLEAN", APART FROM THE MARK AS SHOWN.

FOR MAID SERVICES (U.S. CLS. 100, 103 AND 106).
FIRST USE 11-13-2010; IN COMMERCE 11-13-2010.

JESSICA FATHY, EXAMINING ATTORNEY

CLASS 37—(Continued).

SN 85-245,402. THE DING DOCTOR INC, ONTARIO, CA. FILED 2-17-2011.



NO CLAIM IS MADE TO THE EXCLUSIVE RIGHT TO USE "COMPLETE AUTOMOTIVE RECONDITIONING SPECIALIST CALIFORNIA C.A.R.S.", APART FROM THE MARK AS SHOWN.

THE COLOR(S) GREEN, GRAY, RED, BLACK, BROWN AND BLUE IS/ARE CLAIMED AS A FEATURE OF THE MARK.

THE MARK CONSISTS OF THE OUTLINE OF A GRAY LICENSE PLATE HOLDER WITH THE WORDS "COMPLETE AUTOMOTIVE RECONDITIONING SPECIALIST" IN BLACK AND THE WORDS INSIDE THE LICENSE PLATE HOLDER ARE "CALIFORNIA" IN RED AND "C.A.R.S." IN BLUE WITH TWO PALM TREE DESIGNS IN GREEN AND BROWN ON THE RIGHT AND LEFT SIDE.

FOR AUTOMOBILE BODY REPAIR, PAINTING, MAINTENANCE AND AUTOMOBILE UPHOLSTERY REPAIR; AUTOMOTIVE RESTORATION; MAINTENANCE AND REPAIR OF AUTOMOTIVE ENGINES (U.S. CLS. 100, 103 AND 106).

FIRST USE 0-0-2004; IN COMMERCE 0-0-2004.

JACQUELINE A. LAVINE, EXAMINING ATTORNEY

SN 85-245,465. RED PILL, INC., MILFORD, OH. FILED 2-17-2011.



ProMaster
Home Repair & Handyman Service

NO CLAIM IS MADE TO THE EXCLUSIVE RIGHT TO USE "HOME REPAIR & HANDYMAN SERVICE", APART FROM THE MARK AS SHOWN.

THE MARK CONSISTS OF A FIGURE RUNNING MAN, WEARING A SERVICE HAT WITH A TOOL BOX AND WRENCH. BELOW THERE IS THE STYLIZED TEXT "PRO-MASTER HOME REPAIR & HANDYMAN SERVICE" THE LETTER "O" IS IN A CLOCK IMAGE. TO THE RIGHT OF THE CLOCK IMAGE THERE IS A FIGURE RUNNING MAN, WEARING A SERVICE HAT WITH A TOOL BOX AND WRENCH IN BETWEEN THE WORDS "PRO" AND "MASTER".

FOR HANDYMAN SERVICE, NAMELY, BUILDING REPAIR AND MAINTENANCE (U.S. CLS. 100, 103 AND 106).

FIRST USE 4-8-2010; IN COMMERCE 4-8-2010.

DAWN FELDMAN, EXAMINING ATTORNEY

CLASS 37—(Continued).

SN 85-246,071. OLD CHICAGO PAINT COMPANY, LLC, WILMETTE, IL. FILED 2-18-2011.

Old Chicago Paint Co.

THE MARK CONSISTS OF STANDARD CHARACTERS WITHOUT CLAIM TO ANY PARTICULAR FONT, STYLE, SIZE, OR COLOR.

NO CLAIM IS MADE TO THE EXCLUSIVE RIGHT TO USE "CHICAGO PAINT CO.", APART FROM THE MARK AS SHOWN.

FOR DECORATIVE PAINTING SERVICES; DRYWALL AND PAINTING CONTRACTOR SERVICES; HOUSE PAINTING; INSTALLING FLOOR TILE; PAINTING; PAINTING AND APPLYING COATINGS TO BUILDING INTERIORS AND BUILDING EXTERIORS; PAINTING AND VARNISHING; PAINTING CONTRACTOR SERVICES; TILE INSTALLATION SERVICES; TILE LAYING, BRICKLAYING OR BLOCK LAYING (U.S. CLS. 100, 103 AND 106).

FIRST USE 11-1-2010; IN COMMERCE 11-1-2010.

HANNO RITTNER, EXAMINING ATTORNEY

SN 85-246,142. EXPANDER AMERICAS, INC., COTTONWOOD, AZ. FILED 2-18-2011.

PIVOT MAN

THE MARK CONSISTS OF STANDARD CHARACTERS WITHOUT CLAIM TO ANY PARTICULAR FONT, STYLE, SIZE, OR COLOR.

FOR REPAIR OF METAL PINS FOR USE IN MACHINERIES TO ALLOW MACHINERIES TO ARTICULATE AND MANEUVER (U.S. CLS. 100, 103 AND 106).

JENNY PARK, EXAMINING ATTORNEY

SN 85-246,928. DAN CATBAGAN, REDWOOD CITY, CA. FILED 2-19-2011.

i ♥ green clean

NO CLAIM IS MADE TO THE EXCLUSIVE RIGHT TO USE "GREEN CLEAN", APART FROM THE MARK AS SHOWN.

THE COLOR(S) GREEN AND RED IS/ARE CLAIMED AS A FEATURE OF THE MARK.

THE MARK CONSISTS OF GREEN LETTER "I", RED HEART, GREEN "GREEN CLEAN".

FOR DRY CLEANING (U.S. CLS. 100, 103 AND 106).

FIRST USE 12-31-2010; IN COMMERCE 12-31-2010.

MARGARET POWER, EXAMINING ATTORNEY

CLASS 37—(Continued).

SN 85-247,452. TOTAL BUSINESS MANAGEMENT, INC., DBA GREEN BOX HEATING & AIR, NICHOLASVILLE, KY. FILED 2-21-2011.



NO CLAIM IS MADE TO THE EXCLUSIVE RIGHT TO USE "HEATING & AIR", APART FROM THE MARK AS SHOWN.

THE COLOR(S) GREEN, BLUE, AND GREY IS/ARE CLAIMED AS A FEATURE OF THE MARK.

THE MARK CONSISTS OF A GREEN HOUSE WITH A BLUE ROOF AND CHIMNEY. THE WORDS "GREEN" AND "HEATING" ARE IN GREEN. THE WORDS "BLUE" AND "AIR" ARE IN BLUE. THE AND SYMBOL "&" IS IN GREY.

FOR AIR CONDITIONING CONTRACTOR SERVICES; ELECTRICAL REPAIRS AND INSTALLATION OF HEATING AND AIR CONDITIONING EQUIPMENT; ENVIRONMENTAL SERVICES, NAMELY, INSTALLATION OF ENVIRONMENTALLY COMPLIANT HEATING AND AIR CONDITIONING EQUIPMENT; HEATING CONTRACTOR SERVICES; HEATING EQUIPMENT INSTALLATION AND REPAIR; INSTALLATION AND REPAIR OF AIR CONDITIONING APPARATUS; INSTALLATION AND REPAIR OF HEATING, VENTILATING AND AIR CONDITIONING EQUIPMENT; INSTALLATION AND REPLACEMENT SERVICE FOR HEATING, VENTILATING AND AIR CONDITIONING SYSTEMS; INSTALLATION, REPAIR AND MAINTENANCE OF HEATING EQUIPMENT; MAINTENANCE AND REPAIR OF HEATING INSTALLATIONS (U.S. CLS. 100, 103 AND 106).

FIRST USE 4-30-2010; IN COMMERCE 5-1-2010.
THEODORE MCBRIDE, EXAMINING ATTORNEY

SN 85-248,635. COAST CRANE COMPANY, SEATTLE, WA. FILED 2-22-2011.

COAST CRANE COMPANY

THE MARK CONSISTS OF STANDARD CHARACTERS WITHOUT CLAIM TO ANY PARTICULAR FONT, STYLE, SIZE, OR COLOR.

NO CLAIM IS MADE TO THE EXCLUSIVE RIGHT TO USE "CRANE COMPANY", APART FROM THE MARK AS SHOWN.

FOR CRANE RENTAL AND LEASING FOR CONSTRUCTION PURPOSES (U.S. CLS. 100, 103 AND 106).

FIRST USE 12-31-1984; IN COMMERCE 12-31-1984.
NAKIA HENRY, EXAMINING ATTORNEY

CLASS 37—(Continued).

SN 85-249,267. APEX ENERGY SOLUTIONS OF CINCINNATI LLC, WEST CHESTER, OH. FILED 2-23-2011.

ENERGY ONE

THE MARK CONSISTS OF STANDARD CHARACTERS WITHOUT CLAIM TO ANY PARTICULAR FONT, STYLE, SIZE, OR COLOR.

NO CLAIM IS MADE TO THE EXCLUSIVE RIGHT TO USE "ENERGY", APART FROM THE MARK AS SHOWN.

FOR HOME IMPROVEMENT SERVICES, NAMELY, INSTALLATION OF WINDOWS, SIDING AND DOORS (U.S. CLS. 100, 103 AND 106).

FIRST USE 6-30-2010; IN COMMERCE 6-30-2010.
KAREN K. BUSH, EXAMINING ATTORNEY

SN 85-249,870. TECHNOLOGY WEST GROUP, LLC, LAS VEGAS, NV. FILED 2-23-2011.



NO CLAIM IS MADE TO THE EXCLUSIVE RIGHT TO USE "TECHNOLOGY" AND "GROUP", APART FROM THE MARK AS SHOWN.

THE MARK CONSISTS OF THE WORD "TECHNOLOGY" LOCATED EVENLY ABOVE THE TWO WORDS "WEST GROUP". BETWEEN THE TWO WORDS "WEST" AND "GROUP" THERE IS A GENERIC POWER OR ON/OFF SYMBOL.

FOR INSTALLATION OF VIDEO EQUIPMENT, AUDIO SYSTEMS, INFORMATION TECHNOLOGY SYSTEMS, AND ELECTRONIC CONTROL SYSTEMS (U.S. CLS. 100, 103 AND 106).

FIRST USE 7-7-2007; IN COMMERCE 7-7-2007.
EMILY CHUO, EXAMINING ATTORNEY

SN 85-249,933. NETFXR, INC., LONG BEACH, CA. FILED 2-23-2011.



THE MARK CONSISTS OF THE STYLIZED TEXT "NETFXR" WITH THE LETTER "X" FORMED BY TWO INWARD AND TWO OUTWARD FACING ARROWS.

FOR INSTALLATION, MAINTENANCE AND REPAIR OF ETHERNET AND WIRELESS NETWORKING HARDWARE (U.S. CLS. 100, 103 AND 106).

FIRST USE 6-1-2001; IN COMMERCE 6-1-2001.
ASMAT KHAN, EXAMINING ATTORNEY

CLASS 37—(Continued).

SN 85-250,005. BEST GUY INC., GAINESVILLE, GA. FILED 2-23-2011.



NO CLAIM IS MADE TO THE EXCLUSIVE RIGHT TO USE "PRESSURE WASHING", APART FROM THE MARK AS SHOWN.

THE MARK CONSISTS OF THE SHADED STYLIZED TEXT "BEST GUY" IN LARGE CAPS, WITH EACH LETTER CONTAINING AN UNSHADED SINGLE LINE BORDER, WITH A WATER DROP CONTAINING A WAVE SPLASH DESIGN, BETWEEN THE WORD, "BEST" AND "GUY", WITH THE WORDING, "PRESSURE WASHING" IN SMALLER CAPS BELOW.

FOR PRESSURE WASHING SERVICES (U.S. CLS. 100, 103 AND 106).

FIRST USE 2-1-2009; IN COMMERCE 2-1-2010.
ODESSA BIBBINS, EXAMINING ATTORNEY

SN 85-250,124. JTW INTERNATIONAL, INC., SAINT AUGUSTINE, FL. FILED 2-23-2011.

Zanisol

THE MARK CONSISTS OF STANDARD CHARACTERS WITHOUT CLAIM TO ANY PARTICULAR FONT, STYLE, SIZE, OR COLOR.

FOR APPLICATION OF COATINGS AND SEALERS (U.S. CLS. 100, 103 AND 106).

DEZMONA MIZELLE, EXAMINING ATTORNEY

SN 85-251,010. AMERICAN GUTTER SYSTEMS, INC., ERIE, PA. FILED 2-24-2011.

HOME OF THE HEATED GUTTER

THE MARK CONSISTS OF STANDARD CHARACTERS WITHOUT CLAIM TO ANY PARTICULAR FONT, STYLE, SIZE, OR COLOR.

NO CLAIM IS MADE TO THE EXCLUSIVE RIGHT TO USE "HEATED GUTTER", APART FROM THE MARK AS SHOWN.

FOR INSTALLATION OF GUTTER SYSTEMS INCLUDING MAINTENANCE FREE AND HEATED GUTTERS (U.S. CLS. 100, 103 AND 106).

FIRST USE 1-1-2011; IN COMMERCE 2-21-2011.
MICHAEL WIENER, EXAMINING ATTORNEY

CLASS 37—(Continued).

SN 85-251,507. WEBER SECURITY GROUP, INC., MOUNT CLEMENS, MI. FILED 2-25-2011.



THE MARK CONSISTS OF A CIRCULAR BORDER CONTAINING THREE PARALLEL VERTICAL OBLONG SHAPES WHICH ARE DIVIDED ACROSS THE CENTER OF EACH WHERE THE CENTER OBLONG IS LOWER THAN THE TWO OUTER OBLONGS.

FOR INSTALLATION OF SECURITY SYSTEM (U.S. CLS. 100, 103 AND 106).

FIRST USE 1-1-2005; IN COMMERCE 1-1-2005.
TINA BROWN, EXAMINING ATTORNEY

SN 85-252,258. AIRSTREAM PLUMBING & HEATING, INC., CLIFTON, CO. FILED 2-25-2011.

Your Personal Plumber

THE MARK CONSISTS OF STANDARD CHARACTERS WITHOUT CLAIM TO ANY PARTICULAR FONT, STYLE, SIZE, OR COLOR.

NO CLAIM IS MADE TO THE EXCLUSIVE RIGHT TO USE "PLUMBER", APART FROM THE MARK AS SHOWN.

FOR CONTRACTOR SERVICES, NAMELY, REVIEW OF AND REMEDIAL RECOMMENDATIONS FOR BUILDING PLUMBING, ELECTRICAL AND MECHANICAL SYSTEMS FOR OTHERS; GENERAL CONTRACTOR SERVICES, NAMELY, PLUMBING, HEATING AND AIR CONDITIONING, CARPENTRY, DRYWALL, PAINTING, ELECTRICAL, BUILDING AND FRAMING CONTRACTOR SERVICES; PLUMBING; PLUMBING AND GAS AND WATER INSTALLATION; PLUMBING CONTRACTOR SERVICES; PLUMBING SERVICES; REPAIR OF HOUSEHOLD APPLIANCES AND OF RESIDENTIAL HEATING, PLUMBING, AIR CONDITIONING, AND ELECTRICAL SYSTEMS (U.S. CLS. 100, 103 AND 106).

FIRST USE 1-1-2009; IN COMMERCE 6-1-2009.
ELLEN BURNS, EXAMINING ATTORNEY

CLASS 37—(Continued).

SN 85-252,339. R.B.F. LLC, DBA BETTER BUILDING SYSTEMS, LAS VEGAS, NV. FILED 2-25-2011.



NO CLAIM IS MADE TO THE EXCLUSIVE RIGHT TO USE "BUILDING SYSTEMS", APART FROM THE MARK AS SHOWN.

THE MARK CONSISTS OF AN OUTLINE OF THE BUILDINGS AND A HORIZONTAL LINE WITH THE STYLIZED TEXT "BBS". BELOW THERE IS THE STYLIZED TEXT "BETTER BUILDING SYSTEMS".

FOR CONSTRUCTION AND RENOVATION OF BUILDINGS (U.S. CLS. 100, 103 AND 106).

FIRST USE 9-1-2007; IN COMMERCE 9-1-2007.
JAMES A. RAUEN, EXAMINING ATTORNEY

CLASS 37—(Continued).

SN 85-255,065. ENVIRONMENTAL CERTIFICATIONS, INC., HEATH, TX. FILED 3-1-2011.

eCertified

THE MARK CONSISTS OF STANDARD CHARACTERS WITHOUT CLAIM TO ANY PARTICULAR FONT, STYLE, SIZE, OR COLOR.

FOR BUILDING INSPECTION AND REPAIR, NAMELY, BUILDING ASSESSMENT SERVICES FOR THE PURPOSE OF DETERMINING BUILDING IMPROVEMENTS NEEDED TO IMPROVE USE AND EFFICIENCY (U.S. CLS. 100, 103 AND 106).

FIRST USE 4-17-2009; IN COMMERCE 4-17-2009.
DEIRDRE ROBERTSON, EXAMINING ATTORNEY

SN 85-253,397. THE ROOFING ANNEX, LLC, NORTHBROOK, IL. FILED 2-28-2011.

THE ROOFING ANNEX

THE MARK CONSISTS OF STANDARD CHARACTERS WITHOUT CLAIM TO ANY PARTICULAR FONT, STYLE, SIZE, OR COLOR.

NO CLAIM IS MADE TO THE EXCLUSIVE RIGHT TO USE "ROOFING", APART FROM THE MARK AS SHOWN.

FOR ROOFING INSTALLATION; ROOFING REPAIR; ROOFING SERVICES (U.S. CLS. 100, 103 AND 106).

CURTIS FRENCH, EXAMINING ATTORNEY

SN 85-255,999. SAFETY GROOVING & GRINDING, L.P., NEW KENSINGTON, PA. FILED 3-2-2011.

SGG

THE MARK CONSISTS OF STANDARD CHARACTERS WITHOUT CLAIM TO ANY PARTICULAR FONT, STYLE, SIZE, OR COLOR.

FOR CONSTRUCTION SERVICES, NAMELY, GROOVING OF AIRPORT RUNWAYS, ROADWAY PAVEMENTS, BRIDGE DECKS, AND OTHER SURFACES TO IMPROVE WET-WEATHER TRACTION AND SAFETY; DIAMOND GRINDING OF AIRPORT RUNWAYS, ROADWAY PAVEMENTS, BRIDGE DECKS, AND OTHER SURFACES TO IMPROVE TEXTURE, FRICTION AND RIDE CHARACTERISTICS; AND CUTTING GROOVES TO CREATE RUMBLE STRIPS AND SIMILAR FEATURES ON ROADWAY SHOULDERS AND OTHER LOCATIONS TO IMPROVE ROADWAY SAFETY (U.S. CLS. 100, 103 AND 106).

FIRST USE 8-22-1988; IN COMMERCE 8-22-1988.
ELIZABETH KAJUBI, EXAMINING ATTORNEY

SN 85-253,586. B-LEVEL, LTD., BALTIMORE, OH. FILED 2-28-2011.



THE MARK CONSISTS OF A RUNNING CARTOON BEE WEARING A HAT AND CARRYING A CONTRACTOR'S LEVEL.

FOR CONCRETE REPAIR SERVICES, NAMELY, CONCRETE LIFTING AND LEVELING (U.S. CLS. 100, 103 AND 106).

FIRST USE 5-31-2007; IN COMMERCE 5-31-2007.
CHRISTINE MARTIN, EXAMINING ATTORNEY

SN 85-256,822. KB HOME, LOS ANGELES, CA. FILED 3-3-2011.

EPG

THE MARK CONSISTS OF STANDARD CHARACTERS WITHOUT CLAIM TO ANY PARTICULAR FONT, STYLE, SIZE, OR COLOR.

FOR REAL ESTATE DEVELOPMENT AND CONSTRUCTION OF RESIDENTIAL PROPERTY (U.S. CLS. 100, 103 AND 106).

FIRST USE 2-14-2011; IN COMMERCE 2-14-2011.
LESLIE RICHARDS, EXAMINING ATTORNEY

CLASS 37—(Continued).

SN 85-257,199. DARWIN RICHARD, DBA MR. MOBILE
AUTOMOTIVE SERVICE, RENTON, WA. FILED 3-3-2011.



Mr. Mobile
AUTOMOTIVE SERVICES

"Your On-Site Service Experts."

NO CLAIM IS MADE TO THE EXCLUSIVE RIGHT TO USE "MOBILE AUTOMOTIVE SERVICES "YOUR ON-SITE SERVICE EXPERTS"", APART FROM THE MARK AS SHOWN.

THE MARK CONSISTS OF THE WORDING "MR. MOBILE AUTOMOTIVE SERVICES "YOUR ON-SITE SERVICE EXPERTS"" WITH A HORIZONTAL LINE BETWEEN "MR. MOBILE" AND "AUTOMOTIVE SERVICES" ALL TO THE RIGHT OF A DESIGN OF A SERVICE TRUCK.

FOR AUTOMOBILE REPAIR AND MAINTENANCE; AUTOMOTIVE MAINTENANCE AND REPAIR (U.S. CLS. 100, 103 AND 106).

FIRST USE 9-1-2004; IN COMMERCE 9-1-2004.
AISHA SALEM, EXAMINING ATTORNEY

CLASS 37—(Continued).

SN 85-257,487. THE WILLS GROUP, INC, LAPLATA, MD.
FILED 3-3-2011.

SPLASH IN

THE MARK CONSISTS OF STANDARD CHARACTERS WITHOUT CLAIM TO ANY PARTICULAR FONT, STYLE, SIZE, OR COLOR.

FOR CAR WASHING (U.S. CLS. 100, 103 AND 106).
FIRST USE 9-30-2006; IN COMMERCE 9-30-2006.
WANDA KAY PRICE, EXAMINING ATTORNEY

SN 85-257,990. ROLLINS, INC., ATLANTA, GA. FILED 3-4-2011.

ECOSOLUTIONS

THE MARK CONSISTS OF STANDARD CHARACTERS WITHOUT CLAIM TO ANY PARTICULAR FONT, STYLE, SIZE, OR COLOR.

FOR PEST CONTROL SERVICES (U.S. CLS. 100, 103 AND 106).
RONALD AIKENS, EXAMINING ATTORNEY

SN 85-257,317. CABLE LOCK, INC., HOUSTON, TX. FILED 3-3-2011.



OWNER OF U.S. REG. NO. 1,840,908.
THE COLOR(S) BLACK AND RED IS/ARE CLAIMED AS A FEATURE OF THE MARK.

THE MARK CONSISTS OF THE PHRASE "CABLE LOCK" IN BLACK, STYLIZED LETTERING EXCEPT FOR THE LETTER "L" IN EACH WORD WHICH IS CREATED BY A DESIGN MADE UP OF FOUR RED PARALLELOGRAMS. DIRECTLY TO THE RIGHT IS A RED CIRCLE CONTAINING THE STYLIZED TERM "ST" AND THE STYLIZED TERM "PLUS" IN BLACK LETTERING. A SHADOW EFFECT APPEARS BENEATH THE RED CIRCLE. THE COLOR WHITE IS INTENDED TO INDICATE BACKGROUND, OUTLINING, SHADING OR TRANSPARENT AREAS AND ARE NOT PART OF THE MARK.

FOR REPAIR OR MAINTENANCE OF HOME AND BUILDING FOUNDATIONS (U.S. CLS. 100, 103 AND 106).

FIRST USE 10-0-2010; IN COMMERCE 10-0-2010.
PAM WILLIS, EXAMINING ATTORNEY

SN 85-260,027. QUALITY GROUP OF COMPANIES, L.L.C.,
OVERLAND PARK, KS. FILED 3-7-2011.



THE MARK CONSISTS OF A STYLIZED LETTER "Q".
FOR REAL ESTATE DEVELOPMENT SERVICES IN THE FIELD OF MISSION-CRITICAL AND GOVERNMENT LEASED FACILITIES (U.S. CLS. 100, 103 AND 106).

FIRST USE 7-1-2003; IN COMMERCE 7-1-2003.
SANI KHOURI, EXAMINING ATTORNEY

CLASS 37—(Continued).

SN 85-260,183. WIEST BRYAN E, DBA AUSTIN 360 ROOFING, AUSTIN, TX. FILED 3-7-2011.

Austin 360 Roofing

THE MARK CONSISTS OF STANDARD CHARACTERS WITHOUT CLAIM TO ANY PARTICULAR FONT, STYLE, SIZE, OR COLOR.

NO CLAIM IS MADE TO THE EXCLUSIVE RIGHT TO USE "AUSTIN" AND "ROOFING", APART FROM THE MARK AS SHOWN.

FOR ROOFING SERVICES (U.S. CLS. 100, 103 AND 106).

FIRST USE 10-1-2008; IN COMMERCE 10-1-2008. RAUL CORDOVA, EXAMINING ATTORNEY

CLASS 38—COMMUNICATION

SN 77-315,201. GROUP KAITU, LLC, RICHMOND, VA. FILED 10-27-2007.

EROS SHEMALE ESCORTS

THE MARK CONSISTS OF STANDARD CHARACTERS WITHOUT CLAIM TO ANY PARTICULAR FONT, STYLE, SIZE, OR COLOR.

OWNER OF U.S. REG. NOS. 2,549,369, 2,794,843 AND OTHERS.

NO CLAIM IS MADE TO THE EXCLUSIVE RIGHT TO USE "SHEMALE ESCORTS", APART FROM THE MARK AS SHOWN.

FOR PROVIDING ONLINE CHAT ROOMS AND ELECTRONIC BULLETIN BOARDS FOR TRANSMISSIONS OF MESSAGES AMONG USERS IN THE FIELDS OF ADULT THEMED TOPICS, PRODUCTS, SERVICES AND ENTERTAINMENT; MOBILE MEDIA SERVICES IN THE NATURE OF ELECTRONIC TRANSMISSIONS OF ADULT THEMED TOPICS, PRODUCTS, SERVICES AND ENTERTAINMENT; STREAMING OF AUDIO AND VIDEO MATERIAL ON THE INTERNET (U.S. CLS. 100, 101 AND 104).

LEIGH LOWRY, EXAMINING ATTORNEY

SN 77-713,091. WINKLE BV, DEIL, NETHERLANDS, FILED 4-14-2009.

WINKLE

THE MARK CONSISTS OF STANDARD CHARACTERS WITHOUT CLAIM TO ANY PARTICULAR FONT, STYLE, SIZE, OR COLOR.

PRIORITY CLAIMED UNDER SEC. 44(D) ON ERPNCMNTY TM OFC APPLICATION NO. 8119802, FILED 2-23-2009, REG. NO. 008119802, DATED 12-3-2009, EXPIRES 2-23-2019.

THE ENGLISH TRANSLATION OF "WINKLE" IN THE MARK IS THE VERB "TO DRAW OUT BY FORCE" AND IT IS ALSO AN EDIBLE MOLLUSK.

FOR WIRELESS ELECTRONIC TRANSMISSION OF VOICE SIGNALS, DATA, FACSIMILES, IMAGES AND INFORMATIONS; COMMUNICATION SERVICES, NAMELY, TRANSMISSION OF VOICE, AUDIO, VISUAL IMAGES AND DATA BY TELECOMMUNICATIONS NETWORKS, WIRELESS COMMUNICATION NETWORKS, THE INTERNET, INFORMATION SERVICES NETWORKS AND DATA NETWORKS; COMPUTER-AIDED TRANSMISSION OF MESSAGES; DATA COMMUNICATION BY ELECTRONIC MAIL; DELIVERY OF MESSAGES BY ELECTRONIC TRANSMISSION; DELIVERY OF PERSONALIZED GREETING CARDS TO OTHERS VIA ELECTRONIC MAIL; E-MAIL DATA SERVICES; E-MAIL FORWARDING SERVICES; ELECTRONIC DATA INTERCHANGE; ELECTRONIC DATA INTERCHANGE (EDI) SERVICES; ELECTRONIC DATA TRANSMISSION; ELECTRONIC DELIVERY OF IMAGES AND PHOTOGRAPHS VIA A GLOBAL COMPUTER NETWORK; ELECTRONIC EXCHANGE OF DATA STORED IN DATABASES ACCESSIBLE VIA TELECOMMUNICATION NETWORKS; ELECTRONIC MAIL; ELECTRONIC MAIL AND MESSAGING SERVICES; ELECTRONIC MAIL SERVICES; ELECTRONIC MESSAGE SENDING; ELECTRONIC MESSAGE TRANSMISSION; ELECTRONIC MESSAGING SYSTEM, NAMELY, ELECTRONIC QUEUING SERVICES; ELECTRONIC STORE-AND-FORWARD MESSAGING; ELECTRONIC

SN 85-266,121. TELEVOX SOFTWARE, INC., MOBILE, AL. FILED 3-14-2011.

EasyRemind

THE MARK CONSISTS OF STANDARD CHARACTERS WITHOUT CLAIM TO ANY PARTICULAR FONT, STYLE, SIZE, OR COLOR.

FOR COMPUTER INSTALLATION SERVICES (U.S. CLS. 100, 103 AND 106).

DOMINIC FATHY, EXAMINING ATTORNEY

CLASS 38—(Continued).

TRANSMISSION OF DATA AND DOCUMENTS VIA COMPUTER TERMINALS; ELECTRONIC TRANSMISSION OF DATA AND DOCUMENTS VIA COMPUTER TERMINALS AND ELECTRONIC DEVICES; ELECTRONIC TRANSMISSION OF FACSIMILE COMMUNICATIONS AND DATA FEATURING ENCRYPTION AND DECRYPTION; ELECTRONIC TRANSMISSION OF MAIL AND MESSAGES; ELECTRONIC TRANSMISSION OF MESSAGES; ELECTRONIC TRANSMISSION OF MESSAGES AND DATA; ELECTRONIC TRANSMISSION OF VOICE, DATA AND IMAGES BY TELEVISION AND VIDEO BROADCASTING; ELECTRONIC, ELECTRIC, AND DIGITAL TRANSMISSION OF VOICE, DATA, IMAGES, SIGNALS, AND MESSAGES; INSTANT MESSAGING SERVICES; INTERNET ACCESS PROVIDER SERVICES; INTERNET BROADCASTING SERVICES; INTERNET SERVICE PROVIDER (ISP); MESSAGE COLLECTION AND TRANSMISSION; MESSAGE SENDING AND RECEIVING SERVICES; MESSAGE SENDING, RECEIVING AND FORWARDING; ON-LINE DOCUMENT DELIVERY VIA A GLOBAL COMPUTER NETWORK; ON-LINE SERVICES, NAMELY, MESSAGE SENDING; PROVIDING A HIGH SPEED ACCESS TO AREA NETWORKS AND A GLOBAL COMPUTER INFORMATION NETWORK; PROVIDING ACCESS TO DIGITAL MUSIC WEBSITES ON THE INTERNET; PROVIDING ACCESS TO TELECOMMUNICATION NETWORKS; PROVIDING ACCESS TO THE INTERNET; PROVIDING AN ON-LINE FORUM FOR COMPANIES TO SHOWCASE, DISPLAY, DEMONSTRATE AND PROMOTE NEW AND INNOVATIVE IDEAS, PRODUCTS AND SERVICES IN THE CONVENTION/MEETING MANAGEMENT ARENA; PROVIDING E-MAIL AND INSTANT MESSAGING SERVICES; PROVIDING E-MAIL FAX SERVICES; PROVIDING E-MAIL NOTIFICATION ALERTS OF RATING CHANGES THAT AFFECT FINANCIAL PORTFOLIOS; PROVIDING E-MAIL SERVICES; PROVIDING ELECTRONIC TELECOMMUNICATION CONNECTIONS; PROVIDING INTERNET ACCESS; PROVIDING INTERNET CHAT-ROOMS; PROVIDING MULTIPLE USE ACCESS TO GLOBAL COMPUTER INFORMATION NETWORKS FOR THE TRANSFER AND DISSEMINATION OF A WIDE RANGE OF INFORMATION; PROVIDING MULTIPLE USER ACCESS TO PROPRIETARY COLLECTIONS OF INFORMATION BY MEANS OF GLOBAL COMPUTER INFORMATION NETWORKS; PROVIDING MULTIPLE USER DIAL-UP AND DEDICATED ACCESS TO THE INTERNET; PROVIDING MULTIPLE-USER ACCESS TO A GLOBAL COMPUTER INFORMATION NETWORK; PROVIDING ON-LINE CHAT ROOMS AND ELECTRONIC BULLETIN BOARDS FOR TRANSMISSION OF MESSAGES AMONG USERS IN THE FIELD OF GENERAL INTEREST; PROVIDING ON-LINE COMMUNICATIONS LINKS WHICH TRANSFER THE WEB SITE USER TO OTHER LOCAL AND GLOBAL WEB PAGES; PROVIDING PRIVATE AND SECURE REAL TIME ELECTRONIC COMMUNICATION OVER A COMPUTER NETWORK; PROVIDING REMOTE INTERNET ACCESS; PROVIDING TELECOMMUNICATION CONNECTIONS TO THE INTERNET OR DATABASES; PROVIDING TELECOMMUNICATIONS CONNECTIONS TO A GLOBAL COMPUTER NETWORK; PROVIDING TELECOMMUNICATIONS CONNECTIONS TO THE INTERNET OR DATABASES; PROVIDING USER ACCESS TO A GLOBAL COMPUTER NETWORK; PROVIDING VOICE COMMUNICATION SERVICES VIA THE INTERNET; PROVISION OF ACCESS TO A GLOBAL COMPUTER NETWORK; PROVISION OF ACCESS TO ELECTRONIC SITES; PROVISION OF ACCESS TO THE INTERNET; SECURE E-MAIL SERVICES; TELECOMMUNICATION ACCESS SERVICES; TELECOMMUNICATION CONSULTATION IN THE NATURE OF TECHNICAL CONSULTING IN THE FIELD OF AUDIO, TEXT AND VISUAL DATA TRANSMISSION AND COMMUNICATION; TELECOMMUNICATION SERVICES, NAMELY, PROVIDING INTERNET ACCESS VIA BROADBAND OPTICAL OR WIRELESS NETWORKS; TELECOMMUNICATION SERVICES, NAMELY, TRANSMISSION OF VOICE, DATA, GRAPHICS, IMAGES, AUDIO AND VIDEO BY MEANS OF TELECOMMUNICATIONS NETWORKS, AND THE INTERNET; TELECOMMUNICATION SERVICES, NAMELY, TRANSMISSION OF VOICE, DATA, GRAPHICS, SOUND AND VIDEO BY MEANS OF BROADBAND POWER LINE OR WIRELESS NETWORKS; TELECOMMUNICATION SERVICES, NAMELY, TRANSMISSION OF WEB CASTS; TELECOMMUNICATIONS BY

CLASS 38—(Continued).

E-MAIL; TELECOMMUNICATIONS CONSULTATION; TRANSFER OF DATA BY TELECOMMUNICATION; TRANSFER OF DATA BY TELECOMMUNICATIONS; TRANSMISSION AND DISTRIBUTION OF DATA OR AUDIO VISUAL IMAGES VIA A GLOBAL COMPUTER NETWORK OR THE INTERNET; TRANSMISSION OF INFORMATION BY ELECTRONIC COMMUNICATIONS NETWORKS; TRANSMISSION OF MESSAGES; TRANSMISSION OF MESSAGES OVER ELECTRONIC MEDIA; WEB CASTING SERVICES; WEB CONFERENCING SERVICES; WEB MESSAGING; WEB SITE FORWARDING SERVICES; WEB CASTING SERVICES (U.S. CLS. 100, 101 AND 104).

DAVID C. REIHNER, EXAMINING ATTORNEY

SN 77-799,413. ELECTRIC POWER BOARD AN INDEPENDENT BOARD OF THE CITY OF CHATTANOOGA, CHATTANOOGA, TN. FILED 8-7-2009.

EPB FI TV

THE MARK CONSISTS OF STANDARD CHARACTERS WITHOUT CLAIM TO ANY PARTICULAR FONT, STYLE, SIZE, OR COLOR.

OWNER OF U.S. REG. NOS. 2,939,478 AND 2,969,498. NO CLAIM IS MADE TO THE EXCLUSIVE RIGHT TO USE "TV", APART FROM THE MARK AS SHOWN.

FOR TELECOMMUNICATIONS SERVICES, NAMELY, PROVIDING TRANSMISSION OF TELEVISION SIGNALS VIA A BROADBAND OPTICAL NETWORK (U.S. CLS. 100, 101 AND 104).

JAMES LOVELACE, EXAMINING ATTORNEY

SN 85-090,591. TRIWEST HEALTHCARE ALLIANCE CORPORATION, PHOENIX, AZ. FILED 7-22-2010.

GO GREEN. GO PAPERLESS. GO NOW.

THE MARK CONSISTS OF STANDARD CHARACTERS WITHOUT CLAIM TO ANY PARTICULAR FONT, STYLE, SIZE, OR COLOR.

FOR ELECTRONIC DATA INTERCHANGE SERVICES IN THE FIELD OF HEALTHCARE TRANSACTIONS SUCH AS CLAIMS, ELIGIBILITY, CLAIM STATUS, ELECTRONIC REMITTANCE ADVICE, PRIOR AUTHORIZATIONS, ATTACHMENTS, REFERRALS ETC. THAT ALLOW DIRECT TRANSACTION AND PAYMENT COMMUNICATIONS BETWEEN HEALTHCARE PROVIDERS AND PAYERS (U.S. CLS. 100, 101 AND 104).

FIRST USE 3-31-2010; IN COMMERCE 3-31-2010.

MATTHEW MCDOWELL, EXAMINING ATTORNEY

CLASS 38—(Continued).

SN 85-099,103. A2STREAM INC., DAVIDSON, NC. FILED 8-3-2010.

mailVU

THE MARK CONSISTS OF STANDARD CHARACTERS WITHOUT CLAIM TO ANY PARTICULAR FONT, STYLE, SIZE, OR COLOR.

FOR TELECOMMUNICATIONS BY E-MAIL, NAMELY, PROVIDING A SERVICE TO DELIVER VIDEOS BY E-MAIL (U.S. CLS. 100, 101 AND 104).

FIRST USE 7-14-2010; IN COMMERCE 7-14-2010.
SALLY SHIH, EXAMINING ATTORNEY

CLASS 38—(Continued).

SN 85-133,547. WJXR, INC., MACCLENNY, FL. FILED 9-20-2010.

THE BARGAIN CHANNEL

THE MARK CONSISTS OF STANDARD CHARACTERS WITHOUT CLAIM TO ANY PARTICULAR FONT, STYLE, SIZE, OR COLOR.

NO CLAIM IS MADE TO THE EXCLUSIVE RIGHT TO USE "CHANNEL", APART FROM THE MARK AS SHOWN. SEC. 2(F).

FOR RADIO BROADCASTING (U.S. CLS. 100, 101 AND 104).

FIRST USE 2-1-1985; IN COMMERCE 2-1-1985.
JULIE VEPPIUMTHARA, EXAMINING ATTORNEY

SN 85-115,961. TWENTIETH CENTURY FOX FILM CORPORATION, LOS ANGELES, CA. FILED 8-25-2010.

MYFOXCAM

THE MARK CONSISTS OF STANDARD CHARACTERS WITHOUT CLAIM TO ANY PARTICULAR FONT, STYLE, SIZE, OR COLOR.

OWNER OF U.S. REG. NOS. 1,795,301, 1,840,919 AND 2,301,920.

FOR AUDIO AND VIDEO BROADCASTING SERVICES OVER THE INTERNET OR OTHER COMMUNICATIONS NETWORK, NAMELY, UPLOADING, POSTING, SHOWING, DISPLAYING, TAGGING AND ELECTRONICALLY TRANSMITTING INFORMATION, AUDIO, AND VIDEO CLIPS; PROVIDING ON-LINE CHAT ROOMS AND ELECTRONIC BULLETIN BOARDS FOR TRANSMISSION OF MESSAGES AMONG USERS IN THE FIELD OF GENERAL INTEREST, CURRENT EVENT NEWS, ENTERTAINMENT, SPORTS AND MUSIC (U.S. CLS. 100, 101 AND 104).

KRISTINA MORRIS, EXAMINING ATTORNEY

SN 85-136,836. CRISTA MINISTRIES, SEATTLE, WA. FILED 9-23-2010.

SPIRIT MUSIC

THE MARK CONSISTS OF STANDARD CHARACTERS WITHOUT CLAIM TO ANY PARTICULAR FONT, STYLE, SIZE, OR COLOR.

OWNER OF U.S. REG. NOS. 3,100,794, 3,805,792 AND OTHERS.

NO CLAIM IS MADE TO THE EXCLUSIVE RIGHT TO USE "MUSIC", APART FROM THE MARK AS SHOWN.

FOR RADIO BROADCASTING; STREAMING OF AUDIO MATERIAL ON THE INTERNET (U.S. CLS. 100, 101 AND 104).

FIRST USE 9-0-1999; IN COMMERCE 9-0-1999.
ANNE FARRELL, EXAMINING ATTORNEY

SN 85-123,475. KARMARKAR, AMIT, PALO ALTO, CA. FILED 9-5-2010.

cTXT

THE MARK CONSISTS OF STANDARD CHARACTERS WITHOUT CLAIM TO ANY PARTICULAR FONT, STYLE, SIZE, OR COLOR.

FOR DIGITAL NETWORK TELECOMMUNICATIONS SERVICES (U.S. CLS. 100, 101 AND 104).

ALYSSA STEEL, EXAMINING ATTORNEY

SN 85-141,565. CITIGROUP INC., NEW YORK, NY. FILED 9-29-2010.

GRUSH

THE MARK CONSISTS OF STANDARD CHARACTERS WITHOUT CLAIM TO ANY PARTICULAR FONT, STYLE, SIZE, OR COLOR.

FOR PROVIDING ONLINE ELECTRONIC BULLETIN BOARDS AND CHAT ROOMS FOR TRANSMISSION OF MESSAGES AMONG COMPUTER USERS CONCERNING ELDER CARE, CAREERS, FINANCES AND INSURANCE, CREDIT, TAXES, LEGAL SERVICES, CHARITABLE DONATIONS, PHILANTHROPIC MONETARY DONATIONS, TRUSTS AND INVESTMENT (U.S. CLS. 100, 101 AND 104).

DAVID COLLIER, EXAMINING ATTORNEY

CLASS 38—(Continued).

SN 85-156,850. TRACFONE WIRELESS, INC., MIAMI, FL. FILED 10-20-2010.

TRACFONE HUB SERVICES

THE MARK CONSISTS OF STANDARD CHARACTERS WITHOUT CLAIM TO ANY PARTICULAR FONT, STYLE, SIZE, OR COLOR.

OWNER OF U.S. REG. NOS. 2,114,692, 3,577,200 AND 3,599,354.

NO CLAIM IS MADE TO THE EXCLUSIVE RIGHT TO USE "HUB SERVICES", APART FROM THE MARK AS SHOWN.

FOR TELECOMMUNICATION SERVICES, NAMELY, WIRELESS ROAMING SERVICES; TELECOMMUNICATION SERVICES, NAMELY, PROVIDING THIRD PARTY USERS ACCESS TO TELECOMMUNICATION INFRASTRUCTURE; TELECOMMUNICATION SERVICES, NAMELY, TRANSMISSION OF VOICE, DATA, GRAPHICS, IMAGES, AUDIO AND VIDEO BY MEANS OF TELECOMMUNICATION SERVICES; TELECOMMUNICATION SERVICES, NAMELY, PROVIDING WIRELESS COMMUNICATION NETWORK CONNECTIVITY AND INTERCONNECTIVITY SERVICES FOR THE TRANSMISSION OF VOICE, DATA, GRAPHICS, IMAGES, AUDIO AND VIDEO (U.S. CLS. 100, 101 AND 104).

LINDA E. BLOHM, EXAMINING ATTORNEY

SN 85-170,639. CRISTA MINISTRIES, SEATTLE, WA. FILED 11-5-2010.

THE SPIRIT OF AUSTIN

THE MARK CONSISTS OF STANDARD CHARACTERS WITHOUT CLAIM TO ANY PARTICULAR FONT, STYLE, SIZE, OR COLOR.

OWNER OF U.S. REG. NOS. 3,100,794, 3,805,792 AND OTHERS.

NO CLAIM IS MADE TO THE EXCLUSIVE RIGHT TO USE "AUSTIN", APART FROM THE MARK AS SHOWN.

FOR RADIO BROADCASTING; STREAMING OF AUDIO MATERIAL ON THE INTERNET (U.S. CLS. 100, 101 AND 104).

ANNE FARRELL, EXAMINING ATTORNEY

CLASS 38—(Continued).

SN 85-170,679. CRISTA MINISTRIES, SEATTLE, WA. FILED 11-5-2010.

SPIRIT 105.9

THE MARK CONSISTS OF STANDARD CHARACTERS WITHOUT CLAIM TO ANY PARTICULAR FONT, STYLE, SIZE, OR COLOR.

OWNER OF U.S. REG. NOS. 3,100,794, 3,805,792 AND OTHERS.

NO CLAIM IS MADE TO THE EXCLUSIVE RIGHT TO USE "105.9", APART FROM THE MARK AS SHOWN.

FOR RADIO BROADCASTING; STREAMING OF AUDIO MATERIAL ON THE INTERNET (U.S. CLS. 100, 101 AND 104).

ANNE FARRELL, EXAMINING ATTORNEY

SN 85-173,992. TECHNOCOM CORPORATION, ENCINO, CA. FILED 11-10-2010.

LOCATIONSMART

THE MARK CONSISTS OF STANDARD CHARACTERS WITHOUT CLAIM TO ANY PARTICULAR FONT, STYLE, SIZE, OR COLOR.

FOR TELECOMMUNICATIONS SERVICES, NAMELY, PROVIDING ACCESS TO TELECOMMUNICATIONS NETWORKS FOR MOBILE COMMUNICATIONS AND LOCATION BASED SERVICES (U.S. CLS. 100, 101 AND 104).

KRISTINA MORRIS, EXAMINING ATTORNEY

SN 85-175,152. TSAI, STEVEN C. MARINA DEL REY, CA. AND VISIONS-IN-MOTION, LOS ANGELES, CA. FILED 11-12-2010.

30 Mile Net

THE MARK CONSISTS OF STANDARD CHARACTERS WITHOUT CLAIM TO ANY PARTICULAR FONT, STYLE, SIZE, OR COLOR.

NO CLAIM IS MADE TO THE EXCLUSIVE RIGHT TO USE "NET", APART FROM THE MARK AS SHOWN.

FOR COMPUTER NETWORK ACCESS SERVICES BY MEANS OF A METRO ETHERNET; DIGITAL NETWORK TELECOMMUNICATIONS SERVICES; TRANSMISSION AND DISTRIBUTION OF DATA OR AUDIO VISUAL IMAGES VIA A GLOBAL COMPUTER NETWORK OR THE INTERNET (U.S. CLS. 100, 101 AND 104).

MICHAEL KEATING, EXAMINING ATTORNEY

CLASS 38—(Continued).

SN 85-175,280. NISSAN JIDOSHA KABUSHIKI KAISHA, TA NISSAN MOTOR CO., LTD., YOKOHAMA-SHI, KANAGAWA, JAPAN, FILED 11-12-2010.

INFINITI CONNECTION

THE MARK CONSISTS OF STANDARD CHARACTERS WITHOUT CLAIM TO ANY PARTICULAR FONT, STYLE, SIZE, OR COLOR.

FOR TELECOMMUNICATION SERVICES, NAMELY, ELECTRONIC TRANSMISSION OF VOICE MESSAGES AND DATA; ELECTRONIC TRANSMISSION OF DATA VIA A DEDICATED CHANNEL TO RETRIEVE INFORMATION ON DRIVING MODE (U.S. CLS. 100, 101 AND 104).

NICHOLAS ALTREE, EXAMINING ATTORNEY

SN 85-217,820. COMUNICACIONES SAN MILLAN S.A. DE C.V., SAN LUIS, AZ. FILED 1-14-2011.

LA Z 1260 AM

THE MARK CONSISTS OF STANDARD CHARACTERS WITHOUT CLAIM TO ANY PARTICULAR FONT, STYLE, SIZE, OR COLOR.

NO CLAIM IS MADE TO THE EXCLUSIVE RIGHT TO USE "1260" AND "AM", APART FROM THE MARK AS SHOWN.

FOR BROADCASTING OF RADIO PROGRAMMES (U.S. CLS. 100, 101 AND 104).

FIRST USE 10-23-2009; IN COMMERCE 10-23-2009.

KATINA MISTER, EXAMINING ATTORNEY

SN 85-218,236. COMUNICACIONES SAN MILLAN S.A. DE C.V., SAN LUIS, AZ. FILED 1-14-2011.

RIO DIGITAL 102.5 FM

THE MARK CONSISTS OF STANDARD CHARACTERS WITHOUT CLAIM TO ANY PARTICULAR FONT, STYLE, SIZE, OR COLOR.

NO CLAIM IS MADE TO THE EXCLUSIVE RIGHT TO USE "DIGITAL 102.5 FM", APART FROM THE MARK AS SHOWN.

THE ENGLISH TRANSLATION OF "RIO" IN THE MARK IS "RIVER".

FOR BROADCASTING OF RADIO PROGRAMMES (U.S. CLS. 100, 101 AND 104).

FIRST USE 10-23-2009; IN COMMERCE 10-23-2009.

NAKWAMA ANKRAH, EXAMINING ATTORNEY

CLASS 38—(Continued).

SN 85-218,394. OWN LLC, LOS ANGELES, CA. FILED 1-14-2011.



THE COLOR(S) ORANGE, YELLOW, GREEN, LIGHT GREEN, PURPLE AND LIGHT PURPLE IS/ARE CLAIMED AS A FEATURE OF THE MARK.

THE MARK CONSISTS OF THE WORD "OWN" DEPICTED IN CAPITAL LETTERS WITH VARYING SHADES OF ORANGE FORMING "O" WITH YELLOW APPEARING IN THE CENTER; VARYING SHADES OF GREEN TO LIGHT GREEN FORMING "W" AND VARYING SHADES OF PURPLE TO LIGHT PURPLE FORMING "N" WITH A SHADOW UNDER EACH LETTER THAT IS DEPICTED IN THE SAME COLOR AS THE LETTER.

FOR COMMUNICATIONS SERVICES, NAMELY, TRANSMITTING STREAMED SOUND AND AUDIO-VISUAL RECORDINGS VIA THE INTERNET, CABLE NETWORKS, WIRELESS NETWORKS, SATELLITE, OR INTERACTIVE MULTIMEDIA NETWORKS; AUDIO AND VIDEO BROADCASTING SERVICES OVER THE INTERNET; TRANSMISSION OF INFORMATION IN THE AUDIO-VISUAL FIELD; TELEVISION BROADCASTING SERVICES; CABLE TELEVISION BROADCASTING; SATELLITE TELEVISION BROADCASTING; MOBILE MEDIA SERVICES IN THE NATURE OF ELECTRONIC TRANSMISSION OF ENTERTAINMENT MEDIA CONTENT; PODCASTING SERVICES; WEBCASTING SERVICES; VIDEO-ON-DEMAND TRANSMISSION SERVICES; PROVIDING ON-LINE CHAT ROOMS AND ELECTRONIC BULLETIN BOARDS FOR TRANSMISSION OF MESSAGES AMONG USERS IN THE FIELD OF GENERAL INTEREST (U.S. CLS. 100, 101 AND 104).

THOMAS MANOR, EXAMINING ATTORNEY

SN 85-218,452. COMUNICACIONES SAN MILLAN S.A. DE C.V., SAN LUIS, AZ. FILED 1-14-2011.

ESTEREO JOYA 1080 AM

THE MARK CONSISTS OF STANDARD CHARACTERS WITHOUT CLAIM TO ANY PARTICULAR FONT, STYLE, SIZE, OR COLOR.

NO CLAIM IS MADE TO THE EXCLUSIVE RIGHT TO USE "ESTEREO", "1080" AND "AM", APART FROM THE MARK AS SHOWN.

THE ENGLISH TRANSLATION OF "ESTEREO JOYA" IN THE MARK IS "STEREO JEWEL".

FOR BROADCASTING OF RADIO PROGRAMMES (U.S. CLS. 100, 101 AND 104).

FIRST USE 10-23-2009; IN COMMERCE 10-23-2009.

KATINA MISTER, EXAMINING ATTORNEY

CLASS 38—(Continued).

SN 85-219,959. COMUNICACIONES SAN MILLAN S.A. DE C.V., SAN LUIS, AZ. FILED 1-18-2011.

BRONCO FM

THE MARK CONSISTS OF STANDARD CHARACTERS WITHOUT CLAIM TO ANY PARTICULAR FONT, STYLE, SIZE, OR COLOR.

NO CLAIM IS MADE TO THE EXCLUSIVE RIGHT TO USE "FM", APART FROM THE MARK AS SHOWN.

FOR BROADCASTING OF RADIO PROGRAMMES (U.S. CLS. 100, 101 AND 104).

KATINA MISTER, EXAMINING ATTORNEY

SN 85-242,634. BUCKEYE CABLEVISION, INC., TOLEDO, OH. FILED 2-15-2011.

BUCKEYE PHONE

THE MARK CONSISTS OF STANDARD CHARACTERS WITHOUT CLAIM TO ANY PARTICULAR FONT, STYLE, SIZE, OR COLOR.

OWNER OF U.S. REG. NOS. 3,110,322 AND 3,430,647.

NO CLAIM IS MADE TO THE EXCLUSIVE RIGHT TO USE "PHONE", APART FROM THE MARK AS SHOWN.

FOR CABLE VOIP SERVICES (U.S. CLS. 100, 101 AND 104).

FIRST USE 11-21-2010; IN COMMERCE 11-21-2010.

KIMBERLY PERRY, EXAMINING ATTORNEY

SN 85-245,684. GEMINI SBS, LLC, NEW YORK, NY. FILED 2-18-2011.

RESTful Labs

THE MARK CONSISTS OF STANDARD CHARACTERS WITHOUT CLAIM TO ANY PARTICULAR FONT, STYLE, SIZE, OR COLOR.

FOR ELECTRONIC TRANSMISSION OF MESSAGES AND DATA (U.S. CLS. 100, 101 AND 104).

JULIE GUTTADAURO, EXAMINING ATTORNEY

CLASS 38—(Continued).

SN 85-246,979. SCHUYLER, WILLIAM RANDOLPH, DBA WATER HEATER RESCUE, MARINA, CA. FILED 2-19-2011.

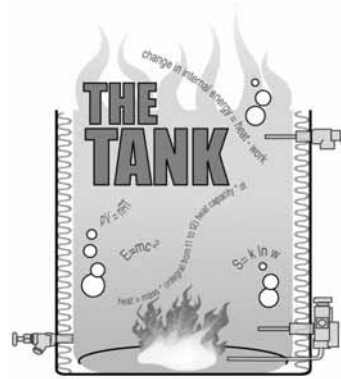

THE MARK CONSISTS OF THE WORDS "THE TANK" APPEARING INSIDE A DESIGN OF THE LOWER HALF OF A WATER HEATER WITH A FIRE BURNING AT ITS BOTTOM. BUBBLES APPEAR WITHIN THE DESIGN AND FLAMES OR STEAM APPEAR AT THE TOP OF THE DESIGN. SCIENTIFIC FORMULAE FLOAT WITHIN THE DESIGN, SPECIFICALLY: "CHANGE IN INTERNAL ENERGY = HEAT - WORK PV = NRT E = MC2 HEAT = MASS * (INTEGRAL FROM T1 TO T2) HEAT CAPACITY * DT S = K LN W".

FOR PROVIDING AN ON-LINE FORUM FOR SOLVING WATER HEATER PROBLEMS (U.S. CLS. 100, 101 AND 104).

FIRST USE 9-30-2004; IN COMMERCE 10-31-2004.

KAELIE KUNG, EXAMINING ATTORNEY

SN 85-247,468. ELINCX CORPORATION, WOOSTER, OH. FILED 2-21-2011.

eLINCx

THE MARK CONSISTS OF STANDARD CHARACTERS WITHOUT CLAIM TO ANY PARTICULAR FONT, STYLE, SIZE, OR COLOR.

FOR PROVIDING ACCESS TO AN ELECTRONIC EXCHANGE OF MEDICAL RECORDS ACROSS A REGIONAL HEALTH INFORMATION NETWORK (U.S. CLS. 100, 101 AND 104).

FIRST USE 6-0-2010; IN COMMERCE 12-0-2010.

BRIAN PINO, EXAMINING ATTORNEY

CLASS 38—(Continued).

SN 85-249,176. MESHIP, LLC, PLANO, TX. FILED 2-23-2011.



THE COLOR(S) BLUE, SILVER AND BLACK IS/ARE CLAIMED AS A FEATURE OF THE MARK.

THE MARK CONSISTS OF THE WORDING "MESHDETECT" SEPARATED BY A BLUE SHIELD WITH SILVER BORDER ON WHICH A SILVER STAR BUST DESIGN TERMINATES IN ITS CENTER THREE BLACK WITH SILVER BORDER LIGHTNING BOLTS. THE SHIELD IS TO THE LEFT OF THE THREE LIGHTNING BOLTS. THE WORD "MESH", IN LOWER CASE LETTERS, IS PLACED ABOVE THE SHIELD AND THE WORD "DETECT", IN UPPERCASE LETTERS, IS PLACED BELOW THE LIGHTNING BOLTS AND TO THE RIGHT OF THE SHIELD.

FOR COMMUNICATION SERVICES, NAMELY, TRANSMISSION OF VOICE, AUDIO, VISUAL IMAGES AND DATA BY TELECOMMUNICATIONS NETWORKS, WIRELESS COMMUNICATION NETWORKS, THE INTERNET, INFORMATION SERVICES NETWORKS AND DATA NETWORKS; TELECOMMUNICATION SERVICES IN THE NATURE OF PROVIDING TELEPHONE SERVICES WITH VARIOUS TELEPHONE FEATURES, NAMELY, A DEDICATED TOLL-FREE NUMBER, VOICEMAIL, MULTIPLE MAILBOX EXTENSIONS, TELEPHONE MESSAGE NOTIFICATION, FAX CAPABILITIES, DETAILED CALL REPORTS, CALL WAITING, CALL IDENTIFICATION, CALL FORWARDING, AND MESSAGE WAITING; TELECOMMUNICATION SERVICES, NAMELY, LOCAL AND LONG DISTANCE TRANSMISSION OF VOICE, DATA, GRAPHICS AND VIDEO BY MEANS OF BROADBAND OPTICAL OR WIRELESS NETWORKS; TELECOMMUNICATION SERVICES, NAMELY, PROVIDING ACCESS TO PICTURES, VIDEO, ALARM STATUS, BUILDING PLANS AND OTHER BUILDING AND SECURITY INFORMATION AT A REMOTE STATION; TELECOMMUNICATION SERVICES, NAMELY, PROVIDING ADVANCED CALLING FEATURES, NAMELY, CHANGING ONE'S CALLER ID, RECORDING CALLS, CHANGING THE SOUND OF ONE'S VOICE OVER THE PHONE, AND STRAIGHT-TO-VOICEMAIL CALLS; TELECOMMUNICATION SERVICES, NAMELY, PROVIDING ELECTRONIC MESSAGE ALERTS VIA THE INTERNET NOTIFYING INDIVIDUALS OF A CHANGED STATUS OR CONDITION OF A SENSING DEVICE IN A SECURITY SYSTEM; TELECOMMUNICATION SERVICES, NAMELY, TRANSMISSION OF VOICE, DATA, GRAPHICS, IMAGES, AUDIO AND VIDEO BY MEANS OF TELECOMMUNICATIONS NETWORKS, WIRELESS COMMUNICATION NETWORKS, AND THE INTERNET; TELECOMMUNICATIONS RESELLER SERVICES FOR BUSINESSES, NAMELY, PROVIDING LONG DISTANCE TELECOMMUNICATION SERVICES, VOICE TELECOMMUNICATION SERVICES, LOCAL TELEPHONE SERVICE, AND INTERNET ACCESS SERVICES; WIRELESS TELEPHONE TELECOMMUNICATIONS SERVICES, NAMELY, WIRELESS MOBILE TELEPHONE CALLING PLANS (U.S. CLS. 100, 101 AND 104).

FIRST USE 2-18-2011; IN COMMERCE 2-18-2011.
TASNEEM HUSSAIN, EXAMINING ATTORNEY

CLASS 38—(Continued).

SN 85-249,535. CINTEX WIRELESS, LLC, ROCKVILLE, MD. FILED 2-23-2011.



OWNER OF U.S. REG. NO. 3,028,240.
THE COLOR(S) YELLOW AND BLACK IS/ARE CLAIMED AS A FEATURE OF THE MARK.

THE MARK CONSISTS OF THE WORD "MOVIDA". THE LETTERS "M", "V", "I", "D", "A" ARE WRITTEN IN BLACK, WHILE THE "O" IS A YELLOW SPHERE.

THE ENGLISH TRANSLATION OF "MOVIDA" IN THE MARK IS MOVE OR MOVEMENT.

FOR TELECOMMUNICATION SERVICES, NAMELY, WIRELESS TELEPHONE SERVICES (U.S. CLS. 100, 101 AND 104).

FIRST USE 4-10-2008; IN COMMERCE 4-10-2008.
INGA ERVIN, EXAMINING ATTORNEY

SN 85-250,667. SORENSON COMMUNICATIONS, INC., SALT LAKE CITY, UT. FILED 2-24-2011.

MYRUMBLE

THE MARK CONSISTS OF STANDARD CHARACTERS WITHOUT CLAIM TO ANY PARTICULAR FONT, STYLE, SIZE, OR COLOR.

FOR TELECOMMUNICATION SERVICES IN THE NATURE OF PROVIDING TELEPHONE AND VIDEOPHONE CALLING FEATURES, NAMELY, PATTERNS OF VIBRATION THAT ENABLE IDENTIFICATION OF CONTACTS AND INCOMING CALLS (U.S. CLS. 100, 101 AND 104).

ALICE BENMAMAN, EXAMINING ATTORNEY

SN 85-251,355. NIKOLAI VLADYCHEVSKI VERESCHAGINA, DBA DEPTRAK SOFTWARE, TOLUCA, MEXICO STATE, MEXICO, FILED 2-25-2011.

WORKENGER

THE MARK CONSISTS OF STANDARD CHARACTERS WITHOUT CLAIM TO ANY PARTICULAR FONT, STYLE, SIZE, OR COLOR.

FOR INSTANT MESSAGING SERVICES; ON-LINE SERVICES, NAMELY, MESSAGE SENDING; PROVIDING E-MAIL AND INSTANT MESSAGING SERVICES; TELECOMMUNICATION SERVICES, NAMELY, PROVIDING ELECTRONIC MESSAGE ALERTS VIA THE INTERNET; WEB MESSAGING (U.S. CLS. 100, 101 AND 104).

ANNE MADDEN, EXAMINING ATTORNEY

CLASS 38—(Continued).

SN 85-254,639. TODOBEBE, INC., MIAMI, FL. FILED 3-1-2011.

TODOFAMILIA

THE MARK CONSISTS OF STANDARD CHARACTERS WITHOUT CLAIM TO ANY PARTICULAR FONT, STYLE, SIZE, OR COLOR.

OWNER OF U.S. REG. NOS. 3,491,814, 3,588,646 AND OTHERS.

THE ENGLISH TRANSLATION OF "TODOFAMILIA" IN THE MARK IS "ALL THINGS FAMILY".

FOR BROADCASTING OF FAMILY-ORIENTED CONTENT VIA TELEVISION, RADIO, MOBILE COMMUNICATION DEVICES AND OVER THE INTERNET (U.S. CLS. 100, 101 AND 104).

KAELIE KUNG, EXAMINING ATTORNEY

SN 85-255,143. COVAD COMMUNICATIONS GROUP, INC., SAN JOSE, CA. FILED 3-1-2011.

MEGAPATH

THE MARK CONSISTS OF STANDARD CHARACTERS WITHOUT CLAIM TO ANY PARTICULAR FONT, STYLE, SIZE, OR COLOR.

FOR TELECOMMUNICATIONS SERVICES, NAMELY THE TRANSMISSION OF VOICE, DATA, IMAGES, AUDIO, VIDEO AND INFORMATION VIA THE INTERNET AND COMPUTER NETWORKS.; INTERNATIONAL, LONG DISTANCE AND LOCAL TELEPHONE, TELEGRAPH AND FACSIMILE TRANSMISSION OF VOICE, DATA, IMAGES, AUDIO, VIDEO AND INFORMATION VIA THE INTERNET AND COMPUTER NETWORKS; ELECTRONIC MAIL SERVICES, VOICEMAIL AND MOBILE TELEPHONE SERVICES; PROVIDING MULTIPLE-USER INTERACTIVE ACCESS TO THE INTERNET AND TO A COMPUTER NETWORK (U.S. CLS. 100, 101 AND 104).

FIRST USE 5-0-2006; IN COMMERCE 5-0-2006.
MATTHEW KLINE, EXAMINING ATTORNEY

SN 85-255,981. KCD IP, LLC, HOFFMAN ESTATES, IL. FILED 3-2-2011.

KENMORE

THE MARK CONSISTS OF STANDARD CHARACTERS WITHOUT CLAIM TO ANY PARTICULAR FONT, STYLE, SIZE, OR COLOR.

OWNER OF U.S. REG. NOS. 522,973, 2,913,066 AND OTHERS.

FOR STREAMING OF AUDIO, VISUAL AND AUDIO-VISUAL MATERIAL ON THE INTERNET (U.S. CLS. 100, 101 AND 104).

KATHERINE STOIDES, EXAMINING ATTORNEY

CLASS 38—(Continued).

SN 85-255,982. ISADIS, LLC, MIAMI, FL. FILED 3-2-2011.



THE COLOR(S) BLACK, DARK GREY, GREY, YELLOW, LIGHT BLUE, GREEN, PLUM, RED AND VIOLET IS/ARE CLAIMED AS A FEATURE OF THE MARK.

THE MARK CONSISTS OF A TELEVISION SET WITH A DARK GREY FRAME, SURROUNDING A GREY FRAME, WITH SIX COLUMNS OF DIFFERENT COLORS, STARTING FROM THE LEFT: YELLOW, LIGHT BLUE, GREEN, PLUM, RED AND VIOLET. ON TOP OF THE TELEVISION SET ARE A PAIR OF ANTENNAE IN BLACK.

FOR BROADCASTING SERVICES AND PROVISION OF TELECOMMUNICATION ACCESS TO VIDEO AND AUDIO CONTENT PROVIDED VIA A VIDEO-ON-DEMAND SERVICE VIA THE INTERNET; COMMUNICATIONS SERVICES, NAMELY, TRANSMITTING STREAMED SOUND AND AUDIO-VISUAL RECORDINGS VIA THE INTERNET; STREAMING OF VIDEO MATERIAL ON THE INTERNET (U.S. CLS. 100, 101 AND 104).

ELIZABETH KAJUBI, EXAMINING ATTORNEY

SN 85-257,249. CALL SCIENCES, INC., GLENCOE, IL. FILED 3-3-2011.

ONEBOX EXECUTIVE

THE MARK CONSISTS OF STANDARD CHARACTERS WITHOUT CLAIM TO ANY PARTICULAR FONT, STYLE, SIZE, OR COLOR.

OWNER OF U.S. REG. NOS. 2,836,857, 3,479,654 AND 3,645,770.

FOR TELECOMMUNICATION SERVICES, NAMELY, PERSONAL COMMUNICATION SERVICES; ELECTRONIC TRANSMISSION OF MESSAGES AND DATA; TRANSMISSION OF SOUND, VIDEO AND INFORMATION; DATA TRANSMISSION AND RECEPTION SERVICES VIA TELECOMMUNICATION MEANS; ELECTRONIC EXCHANGE OF VOICE, DATA, AND GRAPHICS ACCESSIBLE VIA COMPUTER AND TELECOMMUNICATION NETWORKS; INSTANT MESSAGING SERVICES; VOICE OVER IP (VOIP) SERVICES; VIDEO AND AUDIO CONFERENCING SERVICES CONDUCTED VIA THE WEB, TELEPHONE, AND MOBILE DEVICES; COMMUNICATIONS BY COMPUTER TERMINALS; AND TELEPHONE COMMUNICATIONS SERVICES (U.S. CLS. 100, 101 AND 104).

FIRST USE 9-0-2002; IN COMMERCE 9-0-2002.
RONALD AIKENS, EXAMINING ATTORNEY

CLASS 38—(Continued).

SN 85-257,314. FARIBORZ ABBASSI, WOODLAND HILLS, CA. FILED 3-3-2011.

AZADI

THE MARK CONSISTS OF STANDARD CHARACTERS WITHOUT CLAIM TO ANY PARTICULAR FONT, STYLE, SIZE, OR COLOR.

THE ENGLISH TRANSLATION OF "AZADI" IN THE MARK IS "FREEDOM".

FOR BROADCASTING OF VIDEO AND AUDIO PROGRAMMING OVER THE INTERNET; BROADCASTING PROGRAMS VIA A GLOBAL COMPUTER NETWORK; TELEVISION BROADCASTING; WEBCASTING SERVICES (U.S. CLS. 100, 101 AND 104).

FIRST USE 9-12-2002; IN COMMERCE 9-12-2002.
CHRISTINA SOBRAL, EXAMINING ATTORNEY

SN 85-257,828. JARRETT, CHARISSA A, SAN ANTONIO, TX. AND HUCKER, SANDRA M, AUSTIN, TX, TX. FILED 3-4-2011.



THE MARKS CONSISTS OF A CIRCLE WITH A NUMBER OF CONVERGING LINES THERE THROUGH.

FOR PROVIDING A WEBSITE THAT ENCOURAGES AND ACKNOWLEDGES ACTS OF KINDNESS THROUGH COMMUNICATION SERVICES BY PROVIDING ACCESS TO AN INTERACTIVE COMPUTER DATABASE FOR ELECTRONIC TRANSMISSION OF DATA AND DOCUMENTS TO FACILITATE USERS WITH LIKE INTERESTS TO COMMUNICATE, MEET AND/OR GATHER; PROVIDING A WEBSITE FOR TRANSMISSION OF MESSAGES AMONG COMPUTER AND MOBILE DEVICE USERS WITH VARIED COMMON INTERESTS TO ASSIST THESE USERS AND GROUPS IN COORDINATING MEETINGS AND ACTIVITIES VIA ELECTRONIC AND OPTICAL COMMUNICATIONS NETWORKS; PROVIDING ON-LINE CHAT ROOMS FOR TRANSMISSION OF MESSAGES AMONG COMPUTER AND MOBILE DEVICE USERS WITH VARIED COMMON INTERESTS TO ASSIST THESE USERS AND GROUPS IN COORDINATING MEETINGS AND ACTIVITIES VIA ELECTRONIC AND OPTICAL COMMUNICATIONS NETWORKS CONCERNING A WIDE VARIETY OF SUBJECTS (U.S. CLS. 100, 101 AND 104).

FIRST USE 9-1-2010; IN COMMERCE 9-1-2010.
INGA ERVIN, EXAMINING ATTORNEY

CLASS 38—(Continued).

SN 85-265,305. FAY, JOSEPH A., NAPERVILLE, IL. FILED 3-12-2011.

**DOUBLE YOU ENNY DOUBLE
YOU, ELEVEN THREE OH IN
NEW YORK**

THE MARK CONSISTS OF STANDARD CHARACTERS WITHOUT CLAIM TO ANY PARTICULAR FONT, STYLE, SIZE, OR COLOR.

FOR RADIO BROADCASTING; INTERNET RADIO BROADCASTING (U.S. CLS. 100, 101 AND 104).

FIRST USE 1-1-2010; IN COMMERCE 2-22-2011.
JACLYN KIDWELL WALKER, EXAMINING ATTORNEY

SN 85-282,050. SORENSON COMMUNICATIONS, INC., SALT LAKE CITY, UT. FILED 3-31-2011.



NO CLAIM IS MADE TO THE EXCLUSIVE RIGHT TO USE "DEAF KIDS NETWORK", APART FROM THE MARK AS SHOWN.

THE MARK CONSISTS OF THE LETTERS "DKN" ON TOP OF TWO SHADES SQUARES AND A SHADED DIAMOND WITH THE WORDING "DEAF KIDS NETWORK" PRESENTED UNDER THE DESIGN.

FOR INTERNET BROADCASTING SERVICES (U.S. CLS. 100, 101 AND 104).
ALICE BENMAMAN, EXAMINING ATTORNEY

SN 85-300,742. SUPER DUPER INC., DBA SUPER DUPER PUBLICATIONS, GREENVILLE, SC. FILED 4-21-2011.

SUPER DUPER

THE MARK CONSISTS OF STANDARD CHARACTERS WITHOUT CLAIM TO ANY PARTICULAR FONT, STYLE, SIZE, OR COLOR.

OWNER OF U.S. REG. NOS. 1,611,214, 2,664,468 AND OTHERS.

FOR WIRELESS TELECOMMUNICATION SERVICES, NAMELY, TRANSMISSION OF DATA, GRAPHICS, IMAGES, AUDIO AND VIDEO FOR USE IN APPLICATIONS TO MOBILE TELEPHONES AND FOR USE IN ONLINE CONTINUING EDUCATION COURSES (U.S. CLS. 100, 101 AND 104).

FIRST USE 12-7-2010; IN COMMERCE 12-7-2010.
JAY BESCH, EXAMINING ATTORNEY

CLASS 38—(Continued).

SN 85-312,146. TELEVISA, S.A. DE C.V., SANTA FE, MEXICO, FILED 5-4-2011.



OWNER OF MEXICO REG. NO. 984938, DATED 3-16-2007, EXPIRES 3-16-2017.

NO CLAIM IS MADE TO THE EXCLUSIVE RIGHT TO USE "CLÁSICO TV", APART FROM THE MARK AS SHOWN.

THE MARK CONSISTS OF "CLÁSICO TV" AND STYLIZED TELEVISION DESIGN.

THE ENGLISH TRANSLATION OF "CLÁSICO TV" IN THE MARK IS "CLASSIC TV".

FOR TELECOMMUNICATIONS SERVICES, NAMELY, TELEVISION BROADCASTING AND TELECASTING SERVICES RENDERED THROUGH THE MEDIUM OF CABLE, SATELLITE, AND TERRESTRIAL WIRELINE AND WIRELESS DISTRIBUTION SYSTEMS; TRANSMISSION OF TELEVISION PROGRAMS; STREAMING OF AUDIO AND VIDEO MATERIAL ON THE INTERNET (U.S. CLS. 100, 101 AND 104).

KATHERINE E. HALMEN, EXAMINING ATTORNEY

CLASS 39—TRANSPORTATION AND STORAGE

SN 77-761,135. ACI BRANDS INC., OAKVILLE, ONTARIO, CANADA, FILED 6-16-2009.

ACI BRANDS INC.

THE MARK CONSISTS OF STANDARD CHARACTERS WITHOUT CLAIM TO ANY PARTICULAR FONT, STYLE, SIZE, OR COLOR.

PRIORITY CLAIMED UNDER SEC. 44(D) ON CANADA APPLICATION NO. 1422191, FILED 12-17-2008, REG. NO. TMA758099, DATED 1-27-2010, EXPIRES 1-27-2025.

NO CLAIM IS MADE TO THE EXCLUSIVE RIGHT TO USE "BRANDS INC.", APART FROM THE MARK AS SHOWN.

FOR WAREHOUSING SERVICES, NAMELY, STORAGE AND DISTRIBUTION OF GOODS FOR OTHERS (U.S. CLS. 100 AND 105).

CHRISIE B. KING, EXAMINING ATTORNEY

CLASS 39—(Continued).

SN 77-929,475. THE MILESTONE AVIATION GROUP LLC, COLTS NECK, NJ. FILED 2-5-2010.

MILESTONE

THE MARK CONSISTS OF STANDARD CHARACTERS WITHOUT CLAIM TO ANY PARTICULAR FONT, STYLE, SIZE, OR COLOR.

FOR AVIATION LEASING SERVICES, NAMELY, LEASING OF AIRPLANES; LEASING OF AIRCRAFT; BUSINESS JET AND HELICOPTER LEASING SERVICES (U.S. CLS. 100 AND 105).

COLLEEN DOMBROW, EXAMINING ATTORNEY

SN 77-982,030. NEXTPOINT INC., CHICAGO, IL. FILED 1-28-2010.

TRIAL CLOUD

THE MARK CONSISTS OF STANDARD CHARACTERS WITHOUT CLAIM TO ANY PARTICULAR FONT, STYLE, SIZE, OR COLOR.

NO CLAIM IS MADE TO THE EXCLUSIVE RIGHT TO USE "CLOUD", APART FROM THE MARK AS SHOWN.

FOR ELECTRONIC STORAGE OF DATA (U.S. CLS. 100 AND 105).

ANNE E. GUSTASON, EXAMINING ATTORNEY

SN 77-982,031. NEXTPOINT INC., CHICAGO, IL. FILED 1-28-2010.

DISCOVERY CLOUD

THE MARK CONSISTS OF STANDARD CHARACTERS WITHOUT CLAIM TO ANY PARTICULAR FONT, STYLE, SIZE, OR COLOR.

NO CLAIM IS MADE TO THE EXCLUSIVE RIGHT TO USE "CLOUD", APART FROM THE MARK AS SHOWN.

FOR ELECTRONIC STORAGE OF DATA (U.S. CLS. 100 AND 105).

ANNE E. GUSTASON, EXAMINING ATTORNEY

CLASS 39—(Continued).

SN 79-082,463. OVERSEAS COURIER SERVICE CO., LTD., TOKYO 108-8701, JAPAN, FILED 4-2-2010.

I E X

THE MARK CONSISTS OF STANDARD CHARACTERS WITHOUT CLAIM TO ANY PARTICULAR FONT, STYLE, SIZE, OR COLOR.

OWNER OF INTERNATIONAL REGISTRATION 1038394 DATED 4-2-2010, EXPIRES 4-2-2020.

FOR CAR TRANSPORT; MARINE TRANSPORT; AIR TRANSPORT; PACKAGING OF GOODS FOR TRANSPORTATION; FREIGHT BROKERAGE; FREIGHT BROKERAGE, NAMELY, FREIGHT FORWARDING AND FREIGHT FORWARDING AGENTS; FREIGHT BROKERAGE, NAMELY, FREIGHT FORWARDING BY CAR TRANSPORT, MARINE TRANSPORT AND AIR TRANSPORT; CARGO UNLOADING; WAREHOUSING SERVICES (U.S. CLS. 100 AND 105).

CHRISTINE MARTIN, EXAMINING ATTORNEY

SN 79-087,460. AET INC. LIMITED, HAMILTON, BERMUDA, FILED 9-4-2010.

AET

THE MARK CONSISTS OF STANDARD CHARACTERS WITHOUT CLAIM TO ANY PARTICULAR FONT, STYLE, SIZE, OR COLOR.

OWNER OF INTERNATIONAL REGISTRATION 0929567 DATED 6-1-2007, EXPIRES 6-1-2017.

FOR TRANSPORT BY SHIP OF CRUDE OIL, PETROLEUM, REFINED FUELS, PETROCHEMICALS, LIQUEFIED PETROLEUM GAS AND LIQUEFIED NATURAL GAS; FLOATING STORAGE OF LIQUEFIED PETROLEUM GAS (U.S. CLS. 100 AND 105).

WENDY GOODMAN, EXAMINING ATTORNEY

CLASS 39—(Continued).

SN 79-092,727. HANATOUR SERVICE INC., REPUBLIC OF KOREA, FILED 11-5-2010.

OWNER OF INTERNATIONAL REGISTRATION 1065601 DATED 11-5-2010, EXPIRES 11-5-2020.

OWNER OF U.S. REG. NOS. 3,557,622 AND 3,787,586.

THE COLOR(S) MAGENTA, WHITE AND DARK GRAY IS/ARE CLAIMED AS A FEATURE OF THE MARK.

THE MARK CONSISTS OF THE LETTERS "HNT" APPEARING IN WHITE STYLIZED LETTERING WITHIN A MAGENTA OVAL CARRIER, ADJACENT TO DARK GRAY, STYLIZED KOREAN WORDING THAT TRANSLITERATES TO HANATOUR IN ENGLISH.

THE ENGLISH TRANSLATION OF THE FOREIGN WORD(S) IN THE MARK IS ONE TOUR.

THE TRANSLITERATION OF THE NON-LATIN CHARACTERS IN THE MARK IS HANATOUR.

FOR ARRANGING OF TOURS; TRAVEL RESERVATION; TRAVEL INFORMATION SERVICES; ORGANISATION OF EXCURSIONS; BOOKING OF SEATS FOR TRAVEL; TOUR CONDUCTING OR ESCORTING; TOUR CONDUCTING; TRAVEL AND TOUR INFORMATION SERVICE; TRAVEL GUIDE AGENCY; COORDINATING TRAVEL ARRANGEMENTS FOR INDIVIDUALS AND FOR GROUPS; TRAVEL GUIDE SERVICES; ESCORTING OF TRAVELLERS; CONDUCTING SIGHTSEEING TOURS; ORGANIZATION OF EXCURSIONS, DAY TRIPS AND SIGHTSEEING TOURS; ARRANGING OF CRUISES; ARRANGING OF TRAVEL FOR PACKAGE HOLIDAYS; ARRANGING OF OVERSEAS TRAVEL; TRANSPORT OF TRAVELLERS; TRANSPORTATION OF TRAVELLERS; PASSENGER TRANSPORT; AIR TRANSPORT; AIR TRANSPORT AGENCY; AIRPORT SERVICES; BUS TRANSPORT; BUS RENTAL; VAN TRANSPORT; BOAT TRANSPORT; BOAT RENTAL; SAILBOAT TRANSPORT; SHIP TRANSPORT; RENTAL OF VEHICLE FLEETS; PASSENGER SHIP TRANSPORT; RENTAL CAR RESERVATION; PARCEL DELIVERY; TRANSPORTATION AGENCY RESERVATION AND TRANSPORTATION SERVICES; ARRANGEMENT OF TRANSPORTATION FOR EXCURSIONS, CRUISES, DAY TRIPS AND SIGHTSEEING TOURS; FREIGHT TRANSPORT; TRANSPORT RESERVATION; TRANSPORTATION INFORMATION; CAR TRANSPORT; CAR RENTAL; BICYCLE RENTAL; CAR PARKING; PARKING PLACE RENTAL; GARAGE RENTAL; VEHICLE RENTAL; RAILWAY TRANSPORT; LEASING OF AIRCRAFT; RENTAL OF WHEELCHAIRS; WAREHOUSING; STORAGE OF BAGGAGE; STORAGE INFORMATION; STORAGE OF GOODS; GENERAL WAREHOUSING; RENTAL OF WAREHOUSES; STORAGE OF CARGO; FREIGHT WAREHOUSING (U.S. CLS. 100 AND 105).

JUDITH HELFMAN, EXAMINING ATTORNEY

CLASS 39—(Continued).

SN 79-092,728. HANATOUR SERVICE INC., REPUBLIC OF KOREA, FILED 11-5-2010.



OWNER OF INTERNATIONAL REGISTRATION 1065602 DATED 11-5-2010, EXPIRES 11-5-2020.

OWNER OF U.S. REG. NOS. 3,557,622 AND 3,787,586.

THE COLOR(S) MAGENTA, WHITE AND DARK GRAY IS/ARE CLAIMED AS A FEATURE OF THE MARK.

THE MARK CONSISTS OF THE LITERAL ELEMENTS "HNT HANATOUR", WITH THE LETTERS "HNT" APPEARING IN WHITE STYLIZED LETTERING WITHIN A MAGENTA OVAL CARRIER, ADJACENT TO THE WORDING "HANATOUR" APPEARING IN DARK GRAY, STYLIZED LETTERING.

THE TERM "HANATOUR" HAS NO MEANING IN A FOREIGN LANGUAGE.

FOR ARRANGING OF TOURS; TRAVEL RESERVATION; TRAVEL INFORMATION SERVICES; ORGANISATION OF EXCURSIONS; BOOKING OF SEATS FOR TRAVEL; TOUR CONDUCTING OR ESCORTING; TOUR CONDUCTING; TRAVEL AND TOUR INFORMATION SERVICE; TRAVEL GUIDE AGENCY; COORDINATING TRAVEL ARRANGEMENTS FOR INDIVIDUALS AND FOR GROUPS; TRAVEL GUIDE SERVICES; ESCORTING OF TRAVELLERS; CONDUCTING SIGHTSEEING TOURS; ORGANIZATION OF EXCURSIONS, DAY TRIPS AND SIGHTSEEING TOURS; ARRANGING OF CRUISES; ARRANGING OF TRAVEL FOR PACKAGE HOLIDAYS; ARRANGING OF OVERSEAS TRAVEL; TRANSPORT OF TRAVELLERS; TRANSPORTATION OF TRAVELLERS; PASSENGER TRANSPORT; AIR TRANSPORT; AIR TRANSPORT AGENCY; AIRPORT SERVICES; BUS TRANSPORT; BUS RENTAL; VAN TRANSPORT; BOAT TRANSPORT; BOAT RENTAL; SAILBOAT TRANSPORT; SHIP TRANSPORT; RENTAL OF VEHICLE FLEETS; PASSENGER SHIP TRANSPORT; RENTAL CAR RESERVATION; PARCEL DELIVERY; TRANSPORTATION AGENCY RESERVATION AND TRANSPORTATION SERVICES; ARRANGEMENT OF TRANSPORTATION FOR EXCURSIONS, CRUISES, DAY TRIPS AND SIGHTSEEING TOURS; FREIGHT TRANSPORT; TRANSPORT RESERVATION; TRANSPORTATION INFORMATION; CAR TRANSPORT; CAR RENTAL; BICYCLE RENTAL; CAR PARKING; PARKING PLACE RENTAL; GARAGE RENTAL; VEHICLE RENTAL; RAILWAY TRANSPORT; LEASING OF AIRCRAFT; RENTAL OF WHEELCHAIRS; WAREHOUSING; STORAGE OF BAGGAGE; STORAGE INFORMATION; STORAGE OF GOODS; GENERAL WAREHOUSING; RENTAL OF WAREHOUSES; STORAGE OF CARGO; FREIGHT WAREHOUSING (U.S. CLS. 100 AND 105).

JUDITH HELFMAN, EXAMINING ATTORNEY

CLASS 39—(Continued).

SN 79-094,150. TUI AG, 30625 HANNOVER, FED REP GERMANY, FILED 10-9-2010.



PRIORITY DATE OF 9-9-2010 IS CLAIMED.

OWNER OF INTERNATIONAL REGISTRATION 1068661 DATED 10-9-2010, EXPIRES 10-9-2020.

THE MARK CONSISTS OF THE LETTER "A" IN STYLIZED FONT WITH AN ARROW DESIGN POINTING TO THE RIGHT.

FOR TRANSPORT, NAMELY, TRANSPORT OF CURRENCY, VALUABLES AND GOODS, IN PARTICULAR BY ROAD, RAIL, SEA AND AIR; MERCHANDISE PACKAGING FOR OTHERS; STORAGE OF GOODS; TRANSPORT OF PERSONS AND GOODS BY ROAD, RAIL, SEA AND AIR; PORTER SERVICES; TRANSPORT OF MONEY AND VALUABLES; TRAVEL ORGANIZATION, BOOKING AND ARRANGEMENT OF TRAVEL TOURS, EXCURSIONS AND CRUISES; ARRANGEMENT OF TRANSPORT SERVICES; RENTAL OF DIVING SUITS; ORGANIZATION, BOOKING AND ARRANGEMENT OF EXCURSIONS, DAY TRIPS AND SIGHTSEEING TOURS; TRAVEL CONSULTANCY, NAMELY, PROVIDING TRAVEL INFORMATION AND ESCORTING OF TRAVELERS; RENTAL, BOOKING AND PROVIDING TRANSPORT OF AIRCRAFT; RENTAL, BOOKING AND PROVIDING TRANSPORT OF SHIPS FEATURING ROWING AND MOTOR BOATS, SAILING VESSELS AND CANOES; RENTAL, BOOKING AND PROVIDING TRANSPORT OF MOTOR VEHICLES, BICYCLES AND HORSES; PARCEL DELIVERY; ARRANGING AND COORDINATING TRAVEL ARRANGEMENTS FOR INDIVIDUALS AND GROUPS FEATURING HOLIDAY VACATIONS AND SIGHTSEEING TOURS; TRAVEL AGENCY SERVICES, NAMELY, MAKING RESERVATIONS AND BOOKINGS FOR TRANSPORTATION, ARRANGING TRANSPORT SERVICES AND TRAVEL; PROVIDING INFORMATION ABOUT TRAVEL ON THE INTERNET FEATURING ONLINE TRANSPORTATION RESERVATION AND TRAVEL TICKET BOOKING IN THE TOURISM AND BUSINESS TRAVEL SECTOR; DELIVERY OF NEWSPAPERS AND MAGAZINES; TRAVEL BOOKING AGENCY CONSULTATION PROVIDED VIA TELEPHONE CALL CENTERS AND HOTLINES IN THE FIELD OF BUSINESS TRAVEL; CONSULTATION IN THE FIELD OF LOGISTICS, TRANSPORT AND STORAGE OF GOODS; TRANSPORT SERVICES, NAMELY, TRACKING OF PASSENGER OR FREIGHT VEHICLES USING COMPUTERS OR GLOBAL-POSITIONING SYSTEM (GPS); TRAFFIC INFORMATION (U.S. CLS. 100 AND 105).

EMILY CHUO, EXAMINING ATTORNEY

CLASS 39—(Continued).

SN 85-031,652. SOUTHWEST AIRLINES CO., DALLAS, TX. FILED 5-6-2010.

swacargo.com

THE MARK CONSISTS OF STANDARD CHARACTERS WITHOUT CLAIM TO ANY PARTICULAR FONT, STYLE, SIZE, OR COLOR.

OWNER OF U.S. REG. NOS. 1,738,670, 3,011,430 AND OTHERS.

FOR AIR FREIGHT SHIPPING SERVICES; AIR TRANSPORT SERVICES; CARGO HANDLING; DELIVERY OF GOODS BY AIR (U.S. CLS. 100 AND 105).

FIRST USE 2-21-1997; IN COMMERCE 2-21-1997.
KATHERINE CONNOLLY, EXAMINING ATTORNEY

CLASS 39—(Continued).

SN 85-104,986. FILTERS AT YOUR DOOR, INC., MANASSAS, VA. FILED 8-11-2010.



NO CLAIM IS MADE TO THE EXCLUSIVE RIGHT TO USE "FILTERS", APART FROM THE MARK AS SHOWN.

THE MARK CONSISTS OF "FILTERS AT YOUR DOOR" AND A GRAPHIC REPRESENTATION OF A FILTER AND DOOR AND DOORFRAME.

FOR DISTRIBUTION, TRANSPORT AND DELIVERY OF GOODS IN THE NATURE OF CLIMATE CONTROL EQUIPMENT, DEVICES, ACCESSORIES AND SUPPLIES, NAMELY, HEATING, VENTILATION AND AIR CONDITIONING EQUIPMENT, DEVICES, ACCESSORIES AND SUPPLIES; EXPEDITED DISTRIBUTION, TRANSPORT AND DELIVERY OF GOODS IN THE NATURE OF CLIMATE CONTROL EQUIPMENT, DEVICES, ACCESSORIES AND SUPPLIES, NAMELY, HEATING, VENTILATION AND AIR CONDITIONING EQUIPMENT, DEVICES, ACCESSORIES AND SUPPLIES; EXPRESS DISTRIBUTION, TRANSPORT AND DELIVERY OF GOODS IN THE NATURE OF CLIMATE CONTROL EQUIPMENT, DEVICES, ACCESSORIES AND SUPPLIES, NAMELY, HEATING, VENTILATION AND AIR CONDITIONING EQUIPMENT, DEVICES, ACCESSORIES AND SUPPLIES (U.S. CLS. 100 AND 105).

FIRST USE 12-31-2007; IN COMMERCE 12-31-2007.
JACQUELINE A. LAVINE, EXAMINING ATTORNEY

SN 85-100,103. DEAN C. KLAUS, DBA YOUR SPACE STORAGE, MCMINNVILLE, OR. FILED 8-4-2010.



THE COLOR(S) BLUE AND WHITE IS/ARE CLAIMED AS A FEATURE OF THE MARK.

THE MARK CONSISTS OF A STANDING GRIZZLY BEAR HOLDING FLOWERS, ALL IN BLUE AND WHITE.

FOR PROVIDING SELF-STORAGE FACILITIES FOR OTHERS; STORAGE OF GOODS (U.S. CLS. 100 AND 105).

FIRST USE 1-1-1985; IN COMMERCE 1-1-1985.
SARA BENJAMIN, EXAMINING ATTORNEY

SN 85-116,510. MILITARY HISTORICAL TOURS, INC., WOODBRIDGE, VA. FILED 8-26-2010.

European Battlefield Tours

THE MARK CONSISTS OF STANDARD CHARACTERS WITHOUT CLAIM TO ANY PARTICULAR FONT, STYLE, SIZE, OR COLOR.

NO CLAIM IS MADE TO THE EXCLUSIVE RIGHT TO USE "TOURS", APART FROM THE MARK AS SHOWN.

SEC. 2(F).
FOR TOUR OPERATING AND ORGANIZING (U.S. CLS. 100 AND 105).

FIRST USE 3-21-1997; IN COMMERCE 3-21-1997.
NATALIE POLZER, EXAMINING ATTORNEY

CLASS 39—(Continued).

SN 85-116,527. MILITARY HISTORICAL TOURS, INC., WOODBRIDGE, VA. FILED 8-26-2010.

Military Historical Tours

THE MARK CONSISTS OF STANDARD CHARACTERS WITHOUT CLAIM TO ANY PARTICULAR FONT, STYLE, SIZE, OR COLOR.

NO CLAIM IS MADE TO THE EXCLUSIVE RIGHT TO USE "TOURS", APART FROM THE MARK AS SHOWN. SEC. 2(F).

FOR TOUR OPERATING AND ORGANIZING (U.S. CLS. 100 AND 105).

FIRST USE 3-21-1997; IN COMMERCE 3-21-1997.
NATALIE POLZER, EXAMINING ATTORNEY

CLASS 39—(Continued).

SN 85-134,306. AMBIT ENERGY HOLDINGS, L.L.C., DALLAS, TX. FILED 9-21-2010.

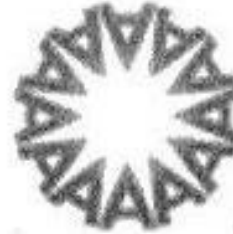

OWNER OF U.S. REG. NOS. 3,389,005, 3,443,624 AND 3,786,848.

THE MARK CONSISTS OF CAPITAL LETTER "A"'S ARRANGED TO FORM A CIRCLE.

FOR DISTRIBUTION OF ENERGY, NAMELY, PROVIDING ELECTRICAL ENERGY AND NATURAL GAS TO RESIDENTIAL AND COMMERCIAL USERS (U.S. CLS. 100 AND 105).

LINDA MICKLEBURGH, EXAMINING ATTORNEY

SN 85-116,564. MILITARY HISTORICAL TOURS, INC., WOODBRIDGE, VA. FILED 8-26-2010.

Vietnam Battlefield Tours

THE MARK CONSISTS OF STANDARD CHARACTERS WITHOUT CLAIM TO ANY PARTICULAR FONT, STYLE, SIZE, OR COLOR.

NO CLAIM IS MADE TO THE EXCLUSIVE RIGHT TO USE "TOURS", APART FROM THE MARK AS SHOWN. SEC. 2(F).

FOR TOUR OPERATING AND ORGANIZING (U.S. CLS. 100 AND 105).

FIRST USE 3-21-1997; IN COMMERCE 3-21-1997.
NATALIE POLZER, EXAMINING ATTORNEY

SN 85-137,986. ECOAMERICA TOURS, LLC, THE WOODLANDS, TX. FILED 9-24-2010.



SN 85-116,569. MILITARY HISTORICAL TOURS, INC., WOODBRIDGE, VA. FILED 8-26-2010.

Pacific Battlefield Tours

THE MARK CONSISTS OF STANDARD CHARACTERS WITHOUT CLAIM TO ANY PARTICULAR FONT, STYLE, SIZE, OR COLOR.

NO CLAIM IS MADE TO THE EXCLUSIVE RIGHT TO USE "TOURS", APART FROM THE MARK AS SHOWN. SEC. 2(F).

FOR TOUR OPERATING AND ORGANIZING (U.S. CLS. 100 AND 105).

FIRST USE 3-21-1997; IN COMMERCE 3-21-1997.
NATALIE POLZER, EXAMINING ATTORNEY

NO CLAIM IS MADE TO THE EXCLUSIVE RIGHT TO USE "TOURS", APART FROM THE MARK AS SHOWN.

THE MARK CONSISTS OF THE WORDING "ECOAMERICA TOURS" AND A PARROT.

FOR TRAVEL AGENCY SERVICES, NAMELY, MAKING RESERVATIONS AND BOOKINGS FOR TRANSPORTATION; TRAVEL AND TOUR INFORMATION SERVICE (U.S. CLS. 100 AND 105).

FIRST USE 7-7-2010; IN COMMERCE 7-7-2010.
APRIL ROACH, EXAMINING ATTORNEY

CLASS 39—(Continued).

SN 85-138,291. AMBIT ENERGY HOLDINGS, LLC, DALLAS, TX. FILED 9-25-2010.



OWNER OF U.S. REG. NOS. 3,389,005, 3,443,624 AND 3,786,848.

NO CLAIM IS MADE TO THE EXCLUSIVE RIGHT TO USE "ENERGY", APART FROM THE MARK AS SHOWN.

THE MARK CONSISTS OF THE WORDS "AMBIT ENERGY" FOLLOWED BY CAPITAL LETTER "A"'S FORMED IN A CIRCLE.

FOR DISTRIBUTION OF ENERGY, NAMELY, PROVIDING ELECTRICAL ENERGY AND NATURAL GAS TO RESIDENTIAL AND COMMERCIAL USERS (U.S. CLS. 100 AND 105).

LINDA MICKLEBURGH, EXAMINING ATTORNEY

SN 85-138,292. AMBIT ENERGY HOLDINGS, LLC, DALLAS, TX. FILED 9-25-2010.



OWNER OF U.S. REG. NOS. 3,389,005, 3,443,624 AND 3,786,848.

NO CLAIM IS MADE TO THE EXCLUSIVE RIGHT TO USE "ENERGY", APART FROM THE MARK AS SHOWN.

THE MARK CONSISTS OF THE WORDS "AMBIT ENERGY" AND ABOVE ARE CAPITAL LETTER "A"'S ARRANGED IN A CIRCLE.

FOR DISTRIBUTION OF ENERGY, NAMELY, PROVIDING ELECTRICAL ENERGY AND NATURAL GAS TO RESIDENTIAL AND COMMERCIAL USERS (U.S. CLS. 100 AND 105).

LINDA MICKLEBURGH, EXAMINING ATTORNEY

CLASS 39—(Continued).

SN 85-143,541. VIP TRAVEL NETWORK LLC, SCOTTSDALE, AZ. FILED 10-1-2010.



THE COLOR(S) BLUE, AQUA, WHITE, TURQUOISE AND BROWN IS/ARE CLAIMED AS A FEATURE OF THE MARK.

THE MARK CONSISTS OF THE FOLLOWING: AN ABSTRACT DESIGN OF HANDS AND A SAIL WITHIN A SHIP PORTAL, WITH THE DESIGN IN BLUE, AQUA, AND WHITE, AND THE PORTAL IN TURQUOISE AND BROWN.

FOR TRAVEL AGENCY SERVICES; ARRANGING OF TOURS AND CRUISES (U.S. CLS. 100 AND 105).

FIRST USE 10-31-2005; IN COMMERCE 10-31-2005.

LINDA M. KING, EXAMINING ATTORNEY

SN 85-175,438. NISSAN JIDOSHA KABUSHIKI KAISHA, TA NISSAN MOTOR CO., LTD., YOKOHAMA-SHI, KANAGAWA, JAPAN, FILED 11-12-2010.

INFINITI CONNECTION

THE MARK CONSISTS OF STANDARD CHARACTERS WITHOUT CLAIM TO ANY PARTICULAR FONT, STYLE, SIZE, OR COLOR.

FOR MOBILE INFORMATION SERVICES, NAMELY, TRAFFIC INFORMATION, FLIGHT ARRIVAL AND DEPARTURE INFORMATION; GPS NAVIGATION SERVICES, NAMELY, PROVIDING BEST FORECAST ROUTE GUIDANCE TO DRIVERS, NAVIGATION SERVICES VIA THE INTERNET, ASSISTANCE WITH DESTINATION SETTING, VOICE ROUTING AND LOCATION ASSISTANCE AND CONVENIENCE SERVICES THROUGH COMPONENTS INTEGRATED INTO A MOTOR VEHICLE, NAMELY, TRANSMITTERS, RECEIVERS, MICROPROCESSORS, SOFTWARE, CELLULAR PHONE, AND ELECTRICAL ARCHITECTURE ALL INTERACTING WITH GLOBAL POSITION SYSTEM AND SATELLITE TECHNOLOGY AND A CUSTOMER SERVICE CENTER (U.S. CLS. 100 AND 105).

NICHOLAS ALTREE, EXAMINING ATTORNEY

CLASS 39—(Continued).

SN 85-175,518. DIVERSIFIED TRANSPORTATION, LLC, LOS ANGELES, CA. FILED 11-12-2010.



NO CLAIM IS MADE TO THE EXCLUSIVE RIGHT TO USE "DIVERSIFIED TRANSPORTATION", APART FROM THE MARK AS SHOWN.

THE MARK CONSISTS OF THE WORDING "DIVERSIFIED TRANSPORTATION" AND TWO ARCH DESIGN ELEMENTS OVER THE WORD "DIVERSIFIED".

FOR TAXI, LIMOUSINE, BUS, SHUTTLE AND CAR TRANSPORT SERVICES (U.S. CLS. 100 AND 105).

FIRST USE 1-15-2007; IN COMMERCE 1-15-2007.
NICHOLAS ALTREE, EXAMINING ATTORNEY

SN 85-213,837. ACADEMIC TRAVEL ABROAD, INC., WASHINGTON, DC. FILED 1-10-2011.



NO CLAIM IS MADE TO THE EXCLUSIVE RIGHT TO USE "TRAVEL", APART FROM THE MARK AS SHOWN.

THE MARK CONSISTS OF THE WORD "AUTHENTICITY" IN LOWER CASE LETTERS ABOVE THE WORDS "TRAVEL DEEPER" AND TWO HORIZONTAL LINES, TO THE LEFT OF WHICH IS A PAGODA SKYLINE SURROUNDED BY TWO ARCING LINES.

FOR ORGANIZATION OF EXCURSIONS AND TRAVEL (U.S. CLS. 100 AND 105).

FIRST USE 10-20-2010; IN COMMERCE 10-20-2010.
PAM WILLIS, EXAMINING ATTORNEY

SN 85-215,416. WINDWARD AVIATION LLC, HENDERSON, NV. FILED 1-11-2011.



NO CLAIM IS MADE TO THE EXCLUSIVE RIGHT TO USE "AVIATION", APART FROM THE MARK AS SHOWN.

THE COLOR(S) BLACK, GREY, STAINLESS STEEL, SILVER, GOLDEN-ORANGE IS/ARE CLAIMED AS A FEATURE OF THE MARK.

THE MARK CONSISTS OF A UNIQUE REPRESENTATION OF A WEATHER CHART WIND BARB SYMBOL, HEREIN REFERRED AS "WIND BARB". IT IS A STYLIZED "W" OF TEXTURED GOLDEN-ORANGE COLOR, WITH

CLASS 39—(Continued).

THE TWO LEFT-MOST OF THE THREE PARALLEL LINES, CANTED ROUGHLY 50 DEGREES FROM THE HORIZONTAL, AND BEING OF EQUAL HEIGHT AND WIDTH. THE THIRD AND RIGHT-MOST OF THE THREE PARALLEL LINES BEING HALF THE HEIGHT AND SAME WIDTH OF THE TWO LEFT-MOST LINES. THE TIPS OF EACH OF THE THREE PARALLEL LINES BEAR AN ARTIST'S BRUSH STROKE TO THE LEFT, DEPICTING A WIND-BLOWN FLAME. THE BOTTOM LEFT-MOST REGION OF THE WIND BARB CONTAINS A SEPARATE THIN BRUSH-STROKE OF THE SAME GOLDEN-ORANGE COLOR WHICH MATCHES THE CONTOUR OF THE LEFT-MOST PARALLEL LINE. ALL THREE OF THE CANTED PARALLEL LINES HAVE A BLACK SHADOW BELOW AND TO THE LEFT, INDICATING THAT A LIGHT SOURCE EXISTS OUTSIDE OF THE RIGHT FRAME OF THE ENTIRE MARK. THE BASE OF THE "W" EXTENDS TO THE RIGHT WITH A SLIGHTLY RISING THEN DESCENDING CONTOURED ARC. THE RIGHT END OF THE ARC TERMINATES TO A FINE TIP. CENTERED BELOW THE WIND BARB IS THE LITERAL ELEMENT OF THE MARK, WINDWARD AVIATION, IN THE ALL CAPS BLACK FONT OF TRAJAN PRO REGULAR. THE LETTER "N" OF "AVIATION" IS STYLIZED WITH THE LOWER-RIGHT POINT OF THE CHARACTER EXTENDED SLIGHTLY BELOW THE LEVEL OF THE REST OF THE LITERAL ELEMENT, AND TERMINATING IN A POINT. THE UPPER-LEFT OF THE "N" IS STYLIZED WITH A BRUSH-STROKE TERMINATING IN A FINE TIP AND EXTENDING UPWARDS AND TO THE LEFT TOWARDS, BUT NOT TOUCHING, THE RIGHT-MOST TERMINATION POINT OF THE CURVING WIND BARB. THIS CURVING AND TAPERED BRUSH-STROKE ON THE "N" BEGINS IN THE LOWER-RIGHT IN THE COLOR BLACK AND FADES INTO THE COLOR GOLDEN-ORANGE, MATCHING THE GOLDEN-ORANGE COLOR OF THE WIND BARB, AS IT EXTENDS UPWARDS AND TO THE LEFT. THE GOLDEN-ORANGE UPPER-LEFT TIP OF THE "N" CONTAINS A THIN BLACK SHADOW BELOW AND TO THE LEFT, INDICATING THAT A LIGHT SOURCE EXISTS OUTSIDE OF THE RIGHT FRAME OF THE ENTIRE MARK. BEHIND THE WIND BARB AND THE LITERAL ELEMENT IS A STYLIZED REPRESENTATION OF THE WESTERN HEMISPHERE CONTINENTS OF A GLOBAL DEPICTION OF EARTH, HEREIN REFERRED TO AS GLOBE. THE CONTINENTS WITHIN THE GLOBE ARE STAINLESS STEEL AND SILVER IN COLOR, WITH A HALOED GREY DROP-SHADOW. THE DEPICTION OF THE GLOBE DOES NOT CONTAIN ANY COLOR OR TEXTURE REPRESENTING THE AREAS WHERE THE WATER WOULD EXIST.

FOR AIRPLANE CHARTERING; CHARITABLE SERVICES, NAMELY, PROVIDING AUTOMOBILES TO BE USED BY RECIPIENTS FOR TRANSPORTATION; CONDUCTING SIGHTSEEING TOURS BY AIRPLANE; CONDUCTING SIGHTSEEING TOURS BY HELICOPTER; DELIVERY OF GOODS BY AIR; DOCUMENT DELIVERY; EXPRESS DELIVERY OF GOODS BY AIR; FREIGHT TRANSPORT BY SHIP; FREIGHT TRANSPORTATION BY AIR; FREIGHT TRANSPORTATION CONSULTATION IN THE FIELD OF FREIGHT TRANSPORTATION BY TRUCK, RAIL, AIR AND OCEAN; GLOBAL TRANSPORTATION OF FREIGHT FOR OTHERS BY ALL AVAILABLE MEANS; GUARDED TRANSPORTATION OF VALUABLES AND MONEY BY TRUCK; HELICOPTER TRANSPORT; ON-LINE COMPUTER SERVICES FOR STORING CONTENT ITEMS SELECTED BY USERS FROM INTERNET WEB PAGES; PROPELLER AIRPLANE TRANSPORT; PROVIDE A WEBSITE FOR THE ARRANGEMENT AND BOOKING

CLASS 39—(Continued).

OF ECO-TRAVEL AND ECO-TOURS; PROVIDING INFORMATION ABOUT AUTOMOBILES FOR LEASE BY MEAN OF THE INTERNET; RENTAL OF AIRPLANES; RENTAL OF VEHICLES AND APPARATUS FOR LOCOMOTION BY AIR; SHIPPING AND DELIVERY SERVICES, NAMELY, PICKUP, TRANSPORTATION, AND DELIVERY OF PACKAGES AND LETTERS BY VARIOUS MODES OF TRANSPORTATION; SUPPLY CHAIN LOGISTICS AND REVERSE LOGISTICS SERVICES, NAMELY, STORAGE, TRANSPORTATION AND DELIVERY OF GOODS FOR OTHERS BY AIR, RAIL, SHIP OR TRUCK; TRANSPORT BY AIRCRAFT; TRANSPORT BY TWO-WHEELED MOTOR VEHICLES; TRANSPORT OF AIRCRAFT BY AIR AND/OR SEA; TRANSPORTATION AND DELIVERY SERVICES BY AIR, ROAD, RAIL AND SEA; TRANSPORTATION OF GOODS, PASSENGERS AND TRAVELLERS BY AIR; TRANSPORTATION OF PASSENGERS AND/OR GOODS BY AIR; TURBOJET AIRPLANE TRANSPORT; VEHICLE ROUTING BY COMPUTER ON DATA NETWORKS (U.S. CLS. 100 AND 105).

FIRST USE 11-13-2009; IN COMMERCE 6-2-2010.
AISHA CLARKE, EXAMINING ATTORNEY

SN 85-222,198. RIGHT CONNECTION, INC., LAS VEGAS, NV. FILED 1-20-2011.

LIFESTYLES CRUISE

THE MARK CONSISTS OF STANDARD CHARACTERS WITHOUT CLAIM TO ANY PARTICULAR FONT, STYLE, SIZE, OR COLOR.

OWNER OF U.S. REG. NOS. 2,008,780 AND 3,467,869.
NO CLAIM IS MADE TO THE EXCLUSIVE RIGHT TO USE "CRUISE", APART FROM THE MARK AS SHOWN.
SEC. 2(F).

FOR TRAVEL AGENCY SERVICES, NAMELY, MAKING RESERVATIONS AND BOOKINGS FOR PARTIAL AND FULL SHIP ADULT TAKE-OVER CRUISES AND SPECIALTY THEMED CRUISES; ARRANGING TRAVEL TOURS AND EXCURSIONS FOR ADULTS (U.S. CLS. 100 AND 105).

FIRST USE 12-0-2008; IN COMMERCE 12-0-2008.
HANNO RITTNER, EXAMINING ATTORNEY

SN 85-242,888. GITIBIN & ASSOCIATES, DBA GO RENTALS, NEWPORT BEACH, CA. FILED 2-15-2011.

jet in, drive out.

THE MARK CONSISTS OF STANDARD CHARACTERS WITHOUT CLAIM TO ANY PARTICULAR FONT, STYLE, SIZE, OR COLOR.

FOR CAR RENTAL (U.S. CLS. 100 AND 105).
FIRST USE 2-1-2011; IN COMMERCE 2-1-2011.
BILL DAWE, EXAMINING ATTORNEY

CLASS 39—(Continued).

SN 85-250,340. GREEN B.E.A.N. INDIANA, LLC, DBA GREEN B.E.A.N. DELIVERY, INDIANAPOLIS, IN. FILED 2-24-2011.

GREEN B.E.A.N. DELIVERY

THE MARK CONSISTS OF STANDARD CHARACTERS WITHOUT CLAIM TO ANY PARTICULAR FONT, STYLE, SIZE, OR COLOR.

NO CLAIM IS MADE TO THE EXCLUSIVE RIGHT TO USE "DELIVERY", APART FROM THE MARK AS SHOWN.

FOR DELIVERY OF GOODS; FOOD DELIVERY; AND, GROCERY DELIVERY SERVICES (U.S. CLS. 100 AND 105).

FIRST USE 9-7-2010; IN COMMERCE 9-7-2010.
H. M. FISHER, EXAMINING ATTORNEY

SN 85-251,710. SAZERAC NORTH AMERICA, INC., FRANKFORT, KY. FILED 2-25-2011.



OWNER OF U.S. REG. NOS. 703,326 AND 940,042.
NO CLAIM IS MADE TO THE EXCLUSIVE RIGHT TO USE "DISTILLERY", APART FROM THE MARK AS SHOWN.

THE MARK CONSISTS OF THE STYLIZED CAPITAL LETTERS "G" AND "D" ON A SHIELD TO THE LEFT OF THE WORDS "GLENMORE DISTILLERY", WHICH ARE IN ALL CAPS.

FOR BOTTLING SERVICES; PACKING, CRATING AND WAREHOUSING SERVICES; SHIPPING OF GOODS; WAREHOUSING SERVICES, NAMELY, STORAGE, DISTRIBUTION, PICK-UP, PACKING, AND SHIPPING OF DISTILLED SPIRITS; ARRANGING AND CONDUCTING DISTILLERY TOURS (U.S. CLS. 100 AND 105).

GRETTA YAO, EXAMINING ATTORNEY

CLASS 39—(Continued).

SN 85-252,059. TRES AGAVES NOMBRE, LLC, BERKELEY, CA. FILED 2-25-2011.

TRES AGAVES

THE MARK CONSISTS OF STANDARD CHARACTERS WITHOUT CLAIM TO ANY PARTICULAR FONT, STYLE, SIZE, OR COLOR.

OWNER OF U.S. REG. NOS. 3,519,948, 3,633,843 AND 3,635,344.

THE ENGLISH TRANSLATION OF "TRES" IN THE MARK IS "THREE".

FOR ARRANGING TRAVEL TOURS; TRAVEL AND TOUR INFORMATION SERVICE (U.S. CLS. 100 AND 105).

SUZANNE BLANE, EXAMINING ATTORNEY

CLASS 39—(Continued).

SN 85-253,365. STAFFORD COMPANIES, LLC, CHICAGO, IL. FILED 2-28-2011.

Goldex

THE MARK CONSISTS OF STANDARD CHARACTERS WITHOUT CLAIM TO ANY PARTICULAR FONT, STYLE, SIZE, OR COLOR.

FOR TRANSPORTATION AND STORAGE OF PRECIOUS METALS IN SECURED VAULTS AND STORAGE (U.S. CLS. 100 AND 105).

ROBERT C. CLARK JR., EXAMINING ATTORNEY

SN 85-252,495. HOLDER, BILL, HANOVER, MD. FILED 2-26-2011.

SAFE HARBOUR WINE STORAGE

THE MARK CONSISTS OF STANDARD CHARACTERS WITHOUT CLAIM TO ANY PARTICULAR FONT, STYLE, SIZE, OR COLOR.

NO CLAIM IS MADE TO THE EXCLUSIVE RIGHT TO USE "WINE STORAGE", APART FROM THE MARK AS SHOWN.

FOR TRANSPORTATION AND STORAGE OF WINE (U.S. CLS. 100 AND 105).

ESTHER A. BORSUK, EXAMINING ATTORNEY

SN 85-254,157. NATIONAL RAILROAD PASSENGER CORPORATION, WASHINGTON, DC. FILED 3-1-2011.

MY TRACK TO SUCCESS

THE MARK CONSISTS OF STANDARD CHARACTERS WITHOUT CLAIM TO ANY PARTICULAR FONT, STYLE, SIZE, OR COLOR.

FOR RAILROAD TRANSPORTATION SERVICES (U.S. CLS. 100 AND 105).

FIRST USE 12-0-2008; IN COMMERCE 12-0-2008.

SAIMA MAKHDOOM, EXAMINING ATTORNEY

SN 85-253,047. SIMPLY WHEELZ LLC, PARK RIDGE, NJ. FILED 2-28-2011.

A-PASS

THE MARK CONSISTS OF STANDARD CHARACTERS WITHOUT CLAIM TO ANY PARTICULAR FONT, STYLE, SIZE, OR COLOR.

FOR VEHICLE RENTAL SERVICES (U.S. CLS. 100 AND 105).

FIRST USE 2-22-2011; IN COMMERCE 2-22-2011.

MEGHAN REINHART, EXAMINING ATTORNEY

SN 85-254,311. PEDAL PARTY HOUSTON, L.L.C., FORMERLY PEDAL PARTY GALVESTON, L.L.C., HOUSTON, TX. FILED 3-1-2011.

Pedal Party

THE MARK CONSISTS OF STANDARD CHARACTERS WITHOUT CLAIM TO ANY PARTICULAR FONT, STYLE, SIZE, OR COLOR.

FOR RENTAL OF MULTIPLE PERSON BICYCLES-VEHICLES (U.S. CLS. 100 AND 105).

FIRST USE 12-1-2009; IN COMMERCE 12-1-2009.

CURTIS FRENCH, EXAMINING ATTORNEY

CLASS 39—(Continued).

SN 85-254,947. FLAGA EXPRESS DELIVERY, LAS VEGAS, NV. FILED 3-1-2011.

Flaga Express Delivery

THE MARK CONSISTS OF STANDARD CHARACTERS WITHOUT CLAIM TO ANY PARTICULAR FONT, STYLE, SIZE, OR COLOR.

NO CLAIM IS MADE TO THE EXCLUSIVE RIGHT TO USE "EXPRESS DELIVERY", APART FROM THE MARK AS SHOWN.

THE ENGLISH TRANSLATION OF THE WORD "FLAGA" IN THE MARK IS "FLAG".

FOR SHIPPING AND DELIVERY SERVICES, NAMELY, PICKUP, TRANSPORTATION, AND DELIVERY OF PACKAGES AND LETTERS BY VARIOUS MODES OF TRANSPORTATION (U.S. CLS. 100 AND 105).

MARK RADEMACHER, EXAMINING ATTORNEY

CLASS 40—(Continued).

SN 77-930,988. VERUTEK TECHNOLOGIES, INC., BLOOMFIELD, CT. FILED 2-8-2010.

CHEM FRAC

THE MARK CONSISTS OF STANDARD CHARACTERS WITHOUT CLAIM TO ANY PARTICULAR FONT, STYLE, SIZE, OR COLOR.

NO CLAIM IS MADE TO THE EXCLUSIVE RIGHT TO USE "CHEM", APART FROM THE MARK AS SHOWN.

FOR ENVIRONMENTAL REMEDIATION SERVICES, NAMELY, SOIL, WASTE AND/OR WATER TREATMENT SERVICES (U.S. CLS. 100, 103 AND 106).

KIMBERLY PERRY, EXAMINING ATTORNEY

SN 85-069,322. ADVANCED PROCESSES, INC., AMBRIDGE, PA. FILED 6-23-2010.



ADVANCED PROCESSES

NO CLAIM IS MADE TO THE EXCLUSIVE RIGHT TO USE "PROCESSES", APART FROM THE MARK AS SHOWN.

THE MARK CONSISTS OF THE WORDS "ADVANCED PROCESSES" AND A CIRCLE ENCLOSED WITH STYLIZED LETTERS "A" AND "P".

SEC. 2(F) AS TO "ADVANCED PROCESSES".

FOR MATERIAL WASTE RECOVERY AND AGGLOMERATION SERVICES, NAMELY, MATERIAL PROCESSING OF MINERAL, OXIDES AND BIOMASS MANUFACTURING BY-PRODUCTS, AND RECYCLING OF WASTE AND CHEMICALS (U.S. CLS. 100, 103 AND 106).

FIRST USE 3-0-1998; IN COMMERCE 3-0-1998.

KIM SAITO, EXAMINING ATTORNEY

CLASS 40—MATERIAL TREATMENT

SN 77-669,022. CARVER, DAVID R, COLORADO SPRINGS, CO. FILED 2-12-2009.

CapZen

THE MARK CONSISTS OF STANDARD CHARACTERS WITHOUT CLAIM TO ANY PARTICULAR FONT, STYLE, SIZE, OR COLOR.

FOR GENERATION OF ENERGY (U.S. CLS. 100, 103 AND 106).

PAM WILLIS, EXAMINING ATTORNEY

SN 85-120,636. SOUTH ISLAND SERVICES, LTD., CENTRAL ISLIP, NY. FILED 9-1-2010.

AFFORDABLE CREMATION SERVICES OF NEW YORK

CLEAN FRAC

THE MARK CONSISTS OF STANDARD CHARACTERS WITHOUT CLAIM TO ANY PARTICULAR FONT, STYLE, SIZE, OR COLOR.

NO CLAIM IS MADE TO THE EXCLUSIVE RIGHT TO USE "CLEAN", APART FROM THE MARK AS SHOWN.

FOR ENVIRONMENTAL REMEDIATION SERVICES, NAMELY, SOIL, WASTE AND/OR WATER TREATMENT SERVICES (U.S. CLS. 100, 103 AND 106).

KIMBERLY PERRY, EXAMINING ATTORNEY

THE MARK CONSISTS OF STANDARD CHARACTERS WITHOUT CLAIM TO ANY PARTICULAR FONT, STYLE, SIZE, OR COLOR.

NO CLAIM IS MADE TO THE EXCLUSIVE RIGHT TO USE "CREMATION SERVICES OF NEW YORK", APART FROM THE MARK AS SHOWN.

FOR CREMATION SERVICES (U.S. CLS. 100, 103 AND 106).

FIRST USE 5-9-2008; IN COMMERCE 5-9-2008.

INGA ERVIN, EXAMINING ATTORNEY

CLASS 40—(Continued).

SN 85-135,078. TSUNAMI CAPITAL GROUP, INC., TORRANCE, CA. FILED 9-21-2010.

Ambiance

THE MARK CONSISTS OF STANDARD CHARACTERS WITHOUT CLAIM TO ANY PARTICULAR FONT, STYLE, SIZE, OR COLOR.

FOR MANUFACTURING SERVICES FOR OTHERS IN THE FIELD OF CLOTH, CLOTHING, FABRIC, TEXTILES, TEXTILE BED COVERS, LINENS, BATHROOM TEXTILES, FINISHING AND COATING OF TEXTILES, PRINTING OF PATTERNS ON TEXTILES, TEXTILE KNITTING, LEATHER AND IMITATIONS OF LEATHER, FOOTWEAR, HEADGEAR, FURNITURE, MIRRORS, PICTURE FRAMES, HOUSEHOLD OR KITCHEN UTENSILS AND CONTAINERS, COMBS, SPONGES, BRUSHES, GLASSWARE, PORCELAIN, EARTHENWARE, ROPES, STRING, NETS, TENTS, AWNINGS, TARPAULINS, SAILS, SACKS, BAGS, POLYESTER AND DOWN FEATHER STUFFING, YARNS AND THREADS FOR TEXTILE USE, CARPETS, RUGS, MATS AND MATTING, LINOLEUM, WALL HANGINGS, AND DECORATIONS FOR CHRISTMAS TREES (U.S. CLS. 100, 103 AND 106).

FIRST USE 0-0-2008; IN COMMERCE 0-0-2009.
ODESSA BIBBINS, EXAMINING ATTORNEY

CLASS 40—(Continued).

SN 85-140,231. RECYCLABLE PLANET, LLC, MIAMI, FL. FILED 9-28-2010.



NO CLAIM IS MADE TO THE EXCLUSIVE RIGHT TO USE THE RECYCLING SYMBOL, APART FROM THE MARK AS SHOWN.

THE COLOR(S) GREEN AND WHITE IS/ARE CLAIMED AS A FEATURE OF THE MARK.

THE MARK CONSISTS OF THE WORDING "RECYCLABLE PLANET" PRESENTED IN STYLIZED FONT, A CIRCLE AND A DEPICTION OF THE UNIVERSAL RECYCLING SIGN COMPRISED OF THREE ARROWS. THE THREE ARROWS ARE ARRANGED IN A CIRCULAR FASHION AND FADE INTERMITTENTLY FROM DARK GREEN TO LIGHT GREEN AND CONTAIN WHITE ACCENT LINES. "RECYCLABLE" IS PRESENTED IN LIGHT GREEN STYLIZED FONT IN AN ARC ABOVE THE ARROWS AND "PLANET" IS PRESENTED IN DARKER GREEN STYLIZED FONT BELOW THE ARROWS. A LIGHT GREEN CIRCLE ENCOMPASSES THESE ELEMENTS. THE MARK IN ITS ENTIRETY APPEARS ON A WHITE BACKGROUND.

FOR RECYCLING OF WASTE (U.S. CLS. 100, 103 AND 106).

FIRST USE 6-1-2010; IN COMMERCE 6-1-2010.
GRETCHEN ULRICH, EXAMINING ATTORNEY

SN 85-135,751. WHITESSELL CORPORATION, MUSCLE SHOALS, AL. FILED 9-22-2010.

ClenchForm

THE MARK CONSISTS OF STANDARD CHARACTERS WITHOUT CLAIM TO ANY PARTICULAR FONT, STYLE, SIZE, OR COLOR.

FOR MACHINE SHOP SERVICES, NAMELY, METAL FORMING FOR OTHERS; MANUFACTURING SERVICES FOR OTHERS IN THE FIELD OF PART INTEGRATION AND ASSEMBLY (U.S. CLS. 100, 103 AND 106).

ROBERT C. CLARK JR., EXAMINING ATTORNEY

SN 85-147,178. PRIMARY PACKAGING, INC., BOLIVAR, OH. FILED 10-7-2010.



NO CLAIM IS MADE TO THE EXCLUSIVE RIGHT TO USE "PACKAGING INC." AND "PACKAGING", APART FROM THE MARK AS SHOWN.

THE MARK CONSISTS OF SPIRAL WITH THE WORDS "PRIMARY PACKAGING INC." TO THE RIGHT AND "PEOPLE PACKAGING INNOVATION" BELOW.

FOR CUSTOM MANUFACTURE OF HEAVY DUTY POLYETHYLENE FILM AND BAGS FOR USE IN THE INSULATION, CHEMICAL, INDUSTRIAL PRODUCTS, FERTILIZER, SPECIALTY ANIMAL PACKAGING, WOOD PELLET AND BIOMASS, AND LAWN AND GARDEN INDUSTRIES (U.S. CLS. 100, 103 AND 106).

FIRST USE 8-5-2009; IN COMMERCE 8-5-2009.
REGINA DRUMMOND, EXAMINING ATTORNEY

CLASS 40—(Continued).

SN 85-165,307. INNOVAGREEN SYSTEMS, DUBLIN, OH. FILED 10-29-2010.



NO CLAIM IS MADE TO THE EXCLUSIVE RIGHT TO USE "SYSTEMS", APART FROM THE MARK AS SHOWN.
 THE MARK CONSISTS OF A STYLIZED LEAF DESIGN TO THE LEFT OF THE WORDING "INNOVAGREEN", WHICH IS PARTIALLY UNDERLINED AND PARTIALLY OVER THE TERM "SYSTEMS". THE SLOGAN "SAVING MOTHER EARTH..AVAILABLE IN ANY COLOR AS LONG AS IT'S GREEN" IS BELOW THE UNDERLINING OF "INNOVAGREEN".
 FOR RECYCLING OF WASTE (U.S. CLS. 100, 103 AND 106).
 LINDA M. KING, EXAMINING ATTORNEY

SN 85-184,925. BOKER'S, INC., MINNEAPOLIS, MN. FILED 11-24-2010.

BOKER'S, INC.

THE MARK CONSISTS OF STANDARD CHARACTERS WITHOUT CLAIM TO ANY PARTICULAR FONT, STYLE, SIZE, OR COLOR.
 NO CLAIM IS MADE TO THE EXCLUSIVE RIGHT TO USE "INC.", APART FROM THE MARK AS SHOWN.
 SEC. 2(F).
 FOR MACHINE SHOP SERVICES, NAMELY, MACHINING PARTS FOR OTHERS; CUSTOM MANUFACTURING OF WASHERS, SPACERS, SHIMS, AND STAMPINGS FOR OTHERS; METAL STAMPING; METAL FORMING; PLASTIC STAMPING (U.S. CLS. 100, 103 AND 106).
 FIRST USE 9-30-1959; IN COMMERCE 9-30-1959.
 LEIGH LOWRY, EXAMINING ATTORNEY

CLASS 40—(Continued).

SN 85-196,998. DANIEL BATEMAN, SAN FRANCISCO, CA. FILED 12-14-2010.

StarPower Energy

THE MARK CONSISTS OF STANDARD CHARACTERS WITHOUT CLAIM TO ANY PARTICULAR FONT, STYLE, SIZE, OR COLOR.
 NO CLAIM IS MADE TO THE EXCLUSIVE RIGHT TO USE "ENERGY", APART FROM THE MARK AS SHOWN.
 FOR ENERGY GENERATION SERVICES; ENERGY RECYCLING SERVICES, NAMELY, CAPTURING AND CONVERSION OF WASTED ENERGY INTO ELECTRICITY AND USEFUL STEAM; GENERATION OF ENERGY; PRODUCTION OF ENERGY (U.S. CLS. 100, 103 AND 106).
 ALICIA COLLINS, EXAMINING ATTORNEY

SN 85-197,882. INTEGRAL SYSTEMS, INC., COLUMBIA, MD. FILED 12-14-2010.



NO CLAIM IS MADE TO THE EXCLUSIVE RIGHT TO USE "SYSTEMS COMPANY", APART FROM THE MARK AS SHOWN.
 THE MARK CONSISTS OF THE WORDS "RT LOGIC AN INTEGRAL SYSTEMS COMPANY" AND STAR DESIGN WITH A POLYGON CENTER.
 FOR CUSTOM MANUFACTURE OF ADVANCED SIGNAL PROCESSING UNITS IN THE SATELLITE GROUND OPERATIONS AND SATELLITE FACTORY TEST MARKETPLACES (U.S. CLS. 100, 103 AND 106).
 FIRST USE 3-26-1997; IN COMMERCE 3-26-1997.
 FLORENTINA BLANDU, EXAMINING ATTORNEY

SN 85-201,722. ADIEL TEL-OREN, DBA GREEN BAKERY, MINNEAPOLIS, MN. FILED 12-20-2010.

BEYOND GLUTEN FREE

THE MARK CONSISTS OF STANDARD CHARACTERS WITHOUT CLAIM TO ANY PARTICULAR FONT, STYLE, SIZE, OR COLOR.
 NO CLAIM IS MADE TO THE EXCLUSIVE RIGHT TO USE "GLUTEN FREE", APART FROM THE MARK AS SHOWN.
 FOR BAKERY SERVICES, NAMELY, THE MANUFACTURE OF BAKERY PRODUCTS TO ORDER AND/OR SPECIFICATION OF OTHERS (U.S. CLS. 100, 103 AND 106).
 FIRST USE 10-23-2010; IN COMMERCE 10-23-2010.
 ROSELLE HERRERA, EXAMINING ATTORNEY

CLASS 40—(Continued).

SN 85-202,451. MEDTECH GROUP HOLDINGS, INC. C/O KRG CAPITAL, DENVER, CO. FILED 12-21-2010.



NO CLAIM IS MADE TO THE EXCLUSIVE RIGHT TO USE "MEDICAL", APART FROM THE MARK AS SHOWN. THE COLOR(S) PURPLE AND GRAY IS/ARE CLAIMED AS A FEATURE OF THE MARK.

THE MARK CONSISTS OF THE WORD "VENTION" GENERALLY IN PURPLE IN CAPS, WITH THE "V" SLANTED TO THE LEFT AND THE "E" APPEARING IN GRAY AS THREE HORIZONTAL LINES. THE WORD "MEDICAL" IS VERTICAL IN GRAY TO THE "N" IN "VENTION". THE WORDS "ADVANCING YOUR INNOVATIONS FOR HEALTH" APPEARS IN GRAY A SMALL FONT UNDERNEATH THE LETTERS "ION" IN "VENTION".

FOR ASSEMBLY OF PRODUCTS FOR OTHERS; CUSTOM MANUFACTURE OF MEDICAL DEVICES AND MEDICAL DEVICE COMPONENTS; CONTRACT MANUFACTURING IN THE FIELD OF MEDICAL DEVICES (U.S. CLS. 100, 103 AND 106).

SKYE YOUNG, EXAMINING ATTORNEY

SN 85-210,412. REFRESH ENVIRONMENTAL, L.L.C., NEW ORLEANS, LA. FILED 1-4-2011.



THE COLOR(S) DARK GREEN, OLIVE GREEN, KELLY GREEN, AND LIGHT GREEN IS/ARE CLAIMED AS A FEATURE OF THE MARK.

THE MARK CONSISTS OF THE FOLLOWING: A DEPICTION OF AN OIL DROP COMPRISED OF THE COLORS LIGHT GREEN, WITH AN INNER KELLY GREEN BORDER AND A SECOND OUTER OLIVE GREEN BORDER, ALL ON THE BACKGROUND OF A DARK GREEN SQUARE.

FOR RECYCLING SERVICES, NAMELY, COLLECTING USED FAT OR VEGETABLE OIL OR COOKING OIL FOR PURPOSES OF CONVERTING IT TO BIOFUEL OR BLENDING IT WITH PETROLEUM DIESEL TO CREATE BIODIESEL FUEL (U.S. CLS. 100, 103 AND 106).

JACQUELINE A. LAVINE, EXAMINING ATTORNEY

CLASS 40—(Continued).

SN 85-212,074. LOBOSTAR, INC., GARDENA, CA. FILED 1-6-2011.



NO CLAIM IS MADE TO THE EXCLUSIVE RIGHT TO USE "INC.", APART FROM THE MARK AS SHOWN. THE COLOR(S) BLUE AND BLACK IS/ARE CLAIMED AS A FEATURE OF THE MARK.

THE MARK CONSISTS OF A BLACK SILHOUETTE OF THE HEAD OF A WOLF TO THE LEFT OF THE WORDING "LOBOSTAR" IN BLUE FONT OUTLINED IN BLACK WITH THE WORD "INC." IN BLACK STYLIZED FONT TO THE RIGHT OF THE WORDING "LOBOSTAR".

THE ENGLISH TRANSLATION OF "LOBO" IN THE MARK IS "WOLF".

FOR CUSTOM FABRICATION OF METAL MARINE HARDWARE (U.S. CLS. 100, 103 AND 106).

FIRST USE 1-1-2011; IN COMMERCE 1-1-2011.

TINA BROWN, EXAMINING ATTORNEY

SN 85-213,133. BLUE HORIZON SOLAR LLC, DBA BLUE HORIZON ENERGY, EDEN PRAIRIE, MN. FILED 1-7-2011.

BLUE HORIZON ENERGY

THE MARK CONSISTS OF STANDARD CHARACTERS WITHOUT CLAIM TO ANY PARTICULAR FONT, STYLE, SIZE, OR COLOR.

NO CLAIM IS MADE TO THE EXCLUSIVE RIGHT TO USE "ENERGY", APART FROM THE MARK AS SHOWN.

FOR CONSULTING SERVICES IN RELATION TO THE FIELD OF ENERGY PRODUCTION; TECHNICAL CONSULTATION IN THE FIELD OF DEVELOPMENT OF RENEWABLE ENERGY EQUIPMENT; PROJECT MANAGEMENT SERVICES IN THE FIELD OF ENERGY GENERATION EQUIPMENT AND RENEWABLE ENERGY EQUIPMENT (U.S. CLS. 100, 103 AND 106).

FRANK LATTUCA, EXAMINING ATTORNEY

SN 85-227,482. ASTOR & BLACK CUSTOM, LTD., COLUMBUS, OH. FILED 1-27-2011.

ASTOR & BLACK BESPOKEN OF

THE MARK CONSISTS OF STANDARD CHARACTERS WITHOUT CLAIM TO ANY PARTICULAR FONT, STYLE, SIZE, OR COLOR.

OWNER OF U.S. REG. NO. 3,608,776.

NO CLAIM IS MADE TO THE EXCLUSIVE RIGHT TO USE "BESPOKEN", APART FROM THE MARK AS SHOWN.

FOR CUSTOM TAILORING SERVICES, NAMELY, SUITS, JACKETS, OVERCOATS, PANTS, SHIRTS, TUXEDOS, TIES AND VESTS (U.S. CLS. 100, 103 AND 106).

GENE MACIOL, EXAMINING ATTORNEY

CLASS 40—(Continued).

SN 85-227,713. COLUMN & POST, INC., FUQUAY-VARINA, NC. FILED 1-27-2011.

Eliminate Your Splitting Headaches

THE MARK CONSISTS OF STANDARD CHARACTERS WITHOUT CLAIM TO ANY PARTICULAR FONT, STYLE, SIZE, OR COLOR.

FOR MANUFACTURING OF PRE-FABRICATED NONMETAL COMPOSITE ARCHITECTURAL COLUMNS (U.S. CLS. 100, 103 AND 106).

FIRST USE 11-1-2008; IN COMMERCE 11-1-2008.
LOURDES AYALA, EXAMINING ATTORNEY

SN 85-240,590. INTEGRAL SYSTEMS, INC., COLUMBIA, MD. FILED 2-11-2011.



NO CLAIM IS MADE TO THE EXCLUSIVE RIGHT TO USE "SYSTEMS COMPANY", APART FROM THE MARK AS SHOWN.

THE MARK CONSISTS OF THE WORDING "LUMISTAR AN INTEGRAL SYSTEMS COMPANY" IN FRONT OF AN ORBIT DESIGN.

FOR CUSTOM DESIGN AND MANUFACTURE OF BOARD-LEVEL TELEMETRY PRODUCTS, NAMELY, RECEIVERS AND DOWN CONVERTER BOARDS, DEMODULATORS, BIT SYNC AND DECOM BOARDS, DIVERSITY COMBINER BOARDS, DISPLAY BOARDS, DYNAMIC DATA SIMULATOR BOARDS, PORTABLE RECEIVERS, BIT SYNCHRONIZERS, AIRBORNE RECEIVERS, TEST TRANSMITTERS WITH SIMULATORS, TEST ANTENNAS, AND DATA PROCESSING SOFTWARE TO DISPLAY REAL TIME FLIGHT TEST OPERATIONS (U.S. CLS. 100, 103 AND 106).

FLORENTINA BLANDU, EXAMINING ATTORNEY

SN 85-241,823. TURBINE ENGINE COMPONENTS TECHNOLOGIES CORPORATION, THOMASVILLE, GA. FILED 2-14-2011.

TECT POWERFORM

THE MARK CONSISTS OF STANDARD CHARACTERS WITHOUT CLAIM TO ANY PARTICULAR FONT, STYLE, SIZE, OR COLOR.

OWNER OF U.S. REG. NOS. 2,762,591, 3,957,130 AND OTHERS.

FOR MACHINING AND FORGING OF LEADING EDGES FOR TURBINE FAN BLADES TO THE ORDER AND SPECIFICATION OF OTHERS (U.S. CLS. 100, 103 AND 106).

KYLE PEETE, EXAMINING ATTORNEY

CLASS 40—(Continued).

SN 85-242,510. TURBINE ENGINE COMPONENTS TECHNOLOGIES CORPORATION, THOMASVILLE, GA. FILED 2-15-2011.

TECT ECOTHRUST

THE MARK CONSISTS OF STANDARD CHARACTERS WITHOUT CLAIM TO ANY PARTICULAR FONT, STYLE, SIZE, OR COLOR.

OWNER OF U.S. REG. NOS. 2,762,591, 3,957,130 AND OTHERS.

FOR MANUFACTURING SERVICES FOR OTHERS OF TURBINE ENGINE COMPONENTS (U.S. CLS. 100, 103 AND 106).

KYLE PEETE, EXAMINING ATTORNEY

SN 85-243,759. THE J.N. PHILLIPS COMPANY, INC., WOBURN, MA. FILED 2-16-2011.



NO CLAIM IS MADE TO THE EXCLUSIVE RIGHT TO USE "WINDSHIELD RECYCLING GUARANTEE EXCLUSIVELY FROM" AND "AUTO GLASS", APART FROM THE MARK AS SHOWN.

THE NAME(S), PORTRAIT(S), AND/OR SIGNATURE(S) SHOWN IN THE MARK DOES NOT IDENTIFY A PARTICULAR LIVING INDIVIDUAL.

THE COLOR(S) GREEN, WHITE AND BLUE IS/ARE CLAIMED AS A FEATURE OF THE MARK.

THE MARK CONSISTS OF THE WORDING "GREENSHIELD WINDSHIELD RECYCLING GUARANTEE" WHICH APPEARS IN THE COLOR GREEN AND THE WORDING "EXCLUSIVELY FROM JN PHILLIPS AUTO GLASS" WHICH APPEARS DIRECTLY UNDERNEATH AND IS IN THE COLOR BLUE. A DESIGN OF A GREEN AND WHITE LEAF APPEARS ABOVE THE LETTER "I" IN "GREENSHIELD" AND A BLUE HORIZONTAL LINE SEPARATES THE WORDING "GREENSHIELD WINDSHIELD RECYCLING GUARANTEE" FROM THE WORDING "JN PHILLIPS AUTO GLASS".

FOR WINDSHIELD RECYCLING SERVICES (U.S. CLS. 100, 103 AND 106).

FIRST USE 11-4-2010; IN COMMERCE 11-4-2010.
ESTHER A. BORSUK, EXAMINING ATTORNEY

CLASS 40—(Continued).

SN 85-246,912. MARK A. JONES, JOHNS CREEK, GA. FILED 2-19-2011.

ATLAS DOCUMENT DESTRUCTION SERVICES

THE MARK CONSISTS OF STANDARD CHARACTERS WITHOUT CLAIM TO ANY PARTICULAR FONT, STYLE, SIZE, OR COLOR.

NO CLAIM IS MADE TO THE EXCLUSIVE RIGHT TO USE "DOCUMENT DESTRUCTION SERVICES", APART FROM THE MARK AS SHOWN.

FOR DOCUMENT DESTRUCTION; DOCUMENT SHREDDING SERVICES (U.S. CLS. 100, 103 AND 106).

FIRST USE 1-31-2011; IN COMMERCE 1-31-2011.
DAVID ELTON, EXAMINING ATTORNEY

SN 85-248,851. WOOD, ELIZABETH, NEWBURYPORT, MA. FILED 2-22-2011.

Karat Gold Party

THE MARK CONSISTS OF STANDARD CHARACTERS WITHOUT CLAIM TO ANY PARTICULAR FONT, STYLE, SIZE, OR COLOR.

NO CLAIM IS MADE TO THE EXCLUSIVE RIGHT TO USE "GOLD", APART FROM THE MARK AS SHOWN.

FOR METAL REFINING SERVICES, NAMELY, GOLD AND SILVER REFINING (U.S. CLS. 100, 103 AND 106).

REBECCA EISINGER, EXAMINING ATTORNEY

SN 85-249,251. CABINetry CONCEPTS, INC., DBA CABINetry CONCEPTS, RAMSEY, MN. FILED 2-23-2011.

Crafting Masterpieces Daily

THE MARK CONSISTS OF STANDARD CHARACTERS WITHOUT CLAIM TO ANY PARTICULAR FONT, STYLE, SIZE, OR COLOR.

FOR CABINET MAKING (U.S. CLS. 100, 103 AND 106).
FIRST USE 3-15-2010; IN COMMERCE 3-15-2010.

MARILYN IZZI, EXAMINING ATTORNEY

CLASS 40—(Continued).

SN 85-249,256. CRI OF TENNESSEE, INC., NASHVILLE, TN. FILED 2-23-2011.

COMBINED RESOURCES

THE MARK CONSISTS OF STANDARD CHARACTERS WITHOUT CLAIM TO ANY PARTICULAR FONT, STYLE, SIZE, OR COLOR.

NO CLAIM IS MADE TO THE EXCLUSIVE RIGHT TO USE "RESOURCES", APART FROM THE MARK AS SHOWN.

FOR RECYCLING; RECYCLING OF WASTE; SORTING OF WASTE AND RECYCLABLE MATERIAL (U.S. CLS. 100, 103 AND 106).

FIRST USE 10-7-1986; IN COMMERCE 10-7-1986.

KAREN K. BUSH, EXAMINING ATTORNEY

SN 85-250,313. DIVINE DELICACIES CUSTOM CAKES, INC., MIAMI, FL. FILED 2-24-2011.



NO CLAIM IS MADE TO THE EXCLUSIVE RIGHT TO USE "DELICACIES" OR "CUSTOM CAKES", APART FROM THE MARK AS SHOWN.

THE MARK CONSISTS OF THE WORDS "DIVINE DELICACIES", ABOVE THE DESIGN OF A CAKE WITH THREE LIGHTED CANDLES ON TOP AND THE LETTERS "DD" IN THE CENTER OF THE FRONT SIDE OF THE CAKE, ABOVE THE WORDS "CUSTOM CAKES".

FOR CUSTOM CAKE DECORATING SERVICES (U.S. CLS. 100, 103 AND 106).

FIRST USE 1-1-2002; IN COMMERCE 1-1-2002.

BARBARA A. GOLD, EXAMINING ATTORNEY

SN 85-250,326. DIVINE DELICACIES CUSTOM CAKES, INC., MIAMI, FL. FILED 2-24-2011.

DIVINE DELICACIES CUSTOM CAKES

THE MARK CONSISTS OF STANDARD CHARACTERS WITHOUT CLAIM TO ANY PARTICULAR FONT, STYLE, SIZE, OR COLOR.

NO CLAIM IS MADE TO THE EXCLUSIVE RIGHT TO USE "DELICACIES CUSTOM CAKES", APART FROM THE MARK AS SHOWN.

FOR CUSTOM CAKE DECORATING SERVICES (U.S. CLS. 100, 103 AND 106).

FIRST USE 1-1-2002; IN COMMERCE 1-1-2002.

BARBARA A. GOLD, EXAMINING ATTORNEY

CLASS 40—(Continued).

SN 85-253,200. CENTROSOLAR AMERICA, INC., SCOTTS-DALE, AZ. FILED 2-28-2011.

CENTROLEASE

THE MARK CONSISTS OF STANDARD CHARACTERS WITHOUT CLAIM TO ANY PARTICULAR FONT, STYLE, SIZE, OR COLOR.

FOR LEASING OF RENEWABLE ENERGY GENERATION EQUIPMENT; LEASING OF SOLAR ENERGY GENERATION EQUIPMENT (U.S. CLS. 100, 103 AND 106).

RONALD AIKENS, EXAMINING ATTORNEY



SN 85-253,259. N.S. FLEXIBLES, LLC, GREENSBORO, NC. FILED 2-28-2011.

KROMASYNC

THE MARK CONSISTS OF STANDARD CHARACTERS WITHOUT CLAIM TO ANY PARTICULAR FONT, STYLE, SIZE, OR COLOR.

FOR COLOR PRINTING SERVICES AND COMPUTER IMPLEMENTED PRINTING SERVICES (U.S. CLS. 100, 103 AND 106).

DORITT L. CARROLL, EXAMINING ATTORNEY



SN 85-253,882. BUK OPTICS, INC., DBA PRECISION GLASS & OPTICS, SANTA ANA, CA. FILED 2-28-2011.

PG&O

THE MARK CONSISTS OF STANDARD CHARACTERS WITHOUT CLAIM TO ANY PARTICULAR FONT, STYLE, SIZE, OR COLOR.

FOR CUSTOM FABRICATION SERVICES OF OPTICAL COMPONENTS NAMELY, REFLECTORS, BEAM SPLITTERS, PRISMS, WINDOWS, AND THIN FILM COATING OF THE SAME (U.S. CLS. 100, 103 AND 106).

FIRST USE 7-1-1991; IN COMMERCE 7-1-1991.
MAYUR VAGHANI, EXAMINING ATTORNEY

CLASS 40—(Continued).

SN 85-254,984. SEMCO PLASTIC COMPANY, INC., ST. LOUIS, MO. FILED S.R. 3-1-2011; AM. P.R. 3-9-2011.

SEMCO

THE MARK CONSISTS OF STANDARD CHARACTERS WITHOUT CLAIM TO ANY PARTICULAR FONT, STYLE, SIZE, OR COLOR.

FOR INJECTION MOLDING OF PLASTIC FOR OTHERS; BLOW-MOLDING OF PLASTIC FOR OTHERS; CONTRACT MANUFACTURING IN THE FIELD OF FURNITURE, GARDEN SUPPLIES, NAMELY, WASTE BINS AND WATERING CANS, AND OFFICE SUPPLIES, NAMELY, MEDIA STANDS, WIPE BOARDS AND GENERAL USE HOOKS OR STRAPS (U.S. CLS. 100, 103 AND 106).

FIRST USE 1-1-1980; IN COMMERCE 1-1-1980.
KATHERINE STOIDES, EXAMINING ATTORNEY



SN 85-255,354. GFS CHEMICALS, INC., POWELL, OH. FILED 3-2-2011.

GFS

THE MARK CONSISTS OF STANDARD CHARACTERS WITHOUT CLAIM TO ANY PARTICULAR FONT, STYLE, SIZE, OR COLOR.

FOR PROVIDING TECHNICAL INFORMATION IN THE FIELD OF CHEMICAL MANUFACTURING (U.S. CLS. 100, 103 AND 106).

FIRST USE 11-30-2010; IN COMMERCE 11-30-2010.
KATHLEEN LORENZO, EXAMINING ATTORNEY



SN 85-257,050. FAB2ORDER, INC., INDIANAPOLIS, IN. FILED 3-3-2011.

FAB2ORDER

THE MARK CONSISTS OF STANDARD CHARACTERS WITHOUT CLAIM TO ANY PARTICULAR FONT, STYLE, SIZE, OR COLOR.

OWNER OF U.S. REG. NO. 2,543,579.
FOR PRECISION METAL FABRICATING, NAMELY, PLASMA CUTTING, LASER CUTTING, CNC PUNCH PRESSING, CNC FORMING, AND CNC MACHINING (U.S. CLS. 100, 103 AND 106).

FIRST USE 12-31-2002; IN COMMERCE 12-31-2002.
JACLYN KIDWELL WALKER, EXAMINING ATTORNEY

CLASS 40—(Continued).

SN 85-263,047. SPC RESOURCES, INC., HARTSVILLE, SC.
FILED 3-10-2011.

**LANDFILL FREE...THE WAY
LIFE SHOULD BE.**

THE MARK CONSISTS OF STANDARD CHARACTERS
WITHOUT CLAIM TO ANY PARTICULAR FONT, STYLE,
SIZE, OR COLOR.

FOR WASTE MANAGEMENT SERVICES AND RECY-
CLING SERVICES, AND CONSULTATION IN CONNEC-
TION THEREWITH (U.S. CLS. 100, 103 AND 106).
ELLEN PERKINS, EXAMINING ATTORNEY

SN 85-278,385. EASY RECYCLING & SALVAGE, INC., RUSK,
TX. FILED 3-28-2011.

GO GREEN GET PAID

THE MARK CONSISTS OF STANDARD CHARACTERS
WITHOUT CLAIM TO ANY PARTICULAR FONT, STYLE,
SIZE, OR COLOR.

NO CLAIM IS MADE TO THE EXCLUSIVE RIGHT TO
USE "GO GREEN", APART FROM THE MARK AS SHOWN.
FOR RECYCLING (U.S. CLS. 100, 103 AND 106).
PAUL F. GAST, EXAMINING ATTORNEY

SN 85-278,389. EASY RECYCLING & SALVAGE, INC., RUSK,
TX. FILED 3-28-2011.

GO GREEN GIRLS

THE MARK CONSISTS OF STANDARD CHARACTERS
WITHOUT CLAIM TO ANY PARTICULAR FONT, STYLE,
SIZE, OR COLOR.

NO CLAIM IS MADE TO THE EXCLUSIVE RIGHT TO
USE "GO GREEN", APART FROM THE MARK AS SHOWN.
FOR RECYCLING (U.S. CLS. 100, 103 AND 106).
PAUL F. GAST, EXAMINING ATTORNEY

CLASS 40—(Continued).

SN 85-287,515. SPC RESOURCES, INC., HARTSVILLE, SC.
FILED 4-6-2011.

MIRRORINK

THE MARK CONSISTS OF STANDARD CHARACTERS
WITHOUT CLAIM TO ANY PARTICULAR FONT, STYLE,
SIZE, OR COLOR.

FOR PRINTING SERVICES FOR USE ON FLEXIBLE
PACKAGING (U.S. CLS. 100, 103 AND 106).
ELLEN PERKINS, EXAMINING ATTORNEY

SN 85-309,559. MINUTEMAN PRESS INTERNATIONAL,
INC., FARMINGDALE, NY. FILED 5-2-2011.



OWNER OF U.S. REG. NOS. 2,314,083, 3,304,742 AND
3,304,743.

THE MARK CONSISTS OF THE WORDS "SHOPMINUTE-
MAN" SUPERIMPOSED ON PARALLEL WAVY RIBBON-
LIKE LINES. BETWEEN THE LETTERS "H" AND "O" OF
THE WORD "SHOP" IS AN ARROW POINTING UPWARD
AND TO THE LEFT, AND TO THE RIGHT OF THE
PARALLEL RIBBON-LIKE LINES IS A REPRESENTATION
OF A PIECE OF PAPER WITH THE LOWER RIGHT
CORNER OF THE PAPER FOLDED OVER.

FOR CUSTOM ON-LINE PRINTING SERVICES (U.S.
CLS. 100, 103 AND 106).

WENDY JUN, EXAMINING ATTORNEY

SN 85-321,157. JOHNSON, ARRON, SONOMA, CA. FILED 5-
14-2011.

Bad Ass Cars

THE MARK CONSISTS OF STANDARD CHARACTERS
WITHOUT CLAIM TO ANY PARTICULAR FONT, STYLE,
SIZE, OR COLOR.

NO CLAIM IS MADE TO THE EXCLUSIVE RIGHT TO
USE "CARS", APART FROM THE MARK AS SHOWN.

FOR CUSTOM BUILDING OF RACING ENGINES,
RACE CARS, STREET ENGINES, AND STREET CARS
(U.S. CLS. 100, 103 AND 106).

FIRST USE 4-10-1994; IN COMMERCE 4-10-1994.

SANDRA BUJA, EXAMINING ATTORNEY

CLASS 41—EDUCATION AND ENTERTAINMENT

SN 76-697,998. NATIONAL DUSTERS, QUADS AND SEARCHLIGHTS ASSOCIATION, AVILLA, IN. FILED 6-22-2009.

**DUSTERS, QUADS, SEARCHLIGHTS,
VULCANS & HAWKS**

THE MARK CONSISTS OF STANDARD CHARACTERS WITHOUT CLAIM TO ANY PARTICULAR FONT, STYLE, SIZE, OR COLOR.

FOR SPECIAL EVENT PLANNING, NAMELY, ORGANIZING AND CONDUCTING VIETNAM VETERANS REUNIONS; PUBLISHING NEWSLETTERS FEATURING INFORMATION AND INDIVIDUAL STORIES OF VIETNAM VETERANS (U.S. CLS. 100, 101 AND 107).

FIRST USE 0-0-2004; IN COMMERCE 0-0-2004.

HOWARD B. LEVINE, EXAMINING ATTORNEY

SN 76-701,693. PROJECT LEAD THE WAY, CLIFTON PARK, NY. AND SKILLSUSA, INC., LEESBURG, VA. AND TECHNOLOGY STUDENT ASSOCIATION, RESTON, VA. AND PROJECT LEAD THE WAY, CLIFTON PARK, NY. FILED 2-18-2010.



NO CLAIM IS MADE TO THE EXCLUSIVE RIGHT TO USE "ENGINEERING ALLIANCE", APART FROM THE MARK AS SHOWN.

THE COLOR(S) BLUE AND BLACK IS/ARE CLAIMED AS A FEATURE OF THE MARK.

THE COLOR BLUE APPEARS IN THE LETTER "E" THE COLOR BLACK APPEARS IN THE LETTER "A" AND IN THE WORDING "ENGINEERING ALLIANCE" THAT APPEARS BENEATH THE LETTERS "E", "A".

FOR EDUCATIONAL SERVICES, NAMELY, PROVIDING CLASSES, SEMINARS, AND WORKSHOPS, E-LEARNING MODULES IN THE NATURE OF ONLINE COURSES OF INSTRUCTION IN THE FIELDS OF SCIENCE, TECHNOLOGY, ENGINEERING, AND MATHEMATICS TO SUPPORT TEACHERS AND EXCITE STUDENTS ABOUT INNOVATIVE TECHNOLOGY AND ENGINEERING OPPORTUNITIES AND DISTRIBUTION OF PRINTED STUDENT AND TEACHER RESOURCES IN THE NATURE OF BOOKS IN CONNECTION THEREWITH; EDUCATION LEADERSHIP DEVELOPMENT, NAMELY, TRAINING COURSES, ENTERTAINMENT IN THE NATURE OF COMPETITIONS, DEVELOPING CURRICULA FOR TEACHERS, AND PROVIDING ONLINE BROCHURES ALL IN THE FIELDS OF SCIENCE, TECHNOLOGY, ENGINEERING, AND MATHEMATICS TO SUPPORT TEACHERS AND EXCITE STUDENTS ABOUT INNOVATIVE TECHNOLOGY AND ENGINEERING OPPORTUNITIES (U.S. CLS. 100, 101 AND 107).

FIRST USE 11-12-2009; IN COMMERCE 1-1-2010.

RAMONA ORTIGA, EXAMINING ATTORNEY

CLASS 41—(Continued).

SN 76-703,122. CHILD CARE RESOURCES, SEATTLE, WA. FILED 5-26-2010.

KALEIDOSCOPE PLAY & LEARN

THE MARK CONSISTS OF STANDARD CHARACTERS WITHOUT CLAIM TO ANY PARTICULAR FONT, STYLE, SIZE, OR COLOR.

NO CLAIM IS MADE TO THE EXCLUSIVE RIGHT TO USE "PLAY & LEARN", APART FROM THE MARK AS SHOWN.

FOR CHARITABLE SERVICES, NAMELY, PROVIDING TRAINING TO SOCIAL AND EDUCATIONAL SERVICE ORGANIZATIONS IN THE IMPLEMENTATION OF AN ORGANIZED FACILITATED NEIGHBORHOOD PLAY GROUP MODEL THAT INVOLVES CHILDREN AGES BIRTH TO SIX YEARS OLD AND THEIR PARENTS, FAMILY, FRIENDS AND NEIGHBOR CHILD CARE PROVIDERS IN ORDER TO PROMOTE HOME-BASED EARLY LEARNING AND HEALTHY DEVELOPMENT OF CHILDREN IN THEIR CARE; DEVELOPMENT AND DISSEMINATION TO SOCIAL AND EDUCATIONAL SERVICE ORGANIZATIONS OF EDUCATIONAL MATERIALS FEATURING GUIDELINES, STANDARDS AND RESOURCES IN THE FIELD OF IMPLEMENTATION OF AN ORGANIZED FACILITATED NEIGHBORHOOD PLAY GROUP MODEL THAT INVOLVES CHILDREN AGES BIRTH TO SIX YEARS OLD AND THEIR PARENTS, FAMILY, FRIENDS AND NEIGHBOR CHILD CARE PROVIDERS IN ORDER TO PROMOTE HOME-BASED EARLY LEARNING AND HEALTHY DEVELOPMENT OF CHILDREN IN THEIR CARE (U.S. CLS. 100, 101 AND 107).

FIRST USE 4-14-2010; IN COMMERCE 4-14-2010.

PAM WILLIS, EXAMINING ATTORNEY

SN 76-706,012. GOOD LIFE FITNESS, LLC, LINCOLN, NE. FILED 1-14-2011.

N-10SIVE

THE MARK CONSISTS OF STANDARD CHARACTERS WITHOUT CLAIM TO ANY PARTICULAR FONT, STYLE, SIZE, OR COLOR.

FOR PHYSICAL FITNESS INSTRUCTION (U.S. CLS. 100, 101 AND 107).

FIRST USE 1-1-2009; IN COMMERCE 1-1-2009.

REBECCA SMITH, EXAMINING ATTORNEY

CLASS 41—(Continued).

SN 76-706,186. ALL AXESS, LLC, LOS ANGELES, CA. FILED 1-31-2011.



THE MARK CONSISTS OF THE WORDING "ALL AXESS" IN STYLIZED FONT WITH A STYLIZED HUMAN WEARING A GUITAR WITH HIS HANDS UPRAISED FORMING THE LETTER "X".

FOR EDUCATIONAL AND ENTERTAINMENT SERVICES, NAMELY, PROVIDING A WEBSITE FEATURING A DATABASE ABOUT WELL-KNOWN GUITAR PLAYERS, A BLOG FOR THE DISCUSSION OF TOPICS RELATED TO GUITARS AND GUITAR PLAYING, AND ON-LINE GUITAR PLAYING INSTRUCTIONS (U.S. CLS. 100, 101 AND 107).

JULIE VEPPUMTHARA, EXAMINING ATTORNEY

SN 76-706,412. ONEIDA BAPTIST INSTITUTE, ONEIDA, KY. FILED 2-14-2011.



Education for Time and Eternity

NO CLAIM IS MADE TO THE EXCLUSIVE RIGHT TO USE "EDUCATION", APART FROM THE MARK AS SHOWN.

THE MARK CONSISTS OF THE WORDING "OBI EDUCATION FOR TIME AND ETERNITY", WITH A DESIGN OF A CROSS BETWEEN THE "O" AND "B", A DESIGN OF MOUNTAINS WITHIN THE "O", A DESIGN OF A BIBLE BENEATH THE "O" AND CROSS, AND UNDERLINING UNDER THE "B" AND "I".

FOR EDUCATION SERVICES, NAMELY, PROVIDING 6TH - 12TH GRADE CLASSROOM INSTRUCTION (U.S. CLS. 100, 101 AND 107).

FIRST USE 4-1-1995; IN COMMERCE 4-1-1995.
FRED CARL, EXAMINING ATTORNEY

CLASS 41—(Continued).

SN 76-706,603. IOLA OLD CAR SHOW, INC., IOLA, WI. FILED 2-28-2011.

TEAMED TO LEARN

THE MARK CONSISTS OF STANDARD CHARACTERS WITHOUT CLAIM TO ANY PARTICULAR FONT, STYLE, SIZE, OR COLOR.

FOR ENTERTAINMENT AND EDUCATIONAL SERVICES IN THE NATURE OF CONDUCTING SEMINARS AND WORKSHOPS REGARDING THE RESTORATION OF ANTIQUE AND COLLECTOR VEHICLES AS WELL AS THE SIGNIFICANCE OF SUCH VEHICLES IN AUTOMOTIVE HISTORY, OFFERED AS A PART OF AN ANNUAL ANTIQUE CAR SHOW (U.S. CLS. 100, 101 AND 107).

FIRST USE 5-26-2008; IN COMMERCE 5-26-2008.
KIMBERLY FRYE, EXAMINING ATTORNEY

SN 76-706,614. SPORTSPROASSIST, LLC, WEST FRIENDSHIP, MD. FILED 2-28-2011.

GOLFPROASSIST

THE MARK CONSISTS OF STANDARD CHARACTERS WITHOUT CLAIM TO ANY PARTICULAR FONT, STYLE, SIZE, OR COLOR.

FOR SERVICE TO ALLOW GOLF PROS AND GOLFERS TO COMMUNICATE, NAMELY, PROVIDING A WEBSITE FOR GOLFERS TO RECEIVE ONGOING INTERACTIVE GOLF INSTRUCTION FROM GOLF PROS THROUGH PERIODIC COMMUNICATIONS VIA THE INTERNET (U.S. CLS. 100, 101 AND 107).

FIRST USE 2-11-2008; IN COMMERCE 2-11-2008.
KATHRYN COWARD, EXAMINING ATTORNEY

SN 76-706,685. AMERICAN AEROBIC ASSOCIATION INTERNATIONAL, INC., NEW HOPE, PA. FILED 3-4-2011.

AAAI/ISMA STRIDE

THE MARK CONSISTS OF STANDARD CHARACTERS WITHOUT CLAIM TO ANY PARTICULAR FONT, STYLE, SIZE, OR COLOR.

OWNER OF U.S. REG. NO. 2,021,714.
FOR DANCE AEROBICS FITNESS INSTRUCTION; AND DANCE AEROBICS FITNESS INSTRUCTORS, NAMELY, PROVIDING TRAINING FOR CERTIFICATION OF DANCE AEROBIC FITNESS INSTRUCTORS (U.S. CLS. 100, 101 AND 107).

FIRST USE 4-1-2010; IN COMMERCE 4-1-2010.
ELI HELLMAN, EXAMINING ATTORNEY

CLASS 41—(Continued).

SN 76-706,686. AMERICAN AEROBIC ASSOCIATION INTERNATIONAL, INC., NEW HOPE, PA. FILED 3-4-2011.

AAA/ISMA IN-LIGHT-IN

THE MARK CONSISTS OF STANDARD CHARACTERS WITHOUT CLAIM TO ANY PARTICULAR FONT, STYLE, SIZE, OR COLOR.

OWNER OF U.S. REG. NO. 2,021,714.
FOR DANCE AEROBICS FITNESS INSTRUCTION; AND DANCE AEROBICS FITNESS INSTRUCTORS, NAMELY, PROVIDING TRAINING FOR CERTIFICATION OF DANCE AEROBIC FITNESS INSTRUCTORS (U.S. CLS. 100, 101 AND 107).

FIRST USE 4-1-2010; IN COMMERCE 4-1-2010.
ELI HELLMAN, EXAMINING ATTORNEY

SN 76-706,687. AMERICAN AEROBIC ASSOCIATION INTERNATIONAL, INC., NEW HOPE, PA. FILED 3-4-2011.

Y.E.S.S.S.

THE MARK CONSISTS OF STANDARD CHARACTERS WITHOUT CLAIM TO ANY PARTICULAR FONT, STYLE, SIZE, OR COLOR.

FOR DANCE AEROBICS FITNESS INSTRUCTION; AND DANCE AEROBICS FITNESS INSTRUCTION CERTIFICATION, NAMELY, PROVIDING TRAINING FOR CERTIFICATION OF DANCE AEROBICS FITNESS INSTRUCTORS (U.S. CLS. 100, 101 AND 107).

FIRST USE 4-1-2010; IN COMMERCE 4-1-2010.
ELI HELLMAN, EXAMINING ATTORNEY

SN 76-706,730. BLUE PLANET TRAINING, LLC, VERONA, NJ. FILED 3-10-2011.

BLUE PLANET

THE MARK CONSISTS OF STANDARD CHARACTERS WITHOUT CLAIM TO ANY PARTICULAR FONT, STYLE, SIZE, OR COLOR.

FOR EDUCATIONAL SERVICES IN THE NATURE OF INTERACTIVE SEMINARS ABOUT PUBLIC SPEAKING (U.S. CLS. 100, 101 AND 107).

FIRST USE 8-10-2010; IN COMMERCE 8-10-2010.
TIMOTHY FINNEGAN, EXAMINING ATTORNEY

CLASS 41—(Continued).

SN 76-707,272. WILLIAM MARSH RICE UNIVERSITY, HOUSTON, TX. FILED 4-14-2011.

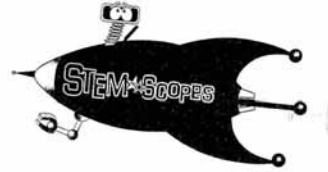

OWNER OF U.S. REG. NO. 3,907,350.
THE MARK CONSISTS OF DESIGN OF AN ANIMATED SPACESHIP WITH EYES ON TOP AND THE WORDING "STEM SCOPE" ON THE BODY OF THE SPACESHIP WITH TWO STARS APPEARING BETWEEN "STEM" AND "SCOPE".

FOR EDUCATIONAL SERVICES, NAMELY, PROVIDING TRAINING FOR TEACHERS OF GRADES PRE-K THROUGH HIGH SCHOOL IN SCIENCE, MATHEMATICS, LANGUAGE ARTS AND SOCIAL STUDIES AND PRINTABLE TEACHING MATERIALS DISTRIBUTED THEREWITH; AND PROVIDING AN ON-LINE WEBSITE FEATURING EDUCATIONAL LESSONS AND EXERCISES FOR GRADES PRE-K THROUGH HIGH SCHOOL STUDENTS IN SCIENCE, MATHEMATICS, LANGUAGE ARTS AND SOCIAL STUDIES (U.S. CLS. 100, 101 AND 107).

CARYN GLASSER, EXAMINING ATTORNEY

SN 76-707,273. WILLIAM MARSH RICE UNIVERSITY, HOUSTON, TX. FILED 4-14-2011.

STEM SCOPES

THE MARK CONSISTS OF STANDARD CHARACTERS WITHOUT CLAIM TO ANY PARTICULAR FONT, STYLE, SIZE, OR COLOR.

OWNER OF U.S. REG. NO. 3,907,350.
FOR EDUCATIONAL SERVICES, NAMELY, PROVIDING TRAINING FOR TEACHERS OF GRADES PRE-K THROUGH HIGH SCHOOL IN SCIENCE, MATHEMATICS, LANGUAGE ARTS AND SOCIAL STUDIES AND PRINTABLE TEACHING MATERIALS DISTRIBUTED THEREWITH; AND PROVIDING AN ON-LINE WEBSITE FEATURING EDUCATIONAL LESSONS AND EXERCISES FOR GRADES PRE-K THROUGH HIGH SCHOOL STUDENTS IN SCIENCE, MATHEMATICS, LANGUAGE ARTS AND SOCIAL STUDIES (U.S. CLS. 100, 101 AND 107).

CARYN GLASSER, EXAMINING ATTORNEY

CLASS 41—(Continued).

SN 77-037,455. BLOCKBUSTER INC., DALLAS, TX. FILED 11-6-2006.



OWNER OF U.S. REG. NOS. 1,413,706, 2,967,024 AND OTHERS.

THE MARK CONSISTS OF THE WORDING "BLOCKBUSTER" SUPERIMPOSED ON A TORN TICKET SURROUNDED BY AN UNTORN TICKET WITH THE WORDING "TOTAL ACCESS".

FOR RENTAL AND ON-LINE RENTAL SERVICES FEATURING AUDIO-VIDEO RECORDINGS OF FILMS, MOVIES AND MOTION PICTURES, DIGITAL VERSATILE DISCS (DVDS) FEATURING MOTION PICTURE FILMS IN A VARIETY OF GENRES, PRE-RECORDED VIDEO CASSETTES FEATURING MOTION PICTURE FILMS, AUDIO RECORDINGS AND COMPUTERIZED AND ELECTRONIC VIDEO GAMES AND DVDS FEATURING GAMES IN ALL FORMATS; ENTERTAINMENT SERVICES, NAMELY, PROVIDING ENTERTAINMENT INFORMATION ABOUT FILMS, MOVIES, MOTION PICTURES AND DIGITAL VERSATILE DISCS (DVDS) IN A VARIETY OF GENRES, AND ABOUT ELECTRONIC AND COMPUTERIZED VIDEO GAMES AND DVDS FEATURING GAMES IN ALL FORMATS VIA THE INTERNET (U.S. CLS. 100, 101 AND 107).

FIRST USE 11-1-2006; IN COMMERCE 11-1-2006.
LEIGH LOWRY, EXAMINING ATTORNEY

CLASS 41—(Continued).

SN 77-315,205. GROUP KAITU, LLC, RICHMOND, VA. FILED 10-27-2007.

EROS SHEMALE ESCORTS

THE MARK CONSISTS OF STANDARD CHARACTERS WITHOUT CLAIM TO ANY PARTICULAR FONT, STYLE, SIZE, OR COLOR.

OWNER OF U.S. REG. NOS. 2,549,369, 2,794,843 AND OTHERS.

NO CLAIM IS MADE TO THE EXCLUSIVE RIGHT TO USE "SHEMALE ESCORTS", APART FROM THE MARK AS SHOWN.

FOR ONLINE JOURNALS, NAMELY, BLOGS FEATURING SUBJECT MATTER IN THE FIELDS OF ADULT THEMED TOPICS, PRODUCTS, SERVICES AND ENTERTAINMENT (U.S. CLS. 100, 101 AND 107).

LEIGH LOWRY, EXAMINING ATTORNEY

SN 77-143,925. XTREME SPORTS IMPORTACAO EXPORTACAO E COMERCIO LTDA., SAO PAULO, BRAZIL, FILED 3-29-2007.



OWNER OF BRAZIL REG. NO. 900126612, DATED 10-6-2009, EXPIRES 10-6-2019.

OWNER OF U.S. REG. NO. 2,970,853.

THE STIPPLING IS FOR SHADING PURPOSES ONLY.

THE MARK CONSISTS OF THE WORDS "RED NOSE" IN STYLIZED LETTERING TO THE RIGHT OF WHICH IS A DESIGN OF A SNARLING DOG WEARING A STUDED COLLAR.

FOR MOTION PICTURE FILM PRODUCTION (U.S. CLS. 100, 101 AND 107).

BRENDAN REGAN, EXAMINING ATTORNEY

SN 77-431,404. METRO-GOLDWYN-MAYER STUDIOS INC., LOS ANGELES, CA. FILED 3-25-2008.

RONIN

THE MARK CONSISTS OF STANDARD CHARACTERS WITHOUT CLAIM TO ANY PARTICULAR FONT, STYLE, SIZE, OR COLOR.

FOR ENTERTAINMENT SERVICES, NAMELY, AN ONGOING TELEVISION SERIES FEATURING DRAMAS, COMEDIES, ROMANCES, SCIENCE FICTION, ACTION AND ADVENTURES, MYSTERIES AND WESTERNS (U.S. CLS. 100, 101 AND 107).

DAWN FELDMAN, EXAMINING ATTORNEY

CLASS 41—(Continued).

SN 77-653,451. CAREGGI PUBLISHING LIMITED, ROAD TOWN, TORTOLA, BR.VIRGIN ISLANDS, FILED 1-21-2009.

FREEDOM TO CREATE PRIZE

THE MARK CONSISTS OF STANDARD CHARACTERS WITHOUT CLAIM TO ANY PARTICULAR FONT, STYLE, SIZE, OR COLOR.

OWNER OF SINGAPORE REG. NO. T0900660Z, DATED 1-20-2009, EXPIRES 1-20-2019.

NO CLAIM IS MADE TO THE EXCLUSIVE RIGHT TO USE "PRIZE", APART FROM THE MARK AS SHOWN.

FOR ARRANGING AND CONDUCTING OF COMPETITIONS FOR PRIZES IN THE FIELD OF DANCE, PAINTING, DRAWING, PHOTOGRAPHY, SCULPTURE, CERAMICS, FILM, VIDEO, THEATRE PRODUCTIONS AND MUSIC FOR THE PROMOTION OF HUMAN RIGHTS AND FREEDOM OF EXPRESSION THROUGH THE ARTS; ORGANIZATION OF EXHIBITIONS FOR CULTURAL OR EDUCATIONAL PURPOSES; PRESENTATION OF LIVE SHOW PERFORMANCES; PUBLICATION OF BOOKS; PUBLICATION OF PRINTED MATTER, PRINTED PUBLICATIONS, BOOKS, MAGAZINES, JOURNALS, PERIODICALS; PUBLICATION OF BOOKS, PUBLICATIONS, MAGAZINES, JOURNALS AND PERIODICALS; PROVIDING RECOGNITION AND INCENTIVES BY THE AWARD OF PRIZES FOR THE EFFECTIVE USE OF DANCE, PAINTING, DRAWING, PHOTOGRAPHY, SCULPTURE, CERAMICS, FILM, VIDEO, THEATRE PRODUCTIONS AND MUSIC AS MODES OF RAISING AWARENESS OF SOCIAL AND HUMANITARIAN ISSUES; FILM PRODUCTION; PRODUCTION OF RADIO AND TELEVISION PROGRAMS; VIDEO TAPE FILM PRODUCTION; ARRANGING AND CONDUCTING OF EDUCATIONAL CONFERENCES, CONGRESSES, SEMINARS AND SYMPOSIUMS IN THE FIELD OF DANCE, PAINTING, DRAWING, PHOTOGRAPHY, SCULPTURE, CERAMICS, FILM, VIDEO, THEATRE PRODUCTIONS AND MUSIC AS MODES OF RAISING AWARENESS OF SOCIAL AND HUMANITARIAN ISSUES; EDUCATIONAL SERVICES, NAMELY, PROVIDING RECOGNITION AND INCENTIVES BY WAY OF AWARDS AND CONTESTS TO INDIVIDUALS TO DEMONSTRATE EXCELLENCE IN THE ARTS AND ENCOURAGING FREEDOM OF EXPRESSION IN THE ARTS AND THE ARTS AND THE MEDIA (U.S. CLS. 100, 101 AND 107).

Laura Hammel, Examining Attorney

SN 77-667,493. URBAN PREP ACADEMIES, CHICAGO, IL, FILED 2-10-2009.

URBAN PREP

THE MARK CONSISTS OF STANDARD CHARACTERS WITHOUT CLAIM TO ANY PARTICULAR FONT, STYLE, SIZE, OR COLOR.

NO CLAIM IS MADE TO THE EXCLUSIVE RIGHT TO USE "PREP", APART FROM THE MARK AS SHOWN. SEC. 2(F).

FOR EDUCATIONAL SERVICES, NAMELY, PROVIDING CLASSES, SEMINARS, WORKSHOPS, TUTORING, COUNSELING, AND MENTORING AT THE HIGH SCHOOL LEVEL (U.S. CLS. 100, 101 AND 107).

FIRST USE 7-1-2002; IN COMMERCE 7-1-2005.
Alicia Collins, Examining Attorney

CLASS 41—(Continued).

SN 77-707,681. KIMBERLY KEARNEY, DULUTH, GA, FILED 4-6-2009.

BIG GIRLS NEED LOVE TOO

THE MARK CONSISTS OF STANDARD CHARACTERS WITHOUT CLAIM TO ANY PARTICULAR FONT, STYLE, SIZE, OR COLOR.

FOR ENTERTAINMENT SERVICES, NAMELY, AN ON-GOING SERIES FEATURING PLUS SIZED PEOPLE LOOKING FOR LOVE PROVIDED THROUGH TELEVISION, WEBCASTS, PODCASTS AND FILM (U.S. CLS. 100, 101 AND 107).

Michelle Dubois, Examining Attorney

SN 77-870,792. BAISDEN MEDIA GROUP, LLC, DALLAS, TX, FILED 11-11-2009.

FIX OUR FOOD

THE MARK CONSISTS OF STANDARD CHARACTERS WITHOUT CLAIM TO ANY PARTICULAR FONT, STYLE, SIZE, OR COLOR.

NO CLAIM IS MADE TO THE EXCLUSIVE RIGHT TO USE "FOOD", APART FROM THE MARK AS SHOWN.

FOR EDUCATIONAL SERVICES, NAMELY, PROVIDING INSTRUCTION IN THE FIELDS OF FOOD, FOOD SELECTION, FOOD PREPARATION, AND FOOD PRESENTATION VIA THE INTERNET, TELEVISION, AND RADIO; EDUCATIONAL SERVICES, NAMELY, CONDUCTING CONFERENCES, SEMINARS, WEBINARS, WORKSHOPS, AND CLASSES IN THE FIELDS OF FOOD, FOOD SELECTION, FOOD PREPARATION, AND FOOD PRESENTATION; ONLINE JOURNALS, NAMELY, BLOGS FEATURING DISCUSSIONS AND INFORMATION ON FOOD, FOOD SELECTION, FOOD PREPARATION, AND FOOD PRESENTATION; EDUCATIONAL SERVICES, NAMELY, CONDUCTING CONFERENCES, SEMINARS, WEBINARS, WORKSHOPS, AND CLASSES IN THE FIELDS OF COOKING, FOOD, DRINK, WINE, NUTRITION, AND DIET AND COURSE MATERIALS DISTRIBUTED THEREWITH; PROVIDING ONLINE PUBLICATIONS IN THE NATURE OF MAGAZINES, COLUMNS, FEATURES, SECTIONS, NEWSLETTERS, AND JOURNALS IN THE FIELDS OF FOOD, FOOD SELECTION, FOOD PREPARATION, AND FOOD

CLASS 41—(Continued).

PRESENTATION; PROVIDING WEBCASTS, PODCASTS, AND MULTIMEDIA PROGRAMS VIA THE INTERNET FEATURING INFORMATION ABOUT FOOD, FOOD SELECTION, FOOD PREPARATION, AND FOOD PRESENTATION; EDUCATIONAL SERVICES, NAMELY, PROGRAM PRESENTATIONS FEATURING PUBLIC SERVICE ANNOUNCEMENTS CONTAINING INFORMATION REGARDING THE SELECTION, HANDLING, AND PREPARATION OF VARIOUS FOODS; EDUCATIONAL SERVICES, NAMELY, PROVIDING ONLINE INSTRUCTIONAL PRESENTATIONS THAT FEATURE INFORMATION ON FOOD PREPARATION AND FOOD PRESENTATION; EDUCATIONAL SERVICES, NAMELY, ONLINE INSTRUCTIONAL PRESENTATIONS FEATURING AUDIO AND VIDEO MEDIA FEATURING INFORMATION ABOUT FOOD, FOOD SELECTION, FOOD PREPARATION, AND FOOD PRESENTATION; EDUCATIONAL SERVICES, NAMELY, ONLINE INSTRUCTIONAL PRESENTATIONS FEATURING NUTRITIONAL INFORMATION ON FOODS AND FOOD SELECTION (U.S. CLS. 100, 101 AND 107).

BRIAN NEVILLE, EXAMINING ATTORNEY

SN 77-870,793. BAISDEN MEDIA GROUP, LLC, DALLAS, TX. FILED 11-11-2009.

FIX ON FOOD

THE MARK CONSISTS OF STANDARD CHARACTERS WITHOUT CLAIM TO ANY PARTICULAR FONT, STYLE, SIZE, OR COLOR.

NO CLAIM IS MADE TO THE EXCLUSIVE RIGHT TO USE "FOOD", APART FROM THE MARK AS SHOWN.

FOR EDUCATIONAL SERVICES, NAMELY, PROVIDING INSTRUCTION IN THE FIELDS OF FOOD, FOOD SELECTION, FOOD PREPARATION, AND FOOD PRESENTATION VIA THE INTERNET, TELEVISION, AND RADIO; EDUCATIONAL SERVICES, NAMELY, CONDUCTING CONFERENCES, SEMINARS, WEBINARS, WORKSHOPS, AND CLASSES IN THE FIELDS OF FOOD, FOOD SELECTION, FOOD PREPARATION, AND FOOD PRESENTATION; ONLINE JOURNALS, NAMELY, BLOGS FEATURING DISCUSSIONS AND INFORMATION ON FOOD, FOOD SELECTION, FOOD PREPARATION, AND FOOD PRESENTATION; EDUCATIONAL SERVICES, NAMELY, CONDUCTING CONFERENCES, SEMINARS, WEBINARS, WORKSHOPS, AND CLASSES IN THE FIELDS OF COOKING, FOOD, DRINK, WINE, NUTRITION, AND DIET AND COURSE MATERIALS DISTRIBUTED THEREWITH; PROVIDING ONLINE PUBLICATIONS IN THE NATURE OF MAGAZINES, COLUMNS, FEATURES, SECTIONS, NEWSLETTERS, AND JOURNALS IN THE FIELDS OF FOOD, FOOD SELECTION, FOOD PREPARATION, AND FOOD PRESENTATION; PROVIDING WEBCASTS, PODCASTS, AND MULTIMEDIA PROGRAMS VIA THE INTERNET FEATURING INFORMATION ABOUT FOOD, FOOD SELECTION, FOOD PREPARATION, AND FOOD PRESENTATION; EDUCATIONAL SERVICES, NAMELY, PROGRAM PRESENTATIONS FEATURING PUBLIC SERVICE ANNOUNCEMENTS CONTAINING INFORMATION REGARDING THE SELECTION, HANDLING, AND PREPARATION OF VARIOUS FOODS; EDUCATIONAL SERVICES, NAMELY, PROVIDING ONLINE INSTRUCTIONAL PRESENTATIONS THAT FEATURE INFORMATION ON FOOD PREPARATION AND FOOD PRESENTATION; EDUCATIONAL SERVICES, NAMELY, ONLINE INSTRUCTIONAL PRESENTATIONS FEATURING AUDIO AND VIDEO MEDIA FEATURING INFORMATION ABOUT FOOD, FOOD SELECTION, FOOD PREPARATION, AND FOOD PRESENTATION (U.S. CLS. 100, 101 AND 107).

BRIAN NEVILLE, EXAMINING ATTORNEY

CLASS 41—(Continued).

SN 77-897,556. THE BREAD IS RISING POETRY COLLECTIVE, BROOKLYN, NY. FILED 12-19-2009.

The Bread is Rising

THE MARK CONSISTS OF STANDARD CHARACTERS WITHOUT CLAIM TO ANY PARTICULAR FONT, STYLE, SIZE, OR COLOR.

FOR ENTERTAINMENT SERVICES IN THE NATURE OF POETRY READING PERFORMANCES (U.S. CLS. 100, 101 AND 107).

JANET LEE, EXAMINING ATTORNEY

SN 77-912,060. DUNDEE CORPORATION, TORONTO, ONTARIO, CANADA, FILED 1-14-2010.

MANAGING AT WEALTH

THE MARK CONSISTS OF STANDARD CHARACTERS WITHOUT CLAIM TO ANY PARTICULAR FONT, STYLE, SIZE, OR COLOR.

PRIORITY CLAIMED UNDER SEC. 44(D) ON CANADA APPLICATION NO. 1463258, FILED 12-17-2009, REG. NO. 779279, DATED 10-6-2010, EXPIRES 10-6-2025.

FOR EDUCATIONAL SERVICES, NAMELY, MANAGEMENT TRAINING PROGRAMS ON BEING ABLE TO COMBINE THE SKILLS OF BEING PRODUCTIVE WITH THE SKILLS OF BUILDING AND MAINTAINING BUSINESS RELATIONSHIPS (U.S. CLS. 100, 101 AND 107).

RAMONA ORTIGA, EXAMINING ATTORNEY

CLASS 41—(Continued).

SN 77-915,816. CARR, GARY JAY, DBA GARY PHOTO, ALEXANDRIA, VA. FILED 1-20-2010.



THE COLOR(S) RED AND BLACK IS/ARE CLAIMED AS A FEATURE OF THE MARK.

THE MARK CONSISTS OF A STYLIZED CAPITAL LETTER "G" IN RED AND OUTLINED IN BLACK.

FOR PHOTOGRAPHY SERVICES (U.S. CLS. 100, 101 AND 107).

FIRST USE 9-1-1980; IN COMMERCE 9-1-1980.

KATHLEEN M. VANSTON, EXAMINING ATTORNEY

CLASS 41—(Continued).

SN 77-926,085. FAST LANE RODEO, LLC, WANN, OK. FILED 2-2-2010.

Fast Lane Rodeo

THE MARK CONSISTS OF STANDARD CHARACTERS WITHOUT CLAIM TO ANY PARTICULAR FONT, STYLE, SIZE, OR COLOR.

NO CLAIM IS MADE TO THE EXCLUSIVE RIGHT TO USE "RODEO", APART FROM THE MARK AS SHOWN.

FOR ORGANIZING AND CONDUCTING RODEO EVENTS FEATURING DUMMY ROPING (U.S. CLS. 100, 101 AND 107).

FIRST USE 11-10-1989; IN COMMERCE 11-10-1989.

DAVID ELTON, EXAMINING ATTORNEY

SN 77-937,422. USH ENTERTAINMENT, INC., NEW YORK, NY. FILED 2-17-2010.

USH

Reach Up!

THE MARK CONSISTS OF STANDARD CHARACTERS WITHOUT CLAIM TO ANY PARTICULAR FONT, STYLE, SIZE, OR COLOR.

FOR ENTERTAINMENT SERVICES, NAMELY, PROVIDING A WEB SITE FEATURING PHOTOGRAPHIC, AUDIO, VIDEO AND PROSE PRESENTATIONS FEATURING INFORMATION, NEWS AND COMMENTARY IN THE FIELD OF RECREATION, LEISURE ACTIVITIES, SPORTS, FITNESS AND EXERCISE; ENTERTAINMENT SERVICES IN THE NATURE OF TELEVISION AND CABLE PROGRAMMING IN THE FIELDS OF RECREATION, LEISURE ACTIVITIES, SPORTS, FITNESS, EXERCISE, AND THE PROMOTION OF SELF-ESTEEM AMONG YOUNG WOMEN (U.S. CLS. 100, 101 AND 107).

BRENDAN MCCAULEY, EXAMINING ATTORNEY

THE MARK CONSISTS OF STANDARD CHARACTERS WITHOUT CLAIM TO ANY PARTICULAR FONT, STYLE, SIZE, OR COLOR.

THE NAME "USH" IDENTIFIES A LIVING INDIVIDUAL WHOSE CONSENT IS OF RECORD.

FOR ENTERTAINMENT SERVICES IN THE NATURE OF PRODUCTION AND DISTRIBUTION OF VIDEO AND/OR AUDIO PROGRAMMING IN THE NATURE OF MOTION PICTURES, TELEVISION SHOWS AND RADIO PROGRAMS, TELEVISION PROGRAMMING, TELEVISION AND MOTION PICTURE PROGRAMMING ON A GLOBAL COMPUTER NETWORK, PRODUCTION AND DISTRIBUTION OF TELEVISION AND MOTION PICTURE PROGRAMMING FOR TELEVISION BROADCASTING, SUCH PROGRAMMING FEATURING COMEDY, SCREENPLAYS, DRAMA, ACTION, ADVENTURE, SPORTS, MUSICAL PERFORMANCES, AND/OR ANIMATION (U.S. CLS. 100, 101 AND 107).

SARA BENJAMIN, EXAMINING ATTORNEY

CLASS 41—(Continued).

SN 77-937,429. USH ENTERTAINMENT, INC., NEW YORK, NY. FILED 2-17-2010.

USH ENTERTAINMENT

THE MARK CONSISTS OF STANDARD CHARACTERS WITHOUT CLAIM TO ANY PARTICULAR FONT, STYLE, SIZE, OR COLOR.

NO CLAIM IS MADE TO THE EXCLUSIVE RIGHT TO USE "ENTERTAINMENT", APART FROM THE MARK AS SHOWN.

THE NAME "USH" IDENTIFIES A LIVING INDIVIDUAL WHOSE CONSENT IS OF RECORD.

FOR ENTERTAINMENT SERVICES IN THE NATURE OF PRODUCTION AND DISTRIBUTION OF VIDEO AND/OR AUDIO PROGRAMMING IN THE NATURE OF MOTION PICTURES, TELEVISION SHOWS AND RADIO PROGRAMS, TELEVISION PROGRAMMING, TELEVISION AND MOTION PICTURE PROGRAMMING ON A GLOBAL COMPUTER NETWORK, PRODUCTION AND DISTRIBUTION OF TELEVISION AND MOTION PICTURE PROGRAMMING FOR TELEVISION BROADCASTING, SUCH PROGRAMMING FEATURING COMEDY, SCREENPLAYS, DRAMA, ACTION, ADVENTURE, SPORTS, MUSICAL PERFORMANCES, AND/OR ANIMATION (U.S. CLS. 100, 101 AND 107).

SARA BENJAMIN, EXAMINING ATTORNEY

CLASS 41—(Continued).

SN 77-948,896. GREATER NORTH MICHIGAN AVENUE ASSOCIATION, CHICAGO, IL. FILED 3-2-2010.

THE MAGNIFICENT MILE ART FESTIVAL

THE MARK CONSISTS OF STANDARD CHARACTERS WITHOUT CLAIM TO ANY PARTICULAR FONT, STYLE, SIZE, OR COLOR.

OWNER OF U.S. REG. NOS. 2,409,899, 3,414,516 AND OTHERS.

NO CLAIM IS MADE TO THE EXCLUSIVE RIGHT TO USE "ART FESTIVAL", APART FROM THE MARK AS SHOWN.

FOR CONDUCTING ENTERTAINMENT EXHIBITIONS IN THE NATURE OF ARTS AND CRAFTS FOR PURPOSES OF A COMMUNITY FESTIVAL; ENTERTAINMENT IN THE NATURE OF CONDUCTING AN ARTS AND CRAFTS FAIR; PROVIDING ONLINE ENTERTAINMENT INFORMATION ABOUT ARTS AND CRAFTS; ENTERTAINMENT SERVICES, NAMELY, CONDUCTING FAIRS; ORGANIZATION OF EXHIBITIONS FOR CULTURAL OR EDUCATIONAL PURPOSES; ORGANIZING COMMUNITY FESTIVALS FEATURING A VARIETY OF ACTIVITIES, NAMELY, ART EXHIBITIONS, HERITAGE MARKETS, ETHNIC DANCES, AND THE LIKE (U.S. CLS. 100, 101 AND 107).

B. PARADEWELAI, EXAMINING ATTORNEY

SN 77-940,990. VEGA ELVIN, MILILANI, HI. FILED 2-22-2010.

LEGACYTRACKZ

THE MARK CONSISTS OF STANDARD CHARACTERS WITHOUT CLAIM TO ANY PARTICULAR FONT, STYLE, SIZE, OR COLOR.

FOR ENTERTAINMENT SERVICES, NAMELY, MUSIC AND VIDEO PRODUCTION FEATURING HIP HOP MUSIC ARTISTS OF ALL AGES (U.S. CLS. 100, 101 AND 107).

FIRST USE 9-25-1998; IN COMMERCE 3-1-2004.
PATRICIA EVANKO, EXAMINING ATTORNEY

SN 77-953,051. NEGATIVE ION, INC., DBA NEGATIVE ION, RICE, MN. FILED 3-8-2010.



THE MARK CONSISTS OF A STYLIZED VERSION OF THE WORD "NETLINGS".

FOR ENTERTAINMENT SERVICES, NAMELY, PROVIDING AN ON-LINE COMPUTER GAME (U.S. CLS. 100, 101 AND 107).

ELIZABETH HUGHITT, EXAMINING ATTORNEY

CLASS 41—(Continued).

SN 77-963,785. UNIVERSAL MUSIC- Z TUNES LLC, SANTA MONICA, CA. FILED 3-19-2010.



OWNER OF U.S. REG. NO. 2,756,125.

NO CLAIM IS MADE TO THE EXCLUSIVE RIGHT TO USE "MUSIC", APART FROM THE MARK AS SHOWN.

THE MARK CONSISTS OF THE WORDING "X-RAY MUSIC" WITH A SPIRAL OR CIRCULAR DESIGN SURROUNDING THE HYPHEN BETWEEN "X" AND "RAY" AND AN OVAL SURROUNDING THE ENTIRE WORDING AND DESIGN.

FOR AUDIO AND SOUND RECORDING AND PRODUCTION; ENTERTAINMENT SERVICES IN THE NATURE OF LIVE PERFORMANCES RENDERED BY MUSICAL ARTISTS THROUGH THE MEDIUM OF TELEVISION, AND RADIO; ENTERTAINMENT SERVICES, NAMELY, PERFORMANCES BY MUSICAL ARTISTS RENDERED LIVE AND RECORDED FOR FUTURE DISTRIBUTION; MUSIC COMPOSITION SERVICES FOR OTHERS; MUSIC PUBLISHING SERVICES; ONLINE MUSIC LIBRARY SERVICES, NAMELY, PROVIDING ELECTRONIC LIBRARY SERVICES WHICH FEATURE MUSICAL SOUND RECORDINGS VIA AN ONLINE COMPUTER NETWORK; PROVIDING AN ONLINE SEARCHABLE DATABASE FEATURING CATALOGED AND INDEXED RECORDED MUSIC AND SOUND EFFECTS; PROVIDING INFORMATION ABOUT PERFORMANCES OF MUSICAL ARTISTS AND PROVIDING LIVE PERFORMANCES OF MUSICAL ARTISTS BY MEANS OF A GLOBAL COMPUTER INFORMATION NETWORK; PROVIDING MUSIC LIBRARIES FOR USE BY PRODUCERS OF TELEVISION SHOWS, TELEVISION ADVERTISEMENTS, MOTION PICTURES, VIDEO RECORDINGS, IN-HOUSE PRODUCTIONS, AND MULTIMEDIA APPLICATIONS; PROVIDING ONLINE ENTERTAINMENT, NAMELY, PROVIDING SOUND AND VIDEO RECORDINGS IN THE FIELD OF MUSIC AND MUSIC-BASED ENTERTAINMENT; AND RENTAL AND LEASING OF SOUND RECORDINGS AND RECORDED SOUND EFFECTS FOR BROADCASTS, TRADE PRESENTATIONS, AUDIO-VISUAL SHOWS AND FILM SCORES (U.S. CLS. 100, 101 AND 107).

FIRST USE 3-28-2001; IN COMMERCE 3-28-2001.
SUE LAWRENCE, EXAMINING ATTORNEY

SN 78-911,088. BAIKO, KEVIN PATRICK, CHESAPEAKE, VA. FILED 6-19-2006.

DOCTOR SPARKLES

THE MARK CONSISTS OF STANDARD CHARACTERS WITHOUT CLAIM TO ANY PARTICULAR FONT, STYLE, SIZE, OR COLOR.

FOR ENTERTAINMENT SERVICES, NAMELY, LIVE, TELEvised AND MOVIE APPEARANCES BY A PROFESSIONAL ENTERTAINER; ENTERTAINMENT, NAMELY, A CONTINUING CHILDREN'S EDUCATIONAL AND ENTERTAINMENT SHOW BROADCAST OVER TELEVISION, SATELLITE, AUDIO, AND VIDEO MEDIA (U.S. CLS. 100, 101 AND 107).

FIRST USE 12-17-2005; IN COMMERCE 4-1-2006.
RONALD DELGIZZI, EXAMINING ATTORNEY

CLASS 41—(Continued).

SN 79-023,168. ONGAME E-SOLUTIONS AB, SWEDEN, FILED 12-19-2005.



PRIORITY DATE OF 10-27-2005 IS CLAIMED.

OWNER OF INTERNATIONAL REGISTRATION 0883092 DATED 12-19-2005. EXPIRES 12-19-2015.

NO CLAIM IS MADE TO THE EXCLUSIVE RIGHT TO USE "NETWORK", APART FROM THE MARK AS SHOWN.

FOR INSTRUCTION OF OTHERS IN THE FIELD OF PROVIDING USER ACCESS TO COMPUTER DATABASES FOR POKER GAMES AND CASINO GAMES, FOR THE PROVISION OF ACCESS TO LOCAL AND GLOBAL COMPUTER NETWORKS FOR ONLINE GAMING, THE PROVISION OF ACCESS TO DATABASES AND USERS RIGHTS TO DATABASES FOR ONLINE GAMING; EDUCATIONAL SERVICES, NAMELY, CONDUCTING CLASSES AND SEMINARS IN THE FIELD OF PROVIDING USER ACCESS TO COMPUTER DATABASES FOR POKER GAMES AND CASINO GAMES, THE PROVISION OF ACCESS TO LOCAL AND GLOBAL COMPUTER NETWORKS; NAMELY, ON HOW TO PROVIDE ONLINE ACCESS TO A SYSTEM AND DATABASE FOR USE BY WEBSITE OPERATORS IN OFFERING ONLINE GAMING SERVICES, HOW TO PROVIDE A WEB-BASED SYSTEM AND ONLINE PORTAL TO ENABLE CUSTOMERS TO PARTICIPATE IN ONLINE GAMING AND HOW TO PROVIDE ACCESS TO DATABASES AND USERS RIGHTS TO DATABASES FOR ONLINE GAMING (U.S. CLS. 100, 101 AND 107).

SUSAN LESLIE DUBOIS, EXAMINING ATTORNEY

CLASS 41—(Continued).

SN 79-084,955. COMMUNITY OF EUROPEAN MANAGEMENT SCHOOLS H.E.C. (ASSOCIATION LOI 1901), JOUY-EN-JOSAS, FRANCE, FILED 4-20-2010.



PRIORITY DATE OF 2-16-2010 IS CLAIMED.
OWNER OF INTERNATIONAL REGISTRATION 1044846 DATED 4-20-2010, EXPIRES 4-20-2020.

NO CLAIM IS MADE TO THE EXCLUSIVE RIGHT TO USE "THE GLOBAL ALLIANCE IN MANAGEMENT EDUCATION", APART FROM THE MARK AS SHOWN.

THE COLOR(S) WHITE, YELLOW AND BLUE IS/ARE CLAIMED AS A FEATURE OF THE MARK.

THE MARK CONSISTS OF THE FOLLOWING: THE COLOR BLUE APPEARS IN THE LETTER "C" AND THE WORDING "CEMS" AND "THE GLOBAL ALLIANCE IN MANAGEMENT EDUCATION"; THE COLOR YELLOW APPEARS IN A REVERSED LETTER "C"; THE COLOR WHITE APPEARS IN THE BACKGROUND OF THE MARK.

FOR EDUCATION SERVICES IN THE NATURE OF COURSES AT THE UNIVERSITY LEVEL AND COURSES FOR BUSINESS PROFESSIONALS IN THE FIELDS OF BUSINESS ADMINISTRATION, MANAGEMENT, PUBLIC AFFAIRS, INTERNATIONAL TRADE, SCIENCE, LAW, INFORMATION TECHNOLOGY, AND HUMANITIES; TEACHING AND TRAINING SERVICES, NAMELY, TEACHING AT THE UNIVERSITY LEVEL AND TEACHING TO WORKING PROFESSIONALS IN THE FIELDS OF BUSINESS ADMINISTRATION, MANAGEMENT, PUBLIC AFFAIRS, INTERNATIONAL TRADE, SCIENCE, LAW, INFORMATION TECHNOLOGY, AND HUMANITIES; EDUCATIONAL SERVICES, NAMELY, ORGANIZATION OF SEMINARS AND COLLOQUIUMS IN THE FIELDS OF BUSINESS ADMINISTRATION, MANAGEMENT, PUBLIC AFFAIRS, INTERNATIONAL TRADE, SCIENCE, LAW, INFORMATION TECHNOLOGY, AND HUMANITIES; EDUCATIONAL RESEARCH; PROVIDING ACADEMIC AND PROFESSIONAL INTERNSHIPS IN THE FIELDS OF BUSINESS ADMINISTRATION, MANAGEMENT, PUBLIC AFFAIRS, INTERNATIONAL TRADE, SCIENCE, LAW, INFORMATION TECHNOLOGY, AND HUMANITIES; ORGANIZATION OF COMPETITIONS IN THE FIELD OF EDUCATION AND OTHER NON-BUSINESS AND NON-COMMERCIAL FIELDS, AND ORGANIZATION OF EDUCATIONAL EXAMINATIONS; PRODUCTION OF DOCUMENTS ON TEACHING, NAMELY, PUBLICATION OF THE DOCUMENTS OF OTHERS IN THE FIELDS OF TEACHING, TRAINING, BUSINESS ADMINISTRATION, MANAGEMENT, PUBLIC AFFAIRS, INTERNATIONAL TRADE, SCIENCE, RESEARCH, LAW, INFORMATION TECHNOLOGY, AND HUMANITIES (U.S. CLS. 100, 101 AND 107).

LEIGH LOWRY, EXAMINING ATTORNEY

CLASS 41—(Continued).

SN 79-086,947. ARCHIBEL, SOCIÉTÉ ANONYME, BELGIUM, FILED 7-14-2010.

RADAROPUS

THE MARK CONSISTS OF STANDARD CHARACTERS WITHOUT CLAIM TO ANY PARTICULAR FONT, STYLE, SIZE, OR COLOR.

PRIORITY DATE OF 2-15-2010 IS CLAIMED.

OWNER OF INTERNATIONAL REGISTRATION 1049989 DATED 7-14-2010, EXPIRES 7-14-2020.

FOR ORGANIZATION OF COURSES AND SEMINARS IN THE FIELDS OF HOMEOPATHY, COMPUTERS AND COMPUTER SOFTWARE; TRAINING USERS OF INSTALLED COMPUTER APPLICATIONS; ARRANGING AND CONDUCTING OF TRAINING WORKSHOPS, COLLOQUIUMS, CONFERENCES AND CONGRESSES IN THE FIELDS OF HOMEOPATHY, COMPUTERS AND COMPUTER SOFTWARE; ORGANIZATION OF EXHIBITIONS FOR CULTURAL OR EDUCATIONAL PURPOSES; PUBLICATION OF ELECTRONIC BOOKS AND JOURNALS ON-LINE; ON-LINE DIGITAL IMAGING SERVICES FOR ALL INDUSTRIES, ESPECIALLY FOR HOMEOPATHIC DOCTORS (U.S. CLS. 100, 101 AND 107).

KRISTINA MORRIS, EXAMINING ATTORNEY

SN 85-001,217. JONNA M. SPILBOR, ESQ., POUGHKEEPSIE, NY, FILED 3-29-2010.



THE COLOR(S) BROWN, BEIGE, BLUE, BLACK, WHITE, GRAY, RED AND GOLD IS/ARE CLAIMED AS A FEATURE OF THE MARK.

THE MARK CONSISTS OF A CARICATURE OF A FEMALE ATTORNEY SITTING ON A BROOM, HOLDING A LAW BOOK IN ONE ARM, AND A SMALL DOG IN THE OTHER. THE BROOM IS BROWN WITH GOLD AND BEIGE BRISTLES. THE DOG IS GRAY WITH BLACK EYES AND NOSE AND A GOLD AND BEIGE COLLAR AND TAG BEARING THE LETTERS "ITCH" IN STYLIZED BLACK FONT. THE WOMAN IS PRESENTED WITH BROWN HAIR AND EYES, BEIGE SKIN AND FACIAL DETAILS IN BLACK, WHITE AND BROWN. SHE WEARS A BLACK NECKLACE WITH A BLACK STYLIZED LETTER "B" PENDANT, A BLUE BLOUSE WITH BLACK BUTTONS, BLACK SKIRT AND BLUE SHOES AND IS HOLDING A RED COVERED BOOK WITH WHITE PAGES AND THE WORD "LAW" IN BEIGE STYLIZED FONT ON ITS COVER.

FOR ON-LINE JOURNALS, NAMELY, BLOGS ON THE SUBJECT OF LEGAL OPINION (U.S. CLS. 100, 101 AND 107).

FIRST USE 3-21-2010; IN COMMERCE 3-21-2010.

STEVEN PEREZ, EXAMINING ATTORNEY

CLASS 41—(Continued).

SN 85-004,549. PERFORMANCE DENTAL COACHING LLC, TUPELO, MS. FILED 4-1-2010.

LOVE YOUR PRACTICE AGAIN

THE MARK CONSISTS OF STANDARD CHARACTERS WITHOUT CLAIM TO ANY PARTICULAR FONT, STYLE, SIZE, OR COLOR.

FOR PROFESSIONAL COACHING, NAMELY, ONE-ON-ONE TEACHING OF OTHERS IN THE FIELD OF DENTAL PRACTICE MANAGEMENT; PROVIDING EDUCATIONAL WORKSHOPS AND TRAINING COURSES IN THE FIELD OF DENTAL PRACTICE MANAGEMENT (U.S. CLS. 100, 101 AND 107).

FIRST USE 6-1-2009; IN COMMERCE 6-1-2009.
CORY BOONE, EXAMINING ATTORNEY

SN 85-017,089. BEST LIFE DESIGN, LLC, CEDAR RAPIDS, IA. FILED 4-19-2010.

Make Money, Have Fun, Do
Good

THE MARK CONSISTS OF STANDARD CHARACTERS WITHOUT CLAIM TO ANY PARTICULAR FONT, STYLE, SIZE, OR COLOR.

FOR EDUCATIONAL SERVICES, NAMELY, CONDUCTING WORKSHOPS AND SEMINARS IN THE FIELD OF PERSONAL FINANCE AND LIFE DESIGN THAT SUPPORT PEOPLE IN MAKING MORE MONEY IN A WAY THAT FUELS THEIR LIFE, AND ALLOWS THEM TO HELP MORE OF THE PEOPLE THEY WERE MEANT TO SERVE (U.S. CLS. 100, 101 AND 107).

FIRST USE 1-15-2009; IN COMMERCE 2-15-2009.
REBECCA SMITH, EXAMINING ATTORNEY

CLASS 41—(Continued).

SN 85-022,660. MICHAEL ELLIOT HOLDINGS PTY LTD AS TRUSTEE FOR THE MICHAEL ELLIOT TRUST, PERTH, AUSTRALIA, FILED 4-26-2010.

ZEDIA

THE MARK CONSISTS OF STANDARD CHARACTERS WITHOUT CLAIM TO ANY PARTICULAR FONT, STYLE, SIZE, OR COLOR.

PRIORITY CLAIMED UNDER SEC. 44(D) ON AUSTRALIA APPLICATION NO. 1339030, FILED 12-30-2009, REG. NO. 1263810, DATED 9-23-2008, EXPIRES 9-23-2018.

THE NAME(S), PORTRAIT(S), AND/OR SIGNATURE(S) SHOWN IN THE MARK DOES NOT IDENTIFY A PARTICULAR LIVING INDIVIDUAL.

THE WORDING "ZEDIA" HAS NO MEANING IN A FOREIGN LANGUAGE.

THE NON-LATIN CHARACTERS IN THE MARK TRANSLITERATE TO "ZEDIA" AND THIS HAS NO MEANING IN A FOREIGN LANGUAGE.

FOR PROVISION OF WEBSITES FEATURING AUDIO-VISUAL CONTENT IN THE FIELD OF ENTERTAINMENT OVER THE INTERNET OR LOCAL AREA NETWORK; PROVISION OF INFORMATION IN THE FIELD OF ENTERTAINMENT VIA THE INTERNET OR LOCAL AREA NETWORK ; PROVISION OF ELECTRONIC PUBLISHING SERVICES FOR AUDIO-VISUAL WORKS OF OTHERS ONLINE IN THE FIELD OF ENTERTAINMENT FOR STREAMING, DOWNLOADING AND/OR PODCASTS; PROVISION OF ONLINE INTERACTIVE RESOURCE AND PROGRAMMING GUIDES IN THE FIELD OF ENTERTAINMENT TAILORED TO VIEWER'S PROGRAMMING PREFERENCES; PROVISION OF INTERACTIVE ONLINE GAME ENTERTAINMENT SERVICES (U.S. CLS. 100, 101 AND 107).

FIRST USE 9-23-2008; IN COMMERCE 9-23-2008.
LINDA MICKLEBURGH, EXAMINING ATTORNEY

SN 85-044,082. DADA ROCKS, LTD, NEW YORK, NY. FILED 5-20-2010.

Who's the bigger baby

THE MARK CONSISTS OF STANDARD CHARACTERS WITHOUT CLAIM TO ANY PARTICULAR FONT, STYLE, SIZE, OR COLOR.

FOR CONDUCTING EDUCATIONAL EXHIBITIONS IN THE NATURE OF DISCUSSIONS, FEATURES AND PROGRAMMING FOR THE BENEFIT OF FATHERS, CHILDREN AND FAMILY RELATIONS; ENTERTAINMENT AND EDUCATION SERVICES IN THE NATURE OF A SERIES OF SHORT SHOWS FEATURING FATHERS, CHILDREN AND FAMILY RELATIONS DISTRIBUTED TO MOBILE HANDSETS, WHICH MAY INCLUDE VIDEO, TEXT, PHOTOS, ILLUSTRATIONS OR HYPERTEXT; ENTERTAINMENT AND EDUCATIONAL SERVICES IN THE NATURE OF ON-LINE COMPETITIONS IN THE FIELD OF ENTERTAINMENT, EDUCATION, CULTURE, SPORTS, AND OTHER NON-BUSINESS AND NON-COMMERCIAL FIELDS; ENTERTAINMENT AND EDUCATIONAL SERVICES, NAMELY, PROVIDING A WEBSITE THAT DISPLAYS VARIOUS REQUESTS, REVIEWS, RECOMMENDATIONS, RANKINGS, TRACKINGS, VOTES, AND INFORMATION RELATING TO UNCREATED, UNRELEASED, NEW, SPECIAL, POPULAR, AND RARE PRODUCTS, SERVICES, AND EVENTS IN THE FIELDS OF POP CUL-

CLASS 41—(Continued).

TURE, ENTERTAINMENT, EDUCATION, AND SPORTS, ALL EXCLUSIVELY FOR NON-BUSINESS AND NON-COMMERCIAL TRANSACTIONS AND PURPOSES; ENTERTAINMENT AND EDUCATIONAL SERVICES, NAMELY, PROVIDING ADVICE AND INFORMATION FOR MUSIC, VIDEO AND FILM CONCEPT AND SCRIPT DEVELOPMENT; ENTERTAINMENT AND EDUCATIONAL SERVICES, NAMELY, THE PRESENTATION OF SEMINARS, LECTURES, WORKSHOPS AND PANEL DISCUSSIONS, AND ONGOING TELEVISION AND RADIO TALK SHOWS ALL IN THE FIELD OF PUBLIC INTEREST CONCERNING FATHERS CHILDREN AND FAMILY RELATIONS; ENTERTAINMENT IN THE NATURE OF ON-GOING TELEVISION PROGRAMS IN THE FIELD OF FATHERS, CHILDREN AND FAMILY RELATIONS; ENTERTAINMENT IN THE NATURE OF BLOGS DISCUSSING INFORMATION RELATED TO AND FOR FATHERS AND THEIR FAMILY RELATIONS, PRODUCTS AND SERVICES AVAILABLE, COMMENTARY ON FAMILY ISSUES; AND OTHER NEW MEDIA DISTRIBUTION; PROVIDING NEW MEDIA SERVICES, NAMELY, PROVIDING BLOGS, INTERNET SITES, AND ON-GOING TELEVISION PROGRAMS IN THE FIELD OF FAMILY ISSUES; ENTERTAINMENT SERVICES IN THE NATURE OF AN ONGOING IPTV (INTERNET PROTOCOL TELEVISION), TELEVISION PROGRAMMING SEGMENTS IN THE FIELD OF POSITIVE PSYCHOLOGY, PERSONAL RELATIONSHIPS, THE ART AND SCIENCE OF HAPPINESS; ENTERTAINMENT SERVICES IN THE NATURE OF COMEDY SHOWS; ENTERTAINMENT SERVICES IN THE NATURE OF DEVELOPMENT, CREATION, PRODUCTION AND POST-PRODUCTION SERVICES OF MULTIMEDIA ENTERTAINMENT CONTENT; ENTERTAINMENT SERVICES, NAMELY, PROVIDING A WEB SITE FEATURING NON-DOWNLOADABLE MUSICAL PERFORMANCES, MUSICAL VIDEOS, RELATED FILM CLIPS, PHOTOGRAPHS, AND OTHER MULTIMEDIA MATERIALS FEATURING FATHERS CHILDREN AND FAMILY RELATIONS; ENTERTAINMENT SERVICES, NAMELY, PROVIDING A WEB SITE FEATURING PHOTOGRAPHIC AND PROSE PRESENTATIONS FEATURING FATHERS, CHILDREN AND FAMILY RELATIONS; ENTERTAINMENT SERVICES, NAMELY, PROVIDING ON-LINE REVIEWS OF ALL MEDIA AND PRODUCTIONS RELATING TO FATHERS, CHILDREN AND FAMILY RELATIONS; ENTERTAINMENT SERVICES, NAMELY, PROVIDING VIDEO PODCASTS IN THE FIELD OF FATHERS, CHILDREN AND FAMILY RELATIONS; ENTERTAINMENT SERVICES, NAMELY, PROVIDING WEBCASTS IN THE FIELD OF FATHERS, CHILDREN AND FAMILY RELATIONS; ENTERTAINMENT SERVICES, NAMELY, THE PROVISION OF CONTINUING INTERNET, TELEVISION, RADIO, AND OTHER BROADCAST CHANNELS, FEATURING OPINIONS, ANALYSIS, REVIEWS, AND INFORMATION DELIVERED BY RADIO, TV, WEB, SHORT DISTRIBUTIONS VIA NEW MEDIA OF INFORMATION TO FOLLOWERS, PHONES; ENTERTAINMENT, NAMELY, A CONTINUING VARIETY, INFORMATIONAL, AND NEWS SHOW BROADCAST OVER TELEVISION, SATELLITE, AUDIO, AND VIDEO MEDIA; ENTERTAINMENT, NAMELY, A CONTINUING VARIETY, INFORMATION AND NEWS SHOW BROADCAST OVER WEB, TV, RADIO, TELEPHONE DELIVERY, AND NEW MEDIA; ENTERTAINMENT, NAMELY, PRODUCTION OF ENTERTAINMENT AND INFORMATION PROVIDING ENTERTAINING INFORMATION DIRECTED TOWARDS AND RELATING TO FATHERS, CHILDREN AND FAMILIES; ON-LINE ADMISSION TICKET AGENCY SERVICES FOR ENTERTAINMENT, EDUCATIONAL, SPORTING AND CULTURAL EVENTS; ON-LINE EDUCATIONAL PARENTAL TRAINING CLASSES; ON-LINE ENTERTAINMENT TICKET AGENCY SERVICES (U.S. CLS. 100, 101 AND 107).

FIRST USE 1-1-2010; IN COMMERCE 1-1-2010.

SEAN CROWLEY, EXAMINING ATTORNEY

CLASS 41—(Continued).

SN 85-078,768. HTV MEDIA GROUP, LLC, WEST PALM BEACH, FL. FILED 7-6-2010.

CELEBRITYGPS

THE MARK CONSISTS OF STANDARD CHARACTERS WITHOUT CLAIM TO ANY PARTICULAR FONT, STYLE, SIZE, OR COLOR.

FOR ENTERTAINMENT SERVICES IN THE NATURE OF A TELEVISION SERIES IN THE FIELD OF CELEBRITY ENTERTAINMENT NEWS; ENTERTAINMENT SERVICES, NAMELY, PROVIDING A WEBSITE FEATURING CELEBRITY ENTERTAINMENT NEWS AND INFORMATION, CELEBRITY INTERVIEWS IN THE FIELD OF MOVIES, MUSIC, TELEVISION, AND SPORTS; ENTERTAINMENT SERVICES, NAMELY, PROVIDING NON-DOWNLOADABLE VIDEOS, FILM CLIPS, PHOTOGRAPHS, AND OTHER MULTIMEDIA MATERIALS IN THE FIELD OF MOVIES, MUSIC, TELEVISION AND SPORTS FOR ENTERTAINMENT PURPOSES (U.S. CLS. 100, 101 AND 107).

FIRST USE 0-0-2008; IN COMMERCE 0-0-2008.

PRISCILLA MILTON, EXAMINING ATTORNEY

SN 85-083,989. MARLY BERGERUD, PALM DESERT, CA. FILED 7-14-2010.

3D Content Connection

THE MARK CONSISTS OF STANDARD CHARACTERS WITHOUT CLAIM TO ANY PARTICULAR FONT, STYLE, SIZE, OR COLOR.

NO CLAIM IS MADE TO THE EXCLUSIVE RIGHT TO USE "3D CONTENT", APART FROM THE MARK AS SHOWN.

FOR EDUCATIONAL SERVICES, NAMELY, PROVIDING EDUCATIONAL CLASSES BOTH ONLINE AND OFFLINE, IN THE FIELD OF COMPUTER-GENERATED 3D OBJECTS, COMPUTER MODULES AND COMPUTER APPLICATIONS, DELIVERED VIA COMPUTER NETWORKS, TELEVISIONS, MOBILE PHONES AND COMPUTER AND ELECTRONIC DEVICES (U.S. CLS. 100, 101 AND 107).

DAWN HAN, EXAMINING ATTORNEY

CLASS 41—(Continued).

SN 85-085,010. DIVERSITY FORCE LLC, NEW YORK, NY.
FILED 7-15-2010.

THE HOURGLASS PRINCIPLE

THE MARK CONSISTS OF STANDARD CHARACTERS WITHOUT CLAIM TO ANY PARTICULAR FONT, STYLE, SIZE, OR COLOR.

NO CLAIM IS MADE TO THE EXCLUSIVE RIGHT TO USE "PRINCIPLE", APART FROM THE MARK AS SHOWN. FOR EDUCATIONAL SERVICES, NAMELY, CONDUCTING WORKSHOPS, SEMINARS AND PROGRAMS IN THE FIELD OF CAREER COUNSELING, AND DISTRIBUTION OF PRINTED MATERIALS IN CONNECTION THEREWITH; LIFE COACHING SERVICES IN THE FIELD OF CAREER COUNSELING (U.S. CLS. 100, 101 AND 107).

MARC LEIPZIG, EXAMINING ATTORNEY

CLASS 41—(Continued).

SN 85-091,082. ROCHA, ROGER, SAN FRANCISCO, CA.
FILED 7-22-2010.

THE GOLDENHEARTS

THE MARK CONSISTS OF STANDARD CHARACTERS WITHOUT CLAIM TO ANY PARTICULAR FONT, STYLE, SIZE, OR COLOR.

FOR ENTERTAINMENT, NAMELY, LIVE MUSIC CONCERTS; ENTERTAINMENT, NAMELY, LIVE PERFORMANCES BY A MUSICAL BAND (U.S. CLS. 100, 101 AND 107).

FIRST USE 12-13-2007; IN COMMERCE 12-13-2007.
LINDA LAVACHE, EXAMINING ATTORNEY

SN 85-086,600. TOKYO BROADCASTING SYSTEM TELEVISION, INC., TOKYO, JAPAN, FILED 7-16-2010.

AMERICAN NINJA WARRIOR

THE MARK CONSISTS OF STANDARD CHARACTERS WITHOUT CLAIM TO ANY PARTICULAR FONT, STYLE, SIZE, OR COLOR.

OWNER OF U.S. REG. NOS. 3,387,835 AND 3,680,200.

NO CLAIM IS MADE TO THE EXCLUSIVE RIGHT TO USE "AMERICAN" OR "WARRIOR", APART FROM THE MARK AS SHOWN.

FOR PRODUCTION OF TELEVISION PROGRAMS, SERIES AND SEGMENTS, PRE-RECORDED OPTICAL, ELECTRONIC, DIGITAL, AND MAGNETIC MEDIA IN THE NATURE OF COMPACT DISCS, LASER DISCS, CD-ROMS, DVDS, DVD-ROMS, VIDEOTAPES AND VIDEOCASSETTES FEATURING COMPETITION-BASED ENTERTAINMENT AND COMPANION PROGRAMMING IN WHICH ACTUAL AND/OR FICTIONAL CHARACTERS TRAIN AND PARTICIPATE IN CHALLENGES INVOLVING JAPANESE MARTIAL ARTS BROADCAST OVER TELEVISION, SATELLITE, AUDIO AND VIDEO MEDIA, AND VIA A GLOBAL COMPUTER NETWORK (U.S. CLS. 100, 101 AND 107).

AMEEN IMAM, EXAMINING ATTORNEY

SN 85-091,428. THE RELIGION OF BASIS, CHICAGO, IL.
FILED 7-23-2010.

The Religion of Basis

THE MARK CONSISTS OF STANDARD CHARACTERS WITHOUT CLAIM TO ANY PARTICULAR FONT, STYLE, SIZE, OR COLOR.

NO CLAIM IS MADE TO THE EXCLUSIVE RIGHT TO USE "RELIGION", APART FROM THE MARK AS SHOWN.

FOR RELIGIOUS INSTRUCTION SERVICES; EDUCATION SERVICES, NAMELY, PROVIDING WORKSHOPS IN THE FIELD OF RELIGION AND SCIENCE COEXISTENCE AND DISTRIBUTION OF COURSE MATERIAL IN CONNECTION THEREWITH; HOSTING AND ORGANIZING EDUCATIONAL LECTURES ON SCIENTIFIC AND RELIGIOUS TOPICS (U.S. CLS. 100, 101 AND 107).

JOHN SCHUYLER YARD, EXAMINING ATTORNEY

CLASS 41—(Continued).

SN 85-091,802. QUIET STORM PRODUCTIONS PTY LTD, PALM BEACH QLD, AUSTRALIA, FILED 7-23-2010.



NO CLAIM IS MADE TO THE EXCLUSIVE RIGHT TO USE "GREATEST ATHLETE", APART FROM THE MARK AS SHOWN.

THE MARK CONSISTS OF THE WORDING "GREATEST ATHLETE" PRECEDED WITH STYLIZED LETTERS "GA", THE "G" BEING STYLIZED AS INCLUDING A WING EXTENDING FROM ITS TOP AND LEFT SIDE, AND THE "A" BEING STYLIZED WITH THE SILHOUETTE OF A PERSON FORMING THE VOID SPACE BETWEEN THE LEGS OF THE "A".

FOR PROVIDING PRODUCTION SERVICES FOR FILM, THEATRE, TELEVISION SHOWS AND RADIO SHOWS; PROVIDING FACILITIES FOR CINEMA PRODUCTIONS; PROVIDING AN ONGOING, LIVE TELEVISION SHOW IN THE FIELD OF ATHLETIC COMPETITIONS; PRODUCTION OF VIDEO TAPES AND VIDEO DISCS BEING THE PRODUCTION OF VIDEO TAPES AND DISCS OF TELEVISION PROGRAMS; ARRANGING AND CONDUCTING ATHLETIC COMPETITIONS FOR ENTERTAINMENT; INTERACTIVE ENTERTAINMENT SERVICES NAMELY AN ONGOING TELEVISION PROGRAM IN THE FIELD OF ATHLETIC COMPETITIONS FEATURING AUDIENCE PARTICIPATION BY TELEPHONE, EMAIL AND VIA THE WORLD WIDE WEB OR INTERNET; RENTAL OF SOUND RECORDINGS AND PRE-RECORDED SHOWS, FILMS, RADIO AND TELEVISION PERFORMANCES; DUBBING SERVICES AND FILM, TELEVISION AND SOUND RECORDING EDITING SERVICES (U.S. CLS. 100, 101 AND 107).

SEAN CROWLEY, EXAMINING ATTORNEY

SN 85-092,928. THE PROCTER & GAMBLE COMPANY, CINCINNATI, OH. FILED 7-26-2010.

THE MOMUMENTARY PROJECT

THE MARK CONSISTS OF STANDARD CHARACTERS WITHOUT CLAIM TO ANY PARTICULAR FONT, STYLE, SIZE, OR COLOR.

NO CLAIM IS MADE TO THE EXCLUSIVE RIGHT TO USE "PROJECT", APART FROM THE MARK AS SHOWN.

FOR ENTERTAINMENT SERVICES, NAMELY, AN ONGOING SERIES OF DOCUMENTARIES ON PARENTING AND SPORTS PROVIDED THROUGH TELEVISION, INTERNET AND MOBILE WIRELESS FORM (U.S. CLS. 100, 101 AND 107).

EDWARD NELSON, EXAMINING ATTORNEY

CLASS 41—(Continued).

SN 85-093,368. MAHJONG POKER, INC., AKA MJP GAMES, INC., ALAMEDA, CA. FILED 7-26-2010.



THE MARK CONSISTS OF ONE WORD "SHORTIE" WHICH HAS ALL CAPITAL LETTERS; TWO SYMBOLS IN POKER ARE USED IN THIS WORD; SPECIFICALLY, THE LETTER "O" IS REPLACED BY A SPADE AND THE LETTER "E" IS REPLACED BY A DIAMOND.

FOR ENTERTAINMENT SERVICES, NAMELY, PROVIDING LIVE GAMES OF CHANCES IN CASINOS (U.S. CLS. 100, 101 AND 107).

FIRST USE 7-19-2010; IN COMMERCE 7-19-2010.

RICHARD WHITE, EXAMINING ATTORNEY

SN 85-095,332. UNIVERSE KONADU LLC, CLIFTON, NJ. FILED 7-28-2010.



THE NAME "UNIVERSE KONADU" IDENTIFIES A LIVING INDIVIDUAL WHOSE CONSENT IS OF RECORD.

THE MARK CONSISTS OF TWO CIRCLES CONTAINING A STAR OR GALAXY LIKE BACKGROUND, A SILHOUETTE OF A LADY'S FACE AND A SHADED AREA UNDERNEATH. THE STYLIZED TEXT "UNIVERSE KONADU" EMANATES FROM THE CIRCLES AND A RECTANGLE CONTAINING THE WORDING "EMPOWERING GIRLS AND WOMEN WORLDWIDE" APPEARS BELOW.

FOR EDUCATION SERVICES, NAMELY, PROVIDING CONFERENCES, SEMINARS, WORKSHOPS, RETREATS, MENTORING PROGRAMS, AND IN-SCHOOL AND AFTER-SCHOOL PROGRAMS IN THE FIELD OF LIFE SKILLS AND PERSONAL DEVELOPMENT (U.S. CLS. 100, 101 AND 107).

FIRST USE 6-14-2010; IN COMMERCE 6-14-2010.

BRENDAN MCCAULEY, EXAMINING ATTORNEY

CLASS 41—(Continued).

SN 85-095,569. INTERVAL INTERNATIONAL, INC., MIAMI, FL. FILED 7-29-2010.

**INTERVAL INTERNATIONAL
PREMIER BOUTIQUE RESORT**

THE MARK CONSISTS OF STANDARD CHARACTERS WITHOUT CLAIM TO ANY PARTICULAR FONT, STYLE, SIZE, OR COLOR.

OWNER OF U.S. REG. NOS. 1,477,164, 3,704,060 AND OTHERS.

NO CLAIM IS MADE TO THE EXCLUSIVE RIGHT TO USE "PREMIER BOUTIQUE RESORT", APART FROM THE MARK AS SHOWN.

SEC. 2(F) AS TO "INTERVAL INTERNATIONAL".

FOR PROVIDING RECOGNITION BY WAY OF AWARDS TO DEMONSTRATE EXCELLENCE IN THE FIELD OF VACATION RESORTS (U.S. CLS. 100, 101 AND 107).

FIRST USE 4-0-2010; IN COMMERCE 4-0-2010.

H. M. FISHER, EXAMINING ATTORNEY

SN 85-096,619. O'NEILL, MICHAEL M., YUKON, OK. FILED 7-30-2010.

Winning at Life

THE MARK CONSISTS OF STANDARD CHARACTERS WITHOUT CLAIM TO ANY PARTICULAR FONT, STYLE, SIZE, OR COLOR.

FOR EDUCATIONAL AND ENTERTAINMENT SERVICES, NAMELY, A CONTINUING PROGRAM ABOUT FINANCIAL PLANNING ACCESSIBLE BY RADIO, TELEVISION, SATELLITE, AUDIO, VIDEO AND COMPUTER NETWORKS (U.S. CLS. 100, 101 AND 107).

FIRST USE 6-8-2010; IN COMMERCE 6-8-2010.

MARC LEIPZIG, EXAMINING ATTORNEY

SN 85-099,376. SALT LAKE FILM PRODUCTIONS, LLC, ALPINE, UT. FILED 8-3-2010.

Unicorn City

THE MARK CONSISTS OF STANDARD CHARACTERS WITHOUT CLAIM TO ANY PARTICULAR FONT, STYLE, SIZE, OR COLOR.

FOR ENTERTAINMENT SERVICES, NAMELY, THE PROVISION OF CONTINUING MOVIES FEATURING COMEDY DELIVERED BY TELEVISION; PRODUCTION AND DISTRIBUTION OF COMEDY FILMS AND MOVIES (U.S. CLS. 100, 101 AND 107).

FIRST USE 7-1-2010; IN COMMERCE 7-1-2010.

SAIMA MAKHDOOM, EXAMINING ATTORNEY

CLASS 41—(Continued).

SN 85-099,700. KELLY HARTMAN-SELLER, DBA ANGEL-HART PRODUCTIONS, WHITNEY POINT, NY. FILED 8-4-2010.

SPONTANEOUS RUKKUS

THE MARK CONSISTS OF STANDARD CHARACTERS WITHOUT CLAIM TO ANY PARTICULAR FONT, STYLE, SIZE, OR COLOR.

FOR ENTERTAINMENT, NAMELY, A CONTINUING MUSIC AND INTERVIEW SHOW BROADCAST OVER TELEVISION, RADIO, CABLE, SATELLITE, AUDIO AND VIDEO MEDIA (U.S. CLS. 100, 101 AND 107).

FIRST USE 4-30-1998; IN COMMERCE 7-12-2008.

JOHN DWYER, EXAMINING ATTORNEY

SN 85-100,447. LOCAL COLORS OF WESTERN VIRGINIA, INC., ROANOKE, VA. FILED 8-4-2010.



THE COLOR(S) ORANGE, LIGHT ORANGE, YELLOW, LIGHT YELLOW, BLUE, LIGHT BLUE, MAGENTA, LIGHT MAGENTA, GREEN, LIGHT GREEN, WHITE AND BLACK IS/ARE CLAIMED AS A FEATURE OF THE MARK.

THE MARK CONSISTS OF A LIGHT GREEN SQUARE CONTAINING FOUR HANDS DISPLAYED AROUND THE PERIMETER OF A GLOBE. THE HAND ON TOP OF THE GLOBE IS YELLOW AND LIGHT YELLOW. THE HAND ON THE RIGHT OF THE GLOBE IS BLUE AND LIGHT BLUE. THE HAND ON THE BOTTOM OF THE GLOBE IS MAGENTA AND LIGHT MAGENTA. THE HAND ON THE LEFT OF THE GLOBE IS ORANGE AND LIGHT ORANGE. ALL FOUR HANDS ARE OUTLINED IN WHITE AND BLACK. THE GLOBE IS OUTLINED IN BLACK AND WHITE AND DISPLAYS GREEN CONTINENTS AND A BLUE OCEAN WITH THE CONTINENTS OUTLINED IN BLACK. THE WHITE BACKGROUND IS NOT A PART OF THE MARK.

FOR ENTERTAINMENT IN THE NATURE OF ORGANIZING CULTURAL DIVERSITY EVENTS FOR ENTERTAINMENT OR EDUCATIONAL PURPOSES; ORGANIZING COMMUNITY FESTIVALS FEATURING A VARIETY OF ACTIVITIES, NAMELY, ART EXHIBITS, ETHNIC DANCES, CRAFT EXHIBITS, LIVE MUSICAL PERFORMANCES, ETHNIC CLOTHING EXHIBITIONS AND FOOD TASTINGS; EDUCATIONAL SERVICES, NAMELY, PROVIDING TRAINING AND LECTURES IN THE FIELD OF CULTURAL DIVERSITY (U.S. CLS. 100, 101 AND 107).

FIRST USE 1-1-2004; IN COMMERCE 3-1-2004.

RENEE SERVANCE, EXAMINING ATTORNEY

CLASS 41—(Continued).

SN 85-100,534. THE E.W. SCRIPPS COMPANY, CINCINNATI, OH. FILED 8-4-2010.

SCRIPPS NATIONAL SPELLING
BEE

THE MARK CONSISTS OF STANDARD CHARACTERS WITHOUT CLAIM TO ANY PARTICULAR FONT, STYLE, SIZE, OR COLOR.

OWNER OF U.S. REG. NO. 2,009,905.

NO CLAIM IS MADE TO THE EXCLUSIVE RIGHT TO USE "SPELLING BEE", APART FROM THE MARK AS SHOWN.

SEC. 2(F) AS TO "NATIONAL".

FOR ENTERTAINMENT SERVICES IN THE NATURE OF SPELLING CONTESTS INTENDED TO PROMOTE THE IMPORTANCE OF CORRECT SPELLING IN PRIMARY SCHOOL CURRICULA (U.S. CLS. 100, 101 AND 107).

FIRST USE 12-31-2004; IN COMMERCE 12-31-2004.

DEBRA LEE, EXAMINING ATTORNEY

CLASS 41—(Continued).

SN 85-103,399. THE HOUSE OF PRAYER - AN ARMED DIAMEN, AKA GIFTS ORDAINED BY DIRECTION, TRUMBULL, CT. FILED 8-9-2010.

GOD's Coach

THE MARK CONSISTS OF STANDARD CHARACTERS WITHOUT CLAIM TO ANY PARTICULAR FONT, STYLE, SIZE, OR COLOR.

NO CLAIM IS MADE TO THE EXCLUSIVE RIGHT TO USE "COACH", APART FROM THE MARK AS SHOWN.

FOR PERSONAL COACHING, TRAINING, MOTIVATIONAL SPEAKING, AND MENTORING IN THE FIELD OF CHRISTIAN LEADERSHIP, MINISTRY AND CHARACTER DEVELOPMENT; ON-LINE ELECTRONIC NEWSLETTERS DELIVERED BY E-MAIL IN THE FIELD OF CHRISTIAN LEADERSHIP COACHING (U.S. CLS. 100, 101 AND 107).

FIRST USE 4-24-2004; IN COMMERCE 5-1-2005.

ERIN FALK, EXAMINING ATTORNEY

SN 85-103,697. TIMES PUBLISHING LLC, MIDDLEFIELD, CT. FILED 8-10-2010.

BBQ PIT BOYS

THE MARK CONSISTS OF STANDARD CHARACTERS WITHOUT CLAIM TO ANY PARTICULAR FONT, STYLE, SIZE, OR COLOR.

NO CLAIM IS MADE TO THE EXCLUSIVE RIGHT TO USE "BBQ PIT", APART FROM THE MARK AS SHOWN.

FOR ENTERTAINMENT SERVICES, NAMELY, AN ON-GOING SERIES FEATURING A FOOD AND COOKING SHOW PROVIDED THROUGH ONLINE VIDEOS AND WEBCASTS; ENTERTAINMENT SERVICES, NAMELY, PROVIDING WEBCASTS IN THE FIELD OF FOOD AND COOKING (U.S. CLS. 100, 101 AND 107).

FIRST USE 10-0-2007; IN COMMERCE 10-0-2007.

WILLIAM BRECKENFELD, EXAMINING ATTORNEY

SN 85-102,340. ZELL, WAYNE M., RESTON, VA. FILED 8-6-2010.

BLUEPRINT FOR WEALTH

THE MARK CONSISTS OF STANDARD CHARACTERS WITHOUT CLAIM TO ANY PARTICULAR FONT, STYLE, SIZE, OR COLOR.

NO CLAIM IS MADE TO THE EXCLUSIVE RIGHT TO USE "WEALTH", APART FROM THE MARK AS SHOWN.

FOR (BASED ON USE) EDUCATIONAL AND ENTERTAINMENT SERVICES, NAMELY, A CONTINUING PROGRAM ABOUT TAXES, BUSINESS AND ESTATE PLANNING, LAW AND ENTREPRENEURSHIP ACCESSIBLE BY RADIO AND COMPUTER NETWORKS; (BASED ON INTENT TO USE) ENTERTAINMENT AND EDUCATIONAL SERVICES, NAMELY, THE PRESENTATION OF LECTURES IN THE FIELDS OF TAXES, BUSINESS AND ESTATE PLANNING, LAW AND ENTREPRENEURSHIP (U.S. CLS. 100, 101 AND 107).

FIRST USE 2-4-2007; IN COMMERCE 2-4-2007.

JOHN SCHUYLER YARD, EXAMINING ATTORNEY

SN 85-103,725. QD IDEAS, LLC, DURHAM, NC. FILED 8-10-2010.

BUNCO BLAST

THE MARK CONSISTS OF STANDARD CHARACTERS WITHOUT CLAIM TO ANY PARTICULAR FONT, STYLE, SIZE, OR COLOR.

NO CLAIM IS MADE TO THE EXCLUSIVE RIGHT TO USE "BUNCO", APART FROM THE MARK AS SHOWN.

FOR ENTERTAINMENT SERVICES, NAMELY, PROVIDING ON-LINE COMPUTER GAMES AND ELECTRONIC GAMES (U.S. CLS. 100, 101 AND 107).

FIRST USE 8-3-2010; IN COMMERCE 8-5-2010.

MARC LEIPZIG, EXAMINING ATTORNEY

CLASS 41—(Continued).

SN 85-106,304. ISEGHOGHI, AMEN, SCOTTSDALE, AZ. FILED 8-12-2010.

WHAT'S IN YOUR HOOD?

THE MARK CONSISTS OF STANDARD CHARACTERS WITHOUT CLAIM TO ANY PARTICULAR FONT, STYLE, SIZE, OR COLOR.

FOR PROVIDING PHYSICAL FITNESS INSTRUCTION FOR CHILDREN; PROVIDING A PHYSICAL FITNESS PROGRAM FOR CHILDREN, FOCUSED ON THE PREVENTION OF CHILDHOOD OBESITY (U.S. CLS. 100, 101 AND 107).

SUSAN LESLIE DUBOIS, EXAMINING ATTORNEY

SN 85-106,531. HILL, CASSANDRA, DBA PREP FOR LAW, HOUSTON, TX. FILED 8-12-2010.

Prep for Law

THE MARK CONSISTS OF STANDARD CHARACTERS WITHOUT CLAIM TO ANY PARTICULAR FONT, STYLE, SIZE, OR COLOR.

NO CLAIM IS MADE TO THE EXCLUSIVE RIGHT TO USE "LAW", APART FROM THE MARK AS SHOWN.

FOR TRAINING SERVICES IN THE FIELD OF LAW (U.S. CLS. 100, 101 AND 107).

FIRST USE 10-12-2006; IN COMMERCE 2-8-2007.

C. DIONNE CLYBURN, EXAMINING ATTORNEY

CLASS 41—(Continued).

SN 85-107,044. MENTORN BARRA CLOUGH CAREY PRODUCTIONS LIMITED, LONDON, UNITED KINGDOM, FILED 8-13-2010.

MOVE A MILLION

THE MARK CONSISTS OF STANDARD CHARACTERS WITHOUT CLAIM TO ANY PARTICULAR FONT, STYLE, SIZE, OR COLOR.

OWNER OF U.S. REG. NO. 2,823,021.

FOR ENTERTAINMENT SERVICES, NAMELY, AN ON-GOING TELEVISION GAME SHOW; INTERACTIVE ENTERTAINMENT SERVICES PROVIDED VIA THE INTERNET FOR OTHER COMPUTER NETWORKS, NAMELY, PROVIDING AN ON-LINE COMPUTER GAME; NEWS AGENCY SERVICES, NAMELY, GATHERING AND DISSEMINATION OF NEWS RELATING TO ENTERTAINMENT, MUSIC, TELEVISION AND MOVIES; PRODUCTION, DISTRIBUTION AND SYNDICATION OF TELEVISION PROGRAMS, RADIO PROGRAMS; PRODUCTION AND DISTRIBUTION OF MOTION PICTURES; PRODUCTION AND DISTRIBUTION OF MONOSCOPIC, ELECTRONIC, AND DIGITAL FILMS; PRODUCTION OF VIDEO AND OF SOUND/VIDEO RECORDINGS; RENTAL OF VIDEOTAPES, VIDEOCASSETTES, AND SOUND/VIDEO RECORDINGS IN THE NATURE OF MOTION PICTURES; PROVIDING PRODUCTION OF SHOWS AND LIVE EVENTS IN THE NATURE OF GAME SHOWS; ORGANIZATION OF COMPETITIONS IN THE FIELD OF GAME SHOWS; PUBLICATION OF BOOKS, MAGAZINES, AND TEXTS RELATING TO ENTERTAINMENT PROGRAMS FOR OTHERS; ELECTRONIC PUBLISHING SERVICES, NAMELY, PUBLICATION OF TEXT AND GRAPHIC WORKS OF OTHERS ON CD ROM, DVD OR ONLINE, FEATURING GAME SHOWS, THE FOREGOING ALL RELATING TO BROADCAST ENTERTAINMENT PROGRAMS; NON-DOWNLOADABLE ON-LINE ELECTRONIC GAMES PROVIDED BY MEANS OF THE INTERNET (U.S. CLS. 100, 101 AND 107).

ADA HAN, EXAMINING ATTORNEY

SN 85-107,491. ASSOCIATION OF BLACK CARDIOLOGISTS, AKA ABC, ATLANTA, GA. FILED 8-13-2010.

CODE RED

THE MARK CONSISTS OF STANDARD CHARACTERS WITHOUT CLAIM TO ANY PARTICULAR FONT, STYLE, SIZE, OR COLOR.

FOR PROVIDING CONTINUING MEDICAL EDUCATION COURSES AND SEMINARS (U.S. CLS. 100, 101 AND 107).

SIMON TENG, EXAMINING ATTORNEY

CLASS 41—(Continued).

SN 85-107,707. SASHA DUERR, DBA PERMACOUTURE INSTITUTE, SAN FRANCISCO, CA. FILED 8-14-2010.

PERMACOUTURE

THE MARK CONSISTS OF STANDARD CHARACTERS WITHOUT CLAIM TO ANY PARTICULAR FONT, STYLE, SIZE, OR COLOR.

FOR EDUCATION SERVICES, NAMELY, PROVIDING, ARRANGING AND CONDUCTING CLASSES, SEMINARS AND WORKSHOPS IN THE FIELD OF ENVIRONMENTALLY-SUSTAINABLE PRACTICES FOR FASHION, TEXTILES AND CLOTHING (U.S. CLS. 100, 101 AND 107).

FIRST USE 4-0-2006; IN COMMERCE 4-0-2006.
LINDA E. BLOHM, EXAMINING ATTORNEY

SN 85-107,970. THE GEORGINA JOSHI FOUNDATION, INC., SOUTH BEND, IN. FILED 8-16-2010.



NO CLAIM IS MADE TO THE EXCLUSIVE RIGHT TO USE "BIKE THE BEND", APART FROM THE MARK AS SHOWN.

THE MARK CONSISTS OF THE WORDS "BIKE THE BEND". THE MARK ALSO INCLUDES 2 PEOPLE FIGURES RIDING ON BICYCLES NEXT TO A FLOWING RIVER OF WATER.

FOR ORGANIZING BICYCLE RIDES (U.S. CLS. 100, 101 AND 107).

FIRST USE 1-0-2010; IN COMMERCE 1-0-2010.
KIM SAITO, EXAMINING ATTORNEY

CLASS 41—(Continued).

SN 85-108,535. VIACOM INTERNATIONAL INC., NEW YORK, NY. FILED 8-16-2010.

tr3s

OWNER OF U.S. REG. NOS. 3,277,975, 3,350,405 AND OTHERS.

THE MARK CONSISTS OF THE WORD "TRES" WITH THE NUMERAL "3" REPLACING THE LETTER "E" AND WITH A STYLIZED ACCENT MARK OVER THE NUMBER "3".

THE ENGLISH TRANSLATION OF "TRES" IN THE MARK IS "THREE".

FOR ENTERTAINMENT SERVICES, NAMELY, TELEVISION PROGRAMS FEATURING LIVE ACTION, DRAMA, COMEDY, ANIMATION, MUSIC, NEWS, AND GENERAL ENTERTAINMENT; PROVIDING ONLINE INFORMATION IN THE FIELD OF ENTERTAINMENT CONCERNING TELEVISION PROGRAMS (U.S. CLS. 100, 101 AND 107).

FIRST USE 7-12-2010; IN COMMERCE 7-12-2010.
JOHN DWYER, EXAMINING ATTORNEY

SN 85-108,676. UPPER ECHELON FITNESS, LLC, PORTLAND, OR. FILED 8-16-2010.

UPPER ECHELON FITNESS

THE MARK CONSISTS OF STANDARD CHARACTERS WITHOUT CLAIM TO ANY PARTICULAR FONT, STYLE, SIZE, OR COLOR.

NO CLAIM IS MADE TO THE EXCLUSIVE RIGHT TO USE "FITNESS", APART FROM THE MARK AS SHOWN. FOR ATHLETIC COACHING SERVICES (U.S. CLS. 100, 101 AND 107).

FIRST USE 0-0-1998; IN COMMERCE 0-0-1998.
JIM RINGLE, EXAMINING ATTORNEY

CLASS 41—(Continued).

SN 85-109,224. SCOTT, KATHERINE TYLER, INDIANAPOLIS, IN. FILED 8-17-2010.

Hold in Trust

THE MARK CONSISTS OF STANDARD CHARACTERS WITHOUT CLAIM TO ANY PARTICULAR FONT, STYLE, SIZE, OR COLOR.

FOR DEVELOPMENT AND DISSEMINATION OF EDUCATIONAL MATERIALS FOR OTHERS IN THE FIELDS OF LEADERSHIP DEVELOPMENT, ORGANIZATIONAL DEVELOPMENT, CHANGE MANAGEMENT AND CONFLICT MANAGEMENT, AND EDUCATIONAL SERVICES, NAMELY, CONDUCTING WORKSHOPS, SEMINARS AND FORUMS IN THESE FIELDS AND TRAINING PROFESSIONALS IN THE USE OF EDUCATIONAL MATERIALS (U.S. CLS. 100, 101 AND 107).

MARK SHINER, EXAMINING ATTORNEY

CLASS 41—(Continued).

SN 85-111,897. TEKLE, ABIYE G., ALEXANDRIA, VA. FILED 8-20-2010.

ETHIOPIAN AMERICAN SPELLING BEE LET YOUR CHILD SPELL!

THE MARK CONSISTS OF STANDARD CHARACTERS WITHOUT CLAIM TO ANY PARTICULAR FONT, STYLE, SIZE, OR COLOR.

NO CLAIM IS MADE TO THE EXCLUSIVE RIGHT TO USE "ETHIOPIAN AMERICAN SPELLING BEE" AND "CHILD SPELL", APART FROM THE MARK AS SHOWN.

FOR ENTERTAINMENT IN THE NATURE OF COMPETITIONS IN THE FIELD OF ETHIOPIAN AMERICAN SPELLING BEES (U.S. CLS. 100, 101 AND 107).

TRACY WHITTAKER-BROWN, EXAMINING ATTORNEY

SN 85-110,137. NWI HOCKEY LLC, SAINT JOHN, IN. FILED 8-18-2010.



NO CLAIM IS MADE TO THE EXCLUSIVE RIGHT TO USE "CHI-TOWN", APART FROM THE MARK AS SHOWN.

THE MARK CONSISTS OF A CIRCLE WITH THE WORD "CHI-TOWN" ON THE TOP LEFT BORDER OF THE CIRCLE, A HOCKEY STICK THROUGH THE CENTER OF THE CIRCLE STRIKING TWO DICE AT THE BOTTOM OF THE CIRCLE WHICH CONTAIN 15 DOTS IN THE LEFT DIE AND FIVE DOTS ON THE RIGHT DIE; THE STRIKING OF THE DICE IS ILLUSTRATED WITH A 8-POINT STAR; AND THE STYLIZED WORD "SHOOTERS" IN THE CENTER OF THE CIRCLE WITHIN A BANNER DESIGN.

FOR ENTERTAINMENT IN THE NATURE OF HOCKEY GAMES (U.S. CLS. 100, 101 AND 107).

FIRST USE 8-1-2007; IN COMMERCE 9-2-2009.
MAYUR VAGHANI, EXAMINING ATTORNEY

SN 85-112,958. EVANS-NORRIS, TANYA, AKA TANYA EVANS, LOS ANGELES, CA. FILED 8-22-2010.

THE LADY & THE CHAMP

THE MARK CONSISTS OF STANDARD CHARACTERS WITHOUT CLAIM TO ANY PARTICULAR FONT, STYLE, SIZE, OR COLOR.

FOR ENTERTAINMENT IN THE NATURE OF AN ONGOING REALITY BASED TELEVISION PROGRAM ABOUT FAMILY, RELATIONSHIPS AND THE ENTERTAINMENT INDUSTRY; ENTERTAINMENT INFORMATION ABOUT TELEVISION PROGRAMS VIA A GLOBAL COMPUTER NETWORK AND VIA WIRELESS COMMUNICATION DEVICES; PROVIDING ON-LINE PUBLICATIONS IN THE NATURE OF BLOGS FEATURING ENTERTAINMENT INFORMATION ABOUT TELEVISION PROGRAMS (U.S. CLS. 100, 101 AND 107).

SHAUNIA CARLYLE, EXAMINING ATTORNEY

CLASS 41—(Continued).

SN 85-113,697. BROOKLYN LAW SCHOOL, BROOKLYN, NY. FILED 8-23-2010.

BROOKLYN LAW SCHOOL

THE MARK CONSISTS OF STANDARD CHARACTERS WITHOUT CLAIM TO ANY PARTICULAR FONT, STYLE, SIZE, OR COLOR.

NO CLAIM IS MADE TO THE EXCLUSIVE RIGHT TO USE "LAW SCHOOL", APART FROM THE MARK AS SHOWN.

SEC. 2(F).

FOR EDUCATIONAL SERVICES, NAMELY, CONDUCTING CLASSES, SEMINARS, CLINICS, CERTIFICATE PROGRAMS, JOINT DEGREES, AND WORKSHOPS IN THE FIELD OF LAW; PROVIDING POST-GRADUATE EDUCATIONAL CLASSES, COURSES OF INSTRUCTION, SEMINARS AND WORKSHOPS IN THE FIELD OF LAW, BUSINESS ADMINISTRATION, CITY AND REGIONAL PLANNING, LIBRARY INFORMATION SCIENCE, POLITICAL SCIENCE, URBAN PLANNING; CERTIFICATE PROGRAMS IN BUSINESS LAW, CRIMINAL LAW, INTELLECTUAL PROPERTY LAW, INTERNATIONAL LAW, AND REAL ESTATE (U.S. CLS. 100, 101 AND 107).

FIRST USE 0-0-1901; IN COMMERCE 0-0-1901.
HOWARD SMIGA, EXAMINING ATTORNEY

CLASS 41—(Continued).

SN 85-113,818. BROOKLYN LAW SCHOOL, BROOKLYN, NY. FILED 8-23-2010.

BROOKLAW

THE MARK CONSISTS OF STANDARD CHARACTERS WITHOUT CLAIM TO ANY PARTICULAR FONT, STYLE, SIZE, OR COLOR.

FOR PROVIDING NEWSLETTERS VIA E-MAIL FEATURING RESOURCES, NAMELY, LINKS TO EDUCATIONAL AND ENTERTAINMENT INFORMATION, ACTIVITIES AND EVENTS, ENTERTAINMENT PERFORMANCES, NAMELY, DANCE PERFORMANCES, THEATER, MUSIC, ART SHOWS, ATHLETIC EVENTS, EDUCATIONAL SEMINARS, CONCERTS, FILM (U.S. CLS. 100, 101 AND 107).

FIRST USE 8-0-2010; IN COMMERCE 8-0-2010.
HOWARD SMIGA, EXAMINING ATTORNEY

SN 85-113,843. BROOKLYN LAW SCHOOL, BROOKLYN, NY. FILED 8-23-2010.



SN 85-113,730. BROOKLYN LAW SCHOOL, BROOKLYN, NY. FILED 8-23-2010.



THE MARK CONSISTS OF THE FANCIFUL DESIGN OF A BRIDGE.

FOR EDUCATIONAL SERVICES, NAMELY, CONDUCTING CLASSES, SEMINARS, CLINICS, CERTIFICATE PROGRAMS, JOINT DEGREES, AND WORKSHOPS IN THE FIELD OF LAW; PROVIDING POST-GRADUATE EDUCATIONAL CLASSES, COURSES OF INSTRUCTION, SEMINARS AND WORKSHOPS IN THE FIELD OF LAW, BUSINESS ADMINISTRATION, CITY AND REGIONAL PLANNING, LIBRARY INFORMATION SCIENCE, POLITICAL SCIENCE, URBAN PLANNING; CERTIFICATE PROGRAMS IN BUSINESS LAW, CRIMINAL LAW, INTELLECTUAL PROPERTY LAW, INTERNATIONAL LAW, AND REAL ESTATE (U.S. CLS. 100, 101 AND 107).

FIRST USE 0-0-2003; IN COMMERCE 0-0-2003.
HOWARD SMIGA, EXAMINING ATTORNEY

NO CLAIM IS MADE TO THE EXCLUSIVE RIGHT TO USE "LAW SCHOOL", APART FROM THE MARK AS SHOWN.

THE MARK CONSISTS OF THE FANCIFUL DESIGN OF A BRIDGE OVER THE WORDS "BROOKLYN LAW SCHOOL".

SEC. 2(F) AS TO "BROOKLYN LAW SCHOOL".

FOR EDUCATIONAL SERVICES, NAMELY, CONDUCTING CLASSES, SEMINARS, CLINICS, CERTIFICATE PROGRAMS, JOINT DEGREES, AND WORKSHOPS IN THE FIELD OF LAW; PROVIDING POST-GRADUATE EDUCATIONAL CLASSES, COURSES OF INSTRUCTION, SEMINARS AND WORKSHOPS IN THE FIELD OF LAW, BUSINESS ADMINISTRATION, CITY AND REGIONAL PLANNING, LIBRARY INFORMATION SCIENCE, POLITICAL SCIENCE, URBAN PLANNING; CERTIFICATE PROGRAMS IN BUSINESS LAW, CRIMINAL LAW, INTELLECTUAL PROPERTY LAW, INTERNATIONAL LAW, AND REAL ESTATE (U.S. CLS. 100, 101 AND 107).

FIRST USE 0-0-2003; IN COMMERCE 0-0-2003.
HOWARD SMIGA, EXAMINING ATTORNEY

CLASS 41—(Continued).

SN 85-114,097. DELAHANT, BRIAN, POINT PLEASANT, NJ. FILED 8-23-2010.

**US Amateur Baseball League
(U.S.A.B.L)**

THE MARK CONSISTS OF STANDARD CHARACTERS WITHOUT CLAIM TO ANY PARTICULAR FONT, STYLE, SIZE, OR COLOR.

NO CLAIM IS MADE TO THE EXCLUSIVE RIGHT TO USE "US AMATEUR BASEBALL LEAGUE", APART FROM THE MARK AS SHOWN.

FOR ORGANIZING AND OPERATING A BASEBALL LEAGUE FOR AGES 7 THROUGH 19 YEARS OLD (U.S. CLS. 100, 101 AND 107).

FIRST USE 9-1-1993; IN COMMERCE 4-1-1994.

C. DIONNE CLYBURN, EXAMINING ATTORNEY

SN 85-114,112. LAB CHICAGO, LLC, CHICAGO, IL. FILED 8-23-2010.

THE LAB

THE MARK CONSISTS OF STANDARD CHARACTERS WITHOUT CLAIM TO ANY PARTICULAR FONT, STYLE, SIZE, OR COLOR.

FOR YOGA INSTRUCTION (U.S. CLS. 100, 101 AND 107).

FIRST USE 12-10-2009; IN COMMERCE 3-1-2010.

C. DIONNE CLYBURN, EXAMINING ATTORNEY

CLASS 41—(Continued).

SN 85-115,958. TWENTIETH CENTURY FOX FILM CORPORATION, LOS ANGELES, CA. FILED 8-25-2010.

MYFOXCAM

THE MARK CONSISTS OF STANDARD CHARACTERS WITHOUT CLAIM TO ANY PARTICULAR FONT, STYLE, SIZE, OR COLOR.

OWNER OF U.S. REG. NOS. 2,274,507, 3,417,581 AND OTHERS.

FOR ENTERTAINMENT SERVICES, NAMELY, PROVIDING A WEBSITE FEATURING NON-DOWNLOADABLE AUDIO CLIPS IN THE FIELD OF CURRENT EVENT NEWS, ENTERTAINMENT, SPORTS AND MUSIC, VIDEO CLIPS IN THE FIELD OF CURRENT EVENT NEWS, ENTERTAINMENT, SPORTS AND MUSIC, MUSICAL PERFORMANCES, FILM CLIPS, PHOTOGRAPHS, OTHER MULTIMEDIA MATERIALS IN THE FIELD OF CURRENT EVENT NEWS, ENTERTAINMENT, SPORTS AND MUSIC, AND PROVIDING ENTERTAINMENT INFORMATION VIA ONLINE NON-DOWNLOADABLE AUDIO CLIPS, VIDEO CLIPS, MUSICAL PERFORMANCES, FILM CLIPS, PHOTOGRAPHS, AND OTHER MULTIMEDIA MATERIALS; PROVIDING ON-LINE INFORMATION IN THE FIELD OF CURRENT EVENT NEWS, ENTERTAINMENT, SPORTS AND MUSIC VIA THE INTERNET AND WIRELESS COMMUNICATION NETWORKS; PRESENTATION AND DISTRIBUTION OF NON-DOWNLOADABLE VIDEOS AND IMAGES IN THE FIELD OF CURRENT EVENT NEWS, ENTERTAINMENT, SPORTS AND MUSIC TRANSMITTED VIA THE INTERNET AND WIRELESS COMMUNICATION NETWORKS; ON-LINE JOURNALS, NAMELY, BLOGS FEATURING PERSONAL OPINIONS IN THE FIELD OF GENERAL INTEREST, CURRENT EVENT NEWS, ENTERTAINMENT, SPORTS AND MUSIC (U.S. CLS. 100, 101 AND 107).

KRISTINA MORRIS, EXAMINING ATTORNEY

SN 85-117,010. HICKEN, WILLIAM M., MOUNT PLEASANT, SC. FILED 8-26-2010.



THE MARK CONSISTS OF STYLIZED LETTERS "YB" AND WINGS.

FOR AUDIO AND VIDEO RECORDING SERVICES; MUSIC PRODUCTION SERVICES; MUSIC PUBLISHING SERVICES; NIGHT CLUBS; RECORDING STUDIO SERVICES; SOUND RECORDING STUDIOS (U.S. CLS. 100, 101 AND 107).

ARETHA SOMERVILLE, EXAMINING ATTORNEY

CLASS 41—(Continued).

SN 85-117,068. THE CHANDLER SOURCE, LLC, HOLBROOK, NY. FILED 8-26-2010.



THE COLOR(S) WHITE, HOT PINK, AND BLACK IS/ARE CLAIMED AS A FEATURE OF THE MARK.

THE MARK CONSISTS OF THE HOT PINK STYLIZED LETTERS "DA" WITHIN A BLACK AND WHITE RECTANGULAR COMPUTER-BUTTON-LIKE DESIGN, ALL APPEARING TO THE LEFT OF THE STYLIZED WORDING "DOUCHEACADEMY.COM", WITH THE "DOUCHEACADEMY" PORTION APPEARING IN BLACK AND WHITE AND THE ".COM" PORTION APPEARING IN HOT PINK; ALL OF THE AFOREMENTIONED APPEARS ON A BLACK BACKGROUND.

FOR ENTERTAINMENT SERVICES, NAMELY, NON-DOWNLOADABLE RINGTONES, PRE-RECORDED MUSIC, AND GRAPHICS PRESENTED TO MOBILE COMMUNICATIONS DEVICES VIA A GLOBAL COMPUTER NETWORK AND WIRELESS NETWORKS; PROVIDING A WEBSITE FOR ENTERTAINMENT PURPOSES WHERE USERS CAN VIEW AND POST PHOTOGRAPHS AND VIDEOS FEATURING MEN AND WOMEN WITH A VARIETY OF NEGATIVE QUALITIES, SPECIFICALLY ARROGANCE AND ENGAGING IN OBNOXIOUS AND/OR IRRITATING BEHAVIOR WITHOUT MALICIOUS INTENT (U.S. CLS. 100, 101 AND 107).

FIRST USE 4-1-2010; IN COMMERCE 4-1-2010.
KEVIN CORWIN, EXAMINING ATTORNEY

CLASS 41—(Continued).

SN 85-119,016. MANHATTAN GROUP, LLC, MINNEAPOLIS, MN. FILED 8-30-2010.

GROOVY GIRLS

THE MARK CONSISTS OF STANDARD CHARACTERS WITHOUT CLAIM TO ANY PARTICULAR FONT, STYLE, SIZE, OR COLOR.

OWNER OF U.S. REG. NOS. 2,344,957, 2,567,435 AND OTHERS.

NO CLAIM IS MADE TO THE EXCLUSIVE RIGHT TO USE "GIRLS", APART FROM THE MARK AS SHOWN.

FOR ENTERTAINMENT SERVICES IN THE NATURE OF A SOCIAL CLUB FOR CHILDREN, NAMELY, ARRANGING, ORGANIZING, AND HOSTING SOCIAL EVENTS, GET-TOGETHERS, AND PARTIES FOR CLUB MEMBERS; PARTY PLANNING FOR CHILDREN'S PARTIES; MOTION PICTURE FILM PRODUCTION; ENTERTAINMENT SERVICES, NAMELY, CONTINUING PROGRAMS IN THE FIELD OF CHILDREN'S ENTERTAINMENT BROADCAST OVER TELEVISION, SATELLITE, AUDIO AND VIDEO MEDIA; ENTERTAINMENT IN THE NATURE OF LIVE PROGRAMS FOR CHILDREN, NAMELY, THE PRODUCTION AND PRESENTATION OF LIVE THEATRICAL, MUSICAL, DANCE, AND VARIETY SHOW PERFORMANCES; ENTERTAINMENT SERVICES, NAMELY, PROVIDING A WEBSITE FEATURING ONLINE COMPUTER GAMES, ONLINE VIDEO PRESENTATIONS, ONLINE AUDIO PRESENTATIONS, ONLINE IMAGES, CONDUCTING CONTESTS, ONLINE PRODUCT TRIVIA GAMES, ONLINE INFORMATION ON CRAFT PROJECT ACTIVITIES INSTRUCTION, ONLINE TEXT FEATURING CHILDREN'S STORIES, NONDOWNLOADABLE PRE-RECORDED MUSIC, PODCASTS, AND WEBCASTS, ALL FEATURING CHILDREN'S ENTERTAINMENT THEMES (U.S. CLS. 100, 101 AND 107).

TARA PATE, EXAMINING ATTORNEY

SN 85-117,434. IMPERIAL MUSIC INC., NEW YORK, NY. FILED 8-27-2010.

Imperial Music

THE MARK CONSISTS OF STANDARD CHARACTERS WITHOUT CLAIM TO ANY PARTICULAR FONT, STYLE, SIZE, OR COLOR.

NO CLAIM IS MADE TO THE EXCLUSIVE RIGHT TO USE "MUSIC", APART FROM THE MARK AS SHOWN.

FOR MULTIMEDIA ENTERTAINMENT SERVICES IN THE NATURE OF RECORDING, PRODUCTION AND POST-PRODUCTION SERVICES IN THE FIELDS OF MUSIC, VIDEO, AND FILMS; ENTERTAINMENT SERVICES BY A MUSICAL ARTIST AND PRODUCER, NAMELY, MUSICAL COMPOSITION FOR OTHERS AND PRODUCTION OF MUSICAL SOUND RECORDINGS; SONG WRITING SERVICES; MUSIC PUBLISHING SERVICES; BOOK PUBLISHING SERVICES; ENTERTAINMENT SERVICES IN THE NATURE OF LIVE MUSICAL PERFORMANCES (U.S. CLS. 100, 101 AND 107).

FIRST USE 8-1-2008; IN COMMERCE 7-28-2010.
JIM RINGLE, EXAMINING ATTORNEY

CLASS 41—(Continued).

SN 85-119,023. MANHATTAN GROUP, LLC, MINNEAPOLIS, MN. FILED 8-30-2010.



OWNER OF U.S. REG. NOS. 2,609,848, 3,379,028 AND OTHERS.

NO CLAIM IS MADE TO THE EXCLUSIVE RIGHT TO USE "GIRLS", APART FROM THE MARK AS SHOWN.

THE MARK CONSISTS OF THE STYLIZED WORDS "GROOVY GIRLS", WITH TWO SMALL, FIVE-PETALLED FLOWERS FORMING PART OF THE TWO LETTERS "O" IN "GROOVY", A SMALL, FIVE-PETALLED FLOWER TO THE LEFT OF THE WORD "GROOVY" AND A SMALL, FIVE-PETALLED FLOWER TO THE RIGHT OF THE WORD "GIRLS", ALL WITHIN A FIVE-PETALLED FLOWER, WITHIN WHICH, SLIGHTLY OFF-CENTER, IS A CIRCLE AROUND THE TWO LETTERS "O" OF THE WORD "GROOVY".

FOR ENTERTAINMENT SERVICES IN THE NATURE OF A SOCIAL CLUB FOR CHILDREN, NAMELY, ARRANGING, ORGANIZING, AND HOSTING SOCIAL EVENTS, GET-TOGETHERS, AND PARTIES FOR CLUB MEMBERS; PARTY PLANNING FOR CHILDREN'S PARTIES; MOTION PICTURE FILM PRODUCTION; ENTERTAINMENT SERVICES, NAMELY, CONTINUING PROGRAMS IN THE FIELD OF CHILDREN'S ENTERTAINMENT BROADCAST OVER TELEVISION, SATELLITE, AUDIO AND VIDEO MEDIA; ENTERTAINMENT IN THE NATURE OF LIVE PROGRAMS FOR CHILDREN, NAMELY, THE PRODUCTION AND PRESENTATION OF LIVE THEATRICAL, MUSICAL, DANCE, AND VARIETY SHOW PERFORMANCES; ENTERTAINMENT SERVICES, NAMELY, PROVIDING A WEBSITE FEATURING ONLINE COMPUTER GAMES, ONLINE VIDEO PRESENTATIONS, ONLINE AUDIO PRESENTATIONS, ONLINE IMAGES, CONDUCTING CONTESTS, ONLINE PRODUCT TRIVIA GAMES, ONLINE INFORMATION ON CRAFT PROJECT ACTIVITIES INSTRUCTION, ONLINE TEXT FEATURING CHILDREN'S STORIES, NONDOWNLOADABLE PRE-RECORDED MUSIC, PODCASTS, AND WEBCASTS, ALL FEATURING CHILDREN'S ENTERTAINMENT THEMES (U.S. CLS. 100, 101 AND 107).

TARA PATE, EXAMINING ATTORNEY

CLASS 41—(Continued).

SN 85-121,234. WASHINGTON DC REGION SCCA, INC., SILVER SPRING, MD. FILED 9-1-2010.

Mid Atlantic Road Racing Series MARRS

THE MARK CONSISTS OF STANDARD CHARACTERS WITHOUT CLAIM TO ANY PARTICULAR FONT, STYLE, SIZE, OR COLOR.

NO CLAIM IS MADE TO THE EXCLUSIVE RIGHT TO USE "ROAD RACING SERIES", APART FROM THE MARK AS SHOWN.

SEC. 2(F) AS TO "MID ATLANTIC ROAD RACING SERIES".

FOR MEMBERSHIP CLUB SERVICES, IN THE NATURE OF CONDUCTING AUTO RACING (U.S. CLS. 100, 101 AND 107).

FIRST USE 8-2-1978; IN COMMERCE 8-2-1978.
DAVID HOFFMAN, EXAMINING ATTORNEY

SN 85-122,638. SIEGEL, BETTINA E., HOUSTON, TX. FILED 9-3-2010.

The Lunch Tray

THE MARK CONSISTS OF STANDARD CHARACTERS WITHOUT CLAIM TO ANY PARTICULAR FONT, STYLE, SIZE, OR COLOR.

NO CLAIM IS MADE TO THE EXCLUSIVE RIGHT TO USE "LUNCH", APART FROM THE MARK AS SHOWN.

FOR ON-LINE JOURNALS, NAMELY, BLOGS FEATURING INFORMATION REGARDING CHILDREN, FOOD, NUTRITION, SCHOOL FOOD REFORM AND RECIPES (U.S. CLS. 100, 101 AND 107).

FIRST USE 5-26-2010; IN COMMERCE 5-26-2010.
EDWARD FENNESSY, EXAMINING ATTORNEY

SN 85-122,843. HUNTINGS MY LIFE, L.L.C., ODEBOLT, IA. FILED 9-3-2010.

HUNTING IS MY LIFE

THE MARK CONSISTS OF STANDARD CHARACTERS WITHOUT CLAIM TO ANY PARTICULAR FONT, STYLE, SIZE, OR COLOR.

NO CLAIM IS MADE TO THE EXCLUSIVE RIGHT TO USE "HUNTING", APART FROM THE MARK AS SHOWN.

FOR PROVIDING INFORMATION IN THE FIELD OF HUNTING VIA THE INTERNET (U.S. CLS. 100, 101 AND 107).

DEZMONA MIZELLE, EXAMINING ATTORNEY

CLASS 41—(Continued).

SN 85-130,878. MADISON CHILDREN'S MUSEUM, MADISON, WI. FILED 9-16-2010.

POSSIBLE-OPOLIS

THE MARK CONSISTS OF STANDARD CHARACTERS WITHOUT CLAIM TO ANY PARTICULAR FONT, STYLE, SIZE, OR COLOR.

FOR EDUCATIONAL AND ENTERTAINMENT SERVICES FOR CHILDREN PROVIDED IN A CHILDREN'S MUSEUM, NAMELY, PROVIDING INTERACTIVE PLAY AREAS AND INSTRUCTIONAL PROGRAMS IN THE FIELDS OF ART, SCIENCE, TECHNOLOGY, HISTORY, AND CULTURE, AND SOCIAL GATHERINGS FOR CHILDREN, ALL PERTAINING TO INVENTION AND CREATIVITY (U.S. CLS. 100, 101 AND 107).

FIRST USE 8-14-2010; IN COMMERCE 8-14-2010.
SKYE YOUNG, EXAMINING ATTORNEY

CLASS 41—(Continued).

SN 85-137,565. WATERWORKS AQUATICS, AKA WATERWORKS SWIM SCHOOL, IRVINE, CA. FILED 9-24-2010.



THE COLOR(S) BLUE, WHITE, ORANGE AND AQUA-BLUE IS/ARE CLAIMED AS A FEATURE OF THE MARK.

THE MARK CONSISTS OF A DESIGN OF AN ORANGE TIGER SHARK OUTLINED IN BLUE WITH A WHITE UNDERSIDE, TONGUE AND EYES, WITH A BLUE DORSAL FIN AND BLUE STRIPES ALONG THE BACK AND ORANGE PECTORAL FINS AND TAIL, AND AN AQUA BLUE EYEBALL.

FOR ORGANIZING SPORTING EVENTS, NAMELY, SWIM MEETS; PROVIDING SWIMMING POOLS; SWIMMING INSTRUCTION (U.S. CLS. 100, 101 AND 107).

FIRST USE 4-1-2010; IN COMMERCE 4-1-2010.
LAURA KOVALSKY, EXAMINING ATTORNEY

SN 85-130,956. BODODEA, TEODOR, SAN FRANCISCO, CA. FILED 9-16-2010.

**LYMPH LAVA - Lymphatic
Drainage Activation System**

THE MARK CONSISTS OF STANDARD CHARACTERS WITHOUT CLAIM TO ANY PARTICULAR FONT, STYLE, SIZE, OR COLOR.

NO CLAIM IS MADE TO THE EXCLUSIVE RIGHT TO USE "LYMPH" AND "LYMPHATIC DRAINAGE ACTIVATION SYSTEM", APART FROM THE MARK AS SHOWN.

FOR EDUCATION SERVICES, NAMELY, PROVIDING SEMINARS, WORKSHOPS, CLASSES, COURSES AND WEB BASED TRAINING IN THE FIELD OF ORGANIZED EXERCISES STRUCTURED TO ENHANCE THE FLOW OF THE LYMPHATIC TISSUE AND TO STIMULATE THE DETOXIFICATION OF THE BODY AND DISTRIBUTING WRITTEN COURSE MATERIAL IN CONNECTION THEREWITH (U.S. CLS. 100, 101 AND 107).

BARBARA BROWN, EXAMINING ATTORNEY

SN 85-138,099. CRAIGSLIST, INC., SAN FRANCISCO, CA. FILED 9-24-2010.

CRAIGSLIST

THE MARK CONSISTS OF STANDARD CHARACTERS WITHOUT CLAIM TO ANY PARTICULAR FONT, STYLE, SIZE, OR COLOR.

OWNER OF U.S. REG. NOS. 2,395,628, 2,985,065 AND OTHERS.

FOR PROVIDING A WEBSITE FEATURING NON-DOWNLOADABLE VIDEOS AND WEBCASTS IN THE FIELDS OF ENTERTAINMENT, CURRENT EVENTS, ARTS, AND COMMUNITY; EDUCATION AND ENTERTAINMENT SERVICES, NAMELY, PROVIDING A WEBSITE FEATURING AUDIO, VIDEO AND FILM CLIPS IN THE FIELDS OF ENTERTAINMENT, CURRENT EVENTS, ARTS, AND COMMUNITY; ENTERTAINMENT SERVICES, NAMELY, AN ON-GOING SERIES IN THE NATURE OF AN ON-GOING REALITY BASED WEBCAST PROGRAM; ENTERTAINMENT SERVICES, NAMELY, A MULTIMEDIA PROGRAM SERIES FEATURING COMEDY, ACTION AND ADVENTURE DISTRIBUTED ONLINE (U.S. CLS. 100, 101 AND 107).

FIRST USE 5-6-2010; IN COMMERCE 5-6-2010.
STEVEN JACKSON, EXAMINING ATTORNEY

CLASS 41—(Continued).

SN 85-138,112. LAUREN & TOM DEL SARTO COMPANIES, INC., DBA DESERT HEALTH, LA QUINTA, CA. FILED 9-24-2010.

Desert Health

THE MARK CONSISTS OF STANDARD CHARACTERS WITHOUT CLAIM TO ANY PARTICULAR FONT, STYLE, SIZE, OR COLOR.

NO CLAIM IS MADE TO THE EXCLUSIVE RIGHT TO USE "HEALTH", APART FROM THE MARK AS SHOWN.

FOR NEWSPAPER PUBLICATION (U.S. CLS. 100, 101 AND 107).

APRIL ROACH, EXAMINING ATTORNEY

CLASS 41—(Continued).

SN 85-141,639. MAPES, JAMES, WILTON, CT. FILED 9-30-2010.

QUANTUM LEAP THINKING

THE MARK CONSISTS OF STANDARD CHARACTERS WITHOUT CLAIM TO ANY PARTICULAR FONT, STYLE, SIZE, OR COLOR.

FOR EDUCATIONAL SERVICES, NAMELY, CONDUCTING SEMINARS, CONFERENCES, RETREATS AND WORKSHOPS IN THE FIELD OF BREAKTHROUGH THINKING, CHANGE MANAGEMENT, HIGH-PERFORMANCE, TEAM BUILDING AND TRANSFORMATIONAL LEADERSHIP; ENTERTAINMENT SERVICES, NAMELY, PERSONAL APPEARANCES ON RADIO AND TELEVISION BY A MOTIVATIONAL SPEAKER; ENTERTAINMENT SERVICES, NAMELY, PROVIDING A LIVE MOTIVATIONAL SPEAKER (U.S. CLS. 100, 101 AND 107).

FIRST USE 6-1-1982; IN COMMERCE 6-1-1982.

CAROLYN CATALDO, EXAMINING ATTORNEY

SN 85-140,774. MICHAEL DEWOLFE, CHICAGO, IL. FILED 9-29-2010.

5IVE STAR

THE MARK CONSISTS OF STANDARD CHARACTERS WITHOUT CLAIM TO ANY PARTICULAR FONT, STYLE, SIZE, OR COLOR.

FOR ENTERTAINMENT, NAMELY, LIVE MUSIC CONCERTS AND PERFORMANCES BY A MUSICAL ARTIST; PROVIDING A WEBSITE ON A GLOBAL COMPUTER NETWORK FEATURING INFORMATION ON THE MUSICAL ARTIST AND HIS MUSICAL PERFORMANCES, PICTURES, TOUR INFORMATION, BIOGRAPHIES AND PERSONAL APPEARANCES; PROVIDING A WEBSITE ON A GLOBAL COMPUTER NETWORK FEATURING NON-DOWNLOADABLE PLAYBACK OF MUSIC AND NON-DOWNLOADABLE SAMPLE MUSIC VIDEO CLIPS (U.S. CLS. 100, 101 AND 107).

FIRST USE 1-15-2006; IN COMMERCE 1-15-2006.

COURTNEY ALVAREZ, EXAMINING ATTORNEY

SN 85-141,878. THE FITNESS FORMULA, LTD., CHICAGO, IL. FILED 9-30-2010.

TRIMONSTER

THE MARK CONSISTS OF STANDARD CHARACTERS WITHOUT CLAIM TO ANY PARTICULAR FONT, STYLE, SIZE, OR COLOR.

FOR COACHING INSTRUCTION AND PROVIDING INFORMATION IN THE FIELD OF TRAINING PROGRAMS AND TRAINING FOR TRIATHLON, SWIMMING, CYCLING, RUNNING AND OTHER ENDURANCE SPORTS EVENTS (U.S. CLS. 100, 101 AND 107).

FIRST USE 1-1-2004; IN COMMERCE 10-22-2009.

CARYN GLASSER, EXAMINING ATTORNEY

CLASS 41—(Continued).

SN 85-142,002. TOBIAS, HEIDI RAYDEN, LOS ANGELES, CA. FILED 9-30-2010.

FREE YOUR SOUL TV

THE MARK CONSISTS OF STANDARD CHARACTERS WITHOUT CLAIM TO ANY PARTICULAR FONT, STYLE, SIZE, OR COLOR.

NO CLAIM IS MADE TO THE EXCLUSIVE RIGHT TO USE "TV", APART FROM THE MARK AS SHOWN.

FOR A BROADCAST TELEVISION SERIES HOSTED BY HEIDI RAYDEN VISITING CITIES AND COMMUNITIES IN THE UNITED STATES AND IN FOREIGN COUNTRIES TO PROVIDE INFORMATION ABOUT THE LOCATION VISITED, THE PEOPLE WHO LIVE THERE, AND OTHER UNIQUE FEATURES OF THE LOCATION BEING VISITED WITH A FOCUS AND THEME OF SPIRITUAL EXPERIENCES AND SPIRITUALITY FOR INFORMATIONAL, ENTERTAINMENT AND EDUCATIONAL PURPOSES (U.S. CLS. 100, 101 AND 107).

GENE MACIOL, EXAMINING ATTORNEY

SN 85-143,480. PHN, LLC, DANVILLE, CA. FILED 10-1-2010.



NO CLAIM IS MADE TO THE EXCLUSIVE RIGHT TO USE "KRAV MAGA", APART FROM THE MARK AS SHOWN.

THE MARK CONSISTS OF THE WORD "VANGUARD" IN ALL CAPITAL LETTERS ARCHING OVER THE LETTERS "V", A BACKWARDS "K", AND THE LETTER "M", AND THE WORDS "KRAV MAGA" IN ALL CAPITAL LETTERS ARCHING UNDERNEATH THE LETTERS "VKM". A SOLID STAR APPEARS ON THE LEFT SIDE OF THE LETTER "V" AND A STAR OF DAVID APPEARS ON THE RIGHT SIDE OF THE LETTER "M". A LINE APPEARS THROUGH THE CENTER OF THE LETTERS "VKM".

THE ENGLISH TRANSLATION OF "KRAV MAGA" IN THE MARK IS "CONTACT COMBAT".

FOR EXERCISE PROGRAM INCORPORATING DRILLS AND EXERCISES BASED ON FIGHTING AND SELF-DEFENSE SKILLS; EDUCATIONAL SERVICES, NAMELY, CONDUCTING CERTIFICATION CLASSES AND PROVIDING LESSON PLANS FOR INSTRUCTOR TRAINING IN EXERCISE PROGRAM INCORPORATING DRILLS AND EXERCISES BASED ON FIGHTING AND SELF-DEFENSE SKILLS (U.S. CLS. 100, 101 AND 107).

FIRST USE 2-1-2010; IN COMMERCE 2-1-2010.

ROBERT C. CLARK JR., EXAMINING ATTORNEY

CLASS 41—(Continued).

SN 85-143,714. DUDLEY, TEKULVE, R, FUQUAY VARINA, NC. FILED 10-2-2010.

Steel Roll'n Motorcycle Club

THE MARK CONSISTS OF STANDARD CHARACTERS WITHOUT CLAIM TO ANY PARTICULAR FONT, STYLE, SIZE, OR COLOR.

NO CLAIM IS MADE TO THE EXCLUSIVE RIGHT TO USE "MOTORCYCLE CLUB", APART FROM THE MARK AS SHOWN.

FOR ENTERTAINMENT SERVICES IN THE NATURE OF ORGANIZING, ARRANGING AND CONDUCTING MOTORCYCLE RIDING EXCURSIONS (U.S. CLS. 100, 101 AND 107).

FIRST USE 11-9-2005; IN COMMERCE 11-9-2005.

TARA PATE, EXAMINING ATTORNEY

SN 85-145,173. SKYDIVE KY LLC, GREENSBURG, KY. FILED 10-5-2010.



NO CLAIM IS MADE TO THE EXCLUSIVE RIGHT TO USE "SKYDIVE", APART FROM THE MARK AS SHOWN.

THE MARK CONSISTS OF THE WORDING "SKYDIVE KENTUCKY" AND A STYLIZED DESIGN OF A HUMAN UNDER A PARACHUTE.

SEC. 2(F) AS TO "SKYDIVE KENTUCKY".

FOR INSTRUCTION IN THE FIELD OF SKYDIVING; EDUCATIONAL DEMONSTRATIONS OF SKYDIVING; ENTERTAINMENT SERVICES IN THE NATURE OF ORGANIZING, ARRANGING AND CONDUCTING SKYDIVING EXCURSIONS (U.S. CLS. 100, 101 AND 107).

FIRST USE 4-0-2008; IN COMMERCE 4-0-2008.

AISHA SALEM, EXAMINING ATTORNEY

CLASS 41—(Continued).

SN 85-149,075. ELISSA AL-CHOKHACHY, AMESBURY, MA. FILED 10-9-2010.

MIRACULOUS MOMENTS

THE MARK CONSISTS OF STANDARD CHARACTERS WITHOUT CLAIM TO ANY PARTICULAR FONT, STYLE, SIZE, OR COLOR.

FOR EDUCATION SERVICES, NAMELY, CONDUCTING SYMPOSIUMS, TRAINING PROGRAMS, CLASSES, SEMINARS, CONFERENCES, WORKSHOPS TO TRAIN HEALTH CARE WORKERS, HEALTH CARE PROVIDERS, HOSPITAL PERSONNEL, HOME CARE GIVERS AND HOSPICE ORGANIZATIONS' STAFF, IN DEVELOPING, IMPLEMENTING, MANAGING AND CONDUCTING EDUCATIONAL AND COUNSELING PROGRAMS AND HOW TO COORDINATE AND INTEGRATE SUCH PROGRAMS WITH DELIVERY AND MANAGEMENT OF MAINSTREAM MEDICAL CARE AND SERVICES FOR TERMINALLY ILL PATIENTS, THEIR FAMILIES AND CAREGIVERS THAT ADDRESS PSYCHOLOGICAL, SOCIAL AND SPIRITUAL ISSUES AND PATIENT NEEDS RELATED TO TERMINAL ILLNESS, END-OF-LIFE CARE AND BEREAVEMENT; PROVIDING TRAINING, RETREATS, CLASSES, COACHING AND INSTRUCTION IN THE FIELD OF PALLIATIVE CARE, HOSPICE SERVICES, END OF LIFE CARE AND BEREAVEMENT; AND DISTRIBUTING COURSE MATERIAL IN CONNECTION THEREWITH (U.S. CLS. 100, 101 AND 107).

FIRST USE 7-1-2010; IN COMMERCE 7-10-2010.
 NAAKWAMA ANKRAH, EXAMINING ATTORNEY

CLASS 41—(Continued).

SN 85-150,273. ABIYE TEKLE, ALEXANDRIA, VA. FILED 10-12-2010.

**Ethiopian Spelling Bee
 Let Your Child Spell!**

THE MARK CONSISTS OF STANDARD CHARACTERS WITHOUT CLAIM TO ANY PARTICULAR FONT, STYLE, SIZE, OR COLOR.

NO CLAIM IS MADE TO THE EXCLUSIVE RIGHT TO USE "ETHIOPIAN SPELLING BEE" AND "CHILD SPELL", APART FROM THE MARK AS SHOWN.

FOR ENTERTAINMENT IN THE NATURE OF COMPETITIONS IN THE FIELD OF SPELLING BEE (U.S. CLS. 100, 101 AND 107).

TRACY WHITTAKER-BROWN, EXAMINING ATTORNEY

SN 85-150,190. GRUN, MORDECHAI, NIAGARA FALLS, CANADA, FILED 10-12-2010.

YOUSTUDIOS

THE MARK CONSISTS OF STANDARD CHARACTERS WITHOUT CLAIM TO ANY PARTICULAR FONT, STYLE, SIZE, OR COLOR.

FOR ORGANIZING AND CONDUCTING STAGE SHOWS, NIGHT CLUB EVENTS, CONTESTS, DANCE PERFORMANCES, AND PARTIES FOR ENTERTAINMENT PURPOSES; MUSIC VIDEO PRODUCTION AND MOTION PICTURE FILM PRODUCTION; PROVIDING A WEBSITE FEATURING NON-DOWNLOADABLE VIDEOS FEATURING STAGE SHOWS, NIGHT CLUB EVENTS, CONTESTS, DANCE PERFORMANCES, AND PARTIES FOR ENTERTAINMENT PURPOSES (U.S. CLS. 100, 101 AND 107).

ALICIA COLLINS, EXAMINING ATTORNEY

SN 85-150,949. NATIONAL UNIVERSITY, LA JOLLA, CA. FILED 10-12-2010.



OWNER OF U.S. REG. NO. 2,690,576.
 NO CLAIM IS MADE TO THE EXCLUSIVE RIGHT TO USE "NATIONAL UNIVERSITY", APART FROM THE MARK AS SHOWN.

THE MARK CONSISTS OF A CIRCLE WITH THE WORDS "NATIONAL UNIVERSITY" WITHIN A CIRCULAR BAND AND A CENTRAL DOMED ACADEMIC BUILDING.

SEC. 2(F) AS TO "NATIONAL UNIVERSITY".
 FOR EDUCATIONAL SERVICES IN THE NATURE OF PROVIDING COURSES AT THE UNIVERSITY LEVEL (U.S. CLS. 100, 101 AND 107).

FIRST USE 1-1-1993; IN COMMERCE 1-1-1993.
 DEIRDRE ROBERTSON, EXAMINING ATTORNEY

CLASS 41—(Continued).

SN 85-150,996. NATIONAL UNIVERSITY, LA JOLLA, CA. FILED 10-12-2010.

**NATIONAL UNIVERSITY
INTERNATIONAL**

THE MARK CONSISTS OF STANDARD CHARACTERS WITHOUT CLAIM TO ANY PARTICULAR FONT, STYLE, SIZE, OR COLOR.

OWNER OF U.S. REG. NO. 2,690,576.
NO CLAIM IS MADE TO THE EXCLUSIVE RIGHT TO USE "UNIVERSITY INTERNATIONAL", APART FROM THE MARK AS SHOWN.

SEC. 2(F) AS TO "NATIONAL UNIVERSITY".
FOR EDUCATIONAL SERVICES IN THE NATURE OF COURSES, AT THE UNIVERSITY LEVEL, FOR ENGLISH AS A SECOND LANGUAGE AND FOR TEACHING INSTRUCTORS OF ENGLISH AS A SECOND LANGUAGE COURSE ALL PROVIDED ON-LINE (U.S. CLS. 100, 101 AND 107).

FIRST USE 8-30-2005; IN COMMERCE 8-30-2005.
STEVEN JACKSON, EXAMINING ATTORNEY

CLASS 41—(Continued).

SN 85-151,494. EKO GROUP INC., SAN FRANCISCO, CA. FILED 10-13-2010.

EKO

THE MARK CONSISTS OF STANDARD CHARACTERS WITHOUT CLAIM TO ANY PARTICULAR FONT, STYLE, SIZE, OR COLOR.

FOR PROVIDING ON-LINE TRAINING, NAMELY, COURSES, SEMINARS, WEBINARS AND WORKSHOPS, IN THE FIELD OF EMPLOYMENT, HUMAN RESOURCES, AND EDUCATIONAL SOLUTIONS FOR BUSINESSES (U.S. CLS. 100, 101 AND 107).

FIRST USE 6-1-2010; IN COMMERCE 6-1-2010.
MICHAEL SOUDERS, EXAMINING ATTORNEY

SN 85-151,944. NATIONAL UNIVERSITY, LA JOLLA, CA. FILED 10-13-2010.

SN 85-151,046. NATIONAL UNIVERSITY, LA JOLLA, CA. FILED 10-12-2010.

**NUGA NATIONAL UNIVERSITY
GOLF ACADEMY**



**NATIONAL UNIVERSITY
GOLF ACADEMY**

THE MARK CONSISTS OF STANDARD CHARACTERS WITHOUT CLAIM TO ANY PARTICULAR FONT, STYLE, SIZE, OR COLOR.

OWNER OF U.S. REG. NO. 2,690,576.
NO CLAIM IS MADE TO THE EXCLUSIVE RIGHT TO USE "UNIVERSITY GOLF ACADEMY", APART FROM THE MARK AS SHOWN.

SEC. 2(F) "NATIONAL UNIVERSITY".
FOR EDUCATIONAL SERVICES IN THE NATURE OF GOLF INSTRUCTION; CAREER COUNSELING IN THE FIELD OF GOLF MANAGEMENT; COACHING AND INSTRUCTION SERVICES IN THE FIELD OF THE BIOMECHANICS OF GOLF (U.S. CLS. 100, 101 AND 107).

FIRST USE 7-1-2009; IN COMMERCE 7-1-2009.
DEIRDRE ROBERTSON, EXAMINING ATTORNEY

OWNER OF U.S. REG. NO. 2,690,576.
NO CLAIM IS MADE TO THE EXCLUSIVE RIGHT TO USE "UNIVERSITY" AND "GOLF ACADEMY", APART FROM THE MARK AS SHOWN.

THE MARK CONSISTS OF THE LETTERS "NUGA" IN A CIRCLE SURROUNDED BY A WREATH SEAL ABOVE THE WORDS "NATIONAL UNIVERSITY" ABOVE THE LINE AND "GOLF ACADEMY" BELOW THE LINE.

SEC. 2(F) AS TO "NATIONAL UNIVERSITY".
FOR EDUCATIONAL SERVICES IN THE NATURE OF GOLF INSTRUCTION; CAREER COUNSELING IN THE FIELD OF GOLF MANAGEMENT; COACHING AND INSTRUCTION SERVICES IN THE FIELD OF THE BIOMECHANICS OF GOLF (U.S. CLS. 100, 101 AND 107).

FIRST USE 7-1-2009; IN COMMERCE 7-1-2009.
DEIRDRE ROBERTSON, EXAMINING ATTORNEY

CLASS 41—(Continued).

SN 85-152,738. NATIONAL UNIVERSITY, LA JOLLA, CA.
FILED 10-14-2010.

NATIONAL UNIVERSITY ACADEMY

THE MARK CONSISTS OF STANDARD CHARACTERS WITHOUT CLAIM TO ANY PARTICULAR FONT, STYLE, SIZE, OR COLOR.

OWNER OF U.S. REG. NO. 2,690,576.
NO CLAIM IS MADE TO THE EXCLUSIVE RIGHT TO USE "UNIVERSITY ACADEMY", APART FROM THE MARK AS SHOWN.

SEC. 2(F) AS TO "NATIONAL UNIVERSITY".
FOR EDUCATIONAL SERVICES IN THE NATURE OF COURSES FOR K THROUGH 12TH GRADE PROVIDED ON-LINE (U.S. CLS. 100, 101 AND 107).

FIRST USE 4-30-2008; IN COMMERCE 4-30-2008.
ANDREW LEASER, EXAMINING ATTORNEY

SN 85-153,472. METROGAMES US, INC., MOUNTAIN VIEW,
CA. FILED 10-15-2010.

Texas Grand Poker

THE MARK CONSISTS OF STANDARD CHARACTERS WITHOUT CLAIM TO ANY PARTICULAR FONT, STYLE, SIZE, OR COLOR.

NO CLAIM IS MADE TO THE EXCLUSIVE RIGHT TO USE "TEXAS" AND "POKER", APART FROM THE MARK AS SHOWN.

FOR ENTERTAINMENT SERVICES, NAMELY, PROVIDING ON-LINE COMPUTER GAMES (U.S. CLS. 100, 101 AND 107).

GISELLE AGOSTO, EXAMINING ATTORNEY

SN 85-154,853. NATIONAL UNIVERSITY, LA JOLLA, CA.
FILED 10-18-2010.

NATIONAL UNIVERSITY ACADEMY

OWNER OF U.S. REG. NO. 2,690,576.
NO CLAIM IS MADE TO THE EXCLUSIVE RIGHT TO USE "UNIVERSITY ACADEMY", APART FROM THE MARK AS SHOWN.

THE MARK CONSISTS OF THE STYLIZED LETTERS "NUA" ABOVE THE WORDS "NATIONAL UNIVERSITY ACADEMY".

SEC. 2(F) AS TO "NATIONAL UNIVERSITY".
FOR EDUCATIONAL SERVICES IN THE NATURE OF COURSES FOR K THROUGH 12TH GRADE PROVIDED ON-LINE (U.S. CLS. 100, 101 AND 107).

FIRST USE 4-30-2008; IN COMMERCE 4-30-2008.
ANDREW LEASER, EXAMINING ATTORNEY

CLASS 41—(Continued).

SN 85-159,276. JOBS FOR THE FUTURE, INC., AKA JFF,
BOSTON, MA. FILED 10-22-2010.

Early College Designs

THE MARK CONSISTS OF STANDARD CHARACTERS WITHOUT CLAIM TO ANY PARTICULAR FONT, STYLE, SIZE, OR COLOR.

NO CLAIM IS MADE TO THE EXCLUSIVE RIGHT TO USE "COLLEGE", APART FROM THE MARK AS SHOWN.

FOR EDUCATIONAL SERVICES, NAMELY, PROVIDING CONSULTING, TRAINING, AND PROFESSIONAL DEVELOPMENT COURSES IN THE FIELDS OF DEVELOPING AND SUSTAINING INNOVATIVE NEW SCHOOLS AND PATHWAYS THAT PROMOTE POST SECONDARY SUCCESS FOR ALL STUDENTS THROUGH THE USE OF COLLEGE WORK IN HIGH SCHOOL AND EXTENSIVE STUDENT SUPPORTS (U.S. CLS. 100, 101 AND 107).

FIRST USE 8-1-2010; IN COMMERCE 8-1-2010.
GRETTA YAO, EXAMINING ATTORNEY

SN 85-160,985. AMERICAN MAJORITY, PURCELLVILLE,
VA. FILED 10-26-2010.



NO CLAIM IS MADE TO THE EXCLUSIVE RIGHT TO USE "AMERICAN", APART FROM THE MARK AS SHOWN.

THE MARK CONSISTS OF THE CAPITAL LETTER "A" AND A LOWER CASE "M" WHERE THE CROSS BAR OF THE "A" IS A PARTIAL STAR CONNECTING TO THE "M" ALL OVER THE WORDS "AMERICAN MAJORITY" IN CAPITAL LETTERS.

FOR EDUCATIONAL SERVICES, NAMELY, CONDUCTING CLASSES, SEMINARS, CONFERENCES, WORKSHOPS, WEBINARS IN THE FIELD OF POLITICS, POLITICAL CAMPAIGNING, ACTIVISM, HISTORY, COMMUNICATION AND DISTRIBUTION OF PRINTED MATERIALS IN CONNECTION THEREWITH IN HARD COPY OR ELECTRONIC FORMAT ON THE SAME TOPICS (U.S. CLS. 100, 101 AND 107).

FIRST USE 1-31-2008; IN COMMERCE 1-31-2008.
JANET LEE, EXAMINING ATTORNEY

CLASS 41—(Continued).

SN 85-165,043. KELLER ENTERTAINMENT GROUP, INC., LOS ANGELES, CA. FILED 10-29-2010.

Miami H.E.A.T.

THE MARK CONSISTS OF STANDARD CHARACTERS WITHOUT CLAIM TO ANY PARTICULAR FONT, STYLE, SIZE, OR COLOR.

NO CLAIM IS MADE TO THE EXCLUSIVE RIGHT TO USE "MIAMI", APART FROM THE MARK AS SHOWN.

FOR ENTERTAINMENT SERVICES, NAMELY, A CONTINUING PROGRAM ABOUT A GROUP COMBATING TERRORISM ACCESSIBLE BY TELEVISION (U.S. CLS. 100, 101 AND 107).

ANDREA HACK, EXAMINING ATTORNEY

CLASS 41—(Continued).

SN 85-170,695. CRISTA MINISTRIES, SEATTLE, WA. FILED 11-5-2010.

SPIRIT MUSIC COUNTDOWN

THE MARK CONSISTS OF STANDARD CHARACTERS WITHOUT CLAIM TO ANY PARTICULAR FONT, STYLE, SIZE, OR COLOR.

OWNER OF U.S. REG. NOS. 3,100,794, 3,805,792 AND OTHERS.

NO CLAIM IS MADE TO THE EXCLUSIVE RIGHT TO USE "MUSIC COUNTDOWN", APART FROM THE MARK AS SHOWN.

FOR ENTERTAINMENT IN THE NATURE OF PROVIDING ON-GOING RADIO AND AUDIO PROGRAMS DELIVERED VIA RADIO; RADIO PROGRAMMING (U.S. CLS. 100, 101 AND 107).

ANNE FARRELL, EXAMINING ATTORNEY

SN 85-171,066. DAYE JR, MICHAEL, GREENVILLE, NC. AND MAVEN MADE LLC, HENDERSON, NV. FILED 11-8-2010.

MAVEN MADE

THE MARK CONSISTS OF STANDARD CHARACTERS WITHOUT CLAIM TO ANY PARTICULAR FONT, STYLE, SIZE, OR COLOR.

FOR RECORD PRODUCTION; MUSIC PRODUCTION; AUDIO RECORDING AND PRODUCTION; VIDEOTAPE PRODUCTION; MOTION PICTURE SONG PRODUCTION; PRODUCTION OF VIDEO DISCS FOR OTHERS; RECORDING STUDIOS; ENTERTAINMENT SERVICES, NAMELY, PRODUCING MUSICAL AUDIO AND VIDEO RECORDINGS; MUSIC COMPOSITION AND TRANSCRIPTION FOR OTHERS; SONG WRITING SERVICES; MUSIC PUBLISHING SERVICES; ENTERTAINMENT IN THE NATURE OF LIVE PERFORMANCES BY A LIVE MUSICAL PERFORMER, MUSICAL BAND OR MUSICAL GROUP; ENTERTAINMENT IN THE NATURE OF VISUAL AND AUDIO PERFORMANCES BY A MUSICAL ARTIST, MUSICAL GROUP AND MUSICAL BAND; ENTERTAINMENT, NAMELY, LIVE MUSIC CONCERTS; ENTERTAINMENT, NAMELY, PERSONAL APPEARANCES BY A MUSICIAN, MUSICAL GROUP OR MUSICAL BAND; ENTERTAINMENT, NAMELY, PERSONAL APPEARANCES BY A TELEVISION STAR, MOVIE STAR, COMEDIAN, RADIO PERSONALITY; ENTERTAINMENT SERVICES, NAMELY, PROVIDING A WEB SITE FEATURING MUSICAL PERFORMANCES, MUSICAL VIDEOS, RELATED FILM CLIPS, PHOTOGRAPHS, AND OTHER MULTIMEDIA MATERIALS FEATURING MUSIC, PHOTOGRAPHS AND VIDEOS; ENTERTAINMENT SERVICES, NAMELY, PROVIDING NONDOWNLOADABLE PRERECORDED MUSIC, INFORMATION IN THE FIELD OF MUSIC, COMMENTARY AND ARTICLES ABOUT MUSIC, ALL ONLINE VIA A GLOBAL COMPUTER NETWORK; ENTERTAINMENT SERVICES, NAMELY, PROVIDING A WEB SITE FEATURING NONDOWNLOADABLE ANIMATIONS, CARTOON CHARACTERS, DRAWINGS, PHOTOGRAPHS, AND RELATED ENTERTAINMENT PERTAINING THERETO, AND OTHER MULTIMEDIA MATERIALS, ALL FEATURING MUSIC, PHOTOGRAPHS AND VIDEOS; PROVIDING A COMPUTER GAME FOR USE NETWORK-WIDE BY NETWORK USERS; TELEVISION AND RADIO PROGRAM PRO-

SN 85-170,437. PGA TOUR, INC., PONTE VEDRA BEACH, FL. FILED 11-5-2010.



OWNER OF U.S. REG. NOS. 3,417,509 AND 3,541,219. THE MARK CONSISTS OF A STYLIZED "Q" IN A BOX WITH THE WORD "SCHOOL" ON THE BOTTOM.

FOR ORGANIZING AND ARRANGING PROFESSIONAL GOLF TOURNAMENTS IN WHICH PARTICIPANTS QUALIFY FOR PGA TOUR MEMBERSHIP (U.S. CLS. 100, 101 AND 107).

FIRST USE 9-0-2010; IN COMMERCE 9-0-2010.

TRICIA SONNEBORN, EXAMINING ATTORNEY

CLASS 41—(Continued).

DUCTION; TELEVISION SHOW PRODUCTION; CABLE TELEVISION SHOW PRODUCTION; RADIO ENTERTAINMENT PRODUCTION; MOTION PICTURE FILM PRODUCTION; FILM EDITING; SPECIAL EFFECTS ANIMATION SERVICES FOR FILM AND VIDEO; ENTERTAINMENT IN THE NATURE OF ON-GOING TELEVISION, CABLE TELEVISION AND RADIO PROGRAMS FEATURING MUSICAL, COMEDIC AND DRAMATIC ACTS AS WELL AS PROGRAMS THAT FEATURE ACTION AND ADVENTURE STORIES, ANIMATION AND CARTOONS; ON-GOING TELEVISION AND CABLE TELEVISION PROGRAMS FEATURING MUSIC, DRAMA, COMEDY, ACTION AND ADVENTURE STORIES, ANIMATION AND CARTOONS DELIVERED VIA THE INTERNET; PROVIDING A CONTINUING VARIETY SHOW DISTRIBUTED OVER TELEVISION, CABLE TELEVISION, RADIO, SATELLITE, AUDIO AND VIDEO MEDIA; THEATRE PRODUCTIONS; ENTERTAINMENT IN THE NATURE OF LIVE MUSIC, DRAMATIC OR COMEDY PERFORMANCES (U.S. CLS. 100, 101 AND 107).

MARK PILARO, EXAMINING ATTORNEY

SN 85-174,950. MURPHY, KATHLEEN, DBA AISLE CANDY, SANDWICH, MA. FILED 11-11-2010.

AISLE CANDY

THE MARK CONSISTS OF STANDARD CHARACTERS WITHOUT CLAIM TO ANY PARTICULAR FONT, STYLE, SIZE, OR COLOR.

FOR ON-LINE JOURNALS, FEATURING NON-DOWNLOADABLE INFORMATION IN THE FIELDS OF WEDDING FASHION, WEDDING ETIQUETTE AND WEDDING CEREMONIES (U.S. CLS. 100, 101 AND 107).

FIRST USE 9-29-2010; IN COMMERCE 9-29-2010.
TAMARA FRAZIER, EXAMINING ATTORNEY

SN 85-176,360. NELL MARIE MCKAY, AKA NELLIE MCKAY, POCONO MANOR, PA. FILED 11-14-2010.

Nellie McKay

THE MARK CONSISTS OF STANDARD CHARACTERS WITHOUT CLAIM TO ANY PARTICULAR FONT, STYLE, SIZE, OR COLOR.

THE NAME "NELLIE MCKAY" IDENTIFIES A LIVING INDIVIDUAL WHOSE CONSENT IS OF RECORD.

FOR ENTERTAINMENT AND EDUCATION SERVICES IN THE NATURE OF LIVE DANCE AND MUSICAL PERFORMANCES; ENTERTAINMENT IN THE NATURE OF AN ON-GOING SPECIAL VARIETY, NEWS, MUSIC OR COMEDY SHOW FEATURING MUSICAL PERFORMANCES BY NELLIE MCKAY BROADCAST OVER TELEVISION, SATELLITE, AUDIO, AND VIDEO MEDIA; ENTERTAINMENT IN THE NATURE OF DANCE PERFORMANCES; ENTERTAINMENT IN THE NATURE OF LIVE PERFORMANCES BY A SINGER/ACTOR; ENTERTAINMENT IN THE NATURE OF LIVE RADIO PERSONALITY PERFORMANCES; ENTERTAINMENT IN THE NATURE OF LIVE STAGE PERFORMANCES IN THE NATURE OF CONCERTS AND PLAYS OR LECTURE FOR HIRE IN THE FIELD OF ENTERTAINMENT BY AN INDIVIDUAL; ENTERTAINMENT IN THE NATURE OF VISUAL AND AUDIO PERFORMANCES BY A SINGER/ACTOR; ENTERTAINMENT IN THE NATURE OF VISUAL AND AUDIO PERFORMANCES, AND MUSICAL, VARIETY, NEWS AND COMEDY SHOWS; ENTERTAINMENT IN THE NATURE OF VISUAL AND AUDIO PERFORMANCES, NAMELY, MUSICAL BAND, ROCK GROUP, GYMNASTIC, DANCE, AND BALLET PERFORMANCES; ENTERTAINMENT IN THE NATURE OF LIVE PERFORMANCES BY A SINGER/ACTOR; ENTERTAINMENT SERVICES BY A MUSICAL ARTIST AND PRODUCER, NAMELY, MUSICAL COMPOSITION FOR OTHER AND PRODUCTION OF MUSICAL SOUND RECORDINGS; ENTERTAINMENT SERVICES IN THE NATURE OF LIVE MUSICAL PERFORMANCES; ENTERTAINMENT SERVICES IN THE NATURE OF PRESENTING LIVE MUSICAL PERFORMANCES; ENTERTAINMENT SERVICES IN THE NATURE OF RECORDING, PRODUCTION AND POST-PRODUCTION SERVICES IN THE FIELD OF MUSIC; ENTERTAINMENT SERVICES, NAMELY, AN ON-GOING SERIES FEATURING MUSIC AND COMEDY PROVIDED THROUGH RADIO AND WEBCASTS; ENTERTAINMENT SERVICES, NAMELY, LIVE, TELEVISED AND MOVIE APPEARANCES BY A PROFESSIONAL ENTERTAINER; ENTERTAINMENT SERVICES, NAMELY, PERSONAL APPEARANCES BY A SINGER/ACTOR; ENTERTAINMENT SERVICES, NAMELY, PROVIDING A WEB SITE FEATURING NON-DOWNLOADABLE MUSICAL PERFORMANCES, MUSICAL VIDEOS, RELATED FILM CLIPS, PHOTOGRAPHS, AND OTHER MULTIMEDIA MATERIALS FEATURING MUSIC; ENTERTAINMENT SERVICES, NAMELY, PROVIDING A WEB SITE FEATURING PHOTOGRAPHIC, AUDIO, VIDEO AND PROSE PRESENTATIONS FEATURING MUSICAL ENTERTAINMENT; ENTERTAINMENT, NAMELY, LIVE MUSIC CONCERTS; ENTERTAINMENT, NAMELY, LIVE PERFORMANCES BY A MUSICAL BAND; ENTERTAINMENT, NAMELY, LIVE PERFORMANCES BY MUSICAL BANDS; ENTERTAINMENT, NAMELY, LIVE PERFORMANCES BY ROCK GROUPS; ENTERTAINMENT, NAMELY, PRODUCTION OF MUSIC, PLAYS, TV SHOWS, MOVIES; LIVE PERFORMANCES BY A MUSICAL GROUP; LIVE PERFORMANCES FEATURING PRERECORDED VOCAL AND INSTRUMENTAL PERFORMANCES VIEWED ON A BIG SCREEN; PRESENTATION OF LIVE SHOW PERFORMANCES; PRESENTATION OF MUSICAL PERFORMANCE; PROVIDING A WEBSITE FOR ENTERTAINMENT PURPOSES WHERE USERS CAN VIEW AND POST COMMENTS, PHOTOS, AND VIDEOS FEATURING MUSIC (U.S. CLS. 100, 101 AND 107).

CLASS 41—(Continued).

FIRST USE 3-23-2003; IN COMMERCE 3-23-2003.
CIMMERIAN COLEMAN, EXAMINING ATTORNEY

SN 85-179,236. SCHWANTZ RACING, INC., DBA SCHWANTZ SCHOOL, LEEDS, AL. FILED 11-17-2010.

Schwantz School

THE MARK CONSISTS OF STANDARD CHARACTERS WITHOUT CLAIM TO ANY PARTICULAR FONT, STYLE, SIZE, OR COLOR.

NO CLAIM IS MADE TO THE EXCLUSIVE RIGHT TO USE "SCHOOL", APART FROM THE MARK AS SHOWN. SEC. 2(F).

FOR EDUCATIONAL SERVICES IN THE NATURE OF MOTORCYCLE RIDING SCHOOLS (U.S. CLS. 100, 101 AND 107).

FIRST USE 2-26-2002; IN COMMERCE 2-26-2002.
PRISCILLA MILTON, EXAMINING ATTORNEY

CLASS 41—(Continued).

SN 85-181,897. ALIOTTI, GILLIAN, NORTH HOLLYWOOD, CA. FILED 11-21-2010.

Artistalive!

THE MARK CONSISTS OF STANDARD CHARACTERS WITHOUT CLAIM TO ANY PARTICULAR FONT, STYLE, SIZE, OR COLOR.

OWNER OF U.S. REG. NO. 3,264,565.

FOR ENTERTAINMENT SERVICES, NAMELY, PROVIDING A WEB SITE FEATURING PHOTOGRAPHIC, VIDEO, AND PROSE PRESENTATIONS FEATURING NON-DOWNLOADABLE ELECTRONIC PUBLICATIONS IN THE NATURE OF MANUALS, BOOKS, AND OTHER WRITTEN RESOURCES, WITH ALL OF THE AFOREMENTIONED BEING IN THE FIELDS OF MUSIC, DANCE, VISUAL ART, TELEVISION, FILM, THEATER, AND ENTERTAINMENT GENERALLY, AND WITH SAID NON-DOWNLOADABLE ELECTRONIC PUBLICATIONS BEING INTENDED FOR USE AS PRIVATE AND PUBLIC ENTERTAINMENT BY ALL, INCLUDING ARTISTS OF ALL GENRES, MUSICIANS, ACTORS, DANCERS, CREATIVE INDIVIDUALS, AND BUSINESS STAFF; ENTERTAINMENT SERVICES, NAMELY, PROVIDING A WEB SITE FEATURING PHOTOGRAPHIC, VIDEO, AND PROSE PRESENTATIONS FEATURING INFORMATION IN THE FIELDS OF LIFE COACHING, ART, EDUCATIONAL PROGRAMS, SEMINARS, WORKSHOPS, AND CLASSES, AND ARTISTIC EXPRESSION IN THE FIELDS OF MUSIC, DANCE, VISUAL ART, TELEVISION, FILM, THEATER, AND ENTERTAINMENT GENERALLY, AND WITH SAID INFORMATION BEING INTENDED FOR USE AS PRIVATE AND PUBLIC ENTERTAINMENT BY ALL, INCLUDING ARTISTS OF ALL GENRES, MUSICIANS, ACTORS, DANCERS, CREATIVE INDIVIDUALS, AND BUSINESS STAFF (U.S. CLS. 100, 101 AND 107).

FIRST USE 10-1-2010; IN COMMERCE 10-1-2010.

KEVIN CORWIN, EXAMINING ATTORNEY

SN 85-183,061. WHATSSUP STAND UP PADDLE & SURF, BOTHELL, WA. FILED 11-23-2010.



NO CLAIM IS MADE TO THE EXCLUSIVE RIGHT TO USE "STAND UP PADDLE & SURF" AND "BOTHELL, WASHINGTON", APART FROM THE MARK AS SHOWN.

THE COLOR(S) BLUE, BLACK, YELLOW AND WHITE IS/ARE CLAIMED AS A FEATURE OF THE MARK.

THE MARK CONSISTS OF LOGO WHICH IS OVAL

CLASS 41—(Continued).

SHAPED IN BLUE COLOR AND OUTLINED IN BLACK, THE WORDS "WHATSSUP" IN A YELLOW COLOR("WHATSSUP" SEPARATED BETWEEN THE "S" AND "S" WITH BLACK SILHOUETTE OF A GIRL ON A STAND UP PADDLE BOARD WITH PADDLE)BENEATH "WHATSSUP" ARE THE WORDS "STAND UP PADDLE & SURF" IN BLACK LETTERS UNDER THAT OUR EMAIL ADDRESS "WWW.WHATSSUP.NET" IN WHITE LETTERS AND UNDER THAT OUR LOCATION "BOTHELL, WASHINGTON" IN BLACK LETTERS.

FOR PROVIDING SURFING LESSONS; RENTAL OF SURF BOARDS AND THEIR ACCESSORIES (U.S. CLS. 100, 101 AND 107).

FIRST USE 10-1-2010; IN COMMERCE 10-1-2010.

KAREN BRACEY, EXAMINING ATTORNEY

SN 85-184,983. OHAYOCON LLC, DBA OHAYOCON, HEBRON, KY. FILED 11-24-2010.

Ohayocon

THE MARK CONSISTS OF STANDARD CHARACTERS WITHOUT CLAIM TO ANY PARTICULAR FONT, STYLE, SIZE, OR COLOR.

SEC. 2(F).

FOR ANIMATION CONVENTION FOR THE PURPOSE OF EDUCATING THE PUBLIC TO JAPANESE POPULAR CULTURE (U.S. CLS. 100, 101 AND 107).

FIRST USE 4-4-2010; IN COMMERCE 4-4-2010.

AISHA CLARKE, EXAMINING ATTORNEY

SN 85-185,048. OUTFIT7 LTD., PREDDVOR, SLOVENIA, FILED 11-24-2010.

OUTFIT7

THE MARK CONSISTS OF STANDARD CHARACTERS WITHOUT CLAIM TO ANY PARTICULAR FONT, STYLE, SIZE, OR COLOR.

FOR ENTERTAINMENT IN THE NATURE OF COMPETITIONS IN THE FIELD OF COMPUTER AND VIDEO GAMES; ENTERTAINMENT SERVICES, NAMELY, PROVIDING ONLINE VIDEO GAMES VIA MOBILE OR CELLULAR TELEPHONE AND/OR OTHER WIRELESS DEVICES; ENTERTAINMENT SERVICES, NAMELY, PROVIDING ONLINE VIDEO GAMES VIA THE INTERNET OR OTHER COMPUTER NETWORK; ONLINE GAMING SERVICES, NAMELY, PROVIDING ONLINE COMPUTER GAMES AND ONLINE VIDEO GAMES; PRODUCTION OF SHORT VIDEO AND AUDIO RECORDINGS; PROVIDING A WEB SITE FEATURING NON-DOWNLOADABLE MUSICAL PERFORMANCES, MUSICAL VIDEOS, FILM CLIPS, PHOTOGRAPHS AND OTHER NON-DOWNLOADABLE MULTIMEDIA CONTENT IN THE FIELD OF ENTERTAINMENT; PROVIDING A WEB SITE FEATURING NON-DOWNLOADABLE VIDEO AND AUDIO RECORDINGS MADE WITHIN COMPUTER GAMES; PROVIDING ONLINE COMPUTER AND VIDEO GAMES ACCESSED AND PLAYED VIA MOBILE AND CELLULAR PHONES AND OTHER WIRELESS DEVICES; PROVIDING ENTERTAINMENT, NAMELY, NON-DOWNLOADABLE MUSICAL PERFORMANCES, MUSICAL VIDEOS, FILM CLIPS, PHOTOGRAPHS AND OTHER NON-DOWNLOADABLE

CLASS 41—(Continued).

MULTIMEDIA CONTENT FEATURING ANIMATED CHARACTERS DISTRIBUTED OVER ELECTRONIC MEDIA, INCLUDING GLOBAL AND LOCAL AREA COMPUTER NETWORKS; PROVIDING TOUCH AND VOICE DRIVEN ONLINE COMPUTER AND VIDEO GAMES FOR ELECTRONIC DIGITAL MOBILE DEVICES; PROVIDING ONLINE VIDEO AND COMPUTER GAMES FOR USE ON MOBILE DEVICES; PROVIDING NEWS AND INFORMATION IN THE FIELD OF ENTERTAINMENT REGARDING INTERACTIVE COMPUTER GAME SOFTWARE, INTERACTIVE VIDEO GAME SOFTWARE AND INTERACTIVE COMPUTER AND VIDEO GAMES, VIA ELECTRONIC, WIRELESS AND COMPUTER NETWORKS; PROVIDING ONLINE COMPUTER AND VIDEO GAMES ACCESSED AND PLAYED VIA ELECTRONIC, WIRELESS AND COMPUTER NETWORKS; PROVIDING ONLINE ENTERTAINMENT IN THE NATURE OF MULTIPLAYER ONLINE COMPUTER GAME AND VIDEO GAME TOURNAMENTS; PRODUCTION AND DISTRIBUTION OF VIDEOS IN THE FIELD OF ENTERTAINMENT; ANIMATION PRODUCTION SERVICES, NAMELY, CREATION AND PRODUCTION OF ANIMATION AND COMPUTER-GENERATED IMAGES FOR ONLINE VIDEO AND COMPUTER GAMES (U.S. CLS. 100, 101 AND 107).

LIEF MARTIN, EXAMINING ATTORNEY

CLASS 41—(Continued).

VOICE DRIVEN ONLINE COMPUTER AND VIDEO GAMES FOR ELECTRONIC DIGITAL MOBILE DEVICES; PROVIDING ONLINE VIDEO AND COMPUTER GAMES FOR USE ON MOBILE DEVICES; PROVIDING NEWS AND INFORMATION IN THE FIELD OF ENTERTAINMENT REGARDING INTERACTIVE COMPUTER GAME SOFTWARE, INTERACTIVE VIDEO GAME SOFTWARE AND INTERACTIVE COMPUTER AND VIDEO GAMES, VIA ELECTRONIC, WIRELESS AND COMPUTER NETWORKS; PROVIDING ONLINE COMPUTER AND VIDEO GAMES ACCESSED AND PLAYED VIA ELECTRONIC, WIRELESS AND COMPUTER NETWORKS; PROVIDING ONLINE ENTERTAINMENT IN THE NATURE OF MULTIPLAYER ONLINE COMPUTER GAME AND VIDEO GAME TOURNAMENTS; PRODUCTION AND DISTRIBUTION OF VIDEOS IN THE FIELD OF ENTERTAINMENT; ANIMATION PRODUCTION SERVICES, NAMELY, CREATION AND PRODUCTION OF ANIMATION AND COMPUTER-GENERATED IMAGES FOR ONLINE VIDEO AND COMPUTER GAMES (U.S. CLS. 100, 101 AND 107).

LIEF MARTIN, EXAMINING ATTORNEY

SN 85-185,059. OUTFIT7 LTD., PREDDVOR, SLOVENIA,
FILED 11-24-2010.

SN 85-185,176. TRANSIENT SOUND INC., CHICAGO, IL,
FILED 11-24-2010.

TALKING BACTERIA

THE MARK CONSISTS OF STANDARD CHARACTERS WITHOUT CLAIM TO ANY PARTICULAR FONT, STYLE, SIZE, OR COLOR.

FOR ENTERTAINMENT IN THE NATURE OF COMPETITIONS IN THE FIELD OF COMPUTER AND VIDEO GAMES; ENTERTAINMENT SERVICES, NAMELY, PROVIDING ONLINE VIDEO GAMES VIA MOBILE OR CELLULAR TELEPHONE AND/OR OTHER WIRELESS DEVICES; ENTERTAINMENT SERVICES, NAMELY, PROVIDING ONLINE VIDEO GAMES VIA THE INTERNET OR OTHER COMPUTER NETWORK; ONLINE GAMING SERVICES, NAMELY, PROVIDING ONLINE COMPUTER GAMES AND ONLINE VIDEO GAMES; PRODUCTION OF SHORT VIDEO AND AUDIO RECORDINGS; PROVIDING A WEB SITE FEATURING NON-DOWNLOADABLE MUSICAL PERFORMANCES, MUSICAL VIDEOS, FILM CLIPS, PHOTOGRAPHS AND OTHER NON-DOWNLOADABLE MULTIMEDIA CONTENT IN THE FIELD OF ENTERTAINMENT; PROVIDING A WEB SITE FEATURING NON-DOWNLOADABLE VIDEO AND AUDIO RECORDINGS MADE WITHIN COMPUTER GAMES; PROVIDING ONLINE COMPUTER AND VIDEO GAMES ACCESSED AND PLAYED VIA MOBILE AND CELLULAR PHONES AND OTHER WIRELESS DEVICES; PROVIDING ENTERTAINMENT, NAMELY, NON-DOWNLOADABLE MUSICAL PERFORMANCES, MUSICAL VIDEOS, FILM CLIPS, PHOTOGRAPHS AND OTHER NON-DOWNLOADABLE MULTIMEDIA CONTENT FEATURING ANIMATED CHARACTERS DISTRIBUTED OVER ELECTRONIC MEDIA, INCLUDING GLOBAL AND LOCAL AREA COMPUTER NETWORKS; PROVIDING TOUCH AND

Transient Sound

THE MARK CONSISTS OF STANDARD CHARACTERS WITHOUT CLAIM TO ANY PARTICULAR FONT, STYLE, SIZE, OR COLOR.

NO CLAIM IS MADE TO THE EXCLUSIVE RIGHT TO USE "SOUND", APART FROM THE MARK AS SHOWN.

FOR ENTERTAINMENT SERVICES, NAMELY, MUSIC PRODUCTION, CONSULTATION IN MUSIC PRODUCTION AND RECORDING, SOUND DESIGN AND MUSIC RECORDING OF MUSICAL COMPOSITIONS FOR MUSICAL ARTISTS AND COMMERCIAL CLIENTS; PROVIDING A WEBSITE VIA A GLOBAL COMPUTER NETWORK FEATURING INFORMATION ON MUSIC PRODUCTION AND PRODUCERS' MUSIC CATALOGUE, MUSIC SONG AND VIDEO SAMPLE CLIPS, PICTURES AND BIOGRAPHIES (U.S. CLS. 100, 101 AND 107).

FIRST USE 12-9-2005; IN COMMERCE 12-9-2005.

SUZANNE BLANE, EXAMINING ATTORNEY

CLASS 41—(Continued).

SN 85-185,803. POTASZNIK, AMANDA, AKA AMANDA ROSE, MESQUITE, TX. FILED 11-28-2010.

StudyTunes

THE MARK CONSISTS OF STANDARD CHARACTERS WITHOUT CLAIM TO ANY PARTICULAR FONT, STYLE, SIZE, OR COLOR.

FOR AUDIO RECORDING AND PRODUCTION; COMPOSITION OF MUSIC FOR OTHERS; EDUCATION SERVICES, NAMELY, PROVIDING ON-LINE SONG-BASED CLASSES IN THE FIELD OF ARTS AND SCIENCES; EDUCATIONAL SERVICES, NAMELY, CONDUCTING SONG-BASED CLASSES IN THE FIELD OF ARTS AND SCIENCES AND DISTRIBUTION OF PRINTED MATERIALS IN CONNECTION THEREWITH IN HARD COPY OR ELECTRONIC FORMAT ON THE SAME TOPICS; EDUCATIONAL SERVICES, NAMELY, PROVIDING A CONTINUING PRERECORDED AUDIO PROGRAM IN THE FIELD OF ARTS AND SCIENCES ACCESSIBLE OVER THE INTERNET; EDUCATIONAL SERVICES, NAMELY, PROVIDING ON-LINE SONG-BASED EDUCATION IN THE FIELD OF ARTS AND SCIENCES (U.S. CLS. 100, 101 AND 107).

FIRST USE 9-1-2010; IN COMMERCE 9-1-2010.
KELLY BOULTON, EXAMINING ATTORNEY

CLASS 41—(Continued).

SN 85-186,260. AGNES SCOTT COLLEGE, INC., DECATUR, GA. FILED 11-29-2010.

SMART WOMEN SWEAT

THE MARK CONSISTS OF STANDARD CHARACTERS WITHOUT CLAIM TO ANY PARTICULAR FONT, STYLE, SIZE, OR COLOR.

FOR EDUCATIONAL AND ENTERTAINMENT SERVICES, NAMELY, ORGANIZING AND CONDUCTING COLLEGE ATHLETIC PROGRAMS IN THE FIELDS OF BASKETBALL, LACROSSE, SOCCER, SOFTBALL, TENNIS, AND VOLLEYBALL (U.S. CLS. 100, 101 AND 107).

FIRST USE 10-0-2005; IN COMMERCE 10-0-2005.
JIM RINGLE, EXAMINING ATTORNEY

SN 85-189,131. OUTFIT7 LTD., PREDDVOR, SLOVENIA, FILED 12-2-2010.

TALKING BACTERIA JOHN, JOHN & JOHN

THE MARK CONSISTS OF STANDARD CHARACTERS WITHOUT CLAIM TO ANY PARTICULAR FONT, STYLE, SIZE, OR COLOR.

PRIORITY CLAIMED UNDER SEC. 44(D) ON ERPNCMNTY TM OFC APPLICATION NO. 009493826, FILED 11-3-2010.

FOR ENTERTAINMENT IN THE NATURE OF COMPETITIONS IN THE FIELD OF COMPUTER AND VIDEO GAMES; ENTERTAINMENT SERVICES, NAMELY, PROVIDING ONLINE VIDEO GAMES VIA MOBILE OR CELLULAR TELEPHONE AND/OR OTHER WIRELESS DEVICES; ENTERTAINMENT SERVICES, NAMELY, PROVIDING ONLINE VIDEO GAMES VIA THE INTERNET OR OTHER COMPUTER NETWORK; ONLINE GAMING SERVICES, NAMELY, PROVIDING ONLINE COMPUTER GAMES AND ONLINE VIDEO GAMES; PRODUCTION OF SHORT VIDEO AND AUDIO RECORDINGS; PROVIDING A WEB SITE FEATURING NON-DOWNLOADABLE MUSICAL PERFORMANCES, MUSICAL VIDEOS, FILM CLIPS, PHOTOGRAPHS AND OTHER NON-DOWNLOADABLE MULTIMEDIA CONTENT IN THE FIELD OF ENTERTAINMENT; PROVIDING A WEB SITE FEATURING NON-DOWNLOADABLE VIDEO AND AUDIO RECORDINGS MADE WITHIN COMPUTER GAMES; PROVIDING ONLINE COMPUTER AND VIDEO GAMES ACCESSED AND PLAYED VIA MOBILE AND CELLULAR PHONES AND OTHER WIRELESS DEVICES; PROVIDING ENTERTAINMENT, NAMELY, NON-DOWNLOADABLE MUSICAL PERFORMANCES, MUSICAL VIDEOS, FILM CLIPS, PHOTOGRAPHS AND OTHER NON-DOWNLOADABLE MULTIMEDIA CONTENT FEATURING ANIMATED CHARACTERS DISTRIBUTED OVER ELECTRONIC MEDIA, INCLUDING GLOBAL AND LOCAL AREA COMPUTER NETWORKS; PROVIDING TOUCH AND

SN 85-186,116. ONEIDA INDIAN NATION OF NEW YORK, AKA ONEIDA NATION OF NEW YORK, THE ONEIDA INDIAN NATION OF NEW YORK, THE ONEIDA INDIAN NATION, ONEIDA INDIAN NATION, THE ONEIDA NATION, OR ONEIDA NATION, ONEIDA, NY. FILED 11-29-2010.

EMPIRE STATE HOLD 'EM CHAMPIONSHIPS

THE MARK CONSISTS OF STANDARD CHARACTERS WITHOUT CLAIM TO ANY PARTICULAR FONT, STYLE, SIZE, OR COLOR.

OWNER OF U.S. REG. NO. 2,907,401.

NO CLAIM IS MADE TO THE EXCLUSIVE RIGHT TO USE "HOLD 'EM CHAMPIONSHIPS", APART FROM THE MARK AS SHOWN.

SEC. 2(F).

FOR ENTERTAINMENT SERVICES IN THE NATURE OF CARD TOURNAMENTS (U.S. CLS. 100, 101 AND 107).

FIRST USE 8-12-2003; IN COMMERCE 8-12-2003.

KATHLEEN M. VANSTON, EXAMINING ATTORNEY

CLASS 41—(Continued).

VOICE DRIVEN ONLINE COMPUTER AND VIDEO GAMES FOR ELECTRONIC DIGITAL MOBILE DEVICES; PROVIDING ONLINE VIDEO AND COMPUTER GAMES FOR USE ON MOBILE DEVICES; PROVIDING NEWS AND INFORMATION IN THE FIELD OF ENTERTAINMENT REGARDING INTERACTIVE COMPUTER GAME SOFTWARE, INTERACTIVE VIDEO GAME SOFTWARE AND INTERACTIVE COMPUTER AND VIDEO GAMES, VIA ELECTRONIC, WIRELESS AND COMPUTER NETWORKS; PROVIDING ONLINE COMPUTER AND VIDEO GAMES ACCESSED AND PLAYED VIA ELECTRONIC, WIRELESS AND COMPUTER NETWORKS; PROVIDING ONLINE ENTERTAINMENT IN THE NATURE OF MULTIPLAYER ONLINE COMPUTER GAME AND VIDEO GAME TOURNAMENTS; PRODUCTION AND DISTRIBUTION OF VIDEOS IN THE FIELD OF ENTERTAINMENT; ANIMATION PRODUCTION SERVICES, NAMELY, CREATION AND PRODUCTION OF ANIMATION AND COMPUTER-GENERATED IMAGES FOR ONLINE VIDEO AND COMPUTER GAMES (U.S. CLS. 100, 101 AND 107).

LIEF MARTIN, EXAMINING ATTORNEY

SN 85-191,480. DOOBIC CO., LTD., SEOCHO GU, SEOUL, REPUBLIC OF KOREA, FILED 12-6-2010.



NO CLAIM IS MADE TO THE EXCLUSIVE RIGHT TO USE "COMPANY", APART FROM THE MARK AS SHOWN. THE COLOR(S) BLACK, WHITE AND ORANGE IS/ARE CLAIMED AS A FEATURE OF THE MARK.

THE MARK CONSISTS OF THE TERMS "SHADOW COMPANY" IN WHITE AGAINST A BLACK BACKGROUND AND APPEARING ABOVE THE TERMS "THE MERCENARY WAR" IN BLACK AND APPEARING AGAINST AN ORANGE BACKGROUND, WHEREIN A SILHOUETTE OF A SOLDIER IN BLACK APPEARS OVER THE LETTER "O" IN THE TERM "SHADOW".

FOR PERSONAL COMPUTER GAME ROOM OPERATION; CASINO GAMING SERVICES; PROVIDING AMUSEMENT ARCADE SERVICES; PROVIDING GAME INFORMATION RELATING TO COMPUTER GAMES; PROVIDING ON-LINE GAME SERVICES FROM A COMPUTER NETWORK; PROVIDING AND OPERATING OF AMUSEMENT FACILITIES; PROVIDING SPORTING COMPETITIONS; ORGANIZING SPORTING COMPETITIONS; ARRANGING SPORTING COMPETITIONS (U.S. CLS. 100, 101 AND 107).

ALICIA COLLINS, EXAMINING ATTORNEY

CLASS 41—(Continued).

SN 85-205,210. BURGI, KARL, BARABOO, WI. FILED 12-23-2010.

SAVE COWS

THE MARK CONSISTS OF STANDARD CHARACTERS WITHOUT CLAIM TO ANY PARTICULAR FONT, STYLE, SIZE, OR COLOR.

NO CLAIM IS MADE TO THE EXCLUSIVE RIGHT TO USE "COWS", APART FROM THE MARK AS SHOWN.

FOR EDUCATIONAL AND TRAINING SERVICES, NAMELY, CONDUCTING CLASSES, SEMINARS, WORKSHOPS, CONFERENCES AND LECTURES, ALL IN THE FIELDS OF ANIMAL HOOF CARE, ANIMAL HOOF HEALTH, ANIMAL HOOF AND CLAW TRIMMING, ANIMAL HOOF HEALTH RECORD KEEPING, NUTRITIONAL ISSUES RELATING TO ANIMAL HOOF HEALTH, SHARPENING OF TOOLS USED IN THE TRIMMING OF ANIMAL HOOVES AND CLAWS, AND MANAGING AND OPERATING AN ANIMAL HOOF CARE AND TRIMMING BUSINESS; AND EDUCATIONAL AND TRAINING SERVICES, NAMELY, CONDUCTING CLASSES, SEMINARS, WORKSHOPS, CONFERENCES AND LECTURES, ALL IN THE FIELDS OF THE IDENTIFICATION, TREATMENT AND PREVENTION OF BOVINE HOOF AND SOFT TISSUE RELATED DISEASES AND ILLNESSES, IDENTIFICATION, TREATMENT AND PREVENTION OF LAMINITIS AND LAMENESS IN CATTLE, BOVINE LOWER LEG ANATOMY, BOVINE BIOMECHANICS, DAIRY ENVIRONMENTS AND HOW THEY INFLUENCE BOVINE HOOF HEALTH, AND PRACTICAL CATTLE HANDLING (U.S. CLS. 100, 101 AND 107).

FIRST USE 9-30-2009; IN COMMERCE 11-12-2009.

TRICIA SONNEBORN, EXAMINING ATTORNEY

SN 85-206,363. EDVANTIA, INC., CHARLESTON, WV. FILED 12-28-2010.

PROFESSIONAL DEVELOPMENT YOUR WAY

THE MARK CONSISTS OF STANDARD CHARACTERS WITHOUT CLAIM TO ANY PARTICULAR FONT, STYLE, SIZE, OR COLOR.

NO CLAIM IS MADE TO THE EXCLUSIVE RIGHT TO USE "PROFESSIONAL DEVELOPMENT", APART FROM THE MARK AS SHOWN.

FOR PROFESSIONAL DEVELOPMENT ASSESSMENT AND COACHING SERVICES FOR SCHOOL DISTRICTS, SCHOOLS, EDUCATORS, AND UNIVERSITIES (U.S. CLS. 100, 101 AND 107).

FIRST USE 9-7-2010; IN COMMERCE 9-7-2010.

MARK PILARO, EXAMINING ATTORNEY

CLASS 41—(Continued).

SN 85-206,412. MACAULAY, MAURA KATH, DBA POCKET SKETCHING, TUCSON, AZ. FILED 12-28-2010.

Pocket Sketching

THE MARK CONSISTS OF STANDARD CHARACTERS WITHOUT CLAIM TO ANY PARTICULAR FONT, STYLE, SIZE, OR COLOR.

NO CLAIM IS MADE TO THE EXCLUSIVE RIGHT TO USE "SKETCHING", APART FROM THE MARK AS SHOWN.

FOR EDUCATION SERVICES, NAMELY, PROVIDING MENTORING, TUTORING, CLASSES, SEMINARS AND WORKSHOPS IN THE FIELD OF VISUAL ART (U.S. CLS. 100, 101 AND 107).

FIRST USE 2-18-1998; IN COMMERCE 2-18-1998.
ALLISON HOLTZ, EXAMINING ATTORNEY

SN 85-207,114. HAWKS RIDGE GOLF CLUB, LLC, BALL GROUND, GA. FILED 12-29-2010.

HAWKS RIDGE

THE MARK CONSISTS OF STANDARD CHARACTERS WITHOUT CLAIM TO ANY PARTICULAR FONT, STYLE, SIZE, OR COLOR.

FOR PROVIDING FACILITIES FOR THE PLAYING OF GOLF; PROVIDING GOLF COURSES AND GOLF PRACTICE FACILITIES, NAMELY, DRIVING RANGE FACILITIES, SHORT-GAME/CHIPPING PRACTICE FACILITIES, PUTTING PRACTICE FACILITIES, AND A GOLF PRACTICE TRAINING CENTER WITH HITTING BAYS; PROVIDING GOLF CLUB HOUSE FACILITIES; PROVIDING COUNTRY CLUB SERVICES; PROVIDING FACILITIES FOR EVENTS, NAMELY, GOLF TOURNAMENTS, GOLF OUTINGS, AND PRIVATE FUNCTIONS IN THE NATURE OF WEDDINGS AND PARTIES (U.S. CLS. 100, 101 AND 107).

FIRST USE 4-1-1999; IN COMMERCE 4-1-1999.
TIMOTHY FINNEGAN, EXAMINING ATTORNEY

CLASS 41—(Continued).

SN 85-210,466. TEXAS HEALTHCARE CAREERS LLC, DALLAS, TX. FILED 1-4-2011.



NO CLAIM IS MADE TO THE EXCLUSIVE RIGHT TO USE "TRAINING", APART FROM THE MARK AS SHOWN.

THE MARK CONSISTS OF AN INCOMPLETE HEART DESIGN CARRYING THE TEXT "HEARTS IN TRAINING", WITH "HEARTS" IN LARGE FONT AND "IN TRAINING" IN SMALLER SCRIPT FONT AND EXTENDING BEYOND THE OPENING IN THE HEART.

FOR VOCATIONAL EDUCATION IN THE FIELD OF HEALTH CARE AND MEDICINE (U.S. CLS. 100, 101 AND 107).

FIRST USE 10-1-2009; IN COMMERCE 12-15-2009.
SANDRA BUJA, EXAMINING ATTORNEY

SN 85-212,275. LINDSAY PARROTT, CHICAGO, IL. FILED 1-6-2011.

PARROTT PARTY PRODUCTIONS

THE MARK CONSISTS OF STANDARD CHARACTERS WITHOUT CLAIM TO ANY PARTICULAR FONT, STYLE, SIZE, OR COLOR.

NO CLAIM IS MADE TO THE EXCLUSIVE RIGHT TO USE "PARTY PRODUCTIONS", APART FROM THE MARK AS SHOWN.

FOR PARTY PLANNING SERVICES; SPECIAL EVENT PLANNING FOR SOCIAL ENTERTAINMENT PURPOSES (U.S. CLS. 100, 101 AND 107).

MARIA-VICTORIA SUAREZ, EXAMINING ATTORNEY

CLASS 41—(Continued).

SN 85-212,530. LEITE'S CULINARIA, INC., NEW YORK, NY.
FILED 1-7-2011.

THE ARSENAL

THE MARK CONSISTS OF STANDARD CHARACTERS WITHOUT CLAIM TO ANY PARTICULAR FONT, STYLE, SIZE, OR COLOR.

FOR PROVIDING ON-LINE, NON-DOWNLOADABLE PUBLICATIONS IN THE NATURE OF NEWSLETTERS IN THE FIELD OF COOKING AND RECIPES (U.S. CLS. 100, 101 AND 107).

FIRST USE 1-1-2011; IN COMMERCE 1-1-2011.
MARK T. MULLEN, EXAMINING ATTORNEY

SN 85-216,794. ROSEWOOD RANCH LP, WICKENBURG, AZ.
FILED 1-13-2011.

THE ROSEWOOD INSTITUTE

THE MARK CONSISTS OF STANDARD CHARACTERS WITHOUT CLAIM TO ANY PARTICULAR FONT, STYLE, SIZE, OR COLOR.

OWNER OF U.S. REG. NOS. 2,597,108, 3,831,381 AND OTHERS.

NO CLAIM IS MADE TO THE EXCLUSIVE RIGHT TO USE "INSTITUTE", APART FROM THE MARK AS SHOWN.

FOR EDUCATION SERVICES, NAMELY, CONDUCTING CLASSES, SEMINARS, CONFERENCES, WORKSHOPS AND TRAINING IN THE FIELD OF EATING DISORDERS (U.S. CLS. 100, 101 AND 107).

FIRST USE 12-20-2010; IN COMMERCE 12-20-2010.
ANDREW LEASER, EXAMINING ATTORNEY

SN 85-216,988. WILLIAM R. MCCARTHY, STILLWATER, MN. FILED 1-13-2011.

**From the Workplace to the
World**

THE MARK CONSISTS OF STANDARD CHARACTERS WITHOUT CLAIM TO ANY PARTICULAR FONT, STYLE, SIZE, OR COLOR.

FOR EDUCATIONAL SERVICES, NAMELY, DEVELOPING CURRICULUM FOR OTHERS IN THE FIELD OF RETIRING/TRANSITIONING FROM CORPORATE ROLES TO THE NEXT STAGE OF LIFE, AND IMPLEMENTING A CURRICULUM BY CONDUCTING PROGRAMS FOR EXECUTIVES IN THE FIELD OF RETIRING/TRANSITIONING FROM CORPORATE ROLES TO THE NEXT STAGE OF LIFE (U.S. CLS. 100, 101 AND 107).

TARA PATE, EXAMINING ATTORNEY

CLASS 41—(Continued).

SN 85-218,211. OWN LLC, LOS ANGELES, CA. FILED 1-14-2011.



THE COLOR(S) ORANGE, YELLOW, GREEN, LIGHT GREEN, PURPLE AND LIGHT PURPLE IS/ARE CLAIMED AS A FEATURE OF THE MARK.

THE MARK CONSISTS OF THE WORD "OWN" DEPICTED IN CAPITAL LETTERS WITH VARYING SHADES OF ORANGE FORMING "O" WITH YELLOW APPEARING IN THE CENTER; VARYING SHADES OF GREEN TO LIGHT GREEN FORMING "W" AND VARYING SHADES OF PURPLE TO LIGHT PURPLE FORMING "N" WITH A SHADOW UNDER EACH LETTER THAT IS DEPICTED IN THE SAME COLOR AS THE LETTER.

FOR ENTERTAINMENT SERVICES, NAMELY, MULTIMEDIA PROGRAMS IN THE FIELD OF GENERAL HUMAN INTEREST, DISTRIBUTED VIA VARIOUS PLATFORMS ACROSS MULTIPLE FORMS OF TRANSMISSION MEDIA; PROVIDING ENTERTAINMENT INFORMATION REGARDING ONGOING TELEVISION PROGRAMS VIA A GLOBAL COMPUTER NETWORK; PRODUCTION OF TELEVISION PROGRAMS; PRODUCTION OF MULTIMEDIA PROGRAMS (U.S. CLS. 100, 101 AND 107).

THOMAS MANOR, EXAMINING ATTORNEY

SN 85-218,752. LUCAS, DANIEL SCOTT, NORTH HOLLYWOOD, CA. FILED 1-16-2011.

DANNY DANGEROUS

THE MARK CONSISTS OF STANDARD CHARACTERS WITHOUT CLAIM TO ANY PARTICULAR FONT, STYLE, SIZE, OR COLOR.

FOR ENTERTAINMENT SERVICES IN THE NATURE OF LIVE MUSICAL PERFORMANCES; ENTERTAINMENT SERVICES IN THE NATURE OF PRESENTING LIVE MUSICAL PERFORMANCES; ENTERTAINMENT, NAMELY, LIVE MUSIC CONCERTS (U.S. CLS. 100, 101 AND 107).

FIRST USE 6-1-1986; IN COMMERCE 9-1-1987.
JILL C. ALT, EXAMINING ATTORNEY

CLASS 41—(Continued).

SN 85-218,753. HUTCHINSON, JOSEPH FRANCIS, NORTH HOLLYWOOD, CA. FILED 1-16-2011.

JOE NORMAL

THE MARK CONSISTS OF STANDARD CHARACTERS WITHOUT CLAIM TO ANY PARTICULAR FONT, STYLE, SIZE, OR COLOR.

FOR ENTERTAINMENT SERVICES IN THE NATURE OF LIVE MUSICAL PERFORMANCES; ENTERTAINMENT SERVICES IN THE NATURE OF PRESENTING LIVE MUSICAL PERFORMANCES; ENTERTAINMENT, NAMELY, LIVE MUSIC CONCERTS (U.S. CLS. 100, 101 AND 107).

FIRST USE 10-1-1982; IN COMMERCE 2-1-1985.
JILL C. ALT, EXAMINING ATTORNEY

SN 85-218,765. BONNER, TREVOR D, DBA BONNERFIED ENTERTAINMENT, BROOKLYN, NY. FILED 1-16-2011.



COMEDY
SPILLAGE

NO CLAIM IS MADE TO THE EXCLUSIVE RIGHT TO USE "COMEDY", APART FROM THE MARK AS SHOWN.

THE COLOR(S) BLACK AND YELLOW IS/ARE CLAIMED AS A FEATURE OF THE MARK.

THE MARK CONSISTS OF "COMEDY SPILLAGE" IN BLACK WITH A YELLOW FACE WITH BLACK FEATURES SMILING IN THE LETTER "O" IN "COMEDY".

FOR ENTERTAINMENT IN THE NATURE OF AN ONGOING SPECIAL VARIETY, NEWS, MUSIC OR COMEDY SHOW FEATURING COMEDIANS, MUSICAL PERFORMERS, RADIO PERSONALITIES, INTERNET CONTENT AND SUBJECT MATTER INCLUDING INTERNET VIDEO CLIPS FEATURING COMEDIANS, INFORMATION FROM INTERNET WEBSITES IN THE FIELD OF COMEDY, HEALTH, AND FITNESS, POETS, HEALTH INFORMATION, FITNESS INFORMATION, BROADCAST OVER TELEVISION, SATELLITE, AUDIO, AND VIDEO MEDIA (U.S. CLS. 100, 101 AND 107).

FIRST USE 10-17-2010; IN COMMERCE 10-17-2010.
LINDSEY RUBIN, EXAMINING ATTORNEY

CLASS 41—(Continued).

SN 85-219,230. SWERDLICK, MARC, NAPERVILLE, IL. FILED 1-17-2011.

Dark Lord

THE MARK CONSISTS OF STANDARD CHARACTERS WITHOUT CLAIM TO ANY PARTICULAR FONT, STYLE, SIZE, OR COLOR.

THE WORDING "DARK LORD" IDENTIFIES THE PSEUDONYM, STAGE NAME OR NICKNAME OF "MARC SWERDLICK", A LIVING INDIVIDUAL WHOSE CONSENT IS OF RECORD.

FOR EDUCATIONAL SERVICES, NAMELY, PROVIDING SEMINARS, CLASSES, WORKSHOPS AND ONE ON ONE PRIVATE CLASSES IN THE FIELD OF SELF- AND PERSONAL IMPROVEMENT, TIME MANAGEMENT AND GOAL SETTING AND DISTRIBUTION OF COURSE MATERIAL IN CONNECTION THEREWITH (U.S. CLS. 100, 101 AND 107).

FIRST USE 7-25-2000; IN COMMERCE 7-25-2000.
LINDA ESTRADA, EXAMINING ATTORNEY

SN 85-220,312. MARTIN V. GALLATIN, NEW YORK, NY. FILED S.R. 1-18-2011; AM. P.R. 6-7-2011.

Be a Hit

THE MARK CONSISTS OF STANDARD CHARACTERS WITHOUT CLAIM TO ANY PARTICULAR FONT, STYLE, SIZE, OR COLOR.

FOR CONDUCTING CLASSES, SEMINARS, AND INSPIRATIONAL LECTURES IN THE FIELDS OF BUSINESS AND PERSONAL DEVELOPMENT INCLUDING; SALES, CAREER DEVELOPMENT, MAKING PRESENTATIONS AND CHOOSING A MATE (U.S. CLS. 100, 101 AND 107).

FIRST USE 9-11-2000; IN COMMERCE 9-11-2000.
STEVEN JACKSON, EXAMINING ATTORNEY

SN 85-220,359. LIGHT, PHILIP, BURKESVILLE, KY. FILED 1-18-2011.



TMPC

THE MARK CONSISTS OF STANDARD CHARACTERS WITHOUT CLAIM TO ANY PARTICULAR FONT, STYLE, SIZE, OR COLOR.

FOR ARRANGING AND CONDUCTING EDUCATIONAL CONFERENCES (U.S. CLS. 100, 101 AND 107).

FIRST USE 10-2-2008; IN COMMERCE 10-2-2008.
RAUL CORDOVA, EXAMINING ATTORNEY

CLASS 41—(Continued).

SN 85-221,931. PEOPLE POSSIBILITIES, LLC, HOUSTON, TX. FILED 1-20-2011.

The Curiosity Board

THE MARK CONSISTS OF STANDARD CHARACTERS WITHOUT CLAIM TO ANY PARTICULAR FONT, STYLE, SIZE, OR COLOR.

FOR EDUCATIONAL SERVICES, NAMELY, PROFESSIONAL COACHING SERVICES IN THE FIELD OF HUMAN RESOURCES DEVELOPMENT, NAMELY, FOR THE PROMOTION OF EMPLOYEE RETENTION, CAREER GROWTH, AND INCREASED PRODUCTIVITY FOR EMPLOYEES AND EMPLOYERS (U.S. CLS. 100, 101 AND 107).

AMY HELLA, EXAMINING ATTORNEY

SN 85-222,359. WILLIAM S. VIVES, SHAVANO PARK, TX. FILED 1-20-2011.

NEOSAVAGE

THE MARK CONSISTS OF STANDARD CHARACTERS WITHOUT CLAIM TO ANY PARTICULAR FONT, STYLE, SIZE, OR COLOR.

FOR PHYSICAL FITNESS TRAINING; LIFESTYLE TRAINING, NAMELY, CONDUCTING CLASSES, SEMINARS, WORKSHOPS, PRESENTATIONS, AND PERSONAL INSTRUCTION IN THE FIELD OF PHYSICAL CONDITIONING, NUTRITION, AND HEALTHY LIVING (U.S. CLS. 100, 101 AND 107).

FIRST USE 1-0-2005; IN COMMERCE 1-0-2005.
APRIL HESIK, EXAMINING ATTORNEY

SN 85-224,057. AUSTRALIAN GOLFER P/L, SYDNEY, AUSTRALIA, FILED 1-24-2011.



NO CLAIM IS MADE TO THE EXCLUSIVE RIGHT TO USE "GOLFER", APART FROM THE MARK AS SHOWN.

THE MARK CONSISTS OF THE NAME "GOLFER" WHERE THE LETTERS "G" AND "O" HAVE BEEN FORMED BY THE PATH OF A GOLF BALL, WHICH ITSELF FORMS THE PRECEDING PERIOD.

FOR PROVIDING A WEBSITE FEATURING INFORMATION ON GOLF AND GOLF INSTRUCTION (U.S. CLS. 100, 101 AND 107).

FIRST USE 1-24-2011; IN COMMERCE 1-24-2011.
GRETTA YAO, EXAMINING ATTORNEY

CLASS 41—(Continued).

SN 85-224,676. FITNESS ON THE RUN, INC., NEWBURY PARK, CA. FILED 1-24-2011.



NO CLAIM IS MADE TO THE EXCLUSIVE RIGHT TO USE "FITNESS", APART FROM THE MARK AS SHOWN.

THE MARK CONSISTS OF THE WORDS "FITNESS ON THE RUN" WITH A STYLIZED FIGURE OF A FEMALE RUNNER CARRYING A SINGLE DUMBBELL, PARTIALLY CROSSING OVER THE LETTER "U" IN THE WORD "RUN".

FOR PERSONAL FITNESS TRAINING AND CONSULTANCY; PROVIDING A WEBSITE FEATURING INFORMATION ON EXERCISE AND FITNESS; PROVIDING A WEBSITE FEATURING ONLINE SPORTS TRAINING AND TRAINING ADVICE AND THE RECORDING OF TRAINING AND WORKOUTS; PROVIDING A WEBSITE FEATURING BLOGS, NON-DOWNLOADABLE INSTRUCTIONAL VIDEOS, AND NON-DOWNLOADABLE PUBLICATIONS IN THE NATURE OF ARTICLES, ALL IN THE FIELD OF FITNESS TRAINING; PROVIDING AN INTERACTIVE WEBSITE FEATURING INFORMATION AND LINKS RELATING TO FITNESS TRAINING (U.S. CLS. 100, 101 AND 107).

FIRST USE 10-31-2003; IN COMMERCE 10-31-2003.
BARBARA A. GOLD, EXAMINING ATTORNEY

SN 85-224,780. GREER, ROY, POMONA, CA. FILED 1-24-2011.

Pamper-Her-Friday by Rg2

THE MARK CONSISTS OF STANDARD CHARACTERS WITHOUT CLAIM TO ANY PARTICULAR FONT, STYLE, SIZE, OR COLOR.

THE "RG2" IN THE MARK IDENTIFIES ROY GREER, A LIVING INDIVIDUAL WHOSE CONSENT IS OF RECORD.

FOR ON-LINE JOURNALS, NAMELY, BLOGS FEATURING COMMENTARY ABOUT ROMANCE AND RELATIONSHIPS; PROVIDING A WEBSITE FEATURING NON-DOWNLOADABLE FICTION WORK, NAMELY, NOVELS, PROSE AND POETRY (U.S. CLS. 100, 101 AND 107).

WILLIAM VERHOSEK, EXAMINING ATTORNEY

CLASS 41—(Continued).

SN 85-226,156. REVELATION WELLNESS FOUNDATION, DBA REVELATION WELLNESS, PHOENIX, AZ. FILED 1-25-2011.

Weigh Less to Feed More

THE MARK CONSISTS OF STANDARD CHARACTERS WITHOUT CLAIM TO ANY PARTICULAR FONT, STYLE, SIZE, OR COLOR.

FOR PROVIDING INFORMATION ON EXERCISE AND FITNESS; INSTRUCTION IN THE FIELD OF EXERCISE, FITNESS AND NUTRITION; EDUCATIONAL SERVICES, NAMELY, CONDUCTING CLASSES, WORKSHOPS AND CONFERENCES IN THE FIELD OF EXERCISE, FITNESS AND NUTRITION AND DISTRIBUTION OF COURSE MATERIAL IN CONNECTION THEREWITH (U.S. CLS. 100, 101 AND 107).

FIRST USE 11-1-2008; IN COMMERCE 1-15-2009.
MARIA-VICTORIA SUAREZ, EXAMINING ATTORNEY

SN 85-230,158. MOREHEAD MARKETING DESIGN INC., DBA CHRISTIANGAMESANDCRAFTS.COM, MINERAL WELLS, WV. FILED 1-31-2011.

ChristianGamesandCrafts.com

NO CLAIM IS MADE TO THE EXCLUSIVE RIGHT TO USE "CHRISTIANGAMESANDCRAFTS.COM", APART FROM THE MARK AS SHOWN.

THE MARK CONSISTS OF THE WORDING "CHRISTIANGAMESANDCRAFTS.COM" WITH A STYLIZED DESIGN OF THE CHRISTIAN FISH SYMBOL LOCATED ABOVE THE WORD "AND" AND CROSSING OVER THE CAPITAL "C" OF THE WORD "CRAFTS". THE ACRONYM ".COM" APPEARS IN A RECTANGLE ABOVE AND EXTENDING RIGHTWARD FROM THE LETTER "S".

FOR PROVISION OF INFORMATION IN THE FIELD OF CHILDREN'S EDUCATION (U.S. CLS. 100, 101 AND 107).

FIRST USE 2-28-2010; IN COMMERCE 2-28-2010.
PAULA MAHONEY, EXAMINING ATTORNEY

SN 85-232,729. MANDEL COMMUNICATIONS, INC., CAPITOLA, CA. FILED 2-2-2011.

**SITUATION COMPLICATION
IMPLICATION POSITION
ACTION BENEFIT**

THE MARK CONSISTS OF STANDARD CHARACTERS WITHOUT CLAIM TO ANY PARTICULAR FONT, STYLE, SIZE, OR COLOR.

FOR EDUCATION AND TRAINING, NAMELY, PROVIDING COURSES PERTAINING TO COMMUNICATIONS SKILLS DEVELOPMENT, AND MANUALS ASSOCIATED THEREWITH (U.S. CLS. 100, 101 AND 107).

JEFF DEFORD, EXAMINING ATTORNEY

CLASS 41—(Continued).

SN 85-233,152. EXPONENTS, INC., NEW YORK, NY. FILED 2-3-2011.

ARRIVE

THE MARK CONSISTS OF STANDARD CHARACTERS WITHOUT CLAIM TO ANY PARTICULAR FONT, STYLE, SIZE, OR COLOR.

FOR EDUCATIONAL SERVICES, NAMELY, PROVIDING CLASSES AND WORKSHOPS IN THE FIELD OF HIV/AIDS AWARENESS AND PREVENTION, DRUG RELAPSE PREVENTION AND ENTRY INTO SOCIETY AFTER SERVING JAIL TIME, AND DISTRIBUTING COURSE MATERIALS IN CONNECTION THEREWITH (U.S. CLS. 100, 101 AND 107).

FIRST USE 1-1-1990; IN COMMERCE 1-1-1990.
GINA FINK, EXAMINING ATTORNEY

SN 85-234,235. IDAHO BOTANICAL GARDEN, INC., BOISE, ID. FILED 2-4-2011.

**OUTLAW FIELD SUMMER
CONCERT SERIES**

THE MARK CONSISTS OF STANDARD CHARACTERS WITHOUT CLAIM TO ANY PARTICULAR FONT, STYLE, SIZE, OR COLOR.

NO CLAIM IS MADE TO THE EXCLUSIVE RIGHT TO USE "SUMMER CONCERT SERIES", APART FROM THE MARK AS SHOWN.

FOR ARRANGING AND CONDUCTING OF CONCERTS; ENTERTAINMENT, NAMELY, LIVE MUSIC CONCERTS (U.S. CLS. 100, 101 AND 107).

FIRST USE 4-30-2008; IN COMMERCE 4-30-2008.
GRETTA YAO, EXAMINING ATTORNEY

CLASS 41—(Continued).

SN 85-235,013. VALAVANIS, WILLIAM N., WEST HENRIET-
TA, NY. FILED 2-5-2011.



NO CLAIM IS MADE TO THE EXCLUSIVE RIGHT TO USE "BONSAI" AND "2010 US NATIONAL EXHIBITION", APART FROM THE MARK AS SHOWN.

THE MARK CONSISTS OF A HANGING PINE TREE BRANCH WITH NEEDLES ABOVE A STYLIZED RENDERING OF THE WORDING "BONSAI", AND "2010 US NATIONAL EXHIBITION" ALL INSIDE OF A SQUARE DESIGN WITH NO TOP BORDER.

FOR CONDUCTING EDUCATIONAL EXHIBITIONS IN THE NATURE OF PRESENTATION AND DISPLAY OF BONSAI TREES AND ASSOCIATED ITEMS AND ACCESSORIES (U.S. CLS. 100, 101 AND 107).

FIRST USE 12-29-2009; IN COMMERCE 12-29-2009.
SCOTT BIBB, EXAMINING ATTORNEY

CLASS 41—(Continued).

SN 85-235,856. COLEMAN, LYNN DEE, TA AERIAL FABRIC
ACROBATICS, LLC, DENVER, CO. FILED 2-7-2011.



OWNER OF U.S. REG. NO. 3,855,229.

NO CLAIM IS MADE TO THE EXCLUSIVE RIGHT TO USE "AERIAL FABRIC ACROBATICS", APART FROM THE MARK AS SHOWN.

THE COLOR(S) WHITE, GREY AND BURGUNDY IS/ARE CLAIMED AS A FEATURE OF THE MARK.

THE MARK CONSISTS OF AN AERIAL ACROBAT IN SPLITS POSITION ON AERIAL FABRIC IN THE COLOR WHITE WITHIN A CIRCLE THAT IS IN THE COLOR GREY WHICH IS ABOVE THE WORDING "AERIAL FABRIC ACROBATICS" ALL IN LOWER CASE LETTERING; THE TERMS "AERIAL" AND "ACROBATICS" ARE IN THE COLOR WHITE AND THE TERM "FABRIC" IS IN THE COLOR GREY WITH A HORIZONTAL LINE BETWEEN THE TERMS "AERIAL FABRIC" AND "ACROBATICS" IN LIGHT BURGUNDY, ALL SUPERIMPOSED OVER A BURGUNDY BACKGROUND.

FOR EDUCATION SERVICES, NAMELY, PROVIDING AERIAL ACROBATICS INSTRUCTION AND PERFORMANCE PREPARATION ON AERIAL FABRIC, HOOP, TRAPEZE, AERIAL AND YOGA HAMMOCK, BUNGEE TRAPEZE; ENTERTAINMENT IN THE NATURE OF LIVE PERFORMANCES IN THE FIELD OF AERIAL ACROBATIC ARTS (U.S. CLS. 100, 101 AND 107).

FIRST USE 10-10-2010; IN COMMERCE 10-10-2010.
BARBARA RUTLAND, EXAMINING ATTORNEY

SN 85-235,720. MENKEN, ANNA ROSE, NEW YORK, NY.
FILED 2-7-2011.

ANNA ROSE

THE MARK CONSISTS OF STANDARD CHARACTERS WITHOUT CLAIM TO ANY PARTICULAR FONT, STYLE, SIZE, OR COLOR.

THE NAME(S), PORTRAIT(S), AND/OR SIGNATURE(S) SHOWN IN THE MARK IDENTIFIES ANNA ROSE MENKEN, WHOSE CONSENT(S) TO REGISTER IS MADE OF RECORD.

FOR ENTERTAINMENT SERVICES IN THE NATURE OF LIVE MUSICAL PERFORMANCES (U.S. CLS. 100, 101 AND 107).

FIRST USE 4-24-2007; IN COMMERCE 4-24-2007.
THEODORE MCBRIDE, EXAMINING ATTORNEY

CLASS 41—(Continued).

SN 85-235,895. LOUP LOUP SKI EDUCATION FOUNDATION, DBA LOUP LOUP SKI AREA, LOUP LOUP SKI BOWL, LOUP RENTAL EQUIPMENT SHOP, LOUP SNOW SPORT SCHOOL, & LOUP LOUP BASIN, OKANOGAN, WA. FILED 2-7-2011.



NO CLAIM IS MADE TO THE EXCLUSIVE RIGHT TO USE "LOUP LOUP SKI BOWL", APART FROM THE MARK AS SHOWN.

THE MARK CONSISTS OF THE OUTLINE OF AN APPLE WITHIN WHICH APPEARS A STYLIZED IMAGE OF A WOLF'S HEAD BELOW THE WORDS "LOUP LOUP SKI BOWL" WITH THE TAIL END OF THE "P" IN THE SECOND WORD "LOUP" SWOOPING DOWN AND UNDERLINING THE TERM "LOUP LOUP".

THE ENGLISH TRANSLATION OF "LOUP" IN THE MARK IS "WOLF".

FOR PROVIDING SKI SLOPES; PROVIDING SPORTS FACILITIES FOR SPORTS SUCH AS, BUT NOT LIMITED TO, SKIING AND SNOWBOARDING; RENTAL OF SKI EQUIPMENT; RENTAL OF SKIS; SKI INSTRUCTION; SKI RESORTS (U.S. CLS. 100, 101 AND 107).

FIRST USE 1-1-2008; IN COMMERCE 1-1-2008.
KRISTINA MORRIS, EXAMINING ATTORNEY

SN 85-236,946. BAKER & HOSTETLER LLP, CLEVELAND, OH. FILED 2-8-2011.

HOSPITALITY LAWG

THE MARK CONSISTS OF STANDARD CHARACTERS WITHOUT CLAIM TO ANY PARTICULAR FONT, STYLE, SIZE, OR COLOR.

NO CLAIM IS MADE TO THE EXCLUSIVE RIGHT TO USE "HOSPITALITY", APART FROM THE MARK AS SHOWN.

FOR ON-LINE JOURNAL, NAMELY, A BLOG FEATURING HOSPITALITY INDUSTRY ISSUES (U.S. CLS. 100, 101 AND 107).

FIRST USE 2-8-2011; IN COMMERCE 2-8-2011.
LINDA ORNDORFF, EXAMINING ATTORNEY

CLASS 41—(Continued).

SN 85-237,605. JEWISH COMMUNITY CENTERS OF GREATER BOSTON, INC., NEWTON, MA. FILED 2-9-2011.

JEWISH MY WAY

THE MARK CONSISTS OF STANDARD CHARACTERS WITHOUT CLAIM TO ANY PARTICULAR FONT, STYLE, SIZE, OR COLOR.

NO CLAIM IS MADE TO THE EXCLUSIVE RIGHT TO USE "JEWISH", APART FROM THE MARK AS SHOWN.

FOR EDUCATIONAL SERVICES, NAMELY, CONDUCTING CLASSES IN THE FIELDS OF HEALTH, WELLNESS, AND FITNESS; PROVIDING FITNESS AND EXERCISE FACILITIES AND EQUIPMENT; EDUCATIONAL PROGRAMS, NAMELY, PRE-SCHOOL AND EXPERIENTIAL EDUCATION CLASSES IN THE FIELDS OF HEALTH, WELLNESS, FITNESS, ARTS AND CULTURE; ORGANIZING FAMILY CULTURAL AND ARTS EVENTS; PROVIDING DAY CAMP AND OVERNIGHT CAMP SERVICES (U.S. CLS. 100, 101 AND 107).

TEJBIR SINGH, EXAMINING ATTORNEY

SN 85-239,027. AISC HOLDINGS, INC., CHICAGO, IL. FILED 2-10-2011.

**STUDENT STEEL BRIDGE
COMPETITION**

THE MARK CONSISTS OF STANDARD CHARACTERS WITHOUT CLAIM TO ANY PARTICULAR FONT, STYLE, SIZE, OR COLOR.

NO CLAIM IS MADE TO THE EXCLUSIVE RIGHT TO USE "BRIDGE COMPETITION", APART FROM THE MARK AS SHOWN.

SEC. 2(F).
FOR ENTERTAINMENT IN THE NATURE OF COMPETITIONS IN THE FIELD OF STEEL BRIDGE DESIGN, FABRICATION, AND CONSTRUCTION (U.S. CLS. 100, 101 AND 107).

FIRST USE 12-31-1998; IN COMMERCE 12-31-1998.
TARA PATE, EXAMINING ATTORNEY

CLASS 41—(Continued).

SN 85-240,429. RADAR ONLINE, LLC, BOCA RATON, FL.
FILED 2-11-2011.

RADAR ONLINE

THE MARK CONSISTS OF STANDARD CHARACTERS WITHOUT CLAIM TO ANY PARTICULAR FONT, STYLE, SIZE, OR COLOR.

OWNER OF U.S. REG. NOS. 3,154,672 AND 3,531,006.

NO CLAIM IS MADE TO THE EXCLUSIVE RIGHT TO USE "ONLINE", APART FROM THE MARK AS SHOWN.

FOR ENTERTAINMENT SERVICES IN THE NATURE OF RADIO AND TELEVISION PROGRAMMING (U.S. CLS. 100, 101 AND 107).

SHAUNIA CARLYLE, EXAMINING ATTORNEY

CLASS 41—(Continued).

SN 85-241,365. SYNIMAGIC, INC, HOFFMAN ESTATES, IL.
FILED 2-14-2011.



NO CLAIM IS MADE TO THE EXCLUSIVE RIGHT TO USE "GAME SHOW", APART FROM THE MARK AS SHOWN.

THE MARK CONSISTS OF THE OUTLINE OF A SILHOUETTE OF A HEAD WITH A CIRCLE INSIDE THAT CONTAINS ABSTRACT DESIGNS. THE TERM "GAME SHOW GURUS" APPEARS TO THE RIGHT OF THE DESIGN.

FOR ENTERTAINMENT SERVICES, NAMELY, PRODUCTION AND DISTRIBUTION OF A GAME SHOW (U.S. CLS. 100, 101 AND 107).

FIRST USE 9-1-2001; IN COMMERCE 9-1-2001.

SUSAN LESLIE DUBOIS, EXAMINING ATTORNEY

SN 85-242,203. GILBRIDE, JEFF, JAMAICA PLAIN, MA.
FILED 2-15-2011.

DJ KNIFE

THE MARK CONSISTS OF STANDARD CHARACTERS WITHOUT CLAIM TO ANY PARTICULAR FONT, STYLE, SIZE, OR COLOR.

NO CLAIM IS MADE TO THE EXCLUSIVE RIGHT TO USE "DJ", APART FROM THE MARK AS SHOWN.

FOR DISC JOCKEY SERVICES (U.S. CLS. 100, 101 AND 107).

FIRST USE 9-16-1999; IN COMMERCE 9-16-1999.

CAROLINE WOOD, EXAMINING ATTORNEY

SN 85-240,898. BUTLER, LILLIAN, NEW YORK, NY. AND
ROBINSON, EDDIE, NEW YORK, NY. FILED 2-12-2011.

RAW SOUL

THE MARK CONSISTS OF STANDARD CHARACTERS WITHOUT CLAIM TO ANY PARTICULAR FONT, STYLE, SIZE, OR COLOR.

NO CLAIM IS MADE TO THE EXCLUSIVE RIGHT TO USE "RAW", APART FROM THE MARK AS SHOWN.

FOR EDUCATION SERVICES, NAMELY, PROVIDING CLASSES, SEMINARS, WORKSHOPS, RETREATS, MENTORING AND TUTORING IN THE FIELD OF RAW AND LIVING FOOD PREPARATION AND CUISINE, AND DISTRIBUTION OF TRAINING MATERIALS IN CONNECTION THEREWITH; CHEF TRAINING AND INSTRUCTION IN THE FIELD OF RAW AND LIVING FOOD PREPARATION AND CUISINE, AND DISTRIBUTION OF TRAINING MATERIALS IN CONNECTION THEREWITH; EDUCATION SERVICES, NAMELY, ONE-ON-ONE MENTORING IN THE FIELD OF RAW AND LIVING FOOD PREPARATION AND CUISINE; PROVIDING ON-LINE PUBLICATIONS IN THE NATURE OF E-BOOKS IN THE FIELD OF RAW AND LIVING FOOD PREPARATION AND CUISINE (U.S. CLS. 100, 101 AND 107).

FIRST USE 3-0-2003; IN COMMERCE 3-0-2003.

INGRID C. EULIN, EXAMINING ATTORNEY

SN 85-242,240. MAGNETTA, DURGA, TA EVERYDAY
YOGINI, REDONDO BEACH, CA. FILED 2-15-2011.

Everyday Yogini

THE MARK CONSISTS OF STANDARD CHARACTERS WITHOUT CLAIM TO ANY PARTICULAR FONT, STYLE, SIZE, OR COLOR.

NO CLAIM IS MADE TO THE EXCLUSIVE RIGHT TO USE "YOGINI", APART FROM THE MARK AS SHOWN.

FOR MEDITATION TRAINING (U.S. CLS. 100, 101 AND 107).

MARK SHINER, EXAMINING ATTORNEY

CLASS 41—(Continued).

SN 85-242,242. SENYVONG, MAX, CONCORD, CA. FILED 2-15-2011.



NO CLAIM IS MADE TO THE EXCLUSIVE RIGHT TO USE "ENT", APART FROM THE MARK AS SHOWN.

THE COLOR(S) GREEN, BLACK, GRAY, AND WHITE IS/ARE CLAIMED AS A FEATURE OF THE MARK.

THE MARK CONSISTS OF THE LETTERS "I C G" IN GREEN SURROUNDED BY A BLACK CIRCLE, NEXT TO THE "G" IS THE TERM "ENT" IN WHITE. BELOW THE BLACK CIRCLE FEATURES THE LETTERS "I C" IN BLACK, NEXT TO THE TERM "GREEN", WHICH APPEARS IN GREEN WITH BLACK SHADOWING. THESE TERMS ARE INCASED BY TWO, GREEN DOLLAR SYMBOLS, AND A GRAY LINE ABOVE AND BELOW THE TERMS.

FOR ENTERTAINMENT SERVICES IN THE NATURE OF RECORDING, PRODUCTION AND POST-PRODUCTION SERVICES IN THE FIELD OF MUSIC; MULTI-MEDIA ENTERTAINMENT SERVICES IN THE NATURE OF RECORDING, PRODUCTION AND POST-PRODUCTION SERVICES IN THE FIELDS OF MUSIC, VIDEO, AND FILMS; MUSIC PRODUCTION SERVICES (U.S. CLS. 100, 101 AND 107).

JORDAN BAKER, EXAMINING ATTORNEY

SN 85-242,902. KENTUCKY LOTTERY CORPORATION, LOUISVILLE, KY. FILED 2-15-2011.



OWNER OF U.S. REG. NOS. 1,642,264, 3,542,370 AND OTHERS.

NO CLAIM IS MADE TO THE EXCLUSIVE RIGHT TO USE "KENTUCKY LOTTERY", APART FROM THE MARK AS SHOWN.

THE COLOR(S) RED, BLACK AND WHITE IS/ARE CLAIMED AS A FEATURE OF THE MARK.

THE MARK CONSISTS OF THE WORDS "NOT 18?" IN STYLIZED RED CHARACTERS OUTLINED IN WHITE, OVER THE WORDS "NO WAY! NO PLAY!" IN BLACK

CLASS 41—(Continued).

CHARACTERS OUTLINED IN WHITE, OVER THE WORDS "KENTUCKY LOTTERY" IN WHITE TO THE LEFT OF A STYLIZED WHITE EXCLAMATION POINT FEATURING A BLACK STYLIZED DESIGN OF A PERSON JUMPING WITH OUTSTRETCHED ARMS. TO THE RIGHT OF THE EXCLAMATION POINT APPEARS A PARTIAL CIRCLE OF WHITE DOTS AND A WHITE OVAL APPEARS UNDER THE EXCLAMATION POINT. ALL OF THESE FEATURES APPEAR WITHIN A BLACK CIRCLE WITH TWO CROSSING RED LINES BEHIND THE LETTERING.

FOR LOTTERY SERVICES (U.S. CLS. 100, 101 AND 107).

FIRST USE 2-28-2009; IN COMMERCE 2-28-2009.
ELLEN PERKINS, EXAMINING ATTORNEY

SN 85-242,933. KENTUCKY LOTTERY CORPORATION, LOUISVILLE, KY. FILED 2-15-2011.



OWNER OF U.S. REG. NOS. 1,642,264, 3,542,370 AND OTHERS.

NO CLAIM IS MADE TO THE EXCLUSIVE RIGHT TO USE "KENTUCKY LOTTERY", APART FROM THE MARK AS SHOWN.

THE COLOR(S) YELLOW AND BLACK IS/ARE CLAIMED AS A FEATURE OF THE MARK.

THE MARK CONSISTS OF THE WORDS "KENTUCKY LOTTERY" IN BLACK, APPEARING OVER THE WORDS "PLAY RESPONSIBLY" IN BLACK OUTLINED IN YELLOW AND BLACK, APPEARING TO THE LEFT OF A YELLOW TRIANGLE OUTLINED IN BLACK AND CONTAINING A BLACK EXCLAMATION POINT.

FOR LOTTERY SERVICES (U.S. CLS. 100, 101 AND 107).

FIRST USE 8-1-2009; IN COMMERCE 8-1-2009.
ELLEN PERKINS, EXAMINING ATTORNEY

SN 85-242,937. KATHERINE A. DASTA, LAWRENCE, KS. AND KELLY A. MCCARTHY-RETTIG, LAWRENCE, KS. FILED 2-15-2011.

THE INNER ESSENCE PROJECT

THE MARK CONSISTS OF STANDARD CHARACTERS WITHOUT CLAIM TO ANY PARTICULAR FONT, STYLE, SIZE, OR COLOR.

NO CLAIM IS MADE TO THE EXCLUSIVE RIGHT TO USE "PROJECT", APART FROM THE MARK AS SHOWN.

FOR EDUCATION SERVICES, NAMELY, PROVIDING CLASSES, SEMINARS, WORKSHOPS, AND MENTORING, ALL DIRECTED TO OR CONCERNING CHILDREN, IN THE FIELDS OF EMOTIONAL, SPIRITUAL, AND INTELLECTUAL GROWTH, AND PROVIDING COURSE MATERIALS IN CONNECTION THEREWITH (U.S. CLS. 100, 101 AND 107).

CHRISIE B. KING, EXAMINING ATTORNEY

CLASS 41—(Continued).

SN 85-242,977. MNO, INC., DOWNINGTOWN, PA. FILED S.R. 2-15-2011; AM. P.R. 6-1-2011.

CLASS 41—(Continued).

SN 85-243,739. PEACE LOVE WINGS, LLC, FESTUS, MO. FILED 2-16-2011.

Modern Happiness



THE MARK CONSISTS OF STANDARD CHARACTERS WITHOUT CLAIM TO ANY PARTICULAR FONT, STYLE, SIZE, OR COLOR.

FOR LIFE COACHING SERVICES FOR INDIVIDUALS AND GROUPS IN THE FIELDS OF PERSONAL AND PROFESSIONAL DEVELOPMENT; EDUCATIONAL SERVICES, NAMELY, CONDUCTING SEMINARS, CONFERENCES, AND WORKSHOPS IN THE FIELDS OF PERSONAL AND PROFESSIONAL DEVELOPMENT AND DISTRIBUTION OF COURSE MATERIALS IN CONNECTION THEREWITH (U.S. CLS. 100, 101 AND 107).

FIRST USE 5-4-2010; IN COMMERCE 2-14-2011.
MICHAEL SOUDERS, EXAMINING ATTORNEY

THE COLOR(S) BLACK, PINK, PURPLE, BLUE, DARK BLUE, GREEN, DARK GREEN, ORANGE AND RED IS/ ARE CLAIMED AS A FEATURE OF THE MARK.

THE MARK CONSISTS OF A PURPLE HEART WITH ORANGE AND RED LINES AND SHADING COMING OFF THE RIGHT AND LEFT SIDE, ABOVE THE HEART IS A PINK CIRCLE WITH BLUE PEACE SIGN LINES, ABOVE THE CIRCLE IS A BLACK SPIRAL SWIRL, AND THESE ELEMENTS ARE SURROUNDED BY BLUE SHADING; BELOW THE HEART IS A CURVED GREEN BAND WITH TWO DARK GREEN CURVED LINES INSIDE; AND OUTSIDE THE GREEN BAND ON THE LEFT AND RIGHT IS DARK BLUE AND BLUE SHADING.

FOR EDUCATIONAL SERVICES, NAMELY, CONDUCTING CLASSES, SEMINARS, WORKSHOPS AND ONE ON ONE MENTORING IN THE FIELD OF SPIRITUALITY, LIFE IMPROVEMENT, MEDITATION, POSITIVE AFFIRMATIONS, POSITIVE THINKING, AND POSITIVE VISUALIZATION TECHNIQUES, CONNECTING WITH A PERSON'S INNER CHILD, INNER SELF AND INNER BEING, ALTERNATIVE HEALTHCARE, CHIROPRACTIC CARE, ACUPUNCTURE, MASSAGE THERAPY, ENERGY HEALING, AND NUTRITION, AND DISTRIBUTION OF COURSE MATERIALS IN CONNECTION THEREWITH, AND EDUCATION CONSULTING RELATED THERETO; ON-LINE JOURNALS, NAMELY, BLOGS FEATURING SPIRITUALITY, LIFE IMPROVEMENT, MEDITATION, POSITIVE AFFIRMATIONS, POSITIVE THINKING, AND POSITIVE VISUALIZATION TECHNIQUES, CONNECTING WITH A PERSON'S INNER CHILD, INNER SELF AND INNER BEING, ALTERNATIVE HEALTHCARE, CHIROPRACTIC CARE, ACUPUNCTURE, MASSAGE THERAPY, ENERGY HEALING, AND NUTRITION; BUSINESS EDUCATION AND TRAINING SERVICES, NAMELY, DEVELOPING, AND FACILITATING CUSTOMIZED IN-COMPANY LEADERSHIP AND EXECUTIVE DEVELOPMENT PROGRAMS, PROVIDING EXECUTIVE COACHING SERVICES, AND PROVIDING PUBLIC AND IN-COMPANY KEYNOTE PRESENTATIONS TO BUSINESS LEADERS (U.S. CLS. 100, 101 AND 107).

FIRST USE 6-1-2010; IN COMMERCE 6-1-2010.
MARC LEIPZIG, EXAMINING ATTORNEY

SN 85-243,148. ELITE CAPABILITIES, LLC, WOODBRIDGE, VA. FILED 2-15-2011.



NO CLAIM IS MADE TO THE EXCLUSIVE RIGHT TO USE "LLC", APART FROM THE MARK AS SHOWN.

THE MARK CONSISTS OF THE DESIGN OF AN EAGLE WITH ITS WINGS SPREAD AND THE STYLIZED INITIALS "E","C" AND STAR DESIGN IS INCORPORATED WITHIN THE BODY OF THE EAGLE. UNDERNEATH THE STYLIZED INITIALS "E","C" AND STAR DESIGN IS "ELITE CAPABILITIES, LLC."

FOR DEVELOPING TRAINING SYSTEMS AND LEARNING METHODOLOGIES FOR OTHERS (U.S. CLS. 100, 101 AND 107).

FIRST USE 7-22-2010; IN COMMERCE 7-22-2010.
KAREN K. BUSH, EXAMINING ATTORNEY

CLASS 41—(Continued).

SN 85-243,754. THE NANNY GODMOTHER LLC, WILMINGTON, DE. FILED 2-16-2011.

The Nanny Godmother

THE MARK CONSISTS OF STANDARD CHARACTERS WITHOUT CLAIM TO ANY PARTICULAR FONT, STYLE, SIZE, OR COLOR.

FOR PROVIDING A WEBSITE FEATURING BLOGS AND NON-DOWNLOADABLE PUBLICATIONS IN THE NATURE OF ARTICLES, ESSAYS, AND MANUALS IN THE FIELDS OF CHILDCARE, CHILD REARING, PARENTING AND PARENT-CHILD RELATIONSHIPS (U.S. CLS. 100, 101 AND 107).

FIRST USE 1-21-2011; IN COMMERCE 1-21-2011.
KIMBERLY FRYE, EXAMINING ATTORNEY

SN 85-243,824. ARMSTRONG, SANTIAGO, SCOTTSDALE, AZ. FILED 2-16-2011.



NO CLAIM IS MADE TO THE EXCLUSIVE RIGHT TO USE "SYSTEM OF MARTIAL ARTS", APART FROM THE MARK AS SHOWN.

THE MARK CONSISTS OF A CIRCLE WITH A TRIANGLE IN THE MIDDLE. THE TOP RIM READS "THE HOTEIKAN SYSTEM OF MARTIAL ARTS". WITHIN THE TRIANGLE READS THE JAPANESE SYMBOL FOR WAY OF THE WARRIOR. IN THE BOTTOM SECTION IS AN IMAGE OF A THROW.

THE ENGLISH TRANSLATION OF THE WORD "HOTEIKAN" IN THE MARK IS HOUSE OF HOTEL.

THE NON-LATIN CHARACTERS IN THE MARK TRANSLITERATE TO "BU-SHI-DO", WHICH MEANS "WAY OF THE WARRIOR" IN ENGLISH.

FOR MARTIAL ARTS INSTRUCTION (U.S. CLS. 100, 101 AND 107).

CARRIE GENOVESE, EXAMINING ATTORNEY

CLASS 41—(Continued).

SN 85-243,883. INTERNATIONAL COMMUNICATIONS INDUSTRIES ASSOCIATION, INC., DBA INFOCOMM INTERNATIONAL, FAIRFAX, VA. FILED 2-16-2011.

INFOCOMM UNIVERSITY

THE MARK CONSISTS OF STANDARD CHARACTERS WITHOUT CLAIM TO ANY PARTICULAR FONT, STYLE, SIZE, OR COLOR.

OWNER OF U.S. REG. NOS. 1,533,575, 2,718,798 AND OTHERS.

NO CLAIM IS MADE TO THE EXCLUSIVE RIGHT TO USE "UNIVERSITY", APART FROM THE MARK AS SHOWN.

FOR EDUCATIONAL SERVICES, NAMELY, DEVELOPING AND DELIVERING COURSES OF INSTRUCTION ONLINE AND FACE-TO-FACE AT THE SECONDARY AND POST-SECONDARY LEVEL IN THE FIELD OF AUDIOVISUAL COMMUNICATIONS AND ELECTRONIC SYSTEMS INCLUDING DESIGN, INSTALLATION, LIVE EVENTS, SALES, OPERATION, MAINTENANCE AND REPAIR, PROJECT MANAGEMENT, BUSINESS PRACTICES, AND DISTRIBUTING COURSE MATERIAL IN CONNECTION THEREWITH (U.S. CLS. 100, 101 AND 107).

C. DIONNE CLYBURN, EXAMINING ATTORNEY

SN 85-244,514. DUVALL, WILLIAM, WASHINGTON, DC. FILED 2-17-2011.

GHETTO EXPRESS ENTERTAINMENT

THE MARK CONSISTS OF STANDARD CHARACTERS WITHOUT CLAIM TO ANY PARTICULAR FONT, STYLE, SIZE, OR COLOR.

NO CLAIM IS MADE TO THE EXCLUSIVE RIGHT TO USE "ENTERTAINMENT", APART FROM THE MARK AS SHOWN.

FOR ENTERTAINMENT SERVICES IN THE NATURE OF LIVE MUSICAL PERFORMANCES; ENTERTAINMENT SERVICES IN THE NATURE OF PRESENTING LIVE MUSICAL PERFORMANCES; ENTERTAINMENT SERVICES IN THE NATURE OF RECORDING, PRODUCTION AND POST-PRODUCTION SERVICES IN THE FIELD OF MUSIC; ENTERTAINMENT, NAMELY, LIVE MUSIC CONCERTS; ENTERTAINMENT, NAMELY, LIVE PERFORMANCES BY A MUSICAL BAND; MUSIC PRODUCTION SERVICES; PRODUCTION OF MUSICAL VIDEOS (U.S. CLS. 100, 101 AND 107).

JOHN E. MICHOS, EXAMINING ATTORNEY

CLASS 41—(Continued).

SN 85-244,872. JOHNSON, NEIL, E., ESCONDIDO, CA. FILED 2-17-2011.

Discover Tennis

THE MARK CONSISTS OF STANDARD CHARACTERS WITHOUT CLAIM TO ANY PARTICULAR FONT, STYLE, SIZE, OR COLOR.

NO CLAIM IS MADE TO THE EXCLUSIVE RIGHT TO USE "TENNIS", APART FROM THE MARK AS SHOWN.

FOR RATING TENNIS PLAYERS AND TENNIS PROGRAMS BY ASSIGNING NUMERIC MEASURE (U.S. CLS. 100, 101 AND 107).

FIRST USE 11-16-1995; IN COMMERCE 11-16-2001.
WON TEAK OH, EXAMINING ATTORNEY

CLASS 41—(Continued).

SN 85-245,348. WORLD WRESTLING ENTERTAINMENT, INC., STAMFORD, CT. FILED 2-17-2011.

WWE BRAWL

THE MARK CONSISTS OF STANDARD CHARACTERS WITHOUT CLAIM TO ANY PARTICULAR FONT, STYLE, SIZE, OR COLOR.

OWNER OF U.S. REG. NOS. 3,412,176, 3,621,017 AND OTHERS.

FOR ENTERTAINMENT SERVICES, NAMELY, PROVIDING A WEBSITE FEATURING GAMES AND PUZZLES FOR CHILDREN; ENTERTAINMENT SERVICES IN THE NATURE OF ON-GOING TELEVISION PROGRAMS IN THE FIELD OF CHILDREN'S ENTERTAINMENT; ENTERTAINMENT SERVICES IN THE NATURE OF AN ON-GOING CHILDREN'S TELEVISION SHOW; ANIMATION PRODUCTION SERVICES; PROVIDING A WEBSITE FEATURING INFORMATION IN THE FIELDS OF EDUCATION AND ENTERTAINMENT FOR CHILDREN; PROVIDING A WEBSITE FEATURING CHILDREN'S ENTERTAINMENT INFORMATION; PROVIDING INFORMATION, NEWS AND COMMENTARY IN THE FIELD OF CHILDREN'S ENTERTAINMENT; PROVISION OF INFORMATION RELATING TO CHILDREN'S ENTERTAINMENT (U.S. CLS. 100, 101 AND 107).

JOHN GARTNER, EXAMINING ATTORNEY

SN 85-245,606. LOCKWOOD-DEVRIES, IRINA, SAN DIEGO, CA. FILED 2-18-2011.

SN 85-245,125. CEDAR CREST COLLEGE, ALLENTOWN, PA. FILED 2-17-2011.

Cedar Crest College



THE MARK CONSISTS OF STANDARD CHARACTERS WITHOUT CLAIM TO ANY PARTICULAR FONT, STYLE, SIZE, OR COLOR.

NO CLAIM IS MADE TO THE EXCLUSIVE RIGHT TO USE "COLLEGE", APART FROM THE MARK AS SHOWN.

FOR EDUCATION SERVICES IN THE NATURE OF COURSES AT THE UNIVERSITY LEVEL (U.S. CLS. 100, 101 AND 107).

FIRST USE 6-30-1868; IN COMMERCE 6-30-1868.
WILLIAM P. SHANAHAN, EXAMINING ATTORNEY

THE COLOR(S) RED AND BLACK IS/ARE CLAIMED AS A FEATURE OF THE MARK.

THE MARK CONSISTS OF THE LITERAL ELEMENTS "L4L" WHEREIN THE FIRST LETTER "L" IS RED IN COLOR AND THE ELEMENTS "4L" ARE BLACK IN COLOR AND THE MARK IS WRITTEN DIAGONALLY. THE WHITE COLOR BACKGROUND IS NOT CLAIMED AS A FEATURE OF THE MARK.

FOR PET TRAINING SERVICES (U.S. CLS. 100, 101 AND 107).

FIRST USE 1-1-1998; IN COMMERCE 1-1-1998.
MARLENE BELL, EXAMINING ATTORNEY

CLASS 41—(Continued).

SN 85-245,710. MICHAEL J. BONAVIDA, SMITHTOWN, NY.
FILED 2-18-2011.

CROSS COUNTRY KARAOKE

THE MARK CONSISTS OF STANDARD CHARACTERS WITHOUT CLAIM TO ANY PARTICULAR FONT, STYLE, SIZE, OR COLOR.

NO CLAIM IS MADE TO THE EXCLUSIVE RIGHT TO USE "KARAOKE", APART FROM THE MARK AS SHOWN. FOR ENTERTAINMENT, NAMELY, CONDUCTING SINGING CONTESTS (U.S. CLS. 100, 101 AND 107).

DAVID ELTON, EXAMINING ATTORNEY

SN 85-245,983. RUSSELL, HOLLY, MICHIGAN CITY, IN.
FILED 2-18-2011.

**LADY AND THE LENS
PHOTOGRAPHY**

THE MARK CONSISTS OF STANDARD CHARACTERS WITHOUT CLAIM TO ANY PARTICULAR FONT, STYLE, SIZE, OR COLOR.

NO CLAIM IS MADE TO THE EXCLUSIVE RIGHT TO USE "PHOTOGRAPHY", APART FROM THE MARK AS SHOWN.

FOR PHOTOGRAPHY; PHOTOGRAPHY SERVICES; PORTRAIT PHOTOGRAPHY (U.S. CLS. 100, 101 AND 107).

FIRST USE 11-0-2007; IN COMMERCE 11-0-2007.
JUSTINE D. PARKER, EXAMINING ATTORNEY

SN 85-246,243. DIONISIO, DANIEL, SANDY SPRING, MD.
FILED 2-18-2011.

SCREAM CITY

THE MARK CONSISTS OF STANDARD CHARACTERS WITHOUT CLAIM TO ANY PARTICULAR FONT, STYLE, SIZE, OR COLOR.

FOR ENTERTAINMENT IN THE NATURE OF A HAUNTED HOUSE ATTRACTION FEATURING PRIMARILY WALKING TRAILS, HAUNTED HOUSE, HAYRIDES, HAUNTED HAYRIDES, BONFIRES, GAMES, OTHER FESTIVAL TYPE ACTIVITIES AND ALSO FEATURING CONCESSIONS (U.S. CLS. 100, 101 AND 107).

NATALIE POLZER, EXAMINING ATTORNEY

CLASS 41—(Continued).

SN 85-247,250. SCHLAGER GROUP INC., DALLAS, TX.
FILED 2-21-2011.

Ditch the Textbook

THE MARK CONSISTS OF STANDARD CHARACTERS WITHOUT CLAIM TO ANY PARTICULAR FONT, STYLE, SIZE, OR COLOR.

FOR PROVIDING WEB SITES FEATURING ONLINE NON-DOWNLOADABLE PUBLICATIONS FOR USE AS A TEXTBOOK ALTERNATIVE IN THE NATURE OF DOCUMENTS, BIOGRAPHIES, ARTICLES, PAPER TOPICS, TIMELINES, AND STUDENT RESEARCH MATERIALS. IN THE FIELDS OF HISTORY, POLITICAL SCIENCE, GOVERNMENT, RELIGION AND PHILOSOPHY (U.S. CLS. 100, 101 AND 107).

FIRST USE 1-6-2011; IN COMMERCE 1-6-2011.
PATRICIA EVANKO, EXAMINING ATTORNEY

SN 85-247,274. UBER PRO AUDIO LLC, WILLISTON, VT.
FILED 2-21-2011.

Uber Pro Audio

THE MARK CONSISTS OF STANDARD CHARACTERS WITHOUT CLAIM TO ANY PARTICULAR FONT, STYLE, SIZE, OR COLOR.

NO CLAIM IS MADE TO THE EXCLUSIVE RIGHT TO USE "PRO AUDIO", APART FROM THE MARK AS SHOWN. FOR PROVIDING ONLINE INTERVIEWS FEATURING MUSICIANS IN THE FIELD OF MUSIC FOR ENTERTAINMENT PURPOSES (U.S. CLS. 100, 101 AND 107).

FIRST USE 7-2-2007; IN COMMERCE 7-2-2007.
MICHAEL GAFFAR, EXAMINING ATTORNEY

CLASS 41—(Continued).

SN 85-247,563. STATE UNIVERSITY OF NEW YORK AT NEW PALTZ, NEW PALTZ, NY. FILED 2-21-2011.



FOR EDUCATION SERVICES IN THE NATURE OF COURSES AT THE UNIVERSITY LEVEL; MUSEUM SERVICES (U.S. CLS. 100, 101 AND 107).
FIRST USE 1-1-2011; IN COMMERCE 1-1-2011.
MARK PILARO, EXAMINING ATTORNEY

CLASS 41—(Continued).

SN 85-247,697. BOHAN, FRANK, DBA ZYDECO FLAMES, SAN ANSELMO, CA. FILED 2-21-2011.

Zydeco Flames

THE MARK CONSISTS OF STANDARD CHARACTERS WITHOUT CLAIM TO ANY PARTICULAR FONT, STYLE, SIZE, OR COLOR.

NO CLAIM IS MADE TO THE EXCLUSIVE RIGHT TO USE "ZYDECO", APART FROM THE MARK AS SHOWN.

FOR ENTERTAINMENT IN THE NATURE OF VISUAL AND AUDIO PERFORMANCES, NAMELY, MUSICAL BAND, ROCK GROUP, GYMNASTIC, DANCE, AND BALLET PERFORMANCES; ENTERTAINMENT IN THE NATURE OF MUSICAL PERFORMANCES; ENTERTAINMENT SERVICES IN THE NATURE OF LIVE MUSICAL PERFORMANCES (U.S. CLS. 100, 101 AND 107).

FIRST USE 1-1-1990; IN COMMERCE 1-1-1990.
RENEE MCCRAY, EXAMINING ATTORNEY

SN 85-247,674. SKY HIGH SPORTS, CARSON CITY, NV. FILED 2-21-2011.



OWNER OF U.S. REG. NO. 3,897,407.
NO CLAIM IS MADE TO THE EXCLUSIVE RIGHT TO USE "SPORTS", APART FROM THE MARK AS SHOWN.

THE MARK CONSISTS OF THE WORDS "SKY HIGH SPORTS", WITH "SKY HIGH" ABOVE THE WORD "SPORTS"; ALL WORDING APPEARS ABOVE A HORIZONTAL BAR. ABOVE THE WORDING IS THE DEPICTION OF A GROTESQUE MAN STRETCHED HORIZONTALLY ACROSS THE WORDING, HOLDING A BALL IN HIS LEFT HAND. AN INCOMPLETE RECTANGLE APPEARS ON THE LEFT SIDE OF THE MAN, FADING INTO THE RIGHT SIDE OF THE MAN.

FOR ENTERTAINMENT SERVICES, NAMELY, CONDUCTING PARTIES; GYMNASIUMS; EDUCATION SERVICES, NAMELY, PROVIDING INSTRUCTION IN THE FIELDS OF EXERCISE AND FITNESS (U.S. CLS. 100, 101 AND 107).

FIRST USE 10-15-2006; IN COMMERCE 10-15-2006.
HENRY S. ZAK, EXAMINING ATTORNEY

SN 85-247,780. LIFESTYLE WATCHERS, INC., LANSDOWNE, PA. FILED 2-21-2011.

Lifestyle Watchers

THE MARK CONSISTS OF STANDARD CHARACTERS WITHOUT CLAIM TO ANY PARTICULAR FONT, STYLE, SIZE, OR COLOR.

NO CLAIM IS MADE TO THE EXCLUSIVE RIGHT TO USE "LIFESTYLE", APART FROM THE MARK AS SHOWN.

FOR CONDUCTING WORKSHOPS AND SEMINARS IN PERSONAL AWARENESS; CONDUCTING WORKSHOPS AND SEMINARS IN SELF AWARENESS; CONDUCTING WORKSHOPS AND SEMINARS IN SELF-CARE AND SELF-ACCEPTANCE FOR ALL SIZES, DEVELOPING EDUCATIONAL MANUALS FOR OTHERS IN THE FIELD OF BODY ACCEPTANCE, HEALTHY EATING, AND HEALTHY LIFESTYLES INDEPENDENT OF WEIGHT - WHICH MEANS WITHOUT WEIGHT LOSS GOALS. EDUCATION IN THE FIELD OF HEALTHY LIFESTYLES RENDERED THROUGH CORRESPONDENCE COURSES; EDUCATION IN THE FIELD OF HEALTHY LIVING FOR ALL SIZES RENDERED THROUGH VIDEO CONFERENCE; EDUCATION SERVICES, NAMELY, ONE-ON-ONE MENTORING IN THE FIELDS OF BODY-APPRECIATION, HEALTHY EATING FOR ALL SIZES; EDUCATIONAL AND ENTERTAINMENT SERVICES, NAMELY, PROVIDING MOTIVATIONAL SPEAKING SERVICES IN THE FIELD OF BODY-ACCEPTANCE AND A FOCUS ON HEALTH FOR ALL SIZES; EDUCATIONAL SERVICES, NAMELY, CONDUCTING INFORMAL ON-LINE PROGRAMS IN THE FIELDS OF SELF-CARE AND SELF-ACCEPTANCE,

CLASS 41—(Continued).

AND PRINTABLE MATERIALS DISTRIBUTED THEREWITH; EDUCATIONAL SERVICES, NAMELY, CONDUCTING INFORMAL PROGRAMS IN THE FIELDS OF HEALTHY LIVING INDEPENDENT OF WEIGHT - WHICH MEANS WITHOUT WEIGHT LOSS GOALS, USING ON-LINE ACTIVITIES AND INTERACTIVE EXHIBITS, AND PRINTABLE MATERIALS DISTRIBUTED THEREWITH; EDUCATIONAL SERVICES, NAMELY, CONDUCTING INDIVIDUAL CONSULTATIONS, CLASSES, SEMINARS, ONLINE VIDEO GROUPS, AND WORKSHOPS IN THE FIELD OF HEALTH AT EVERY SIZE, AKA HAES, AND DISTRIBUTION OF PRINTED MATERIALS IN CONNECTION THEREWITH IN HARD COPY OR ELECTRONIC FORMAT ON THE SAME TOPICS; EDUCATIONAL SERVICES, NAMELY, CONDUCTING INDIVIDUAL CONSULTATIONS, CLASSES, SEMINARS, ONLINE VIDEO GROUPS, AND WORKSHOPS IN THE FIELD OF HEALTH AT EVERY SIZE, AKA HAES, AND DISTRIBUTION OF COURSE AND EDUCATIONAL MATERIALS IN CONNECTION THEREWITH (U.S. CLS. 100, 101 AND 107).

FIRST USE 9-27-2009; IN COMMERCE 9-27-2009.
SALLY SHIH, EXAMINING ATTORNEY

SN 85-247,824. BALAKHAN MEDIA LLC, JUPITER, FL. FILED 2-21-2011.

AFFLUENTIAL MAGAZINE

THE MARK CONSISTS OF STANDARD CHARACTERS WITHOUT CLAIM TO ANY PARTICULAR FONT, STYLE, SIZE, OR COLOR.

NO CLAIM IS MADE TO THE EXCLUSIVE RIGHT TO USE "MAGAZINE", APART FROM THE MARK AS SHOWN.

FOR ON-LINE JOURNALS, NAMELY, BLOGS FEATURING EDITORIAL CONTENT ON LUXURY LIFESTYLE, LUXURY GOODS AND SERVICES, CLOTHING, FOOD, WINE, REAL ESTATE, LUXURY AUTOMOBILES, YACHTS, ELECTRONICS, TRAVEL, AND PRIVATE JETS (U.S. CLS. 100, 101 AND 107).

FIRST USE 2-15-2011; IN COMMERCE 2-15-2011.
APRIL ROACH, EXAMINING ATTORNEY

SN 85-248,228. O'NEILL, WILLIAM, MARGATE, FL. FILED 2-22-2011.

SUPERBOX

THE MARK CONSISTS OF STANDARD CHARACTERS WITHOUT CLAIM TO ANY PARTICULAR FONT, STYLE, SIZE, OR COLOR.

FOR ENTERTAINMENT IN THE NATURE OF BOXING CONTESTS (U.S. CLS. 100, 101 AND 107).

FIRST USE 11-15-1985; IN COMMERCE 11-15-1985.
LAURA KOVALSKY, EXAMINING ATTORNEY

CLASS 41—(Continued).

SN 85-248,234. PEEVY, RODERICK A. JR., ORANGE BEACH, AL. FILED 2-22-2011.

Waves of Wine

THE MARK CONSISTS OF STANDARD CHARACTERS WITHOUT CLAIM TO ANY PARTICULAR FONT, STYLE, SIZE, OR COLOR.

NO CLAIM IS MADE TO THE EXCLUSIVE RIGHT TO USE "WINE", APART FROM THE MARK AS SHOWN.

FOR CONDUCTING ENTERTAINMENT EXHIBITIONS IN THE NATURE OF WINE FESTIVALS (U.S. CLS. 100, 101 AND 107).

FIRST USE 2-2-2011; IN COMMERCE 2-15-2011.
TOBY BULLOFF, EXAMINING ATTORNEY

SN 85-248,253. THE CENTER FOR EDUCATION REFORM, BETHESDA, MD. FILED 2-22-2011.



NO CLAIM IS MADE TO THE EXCLUSIVE RIGHT TO USE "MEDIA", APART FROM THE MARK AS SHOWN.

THE MARK CONSISTS OF A BANNER GRAPHIC THE STYLIZED TEXT "THE MEDIA". THE STYLIZED TEXT "BULLPEN" IS IN A RECTANGULAR SPEECH BUBBLE.

FOR PUBLICATION OF ELECTRONIC NEWSPAPERS CONTAINING INFORMATION, NEWS AND COMMENTARY IN THE FIELD OF K-12 EDUCATION AND EDUCATION REFORM ACCESSIBLE VIA A GLOBAL COMPUTER NETWORK; PROVIDING INFORMATION, NEWS AND COMMENTARY IN THE FIELD OF K-12 EDUCATION AND EDUCATION REFORM (U.S. CLS. 100, 101 AND 107).

FIRST USE 4-1-2008; IN COMMERCE 4-1-2008.
JEFF DEFORD, EXAMINING ATTORNEY

SN 85-248,734. JND FILMS, LLC, MEMPHIS, TN. FILED 2-22-2011.

JND

THE MARK CONSISTS OF STANDARD CHARACTERS WITHOUT CLAIM TO ANY PARTICULAR FONT, STYLE, SIZE, OR COLOR.

FOR ENTERTAINMENT SERVICES IN THE NATURE OF DEVELOPMENT AND PRODUCTION OF MOTION PICTURE FILMS, FEATURE FILMS, TELEFILMS AND TELEVISION PROGRAMS (U.S. CLS. 100, 101 AND 107).

FONG HSU, EXAMINING ATTORNEY

CLASS 41—(Continued).

SN 85-249,050. JOHNSON, RICHARD G., NORTH EAST, PA. FILED 2-23-2011.

BRAINTRADE EDUCATION SERVICES

THE MARK CONSISTS OF STANDARD CHARACTERS WITHOUT CLAIM TO ANY PARTICULAR FONT, STYLE, SIZE, OR COLOR.

NO CLAIM IS MADE TO THE EXCLUSIVE RIGHT TO USE "EDUCATION SERVICES", APART FROM THE MARK AS SHOWN.

FOR PROVIDING INTERNATIONAL EDUCATION CONSULTING SERVICES BETWEEN EDUCATIONAL INSTITUTIONS AND STUDENTS; EDUCATION INFORMATION; EDUCATIONAL EXAMINATION; ORGANIZATION OF EXHIBITION FOR CULTURAL OR EDUCATIONAL PURPOSES; VOCATIONAL GUIDANCE; ORGANIZATION OF EDUCATIONAL COMPETITIONS (U.S. CLS. 100, 101 AND 107).

JACLYN KIDWELL WALKER, EXAMINING ATTORNEY

CLASS 41—(Continued).

SN 85-249,520. GIRLS WITH SOLE, ROCKY RIVER, OH. FILED 2-23-2011.



THE COLOR(S) BLACK, GREEN, RED AND YELLOW IS/ ARE CLAIMED AS A FEATURE OF THE MARK.

THE MARK CONSISTS OF A STYLIZED GREEN GIRL WITH A RED HEART OUTLINED IN BLACK WITH YELLOW LINES EMANATING FROM IT AND YELLOW SHOES WITH BLACK LACES.

FOR CHARITABLE SERVICES, NAMELY, PROVIDING CLASSES, WORKSHOPS, SEMINARS, AND CAMPS IN THE FIELD OF FITNESS, EXERCISE, BOXING, KICK-BOXING, MIXED MARTIAL ARTS AND SPORTS TO VICTIMS OF ABUSE (U.S. CLS. 100, 101 AND 107).

FIRST USE 10-1-2009; IN COMMERCE 10-1-2009.

KATHERINE CONNOLLY, EXAMINING ATTORNEY

SN 85-249,370. TOWNSQUARE MEDIA OF EL PASO, INC., EL PASO, TX. FILED 2-23-2011.

TASTE OF EL PASO

THE MARK CONSISTS OF STANDARD CHARACTERS WITHOUT CLAIM TO ANY PARTICULAR FONT, STYLE, SIZE, OR COLOR.

NO CLAIM IS MADE TO THE EXCLUSIVE RIGHT TO USE "EL PASO", APART FROM THE MARK AS SHOWN.

FOR ORGANIZING CULTURAL AND ARTS EVENTS; CONDUCTING ENTERTAINMENT EXHIBITIONS IN THE NATURE OF FOOD TASTING FESTIVALS (U.S. CLS. 100, 101 AND 107).

FIRST USE 12-1-2007; IN COMMERCE 12-1-2007.

JIM RINGLE, EXAMINING ATTORNEY

SN 85-249,737. ALL IN RECORDS, LLC, ATLANTA, GA. FILED 2-23-2011.

THE FARM INC. NASHVILLE, TN

THE MARK CONSISTS OF STANDARD CHARACTERS WITHOUT CLAIM TO ANY PARTICULAR FONT, STYLE, SIZE, OR COLOR.

NO CLAIM IS MADE TO THE EXCLUSIVE RIGHT TO USE "NASHVILLE, TN", APART FROM THE MARK AS SHOWN.

FOR ENTERTAINMENT SERVICES, NAMELY, VOCAL PERFORMANCES BY A MUSICAL GROUP; PROVIDING A WEB SITE FEATURING PRERECORDED MUSICAL CLIPS, AUDIOVISUAL CLIPS, PHOTOGRAPHS, NEWS IN CONNECTION WITH A MUSICAL GROUP (U.S. CLS. 100, 101 AND 107).

JANICE L. MCMORROW, EXAMINING ATTORNEY

CLASS 41—(Continued).

SN 85-249,861. TEAMS OF TOMORROW, LLC, WEST MONROE, LA. FILED 2-23-2011.

TEAMS OF TOMORROW

THE MARK CONSISTS OF STANDARD CHARACTERS WITHOUT CLAIM TO ANY PARTICULAR FONT, STYLE, SIZE, OR COLOR.

OWNER OF U.S. REG. NO. 3,660,401.
NO CLAIM IS MADE TO THE EXCLUSIVE RIGHT TO USE "TEAMS", APART FROM THE MARK AS SHOWN.
FOR EDUCATIONAL SERVICES, NAMELY, PROVIDING INSTRUCTION IN THE FIELDS OF CHILDREN'S ATHLETIC TRAINING (U.S. CLS. 100, 101 AND 107).
FIRST USE 10-1-2002; IN COMMERCE 10-1-2002.
ESTHER A. BORSUK, EXAMINING ATTORNEY

SN 85-250,045. TARGETSAFETY.COM, INC., SAN DIEGO, CA. FILED 2-23-2011.

TARGETSOLUTIONS

THE MARK CONSISTS OF STANDARD CHARACTERS WITHOUT CLAIM TO ANY PARTICULAR FONT, STYLE, SIZE, OR COLOR.

OWNER OF U.S. REG. NO. 3,844,402.
FOR EDUCATIONAL SERVICES, NAMELY, CONDUCTING ON-LINE AND WEB-BASED RISK MANAGEMENT TRAINING TO PUBLIC ENTITIES AND PRIVATE ENTERPRISES FEATURING BOTH GENERAL AND CUSTOMIZED, SAFETY PROGRAMS, COMPLIANCE TASK MANAGEMENT, DOCUMENT DISTRIBUTION AND MANAGEMENT, AND SELF-ASSESSMENT, AND DISTRIBUTION OF COURSE MATERIALS IN CONNECTION THEREWITH; PROVIDING INDUSTRY CERTIFICATION COURSES AND CONTINUING EDUCATION COURSES FOR THE PURPOSES OF INDUSTRY CERTIFICATION IN THE FIELD OF RISK MANAGEMENT; DRIVER SAFETY TRAINING (U.S. CLS. 100, 101 AND 107).
LINDA POWELL, EXAMINING ATTORNEY

CLASS 41—(Continued).

SN 85-250,075. MCGUINNESS, NIALL P., SOUTH LAKE TAHOE, CA. FILED 2-23-2011.

New World Jazz Project

THE MARK CONSISTS OF STANDARD CHARACTERS WITHOUT CLAIM TO ANY PARTICULAR FONT, STYLE, SIZE, OR COLOR.

NO CLAIM IS MADE TO THE EXCLUSIVE RIGHT TO USE "WORLD JAZZ PROJECT", APART FROM THE MARK AS SHOWN.

FOR ENTERTAINMENT IN THE NATURE OF VISUAL AND AUDIO PERFORMANCES, NAMELY, MUSICAL BAND, ROCK GROUP, GYMNASTIC, DANCE, AND BALLET PERFORMANCES (U.S. CLS. 100, 101 AND 107).
FIRST USE 10-1-2004; IN COMMERCE 12-16-2007.
TINA MAI, EXAMINING ATTORNEY

SN 85-250,169. TRANSFORMATION STUDIOS, INC., BAY-SIDE, NY. FILED 2-24-2011.



NO CLAIM IS MADE TO THE EXCLUSIVE RIGHT TO USE "STUDIOS", APART FROM THE MARK AS SHOWN.

THE MARK CONSISTS OF THE WORDING "TRANSFORMATION STUDIOS" SUPERIMPOSED OVER THE IMAGE OF A SUN.

FOR PERSONAL FITNESS TRAINING SERVICES AND CONSULTANCY; PHYSICAL FITNESS CONSULTATION; PHYSICAL FITNESS INSTRUCTION; PHYSICAL FITNESS STUDIO SERVICES, NAMELY, PROVIDING GROUP EXERCISE INSTRUCTION, EQUIPMENT, AND FACILITIES; PHYSICAL FITNESS TRAINING SERVICES; PROVIDING FITNESS AND EXERCISE FACILITIES; PROVIDING FITNESS AND EXERCISE STUDIO SERVICES, NAMELY, PILATES INSTRUCTION AND TRAINING; YOGA INSTRUCTION (U.S. CLS. 100, 101 AND 107).
JAMES MACFARLANE, EXAMINING ATTORNEY

SN 85-250,182. HATTON, LYNDA, SHILOH, IL. FILED 2-24-2011.

BATCAVE RECORDS

THE MARK CONSISTS OF STANDARD CHARACTERS WITHOUT CLAIM TO ANY PARTICULAR FONT, STYLE, SIZE, OR COLOR.

NO CLAIM IS MADE TO THE EXCLUSIVE RIGHT TO USE "RECORDS", APART FROM THE MARK AS SHOWN.

FOR ENTERTAINMENT SERVICES IN THE NATURE OF RECORDING, PRODUCTION AND POST-PRODUCTION SERVICES IN THE FIELD OF MUSIC (U.S. CLS. 100, 101 AND 107).
ANDREW RHIM, EXAMINING ATTORNEY

CLASS 41—(Continued).

SN 85-250,197. SCOTT-REYES, LAURIE, HAWTHORNE, FL.
FILED 2-24-2011.

CLASS 41—(Continued).

SN 85-250,356. SUFFOLK UNIVERSITY, BOSTON, MA.
FILED 2-24-2011.

LOCO-MOTION FITNESS

THE MARK CONSISTS OF STANDARD CHARACTERS WITHOUT CLAIM TO ANY PARTICULAR FONT, STYLE, SIZE, OR COLOR.

NO CLAIM IS MADE TO THE EXCLUSIVE RIGHT TO USE "FITNESS", APART FROM THE MARK AS SHOWN.

FOR PHYSICAL FITNESS AND EXERCISE TRAINING SERVICES; PHYSICAL FITNESS INSTRUCTION AND CONSULTATION (U.S. CLS. 100, 101 AND 107).

RONALD MCMORROW, EXAMINING ATTORNEY



SN 85-250,354. MACAGNONE, ANTHONY, NEW YORK, NY.
FILED 2-24-2011.

A.I.M.
Alchemy in Movement

THE MARK CONSISTS OF STANDARD CHARACTERS WITHOUT CLAIM TO ANY PARTICULAR FONT, STYLE, SIZE, OR COLOR.

FOR PROVIDING ASSISTANCE, PERSONAL TRAINING AND PHYSICAL FITNESS CONSULTATION TO INDIVIDUALS TO HELP THEM MAKE PHYSICAL FITNESS, STRENGTH, CONDITIONING, AND EXERCISE IMPROVEMENT IN THEIR DAILY LIVING (U.S. CLS. 100, 101 AND 107).

FIRST USE 1-0-2000; IN COMMERCE 1-0-2000.

BARBARA A. GOLD, EXAMINING ATTORNEY

OWNER OF U.S. REG. NO. 2,866,081.

NO CLAIM IS MADE TO THE EXCLUSIVE RIGHT TO USE "UNIVERSITY", "BOSTON", AND "LAW SCHOOL 1906", APART FROM THE MARK AS SHOWN.

THE MARK CONSISTS OF A CIRCULAR SEAL CONTAINING ON ITS MARGINAL RIM THE WORDS "SUFFOLK UNIVERSITY LAW SCHOOL 1906," ENCIRCLING A FLAME TORCH, TWO STARS, A BUILDING WITH LANDSCAPE, WITH THE WORDS "HONESTAS ET DILIGENTIA" AND "BOSTON" POSITIONED HORIZONTALLY ACROSS.

THE ENGLISH TRANSLATION OF HONESTAS ET DILIGENTIA IN THE MARK IS "HONESTY AND DILIGENCE". SEC. 2(F) AS TO "SUFFOLK".

FOR EDUCATIONAL SERVICES, NAMELY, PROVIDING COURSES OF INSTRUCTION AND TRAINING AT THE UNIVERSITY LEVEL, INCLUDING THOSE IN THE FIELD OF LAW AND SUBJECTS RELATING TO THE LAW (U.S. CLS. 100, 101 AND 107).

FIRST USE 12-31-1999; IN COMMERCE 12-31-1999.

ODESSA BIBBINS, EXAMINING ATTORNEY

CLASS 41—(Continued).

SN 85-250,374. SUFFOLK UNIVERSITY, BOSTON, MA.
FILED 2-24-2011.



OWNER OF U.S. REG. NO. 2,866,081.

NO CLAIM IS MADE TO THE EXCLUSIVE RIGHT TO USE "UNIVERSITY", "BOSTON", AND "1906", APART FROM THE MARK AS SHOWN.

THE MARK CONSISTS OF A CIRCULAR SEAL CONTAINING ON ITS MARGINAL RIM THE WORDS "SUFFOLK UNIVERSITY 1906," ENCIRCLING A FLAME TORCH, TWO STARS, A BUILDING WITH LANDSCAPE, WITH THE WORDS "HONESTAS ET DILIGENTIA" AND "BOSTON" POSITIONED HORIZONTALLY ACROSS.

THE ENGLISH TRANSLATION OF "HONESTAS ET DILIGENTIA" IN THE MARK IS "HONESTY AND DILIGENCE".

SEC. 2(F) AS TO "SUFFOLK".

FOR EDUCATIONAL SERVICES, NAMELY, PROVIDING COURSES OF INSTRUCTION AND TRAINING AT THE UNDERGRADUATE, GRADUATE, POST-GRADUATE, AND PROFESSIONAL LEVELS; ENTERTAINMENT SERVICES, NAMELY, ORGANIZING, PROMOTING, AND CONDUCTING ATHLETIC EVENTS, LECTURES, CONCERTS, FINE ART EXHIBITIONS, AND THEATER PRODUCTIONS (U.S. CLS. 100, 101 AND 107).

FIRST USE 12-31-1990; IN COMMERCE 12-31-1990.

ODESSA BIBBINS, EXAMINING ATTORNEY

SN 85-250,613. HARD CORE ANGLER, BELLINGHAM, MA.
FILED 2-24-2011.

Hard Core Angler

THE MARK CONSISTS OF STANDARD CHARACTERS WITHOUT CLAIM TO ANY PARTICULAR FONT, STYLE, SIZE, OR COLOR.

NO CLAIM IS MADE TO THE EXCLUSIVE RIGHT TO USE "ANGLER", APART FROM THE MARK AS SHOWN.

FOR ENTERTAINMENT, NAMELY, A CONTINUING FISHING SHOW BROADCAST OVER TELEVISION, SATELLITE, AUDIO AND VIDEO MEDIA (U.S. CLS. 100, 101 AND 107).

JASON BLAIR, EXAMINING ATTORNEY

CLASS 41—(Continued).

SN 85-250,839. RAYMOND ARI DESIGN, INC., HUNTINGTON BEACH, CA. FILED 2-24-2011.

The logo for Flutterflix features the word "flutterflix" in a lowercase, bold, sans-serif font. Above the letter "i" in "flix", there are three stylized, multi-pointed starburst symbols of varying sizes.

THE MARK CONSISTS OF THE STYLIZED TEXT "FLUTTERFLIX" WITH THREE STARS APPEARING ON THE OF THE LETTER "I" IN "FLIX".

FOR FILM AND VIDEO PRODUCTION (U.S. CLS. 100, 101 AND 107).

NAAKWAMA ANKRAH, EXAMINING ATTORNEY

SN 85-251,024. ALAN DAMIEN, DBA ALAN DAMIEN, HOLLYWOOD, CA. AND TAKA TAMADA, LOS ANGELES, CA. FILED 2-24-2011.

LIVING DEAD LIGHTS

THE MARK CONSISTS OF STANDARD CHARACTERS WITHOUT CLAIM TO ANY PARTICULAR FONT, STYLE, SIZE, OR COLOR.

FOR ENTERTAINMENT SERVICES IN THE NATURE OF A MUSICAL GROUP (U.S. CLS. 100, 101 AND 107).

FIRST USE 12-1-2006; IN COMMERCE 1-16-2008.

APRIL ROACH, EXAMINING ATTORNEY

CLASS 41—(Continued).

SN 85-251,117. TARGETSAFETY.COM, INC., SAN DIEGO, CA. FILED 2-24-2011.



OWNER OF U.S. REG. NO. 3,844,402.

THE MARK CONSISTS OF A STYLIZED ROUND TARGET WITH THREE RINGS AND THE OUTER TWO RINGS NOT BEING CLOSED COMPLETELY AS THE TWO RINGS INTERSECT WITH THE BEGINNING "T" IN THE LOWER CASE WORD "TARGETSOLUTIONS" WITH THE LETTERS "SOLUTIONS" BEING IN A WIDER FONT LETTERING.

FOR EDUCATIONAL SERVICES, NAMELY, CONDUCTING ON-LINE AND WEB-BASED RISK MANAGEMENT TRAINING TO PUBLIC ENTITIES AND PRIVATE ENTERPRISES FEATURING BOTH GENERAL AND CUSTOMIZED, SAFETY PROGRAMS, COMPLIANCE TASK MANAGEMENT, DOCUMENT DISTRIBUTION AND MANAGEMENT, AND SELF-ASSESSMENT, AND DISTRIBUTION OF COURSE MATERIALS IN CONNECTION THEREWITH; PROVIDING INDUSTRY CERTIFICATION COURSES AND CONTINUING EDUCATION COURSES FOR THE PURPOSES OF INDUSTRY CERTIFICATION IN THE FIELD OF RISK MANAGEMENT; DRIVER SAFETY TRAINING (U.S. CLS. 100, 101 AND 107).

LINDA POWELL, EXAMINING ATTORNEY

SN 85-251,155. KIDSART - ORANGE COUNTY, INC., YORBA LINDA, CA. FILED 2-24-2011.

ART STEPS

THE MARK CONSISTS OF STANDARD CHARACTERS WITHOUT CLAIM TO ANY PARTICULAR FONT, STYLE, SIZE, OR COLOR.

NO CLAIM IS MADE TO THE EXCLUSIVE RIGHT TO USE "ART", APART FROM THE MARK AS SHOWN.

FOR EDUCATION SERVICES, NAMELY, PROVIDING CLASSES IN THE FIELD OF ART (U.S. CLS. 100, 101 AND 107).

FLORENTINA BLANDU, EXAMINING ATTORNEY

CLASS 41—(Continued).

SN 85-251,207. VAN, SONNY LEE, DBA PROJECT UNKNOWN, DAVIS, CA. FILED 2-24-2011.

Project Unknown

THE MARK CONSISTS OF STANDARD CHARACTERS WITHOUT CLAIM TO ANY PARTICULAR FONT, STYLE, SIZE, OR COLOR.

FOR MULTIMEDIA ENTERTAINMENT SERVICES IN THE NATURE OF RECORDING, PRODUCTION AND POST-PRODUCTION SERVICES IN THE FIELDS OF MUSIC, VIDEO, AND FILMS (U.S. CLS. 100, 101 AND 107).

FIRST USE 0-0-2006; IN COMMERCE 0-0-2006.
BRENDAN REGAN, EXAMINING ATTORNEY

SN 85-251,229. TARGETSAFETY.COM, INC., SAN DIEGO, CA. FILED 2-24-2011.



OWNER OF U.S. REG. NO. 3,844,401.

THE MARK CONSISTS OF LOWER CASE LETTERING "PREVENTIONLINK" WITH THE LETTERS "LINK" BEING IN A WIDER FONT, AND A STYLIZED ROUND TARGET WITH THREE RINGS TO THE RIGHT OF THE WORD WITH THE OUTER TWO RINGS NOT BEING CLOSED COMPLETELY AS THE TWO RINGS INTERSECT WITH THE "K" IN "PREVENTIONLINK".

FOR EDUCATIONAL SERVICES, NAMELY, CONDUCTING ON-LINE AND WEB-BASED RISK MANAGEMENT TRAINING TO PUBLIC ENTITIES AND PRIVATE ENTERPRISES FEATURING BOTH GENERAL AND CUSTOMIZED, SAFETY PROGRAMS, COMPLIANCE TASK MANAGEMENT, DOCUMENT DISTRIBUTION AND MANAGEMENT, AND SELF-ASSESSMENT, AND DISTRIBUTION OF COURSE MATERIALS IN CONNECTION THEREWITH; PROVIDING INDUSTRY CERTIFICATION COURSES AND CONTINUING EDUCATION COURSES FOR THE PURPOSES OF INDUSTRY CERTIFICATION IN THE FIELD OF RISK MANAGEMENT; DRIVER SAFETY TRAINING (U.S. CLS. 100, 101 AND 107).

LINDA POWELL, EXAMINING ATTORNEY

CLASS 41—(Continued).

SN 85-251,234. JAMMIN' WITH YOU!, WELLESLEY, MA. FILED 2-24-2011.



THE MARK CONSISTS OF THE WORDING "JAMBABY" IN STYLIZED FONT.

FOR EDUCATIONAL SERVICES, NAMELY, PROVIDING CLASSES THAT FOCUS ON LEARNING, SOCIALIZATION, BONDING AND THE INTRODUCTION OF MUSIC FOR INFANTS AND TODDLERS, RANGING FROM SIX MONTHS TO FOUR YEARS OLD (U.S. CLS. 100, 101 AND 107).

FIRST USE 6-7-2010; IN COMMERCE 6-7-2010.
ALEXANDER L. POWERS, EXAMINING ATTORNEY

SN 85-251,254. DANGELO, REYNALDO, COSTA MESA, CA. FILED 2-24-2011.

Portal Languages

THE MARK CONSISTS OF STANDARD CHARACTERS WITHOUT CLAIM TO ANY PARTICULAR FONT, STYLE, SIZE, OR COLOR.

NO CLAIM IS MADE TO THE EXCLUSIVE RIGHT TO USE "LANGUAGES", APART FROM THE MARK AS SHOWN.

FOR LANGUAGE SCHOOLS FEATURING SPANISH, PORTUGUESE, ITALIAN, MANDARIN, FRENCH, GERMAN, RUSSIAN, ARABIC, KOREAN, JAPANESE, AND VIETNAMESE (U.S. CLS. 100, 101 AND 107).

FIRST USE 1-1-2009; IN COMMERCE 1-1-2009.
BARBARA BROWN, EXAMINING ATTORNEY

CLASS 41—(Continued).

SN 85-251,427. GET YOUR LIFE IN GEAR, LLC, ATHENS, GA. FILED 2-25-2011.



THE COLOR(S) BLUE AND BLACK IS/ARE CLAIMED AS A FEATURE OF THE MARK.

THE MARK CONSISTS OF THE WORDS "GET YOUR LIFE IN GEAR" IN BLACK TEXT USING STYLIZED FONT WITH IMAGES OF BLUE GEARS IN VARIOUS SIZES. THE DOTS OF BOTH "I"'S IN THE WORDS "LIFE" AND "IN" ARE IMAGES OF BLACK GEARS.

FOR (BASED ON USE IN COMMERCE) PEER TO PEER COACHING SERVICES IN THE FIELD OF CAREER DEVELOPMENT, RELATIONSHIP ENHANCEMENT, SPIRITUAL GROWTH, LIFESTYLE MANAGEMENT, LIFE BALANCE, DECISION MAKING, AND ACHIEVING SHORT-TERM AND LONG-TERM GOALS; PROVIDING GROUP COACHING IN THE FIELD OF CAREER DEVELOPMENT, RELATIONSHIP ENHANCEMENT, SPIRITUAL GROWTH, LIFESTYLE MANAGEMENT, LIFE BALANCE, DECISION MAKING, AND ACHIEVING SHORT-TERM AND LONG-TERM GOALS. (BASED ON INTENT TO USE) PROVIDING ON-LINE PUBLICATIONS IN THE NATURE OF AN E-BOOK IN THE FIELD OF CAREER DEVELOPMENT, RELATIONSHIP ENHANCEMENT, SPIRITUAL GROWTH, LIFESTYLE MANAGEMENT, LIFE BALANCE, DECISION MAKING, AND ACHIEVING SHORT-TERM AND LONG-TERM GOALS (U.S. CLS. 100, 101 AND 107).

FIRST USE 10-15-2010; IN COMMERCE 10-15-2010.
DAWN FELDMAN, EXAMINING ATTORNEY

SN 85-251,654. ARCH, ELIZABETH K., AKA LIZ ARCH, VENICE, CA. FILED 2-25-2011.

PRIMAL YOGA

THE MARK CONSISTS OF STANDARD CHARACTERS WITHOUT CLAIM TO ANY PARTICULAR FONT, STYLE, SIZE, OR COLOR.

NO CLAIM IS MADE TO THE EXCLUSIVE RIGHT TO USE "YOGA", APART FROM THE MARK AS SHOWN.

FOR YOGA INSTRUCTION, MARTIAL ARTS INSTRUCTION, MEDITATION INSTRUCTION, AND GROUP FITNESS INSTRUCTION (U.S. CLS. 100, 101 AND 107).

FIRST USE 12-20-2009; IN COMMERCE 12-20-2009.
PAUL F. GAST, EXAMINING ATTORNEY

CLASS 41—(Continued).

SN 85-251,675. O'BRIEN, GLENN, NEW YORK, NY. FILED 2-25-2011.

TV PARTY

THE MARK CONSISTS OF STANDARD CHARACTERS WITHOUT CLAIM TO ANY PARTICULAR FONT, STYLE, SIZE, OR COLOR.

NO CLAIM IS MADE TO THE EXCLUSIVE RIGHT TO USE "TV", APART FROM THE MARK AS SHOWN.

FOR ENTERTAINMENT SERVICES, NAMELY, AN ON-GOING SERIES FEATURING VARIETY ENTERTAINMENT PROVIDED THROUGH TELEVISION, CABLE, SATELLITE, RADIO AND INTERNET (U.S. CLS. 100, 101 AND 107).

MAYUR VAGHANI, EXAMINING ATTORNEY

SN 85-251,702. SAZERAC NORTH AMERICA, INC., FRANKFORT, KY. FILED 2-25-2011.



OWNER OF U.S. REG. NOS. 683,398 AND 2,329,608.
THE MARK CONSISTS OF THE CAPITAL LETTER "B" IN A CIRCLE TO THE LEFT OF THE WORD "BARTON", WHICH IS IN ALL CAPS.

FOR EDUCATIONAL SERVICES, NAMELY, PROVIDING CLASSES, SEMINARS, WORKSHOPS, AND PRESENTATIONS ON THE HISTORY OF AMERICAN WHISKEY AND PRODUCTION, BOTTLING AND DISTRIBUTION PROCESSES FOR WHISKEY AND VODKA; PROVIDING EDUCATIONAL INFORMATION ONLINE RELATING TO THE HISTORY OF AMERICAN WHISKEY PRODUCTION AND BOTTLING; ENTERTAINMENT SERVICES, NAMELY, WHISKEY AND FOOD TASTINGS, AND CIGAR LOUNGE SERVICES (U.S. CLS. 100, 101 AND 107).

GRETTA YAO, EXAMINING ATTORNEY

CLASS 41—(Continued).

SN 85-251,838. THE PRODUCTION STOP, LLC., BEVERLY HILLS, CA. FILED 2-25-2011.

THE PRODUCTION STOP

THE MARK CONSISTS OF STANDARD CHARACTERS WITHOUT CLAIM TO ANY PARTICULAR FONT, STYLE, SIZE, OR COLOR.

NO CLAIM IS MADE TO THE EXCLUSIVE RIGHT TO USE "PRODUCTION", APART FROM THE MARK AS SHOWN.

FOR PROVIDING FACILITIES FOR PRODUCING VIDEO, CINEMA AND PHOTOGRAPHY PRODUCTIONS; RENTAL OF STAGE AND MOVIE EQUIPMENT, NAMELY, CAMERA EQUIPMENT, LIGHTING EQUIPMENT AND GRIP EQUIPMENT (U.S. CLS. 100, 101 AND 107).

FLORENTINA BLANDU, EXAMINING ATTORNEY

SN 85-252,077. OREET JEHASSI SCHWARTZ, SAN FRANCISCO, CA. FILED 2-25-2011.



NO CLAIM IS MADE TO THE EXCLUSIVE RIGHT TO USE "BELLYDANCE WORKOUT", APART FROM THE MARK AS SHOWN.

THE MARK CONSISTS OF THE STYLIZED TERM, "SHARQUI", WITH THE LETTERS, "S" AND "Q" IN STYLIZED CAPS, AND THE DOT OVER THE LETTER "I" REPRESENTED BY A SWOOSH, WITH THE WORDING, "THE BELLYDANCE WORKOUT" BELOW.

THE ENGLISH TRANSLATION OF THE ARABIC WORD "SHARQUI" IN THE MARK IS "EAST".

THE TRANSLATION OF THE ARABIC WORD "SHARQUI" IS "EAST".

FOR ATHLETIC TRAINING SERVICES (U.S. CLS. 100, 101 AND 107).

FIRST USE 2-3-2001; IN COMMERCE 2-3-2001.

ODESSA BIBBINS, EXAMINING ATTORNEY

SN 85-252,187. SPOTLIGHT ENTERTAINMENT PRODUCTIONS, INC., FORT LAUDERDALE, FL. FILED 2-25-2011.

The Aussie Boys

THE MARK CONSISTS OF STANDARD CHARACTERS WITHOUT CLAIM TO ANY PARTICULAR FONT, STYLE, SIZE, OR COLOR.

FOR ENTERTAINMENT SERVICES IN THE NATURE OF LIVE MUSICAL PERFORMANCES (U.S. CLS. 100, 101 AND 107).

TIMOTHY FINNEGAN, EXAMINING ATTORNEY

CLASS 41—(Continued).

SN 85-252,211. AUTOBODYMANAGEMENT SOLUTIONS, LLC, AMSTERDAM, NY. FILED 2-25-2011.

Lean Collision

THE MARK CONSISTS OF STANDARD CHARACTERS WITHOUT CLAIM TO ANY PARTICULAR FONT, STYLE, SIZE, OR COLOR.

NO CLAIM IS MADE TO THE EXCLUSIVE RIGHT TO USE "COLLISION", APART FROM THE MARK AS SHOWN, FOR TRAINING IN THE FIELD OF AUTOMOTIVE REPAIR (U.S. CLS. 100, 101 AND 107).

LAURIE MAYES, EXAMINING ATTORNEY

CLASS 41—(Continued).

SN 85-252,540. ARTS BEATS & EATS, INC., PONTIAC, MI. FILED 2-26-2011.

ARTS BEATS & EATS

THE MARK CONSISTS OF STANDARD CHARACTERS WITHOUT CLAIM TO ANY PARTICULAR FONT, STYLE, SIZE, OR COLOR.

FOR CONDUCTING ENTERTAINMENT EXHIBITIONS IN THE NATURE OF FOOD SAMPLINGS, MUSIC PERFORMANCES AND ART EXHIBITS (U.S. CLS. 100, 101 AND 107).

FIRST USE 3-1-1998; IN COMMERCE 3-1-1998.
SKYE YOUNG, EXAMINING ATTORNEY

SN 85-252,272. LITTLE, ANDREW, MCROBERTS, NASHVILLE, TN. FILED 2-25-2011.

CRASH LIKE THIS

THE MARK CONSISTS OF STANDARD CHARACTERS WITHOUT CLAIM TO ANY PARTICULAR FONT, STYLE, SIZE, OR COLOR.

FOR ENTERTAINMENT SERVICES IN THE NATURE OF LIVE MUSICAL PERFORMANCES (U.S. CLS. 100, 101 AND 107).

FIRST USE 1-28-2010; IN COMMERCE 8-15-2010.
ELLEN BURNS, EXAMINING ATTORNEY

SN 85-252,542. RANDY J ROBINSON, ORLANDO, FL. FILED 2-26-2011.

Kung Fu Fairies

THE MARK CONSISTS OF STANDARD CHARACTERS WITHOUT CLAIM TO ANY PARTICULAR FONT, STYLE, SIZE, OR COLOR.

FOR ENTERTAINMENT SERVICES, NAMELY, A MULTIMEDIA PROGRAM SERIES FEATURING COMEDY, ACTION AND ADVENTURE DISTRIBUTED VIA VARIOUS PLATFORMS ACROSS MULTIPLE FORMS OF TRANSMISSION MEDIA (U.S. CLS. 100, 101 AND 107).

SKYE YOUNG, EXAMINING ATTORNEY

SN 85-252,359. ELDERWISE, A NONPROFIT CORPORATION, SEATTLE, WA. FILED 2-25-2011.

ELDERWISE

THE MARK CONSISTS OF STANDARD CHARACTERS WITHOUT CLAIM TO ANY PARTICULAR FONT, STYLE, SIZE, OR COLOR.

FOR EDUCATION SERVICES, NAMELY, PROVIDING CLASSES, SEMINARS, WORKSHOPS, TUTORING, AND MENTORING IN THE FIELD OF SERVICES TO OLDER ADULTS; OFFERING BOTH WEB-BASED AND CLASSROOM TRAINING FOR CERTIFICATION OF CAREGIVERS FOR OLDER ADULTS (U.S. CLS. 100, 101 AND 107).

FIRST USE 2-5-2004; IN COMMERCE 6-14-2008.
CHARISMA HAMPTON, EXAMINING ATTORNEY

SN 85-252,561. NATIONAL CABLE SATELLITE CORPORATION, WASHINGTON, DC. FILED 2-26-2011.

History Bookshelf

THE MARK CONSISTS OF STANDARD CHARACTERS WITHOUT CLAIM TO ANY PARTICULAR FONT, STYLE, SIZE, OR COLOR.

NO CLAIM IS MADE TO THE EXCLUSIVE RIGHT TO USE "HISTORY", APART FROM THE MARK AS SHOWN.

FOR EDUCATION AND ENTERTAINMENT SERVICES IN THE NATURE OF ONGOING TELEVISION PROGRAMS IN THE FIELD OF INTERVIEWS AND CONVERSATIONS WITH AUTHORS (U.S. CLS. 100, 101 AND 107).

FIRST USE 11-20-2010; IN COMMERCE 11-20-2010.
TINA BROWN, EXAMINING ATTORNEY

CLASS 41—(Continued).

SN 85-252,697. MAHESWARAN, KAIL, MIAMI, FL. FILED 2-26-2011.



NO CLAIM IS MADE TO THE EXCLUSIVE RIGHT TO USE "MUSIC", APART FROM THE MARK AS SHOWN.

THE MARK CONSISTS OF THE STYLIZED TEXT "MOOSHIKA MUSIC" WITH AN IMAGE OF A RAT CURLED UP.

FOR MULTIMEDIA ENTERTAINMENT SERVICES IN THE NATURE OF DEVELOPMENT, PRODUCTION AND POST-PRODUCTION SERVICES IN THE FIELDS OF VIDEO AND FILMS (U.S. CLS. 100, 101 AND 107).

JAMES MACFARLANE, EXAMINING ATTORNEY

SN 85-252,719. HAN, PETER, CONROE, TX. AND FERNANDEZ, MARIA E., CONROE, TX. FILED 2-26-2011.

play.fully.creative

THE MARK CONSISTS OF STANDARD CHARACTERS WITHOUT CLAIM TO ANY PARTICULAR FONT, STYLE, SIZE, OR COLOR.

FOR EDUCATIONAL SERVICES, NAMELY, CONDUCTING CLASSES, COURSES, SEMINARS, CONFERENCES, TUTORING AND COACHING SESSIONS, WORKSHOPS, RETREATS, CAMPS, AND FIELD TRIPS IN THE FIELD OF CREATIVITY, IMAGINATION, PLAYFULNESS, CREATIVE THINKING, CREATIVE PROBLEM-SOLVING AND DISTRIBUTION OF RELATED TRAINING AND EDUCATIONAL MATERIAL IN CONNECTION THEREWITH (U.S. CLS. 100, 101 AND 107).

FIRST USE 8-2-2010; IN COMMERCE 8-2-2010.
BARBARA BROWN, EXAMINING ATTORNEY

CLASS 41—(Continued).

SN 85-252,800. JEFFREY SCOTT SAYRE, PARENT OF BRANDON ALEXANDER SAYRE, ROWLETT, TX. FILED 2-27-2011.

Crël

THE MARK CONSISTS OF STANDARD CHARACTERS WITHOUT CLAIM TO ANY PARTICULAR FONT, STYLE, SIZE, OR COLOR.

THE WORD "CRËL" HAS NO MEANING IN A FOREIGN LANGUAGE.

FOR ENTERTAINMENT IN THE NATURE OF VISUAL AND AUDIO PERFORMANCES, NAMELY, MUSICAL BAND, ROCK GROUP, GYMNASTIC, DANCE, AND BALLET PERFORMANCES (U.S. CLS. 100, 101 AND 107).

FIRST USE 6-6-2010; IN COMMERCE 2-2-2011.

DAVID YONTEF, EXAMINING ATTORNEY

SN 85-253,001. JONES, MICHAEL, FAIRFIELD, CA. FILED 2-28-2011.

HEATER HOUSE PRODUCTIONS

THE MARK CONSISTS OF STANDARD CHARACTERS WITHOUT CLAIM TO ANY PARTICULAR FONT, STYLE, SIZE, OR COLOR.

NO CLAIM IS MADE TO THE EXCLUSIVE RIGHT TO USE "PRODUCTIONS", APART FROM THE MARK AS SHOWN.

FOR AUDIO RECORDING AND PRODUCTION (U.S. CLS. 100, 101 AND 107).

FIRST USE 1-1-2011; IN COMMERCE 1-1-2011.

JOHN GARTNER, EXAMINING ATTORNEY

SN 85-253,030. ISLE OF CAPRI CASINOS, INC., ST. LOUIS, MS. FILED 2-28-2011.

BATTLES AT THE BEACH

THE MARK CONSISTS OF STANDARD CHARACTERS WITHOUT CLAIM TO ANY PARTICULAR FONT, STYLE, SIZE, OR COLOR.

FOR ENTERTAINMENT SERVICES, NAMELY, CONDUCTING LIVE POKER GAMES; GAMBLING SERVICES (U.S. CLS. 100, 101 AND 107).

FIRST USE 3-22-2009; IN COMMERCE 3-22-2009.

MEGHAN REINHART, EXAMINING ATTORNEY

CLASS 41—(Continued).

SN 85-253,080. PAUL HARRIS, HOLLISTER, MO. FILED 2-28-2011.

The Cleverly's

THE MARK CONSISTS OF STANDARD CHARACTERS WITHOUT CLAIM TO ANY PARTICULAR FONT, STYLE, SIZE, OR COLOR.

FOR ENTERTAINMENT SERVICES IN THE NATURE OF LIVE MUSICAL PERFORMANCES BY A GROUP (U.S. CLS. 100, 101 AND 107).

FIRST USE 0-0-2007; IN COMMERCE 2-19-2009.
CARRIE GENOVESE, EXAMINING ATTORNEY

CLASS 41—(Continued).

SN 85-253,318. THE CARTOON NETWORK, INC., ATLANTA, GA. FILED 2-28-2011.

THE HEART, SHE HOLLER

THE MARK CONSISTS OF STANDARD CHARACTERS WITHOUT CLAIM TO ANY PARTICULAR FONT, STYLE, SIZE, OR COLOR.

FOR ENTERTAINMENT SERVICES, NAMELY, PROVISION OF ONGOING MULTIMEDIA PROGRAMS IN THE FIELD OF COMEDY, ACTION AND ADVENTURE DISTRIBUTED VIA VARIOUS PLATFORMS ACROSS MULTIPLE FORMS OF TRANSMISSION MEDIA (U.S. CLS. 100, 101 AND 107).

PAUL F. GAST, EXAMINING ATTORNEY

SN 85-253,088. ILLINOIS AGRICULTURAL ASSOCIATION, BLOOMINGTON, IL. FILED 2-28-2011.

ADOPT-A-LEGISLATOR

THE MARK CONSISTS OF STANDARD CHARACTERS WITHOUT CLAIM TO ANY PARTICULAR FONT, STYLE, SIZE, OR COLOR.

FOR EDUCATION SERVICES, NAMELY, PROVIDING EDUCATIONAL PROGRAMS IN THE FIELD OF AGRICULTURE AND ITS ECONOMIC AND ENVIRONMENTAL ASPECTS FOR ELECTED OFFICIALS OR INDIVIDUALS SEEKING ELECTED OFFICE (U.S. CLS. 100, 101 AND 107).

FIRST USE 12-1-1999; IN COMMERCE 12-1-1999.
TINA BROWN, EXAMINING ATTORNEY

SN 85-253,427. CITY OF MONTGOMERY, MONTGOMERY, AL. FILED 2-28-2011.

Questplex

THE MARK CONSISTS OF STANDARD CHARACTERS WITHOUT CLAIM TO ANY PARTICULAR FONT, STYLE, SIZE, OR COLOR.

FOR MUSEUM SERVICES, NAMELY, A FACILITY AT WHICH EDUCATIONAL AND SCIENTIFIC EXHIBITS AND RECREATIONAL FACILITIES ARE MADE AVAILABLE PRIMARILY FOR CHILDREN (U.S. CLS. 100, 101 AND 107).

FIRST USE 2-18-2011; IN COMMERCE 2-18-2011.
HEATHER SAPP, EXAMINING ATTORNEY

SN 85-253,130. WALKER, GREGG, NEW YORK, NY. FILED 2-28-2011.

Upscale Uproar

THE MARK CONSISTS OF STANDARD CHARACTERS WITHOUT CLAIM TO ANY PARTICULAR FONT, STYLE, SIZE, OR COLOR.

FOR COMEDY CLUB SERVICES; ENTERTAINMENT SERVICES IN THE NATURE OF COMEDY SHOWS (U.S. CLS. 100, 101 AND 107).

BRENDAN REGAN, EXAMINING ATTORNEY

SN 85-253,460. ACTIVATED STRATEGIES, INC., AUSTIN, TX. FILED 2-28-2011.

ACTIVATED STRATEGIES

THE MARK CONSISTS OF STANDARD CHARACTERS WITHOUT CLAIM TO ANY PARTICULAR FONT, STYLE, SIZE, OR COLOR.

NO CLAIM IS MADE TO THE EXCLUSIVE RIGHT TO USE "STRATEGIES", APART FROM THE MARK AS SHOWN.

FOR EDUCATIONAL SERVICES, NAMELY, CONDUCTING CLASSES AND SEMINARS IN THE FIELD OF PERSONAL IMPROVEMENT (U.S. CLS. 100, 101 AND 107).

GEOFFREY FOSDICK, EXAMINING ATTORNEY

CLASS 41—(Continued).

SN 85-253,507. HITCH FIT HOLDINGS, LLC, KANSAS CITY, MO. FILED 2-28-2011.

HITCH FIT

THE MARK CONSISTS OF STANDARD CHARACTERS WITHOUT CLAIM TO ANY PARTICULAR FONT, STYLE, SIZE, OR COLOR.

NO CLAIM IS MADE TO THE EXCLUSIVE RIGHT TO USE "FIT", APART FROM THE MARK AS SHOWN.

FOR PERSONAL FITNESS TRAINING SERVICES AND CONSULTANCY (U.S. CLS. 100, 101 AND 107).

FIRST USE 2-28-2009; IN COMMERCE 2-28-2009.

JORDAN BAKER, EXAMINING ATTORNEY

CLASS 41—(Continued).

SN 85-253,703. YOUNG SURVIVAL COALITION, INC, NEW YORK, NY. FILED 2-28-2011.



THE MARK CONSISTS OF THE LETTERS AND NUMBER "C4YW" WITH A DESIGN OF A RIBBON EXTENDING FROM THE "W".

FOR EDUCATIONAL SERVICES, NAMELY, CONDUCTING, ARRANGING AND PROMOTING EDUCATIONAL CONFERENCES, SEMINARS, WEB CASTS AND COMMUNITY OUTREACH IN THE FORM OF LECTURES AT NON-PROFIT EVENTS, EDUCATIONAL INSTITUTIONS, COMMUNITY ORGANIZATIONS AND MEDIA EVENTS TO RAISE AWARENESS OF BREAST CANCER, AND DISTRIBUTION OF EDUCATIONAL MATERIALS IN THE FORM OF BROCHURES IN CONNECTION THEREWITH (U.S. CLS. 100, 101 AND 107).

FIRST USE 2-25-2011; IN COMMERCE 2-25-2011.

KATHLEEN LORENZO, EXAMINING ATTORNEY

SN 85-253,547. MINNESOTA STATE COLLEGES AND UNIVERSITIES, AKA MNSCU, ST. PAUL, MN. AND HENNEPIN TECHNICAL COLLEGE, AKA HTC, BROOKLYN PARK, MN. FILED 2-28-2011.



THE COLOR(S) RED, WHITE, AND BLACK IS/ARE CLAIMED AS A FEATURE OF THE MARK.

THE MARK CONSISTS OF A RED CIRCLE WITH A CUT-OUT WHITE "M" IN IT. THE WORD "POWERED" IS IN BLACK AND DIRECTLY TO THE RIGHT OF THE CIRCLE. THERE IS A THIN, RED ARROW UNDERLINING THE WORD "POWERED" POINTING TO THE RIGHT. THE WORDS "MANUFACTURING—MOVING US FORWARD" ARE IN BLACK AND ARE DIRECTLY BELOW THE WORD "POWERED".

FOR EDUCATION SERVICES, NAMELY, PROVIDING LIVE AND ON-LINE INSTRUCTION FOR ADULT LEARNERS IN THE FIELD OF MANUFACTURING (U.S. CLS. 100, 101 AND 107).

FIRST USE 11-1-2006; IN COMMERCE 1-31-2007.

ANDREW LEASER, EXAMINING ATTORNEY

SN 85-253,711. GAPOIP, LLC, PINECREST, FL. FILED 2-28-2011.

PinkTube

SN 85-253,693. AMERICAN LUNG ASSOCIATION, NEW YORK, NY. FILED 2-28-2011.

N-O-T NOT ON TOBACCO

THE MARK CONSISTS OF STANDARD CHARACTERS WITHOUT CLAIM TO ANY PARTICULAR FONT, STYLE, SIZE, OR COLOR.

FOR EDUCATIONAL SERVICES, NAMELY, SEMINARS IN THE FIELD OF SMOKING CESSATION, AND DISTRIBUTION OF COURSE MATERIALS IN CONNECTION THEREWITH (U.S. CLS. 100, 101 AND 107).

FIRST USE 12-15-1998; IN COMMERCE 12-15-1998.

TINA MAI, EXAMINING ATTORNEY

THE MARK CONSISTS OF STANDARD CHARACTERS WITHOUT CLAIM TO ANY PARTICULAR FONT, STYLE, SIZE, OR COLOR.

FOR ENTERTAINMENT SERVICES, NAMELY, PROVIDING A WEB SITE FEATURING PHOTOGRAPHIC, AUDIO, VIDEO AND PROSE PRESENTATIONS FEATURING ADULT-ORIENTED SUBJECT MATTER (U.S. CLS. 100, 101 AND 107).

LAKEISHA LEWIS, EXAMINING ATTORNEY

CLASS 41—(Continued).

SN 85-253,989. LEAK, RYAN, JAMAICA, NY. FILED 2-28-2011.

**Leak's Physiques**

THE STIPPLING IS FOR SHADING PURPOSES ONLY.
THE MARK CONSISTS OF SWEAT COMING DOWN FROM EACH LETTER, A MEASURING TAPE WITH LINES AND NUMBERS ON IT AND IT'S SQUEEZING THE LETTERS "LP", AND A CIRCLE IS ALSO GOING AROUND THE LETTERS "LP". THE ARCH ON THE "P" FORMS AN ARM FLEXING AS WELL.

FOR PHYSICAL FITNESS TRAINING SERVICES (U.S. CLS. 100, 101 AND 107).

JOHN E. MICHOS, EXAMINING ATTORNEY

SN 85-254,021. SONY ONLINE ENTERTAINMENT LLC, SAN DIEGO, CA. FILED 2-28-2011.

DRAGONBROOD THE ANARCHS

THE MARK CONSISTS OF STANDARD CHARACTERS WITHOUT CLAIM TO ANY PARTICULAR FONT, STYLE, SIZE, OR COLOR.

FOR ENTERTAINMENT SERVICES, NAMELY, OPERATING A MULTIPLAYER, ROLE PLAYING, REAL TIME GAME FOR OTHERS VIA THE INTERNET AND LOCAL AREA COMPUTER NETWORKS (U.S. CLS. 100, 101 AND 107).

FIRST USE 10-14-2010; IN COMMERCE 10-14-2010.
HANNO RITTNER, EXAMINING ATTORNEY

SN 85-254,024. SONY ONLINE ENTERTAINMENT LLC, SAN DIEGO, CA. FILED 2-28-2011.

OATHBOUND

THE MARK CONSISTS OF STANDARD CHARACTERS WITHOUT CLAIM TO ANY PARTICULAR FONT, STYLE, SIZE, OR COLOR.

FOR ENTERTAINMENT SERVICES, NAMELY, OPERATING A MULTIPLAYER, ROLE PLAYING, REAL TIME GAME FOR OTHERS VIA THE INTERNET AND LOCAL AREA COMPUTER NETWORKS (U.S. CLS. 100, 101 AND 107).

FIRST USE 8-14-2007; IN COMMERCE 8-14-2007.
HANNO RITTNER, EXAMINING ATTORNEY

CLASS 41—(Continued).

SN 85-254,026. SONY ONLINE ENTERTAINMENT LLC, SAN DIEGO, CA. FILED 2-28-2011.

ETHERNAUTS

THE MARK CONSISTS OF STANDARD CHARACTERS WITHOUT CLAIM TO ANY PARTICULAR FONT, STYLE, SIZE, OR COLOR.

FOR ENTERTAINMENT SERVICES, NAMELY, OPERATING A MULTIPLAYER, ROLE PLAYING, REAL TIME GAME FOR OTHERS VIA THE INTERNET AND LOCAL AREA COMPUTER NETWORKS (U.S. CLS. 100, 101 AND 107).

FIRST USE 10-9-2008; IN COMMERCE 10-9-2008.
HANNO RITTNER, EXAMINING ATTORNEY

SN 85-254,027. SONY ONLINE ENTERTAINMENT LLC, SAN DIEGO, CA. FILED 2-28-2011.

AGAINST THE VOID

THE MARK CONSISTS OF STANDARD CHARACTERS WITHOUT CLAIM TO ANY PARTICULAR FONT, STYLE, SIZE, OR COLOR.

FOR ENTERTAINMENT SERVICES, NAMELY, OPERATING A MULTIPLAYER, ROLE PLAYING, REAL TIME GAME FOR OTHERS VIA THE INTERNET AND LOCAL AREA COMPUTER NETWORKS (U.S. CLS. 100, 101 AND 107).

FIRST USE 2-12-2009; IN COMMERCE 2-12-2009.
HANNO RITTNER, EXAMINING ATTORNEY

SN 85-254,028. SONY ONLINE ENTERTAINMENT LLC, SAN DIEGO, CA. FILED 2-28-2011.

OATHBREAKER

THE MARK CONSISTS OF STANDARD CHARACTERS WITHOUT CLAIM TO ANY PARTICULAR FONT, STYLE, SIZE, OR COLOR.

FOR ENTERTAINMENT SERVICES, NAMELY, OPERATING A MULTIPLAYER, ROLE PLAYING, REAL TIME GAME FOR OTHERS VIA THE INTERNET AND LOCAL AREA COMPUTER NETWORKS (U.S. CLS. 100, 101 AND 107).

FIRST USE 6-16-2008; IN COMMERCE 6-16-2008.
HANNO RITTNER, EXAMINING ATTORNEY

CLASS 41—(Continued).

SN 85-254,029. SONY ONLINE ENTERTAINMENT LLC, SAN DIEGO, CA. FILED 2-28-2011.

INQUISITOR

THE MARK CONSISTS OF STANDARD CHARACTERS WITHOUT CLAIM TO ANY PARTICULAR FONT, STYLE, SIZE, OR COLOR.

FOR ENTERTAINMENT SERVICES, NAMELY, OPERATING A MULTIPLAYER, ROLE PLAYING, REAL TIME GAME FOR OTHERS VIA THE INTERNET AND LOCAL AREA COMPUTER NETWORKS (U.S. CLS. 100, 101 AND 107).

FIRST USE 3-7-2008; IN COMMERCE 3-7-2008.
HANNO RITTNER, EXAMINING ATTORNEY

CLASS 41—(Continued).

SN 85-254,037. SONY ONLINE ENTERTAINMENT LLC, SAN DIEGO, CA. FILED 2-28-2011.

TRAVELERS

THE MARK CONSISTS OF STANDARD CHARACTERS WITHOUT CLAIM TO ANY PARTICULAR FONT, STYLE, SIZE, OR COLOR.

FOR ENTERTAINMENT SERVICES, NAMELY, OPERATING A MULTIPLAYER, ROLE PLAYING, REAL TIME GAME FOR OTHERS VIA THE INTERNET AND LOCAL AREA COMPUTER NETWORKS (U.S. CLS. 100, 101 AND 107).

FIRST USE 10-13-2009; IN COMMERCE 10-13-2009.
HANNO RITTNER, EXAMINING ATTORNEY

SN 85-254,031. SONY ONLINE ENTERTAINMENT LLC, SAN DIEGO, CA. FILED 2-28-2011.

FORSWORN

THE MARK CONSISTS OF STANDARD CHARACTERS WITHOUT CLAIM TO ANY PARTICULAR FONT, STYLE, SIZE, OR COLOR.

FOR ENTERTAINMENT SERVICES, NAMELY, OPERATING A MULTIPLAYER, ROLE PLAYING, REAL TIME GAME FOR OTHERS VIA THE INTERNET AND LOCAL AREA COMPUTER NETWORKS (U.S. CLS. 100, 101 AND 107).

FIRST USE 12-19-2007; IN COMMERCE 12-19-2007.
HANNO RITTNER, EXAMINING ATTORNEY

SN 85-254,043. SONY ONLINE ENTERTAINMENT LLC, SAN DIEGO, CA. FILED 2-28-2011.

DOOM OF THE ANCIENT ONES

THE MARK CONSISTS OF STANDARD CHARACTERS WITHOUT CLAIM TO ANY PARTICULAR FONT, STYLE, SIZE, OR COLOR.

FOR ENTERTAINMENT SERVICES, NAMELY, OPERATING A MULTIPLAYER, ROLE PLAYING, REAL TIME GAME FOR OTHERS VIA THE INTERNET AND LOCAL AREA COMPUTER NETWORKS (U.S. CLS. 100, 101 AND 107).

FIRST USE 6-15-2010; IN COMMERCE 6-15-2010.
HANNO RITTNER, EXAMINING ATTORNEY

SN 85-254,036. SONY ONLINE ENTERTAINMENT LLC, SAN DIEGO, CA. FILED 2-28-2011.

STORM BREAK

THE MARK CONSISTS OF STANDARD CHARACTERS WITHOUT CLAIM TO ANY PARTICULAR FONT, STYLE, SIZE, OR COLOR.

FOR ENTERTAINMENT SERVICES, NAMELY, OPERATING A MULTIPLAYER, ROLE PLAYING, REAL TIME GAME FOR OTHERS VIA THE INTERNET AND LOCAL AREA COMPUTER NETWORKS (U.S. CLS. 100, 101 AND 107).

FIRST USE 7-9-2009; IN COMMERCE 7-9-2009.
HANNO RITTNER, EXAMINING ATTORNEY

SN 85-254,121. DADZIE, JOHN, LOS ANGELES, CA. FILED 3-1-2011.

12th Planet

THE MARK CONSISTS OF STANDARD CHARACTERS WITHOUT CLAIM TO ANY PARTICULAR FONT, STYLE, SIZE, OR COLOR.

FOR ENTERTAINMENT SERVICES BY A MUSICAL ARTIST AND PRODUCER, NAMELY, MUSICAL COMPOSITION FOR OTHERS AND PRODUCTION OF MUSICAL SOUND RECORDINGS; ENTERTAINMENT SERVICES IN THE NATURE OF LIVE MUSICAL PERFORMANCES (U.S. CLS. 100, 101 AND 107).

FIRST USE 10-6-2007; IN COMMERCE 10-6-2007.
DOMINIC FATHY, EXAMINING ATTORNEY

CLASS 41—(Continued).

SN 85-254,168. KLEMP,NATHANIEL, AGOURA HILLS, CA. FILED 3-1-2011.

LIFE BEYOND LOGIC

THE MARK CONSISTS OF STANDARD CHARACTERS WITHOUT CLAIM TO ANY PARTICULAR FONT, STYLE, SIZE, OR COLOR.

FOR ON-LINE JOURNALS, NAMELY, BLOGS FEATURING PERSONAL DEVELOPMENT AND PHILOSOPHY AS AN ART OF LIVING (U.S. CLS. 100, 101 AND 107).

FIRST USE 12-1-2010; IN COMMERCE 2-15-2011.
BILL DAWE, EXAMINING ATTORNEY

SN 85-254,401. U-PICKIT.COM, BEAR, DE. FILED 3-1-2011.

U-PICK-IT.COM

THE MARK CONSISTS OF STANDARD CHARACTERS WITHOUT CLAIM TO ANY PARTICULAR FONT, STYLE, SIZE, OR COLOR.

FOR LOTTERY SERVICES PROVIDED OVER A GLOBAL COMPUTER NETWORK (U.S. CLS. 100, 101 AND 107).

FIRST USE 12-15-2010; IN COMMERCE 12-27-2010.
MARILYN IZZI, EXAMINING ATTORNEY

SN 85-254,404. WILKERSON, CARRIE D., SPRINGTOWN, TX. FILED 3-1-2011.

Fill Your Stadium

THE MARK CONSISTS OF STANDARD CHARACTERS WITHOUT CLAIM TO ANY PARTICULAR FONT, STYLE, SIZE, OR COLOR.

FOR EDUCATION SERVICES, NAMELY, PROVIDING LIVE AND ON-LINE CLASSES, SEMINARS, MENTORING, AND WORKSHOPS IN THE FIELD OF MARKETING (U.S. CLS. 100, 101 AND 107).

FIRST USE 5-28-2010; IN COMMERCE 2-23-2011.
PAM WILLIS, EXAMINING ATTORNEY

CLASS 41—(Continued).

SN 85-254,419. YMFITNESS, NEW YORK, NY. FILED 3-1-2011.

YMFITNESS

THE MARK CONSISTS OF STANDARD CHARACTERS WITHOUT CLAIM TO ANY PARTICULAR FONT, STYLE, SIZE, OR COLOR.

FOR PERSONAL FITNESS TRAINING SERVICES AND CONSULTANCY; PERSONAL TRAINER SERVICES; PHYSICAL FITNESS CONSULTATION; PHYSICAL FITNESS INSTRUCTION; PHYSICAL FITNESS TRAINING SERVICES (U.S. CLS. 100, 101 AND 107).

FIRST USE 12-29-2010; IN COMMERCE 1-14-2011.
MARK RADEMACHER, EXAMINING ATTORNEY

SN 85-254,546. AMERICAN SOCIETY FOR BIOCHEMISTRY AND MOLECULAR BIOLOGY, BETHESDA, MD. FILED 3-1-2011.

JOURNAL OF BIOLOGICAL CHEMISTRY

THE MARK CONSISTS OF STANDARD CHARACTERS WITHOUT CLAIM TO ANY PARTICULAR FONT, STYLE, SIZE, OR COLOR.

NO CLAIM IS MADE TO THE EXCLUSIVE RIGHT TO USE "JOURNAL", APART FROM THE MARK AS SHOWN. SEC. 2(F).

FOR COMPUTER SERVICES, NAMELY PROVIDING ONLINE JOURNALS IN THE FIELD OF SCIENCE (U.S. CLS. 100, 101 AND 107).

FIRST USE 5-22-1995; IN COMMERCE 5-22-1995.
REBECCA EISINGER, EXAMINING ATTORNEY

SN 85-254,560. 8NINE8 LLC, LOS ANGELES, CA. FILED 3-1-2011.

sub5zero

THE MARK CONSISTS OF STANDARD CHARACTERS WITHOUT CLAIM TO ANY PARTICULAR FONT, STYLE, SIZE, OR COLOR.

FOR PROVIDING A WEBSITE FEATURING BLOGS AND NON-DOWNLOADABLE PUBLICATIONS IN THE NATURE OF NEWS STORIES AND COMMENTARY IN THE FIELD(S) OF PERFORMANCE AND EXOTIC AUTOMOBILES AND AUTOMOBILE CULTURE (U.S. CLS. 100, 101 AND 107).

FIRST USE 9-9-2008; IN COMMERCE 9-9-2008.
REBECCA EISINGER, EXAMINING ATTORNEY

CLASS 41—(Continued).

SN 85-254,624. DIGITAL DOMAIN PRODUCTIONS, INC.,
VENICE, CA. FILED 3-1-2011.

DIGITAL DOMAIN INSTITUTE

THE MARK CONSISTS OF STANDARD CHARACTERS WITHOUT CLAIM TO ANY PARTICULAR FONT, STYLE, SIZE, OR COLOR.
OWNER OF U.S. REG. NOS. 2,015,945, 2,948,483 AND OTHERS.

NO CLAIM IS MADE TO THE EXCLUSIVE RIGHT TO USE "INSTITUTE", APART FROM THE MARK AS SHOWN.
FOR EDUCATIONAL SERVICES, NAMELY COURSES IN ANIMATION, VIDEO GAME DEVELOPMENT, MILITARY SIMULATION AND SPECIAL VISUAL EFFECTS (U.S. CLS. 100, 101 AND 107).

KAELIE KUNG, EXAMINING ATTORNEY

SN 85-254,641. VOICES OF GLORY LLC, BRANSON, MO.
FILED 3-1-2011.

VOG - VOICES OF GLORY

THE MARK CONSISTS OF STANDARD CHARACTERS WITHOUT CLAIM TO ANY PARTICULAR FONT, STYLE, SIZE, OR COLOR.

FOR ENTERTAINMENT, NAMELY, LIVE MUSIC CONCERTS (U.S. CLS. 100, 101 AND 107).

FIRST USE 1-7-2011; IN COMMERCE 1-7-2011.

KAELIE KUNG, EXAMINING ATTORNEY

SN 85-254,667. FISHING EXCHANGE INC., NAPERVILLE,
IL. FILED 3-1-2011.



NO CLAIM IS MADE TO THE EXCLUSIVE RIGHT TO USE "FISHINGEXCHANGE.COM" AND "BUY SELL TRADE", APART FROM THE MARK AS SHOWN.

THE COLOR(S) BLUE, ORANGE, BLACK, RED, AND WHITE IS/ARE CLAIMED AS A FEATURE OF THE MARK.

THE MARK CONSISTS OF THE TEXT "FISHING" IN ORANGE LETTERS AND THE TEXT "EXCHANGE" AND "COM" IN BLUE LETTERS SLIGHTLY LOWER THAN THE TEXT "FISHING." THE "X" IN "EXCHANGE" IS FORMED BY TWO FISHING POLES. THE FISHING POLES HAVE

CLASS 41—(Continued).

BLUE HANDLES AND THE UPPER PORTIONS OF THE POLES ARE BLACK, WITH WHITE ACCESSORIES OUTLINED IN BLACK. THE "." BETWEEN "EXCHANGE" AND "COM" CONSISTS OF A FISHING BOBBER, THE LOWER HALF OF WHICH IS RED AND THE UPPER HALF OF WHICH IS WHITE AND OUTLINED IN RED. IN SMALLER LETTERS BELOW "FISHINGEXCHANGE.COM" THE WORDS "BUY SELL TRADE" APPEAR. THE WORDS "BUY" AND "TRADE" ARE ORANGE, AND THE WORD "SELL" IS BLUE.

FOR PROVIDING AN INTERNET WEBSITE FEATURING INFORMATION IN THE FIELD OF FISHING (U.S. CLS. 100, 101 AND 107).

MICHAEL KEATING, EXAMINING ATTORNEY

SN 85-254,987. AHMAD GIVENS, RANCHO PALOS VERDES,
CA. AND KAMAL GIVENS, RANCHO PALOS VERDES,
CA. AND MICAH GIVENS, RANCHO PALOS VERDES,
CA. FILED 3-1-2011.

STALLIONAIRES

THE MARK CONSISTS OF STANDARD CHARACTERS WITHOUT CLAIM TO ANY PARTICULAR FONT, STYLE, SIZE, OR COLOR.

FOR ENTERTAINMENT IN THE NATURE OF LIVE PERFORMANCES BY MUSICAL ARTISTS, BANDS, AND ACTORS; ENTERTAINMENT IN THE NATURE OF LIVE RADIO PERSONALITY PERFORMANCES; ENTERTAINMENT IN THE NATURE OF ON-GOING TELEVISION PROGRAMS IN THE FIELD OF REALITY, MUSIC AND COMEDY; ENTERTAINMENT IN THE NATURE OF VISUAL AND AUDIO PERFORMANCES BY MUSICAL ARTISTS, BANDS, AND ACTORS; ENTERTAINMENT IN THE NATURE OF VISUAL AND AUDIO PERFORMANCES, AND MUSICAL, VARIETY, NEWS AND COMEDY SHOWS; ENTERTAINMENT IN THE NATURE OF VISUAL AND AUDIO PERFORMANCES, NAMELY, MUSICAL BAND, ROCK GROUP, GYMNASTIC, DANCE, AND BALLET PERFORMANCES; ENTERTAINMENT IN THE NATURE OF VISUAL AND AUDIO PERFORMANCES BY AN ACTOR; LIVE MUSICAL PERFORMANCES FEATURING PRERECORDED VOCAL AND INSTRUMENTAL PERFORMANCES VIEWED ON A BIG SCREEN; ENTERTAINMENT IN THE NATURE OF LIVE MUSICAL PERFORMANCES, AND REALITY AND COMEDY PERFORMANCES; ENTERTAINMENT SERVICES BY A MUSICAL ARTIST AND PRODUCER, NAMELY, MUSICAL COMPOSITION FOR OTHERS AND PRODUCTION OF MUSICAL SOUND RECORDINGS; ENTERTAINMENT SERVICES IN THE NATURE OF AN ON-GOING REALITY BASED TELEVISION PROGRAM; ENTERTAINMENT SERVICES IN THE NATURE OF LIVE MUSICAL PERFORMANCES; ENTERTAINMENT SERVICES IN THE NATURE OF PRESENTING LIVE MUSICAL PERFORMANCES; ENTERTAINMENT SERVICES IN THE NATURE OF RECORDING, PRODUCTION AND POST-PRODUCTION SERVICES IN THE FIELD OF MUSIC; ENTERTAINMENT SERVICES, NAMELY, AN ON-GOING SERIES FEATURING MUSICAL PERFORMANCES, REALITY TELEVISION AND DOCUMENTARY-TYPE MOVIES PROVIDED THROUGH TELEVISION, WEBCASTS, STREAMING TECHNOLOGY, MOBILE DEVICES, THE INTERNET AND SATELLITE NETWORKS; ENTERTAINMENT SERVICES, NAMELY, LIVE, TELEvised AND MOVIE APPEARANCES BY A PROFESSIONAL ENTERTAINER; ENTERTAINMENT SERVICES, NAMELY, MULTIMEDIA PRODUCTION SERVICES;

CLASS 41—(Continued).

ENTERTAINMENT SERVICES, NAMELY, PERSONAL APPEARANCES BY A MUSICAL BAND, MUSICAL ARTISTS, AND ACTORS; ENTERTAINMENT SERVICES, NAMELY, PROVIDING ON-GOING TELEVISION PROGRAMS IN THE FIELD OF MUSICAL PERFORMANCES, REALITY AND COMEDY VIA A GLOBAL COMPUTER NETWORK; ENTERTAINMENT SERVICES, NAMELY, PROVIDING ON-GOING WEBISODES FEATURING MUSICAL PERFORMANCES, REALITY AND COMEDY VIA A GLOBAL COMPUTER NETWORK; ENTERTAINMENT SERVICES, NAMELY, THE PROVISION OF CONTINUING PROGRAMS, MOVIES, SHOWS, EPISODES AND CONCERTS FEATURING MUSICAL PERFORMANCES, REALITY, AND COMEDY DELIVERED BY LIVE, RADIO, TELEVISION, GLOBAL COMPUTER NETWORK, SATELLITE, AND THE INTERNET; ENTERTAINMENT, NAMELY, LIVE MUSIC CONCERTS; ENTERTAINMENT, NAMELY, LIVE PERFORMANCES BY MUSICAL BANDS; ENTERTAINMENT, NAMELY, LIVE PERFORMANCES BY ROCK GROUPS (U.S. CLS. 100, 101 AND 107).

FIRST USE 10-12-2006; IN COMMERCE 10-12-2006.
KATHERINE STOIDES, EXAMINING ATTORNEY

SN 85-255,111. JIM MARSHALL PHOTOGRAPHY LLC, SAN FRANCISCO, CA. FILED 3-1-2011.

CARS, GUNS, CAMERAS...

THE MARK CONSISTS OF STANDARD CHARACTERS WITHOUT CLAIM TO ANY PARTICULAR FONT, STYLE, SIZE, OR COLOR.

FOR ONLINE JOURNALS, NAMELY, BLOGS FEATURING WRITING AND PHOTOGRAPHS ON THE SUBJECT OF PHOTOGRAPHY, MUSIC, AND REFLECTIONS ON THE LIFE OF LEGENDARY MUSIC PHOTOGRAPHER JIM MARSHALL (U.S. CLS. 100, 101 AND 107).

FIRST USE 1-13-2011; IN COMMERCE 1-13-2011.
JORDAN BAKER, EXAMINING ATTORNEY

SN 85-255,219. WEISENBERGER, COLBY W, ARVADA, CO. FILED 3-1-2011.

SIN FIX

THE MARK CONSISTS OF STANDARD CHARACTERS WITHOUT CLAIM TO ANY PARTICULAR FONT, STYLE, SIZE, OR COLOR.

FOR ENTERTAINMENT SERVICES IN THE NATURE OF LIVE PERFORMANCES BY A MUSICAL GROUP (U.S. CLS. 100, 101 AND 107).

FIRST USE 11-20-2009; IN COMMERCE 11-20-2009.
JAY FLOWERS, EXAMINING ATTORNEY

CLASS 41—(Continued).

SN 85-255,729. VETRI FOUNDATION FOR CHILDREN, PHILADELPHIA, PA. FILED 3-2-2011.

EATIQUETTE

THE MARK CONSISTS OF STANDARD CHARACTERS WITHOUT CLAIM TO ANY PARTICULAR FONT, STYLE, SIZE, OR COLOR.

FOR EDUCATIONAL SERVICES, NAMELY, CONDUCTING PROGRAMS IN THE FIELD OF ESTABLISHING HEALTHY EATING GUIDELINES AND PRACTICES (U.S. CLS. 100, 101 AND 107).

IRA J. GOODSaid, EXAMINING ATTORNEY

SN 85-255,735. INFORMATION ACCESS SYSTEMS, INC., ORLANDO, FL. FILED 3-2-2011.

Kindling

THE MARK CONSISTS OF STANDARD CHARACTERS WITHOUT CLAIM TO ANY PARTICULAR FONT, STYLE, SIZE, OR COLOR.

FOR DEVELOPING TRAINING SYSTEMS AND LEARNING METHODOLOGIES FOR OTHERS (U.S. CLS. 100, 101 AND 107).

IRA J. GOODSaid, EXAMINING ATTORNEY

SN 85-255,873. BRANNON, DATHAN E., ASHEVILLE, NC. FILED 3-2-2011.



THE MARK CONSISTS OF THREE NON-OVERLAPPING OVALS STACKED ONE ABOVE THE OTHER AND INCREASING IN SIZE FROM BOTTOM TO TOP REPRESENTING SOUND WAVES, AND A REPRESENTATION OF A FLAME IN THREE SEGMENTS BEGINNING GENERALLY WITHIN THE TOP OVAL.

FOR MUSIC PUBLISHING SERVICES; ONLINE ELECTRONIC PUBLISHING OF MUSIC (U.S. CLS. 100, 101 AND 107).

KEVON CHISOLM, EXAMINING ATTORNEY

CLASS 41—(Continued).

SN 85-255,895. CRAIGMORE CREATIONS LLC, PORTLAND, OR. FILED 3-2-2011.

TERRA TEMPO

THE MARK CONSISTS OF STANDARD CHARACTERS WITHOUT CLAIM TO ANY PARTICULAR FONT, STYLE, SIZE, OR COLOR.

THE ENGLISH TRANSLATION OF TERRA TEMPO IN THE MARK IS EARTH TIME.

FOR PROVIDING ONLINE NON-DOWNLOADABLE GRAPHIC NOVELS (U.S. CLS. 100, 101 AND 107).
KRISTINA MORRIS, EXAMINING ATTORNEY

SN 85-255,974. AMERICAN ACADEMY FOR RUSSIAN MARTIAL ART AND COMBAT SKILL INC, DBA RMAX.TV PRODUCTIONS, ALPHARETTA, GA. FILED 3-2-2011.

TACGYM

THE MARK CONSISTS OF STANDARD CHARACTERS WITHOUT CLAIM TO ANY PARTICULAR FONT, STYLE, SIZE, OR COLOR.

FOR EXERCISE INSTRUCTION SERVICES, EDUCATIONAL SERVICES, NAMELY, CONDUCTING CLASSES, SEMINARS, WORKSHOPS IN THE FIELD OF FITNESS AND DISTRIBUTION OF COURSE MATERIAL IN CONNECTION THEREWITH; PHYSICAL FITNESS CONDITIONING CLASSES; PHYSICAL FITNESS CONSULTATION; PHYSICAL FITNESS INSTRUCTION; WORKSHOPS AND SEMINARS IN THE FIELD OF FITNESS (U.S. CLS. 100, 101 AND 107).
MATTHEW KLINE, EXAMINING ATTORNEY

SN 85-256,057. CRAIGMORE CREATIONS LLC, PORTLAND, OR. FILED 3-2-2011.

URBAN WILD

THE MARK CONSISTS OF STANDARD CHARACTERS WITHOUT CLAIM TO ANY PARTICULAR FONT, STYLE, SIZE, OR COLOR.

FOR PROVIDING ONLINE NON-DOWNLOADABLE COMIC STRIPS (U.S. CLS. 100, 101 AND 107).
FIRST USE 10-19-2010; IN COMMERCE 10-19-2010.
KRISTINA MORRIS, EXAMINING ATTORNEY

CLASS 41—(Continued).

SN 85-256,245. LOYOLA UNIVERSITY OF CHICAGO, CHICAGO, IL. FILED 3-2-2011.

PROLAW

THE MARK CONSISTS OF STANDARD CHARACTERS WITHOUT CLAIM TO ANY PARTICULAR FONT, STYLE, SIZE, OR COLOR.

FOR EDUCATIONAL SERVICES, NAMELY, CONDUCTING PROGRAMS IN THE FIELD OF LAW; EDUCATIONAL SERVICES, NAMELY, CONDUCTING CLASSES, SEMINARS, WORKSHOPS, AND PROGRAMS IN THE FIELDS OF RULE OF LAW AND DISTRIBUTION OF TRAINING MATERIALS IN CONNECTION THEREWITH; EDUCATIONAL SERVICES, NAMELY, CONDUCTING CLASSES, SEMINARS, WORKSHOPS, AND PROGRAMS IN THE FIELD OF LAW AND DISTRIBUTION OF COURSE AND EDUCATIONAL MATERIALS IN CONNECTION THEREWITH; PROVIDING COURSES OF INSTRUCTION AT THE POST-GRADUATE LEVEL (U.S. CLS. 100, 101 AND 107).

FIRST USE 11-15-2010; IN COMMERCE 11-15-2010.
ESTHER A. BORSUK, EXAMINING ATTORNEY

SN 85-256,276. "WHAT'S YOUR PAIN POINT?" LLC, WALNUT CREEK, CA. FILED 3-2-2011.

**"Dental school made you a
dentist; I will make you a
CEO."**

THE MARK CONSISTS OF STANDARD CHARACTERS WITHOUT CLAIM TO ANY PARTICULAR FONT, STYLE, SIZE, OR COLOR.

FOR PEER TO PEER AND GROUP COACHING SERVICES IN THE FIELD OF BUSINESS (U.S. CLS. 100, 101 AND 107).

FIRST USE 5-21-2010; IN COMMERCE 5-21-2010.
DORITT L. CARROLL, EXAMINING ATTORNEY

SN 85-256,502. TURNING TECHNOLOGIES, LLC, YOUNGSTOWN, OH. FILED 3-3-2011.

10 A DAY

THE MARK CONSISTS OF STANDARD CHARACTERS WITHOUT CLAIM TO ANY PARTICULAR FONT, STYLE, SIZE, OR COLOR.

FOR EDUCATION SERVICES, NAMELY, CONSULTATION IN THE FIELD OF K-12 EDUCATIONAL SYSTEMS AND TRACKING OF STUDENT PERFORMANCE (U.S. CLS. 100, 101 AND 107).

FIRST USE 7-1-2010; IN COMMERCE 9-1-2010.
JENNIFER MARTIN, EXAMINING ATTORNEY

CLASS 41—(Continued).

SN 85-256,537. INFECTIOUS DISEASES SOCIETY OF AMERICA, ARLINGTON, VA. FILED 3-3-2011.

ADVANCING SCIENCE, IMPROVING CARE

THE MARK CONSISTS OF STANDARD CHARACTERS WITHOUT CLAIM TO ANY PARTICULAR FONT, STYLE, SIZE, OR COLOR.

FOR EDUCATIONAL SERVICES, NAMELY, CONDUCTING CONFERENCES IN THE FIELD OF HEALTH AND DISEASES AND DISTRIBUTION OF COURSE MATERIAL IN CONNECTION THEREWITH (U.S. CLS. 100, 101 AND 107).

ASMAT KHAN, EXAMINING ATTORNEY

SN 85-256,606. MARKET AMERICA, INC., GREENSBORO, NC. FILED 3-3-2011.

Sing to Stardom

THE MARK CONSISTS OF STANDARD CHARACTERS WITHOUT CLAIM TO ANY PARTICULAR FONT, STYLE, SIZE, OR COLOR.

FOR ENTERTAINMENT SERVICES IN THE NATURE OF AN ONLINE TALENT SEARCH CONTEST (U.S. CLS. 100, 101 AND 107).

DARRYL SPRUILL, EXAMINING ATTORNEY

SN 85-256,739. MURPHY, THERESA, CUMBERLAND, RI. FILED 3-3-2011.

YinYasa

THE MARK CONSISTS OF STANDARD CHARACTERS WITHOUT CLAIM TO ANY PARTICULAR FONT, STYLE, SIZE, OR COLOR.

FOR EDUCATION SERVICES, NAMELY, PROVIDING CLASSES, WORKSHOPS, AND RETREATS IN THE FIELD OF YOGA; YOGA INSTRUCTION (U.S. CLS. 100, 101 AND 107).

FIRST USE 1-15-2008; IN COMMERCE 1-15-2008.
CAROLYN CATALDO, EXAMINING ATTORNEY

CLASS 41—(Continued).

SN 85-256,776. BOHEMIA INTERACTIVE A.S., MNÍEK POD BRDY 25210, CZECH REPUBLIC, FILED 3-3-2011.

TAKE ON HELICOPTERS

THE MARK CONSISTS OF STANDARD CHARACTERS WITHOUT CLAIM TO ANY PARTICULAR FONT, STYLE, SIZE, OR COLOR.

FOR ENTERTAINMENT SERVICES, NAMELY, PROVIDING AN ON-LINE COMPUTER GAME SERVICE PROVIDED BY COMPUTER TERMINALS; PROVIDING ONLINE COMPUTER GAMES VIA NETWORK BETWEEN COMMUNICATIONS NETWORKS; PROVIDING ONLINE GAME SERVICES VIA WORLDWIDE AND LOCAL COMPUTER NETWORKS; PROVIDING MULTI-PLAYER VIDEO GAMING VIA WORLDWIDE AND LOCAL COMPUTER NETWORKS; PROVIDING ONLINE WEB LOGS, ARTICLES AND EDITORIAL PUBLICATIONS IN THE FIELD OF COMPUTER GAMING; PROVIDING ONLINE COMPUTER GAMES BY MEANS OF COMMUNICATIONS BY COMPUTER TERMINALS, VIDEO GAME MACHINES OR MOBILE TELEPHONES (U.S. CLS. 100, 101 AND 107).

ZACHARY BELLO, EXAMINING ATTORNEY

SN 85-256,848. MEYER, JAYMIE, NEW YORK, NY. FILED 3-3-2011.

BRINGING WOO-WOO TO YOU

THE MARK CONSISTS OF STANDARD CHARACTERS WITHOUT CLAIM TO ANY PARTICULAR FONT, STYLE, SIZE, OR COLOR.

FOR ENTERTAINMENT SERVICES, NAMELY, PROVIDING PODCASTS IN THE FIELDS OF HEALTH CARE AND WELL-BEING; PROVIDING ONLINE INTERVIEWS FEATURING HEALTH CARE PROFESSIONALS IN THE FIELDS OF HEALTH AND WELL-BEING FOR EDUCATIONAL PURPOSES (U.S. CLS. 100, 101 AND 107).

LAKEISHA LEWIS, EXAMINING ATTORNEY

CLASS 41—(Continued).

SN 85-256,889. INTERNATIONAL PROFESSIONAL GROOMERS, INC., SALEM, OR. FILED 3-3-2011.



THE COLOR(S) BLACK, WHITE AND BLUE IS/ARE CLAIMED AS A FEATURE OF THE MARK.

THE MARK CONSISTS OF THE LETTERS "IPG" IN BLACK BESIDE A SOLID BLACK POODLE IN FRONT OF A BLUE AND WHITE GLOBE. THE BACKGROUND OF THE MARK IS TRANSPARENT.

FOR EDUCATIONAL SERVICES, NAMELY, PROVIDING EDUCATIONAL PROGRAMS IN THE FIELD OF PROFESSIONAL PET GROOMING (U.S. CLS. 100, 101 AND 107).

FIRST USE 8-1-2009; IN COMMERCE 8-1-2009.
SUZANNE BLANE, EXAMINING ATTORNEY

CLASS 41—(Continued).

SN 85-257,020. DECANTED, LLC, DBA DECANTED WINE & BEER, NAPLES, FL. FILED 3-3-2011.

Ultimate Wine Throwdown

THE MARK CONSISTS OF STANDARD CHARACTERS WITHOUT CLAIM TO ANY PARTICULAR FONT, STYLE, SIZE, OR COLOR.

NO CLAIM IS MADE TO THE EXCLUSIVE RIGHT TO USE "ULTIMATE WINE", APART FROM THE MARK AS SHOWN.

FOR ENTERTAINMENT SERVICES, NAMELY, WINE TASTINGS (U.S. CLS. 100, 101 AND 107).

FIRST USE 1-1-2010; IN COMMERCE 2-25-2010.
WENDY JUN, EXAMINING ATTORNEY

SN 85-256,937. WEE SCHOLARS ACADEMY, L.L.C., NETCONG, NJ. FILED 3-3-2011.

Building a foundation for student achievement

THE MARK CONSISTS OF STANDARD CHARACTERS WITHOUT CLAIM TO ANY PARTICULAR FONT, STYLE, SIZE, OR COLOR.

NO CLAIM IS MADE TO THE EXCLUSIVE RIGHT TO USE "STUDENT ACHIEVEMENT", APART FROM THE MARK AS SHOWN.

FOR EDUCATIONAL PROGRAMS, NAMELY, PRE-SCHOOLS; NURSERY SCHOOLS; PROVIDING AFTER SCHOOL EDUCATIONAL PROGRAMS FOR CHILDREN IN GRADES PRE-K THROUGH 12 AND PLAY FACILITIES FOR CHILDREN (U.S. CLS. 100, 101 AND 107).

FIRST USE 8-1-2010; IN COMMERCE 1-1-2011.
DOMINIC J. FERRAIUOLO, EXAMINING ATTORNEY

SN 85-257,067. HUGGINS, EVAN, WEST HAVEN, CT. FILED 3-3-2011.

Musionology

THE MARK CONSISTS OF STANDARD CHARACTERS WITHOUT CLAIM TO ANY PARTICULAR FONT, STYLE, SIZE, OR COLOR.

FOR ON-LINE JOURNALS, NAMELY, BLOGS FEATURING THE SUBJECT OF FASHION, MUSIC, AND TECHNOLOGY (U.S. CLS. 100, 101 AND 107).

FIRST USE 11-23-2009; IN COMMERCE 11-23-2009.
JANET LEE, EXAMINING ATTORNEY

SN 85-256,938. MCANALLY, KACI A, DBA HEROINES OF TODAY, COLLIERVILLE, TN. AND ZEHNER, TORI A, DBA HEROINES OF TODAY, COLLIERVILLE, TN. FILED 3-3-2011.

Heroines of Today

THE MARK CONSISTS OF STANDARD CHARACTERS WITHOUT CLAIM TO ANY PARTICULAR FONT, STYLE, SIZE, OR COLOR.

FOR ENTERTAINMENT IN THE NATURE OF VISUAL AND AUDIO PERFORMANCES, NAMELY, MUSICAL BAND, ROCK GROUP, GYMNASTIC, DANCE, AND BALLET PERFORMANCES (U.S. CLS. 100, 101 AND 107).

DOMINIC J. FERRAIUOLO, EXAMINING ATTORNEY

SN 85-257,268. GENER8ED, LLC, RIDGEWOOD, NJ. FILED 3-3-2011.

BOTBAND

THE MARK CONSISTS OF STANDARD CHARACTERS WITHOUT CLAIM TO ANY PARTICULAR FONT, STYLE, SIZE, OR COLOR.

FOR ENTERTAINMENT SERVICES, NAMELY, PROVIDING ONLINE ELECTRONIC GAMES (U.S. CLS. 100, 101 AND 107).

ANNE MADDEN, EXAMINING ATTORNEY

CLASS 41—(Continued).

SN 85-257,277. NORDSTROM'S AUTOMOTIVE, INC., GARETSON, SD. FILED 3-3-2011.

Tune-In And Tune-Up

THE MARK CONSISTS OF STANDARD CHARACTERS WITHOUT CLAIM TO ANY PARTICULAR FONT, STYLE, SIZE, OR COLOR.

FOR ENTERTAINMENT AND EDUCATION SERVICES, NAMELY, PROVIDING A RADIO PROGRAM IN THE FIELD OF MOTOR VEHICLES; ENTERTAINMENT AND EDUCATION SERVICES, NAMELY, PROVIDING A RADIO PROGRAM IN THE FIELD OF MOTOR VEHICLES VIA GLOBAL COMPUTER NETWORK (U.S. CLS. 100, 101 AND 107).

FIRST USE 0-0-2006; IN COMMERCE 0-0-2006.
DAWN HAN, EXAMINING ATTORNEY

SN 85-257,291. WIZARD WORLD, INC., NORTHBROOK, IL. FILED 3-3-2011.

WIZARD WORLD

THE MARK CONSISTS OF STANDARD CHARACTERS WITHOUT CLAIM TO ANY PARTICULAR FONT, STYLE, SIZE, OR COLOR.

FOR CONDUCTING ENTERTAINMENT EXHIBITIONS IN THE NATURE OF CONVENTIONS FOR ENTHUSIASTS OF POP CULTURE GENRES (E.G., GAMES, TOYS, MEDIA, COMIC BOOKS) (U.S. CLS. 100, 101 AND 107).

FIRST USE 0-0-1998; IN COMMERCE 0-0-1998.
ANNE MADDEN, EXAMINING ATTORNEY

SN 85-257,296. VALENCIA PROMOTIONS, INC., SAN JOSE, CA. FILED 3-3-2011.

El Baile Del Recuerdo

THE MARK CONSISTS OF STANDARD CHARACTERS WITHOUT CLAIM TO ANY PARTICULAR FONT, STYLE, SIZE, OR COLOR.

OWNER OF U.S. REG. NO. 3,862,685.

THE ENGLISH TRANSLATION OF EL BAILE DEL RECUERDO IN THE MARK IS "THE DANCE OF REMEMBRANCE".

FOR ARRANGING AND CONDUCTING SPECIAL EVENTS FOR SOCIAL ENTERTAINMENT PURPOSES; ARRANGING FOR TICKET RESERVATIONS FOR SHOWS AND OTHER ENTERTAINMENT EVENTS; ENTERTAINMENT SERVICES IN THE NATURE OF PRESENTING LIVE MUSICAL PERFORMANCES; ENTERTAINMENT, NAMELY, LIVE PERFORMANCES BY MUSICAL BANDS (U.S. CLS. 100, 101 AND 107).

FIRST USE 6-1-2006; IN COMMERCE 6-1-2006.
LINDA MICKLEBURGH, EXAMINING ATTORNEY

CLASS 41—(Continued).

SN 85-257,313. TWINS ON FIRE, MENLO PARK, CA. FILED 3-3-2011.

Twins on Fire

THE MARK CONSISTS OF STANDARD CHARACTERS WITHOUT CLAIM TO ANY PARTICULAR FONT, STYLE, SIZE, OR COLOR.

FOR ENTERTAINMENT IN THE NATURE OF ONGOING TELEVISION PROGRAMS IN THE FIELD OF FIREWORKS, FIRE, AND PYROTECHNICS (U.S. CLS. 100, 101 AND 107).

FIRST USE 12-17-2010; IN COMMERCE 1-27-2011.
TOBY BULLOFF, EXAMINING ATTORNEY

SN 85-257,327. DANIEL J. MARSHALL, CARSON CITY, NV. FILED 3-3-2011.

BROKEN NECKLACE

THE MARK CONSISTS OF STANDARD CHARACTERS WITHOUT CLAIM TO ANY PARTICULAR FONT, STYLE, SIZE, OR COLOR.

FOR ENTERTAINMENT, NAMELY, LIVE PERFORMANCES BY A MUSICAL BAND (U.S. CLS. 100, 101 AND 107).

VIVIAN MICZNIK FIRST, EXAMINING ATTORNEY

SN 85-257,329. TYCO VALVES & CONTROLS INC., HOUSTON, TX. FILED 3-3-2011.

TECSMART

THE MARK CONSISTS OF STANDARD CHARACTERS WITHOUT CLAIM TO ANY PARTICULAR FONT, STYLE, SIZE, OR COLOR.

FOR TRAINING SERVICES IN THE FIELD OF VALVES AND CONTROLS FOR SERVICE TECHNICIANS (U.S. CLS. 100, 101 AND 107).

VIVIAN MICZNIK FIRST, EXAMINING ATTORNEY

CLASS 41—(Continued).

SN 85-257,347. LIVE NATION ENTERTAINMENT, INC., BEVERLY HILLS, CA. FILED 3-3-2011.

ME + 3

THE MARK CONSISTS OF STANDARD CHARACTERS WITHOUT CLAIM TO ANY PARTICULAR FONT, STYLE, SIZE, OR COLOR.

FOR ARRANGING FOR TICKET RESERVATIONS FOR MUSICAL CONCERTS AND OTHER ENTERTAINMENT EVENTS (U.S. CLS. 100, 101 AND 107).
HAI-LY LAM, EXAMINING ATTORNEY

SN 85-257,359. CREATIVE MOTION ALLIANCE, INC., ELGIN, IL. FILED 3-3-2011.

CREATIVE MOTION

THE MARK CONSISTS OF STANDARD CHARACTERS WITHOUT CLAIM TO ANY PARTICULAR FONT, STYLE, SIZE, OR COLOR.

FOR EDUCATION SERVICES, NAMELY, PROVIDING CLASSES, WORKSHOPS, AND SEMINARS IN THE FIELD OF DANCE AND MUSIC (U.S. CLS. 100, 101 AND 107).

FIRST USE 1-1-1951; IN COMMERCE 1-1-1951.
LIEF MARTIN, EXAMINING ATTORNEY

SN 85-257,442. A HIGHER POSSIBILITY, SAN RAFAEL, CA. FILED 3-3-2011.

**CREATE THE LOVE OF YOUR
LIFE - KEEP THE LIFE IN
YOUR LOVE.**

THE MARK CONSISTS OF STANDARD CHARACTERS WITHOUT CLAIM TO ANY PARTICULAR FONT, STYLE, SIZE, OR COLOR.

FOR EDUCATION SERVICES, NAMELY, PROVIDING WORKSHOPS AND SEMINARS IN THE FIELD OF RELATIONSHIPS; PERSONAL COACHING SERVICES IN THE FIELD OF RELATIONSHIPS (U.S. CLS. 100, 101 AND 107).

FIRST USE 0-0-2010; IN COMMERCE 0-0-2010.
WENDY GOODMAN, EXAMINING ATTORNEY

CLASS 41—(Continued).

SN 85-257,502. RICH, GARY, DENTON, TX. FILED 3-3-2011.

INAPPROPRIATE MAN

THE MARK CONSISTS OF STANDARD CHARACTERS WITHOUT CLAIM TO ANY PARTICULAR FONT, STYLE, SIZE, OR COLOR.

FOR ON-LINE JOURNALS, NAMELY, BLOGS FEATURING HUMOR AND SATIRE (U.S. CLS. 100, 101 AND 107).

WANDA KAY PRICE, EXAMINING ATTORNEY

SN 85-257,545. MUSIC OF OUR NATURE, LLC, POMONA, NY. FILED 3-3-2011.



THE MARK CONSISTS OF THE STYLIZED LETTERS "M.O.O.N M.O.O.N M.O.". AN IMAGE OF HALF A MOON AND VINYL RECORD.

FOR MULTIMEDIA ENTERTAINMENT SERVICES IN THE NATURE OF RECORDING, PRODUCTION AND POST-PRODUCTION SERVICES IN THE FIELDS OF MUSIC, VIDEO, AND FILMS (U.S. CLS. 100, 101 AND 107).

VIVIAN MICZNIK FIRST, EXAMINING ATTORNEY

SN 85-257,608. GADGETMADNESS LLC, FRISCO, TX. FILED 3-3-2011.

GadgetMadness

THE MARK CONSISTS OF STANDARD CHARACTERS WITHOUT CLAIM TO ANY PARTICULAR FONT, STYLE, SIZE, OR COLOR.

FOR ON-LINE JOURNALS, NAMELY, BLOGS FEATURING CONSUMER INFORMATION IN THE FIELD OF COMPUTER HARDWARE, COMPUTER SOFTWARE AND ELECTRONIC DEVICES (U.S. CLS. 100, 101 AND 107).

FIRST USE 5-13-2003; IN COMMERCE 5-13-2003.
COURTNEY ALVAREZ, EXAMINING ATTORNEY

CLASS 41—(Continued).

SN 85-257,686. BEARMANOR MEDIA LLC, ALBANY, GA.
FILED 3-4-2011.



THE MARK CONSISTS OF AN IMAGE OF PANDA LOOKING TOWARDS RIGHT. BELOW THE IMAGE THE WORDS "BEARMANORMEDIA.COM" ARE WRITTEN AS SHOWN IN THE MARK.

FOR PUBLISHING OF BOOKS, AUDIO-BOOKS, AND DVDS (U.S. CLS. 100, 101 AND 107).
FIRST USE 1-20-2001; IN COMMERCE 1-20-2001.
JUSTINE D. PARKER, EXAMINING ATTORNEY

SN 85-257,700. HIGMAN, WILL, NEWPORT BEACH, CA.
FILED 3-4-2011.

FEAR THE CROC

THE MARK CONSISTS OF STANDARD CHARACTERS WITHOUT CLAIM TO ANY PARTICULAR FONT, STYLE, SIZE, OR COLOR.

FOR ENTERTAINMENT SERVICES IN THE NATURE OF AUTOMOBILE RACING AND EXHIBITIONS (U.S. CLS. 100, 101 AND 107).

FIRST USE 6-28-2006; IN COMMERCE 7-27-2007.
ZACHARY BELLO, EXAMINING ATTORNEY

SN 85-257,721. FUNEDUCATION.COM, INC., DBA FUNEDUCATION, INC., SAN DIEGO, CA. FILED 3-4-2011.

THE MORE YOU LEARN THE MORE
YOU WANT TO LEARN MORE

THE MARK CONSISTS OF STANDARD CHARACTERS WITHOUT CLAIM TO ANY PARTICULAR FONT, STYLE, SIZE, OR COLOR.

FOR EDUCATION SERVICES, NAMELY, PROVIDING ONLINE COGNITIVE ASSESSMENTS AND TRAINING PROGRAMS THAT HELP IDENTIFY COGNITIVE STRENGTHS AND WEAKNESSES OF AN INDIVIDUAL (U.S. CLS. 100, 101 AND 107).

ROSELLE HERRERA, EXAMINING ATTORNEY

CLASS 41—(Continued).

SN 85-257,810. ROCK THE GREEN, INC., MILWAUKEE, WI.
FILED 3-4-2011.



THE MARK CONSISTS OF THE WORDS ROCK THE GREEN. THE LETTER "O" CONSISTS OF A GUITAR WITH A TREE GROWING FROM IT.

FOR EVENT PLANNING SERVICES FOR EDUCATIONAL, CHARITABLE, AND ENTERTAINMENT PURPOSES (U.S. CLS. 100, 101 AND 107).

FIRST USE 8-26-2010; IN COMMERCE 8-26-2010.
JUSTINE D. PARKER, EXAMINING ATTORNEY

SN 85-258,301. DONNELL, EVETTE, HUMBLE, TX. FILED 3-4-2011.

DARLINGS by Design

THE MARK CONSISTS OF STANDARD CHARACTERS WITHOUT CLAIM TO ANY PARTICULAR FONT, STYLE, SIZE, OR COLOR.

FOR TRAINING SERVICES IN THE FIELD OF HOME MAINTENANCE AND HOSTING SOCIAL EVENTS (U.S. CLS. 100, 101 AND 107).

LAURA KOVALSKY, EXAMINING ATTORNEY

SN 85-258,339. POLO LINE, INC., ROYAL PALM BEACH, FL.
FILED 3-4-2011.



NO CLAIM IS MADE TO THE EXCLUSIVE RIGHT TO USE "WORLD POLO TOUR", APART FROM THE MARK AS SHOWN.

THE COLOR(S) BROWN, BLACK, GRAY, AND WHITE IS/ARE CLAIMED AS A FEATURE OF THE MARK.

THE MARK CONSISTS OF THE WORDING "WORLD

CLASS 41—(Continued).

POLO TOUR" IN BLACK ABOVE THE LETTERS "W", "P", "T" IN BROWN, ALL ON A WHITE BACKGROUND. ABOVE THE WORDING ARE TWO CONE SHAPE COLUMNS STRIPED IN GRAY AND WHITE WITH A BLACK FLAG AT THE TOP OF EACH OF THE COLUMNS, AND BETWEEN THE COLUMNS IS A HORSEBACK POLO PLAYER SHAPE IN BLACK AND OUTLINED IN WHITE. ON A BROWN BACKGROUND, THE ENTIRE MARK IS ENCASED IN A BLACK SINGLE LINE RECTANGULAR SHAPE WITH CURVED EDGES.

FOR AMATEUR YOUTH SPORTS SERVICES, NAMELY, ORGANIZING AND PROVIDING YOUTH SPORTS ACTIVITIES; BOOKING OF SEATS FOR SHOWS AND SPORTS EVENTS; ENTERTAINMENT IN THE NATURE OF HORSEBACK GAMES; ENTERTAINMENT SERVICES, NAMELY, PARTICIPATION IN POLO TOURNAMENTS AND EXHIBITIONS; ON-LINE ADMISSION TICKET AGENCY SERVICES FOR ENTERTAINMENT, EDUCATIONAL, SPORTING AND CULTURAL EVENTS; ORGANISATION OF SPORTS COMPETITIONS; ORGANIZING EXHIBITIONS FOR POLO; PROVIDING A WEB SITE FEATURING SPORTING INFORMATION; PROVIDING A WEB SITE THAT PROVIDES SPORTS LEAGUE PLAYER STATISTICS; PROVIDING FACILITIES FOR SPORTS TOURNAMENTS; RENTAL OF SPORTS EQUIPMENT; RENTAL OF SPORTS GROUNDS; SPORTS INSTRUCTION SERVICES; SPORTS REFEREEING AND OFFICIATING; SPORTS TRAINING SERVICES; TICKET RESERVATION AND BOOKING SERVICES FOR ENTERTAINMENT, SPORTING AND CULTURAL EVENTS (U.S. CLS. 100, 101 AND 107).

Laura KOVALSKY, EXAMINING ATTORNEY

SN 85-259,026. THE LONG LIVE YOU FOUNDATION, PLEASANTON, CA. FILED 3-5-2011.

LONG LIVE YOU

THE MARK CONSISTS OF STANDARD CHARACTERS WITHOUT CLAIM TO ANY PARTICULAR FONT, STYLE, SIZE, OR COLOR.

FOR EDUCATION SERVICES, NAMELY, CONDUCTING SEMINARS, WORKSHOPS, EDUCATIONAL LECTURES, PRESENTATIONS IN THE FIELD OF CHRONIC DISEASE PREVENTION AND DISTRIBUTION OF PRINTED MATERIALS IN CONNECTION THEREWITH IN HARD COPY OR ELECTRONIC FORMAT ON THE SAME TOPICS (U.S. CLS. 100, 101 AND 107).

ANDREA K. NADELMAN, EXAMINING ATTORNEY

SN 85-259,285. MITCHELL, YING, PALO ALTO, CA. FILED 3-7-2011.

VIVASIA

THE MARK CONSISTS OF STANDARD CHARACTERS WITHOUT CLAIM TO ANY PARTICULAR FONT, STYLE, SIZE, OR COLOR.

THE WORDING "VIVASIA" HAS NO MEANING IN A FOREIGN LANGUAGE.

FOR EDUCATION SERVICES, NAMELY, PROVIDING CLASSES, WORKSHOPS, TRAINING IN THE FIELD OF PHYSICAL FITNESS (U.S. CLS. 100, 101 AND 107).

ELLEN PERKINS, EXAMINING ATTORNEY

CLASS 41—(Continued).

SN 85-260,011. GARABEDIAN, MARK D, WASHINGTON, DC. FILED 3-7-2011.

THE FANTASY SPORTS THIEF

THE MARK CONSISTS OF STANDARD CHARACTERS WITHOUT CLAIM TO ANY PARTICULAR FONT, STYLE, SIZE, OR COLOR.

NO CLAIM IS MADE TO THE EXCLUSIVE RIGHT TO USE "FANTASY SPORTS", APART FROM THE MARK AS SHOWN.

FOR PROVIDING SPORTS INFORMATION VIA A GLOBAL COMPUTER INFORMATION NETWORK; PROVIDING A WEBSITE FEATURING INFORMATION AND ADVICE RELATING TO FANTASY SPORTS LEAGUES; PROVISION OF INFORMATION RELATING TO SPORTS AND SPORTING EVENTS (U.S. CLS. 100, 101 AND 107).

FIRST USE 12-4-2009; IN COMMERCE 12-4-2009.
REBECCA SMITH, EXAMINING ATTORNEY

SN 85-260,302. ENVIROCHEM SOLUTIONS LLC, NEW WAVERLY, TX. FILED 3-7-2011.

Say Hello To Wealth

THE MARK CONSISTS OF STANDARD CHARACTERS WITHOUT CLAIM TO ANY PARTICULAR FONT, STYLE, SIZE, OR COLOR.

FOR EDUCATIONAL SERVICES, NAMELY, CONDUCTING CLASSES AND SEMINARS IN THE FIELD OF PERSONAL SELF-HELP, PERSONAL DEVELOPMENT, AND THE POWER OF PERSONAL AND BUSINESS NETWORKING AND DISTRIBUTION OF COURSE MATERIAL IN CONNECTION THEREWITH (U.S. CLS. 100, 101 AND 107).

ELLEN PERKINS, EXAMINING ATTORNEY

SN 85-263,202. MYPARTY PLAYHOUSE, AGOURA HILLS, CA. FILED 3-10-2011.

MyParty
PLAYHOUSE

FOR PROVISION OF INDOOR PLAYGROUNDS FOR CHILDREN; PROVIDING CHILDREN'S PARTY CENTERS FOR THE PURPOSE OF ENTERTAINING CHILDREN AND CELEBRATING BIRTHDAYS (U.S. CLS. 100, 101 AND 107).

FIRST USE 1-1-2011; IN COMMERCE 1-1-2011.
JENNIFER DIXON, EXAMINING ATTORNEY

CLASS 41—(Continued).

SN 85-264,767. FORD, EMMANUEL LEE, ATLANTA, GA. FILED 3-11-2011.

Boobah Preach

THE MARK CONSISTS OF STANDARD CHARACTERS WITHOUT CLAIM TO ANY PARTICULAR FONT, STYLE, SIZE, OR COLOR.

NO CLAIM IS MADE TO THE EXCLUSIVE RIGHT TO USE "PREACH", APART FROM THE MARK AS SHOWN.

THE NAME "BOOBAH PREACH" IDENTIFIES A LIVING INDIVIDUAL WHOSE CONSENT IS OF RECORD.

FOR ENTERTAINMENT IN THE NATURE OF LIVE PERFORMANCES BY A RECORDING ARTIST; ENTERTAINMENT IN THE NATURE OF VISUAL AND AUDIO PERFORMANCES BY A RECORDING ARTIST; ENTERTAINMENT SERVICES BY A MUSICAL ARTIST AND PRODUCER, NAMELY, MUSICAL COMPOSITION FOR OTHERS AND PRODUCTION OF MUSICAL SOUND RECORDINGS; ENTERTAINMENT SERVICES IN THE NATURE OF LIVE MUSICAL PERFORMANCES; ENTERTAINMENT SERVICES IN THE NATURE OF RECORDING, PRODUCTION AND POST-PRODUCTION SERVICES IN THE FIELD OF MUSIC (U.S. CLS. 100, 101 AND 107).

FIRST USE 3-21-2007; IN COMMERCE 3-16-2009.
ALEXANDER L. POWERS, EXAMINING ATTORNEY

SN 85-268,834. LOUP LOUP SKI EDUCATION FOUNDATION, DBA LOUP LOUP SKI AREA, LOUP LOUP SKI BOWL, LOUP RENTAL EQUIPMENT SHOP, LOUP SNOW SPORT SCHOOL, & LOUP LOUP BASIN, OKANAGON, WA. FILED 3-16-2011.



NO CLAIM IS MADE TO THE EXCLUSIVE RIGHT TO USE "SKI", APART FROM THE MARK AS SHOWN.

THE MARK CONSISTS OF A WOLF'S HEAD POINTED UP AND TO THE RIGHT WITH THE WORDS "SKI THE LOUP" APPEARING ABOVE AND TO THE LEFT OF THE WOLF'S HEAD.

FOR PROVIDING SKI SLOPES; PROVIDING SPORTS FACILITIES FOR SPORTS SUCH AS, BUT NOT LIMITED TO, SKIING AND SNOWBOARDING; RENTAL OF SKI EQUIPMENT; RENTAL OF SKIS; SKI INSTRUCTION; SKI RESORTS (U.S. CLS. 100, 101 AND 107).

FIRST USE 1-1-1999; IN COMMERCE 1-1-1999.
KRISTINA MORRIS, EXAMINING ATTORNEY

CLASS 41—(Continued).

SN 85-269,511. SALVADOR RIZO, MEXICO CITY, MEXICO, FILED 3-17-2011.

STAR CENTRAL

THE MARK CONSISTS OF STANDARD CHARACTERS WITHOUT CLAIM TO ANY PARTICULAR FONT, STYLE, SIZE, OR COLOR.

FOR ENTERTAINMENT SERVICES IN THE NATURE OF AN ON-GOING REALITY BASED TELEVISION PROGRAM (U.S. CLS. 100, 101 AND 107).

FIRST USE 4-19-2011; IN COMMERCE 4-19-2011.
BARBARA RUTLAND, EXAMINING ATTORNEY

SN 85-273,081. WORLD WRESTLING ENTERTAINMENT, INC., STAMFORD, CT. FILED 3-22-2011.

TEAM BRING IT

THE MARK CONSISTS OF STANDARD CHARACTERS WITHOUT CLAIM TO ANY PARTICULAR FONT, STYLE, SIZE, OR COLOR.

NO CLAIM IS MADE TO THE EXCLUSIVE RIGHT TO USE "TEAM", APART FROM THE MARK AS SHOWN.

FOR ENTERTAINMENT SERVICES, NAMELY, WRESTLING EXHIBITIONS AND PERFORMANCES BY A PROFESSIONAL WRESTLER AND ENTERTAINER; PROVIDING WRESTLING NEWS AND INFORMATION VIA A GLOBAL COMPUTER NETWORK; ENTERTAINMENT SERVICES, NAMELY, THE PRODUCTION AND EXHIBITION OF PROFESSIONAL WRESTLING EVENTS RENDERED LIVE AND THROUGH THE MEDIA OF TELEVISION (U.S. CLS. 100, 101 AND 107).

JOHN GARTNER, EXAMINING ATTORNEY

SN 85-273,677. VIACOM INTERNATIONAL INC., NEW YORK, NY. FILED 3-22-2011.

EXTREME CRIBS

THE MARK CONSISTS OF STANDARD CHARACTERS WITHOUT CLAIM TO ANY PARTICULAR FONT, STYLE, SIZE, OR COLOR.

OWNER OF U.S. REG. NO. 2,453,210.

NO CLAIM IS MADE TO THE EXCLUSIVE RIGHT TO USE "CRIBS", APART FROM THE MARK AS SHOWN.

FOR ENTERTAINMENT SERVICES IN THE NATURE OF CONTINUING PROGRAM SERIES, FEATURING LIVE ACTION, COMEDY AND DRAMA PROVIDED THROUGH CABLE TELEVISION, BROADCAST TELEVISION, INTERNET, VIDEO-ON-DEMAND, AND THROUGH OTHER DISTRIBUTION PLATFORMS; PROVIDING ONLINE INFORMATION IN THE FIELD OF ENTERTAINMENT CONCERNING TELEVISION PROGRAMS (U.S. CLS. 100, 101 AND 107).

MICHAEL SOUDERS, EXAMINING ATTORNEY

CLASS 41—(Continued).

SN 85-279,806. EPISCOPAL RELIEF AND DEVELOPMENT, NEW YORK, NY. FILED 3-29-2011.

ACT OUT EMPOWERING YOUTH
TO HEAL A HURTING WORLD

THE MARK CONSISTS OF STANDARD CHARACTERS WITHOUT CLAIM TO ANY PARTICULAR FONT, STYLE, SIZE, OR COLOR.

FOR EDUCATIONAL SERVICES IN THE NATURE OF A YOUTH EDUCATION CURRICULUM, NAMELY, CONDUCTING CLASSES AND SEMINARS FOCUSED ON THE NEEDS AND HOPES OF THE WORLD AND SCRIPTURE AND DISTRIBUTING COURSE MATERIALS IN CONNECTION THEREWITH (U.S. CLS. 100, 101 AND 107).

FIRST USE 11-3-2010; IN COMMERCE 11-3-2010.
INGRID C. EULIN, EXAMINING ATTORNEY

SN 85-279,822. EPISCOPAL RELIEF AND DEVELOPMENT, NEW YORK, NY. FILED 3-29-2011.



THE COLOR(S) BLACK, BLUE AND RED IS/ARE CLAIMED AS A FEATURE OF THE MARK.

THE MARK CONSISTS OF SKETCH OF A GLOBE, INCLUDING SOME BLACK LATITUDE AND LONGITUDE LINES, THE LEFT SIDE OF THE GLOBE IS PARTIALLY SHADED BLUE WITH THE IMAGE OF THE LETTER "T" IN THE FORM OF A CROSS IN RED PLACED OVER THE SHADING, BENEATH THE GLOBE IS A SOLID BLACK SHAPE OF A HAND HOLDING THE GLOBE IMAGE, TO THE LEFT OF THE GLOBE IMAGE THE WORDS "ACT OUT" ARE PRINTED, THE LETTERS "A", "C", "T", "O", "U" ARE PRINTED IN BOLD BLACK LETTERS, THE LETTER "T" IS REPRESENTED BY A CROSS, IN RED, IN THE CENTER OF THE GLOBE IMAGE; THE WORDS "EMPOWERING YOUTH TO HEAL A HURTING WORLD" ARE PRINTED IN RED LETTERS BENEATH THE WORDS "ACT OUT".

FOR EDUCATIONAL SERVICES IN THE NATURE OF A YOUTH EDUCATION CURRICULUM, NAMELY, CONDUCTING CLASSES AND SEMINARS FOCUSED ON THE NEEDS AND HOPES OF THE WORLD AND SCRIPTURE AND DISTRIBUTING COURSE MATERIALS IN CONNECTION THEREWITH (U.S. CLS. 100, 101 AND 107).

FIRST USE 11-3-2010; IN COMMERCE 11-3-2010.
INGRID C. EULIN, EXAMINING ATTORNEY

CLASS 41—(Continued).

SN 85-289,475. E! ENTERTAINMENT TELEVISION, LLC, LOS ANGELES, CA. FILED 4-7-2011.

AFTER LATELY

THE MARK CONSISTS OF STANDARD CHARACTERS WITHOUT CLAIM TO ANY PARTICULAR FONT, STYLE, SIZE, OR COLOR.

FOR ENTERTAINMENT IN THE NATURE OF AN ONGOING COMEDY TELEVISION SERIES; ENTERTAINMENT IN THE NATURE OF AN ONGOING COMEDY TELEVISION SERIES VIA A GLOBAL COMPUTER NETWORK AND VIA WIRELESS COMMUNICATION DEVICES; ON-LINE JOURNALS, NAMELY, BLOGS ABOUT COMEDY TELEVISION PROGRAMS (U.S. CLS. 100, 101 AND 107).

Laura KOVALSKY, EXAMINING ATTORNEY

SN 85-291,441. THE CARTOON NETWORK, INC., ATLANTA, GA. FILED 4-11-2011.

BEN 10 OMNIVERSE

THE MARK CONSISTS OF STANDARD CHARACTERS WITHOUT CLAIM TO ANY PARTICULAR FONT, STYLE, SIZE, OR COLOR.

OWNER OF U.S. REG. NOS. 3,080,336, 3,819,704 AND OTHERS.

THE NAME IN THE MARK DOES NOT REFER TO A PARTICULAR LIVING INDIVIDUAL.

FOR ENTERTAINMENT SERVICES, NAMELY, A MULTIMEDIA PROGRAM SERIES FEATURING COMEDY, ACTION AND ADVENTURE DISTRIBUTED VIA VARIOUS PLATFORMS ACROSS MULTIPLE FORMS OF TRANSMISSION MEDIA (U.S. CLS. 100, 101 AND 107).

PAUL F. GAST, EXAMINING ATTORNEY

SN 85-299,550. SPANISH BROADCASTING SYSTEM, INC., COCONUT GROVE, FL. FILED 4-20-2011.

RUTA AL EXITO

THE MARK CONSISTS OF STANDARD CHARACTERS WITHOUT CLAIM TO ANY PARTICULAR FONT, STYLE, SIZE, OR COLOR.

THE ENGLISH TRANSLATION OF "RUTA AL EXITO" IN THE MARK IS "ROUTE TO SUCCESS".

FOR ENTERTAINMENT, NAMELY, A SPANISH LANGUAGE TELEVISION PROGRAM BROADCAST OVER TELEVISION, SATELLITE, CABLE, AUDIO AND VIDEO MEDIA FEATURING DEVELOPING ARTISTS WHICH EXPLORES THE REALITIES OF THE MUSIC BUSINESS (U.S. CLS. 100, 101 AND 107).

WILLIAM P. SHANAHAN, EXAMINING ATTORNEY

CLASS 41—(Continued).

SN 85-301,241. H. J. HEINZ COMPANY, PITTSBURGH, PA. FILED 4-21-2011.

HEINZ FIELD

THE MARK CONSISTS OF STANDARD CHARACTERS WITHOUT CLAIM TO ANY PARTICULAR FONT, STYLE, SIZE, OR COLOR.

OWNER OF U.S. REG. NOS. 1,935,618, 3,251,778 AND OTHERS.

NO CLAIM IS MADE TO THE EXCLUSIVE RIGHT TO USE "FIELD", APART FROM THE MARK AS SHOWN.

FOR ENTERTAINMENT SERVICES, NAMELY, PROVIDING STADIUM FACILITIES FOR SPORTING EVENTS, SPORTING EXHIBITIONS, CONCERTS, MEETINGS, SEMINARS AND CONVENTIONS (U.S. CLS. 100, 101 AND 107).

FIRST USE 10-7-2001; IN COMMERCE 10-7-2001.
ALLISON HOLTZ, EXAMINING ATTORNEY

SN 85-308,061. WARM SPRINGS PRODUCTIONS, LLC, MISSOULA, MT. FILED 4-29-2011.

GUN MONEY

THE MARK CONSISTS OF STANDARD CHARACTERS WITHOUT CLAIM TO ANY PARTICULAR FONT, STYLE, SIZE, OR COLOR.

NO CLAIM IS MADE TO THE EXCLUSIVE RIGHT TO USE "GUN", APART FROM THE MARK AS SHOWN.

FOR ENTERTAINMENT IN THE NATURE OF ON-GOING TELEVISION PROGRAMS IN THE FIELD OF DISTRIBUTING ARMS, WEAPONS AND MILITARY TECHNOLOGY AND EQUIPMENT; ENTERTAINMENT SERVICES IN THE NATURE OF AN ON-GOING REALITY BASED TELEVISION PROGRAM (U.S. CLS. 100, 101 AND 107).

HEATHER THOMPSON, EXAMINING ATTORNEY

CLASS 41—(Continued).

SN 85-308,104. TELEVISA, S.A. DE C.V., SANTA FE, MEXICO, FILED 4-29-2011.



OWNER OF MEXICO REG. NO. 1081443, DATED 8-8-2007, EXPIRES 8-8-2017.

THE MARK CONSISTS OF "DERECHO DE ADMISION" WITHIN A FANCIFUL IRREGULAR CURVILINEAR SHAPE WITH FANCIFUL STAR DESIGNS IN THE LOWER LEFT AND UPPER RIGHT ASPECTS.

THE ENGLISH TRANSLATION OF DERECHO DE ADMISION IS "RIGHT OF ADMISSION".

FOR ENTERTAINMENT SERVICES, NAMELY, PRODUCTION OF RADIO PROGRAMS AND TELEVISION SHOWS (U.S. CLS. 100, 101 AND 107).

KATHERINE E. HALMEN, EXAMINING ATTORNEY

SN 85-311,916. BEACHBODY, LLC, SANTA MONICA, CA. FILED 5-4-2011.

P90X NATION

THE MARK CONSISTS OF STANDARD CHARACTERS WITHOUT CLAIM TO ANY PARTICULAR FONT, STYLE, SIZE, OR COLOR.

OWNER OF U.S. REG. NOS. 2,843,063, 3,812,145 AND OTHERS.

FOR PROVIDING A WEB SITE FEATURING ON-LINE INSTRUCTION IN THE FIELD OF PHYSICAL EXERCISE AND NUTRITION AND TRACKING PROGRESS OF WORKOUTS; EDUCATIONAL SERVICES AND ON-LINE EDUCATIONAL SERVICES, NAMELY, PROVIDING INSTRUCTION IN THE FIELDS OF EXERCISE EQUIPMENT, PHYSICAL EXERCISE AND NUTRITION, AND INSTRUCTIONAL MATERIALS DISTRIBUTED IN CONNECTION THEREWITH; ENTERTAINMENT SERVICES, NAMELY, CONDUCTING CONTESTS; PHYSICAL FITNESS TRAINING SERVICES, NAMELY, TRACKING PROGRESS OF WORKOUTS FOR OTHERS; ENTERTAINMENT SERVICES, NAMELY, PROVIDING A WEBSITE FEATURING NON-DOWNLOADABLE CONTENT, NAMELY, AUDIO CLIPS, VIDEO CLIPS, MUSICAL PERFORMANCES, MUSICAL VIDEOS, FILM CLIPS, PHOTOGRAPHS, OTHER MULTIMEDIA MATERIALS IN THE FIELD OF PHYSICAL EXERCISE, FITNESS AND NUTRITION (U.S. CLS. 100, 101 AND 107).

RONALD MCMORROW, EXAMINING ATTORNEY

CLASS 41—(Continued).

SN 85-313,031. PENA PRODUCTIONS LLC, ABSECON, NJ. FILED 5-5-2011.

DINGLEBERRY'S

THE MARK CONSISTS OF STANDARD CHARACTERS WITHOUT CLAIM TO ANY PARTICULAR FONT, STYLE, SIZE, OR COLOR.

FOR PRESENTATION OF LIVE COMEDY SHOWS (U.S. CLS. 100, 101 AND 107).

INGA ERVIN, EXAMINING ATTORNEY

SN 85-313,437. THE PHILLIES, PHILADELPHIA, PA. FILED 5-5-2011.

PHILLIE PHANATIC

THE MARK CONSISTS OF STANDARD CHARACTERS WITHOUT CLAIM TO ANY PARTICULAR FONT, STYLE, SIZE, OR COLOR.

OWNER OF U.S. REG. NOS. 1,604,774, 3,747,556 AND OTHERS.

FOR ENTERTAINMENT SERVICES IN THE NATURE OF PERFORMANCES AND LIVE APPEARANCES BY A COSTUMED MASCOT CHARACTER AT BASEBALL GAMES AND EXHIBITIONS, CLINICS, PROMOTIONS, SCHOOLS, SPECIAL EVENTS, PARTIES, AND SOCIAL, CULTURAL, CHARITABLE AND EDUCATIONAL EVENTS; PROVIDING RECREATIONAL AREAS IN THE NATURE OF CHILDREN'S PLAY AREAS; FAN CLUB SERVICES; ENTERTAINMENT SERVICES, NAMELY, PROVIDING A READING PROGRAM DESIGNED TO MOTIVATE CHILDREN TO READ; PROVIDING ONLINE NEWSLETTERS IN THE FIELD OF SPORTS; ENTERTAINMENT SERVICES, NAMELY, PROVIDING A WEBSITE FEATURING BASEBALL NEWS, INFORMATION AND DOWNLOADABLE WALLPAPER (U.S. CLS. 100, 101 AND 107).

FIRST USE 4-25-1978; IN COMMERCE 4-25-1978.
RON FAIRBANKS, EXAMINING ATTORNEY

SN 85-315,476. BABY ABUELITA PRODUCTIONS, LLC, MIAMI, FL. FILED 5-9-2011.

FAMILY FIESTA

THE MARK CONSISTS OF STANDARD CHARACTERS WITHOUT CLAIM TO ANY PARTICULAR FONT, STYLE, SIZE, OR COLOR.

FOR ENTERTAINMENT SERVICES IN THE NATURE OF ON-GOING TELEVISION PROGRAMS IN THE FIELD OF CHILDREN'S ENTERTAINMENT AND EDUCATION (U.S. CLS. 100, 101 AND 107).

HANNO RITTNER, EXAMINING ATTORNEY

CLASS 41—(Continued).

SN 85-317,077. BROWN PAPER TICKETS, LLC, DBA BROWN PAPER TICKETS, SEATTLE, WA. FILED 5-10-2011.

BROWN PAPER TICKETS

THE MARK CONSISTS OF STANDARD CHARACTERS WITHOUT CLAIM TO ANY PARTICULAR FONT, STYLE, SIZE, OR COLOR.

OWNER OF U.S. REG. NO. 3,927,297.

NO CLAIM IS MADE TO THE EXCLUSIVE RIGHT TO USE "TICKETS", APART FROM THE MARK AS SHOWN. SEC. 2(F).

FOR ADMISSION TICKET RESERVATION AND BOOKING SERVICES FOR NIGHT CLUBS AND NIGHT CLUB EVENTS; ARRANGING FOR TICKET RESERVATIONS FOR SHOWS AND OTHER ENTERTAINMENT EVENTS; BOOKING OF SEATS FOR SHOWS; BOOKING OF SEATS FOR SHOWS AND BOOKING OF THEATRE TICKETS; BOOKING OF SEATS FOR SHOWS AND SPORTS EVENTS; PROVIDING WILL-CALL TICKET SERVICES; TICKET RESERVATION AND BOOKING SERVICES FOR ENTERTAINMENT, SPORTING AND CULTURAL EVENTS (U.S. CLS. 100, 101 AND 107).

FIRST USE 1-1-2002; IN COMMERCE 1-1-2002.
MICHAEL TANNER, EXAMINING ATTORNEY

SN 85-319,436. KOCH DEVELOPMENT CORPORATION, SANTA CLAUS, IN. FILED 5-12-2011.

HOLIDOG

THE MARK CONSISTS OF STANDARD CHARACTERS WITHOUT CLAIM TO ANY PARTICULAR FONT, STYLE, SIZE, OR COLOR.

FOR AMUSEMENT PARK SERVICES (U.S. CLS. 100, 101 AND 107).

FIRST USE 5-1-1984; IN COMMERCE 5-1-1984.

JACQUELINE A. LAVINE, EXAMINING ATTORNEY

SN 85-319,483. KOCH DEVELOPMENT CORPORATION, SANTA CLAUS, IN. FILED 5-12-2011.

SAFARI SAM

THE MARK CONSISTS OF STANDARD CHARACTERS WITHOUT CLAIM TO ANY PARTICULAR FONT, STYLE, SIZE, OR COLOR.

FOR AMUSEMENT PARK SERVICES (U.S. CLS. 100, 101 AND 107).

FIRST USE 5-1-1993; IN COMMERCE 5-1-1993.

JACQUELINE A. LAVINE, EXAMINING ATTORNEY

CLASS 41—(Continued).

SN 85-320,448. BROWN PAPER TICKETS, LLC, DBA BROWN PAPER TICKETS, SEATTLE, WA. FILED 5-13-2011.



OWNER OF U.S. REG. NO. 3,927,297.
NO CLAIM IS MADE TO THE EXCLUSIVE RIGHT TO USE "TICKETS", APART FROM THE MARK AS SHOWN.

THE COLOR(S) BROWN, BLUE, ORANGE, AND WHITE IS/ARE CLAIMED AS A FEATURE OF THE MARK.

THE MARK CONSISTS OF STYLIZED WORDING "BROWN PAPER TICKETS" AS WELL AS THE DEPICTION OF THREE SEPARATE STYLIZED TICKET STUBS ARRANGED IN A HORIZONTAL LINE. THE COLOR WHITE APPEARS IN THE WORDING "BROWN PAPER TICKETS". THE COLOR BROWN APPEARS ON THE LEFT TICKET STUB THAT SURROUNDS THE WORD "BROWN". THE COLOR BLUE APPEARS ON THE MIDDLE TICKET STUB THAT SURROUNDS THE WORD "PAPER". THE COLOR ORANGE APPEARS ON THE RIGHT TICKET STUB THAT SURROUNDS THE WORD "TICKETS".

SEC. 2(F) AS TO "BROWN PAPER TICKETS".

FOR BOOKING OF SEATS FOR SHOWS; BOOKING OF SEATS FOR SHOWS AND BOOKING OF THEATRE TICKETS; BOOKING OF SEATS FOR SHOWS AND SPORTS EVENTS; ENTERTAINMENT TICKET AGENCY SERVICES; ON-LINE ENTERTAINMENT TICKET AGENCY SERVICES; PROVIDING WILL-CALL TICKET SERVICES (U.S. CLS. 100, 101 AND 107).

FIRST USE 1-1-2001; IN COMMERCE 1-1-2002.

MICHAEL TANNER, EXAMINING ATTORNEY

CLASS 42—(Continued).

SN 77-385,917. DOCTATIONS, INC., GARDEN CITY, NY. FILED 1-31-2008.

iMedicalHome

THE MARK CONSISTS OF STANDARD CHARACTERS WITHOUT CLAIM TO ANY PARTICULAR FONT, STYLE, SIZE, OR COLOR.

FOR PROVIDING A WEBSITE THAT GIVES COMPUTER USERS THE ABILITY TO GENERATE, MANAGE AND EXCHANGE HEALTHCARE INFORMATION AND DOCUMENTATION; PROVIDING ON-LINE NON-DOWNLOADABLE SOFTWARE FOR USE IN UPLOADING AND ACCESSING HEALTHCARE INFORMATION AND DOCUMENTATION, AND FACILITATING COMMUNICATIONS BETWEEN PHYSICIANS AND PATIENTS; APPLICATION SERVICE PROVIDER (ASP) FEATURING SOFTWARE FOR USE IN UPLOADING AND ACCESSING HEALTHCARE INFORMATION AND DOCUMENTATION, AND FACILITATING COMMUNICATIONS BETWEEN PHYSICIANS AND PATIENTS (U.S. CLS. 100 AND 101).

HEATHER THOMPSON, EXAMINING ATTORNEY

SN 77-638,599. COLLABORA LIMITED, LONDON, UNITED KINGDOM, FILED 12-23-2008.

CLASS 42—SCIENTIFIC AND COMPUTER SERVICES

SN 77-217,912. APEX ENGINEERED SOLUTIONS, LLC, ADDISON, TX. FILED 6-28-2007.



NO CLAIM IS MADE TO THE EXCLUSIVE RIGHT TO USE "ENGINEERED", APART FROM THE MARK AS SHOWN.

FOR CONSULTING IN THE FIELDS OF ENGINEERING; ENGINEERING SERVICES, NAMELY, ENGINEERING PLANNING AND DESIGN SERVICES FOR THE MECHANICAL, ELECTRICAL, PLUMBING, INFORMATION TECHNOLOGY AND COMMUNICATIONS FIELDS; TECHNOLOGY CONSULTATION IN THE FIELDS OF DATA COMMUNICATIONS AND INFORMATION TECHNOLOGY; PLANNING, DEVELOPMENT AND TECHNICAL SUPPORT OF DATA COMMUNICATION NETWORKS (U.S. CLS. 100 AND 101).

FIRST USE 12-2-2002; IN COMMERCE 12-2-2002.

ALEXANDER L. POWERS, EXAMINING ATTORNEY

Collabora

THE MARK CONSISTS OF STANDARD CHARACTERS WITHOUT CLAIM TO ANY PARTICULAR FONT, STYLE, SIZE, OR COLOR.

PRIORITY CLAIMED UNDER SEC. 44(D) ON ERPNCMNTY TM OFC APPLICATION NO. 007364383, FILED 11-3-2008, REG. NO. 007364383, DATED 3-15-2011, EXPIRES 11-3-2018.

FOR COMPUTER SOFTWARE DESIGN, CONSULTANCY AND COMPUTER SOFTWARE ADVISORY SERVICES, NAMELY, DEVELOPMENT AND MAINTENANCE OF SOFTWARE EXCLUSIVELY WITHIN THE OPEN SOURCE SECTOR AND PRIMARILY IN RELATION TO MOBILE PHONES, COMMUNICATIONS AND MULTIMEDIA PROCESSING; COMPUTER SOFTWARE DEVELOPMENT IN RELATION TO MOBILE PHONES AND INTERNET BROWSERS (U.S. CLS. 100 AND 101).

SAIMA MAKHDOOM, EXAMINING ATTORNEY

CLASS 42—(Continued).

SN 77-673,284. HEALTH WARE CONCEPTS, INC., WALL, NJ.
FILED 2-18-2009.

HALCYON

THE STIPLING IS FOR SHADING PURPOSES ONLY.
THE MARK CONSISTS OF THE STYLIZED WORD
"HALCYON".

FOR APPLICATION SERVICE PROVIDER (ASP) FEATURING DECISION SUPPORT, BUSINESS INTELLIGENCE AND REVENUE RECOVERY SOFTWARE FOR USE IN HOSPITAL FINANCE (U.S. CLS. 100 AND 101).

FIRST USE 1-9-2009; IN COMMERCE 1-9-2009.
NELSON SNYDER, EXAMINING ATTORNEY

SN 77-786,012. ARROW ELECTRONICS, INC., MELVILLE, NY. FILED 7-21-2009.



NO CLAIM IS MADE TO THE EXCLUSIVE RIGHT TO USE "ENGINEER FOCUSED NAVIGATION", APART FROM THE MARK AS SHOWN.

THE COLOR(S) PURPLE IS/ARE CLAIMED AS A FEATURE OF THE MARK.

THE MARK CONSISTS OF FOUR ARROWS RADIATING FROM A CENTER TO FORM A SQUARE, ADJACENT THE WORDS "ENGINEER FOCUSED NAVIGATION", ALL IN PURPLE.

FOR COMPUTER SERVICES, NAMELY, CREATING INDICES OF INFORMATION AND OTHER RESOURCES AVAILABLE ON COMPUTER NETWORKS (U.S. CLS. 100 AND 101).

DAVID C. REIHNER, EXAMINING ATTORNEY

SN 77-882,794. CSOFT INTERNATIONAL LIMITED, FORMERLY CSOFT SOLUTIONS LIMITED, BEIJING, CHINA, FILED 11-30-2009.

L10NWorks

THE MARK CONSISTS OF STANDARD CHARACTERS WITHOUT CLAIM TO ANY PARTICULAR FONT, STYLE, SIZE, OR COLOR.

FOR COMPUTER SERVICES, NAMELY, CREATING AN ON-LINE COMMUNITY FOR REGISTERED USERS TO PARTICIPATE IN DISCUSSIONS, GET FEEDBACK FROM THEIR PEERS, FORM VIRTUAL COMMUNITIES, AND ENGAGE IN SOCIAL NETWORKING, ON THE TOPIC OF LANGUAGE LOCALIZATION AND TRANSLATION (U.S. CLS. 100 AND 101).

FIRST USE 6-17-2005; IN COMMERCE 6-17-2005.
SHAILA SETTLES, EXAMINING ATTORNEY

CLASS 42—(Continued).

SN 77-884,905. IAMGOLD CORPORATION, TORONTO, ONTARIO, CANADA, FILED 12-2-2009.

ZERO HARM

THE MARK CONSISTS OF STANDARD CHARACTERS WITHOUT CLAIM TO ANY PARTICULAR FONT, STYLE, SIZE, OR COLOR.

PRIORITY CLAIMED UNDER SEC. 44(D) ON CANADA APPLICATION NO. 1440823, FILED 6-10-2009, REG. NO. TMA787325, DATED 1-14-2011, EXPIRES 1-14-2026.

FOR MINING ACTIVITIES AND SERVICES RELATED AND INCIDENTAL THERETO, NAMELY, MINING EXPLORATION AND MINERAL EXPLORATION SERVICES, PLANNING AND DESIGNING OF MINES, MINING EXPLORATION SERVICES, AND PROCESSING OF GOLD AND MINERALS, NAMELY, TESTING, ANALYSIS AND EVALUATION OF GOLD AND MINERALS (U.S. CLS. 100 AND 101).

JANICE KIM, EXAMINING ATTORNEY

SN 77-925,588. ILAIT AB, HISINGS KARRA, SWEDEN, FILED 2-2-2010.

ILAIT

THE MARK CONSISTS OF STANDARD CHARACTERS WITHOUT CLAIM TO ANY PARTICULAR FONT, STYLE, SIZE, OR COLOR.

FOR COMPUTER SERVICES, NAMELY, ACTING AS AN APPLICATION SERVICE PROVIDER HOSTING, MANAGING, DEVELOPING, AND MAINTAINING APPLICATIONS, SOFTWARE, WEBSITES AND DATABASES IN THE FIELD OF BUSINESS; COMPUTER SERVICES, NAMELY, REMOTE AND ON-SITE MANAGEMENT OF ELECTRONIC MESSAGING SYSTEMS AND APPLICATIONS FOR OTHERS; COMPUTER SERVICES, NAMELY, CREATING AN ON-LINE COMMUNITY FOR REGISTERED USERS TO DEVELOP AND COLLABORATE ON ELECTRONIC GREETINGS, ADDRESS BOOKS AND CALENDARS AND TO SHARE CONTENT WITH OTHER REGISTERED USERS; REMOTE COMPUTER BACKUP SERVICES; TECHNICAL SUPPORT SERVICES, NAMELY, TROUBLESHOOTING OF COMPUTER HARDWARE, COMPUTER SOFTWARE, AND NETWORK PROBLEMS; COMPUTER AND COMPUTER SOFTWARE CONSULTATION SERVICES (U.S. CLS. 100 AND 101).

FIRST USE 12-18-2006; IN COMMERCE 8-1-2009.
JILL PRATER, EXAMINING ATTORNEY

CLASS 42—(Continued).

SN 77-943,970. EMBARKONS, INC., PALO ALTO, CA. FILED 2-24-2010.

EMBARKONS

THE MARK CONSISTS OF STANDARD CHARACTERS WITHOUT CLAIM TO ANY PARTICULAR FONT, STYLE, SIZE, OR COLOR.

FOR COMPUTER SERVICES, NAMELY, CREATING AN ON-LINE COMMUNITY FOR REGISTERED USERS TO PARTICIPATE IN DISCUSSIONS AND TO GET FEEDBACK FROM THEIR PEERS REGARDING COMPUTER HARDWARE AND SOFTWARE DEVELOPMENT, COMPUTER AND TECHNOLOGY COMMERCIAL VENTURES, AND FINANCIAL BACKING FOR COMPUTER HARDWARE AND SOFTWARE DEVELOPERS AND COMPUTER AND TECHNOLOGY BUSINESSES; APPLICATION SERVICE PROVIDER (ASP) FEATURING SOFTWARE FOR USE IN DEVELOPING, MARKETING, AND DISTRIBUTING WEB APPLICATIONS, ELECTRONIC BOOKS, AND COMPUTER GAMES (U.S. CLS. 100 AND 101).

JOHN DALIER, EXAMINING ATTORNEY

SN 79-069,517. TTM ANDREAS MAYER, CH-5443 NIEDERROHRDORF, SWITZERLAND, FILED 5-6-2009.

VERT-certified

THE MARK CONSISTS OF STANDARD CHARACTERS WITHOUT CLAIM TO ANY PARTICULAR FONT, STYLE, SIZE, OR COLOR.

PRIORITY DATE OF 11-19-2008 IS CLAIMED.
OWNER OF INTERNATIONAL REGISTRATION 1004285 DATED 5-6-2009, EXPIRES 5-6-2019.

FOR SURVEYING AND TESTING, ANALYSIS AND EVALUATION OF EXHAUST GAS PURIFICATION SYSTEMS, CATALYTIC CONVERTERS AND DIESEL PARTICLE FILTERS (U.S. CLS. 100 AND 101).

JAMES STEIN, EXAMINING ATTORNEY

SN 79-069,580. TTM ANDREAS MAYER, CH-5443 NIEDERROHRDORF, SWITZERLAND, FILED 5-6-2009.

VERT-DPF

THE MARK CONSISTS OF STANDARD CHARACTERS WITHOUT CLAIM TO ANY PARTICULAR FONT, STYLE, SIZE, OR COLOR.

PRIORITY DATE OF 11-19-2008 IS CLAIMED.
OWNER OF INTERNATIONAL REGISTRATION 1004491 DATED 5-6-2009, EXPIRES 5-6-2019.

FOR SURVEYING AND TESTING, ANALYSIS AND EVALUATION OF EXHAUST GAS PURIFICATION SYSTEMS, CATALYTIC CONVERTERS AND DIESEL PARTICLE FILTERS (U.S. CLS. 100 AND 101).

JAMES STEIN, EXAMINING ATTORNEY

CLASS 42—(Continued).

SN 79-091,545. PAIANO ANDREA, ITALY, FILED 10-29-2010.

TUNEDPEOPLE

THE MARK CONSISTS OF STANDARD CHARACTERS WITHOUT CLAIM TO ANY PARTICULAR FONT, STYLE, SIZE, OR COLOR.

PRIORITY DATE OF 9-6-2010 IS CLAIMED.
OWNER OF INTERNATIONAL REGISTRATION 1062307 DATED 10-29-2010, EXPIRES 10-29-2020.

THE ENGLISH TRANSLATION OF THE FOREIGN WORD(S) IN THE MARK IS "TUNED PEOPLE".

FOR PROVIDING TEMPORARY USE OF ONLINE NON-DOWNLOADABLE SOFTWARE TO ENABLE UP-LOADING, POSTING, SHOWING, DISPLAYING, TAGGING, BLOGGING, SHARING OR OTHERWISE PROVIDING ELECTRONIC MEDIA OR INFORMATION OVER THE INTERNET AND OTHER COMMUNICATIONS NETWORKS (U.S. CLS. 100 AND 101).

SUE LAWRENCE, EXAMINING ATTORNEY

SN 85-020,310. BLANCSPOT MEDIA, LLC, SAN FRANCISCO, CA. FILED 4-22-2010.

BLANCSPOT

THE MARK CONSISTS OF STANDARD CHARACTERS WITHOUT CLAIM TO ANY PARTICULAR FONT, STYLE, SIZE, OR COLOR.

FOR COMPUTER SERVICES, NAMELY, CREATING AN ONLINE COMMUNITY FOR REGISTERED USERS IN THE NATURE OF A SOCIAL NETWORKING NEWS PLATFORM WHICH ALLOWS REGISTERED USERS TO PARTICIPATE IN REAL-TIME DISCUSSIONS ABOUT GLOBAL CURRENT EVENT NEWS STORIES IN THE AREAS OF POLITICS, BUSINESS AND OTHER WORLD EVENTS AND ENGAGE IN SOCIAL NETWORKING IN RELATION TO THOSE GLOBAL CURRENT EVENT NEWS STORIES IN THE AREAS OF POLITICS, BUSINESS AND OTHER WORLD EVENTS (U.S. CLS. 100 AND 101).

FIRST USE 8-19-2010; IN COMMERCE 8-19-2010.
ANDREA BUTLER, EXAMINING ATTORNEY

SN 85-037,268. RACK-SOFT, INC., WILMINGTON, DE. FILED 5-13-2010.

4GRID

THE MARK CONSISTS OF STANDARD CHARACTERS WITHOUT CLAIM TO ANY PARTICULAR FONT, STYLE, SIZE, OR COLOR.

FOR CLOUD COMPUTING FEATURING SOFTWARE FOR USE IN THE REMOTE AND ON-SITE MANAGEMENT OF CLOUD COMPUTING SYSTEMS AND APPLICATIONS (U.S. CLS. 100 AND 101).

FIRST USE 6-1-2008; IN COMMERCE 6-1-2008.
MARY BOAGNI, EXAMINING ATTORNEY

CLASS 42—(Continued).

SN 85-058,899. CARBON VERIFICATION SERVICE, LLC, SACRAMENTO, CA. FILED 6-9-2010.



NO CLAIM IS MADE TO THE EXCLUSIVE RIGHT TO USE "CARBON VERIFICATION SERVICE", APART FROM THE MARK AS SHOWN.

THE MARK CONSISTS OF THE STYLIZED TEXT "CARBON VERIFICATION SERVICE" AND A DESIGN. THE DESIGN CONSISTS OF A TORCH. TO THE RIGHT OF THE DESIGN IS THE WORDING "CARBON VERIFICATION SERVICE". THE TERM "CARBON" APPEARS ABOVE THE TERM "VERIFICATION" WHICH IS ABOVE THE TERM "SERVICE". THE TERM "VERIFICATION" IS UNDERLINED.

FOR VERIFICATION SERVICES, NAMELY, THE VERIFICATION OF GREENHOUSE GAS EMISSION REPORTS AND GREENHOUSE GAS OFFSET PROJECTS, NAMELY, THE INSPECTION OF FACILITIES AND BUSINESSES (U.S. CLS. 100 AND 101).

FIRST USE 12-1-2009; IN COMMERCE 12-1-2009.
MARLENE BELL, EXAMINING ATTORNEY

SN 85-075,648. DOT COM TODAY, LLC, WINTER GARDEN, FL. FILED 7-1-2010.



THE COLOR(S) ORANGE AND WHITE IS/ARE CLAIMED AS A FEATURE OF THE MARK.

THE MARK CONSISTS OF AN ORANGE MARBLE WITH WHITE STARBURST ON THE RIGHT SIDE.

FOR DESIGN, CREATION, HOSTING, MAINTENANCE OF WEBSITES FOR OTHERS (U.S. CLS. 100 AND 101).

FIRST USE 6-1-2009; IN COMMERCE 6-1-2009.
ELLEN BURNS, EXAMINING ATTORNEY

CLASS 42—(Continued).

SN 85-079,972. JOHNSON & JOHNSON, NEW BRUNSWICK, NJ. FILED 7-8-2010.

GO-AFTER

THE MARK CONSISTS OF STANDARD CHARACTERS WITHOUT CLAIM TO ANY PARTICULAR FONT, STYLE, SIZE, OR COLOR.

FOR PROVIDING MEDICAL AND SCIENTIFIC RESEARCH INFORMATION IN THE FIELD OF CLINICAL TRIALS OVER THE INTERNET (U.S. CLS. 100 AND 101).
FIRST USE 5-21-2010; IN COMMERCE 5-21-2010.
ROSELLE HERRERA, EXAMINING ATTORNEY

SN 85-079,973. JOHNSON & JOHNSON, NEW BRUNSWICK, NJ. FILED 7-8-2010.

GO-BEFORE

THE MARK CONSISTS OF STANDARD CHARACTERS WITHOUT CLAIM TO ANY PARTICULAR FONT, STYLE, SIZE, OR COLOR.

FOR PROVIDING MEDICAL AND SCIENTIFIC RESEARCH INFORMATION IN THE FIELD OF CLINICAL TRIALS OVER THE INTERNET (U.S. CLS. 100 AND 101).
FIRST USE 5-21-2010; IN COMMERCE 5-21-2010.
ROSELLE HERRERA, EXAMINING ATTORNEY

SN 85-079,974. JOHNSON & JOHNSON, NEW BRUNSWICK, NJ. FILED 7-8-2010.

GO-FORWARD

THE MARK CONSISTS OF STANDARD CHARACTERS WITHOUT CLAIM TO ANY PARTICULAR FONT, STYLE, SIZE, OR COLOR.

FOR PROVIDING MEDICAL AND SCIENTIFIC RESEARCH INFORMATION IN THE FIELD OF CLINICAL TRIALS OVER THE INTERNET (U.S. CLS. 100 AND 101).

FIRST USE 5-21-2010; IN COMMERCE 5-21-2010.
ROSELLE HERRERA, EXAMINING ATTORNEY

CLASS 42—(Continued).

SN 85-088,442. NIPPON DENKI KABUSHIKI KAISHA, DBA NEC CORPORATION, TOKYO, JAPAN, FILED 7-20-2010.

SMARTCLIENT

THE MARK CONSISTS OF STANDARD CHARACTERS WITHOUT CLAIM TO ANY PARTICULAR FONT, STYLE, SIZE, OR COLOR.

FOR LEASING OF COMPUTER HARDWARE AND SOFTWARE; CUSTOMIZATION OF COMPUTER HARDWARE AND SOFTWARE; UPDATING OF COMPUTER SOFTWARE; COMPUTER SOFTWARE MAINTENANCE SERVICES (U.S. CLS. 100 AND 101).

KAREN K. BUSH, EXAMINING ATTORNEY

SN 85-094,176. FITANGO, INC., NEW YORK, NY. FILED 7-27-2010.

Achieve it.

THE MARK CONSISTS OF STANDARD CHARACTERS WITHOUT CLAIM TO ANY PARTICULAR FONT, STYLE, SIZE, OR COLOR.

FOR COMPUTER SERVICES, NAMELY, CREATING AN ON-LINE COMMUNITY FOR REGISTERED USERS TO PARTICIPATE IN COMPETITIONS, SHOWCASE THEIR SKILLS, GET FEEDBACK FROM THEIR PEERS, FORM VIRTUAL COMMUNITIES, ENGAGE IN SOCIAL NETWORKING AND IMPROVE THEIR TALENT (U.S. CLS. 100 AND 101).

FIRST USE 7-25-2010; IN COMMERCE 7-25-2010.
ANDREA BUTLER, EXAMINING ATTORNEY

SN 85-098,997. SPLASHTACULAR, INC., LA QUINTA, CA. FILED 8-3-2010.

SPLASHWORX

THE MARK CONSISTS OF STANDARD CHARACTERS WITHOUT CLAIM TO ANY PARTICULAR FONT, STYLE, SIZE, OR COLOR.

FOR PRODUCT DESIGN AND DEVELOPMENT FOR OTHERS OF RECREATIONAL WATER SLIDES THROUGH THE USE OF SOFTWARE (U.S. CLS. 100 AND 101).

FIRST USE 2-0-2006; IN COMMERCE 2-0-2006.
ANTHONY RINKER, EXAMINING ATTORNEY

CLASS 42—(Continued).

SN 85-099,237. ERA HELICOPTERS, LLC, LAKE CHARLES, LA. FILED 8-3-2010.

ERAWATCH

THE MARK CONSISTS OF STANDARD CHARACTERS WITHOUT CLAIM TO ANY PARTICULAR FONT, STYLE, SIZE, OR COLOR.

FOR SCIENTIFIC AND TECHNOLOGICAL SERVICES, NAMELY, PROVIDING A WEBSITE THAT ENABLES USERS TO DETERMINE AIRCRAFT AND VESSEL LOCATIONS, FLIGHT TRACK AND NAVIGATIONAL HISTORY, WEATHER AND ENVIRONMENTAL CONDITIONS, AND FACILITY LOCATIONS FOR THE PURPOSE OF EFFICIENTLY DEPLOYING EMERGENCY RESPONSE RESOURCES (U.S. CLS. 100 AND 101).

FIRST USE 6-18-2010; IN COMMERCE 6-18-2010.
KELLY BOULTON, EXAMINING ATTORNEY

SN 85-099,754. NOVEL LABS, INC., RALEIGH, NC. FILED 8-4-2010.

FOLDERPAY

THE MARK CONSISTS OF STANDARD CHARACTERS WITHOUT CLAIM TO ANY PARTICULAR FONT, STYLE, SIZE, OR COLOR.

FOR PROVIDING TEMPORARY USE OF ON-LINE, NON-DOWNLOADABLE SOFTWARE FOR USE IN SHARING DATA FILES BETWEEN OTHERS (U.S. CLS. 100 AND 101).

DOMINICK J. SALEMI, EXAMINING ATTORNEY

SN 85-101,406. PURESENSE ENVIRONMENTAL, INC., FRESNO, CA. FILED 8-5-2010.

GUESS LESS GROW MORE

THE MARK CONSISTS OF STANDARD CHARACTERS WITHOUT CLAIM TO ANY PARTICULAR FONT, STYLE, SIZE, OR COLOR.

FOR REMOTE AND ON-SITE IRRIGATION SYSTEMS MONITORING SERVICES; IRRIGATION SYSTEMS ANALYSIS AND RESEARCH SERVICES; DESIGN AND DEVELOPMENT OF IRRIGATION SYSTEMS HARDWARE AND SOFTWARE (U.S. CLS. 100 AND 101).

FIRST USE 3-31-2010; IN COMMERCE 3-31-2010.
RON FAIRBANKS, EXAMINING ATTORNEY

CLASS 42—(Continued).

SN 85-103,083. FLOWMETRIC, INC., DOYLESTOWN, PA. FILED 8-9-2010.

flowmetric

THE MARK CONSISTS OF STANDARD CHARACTERS WITHOUT CLAIM TO ANY PARTICULAR FONT, STYLE, SIZE, OR COLOR.

FOR PHARMACEUTICAL RESEARCH AND ANALYSIS SERVICES, NAMELY, BIOANALYTICAL RESEARCH, POLYCHROMATIC FLOW CYTOMETRY AND IMMUNOHISTOCHEMISTRY SERVICES FOR OTHERS TO USE IN DRUG RESEARCH AND DEVELOPMENT (U.S. CLS. 100 AND 101).

FIRST USE 12-15-2009; IN COMMERCE 5-6-2010.
EMILY CHUO, EXAMINING ATTORNEY

CLASS 42—(Continued).

SN 85-103,685. TOONARCHY, INC., BRONX, NY. FILED 8-10-2010.

TOONARCHY

THE MARK CONSISTS OF STANDARD CHARACTERS WITHOUT CLAIM TO ANY PARTICULAR FONT, STYLE, SIZE, OR COLOR.

FOR PROVIDING A WEBSITE FEATURING ON-LINE NON-DOWNLOADABLE SOFTWARE TOOLS FOR IMAGE EDITING; PROVIDING A WEBSITE FEATURING RESOURCES, NAMELY, A WEBSITE FEATURING PRIMARILY NON-DOWNLOADABLE SOFTWARE FOR UPLOADING, CAPTURING, POSTING, SHOWING, EDITING, PLAYING, STREAMING, VIEWING, PREVIEWING, DISPLAYING, TAGGING, BLOGGING, SHARING, MANIPULATING, DISTRIBUTING, PUBLISHING, REPRODUCING, AND OTHERWISE PROVIDING ELECTRONIC MEDIA, MULTIMEDIA CONTENT, VIDEOS, MOVIES, PICTURES, IMAGES, TEXT, PHOTOS, USER-GENERATED CONTENT, AUDIO CONTENT AND INFORMATION AND ALSO FEATURING NON-DOWNLOADABLE PUBLICATIONS IN THE NATURE OF CARTOONS, COMIC BOOKS, COMIC STRIPS AND GRAPHIC NOVELS FEATURING PHOTOGRAPHS, IMAGES, TEXTS, ANIMATIONS AND MULTIMEDIA CONTENT IN THE FIELD OF COMEDY, PARODY, SATIRE, EDUCATION AND ENTERTAINMENT (U.S. CLS. 100 AND 101).

FIRST USE 7-23-2006; IN COMMERCE 9-4-2008.
HOWARD SMIGA, EXAMINING ATTORNEY

SN 85-103,682. TOONARCHY, INC., BRONX, NY. FILED 8-10-2010.

TOONIMATOR

THE MARK CONSISTS OF STANDARD CHARACTERS WITHOUT CLAIM TO ANY PARTICULAR FONT, STYLE, SIZE, OR COLOR.

FOR PROVIDING A WEBSITE FEATURING ON-LINE NON-DOWNLOADABLE SOFTWARE TOOLS FOR IMAGE EDITING; PROVIDING A WEBSITE FEATURING RESOURCES, NAMELY, A WEBSITE FEATURING PRIMARILY NON-DOWNLOADABLE SOFTWARE FOR UPLOADING, CAPTURING, POSTING, SHOWING, EDITING, PLAYING, STREAMING, VIEWING, PREVIEWING, DISPLAYING, TAGGING, BLOGGING, SHARING, MANIPULATING, DISTRIBUTING, PUBLISHING, REPRODUCING, AND OTHERWISE PROVIDING ELECTRONIC MEDIA, MULTIMEDIA CONTENT, VIDEOS, MOVIES, PICTURES, IMAGES, TEXT, PHOTOS, USER-GENERATED CONTENT, AUDIO CONTENT AND INFORMATION AND ALSO FEATURING NON-DOWNLOADABLE PUBLICATIONS IN THE NATURE OF CARTOONS, COMIC BOOKS, COMIC STRIPS AND GRAPHIC NOVELS FEATURING PHOTOGRAPHS, IMAGES, TEXTS, ANIMATIONS AND MULTIMEDIA CONTENT IN THE FIELD OF COMEDY, PARODY, SATIRE, EDUCATION AND ENTERTAINMENT (U.S. CLS. 100 AND 101).

FIRST USE 1-13-2009; IN COMMERCE 7-21-2010.
HOWARD SMIGA, EXAMINING ATTORNEY

SN 85-103,998. REVO AMERICA CORPORATION, COPPELL, TX. FILED 8-10-2010.

REVO REMOTE

THE MARK CONSISTS OF STANDARD CHARACTERS WITHOUT CLAIM TO ANY PARTICULAR FONT, STYLE, SIZE, OR COLOR.

NO CLAIM IS MADE TO THE EXCLUSIVE RIGHT TO USE "REMOTE", APART FROM THE MARK AS SHOWN.

FOR PROVIDING USE OF NON-DOWNLOADABLE COMPUTER PROGRAMS FOR COMPUTER CONTROL OVER PREMISES AUTOMATIONS SYSTEMS, AND ENVIRONMENTAL ACCESS AND SECURITY SYSTEMS (U.S. CLS. 100 AND 101).

FIRST USE 11-2-2009; IN COMMERCE 5-1-2010.
JULIE WATSON, EXAMINING ATTORNEY

CLASS 42—(Continued).

SN 85-104,443. COWLES PUBLISHING COMPANY, SPOKANE, WA. FILED 8-10-2010.



OWNER OF U.S. REG. NO. 3,803,875.
THE COLOR(S) BLUE, BLACK, WHITE AND ORANGE IS/
ARE CLAIMED AS A FEATURE OF THE MARK.

THE COLOR WHITE APPEARS IN THE LETTERS "D" AND "E", THE WORDING "AND PLANET EARTH", AND THE FRAME AND HANDLEBAR TIPS OF THE BICYCLE DESIGN. THE COLOR BLUE APPEARS IN THE TIRE WHEEL AND HORIZONTAL PORTION OF THE HANDLEBAR. THE COLOR ORANGE APPEARS IN THE CIRCLE AND THE COLOR BLACK APPEARS IN THE OUTLINE OF THE CIRCLE.

FOR HOSTING AN ONLINE WEBSITE FEATURING INFORMATION CONCERNING GLOBAL WARMING AND ITS EFFECT ON NATURE AND THE ENVIRONMENT, CLIMATE CHANGE AND BIO-DIVERSITY, AND TECHNOLOGICAL AND SCIENTIFIC INFORMATION ABOUT ENVIRONMENTALLY-CONSCIOUS AND GREEN INNOVATIONS (U.S. CLS. 100 AND 101).
SUSAN STIGLITZ, EXAMINING ATTORNEY

SN 85-107,111. REVELATION, INC., PORTLAND, OR. FILED 8-13-2010.

MEANING ENGINE

THE MARK CONSISTS OF STANDARD CHARACTERS WITHOUT CLAIM TO ANY PARTICULAR FONT, STYLE, SIZE, OR COLOR.

FOR PROVIDING ONLINE NON-DOWNLOADABLE TEMPORARY USE OF COMPUTER SOFTWARE FOR COMPILATION, ORGANIZATION, AND ANALYSIS OF MARKET AND CONSUMER RESEARCH DATA; PROVIDING ONLINE NON-DOWNLOADABLE TEMPORARY USE OF COMPUTER SOFTWARE FOR COMPILATION, ORGANIZATION, AND ANALYSIS OF TEXT, PICTURES, VIDEO, AND AUDIO SUPPLIED BY CONSUMERS DURING CONSUMER BEHAVIOR AND OPINION RESEARCH STUDIES (U.S. CLS. 100 AND 101).
WILLIAM P. SHANAHAN, EXAMINING ATTORNEY

CLASS 42—(Continued).

SN 85-108,529. FELDMAN, JOHN, BARRINGTON, IL. FILED 8-16-2010.

CRITICAL PATHWAYS

THE MARK CONSISTS OF STANDARD CHARACTERS WITHOUT CLAIM TO ANY PARTICULAR FONT, STYLE, SIZE, OR COLOR.

FOR APPLICATION SERVICE PROVIDER (ASP) FEATURING SOFTWARE IN THE FIELD OF WEB-BASED CONTENT REPOSITORIES USED TO DOWNLOAD/IMPORT CONTENT OR SUBROUTINES IN CONNECTION AND THE DEVELOPMENT OF DECISION SUPPORT SYSTEMS, DATA CAPTURE AND ANALYSIS, PROCESS MANAGEMENT SOFTWARE AND RELATIONSHIP MARKETING SOFTWARE APPLICATIONS IN THE FIELD OF WEB-BASED CONTENT REPOSITORIES; PROVIDING TEMPORARY USE OF ON-LINE NON-DOWNLOADABLE SOFTWARE AND APPLICATIONS IN THE FIELD OF WEB-BASED CONTENT REPOSITORIES USED TO DOWNLOAD/IMPORT CONTENT OR SUBROUTINES IN CONNECTION AND THE DEVELOPMENT OF DECISION SUPPORT SYSTEMS, DATA CAPTURE AND ANALYSIS, PROCESS MANAGEMENT SOFTWARE AND RELATIONSHIP MARKETING SOFTWARE APPLICATIONS IN THE FIELD OF WEB-BASED CONTENT REPOSITORIES (U.S. CLS. 100 AND 101).
MAYUR VAGHANI, EXAMINING ATTORNEY

SN 85-109,136. THE KUNYAR INSTITUTE, WELLESLEY, MA. FILED 8-17-2010.

THE KUNYAR INSTITUTE

THE MARK CONSISTS OF STANDARD CHARACTERS WITHOUT CLAIM TO ANY PARTICULAR FONT, STYLE, SIZE, OR COLOR.

NO CLAIM IS MADE TO THE EXCLUSIVE RIGHT TO USE "INSTITUTE", APART FROM THE MARK AS SHOWN.

THE WORDING "KUNYAR" HAS NO MEANING IN A FOREIGN LANGUAGE.

FOR PROVIDING A WEBSITE FEATURING INFORMATION ABOUT INVESTIGATIONAL MEDICAL DEVICES, DIAGNOSTIC EQUIPMENT AND DRUGS; PROVIDING MEDICAL, AND SCIENTIFIC, AND BIOTECHNOLOGY RESEARCH INFORMATION IN THE FIELD OF PHARMACEUTICALS AND CLINICAL TRIALS; SOFTWARE AS A SERVICE (SAAS) SERVICES, NAMELY, HOSTING SOFTWARE FOR USE BY OTHERS FOR HEALTH OR HEALTH CARE RELATED DATABASE MANAGEMENT PROVIDED TO PATIENTS, DOCTORS, SCIENTISTS AND/OR THE GENERAL HEALTH CARE COMMUNITY. WEBSITE CONSULTING, NAMELY, CONSULTANCY WITH REGARD TO WEBPAGE DESIGN AND CONTENT PERTAINING TO HEALTH OR HEALTHCARE (U.S. CLS. 100 AND 101).
ANDREA K. NADELMAN, EXAMINING ATTORNEY

CLASS 42—(Continued).

SN 85-109,787. ORCHARD ENTERPRISES NY, INC., NEW YORK, NY. FILED 8-17-2010.

THE ORCHARD

THE MARK CONSISTS OF STANDARD CHARACTERS WITHOUT CLAIM TO ANY PARTICULAR FONT, STYLE, SIZE, OR COLOR.

OWNER OF U.S. REG. NO. 3,180,690.

FOR APPLICATION SERVICE PROVIDER, NAMELY, HOSTING, MANAGING, DEVELOPING, AND MAINTAINING AN INTERNET SOFTWARE APPLICATION THAT ENABLES USERS TO ACCESS THIRD-PARTY MARKETING, SALES, AND ANALYTICS SOFTWARE APPLICATIONS IN THE FIELD OF MARKETING AND MANAGING DIGITAL ENTERTAINMENT CONTENT (U.S. CLS. 100 AND 101).

FIRST USE 3-11-2008; IN COMMERCE 3-11-2008.

MICHAEL LITZAU, EXAMINING ATTORNEY

CLASS 42—(Continued).

SN 85-114,489. TYPE HERE ENTERPRISES CORPORATION, SEATTLE, WA. FILED 8-24-2010.

TYPETRIGGER

THE MARK CONSISTS OF STANDARD CHARACTERS WITHOUT CLAIM TO ANY PARTICULAR FONT, STYLE, SIZE, OR COLOR.

FOR COMPUTER SERVICES, NAMELY, HOSTING AND MAINTAINING AN ONLINE WEBSITE FOR REGISTERED USERS TO SHOWCASE THEIR WRITING SKILLS, SHARE, POST, OR DISPLAY THEIR WRITTEN WORKS ON A WIDE RANGE OF INFORMATION, AND ENGAGE IN SOCIAL NETWORKING; PEER TO BROWSER WRITTEN WORKS SHARING SERVICES NAMELY, PROVIDING A WEBSITE FEATURING TECHNOLOGY ENABLING USERS TO UPLOAD, VIEW AND DOWNLOAD WRITTEN WORKS ON A WIDE RANGE OF INFORMATION (U.S. CLS. 100 AND 101).

FIRST USE 6-1-2010; IN COMMERCE 8-23-2010.

GRETCHEN ULRICH, EXAMINING ATTORNEY

SN 85-114,979. JOHN REAVES, NEW YORK, NY. FILED 8-24-2010.

independence@home

THE MARK CONSISTS OF STANDARD CHARACTERS WITHOUT CLAIM TO ANY PARTICULAR FONT, STYLE, SIZE, OR COLOR.

FOR DEVELOPMENT OF NEW TECHNOLOGY FOR OTHERS IN THE FIELD OF HOME CARE OR LONG-TERM CARE; RESEARCH AND DEVELOPMENT OF NEW PRODUCTS (U.S. CLS. 100 AND 101).

FIRST USE 8-4-2010; IN COMMERCE 8-4-2010.

ANNE MADDEN, EXAMINING ATTORNEY

SN 85-111,006. LEMON SQUAD, LLC, FORMERLY AUTO NERDS MECHANICAL INSPECTORS, MINNEAPOLIS, MN. FILED 8-19-2010.

LEMON SQUAD

THE MARK CONSISTS OF STANDARD CHARACTERS WITHOUT CLAIM TO ANY PARTICULAR FONT, STYLE, SIZE, OR COLOR.

NO CLAIM IS MADE TO THE EXCLUSIVE RIGHT TO USE "LEMON", APART FROM THE MARK AS SHOWN.

FOR INSPECTION SERVICES FOR NEW AND USED VEHICLES FOR PERSONS BUYING OR SELLING THEIR VEHICLES (U.S. CLS. 100 AND 101).

FIRST USE 8-19-2010; IN COMMERCE 8-19-2010.

EDWARD FENNESSY, EXAMINING ATTORNEY

SN 85-116,712. GLOBYS, INC., SEATTLE, WA. FILED 8-26-2010.

BILL ANALYST

THE MARK CONSISTS OF STANDARD CHARACTERS WITHOUT CLAIM TO ANY PARTICULAR FONT, STYLE, SIZE, OR COLOR.

SEC. 2(F).

FOR PROVIDING ONLINE, NON-DOWNLOADABLE ANALYTICS AND REPORTING SOFTWARE APPLICATIONS FOR CONSOLIDATING BILLING AND SERVICES INFORMATION (U.S. CLS. 100 AND 101).

FIRST USE 2-28-2004; IN COMMERCE 2-28-2004.

LINDA LAVACHE, EXAMINING ATTORNEY

CLASS 42—(Continued).

SN 85-128,104. PERKVILLE, INC., DBA PERKVILLE, SAN FRANCISCO, CA. FILED 9-13-2010.

Perkville

THE MARK CONSISTS OF STANDARD CHARACTERS WITHOUT CLAIM TO ANY PARTICULAR FONT, STYLE, SIZE, OR COLOR.

FOR CUSTOMER REWARD AND LOYALTY SOLUTION, NAMELY, AN APPLICATION SERVICE PROVIDER FEATURING SOFTWARE FOR USE IN CREATING CUSTOMER LOYALTY PROGRAMS (U.S. CLS. 100 AND 101).

FIRST USE 4-26-2010; IN COMMERCE 5-11-2010.
SAIMA MAKHDOOM, EXAMINING ATTORNEY

SN 85-135,628. QUATTROSOURCE, INC., CHICAGO, IL. FILED 9-22-2010.



THE COLOR(S) GREEN, WHITE AND GRAY IS/ARE CLAIMED AS A FEATURE OF THE MARK.

THE MARK CONSISTS OF A GREEN DIAMOND OUTLINE WITH THE LEFT SIDE/POINT OF THE DIAMOND SEPARATED BY WHITE SPACE AND IN GRAY. THE DIAMOND IS FILLED WITH WHITE EXCEPT THAT A GRAY GREATER-THAN SYMBOL IS CENTERED INSIDE THE DIAMOND. TO THE RIGHT OF THE DIAMOND IS THE WORD "QUATTRO" ALL IN CAPITAL LETTERS AND IN THE SAME GREEN COLOR AS THE DIAMOND. IMMEDIATELY BELOW THE WORD "QUATTRO" AND TO THE RIGHT OF THE DIAMOND IS THE WORD "SOURCE" ALL IN CAPITAL LETTERS AND IN THE SAME GRAY COLOR AS THE GREATER-THAN SYMBOL AND LEFT SIDE/POINT OF THE DIAMOND.

THE ENGLISH TRANSLATION OF "QUATTRO" IS "FOUR".

FOR CONSULTING IN THE FIELD OF DESIGN, DEVELOPMENT, MODIFICATION AND TROUBLESHOOTING OF COMPUTER SOFTWARE, COMPUTER MODULES AND COMPUTER PROGRAMS (U.S. CLS. 100 AND 101).

FIRST USE 8-31-2010; IN COMMERCE 8-31-2010.
JOHN SCHUYLER YARD, EXAMINING ATTORNEY

CLASS 42—(Continued).

SN 85-142,704. CREATIVE JUGGERNAUTS, S.A. DE C.V., SAN PEDRO GARZA GARCÍA, MEXICO, FILED 9-30-2010.

ANAGRAMA

THE MARK CONSISTS OF STANDARD CHARACTERS WITHOUT CLAIM TO ANY PARTICULAR FONT, STYLE, SIZE, OR COLOR.

THE ENGLISH TRANSLATION OF "ANAGRAMA" IN THE MARK IS "ANAGRAM".

FOR COMPUTER AIDED GRAPHIC DESIGN; DESIGN OF INFORMATION GRAPHICS AND DATA VISUALIZATION MATERIALS; GRAPHIC ART DESIGN; GRAPHIC DESIGN; GRAPHIC DESIGN SERVICES; GRAPHIC ILLUSTRATION AND DRAWING SERVICES, NAMELY, PROVIDING GRAPHIC ILLUSTRATIONS AND DRAWINGS OF COMMERCIAL AND INDUSTRIAL BUILDING DESIGNS, AND CONVERTING BUILDING DESIGNS OR MARKUPS TO ELECTRONIC CAD DRAWINGS; INDUSTRIAL AND GRAPHIC ART DESIGN; MULTIDISCIPLINARY GRAPHIC DESIGN SERVICES; PROVIDING GRAPHIC AND MULTIMEDIA DESIGN SERVICES FOR THE PURPOSE OF PROMOTING THE GOODS AND SERVICES OF OTHERS (U.S. CLS. 100 AND 101).

FIRST USE 10-1-2009; IN COMMERCE 10-1-2009.
JOHN DWYER, EXAMINING ATTORNEY

SN 85-144,863. MEDANYWHERE, LLC, MANASSAS, VA. FILED 10-5-2010.

MEDANYWHERE

THE MARK CONSISTS OF STANDARD CHARACTERS WITHOUT CLAIM TO ANY PARTICULAR FONT, STYLE, SIZE, OR COLOR.

FOR PROVIDING TEMPORARY USE OF ONLINE, NON-DOWNLOADABLE SOFTWARE FOR CONSUMERS AND DOCTORS OF ALL AGES, NAMELY, SOFTWARE THAT ALLOWS FOR ONLINE ACCESS TO A MEDICAL OFFICE'S PRACTICE MANAGEMENT INFORMATION, ELECTRONIC COPIES OF PATIENT MEDICAL RECORDS, ELECTRONIC COPIES OF RADIOLOGY IMAGES AND INFORMATION, AND SOFTWARE FOR CONTROLLING AND MANAGING PATIENT MEDICAL INFORMATION (U.S. CLS. 100 AND 101).

FIRST USE 5-2-2008; IN COMMERCE 5-2-2008.
ANDREA HACK, EXAMINING ATTORNEY

CLASS 42—(Continued).

SN 85-149,340. SKOODAT, LLC, CHATTANOOGA, TN. FILED 10-11-2010.



THE MARK CONSISTS OF THE WORDS "SKOODAT EXODUS" IN STYLIZED FORM WITH AN INFINITY SYMBOL COMPRISING THE TWO "O"'S IN "SKOODAT".

FOR CLOUD COMPUTING FEATURING SOFTWARE FOR USE IN THE FIELD OF EDUCATION TO ASSIST SCHOOL SYSTEMS WITH ADMINISTRATIVE DUTIES, NAMELY, FOR ALLOWING USERS TO POST AND MONITOR THE STATUS OF ASSIGNMENTS, AND FOR THE COLLECTION AND ORGANIZING OF INFORMATION RELATED TO ATTENDANCE, CALENDARS, ENROLLMENT, GRADE BOOKS, HEALTH AND IMMUNIZATION RECORDS, STUDENT AND TEACHER PERFORMANCE, RECRUITING, AND REGISTRATION; CLOUD COMPUTING FEATURING PHYSICAL SITE EDUCATION FACILITIES MANAGEMENT SOFTWARE TO CONTROL BUILDING ENVIRONMENT, ACCESS AND SECURITY SYSTEMS (U.S. CLS. 100 AND 101).

FIRST USE 6-28-2010; IN COMMERCE 6-28-2010.
TARA PATE, EXAMINING ATTORNEY

CLASS 42—(Continued).

SN 85-150,446. SYNTECH RESEARCH, INC., DBA SYNTECH RESEARCH, INC., DAVIS, CA. FILED 10-12-2010.



OWNER OF U.S. REG. NO. 2,937,202.

NO CLAIM IS MADE TO THE EXCLUSIVE RIGHT TO USE "RESEARCH", APART FROM THE MARK AS SHOWN. THE COLOR(S) DARK GREEN AND LIGHT GREEN IS/ARE CLAIMED AS A FEATURE OF THE MARK.

THE MARK CONSISTS OF DARK GREEN LETTERS FOR THE WORD "SYNTECH" WITH A SOFTER GREEN LEAF IN THE TOP END OF THE "S" AND LIGHTER GREEN LETTERS FOR THE WORD "RESEARCH".

FOR AGRICULTURAL RESEARCH (U.S. CLS. 100 AND 101).

FIRST USE 9-13-2010; IN COMMERCE 9-13-2010.
GENE MACIOL, EXAMINING ATTORNEY

SN 85-156,595. EPHIPHONY INCORPORATED, MINNEAPOLIS, MN. FILED 10-19-2010.



THE COLOR(S) RED, WHITE, AND BLACK IS/ARE CLAIMED AS A FEATURE OF THE MARK.

THE MARK CONSISTS OF THE WORDS "RIGHT ON" WITH A TARGET AND ARROW TAKING THE PLACE OF THE "O" IN "ON". THE TARGET IS RED AND WHITE WITH FOUR RED RINGS, THREE WHITE RINGS, AND A WHITE CENTER BULLEYE CIRCLE. AT THE BULLEYE IS A BLACK MOUSE CURSOR IN THE SHAPE OF AN ARROW WITH A WHITE OUTLINE. THE WORD "RIGHT" AND THE LETTER "N" IN "ON" ARE BLACK.

FOR SOFTWARE AS A SERVICE (SAAS) SERVICES FEATURING SOFTWARE FOR AUTOMATING THE TASK OF REPLENISHING INVENTORY IN THE FIELDS OF OPTIMIZED SUPPLY PLANNING, INVENTORY POLICY, PRODUCTION SCHEDULING, ORDERING, PURCHASE PLANNING AND DISTRIBUTION PLANNING.; SOFTWARE AS A SERVICE (SAAS) SERVICES FEATURING SOFTWARE FOR AUTOMATING THE TASK OF REPLENISHING INVENTORY IN THE FIELD OF BUSINESS SCHEDULING, PLANNING, MANUFACTURING, SUPPLY CHAIN MANAGEMENT, AND STRATEGIC PLANNING; SOFTWARE AS A SERVICE (SAAS) SERVICES, NAMELY, HOSTING SOFTWARE FOR USE BY OTHERS FOR AUTOMATING THE TASK OF REPLENISHING INVENTORY IN THE FIELDS OF OPTIMIZED SUPPLY PLANNING, INVENTORY POLICY, PRODUCTION SCHEDULING, ORDERING, PURCHASE PLANNING AND DISTRIBUTION PLANNING (U.S. CLS. 100 AND 101).

FIRST USE 7-21-2010; IN COMMERCE 9-29-2010.
SARA BENJAMIN, EXAMINING ATTORNEY

SN 85-149,343. SKOODAT, LLC, CHATTANOOGA, TN. FILED 10-11-2010.



THE MARK CONSISTS OF THE WORD "SKOODAT" IN STYLIZED FORM WITH AN INFINITY SYMBOL COMPRISING THE TWO "O"'S.

FOR CLOUD COMPUTING FEATURING SOFTWARE FOR USE IN THE FIELD OF EDUCATION TO ASSIST SCHOOL SYSTEMS WITH ADMINISTRATIVE DUTIES, NAMELY, FOR ALLOWING USERS TO POST AND MONITOR THE STATUS OF ASSIGNMENTS, AND FOR THE COLLECTION AND ORGANIZING OF INFORMATION RELATED TO ATTENDANCE, CALENDARS, ENROLLMENT, GRADE BOOKS, HEALTH AND IMMUNIZATION RECORDS, STUDENT AND TEACHER PERFORMANCE, RECRUITING, AND REGISTRATION; CLOUD COMPUTING FEATURING PHYSICAL SITE EDUCATION FACILITIES MANAGEMENT SOFTWARE TO CONTROL BUILDING ENVIRONMENT, ACCESS AND SECURITY SYSTEMS (U.S. CLS. 100 AND 101).

FIRST USE 10-6-2008; IN COMMERCE 10-6-2008.
TARA PATE, EXAMINING ATTORNEY

CLASS 42—(Continued).

SN 85-162,484. DASKO COMMUNICATIONS, DEL MAR, CA.
FILED 10-27-2010.

ResponseCoach

THE MARK CONSISTS OF STANDARD CHARACTERS WITHOUT CLAIM TO ANY PARTICULAR FONT, STYLE, SIZE, OR COLOR.

FOR SOFTWARE AS A SERVICE (SAAS) SERVICES FEATURING SOFTWARE FOR USE IN REMOTE COACHING SPECIFICALLY FOR INTERPERSONAL COMMUNICATION SKILLS (U.S. CLS. 100 AND 101).

FIRST USE 10-22-2010; IN COMMERCE 10-22-2010.
JESSICA A. POWERS, EXAMINING ATTORNEY

CLASS 42—(Continued).

SN 85-164,634. DOCKVINE, INC., WOODLAND HILLS, CA.
FILED 10-29-2010.

DOCKVINE

THE MARK CONSISTS OF STANDARD CHARACTERS WITHOUT CLAIM TO ANY PARTICULAR FONT, STYLE, SIZE, OR COLOR.

FOR PROVIDING A WEBSITE FEATURING TEMPORARY USE OF ONLINE NON-DOWNLOADABLE SOFTWARE FOR USE IN AGGREGATING AND DISPLAYING ONLINE DIGITAL CONTENT SUCH AS PHOTOS, VIDEOS, AUDIO, TEXT AND OTHER TYPES OF DIGITAL MEDIA AND ONLINE SOCIAL MEDIA CONTENT; APPLICATION SERVICE PROVIDER (ASP) FEATURING SOFTWARE FOR USE IN AGGREGATING AND DISPLAYING ONLINE DIGITAL CONTENT SUCH AS PHOTOS, VIDEOS, AUDIO, TEXT AND OTHER TYPES OF DIGITAL MEDIA AND ONLINE SOCIAL MEDIA CONTENT (U.S. CLS. 100 AND 101).

DOMINICK J. SALEMI, EXAMINING ATTORNEY

SN 85-164,335. STANFORD, MICHAEL, WASHINGTON TERRACE, UT. FILED 10-29-2010.



NO CLAIM IS MADE TO THE EXCLUSIVE RIGHT TO USE "HOME INSPECTORS", APART FROM THE MARK AS SHOWN.

THE MARK CONSISTS OF A SILHOUETTED, CROSS-SECTIONED ROOF AND WALL OF A HOME, COVERING THE WORDING "WATCH DOGS HOME INSPECTORS" AND THE DESIGN OF A DOG FACING FORWARD BETWEEN THE WORDS "WATCH" AND "DOGS".

FOR APARTMENT, CONDOMINIUM AND HOME STAGING SERVICES FOR THE PURPOSE OF INCREASING THE APPEAL OF THE PROPERTY TO PROSPECTIVE BUYERS AND/OR RENTERS; DESIGN AND INSPECTION OF FIRE ALARM, DETECTION AND SUPPRESSION SYSTEMS; EVALUATION OF THE HOME BUILDING AND REMODELING SERVICES OF HOME BUILDERS AND REMODELERS FOR THE PURPOSE OF CERTIFICATION OF NEW AND REMODELED HOME CONSTRUCTION OTHER THAN FOR GOVERNMENTAL REGULATORY PURPOSES DURING CONSTRUCTION; FIRE ESCAPE INSPECTION SERVICES; INSPECTING BUILDINGS FOR THE EXISTENCE OF MOLD; INSPECTION SERVICES, NAMELY, DETECTION OF PLUMBING AND ROOF LEAKS, TERMITES, AND ELECTRICAL CONDITIONS IN THE INACCESSIBLE AREAS OF AN EXISTING STRUCTURE OR HOME AND/OR WALL(S) AND VOID(S) BY MEANS OF INFRA-RED IMAGING UNITS; INSPECTIONS OF HOMES (U.S. CLS. 100 AND 101).

FIRST USE 7-10-2006; IN COMMERCE 7-10-2006.
JOHN DALIER, EXAMINING ATTORNEY

SN 85-169,607. PARKINGSOFT, LLC, BALTIMORE, MD.
FILED 11-4-2010.

Moving Parking Forward

THE MARK CONSISTS OF STANDARD CHARACTERS WITHOUT CLAIM TO ANY PARTICULAR FONT, STYLE, SIZE, OR COLOR.

FOR PROVIDING A WEBSITE FEATURING TEMPORARY USE OF NON-DOWNLOADABLE SOFTWARE FOR USE IN DATABASE, HUMAN RESOURCE AND FACILITY MANAGEMENT, TRACKING OF FINANCIAL DATA, READING AND STORING SALES DATA, GENERAL LEDGER MANAGEMENT, THE PROCESSING AND FORMATTING OF REPORTS AND SPREADSHEETS, THE FORMULATION OF STATISTICAL ANALYSIS, AND THE PROCESSING OF PRINTABLE PARKING VOUCHERS, PARKING VALIDATIONS, AND PARKING RECEIPTS IN THE FIELD OF COMMERCIAL PARKING (U.S. CLS. 100 AND 101).

FIRST USE 7-25-2010; IN COMMERCE 7-25-2010.
MICHAEL SOUDERS, EXAMINING ATTORNEY

CLASS 42—(Continued).

SN 85-172,340. LOCAL FOCAL, INC., DBA NET DRIVEN, SCRANTON, PA. FILED 11-9-2010.

NET DRIVEN

THE MARK CONSISTS OF STANDARD CHARACTERS WITHOUT CLAIM TO ANY PARTICULAR FONT, STYLE, SIZE, OR COLOR.

NO CLAIM IS MADE TO THE EXCLUSIVE RIGHT TO USE "NET", APART FROM THE MARK AS SHOWN.

FOR COMPUTER SERVICES FOR THE AUTOMOTIVE INDUSTRY, NAMELY, CREATING AND MAINTAINING WEB SITES FOR OTHERS THAT ENABLE USERS TO CONDUCT ONLINE COMMERCE, PUBLISH CONTENT AND AUTOMATE BUSINESS PROCESSES; HOSTING OF DIGITAL CONTENT ON THE INTERNET; PROVIDING ON-LINE NON-DOWNLOADABLE SOFTWARE FOR USE IN CONNECTION WITH ENHANCING MARKETING, SALES, SUPPORT, AND ELECTRONIC COMMERCE FUNCTIONS, NAMELY, ORDER PROCESSING, CATALOG CREATION, SHOPPING CART INTEGRATION, TO ENABLE COMMERCIAL TRANSACTIONS OVER A GLOBAL COMPUTER INFORMATION NETWORK; COMPUTER SOFTWARE CONSULTING; TECHNICAL SUPPORT SERVICES, NAMELY, TROUBLESHOOTING OF COMPUTER SOFTWARE PROBLEMS; COMPUTER SERVICES, NAMELY, SEARCH ENGINE OPTIMIZATION (U.S. CLS. 100 AND 101).

FIRST USE 12-31-2008; IN COMMERCE 12-31-2008.
CAROLINE WOOD, EXAMINING ATTORNEY

CLASS 42—(Continued).

SN 85-177,172. GENERAL DYNAMICS LAND SYSTEMS INC., STERLING HEIGHTS, MI. FILED 11-15-2010.

MC2

THE MARK CONSISTS OF STANDARD CHARACTERS WITHOUT CLAIM TO ANY PARTICULAR FONT, STYLE, SIZE, OR COLOR.

FOR RESEARCH AND DEVELOPMENT OF NEW PRODUCTS CONDUCTED IN PHYSICAL LABORATORIES, DEMONSTRATION AREAS AND COLLABORATIVE FACILITIES; PROVIDING AN INTERNET WEBSITE PORTAL IN THE FIELDS OF TECHNOLOGY FOR USE BY MEMBER ORGANIZATIONS COMPRISED OF CORPORATIONS, GOVERNMENT AGENCIES AND ACADEMIC INSTITUTIONS, TO COLLABORATE, CREATE, DEVELOP, DESIGN, AND INTEGRATE TECHNOLOGY OF VEHICLES USED BY WAR FIGHTERS OR OTHER TACTICAL TEAMS (U.S. CLS. 100 AND 101).

ERIN FALK, EXAMINING ATTORNEY

SN 85-185,050. OUTFIT7 LTD., PREDDVOR, SLOVENIA, FILED 11-24-2010.

OUTFIT7

THE MARK CONSISTS OF STANDARD CHARACTERS WITHOUT CLAIM TO ANY PARTICULAR FONT, STYLE, SIZE, OR COLOR.

FOR DEVELOPMENT, CONSULTANCY ON AND DESIGNING OF COMPUTER SOFTWARE; COMPUTER PROGRAMMING; COMPUTER SYSTEMS ANALYSIS; CONVERSION OF DATA FROM PHYSICAL TO ELECTRONIC MEDIA; DESIGN OF COMPUTER SYSTEMS; DEVELOPMENT, CONSULTANCY ON AND DESIGNING OF TOUCH AND VOICE DRIVEN COMPUTER SOFTWARE FOR ELECTRONIC DIGITAL MOBILE DEVICES; ENGINEERING AND EXPERT CONSULTING SERVICES IN THE FIELD OF COMPUTER SCIENCE; SERVICES OF ASSEMBLING, MAINTENANCE AND SERVICING OF COMPUTER SOFTWARE; UPDATING AND MAINTENANCE OF COMPUTER SOFTWARE, INCLUDING TOUCH AND VOICE DRIVEN COMPUTER SOFTWARE FOR ELECTRONIC DIGITAL MOBILE DEVICES; HOSTING A WEB SITE FEATURING USER GENERATED CONTENT; PROVIDING COMPUTER PROGRAMMING IN THE FIELD OF ENTERTAINMENT REGARDING INTERACTIVE COMPUTER GAME SOFTWARE, INTERACTIVE VIDEO GAME SOFTWARE AND INTERACTIVE COMPUTER AND VIDEO GAMES, VIA ELECTRONIC, WIRELESS AND COMPUTER NETWORKS (U.S. CLS. 100 AND 101).

LIEF MARTIN, EXAMINING ATTORNEY

SN 85-175,444. NISSAN JIDOSHA KABUSHIKI KAISHA, TA NISSAN MOTOR CO., LTD., YOKOHAMA-SHI, KANAGAWA, JAPAN, FILED 11-12-2010.

INFINITI CONNECTION

THE MARK CONSISTS OF STANDARD CHARACTERS WITHOUT CLAIM TO ANY PARTICULAR FONT, STYLE, SIZE, OR COLOR.

FOR MOBILE INFORMATION SERVICES, NAMELY, WEATHER INFORMATION (U.S. CLS. 100 AND 101).

NICHOLAS ALTREE, EXAMINING ATTORNEY

CLASS 42—(Continued).

SN 85-185,061. OUTFIT7 LTD., PREDDVOR, SLOVENIA, FILED 11-24-2010.

TALKING BACTERIA

THE MARK CONSISTS OF STANDARD CHARACTERS WITHOUT CLAIM TO ANY PARTICULAR FONT, STYLE, SIZE, OR COLOR.

FOR DEVELOPMENT, CONSULTANCY ON AND DESIGNING OF COMPUTER SOFTWARE; COMPUTER PROGRAMMING; COMPUTER SYSTEMS ANALYSIS; CONVERSION OF DATA FROM PHYSICAL TO ELECTRONIC MEDIA; DESIGN OF COMPUTER SYSTEMS; DEVELOPMENT, CONSULTANCY ON AND DESIGNING OF TOUCH AND VOICE DRIVEN COMPUTER SOFTWARE FOR ELECTRONIC DIGITAL MOBILE DEVICES; ENGINEERING AND EXPERT CONSULTING SERVICES IN THE FIELD OF COMPUTER SCIENCE; SERVICES OF ASSEMBLING, MAINTENANCE AND SERVICING OF COMPUTER SOFTWARE; UPDATING AND MAINTENANCE OF COMPUTER SOFTWARE, INCLUDING TOUCH AND VOICE DRIVEN COMPUTER SOFTWARE FOR ELECTRONIC DIGITAL MOBILE DEVICES; HOSTING A WEB SITE FEATURING USER GENERATED CONTENT; PROVIDING COMPUTER PROGRAMMING IN THE FIELD OF ENTERTAINMENT REGARDING INTERACTIVE COMPUTER GAME SOFTWARE, INTERACTIVE VIDEO GAME SOFTWARE AND INTERACTIVE COMPUTER AND VIDEO GAMES, VIA ELECTRONIC, WIRELESS AND COMPUTER NETWORKS (U.S. CLS. 100 AND 101).

LIEF MARTIN, EXAMINING ATTORNEY

SN 85-186,661. SOCIETY OF ARCHITECTURAL HISTORIANS, CHICAGO, IL. FILED 11-29-2010.

SAH ARCHIPEDIA

THE MARK CONSISTS OF STANDARD CHARACTERS WITHOUT CLAIM TO ANY PARTICULAR FONT, STYLE, SIZE, OR COLOR.

FOR PROVIDING AN ONLINE SEARCHABLE DATABASE IN THE FIELD OF ARCHITECTURAL INFORMATION FEATURING TEXT, ILLUSTRATIONS, NON-DOWNLOADABLE VIDEOS AND MULTIMEDIA IMAGES DOCUMENTING AND INTERPRETING SIGNIFICANT BUILDINGS, LANDSCAPES, AND URBAN GARDENS, PARKS, SCULPTURES AND STRUCTURES VIA A GLOBAL COMPUTER NETWORK AND MOBILE COMMUNICATIONS DEVICES (U.S. CLS. 100 AND 101).

PRISCILLA MILTON, EXAMINING ATTORNEY

CLASS 42—(Continued).

SN 85-189,122. OUTFIT7 LTD., PREDDVOR, SLOVENIA, FILED 12-2-2010.

**TALKING BACTERIA JOHN,
JOHN & JOHN**

THE MARK CONSISTS OF STANDARD CHARACTERS WITHOUT CLAIM TO ANY PARTICULAR FONT, STYLE, SIZE, OR COLOR.

PRIORITY CLAIMED UNDER SEC. 44(D) ON ERPN CMNTY TM OFC APPLICATION NO. 009493826, FILED 11-3-2010.

FOR DEVELOPMENT, CONSULTANCY ON AND DESIGNING OF COMPUTER SOFTWARE; COMPUTER PROGRAMMING; COMPUTER SYSTEMS ANALYSIS; CONVERSION OF DATA FROM PHYSICAL TO ELECTRONIC MEDIA; DESIGN OF COMPUTER SYSTEMS; DEVELOPMENT, CONSULTANCY ON AND DESIGNING OF TOUCH AND VOICE DRIVEN COMPUTER SOFTWARE FOR ELECTRONIC DIGITAL MOBILE DEVICES; ENGINEERING AND EXPERT CONSULTING SERVICES IN THE FIELD OF COMPUTER SCIENCE; SERVICES OF ASSEMBLING, MAINTENANCE AND SERVICING OF COMPUTER SOFTWARE; UPDATING AND MAINTENANCE OF COMPUTER SOFTWARE, INCLUDING TOUCH AND VOICE DRIVEN COMPUTER SOFTWARE FOR ELECTRONIC DIGITAL MOBILE DEVICES; HOSTING A WEB SITE FEATURING USER GENERATED CONTENT; PROVIDING COMPUTER PROGRAMMING IN THE FIELD OF ENTERTAINMENT REGARDING INTERACTIVE COMPUTER GAME SOFTWARE, INTERACTIVE VIDEO GAME SOFTWARE AND INTERACTIVE COMPUTER AND VIDEO GAMES, VIA ELECTRONIC, WIRELESS AND COMPUTER NETWORKS (U.S. CLS. 100 AND 101).

LIEF MARTIN, EXAMINING ATTORNEY

SN 85-199,290. AMY FREEZE, OAK PARK, IL. FILED 12-16-2010.

iWITNESSWEATHER

THE MARK CONSISTS OF STANDARD CHARACTERS WITHOUT CLAIM TO ANY PARTICULAR FONT, STYLE, SIZE, OR COLOR.

FOR PROVIDING A WEB SITE FEATURING WEATHER INFORMATION (U.S. CLS. 100 AND 101).

FIRST USE 4-29-2008; IN COMMERCE 5-2-2008.

KATHERINE E. HALMEN, EXAMINING ATTORNEY

CLASS 42—(Continued).

SN 85-203,606. WEBVENT, INC., BOSTON, MA. FILED S.R. 12-22-2010; AM. P.R. 5-31-2011.

Webvent

THE MARK CONSISTS OF STANDARD CHARACTERS WITHOUT CLAIM TO ANY PARTICULAR FONT, STYLE, SIZE, OR COLOR.

FOR SOFTWARE AS A SERVICE (SAAS) SERVICES FEATURING SOFTWARE FOR CREATING AN ONLINE COMMUNITY FOR REGISTERED USERS TO ENGAGE IN WEBINARS, PARTICIPATE IN DISCUSSIONS, FORM VIRTUAL COMMUNITIES AND ENGAGE IN SOCIAL NETWORKING IN THE FIELDS OF BUSINESS, ACADEMIA, NON-PROFIT, GOVERNMENT, AND PERSONAL USE (U.S. CLS. 100 AND 101).

FIRST USE 12-12-2010; IN COMMERCE 12-16-2010.
GISELLE AGOSTO, EXAMINING ATTORNEY

SN 85-206,360. EDVANTIA, INC., CHARLESTON, WV. FILED 12-28-2010.

Yardstick-12

THE MARK CONSISTS OF STANDARD CHARACTERS WITHOUT CLAIM TO ANY PARTICULAR FONT, STYLE, SIZE, OR COLOR.

FOR RESEARCH IN THE FIELD OF EDUCATION, EDUCATIONAL TESTING DATA ANALYSIS, AND ACADEMIC PERFORMANCE EVALUATION SERVICES, ALL FOR SCHOOL DISTRICTS (U.S. CLS. 100 AND 101).

FIRST USE 9-20-2010; IN COMMERCE 9-20-2010.
MARK PILARO, EXAMINING ATTORNEY

SN 85-207,517. MOSES, OMO, JAMAICA PLAIN, MA. FILED 12-29-2010.

ThePeopleStories

THE MARK CONSISTS OF STANDARD CHARACTERS WITHOUT CLAIM TO ANY PARTICULAR FONT, STYLE, SIZE, OR COLOR.

FOR DESIGN AND DEVELOPMENT OF COMPUTER SOFTWARE; PROVIDING A WEBSITE THAT GIVES USERS THE ABILITY TO CREATE CUSTOMIZED WEB PAGES FEATURING USER-DEFINED INFORMATION; PROVIDING A WEBSITE FEATURING TECHNOLOGY THAT ENABLES USERS TO PERSONALIZE WEB PAGES AND SHARE THEIR INTERNET EXPERIENCE THROUGH THE UPLOADING AND SHARING OF VIDEOS AND TEXT (U.S. CLS. 100 AND 101).

JULIE VEPPUMTHARA, EXAMINING ATTORNEY

CLASS 42—(Continued).

SN 85-208,050. ONE CALL CONCEPTS, INC., DBA NATIONAL TICKET MANAGEMENT SYSTEM, HANOVER, MD. FILED 12-30-2010.

TICKET CHECK

THE MARK CONSISTS OF STANDARD CHARACTERS WITHOUT CLAIM TO ANY PARTICULAR FONT, STYLE, SIZE, OR COLOR.

NO CLAIM IS MADE TO THE EXCLUSIVE RIGHT TO USE "TICKET", APART FROM THE MARK AS SHOWN.

FOR COMPUTER SERVICES, NAMELY, ACTING AS AN APPLICATION SERVICE PROVIDER IN THE FIELD OF KNOWLEDGE MANAGEMENT TO HOST COMPUTER APPLICATION SOFTWARE FOR CREATING SEARCHABLE DATABASES OF INFORMATION FOR EVALUATING, SORTING AND ANALYZING INFORMATION IN RELATION TO UNDERGROUND FACILITIES IN THE NATURE OF PIPES, LINES AND CABLES (U.S. CLS. 100 AND 101).

FIRST USE 7-1-2001; IN COMMERCE 7-1-2001.
MARC LEIPZIG, EXAMINING ATTORNEY

SN 85-212,177. ABRIGHT, DAVID B., DESOTO, TX. FILED 1-6-2011.

Fetchitopia

THE MARK CONSISTS OF STANDARD CHARACTERS WITHOUT CLAIM TO ANY PARTICULAR FONT, STYLE, SIZE, OR COLOR.

OWNER OF U.S. REG. NO. 3,889,870.

FOR APPLICATION SERVICE PROVIDER (ASP) FEATURING SOFTWARE TO ACCEPT ORDERS FOR PUBLIC RECORDS AND PHOTOGRAPHS OF PERSONS, PLACES, OR THINGS; APPLICATION SERVICE PROVIDER (ASP) FEATURING SOFTWARE FOR CONDUCTING SURVEYS AND PRODUCT RESEARCH; APPLICATION SERVICE PROVIDER (ASP) FEATURING SOFTWARE FOR SCHEDULING DELIVERY OF CONSUMER PRODUCTS (U.S. CLS. 100 AND 101).

CHARLES L. JENKINS, EXAMINING ATTORNEY

CLASS 42—(Continued).

SN 85-213,081. GDSX, LTD., ALLEN, TX. FILED 1-7-2011.



THE COLOR(S) BLACK, WHITE, YELLOW AND ORANGE IS/ARE CLAIMED AS A FEATURE OF THE MARK. THE MARK CONSISTS OF BLACK LETTERS "G", "D" AND "S", WITH A BLACK DASH IMMEDIATELY BEFORE AND AFTER EACH OF THOSE LETTERS, FOLLOWED BY A LARGER FANCIFUL LETTER "X", WHICH IS YELLOW IN THE CENTER, CHANGING GRADUALLY TO ORANGE OUTWARD. THE "X" IS ALSO FOLLOWED BY A BLACK DASH. ALL OF THE FOREGOING ELEMENTS ARE AGAINST A WHITE BACKGROUND.

FOR PROVIDING ONLINE MID-OFFICE DATA AUTOMATION USING NON-DOWNLOADABLE PROPRIETARY SOFTWARE FOR EVALUATING, ANALYZING AND COLLECTING PROCESSING FUNCTION DATA AND QUALITY CONTROL SERVICES FOR THE PROCESSING FUNCTIONS OF OTHERS, ALL IN THE FIELD OF CORPORATE TRAVEL MANAGEMENT (U.S. CLS. 100 AND 101).

FIRST USE 8-1-2008; IN COMMERCE 8-1-2008.
 JASON TURNER, EXAMINING ATTORNEY

CLASS 42—(Continued).

SN 85-216,267. ABRIGHT, DAVID B., DESOTO, TX. FILED 1-12-2011.



THE COLOR(S) GOLD AND WHITE IS/ARE CLAIMED AS A FEATURE OF THE MARK.

THE MARK CONSISTS OF A GOLD AND WHITE MALE CARICATURE WEARING A HAT WITH A GOLD REFLECTION.

FOR APPLICATION SERVICE PROVIDER (ASP) FEATURING SOFTWARE TO ACCEPT ORDERS FOR PUBLIC RECORDS AND PHOTOGRAPHS OF PERSONS, PLACES, OR THINGS; APPLICATION SERVICE PROVIDER (ASP) FEATURING SOFTWARE FOR CONDUCTING SURVEYS AND PRODUCT RESEARCH; APPLICATION SERVICE PROVIDER (ASP) FEATURING SOFTWARE FOR SCHEDULING DELIVERY OF CONSUMER PRODUCTS (U.S. CLS. 100 AND 101).
 CHARLES L. JENKINS, EXAMINING ATTORNEY

SN 85-216,249. ABRIGHT, DAVID B., DESOTO, TX. FILED 1-12-2011.

**Needs, Wishes and Dreams
 Delivered**

THE MARK CONSISTS OF STANDARD CHARACTERS WITHOUT CLAIM TO ANY PARTICULAR FONT, STYLE, SIZE, OR COLOR.

FOR APPLICATION SERVICE PROVIDER (ASP) FEATURING SOFTWARE TO ACCEPT ORDERS FOR PUBLIC RECORDS AND PHOTOGRAPHS OF PEOPLE, PLACES, OR THINGS; APPLICATION SERVICE PROVIDER (ASP) FEATURING SOFTWARE FOR CONDUCTING SURVEYS AND PRODUCT RESEARCH; APPLICATION SERVICE PROVIDER (ASP) FEATURING SOFTWARE FOR SCHEDULING DELIVERY OF CONSUMER PRODUCTS (U.S. CLS. 100 AND 101).

CHARLES L. JENKINS, EXAMINING ATTORNEY

SN 85-216,373. L1 TECHNOLOGIES, INC., SAN DIEGO, CA. FILED 1-12-2011.

IGOLF SWING

THE MARK CONSISTS OF STANDARD CHARACTERS WITHOUT CLAIM TO ANY PARTICULAR FONT, STYLE, SIZE, OR COLOR.

OWNER OF U.S. REG. NOS. 3,451,915, 3,491,055 AND 3,932,160.

NO CLAIM IS MADE TO THE EXCLUSIVE RIGHT TO USE "SWING", APART FROM THE MARK AS SHOWN.

FOR PROVIDING A WEBSITE THAT GIVES COMPUTER USERS THE ABILITY TO UPLOAD PHOTOS, AND VIDEO OF GOLF SWINGS TO COMPARE AND ANALYZE THE USER'S GOLF SWING (U.S. CLS. 100 AND 101).

PAULA MAHONEY, EXAMINING ATTORNEY

CLASS 42—(Continued).

SN 85-217,674. GUILLOT, LISA G, DBA STEP BRIGHTLY CREATIVE GROUP, OAK PARK, IL. FILED 1-14-2011.

STEP BRIGHTLY

THE MARK CONSISTS OF STANDARD CHARACTERS WITHOUT CLAIM TO ANY PARTICULAR FONT, STYLE, SIZE, OR COLOR.
 FOR GRAPHIC DESIGN SERVICES (U.S. CLS. 100 AND 101).
 FIRST USE 1-12-2011; IN COMMERCE 1-12-2011.
 VIVIAN MICZNIK FIRST, EXAMINING ATTORNEY

SN 85-219,196. TJR FULFILLMENT, INC., OMAHA, NE. FILED 1-17-2011.

VERSASHIP

THE MARK CONSISTS OF STANDARD CHARACTERS WITHOUT CLAIM TO ANY PARTICULAR FONT, STYLE, SIZE, OR COLOR.
 FOR PROVIDING TEMPORARY USE OF ON-LINE, NON-DOWNLOADABLE SOFTWARE FOR MONITORING ELECTRONIC COMMERCE WITH RESPECT TO MONITORING INVENTORY AND THE SALE OF GOODS AND MONITORING ORDER FULFILLMENT (U.S. CLS. 100 AND 101).
 SETH A. RAPPAPORT, EXAMINING ATTORNEY

SN 85-222,451. GLAUCUS, INC., ROCKVILLE, MD. FILED 1-20-2011.

MULU

THE MARK CONSISTS OF STANDARD CHARACTERS WITHOUT CLAIM TO ANY PARTICULAR FONT, STYLE, SIZE, OR COLOR.
 THE ENGLISH TRANSLATION OF "MULU" IN THE MARK IS "CATALOGUE" IN CHINESE.
 FOR PROVIDING AN ONLINE, SECURE, PRIVATE, CUSTOMIZABLE AND SEARCHABLE INTERFACE THAT ALLOWS USERS IN A PASSWORD PROTECTED ENVIRONMENT TO STORE AND ORGANIZE DIGITAL FILES, TO STORE, ORGANIZE, AND TRACK CONTACT INFORMATION AND PREFERENCES RELATED TO SUCH FILES, TO SEND FILES TO NAMED INDIVIDUAL RECIPIENTS, TO CREATE AND ORGANIZE MESSAGES RELATED TO SUCH FILES AND TO PROCESS ORDERS RELATED TO SUCH FILES (U.S. CLS. 100 AND 101).
 NATALIE POLZER, EXAMINING ATTORNEY

CLASS 42—(Continued).

SN 85-223,072. CREATIVE ACCOMPLICE, INC., SEATTLE, WA. FILED 1-21-2011.

CREATIVE ACCOMPLICE

THE MARK CONSISTS OF STANDARD CHARACTERS WITHOUT CLAIM TO ANY PARTICULAR FONT, STYLE, SIZE, OR COLOR.
 NO CLAIM IS MADE TO THE EXCLUSIVE RIGHT TO USE "CREATIVE", APART FROM THE MARK AS SHOWN.
 FOR GRAPHIC ART DESIGN SERVICES (U.S. CLS. 100 AND 101).
 FIRST USE 11-1-2001; IN COMMERCE 11-19-2001.
 BRENDAN REGAN, EXAMINING ATTORNEY

SN 85-223,299. ERIEZ MANUFACTURING CO., ERIE, PA. FILED 1-21-2011.

CLEAN STREAM

THE MARK CONSISTS OF STANDARD CHARACTERS WITHOUT CLAIM TO ANY PARTICULAR FONT, STYLE, SIZE, OR COLOR.
 NO CLAIM IS MADE TO THE EXCLUSIVE RIGHT TO USE "CLEAN", APART FROM THE MARK AS SHOWN.
 FOR ENGINEERING AND DESIGN SERVICES FOR SCRAP METAL PROCESSING (U.S. CLS. 100 AND 101).
 CAROLYN CATALDO, EXAMINING ATTORNEY

SN 85-225,635. BRAD A GUNDERSON, DBA ABOUT2BUY, NORTH SIOUX CITY, SD. FILED 1-25-2011.

About2Buy

THE MARK CONSISTS OF STANDARD CHARACTERS WITHOUT CLAIM TO ANY PARTICULAR FONT, STYLE, SIZE, OR COLOR.
 FOR PROVIDING A WEB SITE FEATURING TECHNOLOGY THAT ENABLES USERS TO BROADCAST AND INTERACT TO PROMOTE THEIR PRODUCTS OR SERVICES (U.S. CLS. 100 AND 101).
 FIRST USE 1-20-2011; IN COMMERCE 1-24-2011.
 ELIZABETH KAJUBI, EXAMINING ATTORNEY

CLASS 42—(Continued).

SN 85-226,147. CHRISTIE, JOE, AUSTIN, TX. FILED 1-25-2011.

EmergenTEXT

THE MARK CONSISTS OF STANDARD CHARACTERS WITHOUT CLAIM TO ANY PARTICULAR FONT, STYLE, SIZE, OR COLOR.

FOR COMPUTER SERVICES, NAMELY, PROVIDING A WEB-BASED SYSTEM FEATURING ON-LINE NON-DOWNLOADABLE SOFTWARE THAT ENABLES USERS TO ACCESS A TWO-WAY TEXT MESSAGING SYSTEM UTILIZING THE DATA CHANNEL OF THE CELLULAR TELEPHONE NETWORK THAT ALLOWS USERS TO COMMUNICATE WITH EACH OTHER ON A REAL-TIME BASIS (U.S. CLS. 100 AND 101).

FIRST USE 8-20-2010; IN COMMERCE 9-10-2010.
KATHLEEN LORENZO, EXAMINING ATTORNEY

CLASS 42—(Continued).

SN 85-231,091. SURVEY & BALLOT SYSTEMS, INC., EDEN PRAIRIE, MN. FILED 2-1-2011.

myDirectVote

THE MARK CONSISTS OF STANDARD CHARACTERS WITHOUT CLAIM TO ANY PARTICULAR FONT, STYLE, SIZE, OR COLOR.

OWNER OF U.S. REG. NO. 2,898,201.
FOR PROVIDING TEMPORARY USE OF NON-DOWNLOADABLE SOFTWARE FOR CONDUCTING ELECTIONS AND MANAGING AND ADMINISTERING THE VOTING PROCESS (U.S. CLS. 100 AND 101).
CHARLES L. JENKINS, EXAMINING ATTORNEY

SN 85-230,924. COMPASS GROUP USA, INC., CHARLOTTE, NC. FILED 2-1-2011.



THE MARK CONSISTS OF THE WORDING "CO2" BE-SIDE A FOOT PRINT HAVING A TOMATO AS THE BIG TOE, ALL ABOVE THE WORDING "MINIMIZE YOUR CARBON FOOTPRINT".

FOR PROVIDING INFORMATION IN THE FIELD OF TRACKING AND LOWERING GREENHOUSE GAS EMISSIONS FOR THE CONTRACT FOOD INDUSTRY (U.S. CLS. 100 AND 101).

LINDA POWELL, EXAMINING ATTORNEY

SN 85-231,457. DAILEY, ANNA, BENSLEM, PA. FILED 2-1-2011.

DAY FRAMER

THE MARK CONSISTS OF STANDARD CHARACTERS WITHOUT CLAIM TO ANY PARTICULAR FONT, STYLE, SIZE, OR COLOR.

NO CLAIM IS MADE TO THE EXCLUSIVE RIGHT TO USE "DAY", APART FROM THE MARK AS SHOWN.
FOR PROVIDING A WEB SITE FEATURING TECHNOLOGY THAT ENABLES USERS TO CREATE A CHRONOLOGICAL SCHEDULE OF EVENTS (U.S. CLS. 100 AND 101).

LINDA M. KING, EXAMINING ATTORNEY

CLASS 42—(Continued).

SN 85-232,496. LEARDON SOLUTIONS, ESCONDIDO, CA.
FILED 2-2-2011.

Leardon Solutions

THE MARK CONSISTS OF STANDARD CHARACTERS WITHOUT CLAIM TO ANY PARTICULAR FONT, STYLE, SIZE, OR COLOR.

NO CLAIM IS MADE TO THE EXCLUSIVE RIGHT TO USE "SOLUTIONS", APART FROM THE MARK AS SHOWN.

FOR COMPUTER-AIDED ENGINEERING SERVICES FOR OTHERS; CONSULTING SERVICES IN THE FIELD OF THE DESIGN OF MECHANICAL AND ELECTRICAL PRODUCTS, NAMELY, PROOF-OF CONCEPT PROTOTYPES, INTEGRATED DESIGN PROTOTYPES, AND PRODUCTION PROTOTYPES; CUSTOM DESIGN AND ENGINEERING OF MECHANICAL AND ELECTRICAL PRODUCTS, NAMELY, PROOF-OF CONCEPT PROTOTYPES, INTEGRATED DESIGN PROTOTYPES, AND PRODUCTION PROTOTYPES; DESIGN AND TESTING FOR NEW PRODUCT DEVELOPMENT; DESIGN AND TESTING OF NEW PRODUCTS FOR OTHERS; DESIGN OF MECHANICAL AND MICROMECHANICAL COMPONENTS; DESIGN OF MECHANICAL, ELECTROMECHANICAL AND OPTOELECTRONIC APPARATUS AND INSTRUMENTS; INDUSTRIAL DESIGN; INDUSTRIAL DESIGN SERVICES; NEW PRODUCT DESIGN SERVICES; PACKAGING DESIGN; PACKAGING DESIGN FOR OTHERS; PRODUCT DESIGN AND DEVELOPMENT IN THE FIELD OF MECHANICAL AND ELECTRICAL PRODUCTS, NAMELY, PROOF-OF CONCEPT PROTOTYPES, INTEGRATED DESIGN PROTOTYPES, AND PRODUCTION PROTOTYPES (U.S. CLS. 100 AND 101).

FIRST USE 11-22-2005; IN COMMERCE 12-28-2005.
SUZANNE BLANE, EXAMINING ATTORNEY

CLASS 42—(Continued).

SN 85-242,202. FOUNDATIONS IN LEARNING, INC., IOWA CITY, IA. FILED 2-15-2011.

FOUNDATIONS IN READING

THE MARK CONSISTS OF STANDARD CHARACTERS WITHOUT CLAIM TO ANY PARTICULAR FONT, STYLE, SIZE, OR COLOR.

NO CLAIM IS MADE TO THE EXCLUSIVE RIGHT TO USE "READING", APART FROM THE MARK AS SHOWN.

FOR ON-LINE NON-DOWNLOADABLE WEB-DELIVERED SOFTWARE FOR IMPROVING READING SKILLS OF 2ND- 6TH GRADERS WHO ARE BELOW GRADE-LEVEL (U.S. CLS. 100 AND 101).

WILLIAM BRECKENFELD, EXAMINING ATTORNEY

SN 85-242,974. ADAMS, KEISHA ANDREA MADISON, GENOVA, ITALY, FILED 2-15-2011.

CIÂVE

SN 85-242,198. RENT YOUR CIO, LLC, HOUSTON, TX.
FILED 2-15-2011.

RENT YOUR CIO

THE MARK CONSISTS OF STANDARD CHARACTERS WITHOUT CLAIM TO ANY PARTICULAR FONT, STYLE, SIZE, OR COLOR.

NO CLAIM IS MADE TO THE EXCLUSIVE RIGHT TO USE "CIO", APART FROM THE MARK AS SHOWN.

FOR INFORMATION TECHNOLOGY CONSULTING SERVICES (U.S. CLS. 100 AND 101).

FIRST USE 6-10-2006; IN COMMERCE 6-10-2006.
CAROLINE WOOD, EXAMINING ATTORNEY

THE MARK CONSISTS OF STANDARD CHARACTERS WITHOUT CLAIM TO ANY PARTICULAR FONT, STYLE, SIZE, OR COLOR.

THE ENGLISH TRANSLATION OF "CIÂVE" IN THE MARK IS "KEY".

FOR COMPUTER SERVICES, NAMELY, CREATING AN ON-LINE COMMUNITY FOR REGISTERED USERS TO PARTICIPATE IN COMPETITIONS, SHOWCASE THEIR SKILLS, GET FEEDBACK FROM THEIR PEERS, FORM VIRTUAL COMMUNITIES, ENGAGE IN SOCIAL NETWORKING AND IMPROVE THEIR TALENT (U.S. CLS. 100 AND 101).

FIRST USE 1-31-2011; IN COMMERCE 1-31-2011.
KATHERINE M. DUBRAY, EXAMINING ATTORNEY

CLASS 42—(Continued).

SN 85-243,752. VENENUM BIODESIGN, LLC, HAMILTON, NJ. FILED 2-16-2011.



NO CLAIM IS MADE TO THE EXCLUSIVE RIGHT TO USE "BIODESIGN", APART FROM THE MARK AS SHOWN. THE MARK CONSISTS OF THE LITERAL ELEMENTS "VENENUM BIODESIGN" AND A STYLIZED OVAL CONTAINING THE DEPICTION OF A CHEMICAL STRUCTURE; THE LETTERS "NENUM" IN "VENENUM" APPEAR IN FRONT OF THE STYLIZED OVAL AND ABOVE THE CHEMICAL STRUCTURE, THE TERM "BIODESIGN" APPEARS IN FRONT OF THE STYLIZED OVAL AND BELOW THE CHEMICAL STRUCTURE; HORIZONTAL STREAKS APPEAR BEHIND THE LITERAL ELEMENTS AND STYLIZED OVAL.

FOR DRUG DISCOVERY SERVICES; PHARMACEUTICAL DRUG DEVELOPMENT SERVICES (U.S. CLS. 100 AND 101).

REBECCA GILBERT, EXAMINING ATTORNEY

SN 85-244,227. POLLMERICA, INC., NEW YORK, NY. FILED 2-16-2011.



THE MARK CONSISTS OF THE WORD "POLLMERICA", APPEARING IN LARGE SIZE, WITH THE WORDS "THE HOMEPAGE OF AMERICAN OPINION" APPEARING UNDERNEATH IN SMALLER SIZE, AND A BALLOON AND STAR DESIGN APPEARING TO THE LEFT.

FOR COMPUTER SERVICES, NAMELY, HOSTING ONLINE WEB FACILITIES FOR OTHERS FOR ORGANIZING AND CONDUCTING ONLINE MEETINGS, GATHERINGS, AND INTERACTIVE DISCUSSIONS; AND COMPUTER SERVICES IN THE NATURE OF CUSTOMIZED WEB PAGES FEATURING USER-DEFINED INFORMATION, PERSONAL PROFILES AND INFORMATION; COMPUTER SERVICES, NAMELY, CREATING AN ON-LINE COMMUNITY FOR REGISTERED USERS TO PARTICIPATE IN DISCUSSION, GET FEEDBACK FROM THEIR PEERS, FORM VIRTUAL COMMUNITIES, AND ENGAGE IN SOCIAL NETWORKING; PEER-TO-BROWSER PHOTO SHARING SERVICES, NAMELY, PROVIDING A WEBSITE FEATURING TECHNOLOGY ENABLING USERS TO UPLOAD, VIEW AND DOWNLOAD DIGITAL PHOTOS (U.S. CLS. 100 AND 101).

DOMINICK J. SALEMI, EXAMINING ATTORNEY

CLASS 42—(Continued).

SN 85-244,310. ALTERYX, LLC, ORANGE, CA. FILED 2-16-2011.

INSPIRING INGENUITY

THE MARK CONSISTS OF STANDARD CHARACTERS WITHOUT CLAIM TO ANY PARTICULAR FONT, STYLE, SIZE, OR COLOR.

FOR SOFTWARE AS A SERVICE SERVICES FEATURING SOFTWARE FOR MARKET ANALYSIS, MANAGEMENT OF DATA AND CREATING DEMOGRAPHIC REPORTS; PROVIDING TEMPORARY USE OF A WEB-BASED SOFTWARE PLATFORMS AND APPLICATIONS FOR MARKET ANALYSIS, MANAGEMENT OF DATA AND CREATING DEMOGRAPHIC REPORTS; APPLICATION SERVICE PROVIDER FEATURING API SOFTWARE FOR MARKET ANALYSIS, MANAGEMENT OF DATA AND CREATING DEMOGRAPHIC REPORTS; SOFTWARE AS A SERVICE SERVICES FOR BUSINESS AND MARKETING SERVICES, NAMELY, PROVISION OF MARKET ANALYSIS AND DATA MANAGEMENT FOR OTHERS, NAMELY, COLLECTING AND ORGANIZING GEOGRAPHIC DATA FOR USE IN CONNECTION WITH RETAIL STORE SERVICES AND MARKETING SERVICES; SOFTWARE AS A SERVICE SERVICES FOR DEMOGRAPHIC DATA MANAGEMENT FOR OTHERS, NAMELY, FOR USE IN COLLECTING AND ORGANIZING DEMOGRAPHIC INFORMATION FOR USE IN CONNECTION WITH PUBLIC AND PRIVATE SECTOR BUSINESS DEVELOPMENT, AND FOR USE IN CONNECTION WITH DEMOGRAPHIC DATA ANALYSIS; PROVIDING TEMPORARY USE OF A WEB-BASED SOFTWARE PLATFORMS AND APPLICATIONS FOR BUSINESS AND MARKETING SERVICES, NAMELY, PROVISION OF MARKET ANALYSIS AND DATA MANAGEMENT FOR OTHERS, NAMELY, COLLECTING AND ORGANIZING GEOGRAPHIC DATA FOR USE IN CONNECTION WITH RETAIL STORE SERVICES AND MARKETING SERVICES; PROVIDING TEMPORARY USE OF A WEB-BASED SOFTWARE PLATFORMS AND APPLICATIONS FOR DEMOGRAPHIC DATA MANAGEMENT FOR OTHERS, NAMELY, FOR USE IN COLLECTING AND ORGANIZING DEMOGRAPHIC INFORMATION FOR USE IN CONNECTION WITH PUBLIC AND PRIVATE SECTOR BUSINESS DEVELOPMENT, AND FOR USE IN CONNECTION WITH DEMOGRAPHIC DATA ANALYSIS (U.S. CLS. 100 AND 101).

FIRST USE 1-1-2011; IN COMMERCE 1-1-2011.

JUDITH HELFMAN, EXAMINING ATTORNEY

CLASS 42—(Continued).

SN 85-244,337. TERAGREN LLC, BAINBRIDGE ISLAND, WA. FILED 2-16-2011.

TERAGREN

THE MARK CONSISTS OF STANDARD CHARACTERS WITHOUT CLAIM TO ANY PARTICULAR FONT, STYLE, SIZE, OR COLOR.

OWNER OF U.S. REG. NOS. 3,029,775, 3,204,279 AND OTHERS.

THE WORDING "TERAGREN" HAS NO MEANING IN A FOREIGN LANGUAGE.

FOR PROVIDING A WEBSITE FEATURING INFORMATION IN THE FIELD OF INTERIOR DESIGN AND ARCHITECTURE; PROVIDING A WEBSITE FEATURING INFORMATION ABOUT GREEN ARCHITECTURE AND INTERIOR DESIGN; COLOR ANALYSIS FOR PURPOSES OF INTERIOR DESIGN; INTERIOR DESIGN SERVICES; INDUSTRIAL DESIGN SERVICES; HOSTING OF DIGITAL CONTENT ON THE INTERNET (U.S. CLS. 100 AND 101).

ALEX KEAM, EXAMINING ATTORNEY

CLASS 42—(Continued).

SN 85-246,065. FIRST CALL COMPUTER SOLUTIONS, MISSOULA, MT. FILED 2-18-2011.

First Call Computer Solutions

THE MARK CONSISTS OF STANDARD CHARACTERS WITHOUT CLAIM TO ANY PARTICULAR FONT, STYLE, SIZE, OR COLOR.

NO CLAIM IS MADE TO THE EXCLUSIVE RIGHT TO USE "COMPUTER SOLUTIONS", APART FROM THE MARK AS SHOWN.

FOR BUSINESS TECHNOLOGY SOFTWARE CONSULTATION SERVICES; COMPUTER SERVICES, NAMELY, ON-SITE MANAGEMENT OF THE INFORMATION TECHNOLOGY (IT) SYSTEMS; COMPUTER SERVICES, NAMELY, REMOTE AND ON-SITE MANAGEMENT OF THE INFORMATION TECHNOLOGY (IT) CLOUD COMPUTING SYSTEMS OF OTHERS; COMPUTER SERVICES, NAMELY, REMOTE AND ON-SITE MANAGEMENT OF THE INFORMATION TECHNOLOGY (IT) SYSTEMS OF OTHERS; COMPUTER SERVICES, NAMELY, REMOTE MANAGEMENT OF THE INFORMATION TECHNOLOGY (IT) SYSTEMS OF OTHERS; COMPUTER TECHNOLOGY SUPPORT SERVICES, NAMELY, HELP DESK SERVICES; CONSULTING IN THE FIELD OF INFORMATION TECHNOLOGY; CONSULTING IN THE FIELD OF TELECOMMUNICATIONS TECHNOLOGY; INFORMATION TECHNOLOGY CONSULTATION; PLANNING, DESIGN AND MANAGEMENT OF INFORMATION TECHNOLOGY SYSTEMS; PROVIDING A WEB HOSTING PLATFORM FOR BUSINESS WEBSITES (U.S. CLS. 100 AND 101).

FIRST USE 1-1-1998; IN COMMERCE 2-2-1998.
HANNO RITTNER, EXAMINING ATTORNEY

SN 85-245,299. NEXTDAY APOINTEMENTS, LLC, NEW YORK, NY. FILED 2-17-2011.



NO CLAIM IS MADE TO THE EXCLUSIVE RIGHT TO USE "24 7", APART FROM THE MARK AS SHOWN.

THE MARK CONSISTS OF THE TEXT "OPENDOCTORS" NEXT TO A ROUNDED SQUARE CONTAINING THE NUMBER "24" WITH A SUPERSCRIP "7".

FOR PROVIDING A WEBSITE FEATURING NON-DOWNLOADABLE SOFTWARE FOR ONLINE HEALTH-CARE APPOINTMENT SCHEDULING (U.S. CLS. 100 AND 101).

FIRST USE 1-28-2011; IN COMMERCE 1-28-2011.
EMILY CHUO, EXAMINING ATTORNEY

SN 85-246,442. ELSKAMP EDWARD J., MIDDLETON, WI. AND MASON STEPHEN J., MADISON, WI. FILED 2-18-2011.

Marshall Erdman & Associates

THE MARK CONSISTS OF STANDARD CHARACTERS WITHOUT CLAIM TO ANY PARTICULAR FONT, STYLE, SIZE, OR COLOR.

NO CLAIM IS MADE TO THE EXCLUSIVE RIGHT TO USE "ASSOCIATES", APART FROM THE MARK AS SHOWN.

THE NAME(S), PORTRAIT(S), AND/OR SIGNATURE(S) SHOWN IN THE MARK DOES NOT IDENTIFY A PARTICULAR LIVING INDIVIDUAL.

FOR ARCHITECTURAL DESIGN; INTERIOR DESIGN SERVICES; LANDSCAPE ARCHITECTURAL DESIGN (U.S. CLS. 100 AND 101).

AISHA CLARKE, EXAMINING ATTORNEY

CLASS 42—(Continued).

SN 85-246,444. MODERN SPECIES LLC, MADISON, WI. FILED 2-18-2011.

MODERN SPECIES

THE MARK CONSISTS OF STANDARD CHARACTERS WITHOUT CLAIM TO ANY PARTICULAR FONT, STYLE, SIZE, OR COLOR.

FOR GRAPHIC DESIGN SERVICES (U.S. CLS. 100 AND 101).

FIRST USE 5-5-2011; IN COMMERCE 5-5-2011.
AISHA CLARKE, EXAMINING ATTORNEY

SN 85-247,496. IOD INCORPORATED, GREEN BAY, WI. FILED 2-21-2011.



NO CLAIM IS MADE TO THE EXCLUSIVE RIGHT TO USE "RAC" OR "MEDICAL CASE AUDIT MANAGEMENT", APART FROM THE MARK AS SHOWN.

THE COLOR(S) TEAL AND BLACK IS/ARE CLAIMED AS A FEATURE OF THE MARK.

THE MARK CONSISTS OF THE LITERAL ELEMENTS "RAC ASSIST MEDICAL CASE AUDIT MANAGEMENT" IN A RECTANGULAR BOX WITH THE TWO OF ITS SIDES ARE SHOWN IN HALF CIRCULAR SHAPE WITH A TEAL BOUNDARY, WHEREIN THERE IS A CIRCULAR IMAGE COMPRISING OF SEVERAL CONCENTRIC SHAPES, THE WORD "RAC" IS IN BLACK COLOR AND VERTICAL TILTED TO THE LEFT OF THE WORD "ASSIST" WHICH IS IN TEAL COLOR UNDER WHICH THE WORDS "MEDICAL CASE AUDIT MANAGEMENT" IS WRITTEN IN BLACK AS SHOWN IN THE MARK.

FOR APPLICATION SERVICE PROVIDER (ASP) FEATURING SOFTWARE FOR USE IN HEALTH INDUSTRY TO MANAGE DATA SUCH AS DENIALS AND APPEALS (U.S. CLS. 100 AND 101).

FIRST USE 7-21-2008; IN COMMERCE 1-12-2009.
CARRIE GENOVESE, EXAMINING ATTORNEY

SN 85-247,973. INTECONNECT, INC., CEDAR RAPIDS, IA. FILED 2-22-2011.



THE MARK CONSISTS OF A CURVED MOBIUS POSITIONED TO THE LEFT OF THE WORD "INTECONNEX", WHICH FEATURES A CAPITAL LETTER "I".

FOR INTEGRATION OF COMPUTER SYSTEMS AND NETWORKS (U.S. CLS. 100 AND 101).

FIRST USE 2-1-2011; IN COMMERCE 2-1-2011.
JORDAN BAKER, EXAMINING ATTORNEY

CLASS 42—(Continued).

SN 85-248,123. RED BRICK DESIGNS LLC, OKLAHOMA CITY, OK. FILED 2-22-2011.



THE MARK CONSISTS OF A STYLIZED FISH DESIGN TOGETHER WITH THE WORDS "LIQUIDFISH".

FOR GRAPHIC DESIGN SERVICES; WEB SITE DEVELOPMENT SERVICES FOR OTHERS (U.S. CLS. 100 AND 101).

ALEX KEAM, EXAMINING ATTORNEY

SN 85-248,169. LAN MASTERS, INC., ORLANDO, FL. FILED 2-22-2011.

LAN Masters, Inc.

THE MARK CONSISTS OF STANDARD CHARACTERS WITHOUT CLAIM TO ANY PARTICULAR FONT, STYLE, SIZE, OR COLOR.

NO CLAIM IS MADE TO THE EXCLUSIVE RIGHT TO USE "LAN" AND "INC.", APART FROM THE MARK AS SHOWN.

FOR COMPUTER CONSULTATION; COMPUTER SERVICES, NAMELY, REMOTE AND ON-SITE MANAGEMENT OF THE INFORMATION TECHNOLOGY (IT) SYSTEMS OF OTHERS; COMPUTER VIRUS PROTECTION SERVICES; INSTALLATION, MAINTENANCE AND REPAIR OF COMPUTER SOFTWARE; RECOVERY OF COMPUTER DATA (U.S. CLS. 100 AND 101).

FIRST USE 8-16-2010; IN COMMERCE 8-16-2010.
LEIGH CAROLINE CASE, EXAMINING ATTORNEY

CLASS 42—(Continued).

SN 85-248,262. APPSBIDDER INC, BROOLYN, NY. FILED 2-22-2011.

AppsBidder

THE MARK CONSISTS OF STANDARD CHARACTERS WITHOUT CLAIM TO ANY PARTICULAR FONT, STYLE, SIZE, OR COLOR.

FOR APPLICATION SERVICE PROVIDER, NAMELY, PROVIDING, HOSTING, MANAGING, DEVELOPING AND MAINTAINING APPLICATIONS, SOFTWARE, WEBSITES AND DATABASES FOR OTHERS IN THE FIELDS OF PERSONAL PRODUCTIVITY, WIRELESS COMMUNICATION, MOBILE INFORMATION ACCESS, AND REMOTE DATA MANAGEMENT FOR WIRELESS DELIVERY OF CONTENT TO WIRELESS COMPUTING AND TELECOMMUNICATIONS DEVICES; COMPUTER SOFTWARE DEVELOPMENT IN THE FIELD OF MOBILE APPLICATIONS (U.S. CLS. 100 AND 101).
JEFF DEFORD, EXAMINING ATTORNEY

CLASS 42—(Continued).

SN 85-248,552. GOCH, MARKUS, HANNOVER, FED REP GERMANY, FILED 2-22-2011.

EASYDISPLAY

THE MARK CONSISTS OF STANDARD CHARACTERS WITHOUT CLAIM TO ANY PARTICULAR FONT, STYLE, SIZE, OR COLOR.

OWNER OF U.S. REG. NO. 3,940,984.
FOR COMPUTER AND SCIENTIFIC SERVICES, NAMELY, COMPUTER GRAPHIC SERVICES, COMPUTER PROGRAMMING SERVICES, AND DESIGN OF ADVERTISING DISPLAYS THROUGH DIGITAL FORMATTING OF IMAGES, TEXT AND MUSIC (U.S. CLS. 100 AND 101).
TRICIA SONNEBORN, EXAMINING ATTORNEY

SN 85-248,796. CLOUDSURFING LLC, BELLEVUE, WA. FILED 2-22-2011.

CloudSurfing

THE MARK CONSISTS OF STANDARD CHARACTERS WITHOUT CLAIM TO ANY PARTICULAR FONT, STYLE, SIZE, OR COLOR.

FOR PROVIDING A WEBSITE THAT GIVES COMPUTER USERS THE ABILITY TO REVIEW AND DISCUSS WEB APPLICATIONS (U.S. CLS. 100 AND 101).
FIRST USE 1-20-2011; IN COMMERCE 1-20-2011.
IRA J. GOODSaid, EXAMINING ATTORNEY

SN 85-248,277. INVENTIA HEALTHCARE PVT LTD, MUMBAI, INDIA, FILED 2-22-2011.



THE MARK CONSISTS OF THE WORD "INVENTIA" WITH A DESIGN OF A SQUARE ABOVE THE FIRST LETTER "I"; BOTH THE LETTERS "I" ARE PUNCTUATED WITH A SMALL STYLIZED CIRCLE.

THE WORDING "INVENTIA" HAS NO MEANING IN A FOREIGN LANGUAGE.

FOR SCIENTIFIC RESEARCH AND TECHNOLOGICAL SERVICES IN THE FIELD OF MEDICAL, PHARMACEUTICAL PRODUCTS; RESEARCH AND DEVELOPMENT OF NEW PRODUCTS; BIOLOGICAL RESEARCH; CHEMICAL RESEARCH; CONSULTATION, ADVISORY, AND INFORMATION SERVICES FOR OR IN THE FIELD OF HEALTH PRODUCT DEVELOPMENT, IN RELATION TO HUMAN BEINGS (U.S. CLS. 100 AND 101).
MARC LEIPZIG, EXAMINING ATTORNEY

SN 85-248,831. CLOUDSURFING LLC, BELLEVUE, WA. FILED 2-22-2011.

CloudSurfers

THE MARK CONSISTS OF STANDARD CHARACTERS WITHOUT CLAIM TO ANY PARTICULAR FONT, STYLE, SIZE, OR COLOR.

FOR PROVIDING A WEBSITE THAT GIVES COMPUTER USERS THE ABILITY TO JOIN AN ON-LINE COMMUNITY VIA THEIR PROFILE INFORMATION TO DISCUSS AND REVIEW WEB APPLICATIONS (U.S. CLS. 100 AND 101).
FIRST USE 10-10-2008; IN COMMERCE 1-20-2011.
IRA J. GOODSaid, EXAMINING ATTORNEY

CLASS 42—(Continued).

SN 85-250,051. TARGETSAFETY.COM, INC., SAN DIEGO, CA. FILED 2-23-2011.

TARGETSOLUTIONS

THE MARK CONSISTS OF STANDARD CHARACTERS WITHOUT CLAIM TO ANY PARTICULAR FONT, STYLE, SIZE, OR COLOR.

OWNER OF U.S. REG. NO. 3,834,458.

FOR WORKPLACE CERTIFICATION SERVICES, NAMELY, CONDUCTING SURVEYS AND TESTING FOR WORKPLACE EXCELLENCE; TESTING, ANALYSIS AND EVALUATING THE KNOWLEDGE, SKILLS AND ABILITIES OF OTHERS FOR THE PURPOSE OF CERTIFICATION IN THE FIELD OF RISK MANAGEMENT; TESTING, ANALYSIS AND EVALUATION OF THE GOODS AND SERVICES OF OTHERS FOR THE PURPOSE OF CERTIFICATION; COMPUTER SERVICES, NAMELY, CREATING AN ON-LINE COMMUNITY FOR REGISTERED USERS TO PARTICIPATE IN DISCUSSIONS, SHARE INFORMATION CONCERNING CERTIFIED TRAINING AND IDEAS TO MAINTAIN COMPLIANCE WITH INDUSTRY STANDARDS AND LEGAL REQUIREMENTS (U.S. CLS. 100 AND 101).
LINDA POWELL, EXAMINING ATTORNEY

CLASS 42—(Continued).

SN 85-250,669. SHASH, KIMBERLY, DBA KAELISE DESIGNS, CHARLOTTE, NC. FILED 2-24-2011.

KAELISE DESIGNS

THE MARK CONSISTS OF STANDARD CHARACTERS WITHOUT CLAIM TO ANY PARTICULAR FONT, STYLE, SIZE, OR COLOR.

NO CLAIM IS MADE TO THE EXCLUSIVE RIGHT TO USE "DESIGNS", APART FROM THE MARK AS SHOWN.

FOR FASHION DESIGN CONSULTING SERVICES; INTERIOR AND FURNITURE DESIGN SERVICES; INTERIOR LIGHTING AND LANDSCAPE LIGHTING DESIGN SERVICES (U.S. CLS. 100 AND 101).

FIRST USE 6-30-2010; IN COMMERCE 6-30-2010.
IRA J. GOODSaid, EXAMINING ATTORNEY

SN 85-251,169. TARGETSAFETY.COM, INC., SAN DIEGO, CA. FILED 2-24-2011.

SN 85-250,519. PACIFIC STRUCTURAL & FORENSIC ENGINEERS GROUP INC., VENTURA, CA. FILED 2-24-2011.



THE COLOR(S) RED, WHITE AND BLUE IS/ARE CLAIMED AS A FEATURE OF THE MARK.

THE MARK CONSISTS OF A RECTANGLE OF THE AMERICAN FLAG ON A LIGHT BLUE BACKGROUND AND A WAVE OF DARK BLUE BELOW WITH THE STYLIZED LETTERS "PSFEG".

FOR STRUCTURAL AND FORENSIC ENGINEERING (U.S. CLS. 100 AND 101).
FIRST USE 5-1-2010; IN COMMERCE 5-1-2010.
JILL PRATER, EXAMINING ATTORNEY



OWNER OF U.S. REG. NO. 3,834,458.

THE MARK CONSISTS OF A STYLIZED ROUND TARGET WITH THREE RINGS AND THE OUTER TWO RINGS NOT BEING CLOSED COMPLETELY AS THE TWO RINGS INTERSECT WITH THE BEGINNING "T" IN THE LOWER CASE WORD "TARGETSOLUTIONS" WITH THE LETTERS "SOLUTIONS" BEING IN A WIDER FONT LETTERING.

FOR WORKPLACE CERTIFICATION SERVICES, NAMELY, CONDUCTING SURVEYS AND TESTING FOR WORKPLACE EXCELLENCE; TESTING, ANALYSIS AND EVALUATING THE KNOWLEDGE, SKILLS AND ABILITIES OF OTHERS FOR THE PURPOSE OF CERTIFICATION IN THE FIELD OF RISK MANAGEMENT; TESTING, ANALYSIS AND EVALUATION OF THE GOODS AND SERVICES OF OTHERS FOR THE PURPOSE OF CERTIFICATION; COMPUTER SERVICES, NAMELY, CREATING AN ON-LINE COMMUNITY FOR REGISTERED USERS TO PARTICIPATE IN DISCUSSIONS, SHARE INFORMATION CONCERNING CERTIFIED TRAINING AND IDEAS TO MAINTAIN COMPLIANCE WITH INDUSTRY STANDARDS AND LEGAL REQUIREMENTS (U.S. CLS. 100 AND 101).
LINDA POWELL, EXAMINING ATTORNEY

CLASS 42—(Continued).

SN 85-251,238. TARGETSAFETY.COM, INC., SAN DIEGO, CA. FILED 2-24-2011.



OWNER OF U.S. REG. NO. 3,844,401.
 THE MARK CONSISTS OF LOWER CASE LETTERING "PREVENTIONLINK" WITH THE LETTERS "LINK" BEING IN A WIDER FONT, AND A STYLIZED ROUND TARGET WITH THREE RINGS TO THE RIGHT OF THE WORD WITH THE OUTER TWO RINGS NOT BEING CLOSED COMPLETELY AS THE TWO RINGS INTERSECT WITH THE "K" IN "PREVENTIONLINK".
 FOR WORKPLACE CERTIFICATION SERVICES, NAMELY, CONDUCTING SURVEYS AND TESTING FOR WORKPLACE EXCELLENCE; TESTING, ANALYSIS AND EVALUATING THE KNOWLEDGE, SKILLS AND ABILITIES OF OTHERS FOR THE PURPOSE OF CERTIFICATION IN THE FIELD OF RISK MANAGEMENT; TESTING, ANALYSIS AND EVALUATION OF THE GOODS AND SERVICES OF OTHERS FOR THE PURPOSE OF CERTIFICATION; COMPUTER SERVICES, NAMELY, CREATING AN ON-LINE COMMUNITY FOR REGISTERED USERS TO PARTICIPATE IN DISCUSSIONS, SHARE INFORMATION CONCERNING CERTIFIED TRAINING AND IDEAS TO MAINTAIN COMPLIANCE WITH INDUSTRY STANDARDS AND LEGAL REQUIREMENTS (U.S. CLS. 100 AND 101).
 LINDA POWELL, EXAMINING ATTORNEY

CLASS 42—(Continued).

SN 85-251,491. HERSHEY CHOCOLATE & CONFECTIONERY CORPORATION, WHEAT RIDGE, CO. FILED 2-25-2011.



OWNER OF U.S. REG. NOS. 54,041, 3,631,154 AND OTHERS.
 THE MARK CONSISTS OF A GRAPHICAL REPRESENTATION OF A BUILDING WITH FOUR COLUMNS AND FOUR STEPS WITH THE TRIANGULAR ROOF OF THE BUILDING HAVING A PLUME DEVICE EXTENDING FROM THE CENTER OF THE ROOF UPWARDS AND TO THE RIGHT AND CONTAINING THE WORD "HERSHEY'S". A SEMICIRCLE, EMANATING FROM THE STEPS, SURROUNDS THE BUILDING.
 FOR SCIENTIFIC RESEARCH IN THE FIELD OF CHOCOLATE, COCOA AND NUTS (U.S. CLS. 100 AND 101).
 FIRST USE 8-22-2007; IN COMMERCE 8-22-2007.
 JACQUELINE A. LAVINE, EXAMINING ATTORNEY

SN 85-251,872. FOOD52, INC., BROOKLYN, NY. FILED 2-25-2011.



THE MARK CONSISTS OF STANDARD CHARACTERS WITHOUT CLAIM TO ANY PARTICULAR FONT, STYLE, SIZE, OR COLOR.
 FOR COMPUTER SERVICES, NAMELY, HOSTING AND MAINTAINING AN ON-LINE WEB SITE FOR OTHERS TO VIEW, SHARE AND RATE RECIPES, ASK QUESTIONS AND RECEIVE ANSWERS ABOUT COOKING AND RECIPES; COMPUTER SERVICES, NAMELY, INTERACTIVE HOSTING SERVICES WHICH ALLOW THE USER TO PUBLISH AND SHARE THEIR OWN CONTENT AND IMAGES ON-LINE; HOSTING AN ON-LINE COMMUNITY WEB SITE FEATURING COOKING INFORMATION AND RECIPES; COMPUTER SERVICES, NAMELY, CREATING AN ON-LINE COMMUNITY FOR REGISTERED USERS TO PARTICIPATE IN COMPETITIONS, SHOWCASE THEIR SKILLS, GET FEEDBACK FROM THEIR PEERS, FORM VIRTUAL COMMUNITIES, ENGAGE IN SOCIAL NETWORKING AND IMPROVE THEIR TALENT; COMPUTER SERVICES, NAMELY, CREATING AN ON-LINE COMMUNITY FOR REGISTERED USERS TO PARTICIPATE IN DISCUSSIONS, GET FEEDBACK FROM THEIR PEERS, FORM VIRTUAL COMMUNITIES, AND ENGAGE IN SOCIAL NETWORKING FEATURING COOKING AND RECIPES; PROVIDING A WEB SITE FEATURING TECHNOLOGY THAT ENABLES USERS TO REQUEST AND RECORD IDEAS, SUGGESTIONS, AND COMMENTS FROM OTHER USERS IN THE FIELD OF COOKING AND RECIPES (U.S. CLS. 100 AND 101).
 FIRST USE 9-1-2009; IN COMMERCE 9-1-2009.
 JERI J. FICKES, EXAMINING ATTORNEY

CLASS 42—(Continued).

SN 85-251,884. FOOD52, INC., BROOKLYN, NY. FILED 2-25-2011.

foodpickle

THE MARK CONSISTS OF STANDARD CHARACTERS WITHOUT CLAIM TO ANY PARTICULAR FONT, STYLE, SIZE, OR COLOR.

FOR COMPUTER SERVICES, NAMELY, HOSTING AND MAINTAINING AN ON-LINE WEB SITE FOR OTHERS TO VIEW, SHARE AND RATE RECIPES, ASK QUESTIONS AND RECEIVE ANSWERS ABOUT COOKING AND RECIPES; COMPUTER SERVICES, NAMELY, INTERACTIVE HOSTING SERVICES WHICH ALLOW THE USER TO PUBLISH AND SHARE THEIR OWN CONTENT AND IMAGES ON-LINE; COMPUTER SERVICES, NAMELY, CREATING AN ON-LINE COMMUNITY FOR REGISTERED USERS TO PARTICIPATE IN COMPETITIONS, SHOWCASE THEIR SKILLS, GET FEEDBACK FROM THEIR PEERS, FORM VIRTUAL COMMUNITIES, ENGAGE IN SOCIAL NETWORKING AND IMPROVE THEIR TALENT; COMPUTER SERVICES, NAMELY, CREATING AN ON-LINE COMMUNITY FOR REGISTERED USERS TO PARTICIPATE IN DISCUSSIONS, GET FEEDBACK FROM THEIR PEERS, FORM VIRTUAL COMMUNITIES, AND ENGAGE IN SOCIAL NETWORKING FEATURING COOKING AND RECIPES; PROVIDING A WEB SITE FEATURING TECHNOLOGY THAT ENABLES USERS TO REQUEST AND RECORD IDEAS, SUGGESTIONS, AND COMMENTS FROM OTHER USERS IN THE FIELD OF COOKING AND RECIPES (U.S. CLS. 100 AND 101).

FIRST USE 9-1-2009; IN COMMERCE 9-1-2009.
JERI J. FICKES, EXAMINING ATTORNEY

SN 85-252,224. SHOPLINKZ, LLC, LITTLE ROCK, AR. FILED 2-25-2011.

SHOPLINKZ

THE MARK CONSISTS OF STANDARD CHARACTERS WITHOUT CLAIM TO ANY PARTICULAR FONT, STYLE, SIZE, OR COLOR.

FOR COMPUTER SERVICES, NAMELY, CREATING ON-LINE VIRTUAL COMMUNITIES FOR REGISTERED USERS TO ORGANIZE GROUPS AND EVENTS, PARTICIPATE IN DISCUSSIONS, AND ENGAGE IN SOCIAL, BUSINESS AND COMMUNITY NETWORKING ; COMPUTER SERVICES, NAMELY, HOSTING ELECTRONIC FACILITIES FOR OTHERS FOR ORGANIZING AND CONDUCTING MEETINGS, EVENTS AND INTERACTIVE DISCUSSIONS VIA COMMUNICATION NETWORKS ; APPLICATION SERVICE PROVIDER (ASP) NAMELY, HOSTING COMPUTER SOFTWARE APPLICATIONS OF OTHERS ; APPLICATION SERVICE PROVIDER (ASP) FEATURING SOFTWARE TO ENABLE OR FACILITATE THE UPLOADING, DOWNLOADING, STREAMING, POSTING, DISPLAYING, BLOGGING, LINKING, SHARING OR OTHERWISE PROVIDING ELECTRONIC MEDIA OR INFORMATION OVER COMMUNICATION NETWORKS ; PROVIDING AN ONLINE NETWORK SERVICE THAT ENABLES USERS TO TRANSFER PERSONAL IDENTITY DATA TO AND SHARE PERSONAL IDENTITY DATA WITH AND AMONG MULTIPLE WEBSITES ; PROVIDING A WEB SITE FEATURING TECHNOLOGY THAT ENABLES ON-LINE USERS TO CREATE PERSONAL PROFILES FEATURING

CLASS 42—(Continued).

TURING SOCIAL NETWORKING INFORMATION AND TO TRANSFER AND SHARE SUCH INFORMATION AMONG MULTIPLE WEBSITES ; COMPUTER SERVICES, NAMELY, CREATING INDEXES OF INFORMATION, SITES AND OTHER RESOURCES AVAILABLE ON COMPUTER NETWORKS ; PROVIDING TEMPORARY USE OF NON-DOWNLOADABLE SOFTWARE APPLICATIONS FOR SOCIAL NETWORKING, CREATING A VIRTUAL COMMUNITY, AND TRANSMISSION OF AUDIO, VIDEO, PHOTOGRAPHIC IMAGES, TEXT, GRAPHICS AND DATA ; COMPUTER SERVICES IN THE NATURE OF CUSTOMIZED WEB PAGES FEATURING USER-DEFINED OR SPECIFIED INFORMATION, PERSONAL PROFILES, AUDIO, VIDEO, PHOTOGRAPHIC IMAGES, TEXT, GRAPHICS AND DATA ; PEER-TO-BROWSER PHOTO SHARING SERVICES, NAMELY, PROVIDING A WEBSITE FEATURING TECHNOLOGY ENABLING USERS TO UPLOAD, VIEW, AND DOWNLOAD DIGITAL PHOTOS; PROVIDING A WEB SITE FEATURING TECHNOLOGY THAT ENABLES USERS TO UPLOAD AND SHARE VIDEO, PHOTOS, TEXT, GRAPHICS AND DATA ; CREATING AND MAINTAINING BLOGS FOR OTHERS (U.S. CLS. 100 AND 101).

FIRST USE 3-14-2010; IN COMMERCE 3-14-2010.
JAMES GRIFFIN, EXAMINING ATTORNEY

SN 85-252,226. SHOPLINKZ, LLC, LITTLE ROCK, AR. FILED 2-25-2011.

SHOPLINK

THE MARK CONSISTS OF STANDARD CHARACTERS WITHOUT CLAIM TO ANY PARTICULAR FONT, STYLE, SIZE, OR COLOR.

FOR COMPUTER SERVICES, NAMELY, CREATING ON-LINE VIRTUAL COMMUNITIES FOR REGISTERED USERS TO ORGANIZE GROUPS AND EVENTS, PARTICIPATE IN DISCUSSIONS, AND ENGAGE IN SOCIAL, BUSINESS AND COMMUNITY NETWORKING ; COMPUTER SERVICES, NAMELY, HOSTING ELECTRONIC FACILITIES FOR OTHERS FOR ORGANIZING AND CONDUCTING MEETINGS, EVENTS AND INTERACTIVE DISCUSSIONS VIA COMMUNICATION NETWORKS ; APPLICATION SERVICE PROVIDER (ASP) SERVICES, NAMELY, HOSTING COMPUTER SOFTWARE APPLICATIONS OF OTHERS ; APPLICATION SERVICE PROVIDER (ASP) FEATURING SOFTWARE TO ENABLE OR FACILITATE THE UPLOADING, DOWNLOADING, STREAMING, POSTING, DISPLAYING, BLOGGING, LINKING, SHARING OR OTHERWISE PROVIDING ELECTRONIC MEDIA OR INFORMATION OVER COMMUNICATION NETWORKS ; PROVIDING AN ONLINE NETWORK SERVICE THAT ENABLES USERS TO TRANSFER PERSONAL IDENTITY DATA TO AND SHARE PERSONAL IDENTITY DATA WITH AND AMONG MULTIPLE WEBSITES ; PROVIDING A WEB SITE FEATURING TECHNOLOGY THAT ENABLES ONLINE USERS TO CREATE PERSONAL PROFILES FEATURING SOCIAL NETWORKING INFORMATION AND TO TRANSFER AND SHARE SUCH INFORMATION AMONG MULTIPLE WEBSITES

CLASS 42—(Continued).

; COMPUTER SERVICES, NAMELY, CREATING INDEXES OF INFORMATION, SITES AND OTHER RESOURCES AVAILABLE ON COMPUTER NETWORKS ; PROVIDING TEMPORARY USE OF NON-DOWNLOADABLE SOFTWARE APPLICATIONS FOR SOCIAL NETWORKING, CREATING A VIRTUAL COMMUNITY, AND TRANSMISSION OF AUDIO, VIDEO, PHOTOGRAPHIC IMAGES, TEXT, GRAPHICS AND DATA ; COMPUTER SERVICES IN THE NATURE OF CUSTOMIZED WEB PAGES FEATURING USER-DEFINED OR SPECIFIED INFORMATION, PERSONAL PROFILES, AUDIO, VIDEO, PHOTOGRAPHIC IMAGES, TEXT, GRAPHICS AND DATA ; PEER-TO-BROWSER PHOTO SHARING SERVICES, NAMELY, PROVIDING A WEBSITE FEATURING TECHNOLOGY ENABLING USERS TO UPLOAD, VIEW, AND DOWNLOAD DIGITAL PHOTOS ; PROVIDING A WEB SITE FEATURING TECHNOLOGY THAT ENABLES USERS TO UPLOAD AND SHARE VIDEO, PHOTOS, TEXT, GRAPHICS AND DATA ; CREATING AND MAINTAINING BLOGS FOR OTHERS (U.S. CLS. 100 AND 101).

FIRST USE 3-14-2010; IN COMMERCE 3-14-2010.
JAMES GRIFFIN, EXAMINING ATTORNEY

SN 85-252,325. JORDAN SCOTT, AMY, KINGWOOD, TX. FILED 2-25-2011.

CV Prescription

THE MARK CONSISTS OF STANDARD CHARACTERS WITHOUT CLAIM TO ANY PARTICULAR FONT, STYLE, SIZE, OR COLOR.

NO CLAIM IS MADE TO THE EXCLUSIVE RIGHT TO USE "CV", APART FROM THE MARK AS SHOWN.

FOR PROVIDING A WEBSITE FEATURING TECHNOLOGY THAT ENABLES USERS IN THE HEALTHCARE FIELD TO CREATE CUSTOM-DESIGNED RESUME PACKAGES (U.S. CLS. 100 AND 101).

JUDITH HELFMAN, EXAMINING ATTORNEY

SN 85-252,351. PIETECH, INC., POWHATAN, VA. FILED 2-25-2011.

PLAY ZONE

THE MARK CONSISTS OF STANDARD CHARACTERS WITHOUT CLAIM TO ANY PARTICULAR FONT, STYLE, SIZE, OR COLOR.

FOR PROVIDING ON-LINE, NON-DOWNLOADABLE SOFTWARE FOR THE CREATION, MARKETING AND PRESENTATION OF FINANCIAL PLANS FOR FINANCIAL ADVISORS AND CONSUMERS (U.S. CLS. 100 AND 101).

FIRST USE 5-4-2009; IN COMMERCE 11-2-2009.
KIMBERLY FRYE, EXAMINING ATTORNEY

CLASS 42—(Continued).

SN 85-252,531. SIMBIONIX USA CORPORATION, CLEVELAND, OH. FILED 2-26-2011.

SIMPOSIA

THE MARK CONSISTS OF STANDARD CHARACTERS WITHOUT CLAIM TO ANY PARTICULAR FONT, STYLE, SIZE, OR COLOR.

FOR HOSTING A WEBSITE AND MOBILE-BASED SERVICE FOR TRANSMITTING RICH MEDIA CONTENT, NAMELY, PROCEDURAL VIDEO CLIPS, CASE SIMULATIONS, AND INSTRUCTION, TO HEALTHCARE PROFESSIONALS; HOSTING A WEBSITE AND MOBILE-BASED SERVICE FOR TRANSMITTING RICH MEDIA-ENABLED VIRTUAL CONSULTATIONS BETWEEN GROUPS OF HEALTHCARE PROFESSIONALS; HOSTING A WEBSITE AND MOBILE-BASED SERVICE PROVIDING POLLING SERVICES TO HEALTHCARE PROFESSIONALS (U.S. CLS. 100 AND 101).

SKYE YOUNG, EXAMINING ATTORNEY

SN 85-252,760. TELVENT DTN, INC., OMAHA, NE. FILED 2-27-2011.

FLIGHT BRIEF

THE MARK CONSISTS OF STANDARD CHARACTERS WITHOUT CLAIM TO ANY PARTICULAR FONT, STYLE, SIZE, OR COLOR.

FOR PROVIDING TEMPORARY USE OF ON-LINE NON-DOWNLOADABLE SOFTWARE FOR USE IN ACCESSING AND DISPLAYING WEATHER INFORMATION (U.S. CLS. 100 AND 101).

FIRST USE 1-1-2002; IN COMMERCE 1-1-2002.
MORGAN WYNNE, EXAMINING ATTORNEY

SN 85-253,277. PRINCETON THEOLOGICAL SEMINARY, PRINCETON, NJ. FILED 2-28-2011.

CALLED TO COMMUNITY

THE MARK CONSISTS OF STANDARD CHARACTERS WITHOUT CLAIM TO ANY PARTICULAR FONT, STYLE, SIZE, OR COLOR.

FOR COMPUTER SERVICES, NAMELY, CREATING AN ON-LINE COMMUNITY IN THE FIELD OF RELIGIOUS MINISTRY FOR REGISTERED USERS SERVING IN ORDAINED VOCATIONS TO PARTICIPATE IN DISCUSSIONS, GET FEEDBACK FROM THEIR PEERS, FORM VIRTUAL COMMUNITIES, AND ENGAGE IN SOCIAL NETWORKING (U.S. CLS. 100 AND 101).

FIRST USE 1-1-2010; IN COMMERCE 1-1-2010.
SANDRA BUJA, EXAMINING ATTORNEY

CLASS 42—(Continued).

SN 85-253,390. TEGG CORPORATION, PITTSBURGH, PA. FILED 2-28-2011.

TEGGSENTINEL

THE MARK CONSISTS OF STANDARD CHARACTERS WITHOUT CLAIM TO ANY PARTICULAR FONT, STYLE, SIZE, OR COLOR.

OWNER OF U.S. REG. NO. 1,776,044.

FOR SERVICE PROVIDING ONLINE MONITORING OF FACILITY POWER CONSUMPTION AND POWER QUALITY, FOR THIRD PARTIES, AT ONE OR MORE POINTS WITHIN THE FACILITY (U.S. CLS. 100 AND 101).

CURTIS FRENCH, EXAMINING ATTORNEY

CLASS 42—(Continued).

SN 85-253,598. AUDITIONBOOTH, NEW YORK, NY. FILED 2-28-2011.



THE MARK CONSISTS OF THE LETTER @, WITH A SMALL STAR IN THE @ SIGN, NEXT TO THE LETTER B. BOTH LETTERS ARE LOWER-CASE.

FOR APPLICATION SERVICE PROVIDER FEATURING SOFTWARE FOR USE IN PROCESSING OF MEDIA AND MEDIA BASED TRANSACTIONS SUCH AS MUSIC AND VIDEO FOR THIRD PARTIES BY WAY OF A REMOTE SERVER, VIA THE INTERNET; COMPUTER SERVICES, NAMELY, CREATING AN ON-LINE COMMUNITY FOR REGISTERED USERS TO PARTICIPATE IN DISCUSSIONS, GET FEEDBACK FROM THEIR PEERS, FORM VIRTUAL FAN CLUB COMMUNITIES AND ENGAGE IN SOCIAL NETWORKING (U.S. CLS. 100 AND 101).

FIRST USE 6-30-2010; IN COMMERCE 11-15-2010.
CHARLES L. JENKINS, EXAMINING ATTORNEY

SN 85-253,558. HYDRONALIX, INC., SAHUARITA, AZ. FILED 2-28-2011.

HYDRONALIX

THE MARK CONSISTS OF STANDARD CHARACTERS WITHOUT CLAIM TO ANY PARTICULAR FONT, STYLE, SIZE, OR COLOR.

FOR DESIGN, ENGINEERING, RESEARCH, DEVELOPMENT AND TESTING SERVICES IN THE FIELD OF MARITIME ROBOTIC TECHNOLOGY (U.S. CLS. 100 AND 101).

FIRST USE 6-12-2009; IN COMMERCE 6-12-2009.
ANDREW LEASER, EXAMINING ATTORNEY

SN 85-253,981. MOFUSE, INC, PAWTUCKET, RI. FILED 2-28-2011.

MoFuse

THE MARK CONSISTS OF STANDARD CHARACTERS WITHOUT CLAIM TO ANY PARTICULAR FONT, STYLE, SIZE, OR COLOR.

FOR APPLICATION SERVICE PROVIDER (ASP), NAMELY, HOSTING COMPUTER SOFTWARE APPLICATIONS OF OTHERS; PLATFORM AS A SERVICE (PAAS) FEATURING COMPUTER SOFTWARE PLATFORMS FOR BUSINESSES TO BUILD AND MANAGE THEIR MOBILE WEBSITE EXPERIENCES, PROVIDING BUILDING TOOLS, MOBILE AD MANAGEMENT, MOBILE ANALYTICS AND A NUMBER OF MOBILE LOCATION BASED SERVICES (U.S. CLS. 100 AND 101).

FIRST USE 7-1-2007; IN COMMERCE 11-1-2007.
JOHN E. MICHOS, EXAMINING ATTORNEY

CLASS 42—(Continued).

SN 85-254,192. VIACODE CONSULTING LLC, AKA VIACODE, WEST HARTFORD, CT. FILED 3-1-2011.

VIACODE

THE MARK CONSISTS OF STANDARD CHARACTERS WITHOUT CLAIM TO ANY PARTICULAR FONT, STYLE, SIZE, OR COLOR.

FOR COMPUTER SOFTWARE DESIGN, COMPUTER PROGRAMMING, OR MAINTENANCE OF COMPUTER SOFTWARE (U.S. CLS. 100 AND 101).

FIRST USE 10-1-2010; IN COMMERCE 10-1-2010.
PATRICIA EVANKO, EXAMINING ATTORNEY

SN 85-254,323. MCGIBNEY, JAMES, LAS VEGAS, NV. FILED 3-1-2011.

Karmaville

THE MARK CONSISTS OF STANDARD CHARACTERS WITHOUT CLAIM TO ANY PARTICULAR FONT, STYLE, SIZE, OR COLOR.

FOR CREATING AND MAINTAINING BLOGS FOR OTHERS; PROVIDING CUSTOMIZED ON-LINE WEB PAGES AND DATA FEEDS FEATURING USER-DEFINED INFORMATION, WHICH INCLUDES BLOG POSTS, NEW MEDIA CONTENT, OTHER ON-LINE CONTENT, AND ON-LINE WEB LINKS TO OTHER WEBSITES (U.S. CLS. 100 AND 101).

JESSICA FATHY, EXAMINING ATTORNEY

SN 85-254,433. MARCUS, COOPER, DBA WISHERY, SAN FRANCISCO, CA. FILED 3-1-2011.

Wishery

THE MARK CONSISTS OF STANDARD CHARACTERS WITHOUT CLAIM TO ANY PARTICULAR FONT, STYLE, SIZE, OR COLOR.

FOR COMPUTER SOFTWARE DEVELOPMENT, COMPUTER PROGRAMMING AND MAINTENANCE OF COMPUTER SOFTWARE FOR THE COMPILATION AND PROCESSING OF DATA FOR CENTRAL DATABASE THROUGH LOCAL AND GLOBAL NETWORKS; PROVIDING TEMPORARY USE OF ON-LINE NON-DOWNLOADABLE SOFTWARE, NAMELY, GRAPHICAL USER INTERFACE SOFTWARE FOR USE IN MANAGING CUSTOMER RELATIONSHIPS (U.S. CLS. 100 AND 101).

FIRST USE 1-1-2011; IN COMMERCE 1-1-2011.
ALYSSA STEEL, EXAMINING ATTORNEY

CLASS 42—(Continued).

SN 85-254,479. CANCER THERAPEUTICS INNOVATION GROUP, LLC, CAMBRIDGE, MA. FILED 3-1-2011.

CTIG

THE MARK CONSISTS OF STANDARD CHARACTERS WITHOUT CLAIM TO ANY PARTICULAR FONT, STYLE, SIZE, OR COLOR.

FOR CONDUCTING RESEARCH AND CLINICAL TRIALS RELATING TO PHARMACEUTICALS (U.S. CLS. 100 AND 101).

KIMBERLY PERRY, EXAMINING ATTORNEY

SN 85-254,731. LONGWOOD SOFTWARE, INC., MAYNARD, MA. FILED 3-1-2011.

REVBASE

THE MARK CONSISTS OF STANDARD CHARACTERS WITHOUT CLAIM TO ANY PARTICULAR FONT, STYLE, SIZE, OR COLOR.

OWNER OF U.S. REG. NO. 3,814,979.

FOR SOFTWARE AS A SERVICE (SAAS) SERVICES, NAMELY, HOSTING SOFTWARE FOR USE BY OTHERS FOR USE TO STORE, MANAGE, TRACK, ANALYZE, AND REPORT DATA IN THE FIELD OF MARKETING, PROMOTION, SALES, CUSTOMER INFORMATION, CUSTOMER RELATIONSHIP MANAGEMENT, SALES SUPPORT AND EMPLOYEE EFFICIENCY; PROVIDING TEMPORARY USE OF ON-LINE NON-DOWNLOADABLE SOFTWARE TO FACILITATE COMMUNICATING AMONG PEER PROFESSIONALS IN THE ADVERTISING, MARKETING AND BUSINESS SERVICES FIELDS (U.S. CLS. 100 AND 101).

FIRST USE 2-1-2010; IN COMMERCE 2-1-2010.
DANNEAN HETZEL, EXAMINING ATTORNEY

CLASS 42—(Continued).

SN 85-254,896. PERFECT WORKING SPACES, MILL VALLEY, CA. FILED 3-1-2011.



THE COLOR(S) TAN, PURPLE, TEAL, AND PINK IS/ARE CLAIMED AS A FEATURE OF THE MARK.

THE MARK CONSISTS OF A DESIGN OF A CIRCULAR OBJECT, THE OUTER CIRCLE IS IN THE COLOR OF TAN, WITHIN THE TAN CIRCLE IS A CIRCLE IN THE COLOR OF PURPLE, WITHIN THE PURPLE CIRCLE IS A CIRCLE IN THE COLOR OF TEAL AND WITHIN THE TEAL CIRCLE IS A CIRCLE IN THE COLOR OF PINK; DIRECTLY TO THE RIGHT OF THE CIRCULAR DESIGN IS THE WORDING "PERFECT WORKING SPACES" IN STYLIZED FONT AND IN THE COLOR OF TEAL.

FOR BUSINESS TECHNOLOGY SOFTWARE CONSULTATION SERVICES; COMPUTER CONSULTATION; COMPUTER PROGRAMMING CONSULTANCY; COMPUTER SERVICES, NAMELY, MANAGING WEB SITES FOR OTHERS; COMPUTER SERVICES, NAMELY, SEARCH ENGINE OPTIMIZATION; CONSULTANCY WITH REGARD TO WEBPAGE DESIGN; CONSULTATION SERVICES IN THE FIELD OF SEARCH ENGINE OPTIMIZATION; CONSULTING IN THE FIELD OF INFORMATION TECHNOLOGY; CONSULTING SERVICES IN THE FIELD OF COMPUTER-BASED INFORMATION SYSTEMS FOR BUSINESSES; DESIGN AND MAINTENANCE OF WEB SITES FOR OTHERS; DESIGN, CREATION, HOSTING, MAINTENANCE OF WEBSITES FOR OTHERS; GRAPHIC DESIGN; GRAPHIC DESIGN SERVICES; HOSTING OF WEB SITES; HOSTING THE WEB SITES OF OTHERS; HOSTING THE WEB SITES OF OTHERS ON A COMPUTER SERVER FOR A GLOBAL COMPUTER NETWORK; INFORMATION TECHNOLOGY CONSULTATION; IT CONSULTING SERVICES; MAINTENANCE OF WEBSITES AND HOSTING ONLINE WEB FACILITIES FOR OTHERS; MANAGING WEB SITES FOR OTHERS; PLANNING, DESIGN, DEVELOPMENT, MAINTENANCE AND OPTIMIZATION OF ONLINE WEBSITES FOR THIRD PARTIES; PRODUCT DEVELOPMENT CONSULTATION; TECHNICAL CONSULTING AND ASSISTANCE WITH COMPUTER-BASED INFORMATION SYSTEMS AND COMPONENTS; WEB SITE DESIGN; WEB SITE DEVELOPMENT FOR OTHERS; WEB SITE HOSTING SERVICES (U.S. CLS. 100 AND 101).

FIRST USE 10-1-2008; IN COMMERCE 10-1-2008.
CARRIE GENOVESE, EXAMINING ATTORNEY

SN 85-254,980. MOUNT VERNON BUSINESS SYSTEMS INC., ALEXANDRIA, VA. FILED 3-1-2011.

SNORALYZER

THE MARK CONSISTS OF STANDARD CHARACTERS WITHOUT CLAIM TO ANY PARTICULAR FONT, STYLE, SIZE, OR COLOR.

OWNER OF U.S. REG. NO. 2,929,072.
FOR PROVIDING A WEB SITE FEATURING TEMPORARY USE OF NON-DOWNLOADABLE SOFTWARE FOR THE ANALYSIS OF SNORING (U.S. CLS. 100 AND 101).

KATHERINE STOIDES, EXAMINING ATTORNEY

CLASS 42—(Continued).

SN 85-255,021. HERITAGE PRESERVATION CORPORATION, SPARTANBURG, SC. FILED 3-1-2011.

CUSTOMPLAN

THE MARK CONSISTS OF STANDARD CHARACTERS WITHOUT CLAIM TO ANY PARTICULAR FONT, STYLE, SIZE, OR COLOR.

FOR PROVIDING TEMPORARY USE OF NON-DOWNLOADABLE SOFTWARE TO CUSTOMERS VIA A GLOBAL COMPUTER NETWORK FOR GENERATING CUSTOMIZED ENROLLMENT DOCUMENTS AND ANNUAL OFFERING REVIEWS FOR THE RETIREMENT SERVICES INDUSTRY, IN PRINT OR ELECTRONIC FORM (U.S. CLS. 100 AND 101).

GENE MACIOL, EXAMINING ATTORNEY

SN 85-255,022. EDISON WATSON LLC, DOVER, DE. FILED 3-1-2011.

EDISON WATSON

THE MARK CONSISTS OF STANDARD CHARACTERS WITHOUT CLAIM TO ANY PARTICULAR FONT, STYLE, SIZE, OR COLOR.

THE NAME "EDISON WATSON" DOES NOT IDENTIFY A LIVING INDIVIDUAL.

FOR INDUSTRIAL DESIGN; INDUSTRIAL DESIGN SERVICES (U.S. CLS. 100 AND 101).

ANDREA HACK, EXAMINING ATTORNEY

SN 85-255,043. EPIC SYSTEM CORPORATION, VERONA, WI. FILED 3-1-2011.

Community Connect

THE MARK CONSISTS OF STANDARD CHARACTERS WITHOUT CLAIM TO ANY PARTICULAR FONT, STYLE, SIZE, OR COLOR.

FOR INSTALLATION AND MAINTENANCE OF COMPUTER SOFTWARE (U.S. CLS. 100 AND 101).

FIRST USE 11-7-2007; IN COMMERCE 8-20-2009.
BENJAMIN OKEKE, EXAMINING ATTORNEY

CLASS 42—(Continued).

SN 85-255,056. SPORTSGRANTS, INC., HOOD RIVER, OR.
FILED 3-1-2011.

SHARE EVERYWHERE

THE MARK CONSISTS OF STANDARD CHARACTERS WITHOUT CLAIM TO ANY PARTICULAR FONT, STYLE, SIZE, OR COLOR.

FOR COMPUTER SERVICES, NAMELY, PROVIDING A WEB-BASED SYSTEM AND ONLINE PORTAL FEATURING ON-LINE NONDOWNLOADABLE SOFTWARE THAT ENABLES USERS TO SOLICIT CHARITABLE DONATIONS AND SHARE INFORMATION ON CHARITABLE CAUSES ACROSS SOCIAL NETWORKS (U.S. CLS. 100 AND 101).

APRIL HESIK, EXAMINING ATTORNEY

SN 85-255,103. DIEBOLD, INCORPORATED, NORTH CANTON, OH. FILED 3-1-2011.

OPTEVA TRUSENTRYGARD

THE MARK CONSISTS OF STANDARD CHARACTERS WITHOUT CLAIM TO ANY PARTICULAR FONT, STYLE, SIZE, OR COLOR.

OWNER OF U.S. REG. NOS. 2,841,649 AND 2,879,370. FOR MAINTENANCE OF COMPUTER SOFTWARE RELATING TO COMPUTER SECURITY AND PREVENTION OF COMPUTER RISKS (U.S. CLS. 100 AND 101).

JANICE L. MCMORROW, EXAMINING ATTORNEY

SN 85-255,581. SUCCESSQUEST INTERNATIONAL LLC, EDEN PRAIRIE, MN. FILED 3-2-2011.

PROJECTPOD

THE MARK CONSISTS OF STANDARD CHARACTERS WITHOUT CLAIM TO ANY PARTICULAR FONT, STYLE, SIZE, OR COLOR.

FOR PROVIDING TEMPORARY USE OF A WEB-BASED SOFTWARE APPLICATION FOR PLANNING, MANAGEMENT, AND MONITORING OF COMPANY COMMITMENTS AND EMPLOYEE RESPONSIBILITIES (U.S. CLS. 100 AND 101).

HANNO RITTNER, EXAMINING ATTORNEY

CLASS 42—(Continued).

SN 85-255,582. SUCCESSQUEST INTERNATIONAL LLC, EDEN PRAIRIE, MN. FILED 3-2-2011.

REFERRALPOD

THE MARK CONSISTS OF STANDARD CHARACTERS WITHOUT CLAIM TO ANY PARTICULAR FONT, STYLE, SIZE, OR COLOR.

FOR PROVIDING TEMPORARY USE OF A WEB-BASED SOFTWARE APPLICATION FOR ESTABLISHING, TRACKING, AND RECORDING COMMUNICATIONS RELATED TO REFERRALS (U.S. CLS. 100 AND 101).

HANNO RITTNER, EXAMINING ATTORNEY

SN 85-255,585. SUCCESSQUEST INTERNATIONAL LLC, EDEN PRAIRIE, MN. FILED 3-2-2011.

SUCCESSQUEST

THE MARK CONSISTS OF STANDARD CHARACTERS WITHOUT CLAIM TO ANY PARTICULAR FONT, STYLE, SIZE, OR COLOR.

FOR PROVIDING TEMPORARY USE OF A WEB-BASED SOFTWARE APPLICATION FOR ANALYSIS, ASSESSMENT, AND MANAGEMENT OF PERSONAL AND CORPORATE PRODUCTIVITY (U.S. CLS. 100 AND 101).

HANNO RITTNER, EXAMINING ATTORNEY

SN 85-255,669. WHETTSTONE BUSINESS SOLUTIONS, LLC, OMAHA, NE. FILED 3-2-2011.

WEBHORNET

THE MARK CONSISTS OF STANDARD CHARACTERS WITHOUT CLAIM TO ANY PARTICULAR FONT, STYLE, SIZE, OR COLOR.

FOR PROVIDING A WEBSITE THAT GIVES USERS THE ABILITY TO CREATE CUSTOMIZED WEB PAGES FEATURING USER-DEFINED INFORMATION (U.S. CLS. 100 AND 101).

FIRST USE 9-1-2010; IN COMMERCE 9-1-2010.
CHRISTOPHER BUONGIORNO, EXAMINING ATTORNEY

CLASS 42—(Continued).

SN 85-255,739. AMBER TECHNOLOGIES, LLC, ORLAND PARK, IL. FILED 3-2-2011.

VIRTUALLY ME

THE MARK CONSISTS OF STANDARD CHARACTERS WITHOUT CLAIM TO ANY PARTICULAR FONT, STYLE, SIZE, OR COLOR.

FOR COMPUTER SERVICES IN THE NATURE OF CUSTOMIZED WEB PAGES FEATURING USER-DEFINED INFORMATION, PERSONAL PROFILES AND INFORMATION; COMPUTER SERVICES, NAMELY, CREATING INDEXES OF INFORMATION, SITES AND OTHER RESOURCES AVAILABLE ON COMPUTER NETWORKS; COMPUTER SERVICES, NAMELY, PROVIDING SEARCH ENGINES FOR OBTAINING PERSONALIZED DATA AND OTHER INFORMATION THAT IS SPECIFIC TO A PERSON'S ATTRIBUTES ON A GLOBAL COMPUTER NETWORK (U.S. CLS. 100 AND 101).

KATHERINE STOIDES, EXAMINING ATTORNEY

SN 85-255,753. WHETTSTONE BUSINESS SOLUTIONS, LLC, OMAHA, NE. FILED 3-2-2011.



THE MARK CONSISTS OF THE WORD "WEBHORNET" AND TO THE LEFT OF THE WORD "WEBHORNET" IS A FACE OF A HORNET.

FOR PROVIDING A WEBSITE THAT GIVES USERS THE ABILITY TO CREATE CUSTOMIZED WEB PAGES FEATURING USER-DEFINED INFORMATION (U.S. CLS. 100 AND 101).

FIRST USE 9-1-2010; IN COMMERCE 9-1-2010.

CHRISTOPHER BUONGIORNO, EXAMINING ATTORNEY

SN 85-255,821. TRUECONTEXT CORPORATION, OTTAWA, ONTARIO, CANADA, FILED 3-2-2011.

PRONTOFORMS

THE MARK CONSISTS OF STANDARD CHARACTERS WITHOUT CLAIM TO ANY PARTICULAR FONT, STYLE, SIZE, OR COLOR.

FOR PROVIDING TEMPORARY USE OF NON-DOWNLOADABLE COMPUTER SOFTWARE APPLICATIONS FOR MOBILE PHONES AND PORTABLE DEVICES ALLOWING A USER TO CREATE AND USE CUSTOMIZED AND GENERIC FORMS; COMPUTER SOFTWARE DEVELOPMENT IN THE FIELD OF MOBILE APPLICATIONS (U.S. CLS. 100 AND 101).

FIRST USE 3-19-2007; IN COMMERCE 3-19-2007.

LINDA MICKLEBURGH, EXAMINING ATTORNEY

CLASS 42—(Continued).

SN 85-255,997. MYVC, LTD., NEW YORK, NY. FILED 3-2-2011.

My Virtual Confession

THE MARK CONSISTS OF STANDARD CHARACTERS WITHOUT CLAIM TO ANY PARTICULAR FONT, STYLE, SIZE, OR COLOR.

FOR COMPUTER SERVICES, NAMELY, CREATING AN ON-LINE COMMUNITY FOR REGISTERED USERS TO PARTICIPATE IN DISCUSSIONS, GET FEEDBACK FROM THEIR PEERS, FORM VIRTUAL COMMUNITIES, AND ENGAGE IN SOCIAL NETWORKING (U.S. CLS. 100 AND 101).

BILL DAWÉ, EXAMINING ATTORNEY

SN 85-256,211. SURVEY & BALLOT SYSTEMS, INC., EDEN PRAIRIE, MN. FILED 3-2-2011.



OWNER OF U.S. REG. NO. 2,898,201.

THE MARK CONSISTS OF THE WORD "MY" INSIDE A SHADED QUOTATION MARK FOLLOWED BY THE TERM "DIRECTVOTE".

FOR PROVIDING TEMPORARY USE OF NON-DOWNLOADABLE SOFTWARE FOR CONDUCTING ELECTIONS AND MANAGING AND ADMINISTERING THE VOTING PROCESS (U.S. CLS. 100 AND 101).

CHARLES L. JENKINS, EXAMINING ATTORNEY

CLASS 42—(Continued).

SN 85-256,227. TOVANI ARCHITECTS, PLLC, OLYMPIA, WA. FILED 3-2-2011.



NO CLAIM IS MADE TO THE EXCLUSIVE RIGHT TO USE "ARCHITECTS", APART FROM THE MARK AS SHOWN.

THE COLOR(S) BLACK, RED, AND WHITE IS/ARE CLAIMED AS A FEATURE OF THE MARK.

THE MARK CONSISTS OF A VERTICAL RECTANGULAR DESIGN WITH THE UPPER PORTION IN BLACK AND LOWER PORTION IN RED. THE WORDING "TOVANI" APPEARS IN WHITE WITHIN THE RED PORTION. THE WORDING "ARCHITECTS" APPEARS IN BLACK BENEATH THE RECTANGULAR DESIGN.

FOR ARCHITECTURAL DESIGN; GRAPHIC DESIGN (U.S. CLS. 100 AND 101).

FIRST USE 3-1-2010; IN COMMERCE 3-1-2010.
EMILY CHUO, EXAMINING ATTORNEY

SN 85-256,282. CLEAN CRAB LLC, OREM, UT. FILED 3-2-2011.



THE MARK CONSISTS OF AN IMAGE OF A CRAB BENEATH THE TEXT "CLEAN CRAB", WITH THE LETTER "C" IN "CRAB" IN THE FORM OF THE CRAB'S LEFT CLAW.

FOR DESIGN, CREATION, HOSTING, MAINTENANCE OF WEBSITES FOR OTHERS (U.S. CLS. 100 AND 101).

STEVEN JACKSON, EXAMINING ATTORNEY

CLASS 42—(Continued).

SN 85-256,311. SEOMIKE, LLC, LEAWOOD, KS. FILED 3-2-2011.

SEOMike

THE MARK CONSISTS OF STANDARD CHARACTERS WITHOUT CLAIM TO ANY PARTICULAR FONT, STYLE, SIZE, OR COLOR.

FOR COMPUTER SERVICES, NAMELY, SEARCH ENGINE OPTIMIZATION ; PLANNING, DESIGN, DEVELOPMENT, MAINTENANCE AND OPTIMIZATION OF ONLINE WEBSITES FOR THIRD PARTIES ; DESIGN, CREATION, HOSTING, MAINTENANCE OF WEBSITES FOR OTHERS ; WEBSITE DESIGN CONSULTATION (U.S. CLS. 100 AND 101).

FIRST USE 6-13-2003; IN COMMERCE 6-13-2003.
RONALD MCMORROW, EXAMINING ATTORNEY

SN 85-256,409. PADHANDED LLC, SEATTLE, WA. FILED 3-3-2011.

Padhanded

THE MARK CONSISTS OF STANDARD CHARACTERS WITHOUT CLAIM TO ANY PARTICULAR FONT, STYLE, SIZE, OR COLOR.

FOR SOFTWARE DEVELOPMENT AND PRODUCT DEVELOPMENT IN THE FIELD OF AUGMENTATIVE AND ALTERNATIVE COMMUNICATION (U.S. CLS. 100 AND 101).

FIRST USE 3-2-2011; IN COMMERCE 3-2-2011.
RONALD DELGIZZI, EXAMINING ATTORNEY

SN 85-257,018. ENERGY PLATFORMS, LLC, SHAKOPEE, MN. FILED 3-3-2011.

NEEDS

THE MARK CONSISTS OF STANDARD CHARACTERS WITHOUT CLAIM TO ANY PARTICULAR FONT, STYLE, SIZE, OR COLOR.

FOR COMPUTER SOFTWARE DEVELOPMENT, COMPUTER PROGRAMMING AND MAINTENANCE OF COMPUTER SOFTWARE IN THE FIELD OF ENERGY USAGE MANAGEMENT AND ENERGY EFFICIENCY (U.S. CLS. 100 AND 101).

PATRICIA EVANKO, EXAMINING ATTORNEY

CLASS 42—(Continued).

SN 85-257,032. DUSTIN ROBBINS, DBA PHORFRONT, ALEXANDRIA, VA. AND SARA OSORIO, DBA PHORFRONT, ALEXANDRIA, VA. FILED 3-3-2011.

Phorfront

THE MARK CONSISTS OF STANDARD CHARACTERS WITHOUT CLAIM TO ANY PARTICULAR FONT, STYLE, SIZE, OR COLOR.

FOR INFORMATION TECHNOLOGY CONSULTATION; PLANNING, DESIGN AND MANAGEMENT OF INFORMATION TECHNOLOGY SYSTEMS (U.S. CLS. 100 AND 101).

FIRST USE 0-0-2011; IN COMMERCE 0-0-2011.
CYNTHIA SLOAN, EXAMINING ATTORNEY

SN 85-257,179. CHARITY PANDA, LLC, KATONAH, NY. FILED 3-3-2011.

Charity Panda

THE MARK CONSISTS OF STANDARD CHARACTERS WITHOUT CLAIM TO ANY PARTICULAR FONT, STYLE, SIZE, OR COLOR.

NO CLAIM IS MADE TO THE EXCLUSIVE RIGHT TO USE "CHARITY", APART FROM THE MARK AS SHOWN.

FOR CHARITABLE SERVICES, NAMELY, PROVIDING A WEBSITE THAT FEATURES TECHNOLOGY THAT ENABLES HOSTS OF COMMEMORATIVE OCCASIONS TO INVITE GUESTS, INVITEES AND OTHER INVITATION RECIPIENTS TO DIRECT CONTRIBUTIONS TO CHARITABLE ORGANIZATIONS (U.S. CLS. 100 AND 101).

CHARISMA HAMPTON, EXAMINING ATTORNEY

SN 85-257,262. OTHERPAGE, LLC, SEATTLE, WA. FILED 3-3-2011.

likester

THE MARK CONSISTS OF STANDARD CHARACTERS WITHOUT CLAIM TO ANY PARTICULAR FONT, STYLE, SIZE, OR COLOR.

FOR PROVIDING A WEBSITE THAT GIVES COMPUTER USERS THE ABILITY TO VIEW WHAT THEIR FRIENDS LIKE, VIEW WHAT EVERYONE LIKES, AND VIEW WHAT PEOPLE IN THEIR OWN NEIGHBORHOOD, OR ACROSS THE WORLD, LIKES (U.S. CLS. 100 AND 101).

FIRST USE 2-1-2011; IN COMMERCE 2-1-2011.
RONALD AIKENS, EXAMINING ATTORNEY

CLASS 42—(Continued).

SN 85-257,484. SANJAY SACHIDANAND, EGG HARBOR TOWNSHIP, NJ. FILED 3-3-2011.

ProductPals

THE MARK CONSISTS OF STANDARD CHARACTERS WITHOUT CLAIM TO ANY PARTICULAR FONT, STYLE, SIZE, OR COLOR.

FOR COMPUTER SERVICES, NAMELY, CREATING AN ON-LINE COMMUNITY FOR REGISTERED USERS TO PARTICIPATE IN DISCUSSIONS, GET FEEDBACK FROM THEIR PEERS, FORM VIRTUAL COMMUNITIES, AND ENGAGE IN SOCIAL NETWORKING FEATURING PRODUCT INFORMATION AND MEDIA CONTENT (U.S. CLS. 100 AND 101).

ALYSSA STEEL, EXAMINING ATTORNEY

SN 85-257,648. CONWERGE WEB SERVICES PVT LTD, BANGALORE, INDIA, FILED 3-4-2011.

Grupur

THE MARK CONSISTS OF STANDARD CHARACTERS WITHOUT CLAIM TO ANY PARTICULAR FONT, STYLE, SIZE, OR COLOR.

THE WORDING GRUPUR HAS NO MEANING IN A FOREIGN LANGUAGE.

FOR PROVIDING A WEBSITE THAT GIVES COMPUTER USERS THE ABILITY TO GATHER INPUT FROM A PUBLIC OR PRIVATE GROUP FOR ANY PURPOSE OR OCCASION ALONG WITH THE ABILITY TO CONDUCT ONLINE FUND RAISING FOR SUCH GROUP, TO GIVE COMPUTER USERS THE ABILITY TO POOL SUPPLY OR DEMAND FOR A SPECIFIC PRODUCT OR SERVICE, AND TO GIVE COMPUTER USERS THE ABILITY TO MANAGE AND TRACK THE WORK TO BE PERFORMED BY A GROUP OF PEOPLE (U.S. CLS. 100 AND 101).

FIRST USE 2-15-2011; IN COMMERCE 2-15-2011.
ALEX KEAM, EXAMINING ATTORNEY

SN 85-257,953. JONES, KEVIN, SAN DIEGO, CA. FILED 3-4-2011.

UJOUST

THE MARK CONSISTS OF STANDARD CHARACTERS WITHOUT CLAIM TO ANY PARTICULAR FONT, STYLE, SIZE, OR COLOR.

FOR PROVISION OF INTERNET SEARCH ENGINES (U.S. CLS. 100 AND 101).

FIRST USE 8-1-2010; IN COMMERCE 8-1-2010.

THEODORE MCBRIDE, EXAMINING ATTORNEY

CLASS 42—(Continued).

SN 85-260,890. TEGG CORPORATION, PITTSBURGH, PA.
FILED 3-8-2011.

TEGGPro

THE MARK CONSISTS OF STANDARD CHARACTERS WITHOUT CLAIM TO ANY PARTICULAR FONT, STYLE, SIZE, OR COLOR.

OWNER OF U.S. REG. NO. 1,776,044.
FOR NON-DOWNLOADABLE ELECTRICAL MAINTENANCE AND PLANNING SOFTWARE, NAMELY, SOFTWARE FOR PRICING AND PROPOSAL GENERATION, SALES SUPPORT, TASKING FOR TESTING AND MAINTENANCE OF ELECTRICAL SYSTEMS, AND REPORT GENERATION (U.S. CLS. 100 AND 101).

FIRST USE 9-15-2010; IN COMMERCE 9-15-2010.
CURTIS FRENCH, EXAMINING ATTORNEY

SN 85-260,894. MICRON SYSTEMS INC., GLEN ROCK, NJ.
FILED 3-8-2011.

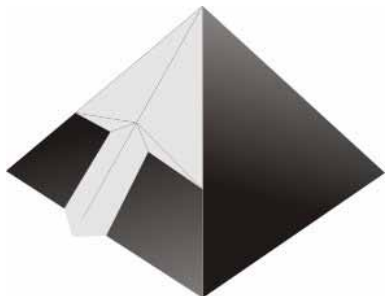

THE MARK CONSISTS OF A STYLIZED PYRAMID WITH AN ARROW POINTING UP ON THE LEFT FACE.

FOR PROVIDING TEMPORARY USE OF NON-DOWNLOADABLE SOFTWARE FOR USE IN THE FIELD OF HUMAN RESOURCES, FOR EVALUATING AND TRACKING EMPLOYEE PERFORMANCE (U.S. CLS. 100 AND 101).

FIRST USE 4-9-2010; IN COMMERCE 4-9-2010.
REBECCA SMITH, EXAMINING ATTORNEY

SN 85-261,313. OAK STUDIOS, LLC, BROOKLYN, NY.
FILED 3-8-2011.

DROPMARK

THE MARK CONSISTS OF STANDARD CHARACTERS WITHOUT CLAIM TO ANY PARTICULAR FONT, STYLE, SIZE, OR COLOR.

FOR PROVIDING ONLINE NON-DOWNLOADABLE SOFTWARE FOR COLLABORATION AND SHARING OF PHOTOS, AUDIO, VIDEO, NOTES, AND DOCUMENTS (U.S. CLS. 100 AND 101).

FIRST USE 1-1-2010; IN COMMERCE 3-3-2011.
GIANCARLO CASTRO, EXAMINING ATTORNEY

CLASS 42—(Continued).

SN 85-262,428. FARM CREDIT SERVICES OF AMERICA, ACA, OMAHA, NE. FILED 3-9-2011.

VISUAL VALUATION

THE MARK CONSISTS OF STANDARD CHARACTERS WITHOUT CLAIM TO ANY PARTICULAR FONT, STYLE, SIZE, OR COLOR.

NO CLAIM IS MADE TO THE EXCLUSIVE RIGHT TO USE "VALUATION", APART FROM THE MARK AS SHOWN.

FOR PROVIDING TEMPORARY USE OF ONLINE, NONDOWNLOADABLE COMPUTER SOFTWARE THAT ENABLES USERS TO ACCESS COMPUTER DATABASES, REPORTS, AND OTHER INFORMATION AND BUSINESS UTILITIES AND TOOLS IN THE FIELD OF REAL ESTATE APPRAISAL; INSTALLATION OF COMPUTER SOFTWARE; COMPUTER SERVICES, NAMELY, HOSTING AND MAINTAINING ON-LINE WEB SITES FOR OTHERS TO ENABLE USERS TO ACCESS COMPUTER DATABASES, REPORTS, AND OTHER INFORMATION AND BUSINESS UTILITIES AND TOOLS IN THE FIELD OF REAL ESTATE APPRAISAL (U.S. CLS. 100 AND 101).

ALEXANDER L. POWERS, EXAMINING ATTORNEY

SN 85-263,146. KOLLSMAN, INC., MERRIMACK, NH.
FILED 3-10-2011.

"NOTHING IS SAFER THAN SEEING"

THE MARK CONSISTS OF STANDARD CHARACTERS WITHOUT CLAIM TO ANY PARTICULAR FONT, STYLE, SIZE, OR COLOR.

FOR DESIGN AND DEVELOPMENT OF AIRCRAFT COCKPIT INSTRUMENTATION CONSISTING OF ADVANCED SENSORS, DATABASES, HEAD-UP DISPLAYS AND/OR HEAD-DOWN DISPLAYS THAT PROVIDE INCREASED PILOT VISIBILITY FOR TAKING OFF AND LANDING AIRCRAFT (U.S. CLS. 100 AND 101).

FIRST USE 10-6-2008; IN COMMERCE 10-6-2008.
THOMAS MANOR, EXAMINING ATTORNEY

CLASS 42—(Continued).

SN 85-263,275. JHB SOLUTIONS, LLC., DBA EZGOVOPPS, SAVAGE, MD. FILED 3-10-2011.

EZGovOpps

THE MARK CONSISTS OF STANDARD CHARACTERS WITHOUT CLAIM TO ANY PARTICULAR FONT, STYLE, SIZE, OR COLOR.

FOR PROVIDING AN ONLINE NON-DOWNLOADABLE INTERNET-BASED SYSTEM APPLICATION FEATURING TECHNOLOGY ENABLING USERS TO STORE, MANAGE, TRACK, ANALYZE, AND REPORT DATA IN THE FIELD OF BUSINESS INTELLIGENCE, MARKETING, PROCUREMENT AND TO FACILITATE COMMUNICATING AMONG PEER PROFESSIONALS IN THE PROCUREMENT AND BUSINESS SERVICES FIELDS (U.S. CLS. 100 AND 101).

FIRST USE 4-21-2011; IN COMMERCE 4-21-2011.
MARK PILARO, EXAMINING ATTORNEY

SN 85-264,346. ADVANTAGE SALES AND MARKETING LLC, IRVINE, CA. FILED 3-11-2011.

ASM 360

THE MARK CONSISTS OF STANDARD CHARACTERS WITHOUT CLAIM TO ANY PARTICULAR FONT, STYLE, SIZE, OR COLOR.

FOR PROVIDING TEMPORARY USE OF NON-DOWNLOADABLE COMPUTER SOFTWARE, NAMELY, A REPORTING AND ANALYTICS ENGINE THAT PULLS DATA FROM MANY OTHER SYSTEMS FOR USE IN THE FOOD BROKERAGE INDUSTRY (U.S. CLS. 100 AND 101).

CAROLYN CATALDO, EXAMINING ATTORNEY

SN 85-266,125. TELEVOX SOFTWARE, INC., MOBILE, AL. FILED 3-14-2011.

EasyRemind

THE MARK CONSISTS OF STANDARD CHARACTERS WITHOUT CLAIM TO ANY PARTICULAR FONT, STYLE, SIZE, OR COLOR.

FOR SUPPORT SERVICES, NAMELY, COMPUTER CONSULTATION IN THE NATURE OF ADVICE ON THE USE AND OPERATION OF COMPUTER SOFTWARE AND COMPUTER SYSTEMS; LEASING OF COMPUTERS AND COMPUTER SOFTWARE; AND INTEGRATION OF COMPUTER SOFTWARE AND COMPUTER HARDWARE (U.S. CLS. 100 AND 101).

DOMINIC FATHY, EXAMINING ATTORNEY

CLASS 42—(Continued).

SN 85-266,800. D&N IPROPERTIES LLC, WINTER PARK, FL. FILED 3-14-2011.

WORLD FITNESS ELITE

THE MARK CONSISTS OF STANDARD CHARACTERS WITHOUT CLAIM TO ANY PARTICULAR FONT, STYLE, SIZE, OR COLOR.

NO CLAIM IS MADE TO THE EXCLUSIVE RIGHT TO USE "FITNESS", APART FROM THE MARK AS SHOWN.

FOR COMPUTER SERVICES, NAMELY, CREATING AN ONLINE COMMUNITY FOR FITNESS EXPERTS TO SHOWCASE THEIR FIELDS OF EXPERTISE VIA VIDEO, AUDIO AND TEXT TO CONSUMERS AND JOURNALISTS (U.S. CLS. 100 AND 101).

MELISSA VALLILLO, EXAMINING ATTORNEY

SN 85-267,760. NEXLEN CONSULTING LLC, AUSTIN, TX. FILED 3-15-2011.

VANGLE

THE MARK CONSISTS OF STANDARD CHARACTERS WITHOUT CLAIM TO ANY PARTICULAR FONT, STYLE, SIZE, OR COLOR.

FOR CONSUMER PRODUCT SAFETY TESTING CONSULTATION (U.S. CLS. 100 AND 101).

SUNG IN, EXAMINING ATTORNEY

SN 85-280,188. JACK N. MCCRARY, HOUSTON, TX. FILED 3-29-2011.

Innovative Ideas to Reality

THE MARK CONSISTS OF STANDARD CHARACTERS WITHOUT CLAIM TO ANY PARTICULAR FONT, STYLE, SIZE, OR COLOR.

FOR DESIGN AND DEVELOPMENT OF MEDICAL DEVICES FOR OTHERS (U.S. CLS. 100 AND 101).

FIRST USE 12-31-1985; IN COMMERCE 12-31-1985.
ANNE E. GUSTASON, EXAMINING ATTORNEY

CLASS 42—(Continued).

SN 85-280,411. ELEMENTEK, LLC, DBA PEAKCOLO, DENVER, CO. FILED 3-29-2011.

WhiteCloud Service

THE MARK CONSISTS OF STANDARD CHARACTERS WITHOUT CLAIM TO ANY PARTICULAR FONT, STYLE, SIZE, OR COLOR.

NO CLAIM IS MADE TO THE EXCLUSIVE RIGHT TO USE "SERVICE", APART FROM THE MARK AS SHOWN.

FOR COMPUTER CO-LOCATION SERVICES, NAMELY, PROVIDING FACILITIES FOR THE LOCATION OF COMPUTER SERVERS WITH THE EQUIPMENT OF OTHERS; COMPUTER SERVICES, NAMELY, PROVIDING VIRTUAL AND NON VIRTUAL APPLICATION SERVERS, WEB SERVERS, FILE SERVERS, CO-LOCATION SERVERS, LOAD BALANCING SERVERS, REDUNDANCY SERVERS, MEDIA SERVERS AND DATABASE SERVERS OF VARIABLE CAPACITY TO THIRD PARTY COMPUTING AND DATA STORAGE FACILITIES; RENTAL OF SPACE IN A COMPUTER CO-LOCATION FACILITY FOR CONTAINERIZED DATA CENTERS OF OTHERS (U.S. CLS. 100 AND 101).
ANTHONY RINKER, EXAMINING ATTORNEY

SN 85-280,515. ELEMENTEK, LLC, DBA PEAKCOLO, DENVER, CO. FILED 3-29-2011.

THINK OUTSIDE THE RACK

THE MARK CONSISTS OF STANDARD CHARACTERS WITHOUT CLAIM TO ANY PARTICULAR FONT, STYLE, SIZE, OR COLOR.

FOR COMPUTER CO-LOCATION SERVICES, NAMELY, PROVIDING FACILITIES FOR THE LOCATION OF COMPUTER SERVERS WITH THE EQUIPMENT OF OTHERS; COMPUTER SERVICES, NAMELY, PROVIDING VIRTUAL AND NON VIRTUAL APPLICATION SERVERS, WEB SERVERS, FILE SERVERS, CO-LOCATION SERVERS, LOAD BALANCING SERVERS, REDUNDANCY SERVERS, MEDIA SERVERS AND DATABASE SERVERS OF VARIABLE CAPACITY TO THIRD PARTY COMPUTING AND DATA STORAGE FACILITIES; RENTAL OF SPACE IN A COMPUTER CO-LOCATION FACILITY FOR CONTAINERIZED DATA CENTERS OF OTHERS (U.S. CLS. 100 AND 101).
FIRST USE 2-16-2011; IN COMMERCE 2-16-2011.

ANTHONY RINKER, EXAMINING ATTORNEY

CLASS 42—(Continued).

SN 85-281,249. COMPASS GROUP USA, INC., CHARLOTTE, NC. FILED 3-30-2011.

CARBON FOOTPRINT

THE MARK CONSISTS OF STANDARD CHARACTERS WITHOUT CLAIM TO ANY PARTICULAR FONT, STYLE, SIZE, OR COLOR.

FOR PROVIDING INFORMATION IN THE FIELD OF TRACKING AND LOWERING GREENHOUSE GAS EMISSIONS FOR THE CONTRACT FOOD INDUSTRY (U.S. CLS. 100 AND 101).

LINDA POWELL, EXAMINING ATTORNEY

SN 85-283,647. PING IDENTITY CORPORATION, DENVER, CO. FILED 4-1-2011.

PINGONE

THE MARK CONSISTS OF STANDARD CHARACTERS WITHOUT CLAIM TO ANY PARTICULAR FONT, STYLE, SIZE, OR COLOR.

OWNER OF U.S. REG. NOS. 3,017,959, 3,336,775 AND OTHERS.

FOR SOFTWARE AS A SERVICE (SAAS) SERVICES, NAMELY, HOSTING NON-DOWNLOADABLE COMPUTER SOFTWARE FOR USE BY OTHERS THAT FACILITATES IDENTITY FEDERATION IN THE FIELD OF DIGITAL SECURITY AND IDENTIFICATION (U.S. CLS. 100 AND 101).

AMY HELLA, EXAMINING ATTORNEY

SN 85-303,494. MICRON SYSTEMS INC., GLEN ROCK, NJ. FILED 4-25-2011.

EAGLEWORKS

THE MARK CONSISTS OF STANDARD CHARACTERS WITHOUT CLAIM TO ANY PARTICULAR FONT, STYLE, SIZE, OR COLOR.

FOR CLOUD COMPUTING FEATURING WORK ALLOCATION SOFTWARE THAT ALLOWS ORGANIZATIONS TO ASSIGN WORK PROJECTS TO INDIVIDUALS AND GROUPS, TRACK THEIR PROGRESS AND EVALUATE THEIR EFFORTS (U.S. CLS. 100 AND 101).

REBECCA SMITH, EXAMINING ATTORNEY

CLASS 42—(Continued).

SN 85-326,106. JHB SOLUTIONS, LLC., DBA EZGOVOPPS, SAVAGE, MD. FILED 5-20-2011.

Big Business Tool. Small Business Budget.

THE MARK CONSISTS OF STANDARD CHARACTERS WITHOUT CLAIM TO ANY PARTICULAR FONT, STYLE, SIZE, OR COLOR.

FOR PROVIDING AN ONLINE NON-DOWNLOADABLE INTERNET-BASED SYSTEM APPLICATION FEATURING TECHNOLOGY ENABLING USERS TO STORE, MANAGE, TRACK, ANALYZE, AND REPORT DATA IN THE FIELD OF BUSINESS INTELLIGENCE, MARKETING, PROCUREMENT AND TO FACILITATE COMMUNICATING AMONG PEER PROFESSIONALS IN THE PROCUREMENT AND BUSINESS SERVICES FIELDS (U.S. CLS. 100 AND 101).

FIRST USE 4-21-2011; IN COMMERCE 4-21-2011.
MARK PILARO, EXAMINING ATTORNEY

CLASS 43—HOTEL AND RESTAURANT SERVICES

SN 76-704,827. HDYR, L.L.C., AUSTIN, TX. FILED 10-12-2010.

FREQUENT ROLLER

THE MARK CONSISTS OF STANDARD CHARACTERS WITHOUT CLAIM TO ANY PARTICULAR FONT, STYLE, SIZE, OR COLOR.

FOR RESTAURANT SERVICES FEATURING A FREQUENT DINER BONUS PROGRAM (U.S. CLS. 100 AND 101).

FIRST USE 10-27-2008; IN COMMERCE 10-27-2008.
GINA FINK, EXAMINING ATTORNEY

SN 76-704,831. HDYR, L.L.C., AUSTIN, TX. FILED 10-12-2010.

HIGH ROLLER

THE MARK CONSISTS OF STANDARD CHARACTERS WITHOUT CLAIM TO ANY PARTICULAR FONT, STYLE, SIZE, OR COLOR.

FOR RESTAURANT SERVICES FEATURING A FREQUENT DINER BONUS PROGRAM (U.S. CLS. 100 AND 101).

FIRST USE 5-1-2011; IN COMMERCE 5-1-2011.
GINA FINK, EXAMINING ATTORNEY

CLASS 43—(Continued).

SN 76-705,070. RAHIN, HAMEDULLA, DBA AHRIA CORPORATION, MORRISTOWN, NJ. FILED 10-26-2010.

PAMIR

THE MARK CONSISTS OF STANDARD CHARACTERS WITHOUT CLAIM TO ANY PARTICULAR FONT, STYLE, SIZE, OR COLOR.

FOR RESTAURANT SERVICES FEATURING AFGHANI-STYLE FOOD (U.S. CLS. 100 AND 101).

FIRST USE 0-0-1979; IN COMMERCE 0-0-1979.
DAVID HOFFMAN, EXAMINING ATTORNEY

SN 77-378,047. COWGIRLS FRANCHISING LLC, WOODINVILLE, WA. FILED 1-23-2008.



NO CLAIM IS MADE TO THE EXCLUSIVE RIGHT TO USE "ESPRESSO", APART FROM THE MARK AS SHOWN. THE COLOR(S) BLACK, WHITE AND PINK IS/ARE CLAIMED AS A FEATURE OF THE MARK.

THE MARK CONSISTS OF THE WORDING "COWGIRLS" IN BLACK WITH A PINK STAR ABOVE THE LETTER "I". "ESPRESSO" IS IN BLACK WITH A PINK RECTANGULAR BACKGROUND. "GIDDY UP!" IS IN BLACK. TO THE RIGHT OF THE WORDING IS A WOMAN IN WHITE WITH BLACK HAIR AND A SWIMSUIT, HAT, AND BOOTS IN PINK AND BLACK.

FOR COFFEE SHOPS IN THE NATURE OF A DRIVE-THROUGH COFFEE STAND (U.S. CLS. 100 AND 101).

FIRST USE 5-0-2007; IN COMMERCE 5-0-2007.
KAPIL BHANOT, EXAMINING ATTORNEY

SN 77-480,378. MAX HAMBURGERRESTAURANGER AB, LULEA, SWEDEN, FILED 5-21-2008.



OWNER OF SWEDEN REG. NO. 196014, DATED 5-3-1985, EXPIRES 5-3-2015.

THE MARK CONSISTS OF THE WORD "MAX" IN STYLIZED LETTERING WITH A THIN BORDER AROUND THE LETTERS.

FOR RESTAURANT SERVICES (U.S. CLS. 100 AND 101).

EVELYN BRADLEY, EXAMINING ATTORNEY

CLASS 43—(Continued).

SN 77-686,056. RED BULL GMBH, FUSCHL AM SEE, AUSTRIA, FILED 3-8-2009.

CLASS 43—(Continued).

SN 77-881,563. LOTTERIA CO., LTD., SEOUL, REPUBLIC OF KOREA, FILED 11-27-2009.

RED BULL

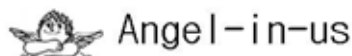

THE MARK CONSISTS OF STANDARD CHARACTERS WITHOUT CLAIM TO ANY PARTICULAR FONT, STYLE, SIZE, OR COLOR.

OWNER OF U.S. REG. NOS. 1,935,272, 3,561,283 AND OTHERS.

FOR RESTAURANT SERVICES (U.S. CLS. 100 AND 101).

CHRISTINE COOPER, EXAMINING ATTORNEY

OWNER OF AUSTRALIA REG. NO. 1334092, DATED 7-9-2010, EXPIRES 11-30-2019.

THE MARK CONSISTS OF THE IMAGE OF A CURLY HAired HEAD AND SMILING FACE OF AN ANGEL, WINGS OUTSPREAD, RESTING UPON CROSSED ARMS PRECEDING THE WORDS "ANGEL-IN-US".

FOR CAFES; COFFEE SHOPS; RESTAURANTS (U.S. CLS. 100 AND 101).

JULIE WATSON, EXAMINING ATTORNEY

SN 77-881,562. LOTTERIA CO., LTD., SEOUL, REPUBLIC OF KOREA, FILED 11-27-2009.

SN 85-002,040. COHEN, ANDREW, NORTH BERGEN, NJ, FILED 3-30-2010.



STACKS OF HOBOKEN

OWNER OF PHILIPPINES REG. NO. 4-2010-00535, DATED 12-23-2010, EXPIRES 12-23-2020.

THE COLOR(S) RED, YELLOW AND BLACK IS/ARE CLAIMED AS A FEATURE OF THE MARK.

THE MARK CONSISTS OF A RED ANGLE INTERSECTING WITH A SOLID YELLOW CIRCLE FORMING THE STYLIZED LETTERS "LO" AND PRECEDING THE WORD "LOTTERIA" IN BLACK LETTERING.

THE ENGLISH TRANSLATION OF "LOTTERIA" IN THE MARK IS "LOTTERY".

FOR RESTAURANTS SPECIALIZING IN HAMBURGER; RESTAURANTS; FAST-FOOD RESTAURANTS; CAFES (U.S. CLS. 100 AND 101).

JULIE WATSON, EXAMINING ATTORNEY

THE MARK CONSISTS OF STANDARD CHARACTERS WITHOUT CLAIM TO ANY PARTICULAR FONT, STYLE, SIZE, OR COLOR.

OWNER OF U.S. REG. NOS. 3,964,270 AND 3,964,716.

NO CLAIM IS MADE TO THE EXCLUSIVE RIGHT TO USE "OF HOBOKEN", APART FROM THE MARK AS SHOWN.

FOR RESTAURANT SERVICES, NAMELY, PROVIDING OF FOOD AND BEVERAGES FOR CONSUMPTION ON AND OFF THE PREMISES (U.S. CLS. 100 AND 101).

LINDA ESTRADA, EXAMINING ATTORNEY

CLASS 43—(Continued).

SN 85-039,869. CAJUN STEAMER VENTURES, LLC, LONGVIEW, TX. FILED 5-17-2010.



NO CLAIM IS MADE TO THE EXCLUSIVE RIGHT TO USE "BAR & GRILL", APART FROM THE MARK AS SHOWN.

THE COLOR(S) RED AND BLACK IS/ARE CLAIMED AS A FEATURE OF THE MARK.

THE MARK CONSISTS OF THE WORDS "CAJUN STEAMER BAR & GRILL" WRITTEN IN RED TEXT. THE WORDS "CAJUN STEAMER" APPEAR AT THE TOP OF THE MARK WHILE THE WORDS "BAR & GRILL" APPEAR AT THE BOTTOM OF THE MARK WITH BOTH PHRASES SEPARATED BY A BLACK HORIZONTAL LINE.

SEC. 2(F) "CAJUN STEAMER".

FOR RESTAURANT SERVICES (U.S. CLS. 100 AND 101).

FIRST USE 5-25-2004; IN COMMERCE 5-25-2004.
JOHN DWYER, EXAMINING ATTORNEY

SN 85-039,942. CAJUN STEAMER VENTURES, LLC, LONGVIEW, TX. FILED 5-17-2010.



NO CLAIM IS MADE TO THE EXCLUSIVE RIGHT TO USE "BAR & GRILL", APART FROM THE MARK AS SHOWN.

THE COLOR(S) RED, BLACK, WHITE AND YELLOW IS/ARE CLAIMED AS A FEATURE OF THE MARK.

THE MARK CONSISTS OF THE WORDS "CAJUN STEAMER BAR & GRILL LAISSEZ LES BON TEMPS ROULER". THE WORDS "CAJUN STEAMER" APPEAR DIRECTLY ABOVE THE WORDS "BAR & GRILL" WITH BOTH PHRASES WRITTEN IN RED TEXT AND SEPARATED BY A BLACK HORIZONTAL LINE. DIRECTLY TO THE LEFT OF THE WORDS "CAJUN STEAMER BAR & GRILL" APPEARS A BLACK POT WITH A RED CRAWFISH INSIDE ADORNED WITH YELLOW BEADS AND HOLDING A YELLOW BEVERAGE. AT THE BASE OF THE BLACK

CLASS 43—(Continued).

POT APPEARS THE WORDS "LAISSEZ LES BON TEMPS ROULER" IN RED CAPITALIZED LETTERS WITH WHITE OUTLINING. THE WORDS "LAISSEZ LES BON" APPEAR DIRECTLY ABOVE THE WORDS "TEMPS ROULER". DIRECTLY BEHIND THE BLACK POT AND RED CRAWFISH APPEARS TWO BLACK RECTANGULAR OUTLINES TURNED VERTICALLY WITH A THICKER BLACK RECTANGULAR OUTLINE ON THE EXTERIOR AND A THINNER BLACK RECTANGULAR OUTLINE ON THE INTERIOR.

THE ENGLISH TRANSLATION OF "LAISSEZ LES BON TEMPS ROULER" IN THE MARK IS "LET THE GOOD TIMES ROLL".

SEC. 2(F) "CAJUN STEAMER".

FOR RESTAURANT SERVICES (U.S. CLS. 100 AND 101).

FIRST USE 5-25-2004; IN COMMERCE 5-25-2004.

JOHN DWYER, EXAMINING ATTORNEY

SN 85-040,475. NATIONAL COMMUNITY CHURCH, WASHINGTON, DC. FILED 5-17-2010.

EBENEZERS

THE MARK CONSISTS OF STANDARD CHARACTERS WITHOUT CLAIM TO ANY PARTICULAR FONT, STYLE, SIZE, OR COLOR.

FOR CAFE AND RESTAURANT SERVICES; COFFEE SHOPS (U.S. CLS. 100 AND 101).

FIRST USE 3-15-2006; IN COMMERCE 3-15-2006.

IRA J. GOODSaid, EXAMINING ATTORNEY

SN 85-089,289. J BURNS PIZZA, LLC, LAKELAND, FL. FILED 7-21-2010.

J BURNS' PIZZA

THE MARK CONSISTS OF STANDARD CHARACTERS WITHOUT CLAIM TO ANY PARTICULAR FONT, STYLE, SIZE, OR COLOR.

NO CLAIM IS MADE TO THE EXCLUSIVE RIGHT TO USE "PIZZA", APART FROM THE MARK AS SHOWN.

"J BURNS" IN THE MARK DOES NOT IDENTIFY A LIVING INDIVIDUAL.

FOR RESTAURANT AND CARRY-OUT RESTAURANT SERVICES (U.S. CLS. 100 AND 101).

DAWN HAN, EXAMINING ATTORNEY

CLASS 43—(Continued).

SN 85-090,173. THE VICTORY CAFE - GALENA, INC., GALENA, IL. FILED 7-22-2010.

THE VICTORY CAFE

THE MARK CONSISTS OF STANDARD CHARACTERS WITHOUT CLAIM TO ANY PARTICULAR FONT, STYLE, SIZE, OR COLOR.

NO CLAIM IS MADE TO THE EXCLUSIVE RIGHT TO USE "CAFE", APART FROM THE MARK AS SHOWN.

FOR RESTAURANT SERVICES, NAMELY, SERVICES FOR PROVIDING FOOD AND DRINK FOR CONSUMERS (U.S. CLS. 100 AND 101).

DAVID HOFFMAN, EXAMINING ATTORNEY

SN 85-092,332. WICKED WICHES, LLC, DBA WICKED WICHES, FOUNTAIN VALLEY, CA. FILED 7-25-2010.

**Wicked 'Wiches
Wickedly Delicious
Sandwiches & More**

THE MARK CONSISTS OF STANDARD CHARACTERS WITHOUT CLAIM TO ANY PARTICULAR FONT, STYLE, SIZE, OR COLOR.

NO CLAIM IS MADE TO THE EXCLUSIVE RIGHT TO USE "DELICIOUS SANDWICHES", APART FROM THE MARK AS SHOWN.

FOR RESTAURANT, BAR AND CATERING SERVICES (U.S. CLS. 100 AND 101).

FIRST USE 12-1-2009; IN COMMERCE 12-9-2009.
EMILY CHUO, EXAMINING ATTORNEY

CLASS 43—(Continued).

SN 85-115,007. FILL-ER-UP COFFEE STATION LLC, MIDWAY, UT. FILED 8-24-2010.



NO CLAIM IS MADE TO THE EXCLUSIVE RIGHT TO USE "COFFEE STATION", APART FROM THE MARK AS SHOWN.

THE COLOR(S) RED, ORANGE, BLUE, WHITE, GREEN, GRAY, TAN AND BROWN IS/ARE CLAIMED AS A FEATURE OF THE MARK.

THE MARK CONSISTS OF A GREEN COFFEE CUP ON A GRAY AND BLUE SURFACE OVER A LIGHT BLUE AND WHITE BACKGROUND WITH VARYING SHADES OF A BROWN AND WHITE LIQUID BEING Poured INTO THE CUP AND BLUE AND WHITE STEAM RISING FROM THE TOP OF THE CUP ALL SURROUNDED BY A RED CIRCLE HAVING AN INNER AND OUTER ORANGE BORDER AND THE LETTERING "FILL'ER UP COFFEE STATION" IN WHITE.

FOR COFFEE AND JUICE BAR SERVICES; COFFEE AND TEA BARS; COFFEE BARS; COFFEE SHOPS; COFFEE-HOUSE AND SNACK-BAR SERVICES (U.S. CLS. 100 AND 101).

FIRST USE 7-17-2010; IN COMMERCE 7-17-2010.
JOHN SCHUYLER YARD, EXAMINING ATTORNEY

SN 85-132,874. MARGARITA ENTERTAINMENT, INC, DBA SPLASH BAR, SACRAMENTO, CA. FILED 9-18-2010.

Splash Bar

THE MARK CONSISTS OF STANDARD CHARACTERS WITHOUT CLAIM TO ANY PARTICULAR FONT, STYLE, SIZE, OR COLOR.

NO CLAIM IS MADE TO THE EXCLUSIVE RIGHT TO USE "BAR", APART FROM THE MARK AS SHOWN.

FOR BAR AND RESTAURANT SERVICES (U.S. CLS. 100 AND 101).

FIRST USE 9-6-2010; IN COMMERCE 9-6-2010.
KATHERINE M. DUBRAY, EXAMINING ATTORNEY

CLASS 43—(Continued).

SN 85-132,968. TRIBECA TAVERN, LLC, RALEIGH, NC.
FILED 9-19-2010.

Tribeca Tavern

THE MARK CONSISTS OF STANDARD CHARACTERS WITHOUT CLAIM TO ANY PARTICULAR FONT, STYLE, SIZE, OR COLOR.

NO CLAIM IS MADE TO THE EXCLUSIVE RIGHT TO USE "TAVERN", APART FROM THE MARK AS SHOWN.

FOR RESTAURANT SERVICES FEATURING GOURMET BURGERS MADE WITH LOCAL PRODUCE AND GRASS FEED BEEF; TAVERN SERVICES (U.S. CLS. 100 AND 101).

FIRST USE 2-1-2010; IN COMMERCE 2-19-2010.
ROBERT C. CLARK JR., EXAMINING ATTORNEY

SN 85-156,723. AMERICA'S PIE, LLC, GARNET VALLEY, PA. FILED 10-20-2010.

Pizza For The People

THE MARK CONSISTS OF STANDARD CHARACTERS WITHOUT CLAIM TO ANY PARTICULAR FONT, STYLE, SIZE, OR COLOR.

NO CLAIM IS MADE TO THE EXCLUSIVE RIGHT TO USE "PIZZA", APART FROM THE MARK AS SHOWN.

FOR PIZZA PARLORS (U.S. CLS. 100 AND 101).
FIRST USE 4-1-2010; IN COMMERCE 4-1-2010.

WILLIAM ROSSMAN, EXAMINING ATTORNEY

SN 85-156,760. AMERICA'S PIE, LLC, GARNET VALLEY, PA. FILED 10-20-2010.



NO CLAIM IS MADE TO THE EXCLUSIVE RIGHT TO USE "AMERICA'S PIE" AND "PIZZA", APART FROM THE MARK AS SHOWN.

THE COLOR(S) RED, WHITE, AND BLUE IS/ARE CLAIMED AS A FEATURE OF THE MARK.

THE MARK CONSISTS OF THE WORDS "AMERICA'S PIE" STYLIZED IN BLUE FONT ABOVE A DESIGN, SIMILAR TO A FLAG, WHICH CONTAINS 12 BLUE STARS TO THE LEFT AND 3 RED STRIPES TO THE RIGHT, WHICH IS ABOVE THE WORDS "PIZZA FOR THE PEOPLE" STYLIZED IN BLUE FONT, ALL SET AGAINST A WHITE BACKGROUND.

FOR PIZZA PARLORS (U.S. CLS. 100 AND 101).
FIRST USE 4-1-2010; IN COMMERCE 4-1-2010.
WILLIAM ROSSMAN, EXAMINING ATTORNEY

CLASS 43—(Continued).

SN 85-161,294. BAUM DEVELOPMENT COMPANY, INC.,
DBA STEVEN'S PLACE, TRAVERSE CITY, MI. FILED 10-26-2010.

V.I.P. Cinema

NO CLAIM IS MADE TO THE EXCLUSIVE RIGHT TO USE "CINEMA", APART FROM THE MARK AS SHOWN.

THE MARK CONSISTS OF THE STYLIZED LETTERS "V.I.P." FOLLOWED BY THE STYLIZED WORD "CINEMA".

FOR RESTAURANT SERVICES FEATURING MOVIE EXHIBITIONS (U.S. CLS. 100 AND 101).

FIRST USE 10-9-2010; IN COMMERCE 10-9-2010.
RONALD AIKENS, EXAMINING ATTORNEY

SN 85-166,895. LA DUNI CONCEPTS L.L.C., DALLAS, TX.
FILED 11-2-2010.



OWNER OF U.S. REG. NOS. 2,911,151, 2,994,412 AND 7,834,735.

THE MARK CONSISTS OF A WREATH WITH THE WORDS "LA DUNI" ABOVE, THE LETTER "D" IN THE CENTER, AND THE WORDS "TASTE LOVE" UNDERNEATH, WITH A RIBBON AND A FLOWER ON THE BOTTOM OF THE WREATH, AND A FLOWER AT THE TOP OF THE WREATH, AND A CURVED LINE ON EITHER SIDE OF THE WREATH CONNECTING "LA DUNI" WITH "TASTE LOVE".

THE ENGLISH TRANSLATION OF "LA DUNI" IN THE MARK IS "THE DOWN".

FOR CAFE AND RESTAURANT SERVICES (U.S. CLS. 100 AND 101).

FIRST USE 3-0-2007; IN COMMERCE 3-0-2007.
ANNE E. GUSTASON, EXAMINING ATTORNEY

CLASS 43—(Continued).

SN 85-189,797. ROASTER FAMILY COFFEE, INC., ALHAMBRA, CA. FILED 12-2-2010.



NO CLAIM IS MADE TO THE EXCLUSIVE RIGHT TO USE "ROASTER FAMILY", "COFFEE", "SINCE 1990" AND THE NON-LATIN CHARACTERS THAT TRANSLITERATE TO "HONG PEI ZHE KA FEI", APART FROM THE MARK AS SHOWN.

THE MARK CONSISTS OF A SHIELD WITH THE WORDS "ROASTER FAMILY" IN THE CENTER, A BRANCH WITH LEAVES ON THE UPPER LEFT SIDE, A DESIGN WITH STRIPES ON THE UPPER RIGHT SIDE, AND THE STYLIZED DEPICTION OF COFFEE BEANS IN THE BOTTOM; AROUND THE SHIELD ARE FLORAL-LIKE DESIGNS; BELOW THE SHIELD IS A BANNER WITH THE WORD "COFFEE" IN IT, WITH THE WORDS "SINCE 1990" UNDER THE BANNER. AT THE BOTTOM OF THE MARK ARE FIVE CHINESE CHARACTERS WHICH TRANSLITERATE TO "HONG PEI ZHE KA FEI" AND TRANSLATE AS "ROASTER COFFEE". A STYLIZED LINE IS LOCATED UNDER THE CHINESE CHARACTERS.

THE NON-LATIN CHARACTERS IN THE MARK TRANSLITERATE TO "HONG PEI ZHE KA FEI" AND THIS MEANS "ROASTER COFFEE" IN ENGLISH.

FOR CAFE AND RESTAURANT SERVICES (U.S. CLS. 100 AND 101).

FIRST USE 5-1-2010; IN COMMERCE 5-1-2010.
WENDY GOODMAN, EXAMINING ATTORNEY

SN 85-194,558. EL TIZONCITO, S.A. DE CV, MEXICO, MEXICO, FILED 12-9-2010.

LOS CREADORES DEL TACO AL
PASTOR EL TIZONCITO

THE MARK CONSISTS OF STANDARD CHARACTERS WITHOUT CLAIM TO ANY PARTICULAR FONT, STYLE, SIZE, OR COLOR.

NO CLAIM IS MADE TO THE EXCLUSIVE RIGHT TO USE "LOS CREADORES DEL TACO AL PASTOR", APART FROM THE MARK AS SHOWN.

THE ENGLISH TRANSLATION OF "LOS CREADORES DEL TACO EL PASTOR" IN THE MARK IS "THE CREATORS OF MARINATED PORK TACOS LITTLE COAL".

FOR RESTAURANT SERVICES (U.S. CLS. 100 AND 101).

ANNE FARRELL, EXAMINING ATTORNEY

CLASS 43—(Continued).

SN 85-205,512. WINE ROAD LLC, MIAMI BEACH, FL. FILED 12-24-2010.

Bistro 555

THE MARK CONSISTS OF STANDARD CHARACTERS WITHOUT CLAIM TO ANY PARTICULAR FONT, STYLE, SIZE, OR COLOR.

NO CLAIM IS MADE TO THE EXCLUSIVE RIGHT TO USE "BISTRO", APART FROM THE MARK AS SHOWN.

FOR BISTRO SERVICES; CAFE (U.S. CLS. 100 AND 101).

FIRST USE 1-1-2010; IN COMMERCE 1-1-2010.
ALLISON HOLTZ, EXAMINING ATTORNEY

SN 85-215,300. GOODSON ENTERPRISES, LLC, FRANKLIN, TN. FILED 1-11-2011.

THE BUNGANUT PIG

THE MARK CONSISTS OF STANDARD CHARACTERS WITHOUT CLAIM TO ANY PARTICULAR FONT, STYLE, SIZE, OR COLOR.

FOR BAR AND RESTAURANT SERVICES (U.S. CLS. 100 AND 101).

FIRST USE 0-0-1986; IN COMMERCE 0-0-1986.
PAULA MAHONEY, EXAMINING ATTORNEY

SN 85-219,040. AUTO EUROPE, LLC, PORTLAND, ME. FILED 1-17-2011.

NO CLAIM IS MADE TO THE EXCLUSIVE RIGHT TO USE "EXCELLENT HOTELS", APART FROM THE MARK AS SHOWN.

THE MARK CONSISTS OF A STYLIZED VERSION OF THE PHRASE "EXCELLENT HOTELS" UNDER A SHAPE THAT IS THE DEPICTION OF A ROOFLINE.

FOR MAKING HOTEL RESERVATION SERVICES FOR OTHERS; PROVIDING TEMPORARY HOUSING ACCOMMODATIONS (U.S. CLS. 100 AND 101).

FIRST USE 5-5-2011; IN COMMERCE 5-5-2011.
LEIGH LOWRY, EXAMINING ATTORNEY

CLASS 43—(Continued).

SN 85-220,968. SUNNYSIDE GROUP LLC, WASHINGTON, DC. FILED 1-19-2011.

GOOD STUFF EATERY

THE MARK CONSISTS OF STANDARD CHARACTERS WITHOUT CLAIM TO ANY PARTICULAR FONT, STYLE, SIZE, OR COLOR.

NO CLAIM IS MADE TO THE EXCLUSIVE RIGHT TO USE "EATERY", APART FROM THE MARK AS SHOWN. FOR RESTAURANT SERVICES (U.S. CLS. 100 AND 101).

FIRST USE 12-11-2007; IN COMMERCE 7-4-2008.
JIM RINGLE, EXAMINING ATTORNEY

CLASS 43—(Continued).

SN 85-235,303. APIZZA DI NAPOLI, LLC, AIKEN, SC. FILED 2-7-2011.



NO CLAIM IS MADE TO THE EXCLUSIVE RIGHT TO USE "APIZZA DI NAPOLI", APART FROM THE MARK AS SHOWN.

THE MARK CONSISTS OF THE WORDS "APIZZA DI NAPOLI" WITH AN OUTLINE OF A VOLCANO TOP WITH SMOKE ABOVE THE NAME IN THE UPPER RIGHT STRETCHING FROM THE SECOND "A" IN APIZZA TO THE "I" IN NAPOLI.

THE ENGLISH TRANSLATION OF "DI NAPOLI" IN THE MARK IS "OF NAPLES."

FOR PIZZA PARLORS (U.S. CLS. 100 AND 101).

FIRST USE 12-15-2010; IN COMMERCE 2-4-2011.
RAMONA ORTIGA, EXAMINING ATTORNEY

SN 85-221,940. GAYLORD ENTERTAINMENT COMPANY, NASHVILLE, TN. FILED 1-20-2011.

GET Green

THE MARK CONSISTS OF STANDARD CHARACTERS WITHOUT CLAIM TO ANY PARTICULAR FONT, STYLE, SIZE, OR COLOR.

NO CLAIM IS MADE TO THE EXCLUSIVE RIGHT TO USE "GREEN", APART FROM THE MARK AS SHOWN. FOR HOTEL SERVICES (U.S. CLS. 100 AND 101).

MARY CRAWFORD, EXAMINING ATTORNEY

SN 85-235,437. CVI.CHE 105, INC., MIAMI, FL. FILED 2-7-2011.

CVI.CHE 105

THE MARK CONSISTS OF STANDARD CHARACTERS WITHOUT CLAIM TO ANY PARTICULAR FONT, STYLE, SIZE, OR COLOR.

NO CLAIM IS MADE TO THE EXCLUSIVE RIGHT TO USE "CEVICHE", APART FROM THE MARK AS SHOWN.

FOR CAFE AND RESTAURANT SERVICES (U.S. CLS. 100 AND 101).

FIRST USE 11-18-2008; IN COMMERCE 11-18-2008.

TINA L. SNAPP, EXAMINING ATTORNEY

SN 85-233,798. TAHITI BEACHCOMBER, S.A., TAHITI, FRENCH POLYNESIA, FILED 2-3-2011.

TETIAROA

THE MARK CONSISTS OF STANDARD CHARACTERS WITHOUT CLAIM TO ANY PARTICULAR FONT, STYLE, SIZE, OR COLOR.

FOR HOTEL, RESORT HOTEL, AND RESTAURANT SERVICES (U.S. CLS. 100 AND 101).

THEODORE MCBRIDE, EXAMINING ATTORNEY

SN 85-235,839. DFO, LLC, SPARTANBURG, SC. FILED 2-7-2011.

Siempre abiertos, siempre a gusto.

THE MARK CONSISTS OF STANDARD CHARACTERS WITHOUT CLAIM TO ANY PARTICULAR FONT, STYLE, SIZE, OR COLOR.

THE ENGLISH TRANSLATION OF "SIEMPRE ABIERTOS, SIEMPRE A GUSTO" IN THE MARK IS "WE ARE ALWAYS OPEN, YOU'RE ALWAYS SATISFIED".

FOR RESTAURANT SERVICES, NAMELY, PROVIDING OF FOOD AND BEVERAGES FOR CONSUMPTION ON AND OFF THE PREMISES (U.S. CLS. 100 AND 101).

FIRST USE 1-18-2011; IN COMMERCE 1-18-2011.

COLLEEN DOMBROW, EXAMINING ATTORNEY

CLASS 43—(Continued).

SN 85-241,846. LEGACY BG, LLC, ATLANTA, GA. FILED 2-14-2011.



NO CLAIM IS MADE TO THE EXCLUSIVE RIGHT TO USE "DER BIERGARTEN", "RESTAURANT" OR "FESTIVALS", APART FROM THE MARK AS SHOWN.

THE MARK CONSISTS OF A DRAWING OF THE PROFILE OF A LION INSIDE A DOUBLE CIRCLE, WITH THE WORDS "DER BIERGARTEN", "RESTAURANT", AND "FESTIVALS" BETWEEN THE TWO CIRCLES.

THE ENGLISH TRANSLATION OF "DER BIERGARTEN" IN THE MARK IS "THE BEER GARDEN".

FOR RESTAURANT AND BAR SERVICES (U.S. CLS. 100 AND 101).

FIRST USE 9-13-2010; IN COMMERCE 9-13-2010.
ANNE MADDEN, EXAMINING ATTORNEY

SN 85-243,004. RONO, JUSTIN CHRISTIAN C., SAN JOSE, CA. AND RONO, ASHLEY KIRSTEN C., SAN JOSE, CA. FILED 2-15-2011.

Barrio Fiesta Express

THE MARK CONSISTS OF STANDARD CHARACTERS WITHOUT CLAIM TO ANY PARTICULAR FONT, STYLE, SIZE, OR COLOR.

NO CLAIM IS MADE TO THE EXCLUSIVE RIGHT TO USE "EXPRESS", APART FROM THE MARK AS SHOWN.

THE ENGLISH TRANSLATION OF "BARRIO FIESTA" IN THE MARK IS "NEIGHBORHOOD PARTY".

FOR FAST-FOOD RESTAURANTS (U.S. CLS. 100 AND 101).

FIRST USE 1-3-2011; IN COMMERCE 1-3-2011.
DAWN FELDMAN, EXAMINING ATTORNEY

CLASS 43—(Continued).

SN 85-243,015. SMALLEY, KIRBIE, STATESBORO, GA. AND WARREN, JACOB, STATESBORO, GA. FILED 2-15-2011.

Yo Pizza

THE MARK CONSISTS OF STANDARD CHARACTERS WITHOUT CLAIM TO ANY PARTICULAR FONT, STYLE, SIZE, OR COLOR.

NO CLAIM IS MADE TO THE EXCLUSIVE RIGHT TO USE "PIZZA", APART FROM THE MARK AS SHOWN.

FOR RESTAURANT (U.S. CLS. 100 AND 101).
RUSS HERMAN, EXAMINING ATTORNEY

SN 85-243,438. KOCAFE, LLC, MAPLEWOOD, NJ. FILED 2-16-2011.



THE COLOR(S) BLACK, GREEN, AND WHITE IS/ARE CLAIMED AS A FEATURE OF THE MARK.

THE MARK CONSISTS OF THE WORDING "KOCAFE" IN BLACK AND A GREEN LEAF WITH A WHITE INNER LINING IN THE CENTER.

FOR COFFEE AND JUICE BAR SERVICES (U.S. CLS. 100 AND 101).

FIRST USE 1-3-2011; IN COMMERCE 2-14-2011.
CHRISTINA SOBRAL, EXAMINING ATTORNEY

SN 85-245,974. HLT DOMESTIC IP LLC, MCLEAN, VA. FILED 2-18-2011.

YOU CAN COUNT ON US. GUARANTEED.

THE MARK CONSISTS OF STANDARD CHARACTERS WITHOUT CLAIM TO ANY PARTICULAR FONT, STYLE, SIZE, OR COLOR.

NO CLAIM IS MADE TO THE EXCLUSIVE RIGHT TO USE "GUARANTEED", APART FROM THE MARK AS SHOWN.

FOR HOTEL SERVICES (U.S. CLS. 100 AND 101).
ANGELA DUONG, EXAMINING ATTORNEY

CLASS 43—(Continued).

SN 85-246,571. QUEST FOOD MANAGEMENT SERVICES, INC., LOMBARD, IL. FILED 2-18-2011.

QUEST FOR LIFE

THE MARK CONSISTS OF STANDARD CHARACTERS WITHOUT CLAIM TO ANY PARTICULAR FONT, STYLE, SIZE, OR COLOR.

FOR CONSULTING SERVICES IN THE FIELD OF CULINARY ARTS FOR SCHOOLS OR BUSINESSES; FOOD PREPARATION SERVICES FEATURING FOOD CONTAINING QUALITY INGREDIENTS; PROVIDING FOOD AND DRINK (U.S. CLS. 100 AND 101).

FIRST USE 2-1-2011; IN COMMERCE 2-1-2011.
ROSELLE HERRERA, EXAMINING ATTORNEY

CLASS 43—(Continued).

SN 85-247,812. QSL INTELLECTUAL PROPERTIES CORP., SHARON, PA. FILED 2-21-2011.

PICK-UP WINGO WINDOW

THE MARK CONSISTS OF STANDARD CHARACTERS WITHOUT CLAIM TO ANY PARTICULAR FONT, STYLE, SIZE, OR COLOR.

NO CLAIM IS MADE TO THE EXCLUSIVE RIGHT TO USE "PICK-UP" OR "WINDOW", APART FROM THE MARK AS SHOWN.

FOR RESTAURANT SERVICES (U.S. CLS. 100 AND 101).

FIRST USE 12-31-1988; IN COMMERCE 12-31-1988.
DORITT L. CARROLL, EXAMINING ATTORNEY

SN 85-247,657. FLORES, RAYMON, TUCSON, AZ. FILED 2-21-2011.

SN 85-248,250. BORSCHT BELT, LLC, NEW YORK, NY. FILED 2-22-2011.

Borscht Belt

THE MARK CONSISTS OF STANDARD CHARACTERS WITHOUT CLAIM TO ANY PARTICULAR FONT, STYLE, SIZE, OR COLOR.

NO CLAIM IS MADE TO THE EXCLUSIVE RIGHT TO USE "BORSCHT", APART FROM THE MARK AS SHOWN.

FOR RESTAURANT (U.S. CLS. 100 AND 101).
JEFF DEFORD, EXAMINING ATTORNEY

OWNER OF U.S. REG. NO. 3,962,567.
NO CLAIM IS MADE TO THE EXCLUSIVE RIGHT TO USE "TACO", APART FROM THE MARK AS SHOWN.
THE NAME "SIR VEZA" DOES NOT IDENTIFY A LIVING INDIVIDUAL.

THE MARK CONSISTS OF THE WORDS, "SIR VEZA'S" IN STYLIZED FONT WITH A SLICE OF FRUIT GARNISH IN THE POSITION OF THE POSSESSIVE AND FORMING THE APOSTROPHE. THE WORDS, "TACO GARAGE", APPEAR IN SMALLER, BUT CAPITALIZED LETTERS UNDERNEATH "SIR VEZA'S", ALSO IN A STYLIZED FONT, AND EMBEDDED IN A BANNER THAT APPEARS TO FLOW FROM RIGHT TO LEFT AND ENDING WITH A BURNING FLAME SHAPE THAT APPEARS AT THE LEFTHAND SIDE OF THE BANNER. THE LETTERING FOR "TACO GARAGE" APPEARS TO BEND WITH THE BANNER AND BECOMES SMALLER FROM RIGHT TO LEFT SO THAT THE "T" IN "TACO" IS LARGER THAN THE FINAL "E" IN "GARAGE" AND THE LETTERS IN BETWEEN GRADUALLY DECREASE IN SIZE FROM THE "T" TO THE "E".

FOR BAR AND RESTAURANT SERVICES (U.S. CLS. 100 AND 101).
FIRST USE 10-5-2009; IN COMMERCE 10-5-2009.
JENNIFER MARTIN, EXAMINING ATTORNEY

SN 85-248,562. COCO GROUP CORPORATION, EL PASO, TX. FILED 2-22-2011.

COCO.MIEL

THE MARK CONSISTS OF STANDARD CHARACTERS WITHOUT CLAIM TO ANY PARTICULAR FONT, STYLE, SIZE, OR COLOR.

THE ENGLISH TRANSLATION OF "MIEL" IN THE MARK IS "HONEY".

FOR RESTAURANT AND BAR SERVICES (U.S. CLS. 100 AND 101).

FIRST USE 6-29-2009; IN COMMERCE 6-29-2009.
RONALD MCMORROW, EXAMINING ATTORNEY

CLASS 43—(Continued).

SN 85-249,045. ED & BUB, LLC, GEORGETOWN, TX. FILED 2-23-2011.

HARDTAILS BAR & GRILL

THE MARK CONSISTS OF STANDARD CHARACTERS WITHOUT CLAIM TO ANY PARTICULAR FONT, STYLE, SIZE, OR COLOR.

NO CLAIM IS MADE TO THE EXCLUSIVE RIGHT TO USE "BAR & GRILL", APART FROM THE MARK AS SHOWN.

FOR RESTAURANT AND BAR SERVICES (U.S. CLS. 100 AND 101).

FIRST USE 4-4-2006; IN COMMERCE 9-4-2009.
DAVID TOOLEY, EXAMINING ATTORNEY

SN 85-249,332. CHOUNG, JAMES, MEDFORD, NY. FILED 2-23-2011.

truth & seoul

THE MARK CONSISTS OF STANDARD CHARACTERS WITHOUT CLAIM TO ANY PARTICULAR FONT, STYLE, SIZE, OR COLOR.

FOR BAR AND RESTAURANT SERVICES (U.S. CLS. 100 AND 101).

JAMES GRIFFIN, EXAMINING ATTORNEY

SN 85-249,511. GARY WAGNER, CABO SAN LUCAS, MEXICO, FILED 2-23-2011.

THE GIGGLING MARLIN

OWNER OF U.S. REG. NO. 3,779,555.

THE MARK CONSISTS OF A CARTOON DRAWING OF A MAN HANGING UPSIDE DOWN FROM A WOODEN BEAM. STANDING NEXT TO THE MAN IS A MARLIN WITH HUMAN CHARACTERISTICS. THE MARLIN WEARS SUNGLASSES AND A FISHERMAN'S HAT, AND IS SMILING, WITH HUMAN-LIKE TEETH. THE MARLIN HOLDS A FISHING ROD IN ITS LEFT PECTORAL FIN AND EXTENDS ITS RIGHT PECTORAL FIN TOWARD THE MAN, AS THOUGH POSING FOR A PHOTOGRAPH WITH ITS CATCH.

FOR BAR AND RESTAURANT SERVICES (U.S. CLS. 100 AND 101).

ANNE MADDEN, EXAMINING ATTORNEY

CLASS 43—(Continued).

SN 85-249,527. WEDDINGTON, DANIEL, ELKHART, IN. AND SHERROD SR., ERROL TYRESE, ELKHART, IN. FILED 2-23-2011.

**BLEU 23**

THE COLOR(S) BLUE, WHITE AND BLACK IS/ARE CLAIMED AS A FEATURE OF THE MARK.

THE MARK CONSISTS OF A STYLIZED NUMBER "23" IN LARGE TYPE IN THE COLOR BLUE TRIMMED IN WHITE AND BLACK. DIRECTLY BELOW THE NUMBER "23" IS "BLEU 23" IN THE COLOR BLACK.

THE ENGLISH TRANSLATION OF THE WORD "BLEU" IN THE MARK IS "BLUE".

FOR PROVIDING OF FOOD AND DRINK VIA A MOBILE TRUCK (U.S. CLS. 100 AND 101).

MARK T. MULLEN, EXAMINING ATTORNEY

SN 85-250,521. ALEXANDER M STUPAK, BROOKLYN, NY. FILED 2-24-2011.

EMPELLON

THE MARK CONSISTS OF STANDARD CHARACTERS WITHOUT CLAIM TO ANY PARTICULAR FONT, STYLE, SIZE, OR COLOR.

THE ENGLISH TRANSLATION OF THE WORD EMPPELLON IN THE MARK IS "SHOVE OR PUSH".

FOR BAR AND RESTAURANT SERVICES (U.S. CLS. 100 AND 101).

JILL PRATER, EXAMINING ATTORNEY

CLASS 43—(Continued).

SN 85-250,654. SKYLINE INTERNATIONAL, INC, ARLINGTON HEIGHTS, IL. FILED 2-24-2011.

USMANIA

THE MARK CONSISTS OF STANDARD CHARACTERS WITHOUT CLAIM TO ANY PARTICULAR FONT, STYLE, SIZE, OR COLOR.

FOR CATERING SERVICES; PROVIDING BANQUET AND SOCIAL FUNCTION FACILITIES FOR SPECIAL OCCASIONS; RESTAURANT SERVICES (U.S. CLS. 100 AND 101).

FIRST USE 8-28-2000; IN COMMERCE 9-29-2000.
HEATHER SAPP, EXAMINING ATTORNEY

SN 85-251,003. WORLD YACHT L.L.C., NEW YORK, NY. FILED 2-24-2011.

DESTINY ROOFTOP

THE MARK CONSISTS OF STANDARD CHARACTERS WITHOUT CLAIM TO ANY PARTICULAR FONT, STYLE, SIZE, OR COLOR.

FOR BAR, COCKTAIL LOUNGE, AND RESTAURANT SERVICES OFFERED ABOARD A CRUISE SHIP (U.S. CLS. 100 AND 101).

KIMBERLY FRYE, EXAMINING ATTORNEY

SN 85-251,034. WORLD YACHT L.L.C., NEW YORK, NY. FILED 2-24-2011.

DUCHESS ROOFTOP

THE MARK CONSISTS OF STANDARD CHARACTERS WITHOUT CLAIM TO ANY PARTICULAR FONT, STYLE, SIZE, OR COLOR.

FOR BAR, COCKTAIL LOUNGE, AND RESTAURANT SERVICES OFFERED ABOARD A CRUISE SHIP (U.S. CLS. 100 AND 101).

KIMBERLY FRYE, EXAMINING ATTORNEY

CLASS 43—(Continued).

SN 85-252,522. JIMMY LOPEZ, JR., AUSTIN, TX. FILED 2-26-2011.

Playa Tacos

THE MARK CONSISTS OF STANDARD CHARACTERS WITHOUT CLAIM TO ANY PARTICULAR FONT, STYLE, SIZE, OR COLOR.

NO CLAIM IS MADE TO THE EXCLUSIVE RIGHT TO USE "TACOS", APART FROM THE MARK AS SHOWN.

THE ENGLISH TRANSLATION OF "PLAYA" IN THE MARK IS "BEACH".

FOR RESTAURANT SERVICES (U.S. CLS. 100 AND 101).

BARBARA BROWN, EXAMINING ATTORNEY

SN 85-253,398. SHIGETA AMERICA, INC., GARDENA, CA. FILED 2-28-2011.

Shin-Sen-Gumi

THE MARK CONSISTS OF STANDARD CHARACTERS WITHOUT CLAIM TO ANY PARTICULAR FONT, STYLE, SIZE, OR COLOR.

"SHIN-SEN-GUMI" WAS THE NAME GIVEN TO A GROUP OF SAMURAI TASKED TO PROTECT THE EMPEROR IN 1800S JAPAN. THE WORDING HAS NO MEANING IN RELATION TO THE SERVICES OTHER THAN TRADEMARK SIGNIFICANCE.

FOR CAFE AND RESTAURANT SERVICES (U.S. CLS. 100 AND 101).

FIRST USE 7-20-1992; IN COMMERCE 7-20-1992.

CURTIS FRENCH, EXAMINING ATTORNEY

CLASS 43—(Continued).

SN 85-253,449. BRIAR PATCH BED & BREAKFAST, LLC, DBA THE FOX DEN AT BRIAR PATCH, MIDDLEBURG, VA. FILED 2-28-2011.



OWNER OF U.S. REG. NO. 3,904,092.

THE MARK CONSISTS OF THE STYLIZED LETTERING FOR THE WORDS "THE FOX DEN AT BRIAR PATCH" WITH THE IMAGE OF A FOX IN A LYING DOWN POSITION APPEARS ABOVE "FOX DEN" AND A SMALL FLORAL LIKE DESIGN APPEARS IN THE LEFT LOWER CORNER OF THE IMAGE.

FOR PROVIDING BANQUET AND SOCIAL FUNCTION FACILITIES FOR SPECIAL OCCASIONS; PROVIDING SOCIAL MEETING, BANQUET AND SOCIAL FUNCTION FACILITIES; PROVISION OF CONFERENCE, EXHIBITION AND MEETING FACILITIES; PROVISION OF FACILITIES FOR CONVENTIONS (U.S. CLS. 100 AND 101).

FIRST USE 6-24-2007; IN COMMERCE 6-24-2007.
JAMES LOVELACE, EXAMINING ATTORNEY

CLASS 43—(Continued).

SN 85-253,591. 19 THINGS, LLC, SAN FRANCISCO, CA. FILED 2-28-2011.



NO CLAIM IS MADE TO THE EXCLUSIVE RIGHT TO USE "BAR", APART FROM THE MARK AS SHOWN.

THE COLOR(S) ORANGE, GRAY, BLACK, AND BURGUNDY IS/ARE CLAIMED AS A FEATURE OF THE MARK.

THE MARK CONSISTS OF THE WORD "PRONTO" IN CAPITAL LETTERS IN ORANGE. BELOW IS SMALLER LETTERS IS THE WORD "BY" IN CAPITAL LETTERS IN BLACK. NEXT TO SAID WORD ARE THE WORDS "BAR BAMBINO". THE LETTERS "BAR" ARE IN BLACK, THE LETTERS "BAMBINO" ARE IN BURGUNDY, THERE IS A GRAY CIRCLE WHICH ENCOMPASSES PART OF THE WORD "PRONTO" AND ALL OF THE WORDS "BY BAR BAMBINO".

THE ENGLISH TRANSLATION OF "PRONTO" IN THE MARK IS "IMMEDIATELY" AND THE TRANSLATION OF "BAMBINO" IS "BABY."

FOR CAFE AND RESTAURANT SERVICES (U.S. CLS. 100 AND 101).

MARILYN IZZI, EXAMINING ATTORNEY

SN 85-254,600. FYI DIGEST LLC, FOREST HILLS, NY. FILED 3-1-2011.



SN 85-253,590. 19 THINGS LLC, SAN FRANCISCO, CA. FILED 2-28-2011.

PRONTO BY BAR BAMBINO

THE MARK CONSISTS OF STANDARD CHARACTERS WITHOUT CLAIM TO ANY PARTICULAR FONT, STYLE, SIZE, OR COLOR.

NO CLAIM IS MADE TO THE EXCLUSIVE RIGHT TO USE "BAR", APART FROM THE MARK AS SHOWN.

THE ENGLISH TRANSLATION OF "PRONTO" IN THE MARK IS "IMMEDIATELY" AND THE TRANSLATION OF "BAMBINO" IS IN THE MARK IS "BABY."

FOR CAFE AND WINE BAR (U.S. CLS. 100 AND 101).
MARILYN IZZI, EXAMINING ATTORNEY

NO CLAIM IS MADE TO THE EXCLUSIVE RIGHT TO USE "CHURRASCARIA", APART FROM THE MARK AS SHOWN.

THE COLOR(S) GREEN, GRAY, ORANGE, YELLOW, BLACK AND WHITE FOR SHADING IS/ARE CLAIMED AS A FEATURE OF THE MARK.

THE MARK CONSISTS OF "RAINHAS" IS GREEN STYLIZED FONT WITH "CHURRASCARIA" IN GRAY STYLIZED FONT; ABOVE THE WORDS IS A BLACK SILHOUETTE OF A COWBOY WITH WHITE SHADING SURROUNDED BY ORANGE AND YELLOW STYLIZED DESIGNS.

THE ENGLISH TRANSLATION OF RAINHAS CHURRASCARIA IN THE MARK IS "QUEENS BARBECUE RESTAURANT OR STEAKHOUSE".

FOR BAR AND RESTAURANT SERVICES (U.S. CLS. 100 AND 101).

KATHERINE STOIDES, EXAMINING ATTORNEY

CLASS 43—(Continued).

SN 85-254,983. GK SOLUTIONS LLC, DALLAS, TX. FILED 3-1-2011.



NO CLAIM IS MADE TO THE EXCLUSIVE RIGHT TO USE "GREEN KITCHEN SOLUTIONS LLC", APART FROM THE MARK AS SHOWN.

THE MARK CONSISTS OF THE STYLIZED TEXT "GREEN KITCHEN SOLUTIONS LLC" WITH A FEATHER AFTER THE LETTER "N" IN "GREEN".

FOR CONSULTING SERVICES RELATING TO ENVIRONMENTALLY-FRIENDLY MATTERS IN THE FIELD OF RESTAURANTS (U.S. CLS. 100 AND 101).

FIRST USE 7-15-2009; IN COMMERCE 9-24-2009.
KATHERINE STOIDES, EXAMINING ATTORNEY

CLASS 43—(Continued).

SN 85-255,127. JOHNNY CHICAGO'S, LLC, ANCHORAGE, AK. FILED 3-1-2011.



FOR RESTAURANT, BAR AND CATERING SERVICES (U.S. CLS. 100 AND 101).

FIRST USE 6-19-2010; IN COMMERCE 6-19-2010.
MATTHEW KLINE, EXAMINING ATTORNEY

SN 85-255,691. BAR LA GRASSA, LLC, MINNEAPOLIS, MN. FILED 3-2-2011.

BLG

THE MARK CONSISTS OF STANDARD CHARACTERS WITHOUT CLAIM TO ANY PARTICULAR FONT, STYLE, SIZE, OR COLOR.

FOR RESTAURANT AND BAR SERVICES (U.S. CLS. 100 AND 101).
FIRST USE 10-9-2009; IN COMMERCE 10-9-2009.
BARBARA BROWN, EXAMINING ATTORNEY

SN 85-255,050. AGRARIA, LLC, JAMESTOWN, ND. FILED 3-1-2011.



**FARMERS
& FISHERS**

THE MARK CONSISTS OF THE WORDS "FARMERS & FISHERS" UNDERNEATH A DESIGN OF A STYLIZED PLANT INSCRIBED INSIDE OF A DARK CIRCLE.

FOR RESTAURANT AND BAR SERVICES, INCLUDING RESTAURANT CARRYOUT SERVICES (U.S. CLS. 100 AND 101).

FIRST USE 11-16-2009; IN COMMERCE 11-16-2009.
GENE MACIOL, EXAMINING ATTORNEY

SN 85-256,074. ROSA'S CAFES, INC., FT. WORTH, TX. FILED 3-2-2011.

STOP AND SMELL THE ROSA'S

THE MARK CONSISTS OF STANDARD CHARACTERS WITHOUT CLAIM TO ANY PARTICULAR FONT, STYLE, SIZE, OR COLOR.

OWNER OF U.S. REG. NOS. 1,531,451, 2,442,321 AND 3,142,117.

FOR RESTAURANT SERVICES (U.S. CLS. 100 AND 101).
TRACY WHITTAKER-BROWN, EXAMINING ATTORNEY

CLASS 43—(Continued).

SN 85-256,236. QUEST FOOD MANAGEMENT SERVICES, INC., LOMBARD, IL. FILED 3-2-2011.

DELISH CAFE

THE MARK CONSISTS OF STANDARD CHARACTERS WITHOUT CLAIM TO ANY PARTICULAR FONT, STYLE, SIZE, OR COLOR.

NO CLAIM IS MADE TO THE EXCLUSIVE RIGHT TO USE "CAFE", APART FROM THE MARK AS SHOWN.

FOR BUSINESS FOOD SERVICES, NAMELY, CAFETERIAS, RESTAURANTS AND FOOD OUTLETS IN COMMERCIAL BUILDINGS AND OTHER RETAIL LOCATIONS (U.S. CLS. 100 AND 101).

ROSELLE HERRERA, EXAMINING ATTORNEY

CLASS 43—(Continued).

SN 85-256,345. THE DINEX GROUP, LLC, NEW YORK, NY. FILED 3-2-2011.



DANIEL

OWNER OF U.S. REG. NO. 2,928,718.

THE MARK CONSISTS OF THE WORD "DANIEL" UNDERNEATH TWO INTERLOCKING, DOTTED CIRCLES.

FOR RESTAURANT SERVICES (U.S. CLS. 100 AND 101).

FIRST USE 9-8-2008; IN COMMERCE 9-8-2008.

ALEXANDER L. POWERS, EXAMINING ATTORNEY

SN 85-256,408. COTTERILL, MALI A., WAUWATOSA, WI. FILED 3-3-2011.

Gobble Up

THE MARK CONSISTS OF STANDARD CHARACTERS WITHOUT CLAIM TO ANY PARTICULAR FONT, STYLE, SIZE, OR COLOR.

FOR RESTAURANT (U.S. CLS. 100 AND 101).

RONALD DELGIZZI, EXAMINING ATTORNEY

SN 85-256,637. ANGR HOLDINGS, LLC, DENVER, CO. FILED 3-3-2011.



THE COLOR(S) RED, ORANGE, YELLOW, AND WHITE IS/ARE CLAIMED AS A FEATURE OF THE MARK.

THE MARK CONSISTS OF THE STYLIZED WORD "ZABU" PRESENTED IN A VERTICAL MANNER. THE RED "Z" IS ABOVE "AB". "A" IS ORANGE AND "B" IS YELLOW. UNDERNEATH "AB" IS THE LETTER "U" IN WHITE. THE BLACK BACKGROUND IS NOT PART OF THE MARK.

FOR RESTAURANT SERVICES (U.S. CLS. 100 AND 101).

FIRST USE 3-1-2007; IN COMMERCE 3-1-2007.

SIMON TENG, EXAMINING ATTORNEY

THE SPORTS WRAP

THE MARK CONSISTS OF STANDARD CHARACTERS WITHOUT CLAIM TO ANY PARTICULAR FONT, STYLE, SIZE, OR COLOR.

FOR RESTAURANT SERVICES; TAKE-OUT RESTAURANT SERVICES (U.S. CLS. 100 AND 101).

LINDA POWELL, EXAMINING ATTORNEY

CLASS 43—(Continued).

SN 85-256,705. ANGR HOLDINGS, LLC, DENVER, CO.
FILED 3-3-2011.

GRILL'BILLIES

THE MARK CONSISTS OF STANDARD CHARACTERS
WITHOUT CLAIM TO ANY PARTICULAR FONT, STYLE,
SIZE, OR COLOR.

FOR RESTAURANT SERVICES; TAKE-OUT RESTAU-
RANT SERVICES (U.S. CLS. 100 AND 101).
LINDA POWELL, EXAMINING ATTORNEY

SN 85-256,743. ANGR HOLDINGS, LLC, DENVER, CO.
FILED 3-3-2011.

SOUL DADDY

THE MARK CONSISTS OF STANDARD CHARACTERS
WITHOUT CLAIM TO ANY PARTICULAR FONT, STYLE,
SIZE, OR COLOR.

FOR RESTAURANT SERVICES; TAKE-OUT RESTAU-
RANT SERVICES (U.S. CLS. 100 AND 101).
LINDA POWELL, EXAMINING ATTORNEY

SN 85-256,876. NEIGHBORHOOD GRILLS, LLC, SEATTLE,
WA. FILED 3-3-2011.

LUNCHBOX LABORATORY

THE MARK CONSISTS OF STANDARD CHARACTERS
WITHOUT CLAIM TO ANY PARTICULAR FONT, STYLE,
SIZE, OR COLOR.

FOR RESTAURANT AND BAR SERVICES (U.S. CLS.
100 AND 101).
FIRST USE 8-1-2007; IN COMMERCE 1-29-2011.
JUDITH HELFMAN, EXAMINING ATTORNEY

CLASS 43—(Continued).

SN 85-257,115. 229-231 DUFFIELD LLC, BROOKLYN, NY.
FILED 3-3-2011.

HOTEL 718

THE MARK CONSISTS OF STANDARD CHARACTERS
WITHOUT CLAIM TO ANY PARTICULAR FONT, STYLE,
SIZE, OR COLOR.

NO CLAIM IS MADE TO THE EXCLUSIVE RIGHT TO
USE "HOTEL", APART FROM THE MARK AS SHOWN.

FOR HOTEL, RESORT LODGING SERVICES; RES-
TAURANT AND BAR SERVICES; PROVIDING TEM-
PORARY LODGING ACCOMMODATIONS;
PROVIDING RESORT HOTEL SERVICES AND CON-
FERENCE CENTER SERVICES; PROVIDING SPA SER-
VICES, NAMELY, PROVIDING TEMPORARY
ACCOMMODATIONS TO CLIENTS OF A HEALTH OR
BEAUTY SPA (U.S. CLS. 100 AND 101).
TASNEEM HUSSAIN, EXAMINING ATTORNEY

SN 85-257,125. 229-231 DUFFIELD LLC, BROOKLYN, NY.
FILED 3-3-2011.

HOTEL SEVEN ONE EIGHT

THE MARK CONSISTS OF STANDARD CHARACTERS
WITHOUT CLAIM TO ANY PARTICULAR FONT, STYLE,
SIZE, OR COLOR.

NO CLAIM IS MADE TO THE EXCLUSIVE RIGHT TO
USE "HOTEL", APART FROM THE MARK AS SHOWN.

FOR HOTEL, RESORT LODGING SERVICES; RES-
TAURANT AND BAR SERVICES; PROVIDING TEM-
PORARY LODGING ACCOMMODATIONS;
PROVIDING RESORT HOTEL SERVICES AND CON-
FERENCE CENTER SERVICES; PROVIDING SPA SER-
VICES, NAMELY, PROVIDING TEMPORARY
ACCOMMODATIONS TO CLIENTS OF A HEALTH OR
BEAUTY SPA (U.S. CLS. 100 AND 101).
TASNEEM HUSSAIN, EXAMINING ATTORNEY

SN 85-257,258. HARBOR HEAVEN, LLC, ROCKWALL, TX.
FILED 3-3-2011.

HARBOR HEAVEN

THE MARK CONSISTS OF STANDARD CHARACTERS
WITHOUT CLAIM TO ANY PARTICULAR FONT, STYLE,
SIZE, OR COLOR.

FOR RESTAURANT AND BAR SERVICES (U.S. CLS.
100 AND 101).
RONALD AIKENS, EXAMINING ATTORNEY

CLASS 43—(Continued).

SN 85-257,400. LUNCH CUBE LLC, MINNEAPOLIS, MN.
FILED 3-3-2011.

Lunch Delivered to Your Cube

THE MARK CONSISTS OF STANDARD CHARACTERS
WITHOUT CLAIM TO ANY PARTICULAR FONT, STYLE,
SIZE, OR COLOR.

FOR RESTAURANT AND CATERING SERVICES (U.S.
CLS. 100 AND 101).

FIRST USE 2-28-2008; IN COMMERCE 2-28-2008.
JULIE VEPPUMTHARA, EXAMINING ATTORNEY

SN 85-257,509. PADI'S PLACE, INC., SAN JUAN, METRO
MANILA, PHILIPPINES, FILED 3-3-2011.



NO CLAIM IS MADE TO THE EXCLUSIVE RIGHT TO
USE "RESTAURANT & BAR", APART FROM THE MARK
AS SHOWN.

THE MARK CONSISTS OF THE WORDS "PADI'S POINT
RESTAURANT & BAR" WITH THE DEPICTION OF A
COMPASS POINTING NORTHWEST WITHIN OVERLAP-
PING RECTANGULAR DESIGNS.

FOR RESTAURANT SERVICES, BAR SERVICES, AND
CATERING SERVICES (U.S. CLS. 100 AND 101).

WENDY JUN, EXAMINING ATTORNEY

SN 85-257,650. GDINE, LLC, CHICAGO, IL. FILED 3-4-2011.

GDINE

THE MARK CONSISTS OF STANDARD CHARACTERS
WITHOUT CLAIM TO ANY PARTICULAR FONT, STYLE,
SIZE, OR COLOR.

FOR ONLINE SERVICE FOR THE RESERVATION OF
RESTAURANTS AND OTHER DINING FACILITIES
(U.S. CLS. 100 AND 101).

FIRST USE 1-5-2011; IN COMMERCE 2-28-2011.
ALEX KEAM, EXAMINING ATTORNEY

CLASS 43—(Continued).

SN 85-257,728. LEGACY ESCAPES, LLC., WINDERMERE,
FL. FILED 3-4-2011.

LEGACY ESCAPES

THE MARK CONSISTS OF STANDARD CHARACTERS
WITHOUT CLAIM TO ANY PARTICULAR FONT, STYLE,
SIZE, OR COLOR.

FOR RESORT LODGING SERVICES, RESORT HO-
TELS; HEALTH RESORT SERVICES, NAMELY, PRO-
VIDING FOOD AND LODGING THAT SPECIALIZE IN
PROMOTING PATRONS' GENERAL HEALTH AND
WELL-BEING; VACATION CLUB SERVICES, NAMELY
PROVIDING TEMPORARY LODGING ACCOMMODA-
TIONS; ARRANGING FOR ACCESS TO RESORT AME-
NITIES, NAMELY RESTAURANTS; PROVIDING
INFORMATION TO OTHERS RELATED TO RESORT
LODGING SERVICES, AMENITIES RELATED THERE-
TO, AND THE AVAILABILITY THEREOF; PROVIDING
INFORMATION TO OTHERS REGARDING RESTAU-
RANTS, AND OTHER ESTABLISHMENTS FOR THE
CONSUMPTION OF FOOD AND DRINK; PROVIDING
INFORMATION TO OTHERS REGARDING MEMBER-
SHIP IN A LUXURY RESIDENCE CLUB; PROVIDING
INFORMATION TO OTHERS RELATED TO RESORT
LODGING SERVICES; PRIVATE RESORT CLUB SER-
VICES, NAMELY, PROVISION TO CLUB MEMBERS OF
TEMPORARY ACCOMMODATIONS IN COMPANY
OWNED OR LEASED PRIVATE RESIDENCES (U.S.
CLS. 100 AND 101).

KIMBERLY PERRY, EXAMINING ATTORNEY

SN 85-257,869. BROOKS, GLENN, ATLANTA, GA. FILED 3-
4-2011.

CHIC'S SPORTSBAR AND GRILL

THE MARK CONSISTS OF STANDARD CHARACTERS
WITHOUT CLAIM TO ANY PARTICULAR FONT, STYLE,
SIZE, OR COLOR.

NO CLAIM IS MADE TO THE EXCLUSIVE RIGHT TO
USE "SPORTSBAR AND GRILL", APART FROM THE
MARK AS SHOWN.

FOR RESTAURANT AND BAR SERVICES, INCLUD-
ING RESTAURANT CARRYOUT SERVICES (U.S. CLS.
100 AND 101).

TASNEEM HUSSAIN, EXAMINING ATTORNEY

CLASS 43—(Continued).

SN 85-257,884. WACKY WOK, INC., VENICE, CA. FILED 3-4-2011.

wacky wok
NEW YORK STYLE CHINESE CUISINE

NO CLAIM IS MADE TO THE EXCLUSIVE RIGHT TO USE "NEW YORK STYLE CHINESE CUISINE", APART FROM THE MARK AS SHOWN.

THE MARK CONSISTS OF THE STYLIZED TEXT "WACKY WOK NEW YORK STYLE CHINESE CUISINE".

FOR RESTAURANTS (U.S. CLS. 100 AND 101).

FIRST USE 3-21-2007; IN COMMERCE 3-21-2007.

TASNEEM HUSSAIN, EXAMINING ATTORNEY

SN 85-261,970. KO CATERING AND PIES, LLC, SOUTH BOSTON, MA. FILED 3-9-2011.

IT'S A PIE, MATE!

THE MARK CONSISTS OF STANDARD CHARACTERS WITHOUT CLAIM TO ANY PARTICULAR FONT, STYLE, SIZE, OR COLOR.

NO CLAIM IS MADE TO THE EXCLUSIVE RIGHT TO USE "PIE", APART FROM THE MARK AS SHOWN.

FOR CATERING SERVICES; PROVIDING OF FOOD AND DRINK VIA A MOBILE TRUCK; RESTAURANT SERVICES FEATURING AUSTRALIAN CUISINE (U.S. CLS. 100 AND 101).

CHRISTINE MARTIN, EXAMINING ATTORNEY

SN 85-262,735. HAWAII GOURMET SOCIETY LLC, KAMUELA, HI. FILED 3-9-2011.

Red Water Cafe

THE MARK CONSISTS OF STANDARD CHARACTERS WITHOUT CLAIM TO ANY PARTICULAR FONT, STYLE, SIZE, OR COLOR.

NO CLAIM IS MADE TO THE EXCLUSIVE RIGHT TO USE "CAFE", APART FROM THE MARK AS SHOWN.

FOR RESTAURANTS (U.S. CLS. 100 AND 101).

FIRST USE 8-2-2010; IN COMMERCE 10-17-2010.

TEJBIR SINGH, EXAMINING ATTORNEY

CLASS 43—(Continued).

SN 85-266,931. ZUPELY, S.A., PISO 17, MONTEVIDEO, URUGUAY, FILED 3-15-2011.

LA MAR MADISON

THE MARK CONSISTS OF STANDARD CHARACTERS WITHOUT CLAIM TO ANY PARTICULAR FONT, STYLE, SIZE, OR COLOR.

THE ENGLISH TRANSLATION OF "LA MAR" IN THE MARK IS "THE SEA".

FOR RESTAURANT SERVICES, NAMELY, SEAFOOD RESTAURANT SERVICES (U.S. CLS. 100 AND 101).

EDWARD FENNESSY, EXAMINING ATTORNEY

SN 85-303,548. ROSA'S CAFES, INC., FT. WORTH, TX. FILED 4-25-2011.

ROSA'S CAFE

THE MARK CONSISTS OF STANDARD CHARACTERS WITHOUT CLAIM TO ANY PARTICULAR FONT, STYLE, SIZE, OR COLOR.

OWNER OF U.S. REG. NOS. 1,531,451, 2,442,321 AND 3,142,117.

NO CLAIM IS MADE TO THE EXCLUSIVE RIGHT TO USE "CAFE", APART FROM THE MARK AS SHOWN.

FOR RESTAURANT SERVICES (U.S. CLS. 100 AND 101).

FIRST USE 8-1-1984; IN COMMERCE 8-1-1984.

TRACY WHITTAKER-BROWN, EXAMINING ATTORNEY

CLASS 44—MEDICAL, BEAUTY AND AGRICULTURAL SERVICES

SN 76-705,816. AIM TO PLEASE INC., HIGH RIDGE, MO. FILED 12-27-2010.

**AIM TO PLEASE**

THE MARK CONSISTS OF A STYLIZED DEPICTION OF A TREE. AT THE BASE OF THE TREE ONE MAN IS STANDING ON THE GROUND HOLDING A ROPE GOING INTO THE TREE'S FOLIAGE, AND PARTIALLY UP IN THE TREE ANOTHER MAN IS ATTACHED TO THE ROPE, HOLDING A CHAIN SAW AND IN THE PROCESS OF CUTTING A TREE LIMB.

FOR GARDEN TREE PLANTING; LANDSCAPE DESIGN; LANDSCAPE GARDENING DESIGN FOR OTHERS; TREE CARE SERVICES; TREE REMOVAL SERVICES; TREE SURGERY (U.S. CLS. 100 AND 101).

FIRST USE 1-24-1991; IN COMMERCE 1-1-2007.
RONALD AIKENS, EXAMINING ATTORNEY

SN 77-284,559. NOVARTIS AG, BASEL, SWITZERLAND, FILED 9-20-2007.



THE MARK CONSISTS OF THE WORDS "RIBBON OF PINK" WITH THE "O" IN "OF" FORMED BY A SPOOL OF RIBBON. THE COLOR GRAY IS INTENDED TO SHOW SHADING OR CONTRAST ONLY. COLOR IS NOT CLAIMED AS A FEATURE OF THE MARK AND THE DRAWING OF THE MARK IS NOT IN COLOR.

FOR PROVIDING HEALTH INFORMATION (U.S. CLS. 100 AND 101).

FIRST USE 11-30-2004; IN COMMERCE 11-30-2004.
DEBRA LEE, EXAMINING ATTORNEY

SN 77-666,496. SHARECARE, INC., ATLANTA, GA. FILED 2-9-2009.

SHARE CARE

THE MARK CONSISTS OF STANDARD CHARACTERS WITHOUT CLAIM TO ANY PARTICULAR FONT, STYLE, SIZE, OR COLOR.

FOR PROVIDING A WIDE RANGE OF INFORMATION IN TRADITIONAL FIELDS OF HEALTH, HEALTHCARE, MEDICAL TREATMENTS, AND MEDICINE VIA A GLOBAL COMPUTER NETWORK (U.S. CLS. 100 AND 101).

ANDREW RHIM, EXAMINING ATTORNEY

CLASS 44—(Continued).

SN 77-775,147. MONIZ-LECCE, GIUSEPPE E., AKA MONIZ-LECCE, JOEY, SURREY, BC, CANADA, FILED 7-6-2009.

Greener Ever After

THE MARK CONSISTS OF STANDARD CHARACTERS WITHOUT CLAIM TO ANY PARTICULAR FONT, STYLE, SIZE, OR COLOR.

PRIORITY CLAIMED UNDER SEC. 44(D) ON CANADA APPLICATION NO. 1443835, FILED 7-6-2009, REG. NO. TMA796932, DATED 5-9-2011, EXPIRES 5-9-2026.

FOR HORTICULTURAL PROCESSES AND TURF OR LAWN CARE SERVICES, NAMELY, PROVIDING PREPARATION AND DEVELOPMENT OF TURFGRASS AND/OR SOIL FOR PROVIDING AN ENVIRONMENT THAT ENCOURAGES IMPROVED GROWTH ATTRIBUTES; LANDSCAPE DESIGN; LANDSCAPE GARDENING; LANDSCAPE GARDENING DESIGN FOR OTHERS; LAWN CARE; LAWN MOWING SERVICES; PROVIDING A WEBSITE FEATURING INFORMATION IN THE FIELD OF LANDSCAPE DESIGN FOR USE BY INTERIOR DESIGNERS AND ARCHITECTS; PROVIDING INFORMATION ABOUT DROUGHT TOLERANT LANDSCAPE DESIGN AND INSTALLATION (U.S. CLS. 100 AND 101).

AISHA CLARKE, EXAMINING ATTORNEY

SN 77-780,911. EYE PHYSICIANS AND SURGEONS OF AUGUSTA, P.C., AUGUSTA, GA. FILED 7-14-2009.

EYE GUYS

THE MARK CONSISTS OF STANDARD CHARACTERS WITHOUT CLAIM TO ANY PARTICULAR FONT, STYLE, SIZE, OR COLOR.

APPLICANT CLAIMS EXCLUSIVE RIGHT TO USE THE MARK IN THE AREA COMPRISING THE ENTIRE UNITED STATES WITH THE EXCEPTION OF FLORIDA. APPLICANT USES ITS MARK IN ADVERTISING FOR ITS SERVICES. TO APPLICANT'S KNOWLEDGE, THE ONLY EXCEPTION TO APPLICANT'S CLAIM OF EXCLUSIVE USE IS USE BY ATLANTIC EYE INSTITUTE, P.A., THE OWNER OF US REG. NO. 3962326 FOR THE MARK THE EYE GUYS FOR "COSMETIC AND PLASTIC SURGERY; EYEGLASS FITTING; FITTING OF CONTACT LENSES; FITTING OF OPTICAL LENSES; LASER AND INTENSE PULSE LIGHT SKIN ENHANCEMENT PROCEDURES; LASER VISION CORRECTION SERVICES; LASER VISION

CLASS 44—(Continued).

SURGERY SERVICES; NON-INVASIVE COSMETIC MEDICAL PROCEDURES; OPHTHALMOLOGY SERVICES; OPTOMETRY SERVICES; TREATMENT OF EYE DISEASE AND CONDITIONS," IN INTERNATIONAL CLASS 44. IT IS BELIEVED SUCH USE BEGAN IN COMMERCE ON JULY 31, 2007, AND HAS BEEN LIMITED TO FLORIDA. TO THE BEST OF APPLICANT'S KNOWLEDGE AND BELIEF NO OTHER PERSON, FIRM, CORPORATION OR ASSOCIATION EXCEPT AS SPECIFIED ABOVE HAS THE RIGHT TO USE SAID MARK IN COMMERCE.

NO CLAIM IS MADE TO THE EXCLUSIVE RIGHT TO USE "EYE", APART FROM THE MARK AS SHOWN.

FOR COSMETIC AND PLASTIC SURGERY; LASER VISION CORRECTION SERVICES; LASER VISION SURGERY SERVICES; NON-INVASIVE COSMETIC MEDICAL PROCEDURES; OPHTHALMOLOGY SERVICES; OPTOMETRY SERVICES; TREATMENT OF EYE DISEASES AND CONDITIONS (U.S. CLS. 100 AND 101).

FIRST USE 8-30-2001; IN COMMERCE 9-15-2001.

ALEXANDER L. POWERS, EXAMINING ATTORNEY

CLASS 44—(Continued).

SN 77-853,410. CARESMART, LLC, LA JOLLA, CA. FILED 10-21-2009.

CareSmart

THE MARK CONSISTS OF STANDARD CHARACTERS WITHOUT CLAIM TO ANY PARTICULAR FONT, STYLE, SIZE, OR COLOR.

FOR MAINTAINING PATIENT FILES AND RECORDS CONCERNING THE MEDICAL CONDITION AND PERSONAL MEDICAL HISTORY OF INDIVIDUALS AND PROVIDING MEDICAL INFORMATION AND CONSULTATIONS FOR MEDICAL CLINICS, URGENT CARE CENTERS, HOSPITALS, PHARMACIES, SCHOOLS AND UNIVERSITIES, BUSINESSES, AND GOVERNMENT AGENCIES (U.S. CLS. 100 AND 101).

FIRST USE 3-30-1999; IN COMMERCE 3-30-1999.

MARK SPARACINO, EXAMINING ATTORNEY

SN 77-835,409. HEAR IN MANAGEMENT SERVICES INC., EDMONTON, ALBERTA, CANADA, FILED 9-25-2009.

HEAR IN

SN 79-094,767. SOMNOMED LIMITED, AUSTRALIA, FILED 3-1-2011.

SomCentre

THE MARK CONSISTS OF STANDARD CHARACTERS WITHOUT CLAIM TO ANY PARTICULAR FONT, STYLE, SIZE, OR COLOR.

PRIORITY CLAIMED UNDER SEC. 44(D) ON CANADA APPLICATION NO. 1432584, FILED 3-26-2009, REG. NO. 796,744, DATED 5-5-2011, EXPIRES 5-5-2026.

NO CLAIM IS MADE TO THE EXCLUSIVE RIGHT TO USE "HEAR", APART FROM THE MARK AS SHOWN.

FOR HEARING AID SERVICES, NAMELY, PROVIDING FITTINGS AND ADJUSTMENTS FOR HEARING AIDS AND ASSISTIVE LISTENING DEVICES; ADMINISTERING OF MEDICAL HEARING TESTS; PROVIDING HEARING SCREENING SERVICES, NAMELY, HEARING TESTING AND HEARING AID EVALUATION; AUDIOLOGICAL CONSULTING SERVICES, NAMELY ASSESSMENT AND TREATMENT OF PERSONS WITH A HEARING IMPAIRMENT; MEDICAL TESTING FOR MEDICAL HEARING DIAGNOSTIC OR TREATMENT PURPOSES TO PERSONS WITH A HEARING IMPAIRMENT; CONSULTING SERVICES IN THE FIELD OF DIAGNOSTIC MEDICAL TESTING FOR PERSONS WITH A HEARING IMPAIRMENT (U.S. CLS. 100 AND 101).

JASON TURNER, EXAMINING ATTORNEY

THE MARK CONSISTS OF STANDARD CHARACTERS WITHOUT CLAIM TO ANY PARTICULAR FONT, STYLE, SIZE, OR COLOR.

PRIORITY DATE OF 9-2-2010 IS CLAIMED.

OWNER OF INTERNATIONAL REGISTRATION 1070234 DATED 3-1-2011, EXPIRES 3-1-2021.

FOR MEDICAL AND MEDICAL ASSISTANCE SERVICES NAMELY SERVICES FOR THE TREATMENT OF SNORING AND SLEEP DISORDERS (U.S. CLS. 100 AND 101).

PAUL MORENO, EXAMINING ATTORNEY

CLASS 44—(Continued).

SN 85-066,106. ADVANCED SLEEP MEDICINE SERVICES, INC., LOS ANGELES, CA. FILED 6-18-2010.

**ADVANCED SLEEP MEDICINE
SERVICES**

THE MARK CONSISTS OF STANDARD CHARACTERS WITHOUT CLAIM TO ANY PARTICULAR FONT, STYLE, SIZE, OR COLOR.

NO CLAIM IS MADE TO THE EXCLUSIVE RIGHT TO USE "SLEEP MEDICINE SERVICES", APART FROM THE MARK AS SHOWN.

FOR HEALTHCARE SERVICES, NAMELY, TREATMENT OF PATIENTS WITH SNORING, SLEEP APNEA, AND OTHER SLEEP DISORDERS; PROVIDING INFORMATION IN THE FIELD OF SLEEP APNEA AND RELATED SLEEP DISORDERS FOR DOCTORS AND PATIENTS; HEALTH ASSESSMENT SERVICES, NAMELY, PROVIDING A DATABASE IN THE FIELD OF SLEEP APNEA AND OTHER SLEEP DISORDERS, AND HOME SLEEP DIAGNOSTIC INFORMATION BASED ON COLLECTED DATA AND INFORMATION FOR TREATMENT AND DIAGNOSTIC PURPOSES; AND PROVIDING AN INTERNET WEB SITE FOR MEDICAL PROFESSIONALS AND PATIENTS PROVIDING INFORMATION RELATING TO SLEEP APNEA, SNORING, AND OTHER SLEEP DISORDERS (U.S. CLS. 100 AND 101).

FIRST USE 12-31-2004; IN COMMERCE 12-31-2004.
DAVID TAYLOR, EXAMINING ATTORNEY

SN 85-095,748. JOHNSON & JOHNSON, NEW BRUNSWICK, NJ. FILED 7-29-2010.

PSA VOICES

THE MARK CONSISTS OF STANDARD CHARACTERS WITHOUT CLAIM TO ANY PARTICULAR FONT, STYLE, SIZE, OR COLOR.

NO CLAIM IS MADE TO THE EXCLUSIVE RIGHT TO USE "PSA", APART FROM THE MARK AS SHOWN.

FOR PROVIDING AN INTERACTIVE WEBSITE FEATURING MEDICAL INFORMATION IN THE FIELD OF PSORIATIC ARTHRITIS (U.S. CLS. 100 AND 101).

JAMES MACFARLANE, EXAMINING ATTORNEY

CLASS 44—(Continued).

SN 85-100,297. SMARTCOMP, LLC, WASHINGTON, PA. FILED 8-4-2010.

GOLD STANDARD INCONCLUSIVE

THE MARK CONSISTS OF STANDARD CHARACTERS WITHOUT CLAIM TO ANY PARTICULAR FONT, STYLE, SIZE, OR COLOR.

NO CLAIM IS MADE TO THE EXCLUSIVE RIGHT TO USE "GOLD STANDARD", APART FROM THE MARK AS SHOWN.

FOR CONSULTING SERVICES IN THE FIELD OF MEDICAL CARE (U.S. CLS. 100 AND 101).

INGRID C. EULIN, EXAMINING ATTORNEY

SN 85-101,106. WISER COMPANY, LLC, MURFREESBORO, TN. FILED 8-5-2010.

LIVE WISER

THE MARK CONSISTS OF STANDARD CHARACTERS WITHOUT CLAIM TO ANY PARTICULAR FONT, STYLE, SIZE, OR COLOR.

FOR HEALTH CARE SERVICES, NAMELY, WELLNESS PROGRAMS; AND PROVIDING INFORMATION IN THE FIELD OF NUTRITION, HEALTH, AND WELLNESS (U.S. CLS. 100 AND 101).

FIRST USE 4-30-2010; IN COMMERCE 6-30-2010.
PRISCILLA MILTON, EXAMINING ATTORNEY

SN 85-101,116. WISER COMPANY, LLC, MURFREESBORO, TN. FILED 8-5-2010.

THE MARK CONSISTS OF "LIVE" IN STYLIZED LETTERS AND DESIGN ADJACENT TO A STYLIZED DESIGN OF AN OUTLINE OF A HUMAN IN A RUNNING POSITION FOLLOWED BY AND ADJACENT TO "WISER" IN STYLIZED LETTERS AND DESIGN, WITH THE FOREGOING UNDERLINED BY A PATTERN OF STYLIZED LINES DECREASING IN LENGTH.

FOR HEALTH CARE SERVICES, NAMELY, WELLNESS PROGRAMS; AND PROVIDING INFORMATION IN THE FIELD OF NUTRITION, HEALTH, AND WELLNESS (U.S. CLS. 100 AND 101).

FIRST USE 4-30-2010; IN COMMERCE 6-30-2010.
PRISCILLA MILTON, EXAMINING ATTORNEY

CLASS 44—(Continued).

SN 85-101,222. AUTISM AWAKENING, INC., CHINO HILLS, CA. FILED 8-5-2010.

CLASS 44—(Continued).

SN 85-106,361. LINDA STARCK FOUNDATION FOR INTEGRATIVE CANCER CARE, BOULDER, CO. FILED 8-12-2010.

AUTISM AWAKENING

THE MARK CONSISTS OF STANDARD CHARACTERS WITHOUT CLAIM TO ANY PARTICULAR FONT, STYLE, SIZE, OR COLOR.

NO CLAIM IS MADE TO THE EXCLUSIVE RIGHT TO USE "AUTISM", APART FROM THE MARK AS SHOWN.

FOR PROVIDING AN INTERNET WEBSITE FEATURING NEWS AND INFORMATION RELATING TO DIAGNOSIS AND TREATMENT OF AUTISM (U.S. CLS. 100 AND 101).

FIRST USE 1-1-2007; IN COMMERCE 1-1-2007.

PRISCILLA MILTON, EXAMINING ATTORNEY



SN 85-102,527. VIRTUOX, INC., CORAL SPRINGS, FL. FILED 8-7-2010.

HOST

THE MARK CONSISTS OF STANDARD CHARACTERS WITHOUT CLAIM TO ANY PARTICULAR FONT, STYLE, SIZE, OR COLOR.

FOR HEALTH ASSESSMENT SERVICES, NAMELY, MEDICAL TESTING FOR DIAGNOSTIC AND TREATMENT PURPOSES FOR SLEEP DISORDERED BREATHING (SDB) DISORDERS, NAMELY, OBSTRUCTIVE SLEEP APNEA AND HYPOPNEA, PROVIDING A DATABASE IN THE FIELD OF SLEEP APNEA AND HOME SLEEP TESTING DIAGNOSTIC INFORMATION BASED ON COLLECTED DATA AND INFORMATION ALL FOR TREATMENT AND DIAGNOSTIC PURPOSES; HEALTHCARE SERVICES, NAMELY, DIAGNOSIS AND TREATMENT OF PATIENTS WITH SNORING AND SLEEP APNEA DISORDERS; PROVIDING AN INTERNET WEB SITE FOR MEDICAL PROFESSIONALS AND MEDICAL PATIENTS RELATING TO SLEEP APNEA AND RELATED DIAGNOSTIC DATA INPUT FROM REMOTE LOCATIONS USING ELECTRONIC PATIENT MONITORING DEVICES THAT FEED INFORMATION TO THE WEB SITE FOR USE BY MEDICAL PROFESSIONALS FOR PURPOSES OF MONITORING AND DIAGNOSING MEDICAL CONDITIONS; PROVIDING INFORMATION IN THE FIELD OF SLEEP APNEA AND RELATED SLEEP DISORDERS FOR DOCTORS AND PATIENTS (U.S. CLS. 100 AND 101).

PRISCILLA MILTON, EXAMINING ATTORNEY

THE COLOR(S) DARK BLUE, LIGHT BLUE, AND WHITE IS/ARE CLAIMED AS A FEATURE OF THE MARK.

THE MARK CONSISTS OF TWO OVERLAPPING SETS OF CONCENTRIC CIRCLES IN DARK BLUE AND LIGHT BLUE TO THE LEFT OF THE WORD "EMBODIWORKS" WHERE THE "EMBODI" APPEARS IN DARK BLUE AND THE "WORKS" APPEARS IN LIGHT BLUE AND UNDERNEATH AND TO THE RIGHT OF THE WORD "EMBODIWORKS", APPEARS THE PHRASE "WHOLE MATTERS." PRINTED IN DARK BLUE.

FOR CONSULTING SERVICES IN THE FIELD OF HEALTH; COUNSELING SERVICES IN THE FIELDS OF HEALTH, NUTRITION AND LIFESTYLE WELLNESS; HEALTH CARE SERVICES, NAMELY, DISEASE MANAGEMENT PROGRAMS; PROVIDING A WEB SITE FEATURING INFORMATION ON HEALTH AND NUTRITION; PROVIDING A WEB SITE FEATURING MEDICAL INFORMATION; PROVIDING A WEBSITE VIA A GLOBAL COMPUTER NETWORK FEATURING INFORMATION AND COMPREHENSIVE CONTENT IN THE FIELDS OF HEALTH, CANCER, CANCER RECOVERY AND SURVIVAL; PROVIDING HEALTH INFORMATION (U.S. CLS. 100 AND 101).

C. DIONNE CLYBURN, EXAMINING ATTORNEY

CLASS 44—(Continued).

SN 85-106,425. LINDA STARCK FOUNDATION FOR INTEGRATIVE CANCER CARE, BOULDER, CO. FILED 8-12-2010.



THE COLOR(S) DARK BLUE, LIGHT BLUE, AND WHITE IS/ARE CLAIMED AS A FEATURE OF THE MARK.

THE MARK CONSISTS OF TWO OVERLAPPING SETS OF CONCENTRIC CIRCLES IN DARK BLUE AND LIGHT BLUE TO THE LEFT OF THE WORD "EMBODIWORKS" WHERE THE "EMBODI" APPEARS IN DARK BLUE AND THE "WORKS" APPEARS IN LIGHT BLUE.

FOR CONSULTING SERVICES IN THE FIELD OF HEALTH; CONSULTING SERVICES IN THE FIELDS OF HEALTH AND NUTRITION; HEALTH CARE SERVICES, NAMELY, DISEASE MANAGEMENT PROGRAMS; PROVIDING A WEB SITE FEATURING INFORMATION ON HEALTH AND NUTRITION; PROVIDING A WEB SITE FEATURING MEDICAL INFORMATION; PROVIDING A WEBSITE VIA A GLOBAL COMPUTER NETWORK FEATURING INFORMATION AND COMPREHENSIVE CONTENT IN THE FIELDS OF HEALTH, CANCER, CANCER RECOVERY AND SURVIVAL; PROVIDING HEALTH INFORMATION (U.S. CLS. 100 AND 101).

C. DIONNE CLYBURN, EXAMINING ATTORNEY

CLASS 44—(Continued).

SN 85-120,251. PUTT TEE GREENS, WASHINGTON, DC. FILED 8-31-2010.



NO CLAIM IS MADE TO THE EXCLUSIVE RIGHT TO USE "GREENS", APART FROM THE MARK AS SHOWN.

THE MARK CONSISTS OF A SILHOUETTE OF A PERSON KNEELING DOWN HOLDING A PUTTER AND LINING UP A SHOT. THE IMAGE HAS A CIRCLE STARTING FROM THE LEFT KNEE TO THE RIGHT KNEE. THE STYLIZED TEXT "PUTT TEE GREENS" APPEARS ON TOP INSIDE THE CIRCLE.

FOR LANDSCAPING SERVICES, NAMELY, DESIGN AND INSTALLATION OF PRACTICE PUTTING GREENS FOR RESIDENTIAL AND COMMERCIAL PROPERTIES (U.S. CLS. 100 AND 101).

LINDA LAVACHE, EXAMINING ATTORNEY

SN 85-135,778. MORGENSTERN CENTER FOR ORBITAL AND FACIAL PLASTIC SURGERY INC., WAYNE, PA. FILED 9-22-2010.



SN 85-109,929. GUNDERSHEIMER, JEROME, SHERMAN, TX. FILED 8-18-2010.

EYE-DO

THE MARK CONSISTS OF STANDARD CHARACTERS WITHOUT CLAIM TO ANY PARTICULAR FONT, STYLE, SIZE, OR COLOR.

FOR OPTOMETRY SERVICES; OPTICAL DISPENSARY SERVICES, NAMELY, DISPENSING OPTICAL MEDICATION (U.S. CLS. 100 AND 101).

ODESSA BIBBINS, EXAMINING ATTORNEY

THE MARK CONSISTS OF THE DRAWING OF A WOMAN'S FACE.

FOR MEDICAL CONSULTATIONS; MEDICAL SERVICES; SURGERY (U.S. CLS. 100 AND 101). FIRST USE 6-0-2007; IN COMMERCE 6-0-2007.

JERI J. FICKES, EXAMINING ATTORNEY

CLASS 44—(Continued).

SN 85-159,945. KAWALIT, ISSA AFIF, AMMAN, JORDAN, FILED 10-25-2010.



NO CLAIM IS MADE TO THE EXCLUSIVE RIGHT TO USE "INTERNATIONAL RENAL CARE GROUP", APART FROM THE MARK AS SHOWN.

THE COLOR(S) BROWN, DARK GRAY, LIGHT GRAY AND WHITE IS/ARE CLAIMED AS A FEATURE OF THE MARK.

THE MARK CONSISTS OF THE STYLIZED LETTERS "I R C G" AND THE STYLIZED WORDING "INTERNATIONAL RENAL CARE GROUP" IN A CIRCULAR ORIENTATION AROUND THE DESIGN OF CONCENTRIC CIRCLES, THE DESIGN OF CONTINENTS WITHIN THE INNERMOST CIRCLE, AND THE OUTLINE OF TWO KIDNEY SHAPED OUTLINES WITHIN THE INNERMOST CIRCLE. THE COLOR BROWN APPEARS IN THE DESIGN OF THE TWO KIDNEY SHAPED OUTLINES. THE COLOR DARK GRAY APPEARS IN THE STYLIZED LETTERS "I R C G" AND THE STYLIZED WORDING "INTERNATIONAL RENAL CARE GROUP" AND IN THE DESIGN OF THE CONTINENTS. THE COLOR LIGHT GRAY APPEARS IN THE OUTLINE OF THE OUTERMOST CIRCLE AND IN THE SHADING OF THE INNERMOST CIRCLE. THE COLOR WHITE APPEARS IN THE DESIGN OF AN OUTLINE OF A CIRCLE AROUND THE CONTINENTS.

FOR PROVIDING A WEB SITE FEATURING INFORMATION IN THE FIELD OF RENAL CARE (U.S. CLS. 100 AND 101).

FIRST USE 2-23-2009; IN COMMERCE 2-23-2009.
VERNA BETH RIRIE, EXAMINING ATTORNEY

SN 85-163,404. EUROLUX, INC., LOS ANGELES, CA. FILED 10-28-2010.



THE MARK CONSISTS OF THE WORDS "LE POSH" IN A STYLIZED FONT. ABOVE THE WORDS "LE POSH" APPEARS A RECTANGLE WITH ROUNDED CORNERS. IN THE RECTANGLE APPEAR THE INITIALS "LP" IN A STYLIZED FONT.

FOR HAIR SALON AND BARBER SERVICES; HEALTH SPA SERVICES, NAMELY, NAIL CARE, FACIALS, MASSAGE, BODY SCRUBS, BODY WRAPS; BODY WAXING AND TANNING SALON SERVICES; LASER HAIR REMOVAL SERVICES (U.S. CLS. 100 AND 101).

LAURIE MAYES, EXAMINING ATTORNEY

CLASS 44—(Continued).

SN 85-165,637. GISELLE FAUBEL, PSY., D., P.A., SOUTH-WEST RANCHES, FL. FILED 10-31-2010.

EQUULIBRIUM

THE MARK CONSISTS OF STANDARD CHARACTERS WITHOUT CLAIM TO ANY PARTICULAR FONT, STYLE, SIZE, OR COLOR.

THE WORDING "EQUULIBRIUM" HAS NO MEANING IN A FOREIGN LANGUAGE.

FOR THERAPY FOR HUMANS WITH USE OF HORSES (U.S. CLS. 100 AND 101).

FIRST USE 11-19-2009; IN COMMERCE 11-19-2009.
BILL DAWE, EXAMINING ATTORNEY

SN 85-173,496. MERCY SHIPS, GARDEN VALLEY, TX. FILED 11-10-2010.

AFRICA MERCY

THE MARK CONSISTS OF STANDARD CHARACTERS WITHOUT CLAIM TO ANY PARTICULAR FONT, STYLE, SIZE, OR COLOR.

FOR CHARITABLE SERVICES, NAMELY, PROVIDING MEDICAL CARE, HEALTH CARE, SURGERIES, DENTAL CARE, HYGIENIC CARE, IMMUNIZATIONS, MEDICAL TOOLS AND SUPPLIES, AND AGRICULTURAL ADVICE, ALL PROVIDED VIA A HOSPITAL SHIP; PROVIDING INFORMATION VIA A GLOBAL COMMUNICATIONS NETWORK IN THE FIELDS OF MEDICAL CARE, HEALTH CARE, SURGERIES, DENTAL CARE, HYGIENIC CARE, IMMUNIZATIONS, AND AGRICULTURAL ADVICE (U.S. CLS. 100 AND 101).

FIRST USE 12-15-1999; IN COMMERCE 12-15-1999.
ARETHA SOMERVILLE, EXAMINING ATTORNEY

SN 85-173,508. ORTHOMED PRODUCTS, INC., DBA AQUASHIELD USA, GRASS VALLEY, CA. FILED 11-10-2010.

AquaShield

THE MARK CONSISTS OF STANDARD CHARACTERS WITHOUT CLAIM TO ANY PARTICULAR FONT, STYLE, SIZE, OR COLOR.

OWNER OF U.S. REG. NO. 2,377,569.

FOR PROTECTIVE COVERINGS SPECIALLY FITTED FOR PLASTER CASTS FOR ORTHOPEDIC PURPOSES AND FOR SPLINTS FOR MEDICAL PURPOSES (U.S. CLS. 100 AND 101).

FIRST USE 3-12-1987; IN COMMERCE 3-12-1987.
DORITT L. CARROLL, EXAMINING ATTORNEY

CLASS 44—(Continued).

SN 85-178,473. COLEMAN, ERIC A., M.D., M.P.H., AURORA, CO. FILED 11-16-2010.

WWW.CARETRANSITIONS.ORG

THE MARK CONSISTS OF STANDARD CHARACTERS WITHOUT CLAIM TO ANY PARTICULAR FONT, STYLE, SIZE, OR COLOR.

SEC. 2(F).

FOR HEALTH CARE SERVICES FOR IMPROVING QUALITY CARE AND SAFETY OF PATIENTS DURING TRANSITIONS ACROSS CARE SETTINGS (U.S. CLS. 100 AND 101).

FIRST USE 3-0-2005; IN COMMERCE 3-0-2005.

BRIAN NEVILLE, EXAMINING ATTORNEY

SN 85-192,354. WESTMED MEDICAL GROUP, P.C., WHITE PLAINS, NY. FILED 12-7-2010.



OWNER OF U.S. REG. NO. 3,589,693.

NO CLAIM IS MADE TO THE EXCLUSIVE RIGHT TO USE "MEDICAL GROUP", APART FROM THE MARK AS SHOWN.

THE MARK CONSISTS OF A STYLIZED "W" AND A STYLIZED "M" TO THE LEFT OF THE WORDS "WESTMED MEDICAL GROUP".

FOR MEDICAL SERVICES; PHYSICIAN SERVICES (U.S. CLS. 100 AND 101).

FIRST USE 9-22-2009; IN COMMERCE 9-22-2009.

DEZMONA MIZELLE, EXAMINING ATTORNEY

SN 85-192,412. WESTMED MEDICAL GROUP, P.C., WHITE PLAINS, NY. FILED 12-7-2010.

WESTMED MEDICAL GROUP

THE MARK CONSISTS OF STANDARD CHARACTERS WITHOUT CLAIM TO ANY PARTICULAR FONT, STYLE, SIZE, OR COLOR.

NO CLAIM IS MADE TO THE EXCLUSIVE RIGHT TO USE "MEDICAL GROUP", APART FROM THE MARK AS SHOWN.

FOR MEDICAL SERVICES; PHYSICIAN SERVICES (U.S. CLS. 100 AND 101).

FIRST USE 9-22-2009; IN COMMERCE 9-22-2009.

DEZMONA MIZELLE, EXAMINING ATTORNEY

CLASS 44—(Continued).

SN 85-195,428. CAREPARTNERS PLUS LLC, HORSHAM, PA. FILED 12-10-2010.

ENGAGING PATIENTS
IMPROVING OUTCOMES

THE MARK CONSISTS OF STANDARD CHARACTERS WITHOUT CLAIM TO ANY PARTICULAR FONT, STYLE, SIZE, OR COLOR.

FOR LEASING OF MEDICAL EQUIPMENT, NAMELY, A TOUCHSCREEN INTERACTIVE PATIENT INTERVIEW SYSTEM FOR COLLECTING PATIENT REPORTED DATA AND PROVIDING PRINTED MATERIALS, INSTRUCTIONS, AND SURVEYS THEREWITH; PROVIDING MEDICAL RECORD ANALYSIS SERVICES BASED ON MEDICAL PROTOCOLS RELATIVE TO PATIENT REPORTED DATA (U.S. CLS. 100 AND 101).

DAVID TAYLOR, EXAMINING ATTORNEY

SN 85-200,414. OWASA FAMILY MEDICINE SHAREHOLDERS, CALHOUN, GA. FILED 12-17-2010.



NO CLAIM IS MADE TO THE EXCLUSIVE RIGHT TO USE "FAMILY MEDICINE", APART FROM THE MARK AS SHOWN.

THE MARK CONSISTS OF THE WORD "OWASA" WITH THE WORDING "FAMILY MEDICINE" CENTERED BELOW IT. THE SILHOUETTES OF A MAN AND WOMAN STANDING BEHIND THE SILHOUETTES OF TWO CHILDREN APPEAR IN THE CENTER OF THE LETTER "O" IN THE WORD "OWASA".

FOR MEDICAL SERVICES (U.S. CLS. 100 AND 101).

FIRST USE 6-1-1998; IN COMMERCE 6-1-1998.

TINA BROWN, EXAMINING ATTORNEY

SN 85-204,685. BERNSTEIN, LAURIE, BOULDER, CO. FILED 12-23-2010.

Network PKU

THE MARK CONSISTS OF STANDARD CHARACTERS WITHOUT CLAIM TO ANY PARTICULAR FONT, STYLE, SIZE, OR COLOR.

SEC. 2(F).

FOR COUNSELING SERVICES IN THE FIELDS OF HEALTH, NUTRITION AND LIFESTYLE WELLNESS (U.S. CLS. 100 AND 101).

FIRST USE 6-1-2004; IN COMMERCE 10-1-2004.

ALLISON HOLTZ, EXAMINING ATTORNEY

CLASS 44—(Continued).

SN 85-212,531. LIFECARE, INC., SHELTON, CT. FILED 1-7-2011.

PERFECT AGING

THE MARK CONSISTS OF STANDARD CHARACTERS WITHOUT CLAIM TO ANY PARTICULAR FONT, STYLE, SIZE, OR COLOR.

NO CLAIM IS MADE TO THE EXCLUSIVE RIGHT TO USE "AGING", APART FROM THE MARK AS SHOWN.

FOR HEALTH CARE SERVICES, NAMELY, WELLNESS PROGRAMS; PROVIDING HEALTH CARE INFORMATION BY TELEPHONE AND THE INTERNET; PROVIDING HEALTH INFORMATION; COUNSELING IN THE FIELD OF HEALTH AND LIFESTYLE WELLNESS; PROVIDING A WEB SITE FEATURING INFORMATION IN THE FIELD OF HEALTH, WELLNESS, HEALTHY AGING, MEMORY IMPROVEMENT, WEIGHT LOSS AND NUTRITION; PROVIDING INFORMATION IN THE FIELD OF HEALTH AND WELLNESS TO CORPORATE CLIENTS TO HELP THEIR EMPLOYEES MAKE HEALTH, WELLNESS, AND NUTRITIONAL CHANGES IN THEIR DAILY LIVING TO IMPROVE HEALTH AND WELLNESS (U.S. CLS. 100 AND 101).

FIRST USE 1-12-2010; IN COMMERCE 4-0-2011.

EVELYN BRADLEY, EXAMINING ATTORNEY

CLASS 44—(Continued).

SN 85-218,147. OWN LLC, LOS ANGELES, CA. FILED 1-14-2011.



THE COLOR(S) ORANGE, YELLOW, GREEN, LIGHT GREEN, PURPLE AND LIGHT PURPLE IS/ARE CLAIMED AS A FEATURE OF THE MARK.

THE MARK CONSISTS OF THE WORD "OWN" DEPICTED IN CAPITAL LETTERS WITH VARYING SHADES OF ORANGE FORMING "O" WITH YELLOW APPEARING IN THE CENTER; VARYING SHADES OF GREEN TO LIGHT GREEN FORMING "W" AND VARYING SHADES OF PURPLE TO LIGHT PURPLE FORMING "N" WITH A SHADOW UNDER EACH LETTER THAT IS DEPICTED IN THE SAME COLOR AS THE LETTER.

FOR PROVIDING HEALTHCARE INFORMATION TO OTHERS VIA A GLOBAL COMPUTER NETWORK (U.S. CLS. 100 AND 101).

THOMAS MANOR, EXAMINING ATTORNEY

SN 85-216,990. JENNELLE, JANN, ROSWELL, GA. FILED 1-13-2011.



THE MARK CONSISTS OF THE WORDING "GUIDED MOTION" IN STYLIZED FONT HAVING A HEART WITH WINGS IN THE BACKGROUND DIRECTLY BEHIND THE LETTERS.

FOR HEALTH CARE SERVICES; NAMELY, COMPREHENSIVE THERAPEUTIC HEALING TOUCH SERVICES AND WELLNESS PROGRAMS (U.S. CLS. 100 AND 101).

FIRST USE 1-1-1991; IN COMMERCE 12-31-2001.

WILLIAM VERHOSEK, EXAMINING ATTORNEY

SN 85-220,748. EDWARDS, WILLIAM, BENTONVILLE, AR. FILED 1-19-2011.



NO CLAIM IS MADE TO THE EXCLUSIVE RIGHT TO USE "EXCELLENCE OF HAIR DESIGN", APART FROM THE MARK AS SHOWN.

THE MARK CONSISTS OF THE WORD "GORILLA" OVER AN ABSTRACT DESIGN OF WAVY LINES ABOVE THE WORDING "THE RAW EXCELLENCE OF HAIR DESIGN".

FOR HAIR SALON SERVICES (U.S. CLS. 100 AND 101).

FIRST USE 12-15-1999; IN COMMERCE 5-1-2002.

SALLY SHIH, EXAMINING ATTORNEY

CLASS 44—(Continued).

SN 85-226,901. BIANCO, PAT, FRANKLIN LAKES, NJ. AND QUINN, JOHN C., GLEN ROCK, NJ. FILED 1-26-2011.



NO CLAIM IS MADE TO THE EXCLUSIVE RIGHT TO USE "HEALTH, LLC", APART FROM THE MARK AS SHOWN.

THE COLOR(S) PURPLE, LIGHT PURPLE, DARK PURPLE, WHITE AND BLACK IS/ARE CLAIMED AS A FEATURE OF THE MARK.

THE MARK CONSISTS OF THE MARK CONSISTS OF A BLACK SQUARE AND WITHIN THE BLACK SQUARE WITHIN THE FIRST PARTIAL PURPLE ELLIPSE, A WHITE PARTIAL ELLIPSE, A SECOND PARTIAL PURPLE ELLIPSE, A LIGHT PURPLE PARTIAL ELLIPSE, A THIRD PARTIAL PURPLE ELLIPSE, A DARK PURPLE PARTIAL ELLIPSE, A FOURTH PARTIAL PURPLE ELLIPSE, AND ON THE OUTSIDE BOTTOM PORTION OF THE BLACK SQUARE THE WORDS"HEALTH, LLC." IN PURPLE LETTERING.

FOR WELLNESS AND HEALTH-RELATED CONSULTING SERVICES, FEATURING CONSULTATION IN THE AREAS OF PREVENTATIVE MEDICINE AND THE ROLE OF NUTRITION, NUTRACEUTICALS, HORMONE REPLACEMENT THERAPY, BIOIDENTICAL HORMONE REPLACEMENT THERAPY, AND FITNESS IN A HEALTHY LIFESTYLE (U.S. CLS. 100 AND 101).

MARC LEIPZIG, EXAMINING ATTORNEY

CLASS 44—(Continued).

SN 85-228,586. KAHANA, DORON D., DBA CENTER FOR DIGESTIVE HEALTH AND NUTRITIONAL EXCELLENCE, LOS ANGELES, CA. FILED 1-28-2011.



NO CLAIM IS MADE TO THE EXCLUSIVE RIGHT TO USE "DIGESTIVE HEALTH" AND "NUTRITIONAL EXCELLENCE", APART FROM THE MARK AS SHOWN.

THE COLOR(S) GREEN, BROWN, GRAY, BLACK AND WHITE IS/ARE CLAIMED AS A FEATURE OF THE MARK.

THE MARK CONSISTS OF A HALF PEAR CUT LONGITUDINALLY IN GRAY WITH WHITE AND BROWN SHADING, GREEN SKIN, A BROWN STEM, AND TWO BLACK SEEDS INSIDE A BROWN PIT. ABOVE THE PEAR IS THE CURVED WORDING "DIGESTIVE HEALTH" IN BROWN WITH A BROWN DOT ON EITHER SIDE. BELOW THE PEAR IS THE CURVED WORDING "NUTRITIONAL EXCELLENCE" IN GREEN.

FOR CONSULTING SERVICES IN THE FIELDS OF DIAGNOSTIC MEDICAL TESTING AND NUTRITION; MEDICAL CLINIC PROVIDING WEIGHT LOSS SOLUTIONS, SERVICES AND PROGRAMS, NUTRITION COUNSELING, HORMONE THERAPY, INCLUDING, BIOIDENTICAL HORMONE REPLACEMENT, ANTI AGING THERAPY, AND NATURAL HORMONE THERAPY, MEDICAL AESTHETIC PROCEDURES, INCLUDING, LASER HAIR REMOVAL, LASER PEELS, BOTULINUM TOXIN TREATMENTS, MICRODERMABRASION, LIPOSUCTION, VEIN TREATMENTS, VEIN THERAPY, CELLULITE TREATMENTS, BODY CONTOURING TREATMENTS, INJECTABLE FILLER TREATMENTS, FACIALS, AND SKIN CARE (U.S. CLS. 100 AND 101).

FIRST USE 1-25-2011; IN COMMERCE 1-27-2011.
ALYSSA STEEL, EXAMINING ATTORNEY

SN 85-229,439. FRIENDLY FOOT CARE P.C., MUNSTER, IN. FILED 1-29-2011.

IT ALL STARTS WITH CARING

THE MARK CONSISTS OF STANDARD CHARACTERS WITHOUT CLAIM TO ANY PARTICULAR FONT, STYLE, SIZE, OR COLOR.

FOR PODIATRIC MEDICAL AND SURGICAL SERVICES (U.S. CLS. 100 AND 101).

FIRST USE 11-7-2004; IN COMMERCE 11-7-2004.
COLLEEN KEARNEY, EXAMINING ATTORNEY

CLASS 44—(Continued).

SN 85-233,535. AKSM MEDICAL VENTURES, INC., COLUMBUS, OH. FILED 2-3-2011.



NO CLAIM IS MADE TO THE EXCLUSIVE RIGHT TO USE "UROLOGY SPECIALISTS OF AMERICA" OR "USA", APART FROM THE MARK AS SHOWN.

THE MARK CONSISTS OF THE WORDING "UROLOGY SPECIALISTS OF AMERICA" AND A STETHOSCOPE DESIGN INCORPORATING THE LETTER "U" IN THE WORD "USA".

FOR PROFESSIONAL MEDICAL SERVICES (U.S. CLS. 100 AND 101).

FIRST USE 11-1-2010; IN COMMERCE 11-1-2010.
HANNO RITTNER, EXAMINING ATTORNEY

CLASS 44—(Continued).

SN 85-238,027. INTERACTIVE WELLNESS, LLC, MIAMI BEACH, FL. FILED 2-9-2011.

MILO KIDS

THE MARK CONSISTS OF STANDARD CHARACTERS WITHOUT CLAIM TO ANY PARTICULAR FONT, STYLE, SIZE, OR COLOR.

NO CLAIM IS MADE TO THE EXCLUSIVE RIGHT TO USE "KIDS", APART FROM THE MARK AS SHOWN.

FOR HEALTH CARE SERVICES, NAMELY, PROVIDING CHILD WELLNESS PROGRAM THROUGH AN INTERACTIVE, CUSTOMIZABLE WEBSITE THAT TRACKS CHILDREN'S WELLNESS ACTIVITIES AND HEALTH INDICATORS AND THAT FEATURES INFORMATION ABOUT WELLNESS, HEALTH, EXERCISE AS IT RELATES TO OVERALL HEALTH AND WELLNESS, AND NUTRITION (U.S. CLS. 100 AND 101).

CHRISTINA SOBRAL, EXAMINING ATTORNEY

SN 85-233,772. THE TRANSFORMATION ARCADE, LLC, INDEPENDENCE, LA. FILED 2-3-2011.



NO CLAIM IS MADE TO THE EXCLUSIVE RIGHT TO USE "HEALTH AND WELLNESS CENTER", APART FROM THE MARK AS SHOWN.

THE COLOR(S) BLUE, YELLOW, BLACK, GREEN, BROWN, BEIGE, AND WHITE IS/ARE CLAIMED AS A FEATURE OF THE MARK.

THE MARK CONSISTS OF AN AFRICAN AMERICAN FEMALE CHARACTER WITH BLACK ETHNIC HAIR AND A BROWN FACE WEARING A SMALL EARRING AND A CAUCASIAN MALE WITH A BEIGE FACE AND BLACK HAIR; THE FIGURES ARE OUTLINED IN BLACK AND THEIR EYEBROWS, EYES AND LIPS ARE LINED IN BLACK; BOTH THE MALE AND THE FEMALE ARE WEARING A BLUE T-SHIRT WITH A WHITE CIRCULAR DESIGN ON THE FRONT OF THE SHIRT, INSIDE THE CIRCULAR DESIGN IS A BLUE "V" DESIGN; THEY ARE WEARING WHITE SHOES AND BLACK PANTS; BOTH THE MALE AND FEMALE ARE LIFTING BLACK DUMBBELL WEIGHTS AND STANDING ON A GREEN OVAL DESIGN; THERE IS A YELLOW GEOMETRIC SHAPE IN THE BACKGROUND; THE WORDS "TRANSFORMATION ARCADE HEALTH AND WELLNESS CENTER" APPEAR BENEATH THE DESIGN IN BLACK; THE COLOR WHITE IN THE BACKGROUND IS NOT A FEATURE OF THE MARK.

FOR HEALTH CARE SERVICES, NAMELY, HEALTH AND WELLNESS PROGRAMS IN FIELD OF CHILDHOOD OBESITY (U.S. CLS. 100 AND 101).

FIRST USE 9-1-2010; IN COMMERCE 9-1-2010.
GINA HAYES, EXAMINING ATTORNEY

SN 85-241,106. OPERATIONAL PSYCHOLOGY SERVICES, LLC, BETHESDA, VA. FILED 2-13-2011.



NO CLAIM IS MADE TO THE EXCLUSIVE RIGHT TO USE "OPERATIONAL PSYCHOLOGY SERVICES" AND THE SYMBOL FOR THE GREEK LETTER PSI, APART FROM THE MARK AS SHOWN.

THE COLOR(S) BLUE, WHITE, GRAY, AND BLACK IS/ARE CLAIMED AS A FEATURE OF THE MARK.

THE MARK CONSISTS OF BLUE CIRCLE WITH LIGHT BLUE CENTER AND DARK BLUE AROUND THE EDGES AND THE LOWER RIGHT THIRD OF THE CIRCLE, THE GREEK LETTER PSI IN WHITE IN THE CENTER OF THE CIRCLE, THREE WHITE CURVED LINES BEGINNING ON THE LEFT EDGE OF THE CIRCLE AND TAPERING TO INDIVIDUAL POINTS AT THE LOWER HALF OF THE GREEK LETTER PSI; A THIN GRAY VERTICAL LINE APPEARS TO THE RIGHT OF THE CIRCLE; THE WORDS "OPERATIONAL PSYCHOLOGY SERVICES" APPEAR TO THE RIGHT OF THE VERTICAL LINE, WITH THE FIRST LETTERS "O", "P", AND "S" OF EACH WORD IN BLACK AND THE REMAINING LETTERS IN GRAY.

FOR PSYCHOLOGICAL CONSULTATION (U.S. CLS. 100 AND 101).

MARY CRAWFORD, EXAMINING ATTORNEY

CLASS 44—(Continued).

SN 85-241,325. MARCH OF DIMES FOUNDATION, WHITE PLAINS, NY. FILED 2-14-2011.

PREGNANCY & NEWBORN HEALTH
EDUCATION CENTER

THE MARK CONSISTS OF STANDARD CHARACTERS WITHOUT CLAIM TO ANY PARTICULAR FONT, STYLE, SIZE, OR COLOR.

OWNER OF U.S. REG. NO. 2,835,613.
NO CLAIM IS MADE TO THE EXCLUSIVE RIGHT TO USE "HEALTH EDUCATION", APART FROM THE MARK AS SHOWN.

SEC. 2(F).
FOR PROVIDING HEALTH INFORMATION (U.S. CLS. 100 AND 101).

FIRST USE 4-9-2002; IN COMMERCE 4-9-2002.
MARY CRAWFORD, EXAMINING ATTORNEY

SN 85-241,392. DAVE ON TOP INC., NEW YORK, NY. FILED 2-14-2011.



NO CLAIM IS MADE TO THE EXCLUSIVE RIGHT TO USE "SALON", APART FROM THE MARK AS SHOWN.

THE MARK CONSISTS OF THE SILHOUETTE OF A FEMALE WITH LONG HAIR BENEATH THE WORDS "ADA SALON".

FOR BEAUTY CONSULTATION SERVICES; BEAUTY SALONS; BEAUTY SALON SERVICES; BODY WAXING SERVICES; COSMETIC BODY CARE SERVICES; COSMETIC FACE CARE SERVICES; COSMETIC SKIN CARE SERVICES; COSMETOLOGY SERVICES; DAY SPA SERVICES, NAMELY, NAIL CARE, MANICURES, PEDICURES AND NAIL ENHANCEMENTS; HAIR COLOR SALON SERVICES; HAIR COLOURING SERVICES; HAIR CUTTING SERVICES; HAIR SALON SERVICES; HAIR STYLING; HAIRDRESSING SALONS; HAIRDRESSING SERVICES; MAKE-UP APPLICATION SERVICES; MANICURE SERVICES; NAIL CARE SALONS; NAIL CARE SERVICES; PEDICURE SERVICES; PERSONAL HAIR REMOVAL SERVICES; PROVIDING ON-SITE BEAUTY SERVICES, NAMELY, HAIR STYLING AND MAKE-UP APPLICATION SERVICES (U.S. CLS. 100 AND 101).

JULIE WATSON, EXAMINING ATTORNEY

CLASS 44—(Continued).

SN 85-242,264. LA SPORTS MASSAGE ENTERPRISES LLC, LOS ANGELES, CA. FILED 2-15-2011.



NO CLAIM IS MADE TO THE EXCLUSIVE RIGHT TO USE "SPORTS MASSAGE" AND "SPORT THERAPY", APART FROM THE MARK AS SHOWN.

THE COLOR(S) RED, BLUE AND WHITE IS/ARE CLAIMED AS A FEATURE OF THE MARK.

THE MARK CONSISTS OF RED LINES ON EITHER SIDE OF "LA SPORTS MASSAGE"; "LA" AND "MASSAGE" ARE IN BLUE STYLIZED FONT AND "SPORTS" IN RED STYLIZED FONT; TO THE LEFT OF "LA" ARE THREE BLUE SQUARES WITH WHITE STYLIZED FIGURES RIDING A BIKE, SWIMMING AND RUNNING RESPECTFULLY; BELOW THE RED LINE IS "INNOVATIVE SPORT THERAPY" IN SMALLER BLUE STYLIZED FONT.

SEC. 2(F) AS TO "LA SPORTS MASSAGE".
FOR MASSAGE THERAPY SERVICES (U.S. CLS. 100 AND 101).

FIRST USE 7-1-2005; IN COMMERCE 7-1-2005.
CHARISMA HAMPTON, EXAMINING ATTORNEY

SN 85-243,848. REARDON, LUCIA, CUMBERLAND, ME. FILED 2-16-2011.

FIT (Flexible Interactive
Thinking) Social Cognition
Therapy

THE MARK CONSISTS OF STANDARD CHARACTERS WITHOUT CLAIM TO ANY PARTICULAR FONT, STYLE, SIZE, OR COLOR.

NO CLAIM IS MADE TO THE EXCLUSIVE RIGHT TO USE "FLEXIBLE INTERACTIVE THINKING" AND "SOCIAL COGNITION THERAPY", APART FROM THE MARK AS SHOWN.

FOR SOCIAL COGNITIVE THERAPY SERVICES FOR HELPING INDIVIDUALS WITH SOCIAL COGNITIVE INTERACTION DEFICITS SUCH THAT ARE FOUND IN PEOPLE DIAGNOSED WITH ASPERGERS SYNDROME, HIGH FUNCTIONING AUTISM, PERVASIVE DEVELOPMENTAL DISORDER NOT OTHERWISE SPECIFIED, NONVERBAL LEARNING DISORDER, AND ATTENTION DEFICIT DISORDER (U.S. CLS. 100 AND 101).

FIRST USE 9-20-2009; IN COMMERCE 9-20-2009.
PAUL E. FAHRENKOPF, EXAMINING ATTORNEY

CLASS 44—(Continued).

SN 85-244,401. MCBRIDE, KATE, FORT MORGAN, CO. AND MCBRIDE, JENNIFER, FORT MORGAN, CO. FILED 2-16-2011.

Golden Girls Kennels

THE MARK CONSISTS OF STANDARD CHARACTERS WITHOUT CLAIM TO ANY PARTICULAR FONT, STYLE, SIZE, OR COLOR.

NO CLAIM IS MADE TO THE EXCLUSIVE RIGHT TO USE "KENNELS", APART FROM THE MARK AS SHOWN. FOR KENNEL SERVICES, NAMELY, DOG BREEDING SERVICES (U.S. CLS. 100 AND 101).

FIRST USE 4-19-1994; IN COMMERCE 4-19-1994.
ALEX KEAM, EXAMINING ATTORNEY

CLASS 44—(Continued).

SN 85-246,448. THE IDEAL WEIGH, INC., SIOUX FALLS, SD. FILED 2-18-2011.

We offer lifetime skills, not lifetime memberships!

THE MARK CONSISTS OF STANDARD CHARACTERS WITHOUT CLAIM TO ANY PARTICULAR FONT, STYLE, SIZE, OR COLOR.

FOR PROVIDING WEIGHT LOSS PROGRAM SERVICES; WEIGHT MANAGEMENT SERVICES, NAMELY, PROVIDING WEIGHT LOSS AND/OR WEIGHT MAINTENANCE PROGRAMS (U.S. CLS. 100 AND 101).

FIRST USE 5-1-2009; IN COMMERCE 5-1-2009.
AISHA CLARKE, EXAMINING ATTORNEY

SN 85-245,622. QUIDGEON, CHRIS, CENTRALIA, IL. FILED 2-18-2011.

EVERMORE GALLERY

THE MARK CONSISTS OF STANDARD CHARACTERS WITHOUT CLAIM TO ANY PARTICULAR FONT, STYLE, SIZE, OR COLOR.

NO CLAIM IS MADE TO THE EXCLUSIVE RIGHT TO USE "GALLERY", APART FROM THE MARK AS SHOWN. FOR TATTOO PARLORS; TATTOO AND BODY PIERCING SERVICES (U.S. CLS. 100 AND 101).

FIRST USE 11-1-2004; IN COMMERCE 11-1-2004.
MARLENE BELL, EXAMINING ATTORNEY

SN 85-247,042. GOLD, SIVIA, ROWE, NM. FILED 2-20-2011.

K.I.S.S. (KEEP IT SIMPLE SISTER) TECHNIQUES FOR FULL BODY PHYSICAL AND MENTAL/EMOTIONAL RELEASE IN HORSES THE BIG ERASER AND THE TRIPLE R

THE MARK CONSISTS OF STANDARD CHARACTERS WITHOUT CLAIM TO ANY PARTICULAR FONT, STYLE, SIZE, OR COLOR.

NO CLAIM IS MADE TO THE EXCLUSIVE RIGHT TO USE "TECHNIQUES FOR FULL BODY PHYSICAL AND MENTAL/EMOTIONAL RELEASE IN HORSES", APART FROM THE MARK AS SHOWN.

FOR BODYWORK THERAPY (U.S. CLS. 100 AND 101).
FIRST USE 10-1-2010; IN COMMERCE 11-18-2010.
TINA MAI, EXAMINING ATTORNEY

SN 85-246,106. REVEAL BODY SCULPTING CENTERS, LLC, PITTSBURGH, PA. FILED 2-18-2011.

Reveal BODY SCULPTING CENTERS

NO CLAIM IS MADE TO THE EXCLUSIVE RIGHT TO USE "BODY SCULPTING CENTERS", APART FROM THE MARK AS SHOWN.

THE MARK CONSISTS OF THE WORD "REVEAL" IN CURSIVE OVER A LINE WITH "BODY SCULPTING CENTERS" IN BLOCK LETTERS UNDERNEATH.

FOR MEDICAL CLINIC PROVIDING LASER FAT REMOVAL TREATMENTS, CELLULITE TREATMENTS, AND BODY CONTOURING (U.S. CLS. 100 AND 101).

JASON TURNER, EXAMINING ATTORNEY

SN 85-247,323. REGULATION DIRECTIVE MEDICAL PHYSICS, LLC, FLATWOODS, KY. FILED 2-21-2011.

REGULATION DIRECTIVE MEDICAL PHYSICS

THE MARK CONSISTS OF STANDARD CHARACTERS WITHOUT CLAIM TO ANY PARTICULAR FONT, STYLE, SIZE, OR COLOR.

NO CLAIM IS MADE TO THE EXCLUSIVE RIGHT TO USE "MEDICAL PHYSICS", APART FROM THE MARK AS SHOWN.

FOR CLINICAL MEDICAL PHYSICS SERVICES; CONSULTING IN THE FIELD OF CLINICAL MEDICAL PHYSICS SERVICES (U.S. CLS. 100 AND 101).

FIRST USE 10-0-2010; IN COMMERCE 10-0-2010.
THEODORE MCBRIDE, EXAMINING ATTORNEY

CLASS 44—(Continued).

SN 85-248,080. ERICKSON, THERESA M., POWAY, CA. FILED 2-22-2011.



NO CLAIM IS MADE TO THE EXCLUSIVE RIGHT TO USE "FERTILITY" OR ".TV", APART FROM THE MARK AS SHOWN.

THE MARK CONSISTS OF THE STYLIZED WORDING "FERTILITY 411 .TV", IN WHICH THE LETTERING "ILI" IN THE TERM "FERTILITY" IS STYLIZED SO AS TO RESEMBLE THREE HUMANS AND THE NUMBERING "411" IS SET INSIDE A SHADED CIRCLE.

FOR PROVIDING NEWS, INFORMATION, AND COMMENTARY IN THE FIELD OF MEDICINE, SPECIFICALLY RELATING TO FERTILITY (U.S. CLS. 100 AND 101).

FIRST USE 2-21-2011; IN COMMERCE 2-21-2011.
MICHAEL GAAFAR, EXAMINING ATTORNEY

SN 85-248,230. WIEBE, AMBER, NICEVILLE, FL. AND BROUTIN, OLIVIER, NICEVILLE, FL. FILED 2-22-2011.

Destin Smiles

THE MARK CONSISTS OF STANDARD CHARACTERS WITHOUT CLAIM TO ANY PARTICULAR FONT, STYLE, SIZE, OR COLOR.

NO CLAIM IS MADE TO THE EXCLUSIVE RIGHT TO USE "DESTIN", APART FROM THE MARK AS SHOWN.

FOR COSMETIC DENTISTRY (U.S. CLS. 100 AND 101).
LAURA KOVALSKY, EXAMINING ATTORNEY

SN 85-248,255. HEALTH AND WELLNESS INSTITUTE INC., MOUNTLAKE TERRACE, WA. FILED 2-22-2011.



NO CLAIM IS MADE TO THE EXCLUSIVE RIGHT TO USE "HEALTH&WELLNESS INSTITUTE OF INTEGRATIVE MEDICINE AND CANCER TREATMENT", APART FROM THE MARK AS SHOWN.

THE MARK CONSISTS OF A CYPRESS TREE WITH LEAVES AND THE STYLIZED TEXT "HEALTH&WELLNESS INSTITUTE OF INTEGRATIVE MEDICINE AND CANCER TREATMENT".

FOR MEDICAL SERVICES (U.S. CLS. 100 AND 101).
FIRST USE 1-1-1996; IN COMMERCE 1-1-1996.
JEFF DEFORD, EXAMINING ATTORNEY

CLASS 44—(Continued).

SN 85-248,581. BAPTIST MEMORIAL HEALTH CARE CORPORATION, MEMPHIS, TN. FILED 2-22-2011.

SMART MEDICINE. INSPIRED CARE.

THE MARK CONSISTS OF STANDARD CHARACTERS WITHOUT CLAIM TO ANY PARTICULAR FONT, STYLE, SIZE, OR COLOR.

FOR HEALTH CARE; MEDICAL SERVICES (U.S. CLS. 100 AND 101).

FIRST USE 3-19-2000; IN COMMERCE 3-19-2000.
JERI J. FICKES, EXAMINING ATTORNEY

SN 85-248,746. VERTEX PHARMACEUTICALS INCORPORATED, CAMBRIDGE, MA. FILED 2-22-2011.

BETTER TO KNOW C

THE MARK CONSISTS OF STANDARD CHARACTERS WITHOUT CLAIM TO ANY PARTICULAR FONT, STYLE, SIZE, OR COLOR.

NO CLAIM IS MADE TO THE EXCLUSIVE RIGHT TO USE "C", APART FROM THE MARK AS SHOWN.

FOR PROVIDING A WEBSITE FEATURING INFORMATION ABOUT HEALTH, NAMELY, HEPATITIS AWARENESS, DIAGNOSIS AND INFORMATION ABOUT SCREENING AND TREATMENT (U.S. CLS. 100 AND 101).

FIRST USE 3-2-2011; IN COMMERCE 3-2-2011.
SEAN CROWLEY, EXAMINING ATTORNEY

SN 85-249,259. SOBECK, LINDA, BOULDER, CO. FILED 2-23-2011.

Earth Nurse

THE MARK CONSISTS OF STANDARD CHARACTERS WITHOUT CLAIM TO ANY PARTICULAR FONT, STYLE, SIZE, OR COLOR.

NO CLAIM IS MADE TO THE EXCLUSIVE RIGHT TO USE "NURSE", APART FROM THE MARK AS SHOWN.

FOR PUBLIC HEALTH NURSE CONSULTANT SERVICES (U.S. CLS. 100 AND 101).

KAREN K. BUSH, EXAMINING ATTORNEY

CLASS 44—(Continued).

SN 85-249,382. SYNERON CANADA CORPORATION, RICHMOND HILL, ONTARIO, CANADA, FILED 2-23-2011.

SUBLATIVE REJUVENATION

THE MARK CONSISTS OF STANDARD CHARACTERS WITHOUT CLAIM TO ANY PARTICULAR FONT, STYLE, SIZE, OR COLOR.

NO CLAIM IS MADE TO THE EXCLUSIVE RIGHT TO USE "REJUVENATION", APART FROM THE MARK AS SHOWN.

FOR AESTHETIC SKIN PROCEDURES USING RADIO-FREQUENCY, LIGHT AND ULTRASOUND ENERGY (U.S. CLS. 100 AND 101).

FIRST USE 12-15-2008; IN COMMERCE 12-15-2008.
COLLEEN KEARNEY, EXAMINING ATTORNEY

CLASS 44—(Continued).

SN 85-249,839. CHILDREN'S DENTISTRY OF EL PASO PLLC, EL PASO, TX. FILED 2-23-2011.



NO CLAIM IS MADE TO THE EXCLUSIVE RIGHT TO USE "DENTAL", APART FROM THE MARK AS SHOWN.

THE MARK CONSISTS OF A CIRCULAR DESIGN WITH AN ARK, SUN RAYS AND OCEAN WAVES APPEARING INSIDE THE CIRCLE. THE WORDING "THE DENTAL ARK" APPEARS ABOVE THE CIRCLE, AND THE WORDING "WE CARE FOR KIDS" APPEARS BENEATH THE CIRCLE. TWO CURVED LINES APPEAR ON EACH SIDE OF THE CIRCLE.

FOR DENTISTRY (U.S. CLS. 100 AND 101).
FIRST USE 3-1-2010; IN COMMERCE 3-1-2010.
EMILY CHUO, EXAMINING ATTORNEY

SN 85-249,570. CLARK, QUINCY P, DECATUR, GA. FILED 2-23-2011.

Renaissance Counseling Services

THE MARK CONSISTS OF STANDARD CHARACTERS WITHOUT CLAIM TO ANY PARTICULAR FONT, STYLE, SIZE, OR COLOR.

NO CLAIM IS MADE TO THE EXCLUSIVE RIGHT TO USE "COUNSELING SERVICES", APART FROM THE MARK AS SHOWN.

FOR MENTAL HEALTH SERVICES; PSYCHOLOGICAL COUNSELING (U.S. CLS. 100 AND 101).
FIRST USE 7-29-2005; IN COMMERCE 7-29-2005.
JULIE WATSON, EXAMINING ATTORNEY

SN 85-250,028. NEXTEMR, LLC, FLOURTOWN, PA. FILED 2-23-2011.



NO CLAIM IS MADE TO THE EXCLUSIVE RIGHT TO USE "EMR", APART FROM THE MARK AS SHOWN.

THE MARK CONSISTS OF THE WORD "NEXT" IN LOWER CASE LETTERS FOLLOWED BY THE LETTERS "EMR" IN UPPER CASE LETTERS INSIDE OF A CAPSULE WITH A SPACE DOWN THE CENTER.

FOR PROVIDING AN ONLINE COMPUTER DATABASE FOR ACCESSING ELECTRONIC MEDICAL RECORDS AND ADMINISTRATIVE MEDICAL PRACTICE RECORDS (U.S. CLS. 100 AND 101).

FIRST USE 1-4-2010; IN COMMERCE 1-4-2010.
CHRISTOPHER BUONGIORNO, EXAMINING ATTORNEY

CLASS 44—(Continued).

SN 85-250,108. REAL LIFE FITNESS AND HEALTH, DRAPE, UT. FILED 2-23-2011.



NO CLAIM IS MADE TO THE EXCLUSIVE RIGHT TO USE "FITNESS & HEALTH", APART FROM THE MARK AS SHOWN.

THE MARK CONSISTS OF A FIGURE LEAPING THROUGH A RINGS. BELOW THERE IS THE STYLIZED TEXT "REAL LIFE FITNESS & HEALTH".

FOR PROVIDING INFORMATION ON MAINTAINING A HEALTHY LIFESTYLE AND LOSING WEIGHT; PROVIDING WEIGHT LOSS PROGRAM SERVICES (U.S. CLS. 100 AND 101).

FIRST USE 4-26-2008; IN COMMERCE 4-26-2008.
DOMINICK J. SALEMI, EXAMINING ATTORNEY

CLASS 44—(Continued).

SN 85-250,650. LEPOW PROPERTIES, LLC, HOUSTON, TX. FILED 2-24-2011.



OWNER OF U.S. REG. NO. 3,849,523.

THE COLOR(S) GREEN, PURPLE, BLUE, ORANGE AND WHITE IS/ARE CLAIMED AS A FEATURE OF THE MARK.

THE MARK CONSISTS OF A SQUARE COMPRISED OF FOUR SMALLER SQUARES, EACH FEATURING STICK-LIKE FACES, THE TOP LEFT FACE IN GREEN, THE TOP RIGHT FACE IN PURPLE, THE BOTTOM LEFT FACE IN BLUE, AND THE BOTTOM RIGHT FACE IN ORANGE. ALL OF THE FACIAL FEATURES IN THE SQUARE ARE PRESENTED IN WHITE.

FOR COSMETIC DENTISTRY; DENTAL HYGIENIST SERVICES; DENTIST SERVICES; DENTISTRY; ORTHODONTIC SERVICES; SURGERY (U.S. CLS. 100 AND 101).
FIRST USE 1-1-2011; IN COMMERCE 1-1-2011.

JORDAN BAKER, EXAMINING ATTORNEY

SN 85-250,671. LEPOW PROPERTIES, LLC, HOUSTON, TX. FILED 2-24-2011.

SN 85-250,518. SANCHEZ, GARY L., ALBUQUERQUE, NM. FILED 2-24-2011.

LEPOW KIDS

GREAT TEETH - BETTER LIFE

THE MARK CONSISTS OF STANDARD CHARACTERS WITHOUT CLAIM TO ANY PARTICULAR FONT, STYLE, SIZE, OR COLOR.

OWNER OF U.S. REG. NOS. 3,849,523 AND 3,849,524.
NO CLAIM IS MADE TO THE EXCLUSIVE RIGHT TO USE "KIDS". APART FROM THE MARK AS SHOWN.
SEC. 2(F) AS TO LEPOW.

FOR COSMETIC DENTISTRY; DENTAL HYGIENIST SERVICES; DENTIST SERVICES; DENTISTRY; ORTHODONTIC SERVICES; SURGERY (U.S. CLS. 100 AND 101).

FIRST USE 1-1-2011. THE MARK WAS FIRST USED ANYWHERE IN A DIFFERENT FORM OTHER THAN THAT SOUGHT TO BE REGISTERED AT LEAST AS EARLY AS 12/31/1977; IN COMMERCE 1-1-2011, THE MARK WAS FIRST USED IN COMMERCE IN A DIFFERENT FORM OTHER THAN THAT SOUGHT TO BE REGISTERED AT LEAST AS EARLY AS 12/31/1977.

JORDAN BAKER, EXAMINING ATTORNEY

THE MARK CONSISTS OF STANDARD CHARACTERS WITHOUT CLAIM TO ANY PARTICULAR FONT, STYLE, SIZE, OR COLOR.

FOR DENTIST SERVICES (U.S. CLS. 100 AND 101).
FIRST USE 1-15-2010; IN COMMERCE 1-15-2010.
CORY BOONE, EXAMINING ATTORNEY

CLASS 44—(Continued).

SN 85-251,323. WHITE, JUDITH ANN, DBA WHOLE LIFE COUNSELING, KALAMAZOO, MI. FILED 2-24-2011.

Whole Life Counseling

THE MARK CONSISTS OF STANDARD CHARACTERS WITHOUT CLAIM TO ANY PARTICULAR FONT, STYLE, SIZE, OR COLOR.

NO CLAIM IS MADE TO THE EXCLUSIVE RIGHT TO USE "LIFE COUNSELING", APART FROM THE MARK AS SHOWN.

FOR CLINICAL MENTAL HEALTH COUNSELING SERVICES; MENTAL HEALTH COUNSELING AND PSYCHOTHERAPY AS IT RELATES TO RELATIONSHIPS (U.S. CLS. 100 AND 101).

FIRST USE 6-1-2005; IN COMMERCE 3-5-2007.
LINDSEY RUBIN, EXAMINING ATTORNEY

SN 85-251,579. AMERICAN SOCIETY FOR RADIATION ONCOLOGY, FAIRFAX, VA. FILED 2-25-2011.



OWNER OF U.S. REG. NOS. 3,324,243 AND 3,324,244. NO CLAIM IS MADE TO THE EXCLUSIVE RIGHT TO USE "RT", APART FROM THE MARK AS SHOWN.

THE MARK CONSISTS OF THE LITERAL ELEMENT "RT ANSWERS" AND A SEMI CIRCLE MADE UP OF SMALL DOTS SURROUNDING THE LETTERS "RT".

FOR PROVIDING INFORMATION TO PATIENTS AND THEIR FAMILIES ABOUT CANCER TREATMENT OPTIONS (U.S. CLS. 100 AND 101).

FIRST USE 10-0-2009; IN COMMERCE 10-0-2009.
MARGARET POWER, EXAMINING ATTORNEY

SN 85-252,551. ROBERT H. FISHER, DBA ALLERGY RESEARCH & CARE, GLENDALE, WI. FILED 2-26-2011.

MedBlurb

THE MARK CONSISTS OF STANDARD CHARACTERS WITHOUT CLAIM TO ANY PARTICULAR FONT, STYLE, SIZE, OR COLOR.

FOR PROVIDING HEALTHCARE INFORMATION (U.S. CLS. 100 AND 101).

MAYUR VAGHANI, EXAMINING ATTORNEY

CLASS 44—(Continued).

SN 85-252,981. ROBIN B. WALDROP, SR., DBA FIRST STAGE GREENHOUSE, GROVERTOWN, IN. FILED 2-28-2011.

QUALITY GROWERS...HELPING TO COLOR YOUR WORLD

THE MARK CONSISTS OF STANDARD CHARACTERS WITHOUT CLAIM TO ANY PARTICULAR FONT, STYLE, SIZE, OR COLOR.

FOR GREENHOUSE SERVICES, PLANT NURSERIES (U.S. CLS. 100 AND 101).

FIRST USE 6-1-1998; IN COMMERCE 6-1-1998.

KATHERINE M. DUBRAY, EXAMINING ATTORNEY

SN 85-253,533. ATLANTICARE NURSING SERVICES, INC., DELRAY BEACH, FL. FILED 2-28-2011.

BRING THE CARE HOME

THE MARK CONSISTS OF STANDARD CHARACTERS WITHOUT CLAIM TO ANY PARTICULAR FONT, STYLE, SIZE, OR COLOR.

FOR HOME HEALTH CARE SERVICES (U.S. CLS. 100 AND 101).

ELISSA GARBER KON, EXAMINING ATTORNEY

SN 85-253,743. CANINE PARTNERS FOR LIFE, COCHRANVILLE, PA. FILED 2-28-2011.



THE MARK CONSISTS OF A SILHOUETTE OF AN INDIVIDUAL SEATED IN A WHEELCHAIR WITH A HAND OUTSTRETCHED TO A SEATED DOG, WHICH HAS ITS PAW PLACED ON THE INDIVIDUAL'S KNEE.

FOR CHARITABLE SERVICES, NAMELY, PROVIDING TRAINED SERVICE DOGS TO DISABLED OR CHALLENGED PEOPLE (U.S. CLS. 100 AND 101).

FIRST USE 9-30-1989; IN COMMERCE 9-30-1989.

BENJAMIN OKEKE, EXAMINING ATTORNEY

CLASS 44—(Continued).

SN 85-254,583. STEPHANIE SOLINGER, DVM, NEWBURY, MA. FILED 3-1-2011.



THE MARK CONSISTS OF HAWK DESIGN. FOR VETERINARY SERVICES (U.S. CLS. 100 AND 101).
FIRST USE 2-17-2011; IN COMMERCE 2-17-2011.
JOSETTE BEVERLY, EXAMINING ATTORNEY

SN 85-254,971. ROWDEN, APRIL, IBERIA, MO. FILED 3-1-2011.

HCG LOOSERS

THE MARK CONSISTS OF STANDARD CHARACTERS WITHOUT CLAIM TO ANY PARTICULAR FONT, STYLE, SIZE, OR COLOR.
NO CLAIM IS MADE TO THE EXCLUSIVE RIGHT TO USE "HCG", APART FROM THE MARK AS SHOWN.
FOR PROVIDING A WEBSITE FEATURING INFORMATION ABOUT HEALTH, WELLNESS, NUTRITION AND DIET; PROVIDING INFORMATION ABOUT DIETARY SUPPLEMENTS, NUTRITION AND DIET (U.S. CLS. 100 AND 101).
FIRST USE 5-1-2009; IN COMMERCE 5-1-2009.
SIMON TENG, EXAMINING ATTORNEY

SN 85-255,151. HSAI, STEPHANIE, SAN FRANCISCO, CA. FILED 3-1-2011.

PLANTING SEEDS OT

THE MARK CONSISTS OF STANDARD CHARACTERS WITHOUT CLAIM TO ANY PARTICULAR FONT, STYLE, SIZE, OR COLOR.
NO CLAIM IS MADE TO THE EXCLUSIVE RIGHT TO USE "OT", APART FROM THE MARK AS SHOWN.
FOR OCCUPATIONAL THERAPY SERVICES (U.S. CLS. 100 AND 101).
MARK RADEMACHER, EXAMINING ATTORNEY

CLASS 44—(Continued).

SN 85-255,312. THE J SALON, GRAND RAPIDS, MI. FILED 3-2-2011.

AFFORDABLE LUXURY

THE MARK CONSISTS OF STANDARD CHARACTERS WITHOUT CLAIM TO ANY PARTICULAR FONT, STYLE, SIZE, OR COLOR.
FOR HAIR SALON AND SPA SERVICES, NAMELY HAIR CUTTING, HAIR COLORING, HAIR STYLING, HAIR PERMING, HAIR STRAIGHTENING, HAIR EXTENSION SERVICES, HAIR CONDITIONING, HAIR TREATMENTS, MAKE-UP SERVICES, MANICURE, PEDICURE, MESSAGES, FACIALS, FACIAL TREATMENTS AND ARTIFICIAL NAILS (U.S. CLS. 100 AND 101).
FIRST USE 12-28-2009; IN COMMERCE 3-15-2010.
ZACHARY BELLO, EXAMINING ATTORNEY

SN 85-256,022. KCD IP, LLC, HOFFMAN ESTATES, IL. FILED 3-2-2011.

KENMORE

THE MARK CONSISTS OF STANDARD CHARACTERS WITHOUT CLAIM TO ANY PARTICULAR FONT, STYLE, SIZE, OR COLOR.
OWNER OF U.S. REG. NOS. 522,973, 2,913,066 AND OTHERS.
FOR WEIGHT MANAGEMENT SERVICES, NAMELY, PROVIDING WEIGHT LOSS AND/OR WEIGHT MAINTENANCE PROGRAMS; PROVIDING A WEBSITE FEATURING INFORMATION ABOUT HEALTH, WELLNESS AND NUTRITION; PROVIDING INFORMATION AND RECOMMENDATIONS IN THE AREA OF HEALTH, WELLNESS, NUTRITION AND WEIGHT MANAGEMENT VIA SMART PHONES AND HAND-HELD ELECTRONIC DEVICES; MEDICAL ASSISTANCE SERVICES PROVIDED VIA TELECOMMUNICATION AND GLOBAL COMPUTER NETWORKS FOR INDIVIDUALS WITH HEALTH PROBLEMS THROUGH THE USE OF WEARABLE MEDICAL DEVICES WITH AUTOMATED ALERT AND MONITORING CAPACITY; REMOTE MONITORING OF DATA INDICATIVE OF THE HEALTH OR CONDITION OF AN INDIVIDUAL OR GROUP OF INDIVIDUALS (U.S. CLS. 100 AND 101).
KATHERINE STOIDES, EXAMINING ATTORNEY

CLASS 44—(Continued).

SN 85-256,062. CLARITY WAY, INC., YORK, PA. FILED 3-2-2011.



THE MARK CONSISTS OF A SEMICIRCLE ABOVE TWO HORIZONTALLY EXTENDING SPACED SUBSTANTIALLY PARALLEL SLIGHTLY S-SHAPED SEGMENTS.

FOR REHABILITATION OF ALCOHOL ADDICTED PATIENTS; REHABILITATION OF DRUG ADDICTED PATIENTS (U.S. CLS. 100 AND 101).

FIRST USE 10-0-2010; IN COMMERCE 10-0-2010.
THEODORE MCBRIDE, EXAMINING ATTORNEY

SN 85-257,500. NUTRINEER L3C, MIDDLETON, WI. FILED 3-3-2011.

Nutrineer

THE MARK CONSISTS OF STANDARD CHARACTERS WITHOUT CLAIM TO ANY PARTICULAR FONT, STYLE, SIZE, OR COLOR.

FOR CONSULTING SERVICES IN THE FIELDS OF HEALTH AND NUTRITION; COUNSELING SERVICES IN THE FIELDS OF HEALTH, NUTRITION AND LIFESTYLE WELLNESS; DIETARY AND NUTRITIONAL GUIDANCE; FOOD NUTRITION CONSULTATION; NUTRITION COUNSELING; PROVIDING A WEB SITE FEATURING EDUCATIONAL INFORMATION REGARDING NUTRITION AND GENETICS; PROVIDING A WEB SITE FEATURING INFORMATION ON HEALTH AND NUTRITION; PROVIDING A WEB SITE THAT FEATURES INFORMATION ON CHILDREN'S NUTRITION; PROVIDING A WEBSITE FEATURING INFORMATION ABOUT HEALTH, WELLNESS AND NUTRITION; PROVIDING AN ON-LINE COMPUTER DATABASE FEATURING INFORMATION REGARDING HEALTH AND NUTRITION; PROVIDING HEALTHY LIFESTYLE AND NUTRITION SERVICES, NAMELY, PERSONAL ASSESSMENTS, PERSONALIZED ROUTINES, MAINTENANCE SCHEDULES, AND COUNSELING; PROVIDING INFORMATION ABOUT DIETARY SUPPLEMENTS AND NUTRITION; PROVIDING INFORMATION IN THE FIELDS OF ANIMALS AND PET BREEDING, SELECTION OF THE ANIMALS AND PETS, GROOMING, HEALTH AND NUTRITION; PROVIDING INFORMATION, NEWS AND COMMENTARY IN THE FIELD OF NUTRITION, HEALTH AND WELLNESS; PROVIDING ON-LINE INFORMATION VIA THE INTERNET IN THE FIELDS OF ANIMALS AND PETS, RELATING TO BREEDING, SELECTION OF THE ANIMALS AND PETS, GROOMING, FEEDING AND NUTRITION (U.S. CLS. 100 AND 101).

WANDA KAY PRICE, EXAMINING ATTORNEY

CLASS 44—(Continued).

SN 85-257,675. TAYARA, SHAFIC, TORRANCE, CA. FILED 3-4-2011.

GET FADED, BLOWN, AND NAILED

THE MARK CONSISTS OF STANDARD CHARACTERS WITHOUT CLAIM TO ANY PARTICULAR FONT, STYLE, SIZE, OR COLOR.

FOR BEAUTY SALON SERVICES (U.S. CLS. 100 AND 101).

KATHERINE CHANG, EXAMINING ATTORNEY

SN 85-257,767. THE TRUSTEES OF THE UNIVERSITY OF PENNSYLVANIA, PHILADELPHIA, PA. FILED 3-4-2011.

PENN PHYSICIANLINK

THE MARK CONSISTS OF STANDARD CHARACTERS WITHOUT CLAIM TO ANY PARTICULAR FONT, STYLE, SIZE, OR COLOR.

OWNER OF U.S. REG. NOS. 2,831,667, 3,646,135 AND OTHERS.

NO CLAIM IS MADE TO THE EXCLUSIVE RIGHT TO USE "PHYSICIANLINK", APART FROM THE MARK AS SHOWN.

SEC. 2(F) AS TO PENN.

FOR MEDICAL SERVICES (U.S. CLS. 100 AND 101).

HEATHER SAPP, EXAMINING ATTORNEY

SN 85-257,819. T2 BIOSYSTEMS, INC., LEXINGTON, MA. FILED 3-4-2011.

ENABLING A NEW ERA OF DIAGNOSTICS IN HEALTHCARE

THE MARK CONSISTS OF STANDARD CHARACTERS WITHOUT CLAIM TO ANY PARTICULAR FONT, STYLE, SIZE, OR COLOR.

FOR MEDICAL DIAGNOSTIC SERVICES (U.S. CLS. 100 AND 101).

FIRST USE 2-15-2011; IN COMMERCE 2-15-2011.

GISELLE AGOSTO, EXAMINING ATTORNEY

CLASS 44—(Continued).

SN 85-258,412. LILJA, PAUL, PITTSBURGH, PA. FILED 3-4-2011.

SHAVE SHACK

THE MARK CONSISTS OF STANDARD CHARACTERS WITHOUT CLAIM TO ANY PARTICULAR FONT, STYLE, SIZE, OR COLOR.

NO CLAIM IS MADE TO THE EXCLUSIVE RIGHT TO USE "SHAVE", APART FROM THE MARK AS SHOWN.

FOR BARBER SHOP SERVICES (U.S. CLS. 100 AND 101).

LAURIE MAYES, EXAMINING ATTORNEY

CLASS 44—(Continued).

SN 85-279,730. INTERACTIVE WELLNESS LLC, MIAMI BEACH, FL. FILED 3-29-2011.



NO CLAIM IS MADE TO THE EXCLUSIVE RIGHT TO USE "KIDS", APART FROM THE MARK AS SHOWN.

THE MARK CONSISTS OF A DRAWING OF A CHILD PLUS THE WORDS "MILO KIDS".

FOR HEALTH CARE SERVICES, NAMELY, PROVIDING CHILD WELLNESS PROGRAM THROUGH AN INTERACTIVE, CUSTOMIZABLE WEBSITE THAT TRACKS CHILDREN'S WELLNESS ACTIVITIES AND HEALTH INDICATORS AND THAT FEATURES INFORMATION ABOUT WELLNESS, HEALTH, EXERCISE AS IT RELATES TO OVERALL HEALTH AND WELLNESS, AND NUTRITION (U.S. CLS. 100 AND 101).

CHRISTINA SOBRAL, EXAMINING ATTORNEY

SN 85-260,181. MILLER, DAVID J, BETTENDORF, IA. FILED 3-7-2011.



THE NAME "DAVID MILLER" IDENTIFIES A LIVING INDIVIDUAL WHOSE CONSENT IS OF RECORD.

THE COLOR(S) YELLOW, BLACK, AND WHITE IS/ARE CLAIMED AS A FEATURE OF THE MARK.

THE MARK CONSISTS OF CIRCLE WITH CARICATURE OF THE OWNER INSIDE, UNDERNEATH IT READS "BUILD THE BEST YOU BY DAVID MILLER", INSIDE OF CIRCLE IS YELLOW AND CARICATURE IS ALSO YELLOW.

FOR PROVIDING A WEBSITE FEATURING INFORMATION ABOUT HEALTH, WELLNESS AND NUTRITION (U.S. CLS. 100 AND 101).

FIRST USE 8-8-2010; IN COMMERCE 2-21-2011.

RAUL CORDOVA, EXAMINING ATTORNEY

CLASS 45—PERSONAL AND LEGAL SERVICES

SN 77-900,683. DOT HELP, LLC, FREDERICKSBURG, TX. FILED 12-24-2009.

800 DOT-HELP

THE MARK CONSISTS OF STANDARD CHARACTERS WITHOUT CLAIM TO ANY PARTICULAR FONT, STYLE, SIZE, OR COLOR.

NO CLAIM IS MADE TO THE EXCLUSIVE RIGHT TO USE "800", APART FROM THE MARK AS SHOWN.

FOR VEHICLE FLEET MONITORING SERVICES FOR SAFETY PURPOSES (U.S. CLS. 100 AND 101).

FIRST USE 12-15-2009; IN COMMERCE 12-15-2009.

DOMINICK J. SALEMI, EXAMINING ATTORNEY

CLASS 45—(Continued).

SN 77-926,667. KNOX COUNTY ASSOCIATION FOR RETARDED CITIZENS, INC., AKA KCARC, VINCENNES, IN. FILED 2-3-2010.



THE COLOR(S) BLUE, ORANGE, GREEN, YELLOW, AND BLACK IS/ARE CLAIMED AS A FEATURE OF THE MARK.

THE MARK CONSISTS OF THE WORDING "KCARC FOR LIFE" IN LARGE BLOCK LETTERING WITH THE WORD "KCARC" IN BLUE, THE WORD "FOR" APPEARING IN ORANGE, AND THE LETTERS "LFE" IN THE WORD "LIFE" APPEARING IN GREEN. THE LETTER "I" IS THE WORD "LIFE" IS FORMED BY THE DESIGN OF A DAISY HAVING YELLOW PETALS, AN ORANGE CENTER, GREEN LEAVES, AND A BLACK OUTLINE AND STEM.

FOR PROVIDING LIFETIME PATIENT ADVOCATE SERVICES TO INDIVIDUALS AND FAMILIES WITH SPECIAL NEEDS; PROVIDING LIFETIME PERSONAL SUPPORT SERVICES IN THE NATURE OF EMOTIONAL COUNSELING AND EMOTIONAL SUPPORT TO INDIVIDUALS AND FAMILIES WITH SPECIAL NEEDS (U.S. CLS. 100 AND 101).

DEBRA LEE, EXAMINING ATTORNEY

SN 79-087,546. GODEVENT AB, SWEDEN, FILED 8-25-2010.

BRINGS GOOD NEWS

THE MARK CONSISTS OF STANDARD CHARACTERS WITHOUT CLAIM TO ANY PARTICULAR FONT, STYLE, SIZE, OR COLOR.

PRIORITY DATE OF 8-4-2010 IS CLAIMED.

OWNER OF INTERNATIONAL REGISTRATION 1051653 DATED 8-25-2010, EXPIRES 8-25-2020.

FOR RELIGIOUS SERVICES, NAMELY, PRAYER MEETINGS, PROVIDING CHARITABLE OUTREACH SERVICES IN THE NATURE OF PROVIDING COUNSELING SERVICES IN THE FIELD OF RELIGION, SPIRITUAL COUNSELING, PROVIDING SPIRITUAL REHABILITATION SERVICES, AND PROVIDING SPIRITUAL RETREATS TO ASSIST OTHERS TO DEVELOP AND ENHANCE THEIR SPIRITUAL LIVES; PASTORAL CARE IN THE NATURE OF SPIRITUAL COUNSELING BY CLERGY; RELIGIOUS CONSULTANCY WITH REGARD TO SPIRITUAL GUIDANCE, SPIRITUAL COUNSELING, SPIRITUAL DEVELOPMENT IN THE NATURE OF ENHANCING ONE'S SPIRITUALITY, AND MENTORING IN THE NATURE OF SPIRITUAL COUNSELING; SPIRITUAL MENTORING IN THE NATURE OF SPIRITUAL COUNSELING (U.S. CLS. 100 AND 101).

REBECCA POVARCHUK, EXAMINING ATTORNEY

CLASS 45—(Continued).

SN 85-011,444. CHILDREN'S WISH GROUP OF RI, DBA CHILDREN'S WISHES, PROVIDENCE, RI. FILED 4-12-2010.



NO CLAIM IS MADE TO THE EXCLUSIVE RIGHT TO USE "CHILDREN'S WISHES", APART FROM THE MARK AS SHOWN.

THE COLOR(S) RED, BLACK AND TAN IS/ARE CLAIMED AS A FEATURE OF THE MARK.

THE MARK CONSISTS OF A HEART OUTLINED IN RED FADING TO TAN AROUND LETTERS WITH A STICK FIGURE OF A BOY WITH RED HAT AND RED SHORTS, AND BLACK ARMS, LEGS AND TORSO IN THE UPPER RIGHT CORNER AND A STICK FIGURE OF A GIRL WITH A RED DRESS AND RED BOWS IN HER HAIR, AND BLACK ARMS AND FEET IN THE LOWER LEFT CORNER. BOTH STARS IN THE LITERAL ELEMENT ARE RED. THE WORDING "CHILDREN'S WISHES" LOCATED IN THE MIDDLE OF THE HEART APPEARS IN BLACK. THE WHITE BACKGROUND REPRESENTS TRANSPARENT SECTIONS OF THE MARK AND IS NOT PART OF THE MARK.

FOR CHARITABLE SERVICES, NAMELY, GRANTING WISHES OF SERIOUSLY ILL CHILDREN (U.S. CLS. 100 AND 101).

FIRST USE 4-9-2009; IN COMMERCE 4-9-2009.

ALICE BENMAMAN, EXAMINING ATTORNEY

SN 85-012,336. CHEEKD INC., NEW YORK, NY. FILED 4-13-2010.

CHEEK'D

THE MARK CONSISTS OF STANDARD CHARACTERS WITHOUT CLAIM TO ANY PARTICULAR FONT, STYLE, SIZE, OR COLOR.

FOR COMMUNICATIONS SERVICES, NAMELY, MATCHMAKING FOR CONSUMERS (U.S. CLS. 100 AND 101).

FIRST USE 4-13-2010; IN COMMERCE 5-3-2010.

RONALD AIKENS, EXAMINING ATTORNEY

CLASS 45—(Continued).

SN 85-033,745. LAU, KEVIN, DBA PATENT TOOLS, SAN DIEGO, CA. FILED 5-9-2010.

*PaTent
Tools*

THE MARK CONSISTS OF THE WORDS "PATENT TOOLS" WHERE THE "T" IN "PATENT" IS USED AS THE "T" FOR "TOOLS".

SEC. 2(F).

FOR INTELLECTUAL PROPERTY CONSULTATION; LEGAL SERVICES, NAMELY, INTELLECTUAL PROPERTY CONSULTING SERVICES IN THE FIELD OF INVENTION, IDENTIFICATION, STRATEGY, ANALYTICS, AND INVENTION; LICENSING OF SOFTWARE FOR MANAGEMENT OF INTELLECTUAL PROPERTY; PROVIDING A WEB SITE FEATURING INFORMATION ABOUT PATENTS AND PATENT APPLICATIONS (U.S. CLS. 100 AND 101).

FIRST USE 5-22-2006; IN COMMERCE 5-22-2006.

RENEE MCCRAY, EXAMINING ATTORNEY

SN 85-049,336. FRATERNITE NOTRE DAME, INC., CHICAGO, IL. FILED 5-27-2010.

OUR LADY OF FRECHOU, MOTHER
OF MERCY AND MOTHER OF THE
CHURCH

THE MARK CONSISTS OF STANDARD CHARACTERS WITHOUT CLAIM TO ANY PARTICULAR FONT, STYLE, SIZE, OR COLOR.

NO CLAIM IS MADE TO THE EXCLUSIVE RIGHT TO USE "CHURCH", APART FROM THE MARK AS SHOWN.

FOR EVANGELICAL AND MINISTERIAL SERVICES; CONDUCTING RELIGIOUS PRAYER SERVICES; RELIGIOUS AND SPIRITUAL SERVICES, NAMELY, HOLDING RELIGIOUS RETREATS TO ASSIST OTHERS IN DEVELOPMENT AND ENHANCEMENT OF THEIR SPIRITUAL LIVES; RELIGIOUS MASS INTENTIONS SERVICES, NAMELY, PROVIDING FOR THE ARRANGEMENT OF MASS INTENTIONS FOR THE DECEASED OR LIVING; CHARITABLE SERVICES, NAMELY PROVIDING CLOTHING TO NEEDY PERSONS; AND CHARITABLE OUTREACH SERVICES, NAMELY, PROVIDING COUNSELING SERVICES IN THE FIELD OF RELIGION TO THE NEEDY (U.S. CLS. 100 AND 101).

FIRST USE 1-31-1991; IN COMMERCE 1-31-1991.

TARA PATE, EXAMINING ATTORNEY

CLASS 45—(Continued).

SN 85-072,647. COAKLEY, LISABETH H., BLOOMFIELD HILLS, MI. FILED 6-28-2010.

MORPHSEARCH

THE MARK CONSISTS OF STANDARD CHARACTERS WITHOUT CLAIM TO ANY PARTICULAR FONT, STYLE, SIZE, OR COLOR.

FOR INTELLECTUAL PROPERTY CONSULTATION SERVICES IN THE NATURE OF FACILITATING ASSIGNMENT OF TRADEMARK REGISTRATIONS (U.S. CLS. 100 AND 101).

GRETTA YAO, EXAMINING ATTORNEY

SN 85-076,789. COAKLEY, LISABETH H., BLOOMFIELD HILLS, MI. FILED 7-2-2010.

MORPHMARKS

THE MARK CONSISTS OF STANDARD CHARACTERS WITHOUT CLAIM TO ANY PARTICULAR FONT, STYLE, SIZE, OR COLOR.

FOR INTELLECTUAL PROPERTY CONSULTATION SERVICES IN THE NATURE OF FACILITATING ASSIGNMENT OF TRADEMARK REGISTRATIONS (U.S. CLS. 100 AND 101).

GRETTA YAO, EXAMINING ATTORNEY

SN 85-111,631. MITCHELL KASS, MAPLEWOOD, NJ. FILED 8-19-2010.

TREND COUNCIL

THE MARK CONSISTS OF STANDARD CHARACTERS WITHOUT CLAIM TO ANY PARTICULAR FONT, STYLE, SIZE, OR COLOR.

NO CLAIM IS MADE TO THE EXCLUSIVE RIGHT TO USE "TREND", APART FROM THE MARK AS SHOWN.

FOR PROVIDING NEWS AND INFORMATION IN THE FIELD OF FASHION; FASHION TREND CONSULTING SERVICES; PROVIDING SEARCHABLE DATABASES IN THE FIELD OF FASHION (U.S. CLS. 100 AND 101).

HOWARD B. LEVINE, EXAMINING ATTORNEY

CLASS 45—(Continued).

SN 85-135,978. PLATE BY DZINTRA LLC, AUSTIN, TX. FILED 9-22-2010.



THE MARK CONSISTS OF THE STYLIZED TEXT "PLATE BY DZINTRA" WITH THE LETTER "A" IN THE WORD "PLATE" FORMED WITH NO CROSS BAR BY TWO MARKS RESEMBLING BRUSH STROKES JOINED AT AN ACUTE ANGLE.

FOR PERSONAL CHEF SERVICES (U.S. CLS. 100 AND 101).

FIRST USE 1-1-2008; IN COMMERCE 5-1-2008.
CYNTHIA TRIPI, EXAMINING ATTORNEY

SN 85-142,232. FIREWATCH SECURITY CONSULTANTS, INC., PLAINFIELD, IN. FILED 9-30-2010.



NO CLAIM IS MADE TO THE EXCLUSIVE RIGHT TO USE "SECURITY CONSULTANTS, INC.", APART FROM THE MARK AS SHOWN.

THE MARK CONSISTS OF A PAIR OF WINGS WITH A HALO IN THE CENTER WITH THE WORDS "FIREWATCH SECURITY CONSULTANTS, INC." DIRECTLY BELOW.

FOR SECURITY SERVICES FOR THE PROTECTION OF PROPERTY AND INDIVIDUALS; CONSULTATION ON INDIVIDUAL AND PROPERTY SECURITY ISSUES, SECURITY MONITORING OF INDIVIDUALS AND PROPERTY; SECURITY SERVICES FOR CONTROLLING ADMISSION TO BUILDINGS AND PUBLIC PLACES; NIGHT WATCHMAN SERVICES; SURVEILLANCE OF BURGLAR AND SECURITY DEVICES AND ALARMS; SURVEILLANCE OF PROPERTY AND INDIVIDUALS; AND BODYGUARD SERVICES (U.S. CLS. 100 AND 101).

JAY FLOWERS, EXAMINING ATTORNEY

CLASS 45—(Continued).

SN 85-160,376. N-FLYERS, LLC, WILMINGTON, DE. FILED 10-25-2010.

NFLYERS

THE MARK CONSISTS OF STANDARD CHARACTERS WITHOUT CLAIM TO ANY PARTICULAR FONT, STYLE, SIZE, OR COLOR.

FOR ONLINE SOCIAL NETWORKING SERVICES IN THE FIELD OF FLYING AND AVIATION TOPICS FOR PILOTS AND OTHERS INTERESTED IN AVIATION OVER A GLOBAL COMPUTER INFORMATION NETWORK (U.S. CLS. 100 AND 101).

JEFFERY COWARD, EXAMINING ATTORNEY

SN 85-160,387. N-FLYERS, LLC, WILMINGTON, DE. FILED 10-25-2010.



THE MARK CONSISTS OF A CAPITAL LETTER "N" FOLLOWED BY THE WORD "FLYERS" IN LOWERCASE LETTERS. THE WORDING IS PRECEDED BY A STYLIZED POLYGON.

FOR ONLINE SOCIAL NETWORKING SERVICES IN THE FIELD OF FLYING AND AVIATION TOPICS FOR PILOTS AND OTHERS INTERESTED IN AVIATION OVER A GLOBAL COMPUTER INFORMATION NETWORK (U.S. CLS. 100 AND 101).

JEFFERY COWARD, EXAMINING ATTORNEY

SN 85-164,762. RAFI, EMILY E, ELGIN, IL. FILED 10-29-2010.

LAWWORKS

THE ENTIRE MARK USES THE FONT PMINGLIU. THE FIRST THREE LETTERS ("LAW") APPEAR IN LARGE CAPS AND THE FIRST THREE LETTERS ARE IN BOLD TYPEFACE. THE LAST FOUR LETTERS ("ORKS") IN ARE IN SMALL CAPS.

FOR LEGAL SERVICES (U.S. CLS. 100 AND 101).

FIRST USE 10-29-2010; IN COMMERCE 10-29-2010.

GRETTA YAO, EXAMINING ATTORNEY

CLASS 45—(Continued).

SN 85-193,036. THRU THE CREASE, LLC, CLAYTON, MO.
FILED 12-8-2010.



THE MARK CONSISTS OF THE UPPER CASE LETTERS "TTC" INSIDE A SHIELD DESIGN FOLLOWED BY THE WORDS "THRU THE CREASE" IN INITIAL CAPITAL LETTERS, APPEARING AS ONE WORD.

FOR ONLINE SOCIAL NETWORKING SERVICES PROVIDED THROUGH A SPORTS COMMUNITY WEBSITE (U.S. CLS. 100 AND 101).

FIRST USE 9-1-2010; IN COMMERCE 9-1-2010.

MARTHA SANTOMARTINO, EXAMINING ATTORNEY

SN 85-203,769. CARLIN SR., PAUL W., CROCKETT, TX.
FILED 12-22-2010.

BELIEF THERAPY

THE MARK CONSISTS OF STANDARD CHARACTERS WITHOUT CLAIM TO ANY PARTICULAR FONT, STYLE, SIZE, OR COLOR.

NO CLAIM IS MADE TO THE EXCLUSIVE RIGHT TO USE "THERAPY", APART FROM THE MARK AS SHOWN, FOR RELIGIOUS COUNSELING (U.S. CLS. 100 AND 101).

FIRST USE 9-10-1997; IN COMMERCE 9-10-1997.

CARYN GLASSER, EXAMINING ATTORNEY

SN 85-215,026. POWELL & RUSSELL ASSOCIATES, SOLANA BEACH, CA. FILED 1-11-2011.

Pre-facto Mediation

THE MARK CONSISTS OF STANDARD CHARACTERS WITHOUT CLAIM TO ANY PARTICULAR FONT, STYLE, SIZE, OR COLOR.

NO CLAIM IS MADE TO THE EXCLUSIVE RIGHT TO USE "MEDIATION", APART FROM THE MARK AS SHOWN.

FOR MEDIATION; MEDIATION OF DISPUTES REGARDING ELDERS, THEIR FAMILIES, CAREGIVERS AND STAKEHOLDERS (U.S. CLS. 100 AND 101).

FIRST USE 1-11-2011; IN COMMERCE 1-11-2011.

MARTHA SANTOMARTINO, EXAMINING ATTORNEY

CLASS 45—(Continued).

SN 85-215,200. SUNSHINE, ILENE ROBINSON, NEWTON, MA. AND RAISELLE, NAOMI, WATERTOWN, MA. FILED 1-11-2011.

StyleRevolution

THE MARK CONSISTS OF STANDARD CHARACTERS WITHOUT CLAIM TO ANY PARTICULAR FONT, STYLE, SIZE, OR COLOR.

FOR PERSONAL SHOPPING FOR OTHERS; PERSONAL IMAGE CONSULTING SERVICES; PROVIDING PERSONAL STYLE AND IMAGE CONSULTING ADVICE AND INFORMATION VIA WEBSITE; PROVIDING WEBSITE OFFERING PERSONAL STYLE AND PERSONAL IMAGE CONSULTING ADVICE AND INFORMATION; PHILANTHROPIC SERVICES, NAMELY, PROVIDING PERSONAL STYLE AND MAKEOVER ADVICE AND ASSISTANCE TO WOMEN TRANSITIONING OUT OF HOMELESSNESS AND DONATING STYLE AND MAKEOVER ADVICE AND ASSISTANCE TO CHARITIES FOR THEIR FUNDRAISING PURPOSES (U.S. CLS. 100 AND 101).

DANNEAN HETZEL, EXAMINING ATTORNEY

SN 85-219,919. GODADDY.COM, INC., SCOTTSDALE, AZ.
FILED 1-18-2011.



OWNER OF U.S. REG. NOS. 2,904,954, 3,672,975 AND OTHERS.

THE COLOR(S) ORANGE, YELLOW, GREEN, BLACK AND WHITE IS/ARE CLAIMED AS A FEATURE OF THE MARK.

THE MARK CONSISTS OF A STYLIZED BUST OF A MAN'S HEAD OUTLINED IN BLACK AND SHADED IN WHITE, WEARING GLASSES OUTLINED IN BLACK WITH GREEN LENSES, A YELLOW STAR OUTLINED IN BLACK AT THE TOP LEFT OF THE HEAD AND CURVED ORANGE LINES AT THE TOP OF THE HEAD AND A BLACK CURVED LINE INDICATING A SMILE TO THE LEFT OF THE STYLIZED WORD "GODADDY.CO" WITH THE "GODADDY" PORTION SHADED IN BLACK TO THE LEFT OF THE ".CO" PORTION BOLDED AND SHADED IN ORANGE.

FOR REGISTRATION, TRANSFER AND ACCOUNT MANAGEMENT SERVICES OF DOMAIN NAMES FOR IDENTIFICATION OF USERS ON A GLOBAL COMPUTER NETWORK (U.S. CLS. 100 AND 101).

DAVID TOOLEY, EXAMINING ATTORNEY

CLASS 45—(Continued).

SN 85-234,747. STEWART, WILLIAM, ESCONDIDO, CA. FILED 2-4-2011.

SENSI SOULMATES

THE MARK CONSISTS OF STANDARD CHARACTERS WITHOUT CLAIM TO ANY PARTICULAR FONT, STYLE, SIZE, OR COLOR.

THE ENGLISH TRANSLATION OF "SENSI" IN THE MARK IS "SENSES".

FOR INTERNET-BASED DATING, SOCIAL INTRODUCTION AND SOCIAL NETWORKING SERVICES (U.S. CLS. 100 AND 101).

LINDA LAVACHE, EXAMINING ATTORNEY

SN 85-237,899. NAVSEEKER, INC., SCOTTSDALE, AZ. FILED 2-9-2011.

FleetDaddy

THE MARK CONSISTS OF STANDARD CHARACTERS WITHOUT CLAIM TO ANY PARTICULAR FONT, STYLE, SIZE, OR COLOR.

FOR VEHICLE AND DRIVER TELEMATIC SERVICES IN THE NATURE OF PROVIDING INFORMATION CONCERNING SAFETY RISKS ON DRIVER BEHAVIOR TO CONSUMERS AND AUTOMOBILE INSURANCE COMPANIES (U.S. CLS. 100 AND 101).

FIRST USE 2-2-2010; IN COMMERCE 2-2-2010.

PATRICIA EVANKO, EXAMINING ATTORNEY

SN 85-240,490. PEARL LAW LLC, PORTLAND, OR. FILED 2-11-2011.

PEARL LAW LLC

THE MARK CONSISTS OF STANDARD CHARACTERS WITHOUT CLAIM TO ANY PARTICULAR FONT, STYLE, SIZE, OR COLOR.

NO CLAIM IS MADE TO THE EXCLUSIVE RIGHT TO USE "LAW LLC", APART FROM THE MARK AS SHOWN.

FOR LEGAL SERVICES (U.S. CLS. 100 AND 101).

FIRST USE 1-1-2008; IN COMMERCE 1-1-2008.

JORDAN BAKER, EXAMINING ATTORNEY

CLASS 45—(Continued).

SN 85-240,661. HALL, JORDAN, MONUMENT, CO. FILED 2-11-2011.

Rock Your Marriage

THE MARK CONSISTS OF STANDARD CHARACTERS WITHOUT CLAIM TO ANY PARTICULAR FONT, STYLE, SIZE, OR COLOR.

FOR PROVIDING MARRIAGE COUNSELING SERVICES, INCLUDING MARRIAGE COUNSELING RENDERED THROUGH COUPLES RETREATS FEATURING EXPERIENTIAL THERAPY (U.S. CLS. 100 AND 101).

FIRST USE 2-1-2010; IN COMMERCE 6-1-2010.

LINDA LAVACHE, EXAMINING ATTORNEY

SN 85-241,589. MARKHAM, AMY N., CHESTER SPRINGS, PA. FILED 2-14-2011.

DIVINATION DIVA

THE MARK CONSISTS OF STANDARD CHARACTERS WITHOUT CLAIM TO ANY PARTICULAR FONT, STYLE, SIZE, OR COLOR.

FOR TAROT CARD READING SERVICES (U.S. CLS. 100 AND 101).

FIRST USE 6-7-2010; IN COMMERCE 6-7-2010.

WON TEAK OH, EXAMINING ATTORNEY

SN 85-242,281. THE CHURCH OF GOD OF NORTH CAROLINA, INC., DUNN, NC. FILED 2-15-2011.

ASSEMBLY BAND MOVEMENT



NO CLAIM IS MADE TO THE EXCLUSIVE RIGHT TO USE "DEPARTMENT OF PASTORAL CARE", APART FROM THE MARK AS SHOWN.

THE MARK CONSISTS OF THE WORDS "ASSEMBLY BAND MOVEMENT" ABOVE THE STYLIZED LETTERS "ABM" THAT INCLUDES A CROSS, A SHEPHERD CANE AND A SHEEP. THE WORDS "DEPARTMENT OF PASTORAL CARE" UNDERNEATH THE "M".

FOR MINISTERIAL SERVICES (U.S. CLS. 100 AND 101).

FIRST USE 2-1-2011; IN COMMERCE 2-1-2011.

RICHARD WHITE, EXAMINING ATTORNEY

CLASS 45—(Continued).

SN 85-242,287. THE CHURCH OF GOD OF NORTH CAROLINA, INC., DUNN, NC. FILED 2-15-2011.

BIBLE TRAINING INSTITUTE



NO CLAIM IS MADE TO THE EXCLUSIVE RIGHT TO USE "BIBLE TRAINING INSTITUTE" AND "THE CHURCH OF GOD OF NC", APART FROM THE MARK AS SHOWN. THE MARK CONSISTS OF THE WORDS "BIBLE TRAINING INSTITUTE" ABOVE A CIRCLE THAT INCLUDES "THE CHURCH OF GOD OF NC". INSIDE THE CIRCLE IS AN OPEN BOOK WITH THE LETTERS "BTI" A TORCH IS IN THE BACKGROUND.

FOR MINISTERIAL SERVICES (U.S. CLS. 100 AND 101).

FIRST USE 2-1-2011; IN COMMERCE 2-1-2011.
RICHARD WHITE, EXAMINING ATTORNEY

CLASS 45—(Continued).

SN 85-242,306. THE CHURCH OF GOD OF NORTH CAROLINA, INC., DUNN, NC. FILED 2-15-2011.

WOMENS MISSIONARY BAND



NO CLAIM IS MADE TO THE EXCLUSIVE RIGHT TO USE "WOMENS MISSIONARY BAND" AND "HOLY BIBLE", APART FROM THE MARK AS SHOWN.

THE MARK CONSISTS OF THE WORDS "WOMENS MISSIONARY BAND" ABOVE A CIRCLE THAT INCLUDES THE WORDS "THE WHOLE GOSPEL FOR THE WHOLE WORLD". THERE IS A GLOBE DESIGN INSIDE THE CIRCLE. THE LETTERS "WMB" ARE A PART OF THE BOTTOM OF THE CIRCLE. THE CIRCLE IS RESTING ON AN OPEN HOLY BIBLE.

FOR MINISTERIAL SERVICES (U.S. CLS. 100 AND 101).

FIRST USE 2-1-2011; IN COMMERCE 2-1-2011.
RICHARD WHITE, EXAMINING ATTORNEY

SN 85-242,291. THE CHURCH OF GOD OF NORTH CAROLINA, INC., DUNN, NC. FILED 2-15-2011.

CHURCH OF PROPHECY
MARKER ASSOCIATION



NO CLAIM IS MADE TO THE EXCLUSIVE RIGHT TO USE "CHURCH" AND "MARKER ASSOCIATION" AND "HOLY BIBLE", APART FROM THE MARK AS SHOWN.

THE MARK CONSISTS OF THE WORDS "CHURCH OF PROPHECY MARKER ASSOCIATION" ABOVE A GLOBE DESIGN THAT INCLUDES TWO WINGS HOLDING UP A HOLY BIBLE AND THE LETTERS "CPMA" ABOVE THE GLOBE AND THE WORDS "WINGS OF PROPHECY" BELOW THE GLOBE.

FOR MINISTERIAL SERVICES (U.S. CLS. 100 AND 101).

FIRST USE 2-1-2011; IN COMMERCE 2-1-2011.
RICHARD WHITE, EXAMINING ATTORNEY

SN 85-242,413. RUISE JANIS, DBA JANIS RUISE MINISTRIES, BRYN MAWR, PA. FILED 2-15-2011.



THE COLOR(S) BLACK AND PINK IS/ARE CLAIMED AS A FEATURE OF THE MARK.

THE MARK CONSISTS OF BLACK CAPITALIZED LETTERS "J U S T C A L L M E", WITH A SPACE BETWEEN THE WORDS "JUST CALL ME", FOLLOWED BY THREE DOTS AT THE TOP OF A GRAPHIC REPRESENTATION OF, IN THE COLOR PINK, A STYLIZED CAPITAL LETTER "G" WITH A FLOURISH AT THE BOTTOM OF THE LETTER, FOLLOWED BY THE LOWER CASE ITALICIZED LETTERS "R A T E F U L", SLIGHTLY SUPERIMPOSED OVER A STYLIZED GRAPHIC REPRESENTATION, IN THE COLOR BLACK, OF A CAPITAL LETTER "G", WITH A FLOURISH AT THE BOTTOM OF THE LETTER, FOLLOWED BY THE CAPITAL LETTERS "Y R L".

FOR CHRISTIAN MINISTRY SERVICES (U.S. CLS. 100 AND 101).

FIRST USE 1-1-2011; IN COMMERCE 1-1-2011.
CHERYL CLAYTON, EXAMINING ATTORNEY

CLASS 45—(Continued).

SN 85-243,666. MOTHERS AGAINST DRUNK DRIVING, IRVING, TX. FILED 2-16-2011.



OWNER OF U.S. REG. NO. 1,538,623.
 THE MARK CONSISTS OF A DESIGN ELEMENT CONSISTING OF A GLASS AND A KEY ENCIRCLED BY "X" SHAPED BRUSHSTROKES.
 FOR PROVIDING PERSONAL SUPPORT SERVICES FOR VICTIMS OF DRUNK DRIVING AND THEIR FAMILIES AND FRIENDS, NAMELY, COMPANIONSHIP, HELP WITH LEGAL, FINANCIAL AND MEDICAL FORMS, COUNSELING AND EMOTIONAL SUPPORT (U.S. CLS. 100 AND 101).
 LINDA M. KING, EXAMINING ATTORNEY

SN 85-246,375. OBERMAN, STEVEN, DBA OBERMAN & RICE, TRIAL ATTORNEYS, KNOXVILLE, TN. FILED 2-18-2011.

YOUR FUTURE IS OUR PRESENT
 CONCERN

THE MARK CONSISTS OF STANDARD CHARACTERS WITHOUT CLAIM TO ANY PARTICULAR FONT, STYLE, SIZE, OR COLOR.
 FOR LEGAL SERVICES RENDERED BY LAWYERS TO INDIVIDUALS, GROUPS OF INDIVIDUALS, ORGANIZATIONS AND ENTERPRISES (U.S. CLS. 100 AND 101).
 FIRST USE 11-22-2010; IN COMMERCE 11-22-2010.
 KELLY BOULTON, EXAMINING ATTORNEY

SN 85-249,766. SELDEN & COMPANY PC, AUSTIN, TX. FILED 2-23-2011.

That's No Accident

THE MARK CONSISTS OF STANDARD CHARACTERS WITHOUT CLAIM TO ANY PARTICULAR FONT, STYLE, SIZE, OR COLOR.
 FOR LEGAL SERVICES (U.S. CLS. 100 AND 101).
 FIRST USE 2-3-2010; IN COMMERCE 2-3-2010.
 AMY C. KEAN, EXAMINING ATTORNEY

CLASS 45—(Continued).

SN 85-250,056. TARGETSAFETY.COM, INC., SAN DIEGO, CA. FILED 2-23-2011.

TARGETSOLUTIONS

THE MARK CONSISTS OF STANDARD CHARACTERS WITHOUT CLAIM TO ANY PARTICULAR FONT, STYLE, SIZE, OR COLOR.
 OWNER OF U.S. REG. NO. 3,834,459.
 FOR CONSULTING IN THE FIELD OF WORKPLACE AND JOBSITE SAFETY; CONSULTATION SERVICES IN THE FIELD OF SAFETY NEEDS OF COMMERCIAL AND INDUSTRIAL COMPANIES AND PUBLIC ENTITIES; REVIEWING STANDARDS AND PRACTICES TO ASSURE ENTERPRISE COMPLIANCE WITH FEDERAL AND STATE LAWS AND REGULATIONS, AND ORGANIZATIONAL POLICIES IN THE FIELDS OF RISK MANAGEMENT AND WORKPLACE AND JOB SITE SAFETY, AND SHARING SUCH INFORMATION VIA AN ON-LINE DATABASE TO ASSIST OTHER ORGANIZATIONS IN THEIR KNOWLEDGE AND UNDERSTANDING OF LAWS, RULES AND REGULATIONS IN THE FIELDS OF RISK MANAGEMENT AND WORKPLACE AND JOB SITE SAFETY (U.S. CLS. 100 AND 101).
 LINDA POWELL, EXAMINING ATTORNEY

SN 85-251,195. TARGETSAFETY.COM, INC., SAN DIEGO, CA. FILED 2-24-2011.



OWNER OF U.S. REG. NO. 3,834,459.
 THE MARK CONSISTS OF A STYLIZED ROUND TARGET WITH THREE RINGS AND THE OUTER TWO RINGS NOT BEING CLOSED COMPLETELY AS THE TWO RINGS INTERSECT WITH THE BEGINNING "T" IN THE LOWER CASE WORD "TARGETSOLUTIONS" WITH THE LETTERS "SOLUTIONS" BEING IN A WIDER FONT LETTERING.
 FOR CONSULTING IN THE FIELD OF WORKPLACE AND JOBSITE SAFETY; CONSULTATION SERVICES IN THE FIELD OF SAFETY NEEDS OF COMMERCIAL AND INDUSTRIAL COMPANIES AND PUBLIC ENTITIES; REVIEWING STANDARDS AND PRACTICES TO ASSURE ENTERPRISE COMPLIANCE WITH FEDERAL AND STATE LAWS AND REGULATIONS, AND ORGANIZATIONAL POLICIES IN THE FIELDS OF RISK MANAGEMENT AND WORKPLACE AND JOB SITE SAFETY, AND SHARING SUCH INFORMATION VIA AN ON-LINE DATABASE TO ASSIST OTHER ORGANIZATIONS IN THEIR KNOWLEDGE AND UNDERSTANDING OF LAWS, RULES AND REGULATIONS IN THE FIELDS OF RISK MANAGEMENT AND WORKPLACE AND JOB SITE SAFETY (U.S. CLS. 100 AND 101).
 LINDA POWELL, EXAMINING ATTORNEY

CLASS 45—(Continued).

SN 85-251,242. TARGETSAFETY.COM, INC., SAN DIEGO, CA. FILED 2-24-2011.



OWNER OF U.S. REG. NO. 3,844,401.
THE MARK CONSISTS OF LOWER CASE LETTERING "PREVENTIONLINK" WITH THE LETTERS "LINK" BEING IN A WIDER FONT, AND A STYLIZED ROUND TARGET WITH THREE RINGS TO THE RIGHT OF THE WORD WITH THE OUTER TWO RINGS NOT BEING CLOSED COMPLETELY AS THE TWO RINGS INTERSECT WITH THE "K" IN "PREVENTIONLINK".

FOR CONSULTING IN THE FIELD OF WORKPLACE AND JOBSITE SAFETY; CONSULTATION SERVICES IN THE FIELD OF SAFETY NEEDS OF COMMERCIAL AND INDUSTRIAL COMPANIES AND PUBLIC ENTITIES; REVIEWING STANDARDS AND PRACTICES TO ASSURE ENTERPRISE COMPLIANCE WITH FEDERAL AND STATE LAWS AND REGULATIONS, AND ORGANIZATIONAL POLICIES IN THE FIELDS OF RISK MANAGEMENT AND WORKPLACE AND JOB SITE SAFETY, AND SHARING SUCH INFORMATION VIA AN ON-LINE DATABASE TO ASSIST OTHER ORGANIZATIONS IN THEIR KNOWLEDGE AND UNDERSTANDING OF LAWS, RULES AND REGULATIONS IN THE FIELDS OF RISK MANAGEMENT AND WORKPLACE AND JOB SITE SAFETY (U.S. CLS. 100 AND 101).
LINDA POWELL, EXAMINING ATTORNEY

SN 85-252,127. STRIVE ZERO, LLC, SAN FRANCISCO, CA. FILED 2-25-2011.

STRIVEZERO

THE MARK CONSISTS OF STANDARD CHARACTERS WITHOUT CLAIM TO ANY PARTICULAR FONT, STYLE, SIZE, OR COLOR.

FOR CONSULTING SERVICES IN THE FIELD OF CONSTRUCTION SAFETY; INFORMATION SERVICES, NAMELY, PROVIDING INFORMATION TO OTHERS IN THE FIELD OF CONSTRUCTION SAFETY (U.S. CLS. 100 AND 101).

FIRST USE 12-16-2010; IN COMMERCE 12-16-2010.
LINDA POWELL, EXAMINING ATTORNEY

CLASS 45—(Continued).

SN 85-252,186. RICHARD A. HARRIS, A PROFESSIONAL CORPORATION, LAS VEGAS, NV. FILED 2-25-2011.

THE DEFENDERS

THE MARK CONSISTS OF STANDARD CHARACTERS WITHOUT CLAIM TO ANY PARTICULAR FONT, STYLE, SIZE, OR COLOR.

FOR LEGAL SERVICES (U.S. CLS. 100 AND 101).
FIRST USE 1-1-2009; IN COMMERCE 1-1-2009.
TIMOTHY FINNEGAN, EXAMINING ATTORNEY

SN 85-252,193. DEBORAH A. AUSBURN, WOODSTOCK, GA. FILED 2-25-2011.

PREVIEW

THE MARK CONSISTS OF STANDARD CHARACTERS WITHOUT CLAIM TO ANY PARTICULAR FONT, STYLE, SIZE, OR COLOR.

FOR LITIGATION CONSULTANCY; LITIGATION SUPPORT SERVICES (U.S. CLS. 100 AND 101).
BRIAN PINO, EXAMINING ATTORNEY

SN 85-252,257. PROTORAE LAW PLLC, TYSONS CORNER, VA. FILED 2-25-2011.

Protoraе Law

THE MARK CONSISTS OF STANDARD CHARACTERS WITHOUT CLAIM TO ANY PARTICULAR FONT, STYLE, SIZE, OR COLOR.

NO CLAIM IS MADE TO THE EXCLUSIVE RIGHT TO USE "LAW", APART FROM THE MARK AS SHOWN.

FOR LEGAL SERVICES (U.S. CLS. 100 AND 101).
FIRST USE 8-31-2010; IN COMMERCE 9-1-2010.
ELLEN BURNS, EXAMINING ATTORNEY

CLASS 45—(Continued).

SN 85-252,549. COX, DEVON, J, DENVER, CO. FILED 2-26-2011.

Buy Local with Benefits

THE MARK CONSISTS OF STANDARD CHARACTERS WITHOUT CLAIM TO ANY PARTICULAR FONT, STYLE, SIZE, OR COLOR.

NO CLAIM IS MADE TO THE EXCLUSIVE RIGHT TO USE "BUY LOCAL", APART FROM THE MARK AS SHOWN.

FOR INTERNET-BASED SOCIAL NETWORKING SERVICES (U.S. CLS. 100 AND 101).

MAYUR VAGHANI, EXAMINING ATTORNEY

SN 85-253,154. JAMES KOHL, LAS VEGAS, NV. FILED 2-28-2011.

WE MAKE TICKETS POINTLESS

THE MARK CONSISTS OF STANDARD CHARACTERS WITHOUT CLAIM TO ANY PARTICULAR FONT, STYLE, SIZE, OR COLOR.

FOR LEGAL SERVICES; LEGAL SERVICES, NAMELY PROVIDING TRAFFIC TICKET AND TRAFFIC INFRACTION LEGAL ADVISEMENT AND DEFENSE SERVICES; LEGAL SERVICES, NAMELY, HANDLING AND RESOLVING LEGAL MATTERS ON BEHALF OF RECIPIENTS OF TRAFFIC TICKETS OR INFRACTIONS ISSUED BY ANY REGULATORY OR LAW ENFORCEMENT AGENCIES IN CONNECTION WITH ANY KIND OF MOTORIZED VEHICLE (U.S. CLS. 100 AND 101).

FIRST USE 2-0-2011; IN COMMERCE 2-0-2011.
GINA FINK, EXAMINING ATTORNEY

SN 85-254,303. SEARCY, JEFFREY S., ST AUGUSTINE, FL. FILED 3-1-2011.

Servant Warrior

THE MARK CONSISTS OF STANDARD CHARACTERS WITHOUT CLAIM TO ANY PARTICULAR FONT, STYLE, SIZE, OR COLOR.

FOR CHRISTIAN MINISTRY SERVICES (U.S. CLS. 100 AND 101).

FIRST USE 9-21-2004; IN COMMERCE 5-1-2009.
SUZANNE BLANE, EXAMINING ATTORNEY

CLASS 45—(Continued).

SN 85-254,435. HEIDI KLUM COMPANY LLC, NEW YORK, NY. FILED 3-1-2011.

PLANET HEIDI

THE MARK CONSISTS OF STANDARD CHARACTERS WITHOUT CLAIM TO ANY PARTICULAR FONT, STYLE, SIZE, OR COLOR.

FOR PROVIDING A WEBSITE FEATURING INFORMATION ON LIFESTYLES AND FASHION (U.S. CLS. 100 AND 101).

JAMES A. RAUEN, EXAMINING ATTORNEY

SN 85-254,439. PRESCOTT HOLDINGS, INC., FRANKLIN, TN. FILED 3-1-2011.

Garlic Salt

THE MARK CONSISTS OF STANDARD CHARACTERS WITHOUT CLAIM TO ANY PARTICULAR FONT, STYLE, SIZE, OR COLOR.

FOR ONLINE SOCIAL NETWORKING SERVICES IN THE FIELD OF GOURMET COOKING (U.S. CLS. 100 AND 101).

JAMES A. RAUEN, EXAMINING ATTORNEY

SN 85-254,459. NEWBY, KIM, FRIENDSHIP, ME. FILED 3-1-2011.

JurisN

THE MARK CONSISTS OF STANDARD CHARACTERS WITHOUT CLAIM TO ANY PARTICULAR FONT, STYLE, SIZE, OR COLOR.

FOR LEGAL SERVICES (U.S. CLS. 100 AND 101).

FIRST USE 8-0-2004; IN COMMERCE 8-0-2004.

WILLIAM P. SHANAHAN, EXAMINING ATTORNEY

CLASS 45—(Continued).

SN 85-254,616. B. SPENCER & ASSOCIATES, P.C., AKA THE SPENCER LAW FIRM, HOUSTON, TX. FILED 3-1-2011.

The Spencer Law Firm

THE MARK CONSISTS OF STANDARD CHARACTERS WITHOUT CLAIM TO ANY PARTICULAR FONT, STYLE, SIZE, OR COLOR.

NO CLAIM IS MADE TO THE EXCLUSIVE RIGHT TO USE "LAW FIRM", APART FROM THE MARK AS SHOWN. FOR LEGAL SERVICES (U.S. CLS. 100 AND 101). FIRST USE 4-26-2007; IN COMMERCE 4-26-2007. NATALIE POLZER, EXAMINING ATTORNEY



SN 85-255,173. THE TICKTIN LAW GROUP, DEERFIELD BEACH, FL. FILED 3-1-2011.

**THE LAWYERS YOU WANT
BETWEEN YOU AND YOUR
PROBLEMS**

THE MARK CONSISTS OF STANDARD CHARACTERS WITHOUT CLAIM TO ANY PARTICULAR FONT, STYLE, SIZE, OR COLOR.

FOR ATTORNEY SERVICES (U.S. CLS. 100 AND 101). FIRST USE 12-15-2007; IN COMMERCE 1-1-2008. ANNE MADDEN, EXAMINING ATTORNEY



SN 85-255,419. RICHARDS, ERRINGTON, AKA KING ALI BABA, ROSWELL, GA. FILED 3-2-2011.

**IF YUH NOH NETWORK YUH NOH
GET WORK**

THE MARK CONSISTS OF STANDARD CHARACTERS WITHOUT CLAIM TO ANY PARTICULAR FONT, STYLE, SIZE, OR COLOR.

FOR LICENSING OF ADVERTISING SLOGANS AND CARTOON CHARACTERS (U.S. CLS. 100 AND 101). JEAN IM, EXAMINING ATTORNEY

CLASS 45—(Continued).

SN 85-255,680. PARRILLI RENISON LLC, PORTLAND, OR. FILED 3-2-2011.

ENTRYLAW

THE MARK CONSISTS OF STANDARD CHARACTERS WITHOUT CLAIM TO ANY PARTICULAR FONT, STYLE, SIZE, OR COLOR.

FOR LEGAL SERVICES IN THE FIELD OF GLOBAL IMMIGRATION AND MIGRATION LAW (U.S. CLS. 100 AND 101).

FIRST USE 5-0-2007; IN COMMERCE 5-0-2007. CARRIE GENOVESE, EXAMINING ATTORNEY



SN 85-256,729. KANCZEWSKI, EDWARD G, POMPTON PLAINS, NJ. FILED 3-3-2011.



NO CLAIM IS MADE TO THE EXCLUSIVE RIGHT TO USE "PROCESS & COMPLIANCE MANAGEMENT", APART FROM THE MARK AS SHOWN.

THE MARK CONSISTS OF THE WORDING "PROCESS & COMPLIANCE MANAGEMENT", WITH TWO OPPOSING CURVED BANDS COMING TOGETHER TO FORM AN "X" DESIGN BEHIND THE "&" SYMBOL.

FOR REGULATORY COMPLIANCE CONSULTING IN THE FIELD OF LIFE SCIENCE, PHARMACEUTICALS, BIOPHARMACEUTICALS, NUTRACEUTICALS, BIOTECHNOLOGY, BIOLOGICS, MEDICAL DEVICES AND HEALTH CARE; TECHNICAL CONSULTING IN THE FIELD OF PRE- AND POST-REGULATORY AGENCY APPROVAL COMPLIANCE IN THE FIELDS OF LIFE SCIENCE, PHARMACEUTICALS, BIOPHARMACEUTICALS, NUTRACEUTICALS, BIOTECHNOLOGY, BIOLOGICS, MEDICAL DEVICES AND HEALTH CARE (U.S. CLS. 100 AND 101).

FIRST USE 5-0-2010; IN COMMERCE 5-0-2010. CAROLYN CATALDO, EXAMINING ATTORNEY



SN 85-256,781. WOMZ VENTURES PTE LTD., SINGAPORE, SINGAPORE, FILED 3-3-2011.

**CONNECTING BELIEVERS
AROUND THE WORLD**

THE MARK CONSISTS OF STANDARD CHARACTERS WITHOUT CLAIM TO ANY PARTICULAR FONT, STYLE, SIZE, OR COLOR.

FOR INTERNET-BASED SOCIAL NETWORKING SERVICES (U.S. CLS. 100 AND 101).

FIRST USE 11-4-2010; IN COMMERCE 11-4-2010. DOMINIC FATHY, EXAMINING ATTORNEY

CLASS 45—(Continued).

SN 85-256,793. WOMZ VENTURES PTE LTD., SINGAPORE, SINGAPORE, FILED 3-3-2011.

GRACEHOPE.COM

THE MARK CONSISTS OF STANDARD CHARACTERS WITHOUT CLAIM TO ANY PARTICULAR FONT, STYLE, SIZE, OR COLOR.

FOR INTERNET-BASED SOCIAL NETWORKING SERVICES (U.S. CLS. 100 AND 101).

FIRST USE 11-4-2010; IN COMMERCE 11-4-2010.
DOMINIC FATHY, EXAMINING ATTORNEY

SN 85-256,808. WOMZ VENTURES PTE LTD., SINGAPORE, SINGAPORE, FILED 3-3-2011.



THE MARK CONSISTS OF A CIRCLE WITH A THIN TRIM AROUND IT, WITH THE LOWER CASE CURSIVE LETTERS "GH" PRINTED INSIDE THE CIRCLE, AND THE LETTERS ARE ATTACHED INsofar AS THE LEFT VERTICAL SIDE OF THE "H" LEADS INTO THE TAIL OF THE "G".

FOR INTERNET-BASED SOCIAL NETWORKING SERVICES (U.S. CLS. 100 AND 101).

FIRST USE 11-4-2010; IN COMMERCE 11-4-2010.
DOMINIC FATHY, EXAMINING ATTORNEY

CLASS 45—(Continued).

SN 85-257,435. A HIGHER POSSIBILITY, SAN RAFAEL, CA, FILED 3-3-2011.

THE SOULMATE CONNECTION

THE MARK CONSISTS OF STANDARD CHARACTERS WITHOUT CLAIM TO ANY PARTICULAR FONT, STYLE, SIZE, OR COLOR.

FOR DATING SERVICES; DATING SERVICES, NAMELY, PROVIDING AN ON-LINE COMPUTER DATABASE FEATURING SINGLE PEOPLE INTERESTED IN MEETING OTHER SINGLE PEOPLE; INTERNET-BASED DATING, SOCIAL INTRODUCTION AND SOCIAL NETWORKING SERVICES (U.S. CLS. 100 AND 101).

WENDY GOODMAN, EXAMINING ATTORNEY

SN 85-257,706. ELITE PROTECTION SERVICES, LLC, DBA ELITE PROTECTION SERVICES, COLUMBIA, MD, FILED 3-4-2011.



NO CLAIM IS MADE TO THE EXCLUSIVE RIGHT TO USE "PROTECTION SERVICES", APART FROM THE MARK AS SHOWN.

THE MARK CONSISTS OF THE WORD "ELITE" IN ALL CAPITAL TYPE ABOVE THE WORDS "PROTECTION" AND "SERVICES", WITH A PARTIAL OVAL OUTLINE ABOVE, TO THE LEFT OF AND ENCAPSULATING THE LITERAL ELEMENT OF THE MARK, AND WITH A SIX-POINTED STAR AT THE FAR-RIGHT TIP OF THE PARTIAL OVAL OUTLINE.

FOR ADVISORY SERVICES IN THE FIELD OF HOME SECURITY SYSTEMS; CONSULTANCY SERVICES IN THE FIELD OF HOME SECURITY; CONSULTATION IN THE FIELD OF DATA THEFT AND IDENTITY THEFT; ELECTRONIC MONITORING SERVICES FOR SECURITY PURPOSES IN THE FIELD OF RESIDENTIAL AND COMMERCIAL SECURITY AND ASSET PROTECTION; EMERGENCY RESPONSE ALARM MONITORING SERVICES, NAMELY, MONITORING OF ALERT DEVICES BY A REMOTE MONITORING CENTER FOR THE DISPATCH OF EMERGENCY PUBLIC HEALTH AND SECURITY SERVICES AND NOTIFICATION TO THIRD PARTIES; FRAUD AND IDENTITY THEFT PROTECTION SERVICES; HOME SECURITY MONITORING USING WIRELESS AND WIRED SENSORS FOR GLASS BREAKAGE, MOTION DETECTORS, CAMERAS, POOL ALARMS, WATER ALARMS AND SHUTOFF VALVES, GATE, DOOR AND WINDOW CONTACT SENSORS, SEVERE WEATHER ALARMS; LOCKSMITHING, NAMELY, OPENING OF LOCKS; MEDICAL ALARM MONITORING SERVICES; MONITORING ALARMS; MONITORING BURGLAR AND SECURITY ALARMS; MONITORING OF ALARMS; MONITORING OF CREDIT REPORTS, THE INTERNET, AND PUBLIC RECORDS TO FACILITATE THE DETECTION AND PREVENTION OF IDENTITY THEFT AND FRAUD; MONITORING OF SECURITY SYSTEMS; SECURITY GUARD SERVICES; SECURITY GUARDING FOR FACILITIES (U.S. CLS. 100 AND 101).

FIRST USE 11-30-2004; IN COMMERCE 11-30-2004.
MIDGE BUTLER, EXAMINING ATTORNEY

CLASS 45—(Continued).

SN 85-257,779. THE DRAGONFLY FOUNDATION, MASON, OH. FILED 3-4-2011.

Made You Look

THE MARK CONSISTS OF STANDARD CHARACTERS WITHOUT CLAIM TO ANY PARTICULAR FONT, STYLE, SIZE, OR COLOR.

FOR CHARITABLE SERVICES, NAMELY, GRANTING WISHES OF CHILDREN WHO ARE BEING TREATED FOR CANCER AND OTHER BLOOD DISORDERS AND THEIR FAMILIES (U.S. CLS. 100 AND 101).

FIRST USE 3-1-2011; IN COMMERCE 3-1-2011.
KATHERINE CHANG, EXAMINING ATTORNEY

SN 85-257,839. THE DRAGONFLY FOUNDATION, MASON, OH. FILED 3-4-2011.

I Am Still Me

THE MARK CONSISTS OF STANDARD CHARACTERS WITHOUT CLAIM TO ANY PARTICULAR FONT, STYLE, SIZE, OR COLOR.

FOR CHARITABLE SERVICES, NAMELY, GRANTING WISHES OF CHILDREN WHO ARE BEING TREATED FOR CANCER AND OTHER BLOOD DISORDERS AND THEIR FAMILIES (U.S. CLS. 100 AND 101).

FIRST USE 3-1-2011; IN COMMERCE 3-1-2011.
KATHERINE CHANG, EXAMINING ATTORNEY

SN 85-257,861. CLAIMSTREAM, INC., FRIDAY HARBOR, WA. FILED 3-4-2011.

Litimotion

THE MARK CONSISTS OF STANDARD CHARACTERS WITHOUT CLAIM TO ANY PARTICULAR FONT, STYLE, SIZE, OR COLOR.

FOR LITIGATION SUPPORT SERVICES (U.S. CLS. 100 AND 101).

MARIA-VICTORIA SUAREZ, EXAMINING ATTORNEY

CLASS 45—(Continued).

SN 85-257,892. MAXIMIZE MY SPACE, LLC, AURORA, IL. FILED 3-4-2011.



THE MARK CONSISTS OF A SQUARE COMPRISED OF 3 TRIANGLES WITH THE STYLIZED TEXT "MAXIMIZE MY SPACE".

FOR ORGANIZATIONAL SERVICES FOR HOME OR PERSONAL PURPOSES, NAMELY, ORGANIZING ATTICS, BASEMENTS, PANTRIES, KITCHENS, CLOSETS, BATHROOMS, BEDROOMS, LAUNDRY ROOMS, GARAGES, AND LIVING ROOM (U.S. CLS. 100 AND 101).

FIRST USE 1-6-2011; IN COMMERCE 1-6-2011.
JOHN E. MICHOS, EXAMINING ATTORNEY

SN 85-260,325. MUSGROVE, TAMMIE, TUCSON, AZ. FILED 3-7-2011.

Waiting Warriors

THE MARK CONSISTS OF STANDARD CHARACTERS WITHOUT CLAIM TO ANY PARTICULAR FONT, STYLE, SIZE, OR COLOR.

FOR ORGANIZING AND CONDUCTING SUPPORT GROUPS IN THE FIELD OF SUPPORT FOR SPOUSES AND FAMILIES OF MILITARY DEPLOYED MEMBERS (U.S. CLS. 100 AND 101).

FIRST USE 9-1-2006; IN COMMERCE 9-1-2006.
THOMAS MANOR, EXAMINING ATTORNEY

CLASS 45—(Continued).

SN 85-273,991. SH HOLDINGS, LLC, DBA SENIOR HELPERS, SARASOTA, FL. FILED 3-22-2011.



OWNER OF U.S. REG. NOS. 3,072,314, 3,889,071 AND OTHERS.

NO CLAIM IS MADE TO THE EXCLUSIVE RIGHT TO USE "CARE", APART FROM THE MARK AS SHOWN.

THE MARK CONSISTS OF THE WORD "SENIOR" ON TOP OF THE WORD "HELPERS"; THE "H" IN "HELPERS" IS COVERED BY THE TOP OF A TRIANGLE WITH A RECTANGLE ON THE LEFT SIDE OF THE TRIANGLE TO FORM A ROOFTOP; THE WORDS "CARE AND COMFORT AT A MOMENT'S NOTICE." ARE UNDER THE WORD "HELPERS".

SEC. 2(F) AS TO "SENIOR HELPERS".

FOR PROVIDING PERSONAL SUPPORT SERVICES FOR SENIORS AT THEIR RESIDENCES CONSISTING PRIMARILY OF COMPANIONSHIP AND DAILY LIVING PERSONAL CARE SUCH AS BATHING AND DRESSING, AND ALSO INCLUDING, ON AN AS NEEDED BASIS, MEDICATION REMINDERS, LIGHT HOUSEKEEPING, ERRANDS, TRANSPORTATION TO APPOINTMENTS, BILL PAYING, MAIL AND HOUSEHOLD AFFAIRS (U.S. CLS. 100 AND 101).

FIRST USE 3-1-2011; IN COMMERCE 3-1-2011.

LAURIE MAYES, EXAMINING ATTORNEY

SN 85-283,644. PING IDENTITY CORPORATION, DENVER, CO. FILED 4-1-2011.

PINGONE

THE MARK CONSISTS OF STANDARD CHARACTERS WITHOUT CLAIM TO ANY PARTICULAR FONT, STYLE, SIZE, OR COLOR.

OWNER OF U.S. REG. NOS. 3,017,959, 3,336,775 AND OTHERS.

FOR IDENTITY VERIFICATION SERVICES, NAMELY, PROVIDING USER AUTHENTICATION BETWEEN TWO OR MORE ENTITIES IN THE FIELD OF DIGITAL SECURITY (U.S. CLS. 100 AND 101).

AMY HELLA, EXAMINING ATTORNEY

CLASS 45—(Continued).

SN 85-303,144. JESSICA EAVES MATHEWS, ALBUQUERQUE, NM. FILED 4-24-2011.

LEVERAGE-A-LAWYER

THE MARK CONSISTS OF STANDARD CHARACTERS WITHOUT CLAIM TO ANY PARTICULAR FONT, STYLE, SIZE, OR COLOR.

FOR CONSULTING AND LEGAL SERVICES IN THE FIELD OF PRIVACY AND SECURITY LAWS, REGULATIONS, AND REQUIREMENTS; CONSULTING SERVICES CONCERNING LEGAL MATTERS IN THE MEDICAL FIELD; DOMAIN NAME REGISTRATION SERVICES, NAMELY, CONDUCTING DOMAIN NAME SEARCHES FOR THE PURPOSE OF PROVIDING LEGAL ADVICE ON DOMAIN NAME REGISTRATION; LEGAL CONSULTATION SERVICES; LEGAL RESEARCH; LEGAL SERVICES; LEGAL SERVICES, NAMELY, PREPARATION OF APPLICATIONS FOR TRADEMARK REGISTRATION; LEGAL SERVICES, NAMELY, PROVIDING CUSTOMIZED INFORMATION, COUNSELING, ADVICE AND LITIGATION SERVICES IN ALL AREAS OF EMPLOYMENT AND LABOR LAW FOR BOTH EMPLOYEES AND EMPLOYERS; LEGAL SERVICES, NAMELY, TRADEMARK MAINTENANCE SERVICES; LEGAL SERVICES, NAMELY, TRADEMARK SEARCHING AND CLEARANCE SERVICES; LICENSING OF INTELLECTUAL PROPERTY; PROFESSIONAL LEGAL CONSULTATIONS RELATING TO FRANCHISING; PROVIDING AN ON-LINE INTERACTIVE DATABASE FEATURING LEGAL INFORMATION; PROVIDING INFORMATION IN THE FIELD OF INTELLECTUAL PROPERTY LEGAL SERVICES; PROVIDING INFORMATION IN THE FIELD OF WORKPLACE LAW, LEGAL PRACTICES AND LEGAL POLICIES VIA THE INTERNET; PROVIDING INFORMATION RELATING TO LEGAL AFFAIRS; PROVIDING ON-LINE INFORMATION IN THE FIELD OF INTELLECTUAL PROPERTY LEGAL SERVICES (U.S. CLS. 100 AND 101).

FIRST USE 1-10-2011; IN COMMERCE 1-10-2011.

ASMAT KHAN, EXAMINING ATTORNEY

SN 85-309,123. MAHADEO, SHARMILLA, TORONTO, ONTARIO, CANADA, FILED 4-30-2011.

Secret Sex Society

THE MARK CONSISTS OF STANDARD CHARACTERS WITHOUT CLAIM TO ANY PARTICULAR FONT, STYLE, SIZE, OR COLOR.

NO CLAIM IS MADE TO THE EXCLUSIVE RIGHT TO USE "SEX SOCIETY", APART FROM THE MARK AS SHOWN.

FOR DATING SERVICES (U.S. CLS. 100 AND 101).

FIRST USE 5-27-2010; IN COMMERCE 5-27-2010.

JEFFERY COWARD, EXAMINING ATTORNEY

SECTION 4.—PRIOR UNITED STATES CLASSIFICATION

APPLICATION IN ONE CLASS

COLLECTIVE MEMBERSHIP MARKS

CLASS 200—COLLECTIVE MEMBERSHIP
SN 77-463,997. KAPPA ALPHA ORDER, LEXINGTON, VA.
FILED 5-2-2008.



OWNER OF U.S. REG. NO. 2,387,271.
THE COLOR(S) CRIMSON, WHITE AND GOLD IS/ARE CLAIMED AS A FEATURE OF THE MARK.

THE MARK CONSISTS OF A DESIGN FOR A FLAG CONTAINING A WHITE SHIELD TOWARD THE CENTER BEARING THE CRIMSON GREEK ALPHABET LETTERS "K" (KAPPA) AND "A" (ALPHA) ABOVE A CRIMSON-COLORED GREEK CROSS WITH A CRIMSON-COLORED BACKGROUND TO THE LEFT OF THE SHIELD AND A GOLD-COLORED BACKGROUND TO THE RIGHT OF THE SHIELD.

FOR INDICATING MEMBERSHIP IN A COLLEGIATE FRATERNAL ORGANIZATION.

FIRST USE 0-0-1967; IN COMMERCE 0-0-1967.

HEATHER THOMPSON, EXAMINING ATTORNEY

SN 85-214,944. AMERICAN LAND TITLE ASSOCIATION,
WASHINGTON, DC. FILED 1-11-2011.

ALTA

THE MARK CONSISTS OF STANDARD CHARACTERS WITHOUT CLAIM TO ANY PARTICULAR FONT, STYLE, SIZE, OR COLOR.

FOR INDICATING MEMBERSHIP IN AN ASSOCIATION IN THE TITLE INSURANCE INDUSTRY.

FIRST USE 12-31-1960; IN COMMERCE 12-31-1960.

SUZANNE BLANE, EXAMINING ATTORNEY

SN 85-241,280. FARMHOUSE FRATERNITY, KANSAS CITY, MO. FILED 2-14-2011.



NO CLAIM IS MADE TO THE EXCLUSIVE RIGHT TO USE "1905", APART FROM THE MARK AS SHOWN.

THE MARK CONSISTS OF A CREST DESIGN CONSISTING OF A SHIELD DIVIDED INTO THREE SECTIONS; THE FIRST SECTION POSITIONED ON THE TOP RIGHT CONTAINING AN OIL LAMP; A SECOND SECTION POSITIONED DIAGONAL FROM THE TOP LEFT TO THE LOWER RIGHT CONTAINING THREE STARS; AND A THIRD SECTION POSITIONED ON THE LOWER LEFT CONTAINING A SICKLE AND A SHOCK OF WHEAT. ABOVE THE SHIELD IS A MEDIEVAL HELMET AND BELOW THE SHIELD IS A BANNER BEARING "19 FARMHOUSE 05".

FOR INDICATING MEMBERSHIP IN A COLLEGIATE FRATERNITY.

FIRST USE 0-0-1911; IN COMMERCE 0-0-1911.

MARK SPARACINO, EXAMINING ATTORNEY

SN 85-250,937. INTERNATIONAL ASSOCIATION FOR HEALTHCARE SECURITY AND SAFETY, INC., GLENDALE HEIGHTS, IL. FILED 2-24-2011.



OWNER OF U.S. REG. NOS. 1,830,733 AND 1,832,718.
NO CLAIM IS MADE TO THE EXCLUSIVE RIGHT TO USE "INTERNATIONAL ASSOCIATION FOR HEALTHCARE SECURITY & SAFETY", APART FROM THE MARK AS SHOWN.

THE COLOR(S) BLUE, MAGENTA AND YELLOW IS/ARE CLAIMED AS A FEATURE OF THE MARK.

THE MARK CONSISTS OF THE LETTERS "IAHSS" IN MAGENTA OVER "INTERNATIONAL ASSOCIATION FOR HEALTHCARE SECURITY & SAFETY" IN YELLOW, ALL TO THE RIGHT OF A STYLISTIC DEPICTION OF A PORTION OF THE EARTH WITH THE CONTINENTS IN YELLOW, THE BODIES OF WATER IN BLUE AND A MAGENTA LINE CUTTING OFF THE LEFT PART OF THE GLOBE.

FOR INDICATING MEMBERSHIP IN AN ORGANIZATION OF HEALTHCARE SECURITY AND SAFETY PROFESSIONALS.

MICHAEL WEBSTER, EXAMINING ATTORNEY

SN 85-266,978. KNIGHTS OF COLUMBUS, NEW HAVEN, CT. FILED 3-15-2011.



NO CLAIM IS MADE TO THE EXCLUSIVE RIGHT TO USE "CHARITY" OR "FRATERNITY", APART FROM THE MARK AS SHOWN.

THE MARK CONSISTS OF DESIGN AND WORDING AS PLACED ON A THREE DIMENSIONAL MEDALLION. THE FRONT FEATURES A LATIN CROSS SURROUNDED BY ELEVEN SMALL CIRCLES, EVENLY SPACED ALONG THE BORDER OF THE CIRCLE, THE TOP MOST OF WHICH ENCLOSES A SMALLER LATIN CROSS. THE BACK FEATURES A CHALICE AND HOST INSCRIBED WITH "IHS" AND THE WORDS "UNITY", "FRATERNITY", AND "CHARITY". THE WORDING "IN SOLIDARITY WITH OUR PRIESTS" APPEARS ON THE EDGE OF THE MEDALLION. THE MATTER SHOWN IN BROKEN LINES IS NOT PART OF THE MARK AND SERVES ONLY TO SHOW THE POSITION OR PLACEMENT OF THE MARK.

FOR INDICATING MEMBERSHIP IN A FRATERNAL BENEFIT SOCIETY THAT PROMOTES VOLUNTEERISM, COMMUNITY LEADERSHIP, AND CHARITABLE WORKS AND CONTRIBUTIONS, AND PROVIDES INSURANCE SERVICES.

FIRST USE 4-1-2011; IN COMMERCE 4-1-2011.
REBECCA POVARCHUK, EXAMINING ATTORNEY

CERTIFICATION MARKS

CLASS A—GOODS

SN 85-079,379. FEDERACION CASTELLANO LEONESA DE INDUSTRIAS LACTEAS, VALLADOLID, SPAIN, FILED 7-7-2010.



NO CLAIM IS MADE TO THE EXCLUSIVE RIGHT TO USE "QUESO", APART FROM THE MARK AS SHOWN.

THE COLOR(S) YELLOW AND BLACK IS/ARE CLAIMED AS A FEATURE OF THE MARK.

THE MARK CONSISTS OF "QUESO CASTELLANO" IN STYLIZED YELLOW LETTERS OVER A BLACK BACKGROUND.

THE ENGLISH TRANSLATION OF "QUESO CASTELLANO" IN THE MARK IS "CASTILLIAN CHEESE".

THE CERTIFICATION MARK, AS INTENDED TO BE USED BY AUTHORIZED PERSONS, IS INTENDED TO CERTIFY THAT THE CHEESE HAS BEEN MANUFACTURED IN THE COMMUNITY OF CASTILLA AND LEON, SPAIN AND THAT THE CHEESE IS MANUFACTURED FROM SHEEP, COW AND GOAT'S MILK IN ACCORDANCE WITH THE STANDARDS OF QUALITY FOR PRODUCTION, CURING AND CONSERVATION SET BY THE CERTIFIER.

FOR CHEESES.
STEVEN PEREZ, EXAMINING ATTORNEY

SN 85-134,091. JERRY WIRTZ, PONCA CITY, OK. FILED 9-20-2010.



NO CLAIM IS MADE TO THE EXCLUSIVE RIGHT TO USE "TESTED AND CERTIFIED" AND "TORNADO PROVEN", APART FROM THE MARK AS SHOWN.

THE COLOR(S) RED, BLACK AND WHITE IS/ARE CLAIMED AS A FEATURE OF THE MARK.

THE MARK CONSISTS OF THE WORDING "TESTED AND CERTIFIED TORNADO PROVEN" AND DESIGN. THE DESIGN CONSISTS OF A RED CIRCLE OUTSIDE OF A BLACK RING AND THE WORDING "TESTED AND CERTIFIED" APPEARS IN WHITE AND IS SUPERIMPOSED AT THE TOP OF THE BLACK RING. WITHIN THE CENTER IS A RED CYCLONE SUPERIMPOSED ON A WHITE BACKGROUND. THE WORDING "TORNADO PROVEN" APPEARS IN WHITE AND IS SUPERIMPOSED ON THE CYCLONE. THE TERM "TORNADO" APPEARS ABOVE THE TERM "PROVEN".

THE CERTIFICATION MARK, AS USED BY AUTHORIZED PERSONS, CERTIFIES THIS SHELTER IS TESTED AND CERTIFIED FOR A SPECIFIED EF TORNADO RATING AND, IF APPLICABLE, TORNADO PROVEN TO A SPECIFIED EF TORNADO RATING.

FOR STORM SHELTERS.
FIRST USE 9-15-2010; IN COMMERCE 9-15-2010.
MARLENE BELL, EXAMINING ATTORNEY

SN 85-141,143. AMERICAN HOME FURNISHINGS ALLIANCE, INC., HIGH POINT, NC. FILED 9-29-2010.

SN 85-152,534. AMERICAN HUMANICS, INC., KANSAS CITY, MO. FILED 10-14-2010.



CNP

NO CLAIM IS MADE TO THE EXCLUSIVE RIGHT TO USE "SAFETY, HEALTH AND ENVIRONMENTAL PROGRAM", APART FROM THE MARK AS SHOWN.

THE MARK CONSISTS OF THE WORD "ECOHOME" WITH THE NUMBER "3" INSIDE THE FIRST "O" IN "ECOHOME" ON TOP OF THE WORDS "AHFA'S SAFETY, HEALTH AND ENVIRONMENTAL PROGRAM".

THE CERTIFICATION MARK, AS INTENDED TO BE USED BY AUTHORIZED PERSONS, IS INTENDED TO CERTIFY THAT THE GOODS MANUFACTURED UNDER THE CERTIFICATION MARK MEET THE ENVIRONMENTAL STANDARDS SET OUT BY THE CERTIFIER AND THAT THE GOODS ARE OFFERED BY A MEMBER IN GOOD STANDING OF THE CERTIFIER, WHICH MEMBER HAS ADHERED TO THE REGULATIONS AND ENVIRONMENTAL STANDARDS ESTABLISHED BY THE CERTIFIER, AND WHICH MEMBER UNDERTAKES TO RESPECT THE NORMS AND DIRECTIVES DEFINED BY THE CERTIFIER WITH RESPECT TO THE GOODS OFFERED FOR SALE UNDER THE CERTIFICATION MARK.

FOR FURNITURE .
WILLIAM P. SHANAHAN, EXAMINING ATTORNEY

THE MARK CONSISTS OF STANDARD CHARACTERS WITHOUT CLAIM TO ANY PARTICULAR FONT, STYLE, SIZE, OR COLOR.

THE CERTIFICATION MARK, AS USED OR INTENDED TO BE USED BY PERSONS AUTHORIZED BY THE CERTIFIER, CERTIFIES THAT THE SERVICES PROVIDED ARE PERFORMED BY A PROFESSIONAL THAT HAS ACHIEVED TRAINING AND EXPERIENCE IN THE FIELD OF NON-PROFIT ORGANIZATION, MANAGEMENT, TRAINING AND LEADERSHIP.

FOR PROFESSIONAL NON-PROFIT BUSINESS MANAGEMENT SERVICES, BUSINESS ADVICE REGARDING NON-PROFIT ORGANIZATIONS, AND BUSINESS LEADERSHIP TRAINING IN THE FIELD OF NON-PROFIT ORGANIZATIONS.

LOURDES AYALA, EXAMINING ATTORNEY

SN 85-307,225. DEMILEC (USA) LLC, ARLINGTON, TX. FILED 4-28-2011.

CLASS B—SERVICES

SN 77-743,650. AMERICAN LEAGUE OF FUNCTIONAL THERAPISTS, LLC, AKA ALOFT, STRATFORD, CT. FILED 5-23-2009.

**Registered Functional
Therapy Associate RFTA**

THE MARK CONSISTS OF STANDARD CHARACTERS WITHOUT CLAIM TO ANY PARTICULAR FONT, STYLE, SIZE, OR COLOR.

NO CLAIM IS MADE TO THE EXCLUSIVE RIGHT TO USE "REGISTERED FUNCTIONAL THERAPY ASSOCIATE", APART FROM THE MARK AS SHOWN.

THE CERTIFICATION MARK, AS USED BY PERSONS AUTHORIZED BY THE CERTIFIER, CERTIFIES OR IS INTENDED TO CERTIFY THAT THE PERSON DISPLAYING THE MARK HAS MET THE CERTIFICATION QUALIFICATIONS AND REQUIREMENTS ESTABLISHED BY THE CERTIFIER, INCLUDING EDUCATION AND COURSE WORK REQUIREMENTS AND WORK EXPERIENCE, AND HAS AGREED TO ADHERE TO THE CERTIFIER'S STANDARDS FOR PROFESSIONAL RESPONSIBILITY, CONTINUING EDUCATION, AND OTHER POST-CERTIFICATION REQUIREMENTS.

FOR OCCUPATIONAL THERAPY SERVICES.
RONALD AIKENS, EXAMINING ATTORNEY



NO CLAIM IS MADE TO THE EXCLUSIVE RIGHT TO USE "ENERGY EFFICIENT RETROFIT", APART FROM THE MARK AS SHOWN.

THE COLOR(S) GREEN, WHITE AND BLACK IS/ARE CLAIMED AS A FEATURE OF THE MARK.

THE MARK CONSISTS OF THE OUTLINE OF A BUILDING IN BLACK WITH THE LETTERS "EER" IN GREEN INSIDE THE BUILDING. THAT IMAGE IS SURROUNDED BY A CIRCLE IN GREEN WITH THE WORDS "ENERGY EFFICIENT RETROFIT" WRITTEN IN WHITE.

THE CERTIFICATION MARK, AS INTENDED TO BE USED BY AUTHORIZED PERSONS, IS INTENDED TO CERTIFY THAT THEY HAVE RECEIVED THE TRAINING AND HAVE MET THE STANDARDS SET BY THE CERTIFIER IN THE INSTALLATION OF FOAM INSULATION.

FOR INSTALLATION OF FOAM INSULATION.
ALEXANDER L. POWERS, EXAMINING ATTORNEY

* * * * *

TRADEMARK REGISTRATIONS ISSUED

PRINCIPAL REGISTER

SECTION 1.— INTERNATIONAL CLASSIFICATION

The short titles associated below with the international class numbers are terms designed merely for quick identification and are not an official part of the international classification. The full names of international classes are given in section 6.1 of the trademark rules of practice.

The designation "U.S. Cl." appearing in this section refers to the U.S. class in effect prior to Sep. 1, 1973 rather than the international class which applies to applications filed on or after that date. For adoption of international classification see notice in the OFFICIAL GAZETTE of Jun. 26, 1973 (911 O.G. TM 210).

CLASS 1—CHEMICALS

- 3,995,526. **ELASTO SEAL (STANDARD CHARACTER)**. ILLINOIS TOOL WORKS INC., (U.S. CLS. 1, 5, 6, 10, 26 AND 46). SN 77-432,596. PUB. 10-14-2008. FILED 3-26-2008.
- 3,995,594. **SYNTOPIX (STANDARD CHARACTER)**. SYNTOPIX GROUP PLC, MULTIPLE CLASS, (INT. CLS. 1, 3, 5, 42 AND 44), (U.S. CLS. 1, 4, 5, 6, 10, 18, 26, 44, 46, 50, 51, 52, 100 AND 101). SN 77-790,591. PUB. 5-3-2011. FILED 7-27-2009.
- 3,995,655. **HEALTHYSOIL (STANDARD CHARACTER)**. WESTERN APPLIED TECHNOLOGIES INC., (U.S. CLS. 1, 5, 6, 10, 26 AND 46). SN 77-887,528. PUB. 5-3-2011. FILED 12-7-2009.
- 3,995,677. **BAYMEDIX (STANDARD CHARACTER)**. BAYER AKTIENGESELLSCHAFT, MULTIPLE CLASS, (INT. CLS. 1, 2, 5 AND 17), (U.S. CLS. 1, 5, 6, 10, 11, 12, 13, 16, 18, 26, 35, 44, 46, 50, 51 AND 52). SN 77-919,678. PUB. 5-3-2011. FILED 1-25-2010.
- 3,995,683. **BOROBOND (STANDARD CHARACTER)**. CERADYNE, INC., (U.S. CLS. 1, 5, 6, 10, 26 AND 46). SN 77-931,548. PUB. 5-3-2011. FILED 2-9-2010.
- 3,995,756. **INOBAKE (STANDARD CHARACTER)**. ASHLAND-SÜDCHEMIE-KERNFEST GMBH, (U.S. CLS. 1, 5, 6, 10, 26 AND 46). SN 79-077,427. PUB. 5-3-2011. FILED 11-2-2009.
- 3,995,784. **CRISTASTONE (STANDARD CHARACTER)**. SCHOCK GMBH, MULTIPLE CLASS, (INT. CLS. 1, 11, 19, 20 AND 27), (U.S. CLS. 1, 2, 5, 6, 10, 12, 13, 19, 20, 21, 22, 23, 25, 26, 31, 32, 33, 34, 37, 42, 46 AND 50). SN 79-081,855. PUB. 5-3-2011. FILED 2-22-2010.
- 3,995,816. **TENCEL (STANDARD CHARACTER)**. LENZING AKTIENGESELLSCHAFT, MULTIPLE CLASS, (INT. CLS. 1, 3, 5, 16, 17, 22, 24, 25, 27 AND 42), (U.S. CLS. 1, 2, 4, 5, 6, 7, 10, 12, 13, 18, 19, 20, 22, 23, 26, 29, 35, 37, 38, 39, 42, 44, 46, 50, 51, 52, 100 AND 101). SN 79-083,651. PUB. 5-3-2011. FILED 10-27-2009.
- 3,995,817. **PAPCAL (STANDARD CHARACTER)**. AFFIVAL, MULTIPLE CLASS, (INT. CLS. 1 AND 6), (U.S. CLS. 1, 2, 5, 6, 10, 12, 13, 14, 23, 25, 26, 46 AND 50). SN 79-083,715. PUB. 5-3-2011. FILED 5-4-2010.
- 3,995,842. **S SANASWEET AND DESIGN**. SANASWEET GMBH, MULTIPLE CLASS, (INT. CLS. 1, 5, 30, 31 AND 35), (U.S. CLS. 1, 5, 6, 10, 18, 26, 44, 46, 51, 52, 100, 101 AND 102). SN 79-084,543. PUB. 5-3-2011. FILED 6-14-2010.
- 3,995,869. **SYLKOLIDE (STANDARD CHARACTER)**. GIVAUDAN S.A., MULTIPLE CLASS, (INT. CLS. 1 AND 3), (U.S. CLS. 1, 4, 5, 6, 10, 26, 46, 50, 51 AND 52). SN 79-085,376. PUB. 5-3-2011. FILED 7-2-2010.
- 3,995,883. **DAXUR (STANDARD CHARACTER)**. BASF SE, MULTIPLE CLASS, (INT. CLS. 1 AND 5), (U.S. CLS. 1, 5, 6, 10, 18, 26, 44, 46, 51 AND 52). SN 79-085,726. PUB. 5-3-2011. FILED 6-10-2010.
- 3,995,890. **ECONYL AND DESIGN**. AQUAFIL S.P.A., MULTIPLE CLASS, (INT. CLS. 1, 17, 22 AND 23), (U.S. CLS. 1, 2, 5, 6, 7, 10, 12, 13, 19, 22, 26, 35, 42, 43, 46 AND 50). SN 79-085,951. PUB. 5-3-2011. FILED 6-9-2010.
- 3,995,904. **SILFAB (STANDARD CHARACTER)**. SILFAB S.P.A., MULTIPLE CLASS, (INT. CLS. 1, 7, 9, 37, 40 AND 42), (U.S. CLS. 1, 5, 6, 10, 13, 19, 21, 23, 26, 31, 34, 35, 36, 38, 46, 100, 101, 103 AND 106). SN 79-086,331. PUB. 5-3-2011. FILED 4-19-2010.
- 3,995,946. **FUCOGEL (STANDARD CHARACTER)**. SOCIETE LA BIOCHIMIE APPLIQUEE (SO.LA.BI.A), (U.S. CLS. 1, 5, 6, 10, 26 AND 46). SN 79-088,569. PUB. 5-3-2011. FILED 9-22-2010.
- 3,995,947. **GLYCOLIFT (STANDARD CHARACTER)**. SOCIETE LA BIOCHIMIE APPLIQUEE (SO.LA.BI.A), (U.S. CLS. 1, 5, 6, 10, 26 AND 46). SN 79-088,588. PUB. 5-3-2011. FILED 9-22-2010.
- 3,995,957. **AVITERA (STANDARD CHARACTER)**. HUNTSMAN ADVANCED MATERIALS (SWITZERLAND) GMBH, MULTIPLE CLASS, (INT. CLS. 1 AND 2), (U.S. CLS. 1, 5, 6, 10, 11, 16, 26 AND 46). SN 79-089,220. PUB. 1-25-2011. FILED 7-27-2010.
- 3,995,979. **CARBOBYK (STANDARD CHARACTER)**. BYK-CHEMIE GMBH, MULTIPLE CLASS, (INT. CLS. 1, 2, 9, 17, 19 AND 40), (U.S. CLS. 1, 5, 6, 10, 11, 12, 13, 16, 21, 23, 26, 33, 35, 36, 38, 46, 50, 100, 103 AND 106). SN 79-090,770. PUB. 5-3-2011. FILED 9-7-2010.
- 3,995,985. **VEROWIND (STANDARD CHARACTER)**. DANIELA VERONICA GUSA DE DRAGAN, MULTIPLE CLASS, (INT. CLS. 1, 4, 6, 11 AND 21), (U.S. CLS. 1, 2, 5, 6, 10, 12, 13, 14, 15, 21, 23, 25, 26, 29, 30, 31, 33, 34, 40, 46 AND 50). SN 79-091,165. PUB. 5-3-2011. FILED 8-2-2010.
- 3,995,986. **VEROWIND AND DESIGN**. DANIELA VERONICA GUSA DE DRAGAN, MULTIPLE CLASS, (INT. CLS. 1, 4, 6, 11 AND 21), (U.S. CLS. 1, 2, 5, 6, 10, 12, 13, 14, 15, 21, 23, 25, 26, 29, 30, 31, 33, 34, 40, 46 AND 50). SN 79-091,166. PUB. 5-3-2011. FILED 8-2-2010.
- 3,995,987. **VEROGAS (STANDARD CHARACTER)**. DANIELA VERONICA GUSA DE DRAGAN, MULTIPLE CLASS, (INT. CLS. 1, 4, 6, 11 AND 21), (U.S. CLS. 1, 2, 5, 6, 10, 12, 13, 14, 15, 21, 23, 25, 26, 29, 30, 31, 33, 34, 40, 46 AND 50). SN 79-091,167. PUB. 5-3-2011. FILED 8-2-2010.
- 3,996,099. **RENOVO (STANDARD CHARACTER)**. ENVIRONMENTAL MANUFACTURING SOLUTIONS, LLC, (U.S. CLS. 1, 5, 6, 10, 26 AND 46). SN 85-030,525. PUB. 5-3-2011. FILED 5-5-2010.
- 3,996,172. **P AND DESIGN**. TPC GROUP LLC, MULTIPLE CLASS, (INT. CLS. 1 AND 40), (U.S. CLS. 1, 5, 6, 10, 26, 46, 100, 103 AND 106). SN 85-042,245. PUB. 5-3-2011. FILED 5-19-2010.
- 3,996,192. **MIDWEST (STANDARD CHARACTER)**. MIDWEST INDUSTRIAL SUPPLY, INC., MULTIPLE CLASS, (INT. CLS. 1, 3, 4, 7, 9, 17, 19 AND 37), (U.S. CLS. 1, 4, 5, 6, 10, 12, 13, 15, 19, 21, 23, 26, 31, 33, 34, 35, 36, 38, 46, 50, 51, 52, 100, 103 AND 106). SN 85-045,049. PUB. 5-3-2011. FILED 5-21-2010.
- 3,996,202. **WELL FLOW (STANDARD CHARACTER)**. WELL FLOW INTERNATIONAL, W.L.L., MULTIPLE CLASS, (INT. CLS. 1, 7 AND 37), (U.S. CLS. 1, 5, 6, 10, 13, 19, 21, 23, 26, 31, 34, 35, 46, 100, 103 AND 106). SN 85-046,011. PUB. 5-3-2011. FILED 5-24-2010.
- 3,996,208. **MARPRO (STANDARD CHARACTER)**. DONOVAN MARINE, INC., MULTIPLE CLASS, (INT. CLS. 1, 2, 3, 4, 20 AND 24), (U.S. CLS. 1, 2, 4, 5, 6, 10, 11, 13, 15, 16, 22, 25, 26, 32, 42, 46, 50, 51 AND 52). SN 85-046,215. PUB. 5-3-2011. FILED 5-24-2010.
- 3,996,313. **EFFECTIOSE (STANDARD CHARACTER)**. PIERRE FABRE DERMO-COSMETIQUE, MULTIPLE CLASS, (INT. CLS. 1, 3 AND 5), (U.S. CLS. 1, 4, 5, 6, 10, 18, 26, 44, 46, 50, 51

- AND 52). SN 85-064,227. PUB. 5-3-2011. FILED 6-16-2010.
- 3,996,371. **CLASSIX (STYLIZED)**. PROPPER MANUFACTURING COMPANY, INC., MULTIPLE CLASS, (INT. CLS. 1 AND 10), (U.S. CLS. 1, 5, 6, 10, 26, 39, 44 AND 46). SN 85-076,177. PUB. 11-30-2010. FILED 7-1-2010.
- 3,996,436. **HOECHST (STANDARD CHARACTER)**. HOECHST GMBH, MULTIPLE CLASS, (INT. CLS. 1 AND 5), (U.S. CLS. 1, 5, 6, 10, 18, 26, 44, 46, 51 AND 52). SN 85-094,773. PUB. 5-3-2011. FILED 7-28-2010.
- 3,996,469. **SODASTREAM AND DESIGN**. SODA-CLUB (CO2) ATLANTIC GMBH, MULTIPLE CLASS, (INT. CLS. 1, 6, 7, 21 AND 32), (U.S. CLS. 1, 2, 5, 6, 10, 12, 13, 14, 19, 21, 23, 25, 26, 29, 30, 31, 33, 34, 35, 40, 45, 46, 48 AND 50). SN 85-107,997. PUB. 5-3-2011. FILED 8-16-2010.
- 3,996,695. **CLAVIS-5 (STANDARD CHARACTER)**. GREENLINE "THE SOIL COMPANY" GMBH, (U.S. CLS. 1, 5, 6, 10, 26 AND 46). SN 85-164,677. PUB. 5-3-2011. FILED 10-29-2010.
- 3,996,712. **JUST ADD HORSES AND DESIGN**. ALEX MILNE ASSOCIATES LTD., (U.S. CLS. 1, 5, 6, 10, 26 AND 46). SN 85-168,128. PUB. 5-3-2011. FILED 11-3-2010.
- 3,996,813. **KWIK-STIK (STANDARD CHARACTER)**. MICROBIOLOGICS, INC., (U.S. CLS. 1, 5, 6, 10, 26 AND 46). SN 85-176,756. PUB. 5-3-2011. FILED 11-15-2010.
- 3,996,875. **TAQMELT (STANDARD CHARACTER)**. ROCHE DIAGNOSTICS GMBH, MULTIPLE CLASS, (INT. CLS. 1 AND 5), (U.S. CLS. 1, 5, 6, 10, 18, 26, 44, 46, 51 AND 52). SN 85-179,995. PUB. 5-3-2011. FILED 11-18-2010.
- 3,996,900. **MPR M P R AND DESIGN**. BARISH, LONNIE MERRITT, (U.S. CLS. 1, 5, 6, 10, 26 AND 46). SN 85-181,811. PUB. 5-3-2011. FILED 11-20-2010.
- 3,997,089. **TRIANGLE BRAND AND DESIGN**. FREEPORT-MCMORAN COPPER & GOLD INC., (U.S. CLS. 1, 5, 6, 10, 26 AND 46). SN 85-188,651. PUB. 5-3-2011. FILED 12-1-2010.
- 3,997,235. **DR. WILLARD'S AND DESIGN**. CAW INDUSTRIES, INC., (U.S. CLS. 1, 5, 6, 10, 26 AND 46). SN 85-192,181. PUB. 5-3-2011. FILED 12-7-2010.
- 3,997,273. **A NATURAL SYSTEMS APPROACH (STANDARD CHARACTER)**. LEBANON SEABOARD CORPORATION, (U.S. CLS. 1, 5, 6, 10, 26 AND 46). SN 85-193,207. PUB. 5-3-2011. FILED 12-8-2010.
- 3,997,289. **REALITE (STANDARD CHARACTER)**. PROP SUPPLY & SERVICE, LLC, AKA RAINBOW CERAMICS, (U.S. CLS. 1, 5, 6, 10, 26 AND 46). SN 85-193,881. PUB. 5-3-2011. FILED 12-9-2010.
- 3,997,362. **SOYSHIELD (STANDARD CHARACTER)**. SCHAEFFER MFG. CO., (U.S. CLS. 1, 5, 6, 10, 26 AND 46). SN 85-197,483. PUB. 5-3-2011. FILED 12-14-2010.
- 3,997,487. **FIBERLOCK (STANDARD CHARACTER)**. CRC INDUSTRIES, INC., (U.S. CLS. 1, 5, 6, 10, 26 AND 46). SN 85-202,833. PUB. 5-3-2011. FILED 12-21-2010.
- 3,997,703. **1 50 IN ONE (STYLIZED)**. JOHN A. THOMSON FOR THOMSON FAMILY PARTNERSHIP, DBA VITAMIN INSTITUTE, (U.S. CLS. 1, 5, 6, 10, 26 AND 46). SN 85-206,611. PUB. 5-3-2011. FILED 12-28-2010.
- 3,997,715. **SUMAGROW AND DESIGN**. BIO SOIL ENHANCERS, INC., (U.S. CLS. 1, 5, 6, 10, 26 AND 46). SN 85-206,815. PUB. 5-3-2011. FILED 12-28-2010.
- 3,997,958. **EXILIS PLUS (STANDARD CHARACTER)**. FINE AGROCHEMICALS LIMITED, (U.S. CLS. 1, 5, 6, 10, 26 AND 46). SN 85-209,856. PUB. 5-3-2011. FILED 1-4-2011.
- 3,998,131. **SPRAY 'N STICK AND DESIGN**. STONEXPRESS, INC., (U.S. CLS. 1, 5, 6, 10, 26 AND 46). SN 85-212,664. PUB. 5-3-2011. FILED 1-7-2011.
- 3,998,237. **TELDENE AND DESIGN**. NATIONAL PETROCHEMICAL INDUSTRIAL COMPANY, (U.S. CLS. 1, 5, 6, 10, 26 AND 46). SN 85-231,370. PUB. 5-3-2011. FILED 2-1-2011.
- 3,998,257. **ACROBAT (STANDARD CHARACTER)**. SMOOTHON, INC., (U.S. CLS. 1, 5, 6, 10, 26 AND 46). SN 85-238,863. PUB. 5-3-2011. FILED 2-10-2011.
- 101). SN 77-882,649. PUB. 5-3-2011. FILED 11-30-2009.
- 3,995,648. **TRUCO INC. (STYLIZED)**. TRUCO, INC., MULTIPLE CLASS, (INT. CLS. 2 AND 37), (U.S. CLS. 6, 11, 16, 100, 103 AND 106). SN 77-883,325. PUB. 5-3-2011. FILED 12-1-2009.
- 3,995,677 (*See Class 1 for this trademark*).
- 3,995,863. **GOLD TO GO AND DESIGN**. INFOS GMBH INVESTMENT FONDS SELECTION, MULTIPLE CLASS, (INT. CLS. 2, 9, 14, 36 AND 40), (U.S. CLS. 2, 6, 11, 16, 21, 23, 26, 27, 28, 36, 38, 50, 100, 101, 102, 103 AND 106). SN 79-085,240. PUB. 5-3-2011. FILED 4-27-2010.
- 3,995,884. **IGLOSS (STANDARD CHARACTER)**. BASF COATINGS GMBH, (U.S. CLS. 6, 11 AND 16). SN 79-085,737. PUB. 5-3-2011. FILED 4-27-2010.
- 3,995,912. **HYDREX AND DESIGN**. BOUD VAN ROMPAY, MULTIPLE CLASS, (INT. CLS. 2, 37 AND 40), (U.S. CLS. 6, 11, 16, 100, 103 AND 106). SN 79-086,665. PUB. 5-3-2011. FILED 8-19-2010.
- 3,995,957 (*See Class 1 for this trademark*).
- 3,995,979 (*See Class 1 for this trademark*).
- 3,996,046. **HI-TEMP 1027 (STANDARD CHARACTER)**. HI-TEMP COATINGS TECHNOLOGY COMPANY, INC., (U.S. CLS. 6, 11 AND 16). SN 85-010,538. PUB. 5-3-2011. FILED 4-9-2010.
- 3,996,047. **HI-TEMP 707 (STANDARD CHARACTER)**. HI-TEMP COATINGS TECHNOLOGY COMPANY, INC., (U.S. CLS. 6, 11 AND 16). SN 85-010,547. PUB. 5-3-2011. FILED 4-9-2010.
- 3,996,193. **RHINO ECO-COAT (STANDARD CHARACTER)**. RHINO LININGS CORPORATION, (U.S. CLS. 6, 11 AND 16). SN 85-045,077. PUB. 5-3-2011. FILED 5-21-2010.
- 3,996,208 (*See Class 1 for this trademark*).
- 3,997,344. **EVERGREEN (STANDARD CHARACTER)**. TURBON INTERNATIONAL INC., (U.S. CLS. 6, 11 AND 16). SN 85-196,596. PUB. 5-3-2011. FILED 12-13-2010.
- 3,997,347. **EVERGREEN AND DESIGN**. TURBON INTERNATIONAL INC., (U.S. CLS. 6, 11 AND 16). SN 85-196,611. PUB. 5-3-2011. FILED 12-13-2010.
- 3,997,376. **ULTRABRITE (STANDARD CHARACTER)**. TITAN COATINGS, INC., (U.S. CLS. 6, 11 AND 16). SN 85-198,172. PUB. 5-3-2011. FILED 12-15-2010.
- 3,997,379. **HONTEK (STANDARD CHARACTER)**. HONTEK CORPORATION, (U.S. CLS. 6, 11 AND 16). SN 85-198,512. PUB. 5-3-2011. FILED 12-15-2010.
- 3,998,190. **PREMIUM PLUS ULTRA (STANDARD CHARACTER)**. BEHR PROCESS CORPORATION, (U.S. CLS. 6, 11 AND 16). SN 85-214,609. PUB. 5-3-2011. FILED 1-11-2011.

CLASS 3—COSMETICS AND CLEANING PREPARATIONS

CLASS 2—PAINTS

- 3,995,523. **OMNILUX NEW-U AND DESIGN**. PHOTO THERAPEUTICS LIMITED, MULTIPLE CLASS, (INT. CLS. 3 AND 10), (U.S. CLS. 1, 4, 6, 26, 39, 44, 50, 51 AND 52). SN 77-328,109. PUB. 1-25-2011. FILED 11-13-2007.
- 3,995,536. **C.BOOTH (STANDARD CHARACTER)**. DELICIOUS BRANDS LLC, (U.S. CLS. 1, 4, 6, 50, 51 AND 52). SN 77-538,006. PUB. 5-3-2011. FILED 8-4-2008.
- 3,995,557. **NICOBLOC (STANDARD CHARACTER)**. HAYES, GERARD, AND HAYMES, ALAN, MULTIPLE CLASS, (INT. CLS. 3, 5 AND 10), (U.S. CLS. 1, 4, 6, 18, 26, 39, 44, 46, 50, 51 AND 52). SN 77-636,167. PUB. 11-2-2010. FILED 12-18-2008.
- 3,995,594 (*See Class 1 for this trademark*).
- 3,995,719. **SAFARILAND (STANDARD CHARACTER)**. SAFARILAND, LLC, MULTIPLE CLASS, (INT. CLS. 3, 4, 6, 8, 9, 13, 18, 20 AND 25), (U.S. CLS. 1, 2, 3, 4, 6, 9, 12, 13, 14, 15, 21, 22, 23, 25, 26, 28, 32, 36, 38, 39, 41, 44, 50, 51 AND 52). SN 77-981,553. PUB. 5-3-2011. FILED 1-13-2009.
- 3,995,723. **MISCELLANEOUS DESIGN**. RECKITT & COLMAN (OVERSEAS) LIMITED, MULTIPLE CLASS, (INT. CLS. 3 AND 5), (U.S. CLS. 1, 4, 6, 18, 44, 46, 50, 51 AND 52). SN 78-887,017. PUB. 5-3-2011. FILED 5-18-2006.
- 3,995,726. **TREES FOR CHANGE (STANDARD CHARACTER)**. RECKITT BENCKISER S.A.R.L., (U.S. CLS. 1, 4, 6, 50, 51 AND 52). SN 78-981,430. PUB. 5-3-2011. FILED 6-5-2006.
- 3,995,647. **IXBEAM (STANDARD CHARACTER)**. U-NICA INTERNATIONAL AG, MULTIPLE CLASS, (INT. CLS. 2, 9 AND 42), (U.S. CLS. 6, 11, 16, 21, 23, 26, 36, 38, 100 AND

- 3,995,737. **VALEO (STANDARD CHARACTER)**. L'ESTÉTIC GMBH, MULTIPLE CLASS, (INT. CLS. 3 AND 5), (U.S. CLS. 1, 4, 6, 18, 44, 46, 50, 51 AND 52). SN 79-066,459. PUB. 8-24-2010. FILED 1-9-2009.
- 3,995,759. **MARKS & SPENCER INDIGO COLLECTION (STANDARD CHARACTER)**. MARKS AND SPENCER PLC, MULTIPLE CLASS, (INT. CLS. 3, 14, 18 AND 25), (U.S. CLS. 1, 2, 3, 4, 6, 22, 27, 28, 39, 41, 50, 51 AND 52). SN 79-077,650. PUB. 5-3-2011. FILED 12-18-2009.
- 3,995,769. **TAUER (STANDARD CHARACTER)**. ANDREAS TAUER, (U.S. CLS. 1, 4, 6, 50, 51 AND 52). SN 79-078,719. PUB. 5-3-2011. FILED 11-30-2009.
- 3,995,789. **LEIF (STANDARD CHARACTER)**. CONTAINER PTY LTD, (U.S. CLS. 1, 4, 6, 50, 51 AND 52). SN 79-082,542. PUB. 5-3-2011. FILED 4-16-2010.
- 3,995,790. **OLIFE (STANDARD CHARACTER)**. PIGEON CORPORATION, (U.S. CLS. 1, 4, 6, 50, 51 AND 52). SN 79-082,595. PUB. 5-3-2011. FILED 4-13-2010.
- 3,995,814. **GENOLIER LABORATOIRES AND DESIGN**. GSMN VAUD SA, MULTIPLE CLASS, (INT. CLS. 3, 5 AND 44), (U.S. CLS. 1, 4, 6, 18, 44, 46, 50, 51, 52, 100 AND 101). SN 79-083,614. PUB. 5-3-2011. FILED 5-4-2010.
- 3,995,816 (*See Class 1 for this trademark*).
- 3,995,824. **COLOGNE ROYALE CHRISTIAN DIOR PARIS AND DESIGN**. PARFUMS CHRISTIAN DIOR, (U.S. CLS. 1, 4, 6, 50, 51 AND 52). SN 79-084,151. PUB. 5-3-2011. FILED 6-4-2010.
- 3,995,848. **PH PERFUME HOLDING (STYLIZED)**. MORRIS PROFUMI S.P.A., (U.S. CLS. 1, 4, 6, 50, 51 AND 52). SN 79-084,830. PUB. 5-3-2011. FILED 6-4-2010.
- 3,995,861. **SET AND DESIGN**. ENSWICO IP AG, MULTIPLE CLASS, (INT. CLS. 3 AND 11), (U.S. CLS. 1, 4, 6, 13, 21, 23, 31, 34, 50, 51 AND 52). SN 79-085,229. PUB. 5-3-2011. FILED 5-19-2010.
- 3,995,869 (*See Class 1 for this trademark*).
- 3,995,871. **LABORATOIRES YVES PONROY (STANDARD CHARACTER)**. INSTITUT DE RECHERCHE BIOLOGIQUE, MULTIPLE CLASS, (INT. CLS. 3 AND 5), (U.S. CLS. 1, 4, 6, 18, 44, 46, 50, 51 AND 52). SN 79-085,403. PUB. 5-3-2011. FILED 6-14-2010.
- 3,995,872. **BIOTIFUL (STYLIZED)**. L'OREAL, (U.S. CLS. 1, 4, 6, 50, 51 AND 52). SN 79-085,421. PUB. 5-3-2011. FILED 4-2-2010.
- 3,995,887. **DREUMEX (STYLIZED)**. DREUMEX B.V., (U.S. CLS. 1, 4, 6, 50, 51 AND 52). SN 79-085,823. PUB. 5-3-2011. FILED 6-2-2010.
- 3,995,911. **ENZYMPRO (STANDARD CHARACTER)**. ENZYMPRO AG, MULTIPLE CLASS, (INT. CLS. 3, 5, 29, 30 AND 44), (U.S. CLS. 1, 4, 6, 18, 44, 46, 50, 51, 52, 100 AND 101). SN 79-086,641. PUB. 5-3-2011. FILED 7-7-2010.
- 3,995,915. **ROADSTER (STANDARD CHARACTER)**. DR. ING. H.C. F. PORSCHE AKTIENGESELLSCHAFT, MULTIPLE CLASS, (INT. CLS. 3, 25 AND 28), (U.S. CLS. 1, 4, 6, 22, 23, 38, 39, 50, 51 AND 52). SN 79-086,792. PUB. 5-3-2011. FILED 6-30-2010.
- 3,995,939. **RYE ACTIVE AND DESIGN**. WORESAN GMBH, MULTIPLE CLASS, (INT. CLS. 3, 5 AND 30), (U.S. CLS. 1, 4, 6, 18, 44, 46, 50, 51 AND 52). SN 79-088,252. PUB. 3-8-2011. FILED 7-19-2010.
- 3,995,953. **TERRACUORE (STYLIZED)**. IDEA INTERNATIONAL CO., LTD., (U.S. CLS. 1, 4, 6, 50, 51 AND 52). SN 79-089,020. PUB. 5-3-2011. FILED 8-3-2010.
- 3,995,975. **FATAL BEAUTY AND DESIGN**. CGBS INTERNATIONAL S.A., (U.S. CLS. 1, 4, 6, 50, 51 AND 52). SN 79-090,558. PUB. 5-3-2011. FILED 9-22-2010.
- 3,996,007. **TOPX (STANDARD CHARACTER)**. BANDO CHEMICAL INDUSTRIES, LTD., (U.S. CLS. 1, 4, 6, 50, 51 AND 52). SN 79-092,861. PUB. 5-3-2011. FILED 12-27-2010.
- 3,996,036. **DR BECKER SKINCARE (STANDARD CHARACTER)**. COSMETIC SOLUTIONS, INC, (U.S. CLS. 1, 4, 6, 50, 51 AND 52). SN 85-001,849. PUB. 5-3-2011. FILED 3-30-2010.
- 3,996,040. **DAZZLING JENNY NEW YORK AND DESIGN**. TOM PEI-YEN DREW, (U.S. CLS. 1, 4, 6, 50, 51 AND 52). SN 85-005,618. PUB. 5-3-2011. FILED 4-3-2010.
- 3,996,043. **EYEKO (STANDARD CHARACTER)**. MAKE MONEY LIMITED, (U.S. CLS. 1, 4, 6, 50, 51 AND 52). SN 85-008,004. PUB. 5-3-2011. FILED 4-7-2010.
- 3,996,076. **K KARISMATIC (STANDARD CHARACTER)**. KARISMATIC, INC., AKA KARISMATIC MAKEUP, (U.S. CLS. 1, 4, 6, 50, 51 AND 52). SN 85-022,843. PUB. 5-3-2011. FILED 4-26-2010.
- 3,996,094. **PROSELECT (STANDARD CHARACTER)**. FERGUSON ENTERPRISES, INC., (U.S. CLS. 1, 4, 6, 50, 51 AND 52). SN 85-029,379. PUB. 5-3-2011. FILED 5-4-2010.
- 3,996,125. **NYOU (STYLIZED)**. CELEBRITIES & NETWORKING LTD., MULTIPLE CLASS, (INT. CLS. 3 AND 5), (U.S. CLS. 1, 4, 6, 18, 44, 46, 50, 51 AND 52). SN 85-035,482. PUB. 10-12-2010. FILED 5-11-2010.
- 3,996,144. **KARMISSIE (STANDARD CHARACTER)**. KARMISSIE, LLC, MULTIPLE CLASS, (INT. CLS. 3, 5 AND 8), (U.S. CLS. 1, 4, 6, 18, 23, 28, 44, 46, 50, 51 AND 52). SN 85-038,361. PUB. 5-3-2011. FILED 5-13-2010.
- 3,996,149. **SUNSHINE FRESH (STANDARD CHARACTER)**. RECKITT BENCKISER LLC, MULTIPLE CLASS, (INT. CLS. 3 AND 5), (U.S. CLS. 1, 4, 6, 18, 44, 46, 50, 51 AND 52). SN 85-039,042. PUB. 5-3-2011. FILED 5-14-2010.
- 3,996,163. **BROOKLYN ATTITUDE (STANDARD CHARACTER)**. GUERRIERO, GLENN, AND GUERRIERO, MARYANN, (U.S. CLS. 1, 4, 6, 50, 51 AND 52). SN 85-041,510. PUB. 5-3-2011. FILED 5-18-2010.
- 3,996,192 (*See Class 1 for this trademark*).
- 3,996,208 (*See Class 1 for this trademark*).
- 3,996,313 (*See Class 1 for this trademark*).
- 3,996,349. **OXYGÉNISTE (STANDARD CHARACTER)**. L'OREAL, (U.S. CLS. 1, 4, 6, 50, 51 AND 52). SN 85-071,410. PUB. 5-3-2011. FILED 6-25-2010.
- 3,996,354. **CHAMONIX (STANDARD CHARACTER)**. UNIMED INTERNATIONAL, INC., (U.S. CLS. 1, 4, 6, 50, 51 AND 52). SN 85-072,447. PUB. 5-3-2011. FILED 6-27-2010.
- 3,996,377. **CHROMA CARE (STANDARD CHARACTER)**. L'OREAL, (U.S. CLS. 1, 4, 6, 50, 51 AND 52). SN 85-079,339. PUB. 5-3-2011. FILED 7-7-2010.
- 3,996,406. **COLORCHANGE (STYLIZED)**. L'OREAL, (U.S. CLS. 1, 4, 6, 50, 51 AND 52). SN 85-088,415. PUB. 5-3-2011. FILED 7-20-2010.
- 3,996,457. **30 SECOND SMILE (STANDARD CHARACTER)**. HYDRABRUSH, INC., MULTIPLE CLASS, (INT. CLS. 3 AND 21), (U.S. CLS. 1, 2, 4, 6, 13, 23, 29, 30, 33, 40, 50, 51 AND 52). SN 85-103,613. PUB. 1-25-2011. FILED 8-9-2010.
- 3,996,488. **MISCELLANEOUS DESIGN**. DS LABORATORIES, INC., MULTIPLE CLASS, (INT. CLS. 3 AND 5), (U.S. CLS. 1, 4, 6, 18, 44, 46, 50, 51 AND 52). SN 85-116,125. PUB. 5-3-2011. FILED 8-26-2010.
- 3,996,505. **BEAUTIES FACTORY AND DESIGN**. JIM KAI YING, DBA Y2 INTERNATIONAL TRADING COMPANY, (U.S. CLS. 1, 4, 6, 50, 51 AND 52). SN 85-122,421. PUB. 5-3-2011. FILED 9-3-2010.
- 3,996,677. **MASSIMO FAUST (STANDARD CHARACTER)**. THE STEPHAN CO., (U.S. CLS. 1, 4, 6, 50, 51 AND 52). SN 85-161,341. PUB. 5-3-2011. FILED 10-26-2010.
- 3,996,693. **GREEN OPTIONS (STANDARD CHARACTER)**. CLINE, RODNEY, (U.S. CLS. 1, 4, 6, 50, 51 AND 52). SN 85-164,591. PUB. 5-3-2011. FILED 10-29-2010.
- 3,996,737. **SAMPSON'S REVENGE THE FOUNTAIN OF YOUTH FOR YOUR HAIR AND DESIGN**. SDY HAIR SOLUTIONS, LLC, (U.S. CLS. 1, 4, 6, 50, 51 AND 52). SN 85-170,918. PUB. 5-3-2011. FILED 11-6-2010.
- 3,996,738. **DELILAH'S REWARD THE FOUNTAIN OF YOUTH FOR YOUR HAIR AND DESIGN**. SDY HAIR SOLUTIONS, LLC, (U.S. CLS. 1, 4, 6, 50, 51 AND 52). SN 85-170,919. PUB. 5-3-2011. FILED 11-6-2010.
- 3,996,777. **STAY STRONG (STANDARD CHARACTER)**. TRUSKIN, INC., DBA B*TRU, INC., (U.S. CLS. 1, 4, 6, 50, 51 AND 52). SN 85-174,564. PUB. 3-29-2011. FILED 11-11-2010.
- 3,996,788. **RAWLEIGH (STANDARD CHARACTER)**. GOLDEN PRIDE, INC., MULTIPLE CLASS, (INT. CLS. 3, 5, 29 AND 30), (U.S. CLS. 1, 4, 6, 18, 44, 46, 50, 51 AND 52). SN 85-175,193. PUB. 5-3-2011. FILED 11-12-2010.
- 3,996,822. **WRINKLEFREE DHEA (STANDARD CHARACTER)**. WONG, MIRIAM M., (U.S. CLS. 1, 4, 6, 50, 51 AND 52). SN 85-177,310. PUB. 5-3-2011. FILED 11-15-2010.
- 3,996,848. **ERNO LASZLO (STANDARD CHARACTER)**. ERNO LASZLO, INC., (U.S. CLS. 1, 4, 6, 50, 51 AND 52). SN 85-178,873. PUB. 5-3-2011. FILED 11-17-2010.
- 3,996,890. **MAL'AK NATURAL (STANDARD CHARACTER)**. MAL'AK NATURAL, LLC, (U.S. CLS. 1, 4, 6, 50, 51 AND

- 52). SN 85-181,512. PUB. 5-3-2011. FILED 11-19-2010.
- 3,996,993. **SOPHISTICATED SYRUP (STANDARD CHARACTER)**. HABER, SANDRA L, (U.S. CLS. 1, 4, 6, 50, 51 AND 52). SN 85-186,463. PUB. 5-3-2011. FILED 11-29-2010.
- 3,997,069. **THERAPIST'S CHOICE (STANDARD CHARACTER)**. CLINICAL HEALTH SERVICES, INC., (U.S. CLS. 1, 4, 6, 50, 51 AND 52). SN 85-188,250. PUB. 5-3-2011. FILED 12-1-2010.
- 3,997,267. **GREEN GOO (STANDARD CHARACTER)**. SIERRA SAGE HERBS LLC, (U.S. CLS. 1, 4, 6, 50, 51 AND 52). SN 85-193,054. PUB. 5-3-2011. FILED 12-8-2010.
- 3,997,280. **BEAUTYGAMES (STANDARD CHARACTER)**. FACEGAMES, INC., (U.S. CLS. 1, 4, 6, 50, 51 AND 52). SN 85-193,485. PUB. 5-3-2011. FILED 12-8-2010.
- 3,997,303. **JOICO (STANDARD CHARACTER)**. ZOTOS INTERNATIONAL, INC., MULTIPLE CLASS, (INT. CLS. 3 AND 41), (U.S. CLS. 1, 4, 6, 50, 51, 52, 100, 101 AND 107). SN 85-194,392. PUB. 5-3-2011. FILED 12-9-2010.
- 3,997,314. **UN JARDIN SUR LE TOIT (STANDARD CHARACTER)**. COMPTOIR NOUVEAU DE LA PARFUMERIE, (U.S. CLS. 1, 4, 6, 50, 51 AND 52). SN 85-194,874. PUB. 5-3-2011. FILED 12-10-2010.
- 3,997,324. **LA'S TOTALLY AWESOME (STANDARD CHARACTER)**. AWESOME PRODUCTS, INC., (U.S. CLS. 1, 4, 6, 50, 51 AND 52). SN 85-195,101. PUB. 5-3-2011. FILED 12-10-2010.
- 3,997,338. **NANOVERA (STANDARD CHARACTER)**. MEDI-DERM LABORATORIES, LLC, (U.S. CLS. 1, 4, 6, 50, 51 AND 52). SN 85-195,888. PUB. 5-3-2011. FILED 12-11-2010.
- 3,997,421. **COVIDIEN (STANDARD CHARACTER)**. COVIDIEN AG, MULTIPLE CLASS, (INT. CLS. 3, 5, 9 AND 10), (U.S. CLS. 1, 4, 6, 18, 21, 23, 26, 36, 38, 39, 44, 46, 50, 51 AND 52). SN 85-200,339. PUB. 5-3-2011. FILED 12-17-2010.
- 3,997,432. **WEARABLE BACKING AND DESIGN**. THE BLACK AND DECKER CORPORATION, MULTIPLE CLASS, (INT. CLS. 3 AND 7), (U.S. CLS. 1, 4, 6, 13, 19, 21, 23, 31, 34, 35, 50, 51 AND 52). SN 85-200,756. PUB. 5-3-2011. FILED 12-17-2010.
- 3,997,472. **TSHOMBE AND DESIGN**. MIRIAM T. BELL, (U.S. CLS. 1, 4, 6, 50, 51 AND 52). SN 85-202,570. PUB. 5-3-2011. FILED 12-21-2010.
- 3,997,515. **HAIROBI (STANDARD CHARACTER)**. CHAPMAN PRODUCTS CO., INC., (U.S. CLS. 1, 4, 6, 50, 51 AND 52). SN 85-203,988. PUB. 5-3-2011. FILED 12-22-2010.
- 3,997,532. **PETITE MORT (STANDARD CHARACTER)**. MARC ATLAN DESIGN, INC., (U.S. CLS. 1, 4, 6, 50, 51 AND 52). SN 85-204,461. PUB. 5-3-2011. FILED 12-22-2010.
- 3,997,616. **MISCELLANEOUS DESIGN**. PURESTPETS, LLC, (U.S. CLS. 1, 4, 6, 50, 51 AND 52). SN 85-205,494. PUB. 5-3-2011. FILED 12-24-2010.
- 3,997,626. **BRIGHTAMIN-C (STANDARD CHARACTER)**. MYBODY, L.L.C., (U.S. CLS. 1, 4, 6, 50, 51 AND 52). SN 85-205,678. PUB. 5-3-2011. FILED 12-26-2010.
- 3,997,629. **CALM AFTER THE STORM (STANDARD CHARACTER)**. MYBODY, L.L.C., (U.S. CLS. 1, 4, 6, 50, 51 AND 52). SN 85-205,691. PUB. 5-3-2011. FILED 12-26-2010.
- 3,997,631. **BAAM (STANDARD CHARACTER)**. BEFORE AND AFTER CANDY, LLC, (U.S. CLS. 1, 4, 6, 50, 51 AND 52). SN 85-205,736. PUB. 5-3-2011. FILED 12-26-2010.
- 3,997,684. **YOUTH OVERNIGHT (STANDARD CHARACTER)**. MYBODY, L.L.C., (U.S. CLS. 1, 4, 6, 50, 51 AND 52). SN 85-206,424. PUB. 5-3-2011. FILED 12-28-2010.
- 3,997,692. **MYSUNPROTECTOR (STANDARD CHARACTER)**. MYBODY, L.L.C., (U.S. CLS. 1, 4, 6, 50, 51 AND 52). SN 85-206,462. PUB. 5-3-2011. FILED 12-28-2010.
- 3,997,693. **MYTREATMENT (STANDARD CHARACTER)**. MYBODY, L.L.C., MULTIPLE CLASS, (INT. CLS. 3 AND 5), (U.S. CLS. 1, 4, 6, 18, 44, 46, 50, 51 AND 52). SN 85-206,466. PUB. 5-3-2011. FILED 12-28-2010.
- 3,997,694. **MYHYDRATOR (STANDARD CHARACTER)**. MYBODY, L.L.C., (U.S. CLS. 1, 4, 6, 50, 51 AND 52). SN 85-206,468. PUB. 5-3-2011. FILED 12-28-2010.
- 3,997,696. **MYCLEANSER (STANDARD CHARACTER)**. MYBODY, L.L.C., (U.S. CLS. 1, 4, 6, 50, 51 AND 52). SN 85-206,484. PUB. 5-3-2011. FILED 12-28-2010.
- 3,997,697. **THE BLUEBEARDS REVENGE AND DESIGN**. BLUEBEARDS INC, DBA BLUEBEARDS ORIGINAL, (U.S. CLS. 1, 4, 6, 50, 51 AND 52). SN 85-206,499. PUB. 5-3-2011. FILED 12-28-2010.
- 3,997,706. **FROM NATURE WITH LOVE (STANDARD CHARACTER)**. NATURAL SOURCING, LLC, MULTIPLE CLASS, (INT. CLS. 3, 4 AND 21), (U.S. CLS. 1, 2, 4, 6, 13, 15, 23, 29, 30, 33, 40, 50, 51 AND 52). SN 85-206,666. PUB. 5-3-2011. FILED 12-28-2010.
- 3,997,727. **RESCULPTING BODY CREAM (STANDARD CHARACTER)**. TRACIE MARTYN, INC., (U.S. CLS. 1, 4, 6, 50, 51 AND 52). SN 85-207,006. PUB. 5-3-2011. FILED 12-29-2010.
- 3,997,823. **SENSIJEL (STANDARD CHARACTER)**. DR FRESH INC, (U.S. CLS. 1, 4, 6, 50, 51 AND 52). SN 85-208,328. PUB. 5-3-2011. FILED 12-30-2010.
- 3,997,878. **2 HOT (STANDARD CHARACTER)**. PARFUMS DE COEUR, LTD., (U.S. CLS. 1, 4, 6, 50, 51 AND 52). SN 85-208,824. PUB. 5-3-2011. FILED 1-2-2011.
- 3,997,948. **MYBODY AND DESIGN**. MYBODY, L.L.C., (U.S. CLS. 1, 4, 6, 50, 51 AND 52). SN 85-209,724. PUB. 5-3-2011. FILED 1-4-2011.
- 3,997,951. **MYBODY AND DESIGN**. MYBODY, L.L.C., (U.S. CLS. 1, 4, 6, 50, 51 AND 52). SN 85-209,740. PUB. 5-3-2011. FILED 1-4-2011.
- 3,997,952. **MYBODY AND DESIGN**. MYBODY, L.L.C., (U.S. CLS. 1, 4, 6, 50, 51 AND 52). SN 85-209,743. PUB. 5-3-2011. FILED 1-4-2011.
- 3,997,989. **LOTION + AID (STANDARD CHARACTER)**. COMFORT CREAMS, INC., (U.S. CLS. 1, 4, 6, 50, 51 AND 52). SN 85-210,283. PUB. 5-3-2011. FILED 1-4-2011.
- 3,998,050. **PERFECTSENSE (STANDARD CHARACTER)**. FOREVER YOUNG INTERNATIONAL, INC., MULTIPLE CLASS, (INT. CLS. 3 AND 10), (U.S. CLS. 1, 4, 6, 26, 39, 44, 50, 51 AND 52). SN 85-211,212. PUB. 5-3-2011. FILED 1-5-2011.
- 3,998,087. **BE GREEN BATH AND BODY (STANDARD CHARACTER)**. BE GREEN BATH AND BODY, (U.S. CLS. 1, 4, 6, 50, 51 AND 52). SN 85-211,809. PUB. 5-3-2011. FILED 1-6-2011.
- 3,998,092. **TALL DRINK (STANDARD CHARACTER)**. THE JOCK SOAP COMPANY, INC., (U.S. CLS. 1, 4, 6, 50, 51 AND 52). SN 85-211,894. PUB. 5-3-2011. FILED 1-6-2011.
- 3,998,096. **REVIVIFY-C (STANDARD CHARACTER)**. THE JOCK SOAP COMPANY, INC., (U.S. CLS. 1, 4, 6, 50, 51 AND 52). SN 85-211,983. PUB. 5-3-2011. FILED 1-6-2011.
- 3,998,198. **JET SET (STANDARD CHARACTER)**. GOSMILE, INC., (U.S. CLS. 1, 4, 6, 50, 51 AND 52). SN 85-216,382. PUB. 5-3-2011. FILED 1-12-2011.
- 3,998,212. **SEX APPEAL (STANDARD CHARACTER)**. COTY US LLC, (U.S. CLS. 1, 4, 6, 50, 51 AND 52). SN 85-222,364. PUB. 5-3-2011. FILED 1-20-2011.
- 3,998,219. **PREPPY PRINCESS (STANDARD CHARACTER)**. COTY US LLC, (U.S. CLS. 1, 4, 6, 50, 51 AND 52). SN 85-224,185. PUB. 5-3-2011. FILED 1-24-2011.

CLASS 4—LUBRICANTS AND FUELS

- 3,995,719 (*See Class 3 for this trademark*).
- 3,995,839. **A ARCE AND DESIGN**. ARCE S.P.A., MULTIPLE CLASS, (INT. CLS. 4, 11 AND 37), (U.S. CLS. 1, 6, 13, 15, 21, 23, 31, 34, 100, 103 AND 106). SN 79-084,508. PUB. 5-3-2011. FILED 5-28-2010.
- 3,995,985 (*See Class 1 for this trademark*).
- 3,995,986 (*See Class 1 for this trademark*).
- 3,995,987 (*See Class 1 for this trademark*).
- 3,996,192 (*See Class 1 for this trademark*).
- 3,996,208 (*See Class 1 for this trademark*).
- 3,996,274. **LIQUI-FOIL (STANDARD CHARACTER)**. AMERICAN DENTAL SUPPLY, INC., AKA ADS, INC., (U.S. CLS. 1, 6 AND 15). SN 85-054,624. PUB. 5-3-2011. FILED 6-4-2010.
- 3,996,487. **EVENT PACK (STANDARD CHARACTER)**. CANDLE ARTISANS, INC., (U.S. CLS. 1, 6 AND 15). SN 85-115,680. PUB. 5-3-2011. FILED 8-25-2010.
- 3,996,748. **TU VISION AND DESIGN**. VISION CANDLES INC., (U.S. CLS. 1, 6 AND 15). SN 85-172,488. PUB. 5-3-2011. FILED 11-9-2010.
- 3,996,907. **PENNYWICK CANDLES AND DESIGN**. PENNYWICK CANDLES LLC, AKA PENNYWICK CANDLES,

- (U.S. CLS. 1, 6 AND 15), SN 85-182,240. PUB. 5-3-2011. FILED 11-22-2010.
- 3,996,937. **INDOL (STANDARD CHARACTER)**, CHS INC., (U.S. CLS. 1, 6 AND 15), SN 85-183,654. PUB. 5-3-2011. FILED 11-23-2010.
- 3,997,055. **LIEBESTRICKEN (STANDARD CHARACTER)**, KRONBICHLER, ELISABETH, (U.S. CLS. 1, 6 AND 15), SN 85-187,779. PUB. 5-3-2011. FILED 11-30-2010.
- 3,997,144. **ES AND DESIGN**, EDDY'S INTERNATIONAL TRADING INC., MULTIPLE CLASS, (INT. CLS. 4, 11 AND 21), (U.S. CLS. 1, 2, 6, 13, 15, 21, 23, 29, 30, 31, 33, 34, 40 AND 50), SN 85-189,590. PUB. 5-3-2011. FILED 12-2-2010.
- 3,997,536. **SKY (STANDARD CHARACTER)**, SIEGEL OIL COMPANY, (U.S. CLS. 1, 6 AND 15), SN 85-204,586. PUB. 5-3-2011. FILED 12-23-2010.
- 3,997,706 (*See Class 3 for this trademark*).
- 3,997,766. **BEE LASSO (STANDARD CHARACTER)**, SKYLER STEWART, DBA BEE LASSO, (U.S. CLS. 1, 6 AND 15), SN 85-207,581. PUB. 5-3-2011. FILED 12-29-2010.
- 3,997,850. **LIVE LOVE LAUGH (STANDARD CHARACTER)**, D-GENERATION, INC., (U.S. CLS. 1, 6 AND 15), SN 85-208,626. PUB. 5-3-2011. FILED 12-31-2010.
- 3,997,927. **AGRAGAS (STANDARD CHARACTER)**, SOLECTRA, MULTIPLE CLASS, (INT. CLS. 4 AND 40), (U.S. CLS. 1, 6, 15, 100, 103 AND 106), SN 85-209,417. PUB. 5-3-2011. FILED 1-3-2011.
- 3,998,147. **MOC (STANDARD CHARACTER)**, FSHS OF SOUTH FLORIDA, INC., (U.S. CLS. 1, 6 AND 15), SN 85-213,094. PUB. 5-3-2011. FILED 1-7-2011.
- (U.S. CLS. 6, 18, 44, 46, 51, 52, 100 AND 101), SN 79-084,377. PUB. 5-3-2011. FILED 5-19-2010.
- 3,995,842 (*See Class 1 for this trademark*).
- 3,995,871 (*See Class 3 for this trademark*).
- 3,995,874. **ARTHROSAMID (STANDARD CHARACTER)**, CONTURA A/S, MULTIPLE CLASS, (INT. CLS. 5 AND 10), (U.S. CLS. 6, 18, 26, 39, 44, 46, 51 AND 52), SN 79-085,553. PUB. 5-3-2011. FILED 3-3-2010.
- 3,995,883 (*See Class 1 for this trademark*).
- 3,995,898. **ART'NCARE (STANDARD CHARACTER)**, VA-TECH CO., LTD., MULTIPLE CLASS, (INT. CLS. 5, 7, 9 AND 11), (U.S. CLS. 6, 13, 18, 19, 21, 23, 26, 31, 34, 35, 36, 38, 44, 46, 51 AND 52), SN 79-086,141. PUB. 5-3-2011. FILED 3-24-2010.
- 3,995,901. **HOPE (STANDARD CHARACTER)**, MICRO MEGA INTERNATIONAL MANUFACTURES, (U.S. CLS. 6, 18, 44, 46, 51 AND 52), SN 79-086,236. PUB. 5-3-2011. FILED 7-22-2010.
- 3,995,911 (*See Class 3 for this trademark*).
- 3,995,939 (*See Class 3 for this trademark*).
- 3,995,950. **AGENNIX (STYLIZED)**, AGENNIX AG, MULTIPLE CLASS, (INT. CLS. 5 AND 42), (U.S. CLS. 6, 18, 44, 46, 51, 52, 100 AND 101), SN 79-088,741. PUB. 5-3-2011. FILED 7-19-2010.
- 3,995,955. **TAMIA (STANDARD CHARACTER)**, MARLAFIN AG, MULTIPLE CLASS, (INT. CLS. 5 AND 10), (U.S. CLS. 6, 18, 26, 39, 44, 46, 51 AND 52), SN 79-089,138. PUB. 5-3-2011. FILED 9-20-2010.
- 3,996,009. **CAXADE (STYLIZED)**, ASTELLAS PHARMA INC., (U.S. CLS. 6, 18, 44, 46, 51 AND 52), SN 79-092,966. PUB. 5-3-2011. FILED 1-4-2011.
- 3,996,010. **ETOGLER (STYLIZED)**, ASTELLAS PHARMA INC., (U.S. CLS. 6, 18, 44, 46, 51 AND 52), SN 79-092,967. PUB. 5-3-2011. FILED 1-4-2011.
- 3,996,011. **GREMOVI (STYLIZED)**, ASTELLAS PHARMA INC., (U.S. CLS. 6, 18, 44, 46, 51 AND 52), SN 79-092,968. PUB. 5-3-2011. FILED 1-4-2011.
- 3,996,012. **MEVONI (STYLIZED)**, ASTELLAS PHARMA INC., (U.S. CLS. 6, 18, 44, 46, 51 AND 52), SN 79-092,969. PUB. 5-3-2011. FILED 1-4-2011.
- 3,996,013. **SUGLAT (STYLIZED)**, ASTELLAS PHARMA INC., (U.S. CLS. 6, 18, 44, 46, 51 AND 52), SN 79-092,970. PUB. 5-3-2011. FILED 1-4-2011.
- 3,996,014. **THYROSYNERGY (STANDARD CHARACTER)**, WELLNESS COACHING PTY LTD, (U.S. CLS. 6, 18, 44, 46, 51 AND 52), SN 79-092,977. PUB. 5-3-2011. FILED 1-4-2011.
- 3,996,018. **CIMARA (STANDARD CHARACTER)**, VOCO GMBH, (U.S. CLS. 6, 18, 44, 46, 51 AND 52), SN 79-093,929. PUB. 5-3-2011. FILED 12-22-2010.
- 3,996,019. **R Q AND DESIGN**, RAQUALIA PHARMA INC., MULTIPLE CLASS, (INT. CLS. 5 AND 42), (U.S. CLS. 6, 18, 44, 46, 51, 52, 100 AND 101), SN 79-093,979. PUB. 5-3-2011. FILED 11-30-2010.
- 3,996,022. **LEBAURO (STANDARD CHARACTER)**, BOEHRINGER INGELHEIM INTERNATIONAL GMBH, (U.S. CLS. 6, 18, 44, 46, 51 AND 52), SN 79-094,051. PUB. 5-3-2011. FILED 12-20-2010.
- 3,996,026. **FARIDAK (STANDARD CHARACTER)**, NOVARTIS AG, (U.S. CLS. 6, 18, 44, 46, 51 AND 52), SN 79-094,221. PUB. 5-3-2011. FILED 1-31-2011.
- 3,996,030. **RECONVAN (STANDARD CHARACTER)**, FRESENIUS KABI AG, (U.S. CLS. 6, 18, 44, 46, 51 AND 52), SN 79-094,493. PUB. 5-3-2011. FILED 12-16-2010.
- 3,996,069. **WELLNESS INNOVATIONS AND DESIGN**, DR. CATHERINE WILBERT, (U.S. CLS. 6, 18, 44, 46, 51 AND 52), SN 85-020,113. PUB. 5-3-2011. FILED 4-21-2010.
- 3,996,072. **ELLANSÉ (STANDARD CHARACTER)**, AQTIS I.P. B.V., (U.S. CLS. 6, 18, 44, 46, 51 AND 52), SN 85-021,910. PUB. 5-3-2011. FILED 4-23-2010.
- 3,996,097. **DR. SCHULZE'S ENERGY "SHOT" (STANDARD CHARACTER)**, AMERICAN BOTANICAL PHARMACY, (U.S. CLS. 6, 18, 44, 46, 51 AND 52), SN 85-029,748. PUB. 5-3-2011. FILED 5-4-2010.
- 3,996,125 (*See Class 3 for this trademark*).
- 3,996,133. **LIPO-IGNITE (STANDARD CHARACTER)**, A BETTER WEIGH, INC., (U.S. CLS. 6, 18, 44, 46, 51 AND 52), SN 85-037,155. PUB. 5-3-2011. FILED 5-12-2010.

CLASS 5—PHARMACEUTICALS

- 3,995,492. **ESCAPE TO SLEEP AND DESIGN**, PLAIA, GERALDINE, (U.S. CLS. 6, 18, 44, 46, 51 AND 52), SN 76-705,723. PUB. 5-3-2011. FILED 12-20-2010.
- 3,995,557 (*See Class 3 for this trademark*).
- 3,995,571. **CONTINUOUS STIMULUS (STANDARD CHARACTER)**, REGENOVATE ENDOGEN INC., (U.S. CLS. 6, 18, 44, 46, 51 AND 52), SN 77-703,257. PUB. 5-3-2011. FILED 3-31-2009.
- 3,995,572. **K.I.S.S. (STANDARD CHARACTER)**, REGENOVATE ENDOGEN INC., (U.S. CLS. 6, 18, 44, 46, 51 AND 52), SN 77-703,312. PUB. 5-3-2011. FILED 3-31-2009.
- 3,995,586. **ISOCELL (STANDARD CHARACTER)**, AKRYON, (U.S. CLS. 6, 18, 44, 46, 51 AND 52), SN 77-755,913. PUB. 2-16-2010. FILED 6-10-2009.
- 3,995,594 (*See Class 1 for this trademark*).
- 3,995,609. **INSEAZ AND DESIGN**, INNOVACTIV INC., (U.S. CLS. 6, 18, 44, 46, 51 AND 52), SN 77-837,590. PUB. 5-3-2011. FILED 9-29-2009.
- 3,995,615. **DRINKWEL (STANDARD CHARACTER)**, DRINKWEL, LLC, (U.S. CLS. 6, 18, 44, 46, 51 AND 52), SN 77-843,542. PUB. 5-3-2011. FILED 10-7-2009.
- 3,995,628. **4LIFE AND DESIGN**, 4LIFE TRADEMARKS, LLC, (U.S. CLS. 6, 18, 44, 46, 51 AND 52), SN 77-863,027. PUB. 5-3-2011. FILED 11-2-2009.
- 3,995,639. **4LIFE AND DESIGN**, 4LIFE TRADEMARKS, LLC, (U.S. CLS. 6, 18, 44, 46, 51 AND 52), SN 77-867,057. PUB. 5-3-2011. FILED 11-6-2009.
- 3,995,641. **LIP LIBATIONS HERBAL BALM (STANDARD CHARACTER)**, ANAGALLIS HERBS LLC, (U.S. CLS. 6, 18, 44, 46, 51 AND 52), SN 77-868,556. PUB. 5-3-2011. FILED 11-9-2009.
- 3,995,677 (*See Class 1 for this trademark*).
- 3,995,721. **GREEN THUMB (STANDARD CHARACTER)**, TRUE VALUE COMPANY, (U.S. CLS. 6, 18, 44, 46, 51 AND 52), SN 78-595,971. PUB. 5-3-2011. FILED 3-28-2005.
- 3,995,723 (*See Class 3 for this trademark*).
- 3,995,737 (*See Class 3 for this trademark*).
- 3,995,782. **GO! EASY (STANDARD CHARACTER)**, FIRST SCIENTIFIC DENTAL GMBH, (U.S. CLS. 6, 18, 44, 46, 51 AND 52), SN 79-080,950. PUB. 5-3-2011. FILED 2-11-2010.
- 3,995,814 (*See Class 3 for this trademark*).
- 3,995,816 (*See Class 1 for this trademark*).
- 3,995,835. **CELLMADE (STANDARD CHARACTER)**, CELLMADE SAS, MULTIPLE CLASS, (INT. CLS. 5, 42 AND 44),

- 3,996,144 (*See Class 3 for this trademark*).
- 3,996,149 (*See Class 3 for this trademark*).
- 3,996,184. **ELEVATE YOUR PERFORMANCE (STANDARD CHARACTER)**. SOUTHERN GROUP ENTERPRISES, LLC, MULTIPLE CLASS, (INT. CLS. 5 AND 32), (U.S. CLS. 6, 18, 44, 45, 46, 48, 51 AND 52). SN 85-043,424. PUB. 5-3-2011. FILED 5-20-2010.
- 3,996,240. **MYRTLE BEACH DIET (STANDARD CHARACTER)**. T AND O PROPERTIES, LLC, MULTIPLE CLASS, (INT. CLS. 5 AND 44), (U.S. CLS. 6, 18, 44, 46, 51, 52, 100 AND 101). SN 85-049,378. PUB. 5-3-2011. FILED 5-27-2010.
- 3,996,313 (*See Class 1 for this trademark*).
- 3,996,355. **CHAMONIX NUTRACEUTICALS (STANDARD CHARACTER)**. UNIMED INTERNATIONAL, INC., (U.S. CLS. 6, 18, 44, 46, 51 AND 52). SN 85-072,449. PUB. 5-3-2011. FILED 6-27-2010.
- 3,996,436 (*See Class 1 for this trademark*).
- 3,996,472. **MISCELLANEOUS DESIGN**. EHP PRODUCTS, INC., (U.S. CLS. 6, 18, 44, 46, 51 AND 52). SN 85-108,089. PUB. 1-25-2011. FILED 8-16-2010.
- 3,996,488 (*See Class 3 for this trademark*).
- 3,996,492. **HURT-FREE (STANDARD CHARACTER)**. JOHNSON & JOHNSON, (U.S. CLS. 6, 18, 44, 46, 51 AND 52). SN 85-117,240. PUB. 5-3-2011. FILED 8-27-2010.
- 3,996,535. **NUTRIQUEST AND DESIGN**. VALUE ADDED SCIENCE & TECHNOLOGIES, LLC, MULTIPLE CLASS, (INT. CLS. 5 AND 31), (U.S. CLS. 1, 6, 18, 44, 46, 51 AND 52). SN 85-129,137. PUB. 5-3-2011. FILED 9-14-2010.
- 3,996,582. **GLUTEN FREEZE (STANDARD CHARACTER)**. ATRIUM INNOVATIONS INC., (U.S. CLS. 6, 18, 44, 46, 51 AND 52). SN 85-139,654. PUB. 5-3-2011. FILED 9-28-2010.
- 3,996,583. **YEAST FREEZE (STANDARD CHARACTER)**. ATRIUM INNOVATIONS INC., (U.S. CLS. 6, 18, 44, 46, 51 AND 52). SN 85-139,819. PUB. 5-3-2011. FILED 9-28-2010.
- 3,996,603. **PREMIER PROTEIN (STANDARD CHARACTER)**. PREMIER NUTRITION, INC., (U.S. CLS. 6, 18, 44, 46, 51 AND 52). SN 85-145,755. PUB. 5-3-2011. FILED 10-5-2010.
- 3,996,633. **ZONLYST (STANDARD CHARACTER)**. CELGENE CORPORATION, (U.S. CLS. 6, 18, 44, 46, 51 AND 52). SN 85-150,746. PUB. 5-3-2011. FILED 10-12-2010.
- 3,996,637. **ZENERECT (STANDARD CHARACTER)**. BIG APPLE SUPPLEMENTS, (U.S. CLS. 6, 18, 44, 46, 51 AND 52). SN 85-152,077. PUB. 5-3-2011. FILED 10-13-2010.
- 3,996,659. **CHLORELLINA (STANDARD CHARACTER)**. SAR-TA, RICHARD, (U.S. CLS. 6, 18, 44, 46, 51 AND 52). SN 85-157,785. PUB. 5-3-2011. FILED 10-21-2010.
- 3,996,664. **DYSRUX (STANDARD CHARACTER)**. SANOFI-AVENTIS, (U.S. CLS. 6, 18, 44, 46, 51 AND 52). SN 85-158,953. PUB. 5-3-2011. FILED 10-22-2010.
- 3,996,665. **TIVOLZA (STANDARD CHARACTER)**. SANOFI-AVENTIS, (U.S. CLS. 6, 18, 44, 46, 51 AND 52). SN 85-158,960. PUB. 5-3-2011. FILED 10-22-2010.
- 3,996,666. **TURSEGE (STANDARD CHARACTER)**. SANOFI-AVENTIS, (U.S. CLS. 6, 18, 44, 46, 51 AND 52). SN 85-158,968. PUB. 5-3-2011. FILED 10-22-2010.
- 3,996,670. **M.P.H. DROPS (STANDARD CHARACTER)**. MEDIPURE PRODUCTS INC., TA MEDIPURE PRODUCTS INC, (U.S. CLS. 6, 18, 44, 46, 51 AND 52). SN 85-159,956. PUB. 5-3-2011. FILED 10-25-2010.
- 3,996,673. **TRI PROTEIN PLUS (STANDARD CHARACTER)**. COUNTRY LIFE, LLC, (U.S. CLS. 6, 18, 44, 46, 51 AND 52). SN 85-160,452. PUB. 5-3-2011. FILED 10-25-2010.
- 3,996,691. **OPTIDIAL (STANDARD CHARACTER)**. HOECHST GMBH, MULTIPLE CLASS, (INT. CLS. 5 AND 10), (U.S. CLS. 6, 18, 26, 39, 44, 46, 51 AND 52). SN 85-164,448. PUB. 5-3-2011. FILED 10-29-2010.
- 3,996,694. **ISO FORT (STANDARD CHARACTER)**. NUTRITION DISCOUNTERS, INC, (U.S. CLS. 6, 18, 44, 46, 51 AND 52). SN 85-164,659. PUB. 5-3-2011. FILED 10-29-2010.
- 3,996,741. **GUN POWDER (STANDARD CHARACTER)**. KRAUSE, FREDRIC J, (U.S. CLS. 6, 18, 44, 46, 51 AND 52). SN 85-171,480. PUB. 5-3-2011. FILED 11-8-2010.
- 3,996,752. **PHYTO-MAST (STANDARD CHARACTER)**. KAR-REMAN, HUBERT J., (U.S. CLS. 6, 18, 44, 46, 51 AND 52). SN 85-172,848. PUB. 5-3-2011. FILED 11-9-2010.
- 3,996,786. **SAFE BREAD (STANDARD CHARACTER)**. PARRY, CLARISSA, DBA PARRY'S GLUTEN-FREE BAKERY, (U.S. CLS. 6, 18, 44, 46, 51 AND 52). SN 85-174,989. PUB. 5-3-2011. FILED 11-11-2010.
- 3,996,788 (*See Class 3 for this trademark*).
- 3,996,793. **ETERNAL SPRING OF LIFE HERBS (STANDARD CHARACTER)**. RUTH A. MCCARTY, DBA TCM BIOTHERAPEUTICS, LLC, (U.S. CLS. 6, 18, 44, 46, 51 AND 52). SN 85-175,598. PUB. 5-3-2011. FILED 11-12-2010.
- 3,996,875 (*See Class 1 for this trademark*).
- 3,996,880. **A SWEET WAY TO PREVENT TOOTH DECAY (STANDARD CHARACTER)**. HEALTHY SWEET BEVERAGES, LLC, MULTIPLE CLASS, (INT. CLS. 5 AND 32), (U.S. CLS. 6, 18, 44, 45, 46, 48, 51 AND 52). SN 85-180,850. PUB. 5-3-2011. FILED 11-19-2010.
- 3,996,910. **VITALI-C PLUS (STANDARD CHARACTER)**. DOCTOR'S SIGNATURE SALES & MARKETING INTERNATIONAL CORP., (U.S. CLS. 6, 18, 44, 46, 51 AND 52). SN 85-182,603. PUB. 5-3-2011. FILED 11-22-2010.
- 3,996,915. **DEER DEFEAT (STANDARD CHARACTER)**. DEER DEFEAT LLC, (U.S. CLS. 6, 18, 44, 46, 51 AND 52). SN 85-182,831. PUB. 5-3-2011. FILED 11-22-2010.
- 3,997,013. **GOOSE STOPPER (STANDARD CHARACTER)**. BIG BUCKS ENTERPRISES, INC., DBA MESSINA WILDLIFE MANAGEMENT, (U.S. CLS. 6, 18, 44, 46, 51 AND 52). SN 85-186,955. PUB. 5-3-2011. FILED 11-30-2010.
- 3,997,059. **FLEXICOSEPLUS (STANDARD CHARACTER)**. SEACRA ENTERPRISES, INC., DBA DTC HEALTH, (U.S. CLS. 6, 18, 44, 46, 51 AND 52). SN 85-187,908. PUB. 5-3-2011. FILED 12-1-2010.
- 3,997,068. **PAIN GUARD (STANDARD CHARACTER)**. THE HAMILTON GROUP, INC, DBA HAMILTON LABS, (U.S. CLS. 6, 18, 44, 46, 51 AND 52). SN 85-188,243. PUB. 5-3-2011. FILED 12-1-2010.
- 3,997,083. **EASY SHOT (STANDARD CHARACTER)**. JOINT JUICE, INC., (U.S. CLS. 6, 18, 44, 46, 51 AND 52). SN 85-188,487. PUB. 5-3-2011. FILED 12-1-2010.
- 3,997,132. **YUM EARTH (STANDARD CHARACTER)**. YUM-MYEARTH, INC., MULTIPLE CLASS, (INT. CLS. 5 AND 30), (U.S. CLS. 6, 18, 44, 46, 51 AND 52). SN 85-189,431. PUB. 5-3-2011. FILED 12-2-2010.
- 3,997,138. **BIKERS DEFENSE AND DESIGN**. MIKOLAJCZYK, WILLIAM, (U.S. CLS. 6, 18, 44, 46, 51 AND 52). SN 85-189,544. PUB. 5-3-2011. FILED 12-2-2010.
- 3,997,147. **OMEGA RX (STANDARD CHARACTER)**. BARRY D. SEARS, PH.D., (U.S. CLS. 6, 18, 44, 46, 51 AND 52). SN 85-189,621. PUB. 5-3-2011. FILED 12-2-2010.
- 3,997,175. **OS2 (STYLIZED)**. AMERISCIENCES, LP, (U.S. CLS. 6, 18, 44, 46, 51 AND 52). SN 85-190,107. PUB. 5-3-2011. FILED 12-3-2010.
- 3,997,223. **MISCELLANEOUS DESIGN**. HOLTORF, KENT, MULTIPLE CLASS, (INT. CLS. 5 AND 44), (U.S. CLS. 6, 18, 44, 46, 51, 52, 100 AND 101). SN 85-191,692. PUB. 5-3-2011. FILED 12-6-2010.
- 3,997,299. **HCG FUSION (STANDARD CHARACTER)**. NUTRIFUSION SYSTEMS, LLC, DBA HCG FUSION, (U.S. CLS. 6, 18, 44, 46, 51 AND 52). SN 85-194,151. PUB. 5-3-2011. FILED 12-9-2010.
- 3,997,328. **DR. ZEN'S LIQUID CALM (STANDARD CHARACTER)**. CASSEL GROUP, LLC, (U.S. CLS. 6, 18, 44, 46, 51 AND 52). SN 85-195,170. PUB. 5-3-2011. FILED 12-10-2010.
- 3,997,333. **MEDIPURE PRODUCTS (STANDARD CHARACTER)**. MEDIPURE PRODUCTS INC., (U.S. CLS. 6, 18, 44, 46, 51 AND 52). SN 85-195,506. PUB. 5-3-2011. FILED 12-10-2010.
- 3,997,408. **ROOMSHOCKER (STANDARD CHARACTER)**. SMM DISTRIBUTORS LLC, (U.S. CLS. 6, 18, 44, 46, 51 AND 52). SN 85-200,092. PUB. 5-3-2011. FILED 12-16-2010.
- 3,997,421 (*See Class 3 for this trademark*).
- 3,997,473. **ONCOMUN (STANDARD CHARACTER)**. ANTI-SENSE PHARMA GMBH, (U.S. CLS. 6, 18, 44, 46, 51 AND 52). SN 85-202,598. PUB. 5-3-2011. FILED 12-21-2010.
- 3,997,583. **PAIN RELIEF WITHOUT THE PILLS (STANDARD CHARACTER)**. PRINCE OF PEACE ENTERPRISES, INC., (U.S. CLS. 6, 18, 44, 46, 51 AND 52). SN 85-205,064. PUB. 5-3-2011. FILED 12-23-2010.
- 3,997,601. **RODRASTIN (STANDARD CHARACTER)**. AXLEY, GARY, (U.S. CLS. 6, 18, 44, 46, 51 AND 52). SN 85-205,268. PUB. 5-3-2011. FILED 12-23-2010.
- 3,997,624. **AGMASET (STANDARD CHARACTER)**. GILAD GAD M, AND GILAD VARDA, (U.S. CLS. 6, 18, 44, 46, 51

- AND 52). SN 85-205,611. PUB. 5-3-2011. FILED 12-24-2010.
- 3,997,627. **LET ME CLARIFY (STANDARD CHARACTER)**. MYBODY, L.L.C., (U.S. CLS. 6, 18, 44, 46, 51 AND 52). SN 85-205,688. PUB. 5-3-2011. FILED 12-26-2010.
- 3,997,628. **LIGHT THE WAY (STANDARD CHARACTER)**. MYBODY, L.L.C., (U.S. CLS. 6, 18, 44, 46, 51 AND 52). SN 85-205,690. PUB. 5-3-2011. FILED 12-26-2010.
- 3,997,665. **EASTERN ZEN WESTERN ENERGY (STANDARD CHARACTER)**. NEEL ALAN ENTERPRISES, (U.S. CLS. 6, 18, 44, 46, 51 AND 52). SN 85-206,123. PUB. 5-3-2011. FILED 12-27-2010.
- 3,997,693 (*See Class 3 for this trademark*).
- 3,997,810. **JUST STOP (STANDARD CHARACTER)**. PARADOCS ALL NATURAL INC, (U.S. CLS. 6, 18, 44, 46, 51 AND 52). SN 85-208,211. PUB. 5-3-2011. FILED 12-30-2010.
- 3,997,829. **MOODASSURE (STANDARD CHARACTER)**. MAXIMUM LIVING, INC., (U.S. CLS. 6, 18, 44, 46, 51 AND 52). SN 85-208,368. PUB. 5-3-2011. FILED 12-30-2010.
- 3,997,870. **AFTER BURNER (STANDARD CHARACTER)**. RMK DIVERSIFIED, LLC, (U.S. CLS. 6, 18, 44, 46, 51 AND 52). SN 85-208,713. PUB. 5-3-2011. FILED 12-31-2010.
- 3,997,980. **THE POWER OF THE PARENTS (STANDARD CHARACTER)**. PESKIN, BRIAN, (U.S. CLS. 6, 18, 44, 46, 51 AND 52). SN 85-210,192. PUB. 5-3-2011. FILED 1-4-2011.
- 3,997,981. **HYPEROX (STANDARD CHARACTER)**. INDUS BIOTECH PRIVATE LIMITED, (U.S. CLS. 6, 18, 44, 46, 51 AND 52). SN 85-210,199. PUB. 5-3-2011. FILED 1-4-2011.
- 3,997,984. **TORABOLIC (STANDARD CHARACTER)**. INDUS BIOTECH PRIVATE LIMITED, (U.S. CLS. 6, 18, 44, 46, 51 AND 52). SN 85-210,245. PUB. 5-3-2011. FILED 1-4-2011.
- 3,997,985. **TESTOSURGE (STANDARD CHARACTER)**. INDUS BIOTECH PRIVATE LIMITED, (U.S. CLS. 6, 18, 44, 46, 51 AND 52). SN 85-210,253. PUB. 5-3-2011. FILED 1-4-2011.
- 3,998,031. **VIBRAMINS (STANDARD CHARACTER)**. VIBRATIONAL NUTRITION RESEARCH, LLC, (U.S. CLS. 6, 18, 44, 46, 51 AND 52). SN 85-210,880. PUB. 5-3-2011. FILED 1-5-2011.
- 3,998,067. **AQUA LIFT (STANDARD CHARACTER)**. MEDIUM PURE PRODUCTS INC, (U.S. CLS. 6, 18, 44, 46, 51 AND 52). SN 85-211,428. PUB. 5-3-2011. FILED 1-5-2011.
- 3,998,134. **THIN CENTERS MD AND DESIGN**. THIN CENTERS, LLC, (U.S. CLS. 6, 18, 44, 46, 51 AND 52). SN 85-212,841. PUB. 5-3-2011. FILED 1-7-2011.
- 3,998,162. **MASFLEX (STANDARD CHARACTER)**. FORTIER, CARLOS R., (U.S. CLS. 6, 18, 44, 46, 51 AND 52). SN 85-213,536. PUB. 5-3-2011. FILED 1-8-2011.
- 3,995,764. **TAPER-HI-LITE (STANDARD CHARACTER)**. BLANC AERO INDUSTRIES; (SOCIÉTÉ PAR ACTIONS SIMPLIFIÉE), (U.S. CLS. 2, 12, 13, 14, 23, 25 AND 50). SN 79-078,350. PUB. 5-3-2011. FILED 7-30-2009.
- 3,995,770. **DOORHAN AND DESIGN**. OBCHTCHISTVO S OGRANITCHENNOI; OTVETSTVENNOSTYOU; "DOR-KHAN", MULTIPLE CLASS, (INT. CLS. 6 AND 42), (U.S. CLS. 2, 12, 13, 14, 23, 25, 50, 100 AND 101). SN 79-078,885. PUB. 5-3-2011. FILED 6-23-2009.
- 3,995,772. **DYNOR (STANDARD CHARACTER)**. VON ROLL UMWELTTECHNIK AG, MULTIPLE CLASS, (INT. CLS. 6, 11 AND 37), (U.S. CLS. 2, 12, 13, 14, 21, 23, 25, 31, 34, 50, 100, 103 AND 106). SN 79-079,180. PUB. 5-3-2011. FILED 12-18-2009.
- 3,995,775. **DISPLAYINTERNATIONAL (STYLIZED)**. DISPLAY INTERNATIONAL SCHWENDINGER; GMBH & CO. KG, MULTIPLE CLASS, (INT. CLS. 6, 19, 20, 35, 37, 42 AND 43), (U.S. CLS. 1, 2, 12, 13, 14, 22, 23, 25, 32, 33, 50, 100, 101, 102, 103 AND 106). SN 79-079,690. PUB. 5-3-2011. FILED 12-15-2009.
- 3,995,808. **SANISTEEL AND DESIGN**. LAMPRE INTERNATIONAL B.V., (U.S. CLS. 2, 12, 13, 14, 23, 25 AND 50). SN 79-083,494. PUB. 5-3-2011. FILED 5-4-2010.
- 3,995,817 (*See Class 1 for this trademark*).
- 3,995,879. **MISCELLANEOUS DESIGN**. GEA PROCESS ENGINEERING A/S, MULTIPLE CLASS, (INT. CLS. 6, 7, 11, 37 AND 42), (U.S. CLS. 2, 12, 13, 14, 19, 21, 23, 25, 31, 34, 35, 50, 100, 101, 103 AND 106). SN 79-085,635. PUB. 5-3-2011. FILED 6-28-2010.
- 3,995,927. **NIDYON (STANDARD CHARACTER)**. NIDYON COSTRUZIONI S.R.L. -, MULTIPLE CLASS, (INT. CLS. 6, 7 AND 19), (U.S. CLS. 1, 2, 12, 13, 14, 19, 21, 23, 25, 31, 33, 34, 35 AND 50). SN 79-087,794. PUB. 5-3-2011. FILED 7-13-2010.
- 3,995,959. **LINNUM (STYLIZED)**. JIMTEN, S.A., MULTIPLE CLASS, (INT. CLS. 6 AND 11), (U.S. CLS. 2, 12, 13, 14, 21, 23, 25, 31, 34 AND 50). SN 79-089,495. PUB. 5-3-2011. FILED 9-16-2010.
- 3,995,962. **MRX (STANDARD CHARACTER)**. MIYAGAWA CORPORATION, (U.S. CLS. 2, 12, 13, 14, 23, 25 AND 50). SN 79-089,670. PUB. 5-3-2011. FILED 10-15-2010.
- 3,995,985 (*See Class 1 for this trademark*).
- 3,995,986 (*See Class 1 for this trademark*).
- 3,995,987 (*See Class 1 for this trademark*).
- 3,995,989. **ARMOFOR (STANDARD CHARACTER)**. NV BEKAERT SA, MULTIPLE CLASS, (INT. CLS. 6 AND 17), (U.S. CLS. 1, 2, 5, 12, 13, 14, 23, 25, 35 AND 50). SN 79-091,283. PUB. 5-3-2011. FILED 10-18-2010.
- 3,996,000. **NFF (STYLIZED)**. JIANGYIN NANFANG PIPE FITTING MAKING CO., LTD., (U.S. CLS. 2, 12, 13, 14, 23, 25 AND 50). SN 79-092,146. PUB. 5-3-2011. FILED 1-4-2011.
- 3,996,098. **EXTREME (STANDARD CHARACTER)**. CIW ENTERPRISES, MULTIPLE CLASS, (INT. CLS. 6 AND 19), (U.S. CLS. 1, 2, 12, 13, 14, 23, 25, 33 AND 50). SN 85-029,923. PUB. 5-3-2011. FILED 5-4-2010.
- 3,996,135. **WORLD'S STRONGEST FASTENER (STANDARD CHARACTER)**. WINGITS INNOVATIONS, LLC, MULTIPLE CLASS, (INT. CLS. 6 AND 20), (U.S. CLS. 2, 12, 13, 14, 22, 23, 25, 32 AND 50). SN 85-037,257. PUB. 5-3-2011. FILED 5-13-2010.
- 3,996,245. **CYCLE-MASTER (STANDARD CHARACTER)**. CIW ENTERPRISES, MULTIPLE CLASS, (INT. CLS. 6 AND 19), (U.S. CLS. 1, 2, 12, 13, 14, 23, 25, 33 AND 50). SN 85-050,636. PUB. 5-3-2011. FILED 5-28-2010.
- 3,996,262. **PD-135 (STANDARD CHARACTER)**. FREEPORT-MCMORAN COPPER & GOLD INC., (U.S. CLS. 2, 12, 13, 14, 23, 25 AND 50). SN 85-052,641. PUB. 5-3-2011. FILED 6-2-2010.
- 3,996,263. **PD-35EF (STANDARD CHARACTER)**. FREEPORT-MCMORAN COPPER & GOLD INC., (U.S. CLS. 2, 12, 13, 14, 23, 25 AND 50). SN 85-052,649. PUB. 5-3-2011. FILED 6-2-2010.
- 3,996,264. **PD-80EF (STANDARD CHARACTER)**. FREEPORT-MCMORAN COPPER & GOLD INC., (U.S. CLS. 2, 12, 13, 14, 23, 25 AND 50). SN 85-052,654. PUB. 5-3-2011. FILED 6-2-2010.
- 3,996,322. **MARPAC (STANDARD CHARACTER)**. DONOVAN MARINE, INC., MULTIPLE CLASS, (INT. CLS. 6, 7, 9, 11, 12, 16, 17, 20, 22 AND 35), (U.S. CLS. 1, 2, 5, 7, 12, 13, 14, 19,

CLASS 6—METAL GOODS

- 3,995,580. **SILENTFLO (STANDARD CHARACTER)**. NOISE SOLUTIONS INC., MULTIPLE CLASS, (INT. CLS. 6, 7, 17 AND 42), (U.S. CLS. 1, 2, 5, 12, 13, 14, 19, 21, 23, 25, 31, 34, 35, 50, 100 AND 101). SN 77-739,103. PUB. 10-19-2010. FILED 5-18-2009.
- 3,995,589. **S AND DESIGN**. SALICE PAOLO SRL, MULTIPLE CLASS, (INT. CLS. 6, 20 AND 21), (U.S. CLS. 2, 12, 13, 14, 22, 23, 25, 29, 30, 32, 33, 40 AND 50). SN 77-774,647. PUB. 2-1-2011. FILED 7-6-2009.
- 3,995,719 (*See Class 3 for this trademark*).
- 3,995,720. **GERRESHEIMER (STYLIZED)**. GERRESHEIMER GLAS GMBH, MULTIPLE CLASS, (INT. CLS. 6, 9, 10, 20, 21 AND 42), (U.S. CLS. 2, 12, 13, 14, 21, 22, 23, 25, 26, 29, 30, 32, 33, 36, 38, 39, 40, 44, 50, 100 AND 101). SN 78-446,403. PUB. 5-3-2011. FILED 7-6-2004.
- 3,995,734. **POWERBLADES AND DESIGN**. REPOWER SYSTEMS AG, MULTIPLE CLASS, (INT. CLS. 6, 7, 9, 35, 37, 38 AND 42), (U.S. CLS. 2, 12, 13, 14, 19, 21, 23, 25, 26, 31, 34, 35, 36, 38, 50, 100, 101, 102, 103, 104 AND 106). SN 79-065,654. PUB. 5-3-2011. FILED 10-31-2008.
- 3,995,735. **SCHÖNENBERGER AND DESIGN**. RSL LOGISTIK GMBH & CO. KG, MULTIPLE CLASS, (INT. CLS. 6, 7, 9, 12, 16, 35, 36, 37, 39, 41, 42 AND 45), (U.S. CLS. 2, 5, 12, 13, 14, 19, 21, 22, 23, 25, 26, 29, 31, 34, 35, 36, 37, 38, 44, 50, 100, 101, 102, 103, 105, 106 AND 107). SN 79-066,339. PUB. 5-3-2011. FILED 8-6-2008.

- 21, 22, 23, 25, 26, 29, 31, 32, 34, 35, 36, 37, 38, 42, 44, 50, 100, 101 AND 102). SN 85-065,774. PUB. 5-3-2011. FILED 6-17-2010.
- 3,996,341. **GMI (STANDARD CHARACTER)**. GATEWAY MANUFACTURING, INC., MULTIPLE CLASS, (INT. CLS. 1, 2, 12, 13, 14, 23, 25, 33 AND 50). SN 85-069,953. PUB. 5-3-2011. FILED 6-23-2010.
- 3,996,381. **STEIN-MEGAFIL (STANDARD CHARACTER)**. DRAHTZUG STEIN WIRE & WELDING GMBH & CO. KG, (U.S. CLS. 2, 12, 13, 14, 23, 25 AND 50). SN 85-080,084. PUB. 5-3-2011. FILED 7-8-2010.
- 3,996,416. **TRUE-STUD (STANDARD CHARACTER)**. TELLING INDUSTRIES, LLC, (U.S. CLS. 2, 12, 13, 14, 23, 25 AND 50). SN 85-090,648. PUB. 1-25-2011. FILED 7-22-2010.
- 3,996,469 (*See Class 1 for this trademark*).
- 3,996,768. **MERCER (STANDARD CHARACTER)**. TOTO U.S.A., INC., (U.S. CLS. 2, 12, 13, 14, 23, 25 AND 50). SN 85-173,961. PUB. 5-3-2011. FILED 11-10-2010.
- 3,996,835. **OSLO (STANDARD CHARACTER)**. UNISON HARDWARE, INC., (U.S. CLS. 2, 12, 13, 14, 23, 25 AND 50). SN 85-178,330. PUB. 5-3-2011. FILED 11-16-2010.
- 3,996,908. **DUOBEAR (STANDARD CHARACTER)**. GOAD COMPANY, (U.S. CLS. 2, 12, 13, 14, 23, 25 AND 50). SN 85-182,380. PUB. 5-3-2011. FILED 11-22-2010.
- 3,997,577. **BATTLEWAGON (STANDARD CHARACTER)**. BATTLEWAGON MOUNTS, LLC, (U.S. CLS. 2, 12, 13, 14, 23, 25 AND 50). SN 85-204,982. PUB. 5-3-2011. FILED 12-23-2010.
- 3,997,598. **OUR BUSINESS HINGES ON YOUR BUSINESS (STANDARD CHARACTER)**. S & D PRODUCTS, INC., MULTIPLE CLASS, (INT. CLS. 6 AND 35), (U.S. CLS. 2, 12, 13, 14, 23, 25, 50, 100, 101 AND 102). SN 85-205,247. PUB. 5-3-2011. FILED 12-23-2010.
- 3,997,654. **PONY (STANDARD CHARACTER)**. GRANITE SECURITY PRODUCTS, INC., (U.S. CLS. 2, 12, 13, 14, 23, 25 AND 50). SN 85-205,981. PUB. 5-3-2011. FILED 12-27-2010.
- 3,997,691. **SILVERADO (STANDARD CHARACTER)**. GRANITE SECURITY PRODUCTS, INC., (U.S. CLS. 2, 12, 13, 14, 23, 25 AND 50). SN 85-206,457. PUB. 5-3-2011. FILED 12-28-2010.
- 3,997,698. **TRADITION (STANDARD CHARACTER)**. GRANITE SECURITY PRODUCTS, INC., (U.S. CLS. 2, 12, 13, 14, 23, 25 AND 50). SN 85-206,516. PUB. 5-3-2011. FILED 12-28-2010.
- 3,997,705. **IK (STANDARD CHARACTER)**. I KANG ENTERPRISE CO., LTD., (U.S. CLS. 2, 12, 13, 14, 23, 25 AND 50). SN 85-206,662. PUB. 5-3-2011. FILED 12-28-2010.
- 3,998,106. **CIRA (STANDARD CHARACTER)**. THE DELANEY CO., (U.S. CLS. 2, 12, 13, 14, 23, 25 AND 50). SN 85-212,156. PUB. 5-3-2011. FILED 1-6-2011.
- 3,998,122. **THE BEST VALUE IN SPACE (STANDARD CHARACTER)**. CENTURIA STEEL BUILDINGS CORP., (U.S. CLS. 2, 12, 13, 14, 23, 25 AND 50). SN 85-212,500. PUB. 5-3-2011. FILED 1-7-2011.
- 3,998,128. **MUNICH (STANDARD CHARACTER)**. UNISON HARDWARE, INC., (U.S. CLS. 2, 12, 13, 14, 23, 25 AND 50). SN 85-212,603. PUB. 5-3-2011. FILED 1-7-2011.
- 3,998,168. **STUTTGART (STANDARD CHARACTER)**. UNISON HARDWARE, INC., (U.S. CLS. 2, 12, 13, 14, 23, 25 AND 50). SN 85-213,853. PUB. 5-3-2011. FILED 1-10-2011.
- 3,995,530. **THE ONE ABOVE POGO LIFT AND DESIGN**. POGO INDUSTRIES INC., (U.S. CLS. 13, 19, 21, 23, 31, 34 AND 35). SN 77-449,444. PUB. 10-19-2010. FILED 4-16-2008.
- 3,995,531. **BLUEGRID AND DESIGN**. NGRID INTELLECTUAL PROPERTY LIMITED, MULTIPLE CLASS, (INT. CLS. 7, 9, 11, 16, 35, 37, 39, 40 AND 42), (U.S. CLS. 2, 5, 13, 19, 21, 22, 23, 26, 29, 31, 34, 35, 36, 37, 38, 50, 100, 101, 102, 103, 105 AND 106). SN 77-469,344. PUB. 5-3-2011. FILED 5-8-2008.
- 3,995,580 (*See Class 6 for this trademark*).
- 3,995,596. **TRUE WASH (STANDARD CHARACTER)**. LG ELECTRONICS INC., MULTIPLE CLASS, (INT. CLS. 7 AND 11), (U.S. CLS. 13, 19, 21, 23, 31, 34 AND 35). SN 77-797,632. PUB. 5-3-2011. FILED 8-5-2009.
- 3,995,660. **SOLUTIONS FOR COUNTRY LIVING (STANDARD CHARACTER)**. SPEECO, INCORPORATED, (U.S. CLS. 13, 19, 21, 23, 31, 34 AND 35). SN 77-897,741. PUB. 5-3-2011. FILED 12-20-2009.
- 3,995,714. **TITAN EQUIPMENT AND DESIGN**. TITAN EQUIPMENT SERVICES, INC., (U.S. CLS. 13, 19, 21, 23, 31, 34 AND 35). SN 77-980,493. PUB. 1-25-2011. FILED 10-14-2008.
- 3,995,733. **MISCELLANEOUS DESIGN**. HAUZER TECHNO COATING BV, MULTIPLE CLASS, (INT. CLS. 7 AND 40), (U.S. CLS. 13, 19, 21, 23, 31, 34, 35, 100, 103 AND 106). SN 79-065,439. PUB. 5-3-2011. FILED 11-28-2008.
- 3,995,734 (*See Class 6 for this trademark*).
- 3,995,735 (*See Class 6 for this trademark*).
- 3,995,748. **ECOMAU AND DESIGN**. COMAU SPA, MULTIPLE CLASS, (INT. CLS. 7 AND 9), (U.S. CLS. 13, 19, 21, 23, 26, 31, 34, 35, 36 AND 38). SN 79-075,599. PUB. 5-3-2011. FILED 7-29-2009.
- 3,995,765. **TRIPLEX SL 1 SHOT AND DESIGN**. NORDMECANICA S.P.A., MULTIPLE CLASS, (INT. CLS. 7 AND 9), (U.S. CLS. 13, 19, 21, 23, 26, 31, 34, 35, 36 AND 38). SN 79-078,365. PUB. 5-3-2011. FILED 11-4-2009.
- 3,995,792. **M MOULD TECHNOLOGIES GROUP AND DESIGN**. MOULD TECHNOLOGIES HOLDING AG, MULTIPLE CLASS, (INT. CLS. 7, 42 AND 45), (U.S. CLS. 13, 19, 21, 23, 31, 34, 35, 100 AND 101). SN 79-082,703. PUB. 5-3-2011. FILED 3-24-2010.
- 3,995,795. **GOTO (STYLIZED)**. GUANGZHOU SHUOJIN MECHATRONICS; CO., LTD., MULTIPLE CLASS, (INT. CLS. 7 AND 12), (U.S. CLS. 13, 19, 21, 23, 31, 34, 35 AND 44). SN 79-082,822. PUB. 5-3-2011. FILED 5-11-2010.
- 3,995,797. **LBT (STYLIZED)**. JIANGYIN LONG-BRIGHT DRILL PIPE; MANUFACTURE CO., LTD., (U.S. CLS. 13, 19, 21, 23, 31, 34 AND 35). SN 79-082,952. PUB. 5-3-2011. FILED 5-7-2010.
- 3,995,799. **BRECOBASIC (STANDARD CHARACTER)**. BRECO ANTRIEBSTECHNIK BREHER GMBH + CO, MULTIPLE CLASS, (INT. CLS. 7 AND 12), (U.S. CLS. 13, 19, 21, 23, 31, 34, 35 AND 44). SN 79-082,973. PUB. 5-3-2011. FILED 5-14-2010.
- 3,995,810. **DEMOCRATIC ECOLOGY BY STARCK (STANDARD CHARACTER)**. PHILIPPE STARCK, (U.S. CLS. 13, 19, 21, 23, 31, 34 AND 35). SN 79-083,512. PUB. 5-3-2011. FILED 5-11-2010.
- 3,995,813. **W2PS (STYLIZED)**. WIND TO POWER SYSTEM, S.L., MULTIPLE CLASS, (INT. CLS. 7, 9, 11, 37, 40 AND 42), (U.S. CLS. 13, 19, 21, 23, 26, 31, 34, 35, 36, 38, 100, 101, 103 AND 106). SN 79-083,594. PUB. 5-3-2011. FILED 5-6-2010.
- 3,995,821. **RESEARCH-COTTRELL DRY COOLING (STANDARD CHARACTER)**. HAMON & CIE (INTERNATIONAL) S.A., MULTIPLE CLASS, (INT. CLS. 7, 11, 37 AND 42), (U.S. CLS. 13, 19, 21, 23, 31, 34, 35, 100, 101, 103 AND 106). SN 79-084,001. PUB. 5-3-2011. FILED 4-19-2010.
- 3,995,837. **NPC AND DESIGN**. KABUSHIKI KAISHA NPC (ALSO TRADING AS NPC INCORPORATED), (U.S. CLS. 13, 19, 21, 23, 31, 34 AND 35). SN 79-084,454. PUB. 5-3-2011. FILED 6-1-2010.
- 3,995,854. **BROADCROWN (STANDARD CHARACTER)**. BROADCROWN HOLDINGS PLC, MULTIPLE CLASS, (INT. CLS. 7 AND 37), (U.S. CLS. 13, 19, 21, 23, 31, 34, 35, 100, 103 AND 106). SN 79-085,031. PUB. 5-3-2011. FILED 5-26-2010.
- 3,995,860. **CAPELLO AND DESIGN**. CAPELLO S.R.L., (U.S. CLS. 13, 19, 21, 23, 31, 34 AND 35). SN 79-085,165. PUB. 5-3-2011. FILED 7-2-2010.

CLASS 7—MACHINERY

- 3,995,470. **IMPCO AND DESIGN**. IMPCO TECHNOLOGIES, INC., (U.S. CLS. 13, 19, 21, 23, 31, 34 AND 35). SN 76-702,993. PUB. 5-3-2011. FILED 5-17-2010.
- 3,995,518. **FASTPHASER (STANDARD CHARACTER)**. HYDRAULIK-RING GMBH, MULTIPLE CLASS, (INT. CLS. 7, 12 AND 16), (U.S. CLS. 2, 5, 13, 19, 21, 22, 23, 29, 31, 34, 35, 37, 38, 44 AND 50). SN 77-247,076. PUB. 3-17-2009. FILED 8-3-2007.
- 3,995,524. **BLUEGRID (STANDARD CHARACTER)**. NGRID INTELLECTUAL PROPERTY LIMITED, MULTIPLE CLASS, (INT. CLS. 7, 9, 11, 16, 35, 37, 39, 40 AND 42), (U.S. CLS. 2, 5, 13, 19, 21, 22, 23, 26, 29, 31, 34, 35, 36, 37, 38, 50, 100, 101, 102, 103, 105 AND 106). SN 77-414,859. PUB. 5-3-2011. FILED 3-6-2008.

- 3,995,875. **DRY9000 (STANDARD CHARACTER)**, INTERSEAL DIPL.-ING. ROLF SCHMITZ GMBH, MULTIPLE CLASS, (INT. CLS. 7, 9 AND 17), (U.S. CLS. 1, 5, 12, 13, 19, 21, 23, 26, 31, 34, 35, 36, 38 AND 50). SN 79-085,555. PUB. 5-3-2011. FILED 4-12-2010.
- 3,995,879 (*See Class 6 for this trademark*).
- 3,995,885. **CMP AND DESIGN**. AGR SUBSEA AS, MULTIPLE CLASS, (INT. CLS. 7 AND 37), (U.S. CLS. 13, 19, 21, 23, 31, 34, 35, 100, 103 AND 106). SN 79-085,748. PUB. 5-3-2011. FILED 4-9-2010.
- 3,995,889. **CALLIDUS (STANDARD CHARACTER)**. CALLIDUS INVESTMENTS B.V., (U.S. CLS. 13, 19, 21, 23, 31, 34 AND 35). SN 79-085,917. PUB. 5-3-2011. FILED 3-12-2010.
- 3,995,898 (*See Class 5 for this trademark*).
- 3,995,904 (*See Class 1 for this trademark*).
- 3,995,926. **MISCELLANEOUS DESIGN**. ERICH SCHEUGENPFLUG, MULTIPLE CLASS, (INT. CLS. 7 AND 42), (U.S. CLS. 13, 19, 21, 23, 31, 34, 35, 100 AND 101). SN 79-087,760. PUB. 5-3-2011. FILED 6-1-2010.
- 3,995,927 (*See Class 6 for this trademark*).
- 3,995,938. **PIGRIP (STANDARD CHARACTER)**. PIAB AB, (U.S. CLS. 13, 19, 21, 23, 31, 34 AND 35). SN 79-088,165. PUB. 5-3-2011. FILED 9-9-2010.
- 3,995,944. **ECOROAD AND DESIGN**. J.C.BAMFORD EXCAVATORS LIMITED, (U.S. CLS. 13, 19, 21, 23, 31, 34 AND 35). SN 79-088,446. PUB. 5-3-2011. FILED 9-22-2010.
- 3,995,948. **M-TYPHOON (STYLIZED)**. MARICAP OY, MULTIPLE CLASS, (INT. CLS. 7, 37 AND 39), (U.S. CLS. 13, 19, 21, 23, 31, 34, 35, 100, 103, 105 AND 106). SN 79-088,666. PUB. 5-3-2011. FILED 6-7-2010.
- 3,995,960. **ENABLER (STANDARD CHARACTER)**. EPU PTY LTD, (U.S. CLS. 13, 19, 21, 23, 31, 34 AND 35). SN 79-089,560. PUB. 5-3-2011. FILED 10-13-2010.
- 3,996,132. **STANLEY FILTER BY OILMEN FOR OILMEN AND DESIGN**. STANLEY FILTER COMPANY, LLC, (U.S. CLS. 13, 19, 21, 23, 31, 34 AND 35). SN 85-036,520. PUB. 5-3-2011. FILED 5-12-2010.
- 3,996,177. **KURARAY (STYLIZED)**. KURARAY CO., LTD., MULTIPLE CLASS, (INT. CLS. 7, 11 AND 12), (U.S. CLS. 13, 19, 21, 23, 31, 34, 35 AND 44). SN 85-042,724. PUB. 12-21-2010. FILED 5-19-2010.
- 3,996,192 (*See Class 1 for this trademark*).
- 3,996,202 (*See Class 1 for this trademark*).
- 3,996,206. **MARPAC PREMIER (STANDARD CHARACTER)**. DONOVAN MARINE, INC., MULTIPLE CLASS, (INT. CLS. 7, 9, 11, 12 AND 22), (U.S. CLS. 1, 2, 7, 13, 19, 21, 22, 23, 26, 31, 34, 35, 36, 38, 42, 44 AND 50). SN 85-046,182. PUB. 5-3-2011. FILED 5-24-2010.
- 3,996,296. **P*TRACK (STANDARD CHARACTER)**. MIN, WEIXING, (U.S. CLS. 13, 19, 21, 23, 31, 34 AND 35). SN 85-060,661. PUB. 5-3-2011. FILED 6-11-2010.
- 3,996,308. **TERRANOX (STANDARD CHARACTER)**. ATLAS COPCO CRAELIUS AB, MULTIPLE CLASS, (INT. CLS. 7 AND 37), (U.S. CLS. 13, 19, 21, 23, 31, 34, 35, 100, 103 AND 106). SN 85-063,510. PUB. 4-12-2011. FILED 6-15-2010.
- 3,996,322 (*See Class 6 for this trademark*).
- 3,996,384. **IDP (STANDARD CHARACTER)**. MITSUBISHI PAPER MILLS LIMITED, (U.S. CLS. 13, 19, 21, 23, 31, 34 AND 35). SN 85-081,075. PUB. 5-3-2011. FILED 7-9-2010.
- 3,996,385. **WSO AND DESIGN**. WORLDPAK, INC., MULTIPLE CLASS, (INT. CLS. 7 AND 12), (U.S. CLS. 13, 19, 21, 23, 31, 34, 35 AND 44). SN 85-081,365. PUB. 5-3-2011. FILED 7-9-2010.
- 3,996,442. **STITCHLINER (STANDARD CHARACTER)**. HORIZON INTERNATIONAL INC., (U.S. CLS. 13, 19, 21, 23, 31, 34 AND 35). SN 85-096,475. PUB. 5-3-2011. FILED 7-30-2010.
- 3,996,446. **SILENCEPLUS (STANDARD CHARACTER)**. BSH BOSCH UND SIEMENS HAUSGERAETE GMBH, (U.S. CLS. 13, 19, 21, 23, 31, 34 AND 35). SN 85-099,012. PUB. 5-3-2011. FILED 8-3-2010.
- 3,996,469 (*See Class 1 for this trademark*).
- 3,996,526. **SAND MAN (STANDARD CHARACTER)**. H. BARBER & SONS, INC., (U.S. CLS. 13, 19, 21, 23, 31, 34 AND 35). SN 85-126,958. PUB. 5-3-2011. FILED 9-10-2010.
- 3,996,554. **MISCELLANEOUS DESIGN**. THE ARMOR GROUP, INC., MULTIPLE CLASS, (INT. CLS. 7, 12, 21 AND 40), (U.S. CLS. 2, 13, 19, 21, 23, 29, 30, 31, 33, 34, 35, 40, 44, 50, 100, 103 AND 106). SN 85-133,342. PUB. 5-3-2011. FILED 9-20-2010.
- 3,996,562. **ISTART (STANDARD CHARACTER)**. ISTART PARTNERS, LTD., (U.S. CLS. 13, 19, 21, 23, 31, 34 AND 35). SN 85-134,737. PUB. 5-3-2011. FILED 9-21-2010.
- 3,996,564. **CORCEL (STANDARD CHARACTER)**. CORCEL IP LIMITED, MULTIPLE CLASS, (INT. CLS. 7, 16 AND 20), (U.S. CLS. 2, 5, 13, 19, 21, 22, 23, 25, 29, 31, 32, 34, 35, 37, 38 AND 50). SN 85-135,114. PUB. 5-3-2011. FILED 9-22-2010.
- 3,996,622. **ARC AND DESIGN**. ADANCED RAIL CONCEPTS, LLC, (U.S. CLS. 13, 19, 21, 23, 31, 34 AND 35). SN 85-149,904. PUB. 5-3-2011. FILED 10-11-2010.
- 3,996,635. **STEALTHZONE (STANDARD CHARACTER)**. MATERIAL HANDLING TECHNOLOGIES, INC., (U.S. CLS. 13, 19, 21, 23, 31, 34 AND 35). SN 85-151,240. PUB. 5-3-2011. FILED 10-13-2010.
- 3,996,745. **VACSOC (STANDARD CHARACTER)**. PLASTIFLEX CANADA INC., (U.S. CLS. 13, 19, 21, 23, 31, 34 AND 35). SN 85-171,623. PUB. 5-3-2011. FILED 11-8-2010.
- 3,996,800. **SBE SITE BASED ENERGY AND DESIGN**. SITE BASED ENERGY, MULTIPLE CLASS, (INT. CLS. 7 AND 37), (U.S. CLS. 13, 19, 21, 23, 31, 34, 35, 100, 103 AND 106). SN 85-176,072. PUB. 5-3-2011. FILED 11-12-2010.
- 3,996,844. **3D PUSHBLOCK (STANDARD CHARACTER)**. MICRO JIG, (U.S. CLS. 13, 19, 21, 23, 31, 34 AND 35). SN 85-178,719. PUB. 5-3-2011. FILED 11-17-2010.
- 3,997,080. **DIALINE (STANDARD CHARACTER)**. ACCU-STREAM, INC., (U.S. CLS. 13, 19, 21, 23, 31, 34 AND 35). SN 85-188,434. PUB. 5-3-2011. FILED 12-1-2010.
- 3,997,236. **BIG GUN EXHAUST SYSTEMS AND DESIGN**. LARRYJ. RIGGS, (U.S. CLS. 13, 19, 21, 23, 31, 34 AND 35). SN 85-192,201. PUB. 5-3-2011. FILED 12-7-2010.
- 3,997,320. **TAWS (STANDARD CHARACTER)**. PETTER INVESTMENTS, INC., (U.S. CLS. 13, 19, 21, 23, 31, 34 AND 35). SN 85-195,050. PUB. 5-3-2011. FILED 12-10-2010.
- 3,997,432 (*See Class 3 for this trademark*).
- 3,997,497. **ENVISION AND DESIGN**. ENVISION ENERGY (JIANGYIN) CO., LTD., (U.S. CLS. 13, 19, 21, 23, 31, 34 AND 35). SN 85-203,507. PUB. 5-3-2011. FILED 12-22-2010.
- 3,997,579. **J'S RACING (STANDARD CHARACTER)**. J'S RACING USA LLC, MULTIPLE CLASS, (INT. CLS. 7 AND 12), (U.S. CLS. 13, 19, 21, 23, 31, 34, 35 AND 44). SN 85-204,999. PUB. 5-3-2011. FILED 12-23-2010.
- 3,997,582. **V SUN MASTER AND DESIGN**. SHUN CHUAN MACHINERY IND. CO., LTD., (U.S. CLS. 13, 19, 21, 23, 31, 34 AND 35). SN 85-205,046. PUB. 5-3-2011. FILED 12-23-2010.
- 3,997,611. **WOW (STANDARD CHARACTER)**. BALBOA WATER GROUP, INC., (U.S. CLS. 13, 19, 21, 23, 31, 34 AND 35). SN 85-205,417. PUB. 5-3-2011. FILED 12-23-2010.
- 3,997,647. **DYNAX (STANDARD CHARACTER)**. HERRAMIENTAS PREZISS, S.A., (U.S. CLS. 13, 19, 21, 23, 31, 34 AND 35). SN 85-205,924. PUB. 5-3-2011. FILED 12-27-2010.
- 3,997,662. **CPW (STANDARD CHARACTER)**. YUNN CHAANG HAULAGE MECHANICAL CO. LTD., (U.S. CLS. 13, 19, 21, 23, 31, 34 AND 35). SN 85-206,099. PUB. 5-3-2011. FILED 12-27-2010.
- 3,997,754. **SHARP STEEL-N-STROP (STANDARD CHARACTER)**. EDGE-CRAFT CORPORATION, (U.S. CLS. 13, 19, 21, 23, 31, 34 AND 35). SN 85-207,426. PUB. 5-3-2011. FILED 12-29-2010.
- 3,997,792. **HIGHLANDER (STANDARD CHARACTER)**. HARMAR SUMMIT, LLC, (U.S. CLS. 13, 19, 21, 23, 31, 34 AND 35). SN 85-208,003. PUB. 5-3-2011. FILED 12-30-2010.
- 3,997,942. **MISCELLANEOUS DESIGN**. KAMAK DYNAMICS USA GROUP, (U.S. CLS. 13, 19, 21, 23, 31, 34 AND 35). SN 85-209,626. PUB. 5-3-2011. FILED 1-4-2011.
- 3,997,966. **POWER TOWER (STANDARD CHARACTER)**. PARSLAW, HAROLD W., (U.S. CLS. 13, 19, 21, 23, 31, 34 AND 35). SN 85-209,979. PUB. 5-3-2011. FILED 1-4-2011.
- 3,998,040. **DURA-RELEASE (STANDARD CHARACTER)**. VALLEY ROLLER COMPANY, INC., (U.S. CLS. 13, 19, 21, 23, 31, 34 AND 35). SN 85-211,073. PUB. 5-3-2011. FILED 1-5-2011.
- 3,998,043. **VALTHANE (STANDARD CHARACTER)**. VALLEY ROLLER COMPANY, INC., (U.S. CLS. 13, 19, 21, 23, 31, 34 AND 35). SN 85-211,132. PUB. 5-3-2011. FILED 1-5-2011.
- 3,998,045. **VAL-COAT (STANDARD CHARACTER)**. VALLEY ROLLER COMPANY, INC., (U.S. CLS. 13, 19, 21, 23, 31, 34 AND 35). SN 85-211,152. PUB. 5-3-2011. FILED 1-5-2011.

- 3,998,046. **ULTIMATE VAL-COAT (STANDARD CHARACTER)**. VALLEY ROLLER COMPANY, INC., (U.S. CLS. 13, 19, 21, 23, 31, 34 AND 35). SN 85-211,165. PUB. 5-3-2011. FILED 1-5-2011.
- 3,998,200. **MISCELLANEOUS DESIGN**. SAFEWORKS, LLC, (U.S. CLS. 13, 19, 21, 23, 31, 34 AND 35). SN 85-216,964. PUB. 5-3-2011. FILED 1-13-2011.

CLASS 8—HAND TOOLS

- 3,995,718. **PROGRADE (STANDARD CHARACTER)**. COSCO MANAGEMENT, INC., MULTIPLE CLASS, (INT. CLS. 8, 10 AND 12), (U.S. CLS. 19, 21, 23, 26, 28, 31, 35, 39 AND 44). SN 77-981,535. PUB. 5-3-2011. FILED 1-26-2010.
- 3,995,719 (*See Class 3 for this trademark*).
- 3,995,893. **AMBROSIA (STANDARD CHARACTER)**. SKY CHAIN TRADING LIMITED, MULTIPLE CLASS, (INT. CLS. 8 AND 21), (U.S. CLS. 2, 13, 23, 28, 29, 30, 33, 40, 44 AND 50). SN 79-085,991. PUB. 5-3-2011. FILED 6-11-2010.
- 3,995,925. **PEDIBELLE (STYLIZED)**. PROMED GMBH MEDIZINISCHE GERÄTE UND KOSMETISCHE ERZEUGNISSE, (U.S. CLS. 23, 28 AND 44). SN 79-087,754. PUB. 5-3-2011. FILED 5-14-2010.
- 3,996,144 (*See Class 3 for this trademark*).
- 3,996,360. **TROPHY STAG (STANDARD CHARACTER)**. FROST, JAMES A., DBA FROST CUTLERY, (U.S. CLS. 23, 28 AND 44). SN 85-074,023. PUB. 5-3-2011. FILED 6-29-2010.
- 3,996,857. **DEXSTEEL (STANDARD CHARACTER)**. DEXTER-RUSSELL, INC., (U.S. CLS. 23, 28 AND 44). SN 85-179,214. PUB. 5-3-2011. FILED 11-17-2010.
- 3,997,063. **BETTER HOMES AND GARDENS (STANDARD CHARACTER)**. MEREDITH CORPORATION, (U.S. CLS. 23, 28 AND 44). SN 85-188,049. PUB. 5-3-2011. FILED 12-1-2010.
- 3,997,360. **RCC (STANDARD CHARACTER)**. QUEEN CUTLERY COMPANY, (U.S. CLS. 23, 28 AND 44). SN 85-197,383. PUB. 5-3-2011. FILED 12-14-2010.
- 3,997,439. **BOMB SIGHT DRILL CLAMP AND DESIGN**. ALL AMERICAN PRODUCTS GROUP, INC., (U.S. CLS. 23, 28 AND 44). SN 85-201,072. PUB. 5-3-2011. FILED 12-17-2010.
- 3,998,276. **FATMAX XTREME (STANDARD CHARACTER)**. STANLEY LOGISTICS, L.L.C., (U.S. CLS. 23, 28 AND 44). SN 85-245,984. PUB. 5-3-2011. FILED 2-18-2011.

CLASS 9—ELECTRICAL AND SCIENTIFIC APPARATUS

- 3,995,465. **BRIGHT-WAY (STANDARD CHARACTER)**. HOWARD BERGER CO., INC., MULTIPLE CLASS, (INT. CLS. 9 AND 11), (U.S. CLS. 13, 21, 23, 26, 31, 34, 36 AND 38). SN 76-701,074. PUB. 5-3-2011. FILED 1-4-2010.
- 3,995,474. **ION (STANDARD CHARACTER)**. ASD SPECIALTY HEALTHCARE, INC., MULTIPLE CLASS, (INT. CLS. 9, 16, 35 AND 41), (U.S. CLS. 2, 5, 21, 22, 23, 26, 29, 36, 37, 38, 50, 100, 101, 102 AND 107). SN 76-703,455. PUB. 5-3-2011. FILED 6-21-2010.
- 3,995,511. **COMVENIENT (STANDARD CHARACTER)**. COMVENIENT GMBH & CO. KG, MULTIPLE CLASS, (INT. CLS. 9, 38, 41 AND 42), (U.S. CLS. 21, 23, 26, 36, 38, 100, 101, 104 AND 107). SN 77-065,308. PUB. 4-12-2011. FILED 12-15-2006.
- 3,995,512. **CONNEXASSIST (STANDARD CHARACTER)**. GLOBESTAR SYSTEMS INC., (U.S. CLS. 21, 23, 26, 36 AND 38). SN 77-078,782. PUB. 5-3-2011. FILED 1-9-2007.
- 3,995,514. **BODY MECHANICS AND DESIGN**. BIG RED FROG LIMITED, MULTIPLE CLASS, (INT. CLS. 9, 16, 38 AND 41), (U.S. CLS. 2, 5, 21, 22, 23, 26, 29, 36, 37, 38, 50, 100, 101, 104 AND 107). SN 77-124,077. PUB. 4-12-2011. FILED 3-7-2007.
- 3,995,515. **SOBAY (STANDARD CHARACTER)**. WIPRO TRADEMARKS HOLDING COMPANY, MULTIPLE CLASS, (INT. CLS. 9, 35, 37 AND 42), (U.S. CLS. 21, 23, 26, 36, 38, 100,

- 101, 102, 103 AND 106). SN 77-143,648. PUB. 3-30-2010. FILED 3-29-2007.
- 3,995,521. **OPERATION CREATURE FEATURE (STANDARD CHARACTER)**. SONY COMPUTER ENTERTAINMENT EUROPE LIMITED, (U.S. CLS. 21, 23, 26, 36 AND 38). SN 77-303,036. PUB. 5-3-2011. FILED 10-12-2007.
- 3,995,524 (*See Class 7 for this trademark*).
- 3,995,531 (*See Class 7 for this trademark*).
- 3,995,534. **MISCELLANEOUS DESIGN**. DIVERSITECH CORPORATION, (U.S. CLS. 21, 23, 26, 36 AND 38). SN 77-525,657. PUB. 5-3-2011. FILED 7-18-2008.
- 3,995,540. **FOREVERMARK DIAMOND INSTITUTE (STANDARD CHARACTER)**. DE BEERS CENTENARY AG, MULTIPLE CLASS, (INT. CLS. 9, 35, 37, 40, 41 AND 42), (U.S. CLS. 21, 23, 26, 36, 38, 100, 101, 102, 103, 106 AND 107). SN 77-576,952. PUB. 5-3-2011. FILED 9-23-2008.
- 3,995,548. **FLEXIBLE POWER (STANDARD CHARACTER)**. JK-HOLDING GMBH, MULTIPLE CLASS, (INT. CLS. 9, 10, 11, 41 AND 44), (U.S. CLS. 13, 21, 23, 26, 31, 34, 36, 38, 39, 44, 100, 101 AND 107). SN 77-584,964. PUB. 3-30-2010. FILED 10-3-2008.
- 3,995,552. **CLEARCANVAS AND DESIGN**. CLEARCANVAS INC., MULTIPLE CLASS, (INT. CLS. 9, 41 AND 42), (U.S. CLS. 21, 23, 26, 36, 38, 100, 101 AND 107). SN 77-601,535. PUB. 5-3-2011. FILED 10-27-2008.
- 3,995,553. **ALL OF THE ABOVE (STANDARD CHARACTER)**. ALL OF THE ABOVE, MULTIPLE CLASS, (INT. CLS. 9 AND 41), (U.S. CLS. 21, 23, 26, 36, 38, 100, 101 AND 107). SN 77-611,493. PUB. 5-3-2011. FILED 11-10-2008.
- 3,995,558. **SUNWORKS (STANDARD CHARACTER)**. SUNWORKS SOLAR LLC, (U.S. CLS. 21, 23, 26, 36 AND 38). SN 77-643,288. PUB. 5-26-2009. FILED 1-5-2009.
- 3,995,567. **THERMTROL (STANDARD CHARACTER)**. THERMTROL CORPORATION, MULTIPLE CLASS, (INT. CLS. 9 AND 12), (U.S. CLS. 19, 21, 23, 26, 31, 35, 36, 38 AND 44). SN 77-681,984. PUB. 5-3-2011. FILED 3-3-2009.
- 3,995,570. **LOCKPICK (STANDARD CHARACTER)**. COASTAL ELECTRONIC TECHNOLOGIES, INC., (U.S. CLS. 21, 23, 26, 36 AND 38). SN 77-699,102. PUB. 1-26-2010. FILED 3-25-2009.
- 3,995,573. **EGALAX TOUCH AND DESIGN**. EGALAX—EMPIA TECHNOLOGY INC., MULTIPLE CLASS, (INT. CLS. 9 AND 42), (U.S. CLS. 21, 23, 26, 36, 38, 100 AND 101). SN 77-705,354. PUB. 5-3-2011. FILED 4-2-2009.
- 3,995,574. **IPX AND DESIGN**. IPX INTERNATIONAL INC., (U.S. CLS. 21, 23, 26, 36 AND 38). SN 77-716,563. PUB. 5-3-2011. FILED 4-17-2009.
- 3,995,585. **ECOSMART (STANDARD CHARACTER)**. LG ELECTRONICS INC., (U.S. CLS. 21, 23, 26, 36 AND 38). SN 77-754,538. PUB. 5-3-2011. FILED 6-8-2009.
- 3,995,592. **BABY COW AND DESIGN**. BABY COW PRODUCTIONS LTD., MULTIPLE CLASS, (INT. CLS. 9, 16, 35, 38 AND 41), (U.S. CLS. 2, 5, 21, 22, 23, 26, 29, 36, 37, 38, 50, 100, 101, 102, 104 AND 107). SN 77-787,796. PUB. 4-26-2011. FILED 7-23-2009.
- 3,995,606. **SECUKEYBOARD (STANDARD CHARACTER)**. SHINING UNION LIMITED, (U.S. CLS. 21, 23, 26, 36 AND 38). SN 77-826,637. PUB. 5-3-2011. FILED 9-15-2009.
- 3,995,618. **ENERSIM (STANDARD CHARACTER)**. BAE SYSTEMS PLC, MULTIPLE CLASS, (INT. CLS. 9, 16, 35 AND 42), (U.S. CLS. 2, 5, 21, 22, 23, 26, 29, 36, 37, 38, 50, 100, 101 AND 102). SN 77-845,729. PUB. 3-29-2011. FILED 10-9-2009.
- 3,995,623. **CHILL (STANDARD CHARACTER)**. STAR GROUP COMMUNICATIONS, INC., (U.S. CLS. 21, 23, 26, 36 AND 38). SN 77-857,051. PUB. 5-3-2011. FILED 10-26-2009.
- 3,995,624. **RESURFICA (STANDARD CHARACTER)**. MILUX HOLDING S.A., MULTIPLE CLASS, (INT. CLS. 9, 10 AND 44), (U.S. CLS. 21, 23, 26, 36, 38, 39, 44, 100 AND 101). SN 77-858,169. PUB. 5-3-2011. FILED 10-27-2009.
- 3,995,625. **MEDICALTREE (STANDARD CHARACTER)**. MILUX HOLDING S.A., MULTIPLE CLASS, (INT. CLS. 9, 10, 36 AND 44), (U.S. CLS. 21, 23, 26, 36, 38, 39, 44, 100, 101 AND 102). SN 77-858,209. PUB. 5-3-2011. FILED 10-27-2009.
- 3,995,627. **CASECODER CONFIDENT CODING AT YOUR FINGERTIPS AND DESIGN**. CATALETTO, BARBARA, DBA CASECODER LLC, (U.S. CLS. 21, 23, 26, 36 AND 38). SN 77-863,017. PUB. 5-3-2011. FILED 11-2-2009.
- 3,995,630. **VECTASTAR (STANDARD CHARACTER)**. CAM-

- BRIDGE BROADBAND NETWORKS LIMITED, MULTIPLE CLASS, (INT. CLS. 9 AND 38), (U.S. CLS. 21, 23, 26, 36, 38, 100, 101 AND 104). SN 77-863,869. PUB. 4-6-2010. FILED 11-3-2009.
- 3,995,642. **AGENCYPORTAL (STANDARD CHARACTER)**. AGENCYPORT INSURANCE SERVICES, INC., (U.S. CLS. 21, 23, 26, 36 AND 38). SN 77-868,582. PUB. 5-3-2011. FILED 11-9-2009.
- 3,995,647 (*See Class 2 for this trademark*).
- 3,995,663. **IBASE (STANDARD CHARACTER)**. IBASE TECHNOLOGY INC., (U.S. CLS. 21, 23, 26, 36 AND 38). SN 77-901,404. PUB. 5-3-2011. FILED 12-28-2009.
- 3,995,699. **QUADRACLEAR (STANDARD CHARACTER)**. GETAC TECHNOLOGY CORPORATION, (U.S. CLS. 21, 23, 26, 36 AND 38). SN 77-950,519. PUB. 5-3-2011. FILED 3-4-2010.
- 3,995,703. **GERMAN ABSINEERING (STANDARD CHARACTER)**. KLAUS REITHMEIER, MULTIPLE CLASS, (INT. CLS. 9 AND 41), (U.S. CLS. 21, 23, 26, 36, 38, 100, 101 AND 107). SN 77-952,034. PUB. 2-8-2011. FILED 3-5-2010.
- 3,995,705. **PROMRI (STANDARD CHARACTER)**. BIOTRONIK SE & CO. KG, MULTIPLE CLASS, (INT. CLS. 9, 10, 38 AND 44), (U.S. CLS. 21, 23, 26, 36, 38, 39, 44, 100, 101 AND 104). SN 77-955,850. PUB. 1-11-2011. FILED 3-10-2010.
- 3,995,715. **N NATURAL HISTORY MUSEUM (STYLIZED)**. TRUSTEES OF THE NATURAL HISTORY MUSEUM, MULTIPLE CLASS, (INT. CLS. 9, 14, 16, 19, 20, 24, 28 AND 30), (U.S. CLS. 1, 2, 5, 12, 13, 21, 22, 23, 25, 26, 27, 28, 29, 32, 33, 36, 37, 38, 42, 46 AND 50). SN 77-981,497. PUB. 4-12-2011. FILED 11-9-2009.
- 3,995,719 (*See Class 3 for this trademark*).
- 3,995,720 (*See Class 6 for this trademark*).
- 3,995,727. **COMMENT IS FREE (STANDARD CHARACTER)**. GUARDIAN NEWS & MEDIA LIMITED, MULTIPLE CLASS, (INT. CLS. 9, 16, 38 AND 41), (U.S. CLS. 2, 5, 21, 22, 23, 26, 29, 36, 37, 38, 50, 100, 101, 104 AND 107). SN 78-981,476. PUB. 4-20-2010. FILED 2-3-2006.
- 3,995,728. **EGIS PROJECTS (STANDARD CHARACTER)**. EGIS PROJECTS, MULTIPLE CLASS, (INT. CLS. 9, 35, 36, 37, 39, 42 AND 45), (U.S. CLS. 21, 23, 26, 36, 38, 100, 101, 102, 103, 105 AND 106). SN 79-046,844. PUB. 5-3-2011. FILED 4-10-2007.
- 3,995,730. **NETVIEWER AND DESIGN**. NETVIEWER AG, MULTIPLE CLASS, (INT. CLS. 9 AND 42), (U.S. CLS. 21, 23, 26, 36, 38, 100 AND 101). SN 79-058,836. PUB. 5-3-2011. FILED 6-20-2008.
- 3,995,734 (*See Class 6 for this trademark*).
- 3,995,735 (*See Class 6 for this trademark*).
- 3,995,738. **SCUDERIA FERRARI AUTO-AVIO COSTRUZIONI (STANDARD CHARACTER)**. FERRARI S.P.A., MULTIPLE CLASS, (INT. CLS. 9, 12, 25, 28, 35, 37 AND 42), (U.S. CLS. 19, 21, 22, 23, 26, 31, 35, 36, 38, 39, 44, 50, 100, 101, 102, 103 AND 106). SN 79-070,792. PUB. 5-3-2011. FILED 12-24-2008.
- 3,995,739. **HUMMING HEADS SECURITY PLATFORM (STYLIZED)**. HUMMING HEADS KABUSHIKI KAISHA, MULTIPLE CLASS, (INT. CLS. 9 AND 42), (U.S. CLS. 21, 23, 26, 36, 38, 100 AND 101). SN 79-071,797. PUB. 5-3-2011. FILED 2-2-2009.
- 3,995,740. **HUMMING HEADS INTELLIGENCE PLATFORM (STYLIZED)**. HUMMING HEADS KABUSHIKI KAISHA, MULTIPLE CLASS, (INT. CLS. 9 AND 42), (U.S. CLS. 21, 23, 26, 36, 38, 100 AND 101). SN 79-071,798. PUB. 5-3-2011. FILED 2-2-2009.
- 3,995,741. **INTELLIGENCE PLATFORM AND DESIGN**. HUMMING HEADS KABUSHIKI KAISHA, MULTIPLE CLASS, (INT. CLS. 9 AND 42), (U.S. CLS. 21, 23, 26, 36, 38, 100 AND 101). SN 79-071,799. PUB. 5-3-2011. FILED 2-2-2009.
- 3,995,742. **INTELLIGENCE PLATFORM AND DESIGN**. HUMMING HEADS KABUSHIKI KAISHA, MULTIPLE CLASS, (INT. CLS. 9 AND 42), (U.S. CLS. 21, 23, 26, 36, 38, 100 AND 101). SN 79-071,800. PUB. 5-3-2011. FILED 2-2-2009.
- 3,995,743. **HUMMING HEADS QUALITY EVALUATION CENTER (STYLIZED)**. HUMMING HEADS KABUSHIKI KAISHA, MULTIPLE CLASS, (INT. CLS. 9 AND 42), (U.S. CLS. 21, 23, 26, 36, 38, 100 AND 101). SN 79-071,801. PUB. 5-3-2011. FILED 2-2-2009.
- 3,995,744. **INSTREAMER (STANDARD CHARACTER)**. BARIX AG, MULTIPLE CLASS, (INT. CLS. 9 AND 42), (U.S. CLS. 21, 23, 26, 36, 38, 100 AND 101). SN 79-071,936. PUB. 5-3-2011. FILED 4-24-2009.
- 3,995,745. **ZINGZILLAS (STANDARD CHARACTER)**. THE BRITISH BROADCASTING CORPORATION, MULTIPLE CLASS, (INT. CLS. 9, 16, 25, 28, 38 AND 41), (U.S. CLS. 2, 5, 21, 22, 23, 26, 29, 36, 37, 38, 39, 50, 100, 101, 104 AND 107). SN 79-072,566. PUB. 1-25-2011. FILED 5-20-2009.
- 3,995,747. **4ELEMENTS TESTING (STANDARD CHARACTER)**. QED GROUP A.S., MULTIPLE CLASS, (INT. CLS. 9, 35, 41 AND 42), (U.S. CLS. 21, 23, 26, 36, 38, 100, 101, 102 AND 107). SN 79-073,905. PUB. 5-3-2011. FILED 4-22-2009.
- 3,995,748 (*See Class 7 for this trademark*).
- 3,995,750. **BALTIC EXCHANGE SUPRAMAX INDEX (STANDARD CHARACTER)**. THE BALTIC EXCHANGE LIMITED, MULTIPLE CLASS, (INT. CLS. 9, 35 AND 36), (U.S. CLS. 21, 23, 26, 36, 38, 100, 101 AND 102). SN 79-076,312. PUB. 5-3-2011. FILED 11-6-2009.
- 3,995,751. **BALTIC EXCHANGE PANAMAX INDEX (STANDARD CHARACTER)**. THE BALTIC EXCHANGE LIMITED, MULTIPLE CLASS, (INT. CLS. 9, 35 AND 36), (U.S. CLS. 21, 23, 26, 36, 38, 100, 101 AND 102). SN 79-076,313. PUB. 5-3-2011. FILED 11-6-2009.
- 3,995,752. **BALTIC EXCHANGE HANDYSIZE INDEX (STANDARD CHARACTER)**. THE BALTIC EXCHANGE LIMITED, MULTIPLE CLASS, (INT. CLS. 9, 35 AND 36), (U.S. CLS. 21, 23, 26, 36, 38, 100, 101 AND 102). SN 79-076,314. PUB. 5-3-2011. FILED 11-6-2009.
- 3,995,753. **DMAC (STANDARD CHARACTER)**. OXLEY DEVELOPMENTS COMPANY LIMITED, MULTIPLE CLASS, (INT. CLS. 9 AND 11), (U.S. CLS. 13, 21, 23, 26, 31, 34, 36 AND 38). SN 79-076,705. PUB. 5-3-2011. FILED 11-25-2009.
- 3,995,754. **TMAC (STANDARD CHARACTER)**. OXLEY DEVELOPMENTS COMPANY LIMITED, MULTIPLE CLASS, (INT. CLS. 9 AND 11), (U.S. CLS. 13, 21, 23, 26, 31, 34, 36 AND 38). SN 79-076,706. PUB. 5-3-2011. FILED 11-25-2009.
- 3,995,760. **BMG (STANDARD CHARACTER)**. BMG RIGHTS MANAGEMENT GMBH, MULTIPLE CLASS, (INT. CLS. 9, 16, 35, 38, 41 AND 45), (U.S. CLS. 2, 5, 21, 22, 23, 26, 29, 36, 37, 38, 50, 100, 101, 102, 104 AND 107). SN 79-077,795. PUB. 5-3-2011. FILED 10-20-2009.
- 3,995,765 (*See Class 7 for this trademark*).
- 3,995,766. **SOLAR FABRIK AND DESIGN**. SOLAR-FABRIK AG, MULTIPLE CLASS, (INT. CLS. 9 AND 11), (U.S. CLS. 13, 21, 23, 26, 31, 34, 36 AND 38). SN 79-078,402. PUB. 5-3-2011. FILED 10-2-2009.
- 3,995,768. **CAMPUS VEOLIA ENVIRONNEMENT AND DESIGN**. VEOLIA ENVIRONNEMENT, MULTIPLE CLASS, (INT. CLS. 9, 16, 35 AND 41), (U.S. CLS. 2, 5, 21, 22, 23, 26, 29, 36, 37, 38, 50, 100, 101, 102 AND 107). SN 79-078,662. PUB. 5-3-2011. FILED 9-16-2009.
- 3,995,779. **TCCS (STANDARD CHARACTER)**. ANSALDO STS S.P.A., MULTIPLE CLASS, (INT. CLS. 9, 37, 38 AND 42), (U.S. CLS. 21, 23, 26, 36, 38, 100, 101, 103, 104 AND 106). SN 79-080,730. PUB. 5-3-2011. FILED 12-3-2009.
- 3,995,780. **BORA AND DESIGN**. SMETHURST NICHOLAS, MULTIPLE CLASS, (INT. CLS. 9, 38 AND 42), (U.S. CLS. 21, 23, 26, 36, 38, 100, 101 AND 104). SN 79-080,837. PUB. 5-3-2011. FILED 11-4-2009.
- 3,995,785. **QUANTUM ENTRAINMENT (STANDARD CHARACTER)**. VAK VERLAGS GMBH, MULTIPLE CLASS, (INT. CLS. 9, 16, 35 AND 41), (U.S. CLS. 2, 5, 21, 22, 23, 26, 29, 36, 37, 38, 50, 100, 101, 102 AND 107). SN 79-081,870. PUB. 1-25-2011. FILED 1-21-2010.
- 3,995,798. **DUALFLOW (STANDARD CHARACTER)**. NEWTEC CY NV, MULTIPLE CLASS, (INT. CLS. 9, 38 AND 42), (U.S. CLS. 21, 23, 26, 36, 38, 100, 101 AND 104). SN 79-082,956. PUB. 1-25-2011. FILED 3-16-2010.
- 3,995,800. **D L C A P (STYLIZED)**. NIPPON CHEMI-CON CORPORATION, (U.S. CLS. 21, 23, 26, 36 AND 38). SN 79-083,056. PUB. 5-3-2011. FILED 4-30-2010.
- 3,995,809. **CYTOO AND DESIGN**. CYTOO, (U.S. CLS. 21, 23, 26, 36 AND 38). SN 79-083,496. PUB. 5-3-2011. FILED 4-30-2010.
- 3,995,813 (*See Class 7 for this trademark*).
- 3,995,818. **SPM HD (STYLIZED)**. SPM INSTRUMENT AB, (U.S. CLS. 21, 23, 26, 36 AND 38). SN 79-083,753. PUB. 5-3-2011. FILED 5-10-2010.
- 3,995,819. **DEPTHSENSE (STANDARD CHARACTER)**. OPTRIMA, NAAMLOZE VENNOOTSCHAP, MULTIPLE

- CLASS. (INT. CLS. 9 AND 42), (U.S. CLS. 21, 23, 26, 36, 38, 100 AND 101). SN 79-083,786. PUB. 5-3-2011. FILED 5-17-2010.
- 3,995,823. **EVERSENSE (STYLIZED)**. SOLETANCHE FREYSINET, MULTIPLE CLASS. (INT. CLS. 9, 37 AND 42), (U.S. CLS. 21, 23, 26, 36, 38, 100, 101, 103 AND 106). SN 79-084,125. PUB. 5-3-2011. FILED 3-12-2010.
- 3,995,846. **COLLABORATION INTELLIGENCE (STANDARD CHARACTER)**. TRYANE, MULTIPLE CLASS. (INT. CLS. 9 AND 42), (U.S. CLS. 21, 23, 26, 36, 38, 100 AND 101). SN 79-084,798. PUB. 5-3-2011. FILED 4-30-2010.
- 3,995,857. **ULTIMHEAT (STYLIZED)**. IPCI CONTROLS FOSHAN GAOMING CO., LTD., MULTIPLE CLASS. (INT. CLS. 9, 11 AND 20), (U.S. CLS. 2, 13, 21, 22, 23, 25, 26, 31, 32, 34, 36, 38 AND 50). SN 79-085,093. PUB. 5-3-2011. FILED 5-11-2010.
- 3,995,863 (*See Class 2 for this trademark*).
- 3,995,867. **INIZIO (STANDARD CHARACTER)**. LAUTSPRECHER TEUFEL GMBH, MULTIPLE CLASS. (INT. CLS. 9, 35 AND 41), (U.S. CLS. 21, 23, 26, 36, 38, 100, 101, 102 AND 107). SN 79-085,306. PUB. 5-3-2011. FILED 6-23-2010.
- 3,995,868. **MISCELLANEOUS DESIGN**. REDPIXIE LIMITED, MULTIPLE CLASS. (INT. CLS. 9, 37 AND 42), (U.S. CLS. 21, 23, 26, 36, 38, 100, 101, 103 AND 106). SN 79-085,344. PUB. 5-3-2011. FILED 4-22-2010.
- 3,995,875 (*See Class 7 for this trademark*).
- 3,995,876. **3 E ECO EFFICIENCY EVALUATIONS AND DESIGN**. RHODIA OPERATIONS, MULTIPLE CLASS. (INT. CLS. 9, 35 AND 42), (U.S. CLS. 21, 23, 26, 36, 38, 100, 101 AND 102). SN 79-085,559. PUB. 5-3-2011. FILED 6-1-2010.
- 3,995,877. **AUREOL (STANDARD CHARACTER)**. LAUTSPRECHER TEUFEL GMBH, MULTIPLE CLASS. (INT. CLS. 9, 35 AND 41), (U.S. CLS. 21, 23, 26, 36, 38, 100, 101, 102 AND 107). SN 79-085,595. PUB. 5-3-2011. FILED 6-23-2010.
- 3,995,878. **CONSONO (STANDARD CHARACTER)**. LAUTSPRECHER TEUFEL GMBH, MULTIPLE CLASS. (INT. CLS. 9, 35 AND 41), (U.S. CLS. 21, 23, 26, 36, 38, 100, 101, 102 AND 107). SN 79-085,596. PUB. 5-3-2011. FILED 6-23-2010.
- 3,995,896. **HI-HEAD (STANDARD CHARACTER)**. ADALBERTO GROSSI, MULTIPLE CLASS. (INT. CLS. 9 AND 25), (U.S. CLS. 21, 22, 23, 26, 36, 38 AND 39). SN 79-086,077. PUB. 5-3-2011. FILED 2-19-2010.
- 3,995,898 (*See Class 5 for this trademark*).
- 3,995,903. **GENELONG AND DESIGN**. ZHEJIANG ZHENLONG BATTERY CO., LTD., (U.S. CLS. 21, 23, 26, 36 AND 38). SN 79-086,321. PUB. 5-3-2011. FILED 8-3-2010.
- 3,995,904 (*See Class 1 for this trademark*).
- 3,995,907. **DOCUSUITE (STANDARD CHARACTER)**. EDATA-UNITED GMBH, MULTIPLE CLASS. (INT. CLS. 9, 35, 38 AND 42), (U.S. CLS. 21, 23, 26, 36, 38, 100, 101, 102 AND 104). SN 79-086,475. PUB. 5-3-2011. FILED 4-15-2010.
- 3,995,908. **BLOCKMASTER (STANDARD CHARACTER)**. BLOCKMASTER AB, MULTIPLE CLASS. (INT. CLS. 9 AND 42), (U.S. CLS. 21, 23, 26, 36, 38, 100 AND 101). SN 79-086,519. PUB. 5-3-2011. FILED 6-16-2010.
- 3,995,928. **MPR2LOGO (STANDARD CHARACTER)**. RAUMEDIC AG, MULTIPLE CLASS. (INT. CLS. 9 AND 10), (U.S. CLS. 21, 23, 26, 36, 38, 39 AND 44). SN 79-087,826. PUB. 5-3-2011. FILED 9-1-2010.
- 3,995,929. **SAGAWAFUJII AND DESIGN**. KIM, DAE IL, (U.S. CLS. 21, 23, 26, 36 AND 38). SN 79-087,852. PUB. 5-3-2011. FILED 8-18-2010.
- 3,995,931. **NETCURY (STYLIZED)**. HYUN JIN, AHN, (U.S. CLS. 21, 23, 26, 36 AND 38). SN 79-087,918. PUB. 5-3-2011. FILED 8-23-2010.
- 3,995,932. **MADE FOR ALL (STANDARD CHARACTER)**. FAST RETAILING CO., LTD., MULTIPLE CLASS. (INT. CLS. 9, 18 AND 25), (U.S. CLS. 1, 2, 3, 21, 22, 23, 26, 36, 38, 39 AND 41). SN 79-087,959. PUB. 5-3-2011. FILED 9-7-2010.
- 3,995,934. **TIMESENSOR AND DESIGN**. DANIEL NESTOR SOLENTHALER, (U.S. CLS. 21, 23, 26, 36 AND 38). SN 79-088,023. PUB. 5-3-2011. FILED 9-9-2010.
- 3,995,937. **OIRAN (STANDARD CHARACTER)**. UNIVERSAL ENTERTAINMENT CORPORATION, MULTIPLE CLASS. (INT. CLS. 9 AND 28), (U.S. CLS. 21, 22, 23, 26, 36, 38 AND 50). SN 79-088,156. PUB. 5-3-2011. FILED 8-5-2010.
- 3,995,940. **SUBSTITUTE (STANDARD CHARACTER)**. OSRAM GESELLSCHAFT MIT BESCHRÄNKTER HAFTUNG, DBA OSRAM GMBH, MULTIPLE CLASS. (INT. CLS. 9 AND 11), (U.S. CLS. 13, 21, 23, 26, 31, 34, 36 AND 38). SN 79-088,302. PUB. 5-3-2011. FILED 7-6-2010.
- 3,995,942. **VECTORWISE AND DESIGN**. VECTORWISE B.V., MULTIPLE CLASS. (INT. CLS. 9 AND 42), (U.S. CLS. 21, 23, 26, 36, 38, 100 AND 101). SN 79-088,378. PUB. 5-3-2011. FILED 8-4-2010.
- 3,995,943. **ADMANTX (STANDARD CHARACTER)**. SPOTON S.R.L., MULTIPLE CLASS. (INT. CLS. 9, 35 AND 42), (U.S. CLS. 21, 23, 26, 36, 38, 100, 101 AND 102). SN 79-088,436. PUB. 5-3-2011. FILED 8-26-2010.
- 3,995,952. **ZLED (STANDARD CHARACTER)**. ZETT OPTICS GMBH, MULTIPLE CLASS. (INT. CLS. 9, 10 AND 11), (U.S. CLS. 13, 21, 23, 26, 31, 34, 36, 38, 39 AND 44). SN 79-088,964. PUB. 5-3-2011. FILED 8-4-2010.
- 3,995,958. **DK DEMIRER KABLO (STYLIZED)**. DEMIRER KABLO TESISLERI SANAYI VE TICARET ANONIM SIRKETI, (U.S. CLS. 21, 23, 26, 36 AND 38). SN 79-089,426. PUB. 5-3-2011. FILED 5-18-2010.
- 3,995,966. **TISSUEPURE (STANDARD CHARACTER)**. TOSHIBA MEDICAL SYSTEMS CORPORATION, MULTIPLE CLASS. (INT. CLS. 9 AND 10), (U.S. CLS. 21, 23, 26, 36, 38, 39 AND 44). SN 79-089,838. PUB. 5-3-2011. FILED 10-28-2010.
- 3,995,967. **SPIRODOC AND DESIGN**. MIR SRL MEDICAL INTERNATIONAL RESEARCH, MULTIPLE CLASS. (INT. CLS. 9 AND 10), (U.S. CLS. 21, 23, 26, 36, 38, 39 AND 44). SN 79-090,001. PUB. 5-3-2011. FILED 7-15-2010.
- 3,995,969. **CIPURSE (STANDARD CHARACTER)**. INFINEON TECHNOLOGIES AG, MULTIPLE CLASS. (INT. CLS. 9, 16, 36 AND 42), (U.S. CLS. 2, 5, 21, 22, 23, 26, 29, 36, 37, 38, 50, 100, 101 AND 102). SN 79-090,085. PUB. 5-3-2011. FILED 9-9-2010.
- 3,995,979 (*See Class 1 for this trademark*).
- 3,995,988. **IMASCHINE (STANDARD CHARACTER)**. NATIVE INSTRUMENTS GMBH, (U.S. CLS. 21, 23, 26, 36 AND 38). SN 79-091,175. PUB. 5-3-2011. FILED 10-7-2010.
- 3,995,996. **SIEXPRESS (STANDARD CHARACTER)**. SIEMENS AKTIENGESELLSCHAFT, MULTIPLE CLASS. (INT. CLS. 9 AND 42), (U.S. CLS. 21, 23, 26, 36, 38, 100 AND 101). SN 79-091,824. PUB. 5-3-2011. FILED 11-17-2010.
- 3,996,003. **NUSMART (STYLIZED)**. BEIJING NUFRONT MOBILE MULTIMEDIA TECHNOLOGY CO., LTD. (U.S. CLS. 21, 23, 26, 36 AND 38). SN 79-092,451. PUB. 5-3-2011. FILED 1-4-2011.
- 3,996,016. **RIWA (STYLIZED)**. GLOBAL BEST WAY CO., LTD., (U.S. CLS. 21, 23, 26, 36 AND 38). SN 79-093,728. PUB. 5-3-2011. FILED 1-4-2011.
- 3,996,021. **GLACIER PLUS (STANDARD CHARACTER)**. SHAMIR OPTICAL INDUSTRY LTD., (U.S. CLS. 21, 23, 26, 36 AND 38). SN 79-094,038. PUB. 5-3-2011. FILED 1-3-2011.
- 3,996,024. **CMD (STANDARD CHARACTER)**. C.E.I.A. - COSTRUZIONI ELETTRONICHE INDUSTRIALI AUTOMATISMI S.P.A., (U.S. CLS. 21, 23, 26, 36 AND 38). SN 79-094,133. PUB. 5-3-2011. FILED 12-16-2010.
- 3,996,027. **NUSMART (STYLIZED)**. BEIJING NUFRONT MOBILE MULTIMEDIA TECHNOLOGY CO., LTD. (U.S. CLS. 21, 23, 26, 36 AND 38). SN 79-094,273. PUB. 5-3-2011. FILED 1-4-2011.
- 3,996,029. **BAOSIGHT (STYLIZED)**. SHANGHAI BAOSIGHT SOFTWARE CO., LTD., MULTIPLE CLASS. (INT. CLS. 9 AND 42), (U.S. CLS. 21, 23, 26, 36, 38, 100 AND 101). SN 79-094,314. PUB. 5-3-2011. FILED 12-29-2010.
- 3,996,031. **VERSACE (STANDARD CHARACTER)**. GIANNI VERSACE S.P.A., (U.S. CLS. 21, 23, 26, 36 AND 38). SN 79-975,170. PUB. 5-3-2011. FILED 9-3-2009.
- 3,996,035. **MEDIFORMS (STANDARD CHARACTER)**. IDEA OVEN LLC, (U.S. CLS. 21, 23, 26, 36 AND 38). SN 85-001,436. PUB. 5-3-2011. FILED 3-29-2010.
- 3,996,037. **SILVERMOUSE (STANDARD CHARACTER)**. ADELPHOI LIMITED, MULTIPLE CLASS. (INT. CLS. 9, 35, 42 AND 45), (U.S. CLS. 21, 23, 26, 36, 38, 100, 101 AND 102). SN 85-002,152. PUB. 5-3-2011. FILED 3-30-2010.
- 3,996,053. **AUDIO ASSIST (STANDARD CHARACTER)**. VTECH COMMUNICATIONS, INC., (U.S. CLS. 21, 23, 26, 36 AND 38). SN 85-015,131. PUB. 5-3-2011. FILED 4-15-2010.
- 3,996,054. **MESSAGE GUARD (STANDARD CHARACTER)**. VTECH COMMUNICATIONS, INC., (U.S. CLS. 21, 23, 26, 36 AND 38). SN 85-015,140. PUB. 5-3-2011. FILED 4-15-2010.

- 3,996,057. **ACCESSORYONE (STANDARD CHARACTER)**. ACCESSORYONE, (U.S. CLS. 21, 23, 26, 36 AND 38). SN 85-016,341. PUB. 5-3-2011. FILED 4-16-2010.
- 3,996,058. **HOTELPAL (STANDARD CHARACTER)**. MOBIA-TA, LLC, MULTIPLE CLASS, (INT. CLS. 9 AND 43), (U.S. CLS. 21, 23, 26, 36, 38, 100 AND 101). SN 85-016,954. PUB. 5-3-2011. FILED 4-19-2010.
- 3,996,062. **THIRD RAIL DEVICES (STANDARD CHARACTER)**. THIRD RAIL DEVICES, LLC, (U.S. CLS. 21, 23, 26, 36 AND 38). SN 85-018,027. PUB. 5-3-2011. FILED 4-20-2010.
- 3,996,067. **MISCELLANEOUS DESIGN**. CROPS CO., LTD., (U.S. CLS. 21, 23, 26, 36 AND 38). SN 85-019,067. PUB. 5-3-2011. FILED 4-21-2010.
- 3,996,081. **FLOW3 AND DESIGN**. TYPO3 ASSOCIATION E.V., (U.S. CLS. 21, 23, 26, 36 AND 38). SN 85-024,414. PUB. 10-12-2010. FILED 4-27-2010.
- 3,996,083. **EXPRESS TELLER SERVICES ATM SALES AND SERVICE AND DESIGN**. EXPRESS TELLER SERVICES, INC., (U.S. CLS. 21, 23, 26, 36 AND 38). SN 85-025,292. PUB. 5-3-2011. FILED 4-28-2010.
- 3,996,088. **BANANATOOTH (STANDARD CHARACTER)**. DIVENTION DESIGN, LLC, (U.S. CLS. 21, 23, 26, 36 AND 38). SN 85-026,359. PUB. 5-3-2011. FILED 4-29-2010.
- 3,996,092. **COURREGES (STANDARD CHARACTER)**. COURREGES DESIGN, MULTIPLE CLASS, (INT. CLS. 9 AND 24), (U.S. CLS. 21, 23, 26, 36, 38, 42 AND 50). SN 85-028,547. PUB. 5-3-2011. FILED 5-3-2010.
- 3,996,102. **NUMA (STANDARD CHARACTER)**. NUMA TACTICAL, LLC, (U.S. CLS. 21, 23, 26, 36 AND 38). SN 85-031,160. PUB. 5-3-2011. FILED 5-5-2010.
- 3,996,119. **KREEP (STANDARD CHARACTER)**. PIROZZI, BRETT, MULTIPLE CLASS, (INT. CLS. 9 AND 41), (U.S. CLS. 21, 23, 26, 36, 38, 100, 101 AND 107). SN 85-035,117. PUB. 5-3-2011. FILED 5-11-2010.
- 3,996,128. **PICOWATT (STANDARD CHARACTER)**. TENREHTE TECHNOLOGIES, INC., (U.S. CLS. 21, 23, 26, 36 AND 38). SN 85-036,028. PUB. 5-3-2011. FILED 5-12-2010.
- 3,996,162. **LOAN + AND DESIGN**. PROCONGPS, INC., (U.S. CLS. 21, 23, 26, 36 AND 38). SN 85-041,161. PUB. 5-3-2011. FILED 5-18-2010.
- 3,996,181. **NEUROSCRIPT (STANDARD CHARACTER)**. NEUROSCRIPT, LLC, (U.S. CLS. 21, 23, 26, 36 AND 38). SN 85-043,046. PUB. 5-3-2011. FILED 5-19-2010.
- 3,996,183. **SWAMICITY (STANDARD CHARACTER)**. JONATHAN H. BASSAN, (U.S. CLS. 21, 23, 26, 36 AND 38). SN 85-043,202. PUB. 5-3-2011. FILED 5-19-2010.
- 3,996,187. **MAGIC WINDOW (STANDARD CHARACTER)**. JETSON CREATIVE LLC, (U.S. CLS. 21, 23, 26, 36 AND 38). SN 85-044,282. PUB. 5-3-2011. FILED 5-20-2010.
- 3,996,192 (*See Class 1 for this trademark*).
- 3,996,197. **UNIVERSAL MUSIC GROUP (STANDARD CHARACTER)**. UNIVERSAL CITY STUDIOS LLLP, (U.S. CLS. 21, 23, 26, 36 AND 38). SN 85-045,416. PUB. 5-3-2011. FILED 5-21-2010.
- 3,996,203. **THE FIRST AIDER (STANDARD CHARACTER)**. CRAMER PRODUCTS, INC., (U.S. CLS. 21, 23, 26, 36 AND 38). SN 85-046,134. PUB. 5-3-2011. FILED 5-24-2010.
- 3,996,204. **FINGERIST (STANDARD CHARACTER)**. TRINITY, INC., MULTIPLE CLASS, (INT. CLS. 9 AND 15), (U.S. CLS. 2, 21, 23, 26, 36 AND 38). SN 85-046,156. PUB. 5-3-2011. FILED 5-24-2010.
- 3,996,206 (*See Class 7 for this trademark*).
- 3,996,207. **VPOWERHOUSE (STANDARD CHARACTER)**. FOLEY, PATRICK, (U.S. CLS. 21, 23, 26, 36 AND 38). SN 85-046,196. PUB. 5-3-2011. FILED 5-24-2010.
- 3,996,215. **MISCELLANEOUS DESIGN**. ANTON PAAR USA, INC., (U.S. CLS. 21, 23, 26, 36 AND 38). SN 85-046,657. PUB. 5-3-2011. FILED 5-24-2010.
- 3,996,234. **AMOEBIA MUSIC AND DESIGN**. AMOEBIA MUSIC, INC., MULTIPLE CLASS, (INT. CLS. 9, 12, 16, 18, 25, 26, 35 AND 41), (U.S. CLS. 1, 2, 3, 5, 19, 21, 22, 23, 26, 29, 31, 35, 36, 37, 38, 39, 40, 41, 42, 44, 50, 100, 101, 102 AND 107). SN 85-048,444. PUB. 5-3-2011. FILED 5-26-2010.
- 3,996,235. **AMOEBIA (STANDARD CHARACTER)**. AMOEBIA MUSIC, INC., MULTIPLE CLASS, (INT. CLS. 9, 12, 16, 18, 25, 26, 35 AND 41), (U.S. CLS. 1, 2, 3, 5, 19, 21, 22, 23, 26, 29, 31, 35, 36, 37, 38, 39, 40, 41, 42, 44, 50, 100, 101, 102 AND 107). SN 85-048,488. PUB. 5-3-2011. FILED 5-26-2010.
- 3,996,238. **ULTRA MAX (STANDARD CHARACTER)**. POWERMAX USA, INC, (U.S. CLS. 21, 23, 26, 36 AND 38). SN 85-048,885. PUB. 5-3-2011. FILED 5-27-2010.
- 3,996,253. **GREEN CORTEX, INC (STANDARD CHARACTER)**. ARTIFICIAL LIFE ASIA LIMITED, MULTIPLE CLASS, (INT. CLS. 9, 38 AND 42), (U.S. CLS. 21, 23, 26, 36, 38, 100, 101 AND 104). SN 85-051,337. PUB. 5-3-2011. FILED 6-1-2010.
- 3,996,254. **MENU BOARD IN-A-BOX (STANDARD CHARACTER)**. MARKETING DISPLAYS INC., (U.S. CLS. 21, 23, 26, 36 AND 38). SN 85-051,373. PUB. 5-3-2011. FILED 6-1-2010.
- 3,996,267. **SHOTZOOM (STANDARD CHARACTER)**. SHOTZOOM, LLC., (U.S. CLS. 21, 23, 26, 36 AND 38). SN 85-052,816. PUB. 5-3-2011. FILED 6-2-2010.
- 3,996,272. **ENTERTAINMENT MINUTE (STANDARD CHARACTER)**. MANNING, JAMES, (U.S. CLS. 21, 23, 26, 36 AND 38). SN 85-054,493. PUB. 5-3-2011. FILED 6-4-2010.
- 3,996,280. **HEBA THE HO'OPONOISOIST (STANDARD CHARACTER)**. SURDHAR, GURCHARAN KAUR, MULTIPLE CLASS, (INT. CLS. 9, 16, 25, 28 AND 41), (U.S. CLS. 2, 5, 21, 22, 23, 26, 29, 36, 37, 38, 39, 50, 100, 101 AND 107). SN 85-055,842. PUB. 4-5-2011. FILED 6-7-2010.
- 3,996,287. **RAP IS A JOKE (STANDARD CHARACTER)**. JONES, FRANCESCO, (U.S. CLS. 21, 23, 26, 36 AND 38). SN 85-057,964. PUB. 5-3-2011. FILED 6-9-2010.
- 3,996,288. **WORLD OF ATLANTIS (STANDARD CHARACTER)**. CRYTEK GMBH, (U.S. CLS. 21, 23, 26, 36 AND 38). SN 85-058,477. PUB. 5-3-2011. FILED 6-9-2010.
- 3,996,298. **SONS OF FIRE (STANDARD CHARACTER)**. HORNYAK, DAVID M, MULTIPLE CLASS, (INT. CLS. 9 AND 41), (U.S. CLS. 21, 23, 26, 36, 38, 100, 101 AND 107). SN 85-061,480. PUB. 5-3-2011. FILED 6-13-2010.
- 3,996,309. **ERIC PEPIN (STANDARD CHARACTER)**. HIGHER BALANCE INSTITUTE, AKA HIGHER BALANCE, MULTIPLE CLASS, (INT. CLS. 9 AND 16), (U.S. CLS. 2, 5, 21, 22, 23, 26, 29, 36, 37, 38 AND 50). SN 85-063,724. PUB. 5-3-2011. FILED 6-15-2010.
- 3,996,319. **GODONOMICS AND DESIGN**. HOVIND, CHAD, (U.S. CLS. 21, 23, 26, 36 AND 38). SN 85-065,142. PUB. 5-3-2011. FILED 6-17-2010.
- 3,996,322 (*See Class 6 for this trademark*).
- 3,996,326. **DATAWAVE TECHNOLOGIES (STANDARD CHARACTER)**. DATAWAVE TECHNOLOGIES CORPORATION, (U.S. CLS. 21, 23, 26, 36 AND 38). SN 85-066,797. PUB. 5-3-2011. FILED 6-18-2010.
- 3,996,333. **KENEXA 2X ONBOARD (STANDARD CHARACTER)**. KENEXA CORPORATION, MULTIPLE CLASS, (INT. CLS. 9 AND 42), (U.S. CLS. 21, 23, 26, 36, 38, 100 AND 101). SN 85-068,636. PUB. 5-3-2011. FILED 6-22-2010.
- 3,996,338. **DR TEDDY CARE (STANDARD CHARACTER)**. THE WIGGLES PTY LIMITED, MULTIPLE CLASS, (INT. CLS. 9, 16, 25, 28 AND 41), (U.S. CLS. 2, 5, 21, 22, 23, 26, 29, 36, 37, 38, 39, 50, 100, 101 AND 107). SN 85-069,550. PUB. 4-19-2011. FILED 6-23-2010.
- 3,996,342. **NIRMASTER (STANDARD CHARACTER)**. BÜCHI LABORTECHNIK AG, MULTIPLE CLASS, (INT. CLS. 9 AND 42), (U.S. CLS. 21, 23, 26, 36, 38, 100 AND 101). SN 85-069,965. PUB. 5-3-2011. FILED 6-23-2010.
- 3,996,359. **FLIP IT! (STANDARD CHARACTER)**. FAT FISH APPS, INC., (U.S. CLS. 21, 23, 26, 36 AND 38). SN 85-073,371. PUB. 11-23-2010. FILED 6-28-2010.
- 3,996,375. **CARIBOU RECORDS (STANDARD CHARACTER)**. GUERCIO, JAMES W., (U.S. CLS. 21, 23, 26, 36 AND 38). SN 85-079,013. PUB. 5-3-2011. FILED 7-6-2010.
- 3,996,391. **TELENAV TRACK (STANDARD CHARACTER)**. TELENAV, INC., MULTIPLE CLASS, (INT. CLS. 9 AND 42), (U.S. CLS. 21, 23, 26, 36, 38, 100 AND 101). SN 85-082,854. PUB. 11-23-2010. FILED 7-12-2010.
- 3,996,392. **CARIBOU RECORDS AND DESIGN**. GUERCIO, JAMES W., (U.S. CLS. 21, 23, 26, 36 AND 38). SN 85-082,917. PUB. 5-3-2011. FILED 7-12-2010.
- 3,996,394. **MERCURY EXTREME (STANDARD CHARACTER)**. NEW CONCEPTS DEVELOPMENT CORPORATION, (U.S. CLS. 21, 23, 26, 36 AND 38). SN 85-083,163. PUB. 5-3-2011. FILED 7-13-2010.
- 3,996,422. **I/O SENTINEL (STANDARD CHARACTER)**. BROADCAST TOOLS, INC., (U.S. CLS. 21, 23, 26, 36 AND 38). SN 85-091,843. PUB. 1-25-2011. FILED 7-23-2010.
- 3,996,444. **VARIPLUS (STANDARD CHARACTER)**. IKONIX

- GROUP, INC., (U.S. CLS. 21, 23, 26, 36 AND 38). SN 85-097,991. PUB. 5-3-2011. FILED 8-2-2010.
- 3,996,447. **EVERYTHING UNDER (STANDARD CHARACTER)**. HEIDECHE, MARK JOSEPH, MULTIPLE CLASS, (INT. CLS. 9 AND 41), (U.S. CLS. 21, 23, 26, 36, 38, 100, 101 AND 107). SN 85-099,147. PUB. 5-3-2011. FILED 8-3-2010.
- 3,996,483. **JOVOTO (STANDARD CHARACTER)**. JOVOTO GMBH, MULTIPLE CLASS, (INT. CLS. 9, 35, 38, 41 AND 42), (U.S. CLS. 21, 23, 26, 36, 38, 100, 101, 102, 104 AND 107). SN 85-114,599. PUB. 5-3-2011. FILED 8-24-2010.
- 3,996,496. **SIGHT DEFENSE AND DESIGN**. GHC SPECIALTY BRANDS, LLC, (U.S. CLS. 21, 23, 26, 36 AND 38). SN 85-117,947. PUB. 5-3-2011. FILED 8-27-2010.
- 3,996,499. **CASHMAN FEVER AND DESIGN**. ARISTOCRAT TECHNOLOGIES AUSTRALIA PTY LTD, (U.S. CLS. 21, 23, 26, 36 AND 38). SN 85-119,784. PUB. 5-3-2011. FILED 8-31-2010.
- 3,996,503. **APPTITUDE (STANDARD CHARACTER)**. APPDNA, INC., (U.S. CLS. 21, 23, 26, 36 AND 38). SN 85-122,247. PUB. 5-3-2011. FILED 9-2-2010.
- 3,996,509. **FF (STYLIZED)**. FSI FONTSHOP INTERNATIONAL GMBH, MULTIPLE CLASS, (INT. CLS. 9 AND 16), (U.S. CLS. 2, 5, 21, 22, 23, 26, 29, 36, 37, 38 AND 50). SN 85-123,684. PUB. 5-3-2011. FILED 9-7-2010.
- 3,996,517. **CAREK12 (STANDARD CHARACTER)**. ALPHAVISTA SERVICES, INC., (U.S. CLS. 21, 23, 26, 36 AND 38). SN 85-125,519. PUB. 5-3-2011. FILED 9-9-2010.
- 3,996,521. **MAGIC PIANO (STANDARD CHARACTER)**. SMULE, INC., (U.S. CLS. 21, 23, 26, 36 AND 38). SN 85-126,165. PUB. 5-3-2011. FILED 9-9-2010.
- 3,996,533. **CS (STYLIZED)**. RICHMEG INDUSTRY CO., LTD., (U.S. CLS. 21, 23, 26, 36 AND 38). SN 85-128,427. PUB. 5-3-2011. FILED 9-13-2010.
- 3,996,542. **3 (STYLIZED)**. PALMERSTON LIMITED, (U.S. CLS. 21, 23, 26, 36 AND 38). SN 85-130,239. PUB. 5-3-2011. FILED 9-15-2010.
- 3,996,556. **CHECKTIME (STANDARD CHARACTER)**. UNIVERSITY CORPORATION FOR ATMOSPHERIC RESEARCH, (U.S. CLS. 21, 23, 26, 36 AND 38). SN 85-133,653. PUB. 5-3-2011. FILED 9-20-2010.
- 3,996,558. **THE WHEEL WORKERS (STANDARD CHARACTER)**. HIGGINBOTHAM, STEVEN K, DBA THE WHEEL WORKERS, MULTIPLE CLASS, (INT. CLS. 9 AND 41), (U.S. CLS. 21, 23, 26, 36, 38, 100, 101 AND 107). SN 85-133,822. PUB. 5-3-2011. FILED 9-20-2010.
- 3,996,574. **NATIONAL FISHING REPORT AND DESIGN**. H & B VENTURE, LLC, (U.S. CLS. 21, 23, 26, 36 AND 38). SN 85-137,553. PUB. 5-3-2011. FILED 9-24-2010.
- 3,996,579. **MMI (STANDARD CHARACTER)**. AUDI AG, MULTIPLE CLASS, (INT. CLS. 9 AND 12), (U.S. CLS. 19, 21, 23, 26, 31, 35, 36, 38 AND 44). SN 85-138,632. PUB. 5-3-2011. FILED 9-27-2010.
- 3,996,597. **GLOWS WHEN IT BLOWS (STANDARD CHARACTER)**. KAPER II, INC., (U.S. CLS. 21, 23, 26, 36 AND 38). SN 85-144,660. PUB. 5-3-2011. FILED 10-4-2010.
- 3,996,601. **VARAN MONITOR (STANDARD CHARACTER)**. HARRINGTON, STEPHEN, DBA ESERVICES INC., (U.S. CLS. 21, 23, 26, 36 AND 38). SN 85-145,640. PUB. 5-3-2011. FILED 10-5-2010.
- 3,996,610. **MAKING A LIVING AT WHAT YOU LOVE (STANDARD CHARACTER)**. OUR CORPORATE LIFE LLC, MULTIPLE CLASS, (INT. CLS. 9, 35 AND 41), (U.S. CLS. 21, 23, 26, 36, 38, 100, 101, 102 AND 107). SN 85-146,560. PUB. 5-3-2011. FILED 10-6-2010.
- 3,996,611. **ORCA MD (STANDARD CHARACTER)**. ORCA MD LLC, (U.S. CLS. 21, 23, 26, 36 AND 38). SN 85-147,067. PUB. 5-3-2011. FILED 10-7-2010.
- 3,996,624. **BEAUTY CALLS (STANDARD CHARACTER)**. ENDLESSBEAUTY.COM, LLC, (U.S. CLS. 21, 23, 26, 36 AND 38). SN 85-149,984. PUB. 5-3-2011. FILED 10-11-2010.
- 3,996,629. **WEBAV AND DESIGN**. THE TALBOT GROUP INC., (U.S. CLS. 21, 23, 26, 36 AND 38). SN 85-150,518. PUB. 5-3-2011. FILED 10-12-2010.
- 3,996,638. **THE SINGERS UNLIMITED (STANDARD CHARACTER)**. HERMAN, BONNIE, AND SHELTON, DON R., AND PUERLING, HELEN, AND DRESSLAR, DOROTHY, (U.S. CLS. 21, 23, 26, 36 AND 38). SN 85-152,418. PUB. 5-3-2011. FILED 10-14-2010.
- 3,996,639. **NBS (STYLIZED)**. NBS-KASTLE, INC., DBA NBS AUDIO CABLES, (U.S. CLS. 21, 23, 26, 36 AND 38). SN 85-152,944. PUB. 5-3-2011. FILED 10-14-2010.
- 3,996,640. **IWIN PRESS (STANDARD CHARACTER)**. MELANIE REMBRANDT, DBA REMBRANDT COMMUNICATIONS, LLC, MULTIPLE CLASS, (INT. CLS. 9 AND 41), (U.S. CLS. 21, 23, 26, 36, 38, 100, 101 AND 107). SN 85-153,172. PUB. 5-3-2011. FILED 10-14-2010.
- 3,996,644. **MYBATTERY PLATFORM (STANDARD CHARACTER)**. LONG, SHUNYOU, (U.S. CLS. 21, 23, 26, 36 AND 38). SN 85-154,624. PUB. 5-3-2011. FILED 10-18-2010.
- 3,996,646. **VELA (STANDARD CHARACTER)**. DB MUSIC PRODUCTIONS, INC, MULTIPLE CLASS, (INT. CLS. 9 AND 41), (U.S. CLS. 21, 23, 26, 36, 38, 100, 101 AND 107). SN 85-154,754. PUB. 5-3-2011. FILED 10-18-2010.
- 3,996,654. **TADA AND DESIGN**. SHOPZILLA, INC., MULTIPLE CLASS, (INT. CLS. 9, 35 AND 41), (U.S. CLS. 21, 23, 26, 36, 38, 100, 101, 102 AND 107). SN 85-156,219. PUB. 5-3-2011. FILED 10-19-2010.
- 3,996,672. **EXP (STYLIZED)**. EXPLOTRAIN, LLC, (U.S. CLS. 21, 23, 26, 36 AND 38). SN 85-160,128. PUB. 5-3-2011. FILED 10-25-2010.
- 3,996,674. **EXPLOTRAIN (STANDARD CHARACTER)**. EXPLOTRAIN, LLC, (U.S. CLS. 21, 23, 26, 36 AND 38). SN 85-160,684. PUB. 5-3-2011. FILED 10-25-2010.
- 3,996,675. **XK XTREME KNIGHT XTREMEKNIGHT = LIFE WWW.XTREMEKNIGHT.COM (STYLIZED)**. KNIGHT, JASON, DBA XTREME KNIGHT, (U.S. CLS. 21, 23, 26, 36 AND 38). SN 85-160,695. PUB. 5-3-2011. FILED 10-25-2010.
- 3,996,692. **M-PACT (STANDARD CHARACTER)**. SATORIUS AG, (U.S. CLS. 21, 23, 26, 36 AND 38). SN 85-164,503. PUB. 5-3-2011. FILED 10-29-2010.
- 3,996,711. **ELECTRIC ENERGY (STANDARD CHARACTER)**. RMEL, MULTIPLE CLASS, (INT. CLS. 9 AND 16), (U.S. CLS. 2, 5, 21, 22, 23, 26, 29, 36, 37, 38 AND 50). SN 85-168,121. PUB. 5-3-2011. FILED 11-3-2010.
- 3,996,715. **GOAL STAR (STANDARD CHARACTER)**. SANOFI-AVENTIS, MULTIPLE CLASS, (INT. CLS. 9 AND 10), (U.S. CLS. 21, 23, 26, 36, 38, 39 AND 44). SN 85-168,392. PUB. 5-3-2011. FILED 11-3-2010.
- 3,996,718. **KNOW WHAT (STANDARD CHARACTER)**. ESCAPE APPS, LLC, (U.S. CLS. 21, 23, 26, 36 AND 38). SN 85-168,744. PUB. 5-3-2011. FILED 11-4-2010.
- 3,996,722. **CASHVIEW (STANDARD CHARACTER)**. COMPUTEFLEX CORPORATION, (U.S. CLS. 21, 23, 26, 36 AND 38). SN 85-169,154. PUB. 5-3-2011. FILED 11-4-2010.
- 3,996,732. **ARIES CAREER SYSTEMS (STANDARD CHARACTER)**. GENESIS CAREER SYSTEMS, LLC, MULTIPLE CLASS, (INT. CLS. 9 AND 41), (U.S. CLS. 21, 23, 26, 36, 38, 100, 101 AND 107). SN 85-170,665. PUB. 5-3-2011. FILED 11-5-2010.
- 3,996,743. **THE STANDARD FOR BENCHMARKING (STANDARD CHARACTER)**. GLOBAL WIRELESS SOLUTIONS, INC., MULTIPLE CLASS, (INT. CLS. 9, 16, 35 AND 42), (U.S. CLS. 2, 5, 21, 22, 23, 26, 29, 36, 37, 38, 50, 100, 101 AND 102). SN 85-171,550. PUB. 5-3-2011. FILED 11-8-2010.
- 3,996,744. **CHILDPROTECT ONLINE (STYLIZED)**. DREAM2-DESIGN, LLC, (U.S. CLS. 21, 23, 26, 36 AND 38). SN 85-171,558. PUB. 5-3-2011. FILED 11-8-2010.
- 3,996,764. **TANDBERG DATA (STANDARD CHARACTER)**. TANDBERG DATA HOLDINGS S.A.R.L., (U.S. CLS. 21, 23, 26, 36 AND 38). SN 85-173,446. PUB. 3-29-2011. FILED 11-10-2010.
- 3,996,787. **1 IDEACASE AND DESIGN**. SHENZHEN FUTURE TECHNOLOGY COMPANY LIMITED, (U.S. CLS. 21, 23, 26, 36 AND 38). SN 85-175,145. PUB. 5-3-2011. FILED 11-12-2010.
- 3,996,790. **MECHOLUX (STANDARD CHARACTER)**. MECHOSHADOW SYSTEMS, INC., (U.S. CLS. 21, 23, 26, 36 AND 38). SN 85-175,310. PUB. 5-3-2011. FILED 11-12-2010.
- 3,996,807. **COURAGE UNLIMITED AND DESIGN**. COURAGE UNLIMITED CORPORATION, MULTIPLE CLASS, (INT. CLS. 9, 16 AND 28), (U.S. CLS. 2, 5, 21, 22, 23, 26, 29, 36, 37, 38 AND 50). SN 85-176,481. PUB. 5-3-2011. FILED 11-15-2010.
- 3,996,809. **METIS SECURE SOLUTIONS (STANDARD CHARACTER)**. METIS SECURE SOLUTIONS, LLC, (U.S. CLS. 21, 23, 26, 36 AND 38). SN 85-176,578. PUB. 5-3-2011. FILED 11-15-2010.

- 3,996,810. **METIS SECURE SOLUTIONS AND DESIGN. METIS SECURE SOLUTIONS, LLC**, (U.S. CLS. 21, 23, 26, 36 AND 38). SN 85-176,603. PUB. 5-3-2011. FILED 11-15-2010.
- 3,996,812. **ARMADILLO SIDEMOUNT (STANDARD CHARACTER). STYX MEDIA, INC., DBA GOLEM GEAR, INC.**, (U.S. CLS. 21, 23, 26, 36 AND 38). SN 85-176,719. PUB. 5-3-2011. FILED 11-15-2010.
- 3,996,819. **TEXTILE TESTING SOLUTIONS (STANDARD CHARACTER). SDL ATLAS, L.L.C.**, (U.S. CLS. 21, 23, 26, 36 AND 38). SN 85-177,173. PUB. 5-3-2011. FILED 11-15-2010.
- 3,996,841. **SIMPLE SENSOR (STYLIZED). ORANGE ELECTRONIC NORTH AMERICA, LLC**, (U.S. CLS. 21, 23, 26, 36 AND 38). SN 85-178,625. PUB. 5-3-2011. FILED 11-17-2010.
- 3,996,847. **CB OMNI (STANDARD CHARACTER). THERMO GAMMA-METRICS, LLC**, (U.S. CLS. 21, 23, 26, 36 AND 38). SN 85-178,848. PUB. 5-3-2011. FILED 11-17-2010.
- 3,996,873. **CHEM+MIX PRO (STYLIZED). CHATA BIOSYSTEMS, INC.**, (U.S. CLS. 21, 23, 26, 36 AND 38). SN 85-179,910. PUB. 5-3-2011. FILED 11-18-2010.
- 3,996,877. **SCAN3D AND DESIGN. SCAN3D**, (U.S. CLS. 21, 23, 26, 36 AND 38). SN 85-180,602. PUB. 5-3-2011. FILED 11-18-2010.
- 3,996,879. **TEXUSA (STYLIZED). TEXTRONIC, INC.**, (U.S. CLS. 21, 23, 26, 36 AND 38). SN 85-180,661. PUB. 5-3-2011. FILED 11-19-2010.
- 3,996,884. **PINPOINTER (STANDARD CHARACTER). PINPOINT PROFIT RECOVERY SERVICES, INC.**, (U.S. CLS. 21, 23, 26, 36 AND 38). SN 85-180,952. PUB. 5-3-2011. FILED 11-19-2010.
- 3,996,886. **TRIBAL LEADERSHIP (STANDARD CHARACTER). JEFFERSONLARSONSMITH, LLC. DBA CULTURES SYNC, MULTIPLE CLASS, (INT. CLS. 9, 16 AND 41), (U.S. CLS. 2, 5, 21, 22, 23, 26, 29, 36, 37, 38, 50, 100, 101 AND 107). SN 85-181,045. PUB. 5-3-2011. FILED 11-19-2010.**
- 3,996,936. **THEFIRM (STYLIZED). GAIAM AMERICAS, INC.**, (U.S. CLS. 21, 23, 26, 36 AND 38). SN 85-183,610. PUB. 5-3-2011. FILED S.R. 11-23-2010; AM. P.R. 11-23-2010.
- 3,996,952. **HBO AND DESIGN. HOME BOX OFFICE, INC.**, (U.S. CLS. 21, 23, 26, 36 AND 38). SN 85-184,531. PUB. 5-3-2011. FILED 11-24-2010.
- 3,996,957. **BIZLINK (STANDARD CHARACTER). BIZLINK TECHNOLOGY, INC.**, (U.S. CLS. 21, 23, 26, 36 AND 38). SN 85-184,926. PUB. 5-3-2011. FILED 11-24-2010.
- 3,996,961. **A AND DESIGN. ANONYMIZER, INC., MULTIPLE CLASS, (INT. CLS. 9, 38 AND 42), (U.S. CLS. 21, 23, 26, 36, 38, 100, 101 AND 104). SN 85-185,092. PUB. 5-3-2011. FILED 11-24-2010.**
- 3,997,018. **BLAST-HOLE XPERT (STANDARD CHARACTER). THERMO GAMMA-METRICS, LLC**, (U.S. CLS. 21, 23, 26, 36 AND 38). SN 85-187,018. PUB. 5-3-2011. FILED 11-30-2010.
- 3,997,046. **PUREPC AND DESIGN. PURE PC**, (U.S. CLS. 21, 23, 26, 36 AND 38). SN 85-187,619. PUB. 5-3-2011. FILED 11-30-2010.
- 3,997,057. **KOOLSHADES (STANDARD CHARACTER). YOUNG, GARY GEORGE**, (U.S. CLS. 21, 23, 26, 36 AND 38). SN 85-187,867. PUB. 5-3-2011. FILED 12-1-2010.
- 3,997,072. **SEX AND THE CITY (STANDARD CHARACTER). HOME BOX OFFICE, INC.**, (U.S. CLS. 21, 23, 26, 36 AND 38). SN 85-188,276. PUB. 5-3-2011. FILED 12-1-2010.
- 3,997,114. **APPZILLA (STANDARD CHARACTER). FOSSIL SOFTWARE**, (U.S. CLS. 21, 23, 26, 36 AND 38). SN 85-189,145. PUB. 5-3-2011. FILED 12-2-2010.
- 3,997,117. **FMA FABCAST LOG ON CALL IN INTERACT AND DESIGN. FABRICATORS & MANUFACTURERS ASSOCIATION, INTERNATIONAL, MULTIPLE CLASS, (INT. CLS. 9 AND 41), (U.S. CLS. 21, 23, 26, 36, 38, 100, 101 AND 107). SN 85-189,171. PUB. 5-3-2011. FILED 12-2-2010.**
- 3,997,130. **FALCONVIEW (STANDARD CHARACTER). GEORGIA TECH RESEARCH CORPORATION**, (U.S. CLS. 21, 23, 26, 36 AND 38). SN 85-189,361. PUB. 5-3-2011. FILED 12-2-2010.
- 3,997,133. **DO AND DESIGN. NLU PRODUCTS, LLC**, (U.S. CLS. 21, 23, 26, 36 AND 38). SN 85-189,487. PUB. 5-3-2011. FILED 12-2-2010.
- 3,997,135. **GOT IT COVERED (STANDARD CHARACTER). NLU PRODUCTS, LLC**, (U.S. CLS. 21, 23, 26, 36 AND 38). SN 85-189,507. PUB. 5-3-2011. FILED 12-2-2010.
- 3,997,150. **P2P LINK (STANDARD CHARACTER). STONERIVER, INC., MULTIPLE CLASS, (INT. CLS. 9, 35 AND 42), (U.S. CLS. 21, 23, 26, 36, 38, 100, 101 AND 102). SN 85-189,672. PUB. 5-3-2011. FILED 12-2-2010.**
- 3,997,174. **ASTROAPESTUDIOS SOCIAL.MOBILE.GAMING AND DESIGN. ASTRO APE STUDIOS**, (U.S. CLS. 21, 23, 26, 36 AND 38). SN 85-190,082. PUB. 5-3-2011. FILED 12-3-2010.
- 3,997,176. **AOKO (STYLIZED). LONG PAN**, (U.S. CLS. 21, 23, 26, 36 AND 38). SN 85-190,112. PUB. 5-3-2011. FILED 12-3-2010.
- 3,997,187. **CRYPTGO (STANDARD CHARACTER). CRYPTGO TECHNOLOGIES INC.**, (U.S. CLS. 21, 23, 26, 36 AND 38). SN 85-190,487. PUB. 5-3-2011. FILED 12-3-2010.
- 3,997,195. **RAISE THE VILLAGE (STANDARD CHARACTER). NEW CHARITY ERA, L3C**, (U.S. CLS. 21, 23, 26, 36 AND 38). SN 85-190,887. PUB. 5-3-2011. FILED 12-5-2010.
- 3,997,213. **NULUX (STANDARD CHARACTER). HOYA CORPORATION**, (U.S. CLS. 21, 23, 26, 36 AND 38). SN 85-191,348. PUB. 5-3-2011. FILED 12-6-2010.
- 3,997,224. **TRUSCAM (STANDARD CHARACTER). INDUSTRIAL SENSOR VISION INTERNATIONAL CORPORATION**, (U.S. CLS. 21, 23, 26, 36 AND 38). SN 85-191,699. PUB. 5-3-2011. FILED 12-6-2010.
- 3,997,247. **COGNITIVE ASSISTANCE FOR INDEPENDENT LIVING (STANDARD CHARACTER). RODRIGUEZ, TYMOTHI**, (U.S. CLS. 21, 23, 26, 36 AND 38). SN 85-192,613. PUB. 5-3-2011. FILED 12-7-2010.
- 3,997,255. **SCITECMED (STANDARD CHARACTER). K. DONALDSON LLC**, (U.S. CLS. 21, 23, 26, 36 AND 38). SN 85-192,718. PUB. 5-3-2011. FILED 12-7-2010.
- 3,997,274. **SOLANO (STANDARD CHARACTER). AM GROUP PLUS SPOLKA Z O.O.**, (U.S. CLS. 21, 23, 26, 36 AND 38). SN 85-193,220. PUB. 5-3-2011. FILED 12-8-2010.
- 3,997,290. **DZDOCK (STANDARD CHARACTER). ZAHARAKIS, STEVE**, (U.S. CLS. 21, 23, 26, 36 AND 38). SN 85-193,889. PUB. 5-3-2011. FILED 12-9-2010.
- 3,997,297. **CSIBRIDGE (STANDARD CHARACTER). COMPUTERS AND STRUCTURES, INC.**, (U.S. CLS. 21, 23, 26, 36 AND 38). SN 85-194,092. PUB. 5-3-2011. FILED 12-9-2010.
- 3,997,302. **TAX WORKS AND DESIGN. REDGEAR TECHNOLOGIES, INC.**, (U.S. CLS. 21, 23, 26, 36 AND 38). SN 85-194,372. PUB. 5-3-2011. FILED 12-9-2010.
- 3,997,313. **WORDICUS (STANDARD CHARACTER). DAPPER GENTLEMEN, LLC**, (U.S. CLS. 21, 23, 26, 36 AND 38). SN 85-194,834. PUB. 5-3-2011. FILED 12-10-2010.
- 3,997,335. **VCLEAR (STANDARD CHARACTER). CALSYS, INC.**, (U.S. CLS. 21, 23, 26, 36 AND 38). SN 85-195,634. PUB. 5-3-2011. FILED 12-10-2010.
- 3,997,336. **VSAFER (STANDARD CHARACTER). CALSYS, INC.**, (U.S. CLS. 21, 23, 26, 36 AND 38). SN 85-195,648. PUB. 5-3-2011. FILED 12-10-2010.
- 3,997,337. **ALTISYNCHRO (STANDARD CHARACTER). ALTICAST CORPORATION**, (U.S. CLS. 21, 23, 26, 36 AND 38). SN 85-195,696. PUB. 5-3-2011. FILED 12-10-2010.
- 3,997,342. **VALUELINE (STANDARD CHARACTER). PHOENIX CONTACT DEVELOPMENT AND MANUFACTURING, INC.**, (U.S. CLS. 21, 23, 26, 36 AND 38). SN 85-196,435. PUB. 5-3-2011. FILED 12-13-2010.
- 3,997,357. **TOPAQ (STANDARD CHARACTER). SENSOR PRODUCTS INC.**, (U.S. CLS. 21, 23, 26, 36 AND 38). SN 85-197,369. PUB. 5-3-2011. FILED 12-14-2010.
- 3,997,358. **SWIC (STANDARD CHARACTER). INTELLIGENT SOFTWARE SOLUTIONS, INC., MULTIPLE CLASS, (INT. CLS. 9 AND 42), (U.S. CLS. 21, 23, 26, 36, 38, 100 AND 101). SN 85-197,370. PUB. 5-3-2011. FILED 12-14-2010.**
- 3,997,381. **PTAS (STANDARD CHARACTER). KOGER, INC.**, (U.S. CLS. 21, 23, 26, 36 AND 38). SN 85-198,541. PUB. 5-3-2011. FILED 12-15-2010.
- 3,997,382. **NTAS (STANDARD CHARACTER). KOGER, INC.**, (U.S. CLS. 21, 23, 26, 36 AND 38). SN 85-198,554. PUB. 5-3-2011. FILED 12-15-2010.
- 3,997,392. **WHAT'S IN A WORD (STANDARD CHARACTER). BLANK, HARRY, AND BLANK, JOY**, (U.S. CLS. 21, 23, 26, 36 AND 38). SN 85-199,640. PUB. 5-3-2011. FILED 12-16-2010.
- 3,997,411. **GRID (STANDARD CHARACTER). KOGER, INC.**, (U.S. CLS. 21, 23, 26, 36 AND 38). SN 85-200,226. PUB. 5-3-2011. FILED 12-17-2010.
- 3,997,421 (*See Class 3 for this trademark*).
- 3,997,461. **KIDZONE (STANDARD CHARACTER). DEEMO**,

- LLC, (U.S. CLS. 21, 23, 26, 36 AND 38). SN 85-202,079. PUB. 5-3-2011. FILED 12-20-2010.
- 3,997,465. **MISCELLANEOUS DESIGN**. SYNTONICS LLC, MULTIPLE CLASS, (INT. CLS. 9, 38 AND 42), (U.S. CLS. 21, 23, 26, 36, 38, 100, 101 AND 104). SN 85-202,461. PUB. 5-3-2011. FILED 12-21-2010.
- 3,997,468. **THE EBOOK INSIDER (STANDARD CHARACTER)**. RANDOM HOUSE, INC., (U.S. CLS. 21, 23, 26, 36 AND 38). SN 85-202,486. PUB. 5-3-2011. FILED 12-21-2010.
- 3,997,471. **BLUREX (STANDARD CHARACTER)**. APLICIA JOHN, (U.S. CLS. 21, 23, 26, 36 AND 38). SN 85-202,552. PUB. 5-3-2011. FILED 12-21-2010.
- 3,997,476. **SMART ELECTRICIAN (STANDARD CHARACTER)**. MENARD, INC., MULTIPLE CLASS, (INT. CLS. 9, 11 AND 17), (U.S. CLS. 1, 5, 12, 13, 21, 23, 26, 31, 34, 35, 36, 38 AND 50). SN 85-202,657. PUB. 5-3-2011. FILED 12-21-2010.
- 3,997,477. **MAXWELL (STANDARD CHARACTER)**. PROMEGA CORPORATION, (U.S. CLS. 21, 23, 26, 36 AND 38). SN 85-202,668. PUB. 5-3-2011. FILED 12-21-2010.
- 3,997,516. **P235 (STANDARD CHARACTER)**. F3M3 COMPANIES, INC., (U.S. CLS. 21, 23, 26, 36 AND 38). SN 85-204,028. PUB. 5-3-2011. FILED 12-22-2010.
- 3,997,517. **DATA POSTMAN (STANDARD CHARACTER)**. KIVLOVITZ, DOV, (U.S. CLS. 21, 23, 26, 36 AND 38). SN 85-204,052. PUB. 5-3-2011. FILED 12-22-2010.
- 3,997,518. **PFCAN (STANDARD CHARACTER)**. TENNVAC INC., (U.S. CLS. 21, 23, 26, 36 AND 38). SN 85-204,078. PUB. 5-3-2011. FILED 12-22-2010.
- 3,997,521. **PROFIT SOLVER (STANDARD CHARACTER)**. FEE TECHNOLOGY INC., (U.S. CLS. 21, 23, 26, 36 AND 38). SN 85-204,211. PUB. 5-3-2011. FILED 12-22-2010.
- 3,997,544. **SILENT ORCHESTRA (STANDARD CHARACTER)**. GARZA, CARLOS, AND O'MEARA, RICH, MULTIPLE CLASS, (INT. CLS. 9 AND 41), (U.S. CLS. 21, 23, 26, 36, 38, 100, 101 AND 107). SN 85-204,648. PUB. 5-3-2011. FILED 12-23-2010.
- 3,997,549. **V-PLANNER (STANDARD CHARACTER)**. ROSS HEMINGWAY, (U.S. CLS. 21, 23, 26, 36 AND 38). SN 85-204,672. PUB. 5-3-2011. FILED 12-23-2010.
- 3,997,550. **MULTIDECO (STANDARD CHARACTER)**. ROSS HEMINGWAY, (U.S. CLS. 21, 23, 26, 36 AND 38). SN 85-204,681. PUB. 5-3-2011. FILED 12-23-2010.
- 3,997,553. **MODA (STANDARD CHARACTER)**. ELITE SPIDERS, LLC, (U.S. CLS. 21, 23, 26, 36 AND 38). SN 85-204,697. PUB. 5-3-2011. FILED 12-23-2010.
- 3,997,595. **RTEAM (STANDARD CHARACTER)**. STRETCH COMPUTING, INC., (U.S. CLS. 21, 23, 26, 36 AND 38). SN 85-205,236. PUB. 5-3-2011. FILED 12-23-2010.
- 3,997,635. **MOTOSAFE (STANDARD CHARACTER)**. ALPINE HOLDING B.V., (U.S. CLS. 21, 23, 26, 36 AND 38). SN 85-205,755. PUB. 5-3-2011. FILED 12-27-2010.
- 3,997,636. **MUSICSAFE (STANDARD CHARACTER)**. ALPINE HOLDING B.V., (U.S. CLS. 21, 23, 26, 36 AND 38). SN 85-205,756. PUB. 5-3-2011. FILED 12-27-2010.
- 3,997,637. **HOW TO MAKE RETIREMENT A NEW ADVENTURE (STANDARD CHARACTER)**. THE PACIFIC INSTITUTE INCORPORATED, MULTIPLE CLASS, (INT. CLS. 9 AND 16), (U.S. CLS. 2, 5, 21, 22, 23, 26, 29, 36, 37, 38 AND 50). SN 85-205,783. PUB. 5-3-2011. FILED 12-27-2010.
- 3,997,639. **ENVY EYEWEAR (STANDARD CHARACTER)**. NAVAJO MANUFACTURING COMPANY, (U.S. CLS. 21, 23, 26, 36 AND 38). SN 85-205,800. PUB. 5-3-2011. FILED 12-27-2010.
- 3,997,669. **PRIMESTACK (STANDARD CHARACTER)**. INFINEON TECHNOLOGIES AG, (U.S. CLS. 21, 23, 26, 36 AND 38). SN 85-206,163. PUB. 5-3-2011. FILED 12-27-2010.
- 3,997,677. **LOCKERNOTES (STANDARD CHARACTER)**. SALTMAN, STEVEN, AND PICKER, CHRISTIAN, MULTIPLE CLASS, (INT. CLS. 9 AND 16), (U.S. CLS. 2, 5, 21, 22, 23, 26, 29, 36, 37, 38 AND 50). SN 85-206,354. PUB. 5-3-2011. FILED 12-28-2010.
- 3,997,680. **60MO (STANDARD CHARACTER)**. 60MO, INC., (U.S. CLS. 21, 23, 26, 36 AND 38). SN 85-206,384. PUB. 5-3-2011. FILED 12-28-2010.
- 3,997,685. **FLEXWARE (STANDARD CHARACTER)**. FLEXWARE INTERNATIONAL LLC, (U.S. CLS. 21, 23, 26, 36 AND 38). SN 85-206,431. PUB. 5-3-2011. FILED 12-28-2010.
- 3,997,726. **WISHCLIP (STANDARD CHARACTER)**. TREEPODIA, (U.S. CLS. 21, 23, 26, 36 AND 38). SN 85-206,975. PUB. 5-3-2011. FILED 12-29-2010.
- 3,997,738. **PRESTAN (STANDARD CHARACTER)**. PRESTAN PRODUCTS LLC, (U.S. CLS. 21, 23, 26, 36 AND 38). SN 85-207,153. PUB. 5-3-2011. FILED 12-29-2010.
- 3,997,791. **VIDEOLUCIOUS (STANDARD CHARACTER)**. THE TALK MARKET, INC., (U.S. CLS. 21, 23, 26, 36 AND 38). SN 85-207,996. PUB. 5-3-2011. FILED 12-30-2010.
- 3,997,804. **PHR @ HOME (STANDARD CHARACTER)**. DESAI, HIMANSHU, (U.S. CLS. 21, 23, 26, 36 AND 38). SN 85-208,121. PUB. 5-3-2011. FILED 12-30-2010.
- 3,997,828. **SUMDEX (STANDARD CHARACTER)**. SUMDEX, INC., MULTIPLE CLASS, (INT. CLS. 9 AND 18), (U.S. CLS. 1, 2, 3, 21, 22, 23, 26, 36, 38 AND 41). SN 85-208,348. PUB. 5-3-2011. FILED 12-30-2010.
- 3,997,831. **KMD AND DESIGN**. INNEX, INC., (U.S. CLS. 21, 23, 26, 36 AND 38). SN 85-208,373. PUB. 5-3-2011. FILED 12-30-2010.
- 3,997,833. **MISCELLANEOUS DESIGN**. EAGTAC, LLC, MULTIPLE CLASS, (INT. CLS. 9 AND 11), (U.S. CLS. 13, 21, 23, 26, 31, 34, 36 AND 38). SN 85-208,380. PUB. 5-3-2011. FILED 12-30-2010.
- 3,997,834. **QUICKSTORE24 (STANDARD CHARACTER)**. VENDMORE SYSTEMS, LLC, MULTIPLE CLASS, (INT. CLS. 9 AND 35), (U.S. CLS. 21, 23, 26, 36, 38, 100, 101 AND 102). SN 85-208,391. PUB. 5-3-2011. FILED 12-30-2010.
- 3,997,835. **QUICKSTORE24 AND DESIGN**. VENDMORE SYSTEMS, LLC, MULTIPLE CLASS, (INT. CLS. 9 AND 35), (U.S. CLS. 21, 23, 26, 36, 38, 100, 101 AND 102). SN 85-208,402. PUB. 5-3-2011. FILED 12-30-2010.
- 3,997,836. **QUICKSTORE (STANDARD CHARACTER)**. VENDMORE SYSTEMS, LLC, (U.S. CLS. 21, 23, 26, 36 AND 38). SN 85-208,408. PUB. 5-3-2011. FILED 12-30-2010.
- 3,997,839. **MDRINK (STANDARD CHARACTER)**. VENDMORE SYSTEMS, LLC, MULTIPLE CLASS, (INT. CLS. 9 AND 35), (U.S. CLS. 21, 23, 26, 36, 38, 100, 101 AND 102). SN 85-208,467. PUB. 5-3-2011. FILED 12-31-2010.
- 3,997,840. **MDRINK (STYLIZED)**. VENDMORE SYSTEMS, LLC, MULTIPLE CLASS, (INT. CLS. 9 AND 35), (U.S. CLS. 21, 23, 26, 36, 38, 100, 101 AND 102). SN 85-208,471. PUB. 5-3-2011. FILED 12-31-2010.
- 3,997,862. **GOVERNANCE AS A SERVICE (STANDARD CHARACTER)**. CONFIDENT GOVERNANCE, AKA ENCRISP LLC, (U.S. CLS. 21, 23, 26, 36 AND 38). SN 85-208,681. PUB. 5-3-2011. FILED 12-31-2010.
- 3,997,868. **EVENTGENIE (STANDARD CHARACTER)**. SCHULER, SERGIO, (U.S. CLS. 21, 23, 26, 36 AND 38). SN 85-208,703. PUB. 5-3-2011. FILED 12-31-2010.
- 3,997,869. **DE2 (STYLIZED)**. PRAGMATICA INNOVATIONS, LLC, (U.S. CLS. 21, 23, 26, 36 AND 38). SN 85-208,708. PUB. 5-3-2011. FILED 12-31-2010.
- 3,997,876. **PAINTED ON WATER (STANDARD CHARACTER)**. GNL ENTERTAINMENT, INC., (U.S. CLS. 21, 23, 26, 36 AND 38). SN 85-208,769. PUB. 5-3-2011. FILED 1-1-2011.
- 3,997,879. **MISCELLANEOUS DESIGN**. TIME TO KNOW LIMITED, MULTIPLE CLASS, (INT. CLS. 9 AND 41), (U.S. CLS. 21, 23, 26, 36, 38, 100, 101 AND 107). SN 85-208,827. PUB. 5-3-2011. FILED 1-2-2011.
- 3,997,883. **DRUGTRAIL (STANDARD CHARACTER)**. ABDEL FAHMY, (U.S. CLS. 21, 23, 26, 36 AND 38). SN 85-208,917. PUB. 5-3-2011. FILED 1-3-2011.
- 3,997,904. **S3 (STANDARD CHARACTER)**. ESCORT INC., (U.S. CLS. 21, 23, 26, 36 AND 38). SN 85-209,153. PUB. 5-3-2011. FILED 1-3-2011.
- 3,997,919. **ACCENT (STANDARD CHARACTER)**. FISHER HAMILTON L.L.C., (U.S. CLS. 21, 23, 26, 36 AND 38). SN 85-209,310. PUB. 5-3-2011. FILED 1-3-2011.
- 3,997,921. **MOBILE PRESENCE (STANDARD CHARACTER)**. MOBEGIC, INCORPORATED, DBA UNBOUND COMMERCE, (U.S. CLS. 21, 23, 26, 36 AND 38). SN 85-209,354. PUB. 5-3-2011. FILED 1-3-2011.
- 3,997,923. **FOTOLIA (STANDARD CHARACTER)**. FOTOLIA LLC, MULTIPLE CLASS, (INT. CLS. 9, 35, 38, 42 AND 45), (U.S. CLS. 21, 23, 26, 36, 38, 100, 101, 102 AND 104). SN 85-209,369. PUB. 5-3-2011. FILED 1-3-2011.
- 3,997,928. **MISCELLANEOUS DESIGN**. FOTOLIA LLC, MULTIPLE CLASS, (INT. CLS. 9, 35, 38, 42 AND 45), (U.S. CLS. 21, 23, 26, 36, 38, 100, 101, 102 AND 104). SN 85-209,435. PUB.

- 5-3-2011. FILED 1-3-2011.
- 3,997,935. **VILLAIN (STANDARD CHARACTER)**. VILLAIN LLC, (U.S. CLS. 21, 23, 26, 36 AND 38). SN 85-209,516. PUB. 5-3-2011. FILED 1-3-2011.
- 3,997,936. **SPIT (STANDARD CHARACTER)**. CORBO, VINCENT, JR., MULTIPLE CLASS, (INT. CLS. 9 AND 41), (U.S. CLS. 21, 23, 26, 36, 38, 100, 101 AND 107). SN 85-209,519. PUB. 5-3-2011. FILED 1-3-2011.
- 3,997,955. **E-PCS (STANDARD CHARACTER)**. DATA-BUILDER, INC., (U.S. CLS. 21, 23, 26, 36 AND 38). SN 85-209,798. PUB. 5-3-2011. FILED 1-4-2011.
- 3,997,960. **CHARTGEN (STANDARD CHARACTER)**. MYERS-HOLUM, INC., (U.S. CLS. 21, 23, 26, 36 AND 38). SN 85-209,888. PUB. 5-3-2011. FILED 1-4-2011.
- 3,997,972. **RYOMAX (STYLIZED)**. JVC KENWOOD HOLDINGS, INC., (U.S. CLS. 21, 23, 26, 36 AND 38). SN 85-210,041. PUB. 5-3-2011. FILED 1-4-2011.
- 3,997,994. **MOISTTECH (STANDARD CHARACTER)**. SENSORTECH SYSTEMS, INC., (U.S. CLS. 21, 23, 26, 36 AND 38). SN 85-210,382. PUB. 5-3-2011. FILED 1-4-2011.
- 3,998,005. **INSPORTS (STANDARD CHARACTER)**. INSPORTS, INC., MULTIPLE CLASS, (INT. CLS. 9, 38 AND 42), (U.S. CLS. 21, 23, 26, 36, 38, 100, 101 AND 104). SN 85-210,499. PUB. 5-3-2011. FILED 1-4-2011.
- 3,998,008. **XENEXX (STYLIZED)**. XENEXX CORP. LIMITED, (U.S. CLS. 21, 23, 26, 36 AND 38). SN 85-210,544. PUB. 5-3-2011. FILED 1-5-2011.
- 3,998,019. **LENS2SCOPE (STANDARD CHARACTER)**. CHAO-WEN LIANG, (U.S. CLS. 21, 23, 26, 36 AND 38). SN 85-210,696. PUB. 5-3-2011. FILED 1-5-2011.
- 3,998,023. **REAPER (STANDARD CHARACTER)**. COCKOS INCORPORATED, (U.S. CLS. 21, 23, 26, 36 AND 38). SN 85-210,811. PUB. 5-3-2011. FILED 1-5-2011.
- 3,998,025. **FOODCACHING (STANDARD CHARACTER)**. LIGHTVANTAGE, (U.S. CLS. 21, 23, 26, 36 AND 38). SN 85-210,840. PUB. 5-3-2011. FILED 1-5-2011.
- 3,998,027. **FOLDO (STANDARD CHARACTER)**. MOFTWARE INC, (U.S. CLS. 21, 23, 26, 36 AND 38). SN 85-210,846. PUB. 5-3-2011. FILED 1-5-2011.
- 3,998,052. **TEXTBOARD (STANDARD CHARACTER)**. ROCKWELL, JUSTIN H., (U.S. CLS. 21, 23, 26, 36 AND 38). SN 85-211,235. PUB. 5-3-2011. FILED 1-5-2011.
- 3,998,064. **DIVADELIC (STANDARD CHARACTER)**. FARJAH, HIRBOD, MULTIPLE CLASS, (INT. CLS. 9 AND 25), (U.S. CLS. 21, 22, 23, 26, 36, 38 AND 39). SN 85-211,418. PUB. 5-3-2011. FILED 1-5-2011.
- 3,998,066. **HOWSIMPLE (STANDARD CHARACTER)**. HOWSIMPLE, LLC, MULTIPLE CLASS, (INT. CLS. 9 AND 42), (U.S. CLS. 21, 23, 26, 36, 38, 100 AND 101). SN 85-211,426. PUB. 5-3-2011. FILED 1-5-2011.
- 3,998,073. **KATA (STANDARD CHARACTER)**. FUTURE MASTER INTERNATIONAL LTD, (U.S. CLS. 21, 23, 26, 36 AND 38). SN 85-211,493. PUB. 5-3-2011. FILED 1-5-2011.
- 3,998,074. **EMOTIV (STANDARD CHARACTER)**. EMOTIV LIMITED, (U.S. CLS. 21, 23, 26, 36 AND 38). SN 85-211,544. PUB. 5-3-2011. FILED 1-6-2011.
- 3,998,076. **WOTANCRAFT (STYLIZED)**. CHIH CHIEH HSU, MULTIPLE CLASS, (INT. CLS. 9 AND 18), (U.S. CLS. 1, 2, 3, 21, 22, 23, 26, 36, 38 AND 41). SN 85-211,587. PUB. 5-3-2011. FILED 1-6-2011.
- 3,998,084. **FB ALIX (STANDARD CHARACTER)**. THE FONT BUREAU, INC., (U.S. CLS. 21, 23, 26, 36 AND 38). SN 85-211,756. PUB. 5-3-2011. FILED 1-6-2011.
- 3,998,085. **INVISIPAY (STANDARD CHARACTER)**. MAGID MINA, DBA INVICORP, INC., (U.S. CLS. 21, 23, 26, 36 AND 38). SN 85-211,777. PUB. 5-3-2011. FILED 1-6-2011.
- 3,998,086. **INVISICODE (STANDARD CHARACTER)**. MAGID MINA, DBA INVICORP, INC., (U.S. CLS. 21, 23, 26, 36 AND 38). SN 85-211,787. PUB. 5-3-2011. FILED 1-6-2011.
- 3,998,093. **WE'RE HELPING PEOPLE PRINT SMARTER (STANDARD CHARACTER)**. EQUITRAC CORPORATION, (U.S. CLS. 21, 23, 26, 36 AND 38). SN 85-211,900. PUB. 5-3-2011. FILED 1-6-2011.
- 3,998,099. **FLOW-CLIK (STANDARD CHARACTER)**. HUNTER INDUSTRIES, INC., (U.S. CLS. 21, 23, 26, 36 AND 38). SN 85-212,012. PUB. 5-3-2011. FILED 1-6-2011.
- 3,998,112. **POCKETGEMS AND DESIGN**. POCKET GEMS, INC., (U.S. CLS. 21, 23, 26, 36 AND 38). SN 85-212,299. PUB. 5-3-2011. FILED 1-6-2011.
- 3,998,119. **E AND DESIGN**. EMOTIV LIMITED, (U.S. CLS. 21, 23, 26, 36 AND 38). SN 85-212,477. PUB. 5-3-2011. FILED 1-7-2011.
- 3,998,133. **EMERGENCY 1 (STANDARD CHARACTER)**. WOLO MANUFACTURING CORP., (U.S. CLS. 21, 23, 26, 36 AND 38). SN 85-212,799. PUB. 5-3-2011. FILED 1-7-2011.
- 3,998,141. **MISCELLANEOUS DESIGN**. CREE, INC., (U.S. CLS. 21, 23, 26, 36 AND 38). SN 85-212,992. PUB. 5-3-2011. FILED 1-7-2011.
- 3,998,144. **THE VALUE OF 168 (STANDARD CHARACTER)**. RPM INTERNATIONAL INC., MULTIPLE CLASS, (INT. CLS. 9 AND 16), (U.S. CLS. 2, 5, 21, 22, 23, 26, 29, 36, 37, 38 AND 50). SN 85-213,021. PUB. 5-3-2011. FILED 1-7-2011.
- 3,998,151. **PORTALGUARD (STANDARD CHARACTER)**. PISTOLSTAR, INC., (U.S. CLS. 21, 23, 26, 36 AND 38). SN 85-213,180. PUB. 5-3-2011. FILED 1-7-2011.
- 3,998,157. **SALESPAL (STANDARD CHARACTER)**. INFLUENCE, (U.S. CLS. 21, 23, 26, 36 AND 38). SN 85-213,369. PUB. 5-3-2011. FILED 1-7-2011.
- 3,998,166. **WATERWELL (STYLIZED)**. AMERICAN WATERWELL INTERNATIONAL CORPORATION, (U.S. CLS. 21, 23, 26, 36 AND 38). SN 85-213,664. PUB. 5-3-2011. FILED 1-9-2011.
- 3,998,170. **NEURAJET17 (STANDARD CHARACTER)**. NEURALOG, INC., (U.S. CLS. 21, 23, 26, 36 AND 38). SN 85-214,213. PUB. 5-3-2011. FILED 1-10-2011.
- 3,998,171. **MISCELLANEOUS DESIGN**. SAINT LOUIS UNIVERSITY, (U.S. CLS. 21, 23, 26, 36 AND 38). SN 85-214,219. PUB. 5-3-2011. FILED 1-10-2011.
- 3,998,176. **TALON (STANDARD CHARACTER)**. UNCLE SAM'S FIREWORKS CITY, INC., (U.S. CLS. 21, 23, 26, 36 AND 38). SN 85-214,287. PUB. 5-3-2011. FILED 1-10-2011.
- 3,998,178. **READWORKS (STANDARD CHARACTER)**. URBAN EDUCATION EXCHANGE, INC., MULTIPLE CLASS, (INT. CLS. 9, 16, 35 AND 41), (U.S. CLS. 2, 5, 21, 22, 23, 26, 29, 36, 37, 38, 50, 100, 101, 102 AND 107). SN 85-214,293. PUB. 5-3-2011. FILED 1-10-2011.
- 3,998,181. **FINALYSER (STANDARD CHARACTER)**. FEHRMANN KSCHUK SERVICES LLC, (U.S. CLS. 21, 23, 26, 36 AND 38). SN 85-214,326. PUB. 5-3-2011. FILED 1-10-2011.
- 3,998,186. **EXAM-PAD (STANDARD CHARACTER)**. COACTIV, LLC, (U.S. CLS. 21, 23, 26, 36 AND 38). SN 85-214,403. PUB. 5-3-2011. FILED 1-10-2011.
- 3,998,197. **SPEAK (STANDARD CHARACTER)**. EDUCATIONAL TESTING SERVICE, MULTIPLE CLASS, (INT. CLS. 9 AND 16), (U.S. CLS. 2, 5, 21, 22, 23, 26, 29, 36, 37, 38 AND 50). SN 85-216,226. PUB. 5-3-2011. FILED 1-12-2011.
- 3,998,214. **KIDDIE COCKTAILS (STANDARD CHARACTER)**. FONT DINER, INC., (U.S. CLS. 21, 23, 26, 36 AND 38). SN 85-222,996. PUB. 5-3-2011. FILED 1-21-2011.
- 3,998,215. **MOSQUITO FIESTA (STANDARD CHARACTER)**. FONT DINER, INC., (U.S. CLS. 21, 23, 26, 36 AND 38). SN 85-223,091. PUB. 5-3-2011. FILED 1-21-2011.
- 3,998,216. **VOLCANO KING (STANDARD CHARACTER)**. FONT DINER, INC., (U.S. CLS. 21, 23, 26, 36 AND 38). SN 85-223,115. PUB. 5-3-2011. FILED 1-21-2011.
- 3,998,220. **RADSEEKER (STANDARD CHARACTER)**. SMITHS DETECTION INC., (U.S. CLS. 21, 23, 26, 36 AND 38). SN 85-224,199. PUB. 5-3-2011. FILED 1-24-2011.
- 3,998,221. **SLEEPSOFT (STANDARD CHARACTER)**. ALPINE HOLDING B.V., (U.S. CLS. 21, 23, 26, 36 AND 38). SN 85-224,538. PUB. 5-3-2011. FILED 1-24-2011.
- 3,998,225. **PERSIAN EMPIRE (STANDARD CHARACTER)**. BALLY GAMING, INC., DBA BALLY TECHNOLOGIES, (U.S. CLS. 21, 23, 26, 36 AND 38). SN 85-225,940. PUB. 5-3-2011. FILED 1-25-2011.
- 3,998,226. **ISLAND WINS (STANDARD CHARACTER)**. BALLY GAMING, INC., DBA BALLY TECHNOLOGIES, (U.S. CLS. 21, 23, 26, 36 AND 38). SN 85-225,951. PUB. 5-3-2011. FILED 1-25-2011.
- 3,998,227. **ASIAN TREASURES (STANDARD CHARACTER)**. BALLY GAMING, INC., DBA BALLY TECHNOLOGIES, (U.S. CLS. 21, 23, 26, 36 AND 38). SN 85-225,971. PUB. 5-3-2011. FILED 1-25-2011.
- 3,998,228. **MAYAN TREASURES (STANDARD CHARACTER)**. BALLY GAMING, INC., DBA BALLY TECHNOLOGIES, (U.S. CLS. 21, 23, 26, 36 AND 38). SN 85-225,977. PUB. 5-3-

2011. FILED 1-25-2011.
- 3,998,231. **MISCELLANEOUS DESIGN**. KABBALAH CENTRE INTERNATIONAL, INC., (U.S. CLS. 21, 23, 26, 36 AND 38). SN 85-226,580. PUB. 5-3-2011. FILED 1-26-2011.
- 3,998,234. **SMARTDRAFT (STANDARD CHARACTER)**. WETLAND STUDIES AND SOLUTIONS, INC., (U.S. CLS. 21, 23, 26, 36 AND 38). SN 85-230,118. PUB. 5-3-2011. FILED 1-31-2011.
- 3,998,245. **BUILDING LANGUAGE FOR LITERACY (STYLIZED)**. SCHOLASTIC INC., (U.S. CLS. 21, 23, 26, 36 AND 38). SN 85-233,478. PUB. 5-3-2011. FILED 2-3-2011.
- 3,998,246. **MOBILEDRINK (STANDARD CHARACTER)**. VENDMORE SYSTEMS, LLC, MULTIPLE CLASS, (INT. CLS. 9 AND 35), (U.S. CLS. 21, 23, 26, 36, 38, 100, 101 AND 102). SN 85-233,578. PUB. 5-3-2011. FILED 2-3-2011.
- 3,998,247. **MOBILEDRINK (STYLIZED)**. VENDMORE SYSTEMS, LLC, MULTIPLE CLASS, (INT. CLS. 9 AND 35), (U.S. CLS. 21, 23, 26, 36, 38, 100, 101 AND 102). SN 85-233,636. PUB. 5-3-2011. FILED 2-3-2011.
- 3,998,251. **CTC AND DESIGN**. COMMONWEALTH TRADING COMPANY, INC., MULTIPLE CLASS, (INT. CLS. 9, 25 AND 35), (U.S. CLS. 21, 22, 23, 26, 36, 38, 39, 100, 101 AND 102). SN 85-234,798. PUB. 5-3-2011. FILED 2-4-2011.
- 3,998,261. **FLYFIT (STANDARD CHARACTER)**. ALPINE HOLDING B.V., (U.S. CLS. 21, 23, 26, 36 AND 38). SN 85-239,280. PUB. 5-3-2011. FILED 2-10-2011.
- 3,998,262. **MONA.VIE (STANDARD CHARACTER)**. MONA-VIE LLC, (U.S. CLS. 21, 23, 26, 36 AND 38). SN 85-239,401. PUB. 5-3-2011. FILED 2-10-2011.
- 3,998,266. **GARD-N-POST (STANDARD CHARACTER)**. ARLINGTON INDUSTRIES, INC., (U.S. CLS. 21, 23, 26, 36 AND 38). SN 85-243,245. PUB. 5-3-2011. FILED 2-15-2011.
- 3,998,269. **MISCELLANEOUS DESIGN**. THOUGHTBOT, INC., MULTIPLE CLASS, (INT. CLS. 9, 41 AND 42), (U.S. CLS. 21, 23, 26, 36, 38, 100, 101 AND 107). SN 85-244,284. PUB. 5-3-2011. FILED 2-16-2011.
- 3,998,270. **THOUGHTBOT (STANDARD CHARACTER)**. THOUGHTBOT, INC., MULTIPLE CLASS, (INT. CLS. 9, 41 AND 42), (U.S. CLS. 21, 23, 26, 36, 38, 100, 101 AND 107). SN 85-244,292. PUB. 5-3-2011. FILED 2-16-2011.
- 3,998,273. **CID (STANDARD CHARACTER)**. RADWARE LTD., (U.S. CLS. 21, 23, 26, 36 AND 38). SN 85-244,983. PUB. 5-3-2011. FILED 2-17-2011.
- 3,998,275. **TRAIL MATE (STANDARD CHARACTER)**. TIMEX GROUP USA, INC., MULTIPLE CLASS, (INT. CLS. 9 AND 14), (U.S. CLS. 2, 21, 23, 26, 27, 28, 36, 38 AND 50). SN 85-245,950. PUB. 5-3-2011. FILED 2-18-2011.
- 3,998,277. **ACHIEVING YOUR POTENTIAL (STANDARD CHARACTER)**. THE PACIFIC INSTITUTE INCORPORATED, MULTIPLE CLASS, (INT. CLS. 9, 16 AND 41), (U.S. CLS. 2, 5, 21, 22, 23, 26, 29, 36, 37, 38, 50, 100, 101 AND 107). SN 85-246,476. PUB. 5-3-2011. FILED 2-18-2011.
- 3,998,289. **DIRECTEXTRACT (STANDARD CHARACTER)**. ZL TECHNOLOGIES, INC., (U.S. CLS. 21, 23, 26, 36 AND 38). SN 85-251,143. PUB. 5-3-2011. FILED 2-24-2011.
- 3,998,290. **HERON (STANDARD CHARACTER)**. THE FONT BUREAU INC., (U.S. CLS. 21, 23, 26, 36 AND 38). SN 85-252,579. PUB. 5-3-2011. FILED 2-26-2011.
- 3,998,291. **BIG FIGGINS (STANDARD CHARACTER)**. THE FONT BUREAU INC., AND CARTER & CONE TYPE INC., (U.S. CLS. 21, 23, 26, 36 AND 38). SN 85-253,090. PUB. 5-3-2011. FILED 2-28-2011.
- GING & SIMULATIONS CORP., (U.S. CLS. 26, 39 AND 44). SN 77-746,890. PUB. 5-3-2011. FILED 5-28-2009.
- 3,995,613. **VINCI MED-X CARE (STANDARD CHARACTER)**. LES INDUSTRIES HOLMONT LTÉE, (U.S. CLS. 26, 39 AND 44). SN 77-840,431. PUB. 5-3-2011. FILED 10-2-2009.
- 3,995,624 (*See Class 9 for this trademark*).
- 3,995,625 (*See Class 9 for this trademark*).
- 3,995,670. **INSPIRATION (STANDARD CHARACTER)**. LRC PRODUCTS LIMITED, (U.S. CLS. 26, 39 AND 44). SN 77-910,255. PUB. 11-23-2010. FILED 1-12-2010.
- 3,995,673. **PSORIA-LIGHT (STANDARD CHARACTER)**. PSORIA-SHIELD, INC., (U.S. CLS. 26, 39 AND 44). SN 77-916,236. PUB. 5-3-2011. FILED 1-20-2010.
- 3,995,705 (*See Class 9 for this trademark*).
- 3,995,718 (*See Class 8 for this trademark*).
- 3,995,720 (*See Class 6 for this trademark*).
- 3,995,757. **CAPPA C-NAV (STANDARD CHARACTER)**. SIEMENS AKTIENGESELLSCHAFT, MULTIPLE CLASS, (INT. CLS. 10, 41 AND 42), (U.S. CLS. 26, 39, 44, 100, 101 AND 107). SN 79-077,429. PUB. 5-3-2011. FILED 11-20-2009.
- 3,995,805. **REGENCELL (STANDARD CHARACTER)**. REGEN LAB SA, (U.S. CLS. 26, 39 AND 44). SN 79-083,268. PUB. 1-25-2011. FILED 4-21-2010.
- 3,995,856. **AIRSTACK (STANDARD CHARACTER)**. MANGAR INTERNATIONAL LIMITED, (U.S. CLS. 26, 39 AND 44). SN 79-085,080. PUB. 5-3-2011. FILED 6-18-2010.
- 3,995,862. **KIBODAN (STANDARD CHARACTER)**. KIBODAN A/S, (U.S. CLS. 26, 39 AND 44). SN 79-085,233. PUB. 5-3-2011. FILED 3-2-2010.
- 3,995,874 (*See Class 5 for this trademark*).
- 3,995,919. **VICTOR HD (STANDARD CHARACTER)**. RICHARD WOLF GMBH, (U.S. CLS. 26, 39 AND 44). SN 79-087,048. PUB. 5-3-2011. FILED 6-12-2010.
- 3,995,928 (*See Class 9 for this trademark*).
- 3,995,952 (*See Class 9 for this trademark*).
- 3,995,955 (*See Class 5 for this trademark*).
- 3,995,966 (*See Class 9 for this trademark*).
- 3,995,967 (*See Class 9 for this trademark*).
- 3,996,023. **VASOCT (STANDARD CHARACTER)**. KONINKLIJKE PHILIPS ELECTRONICS N.V., (U.S. CLS. 26, 39 AND 44). SN 79-094,087. PUB. 5-3-2011. FILED 12-10-2010.
- 3,996,371 (*See Class 1 for this trademark*).
- 3,996,388. **PATIENT ACCESS ZONE (STANDARD CHARACTER)**. GAYMAR INDUSTRIES, INC., (U.S. CLS. 26, 39 AND 44). SN 85-082,454. PUB. 5-3-2011. FILED 7-12-2010.
- 3,996,420. **DISPOS-A-VENT (STANDARD CHARACTER)**. OLIVER-TOLAS HEALTHCARE PACKAGING, LLC, (U.S. CLS. 26, 39 AND 44). SN 85-091,750. PUB. 5-3-2011. FILED 7-23-2010.
- 3,996,429. **TELLS YOU WHERE YOU ARE ...NO MATTER WHERE YOU'RE AT (STANDARD CHARACTER)**. CORPAK MEDSYSTEMS, INC., (U.S. CLS. 26, 39 AND 44). SN 85-093,930. PUB. 5-3-2011. FILED 7-27-2010.
- 3,996,464. **NATURAL BALANCE (STANDARD CHARACTER)**. JB ORTHOTICS & SHOES, (U.S. CLS. 26, 39 AND 44). SN 85-105,080. PUB. 1-25-2011. FILED 8-11-2010.
- 3,996,474. **PAINSHIELD (STANDARD CHARACTER)**. NANO-VIBRONIX, INC., (U.S. CLS. 26, 39 AND 44). SN 85-108,930. PUB. 5-3-2011. FILED 8-17-2010.
- 3,996,490. **MAGICIAN (STANDARD CHARACTER)**. ALTIMATE MEDICAL, INC., (U.S. CLS. 26, 39 AND 44). SN 85-116,797. PUB. 5-3-2011. FILED 8-26-2010.
- 3,996,506. **AESLIGHT AND DESIGN**. BEIJING HONKON TECHNOLOGY CO., LTD., (U.S. CLS. 26, 39 AND 44). SN 85-122,449. PUB. 5-3-2011. FILED 9-3-2010.
- 3,996,532. **OXUS (STANDARD CHARACTER)**. OXUS AMERICA, INC., MULTIPLE CLASS, (INT. CLS. 10 AND 11), (U.S. CLS. 13, 21, 23, 26, 31, 34, 39 AND 44). SN 85-128,291. PUB. 5-3-2011. FILED 9-13-2010.
- 3,996,658. **SONIC SAFE (STANDARD CHARACTER)**. BACON, BRETT, E., DBA SONIC SAFE, (U.S. CLS. 26, 39 AND 44). SN 85-156,875. PUB. 5-3-2011. FILED 10-20-2010.
- 3,996,688. **CONFIDENTURES AND DESIGN**. DENTODOLOGY SCIENCES COMPANY, LLC, (U.S. CLS. 26, 39 AND 44). SN 85-163,597. PUB. 5-3-2011. FILED 10-28-2010.
- 3,996,691 (*See Class 5 for this trademark*).
- 3,996,715 (*See Class 9 for this trademark*).
- 3,996,730. **GLIDER (STANDARD CHARACTER)**. ALTIMATE

CLASS 10—MEDICAL APPARATUS

- 3,995,482. **GEL FORCE (STANDARD CHARACTER)**. MAVERICK SPORTS MEDICINE, INC., DBA DBA PRO-TEC ATHLETICS, (U.S. CLS. 26, 39 AND 44). SN 76-704,258. PUB. 1-25-2011. FILED 8-26-2010.
- 3,995,523 (*See Class 3 for this trademark*).
- 3,995,538. **EQUASHIELD (STANDARD CHARACTER)**. PLASTMED LTD., (U.S. CLS. 26, 39 AND 44). SN 77-569,689. PUB. 10-12-2010. FILED 9-15-2008.
- 3,995,548 (*See Class 9 for this trademark*).
- 3,995,557 (*See Class 3 for this trademark*).
- 3,995,583. **FIREDCR (STANDARD CHARACTER)**. 3D IMA-

- MEDICAL, INC., (U.S. CLS. 26, 39 AND 44). SN 85-170,440. PUB. 5-3-2011. FILED 11-5-2010.
- 3,997,143. **IGROW (STANDARD CHARACTER)**. APIRA SCIENCE INC., (U.S. CLS. 26, 39 AND 44). SN 85-189,588. PUB. 5-3-2011. FILED 12-2-2010.
- 3,997,178. **SREE MEDICAL SYSTEMS (STANDARD CHARACTER)**. ADVANCED IMAGING RESEARCH, INC., (U.S. CLS. 26, 39 AND 44). SN 85-190,191. PUB. 5-3-2011. FILED 12-3-2010.
- 3,997,321. **METAFORM (STANDARD CHARACTER)**. LETHAN CORPORATION, (U.S. CLS. 26, 39 AND 44). SN 85-195,056. PUB. 5-3-2011. FILED 12-10-2010.
- 3,997,421 (*See Class 3 for this trademark*).
- 3,997,433. **KOALA T AND DESIGN**. NOVAMED-USA INC., (U.S. CLS. 26, 39 AND 44). SN 85-200,804. PUB. 5-3-2011. FILED 12-17-2010.
- 3,997,488. **C-FLEX (STANDARD CHARACTER)**. ALLEN MEDICAL SYSTEMS, INC., (U.S. CLS. 26, 39 AND 44). SN 85-202,859. PUB. 5-3-2011. FILED 12-21-2010.
- 3,997,503. **DERMALIFE (STANDARD CHARACTER)**. PRETIKA CORPORATION, (U.S. CLS. 26, 39 AND 44). SN 85-203,770. PUB. 5-3-2011. FILED 12-22-2010.
- 3,997,523. **NUCOMFORT (STANDARD CHARACTER)**. ASCEND EAGLE INC., (U.S. CLS. 26, 39 AND 44). SN 85-204,236. PUB. 5-3-2011. FILED 12-22-2010.
- 3,997,760. **3PP (STANDARD CHARACTER)**. 3-POINT PRODUCTS, INC., (U.S. CLS. 26, 39 AND 44). SN 85-207,452. PUB. 5-3-2011. FILED 12-29-2010.
- 3,997,777. **SKINSATIONAL (STANDARD CHARACTER)**. 3-POINT PRODUCTS, INC., (U.S. CLS. 26, 39 AND 44). SN 85-207,731. PUB. 5-3-2011. FILED 12-30-2010.
- 3,997,913. **CORELINK (STANDARD CHARACTER)**. CORELINK, LLC, (U.S. CLS. 26, 39 AND 44). SN 85-209,214. PUB. 5-3-2011. FILED 1-3-2011.
- 3,997,988. **MYLABTOUCH (STANDARD CHARACTER)**. ESAOTE S.P.A., (U.S. CLS. 26, 39 AND 44). SN 85-210,280. PUB. 5-3-2011. FILED 1-4-2011.
- 3,998,050 (*See Class 3 for this trademark*).
- 3,998,108. **TROJAN MAGNUM ECSTASY (STANDARD CHARACTER)**. CHURCH & DWIGHT CO., INC., (U.S. CLS. 26, 39 AND 44). SN 85-212,199. PUB. 5-3-2011. FILED 1-6-2011.
- 3,998,123. **KIDZ-MED (STANDARD CHARACTER)**. AMERICAN SCIENTIFIC RESOURCES, INC., (U.S. CLS. 26, 39 AND 44). SN 85-212,509. PUB. 5-3-2011. FILED 1-7-2011.
- 3,998,239. **STEPTech (STANDARD CHARACTER)**. DEPUY, INC., (U.S. CLS. 26, 39 AND 44). SN 85-231,493. PUB. 5-3-2011. FILED 2-1-2011.
- 3,995,861 (*See Class 3 for this trademark*).
- 3,995,879 (*See Class 6 for this trademark*).
- 3,995,897. **WALDMANN PRESS + PROOF (STANDARD CHARACTER)**. HERBERT WALDMANN GMBH & CO. KG., (U.S. CLS. 13, 21, 23, 31 AND 34). SN 79-086,120. PUB. 5-3-2011. FILED 7-28-2010.
- 3,995,898 (*See Class 5 for this trademark*).
- 3,995,902. **STREAMER AND DESIGN**. DAIKIN INDUSTRIES, LTD., (U.S. CLS. 13, 21, 23, 31 AND 34). SN 79-086,270. PUB. 5-3-2011. FILED 3-10-2010.
- 3,995,922. **MARTIN MARGIELA (STANDARD CHARACTER)**. NEUF, MULTIPLE CLASS, (INT. CLS. 11, 16, 20 AND 28), (U.S. CLS. 2, 5, 13, 21, 22, 23, 25, 29, 31, 32, 34, 37, 38 AND 50). SN 79-087,569. PUB. 5-3-2011. FILED 6-22-2010.
- 3,995,940 (*See Class 9 for this trademark*).
- 3,995,952 (*See Class 9 for this trademark*).
- 3,995,956. **EMH (STANDARD CHARACTER)**. OSRAM GESELLSCHAFT MIT BESCHRÄNKTER HAFTUNG, (U.S. CLS. 13, 21, 23, 31 AND 34). SN 79-089,217. PUB. 5-3-2011. FILED 9-22-2010.
- 3,995,959 (*See Class 6 for this trademark*).
- 3,995,985 (*See Class 1 for this trademark*).
- 3,995,986 (*See Class 1 for this trademark*).
- 3,995,987 (*See Class 1 for this trademark*).
- 3,996,017. **WHITEFFICIENCY (STANDARD CHARACTER)**. RATIONAL AG, (U.S. CLS. 13, 21, 23, 31 AND 34). SN 79-093,763. PUB. 5-3-2011. FILED 12-20-2010.
- 3,996,042. **GEOCOLUMN (STANDARD CHARACTER)**. GEENERGY ENTERPRISES, LLC, (U.S. CLS. 13, 21, 23, 31 AND 34). SN 85-007,384. PUB. 5-3-2011. FILED 4-6-2010.
- 3,996,090. **FLOWPAC (STANDARD CHARACTER)**. ALSTOM POWER INC., (U.S. CLS. 13, 21, 23, 31 AND 34). SN 85-026,759. PUB. 5-3-2011. FILED 4-29-2010.
- 3,996,136. **ULTRA-TROL (STANDARD CHARACTER)**. DFT, INC., (U.S. CLS. 13, 21, 23, 31 AND 34). SN 85-037,417. PUB. 5-3-2011. FILED 5-13-2010.
- 3,996,137. **UNIFLO (STANDARD CHARACTER)**. DFT, INC., (U.S. CLS. 13, 21, 23, 31 AND 34). SN 85-037,514. PUB. 5-3-2011. FILED 5-13-2010.
- 3,996,177 (*See Class 7 for this trademark*).
- 3,996,206 (*See Class 7 for this trademark*).
- 3,996,284. **VERTEX (STANDARD CHARACTER)**. VERTEX INDUSTRIALS, INC., (U.S. CLS. 13, 21, 23, 31 AND 34). SN 85-056,702. PUB. 5-3-2011. FILED 6-7-2010.
- 3,996,322 (*See Class 6 for this trademark*).
- 3,996,323. **GROWOP TECHNOLOGY AND DESIGN**. GROWOP TECHNOLOGY, LTD, (U.S. CLS. 13, 21, 23, 31 AND 34). SN 85-065,971. PUB. 5-3-2011. FILED 6-17-2010.
- 3,996,370. **MISTFIX (STANDARD CHARACTER)**. AMISTCO SEPARATION PRODUCTS, INC., (U.S. CLS. 13, 21, 23, 31 AND 34). SN 85-076,092. PUB. 5-3-2011. FILED 7-1-2010.
- 3,996,376. **SHAPING THE FUTURE OF HOME DESIGN (STANDARD CHARACTER)**. ADESSO INC., MULTIPLE CLASS, (INT. CLS. 11 AND 20), (U.S. CLS. 2, 13, 21, 22, 23, 25, 31, 32, 34 AND 50). SN 85-079,126. PUB. 5-3-2011. FILED 7-7-2010.
- 3,996,411. **RA ENERGY (STANDARD CHARACTER)**. FOREFRONT LLC, (U.S. CLS. 13, 21, 23, 31 AND 34). SN 85-089,922. PUB. 5-3-2011. FILED 7-21-2010.
- 3,996,450. **VALUEMAX (STYLIZED)**. HANGZHOU GREAT STAR INDUSTRIAL CO., LTD., (U.S. CLS. 13, 21, 23, 31 AND 34). SN 85-101,282. PUB. 5-3-2011. FILED 8-5-2010.
- 3,996,532 (*See Class 10 for this trademark*).
- 3,996,560. **POWERFLEX (STYLIZED)**. JAMES L SCHUPPE, DBA INDUCTION SYSTEMS, INC., (U.S. CLS. 13, 21, 23, 31 AND 34). SN 85-134,466. PUB. 5-3-2011. FILED 9-21-2010.
- 3,996,765. **HTL HIGH TECH LIGHTING (STANDARD CHARACTER)**. HIGH TECH LIGHTING AND AUDIO INC., DBA DJ STAGE SHOP CO., (U.S. CLS. 13, 21, 23, 31 AND 34). SN 85-173,544. PUB. 5-3-2011. FILED 11-10-2010.
- 3,996,865. **CAMPUS LIGHTS AND DESIGN**. GAMETIME LIGHTS, LLC, (U.S. CLS. 13, 21, 23, 31 AND 34). SN 85-179,704. PUB. 5-3-2011. FILED 11-18-2010.
- 3,996,882. **FRESH TO PLATE (STANDARD CHARACTER)**. EVO, INC., (U.S. CLS. 13, 21, 23, 31 AND 34). SN 85-180,923. PUB. 5-3-2011. FILED 11-19-2010.
- 3,996,942. **SMOKERIN (STYLIZED)**. VILLA OLYMPIC INC., (U.S. CLS. 13, 21, 23, 31 AND 34). SN 85-183,816. PUB. 5-3-

CLASS 11—ENVIRONMENTAL CONTROL APPARATUS

- 3,995,465 (*See Class 9 for this trademark*).
- 3,995,524 (*See Class 7 for this trademark*).
- 3,995,531 (*See Class 7 for this trademark*).
- 3,995,548 (*See Class 9 for this trademark*).
- 3,995,596 (*See Class 7 for this trademark*).
- 3,995,753 (*See Class 9 for this trademark*).
- 3,995,754 (*See Class 9 for this trademark*).
- 3,995,766 (*See Class 9 for this trademark*).
- 3,995,772 (*See Class 6 for this trademark*).
- 3,995,784 (*See Class 1 for this trademark*).
- 3,995,793. **SPACIAL (STANDARD CHARACTER)**. FLUIDRA COMMERCIAL, S.A.U., MULTIPLE CLASS, (INT. CLS. 11, 37 AND 44), (U.S. CLS. 13, 21, 23, 31, 34, 100, 101, 103 AND 106). SN 79-082,730. PUB. 5-3-2011. FILED 4-21-2010.
- 3,995,813 (*See Class 7 for this trademark*).
- 3,995,821 (*See Class 7 for this trademark*).
- 3,995,839 (*See Class 4 for this trademark*).
- 3,995,857 (*See Class 9 for this trademark*).
- 3,995,858. **OILON (STYLIZED)**. OILON INTERNATIONAL OY, (U.S. CLS. 13, 21, 23, 31 AND 34). SN 79-085,124. PUB. 5-3-2011. FILED 6-17-2010.
- 3,995,859. **EFFITREAT (STANDARD CHARACTER)**. SAFED SUISSE SA, (U.S. CLS. 13, 21, 23, 31 AND 34). SN 79-085,163. PUB. 5-3-2011. FILED 3-22-2010.

2011. FILED 11-23-2010.
 3,996,948. **BAHNSON AND DESIGN. BAHNSON, INC.**, (U.S. CLS. 13, 21, 23, 31 AND 34). SN 85-184,379. PUB. 5-3-2011. FILED 11-24-2010.
 3,996,960. **MILLENNIUM SERIES (STYLIZED)**, OPTRONICS INTERNATIONAL, LLC, (U.S. CLS. 13, 21, 23, 31 AND 34). SN 85-184,982. PUB. 5-3-2011. FILED 11-24-2010.
 3,997,049. **WWW.GOGALLEY.COM GOGALLEY GRILL, SMOKE, FRY, BOIL. COOK ANYTHING ANYWHERE. AND DESIGN.** GO GALLEY LLC, (U.S. CLS. 13, 21, 23, 31 AND 34). SN 85-187,645. PUB. 5-3-2011. FILED 11-30-2010.
 3,997,134. **NANTUCKET HOME (STANDARD CHARACTER).** CHRISTMAS TREE SHOPS, INC., MULTIPLE CLASS, (INT. CLS. 11, 16, 20, 21, 24 AND 27), (U.S. CLS. 2, 5, 13, 19, 20, 21, 22, 23, 25, 29, 30, 31, 32, 33, 34, 37, 38, 40, 42 AND 50). SN 85-189,492. PUB. 5-3-2011. FILED 12-2-2010.
 3,997,144 (*See Class 4 for this trademark*).
 3,997,315. **AXIUM AND DESIGN.** MASTER BRANDS HK LIMITED, (U.S. CLS. 13, 21, 23, 31 AND 34). SN 85-194,877. PUB. 5-3-2011. FILED 12-10-2010.
 3,997,317. **AXIUM (STANDARD CHARACTER).** MASTER BRANDS HK LIMITED, (U.S. CLS. 13, 21, 23, 31 AND 34). SN 85-194,906. PUB. 5-3-2011. FILED 12-10-2010.
 3,997,318. **EXTREME TURBULENCE (STANDARD CHARACTER).** MASTER BRANDS HK LIMITED, (U.S. CLS. 13, 21, 23, 31 AND 34). SN 85-194,928. PUB. 5-3-2011. FILED 12-10-2010.
 3,997,373. **BUMPER DUMPER (STANDARD CHARACTER).** SOFFAR,RANDALL JAY, (U.S. CLS. 13, 21, 23, 31 AND 34). SN 85-198,140. PUB. 5-3-2011. FILED 12-15-2010.
 3,997,476 (*See Class 9 for this trademark*).
 3,997,749. **SOJI (STANDARD CHARACTER).** ALLSOP, INC., (U.S. CLS. 13, 21, 23, 31 AND 34). SN 85-207,361. PUB. 5-3-2011. FILED 12-29-2010.
 3,997,751. **SAFeway TUB DOOR (STANDARD CHARACTER).** SAFEWAY SAFETY STEP, LLC, MULTIPLE CLASS, (INT. CLS. 11 AND 37), (U.S. CLS. 13, 21, 23, 31, 34, 100, 103 AND 106). SN 85-207,398. PUB. 5-3-2011. FILED 12-29-2010.
 3,997,833 (*See Class 9 for this trademark*).
 3,997,918. **HOOVER AND DESIGN.** TECHTRONIC FLOOR CARE TECHNOLOGY LIMITED, (U.S. CLS. 13, 21, 23, 31 AND 34). SN 85-209,308. PUB. 5-3-2011. FILED 1-3-2011.
 3,998,007. **G-MIDIFIER (STANDARD CHARACTER).** WON, HAION, (U.S. CLS. 13, 21, 23, 31 AND 34). SN 85-210,534. PUB. 5-3-2011. FILED 1-5-2011.
 3,998,102. **GSE AND DESIGN.** GREENSUN ENERGY LTD., (U.S. CLS. 13, 21, 23, 31 AND 34). SN 85-212,085. PUB. 5-3-2011. FILED 1-6-2011.
 3,998,142. **MISCELLANEOUS DESIGN.** CREE, INC., (U.S. CLS. 13, 21, 23, 31 AND 34). SN 85-212,994. PUB. 5-3-2011. FILED 1-7-2011.
 3,998,185. **KANDLE BY OZERI AND DESIGN.** COMMON-PATH, LLC, (U.S. CLS. 13, 21, 23, 31 AND 34). SN 85-214,356. PUB. 5-3-2011. FILED 1-10-2011.
-
- CLASS 12—VEHICLES**
- 3,995,463. **SCREAMIN' EAGLE AND DESIGN.** H-D MICHIGAN, LLC, (U.S. CLS. 19, 21, 23, 31, 35 AND 44). SN 76-698,061. PUB. 12-15-2009. FILED 6-24-2009.
 3,995,518 (*See Class 7 for this trademark*).
 3,995,519. **APOLLO (STYLIZED).** APOLLO TYRES LTD., (U.S. CLS. 19, 21, 23, 31, 35 AND 44). SN 77-272,758. PUB. 10-19-2010. FILED 9-6-2007.
 3,995,567 (*See Class 9 for this trademark*).
 3,995,584. **DUETTO (STANDARD CHARACTER).** FIAT AUTO S.P.A., (U.S. CLS. 19, 21, 23, 31, 35 AND 44). SN 77-754,252. PUB. 5-3-2011. FILED 6-8-2009.
 3,995,591. **CONTIPOWERCONTACT (STANDARD CHARACTER).** CONTINENTAL REIFEN DEUTSCHLAND GMBH, (U.S. CLS. 19, 21, 23, 31, 35 AND 44). SN 77-780,354. PUB. 10-19-2010. FILED 7-14-2009.
 3,995,718 (*See Class 8 for this trademark*).
 3,995,735 (*See Class 6 for this trademark*).
 3,995,738 (*See Class 9 for this trademark*).
 3,995,778. **SUPER PRO AND DESIGN.** FULCRUM SUSPENSIONS PTY LTD, (U.S. CLS. 19, 21, 23, 31, 35 AND 44). SN 79-080,410. PUB. 3-29-2011. FILED 11-23-2009.
 3,995,795 (*See Class 7 for this trademark*).
 3,995,799 (*See Class 7 for this trademark*).
 3,995,841. **MULTI TROLLEY AND DESIGN.** SVEFLYTT AKTIEBOLAG, (U.S. CLS. 19, 21, 23, 31, 35 AND 44). SN 79-084,541. PUB. 5-3-2011. FILED 6-9-2010.
 3,995,847. **GREEN ENGAGEMENT AND DESIGN.** MAGNETI MARELLI S.P.A., MULTIPLE CLASS, (INT. CLS. 12, 25, 35 AND 41), (U.S. CLS. 19, 21, 22, 23, 31, 35, 39, 44, 100, 101, 102 AND 107). SN 79-084,818. PUB. 5-3-2011. FILED 4-7-2010.
 3,995,849. **PEUGEOT AND DESIGN.** AUTOMOBILES PEUGEOT, MULTIPLE CLASS, (INT. CLS. 12, 36, 37 AND 39), (U.S. CLS. 19, 21, 23, 31, 35, 44, 100, 101, 102, 103, 105 AND 106). SN 79-084,840. PUB. 5-3-2011. FILED 5-21-2010.
 3,995,870. **PEUGEOT MOTION & EMOTION AND DESIGN.** AUTOMOBILES PEUGEOT, MULTIPLE CLASS, (INT. CLS. 12, 37 AND 39), (U.S. CLS. 19, 21, 23, 31, 35, 44, 100, 103, 105 AND 106). SN 79-085,402. PUB. 5-3-2011. FILED 6-11-2010.
 3,995,899. **RSM (STANDARD CHARACTER).** RENAULT-SAMSUNG MOTORS CO., LTD., MULTIPLE CLASS, (INT. CLS. 12 AND 37), (U.S. CLS. 19, 21, 23, 31, 35, 44, 100, 103 AND 106). SN 79-086,145. PUB. 5-3-2011. FILED 6-28-2010.
 3,995,923. **IMGCITEC (STANDARD CHARACTER).** DR. MORITZ FRIEBEL & DR. JOACHIM PAPROTH GBR (VERTRETUNGSBERECHTIGTE GESELLSCHAFT): DR. JOACHIM PAPROTH, 14513 TELTOW; DR. MORITZ FRIEBEL, 14193 BERLIN), (U.S. CLS. 19, 21, 23, 31, 35 AND 44). SN 79-087,609. PUB. 5-3-2011. FILED 8-9-2010.
 3,995,965. **AKEBONO BRAKE EXPERTS AND DESIGN.** AKEBONO BRAKE INDUSTRY CO., LTD., (U.S. CLS. 19, 21, 23, 31, 35 AND 44). SN 79-089,797. PUB. 5-3-2011. FILED 8-30-2010.
 3,996,002. **EXWD (STANDARD CHARACTER).** SAAB AUTOMOBILE AB, (U.S. CLS. 19, 21, 23, 31, 35 AND 44). SN 79-092,450. PUB. 5-3-2011. FILED 12-22-2010.
 3,996,025. **STORM (STANDARD CHARACTER).** GUSTAV MAGENWIRTH GMBH & CO. KG, (U.S. CLS. 19, 21, 23, 31, 35 AND 44). SN 79-094,192. PUB. 5-3-2011. FILED 10-8-2010.
 3,996,071. **SLOCUM (STANDARD CHARACTER).** TELEDYNE BENTHOS, INC., DBA TELEDYNE WEBB RESEARCH, (U.S. CLS. 19, 21, 23, 31, 35 AND 44). SN 85-021,083. PUB. 5-3-2011. FILED 4-22-2010.
 3,996,177 (*See Class 7 for this trademark*).
 3,996,206 (*See Class 7 for this trademark*).
 3,996,234 (*See Class 9 for this trademark*).
 3,996,235 (*See Class 9 for this trademark*).
 3,996,304. **MORTOP (STYLIZED).** BIKEFORCE INTERNATIONAL CO.,LTD., (U.S. CLS. 19, 21, 23, 31, 35 AND 44). SN 85-063,125. PUB. 5-3-2011. FILED 6-15-2010.
 3,996,322 (*See Class 6 for this trademark*).
 3,996,367. **TOUGH GUY PREMIER (STANDARD CHARACTER).** DONOVAN MARINE, INC., (U.S. CLS. 19, 21, 23, 31, 35 AND 44). SN 85-075,052. PUB. 5-3-2011. FILED 6-30-2010.
 3,996,383. **HAVOC (STANDARD CHARACTER).** INNOVATIVE VEHICLE SOLUTIONS, LLC, (U.S. CLS. 19, 21, 23, 31, 35 AND 44). SN 85-080,732. PUB. 5-3-2011. FILED 7-8-2010.
 3,996,385 (*See Class 7 for this trademark*).
 3,996,395. **STHEBSON AND DESIGN.** SOLIS, RODOLFO, (U.S. CLS. 19, 21, 23, 31, 35 AND 44). SN 85-083,252. PUB. 5-3-2011. FILED 7-13-2010.
 3,996,434. **R 63 (STANDARD CHARACTER).** DAIMLER AG, MULTIPLE CLASS, (INT. CLS. 12 AND 28), (U.S. CLS. 19, 21, 22, 23, 31, 35, 38, 44 AND 50). SN 85-094,472. PUB. 5-3-2011. FILED 7-28-2010.
 3,996,438. **ENVE (STANDARD CHARACTER).** EDGE COMPOSITES, LLC, MULTIPLE CLASS, (INT. CLS. 12, 35 AND 40), (U.S. CLS. 19, 21, 23, 31, 35, 44, 100, 101, 102, 103 AND 106). SN 85-094,965. PUB. 5-3-2011. FILED 7-28-2010.
 3,996,454. **KILIN (STANDARD CHARACTER).** HUGE RAINBOW INTERNATIONAL INC., (U.S. CLS. 19, 21, 23, 31, 35 AND 44). SN 85-102,759. PUB. 5-3-2011. FILED 8-9-2010.
 3,996,476. **ENVE AND DESIGN.** EDGE COMPOSITES, LLC, MULTIPLE CLASS, (INT. CLS. 12, 35 AND 40), (U.S. CLS.

- 19, 21, 23, 31, 35, 44, 100, 101, 102, 103 AND 106). SN 85-110,624. PUB. 5-3-2011. FILED 8-18-2010.
 3,996,554 (*See Class 7 for this trademark.*)
 3,996,579 (*See Class 9 for this trademark.*)
 3,996,584. **LB LB PERFORMANCE AND DESIGN**. WATARU KATO, (U.S. CLS. 19, 21, 23, 31, 35 AND 44). SN 85-139,831. PUB. 5-3-2011. FILED 9-28-2010.
 3,996,710. **ZOOMBOYS (STYLIZED)**. WEBSITESALES3 LLC, (U.S. CLS. 19, 21, 23, 31, 35 AND 44). SN 85-168,058. PUB. 3-29-2011. FILED 11-3-2010.
 3,996,971. **PURE POLY (STYLIZED)**. CHL AUTO PARTS CO., LTD., (U.S. CLS. 19, 21, 23, 31, 35 AND 44). SN 85-185,622. PUB. 5-3-2011. FILED 11-27-2010.
 3,996,972. **S CYCLING STEP AND DESIGN**. HUANG, STEPHEN, (U.S. CLS. 19, 21, 23, 31, 35 AND 44). SN 85-185,635. PUB. 5-3-2011. FILED 11-27-2010.
 3,996,979. **FORFOUR (STANDARD CHARACTER)**. DAIMLER AG, MULTIPLE CLASS, (INT. CLS. 12, 28 AND 37), (U.S. CLS. 19, 21, 22, 23, 31, 35, 38, 44, 50, 100, 103 AND 106). SN 85-186,011. PUB. 5-3-2011. FILED 11-29-2010.
 3,996,998. **ALAGATECARTE AND DESIGN**. WATSON PRODUCTIONS, (U.S. CLS. 19, 21, 23, 31, 35 AND 44). SN 85-186,589. PUB. 5-3-2011. FILED 11-29-2010.
 3,997,003. **JP MARINE (STYLIZED)**. POWERSPORTS GROUP, INC, DBA JP MARINE, AND PALMER, JOSHUA, (U.S. CLS. 19, 21, 23, 31, 35 AND 44). SN 85-186,700. PUB. 5-3-2011. FILED 11-29-2010.
 3,997,131. **RYCA (STYLIZED)**. RYCA MOTORS, (U.S. CLS. 19, 21, 23, 31, 35 AND 44). SN 85-189,383. PUB. 5-3-2011. FILED 12-2-2010.
 3,997,157. **BIKESTACHE (STANDARD CHARACTER)**. CARSTACHE LLC, DBA CARSTACHE, (U.S. CLS. 19, 21, 23, 31, 35 AND 44). SN 85-189,779. PUB. 5-3-2011. FILED 12-2-2010.
 3,997,231. **ROCKYMOUNTS (STYLIZED)**. ROCKYMOUNTS, INC., (U.S. CLS. 19, 21, 23, 31, 35 AND 44). SN 85-192,030. PUB. 5-3-2011. FILED 12-7-2010.
 3,997,257. **RETROSPEC (STANDARD CHARACTER)**. GLOBAL HOUSE OF TRIMS, DBA RETROSPEC CYCLING CLUB, (U.S. CLS. 19, 21, 23, 31, 35 AND 44). SN 85-192,771. PUB. 5-3-2011. FILED S.R. 12-8-2010; AM. P.R. 3-14-2011.
 3,997,276. **PREMIER (STANDARD CHARACTER)**. ACCUBUILT, INC., (U.S. CLS. 19, 21, 23, 31, 35 AND 44). SN 85-193,319. PUB. 5-3-2011. FILED 12-8-2010.
 3,997,326. **SEWFINE AND DESIGN**. SLICK RIDES, INC., DBA SEWFINE INTERIOR PRODUCTS, MULTIPLE CLASS, (INT. CLS. 12, 27 AND 40), (U.S. CLS. 19, 20, 21, 23, 31, 35, 37, 42, 44, 50, 100, 103 AND 106). SN 85-195,165. PUB. 5-3-2011. FILED 12-10-2010.
 3,997,499. **AIRFLOW (STANDARD CHARACTER)**. KODIAK INNOVATIONS, LLC, (U.S. CLS. 19, 21, 23, 31, 35 AND 44). SN 85-203,639. PUB. 5-3-2011. FILED 12-22-2010.
 3,997,579 (*See Class 7 for this trademark.*)
 3,997,845. **EDV (STYLIZED)**. MAJERIK, MATTHEW M., (U.S. CLS. 19, 21, 23, 31, 35 AND 44). SN 85-208,592. PUB. 5-3-2011. FILED 12-31-2010.
 3,997,903. **ARMANO (STANDARD CHARACTER)**. SUPER SONIC WHEELS (USA) INC., (U.S. CLS. 19, 21, 23, 31, 35 AND 44). SN 85-209,152. PUB. 5-3-2011. FILED 1-3-2011.
 3,998,032. **MORPHEUS (STANDARD CHARACTER)**. MORPHEUS CYCLES LLC, (U.S. CLS. 19, 21, 23, 31, 35 AND 44). SN 85-210,944. PUB. 5-3-2011. FILED 1-5-2011.
 3,998,059. **TECMATIC (STANDARD CHARACTER)**. WISSWELL, ROBERT L., (U.S. CLS. 19, 21, 23, 31, 35 AND 44). SN 85-211,385. PUB. 5-3-2011. FILED 1-5-2011.

CLASS 13—FIREARMS

- 3,995,719 (*See Class 3 for this trademark.*)
 3,995,834. **HEXOSHEET (STYLIZED)**. EURENCO, (U.S. CLS. 2 AND 9). SN 79-084,367. PUB. 5-3-2011. FILED 5-31-2010.
 3,995,851. **FLEXICUT (STYLIZED)**. EURENCO, (U.S. CLS. 2 AND 9). SN 79-084,982. PUB. 5-3-2011. FILED 5-31-2010.
 3,995,852. **HEXOTUBE (STYLIZED)**. EURENCO, (U.S. CLS. 2 AND 9). SN 79-084,983. PUB. 5-3-2011. FILED 5-31-2010.
 3,995,864. **HEXOMAX (STYLIZED)**. EURENCO, (U.S. CLS. 2 AND 9). SN 79-085,249. PUB. 5-3-2011. FILED 5-31-2010.

- 3,995,865. **HEXOTAPE (STYLIZED)**. EURENCO, (U.S. CLS. 2 AND 9). SN 79-085,250. PUB. 5-3-2011. FILED 5-31-2010.
 3,996,935. **SMITH CREEK LEATHER CO SCL AND DESIGN**. SMITH, BRENT, (U.S. CLS. 2 AND 9). SN 85-183,426. PUB. 5-3-2011. FILED 11-23-2010.
 3,997,568. **GRIZZLY (STANDARD CHARACTER)**. GRIZZLY CARTRIDGE CO., (U.S. CLS. 2 AND 9). SN 85-204,882. PUB. 5-3-2011. FILED 12-23-2010.
 3,998,213. **SPORTSMAN (STANDARD CHARACTER)**. RA BRANDS, L.L.C., (U.S. CLS. 2 AND 9). SN 85-222,937. PUB. 5-3-2011. FILED 1-21-2011.

CLASS 14—JEWELRY

- 3,995,551. **33 BY KUHO (STANDARD CHARACTER)**. CHEIL INDUSTRIES INC., MULTIPLE CLASS, (INT. CLS. 14, 18, 25 AND 35), (U.S. CLS. 1, 2, 3, 22, 27, 28, 39, 41, 50, 100, 101 AND 102). SN 77-599,276. PUB. 5-3-2011. FILED 10-23-2008.
 3,995,597. **CHERISH WHO YOU ARE HEATHER B. MOORE AND DESIGN**. HEATHER B. MOORE, INC., (U.S. CLS. 2, 27, 28 AND 50). SN 77-803,647. PUB. 5-3-2011. FILED 8-13-2009.
 3,995,646. **ECOAU (STANDARD CHARACTER)**. CALLAWAY CONSOLIDATED, INC., (U.S. CLS. 2, 27, 28 AND 50). SN 77-882,246. PUB. 5-3-2011. FILED 11-30-2009.
 3,995,715 (*See Class 9 for this trademark.*)
 3,995,759 (*See Class 3 for this trademark.*)
 3,995,761. **BEADS 925 SILVER BY BIJOU BRIGITTE (STYLIZED)**. BIJOU BRIGITTE MODISCHE ACCESSOIRES AG, MULTIPLE CLASS, (INT. CLS. 14 AND 16), (U.S. CLS. 2, 5, 22, 23, 27, 28, 29, 37, 38 AND 50). SN 79-077,831. PUB. 5-3-2011. FILED 12-10-2009.
 3,995,815. **MISCELLANEOUS DESIGN**. MONTRES TUDOR SA, (U.S. CLS. 2, 27, 28 AND 50). SN 79-083,631. PUB. 5-3-2011. FILED 5-27-2010.
 3,995,863 (*See Class 2 for this trademark.*)
 3,995,873. **TUDOR HERITAGE (STANDARD CHARACTER)**. MONTRES TUDOR SA, (U.S. CLS. 2, 27, 28 AND 50). SN 79-085,459. PUB. 5-3-2011. FILED 7-13-2010.
 3,995,909. **PATRICE BREAL (STANDARD CHARACTER)**. PAULINE, MULTIPLE CLASS, (INT. CLS. 14, 18 AND 25), (U.S. CLS. 1, 2, 3, 22, 27, 28, 39, 41 AND 50). SN 79-086,558. PUB. 5-3-2011. FILED 5-26-2010.
 3,995,974. **MISCELLANEOUS DESIGN**. GIOVANNI BALESTRA & FIGLI S.P.A., (U.S. CLS. 2, 27, 28 AND 50). SN 79-090,431. PUB. 5-3-2011. FILED 6-12-2009.
 3,995,976. **MISCELLANEOUS DESIGN**. FORMISANO LAURENT, (U.S. CLS. 2, 27, 28 AND 50). SN 79-090,559. PUB. 5-3-2011. FILED 10-13-2010.
 3,996,109. **BIJAN (STANDARD CHARACTER)**. FASHION WORLD, INC., DBA BIJAN, (U.S. CLS. 2, 27, 28 AND 50). SN 85-033,073. PUB. 5-3-2011. FILED 5-7-2010.
 3,996,111. **SUN FIRE (STANDARD CHARACTER)**. BEN HAKMAN & COMPANY LLC, (U.S. CLS. 2, 27, 28 AND 50). SN 85-033,614. PUB. 5-3-2011. FILED 5-8-2010.
 3,996,227. **REDLINE (STYLIZED)**. SWISS WATCH INTERNATIONAL, INC., (U.S. CLS. 2, 27, 28 AND 50). SN 85-047,926. PUB. 5-3-2011. FILED 5-26-2010.
 3,996,233. **GLAMOROUS GOLFER (STANDARD CHARACTER)**. LA PIERRE, JILL, (U.S. CLS. 2, 27, 28 AND 50). SN 85-048,361. PUB. 5-3-2011. FILED 5-26-2010.
 3,996,249. **CHEEKY COUTURE (STANDARD CHARACTER)**. CHEEKY COUTURE, (U.S. CLS. 2, 27, 28 AND 50). SN 85-050,794. PUB. 5-3-2011. FILED 5-28-2010.
 3,996,336. **J X O K (STYLIZED)**. IMJEWELEE, LLC, (U.S. CLS. 2, 27, 28 AND 50). SN 85-069,409. PUB. 5-3-2011. FILED 6-23-2010.
 3,996,397. **JIVASUKHA AND DESIGN**. ANCIENT MODERN ART, LLC, (U.S. CLS. 2, 27, 28 AND 50). SN 85-083,736. PUB. 5-3-2011. FILED 7-13-2010.
 3,996,627. **TECHNO PAVE (STANDARD CHARACTER)**. CHANDRU LAKHATI, DBA A1 WATCHES INC, (U.S. CLS. 2, 27, 28 AND 50). SN 85-150,390. PUB. 5-3-2011. FILED 10-12-2010.
 3,996,705. **BECCA LOCKHART B DEZIGNED AND DESIGN**. BECCA LOCKHART, DBA B DEZIGNED, (U.S. CLS. 2, 27,

28 AND 50). SN 85-167,033. PUB. 5-3-2011. FILED 11-2-2010.
 3,996,757. **RST (STANDARD CHARACTER)**. HETAL DIAMONDS INC., (U.S. CLS. 2, 27, 28 AND 50). SN 85-173,136. PUB. 5-3-2011. FILED 11-10-2010.
 3,996,834. **CASA CRISTO REY AND DESIGN**. ROBERTO TREVINO AMADOR, MULTIPLE CLASS, (INT. CLS. 14, 16 AND 20), (U.S. CLS. 2, 5, 13, 22, 23, 25, 27, 28, 29, 32, 37, 38 AND 50). SN 85-178,285. PUB. 5-3-2011. FILED 11-16-2010.
 3,996,869. **RP (STYLIZED)**. RAND & PASEKA MFG. CO., INC., (U.S. CLS. 2, 27, 28 AND 50). SN 85-179,824. PUB. 5-3-2011. FILED 11-18-2010.
 3,997,038. **GLAM GLOBES (STANDARD CHARACTER)**. GLAM GLOBAL, LLC, (U.S. CLS. 2, 27, 28 AND 50). SN 85-187,464. PUB. 5-3-2011. FILED 11-30-2010.
 3,997,126. **TRIBANDZ (STANDARD CHARACTER)**. TRIBANDZ LLC, (U.S. CLS. 2, 27, 28 AND 50). SN 85-189,273. PUB. 5-3-2011. FILED 12-2-2010.
 3,997,127. **TIBBS (STANDARD CHARACTER)**. TRIBANDZ LLC, (U.S. CLS. 2, 27, 28 AND 50). SN 85-189,294. PUB. 5-3-2011. FILED 12-2-2010.
 3,997,208. **ROCKRECYCLED AND DESIGN**. WEAR YOUR MUSIC, LLC, (U.S. CLS. 2, 27, 28 AND 50). SN 85-191,221. PUB. 5-3-2011. FILED 12-6-2010.
 3,997,244. **BRAVADO (STANDARD CHARACTER)**. BRAVADO INTERNATIONAL GROUP LIMITED, (U.S. CLS. 2, 27, 28 AND 50). SN 85-192,567. PUB. 5-3-2011. FILED 12-7-2010.
 3,997,250. **CHINACAT CREATIONS (STANDARD CHARACTER)**. ZIMMERLEY, LEE, (U.S. CLS. 2, 27, 28 AND 50). SN 85-192,683. PUB. 5-3-2011. FILED 12-7-2010.
 3,997,387. **M 925 AND DESIGN**. 1400446 ALBERTA LTD., (U.S. CLS. 2, 27, 28 AND 50). SN 85-199,247. PUB. 5-3-2011. FILED 12-16-2010.
 3,997,586. **HONOR (STANDARD CHARACTER)**. FANTASY DIAMOND CORPORATION, (U.S. CLS. 2, 27, 28 AND 50). SN 85-205,077. PUB. 5-3-2011. FILED 12-23-2010.
 3,997,603. **PARACHUTE PROMISE AND DESIGN**. MCCULLOUGH, KATHLEEN, (U.S. CLS. 2, 27, 28 AND 50). SN 85-205,303. PUB. 5-3-2011. FILED 12-23-2010.
 3,997,670. **TALIA M. SANTINO AND DESIGN**. MARCELLO, CHRISTINE, (U.S. CLS. 2, 27, 28 AND 50). SN 85-206,188. PUB. 5-3-2011. FILED 12-27-2010.
 3,997,679. **INVEST IN LOVE (STANDARD CHARACTER)**. JAMES M. FORTESCUE, (U.S. CLS. 2, 27, 28 AND 50). SN 85-206,380. PUB. 5-3-2011. FILED 12-28-2010.
 3,997,711. **B BABIKI AND DESIGN**. INNOVATION JEWELRY, INC., (U.S. CLS. 2, 27, 28 AND 50). SN 85-206,739. PUB. 5-3-2011. FILED 12-28-2010.
 3,997,832. **FURISS AND DESIGN**. LI SHERRY HAIXIA, (U.S. CLS. 2, 27, 28 AND 50). SN 85-208,379. PUB. 5-3-2011. FILED 12-30-2010.
 3,997,939. **ADD-A-PET (STANDARD CHARACTER)**. ST. BRENDAN'S RULE, (U.S. CLS. 2, 27, 28 AND 50). SN 85-209,577. PUB. 5-3-2011. FILED 1-3-2011.
 3,997,987. **BALLSIES (STANDARD CHARACTER)**. BALLSIES, L.L.C., (U.S. CLS. 2, 27, 28 AND 50). SN 85-210,279. PUB. 5-3-2011. FILED 1-4-2011.
 3,998,169. **MISCELLANEOUS DESIGN**. SAINT LOUIS UNIVERSITY, (U.S. CLS. 2, 27, 28 AND 50). SN 85-214,201. PUB. 5-3-2011. FILED 1-10-2011.
 3,998,275 (*See Class 9 for this trademark*).
 3,998,278. **L3 (STANDARD CHARACTER)**. D-GENERATION, INC., (U.S. CLS. 2, 27, 28 AND 50). SN 85-246,952. PUB. 5-3-2011. FILED 2-19-2011.

CLASS 15—MUSICAL INSTRUMENTS

3,995,564. **MISCELLANEOUS DESIGN**. TRUSSART, JAMES, DBA JAMES TRUSSART CUSTOM GUITARS, (U.S. CLS. 2, 21 AND 36). SN 77-673,519. PUB. 2-16-2010. FILED 2-19-2009.
 3,995,661. **PLANET EDUCATION (STANDARD CHARACTER)**. PLANET MUSIC USA CORPORATION, MULTIPLE CLASS, (INT. CLS. 15 AND 28), (U.S. CLS. 2, 21, 22, 23, 36, 38 AND 50). SN 77-899,945. PUB. 5-3-2011. FILED 12-23-2009.
 3,995,700. **FALLEN BRANCH (STANDARD CHARACTER)**. DALE ROBERTSON, (U.S. CLS. 2, 21 AND 36). SN 77-

951,401. PUB. 5-3-2011. FILED 3-5-2010.
 3,995,736. **RANCO (STYLIZED)**. RANCO ANTONIO DI RANCO GIUSEPPE, (U.S. CLS. 2, 21 AND 36). SN 79-066,413. PUB. 3-29-2011. FILED 9-29-2008.
 3,995,992. **MIRAPHONE AND DESIGN**. MIRAPHONE GRASLITZER MUSIKINSTRUMENTENERZEUGER E.G., (U.S. CLS. 2, 21 AND 36). SN 79-091,493. PUB. 5-3-2011. FILED 10-21-2010.
 3,996,204 (*See Class 9 for this trademark*).
 3,996,735. **J.BACKLUND DESIGN (STANDARD CHARACTER)**. BML, INC., (U.S. CLS. 2, 21 AND 36). SN 85-170,892. PUB. 5-3-2011. FILED 11-6-2010.
 3,997,160. **BARCELONA AND DESIGN**. AUSTIN BAZAAR INC., (U.S. CLS. 2, 21 AND 36). SN 85-189,791. PUB. 5-3-2011. FILED 12-2-2010.
 3,997,398. **G BONE (STANDARD CHARACTER)**. GRAHAM, JAN G., (U.S. CLS. 2, 21 AND 36). SN 85-199,824. PUB. 5-3-2011. FILED 12-16-2010.
 3,997,896. **DRUM RÖHL (STANDARD CHARACTER)**. DRUM RÖHL, LLC, (U.S. CLS. 2, 21 AND 36). SN 85-209,042. PUB. 5-3-2011. FILED 1-3-2011.
 3,998,114. **GIUSEPPE AND DESIGN**. MEYER MUSIC COMPANY, (U.S. CLS. 2, 21 AND 36). SN 85-212,344. PUB. 5-3-2011. FILED 1-6-2011.

CLASS 16—PAPER GOODS AND PRINTED MATTER

3,995,466. **MICHIGAN STATE MEDICAL SOCIETY 1866 AND DESIGN**. MICHIGAN STATE MEDICAL SOCIETY, MULTIPLE CLASS, (INT. CLS. 16, 35 AND 44 AND U.S. CL. 200), (U.S. CLS. 2, 5, 22, 23, 29, 37, 38, 50, 100, 101 AND 102). SN 76-701,257. PUB. 5-3-2011. FILED 1-19-2010.
 3,995,474 (*See Class 9 for this trademark*).
 3,995,477. **CONNECT COLLABORATE CELEBRATE WAY-POINT LIVING SPACES (STANDARD CHARACTER)**. AMERICAN WOODMARK CORPORATION, (U.S. CLS. 2, 5, 22, 23, 29, 37, 38 AND 50). SN 76-703,916. PUB. 5-3-2011. FILED 7-26-2010.
 3,995,478. **CONNECT COLLABORATE CELEBRATE WAY-POINT LIVING SPACES AND DESIGN**. AMERICAN WOODMARK CORPORATION, (U.S. CLS. 2, 5, 22, 23, 29, 37, 38 AND 50). SN 76-703,917. PUB. 5-3-2011. FILED 7-26-2010.
 3,995,504. **DESKTEX (STANDARD CHARACTER)**. FLOOR-TEX EUROPE LIMITED, (U.S. CLS. 2, 5, 22, 23, 29, 37, 38 AND 50). SN 76-705,894. PUB. 5-3-2011. FILED 1-4-2011.
 3,995,514 (*See Class 9 for this trademark*).
 3,995,518 (*See Class 7 for this trademark*).
 3,995,524 (*See Class 7 for this trademark*).
 3,995,529. **TRANSFORM (STANDARD CHARACTER)**. LASER SUBSTRATES, INC., (U.S. CLS. 2, 5, 22, 23, 29, 37, 38 AND 50). SN 77-439,388. PUB. 5-3-2011. FILED 4-3-2008.
 3,995,531 (*See Class 7 for this trademark*).
 3,995,533. **MAKING A WORLD OF DIFFERENCE IN CANCER CARE (STANDARD CHARACTER)**. AMERICAN SOCIETY OF CLINICAL ONCOLOGY, MULTIPLE CLASS, (INT. CLS. 16, 35, 36, 41, 42 AND 44), (U.S. CLS. 2, 5, 22, 23, 29, 37, 38, 50, 100, 101, 102 AND 107). SN 77-496,310. PUB. 5-3-2011. FILED 6-11-2008.
 3,995,545. **NINTENDODSI (STANDARD CHARACTER)**. NINTENDO OF AMERICA INC., (U.S. CLS. 2, 5, 22, 23, 29, 37, 38 AND 50). SN 77-583,732. PUB. 10-19-2010. FILED 10-2-2008.
 3,995,592 (*See Class 9 for this trademark*).
 3,995,618 (*See Class 9 for this trademark*).
 3,995,640. **BOUNTY EXTRA SOFT (STANDARD CHARACTER)**. THE PROCTER & GAMBLE COMPANY, (U.S. CLS. 2, 5, 22, 23, 29, 37, 38 AND 50). SN 77-868,323. PUB. 5-3-2011. FILED 11-9-2009.
 3,995,665. **PRE-K STORYPATH (STANDARD CHARACTER)**. MARGIT E. MCGUIRE, DBA MARGIT E. MCGUIRE, (U.S. CLS. 2, 5, 22, 23, 29, 37, 38 AND 50). SN 77-903,576. PUB. 7-13-2010. FILED 12-31-2009.
 3,995,680. **VETERANS ADVANTAGE (STANDARD CHARACTER)**. VETERANSADVANTAGE, INC., MULTIPLE CLASS, (INT. CLS. 16, 35 AND 36), (U.S. CLS. 2, 5, 22, 23,

- 29, 37, 38, 50, 100, 101 AND 102). SN 77-929,314. PUB. 5-3-2011. FILED 2-5-2010.
- 3,995,681. **MISCELLANEOUS DESIGN. VETERANSADVANTAGE, INC., MULTIPLE CLASS, (INT. CLS. 16, 35 AND 36), (U.S. CLS. 2, 5, 22, 23, 29, 37, 38, 50, 100, 101 AND 102).** SN 77-929,388. PUB. 5-3-2011. FILED 2-5-2010.
- 3,995,701. **PARA-KIN (STANDARD CHARACTER). MY PARA-KIN,LLC, FORMERLY PARA-MORE,LLC, MULTIPLE CLASS, (INT. CLS. 16 AND 25), (U.S. CLS. 2, 5, 22, 23, 29, 37, 38, 39 AND 50).** SN 77-951,594. PUB. 5-3-2011. FILED 3-5-2010.
- 3,995,715 (*See Class 9 for this trademark.*).
- 3,995,725. **PRISA (STANDARD CHARACTER). PROMOTORA DE INFORMACIONES, S.A., MULTIPLE CLASS, (INT. CLS. 16, 38 AND 41), (U.S. CLS. 2, 5, 22, 23, 29, 37, 38, 50, 100, 101, 104 AND 107).** SN 78-928,904. PUB. 3-2-2010. FILED 7-13-2006.
- 3,995,727 (*See Class 9 for this trademark.*).
- 3,995,735 (*See Class 6 for this trademark.*).
- 3,995,745 (*See Class 9 for this trademark.*).
- 3,995,760 (*See Class 9 for this trademark.*).
- 3,995,761 (*See Class 14 for this trademark.*).
- 3,995,762. **ANYWHERE'S A PLAYGROUND (STANDARD CHARACTER). SCHLEICH GMBH, MULTIPLE CLASS, (INT. CLS. 16, 28 AND 41), (U.S. CLS. 2, 5, 22, 23, 29, 37, 38, 50, 100, 101 AND 107).** SN 79-078,175. PUB. 5-3-2011. FILED 12-18-2009.
- 3,995,768 (*See Class 9 for this trademark.*).
- 3,995,783. **FOOTPRINT EXPERT (STANDARD CHARACTER). CARBON TRUST FOOTPRINTING; COMPANY LIMITED, MULTIPLE CLASS, (INT. CLS. 16, 35, 41 AND 42), (U.S. CLS. 2, 5, 22, 23, 29, 37, 38, 50, 100, 101, 102 AND 107).** SN 79-081,324. PUB. 5-3-2011. FILED 12-10-2009.
- 3,995,785 (*See Class 9 for this trademark.*).
- 3,995,816 (*See Class 1 for this trademark.*).
- 3,995,882. **MISCELLANEOUS DESIGN. RABO VASTGOED-GROEP HOLDING N.V., MULTIPLE CLASS, (INT. CLS. 16, 35, 36, 37, 42 AND 45), (U.S. CLS. 2, 5, 22, 23, 29, 37, 38, 50, 100, 101, 102, 103 AND 106).** SN 79-085,710. PUB. 5-3-2011. FILED 3-25-2010.
- 3,995,914. **HORN AND DESIGN. ALBERT HORN SÖHNE GMBH & CO. KG, (U.S. CLS. 2, 5, 22, 23, 29, 37, 38 AND 50).** SN 79-086,782. PUB. 5-3-2011. FILED 8-9-2010.
- 3,995,922 (*See Class 11 for this trademark.*).
- 3,995,969 (*See Class 9 for this trademark.*).
- 3,996,032. **CENTURY BUSINESS SOLUTIONS (STANDARD CHARACTER). NCD ACQUISITION INC., (U.S. CLS. 2, 5, 22, 23, 29, 37, 38 AND 50).** SN 85-000,140. PUB. 5-3-2011. FILED 3-27-2010.
- 3,996,044. **FOUND (STANDARD CHARACTER). ADBASE INC., MULTIPLE CLASS, (INT. CLS. 16, 35 AND 41), (U.S. CLS. 2, 5, 22, 23, 29, 37, 38, 50, 100, 101, 102 AND 107).** SN 85-009,144. PUB. 5-3-2011. FILED 4-8-2010.
- 3,996,052. **HOBET (STANDARD CHARACTER). ASSESSMENT TECHNOLOGIES INSTITUTE, L.L.C., MULTIPLE CLASS, (INT. CLS. 16 AND 41), (U.S. CLS. 2, 5, 22, 23, 29, 37, 38, 50, 100, 101 AND 107).** SN 85-013,591. PUB. 5-3-2011. FILED 4-14-2010.
- 3,996,085. **CULTURAME AND DESIGN. CULTURAME!, LLC, (U.S. CLS. 2, 5, 22, 23, 29, 37, 38 AND 50).** SN 85-025,897. PUB. 5-3-2011. FILED 4-29-2010.
- 3,996,101. **OFFBEAT (STANDARD CHARACTER). OFFBEAT, INC., (U.S. CLS. 2, 5, 22, 23, 29, 37, 38 AND 50).** SN 85-030,791. PUB. 5-3-2011. FILED 5-5-2010.
- 3,996,124. **SMART PARTNERS...SMARTER SOLUTIONS (STANDARD CHARACTER). GREEN BAY PACKAGING, INC., (U.S. CLS. 2, 5, 22, 23, 29, 37, 38 AND 50).** SN 85-035,364. PUB. 5-3-2011. FILED 5-11-2010.
- 3,996,186. **BLACKROCK ELITE ADVISOR (STANDARD CHARACTER). BLACKROCK, INC., MULTIPLE CLASS, (INT. CLS. 16 AND 36), (U.S. CLS. 2, 5, 22, 23, 29, 37, 38, 50, 100, 101 AND 102).** SN 85-044,101. PUB. 5-3-2011. FILED 5-20-2010.
- 3,996,188. **HEARD ON THE BEACH (STANDARD CHARACTER). GREEN STREET ADVISORS, INC., (U.S. CLS. 2, 5, 22, 23, 29, 37, 38 AND 50).** SN 85-044,427. PUB. 5-3-2011. FILED 5-20-2010.
- 3,996,234 (*See Class 9 for this trademark.*).
- 3,996,235 (*See Class 9 for this trademark.*).
- 3,996,261. **SPUDDY BUDDY (STANDARD CHARACTER). STATE OF IDAHO POTATO COMMISSION, MULTIPLE CLASS, (INT. CLS. 16, 28 AND 35), (U.S. CLS. 2, 5, 22, 23, 29, 37, 38, 50, 100, 101 AND 102).** SN 85-052,571. PUB. 5-3-2011. FILED 6-2-2010.
- 3,996,280 (*See Class 9 for this trademark.*).
- 3,996,309 (*See Class 9 for this trademark.*).
- 3,996,322 (*See Class 6 for this trademark.*).
- 3,996,338 (*See Class 9 for this trademark.*).
- 3,996,363. **QUILTING CHANGES EVERYTHING (STANDARD CHARACTER). MEREDITH CORPORATION, (U.S. CLS. 2, 5, 22, 23, 29, 37, 38 AND 50).** SN 85-074,735. PUB. 5-3-2011. FILED 6-30-2010.
- 3,996,374. **PRESCHOOL UNIVERSITY (STANDARD CHARACTER). COLOMBINI, RICHARD V, (U.S. CLS. 2, 5, 22, 23, 29, 37, 38 AND 50).** SN 85-079,008. PUB. 5-3-2011. FILED 7-6-2010.
- 3,996,418. **THE MORGAN LIBRARY & MUSEUM (STANDARD CHARACTER). THE PIERPONT MORGAN LIBRARY, (U.S. CLS. 2, 5, 22, 23, 29, 37, 38 AND 50).** SN 85-090,981. PUB. 5-3-2011. FILED 7-22-2010.
- 3,996,423. **PGI AND DESIGN. PGI/PHOENIX GRAPHIX, INC., (U.S. CLS. 2, 5, 22, 23, 29, 37, 38 AND 50).** SN 85-091,957. PUB. 5-3-2011. FILED 7-23-2010.
- 3,996,424. **PHOENIX GRAPHIX (STANDARD CHARACTER). PGI/PHOENIX GRAPHIX, INC., (U.S. CLS. 2, 5, 22, 23, 29, 37, 38 AND 50).** SN 85-091,998. PUB. 5-3-2011. FILED 7-23-2010.
- 3,996,426. **CORPORATE ACCOUNTABILITY REPORT (STANDARD CHARACTER). THE BUREAU OF NATIONAL AFFAIRS, INC., MULTIPLE CLASS, (INT. CLS. 16 AND 41), (U.S. CLS. 2, 5, 22, 23, 29, 37, 38, 50, 100, 101 AND 107).** SN 85-092,759. PUB. 5-3-2011. FILED 7-26-2010.
- 3,996,448. **PGI PHOENIX GRAPHIX "ANY DECAL, ANY CAR, ANY YEAR!" AND DESIGN. PGI/PHOENIX GRAPHIX, INC., (U.S. CLS. 2, 5, 22, 23, 29, 37, 38 AND 50).** SN 85-099,466. PUB. 5-3-2011. FILED 8-3-2010.
- 3,996,468. **SHRI KRISHNA NIDHI FOUNDATION AND DESIGN. SHRI KRISHNA NIDHI FOUNDATION, AKA SKN FOUNDATION, (U.S. CLS. 2, 5, 22, 23, 29, 37, 38 AND 50).** SN 85-107,678. PUB. 5-3-2011. FILED 8-14-2010.
- 3,996,509 (*See Class 9 for this trademark.*).
- 3,996,529. **MATH MAVERICK (STANDARD CHARACTER). MATH MAVERICK, LLC, MULTIPLE CLASS, (INT. CLS. 16 AND 41), (U.S. CLS. 2, 5, 22, 23, 29, 37, 38, 50, 100, 101 AND 107).** SN 85-127,541. PUB. 5-3-2011. FILED 9-11-2010.
- 3,996,530. **MISCELLANEOUS DESIGN. MATH MAVERICK, LLC, MULTIPLE CLASS, (INT. CLS. 16 AND 41), (U.S. CLS. 2, 5, 22, 23, 29, 37, 38, 50, 100, 101 AND 107).** SN 85-127,807. PUB. 5-3-2011. FILED 9-13-2010.
- 3,996,564 (*See Class 7 for this trademark.*).
- 3,996,656. **MCLENDON . COMPLETE . . HARDWARE . AND DESIGN. MCLENDON HARDWARE, INC., MULTIPLE CLASS, (INT. CLS. 16, 25, 35 AND 37), (U.S. CLS. 2, 5, 22, 23, 29, 37, 38, 39, 50, 100, 101, 102, 103 AND 106).** SN 85-156,737. PUB. 5-3-2011. FILED 10-20-2010.
- 3,996,711 (*See Class 9 for this trademark.*).
- 3,996,743 (*See Class 9 for this trademark.*).
- 3,996,780. **SLATEMATE (STANDARD CHARACTER). D AND S CORLEY LIMITED, DBA DSC LABORATORIES, (U.S. CLS. 2, 5, 22, 23, 29, 37, 38 AND 50).** SN 85-174,805. PUB. 5-3-2011. FILED 11-11-2010.
- 3,996,781. **TRILOGY DESIGNS AND DESIGN. TRILOGY DESIGNS, LLC, MULTIPLE CLASS, (INT. CLS. 16 AND 21), (U.S. CLS. 2, 5, 13, 22, 23, 29, 30, 33, 37, 38, 40 AND 50).** SN 85-174,821. PUB. 5-3-2011. FILED 11-11-2010.
- 3,996,783. **CAMBOOK (STANDARD CHARACTER). D AND S CORLEY LIMITED, DBA DSC LABORATORIES, (U.S. CLS. 2, 5, 22, 23, 29, 37, 38 AND 50).** SN 85-174,944. PUB. 5-3-2011. FILED 11-11-2010.
- 3,996,797. **PW PUBLISHERS WEEKLY SHOW DAILY AND DESIGN. PWXYZ, LLC, (U.S. CLS. 2, 5, 22, 23, 29, 37, 38 AND 50).** SN 85-175,827. PUB. 5-3-2011. FILED 11-12-2010.
- 3,996,807 (*See Class 9 for this trademark.*).
- 3,996,820. **CUE PITTSBURGH AND DESIGN. CUE MAGAZINE INC., (U.S. CLS. 2, 5, 22, 23, 29, 37, 38 AND 50).** SN 85-177,215. PUB. 5-3-2011. FILED 11-15-2010.

- 3,996,834 (*See Class 14 for this trademark.*)
 3,996,886 (*See Class 9 for this trademark.*)
 3,996,949. **POWER LITERACY CLASSROOM TEACHING FRAMEWORK (CTF) (STANDARD CHARACTER)**. POWER LITERACY, L.L.C., (U.S. CLS. 2, 5, 22, 23, 29, 37, 38 AND 50). SN 85-184,441. PUB. 5-3-2011. FILED 11-24-2010.
 3,996,986. **RULON BROWN (STANDARD CHARACTER)**. BROWN, NATHAN OWEN, (U.S. CLS. 2, 5, 22, 23, 29, 37, 38 AND 50). SN 85-186,140. PUB. 5-3-2011. FILED 11-29-2010.
 3,997,008. **ANNSCOTT (STANDARD CHARACTER)**. ANN SCOTT DESIGN, (U.S. CLS. 2, 5, 22, 23, 29, 37, 38 AND 50). SN 85-186,923. PUB. 5-3-2011. FILED 11-30-2010.
 3,997,064. **LUNCH BOX QUILTS AND DESIGN**. LUNCH BOX QUILTS, LLC, (U.S. CLS. 2, 5, 22, 23, 29, 37, 38 AND 50). SN 85-188,052. PUB. 5-3-2011. FILED 12-1-2010.
 3,997,065. **SPRING LEAF CONCEPTS & DESIGN (STANDARD CHARACTER)**. SPRING LEAF CONCEPTS & DESIGN, INC., MULTIPLE CLASS, (INT. CLS. 16 AND 25), (U.S. CLS. 2, 5, 22, 23, 29, 37, 38, 39 AND 50). SN 85-188,146. PUB. 5-3-2011. FILED 12-1-2010.
 3,997,077. **MISCELLANEOUS DESIGN**. TINY PRINTS, INC., MULTIPLE CLASS, (INT. CLS. 16, 35, 40 AND 42), (U.S. CLS. 2, 5, 22, 23, 29, 37, 38, 50, 100, 101, 102, 103 AND 106). SN 85-188,347. PUB. 5-3-2011. FILED 12-1-2010.
 3,997,078. **BIG IMPRESSIONS (STANDARD CHARACTER)**. TINY PRINTS, INC., MULTIPLE CLASS, (INT. CLS. 16, 35, 40 AND 42), (U.S. CLS. 2, 5, 22, 23, 29, 37, 38, 50, 100, 101, 102, 103 AND 106). SN 85-188,355. PUB. 5-3-2011. FILED 12-1-2010.
 3,997,079. **TEENACE (STANDARD CHARACTER)**. DOW-RICK, PETER W., (U.S. CLS. 2, 5, 22, 23, 29, 37, 38 AND 50). SN 85-188,411. PUB. 5-3-2011. FILED 12-1-2010.
 3,997,092. **ACR (STANDARD CHARACTER)**. B&D LITHO OF ARIZONA, INC., DBA B&D LITHO, (U.S. CLS. 2, 5, 22, 23, 29, 37, 38 AND 50). SN 85-188,729. PUB. 5-3-2011. FILED 12-1-2010.
 3,997,097. **LETTERLICIOUS (STANDARD CHARACTER)**. SYNDICATED PUZZLES, MULTIPLE CLASS, (INT. CLS. 16 AND 41), (U.S. CLS. 2, 5, 22, 23, 29, 37, 38, 50, 100, 101 AND 107). SN 85-188,782. PUB. 5-3-2011. FILED 12-1-2010.
 3,997,129. **AMOS AUTO ENTHUSIAST (STANDARD CHARACTER)**. AMOS PRESS, INC., (U.S. CLS. 2, 5, 22, 23, 29, 37, 38 AND 50). SN 85-189,354. PUB. 5-3-2011. FILED 12-2-2010.
 3,997,134 (*See Class 11 for this trademark.*)
 3,997,141. **ENCORE STONE AND DESIGN**. COMMAND PACKAGING, (U.S. CLS. 2, 5, 22, 23, 29, 37, 38 AND 50). SN 85-189,560. PUB. 5-3-2011. FILED 12-2-2010.
 3,997,163. **SOCIETAS ROSICRUCIANA IN AMERICA (STANDARD CHARACTER)**. SOCIETY OF ROSICRUCIANS AND SOCIETAS ROSICRUCIANA IN AMERICA, INC., MULTIPLE CLASS, (INT. CLS. 16 AND 41), (U.S. CLS. 2, 5, 22, 23, 29, 37, 38, 50, 100, 101 AND 107). SN 85-189,846. PUB. 5-3-2011. FILED 12-2-2010.
 3,997,206. **THE FIRST-EVER SHAPE-CHANGING BOOK (STANDARD CHARACTER)**. HIS BREATH NOW PUBLICATIONS, LLC, (U.S. CLS. 2, 5, 22, 23, 29, 37, 38 AND 50). SN 85-191,181. PUB. 5-3-2011. FILED 12-6-2010.
 3,997,284. **EASY DAYSIES (STANDARD CHARACTER)**. COMEAU, ELAINE, (U.S. CLS. 2, 5, 22, 23, 29, 37, 38 AND 50). SN 85-193,711. PUB. 5-3-2011. FILED 12-8-2010.
 3,997,316. **EMPRESARIOS AEM (STANDARD CHARACTER)**. ASOCIACION DE EMPRESARIOS MEXICANOS, (U.S. CLS. 2, 5, 22, 23, 29, 37, 38 AND 50). SN 85-194,878. PUB. 5-3-2011. FILED 12-10-2010.
 3,997,334. **CRDTS (STANDARD CHARACTER)**. CENTRAL REGIONAL DENTAL TESTING SERVICE, INC., MULTIPLE CLASS, (INT. CLS. 16 AND 42), (U.S. CLS. 2, 5, 22, 23, 29, 37, 38, 50, 100 AND 101). SN 85-195,530. PUB. 5-3-2011. FILED 12-10-2010.
 3,997,353. **PUMA PRESS AND DESIGN**. PUMA PRESS, LLC, (U.S. CLS. 2, 5, 22, 23, 29, 37, 38 AND 50). SN 85-196,903. PUB. 5-3-2011. FILED 12-13-2010.
 3,997,394. **BOOKFLIP (STANDARD CHARACTER)**. MWR, LLC, (U.S. CLS. 2, 5, 22, 23, 29, 37, 38 AND 50). SN 85-199,661. PUB. 5-3-2011. FILED 12-16-2010.
 3,997,438. **ELEGANZA AND DESIGN**. RING CO., LTD., MULTIPLE CLASS, (INT. CLS. 16, 18 AND 25), (U.S. CLS. 1, 2, 3, 5, 22, 23, 29, 37, 38, 39, 41 AND 50). SN 85-200,949. PUB. 5-3-2011. FILED 12-17-2010.
 3,997,446. **MISCELLANEOUS DESIGN**. NYSTROM, MATTHEW P., DBA GUZZLED.ORG, (U.S. CLS. 2, 5, 22, 23, 29, 37, 38 AND 50). SN 85-201,311. PUB. 5-3-2011. FILED 12-18-2010.
 3,997,451. **FALLEN PINE AND DESIGN**. FALLEN PINE LLC, MULTIPLE CLASS, (INT. CLS. 16, 20 AND 28), (U.S. CLS. 2, 5, 13, 22, 23, 25, 29, 32, 37, 38 AND 50). SN 85-201,720. PUB. 5-3-2011. FILED 12-20-2010.
 3,997,469. **WHAT WILL THEY LEARN? (STANDARD CHARACTER)**. AMERICAN COUNCIL OF TRUSTEES AND ALUMNI, MULTIPLE CLASS, (INT. CLS. 16 AND 41), (U.S. CLS. 2, 5, 22, 23, 29, 37, 38, 50, 100, 101 AND 107). SN 85-202,489. PUB. 5-3-2011. FILED 12-21-2010.
 3,997,494. **THE ART OF MY LIFE (STANDARD CHARACTER)**. LIFE PLUS STYLE LTD., (U.S. CLS. 2, 5, 22, 23, 29, 37, 38 AND 50). SN 85-203,226. PUB. 5-3-2011. FILED 12-21-2010.
 3,997,600. **E) AND DESIGN**. RICK FEDERMAN, (U.S. CLS. 2, 5, 22, 23, 29, 37, 38 AND 50). SN 85-205,261. PUB. 5-3-2011. FILED 12-23-2010.
 3,997,614. **T2T (STANDARD CHARACTER)**. CHAD BORKOWSKI, MULTIPLE CLASS, (INT. CLS. 16 AND 25), (U.S. CLS. 2, 5, 22, 23, 29, 37, 38, 39 AND 50). SN 85-205,474. PUB. 5-3-2011. FILED 12-23-2010.
 3,997,637 (*See Class 9 for this trademark.*)
 3,997,650. **THE ELY TIMES (STANDARD CHARACTER)**. STEPHENS MEDIA LLC, DBA ELY TIMES, (U.S. CLS. 2, 5, 22, 23, 29, 37, 38 AND 50). SN 85-205,959. PUB. 5-3-2011. FILED 12-27-2010.
 3,997,677 (*See Class 9 for this trademark.*)
 3,997,743. **EARTH DELICATE (STANDARD CHARACTER)**. BAY CONVERTING INC., (U.S. CLS. 2, 5, 22, 23, 29, 37, 38 AND 50). SN 85-207,275. PUB. 5-3-2011. FILED 12-29-2010.
 3,997,755. **DASHBOARD DOODLES (STANDARD CHARACTER)**. DASHBOARD DOODLES, (U.S. CLS. 2, 5, 22, 23, 29, 37, 38 AND 50). SN 85-207,429. PUB. 5-3-2011. FILED 12-29-2010.
 3,997,764. **CRIMINAL MINDS (STANDARD CHARACTER)**. CBS STUDIOS INC., (U.S. CLS. 2, 5, 22, 23, 29, 37, 38 AND 50). SN 85-207,472. PUB. 5-3-2011. FILED 12-29-2010.
 3,997,795. **BIPOLAR BEACON OF HOPE (STANDARD CHARACTER)**. BIPOLAR BEACON OF HOPE, (U.S. CLS. 2, 5, 22, 23, 29, 37, 38 AND 50). SN 85-208,024. PUB. 5-3-2011. FILED 12-30-2010.
 3,997,809. **HOOPOE AND DESIGN**. INSTITUTE FOR THE STUDY OF HUMAN KNOWLEDGE, (U.S. CLS. 2, 5, 22, 23, 29, 37, 38 AND 50). SN 85-208,183. PUB. 5-3-2011. FILED 12-30-2010.
 3,997,880. **MI BANDERA (STANDARD CHARACTER)**. VOIP CARDS, LLC, (U.S. CLS. 2, 5, 22, 23, 29, 37, 38 AND 50). SN 85-208,842. PUB. 5-3-2011. FILED 1-2-2011.
 3,997,887. **RIVERCAT (STANDARD CHARACTER)**. COCHREN, LESLIE JAMES, DBA RIVERCAT, (U.S. CLS. 2, 5, 22, 23, 29, 37, 38 AND 50). SN 85-208,974. PUB. 5-3-2011. FILED 1-3-2011.
 3,997,908. **FR FIRST RISE AND DESIGN**. FIRST RISE, LLC, (U.S. CLS. 2, 5, 22, 23, 29, 37, 38 AND 50). SN 85-209,184. PUB. 5-3-2011. FILED 1-3-2011.
 3,997,922. **MAGNOLIA PRESS (STANDARD CHARACTER)**. TINY PRINTS, INC., (U.S. CLS. 2, 5, 22, 23, 29, 37, 38 AND 50). SN 85-209,356. PUB. 5-3-2011. FILED 1-3-2011.
 3,997,924. **HOOT & DOODLE (STANDARD CHARACTER)**. TIG'S BACKYARD, LLC, MULTIPLE CLASS, (INT. CLS. 16 AND 25), (U.S. CLS. 2, 5, 22, 23, 29, 37, 38, 39 AND 50). SN 85-209,372. PUB. 5-3-2011. FILED 1-3-2011.
 3,997,932. **BE YOUR OWN REASON! (STYLIZED)**. HUDDLE, SANDY, DBA BE YOUR OWN REASON!, (U.S. CLS. 2, 5, 22, 23, 29, 37, 38 AND 50). SN 85-209,483. PUB. 5-3-2011. FILED 1-3-2011.
 3,997,933. **BE THE LIGHT, BE THE CHANGE, BE YOUR OWN REASON! (STYLIZED)**. HUDDLE, SANDY, DBA BE YOUR OWN REASON!, (U.S. CLS. 2, 5, 22, 23, 29, 37, 38 AND 50). SN 85-209,494. PUB. 5-3-2011. FILED 1-3-2011.
 3,997,995. **AUNT MARTHA'S AND DESIGN**. COLONIAL PATTERNS, INC., (U.S. CLS. 2, 5, 22, 23, 29, 37, 38 AND 50). SN 85-210,401. PUB. 5-3-2011. FILED 1-4-2011.
 3,997,996. **GMT (STANDARD CHARACTER)**. GMT PUBLISHING SARL, (U.S. CLS. 2, 5, 22, 23, 29, 37, 38 AND 50). SN 85-

- 210,402. PUB. 5-3-2011. FILED 1-4-2011.
- 3,998,011. **LETTERLICIOUS (STANDARD CHARACTER)**. SYNDICATED PUZZLES, (U.S. CLS. 2, 5, 22, 23, 29, 37, 38 AND 50). SN 85-210,594. PUB. 5-3-2011. FILED 1-5-2011.
- 3,998,041. **ONE ARM BANDIT (STANDARD CHARACTER)**. KITARU INNOVATIONS INC., (U.S. CLS. 2, 5, 22, 23, 29, 37, 38 AND 50). SN 85-211,091. PUB. 5-3-2011. FILED 1-5-2011.
- 3,998,061. **ZONING (STANDARD CHARACTER)**. EDWARDS, SALLY, DBA HEART ZONES, (U.S. CLS. 2, 5, 22, 23, 29, 37, 38 AND 50). SN 85-211,398. PUB. 5-3-2011. FILED 1-5-2011.
- 3,998,100. **BELIEVE BEGIN BECOME (STANDARD CHARACTER)**. BOARD OF REGENTS OF THE UNIVERSITY SYSTEM OF GEORGIA, MULTIPLE CLASS, (INT. CLS. 16, 18, 25 AND 41), (U.S. CLS. 1, 2, 3, 5, 22, 23, 29, 37, 38, 39, 41, 50, 100, 101 AND 107). SN 85-212,018. PUB. 5-3-2011. FILED 1-6-2011.
- 3,998,144 (*See Class 9 for this trademark*).
- 3,998,149. **THE LIFE I LIVE (STANDARD CHARACTER)**. LIFE PLUS STYLE LTD., (U.S. CLS. 2, 5, 22, 23, 29, 37, 38 AND 50). SN 85-213,132. PUB. 5-3-2011. FILED 1-7-2011.
- 3,998,152. **CHICKEN SCRATCH (STANDARD CHARACTER)**. LIFE PLUS STYLE LTD., (U.S. CLS. 2, 5, 22, 23, 29, 37, 38 AND 50). SN 85-213,185. PUB. 5-3-2011. FILED 1-7-2011.
- 3,998,159. **THE DECISION IS YOURS (STANDARD CHARACTER)**. FRANKLIN COVEY, CO., MULTIPLE CLASS, (INT. CLS. 16 AND 41), (U.S. CLS. 2, 5, 22, 23, 29, 37, 38, 50, 100, 101 AND 107). SN 85-213,433. PUB. 5-3-2011. FILED 1-8-2011.
- 3,998,172. **MISCELLANEOUS DESIGN**. SAINT LOUIS UNIVERSITY, (U.S. CLS. 2, 5, 22, 23, 29, 37, 38 AND 50). SN 85-214,246. PUB. 5-3-2011. FILED 1-10-2011.
- 3,998,178 (*See Class 9 for this trademark*).
- 3,998,192. **A LITTLE BIRD TOLD ME (STANDARD CHARACTER)**. LIFE PLUS STYLE LTD., (U.S. CLS. 2, 5, 22, 23, 29, 37, 38 AND 50). SN 85-215,935. PUB. 5-3-2011. FILED 1-12-2011.
- 3,998,195. **RANDOM THOUGHTS (STANDARD CHARACTER)**. LIFE PLUS STYLE LTD., (U.S. CLS. 2, 5, 22, 23, 29, 37, 38 AND 50). SN 85-216,046. PUB. 5-3-2011. FILED 1-12-2011.
- 3,998,197 (*See Class 9 for this trademark*).
- 3,998,232. **LIVE LOVE LAUGH (STANDARD CHARACTER)**. D-GENERATION, INC., (U.S. CLS. 2, 5, 22, 23, 29, 37, 38 AND 50). SN 85-228,722. PUB. 5-3-2011. FILED 1-28-2011.
- 3,998,264. **XAVIER (STYLIZED)**. XAVIER UNIVERSITY CORPORATION, DBA XAVIER UNIVERSITY, MULTIPLE CLASS, (INT. CLS. 16, 25 AND 41), (U.S. CLS. 2, 5, 22, 23, 29, 37, 38, 39, 50, 100, 101 AND 107). SN 85-240,041. PUB. 5-3-2011. FILED 2-11-2011.
- 3,998,277 (*See Class 9 for this trademark*).
- 3,998,299. **ENERGY SNX (STANDARD CHARACTER)**. JOHN B. SANFILIPPO & SON, INC., (U.S. CLS. 2, 5, 22, 23, 29, 37, 38 AND 50). SN 85-975,071. PUB. 5-3-2011. FILED S.R. 10-20-2010; AM. P.R. 2-16-2011.

CLASS 17—RUBBER GOODS

- 3,995,580 (*See Class 6 for this trademark*).
- 3,995,677 (*See Class 1 for this trademark*).
- 3,995,816 (*See Class 1 for this trademark*).
- 3,995,875 (*See Class 7 for this trademark*).
- 3,995,890 (*See Class 1 for this trademark*).
- 3,995,918. **RENOLIT COVAREN (STANDARD CHARACTER)**. RENOLIT AG, MULTIPLE CLASS, (INT. CLS. 17, 19 AND 20), (U.S. CLS. 1, 2, 5, 12, 13, 22, 25, 32, 33, 35 AND 50). SN 79-086,996. PUB. 5-3-2011. FILED 4-28-2010.
- 3,995,971. **UNITRIX (STYLIZED)**. CONTITECH SCHLAUCH GMBH, (U.S. CLS. 1, 5, 12, 13, 35 AND 50). SN 79-090,118. PUB. 3-8-2011. FILED 10-6-2010.
- 3,995,979 (*See Class 1 for this trademark*).
- 3,995,989 (*See Class 6 for this trademark*).
- 3,995,990. **SIKAPROOF (STANDARD CHARACTER)**. SIKA AG, (U.S. CLS. 1, 5, 12, 13, 35 AND 50). SN 79-091,295. PUB. 5-3-2011. FILED 10-15-2010.
- 3,996,192 (*See Class 1 for this trademark*).
- 3,996,322 (*See Class 6 for this trademark*).

- 3,996,495. **ENVIRO SORB AND DESIGN**. GHC SPECIALTY BRANDS, LLC, (U.S. CLS. 1, 5, 12, 13, 35 AND 50). SN 85-117,935. PUB. 5-3-2011. FILED 8-27-2010.
- 3,997,251. **CWC (STANDARD CHARACTER)**. CONTINENTAL WESTERN CORPORATION, MULTIPLE CLASS, (INT. CLS. 17, 22 AND 35), (U.S. CLS. 1, 2, 5, 7, 12, 13, 19, 22, 35, 42, 50, 100, 101 AND 102). SN 85-192,693. PUB. 5-3-2011. FILED 12-7-2010.
- 3,997,275. **ZIALOC AND DESIGN**. TB PHILLY, INC, DBA TBP CONVERTING, (U.S. CLS. 1, 5, 12, 13, 35 AND 50). SN 85-193,269. PUB. 5-3-2011. FILED 12-8-2010.
- 3,997,476 (*See Class 9 for this trademark*).
- 3,997,756. **PYROMID (STANDARD CHARACTER)**. VON ROLL USA, INC., (U.S. CLS. 1, 5, 12, 13, 35 AND 50). SN 85-207,431. PUB. 5-3-2011. FILED 12-29-2010.
- 3,997,818. **BRIDJIT (STANDARD CHARACTER)**. BRIDJIT INC., (U.S. CLS. 1, 5, 12, 13, 35 AND 50). SN 85-208,276. PUB. 5-3-2011. FILED 12-30-2010.
- 3,998,026. **CORETECH (STANDARD CHARACTER)**. SAINT-GOBAIN PERFORMANCE PLASTICS CORPORATION, (U.S. CLS. 1, 5, 12, 13, 35 AND 50). SN 85-210,843. PUB. 5-3-2011. FILED 1-5-2011.
- 3,998,143. **SAFESEAL (STANDARD CHARACTER)**. ROBERN INC., (U.S. CLS. 1, 5, 12, 13, 35 AND 50). SN 85-213,000. PUB. 5-3-2011. FILED 1-7-2011.
- 3,998,158. **EARTHCURB (STANDARD CHARACTER)**. NOVEL IDEAS, INC., (U.S. CLS. 1, 5, 12, 13, 35 AND 50). SN 85-213,393. PUB. 5-3-2011. FILED 1-8-2011.

CLASS 18—LEATHER GOODS

- 3,995,551 (*See Class 14 for this trademark*).
- 3,995,593. **BLUE MOUNTAIN UMBRELLA AND DESIGN**. BJ TOY COMPANY, INC., (U.S. CLS. 1, 2, 3, 22 AND 41). SN 77-790,081. PUB. 5-3-2011. FILED 7-27-2009.
- 3,995,719 (*See Class 3 for this trademark*).
- 3,995,759 (*See Class 3 for this trademark*).
- 3,995,781. **MISCELLANEOUS DESIGN**. SENZ TECHNOLOGIES B.V., (U.S. CLS. 1, 2, 3, 22 AND 41). SN 79-080,908. PUB. 5-3-2011. FILED 3-10-2010.
- 3,995,838. **E ECHOLAC AND DESIGN**. SHANGHAI CONWOOD INTERNATIONAL CO., LTD., (U.S. CLS. 1, 2, 3, 22 AND 41). SN 79-084,485. PUB. 5-3-2011. FILED 6-3-2010.
- 3,995,850. **SQUIRE (STANDARD CHARACTER)**. MARKER VÖLKL (INTERNATIONAL) GMBH, MULTIPLE CLASS, (INT. CLS. 18, 25 AND 28), (U.S. CLS. 1, 2, 3, 22, 23, 38, 39, 41 AND 50). SN 79-084,925. PUB. 5-3-2011. FILED 5-14-2010.
- 3,995,909 (*See Class 14 for this trademark*).
- 3,995,932 (*See Class 9 for this trademark*).
- 3,995,954. **AGRESA (STANDARD CHARACTER)**. AGRESSOR CORPORATION PTY LTD, (U.S. CLS. 1, 2, 3, 22 AND 41). SN 79-089,076. PUB. 5-3-2011. FILED 9-8-2010.
- 3,995,972. **WHOOPEE' (STYLIZED)**. WHOOP'-DE-DOO' CO., LTD, MULTIPLE CLASS, (INT. CLS. 18 AND 25), (U.S. CLS. 1, 2, 3, 22, 39 AND 41). SN 79-090,208. PUB. 5-3-2011. FILED 8-20-2010.
- 3,995,973. **EB AND DESIGN**. BRÜTTING & CO. EB-SPORT-INTERNATIONAL GMBH, MULTIPLE CLASS, (INT. CLS. 18, 25 AND 35), (U.S. CLS. 1, 2, 3, 22, 39, 41, 100, 101 AND 102). SN 79-090,294. PUB. 5-3-2011. FILED 4-15-2010.
- 3,995,982. **ROBIN RUTH (STANDARD CHARACTER)**. AVERAHAMI BOAZ, MULTIPLE CLASS, (INT. CLS. 18, 25 AND 35), (U.S. CLS. 1, 2, 3, 22, 39, 41, 100, 101 AND 102). SN 79-090,825. PUB. 5-3-2011. FILED 9-16-2010.
- 3,996,234 (*See Class 9 for this trademark*).
- 3,996,235 (*See Class 9 for this trademark*).
- 3,996,260. **G GIORRY AND DESIGN**. GIORRY LIMITED, (U.S. CLS. 1, 2, 3, 22 AND 41). SN 85-052,145. PUB. 5-3-2011. FILED 6-1-2010.
- 3,996,344. **BABYOSO (STANDARD CHARACTER)**. GALAXY WEB DESIGNS, LLC, DBA BABYOSO.COM, (U.S. CLS. 1, 2, 3, 22 AND 41). SN 85-070,558. PUB. 5-3-2011. FILED 6-24-2010.
- 3,996,453. **HELLO MY NAME IS (STANDARD CHARACTER)**. SPRAYGROUND LLC, (U.S. CLS. 1, 2, 3, 22 AND 41). SN 85-102,364. PUB. 5-3-2011. FILED 8-6-2010.

- 3,996,541. **ECOVERSE (STANDARD CHARACTER)**. SHE-DRAIN CORPORATION, (U.S. CLS. 1, 2, 3, 22 AND 41). SN 85-130,214. PUB. 3-29-2011. FILED 9-15-2010.
- 3,996,543. **D.CLAIRE STYLE AS UNIQUE AS YOU AND DESIGN**. D.CLAIRE, (U.S. CLS. 1, 2, 3, 22 AND 41). SN 85-130,664. PUB. 5-3-2011. FILED 9-15-2010.
- 3,996,758. **IRON PHI AND DESIGN**. PHI DELTA THETA FRATERNITY, MULTIPLE CLASS, (INT. CLS. 18 AND 25), (U.S. CLS. 1, 2, 3, 22, 39 AND 41). SN 85-173,166. PUB. 5-3-2011. FILED 11-10-2010.
- 3,996,759. **IRON PHI BROTHERHOOD OF ATHLETES AND DESIGN**. PHI DELTA THETA FRATERNITY, MULTIPLE CLASS, (INT. CLS. 18 AND 25), (U.S. CLS. 1, 2, 3, 22, 39 AND 41). SN 85-173,168. PUB. 5-3-2011. FILED 11-10-2010.
- 3,996,940. **HEIRLOOM (STANDARD CHARACTER)**. LU, LYNN, AND WU, TIFFANY, (U.S. CLS. 1, 2, 3, 22 AND 41). SN 85-183,707. PUB. 5-3-2011. FILED 11-23-2010.
- 3,997,039. **SUMMER BUMMER (STANDARD CHARACTER)**. CASSANITI, ALEXANDRA, MULTIPLE CLASS, (INT. CLS. 18 AND 25), (U.S. CLS. 1, 2, 3, 22, 39 AND 41). SN 85-187,485. PUB. 5-3-2011. FILED 11-30-2010.
- 3,997,041. **ALEXANDRA CASSANITI (STANDARD CHARACTER)**. CASSANITI, ALEXANDRA, MULTIPLE CLASS, (INT. CLS. 18 AND 25), (U.S. CLS. 1, 2, 3, 22, 39 AND 41). SN 85-187,505. PUB. 5-3-2011. FILED 11-30-2010.
- 3,997,075. **ROYAL ANIMALS (STYLIZED)**. ROYAL ANIMALS LTD., MULTIPLE CLASS, (INT. CLS. 18, 20 AND 28), (U.S. CLS. 1, 2, 3, 13, 22, 23, 25, 32, 38, 41 AND 50). SN 85-188,293. PUB. 5-3-2011. FILED 12-1-2010.
- 3,997,086. **TALLOOK (STYLIZED)**. SNOW, NACHE, (U.S. CLS. 1, 2, 3, 22 AND 41). SN 85-188,546. PUB. 5-3-2011. FILED 12-1-2010.
- 3,997,343. **PALMBRELLA (STANDARD CHARACTER)**. BRAITHWAITE MARY M, (U.S. CLS. 1, 2, 3, 22 AND 41). SN 85-196,589. PUB. 5-3-2011. FILED 12-13-2010.
- 3,997,438 (*See Class 16 for this trademark*).
- 3,997,482. **PS (STYLIZED)**. PROENZA SCOULER, LLC, (U.S. CLS. 1, 2, 3, 22 AND 41). SN 85-202,754. PUB. 5-3-2011. FILED 12-21-2010.
- 3,997,498. **MISCELLANEOUS DESIGN**. ARITZIA LP, (U.S. CLS. 1, 2, 3, 22 AND 41). SN 85-203,519. PUB. 5-3-2011. FILED 12-22-2010.
- 3,997,592. **E :) AND DESIGN**. RICK FEDERMAN, MULTIPLE CLASS, (INT. CLS. 18 AND 25), (U.S. CLS. 1, 2, 3, 22, 39 AND 41). SN 85-205,190. PUB. 5-3-2011. FILED 12-23-2010.
- 3,997,717. **LEIGHTON (STANDARD CHARACTER)**. FUTAI, INC. (USA), (U.S. CLS. 1, 2, 3, 22 AND 41). SN 85-206,864. PUB. 5-3-2011. FILED 12-28-2010.
- 3,997,739. **KK (STYLIZED)**. KATIE KALSI, LLC, (U.S. CLS. 1, 2, 3, 22 AND 41). SN 85-207,180. PUB. 5-3-2011. FILED 12-29-2010.
- 3,997,781. **BEST FRIEND (STANDARD CHARACTER)**. J. MITTON & ASSOCIATES, INC., DBA INTREPID INTERNATIONAL, (U.S. CLS. 1, 2, 3, 22 AND 41). SN 85-207,777. PUB. 5-3-2011. FILED 12-30-2010.
- 3,997,828 (*See Class 9 for this trademark*).
- 3,998,076 (*See Class 9 for this trademark*).
- 3,998,100 (*See Class 16 for this trademark*).
- 3,998,150. **LUCKY BRAND (STANDARD CHARACTER)**. LUCKY BRAND DUGAREES, INC., (U.S. CLS. 1, 2, 3, 22 AND 41). SN 85-213,150. PUB. 5-3-2011. FILED 1-7-2011.
- 3,998,153. **SENSE-IBLE (STANDARD CHARACTER)**. SOFT-OUCH CONCEPTS, INC., (U.S. CLS. 1, 2, 3, 22 AND 41). SN 85-213,187. PUB. 5-3-2011. FILED 1-7-2011.
- 3,998,154. **SOF-LOOP (STANDARD CHARACTER)**. SOFT-OUCH CONCEPTS, INC., (U.S. CLS. 1, 2, 3, 22 AND 41). SN 85-213,200. PUB. 5-3-2011. FILED 1-7-2011.
- MULTIPLE CLASS, (INT. CLS. 19 AND 37), (U.S. CLS. 1, 12, 33, 50, 100, 103 AND 106). SN 79-085,765. PUB. 5-3-2011. FILED 6-18-2010.
- 3,995,913. **RESISTAL (STYLIZED)**. DIDIER-WERKE AG, (U.S. CLS. 1, 12, 33 AND 50). SN 79-086,780. PUB. 5-3-2011. FILED 4-29-2010.
- 3,995,918 (*See Class 17 for this trademark*).
- 3,995,927 (*See Class 6 for this trademark*).
- 3,995,979 (*See Class 1 for this trademark*).
- 3,995,981. **TENNIS FORCE (STANDARD CHARACTER)**. SPORTAS GMBH SPORTANLAGEN-SPORTBODENBAU, MULTIPLE CLASS, (INT. CLS. 19 AND 27), (U.S. CLS. 1, 12, 19, 20, 33, 37, 42 AND 50). SN 79-090,810. PUB. 5-3-2011. FILED 10-27-2010.
- 3,996,098 (*See Class 6 for this trademark*).
- 3,996,192 (*See Class 1 for this trademark*).
- 3,996,194. **FASCO (STANDARD CHARACTER)**. SILPRO, LLC, (U.S. CLS. 1, 12, 33 AND 50). SN 85-045,302. PUB. 5-3-2011. FILED 5-21-2010.
- 3,996,245 (*See Class 6 for this trademark*).
- 3,996,278. **DYNAMIC SHELTERS (STANDARD CHARACTER)**. DYNAMIC SHELTERS INC., (U.S. CLS. 1, 12, 33 AND 50). SN 85-055,390. PUB. 5-3-2011. FILED 6-4-2010.
- 3,996,301. **MOPLY (STANDARD CHARACTER)**. TEXSA, S.A., (U.S. CLS. 1, 12, 33 AND 50). SN 85-062,096. PUB. 5-3-2011. FILED 6-14-2010.
- 3,996,302. **MAGIRA (STANDARD CHARACTER)**. SCHOTT AG, MULTIPLE CLASS, (INT. CLS. 19 AND 21), (U.S. CLS. 1, 2, 12, 13, 23, 29, 30, 33, 40 AND 50). SN 85-062,141. PUB. 9-21-2010. FILED 6-14-2010.
- 3,996,341 (*See Class 6 for this trademark*).
- 3,996,588. **EPOXYPLUS (STANDARD CHARACTER)**. TEXAS CEMENT PRODUCTS, INC., (U.S. CLS. 1, 12, 33 AND 50). SN 85-141,751. PUB. 5-3-2011. FILED 9-30-2010.
- 3,996,589. **PORCELAIN TS (STANDARD CHARACTER)**. TEXAS CEMENT PRODUCTS, INC., (U.S. CLS. 1, 12, 33 AND 50). SN 85-141,951. PUB. 5-3-2011. FILED 9-30-2010.
- 3,996,713. **PENNSYLVANIA PINK (STANDARD CHARACTER)**. THREE RIVERS MARINE & RAIL TERMINALS, L.P., (U.S. CLS. 1, 12, 33 AND 50). SN 85-168,190. PUB. 5-3-2011. FILED 11-3-2010.
- 3,996,763. **AKASHA THE LEADER IN DECORATIVE ACCENTS! AND DESIGN**. AKASHA, MULTIPLE CLASS, (INT. CLS. 19, 20, 21 AND 26), (U.S. CLS. 1, 2, 12, 13, 22, 23, 25, 29, 30, 32, 33, 37, 39, 40, 42 AND 50). SN 85-173,252. PUB. 5-3-2011. FILED 11-10-2010.
- 3,996,816. **BULL CRETE (STANDARD CHARACTER)**. THORWORKS INDUSTRIES, INC., (U.S. CLS. 1, 12, 33 AND 50). SN 85-177,055. PUB. 5-3-2011. FILED 11-15-2010.
- 3,996,845. **OUT OF THE WOODS GRANITE AND DESIGN**. OUT OF THE WOODS GRANITE, LLC, MULTIPLE CLASS, (INT. CLS. 19 AND 40), (U.S. CLS. 1, 12, 33, 50, 100, 103 AND 106). SN 85-178,767. PUB. 5-3-2011. FILED 11-17-2010.
- 3,997,076. **POWER(SHIELD) (STANDARD CHARACTER)**. TANDUS US, LLC, (U.S. CLS. 1, 12, 33 AND 50). SN 85-188,318. PUB. 5-3-2011. FILED 12-1-2010.
- 3,997,164. **MOKK (STANDARD CHARACTER)**. YUAN, SHUAI, (U.S. CLS. 1, 12, 33 AND 50). SN 85-189,919. PUB. 5-3-2011. FILED 12-3-2010.
- 3,997,331. **MODENA (STANDARD CHARACTER)**. AZEK BUILDING PRODUCTS, INC., (U.S. CLS. 1, 12, 33 AND 50). SN 85-195,469. PUB. 5-3-2011. FILED 12-10-2010.
- 3,997,641. **HP2 (STANDARD CHARACTER)**. HYDROHOIST MARINE GROUP, INC., (U.S. CLS. 1, 12, 33 AND 50). SN 85-205,825. PUB. 5-3-2011. FILED 12-27-2010.
- 3,997,859. **LIVE LOVE LAUGH (STANDARD CHARACTER)**. D-GENERATION, INC, (U.S. CLS. 1, 12, 33 AND 50). SN 85-208,667. PUB. 5-3-2011. FILED 12-31-2010.
- 3,998,218. **SCOURSTOP (STANDARD CHARACTER)**. L&P PROPERTY MANAGEMENT COMPANY, (U.S. CLS. 1, 12, 33 AND 50). SN 85-224,141. PUB. 5-3-2011. FILED 1-24-2011.

CLASS 19—NON-METALLIC BUILDING MATERIALS

3,995,715 (*See Class 9 for this trademark*).

3,995,775 (*See Class 6 for this trademark*).

3,995,784 (*See Class 1 for this trademark*).

3,995,886. **KRONOPOL AND DESIGN**. "KRONOPOL" SPÓLKA Z OGRANICZONA ODPOWIEDZIALNOSCIA,

CLASS 20—FURNITURE AND ARTICLES NOT OTHERWISE CLASSIFIED

3,995,469. **VIGHANO (STANDARD CHARACTER)**. UNITED ROYAL LINEN, INC., MULTIPLE CLASS, (INT. CLS. 20, 21, 24 AND 27), (U.S. CLS. 2, 13, 19, 20, 22, 23, 25, 29, 30, 32, 33, 37, 40, 42 AND 50). SN 76-702,772. PUB. 5-3-2011. FILED 5-3-2010.

3,995,562. **PRESSURE-LOK (STANDARD CHARACTER)**. STEELE, MARK A., (U.S. CLS. 2, 13, 22, 25, 32 AND 50). SN 77-653,480. PUB. 5-3-2011. FILED 1-21-2009.

3,995,589 (*See Class 6 for this trademark*).

3,995,616. **ALBOR AND DESIGN**. ALBOR S.P.A., (U.S. CLS. 2, 13, 22, 25, 32 AND 50). SN 77-843,717. PUB. 3-8-2011. FILED 10-7-2009.

3,995,617. **LONE STAR (STANDARD CHARACTER)**. Y-TEX CORPORATION, (U.S. CLS. 2, 13, 22, 25, 32 AND 50). SN 77-845,661. PUB. 5-3-2011. FILED 10-9-2009.

3,995,692. **WALKLET (STANDARD CHARACTER)**. REBAR GROUP, INC., (U.S. CLS. 2, 13, 22, 25, 32 AND 50). SN 77-945,532. PUB. 5-3-2011. FILED 2-26-2010.

3,995,715 (*See Class 9 for this trademark*).

3,995,719 (*See Class 3 for this trademark*).

3,995,720 (*See Class 6 for this trademark*).

3,995,775 (*See Class 6 for this trademark*).

3,995,784 (*See Class 1 for this trademark*).

3,995,803. **CLIP IT EASY (STANDARD CHARACTER)**. ARPER S.P.A., (U.S. CLS. 2, 13, 22, 25, 32 AND 50). SN 79-083,183. PUB. 5-3-2011. FILED 5-6-2010.

3,995,804. **CLIP.IT.EASY AND DESIGN**. ARPER S.P.A., (U.S. CLS. 2, 13, 22, 25, 32 AND 50). SN 79-083,184. PUB. 5-3-2011. FILED 5-6-2010.

3,995,857 (*See Class 9 for this trademark*).

3,995,918 (*See Class 17 for this trademark*).

3,995,922 (*See Class 11 for this trademark*).

3,996,005. **DBI (STANDARD CHARACTER)**. DBI PLASTICS A/S, (U.S. CLS. 2, 13, 22, 25, 32 AND 50). SN 79-092,641. PUB. 5-3-2011. FILED 1-7-2011.

3,996,020. **SUNCOVER AND DESIGN**. SUNCOVER S.P.A., MULTIPLE CLASS, (INT. CLS. 20 AND 24), (U.S. CLS. 2, 13, 22, 25, 32, 42 AND 50). SN 79-094,031. PUB. 5-3-2011. FILED 10-22-2010.

3,996,089. **INTUITIVE (STANDARD CHARACTER)**. PARAGON FURNITURE, L.P., (U.S. CLS. 2, 13, 22, 25, 32 AND 50). SN 85-026,699. PUB. 5-3-2011. FILED 4-29-2010.

3,996,091. **FLEXWRAP (STANDARD CHARACTER)**. WS PACKAGING GROUP, INC., (U.S. CLS. 2, 13, 22, 25, 32 AND 50). SN 85-027,741. PUB. 5-3-2011. FILED 4-30-2010.

3,996,135 (*See Class 6 for this trademark*).

3,996,208 (*See Class 1 for this trademark*).

3,996,230. **KATIE PUFF (STANDARD CHARACTER)**. ANIMALS MATTER, INC., (U.S. CLS. 2, 13, 22, 25, 32 AND 50). SN 85-048,209. PUB. 5-3-2011. FILED 5-26-2010.

3,996,251. **IT'S MERINO MAGIC! (STANDARD CHARACTER)**. ABDULLAIEVA INTERNATIONAL TRADE COMPANY, DBA SLEEP & BEYOND, MULTIPLE CLASS, (INT. CLS. 20 AND 24), (U.S. CLS. 2, 13, 22, 25, 32, 42 AND 50). SN 85-051,048. PUB. 5-3-2011. FILED 5-30-2010.

3,996,322 (*See Class 6 for this trademark*).

3,996,376 (*See Class 11 for this trademark*).

3,996,396. **VISCOLITE (STANDARD CHARACTER)**. WERNER MEDIA PARTNERS, LLC, DBA NATURE'S SLEEP, LLC, (U.S. CLS. 2, 13, 22, 25, 32 AND 50). SN 85-083,732. PUB. 5-3-2011. FILED 7-13-2010.

3,996,399. **STOR-MATE (STANDARD CHARACTER)**. TRUCK ACCESSORIES GROUP, LLC, (U.S. CLS. 2, 13, 22, 25, 32 AND 50). SN 85-084,751. PUB. 5-3-2011. FILED 7-14-2010.

3,996,498. **VANITY PILLOW (STANDARD CHARACTER)**. PAMELA GOVERNALE, (U.S. CLS. 2, 13, 22, 25, 32 AND 50). SN 85-119,743. PUB. 5-3-2011. FILED 8-31-2010.

3,996,564 (*See Class 7 for this trademark*).

3,996,763 (*See Class 19 for this trademark*).

3,996,834 (*See Class 14 for this trademark*).

3,996,843. **OLD POST TRADING (STANDARD CHARACTER)**. MAGNUSSEN INTERNATIONAL CORP., (U.S. CLS. 2, 13, 22, 25, 32 AND 50). SN 85-178,717. PUB. 5-3-2011. FILED 11-17-2010.

3,996,853. **CHARLESTON CHOPS AND DESIGN**. CHARLESTON WOODWORKS, INC., MULTIPLE CLASS, (INT. CLS.

20 AND 21), (U.S. CLS. 2, 13, 22, 23, 25, 29, 30, 32, 33, 40 AND 50). SN 85-178,996. PUB. 5-3-2011. FILED 11-17-2010.

3,997,014. **EZTOTE (STANDARD CHARACTER)**. HOOVER MATERIALS HANDLING GROUP, INC., (U.S. CLS. 2, 13, 22, 25, 32 AND 50). SN 85-186,958. PUB. 5-3-2011. FILED 11-30-2010.

3,997,075 (*See Class 18 for this trademark*).

3,997,095. **STIMULITE (STANDARD CHARACTER)**. SUPRACOR, INC., MULTIPLE CLASS, (INT. CLS. 20, 24, 25 AND 28), (U.S. CLS. 2, 13, 22, 23, 25, 32, 38, 39, 42 AND 50). SN 85-188,763. PUB. 5-3-2011. FILED 12-1-2010.

3,997,134 (*See Class 11 for this trademark*).

3,997,272. **HUG AN ACTUARY WITH INCREASING FREQUENCY (STANDARD CHARACTER)**. SGRISK, (U.S. CLS. 2, 13, 22, 25, 32 AND 50). SN 85-193,180. PUB. 5-3-2011. FILED 12-8-2010.

3,997,352. **DAVE'S DONUTS (STANDARD CHARACTER)**. GOODWIN, ROBERT W., (U.S. CLS. 2, 13, 22, 25, 32 AND 50). SN 85-196,836. PUB. 5-3-2011. FILED 12-13-2010.

3,997,412. **COMFORTILT (STANDARD CHARACTER)**. L&P PROPERTY MANAGEMENT COMPANY, (U.S. CLS. 2, 13, 22, 25, 32 AND 50). SN 85-200,246. PUB. 5-3-2011. FILED 12-17-2010.

3,997,451 (*See Class 16 for this trademark*).

3,997,490. **MCROSKEY (STANDARD CHARACTER)**. MCROSKEY MATTRESS COMPANY, MULTIPLE CLASS, (INT. CLS. 20 AND 35), (U.S. CLS. 2, 13, 22, 25, 32, 50, 100, 101 AND 102). SN 85-203,029. PUB. 5-3-2011. FILED 12-21-2010.

3,997,893. **ROBERTS & SONS (STANDARD CHARACTER)**. ROBERTS & SONS, (U.S. CLS. 2, 13, 22, 25, 32 AND 50). SN 85-209,024. PUB. 5-3-2011. FILED 1-3-2011.

3,997,926. **IFLEX (STANDARD CHARACTER)**. MOORECO, INC., (U.S. CLS. 2, 13, 22, 25, 32 AND 50). SN 85-209,403. PUB. 5-3-2011. FILED 1-3-2011.

3,998,028. **ADD-A-DRAWER (STANDARD CHARACTER)**. SMART SOLUTIONS RECREATIONAL PRODUCTS, INC., (U.S. CLS. 2, 13, 22, 25, 32 AND 50). SN 85-210,856. PUB. 5-3-2011. FILED 1-5-2011.

3,998,094. **CELLO-GREEN (STANDARD CHARACTER)**. THE CELL-O-CORE COMPANY, (U.S. CLS. 2, 13, 22, 25, 32 AND 50). SN 85-211,913. PUB. 5-3-2011. FILED 1-6-2011.

3,998,155. **SAHARA NIGHTS (STANDARD CHARACTER)**. SOBEL WESTEX, (U.S. CLS. 2, 13, 22, 25, 32 AND 50). SN 85-213,210. PUB. 5-3-2011. FILED 1-7-2011.

3,998,240. **AEROPOD (STANDARD CHARACTER)**. JACKSON, DEAN, D., (U.S. CLS. 2, 13, 22, 25, 32 AND 50). SN 85-231,822. PUB. 5-3-2011. FILED 2-1-2011.

CLASS 21—HOUSEWARES AND GLASS

3,995,469 (*See Class 20 for this trademark*).

3,995,589 (*See Class 6 for this trademark*).

3,995,600. **MASTERPIECE FLOWER COMPANY (STANDARD CHARACTER)**. MASTERPIECE FLOWER COMPANY, MULTIPLE CLASS, (INT. CLS. 21 AND 31), (U.S. CLS. 1, 2, 13, 23, 29, 30, 33, 40, 46 AND 50). SN 77-806,501. PUB. 5-3-2011. FILED 8-17-2009.

3,995,688. **SAPO DE PAPEL (STANDARD CHARACTER)**. BRAZOS INTERNATIONAL, INC., (U.S. CLS. 2, 13, 23, 29, 30, 33, 40 AND 50). SN 77-937,625. PUB. 5-3-2011. FILED 2-17-2010.

3,995,720 (*See Class 6 for this trademark*).

3,995,893 (*See Class 8 for this trademark*).

3,995,985 (*See Class 1 for this trademark*).

3,995,986 (*See Class 1 for this trademark*).

3,995,987 (*See Class 1 for this trademark*).

3,996,223. **GREATEST PRODUCTS UNDER THE SUN (STANDARD CHARACTER)**. CALIFORNIA INNOVATIONS INC., (U.S. CLS. 2, 13, 23, 29, 30, 33, 40 AND 50). SN 85-047,347. PUB. 5-3-2011. FILED 5-25-2010.

3,996,228. **REVERSE THE JINX (STANDARD CHARACTER)**. MAHOOD, JEFFERY, (U.S. CLS. 2, 13, 23, 29, 30, 33, 40 AND 50). SN 85-047,945. PUB. 4-12-2011. FILED 5-26-2010.

3,996,283. **LEPARC GREEN SCENE AND DESIGN**. LEPARC INTERNATIONAL CO., LTD., (U.S. CLS. 2, 13, 23, 29, 30, 33, 40 AND 50). SN 85-056,666. PUB. 5-3-2011. FILED 6-7-2010.

3,996,302 (*See Class 19 for this trademark*).
 3,996,329. **SNOWBABIES (STANDARD CHARACTER)**. ESCROW ASSOCIATES, LLC, MULTIPLE CLASS, (INT. CLS. 21 AND 28), (U.S. CLS. 2, 13, 22, 23, 29, 30, 33, 38, 40 AND 50). SN 85-068,244. PUB. 5-3-2011. FILED 6-22-2010.
 3,996,457 (*See Class 3 for this trademark*).
 3,996,458. **MARINATING MADE EASY (STANDARD CHARACTER)**. INNO-LABS LP, (U.S. CLS. 2, 13, 23, 29, 30, 33, 40 AND 50). SN 85-103,675. PUB. 5-3-2011. FILED 8-9-2010.
 3,996,469 (*See Class 1 for this trademark*).
 3,996,484. **ALWAYS FULL OF FUN (STANDARD CHARACTER)**. TERVIS TUMBLER COMPANY, (U.S. CLS. 2, 13, 23, 29, 30, 33, 40 AND 50). SN 85-114,906. PUB. 5-3-2011. FILED 8-24-2010.
 3,996,554 (*See Class 7 for this trademark*).
 3,996,754. **MISCELLANEOUS DESIGN**. TERVIS TUMBLER COMPANY, (U.S. CLS. 2, 13, 23, 29, 30, 33, 40 AND 50). SN 85-172,862. PUB. 5-3-2011. FILED 11-9-2010.
 3,996,763 (*See Class 19 for this trademark*).
 3,996,771. **TUSCANO COOKING STONE AND DESIGN**. EUROPEAN MARBLE CO., INC., (U.S. CLS. 2, 13, 23, 29, 30, 33, 40 AND 50). SN 85-174,094. PUB. 5-3-2011. FILED 11-10-2010.
 3,996,781 (*See Class 16 for this trademark*).
 3,996,853 (*See Class 20 for this trademark*).
 3,997,134 (*See Class 11 for this trademark*).
 3,997,144 (*See Class 4 for this trademark*).
 3,997,323. **LUNCHIN' LADIES (STANDARD CHARACTER)**. HANNON GROUP LTD., (U.S. CLS. 2, 13, 23, 29, 30, 33, 40 AND 50). SN 85-195,067. PUB. 5-3-2011. FILED 12-10-2010.
 3,997,445. **MISCELLANEOUS DESIGN**. AQUATICA GALLERY LLC, (U.S. CLS. 2, 13, 23, 29, 30, 33, 40 AND 50). SN 85-201,304. PUB. 5-3-2011. FILED 12-18-2010.
 3,997,455. **THE GOOD LIFE GROWS IN POCKETS (STANDARD CHARACTER)**. WOOLLY POCKET CORPORATION, INC., (U.S. CLS. 2, 13, 23, 29, 30, 33, 40 AND 50). SN 85-201,938. PUB. 5-3-2011. FILED 12-20-2010.
 3,997,456. **WOOLLY POCKET (STANDARD CHARACTER)**. WOOLLY POCKET CORPORATION, INC., (U.S. CLS. 2, 13, 23, 29, 30, 33, 40 AND 50). SN 85-201,969. PUB. 5-3-2011. FILED 12-20-2010.
 3,997,706 (*See Class 3 for this trademark*).
 3,997,848. **CUPANION (STANDARD CHARACTER)**. GREEN MENU INC, (U.S. CLS. 2, 13, 23, 29, 30, 33, 40 AND 50). SN 85-208,600. PUB. 5-3-2011. FILED 12-31-2010.
 3,997,909. **HELIUM (STANDARD CHARACTER)**. FUELBELT, INC., (U.S. CLS. 2, 13, 23, 29, 30, 33, 40 AND 50). SN 85-209,192. PUB. 5-3-2011. FILED 1-3-2011.
 3,997,910. **SPRINT (STANDARD CHARACTER)**. FUELBELT, INC., (U.S. CLS. 2, 13, 23, 29, 30, 33, 40 AND 50). SN 85-209,200. PUB. 5-3-2011. FILED 1-3-2011.
 3,997,911. **STAY HYDRATED (STANDARD CHARACTER)**. FUELBELT, INC., (U.S. CLS. 2, 13, 23, 29, 30, 33, 40 AND 50). SN 85-209,204. PUB. 5-3-2011. FILED 1-3-2011.

CLASS 22—CORDAGE AND FIBERS

3,995,816 (*See Class 1 for this trademark*).
 3,995,890 (*See Class 1 for this trademark*).
 3,995,906. **THERMOLACTYL EVOLUTION AND DESIGN**. DAMART-SERVIPOSTE, MULTIPLE CLASS, (INT. CLS. 22, 24 AND 25), (U.S. CLS. 1, 2, 7, 19, 22, 39, 42 AND 50). SN 79-086,454. PUB. 5-3-2011. FILED 5-6-2010.
 3,996,206 (*See Class 7 for this trademark*).
 3,996,322 (*See Class 6 for this trademark*).
 3,996,328. **MOMOI (STANDARD CHARACTER)**. MOMOI SEIMO KABUSHIKI KAISHA, DBA MOMOI FISHING NET MFG. CO., LTD., MULTIPLE CLASS, (INT. CLS. 22 AND 28), (U.S. CLS. 1, 2, 7, 19, 22, 23, 38, 42 AND 50). SN 85-067,312. PUB. 5-3-2011. FILED 6-21-2010.
 3,997,189. **IRONWORKS (STANDARD CHARACTER)**. KOLE, TED, MULTIPLE CLASS, (INT. CLS. 22 AND 25), (U.S. CLS. 1, 2, 7, 19, 22, 39, 42 AND 50). SN 85-190,532. PUB. 5-3-2011. FILED 12-3-2010.
 3,997,251 (*See Class 17 for this trademark*).
 3,997,384. **RECORE (STANDARD CHARACTER)**. LANUZA,

CRAIG S., (U.S. CLS. 1, 2, 7, 19, 22, 42 AND 50). SN 85-198,821. PUB. 5-3-2011. FILED 12-15-2010.
 3,997,993. **SHADE SHACK AND DESIGN**. DEMCO INCORPORATED, (U.S. CLS. 1, 2, 7, 19, 22, 42 AND 50). SN 85-210,377. PUB. 5-3-2011. FILED 1-4-2011.

CLASS 23—YARNS AND THREADS

3,995,693. **COOL-WICK (STANDARD CHARACTER)**. SAPO-NA MANUFACTURING COMPANY, INC., (U.S. CL. 43). SN 77-946,964. PUB. 5-3-2011. FILED 3-1-2010.
 3,995,890 (*See Class 1 for this trademark*).
 3,995,936. **HAKRO ACTIVEWEAR AND DESIGN**. HAKRO GMBH, MULTIPLE CLASS, (INT. CLS. 23 AND 25), (U.S. CLS. 22, 39 AND 43). SN 79-088,066. PUB. 5-3-2011. FILED 9-13-2010.

CLASS 24—FABRICS

3,995,469 (*See Class 20 for this trademark*).
 3,995,715 (*See Class 9 for this trademark*).
 3,995,816 (*See Class 1 for this trademark*).
 3,995,906 (*See Class 22 for this trademark*).
 3,996,020 (*See Class 20 for this trademark*).
 3,996,092 (*See Class 9 for this trademark*).
 3,996,208 (*See Class 1 for this trademark*).
 3,996,251 (*See Class 20 for this trademark*).
 3,996,507. **MADE WITH AND DESIGN**. WYATT, REBECCA ANN, DBA AUNT BUCKY, (U.S. CLS. 42 AND 50). SN 85-123,118. PUB. 5-3-2011. FILED 9-3-2010.
 3,996,912. **WEATHERVANE HILL AND DESIGN**. THOMAS ROTH, LLC, (U.S. CLS. 42 AND 50). SN 85-182,745. PUB. 5-3-2011. FILED 11-22-2010.
 3,996,975. **MURELLA (STANDARD CHARACTER)**. ZAMBAITI PARATI S.P.A., MULTIPLE CLASS, (INT. CLS. 24 AND 27), (U.S. CLS. 19, 20, 37, 42 AND 50). SN 85-185,904. PUB. 5-3-2011. FILED 11-29-2010.
 3,997,095 (*See Class 20 for this trademark*).
 3,997,134 (*See Class 11 for this trademark*).
 3,997,351. **XEFLEX (STANDARD CHARACTER)**. CONOLLY, BRIAN, MULTIPLE CLASS, (INT. CLS. 24 AND 25), (U.S. CLS. 22, 39, 42 AND 50). SN 85-196,754. PUB. 5-3-2011. FILED 12-13-2010.
 3,997,645. **BODY FLOSSER (STANDARD CHARACTER)**. AIKATERINA LLC, (U.S. CLS. 42 AND 50). SN 85-205,871. PUB. 5-3-2011. FILED 12-27-2010.
 3,998,164. **MISCELLANEOUS DESIGN**. AMY SECKINGER, (U.S. CLS. 42 AND 50). SN 85-213,635. PUB. 5-3-2011. FILED 1-9-2011.
 3,998,173. **MISCELLANEOUS DESIGN**. SAINT LOUIS UNIVERSITY, (U.S. CLS. 42 AND 50). SN 85-214,258. PUB. 5-3-2011. FILED 1-10-2011.
 3,998,263. **HOMESENSE AND DESIGN**. WADHWANI, CHANDRU, (U.S. CLS. 42 AND 50). SN 85-239,775. PUB. 5-3-2011. FILED 2-11-2011.

CLASS 25—CLOTHING

3,995,517. **SA AND DESIGN**. VISUAL IMPACT PRODUCTS, LLC, (U.S. CLS. 22 AND 39). SN 77-225,670. PUB. 10-28-2008. FILED 7-10-2007.
 3,995,520. **CURVE AND DESIGN**. CURVE INC., DBA CURVE CYCLING COMPONENTS, (U.S. CLS. 22 AND 39). SN 77-302,410. PUB. 5-3-2011. FILED 10-12-2007.
 3,995,539. **PANAMA CITY BIKE WEEK (STANDARD CHARACTER)**. BIGGS, JOSEPH W., (U.S. CLS. 22 AND 39). SN 77-572,901. PUB. 8-18-2009. FILED 9-18-2008.
 3,995,549. **TIE RACK LONDON AND DESIGN**. TIE RACK TRADING LIMITED, (U.S. CLS. 22 AND 39). SN 77-597,222. PUB. 5-3-2011. FILED 10-21-2008.
 3,995,551 (*See Class 14 for this trademark*).

- 3,995,561. **T I A N A B. (STYLIZED)**. JUMP APPAREL CO., INC., (U.S. CLS. 22 AND 39). SN 77-652,015. PUB. 5-3-2011. FILED 1-19-2009.
- 3,995,568. **DANIEL BUCHLER (STANDARD CHARACTER)**. DJ SALES LLC, (U.S. CLS. 22 AND 39). SN 77-683,553. PUB. 5-3-2011. FILED 3-4-2009.
- 3,995,582. **STOP HATE .COM AND DESIGN**. SUMRALL, DAVID, (U.S. CLS. 22 AND 39). SN 77-746,493. PUB. 5-3-2011. FILED 5-28-2009.
- 3,995,601. **IRON FIST ROYAL HOUSE OF THE IMMORTALS AND DESIGN**. IRON FIST INTERNATIONAL, INC., (U.S. CLS. 22 AND 39). SN 77-807,020. PUB. 5-3-2011. FILED 8-18-2009.
- 3,995,605. **SHYST3R (STANDARD CHARACTER)**. GREG OTHOLT, (U.S. CLS. 22 AND 39). SN 77-820,990. PUB. 5-3-2011. FILED 9-5-2009.
- 3,995,608. **FUZZ CLUB AND DESIGN**. OX PRODUCTION V/ PETERSEN, (U.S. CLS. 22 AND 39). SN 77-834,961. PUB. 5-3-2011. FILED 9-25-2009.
- 3,995,610. **WOOL WARRIORS (STANDARD CHARACTER)**. PROFESSIONAL BULL RIDERS, INC., (U.S. CLS. 22 AND 39). SN 77-837,943. PUB. 5-3-2011. FILED 9-30-2009.
- 3,995,614. **ECO SHOW RESPECT AND DESIGN**. ECO PROMOTIONAL PRODUCTS, INC., MULTIPLE CLASS, (INT. CLS. 25 AND 35), (U.S. CLS. 22, 39, 100, 101 AND 102). SN 77-843,214. PUB. 5-3-2011. FILED 10-7-2009.
- 3,995,638. **VICTOVIVI AND DESIGN**. JANG, JAE YEUN, (U.S. CLS. 22 AND 39). SN 77-866,626. PUB. 5-3-2011. FILED 11-6-2009.
- 3,995,697. **S SPORTSCRAFT ESTABLISHED 1952 AND DESIGN**. APPAREL GROUP PTY LTD, (U.S. CLS. 22 AND 39). SN 77-949,039. PUB. 5-3-2011. FILED 3-3-2010.
- 3,995,701 (*See Class 16 for this trademark*).
- 3,995,711. **TW TEAMWORX BY OZARK OVERALL CO AND DESIGN**. OZARK OVERALL CO, INC., (U.S. CLS. 22 AND 39). SN 77-964,171. PUB. 1-25-2011. FILED 3-20-2010.
- 3,995,719 (*See Class 3 for this trademark*).
- 3,995,724. **FIREBREATHERS (STANDARD CHARACTER)**. M47I INC., (U.S. CLS. 22 AND 39). SN 78-926,532. PUB. 5-3-2011. FILED 7-11-2006.
- 3,995,738 (*See Class 9 for this trademark*).
- 3,995,745 (*See Class 9 for this trademark*).
- 3,995,758. **MIRACLE AND DESIGN**. OBCHTCHESTVO S OGRANITCHENNOY OTVETSTVENNOSTYOU "GRICHKO", (U.S. CLS. 22 AND 39). SN 79-077,467. PUB. 5-3-2011. FILED 10-21-2009.
- 3,995,759 (*See Class 3 for this trademark*).
- 3,995,767. **FIBA WE ARE BASKETBALL AND DESIGN**. FIBA; FÉDÉRATION INTERNATIONALE DE BASKETBALL, MULTIPLE CLASS, (INT. CLS. 25, 28, 35, 38 AND 41), (U.S. CLS. 22, 23, 38, 39, 50, 100, 101, 102, 104 AND 107). SN 79-078,578. PUB. 5-3-2011. FILED 9-24-2009.
- 3,995,771. **VALKRY (STANDARD CHARACTER)**. SHANE TAYLOR, MULTIPLE CLASS, (INT. CLS. 25, 28 AND 35), (U.S. CLS. 22, 23, 38, 39, 50, 100, 101 AND 102). SN 79-079,015. PUB. 5-3-2011. FILED 1-4-2010.
- 3,995,786. **STEFANO CONTI (STANDARD CHARACTER)**. JEFFREY HAMMOND, (U.S. CLS. 22 AND 39). SN 79-081,883. PUB. 5-3-2011. FILED 3-26-2010.
- 3,995,816 (*See Class 1 for this trademark*).
- 3,995,836. **DUB & DRINO (STYLIZED)**. DESMAZIERES DRINO BONNETERIE FABRICATION, (U.S. CLS. 22 AND 39). SN 79-084,385. PUB. 5-3-2011. FILED 5-20-2010.
- 3,995,847 (*See Class 12 for this trademark*).
- 3,995,850 (*See Class 18 for this trademark*).
- 3,995,853. **CINI (STANDARD CHARACTER)**. COMPAGNIA MERCANTILE S.R.L., (U.S. CLS. 22 AND 39). SN 79-084,998. PUB. 5-3-2011. FILED 6-24-2010.
- 3,995,891. **SUPERTRASH (STANDARD CHARACTER)**. 2STEP-ZAHEAD B.V., (U.S. CLS. 22 AND 39). SN 79-085,961. PUB. 5-3-2011. FILED 7-15-2010.
- 3,995,896 (*See Class 9 for this trademark*).
- 3,995,906 (*See Class 22 for this trademark*).
- 3,995,909 (*See Class 14 for this trademark*).
- 3,995,915 (*See Class 3 for this trademark*).
- 3,995,924. **NATURAL SKIN (STANDARD CHARACTER)**. FAST RETAILING CO., LTD., (U.S. CLS. 22 AND 39). SN 79-087,715. PUB. 5-3-2011. FILED 9-7-2010.
- 3,995,932 (*See Class 9 for this trademark*).
- 3,995,936 (*See Class 23 for this trademark*).
- 3,995,945. **RIPBOARD AND DESIGN**. RIPBOARD LIMITED, (U.S. CLS. 22 AND 39). SN 79-088,477. PUB. 5-3-2011. FILED 5-7-2010.
- 3,995,968. **UNITED VII SPIRIT AND DESIGN**. DACOROGNA, DUBUIS, EMMA & FRAGNIÈRE, MULTIPLE CLASS, (INT. CLS. 25 AND 35), (U.S. CLS. 22, 39, 100, 101 AND 102). SN 79-090,046. PUB. 5-3-2011. FILED 10-14-2010.
- 3,995,970. **MISCELLANEOUS DESIGN**. ANDREAS FISCHER, MULTIPLE CLASS, (INT. CLS. 25, 28 AND 41), (U.S. CLS. 22, 23, 38, 39, 50, 100, 101 AND 107). SN 79-090,103. PUB. 5-3-2011. FILED 8-25-2010.
- 3,995,972 (*See Class 18 for this trademark*).
- 3,995,973 (*See Class 18 for this trademark*).
- 3,995,982 (*See Class 18 for this trademark*).
- 3,995,983. **T*L*S VINTAGE FASHION SHOES AND DESIGN**. TRAN THI LAN, (U.S. CLS. 22 AND 39). SN 79-090,828. PUB. 5-3-2011. FILED 10-27-2010.
- 3,996,004. **GOGH (STANDARD CHARACTER)**. FITFLOP LIMITED, (U.S. CLS. 22 AND 39). SN 79-092,535. PUB. 5-3-2011. FILED 12-23-2010.
- 3,996,028. **FRESHYPE (STANDARD CHARACTER)**. SYSTEM SERVICE S.R.L., (U.S. CLS. 22 AND 39). SN 79-094,280. PUB. 5-3-2011. FILED 12-30-2010.
- 3,996,033. **SOMNOIR (STYLIZED)**. HILLIARD, SAMUEL, (U.S. CLS. 22 AND 39). SN 85-000,310. PUB. 5-3-2011. FILED 3-28-2010.
- 3,996,039. **YARD VARK (STANDARD CHARACTER)**. BERNATZ, THOMAS H., MULTIPLE CLASS, (INT. CLS. 25 AND 28), (U.S. CLS. 22, 23, 38, 39 AND 50). SN 85-005,245. PUB. 5-3-2011. FILED 4-2-2010.
- 3,996,066. **J.D.C. JEANSERIA DEL CORSO (STANDARD CHARACTER)**. ALCORINVEST S.R.L., (U.S. CLS. 22 AND 39). SN 85-018,998. PUB. 2-1-2011. FILED 4-21-2010.
- 3,996,134. **BALTIMORE AND DESIGN**. BALTIMORE ORIOLES LIMITED PARTNERSHIP, (U.S. CLS. 22 AND 39). SN 85-037,247. PUB. 5-3-2011. FILED 5-13-2010.
- 3,996,143. **THE ARMED FORCES MILITARY MUSEUM (STANDARD CHARACTER)**. THE ARMED FORCES MILITARY MUSEUM, INC., (U.S. CLS. 22 AND 39). SN 85-038,349. PUB. 5-3-2011. FILED 5-13-2010.
- 3,996,145. **MISCELLANEOUS DESIGN**. WRANGLER APPAREL CORP., (U.S. CLS. 22 AND 39). SN 85-038,453. PUB. 5-3-2011. FILED 5-14-2010.
- 3,996,146. **MISCELLANEOUS DESIGN**. WRANGLER APPAREL CORP., (U.S. CLS. 22 AND 39). SN 85-038,454. PUB. 5-3-2011. FILED 5-14-2010.
- 3,996,151. **4 PINE DESIGNSNOW.COM AND DESIGN**. LATERRA, STEPHEN, (U.S. CLS. 22 AND 39). SN 85-039,417. PUB. 5-3-2011. FILED 5-14-2010.
- 3,996,170. **VELOSTRETCH (STANDARD CHARACTER)**. ASICS CORPORATION, (U.S. CLS. 22 AND 39). SN 85-042,224. PUB. 5-3-2011. FILED 5-19-2010.
- 3,996,171. **MYLES II (STANDARD CHARACTER)**. ASICS CORPORATION, (U.S. CLS. 22 AND 39). SN 85-042,241. PUB. 5-3-2011. FILED 5-19-2010.
- 3,996,180. **INTERNATIONAL BEACH POLO ASSOCIATION AND DESIGN**. ALEXANDER G. WEBBE, MULTIPLE CLASS, (INT. CLS. 25 AND 41), (U.S. CLS. 22, 39, 100, 101 AND 107). SN 85-042,961. PUB. 5-3-2011. FILED 5-19-2010.
- 3,996,212. **SEARCH & RESCUE (STANDARD CHARACTER)**. ARMYNAVYDEALS.COM CORP., (U.S. CLS. 22 AND 39). SN 85-046,276. PUB. 5-3-2011. FILED 5-24-2010.
- 3,996,234 (*See Class 9 for this trademark*).
- 3,996,235 (*See Class 9 for this trademark*).
- 3,996,236. **TKEES (STANDARD CHARACTER)**. TKEES, INC., (U.S. CLS. 22 AND 39). SN 85-048,613. PUB. 5-3-2011. FILED 5-26-2010.
- 3,996,250. **SOCIETY BRAND CLOTHING CO. HUMANITY CULTURE CIVILIZATION AND DESIGN**. SCOFIELD, JOHN P, DBA SOCIETY BRAND CLOTHING COMPANY, AND SCOFIELD, LAVINA J, DBA SOCIETY BRAND CLOTHING COMPANY, (U.S. CLS. 22 AND 39). SN 85-050,911. PUB. 5-3-2011. FILED 5-29-2010.
- 3,996,280 (*See Class 9 for this trademark*).
- 3,996,292. **ECOTEX AND DESIGN**. ECO TEXTILES GROUP, INC., (U.S. CLS. 22 AND 39). SN 85-058,834. PUB. 5-3-2011.

- FILED 6-9-2010.
- 3,996,311. **CHICAGO (STYLIZED)**. CHICAGO CUBS BASEBALL CLUB, LLC, (U.S. CLS. 22 AND 39). SN 85-063,854. PUB. 5-3-2011. FILED 6-15-2010.
- 3,996,338 (*See Class 9 for this trademark*).
- 3,996,361. **404 (STANDARD CHARACTER)**. JENSEN, GREG N., DBA 404, (U.S. CLS. 22 AND 39). SN 85-074,385. PUB. 5-3-2011. FILED 6-29-2010.
- 3,996,393. **CARIBOU RANCH AND DESIGN**. GUERCIO, JAMES W., (U.S. CLS. 22 AND 39). SN 85-082,921. PUB. 5-3-2011. FILED 7-12-2010.
- 3,996,408. **7 WALKERS (STANDARD CHARACTER)**. BILL KREUTZMANN, MULTIPLE CLASS, (INT. CLS. 25 AND 41), (U.S. CLS. 22, 39, 100, 101 AND 107). SN 85-088,935. PUB. 5-3-2011. FILED 7-20-2010.
- 3,996,425. **FLYING PASTIES (STANDARD CHARACTER)**. FLYING PASTIES INTERNATIONAL LLC, (U.S. CLS. 22 AND 39). SN 85-092,263. PUB. 5-3-2011. FILED 7-24-2010.
- 3,996,443. **MISSCHIEF AND DESIGN**. LANG, LISA, (U.S. CLS. 22 AND 39). SN 85-097,469. PUB. 5-3-2011. FILED 7-31-2010.
- 3,996,445. **V.K. NAGRANI (STANDARD CHARACTER)**. THE OVADAFUT HOSIERY COMPANY, MULTIPLE CLASS, (INT. CLS. 25 AND 35), (U.S. CLS. 22, 39, 100, 101 AND 102). SN 85-098,042. PUB. 5-3-2011. FILED 8-2-2010.
- 3,996,452. **BALTIMORE (STYLIZED)**. BALTIMORE ORIOLES LIMITED PARTNERSHIP, (U.S. CLS. 22 AND 39). SN 85-102,266. PUB. 5-3-2011. FILED 8-6-2010.
- 3,996,467. **WT AND DESIGN**. WILD THINGS, LLC, (U.S. CLS. 22 AND 39). SN 85-107,331. PUB. 5-3-2011. FILED 8-13-2010.
- 3,996,475. **EAGLERIDER MOTORCYCLES USA AND DESIGN**. J.C. BROMAC CORPORATION, MULTIPLE CLASS, (INT. CLS. 25, 35 AND 39), (U.S. CLS. 22, 39, 100, 101, 102 AND 105). SN 85-110,291. PUB. 5-3-2011. FILED 8-18-2010.
- 3,996,478. **TEST CLOTHING (STANDARD CHARACTER)**. VISTAN DESIGN LLC, DBA TEST CLOTHING, (U.S. CLS. 22 AND 39). SN 85-111,178. PUB. 5-3-2011. FILED 8-19-2010.
- 3,996,502. **FOOTBALLIDAY (STANDARD CHARACTER)**. MILLERCOORS LLC, (U.S. CLS. 22 AND 39). SN 85-121,218. PUB. 5-3-2011. FILED 9-1-2010.
- 3,996,523. **ALL JAZZED UP BY RCS AND DESIGN**. SOURCE ADVANTAGE, LLC, DBA RED CARPET STUDIOS, LTD, (U.S. CLS. 22 AND 39). SN 85-126,212. PUB. 5-3-2011. FILED 9-9-2010.
- 3,996,536. **DAL COSTA AND DESIGN**. CONFECÇÕES DAL COSTA LTDA, (U.S. CLS. 22 AND 39). SN 85-129,200. PUB. 5-3-2011. FILED 9-14-2010.
- 3,996,548. **MISCELLANEOUS DESIGN**. GUANGZHOU NANDADI TEXTILE GARMENT CO., LTD, (U.S. CLS. 22 AND 39). SN 85-131,788. PUB. 5-3-2011. FILED 9-17-2010.
- 3,996,553. **LIFE DOESN'T SUCK AND DESIGN**. DOESN'T SUCK PRODUCTIONS, LLC, MULTIPLE CLASS, (INT. CLS. 25 AND 45), (U.S. CLS. 22, 39, 100 AND 101). SN 85-132,808. PUB. 5-3-2011. FILED 9-18-2010.
- 3,996,570. **THORWICK AND DESIGN**. JAMES L. THRONEBURG, (U.S. CLS. 22 AND 39). SN 85-136,576. PUB. 1-25-2011. FILED 9-23-2010.
- 3,996,572. **GROOVE PHI GROOVE 1962 AND DESIGN**. GROOVE PHI GROOVE SOCIAL FELLOWSHIP, INC., (U.S. CLS. 22 AND 39). SN 85-136,714. PUB. 5-3-2011. FILED 9-23-2010.
- 3,996,598. **CHETTA B EVENING (STANDARD CHARACTER)**. CHA INTERNATIONAL, LLC, (U.S. CLS. 22 AND 39). SN 85-144,746. PUB. 5-3-2011. FILED 10-4-2010.
- 3,996,656 (*See Class 16 for this trademark*).
- 3,996,683. **REGENT & COMPANY (STANDARD CHARACTER)**. CROWLEY DESIGN GROUP INC., (U.S. CLS. 22 AND 39). SN 85-162,914. PUB. 5-3-2011. FILED 10-27-2010.
- 3,996,758 (*See Class 18 for this trademark*).
- 3,996,759 (*See Class 18 for this trademark*).
- 3,996,784. **KARENKLEIN (STANDARD CHARACTER)**. KAREN KLEIN FASHION, INC, (U.S. CLS. 22 AND 39). SN 85-174,972. PUB. 5-3-2011. FILED 11-11-2010.
- 3,996,798. **EARBEATAZ AND DESIGN**. SENDLER JOSEPH, DBA THE EARBEATAZ, AND YARLEY GEFFRARD, DBA THE EARBEATAZ, (U.S. CLS. 22 AND 39). SN 85-175,976. PUB. 5-3-2011. FILED 11-12-2010.
- 3,996,802. **EGOIII AND DESIGN**. EGOIII, (U.S. CLS. 22 AND 39). SN 85-176,092. PUB. 5-3-2011. FILED 11-13-2010.
- 3,996,825. **GREGORY SYLVIA (STANDARD CHARACTER)**. GREGORY SYLVIA LLC, (U.S. CLS. 22 AND 39). SN 85-177,485. PUB. 5-3-2011. FILED 11-16-2010.
- 3,996,863. **MALIBU NATIVE (STANDARD CHARACTER)**. SEVEN CEDARS LLC, (U.S. CLS. 22 AND 39). SN 85-179,517. PUB. 5-3-2011. FILED 11-17-2010.
- 3,996,867. **RYEP RECYCLED CASHMERE (STANDARD CHARACTER)**. EVANS, REBECCA, (U.S. CLS. 22 AND 39). SN 85-179,792. PUB. 5-3-2011. FILED 11-18-2010.
- 3,996,909. **TURBIE BAND (STANDARD CHARACTER)**. TURBIE TWIST, LLC, (U.S. CLS. 22 AND 39). SN 85-182,586. PUB. 5-3-2011. FILED 11-22-2010.
- 3,996,963. **RULON BROWN (STANDARD CHARACTER)**. BROWN, NATHAN OWEN, (U.S. CLS. 22 AND 39). SN 85-185,165. PUB. 5-3-2011. FILED 11-24-2010.
- 3,996,977. **BITE DOWN BITE DOWN AND DESIGN**. BITE DOWN, (U.S. CLS. 22 AND 39). SN 85-185,993. PUB. 5-3-2011. FILED 11-29-2010.
- 3,997,001. **FISH . SURF . DIVE MONSTER HOLE SEBASTIAN INLET, FLORIDA AND DESIGN**. TALMADGE, JOHN ROBERT, (U.S. CLS. 22 AND 39). SN 85-186,645. PUB. 5-3-2011. FILED 11-29-2010.
- 3,997,020. **MISCELLANEOUS DESIGN**. LEVI STRAUSS & CO., (U.S. CLS. 22 AND 39). SN 85-187,053. PUB. 5-3-2011. FILED 11-30-2010.
- 3,997,032. **INSECT BLOCKER AND DESIGN**. COLUMBIA SPORTSWEAR NORTH AMERICA, INC., (U.S. CLS. 22 AND 39). SN 85-187,283. PUB. 5-3-2011. FILED 11-30-2010.
- 3,997,039 (*See Class 18 for this trademark*).
- 3,997,041 (*See Class 18 for this trademark*).
- 3,997,050. **LOVE J U.S.A. (STYLIZED)**. COMMA DESIGN CORPORATION, (U.S. CLS. 22 AND 39). SN 85-187,679. PUB. 5-3-2011. FILED 11-30-2010.
- 3,997,065 (*See Class 16 for this trademark*).
- 3,997,095 (*See Class 20 for this trademark*).
- 3,997,119. **URBANE SPORT (STANDARD CHARACTER)**. LANDAU UNIFORMS, INCORPORATED, (U.S. CLS. 22 AND 39). SN 85-189,191. PUB. 5-3-2011. FILED 12-2-2010.
- 3,997,121. **COOKING UP ENGLISH AND DESIGN**. COOKING UP ENGLISH, MULTIPLE CLASS, (INT. CLS. 25 AND 41), (U.S. CLS. 22, 39, 100, 101 AND 107). SN 85-189,195. PUB. 5-3-2011. FILED 12-2-2010.
- 3,997,182. **I STREET FOOD AND DESIGN**. LA COCINA, INC., MULTIPLE CLASS, (INT. CLS. 25 AND 41), (U.S. CLS. 22, 39, 100, 101 AND 107). SN 85-190,307. PUB. 5-3-2011. FILED 12-3-2010.
- 3,997,185. **SUREFIND PIPELINE MARKERS AND DESIGN**. SUREFIND PIPELINE MARKERS, LLC, (U.S. CLS. 22 AND 39). SN 85-190,466. PUB. 5-3-2011. FILED 12-3-2010.
- 3,997,189 (*See Class 22 for this trademark*).
- 3,997,204. **SHONNER (STYLIZED)**. DRISCOLL, SHAWN, (U.S. CLS. 22 AND 39). SN 85-191,129. PUB. 5-3-2011. FILED 12-6-2010.
- 3,997,211. **INVIZALINE BIKINI (STANDARD CHARACTER)**. YAYA'S BIKINIS, (U.S. CLS. 22 AND 39). SN 85-191,272. PUB. 5-3-2011. FILED 12-6-2010.
- 3,997,214. **POOPSIES AND DESIGN**. ANNEMARIE WATERS, (U.S. CLS. 22 AND 39). SN 85-191,370. PUB. 5-3-2011. FILED 12-6-2010.
- 3,997,233. **SASSY SHOES LLC AND DESIGN**. SASSY SHOES, LLC, (U.S. CLS. 22 AND 39). SN 85-192,054. PUB. 5-3-2011. FILED 12-7-2010.
- 3,997,234. **MISCELLANEOUS DESIGN**. ANNEMARIE WATERS, (U.S. CLS. 22 AND 39). SN 85-192,081. PUB. 5-3-2011. FILED 12-7-2010.
- 3,997,240. **MERAMEC AND DESIGN**. THE MERAMEC GROUP, INC., (U.S. CLS. 22 AND 39). SN 85-192,437. PUB. 5-3-2011. FILED 12-7-2010.
- 3,997,271. **COCO CAVANNA WWW.COCOCAVANNA.COM AND DESIGN**. CAVANAUGH, CRYSTAL L., DBA COCO CAVANNA, (U.S. CLS. 22 AND 39). SN 85-193,173. PUB. 5-3-2011. FILED 12-8-2010.
- 3,997,296. **LOVE MY BALLS AND DESIGN**. MISSION APPAREL, LLC, (U.S. CLS. 22 AND 39). SN 85-194,088. PUB. 5-3-2011. FILED 12-9-2010.
- 3,997,309. **WTL (STANDARD CHARACTER)**. WORK TO LIVE LLC, (U.S. CLS. 22 AND 39). SN 85-194,669. PUB. 5-3-2011.

- FILED 12-9-2010.
- 3,997,340. **METAL SUCKS (STANDARD CHARACTER)**. NEILSTEIN, ROSENBERG AND ASSOCIATES, LLC, DBA METALSUCKS, MULTIPLE CLASS, (INT. CLS. 25 AND 41), (U.S. CLS. 22, 39, 100, 101 AND 107). SN 85-195,923. PUB. 5-3-2011. FILED 12-11-2010.
- 3,997,351 (*See Class 24 for this trademark*).
- 3,997,361. **MISCELLANEOUS DESIGN**. DESCENTE NORTH AMERICA, INC., (U.S. CLS. 22 AND 39). SN 85-197,444. PUB. 5-3-2011. FILED 12-14-2010.
- 3,997,363. **DNA (STYLIZED)**. DESCENTE NORTH AMERICA, INC., (U.S. CLS. 22 AND 39). SN 85-197,522. PUB. 5-3-2011. FILED 12-14-2010.
- 3,997,372. **MISCELLANEOUS DESIGN**. RETAIL ROYALTY COMPANY, (U.S. CLS. 22 AND 39). SN 85-198,055. PUB. 5-3-2011. FILED 12-15-2010.
- 3,997,380. **ARCHIBALD (STANDARD CHARACTER)**. JEANNE SIMMONS ACCESSORIES INC, (U.S. CLS. 22 AND 39). SN 85-198,520. PUB. 5-3-2011. FILED 12-15-2010.
- 3,997,383. **ESHEL AND DESIGN**. ESEL LLC, (U.S. CLS. 22 AND 39). SN 85-198,580. PUB. 5-3-2011. FILED 12-15-2010.
- 3,997,436. **SJOBECK (STANDARD CHARACTER)**. SGBECK, (U.S. CLS. 22 AND 39). SN 85-200,901. PUB. 5-3-2011. FILED 12-17-2010.
- 3,997,438 (*See Class 16 for this trademark*).
- 3,997,449. **MISCELLANEOUS DESIGN**. PHIL THE THRILL LLC, (U.S. CLS. 22 AND 39). SN 85-201,680. PUB. 5-3-2011. FILED 12-20-2010.
- 3,997,457. **GOT MEDS (STANDARD CHARACTER)**. CREATIVE VENTURES, LLC, (U.S. CLS. 22 AND 39). SN 85-201,982. PUB. 5-3-2011. FILED 12-20-2010.
- 3,997,496. **THE UNTOUCHABLES (STYLIZED)**. THE UNTOUCHABLES BRAND, (U.S. CLS. 22 AND 39). SN 85-203,409. PUB. 5-3-2011. FILED 12-21-2010.
- 3,997,514. **SHASHI AND DESIGN**. SHASHI, LLC, (U.S. CLS. 22 AND 39). SN 85-203,973. PUB. 5-3-2011. FILED 12-22-2010.
- 3,997,531. **WESTWOOD GROVE (STANDARD CHARACTER)**. SUH, DANIEL, (U.S. CLS. 22 AND 39). SN 85-204,426. PUB. 5-3-2011. FILED 12-22-2010.
- 3,997,547. **WISDOMWEAR (STANDARD CHARACTER)**. WISDOM, PRODUCTIVE DECISION MAKING, LOVE AND MAGIC LLC, MULTIPLE CLASS, (INT. CLS. 25 AND 42), (U.S. CLS. 22, 39, 100 AND 101). SN 85-204,665. PUB. 5-3-2011. FILED 12-23-2010.
- 3,997,556. **FITPRO (STANDARD CHARACTER)**. PROPHET CORPORATION, DBA GOPHER SPORT CORPORATION, (U.S. CLS. 22 AND 39). SN 85-204,736. PUB. 5-3-2011. FILED 12-23-2010.
- 3,997,575. **WHAT DO I KNOW? (STANDARD CHARACTER)**. CHULICK, JOSEPH S., DBA POJO ENTERPRISES, (U.S. CLS. 22 AND 39). SN 85-204,962. PUB. 5-3-2011. FILED 12-23-2010.
- 3,997,592 (*See Class 18 for this trademark*).
- 3,997,614 (*See Class 16 for this trademark*).
- 3,997,656. **CLOFIT (STANDARD CHARACTER)**. YANG, JIN SEOK, (U.S. CLS. 22 AND 39). SN 85-206,021. PUB. 5-3-2011. FILED 12-27-2010.
- 3,997,671. **SAY-IT WEAR (STANDARD CHARACTER)**. SAVITT, ROBIN, (U.S. CLS. 22 AND 39). SN 85-206,196. PUB. 5-3-2011. FILED 12-27-2010.
- 3,997,676. **DISTINCT LIFE R. AND DESIGN**. RICHARD JAMES WILLIAMS, (U.S. CLS. 22 AND 39). SN 85-206,270. PUB. 5-3-2011. FILED 12-27-2010.
- 3,997,682. **SOLEFUTURE (STANDARD CHARACTER)**. GREENOVO RESEARCH, INC., (U.S. CLS. 22 AND 39). SN 85-206,421. PUB. 5-3-2011. FILED 12-28-2010.
- 3,997,709. **MISCELLANEOUS DESIGN**. CHICKED, LLC, (U.S. CLS. 22 AND 39). SN 85-206,717. PUB. 5-3-2011. FILED 12-28-2010.
- 3,997,710. **TOTALCYCLIST (STANDARD CHARACTER)**. PER4MANCE TRAINING LLC, DBA TOTALCYCLIST LLC, MULTIPLE CLASS, (INT. CLS. 25 AND 41), (U.S. CLS. 22, 39, 100, 101 AND 107). SN 85-206,730. PUB. 5-3-2011. FILED 12-28-2010.
- 3,997,720. **MISCELLANEOUS DESIGN**. SNEAKER HEADZ, LLC, DBA BURN RUBBER, (U.S. CLS. 22 AND 39). SN 85-206,916. PUB. 5-3-2011. FILED 12-28-2010.
- 3,997,721. **TASTE LIFE N MAKE IT REAL (STANDARD CHARACTER)**. CAMPISI RICHARD, DBA R. M. CAMPISI, (U.S. CLS. 22 AND 39). SN 85-206,931. PUB. 5-3-2011. FILED 12-29-2010.
- 3,997,723. **HOOSIER DADDY? (STANDARD CHARACTER)**. HENRY, KENT, (U.S. CLS. 22 AND 39). SN 85-206,937. PUB. 5-3-2011. FILED 12-29-2010.
- 3,997,733. **ESOTERIC BODYWORK THE OTHER SIDE OF MASSAGE THERAPY (STANDARD CHARACTER)**. MELMOTH, CHRISTOPHER, (U.S. CLS. 22 AND 39). SN 85-207,051. PUB. 5-3-2011. FILED 12-29-2010.
- 3,997,744. **GALAXXXY ROCKS! (STANDARD CHARACTER)**. JOE INTERNATIONAL CORPORATION, (U.S. CLS. 22 AND 39). SN 85-207,295. PUB. 5-3-2011. FILED 12-29-2010.
- 3,997,780. **TIME TO LIVE (STANDARD CHARACTER)**. SEEK SIMPLE, INC., (U.S. CLS. 22 AND 39). SN 85-207,766. PUB. 5-3-2011. FILED 12-30-2010.
- 3,997,798. **LONELY SEAL APPAREL (STANDARD CHARACTER)**. ZAIDI, HAMMAD, (U.S. CLS. 22 AND 39). SN 85-208,040. PUB. 5-3-2011. FILED 12-30-2010.
- 3,997,807. **RUFFWEAR (STANDARD CHARACTER)**. RUFFWEAR, INC., (U.S. CLS. 22 AND 39). SN 85-208,156. PUB. 5-3-2011. FILED 12-30-2010.
- 3,997,814. **PIG EVIL (STANDARD CHARACTER)**. PIG EVIL, INC., (U.S. CLS. 22 AND 39). SN 85-208,238. PUB. 5-3-2011. FILED 12-30-2010.
- 3,997,820. **CON BRO CHILL (STANDARD CHARACTER)**. MARTIN, JAMES, (U.S. CLS. 22 AND 39). SN 85-208,280. PUB. 5-3-2011. FILED 12-30-2010.
- 3,997,882. **FOR GAMES FOR LIFE (STANDARD CHARACTER)**. 4 LACES, LLC, (U.S. CLS. 22 AND 39). SN 85-208,879. PUB. 5-3-2011. FILED 1-2-2011.
- 3,997,902. **NO UGLIES ALLOWED (STANDARD CHARACTER)**. BROWN MOLASSES CO., INCORPORATED, (U.S. CLS. 22 AND 39). SN 85-209,139. PUB. 5-3-2011. FILED 1-3-2011.
- 3,997,920. **THE DOMESTIC DAME WWW.THEDOMESTIC-DAME.COM AND DESIGN**. BARNETT, LAUREN E., DBA THE DOMESTIC DAME, (U.S. CLS. 22 AND 39). SN 85-209,338. PUB. 5-3-2011. FILED 1-3-2011.
- 3,997,924 (*See Class 16 for this trademark*).
- 3,997,925. **CHIEFY (STANDARD CHARACTER)**. MATHIE, JAMES, M, (U.S. CLS. 22 AND 39). SN 85-209,390. PUB. 5-3-2011. FILED 1-3-2011.
- 3,997,929. **BUSTED LIP (STANDARD CHARACTER)**. KETCHUM, MICHAEL, AND MAURER, SCOTT, (U.S. CLS. 22 AND 39). SN 85-209,448. PUB. 5-3-2011. FILED 1-3-2011.
- 3,997,947. **JACK SPADE (STANDARD CHARACTER)**. KATE SPADE, LLC, (U.S. CLS. 22 AND 39). SN 85-209,722. PUB. 5-3-2011. FILED 1-4-2011.
- 3,997,964. **EMBRACE LIFE TODAY (STANDARD CHARACTER)**. RHEAULT, PEGGY, (U.S. CLS. 22 AND 39). SN 85-209,925. PUB. 5-3-2011. FILED 1-4-2011.
- 3,998,013. **ZX SURF AND DESIGN**. STUDIO RAY, LLC, (U.S. CLS. 22 AND 39). SN 85-210,604. PUB. 5-3-2011. FILED 1-5-2011.
- 3,998,057. **BTICH (STANDARD CHARACTER)**. KNOX, RACHEL, (U.S. CLS. 22 AND 39). SN 85-211,369. PUB. 5-3-2011. FILED 1-5-2011.
- 3,998,060. **ROSEGIRL AND DESIGN**. SHEN LING GROUP INC., (U.S. CLS. 22 AND 39). SN 85-211,391. PUB. 5-3-2011. FILED 1-5-2011.
- 3,998,062. **MISCELLANEOUS DESIGN**. SHEN LING GROUP INC., (U.S. CLS. 22 AND 39). SN 85-211,402. PUB. 5-3-2011. FILED 1-5-2011.
- 3,998,064 (*See Class 9 for this trademark*).
- 3,998,068. **H (STYLIZED)**. HALF OUNCE OF LIFE LLC, AKA HALF OUNCE OF LIFE CLOTHING, (U.S. CLS. 22 AND 39). SN 85-211,430. PUB. 5-3-2011. FILED 1-5-2011.
- 3,998,091. **THERMA-HEAT (STANDARD CHARACTER)**. DEBRA J. READING, (U.S. CLS. 22 AND 39). SN 85-211,878. PUB. 5-3-2011. FILED 1-6-2011.
- 3,998,100 (*See Class 16 for this trademark*).
- 3,998,109. **G (STYLIZED)**. GREYWELL LLC, AKA GREYWELL, (U.S. CLS. 22 AND 39). SN 85-212,211. PUB. 5-3-2011. FILED 1-6-2011.
- 3,998,116. **EDDIE JOHNSON (STANDARD CHARACTER)**. EDDIE JOHNSON LLC, (U.S. CLS. 22 AND 39). SN 85-212,433. PUB. 5-3-2011. FILED 1-6-2011.

- 3,998,127. **MRS AND DESIGN. TRAILERLOGIC**, DBA MORTUARY RESPONSE SOLUTIONS, (U.S. CLS. 22 AND 39). SN 85-212,550. PUB. 5-3-2011. FILED 1-7-2011.
- 3,998,135. **FUZZY BABBA (STANDARD CHARACTER)**. HIGH POINT DESIGN LLC, (U.S. CLS. 22 AND 39). SN 85-212,866. PUB. 5-3-2011. FILED 1-7-2011.
- 3,998,139. **BLACK CREEK (STANDARD CHARACTER)**. F&M HAT COMPANY, INC., (U.S. CLS. 22 AND 39). SN 85-212,975. PUB. 5-3-2011. FILED 1-7-2011.
- 3,998,140. **BLACK CREEK AND DESIGN**. F&M HAT COMPANY, INC., (U.S. CLS. 22 AND 39). SN 85-212,979. PUB. 5-3-2011. FILED 1-7-2011.
- 3,998,161. **PRO DAY (STANDARD CHARACTER)**. WILLIAMS, EMORY L., (U.S. CLS. 22 AND 39). SN 85-213,511. PUB. 5-3-2011. FILED 1-8-2011.
- 3,998,251 (*See Class 9 for this trademark*).
- 3,998,256. **C.E. SCHMIDT (STANDARD CHARACTER)**. TRACTOR SUPPLY CO. OF TEXAS, LP, (U.S. CLS. 22 AND 39). SN 85-238,590. PUB. 5-3-2011. FILED 2-10-2011.
- 3,998,264 (*See Class 16 for this trademark*).
- 3,998,268. **SAINT LOUIS UNIVERSITY AD . MAJOREM . DEI . GLORIAM IHS 1818 AND DESIGN**. SAINT LOUIS UNIVERSITY, (U.S. CLS. 22 AND 39). SN 85-243,743. PUB. 5-3-2011. FILED 2-16-2011.
- 3,998,288. **40 SPEED SHOE (STANDARD CHARACTER)**. WILLIAMS, EMORY L., (U.S. CLS. 22 AND 39). SN 85-251,079. PUB. 5-3-2011. FILED 2-24-2011.

CLASS 26—FANCY GOODS

- 3,995,994. **AOHUA AND DESIGN. ZHEJIANG AOHUA GARMENT & ORNAMENT INDUSTRIAL CO., LTD.**, (U.S. CLS. 37, 39, 40, 42 AND 50). SN 79-091,549. PUB. 5-3-2011. FILED 8-17-2010.
- 3,996,234 (*See Class 9 for this trademark*).
- 3,996,235 (*See Class 9 for this trademark*).
- 3,996,763 (*See Class 19 for this trademark*).
- 3,997,975. **ZENOBIA (STANDARD CHARACTER)**. MILAN INDUSTRIES, INC., (U.S. CLS. 37, 39, 40, 42 AND 50). SN 85-210,117. PUB. 5-3-2011. FILED 1-4-2011.

CLASS 27—FLOOR COVERINGS

- 3,995,469 (*See Class 20 for this trademark*).
- 3,995,501. **ADVANTAGEMAT (STANDARD CHARACTER)**. FLOORTEX EUROPE LIMITED, (U.S. CLS. 19, 20, 37, 42 AND 50). SN 76-705,889. PUB. 5-3-2011. FILED 1-4-2011.
- 3,995,502. **VALUEMAT (STANDARD CHARACTER)**. FLOORTEX EUROPE LIMITED, (U.S. CLS. 19, 20, 37, 42 AND 50). SN 76-705,891. PUB. 5-3-2011. FILED 1-4-2011.
- 3,995,503. **ULTIMAT (STANDARD CHARACTER)**. FLOORTEX EUROPE LIMITED, (U.S. CLS. 19, 20, 37, 42 AND 50). SN 76-705,892. PUB. 5-3-2011. FILED 1-4-2011.
- 3,995,505. **CLEARTEX (STANDARD CHARACTER)**. FLOORTEX EUROPE LIMITED, (U.S. CLS. 19, 20, 37, 42 AND 50). SN 76-705,896. PUB. 5-3-2011. FILED 1-4-2011.
- 3,995,506. **COMPUTEX (STANDARD CHARACTER)**. FLOORTEX EUROPE LIMITED, (U.S. CLS. 19, 20, 37, 42 AND 50). SN 76-705,897. PUB. 5-3-2011. FILED 1-4-2011.
- 3,995,507. **DOORTEX (STANDARD CHARACTER)**. FLOORTEX EUROPE LIMITED, (U.S. CLS. 19, 20, 37, 42 AND 50). SN 76-705,898. PUB. 5-3-2011. FILED 1-4-2011.
- 3,995,784 (*See Class 1 for this trademark*).
- 3,995,816 (*See Class 1 for this trademark*).
- 3,995,981 (*See Class 19 for this trademark*).
- 3,995,984. **DESSO AND DESIGN. DESSO B.V.**, (U.S. CLS. 19, 20, 37, 42 AND 50). SN 79-091,071. PUB. 5-3-2011. FILED 10-27-2010.
- 3,996,975 (*See Class 24 for this trademark*).
- 3,997,134 (*See Class 11 for this trademark*).
- 3,997,326 (*See Class 12 for this trademark*).
- 3,997,655. **THE ALPHABET CITY (STANDARD CHARACTER)**. JOANNE DUGAN PHOTOGRAPHY LLC, DBA

- THE ALPHABET CITY, (U.S. CLS. 19, 20, 37, 42 AND 50). SN 85-206,020. PUB. 5-3-2011. FILED 12-27-2010.
- 3,997,854. **LIVE LOVE LAUGH (STANDARD CHARACTER)**. D-GENERATION, INC, (U.S. CLS. 19, 20, 37, 42 AND 50). SN 85-208,643. PUB. 5-3-2011. FILED 12-31-2010.

CLASS 28—TOYS AND SPORTING GOODS

- 3,995,467. **FUSHIGI (STANDARD CHARACTER)**. ZOOM TV PRODUCTS, LLC, (U.S. CLS. 22, 23, 38 AND 50). SN 76-701,571. PUB. 5-3-2011. FILED 2-12-2010.
- 3,995,485. **SOMATRAC (STANDARD CHARACTER)**. BOREN, JOHN, (U.S. CLS. 22, 23, 38 AND 50). SN 76-705,479. PUB. 5-3-2011. FILED 11-26-2010.
- 3,995,510. **LITTLE CONFUCIUS (STANDARD CHARACTER)**. KINGKA LLC, (U.S. CLS. 22, 23, 38 AND 50). SN 77-043,071. PUB. 5-3-2011. FILED 11-13-2006.
- 3,995,544. **WISPORTSRESORT (STANDARD CHARACTER)**. NINTENDO OF AMERICA INC., (U.S. CLS. 22, 23, 38 AND 50). SN 77-583,727. PUB. 10-12-2010. FILED 10-2-2008.
- 3,995,565. **TM TOKYO MARUI (STYLIZED)**. TOKYO MARUI CO., LTD., (U.S. CLS. 22, 23, 38 AND 50). SN 77-680,953. PUB. 11-16-2010. FILED 3-1-2009.
- 3,995,566. **TM TOKYO MARUI AND DESIGN**. TOKYO MARUI CO., LTD., (U.S. CLS. 22, 23, 38 AND 50). SN 77-680,955. PUB. 11-16-2010. FILED 3-1-2009.
- 3,995,661 (*See Class 15 for this trademark*).
- 3,995,676. **4 AND DESIGN. NATHANIEL GEORGE**, (U.S. CLS. 22, 23, 38 AND 50). SN 77-918,874. PUB. 5-3-2011. FILED 1-24-2010.
- 3,995,715 (*See Class 9 for this trademark*).
- 3,995,716. **MISCELLANEOUS DESIGN. CARROLL HALL SHELBY TRUST**, (U.S. CLS. 22, 23, 38 AND 50). SN 77-981,498. PUB. 5-3-2011. FILED 12-19-2007.
- 3,995,717. **MISCELLANEOUS DESIGN. CARROLL HALL SHELBY TRUST**, (U.S. CLS. 22, 23, 38 AND 50). SN 77-981,501. PUB. 5-3-2011. FILED 12-19-2007.
- 3,995,738 (*See Class 9 for this trademark*).
- 3,995,745 (*See Class 9 for this trademark*).
- 3,995,762 (*See Class 16 for this trademark*).
- 3,995,767 (*See Class 25 for this trademark*).
- 3,995,771 (*See Class 25 for this trademark*).
- 3,995,850 (*See Class 18 for this trademark*).
- 3,995,915 (*See Class 3 for this trademark*).
- 3,995,922 (*See Class 11 for this trademark*).
- 3,995,937 (*See Class 9 for this trademark*).
- 3,995,970 (*See Class 25 for this trademark*).
- 3,995,997. **BENWILSONSURF AND DESIGN. DIRECT SURF LIFESTYLES INDUSTRIES LTD.**, (U.S. CLS. 22, 23, 38 AND 50). SN 79-091,874. PUB. 5-3-2011. FILED 10-28-2010.
- 3,996,039 (*See Class 25 for this trademark*).
- 3,996,100. **SHOCK BAIT (STANDARD CHARACTER)**. JACKSON & JACKSON ELECTRONIC ALL STAR LURES, INC., (U.S. CLS. 22, 23, 38 AND 50). SN 85-030,735. PUB. 5-3-2011. FILED 5-5-2010.
- 3,996,191. **PRO BOO BUG (STANDARD CHARACTER)**. EBS-CO INDUSTRIES, INC., (U.S. CLS. 22, 23, 38 AND 50). SN 85-044,951. PUB. 5-3-2011. FILED 5-21-2010.
- 3,996,195. **THUMB CADDY AND DESIGN. GLOBAL GOLF TRAINING PRODUCTS, INC.**, (U.S. CLS. 22, 23, 38 AND 50). SN 85-045,318. PUB. 5-3-2011. FILED 5-21-2010.
- 3,996,213. **KINGSPON (STANDARD CHARACTER)**. GATOR LURES, LLC, (U.S. CLS. 22, 23, 38 AND 50). SN 85-046,290. PUB. 5-3-2011. FILED 5-24-2010.
- 3,996,225. **SANTASTIC (STANDARD CHARACTER)**. GENERAL GROWTH MANAGEMENT, INC., (U.S. CLS. 22, 23, 38 AND 50). SN 85-047,580. PUB. 5-3-2011. FILED 5-25-2010.
- 3,996,261 (*See Class 16 for this trademark*).
- 3,996,269. **REALMOUSE (STANDARD CHARACTER)**. OURPET'S COMPANY, (U.S. CLS. 22, 23, 38 AND 50). SN 85-053,014. PUB. 5-3-2011. FILED 6-2-2010.
- 3,996,280 (*See Class 9 for this trademark*).
- 3,996,281. **VAT VIBRATION AMPLIFICATION TECHNOLOGY (STANDARD CHARACTER)**. NORSEMEN OUTDOORS, INC., (U.S. CLS. 22, 23, 38 AND 50). SN 85-055,890. PUB. 5-3-2011. FILED 6-7-2010.

- 3,996,328 (*See Class 22 for this trademark.*)
 3,996,329 (*See Class 21 for this trademark.*)
 3,996,338 (*See Class 9 for this trademark.*)
 3,996,356. **TOP TONER (STANDARD CHARACTER)**. GECCO VISION, (U.S. CLS. 22, 23, 38 AND 50). SN 85-072,460. PUB. 5-3-2011. FILED 6-27-2010.
 3,996,369. **MISCELLANEOUS DESIGN**. JAVED, MIAN M N, (U.S. CLS. 22, 23, 38 AND 50). SN 85-075,571. PUB. 5-3-2011. FILED 7-1-2010.
 3,996,427. **DEAD-ON RANGE FINDER (STANDARD CHARACTER)**. NORDCO, LLC, DBA DEAD-ON ARCHERY, (U.S. CLS. 22, 23, 38 AND 50). SN 85-093,385. PUB. 5-3-2011. FILED 7-27-2010.
 3,996,434 (*See Class 12 for this trademark.*)
 3,996,437. **GRIP SOLID (STANDARD CHARACTER)**. NEWMAN, MICHAEL J, (U.S. CLS. 22, 23, 38 AND 50). SN 85-094,891. PUB. 5-3-2011. FILED 7-28-2010.
 3,996,471. **THE TOTAL SERVE (STANDARD CHARACTER)**. DODSON, LISA E., DBA THE TOTAL SERVE, (U.S. CLS. 22, 23, 38 AND 50). SN 85-108,081. PUB. 5-3-2011. FILED 8-16-2010.
 3,996,642. **PUMPONINI (STANDARD CHARACTER)**. DONNA A. RAMERE, (U.S. CLS. 22, 23, 38 AND 50). SN 85-154,453. PUB. 5-3-2011. FILED 10-17-2010.
 3,996,720. **LIFEBALANCE STATION BY RA RIGHTANGLE AND DESIGN**. DUODESK, AND K & A MANUFACTURING, DBA RIGHT ANGLE PRODUCTS, (U.S. CLS. 22, 23, 38 AND 50). SN 85-169,090. PUB. 5-3-2011. FILED 11-4-2010.
 3,996,807 (*See Class 9 for this trademark.*)
 3,996,827. **J PECHAUER (STANDARD CHARACTER)**. J PECHAUER CUSTOM CUES INC, (U.S. CLS. 22, 23, 38 AND 50). SN 85-177,745. PUB. 5-3-2011. FILED 11-16-2010.
 3,996,839. **LOYD (STANDARD CHARACTER)**. FATSEAS, TONY, (U.S. CLS. 22, 23, 38 AND 50). SN 85-178,552. PUB. 5-3-2011. FILED 11-17-2010.
 3,996,849. **MY 1ST TRAMPOLINE AND DESIGN**. SPORTSPOWER, LTD., (U.S. CLS. 22, 23, 38 AND 50). SN 85-178,891. PUB. 5-3-2011. FILED 11-17-2010.
 3,996,893. **LENNY THE LAMB (STANDARD CHARACTER)**. SCENTSY, INC., (U.S. CLS. 22, 23, 38 AND 50). SN 85-181,631. PUB. 5-3-2011. FILED 11-19-2010.
 3,996,894. **MOLLIE THE MONKEY (STANDARD CHARACTER)**. SCENTSY, INC., (U.S. CLS. 22, 23, 38 AND 50). SN 85-181,635. PUB. 5-3-2011. FILED 11-19-2010.
 3,996,895. **OLLIE THE ELEPHANT (STANDARD CHARACTER)**. SCENTSY, INC., (U.S. CLS. 22, 23, 38 AND 50). SN 85-181,641. PUB. 5-3-2011. FILED 11-19-2010.
 3,996,896. **PENNY THE PIG (STANDARD CHARACTER)**. SCENTSY, INC., (U.S. CLS. 22, 23, 38 AND 50). SN 85-181,647. PUB. 5-3-2011. FILED 11-19-2010.
 3,996,897. **RIBBERT THE FROG (STANDARD CHARACTER)**. SCENTSY, INC., (U.S. CLS. 22, 23, 38 AND 50). SN 85-181,653. PUB. 5-3-2011. FILED 11-19-2010.
 3,996,898. **ROARBERT THE LION (STANDARD CHARACTER)**. SCENTSY, INC., (U.S. CLS. 22, 23, 38 AND 50). SN 85-181,660. PUB. 5-3-2011. FILED 11-19-2010.
 3,996,899. **S. LOYD. (STANDARD CHARACTER)**. FATSEAS, TONY, (U.S. CLS. 22, 23, 38 AND 50). SN 85-181,764. PUB. 5-3-2011. FILED 11-20-2010.
 3,996,979 (*See Class 12 for this trademark.*)
 3,997,006. **INVISIBLE MINNOW RIG (STANDARD CHARACTER)**. DONALD L. WRIGHT, DBA INVISIBLE MINNOW RIG, (U.S. CLS. 22, 23, 38 AND 50). SN 85-186,770. PUB. 5-3-2011. FILED 11-29-2010.
 3,997,044. **KIT'S TACKLE "JIGGIN' THE DREAM" (STANDARD CHARACTER)**. TJ TACKLE ENTERPRISES, LLC, (U.S. CLS. 22, 23, 38 AND 50). SN 85-187,587. PUB. 5-3-2011. FILED 11-30-2010.
 3,997,045. **CODE RED (STANDARD CHARACTER)**. RIPCORD TECHNOLOGIES, INC., (U.S. CLS. 22, 23, 38 AND 50). SN 85-187,597. PUB. 5-3-2011. FILED 11-30-2010.
 3,997,075 (*See Class 18 for this trademark.*)
 3,997,095 (*See Class 20 for this trademark.*)
 3,997,217. **TICKET BLASTER AND DESIGN**. CEC ENTERTAINMENT CONCEPTS, L.P., (U.S. CLS. 22, 23, 38 AND 50). SN 85-191,428. PUB. 5-3-2011. FILED 12-6-2010.
 3,997,300. **JACK ATTACK (STANDARD CHARACTER)**. FOXPRO, INC., (U.S. CLS. 22, 23, 38 AND 50). SN 85-194,252. PUB. 5-3-2011. FILED 12-9-2010.
 3,997,444. **ATG AND DESIGN**. AIR TO GROUND CALLS INC, (U.S. CLS. 22, 23, 38 AND 50). SN 85-201,267. PUB. 5-3-2011. FILED 12-18-2010.
 3,997,451 (*See Class 16 for this trademark.*)
 3,997,559. **TUMBLEPRO (STANDARD CHARACTER)**. PROPHET CORPORATION, DBA GOPHER SPORT CORPORATION, (U.S. CLS. 22, 23, 38 AND 50). SN 85-204,794. PUB. 5-3-2011. FILED 12-23-2010.
 3,997,564. **RINKPRO (STANDARD CHARACTER)**. PROPHET CORPORATION, DBA GOPHER SPORT CORPORATION, (U.S. CLS. 22, 23, 38 AND 50). SN 85-204,847. PUB. 5-3-2011. FILED 12-23-2010.
 3,997,604. **VOLLEZE PASS WITHOUT PAIN AND DESIGN**. ALLRED, ALAN, (U.S. CLS. 22, 23, 38 AND 50). SN 85-205,328. PUB. 5-3-2011. FILED 12-23-2010.
 3,997,663. **BOWPLANE (STANDARD CHARACTER)**. DOUBLETAKE ARCHERY, (U.S. CLS. 22, 23, 38 AND 50). SN 85-206,102. PUB. 5-3-2011. FILED 12-27-2010.
 3,997,668. **HYDRO-FLO (STANDARD CHARACTER)**. PLANO MOLDING COMPANY, (U.S. CLS. 22, 23, 38 AND 50). SN 85-206,161. PUB. 5-3-2011. FILED 12-27-2010.
 3,997,740. **TRANSITION (STANDARD CHARACTER)**. DOUBLETAKE ARCHERY, (U.S. CLS. 22, 23, 38 AND 50). SN 85-207,198. PUB. 5-3-2011. FILED 12-29-2010.
 3,997,742. **NOCKTURNAL (STANDARD CHARACTER)**. DOUBLETAKE ARCHERY, (U.S. CLS. 22, 23, 38 AND 50). SN 85-207,248. PUB. 5-3-2011. FILED 12-29-2010.
 3,997,775. **CONNECTING GENERATIONS (STANDARD CHARACTER)**. QUEEN GAMES GMBH, (U.S. CLS. 22, 23, 38 AND 50). SN 85-207,718. PUB. 5-3-2011. FILED 12-30-2010.
 3,997,846. **THE SLIPPERY SLOPE (STANDARD CHARACTER)**. KRISTA SMITH, (U.S. CLS. 22, 23, 38 AND 50). SN 85-208,594. PUB. 5-3-2011. FILED 12-31-2010.
 3,997,858. **IDENTITY PURSUIT (STANDARD CHARACTER)**. IPG HOLDING SA, (U.S. CLS. 22, 23, 38 AND 50). SN 85-208,662. PUB. 5-3-2011. FILED 12-31-2010.
 3,997,890. **THE HIPCHECK AND DESIGN**. THE HIPCHECK, LLC, (U.S. CLS. 22, 23, 38 AND 50). SN 85-208,979. PUB. 5-3-2011. FILED 1-3-2011.
 3,997,897. **FAZ-FIT (STANDARD CHARACTER)**. CLUB-CONEX, INC., (U.S. CLS. 22, 23, 38 AND 50). SN 85-209,061. PUB. 5-3-2011. FILED 1-3-2011.
 3,997,963. **BRICKFORGE (STANDARD CHARACTER)**. BRICKFORGE, (U.S. CLS. 22, 23, 38 AND 50). SN 85-209,922. PUB. 5-3-2011. FILED 1-4-2011.
 3,998,021. **HELIX (STANDARD CHARACTER)**. LIBERTY SKIS CORPORATION, (U.S. CLS. 22, 23, 38 AND 50). SN 85-210,763. PUB. 5-3-2011. FILED 1-5-2011.
 3,998,058. **PUZZLETWIST AND DESIGN**. MAYNARD'S, LLC, (U.S. CLS. 22, 23, 38 AND 50). SN 85-211,381. PUB. 5-3-2011. FILED 1-5-2011.
 3,998,083. **PARAGON (STANDARD CHARACTER)**. MITSUSHIBIA INTERNATIONAL, INC., DBA PARAGON SPORTS, (U.S. CLS. 22, 23, 38 AND 50). SN 85-211,732. PUB. 5-3-2011. FILED 1-6-2011.
 3,998,156. **X50 (STANDARD CHARACTER)**. CABELA'S INC., (U.S. CLS. 22, 23, 38 AND 50). SN 85-213,263. PUB. 5-3-2011. FILED 1-7-2011.
 3,998,177. **CRAFTGEEK (STANDARD CHARACTER)**. PURPLE COWS, INC., (U.S. CLS. 22, 23, 38 AND 50). SN 85-214,288. PUB. 5-3-2011. FILED 1-10-2011.
 3,998,205. **GRAND (STANDARD CHARACTER)**. GRAND GOLF COMPANY, LLC, (U.S. CLS. 22, 23, 38 AND 50). SN 85-218,760. PUB. 5-3-2011. FILED 1-16-2011.
 3,998,208. **G GRAND GOLF (STYLIZED)**. GRAND GOLF COMPANY, LLC, (U.S. CLS. 22, 23, 38 AND 50). SN 85-220,550. PUB. 5-3-2011. FILED 1-19-2011.
 3,998,254. **COME FIND YOURSELF (STANDARD CHARACTER)**. IPG HOLDING SA, (U.S. CLS. 22, 23, 38 AND 50). SN 85-238,286. PUB. 5-3-2011. FILED 2-9-2011.
 3,998,260. **MISCELLANEOUS DESIGN**. HARTLINE INDUSTRIES, INC., (U.S. CLS. 22, 23, 38 AND 50). SN 85-239,100. PUB. 5-3-2011. FILED 2-10-2011.

CLASS 29—MEATS AND PROCESSED FOODS

- 3,995,462. **LEE KUM KEE HONG KONG AND DESIGN. LEE KUM KEE COMPANY LIMITED, MULTIPLE CLASS,** (INT. CLS. 29 AND 30), (U.S. CL. 46). SN 76-696,699. PUB. 9-7-2010. FILED 4-6-2009.
- 3,995,483. **MRS. CHRIS (STANDARD CHARACTER). P.A. CHA-FONG & ASSOCIATES, MULTIPLE CLASS,** (INT. CLS. 29, 30 AND 32), (U.S. CLS. 45, 46 AND 48). SN 76-704,275. PUB. 5-3-2011. FILED 8-27-2010.
- 3,995,493. **FELA (STANDARD CHARACTER). GONZALEZ AND TAPANES FOODS, INC.,** (U.S. CL. 46). SN 76-705,742. PUB. 5-3-2011. FILED 12-20-2010.
- 3,995,497. **MAIZETE AND DESIGN. MALGOR & CO., INC.,** (U.S. CL. 46). SN 76-705,840. PUB. 5-3-2011. FILED 12-29-2010.
- 3,995,528. **REVOLUTIONARY FOOD CO. (STANDARD CHARACTER). POLITI, PAMELA,** (U.S. CL. 46). SN 77-438,473. PUB. 5-3-2011. FILED 4-2-2008.
- 3,995,555. **EN ROUTE AND DESIGN. EN ROUTE INTERNATIONAL LTD., MULTIPLE CLASS,** (INT. CLS. 29, 30 AND 43), (U.S. CLS. 46, 100 AND 101). SN 77-622,481. PUB. 10-12-2010. FILED 11-26-2008.
- 3,995,556. **ME MYSELF & MY ... (STANDARD CHARACTER). EN ROUTE INTERNATIONAL LTD., MULTIPLE CLASS,** (INT. CLS. 29, 30 AND 43), (U.S. CLS. 46, 100 AND 101). SN 77-622,490. PUB. 4-13-2010. FILED 11-26-2008.
- 3,995,560. **LA COLMENA (STANDARD CHARACTER). LA COLMENA, INC., MULTIPLE CLASS,** (INT. CLS. 29 AND 30), (U.S. CL. 46). SN 77-649,172. PUB. 5-3-2011. FILED 1-14-2009.
- 3,995,746. **AURA (STANDARD CHARACTER). VIVA INTERNATIONAL LIMITED, MULTIPLE CLASS,** (INT. CLS. 29 AND 30), (U.S. CL. 46). SN 79-072,788. PUB. 5-11-2010. FILED 6-19-2009.
- 3,995,787. **MISCELLANEOUS DESIGN. BONGRAIN S.A.,** (U.S. CL. 46). SN 79-082,180. PUB. 5-3-2011. FILED 4-13-2010.
- 3,995,812. **RAGUSANO (STANDARD CHARACTER). MINISTERO DELLE POLITICHE AGRICOLE.; ALIMENTARI E FORESTALI -; DIPARTIMENTO DELLE POLITICHE; COMPETITIVE DEL MONDO RURALE; E DELLA QUALITA' -; DIREZIONE GENERALE PER LO; SVILUPPO AGROALIMENTARE.; LA QUALITA' E LA TUTELA; DEL CONSUMATORE,** (U.S. CL. 46). SN 79-083,550. PUB. 5-3-2011. FILED 4-21-2010.
- 3,995,830. **FUNGO DI BORGOTARO (STANDARD CHARACTER). MINISTERO DELLE POLITICHE AGRICOLE.; ALIMENTARI E FORESTALI -; DIPARTIMENTO DELLE POLITICHE; COMPETITIVE DEL MONDO RURALE; E DELLA QUALITA' -; DIREZIONE GENERALE PER LO; SVILUPPO AGROALIMENTARE.; LA QUALITA' E LA TUTELA; DEL CONSUMATORE, MULTIPLE CLASS,** (INT. CLS. 29 AND 31), (U.S. CLS. 1 AND 46). SN 79-084,246. PUB. 5-3-2011. FILED 4-19-2010.
- 3,995,880. **SARELLE AND DESIGN. SANSET GIDA TURIZM SANAYI VE TICARET ANONIM SIRKETI, MULTIPLE CLASS,** (INT. CLS. 29 AND 30), (U.S. CL. 46). SN 79-085,674. PUB. 5-3-2011. FILED 3-1-2010.
- 3,995,911 (*See Class 3 for this trademark*).
- 3,995,951. **DOLCEVEGI (STANDARD CHARACTER). VEGETALIA S.P.A., MULTIPLE CLASS,** (INT. CLS. 29, 30 AND 32), (U.S. CLS. 45, 46 AND 48). SN 79-088,862. PUB. 5-3-2011. FILED 7-16-2010.
- 3,995,978. **URBANI FUNGHI - MUSHROOMS AND DESIGN. URBANI TARTUFI S.R.L.,** (U.S. CL. 46). SN 79-090,643. PUB. 5-3-2011. FILED 9-30-2010.
- 3,996,084. **TOREADOS (STANDARD CHARACTER). GRUPO BIMBO, S.A.B. DE C.V.,** (U.S. CL. 46). SN 85-025,376. PUB. 5-3-2011. FILED 4-28-2010.
- 3,996,167. **100% ITALIA AND DESIGN. AUGELLO, LLC., MULTIPLE CLASS,** (INT. CLS. 29, 30 AND 32), (U.S. CLS. 45, 46 AND 48). SN 85-041,808. PUB. 10-19-2010. FILED 5-18-2010.
- 3,996,176. **VICAKO (STYLIZED). MAESTRO SUISSE HOLDING (H.K.) LIMITED, MULTIPLE CLASS,** (INT. CLS. 29, 30 AND 32), (U.S. CLS. 45, 46 AND 48). SN 85-042,511. PUB. 5-3-2011. FILED 5-19-2010.
- 3,996,265. **MISCELLANEOUS DESIGN. KAWASHO FOODS CORPORATION,** (U.S. CL. 46). SN 85-052,732. PUB. 5-3-2011. FILED 6-2-2010.
- 3,996,270. **BEVERLY HILLS (STANDARD CHARACTER). SUPREME OIL COMPANY, INC., MULTIPLE CLASS,** (INT. CLS. 29 AND 30), (U.S. CL. 46). SN 85-054,238. PUB. 5-3-2011. FILED 6-3-2010.
- 3,996,289. **SNACK LIGHTS (STANDARD CHARACTER). VALIO LTD,** (U.S. CL. 46). SN 85-058,671. PUB. 5-3-2011. FILED 6-9-2010.
- 3,996,290. **SNACK RIGHTS (STANDARD CHARACTER). VALIO LTD,** (U.S. CL. 46). SN 85-058,699. PUB. 5-3-2011. FILED 6-9-2010.
- 3,996,331. **BLUE BUCK BLUEBERRIES AND DESIGN. MACRIE BROTHERS BLUEBERRY FARM LLC, MULTIPLE CLASS,** (INT. CLS. 29 AND 31), (U.S. CLS. 1 AND 46). SN 85-068,333. PUB. 5-3-2011. FILED 6-22-2010.
- 3,996,493. **MAN DIP AND DESIGN. TED & ANDY, LLC,** (U.S. CL. 46). SN 85-117,862. PUB. 5-3-2011. FILED 8-27-2010.
- 3,996,580. **YANGLE EGGS AND DESIGN. KINDLY EGGS CO., LTD.,** (U.S. CL. 46). SN 85-139,121. PUB. 5-3-2011. FILED 9-27-2010.
- 3,996,621. **SEAFOOD SENSATIONS (STANDARD CHARACTER). KING & PRINCE SEAFOOD CORPORATION,** (U.S. CL. 46). SN 85-149,654. PUB. 5-3-2011. FILED 10-11-2010.
- 3,996,628. **PUEBLO (STANDARD CHARACTER). PUEBLO INC.,** (U.S. CL. 46). SN 85-150,443. PUB. 5-3-2011. FILED 10-12-2010.
- 3,996,788 (*See Class 3 for this trademark*).
- 3,996,824. **CASA DE TAMALES (STANDARD CHARACTER). CASA DE TAMALES, LLC, MULTIPLE CLASS,** (INT. CLS. 29 AND 43), (U.S. CLS. 46, 100 AND 101). SN 85-177,411. PUB. 5-3-2011. FILED 11-16-2010.
- 3,996,854. **SOY KITCHEN AND DESIGN. IP WING KONG,** (U.S. CL. 46). SN 85-179,032. PUB. 5-3-2011. FILED 11-17-2010.
- 3,996,914. **SILA (STANDARD CHARACTER). KIPROV, DOBRI D., MULTIPLE CLASS,** (INT. CLS. 29 AND 30), (U.S. CL. 46). SN 85-182,807. PUB. 5-3-2011. FILED 11-22-2010.
- 3,996,953. **KIKIRI QUIRCH AND DESIGN. QUIRCH FOODS CO.,** (U.S. CL. 46). SN 85-184,672. PUB. 5-3-2011. FILED 11-24-2010.
- 3,997,070. **CHOP CHOP (STANDARD CHARACTER). CHOP CHOP PRODUCTS, INC.,** (U.S. CL. 46). SN 85-188,262. PUB. 5-3-2011. FILED 12-1-2010.
- 3,997,148. **MAMÁ ELVIRA (STANDARD CHARACTER). ARSA DISTRIBUTING, INC., MULTIPLE CLASS,** (INT. CLS. 29 AND 30), (U.S. CL. 46). SN 85-189,646. PUB. 5-3-2011. FILED 12-2-2010.
- 3,997,159. **DAVIDSON OF DUNDEE DUNDEE, FLORIDA 33838 AND DESIGN. DAVIDSON OF DUNDEE, MULTIPLE CLASS,** (INT. CLS. 29 AND 30), (U.S. CL. 46). SN 85-189,790. PUB. 5-3-2011. FILED 12-2-2010.
- 3,997,301. **SALMOLUX (STANDARD CHARACTER). DULCICH, INC.,** (U.S. CL. 46). SN 85-194,355. PUB. 5-3-2011. FILED 12-9-2010.
- 3,997,548. **MOTHER EARTH (STANDARD CHARACTER). C.P. YEATMAN & SONS, INC.,** (U.S. CL. 46). SN 85-204,667. PUB. 5-3-2011. FILED 12-23-2010.
- 3,997,551. **WASONTUXET (STANDARD CHARACTER). ALLEN CREEK LLC,** (U.S. CL. 46). SN 85-204,689. PUB. 5-3-2011. FILED 12-23-2010.
- 3,997,570. **PROMISE TRACKER (STANDARD CHARACTER). APPLGATE FARMS, LLC, MULTIPLE CLASS,** (INT. CLS. 29 AND 35), (U.S. CLS. 46, 100, 101 AND 102). SN 85-204,888. PUB. 5-3-2011. FILED 12-23-2010.
- 3,997,811. **ASIAN ISLAND CRUNCH (STANDARD CHARACTER). DOLE FOOD COMPANY, INC.,** (U.S. CL. 46). SN 85-208,222. PUB. 5-3-2011. FILED 12-30-2010.
- 3,997,812. **AUTUMN SPLENDOR (STANDARD CHARACTER). DOLE FOOD COMPANY, INC.,** (U.S. CL. 46). SN 85-208,228. PUB. 5-3-2011. FILED 12-30-2010.
- 3,997,813. **HEARTS DELIGHT (STANDARD CHARACTER). DOLE FOOD COMPANY, INC.,** (U.S. CL. 46). SN 85-208,235. PUB. 5-3-2011. FILED 12-30-2010.
- 3,997,815. **PERFECT HARVEST (STANDARD CHARACTER). DOLE FOOD COMPANY, INC.,** (U.S. CL. 46). SN 85-208,254. PUB. 5-3-2011. FILED 12-30-2010.
- 3,997,816. **SPRING FLING (STANDARD CHARACTER). DOLE FOOD COMPANY, INC.,** (U.S. CL. 46). SN 85-208,262. PUB.

- 5-3-2011. FILED 12-30-2010.
 3,997,819. **SELECTIONS OF THE SEASON (STANDARD CHARACTER)**. DOLE FOOD COMPANY, INC., (U.S. CL. 46). SN 85-208,279. PUB. 5-3-2011. FILED 12-30-2010.
 3,997,967. **DEEP RIVER SNACKS (STANDARD CHARACTER)**. OLD LYME GOURMET COMPANY, DBA DEEP RIVER SNACKS, MULTIPLE CLASS, (INT. CLS. 29 AND 30), (U.S. CL. 46). SN 85-209,995. PUB. 5-3-2011. FILED 1-4-2011.
 3,998,182. **SAN-J (STANDARD CHARACTER)**. SAN-J INTERNATIONAL, INC., (U.S. CL. 46). SN 85-214,340. PUB. 5-3-2011. FILED 1-10-2011.
 3,998,183. **MISCELLANEOUS DESIGN**. SAN-J INTERNATIONAL, INC., (U.S. CL. 46). SN 85-214,348. PUB. 5-3-2011. FILED 1-10-2011.
 3,998,187. **NUE (STANDARD CHARACTER)**. BLACK MICHAEL L., (U.S. CL. 46). SN 85-214,447. PUB. 5-3-2011. FILED 1-10-2011.

CLASS 30—STAPLE FOODS

- 3,995,462 (*See Class 29 for this trademark*).
 3,995,483 (*See Class 29 for this trademark*).
 3,995,547. **NINTENDODSI AND DESIGN**. NINTENDO OF AMERICA INC., (U.S. CL. 46). SN 77-583,788. PUB. 10-19-2010. FILED 10-2-2008.
 3,995,555 (*See Class 29 for this trademark*).
 3,995,556 (*See Class 29 for this trademark*).
 3,995,560 (*See Class 29 for this trademark*).
 3,995,577. **LILLIPUT EGGZTRA (STANDARD CHARACTER)**. THE ALLAN CANDY COMPANY LIMITED, (U.S. CL. 46). SN 77-726,702. PUB. 5-3-2011. FILED 5-1-2009.
 3,995,578. **LILLIPUT EGGHEADZ (STANDARD CHARACTER)**. THE ALLAN CANDY COMPANY LIMITED, (U.S. CL. 46). SN 77-726,745. PUB. 5-3-2011. FILED 5-1-2009.
 3,995,645. **TERRA SPICE (STANDARD CHARACTER)**. GREENIES, LLC, DBA TERRA SPICE COMPANY, (U.S. CL. 46). SN 77-881,220. PUB. 5-3-2011. FILED 11-25-2009.
 3,995,675. **PIZZEROLAS (STANDARD CHARACTER)**. FRITOLAY NORTH AMERICA, INC., (U.S. CL. 46). SN 77-917,600. PUB. 1-25-2011. FILED 1-22-2010.
 3,995,685. **JOIE (STANDARD CHARACTER)**. LUM, SELENE, (U.S. CL. 46). SN 77-935,287. PUB. 5-3-2011. FILED 2-13-2010.
 3,995,713. **OVERBROOK FARMS (STANDARD CHARACTER)**. REQUEST FOODS, INC., (U.S. CL. 46). SN 77-968,379. PUB. 1-25-2011. FILED 3-25-2010.
 3,995,715 (*See Class 9 for this trademark*).
 3,995,746 (*See Class 29 for this trademark*).
 3,995,794. **99 AND DESIGN**. CHONGQING HONGJIUJIU FOOD CO., LTD., (U.S. CL. 46). SN 79-082,739. PUB. 5-3-2011. FILED 4-20-2010.
 3,995,796. **MISCELLANEOUS DESIGN**. SOVMESTNOE OBCHTCHESTVO S OGRANITCHENNOI OTVETSTVENNOSTI "MOROZPRODOUKT", (U.S. CL. 46). SN 79-082,938. PUB. 5-3-2011. FILED 3-29-2010.
 3,995,833. **NEWBY AND DESIGN**. NEWBY TEAS (U.K.) LIMITED, (U.S. CL. 46). SN 79-084,311. PUB. 5-3-2011. FILED 6-2-2010.
 3,995,842 (*See Class 1 for this trademark*).
 3,995,843. **DANIELI AND DESIGN**. LIDL STIFTUNG & CO. KG, (U.S. CL. 46). SN 79-084,657. PUB. 5-3-2011. FILED 6-14-2010.
 3,995,880 (*See Class 29 for this trademark*).
 3,995,894. **HARDWORKING COFFEE (STANDARD CHARACTER)**. MARS DRINKS UK LTD., MULTIPLE CLASS, (INT. CLS. 30, 35 AND 43), (U.S. CLS. 46, 100, 101 AND 102). SN 79-085,992. PUB. 5-3-2011. FILED 5-10-2010.
 3,995,895. **MISCELLANEOUS DESIGN**. TOVARYSTVO Z OBMEZHENOIU VIDPOVIDALNISTIU "KOMPANIA "RIDNA YIZHA", (U.S. CL. 46). SN 79-086,072. PUB. 5-3-2011. FILED 6-17-2010.
 3,995,911 (*See Class 3 for this trademark*).
 3,995,916. **CLAUDIO CORALLO (STANDARD CHARACTER)**. C. C. & C. - CORALLO CACAU & CAFÉ, LDA, MULTIPLE CLASS, (INT. CLS. 30, 35 AND 43), (U.S. CLS. 46, 100, 101 AND 102). SN 79-086,916. PUB. 5-3-2011. FILED 7-28-2010.
 3,995,920. **LIFE LESS SERIOUS (STANDARD CHARACTER)**. PERFETTI VAN MELLE S.P.A., (U.S. CL. 46). SN 79-087,071. PUB. 5-3-2011. FILED 6-11-2010.
 3,995,921. **FARINA DEL MIO SACCO (STANDARD CHARACTER)**. MOLINO PASINI S.P.A., (U.S. CL. 46). SN 79-087,339. PUB. 5-3-2011. FILED 8-4-2010.
 3,995,939 (*See Class 3 for this trademark*).
 3,995,951 (*See Class 29 for this trademark*).
 3,996,006. **MONOARABICA (STANDARD CHARACTER)**. ILL-YCAFFÈ S.P.A., (U.S. CL. 46). SN 79-092,784. PUB. 5-3-2011. FILED 9-16-2010.
 3,996,041. **GALLETAS PRINCESA (STYLIZED)**. MOLINOS VALLE DEL CIBAO C POR A, (U.S. CL. 46). SN 85-006,234. PUB. 5-3-2011. FILED 4-5-2010.
 3,996,065. **PARK'S ARABICA (STANDARD CHARACTER)**. 3J FOODS CORPORATION, (U.S. CL. 46). SN 85-018,987. PUB. 5-3-2011. FILED 4-21-2010.
 3,996,070. **MRS. FRUIT & NUT (STANDARD CHARACTER)**. THE ALLAN CANDY COMPANY LIMITED, (U.S. CL. 46). SN 85-020,562. PUB. 5-3-2011. FILED 4-22-2010.
 3,996,148. **TOP POT COFFEE (STANDARD CHARACTER)**. DOUGHNUT CORPORATION OF AMERICA, MULTIPLE CLASS, (INT. CLS. 30 AND 43), (U.S. CLS. 46, 100 AND 101). SN 85-038,976. PUB. 5-3-2011. FILED 5-14-2010.
 3,996,167 (*See Class 29 for this trademark*).
 3,996,176 (*See Class 29 for this trademark*).
 3,996,226. **HOMETOWN FUDGE (STANDARD CHARACTER)**. SCHOENBECK, DEBRA, (U.S. CL. 46). SN 85-047,858. PUB. 5-3-2011. FILED 5-26-2010.
 3,996,239. **MATCHA MATCHA AND DESIGN**. DEFOSSEY, TRICIA L., (U.S. CL. 46). SN 85-048,889. PUB. 5-3-2011. FILED 5-27-2010.
 3,996,252. **ALPINE TOFFEE (STANDARD CHARACTER)**. KOESSL, DEENA, (U.S. CL. 46). SN 85-051,073. PUB. 5-3-2011. FILED 5-31-2010.
 3,996,270 (*See Class 29 for this trademark*).
 3,996,273. **GOODY GOOD STUFF AND DESIGN**. FTF SWEETS LTD, (U.S. CL. 46). SN 85-054,500. PUB. 5-3-2011. FILED 6-4-2010.
 3,996,317. **JB AND DESIGN**. ARTINIAN, INC., (U.S. CL. 46). SN 85-064,456. PUB. 5-3-2011. FILED 6-16-2010.
 3,996,347. **CATIE'S WHOLE FOOD WEIGH LESS SPROUTED GRAINS (STANDARD CHARACTER)**. KD DID, INC., DBA ENERGY ESSENTIALS, (U.S. CL. 46). SN 85-071,095. PUB. 5-3-2011. FILED 6-24-2010.
 3,996,387. **POTRERO TEA TEA. GIVE THE GIFT OF GOOD HEALTH (STANDARD CHARACTER)**. POTRERO TRADING COMPANY, (U.S. CL. 46). SN 85-082,127. PUB. 5-3-2011. FILED 7-12-2010.
 3,996,431. **DR. YOU AND DESIGN**. ORION CORPORATION, (U.S. CL. 46). SN 85-094,078. PUB. 5-3-2011. FILED 7-27-2010.
 3,996,432. **EL RED MARIACHI (STANDARD CHARACTER)**. RED MARIACHI FOOD COMPANY, S.A. DE C.V., (U.S. CL. 46). SN 85-094,195. PUB. 5-3-2011. FILED 7-27-2010.
 3,996,433. **LA COCOREÑA (STANDARD CHARACTER)**. RED MARIACHI FOOD COMPANY, S.A. DE C.V., (U.S. CL. 46). SN 85-094,198. PUB. 5-3-2011. FILED 7-27-2010.
 3,996,525. **TUENI CHUP (STANDARD CHARACTER)**. DULCES DE LECHE LA VAQUITA, S.A. DE C.V., (U.S. CL. 46). SN 85-126,741. PUB. 5-3-2011. FILED 9-10-2010.
 3,996,549. **D AND DESIGN**. AED ENTERPRISES, LLC, MULTIPLE CLASS, (INT. CLS. 30 AND 35), (U.S. CLS. 46, 100, 101 AND 102). SN 85-132,262. PUB. 5-3-2011. FILED 9-17-2010.
 3,996,600. **A MAYO ZING (STANDARD CHARACTER)**. BESTTHORN LIMITED, (U.S. CL. 46). SN 85-145,357. PUB. 5-3-2011. FILED 10-5-2010.
 3,996,625. **XTREME! FIBER AND DESIGN**. OLÉ MEXICAN FOODS, INC., (U.S. CL. 46). SN 85-150,137. PUB. 5-3-2011. FILED 10-11-2010.
 3,996,630. **PUEBLO (STANDARD CHARACTER)**. PUEBLO INC., (U.S. CL. 46). SN 85-150,538. PUB. 5-3-2011. FILED 10-12-2010.
 3,996,647. **BENT'S COOKIE FACTORY (STANDARD CHARACTER)**. ATLANTIC HILL CONSTRUCTION INC., (U.S. CL. 46). SN 85-154,861. PUB. 5-3-2011. FILED 10-18-2010.
 3,996,676. **SONNETS SANDWICH SHOP BY BREAD POETS AND DESIGN**. BREAD POETS FRANCHISING, MULTI-

- PLE CLASS, (INT. CLS. 30 AND 43), (U.S. CLS. 46, 100 AND 101). SN 85-161,065. PUB. 5-3-2011. FILED 10-26-2010.
- 3,996,681. **CULTIVÉ FROZEN YOGURT AND DESIGN.** CULTIVE FRANCHISE, LLC, MULTIPLE CLASS, (INT. CLS. 30 AND 43), (U.S. CLS. 46, 100 AND 101). SN 85-162,379. PUB. 5-3-2011. FILED 10-27-2010.
- 3,996,740. **MISCELLANEOUS DESIGN.** SOKOL AND COMPANY, (U.S. CL. 46). SN 85-171,413. PUB. 5-3-2011. FILED 11-8-2010.
- 3,996,788 (*See Class 3 for this trademark.*).
- 3,996,794. **GRANDMA'S HOUSE (STANDARD CHARACTER).** MAIN ST. HOLDINGS, LLC, (U.S. CL. 46). SN 85-175,661. PUB. 5-3-2011. FILED 11-12-2010.
- 3,996,850. **SPICE JUNGLE (STANDARD CHARACTER).** SPICE JUNGLE, LLC, (U.S. CL. 46). SN 85-178,951. PUB. 5-3-2011. FILED 11-17-2010.
- 3,996,914 (*See Class 29 for this trademark.*).
- 3,996,959. **MIAD (STANDARD CHARACTER).** IMPERIAL TEAS (PVT) LTD, (U.S. CL. 46). SN 85-184,981. PUB. 5-3-2011. FILED 11-24-2010.
- 3,997,027. **SIMPLY MELT (STANDARD CHARACTER).** CHOCOMAKER, INC., (U.S. CL. 46). SN 85-187,189. PUB. 5-3-2011. FILED 11-30-2010.
- 3,997,033. **ED'S RED (STANDARD CHARACTER).** ED'S RED, INCORPORATED, (U.S. CL. 46). SN 85-187,294. PUB. 5-3-2011. FILED 11-30-2010.
- 3,997,066. **GRANDMA LUCY'S (STANDARD CHARACTER).** AMERICAN SKIN FOOD GROUP, LLC, (U.S. CL. 46). SN 85-188,185. PUB. 5-3-2011. FILED 12-1-2010.
- 3,997,084. **CAPPUCCINO BAMBINO (STANDARD CHARACTER).** STAR KAY WHITE, INC., (U.S. CL. 46). SN 85-188,508. PUB. 5-3-2011. FILED 12-1-2010.
- 3,997,124. **IRISH DREAMS COOKIES AND DESIGN.** BOGAN, COLLEEN, AND BOGAN, BRIAN, (U.S. CL. 46). SN 85-189,213. PUB. 5-3-2011. FILED 12-2-2010.
- 3,997,132 (*See Class 5 for this trademark.*).
- 3,997,148 (*See Class 29 for this trademark.*).
- 3,997,155. **SOUR LOVERS (STYLIZED).** GIMBAL BROTHERS, INC., (U.S. CL. 46). SN 85-189,750. PUB. 5-3-2011. FILED 12-2-2010.
- 3,997,159 (*See Class 29 for this trademark.*).
- 3,997,188. **THREE LITTLE PIGS MACARONI & CHEESE (STANDARD CHARACTER).** VALENTE, PAUL, (U.S. CL. 46). SN 85-190,504. PUB. 5-3-2011. FILED 12-3-2010.
- 3,997,197. **JAZZYBIRD COFFEE (STANDARD CHARACTER).** JAZZYBIRD CAFE, INC., (U.S. CL. 46). SN 85-190,972. PUB. 5-3-2011. FILED 12-6-2010.
- 3,997,198. **NL (STYLIZED).** NORMAN LOVE CONFECTIONS, INC., MULTIPLE CLASS, (INT. CLS. 30 AND 35), (U.S. CLS. 46, 100, 101 AND 102). SN 85-190,976. PUB. 5-3-2011. FILED 12-6-2010.
- 3,997,199. **PALMSWEET (STANDARD CHARACTER).** ORGANIC NECTARS, (U.S. CL. 46). SN 85-190,982. PUB. 5-3-2011. FILED 12-6-2010.
- 3,997,230. **TACUPETO CHIPS & SALSA (STANDARD CHARACTER).** TACUPETO CHIPS & SALSA INC., (U.S. CL. 46). SN 85-191,896. PUB. 5-3-2011. FILED 12-7-2010.
- 3,997,262. **CLASSIC RECIPES (STANDARD CHARACTER).** ENTERTAINMENT PUBLICATIONS LLC, (U.S. CL. 46). SN 85-192,872. PUB. 5-3-2011. FILED 12-8-2010.
- 3,997,391. **DOMAINE DES VIGNES (STANDARD CHARACTER).** ENCORE SPECIALTY FOODS, LLC, (U.S. CL. 46). SN 85-199,551. PUB. 5-3-2011. FILED 12-16-2010.
- 3,997,508. **GREEN MILL (STANDARD CHARACTER).** U.S. RESTAURANTS CORPORATION, (U.S. CL. 46). SN 85-203,899. PUB. 5-3-2011. FILED 12-22-2010.
- 3,997,546. **WAGALAX (STANDARD CHARACTER).** KAREN JOSEPH, (U.S. CL. 46). SN 85-204,664. PUB. 5-3-2011. FILED 12-23-2010.
- 3,997,584. **SYMPHONY IN WHITE (STANDARD CHARACTER).** ALAKEF COFFEE ROASTERS, INC., (U.S. CL. 46). SN 85-205,065. PUB. 5-3-2011. FILED 12-23-2010.
- 3,997,620. **HOT MESS (STANDARD CHARACTER).** CHARLES J. SILLARI, JR., (U.S. CL. 46). SN 85-205,531. PUB. 5-3-2011. FILED 12-24-2010.
- 3,997,664. **NUMA (STANDARD CHARACTER).** MOTHERGOOD INC., (U.S. CL. 46). SN 85-206,103. PUB. 5-3-2011. FILED 12-27-2010.
- 3,997,783. **NEUROCHOCOLATE (STANDARD CHARACTER).** NEUROCHOCOLATE LLC, (U.S. CL. 46). SN 85-207,870. PUB. 5-3-2011. FILED 12-30-2010.
- 3,997,847. **PAMELA'S (STANDARD CHARACTER).** PAMELA'S PRODUCTS, INC., (U.S. CL. 46). SN 85-208,597. PUB. 5-3-2011. FILED 12-31-2010.
- 3,997,894. **MAMI AND DESIGN.** PAN AMERICAN GRAIN MFG. CO., INC., (U.S. CL. 46). SN 85-209,025. PUB. 5-3-2011. FILED 1-3-2011.
- 3,997,915. **BUMP-A-LICIOUS (STANDARD CHARACTER).** THE CUPCAKE STATION INCORPORATED, (U.S. CL. 46). SN 85-209,247. PUB. 5-3-2011. FILED 1-3-2011.
- 3,997,930. **WHITE & BUTTERY (STANDARD CHARACTER).** AMERICAN POP CORN COMPANY, (U.S. CL. 46). SN 85-209,449. PUB. 5-3-2011. FILED 1-3-2011.
- 3,997,967 (*See Class 29 for this trademark.*).
- 3,998,036. **KEVMAN'S (STANDARD CHARACTER).** BABY LOU BRILLIANT PRODUCTS, LLC, (U.S. CL. 46). SN 85-210,986. PUB. 5-3-2011. FILED 1-5-2011.
- 3,998,048. **GOBBLERITO (STANDARD CHARACTER).** MAD MEX TRADEMARK HOLDING COMPANY, LLC, (U.S. CL. 46). SN 85-211,189. PUB. 5-3-2011. FILED 1-5-2011.
- 3,998,088. **MISCELLANEOUS DESIGN.** COW & CRUMB BAKING COMPANY LLC, (U.S. CL. 46). SN 85-211,837. PUB. 5-3-2011. FILED 1-6-2011.
- 3,998,129. **ST. PATRICK'S RICE (STANDARD CHARACTER).** AMADASUN, PATRICK, I, (U.S. CL. 46). SN 85-212,642. PUB. 5-3-2011. FILED 1-7-2011.
- 3,998,165. **FUN NATURALLY (STANDARD CHARACTER).** IBAKEFOODS, LLC, (U.S. CL. 46). SN 85-213,659. PUB. 5-3-2011. FILED 1-9-2011.
- 3,998,293. **TYSON (STANDARD CHARACTER).** TYSON FOODS, INC., (U.S. CL. 46). SN 85-257,171. PUB. 5-3-2011. FILED 3-3-2011.

CLASS 31—NATURAL AGRICULTURAL PRODUCTS

- 3,995,472. **BULLSEYE WILD GAME ATTRACTANT AND DESIGN.** DLF INTERNATIONAL SEEDS, INC., (U.S. CLS. 1 AND 46). SN 76-703,199. PUB. 5-3-2011. FILED 6-1-2010.
- 3,995,527. **MOONLIGHT BRAND AND DESIGN.** MOONLIGHT PACKING CORPORATION, (U.S. CLS. 1 AND 46). SN 77-434,937. PUB. 11-30-2010. FILED 3-28-2008.
- 3,995,600 (*See Class 21 for this trademark.*).
- 3,995,827. **SCALOGNO DI ROMAGNA (STANDARD CHARACTER).** MINISTERO DELLE POLITICHE AGRICOLE.; ALIMENTARI E FORESTALI -; DIPARTIMENTO DELLE POLITICHE; COMPETITIVE DEL MONDO RURALE; E DELLA QUALITA' -; DIREZIONE GENERALE PER LO SVILUPPO AGROALIMENTARE.; LA QUALITA' E LA TUTELA; DEL CONSUMATORE, (U.S. CLS. 1 AND 46). SN 79-084,227. PUB. 5-3-2011. FILED 4-23-2010.
- 3,995,828. **MARRONE DI ROCCADASPIDE (STANDARD CHARACTER).** MINISTERO DELLE POLITICHE AGRICOLE.; ALIMENTARI E FORESTALI -; DIPARTIMENTO DELLE POLITICHE; COMPETITIVE DEL MONDO RURALE; E DELLA QUALITA' -; DIREZIONE GENERALE PER LO SVILUPPO AGROALIMENTARE.; LA QUALITA' E LA TUTELA; DEL CONSUMATORE, (U.S. CLS. 1 AND 46). SN 79-084,239. PUB. 5-3-2011. FILED 4-19-2010.
- 3,995,829. **MARRONE DEL MUGELLO (STANDARD CHARACTER).** MINISTERO DELLE POLITICHE AGRICOLE.; ALIMENTARI E FORESTALI -; DIPARTIMENTO DELLE POLITICHE; COMPETITIVE DEL MONDO RURALE; E DELLA QUALITA' -; DIREZIONE GENERALE PER LO SVILUPPO AGROALIMENTARE.; LA QUALITA' E LA TUTELA; DEL CONSUMATORE, (U.S. CLS. 1 AND 46). SN 79-084,240. PUB. 5-3-2011. FILED 4-19-2010.
- 3,995,830 (*See Class 29 for this trademark.*).
- 3,995,831. **CASTAGNA DI MONTELLA (STANDARD CHARACTER).** MINISTERO DELLE POLITICHE AGRICOLE.; ALIMENTARI E FORESTALI -; DIPARTIMENTO DELLE POLITICHE; COMPETITIVE DEL MONDO RURALE; E DELLA QUALITA' -; DIREZIONE GENERALE PER LO;

- SVILUPPO AGROALIMENTARE.; LA QUALITA' E LA TUTELA; DEL CONSUMATORE, (U.S. CLS. 1 AND 46). SN 79-084,248. PUB. 5-3-2011. FILED 4-16-2010.
- 3,995,832. **CASTAGNA DI VALLERANO (STANDARD CHARACTER)**. MINISTERO DELLE POLITICHE AGRICOLE.; ALIMENTARI E FORESTALI -; DIPARTIMENTO DELLE POLITICHE; COMPETITIVE DEL MONDO RURALE; E DELLA QUALITA' -; DIREZIONE GENERALE PER LO SVILUPPO AGROALIMENTARE.; LA QUALITA' E LA TUTELA; DEL CONSUMATORE, (U.S. CLS. 1 AND 46). SN 79-084,249. PUB. 5-3-2011. FILED 4-23-2010.
- 3,995,842 (*See Class 1 for this trademark*).
- 3,996,055. **ESTEEM (STANDARD CHARACTER)**. BAR ALE, INC., (U.S. CLS. 1 AND 46). SN 85-015,232. PUB. 5-3-2011. FILED 4-15-2010.
- 3,996,126. **ALLERGY ALERT (STANDARD CHARACTER)**. ANGEL SERVICE DOGS, INC., MULTIPLE CLASS, (INT. CLS. 31, 41 AND 44), (U.S. CLS. 1, 46, 100, 101 AND 107). SN 85-035,598. PUB. 5-3-2011. FILED 5-11-2010.
- 3,996,331 (*See Class 29 for this trademark*).
- 3,996,524. **ALLEGRO (STANDARD CHARACTER)**. GREENHOUSE GROWN FOODS INC., (U.S. CLS. 1 AND 46). SN 85-126,226. PUB. 5-3-2011. FILED 9-9-2010.
- 3,996,535 (*See Class 5 for this trademark*).
- 3,996,594. **CLIFFORD PRODUCE (STANDARD CHARACTER)**. CLIFFORD PRODUCE SALES INC., (U.S. CLS. 1 AND 46). SN 85-143,141. PUB. 5-3-2011. FILED 10-1-2010.
- 3,996,832. **MISCELLANEOUS DESIGN**. RAY & MASCARI INC., (U.S. CLS. 1 AND 46). SN 85-178,071. PUB. 5-3-2011. FILED 11-16-2010.
- 3,996,930. **CLIFFORD PRODUCE AND DESIGN**. CLIFFORD PRODUCE SALES INC., (U.S. CLS. 1 AND 46). SN 85-183,236. PUB. 5-3-2011. FILED 11-23-2010.
- 3,996,931. **PAYSANNE COUNTRY FRESH PRODUCE AND DESIGN**. CLIFFORD PRODUCE SALES INC., (U.S. CLS. 1 AND 46). SN 85-183,260. PUB. 5-3-2011. FILED 11-23-2010.
- 3,997,060. **FLOCK BLOCK (STANDARD CHARACTER)**. PURINA MILLS, LLC, (U.S. CLS. 1 AND 46). SN 85-187,927. PUB. 5-3-2011. FILED 12-1-2010.
- 3,997,091. **GLADHEART FARMS AND DESIGN**. PORTERFIELD, MICHAEL, (U.S. CLS. 1 AND 46). SN 85-188,698. PUB. 5-3-2011. FILED S.R. 12-1-2010; AM. P.R. 3-15-2011.
- 3,997,166. **PIGGY PEARS (STANDARD CHARACTER)**. ASSOCIATED FRUIT COMPANY, (U.S. CLS. 1 AND 46). SN 85-189,922. PUB. 5-3-2011. FILED 12-3-2010.
- 3,997,428. **LOVED BY BIRDS AND BIRD LOVERS (STANDARD CHARACTER)**. CO-OPERATIVE FEED DEALERS, INC., (U.S. CLS. 1 AND 46). SN 85-200,644. PUB. 5-3-2011. FILED 12-17-2010.
- 3,997,429. **YOUR YARD IS YOUR SANCTUARY: FEED THE CHOIR. (STANDARD CHARACTER)**. CO-OPERATIVE FEED DEALERS, INC., (U.S. CLS. 1 AND 46). SN 85-200,663. PUB. 5-3-2011. FILED 12-17-2010.
- 3,997,576. **SUPER BREATH (STANDARD CHARACTER)**. PHYDEAUX ENTERPRISES, INC., (U.S. CLS. 1 AND 46). SN 85-204,981. PUB. 5-3-2011. FILED 12-23-2010.
- 3,997,606. **ECO-PROTEINS (STANDARD CHARACTER)**. ACOCK, JAMES, (U.S. CLS. 1 AND 46). SN 85-205,337. PUB. 5-3-2011. FILED 12-23-2010.
- 3,997,737. **CRAZY FRESH (STANDARD CHARACTER)**. RUSS DAVIS WHOLESALE, INC., (U.S. CLS. 1 AND 46). SN 85-207,146. PUB. 5-3-2011. FILED 12-29-2010.
- 3,997,945. **SEASIDE MULCH AND DESIGN**. PARKER, HACKNEY, (U.S. CLS. 1 AND 46). SN 85-209,715. PUB. 5-3-2011. FILED 1-4-2011.
- 3,997,949. **MOTHER EARTH (STANDARD CHARACTER)**. C.P. YEATMAN & SONS, INC., (U.S. CLS. 1 AND 46). SN 85-209,728. PUB. 5-3-2011. FILED 1-4-2011.
- 3,998,271. **AUTUMN HARVEST (STANDARD CHARACTER)**. KALMBACH FEEDS, INC., (U.S. CLS. 1 AND 46). SN 85-244,697. PUB. 5-3-2011. FILED 2-17-2011.
- FONG & ASSOCIATES, MULTIPLE CLASS, (INT. CLS. 32 AND 34), (U.S. CLS. 2, 8, 9, 17, 45, 46 AND 48). SN 76-704,710. PUB. 5-3-2011. FILED 9-29-2010.
- 3,995,579. **NATURAL HEALTHY SPRING WATER AND DESIGN**. JAQUEZ, RAYMOND, DBA MULTI VITAMIN ENERGY CORP., (U.S. CLS. 45, 46 AND 48). SN 77-731,547. PUB. 1-5-2010. FILED 5-7-2009.
- 3,995,654. **ESTRELLA AZUL AND DESIGN**. INDUSTRIAS LACTEAS SA, (U.S. CLS. 45, 46 AND 48). SN 77-887,111. PUB. 1-25-2011. FILED 12-6-2009.
- 3,995,684. **SQUEEZE ON THE FLAVOR! (STANDARD CHARACTER)**. SALES USA INC, (U.S. CLS. 45, 46 AND 48). SN 77-932,560. PUB. 5-3-2011. FILED 2-10-2010.
- 3,995,777. **P1 AND DESIGN**. LILIEN-VERWALTUNG GMBH & CO. KG, MULTIPLE CLASS, (INT. CLS. 32, 33 AND 43), (U.S. CLS. 45, 46, 47, 48, 49, 100 AND 101). SN 79-080,346. PUB. 1-25-2011. FILED 3-2-2010.
- 3,995,951 (*See Class 29 for this trademark*).
- 3,995,961. **AEROTONIC (STANDARD CHARACTER)**. HIRAFU PTY LTD, (U.S. CLS. 45, 46 AND 48). SN 79-089,589. PUB. 5-3-2011. FILED 9-21-2010.
- 3,995,964. **IABOVE (STANDARD CHARACTER)**. HIRAFU PTY LTD, (U.S. CLS. 45, 46 AND 48). SN 79-089,690. PUB. 5-3-2011. FILED 9-21-2010.
- 3,996,008. **HOBGOBLIN (STANDARD CHARACTER)**. MARSTON'S PLC, (U.S. CLS. 45, 46 AND 48). SN 79-092,960. PUB. 5-3-2011. FILED 12-24-2010.
- 3,996,167 (*See Class 29 for this trademark*).
- 3,996,176 (*See Class 29 for this trademark*).
- 3,996,184 (*See Class 5 for this trademark*).
- 3,996,348. **USA XL ENERGY BLAST AND DESIGN**. XL ENERGY DRINK CORP., (U.S. CLS. 45, 46 AND 48). SN 85-071,257. PUB. 5-3-2011. FILED 6-24-2010.
- 3,996,469 (*See Class 1 for this trademark*).
- 3,996,531. **TALLGRASS BREWING CO. BUFFALO SWEAT STOUT AND DESIGN**. TALLGRASS BREWING COMPANY, (U.S. CLS. 45, 46 AND 48). SN 85-128,137. PUB. 5-3-2011. FILED 9-13-2010.
- 3,996,751. **SKY HAG IPA (STANDARD CHARACTER)**. AIRWAYS BREWING COMPANY LLC, DBA AIRWAYS BREWING COMPANY, (U.S. CLS. 45, 46 AND 48). SN 85-172,807. PUB. 5-3-2011. FILED 11-9-2010.
- 3,996,842. **LA FRUTA HECHA AGUA FRESCA (STANDARD CHARACTER)**. MALHER, S.A., (U.S. CLS. 45, 46 AND 48). SN 85-178,715. PUB. 5-3-2011. FILED 11-17-2010.
- 3,996,864. **CHERRY BAY ORCHARDS (STANDARD CHARACTER)**. CHERRY BAY ORCHARDS, INC., (U.S. CLS. 45, 46 AND 48). SN 85-179,611. PUB. 5-3-2011. FILED 11-18-2010.
- 3,996,880 (*See Class 5 for this trademark*).
- 3,996,958. **ZEIGLER'S (STANDARD CHARACTER)**. M.H. ZEIGLER & SONS, LLC, (U.S. CLS. 45, 46 AND 48). SN 85-184,934. PUB. 5-3-2011. FILED 11-24-2010.
- 3,996,999. **PALE 31 (STANDARD CHARACTER)**. FIRESTONE WALKER LLC, (U.S. CLS. 45, 46 AND 48). SN 85-186,603. PUB. 5-3-2011. FILED 11-29-2010.
- 3,997,081. **CITY MILLS WHEAT THE CANNON BREWPUB AND DESIGN**. WARNER & WORTH, INC., DBA THE CANNON BREWPUB, (U.S. CLS. 45, 46 AND 48). SN 85-188,452. PUB. 5-3-2011. FILED 12-1-2010.
- 3,997,085. **RED JACKET ALE THE CANNON BREWPUB AND DESIGN**. WARNER & WORTH, INC., DBA THE CANNON BREWPUB, (U.S. CLS. 45, 46 AND 48). SN 85-188,521. PUB. 5-3-2011. FILED 12-1-2010.
- 3,997,110. **IRONCLAD DARK STOUT AND DESIGN**. WARNER & WORTH, INC., DBA THE CANNON BREWPUB, (U.S. CLS. 45, 46 AND 48). SN 85-189,029. PUB. 5-3-2011. FILED 12-2-2010.
- 3,997,123. **THE CANNON BREWPUB ROOT BEER AND DESIGN**. WARNER & WORTH, INC., DBA THE CANNON BREWPUB, (U.S. CLS. 45, 46 AND 48). SN 85-189,206. PUB. 5-3-2011. FILED 12-2-2010.
- 3,997,395. **MIZUMI AND DESIGN**. WAN TAI FENG FOOD CO., LTD., (U.S. CLS. 45, 46 AND 48). SN 85-199,667. PUB. 5-3-2011. FILED 12-16-2010.
- 3,997,441. **DEVILS TOWER LAGER WYOMING AND DESIGN**. MARCELLEEN INC., (U.S. CLS. 45, 46 AND 48). SN 85-201,198. PUB. 5-3-2011. FILED 12-18-2010.
- 3,997,475. **PONY MALTA (STANDARD CHARACTER)**. BA-

CLASS 32—LIGHT BEVERAGES

- 3,995,483 (*See Class 29 for this trademark*).
- 3,995,484. **LION OF JUDAH BRAND AND DESIGN**. P.A. CHA-

- VARIA S.A., (U.S. CLS. 45, 46 AND 48). SN 85-202,655. PUB. 5-3-2011. FILED 12-21-2010.
- 3,997,478. **ISLANDER (STANDARD CHARACTER)**. CORONADO BREWING COMPANY, INC., (U.S. CLS. 45, 46 AND 48). SN 85-202,674. PUB. 5-3-2011. FILED 12-21-2010.
- 3,997,480. **IDIOT (STANDARD CHARACTER)**. CORONADO BREWING COMPANY, INC., (U.S. CLS. 45, 46 AND 48). SN 85-202,692. PUB. 5-3-2011. FILED 12-21-2010.
- 3,997,481. **HOPPY DAZE (STANDARD CHARACTER)**. CORONADO BREWING COMPANY, INC., (U.S. CLS. 45, 46 AND 48). SN 85-202,706. PUB. 5-3-2011. FILED 12-21-2010.
- 3,997,483. **NUTTER BROWN (STANDARD CHARACTER)**. CORONADO BREWING COMPANY, INC., (U.S. CLS. 45, 46 AND 48). SN 85-202,759. PUB. 5-3-2011. FILED 12-21-2010.
- 3,997,484. **PONY MALTA ENERGIA NUTRITIVA Y REFRESCANTE AND DESIGN**. BAVARIA S.A., (U.S. CLS. 45, 46 AND 48). SN 85-202,780. PUB. 5-3-2011. FILED 12-21-2010.
- 3,997,561. **G'KNIGHT. (STANDARD CHARACTER)**. OSKAR BLUES BREWERY, LLC, DBA OSKAR BLUES BREWERY, (U.S. CLS. 45, 46 AND 48). SN 85-204,820. PUB. 5-3-2011. FILED 12-23-2010.
- 3,997,562. **ANGRY PLANET (STANDARD CHARACTER)**. FLAT EARTH HOLDINGS, LLC, (U.S. CLS. 45, 46 AND 48). SN 85-204,841. PUB. 5-3-2011. FILED 12-23-2010.
- 3,997,566. **CYGNUS X-1 (STANDARD CHARACTER)**. FLAT EARTH HOLDINGS, LLC, (U.S. CLS. 45, 46 AND 48). SN 85-204,868. PUB. 5-3-2011. FILED 12-23-2010.
- 3,997,569. **NORTHWEST PASSAGE (STANDARD CHARACTER)**. FLAT EARTH HOLDINGS, LLC, (U.S. CLS. 45, 46 AND 48). SN 85-204,883. PUB. 5-3-2011. FILED 12-23-2010.
- 3,997,593. **LA CERVEZA DE COLOMBIA AGUILA FAMOSA DESDE 1913 B SIN IGUAL Y SIEMPRE IGUAL AND DESIGN**. BAVARIA S.A., (U.S. CLS. 45, 46 AND 48). SN 85-205,195. PUB. 5-3-2011. FILED 12-23-2010.
- 3,998,296. **GOLDEN CAP (STANDARD CHARACTER)**. NEW HOLLAND BREWING COMPANY, LLC, (U.S. CLS. 45, 46 AND 48). SN 85-269,225. PUB. 5-3-2011. FILED 3-17-2011.
- 3,998,297. **BLUE SUNDAY (STANDARD CHARACTER)**. NEW HOLLAND BREWING COMPANY, LLC, (U.S. CLS. 45, 46 AND 48). SN 85-269,327. PUB. 5-3-2011. FILED 3-17-2011.
- 3,998,298. **ENVIIOUS (STANDARD CHARACTER)**. NEW HOLLAND BREWING COMPANY, LLC, (U.S. CLS. 45, 46 AND 48). SN 85-269,769. PUB. 5-3-2011. FILED 3-17-2011.
-
- CLASS 33—WINES AND SPIRITS**
- 3,995,535. **DUBAI (STANDARD CHARACTER)**. CADENA LEON JOSE MIGUEL, (U.S. CLS. 47 AND 49). SN 77-536,337. PUB. 5-3-2011. FILED 7-31-2008.
- 3,995,581. **CRUZ ANDINA (STANDARD CHARACTER)**. ALTO DE CASABLANCA S.A., (U.S. CLS. 47 AND 49). SN 77-745,261. PUB. 5-3-2011. FILED 5-27-2009.
- 3,995,604. **LIGHTNING (STANDARD CHARACTER)**. AIRPORT RANCH ESTATES, LLC, DBA AIRFIELD ESTATES, (U.S. CLS. 47 AND 49). SN 77-818,893. PUB. 5-3-2011. FILED 9-2-2009.
- 3,995,658. **VIVE LE MIDI (STANDARD CHARACTER)**. STRANGER & STRANGER LIMITED, (U.S. CLS. 47 AND 49). SN 77-891,678. PUB. 11-9-2010. FILED 12-11-2009.
- 3,995,708. **KING CAR AND DESIGN**. KING CAR FOOD INDUSTRIAL CO., LTD., (U.S. CLS. 47 AND 49). SN 77-962,218. PUB. 5-3-2011. FILED 3-18-2010.
- 3,995,731. **CLOS VICTOIRE (STYLIZED)**. SOCIETE AGRICOLE DE LA DURANCOLE, (U.S. CLS. 47 AND 49). SN 79-060,061. PUB. 5-3-2011. FILED 8-22-2008.
- 3,995,776. **TAVERNELLO 1[°] IN ITALIA AND DESIGN**. PREMIUM S.R.L., (U.S. CLS. 47 AND 49). SN 79-080,109. PUB. 5-3-2011. FILED 1-20-2010.
- 3,995,777 (See Class 32 for this trademark).
- 3,995,806. **JOSEPH PERRIER AND DESIGN**. JOSEPH PERRIER FILS & CIE, (U.S. CLS. 47 AND 49). SN 79-083,271. PUB. 5-3-2011. FILED 5-4-2010.
- 3,995,807. **MISCELLANEOUS DESIGN**. LIQUEUR AND VODKA DISTILLERY; "OSHA", LTD., (U.S. CLS. 47 AND 49). SN 79-083,429. PUB. 5-3-2011. FILED 5-28-2010.
- 3,995,822. **UOMO DEL VINO E DELLA TERRA MARCHIO CERTEZZA ENOSIS AND DESIGN**. ENOSIS S.R.L., (U.S. CLS. 47 AND 49). SN 79-084,101. PUB. 5-3-2011. FILED 5-20-2010.
- 3,995,900. **INALTO AND DESIGN**. MR TRADE DI RABELLINO MARCO, (U.S. CLS. 47 AND 49). SN 79-086,195. PUB. 5-3-2011. FILED 6-15-2010.
- 3,995,930. **SEOIRSE DE BRÚN (STANDARD CHARACTER)**. POSITSIOON OÜ, (U.S. CLS. 47 AND 49). SN 79-087,905. PUB. 5-3-2011. FILED 3-15-2010.
- 3,995,941. **MISCELLANEOUS DESIGN**. SHANXI XINGHUACUN FENJIU DISTILLERY CO., LTD., (U.S. CLS. 47 AND 49). SN 79-088,315. PUB. 5-3-2011. FILED 9-24-2010.
- 3,995,995. **CASTELLI DEL GREVEPESA (STANDARD CHARACTER)**. CASTELLI DEL GREVEPESA SOCIETÀ COOPERATIVA AGRICOLA, (U.S. CLS. 47 AND 49). SN 79-091,748. PUB. 5-3-2011. FILED 10-1-2010.
- 3,995,998. **THE ABSCONDER (STANDARD CHARACTER)**. R G & R T TROTT PTY LTD, (U.S. CLS. 47 AND 49). SN 79-091,893. PUB. 5-3-2011. FILED 12-21-2010.
- 3,996,001. **THE CHOICE OF DELIGHT (STANDARD CHARACTER)**. COGNAC DE LUZE, (U.S. CLS. 47 AND 49). SN 79-092,402. PUB. 5-3-2011. FILED 12-23-2010.
- 3,996,154. **VICE (STANDARD CHARACTER)**. VINELAND ESTATES WINERY LTD., (U.S. CLS. 47 AND 49). SN 85-040,366. PUB. 5-3-2011. FILED 5-17-2010.
- 3,996,159. **BLASTED CHURCH (STANDARD CHARACTER)**. BLASTED CHURCH VINEYARDS INC., (U.S. CLS. 47 AND 49). SN 85-040,756. PUB. 5-3-2011. FILED 5-17-2010.
- 3,996,400. **AWATERE RIVER AND DESIGN**. THE AWATERE RIVER WINE COMPANY LIMITED, (U.S. CLS. 47 AND 49). SN 85-084,884. PUB. 5-3-2011. FILED 7-14-2010.
- 3,996,515. **CANEPA MAGNIFICUM (STANDARD CHARACTER)**. JOSE CANEPA Y CIA. LTDA., (U.S. CLS. 47 AND 49). SN 85-125,310. PUB. 5-3-2011. FILED 9-8-2010.
- 3,996,614. **EL ZARCO TEQUILA GOLD AND DESIGN**. TEQUILA CUERVO LA ROJENA, S.A. DE C.V., (U.S. CLS. 47 AND 49). SN 85-147,919. PUB. 5-3-2011. FILED 10-7-2010.
- 3,996,615. **EL ZARCO AND DESIGN**. TEQUILA CUERVO LA ROJENA, S.A. DE C.V., (U.S. CLS. 47 AND 49). SN 85-147,942. PUB. 5-3-2011. FILED 10-7-2010.
- 3,996,618. **SWING TIME AND DESIGN**. AVV WINERY CO., LLC, (U.S. CLS. 47 AND 49). SN 85-148,408. PUB. 5-3-2011. FILED 10-8-2010.
- 3,996,925. **G AND DESIGN**. GLENELLY CELLARS (PROPRIETARY) LIMITED, (U.S. CLS. 47 AND 49). SN 85-183,110. PUB. 5-3-2011. FILED 11-23-2010.
- 3,996,976. **THE CLASSIC CASK (STANDARD CHARACTER)**. SPIRIT IMPORTS, INC., (U.S. CLS. 47 AND 49). SN 85-185,906. PUB. 5-3-2011. FILED 11-29-2010.
- 3,996,988. **DIEP 9 (STYLIZED)**. FLEMISH LION LLC, (U.S. CLS. 47 AND 49). SN 85-186,157. PUB. 5-3-2011. FILED 11-29-2010.
- 3,996,990. **WOODCHUCK HARD CIDER MARMOTA MONAX MONAX AND DESIGN**. BEVERAGE ACQUISITION GROUP, LLC., (U.S. CLS. 47 AND 49). SN 85-186,341. PUB. 5-3-2011. FILED 11-29-2010.
- 3,997,158. **TRICARDI (STANDARD CHARACTER)**. CATTUZATO, STEFANO, (U.S. CLS. 47 AND 49). SN 85-189,784. PUB. 5-3-2011. FILED 12-2-2010.
- 3,997,528. **ROMANELLI (STANDARD CHARACTER)**. MUTUAL WHOLESALE LIQUOR, INC., DBA INTERNATIONAL IMPORT EXPORT, (U.S. CLS. 47 AND 49). SN 85-204,380. PUB. 5-3-2011. FILED 12-22-2010.
- 3,997,529. **PIERRE DUCHENE (STANDARD CHARACTER)**. MUTUAL WHOLESALE LIQUOR, INC., DBA INTERNATIONAL IMPORT EXPORT, (U.S. CLS. 47 AND 49). SN 85-204,386. PUB. 5-3-2011. FILED 12-22-2010.
- 3,997,530. **JOSEPH HÄNDLER (STANDARD CHARACTER)**. MUTUAL WHOLESALE LIQUOR, INC., DBA INTERNATIONAL IMPORT EXPORT, (U.S. CLS. 47 AND 49). SN 85-204,389. PUB. 5-3-2011. FILED 12-22-2010.
- 3,997,622. **RED ISLAND (STANDARD CHARACTER)**. RED ISLAND INDUSTRIES, (U.S. CLS. 47 AND 49). SN 85-205,573. PUB. 5-3-2011. FILED 12-24-2010.
- 3,997,633. **FALCON AND HIPPO (STANDARD CHARACTER)**. CLARE RANCH LLC, DBA FALCON AND HIPPO WINERY, (U.S. CLS. 47 AND 49). SN 85-205,742. PUB. 5-3-

2011. FILED 12-26-2010.
 3,997,689. **RHUBY DOOBY (STANDARD CHARACTER)**. GUNAN FAMILY WINERY & VINEYARD, INC., DBA SANTA MARIA VINEYARD & WINERY, (U.S. CLS. 47 AND 49). SN 85-206,440. PUB. 5-3-2011. FILED 12-28-2010.
 3,997,707. **PARASOL (STANDARD CHARACTER)**. MARI-LYNN THOMA, (U.S. CLS. 47 AND 49). SN 85-206,692. PUB. 5-3-2011. FILED 12-28-2010.
 3,997,778. **WYBOROWA (STANDARD CHARACTER)**. WYBOROWA S.A., (U.S. CLS. 47 AND 49). SN 85-207,761. PUB. 5-3-2011. FILED 12-30-2010.
 3,997,860. **CELTIC DREAM (STANDARD CHARACTER)**. MAJESTIC LIQUOR STORES, INC., (U.S. CLS. 47 AND 49). SN 85-208,668. PUB. 5-3-2011. FILED 12-31-2010.
 3,997,965. **ALMA DE AGAVE (STANDARD CHARACTER)**. XAMAY IMPORTERS, INC., (U.S. CLS. 47 AND 49). SN 85-209,941. PUB. 5-3-2011. FILED 1-4-2011.
 3,997,977. **CANE & ABE (STANDARD CHARACTER)**. GREENAWALT, NATHAN, (U.S. CLS. 47 AND 49). SN 85-210,142. PUB. 5-3-2011. FILED 1-4-2011.
 3,998,010. **SORCERY (STANDARD CHARACTER)**. MARI-LYNN THOMA, (U.S. CLS. 47 AND 49). SN 85-210,575. PUB. 5-3-2011. FILED 1-5-2011.
 3,998,107. **MAIRENA AND DESIGN**. BLANCO, GABRIEL, (U.S. CLS. 47 AND 49). SN 85-212,159. PUB. 5-3-2011. FILED 1-6-2011.

CLASS 34—SMOKERS' ARTICLES

- 3,995,484 (*See Class 32 for this trademark*).
 3,995,855. **BOGO (STANDARD CHARACTER)**. OETTINGER IMEX AG, (U.S. CLS. 2, 8, 9 AND 17). SN 79-085,060. PUB. 5-3-2011. FILED 6-30-2010.
 3,996,048. **HOROSCOPES (STANDARD CHARACTER)**. HAMMOUD, MOHAMAD, (U.S. CLS. 2, 8, 9 AND 17). SN 85-010,753. PUB. 5-3-2011. FILED 4-9-2010.
 3,996,350. **ROLL-RITE (STANDARD CHARACTER)**. VAN NELLE CANADA LIMITED, (U.S. CLS. 2, 8, 9 AND 17). SN 85-071,450. PUB. 5-3-2011. FILED 6-25-2010.
 3,996,684. **GRAN VIDA (STANDARD CHARACTER)**. TIDEWATER RETAIL GROUP, LLC, DBA EMERSON'S CIGARS, (U.S. CLS. 2, 8, 9 AND 17). SN 85-163,252. PUB. 5-3-2011. FILED 10-28-2010.
 3,996,913. **KINGPIN CAPO DEI CAPI (STANDARD CHARACTER)**. BBK TOBACCO & FOODS, L.L.P., (U.S. CLS. 2, 8, 9 AND 17). SN 85-182,777. PUB. 5-3-2011. FILED 11-22-2010.
 3,997,524. **NOIR (STANDARD CHARACTER)**. SMOKETRONIC, LLC, (U.S. CLS. 2, 8, 9 AND 17). SN 85-204,238. PUB. 5-3-2011. FILED 12-22-2010.
 3,997,789. **BAUWAY SOLUTION PARTNER AND DESIGN**. SHENZHEN BAUWAY TECHNOLOGY LIMITED, (U.S. CLS. 2, 8, 9 AND 17). SN 85-207,974. PUB. 5-3-2011. FILED 12-30-2010.
 3,998,191. **VAPORMAX (STANDARD CHARACTER)**. VAPOR CORP., (U.S. CLS. 2, 8, 9 AND 17). SN 85-215,606. PUB. 5-3-2011. FILED 1-12-2011.
 3,998,201. **ICE (STANDARD CHARACTER)**. FANTASIA DISTRIBUTION, INC., (U.S. CLS. 2, 8, 9 AND 17). SN 85-218,287. PUB. 5-3-2011. FILED 1-14-2011.
 3,998,202. **CUPID'S ARROW (STANDARD CHARACTER)**. FANTASIA DISTRIBUTION, INC., (U.S. CLS. 2, 8, 9 AND 17). SN 85-218,289. PUB. 5-3-2011. FILED 1-14-2011.
 3,998,203. **CACTUS BREEZE (STANDARD CHARACTER)**. FANTASIA DISTRIBUTION, INC., (U.S. CLS. 2, 8, 9 AND 17). SN 85-218,293. PUB. 5-3-2011. FILED 1-14-2011.
 3,998,204. **DRAGON'S BREATH (STANDARD CHARACTER)**. FANTASIA DISTRIBUTION, INC., (U.S. CLS. 2, 8, 9 AND 17). SN 85-218,300. PUB. 5-3-2011. FILED 1-14-2011.

SERVICE MARKS

CLASS 35—ADVERTISING AND BUSINESS

- 3,995,466 (*See Class 16 for this trademark*).
 3,995,473. **ROLLS-ROYCE (STANDARD CHARACTER)**. ROLLS-ROYCE PLC, MULTIPLE CLASS, (INT. CLS. 35, 37, 41 AND 43), (U.S. CLS. 100, 101, 102, 103, 106 AND 107). SN 76-703,386. PUB. 5-3-2011. FILED 6-15-2010.
 3,995,474 (*See Class 9 for this trademark*).
 3,995,475. **CUSTOMER-FOCUSED, RESULTS-DRIVEN (STANDARD CHARACTER)**. FAIRFIELD TERCHNOLOGIES, INC., MULTIPLE CLASS, (INT. CLS. 35 AND 42), (U.S. CLS. 100, 101 AND 102). SN 76-703,469. PUB. 5-3-2011. FILED 6-22-2010.
 3,995,480. **CHESTNUT HILL ADVISORS AND DESIGN**. CHESTNUT HILL ADVISORS LLC, (U.S. CLS. 100, 101 AND 102). SN 76-704,047. PUB. 5-3-2011. FILED 8-9-2010.
 3,995,491. **P3 (STANDARD CHARACTER)**. INTERNATIONAL DIGITAL ENTERPRISE ALLIANCE, INC., (U.S. CLS. 100, 101 AND 102). SN 76-705,686. PUB. 5-3-2011. FILED 12-14-2010.
 3,995,498. **MUSIC CITY METALS (STANDARD CHARACTER)**. MUSIC CITY METALS CO., INC., (U.S. CLS. 100, 101 AND 102). SN 76-705,850. PUB. 5-3-2011. FILED 12-30-2010.
 3,995,499. **MUSIC CITY METALS AND DESIGN**. MUSIC CITY METALS CO., INC., (U.S. CLS. 100, 101 AND 102). SN 76-705,851. PUB. 5-3-2011. FILED 12-30-2010.
 3,995,500. **MISCELLANEOUS DESIGN**. MUSIC CITY METALS CO., INC., (U.S. CLS. 100, 101 AND 102). SN 76-705,852. PUB. 5-3-2011. FILED 12-30-2010.
 3,995,515 (*See Class 9 for this trademark*).
 3,995,524 (*See Class 7 for this trademark*).
 3,995,531 (*See Class 7 for this trademark*).
 3,995,533 (*See Class 16 for this trademark*).
 3,995,540 (*See Class 9 for this trademark*).
 3,995,550. **TIE RACK LONDON AND DESIGN**. TIE RACK TRADING LIMITED, (U.S. CLS. 100, 101 AND 102). SN 77-597,294. PUB. 5-3-2011. FILED 10-21-2008.
 3,995,551 (*See Class 14 for this trademark*).
 3,995,554. **PHIZZLE (STANDARD CHARACTER)**. PHIZZLE, INC., (U.S. CLS. 100, 101 AND 102). SN 77-617,794. PUB. 5-3-2011. FILED 11-19-2008.
 3,995,569. **ONTRACK STAFFING (STANDARD CHARACTER)**. LARK L.L.C., DBA ONTRACK STAFFING, (U.S. CLS. 100, 101 AND 102). SN 77-685,354. PUB. 5-3-2011. FILED 3-6-2009.
 3,995,592 (*See Class 9 for this trademark*).
 3,995,599. **VIAMEDIA (STANDARD CHARACTER)**. VIAMEDIA, INC., MULTIPLE CLASS, (INT. CLS. 35, 38 AND 42), (U.S. CLS. 100, 101, 102 AND 104). SN 77-805,729. PUB. 1-25-2011. FILED 8-17-2009.
 3,995,602. **RELECTRA (STANDARD CHARACTER)**. CCR LOGISTICS SYSTEMS AG, MULTIPLE CLASS, (INT. CLS. 35, 39, 40 AND 42), (U.S. CLS. 100, 101, 102, 103, 105 AND 106). SN 77-808,178. PUB. 5-3-2011. FILED 8-19-2009.
 3,995,607. **FRANCHISE DIRECT TOP 100 GLOBAL FRANCHISES AWARD AND DESIGN**. MCGARRY INTERNET LTD., DBA FRANCHISE DIRECT USA., (U.S. CLS. 100, 101 AND 102). SN 77-833,121. PUB. 5-3-2011. FILED 9-23-2009.
 3,995,612. **PHARMAFORECASTS AND DESIGN**. NOMURA INTERNATIONAL PLC, MULTIPLE CLASS, (INT. CLS. 35 AND 36), (U.S. CLS. 100, 101 AND 102). SN 77-840,260. PUB. 5-3-2011. FILED 10-2-2009.
 3,995,614 (*See Class 25 for this trademark*).
 3,995,618 (*See Class 9 for this trademark*).
 3,995,619. **LOCAL COLLECTION (STANDARD CHARACTER)**. GENERAL GROWTH MANAGEMENT, INC., (U.S. CLS. 100, 101 AND 102). SN 77-849,269. PUB. 5-3-2011. FILED 10-15-2009.
 3,995,620. **LOCAL COLLECTION AND DESIGN**. GENERAL GROWTH MANAGEMENT, INC., (U.S. CLS. 100, 101 AND 102). SN 77-849,347. PUB. 5-3-2011. FILED 10-15-2009.
 3,995,622. **VERIFY RETURN AUTHORIZATION (STANDARD CHARACTER)**. THE RETAIL EQUATION, INC., (U.S. CLS. 100, 101 AND 102). SN 77-855,283. PUB. 5-3-2011. FILED 10-22-2009.
 3,995,629. **MISCELLANEOUS DESIGN**. SUPER HEALTH

- INSTITUTE, INC., (U.S. CLS. 100, 101 AND 102). SN 77-863,253. PUB. 5-3-2011. FILED 11-2-2009.
- 3,995,659. **GOVERNANCE-IN-A-BOX (STANDARD CHARACTER)**. COGNIZANT TECHNOLOGY SOLUTIONS U.S. CORPORATION, MULTIPLE CLASS, (INT. CLS. 35 AND 42), (U.S. CLS. 100, 101 AND 102). SN 77-894,717. PUB. 5-3-2011. FILED 12-16-2009.
- 3,995,664. **CERTIFIED SORTED AND DESIGN**. COARSE BROADS, INC., (U.S. CLS. 100, 101 AND 102). SN 77-901,712. PUB. 5-3-2011. FILED 12-28-2009.
- 3,995,666. **THINKFIRST (STYLIZED)**. THINKFIRST FOUNDATION, (U.S. CLS. 100, 101 AND 102). SN 77-905,606. PUB. 5-3-2011. FILED 1-5-2010.
- 3,995,671. **REAL STYLE NETWORK (STANDARD CHARACTER)**. REAL STYLE NETWORK, INC., MULTIPLE CLASS, (INT. CLS. 35, 38 AND 41), (U.S. CLS. 100, 101, 102, 104 AND 107). SN 77-912,732. PUB. 5-3-2011. FILED 1-15-2010.
- 3,995,674. **G GOVERNANCE-IN-A-BOX AND DESIGN**. COGNIZANT TECHNOLOGY SOLUTIONS U.S. CORPORATION, MULTIPLE CLASS, (INT. CLS. 35 AND 42), (U.S. CLS. 100, 101 AND 102). SN 77-917,191. PUB. 5-3-2011. FILED 1-21-2010.
- 3,995,678. **ENERGY FOR CHANGE (STANDARD CHARACTER)**. PORTLAND ENERGY CONSERVATION, INC., MULTIPLE CLASS, (INT. CLS. 35, 41 AND 42), (U.S. CLS. 100, 101, 102 AND 107). SN 77-919,755. PUB. 5-3-2011. FILED 1-25-2010.
- 3,995,679. **RELENTLESS 27 (STANDARD CHARACTER)**. HEADSTRONG FOUNDATION, MULTIPLE CLASS, (INT. CLS. 35 AND 36), (U.S. CLS. 100, 101 AND 102). SN 77-922,726. PUB. 5-3-2011. FILED 1-28-2010.
- 3,995,680 (*See Class 16 for this trademark*).
- 3,995,681 (*See Class 16 for this trademark*).
- 3,995,691. **TEXAS HUNTING & OUTDOOR CLASSIC AND DESIGN**. HOWARD, DERRICK, (U.S. CLS. 100, 101 AND 102). SN 77-945,307. PUB. 5-3-2011. FILED 2-25-2010.
- 3,995,698. **BLACK COFFEE GALLERY ART AND COFFEE MADE BY ARTISTS AND DESIGN**. CAFE NEGRO GALLERY, S. DE R.L. DE C.V., (U.S. CLS. 100, 101 AND 102). SN 77-949,400. PUB. 5-3-2011. FILED 3-3-2010.
- 3,995,702. **FIGMENT ALL BANDS, NO MUSIC AND DESIGN**. FIGMENT MEDIA LLC, MULTIPLE CLASS, (INT. CLS. 35, 41 AND 42), (U.S. CLS. 100, 101, 102 AND 107). SN 77-951,711. PUB. 5-3-2011. FILED 3-5-2010.
- 3,995,704. **BEYOND THE BOOKSTORE (STANDARD CHARACTER)**. AKADEMOS, INC., (U.S. CLS. 100, 101 AND 102). SN 77-954,018. PUB. 5-3-2011. FILED 3-9-2010.
- 3,995,706. **EAGLE ROCK ENERGY PARTNERS AND DESIGN**. EAGLE ROCK ENERGY PARTNERS, L.P., MULTIPLE CLASS, (INT. CLS. 35, 36, 39 AND 40), (U.S. CLS. 100, 101, 102, 103, 105 AND 106). SN 77-956,627. PUB. 5-3-2011. FILED 3-11-2010.
- 3,995,710. **VINUM WINE IMPORTING & DISTRIBUTING (STANDARD CHARACTER)**. VINUM WINE IMPORTERS & DISTRIBUTERS, LLC, (U.S. CLS. 100, 101 AND 102). SN 77-963,749. PUB. 5-3-2011. FILED 3-19-2010.
- 3,995,712. **PSA PHOTOGRAPHIC SOCIETY OF AMERICA AND DESIGN**. PHOTOGRAPHIC SOCIETY OF AMERICA, INC., MULTIPLE CLASS, (INT. CLS. 35 AND 41), (U.S. CLS. 100, 101, 102 AND 107). SN 77-966,241. PUB. 5-3-2011. FILED 3-23-2010.
- 3,995,722. **SMARTHOME (STANDARD CHARACTER)**. SMARTLABS, INC., (U.S. CLS. 100, 101 AND 102). SN 78-656,443. PUB. 10-27-2009. FILED 6-22-2005.
- 3,995,728 (*See Class 9 for this trademark*).
- 3,995,729. **K-1 AND DESIGN**. ISHII KAZUYOSHI, MULTIPLE CLASS, (INT. CLS. 35 AND 41), (U.S. CLS. 100, 101, 102 AND 107). SN 79-056,078. PUB. 5-3-2011. FILED 4-23-2008.
- 3,995,734 (*See Class 6 for this trademark*).
- 3,995,735 (*See Class 6 for this trademark*).
- 3,995,738 (*See Class 9 for this trademark*).
- 3,995,747 (*See Class 9 for this trademark*).
- 3,995,750 (*See Class 9 for this trademark*).
- 3,995,751 (*See Class 9 for this trademark*).
- 3,995,752 (*See Class 9 for this trademark*).
- 3,995,755. **MEDIAMONKS (STANDARD CHARACTER)**. MEDIAMONKS MULTIMEDIA HOLDING B.V., MULTIPLE CLASS, (INT. CLS. 35, 38 AND 42), (U.S. CLS. 100, 101, 102 AND 104). SN 79-077,014. PUB. 5-3-2011. FILED 11-16-2009.
- 3,995,760 (*See Class 9 for this trademark*).
- 3,995,763. **TARGETZERO (STANDARD CHARACTER)**. HUSKY INJECTION MOLDING SYSTEMS LTD., MULTIPLE CLASS, (INT. CLS. 35 AND 42), (U.S. CLS. 100, 101 AND 102). SN 79-078,229. PUB. 5-3-2011. FILED 11-12-2009.
- 3,995,767 (*See Class 25 for this trademark*).
- 3,995,768 (*See Class 9 for this trademark*).
- 3,995,771 (*See Class 25 for this trademark*).
- 3,995,773. **CERTIFICAT HYPOTHECAIRE OBEGI (STYLIZED)**. OBEGI RIAD, MULTIPLE CLASS, (INT. CLS. 35 AND 36), (U.S. CLS. 100, 101 AND 102). SN 79-079,238. PUB. 5-3-2011. FILED 1-6-2010.
- 3,995,774. **OBEGI MORTGAGE CERTIFICATE (STYLIZED)**. OBEGI RIAD, MULTIPLE CLASS, (INT. CLS. 35 AND 36), (U.S. CLS. 100, 101 AND 102). SN 79-079,239. PUB. 5-3-2011. FILED 1-6-2010.
- 3,995,775 (*See Class 6 for this trademark*).
- 3,995,783 (*See Class 16 for this trademark*).
- 3,995,785 (*See Class 9 for this trademark*).
- 3,995,801. **RENTENBANK AND DESIGN**. LANDWIRTSCHAFTLICHE RENTENBANK -; ANSTALT DES OFFENTLICHEN RECHTS, MULTIPLE CLASS, (INT. CLS. 35 AND 36), (U.S. CLS. 100, 101 AND 102). SN 79-083,123. PUB. 5-3-2011. FILED 3-4-2010.
- 3,995,802. **WEB.ANALYSIS AND DESIGN**. PRIME; RESEARCH INTERNATIONAL AG & CO KG, MULTIPLE CLASS, (INT. CLS. 35, 38 AND 42), (U.S. CLS. 100, 101, 102 AND 104). SN 79-083,157. PUB. 5-3-2011. FILED 3-2-2010.
- 3,995,820. **PRELIOS (STANDARD CHARACTER)**. PIRELLI & C.S.P.A., MULTIPLE CLASS, (INT. CLS. 35, 36, 37 AND 42), (U.S. CLS. 100, 101, 102, 103 AND 106). SN 79-083,961. PUB. 5-3-2011. FILED 5-21-2010.
- 3,995,825. **VERYFLOW (STANDARD CHARACTER)**. KATRIN KLEYBOLDT, MULTIPLE CLASS, (INT. CLS. 35, 36, 38 AND 42), (U.S. CLS. 100, 101, 102 AND 104). SN 79-084,171. PUB. 5-3-2011. FILED 12-31-2009.
- 3,995,826. **VETAFLOW (STANDARD CHARACTER)**. KATRIN KLEYBOLDT, MULTIPLE CLASS, (INT. CLS. 35, 36, 38 AND 42), (U.S. CLS. 100, 101, 102 AND 104). SN 79-084,172. PUB. 5-3-2011. FILED 12-31-2009.
- 3,995,842 (*See Class 1 for this trademark*).
- 3,995,845. **DEALSTREET (STANDARD CHARACTER)**. UPSIDE SHOPPING GMBH, MULTIPLE CLASS, (INT. CLS. 35 AND 38), (U.S. CLS. 100, 101, 102 AND 104). SN 79-084,713. PUB. 5-3-2011. FILED 1-26-2010.
- 3,995,847 (*See Class 12 for this trademark*).
- 3,995,867 (*See Class 9 for this trademark*).
- 3,995,876 (*See Class 9 for this trademark*).
- 3,995,877 (*See Class 9 for this trademark*).
- 3,995,878 (*See Class 9 for this trademark*).
- 3,995,881. **SIX TELEKURS (STANDARD CHARACTER)**. SIX GROUP AG, MULTIPLE CLASS, (INT. CLS. 35, 36, 38, 41 AND 42), (U.S. CLS. 100, 101, 102, 104 AND 107). SN 79-085,686. PUB. 5-3-2011. FILED 3-8-2010.
- 3,995,882 (*See Class 16 for this trademark*).
- 3,995,894 (*See Class 30 for this trademark*).
- 3,995,907 (*See Class 9 for this trademark*).
- 3,995,910. **INDIVISION (STANDARD CHARACTER)**. EVERSTONE CAPITAL ASIA PTE. LTD., MULTIPLE CLASS, (INT. CLS. 35 AND 36), (U.S. CLS. 100, 101 AND 102). SN 79-086,638. PUB. 5-3-2011. FILED 8-6-2010.
- 3,995,916 (*See Class 30 for this trademark*).
- 3,995,917. **EVERSTONE (STANDARD CHARACTER)**. EVERSTONE CAPITAL ASIA PTE. LTD., MULTIPLE CLASS, (INT. CLS. 35 AND 36), (U.S. CLS. 100, 101 AND 102). SN 79-086,968. PUB. 5-3-2011. FILED 8-6-2010.
- 3,995,933. **BO YU AND DESIGN**. SHENYANG BOYU NON-FERROUS METAL & FERROALLOY CO., LTD., (U.S. CLS. 100, 101 AND 102). SN 79-088,016. PUB. 5-3-2011. FILED 8-11-2010.
- 3,995,943 (*See Class 9 for this trademark*).
- 3,995,949. **MISCELLANEOUS DESIGN**. JASON CROPPER, (U.S. CLS. 100, 101 AND 102). SN 79-088,693. PUB. 5-3-2011. FILED 10-2-2010.
- 3,995,968 (*See Class 25 for this trademark*).
- 3,995,973 (*See Class 18 for this trademark*).
- 3,995,977. **TOMORROW UNLIMITED (STANDARD CHAR-**

- ACTER). SBI MANAGEMENT GMBH, MULTIPLE CLASS, (INT. CLS. 35, 41 AND 42), (U.S. CLS. 100, 101, 102 AND 107). SN 79-090,614. PUB. 5-3-2011. FILED 9-23-2010.
- 3,995,980. **LIPOWEG (STANDARD CHARACTER)**. UTA SCHNAPPINGER, MULTIPLE CLASS, (INT. CLS. 35, 41 AND 44), (U.S. CLS. 100, 101, 102 AND 107). SN 79-090,773. PUB. 5-3-2011. FILED 10-25-2010.
- 3,995,982 (*See Class 18 for this trademark*).
- 3,996,015. **CM SERVICIOS DE IMAGEN CLASSMAKERS CM AND DESIGN**. ISABEL ARAGON VILLACASTIN, MULTIPLE CLASS, (INT. CLS. 35 AND 45), (U.S. CLS. 100, 101 AND 102). SN 79-093,558. PUB. 5-3-2011. FILED 10-20-2010.
- 3,996,037 (*See Class 9 for this trademark*).
- 3,996,044 (*See Class 16 for this trademark*).
- 3,996,056. **MOBILE ASSISTANT AND DESIGN**. U.S. TRANSCRIPTION, INC., (U.S. CLS. 100, 101 AND 102). SN 85-015,643. PUB. 5-3-2011. FILED 4-16-2010.
- 3,996,060. **LOANPLUS (STANDARD CHARACTER)**. PROCONGOPS, INC., (U.S. CLS. 100, 101 AND 102). SN 85-017,262. PUB. 5-3-2011. FILED 4-19-2010.
- 3,996,074. **EMERGING ENERGY RESEARCH (STANDARD CHARACTER)**. EMERGING ENERGY RESEARCH, LLC, (U.S. CLS. 100, 101 AND 102). SN 85-022,207. PUB. 5-3-2011. FILED 4-23-2010.
- 3,996,079. **SKILLPROOF (STANDARD CHARACTER)**. HENNING SEIP, (U.S. CLS. 100, 101 AND 102). SN 85-024,294. PUB. 5-3-2011. FILED 4-27-2010.
- 3,996,080. **TEXTTUNER (STANDARD CHARACTER)**. LIVECAREER, LTD., (U.S. CLS. 100, 101 AND 102). SN 85-024,385. PUB. 5-3-2011. FILED 4-27-2010.
- 3,996,086. **LUCKY MOTORS (STANDARD CHARACTER)**. LUCKY MOTORS, INC., (U.S. CLS. 100, 101 AND 102). SN 85-026,256. PUB. 5-3-2011. FILED 4-29-2010.
- 3,996,087. **EDUWAY (STANDARD CHARACTER)**. SCANDINAVIAN INTERNET GROUP AB, MULTIPLE CLASS, (INT. CLS. 35, 38 AND 41), (U.S. CLS. 100, 101, 102, 104 AND 107). SN 85-026,312. PUB. 5-3-2011. FILED 4-29-2010.
- 3,996,093. **ALEXANDRIA IDEAL AND DESIGN**. ALEXANDRIA ECONOMIC DEVELOPMENT PARTNERSHIP, INC., (U.S. CLS. 100, 101 AND 102). SN 85-029,360. PUB. 5-3-2011. FILED 5-4-2010.
- 3,996,108. **ONDEMAND FM (STANDARD CHARACTER)**. TOTALFACILITY, INC., (U.S. CLS. 100, 101 AND 102). SN 85-033,063. PUB. 5-3-2011. FILED 5-7-2010.
- 3,996,112. **THE SHOE HIVE (STANDARD CHARACTER)**. THE SHOE HIVE, L.L.C., (U.S. CLS. 100, 101 AND 102). SN 85-033,924. PUB. 5-3-2011. FILED 5-10-2010.
- 3,996,113. **THE SHOE HIVE AND DESIGN**. THE SHOE HIVE, L.L.C., (U.S. CLS. 100, 101 AND 102). SN 85-033,928. PUB. 5-3-2011. FILED 5-10-2010.
- 3,996,115. **INFOZONE (STANDARD CHARACTER)**. TARGUS INFORMATION CORPORATION, (U.S. CLS. 100, 101 AND 102). SN 85-034,300. PUB. 5-3-2011. FILED 5-10-2010.
- 3,996,117. **JEANOLOGY BASIC (STANDARD CHARACTER)**. SIGNATURE STYLES, LLC, (U.S. CLS. 100, 101 AND 102). SN 85-034,419. PUB. 5-3-2011. FILED 5-10-2010.
- 3,996,120. **RPAC AND DESIGN**. RELIABLE POWER ALTERNATIVES CORPORATION, (U.S. CLS. 100, 101 AND 102). SN 85-035,168. PUB. 5-3-2011. FILED 5-11-2010.
- 3,996,121. **RPAC (STANDARD CHARACTER)**. RELIABLE POWER ALTERNATIVES CORPORATION, (U.S. CLS. 100, 101 AND 102). SN 85-035,174. PUB. 5-3-2011. FILED 5-11-2010.
- 3,996,122. **RELIABLE POWER ALTERNATIVES CORPORATION (STANDARD CHARACTER)**. RELIABLE POWER ALTERNATIVES CORPORATION, (U.S. CLS. 100, 101 AND 102). SN 85-035,191. PUB. 5-3-2011. FILED 5-11-2010.
- 3,996,123. **AQMATRIX RATINGS & BENCHMARKS (STYLIZED)**. AQMETRIX RATINGS GLOBAL, S.L.U., MULTIPLE CLASS, (INT. CLS. 35, 36 AND 38), (U.S. CLS. 100, 101, 102 AND 104). SN 85-035,246. PUB. 5-3-2011. FILED 5-11-2010.
- 3,996,140. **TLC TRADES LABOR CORPORATION AND DESIGN**. TRADES LABOUR CORPORATION, (U.S. CLS. 100, 101 AND 102). SN 85-037,703. PUB. 5-3-2011. FILED 5-13-2010.
- 3,996,141. **ENERGYWISE (STYLIZED)**. RELIANT ENERGY RETAIL HOLDINGS, LLC, MULTIPLE CLASS, (INT. CLS. 35 AND 41), (U.S. CLS. 100, 101, 102 AND 107). SN 85-037,788. PUB. 5-3-2011. FILED 5-13-2010.
- 3,996,147. **WONDERS OF LIFE AND DESIGN**. LIFE AND HEALTH INSURANCE FOUNDATION FOR EDUCATION, (U.S. CLS. 100, 101 AND 102). SN 85-038,822. PUB. 5-3-2011. FILED 5-14-2010.
- 3,996,155. **CENTER FOR GREAT APES ORANGUTAN AND CHIMPANZEE CONSERVATION AND DESIGN**. CENTER FOR ORANGUTAN AND CHIMPANZEE CONSERVATION, INC., MULTIPLE CLASS, (INT. CLS. 35 AND 36), (U.S. CLS. 100, 101 AND 102). SN 85-040,372. PUB. 5-3-2011. FILED 5-17-2010.
- 3,996,156. **ALLOY DIGITAL (STANDARD CHARACTER)**. ALLOY MEDIA, LLC, MULTIPLE CLASS, (INT. CLS. 35 AND 41), (U.S. CLS. 100, 101, 102 AND 107). SN 85-040,469. PUB. 5-3-2011. FILED 5-17-2010.
- 3,996,161. **ARCHIMEDES LANTERN AND DESIGN**. ARCHIMEDES GLOBAL, INC., (U.S. CLS. 100, 101 AND 102). SN 85-041,141. PUB. 5-3-2011. FILED 5-18-2010.
- 3,996,166. **MODERN MOM (STANDARD CHARACTER)**. MOM, INC., (U.S. CLS. 100, 101 AND 102). SN 85-041,724. PUB. 5-3-2011. FILED 5-18-2010.
- 3,996,173. **LIVE FOR REAL (STANDARD CHARACTER)**. MANNATECH, INCORPORATED, MULTIPLE CLASS, (INT. CLS. 35 AND 41), (U.S. CLS. 100, 101, 102 AND 107). SN 85-042,319. PUB. 5-3-2011. FILED 5-19-2010.
- 3,996,174. **USCC U S CYBER CHALLENGE (STANDARD CHARACTER)**. CENTER FOR INTERNET SECURITY, MULTIPLE CLASS, (INT. CLS. 35, 36 AND 41), (U.S. CLS. 100, 101, 102 AND 107). SN 85-042,375. PUB. 5-3-2011. FILED 5-19-2010.
- 3,996,185. **OFFPRICE (STYLIZED)**. OFF-PRICE SPECIALIST CENTER, (U.S. CLS. 100, 101 AND 102). SN 85-043,891. PUB. 5-3-2011. FILED 5-20-2010.
- 3,996,196. **NURTURED BY DESIGN AND DESIGN**. JACKSON, YAMILE C., (U.S. CLS. 100, 101 AND 102). SN 85-045,406. PUB. 5-3-2011. FILED 5-21-2010.
- 3,996,205. **DONOVAN MARINE (STANDARD CHARACTER)**. DONOVAN MARINE, INC., (U.S. CLS. 100, 101 AND 102). SN 85-046,162. PUB. 5-3-2011. FILED 5-24-2010.
- 3,996,216. **WORLDWIDE MANIAC (STANDARD CHARACTER)**. WORLDWIDEMANIAC, INC., (U.S. CLS. 100, 101 AND 102). SN 85-046,857. PUB. 5-3-2011. FILED 5-24-2010.
- 3,996,217. **RANGER PARTNERS QUALITY LEADERSHIP IN CLIENT SERVICES AND DESIGN**. STEPHEN D. TOWNES, (U.S. CLS. 100, 101 AND 102). SN 85-046,912. PUB. 5-3-2011. FILED 5-25-2010.
- 3,996,229. **MICROINTERVIEW (STANDARD CHARACTER)**. MICRONOTES, INC., (U.S. CLS. 100, 101 AND 102). SN 85-048,139. PUB. 5-3-2011. FILED 5-26-2010.
- 3,996,231. **MICRONOTES (STANDARD CHARACTER)**. MICRONOTES, INC., (U.S. CLS. 100, 101 AND 102). SN 85-048,227. PUB. 5-3-2011. FILED 5-26-2010.
- 3,996,232. **COLLEGEQUEST (STANDARD CHARACTER)**. CUNET, LLC, (U.S. CLS. 100, 101 AND 102). SN 85-048,327. PUB. 5-3-2011. FILED 5-26-2010.
- 3,996,234 (*See Class 9 for this trademark*).
- 3,996,235 (*See Class 9 for this trademark*).
- 3,996,246. **SAFE-GUARD (STANDARD CHARACTER)**. SAFE-GUARD PRODUCTS INTERNATIONAL, LLC, (U.S. CLS. 100, 101 AND 102). SN 85-050,649. PUB. 11-2-2010. FILED 5-28-2010.
- 3,996,257. **STAYING POWER (STANDARD CHARACTER)**. JPMORGAN CHASE & CO., MULTIPLE CLASS, (INT. CLS. 35 AND 36), (U.S. CLS. 100, 101 AND 102). SN 85-051,978. PUB. 5-3-2011. FILED 6-1-2010.
- 3,996,259. **APTURA TRANSFORMATIONS (STANDARD CHARACTER)**. DIRECT SUPPLY, INC., MULTIPLE CLASS, (INT. CLS. 35 AND 41), (U.S. CLS. 100, 101, 102 AND 107). SN 85-052,079. PUB. 5-3-2011. FILED 6-1-2010.
- 3,996,261 (*See Class 16 for this trademark*).
- 3,996,271. **OEP - OCCUPANT ENGAGEMENT PROGRAM FOR SUSTAINABLE PRACTICE (STANDARD CHARACTER)**. HOK, INC., (U.S. CLS. 100, 101 AND 102). SN 85-054,322. PUB. 5-3-2011. FILED 6-3-2010.
- 3,996,275. **DON'T TEXT & DRIVE PARKVIEW TRAUMA CENTER AND DESIGN**. PARKVIEW HEALTH SYSTEM, INC., (U.S. CLS. 100, 101 AND 102). SN 85-055,114. PUB. 5-3-

2011. FILED 6-4-2010.
- 3,996,282. **READY WHEN THE TIME COMES AND DESIGN.** THE AMERICAN RED CROSS, DBA AMERICAN RED CROSS AND RED CROSS, MULTIPLE CLASS, (INT. CLS. 35 AND 41), (U.S. CLS. 100, 101, 102 AND 107). SN 85-056,280. PUB. 5-3-2011. FILED 6-7-2010.
- 3,996,285. **INTELAHOME (STANDARD CHARACTER).** INTEL-LAGRID LLC, (U.S. CLS. 100, 101 AND 102). SN 85-057,272. PUB. 5-3-2011. FILED 6-8-2010.
- 3,996,293. **WIZ ADDRESS AND DESIGN.** KIM, JONG MYOUNG, (U.S. CLS. 100, 101 AND 102). SN 85-058,980. PUB. 5-3-2011. FILED 6-9-2010.
- 3,996,294. **MISCELLANEOUS DESIGN.** KGPR INC, DBA AIRHEAD PARTS, (U.S. CLS. 100, 101 AND 102). SN 85-059,531. PUB. 5-3-2011. FILED 6-10-2010.
- 3,996,297. **NRG GLOBAL GIVING GG AND DESIGN.** NRG ENERGY, INC., MULTIPLE CLASS, (INT. CLS. 35 AND 36), (U.S. CLS. 100, 101 AND 102). SN 85-061,004. PUB. 5-3-2011. FILED 6-11-2010.
- 3,996,299. **TOTAL ALIGNMENT (STANDARD CHARACTER).** INFOTRAC, INC., DBA INFOTRAC, INC., (U.S. CLS. 100, 101 AND 102). SN 85-061,486. PUB. 5-3-2011. FILED 6-13-2010.
- 3,996,300. **ALINEACIÓN TOTAL (STANDARD CHARACTER).** INFOTRAC, INC., DBA INFOTRAC, INC., (U.S. CLS. 100, 101 AND 102). SN 85-061,490. PUB. 5-3-2011. FILED 6-13-2010.
- 3,996,310. **LOCAL SPLASH (STANDARD CHARACTER).** RELEVANT ADS, INC., (U.S. CLS. 100, 101 AND 102). SN 85-063,836. PUB. 5-3-2011. FILED 6-15-2010.
- 3,996,322 (*See Class 6 for this trademark*).
- 3,996,325. **BENNU (STANDARD CHARACTER).** BENNU, LLC, (U.S. CLS. 100, 101 AND 102). SN 85-066,572. PUB. 5-3-2011. FILED 6-18-2010.
- 3,996,334. **TECHPUBS IN A BOX (STANDARD CHARACTER).** WRITE QUICK, INC., (U.S. CLS. 100, 101 AND 102). SN 85-068,802. PUB. 5-3-2011. FILED 6-22-2010.
- 3,996,335. **PAGAN'S MC AND DESIGN.** PAGANS MOTOR-CYCLE CLUB L.L.C., (U.S. CLS. 100, 101 AND 102). SN 85-068,938. PUB. 5-3-2011. FILED 6-22-2010.
- 3,996,343. **W WOODLINE SOLUTIONS AND DESIGN.** WOODLINE SOLUTIONS, LLC, MULTIPLE CLASS, (INT. CLS. 35 AND 42), (U.S. CLS. 100, 101 AND 102). SN 85-070,409. PUB. 5-3-2011. FILED 6-24-2010.
- 3,996,345. **I3 AND DESIGN.** INGENIX, INC., (U.S. CLS. 100, 101 AND 102). SN 85-070,646. PUB. 5-3-2011. FILED 6-24-2010.
- 3,996,351. **ONLY AT FAO (STANDARD CHARACTER).** THE TRUSTEES OF THE FAO SCHWARZ FAMILY FOUNDATION, (U.S. CLS. 100, 101 AND 102). SN 85-071,727. PUB. 5-3-2011. FILED 6-25-2010.
- 3,996,362. **PARAGON (STANDARD CHARACTER).** LPS IP HOLDING COMPANY, LLC, MULTIPLE CLASS, (INT. CLS. 35, 36 AND 42), (U.S. CLS. 100, 101 AND 102). SN 85-074,549. PUB. 5-3-2011. FILED 6-30-2010.
- 3,996,372. **SPEARHEAD INTERNATIONAL (STANDARD CHARACTER).** AQUASCORP, INC., (U.S. CLS. 100, 101 AND 102). SN 85-076,687. PUB. 5-3-2011. FILED 7-2-2010.
- 3,996,386. **PLANET ICE THE GALAXY'S BEST TREATS AND DESIGN.** STAUFFENBERG, DANIEL E, (U.S. CLS. 100, 101 AND 102). SN 85-081,991. PUB. 5-3-2011. FILED S.R. 7-10-2010; AM. P.R. 3-7-2011.
- 3,996,401. **UNITED WE SAVE (STANDARD CHARACTER).** BORIC, BOGDAN, (U.S. CLS. 100, 101 AND 102). SN 85-085,342. PUB. 1-25-2011. FILED 7-15-2010.
- 3,996,404. **GLOBAL HOPE RESOURCES (STANDARD CHARACTER).** CELESTIA TRACY, STEVEN TRACY, (U.S. CLS. 100, 101 AND 102). SN 85-088,243. PUB. 5-3-2011. FILED 7-20-2010.
- 3,996,412. **IGRS ALLIANCE AND DESIGN.** IGRS ENGINEERING LAB LTD., (U.S. CLS. 100, 101 AND 102). SN 85-089,966. PUB. 5-3-2011. FILED 7-21-2010.
- 3,996,430. **STAND OUT FROM THE CROWD. (STANDARD CHARACTER).** CURRENT USA, INC., MULTIPLE CLASS, (INT. CLS. 35 AND 40), (U.S. CLS. 100, 101, 102, 103 AND 106). SN 85-093,948. PUB. 5-3-2011. FILED 7-27-2010.
- 3,996,438 (*See Class 12 for this trademark*).
- 3,996,439. **NEXT FITNESS EVOLUTION (STANDARD CHARACTER).** NEXT FITNESS EVOLUTION LLC, MULTIPLE CLASS, (INT. CLS. 35, 41 AND 44), (U.S. CLS. 100, 101, 102 AND 107). SN 85-095,382. PUB. 5-3-2011. FILED 7-28-2010.
- 3,996,445 (*See Class 25 for this trademark*).
- 3,996,459. **BETWEEN FRIENDS AND FAMILY AND DESIGN.** OPPORTUNITY BUYS, INC., (U.S. CLS. 100, 101 AND 102). SN 85-104,093. PUB. 1-25-2011. FILED 8-10-2010.
- 3,996,463. **EAT FIT (STANDARD CHARACTER).** EAT FIT, LLC, (U.S. CLS. 100, 101 AND 102). SN 85-104,926. PUB. 5-3-2011. FILED 8-11-2010.
- 3,996,470. **VIRGINIA LAKE MANAGEMENT (STANDARD CHARACTER).** VIRGINIA LAKE MANAGEMENT CO., INC., MULTIPLE CLASS, (INT. CLS. 35 AND 37), (U.S. CLS. 100, 101, 102, 103 AND 106). SN 85-108,003. PUB. 5-3-2011. FILED 8-16-2010.
- 3,996,475 (*See Class 25 for this trademark*).
- 3,996,476 (*See Class 12 for this trademark*).
- 3,996,479. **ONE IOWA (STANDARD CHARACTER).** ONE IOWA, (U.S. CLS. 100, 101 AND 102). SN 85-111,295. PUB. 5-3-2011. FILED 8-19-2010.
- 3,996,480. **MR. CHURROS USA CREAM FILLED CHURROS AND DESIGN.** MR CHURROS INTERNATIONAL, CORP., (U.S. CLS. 100, 101 AND 102). SN 85-111,361. PUB. 5-3-2011. FILED 8-19-2010.
- 3,996,483 (*See Class 9 for this trademark*).
- 3,996,491. **INCENTIVE RABBIT (STANDARD CHARACTER).** A&A MARKETING, INC., (U.S. CLS. 100, 101 AND 102). SN 85-117,060. PUB. 5-3-2011. FILED 8-26-2010.
- 3,996,494. **ILN INNOVATION LEARNING NETWORK AND DESIGN.** KAISER FOUNDATION HEALTH PLAN, INC., (U.S. CLS. 100, 101 AND 102). SN 85-117,864. PUB. 5-3-2011. FILED 8-27-2010.
- 3,996,508. **USLILY AND DESIGN.** FREUND, LILY, (U.S. CLS. 100, 101 AND 102). SN 85-123,672. PUB. 5-3-2011. FILED 9-7-2010.
- 3,996,514. **ARAB AMERICA AND DESIGN.** TURAATH MEDIA, L.L.C., DBA ARAB AMERICA, MULTIPLE CLASS, (INT. CLS. 35 AND 41), (U.S. CLS. 100, 101, 102 AND 107). SN 85-125,265. PUB. 5-3-2011. FILED 9-8-2010.
- 3,996,519. **TEA TEXAS EDUCATION AGENCY AND DESIGN.** TEXAS EDUCATION AGENCY, (U.S. CLS. 100, 101 AND 102). SN 85-125,992. PUB. 5-3-2011. FILED 9-9-2010.
- 3,996,520. **THE CENTER FOR VICTIMS OF TORTURE (STANDARD CHARACTER).** THE CENTER FOR VICTIMS OF TORTURE, MULTIPLE CLASS, (INT. CLS. 35 AND 44), (U.S. CLS. 100, 101 AND 102). SN 85-126,084. PUB. 5-3-2011. FILED 9-9-2010.
- 3,996,528. **MICHIGAN ECONOMIC DEVELOPMENT CORPORATION AND DESIGN.** MICHIGAN ECONOMIC DEVELOPMENT CORPORATION, (U.S. CLS. 100, 101 AND 102). SN 85-127,224. PUB. 5-3-2011. FILED 9-10-2010.
- 3,996,545. **FLY (STANDARD CHARACTER).** FRESH LIFELINES FOR YOUTH, INC., MULTIPLE CLASS, (INT. CLS. 35 AND 36), (U.S. CLS. 100, 101 AND 102). SN 85-131,276. PUB. 5-3-2011. FILED 9-16-2010.
- 3,996,546. **S.H.I.F.T. AND DESIGN.** FLAXINGTON, BEVERLY, (U.S. CLS. 100, 101 AND 102). SN 85-131,621. PUB. 5-3-2011. FILED 9-16-2010.
- 3,996,549 (*See Class 30 for this trademark*).
- 3,996,550. **EXTRAS FROM CENTERPOINT ENERGY AND DESIGN.** CENTERPOINT ENERGY, INC., (U.S. CLS. 100, 101 AND 102). SN 85-132,388. PUB. 5-3-2011. FILED 9-17-2010.
- 3,996,555. **FMS AND DESIGN.** FOCUSED MARKETING SOLUTIONS, INC., (U.S. CLS. 100, 101 AND 102). SN 85-133,510. PUB. 5-3-2011. FILED 9-20-2010.
- 3,996,561. **QHOST ENABLING BUSINESS (STYLIZED).** CYBERTRAILS LLC, (U.S. CLS. 100, 101 AND 102). SN 85-134,676. PUB. 5-3-2011. FILED 9-21-2010.
- 3,996,566. **DOWNEAST LAKES LAND TRUST AND DESIGN.** DOWNEAST LAKES LAND TRUST, (U.S. CLS. 100, 101 AND 102). SN 85-135,155. PUB. 5-3-2011. FILED 9-22-2010.
- 3,996,567. **BUNK BED KING (STANDARD CHARACTER).** DON BUMGARDNER, (U.S. CLS. 100, 101 AND 102). SN 85-135,231. PUB. 5-3-2011. FILED 9-22-2010.
- 3,996,568. **I DO VENUES (STANDARD CHARACTER).** I DO VENUES, MULTIPLE CLASS, (INT. CLS. 35 AND 41), (U.S. CLS. 100, 101, 102 AND 107). SN 85-136,024. PUB. 5-3-2011.

- FILED 9-22-2010.
- 3,996,569. **A BRAND ADOPTION AND DESIGN. BRAND ADOPTION, LLC, DBA BRAND ADOPTION,** (U.S. CLS. 100, 101 AND 102). SN 85-136,111. PUB. 5-3-2011. FILED 9-22-2010.
- 3,996,578. **MUM INDUSTRIES (STANDARD CHARACTER).** MUM INDUSTRIES, LIMITED, MULTIPLE CLASS, (INT. CLS. 35, 40 AND 42), (U.S. CLS. 100, 101, 102, 103 AND 106). SN 85-138,513. PUB. 5-3-2011. FILED 9-27-2010.
- 3,996,587. **DEFINING EXPERIENCES (STANDARD CHARACTER).** MARKEY'S AUDIO/VISUAL, INC., AKA MARKEY'S RENTAL & STAGING, MULTIPLE CLASS, (INT. CLS. 35 AND 41), (U.S. CLS. 100, 101, 102 AND 107). SN 85-141,146. PUB. 5-3-2011. FILED 9-29-2010.
- 3,996,590. **E R ELECTRONIC RESOURCES LTD. AND DESIGN.** BERNARDO SHTEREMBERG, (U.S. CLS. 100, 101 AND 102). SN 85-142,306. PUB. 5-3-2011. FILED 9-30-2010.
- 3,996,591. **SENATOR INTERNATIONAL AND DESIGN.** SENATOR INTERNATIONAL HOLDINGS LLC, MULTIPLE CLASS, (INT. CLS. 35, 36 AND 39), (U.S. CLS. 100, 101, 102 AND 105). SN 85-142,497. PUB. 5-3-2011. FILED 9-30-2010.
- 3,996,602. **DIESEL MACHINE WORKS AND DESIGN.** DIESEL MACHINE WORKS, MULTIPLE CLASS, (INT. CLS. 35 AND 40), (U.S. CLS. 100, 101, 102, 103 AND 106). SN 85-145,643. PUB. 5-3-2011. FILED 10-5-2010.
- 3,996,606. **NEVEROUT (STANDARD CHARACTER).** APPLIED INDUSTRIAL TECHNOLOGIES, INC., (U.S. CLS. 100, 101 AND 102). SN 85-146,297. PUB. 5-3-2011. FILED 10-6-2010.
- 3,996,607. **HOLT (STANDARD CHARACTER).** HOLT TEXAS, LTD., (U.S. CLS. 100, 101 AND 102). SN 85-146,366. PUB. 5-3-2011. FILED 10-6-2010.
- 3,996,608. **PHOENIX LEGAL (STANDARD CHARACTER).** PHOENIX LEGAL INC., (U.S. CLS. 100, 101 AND 102). SN 85-146,444. PUB. 5-3-2011. FILED 10-6-2010.
- 3,996,610 (*See Class 9 for this trademark*).
- 3,996,612. **SHATTUCK HAMMOND PARTNERS (STANDARD CHARACTER).** MK ASSET, INC., MULTIPLE CLASS, (INT. CLS. 35 AND 36), (U.S. CLS. 100, 101 AND 102). SN 85-147,159. PUB. 5-3-2011. FILED 10-7-2010.
- 3,996,616. **XBANDITS (STANDARD CHARACTER).** KING, ROBERT, (U.S. CLS. 100, 101 AND 102). SN 85-148,048. PUB. 5-3-2011. FILED 10-8-2010.
- 3,996,619. **RR REVEL ADVERTISING (STYLIZED),** PURPLE RAM, LLC, DBA REVEL ADVERTISING, (U.S. CLS. 100, 101 AND 102). SN 85-148,710. PUB. 5-3-2011. FILED 10-8-2010.
- 3,996,620. **TEAM READINESS (STANDARD CHARACTER).** TEAMREADINESS, INC., MULTIPLE CLASS, (INT. CLS. 35 AND 42), (U.S. CLS. 100, 101 AND 102). SN 85-149,128. PUB. 5-3-2011. FILED 10-9-2010.
- 3,996,623. **PROMOTIONAL ALLIANCE INTERNATIONAL (STANDARD CHARACTER).** PROMOTIONAL ALLIANCE INTERNATIONAL, INC., (U.S. CLS. 100, 101 AND 102). SN 85-149,978. PUB. 5-3-2011. FILED 10-11-2010.
- 3,996,626. **E SOFT SYSTEMS AND DESIGN.** 3DPLAN APS, MULTIPLE CLASS, (INT. CLS. 35, 41 AND 42), (U.S. CLS. 100, 101, 102 AND 107). SN 85-150,235. PUB. 5-3-2011. FILED 10-12-2010.
- 3,996,643. **AMERICAN VILLAGE (STYLIZED),** AMERICAN VILLAGE, (U.S. CLS. 100, 101 AND 102). SN 85-154,481. PUB. 5-3-2011. FILED 10-17-2010.
- 3,996,648. **TALENT ON HOLD THE ON-HOLD AND VOICE-MAIL TALENT COMPANY AND DESIGN.** TALENT ON HOLD, LLC, (U.S. CLS. 100, 101 AND 102). SN 85-154,911. PUB. 5-3-2011. FILED 10-18-2010.
- 3,996,649. **TEST DRIVE GRAD SCHOOL ONLINE (STANDARD CHARACTER).** EDUCATIONDYNAMICS, LLC, MULTIPLE CLASS, (INT. CLS. 35 AND 41), (U.S. CLS. 100, 101, 102 AND 107). SN 85-155,179. PUB. 5-3-2011. FILED 10-18-2010.
- 3,996,650. **TEST DRIVE COLLEGE ONLINE (STANDARD CHARACTER).** EDUCATIONDYNAMICS, LLC, MULTIPLE CLASS, (INT. CLS. 35, 38 AND 41), (U.S. CLS. 100, 101, 102, 104 AND 107). SN 85-155,190. PUB. 5-3-2011. FILED 10-18-2010.
- 3,996,654 (*See Class 9 for this trademark*).
- 3,996,656 (*See Class 16 for this trademark*).
- 3,996,657. **MCLENDON (STANDARD CHARACTER).** MCLENDON HARDWARE, INC., MULTIPLE CLASS, (INT. CLS. 35 AND 37), (U.S. CLS. 100, 101, 102, 103 AND 106). SN 85-156,750. PUB. 5-3-2011. FILED 10-20-2010.
- 3,996,662. **DOCTORS IMPROVING HEALTHCARE (STANDARD CHARACTER).** DOCTORS IMPROVING HEALTHCARE, INC., (U.S. CLS. 100, 101 AND 102). SN 85-158,416. PUB. 5-3-2011. FILED 10-21-2010.
- 3,996,663. **FOR SALE BY BUILDER & OWNER AND DESIGN.** FOR SALE BY BUILDER AND OWNER, INC., (U.S. CLS. 100, 101 AND 102). SN 85-158,875. PUB. 5-3-2011. FILED 10-22-2010.
- 3,996,669. **US GREENJOBS NETWORK AND DESIGN.** WILLIAM, JEAN, DBA GREENVESTING, LLC, (U.S. CLS. 100, 101 AND 102). SN 85-159,858. PUB. 5-3-2011. FILED 10-24-2010.
- 3,996,680. **FTW MAGS (STANDARD CHARACTER).** ACCURATE MARKETING ADVANTAGES INC., (U.S. CLS. 100, 101 AND 102). SN 85-162,203. PUB. 5-3-2011. FILED 10-27-2010.
- 3,996,682. **UNIK PARTIES & MORE AND DESIGN.** GALLOWAY, SHAMARO N., DBA UNIK PARTIES & MORE, SOLE PROPRIETORSHIP OF MISSISSIPPI, (U.S. CLS. 100, 101 AND 102). SN 85-162,906. PUB. 5-3-2011. FILED 10-27-2010.
- 3,996,690. **SEED AND GARDEN AND DESIGN.** SEED AND GARDEN LLC, (U.S. CLS. 100, 101 AND 102). SN 85-164,049. PUB. 5-3-2011. FILED 10-28-2010.
- 3,996,699. **PRIMEONE REALTY AND DESIGN.** LANDMAN, DAVID A., DBA PRIMEONEREALTY LLC, (U.S. CLS. 100, 101 AND 102). SN 85-165,989. PUB. 5-3-2011. FILED 11-1-2010.
- 3,996,701. **MAE MAE AND DESIGN.** MAE MAE HOLDINGS INC., (U.S. CLS. 100, 101 AND 102). SN 85-166,486. PUB. 5-3-2011. FILED 11-1-2010.
- 3,996,709. **NAPAC (STANDARD CHARACTER),** NATIONAL ASSOCIATION OF PROFESSIONALLY ACCREDITED CONTRACTORS LLC, MULTIPLE CLASS, (INT. CLS. 35, 37 AND 41), (U.S. CLS. 100, 101, 102, 103, 106 AND 107). SN 85-167,438. PUB. 5-3-2011. FILED 11-2-2010.
- 3,996,721. **GHOULTIDE GATHERING (STANDARD CHARACTER).** SMITH, SCOTT D, DBA GHOULTIDE GATHERING, (U.S. CLS. 100, 101 AND 102). SN 85-169,128. PUB. 5-3-2011. FILED 11-4-2010.
- 3,996,723. **N . A . P . A . C AND DESIGN.** NATIONAL ASSOCIATION OF PROFESSIONALLY ACCREDITED CONTRACTORS LLC, MULTIPLE CLASS, (INT. CLS. 35, 37 AND 41), (U.S. CLS. 100, 101, 102, 103, 106 AND 107). SN 85-169,344. PUB. 5-3-2011. FILED 11-4-2010.
- 3,996,734. **MISCELLANEOUS DESIGN.** U. S. VISION, INC., MULTIPLE CLASS, (INT. CLS. 35 AND 44), (U.S. CLS. 100, 101 AND 102). SN 85-170,884. PUB. 5-3-2011. FILED 11-6-2010.
- 3,996,743 (*See Class 9 for this trademark*).
- 3,996,746. **EGO SHOES (STANDARD CHARACTER).** NUÑEZ, KELVYN L., DBA EGO VANITY STORE, EGO, (U.S. CLS. 100, 101 AND 102). SN 85-171,687. PUB. 5-3-2011. FILED 11-8-2010.
- 3,996,756. **ALL ABOUT SPEED 1 2 3 4 5 6 7 M C AND DESIGN.** LOPEZ, BLANCA, (U.S. CLS. 100, 101 AND 102). SN 85-173,026. PUB. 5-3-2011. FILED 11-9-2010.
- 3,996,767. **YOUR TRUSTED ADVISOR IN WASHINGTON (STANDARD CHARACTER).** CASSIDY & ASSOCIATES, INC., (U.S. CLS. 100, 101 AND 102). SN 85-173,832. PUB. 5-3-2011. FILED 11-10-2010.
- 3,996,775. **WHERETOSHOOOT.ORG (STANDARD CHARACTER).** NATIONAL SHOOTING SPORTS FOUNDATION, INC., (U.S. CLS. 100, 101 AND 102). SN 85-174,436. PUB. 5-3-2011. FILED 11-11-2010.
- 3,996,778. **PERSONALIZATIONMALL.COM (STANDARD CHARACTER).** PERSONALIZATIONMALL.COM, INC., (U.S. CLS. 100, 101 AND 102). SN 85-174,646. PUB. 5-3-2011. FILED 11-11-2010.
- 3,996,791. **MISCELLANEOUS DESIGN.** COLEMAN, CASSANDRA, AND BROWN, FAWN, (U.S. CLS. 100, 101 AND 102). SN 85-175,540. PUB. 5-3-2011. FILED 11-12-2010.
- 3,996,799. **GETAWAY MEDIA CORP (STANDARD CHARACTER).** GETAWAY MEDIA CORP, (U.S. CLS. 100, 101 AND 102). SN 85-176,053. PUB. 5-3-2011. FILED 11-12-2010.

- 3,996,806. **RUN WITH KENYANS (STANDARD CHARACTER)**. RUN WITH THE KENYANS, LLC, (U.S. CLS. 100, 101 AND 102). SN 85-176,366. PUB. 5-3-2011. FILED 11-15-2010.
- 3,996,830. **COLLECTIVE EDITORIAL (STANDARD CHARACTER)**. COLLECTIVE EDITORIAL, LLC, (U.S. CLS. 100, 101 AND 102). SN 85-177,959. PUB. 5-3-2011. FILED 11-16-2010.
- 3,996,840. **SOCIETY FOR PEDIATRIC ANESTHESIA EDUCATION . RESEARCH . PATIENT SAFETY AND DESIGN. SOCIETY FOR PEDIATRIC ANESTHESIA**, (U.S. CLS. 100, 101 AND 102). SN 85-178,587. PUB. 5-3-2011. FILED 11-17-2010.
- 3,996,852. **AFFILIATE PROGRAM AND DESIGN. NATIONAL AUTOMATED CLEARING HOUSE ASSOCIATION**, (U.S. CLS. 100, 101 AND 102). SN 85-178,989. PUB. 5-3-2011. FILED 11-17-2010.
- 3,996,856. **CLEAREDCANDIDATES.COM (STANDARD CHARACTER)**. CLEAREDCANDIDATES.COM LLC., (U.S. CLS. 100, 101 AND 102). SN 85-179,194. PUB. 5-3-2011. FILED 11-17-2010.
- 3,996,866. **SUBNETWORK (STANDARD CHARACTER)**. PS HOLDINGS, L.L.C., (U.S. CLS. 100, 101 AND 102). SN 85-179,730. PUB. 5-3-2011. FILED 11-18-2010.
- 3,996,871. **BIKINGBILLBOARDS (STANDARD CHARACTER)**. BIKING BILLBOARDS, LLC, (U.S. CLS. 100, 101 AND 102). SN 85-179,874. PUB. 5-3-2011. FILED 11-18-2010.
- 3,996,878. **NUPRENU ESTABLISHING NEW ENTREPRENEURS AND DESIGN**. NUPRENU INC., AKA NUPRENU, (U.S. CLS. 100, 101 AND 102). SN 85-180,624. PUB. 5-3-2011. FILED 11-19-2010.
- 3,996,887. **POLICY SMART AND DESIGN**. CMR & ASSOCIATES, INC., MULTIPLE CLASS, (INT. CLS. 35 AND 36), (U.S. CLS. 100, 101 AND 102). SN 85-181,127. PUB. 5-3-2011. FILED 11-19-2010.
- 3,996,904. **MARYLAND OF OPPORTUNITY. AND DESIGN**. STATE OF MARYLAND DEPARTMENT OF BUSINESS AND ECONOMIC DEVELOPMENT, (U.S. CLS. 100, 101 AND 102). SN 85-182,144. PUB. 5-3-2011. FILED 11-22-2010.
- 3,996,911. **AFFINITON AND DESIGN**. AFFINITON, (U.S. CLS. 100, 101 AND 102). SN 85-182,655. PUB. 5-3-2011. FILED 11-22-2010.
- 3,996,916. **FATTY HITS MKTG. FFH AND DESIGN**. TYLER BAILEY, DBA FATTY HITS MARKETING, (U.S. CLS. 100, 101 AND 102). SN 85-182,874. PUB. 5-3-2011. FILED 11-22-2010.
- 3,996,917. **UNDER THE BOW A GIFT AND WRAP SHOPPE AND DESIGN**. UNDER THE BOW, MULTIPLE CLASS, (INT. CLS. 35 AND 45), (U.S. CLS. 100, 101 AND 102). SN 85-182,895. PUB. 5-3-2011. FILED 11-22-2010.
- 3,996,921. **COMPOCLAY AND DESIGN**. COMPOCLAY USA LLC, (U.S. CLS. 100, 101 AND 102). SN 85-182,998. PUB. 5-3-2011. FILED 11-22-2010.
- 3,996,924. **SOULI SKINSPA, LLC (STANDARD CHARACTER)**. STROUMBOS, KIM, MULTIPLE CLASS, (INT. CLS. 35 AND 44), (U.S. CLS. 100, 101 AND 102). SN 85-183,085. PUB. 5-3-2011. FILED 11-23-2010.
- 3,996,933. **THE CAMELEER AND DESIGN**. CAMELEER INC., THE, (U.S. CLS. 100, 101 AND 102). SN 85-183,327. PUB. 5-3-2011. FILED 11-23-2010.
- 3,996,934. **A WORLD FIT FOR KIDS! USA AND DESIGN**. A WORLD FIT FOR KIDS, MULTIPLE CLASS, (INT. CLS. 35 AND 41), (U.S. CLS. 100, 101, 102 AND 107). SN 85-183,415. PUB. 5-3-2011. FILED 11-23-2010.
- 3,996,941. **BONQO (STANDARD CHARACTER)**. ELLA INTERNET TECHNOLOGIES, INC., (U.S. CLS. 100, 101 AND 102). SN 85-183,810. PUB. 5-3-2011. FILED 11-23-2010.
- 3,996,943. **MISCELLANEOUS DESIGN**. FACELUXE LICENSING I, LLC, MULTIPLE CLASS, (INT. CLS. 35 AND 44), (U.S. CLS. 100, 101 AND 102). SN 85-183,983. PUB. 5-3-2011. FILED 11-23-2010.
- 3,996,944. **FACELUXE (STANDARD CHARACTER)**. FACELUXE LICENSING I, LLC, MULTIPLE CLASS, (INT. CLS. 35 AND 44), (U.S. CLS. 100, 101 AND 102). SN 85-184,000. PUB. 5-3-2011. FILED 11-23-2010.
- 3,996,954. **ARMORMAN APPROVED OFFICIAL SEAL PEACE OF MIND AND DESIGN**. SLIGHTLY HEROIC MARKETING, LLC, (U.S. CLS. 100, 101 AND 102). SN 85-184,754. PUB. 5-3-2011. FILED 11-24-2010.
- 3,996,968. **ARMADILLO CONSIGNMENT AND DESIGN**. STEPHENS, WAYNE L., DBA ARMADILLO CONSIGNMENT, (U.S. CLS. 100, 101 AND 102). SN 85-185,460. PUB. 5-3-2011. FILED 11-26-2010.
- 3,996,973. **MISCELLANEOUS DESIGN**. GAPWORK CONSULTING LLC, (U.S. CLS. 100, 101 AND 102). SN 85-185,638. PUB. 5-3-2011. FILED 11-27-2010.
- 3,996,974. **TRADEMYBOOK (STANDARD CHARACTER)**. KHAN, LAWRENCE, (U.S. CLS. 100, 101 AND 102). SN 85-185,714. PUB. 5-3-2011. FILED 11-28-2010.
- 3,996,978. **ENVIROPACK (STYLIZED)**. ENVIROPACK, LLC, (U.S. CLS. 100, 101 AND 102). SN 85-186,007. PUB. 5-3-2011. FILED 11-29-2010.
- 3,996,982. **POSITIVELY MINNESOTA (STANDARD CHARACTER)**. MINNESOTA DEPARTMENT OF EMPLOYMENT AND ECONOMIC DEVELOPMENT, FORMERLY MINNESOTA DEPARTMENT OF TRADE AND ECONOMIC DEVELOPMENT, (U.S. CLS. 100, 101 AND 102). SN 85-186,068. PUB. 5-3-2011. FILED 11-29-2010.
- 3,996,984. **HARVEST LOCAL FOODS (STANDARD CHARACTER)**. HARVEST LOCAL FOODS LLC, (U.S. CLS. 100, 101 AND 102). SN 85-186,105. PUB. 5-3-2011. FILED 11-29-2010.
- 3,996,987. **AMERICA SAVES (STANDARD CHARACTER)**. OMX, INC., (U.S. CLS. 100, 101 AND 102). SN 85-186,151. PUB. 5-3-2011. FILED 11-29-2010.
- 3,996,989. **G7 GENERATIONSEVEN STRATEGIC PARTNERS (STYLIZED)**. GENERATION SEVEN STRATEGIC PARTNERS, LLC, (U.S. CLS. 100, 101 AND 102). SN 85-186,257. PUB. 5-3-2011. FILED 11-29-2010.
- 3,996,991. **G7 (STYLIZED)**. GENERATION SEVEN STRATEGIC PARTNERS, LLC, (U.S. CLS. 100, 101 AND 102). SN 85-186,342. PUB. 5-3-2011. FILED 11-29-2010.
- 3,996,994. **PRESCIENTEDGE AND DESIGN**. WALSH, DAVID, (U.S. CLS. 100, 101 AND 102). SN 85-186,490. PUB. 5-3-2011. FILED 11-29-2010.
- 3,997,007. **WIFS WOMEN IN INSURANCE & FINANCIAL SERVICES AND DESIGN**. WIFS: WOMEN IN INSURANCE AND FINANCIAL SERVICES, INC., MULTIPLE CLASS, (INT. CLS. 35 AND 41), (U.S. CLS. 100, 101, 102 AND 107). SN 85-186,862. PUB. 5-3-2011. FILED 11-30-2010.
- 3,997,023. **WITH DENTALTOWN... NO DENTIST WILL EVER HAVE TO PRACTICE SOLO AGAIN. (STANDARD CHARACTER)**. FARRAN MEDIA, L.L.C., (U.S. CLS. 100, 101 AND 102). SN 85-187,123. PUB. 5-3-2011. FILED 11-30-2010.
- 3,997,029. **RADIATOR EXPRESS AND DESIGN**. RADIATOR-EXPRESS.COM, INC, (U.S. CLS. 100, 101 AND 102). SN 85-187,226. PUB. 5-3-2011. FILED 11-30-2010.
- 3,997,035. **MEDICAL BIDLINE (STANDARD CHARACTER)**. MEDICAL BIDLINE, INC., (U.S. CLS. 100, 101 AND 102). SN 85-187,380. PUB. 5-3-2011. FILED 11-30-2010.
- 3,997,054. **360 MK MARKETING 6E+10 AND DESIGN**. THE MK ELEMENT LLC, (U.S. CLS. 100, 101 AND 102). SN 85-187,750. PUB. 5-3-2011. FILED 11-30-2010.
- 3,997,058. **5KORLESS AUTOS.COM OUTSTANDING SERVICE QUALITY CARS NO PAYMENTS AND DESIGN**. ALDRIDGE, MICHAEL D., (U.S. CLS. 100, 101 AND 102). SN 85-187,897. PUB. 5-3-2011. FILED 12-1-2010.
- 3,997,062. **PINK GLOVE DANCE (STANDARD CHARACTER)**. MEDLINE INDUSTRIES, INC., (U.S. CLS. 100, 101 AND 102). SN 85-188,014. PUB. 5-3-2011. FILED 12-1-2010.
- 3,997,077 (*See Class 16 for this trademark*).
- 3,997,078 (*See Class 16 for this trademark*).
- 3,997,082. **L.E.D. PRESENTS (STANDARD CHARACTER)**. TRAMPS AND REJECTS, INC., (U.S. CLS. 100, 101 AND 102). SN 85-188,460. PUB. 5-3-2011. FILED 12-1-2010.
- 3,997,094. **K & G CYCLES (STYLIZED)**. K AND G CYCLES LLC, DBA K AND G CYCLES, (U.S. CLS. 100, 101 AND 102). SN 85-188,752. PUB. 5-3-2011. FILED 12-1-2010.
- 3,997,099. **RMP CAPITAL CORP (STANDARD CHARACTER)**. RMP CAPITAL CORP, MULTIPLE CLASS, (INT. CLS. 35 AND 36), (U.S. CLS. 100, 101 AND 102). SN 85-188,813. PUB. 5-3-2011. FILED 12-1-2010.
- 3,997,100. **HALFDEALS.COM (STANDARD CHARACTER)**. VISTAEDGE INC, (U.S. CLS. 100, 101 AND 102). SN 85-188,823. PUB. 5-3-2011. FILED 12-1-2010.
- 3,997,101. **RMP CAPITAL CORP. AND DESIGN**. RMP CAPI-

- TAL CORP, MULTIPLE CLASS, (INT. CLS. 35 AND 36), (U.S. CLS. 100, 101 AND 102). SN 85-188,827. PUB. 5-3-2011. FILED 12-2-2010.
- 3,997,103. **RMP CAPITAL CORP. WE MAKE FUNDING YOUR BUSINESS EASIER AND DESIGN.** RMP CAPITAL CORP, MULTIPLE CLASS, (INT. CLS. 35 AND 36), (U.S. CLS. 100, 101 AND 102). SN 85-188,837. PUB. 5-3-2011. FILED 12-2-2010.
- 3,997,104. **WIFS WOMEN IN INSURANCE & FINANCIAL SERVICES ATTRACT. DEVELOP. ADVANCE. AND DESIGN.** WIFS: WOMEN IN INSURANCE AND FINANCIAL SERVICES, INC., MULTIPLE CLASS, (INT. CLS. 35 AND 41), (U.S. CLS. 100, 101, 102 AND 107). SN 85-188,869. PUB. 5-3-2011. FILED 12-2-2010.
- 3,997,106. **IT'S MY PLAY AND DESIGN.** GAJIC, MOMIR, (U.S. CLS. 100, 101 AND 102). SN 85-188,970. PUB. 5-3-2011. FILED 12-2-2010.
- 3,997,107. **LAFONTAINE THE FAMILY DEAL.COM AND DESIGN.** MTL MOTORS, LLC, MULTIPLE CLASS, (INT. CLS. 35, 36, 37 AND 39), (U.S. CLS. 100, 101, 102, 103, 105 AND 106). SN 85-188,972. PUB. 5-3-2011. FILED 12-2-2010.
- 3,997,109. **GINDER GREENHOUSE & GARDEN CENTER, INC. BOB'S SPECIAL FERTILIZER GUARANTEED! AND DESIGN.** GINDER GREENHOUSE & GARDEN CENTER, INC., (U.S. CLS. 100, 101 AND 102). SN 85-189,015. PUB. 5-3-2011. FILED 12-2-2010.
- 3,997,111. **FOCUSHEALTHCAREGROUP INNOVATIVE SEARCH SOLUTIONS AND DESIGN.** FOCUS HEALTHCARE GROUP, LLC, (U.S. CLS. 100, 101 AND 102). SN 85-189,050. PUB. 5-3-2011. FILED 12-2-2010.
- 3,997,116. **ACCOUNTAGILITY, LLC (STANDARD CHARACTER).** ACCOUNTAGILITY, LLC, (U.S. CLS. 100, 101 AND 102). SN 85-189,162. PUB. 5-3-2011. FILED 12-2-2010.
- 3,997,122. **BABY TO BEE AND DESIGN.** INUVO, INC., MULTIPLE CLASS, (INT. CLS. 35 AND 41), (U.S. CLS. 100, 101, 102 AND 107). SN 85-189,200. PUB. 5-3-2011. FILED 12-2-2010.
- 3,997,125. **ALL VITAMINS PLUS.COM AND DESIGN.** DIABETICARE LLC, DBA ALL VITAMINS PLUS.COM, (U.S. CLS. 100, 101 AND 102). SN 85-189,264. PUB. 5-3-2011. FILED 12-2-2010.
- 3,997,142. **TEAM ESTROGEN (STANDARD CHARACTER).** TEAM ESTROGEN, INC., (U.S. CLS. 100, 101 AND 102). SN 85-189,581. PUB. 5-3-2011. FILED 12-2-2010.
- 3,997,145. **ALLUREZ (STANDARD CHARACTER).** SKY 26 ENTERPRISE INC., (U.S. CLS. 100, 101 AND 102). SN 85-189,616. PUB. 5-3-2011. FILED 12-2-2010.
- 3,997,150 (*See Class 9 for this trademark*).
- 3,997,151. **AMERICAN SOCIETY ON AGING (STANDARD CHARACTER).** AMERICAN SOCIETY ON AGING, (U.S. CLS. 100, 101 AND 102). SN 85-189,675. PUB. 5-3-2011. FILED 12-2-2010.
- 3,997,153. **TETRADIGM GROUP (STANDARD CHARACTER).** TETRADIGM GROUP, LLC, MULTIPLE CLASS, (INT. CLS. 35 AND 36), (U.S. CLS. 100, 101 AND 102). SN 85-189,712. PUB. 5-3-2011. FILED 12-2-2010.
- 3,997,154. **TETRADIGM GROUP AND DESIGN.** TETRADIGM GROUP, LLC, MULTIPLE CLASS, (INT. CLS. 35 AND 36), (U.S. CLS. 100, 101 AND 102). SN 85-189,721. PUB. 5-3-2011. FILED 12-2-2010.
- 3,997,156. **COASTAL CLASSIC CREATIONS AND DESIGN.** COASTAL CLASSIC CREATIONS, (U.S. CLS. 100, 101 AND 102). SN 85-189,751. PUB. 5-3-2011. FILED 12-2-2010.
- 3,997,168. **PROVIDERSELECT: MD (STANDARD CHARACTER).** PREMIER, INC., (U.S. CLS. 100, 101 AND 102). SN 85-189,964. PUB. 5-3-2011. FILED 12-3-2010.
- 3,997,172. **MAIO CONSULTING (STANDARD CHARACTER).** MAIO CONSULTING, LLC, MULTIPLE CLASS, (INT. CLS. 35 AND 42), (U.S. CLS. 100, 101 AND 102). SN 85-190,031. PUB. 5-3-2011. FILED 12-3-2010.
- 3,997,173. **PETER'S HARDWARE CENTER AND DESIGN.** PALA, INC, (U.S. CLS. 100, 101 AND 102). SN 85-190,079. PUB. 5-3-2011. FILED 12-3-2010.
- 3,997,177. **EMPOWER TRUST. (STANDARD CHARACTER).** TRAX TECHNOLOGIES, INC., MULTIPLE CLASS, (INT. CLS. 35, 36 AND 42), (U.S. CLS. 100, 101 AND 102). SN 85-190,179. PUB. 5-3-2011. FILED 12-3-2010.
- 3,997,180. **AMG RESTAURANTS (STANDARD CHARACTER).**
- 217 ATLANTIC LLC, MULTIPLE CLASS, (INT. CLS. 35 AND 43), (U.S. CLS. 100, 101 AND 102). SN 85-190,290. PUB. 5-3-2011. FILED 12-3-2010.
- 3,997,181. **PRECIOUS CARGO TRANSITION SPECIALISTS FOR YOUR LIFE YOUR TREASURES YOUR HOME AND DESIGN.** WILSON, PAMELA D., MULTIPLE CLASS, (INT. CLS. 35, 36 AND 41), (U.S. CLS. 100, 101, 102 AND 107). SN 85-190,305. PUB. 5-3-2011. FILED 12-3-2010.
- 3,997,183. **ADIDAS (STYLIZED).** ADIDAS AG, MULTIPLE CLASS, (INT. CLS. 35 AND 41), (U.S. CLS. 100, 101, 102 AND 107). SN 85-190,310. PUB. 5-3-2011. FILED 12-3-2010.
- 3,997,190. **ZONE 3 ENVIRONMENTAL CORP. AND DESIGN.** ZONE 3 ENVIRONMENTAL, CORP, (U.S. CLS. 100, 101 AND 102). SN 85-190,585. PUB. 5-3-2011. FILED 12-3-2010.
- 3,997,194. **EZ QUOTE (STANDARD CHARACTER).** FEDERAL MARKETING CORP., (U.S. CLS. 100, 101 AND 102). SN 85-190,854. PUB. 5-3-2011. FILED 12-5-2010.
- 3,997,198 (*See Class 30 for this trademark*).
- 3,997,209. **REFACING AND MORE (STANDARD CHARACTER).** SHOWPLACE WOOD PRODUCTS, INC., (U.S. CLS. 100, 101 AND 102). SN 85-191,267. PUB. 5-3-2011. FILED 12-6-2010.
- 3,997,212. **SAVVY BRIDE (STANDARD CHARACTER).** FU WONG, (U.S. CLS. 100, 101 AND 102). SN 85-191,322. PUB. 5-3-2011. FILED 12-6-2010.
- 3,997,238. **SAGE WEDDING PROS (STANDARD CHARACTER).** SAGE WEDDING PROS, MULTIPLE CLASS, (INT. CLS. 35 AND 41), (U.S. CLS. 100, 101, 102 AND 107). SN 85-192,273. PUB. 5-3-2011. FILED 12-7-2010.
- 3,997,245. **FNC RESIDENTIAL PRICE INDEX (STANDARD CHARACTER).** FNC, INC., (U.S. CLS. 100, 101 AND 102). SN 85-192,570. PUB. 5-3-2011. FILED 12-7-2010.
- 3,997,248. **VISITGLENWOOD.COM (STANDARD CHARACTER).** GLENWOOD SPRINGS CHAMBER RESORT ASSOCIATION, INC., (U.S. CLS. 100, 101 AND 102). SN 85-192,669. PUB. 5-3-2011. FILED 12-7-2010.
- 3,997,251 (*See Class 17 for this trademark*).
- 3,997,254. **SNEAKERCHANGE AND DESIGN.** SNEAKERCHANGE, (U.S. CLS. 100, 101 AND 102). SN 85-192,706. PUB. 5-3-2011. FILED 12-7-2010.
- 3,997,258. **CURRY UP NOW INDIAN STREET FOOD AND DESIGN.** AKURANVYKA USA INC., DBA CURRY UP NOW, (U.S. CLS. 100, 101 AND 102). SN 85-192,784. PUB. 5-3-2011. FILED 12-8-2010.
- 3,997,268. **MEGAVENTION (STANDARD CHARACTER).** FRANCZEK, WILLIAM E., (U.S. CLS. 100, 101 AND 102). SN 85-193,073. PUB. 5-3-2011. FILED 12-8-2010.
- 3,997,287. **WINDOW WORLD (STYLIZED).** WINDOW WORLD INTERNATIONAL, LLC, MULTIPLE CLASS, (INT. CLS. 35 AND 37), (U.S. CLS. 100, 101, 102, 103 AND 106). SN 85-193,791. PUB. 5-3-2011. FILED 12-9-2010.
- 3,997,288. **ILLINOIS FARM FAMILIES (STANDARD CHARACTER).** ILLINOIS AGRICULTURAL ASSOCIATION, (U.S. CLS. 100, 101 AND 102). SN 85-193,838. PUB. 5-3-2011. FILED 12-9-2010.
- 3,997,293. **ILLINOIS FARM FAMILIES AND DESIGN.** ILLINOIS AGRICULTURAL ASSOCIATION, (U.S. CLS. 100, 101 AND 102). SN 85-193,974. PUB. 5-3-2011. FILED 12-9-2010.
- 3,997,295. **ETAJLSALES AND DESIGN.** ETAJLSALES ASSOCIATES, LLC, (U.S. CLS. 100, 101 AND 102). SN 85-194,084. PUB. 5-3-2011. FILED 12-9-2010.
- 3,997,311. **NEVER BORING DESIGN (STANDARD CHARACTER).** NEVER BORING DESIGN ASSOCIATES, INC., MULTIPLE CLASS, (INT. CLS. 35 AND 42), (U.S. CLS. 100, 101 AND 102). SN 85-194,702. PUB. 5-3-2011. FILED 12-9-2010.
- 3,997,312. **PANORAMA SEARCH AROUND THE WORLD AND DESIGN.** THE FERNEBORG GROUP, INC., (U.S. CLS. 100, 101 AND 102). SN 85-194,704. PUB. 5-3-2011. FILED 12-9-2010.
- 3,997,319. **AERODEF MANUFACTURING (STANDARD CHARACTER).** SOCIETY OF MANUFACTURING ENGINEERS, MULTIPLE CLASS, (INT. CLS. 35 AND 41), (U.S. CLS. 100, 101, 102 AND 107). SN 85-194,929. PUB. 5-3-2011. FILED 12-10-2010.
- 3,997,325. **AERODEF MANUFACTURING AND DESIGN.** SOCIETY OF MANUFACTURING ENGINEERS, MULTI-

- PLE CLASS, (INT. CLS. 35 AND 41), (U.S. CLS. 100, 101, 102 AND 107). SN 85-195,151. PUB. 5-3-2011. FILED 12-10-2010.
- 3,997,327. **AB AVIATION (STANDARD CHARACTER)**. ANDREW BETTIS AVIATION, MULTIPLE CLASS, (INT. CLS. 35 AND 39), (U.S. CLS. 100, 101, 102 AND 105). SN 85-195,167. PUB. 5-3-2011. FILED 12-10-2010.
- 3,997,345. **IDEA CHALLENGES (STANDARD CHARACTER)**. BULBSTORM, INC., (U.S. CLS. 100, 101 AND 102). SN 85-196,597. PUB. 5-3-2011. FILED 12-13-2010.
- 3,997,350. **OJO OFERTAS.COM (STANDARD CHARACTER)**. CHAVARRIA, CESAR, (U.S. CLS. 100, 101 AND 102). SN 85-196,695. PUB. 5-3-2011. FILED 12-13-2010.
- 3,997,354. **CORE ANALYTICS (STANDARD CHARACTER)**. CORE ANALYTICS, LLC, (U.S. CLS. 100, 101 AND 102). SN 85-197,086. PUB. 5-3-2011. FILED 12-14-2010.
- 3,997,355. **SHOPWIZ AND DESIGN**. WIZLY TECHNOLOGIES SARL, (U.S. CLS. 100, 101 AND 102). SN 85-197,134. PUB. 5-3-2011. FILED 12-14-2010.
- 3,997,364. **FIORE ARTISAN OLIVE OILS AND VINEGARS AND DESIGN**. FIORE LLC, (U.S. CLS. 100, 101 AND 102). SN 85-197,604. PUB. 5-3-2011. FILED 12-14-2010.
- 3,997,366. **ILEAN (STANDARD CHARACTER)**. PINNACLE PROCESS SOLUTIONS, INTERNATIONAL, (U.S. CLS. 100, 101 AND 102). SN 85-197,833. PUB. 5-3-2011. FILED 12-14-2010.
- 3,997,369. **WINEVILLA (STANDARD CHARACTER)**. BRANDILLA HOLDINGS LLC, (U.S. CLS. 100, 101 AND 102). SN 85-197,927. PUB. 5-3-2011. FILED 12-14-2010.
- 3,997,370. **COUCH CONTENT (STANDARD CHARACTER)**. PIGNATARO, ANTHONY, (U.S. CLS. 100, 101 AND 102). SN 85-197,948. PUB. 5-3-2011. FILED 12-14-2010.
- 3,997,388. **CERTIFIED AUTO CARE AND DESIGN**. WORLD MEDIA GROUP, LLC, (U.S. CLS. 100, 101 AND 102). SN 85-199,460. PUB. 5-3-2011. FILED 12-16-2010.
- 3,997,389. **KAY YOW CANCER FUND (STANDARD CHARACTER)**. KAY YOW CANCER FOUNDATION, INC., AKA KAY YOW CANCER FUND, MULTIPLE CLASS, (INT. CLS. 35 AND 36), (U.S. CLS. 100, 101 AND 102). SN 85-199,473. PUB. 5-3-2011. FILED 12-16-2010.
- 3,997,390. **GOTCHOO (STANDARD CHARACTER)**. 310 LABS, INC., (U.S. CLS. 100, 101 AND 102). SN 85-199,542. PUB. 5-3-2011. FILED 12-16-2010.
- 3,997,401. **KAY YOW CANCER FUND AND DESIGN**. KAY YOW CANCER FOUNDATION, INC., AKA KAY YOW CANCER FUND, MULTIPLE CLASS, (INT. CLS. 35 AND 36), (U.S. CLS. 100, 101 AND 102). SN 85-199,939. PUB. 5-3-2011. FILED 12-16-2010.
- 3,997,410. **BROTHERS OF THE ROAD AND DESIGN**. PROST, WILLIAM, (U.S. CLS. 100, 101 AND 102). SN 85-200,218. PUB. 5-3-2011. FILED 12-17-2010.
- 3,997,415. **FOCUSEDBUYER (STANDARD CHARACTER)**. FOCUSEDBUYER LLC, MULTIPLE CLASS, (INT. CLS. 35 AND 42), (U.S. CLS. 100, 101 AND 102). SN 85-200,265. PUB. 5-3-2011. FILED 12-17-2010.
- 3,997,418. **BANAH (STANDARD CHARACTER)**. BANAH INTERNATIONAL GROUP, INC., (U.S. CLS. 100, 101 AND 102). SN 85-200,326. PUB. 5-3-2011. FILED 12-17-2010.
- 3,997,420. **B BANAH AND DESIGN**. BANAH INTERNATIONAL GROUP, INC., (U.S. CLS. 100, 101 AND 102). SN 85-200,336. PUB. 5-3-2011. FILED 12-17-2010.
- 3,997,431. **OFF 5TH (STANDARD CHARACTER)**. SAKS & COMPANY, (U.S. CLS. 100, 101 AND 102). SN 85-200,704. PUB. 5-3-2011. FILED 12-17-2010.
- 3,997,434. **RITUALS . COFFEE COMPANY . SINCE 1996 AND DESIGN**. U.S. FOODSERVICE, INC., (U.S. CLS. 100, 101 AND 102). SN 85-200,818. PUB. 5-3-2011. FILED 12-17-2010.
- 3,997,437. **SWEETEN YOUR LIFE (STANDARD CHARACTER)**. BANAH INTERNATIONAL GROUP, INC., (U.S. CLS. 100, 101 AND 102). SN 85-200,931. PUB. 5-3-2011. FILED 12-17-2010.
- 3,997,440. **WE'RE BRINGING ROCKET SCIENCE TO DIGITAL ADVERTISING. (STANDARD CHARACTER)**. ROCKET FUEL INC., (U.S. CLS. 100, 101 AND 102). SN 85-201,137. PUB. 5-3-2011. FILED 12-17-2010.
- 3,997,452. **HABITAT FOR HUMANITY (STANDARD CHARACTER)**. HABITAT FOR HUMANITY INTERNATIONAL, INC., (U.S. CLS. 100, 101 AND 102). SN 85-201,775. PUB. 5-3-2011. FILED 12-20-2010.
- 3,997,459. **H2W (STANDARD CHARACTER)**. H2 WHOLESALE, LLC, (U.S. CLS. 100, 101 AND 102). SN 85-202,054. PUB. 5-3-2011. FILED 12-20-2010.
- 3,997,462. **FAMILIES IN THE LOOP (STANDARD CHARACTER)**. FAMILIES IN THE LOOP, INC., MULTIPLE CLASS, (INT. CLS. 35 AND 41), (U.S. CLS. 100, 101, 102 AND 107). SN 85-202,300. PUB. 5-3-2011. FILED 12-20-2010.
- 3,997,466. **SUCCESS ANGELS (STANDARD CHARACTER)**. WASHINGTON, NATALIE C, DBA SUCCESS ANGELS ISRAEL, (U.S. CLS. 100, 101 AND 102). SN 85-202,466. PUB. 5-3-2011. FILED 12-21-2010.
- 3,997,479. **I HEART SARASOTA AND DESIGN**. SARASOTA CONVENTION AND VISITORS BUREAU, INC., (U.S. CLS. 100, 101 AND 102). SN 85-202,682. PUB. 5-3-2011. FILED 12-21-2010.
- 3,997,486. **ARTIXAN (STANDARD CHARACTER)**. ARTIXAN CONSULTING GROUP LLC, (U.S. CLS. 100, 101 AND 102). SN 85-202,830. PUB. 5-3-2011. FILED 12-21-2010.
- 3,997,489. **HIDDEN CRUSH AND DESIGN**. HIDDEN CRUSH, INC., (U.S. CLS. 100, 101 AND 102). SN 85-202,987. PUB. 5-3-2011. FILED 12-21-2010.
- 3,997,490 (*See Class 20 for this trademark*).
- 3,997,501. **EVERBRAND AND DESIGN**. AARON, LAWRENCE D, DBA EVERBRAND, LLC, (U.S. CLS. 100, 101 AND 102). SN 85-203,660. PUB. 5-3-2011. FILED 12-22-2010.
- 3,997,504. **LOBBY SHOP (STANDARD CHARACTER)**. BOSTWICK, PETER J, (U.S. CLS. 100, 101 AND 102). SN 85-203,843. PUB. 5-3-2011. FILED 12-22-2010.
- 3,997,520. **HR 360 (STANDARD CHARACTER)**. HR 360, INC., (U.S. CLS. 100, 101 AND 102). SN 85-204,181. PUB. 5-3-2011. FILED 12-22-2010.
- 3,997,533. **PAPERCHECK (STANDARD CHARACTER)**. PAPER-CHECK.COM, LLC, DBA PAPERCHECK, MULTIPLE CLASS, (INT. CLS. 35 AND 41), (U.S. CLS. 100, 101, 102 AND 107). SN 85-204,500. PUB. 5-3-2011. FILED 12-22-2010.
- 3,997,535. **LOVELEEN (STANDARD CHARACTER)**. CHHABRA AND SONS, INC., (U.S. CLS. 100, 101 AND 102). SN 85-204,584. PUB. 5-3-2011. FILED 12-23-2010.
- 3,997,537. **IGVAULT (STANDARD CHARACTER)**. IGVAULT CO., LIMITED, (U.S. CLS. 100, 101 AND 102). SN 85-204,590. PUB. 5-3-2011. FILED 12-23-2010.
- 3,997,543. **BRINGING THE WORLD TO NORTH AMERICA AND NORTH AMERICA TO THE WORLD (STANDARD CHARACTER)**. NATIONAL TOUR ASSOCIATION, INC., (U.S. CLS. 100, 101 AND 102). SN 85-204,639. PUB. 5-3-2011. FILED 12-23-2010.
- 3,997,560. **KBS + P (STANDARD CHARACTER)**. KBP HOLDINGS LLC, MULTIPLE CLASS, (INT. CLS. 35 AND 42), (U.S. CLS. 100, 101 AND 102). SN 85-204,800. PUB. 5-3-2011. FILED 12-23-2010.
- 3,997,567. **REAL FOOD HAS A STORY (STANDARD CHARACTER)**. APPLGATE FARMS, LLC, (U.S. CLS. 100, 101 AND 102). SN 85-204,877. PUB. 5-3-2011. FILED 12-23-2010.
- 3,997,570 (*See Class 29 for this trademark*).
- 3,997,572. **HEALTHIER MEMBERS, HEALTHIER BUSINESS. (STANDARD CHARACTER)**. MEDASSURANT, INC., (U.S. CLS. 100, 101 AND 102). SN 85-204,927. PUB. 5-3-2011. FILED 12-23-2010.
- 3,997,574. **MISCELLANEOUS DESIGN**. URBAN PARTNERSHIP BANK, (U.S. CLS. 100, 101 AND 102). SN 85-204,961. PUB. 5-3-2011. FILED 12-23-2010.
- 3,997,581. **HUMANCONCEPTS (STANDARD CHARACTER)**. HUMANCONCEPTS LIMITED LIABILITY COMPANY, (U.S. CLS. 100, 101 AND 102). SN 85-205,041. PUB. 5-3-2011. FILED 12-23-2010.
- 3,997,590. **PAAS (STANDARD CHARACTER)**. SURGERE, INC., (U.S. CLS. 100, 101 AND 102). SN 85-205,156. PUB. 5-3-2011. FILED 12-23-2010.
- 3,997,591. **BLUEGRACE (STANDARD CHARACTER)**. BLUEGRACE I.P. LLC, MULTIPLE CLASS, (INT. CLS. 35 AND 39), (U.S. CLS. 100, 101, 102 AND 105). SN 85-205,180. PUB. 5-3-2011. FILED 12-23-2010.
- 3,997,594. **ORLEAGIAN SNOWBALLS (STANDARD CHARACTER)**. ORLEA-GIAN SNOBALLS, LLC, (U.S. CLS. 100, 101 AND 102). SN 85-205,222. PUB. 5-3-2011. FILED 12-23-2010.
- 3,997,596. **SURGERE (STANDARD CHARACTER)**. SURGERE, INC., (U.S. CLS. 100, 101 AND 102). SN 85-205,239. PUB. 5-3-

2011. FILED 12-23-2010.
- 3,997,597. **BLACKCLOUD AND DESIGN. IT LIFELINE, INC., MULTIPLE CLASS, (INT. CLS. 35 AND 42), (U.S. CLS. 100, 101 AND 102).** SN 85-205,242. PUB. 5-3-2011. FILED 12-23-2010.
- 3,997,598 (*See Class 6 for this trademark.*)
- 3,997,638. **GREENWISE (STYLIZED).** PUBLIX ASSET MANAGEMENT COMPANY, (U.S. CLS. 100, 101 AND 102). SN 85-205,784. PUB. 5-3-2011. FILED 12-27-2010.
- 3,997,640. **BLOOMSTODAY AND DESIGN.** FLOWERS TODAY, INC., (U.S. CLS. 100, 101 AND 102). SN 85-205,814. PUB. 5-3-2011. FILED 12-27-2010.
- 3,997,644. **YO TOPS (STANDARD CHARACTER).** JACKET PROPERTIES INC., (U.S. CLS. 100, 101 AND 102). SN 85-205,865. PUB. 5-3-2011. FILED 12-27-2010.
- 3,997,652. **TRANSFOHRM (STANDARD CHARACTER).** ROBERTS, DENNIS, (U.S. CLS. 100, 101 AND 102). SN 85-205,976. PUB. 5-3-2011. FILED 12-27-2010.
- 3,997,653. **PUROPARTY.NET (STYLIZED).** VARGAS, JOSEPH, (U.S. CLS. 100, 101 AND 102). SN 85-205,978. PUB. 5-3-2011. FILED 12-27-2010.
- 3,997,661. **INK4EVER.COM (STANDARD CHARACTER).** INK4EVER.COM, INC., (U.S. CLS. 100, 101 AND 102). SN 85-206,097. PUB. 5-3-2011. FILED 12-27-2010.
- 3,997,672. **ENGAGED PUBLIC (STANDARD CHARACTER).** HEALTHY OUTCOMES, INC., (U.S. CLS. 100, 101 AND 102). SN 85-206,207. PUB. 5-3-2011. FILED 12-27-2010.
- 3,997,674. **ALA MOANA HOTEL (STANDARD CHARACTER).** ALM MANAGEMENT SERVICES LLC, MULTIPLE CLASS, (INT. CLS. 35, 36 AND 43), (U.S. CLS. 100, 101 AND 102). SN 85-206,234. PUB. 5-3-2011. FILED 12-27-2010.
- 3,997,686. **BUYINGCIRCLE (STANDARD CHARACTER).** XUBA, LLC, (U.S. CLS. 100, 101 AND 102). SN 85-206,433. PUB. 5-3-2011. FILED 12-28-2010.
- 3,997,688. **BLOOMDOLLARS (STANDARD CHARACTER).** XUBA, LLC, (U.S. CLS. 100, 101 AND 102). SN 85-206,437. PUB. 5-3-2011. FILED 12-28-2010.
- 3,997,716. **BRINGING LEADERS TO SMART COMPANIES (STANDARD CHARACTER).** BOYLE OGATA BREGMAN, (U.S. CLS. 100, 101 AND 102). SN 85-206,822. PUB. 5-3-2011. FILED 12-28-2010.
- 3,997,718. **ACCELERATING RESULTS THROUGH COLLABORATION (STANDARD CHARACTER).** GLOBAL INVENTURES, INC., DBA INVENTURES, (U.S. CLS. 100, 101 AND 102). SN 85-206,883. PUB. 5-3-2011. FILED 12-28-2010.
- 3,997,722. **ADIT (STANDARD CHARACTER).** WOEB, INC, (U.S. CLS. 100, 101 AND 102). SN 85-206,934. PUB. 5-3-2011. FILED 12-29-2010.
- 3,997,731. **GREENPATH (STANDARD CHARACTER).** DELAWARE NORTH COMPANIES, INC., (U.S. CLS. 100, 101 AND 102). SN 85-207,040. PUB. 5-3-2011. FILED 12-29-2010.
- 3,997,741. **MELROSE MISSILE (STANDARD CHARACTER).** YOTHER, CECIL L., MULTIPLE CLASS, (INT. CLS. 35 AND 41), (U.S. CLS. 100, 101, 102 AND 107). SN 85-207,233. PUB. 5-3-2011. FILED 12-29-2010.
- 3,997,746. **BUYMYTRONICS (STANDARD CHARACTER).** HANA, LLC, (U.S. CLS. 100, 101 AND 102). SN 85-207,326. PUB. 5-3-2011. FILED 12-29-2010.
- 3,997,748. **MY PHARMACY (STANDARD CHARACTER).** MY PHARMACY OF HOMESTEAD, INC., (U.S. CLS. 100, 101 AND 102). SN 85-207,352. PUB. 5-3-2011. FILED 12-29-2010.
- 3,997,752. **A TO B CARD (STANDARD CHARACTER).** ANDREW BETTIS AVIATION, LLC, (U.S. CLS. 100, 101 AND 102). SN 85-207,417. PUB. 5-3-2011. FILED 12-29-2010.
- 3,997,767. **HR-HAVEN, INC. HR STARTUP TOOLKIT AND DESIGN.** HR-HAVEN, INC., (U.S. CLS. 100, 101 AND 102). SN 85-207,599. PUB. 5-3-2011. FILED 12-29-2010.
- 3,997,768. **MISCELLANEOUS DESIGN.** CORE-MARK INTERNATIONAL, INC., (U.S. CLS. 100, 101 AND 102). SN 85-207,612. PUB. 5-3-2011. FILED 12-29-2010.
- 3,997,769. **CORE-MARK (STANDARD CHARACTER).** CORE-MARK INTERNATIONAL, INC., (U.S. CLS. 100, 101 AND 102). SN 85-207,613. PUB. 5-3-2011. FILED 12-29-2010.
- 3,997,770. **LEADERSHIP EXCELLENCE. ORGANIZATION EFFECTIVENESS (STANDARD CHARACTER).** SARBER GARDNER INCORPORATED, (U.S. CLS. 100, 101 AND 102). SN 85-207,617. PUB. 5-3-2011. FILED 12-29-2010.
- 3,997,782. **BUY DESIGN (STANDARD CHARACTER).** HUNT REAL ESTATE CORPORATION, MULTIPLE CLASS, (INT. CLS. 35 AND 36), (U.S. CLS. 100, 101 AND 102). SN 85-207,818. PUB. 5-3-2011. FILED 12-30-2010.
- 3,997,784. **PARTSTOWN (STANDARD CHARACTER).** PARTS TOWN, LLC, MULTIPLE CLASS, (INT. CLS. 35, 37 AND 39), (U.S. CLS. 100, 101, 102, 103, 105 AND 106). SN 85-207,879. PUB. 5-3-2011. FILED 12-30-2010.
- 3,997,785. **PARTSTOWN AND DESIGN.** PARTS TOWN, LLC, MULTIPLE CLASS, (INT. CLS. 35, 37 AND 39), (U.S. CLS. 100, 101, 102, 103, 105 AND 106). SN 85-207,928. PUB. 5-3-2011. FILED 12-30-2010.
- 3,997,787. **WE'RE ENGINEERING AIR (STANDARD CHARACTER).** WALDRON OF MARYLAND, INC., (U.S. CLS. 100, 101 AND 102). SN 85-207,955. PUB. 5-3-2011. FILED 12-30-2010.
- 3,997,788. **EGOISTA AND DESIGN.** NUÑEZ, KELVYN L., DBA EGO VANITY STORE, EGO, EGOISTA AND NUNEZ RETAIL INVESTMENT COMPANY, (U.S. CLS. 100, 101 AND 102). SN 85-207,970. PUB. 5-3-2011. FILED 12-30-2010.
- 3,997,790. **AUTOBREEZE (STANDARD CHARACTER).** DIGITAL VENTURES MEDIA, LLC, DBA AUTOBREEZE, (U.S. CLS. 100, 101 AND 102). SN 85-207,984. PUB. 5-3-2011. FILED 12-30-2010.
- 3,997,794. **SETTING THE STANDARD FOR INDUSTRY FIRSTS (STANDARD CHARACTER).** SCHUSSLER CREATIVE, INC., (U.S. CLS. 100, 101 AND 102). SN 85-208,018. PUB. 5-3-2011. FILED 12-30-2010.
- 3,997,799. **MARIAH'S CHALLENGE AND DESIGN.** MARIAH DAYE MCCARTHY SCHOLARSHIP FOUNDATION, LLC, DBA MARIAH'S CHALLENGE, (U.S. CLS. 100, 101 AND 102). SN 85-208,077. PUB. 5-3-2011. FILED 12-30-2010.
- 3,997,808. **DEALNU AND DESIGN.** DEAL & U, INC., DBA DEALNU, (U.S. CLS. 100, 101 AND 102). SN 85-208,172. PUB. 5-3-2011. FILED 12-30-2010.
- 3,997,817. **PARADISE SPORTSWAREHOUSE (STANDARD CHARACTER).** PARADISE SPORTS, INC., (U.S. CLS. 100, 101 AND 102). SN 85-208,270. PUB. 5-3-2011. FILED 12-30-2010.
- 3,997,822. **DOYOUKNOWME.ORG (STANDARD CHARACTER).** CYPHERS, DOUG, (U.S. CLS. 100, 101 AND 102). SN 85-208,299. PUB. 5-3-2011. FILED 12-30-2010.
- 3,997,830. **REALLIGHTING (STANDARD CHARACTER).** REALLIGHTING, INC., (U.S. CLS. 100, 101 AND 102). SN 85-208,371. PUB. 5-3-2011. FILED 12-30-2010.
- 3,997,834 (*See Class 9 for this trademark.*)
- 3,997,835 (*See Class 9 for this trademark.*)
- 3,997,838. **VBMA VETERINARY BUSINESS MANAGEMENT ASSOCIATION AND DESIGN.** NATIONAL VETERINARY BUSINESS MANAGEMENT ASSOCIATION, INC., DBA VBMA, (U.S. CLS. 100, 101 AND 102). SN 85-208,453. PUB. 5-3-2011. FILED 12-31-2010.
- 3,997,839 (*See Class 9 for this trademark.*)
- 3,997,840 (*See Class 9 for this trademark.*)
- 3,997,842. **SMARTI-9 (STANDARD CHARACTER).** IMMIGRATION AND CUSTOMS SOLUTIONS, LLC, AKA ICS, LLC, (U.S. CLS. 100, 101 AND 102). SN 85-208,518. PUB. 5-3-2011. FILED 12-31-2010.
- 3,997,851. **AT WORK ON PURPOSE AND DESIGN.** SKILLSOURCE, (U.S. CLS. 100, 101 AND 102). SN 85-208,633. PUB. 5-3-2011. FILED 12-31-2010.
- 3,997,855. **NUCRAFT + CO. (STYLIZED).** NUCRAFT COMPANY, LLC, (U.S. CLS. 100, 101 AND 102). SN 85-208,652. PUB. 5-3-2011. FILED 12-31-2010.
- 3,997,856. **NU AND DESIGN.** NUCRAFT COMPANY, LLC, (U.S. CLS. 100, 101 AND 102). SN 85-208,657. PUB. 5-3-2011. FILED 12-31-2010.
- 3,997,857. **THE FINE ART OF ROMANCE (STANDARD CHARACTER).** THE FINE ART OF ROMANCE, INC., (U.S. CLS. 100, 101 AND 102). SN 85-208,661. PUB. 5-3-2011. FILED 12-31-2010.
- 3,997,872. **BAKER PACIFIC (STANDARD CHARACTER).** BAKER PACIFIC, INC., DBA BAKER PACIFIC, MULTIPLE CLASS, (INT. CLS. 35 AND 36), (U.S. CLS. 100, 101 AND 102). SN 85-208,729. PUB. 5-3-2011. FILED 12-31-2010.
- 3,997,877. **REDEFINING THE RUSH (STANDARD CHARACTER).** CITY OF ANGELS, (U.S. CLS. 100, 101 AND 102). SN 85-208,812. PUB. 5-3-2011. FILED 1-1-2011.

- 3,997,885. **JUICYADS (STANDARD CHARACTER)**. TIGER MEDIA, INC., (U.S. CLS. 100, 101 AND 102). SN 85-208,971. PUB. 5-3-2011. FILED 1-3-2011.
- 3,997,891. **ONE SIMPLE PRICE (STANDARD CHARACTER)**. CURTIS C. GUNN, LTD., FORMERLY CURTIS C. GUNN, INC., (U.S. CLS. 100, 101 AND 102). SN 85-209,009. PUB. 5-3-2011. FILED 1-3-2011.
- 3,997,900. **ONA (STANDARD CHARACTER)**. ONLINE NEWS ASSOCIATION, (U.S. CLS. 100, 101 AND 102). SN 85-209,095. PUB. 5-3-2011. FILED 1-3-2011.
- 3,997,912. **KORPARTNERS (STANDARD CHARACTER)**. KORTERRA, INC., (U.S. CLS. 100, 101 AND 102). SN 85-209,209. PUB. 5-3-2011. FILED 1-3-2011.
- 3,997,914. **AESOP (STYLIZED)**. EMEIS COSMETICS PTY. LTD., (U.S. CLS. 100, 101 AND 102). SN 85-209,217. PUB. 5-3-2011. FILED 1-3-2011.
- 3,997,923 (*See Class 9 for this trademark*).
- 3,997,928 (*See Class 9 for this trademark*).
- 3,997,934. **DOMAINSHERPA (STANDARD CHARACTER)**. WEB X.O MEDIA LLC, MULTIPLE CLASS, (INT. CLS. 35 AND 41), (U.S. CLS. 100, 101, 102 AND 107). SN 85-209,503. PUB. 5-3-2011. FILED 1-3-2011.
- 3,997,937. **PICTURE PEOPLE (STANDARD CHARACTER)**. TPP ACQUISITION, INC., MULTIPLE CLASS, (INT. CLS. 35 AND 41), (U.S. CLS. 100, 101, 102 AND 107). SN 85-209,542. PUB. 5-3-2011. FILED 1-3-2011.
- 3,997,938. **COOLERCAS (STANDARD CHARACTER)**. DIRECT MARKETING STORE, (U.S. CLS. 100, 101 AND 102). SN 85-209,564. PUB. 5-3-2011. FILED 1-3-2011.
- 3,997,941. **BUILDAROSARY.COM (STANDARD CHARACTER)**. THE LETICIA E. SCHMIDT TRUST NO. 101, (U.S. CLS. 100, 101 AND 102). SN 85-209,609. PUB. 5-3-2011. FILED 1-3-2011.
- 3,997,943. **BAYMONT INN & SUITES (STANDARD CHARACTER)**. WHG TM CORP., MULTIPLE CLASS, (INT. CLS. 35 AND 43), (U.S. CLS. 100, 101 AND 102). SN 85-209,685. PUB. 5-3-2011. FILED 1-4-2011.
- 3,997,944. **NINJA HOCKEY AND DESIGN**. YATH, SCOTT, (U.S. CLS. 100, 101 AND 102). SN 85-209,699. PUB. 5-3-2011. FILED 1-4-2011.
- 3,997,950. **RURAL LIVING ROCKS (STANDARD CHARACTER)**. EAST GEORGIA HEALTH COOPERATIVE, INC., (U.S. CLS. 100, 101 AND 102). SN 85-209,730. PUB. 5-3-2011. FILED 1-4-2011.
- 3,997,973. **GOTTA TALK ABOUT IT (STANDARD CHARACTER)**. SAVING PROMISE INC., (U.S. CLS. 100, 101 AND 102). SN 85-210,104. PUB. 5-3-2011. FILED 1-4-2011.
- 3,997,976. **WE MAKE WIPING EASY (STANDARD CHARACTER)**. ERC WIPING PRODUCTS, INC., (U.S. CLS. 100, 101 AND 102). SN 85-210,130. PUB. 5-3-2011. FILED 1-4-2011.
- 3,997,982. **MISCELLANEOUS DESIGN**. NETWORKING RESEARCH GROUP, INC., (U.S. CLS. 100, 101 AND 102). SN 85-210,235. PUB. 5-3-2011. FILED 1-4-2011.
- 3,997,983. **MISCELLANEOUS DESIGN**. NETWORKING RESEARCH GROUP, INC., (U.S. CLS. 100, 101 AND 102). SN 85-210,244. PUB. 5-3-2011. FILED 1-4-2011.
- 3,997,986. **GOULD 2 GOLD AND DESIGN**. CMT MILESTONES UNLIMITED INTERNATIONAL LLC, (U.S. CLS. 100, 101 AND 102). SN 85-210,277. PUB. 5-3-2011. FILED 1-4-2011.
- 3,997,998. **COZYBOOTS (STANDARD CHARACTER)**. WEATHERFLOW, INC., (U.S. CLS. 100, 101 AND 102). SN 85-210,457. PUB. 5-3-2011. FILED 1-4-2011.
- 3,998,000. **FORKINGDEALS AND DESIGN**. WMLEE, LLC, (U.S. CLS. 100, 101 AND 102). SN 85-210,468. PUB. 5-3-2011. FILED 1-4-2011.
- 3,998,003. **LF AND DESIGN**. LF SPORTSWEAR, INC., (U.S. CLS. 100, 101 AND 102). SN 85-210,482. PUB. 5-3-2011. FILED 1-4-2011.
- 3,998,004. **IMAGI-MOVIES (STYLIZED)**. KIM, PHILIP Y., (U.S. CLS. 100, 101 AND 102). SN 85-210,488. PUB. 5-3-2011. FILED 1-4-2011.
- 3,998,014. **MEDICUS A HEALTH & LIFESTYLE MANAGEMENT COMPANY AND DESIGN**. MEDICUS RESOURCE MANAGEMENT, INC., MULTIPLE CLASS, (INT. CLS. 35, 44 AND 45), (U.S. CLS. 100, 101 AND 102). SN 85-210,614. PUB. 5-3-2011. FILED 1-5-2011.
- 3,998,017. **IM IN.COM AND DESIGN**. ONLINE HOLDINGS LLC, (U.S. CLS. 100, 101 AND 102). SN 85-210,657. PUB. 5-3-2011. FILED 1-5-2011.
- 3,998,024. **SHARE THE PASSION (STANDARD CHARACTER)**. GUITAR CENTER, INC., (U.S. CLS. 100, 101 AND 102). SN 85-210,838. PUB. 5-3-2011. FILED 1-5-2011.
- 3,998,029. **SKINNY BILLIONAIRESS AND DESIGN**. WOOD, PAMELA, (U.S. CLS. 100, 101 AND 102). SN 85-210,857. PUB. 5-3-2011. FILED 1-5-2011.
- 3,998,030. **SPEED & SIMPLICITY (STANDARD CHARACTER)**. HARMONY INVESTMENTS LIMITED PARTNERSHIP, (U.S. CLS. 100, 101 AND 102). SN 85-210,875. PUB. 5-3-2011. FILED 1-5-2011.
- 3,998,033. **THE GOOD PEOPLE PEOPLE (STANDARD CHARACTER)**. FINCH MANAGEMENT & INVESTMENT, INC., (U.S. CLS. 100, 101 AND 102). SN 85-210,973. PUB. 5-3-2011. FILED 1-5-2011.
- 3,998,039. **COLOSSUS (STANDARD CHARACTER)**. SYNERGOS TECHNOLOGIES, INC., (U.S. CLS. 100, 101 AND 102). SN 85-211,066. PUB. 5-3-2011. FILED 1-5-2011.
- 3,998,044. **E AND DESIGN**. EXECUTIVES IN ACTION, (U.S. CLS. 100, 101 AND 102). SN 85-211,147. PUB. 5-3-2011. FILED 1-5-2011.
- 3,998,049. **AVANI (STANDARD CHARACTER)**. AVANI HOLDINGS LLC, DBA AVANI, (U.S. CLS. 100, 101 AND 102). SN 85-211,210. PUB. 5-3-2011. FILED 1-5-2011.
- 3,998,063. **DREAMBIDS AND DESIGN**. DREAMBIDS INC., (U.S. CLS. 100, 101 AND 102). SN 85-211,417. PUB. 5-3-2011. FILED 1-5-2011.
- 3,998,072. **SIXARM (STANDARD CHARACTER)**. HENDERSON, JOEL PARKER, DBA SIXARM, (U.S. CLS. 100, 101 AND 102). SN 85-211,490. PUB. 5-3-2011. FILED 1-5-2011.
- 3,998,075. **A ROGUISH HIGHLANDER (STANDARD CHARACTER)**. BRUCE MELNICK, (U.S. CLS. 100, 101 AND 102). SN 85-211,565. PUB. 5-3-2011. FILED 1-6-2011.
- 3,998,080. **3DREX (STANDARD CHARACTER)**. 3DREX & ANIREX STUDIOS, INC., (U.S. CLS. 100, 101 AND 102). SN 85-211,662. PUB. 5-3-2011. FILED 1-6-2011.
- 3,998,081. **THINKRELIABILITY (STANDARD CHARACTER)**. NOVEM, INC., MULTIPLE CLASS, (INT. CLS. 35 AND 41), (U.S. CLS. 100, 101, 102 AND 107). SN 85-211,676. PUB. 5-3-2011. FILED 1-6-2011.
- 3,998,097. **POSH (STANDARD CHARACTER)**. POSH, LLC, (U.S. CLS. 100, 101 AND 102). SN 85-211,984. PUB. 5-3-2011. FILED 1-6-2011.
- 3,998,101. **AMERICA'S PREMIER CERTIFIED ORGANIC DISTRIBUTOR (STANDARD CHARACTER)**. UNITED NATURAL FOODS, INC., (U.S. CLS. 100, 101 AND 102). SN 85-212,055. PUB. 5-3-2011. FILED 1-6-2011.
- 3,998,103. **HILCO (STANDARD CHARACTER)**. HILCO TRADING, LLC, MULTIPLE CLASS, (INT. CLS. 35 AND 36), (U.S. CLS. 100, 101 AND 102). SN 85-212,087. PUB. 5-3-2011. FILED 1-6-2011.
- 3,998,104. **MORE VALUE CREATED MORE WAYS (STANDARD CHARACTER)**. HILCO TRADING, LLC, MULTIPLE CLASS, (INT. CLS. 35 AND 36), (U.S. CLS. 100, 101 AND 102). SN 85-212,132. PUB. 5-3-2011. FILED 1-6-2011.
- 3,998,113. **MOPIX (STANDARD CHARACTER)**. MOPIX, LLC, (U.S. CLS. 100, 101 AND 102). SN 85-212,311. PUB. 5-3-2011. FILED 1-6-2011.
- 3,998,117. **CALLSTAGE (STANDARD CHARACTER)**. CALL STAGE, LLC, (U.S. CLS. 100, 101 AND 102). SN 85-212,456. PUB. 5-3-2011. FILED 1-7-2011.
- 3,998,126. **HELLO HANDY (STANDARD CHARACTER)**. JJNS CAPITAL LLC, (U.S. CLS. 100, 101 AND 102). SN 85-212,549. PUB. 5-3-2011. FILED 1-7-2011.
- 3,998,130. **YUMMY TREASURES (STANDARD CHARACTER)**. CARPENTER, GREG, DBA YUMMY TREASURES, (U.S. CLS. 100, 101 AND 102). SN 85-212,647. PUB. 5-3-2011. FILED 1-7-2011.
- 3,998,138. **WHY WAG A LITTLE WHEN YOU CAN WAG-A LOT (STANDARD CHARACTER)**. KOCH PRODUCTIONS, LLC, MULTIPLE CLASS, (INT. CLS. 35, 41, 43 AND 44), (U.S. CLS. 100, 101, 102 AND 107). SN 85-212,912. PUB. 5-3-2011. FILED 1-7-2011.
- 3,998,145. **PARADISE GOLFWAREHOUSE (STANDARD CHARACTER)**. PARADISE SPORTS, INC., (U.S. CLS. 100, 101 AND 102). SN 85-213,031. PUB. 5-3-2011. FILED 1-7-2011.
- 3,998,174. **POWER-GEN MIDDLE EAST FOCUSING ON**

- POWER GENERATION, T&D AND WATER AND DESIGN.** PENNWELL CORPORATION, (U.S. CLS. 100, 101 AND 102). SN 85-214,264. PUB. 5-3-2011. FILED 1-10-2011.
- 3,998,175. **MARBLES (STANDARD CHARACTER).** MARBLES LLC, MULTIPLE CLASS, (INT. CLS. 35 AND 44), (U.S. CLS. 100, 101 AND 102). SN 85-214,270. PUB. 5-3-2011. FILED 1-10-2011.
- 3,998,178 (*See Class 9 for this trademark*).
- 3,998,194. **ONE STOP WINE SHOP (STANDARD CHARACTER).** SUTTER HOME WINERY, INC., (U.S. CLS. 100, 101 AND 102). SN 85-216,004. PUB. 5-3-2011. FILED 1-12-2011.
- 3,998,196. **WINDOW WORLD (STANDARD CHARACTER).** WINDOW WORLD INTERNATIONAL, LLC, MULTIPLE CLASS, (INT. CLS. 35 AND 37), (U.S. CLS. 100, 101, 102, 103 AND 106). SN 85-216,054. PUB. 5-3-2011. FILED 1-12-2011.
- 3,998,206. **HUBBINGTONS AND DESIGN.** HUBBINGTONS, INC., (U.S. CLS. 100, 101 AND 102). SN 85-219,630. PUB. 5-3-2011. FILED 1-18-2011.
- 3,998,207. **SUDDENLY DARLING (STANDARD CHARACTER).** CASTFAM, INC., (U.S. CLS. 100, 101 AND 102). SN 85-220,369. PUB. 5-3-2011. FILED 1-18-2011.
- 3,998,211. **SOGGY DOLLAR (STANDARD CHARACTER).** WHITE BAY PARTNERS, LLC, (U.S. CLS. 100, 101 AND 102). SN 85-221,324. PUB. 4-26-2011. FILED 1-19-2011.
- 3,998,229. **IDOJOY (STANDARD CHARACTER).** HOPE & JOY, CORP., (U.S. CLS. 100, 101 AND 102). SN 85-226,262. PUB. 5-3-2011. FILED 1-26-2011.
- 3,998,233. **REAL WOMEN TALKING (STANDARD CHARACTER).** MEREDITH CORPORATION, (U.S. CLS. 100, 101 AND 102). SN 85-230,060. PUB. 5-3-2011. FILED 1-31-2011.
- 3,998,246 (*See Class 9 for this trademark*).
- 3,998,247 (*See Class 9 for this trademark*).
- 3,998,250. **GREENWISE (STYLIZED).** PUBLIX ASSET MANAGEMENT COMPANY, (U.S. CLS. 100, 101 AND 102). SN 85-234,350. PUB. 5-3-2011. FILED 2-4-2011.
- 3,998,251 (*See Class 9 for this trademark*).
- 3,998,253. **KILLER BREADQUARTERS (STANDARD CHARACTER).** AVB, INC., (U.S. CLS. 100, 101 AND 102). SN 85-236,244. PUB. 5-3-2011. FILED 2-8-2011.
- 3,998,255. **MR. PHILADELPHIA AND DESIGN.** INDEPENDENCE VISITOR CENTER CORPORATION, MULTIPLE CLASS, (INT. CLS. 35, 39 AND 41), (U.S. CLS. 100, 101, 102, 105 AND 107). SN 85-238,571. PUB. 5-3-2011. FILED 2-10-2011.
- 3,998,258. **NNID (STANDARD CHARACTER).** STATE FARM MUTUAL AUTOMOBILE INSURANCE COMPANY, (U.S. CLS. 100, 101 AND 102). SN 85-238,864. PUB. 5-3-2011. FILED 2-10-2011.
- 3,998,272. **SKECHERS (STANDARD CHARACTER).** SKECHERS U.S.A., INC. II, (U.S. CLS. 100, 101 AND 102). SN 85-244,924. PUB. 5-3-2011. FILED 2-17-2011.
- 3,998,274. **BUTTERCUP BAKE SHOP (STANDARD CHARACTER).** APPEL, JENNIFER C., (U.S. CLS. 100, 101 AND 102). SN 85-245,355. PUB. 5-3-2011. FILED 2-17-2011.
- 3,998,281. **THE RIVER GIFT SHOP (STANDARD CHARACTER).** PINNACLE ENTERTAINMENT, INC., (U.S. CLS. 100, 101 AND 102). SN 85-248,884. PUB. 5-3-2011. FILED 2-22-2011.
- 3,998,286. **THE RIVER GIFT SHOP (STYLIZED).** PINNACLE ENTERTAINMENT, INC., (U.S. CLS. 100, 101 AND 102). SN 85-248,984. PUB. 5-3-2011. FILED 2-22-2011.
- 3,995,495. **A HOPE TO DREAM AND DESIGN.** ASHLEY FURNITURE INDUSTRIES, INC., (U.S. CLS. 100, 101 AND 102). SN 76-705,770. PUB. 5-3-2011. FILED 12-23-2010.
- 3,995,496. **HARTZ MOUNTAIN (STANDARD CHARACTER).** HARTZ MOUNTAIN INDUSTRIES, INC., MULTIPLE CLASS, (INT. CLS. 36 AND 37), (U.S. CLS. 100, 101, 102, 103 AND 106). SN 76-705,779. PUB. 5-3-2011. FILED 12-23-2010.
- 3,995,513. **PENNANT (STANDARD CHARACTER).** PENNANT CAPITAL MANAGEMENT, LLC, (U.S. CLS. 100, 101 AND 102). SN 77-094,792. PUB. 5-3-2011. FILED 1-30-2007.
- 3,995,533 (*See Class 16 for this trademark*).
- 3,995,611. **FREE CHECKING WITH REWARDS CAPITAL O DEBIT BA 0123 4567 89 CUSTOMER SINCE 96 GOOD THRU 08/10 CAPITAL ONE CUSTOMER L WALKER PLANO, TX PAY TO THE ORDER OF DATE \$ 1024 C 30 AND DESIGN.** CAPITAL ONE FINANCIAL CORPORATION, (U.S. CLS. 100, 101 AND 102). SN 77-838,409. PUB. 5-3-2011. FILED 9-30-2009.
- 3,995,612 (*See Class 35 for this trademark*).
- 3,995,625 (*See Class 9 for this trademark*).
- 3,995,649. **SIBARTH PROPERTY MANAGEMENT (STANDARD CHARACTER).** SOCIETE IMMOBILIERE DE SAINT-BARTHELEMY, (U.S. CLS. 100, 101 AND 102). SN 77-885,801. PUB. 11-2-2010. FILED 12-3-2009.
- 3,995,650. **SIBARTH FWI (STANDARD CHARACTER).** SOCIETE IMMOBILIERE DE SAINT-BARTHELEMY, (U.S. CLS. 100, 101 AND 102). SN 77-885,824. PUB. 11-2-2010. FILED 12-3-2009.
- 3,995,651. **SIBARTH VILLAS (STANDARD CHARACTER).** SOCIETE IMMOBILIERE DE SAINT-BARTHELEMY, (U.S. CLS. 100, 101 AND 102). SN 77-885,845. PUB. 11-2-2010. FILED 12-3-2009.
- 3,995,652. **SIBARTH MAINTENANCE (STANDARD CHARACTER).** SOCIETE IMMOBILIERE DE SAINT-BARTHELEMY, (U.S. CLS. 100, 101 AND 102). SN 77-885,854. PUB. 11-2-2010. FILED 12-3-2009.
- 3,995,653. **SIBARTH INTERNATIONAL (STANDARD CHARACTER).** SOCIETE IMMOBILIERE DE SAINT-BARTHELEMY, (U.S. CLS. 100, 101 AND 102). SN 77-885,861. PUB. 11-2-2010. FILED 12-3-2009.
- 3,995,679 (*See Class 35 for this trademark*).
- 3,995,680 (*See Class 16 for this trademark*).
- 3,995,681 (*See Class 16 for this trademark*).
- 3,995,682. **BLUE BELL COUNTRY CLUB COMMUNITY ASSOCIATION (STANDARD CHARACTER).** BLUE BELL COUNTRY CLUB COMMUNITY ASSOCIATION, MULTIPLE CLASS, (INT. CLS. 36 AND 41), (U.S. CLS. 100, 101, 102 AND 107). SN 77-930,571. PUB. 5-3-2011. FILED 2-8-2010.
- 3,995,690. **MISCELLANEOUS DESIGN.** UTICA MUTUAL INSURANCE COMPANY, DBA UTICA NATIONAL INSURANCE GROUP, (U.S. CLS. 100, 101 AND 102). SN 77-939,984. PUB. 5-3-2011. FILED 2-19-2010.
- 3,995,706 (*See Class 35 for this trademark*).
- 3,995,728 (*See Class 9 for this trademark*).
- 3,995,732. **MISCELLANEOUS DESIGN.** OBSHESTVO S OGRANICHENNOJ OTVETSTVENNOSTJU "ALPHALINER", MULTIPLE CLASS, (INT. CLS. 36 AND 39), (U.S. CLS. 100, 101, 102 AND 105). SN 79-064,065. PUB. 5-3-2011. FILED 10-23-2008.
- 3,995,735 (*See Class 6 for this trademark*).
- 3,995,750 (*See Class 9 for this trademark*).
- 3,995,751 (*See Class 9 for this trademark*).
- 3,995,752 (*See Class 9 for this trademark*).
- 3,995,773 (*See Class 35 for this trademark*).
- 3,995,774 (*See Class 35 for this trademark*).
- 3,995,801 (*See Class 35 for this trademark*).
- 3,995,820 (*See Class 35 for this trademark*).
- 3,995,825 (*See Class 35 for this trademark*).
- 3,995,826 (*See Class 35 for this trademark*).
- 3,995,840. **SCORT (STANDARD CHARACTER).** GIGI OERI, MULTIPLE CLASS, (INT. CLS. 36 AND 41), (U.S. CLS. 100, 101, 102 AND 107). SN 79-084,513. PUB. 5-3-2011. FILED 5-31-2010.
- 3,995,849 (*See Class 12 for this trademark*).
- 3,995,863 (*See Class 2 for this trademark*).
- 3,995,866. **FLOW TRADERS (STANDARD CHARACTER).** FLOW TRADERS B.V., MULTIPLE CLASS, (INT. CLS. 36

CLASS 36—INSURANCE AND FINANCIAL

- 3,995,471. **MISCELLANEOUS DESIGN.** LONESTAR SOCCER CLUB OF AUSTIN, INC., MULTIPLE CLASS, (INT. CLS. 36 AND 41), (U.S. CLS. 100, 101, 102 AND 107). SN 76-703,132. PUB. 5-3-2011. FILED 5-27-2010.
- 3,995,481. **HSA PROTRAK (STANDARD CHARACTER).** PROCURA, LLC, MULTIPLE CLASS, (INT. CLS. 36 AND 39), (U.S. CLS. 100, 101, 102 AND 105). SN 76-704,242. PUB. 5-3-2011. FILED 8-25-2010.
- 3,995,489. **LUMINAIRE AWARDS (STANDARD CHARACTER).** INTERNATIONAL DIGITAL ENTERPRISE ALLIANCE, INC., (U.S. CLS. 100, 101 AND 102). SN 76-705,684. PUB. 5-3-2011. FILED 12-14-2010.

- AND 38), (U.S. CLS. 100, 101, 102 AND 104). SN 79-085,254. PUB. 5-3-2011. FILED 6-2-2010.
- 3,995,881 (*See Class 35 for this trademark*).
- 3,995,882 (*See Class 16 for this trademark*).
- 3,995,910 (*See Class 35 for this trademark*).
- 3,995,917 (*See Class 35 for this trademark*).
- 3,995,969 (*See Class 9 for this trademark*).
- 3,995,991. **WITH YOU FROM A-Z. ALLIANZ (STANDARD CHARACTER)**. ALLIANZ SE, (U.S. CLS. 100, 101 AND 102). SN 79-091,414. PUB. 5-3-2011. FILED 10-26-2010.
- 3,995,993. **CORAL TRAVEL AND DESIGN**. ODEON TURIZM ISLETMECILIGI A.S., MULTIPLE CLASS, (INT. CLS. 36 AND 39), (U.S. CLS. 100, 101, 102 AND 105). SN 79-091,532. PUB. 5-3-2011. FILED 3-5-2010.
- 3,996,038. **MINDCASH (STANDARD CHARACTER)**. MINDFILE, INC., (U.S. CLS. 100, 101 AND 102). SN 85-004,800. PUB. 5-3-2011. FILED 4-1-2010.
- 3,996,059. **WRITE TO EDUCATE (STANDARD CHARACTER)**. LANSING AUTOMAKERS FEDERAL CREDIT UNION, (U.S. CLS. 100, 101 AND 102). SN 85-017,212. PUB. 5-3-2011. FILED 4-19-2010.
- 3,996,061. **MARKETEYE (STANDARD CHARACTER)**. MEREDITH CORPORATION, MULTIPLE CLASS, (INT. CLS. 36 AND 41), (U.S. CLS. 100, 101, 102 AND 107). SN 85-018,016. PUB. 5-3-2011. FILED 4-20-2010.
- 3,996,095. **HOMESTAT (STANDARD CHARACTER)**. DATA INTELLIGENCE CORPORATION, (U.S. CLS. 100, 101 AND 102). SN 85-029,552. PUB. 5-3-2011. FILED 5-4-2010.
- 3,996,105. **CATHOLIC FINANCIAL SERVICES (STANDARD CHARACTER)**. CATHOLIC FINANCIAL LIFE, (U.S. CLS. 100, 101 AND 102). SN 85-032,657. PUB. 5-3-2011. FILED 5-7-2010.
- 3,996,123 (*See Class 35 for this trademark*).
- 3,996,155 (*See Class 35 for this trademark*).
- 3,996,164. **THE HOME CIRCLE (STANDARD CHARACTER)**. UNITED SERVICES AUTOMOBILE ASSOCIATION, (U.S. CLS. 100, 101 AND 102). SN 85-041,574. PUB. 5-3-2011. FILED 5-18-2010.
- 3,996,168. **FREEWAY INSURANCE AND DESIGN**. FREEWAY INSURANCE SERVICES, INC., (U.S. CLS. 100, 101 AND 102). SN 85-041,980. PUB. 5-3-2011. FILED 5-18-2010.
- 3,996,174 (*See Class 35 for this trademark*).
- 3,996,179. **MISCELLANEOUS DESIGN**. HOMEAWAY.COM, INC., MULTIPLE CLASS, (INT. CLS. 36 AND 43), (U.S. CLS. 100, 101 AND 102). SN 85-042,855. PUB. 5-3-2011. FILED 5-19-2010.
- 3,996,182. **MISCELLANEOUS DESIGN**. NHB HOLDINGS, INC., (U.S. CLS. 100, 101 AND 102). SN 85-043,051. PUB. 5-3-2011. FILED 5-19-2010.
- 3,996,186 (*See Class 16 for this trademark*).
- 3,996,219. **D AND DESIGN**. DALE OPERATING COMPANY, MULTIPLE CLASS, (INT. CLS. 36 AND 42), (U.S. CLS. 100, 101 AND 102). SN 85-047,009. PUB. 5-3-2011. FILED 5-25-2010.
- 3,996,220. **CENTRE INSURANCE COMPANY (STANDARD CHARACTER)**. CENTRE GROUP HOLDINGS LIMITED, (U.S. CLS. 100, 101 AND 102). SN 85-047,051. PUB. 5-3-2011. FILED 5-25-2010.
- 3,996,221. **CENTRE (STANDARD CHARACTER)**. CENTRE GROUP HOLDINGS LIMITED, (U.S. CLS. 100, 101 AND 102). SN 85-047,054. PUB. 5-3-2011. FILED 5-25-2010.
- 3,996,222. **DAN ZANGER (STANDARD CHARACTER)**. CHARTPATTERN.COM, INC., MULTIPLE CLASS, (INT. CLS. 36 AND 41), (U.S. CLS. 100, 101, 102 AND 107). SN 85-047,224. PUB. 5-3-2011. FILED 5-25-2010.
- 3,996,247. **SAFE-GUARD (STANDARD CHARACTER)**. SAFE-GUARD PRODUCTS INTERNATIONAL, LLC, (U.S. CLS. 100, 101 AND 102). SN 85-050,652. PUB. 11-2-2010. FILED 5-28-2010.
- 3,996,257 (*See Class 35 for this trademark*).
- 3,996,266. **BIG CANOE ATLANTA'S PREMIER MOUNTAIN HOME (STANDARD CHARACTER)**. BIG CANOE CO., LLC, MULTIPLE CLASS, (INT. CLS. 36 AND 37), (U.S. CLS. 100, 101, 102, 103 AND 106). SN 85-052,771. PUB. 5-3-2011. FILED 6-2-2010.
- 3,996,297 (*See Class 35 for this trademark*).
- 3,996,305. **BEACH BUSINESS BANK (STANDARD CHARACTER)**. BEACH BUSINESS BANK, (U.S. CLS. 100, 101 AND 102). SN 85-063,165. PUB. 5-3-2011. FILED 6-15-2010.
- 3,996,332. **TORRENTCLAIMS (STANDARD CHARACTER)**. TORRENT TECHNOLOGIES, INC., (U.S. CLS. 100, 101 AND 102). SN 85-068,615. PUB. 5-3-2011. FILED 6-22-2010.
- 3,996,362 (*See Class 35 for this trademark*).
- 3,996,481. **THOR (STANDARD CHARACTER)**. ROYAL BANK OF CANADA, (U.S. CLS. 100, 101 AND 102). SN 85-113,644. PUB. 5-3-2011. FILED 8-23-2010.
- 3,996,486. **CYBER-CASHIER (STANDARD CHARACTER)**. SOLID GROUP, LLC, (U.S. CLS. 100, 101 AND 102). SN 85-115,653. PUB. 5-3-2011. FILED 8-25-2010.
- 3,996,513. **RYAN'S WELL FOUNDATION (STANDARD CHARACTER)**. RYAN'S WELL FOUNDATION, MULTIPLE CLASS, (INT. CLS. 36, 41 AND 43), (U.S. CLS. 100, 101, 102 AND 107). SN 85-125,227. PUB. 5-3-2011. FILED 9-8-2010.
- 3,996,518. **MLSEXP SEARCH.COM MULTIPLE LISTING SERVICE EXPRESS AND DESIGN**. CITYWIDE MEDIA INC., (U.S. CLS. 100, 101 AND 102). SN 85-125,623. PUB. 5-3-2011. FILED 9-9-2010.
- 3,996,522. **LIVE HERE EAT FREE (STANDARD CHARACTER)**. IMAGINATION HOLDINGS, LLC, (U.S. CLS. 100, 101 AND 102). SN 85-126,190. PUB. 5-3-2011. FILED 9-9-2010.
- 3,996,545 (*See Class 35 for this trademark*).
- 3,996,591 (*See Class 35 for this trademark*).
- 3,996,592. **VANDERPAL METHOD (STANDARD CHARACTER)**. ANONYMOUS HOME, LLC, (U.S. CLS. 100, 101 AND 102). SN 85-142,752. PUB. 5-3-2011. FILED 10-1-2010.
- 3,996,609. **AMERICAN REBOUND (STANDARD CHARACTER)**. BELLESTAR PARTNERS, LLC, (U.S. CLS. 100, 101 AND 102). SN 85-146,503. PUB. 5-3-2011. FILED 10-6-2010.
- 3,996,612 (*See Class 35 for this trademark*).
- 3,996,655. **APARTMENT RENTAL EXPERTS THE EASY WAY HOME (STANDARD CHARACTER)**. APARTMENT RENTAL EXPERTS LLC, (U.S. CLS. 100, 101 AND 102). SN 85-156,711. PUB. 5-3-2011. FILED 10-20-2010.
- 3,996,660. **SWIPEPAY (STANDARD CHARACTER)**. CHRISTOPHER A. WUHRER, (U.S. CLS. 100, 101 AND 102). SN 85-157,909. PUB. 5-3-2011. FILED 10-21-2010.
- 3,996,685. **MISCELLANEOUS DESIGN**. VERTICAL CLAIMS MANAGEMENT, LLC, (U.S. CLS. 100, 101 AND 102). SN 85-163,288. PUB. 5-3-2011. FILED 10-28-2010.
- 3,996,686. **SMART WOMEN BUY HOMES (STANDARD CHARACTER)**. DOUTHITT, JEANIE KAY, (U.S. CLS. 100, 101 AND 102). SN 85-163,521. PUB. 5-3-2011. FILED 10-28-2010.
- 3,996,706. **ASPEN ICLIENT (STANDARD CHARACTER)**. ASPEN GROVE, INC., (U.S. CLS. 100, 101 AND 102). SN 85-167,036. PUB. 5-3-2011. FILED 11-2-2010.
- 3,996,707. **ICC IMPERIAL CREDIT CORPORATION AND DESIGN**. IPFS CORPORATION, (U.S. CLS. 100, 101 AND 102). SN 85-167,128. PUB. 5-3-2011. FILED 11-2-2010.
- 3,996,708. **SUNSHINE HOUSE COMFORT CARE FOR CHILDREN AND DESIGN**. THE SUNSHINE HOUSE, INC., (U.S. CLS. 100, 101 AND 102). SN 85-167,241. PUB. 5-3-2011. FILED 11-2-2010.
- 3,996,717. **ALPINE PAYMENT SYSTEMS AND DESIGN**. IQ PAYMENT SYSTEMS, DBA ALPINE PAYMENT SYSTEMS, (U.S. CLS. 100, 101 AND 102). SN 85-168,548. PUB. 5-3-2011. FILED 11-3-2010.
- 3,996,719. **METABLUE (STANDARD CHARACTER)**. METABANK, (U.S. CLS. 100, 101 AND 102). SN 85-168,929. PUB. 1-25-2011. FILED 11-4-2010.
- 3,996,762. **F FIFTH STREET (STYLIZED)**. FIFTH STREET CAPITAL LLC, (U.S. CLS. 100, 101 AND 102). SN 85-173,247. PUB. 5-3-2011. FILED 11-10-2010.
- 3,996,776. **ICC AND DESIGN**. IPFS CORPORATION, (U.S. CLS. 100, 101 AND 102). SN 85-174,486. PUB. 5-3-2011. FILED 11-11-2010.
- 3,996,808. **PFS PREMIUM FINANCING S P E C I A L I S T S AND DESIGN**. IPFS CORPORATION, (U.S. CLS. 100, 101 AND 102). SN 85-176,500. PUB. 5-3-2011. FILED 11-15-2010.
- 3,996,814. **EXPERIENCE THE DIAMOND STANDARD (STANDARD CHARACTER)**. SCF SECURITIES, INC., (U.S. CLS. 100, 101 AND 102). SN 85-176,827. PUB. 5-3-2011. FILED 11-15-2010.
- 3,996,828. **PAYMENT WORKSUITE (STANDARD CHARACTER)**. 3DELTA SYSTEMS, INC., MULTIPLE CLASS, (INT. CLS. 36, 38 AND 42), (U.S. CLS. 100, 101, 102 AND 104). SN

- 85-177,838. PUB. 5-3-2011. FILED 11-16-2010.
- 3,996,833. **POWER ADVANTAGE EXTENDED SERVICE PLANS AND DESIGN.** 4WARRANTY CORPORATION, (U.S. CLS. 100, 101 AND 102). SN 85-178,198. PUB. 5-3-2011. FILED 11-16-2010.
- 3,996,836. **C A CLAIRENT ADVISORS VALUATION AND TRANSACTION SPECIALISTS AND DESIGN.** CLAIRENT ADVISORS LLC, (U.S. CLS. 100, 101 AND 102). SN 85-178,391. PUB. 5-3-2011. FILED 11-16-2010.
- 3,996,887 (*See Class 35 for this trademark.*).
- 3,996,901. **ENGINEERING FOR THE EARTH AND DESIGN.** WEAVER, ROBERT J, MULTIPLE CLASS, (INT. CLS. 36 AND 42), (U.S. CLS. 100, 101 AND 102). SN 85-181,840. PUB. 5-3-2011. FILED 11-20-2010.
- 3,996,902. **ETAGE REAL ESTATE (STANDARD CHARACTER).** ETAGE REAL ESTATE, LLC, (U.S. CLS. 100, 101 AND 102). SN 85-182,013. PUB. 5-3-2011. FILED 11-22-2010.
- 3,996,932. **FFV SCORECARD (STANDARD CHARACTER).** TRINITY FIDUCIARY PARTNERS, LLC, (U.S. CLS. 100, 101 AND 102). SN 85-183,308. PUB. 5-3-2011. FILED 11-23-2010.
- 3,996,938. **FIRST ROUND CAPITAL AND DESIGN.** FR CAPITAL HOLDINGS, L.P., (U.S. CLS. 100, 101 AND 102). SN 85-183,701. PUB. 5-3-2011. FILED 11-23-2010.
- 3,996,945. **REPAIR6 (STANDARD CHARACTER).** 4WARRANTY CORPORATION, (U.S. CLS. 100, 101 AND 102). SN 85-184,006. PUB. 5-3-2011. FILED 11-23-2010.
- 3,996,965. **MISCELLANEOUS DESIGN.** APPRAISER LOFT, LLC, (U.S. CLS. 100, 101 AND 102). SN 85-185,281. PUB. 5-3-2011. FILED 11-25-2010.
- 3,997,004. **IVILLA (STANDARD CHARACTER).** IVILLA, LLC, (U.S. CLS. 100, 101 AND 102). SN 85-186,709. PUB. 5-3-2011. FILED 11-29-2010.
- 3,997,031. **VISTA ENDOWMENT FUND (STANDARD CHARACTER).** VISTA ENDOWMENT FUND, INC., (U.S. CLS. 100, 101 AND 102). SN 85-187,266. PUB. 5-3-2011. FILED 11-30-2010.
- 3,997,036. **LINCOLN DENTALCONNECT (STANDARD CHARACTER).** LINCOLN NATIONAL LIFE INSURANCE COMPANY, THE, (U.S. CLS. 100, 101 AND 102). SN 85-187,453. PUB. 5-3-2011. FILED 11-30-2010.
- 3,997,087. **OPT FREE CHECKING (STANDARD CHARACTER).** FIDELITY BANK CORPORATION, DBA FIDELITY BANK, (U.S. CLS. 100, 101 AND 102). SN 85-188,592. PUB. 5-3-2011. FILED 12-1-2010.
- 3,997,096. **COCKTAILS CURING CANCER AND DESIGN.** DALL, RENEE ELIZABETH, (U.S. CLS. 100, 101 AND 102). SN 85-188,775. PUB. 5-3-2011. FILED 12-1-2010.
- 3,997,099 (*See Class 35 for this trademark.*).
- 3,997,101 (*See Class 35 for this trademark.*).
- 3,997,103 (*See Class 35 for this trademark.*).
- 3,997,107 (*See Class 35 for this trademark.*).
- 3,997,118. **KOKOPELLI REAL ESTATE AND PROPERTY MANAGEMENT (STANDARD CHARACTER).** RESIDENTIAL PROPERTY MANAGEMENT, INC., (U.S. CLS. 100, 101 AND 102). SN 85-189,185. PUB. 5-3-2011. FILED 12-2-2010.
- 3,997,136. **SOUTH FERRY (STANDARD CHARACTER).** SOUTH FERRY CAPITAL MANAGEMENT, L.P., (U.S. CLS. 100, 101 AND 102). SN 85-189,537. PUB. 5-3-2011. FILED 12-2-2010.
- 3,997,139. **SURF 24 AND DESIGN.** FREDERICK, TANNA, (U.S. CLS. 100, 101 AND 102). SN 85-189,550. PUB. 5-3-2011. FILED 12-2-2010.
- 3,997,146. **SF AND DESIGN.** SOUTH FERRY CAPITAL MANAGEMENT, L.P., (U.S. CLS. 100, 101 AND 102). SN 85-189,617. PUB. 5-3-2011. FILED 12-2-2010.
- 3,997,153 (*See Class 35 for this trademark.*).
- 3,997,154 (*See Class 35 for this trademark.*).
- 3,997,177 (*See Class 35 for this trademark.*).
- 3,997,181 (*See Class 35 for this trademark.*).
- 3,997,207. **BMFN GLOBAL MARKETS DELIVERED LOCALLY AND DESIGN.** BMP STANDARD, LLC, (U.S. CLS. 100, 101 AND 102). SN 85-191,205. PUB. 5-3-2011. FILED 12-6-2010.
- 3,997,222. **REDHAWK AND DESIGN.** REDHAWK WEALTH ADVISORS, INC, (U.S. CLS. 100, 101 AND 102). SN 85-191,633. PUB. 5-3-2011. FILED 12-6-2010.
- 3,997,229. **MEMBER ASSIST (STANDARD CHARACTER).** CUPAR, LLC, (U.S. CLS. 100, 101 AND 102). SN 85-191,828. PUB. 5-3-2011. FILED 12-7-2010.
- 3,997,256. **NEW ALLIANCE REALTY NAR AND DESIGN.** NEW ALLIANCE REALTY, INC., DBA NEW ALLIANCE REALTY, (U.S. CLS. 100, 101 AND 102). SN 85-192,740. PUB. 5-3-2011. FILED 12-7-2010.
- 3,997,259. **VALUCONNECT (STANDARD CHARACTER).** APPRAISER LOFT, LLC, (U.S. CLS. 100, 101 AND 102). SN 85-192,822. PUB. 5-3-2011. FILED 12-8-2010.
- 3,997,260. **VALUCLEAR (STANDARD CHARACTER).** APPRAISER LOFT, LLC, (U.S. CLS. 100, 101 AND 102). SN 85-192,824. PUB. 5-3-2011. FILED 12-8-2010.
- 3,997,263. **ZENO (STANDARD CHARACTER).** ZENO CONSULTING GROUP, LLC, (U.S. CLS. 100, 101 AND 102). SN 85-192,899. PUB. 5-3-2011. FILED 12-8-2010.
- 3,997,264. **ZENO CONSULTING GROUP (STANDARD CHARACTER).** ZENO CONSULTING GROUP, LLC, (U.S. CLS. 100, 101 AND 102). SN 85-192,915. PUB. 5-3-2011. FILED 12-8-2010.
- 3,997,277. **ATTORNEY ADVANTAGE CHECKING (STANDARD CHARACTER).** ESQUIRE BANK FSB, (U.S. CLS. 100, 101 AND 102). SN 85-193,320. PUB. 5-3-2011. FILED 12-8-2010.
- 3,997,292. **MONY AND DESIGN.** MONY LIFE INSURANCE COMPANY, (U.S. CLS. 100, 101 AND 102). SN 85-193,929. PUB. 5-3-2011. FILED 12-9-2010.
- 3,997,322. **BALL PROJECT (STANDARD CHARACTER).** INDIANA SPORTS OUTREACH, INC., (U.S. CLS. 100, 101 AND 102). SN 85-195,059. PUB. 5-3-2011. FILED 12-10-2010.
- 3,997,329. **THE DAILY HOOT (STANDARD CHARACTER).** FIXED INCOME LIVE, LP, (U.S. CLS. 100, 101 AND 102). SN 85-195,225. PUB. 5-3-2011. FILED 12-10-2010.
- 3,997,339. **MARYLAND AREA REGIONAL CENTER LLC (MARC) AND DESIGN.** MARYLAND AREA REGIONAL CENTER LLC, (U.S. CLS. 100, 101 AND 102). SN 85-195,922. PUB. 5-3-2011. FILED 12-11-2010.
- 3,997,377. **MISCELLANEOUS DESIGN.** INDIANA SPORTS OUTREACH, INC., (U.S. CLS. 100, 101 AND 102). SN 85-198,410. PUB. 5-3-2011. FILED 12-15-2010.
- 3,997,389 (*See Class 35 for this trademark.*).
- 3,997,401 (*See Class 35 for this trademark.*).
- 3,997,402. **C&S CHARITIES, INC. (STANDARD CHARACTER).** C&S WHOLESALE GROCERS, INC., (U.S. CLS. 100, 101 AND 102). SN 85-199,986. PUB. 5-3-2011. FILED 12-16-2010.
- 3,997,404. **MISCELLANEOUS DESIGN.** GROSVENOR USA LIMITED, (U.S. CLS. 100, 101 AND 102). SN 85-200,063. PUB. 5-3-2011. FILED 12-16-2010.
- 3,997,406. **LIVING CITIES (STANDARD CHARACTER).** GROSVENOR USA LIMITED, (U.S. CLS. 100, 101 AND 102). SN 85-200,076. PUB. 5-3-2011. FILED 12-16-2010.
- 3,997,417. **SOLOMON'S PLAN INVEST WISELY. LIVE ABUNDANTLY. AND DESIGN.** WIERENGA ASSET MANAGEMENT, INC., DBA SOLOMON'S PLAN, (U.S. CLS. 100, 101 AND 102). SN 85-200,325. PUB. 5-3-2011. FILED 12-17-2010.
- 3,997,424. **CASHLESS KETTLE (STANDARD CHARACTER).** THE SALVATION ARMY, (U.S. CLS. 100, 101 AND 102). SN 85-200,569. PUB. 5-3-2011. FILED 12-17-2010.
- 3,997,464. **MISCELLANEOUS DESIGN.** TRICERION GROUP, LLC, (U.S. CLS. 100, 101 AND 102). SN 85-202,423. PUB. 5-3-2011. FILED 12-21-2010.
- 3,997,474. **LAFUCU AND DESIGN.** LANSING AUTOMAKERS FEDERAL CREDIT UNION, (U.S. CLS. 100, 101 AND 102). SN 85-202,603. PUB. 5-3-2011. FILED 12-21-2010.
- 3,997,500. **MISCELLANEOUS DESIGN.** 38 KEYES AVE SUITE 200, (U.S. CLS. 100, 101 AND 102). SN 85-203,659. PUB. 5-3-2011. FILED 12-22-2010.
- 3,997,506. **STYLIZED T AND V AND DESIGN.** THOMVEST SEED CAPITAL INC., (U.S. CLS. 100, 101 AND 102). SN 85-203,870. PUB. 5-3-2011. FILED 12-22-2010.
- 3,997,510. **NAVIGATING ALL YOUR NEEDS (STANDARD CHARACTER).** NAV ADVISORS INC, (U.S. CLS. 100, 101 AND 102). SN 85-203,927. PUB. 5-3-2011. FILED 12-22-2010.
- 3,997,511. **BUSINESS CHOICE (STANDARD CHARACTER).** ASSOCIATED BANC-CORP, (U.S. CLS. 100, 101 AND 102). SN 85-203,934. PUB. 5-3-2011. FILED 12-22-2010.

- 3,997,512. **A TAYLOR HOUSE (STANDARD CHARACTER)**. NANCY TAYLOR BUBES, (U.S. CLS. 100, 101 AND 102). SN 85-203,966. PUB. 5-3-2011. FILED 12-22-2010.
- 3,997,513. **RACING TO RECOVERY (STANDARD CHARACTER)**. SAM SCHMIDT FOUNDATION, DBA SAM SCHMIDT PARALYSIS FOUNDATION, (U.S. CLS. 100, 101 AND 102). SN 85-203,967. PUB. 5-3-2011. FILED 12-22-2010.
- 3,997,526. **DON'T SETTLE FOR LESS (STANDARD CHARACTER)**. ODESS, DANIEL B., (U.S. CLS. 100, 101 AND 102). SN 85-204,270. PUB. 5-3-2011. FILED 12-22-2010.
- 3,997,542. **A NEW FINANCIAL PLAN DREAM BIG. LIVE SMALL. AND DESIGN. A NEW FINANCIAL PLAN, LLC**, (U.S. CLS. 100, 101 AND 102). SN 85-204,637. PUB. 5-3-2011. FILED 12-23-2010.
- 3,997,565. **ARCANO (STYLIZED)**. ARCANO ASESORES FINANCIEROS, S.L., (U.S. CLS. 100, 101 AND 102). SN 85-204,852. PUB. 5-3-2011. FILED 12-23-2010.
- 3,997,580. **PARCPLACE (STANDARD CHARACTER)**. EMPOWHR, INC., (U.S. CLS. 100, 101 AND 102). SN 85-205,002. PUB. 5-3-2011. FILED 12-23-2010.
- 3,997,585. **MISCELLANEOUS DESIGN. URBAN PARTNERSHIP BANK**, (U.S. CLS. 100, 101 AND 102). SN 85-205,073. PUB. 5-3-2011. FILED 12-23-2010.
- 3,997,587. **GAME DAY. GIVE BACK. (STANDARD CHARACTER)**. AMERICAN LEBANESE SYRIAN ASSOCIATED CHARITIES, INC., (U.S. CLS. 100, 101 AND 102). SN 85-205,104. PUB. 5-3-2011. FILED 12-23-2010.
- 3,997,617. **COMMUTER CHECK OFFICE (STANDARD CHARACTER)**. COMMUTER CHECK SERVICES CORPORATION, (U.S. CLS. 100, 101 AND 102). SN 85-205,502. PUB. 5-3-2011. FILED 12-24-2010.
- 3,997,618. **MY COMMUTER CHECK (STANDARD CHARACTER)**. COMMUTER CHECK SERVICES CORPORATION, (U.S. CLS. 100, 101 AND 102). SN 85-205,503. PUB. 5-3-2011. FILED 12-24-2010.
- 3,997,619. **COMMUTER CHECK FOR BICYCLING (STANDARD CHARACTER)**. COMMUTER CHECK SERVICES CORPORATION, (U.S. CLS. 100, 101 AND 102). SN 85-205,506. PUB. 5-3-2011. FILED 12-24-2010.
- 3,997,625. **AMERICAN BOMBSHELLS (STANDARD CHARACTER)**. AMERICAN BOMBSHELLS ENTERTAINMENT, INC., (U.S. CLS. 100, 101 AND 102). SN 85-205,637. PUB. 5-3-2011. FILED 12-25-2010.
- 3,997,648. **MISCELLANEOUS DESIGN. PARTNER CREDIT UNION**, (U.S. CLS. 100, 101 AND 102). SN 85-205,930. PUB. 5-3-2011. FILED 12-27-2010.
- 3,997,651. **CASHNOWREFI.COM (STANDARD CHARACTER)**. MERIDIAN HOME MORTGAGE CORPORATION, (U.S. CLS. 100, 101 AND 102). SN 85-205,974. PUB. 5-3-2011. FILED 12-27-2010.
- 3,997,657. **FLORIDA FAMILY (STANDARD CHARACTER)**. FLORIDA FAMILY INSURANCE SERVICES, LLC, (U.S. CLS. 100, 101 AND 102). SN 85-206,024. PUB. 5-3-2011. FILED 12-27-2010.
- 3,997,658. **WELCOME TO THE FAMILY (STANDARD CHARACTER)**. FLORIDA FAMILY INSURANCE SERVICES, LLC, (U.S. CLS. 100, 101 AND 102). SN 85-206,042. PUB. 5-3-2011. FILED 12-27-2010.
- 3,997,659. **FLORIDA FAMILY INSURANCE (STANDARD CHARACTER)**. FLORIDA FAMILY INSURANCE SERVICES, LLC, (U.S. CLS. 100, 101 AND 102). SN 85-206,075. PUB. 5-3-2011. FILED 12-27-2010.
- 3,997,660. **HILTON & HYLAND (STANDARD CHARACTER)**. HILTON & HYLAND REAL ESTATE, INC., (U.S. CLS. 100, 101 AND 102). SN 85-206,086. PUB. 5-3-2011. FILED 12-27-2010.
- 3,997,674 (*See Class 35 for this trademark*).
- 3,997,675. **HILTON & HYLAND (STYLIZED)**. HILTON & HYLAND REAL ESTATE, INC., (U.S. CLS. 100, 101 AND 102). SN 85-206,265. PUB. 5-3-2011. FILED 12-27-2010.
- 3,997,687. **RETHINKING ASSET MANAGEMENT (STANDARD CHARACTER)**. BLUE EDGE CAPITAL, LLC, (U.S. CLS. 100, 101 AND 102). SN 85-206,434. PUB. 5-3-2011. FILED 12-28-2010.
- 3,997,700. **MARY FREE BED (STANDARD CHARACTER)**. MARY FREE BED GUILD OF GRAND RAPIDS, MICHIGAN, MULTIPLE CLASS, (INT. CLS. 36, 41, 44 AND 45), (U.S. CLS. 100, 101, 102 AND 107). SN 85-206,529. PUB. 5-3-2011. FILED 12-28-2010.
- 3,997,702. **MAGICAL FOREST (STANDARD CHARACTER)**. OPPORTUNITY VILLAGE FOUNDATION, (U.S. CLS. 100, 101 AND 102). SN 85-206,610. PUB. 5-3-2011. FILED 12-28-2010.
- 3,997,708. **CAN SLIM AND DESIGN. INVESTOR'S BUSINESS DAILY, INC., MULTIPLE CLASS, (INT. CLS. 36 AND 41)**, (U.S. CLS. 100, 101, 102 AND 107). SN 85-206,704. PUB. 5-3-2011. FILED 12-28-2010.
- 3,997,734. **INNOVATIVE SOLUTIONS. OUTSTANDING SERVICE. GREAT PEOPLE. (STANDARD CHARACTER)**. DEALER SERVICES CORPORATION, (U.S. CLS. 100, 101 AND 102). SN 85-207,067. PUB. 5-3-2011. FILED 12-29-2010.
- 3,997,735. **SOLO OUTLOOK (STANDARD CHARACTER)**. ROCKY MOUNTAIN HEALTH MAINTENANCE ORGANIZATION, INCORPORATED, (U.S. CLS. 100, 101 AND 102). SN 85-207,096. PUB. 5-3-2011. FILED 12-29-2010.
- 3,997,782 (*See Class 35 for this trademark*).
- 3,997,786. **MISCELLANEOUS DESIGN. SANCTIFIED REAL ESTATE**, (U.S. CLS. 100, 101 AND 102). SN 85-207,939. PUB. 5-3-2011. FILED 12-30-2010.
- 3,997,805. **M AND DESIGN. THE MENKE GROUP, INC.**, (U.S. CLS. 100, 101 AND 102). SN 85-208,124. PUB. 5-3-2011. FILED 12-30-2010.
- 3,997,806. **JUST ONE (STANDARD CHARACTER)**. HANSON, HEIDI, (U.S. CLS. 100, 101 AND 102). SN 85-208,140. PUB. 5-3-2011. FILED 12-30-2010.
- 3,997,827. **LIFETIME LEGACY (STANDARD CHARACTER)**. AMERICO LIFE, INC., (U.S. CLS. 100, 101 AND 102). SN 85-208,341. PUB. 5-3-2011. FILED 12-30-2010.
- 3,997,872 (*See Class 35 for this trademark*).
- 3,997,892. **THOMCO (STANDARD CHARACTER)**. THOMPSON INSURANCE ENTERPRISES, LLC, (U.S. CLS. 100, 101 AND 102). SN 85-209,018. PUB. 5-3-2011. FILED 1-3-2011.
- 3,997,899. **BE READY FOR ANYTHING (STANDARD CHARACTER)**. CLARK-MORTENSON AGENCY, INC., (U.S. CLS. 100, 101 AND 102). SN 85-209,094. PUB. 5-3-2011. FILED 1-3-2011.
- 3,997,931. **CLARITY 2 PROSPERITY (STANDARD CHARACTER)**. SMITH, JASON L., (U.S. CLS. 100, 101 AND 102). SN 85-209,475. PUB. 5-3-2011. FILED 1-3-2011.
- 3,997,956. **OPENAIR (STANDARD CHARACTER)**. OPENAIR EQUITY PARTNERS, LLC, (U.S. CLS. 100, 101 AND 102). SN 85-209,828. PUB. 5-3-2011. FILED 1-4-2011.
- 3,997,959. **MASSEY QUICK (STANDARD CHARACTER)**. MASSEY, QUICK & CO., LLC, (U.S. CLS. 100, 101 AND 102). SN 85-209,860. PUB. 5-3-2011. FILED 1-4-2011.
- 3,998,002. **COCKTAILS AND CROONING FOR A CURE (STANDARD CHARACTER)**. LYNN, AMY N, AND LYNN, JOHN A, (U.S. CLS. 100, 101 AND 102). SN 85-210,473. PUB. 5-3-2011. FILED 1-4-2011.
- 3,998,012. **BREATHE DEEP (STANDARD CHARACTER)**. LUNGEVITY FOUNDATION, (U.S. CLS. 100, 101 AND 102). SN 85-210,601. PUB. 5-3-2011. FILED 1-5-2011.
- 3,998,016. **PFS AND DESIGN. IPFS CORPORATION**, (U.S. CLS. 100, 101 AND 102). SN 85-210,656. PUB. 5-3-2011. FILED 1-5-2011.
- 3,998,038. **BENITECTS (STANDARD CHARACTER)**. BENITECTS, LLC, (U.S. CLS. 100, 101 AND 102). SN 85-211,028. PUB. 5-3-2011. FILED 1-5-2011.
- 3,998,042. **& (STYLIZED)**. INNOVATIVE RISK CONCEPTS, INC., (U.S. CLS. 100, 101 AND 102). SN 85-211,104. PUB. 5-3-2011. FILED 1-5-2011.
- 3,998,065. **HOME OF HOPE (STANDARD CHARACTER)**. THE WATERFORD FOUNDATION, (U.S. CLS. 100, 101 AND 102). SN 85-211,420. PUB. 5-3-2011. FILED 1-5-2011.
- 3,998,071. **RIGHTSURE (STANDARD CHARACTER)**. THE JEFF ARNOLD COMPANIES, INC., (U.S. CLS. 100, 101 AND 102). SN 85-211,478. PUB. 5-3-2011. FILED 1-5-2011.
- 3,998,103 (*See Class 35 for this trademark*).
- 3,998,104 (*See Class 35 for this trademark*).
- 3,998,199. **YOU'VE EARNED IT. (STANDARD CHARACTER)**. RESIDENTIAL FINANCE CORPORATION, (U.S. CLS. 100, 101 AND 102). SN 85-216,894. PUB. 5-3-2011. FILED 1-13-2011.
- 3,998,235. **MISCELLANEOUS DESIGN. SPRINGBOARD NON-PROFIT CONSUMER CREDIT MANAGEMENT**,

- INC., MULTIPLE CLASS, (INT. CLS. 36 AND 41), (U.S. CLS. 100, 101, 102 AND 107). SN 85-230,220. PUB. 5-3-2011. FILED 1-31-2011.
- 3,998,242. **BRIGHT IDEAS (STANDARD CHARACTER)**. THE PRUDENTIAL INSURANCE COMPANY OF AMERICA, (U.S. CLS. 100, 101 AND 102). SN 85-232,932. PUB. 5-3-2011. FILED 2-3-2011.
- 3,998,243. **BRIGHT IDEAS AND DESIGN**. THE PRUDENTIAL INSURANCE COMPANY OF AMERICA, (U.S. CLS. 100, 101 AND 102). SN 85-233,051. PUB. 5-3-2011. FILED 2-3-2011.
- 3,998,244. **BRIGHT IDEAS AND DESIGN**. THE PRUDENTIAL INSURANCE COMPANY OF AMERICA, (U.S. CLS. 100, 101 AND 102). SN 85-233,094. PUB. 5-3-2011. FILED 2-3-2011.
- 3,998,252. **BELL (STANDARD CHARACTER)**. BELL PARTNERS, INC., (U.S. CLS. 100, 101 AND 102). SN 85-235,645. PUB. 5-3-2011. FILED 2-7-2011.
-
- CLASS 37—CONSTRUCTION AND REPAIR**
- 3,995,473 (*See Class 35 for this trademark*).
- 3,995,496 (*See Class 36 for this trademark*).
- 3,995,515 (*See Class 9 for this trademark*).
- 3,995,524 (*See Class 7 for this trademark*).
- 3,995,531 (*See Class 7 for this trademark*).
- 3,995,540 (*See Class 9 for this trademark*).
- 3,995,648 (*See Class 2 for this trademark*).
- 3,995,686. **MAN LODGES (STANDARD CHARACTER)**. SAGE CREEK DEVELOPMENT, L.L.C., (U.S. CLS. 100, 103 AND 106). SN 77-937,063. PUB. 5-3-2011. FILED 2-16-2010.
- 3,995,728 (*See Class 9 for this trademark*).
- 3,995,734 (*See Class 6 for this trademark*).
- 3,995,735 (*See Class 6 for this trademark*).
- 3,995,738 (*See Class 9 for this trademark*).
- 3,995,772 (*See Class 6 for this trademark*).
- 3,995,775 (*See Class 6 for this trademark*).
- 3,995,779 (*See Class 9 for this trademark*).
- 3,995,793 (*See Class 11 for this trademark*).
- 3,995,813 (*See Class 7 for this trademark*).
- 3,995,820 (*See Class 35 for this trademark*).
- 3,995,821 (*See Class 7 for this trademark*).
- 3,995,823 (*See Class 9 for this trademark*).
- 3,995,839 (*See Class 4 for this trademark*).
- 3,995,844. **LOXIN (STANDARD CHARACTER)**. LOXIN 2002, S.L., (U.S. CLS. 100, 103 AND 106). SN 79-084,680. PUB. 5-3-2011. FILED 2-19-2010.
- 3,995,849 (*See Class 12 for this trademark*).
- 3,995,854 (*See Class 7 for this trademark*).
- 3,995,868 (*See Class 9 for this trademark*).
- 3,995,870 (*See Class 12 for this trademark*).
- 3,995,879 (*See Class 6 for this trademark*).
- 3,995,882 (*See Class 16 for this trademark*).
- 3,995,885 (*See Class 7 for this trademark*).
- 3,995,886 (*See Class 19 for this trademark*).
- 3,995,899 (*See Class 12 for this trademark*).
- 3,995,904 (*See Class 1 for this trademark*).
- 3,995,912 (*See Class 2 for this trademark*).
- 3,995,948 (*See Class 7 for this trademark*).
- 3,996,064. **WINNER CONSTRUCTION (STANDARD CHARACTER)**. WINNER CONSTRUCTION GROUP, INC., (U.S. CLS. 100, 103 AND 106). SN 85-018,702. PUB. 5-3-2011. FILED 4-20-2010.
- 3,996,077. **WHATEVER IT TAKES (STANDARD CHARACTER)**. DASSAULT FALCON JET CORP., (U.S. CLS. 100, 103 AND 106). SN 85-023,864. PUB. 5-3-2011. FILED 4-27-2010.
- 3,996,107. **WDS WORLDWIDE DEEPWATER SOLUTIONS LLC AND DESIGN**. WORLDWIDE DEEPWATER SOLUTIONS, LLC, (U.S. CLS. 100, 103 AND 106). SN 85-032,851. PUB. 5-3-2011. FILED 5-7-2010.
- 3,996,153. **RESTORZ AND DESIGN**. RESTORZ LLC, MULTIPLE CLASS, (INT. CLS. 37 AND 40), (U.S. CLS. 100, 103 AND 106). SN 85-039,997. PUB. 5-3-2011. FILED 5-17-2010.
- 3,996,192 (*See Class 1 for this trademark*).
- 3,996,202 (*See Class 1 for this trademark*).
- 3,996,242. **CONNECTING THE WIRED AND WIRELESS WORLDS (STANDARD CHARACTER)**. UNITEK GLOBAL SERVICES, INC., (U.S. CLS. 100, 103 AND 106). SN 85-050,318. PUB. 5-3-2011. FILED 5-28-2010.
- 3,996,266 (*See Class 36 for this trademark*).
- 3,996,286. **TANCOR CORPORATION (STANDARD CHARACTER)**. TANCOR CORPORATION, (U.S. CLS. 100, 103 AND 106). SN 85-057,937. PUB. 5-3-2011. FILED 6-8-2010.
- 3,996,308 (*See Class 7 for this trademark*).
- 3,996,364. **WESTLINE (STYLIZED)**. WESTLINE COMMERCIAL REALTY, LLC, TA WESTLINE COMMERCIAL REALTY, (U.S. CLS. 100, 103 AND 106). SN 85-074,799. PUB. 5-3-2011. FILED 6-30-2010.
- 3,996,382. **SAFEMART (STANDARD CHARACTER)**. BOLSTER LLC, (U.S. CLS. 100, 103 AND 106). SN 85-080,408. PUB. 5-3-2011. FILED 7-8-2010.
- 3,996,415. **SANDOVAL (STANDARD CHARACTER)**. CAPE CORAL DEVELOPMENT ASSOCIATES, LLC, (U.S. CLS. 100, 103 AND 106). SN 85-090,401. PUB. 5-3-2011. FILED 7-22-2010.
- 3,996,421. **U.S.M.M., INC. (STANDARD CHARACTER)**. U.S.M.M., INC., (U.S. CLS. 100, 103 AND 106). SN 85-091,814. PUB. 5-3-2011. FILED 7-23-2010.
- 3,996,435. **MAIDS ON THE RUN HOME CONCIERGE WE TAKE CARE OF YOUR HOME SO YOU CAN TAKE CARE OF YOUR FAMILY AND DESIGN**. MAIDS ON THE RUN INC, (U.S. CLS. 100, 103 AND 106). SN 85-094,599. PUB. 5-3-2011. FILED 7-28-2010.
- 3,996,470 (*See Class 35 for this trademark*).
- 3,996,557. **WHEN THINGS GET ICKY, JUST CALL RICKY! (STANDARD CHARACTER)**. RICKY ROOTER, (U.S. CLS. 100, 103 AND 106). SN 85-133,680. PUB. 5-3-2011. FILED 9-20-2010.
- 3,996,563. **ANY PIPE ANY PLACE! GAS POOL - SPA SEWER - DRAINS FIRE SPRINKLERS POTABLE - DRINKING AND DESIGN**. BRINK, WILLIAM R, (U.S. CLS. 100, 103 AND 106). SN 85-134,906. PUB. 5-3-2011. FILED 9-21-2010.
- 3,996,599. **ACADIA HOMES & NEIGHBORHOODS AND DESIGN**. ACADIA HOMES & NEIGHBORHOODS, LLC, (U.S. CLS. 100, 103 AND 106). SN 85-145,149. PUB. 5-3-2011. FILED 10-5-2010.
- 3,996,617. **CARPET CLEANING PLUS (STANDARD CHARACTER)**. CARPET CLEANING PLUS, INC., (U.S. CLS. 100, 103 AND 106). SN 85-148,088. PUB. 5-3-2011. FILED 10-8-2010.
- 3,996,656 (*See Class 16 for this trademark*).
- 3,996,657 (*See Class 35 for this trademark*).
- 3,996,697. **PLCCENTER (STANDARD CHARACTER)**. RADWELL INTERNATIONAL, INC., (U.S. CLS. 100, 103 AND 106). SN 85-165,052. PUB. 5-3-2011. FILED 10-29-2010.
- 3,996,709 (*See Class 35 for this trademark*).
- 3,996,723 (*See Class 35 for this trademark*).
- 3,996,728. **ECODUCTS AND DESIGN**. GENTRY HEATING, INC., DBA ECODUCTS ENVIRONMENTAL AIR QUALITY, (U.S. CLS. 100, 103 AND 106). SN 85-170,001. PUB. 5-3-2011. FILED 11-5-2010.
- 3,996,755. **THE CARPET GUYS (STANDARD CHARACTER)**. THE CARPET GUYS, LLC, (U.S. CLS. 100, 103 AND 106). SN 85-172,863. PUB. 5-3-2011. FILED 11-9-2010.
- 3,996,800 (*See Class 7 for this trademark*).
- 3,996,815. **EXCEL ROOFING (STANDARD CHARACTER)**. EXCEL ROOFING, INCORPORATED, (U.S. CLS. 100, 103 AND 106). SN 85-176,921. PUB. 5-3-2011. FILED 11-15-2010.
- 3,996,817. **E P RECON PEST CONTROL AND DESIGN**. E & P RECON PEST CONTROL, LLC, (U.S. CLS. 100, 103 AND 106). SN 85-177,078. PUB. 5-3-2011. FILED 11-15-2010.
- 3,996,870. **IRON CROSS AUDIO AND DESIGN**. IRON CROSS AUDIO LLC, (U.S. CLS. 100, 103 AND 106). SN 85-179,825. PUB. 5-3-2011. FILED 11-18-2010.
- 3,996,979 (*See Class 12 for this trademark*).
- 3,997,022. **THE BBQ CLEANER AND DESIGN**. HUMMINGBIRD ENTERPRISES, INC., (U.S. CLS. 100, 103 AND 106). SN 85-187,098. PUB. 5-3-2011. FILED 11-30-2010.
- 3,997,090. **"YOUR SATISFACTION IS OUR #1 PRIORITY" AND DESIGN**. SAL MANZO'S PLUMBING & HEATING, INC., (U.S. CLS. 100, 103 AND 106). SN 85-188,683. PUB. 5-3-2011. FILED 12-1-2010.
- 3,997,107 (*See Class 35 for this trademark*).
- 3,997,149. **TRAPPER JOHN RODENT & ANIMAL SPECIALIST (STANDARD CHARACTER)**. TRAPPER JOHN ANIMAL CONTROL, INC., (U.S. CLS. 100, 103 AND 106). SN 85-

- 189,658. PUB. 5-3-2011. FILED 12-2-2010.
- 3,997,169. **TAKENAKA AND DESIGN. TAKENAKA CORPORATION**, (U.S. CLS. 100, 103 AND 106). SN 85-189,968. PUB. 5-3-2011. FILED 12-3-2010.
- 3,997,170. **SYBAC SOLAR (STANDARD CHARACTER). SYBAC SOLAR LLC**, MULTIPLE CLASS, (INT. CLS. 37 AND 42), (U.S. CLS. 100, 101, 103 AND 106). SN 85-189,978. PUB. 5-3-2011. FILED 12-3-2010.
- 3,997,252. **MATTHEW 5:16 AND DESIGN. ECONOMY PEST CONTROL, INC.**, (U.S. CLS. 100, 103 AND 106). SN 85-192,694. PUB. 5-3-2011. FILED 12-7-2010.
- 3,997,287 (*See Class 35 for this trademark*).
- 3,997,298. **MISCELLANEOUS DESIGN. J.C. CHEEK CONTRACTORS, INC.**, (U.S. CLS. 100, 103 AND 106). SN 85-194,142. PUB. 5-3-2011. FILED 12-9-2010.
- 3,997,403. **CAN-B-GREEN (STANDARD CHARACTER). CAN-B-GREEN, LLC**, (U.S. CLS. 100, 103 AND 106). SN 85-199,990. PUB. 5-3-2011. FILED 12-16-2010.
- 3,997,493. **MISCELLANEOUS DESIGN. RR INVESTMENTS, INC.**, MULTIPLE CLASS, (INT. CLS. 37 AND 39), (U.S. CLS. 100, 103, 105 AND 106). SN 85-203,206. PUB. 5-3-2011. FILED 12-21-2010.
- 3,997,545. **MEMA MATES (STANDARD CHARACTER). MEMA MATES LLC, DBA MEMA MATES LLC**, (U.S. CLS. 100, 103 AND 106). SN 85-204,655. PUB. 5-3-2011. FILED 12-23-2010.
- 3,997,558. **ASON (STANDARD CHARACTER). ADVANCED STATE OF NETWORKING, INC.**, MULTIPLE CLASS, (INT. CLS. 37 AND 42), (U.S. CLS. 100, 101, 103 AND 106). SN 85-204,782. PUB. 5-3-2011. FILED 12-23-2010.
- 3,997,563. **RED COATS (STANDARD CHARACTER). RED COATS, INC.**, (U.S. CLS. 100, 103 AND 106). SN 85-204,842. PUB. 5-3-2011. FILED 12-23-2010.
- 3,997,678. **FINE LINE (STANDARD CHARACTER). FINE LINE COLLISION CENTER, LLC**, (U.S. CLS. 100, 103 AND 106). SN 85-206,358. PUB. 5-3-2011. FILED 12-28-2010.
- 3,997,730. **REED & REED AND DESIGN. REED & REED, INC.**, (U.S. CLS. 100, 103 AND 106). SN 85-207,031. PUB. 5-3-2011. FILED 12-29-2010.
- 3,997,736. **RC (STYLIZED). RED COATS, INC.**, (U.S. CLS. 100, 103 AND 106). SN 85-207,106. PUB. 5-3-2011. FILED 12-29-2010.
- 3,997,747. **PAINTING SMILES ON FACES EVERYWHERE (STANDARD CHARACTER). CERTA PROPAINTERS, LTD.**, (U.S. CLS. 100, 103 AND 106). SN 85-207,328. PUB. 5-3-2011. FILED 12-29-2010.
- 3,997,751 (*See Class 11 for this trademark*).
- 3,997,757. **SMART. SAFE. GREEN. (STANDARD CHARACTER). RESTAURANT TECHNOLOGIES, INC.**, (U.S. CLS. 100, 103 AND 106). SN 85-207,438. PUB. 5-3-2011. FILED 12-29-2010.
- 3,997,759. **RTI AND DESIGN. RESTAURANT TECHNOLOGIES, INC.**, (U.S. CLS. 100, 103 AND 106). SN 85-207,450. PUB. 5-3-2011. FILED 12-29-2010.
- 3,997,763. **RTI (STANDARD CHARACTER). RESTAURANT TECHNOLOGIES, INC.**, (U.S. CLS. 100, 103 AND 106). SN 85-207,471. PUB. 5-3-2011. FILED 12-29-2010.
- 3,997,784 (*See Class 35 for this trademark*).
- 3,997,785 (*See Class 35 for this trademark*).
- 3,998,009. **SURFACES AND SUBSTRATES WE'VE GOT YOU COVERED (STANDARD CHARACTER). HI-TECH CONCRETE COATINGS, INC.**, (U.S. CLS. 100, 103 AND 106). SN 85-210,559. PUB. 5-3-2011. FILED 1-5-2011.
- 3,998,095. **SWIFTPRO (STANDARD CHARACTER). SWIFT-PRO AUTO GLASS, LLC**, (U.S. CLS. 100, 103 AND 106). SN 85-211,939. PUB. 5-3-2011. FILED 1-6-2011.
- 3,998,196 (*See Class 35 for this trademark*).
- 3,998,259. **SHORTRIDGE INSTRUMENTS (STANDARD CHARACTER). SHORTRIDGE INSTRUMENTS, INC.**, MULTIPLE CLASS, (INT. CLS. 37 AND 42), (U.S. CLS. 100, 101, 103 AND 106). SN 85-238,902. PUB. 5-3-2011. FILED 2-10-2011.
- 3,995,514 (*See Class 9 for this trademark*).
- 3,995,575. **MOBISAT AND DESIGN. ASIA BROADCAST SATELLITE (HK) LIMITED**, (U.S. CLS. 100, 101 AND 104). SN 77-718,840. PUB. 4-20-2010. FILED 4-21-2009.
- 3,995,592 (*See Class 9 for this trademark*).
- 3,995,599 (*See Class 35 for this trademark*).
- 3,995,626. **PEERPROF.COM AND DESIGN. ECAMPUSNATION, LP**, MULTIPLE CLASS, (INT. CLS. 38, 41, 42 AND 45), (U.S. CLS. 100, 101, 104 AND 107). SN 77-862,804. PUB. 5-3-2011. FILED 11-2-2009.
- 3,995,630 (*See Class 9 for this trademark*).
- 3,995,671 (*See Class 35 for this trademark*).
- 3,995,705 (*See Class 9 for this trademark*).
- 3,995,725 (*See Class 16 for this trademark*).
- 3,995,727 (*See Class 9 for this trademark*).
- 3,995,734 (*See Class 6 for this trademark*).
- 3,995,745 (*See Class 9 for this trademark*).
- 3,995,749. **SEN (STANDARD CHARACTER). SEN CORPORATION LIMITED**, MULTIPLE CLASS, (INT. CLS. 38, 39, 41 AND 45), (U.S. CLS. 100, 101, 104, 105 AND 107). SN 79-075,692. PUB. 5-3-2011. FILED 10-8-2009.
- 3,995,755 (*See Class 35 for this trademark*).
- 3,995,760 (*See Class 9 for this trademark*).
- 3,995,767 (*See Class 25 for this trademark*).
- 3,995,779 (*See Class 9 for this trademark*).
- 3,995,780 (*See Class 9 for this trademark*).
- 3,995,798 (*See Class 9 for this trademark*).
- 3,995,802 (*See Class 35 for this trademark*).
- 3,995,825 (*See Class 35 for this trademark*).
- 3,995,826 (*See Class 35 for this trademark*).
- 3,995,845 (*See Class 35 for this trademark*).
- 3,995,866 (*See Class 36 for this trademark*).
- 3,995,881 (*See Class 35 for this trademark*).
- 3,995,907 (*See Class 9 for this trademark*).
- 3,996,045. **SINGLES AROUND ME (STANDARD CHARACTER). SINGLESAROUNDME INC.**, (U.S. CLS. 100, 101 AND 104). SN 85-010,242. PUB. 5-3-2011. FILED 4-9-2010.
- 3,996,087 (*See Class 35 for this trademark*).
- 3,996,123 (*See Class 35 for this trademark*).
- 3,996,138. **KEFI (STANDARD CHARACTER). LISTON, VASILIKI**, (U.S. CLS. 100, 101 AND 104). SN 85-037,549. PUB. 5-3-2011. FILED 5-13-2010.
- 3,996,139. **KEEP ENERGY FLOWING IN AND OUT (STANDARD CHARACTER). LISTON, VASILIKI**, (U.S. CLS. 100, 101 AND 104). SN 85-037,571. PUB. 5-3-2011. FILED 5-13-2010.
- 3,996,253 (*See Class 9 for this trademark*).
- 3,996,403. **CONNECT2HEALTH PATIENT-CENTERED ONLINE CARE COMMUNITIES FOR YOUR HOSPITAL" AND DESIGN. PRIVATE SOCIAL NETWORKS, INC.**, (U.S. CLS. 100, 101 AND 104). SN 85-087,642. PUB. 5-3-2011. FILED 7-19-2010.
- 3,996,483 (*See Class 9 for this trademark*).
- 3,996,650 (*See Class 35 for this trademark*).
- 3,996,667. **SERVICE COMMAND (STANDARD CHARACTER). SCANTRON CORPORATION**, (U.S. CLS. 100, 101 AND 104). SN 85-159,012. PUB. 5-3-2011. FILED 10-22-2010.
- 3,996,703. **PHIL LEMPERS' FNT FOOD NEWS TODAY AND DESIGN. CONSUMER INSIGHT, INC.**, MULTIPLE CLASS, (INT. CLS. 38 AND 41), (U.S. CLS. 100, 101, 104 AND 107). SN 85-166,597. PUB. 5-3-2011. FILED 11-1-2010.
- 3,996,725. **FAIRCALL (STANDARD CHARACTER). FAIRCALL CORPORATION**, (U.S. CLS. 100, 101 AND 104). SN 85-169,722. PUB. 5-3-2011. FILED 11-4-2010.
- 3,996,726. **FAIRCALL AND DESIGN. FAIRCALL CORPORATION**, (U.S. CLS. 100, 101 AND 104). SN 85-169,725. PUB. 5-3-2011. FILED 11-4-2010.
- 3,996,818. **ANY TIME ANY LOCATION (STANDARD CHARACTER). CAREONSITE, INC.**, (U.S. CLS. 100, 101 AND 104). SN 85-177,168. PUB. 5-3-2011. FILED 11-15-2010.
- 3,996,821. **THE REAL NEWS NETWORK (STANDARD CHARACTER). INDEPENDENT WORLD TELEVISION INC.**, (U.S. CLS. 100, 101 AND 104). SN 85-177,222. PUB. 5-3-2011. FILED 11-15-2010.
- 3,996,828 (*See Class 36 for this trademark*).
- 3,996,846. **ANY LOCATION ANY TIME (STANDARD CHARACTER). CAREONSITE, INC.**, (U.S. CLS. 100, 101 AND 104). SN 85-178,812. PUB. 5-3-2011. FILED 11-17-2010.

CLASS 38—COMMUNICATION

3,995,511 (*See Class 9 for this trademark*).

- 3,996,961 (*See Class 9 for this trademark.*)
 3,997,443. **BLANC SQUARE AND DESIGN.** BLANCSQUARE, LLC, (U.S. CLS. 100, 101 AND 104). SN 85-201,227. PUB. 5-3-2011. FILED 12-18-2010.
 3,997,447. **WNOX (STANDARD CHARACTER).** OAK RIDGE FM, INC. (U.S. CLS. 100, 101 AND 104). SN 85-201,406. PUB. 5-3-2011. FILED 12-19-2010.
 3,997,465 (*See Class 9 for this trademark.*)
 3,997,588. **OMEGLE (STANDARD CHARACTER).** K-BROOKS, LEIF C, (U.S. CLS. 100, 101 AND 104). SN 85-205,131. PUB. 5-3-2011. FILED 12-23-2010.
 3,997,589. **TALK TO STRANGERS! (STANDARD CHARACTER).** K-BROOKS, LEIF C, (U.S. CLS. 100, 101 AND 104). SN 85-205,146. PUB. 5-3-2011. FILED 12-23-2010.
 3,997,852. **I AND DESIGN.** COMMONWEALTH PUBLIC BROADCASTING CORPORATION, MULTIPLE CLASS, (INT. CLS. 38 AND 41), (U.S. CLS. 100, 101, 104 AND 107). SN 85-208,639. PUB. 5-3-2011. FILED 12-31-2010.
 3,997,923 (*See Class 9 for this trademark.*)
 3,997,928 (*See Class 9 for this trademark.*)
 3,997,957. **GRADEGURU AND DESIGN.** THE MCGRAW-HILL COMPANIES, INC., (U.S. CLS. 100, 101 AND 104). SN 85-209,848. PUB. 5-3-2011. FILED 1-4-2011.
 3,998,005 (*See Class 9 for this trademark.*)
 3,998,051. **DREW TV (STANDARD CHARACTER).** DREW TV, (U.S. CLS. 100, 101 AND 104). SN 85-211,222. PUB. 5-3-2011. FILED 1-5-2011.
 3,998,121. **WHEREITSCHAT.COM (STANDARD CHARACTER).** RUBICON HOLDINGS, LLC, DBA WHEREITSCHAT.COM, (U.S. CLS. 100, 101 AND 104). SN 85-212,487. PUB. 5-3-2011. FILED 1-7-2011.
 3,998,217. **SAYNOW BROADCAST (STANDARD CHARACTER).** GOOGLE INC., (U.S. CLS. 100, 101 AND 104). SN 85-223,423. PUB. 5-3-2011. FILED 1-21-2011.
 3,998,241. **THE DOCTOR IS IN (STANDARD CHARACTER).** SUMMER INFANT (USA), INC., (U.S. CLS. 100, 101 AND 104). SN 85-232,097. PUB. 5-3-2011. FILED 2-2-2011.
-
- CLASS 39—TRANSPORTATION AND STORAGE**
- 3,995,468. **AERLINGUS.COM AND DESIGN.** AER LINGUS LIMITED, (U.S. CLS. 100 AND 105). SN 76-701,726. PUB. 5-3-2011. FILED 2-22-2010.
 3,995,479. **GARDEN STATE SERVICE INC. NEW JERSEY'S NO. 1 PROFESSIONAL SERVICE FOR FUNERAL DIRECTORS EXCLUSIVELY AND DESIGN.** STEMPINSKI, STANLEY, JOSEPH, (U.S. CLS. 100 AND 105). SN 76-703,951. PUB. 5-3-2011. FILED 7-28-2010.
 3,995,481 (*See Class 36 for this trademark.*)
 3,995,486. **DILLON'S (STANDARD CHARACTER).** COACH AMERICA HOLDINGS, INC., (U.S. CLS. 100 AND 105). SN 76-705,554. PUB. 5-3-2011. FILED 12-3-2010.
 3,995,509. **DILLON'S (STYLIZED).** COACH AMERICA HOLDINGS, INC., (U.S. CLS. 100 AND 105). SN 76-705,946. PUB. 5-3-2011. FILED 1-10-2011.
 3,995,524 (*See Class 7 for this trademark.*)
 3,995,531 (*See Class 7 for this trademark.*)
 3,995,537. **GREENSUV AND DESIGN.** GREEN SUV LLC, (U.S. CLS. 100 AND 105). SN 77-569,325. PUB. 5-3-2011. FILED 9-13-2008.
 3,995,542. **MISCELLANEOUS DESIGN.** LAS VEGAS SANDS CORP., (U.S. CLS. 100 AND 105). SN 77-579,921. PUB. 5-3-2011. FILED 9-26-2008.
 3,995,602 (*See Class 35 for this trademark.*)
 3,995,669. **STORE IT AND DESIGN.** LANSDOWNE STATION SELF STORAGE, LLC, DBA STORE IT, (U.S. CLS. 100 AND 105). SN 77-909,312. PUB. 5-3-2011. FILED 1-11-2010.
 3,995,706 (*See Class 35 for this trademark.*)
 3,995,707. **BOOK YOUR BIG DEAL AND DESIGN.** PRICELINE.COM INCORPORATED, MULTIPLE CLASS, (INT. CLS. 39 AND 43), (U.S. CLS. 100, 101 AND 105). SN 77-961,861. PUB. 5-3-2011. FILED 3-18-2010.
 3,995,728 (*See Class 9 for this trademark.*)
 3,995,732 (*See Class 36 for this trademark.*)
 3,995,735 (*See Class 6 for this trademark.*)
 3,995,749 (*See Class 38 for this trademark.*)
 3,995,788. **FIRST REEF (STANDARD CHARACTER).** GEERT BOLLEN, MULTIPLE CLASS, (INT. CLS. 39 AND 41), (U.S. CLS. 100, 101, 105 AND 107). SN 79-082,488. PUB. 1-25-2011. FILED 9-12-2009.
 3,995,849 (*See Class 12 for this trademark.*)
 3,995,870 (*See Class 12 for this trademark.*)
 3,995,948 (*See Class 7 for this trademark.*)
 3,995,993 (*See Class 36 for this trademark.*)
 3,996,075. **LA ESTANCIA DE CAFAYATE WINE & GOLF AND DESIGN.** HUASI S.A., (U.S. CLS. 100 AND 105). SN 85-022,552. PUB. 5-3-2011. FILED 4-25-2010.
 3,996,244. **NEXT ADVENTURE (STANDARD CHARACTER).** NEXT ADVENTURE, INC., MULTIPLE CLASS, (INT. CLS. 39 AND 43), (U.S. CLS. 100, 101 AND 105). SN 85-050,475. PUB. 5-3-2011. FILED 5-28-2010.
 3,996,279. **HOTELGPS (STANDARD CHARACTER).** ETRAVEL APPLICATIONS, LLC, (U.S. CLS. 100 AND 105). SN 85-055,430. PUB. 5-3-2011. FILED 6-4-2010.
 3,996,291. **NAC NATIONAL AIR CHARTERS, INC. AND DESIGN.** BARNHILL AVIATION, LLC, (U.S. CLS. 100 AND 105). SN 85-058,721. PUB. 5-3-2011. FILED 6-9-2010.
 3,996,337. **SAIL SAN DIEGO AND DESIGN.** SAIL IN SAN DIEGO, (U.S. CLS. 100 AND 105). SN 85-069,514. PUB. 5-3-2011. FILED 6-23-2010.
 3,996,346. **CHRISTOPHERSON BUSINESS TRAVEL (STANDARD CHARACTER).** CB TRAVEL CORP., (U.S. CLS. 100 AND 105). SN 85-070,942. PUB. 5-3-2011. FILED 6-24-2010.
 3,996,378. **TIMECAR AND DESIGN.** TIME TRANSPORTATION HOLDINGS, LLC, (U.S. CLS. 100 AND 105). SN 85-079,562. PUB. 5-3-2011. FILED 7-7-2010.
 3,996,407. **MISCELLANEOUS DESIGN.** VEOLIA ES ALARON, L.L.C., (U.S. CLS. 100 AND 105). SN 85-088,472. PUB. 5-3-2011. FILED 7-20-2010.
 3,996,409. **E AND DESIGN.** MOUNTAIN ENERGY SERVICES, INC., (U.S. CLS. 100 AND 105). SN 85-089,466. PUB. 5-3-2011. FILED 7-21-2010.
 3,996,449. **AMAZING SANTA MONICA RACE (STANDARD CHARACTER).** LARF, INC., (U.S. CLS. 100 AND 105). SN 85-099,762. PUB. 1-25-2011. FILED 8-4-2010.
 3,996,460. **BUY MILES DIVIDEND MILES (STANDARD CHARACTER).** US AIRWAYS, INC., (U.S. CLS. 100 AND 105). SN 85-104,322. PUB. 5-3-2011. FILED 8-10-2010.
 3,996,461. **GIFT MILES DIVIDEND MILES (STANDARD CHARACTER).** US AIRWAYS, INC., (U.S. CLS. 100 AND 105). SN 85-104,342. PUB. 5-3-2011. FILED 8-10-2010.
 3,996,462. **SHARE MILES DIVIDEND MILES (STANDARD CHARACTER).** US AIRWAYS, INC., (U.S. CLS. 100 AND 105). SN 85-104,352. PUB. 5-3-2011. FILED 8-10-2010.
 3,996,475 (*See Class 25 for this trademark.*)
 3,996,591 (*See Class 35 for this trademark.*)
 3,996,645. **LONE STAR VALET AND DESIGN.** LONE STAR VALET PARKING SERVICES, INC., (U.S. CLS. 100 AND 105). SN 85-154,703. PUB. 5-3-2011. FILED 10-18-2010.
 3,996,653. **LONE STAR VALET (STANDARD CHARACTER).** LONE STAR VALET PARKING SERVICES, INC., (U.S. CLS. 100 AND 105). SN 85-156,148. PUB. 5-3-2011. FILED 10-19-2010.
 3,996,749. **KOBUSSEN BUSES (STANDARD CHARACTER).** KOBUSSEN BUSES LTD., (U.S. CLS. 100 AND 105). SN 85-172,637. PUB. 5-3-2011. FILED 11-9-2010.
 3,996,903. **ADVENTURATI (STANDARD CHARACTER).** ADVENTURATI, LLC, (U.S. CLS. 100 AND 105). SN 85-182,125. PUB. 5-3-2011. FILED 11-22-2010.
 3,996,922. **PACK IT. MOVE IT. REUSE IT! (STANDARD CHARACTER).** ENDUROBOX LLC, (U.S. CLS. 100 AND 105). SN 85-183,027. PUB. 5-3-2011. FILED 11-23-2010.
 3,996,923. **ENDUROBOX (STANDARD CHARACTER).** ENDUROBOX LLC, (U.S. CLS. 100 AND 105). SN 85-183,028. PUB. 5-3-2011. FILED 11-23-2010.
 3,997,088. **GOTHAM LIMOUSINE (STANDARD CHARACTER).** GOTHAM CORPORATION, (U.S. CLS. 100 AND 105). SN 85-188,614. PUB. 5-3-2011. FILED 12-1-2010.
 3,997,105. **MATZAFUN TOURS (STANDARD CHARACTER).** WASHINGTON GROUP II, L.L.C., (U.S. CLS. 100 AND 105). SN 85-188,963. PUB. 5-3-2011. FILED 12-2-2010.
 3,997,107 (*See Class 35 for this trademark.*)
 3,997,220. **FREAKY FAST DELIVERY! (STANDARD CHAR-**

- ACTER). JIMMY JOHN'S ENTERPRISES, LLC, MULTIPLE CLASS, (INT. CLS. 39 AND 43), (U.S. CLS. 100, 101 AND 105). SN 85-191,596. PUB. 5-3-2011. FILED 12-6-2010.
- 3,997,283. **DESTINATION DRIVERS (STANDARD CHARACTER)**. PENNINGTON, SEAN D., DBA DESTINATION DRIVERS, (U.S. CLS. 100 AND 105). SN 85-193,671. PUB. 5-3-2011. FILED 12-8-2010.
- 3,997,327 (*See Class 35 for this trademark*).
- 3,997,396. **VONJET (STANDARD CHARACTER)**. JARAMILLO, EDWARD TERRY, (U.S. CLS. 100 AND 105). SN 85-199,755. PUB. 5-3-2011. FILED 12-16-2010.
- 3,997,493 (*See Class 37 for this trademark*).
- 3,997,509. **MYAIRPORTTRIP.COM (STANDARD CHARACTER)**. AARON DIRKS, (U.S. CLS. 100 AND 105). SN 85-203,904. PUB. 5-3-2011. FILED 12-22-2010.
- 3,997,591 (*See Class 35 for this trademark*).
- 3,997,699. **PROUD TO SERVE THOSE WHO SERVE (STANDARD CHARACTER)**. ENTERPRISE HOLDINGS, INC., (U.S. CLS. 100 AND 105). SN 85-206,524. PUB. 5-3-2011. FILED 12-28-2010.
- 3,997,771. **CORE-MARK (STANDARD CHARACTER)**. CORE-MARK INTERNATIONAL, INC., (U.S. CLS. 100 AND 105). SN 85-207,620. PUB. 5-3-2011. FILED 12-29-2010.
- 3,997,772. **MISCELLANEOUS DESIGN**. CORE-MARK INTERNATIONAL, INC., (U.S. CLS. 100 AND 105). SN 85-207,622. PUB. 5-3-2011. FILED 12-29-2010.
- 3,997,784 (*See Class 35 for this trademark*).
- 3,997,785 (*See Class 35 for this trademark*).
- 3,998,180. **EXTRANOMICAL (STANDARD CHARACTER)**. EXTRANOMICAL ADVENTURES, INC, AKA EXTRANOMICAL TOURS, (U.S. CLS. 100 AND 105). SN 85-214,320. PUB. 5-3-2011. FILED 1-10-2011.
- 3,998,255 (*See Class 35 for this trademark*).

CLASS 40—MATERIAL TREATMENT

- 3,995,524 (*See Class 7 for this trademark*).
- 3,995,531 (*See Class 7 for this trademark*).
- 3,995,540 (*See Class 9 for this trademark*).
- 3,995,602 (*See Class 35 for this trademark*).
- 3,995,706 (*See Class 35 for this trademark*).
- 3,995,733 (*See Class 7 for this trademark*).
- 3,995,813 (*See Class 7 for this trademark*).
- 3,995,863 (*See Class 2 for this trademark*).
- 3,995,904 (*See Class 1 for this trademark*).
- 3,995,912 (*See Class 2 for this trademark*).
- 3,995,979 (*See Class 1 for this trademark*).
- 3,996,153 (*See Class 37 for this trademark*).
- 3,996,172 (*See Class 1 for this trademark*).
- 3,996,248. **ENERGY UNDERSTOOD (STANDARD CHARACTER)**. HDR ENGINEERING, INC., MULTIPLE CLASS, (INT. CLS. 40 AND 42), (U.S. CLS. 100, 101, 103 AND 106). SN 85-050,710. PUB. 5-3-2011. FILED 5-28-2010.
- 3,996,255. **ROYAL OAK RECYCLING AND DESIGN**. V&M CORPORATION, DBA ROYAL OAK RECYCLING, (U.S. CLS. 100, 103 AND 106). SN 85-051,852. PUB. 5-3-2011. FILED 6-1-2010.
- 3,996,430 (*See Class 35 for this trademark*).
- 3,996,438 (*See Class 12 for this trademark*).
- 3,996,473. **DAMERON (STANDARD CHARACTER)**. DAMERON ALLOY FOUNDRIES, MULTIPLE CLASS, (INT. CLS. 40 AND 42), (U.S. CLS. 100, 101, 103 AND 106). SN 85-108,197. PUB. 5-3-2011. FILED 8-16-2010.
- 3,996,476 (*See Class 12 for this trademark*).
- 3,996,554 (*See Class 7 for this trademark*).
- 3,996,578 (*See Class 35 for this trademark*).
- 3,996,602 (*See Class 35 for this trademark*).
- 3,996,651. **NL NO LABEL BREWING CO. KATY, TEXAS AND DESIGN**. NO LABEL BREWING COMPANY, DBA NO LABEL, (U.S. CLS. 100, 103 AND 106). SN 85-155,547. PUB. 5-3-2011. FILED 10-18-2010.
- 3,996,789. **PARAMOUNT ELEVATING SLEEP AND DESIGN**. PARAMOUNT INDUSTRIAL COMPANIES, INC., (U.S. CLS. 100, 103 AND 106). SN 85-175,249. PUB. 5-3-2011. FILED 11-12-2010.
- 3,996,795. **ORGANIC SOLUTIONS AND DESIGN**. IMPERIAL WESTERN PRODUCTS, INC., (U.S. CLS. 100, 103 AND 106). SN 85-175,786. PUB. 5-3-2011. FILED 11-12-2010.
- 3,996,826. **GW PLASTICS (STANDARD CHARACTER)**. G W PLASTICS, INC., MULTIPLE CLASS, (INT. CLS. 40 AND 42), (U.S. CLS. 100, 101, 103 AND 106). SN 85-177,488. PUB. 5-3-2011. FILED 11-16-2010.
- 3,996,845 (*See Class 19 for this trademark*).
- 3,996,888. **RJ RACE CARS, INC. (STANDARD CHARACTER)**. R.J. RACE CARS, INC., (U.S. CLS. 100, 103 AND 106). SN 85-181,244. PUB. 5-3-2011. FILED 11-19-2010.
- 3,996,950. **PLAQUE CONCIERGE (STANDARD CHARACTER)**. AMERICAN REGISTRY, LLC, (U.S. CLS. 100, 103 AND 106). SN 85-184,474. PUB. 5-3-2011. FILED 11-24-2010.
- 3,997,056. **RESPONSIBLE ELECTRONICS RECYCLING (STANDARD CHARACTER)**. METECH RECYCLING, INC., (U.S. CLS. 100, 103 AND 106). SN 85-187,858. PUB. 5-3-2011. FILED 12-1-2010.
- 3,997,077 (*See Class 16 for this trademark*).
- 3,997,078 (*See Class 16 for this trademark*).
- 3,997,102. **CREATIVE CONCRETE (STANDARD CHARACTER)**. HERNANDEZ, CESAR, DBA CREATIVE CONCRETE, (U.S. CLS. 100, 103 AND 106). SN 85-188,835. PUB. 5-3-2011. FILED 12-2-2010.
- 3,997,179. **ALL DIGITAL PRINTING & DOCUMENT SERVICES AND DESIGN**. SILLAMAN AND SONS, INC., (U.S. CLS. 100, 103 AND 106). SN 85-190,207. PUB. 5-3-2011. FILED 12-3-2010.
- 3,997,216. **REFACING AND MORE (STANDARD CHARACTER)**. SHOWPLACE WOOD PRODUCTS, INC., (U.S. CLS. 100, 103 AND 106). SN 85-191,393. PUB. 5-3-2011. FILED 12-6-2010.
- 3,997,291. **RAILEAN (STANDARD CHARACTER)**. RAILEAN, KELLY, AND RAILEAN, MATTHEW, (U.S. CLS. 100, 103 AND 106). SN 85-193,911. PUB. 5-3-2011. FILED 12-9-2010.
- 3,997,310. **METECH RECYCLING (STANDARD CHARACTER)**. METECH RECYCLING, INC., (U.S. CLS. 100, 103 AND 106). SN 85-194,671. PUB. 5-3-2011. FILED 12-9-2010.
- 3,997,326 (*See Class 12 for this trademark*).
- 3,997,571. **RAA LEATHER (STANDARD CHARACTER)**. RICARDO ALVAREZ, (U.S. CLS. 100, 103 AND 106). SN 85-204,925. PUB. 5-3-2011. FILED 12-23-2010.
- 3,997,646. **CLICKANDFIT (STANDARD CHARACTER)**. FABTECH SYSTEMS LIMITED LIABILITY COMPANY, (U.S. CLS. 100, 103 AND 106). SN 85-205,917. PUB. 5-3-2011. FILED 12-27-2010.
- 3,997,666. **REKO AND DESIGN**. REKO INTERNATIONAL GROUP, INC., (U.S. CLS. 100, 103 AND 106). SN 85-206,130. PUB. 5-3-2011. FILED 12-27-2010.
- 3,997,927 (*See Class 4 for this trademark*).
- 3,997,979. **MISCELLANEOUS DESIGN**. RICHARD E. BADWEY, (U.S. CLS. 100, 103 AND 106). SN 85-210,184. PUB. 5-3-2011. FILED 1-4-2011.
- 3,998,018. **AAM (STANDARD CHARACTER)**. AMERICAN AXLE & MANUFACTURING, INC., MULTIPLE CLASS, (INT. CLS. 40 AND 42), (U.S. CLS. 100, 101, 103 AND 106). SN 85-210,659. PUB. 5-3-2011. FILED 1-5-2011.
- 3,998,082. **TRANSFORMING MATTERS (STANDARD CHARACTER)**. PROSSER HALLOCK, INC., (U.S. CLS. 100, 103 AND 106). SN 85-211,697. PUB. 5-3-2011. FILED 1-6-2011.
- 3,998,179. **DOTPOPS! (STANDARD CHARACTER)**. DOTPOPS! BAKERY, INC., (U.S. CLS. 100, 103 AND 106). SN 85-214,305. PUB. 5-3-2011. FILED 1-10-2011.
- 3,998,193. **B&D LITHO (STANDARD CHARACTER)**. B&D LITHO OF ARIZONA, INC., (U.S. CLS. 100, 103 AND 106). SN 85-216,002. PUB. 5-3-2011. FILED 1-12-2011.

CLASS 41—EDUCATION AND ENTERTAINMENT

- 3,995,471 (*See Class 36 for this trademark*).
- 3,995,473 (*See Class 35 for this trademark*).
- 3,995,474 (*See Class 9 for this trademark*).
- 3,995,476. **MODE OF FITNESS (STANDARD CHARACTER)**. MODE OF FITNESS, INC., (U.S. CLS. 100, 101 AND 107). SN 76-703,678. PUB. 5-3-2011. FILED 7-6-2010.
- 3,995,494. **NOT JUST ANOTHER GYM (STANDARD CHAR-**

- ACTER). NTENSE WORKOUT, INC., (U.S. CLS. 100, 101 AND 107). SN 76-705,767. PUB. 5-3-2011. FILED 12-23-2010. 3,995,511 (*See Class 9 for this trademark*).
- 3,995,514 (*See Class 9 for this trademark*).
- 3,995,516. **DAN-D (STANDARD CHARACTER)**. AMIR, DANIEL, (U.S. CLS. 100, 101 AND 107). SN 77-192,457. PUB. 5-3-2011. FILED 5-29-2007.
- 3,995,525. **SCAN2GO (STANDARD CHARACTER)**. NEWBOY FZCO, (U.S. CLS. 100, 101 AND 107). SN 77-421,825. PUB. 5-3-2011. FILED 3-14-2008.
- 3,995,533 (*See Class 16 for this trademark*).
- 3,995,540 (*See Class 9 for this trademark*).
- 3,995,548 (*See Class 9 for this trademark*).
- 3,995,552 (*See Class 9 for this trademark*).
- 3,995,553 (*See Class 9 for this trademark*).
- 3,995,563. **ECLIPSE MASTER CLASS (STANDARD CHARACTER)**. FUJITSU TEN LIMITED, (U.S. CLS. 100, 101 AND 107). SN 77-669,936. PUB. 1-25-2011. FILED 2-13-2009.
- 3,995,576. **E SOCIAL WORLD WE'RE NOT YOUR NEWS... WE'RE YOUR LIFE. (STYLIZED)**. E SOCIALWORLD, LLP, (U.S. CLS. 100, 101 AND 107). SN 77-720,807. PUB. 9-1-2009. FILED 4-23-2009.
- 3,995,592 (*See Class 9 for this trademark*).
- 3,995,595. **MASTER THE NIC (STANDARD CHARACTER)**. PAREJA, SHONNA, (U.S. CLS. 100, 101 AND 107). SN 77-796,437. PUB. 5-3-2011. FILED 8-4-2009.
- 3,995,598. **MARTIE KNOWS PARTIES (STANDARD CHARACTER)**. MARTIE DUNCAN, (U.S. CLS. 100, 101 AND 107). SN 77-805,068. PUB. 5-3-2011. FILED 8-14-2009.
- 3,995,621. **TINA ALDATZ (STANDARD CHARACTER)**. FOOT PETALS, (U.S. CLS. 100, 101 AND 107). SN 77-849,635. PUB. 5-3-2011. FILED 10-15-2009.
- 3,995,626 (*See Class 38 for this trademark*).
- 3,995,631. **HOSPICE BRAZOS VALLEY (STANDARD CHARACTER)**. HOSPICE BRAZOS VALLEY, INC., (U.S. CLS. 100, 101 AND 107). SN 77-865,748. PUB. 5-3-2011. FILED 11-5-2009.
- 3,995,634. **HOSPICE BRAZOS VALLEY AND DESIGN**. HOSPICE BRAZOS VALLEY, INC., (U.S. CLS. 100, 101 AND 107). SN 77-865,969. PUB. 5-3-2011. FILED 11-5-2009.
- 3,995,643. **AUNT BARBARA (STANDARD CHARACTER)**. AUNT BARBARA INC., (U.S. CLS. 100, 101 AND 107). SN 77-871,625. PUB. 5-3-2011. FILED 11-12-2009.
- 3,995,656. **SOUTHWEST GENERAL (STANDARD CHARACTER)**. SOUTHWEST GENERAL HEALTH CENTER, MULTIPLE CLASS, (INT. CLS. 41, 42 AND 44), (U.S. CLS. 100, 101 AND 107). SN 77-888,059. PUB. 5-3-2011. FILED 12-7-2009.
- 3,995,657. **SOUTHWEST GENERAL PARTNERING WITH UNIVERSITY HOSPITALS AND DESIGN**. SOUTHWEST GENERAL HEALTH CENTER, MULTIPLE CLASS, (INT. CLS. 41, 42 AND 44), (U.S. CLS. 100, 101 AND 107). SN 77-888,996. PUB. 5-3-2011. FILED 12-8-2009.
- 3,995,671 (*See Class 35 for this trademark*).
- 3,995,678 (*See Class 35 for this trademark*).
- 3,995,682 (*See Class 36 for this trademark*).
- 3,995,695. **BAKING LIFE (STANDARD CHARACTER)**. ZIP-ZAPPLAY INC., (U.S. CLS. 100, 101 AND 107). SN 77-947,812. PUB. 5-3-2011. FILED 3-1-2010.
- 3,995,702 (*See Class 35 for this trademark*).
- 3,995,703 (*See Class 9 for this trademark*).
- 3,995,712 (*See Class 35 for this trademark*).
- 3,995,725 (*See Class 16 for this trademark*).
- 3,995,727 (*See Class 9 for this trademark*).
- 3,995,729 (*See Class 35 for this trademark*).
- 3,995,735 (*See Class 6 for this trademark*).
- 3,995,745 (*See Class 9 for this trademark*).
- 3,995,747 (*See Class 9 for this trademark*).
- 3,995,749 (*See Class 38 for this trademark*).
- 3,995,757 (*See Class 10 for this trademark*).
- 3,995,760 (*See Class 9 for this trademark*).
- 3,995,762 (*See Class 16 for this trademark*).
- 3,995,767 (*See Class 25 for this trademark*).
- 3,995,768 (*See Class 9 for this trademark*).
- 3,995,783 (*See Class 16 for this trademark*).
- 3,995,785 (*See Class 9 for this trademark*).
- 3,995,788 (*See Class 39 for this trademark*).
- 3,995,840 (*See Class 36 for this trademark*).
- 3,995,847 (*See Class 12 for this trademark*).
- 3,995,867 (*See Class 9 for this trademark*).
- 3,995,877 (*See Class 9 for this trademark*).
- 3,995,878 (*See Class 9 for this trademark*).
- 3,995,881 (*See Class 35 for this trademark*).
- 3,995,888. **?WHAT IF! TRAINING (STANDARD CHARACTER)**. ?WHAT IF! HOLDINGS LTD, (U.S. CLS. 100, 101 AND 107). SN 79-085,892. PUB. 5-3-2011. FILED 5-24-2010.
- 3,995,892. **TRADITION MYSTIQUE EGYPTIENNE DU COBRA FONDATION OUAJET AND DESIGN**. FONDATION OUAJET, (U.S. CLS. 100, 101 AND 107). SN 79-085,977. PUB. 5-3-2011. FILED 7-27-2010.
- 3,995,905. **LEARNING BY DESIGN (STANDARD CHARACTER)**. COMMON GROUND PUBLISHING PTY LTD, (U.S. CLS. 100, 101 AND 107). SN 79-086,418. PUB. 5-3-2011. FILED 4-7-2010.
- 3,995,970 (*See Class 25 for this trademark*).
- 3,995,977 (*See Class 35 for this trademark*).
- 3,995,980 (*See Class 35 for this trademark*).
- 3,996,044 (*See Class 16 for this trademark*).
- 3,996,049. **THE BEAR TRAP (STANDARD CHARACTER)**. NICKLAUS COMPANIES, LLC, (U.S. CLS. 100, 101 AND 107). SN 85-012,646. PUB. 5-3-2011. FILED 4-13-2010.
- 3,996,050. **THE NEXT FOOD NETWORK STAR (STANDARD CHARACTER)**. TELEVISION FOOD NETWORK, G.P., (U.S. CLS. 100, 101 AND 107). SN 85-013,057. PUB. 5-3-2011. FILED 4-13-2010.
- 3,996,052 (*See Class 16 for this trademark*).
- 3,996,061 (*See Class 36 for this trademark*).
- 3,996,063. **COLLABORATIVE) FAMILY) LAW) INSTITUTE CFLI BREAKING THE CYCLE OF CONFLICT AND DESIGN**. COLLABORATIVE FAMILY LAW INSTITUTE, INC., (U.S. CLS. 100, 101 AND 107). SN 85-018,605. PUB. 5-3-2011. FILED 4-20-2010.
- 3,996,078. **LEARN ONLINE WITH THE PROS (STANDARD CHARACTER)**. KELBY MEDIA GROUP, INC., (U.S. CLS. 100, 101 AND 107). SN 85-023,873. PUB. 5-3-2011. FILED 4-27-2010.
- 3,996,082. **JOURNAL OF VIROLOGY (STANDARD CHARACTER)**. AMERICAN SOCIETY FOR MICROBIOLOGY, (U.S. CLS. 100, 101 AND 107). SN 85-024,547. PUB. 5-3-2011. FILED 4-27-2010.
- 3,996,087 (*See Class 35 for this trademark*).
- 3,996,096. **POTTS N PAINTS (STANDARD CHARACTER)**. TAMMIE B TAYLOR, DBA POTTS N PAINTS, (U.S. CLS. 100, 101 AND 107). SN 85-029,649. PUB. 5-3-2011. FILED 5-4-2010.
- 3,996,104. **EDISON BEST NEW PRODUCT AWARDS (STANDARD CHARACTER)**. AF NETWORKS LLC, (U.S. CLS. 100, 101 AND 107). SN 85-031,249. PUB. 5-3-2011. FILED 5-5-2010.
- 3,996,110. **ART & SOUL (STANDARD CHARACTER)**. COTTAGE CRAFT PRODUCTIONS, LLC, (U.S. CLS. 100, 101 AND 107). SN 85-033,532. PUB. 5-3-2011. FILED 5-7-2010.
- 3,996,114. **MAGNOLIA PLACE AND DESIGN**. CHILDREN'S BUREAU OF SOUTHERN CALIFORNIA, MULTIPLE CLASS, (INT. CLS. 41 AND 45), (U.S. CLS. 100, 101 AND 107). SN 85-034,093. PUB. 5-3-2011. FILED 5-10-2010.
- 3,996,119 (*See Class 9 for this trademark*).
- 3,996,126 (*See Class 31 for this trademark*).
- 3,996,127. **BARRE N9NE STUDIO (STANDARD CHARACTER)**. CROTEAU, TANYA, (U.S. CLS. 100, 101 AND 107). SN 85-036,017. PUB. 5-3-2011. FILED 5-12-2010.
- 3,996,129. **INTERNET ELECTRICIAN (STANDARD CHARACTER)**. 1121507 ALBERTA LTD., (U.S. CLS. 100, 101 AND 107). SN 85-036,046. PUB. 5-3-2011. FILED 5-12-2010.
- 3,996,131. **THE CDL SCHOOL AND DESIGN**. HANLEY III, ALBERT V., (U.S. CLS. 100, 101 AND 107). SN 85-036,503. PUB. 5-3-2011. FILED 5-12-2010.
- 3,996,141 (*See Class 35 for this trademark*).
- 3,996,142. **SOME LIKE IT SHOT (STANDARD CHARACTER)**. MCGRAW, HOLLAND D, DBA SOME LIKE IT SHOT, AND MCGRAW, ALISHA R, DBA SOME LIKE IT SHOT, (U.S. CLS. 100, 101 AND 107). SN 85-037,915. PUB. 5-3-2011. FILED 5-13-2010.
- 3,996,152. **DJ LUMONEY AND DESIGN**. LECONTE, LUMONY R, AKA DJ LUMONEY, (U.S. CLS. 100, 101 AND 107). SN 85-039,524. PUB. 5-3-2011. FILED 5-15-2010.

- 3,996,156 (*See Class 35 for this trademark*).
- 3,996,157. **C-AHEAD (STANDARD CHARACTER)**. LEMAY-YATES ASSOCIATES INC., (U.S. CLS. 100, 101 AND 107). SN 85-040,537. PUB. 5-3-2011. FILED 5-17-2010.
- 3,996,160. **EARLY ALERT (STANDARD CHARACTER)**. EARLY ALERT, INC., MULTIPLE CLASS, (INT. CLS. 41 AND 45), (U.S. CLS. 100, 101 AND 107). SN 85-041,139. PUB. 5-3-2011. FILED 5-18-2010.
- 3,996,165. **JUMP (STANDARD CHARACTER)**. MBF AND ASSOCIATES, INC., MULTIPLE CLASS, (INT. CLS. 41 AND 42), (U.S. CLS. 100, 101 AND 107). SN 85-041,700. PUB. 5-3-2011. FILED 5-18-2010.
- 3,996,173 (*See Class 35 for this trademark*).
- 3,996,174 (*See Class 35 for this trademark*).
- 3,996,178. **CONNECT AT BERNHEIM (STANDARD CHARACTER)**. ISAAC W. BERNHEIM FOUNDATION, (U.S. CLS. 100, 101 AND 107). SN 85-042,765. PUB. 5-3-2011. FILED 5-19-2010.
- 3,996,180 (*See Class 25 for this trademark*).
- 3,996,198. **AYUH YOGA AND DESIGN**. AYUH SPA & WELLNESS, (U.S. CLS. 100, 101 AND 107). SN 85-045,520. PUB. 5-3-2011. FILED 5-21-2010.
- 3,996,200. **GIRL MATTERS (STANDARD CHARACTER)**. NATIONAL COUNCIL ON CRIME AND DELINQUENCY, (U.S. CLS. 100, 101 AND 107). SN 85-045,908. PUB. 5-3-2011. FILED 5-24-2010.
- 3,996,209. **SKY JUMP LAS VEGAS AND DESIGN**. W2007 STRATOSPHERE PROPCO., L.P., (U.S. CLS. 100, 101 AND 107). SN 85-046,244. PUB. 5-3-2011. FILED 5-24-2010.
- 3,996,210. **SKYJUMP LAS VEGAS (STANDARD CHARACTER)**. W2007 STRATOSPHERE PROPCO., L.P., (U.S. CLS. 100, 101 AND 107). SN 85-046,247. PUB. 5-3-2011. FILED 5-24-2010.
- 3,996,211. **SKYJUMP (STANDARD CHARACTER)**. W2007 STRATOSPHERE PROPCO., L.P., (U.S. CLS. 100, 101 AND 107). SN 85-046,250. PUB. 5-3-2011. FILED 5-24-2010.
- 3,996,214. **SHIFTPOINT (STANDARD CHARACTER)**. SNOWDEN, JULIA, DBA SNOWDEN CONSULTING, (U.S. CLS. 100, 101 AND 107). SN 85-046,571. PUB. 5-3-2011. FILED 5-24-2010.
- 3,996,222 (*See Class 36 for this trademark*).
- 3,996,224. **FANTASY FOOTBALL COMMISSIONER (STANDARD CHARACTER)**. CBS INTERACTIVE INC., (U.S. CLS. 100, 101 AND 107). SN 85-047,477. PUB. 5-3-2011. FILED 5-25-2010.
- 3,996,234 (*See Class 9 for this trademark*).
- 3,996,235 (*See Class 9 for this trademark*).
- 3,996,256. **CASANOVAS (STANDARD CHARACTER)**. CASANOVAS NIGHTCLUB, (U.S. CLS. 100, 101 AND 107). SN 85-051,892. PUB. 5-3-2011. FILED 6-1-2010.
- 3,996,259 (*See Class 35 for this trademark*).
- 3,996,280 (*See Class 9 for this trademark*).
- 3,996,282 (*See Class 35 for this trademark*).
- 3,996,295. **SHOW MY RIDES.COM AND DESIGN**. LB'S SPEEDSHOP, LLC, (U.S. CLS. 100, 101 AND 107). SN 85-060,474. PUB. 5-3-2011. FILED 6-11-2010.
- 3,996,298 (*See Class 9 for this trademark*).
- 3,996,307. **MISCELLANEOUS DESIGN**. BIG BROTHERS-BIG SISTERS OF AMERICA, (U.S. CLS. 100, 101 AND 107). SN 85-063,338. PUB. 5-3-2011. FILED 6-15-2010.
- 3,996,312. **VOTE FOR PLANET EARTH (STANDARD CHARACTER)**. LIFE PURPOSE RESOURCES, (U.S. CLS. 100, 101 AND 107). SN 85-063,886. PUB. 5-3-2011. FILED 6-16-2010.
- 3,996,338 (*See Class 9 for this trademark*).
- 3,996,339. **FANTASY BASKETBALL COMMISSIONER (STANDARD CHARACTER)**. CBS INTERACTIVE INC., (U.S. CLS. 100, 101 AND 107). SN 85-069,770. PUB. 5-3-2011. FILED 6-23-2010.
- 3,996,340. **FANTASY HOCKEY COMMISSIONER (STANDARD CHARACTER)**. CBS INTERACTIVE INC., (U.S. CLS. 100, 101 AND 107). SN 85-069,788. PUB. 5-3-2011. FILED 6-23-2010.
- 3,996,352. **SUNRAY (STANDARD CHARACTER)**. SUNRAY GAMING OF NEW MEXICO, LLC, DBA SUNRAY PARK & CASINO, MULTIPLE CLASS, (INT. CLS. 41 AND 43), (U.S. CLS. 100, 101 AND 107). SN 85-071,959. PUB. 5-3-2011. FILED 6-25-2010.
- 3,996,353. **X-RAYS (STANDARD CHARACTER)**. SUNRAY GAMING OF NEW MEXICO, LLC, DBA SUNRAY PARK & CASINO, MULTIPLE CLASS, (INT. CLS. 41 AND 43), (U.S. CLS. 100, 101 AND 107). SN 85-071,984. PUB. 5-3-2011. FILED 6-25-2010.
- 3,996,357. **LETT (STANDARD CHARACTER)**. SYNERGETHICS, INC., (U.S. CLS. 100, 101 AND 107). SN 85-072,938. PUB. 5-3-2011. FILED 6-28-2010.
- 3,996,358. **MUSIC SUPERVISOR AND DESIGN**. MUSIC SUPERVISOR INC., (U.S. CLS. 100, 101 AND 107). SN 85-072,987. PUB. 5-3-2011. FILED 6-28-2010.
- 3,996,366. **SPORTDNA (STANDARD CHARACTER)**. SPIRALLEDGE, INC., (U.S. CLS. 100, 101 AND 107). SN 85-074,837. PUB. 5-3-2011. FILED 6-30-2010.
- 3,996,368. **O AND DESIGN**. KEVIN J. OWOC, D.M.D., P.C., MULTIPLE CLASS, (INT. CLS. 41 AND 44), (U.S. CLS. 100, 101 AND 107). SN 85-075,234. PUB. 11-30-2010. FILED 6-30-2010.
- 3,996,373. **THE SECRET TO WRITING (STANDARD CHARACTER)**. THE SECRET TO WRITING, LLC, (U.S. CLS. 100, 101 AND 107). SN 85-076,733. PUB. 5-3-2011. FILED 7-2-2010.
- 3,996,379. **HEALTHCENTIVE (STANDARD CHARACTER)**. FAIGEN, STEVE, MULTIPLE CLASS, (INT. CLS. 41 AND 42), (U.S. CLS. 100, 101 AND 107). SN 85-079,947. PUB. 5-3-2011. FILED 7-8-2010.
- 3,996,380. **READ & REACT OFFENSE (STANDARD CHARACTER)**. BETTER BASKETBALL, INC., (U.S. CLS. 100, 101 AND 107). SN 85-080,000. PUB. 5-3-2011. FILED 7-8-2010.
- 3,996,389. **MR CREEP (STANDARD CHARACTER)**. HOUSE OF TORMENT LLC, (U.S. CLS. 100, 101 AND 107). SN 85-082,628. PUB. 5-3-2011. FILED 7-12-2010.
- 3,996,390. **ASK THE AUTHOR . . .LIVE (STANDARD CHARACTER)**. SIMPLY LEARNING, INC., (U.S. CLS. 100, 101 AND 107). SN 85-082,851. PUB. 5-3-2011. FILED 7-14-2010.
- 3,996,398. **SHOWBINE (STANDARD CHARACTER)**. F4 SHOWBINE, LLC, (U.S. CLS. 100, 101 AND 107). SN 85-084,207. PUB. 5-3-2011. FILED 7-14-2010.
- 3,996,402. **NATURAL HEALTH IS OUR BIRTHRIGHT (STANDARD CHARACTER)**. PAUL FANNY, (U.S. CLS. 100, 101 AND 107). SN 85-086,331. PUB. 5-3-2011. FILED 7-16-2010.
- 3,996,408 (*See Class 25 for this trademark*).
- 3,996,410. **THE M-22 CHALLENGE AND DESIGN**. BRONEAH, INC., (U.S. CLS. 100, 101 AND 107). SN 85-089,688. PUB. 5-3-2011. FILED 7-21-2010.
- 3,996,413. **GRAY V (STANDARD CHARACTER)**. SAUCE INDUSTRIES, LLC, DBA GRAY V, (U.S. CLS. 100, 101 AND 107). SN 85-089,972. PUB. 5-3-2011. FILED 7-21-2010.
- 3,996,414. **SOUND. DESIGNED. (STANDARD CHARACTER)**. SAUCE INDUSTRIES, LLC, DBA GRAY V, (U.S. CLS. 100, 101 AND 107). SN 85-089,982. PUB. 5-3-2011. FILED 7-21-2010.
- 3,996,417. **¡PREPÁRATE! PROTEGE A TU FAMILIA U AND DESIGN**. UNIVISION COMMUNICATIONS INC., (U.S. CLS. 100, 101 AND 107). SN 85-090,742. PUB. 5-3-2011. FILED 7-22-2010.
- 3,996,426 (*See Class 16 for this trademark*).
- 3,996,428. **MISCELLANEOUS DESIGN**. HOUSE OF TORMENT LLC, (U.S. CLS. 100, 101 AND 107). SN 85-093,700. PUB. 5-3-2011. FILED 7-27-2010.
- 3,996,439 (*See Class 35 for this trademark*).
- 3,996,440. **BRIDGING THE GAP BETWEEN GOVERNMENT AND THE PRIVATE SECTOR (STANDARD CHARACTER)**. EARLY ALERT, INC., MULTIPLE CLASS, (INT. CLS. 41 AND 45), (U.S. CLS. 100, 101 AND 107). SN 85-095,652. PUB. 5-3-2011. FILED 7-29-2010.
- 3,996,441. **CALUNIVERSITY VISION~BRILLIANCE~SUCCESS CALUNIVERSITY CALIFORNIA INTERCONTINENTAL UNIVERSITY ESTABLISHED 1996 AND DESIGN**. CALIFORNIA INTERCONTINENTAL UNIVERSITY, INC., (U.S. CLS. 100, 101 AND 107). SN 85-096,109. PUB. 5-3-2011. FILED 7-29-2010.
- 3,996,447 (*See Class 9 for this trademark*).
- 3,996,451. **THE ACADEMY FOR PRIVATE DUTY HOME CARE AND DESIGN**. TWEED-JEFFRIES, LLC, (U.S. CLS. 100, 101 AND 107). SN 85-101,841. PUB. 5-3-2011. FILED 8-6-2010.
- 3,996,456. **OPENHIRE (STANDARD CHARACTER)**. SILKROAD TECHNOLOGY, INC., MULTIPLE CLASS, (INT. CLS. 41 AND 42), (U.S. CLS. 100, 101 AND 107). SN 85-

- 103,324. PUB. 5-3-2011. FILED 8-9-2010.
- 3,996,465. **THE BALLOON FLIGHT SCHOOL AND DESIGN.** LOWENSTEIN, ALBERT L, DBA THE BALLOON FLIGHT SCHOOL, (U.S. CLS. 100, 101 AND 107). SN 85-106,900. PUB. 5-3-2011. FILED 8-13-2010.
- 3,996,466. **PEAK MOUNTAIN GUIDES (STANDARD CHARACTER).** PEAK MOUNTAIN GUIDES LLC, (U.S. CLS. 100, 101 AND 107). SN 85-107,233. PUB. 5-3-2011. FILED 8-13-2010.
- 3,996,477. **THE DAILY SHIELD (STANDARD CHARACTER).** INTERSECTIONS INC., (U.S. CLS. 100, 101 AND 107). SN 85-110,805. PUB. 5-3-2011. FILED 8-18-2010.
- 3,996,483 (*See Class 9 for this trademark.*).
- 3,996,500. **FAIRFIELD COUNTY LOOK (STANDARD CHARACTER).** FAIRFIELD COUNTY LOOK, LLC, (U.S. CLS. 100, 101 AND 107). SN 85-119,788. PUB. 5-3-2011. FILED 8-31-2010.
- 3,996,501. **URBANGREEN (STANDARD CHARACTER).** URBANGREEN, INC., MULTIPLE CLASS, (INT. CLS. 41 AND 42), (U.S. CLS. 100, 101 AND 107). SN 85-120,596. PUB. 5-3-2011. FILED 9-1-2010.
- 3,996,512. **THE OLD WEBSTER JAZZ & BLUES FESTIVAL (STANDARD CHARACTER).** CITY OF WEBSTER GROVES, (U.S. CLS. 100, 101 AND 107). SN 85-125,068. PUB. 5-3-2011. FILED 9-8-2010.
- 3,996,513 (*See Class 36 for this trademark.*).
- 3,996,514 (*See Class 35 for this trademark.*).
- 3,996,516. **BOOKISH READING CLUB (STANDARD CHARACTER).** BOOKISH LLC, (U.S. CLS. 100, 101 AND 107). SN 85-125,385. PUB. 5-3-2011. FILED 9-8-2010.
- 3,996,529 (*See Class 16 for this trademark.*).
- 3,996,530 (*See Class 16 for this trademark.*).
- 3,996,537. **NORTHLAND COLLEGE (STANDARD CHARACTER).** NORTHLAND COLLEGE, (U.S. CLS. 100, 101 AND 107). SN 85-129,345. PUB. 5-3-2011. FILED 9-14-2010.
- 3,996,538. **WIKITINUING EDUCATION (STANDARD CHARACTER).** SMITH, PENNY RENEE, AND COLLINS, WANDA LOTT, MULTIPLE CLASS, (INT. CLS. 41 AND 42), (U.S. CLS. 100, 101 AND 107). SN 85-129,552. PUB. 5-3-2011. FILED 9-14-2010.
- 3,996,539. **MISCELLANEOUS DESIGN.** THIS LITTLE PIGGY, (U.S. CLS. 100, 101 AND 107). SN 85-129,973. PUB. 5-3-2011. FILED 9-15-2010.
- 3,996,547. **ARROYO SECO GOLF COURSE (STANDARD CHARACTER).** ARROYO SECO GOLF COURSE LLC., (U.S. CLS. 100, 101 AND 107). SN 85-131,690. PUB. 5-3-2011. FILED 9-16-2010.
- 3,996,551. **MARKETING MONDAYS (STANDARD CHARACTER).** QUARRY INTEGRATED COMMUNICATIONS INC., (U.S. CLS. 100, 101 AND 107). SN 85-132,547. PUB. 5-3-2011. FILED 9-17-2010.
- 3,996,552. **ORWEF (STANDARD CHARACTER).** OREGON WATER EDUCATION FOUNDATION, (U.S. CLS. 100, 101 AND 107). SN 85-132,604. PUB. 5-3-2011. FILED 9-17-2010.
- 3,996,558 (*See Class 9 for this trademark.*).
- 3,996,568 (*See Class 35 for this trademark.*).
- 3,996,575. **ICDC COLLEGE (STANDARD CHARACTER).** INTERNATIONAL CAREER DEVELOPMENT CENTER, INC., DBA ICDC COLLEGE, (U.S. CLS. 100, 101 AND 107). SN 85-137,586. PUB. 5-3-2011. FILED 9-24-2010.
- 3,996,576. **BEST EVER YOU (STANDARD CHARACTER).** BEST EVER YOU, LLC, (U.S. CLS. 100, 101 AND 107). SN 85-138,225. PUB. 5-3-2011. FILED 9-25-2010.
- 3,996,587 (*See Class 35 for this trademark.*).
- 3,996,593. **ICDC (STANDARD CHARACTER).** INTERNATIONAL CAREER DEVELOPMENT CENTER, INC., DBA ICDC COLLEGE, (U.S. CLS. 100, 101 AND 107). SN 85-142,944. PUB. 5-3-2011. FILED 10-1-2010.
- 3,996,596. **ISSA INTERCLEAN (STANDARD CHARACTER).** INTERNATIONAL SANITARY SUPPLY ASSOCIATION, (U.S. CLS. 100, 101 AND 107). SN 85-144,463. PUB. 5-3-2011. FILED 10-4-2010.
- 3,996,610 (*See Class 9 for this trademark.*).
- 3,996,626 (*See Class 35 for this trademark.*).
- 3,996,636. **ELIZAVETA (STANDARD CHARACTER).** KHRIPOUNOVA, ELIZAVETA, (U.S. CLS. 100, 101 AND 107). SN 85-151,589. PUB. 5-3-2011. FILED 10-13-2010.
- 3,996,640 (*See Class 9 for this trademark.*).
- 3,996,646 (*See Class 9 for this trademark.*).
- 3,996,649 (*See Class 35 for this trademark.*).
- 3,996,650 (*See Class 35 for this trademark.*).
- 3,996,652. **THE BRIGHT LIGHT SOCIAL HOUR (STANDARD CHARACTER).** THE BRIGHT LIGHT SOCIAL HOUR, LLC, (U.S. CLS. 100, 101 AND 107). SN 85-155,553. PUB. 5-3-2011. FILED 10-18-2010.
- 3,996,654 (*See Class 9 for this trademark.*).
- 3,996,668. **SAMMY EUBANKS (STANDARD CHARACTER).** EUBANKS SAMMY D., (U.S. CLS. 100, 101 AND 107). SN 85-159,798. PUB. 5-3-2011. FILED 10-24-2010.
- 3,996,671. **SAME DAY TRANSLATIONS AND DESIGN.** SAME DAY TRANSLATIONS, (U.S. CLS. 100, 101 AND 107). SN 85-160,104. PUB. 5-3-2011. FILED 10-25-2010.
- 3,996,678. **WRS WORLD RECORD SUMMIT AND DESIGN.** WORLD RECORD SUMMIT, LLC, (U.S. CLS. 100, 101 AND 107). SN 85-161,942. PUB. 5-3-2011. FILED 10-26-2010.
- 3,996,679. **THE WTA WISE TRAVELER (STANDARD CHARACTER).** ASSOCIATION SERVICES OF AMERICA, INC., (U.S. CLS. 100, 101 AND 107). SN 85-162,143. PUB. 5-3-2011. FILED 10-27-2010.
- 3,996,689. **W PUERTO RICO WINE CHALLENGE AND DESIGN.** MENDEZ & COMPANY, (U.S. CLS. 100, 101 AND 107). SN 85-163,896. PUB. 5-3-2011. FILED 10-28-2010.
- 3,996,698. **THE 2ND MOST IMPORTANT BOOK YOUR KIDS WILL EVER READ (STANDARD CHARACTER).** WALTERS, DAVID C., (U.S. CLS. 100, 101 AND 107). SN 85-165,570. PUB. 5-3-2011. FILED 10-30-2010.
- 3,996,702. **THE RUNNING DOG RANCH AND DESIGN.** THE RUNNING DOG RANCH, (U.S. CLS. 100, 101 AND 107). SN 85-166,547. PUB. 5-3-2011. FILED 11-1-2010.
- 3,996,703 (*See Class 38 for this trademark.*).
- 3,996,704. **INSTITUTE OF HOLISTIC MIDWIFERY AND DESIGN.** INSTITUTE OF HOLISTIC MIDWIFERY, LLC, (U.S. CLS. 100, 101 AND 107). SN 85-166,828. PUB. 5-3-2011. FILED 11-2-2010.
- 3,996,709 (*See Class 35 for this trademark.*).
- 3,996,716. **BUMP CLUB (STANDARD CHARACTER).** CHICAGO CITY MOMS, INC., (U.S. CLS. 100, 101 AND 107). SN 85-168,528. PUB. 5-3-2011. FILED 11-3-2010.
- 3,996,723 (*See Class 35 for this trademark.*).
- 3,996,729. **CINCINNATI CHOCOLATE FESTIVAL EST. 2010 AND DESIGN.** K'HILLAH K'DOSHAH B'NAI YESHURUN, DBA ISAAC M. WISE TEMPLE, (U.S. CLS. 100, 101 AND 107). SN 85-170,381. PUB. 5-3-2011. FILED 11-5-2010.
- 3,996,732 (*See Class 9 for this trademark.*).
- 3,996,742. **OPERATION IGNITE! (STANDARD CHARACTER).** THE HAGERTY GROUP, LLC, (U.S. CLS. 100, 101 AND 107). SN 85-171,528. PUB. 3-29-2011. FILED 11-8-2010.
- 3,996,747. **SEATTLE TILTH (STANDARD CHARACTER).** SEATTLE TILTH ASSOCIATION, (U.S. CLS. 100, 101 AND 107). SN 85-171,784. PUB. 5-3-2011. FILED 11-8-2010.
- 3,996,753. **CHICAGO RIOT (STANDARD CHARACTER).** BASTIC. SHAWN, (U.S. CLS. 100, 101 AND 107). SN 85-172,858. PUB. 5-3-2011. FILED 11-9-2010.
- 3,996,760. **CONTEMPORARY YOUTH ORCHESTRA (STANDARD CHARACTER).** THE CONTEMPORARY YOUTH ORCHESTRA, (U.S. CLS. 100, 101 AND 107). SN 85-173,177. PUB. 5-3-2011. FILED 11-10-2010.
- 3,996,761. **WAY-COOL COOKING SCHOOL (STANDARD CHARACTER).** WAY COOL COOKING SCHOOL INCORPORATED, (U.S. CLS. 100, 101 AND 107). SN 85-173,220. PUB. 5-3-2011. FILED 11-10-2010.
- 3,996,779. **THE SYNERGY SOLUTION (STANDARD CHARACTER).** STRATEGIC ENERGY COACHING, INC, (U.S. CLS. 100, 101 AND 107). SN 85-174,721. PUB. 5-3-2011. FILED 11-11-2010.
- 3,996,785. **CALM DOG (STANDARD CHARACTER).** OKRONGLY, ANTHONY J, AND OKRONGLY, DONNA D, (U.S. CLS. 100, 101 AND 107). SN 85-174,976. PUB. 5-3-2011. FILED 11-11-2010.
- 3,996,803. **NU NORMAL PRODUCTIONS (STYLIZED).** NU NORMAL PRODUCTIONS, LLC, (U.S. CLS. 100, 101 AND 107). SN 85-176,277. PUB. 5-3-2011. FILED 11-14-2010.
- 3,996,805. **MISCELLANEOUS DESIGN.** MARTIN, DONALD C., (U.S. CLS. 100, 101 AND 107). SN 85-176,355. PUB. 5-3-2011. FILED 11-14-2010.
- 3,996,823. **COMEDIVA (STANDARD CHARACTER).** COME-

- DIVA, LLC, (U.S. CLS. 100, 101 AND 107). SN 85-177,361. PUB. 5-3-2011. FILED 11-15-2010.
- 3,996,831. **GREEN MOUNTAIN RANGERS AND DESIGN.** GREEN MOUNTAIN RANGERS, LLC, (U.S. CLS. 100, 101 AND 107). SN 85-178,062. PUB. 5-3-2011. FILED 11-16-2010.
- 3,996,851. **ENDLESS BOUDOIR (STANDARD CHARACTER).** AGNES ZAWADZKA, (U.S. CLS. 100, 101 AND 107). SN 85-178,980. PUB. 5-3-2011. FILED 11-17-2010.
- 3,996,855. **HAPPY HEART PHOTOGRAPHY (STANDARD CHARACTER).** HAPPY HEART PHOTOGRAPHY, LLC, (U.S. CLS. 100, 101 AND 107). SN 85-179,142. PUB. 5-3-2011. FILED 11-17-2010.
- 3,996,860. **34 (STANDARD CHARACTER).** SCHWANTZ RACING, INC., DBA SCHWANTZ SCHOOL, (U.S. CLS. 100, 101 AND 107). SN 85-179,321. PUB. 5-3-2011. FILED 11-17-2010.
- 3,996,861. **ESSENCE OF THE WARRIOR QUEEN (STANDARD CHARACTER).** TOUMA ASSOCIATES GROUP, LLC, DBA MINDSCAPE, (U.S. CLS. 100, 101 AND 107). SN 85-179,405. PUB. 5-3-2011. FILED 11-17-2010.
- 3,996,862. **INCEPTION: MIND CRIME GAME (STANDARD CHARACTER).** WARNER BROS. ENTERTAINMENT INC., (U.S. CLS. 100, 101 AND 107). SN 85-179,513. PUB. 5-3-2011. FILED 11-17-2010.
- 3,996,874. **WELLNESS CULTURE COACHING (STANDARD CHARACTER).** HUMAN RESOURCES INSTITUTE, LLC, (U.S. CLS. 100, 101 AND 107). SN 85-179,954. PUB. 5-3-2011. FILED 11-18-2010.
- 3,996,881. **THE CRITTERS (STANDARD CHARACTER).** SHAPIRO, LEE, (U.S. CLS. 100, 101 AND 107). SN 85-180,877. PUB. 5-3-2011. FILED 11-19-2010.
- 3,996,883. **MOM AT LAST (STANDARD CHARACTER).** MOM AT LAST, LLC, (U.S. CLS. 100, 101 AND 107). SN 85-180,926. PUB. 5-3-2011. FILED 11-19-2010.
- 3,996,886 (*See Class 9 for this trademark*).
- 3,996,918. **WHITECAP INSTITUTE (STANDARD CHARACTER).** WHITECAP INSTITUTE, LLC, (U.S. CLS. 100, 101 AND 107). SN 85-182,906. PUB. 5-3-2011. FILED 11-22-2010.
- 3,996,920. **CHILDLIGHT YOGA (STANDARD CHARACTER).** LISA D. FLYNN, (U.S. CLS. 100, 101 AND 107). SN 85-182,928. PUB. 5-3-2011. FILED 11-22-2010.
- 3,996,934 (*See Class 35 for this trademark*).
- 3,996,951. **PLAY WITH WORDS (STANDARD CHARACTER).** PLAY WITH WORDS, INC., (U.S. CLS. 100, 101 AND 107). SN 85-184,528. PUB. 5-3-2011. FILED 11-24-2010.
- 3,996,955. **SECRET COLOURS (STANDARD CHARACTER).** EVANS, THOMAS, (U.S. CLS. 100, 101 AND 107). SN 85-184,768. PUB. 5-3-2011. FILED 11-24-2010.
- 3,996,962. **RULON BROWN (STANDARD CHARACTER).** BROWN, NATHAN OWEN, (U.S. CLS. 100, 101 AND 107). SN 85-185,132. PUB. 5-3-2011. FILED 11-24-2010.
- 3,996,964. **ANDERS LANGUAGES (STANDARD CHARACTER).** VAN CLEEF, BART PETER, (U.S. CLS. 100, 101 AND 107). SN 85-185,202. PUB. 5-3-2011. FILED 11-24-2010.
- 3,996,967. **SPLASH MONTANA PLAYFAIR PARK . MISSOULA AND DESIGN.** CITY OF MISSOULA, (U.S. CLS. 100, 101 AND 107). SN 85-185,449. PUB. 5-3-2011. FILED 11-26-2010.
- 3,996,969. **HILBILLY YOGA AND DESIGN.** WHITE, GEORGE H., AND WHITE, MICHELE V., (U.S. CLS. 100, 101 AND 107). SN 85-185,488. PUB. 5-3-2011. FILED 11-26-2010.
- 3,996,970. **KUNG FU DYNAMITE (STANDARD CHARACTER).** HANNAH, ROBERT, KELLY, AND MCFEE SEAN MICHAEL, (U.S. CLS. 100, 101 AND 107). SN 85-185,517. PUB. 5-3-2011. FILED 11-26-2010.
- 3,996,980. **FUTURE YOU (STANDARD CHARACTER).** HERITAGE CHRISTIAN SERVICES, INC., (U.S. CLS. 100, 101 AND 107). SN 85-186,014. PUB. 5-3-2011. FILED 11-29-2010.
- 3,996,981. **FUTUREYOU (STANDARD CHARACTER).** HERITAGE CHRISTIAN SERVICES, INC., (U.S. CLS. 100, 101 AND 107). SN 85-186,040. PUB. 5-3-2011. FILED 11-29-2010.
- 3,996,983. **GIFT OF ENGLISH AND DESIGN.** OUTREACH MINISTRIES INTERNATIONAL, (U.S. CLS. 100, 101 AND 107). SN 85-186,070. PUB. 5-3-2011. FILED 11-29-2010.
- 3,996,992. **THE WEDDING ROW (STANDARD CHARACTER).** THE WEDDING ROW, LLC, (U.S. CLS. 100, 101 AND 107). SN 85-186,395. PUB. 5-3-2011. FILED 11-29-2010.
- 3,996,996. **NATIONAL HOSPITALITY INSTITUTE (STANDARD CHARACTER).** NATIONAL HOSPITALITY INSTITUTE, (U.S. CLS. 100, 101 AND 107). SN 85-186,497. PUB. 5-3-2011. FILED 11-29-2010.
- 3,997,000. **FAMILIES OF CHARACTER AND DESIGN.** FAMILIES OF CHARACTER, (U.S. CLS. 100, 101 AND 107). SN 85-186,637. PUB. 5-3-2011. FILED 11-29-2010.
- 3,997,002. **BE FLUENT NYC (STANDARD CHARACTER).** BE FLUENT NYC INC., (U.S. CLS. 100, 101 AND 107). SN 85-186,695. PUB. 5-3-2011. FILED 11-29-2010.
- 3,997,007 (*See Class 35 for this trademark*).
- 3,997,010. **CME SAM AND DESIGN.** MAXWELL, M.D., ROBERT W., (U.S. CLS. 100, 101 AND 107). SN 85-186,930. PUB. 5-3-2011. FILED 11-30-2010.
- 3,997,015. **GREAT HALLOWEEN TRADE (STANDARD CHARACTER).** THE BEST OF ORGANIC LLC, (U.S. CLS. 100, 101 AND 107). SN 85-186,962. PUB. 5-3-2011. FILED 11-30-2010.
- 3,997,016. **DIVOTDOG (STANDARD CHARACTER).** ECOFIC, (U.S. CLS. 100, 101 AND 107). SN 85-186,980. PUB. 5-3-2011. FILED 11-30-2010.
- 3,997,017. **GOSPEL MESSENGERS (STANDARD CHARACTER).** GOSPEL MESSENGERS INC., (U.S. CLS. 100, 101 AND 107). SN 85-187,017. PUB. 5-3-2011. FILED 11-30-2010.
- 3,997,019. **LOVE LEE PHOTOGRAPHY (STANDARD CHARACTER).** LOVE LEE PHOTOGRAPHY, INC., (U.S. CLS. 100, 101 AND 107). SN 85-187,046. PUB. 5-3-2011. FILED 11-30-2010.
- 3,997,024. **ALPHA ASIAN (STANDARD CHARACTER).** FENG, KEVIN, AND CHOI, STEPHEN, (U.S. CLS. 100, 101 AND 107). SN 85-187,141. PUB. 5-3-2011. FILED 11-30-2010.
- 3,997,028. **AUTISM CARES FOUNDATION AND DESIGN.** AUTISM CARES FOUNDATION, (U.S. CLS. 100, 101 AND 107). SN 85-187,191. PUB. 5-3-2011. FILED 11-30-2010.
- 3,997,037. **MISS SAN ANTONIO AND DESIGN.** MISS BEXAR COUNTY ORGANIZATION, INC, (U.S. CLS. 100, 101 AND 107). SN 85-187,463. PUB. 5-3-2011. FILED 11-30-2010.
- 3,997,047. **BEAUTIFUL FEAT LLC AND DESIGN.** BEAUTIFUL FEAT, (U.S. CLS. 100, 101 AND 107). SN 85-187,620. PUB. 5-3-2011. FILED 11-30-2010.
- 3,997,051. **THE JASMINE BRAND (STANDARD CHARACTER).** HENDERSON, JASMINE M., (U.S. CLS. 100, 101 AND 107). SN 85-187,684. PUB. 5-3-2011. FILED 11-30-2010.
- 3,997,052. **RED LIGHT GREEN LIGHT FOODS (STANDARD CHARACTER).** THE BEST OF ORGANIC LLC, (U.S. CLS. 100, 101 AND 107). SN 85-187,722. PUB. 5-3-2011. FILED 11-30-2010.
- 3,997,067. **AEROSTAR TRAINING SERVICES LLC AND DESIGN.** AEROSTAR TRAINING SERVICES, LLC, (U.S. CLS. 100, 101 AND 107). SN 85-188,197. PUB. 5-3-2011. FILED 12-1-2010.
- 3,997,074. **TEAMEDGE (STANDARD CHARACTER).** SYNCRETICS GROUP, INC., THE, (U.S. CLS. 100, 101 AND 107). SN 85-188,292. PUB. 5-3-2011. FILED 12-1-2010.
- 3,997,093. **ROCK & ROLL FREEDOM SHOW (STANDARD CHARACTER).** GONZALES, MISTY, DBA ROCK & ROLL FREEDOM SHOW, AND WILSON, TOM, DBA ROCK & ROLL FREEDOM SHOW, (U.S. CLS. 100, 101 AND 107). SN 85-188,740. PUB. 5-3-2011. FILED 12-1-2010.
- 3,997,097 (*See Class 16 for this trademark*).
- 3,997,104 (*See Class 35 for this trademark*).
- 3,997,112. **CAPE COD MARATHON AND DESIGN.** FALMOUTH TRACK CLUB CORPORATION, (U.S. CLS. 100, 101 AND 107). SN 85-189,054. PUB. 5-3-2011. FILED 12-2-2010.
- 3,997,115. **I LIVE FASHION.COM (STANDARD CHARACTER).** JONATHAN GORDON, (U.S. CLS. 100, 101 AND 107). SN 85-189,153. PUB. 5-3-2011. FILED 12-2-2010.
- 3,997,117 (*See Class 9 for this trademark*).
- 3,997,121 (*See Class 25 for this trademark*).
- 3,997,122 (*See Class 35 for this trademark*).
- 3,997,137. **DIGITAL STREAM (STANDARD CHARACTER).** GRAY DIGITAL MARKETING, INC., (U.S. CLS. 100, 101 AND 107). SN 85-189,538. PUB. 5-3-2011. FILED 12-2-2010.
- 3,997,152. **THEVILLAGECELEBRATION.COM (STANDARD CHARACTER).** VICKIE D. NEWTON, (U.S. CLS. 100, 101 AND 107). SN 85-189,688. PUB. 5-3-2011. FILED 12-2-2010.
- 3,997,161. **INK-N-IRON (STANDARD CHARACTER).** KEEN ENTERTAINMENT LLC, (U.S. CLS. 100, 101 AND 107). SN

- 85-189,804. PUB. 5-3-2011. FILED 12-2-2010.
- 3,997,162. **MEG RUNION STUDIOS AND DESIGN. MEG RUNION STUDIOS**, (U.S. CLS. 100, 101 AND 107). SN 85-189,837. PUB. 5-3-2011. FILED 12-2-2010.
- 3,997,163 (*See Class 16 for this trademark*).
- 3,997,165. **SHANKAR MAHADEVAN ACADEMY (STANDARD CHARACTER). CLOOD ON MUSIC INC.**, (U.S. CLS. 100, 101 AND 107). SN 85-189,920. PUB. 5-3-2011. FILED 12-3-2010.
- 3,997,167. **THE WELCH MARTIAL ART EXPERIENCE FITNESS CONCEPTS EMPOWERING LIFE AND DESIGN. THE WELCH EXPERIENCE, INC.**, (U.S. CLS. 100, 101 AND 107). SN 85-189,958. PUB. 5-3-2011. FILED 12-3-2010.
- 3,997,171. **INNOVATION ENGINEERING AND DESIGN. EUREKA! INSTITUTE, INC.**, (U.S. CLS. 100, 101 AND 107). SN 85-189,993. PUB. 5-3-2011. FILED 12-3-2010.
- 3,997,181 (*See Class 35 for this trademark*).
- 3,997,182 (*See Class 25 for this trademark*).
- 3,997,183 (*See Class 35 for this trademark*).
- 3,997,184. **COMEDY DRIVING SCHOOL (STANDARD CHARACTER). INTERNATIONAL DRIVER TRAINING, INC.**, (U.S. CLS. 100, 101 AND 107). SN 85-190,406. PUB. 5-3-2011. FILED 12-3-2010.
- 3,997,191. **GAMEFRONT AND DESIGN. FILEFRONT, LLC**, (U.S. CLS. 100, 101 AND 107). SN 85-190,635. PUB. 5-3-2011. FILED 12-3-2010.
- 3,997,192. **EPICUREAN CULINARY GROUP AND DESIGN. EPICUREAN CATERING, LLC**, (U.S. CLS. 100, 101 AND 107). SN 85-190,698. PUB. 5-3-2011. FILED 12-4-2010.
- 3,997,193. **ICD-10 CONNECT (STANDARD CHARACTER). MERIYALA, SANTOSH KUMAR**, (U.S. CLS. 100, 101 AND 107). SN 85-190,724. PUB. 5-3-2011. FILED 12-4-2010.
- 3,997,200. **P.A.S.S. SYSTEM (STANDARD CHARACTER). DONOVAN, THOMAS**, (U.S. CLS. 100, 101 AND 107). SN 85-191,018. PUB. 5-3-2011. FILED 12-6-2010.
- 3,997,201. **ARTIST SHOWCASE AND DESIGN. BACKLINE MUSIC GROUP, LLC**, (U.S. CLS. 100, 101 AND 107). SN 85-191,033. PUB. 5-3-2011. FILED 12-6-2010.
- 3,997,205. **NEUROATTENDANT (STANDARD CHARACTER). OTOL INC**, (U.S. CLS. 100, 101 AND 107). SN 85-191,180. PUB. 5-3-2011. FILED 12-6-2010.
- 3,997,218. **BOUNCE MANIA (STANDARD CHARACTER). CANLAN ICE SPORTS CORP.**, (U.S. CLS. 100, 101 AND 107). SN 85-191,466. PUB. 5-3-2011. FILED 12-6-2010.
- 3,997,221. **WINE MINX (STANDARD CHARACTER). EDGERTON, ANNIE**, (U.S. CLS. 100, 101 AND 107). SN 85-191,630. PUB. 5-3-2011. FILED 12-6-2010.
- 3,997,225. **SLOBODY (STYLIZED). SLOBODY LLC**, (U.S. CLS. 100, 101 AND 107). SN 85-191,741. PUB. 5-3-2011. FILED 12-6-2010.
- 3,997,226. **THE ART SPOT AND DESIGN. STOLL, SUSAN DIANE, DBA THE ART SPOT**, (U.S. CLS. 100, 101 AND 107). SN 85-191,742. PUB. 5-3-2011. FILED 12-6-2010.
- 3,997,227. **METRICS MASTERMIND (STANDARD CHARACTER). KEY METRICS LLC**, (U.S. CLS. 100, 101 AND 107). SN 85-191,795. PUB. 5-3-2011. FILED 12-7-2010.
- 3,997,232. **SALES FUNNEL (STANDARD CHARACTER). RAY LEONE, DBA THE LEONE RESOURCE GROUP**, (U.S. CLS. 100, 101 AND 107). SN 85-192,038. PUB. 5-3-2011. FILED 12-7-2010.
- 3,997,238 (*See Class 35 for this trademark*).
- 3,997,246. **THE GOODNESS (STANDARD CHARACTER). ZUHAIRAH Y. SCOTT, AKA ZUHAIRAH Y. SCOTT WASHINGTON**, (U.S. CLS. 100, 101 AND 107). SN 85-192,574. PUB. 5-3-2011. FILED 12-7-2010.
- 3,997,249. **CHRIS COLE (STANDARD CHARACTER). OVERTAKER, LLC**, (U.S. CLS. 100, 101 AND 107). SN 85-192,680. PUB. 5-3-2011. FILED 12-7-2010.
- 3,997,261. **LIFE UNPLUGGED (STANDARD CHARACTER). THE MICHIGAN WOMEN'S FOUNDATION**, (U.S. CLS. 100, 101 AND 107). SN 85-192,826. PUB. 5-3-2011. FILED 12-8-2010.
- 3,997,265. **NEW ORLEANS KATRINA MEMORIAL AND DESIGN. NEW ORLEANS KATRINA MEMORIAL CORPORATION**, (U.S. CLS. 100, 101 AND 107). SN 85-192,955. PUB. 5-3-2011. FILED 12-8-2010.
- 3,997,270. **FOOD FACTOR (STANDARD CHARACTER). UNITED STATES FOUNDATION FOR INSPIRATION AND RECOGNITION OF SCIENCE AND TECHNOLOGY, AKA US FIRST, AND LEGO SYSTEMS, INC., AKA LEGO CORPORATION**, (U.S. CLS. 100, 101 AND 107). SN 85-193,086. PUB. 5-3-2011. FILED 12-8-2010.
- 3,997,278. **EPIC PROGRAMMING. MONUMENTAL VALUE (STANDARD CHARACTER). HOME BOX OFFICE, INC.**, (U.S. CLS. 100, 101 AND 107). SN 85-193,363. PUB. 5-3-2011. FILED 12-8-2010.
- 3,997,285. **BODY PROJECT (STANDARD CHARACTER). BODY PROJECT FITNESS AND HEALTH, LLC**, (U.S. CLS. 100, 101 AND 107). SN 85-193,731. PUB. 5-3-2011. FILED 12-8-2010.
- 3,997,294. **STUDIOWED (STANDARD CHARACTER). STUDIO WED, LLC, DBA STUDIO WED**, (U.S. CLS. 100, 101 AND 107). SN 85-194,004. PUB. 5-3-2011. FILED 12-9-2010.
- 3,997,303 (*See Class 3 for this trademark*).
- 3,997,304. **NATIONAL ACADEMY FOUNDATION AND DESIGN. NATIONAL ACADEMY FOUNDATION**, (U.S. CLS. 100, 101 AND 107). SN 85-194,499. PUB. 5-3-2011. FILED 12-9-2010.
- 3,997,305. **ACADEMY OF ENGINEERING AND DESIGN. NATIONAL ACADEMY FOUNDATION**, (U.S. CLS. 100, 101 AND 107). SN 85-194,515. PUB. 5-3-2011. FILED 12-9-2010.
- 3,997,306. **ACADEMY OF INFORMATION TECHNOLOGY AND DESIGN. NATIONAL ACADEMY FOUNDATION**, (U.S. CLS. 100, 101 AND 107). SN 85-194,524. PUB. 5-3-2011. FILED 12-9-2010.
- 3,997,307. **ACADEMY OF HOSPITALITY & TOURISM AND DESIGN. NATIONAL ACADEMY FOUNDATION**, (U.S. CLS. 100, 101 AND 107). SN 85-194,536. PUB. 5-3-2011. FILED 12-9-2010.
- 3,997,308. **ACADEMY OF FINANCE AND DESIGN. NATIONAL ACADEMY FOUNDATION**, (U.S. CLS. 100, 101 AND 107). SN 85-194,546. PUB. 5-3-2011. FILED 12-9-2010.
- 3,997,319 (*See Class 35 for this trademark*).
- 3,997,325 (*See Class 35 for this trademark*).
- 3,997,330. **YOGA AFLOAT (STANDARD CHARACTER). BIALEK, CYNTHIA**, (U.S. CLS. 100, 101 AND 107). SN 85-195,339. PUB. 5-3-2011. FILED 12-10-2010.
- 3,997,332. **KICK EM TO THE CURB (STANDARD CHARACTER). HOWARD, VICTORIA**, (U.S. CLS. 100, 101 AND 107). SN 85-195,474. PUB. 5-3-2011. FILED 12-10-2010.
- 3,997,340 (*See Class 25 for this trademark*).
- 3,997,346. **MYTOP FREEGAMES (STANDARD CHARACTER). KITARA MEDIA**, (U.S. CLS. 100, 101 AND 107). SN 85-196,601. PUB. 5-3-2011. FILED 12-13-2010.
- 3,997,349. **PLAYPICKLE (STANDARD CHARACTER). KITARA MEDIA**, (U.S. CLS. 100, 101 AND 107). SN 85-196,622. PUB. 5-3-2011. FILED 12-13-2010.
- 3,997,359. **HBO COMEDY AND DESIGN. HOME BOX OFFICE, INC.**, (U.S. CLS. 100, 101 AND 107). SN 85-197,372. PUB. 5-3-2011. FILED 12-14-2010.
- 3,997,365. **MAST ACADEMY (STANDARD CHARACTER). THE SCHOOL BOARD OF MIAMI-DADE COUNTY**, (U.S. CLS. 100, 101 AND 107). SN 85-197,716. PUB. 5-3-2011. FILED 12-14-2010.
- 3,997,367. **TRUST US THIS IS ALL MADE UP (STANDARD CHARACTER). JAGADOWSKI, THOMAS J., AND PASQUESI, DAVID**, (U.S. CLS. 100, 101 AND 107). SN 85-197,838. PUB. 5-3-2011. FILED 12-14-2010.
- 3,997,368. **THE ELEMENTAL ECONOMIST (STANDARD CHARACTER). PURNELL, JAMES E.**, (U.S. CLS. 100, 101 AND 107). SN 85-197,907. PUB. 5-3-2011. FILED 12-14-2010.
- 3,997,386. **BOIPARTY.COM (STANDARD CHARACTER). BOI PROMOTIONS INC.**, (U.S. CLS. 100, 101 AND 107). SN 85-199,136. PUB. 5-3-2011. FILED 12-16-2010.
- 3,997,393. **I LEAGUE INDOOR PROFESSIONAL SOCCER USL UNITED SOCCER LEAGUES AND DESIGN. UNITED SOCCER LEAGUES, LLC**, (U.S. CLS. 100, 101 AND 107). SN 85-199,643. PUB. 5-3-2011. FILED 12-16-2010.
- 3,997,409. **SCIENCE NEWS FOR KIDS (STANDARD CHARACTER). SOCIETY FOR SCIENCE & THE PUBLIC**, (U.S. CLS. 100, 101 AND 107). SN 85-200,165. PUB. 5-3-2011. FILED 12-17-2010.
- 3,997,416. **BAD INFLUENCE (STANDARD CHARACTER). MICHAEL L TASH**, (U.S. CLS. 100, 101 AND 107). SN 85-200,308. PUB. 5-3-2011. FILED 12-17-2010.

- 3,997,419. **NOTHIN' BUT NET (STANDARD CHARACTER)**. NOTHIN' BUT NET HOLDING L.L.C., (U.S. CLS. 100, 101 AND 107). SN 85-200,327. PUB. 5-3-2011. FILED 12-17-2010.
- 3,997,423. **ALOHA WEDDINGS AND DESIGN**. GARDNER, DIANA J., (U.S. CLS. 100, 101 AND 107). SN 85-200,393. PUB. 5-3-2011. FILED 12-17-2010.
- 3,997,426. **HOLLANDER (STANDARD CHARACTER)**. MONTEFORTE, CAMRYN, (U.S. CLS. 100, 101 AND 107). SN 85-200,589. PUB. 5-3-2011. FILED 12-17-2010.
- 3,997,435. **THE R.I.P. FILES (STANDARD CHARACTER)**. THE MARIN GROUP, INC., (U.S. CLS. 100, 101 AND 107). SN 85-200,871. PUB. 5-3-2011. FILED 12-17-2010.
- 3,997,453. **LUNKINATOR (STANDARD CHARACTER)**. PFIP, LLC, (U.S. CLS. 100, 101 AND 107). SN 85-201,776. PUB. 5-3-2011. FILED 12-20-2010.
- 3,997,454. **THE EBOOK INSIDER (STANDARD CHARACTER)**. RANDOM HOUSE, INC., (U.S. CLS. 100, 101 AND 107). SN 85-201,814. PUB. 5-3-2011. FILED 12-20-2010.
- 3,997,460. **DIG DIGITAL INNOVATION GAZETTE AND DESIGN**. STUDIO ONE NETWORKS, INC., (U.S. CLS. 100, 101 AND 107). SN 85-202,074. PUB. 5-3-2011. FILED 12-20-2010.
- 3,997,462 (*See Class 35 for this trademark*).
- 3,997,463. **EQP AND DESIGN**. FISHER, FREDRICK, (U.S. CLS. 100, 101 AND 107). SN 85-202,398. PUB. 5-3-2011. FILED 12-21-2010.
- 3,997,469 (*See Class 16 for this trademark*).
- 3,997,491. **YOU CAN DO WITHOUT THE PAPER; YOU CAN'T DO WITHOUT THE NEWS. (STANDARD CHARACTER)**. DAVIS, THOMAS G, DBA DAVIS MEDIA, (U.S. CLS. 100, 101 AND 107). SN 85-203,121. PUB. 5-3-2011. FILED 12-21-2010.
- 3,997,519. **WEHREBERG THEATRES (STANDARD CHARACTER)**. FRED WEHREBERG CIRCUIT OF THEATRES, INC., (U.S. CLS. 100, 101 AND 107). SN 85-204,134. PUB. 5-3-2011. FILED 12-22-2010.
- 3,997,522. **GIBRALTAR INSTITUTE FOR RESEARCH AND TRAINING (STANDARD CHARACTER)**. GIBRALTAR LABORATORIES, INC., (U.S. CLS. 100, 101 AND 107). SN 85-204,233. PUB. 5-3-2011. FILED 12-22-2010.
- 3,997,525. **HEALTHGURU (STANDARD CHARACTER)**. HEALTH GURU MEDIA, INC., (U.S. CLS. 100, 101 AND 107). SN 85-204,261. PUB. 5-3-2011. FILED 12-22-2010.
- 3,997,527. **HEALTHGURU AND DESIGN**. HEALTH GURU MEDIA, INC., (U.S. CLS. 100, 101 AND 107). SN 85-204,284. PUB. 5-3-2011. FILED 12-22-2010.
- 3,997,533 (*See Class 35 for this trademark*).
- 3,997,538. **IGVAULT (STANDARD CHARACTER)**. IGVAULT CO., LIMITED, (U.S. CLS. 100, 101 AND 107). SN 85-204,591. PUB. 5-3-2011. FILED 12-23-2010.
- 3,997,544 (*See Class 9 for this trademark*).
- 3,997,552. **CHRISTIE'S (STANDARD CHARACTER)**. CHRISTIE MANSON & WOODS LTD., (U.S. CLS. 100, 101 AND 107). SN 85-204,695. PUB. 5-3-2011. FILED 12-23-2010.
- 3,997,554. **SHAKE RHYTHM N' ROLL (STYLIZED)**. LANNA, PAOLO, (U.S. CLS. 100, 101 AND 107). SN 85-204,708. PUB. 5-3-2011. FILED 12-23-2010.
- 3,997,578. **SHELF SENSE (STANDARD CHARACTER)**. DIJPOP, (U.S. CLS. 100, 101 AND 107). SN 85-204,996. PUB. 5-3-2011. FILED 12-23-2010.
- 3,997,599. **WNYHOO-NOW! (STANDARD CHARACTER)**. LE NIHAN, MARY GERARD, (U.S. CLS. 100, 101 AND 107). SN 85-205,249. PUB. 5-3-2011. FILED 12-23-2010.
- 3,997,605. **GAVEL BABBLE (STYLIZED)**. GAVEL BABBLE INC., (U.S. CLS. 100, 101 AND 107). SN 85-205,333. PUB. 5-3-2011. FILED 12-23-2010.
- 3,997,607. **B.A.M. (STANDARD CHARACTER)**. YOUTH GUIDANCE, AKA YG, MULTIPLE CLASS, (INT. CLS. 41 AND 45), (U.S. CLS. 100, 101 AND 107). SN 85-205,350. PUB. 5-3-2011. FILED 12-23-2010.
- 3,997,608. **BECOMING A MAN (STANDARD CHARACTER)**. YOUTH GUIDANCE, AKA YG, MULTIPLE CLASS, (INT. CLS. 41 AND 45), (U.S. CLS. 100, 101 AND 107). SN 85-205,360. PUB. 5-3-2011. FILED 12-23-2010.
- 3,997,609. **SYNCHROPHONIC (STANDARD CHARACTER)**. REARDON, BRIAN, MULTIPLE CLASS, (INT. CLS. 41 AND 45), (U.S. CLS. 100, 101 AND 107). SN 85-205,365. PUB. 5-3-2011. FILED 12-23-2010.
- 3,997,612. **ALIGN YOUR FLOW (STANDARD CHARACTER)**. RIZOPOULOS, NATASHA, (U.S. CLS. 100, 101 AND 107). SN 85-205,423. PUB. 5-3-2011. FILED 12-23-2010.
- 3,997,613. **BFF (STANDARD CHARACTER)**. HERTILUS, JONATHAN, (U.S. CLS. 100, 101 AND 107). SN 85-205,463. PUB. 5-3-2011. FILED 12-23-2010.
- 3,997,621. **IMPROV TRAFFIC SCHOOL (STANDARD CHARACTER)**. IMPROV WEST ASSOCIATES, (U.S. CLS. 100, 101 AND 107). SN 85-205,569. PUB. 5-3-2011. FILED 12-24-2010.
- 3,997,623. **MR. MONEY (STANDARD CHARACTER)**. ROTHSTEIN, MARK S., (U.S. CLS. 100, 101 AND 107). SN 85-205,596. PUB. 5-3-2011. FILED 12-24-2010.
- 3,997,632. **BYLINER (STANDARD CHARACTER)**. JOHN M. TAYMAN, MULTIPLE CLASS, (INT. CLS. 41 AND 42), (U.S. CLS. 100, 101 AND 107). SN 85-205,737. PUB. 5-3-2011. FILED 12-26-2010.
- 3,997,634. **INSTAKILL (STANDARD CHARACTER)**. DORIAN, ARMAND, (U.S. CLS. 100, 101 AND 107). SN 85-205,749. PUB. 5-3-2011. FILED 12-27-2010.
- 3,997,642. **WOLF BRIGADE (STANDARD CHARACTER)**. WALSH, GREGORY, (U.S. CLS. 100, 101 AND 107). SN 85-205,841. PUB. 5-3-2011. FILED 12-27-2010.
- 3,997,643. **MY PINK STAMPER (STANDARD CHARACTER)**. CARDON, ROBYN, (U.S. CLS. 100, 101 AND 107). SN 85-205,845. PUB. 5-3-2011. FILED 12-27-2010.
- 3,997,673. **UPLYTE (STANDARD CHARACTER)**. UPLYTE LLC, (U.S. CLS. 100, 101 AND 107). SN 85-206,224. PUB. 5-3-2011. FILED 12-27-2010.
- 3,997,683. **HDYC AND DESIGN**. SETEBAID SERVICES, INC., (U.S. CLS. 100, 101 AND 107). SN 85-206,423. PUB. 5-3-2011. FILED 12-28-2010.
- 3,997,690. **FORWARD STRIDES AND DESIGN**. IN SHAPE KIDS, INC, (U.S. CLS. 100, 101 AND 107). SN 85-206,444. PUB. 5-3-2011. FILED 12-28-2010.
- 3,997,695. **IMPACT (STANDARD CHARACTER)**. THE COLLEGE NETWORK, INC., (U.S. CLS. 100, 101 AND 107). SN 85-206,478. PUB. 5-3-2011. FILED 12-28-2010.
- 3,997,700 (*See Class 36 for this trademark*).
- 3,997,704. **MAGICAL FOREST (STANDARD CHARACTER)**. OPPORTUNITY VILLAGE FOUNDATION, (U.S. CLS. 100, 101 AND 107). SN 85-206,634. PUB. 5-3-2011. FILED 12-28-2010.
- 3,997,708 (*See Class 36 for this trademark*).
- 3,997,710 (*See Class 25 for this trademark*).
- 3,997,714. **WHIMSICAL (STANDARD CHARACTER)**. SUSAN BERMAN, (U.S. CLS. 100, 101 AND 107). SN 85-206,763. PUB. 5-3-2011. FILED 12-28-2010.
- 3,997,725. **THE CREATIVE LADY (STANDARD CHARACTER)**. THE CREATIVE LADY, LLC, (U.S. CLS. 100, 101 AND 107). SN 85-206,963. PUB. 5-3-2011. FILED 12-29-2010.
- 3,997,741 (*See Class 35 for this trademark*).
- 3,997,750. **AFTERMATH (STANDARD CHARACTER)**. H.A.N. MADE LLC, (U.S. CLS. 100, 101 AND 107). SN 85-207,369. PUB. 5-3-2011. FILED 12-29-2010.
- 3,997,776. **JOC TENS (STANDARD CHARACTER)**. UBM IP LUXEMBOURG S.A.R.L., (U.S. CLS. 100, 101 AND 107). SN 85-207,729. PUB. 5-3-2011. FILED 12-30-2010.
- 3,997,779. **THE C4 EXPERIENCE (STANDARD CHARACTER)**. WRIGHT, LEROY I., (U.S. CLS. 100, 101 AND 107). SN 85-207,763. PUB. 5-3-2011. FILED 12-30-2010.
- 3,997,796. **SETTING THE STANDARD FOR INDUSTRY FIRSTS (STANDARD CHARACTER)**. SCHUSSLER CREATIVE, INC., (U.S. CLS. 100, 101 AND 107). SN 85-208,028. PUB. 5-3-2011. FILED 12-30-2010.
- 3,997,802. **DATE-LIKE-A-MAN.COM (STANDARD CHARACTER)**. TRENTACOSTA, THERESA, (U.S. CLS. 100, 101 AND 107). SN 85-208,098. PUB. 5-3-2011. FILED 12-30-2010.
- 3,997,803. **MISCELLANEOUS DESIGN**. OKINAWA-TE ORGANIZATION, (U.S. CLS. 100, 101 AND 107). SN 85-208,110. PUB. 5-3-2011. FILED 12-30-2010.
- 3,997,821. **AS5 (STANDARD CHARACTER)**. ELEVITCH, NIKOLAS, (U.S. CLS. 100, 101 AND 107). SN 85-208,285. PUB. 5-3-2011. FILED 12-30-2010.
- 3,997,824. **SOCCER & SMILES (STANDARD CHARACTER)**. SOCCER AND SMILES LLC, (U.S. CLS. 100, 101 AND 107). SN 85-208,331. PUB. 5-3-2011. FILED 12-30-2010.
- 3,997,825. **PIXELTOWN (STANDARD CHARACTER)**. PIXELTOWN ARTS, LLC, (U.S. CLS. 100, 101 AND 107). SN 85-208,334. PUB. 5-3-2011. FILED 12-30-2010.

- 3,997,826. **SOCCER & SMILES AND DESIGN**. SOCCER AND SMILES LLC, (U.S. CLS. 100, 101 AND 107). SN 85-208,340. PUB. 5-3-2011. FILED 12-30-2010.
- 3,997,837. **REVELUS AND DESIGN**. BRYAN MCCLANAHAN, (U.S. CLS. 100, 101 AND 107). SN 85-208,438. PUB. 5-3-2011. FILED 12-31-2010.
- 3,997,843. **MINDCHAMBER (STANDARD CHARACTER)**. ORTIZ JR., JOSE A., (U.S. CLS. 100, 101 AND 107). SN 85-208,524. PUB. 5-3-2011. FILED 12-31-2010.
- 3,997,849. **KNOWING GOD CHANGES YOUR LIFE (STANDARD CHARACTER)**. ARKEO, INC., (U.S. CLS. 100, 101 AND 107). SN 85-208,623. PUB. 5-3-2011. FILED 12-31-2010.
- 3,997,852 (*See Class 38 for this trademark*).
- 3,997,853. **AT WORK ON PURPOSE AND DESIGN**. SKILL-SOURCE, (U.S. CLS. 100, 101 AND 107). SN 85-208,642. PUB. 5-3-2011. FILED 12-31-2010.
- 3,997,863. **SCORIES (STANDARD CHARACTER)**. MERITT, GARY J., (U.S. CLS. 100, 101 AND 107). SN 85-208,683. PUB. 5-3-2011. FILED 12-31-2010.
- 3,997,865. **FITSOCIAL (STANDARD CHARACTER)**. SOCIAL-NEXUS, INC., (U.S. CLS. 100, 101 AND 107). SN 85-208,689. PUB. 5-3-2011. FILED 12-31-2010.
- 3,997,871. **PAINTED ON WATER (STANDARD CHARACTER)**. GNL ENTERTAINMENT, INC., (U.S. CLS. 100, 101 AND 107). SN 85-208,714. PUB. 5-3-2011. FILED 12-31-2010.
- 3,997,879 (*See Class 9 for this trademark*).
- 3,997,881. **BROWN BAG IT FOR BOOKS (STYLIZED)**. HOFFMAN, ALLISON M., (U.S. CLS. 100, 101 AND 107). SN 85-208,848. PUB. 5-3-2011. FILED 1-2-2011.
- 3,997,907. **SNOW FOX (STANDARD CHARACTER)**. INDEPENDENCE TELEVISION CO., INC., (U.S. CLS. 100, 101 AND 107). SN 85-209,180. PUB. 5-3-2011. FILED 1-3-2011.
- 3,997,934 (*See Class 35 for this trademark*).
- 3,997,936 (*See Class 9 for this trademark*).
- 3,997,937 (*See Class 35 for this trademark*).
- 3,997,940. **THEMADMIXER (STANDARD CHARACTER)**. DIP, GUILLERMO, (U.S. CLS. 100, 101 AND 107). SN 85-209,589. PUB. 5-3-2011. FILED 1-3-2011.
- 3,997,961. **PAEASY (STANDARD CHARACTER)**. THE MCGRAW-HILL COMPANIES, INC., (U.S. CLS. 100, 101 AND 107). SN 85-209,908. PUB. 5-3-2011. FILED 1-4-2011.
- 3,997,968. **RADREVIEWEASY (STANDARD CHARACTER)**. THE MCGRAW-HILL COMPANIES, INC., (U.S. CLS. 100, 101 AND 107). SN 85-210,000. PUB. 5-3-2011. FILED 1-4-2011.
- 3,997,970. **BEYOND WORDS (STANDARD CHARACTER)**. BEGLER, DAVID, (U.S. CLS. 100, 101 AND 107). SN 85-210,015. PUB. 5-3-2011. FILED 1-4-2011.
- 3,997,974. **THE BIG PICTURE (STANDARD CHARACTER)**. NYT MANAGEMENT SERVICES, INC., (U.S. CLS. 100, 101 AND 107). SN 85-210,113. PUB. 5-3-2011. FILED 1-4-2011.
- 3,997,991. **JAZZ ON THE HILL (STANDARD CHARACTER)**. SAN MATEO COUNTY COMMUNITY COLLEGE DISTRICT, (U.S. CLS. 100, 101 AND 107). SN 85-210,346. PUB. 5-3-2011. FILED 1-4-2011.
- 3,997,992. **VIEW OF THE WORLD (STANDARD CHARACTER)**. PAN AMERICAN PRODUCTIONS INTERNATIONAL S.A., (U.S. CLS. 100, 101 AND 107). SN 85-210,371. PUB. 5-3-2011. FILED 1-4-2011.
- 3,998,001. **MISCELLANEOUS DESIGN**. LIFESPORT FITNESS, (U.S. CLS. 100, 101 AND 107). SN 85-210,469. PUB. 5-3-2011. FILED 1-4-2011.
- 3,998,020. **THE CHAIN OF DEFENSE (STANDARD CHARACTER)**. DOREY POHRTE, KATHYSUE, (U.S. CLS. 100, 101 AND 107). SN 85-210,712. PUB. 5-3-2011. FILED 1-5-2011.
- 3,998,035. **PAEASY (STYLIZED)**. THE MCGRAW-HILL COMPANIES, INC., (U.S. CLS. 100, 101 AND 107). SN 85-210,978. PUB. 5-3-2011. FILED 1-5-2011.
- 3,998,037. **THE VIRTUAL TOUT (STANDARD CHARACTER)**. RESEARCH PUBLISHERS LLC, (U.S. CLS. 100, 101 AND 107). SN 85-210,991. PUB. 5-3-2011. FILED 1-5-2011.
- 3,998,047. **STRAPFIT (STANDARD CHARACTER)**. UNIVERSITY CITY PHYSICAL THERAPY, INC., DBA FUNCTIONSMART, (U.S. CLS. 100, 101 AND 107). SN 85-211,175. PUB. 5-3-2011. FILED 1-5-2011.
- 3,998,054. **NATION'S RESTAURANT NEWS (STANDARD CHARACTER)**. PENTON MEDIA, INC., MULTIPLE CLASS, (INT. CLS. 41 AND 43), (U.S. CLS. 100, 101 AND 107). SN 85-211,275. PUB. 5-3-2011. FILED 1-5-2011.
- 3,998,055. **MISS SOCIAL AND DESIGN**. PLAYBOY ENTERPRISES INTERNATIONAL, INC., (U.S. CLS. 100, 101 AND 107). SN 85-211,293. PUB. 5-3-2011. FILED 1-5-2011.
- 3,998,056. **WEBINARSNOW (STANDARD CHARACTER)**. INSIGHTSNOW, INC., (U.S. CLS. 100, 101 AND 107). SN 85-211,327. PUB. 5-3-2011. FILED 1-5-2011.
- 3,998,081 (*See Class 35 for this trademark*).
- 3,998,089. **WHERE COMMUNITY AND CULTURE CONVERGE. (STYLIZED)**. CITY OF MIRAMAR, (U.S. CLS. 100, 101 AND 107). SN 85-211,857. PUB. 5-3-2011. FILED 1-6-2011.
- 3,998,090. **AWAKENING (STANDARD CHARACTER)**. LIBERTY COUNSEL, INC., (U.S. CLS. 100, 101 AND 107). SN 85-211,871. PUB. 5-3-2011. FILED 1-6-2011.
- 3,998,100 (*See Class 16 for this trademark*).
- 3,998,115. **KNOCKOUT BODIES (STANDARD CHARACTER)**. FIVE NINJAS MARTIAL ARTS, DBA KNOCKOUT BODIES, (U.S. CLS. 100, 101 AND 107). SN 85-212,408. PUB. 5-3-2011. FILED 1-6-2011.
- 3,998,120. **UN Sung (STANDARD CHARACTER)**. TV ONE, LLC, (U.S. CLS. 100, 101 AND 107). SN 85-212,480. PUB. 5-3-2011. FILED 1-7-2011.
- 3,998,124. **THE LEFT FIELD (STANDARD CHARACTER)**. OFF PROPERTY PRODUCTIONS, LLC, (U.S. CLS. 100, 101 AND 107). SN 85-212,514. PUB. 5-3-2011. FILED 1-7-2011.
- 3,998,125. **EQUIMAGE (STANDARD CHARACTER)**. RAWLINS, NANETTE T., (U.S. CLS. 100, 101 AND 107). SN 85-212,529. PUB. 5-3-2011. FILED 1-7-2011.
- 3,998,136. **TRUEFLIX (STANDARD CHARACTER)**. SCHOLASTIC INC., (U.S. CLS. 100, 101 AND 107). SN 85-212,878. PUB. 5-3-2011. FILED 1-7-2011.
- 3,998,137. **INSIDERCONNECT (STANDARD CHARACTER)**. PROSPX, INC., (U.S. CLS. 100, 101 AND 107). SN 85-212,894. PUB. 5-3-2011. FILED 1-7-2011.
- 3,998,138 (*See Class 35 for this trademark*).
- 3,998,146. **SAUSAGE PARTY (STANDARD CHARACTER)**. GRHK IP, LLC, (U.S. CLS. 100, 101 AND 107). SN 85-213,048. PUB. 5-3-2011. FILED 1-7-2011.
- 3,998,148. **SAUSAGE PARTY (STYLIZED)**. GRHK IP, LLC, (U.S. CLS. 100, 101 AND 107). SN 85-213,114. PUB. 5-3-2011. FILED 1-7-2011.
- 3,998,159 (*See Class 16 for this trademark*).
- 3,998,163. **T-COACHING (STANDARD CHARACTER)**. MIND THE GAP LLC, (U.S. CLS. 100, 101 AND 107). SN 85-213,578. PUB. 5-3-2011. FILED 1-9-2011.
- 3,998,167. **LOGO MOTION (STANDARD CHARACTER)**. UNITED STATES FOUNDATION FOR INSPIRATION AND RECOGNITION OF SCIENCE AND TECHNOLOGY, AKA US FIRST, (U.S. CLS. 100, 101 AND 107). SN 85-213,718. PUB. 5-3-2011. FILED 1-10-2011.
- 3,998,178 (*See Class 9 for this trademark*).
- 3,998,188. **CARDIO-TONE (STANDARD CHARACTER)**. RACHEL ARAM, DBA CARDIO-TONE, (U.S. CLS. 100, 101 AND 107). SN 85-214,450. PUB. 5-3-2011. FILED 1-10-2011.
- 3,998,209. **30 MINUTE WARRIOR (STANDARD CHARACTER)**. MARCHTALER, KENNETH ERVIN, DBA WARRIOR MARTIAL ARTS, (U.S. CLS. 100, 101 AND 107). SN 85-220,728. PUB. 5-3-2011. FILED 1-19-2011.
- 3,998,210. **ASM (STANDARD CHARACTER)**. ADRENALINE SPORTS MANAGEMENT INC., (U.S. CLS. 100, 101 AND 107). SN 85-221,085. PUB. 5-3-2011. FILED 1-19-2011.
- 3,998,230. **STEP THRU THE SCREEN (STANDARD CHARACTER)**. TIME WARNER CABLE INC., (U.S. CLS. 100, 101 AND 107). SN 85-226,556. PUB. 5-3-2011. FILED 1-26-2011.
- 3,998,235 (*See Class 36 for this trademark*).
- 3,998,248. **LAKE COMPOUNCE (STANDARD CHARACTER)**. FESTIVAL FUN PARKS, LLC, (U.S. CLS. 100, 101 AND 107). SN 85-234,254. PUB. 5-3-2011. FILED 2-4-2011.
- 3,998,249. **STORY LAND (STANDARD CHARACTER)**. FESTIVAL FUN PARKS, LLC, (U.S. CLS. 100, 101 AND 107). SN 85-234,276. PUB. 5-3-2011. FILED 2-4-2011.
- 3,998,255 (*See Class 35 for this trademark*).
- 3,998,264 (*See Class 16 for this trademark*).
- 3,998,265. **U.S.P.A. (STANDARD CHARACTER)**. UNITED STATES PILATES ASSOCIATION LLC, (U.S. CLS. 100, 101 AND 107). SN 85-241,183. PUB. 5-3-2011. FILED 2-14-2011.
- 3,998,269 (*See Class 9 for this trademark*).

3,998,270 (See Class 9 for this trademark).
 3,998,277 (See Class 9 for this trademark).
 3,998,282. **GIDDY UP GAME ROOM (STANDARD CHARACTER)**. PINNACLE ENTERTAINMENT, INC., (U.S. CLS. 100, 101 AND 107). SN 85-248,915. PUB. 5-3-2011. FILED 2-22-2011.
 3,998,285. **GIDDY UP GAME ROOM AND DESIGN**. PINNACLE ENTERTAINMENT, INC., (U.S. CLS. 100, 101 AND 107). SN 85-248,974. PUB. 5-3-2011. FILED 2-22-2011.

CLASS 42—SCIENTIFIC AND COMPUTER SERVICES

3,995,475 (See Class 35 for this trademark).
 3,995,487. **EMPYREAL AND DESIGN**. EMPYREAL SCIENCES, LLC, (U.S. CLS. 100 AND 101). SN 76-705,582. PUB. 5-3-2011. FILED 12-6-2010.
 3,995,490. **NEXTPUB (STANDARD CHARACTER)**. INTERNATIONAL DIGITAL ENTERPRISE ALLIANCE, INC., (U.S. CLS. 100 AND 101). SN 76-705,685. PUB. 5-3-2011. FILED 12-14-2010.
 3,995,511 (See Class 9 for this trademark).
 3,995,515 (See Class 9 for this trademark).
 3,995,524 (See Class 7 for this trademark).
 3,995,531 (See Class 7 for this trademark).
 3,995,533 (See Class 16 for this trademark).
 3,995,540 (See Class 9 for this trademark).
 3,995,541. **YOUREPORT.COM CUSTOMIZE YOUR NEWS AND DESIGN**. MAINCLOUD LLC, (U.S. CLS. 100 AND 101). SN 77-578,190. PUB. 5-3-2011. FILED 9-24-2008.
 3,995,546. **NINTENDODSI AND DESIGN**. NINTENDO OF AMERICA INC., (U.S. CLS. 100 AND 101). SN 77-583,775. PUB. 10-19-2010. FILED 10-2-2008.
 3,995,552 (See Class 9 for this trademark).
 3,995,573 (See Class 9 for this trademark).
 3,995,580 (See Class 6 for this trademark).
 3,995,594 (See Class 1 for this trademark).
 3,995,599 (See Class 35 for this trademark).
 3,995,602 (See Class 35 for this trademark).
 3,995,603. **MAKING IT EASY (STYLIZED)**. THE CYBRIX GROUP INC., (U.S. CLS. 100 AND 101). SN 77-810,994. PUB. 5-3-2011. FILED 8-24-2009.
 3,995,618 (See Class 9 for this trademark).
 3,995,626 (See Class 38 for this trademark).
 3,995,644. **LIBBY LANGDON (STANDARD CHARACTER)**. LIBBY INTERIORS INC., (U.S. CLS. 100 AND 101). SN 77-879,730. PUB. 10-19-2010. FILED 11-24-2009.
 3,995,647 (See Class 2 for this trademark).
 3,995,656 (See Class 41 for this trademark).
 3,995,657 (See Class 41 for this trademark).
 3,995,659 (See Class 35 for this trademark).
 3,995,662. **EXPERTS EXCHANGE (STANDARD CHARACTER)**. EXPERTS EXCHANGE, LLC, (U.S. CLS. 100 AND 101). SN 77-900,477. PUB. 5-3-2011. FILED 12-23-2009.
 3,995,674 (See Class 35 for this trademark).
 3,995,678 (See Class 35 for this trademark).
 3,995,689. **ONE E APP (STANDARD CHARACTER)**. CALIFORNIA HEALTHCARE FOUNDATION, (U.S. CLS. 100 AND 101). SN 77-938,804. PUB. 5-3-2011. FILED 2-18-2010.
 3,995,702 (See Class 35 for this trademark).
 3,995,720 (See Class 6 for this trademark).
 3,995,728 (See Class 9 for this trademark).
 3,995,730 (See Class 9 for this trademark).
 3,995,734 (See Class 6 for this trademark).
 3,995,735 (See Class 6 for this trademark).
 3,995,738 (See Class 9 for this trademark).
 3,995,739 (See Class 9 for this trademark).
 3,995,740 (See Class 9 for this trademark).
 3,995,741 (See Class 9 for this trademark).
 3,995,742 (See Class 9 for this trademark).
 3,995,743 (See Class 9 for this trademark).
 3,995,744 (See Class 9 for this trademark).
 3,995,747 (See Class 9 for this trademark).
 3,995,755 (See Class 35 for this trademark).
 3,995,757 (See Class 10 for this trademark).
 3,995,763 (See Class 35 for this trademark).

3,995,770 (See Class 6 for this trademark).
 3,995,775 (See Class 6 for this trademark).
 3,995,779 (See Class 9 for this trademark).
 3,995,780 (See Class 9 for this trademark).
 3,995,783 (See Class 16 for this trademark).
 3,995,792 (See Class 7 for this trademark).
 3,995,798 (See Class 9 for this trademark).
 3,995,802 (See Class 35 for this trademark).
 3,995,813 (See Class 7 for this trademark).
 3,995,816 (See Class 1 for this trademark).
 3,995,819 (See Class 9 for this trademark).
 3,995,820 (See Class 35 for this trademark).
 3,995,821 (See Class 7 for this trademark).
 3,995,823 (See Class 9 for this trademark).
 3,995,825 (See Class 35 for this trademark).
 3,995,826 (See Class 35 for this trademark).
 3,995,835 (See Class 5 for this trademark).
 3,995,846 (See Class 9 for this trademark).
 3,995,868 (See Class 9 for this trademark).
 3,995,876 (See Class 9 for this trademark).
 3,995,879 (See Class 6 for this trademark).
 3,995,881 (See Class 35 for this trademark).
 3,995,882 (See Class 16 for this trademark).
 3,995,904 (See Class 1 for this trademark).
 3,995,907 (See Class 9 for this trademark).
 3,995,908 (See Class 9 for this trademark).
 3,995,926 (See Class 7 for this trademark).
 3,995,935. **KINETURA (STANDARD CHARACTER)**. KINETURA BVBA, (U.S. CLS. 100 AND 101). SN 79-088,052. PUB. 5-3-2011. FILED 8-19-2010.
 3,995,942 (See Class 9 for this trademark).
 3,995,943 (See Class 9 for this trademark).
 3,995,950 (See Class 5 for this trademark).
 3,995,963. **FORM FACTORY (STANDARD CHARACTER)**. FORM FACTOR PTY LTD, (U.S. CLS. 100 AND 101). SN 79-089,689. PUB. 5-3-2011. FILED 10-7-2010.
 3,995,969 (See Class 9 for this trademark).
 3,995,977 (See Class 35 for this trademark).
 3,995,996 (See Class 9 for this trademark).
 3,996,019 (See Class 5 for this trademark).
 3,996,029 (See Class 9 for this trademark).
 3,996,037 (See Class 9 for this trademark).
 3,996,051. **J-U-B (STANDARD CHARACTER)**. J-U-B ENGINEERS, INC., (U.S. CLS. 100 AND 101). SN 85-013,218. PUB. 5-3-2011. FILED 4-13-2010.
 3,996,068. **3E BY PRIMEPAY (STANDARD CHARACTER)**. PRIMEPAY, INC., (U.S. CLS. 100 AND 101). SN 85-019,647. PUB. 5-3-2011. FILED 4-21-2010.
 3,996,116. **MISCELLANEOUS DESIGN**. G.T.S. CORPORATION PTY LTD, MULTIPLE CLASS, (INT. CLS. 42 AND 45), (U.S. CLS. 100 AND 101). SN 85-034,409. PUB. 5-3-2011. FILED 5-10-2010.
 3,996,150. **ALLVANT (STANDARD CHARACTER)**. ALLVANT CORPORATION, (U.S. CLS. 100 AND 101). SN 85-039,180. PUB. 5-3-2011. FILED 5-14-2010.
 3,996,158. **ALLVANT AND DESIGN**. ALLVANT CORPORATION, (U.S. CLS. 100 AND 101). SN 85-040,694. PUB. 5-3-2011. FILED 5-17-2010.
 3,996,165 (See Class 41 for this trademark).
 3,996,169. **UNIFIED DESIGN (STANDARD CHARACTER)**. UNIFIED DESIGN CORPORATION, (U.S. CLS. 100 AND 101). SN 85-042,076. PUB. 5-3-2011. FILED 5-18-2010.
 3,996,175. **THERAGENCE (STANDARD CHARACTER)**. THERAGENCE, INC., (U.S. CLS. 100 AND 101). SN 85-042,469. PUB. 5-3-2011. FILED 5-19-2010.
 3,996,190. **JOYENT (STANDARD CHARACTER)**. JOYENT, INC., MULTIPLE CLASS, (INT. CLS. 42 AND 45), (U.S. CLS. 100 AND 101). SN 85-044,555. PUB. 5-3-2011. FILED 5-21-2010.
 3,996,199. **JOYENT AND DESIGN**. JOYENT, INC., MULTIPLE CLASS, (INT. CLS. 42 AND 45), (U.S. CLS. 100 AND 101). SN 85-045,808. PUB. 5-3-2011. FILED 5-23-2010.
 3,996,219 (See Class 36 for this trademark).
 3,996,237. **FOCUSMX (STANDARD CHARACTER)**. APEX IMPACT MARKETING, LLC, DBA FOCUSMX, (U.S. CLS. 100 AND 101). SN 85-048,857. PUB. 5-3-2011. FILED 5-26-2010.
 3,996,243. . **AMERICAN BOARD FOR CERTIFICATION IN**

- INFRASTRUCTURE PROTECTION A.B.C.I.P. . A LOYAL AND TRUSTWORTHY MEMBER SCIENCE . INTEGRITY . JUSTICE AND DESIGN.** ROBERT L. O'BLOCK REVOCABLE TRUST, (U.S. CLS. 100 AND 101). SN 85-050,393. PUB. 5-3-2011. FILED 5-28-2010.
- 3,996,248 (*See Class 40 for this trademark.*)
- 3,996,253 (*See Class 9 for this trademark.*)
- 3,996,276. **SENA (STANDARD CHARACTER).** AURIONPRO SOLUTIONS, INC., (U.S. CLS. 100 AND 101). SN 85-055,204. PUB. 5-3-2011. FILED 6-4-2010.
- 3,996,316. **SCIENERGY (STANDARD CHARACTER).** SCIENTIFIC CONSERVATION INC., (U.S. CLS. 100 AND 101). SN 85-064,349. PUB. 5-3-2011. FILED 6-16-2010.
- 3,996,320. **APPCORE (STYLIZED).** DONAGHY, BRIAN P., (U.S. CLS. 100 AND 101). SN 85-065,271. PUB. 5-3-2011. FILED 6-17-2010.
- 3,996,330. **TELAPPRISE AND DESIGN.** TELAPPRISE LLC, (U.S. CLS. 100 AND 101). SN 85-068,298. PUB. 5-3-2011. FILED 6-22-2010.
- 3,996,333 (*See Class 9 for this trademark.*)
- 3,996,342 (*See Class 9 for this trademark.*)
- 3,996,343 (*See Class 35 for this trademark.*)
- 3,996,362 (*See Class 35 for this trademark.*)
- 3,996,365. **EFOLIOWORLD (STANDARD CHARACTER).** BOARD OF TRUSTEES, MINNESOTA STATE COLLEGES AND UNIVERSITIES, AKA MNSCU, (U.S. CLS. 100 AND 101). SN 85-074,835. PUB. 5-3-2011. FILED 6-30-2010.
- 3,996,379 (*See Class 41 for this trademark.*)
- 3,996,391 (*See Class 9 for this trademark.*)
- 3,996,455. **WINGSPAN (STANDARD CHARACTER).** SILKROAD TECHNOLOGY, INC., (U.S. CLS. 100 AND 101). SN 85-103,291. PUB. 5-3-2011. FILED 8-9-2010.
- 3,996,456 (*See Class 41 for this trademark.*)
- 3,996,473 (*See Class 40 for this trademark.*)
- 3,996,483 (*See Class 9 for this trademark.*)
- 3,996,485. **WINDLOGICS (STYLIZED).** NEXTERA ENERGY, INC., (U.S. CLS. 100 AND 101). SN 85-115,387. PUB. 5-3-2011. FILED 8-25-2010.
- 3,996,497. **REDPOINT AND DESIGN.** REDPOINT GLOBAL INC., (U.S. CLS. 100 AND 101). SN 85-119,086. PUB. 5-3-2011. FILED 8-30-2010.
- 3,996,501 (*See Class 41 for this trademark.*)
- 3,996,538 (*See Class 41 for this trademark.*)
- 3,996,544. **DOSESPOT (STANDARD CHARACTER).** PRN SOFTWARE LLC, (U.S. CLS. 100 AND 101). SN 85-131,003. PUB. 5-3-2011. FILED 9-16-2010.
- 3,996,578 (*See Class 35 for this trademark.*)
- 3,996,581. **HIKO BELL MINING & OIL COMPANY (STANDARD CHARACTER).** HIKO ENERGY CORPORATION, (U.S. CLS. 100 AND 101). SN 85-139,141. PUB. 5-3-2011. FILED 9-27-2010.
- 3,996,585. **GENOME (STANDARD CHARACTER).** EXTERRO, INC., (U.S. CLS. 100 AND 101). SN 85-140,999. PUB. 5-3-2011. FILED 9-29-2010.
- 3,996,586. **FUSION CLOUD (STANDARD CHARACTER).** EXTERRO, INC., (U.S. CLS. 100 AND 101). SN 85-141,121. PUB. 5-3-2011. FILED 9-29-2010.
- 3,996,595. **WORKLIFE MANAGER AND DESIGN.** STRATEGIC RESOURCES GROUP, LLC, DBA HUMAN RESOURCES OUTSOURCING SERVICES, (U.S. CLS. 100 AND 101). SN 85-144,192. PUB. 5-3-2011. FILED 10-4-2010.
- 3,996,604. **CREATE180 DESIGN (STANDARD CHARACTER).** CREATE180, (U.S. CLS. 100 AND 101). SN 85-145,787. PUB. 5-3-2011. FILED 10-5-2010.
- 3,996,620 (*See Class 35 for this trademark.*)
- 3,996,626 (*See Class 35 for this trademark.*)
- 3,996,687. **REFRESH YOUR NEST (STANDARD CHARACTER).** REFRESH YOUR NEST, (U.S. CLS. 100 AND 101). SN 85-163,584. PUB. 5-3-2011. FILED 10-28-2010.
- 3,996,700. **MISCELLANEOUS DESIGN.** 25EIGHT, INC., (U.S. CLS. 100 AND 101). SN 85-166,428. PUB. 5-3-2011. FILED 11-1-2010.
- 3,996,727. **OCUTEC (STANDARD CHARACTER).** OCUTEC LIMITED, (U.S. CLS. 100 AND 101). SN 85-169,940. PUB. 5-3-2011. FILED 11-5-2010.
- 3,996,733. **DIGITALLY FLY (STANDARD CHARACTER).** COLLINS, JOSEPH, (U.S. CLS. 100 AND 101). SN 85-170,779. PUB. 5-3-2011. FILED 11-5-2010.
- 3,996,743 (*See Class 9 for this trademark.*)
- 3,996,770. **INTELLEWEB SOURCES AND DESIGN.** FRYMIRE, JULIE L., DBA INTELLEWEB SOURCES, (U.S. CLS. 100 AND 101). SN 85-174,072. PUB. 5-3-2011. FILED 11-10-2010.
- 3,996,774. **SCHMIDT & STACY AND DESIGN.** SCHMIDT & STACY CONSULTING ENGINEERS, INC., (U.S. CLS. 100 AND 101). SN 85-174,351. PUB. 5-3-2011. FILED 11-11-2010.
- 3,996,782. **STAY AT HOME SCORE (STANDARD CHARACTER).** SH HOLDINGS, LLC, (U.S. CLS. 100 AND 101). SN 85-174,913. PUB. 5-3-2011. FILED 11-11-2010.
- 3,996,792. **MOJA (STYLIZED).** MOJA, INC., (U.S. CLS. 100 AND 101). SN 85-175,556. PUB. 5-3-2011. FILED 11-12-2010.
- 3,996,826 (*See Class 40 for this trademark.*)
- 3,996,828 (*See Class 36 for this trademark.*)
- 3,996,858. **CIA IMPACTINDEX (STANDARD CHARACTER).** HEALTH CARE CONCEPTS, INC., (U.S. CLS. 100 AND 101). SN 85-179,238. PUB. 5-3-2011. FILED 11-17-2010.
- 3,996,859. **RIFE (STANDARD CHARACTER).** GORDY, MARK, (U.S. CLS. 100 AND 101). SN 85-179,314. PUB. 5-3-2011. FILED 11-17-2010.
- 3,996,876. **PERFORMANCE MANAGER (STANDARD CHARACTER).** HEALTHCARESOURCE HR, INC., (U.S. CLS. 100 AND 101). SN 85-180,283. PUB. 5-3-2011. FILED 11-18-2010.
- 3,996,891. **PROTECTED TRUST AND DESIGN.** LEEDY, INGRAM, (U.S. CLS. 100 AND 101). SN 85-181,550. PUB. 5-3-2011. FILED 11-19-2010.
- 3,996,892. **CANVAS INTERIOR DESIGN (STANDARD CHARACTER).** CANVAS INTERIOR DESIGN, INC., (U.S. CLS. 100 AND 101). SN 85-181,599. PUB. 5-3-2011. FILED 11-19-2010.
- 3,996,901 (*See Class 36 for this trademark.*)
- 3,996,926. **OAS (STANDARD CHARACTER).** ONLINE-AUCTIONS SOFTWARE.COM, INC., (U.S. CLS. 100 AND 101). SN 85-183,137. PUB. 5-3-2011. FILED 11-23-2010.
- 3,996,927. **OAS ONLINE-AUCTIONS SOFTWARE.COM INC AND DESIGN.** ONLINE-AUCTIONS SOFTWARE.COM, INC., (U.S. CLS. 100 AND 101). SN 85-183,157. PUB. 5-3-2011. FILED 11-23-2010.
- 3,996,929. **SYMBOLIC SPACES (STANDARD CHARACTER).** NATALIA S PREISS, (U.S. CLS. 100 AND 101). SN 85-183,215. PUB. 5-3-2011. FILED 11-23-2010.
- 3,996,961 (*See Class 9 for this trademark.*)
- 3,997,005. **MISCELLANEOUS DESIGN.** SAMSON INVESTMENTS, LLC, (U.S. CLS. 100 AND 101). SN 85-186,725. PUB. 5-3-2011. FILED 11-29-2010.
- 3,997,011. **ALL NATURAL LANGUAGE PROCESSING (STANDARD CHARACTER).** MORFOLOGICA INC., (U.S. CLS. 100 AND 101). SN 85-186,951. PUB. 5-3-2011. FILED 11-30-2010.
- 3,997,012. **MORFOLOGICA (STANDARD CHARACTER).** MORFOLOGICA INC., (U.S. CLS. 100 AND 101). SN 85-186,954. PUB. 5-3-2011. FILED 11-30-2010.
- 3,997,030. **SLACKER ANIMATION (STANDARD CHARACTER).** SLACKER ANIMATION, LLC, (U.S. CLS. 100 AND 101). SN 85-187,246. PUB. 5-3-2011. FILED 11-30-2010.
- 3,997,077 (*See Class 16 for this trademark.*)
- 3,997,078 (*See Class 16 for this trademark.*)
- 3,997,113. **OA OLSSON ASSOCIATES (STYLIZED).** OLSSON ASSOCIATES, (U.S. CLS. 100 AND 101). SN 85-189,055. PUB. 5-3-2011. FILED 12-2-2010.
- 3,997,140. **BIZMOSIS (STANDARD CHARACTER).** BIZMOSIS, INC., DBA BIZMOSIS, (U.S. CLS. 100 AND 101). SN 85-189,551. PUB. 5-3-2011. FILED 12-2-2010.
- 3,997,150 (*See Class 9 for this trademark.*)
- 3,997,170 (*See Class 37 for this trademark.*)
- 3,997,172 (*See Class 35 for this trademark.*)
- 3,997,177 (*See Class 35 for this trademark.*)
- 3,997,186. **TRUSTON AND DESIGN.** TRUSTON TECHNOLOGIES, INC., (U.S. CLS. 100 AND 101). SN 85-190,481. PUB. 5-3-2011. FILED 12-3-2010.
- 3,997,210. **NYSRCASD NEW YORK STATE REGIONAL CENTERS FOR AUTISM SPECTRUM DISORDERS AND DESIGN.** THE RESEARCH FOUNDATION OF STATE UNIVERSITY OF NEW YORK, (U.S. CLS. 100 AND 101). SN 85-191,268. PUB. 5-3-2011. FILED 12-6-2010.
- 3,997,215. **PRETTY RED ROSE (STANDARD CHARACTER).** LAU, TED C, DBA PRETTY RED ROSE, (U.S. CLS. 100

- AND 101). SN 85-191,377. PUB. 5-3-2011. FILED 12-6-2010.
- 3,997,228. **PROVA (STANDARD CHARACTER)**. PROVA, (U.S. CLS. 100 AND 101). SN 85-191,827. PUB. 5-3-2011. FILED 12-7-2010.
- 3,997,237. **FIELD CONCEPTS (STANDARD CHARACTER)**. STRIKE ZONE PRECISION AG, LLC, (U.S. CLS. 100 AND 101). SN 85-192,272. PUB. 5-3-2011. FILED 12-7-2010.
- 3,997,243. **STAMP THE BAND AND DESIGN**. HARDEEN, DAMIAN, (U.S. CLS. 100 AND 101). SN 85-192,564. PUB. 5-3-2011. FILED 12-7-2010.
- 3,997,253. **DYNAMIC SOLUTIONS GROUP (STANDARD CHARACTER)**. DYNAMIC SOLUTIONS GROUP, INC., (U.S. CLS. 100 AND 101). SN 85-192,701. PUB. 5-3-2011. FILED 12-7-2010.
- 3,997,311 (*See Class 35 for this trademark*).
- 3,997,334 (*See Class 16 for this trademark*).
- 3,997,358 (*See Class 9 for this trademark*).
- 3,997,371. **MYARTSYLUM.COM AND DESIGN**. MYARTSYLUM, INC., (U.S. CLS. 100 AND 101). SN 85-197,982. PUB. 5-3-2011. FILED 12-15-2010.
- 3,997,385. **DRUIDS DRIVING UNDER THE INFLUENCE OF DISABLING SUBSTANCES AND DESIGN**. AFFINITON, (U.S. CLS. 100 AND 101). SN 85-198,886. PUB. 5-3-2011. FILED 12-15-2010.
- 3,997,399. **MAGNICODE (STANDARD CHARACTER)**. MAGNICODE, INC., (U.S. CLS. 100 AND 101). SN 85-199,871. PUB. 5-3-2011. FILED 12-16-2010.
- 3,997,405. **MISCELLANEOUS DESIGN**. GROSVENOR USA LIMITED, (U.S. CLS. 100 AND 101). SN 85-200,073. PUB. 5-3-2011. FILED 12-16-2010.
- 3,997,407. **LIVING CITIES (STANDARD CHARACTER)**. GROSVENOR USA LIMITED, (U.S. CLS. 100 AND 101). SN 85-200,079. PUB. 5-3-2011. FILED 12-16-2010.
- 3,997,413. **FAILSAFE (STANDARD CHARACTER)**. ELECTRA INFORMATION SYSTEMS, INC., (U.S. CLS. 100 AND 101). SN 85-200,248. PUB. 5-3-2011. FILED 12-17-2010.
- 3,997,414. **MYSCORECARD (STANDARD CHARACTER)**. MYSCORECARD LLC, (U.S. CLS. 100 AND 101). SN 85-200,251. PUB. 5-3-2011. FILED 12-17-2010.
- 3,997,415 (*See Class 35 for this trademark*).
- 3,997,427. **BANJO (STANDARD CHARACTER)**. DP SQUARED, INC., (U.S. CLS. 100 AND 101). SN 85-200,599. PUB. 5-3-2011. FILED 12-17-2010.
- 3,997,430. **CONVONATION AND DESIGN**. CONVONATION, LLC, (U.S. CLS. 100 AND 101). SN 85-200,681. PUB. 5-3-2011. FILED 12-17-2010.
- 3,997,450. **I85MEDIA (STANDARD CHARACTER)**. I85MEDIA, INC., (U.S. CLS. 100 AND 101). SN 85-201,713. PUB. 5-3-2011. FILED 12-20-2010.
- 3,997,465 (*See Class 9 for this trademark*).
- 3,997,505. **METRO WORKSTATION (STANDARD CHARACTER)**. MIS QUALITY MANAGEMENT CORP., (U.S. CLS. 100 AND 101). SN 85-203,862. PUB. 5-3-2011. FILED 12-22-2010.
- 3,997,507. **INVOICETIGER (STANDARD CHARACTER)**. DATAMATICS GLOBAL SERVICES, INC., (U.S. CLS. 100 AND 101). SN 85-203,897. PUB. 5-3-2011. FILED 12-22-2010.
- 3,997,534. **C2ROUTEAPP (STANDARD CHARACTER)**. C2LOGIX, INC., FORMERLY WASTBID.COM, (U.S. CLS. 100 AND 101). SN 85-204,524. PUB. 5-3-2011. FILED 12-22-2010.
- 3,997,547 (*See Class 25 for this trademark*).
- 3,997,555. **TOWERING PRIDE (STANDARD CHARACTER)**. ALL STAR PREMIUM PRODUCTS INC., (U.S. CLS. 100 AND 101). SN 85-204,712. PUB. 5-3-2011. FILED 12-23-2010.
- 3,997,558 (*See Class 37 for this trademark*).
- 3,997,560 (*See Class 35 for this trademark*).
- 3,997,573. **THREADSTR (STANDARD CHARACTER)**. ARCH WEB LABS, LLC, (U.S. CLS. 100 AND 101). SN 85-204,948. PUB. 5-3-2011. FILED 12-23-2010.
- 3,997,597 (*See Class 35 for this trademark*).
- 3,997,630. **HIGHCHECK (STANDARD CHARACTER)**. ARIES DESIGN AUTOMATION, LLC, (U.S. CLS. 100 AND 101). SN 85-205,706. PUB. 5-3-2011. FILED 12-26-2010.
- 3,997,632 (*See Class 41 for this trademark*).
- 3,997,649. **WEBCHICK (STANDARD CHARACTER)**. WEB CHICK, LLC, (U.S. CLS. 100 AND 101). SN 85-205,939. PUB. 5-3-2011. FILED 12-27-2010.
- 3,997,701. **GREAT MEDICINES, NATURALLY (STANDARD CHARACTER)**. CONSTANT BIOTECHNOLOGY, (U.S. CLS. 100 AND 101). SN 85-206,567. PUB. 5-3-2011. FILED 12-28-2010.
- 3,997,713. **LIVERAIL (STANDARD CHARACTER)**. LIVERAIL INC., (U.S. CLS. 100 AND 101). SN 85-206,746. PUB. 5-3-2011. FILED 12-28-2010.
- 3,997,728. **BCFMO (STANDARD CHARACTER)**. AMERICAN ASSOCIATION OF PHYSICIAN SPECIALISTS, INC., (U.S. CLS. 100 AND 101). SN 85-207,009. PUB. 5-3-2011. FILED 12-29-2010.
- 3,997,745. **WE TAKE THE PAPER OUT OF PAPERWORK (STANDARD CHARACTER)**. OFLOWS INCORPORATED, (U.S. CLS. 100 AND 101). SN 85-207,309. PUB. 5-3-2011. FILED 12-29-2010.
- 3,997,753. **SMART. SAFE. GREEN. (STANDARD CHARACTER)**. RESTAURANT TECHNOLOGIES, INC., (U.S. CLS. 100 AND 101). SN 85-207,421. PUB. 5-3-2011. FILED 12-29-2010.
- 3,997,758. **RTI AND DESIGN**. RESTAURANT TECHNOLOGIES, INC., (U.S. CLS. 100 AND 101). SN 85-207,444. PUB. 5-3-2011. FILED 12-29-2010.
- 3,997,761. **RTI (STANDARD CHARACTER)**. RESTAURANT TECHNOLOGIES, INC., (U.S. CLS. 100 AND 101). SN 85-207,462. PUB. 5-3-2011. FILED 12-29-2010.
- 3,997,762. **SILLYSIL (STANDARD CHARACTER)**. BROWN, SILVIA, (U.S. CLS. 100 AND 101). SN 85-207,470. PUB. 5-3-2011. FILED 12-29-2010.
- 3,997,773. **NATIVE RIDERS AND DESIGN**. NATIVE RIDERS, (U.S. CLS. 100 AND 101). SN 85-207,633. PUB. 5-3-2011. FILED 12-29-2010.
- 3,997,797. **SETTING THE STANDARD FOR INDUSTRY FIRSTS (STANDARD CHARACTER)**. SCHUSSLER CREATIVE, INC., (U.S. CLS. 100 AND 101). SN 85-208,033. PUB. 5-3-2011. FILED 12-30-2010.
- 3,997,801. **CORRECTCOLLECT (STANDARD CHARACTER)**. CORRECT COLLECT, INC., (U.S. CLS. 100 AND 101). SN 85-208,096. PUB. 5-3-2011. FILED 12-30-2010.
- 3,997,841. **SUNDAYBELL (STANDARD CHARACTER)**. SUNDAYBELL, INC., (U.S. CLS. 100 AND 101). SN 85-208,495. PUB. 5-3-2011. FILED 12-31-2010.
- 3,997,861. **CENTRILLION (STANDARD CHARACTER)**. CENTRILLION TECHNOLOGY HOLDINGS CORPORATION, (U.S. CLS. 100 AND 101). SN 85-208,679. PUB. 5-3-2011. FILED 12-31-2010.
- 3,997,866. **ADTASTIC (STANDARD CHARACTER)**. ADTASTIC HOSTING AND INTERNET SERVICES, LLC, (U.S. CLS. 100 AND 101). SN 85-208,691. PUB. 5-3-2011. FILED 12-31-2010.
- 3,997,895. **THANKSTER (STANDARD CHARACTER)**. BLUE LINK VENTURES, LLC, (U.S. CLS. 100 AND 101). SN 85-209,041. PUB. 5-3-2011. FILED 1-3-2011.
- 3,997,898. **MISCELLANEOUS DESIGN**. KONTRAST WORKSHOP, LLC, (U.S. CLS. 100 AND 101). SN 85-209,090. PUB. 5-3-2011. FILED 1-3-2011.
- 3,997,916. **SST (STANDARD CHARACTER)**. SEMANTIC SPACE TECHNOLOGIES LIMITED, (U.S. CLS. 100 AND 101). SN 85-209,278. PUB. 5-3-2011. FILED 1-3-2011.
- 3,997,923 (*See Class 9 for this trademark*).
- 3,997,928 (*See Class 9 for this trademark*).
- 3,997,946. **WHENEVER YOU'RE FEELING GOOD AND HUNGRY, IT'S SKYLINE TIME. (STANDARD CHARACTER)**. SKYLINE CHILI, INC., (U.S. CLS. 100 AND 101). SN 85-209,718. PUB. 5-3-2011. FILED 1-4-2011.
- 3,997,962. **MYNAPPS (STANDARD CHARACTER)**. NATIONAL ASSOCIATION OF PROFESSIONAL PET SITTERS, INC., (U.S. CLS. 100 AND 101). SN 85-209,915. PUB. 5-3-2011. FILED 1-4-2011.
- 3,997,978. **STATE FARM NATION (STANDARD CHARACTER)**. STATE FARM MUTUAL AUTOMOBILE INSURANCE COMPANY, (U.S. CLS. 100 AND 101). SN 85-210,166. PUB. 5-3-2011. FILED 1-4-2011.
- 3,997,997. **FILTER FOUNDRY (STANDARD CHARACTER)**. FILTER PLATFORMS, INC., (U.S. CLS. 100 AND 101). SN 85-210,419. PUB. 5-3-2011. FILED 1-4-2011.
- 3,998,005 (*See Class 9 for this trademark*).
- 3,998,006. **FOLIOFUND (STANDARD CHARACTER)**. AMERIFOLIO, INC., (U.S. CLS. 100 AND 101). SN 85-210,509. PUB. 5-3-2011. FILED 1-4-2011.

- 3,998,015. **SC SIMPLYCHARGED AND DESIGN**. SIMPLY CHARGED, (U.S. CLS. 100 AND 101). SN 85-210,637. PUB. 5-3-2011. FILED 1-5-2011.
- 3,998,018 (*See Class 40 for this trademark*).
- 3,998,066 (*See Class 9 for this trademark*).
- 3,998,079. **EVENTFAST (STANDARD CHARACTER)**. EVENTFAST.COM LLC, (U.S. CLS. 100 AND 101). SN 85-211,661. PUB. 5-3-2011. FILED 1-6-2011.
- 3,998,098. **THEGOODGUIDE (STYLIZED)**. ACCAM, ALFRED T. (U.S. CLS. 100 AND 101). SN 85-211,985. PUB. 5-3-2011. FILED 1-6-2011.
- 3,998,105. **CPEX (STANDARD CHARACTER)**. THE CENTER FOR PLANNING EXCELLENCE, INC., (U.S. CLS. 100 AND 101). SN 85-212,152. PUB. 5-3-2011. FILED 1-6-2011.
- 3,998,118. **DESIGNO (STANDARD CHARACTER)**. DESIGNO INC., (U.S. CLS. 100 AND 101). SN 85-212,458. PUB. 5-3-2011. FILED 1-7-2011.
- 3,998,184. **KORDUROY (STANDARD CHARACTER)**. SUTTON, CYRUS, (U.S. CLS. 100 AND 101). SN 85-214,349. PUB. 5-3-2011. FILED 1-10-2011.
- 3,998,222. **APPLIED TECHNOLOGY SERVICES (STANDARD CHARACTER)**. QUESTAR CORPORATION, (U.S. CLS. 100 AND 101). SN 85-225,592. PUB. 5-3-2011. FILED 1-25-2011.
- 3,998,223. **ATS AND DESIGN**. QUESTAR CORPORATION, (U.S. CLS. 100 AND 101). SN 85-225,724. PUB. 5-3-2011. FILED 1-25-2011.
- 3,998,238. **FONT SINUSE (STANDARD CHARACTER)**. THE FONT BUREAU, INC., (U.S. CLS. 100 AND 101). SN 85-231,374. PUB. 5-3-2011. FILED 2-1-2011.
- 3,998,259 (*See Class 37 for this trademark*).
- 3,998,269 (*See Class 9 for this trademark*).
- 3,998,270 (*See Class 9 for this trademark*).
- 3,998,292. **RADCLOUD (STANDARD CHARACTER)**. SMITH, DOUGLAS, (U.S. CLS. 100 AND 101). SN 85-256,478. PUB. 5-3-2011. FILED 3-3-2011.

CLASS 43—HOTEL AND RESTAURANT SERVICES

- 3,995,464. **AL-BASHA AND DESIGN**. AL-BASHA, (U.S. CLS. 100 AND 101). SN 76-698,134. PUB. 5-3-2011. FILED 6-29-2009.
- 3,995,473 (*See Class 35 for this trademark*).
- 3,995,488. **LIFE BEGIN AT AURELIO'S (STANDARD CHARACTER)**. AURELIO'S PIZZA, INC., (U.S. CLS. 100 AND 101). SN 76-705,603. PUB. 5-3-2011. FILED 12-7-2010.
- 3,995,522. **MISCELLANEOUS DESIGN**. CAFE RIO, INCORPORATED, (U.S. CLS. 100 AND 101). SN 77-310,181. PUB. 5-3-2011. FILED 10-22-2007.
- 3,995,543. **MISCELLANEOUS DESIGN**. LAS VEGAS SANDS CORP., (U.S. CLS. 100 AND 101). SN 77-579,940. PUB. 5-3-2011. FILED 9-26-2008.
- 3,995,555 (*See Class 29 for this trademark*).
- 3,995,556 (*See Class 29 for this trademark*).
- 3,995,667. **BARÚ URBANO (STANDARD CHARACTER)**. BARU GROUP, LLC, (U.S. CLS. 100 AND 101). SN 77-907,278. PUB. 5-3-2011. FILED 1-7-2010.
- 3,995,668. **BARÚ (STANDARD CHARACTER)**. BARU GROUP, LLC, (U.S. CLS. 100 AND 101). SN 77-907,295. PUB. 5-3-2011. FILED 1-7-2010.
- 3,995,672. **SMITTEN KITCHEN (STANDARD CHARACTER)**. PERELMAN, DEBORAH L., (U.S. CLS. 100 AND 101). SN 77-912,903. PUB. 5-3-2011. FILED 1-15-2010.
- 3,995,696. **PUNK RAWK LABS AND DESIGN**. ALISSA BARTHEL, (U.S. CLS. 100 AND 101). SN 77-948,824. PUB. 5-3-2011. FILED 3-2-2010.
- 3,995,707 (*See Class 39 for this trademark*).
- 3,995,709. **MAC'S SUSHI (STANDARD CHARACTER)**. MAC'S SUSHI INC., (U.S. CLS. 100 AND 101). SN 77-962,385. PUB. 5-3-2011. FILED 3-18-2010.
- 3,995,775 (*See Class 6 for this trademark*).
- 3,995,777 (*See Class 32 for this trademark*).
- 3,995,894 (*See Class 30 for this trademark*).
- 3,995,916 (*See Class 30 for this trademark*).
- 3,996,058 (*See Class 9 for this trademark*).
- 3,996,073. **THE YABBY HUT (STANDARD CHARACTER)**. LE, HUNG, DBA THE YABBY HUT, AND THE YABBY HUT, LLC, DBA THE YABBY HUT, (U.S. CLS. 100 AND 101). SN 85-022,114. PUB. 5-3-2011. FILED 4-23-2010.
- 3,996,103. **THE FOOD DUDE (STANDARD CHARACTER)**. DAVID LISSNER, (U.S. CLS. 100 AND 101). SN 85-031,164. PUB. 5-3-2011. FILED 5-5-2010.
- 3,996,106. **ROAM ARTISAN BURGERS AND DESIGN**. JSS RESTAURANT GROUP, INC., (U.S. CLS. 100 AND 101). SN 85-032,801. PUB. 5-3-2011. FILED 5-7-2010.
- 3,996,118. **WINGTONE (STANDARD CHARACTER)**. MICHAEL D. SIMENS, (U.S. CLS. 100 AND 101). SN 85-034,548. PUB. 5-3-2011. FILED 5-10-2010.
- 3,996,148 (*See Class 30 for this trademark*).
- 3,996,179 (*See Class 36 for this trademark*).
- 3,996,218. **HOUSE OF GREENS AND DESIGN**. HOUSE OF GREENS, INC., (U.S. CLS. 100 AND 101). SN 85-046,953. PUB. 5-3-2011. FILED 5-25-2010.
- 3,996,244 (*See Class 39 for this trademark*).
- 3,996,306. **I KIWI AND DESIGN**. CHICAGO DELIGHTS, LLC, DBA IKIWI, (U.S. CLS. 100 AND 101). SN 85-063,182. PUB. 5-3-2011. FILED 6-15-2010.
- 3,996,324. **BUVETTE GASTROTEQUE (STANDARD CHARACTER)**. JMWILLIAMS LLC, (U.S. CLS. 100 AND 101). SN 85-066,063. PUB. 5-3-2011. FILED 6-18-2010.
- 3,996,327. **BUBBA'S ICE CREAM (STANDARD CHARACTER)**. BUBBA'S SANI-SERV, INC., (U.S. CLS. 100 AND 101). SN 85-067,153. PUB. 5-3-2011. FILED 6-20-2010.
- 3,996,352 (*See Class 41 for this trademark*).
- 3,996,353 (*See Class 41 for this trademark*).
- 3,996,405. **HEALTHIFIED AND DESIGN**. GENERAL MILLS, INC., (U.S. CLS. 100 AND 101). SN 85-088,334. PUB. 5-3-2011. FILED 7-20-2010.
- 3,996,482. **EMBODY FITNESS GOURMET AND DESIGN**. GOOD TO GO CAFE, (U.S. CLS. 100 AND 101). SN 85-113,895. PUB. 5-3-2011. FILED 8-23-2010.
- 3,996,510. **SINCE 1871 GÜLLÜOĞLU AND DESIGN**. GÜLLÜOĞLU, MEHMET NEJAT, (U.S. CLS. 100 AND 101). SN 85-124,383. PUB. 5-3-2011. FILED 9-7-2010.
- 3,996,511. **CIPRIANI DOWNTOWN (STANDARD CHARACTER)**. CIPRIANI GROUP, INC., (U.S. CLS. 100 AND 101). SN 85-124,840. PUB. 5-3-2011. FILED 9-8-2010.
- 3,996,513 (*See Class 36 for this trademark*).
- 3,996,527. **MYWEBREZ.COM (STANDARD CHARACTER)**. RESORT RENTAL, LLC, (U.S. CLS. 100 AND 101). SN 85-127,216. PUB. 5-3-2011. FILED 9-10-2010.
- 3,996,540. **AVILA'S (STYLIZED)**. AVILA'S EL RANCHITO, INC., (U.S. CLS. 100 AND 101). SN 85-130,136. PUB. 5-3-2011. FILED 9-15-2010.
- 3,996,565. **CREATIVE WRAPS (STANDARD CHARACTER)**. MAXIMUS MAX LLC, (U.S. CLS. 100 AND 101). SN 85-135,144. PUB. 5-3-2011. FILED 9-22-2010.
- 3,996,571. **YUMYUM WARRIOR, POWERFUL FOOD FOR EVERYDAY WARRIORS AND DESIGN**. YUMYUM WARRIOR, INC., (U.S. CLS. 100 AND 101). SN 85-136,643. PUB. 5-3-2011. FILED 9-23-2010.
- 3,996,573. **CHAMELEON CHAIR COLLECTION (STANDARD CHARACTER)**. CHAMELEON CHAIRS LLC, (U.S. CLS. 100 AND 101). SN 85-136,944. PUB. 5-3-2011. FILED 9-23-2010.
- 3,996,613. **CIPRIANI DOWNTOWN AND DESIGN**. CIPRIANI GROUP, INC., (U.S. CLS. 100 AND 101). SN 85-147,409. PUB. 5-3-2011. FILED 10-7-2010.
- 3,996,631. **DOG CAMP LA AND DESIGN**. BELL, JULIA, (U.S. CLS. 100 AND 101). SN 85-150,541. PUB. 5-3-2011. FILED 10-12-2010.
- 3,996,676 (*See Class 30 for this trademark*).
- 3,996,681 (*See Class 30 for this trademark*).
- 3,996,724. **APPLE SPICE CAFE BAKERY WE DELIVER . QUALITY FOOD AND DESIGN**. ASJ DEVELOPMENT, LC, (U.S. CLS. 100 AND 101). SN 85-169,634. PUB. 5-3-2011. FILED 11-4-2010.
- 3,996,801. **K AND DESIGN**. KETTLEHOUSE BREWING COMPANY, LLC, (U.S. CLS. 100 AND 101). SN 85-176,074. PUB. 5-3-2011. FILED 11-12-2010.
- 3,996,811. **MARGARITAVILLE GRILLE (STANDARD CHARACTER)**. MARGARITAVILLE ENTERPRISES, LLC, (U.S. CLS. 100 AND 101). SN 85-176,697. PUB. 5-3-2011. FILED 11-15-2010.
- 3,996,824 (*See Class 29 for this trademark*).

- 3,996,906. **MISCELLANEOUS DESIGN**. BUSE, INC., DBA KUMA'S CORNER, (U.S. CLS. 100 AND 101). SN 85-182,235. PUB. 5-3-2011. FILED 11-22-2010.
- 3,996,919. **MEMPHIS Q SMOKEHOUSE & BARBEQUE (STYLIZED)**. MIRAGE RESORTS, INCORPORATED, (U.S. CLS. 100 AND 101). SN 85-182,914. PUB. 5-3-2011. FILED 11-22-2010.
- 3,996,946. **ISLAND FROYO (STANDARD CHARACTER)**. KAOHELO ENTERPRISE LLC, DBA ISLAND FROYO, (U.S. CLS. 100 AND 101). SN 85-184,028. PUB. 5-3-2011. FILED 11-23-2010.
- 3,996,956. **EAT GOOD CITY SANDWICH FEEL GOOD (STYLIZED)**. EAT GOOD FEEL GOOD INC., (U.S. CLS. 100 AND 101). SN 85-184,775. PUB. 5-3-2011. FILED 11-24-2010.
- 3,996,966. **FILM CENTER CAFE (STANDARD CHARACTER)**. MALTA, ROBERT, (U.S. CLS. 100 AND 101). SN 85-185,401. PUB. 5-3-2011. FILED 11-26-2010.
- 3,996,985. **FITDOG (STANDARD CHARACTER)**. FITDOG SPORTS CLUB, (U.S. CLS. 100 AND 101). SN 85-186,110. PUB. 5-3-2011. FILED 11-29-2010.
- 3,997,042. **LUTHERAN HOMES SOCIETY AND DESIGN**. LUTHERAN HOMES SOCIETY, INC., MULTIPLE CLASS, (INT. CLS. 43 AND 44), (U.S. CLS. 100 AND 101). SN 85-187,514. PUB. 5-3-2011. FILED 11-30-2010.
- 3,997,053. **EL DIABLO BURRITO AND DESIGN**. AKBAR, INC., (U.S. CLS. 100 AND 101). SN 85-187,746. PUB. 5-3-2011. FILED 11-30-2010.
- 3,997,098. **TAQUERIA MONTERREY MEXICAN GRILL AND DESIGN**. TAQUERIA FLETCHER, LLC, (U.S. CLS. 100 AND 101). SN 85-188,798. PUB. 5-3-2011. FILED 12-1-2010.
- 3,997,180 (*See Class 35 for this trademark*).
- 3,997,220 (*See Class 39 for this trademark*).
- 3,997,241. **MISCELLANEOUS DESIGN**. LUMAT INC., (U.S. CLS. 100 AND 101). SN 85-192,461. PUB. 5-3-2011. FILED 12-7-2010.
- 3,997,279. **RADICCHIO PASTA & RISOTTO CO. AND DESIGN**. SHARMA, SATINDER, (U.S. CLS. 100 AND 101). SN 85-193,441. PUB. 5-3-2011. FILED 12-8-2010.
- 3,997,282. **1 2 3 4 5 6 DUCKS EATERY AND DESIGN**. HOROWITZ, WILLIAM, (U.S. CLS. 100 AND 101). SN 85-193,570. PUB. 5-3-2011. FILED 12-8-2010.
- 3,997,286. **EDDIE & SAM'S NEW YORK PIZZA (STANDARD CHARACTER)**. EDDIE AND SAM'S NY PIZZA, LLC, (U.S. CLS. 100 AND 101). SN 85-193,776. PUB. 5-3-2011. FILED 12-9-2010.
- 3,997,341. **GYPSY QUEEN CAFÉ (STANDARD CHARACTER)**. GYPSY QUEENS, LLC, (U.S. CLS. 100 AND 101). SN 85-196,270. PUB. 5-3-2011. FILED 12-13-2010.
- 3,997,374. **SUSHI RUNNER AND DESIGN**. TSH ENTERTAINMENT, INC., (U.S. CLS. 100 AND 101). SN 85-198,143. PUB. 5-3-2011. FILED 12-15-2010.
- 3,997,375. **BRAVO BRIO RESTAURANT GROUP (STANDARD CHARACTER)**. BRAVO BRIO RESTAURANT GROUP, (U.S. CLS. 100 AND 101). SN 85-198,149. PUB. 5-3-2011. FILED 12-15-2010.
- 3,997,400. **GLAZE (STANDARD CHARACTER)**. GLAZE TERIYAKI LLC, (U.S. CLS. 100 AND 101). SN 85-199,931. PUB. 5-3-2011. FILED 12-16-2010.
- 3,997,425. **MISCELLANEOUS DESIGN**. KING'S SEAFOOD COMPANY, LLC, DBA WATER GRILL, (U.S. CLS. 100 AND 101). SN 85-200,585. PUB. 5-3-2011. FILED 12-17-2010.
- 3,997,458. **BARLEY CREEK BREWING COMPANY EST. 1995 AND DESIGN**. BARLEY CREEK BREWING COMPANY INC., (U.S. CLS. 100 AND 101). SN 85-202,052. PUB. 5-3-2011. FILED 12-20-2010.
- 3,997,467. **PULEO'S GRILLE (STANDARD CHARACTER)**. VOLCUE, LLC, (U.S. CLS. 100 AND 101). SN 85-202,479. PUB. 5-3-2011. FILED 12-21-2010.
- 3,997,470. **TACOBBERFEST (STANDARD CHARACTER)**. STEPHEN RUFF, (U.S. CLS. 100 AND 101). SN 85-202,496. PUB. 5-3-2011. FILED 12-21-2010.
- 3,997,495. **HAVE HEART (STANDARD CHARACTER)**. STEVE BERGER, AND SARAH BERGER, (U.S. CLS. 100 AND 101). SN 85-203,303. PUB. 5-3-2011. FILED 12-21-2010.
- 3,997,539. **INDUSTRIAL REVOLUTION (STANDARD CHARACTER)**. IMPACT RESTAURANT MANAGEMENT INC., (U.S. CLS. 100 AND 101). SN 85-204,626. PUB. 5-3-2011. FILED 12-23-2010.
- 3,997,540. **MISCELLANEOUS DESIGN**. IMPACT RESTAURANT MANAGEMENT INC., (U.S. CLS. 100 AND 101). SN 85-204,627. PUB. 5-3-2011. FILED 12-23-2010.
- 3,997,541. **SALUTING AMERICA'S GREATNESS (STANDARD CHARACTER)**. IMPACT RESTAURANT MANAGEMENT INC., (U.S. CLS. 100 AND 101). SN 85-204,628. PUB. 5-3-2011. FILED 12-23-2010.
- 3,997,557. **DISTRICT COMMONS (STANDARD CHARACTER)**. PASSION FOOD SIX, LLC, DBA DISTRICT COMMONS, (U.S. CLS. 100 AND 101). SN 85-204,757. PUB. 5-3-2011. FILED 12-23-2010.
- 3,997,610. **RELAXATION IS WELLNESS. WELLNESS IS HAPPINESS. (STANDARD CHARACTER)**. WINTER, DONNIE, (U.S. CLS. 100 AND 101). SN 85-205,373. PUB. 5-3-2011. FILED 12-23-2010.
- 3,997,615. **NAANSTOP (STANDARD CHARACTER)**. NAANSTOP, LLC, (U.S. CLS. 100 AND 101). SN 85-205,487. PUB. 5-3-2011. FILED 12-24-2010.
- 3,997,674 (*See Class 35 for this trademark*).
- 3,997,793. **SUNSET VISTAS (STANDARD CHARACTER)**. PROVIDENT ISLAND RESORTS, LLC, DBA SUNSET VISTAS BEACHFRONT SUITES, (U.S. CLS. 100 AND 101). SN 85-208,014. PUB. 5-3-2011. FILED 12-30-2010.
- 3,997,901. **M AND DESIGN**. JED REICHL INVESTMENTS, LLC, (U.S. CLS. 100 AND 101). SN 85-209,135. PUB. 5-3-2011. FILED 1-3-2011.
- 3,997,906. **GET YOUR ANGUS IN HERE (STANDARD CHARACTER)**. JED REICHL INVESTMENTS, LLC, (U.S. CLS. 100 AND 101). SN 85-209,163. PUB. 5-3-2011. FILED 1-3-2011.
- 3,997,917. **WAYSIDE NOODLES (STANDARD CHARACTER)**. TRAN, DAO, (U.S. CLS. 100 AND 101). SN 85-209,303. PUB. 5-3-2011. FILED 1-3-2011.
- 3,997,943 (*See Class 35 for this trademark*).
- 3,997,953. **GOOD EARTH NATURALLY (STANDARD CHARACTER)**. THE GOOD EARTH CORPORATION, (U.S. CLS. 100 AND 101). SN 85-209,758. PUB. 5-3-2011. FILED 1-4-2011.
- 3,997,954. **MISCELLANEOUS DESIGN**. SQUID, INC., (U.S. CLS. 100 AND 101). SN 85-209,779. PUB. 5-3-2011. FILED 1-4-2011.
- 3,997,969. **TWISTED ROOSTER (STANDARD CHARACTER)**. OCM DEVELOPMENT, LLC, DBA TWISTED ROOSTER, (U.S. CLS. 100 AND 101). SN 85-210,010. PUB. 5-3-2011. FILED 1-4-2011.
- 3,998,054 (*See Class 41 for this trademark*).
- 3,998,070. **FRIENDSCOOK (STANDARD CHARACTER)**. FRIENDSCOOK INC., (U.S. CLS. 100 AND 101). SN 85-211,464. PUB. 5-3-2011. FILED 1-5-2011.
- 3,998,111. **CHICKEN WITH ATTITUDE (STANDARD CHARACTER)**. WE ARE CHICKEN TOO, INC., DBA CHICKEN BONZ, (U.S. CLS. 100 AND 101). SN 85-212,286. PUB. 5-3-2011. FILED 1-6-2011.
- 3,998,132. **RICKY'S (STANDARD CHARACTER)**. JAR, INC., DBA RICKY'S, (U.S. CLS. 100 AND 101). SN 85-212,781. PUB. 5-3-2011. FILED 1-7-2011.
- 3,998,138 (*See Class 35 for this trademark*).
- 3,998,160. **EVERYTHING IS BETTER BY THE BRICK OVEN (STANDARD CHARACTER)**. BERTUCCI'S RESTAURANT CORP., (U.S. CLS. 100 AND 101). SN 85-213,481. PUB. 5-3-2011. FILED 1-8-2011.
- 3,998,189. **MISCELLANEOUS DESIGN**. INDIA HOUSE OF MASSACHUSETTS, INC., (U.S. CLS. 100 AND 101). SN 85-214,479. PUB. 5-3-2011. FILED 1-10-2011.
- 3,998,279. **THIRST N' HOWL TIKI BAR (STANDARD CHARACTER)**. PINNACLE ENTERTAINMENT, INC., (U.S. CLS. 100 AND 101). SN 85-248,844. PUB. 5-3-2011. FILED 2-22-2011.
- 3,998,280. **TURF TERRACE RESTAURANT (STANDARD CHARACTER)**. PINNACLE ENTERTAINMENT, INC., (U.S. CLS. 100 AND 101). SN 85-248,873. PUB. 5-3-2011. FILED 2-22-2011.
- 3,998,283. **THIRST N' HOWL TIKI BAR AND DESIGN**. PINNACLE ENTERTAINMENT, INC., (U.S. CLS. 100 AND 101). SN 85-248,967. PUB. 5-3-2011. FILED 2-22-2011.
- 3,998,284. **TURF TERRACE RESTAURANT AND DESIGN**. PINNACLE ENTERTAINMENT, INC., (U.S. CLS. 100 AND 101). SN 85-248,971. PUB. 5-3-2011. FILED 2-22-2011.
- 3,998,287. **TV THUNDER VALLEY CASINO . RESORT AND**

DESIGN. UNITED AUBURN INDIAN COMMUNITY, (U.S. CLS. 100 AND 101). SN 85-249,747. PUB. 5-3-2011. FILED 2-23-2011.
 3,998,295. **THE CURE FOR HUNGER IS FOOD (STANDARD CHARACTER).** FOOD BANK OF SOUTH JERSEY, INC., (U.S. CLS. 100 AND 101). SN 85-261,304. PUB. 5-3-2011. FILED 3-8-2011.

CLASS 44—MEDICAL, BEAUTY AND AGRICULTURAL SERVICES

- 3,995,466 (*See Class 16 for this trademark.*)
 3,995,508. **MISCELLANEOUS DESIGN.** PLASTIC SURGERY & DERMATOLOGY OF NYC PLLC, (U.S. CLS. 100 AND 101). SN 76-705,933. PUB. 5-3-2011. FILED 1-6-2011.
 3,995,533 (*See Class 16 for this trademark.*)
 3,995,548 (*See Class 9 for this trademark.*)
 3,995,559. **SULWHASOO SPA (STANDARD CHARACTER).** AMOREPACIFIC CORPORATION, (U.S. CLS. 100 AND 101). SN 77-646,170. PUB. 11-9-2010. FILED 1-8-2009.
 3,995,590. **SOCORRO (STANDARD CHARACTER).** CRHELP, INC., (U.S. CLS. 100 AND 101). SN 77-776,751. PUB. 5-3-2011. FILED 7-8-2009.
 3,995,594 (*See Class 1 for this trademark.*)
 3,995,624 (*See Class 9 for this trademark.*)
 3,995,625 (*See Class 9 for this trademark.*)
 3,995,632. **HOSPICE BRAZOS VALLEY (STANDARD CHARACTER).** HOSPICE BRAZOS VALLEY, INC., (U.S. CLS. 100 AND 101). SN 77-865,843. PUB. 5-3-2011. FILED 11-5-2009.
 3,995,635. **HOSPICE BRAZOS VALLEY AND DESIGN.** HOSPICE BRAZOS VALLEY, INC., (U.S. CLS. 100 AND 101). SN 77-865,997. PUB. 5-3-2011. FILED 11-5-2009.
 3,995,656 (*See Class 41 for this trademark.*)
 3,995,657 (*See Class 41 for this trademark.*)
 3,995,705 (*See Class 9 for this trademark.*)
 3,995,793 (*See Class 11 for this trademark.*)
 3,995,814 (*See Class 3 for this trademark.*)
 3,995,835 (*See Class 5 for this trademark.*)
 3,995,911 (*See Class 3 for this trademark.*)
 3,995,980 (*See Class 35 for this trademark.*)
 3,996,034. **GAIN PLAN (STANDARD CHARACTER).** RICHARD KEENAN & COMPANY LIMITED, (U.S. CLS. 100 AND 101). SN 85-000,620. PUB. 3-8-2011. FILED 3-29-2010.
 3,996,126 (*See Class 31 for this trademark.*)
 3,996,201. **BEAUTY SOLUTIONS INTERNATIONAL (STANDARD CHARACTER).** BLANCHARD, ALAN, (U.S. CLS. 100 AND 101). SN 85-045,921. PUB. 5-3-2011. FILED 5-24-2010.
 3,996,240 (*See Class 5 for this trademark.*)
 3,996,241. **PROGRESSION AND DESIGN.** GENESIS REHABILITATION SERVICES, INC., (U.S. CLS. 100 AND 101). SN 85-049,538. PUB. 5-3-2011. FILED 5-27-2010.
 3,996,258. **YA LOOK GREAT! (STANDARD CHARACTER).** YA LOOK GREAT, LLC, (U.S. CLS. 100 AND 101). SN 85-052,027. PUB. 5-3-2011. FILED 6-1-2010.
 3,996,277. **PSI PAIN SPECIALISTS OF IOWA (STYLIZED).** MEDICAL CENTER ANESTHESIOLOGISTS, PC, (U.S. CLS. 100 AND 101). SN 85-055,217. PUB. 5-3-2011. FILED 6-4-2010.
 3,996,303. **ABOVE ALL AND DESIGN.** ABOVE ALL INTELLECTUAL PROPERTIES, (U.S. CLS. 100 AND 101). SN 85-062,899. PUB. 5-3-2011. FILED 6-15-2010.
 3,996,314. **RILEY (STANDARD CHARACTER).** THE TRUSTEES OF INDIANA UNIVERSITY, (U.S. CLS. 100 AND 101). SN 85-064,256. PUB. 5-3-2011. FILED 6-16-2010.
 3,996,315. **RILEY HOSPITAL FOR CHILDREN (STANDARD CHARACTER).** THE TRUSTEES OF INDIANA UNIVERSITY, (U.S. CLS. 100 AND 101). SN 85-064,261. PUB. 5-3-2011. FILED 6-16-2010.
 3,996,318. **RILEY HOSPITAL (STANDARD CHARACTER).** THE TRUSTEES OF INDIANA UNIVERSITY, (U.S. CLS. 100 AND 101). SN 85-064,510. PUB. 5-3-2011. FILED 6-16-2010.
 3,996,321. **STOP, BALANCE, GO! (STANDARD CHARACTER).** SCHINDLER, CASSIE W., DBA THE ALTERNATE PATH, (U.S. CLS. 100 AND 101). SN 85-065,575. PUB. 5-3-2011. FILED 6-17-2010.
 3,996,368 (*See Class 41 for this trademark.*)
 3,996,439 (*See Class 35 for this trademark.*)
 3,996,504. **DOCTORS ON WHEELS AND DESIGN.** DOCTORS ON WHEELS S.C., (U.S. CLS. 100 AND 101). SN 85-122,413. PUB. 5-3-2011. FILED 9-3-2010.
 3,996,520 (*See Class 35 for this trademark.*)
 3,996,534. **S SIGNATURE (STYLIZED).** SIGNATURE HEALTHCARE, LLC, (U.S. CLS. 100 AND 101). SN 85-129,027. PUB. 5-3-2011. FILED 9-14-2010.
 3,996,559. **MISCELLANEOUS DESIGN.** LOS ANGELES BRAIN AND SPINE INSTITUTE, (U.S. CLS. 100 AND 101). SN 85-133,826. PUB. 5-3-2011. FILED 9-20-2010.
 3,996,605. **CAROLINAEAST HEALTH SYSTEM AND DESIGN.** CAROLINAEAST HEALTH SYSTEM, (U.S. CLS. 100 AND 101). SN 85-146,158. PUB. 5-3-2011. FILED 10-6-2010.
 3,996,641. **MY FAMILY DENTAL CARE.COM (STANDARD CHARACTER).** AMERICAN MANAGEMENT GROUP, LLC, (U.S. CLS. 100 AND 101). SN 85-153,818. PUB. 5-3-2011. FILED 10-15-2010.
 3,996,661. **CHILDREN'S DENTAL GROUP AND DESIGN.** CHILDREN'S DENTAL GROUP, INC., (U.S. CLS. 100 AND 101). SN 85-158,113. PUB. 5-3-2011. FILED 10-21-2010.
 3,996,714. **RELIABILITREE AND DESIGN.** WESTAR ENERGY, INC., (U.S. CLS. 100 AND 101). SN 85-168,251. PUB. 5-3-2011. FILED 11-3-2010.
 3,996,731. **CONSCIOUS SUCCESS AND DESIGN.** CONSCIOUS SUCCESS LLC, (U.S. CLS. 100 AND 101). SN 85-170,638. PUB. 5-3-2011. FILED 11-5-2010.
 3,996,734 (*See Class 35 for this trademark.*)
 3,996,736. **ELDERCARE AT HOME KEEPING FAMILIES TOGETHER... AND DESIGN.** FORGIE, ELAYNE, (U.S. CLS. 100 AND 101). SN 85-170,905. PUB. 5-3-2011. FILED 11-6-2010.
 3,996,750. **WHAT'S OUT THERE (STANDARD CHARACTER).** THE CULTURAL LANDSCAPE FOUNDATION, (U.S. CLS. 100 AND 101). SN 85-172,804. PUB. 5-3-2011. FILED 11-9-2010.
 3,996,766. **NATION'S HOME INFUSION (STANDARD CHARACTER).** NATION'S HOME INFUSION, LLC, (U.S. CLS. 100 AND 101). SN 85-173,584. PUB. 5-3-2011. FILED 11-10-2010.
 3,996,772. **FOOD SPIRAL (STANDARD CHARACTER).** FOOD FITNESS FIRST, INC., (U.S. CLS. 100 AND 101). SN 85-174,189. PUB. 5-3-2011. FILED 11-11-2010.
 3,996,796. **MYVITALINK.COM (STANDARD CHARACTER).** VITALAE CORPORATE SERVICES, INC., (U.S. CLS. 100 AND 101). SN 85-175,822. PUB. 5-3-2011. FILED 11-12-2010.
 3,996,804. **THE PAW SQUAD (STANDARD CHARACTER).** PETS A GO GO LLC, MULTIPLE CLASS, (INT. CLS. 44 AND 45), (U.S. CLS. 100 AND 101). SN 85-176,282. PUB. 5-3-2011. FILED 11-14-2010.
 3,996,829. **PV PREMIER VISION AND DESIGN.** PREMIER VISION OPTOMETRY, INC., (U.S. CLS. 100 AND 101). SN 85-177,843. PUB. 5-3-2011. FILED 11-16-2010.
 3,996,837. **CARE TRANSITIONS PROGRAM (STANDARD CHARACTER).** ERIC A. COLEMAN, (U.S. CLS. 100 AND 101). SN 85-178,440. PUB. 5-3-2011. FILED 11-16-2010.
 3,996,838. **CARE TRANSITIONS INTERVENTION (STANDARD CHARACTER).** COLEMAN, ERIC A., (U.S. CLS. 100 AND 101). SN 85-178,449. PUB. 5-3-2011. FILED 11-16-2010.
 3,996,868. **MR TATTOO (STANDARD CHARACTER).** DUFF, JASON, (U.S. CLS. 100 AND 101). SN 85-179,799. PUB. 5-3-2011. FILED 11-18-2010.
 3,996,885. **B B (STYLIZED).** MICHAEL B. BAYLESS AND ASSOCIATES INC., DBA BAYLESS BEHAVIORAL HEALTH SOLUTIONS, (U.S. CLS. 100 AND 101). SN 85-181,013. PUB. 5-3-2011. FILED 11-19-2010.
 3,996,924 (*See Class 35 for this trademark.*)
 3,996,928. **HOPE. HEALING. REHABILITATION. (STANDARD CHARACTER).** SSM SELECT REHAB ST. LOUIS, LLC, (U.S. CLS. 100 AND 101). SN 85-183,168. PUB. 5-3-2011. FILED 11-23-2010.
 3,996,943 (*See Class 35 for this trademark.*)
 3,996,944 (*See Class 35 for this trademark.*)

- 3,996,947. **HORTICOPIA (STANDARD CHARACTER)**. HORTICOPIA, INC., (U.S. CLS. 100 AND 101). SN 85-184,326. PUB. 5-3-2011. FILED 11-24-2010.
- 3,996,997. **SPEECH GUY (STANDARD CHARACTER)**. NICHOLSON, WESLEY, (U.S. CLS. 100 AND 101). SN 85-186,550. PUB. 5-3-2011. FILED 11-29-2010.
- 3,997,021. **TAN 2000 NOTHING BEATS A DAY IN THE SUN AND DESIGN**. BROWN, CHRIS, (U.S. CLS. 100 AND 101). SN 85-187,095. PUB. 5-3-2011. FILED 11-30-2010.
- 3,997,025. **STEPHEN DIMMICK (STANDARD CHARACTER)**. DIMMICK, STEPHEN, (U.S. CLS. 100 AND 101). SN 85-187,146. PUB. 5-3-2011. FILED 11-30-2010.
- 3,997,026. **BETTY'S & NICK'S (STANDARD CHARACTER)**. MEHMETI, BEKIM, (U.S. CLS. 100 AND 101). SN 85-187,187. PUB. 5-3-2011. FILED 11-30-2010.
- 3,997,034. **WELL TOGETHER NEURO REHAB (STANDARD CHARACTER)**. HOROWITZ MOILANEN, NANCY, (U.S. CLS. 100 AND 101). SN 85-187,357. PUB. 5-3-2011. FILED 11-30-2010.
- 3,997,040. **MIRIANA DAY SPA (STANDARD CHARACTER)**. DAY SPA DEVELOPMENT CONSULTANT CORP., (U.S. CLS. 100 AND 101). SN 85-187,504. PUB. 5-3-2011. FILED 11-30-2010.
- 3,997,042 (*See Class 43 for this trademark*).
- 3,997,071. **CNS MULTISPECIALTY CLINIC AND DESIGN**. WELLESLEY NEUROLOGY GROUP, P.C., DBA CNS MULTISPECIALTY CLINIC, (U.S. CLS. 100 AND 101). SN 85-188,268. PUB. 5-3-2011. FILED 12-1-2010.
- 3,997,073. **SLEEP CLINIC OF AMERICA AND DESIGN**. PEDIATRIC AND INTERNAL MEDICINE SPECIALISTS, PA, (U.S. CLS. 100 AND 101). SN 85-188,282. PUB. 5-3-2011. FILED 12-1-2010.
- 3,997,120. **UPDX UNIVERSITY PATHOLOGISTS DIAGNOSTICS AND DESIGN**. UP DIAGNOSTICS LLC, AKA UNIVERSITY PATHOLOGISTS DIAGNOSTICS, (U.S. CLS. 100 AND 101). SN 85-189,192. PUB. 5-3-2011. FILED 12-2-2010.
- 3,997,196. **AFFORDABLE VETERINARY SERVICES AND DESIGN**. AFFORDABLE VETERINARY SERVICES LLC, (U.S. CLS. 100 AND 101). SN 85-190,898. PUB. 5-3-2011. FILED 12-5-2010.
- 3,997,202. **PREVITY CLINIC FOR SURGICAL CARE WHERE PREVENTION AND LONGEVITY MEET AND DESIGN**. PREVITY SURGICAL, PLLC, (U.S. CLS. 100 AND 101). SN 85-191,049. PUB. 5-3-2011. FILED 12-6-2010.
- 3,997,203. **XQUISITE TAN AND DESIGN**. XQUISITE TANS LLC, DBA XQUISITE TAN, (U.S. CLS. 100 AND 101). SN 85-191,111. PUB. 5-3-2011. FILED 12-6-2010.
- 3,997,219. **LOVING CARE GROOMING AND PET SERVICES AND DESIGN**. LCPS FRANCHISING LLC, (U.S. CLS. 100 AND 101). SN 85-191,581. PUB. 5-3-2011. FILED 12-6-2010.
- 3,997,223 (*See Class 5 for this trademark*).
- 3,997,356. **LIFEBANC (STANDARD CHARACTER)**. LIFE-BANC, (U.S. CLS. 100 AND 101). SN 85-197,201. PUB. 5-3-2011. FILED 12-14-2010.
- 3,997,378. **GUIDING AMERICANS TO THEIR BEST HEALTH (STANDARD CHARACTER)**. HEALTH GRADES, INC., (U.S. CLS. 100 AND 101). SN 85-198,416. PUB. 5-3-2011. FILED 12-15-2010.
- 3,997,485. **IMISSURGERY (STANDARD CHARACTER)**. IMIS, PLLC, (U.S. CLS. 100 AND 101). SN 85-202,799. PUB. 5-3-2011. FILED 12-21-2010.
- 3,997,492. **THEMAKEUPLAB ARTISTRY (STANDARD CHARACTER)**. THE MAKEUP LAB, (U.S. CLS. 100 AND 101). SN 85-203,160. PUB. 5-3-2011. FILED 12-21-2010.
- 3,997,602. **HEALTH & FITNESS THROUGH MOVEMENT & BALANCE (STANDARD CHARACTER)**. RAFAEL, JOURAK, (U.S. CLS. 100 AND 101). SN 85-205,276. PUB. 5-3-2011. FILED 12-23-2010.
- 3,997,667. **MERIDIAN CANCER CARE (STANDARD CHARACTER)**. MERIDIAN HEALTH SYSTEM, INC., (U.S. CLS. 100 AND 101). SN 85-206,148. PUB. 5-3-2011. FILED 12-27-2010.
- 3,997,681. **WHAT'S IN YOUR CART? (STANDARD CHARACTER)**. A WEIGH OF LIFE LLC, (U.S. CLS. 100 AND 101). SN 85-206,420. PUB. 5-3-2011. FILED 12-28-2010.
- 3,997,700 (*See Class 36 for this trademark*).
- 3,997,719. **HRS (STANDARD CHARACTER)**. HEALTH RESOURCE SOLUTIONS, INC., (U.S. CLS. 100 AND 101). SN 85-206,886. PUB. 5-3-2011. FILED 12-28-2010.
- 3,997,724. **ULTRASKIN (STANDARD CHARACTER)**. ULTRATAN, INC., (U.S. CLS. 100 AND 101). SN 85-206,939. PUB. 5-3-2011. FILED 12-29-2010.
- 3,997,765. **RUFFIN' WRANGLERS (STANDARD CHARACTER)**. RUFFIN' WRANGLERS LLC, (U.S. CLS. 100 AND 101). SN 85-207,473. PUB. 5-3-2011. FILED 12-29-2010.
- 3,997,774. **DOWNLOAD MY DATA (STANDARD CHARACTER)**. DEPARTMENT OF VETERANS AFFAIRS, (U.S. CLS. 100 AND 101). SN 85-207,644. PUB. 5-3-2011. FILED 12-29-2010.
- 3,997,800. **DR. MARINA JOHNSON (STANDARD CHARACTER)**. D. MARINA JOHNSON MD, PA, (U.S. CLS. 100 AND 101). SN 85-208,081. PUB. 5-3-2011. FILED 12-30-2010.
- 3,997,844. **BE THE CAUSE (STANDARD CHARACTER)**. ROSENBERG, JUDY, (U.S. CLS. 100 AND 101). SN 85-208,534. PUB. 5-3-2011. FILED 12-31-2010.
- 3,997,864. **CANCERSOCIAL (STANDARD CHARACTER)**. SOCIALNEXUS, INC., (U.S. CLS. 100 AND 101). SN 85-208,684. PUB. 5-3-2011. FILED 12-31-2010.
- 3,997,867. **HEALTHSOCIAL (STANDARD CHARACTER)**. SOCIALNEXUS, INC., (U.S. CLS. 100 AND 101). SN 85-208,696. PUB. 5-3-2011. FILED 12-31-2010.
- 3,997,873. **RECOVERYSOCIAL (STANDARD CHARACTER)**. SOCIALNEXUS, INC., (U.S. CLS. 100 AND 101). SN 85-208,749. PUB. 5-3-2011. FILED 1-1-2011.
- 3,997,874. **WEIGHTSOCIAL (STANDARD CHARACTER)**. SOCIALNEXUS, INC., (U.S. CLS. 100 AND 101). SN 85-208,750. PUB. 5-3-2011. FILED 1-1-2011.
- 3,997,875. **AMERICAN MORTALS (STANDARD CHARACTER)**. TAKING BEAUTY, LLC, (U.S. CLS. 100 AND 101). SN 85-208,754. PUB. 5-3-2011. FILED 1-1-2011.
- 3,997,884. **TREATING WHAT DIETS CAN'T. (STANDARD CHARACTER)**. BE-THIN, INC., DBA THE CENTER FOR MEDICAL WEIGHT LOSS, (U.S. CLS. 100 AND 101). SN 85-208,970. PUB. 5-3-2011. FILED 1-3-2011.
- 3,997,886. **WE TREAT WHAT DIETS CAN'T. (STANDARD CHARACTER)**. BE-THIN, INC., DBA THE CENTER FOR MEDICAL WEIGHT LOSS, (U.S. CLS. 100 AND 101). SN 85-208,972. PUB. 5-3-2011. FILED 1-3-2011.
- 3,997,888. **DOCTORS TREAT WHAT DIETS CAN'T. (STANDARD CHARACTER)**. BE-THIN, INC., DBA THE CENTER FOR MEDICAL WEIGHT LOSS, (U.S. CLS. 100 AND 101). SN 85-208,976. PUB. 5-3-2011. FILED 1-3-2011.
- 3,997,889. **DOCTORS TREATING WHAT DIETS CAN'T. (STANDARD CHARACTER)**. BE-THIN, INC., DBA THE CENTER FOR MEDICAL WEIGHT LOSS, (U.S. CLS. 100 AND 101). SN 85-208,977. PUB. 5-3-2011. FILED 1-3-2011.
- 3,997,999. **BLING YOUR NAILS (STANDARD CHARACTER)**. LEE CHU, KIT YING, (U.S. CLS. 100 AND 101). SN 85-210,462. PUB. 5-3-2011. FILED 1-4-2011.
- 3,998,014 (*See Class 35 for this trademark*).
- 3,998,034. **MISCELLANEOUS DESIGN**. MID ATLANTIC CAT SPECIALISTS, LLC, (U.S. CLS. 100 AND 101). SN 85-210,977. PUB. 5-3-2011. FILED 1-5-2011.
- 3,998,138 (*See Class 35 for this trademark*).
- 3,998,175 (*See Class 35 for this trademark*).
- 3,998,224. **AGROLAWN (STANDARD CHARACTER)**. TRU-GREEN LIMITED PARTNERSHIP, (U.S. CLS. 100 AND 101). SN 85-225,795. PUB. 5-3-2011. FILED 1-25-2011.
- 3,998,267. **PALA SPA AND DESIGN**. PALA BAND OF MISSION INDIANS, DBA PALA CASINO, (U.S. CLS. 100 AND 101). SN 85-243,701. PUB. 5-3-2011. FILED 2-16-2011.

CLASS 45—PERSONAL AND LEGAL SERVICES

- 3,995,532. **UMBRELLA LICENSE (STANDARD CHARACTER)**. MOTION PICTURE LICENSING CORPORATION, (U.S. CLS. 100 AND 101). SN 77-479,222. PUB. 5-3-2011. FILED 5-20-2008.
- 3,995,587. **SEX DECOY LOVE STINGS (STANDARD CHARACTER)**. UNIVERSAL INVESTMENTS WORLDWIDE, INC., DBA INTERNATIONAL INTELLIGENCE SERVICES, (U.S. CLS. 100 AND 101). SN 77-757,662. PUB. 10-27-2009. FILED 6-11-2009.

- 3,995,588. **CATALYST IP GROUP (STYLIZED)**. JUE, JEFFREY, (U.S. CLS. 100 AND 101). SN 77-765,151. PUB. 11-30-2010. FILED 6-22-2009.
- 3,995,626 (*See Class 38 for this trademark*).
- 3,995,633. **HOSPICE BRAZOS VALLEY (STANDARD CHARACTER)**. HOSPICE BRAZOS VALLEY, INC., (U.S. CLS. 100 AND 101). SN 77-865,888. PUB. 5-3-2011. FILED 11-5-2009.
- 3,995,636. **HOSPICE BRAZOS VALLEY AND DESIGN**. HOSPICE BRAZOS VALLEY, INC., (U.S. CLS. 100 AND 101). SN 77-866,065. PUB. 5-3-2011. FILED 11-5-2009.
- 3,995,637. **MISCELLANEOUS DESIGN**. HOSPICE BRAZOS VALLEY, INC., (U.S. CLS. 100 AND 101). SN 77-866,216. PUB. 5-3-2011. FILED 11-5-2009.
- 3,995,687. **THE CRADLE (STYLIZED)**. THE CRADLE SOCIETY, (U.S. CLS. 100 AND 101). SN 77-937,343. PUB. 5-3-2011. FILED 2-17-2010.
- 3,995,694. **ZEROHAWK INTERNATIONAL Z AND DESIGN**. PELZMAN, BRIAN M., (U.S. CLS. 100 AND 101). SN 77-947,073. PUB. 5-3-2011. FILED 3-1-2010.
- 3,995,728 (*See Class 9 for this trademark*).
- 3,995,735 (*See Class 6 for this trademark*).
- 3,995,749 (*See Class 38 for this trademark*).
- 3,995,760 (*See Class 9 for this trademark*).
- 3,995,792 (*See Class 7 for this trademark*).
- 3,995,882 (*See Class 16 for this trademark*).
- 3,995,999. **LOVEID (STANDARD CHARACTER)**. DOT COM VENTURES PTY LTD, (U.S. CLS. 100 AND 101). SN 79-092,081. PUB. 5-3-2011. FILED 12-21-2010.
- 3,996,015 (*See Class 35 for this trademark*).
- 3,996,037 (*See Class 9 for this trademark*).
- 3,996,114 (*See Class 41 for this trademark*).
- 3,996,116 (*See Class 42 for this trademark*).
- 3,996,130. **CURBSIDE COUNSEL (STANDARD CHARACTER)**. MED QUEST, LTD, (U.S. CLS. 100 AND 101). SN 85-036,283. PUB. 5-3-2011. FILED 5-12-2010.
- 3,996,160 (*See Class 41 for this trademark*).
- 3,996,189. **D.R.E.S. DIAMOND RUBY EMERALD SAPPHIRE AND DESIGN**. HOLOBI, LLC, (U.S. CLS. 100 AND 101). SN 85-044,538. PUB. 5-3-2011. FILED 5-21-2010.
- 3,996,190 (*See Class 42 for this trademark*).
- 3,996,199 (*See Class 42 for this trademark*).
- 3,996,268. **BIGGER IS NOT BETTER. BETTER IS BETTER. (STANDARD CHARACTER)**. JAVAHERI, PJ, (U.S. CLS. 100 AND 101). SN 85-052,992. PUB. 5-3-2011. FILED 6-2-2010.
- 3,996,419. **CASCADIA IP (STANDARD CHARACTER)**. PATRICK J.S. INOUYE, P.S., (U.S. CLS. 100 AND 101). SN 85-091,150. PUB. 5-3-2011. FILED 7-22-2010.
- 3,996,440 (*See Class 41 for this trademark*).
- 3,996,489. **THRIFT STORE CONFIDENTIAL (STANDARD CHARACTER)**. LISA NICOLE POOLE, (U.S. CLS. 100 AND 101). SN 85-116,189. PUB. 5-3-2011. FILED 8-26-2010.
- 3,996,553 (*See Class 25 for this trademark*).
- 3,996,577. **FAMILY REDESIGN (STANDARD CHARACTER)**. WILLIAMS, SUSAN L., AND THOMAS, JONATHAN, (U.S. CLS. 100 AND 101). SN 85-138,251. PUB. 5-3-2011. FILED 9-25-2010.
- 3,996,634. **I LOVE ME SOME HIM. COM AND DESIGN**. M.A.V. MEDIA WORKS, L.L.C., (U.S. CLS. 100 AND 101). SN 85-151,149. PUB. 5-3-2011. FILED 10-12-2010.
- 3,996,696. **EXPERIENCE OF FAMILY (STANDARD CHARACTER)**. HOWE-PETERSON, INC., (U.S. CLS. 100 AND 101). SN 85-164,838. PUB. 5-3-2011. FILED 10-29-2010.
- 3,996,739. **TREATMENT DIARIES! YOUR DIARY. SHARED HEALING. (STYLIZED)**. SHARE M2, LLC, (U.S. CLS. 100 AND 101). SN 85-171,299. PUB. 5-3-2011. FILED 11-8-2010.
- 3,996,769. **ADULTSPACE (STANDARD CHARACTER)**. CONGLOMERATE MARKETING LLC, (U.S. CLS. 100 AND 101). SN 85-174,049. PUB. 5-3-2011. FILED 11-10-2010.
- 3,996,773. **I-9 SOLVER (STANDARD CHARACTER)**. FOSTERQUAN, LLP, (U.S. CLS. 100 AND 101). SN 85-174,198. PUB. 5-3-2011. FILED 11-11-2010.
- 3,996,804 (*See Class 44 for this trademark*).
- 3,996,872. **BEACON LAW ADVISORS, PLLC AND DESIGN**. BEACON LAW ADVISORS, PLLC, (U.S. CLS. 100 AND 101). SN 85-179,880. PUB. 5-3-2011. FILED 11-18-2010.
- 3,996,889. **INFO CUBIC (STANDARD CHARACTER)**. INFO CUBIC, LLC, (U.S. CLS. 100 AND 101). SN 85-181,494. PUB. 5-3-2011. FILED 11-19-2010.
- 3,996,905. **VISTA ADVOCACY SERVICES (STANDARD CHARACTER)**. VISTA ADVOCACY SERVICES, INC., (U.S. CLS. 100 AND 101). SN 85-182,221. PUB. 5-3-2011. FILED 11-22-2010.
- 3,996,917 (*See Class 35 for this trademark*).
- 3,996,939. **VO AND DESIGN**. VISITING ORPHANS INC., (U.S. CLS. 100 AND 101). SN 85-183,706. PUB. 5-3-2011. FILED 11-23-2010.
- 3,996,995. **JOURNEY TO EXPERIENCE AND DESIGN**. NATIONAL COALITION FOR COMMUNITY EMPOWERMENT STRATEGIES (NCCES), (U.S. CLS. 100 AND 101). SN 85-186,492. PUB. 5-3-2011. FILED 11-29-2010.
- 3,997,009. **LEGAL REPRESENTATION BY LAWRENCE G. WALTERS, ESQ. FIRSTAMENDMENT.COM AND DESIGN**. LAWRENCE G. WALTERS, P.A., DBA WALTERS LAW GROUP, (U.S. CLS. 100 AND 101). SN 85-186,927. PUB. 5-3-2011. FILED 11-30-2010.
- 3,997,043. **BH BROWN AND HELLER, P.A. AND DESIGN**. BROWN AND HELLER, P.A., (U.S. CLS. 100 AND 101). SN 85-187,541. PUB. 5-3-2011. FILED 11-30-2010.
- 3,997,048. **MISCELLANEOUS DESIGN**. MARK WARMESLEY, INC, (U.S. CLS. 100 AND 101). SN 85-187,641. PUB. 5-3-2011. FILED 11-30-2010.
- 3,997,061. **TOBEFAN AND DESIGN**. MUNICIO, FRANCISCO JOSE CARBALLO, (U.S. CLS. 100 AND 101). SN 85-187,951. PUB. 5-3-2011. FILED 12-1-2010.
- 3,997,108. **NEATLY NESTED ORGANIZING SERVICES AND DESIGN**. NEATLY NESTED, LLC, AKA NEATLY NESTED ORGANIZING SERVICES, (U.S. CLS. 100 AND 101). SN 85-189,004. PUB. 5-3-2011. FILED 12-2-2010.
- 3,997,128. **N AND DESIGN**. NEW LEAF LEGAL, LLC, (U.S. CLS. 100 AND 101). SN 85-189,334. PUB. 5-3-2011. FILED 12-2-2010.
- 3,997,239. **LIBERATED SPACES (STANDARD CHARACTER)**. LIBERATED SPACES, (U.S. CLS. 100 AND 101). SN 85-192,433. PUB. 5-3-2011. FILED 12-7-2010.
- 3,997,242. **STYLEAUTEUR (STANDARD CHARACTER)**. STYLEAUTEUR CORPORATION, (U.S. CLS. 100 AND 101). SN 85-192,465. PUB. 5-3-2011. FILED 12-7-2010.
- 3,997,266. **COPYRIGHTDIRECTION (STANDARD CHARACTER)**. ROY S. GORDET, (U.S. CLS. 100 AND 101). SN 85-192,985. PUB. 5-3-2011. FILED 12-8-2010.
- 3,997,269. **N AND DESIGN**. NEW LEAF LEGAL, LLC, (U.S. CLS. 100 AND 101). SN 85-193,077. PUB. 5-3-2011. FILED 12-8-2010.
- 3,997,281. **NEW PARADIGM COUNSEL (STANDARD CHARACTER)**. OFFIT KURMAN, P.A., (U.S. CLS. 100 AND 101). SN 85-193,497. PUB. 5-3-2011. FILED 12-8-2010.
- 3,997,348. **THE JOY OF SOX (STANDARD CHARACTER)**. TOM COSTELLO JR, (U.S. CLS. 100 AND 101). SN 85-196,620. PUB. 5-3-2011. FILED 12-13-2010.
- 3,997,397. **HELPING SURVIVORS SURVIVE (STANDARD CHARACTER)**. MOTHERS AGAINST DRUNK DRIVING, (U.S. CLS. 100 AND 101). SN 85-199,790. PUB. 5-3-2011. FILED 12-16-2010.
- 3,997,422. **PROTECTING YOU SINCE 1852 (STANDARD CHARACTER)**. SMITH & WESSON CORP, (U.S. CLS. 100 AND 101). SN 85-200,357. PUB. 5-3-2011. FILED 12-17-2010.
- 3,997,442. **YOUR INTELLECT. YOUR PROPERTY. (STANDARD CHARACTER)**. SPIEGEL & ASSOCIATES, LLC, (U.S. CLS. 100 AND 101). SN 85-201,204. PUB. 5-3-2011. FILED 12-18-2010.
- 3,997,448. **IDOJOY (STANDARD CHARACTER)**. HOPE & JOY, CORP., (U.S. CLS. 100 AND 101). SN 85-201,407. PUB. 5-3-2011. FILED 12-19-2010.
- 3,997,502. **THE GPS OF BUSINESS LAW (STANDARD CHARACTER)**. STEPHEN M. POTTS & ASSOCIATES, INC., DBA POTTS LAW GROUP, (U.S. CLS. 100 AND 101). SN 85-203,763. PUB. 5-3-2011. FILED 12-22-2010.
- 3,997,607 (*See Class 41 for this trademark*).
- 3,997,608 (*See Class 41 for this trademark*).
- 3,997,609 (*See Class 41 for this trademark*).
- 3,997,700 (*See Class 36 for this trademark*).
- 3,997,712. **VONABY AND DESIGN**. CALIBAN SYCORAX (CALAX), (U.S. CLS. 100 AND 101). SN 85-206,742. PUB. 5-3-2011. FILED 12-28-2010.
- 3,997,729. **REBOOT YOUR LIFE (STANDARD CHARACTER)**. REBOOT PARTNERS LLC, (U.S. CLS. 100 AND 101). SN 85-

- 207,019. PUB. 5-3-2011. FILED 12-29-2010.
- 3,997,732. **SABBATICAL SISTERS (STANDARD CHARACTER)**. REBOOT PARTNERS LLC, (U.S. CLS. 100 AND 101). SN 85-207,048. PUB. 5-3-2011. FILED 12-29-2010.
- 3,997,905. **HEALING A GENERATION AND DESIGN**. NEW COVENANT BELIEVERS' CHURCH, (U.S. CLS. 100 AND 101). SN 85-209,157. PUB. 5-3-2011. FILED 1-3-2011.
- 3,997,923 (*See Class 9 for this trademark*).
- 3,997,928 (*See Class 9 for this trademark*).
- 3,997,971. **WINNING CASES IS NO ACCIDENT (STANDARD CHARACTER)**. JOEL J. KOFKY, (U.S. CLS. 100 AND 101). SN 85-210,035. PUB. 5-3-2011. FILED 1-4-2011.
- 3,997,990. **VICTORIOUS WOMEN OF THE KING (STANDARD CHARACTER)**. CHRISTIAN BIBLE, (U.S. CLS. 100 AND 101). SN 85-210,332. PUB. 5-3-2011. FILED 1-4-2011.
- 3,998,014 (*See Class 35 for this trademark*).
- 3,998,022. **VOOBA (STANDARD CHARACTER)**. STROMBERG, JACK, (U.S. CLS. 100 AND 101). SN 85-210,794. PUB. 5-3-2011. FILED 1-5-2011.
- 3,998,053. **HAVE FUN, DATE DIFFERENTLY! (STANDARD CHARACTER)**. BLONDVIC ENTERPRISES, LLC, (U.S. CLS. 100 AND 101). SN 85-211,255. PUB. 5-3-2011. FILED 1-5-2011.
- 3,998,069. **ADOPTIMISM (STANDARD CHARACTER)**. ADOPTIMISM, (U.S. CLS. 100 AND 101). SN 85-211,440. PUB. 5-3-2011. FILED 1-5-2011.
- 3,998,077. **XPEDITE (STANDARD CHARACTER)**. SELECTION MANAGEMENT SYSTEMS, INC., (U.S. CLS. 100 AND 101). SN 85-211,607. PUB. 5-3-2011. FILED 1-6-2011.
- 3,998,078. **MEDVERIFY (STANDARD CHARACTER)**. SELECTION MANAGEMENT SYSTEMS, INC., (U.S. CLS. 100 AND 101). SN 85-211,611. PUB. 5-3-2011. FILED 1-6-2011.
- 3,998,110. **AMPLIFY THE GOOD. (STANDARD CHARACTER)**. EARTHBONGO, INC., (U.S. CLS. 100 AND 101). SN 85-212,215. PUB. 5-3-2011. FILED 1-6-2011.
- 3,998,236. **VITAL SIGNING (STANDARD CHARACTER)**. BARBER, CORY, (U.S. CLS. 100 AND 101). SN 85-230,606. PUB. 5-3-2011. FILED 1-31-2011.
- 3,998,294. **1-800-CANT-WORK (STANDARD CHARACTER)**. 1-800-CANT-WORK, LLC, (U.S. CLS. 100 AND 101). SN 85-259,491. PUB. 5-3-2011. FILED 3-7-2011.

* * * * *

SECTION 2.—PRIOR UNITED STATES CLASSIFICATION

COLLECTIVE MEMBERSHIP MARKS

3,996,632. **FORBIDDEN WHEELS DETROIT MC AND DESIGN.** FORBIDDEN WHEELS M.C. INC., SN 85-150,645. PUB. 5-3-2011. FILED 10-12-2010.

CLASS 200—COLLECTIVE MEMBERSHIP

3,995,466 (*See Class 16 for this trademark.*)

* * * * *

TRADEMARK REGISTRATIONS ISSUED UNDER SECTION 1(d)

The following marks have registered on the Principal Register pursuant to the intent-to-use provisions of Section 1(d) of the Trademark Act of 1946, as amended.

SECTION 1.— INTERNATIONAL CLASSIFICATION

The short titles associated below with the international class numbers are terms designed merely for quick identification and are not an official part of the international classification. The full names of international classes are given in section 6.1 of the trademark rules of practice.

The designation "U.S. Cl." appearing in this section refers to the U.S. class in effect prior to Sep. 1, 1973 rather than the international class which applies to applications filed on or after that date. For adoption of international classification see notice in the OFFICIAL GAZETTE of Jun. 26, 1973 (911 O.G. TM 210).

Application in more than one class

3,998,301. SACKLER, J.T., NEW YORK, NY. SN 76-468,456.
PUB. 11-13-2007, FILED 11-12-2002.

THE STUDIO

OWNER OF U.S. REG. NO. 2,836,045.

CLASS 16—PAPER GOODS AND PRINTED MATTER

FOR BOOKS IN THE FIELD OF ART, ARCHITECTURE AND DESIGN (U.S. CLS. 2, 5, 22, 23, 29, 37, 38 AND 50).

FIRST USE 0-0-1893; IN COMMERCE 0-0-1893.

CLASS 41—EDUCATION AND ENTERTAINMENT

FOR PROVIDING ON-LINE MAGAZINES IN THE FIELD OF ART, ARCHITECTURE AND DESIGN (U.S. CLS. 100, 101 AND 107).

FIRST USE 6-1-2000; IN COMMERCE 6-1-2000.

3,998,304. JRS INTERNATIONAL, LLC, LYNDHURST, NJ.
SN 76-663,103. PUB. 2-20-2007, FILED 7-14-2006.

INGREDIENTS HOUSE

THE MARK CONSISTS OF STANDARD CHARACTERS WITHOUT CLAIM TO ANY PARTICULAR FONT, STYLE, SIZE, OR COLOR.

NO CLAIM IS MADE TO THE EXCLUSIVE RIGHT TO USE "INGREDIENTS", APART FROM THE MARK AS SHOWN.

CLASS 1—CHEMICALS

FOR FULL LINE OF CHEMICAL ADDITIVES AND INGREDIENTS FOR USE IN THE MANUFACTURE, PROCESSING, AND REPACKAGING OF FOOD, BEVERAGES, AND PHARMACEUTICALS FOR HUMAN AND ANIMAL CONSUMPTION (U.S. CLS. 1, 5, 6, 10, 26 AND 46).

FIRST USE 2-0-2009; IN COMMERCE 2-0-2009.

CLASS 5—PHARMACEUTICALS

FOR FULL LINE OF VITAMIN AND MINERAL PREPARATIONS FOR USE AS INGREDIENTS IN THE MANUFACTURE, PROCESSING AND REPACKAGING OF FOOD, BEVERAGE, AND PHARMACEUTICAL FOR HUMAN AND ANIMAL CONSUMPTION (U.S. CLS. 6, 18, 44, 46, 51 AND 52).

FIRST USE 2-0-2009; IN COMMERCE 2-0-2009.

CLASS 30—STAPLE FOODS

FOR FULL LINE OF FOOD ADDITIVES FOR NON-NUTRITIONAL PURPOSES FOR USE AS FLAVORINGS, INGREDIENTS, OR FILLERS FOR USE IN THE MANUFACTURE, PROCESSING AND REPACKAGING OF FOOD, BEVERAGES, AND PHARMACEUTICALS FOR HUMAN AND ANIMAL CONSUMPTION (U.S. CL. 46).

FIRST USE 12-0-2009; IN COMMERCE 12-0-2009.

3,998,313. VOLKSWAGEN AKTIENGESELLSCHAFT, D-38436 WOLFSBURG, FED REP GERMANY. SN 76-693,763. PUB. 3-2-2010, FILED 10-22-2008.

JETTA TDI CUP

OWNER OF U.S. REG. NOS. 1,176,044, 3,315,029, AND OTHERS.

NO CLAIM IS MADE TO THE EXCLUSIVE RIGHT TO USE "CUP" FOR INTERNATIONAL CLASSES 035 AND 041, APART FROM THE MARK AS SHOWN.

CLASS 6—METAL GOODS

FOR METAL TOOL BOXES (U.S. CLS. 2, 12, 13, 14, 23, 25 AND 50).

FIRST USE 4-15-2008; IN COMMERCE 4-25-2008.

CLASS 9—ELECTRICAL AND SCIENTIFIC APPARATUS

FOR PROTECTIVE HELMETS, NAMELY, RACING, SPORT, SAFETY AND DRIVING HELMETS (U.S. CLS. 21, 23, 26, 36 AND 38).

FIRST USE 4-15-2008; IN COMMERCE 4-25-2008.

CLASS 12—VEHICLES

FOR AUTOMOTIVE VEHICLES, NAMELY, CARS, SPORT UTILITY VEHICLES, TRUCKS, TRAILERS, TRANSPORTATION VEHICLES IN THE NATURE OF VANS, LORRIES, BUSES AND STRUCTURAL PARTS THEREFOR (U.S. CLS. 19, 21, 23, 31, 35 AND 44).

FIRST USE 4-15-2008; IN COMMERCE 4-25-2008.

CLASS 16—PAPER GOODS AND PRINTED MATTER

FOR PAPER PRODUCTS, NAMELY, STICKERS, DECALS, NOTEPADS, POSTERS, PENS; BANNERS OF PAPER; FLAGS OF PAPER (U.S. CLS. 2, 5, 22, 23, 29, 37, 38 AND 50).

FIRST USE 4-15-2008; IN COMMERCE 4-25-2008.

CLASS 18—LEATHER GOODS

FOR LEATHER GOODS AND GOODS MADE OF IMITATION LEATHER, NAMELY, BACKPACKS, DUFFLE BAGS, ALL-PURPOSE ATHLETIC BAGS, CARRY-ON BAGS AND TOTE BAGS (U.S. CLS. 1, 2, 3, 22 AND 41).

FIRST USE 4-15-2008; IN COMMERCE 4-25-2008.

CLASS 20—FURNITURE AND ARTICLES NOT OTHERWISE CLASSIFIED

FOR NON-METAL TOOL BOXES; PLASTIC BANNERS; PLASTIC FLAGS (U.S. CLS. 2, 13, 22, 25, 32 AND 50).

FIRST USE 4-15-2008; IN COMMERCE 4-25-2008.

CLASS 25—CLOTHING

FOR APPAREL, NAMELY, T-SHIRTS, GOLF SHIRTS, SWEATSHIRTS, JACKETS, HATS, CAPS, RACING UNIFORMS AND RACING APPAREL, NAMELY, SUITS AND GLOVES (U.S. CLS. 22 AND 39).

FIRST USE 4-15-2008; IN COMMERCE 4-25-2008.

CLASS 35—ADVERTISING AND BUSINESS

FOR ORGANIZING EXHIBITIONS IN THE FIELD OF VEHICLE RACING FOR COMMERCIAL OR ADVERTISING PURPOSES; PROMOTING THE GOODS AND SERVICES OF OTHERS BY ARRANGING FOR SPONSORS TO AFFILIATE THEIR GOODS AND SERVICES WITH VEHICLE RACING EXHIBITIONS (U.S. CLS. 100, 101 AND 102).

FIRST USE 4-15-2008; IN COMMERCE 4-25-2008.

CLASS 41—EDUCATION AND ENTERTAINMENT

FOR ORGANIZING EXHIBITIONS IN THE FIELD OF VEHICLE RACING FOR CULTURAL OR EDUCATIONAL PURPOSES (U.S. CLS. 100, 101 AND 107).

FIRST USE 4-15-2008; IN COMMERCE 4-25-2008.

3,998,314. DWECK, JOYCE, DEAL, NJ. SN 76-696,761. PUB. 9-28-2010, FILED 4-8-2009.

AROMAS OF ALEPPO

THE MARK CONSISTS OF STANDARD CHARACTERS WITHOUT CLAIM TO ANY PARTICULAR FONT, STYLE, SIZE, OR COLOR.

NO CLAIM IS MADE TO THE EXCLUSIVE RIGHT TO USE "ALEPPO", APART FROM THE MARK AS SHOWN.

CLASS 21—HOUSEWARES AND GLASS

FOR CHINA PLATES, COOKING POTS, HOUSEHOLD UTENSILS, NAMELY, SERVING FORKS, SERVING SPOONS, SERVING LADLES, SERVING TONGS, POT AND PAN SCRAPERS, ROLLING PINS, SPATULAS, TURNERS, WHISKS, BEVERAGE GLASSWARE, PORCELAIN MUGS, AND EARTHENWARE MUGS (U.S. CLS. 2, 13, 23, 29, 30, 33, 40 AND 50).

FIRST USE 4-0-2011; IN COMMERCE 4-0-2011.

CLASS 24—FABRICS

FOR POT HOLDERS, TABLE CLOTHS NOT OF PAPER, TABLE MATS NOT OF PAPER, AND TEXTILE NAPKINS (U.S. CLS. 42 AND 50).

FIRST USE 4-0-2011; IN COMMERCE 4-0-2011.

CLASS 29—MEATS AND PROCESSED FOODS

FOR DRIED FRUITS, COOKED FRUITS, VEGETABLES, NAMELY, PRESERVED VEGETABLES; JELLIES, JAMS, EDIBLE OILS, FATS, FRUIT PRESERVES AND MEAT PRESERVES; PROCESSED NUTS, ALMONDS AND PISTACHIOS; CONFECTIONARY, NAMELY, CANDIED FRUITS AND VEGETABLES (U.S. CL. 46).

FIRST USE 4-0-2011; IN COMMERCE 4-0-2011.

CLASS 30—STAPLE FOODS

FOR COFFEE, TEA, SUGAR, RICE, FLOUR, BREAD, PASTRY; SAUCES AND SPICES; AND SALAD DRESSINGS; PROCESSED GRAINS (U.S. CL. 46).

FIRST USE 4-0-2011; IN COMMERCE 4-0-2011.

CLASS 31—NATURAL AGRICULTURAL PRODUCTS

FOR UNPROCESSED GRAINS (U.S. CLS. 1 AND 46).

FIRST USE 4-0-2011; IN COMMERCE 4-0-2011.

3,998,319. PARAMETRIC TECHNOLOGY CORPORATION, NEEDHAM, MA. SN 76-699,433. PUB. 5-25-2010, FILED 9-14-2009.

MATHCAD PRIME

THE MARK CONSISTS OF STANDARD CHARACTERS WITHOUT CLAIM TO ANY PARTICULAR FONT, STYLE, SIZE, OR COLOR.

OWNER OF U.S. REG. NO. 1,457,219.

CLASS 9—ELECTRICAL AND SCIENTIFIC APPARATUS

FOR COMPUTER SOFTWARE FOR COMPUTER AIDED DESIGN (CAD), COMPUTER AIDED MANUFACTURING (CAM), AND COMPUTER AIDED ENGINEERING (CAE); COMPUTER SOFTWARE THAT ENABLE USERS TO PERFORM, DOCUMENT AND SHARE CALCULATION AND DESIGN WORK; COMPUTER SOFTWARE THAT PROVIDES AN ELECTRONIC SCRATCHPAD FOR USE BY USERS, INCLUDING ENGINEERS, SCIENTISTS, MATHEMATICIANS AND STUDENTS, TO CALCULATE EQUATIONS, GENERATE PLOTS AND TABLES, CREATE TEXT AND PRINT OUT ALL ENTERED WORK AS AN INTEGRATED DISPLAY; AND ACCOMPANYING USER GUIDES SOLD WITH SUCH COMPUTER SOFTWARE AS A UNIT (U.S. CLS. 21, 23, 26, 36 AND 38).

FIRST USE 1-10-2011; IN COMMERCE 1-10-2011.

CLASS 41—EDUCATION AND ENTERTAINMENT

FOR COMPUTER EDUCATION TRAINING SERVICES (U.S. CLS. 100, 101 AND 107).
FIRST USE 1-10-2011; IN COMMERCE 1-10-2011.

3,998,345. BENTLEY MOTORS LIMITED, CREWE, CHESHIRE CW1 3PL, UNITED KINGDOM. SN 76-979,138. PUB. 12-25-2007, FILED 7-26-2004.

BENTLEY

THE MARK CONSISTS OF STANDARD CHARACTERS WITHOUT CLAIM TO ANY PARTICULAR FONT, STYLE, SIZE, OR COLOR.

OWNER OF U.S. REG. NOS. 645,703, 2,569,278, AND OTHERS.
SEC. 2(F).

CLASS 14—JEWELRY

FOR JEWELRY, WATCHES AND CLOCKS, ALL OF THE FOREGOING SOLD EXCLUSIVELY BY AUTHORIZED DEALERS (U.S. CLS. 2, 27, 28 AND 50).
FIRST USE 4-11-2011; IN COMMERCE 4-11-2011.

CLASS 16—PAPER GOODS AND PRINTED MATTER

FOR TEXTS, PERIODICALS, MAGAZINES, BROCHURES, PAMPHLETS, INFORMATION SHEETS PERTAINING TO AUTOMOBILES, THEIR PARTS, FITTINGS, AND ACCESSORIES; POSTERS, STATIONERY, DIARIES, CALENDARS, PAPER COASTERS, PAPER FLAGS, PHOTOGRAPHS, AUTOGRAPH CARDS, POSTCARDS, PHOTOGRAPH AND PICTURE ALBUMS, GREETING CARDS, DECALCOMANIAS, PRINTED SIGNAGE FOR APPLICATION TO WINDOWS AND VEHICLES AND USER MANUALS PERTAINING TO AUTOMOBILES, THEIR PARTS, FITTINGS, AND ACCESSORIES; PASSPORT HOLDERS AND CHECKBOOK HOLDERS MADE OF LEATHER AND IMITATIONS OF LEATHER, ALL OF THE FOREGOING SOLD EXCLUSIVELY BY AUTHORIZED DEALERS (U.S. CLS. 2, 5, 22, 23, 29, 37, 38 AND 50).
FIRST USE 4-11-2011; IN COMMERCE 4-11-2011.

CLASS 18—LEATHER GOODS

FOR LEATHER AND IMITATIONS OF LEATHER AND GOODS MADE THEREFROM, NAMELY, LUGGAGE, WALLETS, PURSES, BELTS, HOLDALLS, HANDBAGS, SPORTS BAGS, BRIEFCASES, ATTACHE CASES, PASSPORT HOLDERS AND CHECKBOOK HOLDERS; BAGS, NAMELY, HANDBAGS, SPORTS BAGS, SHOPPING BAGS OF TEXTILE, LEATHER AND IMITATIONS OF LEATHER, AND CARRIER BAGS; UMBRELLAS AND PARASOLS, ALL OF THE FOREGOING SOLD EXCLUSIVELY BY AUTHORIZED DEALERS (U.S. CLS. 1, 2, 3, 22 AND 41).
FIRST USE 4-11-2011; IN COMMERCE 4-11-2011.

CLASS 25—CLOTHING

FOR CLOTHING, NAMELY, UNDERWEAR AND LINGERIE, TROUSERS, SHORTS, SPORTS CLOTHING, T-SHIRTS, SHIRTS, JACKETS, SUITS FOR MEN AND FOR WOMEN, STOCKINGS, TIGHTS, SOCKS, SKIRTS, BLOUSES, NECKTIES, HANDKERCHIEFS, RAINCOATS AND WATERPROOF JACKETS, COATS AND TROUSERS; FOOTWEAR AND HEADGEAR, NAMELY, HATS, CAPS, RAIN HATS, AND SUN VISORS, ALL OF THE FOREGOING SOLD EXCLUSIVELY AUTHORIZED DEALERS (U.S. CLS. 22 AND 39).
FIRST USE 4-11-2011; IN COMMERCE 4-11-2011.

CLASS 36—INSURANCE AND FINANCIAL

FOR INSURANCE SERVICES, NAMELY, INSURANCE BROKERAGE, INSURANCE CLAIM ADMINISTRATION AND PROCESSING SERVICES AND UNDERWRITING SERVICES FOR ALL TYPES OF INSURANCE; LOAN AND CREDIT SERVICES, NAMELY, THE PROVISION OF LOAN FINANCING AND CREDIT COUNSELING AND RATING SERVICES, ALL RELATING TO AUTOMOBILES, THEIR PARTS, FITTINGS, AND ACCESSORIES; EXTENDED WARRANTY SERVICES, NAMELY, THE PROVISION OF WARRANTIES ON AUTOMOBILES, THEIR PARTS, FITTINGS, AND ACCESSORIES; CREDIT AND DEBIT CARD SERVICES, ALL OF THE FOREGOING SOLD EXCLUSIVELY BY AUTHORIZED DEALERS (U.S. CLS. 100, 101 AND 102).
FIRST USE 4-11-2011; IN COMMERCE 4-11-2011.

CLASS 37—CONSTRUCTION AND REPAIR

FOR REPAIR, INSTALLATION, AND MAINTENANCE SERVICES ALL RELATING TO AUTOMOBILES, INTERNAL COMBUSTION ENGINES AND PARTS AND FITTINGS THEREOF, ALL OF THE FOREGOING SOLD EXCLUSIVELY BY AUTHORIZED DEALERS (U.S. CLS. 100, 103 AND 106).
FIRST USE 4-11-2011; IN COMMERCE 4-11-2011.

3,998,357. WUXI JINMAO FOREIGN TRADE CO., LTD., WUXI, JIANGSU PROVINCE, CHINA. SN 77-061,464. PUB. 3-4-2008, FILED 12-11-2006.

TEMMET

THE MARK CONSISTS OF STANDARD CHARACTERS WITHOUT CLAIM TO ANY PARTICULAR FONT, STYLE, SIZE, OR COLOR.

THE WORD "TEMMET" HAS NO MEANING IN ENGLISH.

CLASS 25—CLOTHING

FOR CLOTHING FOR MEN, WOMEN AND CHILDREN, NAMELY, TOPS, TANK TOPS, SHIRTS, DRESS SUITS, JACKETS, SWEATERS, UNDERWEAR, SWIMWEAR, PANTS, SHORTS, UNDERWEAR, BOXERS, GOWNS, DUSTERS, THONGS, ROBES, JEANS; SLEEPWEAR; HEADGEAR, NAMELY, CAPS, HATS, EARMUFFS, TOQUES, TURBANS, BEANIE CAPS, SCARVES (U.S. CLS. 22 AND 39).
FIRST USE 6-0-2007; IN COMMERCE 5-6-2011.

CLASS 28—TOYS AND SPORTING GOODS

FOR DOLL CLOTHING, STUFFED TOYS, STUFFED TOY ANIMALS (U.S. CLS. 22, 23, 38 AND 50).
FIRST USE 8-0-2007; IN COMMERCE 5-9-2011.

3,998,361. ARROWPOINT CAPITAL CORP., CHARLOTTE, NC. SN 77-076,070. PUB. 2-12-2008, FILED 1-4-2007.



THE MARK CONSISTS OF A CARET RESEMBLING PART OF THE LETTER "A" WITH A LINE DRAWN DOWNWARD BUT UNATTACHED FROM THE CENTER OF THE CARET AND EXTENDING TO THE RIGHT.

CLASS 35—ADVERTISING AND BUSINESS

FOR CONSULTING SERVICES IN THE FIELD OF INSURANCE CLAIMS AUDITING (U.S. CLS. 100, 101 AND 102).

FIRST USE 9-28-2007; IN COMMERCE 9-28-2007.

CLASS 36—INSURANCE AND FINANCIAL

FOR WRITING PROPERTY CASUALTY INSURANCE, UNDERWRITING REINSURANCE, INSURANCE CLAIMS PROCESSING, INSURANCE CLAIMS SERVING, NAMELY, CLAIMS ADMINISTRATION AND PREMIUM RATE COMPUTING, ACTUARIAL SERVICES, AND INSURANCE CONSULTING SERVICES (U.S. CLS. 100, 101 AND 102).

FIRST USE 9-28-2007; IN COMMERCE 9-28-2007.

3,998,362. SUNSTAR, INC., OSAKA, JAPAN. SN 77-082,381. PUB. 1-22-2008, FILED 1-12-2007.

THE MARK CONSISTS OF STANDARD CHARACTERS WITHOUT CLAIM TO ANY PARTICULAR FONT, STYLE, SIZE, OR COLOR.

OWNER OF U.S. REG. NOS. 864,977, 1,904,031, AND 1,997,271.

CLASS 3—COSMETICS AND CLEANING PREPARATIONS

FOR DENTIFRICES; DENTIFRICES, NAMELY, DENTIFICE GELS CONTAINING FLUORIDE (U.S. CLS. 1, 4, 6, 50, 51 AND 52).

FIRST USE 0-0-1985; IN COMMERCE 0-0-2008.

CLASS 5—PHARMACEUTICALS

FOR DENTAL RINSES (U.S. CLS. 6, 18, 44, 46, 51 AND 52).

FIRST USE 0-0-2005; IN COMMERCE 2-0-2008.

3,998,364. CZT/ACN TRADEMARKS, L.L.C., SCHAUMBURG, IL. SN 77-094,959. PUB. 3-18-2008, FILED 1-30-2007.

OWNER OF U.S. REG. NOS. 540,915, 3,230,380, AND OTHERS.

THE COLOR(S) BLUE AND GRAY IS/ARE CLAIMED AS A FEATURE OF THE MARK.

THE MARK CONSISTS OF THE STYLIZED WORD "NIELSEN", IN WHICH THE COLOR BLUE APPEARS IN THE LETTER "N" WHILE THE COLOR GRAY APPEARS IN THE REMAINDER OF THE WORD, "IELSEN", AND IN THE NINE DOTS BENEATH THE STYLIZED WORD.

SEC. 2(F) AS TO "NIELSEN".

CLASS 9—ELECTRICAL AND SCIENTIFIC APPARATUS

FOR COMPUTER SOFTWARE PROGRAMS, DATABASE MANAGEMENT PROGRAMS AND MANUALS SOLD THEREWITH AS A UNIT USED TO CREATE, ACCESS, VIEW, REVIEW, MANIPULATE, CATEGORIZE, ANALYZE, FORMAT, AND PREPARE AND PRINT REPORTS FROM DATA AND INFORMATION REGARDING PRODUCT MANUFACTURERS AND DISTRIBUTORS, RETAIL STORES, MASS MERCHANDISERS, WHOLESALE CLUBS, SUPERCENTERS, DOLLAR STORES, CHAIN DRUG STORES, DEPARTMENT STORES, SPECIALTY RETAILERS, MILITARY BUYING CENTERS, AND OTHER ALTERNATE CHANNEL RETAILERS, FILMS AND TELEVISION PROGRAMMING, MEDIA RATING INFORMATION, RADIO AIRPLAY, BOOK SALES, MUSIC SALES, VIDEO SALES, MEDIA RESEARCH, SALES AND PROFIT INFORMATION, RETAIL AND ON-PREMISES BUSINESS LOCATIONS, DEMOGRAPHIC INFORMATION, AND ADVERTISING, PROMOTION, TRADE AND MARKETING PLANNING, ALL IN DOWNLOADABLE FORM OR RECORDED ON COMPUTER MEDIA; COMPUTER SOFTWARE FOR USE IN COLLECTING, ANALYZING, AND PRODUCING REPORTS REGARDING INFORMATION ABOUT THE TRANSMISSION AND RECEPTION OF SIGNALS DELIVERED VIA OVER-THE-AIR BROADCAST, CABLE, SATELLITE, AND A GLOBAL COMPUTER NETWORK AND THEIR CONTENT, AND THE LISTENING, VIEWING, AND USAGE HABITS OF SIGNAL RECEIVING AUDIENCES AND USER MANUALS SOLD AS A UNIT THEREWITH; COMPUTER SOFTWARE AND HARDWARE FOR USE IN ENCODING, READING, AND ANALYZING BROADCAST, TELEVISION, VIDEO AND AUDIO SIGNALS, AUDIO AND VIDEO CODING AND DECODING OF SAME, NAMELY, COMPUTER SOFTWARE PROGRAM AND COMPUTER HARDWARE AND FIRMWARE, NAMELY, ELECTRONIC AND INTEGRATED CIRCUITS; AUDIO AND VIDEO ENCODERS; AND ELECTRONIC AUDIO AND VIDEO READERS, NAMELY, AUDIO AND VIDEO ENCODERS AND DECODERS; COMPUTER SOFTWARE FOR PLANNING AND SCHEDULING ADVERTISING AND MARKETING IN THE FIELDS OF ADVERTISING AND MARKETING RESEARCH, MARKET RESEARCH, MEDIA RESEARCH AND RATING; AND CORPORATE AND BUSINESS INFORMATION; COMPUTER SOFTWARE FOR PLANNING ADVERTISING AND DETERMINING AND ESTIMATING MEDIA AND MARKETING PLAN EFFECTIVENESS AND FOR MEASURING CONSUMER RESPONSIVENESS TO ADVERTISING; COMPUTER SOFTWARE PROGRAMS THAT MATCH PRODUCT ADVERTISEMENTS, THE BUDGET ALLOCATED FOR ADVERTISING THE INDIVIDUAL PRODUCTS, AND PROBABLE BUYING HABITS OF AN EXPECTED VIEW-

ING AUDIENCE OF TELEVISION PROGRAMMING IN DOWNLOADABLE FORM OR RECORDED ON COMPUTER MEDIA (U.S. CLS. 21, 23, 26, 36 AND 38).
FIRST USE 1-20-2007; IN COMMERCE 1-20-2007.

CLASS 16—PAPER GOODS AND PRINTED MATTER

FOR PRINTED REPORTS, DIRECTORIES, MAGAZINES, AND PUBLICATIONS, NAMELY, NEWSLETTERS, IN THE FIELDS OF MARKETING, MEDIA RESEARCH, MEDIA RATINGS, PROGRAMMING, ADVERTISING, MEDIA RATING SERVICES, MARKET RESEARCH, CONSUMER PURCHASES, CONSUMER MEDIA USAGE, ADVERTISING RESEARCH, BUSINESS RESEARCH AND ANALYSIS, DEMOGRAPHIC RESEARCH, AND MEDIA AND MARKETING MEASUREMENT INFORMATION, ANALYSES, AND DIRECTORIES; PERIODICAL JOURNALS CONTAINING MEDIA VIEWING AND ADVERTISING REPORTS, AND CONSUMER PROMOTION REPORTS; REPORTS, NEWSPAPER COLUMNS, MAGAZINE COLUMNS, PERIODICAL COLUMNS, AND BOOKLETS CONTAINING STATISTICAL AND OTHER INFORMATION CONCERNING FILMS, FILM VIEWING, BOOKS, MUSIC AND VIDEO SALES AND PROMOTIONS, SPORTS EVENTS AND PROMOTIONS; PRINTED MARKET RESEARCH REPORTS, DIARIES FOR ENTRY OF INFORMATION RELATING TO THE LISTENING, VIEWING AND USAGE HABITS OF SIGNAL RECEIVING AUDIENCES, INTERNET AND/OR COMPUTER USERS; PRINTED PUBLICATIONS, NAMELY, BUSINESS-TO-BUSINESS MAGAZINES, PERIODICALS, PRINTED REPORTS, PRESENTATIONS AND RETAIL STORE DIRECTORIES IN THE FIELDS OF ADVERTISING AND MARKETING RESEARCH, MARKET RESEARCH, MEDIA RESEARCH, AND CORPORATE AND BUSINESS INFORMATION, AND DIRECTORIES IN THE FIELDS OF ADVERTISING AND MARKETING RESEARCH, MARKET RESEARCH, MEDIA RESEARCH, AND CORPORATE AND BUSINESS INFORMATION, AND FEATURING RETAIL BUSINESS AND BUSINESS LOCATIONS, ADVERTISING, MARKETING RESEARCH, AND BUSINESS ENTITIES; NEWSLETTERS AND PRINTED PERIODICALS FEATURING INFORMATION RELATED TO BUSINESS, MARKETING, DEVELOPMENTS, AND TRENDS RELATED TO RETAIL MARKETING AND SALES, COMPANIES, RETAILERS, MASS MERCHANDISERS, WHOLESALE CLUBS, SUPERCENTERS, DOLLAR STORES, CHAIN DRUG STORES, DEPARTMENT STORES, SPECIALTY RETAILERS, MILITARY BUYING CENTERS, AND OTHER ALTERNATE CHANNEL RETAILERS; PRINTED CHARTS AND REPORTS FEATURING SOUND RECORDING SALES, RATINGS, AND POPULARITY CHARTS (U.S. CLS. 2, 5, 22, 23, 29, 37, 38 AND 50).

FIRST USE 1-20-2007; IN COMMERCE 1-20-2007.

CLASS 35—ADVERTISING AND BUSINESS

FOR MARKET RESEARCH SERVICES; ADVERTISING RESEARCH SERVICES; BUSINESS RESEARCH SERVICES; RETAIL MARKETING AND SALES INFORMATION SERVICES; CONSUMER PURCHASE AND BEHAVIOR RESEARCH SERVICES; CONDUCTING MARKET, ADVERTISING AND MEDIA USAGE AND RATING RESEARCH, AND ANALYZING, AND PREPARING REPORTS BASED THEREON REGARDING CONSUMER, ADVERTISING, MEDIA VIEWING, MARKET RESEARCH AND BUSINESS RESEARCH SURVEYS, POLLS, OPINION STUDIES, STUDIES, ANALYSES AND EVALUATIONS, AND ON-LINE SURVEY PANELS; BUSINESS AND BRAND CONSULTING SERVICES; MARKET RESEARCH SERVICES RELATED TO NEW RETAIL SALES, PRODUCT PLACEMENT AND POINT-OF-PURCHASE DISPLAYS, AND RETAIL FACILITY INFORMATION, PRODUCT IDEAS, INTRODUCTIONS AND RE-INTRODUCTIONS; PROVIDING MARKETING, ADVERTISING AND BUSINESS CONSULTING SERVICES RELATED TO PRODUCT AND PACKAGE BREAKTHROUGH AND VISIBILITY RELATING TO PRODUCT PACKAGE PERFORMANCE; AND MEDIA AUDIENCE MEASUREMENT SERVICES; MEDIA RESEARCH SERVICES; MEDIA RATING RESEARCH SERVICES; MEDIA RESEARCH SERVICES REGARDING COMPUTERS AND COMPUTER NETWORKS AND THEIR USE; DEMOGRAPHIC AND CONSUMER RE-

SEARCH SERVICES; COLLECTING DATA, CONDUCTING MARKET, ADVERTISING, MEDIA, AND BUSINESS RESEARCH, ANALYZING AND PROVIDING REPORTS BASED THEREON RELATING TO POPULATION AND PRODUCT TREND STUDIES AND INFORMATION; COLLECTING DATA AND PROVIDING REPORTS BASED THEREON CONCERNING THE MARKETING, SALES, AND USAGE OF CONSUMER PRODUCTS, PHARMACEUTICALS AND NUTRACEUTICALS, DURABLE GOODS, BOOKS, MUSIC AND VIDEO MARKETING AND SALES AND CONSUMER BEHAVIOR; MARKET RESEARCH AND BUSINESS RESEARCH SERVICES RELATING TO; CODING AND CONFORMING CLIENT PRODUCT, RETAIL STORE AND MARKETING DATA AND RECORDS; MEDIA RESEARCH AND RATING SERVICES, NAMELY, MARKET RESEARCH SERVICES RELATING TO THE BROADCASTING, NARROW CASTING, CABLE, AND NETWORK TRANSMISSION, SIGNAL RECEIVING AUDIENCE DEMOGRAPHICS AND BEHAVIOR, AND THE LISTENING, VIEWING, AND USAGE HABITS OF SIGNAL RECEIVING AUDIENCES, COMPUTER USERS, AND USERS OF A GLOBAL COMPUTER NETWORK; SALES VOLUME TRACKING FOR OTHERS; SALES VOLUME TRACKING FOR OTHERS THROUGH THE COLLECTION OF SALES DATA AND MARKET RESEARCH AND THE DISTRIBUTION OF THE RESULTS THEREOF FOR OTHERS OF MUSIC, MUSIC VIDEOS, PRERECORDED DVDS, PRERECORDED CD-ROMS, AND AUDIO SELL-THROUGH DATA, PRE-RECORDED VIDEOS ON VHS, VIDEO DVDS, AND VIDEO SELL-THROUGH DATA, BOOKS, INCLUDING AUDIO AND ELECTRONIC BOOKS, SOLD ON-LINE AND BY RETAIL AND WHOLESALE STORES, CONSUMER GOODS, DURABLE GOODS, PHARMACEUTICALS, SPORTS EVENTS, SPORTING GOODS, MUSIC, MUSIC VIDEOS, DVDS, BOOKS, NAMELY, PRINTED, AUDIO AND ELECTRONIC BOOKS SOLD ON-LINE AND BY RETAIL AND WHOLESALE STORES, TELEPHONE AND CELL PHONE RING TONES, RING BACKS, MUSIC-RELATED PRODUCTS AND SERVICES FOR MOBILE TELEPHONE CONSUMERS, ONLINE MUSIC DOWNLOADS, ONLINE VIDEO AND MOVIE DOWNLOADS; COLLECTING AND CORRELATING MARKETING, ADVERTISING, AND BUSINESS INFORMATION REGARDING SPORTS VENUE ADVERTISING AND SIGNAGE, ADVERTISEMENTS, AND SPONSORSHIP MARKETING DERIVED FROM AND INCLUDING IMAGES OF TELEVISION, CABLE, AND RADIO PROGRAMMING AND INTERNET AND PRINT PUBLICATIONS, AS WELL AS REVENUE, FOR STATISTICAL ANALYSIS AND MARKET RESEARCH PURPOSES VIA THE INTERNET AND PREPARATION AND DISSEMINATION OF PRINTED REPORTS BASED THEREON TO THIRD PARTIES; COMPILING INFORMATION ABOUT COMMERCIAL ADVERTISEMENTS TELEVIEWED DURING NATIONAL AND REGIONAL TELECASTS; BROADCAST RECOGNITION INFORMATION SERVICES FOR OTHERS, NAMELY, ELECTRONIC RECOGNITION AND IDENTIFICATION OF PRE-RECORDED MUSIC, COMMERCIALS AND PROGRAMMING ON RADIO, TELEVISION, CABLE STATIONS, AND ONLINE BY USE OF PASSIVE PATTERN RECOGNITION TECHNOLOGY; AND REVIEWING, CODING, AND CONFORMING RETAIL, RETAIL STORE, PRODUCT, AND MARKETING DATA AND RECORDS; PLANNING AND CONDUCTING BUSINESS MEETINGS, AND TRADESHOWS IN THE FIELDS OF ADVERTISING AND MARKETING RESEARCH, MARKET RESEARCH, MEDIA RESEARCH, AND CORPORATE AND BUSINESS INFORMATION; PREPARING MARKET RESEARCH AND BUSINESS RESEARCH REPORTS FROM COMPUTER DATABASES, IN THE FIELDS OF MARKET RESEARCH AND PRODUCT RETAILER AND MANUFACTURER INFORMATION RELATING TO RETAIL SALES, CONSUMER DEMOGRAPHICS, PRODUCT PLACEMENT AND POINT-OF-PURCHASE DISPLAYS, AND RETAIL FACILITY INFORMATION, PRODUCT INFORMATION, PRODUCT CATALOGS, PRODUCT SALES, COMPETITOR INFORMATION, RETAIL CONSUMER INFORMATION, SEGMENTATION AND TARGETING INFORMATION, MANUFACTURING INFORMATION, AND MARKETING; BUSINESS INFORMATION AND MARKET RESEARCH SERVICES, NAMELY, CONDUCTING MARKET, ADVERTISING AND MARKETING RESEARCH, ANALYZING STATISTICAL DATA, PREPARING REPORTS, AND CONSULTING REGARDING BUSINESS AND MARKET RESEARCH INFORMATION; AND PROVIDING ON-LINE INTERACTIVE COMPUTER DATABASES IN THE

FIELDS OF BUSINESS AND MARKET RESEARCH, DEMOGRAPHIC INFORMATION AND DATA RELATING TO THE SALE AND PROMOTION OF CONSUMER AND DURABLE GOODS, CONDUCTING MARKET AND BUSINESS SURVEYS, STUDIES, ANALYSES AND EVALUATIONS; PROVIDING TEMPORARY USE OF ONLINE NON-DOWNLOADABLE ELECTRONIC DATABASES AND WEBSITES IN THE FIELDS OF ADVERTISING, MARKETING, BUSINESS, MEDIA AND MARKET RESEARCH, CONSUMER SURVEYS, PRODUCT RETAILER, RETAIL STORE AND PRODUCT SALES, TRADING AREAS, AND DEMOGRAPHIC INFORMATION; PROVIDING TEMPORARY USE OF ONLINE NON-DOWNLOADABLE DATABASES FOR CREATING, ACCESSING, UPDATING, DOWNLOADING, VIEWING AND MANIPULATING INFORMATION IN THE FIELDS OF MARKET RESEARCH AND PRODUCT RETAILER AND MANUFACTURER INFORMATION RELATING TO RETAIL SALES, CONSUMER DEMOGRAPHICS, PRODUCT PLACEMENT AND POINT-OF-PURCHASE DISPLAYS, AND RETAIL FACILITY INFORMATION, PRODUCT INFORMATION, PRODUCT CATALOGS, PRODUCT SALES, COMPETITOR INFORMATION, RETAIL CONSUMER INFORMATION, SEGMENTATION AND TARGETING INFORMATION, MANUFACTURING INFORMATION, AND MARKETING; PROVIDING TEMPORARY USE OF ONLINE NON-DOWNLOADABLE ELECTRONIC DATABASES FOR USE IN ANALYZING ADVERTISING, MARKETING, SALES, AND PRODUCT INFORMATION IN CONNECTION WITH RETAIL STORE MARKETING SALES, PROMOTION, AND OTHER MARKETING ACTIVITIES (U.S. CLS. 100, 101 AND 102).

FIRST USE 1-20-2007; IN COMMERCE 1-20-2007.

CLASS 41—EDUCATION AND ENTERTAINMENT

FOR PLANNING AND CONDUCTING, BUSINESS AND EDUCATIONAL SEMINARS; AND CONDUCTING WORKSHOPS AND SEMINARS IN MARKET RESEARCH, MARKETING AND ADVERTISING RESEARCH, AND CONSUMER RESEARCH AND CONSULTING (U.S. CLS. 100, 101 AND 107).

FIRST USE 1-20-2007; IN COMMERCE 1-20-2007.

CLASS 42—SCIENTIFIC AND COMPUTER SERVICES

FOR PROVIDING ONLINE NON-DOWNLOADABLE DATABASE MANAGEMENT SOFTWARE FOR CREATING, ACCESSING, UPDATING, DOWNLOADING, VIEWING AND MANIPULATING INFORMATION IN THE FIELDS OF MARKET RESEARCH AND PRODUCT RETAILER AND MANUFACTURER INFORMATION RELATING TO RETAIL SALES, CONSUMER DEMOGRAPHICS, PRODUCT PLACEMENT AND POINT-OF-PURCHASE DISPLAYS, AND RETAIL FACILITY INFORMATION, PRODUCT INFORMATION, PRODUCT CATALOGS, PRODUCT SALES, COMPETITOR INFORMATION, RETAIL CONSUMER INFORMATION, SEGMENTATION AND TARGETING INFORMATION, MANUFACTURING INFORMATION, AND MARKETING; PROVIDING ONLINE NON-DOWNLOADABLE COMPUTER SOFTWARE FOR USE IN ANALYZING ADVERTISING, MARKETING, SALES, AND PRODUCT INFORMATION IN CONNECTION WITH RETAIL STORE MARKETING SALES, PROMOTION, AND OTHER MARKETING ACTIVITIES (U.S. CLS. 100 AND 101).

FIRST USE 1-20-2007; IN COMMERCE 1-20-2007.

3,998,366. DISNEY ENTERPRISES, INC., BURBANK, CA. SN 77-098,469. PUB. 2-19-2008, FILED 2-2-2007.

PRINCESS JASMINE

THE MARK CONSISTS OF STANDARD CHARACTERS WITHOUT CLAIM TO ANY PARTICULAR FONT, STYLE, SIZE, OR COLOR.

THE NAME(S), PORTRAIT(S), AND/OR SIGNATURE(S) SHOWN IN THE MARK DOES NOT IDENTIFY A PARTICULAR LIVING INDIVIDUAL.

CLASS 18—LEATHER GOODS

FOR ARTICLES MADE FROM LEATHER AND IMITATIONS OF LEATHER, NAMELY, LUGGAGE, SATCHELS, AND WAIST PACKS; BAGS, NAMELY, BACKPACKS, BEACH BAGS AND BOOK BAGS; SHOPPING BAGS OF TEXTILE; TOTE BAGS; PURSES; HANDBAGS; WALLET; UMBRELLAS (U.S. CLS. 1, 2, 3, 22 AND 41).

FIRST USE 10-19-2009; IN COMMERCE 10-19-2009.

CLASS 20—FURNITURE AND ARTICLES NOT OTHERWISE CLASSIFIED

FOR PICTURE FRAMES; PILLOWS; WIND CHIMES (U.S. CLS. 2, 13, 22, 25, 32 AND 50).

FIRST USE 10-19-2009; IN COMMERCE 10-19-2009.

CLASS 21—HOUSEWARES AND GLASS

FOR HOUSEWARES, NAMELY, BOWLS, COOKIE CUTTERS, CUPS, DISHES, FIGURINES MADE OF CRYSTAL OR PORCELAIN, MUGS, PLATES, SPORTS BOTTLES SOLD EMPTY, AND THERMAL INSULATED CONTAINERS FOR FOOD OR BEVERAGE; DINNERWARE; BEVERAGeware; PLASTIC CUPS; COOKIE JARS (U.S. CLS. 2, 13, 23, 29, 30, 33, 40 AND 50).

FIRST USE 10-19-2009; IN COMMERCE 10-19-2009.

CLASS 24—FABRICS

FOR APRONS; BATH TOWELS; BED SHEETS; BLANKET THROWS; COMFORTERS; CURTAINS; GOLF TOWELS; HAND TOWELS; HOODED TOWELS; KITCHEN TOWELS; OVEN MITTS; PILLOW CASES; PILLOW COVERS; THROWS; TOWELS; WASHCLOTHS; BED LINEN; BATH LINEN; HOUSEHOLD LINEN (U.S. CLS. 42 AND 50).

FIRST USE 10-19-2009; IN COMMERCE 10-19-2009.

CLASS 30—STAPLE FOODS

FOR COFFEE; TEA (U.S. CL. 46).

FIRST USE 10-19-2009; IN COMMERCE 10-19-2009.

3,998,370. SYNDEV RX, INC., CAMBRIDGE, MA. SN 77-105,132. PUB. 3-11-2008, FILED 2-12-2007.

SynDevRx

THE MARK CONSISTS OF STANDARD CHARACTERS WITHOUT CLAIM TO ANY PARTICULAR FONT, STYLE,

SIZE, OR COLOR.

3,998,372. WEC HOLDINGS, LLC, LAS VEGAS, CA. SN 77-113,830. PUB. 2-19-2008, FILED 2-22-2007.

CLASS 5—PHARMACEUTICALS

FOR DRUG DELIVERY AGENTS CONSISTING OF COMPOUNDS THAT FACILITATE DELIVERY OF A WIDE RANGE OF PHARMACEUTICALS; PHARMACEUTICAL PREPARATIONS AND SUBSTANCES FOR THE TREATMENT OF GASTRO-INTESTINAL DISEASES; PHARMACEUTICAL PREPARATIONS FOR THE PREVENTION OF CANCER; PHARMACEUTICAL PREPARATIONS FOR USE IN CHEMOTHERAPY (U.S. CLS. 6, 18, 44, 46, 51 AND 52).

FIRST USE 5-26-2011; IN COMMERCE 5-26-2011.

CLASS 42—SCIENTIFIC AND COMPUTER SERVICES

FOR CONDUCTING EARLY EVALUATIONS IN THE FIELD OF NEW PHARMACEUTICALS (U.S. CLS. 100 AND 101).

FIRST USE 5-4-2011; IN COMMERCE 5-4-2011.



OWNER OF U.S. REG. NO. 3,119,360.

NO CLAIM IS MADE TO THE EXCLUSIVE RIGHT TO USE "CAGEFIGHTING", APART FROM THE MARK AS SHOWN.

THE MARK CONSISTS OF THE LETTERS "WEC" CENTERED ABOVE THE PHRASE "WORLD EXTREME CAGEFIGHTING."

CLASS 9—ELECTRICAL AND SCIENTIFIC APPARATUS

FOR DIGITAL VIDEO DISCS FEATURING SPORTS EVENTS AND MIXED MARTIAL ARTS (U.S. CLS. 21, 23, 26, 36 AND 38).

FIRST USE 6-30-2007; IN COMMERCE 6-30-2007.

CLASS 25—CLOTHING

FOR JACKETS; JERSEYS; HEADWEAR; WORKOUT AND SPORTS APPAREL, NAMELY, SHORTS, SHIRTS AND JACKETS; SPORTS SHIRTS; TANK TOPS; SHORTS (U.S. CLS. 22 AND 39).

FIRST USE 6-30-2007; IN COMMERCE 6-30-2007.

CLASS 38—COMMUNICATION

FOR VIDEO-ON-DEMAND TRANSMISSION SERVICES (U.S. CLS. 100, 101 AND 104).

FIRST USE 6-30-2007; IN COMMERCE 6-30-2007.

3,998,371. THE MATHWORKS, INC., NATICK, MA. SN 77-105,643. PUB. 3-31-2009, FILED 2-12-2007.

MATHWORKS

THE MARK CONSISTS OF STANDARD CHARACTERS WITHOUT CLAIM TO ANY PARTICULAR FONT, STYLE, SIZE, OR COLOR.

CLASS 9—ELECTRICAL AND SCIENTIFIC APPARATUS

FOR COMPUTER SOFTWARE THAT ASSISTS COMPUTERS IN DEPLOYING PARALLEL APPLICATIONS AND PERFORMING PARALLEL COMPUTATIONS; COMPUTER SOFTWARE FOR BIOLOGICAL SYSTEMS APPLICATION DEPLOYMENT; COMPUTER SOFTWARE THAT FACILITATES NETWORK-MEDIATED KNOWLEDGE SHARING AMONG USERS AND COLLABORATIVE CODING AND PROBLEM SOLVING (U.S. CLS. 21, 23, 26, 36 AND 38).

FIRST USE 10-31-2008; IN COMMERCE 10-31-2008.

CLASS 41—EDUCATION AND ENTERTAINMENT

FOR EDUCATIONAL SERVICES, NAMELY, ONLINE JOURNALS IN THE FIELD OF TECHNICAL COMPUTING; EDUCATIONAL SERVICES, NAMELY, ONLINE JOURNALS IN THE FORM OF WEBLOGS IN THE FIELD OF TECHNICAL COMPUTING (U.S. CLS. 100, 101 AND 107).

FIRST USE 6-30-2010; IN COMMERCE 6-30-2010.

CLASS 42—SCIENTIFIC AND COMPUTER SERVICES

FOR APPLICATION SERVICE PROVIDER, NAMELY, HOSTING COMPUTER SOFTWARE APPLICATIONS FOR OTHERS; TECHNICAL SUPPORT SERVICES FOR COMPUTER SOFTWARE (U.S. CLS. 100 AND 101).

FIRST USE 9-30-2010; IN COMMERCE 9-30-2010.

3,998,383. MICHAEL S. FREAS AND NANCY L. FREAS JOINT VENTURE, THE, HEATH, OH. SN 77-168,468. PUB. 11-16-2010, FILED 4-29-2007.

Serenity, Grace and Speed

THE MARK CONSISTS OF STANDARD CHARACTERS WITHOUT CLAIM TO ANY PARTICULAR FONT, STYLE, SIZE, OR COLOR.

CLASS 16—PAPER GOODS AND PRINTED MATTER

FOR ART PRINTS (U.S. CLS. 2, 5, 22, 23, 29, 37, 38 AND 50).

FIRST USE 6-1-2007; IN COMMERCE 6-1-2007.

CLASS 25—CLOTHING

FOR SHORT-SLEEVED OR LONG-SLEEVED T-SHIRTS (U.S. CLS. 22 AND 39).

FIRST USE 6-1-2007; IN COMMERCE 6-1-2007.

3,998,387. SIERRA HEALTHSTYLES LLC, TUCSON, AZ. SN 77-181,628. PUB. 3-4-2008, FILED 5-15-2007.



OWNER OF U.S. REG. NOS. 2,195,695 AND 3,300,221. THE MARK CONSISTS OF THE LETTER "I" IN STYLIZED FORM.

CLASS 35—ADVERTISING AND BUSINESS

FOR REAL ESTATE MARKETING SERVICES IN THE FIELD OF HOMES (U.S. CLS. 100, 101 AND 102). FIRST USE 5-13-2011; IN COMMERCE 5-13-2011.

CLASS 36—INSURANCE AND FINANCIAL

FOR REAL ESTATE MANAGEMENT AND CONSULTATION SERVICES (U.S. CLS. 100, 101 AND 102). FIRST USE 5-13-2011; IN COMMERCE 5-13-2011.

3,998,388. LADY DIBBLE LLC, PLAINFIELD, NJ. SN 77-182,059. PUB. 3-18-2008, FILED 5-16-2007.

LADY DIBBLE

THE MARK CONSISTS OF STANDARD CHARACTERS WITHOUT CLAIM TO ANY PARTICULAR FONT, STYLE, SIZE, OR COLOR.

THE NAME "LADY DIBBLE" DOES NOT IDENTIFY A LIVING INDIVIDUAL.

CLASS 16—PAPER GOODS AND PRINTED MATTER

FOR PRINTED MATTER, NAMELY, A SERIES OF FICTION BOOKS AND CHILDREN'S BOOKS FOR CHILDREN OF ALL AGES; CHILDREN'S COLORING BOOKS AND ACTIVITY BOOKS, BOOKMARKS (U.S. CLS. 2, 5, 22, 23, 29, 37, 38 AND 50). FIRST USE 6-9-2011; IN COMMERCE 6-9-2011.

CLASS 41—EDUCATION AND ENTERTAINMENT

FOR RADIO ENTERTAINMENT SERVICES, NAMELY, RADIO PROGRAMS FEATURING PERFORMANCES BY AN AUTHOR AND STORYTELLER, AND RADIO PROGRAMS HOSTED BY AN AUTHOR AND STORYTELLER; TELEVISION ENTERTAINMENT SERVICES, NAMELY, ON GOING TELEVISION PROGRAMS FEATURING CHILDREN'S STORIES HOSTED BY AN AUTHOR AND STORYTELLER; ENTERTAINMENT SERVICES, NAMELY, PERSONAL APPEARANCES BY AN AUTHOR AND STORYTELLER ON RADIO, TELEVISION, AT PUBLIC LIBRARIES, AND IN MOVIES; ENTERTAINMENT SERVICES, NAMELY, LIVE, TELEVISED APPEARANCES BY A PROFESSIONAL ENTERTAINER (U.S. CLS. 100, 101 AND 107).

FIRST USE 6-9-2011; IN COMMERCE 6-9-2011.

3,998,396. ASCENDANT MARKETING & MEDIA, LLC, LONG BEACH, CA. SN 77-205,604. PUB. 7-13-2010, FILED 6-13-2007.

KANDY

THE MARK CONSISTS OF STANDARD CHARACTERS WITHOUT CLAIM TO ANY PARTICULAR FONT, STYLE, SIZE, OR COLOR.

CLASS 35—ADVERTISING AND BUSINESS

FOR PROMOTIONAL SERVICES, NAMELY, PROMOTION USING AUDIOVISUAL MEDIA; PROMOTIONAL SERVICES, NAMELY, PROMOTION USING AUDIOVISUAL MEDIA IN THE NATURE OF ONLINE INTERNET MEDIA AND VIDEO STREAMING; PROVIDING MARKETING AND PROMOTION OF SPECIAL EVENTS; PROVIDING ON-LINE REGISTRATION SERVICES FOR EVENTS IN THE NATURE OF DESTINATION EVENTS, CRUISE SHIP CHARTERS, HOTEL AND CASINO PARTIES, PRIVATE MANSION PARTIES, PARTIES IN AIRPLANES, PARTIES UNDER TENTS, PARTIES AND MUSIC IN CONCERT ARENAS AND OUTDOOR AMPHITHEATERS; EMPLOYMENT HIRING, RECRUITING, PLACEMENT, STAFFING AND CAREER NETWORKING SERVICES; EMPLOYMENT STAFFING IN THE FIELD OF ENTERTAINMENT EVENTS; BUSINESS MANAGEMENT FOR ENTERTAINMENT EVENTS (U.S. CLS. 100, 101 AND 102).

FIRST USE 5-31-2006; IN COMMERCE 5-31-2006.

CLASS 38—COMMUNICATION

FOR VIDEO STREAMING SERVICES VIA THE INTERNET FEATURING AUDIO VISUAL FILMS AND TELEVISION PROGRAMS (U.S. CLS. 100, 101 AND 104).

FIRST USE 7-1-2006; IN COMMERCE 7-1-2006.

CLASS 41—EDUCATION AND ENTERTAINMENT

FOR ARRANGING OF BEAUTY CONTESTS, EXCLUDING EVENTS AT NIGHT CLUBS; ARRANGING FOR TICKET RESERVATIONS AND BOOKING OF SEATS FOR SHOWS AND OTHER ENTERTAINMENT EVENTS, THE FOREGOING EXCLUDING EVENTS AT NIGHT CLUBS; MODELING FOR ARTISTS; PHOTOGRAPHY SERVICES; PROVIDING INFORMATION IN THE FIELDS OF ADULT MOTION PICTURES VIA A GLOBAL COMPUTER NETWORK; PROVIDING NON-DOWNLOADABLE ON-GOING AUDIO VISUAL FILMS AND TELEVISION PROGRAMS VIA VIDEO ON DEMAND, THE INTERNET, TELEVISION BROADCAST, CABLE TELEVISION, BROADBAND, AND MOBILE DEVICES (U.S. CLS. 100, 101 AND 107).

FIRST USE 5-31-2006; IN COMMERCE 5-31-2006.

3,998,399. STEFFE, CYNTHIA, NEW YORK, NY. SN 77-225,815. PUB. 3-4-2008, FILED 7-10-2007.

AVA ROSE

THE MARK CONSISTS OF STANDARD CHARACTERS WITHOUT CLAIM TO ANY PARTICULAR FONT, STYLE, SIZE, OR COLOR.

THE NAME(S), PORTRAIT(S), AND/OR SIGNATURE(S) SHOWN IN THE MARK IDENTIFIES "AVA ROSE", WHOSE CONSENT(S) TO REGISTER IS SUBMITTED.

CLASS 14—JEWELRY

FOR JEWELRY, NAMELY, BRACELETS, NECKLACES (U.S. CLS. 2, 27, 28 AND 50).

FIRST USE 9-12-2009; IN COMMERCE 9-12-2009.

CLASS 25—CLOTHING

FOR APPAREL FOR WOMEN, NAMELY, BLOUSES, KNIT TOPS, T-SHIRTS, SHIRTS, SKIRTS, PANTS, SWEATERS, CARDIGANS, BLAZERS, JACKETS, COATS, SUITS, DRESSES, SLEEPWEAR, SCARVES, SHAWLS, HEADWEAR, NAMELY, HATS (U.S. CLS. 22 AND 39).

FIRST USE 9-12-2009; IN COMMERCE 9-12-2009.

3,998,413. VIRGIN AMERICA INC., BURLINGAME, CA. SN 77-272,426. PUB. 3-4-2008, FILED 9-5-2007.

ELEVATE

THE MARK CONSISTS OF STANDARD CHARACTERS WITHOUT CLAIM TO ANY PARTICULAR FONT, STYLE, SIZE, OR COLOR.

CLASS 35—ADVERTISING AND BUSINESS

FOR AIR TRANSPORTATION SERVICES IN THE NATURE OF A FREQUENT FLYER PROGRAM; PROMOTING TRAVEL SERVICES THROUGH THE ADMINISTRATION OF INCENTIVE AWARDS PROGRAMS; PROMOTING THE GOODS AND SERVICES OF OTHERS BY MEANS OF AN INCENTIVE AWARDS PROGRAMS, WHEREBY PURCHASE POINTS ARE AWARDED AND CAN THEN BE REDEEMED FOR TRAVEL, MERCHANDISE, OR OTHER SERVICES; PROMOTING TRAVEL SERVICES, CREDIT CARD USE, CAR RENTALS, AND HOTEL ACCOMMODATIONS THROUGH THE ADMINISTRATION OF AWARD PROGRAMS; BONUS PROGRAM FOR FREQUENT AIR TRAVELERS, NAMELY, PRIORITY BOARDING CHECK-IN, SEATING AND RESERVATION SERVICES, TICKET UPGRADES, AND AUGMENTED FREQUENT FLYER MILEAGE (U.S. CLS. 100, 101 AND 102).

FIRST USE 7-18-2007; IN COMMERCE 7-18-2007.

CLASS 36—INSURANCE AND FINANCIAL

FOR CREDIT CARD SERVICES (U.S. CLS. 100, 101 AND 102).

FIRST USE 10-28-2008; IN COMMERCE 10-29-2008.

3,998,419. COMCAST CORPORATION, PHILADELPHIA, PA. SN 77-282,534. PUB. 2-26-2008, FILED 9-18-2007.

CATCH UP

THE MARK CONSISTS OF STANDARD CHARACTERS WITHOUT CLAIM TO ANY PARTICULAR FONT, STYLE, SIZE, OR COLOR.

CLASS 38—COMMUNICATION

FOR VIDEO-ON-DEMAND TRANSMISSION SERVICES (U.S. CLS. 100, 101 AND 104).

FIRST USE 4-29-2011; IN COMMERCE 4-29-2011.

CLASS 41—EDUCATION AND ENTERTAINMENT

FOR PROVISION OF NON-DOWNLOADABLE FILMS AND TV PROGRAMMES VIA A VIDEO-ON-DEMAND SERVICE (U.S. CLS. 100, 101 AND 107).

FIRST USE 4-29-2011; IN COMMERCE 4-29-2011.

3,998,443. DPE LABEL HOLDING CORP., BROOKLYN, NY. SN 77-319,724. PUB. 2-17-2009, FILED 11-2-2007.

DPHONE

THE MARK CONSISTS OF STANDARD CHARACTERS WITHOUT CLAIM TO ANY PARTICULAR FONT, STYLE, SIZE, OR COLOR.

CLASS 36—INSURANCE AND FINANCIAL

FOR PREPAID TELECOMMUNICATIONS CALLING CARD SERVICES; TELEPHONE CALLING CARD SERVICES (U.S. CLS. 100, 101 AND 102).

FIRST USE 5-8-2011; IN COMMERCE 5-8-2011.

CLASS 38—COMMUNICATION

FOR TELEPHONE TELECOMMUNICATIONS SERVICES PROVIDED VIA PREPAID TELEPHONE CALLING CARDS; TELECOMMUNICATION SERVICES, NAMELY, LOCAL AND LONG DISTANCE TRANSMISSION OF VOICE, DATA, GRAPHICS BY MEANS OF TELEPHONE, TELEGRAPHIC, CABLE, AND SATELLITE TRANSMISSIONS (U.S. CLS. 100, 101 AND 104).

FIRST USE 5-8-2011; IN COMMERCE 5-8-2011.

3,998,448. WABCO IP HOLDINGS LLC, PISCATAWAY, NJ. SN 77-337,816. PUB. 3-24-2009, FILED 11-27-2007.

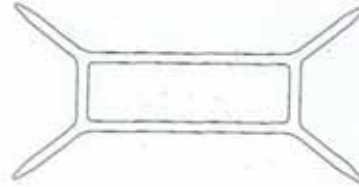

3,998,446. TRUMP, DONALD J., NEW YORK, NY. SN 77-326,858. PUB. 6-17-2008, FILED 11-12-2007.

THE RIVER WALK SHOPS AT
TRUMP INTERNATIONAL

THE MARK CONSISTS OF STANDARD CHARACTERS WITHOUT CLAIM TO ANY PARTICULAR FONT, STYLE, SIZE, OR COLOR.

NO CLAIM IS MADE TO THE EXCLUSIVE RIGHT TO USE "SHOPS", APART FROM THE MARK AS SHOWN.

CLASS 35—ADVERTISING AND BUSINESS

FOR MANAGEMENT OF RETAIL STORES AND RESTAURANTS FOR OTHERS (U.S. CLS. 100, 101 AND 102).

FIRST USE 4-19-2011; IN COMMERCE 4-19-2011.

CLASS 36—INSURANCE AND FINANCIAL

FOR LEASING OF REAL ESTATE, NAMELY, RESTAURANTS AND RETAIL STORES (U.S. CLS. 100, 101 AND 102).

FIRST USE 4-19-2011; IN COMMERCE 4-19-2011.

CLASS 9—ELECTRICAL AND SCIENTIFIC APPARATUS

FOR DIAGNOSTIC SYSTEMS USED TO MEASURE AND MONITOR THE OPERATIONAL STATUS OF FUNCTIONAL SYSTEMS IN LAND VEHICLES, NAMELY, DIAGNOSTIC CONTROLLERS COMPRISED OF A DISPLAY UNIT, PROGRAM CARDS, KEYBOARD, SOCKETS AND CONNECTING CABLES; ELECTRONIC CONTROL UNITS FOR THE PROCESSING AND THE EVALUATION OF SIGNALS GENERATED BY SENSORS WHICH MEASURE THE OPERATIONAL STATUS OF FUNCTIONAL SYSTEMS IN LAND VEHICLES; PRESSURE OPERATED SWITCHES; CONTROL SYSTEMS AND COMPONENTS THEREOF FOR HEATING, VENTILATING AND AIR CONDITIONING IN LAND VEHICLES, NAMELY, FAN MODULES, PULSE MOTORS, DC MOTORS, LIMIT SWITCHES, TEMPERATURE SENSORS, AND OPERATION CONSOLES; ELECTRONIC CONTROL APPARATUS COMPRISED OF SOFTWARE, SENSORS, ANTI-SKID SYSTEMS (ABS) AND PARTS THEREOF, ANTI-SLIP SYSTEMS (ASR) AND PARTS THEREOF OF LAND VEHICLES SOLD AS A UNIT; CONTROL APPARATUS FOR LAND VEHICLE DAMPERS, NAMELY, ELECTRONIC CONTROL UNITS AND SOFTWARE SOLD AS A UNIT; SYSTEMS AND COMPONENTS THEREOF FOR THE CONTROL OF THE MOVEMENT STABILITY OF LAND VEHICLES, NAMELY, SENSORS FOR VEHICLE SIGNALS, ELECTRONIC CONTROL UNITS AND SOFTWARE (U.S. CLS. 21, 23, 26, 36 AND 38).

FIRST USE 12-0-1992; IN COMMERCE 12-0-1992.

CLASS 12—VEHICLES

FOR PNEUMATICALLY AND HYDRAULICALLY OPERATED BRAKING SYSTEMS FOR LAND VEHICLES COMPRISING COMPRESSORS, PUMPS, AIR DRYERS, ANTI-FREEZE APPARATUS, RESERVOIRS, PIPES, FITTINGS, VALVES, COMBINED UNLOADER, PRESSURE REGULATORS, CIRCUIT PROTECTION VALVES, RELAY VALVES, SOLENOID VALVES, WAY VALVES, CONTROL VALVES, BRAKE CYLINDERS, OPERATING CYLINDERS, COUPLING HEADS, SLACK ADJUSTERS, PIPE FITTINGS, SERVO BRAKE UNITS COMPRISED OF A HYDRAULICALLY CONTROLLED PNEUMATIC CONTROL VALVE AND A DIFFERENTIAL CYLINDER UNDER PNEUMATIC PRESSURE WHICH TRANSMITS FORCE TO THE BRAKING MECHANISM OF LAND VEHICLES; WHEEL BRAKES AND COMPONENTS THEREOF, SOLD AS A UNIT; GEAR CONTROL SYSTEMS AND COMPONENTS THEREOF FOR LAND VEHICLES, NAMELY, WORKING CYLINDERS, VALVES, POSITION MEASURING SENSORS, ELECTRONIC CONTROL UNITS AND SOFTWARE, SOLD AS A UNIT; AIR SUSPENSION APPARATUS FOR LAND VEHICLES COMPRISING AIR SPRINGS, HEIGHT SENSORS, VALVES, ELECTRONIC CONTROL UNITS AND REMOTE CONTROL APPARATUS SOLD AS A UNIT; VALVES FOR LAND VEHICLE DAMPERS (U.S. CLS. 19, 21, 23, 31, 35 AND 44).

FIRST USE 12-0-1992; IN COMMERCE 12-0-1992.

3,998,452. INTERNATIONAL CODE COUNCIL, INC., WHITTIER, CA. SN 77-367,974. PUB. 2-16-2010, FILED 1-9-2008.



OWNER OF U.S. REG. NOS. 2,242,343, 3,259,781, AND OTHERS.

THE MARK CONSISTS OF THE STYLIZED LETTERS "ICC", THE STYLIZED WORDING "INTERNATIONAL CODE COUNCIL" AND THE DESIGN OF A PORTION OF A GLOBE FORMED BY LINES INSIDE A SHADED SQUARE. THE LETTERS "ICC" APPEAR IN THE TOP RIGHT OF THE SHADED SQUARE, AND THE WORDING "INTERNATIONAL CODE COUNCIL" APPEARS TO THE RIGHT OF THE SHADED SQUARE.

SEC. 2(F) AS TO "INTERNATIONAL CODE COUNCIL".

CLASS 37—CONSTRUCTION AND REPAIR

FOR PROVIDING AN ON-LINE SEARCHABLE DATABASE IN THE FIELDS OF BUILDING CONSTRUCTION; PROVIDING AN ON-LINE SEARCHABLE DATABASE IN THE FIELDS OF BUILDING CONSTRUCTION, MAINTENANCE AND REPAIR FOR SEARCHING AND RETRIEVING INFORMATION FROM RECOMMENDED BUILDING, CONSTRUCTION, AND SAFETY CODES, STANDARDS, REGULATIONS AND RULES (U.S. CLS. 100, 103 AND 106).

FIRST USE 4-1-2008; IN COMMERCE 4-1-2008.

CLASS 42—SCIENTIFIC AND COMPUTER SERVICES

FOR PROVIDING AN ON-LINE SEARCHABLE DATABASE IN THE FIELDS OF COMMERCIAL AND RESIDENTIAL BUILDING DESIGN FOR SEARCHING AND RETRIEVING INFORMATION FROM RECOMMENDED BUILDING, CONSTRUCTION AND SAFETY CODES, STANDARDS, REGULATIONS AND RULES; PROVIDING A WEBSITE THAT GIVES COMPUTER USERS THE ABILITY TO SUBSCRIBE TO ONLINE PUBLICATIONS PERMITTING SEARCHES OF RECOMMENDED BUILDING, CONSTRUCTION AND SAFETY CODES, STANDARDS, REGULATIONS AND RULES (U.S. CLS. 100 AND 101).

FIRST USE 4-1-2008; IN COMMERCE 4-1-2008.

CLASS 45—PERSONAL AND LEGAL SERVICES

FOR PROVIDING AN ON-LINE SEARCHABLE DATABASE OF RECOMMENDED LAWS AND REGULATIONS IN THE FIELDS OF BUILDING CODES AND STANDARDS, CONSTRUCTION CODES AND STANDARDS, AND SAFETY CODES AND STANDARDS (U.S. CLS. 100 AND 101).

FIRST USE 4-1-2008; IN COMMERCE 4-1-2008.

3,998,458. CONAGRA FOODS RDM, INC., OMAHA, NE. SN 77-382,792. PUB. 3-30-2010, FILED 1-29-2008.

BANQUET SELECT RECIPES

THE MARK CONSISTS OF STANDARD CHARACTERS WITHOUT CLAIM TO ANY PARTICULAR FONT, STYLE,

SIZE, OR COLOR.

OWNER OF U.S. REG. NOS. 680,882, 927,824, AND OTHERS.

NO CLAIM IS MADE TO THE EXCLUSIVE RIGHT TO USE "SELECT RECIPES", APART FROM THE MARK AS SHOWN.

CLASS 29—MEATS AND PROCESSED FOODS

FOR FROZEN PREPARED MEALS AND ENTREES CONSISTING PRIMARILY OF BEEF, PORK, POULTRY, SEAFOOD, OR VEGETABLES; FROZEN PREPARED CHICKEN, NAMELY, FRIED CHICKEN, SKINLESS CHICKEN PIECES, AND ROTISSERIE CHICKEN (U.S. CL. 46).

FIRST USE 6-2-2008; IN COMMERCE 6-2-2008.

CLASS 30—STAPLE FOODS

FOR FROZEN PREPARED MEALS AND ENTREES CONSISTING PRIMARILY OF PASTA (U.S. CL. 46).

FIRST USE 6-2-2008; IN COMMERCE 6-2-2008.

3,998,470. TAKANO CO., LTD., NAGANO 399-4301, JAPAN. SN 77-412,149. PUB. 10-19-2010, FILED 3-4-2008.

HeartWorks

THE MARK CONSISTS OF STANDARD CHARACTERS WITHOUT CLAIM TO ANY PARTICULAR FONT, STYLE, SIZE, OR COLOR.

CLASS 9—ELECTRICAL AND SCIENTIFIC APPARATUS

FOR APPARATUS FOR MEASURING WEIGHT, NAMELY, SCALES (U.S. CLS. 21, 23, 26, 36 AND 38).

FIRST USE 10-19-2000; IN COMMERCE 5-15-2009.

CLASS 10—MEDICAL APPARATUS

FOR APPARATUS FOR MEASURING BLOOD PRESSURE, BODY FAT, WEIGHT AND PULSE, NAMELY, BODY AND HEALTH MONITORING MACHINE FOR STANDARD MEASUREMENTS, NAMELY, WEIGHT, BODY MASS INDEX, BODY FAT CONTENT, HEART RATE AND BLOOD PRESSURE, TO BE OPERATED BY AN INDIVIDUAL IN PUBLIC INDOOR LOCATIONS; THERAPEUTIC MATTRESSES AND CUSHIONS FOR MEDICAL PURPOSES AND MEDICAL SUPPORTING DEVICES, NAMELY, A GRIP ATTACHABLE TO A WALL OR CEILING TO ASSIST AN INDIVIDUAL WITH MOBILITY (U.S. CLS. 26, 39 AND 44).

FIRST USE 10-19-2000; IN COMMERCE 5-15-2009.

CLASS 12—VEHICLES

FOR WHEELCHAIRS; CONVERTIBLE WHEEL CHAIRS AND WHEEL STRETCHERS FOR TRANSPORTING PATIENTS (U.S. CLS. 19, 21, 23, 31, 35 AND 44).

FIRST USE 10-19-2000; IN COMMERCE 5-15-2009.

CLASS 20—FURNITURE AND ARTICLES NOT OTHERWISE CLASSIFIED

FOR FURNITURE; SEATS BEING FURNITURE; CHAIRS; BEDS; TABLES; MATTRESSES; CUSHIONS (U.S. CLS. 2, 13, 22, 25, 32 AND 50).

FIRST USE 10-19-2000; IN COMMERCE 5-15-2009.

3,998,478. ABRAHAM, THOMAS G., MIAMI, FL. SN 77-430,961. PUB. 6-30-2009, FILED 3-25-2008.

USTAR 3D

THE MARK CONSISTS OF STANDARD CHARACTERS WITHOUT CLAIM TO ANY PARTICULAR FONT, STYLE, SIZE, OR COLOR.

NO CLAIM IS MADE TO THE EXCLUSIVE RIGHT TO USE "3D", APART FROM THE MARK AS SHOWN.

CLASS 40—MATERIAL TREATMENT

FOR PHOTOGRAPHIC COMPUTER IMAGING FOR OTHERS, NAMELY, NON-MEDICAL THREE-DIMENSIONAL IMAGING, SCANNING AND BODY SCANNING SERVICES FOR OTHERS; ELECTRONIC IMAGING, SCANNING, DIGITIZING, ALTERATION AND/OR RETOUCHING FOR OTHERS OF PHOTOGRAPHIC IMAGES, ARTWORK AND PAINTINGS (U.S. CLS. 100, 103 AND 106).

FIRST USE 0-0-2007; IN COMMERCE 0-0-2008.

CLASS 41—EDUCATION AND ENTERTAINMENT

FOR PHOTOGRAPHY SERVICES FOR OTHERS; PORTRAIT PHOTOGRAPHY SERVICES; DIGITAL IMAGING SERVICES, NAMELY, NON-MEDICAL THREE-DIMENSIONAL DIGITAL IMAGING OF THE HUMAN BODY FOR OTHERS; NON-MEDICAL THREE-DIMENSIONAL DIGITAL PHOTOGRAPHY SERVICES FOR OTHERS (U.S. CLS. 100, 101 AND 107).

FIRST USE 0-0-2007; IN COMMERCE 0-0-2008.

3,998,479. BRAVE NEW ROCKET LLC, CHESTNUT RIDGE, NY. SN 77-431,429. PUB. 11-3-2009, FILED 3-25-2008.

LET'S KNIT2GETHER

THE MARK CONSISTS OF STANDARD CHARACTERS WITHOUT CLAIM TO ANY PARTICULAR FONT, STYLE, SIZE, OR COLOR.

CLASS 9—ELECTRICAL AND SCIENTIFIC APPARATUS

FOR ELECTRONIC PUBLICATIONS, NAMELY, BOOKS, MAGAZINES, LEAFLETS, NEWSLETTERS, AND JOURNALS FEATURING INFORMATION ON KNITTING, CROCHETING, SPINNING, FIBER ARTS, YARNS, AND FIBERS RECORDED ON DIGITAL MEDIA (U.S. CLS. 21, 23, 26, 36 AND 38).

FIRST USE 9-1-2009; IN COMMERCE 9-1-2009.

CLASS 16—PAPER GOODS AND PRINTED MATTER

FOR PAPER BOOKS, MAGAZINES, LEAFLETS, NEWSLETTERS, AND JOURNALS ON THE SUBJECT OF KNITTING, CROCHETING, SPINNING, FIBER ARTS, YARNS AND FIBERS (U.S. CLS. 2, 5, 22, 23, 29, 37, 38 AND 50).

FIRST USE 9-1-2009; IN COMMERCE 9-2-2009.

CLASS 26—FANCY GOODS

FOR KNITTING KITS COMPRISED OF YARN, WOOL FIBER THREAD, CROCHET HOOKS, NEEDLES, KNITTING NEEDLES, SPINDLES, PATTERNS AND EMBELLISHMENT ITEMS, NAMELY, BUTTONS, ZIPPERS, SNAP FASTENERS, CLOTH PATCHES FOR CLOTHING AND SLIDE FASTENERS, ALL SOLD AS A UNIT (U.S. CLS. 37, 39, 40, 42 AND 50).

FIRST USE 7-22-2010; IN COMMERCE 7-22-2010.

CLASS 35—ADVERTISING AND BUSINESS

FOR BRICK-AND-MORTAR AND ONLINE RETAIL STORE SERVICES FEATURING SUPPLIES FOR KNITTING, CROCHET, FIBER SPINNING, AND FIBER ARTS, INCLUDING YARNS, TEXTILE FIBERS, FABRIC, NEEDLES, PATTERNS, KNITTING AND CROCHET ACCESSORIES, HOME DECORATION ACCESSORIES AND KNITTED APPAREL (U.S. CLS. 100, 101 AND 102).

FIRST USE 9-1-2009; IN COMMERCE 9-1-2009.

3,998,489. ABRAHAM, THOMAS G., CORAL GABLES, FL. SN 77-460,784. PUB. 7-7-2009, FILED 4-29-2008.



NO CLAIM IS MADE TO THE EXCLUSIVE RIGHT TO USE "3D", APART FROM THE MARK AS SHOWN.

THE COLOR(S) BLACK, WHITE, RED AND GRAY IS/ARE CLAIMED AS A FEATURE OF THE MARK.

THE MARK CONSISTS OF THE LETTER "U" IN THE COLOR BLACK TO THE LEFT OF A WHITE AND GRAY 5 POINT STAR TO THE LEFT OF THE NUMBER "3" IN THE COLOR RED TO THE LEFT OF THE LETTER "D" IN THE COLOR BLACK.

CLASS 40—MATERIAL TREATMENT

FOR PHOTOGRAPHIC COMPUTER IMAGING FOR OTHERS, NAMELY, NON-MEDICAL THREE-DIMENSIONAL IMAGING, SCANNING AND BODY SCANNING SERVICES FOR OTHERS; ELECTRONIC IMAGING, SCANNING, DIGITIZING, ALTERATION AND/OR RETOUCHING FOR OTHERS OF PHOTOGRAPHIC IMAGES, ARTWORK AND PAINTINGS (U.S. CLS. 100, 103 AND 106).

FIRST USE 0-0-2009; IN COMMERCE 3-22-2010.

CLASS 41—EDUCATION AND ENTERTAINMENT

FOR PHOTOGRAPHY SERVICES FOR OTHERS; PORTRAIT PHOTOGRAPHY SERVICES; DIGITAL IMAGING SERVICES, NAMELY, NON-MEDICAL THREE-DIMENSIONAL DIGITAL IMAGING OF THE HUMAN BODY FOR OTHERS; NON-MEDICAL THREE-DIMENSIONAL DIGITAL PHOTOGRAPHY SERVICES FOR OTHERS (U.S. CLS. 100, 101 AND 107).

FIRST USE 0-0-2009; IN COMMERCE 3-22-2010.

3,998,500. MIDWEST HARDWOOD CORPORATION, MAPLE GROVE, MN. SN 77-494,484. PUB. 3-9-2010, FILED 6-9-2008.

3,998,504. LIFELINE SCIENTIFIC, INC., ITASCA, IL. SN 77-522,517. PUB. 12-9-2008, FILED 7-15-2008.

UNISOL

WE MAKE GREEN EASY

THE MARK CONSISTS OF STANDARD CHARACTERS WITHOUT CLAIM TO ANY PARTICULAR FONT, STYLE, SIZE, OR COLOR.

CLASS 19—NON-METALLIC BUILDING MATERIALS

FOR NON-METALLIC BUILDING MATERIALS, NAMELY, HARDWOOD LUMBER, HARDWOOD PLYWOOD, HARDWOOD MOULDINGS, HARDWOOD SQUARES, SOFTWOOD LUMBER, SOFTWOOD PLYWOOD, SOFTWOOD MOULDINGS, WOOD VENEERS, LAMINATE FLOORING, MELAMINE LAMINATE FLOORING, PARTICLEBOARD, FIBERBOARD, MEDIUM DENSITY FIBERBOARD, WOOD FLOORING; WOOD FLOORING PARTS, NAMELY, SOLID AND TOP LAYERS FOR ENGINEERING; HARDWOOD DIMENSION, NAMELY, CUT-TO-SIZE SOLID PARTS, SHAPED PARTS, ROUGH SAWN-TO-WIDTH STRIPS AND PLANKS; WOODEN EDGE GLUED PANELS FOR CABINETS, DOORS, MILLWORK; LUMBER, NAMELY, CANTS FOR BLOCKING, STRINGERS, DECKING BOARDS, BRIDGE TIMBERS, BOARD ROAD, DRAG LINE MATS (U.S. CLS. 1, 12, 33 AND 50).
FIRST USE 12-1-2009; IN COMMERCE 12-1-2009.

CLASS 35—ADVERTISING AND BUSINESS

FOR DISTRIBUTORSHIPS IN THE FIELD OF NON-METALLIC BUILDING MATERIALS, NAMELY, HARDWOOD LUMBER, HARDWOOD PLYWOOD, HARDWOOD MOULDINGS, SOFTWOOD LUMBER, SOFTWOOD PLYWOOD, SOFTWOOD MOULDINGS, VENEERS, LAMINATES, MELAMINE LAMINATES, DECORATIVE FOILS, PARTICLEBOARD, FIBERBOARD, MEDIUM DENSITY FIBERBOARD, CABINET COMPONENTS, WOOD FLOORING, WOOD FLOORING PARTS, HARDWOOD DIMENSION, EDGE GLUED PANELS, HARDWOOD SQUARES, PALLET PARTS, CANTS (U.S. CLS. 100, 101 AND 102).
FIRST USE 2-1-2008; IN COMMERCE 2-1-2008.

CLASS 40—MATERIAL TREATMENT

FOR CUSTOM AND CONTRACT MANUFACTURING OF NON-METALLIC BUILDING MATERIALS, NAMELY, HARDWOOD LUMBER, HARDWOOD PLYWOOD, HARDWOOD MOULDINGS, SOFTWOOD LUMBER, SOFTWOOD PLYWOOD, SOFTWOOD MOULDINGS, VENEERS, LAMINATES, MELAMINE LAMINATES, DECORATIVE FOILS, PARTICLEBOARD, FIBERBOARD, MEDIUM DENSITY FIBERBOARD, CABINET COMPONENTS, WOOD FLOORING, WOOD FLOORING PARTS, HARDWOOD DIMENSION, EDGE GLUED PANELS, HARDWOOD SQUARES, PALLET PARTS, CANTS (U.S. CLS. 100, 103 AND 106).
FIRST USE 2-1-2008; IN COMMERCE 2-1-2008.

THE MARK CONSISTS OF STANDARD CHARACTERS WITHOUT CLAIM TO ANY PARTICULAR FONT, STYLE, SIZE, OR COLOR.

OWNER OF U.S. REG. NO. 2,523,074.

CLASS 1—CHEMICALS

FOR SOLUTIONS TO BE USED IN THE RECOVERY AND PRESERVATION OF ORGANS, TISSUES, AND CELLS FOR MEDICAL RESEARCH (U.S. CLS. 1, 5, 6, 10, 26 AND 46).
FIRST USE 10-18-2010; IN COMMERCE 10-18-2010.

CLASS 5—PHARMACEUTICALS

FOR SOLUTIONS TO BE USED IN THE RECOVERY AND PRESERVATION OF ORGANS, TISSUES, AND CELLS FOR TRANSPLANTS (U.S. CLS. 6, 18, 44, 46, 51 AND 52).
FIRST USE 10-18-2010; IN COMMERCE 10-18-2010.

3,998,511. TAMARAC MEDICAL, INC., CENTENNIAL, CO. SN 77-535,643. PUB. 11-30-2010, FILED 7-31-2008.

TAMARACMEDICAL

THE MARK CONSISTS OF STANDARD CHARACTERS WITHOUT CLAIM TO ANY PARTICULAR FONT, STYLE, SIZE, OR COLOR.

CLASS 10—MEDICAL APPARATUS

FOR BLOOD TESTING KITS CONSISTING PRIMARILY OF A LANCET, FILTER PAPER, GAUZE AND BANDAGES (U.S. CLS. 26, 39 AND 44).
FIRST USE 5-9-2011; IN COMMERCE 5-9-2011.

CLASS 42—SCIENTIFIC AND COMPUTER SERVICES

FOR MEDICAL LABORATORY SERVICES (U.S. CLS. 100 AND 101).
FIRST USE 2-0-2008; IN COMMERCE 2-0-2008.

3,998,514. ROCHESTER DAVIS, 80798 MUENCHEN, FED REP GERMANY. SN 77-542,151. PUB. 12-30-2008, FILED 8-8-2008.

It's all Cali

THE MARK CONSISTS OF STANDARD CHARACTERS WITHOUT CLAIM TO ANY PARTICULAR FONT, STYLE, SIZE, OR COLOR.

CLASS 25—CLOTHING

FOR A-SHIRTS; ATHLETIC APPAREL, NAMELY, SHIRTS, PANTS, JACKETS, FOOTWEAR, HATS AND CAPS, ATHLETIC UNIFORMS; BELTS; BIBS NOT OF CLOTH OR PAPER; CAPS; CHILDREN'S AND INFANTS' CLOTH BIBS; CHILDREN'S CLOTH EATING BIBS; CLOTH BIBS; CLOTH BIBS FOR ADULT DINERS; CLOTH BIBS FOR USE BY SENIOR CITIZENS OR PHYSICALLY- OR MENTALLY-CHALLENGED PERSONS; CLOTH DIAPERS; CLOTHING FOR WEAR IN JUDO PRACTICES; CLOTHING FOR WEAR IN WRESTLING GAMES; CLOTHING, NAMELY, ARM WARMERS; CLOTHING, NAMELY, FOLK COSTUMES; CLOTHING, NAMELY, HAND-WARMERS; CLOTHING, NAMELY, KHAKIS; CLOTHING, NAMELY, KNEE WARMERS; CLOTHING, NAMELY, NECK TUBES; CLOTHING, NAMELY, THOBES; CLOTHING, NAMELY, WRAP-AROUNDS; CORSETS; DUSTERS; EYESHADES; FOULARDS; HOODS; INFANT AND TODDLER ONE PIECE CLOTHING; INFANT CLOTH DIAPERS; JERSEYS; LEATHER BELTS; MANTLES; MUFFLERS; NON-DISPOSABLE CLOTH TRAINING PANTS; PAPER HATS FOR USE AS CLOTHING ITEMS; PARTS OF CLOTHING, NAMELY, GUSSETS FOR TIGHTS, GUSSETS FOR STOCKINGS, GUSSETS FOR BATHING SUITS, GUSSETS FOR UNDERWEAR, GUSSETS FOR LEOTARDS AND GUSSETS FOR FOOTLETS; PERSPIRATION ABSORBENT UNDERWEAR CLOTHING; SHIRTS; SHORT SETS; SHOULDER WRAPS; SWADDLING CLOTHES; TIES; TOPS; TRAVEL CLOTHING CONTAINED IN A PACKAGE COMPRISING REVERSIBLE JACKETS, PANTS, SKIRTS, TOPS AND A BELT OR SCARF; TRIATHLON CLOTHING, NAMELY, TRIATHLON TIGHTS, TRIATHLON SHORTS, TRIATHLON SINGLET, TRIATHLON SHIRTS, TRIATHLON SUITS; UNDERARM CLOTHING SHIELDS; WEARABLE GARMENTS AND CLOTHING, NAMELY, SHIRTS; WRAPS (U.S. CLS. 22 AND 39).

FIRST USE 1-30-2009; IN COMMERCE 1-30-2009.

CLASS 35—ADVERTISING AND BUSINESS

FOR ADVERTISING AGENCIES; ADVERTISING AGENCIES PROVIDING THE STRATEGY, DESIGN AND EXECUTION OF PROGRAMS TO PROMOTE BUSINESSES IN THE FOOD AND FOODSERVICE INDUSTRIES; ADVERTISING AGENCIES, NAMELY, PROMOTING THE GOODS AND SERVICES OF OTHERS; ADVERTISING AGENCY SPECIALIZING IN THE DESIGN AND EXECUTION OF WORD OF MOUTH, VIRAL, BUZZ AND EXPERIENTIAL MARKETING PROGRAMS; ADVERTISING AND ADVERTISEMENT SERVICES; ADVERTISING AND BUSINESS ADVICE RELATING TO TELEMATICS' SERVICES; ADVERTISING AND BUSINESS MANAGEMENT CONSULTANCY; ADVERTISING AND BUSINESS SERVICES, NAMELY, SECURING AIRTIME ON ALL FORMS OF MEDIA COMMUNICATIONS STATIONS, SYSTEMS, NETWORKS, AND SERVICES FOR THE PURPOSE OF PROMOTING THE GOODS AND SERVICES OF OTHERS; ADVERTISING AND COMMERCIAL INFORMATION SERVICES, VIA THE INTERNET; ADVERTISING AND MARKETING; ADVERTISING AND PROMOTION SERVICES AND RELATED CONSULTING; ADVERTISING AND PROMOTIONAL SERVICES; ADVERTISING AND PUBLICITY SERVICES; ADVERTISING AND PUBLICITY SERVICES, NAMELY, PROMOTING THE GOODS, SERVICES, BRAND IDENTITY AND COMMERCIAL INFORMATION AND NEWS OF THIRD PARTIES THROUGH PRINT, AUDIO, VI-

DEO, DIGITAL AND ON-LINE MEDIUM; ADVERTISING BUSINESS ESPECIALLY IN THE FIELD OF TELEMATIC AND TELEPHONE NETWORKS; ADVERTISING BY TRANSMISSION OF ON-LINE PUBLICITY FOR THIRD PARTIES THROUGH ELECTRONIC COMMUNICATIONS NETWORKS; ADVERTISING CONSULTATION; ADVERTISING FLYER DISTRIBUTION; ADVERTISING PARTICULARLY SERVICES FOR THE PROMOTION OF GOODS; ADVERTISING RELATING TO PHARMACEUTICAL PRODUCTS AND IN-VIVO IMAGING PRODUCTS; ADVERTISING SERVICES; ADVERTISING SERVICES FOR PROMOTING THE BROKERAGE OF STOCKS AND OTHER SECURITIES; ADVERTISING SERVICES OF A RADIO AND TELEVISION ADVERTISING AGENCY; ADVERTISING SERVICES RELATING TO SANDWICHES; ADVERTISING SERVICES, FOR THIRD PARTIES, IN CONNECTION WITH THE COMMERCIALIZATION AND SALE OF PERFUMERY AND COSMETIC ARTICLES, PRODUCTS FOR HOUSEHOLD PURPOSES, OPTICAL PRODUCTS, CLOCKS AND TIMEPIECES, JEWELLERY, FURNISHING ARTICLES; ADVERTISING SERVICES, NAMELY, COST-PER-ACTION ON-LINE ADVERTISING; ADVERTISING SERVICES, NAMELY, CREATING CORPORATE AND BRAND IDENTITY FOR OTHERS; ADVERTISING SERVICES, NAMELY, CREATING CORPORATE LOGOS FOR OTHERS; ADVERTISING SERVICES, NAMELY, PRODUCTION OF SPECIAL EFFECTS INCLUDING MODEL-MAKING SERVICES, COMPUTER-GENERATED IMAGERY AND COMPUTER-GENERATED GRAPHICS FOR THE PRODUCTION OF COMMERCIALS; ADVERTISING SERVICES, NAMELY, PROMOTING AND MARKETING THE GOODS AND SERVICES OF OTHERS IN THE FIELD OF UPSCALE CHOICES SUCH AS CULTURAL EVENTS, RESTAURANTS, SHOPPING, AND TRAVEL VIA PRINT AND ELECTRONIC MEDIA; ADVERTISING SERVICES, NAMELY, PROMOTING AND MARKETING THE GOODS AND SERVICES OF OTHERS THROUGH ALL PUBLIC COMMUNICATION MEANS; ADVERTISING SERVICES, NAMELY, PROMOTING PROPERTIES FOR SALE BY OWNER VIA THE INTERNET; ADVERTISING SERVICES, NAMELY, PROMOTING THE FOOD AND WINE OF OTHERS; ADVERTISING SERVICES, NAMELY, PROMOTING THE GIFT CARDS OF OTHERS; ADVERTISING SERVICES, NAMELY, PROMOTING THE SANDWICHES OF OTHERS; ADVERTISING SERVICES, NAMELY, PROVIDING ADVERTISING SPACE IN A PERIODICAL; ADVERTISING SERVICES, PUBLIC RELATIONS AND MARKETING SERVICES, NAMELY, PROMOTING AND MARKETING THE GOODS AND SERVICES OF OTHERS THROUGH ALL PUBLIC COMMUNICATION MEANS; ADVERTISING THROUGH ALL PUBLIC COMMUNICATION MEANS; ADVERTISING VIA ELECTRONIC MEDIA AND SPECIFICALLY THE INTERNET; ADVERTISING, INCLUDING PROMOTION OF PRODUCTS AND SERVICES OF THIRD PARTIES THROUGH SPONSORING ARRANGEMENTS AND LICENSE AGREEMENTS RELATING TO INTERNATIONAL SPORTS' EVENTS; ADVERTISING, INCLUDING PROMOTION RELATING TO THE SALE OF ARTICLES AND SERVICES FOR THIRD PARTIES BY THE TRANSMISSION OF ADVERTISING MATERIAL AND THE DISSEMINATION OF ADVERTISING MESSAGES ON COMPUTER NETWORKS; ADVERTISING, MARKETING AND PROMOTION SERVICES; ADVERTISING, MARKETING AND PROMOTIONAL SERVICES FOR AUTOMOTIVE DEALERSHIPS; ADVERTISING, MARKETING AND PROMOTIONAL SERVICES FOR THE DONATION OF HUMAN BLOOD THAT EXACTLY MATCHES THE BLOOD TYPE OF INDIVIDUALS NEEDING TRANSFUSIONS; ADVERTISING, MARKETING AND PROMOTIONAL SERVICES RELATED TO ALL INDUSTRIES FOR THE PURPOSE OF FACILITATING NETWORKING AND SOCIALIZING OPPORTUNITIES FOR BUSINESS PURPOSES; ADVERTISING, PROMOTION AND MARKETING SERVICES IN THE NATURE OF E-MAIL BLAST CAMPAIGNS FOR OTHERS; AGENCIES FOR ADVERTISING TIME AND SPACE; ARRANGING AND CONDUCTING OF FAIRS AND EXHIBITIONS FOR BUSINESS AND ADVERTISING PURPOSES; BUSINESS MANAGEMENT AND CONSULTING SERVICES FOR THE HEALTH CARE INDUSTRY, NAMELY, CUSTOMER SERVICE, ACCOUNTING SERVICES, AND WEB-BASED ADVERTISING AND MARKETING SERVICES; CINEMA ADVERTISING; COMPILATION OF ADVERTISEMENTS FOR USE AS WEB PAGES ON THE INTERNET; CONSUMER LOYALTY SERVICES FOR COMMERCIAL,

PROMOTIONAL, AND/OR ADVERTISING PURPOSES, NAMELY, ADMINISTRATION OF FREQUENT FLYER PROGRAM THAT ALLOWS MEMBERS TO REDEEM MILES FOR POINTS OR AWARDS OFFERED BY OTHER LOYALTY PROGRAMS; COOPERATIVE ADVERTISING AND MARKETING; COOPERATIVE ADVERTISING AND MARKETING SERVICES BY WAY OF SOLICITATION, CUSTOMER SERVICE AND PROVIDING MARKETING INFORMATION VIA WEB SITES ON A GLOBAL COMPUTER NETWORK; CREATING AND UPDATING ADVERTISING MATERIAL; CREATION OF MARKETING TOOLS DESIGNED TO INCREASE A CLIENT COMPANY'S KNOWLEDGE OF CUSTOMER NEEDS, AND ITS COMPETITORS' PRODUCTS AND SERVICES, PRICING, ADVERTISING STRATEGY AND SALES STRATEGY; CUSTOMER LOYALTY SERVICES AND CUSTOMER CLUB SERVICES, FOR COMMERCIAL, PROMOTIONAL AND/OR ADVERTISING PURPOSES; DESIGN OF ADVERTISING FLYERS FOR OTHERS; DESIGN OF ADVERTISING MATERIALS FOR OTHERS; DESIGN OF INTERNET ADVERTISING; DEVELOPMENT, OPERATION AND ADMINISTRATION OF DIGITAL SIGNAGE SYSTEMS AND DIGITAL ADVERTISING SYSTEMS FOR OTHERS, NAMELY, PROVIDING ADVERTISING SPACE BY ELECTRONIC MEANS AND GLOBAL COMPUTER INFORMATION NETWORKS; DIRECT MAIL ADVERTISING; DIRECT MARKETING ADVERTISING FOR OTHERS; DISPLAYING ADVERTISEMENTS FOR OTHERS; DISSEMINATION OF ADVERTISEMENTS; DISSEMINATION OF ADVERTISEMENTS AND OF ADVERTISING MATERIAL; DISSEMINATION OF ADVERTISING FOR OTHERS VIA AN ON-LINE COMMUNICATIONS NETWORK ON THE INTERNET; DISSEMINATION OF ADVERTISING FOR OTHERS VIA THE INTERNET; DISSEMINATION OF ADVERTISING MATERIAL; DISSEMINATION OF ADVERTISING MATTER; DISSEMINATION OF ADVERTISING, SCHEDULING AND MANAGING OF TRAINING COURSES AND PROGRAMS FOR OTHERS VIA A GLOBAL COMPUTER NETWORK; DISTRIBUTION AND DISSEMINATION OF ADVERTISING MATERIALS; DISTRIBUTION OF ADVERTISEMENTS AND COMMERCIAL ANNOUNCEMENTS; DISTRIBUTION OF ADVERTISING MAIL AND OF ADVERTISING SUPPLEMENTS ATTACHED TO REGULAR EDITIONS; DISTRIBUTION OF PRODUCTS FOR ADVERTISING PURPOSES; ELECTRONIC BILLBOARD ADVERTISING; ELECTRONIC COMMERCE SERVICES, NAMELY, PROVIDING INFORMATION ABOUT PRODUCTS VIA TELECOMMUNICATION NETWORKS FOR ADVERTISING AND SALES PURPOSES; ENTERTAINMENT MARKETING SERVICES, NAMELY, MARKETING, PROMOTION AND ADVERTISING FOR INDEPENDENT RECORDING ARTISTS; INTERNET ADVERTISING SERVICES; ISSUING AND UPDATING OF ADVERTISING TEXTS; LAYOUT SERVICES FOR ADVERTISING PURPOSES; MARKETING AND ADVERTISING SERVICES FOR AUTOMOBILE DEALERSHIPS; MARKETING, PROMOTIONAL AND ADVERTISING SERVICES PROVIDED BY MOBILE TELEPHONE CONNECTIONS; MEDIA BUYING ADVICE, NAMELY, ADVISING THE CLIENT HOW MUCH MEDIA TIME, AND AT WHAT TIMES THE CLIENT SHOULD BE PURCHASING ADVERTISING; MEDIA PLANNING, NAMELY, ADVISING THE CLIENT ON THE CORRECT TIMES AND STATIONS TO ADVERTISE BASED ON MEDIA ANALYSIS OF THE MARKET FOR THAT MEDIA; MEDIA PRODUCTION LOCATION SCOUTING SERVICES FOR ADVERTISING PURPOSES; MEDIATION OF ADVERTISING; MODELING FOR ADVERTISING OR SALES PROMOTION; MODELING SERVICES FOR ADVERTISING OR SALES PROMOTION; MUSIC SELECTION SERVICES FOR USE IN ADVERTISING; ON-LINE ADVERTISING AND MARKETING SERVICES; ON-LINE ADVERTISING ON COMPUTER COMMUNICATION NETWORKS; ORGANIZATION AND HOLDING OF FAIRS FOR COMMERCIAL OR ADVERTISING PURPOSES; ORGANIZING EXHIBITIONS FOR COMMERCIAL OR ADVERTISING PURPOSES; ORGANIZING EXHIBITIONS FOR COMMERCIAL OR ADVERTISING PURPOSES; OUT-OF-HOME ADVERTISING SERVICES, NAMELY, RENTAL OF ADVERTISING SPACE, AND PREPARING AND PLACING ADVERTISEMENTS FOR OTHERS; PAY PER CLICK (PPC) ADVERTISING MANAGEMENT SERVICES; PLACING ADVERTISEMENTS FOR OTHERS; PLANNING AND CONDUCTING OF TRADE FAIRS, EXHIBITIONS AND PRESENTATIONS FOR ECONOMIC OR ADVERTISING PURPOSES; PREPARATION AND REALIZATION OF

MEDIA AND ADVERTISING PLANS AND CONCEPTS; PREPARATION OF CUSTOM ADVERTISEMENTS FOR OTHERS; PREPARATION OF CUSTOM OR NON-CUSTOM ADVERTISING FOR BUSINESSES FOR DISSEMINATION VIA THE WEB, CD OR DVD FOR OPTIONAL UPLOAD OR DOWNLOAD TO A COMPUTER; PREPARING ADVERTISEMENTS FOR OTHERS; PREPARING AND PLACING ADVERTISEMENTS FOR OTHERS; PREPARING AND PLACING OF ADVERTISEMENTS; PREPARING AND PLACING OUTDOOR ADVERTISEMENTS FOR OTHERS; PREPARING AUDIOVISUAL PRESENTATIONS FOR USE IN ADVERTISING; PREPARING SPEECHES AND ORAL PRESENTATIONS FOR OTHERS FOR USE IN ADVERTISING; PROCESSING TELEPHONE INQUIRIES REGARDING ADVERTISED GOODS AND SERVICES; PROMOTING THE GOODS AND SERVICES OF OTHERS BY DISTRIBUTING ADVERTISING MATERIALS THROUGH A VARIETY OF METHODS; PROMOTING THE GOODS AND SERVICES OF OTHERS BY PREPARING AND PLACING ADVERTISEMENTS IN AN ELECTRONIC MAGAZINE ACCESSED THROUGH A GLOBAL COMPUTER NETWORK; PROMOTING, ADVERTISING AND MARKETING OF THE ON-LINE WEB SITES OF OTHERS; PROMOTION, ADVERTISING AND MARKETING OF ON-LINE WEB SITES; PROVIDING A SEARCHABLE ONLINE ADVERTISING GUIDE FEATURING THE GOODS AND SERVICES OF OTHER ON-LINE VENDORS ON THE INTERNET; PROVIDING A WEB SITE AT WHICH FITNESS PROFESSIONALS AND FACILITIES CAN POST PROMOTIONAL PROFILES AND RESPOND TO ADVERTISEMENTS FOR THEIR SERVICES; PROVIDING A WEB SITE THAT ENABLES USERS TO POST ITEMS FOR SALE THROUGH ONLINE CLASSIFIED ADVERTISEMENTS; PROVIDING A WEB SITE WHICH FEATURES ADVERTISEMENTS FOR THE GOODS AND SERVICES OF OTHERS ON A GLOBAL COMPUTER NETWORK; PROVIDING ADVERTISING SERVICES USING 3D AND ANIMATION DESIGNS; PROVIDING ADVERTISING, MARKETING AND PROMOTIONAL SERVICES FOR THE PHARMACEUTICAL AND MEDICAL INDUSTRY; PROVIDING ADVERTISING, MARKETING AND PROMOTIONAL SERVICES FOR THE PHARMACEUTICAL AND MEDICAL PRODUCTS OF OTHERS; PROVIDING AN INTERNET WEB SITE FOR CLASSIFIED ADVERTISING TO BUY AND SELL UKRAINIAN RELATED WARES, ART, ANTIQUES, BOOKS, EMBROIDERY, COSTUMES, COLLECTIBLES, INSTRUMENTS, MEMORABILIA AND OTHER ONE-OF-A-KIND ITEMS; PROVIDING AN INTERNET WEB SITE TO ADVERTISE SERVICES OF INTEREST TO THE UKRAINIAN COMMUNITY IN THE UNITED STATES OF AMERICA AND CANADA AND TO ADVERTISE SERVICES PROVIDED BY INDIVIDUALS OF UKRAINIAN ORIGIN; PROVIDING AND RENTAL OF ADVERTISING SPACE ON THE INTERNET; PROVIDING SPACE AT A WEB SITE FOR THE ADVERTISEMENT OF THE GOODS AND SERVICES OF OTHERS; PROVIDING TELEVISION ADVERTISING FOR OTHERS; PROVISION OF ADVERTISING SPACE BY ELECTRONIC MEANS AND GLOBAL INFORMATION NETWORKS; PROVISION OF SPACE ON WEBSITES FOR ADVERTISING GOODS AND SERVICES; PUBLISHING OF ADVERTISING TEXTS; REAL ESTATE ADVERTISING SERVICES; RECRUITMENT ADVERTISEMENT SERVICES, NAMELY, POSTING OF CLINICAL TRIAL NOTICES FOR THE PURPOSE OF RECRUITING PATIENTS FOR PARTICIPATION IN CLINICAL TRIALS FOR THE TESTING OF DRUGS; RENTAL OF ADVERTISEMENT SPACE AND ADVERTISING MATERIAL; RENTAL OF ADVERTISING SPACE; RENTAL OF ADVERTISING SPACE ON WEB SITES; RENTAL OF SIGNS FOR ADVERTISING PURPOSES; RENTING OF ADVERTISING SPACES; SERVICES RENDERED BY A FRANCHISOR, NAMELY, ASSISTANCE IN THE RUNNING OR MANAGEMENT OF INDUSTRIAL OR COMMERCIAL ENTERPRISES; SERVICES TO DETERMINE THE AUDIENCE AFFECTED BY ADVERTISEMENTS; TELEVISION ADVERTISING AGENCIES; TRACKING, LOCATING AND MONITORING OF VEHICLES, MARITIME VESSELS AND AIRCRAFT SERVICES FOR COMMERCIAL PURPOSES (U.S. CLS. 100, 101 AND 102).
FIRST USE 1-30-2009; IN COMMERCE 1-30-2009.

3,998,515. FRIESENS CORPORATION, ALTONA, MB, CANADA. SN 77-545,558. PUB. 3-2-2010, FILED 8-13-2008.

FRIESENS AMERICA

THE MARK CONSISTS OF STANDARD CHARACTERS WITHOUT CLAIM TO ANY PARTICULAR FONT, STYLE, SIZE, OR COLOR.

NO CLAIM IS MADE TO THE EXCLUSIVE RIGHT TO USE "AMERICA", APART FROM THE MARK AS SHOWN.

CLASS 16—PAPER GOODS AND PRINTED MATTER

FOR BOOKS IN THE FIELD OF COOKBOOKS, YEAR-BOOKS, SPORTS BOOKS, AUTOBIOGRAPHY BOOKS, BIOGRAPHY BOOKS, MEDICAL BOOKS, CHILDRENS BOOKS, COFFEE TABLE BOOKS, PICTORIAL BOOKS, PHOTOGRAPHY BOOKS AND HISTORY BOOKS; BOOKS IN THE FIELD OF EDUCATIONAL BOOKS, NAMELY, SELF HELP BOOKS, BOOKS ON THE SUBJECT OF RELIGION, TRAVEL BOOKS, BOOKS ON THE SUBJECT OF HISTORY, BOOKS ON THE SUBJECT OF SPORTS, MUSEUM BOOKS, BOOKS ON THE SUBJECT OF ART, AUTOBIOGRAPHIES, BIOGRAPHIES, BOOKS ON THE SUBJECT OF BUSINESS AND SCHOOL TEXTBOOKS IN THE FIELD OF MATH, SOCIAL STUDIES, BIOLOGY, CHEMISTRY, PHYSICS, ARCHITECTURE, GEOLOGY, HISTORY, ART; SERIES OF FICTION BOOKS; SERIES OF NON-FICTION BOOKS, NAMELY, SELF HELP BOOKS, BOOKS ON THE SUBJECT OF RELIGION, TRAVEL BOOKS, BOOKS ON THE SUBJECT OF HISTORY, BOOKS ON THE SUBJECT OF SPORTS, MUSEUM BOOKS, BOOKS ON THE SUBJECT OF ART, AUTOBIOGRAPHIES, BIOGRAPHIES, BOOKS ON THE SUBJECT OF BUSINESS AND TEXTBOOKS IN THE FIELD OF MATH, SOCIAL STUDIES, BIOLOGY, CHEMISTRY, PHYSICS, ARCHITECTURE, GEOLOGY, HISTORY, ART; CALENDARS; LETTERHEAD PAPER; BOXES OF CARDBOARD OR PAPER; CORRUGATED BOXES; FIBERBOARD BOXES; GIFT BOXES; STATIONERY BOXES; BOOK COVERS; LEATHER BOOK COVERS; PROTECTIVE COVERS FOR BOOKS; STATIONERY CASES; SLIP-CASES SPECIALLY FITTED FOR BOOKS (U.S. CLS. 2, 5, 22, 23, 29, 37, 38 AND 50).

FIRST USE 10-0-2008; IN COMMERCE 10-0-2008.

CLASS 40—MATERIAL TREATMENT

FOR PRINTING OF BOOKS; MANUFACTURING SERVICES FOR OTHERS IN THE FIELD OF BOOKS; PRINTING SERVICES; BINDERY SERVICES FOR OTHERS, NAMELY, COLLATING, FOLDING, STAPLING, PERFORATING, CUTTING AND BINDING OF PRINTED, PHOTOCOPIED AND TYPEWRITTEN MATERIALS; EMBOSsing SERVICES, NAMELY, EMBOSsing WORDS, DESIGNS OR IMAGES ON PRINTED MATERIALS; FOIL STAMPING SERVICES; TYPESETTING SERVICES; COLOR SEPARATION SERVICES; ELECTRONIC IMAGING, SCANNING, DIGITIZING OF PHOTOGRAPHIC IMAGES AND PRINTED MATERIAL (U.S. CLS. 100, 103 AND 106).

FIRST USE 2-28-2007; IN COMMERCE 2-28-2007.

3,998,520. HIGH GEAR MEDIA, INC., PALO ALTO, CA. SN 77-558,789. PUB. 7-21-2009, FILED 8-29-2008.

HIGH GEAR MEDIA

THE MARK CONSISTS OF STANDARD CHARACTERS WITHOUT CLAIM TO ANY PARTICULAR FONT, STYLE, SIZE, OR COLOR.

CLASS 35—ADVERTISING AND BUSINESS

FOR ADVERTISING, MARKETING AND BUSINESS MANAGEMENT SERVICES, NAMELY, DEVELOPING, COLLECTING, ANALYZING, OPTIMIZING AND DISTRIBUTING ADVERTISING, MARKETING AND PROMOTIONAL DATA AND CONTENT FOR OTHERS; ONLINE ADVERTISING AND MARKETING SERVICES; PROVIDING ONLINE DATABASES IN THE FIELDS OF CONSUMER AND MARKET RESEARCH; PROMOTING THE GOODS AND SERVICES OF OTHERS VIA ELECTRONIC COMMUNICATIONS NETWORKS; MARKETING SERVICES, NAMELY, COLLECTING, ANALYZING AND REPORTING INFORMATION CONCERNING CONSUMER TRENDS AND PREFERENCES; COMPUTER-BASED SERVICES IN THE NATURE OF DEVELOPING, MAINTAINING AND ADMINISTERING ONLINE ADVERTISING CAMPAIGNS AND AFFILIATE MARKETING NETWORKS; DEVELOPMENT, MAINTENANCE AND ADMINISTRATION OF ONLINE (U.S. CLS. 100, 101 AND 102).

FIRST USE 12-31-2008; IN COMMERCE 12-31-2008.

CLASS 38—COMMUNICATION

FOR PROVIDING ONLINE FORUMS AND ELECTRONIC BULLETIN BOARDS FOR POSTING, TRANSMITTING, RETRIEVING AND REVIEWING MESSAGES AMONG COMPUTER USERS IN THE FIELD OF GENERAL INTEREST (U.S. CLS. 100, 101 AND 104).

FIRST USE 12-31-2008; IN COMMERCE 12-31-2008.

CLASS 42—SCIENTIFIC AND COMPUTER SERVICES

FOR PROVIDING TEMPORARY USE OF NON-DOWNLOADABLE COMPUTER SOFTWARE FOR USE IN DEVELOPING, COLLECTING, POSTING, TRANSMITTING, RETRIEVING, SEARCHING, ANALYZING, REVIEWING, LINKING AND MANAGING TEXT, VOICE, AUDIO AND VISUAL CONTENT AND DATA VIA COMPUTERS, MOBILE AND HANDHELD COMPUTING DEVICES, AND WIRED AND WIRELESS COMMUNICATION DEVICES; COMPUTER SERVICES, NAMELY, CREATING INDEXES OF INFORMATION, SITES AND OTHER RESOURCES AVAILABLE VIA ELECTRONIC COMMUNICATIONS NETWORKS; APPLICATION SERVICE PROVIDER (ASP) SERVICES FEATURING SOFTWARE FOR TRACKING ONLINE ACTIVITY AND DEVELOPING, MANAGING, MONITORING AND OPTIMIZING THE PERFORMANCE AND EFFECTIVENESS OF MARKETING CAMPAIGNS; APPLICATION SERVICE PROVIDER (ASP) SERVICES, NAMELY, HOSTING COMPUTER SOFTWARE APPLICATIONS FOR OTHERS; APPLICATION SERVICE PROVIDER (ASP) SERVICES FEATURING SOFTWARE USED FOR THE DISSEMINATION AND DISTRIBUTION OF THE MEDIA CONTENT OF OTHERS; DESIGN, CREATION, HOSTING AND MAINTENANCE OF WEBSITES FOR OTHERS; COMPUTER SERVICES, NAMELY, PROVIDING SEARCH ENGINES FOR OBTAINING DATA VIA ELECTRONIC COMMUNICATIONS NETWORKS (U.S. CLS. 100 AND 101).

FIRST USE 12-31-2008; IN COMMERCE 12-31-2008.

3,998,522. INFUSION WELLNESS LLC, LOS ANGELES, CA. SN 77-559,567. PUB. 1-20-2009, FILED 8-30-2008.

Innerverse

THE MARK CONSISTS OF STANDARD CHARACTERS WITHOUT CLAIM TO ANY PARTICULAR FONT, STYLE, SIZE, OR COLOR.

CLASS 9—ELECTRICAL AND SCIENTIFIC APPARATUS

FOR CHILDREN'S VIDEO TAPES; COMPUTER GAME PROGRAMS; ELECTRONIC GAME SOFTWARE FOR CELLULAR TELEPHONES; INTERACTIVE VIDEO GAME PROGRAMS; MOTION PICTURE FILMS AND FILMS FOR TELEVISION FEATURING CHILDREN'S ENTERTAINMENT; VIDEO AND COMPUTER GAME PROGRAMS; VIDEO GAME SOFTWARE (U.S. CLS. 21, 23, 26, 36 AND 38).

FIRST USE 6-6-2007; IN COMMERCE 1-15-2010.

CLASS 16—PAPER GOODS AND PRINTED MATTER

FOR COLORING BOOKS; COMIC BOOKS; ROLE PLAYING GAME EQUIPMENT IN THE NATURE OF GAME BOOK MANUALS; SERIES OF FICTION WORKS, NAMELY, NOVELS AND BOOKS (U.S. CLS. 2, 5, 22, 23, 29, 37, 38 AND 50).

FIRST USE 6-6-2007; IN COMMERCE 1-15-2010.

CLASS 28—TOYS AND SPORTING GOODS

FOR ACTION FIGURES; BOARD GAMES; PRINTED POSITIONABLE TOYS FOR USE IN CHILDREN'S BOARD GAMES (U.S. CLS. 22, 23, 38 AND 50).

FIRST USE 6-6-2007; IN COMMERCE 1-15-2010.

3,998,526. INFOBLOX, INC., SANTA CLARA, CA. SN 77-562,700. PUB. 7-14-2009, FILED 9-4-2008.

BLOXTOOLS

THE MARK CONSISTS OF STANDARD CHARACTERS WITHOUT CLAIM TO ANY PARTICULAR FONT, STYLE, SIZE, OR COLOR.

CLASS 9—ELECTRICAL AND SCIENTIFIC APPARATUS

FOR COMPUTER SOFTWARE FOR THE ADMINISTRATION OF COMPUTER NETWORKS IN THE FIELD OF COMPUTER NETWORKS AND NETWORK SECURITY (U.S. CLS. 21, 23, 26, 36 AND 38).

FIRST USE 9-30-2008; IN COMMERCE 9-30-2008.

CLASS 38—COMMUNICATION

FOR PROVIDING ON-LINE FORUMS FOR TRANSMISSION OF MESSAGES AMONG COMPUTER USERS TO DISCUSS COMPUTERS, COMPUTER NETWORK SECURITY, AND COMPUTER NETWORKING ISSUES; PROVIDING ON-LINE ELECTRONIC BULLETIN BOARDS FOR TRANSMISSION OF MESSAGES AMONG COMPUTER USERS CONCERNING TECHNOLOGY AND COMPUTERS (U.S. CLS. 100, 101 AND 104).

FIRST USE 9-30-2008; IN COMMERCE 9-30-2008.

CLASS 42—SCIENTIFIC AND COMPUTER SERVICES

FOR PROVIDING TECHNICAL CONSULTING AND ASSISTANCE WITH COMPUTER BASED INFORMATION, SYSTEMS AND COMPONENTS VIA THE INTERNET (U.S. CLS. 100 AND 101).

FIRST USE 9-30-2008; IN COMMERCE 9-30-2008.

3,998,528. WEALTH MANAGEMENT, INC., LITTLE ROCK, AR. SN 77-565,364. PUB. 7-28-2009, FILED 9-9-2008.

LIFEONOMICS

THE MARK CONSISTS OF STANDARD CHARACTERS WITHOUT CLAIM TO ANY PARTICULAR FONT, STYLE, SIZE, OR COLOR.

CLASS 16—PAPER GOODS AND PRINTED MATTER

FOR A SERIES OF BOOKS IN THE FIELDS OF CAREERS, LIFE SKILLS, BUSINESS AFFAIRS, AND MONEY MANAGEMENT (U.S. CLS. 2, 5, 22, 23, 29, 37, 38 AND 50).

FIRST USE 4-0-1998; IN COMMERCE 4-0-1998.

CLASS 36—INSURANCE AND FINANCIAL

FOR FINANCIAL PLANNING AND INVESTMENT ADVISORY SERVICES; FINANCIAL PLANNING CONSULTATION; PROVIDING INFORMATION AND ADVICE IN THE FIELD OF FINANCE, FINANCIAL INVESTMENTS, FINANCIAL VALUATIONS, AND THE FINANCIAL ASPECTS OF RETIREMENT AND ESTATE PLANNING; FINANCIAL PLANNING, NAMELY, THE CREATION OF PERSONALIZED STRATEGIES TO ACHIEVE FINANCIAL INDEPENDENCE; ADVICE RELATING TO INVESTMENTS; FINANCIAL AND INVESTMENT SERVICES, NAMELY, MANAGEMENT AND BROKERAGE IN THE FIELDS OF STOCKS, BONDS, OPTIONS, COMMODITIES, FUTURES AND OTHER SECURITIES, AND THE INVESTMENT OF FUNDS OF OTHERS (U.S. CLS. 100, 101 AND 102).

FIRST USE 4-0-1998; IN COMMERCE 4-0-1998.

CLASS 41—EDUCATION AND ENTERTAINMENT

FOR TRAINING, LIFE COACHING AND PERSONAL COACHING SERVICES ALL IN THE FIELDS OF CAREERS, LIFE SKILLS, BUSINESS AFFAIRS AND MONEY MANAGEMENT; EDUCATIONAL SERVICES, NAMELY, PROVIDING MOTIVATIONAL AND EDUCATIONAL SPEAKERS IN THE FIELDS OF CAREERS, LIFE SKILLS, BUSINESS AFFAIRS AND MONEY MANAGEMENT; EDUCATIONAL SERVICES, NAMELY, PROVIDING LIVE AND ON-LINE CLASSES, SEMINARS, AND WORKSHOPS IN THE FIELDS OF CAREERS, LIFE SKILLS, BUSINESS AFFAIRS AND MONEY MANAGEMENT, AND DISTRIBUTION OF COURSE MATERIALS IN CONNECTION THEREWITH (U.S. CLS. 100, 101 AND 107).

FIRST USE 4-0-1998; IN COMMERCE 4-0-1998.

3,998,536. GRACIE, RORION, SANTA BARBARA, CA. SN 77-576,152. PUB. 3-9-2010, FILED 9-22-2008.

GRACIE JIU JITSU

THE MARK CONSISTS OF STANDARD CHARACTERS WITHOUT CLAIM TO ANY PARTICULAR FONT, STYLE, SIZE, OR COLOR.

OWNER OF U.S. REG. NOS. 1,929,719, 2,717,404, AND

OTHERS.

NO CLAIM IS MADE TO THE EXCLUSIVE RIGHT TO USE "JIU JITSU", APART FROM THE MARK AS SHOWN.

CLASS 9—ELECTRICAL AND SCIENTIFIC APPARATUS

FOR DVDS FEATURING LIVE ACTION AND SPORTS ENTERTAINMENT; MOTION PICTURE FILMS ABOUT SPORTS, MIXED MARTIAL ARTS AND FIGHT RELATED EVENTS; MOTION PICTURE FILMS AND DIGITALLY STORED MEDIA, NAMELY, DVDS FEATURING SPORTS AND ENTERTAINMENT; PRE-RECORDED LASER DISKS AND DVDS FEATURING LIVE ACTION AND SPORTS ENTERTAINMENT; PRE-RECORDED DIGITAL MATERIALS, NAMELY, DVDS, DOWNLOADABLE AUDIO AND VIDEO FILES, DIGITAL VIDEO DISCS, DIGITAL VERSATILE DISCS, DOWNLOADABLE AUDIO AND VIDEO RECORDINGS, DVDS, AND HIGH DEFINITION DIGITAL DISKS FEATURING ACTION AND FIGHT SEQUENCES; PRE-RECORDED DIGITAL MEDIA, DIGITAL VIDEO DISCS, DIGITAL VERSATILE DISCS, COMPACT DISCS, AND DVDS ALL FEATURING SPORTS AND ENTERTAINMENT, INSTRUCTIONAL AND TRAINING PROGRAMS IN THE ART OF JIU-JITSU, MARTIAL ARTS, NON-LETHAL MARTIAL ARTS TECHNIQUES, SELF-DEFENSE, ATTACK PREVENTION, SEXUAL ASSAULT PREVENTION, PHYSICAL ATTACK ESCAPE TECHNIQUES, PERSONAL SAFETY, RAPE PREVENTION, PHYSICAL EXERCISE AND EDUCATION, AND PHYSICAL FITNESS; PRERECORDED DVDS FEATURING ENTERTAINMENT, INSTRUCTIONAL AND TRAINING PROGRAMS IN THE ART AND HISTORY OF JIU-JITSU, MARTIAL ARTS, NON-LETHAL MARTIAL ARTS TECHNIQUES, SELF-DEFENSE, ATTACK PREVENTION, PHYSICAL ATTACK ESCAPE TECHNIQUES, PERSONAL SAFETY, PHYSICAL EXERCISE AND EDUCATION, AND PHYSICAL FITNESS; VIDEO RECORDINGS FEATURING SPORTS, MIXED MARTIAL ARTS, AND FIGHT EVENTS AND SPORTS PROGRAMMING (U.S. CLS. 21, 23, 26, 36 AND 38).

FIRST USE 12-31-1991; IN COMMERCE 12-31-1991.

CLASS 25—CLOTHING

FOR HEADWEAR; CLOTHING, NAMELY, ACTIVEWEAR CONSISTING OF SHORTS, T-SHIRTS, AND SWEATSHIRTS; ATHLETIC SUITS, NAMELY, GIS; SPORTSWEAR, NAMELY, SHORTS, T-SHIRTS AND SWEATSHIRTS; BATHING SUITS; BELTS; BOTTOMS; BOXER SHORTS; GYM SHORTS; FLEECE PULLOVERS; HATS; BASEBALL CAPS, JACKETS; SHIRTS; SHORTS; SWEATPANTS; SWEAT TOPS; SWEATSHIRTS; SWIMWEAR; T-SHIRTS; TOPS; TRUNKS; MARTIAL ARTS UNIFORMS (U.S. CLS. 22 AND 39).

FIRST USE 12-31-1980; IN COMMERCE 12-31-1980.

CLASS 41—EDUCATION AND ENTERTAINMENT

FOR ARRANGING AND CONDUCTING MARTIAL ARTS AND MIXED MARTIAL ARTS PERFORMANCES, TOURNAMENTS, EVENTS AND EXHIBITIONS; ARRANGING AND CONDUCTING NATIONAL AND INTERNATIONAL JIU-JITSU CHAMPIONSHIP TOURNAMENTS; CONSULTING SERVICES IN THE FIELDS OF E-LEARNING AND KNOWLEDGE AND INFORMATION MANAGEMENT, NAMELY, DEVELOPING TRAINING PROGRAMS IN THE NATURE OF WORKSHOPS, SEMINARS AND COURSES OF INSTRUCTION RELATING TO JIU-JITSU, MARTIAL ARTS, NON-LETHAL MARTIAL ARTS TECHNIQUES, SELF-DEFENSE, ATTACK PREVENTION, PHYSICAL ATTACK ESCAPE TECHNIQUES, PERSONAL SAFETY, PHYSICAL EXERCISE AND EDUCATION, AND PHYSICAL FITNESS; DEVELOPMENT OF EDUCATIONAL TRAINING MATERIALS AND TECHNICAL DOCUMENTATION FOR OTHERS IN THE FIELD OF MARTIAL ARTS AND JIU-JITSU; EDUCATIONAL AND TRAINING SERVICES, NAMELY, CONDUCTING SEMINARS, WORKSHOPS, COURSES OF INSTRUCTION AND CONFERENCES VIA COMPUTER TERMINALS, INTRANETS, AND GLOBAL COMPUTER NETWORK IN THE FIELDS OF JIU-JITSU, MARTIAL ARTS, NON-LETHAL MARTIAL ARTS TECHNIQUES, SELF-DEFENSE, ATTACK PREVENTION, PHYSICAL ATTACK ESCAPE TECHNIQUES, PERSONAL SAFETY, PHYSICAL EXERCISE AND EDUCATION, AND PHYSICAL FITNESS; OPERATING OF SCHOOLS FOR INSTRUCTION IN THE ART OF JIU-JITSU; ORGANIZATION AND ARRANGEMENT OF MARTIAL

PREVENTION, PHYSICAL ATTACK ESCAPE TECHNIQUES, PERSONAL SAFETY, PHYSICAL EXERCISE AND EDUCATION, AND PHYSICAL FITNESS; EDUCATIONAL INSTRUCTION SERVICES, TRAINING PROGRAMS, SEMINARS, AND CLASSES IN THE FIELDS OF JIU-JITSU, MARTIAL ARTS, NON-LETHAL MARTIAL ARTS TECHNIQUES, SELF-DEFENSE, ATTACK PREVENTION, PHYSICAL ATTACK ESCAPE TECHNIQUES, PERSONAL SAFETY, TACTICS FOR RESISTING ATTACK, AND PHYSICAL FITNESS; EDUCATIONAL SERVICES, NAMELY, ONLINE COURSES DESIGNED TO TRAIN AND TEST EMPLOYEES FOR WORK IN THE MARTIAL ARTS INDUSTRY; EDUCATIONAL SERVICES, NAMELY, PROVIDING CLASSES IN THE FIELD OF JIU-JITSU, MARTIAL ARTS, NON-LETHAL MARTIAL ARTS TECHNIQUES, SELF-DEFENSE, ATTACK PREVENTION, PHYSICAL ATTACK ESCAPE TECHNIQUES, PERSONAL SAFETY, AND PHYSICAL FITNESS FOR THE PURPOSE OF SKILL TESTING AND CERTIFICATION; EDUCATIONAL SERVICES, NAMELY, PROVIDING CLASSES, INSTRUCTION, TRAINING, AND ONLINE EDUCATIONAL COURSES AND INSTRUCTION IN THE MARTIAL ARTS INDUSTRY FOR THE PURPOSE OF CERTIFICATION; EDUCATIONAL SERVICES, NAMELY, PROVIDING INFORMATION ON THE SUBJECT OF SPORTS AND ENTERTAINMENT; EDUCATIONAL SERVICES, NAMELY, PROVIDING TRAINING PROGRAMS AND INSTRUCTIONAL WORKSHOPS AND SEMINARS IN THE ART OF JIU-JITSU, MARTIAL ARTS, NON-LETHAL MARTIAL ARTS TECHNIQUES, SELF-DEFENSE, ATTACK PREVENTION, PHYSICAL ATTACK ESCAPE TECHNIQUES, PERSONAL SAFETY, AND PHYSICAL FITNESS; EDUCATIONAL SERVICES, NAMELY, PROVIDING TRAINING PROGRAMS IN THE FIELD OF JIU-JITSU, MARTIAL ARTS, NON-LETHAL MARTIAL ARTS TECHNIQUES, SELF-DEFENSE, ATTACK PREVENTION, PHYSICAL ATTACK ESCAPE TECHNIQUES, PERSONAL SAFETY, AND PHYSICAL FITNESS; EDUCATIONAL SERVICES, NAMELY, THE OFFERING OF WEB BASED AND CLASSROOM TRAINING FOR CERTIFICATION OF INSTRUCTORS OF MARTIAL ARTS AND PERSONAL TRAINING; EDUCATIONAL TESTING PROVIDED ON GLOBAL COMPUTER NETWORKS TO ACHIEVE OCCUPATIONAL COMPLIANCE IN THE FIELD OF MARTIAL ARTS; ENTERTAINMENT AND EDUCATIONAL SERVICES, NAMELY, PROVIDING A WEBSITE FEATURING INFORMATION RELATING TO SPORTS, MARTIAL ARTS, ENTERTAINMENT, AND LIFESTYLE; ENTERTAINMENT SERVICES, NAMELY, CONDUCTING MARTIAL ARTS COMPETITIONS, EVENTS AND PERSONAL APPEARANCES FOR LIVE AND PRERECORDED TRANSMISSION BY MEANS OF CABLE, BROADCAST, SATELLITE AND OTHER MEDIA; ENTERTAINMENT SERVICES, NAMELY, PRODUCTION OF ENTERTAINMENT SHOWS AND INTERACTIVE ENTERTAINMENT PROGRAMS FOR DISTRIBUTION VIA AUDIO AND VIDEO MEDIA CARTRIDGES, LASER DISCS, COMPUTER DISCS AND ELECTRONIC MEANS; MARTIAL ARTS INSTRUCTION; MARTIAL ARTS INSTRUCTION SERVICES, NON-LETHAL MARTIAL ARTS TECHNIQUES, PERSONAL SAFETY, PHYSICAL ATTACK ESCAPE TECHNIQUES, PHYSICAL EXERCISE AND EDUCATION, TACTICS FOR RESISTING ATTACK, SELF-ASSERTIVENESS, SELF DEFENSE, SELF-HELP, AND SPORTS TRAINING; ONLINE EDUCATIONAL AND TRAINING SERVICES, NAMELY, CONDUCTING SEMINARS, WORKSHOPS, COURSES OF INSTRUCTION AND CONFERENCES VIA COMPUTER TERMINALS, INTRANETS, AND GLOBAL COMPUTER NETWORK IN THE FIELDS OF JIU-JITSU, MARTIAL ARTS, NON-LETHAL MARTIAL ARTS TECHNIQUES, SELF-DEFENSE, ATTACK PREVENTION, PHYSICAL ATTACK ESCAPE TECHNIQUES, PERSONAL SAFETY, PHYSICAL EXERCISE AND EDUCATION, AND PHYSICAL FITNESS; OPERATING OF SCHOOLS FOR INSTRUCTION IN THE ART OF JIU-JITSU; ORGANIZATION AND ARRANGEMENT OF MARTIAL

ARTS COMPETITIONS; PROVIDING CONTINUING EDUCATION FOR INSTRUCTORS OF MARTIAL ARTS AND PERSONAL TRAINING FOR THE PURPOSE OF INSTRUCTION CERTIFICATION; PROVIDING ONLINE TRAINING IN THE FIELD OF JIU-JITSU AND MARTIAL ARTS; SCHOOL FOR INSTRUCTION IN THE ART OF JIU-JITSU; TRAINING PROGRAM REGARDING NON-LETHAL TECHNIQUES FOR CLOSE-QUARTERS COMBAT, HAND-TO-HAND COMBAT, GRAPPLING TECHNIQUES, AND SELF-DEFENSE TRAINING IN ORDER TO CONTROL AND SUBDUCE OPPONENTS (U.S. CLS. 100, 101 AND 107).

FIRST USE 7-31-1980; IN COMMERCE 7-31-1980.

3,998,537. GRACIE, RORION, SANTA BARBARA, CA. SN 77-576,163. PUB. 3-9-2010, FILED 9-22-2008.



OWNER OF U.S. REG. NO. 1,534,728.

THE MARK CONSISTS OF AN INCOMPLETE TRIANGLE IN WHICH TWO FIGURES ARE DEPICTED AS SILHOUETTES OF MEN WHO ARE GRAPPLING IN UNIFORMS.

CLASS 9—ELECTRICAL AND SCIENTIFIC APPARATUS

FOR DVDS FEATURING LIVE ACTION AND SPORTS ENTERTAINMENT; MOTION PICTURE FILMS ABOUT SPORTS, MIXED MARTIAL ARTS AND FIGHT RELATED EVENTS; MOTION PICTURE FILMS AND DIGITALLY STORED MEDIA, NAMELY, DVDS FEATURING SPORTS AND ENTERTAINMENT; PRE-RECORDED LASER DISKS AND DVDS FEATURING LIVE ACTION AND SPORTS ENTERTAINMENT; PRE-RECORDED DIGITAL MATERIALS, NAMELY, DVDS, DOWNLOADABLE AUDIO AND VIDEO FILES, DIGITAL VIDEO DISCS, DIGITAL VERSATILE DISCS, DOWNLOADABLE AUDIO AND VIDEO RECORDINGS, DVDS, AND HIGH DEFINITION DIGITAL DISKS FEATURING ACTION AND FIGHT SEQUENCES; PRE-RECORDED DIGITAL MEDIA, DIGITAL VIDEO DISCS, DIGITAL VERSATILE DISCS, COMPACT DISCS, AND DVDS ALL FEATURING SPORTS AND ENTERTAINMENT, INSTRUCTIONAL AND TRAINING PROGRAMS IN THE ART OF JIU-JITSU, MARTIAL ARTS, NON-LETHAL MARTIAL ARTS TECHNIQUES, SELF-DEFENSE, ATTACK PREVENTION, SEXUAL ASSAULT PREVENTION, PHYSICAL ATTACK ESCAPE TECHNIQUES, PERSONAL SAFETY, RAPE PREVENTION, PHYSICAL EXERCISE AND EDUCATION, AND PHYSICAL FITNESS; PRERECORDED DVDS FEATURING ENTERTAINMENT, INSTRUCTIONAL AND TRAINING PROGRAMS IN THE ART AND HISTORY OF JIU-JITSU, MARTIAL ARTS, NON-DVDS FEATURING LIVE ACTION AND SPORTS ENTERTAINMENT; MOTION PICTURE FILMS ABOUT SPORTS, MIXED MARTIAL ARTS AND FIGHT RELATED EVENTS; MOTION PICTURE FILMS AND DIGITALLY STORED MEDIA, NAMELY, DVDS FEATURING SPORTS AND ENTERTAINMENT; PRE-RECORDED LASER DISKS AND DVDS FEATURING LIVE ACTION AND SPORTS ENTERTAINMENT; PRE-RECORDED DIGITAL MATERIALS, NAMELY, DVDS, DOWNLOADABLE AUDIO AND VIDEO FILES, DIGITAL VIDEO DISCS, DIGITAL VERSATILE DISCS, DOWNLOADABLE

AUDIO AND VIDEO RECORDINGS, DVDS, AND HIGH DEFINITION DIGITAL DISKS FEATURING ACTION AND FIGHT SEQUENCES; PRE-RECORDED DIGITAL MEDIA, DIGITAL VIDEO DISCS, DIGITAL VERSATILE DISCS, COMPACT DISCS, AND DVDS ALL FEATURING SPORTS AND ENTERTAINMENT, INSTRUCTIONAL AND TRAINING PROGRAMS IN THE ART OF JIU-JITSU, MARTIAL ARTS, NON-LETHAL MARTIAL ARTS TECHNIQUES, SELF-DEFENSE, ATTACK PREVENTION, SEXUAL ASSAULT PREVENTION, PHYSICAL ATTACK ESCAPE TECHNIQUES, PERSONAL SAFETY, RAPE PREVENTION, PHYSICAL EXERCISE AND EDUCATION, AND PHYSICAL FITNESS; PRERECORDED DVDS FEATURING ENTERTAINMENT, INSTRUCTIONAL AND TRAINING PROGRAMS IN THE ART AND HISTORY OF JIU-JITSU, MARTIAL ARTS, NON-LETHAL MARTIAL ARTS TECHNIQUES, SELF-DEFENSE, ATTACK PREVENTION, PHYSICAL ATTACK ESCAPE TECHNIQUES, PERSONAL SAFETY, PHYSICAL EXERCISE AND EDUCATION, AND PHYSICAL FITNESS; VIDEO RECORDINGS FEATURING SPORTS, MIXED MARTIAL ARTS, AND FIGHT EVENTS AND SPORTS PROGRAMMING (U.S. CLS. 21, 23, 26, 36 AND 38).

FIRST USE 12-31-1991; IN COMMERCE 12-31-1991.

CLASS 16—PAPER GOODS AND PRINTED MATTER

FOR BOOKS, MANUALS, PAMPHLETS, BROCHURES, AND BOOKLETS IN THE FIELD OF JIU-JITSU AND MARTIAL ARTS POSTERS FEATURING JIU-JITSU AND MARTIAL ARTS; PRINTED MATERIALS, NAMELY, BOOKS, PAMPHLETS, MANUALS, BROCHURES, AND INSTRUCTIONAL BOOKLETS IN THE FIELDS OF ACHIEVEMENT, AEROBICS, DIET, EXERCISE, GOAL SETTING, HEALTH AND FITNESS, HEALING ARTS, JIU-JITSU, LEADERSHIP, MARTIAL ARTS, MARTIAL ARTS INSTRUCTION SERVICES, NON-LETHAL MARTIAL ARTS TECHNIQUES, NUTRITION, PERSONAL DEVELOPMENT, PERSONAL IMPROVEMENT, PERSONAL MOTIVATION, PERSONAL SAFETY, PHYSICAL ATTACK ESCAPE TECHNIQUES, PHYSICAL EXERCISE AND EDUCATION, SELF-ASSERTIVENESS, SELF DEFENSE, SELF-HELP, SPORTS, SEXUAL ASSAULT PREVENTION, SPORTS TRAINING, STRESS RELIEF, TACTICS FOR RESISTING ATTACK, WEIGHT LOSS, WEIGHT MANAGEMENT, AND WELLNESS (U.S. CLS. 2, 5, 22, 23, 29, 37, 38 AND 50).

FIRST USE 12-31-1980; IN COMMERCE 12-31-1980.

CLASS 25—CLOTHING

FOR HEADWEAR; CLOTHING, NAMELY, ACTIVE-WEAR CONSISTING OF SHORTS, T-SHIRTS, AND SWEATSHIRTS; ATHLETIC SUITS, NAMELY, GIs; SPORTSWEAR, NAMELY, SHORTS, T-SHIRTS AND SWEATSHIRTS; BATHING SUITS; BELTS; BOTTOMS; BOXER SHORTS; GYM SHORTS; FLEECE PULLOVERS; HATS; BASEBALL CAPS, JACKETS; SHIRTS; SHORTS; SWEATPANTS; SWEAT TOPS; SWEATSHIRTS; SWIMWEAR; T-SHIRTS; TOPS; TRUNKS; MARTIAL ARTS UNIFORMS (U.S. CLS. 22 AND 39).

FIRST USE 12-31-1980; IN COMMERCE 12-31-1980.

CLASS 41—EDUCATION AND ENTERTAINMENT

FOR ARRANGING AND CONDUCTING MARTIAL ARTS AND MIXED MARTIAL ARTS PERFORMANCES, TOURNAMENTS, EVENTS AND EXHIBITIONS; ARRANGING AND CONDUCTING NATIONAL AND INTERNATIONAL JIU-JITSU CHAMPIONSHIP TOURNAMENTS; CONSULTING SERVICES IN THE FIELDS OF E-LEARNING AND KNOWLEDGE AND INFORMATION MANAGEMENT, NAMELY, DEVELOPING TRAINING PROGRAMS IN THE NATURE OF WORKSHOPS, SEMINARS AND COURSES OF INSTRUCTION RELATING TO JIU-JITSU, MARTIAL ARTS, NON-LETHAL MARTIAL ARTS TECHNIQUES, SELF-DEFENSE, ATTACK PREVENTION, PHYSICAL ATTACK ESCAPE TECHNIQUES, PERSONAL SAFETY, PHYSICAL EXERCISE AND EDUCATION, AND PHYSICAL FITNESS; DEVELOPMENT OF EDUCATIONAL TRAINING MATERIALS AND TECHNICAL DOCUMENTATION FOR OTHERS IN THE FIELD OF MARTIAL

ARTS AND JIU-JITSU; EDUCATIONAL AND TRAINING SERVICES, NAMELY, CONDUCTING SEMINARS, WORKSHOPS, COURSES OF INSTRUCTION AND CONFERENCES VIA COMPUTER TERMINALS, INTRANETS, AND GLOBAL COMPUTER NETWORK IN THE FIELDS OF JIU-JITSU, MARTIAL ARTS, NON-LETHAL MARTIAL ARTS TECHNIQUES, SELF-DEFENSE, ATTACK PREVENTION, PHYSICAL ATTACK ESCAPE TECHNIQUES, PERSONAL SAFETY, PHYSICAL EXERCISE AND EDUCATION, AND PHYSICAL FITNESS; EDUCATIONAL INSTRUCTION SERVICES, TRAINING PROGRAMS, SEMINARS, AND CLASSES IN THE FIELDS OF JIU- JITSU, MARTIAL ARTS, NON-LETHAL MARTIAL ARTS TECHNIQUES, SELF-DEFENSE, ATTACK PREVENTION, PHYSICAL ATTACK ESCAPE TECHNIQUES, PERSONAL SAFETY, TACTICS FOR RESISTING ATTACK, AND PHYSICAL FITNESS; EDUCATIONAL SERVICES, NAMELY, ONLINE COURSES DESIGNED TO TRAIN AND TEST EMPLOYEES FOR WORK IN THE MARTIAL ARTS INDUSTRY; EDUCATIONAL SERVICES, NAMELY, PROVIDING CLASSES IN THE FIELD OF JIU-JITSU, MARTIAL ARTS, NON- LETHAL MARTIAL ARTS TECHNIQUES, SELF-DEFENSE, ATTACK PREVENTION, PHYSICAL ATTACK ESCAPE TECHNIQUES, PERSONAL SAFETY, AND PHYSICAL FITNESS FOR THE PURPOSE OF SKILL TESTING AND CERTIFICATION; EDUCATIONAL SERVICES, NAMELY, PROVIDING CLASSES, INSTRUCTION, TRAINING, AND ONLINE EDUCATIONAL COURSES AND INSTRUCTION IN THE MARTIAL ARTS INDUSTRY FOR THE PURPOSE OF CERTIFICATION; EDUCATIONAL SERVICES, NAMELY, PROVIDING INFORMATION ON THE SUBJECT OF SPORTS AND ENTERTAINMENT; EDUCATIONAL SERVICES, NAMELY, PROVIDING TRAINING PROGRAMS AND INSTRUCTIONAL WORKSHOPS AND SEMINARS IN THE ART OF JIU-JITSU, MARTIAL ARTS, NON- LETHAL MARTIAL ARTS TECHNIQUES, SELF-DEFENSE, ATTACK PREVENTION, PHYSICAL ATTACK ESCAPE TECHNIQUES, PERSONAL SAFETY, AND PHYSICAL FITNESS; EDUCATIONAL SERVICES, NAMELY, THE OFFERING OF WEB BASED AND CLASSROOM TRAINING FOR CERTIFICATION OF INSTRUCTORS OF MARTIAL ARTS AND PERSONAL TRAINING; EDUCATIONAL TESTING PROVIDED ON GLOBAL COMPUTER NETWORKS TO ACHIEVE OCCUPATIONAL COMPLIANCE IN THE FIELD OF MARTIAL ARTS; ENTERTAINMENT AND EDUCATIONAL SERVICES, NAMELY, PROVIDING A WEBSITE FEATURING INFORMATION RELATING TO SPORTS, MARTIAL ARTS, ENTERTAINMENT, AND LIFESTYLE; ENTERTAINMENT SERVICES, NAMELY, CONDUCTING MARTIAL ARTS COMPETITIONS, EVENTS AND PERSONAL APPEARANCES FOR LIVE AND PRERECORDED TRANSMISSION BY MEANS OF CABLE, BROADCAST, SATELLITE AND OTHER MEDIA; ENTERTAINMENT ARRANGING AND CONDUCTING MARTIAL ARTS AND MIXED MARTIAL ARTS PERFORMANCES, TOURNAMENTS, EVENTS AND EXHIBITIONS; ARRANGING AND CONDUCTING NATIONAL AND INTERNATIONAL JIU- JITSU CHAMPIONSHIP TOURNAMENTS; CONSULTING SERVICES IN THE FIELDS OF EARNING AND KNOWLEDGE AND INFORMATION MANAGEMENT, NAMELY, DEVELOPING TRAINING PROGRAMS IN THE NATURE OF WORKSHOPS, SEMINARS AND COURSES OF INSTRUCTION RELATING TO JIU-JITSU, MARTIAL ARTS, NON-LETHAL MARTIAL ARTS TECHNIQUES, SELF-DEFENSE, ATTACK PREVENTION, PHYSICAL ATTACK ESCAPE TECHNIQUES, PERSONAL SAFETY, PHYSICAL EXERCISE AND EDUCATION, AND PHYSICAL FITNESS; DEVELOPMENT OF EDUCATIONAL TRAINING MATERIALS AND TECHNICAL DOCUMENTATION FOR OTHERS IN THE FIELD OF MARTIAL ARTS AND JIU-JITSU; EDUCATIONAL AND TRAINING SERVICES, NAMELY, CONDUCTING SEMINARS, WORKSHOPS, COURSES OF INSTRUCTION AND CONFERENCES VIA COMPUTER TERMINALS, INTRANETS, AND GLOBAL COMPUTER NETWORK IN THE FIELDS OF JIU-JITSU, MARTIAL ARTS, NON-LETHAL MARTIAL ARTS TECHNIQUES, SELF-DEFENSE, ATTACK PREVENTION, PHYSICAL ATTACK ESCAPE TECHNIQUES, PERSONAL SAFETY, PHYSICAL EXERCISE AND EDUCATION, AND PHYSICAL FITNESS; EDUCA-

TIONAL INSTRUCTION SERVICES, TRAINING PROGRAMS, SEMINARS, AND CLASSES IN THE FIELDS OF JIU- JITSU, MARTIAL ARTS, NON-LETHAL MARTIAL ARTS TECHNIQUES, SELF-DEFENSE, ATTACK PREVENTION, PHYSICAL ATTACK ESCAPE TECHNIQUES, PERSONAL SAFETY, TACTICS FOR RESISTING ATTACK, AND PHYSICAL FITNESS; EDUCATIONAL SERVICES, NAMELY, ONLINE COURSES DESIGNED TO TRAIN AND TEST EMPLOYEES FOR WORK IN THE MARTIAL ARTS INDUSTRY; EDUCATIONAL SERVICES, NAMELY, PROVIDING CLASSES IN THE FIELD OF JIU-JITSU, MARTIAL ARTS, NON- LETHAL MARTIAL ARTS TECHNIQUES, SELF-DEFENSE, ATTACK PREVENTION, PHYSICAL ATTACK ESCAPE TECHNIQUES, PERSONAL SAFETY, AND PHYSICAL FITNESS FOR THE PURPOSE OF SKILL TESTING AND CERTIFICATION; EDUCATIONAL SERVICES, NAMELY, PROVIDING CLASSES, INSTRUCTION, TRAINING, AND ONLINE EDUCATIONAL COURSES AND INSTRUCTION IN THE MARTIAL ARTS INDUSTRY FOR THE PURPOSE OF CERTIFICATION; EDUCATIONAL SERVICES, NAMELY, PROVIDING INFORMATION ON THE SUBJECT OF SPORTS AND ENTERTAINMENT; EDUCATIONAL SERVICES, NAMELY, PROVIDING TRAINING PROGRAMS AND INSTRUCTIONAL WORKSHOPS AND SEMINARS IN THE ART OF JIU-JITSU, MARTIAL ARTS, NON- LETHAL MARTIAL ARTS TECHNIQUES, SELF-DEFENSE, ATTACK PREVENTION, PHYSICAL ATTACK ESCAPE TECHNIQUES, PERSONAL SAFETY, AND PHYSICAL FITNESS; EDUCATIONAL SERVICES, NAMELY, PROVIDING TRAINING PROGRAMS IN THE FIELD OF JIU-JITSU, MARTIAL ARTS, NON-LETHAL MARTIAL ARTS TECHNIQUES, SELF-DEFENSE, ATTACK PREVENTION, PHYSICAL ATTACK ESCAPE TECHNIQUES, PERSONAL SAFETY, AND PHYSICAL FITNESS; EDUCATIONAL SERVICES, NAMELY, THE OFFERING OF WEB BASED AND CLASSROOM TRAINING FOR CERTIFICATION OF INSTRUCTORS OF MARTIAL ARTS AND PERSONAL TRAINING; EDUCATIONAL TESTING PROVIDED ON GLOBAL COMPUTER NETWORKS TO ACHIEVE OCCUPATIONAL COMPLIANCE IN THE FIELD OF MARTIAL ARTS; ENTERTAINMENT AND EDUCATIONAL SERVICES, NAMELY, PROVIDING A WEBSITE FEATURING INFORMATION RELATING TO SPORTS, MARTIAL ARTS, ENTERTAINMENT, AND LIFESTYLE; ENTERTAINMENT SERVICES, NAMELY, CONDUCTING MARTIAL ARTS COMPETITIONS, EVENTS AND PERSONAL APPEARANCES FOR LIVE AND PRERECORDED TRANSMISSION BY MEANS OF CABLE, BROADCAST, SATELLITE AND OTHER MEDIA; ENTERTAINMENT SERVICES, NAMELY, PRODUCTION OF ENTERTAINMENT SHOWS AND INTERACTIVE ENTERTAINMENT PROGRAMS FOR DISTRIBUTION VIA AUDIO AND VIDEO MEDIA CARTRIDGES, LASER DISCS, COMPUTER DISCS AND ELECTRONIC MEANS; MARTIAL ARTS INSTRUCTION; MARTIAL ARTS INSTRUCTION SERVICES, NON-LETHAL MARTIAL ARTS TECHNIQUES, PERSONAL SAFETY, PHYSICAL ATTACK ESCAPE TECHNIQUES, PHYSICAL EXERCISE AND EDUCATION, TACTICS FOR RESISTING ATTACK, SELF-ASSERTIVENESS, SELF DEFENSE, SELF-HELP, AND SPORTS TRAINING; ONLINE EDUCATIONAL AND TRAINING SERVICES, NAMELY, CONDUCTING SEMINARS, WORKSHOPS, COURSES OF INSTRUCTION AND CONFERENCES VIA COMPUTER TERMINALS, INTRANETS, AND GLOBAL COMPUTER NETWORK IN THE FIELDS OF JIU-JITSU, MARTIAL ARTS, NON-LETHAL MARTIAL ARTS TECHNIQUES, SELF-DEFENSE, ATTACK PREVENTION, PHYSICAL ATTACK ESCAPE TECHNIQUES, PERSONAL SAFETY, PHYSICAL EXERCISE AND EDUCATION, AND PHYSICAL FITNESS; OPERATING OF SCHOOLS FOR INSTRUCTION IN THE ART OF JIU-JITSU; ORGANIZATION AND ARRANGEMENT OF MARTIAL ARTS COMPETITIONS; PROVIDING CONTINUING EDUCATION FOR INSTRUCTORS OF MARTIAL ARTS AND PERSONAL TRAINING FOR THE PURPOSE OF INSTRUCTION CERTIFICATION; PROVIDING ONLINE TRAINING IN THE FIELD OF JIU-JITSU AND MARTIAL ARTS; SCHOOL FOR INSTRUCTION IN THE ART OF JIU-JITSU; TRAINING PROGRAM REGARDING NON-LETHAL TECHNIQUES FOR CLOSE-QUARTERS COMBAT, HAND-TO-HAND COMBAT, GRAPPLING TECHNIQUES, AND SELF-DEFENSE TRAINING IN ORDER TO CONTROL AND SUBDUCE OPPONENTS (U.S. CLS. 100, 101 AND 107).

FIRST USE 7-31-1980; IN COMMERCE 7-31-1980.

3,998,544. OLIVA CIGAR CO., MIAMI LAKES, FL. SN 77-581,998. PUB. 6-23-2009, FILED 9-30-2008.



THE MARK CONSISTS OF THE DESIGN OF A LEAF.

CLASS 25—CLOTHING

FOR CLOTHING, NAMELY, CAPS AND T-SHIRTS (U.S. CLS. 22 AND 39).
FIRST USE 1-4-2009; IN COMMERCE 1-4-2009.

CLASS 34—SMOKERS' ARTICLES

FOR MATCHES, AND ASHTRAYS (U.S. CLS. 2, 8, 9 AND 17).
FIRST USE 12-4-2008; IN COMMERCE 10-29-2009.

3,998,571. KEBA GESELLSCHAFT M.B.H., OTTENSHEIM, AUSTRIA. SN 77-605,197. PUB. 10-6-2009, FILED 10-31-2008.

KEBA

THE MARK CONSISTS OF STANDARD CHARACTERS WITHOUT CLAIM TO ANY PARTICULAR FONT, STYLE, SIZE, OR COLOR.
OWNER OF U.S. REG. NO. 1,858,393.

CLASS 7—MACHINERY

FOR DRIVE SYSTEM HAVING TWO OR MORE SYNCHRONOUS MOTORS COUPLED THROUGH CLUTCHES TO DRIVE A COMMON LOAD; ELECTRIC MOTORS FOR MACHINES; ELECTRIC MOTORS FOR MACHINES WITH A DIGITAL SERVO DRIVE CONTROLLER; HIGH FREQUENCY MOTOR SPINDLES WITH HIGH FREQUENCY ELECTRIC CONVERTERS AND POWER SUPPLY UNITS; LINEAR MOTORS; MOTORS, NAMELY, ALTERNATING CURRENT MOTORS NOT FOR LAND VEHICLES; MOTORS, NAMELY, SYNCHRONOUS MOTORS NOT FOR LAND VEHICLES, PLANETARY GEAR MOTORS; MULTI-AXIS-DRIVES FOR PLASTICS MACHINES; MULTI-AXIS-DRIVES FOR ROBOT AND HANDLING SYSTEMS; SYNCHRONOUS MOTORS NOT FOR LAND VEHICLES; ASYNCHRONOUS MOTORS NOT FOR LAND VEHICLES; INDUCTION MOTORS NOT FOR LAND VEHICLES; TORQUE MOTORS NOT FOR LAND VEHICLES; STEPPER MOTORS; SYNCHRONOUS SERVO MOTORS; ASYNCHRONOUS SERVO MOTORS; PERMANENT MAGNET SERVO MOTORS; INVERTER MOTORS NOT FOR LAND VEHICLES; GEAR MOTORS NOT FOR LAND VEHICLES; INVERTER INTEGRATED MOTORS NOT FOR LAND VEHICLES; ELECTRIC FAN MOTOR FILTERS (U.S. CLS. 13, 19, 21, 23, 31, 34 AND 35).
FIRST USE 5-29-1998; IN COMMERCE 5-29-1998.

CLASS 9—ELECTRICAL AND SCIENTIFIC APPARATUS

FOR COMPUTER SOFTWARE TO MONITOR AND CONTROL FACTORY MANUFACTURING PROCESSES; ELECTRIC CONTROL PANELS; ELECTRONIC FREQUENCY CONVERTERS FOR HIGH VELOCITY ELECTRO MOTORS; ELECTRONIC MOTOR SWITCHES FOR SWITCHING OFF MOTORS; ELECTRONIC SERVO MOTOR CONTROLLERS; ELECTRONIC CONTROL SYSTEMS FOR MACHINES; ELECTRONIC CONTROLS FOR MOTORS; ELECTRONIC INTERFACE EQUIPMENT FOR MACHINE TOOLS TO INPUT OR OUTPUT CNC (COMPUTER NUMERICAL CONTROL) DATA; INDUSTRIAL AUTOMATION CONTROLS; INDUSTRIAL PROCESS CONTROL SOFTWARE; WIRELESS CONTROLLER TO MONITOR AND CONTROL THE FUNCTIONING OF OTHER ELECTRONIC DEVICES; MULTI-AXIS-FREQUENCY CONVERTERS; SINGLE-AXIS-FREQUENCY CONVERTERS; MULTI-AXIS-DISK DRIVES FEATURING PROGRAMMABLE LOGIC CONTROLLERS (PLC); FREQUENCY CONVERTERS; DISK DRIVE CONTROLLERS; MULTI-AXIS DISK DRIVE CONTROLLER; RECTIFIER; DC-LINK POWER SUPPLY; POWER SUPPLY WITH ACTIVE FRONT END (AFE); MAINS TRANSFORMERS; POWER CHOKES; POWER LINE FILTERS; ELECTRIC RESISTORS FOR BRAKES; DC-LINK RESISTORS; DC-LINK CAPACITORS (U.S. CLS. 21, 23, 26, 36 AND 38).
FIRST USE 5-29-1998; IN COMMERCE 5-29-1998.

3,998,575. UENO FINE CHEMICALS INDUSTRY, LTD., OSAKA, JAPAN. SN 77-612,854. PUB. 4-27-2010, FILED 11-12-2008.

**UENO FINE CHEMICALS
INDUSTRY**

THE MARK CONSISTS OF STANDARD CHARACTERS WITHOUT CLAIM TO ANY PARTICULAR FONT, STYLE, SIZE, OR COLOR.
NO CLAIM IS MADE TO THE EXCLUSIVE RIGHT TO USE "FINE CHEMICALS INDUSTRY", APART FROM THE MARK AS SHOWN.
SEC. 2(F) AS TO "UENO".

CLASS 1—CHEMICALS

FOR CHEMICALS AND CHEMICAL PREPARATIONS, NAMELY, PARABENS, AROMATIC COMPOUNDS, NAMELY, ORGANIC COMPOUNDS HAVING ONE OR MORE BENZENE RINGS, PHENOLS, ORGANIC ACIDS, ESTERS, PRESERVATIVES FOR PHARMACEUTICAL PREPARATIONS, FOOD PRESERVATIVES, AND MILDEW PROOFING AGENTS IN THE NATURE OF CHEMICAL PREPARATIONS TO PREVENT MILDEW (U.S. CLS. 1, 5, 6, 10, 26 AND 46).

FIRST USE 1-31-2001; IN COMMERCE 1-31-2001.

CLASS 5—PHARMACEUTICALS

FOR ANTISEPTICS; ANTIMICROBIAL PRESERVATIVES FOR FOODS, COSMETICS AND PHARMACEUTICALS (U.S. CLS. 6, 18, 44, 46, 51 AND 52).

FIRST USE 1-31-2011; IN COMMERCE 1-31-2001.

3,998,577. EXPED AG, ZURICH, SWITZERLAND. SN 77-613,834. PUB. 1-19-2010, FILED 11-13-2008.



NO CLAIM IS MADE TO THE EXCLUSIVE RIGHT TO USE "EXPEDITION EQUIPMENT", APART FROM THE MARK AS SHOWN.

THE MARK CONSISTS OF THREE SQUARES ARRANGED HORIZONTALLY, THE TWO EXTERIOR SQUARES BEING OF A DARKER SHADE THAN THE MIDDLE SQUARE. THE LEFTMOST SQUARE HAS THE WORD "EXPED" SUBSTANTIALLY CENTRAL, WITH THE "X" BEING BOLDER THAN THE OTHER LETTERS. THE CENTRAL SQUARE HAS A SILHOUETTE OF A STYLIZED WHITE BIRD FLYING TOWARDS THE LEFT, ITS CONTOURS SUBSTANTIALLY THE SAME SHADE AS THE OUTER SQUARES. THE RIGHTMOST SQUARE HAS THE WORDS "EXPEDITION EQUIPMENT".

CLASS 18—LEATHER GOODS

FOR LEATHER AND IMITATION LEATHER BAGS AND CASES FOR SPARE TIME USE; OUTDOOR EQUIPMENT, NAMELY, TRAVELING BAGS, KNAP SACKS AND RUCK SACKS (U.S. CLS. 1, 2, 3, 22 AND 41).

FIRST USE 11-11-2010; IN COMMERCE 11-11-2010.

CLASS 20—FURNITURE AND ARTICLES NOT OTHERWISE CLASSIFIED

FOR MATS FOR CAMPING, SLEEPING BAGS, NON-METAL TENT POLES (U.S. CLS. 2, 13, 22, 25, 32 AND 50).

FIRST USE 11-11-2010; IN COMMERCE 11-11-2010.

CLASS 22—CORDAGE AND FIBERS

FOR CARGO NETS, TENTS, TENT BAGS, TENT SACKS, TENT FLIES, ROPES, SAILS, HAMMOCKS (U.S. CLS. 1, 2, 7, 19, 22, 42 AND 50).

FIRST USE 11-11-2010; IN COMMERCE 11-11-2010.

CLASS 25—CLOTHING

FOR UNDERWEAR, SHOES, SOCKS, GLOVES, PONCHOS, BOOTIES, CHAPS; RAIN WEAR, NAMELY, RAIN HATS, RAIN COATS, RAIN JACKETS, RAIN SUITS AND RAIN TROUSERS (U.S. CLS. 22 AND 39).

FIRST USE 11-11-2010; IN COMMERCE 11-11-2010.

CLASS 28—TOYS AND SPORTING GOODS

FOR SPORTS EQUIPMENT, NAMELY, NORDIC WALKING POLES (U.S. CLS. 22, 23, 38 AND 50).

FIRST USE 11-11-2010; IN COMMERCE 11-11-2010.

3,998,579. MACHOVINA, BRIAN L., CORAL GABLES, FL. SN 77-621,329. PUB. 4-7-2009, FILED 11-25-2008.

YONANAS

THE MARK CONSISTS OF STANDARD CHARACTERS WITHOUT CLAIM TO ANY PARTICULAR FONT, STYLE, SIZE, OR COLOR.

CLASS 11—ENVIRONMENTAL CONTROL APPARATUS

FOR FROZEN DESSERT DISPENSER (U.S. CLS. 13, 21, 23, 31 AND 34).

FIRST USE 5-2-2011; IN COMMERCE 5-2-2011.

CLASS 30—STAPLE FOODS

FOR FROZEN CONFECTIONS (U.S. CL. 46).

FIRST USE 5-2-2011; IN COMMERCE 5-2-2011.

3,998,580. ING DIRECT BANCORP, WILMINGTON, DE. SN 77-622,634. PUB. 9-29-2009, FILED 11-26-2008.



OWNER OF U.S. REG. NO. 2,819,060.

THE COLOR(S) BLACK, WHITE, PEACH, YELLOW, LIGHT ORANGE, DARK ORANGE, RED, BLUE AND GREEN IS/ARE CLAIMED AS A FEATURE OF THE MARK.

THE MARK CONSISTS OF THE DESIGN OF A GIRL WITH PEACH SKIN, WHITE AND BLUE EYES, A RED MOUTH, LIGHT ORANGE HAIR WITH YELLOW HIGHLIGHTS AND RED PONYTAIL HOLDER, A DARK ORANGE SHIRT, DARK ORANGE SHOES, BLUE PANTS, A BLUE BRACELET, AND A BLUE AND GREEN WATCH. THE ELEMENTS OF THE MARK ARE OUTLINED IN BLACK.

CLASS 36—INSURANCE AND FINANCIAL

FOR PROVIDING AN INTERACTIVE WEB SITE FEATURING INFORMATION FOR CHILDREN IN THE FIELD OF BANKING AND FINANCIAL SERVICES (U.S. CLS. 100, 101 AND 102).

FIRST USE 4-22-2009; IN COMMERCE 4-22-2009.

CLASS 41—EDUCATION AND ENTERTAINMENT

FOR EDUCATIONAL SERVICES, NAMELY, PROVIDING A WEB SITE WITH GAMES AND LEARNING ACTIVITIES TO HELP CHILDREN UNDERSTAND MONEY MATTERS AND FINANCIAL MATTERS, EARNING, SAVING, BUDGETING AND INVESTING (U.S. CLS. 100, 101 AND 107).

FIRST USE 4-22-2009; IN COMMERCE 4-22-2009.

3,998,584. NEOM LTD., HORNBEAM BUSINESS PARK, UNITED KINGDOM. SN 77-630,104. PUB. 5-5-2009, FILED 12-10-2008.

NEOM

THE MARK CONSISTS OF STANDARD CHARACTERS WITHOUT CLAIM TO ANY PARTICULAR FONT, STYLE, SIZE, OR COLOR.

CLASS 3—COSMETICS AND CLEANING PREPARATIONS

FOR COSMETICS, NAMELY, FRAGRANCE AND PERFUMERY, PERFUME, COLOGNE, SOAP, SKIN SOAPS, TOILET SOAP, LIQUID SOAP, BODY LOTION, FACE AND BODY CREAMS, HAND CREAM, SKIN CREAMS, SKIN LOTIONS, SKIN MOISTURIZERS, BODY OILS, BATH OILS, ESSENTIAL OILS FOR PERSONAL USE, MASSAGE OIL, AROMATHERAPY SPRAYS; AROMATHERAPY BODY CARE PRODUCTS, NAMELY, BODY LOTION, SHOWER GEL, BODY POLISH, BODY AND FOOT SCRUB, ROOM FRAGRANCES (U.S. CLS. 1, 4, 6, 50, 51 AND 52).

FIRST USE 12-31-2006; IN COMMERCE 7-31-2010.

CLASS 4—LUBRICANTS AND FUELS

FOR CANDLES, SCENTED CANDLES, AROMATHERAPY CANDLES (U.S. CLS. 1, 6 AND 15).

FIRST USE 12-31-2006; IN COMMERCE 7-31-2010.

3,998,588. HPE DESIGN, LLC, DBA HENNESSEY PERFORMANCE ENGINEERING, SEALY, TX. SN 77-630,369. PUB. 9-14-2010, FILED 12-10-2008.

VENOM GT

THE MARK CONSISTS OF STANDARD CHARACTERS WITHOUT CLAIM TO ANY PARTICULAR FONT, STYLE, SIZE, OR COLOR.

NO CLAIM IS MADE TO THE EXCLUSIVE RIGHT TO

USE "GT", APART FROM THE MARK AS SHOWN.

CLASS 7—MACHINERY

FOR AUTOMOBILE PARTS, NAMELY, ENGINE AND MOTOR MUFFLERS (U.S. CLS. 13, 19, 21, 23, 31, 34 AND 35).

FIRST USE 1-1-2010; IN COMMERCE 4-1-2010.

CLASS 12—VEHICLES

FOR AUTOMOBILES AND AUTOMOTIVE VEHICLE PARTS, NAMELY, BRAKE CYLINDERS, TRANSMISSIONS, AUTOMOBILE ENGINES, SHOCK ABSORBERS, SWAY BARS, WHEEL SPACERS WITH STUDS, BRAKES, STEERING WHEELS AND PARTS THEREOF, DIFFERENTIALS, FITTED LEATHER CONVERTIBLE COVERS, FOOTRESTS, CLUTCH PRESSURE PLATES AND CLUTCH DISCS, SHORT THROW SHIFTERS, SHOCK TOWER BRACES, GAS PEDALS, GAS PEDAL LINKAGE, FRONT SPOILERS, CLUTCH CABLES, SPOILER GRILLES, LEATHER HEADLINERS, SUN VISORS, DOOR HANDLES, MAP POCKETS, LEATHER COVERED CONSOLE WITH BRAKE HANDLE, HEATED WINDSHIELDS, PLASTIC AND METAL DECORATIVE EXTERIOR TRIMS, AUTOMOTIVE PRODUCTS FOR HIGH PERFORMANCE MODIFICATION RELATING TO ENGINE TUNING, DRIVELINE TUNING, CHASSIS TUNING, AND COMPREHENSIVE TUNING OF MOTOR VEHICLES, NAMELY, SUSPENSION SYSTEMS, BRAKES AND BRAKE HARDWARE ALL FOR INCREASED POWER, FASTER ACCELERATION AND IMPROVED HANDLING; AND INSTRUMENT PANELS FOR AUTOMOBILES, NAMELY, DASHBOARDS (U.S. CLS. 19, 21, 23, 31, 35 AND 44).

FIRST USE 1-1-2010; IN COMMERCE 4-1-2010.

3,998,592. ROBYN SUE GOLDMAN, SAN FRANCISCO, CA. SN 77-635,581. PUB. 9-21-2010, FILED 12-18-2008.

SMITTEN

THE MARK CONSISTS OF STANDARD CHARACTERS WITHOUT CLAIM TO ANY PARTICULAR FONT, STYLE, SIZE, OR COLOR.

CLASS 30—STAPLE FOODS

FOR ICE CREAMS, ICE MILKS, FROZEN DAIRY DESSERTS, FROZEN DAIRY CONFECTIONS, FROZEN CONFECTIONS (U.S. CL. 46).

FIRST USE 9-29-2009; IN COMMERCE 12-28-2009.

CLASS 35—ADVERTISING AND BUSINESS

FOR RETAIL ICE CREAM PARLOR AND FROZEN CONFECTION STORE SERVICES FEATURING ICE CREAMS, ICE MILKS, FROZEN DAIRY DESSERTS, FROZEN DAIRY CONFECTIONS, FROZEN CONFECTIONS; ONLINE RETAIL STORE SERVICES FEATURING ICE CREAM AND FROZEN CONFECTIONS (U.S. CLS. 100, 101 AND 102).

FIRST USE 9-29-2009; IN COMMERCE 12-28-2009.

3,998,594. KOHLER CO., KOHLER, WI. SN 77-643,586. PUB. 2-1-2011, FILED 1-5-2009.

KOHLER

THE MARK CONSISTS OF STANDARD CHARACTERS WITHOUT CLAIM TO ANY PARTICULAR FONT, STYLE, SIZE, OR COLOR.

OWNER OF U.S. REG. NOS. 590,052 AND 2,443,830. SEC. 2(F).

CLASS 7—MACHINERY

FOR GENERATORS, NAMELY, ELECTRIC POWER GENERATORS (U.S. CLS. 13, 19, 21, 23, 31, 34 AND 35). FIRST USE 12-31-1920; IN COMMERCE 12-31-1920.

CLASS 9—ELECTRICAL AND SCIENTIFIC APPARATUS

FOR SWITCHGEARS; POWER TRANSFER SWITCHES FOR AUTOMATICALLY SWITCHING BETWEEN A PRIMARY POWER SOURCE AND A BACK-UP POWER SOURCE (U.S. CLS. 21, 23, 26, 36 AND 38). FIRST USE 12-31-1974; IN COMMERCE 12-31-1974.

3,998,595. MISSION BREWERY, SAN DIEGO, CA. SN 77-644,162. PUB. 9-21-2010, FILED 1-6-2009.

MISSION BREWERY

THE MARK CONSISTS OF STANDARD CHARACTERS WITHOUT CLAIM TO ANY PARTICULAR FONT, STYLE, SIZE, OR COLOR.

NO CLAIM IS MADE TO THE EXCLUSIVE RIGHT TO USE "BREWERY", APART FROM THE MARK AS SHOWN.

CLASS 32—LIGHT BEVERAGES

FOR BEERS, NAMELY, ALCOHOLIC BEER, NON-ALCOHOLIC BEER, LAGER, ALE, STOUT, PORTER, DRAFT, MICRO-BREW (U.S. CLS. 45, 46 AND 48). FIRST USE 8-10-2007; IN COMMERCE 8-10-2007.

CLASS 43—HOTEL AND RESTAURANT SERVICES

FOR RESTAURANT, BAR, SERVICES; RESTAURANT SERVICES WITH INTEGRATED TASTING ROOM SERVICES (U.S. CLS. 100 AND 101). FIRST USE 4-5-2011; IN COMMERCE 4-5-2011.

3,998,600. APPLIED MATERIALS, INC., SANTA CLARA, CA. SN 77-659,605. PUB. 6-15-2010, FILED 1-29-2009.

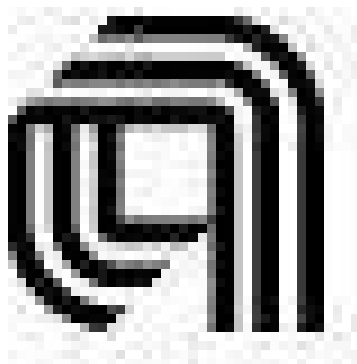

OWNER OF U.S. REG. NO. 1,549,863. THE MARK CONSISTS OF STYLIZED "A".

CLASS 7—MACHINERY

FOR EQUIPMENT AND SYSTEMS COMPRISED OF MACHINERY FOR MAKING SOLAR INSTRUMENTS AND MATERIALS, NAMELY, FOR MAKING PHOTOVOLTAIC SOLAR GENERATORS, FOR MAKING PHOTOVOLTAIC SOLAR CELLS, FOR MAKING INVERTERS, FOR MAKING DIRECT CURRENT CABLES AND FOR MAKING SOLAR RADIATION-RELATED MONITORING AND TRACKING SYSTEMS, ALL FOR THE CONSTRUCTION AND MANUFACTURING OF MACHINES AND INSTRUMENTS FOR THE GENERATION AND TRANSFORMATION OF ELECTRICITY FROM SOLAR ENERGY; SEMICONDUCTOR WAFER PROCESSING EQUIPMENT; EQUIPMENT AND SYSTEMS COMPRISED OF MACHINERY FOR MAKING FLAT PANEL DISPLAYS; PLASMA ETCHERS AND CHEMICAL MECHANICAL POLISHERS (U.S. CLS. 13, 19, 21, 23, 31, 34 AND 35). FIRST USE 7-0-1985; IN COMMERCE 7-0-1985.

CLASS 9—ELECTRICAL AND SCIENTIFIC APPARATUS

FOR SOLAR CELLS; ELECTRONIC SENSORS FOR MEASURING SOLAR RADIATION; PHOTOVOLTAIC CELLS AND MODULES; INTEGRATED CIRCUITS; FLAT PANEL DISPLAYS; SEMICONDUCTOR WAFER PROCESSING COMPONENTS, NAMELY, EPITAXIAL REACTORS, CHEMICAL VAPOR DEPOSITION REACTORS, PHYSICAL VAPOR DEPOSITION REACTORS, ION IMPLANTERS; AND OPERATIONAL SOFTWARE SOLD AS A COMPONENT OF THE FOREGOING; ALL FOR THE PROCESSING AND PRODUCTION OF SEMICONDUCTOR SUBSTRATES, THIN FILMS, SILICON DISCS AND WAFERS (U.S. CLS. 21, 23, 26, 36 AND 38). FIRST USE 7-0-1985; IN COMMERCE 7-0-1985.

CLASS 37—CONSTRUCTION AND REPAIR

FOR MAINTENANCE AND REPAIR OF SEMICONDUCTOR PROCESSING AND PRODUCTION EQUIPMENT; MAINTENANCE AND REPAIR OF SOLAR PRODUCTION EQUIPMENT (U.S. CLS. 100, 103 AND 106). FIRST USE 7-0-1985; IN COMMERCE 7-0-1985.

CLASS 40—MATERIAL TREATMENT

FOR PROVIDING ON LINE INFORMATION AND A WIDE RANGE OF DATA IN THE FIELD OF ELECTRICITY GENERATION AND TRANSFORMATION FROM SOLAR ENERGY THROUGH ELECTRONIC TRANSMISSION OVER A GLOBAL COMPUTER INFORMATION NETWORK (U.S. CLS. 100, 103 AND 106). FIRST USE 7-0-1985; IN COMMERCE 7-0-1985.

CLASS 42—SCIENTIFIC AND COMPUTER SERVICES

FOR TECHNOLOGY PLANNING AND CONSULTING IN THE FIELD OF SOLAR ENERGY, NAMELY, PHOTOVOLTAIC SOLAR MODULE MANUFACTURING EQUIPMENT, SUBSTRATES FOR ELECTRICAL OR THERMAL INSULATION OF SOLAR CELLS, PHOTOVOLTAIC CELLS, AND SOLAR COLLECTORS; ENGINEERING SERVICES, NAMELY, ENGINEERING, DESIGN AND SIMULATION FOR THE CONSTRUCTION AND MANAGEMENT OF SOLAR MATERIALS AND APPLIANCE PRODUCTION FACILITIES (U.S. CLS. 100 AND 101).

FIRST USE 7-0-1985; IN COMMERCE 7-0-1985.

3,998,609. TRINITY CHRISTIAN CENTER OF SANTA ANA, INC., SANTA ANA, CA. SN 77-681,400. PUB. 2-23-2010, FILED 3-2-2009.



THE MARK CONSISTS OF A SMILEY FACE WITH A HALO ABOVE IT.

CLASS 38—COMMUNICATION

FOR TELEVISION BROADCASTING; CABLE TELEVISION BROADCASTING; DIGITAL TELEVISION BROADCASTING; AUDIO BROADCASTING; BROADCASTING PROGRAMS VIA A GLOBAL COMPUTER NETWORK; VIDEO BROADCASTING; STREAMING OF AUDIO AND VIDEO MATERIAL ON THE INTERNET; RADIO BROADCASTING OF INFORMATION AND OTHER PROGRAMS; RADIO PROGRAM BROADCASTING; BROADCASTING SERVICES, NAMELY, BROADCASTING INFORMATION ON TELEVISION BROADCASTING, CABLE TELEVISION BROADCASTING, DIGITAL TELEVISION BROADCASTING, AUDIO BROADCASTING, BROADCASTING PROGRAMS VIA A GLOBAL COMPUTER NETWORK, VIDEO BROADCASTING, AND STREAMING OF AUDIO AND VIDEO MATERIAL VIA THE INTERNET (U.S. CLS. 100, 101 AND 104).

FIRST USE 1-0-2009; IN COMMERCE 1-0-2009.

CLASS 41—EDUCATION AND ENTERTAINMENT

FOR ENTERTAINMENT, NAMELY, TELEVISION NEWS SHOWS; PRODUCTION OF CABLE TELEVISION PROGRAMS; PRODUCTION OF CLOSED CAPTION TELEVISION PROGRAMS; PRODUCTION OF RADIO AND TELEVISION PROGRAMS; TELEVISION PROGRAM SYNDICATION; TELEVISION SHOW PRODUCTION; ENTERTAINMENT IN THE NATURE OF ON-GOING TELEVISION PROGRAMS IN THE FIELD OF NEWS, COMEDY, VARIETY, RELIGION, HEALTH, MUSIC AND GENERAL INTEREST TOPICS FOR YOUTHS, TEENAGERS, ADOLESCENTS, ADULTS AND CHILDREN; ENTERTAINMENT SERVICES, NAMELY, PROVIDING A RADIO PROGRAM IN THE FIELD OF NEWS, RELIGION, HEALTH, VARIETY, MUSIC, COMEDY AND GENERAL INTEREST TOPICS FOR YOUTHS, TEENAGERS, ADOLESCENTS, ADULTS AND CHILDREN VIA A GLOBAL COMPUTER NETWORK; ENTERTAINMENT SERVICES, NAMELY, PROVIDING A TELEVISION PROGRAM IN THE FIELD OF NEWS, RELIGION, HEALTH, VARIETY, MUSIC, COMEDY AND GENERAL INTEREST TOPICS FOR YOUTHS, TEENAGERS, ADOLESCENTS, ADULTS AND CHILDREN; ENTERTAINMENT SERVICES IN THE NATURE OF ON-GOING TELEVISION PROGRAMS IN THE FIELDS OF CHILDREN'S ENTERTAINMENT; ENTERTAINMENT SERVICES IN THE NATURE OF ON-GOING TELEVISION PROGRAMS IN THE FIELDS OF TEEN-AGER, ADOLESCENT AND ADULT ENTERTAINMENT FEATURING NEWS, COMEDY, VARIETY, RELIGION, HEALTH, MUSIC AND GENERAL INTEREST TOPICS; PRODUCTION OF RADIO OR TELEVISION PROGRAMS; RADIO ENTERTAINMENT SERVICES, NAMELY, RADIO PROGRAMS FEATURING PERFORMANCES BY A RADIO PERSONALITY; ENTERTAINMENT NAMELY, PRODUCTION OF TELEVISION SHOWS AND GAME SHOWS; ENTERTAINMENT SERVICES, NAMELY, PRODUCTION AND DISTRIBUTION OF A GAME SHOW; PRODUCTION OF VIDEO CASSETTES; RADIO ENTERTAINMENT PRODUCTION; VIDEOTAPE PRODUCTION; ENTERTAINMENT SERVICES, NAMELY, PROVIDING A WEB SITE FEATURING MUSICAL PERFORMANCES, MUSICAL VIDEOS, RELATED FILM CLIPS, PHOTOGRAPHS, AND OTHER MULTIMEDIA MATERIALS; ENTERTAINMENT SERVICES, NAMELY, AN ONLINE ACTIVITY WHERE ONE CREATES ONE'S OWN MUSIC VIDEOS; ENTERTAINMENT, NAMELY, A CONTINUING NEWS, COMEDY, VARIETY, HEALTH, MUSIC, RELIGIOUS, OR GENERAL INTEREST TOPICS FOR YOUTHS, CHILDREN, TEENAGERS, ADOLESCENTS AND ADULTS SHOW BROADCAST OVER TELEVISION, SATELLITE, AUDIO, AND VIDEO MEDIA; ENTERTAINMENT SERVICES, NAMELY, A CONTINUING VARIETY, COMEDY OR NEWS SHOW BROADCAST OVER TELEVISION FEATURING RELIGIOUS CONTENT; ENTERTAINMENT SERVICES, NAMELY, CONDUCTING ON-GOING TELEVISION AND RADIO PROGRAMS IN THE FIELD OF NEWS, COMEDY, VARIETY, RELIGION, HEALTH, MUSIC OR GENERAL INTEREST TOPICS FOR YOUTHS, TEENAGERS, ADOLESCENTS, ADULTS AND CHILDREN; MOTION PICTURE FILM PRODUCTION; AND PROVIDING INFORMATION ON TELEVISION AND RADIO PRODUCTION AND ENTERTAINMENT SERVICES VIA THE INTERNET (U.S. CLS. 100, 101 AND 107).

FIRST USE 1-0-2009; IN COMMERCE 1-0-2009.

3,998,611. MOTT'S LLP, RYE BROOK, NY. SN 77-682,967. PUB. 7-14-2009, FILED 3-4-2009.



OWNER OF U.S. REG. NOS. 160,454, 3,335,041, AND OTHERS.

THE MARK CONSISTS OF AN APPLE WITH A LEAF, CONTAINING THE WORDS "PINK TO THE CORE" IN STYLIZED SCRIPT INSIDE THE APPLE, AND THE WORD "MOTT'S" INSIDE THE LEAF.

CLASS 18—LEATHER GOODS

FOR ALL-PURPOSE CARRYING BAGS (U.S. CLS. 1, 2, 3, 22 AND 41).
FIRST USE 4-25-2009; IN COMMERCE 4-25-2009.

CLASS 29—MEATS AND PROCESSED FOODS

FOR APPLESAUCE (U.S. CL. 46).
FIRST USE 4-25-2009; IN COMMERCE 4-25-2009.

CLASS 35—ADVERTISING AND BUSINESS

FOR PUBLIC ADVOCACY TO PROMOTE AWARENESS OF BREAST CANCER TREATMENT, PREVENTION AND RESEARCH (U.S. CLS. 100, 101 AND 102).
FIRST USE 4-25-2009; IN COMMERCE 4-25-2009.

3,998,612. AMERICAN TIRE DISTRIBUTORS, INC., HUNTERSVILLE, NC. SN 77-684,725. PUB. 7-7-2009, FILED 3-5-2009.



THE MARK CONSISTS OF COMPUTER MOUSE WITH WHEELS.

CLASS 35—ADVERTISING AND BUSINESS

FOR ON-LINE RETAIL STORE SERVICES FEATURING AUTOMOTIVE AND VEHICLE TIRE TIRES, WHEELS, AUTOMOTIVE EQUIPMENT, AFTER-MARKET ACCESSORIES AND REPLACEMENT PARTS; MATCHING CONSUMERS WITH DEALERS IN THE FIELD OF AUTOMOTIVE AND VEHICLE TIRES, WHEELS, AUTOMOTIVE EQUIPMENT, AFTER-MARKET ACCESSORIES AND REPLACEMENT PARTS; PROVIDING CONSUMER INFORMATION REGARDING LOCALLY AVAILABLE INSTALLATION SERVICES VIA THE INTERNET (U.S. CLS. 100, 101 AND 102).

FIRST USE 11-19-2008; IN COMMERCE 11-19-2008.

CLASS 37—CONSTRUCTION AND REPAIR

FOR PROVIDING INFORMATION REGARDING INSTALLATION OF AUTOMOTIVE AND VEHICLE TIRES, WHEELS, AUTOMOTIVE EQUIPMENT, AFTER-MARKET ACCESSORIES AND REPLACEMENT PARTS VIA THE INTERNET (U.S. CLS. 100, 103 AND 106).

FIRST USE 11-19-2008; IN COMMERCE 11-19-2008.

CLASS 39—TRANSPORTATION AND STORAGE

FOR PROVIDING DELIVERY OF AUTOMOTIVE AND VEHICLE TIRES, WHEELS, AUTOMOTIVE EQUIPMENT, AFTER-MARKET ACCESSORIES AND REPLACEMENT PARTS (U.S. CLS. 100 AND 105).

FIRST USE 11-19-2008; IN COMMERCE 11-19-2008.

3,998,613. PLENTYOFFISH MEDIA, INC., VANCOUVER, CANADA. SN 77-685,458. PUB. 3-9-2010, FILED 3-6-2009.

SERIOUS MEMBER

THE MARK CONSISTS OF STANDARD CHARACTERS WITHOUT CLAIM TO ANY PARTICULAR FONT, STYLE, SIZE, OR COLOR.

NO CLAIM IS MADE TO THE EXCLUSIVE RIGHT TO USE "MEMBER", APART FROM THE MARK AS SHOWN.

CLASS 38—COMMUNICATION

FOR PROVIDING ON-LINE FORUMS FOR THE TRANSMISSION OF MESSAGES AMONG COMPUTER USERS CONCERNING MAKING ACQUAINTANCES, FRIENDSHIP, DATING, LONG-TERM RELATIONSHIPS AND MARRIAGE (U.S. CLS. 100, 101 AND 104).

FIRST USE 4-1-2009; IN COMMERCE 4-1-2009.

CLASS 45—PERSONAL AND LEGAL SERVICES

FOR COMPUTER SERVICES, NAMELY, PROVIDING INFORMATION REGARDING, AND IN THE NATURE OF, ON-LINE DATING AND INTRODUCTION SERVICES (U.S. CLS. 100 AND 101).

FIRST USE 4-1-2009; IN COMMERCE 4-1-2009.

3,998,615. VOGEL SEED & FERTILIZER, INC., DBA SPRING VALLEY TURF PRODUCTS, JACKSON, WI. SN 77-686,574. PUB. 2-23-2010, FILED 3-9-2009.

NATURAL GREEN

THE MARK CONSISTS OF STANDARD CHARACTERS WITHOUT CLAIM TO ANY PARTICULAR FONT, STYLE, SIZE, OR COLOR.

OWNER OF U.S. REG. NO. 2,086,724.

NO CLAIM IS MADE TO THE EXCLUSIVE RIGHT TO USE "GREEN", APART FROM THE MARK AS SHOWN.

CLASS 18—LEATHER GOODS

FOR CELLULOSE-BASED GRANULAR PRODUCT FOR USE AS ANIMAL BEDDING, NAMELY, A PAPER PROCESSING BY-PRODUCT FOR USE IN ANIMAL PENS AND STALLS (U.S. CLS. 1, 2, 3, 22 AND 41).

FIRST USE 8-4-2010; IN COMMERCE 8-4-2010.

CLASS 31—NATURAL AGRICULTURAL PRODUCTS

FOR CELLULOSE-BASED PAPER PROCESSING BY-PRODUCT FOR USE AS AN OIL AND GREASE ABSORBENT (U.S. CLS. 1 AND 46).

FIRST USE 2-25-2011; IN COMMERCE 2-25-2011.

3,998,616. MARILYN JACKSON, FAIRBURN, GA. SN 77-687,165. PUB. 2-23-2010, FILED 3-10-2009.

ImSingleUniverse

THE MARK CONSISTS OF STANDARD CHARACTERS WITHOUT CLAIM TO ANY PARTICULAR FONT, STYLE, SIZE, OR COLOR.

CLASS 42—SCIENTIFIC AND COMPUTER SERVICES

FOR COMPUTER SERVICES, NAMELY, CREATING AN ON-LINE COMMUNITY FOR USERS TO PARTICIPATE IN DISCUSSIONS, POST AND SHARE INFORMATION, GET FEEDBACK, FORM VIRTUAL COMMUNITIES, AND ENGAGE IN SOCIAL NETWORKING (U.S. CLS. 100 AND 101).

FIRST USE 6-26-2009; IN COMMERCE 3-13-2011.

CLASS 45—PERSONAL AND LEGAL SERVICES

FOR ON-LINE SOCIAL NETWORKING SERVICES; INTERNET-BASED DATING, SOCIAL INTRODUCTION AND SOCIAL NETWORKING SERVICES (U.S. CLS. 100 AND 101).

FIRST USE 6-26-2009; IN COMMERCE 3-13-2011.

3,998,620. HILL, STEPHEN R. MUKILTEO, WA. SN 77-691,186. PUB. 9-15-2009, FILED 3-14-2009.

TEO

THE MARK CONSISTS OF STANDARD CHARACTERS WITHOUT CLAIM TO ANY PARTICULAR FONT, STYLE, SIZE, OR COLOR.

CLASS 9—ELECTRICAL AND SCIENTIFIC APPARATUS

FOR TELECOMMUNICATIONS EQUIPMENT, NAMELY, SWITCHES IN THE NATURE OF NETWORK COMPONENTS AND SYSTEMS THAT FACILITATE DATA AND VOICE COMMUNICATIONS, ATTENDANT CONSOLES, NT1 ISDN NETWORK TERMINATION DEVICES, TELECOM POWER SUPPLIES, BATTERY BACK-UP DEVICES, E9-1-1 SYSTEMS IN THE NATURE OF ELECTRONIC DEVICES AND SOFTWARE USED FOR THE TRANSMISSION, IDENTIFICATION, AND ALERTING OF 9-1-1 CALLS, TELEPHONES IN THE NATURE OF BUSINESS SETS USED WITH VOICE OVER INTERNET PROTOCOL (VOIP) SERVICES AND OTHER WIRE LINE SERVICES, NOT INCLUDING MOBILE TELEPHONES, NAMELY, CELLULAR TELEPHONES AND SMARTPHONES, AND APPLICATIONS SOFTWARE FOR ALL OF THE AFORESAID GOODS (U.S. CLS. 21, 23, 26, 36 AND 38).

FIRST USE 7-12-2009; IN COMMERCE 7-12-2009.

CLASS 42—SCIENTIFIC AND COMPUTER SERVICES

FOR TECHNICAL SUPPORT SERVICES, NAMELY, SYSTEMS DESIGN CONSULTING AND SERVICES IN THE FIELD OF TELECOMMUNICATIONS, INSTALLATION SERVICES AND SYSTEM MAINTENANCE OF SOFTWARE, AND TROUBLESHOOTING OF TELECOMMUNICATIONS SOFTWARE PROBLEMS AND DIAGNOSING HARDWARE PROBLEMS, NOT INCLUDING SERVICES RELATED TO MOBILE TELEPHONES, NAMELY, CELLULAR TELEPHONES AND SMARTPHONES (U.S. CLS. 100 AND 101).

FIRST USE 7-12-2009; IN COMMERCE 7-12-2009.

3,998,625. GRAPHIC PACKAGING INTERNATIONAL, INC., MARIETTA, GA. SN 77-698,437. PUB. 7-28-2009, FILED 3-25-2009.

CAP-IT

THE MARK CONSISTS OF STANDARD CHARACTERS WITHOUT CLAIM TO ANY PARTICULAR FONT, STYLE, SIZE, OR COLOR.

CLASS 7—MACHINERY

FOR PACKAGING MACHINES (U.S. CLS. 13, 19, 21, 23, 31, 34 AND 35).

FIRST USE 7-0-1996; IN COMMERCE 7-0-1996.

CLASS 16—PAPER GOODS AND PRINTED MATTER

FOR PAPERBOARD PACKAGING (U.S. CLS. 2, 5, 22, 23, 29, 37, 38 AND 50).

FIRST USE 12-0-2007; IN COMMERCE 12-0-2007.

3,998,640. DREXEL UNIVERSITY, PHILADELPHIA, PA. SN 77-715,016. PUB. 10-5-2010, FILED 4-16-2009.

AMERICAN CULTURAL CONNECTIONS

THE MARK CONSISTS OF STANDARD CHARACTERS WITHOUT CLAIM TO ANY PARTICULAR FONT, STYLE, SIZE, OR COLOR.

NO CLAIM IS MADE TO THE EXCLUSIVE RIGHT TO USE "AMERICAN CULTURAL", APART FROM THE MARK AS SHOWN.

CLASS 41—EDUCATION AND ENTERTAINMENT

FOR EDUCATIONAL SERVICES DIRECTED TOWARD PROVIDING INTERNATIONAL STUDENTS WITH THE TECHNICAL TRAINING, LANGUAGE TRAINING, AND SOCIAL AND CULTURAL TRAINING NECESSARY TO BEGIN UNIVERSITY STUDY IN THE UNITED STATES, NAMELY, ORGANIZING AND CONDUCTING CLASSES FOR INTERNATIONAL STUDENTS IN THE FIELDS OF MATHEMATICS, SCIENCE, SOCIAL STUDIES, COMMUNICATIONS, AND LANGUAGE; ORGANIZING AND PROVIDING CULTURAL ENTERTAINMENT EXCURSIONS; ORGANIZING AND PROVIDING EDUCATIONAL NETWORKING EVENTS FOR INTERNATIONAL STUDENTS (U.S. CLS. 100, 101 AND 107).

FIRST USE 5-25-2011; IN COMMERCE 5-25-2011.

CLASS 45—PERSONAL AND LEGAL SERVICES

FOR PROVIDING ON-LINE SOCIAL NETWORKING SERVICES FOR INTERNATIONAL STUDENTS (U.S. CLS. 100 AND 101).

FIRST USE 5-25-2011; IN COMMERCE 5-25-2011.

3,998,641. INTELLECTUAL TAKEOUT, MINNEAPOLIS, MN. SN 77-715,192. PUB. 10-5-2010, FILED 4-16-2009.

INTELLECTUAL TAKEOUT

THE MARK CONSISTS OF STANDARD CHARACTERS WITHOUT CLAIM TO ANY PARTICULAR FONT, STYLE, SIZE, OR COLOR.

CLASS 35—ADVERTISING AND BUSINESS

FOR PROVIDING A WEBSITE FEATURING INFORMATION IN THE FIELDS OF BUSINESS MATTERS, DEMOGRAPHIC STUDIES, ECONOMICS, POLITICAL SCIENCE AND NATURAL RESOURCE MANAGEMENT (U.S. CLS. 100, 101 AND 102).

FIRST USE 2-1-2009; IN COMMERCE 2-1-2009.

CLASS 41—EDUCATION AND ENTERTAINMENT

FOR PROVIDING A WEBSITE FEATURING INFORMATION IN THE FIELDS OF ART AND ART HISTORY, NATIONAL AND WORLD HISTORY, LITERATURE, PHILOSOPHY, EDUCATIONAL DISCIPLINE IN CRIMINOLOGY, ECONOMICS, EDUCATION MATTERS, LATIN AMERICAN STUDIES, EDUCATIONAL DISCIPLINE IN PSYCHOLOGY, EDUCATIONAL DISCIPLINE IN SOCIOLOGY, AND WORLD STUDIES; ON-LINE JOURNALS, NAMELY, BLOGS FEATURING INFORMATION IN THE FIELDS OF BASIC TECHNOLOGY, GENERAL SCIENCE, SOCIAL SCIENCE, AND HUMANITIES; ON-LINE LIBRARY SERVICES, NAMELY, PROVIDING ELECTRONIC LIBRARY SERVICES WHICH FEATURE NEWSPAPERS, MAGAZINES, PHOTOGRAPHS AND PICTURES VIA AN ON-LINE COMPUTER NETWORK, ALL IN THE FIELDS OF BASIC TECHNOLOGY, GENERAL SCIENCE, SOCIAL SCIENCE, AND HUMANITIES; PROVIDING ON-LINE PUBLICATIONS IN THE NATURE OF BOOKLETS, ARTICLES, AND RESEARCH PAPERS IN THE FIELDS OF BASIC TECHNOLOGY, GENERAL SCIENCE, SOCIAL SCIENCE, AND HUMANITIES (U.S. CLS. 100, 101 AND 107).

FIRST USE 2-1-2009; IN COMMERCE 2-1-2009.

CLASS 42—SCIENTIFIC AND COMPUTER SERVICES

FOR PROVIDING A WEBSITE FEATURING INFORMATION IN THE FIELDS OF AGRICULTURAL SCIENCE, CLIMATE SCIENCE, ENVIRONMENTAL STUDIES, ENVIRONMENTAL SUSTAINABILITY, ENVIRONMENTAL SCIENCE, URBAN PLANNING, URBAN DESIGN PLANNING, INFORMATION TECHNOLOGY, AND HEALTH AND SOCIAL SCIENTIFIC RESEARCH (U.S. CLS. 100 AND 101).

FIRST USE 2-1-2009; IN COMMERCE 2-1-2009.

3,998,652. GREENWOOD FINANCE, INC., WILMINGTON, DE. SN 77-721,740. PUB. 3-23-2010, FILED 4-24-2009.



THE COLOR(S) RED AND ORANGE IS/ARE CLAIMED AS A FEATURE OF THE MARK.

THE MARK CONSISTS OF THE FOLLOWING: AN IMAGE OF A STYLIZED RIDER RIDING A HORSE. THE IMAGE IS MADE UP OF CLUSTERED DOTS THAT APPEAR IN THE COLORS ORANGE AND RED. THE DESIGN IMAGE APPEARS ABOVE THE WORDS "PARX-RACING". THE PORTION OF TEXT, "PARX" APPEARS IN RED AND THE TEXT "RACING" APPEARS IN THE COLOR ORANGE.

CLASS 41—EDUCATION AND ENTERTAINMENT

FOR CASINOS; GAMBLING SERVICES; SLOT MACHINE SERVICES, NAMELY, PROVIDING SLOT MACHINE PARLORS; ENTERTAINMENT SERVICES IN THE NATURE OF LIVE MUSICAL PERFORMANCES BY AN INDIVIDUAL OR GROUP AND LIVE COMEDY PERFORMANCES BY AN INDIVIDUAL OR GROUP; ENTERTAINMENT SERVICES, NAMELY, CONDUCTING HORSE RACES; BETTING AND WAGERING SERVICES; BETTING AND WAGERING SERVICES IN CONNECTION WITH HORSE RACES; ORGANIZING EXHIBITIONS FOR PRE AND POST HORSE RACE ENTERTAINMENT (U.S. CLS. 100, 101 AND 107).

FIRST USE 8-0-2010; IN COMMERCE 8-0-2010.

CLASS 43—HOTEL AND RESTAURANT SERVICES

FOR HOTEL AND RESTAURANT SERVICES (U.S. CLS. 100 AND 101).

FIRST USE 8-0-2010; IN COMMERCE 8-0-2010.

3,998,653. ELLMAN INTERNATIONAL, INC., OCEANSIDE, NY. SN 77-722,160. PUB. 4-20-2010, FILED 4-24-2009.

PELLEVÉ

THE MARK CONSISTS OF STANDARD CHARACTERS WITHOUT CLAIM TO ANY PARTICULAR FONT, STYLE, SIZE, OR COLOR.

THE WORDING "PELLEVÉ" HAS NO MEANING IN A FOREIGN LANGUAGE.

CLASS 5—PHARMACEUTICALS

FOR ACCESSORIES FOR USE WITH MEDICAL DEVICES, NAMELY, TREATMENT GELS FOR USE IN APPLYING RADIO-FREQUENCY WAVE ENERGY TO THE SKIN OF A PATIENT (U.S. CLS. 6, 18, 44, 46, 51 AND 52).

FIRST USE 6-3-2009; IN COMMERCE 6-3-2009.

CLASS 10—MEDICAL APPARATUS

FOR MEDICAL DEVICES, NAMELY, GENERATORS AND HANDPIECES FOR APPLYING RADIO-FREQUENCY WAVE ENERGY TO THE SKIN OF A PATIENT (U.S. CLS. 26, 39 AND 44).

FIRST USE 6-3-2009; IN COMMERCE 6-3-2009.

3,998,654. FIT360, LLC, PROVO, UT. SN 77-723,359. PUB. 3-2-2010, FILED 4-27-2009.

FIT SAVERS

THE MARK CONSISTS OF STANDARD CHARACTERS WITHOUT CLAIM TO ANY PARTICULAR FONT, STYLE, SIZE, OR COLOR.

CLASS 41—EDUCATION AND ENTERTAINMENT

FOR PROVIDING A WEBSITE FEATURING INFORMATION ON PHYSICAL EXERCISE (U.S. CLS. 100, 101 AND 107).

FIRST USE 11-0-2009; IN COMMERCE 11-0-2009.

CLASS 44—MEDICAL, BEAUTY AND AGRICULTURAL SERVICES

FOR PROVIDING A WEB SITE FEATURING INFORMATION ON HEALTH AND NUTRITION (U.S. CLS. 100 AND 101).

FIRST USE 11-0-2009; IN COMMERCE 11-0-2009.

3,998,655. M&G DURAVENT, INC., VACAVILLE, CA. SN 77-723,770. PUB. 3-30-2010, FILED 4-28-2009.

POLYPRO

THE MARK CONSISTS OF STANDARD CHARACTERS WITHOUT CLAIM TO ANY PARTICULAR FONT, STYLE, SIZE, OR COLOR.

CLASS 17—RUBBER GOODS

FOR NON-METALLIC FLEXIBLE PIPES AND FITTINGS THEREFOR, FOR GAS, OIL AND SOLID FUEL APPLIANCES (U.S. CLS. 1, 5, 12, 13, 35 AND 50).

FIRST USE 3-14-2011; IN COMMERCE 3-14-2011.

CLASS 19—NON-METALLIC BUILDING MATERIALS

FOR NON-METAL RIGID PIPES AND FITTINGS THEREFOR, FOR GAS, OIL AND SOLID FUEL APPLIANCES (U.S. CLS. 1, 12, 33 AND 50).

FIRST USE 3-14-2011; IN COMMERCE 3-14-2011.

3,998,661. POMWONDERFUL LLC, LOS ANGELES, CA. SN 77-726,621. PUB. 3-30-2010, FILED 4-30-2009.



NO CLAIM IS MADE TO THE EXCLUSIVE RIGHT TO USE "TEA", APART FROM THE MARK AS SHOWN.

THE MARK CONSISTS OF THE WORD "POMX", WITH A HEART DESIGN IN PLACE OF THE LETTER "O" IN THE WORD "POM" AND WITH A SUBSCRIPT LETTER "X" CONNECTED TO THE LETTER "M" IN THE WORD "POM", WITH A TEA LEAF WITH THE WORD "TEA" EXTENDING FROM THE HEART DESIGN.

CLASS 30—STAPLE FOODS

FOR ICED TEAS AND TEA-BASED BEVERAGES WITH FRUIT FLAVORING (U.S. CL. 46).

FIRST USE 6-15-2009; IN COMMERCE 6-15-2009.

CLASS 32—LIGHT BEVERAGES

FOR NON-ALCOHOLIC FRUIT EXTRACTS USED IN THE PREPARATION OF BEVERAGES; FRUIT FLAVORED BEVERAGES; NON-ALCOHOLIC BEVERAGES CONTAINING FRUIT JUICES; NON-ALCOHOLIC BEVERAGES WITH TEA FLAVOR; LOW CALORIE FRUIT FLAVORED BEVERAGES; LOW CALORIE FRUIT JUICE DRINKS; LOW CALORIE TEA FLAVORED BEVERAGES (U.S. CLS. 45, 46 AND 48).

FIRST USE 6-15-2009; IN COMMERCE 6-15-2009.

3,998,663. CAPSO VISION, INC., SARATOGA, CA. SN 77-730,890. PUB. 4-13-2010, FILED 5-6-2009.

3,998,672. SOUTHWIRE COMPANY, CARROLLTON, GA. SN 77-737,824. PUB. 2-9-2010, FILED 5-15-2009.

CAPSO VISION

THE MARK CONSISTS OF STANDARD CHARACTERS WITHOUT CLAIM TO ANY PARTICULAR FONT, STYLE, SIZE, OR COLOR.

CLASS 9—ELECTRICAL AND SCIENTIFIC APPARATUS

FOR COMPUTER DOCKING STATIONS FOR USE WITH INGESTIBLE DIAGNOSTIC CAMERAS; COMPUTER WORKSTATIONS CONSISTING OF CENTRAL PROCESSING UNITS, MONITORS, KEYBOARDS, AND MICE FOR USE WITH INGESTIBLE DIAGNOSTIC CAMERAS; COMPUTER SOFTWARE FOR IMAGING AND IMAGE ANALYSIS FOR USE WITH INGESTIBLE DIAGNOSTIC CAMERAS AND COMPUTER DOCKING STATIONS AND WORKSTATIONS (U.S. CLS. 21, 23, 26, 36 AND 38).

FIRST USE 1-6-2011; IN COMMERCE 1-6-2011.

CLASS 10—MEDICAL APPARATUS

FOR INGESTIBLE DIAGNOSTIC CAMERAS FOR MEDICAL PURPOSES; COLLECTION AND RETRIEVAL SYSTEM FOR INGESTIBLE DIAGNOSTIC CAMERAS CONSISTING PRIMARILY OF GLOVES, COLLECTION TRAY, WASH BOTTLE, SHIPPING CONTAINER AND DISINFECTANT (U.S. CLS. 26, 39 AND 44).

FIRST USE 1-6-2011; IN COMMERCE 1-6-2011.

3,998,665. EMIT CORPORATION, HOUSTON, TX. SN 77-732,530. PUB. 9-22-2009, FILED 5-8-2009.

EMIT Corporation

THE MARK CONSISTS OF STANDARD CHARACTERS WITHOUT CLAIM TO ANY PARTICULAR FONT, STYLE, SIZE, OR COLOR.

NO CLAIM IS MADE TO THE EXCLUSIVE RIGHT TO USE "CORPORATION", APART FROM THE MARK AS SHOWN.

CLASS 40—MATERIAL TREATMENT

FOR MANUFACTURE OF EMERGENCY MEDICAL TECHNOLOGY AND PRODUCTS TO ORDER AND/OR SPECIFICATION OF OTHERS (U.S. CLS. 100, 103 AND 106).

FIRST USE 5-24-2011; IN COMMERCE 5-24-2011.

CLASS 42—SCIENTIFIC AND COMPUTER SERVICES

FOR RESEARCH AND DEVELOPMENT OF NEW PRODUCTS FOR OTHERS (U.S. CLS. 100 AND 101).

FIRST USE 5-24-2011; IN COMMERCE 5-24-2011.

SIMPULL SOLUTIONS

THE MARK CONSISTS OF STANDARD CHARACTERS WITHOUT CLAIM TO ANY PARTICULAR FONT, STYLE, SIZE, OR COLOR.

OWNER OF U.S. REG. NOS. 3,154,159, 3,242,883, AND 3,394,722.

CLASS 40—MATERIAL TREATMENT

FOR ASSEMBLY FOR OTHERS OF ELECTRICAL WIRE, CABLE AND COMPONENTS THEREOF, AND RELATED DEVICES, NAMELY, PULLING GRIPS AND MULTIPLE ASSEMBLED CIRCUITS STACKED ON ONE REEL (U.S. CLS. 100, 103 AND 106).

FIRST USE 1-0-2010; IN COMMERCE 1-0-2010.

CLASS 42—SCIENTIFIC AND COMPUTER SERVICES

FOR CUSTOM ENGINEERING OF ELECTRICAL WIRE, CABLE AND COMPONENTS THEREOF (U.S. CLS. 100 AND 101).

FIRST USE 1-0-2010; IN COMMERCE 1-0-2010.

3,998,674. AVAIRPROS MANAGEMENT, INC., NAPLES, FL. SN 77-741,301. PUB. 1-18-2011, FILED 5-20-2009.

AvAirPros Management

THE MARK CONSISTS OF STANDARD CHARACTERS WITHOUT CLAIM TO ANY PARTICULAR FONT, STYLE, SIZE, OR COLOR.

NO CLAIM IS MADE TO THE EXCLUSIVE RIGHT TO USE "MANAGEMENT", APART FROM THE MARK AS SHOWN.

CLASS 35—ADVERTISING AND BUSINESS

FOR BUSINESS MANAGEMENT AND BUSINESS CONSULTING SERVICES IN THE FIELDS OF AVIATION, AIRPORT AND AIRLINE INDUSTRY; AVIATION MANAGEMENT SERVICES FOR OTHERS, NAMELY, AIRLINE AND AIRPORT PROGRAM DEVELOPMENT, NAMELY, THE SPECIFICATION AND SCOPE OF WORK OF INDIVIDUAL CAPITAL PROJECTS, PROCUREMENT, INSTALLATION, TESTING AND START UP OF AIRLINE AND AIRPORT FACILITY EQUIPMENT AND OPERATIONS; OPERATION OF AIRPORT FACILITIES FOR OTHERS TO FACILITATE CAPITAL FACILITY DEVELOPMENT PROGRAM CONTROLS AND MONITORING, NAMELY, AIRLINE FACILITY DEVELOPMENT AND OPERATIONS PERTAINING TO THE AVIATION INDUSTRY; MANAGEMENT SERVICES FOR OTHERS IN THE FIELD OF OPERATING AIRPORT TERMINALS, NAMELY, LEASE NEGOTIATION, PROCURING OF CONTRACTS FOR THE PURCHASE OF GOODS AND LABOR CONTRACTING SERVICES OF OTHERS, OPERATING CONCESSIONS STANDS FOR OTHERS; MANAGEMENT OF AIRPORT FACILITIES FOR OTHERS, NAMELY, THE OPERATION OF AIRPORT AND AIRLINE SYSTEMS, EQUIPMENT AND BUILDINGS FOR OTHERS; MANAGEMENT OF AIRPORT COMMON-USE ENVIRONMENTS FOR OTHERS, NAMELY, PROVIDING FULL TURNKEY AIRPORT FACILITIES AND AIRCRAFT GATE LAYOUTS; MANAGEMENT SERVICES FOR OTHERS, NAMELY, THE OPERATION OF AIRLINE, AIRPORT OR AIRPORT RENTAL CAR FACILITIES AND EQUIPMENT FOR OTHERS (U.S. CLS. 100, 101 AND 102).

FIRST USE 6-1-2000; IN COMMERCE 6-1-2000.

CLASS 39—TRANSPORTATION AND STORAGE

FOR AVIATION MANAGEMENT SERVICES, NAMELY, AIRPORT SERVICES (U.S. CLS. 100 AND 105).

FIRST USE 6-1-2000; IN COMMERCE 6-1-2000.

3,998,675. AVAIRPROS MANAGEMENT, INC., NAPLES, FL.
SN 77-741,359. PUB. 10-19-2010, FILED 5-20-2009.



THE MARK CONSISTS OF THE TERM "AVAIRPROS", A LINE UNDERNEATH THE TERM, AND A FOUR-SIDED GEOMETRIC SHAPE.

CLASS 35—ADVERTISING AND BUSINESS

FOR BUSINESS CONSULTING IN THE FIELDS OF AIRLINE AND AIRPORT LEASE NEGOTIATIONS, AIRLINE FACILITY DEVELOPMENT, AND OPERATIONAL ISSUES PERTAINING TO THE AVIATION INDUSTRY; BUSINESS MANAGEMENT SERVICES IN THE FIELD OF AVIATION; BUSINESS MANAGEMENT AND BUSINESS CONSULTING SERVICES FOR THE AVIATION, AIRPORT AND AIRLINE INDUSTRY; BUSINESS CONSULTATION IN THE FIELD OF AIRPORT PRIVATIZATION; BUSINESS CONSULTING SERVICES REGARDING THE SPECIFICATION, PROCUREMENT, INSTALLATION, TESTING AND START UP OF AIRLINE AND AIRPORT FACILITY EQUIPMENT AND SYSTEMS; BUSINESS CONSULTATION IN THE FIELD OF AIRLINE CONSORTIUM DEVELOPMENT; BUSINESS CONSULTING RELATING TO THE PLANNING AND/OR CONSTRUCTION OF AIRLINE AND AIRPORT FACILITIES; BUSINESS CONSULTING IN THE FIELD OF AIRLINES, AIRPORTS AND AVIATION (U.S. CLS. 100, 101 AND 102).

FIRST USE 5-1-2007; IN COMMERCE 5-1-2007.

CLASS 36—INSURANCE AND FINANCIAL

FOR CONSULTING RELATING TO AIRLINE AND AIRPORT FINANCIAL MATTERS; FINANCIAL PLANNING SERVICES FOR THE AVIATION, AIRPORT AND AIRLINE INDUSTRY (U.S. CLS. 100, 101 AND 102).

FIRST USE 5-1-2007; IN COMMERCE 5-1-2007.

CLASS 39—TRANSPORTATION AND STORAGE

FOR AIRPORT SERVICES (U.S. CLS. 100 AND 105).

FIRST USE 5-1-2007; IN COMMERCE 5-1-2007.

3,998,677. AVAIRPROS MANAGEMENT, INC., NAPLES, FL.
SN 77-741,455. PUB. 10-19-2010, FILED 5-20-2009.



THE MARK CONSISTS OF THE TERM "AVAIRPROS", TWO LINES UNDERNEATH THE TERM, AND A FOUR-SIDED GEOMETRIC SHAPE.

CLASS 35—ADVERTISING AND BUSINESS

FOR BUSINESS CONSULTING IN THE FIELDS OF AIRLINE AND AIRPORT LEASE NEGOTIATIONS, AIRLINE FACILITY DEVELOPMENT, AND OPERATIONAL ISSUES PERTAINING TO THE AVIATION INDUSTRY; BUSINESS MANAGEMENT SERVICES IN THE FIELD OF AVIATION; BUSINESS MANAGEMENT AND BUSINESS CONSULTING SERVICES FOR THE AVIATION, AIRPORT AND AIRLINE INDUSTRY; BUSINESS CONSULTATION IN THE FIELD OF AIRPORT PRIVATIZATION; BUSINESS CONSULTING SERVICES REGARDING THE SPECIFICATION, PROCUREMENT, INSTALLATION, TESTING AND START UP OF AIRLINE AND AIRPORT FACILITY EQUIPMENT AND SYSTEMS; BUSINESS CONSULTATION IN THE FIELD OF AIRLINE CONSORTIUM DEVELOPMENT; BUSINESS CONSULTING RELATING TO THE PLANNING AND/OR CONSTRUCTION OF AIRLINE AND AIRPORT FACILITIES; BUSINESS CONSULTING IN THE FIELD OF AIRLINES, AIRPORTS AND AVIATION (U.S. CLS. 100, 101 AND 102).

FIRST USE 6-1-2000; IN COMMERCE 6-1-2000.

CLASS 36—INSURANCE AND FINANCIAL

FOR CONSULTING RELATING TO AIRLINE AND AIRPORT FINANCIAL MATTERS; FINANCIAL PLANNING SERVICES FOR THE AVIATION, AIRPORT AND AIRLINE INDUSTRY (U.S. CLS. 100, 101 AND 102).

FIRST USE 6-1-2000; IN COMMERCE 6-1-2000.

CLASS 39—TRANSPORTATION AND STORAGE

FOR AIRPORT SERVICES (U.S. CLS. 100 AND 105).

FIRST USE 6-1-2000; IN COMMERCE 6-1-2000.

3,998,678. AVAIRPROS MANAGEMENT, INC., NAPLES, FL.
SN 77-741,510. PUB. 1-18-2011, FILED 5-20-2009.



AvAirPros
Management

NO CLAIM IS MADE TO THE EXCLUSIVE RIGHT TO USE "MANAGEMENT", APART FROM THE MARK AS SHOWN.

THE MARK CONSISTS OF THE TERMS "AVAIRPROS" AND "MANAGEMENT" WITH TWO LINES IN BETWEEN THE TERMS, AND A FOUR-SIDED GEOMETRIC SHAPE.

CLASS 35—ADVERTISING AND BUSINESS

FOR BUSINESS MANAGEMENT AND BUSINESS CONSULTING SERVICES IN THE FIELDS OF AVIATION, AIRPORT AND AIRLINE INDUSTRY; AVIATION MANAGEMENT SERVICES FOR OTHERS, NAMELY, AIRLINE AND AIRPORT PROGRAM DEVELOPMENT, NAMELY, THE SPECIFICATION AND SCOPE OF WORK OF INDIVIDUAL CAPITAL PROJECTS, PROCUREMENT, INSTALLATION, TESTING AND START UP OF AIRLINE AND AIRPORT FACILITY EQUIPMENT AND OPERATIONS; OPERATION OF AIRPORT FACILITIES FOR OTHERS TO FACILITATE CAPITAL FACILITY DEVELOPMENT PROGRAM CONTROLS AND MONITORING, NAMELY, AIRLINE FACILITY DEVELOPMENT AND OPERATIONS PERTAINING TO THE AVIATION INDUSTRY; MANAGEMENT SERVICES FOR OTHERS IN THE FIELD OF OPERATING AIRPORT TERMINALS, NAMELY, LEASE NEGOTIATION, PROCURING OF CONTRACTS FOR THE PURCHASE OF GOODS AND LABOR CONTRACTING SERVICES OF OTHERS, OPERATING CONCESSIONS STANDS FOR OTHERS; MANAGEMENT OF AIRPORT FACILITIES FOR OTHERS, NAMELY, THE OPERATION OF AIRPORT AND AIRLINE SYSTEMS, EQUIPMENT AND BUILDINGS FOR OTHERS; MANAGEMENT OF AIRPORT COMMON-USE ENVIRONMENTS FOR OTHERS, NAMELY, PROVIDING FULL TURNKEY AIRPORT FACILITIES AND AIRCRAFT GATE LAYOUTS; MANAGEMENT SERVICES FOR OTHERS, NAMELY, THE OPERATION OF AIRLINE, AIRPORT OR AIRPORT RENTAL CAR FACILITIES AND EQUIPMENT FOR OTHERS (U.S. CLS. 100, 101 AND 102).

FIRST USE 6-1-2000; IN COMMERCE 6-1-2000.

CLASS 39—TRANSPORTATION AND STORAGE

FOR AVIATION MANAGEMENT SERVICES, NAMELY, AIRPORT SERVICES (U.S. CLS. 100 AND 105).
FIRST USE 6-1-2000; IN COMMERCE 6-1-2000.

3,998,684. UNIQUE VALUE MARKETING, LLC, ROCKFORD, MN. SN 77-750,709. PUB. 10-20-2009, FILED 6-3-2009.



ADMETIOR

THE MARK CONSISTS OF STANDARD CHARACTERS WITHOUT CLAIM TO ANY PARTICULAR FONT, STYLE, SIZE, OR COLOR.

CLASS 9—ELECTRICAL AND SCIENTIFIC APPARATUS

FOR FOOD TIMERS; THERMOMETERS; WEIGHING SCALES (U.S. CLS. 21, 23, 26, 36 AND 38).
FIRST USE 4-30-2008; IN COMMERCE 5-30-2008.

CLASS 21—HOUSEWARES AND GLASS

FOR HOUSEHOLD UTENSILS, NAMELY, POTS, PANS, SERVING SPOONS AND TONGS (U.S. CLS. 2, 13, 23, 29, 30, 33, 40 AND 50).
FIRST USE 4-30-2008; IN COMMERCE 5-30-2008.

3,998,693. MARKET PAVILION HOTEL, INC., CHARLESTON, SC. SN 77-762,755. PUB. 5-11-2010, FILED 6-18-2009.



NITROTINI

THE MARK CONSISTS OF STANDARD CHARACTERS WITHOUT CLAIM TO ANY PARTICULAR FONT, STYLE, SIZE, OR COLOR.

CLASS 33—WINES AND SPIRITS

FOR ALCOHOLIC BEVERAGES, EXCEPT BEER (U.S. CLS. 47 AND 49).
FIRST USE 8-14-2009; IN COMMERCE 8-14-2009.

CLASS 43—HOTEL AND RESTAURANT SERVICES

FOR BAR SERVICES (U.S. CLS. 100 AND 101).
FIRST USE 6-2-2011; IN COMMERCE 6-2-2011.

3,998,697. WASABI FROG LIMITED, MANCHESTER, UNITED KINGDOM. SN 77-766,208. PUB. 10-12-2010, FILED S.R. 6-23-2009; AM. P.R. 5-10-2011.



BOOHOO

THE MARK CONSISTS OF STANDARD CHARACTERS WITHOUT CLAIM TO ANY PARTICULAR FONT, STYLE, SIZE, OR COLOR.

OWNER OF ERP CMNTY TM OFC REG. NO. 005085238, DATED 8-13-2007, EXPIRES 5-19-2016.

CLASS 9—ELECTRICAL AND SCIENTIFIC APPARATUS

FOR (BASED ON USE IN COMMERCE) SUNGLASSES (U.S. CLS. 21, 23, 26, 36 AND 38).
FIRST USE 2-13-2009; IN COMMERCE 7-19-2010.

CLASS 14—JEWELRY

FOR (BASED ON 44(E)) JEWELRY (U.S. CLS. 2, 27, 28 AND 50).

CLASS 18—LEATHER GOODS

FOR (BASED ON 44(E)) BAGS, NAMELY, HANDBAGS, SHOULDER BAGS, CLUTCH BAGS, SACHEL BAGS, COSMETIC BAGS SOLD EMPTY AND UNDERARM BAGS, NAMELY, PURSES; ACCESSORIES, NAMELY, PURSES AND UMBRELLAS (U.S. CLS. 1, 2, 3, 22 AND 41).

CLASS 25—CLOTHING

FOR (BASED ON 44(E)) BELTS; SCARVES; T-SHIRTS; VESTS; DRESSES; JACKETS; COATS; JEANS; JOGGING SUITS; KNITWEAR, NAMELY, JUMPERS, SWEATERS, SCARVES, DRESSES, CARDIGANS, T-SHIRTS, TOPS, WAISTCOATS, SHRUGS, TUNICS AND HATS; LEGGINGS; LINGERIE, NAMELY, PAJAMAS, DRESSING GOWNS, CHEMISES, NIGHTSHIRTS, BRAS, STRAPLESS BRAS, T-SHIRT BRAS, PADDED BRAS, PANTIES, HIPSTERS, THONGS, BRIEFS AND CAMISOLES; SHOES; BOOTS SHORTS; SWIMWEAR; TOPS; TROUSERS; ACCESSORIES, NAMELY, HATS AND HOSIERY (U.S. CLS. 22 AND 39).

3,998,705. INTRUST FINANCIAL CORPORATION, WICHITA, KS. SN 77-770,348. PUB. 1-12-2010, FILED 6-29-2009.



OWNER OF U.S. REG. NOS. 1,840,083, 2,197,748, AND OTHERS.

NO CLAIM IS MADE TO THE EXCLUSIVE RIGHT TO USE "ARENA", APART FROM THE MARK AS SHOWN.

THE MARK CONSISTS OF A STYLIZED LETTER "I" AND THE WORDS "INTRUST BANK ARENA".

CLASS 21—HOUSEWARES AND GLASS

FOR MUGS, DRINKING GLASSES, PAPER CUPS, PLASTIC CUPS, AND PORTABLE BEVERAGE COOLERS (U.S. CLS. 2, 13, 23, 29, 30, 33, 40 AND 50).

FIRST USE 1-2-2010; IN COMMERCE 1-2-2010.

CLASS 25—CLOTHING

FOR CLOTHING, NAMELY, POLO SHIRTS, T-SHIRTS, SWEATSHIRTS, JACKETS, CAPS, RUGBY SHIRTS, AND SWEATERS (U.S. CLS. 22 AND 39).

FIRST USE 1-2-2010; IN COMMERCE 1-2-2010.

CLASS 35—ADVERTISING AND BUSINESS

FOR PROMOTING BUSINESS, SPORTS, AND ENTERTAINMENT EVENTS OF OTHERS; ARRANGING AND CONDUCTING CONFERENCES AND EXHIBITIONS FOR BUSINESS PURPOSES; PROVIDING FACILITIES FOR BUSINESS MEETINGS AND EVENTS; PROVIDING FACILITIES FOR TRADE SHOWS; AND PROVIDING CONCESSION STANDS FEATURING FOOD AND SOUVENIRS (U.S. CLS. 100, 101 AND 102).

FIRST USE 1-2-2010; IN COMMERCE 1-2-2010.

CLASS 41—EDUCATION AND ENTERTAINMENT

FOR PROVIDING AND LEASING STADIUM FACILITIES FOR SPORTING EVENTS, AND PROVIDING FACILITIES FOR EDUCATIONAL CONVENTIONS AND SEMINARS; PRODUCTION OF RADIO, TELEVISION, AND CABLE TELEVISION PROGRAMS IN THE FIELDS OF SPORTS AND ENTERTAINMENT EVENTS, CONCERTS, CONVENTIONS, AND PUBLIC EXHIBITIONS; RENTAL OF STADIUM FACILITY SUITES FOR ENTERTAINMENT EVENT-VIEWING PURPOSES, THE PRODUCTION OR COPRODUCTION OF BUSINESS, SPORTS, AND ENTERTAINMENT EVENTS FOR PUBLIC EXHIBITION AND TELEVISION AND RADIO BROADCASTING; ARRANGING AND CONDUCTING ATHLETIC COMPETITIONS; PLANNING ARRANGEMENT OF SHOWING MOVIES, ELECTRONIC LIGHTING, AND LASER DISPLAYS; AND PROVIDING INFORMATION IN THE FIELD OF SPORTS AND ENTERTAINMENT VIA A GLOBAL COMPUTER NETWORK; MUSEUM SERVICES, NAMELY, EXHIBITING TO THE PUBLIC DISPLAYS PERTAINING TO SPORTS MEMORABILIA AND HISTORY (U.S. CLS. 100, 101 AND 107).

FIRST USE 1-2-2010; IN COMMERCE 1-2-2010.

CLASS 43—HOTEL AND RESTAURANT SERVICES

FOR ARENA SERVICES, NAMELY, PROVIDING FACILITIES FOR SPORTS, CONCERTS, CONVENTIONS AND EXHIBITIONS; PROVIDING COMMUNITY CENTERS FOR SOCIAL GATHERINGS AND MEETINGS; CATERING AND RESTAURANT SERVICES (U.S. CLS. 100 AND 101).

FIRST USE 1-2-2010; IN COMMERCE 1-2-2010.

3,998,706. INTRUST FINANCIAL CORPORATION, WICHITA, KS. SN 77-770,364. PUB. 1-12-2010, FILED 6-29-2009.

INTRUST BANK ARENA

THE MARK CONSISTS OF STANDARD CHARACTERS WITHOUT CLAIM TO ANY PARTICULAR FONT, STYLE, SIZE, OR COLOR.

OWNER OF U.S. REG. NOS. 1,840,083, 2,197,748, AND OTHERS.

NO CLAIM IS MADE TO THE EXCLUSIVE RIGHT TO USE "ARENA", APART FROM THE MARK AS SHOWN.

CLASS 21—HOUSEWARES AND GLASS

FOR MUGS, DRINKING GLASSES, PAPER CUPS, PLASTIC CUPS, AND PORTABLE BEVERAGE COOLERS (U.S. CLS. 2, 13, 23, 29, 30, 33, 40 AND 50).

FIRST USE 1-2-2010; IN COMMERCE 1-2-2010.

CLASS 25—CLOTHING

FOR CLOTHING, NAMELY, POLO SHIRTS, T-SHIRTS, SWEATSHIRTS, JACKETS, CAPS, RUGBY SHIRTS, AND SWEATERS (U.S. CLS. 22 AND 39).

FIRST USE 1-2-2010; IN COMMERCE 1-2-2010.

CLASS 35—ADVERTISING AND BUSINESS

FOR PROMOTING BUSINESS, SPORTS, AND ENTERTAINMENT EVENTS OF OTHERS; ARRANGING AND CONDUCTING CONFERENCES AND EXHIBITIONS FOR BUSINESS PURPOSES; PROVIDING FACILITIES FOR BUSINESS MEETINGS AND EVENTS; PROVIDING FACILITIES FOR TRADE SHOWS; AND PROVIDING CONCESSION STANDS FEATURING FOOD AND SOUVENIRS (U.S. CLS. 100, 101 AND 102).

FIRST USE 1-2-2010; IN COMMERCE 1-2-2010.

CLASS 41—EDUCATION AND ENTERTAINMENT

FOR PROVIDING AND LEASING STADIUM FACILITIES FOR SPORTING EVENTS, AND PROVIDING FACILITIES FOR EDUCATIONAL CONVENTIONS AND SEMINARS; PRODUCTION OF RADIO, TELEVISION, AND CABLE TELEVISION PROGRAMS IN THE FIELDS OF SPORTS AND ENTERTAINMENT EVENTS, CONCERTS, CONVENTIONS, AND PUBLIC EXHIBITIONS; RENTAL OF STADIUM FACILITY SUITES FOR ENTERTAINMENT EVENT-VIEWING PURPOSES, THE PRODUCTION OR COPRODUCTION OF BUSINESS, SPORTS, AND ENTERTAINMENT EVENTS FOR PUBLIC EXHIBITION AND TELEVISION AND RADIO BROADCASTING; ARRANGING AND CONDUCTING ATHLETIC COMPETITIONS; PLANNING ARRANGEMENT OF SHOWING MOVIES, ELECTRONIC LIGHTING, AND LASER DISPLAYS; AND PROVIDING INFORMATION IN THE FIELD OF SPORTS AND ENTERTAINMENT VIA A GLOBAL COMPUTER NETWORK; MUSEUM SERVICES, NAMELY, EXHIBITING TO THE PUBLIC DISPLAYS PERTAINING TO SPORTS MEMORABILIA AND HISTORY (U.S. CLS. 100, 101 AND 107).

FIRST USE 1-2-2010; IN COMMERCE 1-2-2010.

CLASS 43—HOTEL AND RESTAURANT SERVICES

FOR ARENA SERVICES, NAMELY, PROVIDING FACILITIES FOR SPORTS, CONCERTS, CONVENTIONS AND EXHIBITIONS; PROVIDING COMMUNITY CENTERS FOR SOCIAL GATHERINGS AND MEETINGS; CATERING AND RESTAURANT SERVICES (U.S. CLS. 100 AND 101).

FIRST USE 1-2-2010; IN COMMERCE 1-2-2010.

3,998,707. GLAM MEDIA, INC., BRISBANE, CA. SN 77-770,424. PUB. 4-6-2010, FILED 6-29-2009.

TINKER

THE MARK CONSISTS OF STANDARD CHARACTERS WITHOUT CLAIM TO ANY PARTICULAR FONT, STYLE, SIZE, OR COLOR.

CLASS 38—COMMUNICATION

FOR TELECOMMUNICATION SERVICES, NAMELY, PROVIDING ONLINE SERVICES TO FACILITATE REAL-TIME INTERACTION BETWEEN AND AMONG USERS OF COMPUTERS, MOBILE AND HANDHELD COMPUTERS, AND WIRED AND WIRELESS COMMUNICATION DEVICES; ENABLING INDIVIDUALS TO SEND AND RECEIVE MESSAGES VIA EMAIL, INSTANT MESSAGING OR A WEBSITE ON THE INTERNET IN THE FIELD OF GENERAL INTEREST; PROVIDING ONLINE CHAT ROOMS AND ELECTRONIC BULLETIN BOARDS FOR TRANSMISSION OF MESSAGES AMONG USERS IN THE FIELD OF GENERAL INTEREST; PROVIDING AN ONLINE COMMUNITY FORUM FOR REGISTERED USERS TO SHARE INFORMATION, PHOTOS, AUDIO AND VIDEO CONTENT ABOUT THEMSELVES, THEIR LIKES AND DISLIKES AND DAILY ACTIVITIES, TO GET FEEDBACK FROM THEIR PEERS, TO FORM VIRTUAL COMMUNITIES, AND TO ENGAGE IN SOCIAL NETWORKING (U.S. CLS. 100, 101 AND 104).

FIRST USE 3-31-2009; IN COMMERCE 3-31-2009.

CLASS 41—EDUCATION AND ENTERTAINMENT

FOR PROVIDING ON-LINE JOURNALS, NAMELY, BLOGS FEATURING USER-DEFINED CONTENT IN THE FIELD OF SOCIAL-NETWORKING (U.S. CLS. 100, 101 AND 107).

FIRST USE 3-31-2009; IN COMMERCE 3-31-2009.

3,998,712. MIDWEST INDUSTRIAL SUPPLY, INC., CANTON, OH. SN 77-783,935. PUB. 1-19-2010, FILED 7-17-2009.

WATER ARMOUR

THE MARK CONSISTS OF STANDARD CHARACTERS WITHOUT CLAIM TO ANY PARTICULAR FONT, STYLE, SIZE, OR COLOR.

NO CLAIM IS MADE TO THE EXCLUSIVE RIGHT TO USE "WATER", APART FROM THE MARK AS SHOWN.

CLASS 1—CHEMICALS

FOR CHEMICALS AND SILICONE PREPARATIONS FOR THE REDUCTION OF WATER ABSORPTION IN BINDING EARTH AND LOAM AND TO PROVIDE A WATER BARRIER FOR USE IN ROAD AND STREET CONSTRUCTION, WATER CONTAINMENT, POND, PIT OR OTHER STRUCTURES (U.S. CLS. 1, 5, 6, 10, 26 AND 46).

FIRST USE 2-9-2009; IN COMMERCE 2-9-2009.

CLASS 19—NON-METALLIC BUILDING MATERIALS

FOR BUILDING MATERIALS NOT OF METAL, NAMELY, AGGREGATE AND DIRT FOR ROAD AND STREET CONSTRUCTION, AND SILICONE-BASED MATERIAL MIXED WITH SOIL AND WATER USED FOR WATER CONTAINMENT FOR USE ON PONDS, PITS, BERMS, OPEN AREAS, AND PILES OF DIRT (U.S. CLS. 1, 12, 33 AND 50).

FIRST USE 2-9-2009; IN COMMERCE 2-9-2009.

3,998,719. ZIPPY SHELL INTERNATIONAL, LLC, JERSEY CITY, NJ. SN 77-789,608. PUB. 12-7-2010, FILED 7-25-2009.

ZIPPY SHELL

THE MARK CONSISTS OF STANDARD CHARACTERS WITHOUT CLAIM TO ANY PARTICULAR FONT, STYLE, SIZE, OR COLOR.

NO CLAIM IS MADE TO THE EXCLUSIVE RIGHT TO USE "SHELL" IN INTERNATIONAL CLASSES 6, 12 AND 39, APART FROM THE MARK AS SHOWN.

CLASS 6—METAL GOODS

FOR GENERAL PURPOSE METAL STORAGE CONTAINERS; STORAGE CONTAINERS, NAMELY, METAL CONTAINERS FOR THE STORAGE AND TRANSPORTATION OF GOODS (U.S. CLS. 2, 12, 13, 14, 23, 25 AND 50).

FIRST USE 11-30-2009; IN COMMERCE 11-30-2009.

CLASS 12—VEHICLES

FOR TRAILERS; STORAGE TRAILERS (U.S. CLS. 19, 21, 23, 31, 35 AND 44).

FIRST USE 11-30-2009; IN COMMERCE 11-30-2009.

CLASS 35—ADVERTISING AND BUSINESS

FOR ADVERTISING AND PROMOTIONAL SERVICES (U.S. CLS. 100, 101 AND 102).

FIRST USE 11-30-2009; IN COMMERCE 11-30-2009.

CLASS 39—TRANSPORTATION AND STORAGE

FOR DELIVERY, REMOVAL IN THE NATURE OF TRANSPORT, AND STORAGE OF STORAGE CONTAINERS AND STORAGE TRAILERS; RENTAL OF STORAGE TRAILERS AND STORAGE CONTAINERS (U.S. CLS. 100 AND 105).

FIRST USE 11-30-2009; IN COMMERCE 11-30-2009.

3,998,728. SONOSITE, INC., BOTHELL, WA. SN 77-797,070. PUB. 5-4-2010, FILED 8-4-2009.

SONOACCESS

THE MARK CONSISTS OF STANDARD CHARACTERS WITHOUT CLAIM TO ANY PARTICULAR FONT, STYLE, SIZE, OR COLOR.

CLASS 41—EDUCATION AND ENTERTAINMENT

FOR EDUCATIONAL SERVICES, NAMELY, PROVIDING ON-LINE INSTRUCTION, CLASSES, WORKSHOPS, SEMINARS, AND PROVIDING COURSE MATERIALS THEREWITH IN THE FIELDS OF MEDICINE, MEDICAL IMAGING, AND HEALTH CARE; ONLINE JOURNALS, NAMELY, BLOGS FEATURING INFORMATION IN THE FIELDS OF MEDICINE, MEDICAL IMAGING, AND HEALTH CARE; PROVIDING CONTINUING MEDICAL EDUCATION COURSES (U.S. CLS. 100, 101 AND 107).

FIRST USE 6-22-2009; IN COMMERCE 6-22-2009.

CLASS 44—MEDICAL, BEAUTY AND AGRICULTURAL SERVICES

FOR PROVIDING ONLINE EDUCATIONAL INFORMATION IN THE FIELDS OF MEDICINE, MEDICAL IMAGING, AND HEALTH CARE (U.S. CLS. 100 AND 101).

FIRST USE 6-22-2009; IN COMMERCE 6-22-2009.

3,998,729. RECORD PROMOCACAO DE EVENTOS E ENTERTENIMENO LTDA., CERQ. CESAR, SAO PAULO, BRAZIL. SN 77-797,996. PUB. 6-29-2010, FILED 8-5-2009.



THE COLOR(S) WHITE, DARK BLUE AND LIGHT BLUE IS/ARE CLAIMED AS A FEATURE OF THE MARK.

THE MARK CONSISTS OF THE PHRASE "R7" IN WHITE AGAINST A BI-COLORED BACKGROUND OF DARKER BLUE AND LIGHTER BLUE, WITH A FILLIP AT THE LOWER LEFT.

CLASS 41—EDUCATION AND ENTERTAINMENT

FOR PROVIDING ON-LINE NEWSPAPERS, MAGAZINES, NEWSLETTERS, AND JOURNALS AIMED AT THE GENERAL PUBLIC IN THE FIELD OF CURRENT EVENT NEWS, SPORTS AND GENERAL ENTERTAINMENT (U.S. CLS. 100, 101 AND 107).

FIRST USE 9-27-2009; IN COMMERCE 9-27-2009.

CLASS 42—SCIENTIFIC AND COMPUTER SERVICES

FOR CONVERSION OF VIDEO FOOTAGE TO ELECTRONIC FORMAT; PROVISION OF INTERNET SEARCH ENGINES; PROVIDING A WEBSITE THAT FEATURES INFORMATION ON COMPUTER AND OTHER TECHNOLOGY (U.S. CLS. 100 AND 101).

FIRST USE 9-27-2009; IN COMMERCE 9-27-2009.

3,998,745. ZEP IP HOLDING LLC, ATLANTA, GA. SN 77-815,529. PUB. 2-2-2010, FILED 8-28-2009.

ZEP 101

THE MARK CONSISTS OF STANDARD CHARACTERS WITHOUT CLAIM TO ANY PARTICULAR FONT, STYLE, SIZE, OR COLOR.

OWNER OF U.S. REG. NOS. 686,052, 1,612,577, AND OTHERS.

CLASS 2—PAINTS

FOR FLOOR COATINGS (U.S. CLS. 6, 11 AND 16).
FIRST USE 11-0-2009; IN COMMERCE 11-0-2009.

CLASS 3—COSMETICS AND CLEANING PREPARATIONS

FOR ALL PURPOSE CLEANING PREPARATIONS; GLASS CLEANERS; SOAPS FOR HANDS; TOILET BOWL CLEANERS; FLOOR STRIPPING/CLEANING PREPARATIONS; DEGREASING PREPARATIONS NOT USED IN MANUFACTURING PROCESSES FOR SURFACES OF AUTOMOBILES, ENGINES, WHEELS, WATER CRAFT, CONCRETE FLOORS, TIRES, VINYL UPHOLSTERY, BARBECUE GRILLS, HAND TOOLS, AND MOTORIZED CONSTRUCTION EQUIPMENT; INDUSTRIAL ABRASIVE CLEANERS, NAMELY, BURNISHING COMPOUNDS FOR USE IN BURNISHING METAL COMPONENTS AND PARTS (U.S. CLS. 1, 4, 6, 50, 51 AND 52).

FIRST USE 11-0-2009; IN COMMERCE 11-0-2009.

CLASS 5—PHARMACEUTICALS

FOR ALL PURPOSE DISINFECTANTS; DISINFECTANT TOILET BOWL CLEANERS (U.S. CLS. 6, 18, 44, 46, 51 AND 52).

FIRST USE 11-0-2009; IN COMMERCE 11-0-2009.

3,998,753. BAUSCH & LOMB INCORPORATED, ROCHESTER, NY. SN 77-820,200. PUB. 6-1-2010, FILED 9-4-2009.

FOGSHIELD SPORT

THE MARK CONSISTS OF STANDARD CHARACTERS WITHOUT CLAIM TO ANY PARTICULAR FONT, STYLE, SIZE, OR COLOR.

OWNER OF U.S. REG. NO. 3,040,953.

NO CLAIM IS MADE TO THE EXCLUSIVE RIGHT TO USE "SPORT", APART FROM THE MARK AS SHOWN.

CLASS 3—COSMETICS AND CLEANING PREPARATIONS

FOR OPTICAL LENS CLEANING PRODUCTS, NAMELY, LENS CLEANING SOLUTIONS FOR SPECTACLE LENSES, EYEGLASSES, SAFETY GOGGLES AND EYEWEAR USED IN ATHLETICS AND IMPREGNATED CLEANING CLOTHS FOR OPTICAL AND SPECTACLE LENSES, EYEGLASSES, SAFETY GOGGLES AND EYEWEAR USED IN ATHLETICS (U.S. CLS. 1, 4, 6, 50, 51 AND 52).

FIRST USE 11-30-2010; IN COMMERCE 11-30-2010.

CLASS 21—HOUSEWARES AND GLASS

FOR OPTICAL LENS CLEANING PRODUCTS, NAMELY, CLEANING CLOTHS FOR OPTICAL AND SPECTACLE LENSES, EYEGLASSES, SAFETY GOGGLES AND EYEWEAR USED IN ATHLETICS (U.S. CLS. 2, 13, 23, 29, 30, 33, 40 AND 50).

FIRST USE 11-30-2010; IN COMMERCE 11-30-2010.

3,998,756. GRUMA CORPORATION, IRVING, TX. SN 77-821,771. PUB. 3-23-2010, FILED 9-8-2009.

MISSION GREEN

THE MARK CONSISTS OF STANDARD CHARACTERS WITHOUT CLAIM TO ANY PARTICULAR FONT, STYLE, SIZE, OR COLOR.

OWNER OF U.S. REG. NOS. 1,216,032, 3,243,446, AND OTHERS.

CLASS 43—HOTEL AND RESTAURANT SERVICES

FOR PROVIDING A DATABASE IN THE FIELD OF RECIPES, PROVIDING RECIPES VIA A WEB SITE (U.S. CLS. 100 AND 101).

FIRST USE 9-20-2010; IN COMMERCE 9-20-2010.

CLASS 44—MEDICAL, BEAUTY AND AGRICULTURAL SERVICES

FOR PROVIDING NUTRITIONAL INFORMATION VIA AN ONLINE WEBSITE (U.S. CLS. 100 AND 101).

FIRST USE 9-20-2010; IN COMMERCE 9-20-2010.

3,998,757. GRUMA CORPORATION, IRVING, TX. SN 77-821,782. PUB. 3-23-2010, FILED 9-8-2009.

ONE PLANET. ONE MISSION.

THE MARK CONSISTS OF STANDARD CHARACTERS WITHOUT CLAIM TO ANY PARTICULAR FONT, STYLE, SIZE, OR COLOR.

CLASS 43—HOTEL AND RESTAURANT SERVICES

FOR PROVIDING A DATABASE IN THE FIELD OF RECIPES, PROVIDING RECIPES VIA A WEB SITE (U.S. CLS. 100 AND 101).

FIRST USE 9-20-2010; IN COMMERCE 9-20-2010.

CLASS 44—MEDICAL, BEAUTY AND AGRICULTURAL SERVICES

FOR PROVIDING NUTRITIONAL INFORMATION VIA AN ONLINE WEBSITE (U.S. CLS. 100 AND 101).

FIRST USE 9-20-2010; IN COMMERCE 9-20-2010.

3,998,758. GRUMA CORPORATION, IRVING, TX. SN 77-821,807. PUB. 3-23-2010, FILED 9-8-2009.



THE MARK CONSISTS OF A CIRCULAR DESIGN WITH A 3 PETALED LEAF DESIGN IN THE MIDDLE.

CLASS 43—HOTEL AND RESTAURANT SERVICES

FOR PROVIDING A DATABASE IN THE FIELD OF RECIPES, PROVIDING RECIPES VIA A WEB SITE (U.S. CLS. 100 AND 101).

FIRST USE 9-20-2010; IN COMMERCE 9-20-2010.

CLASS 44—MEDICAL, BEAUTY AND AGRICULTURAL SERVICES

FOR PROVIDING NUTRITIONAL INFORMATION VIA AN ONLINE WEBSITE (U.S. CLS. 100 AND 101).

FIRST USE 9-20-2010; IN COMMERCE 9-20-2010.

3,998,765. TELOS IDENTITY MANAGEMENT SOLUTIONS, LLC, AKA TELOS ID, ASBURN, VA. SN 77-825,012. PUB. 2-9-2010, FILED 9-11-2009.

MobileAssure

THE MARK CONSISTS OF STANDARD CHARACTERS WITHOUT CLAIM TO ANY PARTICULAR FONT, STYLE, SIZE, OR COLOR.

CLASS 9—ELECTRICAL AND SCIENTIFIC APPARATUS

FOR IDENTITY-BASED ACCESS AND CONTROL SOLUTIONS, NAMELY, HARDWARE AND SOFTWARE FOR USE IN CONTROLLING PHYSICAL ACCESS TO MOBILE AND FIXED INSTALLATIONS (U.S. CLS. 21, 23, 26, 36 AND 38).

FIRST USE 4-22-2011; IN COMMERCE 4-22-2011.

CLASS 42—SCIENTIFIC AND COMPUTER SERVICES

FOR IDENTITY-BASED ACCESS CONTROL SERVICES, NAMELY, CONSULTATION IN USE OF HARDWARE AND SOFTWARE TO CONTROL PHYSICAL ACCESS TO MOBILE AND FIXED INSTALLATIONS (U.S. CLS. 100 AND 101).

FIRST USE 4-22-2011; IN COMMERCE 4-22-2011.

3,998,772. WESTINGHOUSE ELECTRIC COMPANY LLC, CRANBERRY TOWNSHIP, PA. SN 77-829,399. PUB. 6-29-2010, FILED 9-18-2009.



THE MARK CONSISTS OF THE WORD "NUCLEARNING" WITH THE LETTER "L" THEREIN REPRESENTED BY TWO COOLING TOWERS. THE SECOND COOLING TOWER IS ILLUSTRATED SLIGHTLY BEHIND AND SLIGHTLY OFFSET FROM THE FIRST COOLING TOWER SO AS TO LOOK LIKE THE LETTER "L".

CLASS 9—ELECTRICAL AND SCIENTIFIC APPARATUS

FOR ELECTRONIC EDUCATIONAL PUBLICATIONS, NAMELY, TRAINING MANUALS IN THE FIELD OF NUCLEAR ENERGY RECORDED ON COMPUTER MEDIA; DOWNLOADABLE ELECTRONIC EDUCATIONAL PUBLICATIONS IN THE NATURE OF TRAINING MANUALS IN THE FIELD OF NUCLEAR ENERGY (U.S. CLS. 21, 23, 26, 36 AND 38).

FIRST USE 5-2-2011; IN COMMERCE 5-2-2011.

CLASS 16—PAPER GOODS AND PRINTED MATTER

FOR EDUCATIONAL PUBLICATIONS, NAMELY, TRAINING MANUALS IN THE FIELD OF NUCLEAR ENERGY (U.S. CLS. 2, 5, 22, 23, 29, 37, 38 AND 50).

FIRST USE 5-2-2011; IN COMMERCE 5-2-2011.

CLASS 41—EDUCATION AND ENTERTAINMENT

FOR EDUCATIONAL SERVICES, NAMELY, PROVIDING ON-LINE AND LIVE TRAINING CLASSES, SEMINARS, PRESENTATIONS AND WORKSHOPS IN THE FIELDS OF NUCLEAR ENERGY (U.S. CLS. 100, 101 AND 107).

FIRST USE 4-4-2011; IN COMMERCE 4-4-2011.

3,998,785. OPENGAMMA INC., WILMINGTON, DE. SN 77-833,327. PUB. 3-30-2010, FILED 9-23-2009.

OPENGAMMA

THE MARK CONSISTS OF STANDARD CHARACTERS WITHOUT CLAIM TO ANY PARTICULAR FONT, STYLE, SIZE, OR COLOR.

CLASS 9—ELECTRICAL AND SCIENTIFIC APPARATUS

FOR COMPUTER SOFTWARE FOR USE WITH FINANCIAL SERVICES, NAMELY, FOR APPLYING QUANTITATIVE ANALYSIS TO FINANCIAL INSTRUMENTS AND TO ASCERTAIN THE RISKS ASSOCIATED WITH VARIOUS FINANCIAL TRADES (U.S. CLS. 21, 23, 26, 36 AND 38).

FIRST USE 4-28-2011; IN COMMERCE 4-28-2011.

CLASS 42—SCIENTIFIC AND COMPUTER SERVICES

FOR APPLICATION SERVICE PROVIDER FEATURING SOFTWARE USED FOR APPLYING QUANTITATIVE ANALYSIS TO FINANCIAL INSTRUMENTS AND TO ASCERTAIN THE RISKS ASSOCIATED WITH VARIOUS FINANCIAL TRADES; PROVIDING TEMPORARY USE OF NON-DOWNLOADABLE SOFTWARE USED FOR APPLYING QUANTITATIVE ANALYSIS TO FINANCIAL INSTRUMENTS AND TO ASCERTAIN THE RISKS ASSOCIATED WITH VARIOUS FINANCIAL TRADES (U.S. CLS. 100 AND 101).

FIRST USE 4-28-2011; IN COMMERCE 4-28-2011.

3,998,786. ENSPEKTOS, LLC, NEW YORK, NY. SN 77-833,390. PUB. 9-21-2010, FILED 9-23-2009.

ENSPEKTOS

THE MARK CONSISTS OF STANDARD CHARACTERS WITHOUT CLAIM TO ANY PARTICULAR FONT, STYLE, SIZE, OR COLOR.

CLASS 35—ADVERTISING AND BUSINESS

FOR CONSULTANCY IN THE FIELD OF MARKETING PROVIDED TO GOVERNMENT AGENCIES AND THE HEALTHCARE, MEDICAL, PHARMACEUTICAL, MANAGED CARE, AND NON-PROFIT INDUSTRIES; CONSULTANCY IN THE FIELD OF ADVERTISING PROVIDED TO GOVERNMENT AGENCIES AND THE HEALTHCARE, MEDICAL, PHARMACEUTICAL, MANAGED CARE, AND NON-PROFIT INDUSTRIES; CONSULTANCY IN THE FIELD OF COMMUNICATIONS PROVIDED TO GOVERNMENT AGENCIES AND THE HEALTHCARE, MEDICAL, PHARMACEUTICAL, MANAGED CARE, AND NON-PROFIT INDUSTRIES; MARKET RESEARCH SERVICES PROVIDED TO GOVERNMENT AGENCIES AND THE HEALTHCARE, MEDICAL, PHARMACEUTICAL, MANAGED CARE, AND NON-PROFIT INDUSTRIES (U.S. CLS. 100, 101 AND 102).

FIRST USE 1-31-2010; IN COMMERCE 1-31-2010.

CLASS 41—EDUCATION AND ENTERTAINMENT

FOR TRAINING IN THE FIELD OF MARKETING AND COMMUNICATIONS PROVIDED IN-PERSON AND INTERACTIVELY TO GOVERNMENT AGENCIES AND THE HEALTHCARE, MEDICAL, PHARMACEUTICAL, MANAGED CARE, AND NON-PROFIT INDUSTRIES (U.S. CLS. 100, 101 AND 107).

FIRST USE 1-31-2010; IN COMMERCE 1-31-2010.

3,998,788. JACK ROBIE, INC., NEW YORK, NY. SN 77-833,592. PUB. 2-16-2010, FILED 9-23-2009.

Jack Robie

THE MARK CONSISTS OF STANDARD CHARACTERS WITHOUT CLAIM TO ANY PARTICULAR FONT, STYLE, SIZE, OR COLOR.

THE NAME "JACK ROBIE" DOES NOT IDENTIFY A LIVING INDIVIDUAL.

CLASS 25—CLOTHING

FOR MEN'S SHIRTS (U.S. CLS. 22 AND 39).

FIRST USE 10-20-2009; IN COMMERCE 10-20-2009.

CLASS 35—ADVERTISING AND BUSINESS

FOR ON-LINE RETAIL STORE FEATURING CLOTHING AND ACCESSORIES (U.S. CLS. 100, 101 AND 102).

FIRST USE 10-20-2009; IN COMMERCE 10-20-2009.

3,998,793. ARIES INGENIERIA Y SISTEMAS, S.A., 28046 MADRID, SPAIN. SN 77-834,986. PUB. 3-23-2010, FILED 9-25-2009.

ARIES POWER & INDUSTRIAL

THE MARK CONSISTS OF STANDARD CHARACTERS WITHOUT CLAIM TO ANY PARTICULAR FONT, STYLE, SIZE, OR COLOR.

NO CLAIM IS MADE TO THE EXCLUSIVE RIGHT TO USE "POWER & INDUSTRIAL", APART FROM THE MARK AS SHOWN.

CLASS 35—ADVERTISING AND BUSINESS

FOR CONSULTANCY SERVICES IN THE FIELD OF ENERGY AND POWER USE, AND ENERGY EFFICIENCY (U.S. CLS. 100, 101 AND 102).

FIRST USE 5-6-2010; IN COMMERCE 5-6-2010.

CLASS 42—SCIENTIFIC AND COMPUTER SERVICES

FOR ENGINEERING SERVICES; CONSULTING IN THE FIELD OF ENGINEERING RELATED TO THE GENERATION OF ELECTRICITY AND RENEWABLE ENERGY (U.S. CLS. 100 AND 101).

FIRST USE 11-11-2009; IN COMMERCE 11-11-2009.

3,998,794. ARIES INGENIERIA Y SISTEMAS, S.A., 28046 MADRID, SPAIN. SN 77-835,005. PUB. 3-23-2010, FILED 9-25-2009.

ARIES

THE MARK CONSISTS OF STANDARD CHARACTERS WITHOUT CLAIM TO ANY PARTICULAR FONT, STYLE, SIZE, OR COLOR.

CLASS 35—ADVERTISING AND BUSINESS

FOR CONSULTANCY SERVICES IN THE FIELD OF ENERGY AND POWER USE, AND ENERGY EFFICIENCY (U.S. CLS. 100, 101 AND 102).

FIRST USE 5-6-2010; IN COMMERCE 5-6-2010.

CLASS 42—SCIENTIFIC AND COMPUTER SERVICES

FOR ENGINEERING SERVICES; CONSULTING IN THE FIELD OF ENGINEERING RELATED TO THE GENERATION OF ELECTRICITY AND RENEWABLE ENERGY (U.S. CLS. 100 AND 101).

FIRST USE 11-11-2009; IN COMMERCE 11-11-2009.

3,998,798. ALASKA STRUCTURES, INC., ANCHORAGE, AK. SN 77-837,160. PUB. 2-23-2010, FILED 9-29-2009.

AKS

THE MARK CONSISTS OF STANDARD CHARACTERS WITHOUT CLAIM TO ANY PARTICULAR FONT, STYLE, SIZE, OR COLOR.

CLASS 7—MACHINERY

FOR MOBILE ELECTRIC POWER GENERATORS (U.S. CLS. 13, 19, 21, 23, 31, 34 AND 35).

FIRST USE 2-2-2011; IN COMMERCE 2-2-2011.

CLASS 9—ELECTRICAL AND SCIENTIFIC APPARATUS

FOR ELECTRICAL DISTRIBUTION SYSTEMS AND INSTALLATIONS, NAMELY, ELECTRICAL CABLES, POWER DISTRIBUTION PANELS, ELECTRICAL OUTLETS, AND ELECTRIC CONTROL PANELS WITH CIRCUIT BREAKERS AND ON/OFF SWITCHES (U.S. CLS. 21, 23, 26, 36 AND 38).

FIRST USE 8-31-2009; IN COMMERCE 8-31-2009.

CLASS 11—ENVIRONMENTAL CONTROL APPARATUS

FOR ENVIRONMENTAL CONTROL UNITS, NAMELY, MOBILE HEATING, VENTILATION AND AIR CONDITIONING APPARATUS (U.S. CLS. 13, 21, 23, 31 AND 34).

FIRST USE 3-8-2010; IN COMMERCE 3-8-2010.

CLASS 19—NON-METALLIC BUILDING MATERIALS

FOR PORTABLE NON-METAL BUILDINGS, NAMELY, FABRIC-COVERED BUILDINGS AND SHELTERS (U.S. CLS. 1, 12, 33 AND 50).

FIRST USE 3-19-2010; IN COMMERCE 3-19-2010.

CLASS 20—FURNITURE AND ARTICLES NOT OTHERWISE CLASSIFIED

FOR CONTAINERS, NOT OF METAL, FOR COMMERCIAL USE, NAMELY, NON-METAL CONTAINERS FOR THE STORAGE AND SHIPPING OF MATERIAL (U.S. CLS. 2, 13, 22, 25, 32 AND 50).

FIRST USE 7-16-2010; IN COMMERCE 7-16-2010.

3,998,799. ALASKA STRUCTURES, INC., ANCHORAGE, AK. SN 77-837,187. PUB. 2-23-2010, FILED 9-29-2009.



THE MARK CONSISTS OF A TRIANGLE CONTAINING THE WORDS "AKS", WITH A SWOOSH COMING AROUND FROM THE TOP LEFT SIDE OF THE TRIANGLE AND CROSSING THE BOTTOM OF THE TRIANGLE, AND WITH A NARROW CAP RESTING ON THE TOP OF THE TRIANGLE.

CLASS 7—MACHINERY

FOR MOBILE ELECTRIC POWER GENERATORS (U.S. CLS. 13, 19, 21, 23, 31, 34 AND 35).

FIRST USE 2-2-2011; IN COMMERCE 2-2-2011.

CLASS 9—ELECTRICAL AND SCIENTIFIC APPARATUS

FOR ELECTRICAL DISTRIBUTION SYSTEMS AND INSTALLATIONS, NAMELY, ELECTRICAL CABLES, POWER DISTRIBUTION PANELS, ELECTRICAL OUTLETS, AND ELECTRIC CONTROL PANELS WITH CIRCUIT BREAKERS AND ON/OFF SWITCHES (U.S. CLS. 21, 23, 26, 36 AND 38).

FIRST USE 12-1-2010; IN COMMERCE 12-1-2010.

CLASS 11—ENVIRONMENTAL CONTROL APPARATUS

FOR ENVIRONMENTAL CONTROL UNITS, NAMELY, MOBILE HEATING, VENTILATION AND AIR CONDITIONING APPARATUS (U.S. CLS. 13, 21, 23, 31 AND 34).

FIRST USE 7-31-2010; IN COMMERCE 7-31-2010.

CLASS 19—NON-METALLIC BUILDING MATERIALS

FOR PORTABLE NON-METAL BUILDINGS, NAMELY, FABRIC-COVERED BUILDINGS AND SHELTERS (U.S. CLS. 1, 12, 33 AND 50).

FIRST USE 9-8-2010; IN COMMERCE 9-8-2010.

CLASS 20—FURNITURE AND ARTICLES NOT OTHERWISE CLASSIFIED

FOR CONTAINERS, NOT OF METAL, FOR COMMERCIAL USE, NAMELY, NON-METAL CONTAINERS FOR THE STORAGE AND SHIPPING OF MATERIAL (U.S. CLS. 2, 13, 22, 25, 32 AND 50).

FIRST USE 7-16-2010; IN COMMERCE 7-16-2010.

3,998,805. EUI LIMITED, CARDIFF, GREAT BRITAIN. SN 77-837,996. PUB. 3-30-2010, FILED 9-30-2009.

BIG COVERAGE. BIG SAVINGS.

THE MARK CONSISTS OF STANDARD CHARACTERS WITHOUT CLAIM TO ANY PARTICULAR FONT, STYLE, SIZE, OR COLOR.

CLASS 35—ADVERTISING AND BUSINESS

FOR PROVIDING INSURANCE REFERRALS (U.S. CLS. 100, 101 AND 102).

FIRST USE 10-5-2010; IN COMMERCE 10-5-2010.

CLASS 36—INSURANCE AND FINANCIAL

FOR INSURANCE AGENCIES, INSURANCE CARRIER SERVICES, INSURANCE BROKERAGE, INSURANCE CLAIMS ADMINISTRATION AND PROCESSING; INSURANCE UNDERWRITING IN THE FIELD OF MOTOR VEHICLES; INSURANCE CONSULTANCY; PROVIDING ONLINE INFORMATION ON INSURANCE MATTERS (U.S. CLS. 100, 101 AND 102).

FIRST USE 10-5-2010; IN COMMERCE 10-5-2010.

3,998,806. KUKU? GROUP LLC, NEW YORK, NY. SN 77-838,489. PUB. 2-23-2010, FILED 9-30-2009.

KUKU?

THE MARK CONSISTS OF STANDARD CHARACTERS WITHOUT CLAIM TO ANY PARTICULAR FONT, STYLE, SIZE, OR COLOR.

CLASS 25—CLOTHING

FOR CLOTHING AND APPAREL, NAMELY, PANTS, SHIRTS, BELTS; HEADGEAR, NAMELY, HATS, BEANIES, VISORS, HEADBANDS AND BANDANNAS (U.S. CLS. 22 AND 39).

FIRST USE 10-9-2009; IN COMMERCE 10-9-2009.

CLASS 35—ADVERTISING AND BUSINESS

FOR ONLINE RETAIL STORE SERVICES FEATURING EXTREME SPORTS CLOTHING, APPAREL, APPARATUS AND EQUIPMENT (U.S. CLS. 100, 101 AND 102).

FIRST USE 1-1-2011; IN COMMERCE 1-1-2011.

3,998,808. MARINE LAYER PRODUCTIONS, LLC, CARLSBAD, CA. SN 77-838,649. PUB. 3-16-2010, FILED 9-30-2009.

MARINE LAYER PRODUCTIONS

THE MARK CONSISTS OF STANDARD CHARACTERS WITHOUT CLAIM TO ANY PARTICULAR FONT, STYLE, SIZE, OR COLOR.

NO CLAIM IS MADE TO THE EXCLUSIVE RIGHT TO USE "PRODUCTIONS", APART FROM THE MARK AS SHOWN.

CLASS 9—ELECTRICAL AND SCIENTIFIC APPARATUS

FOR DVDS AND CD-ROMS FEATURING SURFING AND SPORTS; DIGITAL MEDIA, NAMELY, DIGITAL VIDEO DISCS, DIGITAL VERSATILE DISCS, DOWNLOADABLE AUDIO AND VIDEO RECORDINGS, DVDS, FEATURING SURFING AND SPORTS (U.S. CLS. 21, 23, 26, 36 AND 38).

FIRST USE 12-0-2010; IN COMMERCE 12-0-2010.

CLASS 38—COMMUNICATION

FOR STREAMING VIDEOS AND AUDIO VIA THE INTERNET; BROADCASTING OF VIDEO AND AUDIO PROGRAMMING OVER THE INTERNET (U.S. CLS. 100, 101 AND 104).

FIRST USE 1-0-2009; IN COMMERCE 1-0-2009.

CLASS 41—EDUCATION AND ENTERTAINMENT

FOR FILM AND VIDEO PRODUCTION; ENTERTAINMENT SERVICES, NAMELY, PROVIDING A WEB SITE FEATURING VIDEOS IN THE FIELD OF SURFING AND SPORTS; PRODUCTION OF DVDS FEATURING SURFING AND SPORTS; ENTERTAINMENT SERVICES, NAMELY, PROVIDING A WEB SITE FEATURING VIDEOS, PHOTOGRAPHS, AND OTHER MULTIMEDIA MATERIALS FEATURING SURFING AND SPORTS; PROVIDING A WEBSITE FEATURING INFORMATION ON SURFING AND SPORTS (U.S. CLS. 100, 101 AND 107).

FIRST USE 1-0-2009; IN COMMERCE 1-0-2009.

3,998,820. TIME WARNER CABLE INC., NEW YORK, NY. SN 77-844,966. PUB. 9-21-2010, FILED 10-9-2009.

A MI MANERA

THE MARK CONSISTS OF STANDARD CHARACTERS WITHOUT CLAIM TO ANY PARTICULAR FONT, STYLE, SIZE, OR COLOR.

THE ENGLISH TRANSLATION OF "A MI MANERA" IN THE MARK IS "MY WAY".

CLASS 38—COMMUNICATION

FOR CABLE TELEVISION BROADCASTING; CABLE TELEVISION TRANSMISSION; TELECOMMUNICATION SERVICES, NAMELY, LOCAL AND LONG DISTANCE TRANSMISSION OF VOICE, DATA, GRAPHICS BY MEANS OF TELEPHONE, TELEGRAPHIC, CABLE AND SATELLITE TRANSMISSIONS; LOCAL AND LONG DISTANCE TELEPHONE SERVICES; TELEPHONE COMMUNICATION SERVICES; ELECTRONIC, ELECTRIC AND DIGITAL TRANSMISSION OF VOICE, DATA, IMAGES, SIGNALS AND MESSAGES; INTERNET TELEPHONE SERVICES; ELECTRONIC VOICE MESSAGING, NAMELY, THE RECORDING AND SUBSEQUENT TRANSMISSION OF VOICE MESSAGES BY TELEPHONE; TELEPHONE VOICE MESSAGING SERVICES; WEB MESSAGING; PROVIDING HIGH SPEED ACCESS TO AREA NETWORKS AND A GLOBAL COMPUTER INFORMATION NETWORK; INTERACTIVE TELEVISION TRANSMISSION SERVICES AND TELEVISION ON DEMAND TRANSMISSION SERVICES AND WIRELESS COMMUNICATION SERVICES, NAMELY, TEXT AND NUMERIC WIRELESS DIGITAL MESSAGING SERVICES, WIRELESS BROADBAND COMMUNICATION SERVICES, TRANSMISSION OF GRAPHICS TO MOBILE TELEPHONES, WIRELESS DIGITAL MESSAGING SERVICES, WIRELESS ELECTRONIC TRANSMISSION OF VOICE SIGNALS, DATA, FACSIMILES, IMAGES AND INFORMATION, WIRELESS FACSIMILE MAIL SERVICES, WIRELESS PBX SERVICES, WIRELESS TELEPHONE TELECOMMUNICATIONS SERVICES, NAMELY, WIRELESS MOBILE TELEPHONE SERVICES AND WIRELESS VOICE MAIL SERVICES, ALL DELIVERED OVER CABLE NETWORKS (U.S. CLS. 100, 101 AND 104).

FIRST USE 2-28-2010; IN COMMERCE 2-28-2010.

CLASS 41—EDUCATION AND ENTERTAINMENT

FOR TELEVISION ON DEMAND IN THE NATURE OF PROVISION OF TELEVISION PROGRAMS VIA VIDEO-ON-DEMAND SERVICES; PRODUCTION OF TELEVISION PROGRAMS, TELEVISION PROGRAMMING SERVICES (U.S. CLS. 100, 101 AND 107).

FIRST USE 2-28-2010; IN COMMERCE 2-28-2010.

CLASS 35—ADVERTISING AND BUSINESS

FOR PROVIDING INFORMATION ON CHARITABLE PROJECTS AROUND THE WORLD FOR THE PURPOSES OF PROVIDING WAYS TO VOLUNTEER AND PROVIDE OTHER NON-FINANCIAL SUPPORT FOR SUCH PROJECTS, VIA AN INTERACTIVE WEBSITE, MOBILE TELEPHONES, WIRELESS DEVICES AND PERSONAL COMMUNICATIONS DEVICES (U.S. CLS. 100, 101 AND 102).

FIRST USE 4-22-2010; IN COMMERCE 4-22-2010.

CLASS 36—INSURANCE AND FINANCIAL

FOR CHARITABLE FUNDRAISING, NAMELY, PROVIDING INFORMATION ON HOW TO DONATE FINANCIAL SUPPORT TO CHARITABLE PROJECTS AROUND THE WORLD VIA AN INTERACTIVE WEBSITE, MOBILE TELEPHONES, WIRELESS DEVICES AND PERSONAL COMMUNICATIONS DEVICES (U.S. CLS. 100, 101 AND 102).

FIRST USE 4-22-2010; IN COMMERCE 4-22-2010.

3,998,839. DOUGHBOY VENTURES, HERMOSA BEACH, CA. SN 77-852,379. PUB. 3-30-2010, FILED 10-20-2009.

3,998,835. NATIONAL GEOGRAPHIC SOCIETY, WASHINGTON, DC. SN 77-851,367. PUB. 9-21-2010, FILED 10-19-2009.

GLOBAL ACTION ATLAS

THE MARK CONSISTS OF STANDARD CHARACTERS WITHOUT CLAIM TO ANY PARTICULAR FONT, STYLE, SIZE, OR COLOR.

NO CLAIM IS MADE TO THE EXCLUSIVE RIGHT TO USE "GLOBAL" AND "ATLAS", APART FROM THE MARK AS SHOWN.

SUM+

THE MARK CONSISTS OF STANDARD CHARACTERS WITHOUT CLAIM TO ANY PARTICULAR FONT, STYLE, SIZE, OR COLOR.

CLASS 5—PHARMACEUTICALS

FOR DIETARY AND NUTRITIONAL SUPPLEMENTS; NUTRITIONALLY FORTIFIED BEVERAGES; POWDERED NUTRITIONAL SUPPLEMENT DRINK MIX (U.S. CLS. 6, 18, 44, 46, 51 AND 52).

FIRST USE 11-17-2010; IN COMMERCE 11-17-2010.

CLASS 30—STAPLE FOODS

FOR CANDY; CANDY MINTS; CHEWING GUM (U.S. CL. 46).

FIRST USE 11-17-2010; IN COMMERCE 11-17-2010.

3,998,856. OPEN MINDS PRODUCTION, LLC, TEMPE, AZ.
SN 77-855,898. PUB. 4-13-2010, FILED 10-23-2009.



THE MARK CONSISTS OF AN OUTER CIRCLE SURROUNDING A JAGGED SPIRAL LEADING TO A CENTER CIRCLE AND DOT NEAR THE CENTER OF THE MARK AND THREE ADJACENT CIRCLES NEAR THE TOP RIGHT OF THE MARK.

CLASS 9—ELECTRICAL AND SCIENTIFIC APPARATUS

FOR ELECTRONIC PUBLICATIONS, NAMELY, DOWNLOADABLE ONLINE MAGAZINES FEATURING ALL ASPECTS RELATING TO ALIENS, EXTRATERRESTRIAL LIFE AND THE UFO PHENOMENON RECORDED ON COMPUTER MEDIA (U.S. CLS. 21, 23, 26, 36 AND 38).

FIRST USE 5-1-2010; IN COMMERCE 5-1-2010.

CLASS 41—EDUCATION AND ENTERTAINMENT

FOR EDUCATIONAL SERVICES, NAMELY, CONDUCTING CONFERENCES AND SEMINARS IN THE FIELD OF ALIENS, EXTRATERRESTRIAL LIFE AND THE UFO PHENOMENON AND DISTRIBUTION OF COURSE MATERIALS IN CONNECTION THEREWITH; PUBLICATION OF ELECTRONIC MAGAZINES; PUBLICATION OF ONLINE MAGAZINES RELATING TO ALL ASPECTS RELATING TO ALL ASPECTS OF ALIENS, EXTRATERRESTRIAL LIFE AND THE UFO PHENOMENON; PUBLISHING OF WEB MAGAZINES (U.S. CLS. 100, 101 AND 107).

FIRST USE 2-23-2011; IN COMMERCE 2-23-2011.

3,998,857. CORELOGIC INFORMATION SOLUTIONS, INC.,
SANTA ANA, CA. SN 77-856,015. PUB. 10-5-2010, FILED
10-23-2009.

CORELOGIC

THE MARK CONSISTS OF STANDARD CHARACTERS WITHOUT CLAIM TO ANY PARTICULAR FONT, STYLE, SIZE, OR COLOR.

OWNER OF U.S. REG. NOS. 3,299,281, 3,338,328, AND OTHERS.

CLASS 9—ELECTRICAL AND SCIENTIFIC APPARATUS

FOR COMPUTER SOFTWARE FOR WHICH PROVIDES PREDICTIVE ANALYTICS FOR LOANS AND LOAN PORTFOLIOS; COMPUTER SOFTWARE FOR MANAGING MORTGAGE LOAN APPLICATIONS, FOR ENABLING LENDERS TO MANAGE APPLICATIONS AND PROFILES BY BROKERS AND SELLERS, FOR ON-LINE PRE-QUALIFICATIONS, CREDIT AND LOAN RISK MANAGEMENT, AUTOMATED UNDERWRITING, AND REAL-TIME LOCK AND PRICING AND FEE INFORMATION, AND USER GUIDES PROVIDED THEREWITH; REAL ESTATE OFFICE MANAGEMENT SOFTWARE FOR TASK MANAGEMENT, ADVERTISING MANAGEMENT, REFERRAL MANAGEMENT, SHOWING MANAGEMENT, LEAD MANAGEMENT, INVENTORY MANAGEMENT AND APPOINTMENT MANAGEMENT AND SCHEDULING; COMPUTER SOFTWARE FOR USING AND MANAGING MULTIPLE LISTING SERVICE DATA IN THE FIELD OF REAL ESTATE; REAL ESTATE OFFICE MANAGEMENT SOFTWARE FOR SALES REPORTING, FINANCIAL REPORTING, COMMISSION STRUCTURE REPORTING, AGENT ACCOUNTABILITY REPORTING, FRANCHISE REPORTING AND LOAN PAYMENT SCHEDULES (U.S. CLS. 21, 23, 26, 36 AND 38).

FIRST USE 6-0-2010; IN COMMERCE 6-0-2010.

CLASS 35—ADVERTISING AND BUSINESS

FOR REAL PROPERTY INFORMATION SERVICES, NAMELY, PROVIDING A DATABASE ON A GLOBAL COMPUTER NETWORK WITH INFORMATION ON REAL PROPERTY TAXES; REAL ESTATE MARKETING SERVICES, NAMELY, PROVIDING A DATABASE ON A GLOBAL COMPUTER NETWORK WITH AERIAL PHOTOGRAPHS OF REAL PROPERTY THAT PROVIDE A VIEW OF PROPERTIES AND THEIR SURROUNDINGS; REAL PROPERTY INFORMATION SERVICES, NAMELY, PROVIDING A DATABASE ON A GLOBAL COMPUTER NETWORK ON REAL PROPERTY CHARACTERISTICS, NAMELY, PRICING, PARCEL SIZE AND LOCATION DATA; MONITORING AND REPORTING SERVICES FOR SECURED REAL PROPERTY, NAMELY, LOCATING AND PROVIDING INFORMATION RELATED TO PUBLIC RECORD ACTIVITIES ON REAL ESTATE, NAMELY, MONITORING AND REPORTING PUBLIC DOCUMENT FILINGS RELATING TO SECURED LOANS FOR REAL PROPERTY; BUSINESS CONSULTATION AND INFORMATION SERVICES; BUSINESS INQUIRY, INVESTIGATION, EVALUATION, APPRAISAL, INFORMATION, AND RESEARCH SERVICES; TAX AND TAXATION PLANNING ADVICE, INFORMATION, AND CONSULTATION SERVICES; DEVELOPMENT OF AND CONSULTATION WITH RESPECT TO SHIPPING AND PACKAGING POLICIES AND PROCEDURES TO MITIGATE THE RISK OF CARGO LOSS AND DAMAGE; VEHICLE FLEET MANAGEMENT SERVICES, NAMELY, PREPARING BUSINESS REPORTS AND INQUIRIES RELATED TO VEHICLE FLEET MANAGEMENT DATA, NAMELY, TRACKING AND MONITORING VEHICLES FOR COMMERCIAL PURPOSES; DELIVERING CAR BUYER LEADS TO CAR DEALERSHIPS; DELIVERING LOAN LEADS TO LENDERS; DEVELOPMENT, PRODUCTION AND PROCESSING OF ELECTRONIC EMPLOYMENT APPLICATIONS; DEVELOPMENT OF, CONSULTATION WITH RESPECT TO, REVIEW, MANAGEMENT, AND OPERATION OF DRUG-FREE WORKPLACE POLICIES AND PROGRAMS; MANAGEMENT OF DRUG TESTING PROGRAMS FOR OTHERS; DEVELOPMENT OF, CONSULTATION WITH RESPECT TO, REVIEW, MANAGEMENT, AND OPERATION OF EMPLOYEE ASSISTANCE PROGRAMS DEALING WITH ANY PERSONAL ISSUE THAT MIGHT AFFECT WORKER PRODUCTIVITY; AUDITING LOANS, LOAN PORTFOLIOS AND LINES OF CREDIT; COMPUTERIZED DATABASE MANAGEMENT FOR DATA REGARDING LOANS, LOAN PORTFOLIOS AND LINES OF CREDIT; BUSINESS MANAGEMENT SERVICES, NAMELY, MANAGING REAL ESTATE APPRAISAL SERVICES FOR THIRD PARTY VENDORS; REAL PROPERTY INFORMATION SERVICES, NAMELY, PROVIDING MAPS TO PROSPECTIVE BUYERS AND TENANTS; PROVIDING AN ON-LINE ELECTRONIC DATABASE ON GLOBAL COMPUTER NETWORKS IN THE FIELD OF REAL PROPERTY INFORMATION, NAMELY, PROVIDING MAPS AND

DIGITIZED IMAGES OF REAL PROPERTY AND MAPS TO PROSPECTIVE BUYERS AND TENANTS; BUSINESS INVESTIGATIONS OF POTENTIAL TENANTS; DEMOGRAPHIC CONSULTATION AND STUDIES, NAMELY, A STUDY, ANALYSIS AND PRESENTATION OF INFORMATION ABOUT DEMOGRAPHICS OF PROPERTIES, RESIDENCES, RESIDENTS, HOMES AND RESIDENTS OF THE HOUSES; REAL ESTATE RESEARCH SERVICES, NAMELY, A STUDY, ANALYSIS AND PRESENTATION OF INFORMATION ABOUT DEMOGRAPHICS OF PROPERTIES, RESIDENCES, RESIDENTS, HOMES AND RESIDENTS OF THE HOUSES (U.S. CLS. 100, 101 AND 102).

FIRST USE 6-0-2010; IN COMMERCE 6-0-2010.

CLASS 36—INSURANCE AND FINANCIAL

FOR REAL PROPERTY INFORMATION SERVICES, NAMELY, PROVIDING OWNERSHIP AND PROPERTY INFORMATION AND DATA ON COMPARABLES, VALUATION AND PRICING DATA, MORTGAGE MARKETING, LOAN RECORDING INFORMATION AND LENDER MARKET SHARE INFORMATION; PROVIDING AN ON-LINE ELECTRONIC DATABASE ON GLOBAL COMPUTER NETWORKS IN THE FIELD OF REAL PROPERTY INFORMATION, NAMELY, OWNERSHIP AND PROPERTY INFORMATION AND DATA ON COMPARABLES, VALUATION AND PRICING DATA, MORTGAGE MARKETING, LOAN RECORDING INFORMATION AND LENDER MARKET SHARE INFORMATION; PROVIDING AN ON-LINE COMPUTER DATABASE IN THE FIELD OF REAL ESTATE THROUGH SEARCH AND DATA RETRIEVAL SOFTWARE FOR ACCESSING AND DOWNLOADING REAL PROPERTY INFORMATION FROM MULTIPLE DATA SOURCES; FINANCIAL ANALYSIS AND CONSULTATION SERVICES, NAMELY, REVIEWING, ANALYZING, EVALUATING, PROVIDING DUE DILIGENCE, UNDERWRITING, QUALITY CONTROL, AND REPORTING ON LOANS, LOAN PORTFOLIOS AND LINES OF CREDIT; CREDIT AND FINANCIAL CONSULTATION, EVALUATION, AND REPORTING SERVICES; CREDIT INQUIRY AND CONSULTATION; PROVIDING A SEARCHABLE DATABASE OF REAL ESTATE, MORTGAGE AND LOAN INFORMATION FOR USE IN TITLE INSURANCE UNDERWRITING; REAL ESTATE SERVICES, NAMELY, MULTIPLE LISTING SERVICES ACCESSIBLE OVER THE INTERNET; PROVIDING VALUATION REPORTS OF RESIDENTIAL REAL ESTATE PROPERTIES, AND ALLOWING A USER TO ORDER VALUATION REPORTS AND CHECK ORDER STATUS, ALL THROUGH A GLOBAL COMPUTER NETWORK; AUTOMATED APPRAISALS OF REAL ESTATE; PROVIDING ON-LINE INFORMATION IN THE FIELD OF REAL ESTATE CONTRACT APPRAISAL AND REAL ESTATE APPRAISAL MANAGEMENT SERVICES, NAMELY, PROVIDING STATUS AND APPRAISAL ORDERING (U.S. CLS. 100, 101 AND 102).

FIRST USE 6-0-2010; IN COMMERCE 6-0-2010.

CLASS 39—TRANSPORTATION AND STORAGE

FOR ELECTRONIC STORAGE FOR OTHERS OF REAL PROPERTY DATA, NAMELY, OWNERSHIP AND PROPERTY INFORMATION AND DATA ON COMPARABLES, MAPS, VALUATION AND PRICING DATA, MORTGAGE MARKETING, LOAN RECORDING INFORMATION, LENDER MARKETING, LOAN RECORDING INFORMATION, LENDER MARKET SHARE INFORMATION AND MAPS; STORAGE OF ELECTRONIC EMPLOYMENT APPLICATIONS; STORAGE OF FINGERPRINTS (U.S. CLS. 100 AND 105).

FIRST USE 6-0-2010; IN COMMERCE 6-0-2010.

CLASS 42—SCIENTIFIC AND COMPUTER SERVICES

FOR PROVIDING ONLINE NON-DOWNLOADABLE SOFTWARE FOR USE BY LENDERS IN THE ANALYSIS, VALIDATION AND VERIFICATION OF DATA; PROVIDING ON-LINE NON-DOWNLOADABLE SOFTWARE FOR USE IN VALUATION OF REAL ESTATE OWNED (REO) REAL PROPERTY; PROVIDING ONLINE NON-DOWNLOADABLE COMPUTER SOFTWARE THAT EVALUATES DATA OF LOAN AGENTS, BORROWERS, AND REAL ESTATE PUBLIC DATA; DEVELOPMENT AND PROVISION OF DRIVER QUALIFICATION SYSTEMS, NAMELY, PROVIDING A NON-DOWNLOADABLE ONLINE TOOL WHEREBY USERS CAN MONITOR COMMERCIAL DRIVERS FOR COMPLIANCE WITH DEPARTMENT OF TRANSPORTATION RULES AND REGULATIONS; COMPUTER SERVICES, NAMELY, DATA RECOVERY SERVICES; PROVIDING ON-LINE NON-DOWNLOADABLE SOFTWARE FOR USE IN VALUATION OF REAL ESTATE; PROVIDING USE OF ON-LINE NON-DOWNLOADABLE SOFTWARE FOR USE IN MANAGING MULTIPLE LISTING SERVICE DATA IN THE FIELD OF REAL ESTATE; PROVIDING USE OF ONLINE NON-DOWNLOADABLE SOFTWARE FOR USE IN MONITORING, SECURING, MANAGING COMPLIANCE WITH MULTIPLE LISTING SERVICE (MLS) DATA IN THE FIELD OF REAL ESTATE; PROVIDING TEMPORARY USE OF NON-DOWNLOADABLE SOFTWARE IN THE REAL ESTATE FIELD FOR APPRAISAL AND VALUATION REPORTS (U.S. CLS. 100 AND 101).

FIRST USE 6-0-2010; IN COMMERCE 6-0-2010.

CLASS 44—MEDICAL, BEAUTY AND AGRICULTURAL SERVICES

FOR DRUG TESTING FOR SUBSTANCE ABUSE; DRIVER DRUG USE SCREENING SERVICES TO ENSURE THAT COMMERCIAL DRIVERS ARE QUALIFIED TO MEET DEPARTMENT OF TRANSPORTATION RULES AND REGULATIONS (U.S. CLS. 100 AND 101).

FIRST USE 6-0-2010; IN COMMERCE 6-0-2010.

CLASS 45—PERSONAL AND LEGAL SERVICES

FOR FRAUD DETECTION SERVICES IN THE FIELD OF MISREPRESENTATION OF PROPERTY VALUES IN THE REAL ESTATE MORTGAGE LENDING INDUSTRY; PROVIDING A DATABASE OF INFORMATION IN THE FIELD OF FRAUD DETECTION AS IT RELATES TO PROPERTY VALUES IN THE REAL ESTATE MORTGAGE LENDING INDUSTRY; BACKGROUND INVESTIGATION SERVICES, PRE-EMPLOYMENT, PRE-RENTING, AND OTHER BACKGROUND INQUIRY, INVESTIGATION, EVALUATION, INFORMATION, RESEARCH, AND SCREENING SERVICES, NAMELY, CONDUCTING PRE-EMPLOYMENT BACKGROUND INVESTIGATIONS, PERSONNEL INVESTIGATIONS, CRIMINAL RECORD INVESTIGATION, DRIVING RECORD INVESTIGATION, MOTOR VEHICLE RECORDS REPORTING, REFERENCE VERIFICATION, EDUCATION VERIFICATION AND LICENSE AND CERTIFICATION VERIFICATION; DEVELOPMENT OF AND CONSULTATION WITH RESPECT TO SUPPLY CHAIN SECURITY PROGRAMS, NAMELY, LOSS EXPOSURE AND COUNTERMEASURE ANALYSIS FOR CARGO THEFT EXPOSURE ON A LANE-BY-LANE OR COUNTRY-BY-COUNTRY BASIS AND FACILITY RISK ASSESSMENT AND EMERGING MARKET ASSESSMENTS; LITIGATION CONSULTATION AND SUPPORT SERVICES; PRIVATE INVESTIGATION SERVICES; FINGERPRINTING SERVICES, NAMELY, PROCESSING AND MANAGEMENT OF FINGERPRINTS; PROVIDING MOTOR VEHICLE AND DRIVER BACKGROUND RECORDS; BACKGROUND INVESTIGATION SERVICES OF POTENTIAL TENANTS; DRIVER SCREENING SERVICES, NAMELY, PRE-EMPLOYMENT BACKGROUND SCREENING TO ENSURE THAT COMMERCIAL DRIVERS ARE QUALIFIED TO MEET DEPARTMENT OF TRANSPORTATION RULES AND REGULATIONS (U.S. CLS. 100 AND 101).

FIRST USE 6-0-2010; IN COMMERCE 6-0-2010.

3,998,860. ROB ASSELIN, E. GREENWICH, RI. SN 77-856,949.
PUB. 3-30-2010, FILED 10-26-2009.

CIVIL

THE MARK CONSISTS OF STANDARD CHARACTERS WITHOUT CLAIM TO ANY PARTICULAR FONT, STYLE, SIZE, OR COLOR.

CLASS 18—LEATHER GOODS

FOR BACKPACKS; MESSENGER BAGS (U.S. CLS. 1, 2, 3, 22 AND 41).
FIRST USE 7-2-2007; IN COMMERCE 5-25-2011.

CLASS 25—CLOTHING

FOR CAPS; HATS; HOODED SWEAT SHIRTS; JACKETS; SHIRTS; SWEAT SHIRTS; T-SHIRTS (U.S. CLS. 22 AND 39).
FIRST USE 7-31-2007; IN COMMERCE 7-31-2007.

CLASS 28—TOYS AND SPORTING GOODS

FOR SKATEBOARD DECKS; SKATEBOARD WHEELS; SKATEBOARDS; BAGS FOR SKATEBOARDS (U.S. CLS. 22, 23, 38 AND 50).
FIRST USE 10-31-2006; IN COMMERCE 10-31-2006.

CLASS 35—ADVERTISING AND BUSINESS

FOR RETAIL STORE SERVICES FEATURING CLOTHING, HEADWEAR, FOOTWEAR, SUNGLASSES, WATCHES, AND SNOWBOARD AND SKATEBOARD EQUIPMENT AND ACCESSORIES; ON-LINE RETAIL STORE SERVICES FEATURING CLOTHING, HEADWEAR, FOOTWEAR, SUNGLASSES, WATCHES, AND SNOWBOARD AND SKATEBOARD EQUIPMENT AND ACCESSORIES (U.S. CLS. 100, 101 AND 102).
FIRST USE 7-31-2007; IN COMMERCE 7-31-2007.

3,998,867. MEDINA, JEFF, MCCALLEN, TX. SN 77-857,881.
PUB. 4-20-2010, FILED 10-26-2009.



THE COLOR(S) RED, ORANGE, YELLOW, BLACK AND WHITE IS/ARE CLAIMED AS A FEATURE OF THE MARK. THE MARK CONSISTS OF THE WORD "THINKGEN" WITH "THINK" IN BLACK STYLIZED LETTERS AND "GEN" IN ORANGE. BELOW THE WORD "THINK" IS A TRIANGULAR DESIGN WITH A VERTICAL LINE STARTING IN THE CENTER OF THE TRIANGLE AND CURVING SLIGHTLY TO THE RIGHT AND FORMING THE LETTER "I" IN "THINK". THE TRIANGLE OUTLINE AND THE

VERTICAL LINE IS BLACK WITH THE PORTION OF THE VERTICAL LINE FORMING THE DOT IN THE LETTER "I" IN ORANGE. THE INTERIOR OF THE TRIANGLE DESIGN IS RED AT THE BOTTOM QUARTER OF THE TRIANGLE, ORANGE IN THE NEXT QUARTER UP, YELLOW IN THE NEXT QUARTER UP AND WHITE IN THE UPPER QUARTER OF THE TRIANGLE DESIGN.

CLASS 16—PAPER GOODS AND PRINTED MATTER

FOR PAPER, CARDBOARD, AND PRINTED MATTER, NAMELY, DECALS, STICKERS, AND GREETING CARDS (U.S. CLS. 2, 5, 22, 23, 29, 37, 38 AND 50).
FIRST USE 2-0-2011; IN COMMERCE 10-7-2010.

CLASS 25—CLOTHING

FOR CLOTHING, NAMELY, SHIRTS, HATS, CAPS, SKICAPS, T-SHIRTS, SWEATSHIRTS, POLO SHIRTS (U.S. CLS. 22 AND 39).
FIRST USE 10-7-2010; IN COMMERCE 10-7-2010.

CLASS 35—ADVERTISING AND BUSINESS

FOR ONLINE RETAIL STORE SERVICES FEATURING CLOTHING, PAPER AND PRINTED MATTER, DECALS, STICKERS AND GREETING CARDS (U.S. CLS. 100, 101 AND 102).
FIRST USE 10-7-2010; IN COMMERCE 5-5-2011.

3,998,870. BUZRUN CO., LTD., SEOCHO-GU SEOUL, REPUBLIC OF KOREA. SN 77-858,542. PUB. 10-5-2010, FILED 10-27-2009.



OWNER OF U.S. REG. NO. 2,358,283. THE COLOR(S) RED AND BLACK IS/ARE CLAIMED AS A FEATURE OF THE MARK. THE MARK CONSISTS OF THE WORD "BUZRUN" IN BLACK, PRECEDED BY A STYLIZED RED CAPITAL LETTER "B" DIVIDED IN HALF VERTICALLY, THE CENTER OF WHICH HAS A RED "Z" DESIGN WHICH CONNECTS THE TWO HALVES.

CLASS 25—CLOTHING

FOR SKI SOCKS, SNOWBOARD SOCKS, SKI SUITS, SNOWBOARD SUITS, SNOWBOARD BOOTS, SKI BOOTS, BATHING CAPS, BATHING DRAWERS, BATHING SUITS, BATHING TRUNKS, BOOT UPPERS, BOOTS, BOOTS FOR SPORTS; SNOWBOARD GLOVES, SKI GLOVES (U.S. CLS. 22 AND 39).
FIRST USE 11-1-2009; IN COMMERCE 11-1-2009.

CLASS 28—TOYS AND SPORTING GOODS

FOR SNOWBOARDS, SKIS, BINDINGS FOR SNOWBOARD, SKI BINDINGS, BAGS ESPECIALLY DESIGNED FOR SKIS, BAGS ESPECIALLY DESIGNED FOR SNOWBOARDS, ROLLER SKATES, IN-LINE SKATES, GOLF GLOVES, GOLF BAGS, GOLF CLUBS, SKATEBOARDS, EDGES OF SKIS (U.S. CLS. 22, 23, 38 AND 50).
FIRST USE 11-1-2009; IN COMMERCE 11-1-2009.

3,998,872. TARGET BRANDS, INC., MINNEAPOLIS, MN. SN 77-859,172. PUB. 1-12-2010, FILED 10-28-2009.



OWNER OF U.S. REG. NOS. 972,082, 3,233,049, AND OTHERS.

NO CLAIM IS MADE TO THE EXCLUSIVE RIGHT TO USE "GIFTCOIN", APART FROM THE MARK AS SHOWN.

THE MARK CONSISTS OF CONCENTRIC CIRCLES REPRESENTING A TARGET OR BULLSEYE DESIGN POSITIONED TO THE LEFT OF THE WORD "GIFTCOIN".

CLASS 16—PAPER GOODS AND PRINTED MATTER

FOR NON-MAGNETICALLY ENCODED REPLENISHABLE STORE VALUE CARDS (U.S. CLS. 2, 5, 22, 23, 29, 37, 38 AND 50).

FIRST USE 11-1-2009; IN COMMERCE 11-1-2009.

CLASS 36—INSURANCE AND FINANCIAL

FOR STORED VALUE PREPAID CARD SERVICES, NAMELY, PROCESSING ELECTRONIC PAYMENTS MADE THROUGH PREPAID CARDS (U.S. CLS. 100, 101 AND 102).

FIRST USE 11-1-2009; IN COMMERCE 11-1-2009.

3,998,877. TÜNKERS MASCHINENBAU GMBH, D-40880 RATINGEN, FED REP GERMANY. SN 77-861,051. PUB. 10-5-2010, FILED 10-30-2009.

TÜNKERS

THE MARK CONSISTS OF STANDARD CHARACTERS WITHOUT CLAIM TO ANY PARTICULAR FONT, STYLE, SIZE, OR COLOR.

THE WORDING "TÜNKERS" HAS NO MEANING IN A FOREIGN LANGUAGE.

CLASS 7—MACHINERY

FOR MECHANICAL CLAMPING FIXTURES, NAMELY, TOGGLE LEVER CLAMPS FOR USE IN MACHINING APPLICATIONS; POWER CLAMPS FOR USE IN MACHINING APPLICATIONS; ELECTRIC CLAMPS FOR USE IN MACHINING APPLICATIONS; PNEUMATIC CLAMPS FOR USE IN MACHINING APPLICATIONS; UNDERFLOOR CLAMPS FOR USE IN MACHINING APPLICATIONS; CAM PLATE CLAMPS FOR USE IN MACHINING APPLICATIONS; UPPER DEAD CENTER CLAMPS FOR USE IN MACHINING APPLICATIONS; ECO CLAMPS FOR USE IN MACHINING APPLICATIONS; HYDRAULIC CLAMPING FIXTURES, NAMELY, PNEUMATIC TOGGLE LEVER CLAMPS FOR USE IN MACHINING APPLICATIONS; CLAMPING ACCESSORIES, NAMELY, CLAMPING FIXTURE BRACKETS AND ONE-WAY RESTRICTORS FOR USE IN MACHINING APPLICATIONS; STAMPING DEVICES, NAMELY, STAMPING PRESSES; PIN TUMBLER CYLINDER UNITS FOR USE IN MACHINING APPLICATIONS; EXPANSION MANDRELS FOR USE IN MACHINING APPLICATIONS; PNEUMATIC CYLINDERS FOR USE IN MACHINING APPLICATIONS; ELECTRIC, GAS AND LASER WELDING CLAMPING FIXTURES; GAS AND LASER MACHINE WELDING TONGS; CONVEYOR MACHINE GRIPPERS; GLUING MACHINES FOR THE PAPER AND PRINTING INDUSTRY; ELECTRIC AND HYDRAULIC VIBRATING RAMMERS AND VIBRATION DAMPERS; ELECTRIC AND HYDRAULIC VIBRATING RAMMERS; VIBRATION EXCITERS FOR USE IN MACHINING APPLICATIONS; INDUSTRIAL ROBOTS; MACHINE TOOLS FOR FORMING METAL; PACKAGING MACHINES (U.S. CLS. 13, 19, 21, 23, 31, 34 AND 35).

FIRST USE 0-0-1962; IN COMMERCE 0-0-1992.

CLASS 8—HAND TOOLS

FOR HAND-OPERATED CLAMPING DEVICES, NAMELY, TOGGLE LEVER CLAMPS; HAND-OPERATED PLIERS; HAND-OPERATED STAMPING PLIERS; HAND-OPERATED FLANGING PLIERS; HAND-OPERATED PUNCHING PLIERS (U.S. CLS. 23, 28 AND 44).

FIRST USE 0-0-1962; IN COMMERCE 0-0-1992.

CLASS 9—ELECTRICAL AND SCIENTIFIC APPARATUS

FOR TOGGLE LEVER CLAMP ELEVATION SENSORS AND CLAMPING ANGLE SENSORS; WELDING EQUIPMENT, NAMELY, COLUMN-TYPE ELECTRIC WELDING TONGS, ELECTRIC ROBOT WELDING TONGS; CLAMPING FIXTURES FOR LASER WELDING DEVICES (U.S. CLS. 21, 23, 26, 36 AND 38).

FIRST USE 0-0-1962; IN COMMERCE 0-0-1992.

CLASS 12—VEHICLES

FOR VEHICLES, NAMELY, ELECTRIC SCOOTERS, ELECTRIC WHEELCHAIRS, ELECTRIC MOTOR DRIVEN CARTS FOR SHOPPING CART AND AIRPORT LUGGAGE CART COLLECTION AND TRANSPORTATION, ELECTRIC MOTOR DRIVEN MATERIAL HANDLING CARTS; ELECTRIC TRANSPORT HAULERS FOR LOGISTIC TASKS FOR IN-COMPANY OR INTRA-URBAN AREAS (U.S. CLS. 19, 21, 23, 31, 35 AND 44).

FIRST USE 0-0-1962; IN COMMERCE 0-0-1992.

3,998,878. TÜNKERS MASCHINENBAU GMBH, D-40880 RATINGEN, FED REP GERMANY. SN 77-861,053. PUB. 10-5-2010, FILED 10-30-2009.



THE MARK CONSISTS OF UPPER CASE LETTER "T" WITHIN A SAW-TOOTHED EDGE CIRCLE AND ALL WITHIN A SQUARE.

CLASS 7—MACHINERY

FOR MECHANICAL CLAMPING FIXTURES, NAMELY, TOGGLE LEVER CLAMPS FOR USE IN MACHINING APPLICATIONS; POWER CLAMPS FOR USE IN MACHINING APPLICATIONS; ELECTRIC CLAMPS FOR USE IN MACHINING APPLICATIONS; PNEUMATIC CLAMPS FOR USE IN MACHINING APPLICATIONS; UNDERFLOOR CLAMPS FOR USE IN MACHINING APPLICATIONS; CAM PLATE CLAMPS FOR USE IN MACHINING APPLICATIONS; UPPER DEAD CENTER CLAMPS FOR USE IN MACHINING APPLICATIONS; ECO CLAMPS FOR USE IN MACHINING APPLICATIONS; HYDRAULIC CLAMPING FIXTURES, NAMELY, PNEUMATIC TOGGLE LEVER CLAMPS FOR USE IN MACHINING APPLICATIONS; CLAMPING ACCESSORIES, NAMELY, CLAMPING FIXTURE BRACKETS AND ONE-WAY RESTRICTORS FOR USE IN MACHINING APPLICATIONS; STAMPING DEVICES, NAMELY, STAMPING PRESSES; PIN TUMBLER CYLINDER UNITS FOR USE IN MACHINING APPLICATIONS; EXPANSION MANDRELS FOR USE IN MACHINING APPLICATIONS; PNEUMATIC CYLINDERS FOR USE IN MACHINING APPLICATIONS; ELECTRIC, GAS AND LASER WELDING CLAMPING FIXTURES; GAS AND LASER MACHINE WELDING TONGS; CONVEYOR MACHINE GRIPPERS; GLUING MACHINES FOR THE PAPER AND PRINTING INDUSTRY; ELECTRIC AND HYDRAULIC VIBRATING RAMMERS AND VIBRATION DAMPERS; ELECTRIC AND HYDRAULIC VIBRATING RAMMERS; VIBRATION EXCITERS FOR USE IN MACHINING APPLICATIONS; INDUSTRIAL ROBOTS; MACHINE TOOLS FOR FORMING METAL; PACKAGING MACHINES (U.S. CLS. 13, 19, 21, 23, 31, 34 AND 35).

FIRST USE 0-0-1962; IN COMMERCE 0-0-1992.

CLASS 8—HAND TOOLS

FOR HAND-OPERATED CLAMPING DEVICES, NAMELY, TOGGLE LEVER CLAMPS; HAND-OPERATED PLIERS; HAND-OPERATED STAMPING PLIERS; HAND-OPERATED FLANGING PLIERS; HAND-OPERATED PUNCHING PLIERS (U.S. CLS. 23, 28 AND 44).

FIRST USE 0-0-1962; IN COMMERCE 0-0-1992.

CLASS 9—ELECTRICAL AND SCIENTIFIC APPARATUS

FOR TOGGLE LEVER CLAMP ELEVATION SENSORS AND CLAMPING ANGLE SENSORS; WELDING EQUIPMENT, NAMELY, COLUMN-TYPE ELECTRIC WELDING TONGS; ELECTRIC ROBOT WELDING TONGS; CLAMPING FIXTURES FOR LASER WELDING DEVICES (U.S. CLS. 21, 23, 26, 36 AND 38).

FIRST USE 0-0-1962; IN COMMERCE 0-0-1992.

CLASS 12—VEHICLES

FOR VEHICLES, NAMELY, ELECTRIC SCOOTERS, ELECTRIC WHEELCHAIRS, ELECTRIC MOTOR DRIVEN CARTS FOR SHOPPING CART AND AIRPORT LUGGAGE CART COLLECTION AND TRANSPORTATION, ELECTRIC MOTOR DRIVEN MATERIAL HANDLING CARTS; ELECTRIC TRANSPORT HAULERS FOR LOGISTIC TASKS FOR IN-COMPANY OR INTRA-URBAN AREAS (U.S. CLS. 19, 21, 23, 31, 35 AND 44).

FIRST USE 0-0-1962; IN COMMERCE 0-0-1992.

3,998,880. NITTO TIRE U.S.A. INC., CYPRESS, CA. SN 77-861,265. PUB. 4-6-2010, FILED 10-30-2009.

DIAMOND TREE

THE MARK CONSISTS OF STANDARD CHARACTERS WITHOUT CLAIM TO ANY PARTICULAR FONT, STYLE, SIZE, OR COLOR.

CLASS 35—ADVERTISING AND BUSINESS

FOR PROMOTING SPORTS COMPETITIONS AND/OR EVENTS OF OTHERS, NAMELY, AUTOMOBILE RACES AND AUTOMOBILE AND RACE-CAR DRIVING EVENTS (U.S. CLS. 100, 101 AND 102).

FIRST USE 11-0-2010; IN COMMERCE 11-0-2010.

CLASS 36—INSURANCE AND FINANCIAL

FOR FINANCIAL SPONSORSHIP OF SPORTING EVENTS AND ACTIVITIES, NAMELY, AUTOMOBILE RACES AND AUTOMOBILE AND RACE-CAR DRIVING EVENTS (U.S. CLS. 100, 101 AND 102).

FIRST USE 11-0-2010; IN COMMERCE 11-0-2010.

CLASS 41—EDUCATION AND ENTERTAINMENT

FOR ENTERTAINMENT IN THE NATURE OF AUTOMOBILE RACES AND RACE-CAR DRIVING EVENTS (U.S. CLS. 100, 101 AND 107).

FIRST USE 11-0-2010; IN COMMERCE 11-0-2010.

3,998,883. GAINES GROUP LLC, HOUSTON, TX. SN 77-861,497. PUB. 3-30-2010, FILED 10-30-2009.

AIRCARE+

THE MARK CONSISTS OF STANDARD CHARACTERS WITHOUT CLAIM TO ANY PARTICULAR FONT, STYLE, SIZE, OR COLOR.

CLASS 3—COSMETICS AND CLEANING PREPARATIONS

FOR ROOM FRAGRANCE REFILLS FOR NON-ELECTRIC ROOM FRAGRANCE DISPENSERS; ROOM FRAGRANCES; ROOM FRAGRANCING PREPARATIONS (U.S. CLS. 1, 4, 6, 50, 51 AND 52).

FIRST USE 5-1-2011; IN COMMERCE 5-1-2011.

CLASS 4—LUBRICANTS AND FUELS

FOR CANDLES; CANDLES FOR LIGHTING; PERFUMED CANDLES; SCENTED CANDLES (U.S. CLS. 1, 6 AND 15).

FIRST USE 5-1-2011; IN COMMERCE 5-1-2011.

CLASS 11—ENVIRONMENTAL CONTROL APPARATUS

FOR DIFFUSERS FOR DISPENSING AIR FRESHENERS (U.S. CLS. 13, 21, 23, 31 AND 34).

FIRST USE 5-1-2011; IN COMMERCE 5-1-2011.

3,998,885. SUPER ELEPHANT CO., LTD., TAIPEI, TAIWAN.
SN 77-862,002. PUB. 10-5-2010, FILED 10-30-2009.

SOPHIE'S KITCHEN

THE MARK CONSISTS OF STANDARD CHARACTERS WITHOUT CLAIM TO ANY PARTICULAR FONT, STYLE, SIZE, OR COLOR.

CLASS 29—MEATS AND PROCESSED FOODS

FOR VEGETARIAN PROCESSED FOOD, NAMELY, VEGGIE BURGER PATTIES, VEGGIE NUGGET, SOY-BASED IMITATION MEAT, SOY-BASED IMITATION SEAFOOD, IMITATION MEAT MADE WITH KONJAC, IMITATION SEAFOOD MADE WITH KONJAC, PROCESSED MUSHROOMS; PREPARED MEALS CONSISTING PRIMARILY OF MEAT SUBSTITUTES; SOY AND VEGETABLE BASED SNACK FOODS; DRIED VEGETABLES (U.S. CL. 46).

FIRST USE 10-1-2009; IN COMMERCE 3-11-2010.

CLASS 30—STAPLE FOODS

FOR PACKAGED MEAL CONSISTING PRIMARILY OF PASTA OR RICE; SANDWICHES; BURRITOS; TACOS (U.S. CL. 46).

FIRST USE 10-1-2009; IN COMMERCE 3-11-2010.

3,998,891. ROZENE DEVELOPMENT INTERNATIONAL, LLC, OMAHA, NE. SN 77-863,459. PUB. 4-6-2010, FILED 11-3-2009.

Rozene

THE MARK CONSISTS OF STANDARD CHARACTERS WITHOUT CLAIM TO ANY PARTICULAR FONT, STYLE, SIZE, OR COLOR.

CLASS 35—ADVERTISING AND BUSINESS

FOR BUSINESS CONSULTATION; BUSINESS CONSULTATION SERVICES; BUSINESS CONSULTING AND INFORMATION SERVICES; BUSINESS CONSULTING SERVICES IN THE FIELD OF INFORMATION ASSURANCE; BUSINESS CONSULTING SERVICES RELATED TO MONITORING, CONTROLLING, AND MANAGING TELEPRESENCE ENVIRONMENTS OF OTHERS; BUSINESS CONSULTING, MANAGEMENT, PLANNING AND SUPERVISION; BUSINESS DEVELOPMENT CONSULTING SERVICES; BUSINESS MANAGEMENT AND CONSULTATION; BUSINESS MANAGEMENT AND CONSULTATION IN THE FIELD OF HEALTHCARE AND TELEMEDICINE; BUSINESS MANAGEMENT AND CONSULTING SERVICES FOR THE HEALTH CARE INDUSTRY, NAMELY, CUSTOMER SERVICE, ACCOUNTING SERVICES, AND MARKETING SERVICES; BUSINESS MANAGEMENT AND CONSULTING SERVICES FOR THE HEALTH CARE INDUSTRY, NAMELY, PROVIDING INDUSTRY EXPERTISE AND SUPPLIER PARTNERSHIPS; BUSINESS MANAGEMENT CONSULTANCY AS WELL AS DEVELOPMENT OF PROCESSES FOR THE ANALYSIS AND THE IMPLEMENTATION OF STRATEGY PLANS AND MANAGEMENT PROJECTS; BUSINESS MANAGEMENT CONSULTANCY SERVICES; BUSINESS MANAGEMENT CONSULTANCY, ALSO VIA THE INTERNET; BUSINESS MANAGEMENT CONSULTING; CONSULTANCY OF PERSONNEL RECRUITMENT; CONSULTING SERVICES IN THE FIELDS OF BUSINESS MANAGEMENT, HUMAN RESOURCES, AND BUSINESS ORGANIZATIONAL DESIGN; EMPLOYMENT AGENCY SERVICES, NAMELY, FILLING THE TEMPORARY AND PERMANENT STAFFING NEEDS OF BUSINESSES; EMPLOYMENT HIRING, RECRUITING, PLACEMENT, STAFFING AND CAREER NETWORKING SERVICES; EMPLOYMENT STAFFING CONSULTATION SERVICES; EMPLOYMENT STAFFING IN THE FIELD OF HEALTHCARE AND TELEMEDICINE; HUMAN RESOURCE ANALYSIS AND CONSULTING SERVICES; PERSONNEL CONSULTANCY (U.S. CLS. 100, 101 AND 102).

FIRST USE 7-1-2010; IN COMMERCE 7-1-2010.

CLASS 44—MEDICAL, BEAUTY AND AGRICULTURAL SERVICES

FOR TELEMEDICINE SERVICES (U.S. CLS. 100 AND 101).

FIRST USE 7-1-2010; IN COMMERCE 7-1-2010.

3,998,893. MELCHER, WESLEY, PLANO, TX. SN 77-864,111.
PUB. 8-31-2010, FILED 11-3-2009.

NETEASY

THE MARK CONSISTS OF STANDARD CHARACTERS WITHOUT CLAIM TO ANY PARTICULAR FONT, STYLE, SIZE, OR COLOR.

CLASS 16—PAPER GOODS AND PRINTED MATTER

FOR PUBLICATIONS IN THE FIELD OF BUSINESS, NAMELY, BOOKS, JOURNALS, HANDBOOKS, BOOKLETS, HANDOUTS, TEACHING MATERIALS, AND TRAINING MANUALS (U.S. CLS. 2, 5, 22, 23, 29, 37, 38 AND 50).

FIRST USE 2-28-2011; IN COMMERCE 2-28-2011.

CLASS 41—EDUCATION AND ENTERTAINMENT

FOR ELECTRONIC NEWSLETTERS ONLINE AND DELIVERED BY EMAIL IN THE FIELD OF BUSINESS; ONLINE JOURNALS, NAMELY, BLOGS FEATURING BUSINESS; PROVIDING AN EDUCATIONAL WEBSITE IN THE FIELD OF BUSINESS (U.S. CLS. 100, 101 AND 107).

FIRST USE 2-28-2011; IN COMMERCE 2-28-2011.

3,998,898. FORMS AND SURFACES, INC., PITTSBURGH, PA. SN 77-864,565. PUB. 10-5-2010, FILED 11-4-2009.

LEVELe

THE MARK CONSISTS OF STANDARD CHARACTERS WITHOUT CLAIM TO ANY PARTICULAR FONT, STYLE, SIZE, OR COLOR.

CLASS 6—METAL GOODS

FOR METAL INTERIOR AND EXTERIOR WALL CLADDING FOR BUILDING AND CONSTRUCTION (U.S. CLS. 2, 12, 13, 14, 23, 25 AND 50).

FIRST USE 0-0-2009; IN COMMERCE 0-0-2009.

CLASS 7—MACHINERY

FOR ELEVATOR WALL PANELS AND ELEVATOR CAB INTERIOR PANEL SYSTEMS, NAMELY, WALL PANELS, CEILINGS, FLOORS, HAND RAILINGS, AND DOORS (U.S. CLS. 13, 19, 21, 23, 31, 34 AND 35).

FIRST USE 0-0-2009; IN COMMERCE 0-0-2009.

CLASS 9—ELECTRICAL AND SCIENTIFIC APPARATUS

FOR ELEVATOR ELECTRICAL PARTS, NAMELY, PUSHBUTTONS, SIGNAL FIXTURES AND EMERGENCY LIGHTING (U.S. CLS. 21, 23, 26, 36 AND 38).

FIRST USE 0-0-2009; IN COMMERCE 0-0-2009.

CLASS 11—ENVIRONMENTAL CONTROL APPARATUS

FOR LIGHTING FIXTURES (U.S. CLS. 13, 21, 23, 31 AND 34).

FIRST USE 0-0-2009; IN COMMERCE 0-0-2009.

3,998,909. GATEFRONT, LLC, COLLIERVILLE, TN. SN 77-869,354. PUB. 4-13-2010, FILED 11-10-2009.

BRINGING WORLD MARKETS TO
YOUR MARKET

THE MARK CONSISTS OF STANDARD CHARACTERS WITHOUT CLAIM TO ANY PARTICULAR FONT, STYLE, SIZE, OR COLOR.

CLASS 1—CHEMICALS

FOR FERTILIZER (U.S. CLS. 1, 5, 6, 10, 26 AND 46).
FIRST USE 6-10-2011; IN COMMERCE 6-10-2011.

CLASS 39—TRANSPORTATION AND STORAGE

FOR DISTRIBUTION SERVICES, NAMELY, DISTRIBUTION AND DELIVERY OF FERTILIZER; WAREHOUSING SERVICES, NAMELY, STORAGE AND DISTRIBUTION OF FERTILIZER (U.S. CLS. 100 AND 105).

FIRST USE 3-0-2010; IN COMMERCE 3-0-2010.

3,998,916. ASHLAND LICENSING AND INTELLECTUAL PROPERTY LLC, DUBLIN, OH. SN 77-873,156. PUB. 4-20-2010, FILED 11-16-2009.

SYN GARD

THE MARK CONSISTS OF STANDARD CHARACTERS WITHOUT CLAIM TO ANY PARTICULAR FONT, STYLE, SIZE, OR COLOR.

OWNER OF U.S. REG. NO. 1,906,265.

CLASS 1—CHEMICALS

FOR AUTOMATIC TRANSMISSION FLUIDS (U.S. CLS. 1, 5, 6, 10, 26 AND 46).

FIRST USE 12-1-2009; IN COMMERCE 12-1-2009.

CLASS 4—LUBRICANTS AND FUELS

FOR GEAR OILS (U.S. CLS. 1, 6 AND 15).

FIRST USE 3-31-2010; IN COMMERCE 3-31-2010.

3,998,919. ARTLIST INTERNATIONAL, INC., NEW YORK, NY. SN 77-873,838. PUB. 9-28-2010, FILED 11-16-2009.

ARTLIST COLLECTION THE DOG

THE MARK CONSISTS OF STANDARD CHARACTERS WITHOUT CLAIM TO ANY PARTICULAR FONT, STYLE, SIZE, OR COLOR.

NO CLAIM IS MADE TO THE EXCLUSIVE RIGHT TO USE "COLLECTION" AND "DOG", APART FROM THE MARK AS SHOWN.

CLASS 3—COSMETICS AND CLEANING PREPARATIONS

FOR SHAMPOOS, HAIR CONDITIONER (U.S. CLS. 1, 4, 6, 50, 51 AND 52).

FIRST USE 4-1-2004; IN COMMERCE 4-1-2004.

CLASS 9—ELECTRICAL AND SCIENTIFIC APPARATUS

FOR EYE GLASS FRAMES; PRERECORDED CDS FEATURING CHILDREN'S STORIES; VIDEO GAME CARTRIDGES (U.S. CLS. 21, 23, 26, 36 AND 38). FIRST USE 7-0-2005; IN COMMERCE 7-0-2005.

CLASS 16—PAPER GOODS AND PRINTED MATTER

FOR COLORING BOOKS, PAPER NAPKINS (U.S. CLS. 2, 5, 22, 23, 29, 37, 38 AND 50). FIRST USE 4-0-2004; IN COMMERCE 4-0-2004.

CLASS 21—HOUSEWARES AND GLASS

FOR PAPER PLATES AND PAPER CUPS (U.S. CLS. 2, 13, 23, 29, 30, 33, 40 AND 50). FIRST USE 4-0-2004; IN COMMERCE 4-0-2004.

CLASS 24—FABRICS

FOR TOWELS (U.S. CLS. 42 AND 50). FIRST USE 3-0-2004; IN COMMERCE 3-0-2004.

CLASS 25—CLOTHING

FOR WEARING APPAREL, NAMELY, T-SHIRTS AND HEADWEAR (U.S. CLS. 22 AND 39). FIRST USE 9-0-2003; IN COMMERCE 9-0-2003.

CLASS 26—FANCY GOODS

FOR HAIR ACCESSORIES, NAMELY, HAIR COMBS (U.S. CLS. 37, 39, 40, 42 AND 50). FIRST USE 4-0-2007; IN COMMERCE 4-0-2007.

CLASS 30—STAPLE FOODS

FOR CANDY, LOLLIPOPS, CANDY JELLY POPS (U.S. CL. 46). FIRST USE 2-0-2009; IN COMMERCE 2-0-2009.

3,998,921. DHARMA GEAR INC., MIAMI, FL. SN 77-874,621. PUB. 4-27-2010, FILED 11-17-2009.



NO CLAIM IS MADE TO THE EXCLUSIVE RIGHT TO USE "GEAR", APART FROM THE MARK AS SHOWN. THE COLOR(S) WHITE, RED, BLUE, YELLOW AND GREEN IS/ARE CLAIMED AS A FEATURE OF THE MARK. THE MARK CONSISTS OF A STYLIZED LETTER "D", "H", "A", "R", "M", "A", "G", "E", "A", "R" IN BLUE. A DEPICTION OF A PERSON SITTING IN MEDITATION WITH RAYS INSIDE APPEARING IN THE FOLLOWING COLORS WHITE, RED, BLUE, YELLOW AND GREEN WITH A BLUE OUTLINE. THE FIRST SET OF RAYS APPEAR ON THE HEAD THE SECOND IN THE TORSO. STARTING WITH THE WHITE ROUGHLY LOCATED IN THE 12 O'CLOCK POSITION, FOLLOWED BY RED, BLUE, YELLOW, AND GREEN WITH THE PATTERN REPEATING

3 TIMES IN BOTH LOCATIONS.

CLASS 25—CLOTHING

FOR ATHLETIC APPAREL, NAMELY, SHIRTS, PANTS, JACKETS, FOOTWEAR, HATS AND CAPS, ATHLETIC UNIFORMS; CHILDREN'S AND INFANT'S APPAREL, NAMELY, JUMPERS, OVERALL SLEEPWEAR, PAJAMAS, RÖMPERS AND ONE-PIECE GARMENTS (U.S. CLS. 22 AND 39). FIRST USE 12-9-2009; IN COMMERCE 1-10-2010.

CLASS 35—ADVERTISING AND BUSINESS

FOR RETAIL APPAREL STORES (U.S. CLS. 100, 101 AND 102). FIRST USE 12-9-2009; IN COMMERCE 1-10-2010.

3,998,931. BRAM STOKER LLC, AIKEN, SC. SN 77-879,342. PUB. 9-21-2010, FILED 11-23-2009.



BRAM STOKER

THE LIKENESS (OR, "PORTRAIT") IN THE MARK DOES NOT IDENTIFY A LIVING INDIVIDUAL. THE MARK CONSISTS OF "BRAM STOKER'S" SIGNATURE AND PRINTED NAME.

CLASS 14—JEWELRY

FOR JEWELRY; WATCHES AND TIMEPIECES (U.S. CLS. 2, 27, 28 AND 50). FIRST USE 12-15-2010; IN COMMERCE 12-15-2010.

CLASS 25—CLOTHING

FOR WEARABLE GARMENTS AND CLOTHING, NAMELY, SHIRTS, PANTS, SKIRTS, DRESSES, BELTS, TIES, UNDERWEAR, SLEEPWEAR, FOOTWEAR, HEADWEAR, FORMAL WEAR, NAMELY, TUXEDOS AND MORNING DRESS, AND OUTERWEAR, NAMELY, JACKETS, COATS, SWEATERS, SWEAT SHIRTS, CAPES, CLOAKS, SCARVES, AND GLOVES (U.S. CLS. 22 AND 39). FIRST USE 12-15-2010; IN COMMERCE 12-15-2010.

3,998,937. WORKING FAMILY SOLUTIONS, INC., MALDEN-ON-HUDSON, NY. SN 77-880,581. PUB. 9-21-2010, FILED 11-25-2009.

SMART SOLUTIONS, TOOLKIT FOR WORKING MOTHERS

THE MARK CONSISTS OF STANDARD CHARACTERS WITHOUT CLAIM TO ANY PARTICULAR FONT, STYLE, SIZE, OR COLOR. NO CLAIM IS MADE TO THE EXCLUSIVE RIGHT TO USE "SOLUTIONS, TOOLKIT FOR WORKING MOTHERS", APART FROM THE MARK AS SHOWN.

CLASS 9—ELECTRICAL AND SCIENTIFIC APPARATUS

FOR DIGITAL MATERIALS, NAMELY, CD-ROM FEATURING FORMS AND TEMPLATES OF DOCUMENTS RELATED TO PREGNANCY, NEWBORN AND BABY CARE FOR WORKING PARENTS (U.S. CLS. 21, 23, 26, 36 AND 38).

FIRST USE 10-1-2010; IN COMMERCE 10-1-2010.

CLASS 16—PAPER GOODS AND PRINTED MATTER

FOR PACKAGED KITS COMPRISING PRINTED INSTRUCTIONAL, EDUCATIONAL, AND TEACHING MATERIALS FOR EDUCATIONAL ACTIVITIES IN THE FIELD OF PREGNANCY, NEWBORN AND BABY CARE FOR WORKING PARENTS (U.S. CLS. 2, 5, 22, 23, 29, 37, 38 AND 50).

FIRST USE 10-1-2010; IN COMMERCE 10-1-2010.

3,998,938. WORKING FAMILY SOLUTIONS, INC., MALDEN-ON-HUDSON, NY. SN 77-880,614. PUB. 10-26-2010, FILED 11-25-2009.



NO CLAIM IS MADE TO THE EXCLUSIVE RIGHT TO USE "SOLUTIONS", "TOOLKIT FOR WORKING MOTHERS", APART FROM THE MARK AS SHOWN.

THE COLOR(S) WHITE, BROWN, BLACK, GRAY, PINK/RED, TURQUOISE BLUE, AND YELLOW IS/ARE CLAIMED AS A FEATURE OF THE MARK.

THE MARK CONSISTS OF THE FOLLOWING: THE STYLIZED WORDING "SMART SOLUTIONS" IN TURQUOISE BLUE WITH A PINK DOT ON THE "I"; STYLIZED WORDING "TOOLKIT FOR WORKING MOTHERS" IN PINK/RED; A DESIGN OF A BABY AT A COMPUTER IN PINK/RED, WHITE, BROWN, BLACK, AND GRAY; THE WHOLE MARK IS WITHIN A YELLOW CIRCLE LINE.

CLASS 9—ELECTRICAL AND SCIENTIFIC APPARATUS

FOR DIGITAL MEDIA, NAMELY, CD-ROMS FEATURING INFORMATION ON PREGNANCY, NEWBORN BABIES AND BABY CARE FOR WORKING PARENTS (U.S. CLS. 21, 23, 26, 36 AND 38).

FIRST USE 10-1-2010; IN COMMERCE 10-1-2010.

CLASS 16—PAPER GOODS AND PRINTED MATTER

FOR PACKAGED KITS COMPRISING PRINTED INSTRUCTIONAL, EDUCATIONAL, AND TEACHING MATERIALS FOR EDUCATIONAL ACTIVITIES IN THE FIELD OF PREGNANCY, NEWBORN AND BABY CARE FOR WORKING PARENTS (U.S. CLS. 2, 5, 22, 23, 29, 37, 38 AND 50).

FIRST USE 10-1-2010; IN COMMERCE 10-1-2010.

3,998,951. HEIFER PROJECT INTERNATIONAL, LITTLE ROCK, AR. SN 77-885,835. PUB. 5-4-2010, FILED 12-3-2009.

HEIFER HOPE

THE MARK CONSISTS OF STANDARD CHARACTERS WITHOUT CLAIM TO ANY PARTICULAR FONT, STYLE, SIZE, OR COLOR.

OWNER OF U.S. REG. NOS. 2,235,711, 2,831,229, AND 3,220,895.

NO CLAIM IS MADE TO THE EXCLUSIVE RIGHT TO USE "HEIFER", APART FROM THE MARK AS SHOWN.

CLASS 36—INSURANCE AND FINANCIAL

FOR CHARITABLE FUND RAISING SERVICES (U.S. CLS. 100, 101 AND 102).

FIRST USE 2-1-2011; IN COMMERCE 2-1-2011.

CLASS 41—EDUCATION AND ENTERTAINMENT

FOR EDUCATIONAL SERVICES, NAMELY, CONDUCTING CLASSES, SEMINARS, AND INDIVIDUAL INSTRUCTION IN ENVIRONMENTAL TRAINING, NAMELY, SUSTAINABLE AGRICULTURE OR ANIMAL HUSBANDRY (U.S. CLS. 100, 101 AND 107).

FIRST USE 2-1-2011; IN COMMERCE 2-1-2011.

3,998,974. SOLSTICE LIVING SOLUTIONS, INC., SCOTTSDALE, AZ. SN 77-894,097. PUB. 11-9-2010, FILED 12-15-2009.

SOLSTICE LIVING SOLUTIONS

THE MARK CONSISTS OF STANDARD CHARACTERS WITHOUT CLAIM TO ANY PARTICULAR FONT, STYLE, SIZE, OR COLOR.

NO CLAIM IS MADE TO THE EXCLUSIVE RIGHT TO USE "LIVING SOLUTIONS", APART FROM THE MARK AS SHOWN.

CLASS 44—MEDICAL, BEAUTY AND AGRICULTURAL SERVICES

FOR MEDICAL SERVICES FOR RESIDENTS IN PRIVATE HOMES AND SENIOR LIVING FACILITIES; MEDICAL ASSISTANCE SERVICES, NAMELY, PROVIDING ASSISTANCE WITH DAILY LIVING ACTIVITIES TO RESIDENTS IN SENIOR LIVING FACILITIES (U.S. CLS. 100 AND 101).

FIRST USE 12-1-2010; IN COMMERCE 12-1-2010.

CLASS 45—PERSONAL AND LEGAL SERVICES

FOR IN-HOME SUPPORT SERVICES TO SENIOR PERSONS, NAMELY, GERIATRIC CARE MANAGEMENT SERVICES AND PERSONAL AFFAIRS MANAGEMENT SERVICES IN THE NATURE OF THE COORDINATION OF NECESSARY SERVICES AND CARE FOR OLDER INDIVIDUALS (U.S. CLS. 100 AND 101).

FIRST USE 12-1-2010; IN COMMERCE 12-1-2010.

3,998,978. KONAMI DIGITAL ENTERTAINMENT CO., LTD., TOKYO, JAPAN. SN 77-894,908. PUB. 10-19-2010, FILED 12-16-2009.

DUEL ACCELERATOR

THE MARK CONSISTS OF STANDARD CHARACTERS WITHOUT CLAIM TO ANY PARTICULAR FONT, STYLE, SIZE, OR COLOR.

CLASS 9—ELECTRICAL AND SCIENTIFIC APPARATUS

FOR VIDEO GAME SOFTWARE; VIDEO GAME PROGRAMS; COMPUTER GAME PROGRAMS; COMPUTER GAME SOFTWARE; ELECTRONIC GAME PROGRAMS (U.S. CLS. 21, 23, 26, 36 AND 38).

FIRST USE 12-18-2009; IN COMMERCE 12-18-2009.

CLASS 41—EDUCATION AND ENTERTAINMENT

FOR PRODUCTION OF VIDEO AND COMPUTER GAME SOFTWARE; ENTERTAINMENT SERVICES, NAMELY, PROVIDING ONLINE COMPUTER GAMES ACCESSIBLE VIA COMPUTERS; PROVIDING ONLINE COMPUTER GAMES VIA NETWORK BETWEEN COMMUNICATIONS NETWORKS AND COMPUTERS; PROVIDING INFORMATION TO GAME PLAYERS ABOUT THE RANKING OF THEIR SCORES OF GAMES THROUGH THE WEB SITES; PROVIDING INFORMATION REGARDING GAMES; ARRANGING, ORGANIZING AND CONDUCTING GAME TOURNAMENTS (U.S. CLS. 100, 101 AND 107).

FIRST USE 12-18-2009; IN COMMERCE 12-18-2009.

3,998,999. WATER POLITICS LLC, LAS VEGAS, NV. SN 77-901,099. PUB. 5-18-2010, FILED 12-26-2009.

Watergy Nexus

THE MARK CONSISTS OF STANDARD CHARACTERS WITHOUT CLAIM TO ANY PARTICULAR FONT, STYLE, SIZE, OR COLOR.

CLASS 35—ADVERTISING AND BUSINESS

FOR BUSINESS ADVISORY SERVICES, CONSULTANCY AND INFORMATION; CONSULTING SERVICES IN THE AREA OF SUSTAINABLE BUSINESS SOLUTIONS; ENERGY USAGE MANAGEMENT INFORMATION SERVICES; INFORMATION IN THE FIELD OF ENERGY EFFICIENCY; PROMOTING AND CONDUCTING TRADE SHOWS IN THE FIELD OF WATER POLICY AND ENERGY LINKAGES (U.S. CLS. 100, 101 AND 102).

FIRST USE 9-6-2010; IN COMMERCE 9-6-2010.

CLASS 41—EDUCATION AND ENTERTAINMENT

FOR CONDUCTING WORKSHOPS AND SEMINARS IN WATER POLICY AND ENERGY LINKAGES; ONLINE PUBLICATIONS IN THE NATURE OF BOOKS, MAGAZINE AND E-ZINE IN THE FIELD OF WATER POLICY AND ENERGY LINKAGES (U.S. CLS. 100, 101 AND 107).

FIRST USE 9-6-2010; IN COMMERCE 9-6-2010.

3,999,007. TRADEMARK TOOLS INC., CONCORD, CANADA. SN 77-904,955. PUB. 11-23-2010, FILED 1-5-2010.

THE COLOR(S) BLACK, GREY AND RED IS/ARE CLAIMED AS A FEATURE OF THE MARK.

THE MARK CONSISTS OF THE WORD "TOOLMASTER" WHICH HAS A GREY BACKGROUND AND A BLACK FOREGROUND. THERE IS A RED LINE THROUGH ALL THE LETTERS EXCEPT FOR THE "T".

CLASS 6—METAL GOODS

FOR METAL TOOL BOXES (U.S. CLS. 2, 12, 13, 14, 23, 25 AND 50).

FIRST USE 2-26-2010; IN COMMERCE 2-26-2010.

CLASS 8—HAND TOOLS

FOR HAND TOOLS, NAMELY, HAMMERS, SAWS, SCREWDRIVERS, PLIERS AND WRENCHES (U.S. CLS. 23, 28 AND 44).

FIRST USE 2-26-2010; IN COMMERCE 2-26-2010.

3,999,008. MATTEL, INC., EL SEGUNDO, CA. SN 77-904,974. PUB. 11-2-2010, FILED 1-5-2010.

A FAIRY SECRET

THE MARK CONSISTS OF STANDARD CHARACTERS WITHOUT CLAIM TO ANY PARTICULAR FONT, STYLE, SIZE, OR COLOR.

CLASS 16—PAPER GOODS AND PRINTED MATTER

FOR PRINTED MATTER AND PAPER GOODS, NAMELY, BOOKS FOR CHILDREN; STICKER BOOKS (U.S. CLS. 2, 5, 22, 23, 29, 37, 38 AND 50).

FIRST USE 1-31-2011; IN COMMERCE 1-31-2011.

CLASS 28—TOYS AND SPORTING GOODS

FOR TOYS, GAMES AND PLAYTHINGS, NAMELY, DOLLS, DOLL CLOTHING AND DOLL ACCESSORIES (U.S. CLS. 22, 23, 38 AND 50).

FIRST USE 9-1-2010; IN COMMERCE 9-1-2010.

CLASS 35—ADVERTISING AND BUSINESS

FOR ADVERTISING AND ADVERTISEMENT SERVICES; ADVERTISING AGENCIES; MARKETING RESEARCH SERVICES; PLANNING MULTIMEDIA ADVERTISING STRATEGIES AND PROMOTIONS FOR OTHERS; SALES AND BRAND PROMOTION FOR OTHERS; MARKET RESEARCH; PUBLIC RELATIONS; DISTRIBUTION AND DISSEMINATION OF ADVERTISING MATERIAL; DIRECT MARKETING SERVICES; BUSINESS CONSULTANCY AND ADVISORY SERVICES; RETAIL STORE SERVICES FEATURING STATIONERY, ARTISTS WORK MATERIALS AND WORKS OF ART; ART GALLERIES; ADVISORY AND CONSULTANCY SERVICES RELATING TO ADVERTISING AND ADVERTISEMENT SERVICES, MARKETING RESEARCH SERVICES, MULTIMEDIA ADVERTISING STRATEGIES AND PROMOTIONS, SALES AND BRAND PROMOTION, PUBLIC RELATIONS, DISTRIBUTION AND DISSEMINATION OF ADVERTISING MATERIAL, DIRECT MARKETING SERVICES, BUSINESS CONSULTANCY AND ADVISORY SERVICES, RETAIL STORE SERVICES FEATURING STATIONERY, ARTISTS WORK MATERIALS AND WORKS OF ART; ADVISORY AND CONSULTANCY SERVICES PROVIDED ON-LINE VIA A COMPUTER DATABASE OR VIA THE INTERNET, RELATING TO ADVERTISING AND ADVERTISEMENT SERVICES, MARKETING RESEARCH SERVICES, MULTIMEDIA ADVERTISING STRATEGIES AND PROMOTIONS, SALES AND BRAND PROMOTION, PUBLIC RELATIONS, DISTRIBUTION AND DISSEMINATION OF ADVERTISING MATERIAL, DIRECT MARKETING SERVICES, BUSINESS CONSULTANCY AND ADVISORY SERVICES, RETAIL STORE SERVICES FEATURING STATIONERY, ARTISTS WORK MATERIALS AND WORKS OF ART (U.S. CLS. 100, 101 AND 102).

FIRST USE 1-30-2007; IN COMMERCE 1-30-2007.

3,999,019. JONES, PAUL, LONDON, UNITED KINGDOM.
SN 77-908,707. PUB. 9-21-2010, FILED 1-11-2010.

ELMS LESTERS

THE MARK CONSISTS OF STANDARD CHARACTERS WITHOUT CLAIM TO ANY PARTICULAR FONT, STYLE, SIZE, OR COLOR.

THE NAME SHOWN IN THE MARK DOES NOT IDENTIFY A PARTICULAR LIVING INDIVIDUAL.

CLASS 6—METAL GOODS

FOR SCULPTURES, STATUES, STATUETTES AND SOUVENIR ORNAMENTS OF BRONZE, STEEL AND OTHER NON-PRECIOUS METALS (U.S. CLS. 2, 12, 13, 14, 23, 25 AND 50).

FIRST USE 1-30-2007; IN COMMERCE 1-30-2007.

CLASS 16—PAPER GOODS AND PRINTED MATTER

FOR PAPER; WRITING PAPER; DRAWING PAPER; PRINTED MATTER, NAMELY, BOOKS, MAGAZINES, PRINTED PERIODICALS, NEWSPAPERS, NEWSLETTERS, CATALOGUES AND BROCHURES ALL IN THE FIELDS OF ARTS; PRINTED EDUCATIONAL AND INSTRUCTIONAL MATERIALS IN THE FIELD OF ARTS; STICKERS; STATIONERY; PENS; PENCILS; CRAYONS; FELT WRITING PENS; ERASERS; GIFT WRAPPING PAPER; PACKAGING MATERIALS MADE FROM PAPER OR CARDBOARD FOR ARTWORKS; GREETINGS CARDS; POSTCARDS; BOOKMARKS; CRAFT PAPER; COLORING BOOKS; NOTE BOOKS; DIARIES; PHOTOGRAPH ALBUMS; CALENDARS; ARTIST'S MATERIALS, NAMELY, MOULDS FOR MODELING CLAYS, ARTISTS' BRUSHES, ARTISTS' PASTELS, ARTISTS' PENCILS, ARTISTS' PENS, CANVAS PANELS FOR ARTISTS; PAINTER'S BRUSHES; PAINTERS' EASELS; PALETTES FOR PAINTING PHOTOGRAPHS; PAINTINGS FRAMED OR UNFRAMED; POSTERS; DECALCOMANIA; PRINT ENGRAVINGS; WORKS OF ART, NAMELY, DRAWINGS ON PAPER OR CANVAS; ETCHINGS; PAPER-MACHE OR CARDBOARD FIGURINES, ORNAMENTS AND STATUES OF PAPER OR PAPIER MACHE (U.S. CLS. 2, 5, 22, 23, 29, 37, 38 AND 50).

FIRST USE 1-30-2007; IN COMMERCE 1-30-2007.

CLASS 41—EDUCATION AND ENTERTAINMENT

FOR EDUCATIONAL SERVICES, NAMELY, PROVIDING COURSES OF INSTRUCTION ON THE SUBJECT OF ART; PROVIDING OF TRAINING IN THE FIELD OF ARTS, MUSIC, DANCE, THEATRE AND PHOTOGRAPHY; ARRANGING AND CONDUCTING SEMINARS RELATING TO ART AND ARTISTS; ARRANGING AND CONDUCTING CONFERENCES RELATING TO ART AND ARTISTS; ARRANGING AND CONDUCTING ART EXHIBITIONS; PROVIDING MUSEUM SERVICES AND FACILITIES; ART CURATION SERVICES; PHOTOGRAPHY SERVICES; PHOTO EDITING AND MANIPULATION SERVICES; PROVIDING SERVICES AND FACILITIES FOR THE ORGANIZATION AND PRESENTATION OF MUSIC CONCERTS AND THEATRICAL AND DANCE PERFORMANCES; PUBLICATION OF ELECTRONIC BOOKS AND JOURNALS RELATED TO ART AND ARTISTS ONLINE; CONSULTANCY AND ADVISORY SERVICES RELATING TO EDUCATIONAL SERVICES, NAMELY, PROVIDING COURSES OF INSTRUCTION ON THE SUBJECT OF ART, ARRANGING AND CONDUCTING SEMINARS RELATING TO ART AND ARTISTS, ARRANGING AND CONDUCTING CONFERENCES RELATING TO ART AND ARTISTS, ARRANGING AND CONDUCTING ART EXHIBITIONS, PROVIDING MUSEUM SERVICES AND FACILITIES, ART CURATION SERVICES, PHOTOGRAPHY SERVICES, PHOTO EDITING AND MANIPULATION SERVICES, PROVIDING SERVICES AND FACILITIES FOR THE ORGANIZATION AND PRESENTATION OF MUSIC CONCERTS AND THEATRICAL AND DANCE PERFORMANCES, PUBLICATION OF ELECTRONIC BOOKS AND JOURNALS RELATED TO ART AND ARTISTS ONLINE (U.S. CLS. 100, 101 AND 107).

FIRST USE 1-30-2007; IN COMMERCE 1-30-2007.

3,999,041. KUNG FU, LLC, ENCINO, CA. SN 77-919,120. PUB. 6-8-2010, FILED 1-25-2010.

DEEP DARK ROBOT

THE MARK CONSISTS OF STANDARD CHARACTERS WITHOUT CLAIM TO ANY PARTICULAR FONT, STYLE, SIZE, OR COLOR.

CLASS 9—ELECTRICAL AND SCIENTIFIC APPARATUS

FOR DOWNLOADABLE MUSICAL SOUND RECORDINGS; MUSICAL SOUND RECORDINGS; MUSICAL VIDEO RECORDINGS (U.S. CLS. 21, 23, 26, 36 AND 38). FIRST USE 12-16-2010; IN COMMERCE 12-16-2010.

CLASS 41—EDUCATION AND ENTERTAINMENT

FOR ENTERTAINMENT SERVICES IN THE NATURE OF LIVE MUSICAL PERFORMANCES (U.S. CLS. 100, 101 AND 107). FIRST USE 12-16-2010; IN COMMERCE 12-16-2010.

3,999,042. CROSCILL HOME LLC, NEW YORK, NY. SN 77-919,515. PUB. 9-21-2010, FILED 1-25-2010.

CROSCILL LIVING

THE MARK CONSISTS OF STANDARD CHARACTERS WITHOUT CLAIM TO ANY PARTICULAR FONT, STYLE, SIZE, OR COLOR.

OWNER OF U.S. REG. NOS. 380,816, 1,503,043, AND OTHERS.

THE WORDING "CROSCILL" HAS NO MEANING IN A FOREIGN LANGUAGE.

CLASS 20—FURNITURE AND ARTICLES NOT OTHERWISE CLASSIFIED

FOR SHOWER RODS; SHOWER CURTAIN HOOKS AND RINGS; DRAPERY HARDWARE, NAMELY, TRAVERSE RODS, POLES, CURTAIN HOOKS, CURTAIN RODS AND FINIALS (U.S. CLS. 2, 13, 22, 25, 32 AND 50). FIRST USE 5-28-2010; IN COMMERCE 5-28-2010.

CLASS 24—FABRICS

FOR BED LINENS, NAMELY, COMFORTERS, BED SPREADS, COMFORTER COVERS, BED SHEETS, PILLOW CASES, PILLOW SHAMS, DUST RUFFLES AND DUVET COVERS; QUILTS; TABLE LINENS, NAMELY, FABRIC NAPKINS, PLACE MATS, TABLECLOTHS AND TABLE ROUNDS; FABRIC SHOWER CURTAINS; FABRIC AND VINYL AND ETHYLENE-VINYL ACETATE BLEND SHOWER CURTAIN LINERS; FABRIC BLANKET TROWS; TOWELS, NAMELY, BATH TOWELS, HAND TOWELS, WASHCLOTHS AND FINGERTIP TOWELS; FABRIC WINDOW TREATMENTS, NAMELY, CURTAINS, TIE BACKS FOR CURTAINS AND DRAPERIES, VALANCES, AND SWAGS; WINDOW TREATMENTS IN THE NATURE OF PANELS AND POLYESTER, COTTON AND WOOL; DYED AND FINISHED FABRICS IN THE PIECE FOR TEXTILE USE COMPOSED OF NATURAL FIBERS; DYED AND FINISHED FABRICS IN THE PIECE FOR TEXTILE USE COMPOSED OF SYNTHETIC FIBERS; DYED AND FINISHED FABRICS IN THE PIECE FOR TEXTILE USE COMPOSED OF COMBINATIONS OF NATURAL AND SYNTHETIC FIBERS (U.S. CLS. 42 AND 50). FIRST USE 5-28-2010; IN COMMERCE 5-28-2010.

CLASS 27—FLOOR COVERINGS

FOR BATH MATS AND RUGS (U.S. CLS. 19, 20, 37, 42 AND 50).

FIRST USE 5-28-2010; IN COMMERCE 5-28-2010.

3,999,052. LINCARE LICENSING INC., CLEARWATER, FL. SN 77-923,555. PUB. 11-2-2010, FILED 1-29-2010.



NO CLAIM IS MADE TO THE EXCLUSIVE RIGHT TO USE "COMPANY", APART FROM THE MARK AS SHOWN.

THE MARK CONSISTS OF THE LETTERS "MDINR" WITH A SEMI-OVAL LOCATED ABOVE THE LETTERS "MD" AND THE WORDING "A LINCARE COMPANY" POSITIONED BELOW THE LETTERS "MDINR".

CLASS 41—EDUCATION AND ENTERTAINMENT

FOR PROVIDING PATIENTS, PHYSICIANS AND NURSES WITH TRAINING IN THE FIELD OF COAGULATION MANAGEMENT AND MONITORING (U.S. CLS. 100, 101 AND 107).

FIRST USE 8-6-2010; IN COMMERCE 8-6-2010.

CLASS 42—SCIENTIFIC AND COMPUTER SERVICES

FOR APPLICATION SERVICE PROVIDER (ASP) FEATURING SOFTWARE FOR MONITORING AND MANAGING COAGULATION PATIENTS (U.S. CLS. 100 AND 101).

FIRST USE 8-6-2010; IN COMMERCE 8-6-2010.

3,999,056. YANG GE ENTERPRISE CO., LTD., TAINAN CITY, TAIWAN. SN 77-926,465. PUB. 1-11-2011, FILED 2-2-2010.

DO

THE MARK CONSISTS OF STANDARD CHARACTERS WITHOUT CLAIM TO ANY PARTICULAR FONT, STYLE, SIZE, OR COLOR.

CLASS 20—FURNITURE AND ARTICLES NOT OTHERWISE CLASSIFIED

FOR NON-METALLIC BOTTLE STOPPERS; PLASTIC STORAGE CONTAINERS FOR COMMERCIAL OR INDUSTRIAL USE; PACKING CONTAINERS OF PLASTIC MATERIAL; PLASTIC BOXES; NON-METAL AND NON-PAPER CLOSURES FOR BOTTLES AND CONTAINERS; BOTTLE RACKS; NON-METAL BINS; FIXED NONMETALLIC TOWEL DISPENSERS (U.S. CLS. 2, 13, 22, 25, 32 AND 50).

FIRST USE 6-5-2009; IN COMMERCE 7-20-2009.

CLASS 21—HOUSEWARES AND GLASS

FOR BOTTLE OPENERS; NON-ELECTRIC EGG BEATERS; PEPPER GRINDERS; CRUETS NOT OF PRECIOUS METAL; NON-ELECTRIC KETTLES; ICE CUBE MOLDS; CUTTING BOARDS; WINE OPENERS; WINE STRAINERS; WINE BUCKETS; BOTTLE STOPPERS SPECIALLY ADAPTED FOR USE WITH WINE BOTTLES; WINE BOTTLE CRADLES; SPORTS BOTTLES SOLD EMPTY; WINE GLASSES; COASTERS NOT OF PAPER AND NOT BEING TABLE LINEN; SERVING TONGS; COFFEE CUPS; WINE OPENERS; CONTAINERS FOR ICE; PLASTIC CUPS; MIXING SPOONS; PORTABLE PLASTIC CONTAINERS FOR STORING HOUSEHOLD AND KITCHEN GOODS; NON-METAL COIN BANKS; PLASTIC STORAGE CONTAINERS FOR HOUSEHOLD OR DOMESTIC USE; HOUSEHOLD CONTAINERS FOR FOODS; BUCKETS; PLASTIC WATER BOTTLES SOLD EMPTY; PLASTIC BUCKETS; GENERAL PURPOSE STORAGE BINS FOR HOUSEHOLD USE; PLASTIC HANDHELD SHOPPING BASKETS; PAPER MACHE BASKETS; LAUNDRY BASKETS; BASKETS OF STRAW AND CLOTH NOT OF METAL AND NOT FOR COMMERCIAL USE (U.S. CLS. 2, 13, 23, 29, 30, 33, 40 AND 50).

FIRST USE 6-5-2009; IN COMMERCE 7-20-2009.

3,999,057. VITAL CARE, INC., MERIDIAN, MS. SN 77-926,716. PUB. 10-19-2010, FILED 2-3-2010.

VITAL CARE APOLLO

THE MARK CONSISTS OF STANDARD CHARACTERS WITHOUT CLAIM TO ANY PARTICULAR FONT, STYLE, SIZE, OR COLOR.

OWNER OF U.S. REG. NOS. 1,647,778, 2,169,655, AND 2,312,058.

CLASS 35—ADVERTISING AND BUSINESS

FOR BUSINESS CONSULTING SERVICES FOR THE PHARMACY INDUSTRY, NAMELY, PROVIDING DATABASE MANAGEMENT, REPORTING, AND DOCUMENTATION FOR REGULATORY REQUIREMENTS ASSOCIATED WITH THE PROVISION OF CLINICAL PHARMACY CARE (U.S. CLS. 100, 101 AND 102).

FIRST USE 6-7-2011; IN COMMERCE 6-7-2011.

CLASS 42—SCIENTIFIC AND COMPUTER SERVICES

FOR PROVIDING ON-LINE NON-DOWNLOADABLE SOFTWARE FOR DATABASE MANAGEMENT, REPORTING, DOCUMENTATION AND ANALYSIS FOR COMPLIANCE WITH THE REQUIREMENTS OF THE UNITED STATES PHARMACOPEIA (USP) SECTION 797 AND OTHER LEGAL AND REGULATORY REQUIREMENTS ASSOCIATED WITH THE PROVISION OF CLINICAL PHARMACY CARE; PROVIDING ON-LINE NON-DOWNLOADABLE SOFTWARE FOR PRIVATE AND SECURE REAL TIME ELECTRONIC COMMUNICATION OVER A COMPUTER NETWORK (U.S. CLS. 100 AND 101).

FIRST USE 6-7-2011; IN COMMERCE 6-7-2011.

CLASS 45—PERSONAL AND LEGAL SERVICES

FOR REGULATORY COMPLIANCE CONSULTING IN THE FIELD OF UNITED STATE PHARMACOPEIA (USP) SECTION 797 AND OTHER LEGAL AND REGULATORY REQUIREMENTS ASSOCIATED WITH THE PROVISION OF CLINICAL PHARMACY CARE (U.S. CLS. 100 AND 101).

FIRST USE 6-7-2011; IN COMMERCE 6-7-2011.

3,999,060. CUSTOM BLENDS TOBACCO AND NEWS INC., HILTON HEAD, SC. SN 77-928,363. PUB. 11-16-2010, FILED 2-4-2010.

FUNK4PEACE

THE MARK CONSISTS OF STANDARD CHARACTERS WITHOUT CLAIM TO ANY PARTICULAR FONT, STYLE, SIZE, OR COLOR.

CLASS 16—PAPER GOODS AND PRINTED MATTER

FOR STICKERS (U.S. CLS. 2, 5, 22, 23, 29, 37, 38 AND 50).

FIRST USE 4-11-2011; IN COMMERCE 4-11-2011.

CLASS 25—CLOTHING

FOR T-SHIRTS, BANDANNAS, SHORTS, HATS (U.S. CLS. 22 AND 39).

FIRST USE 4-11-2011; IN COMMERCE 4-11-2011.

CLASS 41—EDUCATION AND ENTERTAINMENT

FOR ENTERTAINMENT SERVICES IN THE NATURE OF LIVE MUSICAL PERFORMANCES, ARRANGING AND CONDUCTING MUSIC FESTIVALS (U.S. CLS. 100, 101 AND 107).

FIRST USE 4-11-2011; IN COMMERCE 4-11-2011.

3,999,064. TREDEGAR FILM PRODUCTS CORPORATION, RICHMOND, VA. SN 77-929,215. PUB. 11-23-2010, FILED 2-5-2010.

FLOWERTOOL

THE MARK CONSISTS OF STANDARD CHARACTERS WITHOUT CLAIM TO ANY PARTICULAR FONT, STYLE, SIZE, OR COLOR.

NO CLAIM IS MADE TO THE EXCLUSIVE RIGHT TO USE "TOOL", APART FROM THE MARK AS SHOWN.

CLASS 9—ELECTRICAL AND SCIENTIFIC APPARATUS

FOR SOFTWARE PROGRAM FOR THE ANALYSIS AND EVALUATION OF ENVIRONMENTAL IMPACT FOR PRODUCTS AND SERVICES IN A VARIETY OF INDUSTRIES (U.S. CLS. 21, 23, 26, 36 AND 38).

FIRST USE 4-8-2010; IN COMMERCE 4-8-2010.

CLASS 35—ADVERTISING AND BUSINESS

FOR RATING THE ENVIRONMENT QUALITIES AND IMPACT OF CONSUMER PRODUCTS OF OTHERS FOR THE PURPOSE OF MAKING PURCHASING DECISIONS (U.S. CLS. 100, 101 AND 102).

FIRST USE 4-8-2010; IN COMMERCE 4-8-2010.

CLASS 41—EDUCATION AND ENTERTAINMENT

FOR TRAINING AND EDUCATIONAL SERVICES IN THE NATURE OF SEMINARS AND WORKSHOPS REGARDING THE DETERMINATION OF THE ENVIRONMENTAL IMPACT OF PRODUCTS AND SERVICES IN A VARIETY OF INDUSTRIES (U.S. CLS. 100, 101 AND 107).

FIRST USE 4-8-2010; IN COMMERCE 4-8-2010.

CLASS 42—SCIENTIFIC AND COMPUTER SERVICES

FOR EVALUATING AND TESTING THE ENVIRONMENTAL QUALITIES AND IMPACT OF CONSUMER PRODUCTS OF OTHERS (U.S. CLS. 100 AND 101).

FIRST USE 4-8-2010; IN COMMERCE 4-8-2010.

3,999,075. CREATIVE AGENCY SERVICES TEAM, INC., SARASOTA, FL. SN 77-933,180. PUB. 12-7-2010, FILED 2-11-2010.

SELLAVISION

THE MARK CONSISTS OF STANDARD CHARACTERS WITHOUT CLAIM TO ANY PARTICULAR FONT, STYLE, SIZE, OR COLOR.

CLASS 9—ELECTRICAL AND SCIENTIFIC APPARATUS

FOR ELECTRONIC DEVICE THAT IS PLACED ALONG SHOPPING AISLES IN RETAIL STORES FOR CUSTOMERS TO SCAN AN ITEM FOR THE DISPLAY OF PRODUCT INFORMATION, DIGITAL COUPONS, AND OTHER MEDIA (U.S. CLS. 21, 23, 26, 36 AND 38).

FIRST USE 10-1-2009; IN COMMERCE 10-1-2009.

CLASS 35—ADVERTISING AND BUSINESS

FOR ADVERTISING AND MARKETING SERVICES VIA THE USE OF POINT-OF-SALE ELECTRONIC DEVICES INSTALLED IN RETAIL LOCATIONS (U.S. CLS. 100, 101 AND 102).

FIRST USE 10-1-2009; IN COMMERCE 10-1-2009.

3,999,077. AMERICAN TEXTILE COMPANY, DUQUESNE, PA. SN 77-933,898. PUB. 6-29-2010, FILED 2-11-2010.

ALLERGY ESSENTIALS BY ALLER-EASE

THE MARK CONSISTS OF STANDARD CHARACTERS WITHOUT CLAIM TO ANY PARTICULAR FONT, STYLE, SIZE, OR COLOR.

OWNER OF U.S. REG. NOS. 2,080,165, 3,319,027, AND OTHERS.

NO CLAIM IS MADE TO THE EXCLUSIVE RIGHT TO USE "ALLERGY", APART FROM THE MARK AS SHOWN.

CLASS 20—FURNITURE AND ARTICLES NOT OTHERWISE CLASSIFIED

FOR BED PILLOWS (U.S. CLS. 2, 13, 22, 25, 32 AND 50).

FIRST USE 6-30-2010; IN COMMERCE 6-30-2010.

CLASS 24—FABRICS

FOR MATTRESS COVERS; MATTRESS PADS; PILLOW COVERS (U.S. CLS. 42 AND 50).

FIRST USE 6-30-2010; IN COMMERCE 6-30-2010.

3,999,078. ORTHOCON, INC., IRVINGTON, NY. SN 77-934,389. PUB. 8-17-2010, FILED 2-12-2010.



OWNER OF U.S. REG. NO. 3,006,586.

THE MARK CONSISTS OF THE WORD "ORTHOCON" AND A DESIGN OF EMANATION WAVES APPEARING ABOVE AND BELOW THE LETTER "O" THAT APPEARS ADJACENT TO THE LETTER "C" IN THE WORD "ORTHOCON".

CLASS 5—PHARMACEUTICALS

FOR HEMOSTATIC COMPOSITIONS FOR TOPICAL USE ON BONE IN SURGICAL PROCEDURES (U.S. CLS. 6, 18, 44, 46, 51 AND 52).

FIRST USE 3-15-2010; IN COMMERCE 2-15-2011.

CLASS 42—SCIENTIFIC AND COMPUTER SERVICES

FOR PRODUCT RESEARCH AND DEVELOPMENT OF ADVANCED BIOMATERIALS FOR SURGICAL APPLICATIONS (U.S. CLS. 100 AND 101).

FIRST USE 3-15-2010; IN COMMERCE 2-15-2011.

3,999,086. CHROMADEX INC., IRVINE, CA. SN 77-939,870. PUB. 2-8-2011, FILED 2-19-2010.

CHROMADEX

THE MARK CONSISTS OF STANDARD CHARACTERS WITHOUT CLAIM TO ANY PARTICULAR FONT, STYLE, SIZE, OR COLOR.

CLASS 1—CHEMICALS

FOR CHEMICAL REAGENTS FOR NON-MEDICAL PURPOSES; CHEMICAL TEST KITS FOR ANALYTICAL MEASUREMENT OF RAW MATERIAL IDENTITY, POTENCY AND FORMULATION CONSISTENCY FOR LABORATORY OR RESEARCH USE; CHEMICALS FOR USE IN INDUSTRY AND SCIENCE; CHEMICALS FOR USE IN THE BIOCHEMICAL AND CHEMICAL INDUSTRY; ASSAYS FOR RESEARCH PURPOSES (U.S. CLS. 1, 5, 6, 10, 26 AND 46).

FIRST USE 10-0-1999; IN COMMERCE 10-0-1999.

CLASS 42—SCIENTIFIC AND COMPUTER SERVICES

FOR CHEMICAL, BIOCHEMICAL, BIOLOGICAL AND BACTERIOLOGICAL RESEARCH AND ANALYSIS; CONSULTING IN THE FIELD OF PRODUCT DEVELOPMENT IN THE FIELD OF CHEMICALS; DEVELOPMENT AND ESTABLISHMENT OF TESTING SPECIFICATIONS AND PROCEDURES IN THE FIELD OF CHEMICALS; DEVELOPMENT AND TEST OF CHEMICAL PRODUCTION METHODS; DEVELOPMENT OF VOLUNTARY STANDARDS FOR CHEMICALS; EXECUTING OF CHEMICAL ANALYSES; INDUSTRIAL RESEARCH IN THE FIELD OF CHEMICALS; PHARMACEUTICAL RESEARCH AND DEVELOPMENT; PRODUCT RESEARCH AND DEVELOPMENT; RESEARCH AND DEVELOPMENT AND CONSULTATION RELATED THERETO IN THE FIELD OF CHEMICALS; TESTING OF RAW MATERIALS (U.S. CLS. 100 AND 101).

FIRST USE 6-0-2000; IN COMMERCE 6-0-2000.

3,999,090. HOUSEHOLD ESSENTIALS, LLC, HAZELWOOD, MO. SN 77-943,011. PUB. 9-21-2010, FILED 2-23-2010.

HOUSEHOLD ESSENTIALS

THE MARK CONSISTS OF STANDARD CHARACTERS WITHOUT CLAIM TO ANY PARTICULAR FONT, STYLE, SIZE, OR COLOR.

NO CLAIM IS MADE TO THE EXCLUSIVE RIGHT TO USE "HOUSEHOLD" AS TO THE GOODS IDENTIFIED IN CLASSES 6, 12, 20, 21 AND 22, APART FROM THE MARK AS

SHOWN.

CLASS 6—METAL GOODS

FOR METAL FASTENERS FOR FASTENING IRONING BOARD COVERS TO IRONING BOARDS; IRONING BOARD HOOKS MADE OF METAL FOR HANGING ON DOORS (U.S. CLS. 2, 12, 13, 14, 23, 25 AND 50).

FIRST USE 1-0-2011; IN COMMERCE 1-0-2011.

CLASS 12—VEHICLES

FOR ROLLING LAUNDRY CARTS (U.S. CLS. 19, 21, 23, 31, 35 AND 44).

FIRST USE 7-0-2010; IN COMMERCE 7-0-2010.

CLASS 18—LEATHER GOODS

FOR TRAVEL BAGS; TOTE BAGS; HAIR CARE TOTE BAGS SOLD EMPTY; GROOMING ORGANIZERS FOR TRAVEL SOLD EMPTY; JEWELRY POUCHES; TIE CASES (U.S. CLS. 1, 2, 3, 22 AND 41).

FIRST USE 4-0-2011; IN COMMERCE 4-0-2011.

CLASS 20—FURNITURE AND ARTICLES NOT OTHERWISE CLASSIFIED

FOR LAUNDRY HAMPERS, UNDERBED CHESTS; JEWELRY CASES NOT BEING OF METAL IN THE NATURE OF HANGING, FLEXIBLE MATERIALS WITH RECEPTACLES FOR USE IN A DISPLAY CASE; LOCKER ORGANIZERS IN THE NATURE OF HANGING, FLEXIBLE MATERIALS HAVING RECEPTACLES; CLOTHES HANGERS, LAUNDRY SHELVES, HANGING TOWEL RACKS, WARDROBES IN THE NATURE OF FREE-STANDING CLOSETS; IRONING BOARD HOOKS MADE OF PLASTIC FOR HANGING ON DOORS (U.S. CLS. 2, 13, 22, 25, 32 AND 50).

FIRST USE 8-0-2010; IN COMMERCE 8-0-2010.

CLASS 21—HOUSEWARES AND GLASS

FOR LAUNDRY ACCESSORIES, NAMELY, IRONING BOARDS, SHAPED IRONING BOARD COVERS, SHAPED IRONING BOARD PADS, IRONING BOARD HOLDERS, RESTS FOR USE AS HOLDERS FOR HOUSEHOLD IRONS; IRONING BOARD ACCESSORY THAT CLAMPS TO THE BOARD TO KEEP THE IRON CORD OUT OF THE WAY; EMPTY SPRAY BOTTLES; CLOTHES PINS; CLOTHES DRYING RACKS; LAUNDRY SORTERS FOR HOUSEHOLD USE (U.S. CLS. 2, 13, 23, 29, 30, 33, 40 AND 50).

FIRST USE 4-0-2010; IN COMMERCE 4-0-2010.

CLASS 22—CORDAGE AND FIBERS

FOR GARMENT STORAGE BAGS, SHOE STORAGE BAGS; CLOTHES LINES; LAUNDRY BAG; LAUNDRY ORGANIZERS IN THE NATURE OF CLOTH BAGS; CLOTHES PIN BAGS; MESH PRESSING PADS TO PROTECT CLOTHING FROM SHINE AND SCORCH MARKS DURING IRONING; CHRISTMAS TREE STORAGE BAGS; WREATH STORAGE BAGS; GENERAL STORAGE BAGS; LAUNDRY WASH BAGS; HAND-OPERATED HAND-TOOL IN THE NATURE OF A NON-METAL CLOTHES LINE REEL THAT CONTAINS, EXTENDS, AND RETRACTS A CLOTHES LINE (U.S. CLS. 1, 2, 7, 19, 22, 42 AND 50).

FIRST USE 7-0-2010; IN COMMERCE 7-0-2010.

3,999,093. RIVALHEALTH, LLC, RALEIGH, NC. SN 77-944,750. PUB. 2-15-2011, FILED 2-25-2010.

RIVAL FUSION

THE MARK CONSISTS OF STANDARD CHARACTERS WITHOUT CLAIM TO ANY PARTICULAR FONT, STYLE, SIZE, OR COLOR.

CLASS 9—ELECTRICAL AND SCIENTIFIC APPARATUS

FOR VIDEO RECORDINGS FEATURING HEALTH, FITNESS AND NUTRITIONAL TOPICS (U.S. CLS. 21, 23, 26, 36 AND 38).
FIRST USE 10-18-2010; IN COMMERCE 10-18-2010.

CLASS 16—PAPER GOODS AND PRINTED MATTER

FOR PRINTED MATTER, NAMELY, BOOKLETS, NEWSLETTERS, INFORMATION SHEETS, FACT SHEETS, HANDBOOKS, PLANNERS AND GUIDES ALL RELATING TO HEALTH AND LIFESTYLE AND EXERCISE; PRINTED INSTRUCTIONAL AND TEACHING MATERIAL, NAMELY, MAGAZINES, BOOKLETS, NEWSLETTERS, INFORMATION SHEETS, FACT SHEETS, HANDBOOKS, PLANNERS AND GUIDES ALL RELATING TO HEALTH, LIFESTYLE AND EXERCISE; MANUALS AND OTHER PRINTED INSTRUCTIONAL MATERIAL SOLD TOGETHER WITH PRERECORDED VIDEO AND OTHER PRERECORDED MEDIA, ALL CONTAINING EDUCATIONAL AND INSTRUCTIONAL MATERIALS RELATING TO HEALTH, LIFESTYLE AND EXERCISE (U.S. CLS. 2, 5, 22, 23, 29, 37, 38 AND 50).
FIRST USE 10-18-2010; IN COMMERCE 10-18-2010.

CLASS 41—EDUCATION AND ENTERTAINMENT

FOR PROVIDING INFORMATION ON-LINE IN THE FIELDS OF FITNESS AND EXERCISE; DESIGNING AND TRACKING EXERCISE PROGRAMS FOR OTHERS; PERSONALIZED FITNESS TRAINING; PROVIDING ONLINE JOURNALS, NAMELY, BLOGS FEATURING HEALTH, LIFESTYLE AND NUTRITION; PROVIDING CUSTOM WEB SITES FOR USE BY THIRD PARTIES IN THE FIELDS OF EXERCISE AND FITNESS (U.S. CLS. 100, 101 AND 107).
FIRST USE 10-18-2010; IN COMMERCE 10-18-2010.

3,999,094. ACADEMY VIDEO TECHNOLOGIES, INC., MIAMI, FL. SN 77-944,947. PUB. 11-16-2010, FILED 2-25-2010.

Skill U

THE MARK CONSISTS OF STANDARD CHARACTERS WITHOUT CLAIM TO ANY PARTICULAR FONT, STYLE, SIZE, OR COLOR.

NO CLAIM IS MADE TO THE EXCLUSIVE RIGHT TO USE "SKILL", APART FROM THE MARK AS SHOWN.

CLASS 42—SCIENTIFIC AND COMPUTER SERVICES

FOR PROVIDING A WEBSITE FEATURING ON-LINE NON-DOWNLOADABLE SOFTWARE FOR WEB BASED VIDEO ANALYSIS IN THE FIELD OF SPORTS EDUCATION, VIRTUAL SPORTS INSTRUCTION, AND TRAINING (U.S. CLS. 100 AND 101).

FIRST USE 5-1-2011; IN COMMERCE 5-1-2011.

CLASS 45—PERSONAL AND LEGAL SERVICES

FOR PROVIDING ON-LINE SOCIAL NETWORKING SERVICES VIA A WEBSITE IN THE FIELD OF SPORTS EDUCATION AND TRAINING (U.S. CLS. 100 AND 101).

FIRST USE 5-1-2011; IN COMMERCE 5-1-2011.

3,999,098. BOISE CASCADE WOOD PRODUCTS, L.L.C., BOISE, ID. SN 77-945,292. PUB. 10-5-2010, FILED 2-25-2010.

GREAT PRODUCTS ARE ONLY THE BEGINNING

THE MARK CONSISTS OF STANDARD CHARACTERS WITHOUT CLAIM TO ANY PARTICULAR FONT, STYLE, SIZE, OR COLOR.

CLASS 19—NON-METALLIC BUILDING MATERIALS

FOR LUMBER; (BASED ON USE IN COMMERCE) ENGINEERED WOOD PRODUCTS, NAMELY, STUDS, BEAMS, JOISTS AND RIM BOARDS (U.S. CLS. 1, 12, 33 AND 50).

FIRST USE 4-0-2008; IN COMMERCE 4-0-2008.

CLASS 35—ADVERTISING AND BUSINESS

FOR DISTRIBUTORSHIP SERVICES FEATURING LUMBER AND PLYWOOD; (BASED ON USE IN COMMERCE) DISTRIBUTORSHIP SERVICES FEATURING ENGINEERED WOOD PRODUCTS (U.S. CLS. 100, 101 AND 102).

FIRST USE 1-0-2007; IN COMMERCE 1-0-2007.

3,999,114. KISSLING SWISS SWITCHES AG, WEINFELDEN, SWITZERLAND. SN 77-951,410. PUB. 12-21-2010, FILED 3-5-2010.

CORMAR

THE MARK CONSISTS OF STANDARD CHARACTERS WITHOUT CLAIM TO ANY PARTICULAR FONT, STYLE, SIZE, OR COLOR.

CLASS 6—METAL GOODS

FOR METAL VALVES NOT BEING PARTS OF MACHINES (U.S. CLS. 2, 12, 13, 14, 23, 25 AND 50).
FIRST USE 0-0-1992; IN COMMERCE 3-0-2011.

CLASS 9—ELECTRICAL AND SCIENTIFIC APPARATUS

FOR METAL ELECTRIC SWITCH HOUSINGS; MANUALLY, ELECTRICALLY, PNEUMATICALLY AND ELECTROMAGNETICALLY ACTUATED SWITCHES AND RELAYS FOR TURNING ON AND OFF ELECTRICAL CURRENT AND ELECTRONIC DEVICES (U.S. CLS. 21, 23, 26, 36 AND 38).
FIRST USE 0-0-1992; IN COMMERCE 3-0-2011.

CLASS 11—ENVIRONMENTAL CONTROL APPARATUS

FOR REFRIGERATION HARDWARE, NAMELY, REFRIGERATION LIGHTING FIXTURES, CONDENSATE EVAPORATORS, REFRIGERATOR WIRE SHELVING, REFRIGERATION ACCESSORIES, NAMELY, REFRIGERATION CONDENSERS, REFRIGERATING CABINETS, REFRIGERATING APPLIANCES AND INSTALLATIONS; STAINLESS STEEL INVESTMENT CAST WALK-IN HARDWARE, NAMELY, REFRIGERATOR SHELVING, BINS, DRAWERS AND TRAYS; COOLER AND FREEZER LIGHTING FIXTURES AND OUTDOOR WALK-IN HARDWARE, NAMELY, WALK-IN COOLERS AND FREEZERS (U.S. CLS. 13, 21, 23, 31 AND 34).
FIRST USE 7-25-2010; IN COMMERCE 7-25-2010.

3,999,122. COMPONENT HARDWARE GROUP, INC., LAKEWOOD, NJ. SN 77-955,535. PUB. 10-19-2010, FILED 3-10-2010.

3,999,127. ATO PICTURES, LLC, CHARLOTTESVILLE, VA. SN 77-957,763. PUB. 10-19-2010, FILED 3-12-2010.

ART TAKES OVER

THE MARK CONSISTS OF STANDARD CHARACTERS WITHOUT CLAIM TO ANY PARTICULAR FONT, STYLE, SIZE, OR COLOR.

CLASS 9—ELECTRICAL AND SCIENTIFIC APPARATUS

FOR MOTION PICTURES AND MOTION PICTURE FILMS FEATURING DRAMA, ACTION ADVENTURE, COMEDY, DOCUMENTARY, AND HISTORICAL SUBJECT MATTER; PRE-RECORDED DVDS, DVD-ROMS, AND VIDEOTAPES FEATURING DRAMA, ACTION ADVENTURE, COMEDY, DOCUMENTARY, AND HISTORICAL SUBJECT MATTER; DOWNLOADABLE FILMS AND MOVIES FEATURING DRAMA, ACTION ADVENTURE, COMEDY, DOCUMENTARY, AND HISTORICAL SUBJECT MATTER PROVIDED VIA A VIDEO-ON-DEMAND SERVICE (U.S. CLS. 21, 23, 26, 36 AND 38).
FIRST USE 8-20-2010; IN COMMERCE 8-20-2010.

NO CLAIM IS MADE TO THE EXCLUSIVE RIGHT TO USE "COLOR", APART FROM THE MARK AS SHOWN.

THE LINING IS FOR SHADING PURPOSES.

THE COLOR(S) BLUE, GRAY AND WHITE IS/ARE CLAIMED AS A FEATURE OF THE MARK.

THE MARK CONSISTS OF A REPRESENTATION OF AN IGLOO OVER THE TERM "KEIL".

CLASS 36—INSURANCE AND FINANCIAL

FOR FACILITATING AND ARRANGING FOR THE FINANCING OF FILMS AND MOVIES (U.S. CLS. 100, 101 AND 102).

FIRST USE 1-18-2010; IN COMMERCE 1-18-2010.

CLASS 38—COMMUNICATION

FOR VIDEO-ON-DEMAND TRANSMISSIONS (U.S. CLS. 100, 101 AND 104).

FIRST USE 3-29-2011; IN COMMERCE 3-29-2011.

CLASS 6—METAL GOODS

FOR METAL REFRIGERATION HARDWARE, NAMELY, REFRIGERATION EDGEMOUNT LATCHES, NON-RISE EDGEMOUNT HINGES, LIFT-OFF CAM-RISE EDGEMOUNT HINGES, CONCEALED CARTRIDGE HINGES, WALK-IN REFRIGERATION LATCHES, INSIDE SAFETY RELEASE IN THE NATURE OF DOOR HANDLES AND LATCHES, WALK-IN REFRIGERATION HANDLES, WALK-IN REFRIGERATION HINGES, SHELF BRACKETS IN THE NATURE OF SHELF PILASTERS AND CLIPS, GASKET FRAMES, VENT PORTS AND PANEL FASTENERS IN THE NATURE OF BOLTS, NAILS, RIVETS AND SCREWS (U.S. CLS. 2, 12, 13, 14, 23, 25 AND 50).
FIRST USE 7-25-2010; IN COMMERCE 7-25-2010.

CLASS 41—EDUCATION AND ENTERTAINMENT

FOR PROVISION OF NON-DOWNLOADABLE FILMS AND MOVIES VIA A VIDEO-ON-DEMAND SERVICE; PRODUCTION AND DISTRIBUTION OF MOTION PICTURE FILMS; MOTION PICTURE SONG PRODUCTION; MOVIE STUDIOS; ORGANIZING EXHIBITIONS FOR MOTION PICTURE FILMS (U.S. CLS. 100, 101 AND 107).
FIRST USE 7-2-2010; IN COMMERCE 7-2-2010.

3,999,138. IPGENIX, LLC, PENSACOLA, FL. SN 77-962,959.
PUB. 8-10-2010, FILED 3-19-2010.

3,999,139. NATIONAL ASSOCIATION OF HOME BUILDERS
OF THE UNITED STATES, WASHINGTON, DC. SN 77-
965,751. PUB. 11-30-2010, FILED 3-23-2010.



THE COLOR(S) RED, BLUE, BLACK, AND GREY IS/ARE CLAIMED AS A FEATURE OF THE MARK.

THE MARK CONSISTS OF THE LITERAL ELEMENT "IPGENIX" WITH THE FIRST 3 LETTERS IN ALL CAPS; THE "IP" AND THE STYLIZED "X" IN RED, THE LOWER-CASE "I" IN BLACK; THE "GEN" IN BLUE; SHOWING TWO BLACK AND GREY BARS NESTLED IN THE SPACE FORMED BY THE RIGHT-HAND CROSS-BARS OF THE STYLIZED "X"; WITH THE "I" DOTTED WITH A SOLID SQUARE INSTEAD OF A DOT.

CLASS 35—ADVERTISING AND BUSINESS

FOR BUSINESS SERVICES, NAMELY, ASSISTING THE OWNERS OF INTELLECTUAL PROPERTY AND INTANGIBLE ASSETS IN FINDING INVESTORS; CONSULTING REGARDING INTELLECTUAL PROPERTY BUSINESS RISK MITIGATION PROCESSES; CONSULTING SERVICES IN THE FIELD OF MANAGING INTELLECTUAL PROPERTIES; PROVIDING A DATABASE FEATURING INTELLECTUAL AND INDUSTRIAL PROPERTY RIGHTS AVAILABLE FOR POSSIBLE ACQUISITION; PROVIDING ELECTRONIC TRACKING OF INTELLECTUAL AND INDUSTRIAL PROPERTY ASSETS TO OTHERS (U.S. CLS. 100, 101 AND 102).

FIRST USE 9-17-2010; IN COMMERCE 9-17-2010.

CLASS 36—INSURANCE AND FINANCIAL

FOR ADVISING OTHERS CONCERNING INVESTMENTS IN INTELLECTUAL PROPERTY ASSETS AND INTANGIBLE BUSINESS ASSETS, BOTH DIRECTLY AND INDIRECTLY THROUGH OTHER ENTITIES; CONSULTING ON THE SUBJECT OF INTELLECTUAL PROPERTY VALUATION; FINANCIAL CONSULTING SERVICES, NAMELY, ADVISING OTHERS REGARDING INTELLECTUAL PROPERTY INVESTMENTS; INTELLECTUAL PROPERTY VALUATION SERVICES (U.S. CLS. 100, 101 AND 102).

FIRST USE 9-17-2010; IN COMMERCE 9-17-2010.

CLASS 45—PERSONAL AND LEGAL SERVICES

FOR CONSULTING IN THE FIELD OF INTELLECTUAL PROPERTY LICENSING; INTELLECTUAL PROPERTY CONSULTATION; INTELLECTUAL PROPERTY WATCH SERVICES; LEGAL SERVICES, NAMELY, INTELLECTUAL PROPERTY CONSULTING SERVICES IN THE FIELD OF INVENTION, IDENTIFICATION, STRATEGY, ANALYTICS, AND INVENTION; LICENSING OF INTELLECTUAL PROPERTY; PATENT AND INDUSTRIAL PROPERTY CONSULTATION; PATENT LICENSING; PROVIDING INFORMATION ABOUT INTELLECTUAL AND INDUSTRIAL PROPERTY RIGHTS (U.S. CLS. 100 AND 101).

FIRST USE 9-17-2010; IN COMMERCE 9-17-2010.



OWNER OF U.S. REG. NOS. 3,262,955 AND 3,372,669.

NO CLAIM IS MADE TO THE EXCLUSIVE RIGHT TO USE "NATIONAL GREEN BUILDING CERTIFICATION PROGRAM" AND "RESEARCH CENTER", APART FROM THE MARK AS SHOWN.

THE MARK CONSISTS OF THE WORDS "NATIONAL GREEN BUILDING CERTIFICATION PROGRAM" FORMING A CIRCLE AROUND AN OPEN FOUR-SIDED FIGURE CONTAINING THE WORDS "NAHB RESEARCH CENTER".

CLASS 9—ELECTRICAL AND SCIENTIFIC APPARATUS

FOR DOWNLOADABLE PUBLICATIONS, NAMELY, REPORTS CONCERNING THE ENVIRONMENTAL ASPECTS OF HOUSING AND RESIDENTIAL STRUCTURES, BUILDING MATERIALS, AND QUALITY CONSTRUCTION PROCEDURES (U.S. CLS. 21, 23, 26, 36 AND 38).

FIRST USE 1-0-2001; IN COMMERCE 1-0-2011.

CLASS 42—SCIENTIFIC AND COMPUTER SERVICES

FOR TESTING, ANALYSIS AND EVALUATION OF THE SERVICES OF OTHERS FOR THE PURPOSE OF CERTIFICATION TO ENVIRONMENTAL STANDARDS; TECHNICAL SUPPORT SERVICES, NAMELY, PROVIDING TECHNICAL ADVICE RELATED TO THE ENVIRONMENTAL ASPECTS OF HOUSING AND RESIDENTIAL STRUCTURES, BUILDING MATERIALS, AND QUALITY CONSTRUCTION PROCEDURES (U.S. CLS. 100 AND 101).

FIRST USE 1-0-2011; IN COMMERCE 1-0-2011.

3,999,153. GOOGLE INC., MOUNTAIN VIEW, CA. SN 77-980,388. PUB. 6-30-2009, FILED 9-2-2008.

CHROMIUM

THE MARK CONSISTS OF STANDARD CHARACTERS WITHOUT CLAIM TO ANY PARTICULAR FONT, STYLE, SIZE, OR COLOR.

CLASS 9—ELECTRICAL AND SCIENTIFIC APPARATUS

FOR COMPUTER SOFTWARE FOR ACCESSING, BROWSING, SHARING, AND COMMUNICATING INFORMATION OVER COMPUTER NETWORKS AND SECURE PRIVATE NETWORKS; COMPUTER SOFTWARE FOR USE IN CONNECTING TO AND SEARCHING THE CONTENTS OF REMOTE COMPUTERS, COMPUTER NETWORKS, AND SECURE PRIVATE NETWORKS; COMPUTER SOFTWARE FOR ASSISTING USERS IN NAVIGATING THROUGH COMPUTER NETWORKS AND SECURE PRIVATE NETWORKS; COMPUTER SOFTWARE FOR RUNNING WEB APPLICATIONS (U.S. CLS. 21, 23, 26, 36 AND 38).

FIRST USE 12-0-2008; IN COMMERCE 12-0-2008.

CLASS 42—SCIENTIFIC AND COMPUTER SERVICES

FOR TECHNICAL SUPPORT SERVICES, NAMELY, TROUBLESHOOTING OF COMPUTER SOFTWARE PROBLEMS (U.S. CLS. 100 AND 101).

FIRST USE 12-0-2008; IN COMMERCE 12-0-2008.

3,999,172. PROTEUS BIOMEDICAL, INC., REDWOOD CITY, CA. SN 77-982,006. PUB. 3-3-2009, FILED 12-13-2007.



3,999,156. STARBUZZ, LLC, SANTA MONICA, CA. SN 77-981,041. PUB. 12-9-2008, FILED 2-29-2008.

ROCKET HERO

THE MARK CONSISTS OF STANDARD CHARACTERS WITHOUT CLAIM TO ANY PARTICULAR FONT, STYLE, SIZE, OR COLOR.

CLASS 16—PAPER GOODS AND PRINTED MATTER

FOR PRINTS IN THE NATURE OF PHOTOGRAPHS, LITHOGRAPHS AND PICTURES; DECALS; STICKERS; PENS (U.S. CLS. 2, 5, 22, 23, 29, 37, 38 AND 50).

FIRST USE 1-9-2010; IN COMMERCE 1-9-2010.

CLASS 25—CLOTHING

FOR T-SHIRTS; HEADWEAR; SHOES (U.S. CLS. 22 AND 39).

FIRST USE 4-22-2009; IN COMMERCE 4-22-2009.

CLASS 28—TOYS AND SPORTING GOODS

FOR TOY VEHICLES (U.S. CLS. 22, 23, 38 AND 50).

FIRST USE 4-17-2009; IN COMMERCE 5-15-2009.

THE MARK CONSISTS OF 5 NESTED ARCS OF DECREASING SIZE.

CLASS 5—PHARMACEUTICALS

FOR INGESTIBLE MEDICATED AND PHARMACEUTICAL PREPARATIONS, BOTH PRESCRIPTION AND OVER-THE-COUNTER, FOR USE IN CONNECTION WITH HUMANS AND ANIMALS, TO GATHER DATA ON PATIENT STATUS AND CONDITION, TO MONITOR PATIENT CONDITION, PATIENT ADHERENCE TO TREATMENT REGIMENS, AND EFFICACY OF TREATMENT, AND TO ENABLE PERSONALIZED THERAPY FOR THE PURPOSE OF MAXIMIZING PATIENT OUTCOME IN THE DIAGNOSIS, TREATMENT, AND MANAGEMENT OF CANCERS, CHRONIC PAIN, SKIN DISEASE, DISEASES OF THE EAR, NOSE, AND THROAT, INFECTIOUS DISEASE, PSYCHIATRIC DISORDERS, AND DISEASES OF THE CARDIOVASCULAR, RESPIRATORY, METABOLIC, IMMUNE, CENTRAL NERVOUS, ENDOCRINE, GLANDULAR, MUSCULOSKELETAL, DIGESTIVE, EXCRETORY, AND REPRODUCTIVE SYSTEMS (U.S. CLS. 6, 18, 44, 46, 51 AND 52).

FIRST USE 1-18-2008; IN COMMERCE 1-18-2008.

CLASS 9—ELECTRICAL AND SCIENTIFIC APPARATUS

FOR DATA PROCESSING EQUIPMENT, NAMELY, DATA PROCESSORS, COMPUTER HARDWARE AND COMPUTER SOFTWARE FOR USE IN OPERATING AND CONTROLLING MEDICAL DEVICES THAT COMPRISE MICROELECTROMECHANICAL SYSTEMS, AND FOR USE IN DISPENSING INGESTIBLE MEDICATED AND PHARMACEUTICAL PREPARATIONS AND FOR USE IN MONITORING AND DISPENSING ELECTRICAL AND PHARMACEUTICAL THERAPY (U.S. CLS. 21, 23, 26, 36 AND 38).

FIRST USE 1-18-2008; IN COMMERCE 1-18-2008.

CLASS 10—MEDICAL APPARATUS

FOR EXTERNAL MEDICAL DEVICES, NAMELY, INFUSION AND INJECTION DEVICES FOR PHARMACEUTICAL COMPOSITIONS IN THE NATURE OF SYRINGES, VIAL INTRAVENOUS DELIVERY DEVICES, IV BAGS, INFUSION PUMPS, DIALYSIS MACHINES, INHALERS, NEBULIZERS, LIQUID DISPENSERS, INJECTORS AND COMPONENTS THEREOF; MEDICAL MONITORING AND DATA PROCESSING MEDICAL DEVICES, NAMELY, IMPLANTABLE AND WEARABLE DEVICES THAT INCLUDE A RECEIVER CONFIGURED TO RECEIVE AN ELECTRONIC SIGNAL TRANSMITTED FROM A MEDICAL DEVICE, NAMELY, AN IMPLANTED MEDICAL DEVICE, A MEDICATION DELIVERY DEVICE, AN INGESTIBLE PHARMACEUTICAL COMPOSITION OR AN INGESTIBLE EVENT MARKER, AND PROGRAMMING FOR OPERATING SAID DEVICES; IMPLANTABLE MEDICAL DEVICES AND EQUIPMENT COMPRISING MICROELECTROMECHANICAL SYSTEMS, NAMELY, HEART AND BLOOD PRESSURE MONITORS, INTRAVASCULAR IMPLANTS COMPRISED OF ARTIFICIAL MATTER, ELECTRICAL STIMULATION AND SENSING SYSTEMS, AND FUNCTIONAL IMPLANTS COMPRISED OF ARTIFICIAL MATERIALS (U.S. CLS. 26, 39 AND 44).

FIRST USE 1-18-2008; IN COMMERCE 1-18-2008.

CLASS 41—EDUCATION AND ENTERTAINMENT

FOR TRAINING AND TEACHING IN THE AREAS OF PREVENTION, DIAGNOSIS AND TREATMENT OF MEDICAL CONDITIONS (U.S. CLS. 100, 101 AND 107).

FIRST USE 4-12-2010; IN COMMERCE 4-12-2010.

CLASS 42—SCIENTIFIC AND COMPUTER SERVICES

FOR TECHNICAL CONSULTATION IN THE TECHNOLOGY FIELD OF MEDICAL AND SURGICAL EQUIPMENT, APPARATUS, APPLIANCE AND INSTRUMENTS; MEDICAL RESEARCH IN THE FIELD OF MEDICAL AND SURGICAL APPARATUS, APPLIANCES, INSTRUMENTS, THERAPIES AND DRUGS; MEDICAL AND SCIENTIFIC RESEARCH, NAMELY, CONDUCTING CLINICAL TRIALS; MEDICAL AND SCIENTIFIC RESEARCH, NAMELY, CLINICAL TRIAL SERVICES; COMPUTER SOFTWARE DESIGN FOR OTHERS, COMPUTER PROGRAMMING FOR OTHERS, AND UPDATING OF COMPUTER SOFTWARE; MAINTENANCE OF COMPUTER SOFTWARE (U.S. CLS. 100 AND 101).

FIRST USE 4-12-2010; IN COMMERCE 4-12-2010.

CLASS 44—MEDICAL, BEAUTY AND AGRICULTURAL SERVICES

FOR PROFESSIONAL CONSULTATION IN THE FIELD OF MEDICAL AND SURGICAL EQUIPMENT, APPARATUS, APPLIANCES AND INSTRUMENTS, MEDICAL CARE, MEDICAL THERAPY AND SURGERY; PATIENT, CLINICIAN AND CAREGIVER SUPPORT SERVICES RELATING TO THE TREATMENT OF MEDICAL DISORDERS, NAMELY, PROVIDING MEDICAL ONLINE INFORMATION REGARDING PHARMACEUTICAL PREPARATIONS AND MEDICAL DEVICES FOR TREATMENT OF VARIOUS DISEASES; PROVIDING HEALTH AND MEDICAL INFORMATION ABOUT MEDICAL DISORDERS; INFORMATION SERVICES, NAMELY, PROVIDING MEDICAL INFORMATION TO CHRONICALLY ILL PATIENTS; INFORMATION SERVICES RELATING TO MEDICAL SERVICES VIA A GLOBAL COMPUTER NETWORK, NAMELY, PROVIDING MEDICAL CONSULTANCY AND ADVISORY SERVICES VIA A GLOBAL COMPUTER NETWORK (U.S. CLS. 100 AND 101).

FIRST USE 4-12-2010; IN COMMERCE 4-12-2010.

3,999,175. ZUFFA, LLC, LAS VEGAS, NV. SN 77-982,036. PUB. 3-2-2010, FILED 12-10-2008.

UFC GYM

THE MARK CONSISTS OF STANDARD CHARACTERS WITHOUT CLAIM TO ANY PARTICULAR FONT, STYLE, SIZE, OR COLOR.

OWNER OF U.S. REG. NOS. 2,706,754, 3,004,864, AND OTHERS.

NO CLAIM IS MADE TO THE EXCLUSIVE RIGHT TO USE "GYM", APART FROM THE MARK AS SHOWN.

CLASS 41—EDUCATION AND ENTERTAINMENT

FOR PROVIDING HEALTH CLUB SERVICES, NAMELY, PROVIDING FITNESS AND EXERCISE FACILITIES; INSTRUCTION SERVICES, NAMELY, INSTRUCTION IN THE FIELD OF HEALTH AND PHYSICAL FITNESS; EDUCATIONAL SERVICES, NAMELY, INSTRUCTION AND TRAINING IN THE FIELDS OF FITNESS AND NUTRITION; INSTRUCTION PROGRAMS IN THE FIELD OF HEALTH AND PHYSICAL FITNESS, NAMELY, PROVIDING EXERCISE CLASSES FOR GROUPS OF INDIVIDUALS; PROVIDING INFORMATION IN THE FIELD OF FITNESS AND MIXED MARTIAL ARTS TRAINING VIA A GLOBAL COMPUTER NETWORK (U.S. CLS. 100, 101 AND 107).

FIRST USE 12-1-2009; IN COMMERCE 12-1-2009.

CLASS 44—MEDICAL, BEAUTY AND AGRICULTURAL SERVICES

FOR PROVIDING INFORMATION IN THE FIELD OF HEALTH (U.S. CLS. 100 AND 101).

FIRST USE 12-1-2009; IN COMMERCE 12-1-2009.

3,999,176. RETAIL ROYALTY COMPANY, LAS VEGAS, NV. SN 77-982,049. PUB. 9-9-2008, FILED 1-16-2008.

77KIDS BY AMERICAN EAGLE

THE MARK CONSISTS OF STANDARD CHARACTERS WITHOUT CLAIM TO ANY PARTICULAR FONT, STYLE, SIZE, OR COLOR.

OWNER OF U.S. REG. NO. 3,033,841.

CLASS 25—CLOTHING

FOR CLOTHING, NAMELY, RAINWEAR AND LEGWARMERS (U.S. CLS. 22 AND 39).

FIRST USE 10-0-2010; IN COMMERCE 10-0-2010.

CLASS 35—ADVERTISING AND BUSINESS

FOR RETAIL STORE SERVICES FEATURING BAGS, PURSES, PERSONAL CARE PRODUCTS, AND JEWELRY (U.S. CLS. 100, 101 AND 102).

FIRST USE 7-0-2010; IN COMMERCE 7-0-2010.

3,999,184. DIGITAS, INC., BOSTON, MA. SN 77-982,131. PUB. 1-4-2011, FILED 10-17-2008.

AUDIENCE ON DEMAND

THE MARK CONSISTS OF STANDARD CHARACTERS WITHOUT CLAIM TO ANY PARTICULAR FONT, STYLE, SIZE, OR COLOR.

NO CLAIM IS MADE TO THE EXCLUSIVE RIGHT TO USE "AUDIENCE", APART FROM THE MARK AS SHOWN.

CLASS 35—ADVERTISING AND BUSINESS

FOR ADVERTISING AND ADVERTISEMENT SERVICES; ADVERTISING AND BUSINESS SERVICES, NAMELY, SECURING ADVERTISING SPACE ON ALL FORMS OF MEDIA COMMUNICATIONS STATIONS, SYSTEMS, NETWORKS, AND SERVICES FOR THE PURPOSE OF PROMOTING THE GOODS AND SERVICES OF OTHERS; ADVERTISING AND PROMOTION SERVICES AND RELATED CONSULTING; ADVERTISING BY TRANSMISSION OF ON-LINE PUBLICITY FOR THIRD PARTIES THROUGH ELECTRONIC COMMUNICATIONS NETWORKS; ADVERTISING SERVICES, NAMELY, DISSEMINATING ADVERTISEMENTS FOR THE GOODS AND SERVICES OF OTHERS FROM A SINGLE INTERFACE TO SPECIFIC AUDIENCES THROUGH MULTIPLE COMMUNICATIONS MEANS; ADVERTISING SERVICES, NAMELY, PROVIDING INFORMATION AS TO THE AVAILABILITY OF ADVERTISING TIME OR ADVERTISING SPACE BY FACILITATING RELATIONSHIPS WITH, PUBLISHERS, NETWORKS, AND EXCHANGES THROUGH WHICH TO PLACE ADVERTISEMENTS; ADVERTISEMENT SERVICES PROVIDED TO OTHERS VIA AN ONLINE WEB SITE ACCESSED THROUGH A GLOBAL COMPUTER NETWORK; BUSINESS MARKETING CONSULTATION, NAMELY, ADVICE AND INFORMATION ABOUT CUSTOMER SERVICES AND PRODUCT MANAGEMENT AND PRICES ON INTERNET SITES IN CONNECTION WITH PURCHASES MADE OVER THE INTERNET; BUSINESS MARKETING CONSULTING SERVICES; COMPUTERIZED ON-LINE ORDERING SERVICES IN THE FIELD OF ADVERTISING TIME AND ADVERTISING SPACE; ADVERTISING SERVICES, NAMELY, CONSOLIDATION, ORGANIZATION, AND PROVISION OF ADVERTISING SPACE BY ELECTRONIC MEANS AND GLOBAL INFORMATION NETWORKS; CREATION OF MARKETING TOOLS DESIGNED TO INCREASE AWARENESS OF LIKELY CONSUMERS AND DISSEMINATION OF RELATED PROMOTIONAL INFORMATION; DIGITAL MEDIA AND MOBILE MARKETING BUYING AND PLANNING ADVICE, NAMELY, ADVISING CUSTOMERS ABOUT ADVERTISING MEDIA; DISSEMINATION OF ADVERTISING FOR OTHERS VIA AN ON-LINE COMMUNICATIONS NETWORK; DISSEMINATION OF ADVERTISING FOR OTHERS VIA THE INTERNET; TARGETING ADVERTISEMENTS OR PROMOTIONS TO A PARTICULAR GROUP OF PROSPECTIVE CONSUMERS; BUSINESS MARKETING AND ADVERTISING MEDIA BUSINESS MANAGEMENT SERVICES; MARKETING CONSULTING; ON-LINE ADVERTISING ON COMPUTER COMMUNICATION NETWORKS; ON-LINE ORDERING SERVICES FEATURING ADVERTISING SPACE AVAILABLE THROUGH ELECTRONIC MEANS AND GLOBAL INFORMATION NETWORKS; OPERATING ON-LINE MARKETPLACES FEATURING THE BUYING AND SELLING OF ADVERTISING SPACE; PROMOTING THE GOODS AND SERVICES OF OTHERS BY DISTRIBUTING ADVERTISING AND PROMOTIONAL MATERIALS FROM A SINGLE INTERFACE TO SPECIFIC

AUDIENCES THROUGH A VARIETY OF ADVERTISING CHANNELS; PROMOTING THE GOODS AND SERVICES OF OTHERS VIA A GLOBAL COMPUTER NETWORK; PROMOTION AND MARKETING SERVICES AND RELATED CONSULTING; PROVIDING INFORMATION IN THE FIELD OF MARKETING AND ON-LINE MARKETING MEDIA VIA THE INTERNET; ADVERTISING INFORMATION SERVICES, NAMELY, PROVIDING INFORMATION VIA AN ONLINE WEB SITE AS TO THE AVAILABILITY OF PUBLISHERS, NETWORKS, AND EXCHANGES THROUGH WHICH TO PLACE ADVERTISEMENTS (U.S. CLS. 100, 101 AND 102).

FIRST USE 12-31-2008; IN COMMERCE 12-31-2008.

CLASS 42—SCIENTIFIC AND COMPUTER SERVICES

FOR COMPUTER SERVICES, NAMELY, DESIGN OF COMPUTER HARDWARE AND SOFTWARE FOR DISSEMINATING ADVERTISING AND PROMOTIONAL MATERIALS REGARDING THE BRANDS, GOODS, AND SERVICES OF OTHERS FROM A SINGLE INTERFACE TO SPECIFIC AUDIENCES VIA COMPUTER NETWORKS; COMPUTER SERVICES, NAMELY, HOSTING ON-LINE WEB FACILITIES FOR OTHERS TO USE ON-LINE ORDERING SERVICES FEATURING CONSOLIDATION, ORGANIZATION, AND PROVISION OF ADVERTISING SPACE BY ELECTRONIC MEANS AND GLOBAL INFORMATION NETWORKS; COMPUTER SERVICES, NAMELY, HOSTING ON-LINE WEB FACILITIES FOR OPERATING ON-LINE MARKETPLACES FOR BUYING AND SELLING ADVERTISING SPACE FOR OTHERS; COMPUTER SERVICES, NAMELY, HOSTING ON-LINE WEB FACILITIES FOR OTHERS TO BUY AND SELL ADVERTISING SPACE; COMPUTER SERVICES, NAMELY, HOSTING ON-LINE WEB FACILITIES FOR OTHERS TO ORDER SERVICES IN THE FIELD OF ADVERTISING; PROVIDING ON-LINE NON-DOWNLOADABLE SOFTWARE FOR CONSOLIDATING, ORGANIZING, AND PROVISIONING ADVERTISING SPACE; PROVIDING ON-LINE NON-DOWNLOADABLE SOFTWARE FOR DISSEMINATING ADVERTISEMENTS FOR OTHERS VIA AN ON-LINE COMMUNICATIONS NETWORK; PROVIDING ON-LINE NON-DOWNLOADABLE SOFTWARE FOR DISSEMINATING ADVERTISEMENTS FOR OTHERS VIA THE INTERNET; PROVIDING ON-LINE NON-DOWNLOADABLE SOFTWARE FOR DISTRIBUTING ADVERTISING MATERIALS FROM A SINGLE INTERFACE TO SPECIFIC AUDIENCES THROUGH A VARIETY OF ADVERTISING CHANNELS (U.S. CLS. 100 AND 101).

FIRST USE 12-31-2008; IN COMMERCE 12-31-2008.

3,999,187. SOURCE INTERLINK MAGAZINES, LLC, EL SEGUNDO, CA. SN 77-982,146. PUB. 10-19-2010, FILED 12-14-2009.

MOTOR TREND

THE MARK CONSISTS OF STANDARD CHARACTERS WITHOUT CLAIM TO ANY PARTICULAR FONT, STYLE, SIZE, OR COLOR.

OWNER OF U.S. REG. NOS. 2,367,705, 3,547,365, AND 3,694,080.

CLASS 16—PAPER GOODS AND PRINTED MATTER

FOR MONEY CLIPS (U.S. CLS. 2, 5, 22, 23, 29, 37, 38 AND 50).

FIRST USE 4-0-2011; IN COMMERCE 4-0-2011.

CLASS 25—CLOTHING

FOR CLOTHING, NAMELY, SHORT-SLEEVED AND LONG-SLEEVED POLO KNIT SHIRTS, T-SHIRTS, WOVEN SHIRTS, FLEECE CLOTHING, NAMELY, JACKETS, AND HATS (U.S. CLS. 22 AND 39).
FIRST USE 11-0-2010; IN COMMERCE 11-0-2010.

3,999,188. SIKORSKY AIRCRAFT CORPORATION, STRATFORD, CT. SN 78-221,812. PUB. 7-4-2006, FILED 3-5-2003.

BLACK HAWK**CLASS 16—PAPER GOODS AND PRINTED MATTER**

FOR LUNCH BAGS; BOOKS RELATING TO HELICOPTERS; HISTORY BOOKS; CHILDREN'S BOOKS; STICKER BOOKS; COLOR BOOKS; POSTERS; PRINTS; FRAMED POSTERS; FRAMED PHOTOGRAPHS; PHOTOGRAPHS; NOTE PADS; CALENDARS; PENS; PENCILS; DESK SETS; DESKTOP BUSINESS CARD HOLDERS; STATIONERY-TYPE PORTFOLIOS; DECALS; POSTCARDS; BUMPER STICKERS; AND IMPRESSION STAMPS (U.S. CLS. 2, 5, 22, 23, 29, 37, 38 AND 50).
FIRST USE 5-1-1991; IN COMMERCE 5-1-1991.

CLASS 21—HOUSEWARES AND GLASS

FOR PORTABLE BEVERAGE COOLERS; MUGS; CUPS; DRINKING GLASSES; TRAVEL MUGS; AND PLASTIC WATER BOTTLES SOLD EMPTY (U.S. CLS. 2, 13, 23, 29, 30, 33, 40 AND 50).
FIRST USE 5-1-1991; IN COMMERCE 5-1-1991.

CLASS 26—FANCY GOODS

FOR ORNAMENTAL NOVELTY BUTTONS; CLOTH PATCHES FOR CLOTHING (U.S. CLS. 37, 39, 40, 42 AND 50).
FIRST USE 5-1-1991; IN COMMERCE 5-1-1991.

CLASS 28—TOYS AND SPORTING GOODS

FOR TOY MODEL VEHICLES AND RELATED ACCESSORIES SOLD AS A UNIT; RADIO CONTROLLED TOY HELICOPTERS, TOY HELICOPTER BUILDING SETS, TOY HELICOPTERS AND RELATED ACCESSORIES SOLD AS A UNIT, PLUSH TOY BEARS, PLUSH TOY HELICOPTERS, DOLLS, KITES, HAND HELD UNITS FOR PLAYING VIDEO GAMES, BOARD GAMES, JIGSAW AND MANIPULATIVE PUZZLES; AND CHRISTMAS TREE ORNAMENTS (U.S. CLS. 22, 23, 38 AND 50).
FIRST USE 5-28-2003; IN COMMERCE 5-28-2003.

3,999,189. BRASSTECH, INC., SANTA ANA, CA. SN 78-348,616. PUB. 1-25-2011, FILED 1-7-2004.

CHELSEA

THE MARK CONSISTS OF STANDARD CHARACTERS WITHOUT CLAIM TO ANY PARTICULAR FONT, STYLE, SIZE, OR COLOR.

CLASS 6—METAL GOODS

FOR BATH ACCESSORIES, NAMELY, METAL ROBE HOOKS (U.S. CLS. 2, 12, 13, 14, 23, 25 AND 50).
FIRST USE 12-0-1993; IN COMMERCE 12-0-1993.

CLASS 20—FURNITURE AND ARTICLES NOT OTHERWISE CLASSIFIED

FOR BATH ACCESSORIES, NAMELY, GLASS SHELVES (U.S. CLS. 2, 13, 22, 25, 32 AND 50).
FIRST USE 12-0-1993; IN COMMERCE 12-0-1993.

CLASS 21—HOUSEWARES AND GLASS

FOR BATH ACCESSORIES, NAMELY, TOWEL BARS, TOWEL RINGS, TISSUE HOLDERS, TOILET PAPER HOLDERS, AND TOOTHBRUSH-TUMBLER HOLDERS (U.S. CLS. 2, 13, 23, 29, 30, 33, 40 AND 50).
FIRST USE 12-0-1993; IN COMMERCE 12-0-1993.

3,999,192. EMINENCE ORGANIC SKINCARE INC., VANCOUVER, BRITISH COLUMBIA, CANADA. SN 78-632,747. PUB. 8-18-2009, FILED 5-18-2005.

Kolorganique

THE MARK CONSISTS OF STANDARD CHARACTERS WITHOUT CLAIM TO ANY PARTICULAR FONT, STYLE, SIZE, OR COLOR.
OWNER OF U.S. REG. NO. 3,493,852.

CLASS 3—COSMETICS AND CLEANING PREPARATIONS

FOR COSMETIC KITS COMPRISING LIPSTICK, LIP GLOSS, BLUSH, AND EYE SHADOW; COSMETICS, NAMELY, LIPSTICK, CONCEALER, BLUSH, COSMETIC PENCILS, LIP PENCILS, BRONZERS, POWDERS, FOUNDATION CREAM, FOUNDATION LIQUID; MAKE-UP REMOVING MILKS; COSMETIC SUNSCREEN AND SUN-TANNING PREPARATIONS, NAMELY, LOTIONS AND CREAMS FOR SUN-TANNING AND SUN PROTECTION; COSMETIC ACCESSORIES, NAMELY, CLEANER FOR COSMETIC BRUSHES (U.S. CLS. 1, 4, 6, 50, 51 AND 52).
FIRST USE 1-15-2005; IN COMMERCE 6-1-2007.

CLASS 21—HOUSEWARES AND GLASS

FOR COSMETIC BRUSHES (U.S. CLS. 2, 13, 23, 29, 30, 33, 40 AND 50).
FIRST USE 1-15-2005; IN COMMERCE 6-1-2007.

3,999,196. THE PROCTER & GAMBLE COMPANY, CINCINNATI, OH. SN 78-706,291. PUB. 7-25-2006, FILED 9-2-2005.

NOT ALL SNACKS ARE CREATED
EAGLE

THE MARK CONSISTS OF STANDARD CHARACTERS WITHOUT CLAIM TO ANY PARTICULAR FONT, STYLE,

SIZE, OR COLOR.

OWNER OF U.S. REG. NO. 2,916,416.

CLASS 29—MEATS AND PROCESSED FOODS

FOR POTATO CHIPS, ROASTED AND PROCESSED SNACK NUTS, ROASTED AND PROCESSED SNACK SEEDS, SHELF STABLE DIPS, REFRIGERATED DIPS AND BEAN DIPS (U.S. CL. 46).

FIRST USE 9-17-2006; IN COMMERCE 9-17-2006.

CLASS 30—STAPLE FOODS

FOR PRETZELS, CORN-BASED SNACK FOODS, CORN CHIPS, CORN CURLS, POPCORN, POPPED POPCORN, UNPOPPED POPCORN, AND MICROWAVABLE POPCORN, SNACK TOASTED CORN KERNELS, SALSA, TORTILLA CHIPS AND TOSTADA CHIPS (U.S. CL. 46).

FIRST USE 9-17-2006; IN COMMERCE 9-17-2006.

3,999,197. FACILITO OVERSEAS HOLDING CO. LTD., TORTOLA, BR.VIRGIN ISLANDS. SN 78-723,553. PUB. 6-6-2006, FILED 9-29-2005.

COURTS

THE MARK CONSISTS OF STANDARD CHARACTERS WITHOUT CLAIM TO ANY PARTICULAR FONT, STYLE, SIZE, OR COLOR.

CLASS 35—ADVERTISING AND BUSINESS

FOR RETAIL AND WHOLESALE STORE SERVICES AND ONLINE ORDERING VIA GLOBAL COMPUTER NETWORK IN THE FIELD OF ELECTRONICS, HOUSEHOLD ELECTRONIC APPLIANCES AND PRODUCTS (EXCEPT FURNITURE), VIDEO EQUIPMENT, AUDIO EQUIPMENT, PERSONAL COMPUTERS AND OTHER HOME AND OFFICE PRODUCTS, COMPACT DISCS, PRE-RECORDED AUDIO AND VIDEO CASSETTES AND RELATED MERCHANDISE, TELEPHONES (U.S. CLS. 100, 101 AND 102).

FIRST USE 1-0-2010; IN COMMERCE 1-0-2010.

CLASS 36—INSURANCE AND FINANCIAL

FOR PROVIDING FINANCIAL SERVICES IN THE FIELD OF MONEY LENDING, COMMERCIAL LENDING, CONSUMER LENDING (U.S. CLS. 100, 101 AND 102).

FIRST USE 1-0-2010; IN COMMERCE 1-0-2010.

3,999,198. FACILITO OVERSEAS HOLDING CO. LTD., TORTOLA, BR.VIRGIN ISLANDS. SN 78-735,693. PUB. 8-22-2006, FILED 10-18-2005.



THE COLOR(S) BLUE, RED, YELLOW, BLACK AND WHITE IS/ARE CLAIMED AS A FEATURE OF THE MARK. THE COLOR YELLOW APPEARS ON THE BORDER OF

THE RECTANGLE. THE COLOR WHITE APPEARS AS THE WORDING "COURTS". THE COLOR BLACK APPEARS AS THE OUTLINE OF THE WORDING AS WELL AS THE OUTLINE OF THE INTERIOR RECTANGLE SHAPE THAT SURROUNDS THE WORDING AS THE DIVIDING LINES WHICH ARE IN THE BACKGROUND TO THE WORDING. THE COLOR RED APPEARS AS THE FIRST, THIRD, AND FIFTH DIAGONAL STRIPES IN THE BACKGROUND TO THE WORDING. THE COLOR BLUE APPEARS AS THE SECOND, FOURTH AND SIXTH DIAGONAL STRIPES IN THE BACKGROUND TO THE WORDING "COURT".

CLASS 35—ADVERTISING AND BUSINESS

FOR RETAIL AND WHOLESALE STORE SERVICES AND ONLINE ORDERING VIA GLOBAL COMPUTER NETWORK IN THE FIELD OF ELECTRONICS, HOUSEHOLD ELECTRONIC APPLIANCES AND PRODUCTS (EXCEPT FURNITURE), VIDEO EQUIPMENT, AUDIO EQUIPMENT, PERSONAL COMPUTERS AND OTHER HOME AND OFFICE PRODUCTS, COMPACT DISCS, PRE-RECORDED AUDIO AND VIDEO CASSETTES AND RELATED MERCHANDISE, TELEPHONES (U.S. CLS. 100, 101 AND 102).

FIRST USE 1-0-2010; IN COMMERCE 1-0-2010.

CLASS 36—INSURANCE AND FINANCIAL

FOR PROVIDING FINANCIAL SERVICES IN THE FIELD OF MONEY LENDING, COMMERCIAL LENDING, CONSUMER LENDING (U.S. CLS. 100, 101 AND 102).

FIRST USE 1-0-2010; IN COMMERCE 1-0-2010.

3,999,199. YOU ROCK MEDIA GROUP INC., SPARTA, NJ. SN 78-780,528. PUB. 8-7-2007, FILED 12-23-2005.

YOU ROCK THE WORLD.com

THE MARK CONSISTS OF STANDARD CHARACTERS WITHOUT CLAIM TO ANY PARTICULAR FONT, STYLE, SIZE, OR COLOR.

CLASS 35—ADVERTISING AND BUSINESS

FOR ADVERTISING SERVICES; BUSINESS MANAGEMENT SERVICES, NAMELY, ADMINISTRATION OF COMPETITIONS IN THE FIELD OF MUSIC (U.S. CLS. 100, 101 AND 102).

FIRST USE 10-20-2010; IN COMMERCE 10-20-2010.

CLASS 36—INSURANCE AND FINANCIAL

FOR CHARITABLE FUNDRAISING IN THE NATURE OF COMPETITIONS IN THE FIELD OF MUSIC (U.S. CLS. 100, 101 AND 102).

FIRST USE 10-20-2010; IN COMMERCE 10-20-2010.

CLASS 41—EDUCATION AND ENTERTAINMENT

FOR ENTERTAINMENT IN THE NATURE OF COMPETITIONS IN THE FIELD OF MUSIC (U.S. CLS. 100, 101 AND 107).

FIRST USE 10-20-2010; IN COMMERCE 10-20-2010.

3,999,200. SEVEN MINUTES, INC., JONESBORO, AR. SN 78-786,436. PUB. 5-25-2010, FILED 1-6-2006.

3,999,208. MICROSOFT CORPORATION, REDMOND, WA. SN 78-858,279. PUB. 9-21-2010, FILED 4-10-2006.

Seven Minute Difference

THE MARK CONSISTS OF STANDARD CHARACTERS WITHOUT CLAIM TO ANY PARTICULAR FONT, STYLE, SIZE, OR COLOR.

CLASS 16—PAPER GOODS AND PRINTED MATTER

FOR MOTIVATIONAL, FINANCIAL AND PERSONAL PLANNING BOOKS AND MANUALS (U.S. CLS. 2, 5, 22, 23, 29, 37, 38 AND 50).
FIRST USE 5-1-2006; IN COMMERCE 5-1-2006.

CLASS 41—EDUCATION AND ENTERTAINMENT

FOR MOTIVATIONAL, FINANCIAL AND PERSONAL PLANNING SEMINARS (U.S. CLS. 100, 101 AND 107).
FIRST USE 9-8-2005; IN COMMERCE 9-8-2005.

3,999,207. DAN-DEE INTERNATIONAL, LTD., JERSEY CITY, NJ. SN 78-855,878. PUB. 2-26-2008, FILED 4-6-2006.

EARTHWISE

THE MARK CONSISTS OF STANDARD CHARACTERS WITHOUT CLAIM TO ANY PARTICULAR FONT, STYLE, SIZE, OR COLOR.

CLASS 17—RUBBER GOODS

FOR POLYESTER STUFFING MATERIAL (U.S. CLS. 1, 5, 12, 13, 35 AND 50).
FIRST USE 2-28-2011; IN COMMERCE 2-28-2011.

CLASS 20—FURNITURE AND ARTICLES NOT OTHERWISE CLASSIFIED

FOR PILLOWS; SOFT SCULPTURE WALL AND DOOR HANGINGS FOR DECORATIONS (U.S. CLS. 2, 13, 22, 25, 32 AND 50).
FIRST USE 2-28-2011; IN COMMERCE 2-28-2011.

CLASS 28—TOYS AND SPORTING GOODS

FOR STUFFED TOYS AND RAG DOLLS; STUFFED ANIMALS; PLUSH TOYS AND ANIMALS; SEASONAL DECORATIONS, NAMELY, CHRISTMAS STOCKINGS; PET TOYS (U.S. CLS. 22, 23, 38 AND 50).
FIRST USE 2-28-2011; IN COMMERCE 2-28-2011.

WINDOWS LIVE

THE MARK CONSISTS OF STANDARD CHARACTERS WITHOUT CLAIM TO ANY PARTICULAR FONT, STYLE, SIZE, OR COLOR.

PRIORITY CLAIMED UNDER SEC. 44(D) ON FED REP GERMANY APPLICATION NO. 30564272, FILED 10-27-2005.

OWNER OF U.S. REG. NOS. 1,558,816, 3,098,774, AND OTHERS.

NO CLAIM IS MADE TO THE EXCLUSIVE RIGHT TO USE "LIVE", APART FROM THE MARK AS SHOWN.

CLASS 41—EDUCATION AND ENTERTAINMENT

FOR PROVIDING INFORMATION IN A WIDE VARIETY OF FIELDS OVER COMPUTER NETWORKS, WIRELESS NETWORKS AND THE INTERNET, NAMELY, PROVIDING WEB SITES FEATURING LINKS TO NEWS REPORTS IN A WIDE VARIETY OF FIELDS (U.S. CLS. 100, 101 AND 107).
FIRST USE 8-0-2008; IN COMMERCE 8-0-2008.

CLASS 42—SCIENTIFIC AND COMPUTER SERVICES

FOR COMPUTER SERVICES, NAMELY, HOSTING AND MAINTAINING WEB SITES FOR OTHERS (U.S. CLS. 100 AND 101).

FIRST USE 8-0-2008; IN COMMERCE 8-0-2008.

3,999,209. RED BULL GMBH, FUSCHL AM SEE, AUSTRIA. SN 78-871,687. PUB. 1-15-2008, FILED 4-27-2006.



OWNER OF U.S. REG. NOS. 2,494,093, 3,051,994, AND OTHERS.

NO CLAIM IS MADE TO THE EXCLUSIVE RIGHT TO USE "NEW YORK", APART FROM THE MARK AS SHOWN.

THE COLOR(S) RED, BLUE, YELLOW AND WHITE IS/ARE CLAIMED AS A FEATURE OF THE MARK.

THE WORDS "RED BULL" AND THE TWO OPPOSING OR CHARGING BULL FIGURES (AND THE ASSOCIATED MOTION LINES) APPEAR IN RED. THE WORDS "NEW YORK", THE PENTAGONAL PANELS ON THE SOCCER BALL, AND THE OUTLINE OF THE SHIELD DESIGN ALL APPEAR IN BLUE. THE DISK OR SUN IN THE CENTER OF THE DESIGN APPEARS IN YELLOW. THE REMAINDER OF THE SOCCER BALL AND THE BACKGROUND OF THE SHIELD AND MARK ARE WHITE.

CLASS 9—ELECTRICAL AND SCIENTIFIC APPARATUS

FOR CELLULAR PHONE CASES, CELLULAR PHONE COVERS (U.S. CLS. 21, 23, 26, 36 AND 38).
FIRST USE 12-31-2009; IN COMMERCE 12-31-2009.

CLASS 16—PAPER GOODS AND PRINTED MATTER

FOR PRINTED MATTER, NAMELY, MAGAZINES ON THE SUBJECT OF SOCCER, EVENT PROGRAMS; SCHEDULES, SCHEDULE CARDS, SOUVENIR PROGRAMS, ALL FEATURING INFORMATION ABOUT SOCCER GAMES, EXHIBITIONS AND PLAYERS; TICKETS, SPORTS TRADING CARDS, DECALS, BUMPER STICKERS, PRINTED PAPER SIGNS, PENS, PENCILS, COLOR PRINTS AND POSTERS (U.S. CLS. 2, 5, 22, 23, 29, 37, 38 AND 50).
FIRST USE 3-9-2006; IN COMMERCE 3-9-2006.

CLASS 25—CLOTHING

FOR CLOTHING, NAMELY, SHORTS, SHIRTS, SWEATERS, SWEATSHIRTS, JACKETS, JERSEYS, T-SHIRTS, TRAINING TOPS, TRAINING SUITS, SWEAT PANTS, SWEATSUITS; HEADWEAR; HEADGEAR, NAMELY, HATS, CAPS, KNITTED CAPS, BEANIE CAPS; SCARVES (U.S. CLS. 22 AND 39).
FIRST USE 3-9-2006; IN COMMERCE 3-9-2006.

CLASS 28—TOYS AND SPORTING GOODS

FOR STUFFED TOY ANIMALS, PLUSH TOY ANIMALS, SPORTING GOODS, NAMELY, SOCCER BALLS (U.S. CLS. 22, 23, 38 AND 50).
FIRST USE 3-9-2006; IN COMMERCE 3-9-2006.

CLASS 41—EDUCATION AND ENTERTAINMENT

FOR ENTERTAINMENT SERVICES, NAMELY, ORGANIZING, CONDUCTING AND STAGING PROFESSIONAL SOCCER GAMES AND EXHIBITIONS; PRODUCTION OF TELEVISION AND RADIO PROGRAMS IN THE NATURE OF PROFESSIONAL SOCCER GAMES AND EXHIBITIONS (U.S. CLS. 100, 101 AND 107).
FIRST USE 3-20-2010; IN COMMERCE 3-20-2010.

3,999,212. HEIDI KLEIN OF LONDON, LONDON, UNITED KINGDOM. SN 78-904,312. PUB. 3-4-2008, FILED 6-8-2006.

HEIDI KLEIN

THE MARK CONSISTS OF STANDARD CHARACTERS WITHOUT CLAIM TO ANY PARTICULAR FONT, STYLE, SIZE, OR COLOR.

THE NAME(S), PORTRAIT(S), AND/OR SIGNATURE(S) SHOWN IN THE MARK DOES NOT IDENTIFY A PARTICULAR LIVING INDIVIDUAL.

CLASS 18—LEATHER GOODS

FOR BAGS, NAMELY, TOTE BAGS, HANDBAGS, PURSES, SHOULDER BAGS, POCKETBOOKS; LUGGAGE (U.S. CLS. 1, 2, 3, 22 AND 41).
FIRST USE 6-30-2006; IN COMMERCE 6-30-2006.

CLASS 25—CLOTHING

FOR SWIMWEAR, SARONGS, KAFTANS, DRESSES, SKIRTS, SHORTS, SHIRTS, LADIES' TOPS, BLOUSES, HATS; FOOTWEAR (U.S. CLS. 22 AND 39).
FIRST USE 6-30-2006; IN COMMERCE 6-30-2006.

3,999,215. POTHYS, CHENNAI, INDIA. SN 78-938,065. PUB. 3-3-2009, FILED 7-26-2006.



NO CLAIM IS MADE TO THE EXCLUSIVE RIGHT TO USE "SILKS", APART FROM THE MARK AS SHOWN.
THE WORDING "POTHYS" AND "AALAYAM" HAS NO MEANING IN ENGLISH.

CLASS 23—YARNS AND THREADS

FOR YARNS AND THREADS MADE OF SILK FOR TEXTILE USE (U.S. CL. 43).
FIRST USE 1-1-1986; IN COMMERCE 2-13-2011.

CLASS 24—FABRICS

FOR TEXTILES AND TEXTILE GOODS, NAMELY, CLOTH BED AND TABLE COVERS; TEXTILE FABRICS FOR USE IN MANUFACTURING DRESSES; FABRICS USED TO MANUFACTURE CLOTHING; ALL OF SILK (U.S. CLS. 42 AND 50).
FIRST USE 1-1-1986; IN COMMERCE 2-13-2011.

CLASS 25—CLOTHING

FOR CLOTHING, NAMELY, SARIS, SKIRTS, AND BLOUSES; ALL OF SILK (U.S. CLS. 22 AND 39).
FIRST USE 1-1-1986; IN COMMERCE 2-13-2011.

3,999,216. POTHYS, CHENNAI, INDIA. SN 78-938,069. PUB. 4-1-2008, FILED 7-26-2006.

**CLASS 23—YARNS AND THREADS**

FOR YARNS AND THREADS FOR TEXTILE USE (U.S. CL. 43).
FIRST USE 1-1-1991; IN COMMERCE 2-13-2011.

CLASS 24—FABRICS

FOR TEXTILES AND TEXTILE GOODS, NAMELY, CLOTH BED AND TABLE COVERS; TEXTILE FABRICS FOR USE IN MANUFACTURING DRESSES; FABRICS USED TO MANUFACTURE CLOTHING (U.S. CLS. 42 AND 50).

FIRST USE 1-1-1991; IN COMMERCE 2-13-2011.

CLASS 25—CLOTHING

FOR CLOTHING, NAMELY, SARIS, SKIRTS, AND BLOUSES (U.S. CLS. 22 AND 39).

FIRST USE 1-1-1991; IN COMMERCE 2-13-2011.

3,999,217. FMI PRODUCTS, LLC, SANTA ANA, CA. SN 78-940,929. PUB. 1-15-2008, FILED 7-31-2006.

MOSAIC MASONRY

THE MARK CONSISTS OF STANDARD CHARACTERS WITHOUT CLAIM TO ANY PARTICULAR FONT, STYLE, SIZE, OR COLOR.

NO CLAIM IS MADE TO THE EXCLUSIVE RIGHT TO USE "MASONRY", APART FROM THE MARK AS SHOWN.

CLASS 11—ENVIRONMENTAL CONTROL APPARATUS

FOR FIREPLACES (U.S. CLS. 13, 21, 23, 31 AND 34).
FIRST USE 7-31-2006; IN COMMERCE 7-31-2006.

CLASS 19—NON-METALLIC BUILDING MATERIALS

FOR FIREPLACE MANTELS, FIREPLACE SURROUNDS, AND FIREPLACE SURROUNDS INCLUDING MASONRY NOOKS FOR HOLDING WOOD (U.S. CLS. 1, 12, 33 AND 50).

FIRST USE 7-31-2006; IN COMMERCE 7-31-2006.

3,999,220. PROTONEX TECHNOLOGY CORPORATION, SOUTHBOROUGH, MA. SN 78-959,649. PUB. 2-26-2008, FILED 8-24-2006.

THE NEXT GENERATION OF PORTABLE POWER

THE MARK CONSISTS OF STANDARD CHARACTERS WITHOUT CLAIM TO ANY PARTICULAR FONT, STYLE, SIZE, OR COLOR.

CLASS 4—LUBRICANTS AND FUELS

FOR FUEL CARTRIDGES CONTAINING SOLID AND LIQUID FUELS SOLD FOR USE AS PART OF AN ENERGY SYSTEM (U.S. CLS. 1, 6 AND 15).

FIRST USE 3-11-2011; IN COMMERCE 3-11-2011.

CLASS 9—ELECTRICAL AND SCIENTIFIC APPARATUS

FOR FUEL CELLS; PORTABLE POWER SYSTEMS, PRIMARILY COMPOSED OF FUEL CELLS, FUEL REFORMERS AND POWER MANAGERS, FOR COMMERCIAL AND MILITARY USE (U.S. CLS. 21, 23, 26, 36 AND 38).

FIRST USE 8-31-2009; IN COMMERCE 8-31-2009.

CLASS 11—ENVIRONMENTAL CONTROL APPARATUS

FOR ENERGY REACTORS, NAMELY, CHEMICAL ENERGY REACTORS (U.S. CLS. 13, 21, 23, 31 AND 34).

FIRST USE 2-25-2011; IN COMMERCE 2-25-2011.

3,999,224. SURTECO USA INC., GREENSBORO, NC. SN 85-000,798. PUB. 3-8-2011, FILED 3-29-2010.

TopEdge

THE MARK CONSISTS OF STANDARD CHARACTERS WITHOUT CLAIM TO ANY PARTICULAR FONT, STYLE, SIZE, OR COLOR.

CLASS 17—RUBBER GOODS

FOR PACKING AND INSULATING MATERIAL AND MATERIAL FOR FORMING SEALS, NAMELY, PAPER IMPREGNATED WITH RESIN, NAMELY, MELAMINE RESIN TO COAT SURFACES OF WOOD OR PLASTIC WORK PIECES FOR USE IN MANUFACTURING AND THE INDUSTRY; CONTINUOUS PRESSURE LAMINATE SURFACES FOR USE IN MANUFACTURING AND INDUSTRY; SEMI-FINISHED GOODS OF PLASTICS IN THE FORM OF EDGES, EDGE BANDS, AND WALL CONNECTOR BLOCKS FOR USE IN MANUFACTURING AND INDUSTRY; SEMI-WORKED SYNTHETIC PLASTIC AS SEMI-FINISHED PRODUCTS IN THE FORM OF FOILS OTHER THAN FOR PACKAGING (U.S. CLS. 1, 5, 12, 13, 35 AND 50).

FIRST USE 6-0-2010; IN COMMERCE 6-0-2010.

CLASS 20—FURNITURE AND ARTICLES NOT OTHERWISE CLASSIFIED

FOR FURNITURE, PARTS FOR FURNITURE, FRAMES, ALL OF THE AFOREMENTIONED OF WOOD AND SUBSTITUTES THEREFOR, OR OF PLASTICS; FURNITURE EDGES, NOT OF METAL AND NOT OF TEXTILE MATERIAL (U.S. CLS. 2, 13, 22, 25, 32 AND 50).

FIRST USE 6-0-2010; IN COMMERCE 6-0-2010.

3,999,225. MONEY MISSION, LLC, MILWAUKEE, WI. SN 85-001,588. PUB. 9-14-2010, FILED 3-30-2010.



NO CLAIM IS MADE TO THE EXCLUSIVE RIGHT TO USE "MONEY" AS TO CLASSES 16 AND 41, APART FROM

THE MARK AS SHOWN.

THE MARK CONSISTS OF A CARTOON IMAGE OF A HUMAN HEAD WEARING GLASSES AND A LOUPE. THE TOP OF THE HEAD IS MISSING AND DOLLAR BILLS AND COINS ARE COMING OUT OF THE TOP OF THE HEAD. THE HEAD IS SURROUNDED BY A CIRCLE. THE WORD "MONEY" APPEARS TO THE LEFT OF THE CIRCLE, AND THE WORD "MISSION" APPEARS TO THE RIGHT OF THE CIRCLE. THE WORDS "MONEY MISSION", THE HEAD, AND THE CIRCLE APPEAR IN FRONT OF A STYLIZED RULER SURROUNDED BY A BORDER.

CLASS 9—ELECTRICAL AND SCIENTIFIC APPARATUS

FOR COMPUTER PROGRAMS FOR EDUCATIONAL SIMULATIONS IN THE FIELD OF FINANCIAL LITERACY; DVDS FEATURING FINANCIAL LITERACY MATERIALS; MOUSE PADS (U.S. CLS. 21, 23, 26, 36 AND 38).

FIRST USE 5-12-2010; IN COMMERCE 6-12-2010.

CLASS 16—PAPER GOODS AND PRINTED MATTER

FOR PUBLICATIONS, NAMELY, HAND-OUTS, WORKBOOKS, AND STUDY GUIDES IN THE FIELDS OF FINANCIAL LITERACY (U.S. CLS. 2, 5, 22, 23, 29, 37, 38 AND 50).

FIRST USE 4-14-2011; IN COMMERCE 4-14-2011.

CLASS 18—LEATHER GOODS

FOR BACKPACKS (U.S. CLS. 1, 2, 3, 22 AND 41).
FIRST USE 5-12-2010; IN COMMERCE 5-12-2010.

CLASS 21—HOUSEWARES AND GLASS

FOR DRINKING VESSELS; THERMAL INSULATED CONTAINERS FOR FOOD OR BEVERAGES (U.S. CLS. 2, 13, 23, 29, 30, 33, 40 AND 50).

FIRST USE 4-9-2011; IN COMMERCE 4-9-2011.

CLASS 25—CLOTHING

FOR HATS; SHIRTS (U.S. CLS. 22 AND 39).
FIRST USE 5-12-2010; IN COMMERCE 5-12-2010.

CLASS 41—EDUCATION AND ENTERTAINMENT

FOR EDUCATIONAL SERVICES, NAMELY, DEVELOPING AND CONDUCTING TRAINING COURSES AND DISTRIBUTION OF TRAINING MATERIALS IN CONNECTION THEREWITH FOR SUBJECT MATTERS AS REQUESTED BY CUSTOMERS; EDUCATIONAL SERVICES, NAMELY, PROVIDING ON-LINE TRAINING MODULES IN THE FIELD OF FINANCIAL LITERACY (U.S. CLS. 100, 101 AND 107).

FIRST USE 5-12-2010; IN COMMERCE 7-15-2010.

3,999,229. GIANT IMPACT, LLC, SUWANEE, GA. SN 85-004,193. PUB. 8-24-2010, FILED 4-1-2010.

EVERYDAYLEADER

THE MARK CONSISTS OF STANDARD CHARACTERS WITHOUT CLAIM TO ANY PARTICULAR FONT, STYLE, SIZE, OR COLOR.

CLASS 9—ELECTRICAL AND SCIENTIFIC APPARATUS

FOR PRE-RECORDED COMPACT DISCS, DIGITAL VIDEO DISCS, DIGITAL VERSATILE DISCS, DOWNLOADABLE AUDIO AND VIDEO RECORDINGS, DVDS OR HIGH DEFINITION DIGITAL DISCS FEATURING LEADERSHIP DEVELOPMENT AND PERSONAL AND TEAM GROWTH; DIGITAL MEDIA, NAMELY, PRE-RECORDED COMPACT DISCS, DIGITAL VIDEO DISCS, DIGITAL VERSATILE DISCS, DOWNLOADABLE AUDIO AND VIDEO RECORDINGS, DVDS OR HIGH DEFINITION DIGITAL DISCS FEATURING LEADERSHIP DEVELOPMENT AND PERSONAL AND BUSINESS GROWTH (U.S. CLS. 21, 23, 26, 36 AND 38).

FIRST USE 12-31-2009; IN COMMERCE 12-31-2009.

CLASS 16—PAPER GOODS AND PRINTED MATTER

FOR PRINTED MATERIALS, NAMELY, CURRICULA IN THE FIELD OF LEADERSHIP DEVELOPMENT AND PERSONAL AND TEAM GROWTH (U.S. CLS. 2, 5, 22, 23, 29, 37, 38 AND 50).

FIRST USE 12-31-2009; IN COMMERCE 12-31-2009.

3,999,231. VALVA, MARK, CHATHAM, NJ. SN 85-005,109. PUB. 8-24-2010, FILED 4-2-2010.

Revolution Digital

THE MARK CONSISTS OF STANDARD CHARACTERS WITHOUT CLAIM TO ANY PARTICULAR FONT, STYLE, SIZE, OR COLOR.

NO CLAIM IS MADE TO THE EXCLUSIVE RIGHT TO USE "DIGITAL", APART FROM THE MARK AS SHOWN.

CLASS 35—ADVERTISING AND BUSINESS

FOR PLANNING, DESIGN, DEVELOPMENT, MAINTENANCE, TRACKING AND REPORTING OF ONLINE MARKETING ACTIVITIES FOR THIRD PARTIES (U.S. CLS. 100, 101 AND 102).

FIRST USE 8-1-2010; IN COMMERCE 8-1-2010.

CLASS 42—SCIENTIFIC AND COMPUTER SERVICES

FOR COMPUTER SERVICES, NAMELY, DESIGNING AND IMPLEMENTING WEB SITES FOR OTHERS (U.S. CLS. 100 AND 101).

FIRST USE 8-1-2010; IN COMMERCE 8-1-2010.

3,999,237. L. PERRIGO COMPANY, ALLEGAN, MI. SN 85-007,995. PUB. 3-15-2011, FILED 4-7-2010.

GOOD SENSE

THE MARK CONSISTS OF STANDARD CHARACTERS WITHOUT CLAIM TO ANY PARTICULAR FONT, STYLE, SIZE, OR COLOR.

OWNER OF U.S. REG. NOS. 1,763,914, 3,129,568, AND OTHERS.

3,999,250. GEVO, INC., ENGLEWOOD, CO. SN 85-009,958. PUB. 9-28-2010, FILED 4-8-2010.

CLASS 3—COSMETICS AND CLEANING PREPARATIONS

FOR PUMICE STONES (U.S. CLS. 1, 4, 6, 50, 51 AND 52).
FIRST USE 3-24-2011; IN COMMERCE 3-24-2011.

CLASS 8—HAND TOOLS

FOR MANICURE AND PEDICURE IMPLEMENTS, NAMELY, NAIL BUFFERS; CALLUS CUTTERS AND RASPS; TWEEZERS; EYEBROW CURLERS; ELECTRIC AND NON-ELECTRIC EYEBROW HAIR TRIMMERS (U.S. CLS. 23, 28 AND 44).
FIRST USE 3-24-2011; IN COMMERCE 3-24-2011.



THE MARK CONSISTS OF THE WORD "GEVO" WRITTEN IN LOWERCASE LETTERS IN A STYLIZED TEXT ADJACENT TO AN ORNAMENTAL DESIGN.

CLASS 1—CHEMICALS

FOR RENEWABLE CHEMICALS FOR USE IN INDUSTRY (U.S. CLS. 1, 5, 6, 10, 26 AND 46).
FIRST USE 3-31-2010; IN COMMERCE 3-31-2010.

CLASS 4—LUBRICANTS AND FUELS

FOR BIOFUELS (U.S. CLS. 1, 6 AND 15).
FIRST USE 3-31-2010; IN COMMERCE 3-31-2010.

CLASS 40—MATERIAL TREATMENT

FOR CHEMICAL PROCESSING AND PRODUCTION, NAMELY, PROCESSING AND PRODUCING BIOFUELS AND RENEWABLE CHEMICALS FOR OTHERS (U.S. CLS. 100, 103 AND 106).
FIRST USE 3-31-2010; IN COMMERCE 3-31-2010.

CLASS 42—SCIENTIFIC AND COMPUTER SERVICES

FOR RESEARCH AND DEVELOPMENT, AND SCIENTIFIC ADVICE IN THE FIELD OF RENEWABLE ENERGY, NAMELY, BIOFUELS AND RENEWABLE CHEMICALS; TECHNICAL DESIGN ADVICE PERTAINING TO THE RETROFITTING OF ETHANOL PROCESSING PLANTS (U.S. CLS. 100 AND 101).
FIRST USE 3-31-2010; IN COMMERCE 3-31-2010.

3,999,249. MY NEW ENTERPRISE, LLC, SALT LAKE CITY, UT. SN 85-009,665. PUB. 2-15-2011, FILED 4-8-2010.

MY NEW ENTERPRISE

THE MARK CONSISTS OF STANDARD CHARACTERS WITHOUT CLAIM TO ANY PARTICULAR FONT, STYLE, SIZE, OR COLOR.

NO CLAIM IS MADE TO THE EXCLUSIVE RIGHT TO USE "ENTERPRISE", APART FROM THE MARK AS SHOWN.

CLASS 35—ADVERTISING AND BUSINESS

FOR ASSISTING IN ENTREPRENEURSHIP AND BUSINESS PLANNING, GROWTH AND DEVELOPMENT, NAMELY, BUSINESS CONSULTING SERVICE IN THE FIELD OF BUSINESS PLAN DEVELOPMENT, BUSINESS GROWTH STRATEGIES, BUSINESS FUNDING STRATEGIES, SALES AND MARKETING PLANS, TEAM BUILDING, MANAGEMENT DEVELOPMENT, AND CUSTOMER SERVICE (U.S. CLS. 100, 101 AND 102).
FIRST USE 12-1-2010; IN COMMERCE 12-1-2010.

CLASS 41—EDUCATION AND ENTERTAINMENT

FOR ONLINE TRAINING IN THE FORM OF TRAINING COURSES, SEMINARS, AND WORKSHOPS FOR ENTREPRENEURS, STARTUP COMPANIES, AND EXISTING BUSINESSES IN THE FIELDS OF BUSINESS PLANNING, GROWTH AND DEVELOPMENT, BUSINESS BUILDING, INDUSTRY ANALYSIS, COMPETITIVE ANALYSIS, GROWTH PLANNING, FINANCING, BRANDING AND MARKETING, TEAM BUILDING, AND CUSTOMER SERVICE (U.S. CLS. 100, 101 AND 107).
FIRST USE 12-1-2010; IN COMMERCE 12-1-2010.

3,999,256. SUNSHINE SUPPLEMENT, INC., MINDEN, NV. SN 85-013,463. PUB. 2-15-2011, FILED 4-14-2010.

POSITIVELY SUNNY

THE MARK CONSISTS OF STANDARD CHARACTERS WITHOUT CLAIM TO ANY PARTICULAR FONT, STYLE, SIZE, OR COLOR.

CLASS 5—PHARMACEUTICALS

FOR VITAMINS; DIETARY, NUTRITIONAL AND FOOD SUPPLEMENTS (U.S. CLS. 6, 18, 44, 46, 51 AND 52).
FIRST USE 3-1-2010; IN COMMERCE 11-26-2010.

CLASS 44—MEDICAL, BEAUTY AND AGRICULTURAL SERVICES

FOR PROVIDING INFORMATION, NEWS AND COMMENTARY IN THE FIELD OF HEALTH AND WELLNESS (U.S. CLS. 100 AND 101).

FIRST USE 3-1-2010; IN COMMERCE 11-26-2010.

3,999,259. BRIGHTTAG INC., CHICAGO, IL. SN 85-014,231. PUB. 9-21-2010, FILED 4-14-2010.

BRIGHT TAG

THE MARK CONSISTS OF STANDARD CHARACTERS WITHOUT CLAIM TO ANY PARTICULAR FONT, STYLE, SIZE, OR COLOR.

NO CLAIM IS MADE TO THE EXCLUSIVE RIGHT TO USE "TAG", APART FROM THE MARK AS SHOWN.

3,999,258. WOMEN ATTORNEY RESOURCES, INC., CHICAGO, IL. SN 85-013,789. PUB. 9-14-2010, FILED 4-14-2010.

The Legal Balance

THE MARK CONSISTS OF STANDARD CHARACTERS WITHOUT CLAIM TO ANY PARTICULAR FONT, STYLE, SIZE, OR COLOR.

NO CLAIM IS MADE TO THE EXCLUSIVE RIGHT TO USE "LEGAL", APART FROM THE MARK AS SHOWN.

CLASS 35—ADVERTISING AND BUSINESS

FOR PROMOTING THE GOODS AND SERVICES OF OTHERS BY PROVIDING A WEB SITE AT WHICH USERS CAN LINK TO CAREER DEVELOPMENT AND PERSONAL LIFESTYLE RESOURCES; PROMOTING THE GOODS AND SERVICES OF OTHERS BY PROVIDING HYPERTEXT LINKS TO THE WEB SITES OF OTHERS; PROVIDING ON-LINE DIRECTORY INFORMATION SERVICES ALSO FEATURING HYPERLINKS TO OTHER WEB SITES; PROVIDING A WEB SITE WHERE USERS CAN POST RATINGS, REVIEWS AND RECOMMENDATIONS ON PRODUCTS AND SERVICES; PROVIDING CAREER INFORMATION (U.S. CLS. 100, 101 AND 102).

FIRST USE 4-10-2007; IN COMMERCE 4-10-2007.

CLASS 38—COMMUNICATION

FOR PROVIDING ON-LINE LISTSERVERS FOR TRANSMISSION OF MESSAGES AMONG COMPUTER USERS CONCERNING CAREER DEVELOPMENT AND PERSONAL LIFESTYLE ADVICE AND RESOURCES FOR FEMALE ATTORNEYS (U.S. CLS. 100, 101 AND 104).

FIRST USE 4-10-2007; IN COMMERCE 4-10-2007.

CLASS 41—EDUCATION AND ENTERTAINMENT

FOR ON-LINE JOURNALS, NAMELY, BLOGS FEATURING ADVICE, ARTICLES, AND CAREER DEVELOPMENT AND PERSONAL LIFESTYLE RESOURCES FOR FEMALE ATTORNEYS (U.S. CLS. 100, 101 AND 107).

FIRST USE 4-10-2007; IN COMMERCE 4-10-2007.

CLASS 35—ADVERTISING AND BUSINESS

FOR ADVERTISING AND ADVERTISEMENT SERVICES; ADVERTISING MANAGEMENT SERVICES; ON-LINE ADVERTISING SERVICES; ONLINE ADVERTISING SERVICES, NAMELY, MANAGING AND TRACKING ADVERTISING ON DIGITAL MEDIA INCLUDING INTERNET WEBSITES, EMAIL, MOBILE MEDIA, DIGITAL TELEVISION; ONLINE ADVERTISING SERVICES, NAMELY, PROVIDING SERVICES FOR MANAGING ONLINE ADVERTISEMENTS; TRACKING OF ADVERTISING FOR OTHERS VIA THE INTERNET; ADVERTISING SERVICES, NAMELY, PROVIDING AN ONLINE WEBSITE WHERE ADVERTISERS CAN OBTAIN TRACKING INFORMATION FOR THEIR ONLINE ADVERTISEMENTS (U.S. CLS. 100, 101 AND 102).

FIRST USE 7-1-2010; IN COMMERCE 7-1-2010.

CLASS 42—SCIENTIFIC AND COMPUTER SERVICES

FOR SOFTWARE AS A SERVICE (SAAS) SERVICES FEATURING SOFTWARE FOR TAGGING, COLLECTING, TRACKING, ANALYZING, REPORTING, INTEGRATING, CONTROLLING, MANAGING AND SHARING A WIDE VARIETY OF DATA AND INFORMATION IN THE FIELD OF DIGITAL AND ONLINE ADVERTISING, MARKETING, AND ANALYTICS, NAMELY, ANALYTICS FOR THE MEASUREMENT, COLLECTION, ANALYSIS AND REPORTING OF INTERNET DATA, FROM VARIOUS SOURCES THROUGH A SINGLE INTERFACE; SOFTWARE AS A SERVICE (SAAS) SERVICES, NAMELY, HOSTING SOFTWARE FOR USE BY OTHERS THAT ALLOWS TAGGING, COLLECTING, TRACKING, ANALYZING, REPORTING, INTEGRATING, CONTROLLING, MANAGING AND SHARING A WIDE VARIETY OF DATA AND INFORMATION FROM VARIOUS SOURCES FOR IMPROVING THE EFFICIENCY AND EFFECTIVENESS OF ONLINE MARKETING AND ONLINE ADVERTISING; SOFTWARE AS A SERVICE (SAAS) SERVICES FEATURING SOFTWARE FOR TRACKING WEBSITE ACTIVITY AND FOR MANAGING AND MONITORING THE PERFORMANCE AND EFFECTIVENESS OF WEBSITES, ONLINE ADVERTISING AND ONLINE MARKETING CAMPAIGNS; SOFTWARE PLATFORM AS A SERVICE (PAAS) SERVICES FEATURING SOFTWARE FOR TAGGING, COLLECTING, TRACKING, ANALYZING, REPORTING, INTEGRATING, CONTROLLING, MANAGING AND SHARING A WIDE VARIETY OF DATA AND INFORMATION IN THE FIELD OF DIGITAL AND ONLINE ADVERTISING, MARKETING, AND ANALYTICS, NAMELY, ANALYTICS FOR THE MEASUREMENT, COLLECTION, ANALYSIS AND REPORTING OF INTERNET DATA, FROM VARIOUS SOURCES THROUGH A SINGLE INTERFACE; SOFTWARE PLATFORM AS A SERVICE (PAAS) SERVICES, NAMELY, HOSTING SOFTWARE FOR USE BY OTHERS THAT ALLOWS TAGGING, COLLECTING, TRACKING, ANALYZING, REPORTING, INTEGRATING, CONTROLLING, MANAGING AND SHARING A WIDE VARIETY OF DATA AND INFORMATION FROM VARIOUS SOURCES FOR IMPROVING THE EFFICIENCY AND EFFECTIVENESS OF ONLINE MARKETING AND ONLINE ADVERTISING; SOFTWARE PLATFORM AS A SERVICE (PAAS) SERVICES FEATURING SOFTWARE FOR TRACKING WEBSITE ACTIVITY AND FOR

MANAGING AND MONITORING THE PERFORMANCE AND EFFECTIVENESS OF WEBSITES, ONLINE ADVERTISING AND ONLINE MARKETING CAMPAIGNS (U.S. CLS. 100 AND 101).

FIRST USE 7-1-2010; IN COMMERCE 7-1-2010.

3,999,268. MOUNTAIN HIGH ORGANICS, INC., NEW MILFORD, CT. SN 85-015,691. PUB. 10-19-2010, FILED 4-16-2010.



NO CLAIM IS MADE TO THE EXCLUSIVE RIGHT TO USE "NUTRITION", APART FROM THE MARK AS SHOWN.

THE COLOR(S) BLUE, BLACK AND WHITE IS/ARE CLAIMED AS A FEATURE OF THE MARK.

THE MARK CONSISTS OF THE WORDING "TRESOMEGA NUTRITION" WITH "TRESOMEGA" APPEARING IN BLUE SUPERIMPOSED OVER THE LETTER "N" IN BLACK WITH THE WORD "NUTRITION" IN WHITE WITH BLACK OUTLINE UNDER THE LETTER "EGA" IN "TRESOMEGA".

THE WORDING "TRESOMEGA" HAS NO MEANING IN A FOREIGN LANGUAGE.

CLASS 5—PHARMACEUTICALS

FOR DIETARY SUPPLEMENTS IN CAPSULE FORM CONTAINING A BLEND OF FLAX SEED OIL, COCONUT OIL, EVENING PRIMROSE OIL AND BORAGE SEED OIL; DIETARY SUPPLEMENTS IN THE NATURE OF OILS, OIL BLENDS, OIL EMULSIONS, OIL MICROENCAPSULATION AND POWDERS CONTAINING OMEGA-3 FATTY ACIDS; NUTRITIONAL SUPPLEMENTS CONTAINING ESSENTIAL FATTY ACID BLENDS, NAMELY, ONE OR MORE OF FLAX, EVENING PRIMROSE OIL, HEMP, CHIA AND FISH WITH ONE OF MORE OF HERBS, SPICES, ANTIOXIDANTS, BERRIES AND VITAMINS (U.S. CLS. 6, 18, 44, 46, 51 AND 52).

FIRST USE 4-1-2010; IN COMMERCE 4-1-2010.

CLASS 29—MEATS AND PROCESSED FOODS

FOR EDIBLE MILLED FLAX SEED, DRY FRUIT BARS, PROCESSED COCONUT FOR FOOD, DRIED FRUIT, PROCESSED BEANS AND SEEDS (U.S. CL. 46).

FIRST USE 4-1-2010; IN COMMERCE 4-1-2010.

3,999,279. PRUDENT LIVING INC., WINDSOR, VT. SN 85-018,251. PUB. 9-28-2010, FILED 4-20-2010.



THE COLOR(S) WHITE, BLUE AND GREEN IS/ARE CLAIMED AS A FEATURE OF THE MARK.

THE MARK CONSISTS OF THE STYLIZED WORDING "PRUDENT LIVING BECAUSE IT'S TIME" AND A DESIGN OF A HOUSE IN A CIRCLE. THE WORD "PRUDENT" IS IN BLUE. THE WORDING "LIVING BECAUSE IT'S TIME" IS

IN GREEN. THE CIRCLE DESIGN APPEARS BETWEEN THE WORDS "PRUDENT" AND "LIVING". THE HOUSE IS WHITE WITH A BLUE SKY AND GREEN GRASS.

CLASS 9—ELECTRICAL AND SCIENTIFIC APPARATUS

FOR APPARATUS FOR CONVERTING ELECTRONIC RADIATION TO ELECTRICAL ENERGY, NAMELY, PHOTOVOLTAIC CLADDING PANELS; APPARATUS FOR CONVERTING ELECTRONIC RADIATION TO ELECTRICAL ENERGY, NAMELY, PHOTOVOLTAIC ROOFING MEMBERS; APPARATUS FOR CONVERTING ELECTRONIC RADIATION TO ELECTRICAL ENERGY, NAMELY, PHOTOVOLTAIC SOLAR HYBRID MODULES; APPARATUS FOR CONVERTING ELECTRONIC RADIATION TO ELECTRICAL ENERGY, NAMELY, PHOTOVOLTAIC SOLAR MODULES; APPARATUS FOR CONVERTING ELECTRONIC RADIATION TO ELECTRICAL ENERGY, NAMELY, PHOTOVOLTAIC THERMAL HYBRID MODULE; APPARATUS FOR CONVERTING ELECTRONIC RADIATION TO ELECTRICAL ENERGY, NAMELY, PHOTOVOLTAIC THERMAL MODULE; APPARATUS FOR CONVERTING ELECTRONIC RADIATION TO ELECTRICAL ENERGY, NAMELY, PVT (PHOTOVOLTAIC THERMAL) MODULE; APPARATUS FOR CONVERTING THERMAL ENERGY TO ELECTRICAL ENERGY, NAMELY, THERMOELECTRIC CONVERTERS; APPARATUS THAT EMPLOYS LIGHT CONCENTRATING OPTICS TO CONCENTRATE SUNLIGHT AND TO AID IN THE CONVERSION OF SUNLIGHT INTO ELECTRIC AND THERMAL ENERGY; ELECTRIC CONTROL DEVICES FOR HEATING AND ENERGY MANAGEMENT; ELECTRICAL ENERGY UTILIZATION METERING DEVICES COMPLETE WITH RELATED SOFTWARE; PHOTOVOLTAIC SYSTEMS THAT CONVERT SUNLIGHT INTO ELECTRIC AND THERMAL ENERGY; PROGRAMMABLE CONTROLLERS AND ACTUATORS THAT TRACK THE SUN ENABLING CONCENTRATING OPTICS TO MAXIMIZE SOLAR ENERGY INPUT; RENEWABLE BATTERY SYSTEM TO PROVIDE BACKUP POWER (U.S. CLS. 21, 23, 26, 36 AND 38).

FIRST USE 4-20-2011; IN COMMERCE 4-20-2011.

CLASS 35—ADVERTISING AND BUSINESS

FOR ASSISTANCE AND CONSULTANCY SERVICES IN THE FIELD OF BUSINESS MANAGEMENT OF COMPANIES IN THE ENERGY SECTOR; ASSISTANCE, ADVISORY SERVICES AND CONSULTANCY WITH REGARD TO BUSINESS PLANNING, BUSINESS ANALYSIS, BUSINESS MANAGEMENT, AND BUSINESS ORGANIZATION RELATING TO MICRO CREDITS, MICRO FINANCE AND ENERGY PRODUCTS; BUSINESS CONSULTING AND ADVISORY SERVICES IN THE FIELD OF ENERGY EFFICIENCY; BUSINESS CONSULTING SERVICES FOR THE ELECTRIC ENERGY INDUSTRY; BUSINESS VENTURE DEVELOPMENT AND FORMATION CONSULTING SERVICES FOR THE RENEWABLE ENERGY INDUSTRY; CONSULTATION IN THE FIELD OF ENERGY EFFICIENCY; CONSULTING SERVICES IN THE FIELD OF ENERGY USAGE MANAGEMENT AND ENERGY EFFICIENCY; CONSULTING SERVICES IN THE FIELDS OF ENERGY CONSUMPTION AND USAGE CONSERVATION TO IMPROVE ENERGY EFFICIENCY; ENERGY AUDITING; ENERGY MANAGEMENT SERVICES, NAMELY, PROVIDING A SERVICE THAT ALLOWS CUSTOMERS TO PURCHASE ENERGY FROM VARIOUS ENERGY PROVIDERS; ENERGY MANAGEMENT SERVICES, NAMELY, PROVIDING A SERVICE THAT ALLOWS CUSTOMERS TO PURCHASE ENERGY, NAMELY, ELECTRICITY, NATURAL GAS AND RENEWABLE ENERGY, AT A FIXED PRICE; ENERGY PRICE COMPARISON SERVICES; ENERGY USAGE MANAGEMENT; ENERGY USAGE MANAGEMENT INFORMATION SERVICES; HOME ENERGY ASSESSMENT SERVICES FOR THE PURPOSE OF DETERMINING ENERGY EFFICIENCY OR USAGE MANAGEMENT; IMPORT-EXPORT AGENCIES IN THE FIELD OF ENERGY; INFORMATION IN THE FIELD OF ENERGY EFFICIENCY; PROCUREMENT SERVICES, NAMELY, PROCUREMENT OF CONTRACTS FOR OTHERS FOR THE PURCHASE OF ENERGY; PROMOTING THE BENEFITS OF ENERGY EFFICIENT LIGHTING TECHNOLOGIES TO PROFESSIONALS IN THE LIGHTING FIELD; RETAIL ELEC-

TRICITY PROVIDER SERVICES, NAMELY, PROVIDING A SERVICE THAT ALLOWS CUSTOMERS TO PURCHASE ENERGY, NAMELY, ELECTRICITY; RETAIL ELECTRICITY PROVIDER SERVICES, NAMELY, PROVIDING A SERVICE THAT ALLOWS CUSTOMERS TO PURCHASE ENERGY, NAMELY, ELECTRICITY, AND RENEWABLE ENERGY; SUBSCRIPTION MANAGEMENT SERVICES FOR LIBRARIES, NAMELY, MANAGEMENT OF ORDER PRICING, RENEWAL, ACCESS AND REGISTRATION FUNCTIONS THROUGH PUBLISHER AUTHORIZED SUBSCRIPTION AGENT (U.S. CLS. 100, 101 AND 102).

FIRST USE 4-14-2011; IN COMMERCE 4-14-2011.

CLASS 37—CONSTRUCTION AND REPAIR

FOR CONSTRUCTION PROJECT MANAGEMENT SERVICES IN THE FIELD OF CONSTRUCTION OF RENEWABLE ENERGY AND ENERGY GENERATION EQUIPMENT SUPPORT STRUCTURES AND ANCILLARY STRUCTURES FOR SUPPORTING METEOROLOGICAL DATA GATHERING EQUIPMENT; CONSULTING SERVICES IN THE FIELD OF CONSTRUCTION OF WIND ENERGY FACILITIES; HOME ENERGY ASSESSMENT SERVICES FOR THE PURPOSE OF DETERMINING HOME IMPROVEMENTS NEEDED TO IMPROVE ENERGY USE AND EFFICIENCY; INSTALLATION AND MAINTENANCE OF SOLAR ENERGY BASED POWER PLANTS; INSTALLATION OF GEOTHERMAL ENERGY BASED POWER PLANTS; INSTALLATION OF SOLAR ENERGY SYSTEMS AND ALTERNATIVE ENERGY PRODUCTS FOR RESIDENTIAL AND COMMERCIAL USE; REPAIR AND INSTALLATION SERVICES, NAMELY, THE INSTALLATION OF HEATING, COOLING AND ENVIRONMENTAL CONTROL SYSTEMS PRIMARILY USING SOLAR ENERGY, RENEWABLE ENERGY RESOURCES AND RAINWATER (U.S. CLS. 100, 103 AND 106).

FIRST USE 4-14-2011; IN COMMERCE 4-14-2011.

CLASS 40—MATERIAL TREATMENT

FOR CONSULTING SERVICES IN THE FIELD OF PRODUCTION OF WIND ENERGY; ENERGY RECYCLING SERVICES, NAMELY, CAPTURING AND CONVERSION OF WASTED ENERGY INTO ELECTRICITY AND USEFUL STEAM; GENERATION OF ENERGY; LEASING OF ENERGY GENERATING EQUIPMENT; PRODUCTION OF ENERGY; PRODUCTION OF WIND ENERGY; TECHNICAL CONSULTATION IN THE FIELD OF PRODUCTION OF SOLAR ENERGY; WASTE-TO-ENERGY GENERATION SERVICES (U.S. CLS. 100, 103 AND 106).

FIRST USE 3-28-2011; IN COMMERCE 3-28-2011.

CLASS 42—SCIENTIFIC AND COMPUTER SERVICES

FOR ARCHITECTURAL DESIGN; CHARITABLE SERVICES, NAMELY, PROVIDING WEB SITE DESIGN FOR OTHERS; CIVIL ENGINEERING FOR THE DESIGN OF RENEWABLE ENERGY DESIGN; COLOR ANALYSIS FOR PURPOSES OF INTERIOR DESIGN; COMMERCIAL ART DESIGN; COMPUTER AIDED DESIGN FOR OTHERS; COMPUTER AIDED GRAPHIC DESIGN; CONSULTING SERVICES FOR OTHERS IN THE FIELD OF DESIGN, PLANNING, AND IMPLEMENTATION PROJECT MANAGEMENT OF RENEWABLE ENERGY; CONSULTING SERVICES IN THE FIELD OF ARCHITECTURAL DESIGN; CONSULTING SERVICES IN THE FIELDS OF ENERGY MEASUREMENT TO IMPROVE ENERGY EFFICIENCY; CONSULTING SERVICES PROVIDED TO LOCAL GOVERNMENTS IN THE FIELD OF DEVELOPMENT OF ELECTRICAL SERVICES AND RENEWABLE ENERGY RESOURCES; DESIGN AND DEVELOPMENT AND CONSULTING SERVICES RELATED THERETO IN THE FIELD OF CUSTOM HOME THEATRE AUDIO AND VISUAL SYSTEMS; DESIGN AND DEVELOPMENT OF AUTOMATED HOME CONTROLLER SYSTEMS, NAMELY, TEMPERATURE, HUMIDITY, AND ELECTRICAL CONTROLLERS; DESIGN AND DEVELOPMENT OF HOME SECURITY SYSTEMS; DESIGN OF FACTORY BUILDINGS; DESIGN OF INTERIOR DECOR; DESIGN OF SOLAR PHOTOVOLTAIC SYSTEMS; DESIGN OF SPECIALTY INTERIOR AND EXTERIOR ENVIRONMENT SETTINGS;

DESIGN OF TUNNELS AND UNDERGROUND STRUCTURES; DESIGNING OF HEAT EXCHANGERS; DESIGNING OF PACKAGING AND WRAPPING MATERIALS; DOOR DESIGN SERVICES; ELECTRONIC AND ELECTRICAL SYSTEMS DESIGN SERVICES; ENGINEERING AND HABITAT RESTORATION DESIGN SERVICES IN THE FIELD OF WETLAND PRESERVATION; ENGINEERING AND HYDROLOGICAL DESIGN OF RESTORATION OF STREAM CHANNELS, MARSHES, ESTUARIES, AND WETLANDS; ENGINEERING SERVICES IN THE FIELD OF ENERGY EFFICIENCY; ENVIRONMENTAL SERVICES, NAMELY, TECHNICAL CONSULTATION IN THE FIELD OF ENVIRONMENTAL SCIENCE, ENGINEERING SERVICES, DESIGN FOR OTHERS IN THE FIELD OF ENERGY ENGINEERING, DESIGNING AND TESTING OF ENERGY PRODUCTS FOR OTHERS; ENVIRONMENTAL SERVICES, NAMELY, TECHNICAL CONSULTATION IN THE FIELD OF ENVIRONMENTAL SCIENCE, ENGINEERING SERVICES, DESIGN FOR OTHERS IN THE FIELD OF ENVIRONMENTAL ENGINEERING, DESIGNING AND TESTING OF NEW ENVIRONMENTALLY FRIENDLY PRODUCTS FOR OTHERS; INTERIOR DESIGN SERVICES INCLUDING SPACE PLANNING, FURNITURE SELECTION, MATERIAL AND SURFACE SELECTION; LANDSCAPE ARCHITECTURAL DESIGN; LANDSCAPE LIGHTING DESIGN; LIGHTING DESIGN AND TECHNOLOGY SPECIFICATION SERVICES PERTAINING TO PERMANENT OR TEMPORARY ARCHITECTURAL, THEATRICAL, ENTERTAINMENT, COMMERCIAL AND/OR RESIDENTIAL APPLICATIONS; PLANNING AND LAYOUT DESIGN FOR THE INTERIOR SPACE OF RETAIL BUSINESS ESTABLISHMENTS; PLANNING AND LAYOUT DESIGN SERVICES FOR CLEANROOM ENVIRONMENTS; PROVIDING A WEB SITE FEATURING TECHNOLOGY THAT ENABLES USERS TO SHARE, BOOKMARK, INDEX, STORE, COLLECT AND SHOWCASE CONTENT, ARTICLES, IMAGES, CALENDARS, PRODUCTS, PROJECTS, AND OTHER INFORMATION RESOURCES IN ELECTRONIC FORM IN THE NATURE AND FIELD OF CLIMATE CHANGE AND GLOBAL WARMING AND ASSOCIATED RELATED FIELDS INCLUDING GREEN BUILDING, PLANNING, RENEWABLE ENERGY, SUSTAINABLE COMMUNITIES, CONSERVATION, AND OTHER HUMAN ACTIVITIES AFFECTING CARBON USE AND ITS IMPACTS ON THE WORLD AND THE ENVIRONMENT; RESIDENTIAL BUILDING DESIGN; ROOM DESIGN CONSISTING OF SELECTION OF ARTWORK, LIGHTING, AND FURNISHINGS FOR AN ENVIRONMENT DESIGNED TO HELP ACHIEVE MENTAL WELLNESS, INCLUDING STRESS MANAGEMENT AND RELAXATION, USING COMPUTER CONTROLLED ADVANCED SOUND WAVE TECHNOLOGY; SHOP INTERIOR DESIGN; STRUCTURAL ENGINEERING DESIGN SERVICES; SURVEY DESIGN AND RESEARCH; TECHNICAL PLANNING OF SOLAR ENERGY BASED POWER PLANTS; TECHNOLOGY PLANNING AND CONSULTING IN THE FIELD OF SOLAR ENERGY, SPECIFICALLY SPECIALIZING IN SUBSTRATES PRIMARILY OF CERAMIC, SILICON AND NON-METALS FOR ELECTRICAL OR THERMAL INSULATION OF SOLAR CELLS, PHOTOVOLTAIC CELLS, AND SOLAR COLLECTORS; URBAN DESIGN PLANNING SERVICES (U.S. CLS. 100 AND 101).

FIRST USE 4-14-2011; IN COMMERCE 4-14-2011.

3,999,293. KNOWLEDGE NETWORKS, INC., MENLO PARK, CA. SN 85-021,333. PUB. 10-5-2010, FILED 4-22-2010.

Qual[®]

THE MARK CONSISTS OF "QAUL" AND "E" IN SUPERSCRIPT.

CLASS 35—ADVERTISING AND BUSINESS

FOR CONSUMER RESEARCH; MARKET RESEARCH (U.S. CLS. 100, 101 AND 102).
FIRST USE 10-0-2010; IN COMMERCE 10-0-2010.

3,999,346. SUPERNOVA DIAGNOSTICS, INC, DAMMASCUS, MD. SN 85-028,331. PUB. 10-19-2010, FILED 5-3-2010.

CLASS 41—EDUCATION AND ENTERTAINMENT

FOR ON-LINE PUBLICATION THROUGH WEBSITES AND EMAIL OF NEWSLETTERS, REPORTS, AND ARTICLES FEATURING MARKET AND CONSUMER RESEARCH INFORMATION (U.S. CLS. 100, 101 AND 107).
FIRST USE 10-0-2010; IN COMMERCE 10-0-2010.

AMPCRYSTAL

THE MARK CONSISTS OF STANDARD CHARACTERS WITHOUT CLAIM TO ANY PARTICULAR FONT, STYLE, SIZE, OR COLOR.

CLASS 9—ELECTRICAL AND SCIENTIFIC APPARATUS

FOR DIAGNOSTIC APPARATUS FOR TESTING HUMAN AND NON-HUMAN PATHOGENS, PROTEINS AND NUCLEIC ACID, NAMELY, DNA FOR LABORATORY OR RESEARCH USE (U.S. CLS. 21, 23, 26, 36 AND 38).
FIRST USE 3-1-2011; IN COMMERCE 3-1-2011.

3,999,300. GLV FINANCE HUNGARY KFT., ACTING THROUGH ITS LUXEMBOURG BRANCH, LUXEMBOURG, LUXEMBOURG. SN 85-021,624. PUB. 1-4-2011, FILED 4-23-2010.

CLASS 10—MEDICAL APPARATUS

FOR MEDICAL DIAGNOSTIC APPARATUS FOR TESTING HUMAN AND NON-HUMAN PATHOGENS, PROTEINS AND NUCLEIC ACID, NAMELY, DNA (U.S. CLS. 26, 39 AND 44).
FIRST USE 3-1-2011; IN COMMERCE 3-1-2011.

BRINGING WATER TO LIFE

3,999,355. BONARRIGO, PAUL, BRYAN, TX. AND BONARRIGO, SOPHIA MARIE, BRYAN, TX. AND BONARRIGO, KAREN, BRYAN, TX. SN 85-029,428. PUB. 10-5-2010, FILED 5-4-2010.

THE MARK CONSISTS OF STANDARD CHARACTERS WITHOUT CLAIM TO ANY PARTICULAR FONT, STYLE, SIZE, OR COLOR.

Sophia Marie

CLASS 37—CONSTRUCTION AND REPAIR

FOR INSTALLATION, CONSTRUCTION, START UP, MAINTENANCE, SERVICING, REBUILDING AND REPAIR OF APPARATUS AND INSTALLATIONS FOR THE TREATMENT, PROCESSING, PURIFYING AND RECYCLING OF WATER, DRINKING WATER AND WASTE WATER TREATMENT PROCESSING FACILITIES (U.S. CLS. 100, 103 AND 106).
FIRST USE 4-1-2010; IN COMMERCE 9-13-2010.

THE MARK CONSISTS OF STANDARD CHARACTERS WITHOUT CLAIM TO ANY PARTICULAR FONT, STYLE, SIZE, OR COLOR.

THE NAME(S), PORTRAIT(S), AND/OR SIGNATURE(S) SHOWN IN THE MARK IDENTIFIES "SOPHIA MARIE BONARRIGO", WHOSE CONSENT(S) TO REGISTER IS MADE OF RECORD.

CLASS 42—SCIENTIFIC AND COMPUTER SERVICES

FOR SCIENTIFIC AND TECHNOLOGICAL SERVICES PROVIDED TO WASTE WATER TREATMENT FACILITIES IN THE FIELD OF THE TREATMENT, PROCESSING, PURIFYING AND RECYCLING OF WATER, DRINKING WATER AND TECHNICAL OPERATIONS OF WASTE WATER TREATMENT PROCESSING FACILITIES, ENGINEERING AND DESIGN CONSULTING AND RESEARCH AND DESIGN RELATING THERETO; INDUSTRIAL ANALYSIS AND RESEARCH SERVICES; TECHNICAL DEVELOPMENT AND PLANNING OF PROJECTS IN THE FIELD OF THE TREATMENT, PROCESSING, PURIFYING AND RECYCLING OF WATER, DRINKING WATER AND WASTE WATER TREATMENT PROCESSING FACILITIES (U.S. CLS. 100 AND 101).
FIRST USE 4-1-2010; IN COMMERCE 9-13-2010.

CLASS 25—CLOTHING

FOR T-SHIRTS (U.S. CLS. 22 AND 39).
FIRST USE 11-20-2010; IN COMMERCE 4-23-2011.

CLASS 28—TOYS AND SPORTING GOODS

FOR DOLLS AND ACCESSORIES THEREFOR (U.S. CLS. 22, 23, 38 AND 50).
FIRST USE 11-20-2010; IN COMMERCE 5-1-2011.

CLASS 33—WINES AND SPIRITS

FOR WINES (U.S. CLS. 47 AND 49).
FIRST USE 11-20-2010; IN COMMERCE 11-20-2010.

3,999,358. WINDY KNOLL FARM LLC, CHAMBERSBURG, PA. SN 85-029,587. PUB. 10-19-2010, FILED 5-4-2010.

3,999,385. TD AMERITRADE IP COMPANY, INC., OMAHA, NE. SN 85-032,211. PUB. 3-8-2011, FILED 5-6-2010.

WINDY KNOLL FARM

THE MARK CONSISTS OF STANDARD CHARACTERS WITHOUT CLAIM TO ANY PARTICULAR FONT, STYLE, SIZE, OR COLOR.

NO CLAIM IS MADE TO THE EXCLUSIVE RIGHT TO USE "FARM", APART FROM THE MARK AS SHOWN.

CLASS 30—STAPLE FOODS

FOR ICE CREAM (U.S. CL. 46).
FIRST USE 8-1-2010; IN COMMERCE 8-1-2010.

CLASS 35—ADVERTISING AND BUSINESS

FOR WHOLESALE AND RETAIL STORE SERVICES FEATURING GROCERIES (U.S. CLS. 100, 101 AND 102).
FIRST USE 2-6-2008; IN COMMERCE 2-6-2008.

3,999,382. NEXT BIG SOUND, INC., BOULDER, CO. SN 85-032,056. PUB. 10-12-2010, FILED 5-6-2010.

NEXT BIG SOUND

THE MARK CONSISTS OF STANDARD CHARACTERS WITHOUT CLAIM TO ANY PARTICULAR FONT, STYLE, SIZE, OR COLOR.

CLASS 35—ADVERTISING AND BUSINESS

FOR PROVIDING A WEB SITE FEATURING BUSINESS INFORMATION IN THE FIELD OF TRACKING ONLINE PRESENCE OF MUSICIANS AND MUSICAL BANDS ON THE INTERNET; PROVIDING A WEB SITE FEATURING STATISTICAL INFORMATION FOR BUSINESS OR COMMERCIAL PURPOSES REGARDING THE ONLINE PRESENCE OF MUSICIANS AND MUSICAL BANDS (U.S. CLS. 100, 101 AND 102).
FIRST USE 9-0-2010; IN COMMERCE 9-0-2010.

CLASS 41—EDUCATION AND ENTERTAINMENT

FOR PROVIDING A WEB SITE FEATURING INFORMATION FOR ENTERTAINMENT PURPOSES ABOUT TRACKING ONLINE PRESENCE OF MUSICIANS AND MUSICAL BANDS ON THE INTERNET; PROVIDING A WEB SITE FEATURING STATISTICAL INFORMATION FOR ENTERTAINMENT PURPOSES REGARDING THE ONLINE PRESENCE OF MUSICIANS AND MUSICAL BANDS (U.S. CLS. 100, 101 AND 107).
FIRST USE 9-0-2010; IN COMMERCE 9-0-2010.

TRADE ARCHITECT

THE MARK CONSISTS OF STANDARD CHARACTERS WITHOUT CLAIM TO ANY PARTICULAR FONT, STYLE, SIZE, OR COLOR.

NO CLAIM IS MADE TO THE EXCLUSIVE RIGHT TO USE "TRADE", APART FROM THE MARK AS SHOWN.

CLASS 9—ELECTRICAL AND SCIENTIFIC APPARATUS

FOR COMPUTER SOFTWARE RELATED TO FINANCIAL INFORMATION, INVESTMENT, AND TRADING, NAMELY, ELECTRONIC TRADING SOFTWARE, PORTFOLIO MANAGEMENT SOFTWARE; FINANCIAL ANALYTICAL SOFTWARE, FINANCIAL CONTACT MANAGEMENT SOFTWARE, FINANCIAL RISK MODELING SOFTWARE; SOFTWARE FOR PROVIDING ELECTRONIC CONNECTIVITY TO FINANCIAL EXCHANGES AND MARKETS (U.S. CLS. 21, 23, 26, 36 AND 38).
FIRST USE 5-4-2011; IN COMMERCE 5-4-2011.

CLASS 36—INSURANCE AND FINANCIAL

FOR FINANCIAL SERVICES, NAMELY, PROVIDING SECURITIES AND INVESTMENT INFORMATION; COMMODITY TRADING FOR OTHERS (U.S. CLS. 100, 101 AND 102).
FIRST USE 5-4-2011; IN COMMERCE 5-4-2011.

3,999,389. BAHAMA BAY RESORT MANAGEMENT, LLC, DAVENPORT, FL. SN 85-032,606. PUB. 10-12-2010, FILED 5-7-2010.

BAHAMA BAY RESORT & SPA

THE MARK CONSISTS OF STANDARD CHARACTERS WITHOUT CLAIM TO ANY PARTICULAR FONT, STYLE, SIZE, OR COLOR.

NO CLAIM IS MADE TO THE EXCLUSIVE RIGHT TO USE "RESORT & SPA", APART FROM THE MARK AS SHOWN.

CLASS 35—ADVERTISING AND BUSINESS

FOR ADMINISTRATIVE HOTEL MANAGEMENT (U.S. CLS. 100, 101 AND 102).
FIRST USE 12-1-2005; IN COMMERCE 12-1-2005.

CLASS 36—INSURANCE AND FINANCIAL

FOR REAL ESTATE MANAGEMENT AND CONSULTATION (U.S. CLS. 100, 101 AND 102).
FIRST USE 12-1-2005; IN COMMERCE 12-1-2005.

CLASS 39—TRANSPORTATION AND STORAGE

FOR TRAVEL AGENCY SERVICES, NAMELY, MAKING RESERVATIONS AND BOOKINGS FOR TRANSPORTATION; ARRANGING TRAVEL TOURS (U.S. CLS. 100 AND 105).

FIRST USE 12-1-2005; IN COMMERCE 12-1-2005.

CLASS 43—HOTEL AND RESTAURANT SERVICES

FOR WHOLESALE AND RETAIL TRAVEL AGENCY SERVICES, NAMELY, MAKING RESERVATIONS AND BOOKINGS FOR TEMPORARY LODGING; HOTEL SERVICES; EXTENDED-STAY HOTELS; HOTEL AND MOTEL SERVICES; RESERVATION OF HOTEL ROOMS FOR TRAVELERS (U.S. CLS. 100 AND 101).

FIRST USE 12-1-2005; IN COMMERCE 12-1-2005.

3,999,390. SEARS BRANDS, LLC, HOFFMAN ESTATES, IL. SN 85-032,669. PUB. 11-2-2010, FILED 5-7-2010.

FLIP GRILLMAN

THE MARK CONSISTS OF STANDARD CHARACTERS WITHOUT CLAIM TO ANY PARTICULAR FONT, STYLE, SIZE, OR COLOR.

THE NAME "FLIP GRILLMAN" DOES NOT IDENTIFY A LIVING INDIVIDUAL.

CLASS 35—ADVERTISING AND BUSINESS

FOR PROMOTING THE GOODS AND SERVICES OF OTHERS BY PROVIDING A WEBSITE FEATURING BLOGS, COMMENTARY, PRODUCT REVIEWS, AND ADVICE IN THE FIELD OF GRILLING AND GRILLING PRODUCTS; PROVIDING A WEBSITE FEATURING CONSUMER INFORMATION ABOUT GRILLING AND GRILLING PRODUCTS (U.S. CLS. 100, 101 AND 102).

FIRST USE 6-0-2010; IN COMMERCE 6-0-2010.

CLASS 41—EDUCATION AND ENTERTAINMENT

FOR ON-LINE JOURNALS, NAMELY, BLOGS FEATURING COMMENTARY, PRODUCT REVIEWS, ADVICE AND RECIPES RELATING TO GRILLING AND GRILLING PRODUCTS; ENTERTAINMENT SERVICES, NAMELY, PERSONAL APPEARANCES BY AN ONLINE PERSONALITY IN THE FIELD OF GRILLING AND GRILLING PRODUCTS (U.S. CLS. 100, 101 AND 107).

FIRST USE 6-0-2010; IN COMMERCE 6-0-2010.

3,999,406. KENEXA CORPORATION, WAYNE, PA. SN 85-034,343. PUB. 10-12-2010, FILED 5-10-2010.

KENEXA 2x PERFORM

THE MARK CONSISTS OF STANDARD CHARACTERS WITHOUT CLAIM TO ANY PARTICULAR FONT, STYLE,

SIZE, OR COLOR.

OWNER OF U.S. REG. NOS. 2,632,896, 2,672,952, AND OTHERS.

CLASS 9—ELECTRICAL AND SCIENTIFIC APPARATUS

FOR COMPUTER DATABASE MANAGEMENT SOFTWARE FOR USE IN THE FIELD OF EMPLOYEE ASSESSMENT USED TO MANAGE AND TRACK INFORMATION REGARDING EMPLOYEES, EMPLOYEE PERFORMANCE AND ORGANIZATIONAL PERFORMANCE, PROVIDE EMPLOYEE ASSESSMENT TOOLS FOR EMPLOYERS, AND MANAGE ON-LINE EMPLOYEE DEVELOPMENT (U.S. CLS. 21, 23, 26, 36 AND 38).

FIRST USE 9-0-2010; IN COMMERCE 9-0-2010.

CLASS 42—SCIENTIFIC AND COMPUTER SERVICES

FOR PROVIDING TEMPORARY USE OF ON-LINE NON-DOWNLOADABLE SOFTWARE FOR DATABASE MANAGEMENT IN THE FIELD OF EMPLOYEE ASSESSMENT USED TO MANAGE AND TRACK INFORMATION REGARDING EMPLOYEES, EMPLOYEE PERFORMANCE AND ORGANIZATIONAL PERFORMANCE, PROVIDE EMPLOYEE ASSESSMENT TOOLS FOR EMPLOYERS, AND MANAGE ON-LINE EMPLOYEE DEVELOPMENT (U.S. CLS. 100 AND 101).

FIRST USE 9-0-2010; IN COMMERCE 9-0-2010.

3,999,413. MOUNTAIN HIGH ORGANICS, INC., NEW MILFORD, CT. SN 85-035,428. PUB. 10-19-2010, FILED 5-11-2010.

TresOmega Nutrition

THE MARK CONSISTS OF STANDARD CHARACTERS WITHOUT CLAIM TO ANY PARTICULAR FONT, STYLE, SIZE, OR COLOR.

NO CLAIM IS MADE TO THE EXCLUSIVE RIGHT TO USE "NUTRITION", APART FROM THE MARK AS SHOWN.

THE WORDING "TRESOMEGA" HAS NO MEANING IN A FOREIGN LANGUAGE.

CLASS 5—PHARMACEUTICALS

FOR DIETARY SUPPLEMENTS IN CAPSULE FORM CONTAINING A BLEND OF FLAX SEED OIL, COCONUT OIL, EVENING PRIMROSE OIL AND BORAGE SEED OIL; DIETARY SUPPLEMENTS IN THE NATURE OF OILS, OILS BLENDS, OIL EMULSIONS, OIL MICROENCAPSULATION AND POWDERS CONTAINING OMEGA-3 FATTY ACIDS; NUTRITIONAL SUPPLEMENTS CONTAINING ESSENTIAL FATTY ACID BLENDS, NAMELY, ONE OR MORE OF FLAX, EVENING PRIMROSE OIL, HEMP, CHIA AND FISH WITH ONE OR MORE OF HERBS, SPICES, ANTIOXIDANTS, BERRIES AND VITAMINS (U.S. CLS. 6, 18, 44, 46, 51 AND 52).

FIRST USE 4-1-2010; IN COMMERCE 4-1-2010.

CLASS 29—MEATS AND PROCESSED FOODS

FOR EDIBLE MILLED FLAX SEED, DRY FRUIT BARS, PROCESSED COCONUT FOR FOOD, DRIED FRUIT, PROCESSED BEANS AND SEEDS (U.S. CL. 46).

FIRST USE 4-1-2010; IN COMMERCE 4-1-2010.

3,999,414. AMERICAN EXPRESS MARKETING & DEVELOPMENT CORP., NEW YORK, NY. SN 85-035,517. PUB. 10-12-2010, FILED 5-11-2010.

SERVE

THE MARK CONSISTS OF STANDARD CHARACTERS WITHOUT CLAIM TO ANY PARTICULAR FONT, STYLE, SIZE, OR COLOR.

CLASS 9—ELECTRICAL AND SCIENTIFIC APPARATUS

FOR APPARATUS FOR PROCESSING POINT-OF-SALE TRANSACTIONS, NAMELY, MAGNETICALLY-ENCODED CREDIT CARD, CHARGE CARD, STORED VALUE AND DEBIT CARDS; MAGNETICALLY-ENCODED, MACHINE-READABLE, BAR-CODED, STORED VALUE AND DEBIT CARDS; MAGNETICALLY-ENCODED IDENTIFYING CARDS (U.S. CLS. 21, 23, 26, 36 AND 38).

FIRST USE 3-28-2011; IN COMMERCE 3-28-2011.

CLASS 36—INSURANCE AND FINANCIAL

FOR FINANCIAL SERVICES, NAMELY, CREDIT AND CHARGE CARD SERVICES, CONSUMER STORED VALUE AND DEBIT CARD TRANSACTION PROCESSING SERVICES; PROVIDING ELECTRONIC PROCESSING OF STORED VALUE AND DEBIT CARD TRANSACTIONS AND PROVIDING ELECTRONIC PAYMENTS VIA A GLOBAL COMPUTER NETWORK; FINANCIAL SERVICES, NAMELY, ELECTRONIC PROCESSING, VERIFICATION, AND SETTLEMENT OF SALES TRANSACTIONS USING ONLINE ACCOUNTS; STORED VALUE AND DEBIT CARD TRANSACTION VERIFICATION AND SETTLEMENT SERVICES; ELECTRONIC PAYMENT PROCESSING SERVICES, NAMELY, ELECTRONIC PROCESSING OF STORED VALUE AND DEBIT CARD AND ONLINE ACCOUNT PAYMENT DATA; STORED VALUE AND DEBIT CARD SERVICES; PROVIDING FINANCIAL INFORMATION VIA A GLOBAL COMPUTER NETWORK; AND CONSULTATION SERVICES RELATED TO THE FOREGOING (U.S. CLS. 100, 101 AND 102).

FIRST USE 3-28-2011; IN COMMERCE 3-28-2011.

CLASS 38—COMMUNICATION

FOR PROVIDING ELECTRONIC TRANSMISSION OF CREDIT CARD, CHARGE CARD, STORED VALUE AND DEBIT CARD AND ONLINE ACCOUNT PAYMENT DATA VIA A GLOBAL COMPUTER NETWORK (U.S. CLS. 100, 101 AND 104).

FIRST USE 3-28-2011; IN COMMERCE 3-28-2011.

3,999,418. KEWAUNEE SCIENTIFIC CORPORATION, STATESVILLE, NC. SN 85-036,060. PUB. 10-19-2010, FILED 5-12-2010.

KEWAUNEE MATRIX

THE MARK CONSISTS OF STANDARD CHARACTERS WITHOUT CLAIM TO ANY PARTICULAR FONT, STYLE, SIZE, OR COLOR.

OWNER OF U.S. REG. NO. 2,342,649.

CLASS 9—ELECTRICAL AND SCIENTIFIC APPARATUS

FOR LABORATORY FURNITURE (U.S. CLS. 21, 23, 26, 36 AND 38).

FIRST USE 5-10-2011; IN COMMERCE 5-10-2011.

CLASS 20—FURNITURE AND ARTICLES NOT OTHERWISE CLASSIFIED

FOR EDUCATIONAL CLASSROOM FURNITURE (U.S. CLS. 2, 13, 22, 25, 32 AND 50).

FIRST USE 5-10-2011; IN COMMERCE 5-10-2011.

3,999,421. WINDY KNOLL FARM LLC, CHAMBERSBURG, PA. SN 85-036,529. PUB. 10-19-2010, FILED 5-12-2010.



NO CLAIM IS MADE TO THE EXCLUSIVE RIGHT TO USE "FARM", "MARKET & CREAMERY", AND "MILK", APART FROM THE MARK AS SHOWN.

THE COLOR(S) RED, BLUE, TEAL, BLACK, WHITE, BROWN, GREEN, YELLOW, GRAY, AND PINK IS/ARE CLAIMED AS A FEATURE OF THE MARK.

THE MARK CONSISTS OF AN INCOMPLETE CIRCLE SHADED IN WHITE, GRAY AND RED BEARING THE WORDING "WINDY KNOLL FARM MARKET & CREAMERY" IN GRAY AND WHITE STYLIZED LETTERING AND A SEMI-CIRCLE SHAPED INTERIOR FEATURING A BROWN AND YELLOW CAKE, A PINK AND WHITE ICE CREAM SUNDAE, A BLUE, TEAL AND WHITE MILK CARTON, A YELLOW SLICE OF CHEESE, A BLACK, BROWN, WHITE, GRAY AND PINK COW WITH A YELLOW COWBELL AND A GREEN OVAL.

CLASS 30—STAPLE FOODS

FOR ICE CREAM (U.S. CL. 46).

FIRST USE 8-1-2010; IN COMMERCE 8-1-2010.

CLASS 35—ADVERTISING AND BUSINESS

FOR WHOLESALE AND RETAIL STORE SERVICES FEATURING GROCERIES (U.S. CLS. 100, 101 AND 102).

FIRST USE 2-6-2008; IN COMMERCE 2-6-2008.

3,999,425. BOTTLES 'N BRUSHES, LLC, MOUNT PLEASANT, SC. SN 85-036,742. PUB. 10-12-2010, FILED 5-12-2010.

BOTTLES 'N BRUSHES

THE MARK CONSISTS OF STANDARD CHARACTERS WITHOUT CLAIM TO ANY PARTICULAR FONT, STYLE, SIZE, OR COLOR.

CLASS 21—HOUSEWARES AND GLASS

FOR FOAM DRINK HOLDERS (U.S. CLS. 2, 13, 23, 29, 30, 33, 40 AND 50).
FIRST USE 6-0-2009; IN COMMERCE 6-0-2009.

CLASS 25—CLOTHING

FOR SHIRTS; SHORT-SLEEVED OR LONG-SLEEVED T-SHIRTS; T-SHIRTS (U.S. CLS. 22 AND 39).
FIRST USE 5-0-2009; IN COMMERCE 5-0-2009.

CLASS 41—EDUCATION AND ENTERTAINMENT

FOR INSTRUCTION IN THE FIELD OF ART (U.S. CLS. 100, 101 AND 107).
FIRST USE 7-0-2008; IN COMMERCE 7-0-2008.

3,999,426. BOTTLES 'N BRUSHES, LLC, MOUNT PLEASANT, SC. SN 85-036,865. PUB. 10-12-2010, FILED 5-12-2010.

GET YOUR ART BUZZ ON

THE MARK CONSISTS OF STANDARD CHARACTERS WITHOUT CLAIM TO ANY PARTICULAR FONT, STYLE, SIZE, OR COLOR.

NO CLAIM IS MADE TO THE EXCLUSIVE RIGHT TO USE "ART", APART FROM THE MARK AS SHOWN.

CLASS 21—HOUSEWARES AND GLASS

FOR FOAM DRINK HOLDERS (U.S. CLS. 2, 13, 23, 29, 30, 33, 40 AND 50).
FIRST USE 6-3-2011; IN COMMERCE 6-3-2011.

CLASS 25—CLOTHING

FOR SHIRTS; SHORT-SLEEVED OR LONG-SLEEVED T-SHIRTS; T-SHIRTS (U.S. CLS. 22 AND 39).
FIRST USE 4-1-2011; IN COMMERCE 4-1-2011.

CLASS 41—EDUCATION AND ENTERTAINMENT

FOR INSTRUCTION IN THE FIELD OF ART (U.S. CLS. 100, 101 AND 107).
FIRST USE 5-0-2009; IN COMMERCE 5-0-2009.

3,999,456. EMINENCE ORGANIC SKINCARE INC., VANCOUVER, B.C., CANADA. SN 85-041,960. PUB. 10-19-2010, FILED 5-18-2010.

VITASKIN

THE MARK CONSISTS OF STANDARD CHARACTERS WITHOUT CLAIM TO ANY PARTICULAR FONT, STYLE, SIZE, OR COLOR.

THE WORDING "VITASKIN" HAS NO MEANING IN A FOREIGN LANGUAGE.

CLASS 3—COSMETICS AND CLEANING PREPARATIONS

FOR COSMETIC CREAMS; COSMETIC CREAMS FOR SKIN CARE; COSMETIC PREPARATIONS FOR SKIN RENEWAL; COSMETICS; FACIAL CREAMS; LOTIONS FOR COSMETIC PURPOSES; MOISTURIZING PREPARATIONS FOR THE SKIN; NON-MEDICATED SKIN CARE CREAMS AND LOTIONS; NON-MEDICATED SKIN CARE PREPARATIONS; NON-MEDICATED SKIN CREAMS; NON-MEDICATED STIMULATING LOTIONS FOR THE SKIN; SKIN CONDITIONERS; SKIN CONDITIONING CREAMS FOR COSMETIC PURPOSES; SKIN CREAMS; SKIN LOTIONS; SKIN MOISTURIZER; SKIN TONERS (U.S. CLS. 1, 4, 6, 50, 51 AND 52).
FIRST USE 11-1-2010; IN COMMERCE 11-1-2010.

CLASS 5—PHARMACEUTICALS

FOR VITAMIN AND MINERAL SUPPLEMENTS; VITAMIN PREPARATIONS; VITAMIN SUPPLEMENTS; VITAMINS (U.S. CLS. 6, 18, 44, 46, 51 AND 52).
FIRST USE 11-1-2010; IN COMMERCE 11-1-2010.

3,999,462. LOCKHEED MARTIN CORPORATION, BETHESDA, MD. SN 85-042,722. PUB. 9-28-2010, FILED 5-19-2010.



THE MARK CONSISTS OF A STYLIZED VERSION OF THE LETTER "E".

CLASS 9—ELECTRICAL AND SCIENTIFIC APPARATUS

FOR COMPUTER SOFTWARE FOR USE IN CREATING ENTERPRISE COMMUNITIES FOR USERS TO PARTICIPATE IN DISCUSSIONS, GET FEEDBACK FROM THEIR PEERS, FORM VIRTUAL COMMUNITIES, AND ENGAGE IN SOCIAL NETWORKING (U.S. CLS. 21, 23, 26, 36 AND 38).
FIRST USE 7-9-2010; IN COMMERCE 1-24-2011.

CLASS 42—SCIENTIFIC AND COMPUTER SERVICES

FOR COMPUTER CONSULTATION SERVICES; COMPUTER SYSTEMS INTEGRATION; COMPUTER SYSTEMS DESIGN AND INTEGRATION, COMPUTER AND COMMUNICATIONS SYSTEMS MANAGEMENT, NAMELY, THE CONFIGURING AND MANAGEMENT OF COMPUTING AND COMMUNICATIONS RESOURCES AND INFORMATION SYSTEMS; COMPUTER SERVICES, NAMELY, CREATING AN ONLINE ENTERPRISE COMMUNITY FOR USERS TO PARTICIPATE IN DISCUSSIONS, GET FEEDBACK FROM THEIR PEERS, FORM VIRTUAL COMMUNITIES, AND ENGAGE IN SOCIAL NETWORKING (U.S. CLS. 100 AND 101).

FIRST USE 7-9-2010; IN COMMERCE 1-24-2011.

CLASS 45—PERSONAL AND LEGAL SERVICES

FOR SOCIAL NETWORKING SERVICES FOR USE IN AN ENTERPRISE COMPUTING ENVIRONMENT (U.S. CLS. 100 AND 101).

FIRST USE 7-9-2010; IN COMMERCE 1-24-2011.

3,999,463. LOCKHEED MARTIN CORPORATION, BETHESDA, MD. SN 85-042,729. PUB. 9-28-2010, FILED 5-19-2010.

EUREKA STREAMS

THE MARK CONSISTS OF STANDARD CHARACTERS WITHOUT CLAIM TO ANY PARTICULAR FONT, STYLE, SIZE, OR COLOR.

CLASS 9—ELECTRICAL AND SCIENTIFIC APPARATUS

FOR COMPUTER SOFTWARE FOR USE IN CREATING ENTERPRISE COMMUNITIES FOR USERS TO PARTICIPATE IN DISCUSSIONS, GET FEEDBACK FROM THEIR PEERS, FORM VIRTUAL COMMUNITIES, AND ENGAGE IN SOCIAL NETWORKING (U.S. CLS. 21, 23, 26, 36 AND 38).

FIRST USE 7-9-2010; IN COMMERCE 1-24-2011.

CLASS 42—SCIENTIFIC AND COMPUTER SERVICES

FOR COMPUTER CONSULTATION SERVICES; COMPUTER SYSTEMS INTEGRATION; COMPUTER SYSTEMS DESIGN AND INTEGRATION, COMPUTER AND COMMUNICATIONS SYSTEMS MANAGEMENT, NAMELY, THE CONFIGURING AND MANAGEMENT OF COMPUTING AND COMMUNICATIONS RESOURCES AND INFORMATION SYSTEMS; COMPUTER SERVICES, NAMELY, CREATING AN ONLINE ENTERPRISE COMMUNITY FOR USERS TO PARTICIPATE IN DISCUSSIONS, GET FEEDBACK FROM THEIR PEERS, FORM VIRTUAL COMMUNITIES, AND ENGAGE IN SOCIAL NETWORKING (U.S. CLS. 100 AND 101).

FIRST USE 7-9-2010; IN COMMERCE 4-12-2011.

CLASS 45—PERSONAL AND LEGAL SERVICES

FOR SOCIAL NETWORKING SERVICES FOR USE IN AN ENTERPRISE COMPUTING ENVIRONMENT (U.S. CLS. 100 AND 101).

FIRST USE 7-9-2010; IN COMMERCE 1-24-2011.

3,999,468. CONAIR CORPORATION, STAMFORD, CT. SN 85-043,850. PUB. 9-21-2010, FILED 5-20-2010.

Deepshine

THE MARK CONSISTS OF STANDARD CHARACTERS WITHOUT CLAIM TO ANY PARTICULAR FONT, STYLE, SIZE, OR COLOR.

OWNER OF U.S. REG. NO. 3,761,253.

CLASS 9—ELECTRICAL AND SCIENTIFIC APPARATUS

FOR ELECTRIC HAND-HELD HAIR STYLING IRONS (U.S. CLS. 21, 23, 26, 36 AND 38).

FIRST USE 11-30-2010; IN COMMERCE 11-30-2010.

CLASS 11—ENVIRONMENTAL CONTROL APPARATUS

FOR HAND-HELD ELECTRIC HAIR DRYERS (U.S. CLS. 13, 21, 23, 31 AND 34).

FIRST USE 11-30-2010; IN COMMERCE 11-30-2010.

3,999,475. TREK BICYCLE CORPORATION, WATERLOO, WI. SN 85-044,819. PUB. 1-18-2011, FILED 5-21-2010.



THE MARK CONSISTS OF CIRCLE WITHOUT A BORDER; THE CIRCLE IS DIVIDED IN TO THREE PARTS, WITH ONE PART BEING AN OVAL, ONE PART BEING A SEMICIRCLE, ONE PART BEING A TRIANGLE WITH CURVED SIDES. THE IMAGE GIVES THE APPEARANCE OF THE LETTER "B".

CLASS 9—ELECTRICAL AND SCIENTIFIC APPARATUS

FOR BICYCLE HELMETS AND CYCLING COMPUTERS (U.S. CLS. 21, 23, 26, 36 AND 38).

FIRST USE 8-1-2010; IN COMMERCE 8-1-2010.

CLASS 11—ENVIRONMENTAL CONTROL APPARATUS

FOR BICYCLE LIGHTS (U.S. CLS. 13, 21, 23, 31 AND 34).

FIRST USE 8-1-2010; IN COMMERCE 8-1-2010.

CLASS 12—VEHICLES

FOR BICYCLE PARTS AND ACCESSORIES, NAMELY, WHEELS, TIRES, TUBES, PUMPS, BIKE-MOUNTED RACKS, FENDERS, FORKS, SEAT POSTS, SADDLES, STEMS, HANDLEBARS, HANDLEBAR GRIPS, WATER BOTTLE CAGES; PANNIERS AND TRUNK BAGS FOR BICYCLES, BICYCLE SEAT PACKS (U.S. CLS. 19, 21, 23, 31, 35 AND 44).

FIRST USE 8-1-2010; IN COMMERCE 8-1-2010.

3,999,505. SEND THE TREND, INC., NEW YORK, NY. SN 85-052,645. PUB. 10-26-2010, FILED 6-2-2010.

SEND THE TREND

CLASS 18—LEATHER GOODS

FOR BACKPACKS, TEXTILE TOTE BAGS, MESSENGER BAGS, ALL PURPOSE SPORTS BAGS (U.S. CLS. 1, 2, 3, 22 AND 41).

FIRST USE 8-10-2010; IN COMMERCE 8-1-2010.

CLASS 25—CLOTHING

FOR APPAREL, NAMELY, JERSEYS, HATS, SOCKS, SHORTS, TIGHTS, JACKETS, VESTS, GLOVES, T-SHIRTS AND SHOES (U.S. CLS. 22 AND 39).

FIRST USE 8-1-2010; IN COMMERCE 8-1-2010.

THE COLOR(S) BLACK AND TEAL IS/ARE CLAIMED AS A FEATURE OF THE MARK.

THE MARK CONSISTS OF THE WORDS "SEND THE TREND". THE WORD "THE" IN THE MARK IS STYLIZED AND APPEARS IN THE COLOR TEAL. THE WORDS "SEND" AND "TREND" IN THE MARK APPEAR IN THE COLOR BLACK.

CLASS 35—ADVERTISING AND BUSINESS

FOR PROVIDING AN ON-LINE SHOWROOM FOR THE GOODS OF OTHERS IN THE FIELD OF WOMEN'S ACCESSORIES (U.S. CLS. 100, 101 AND 102).

FIRST USE 8-16-2010; IN COMMERCE 8-16-2010.

3,999,486. GUITAR STRAPS ONLINE, LLC, ARVADA, CO. SN 85-047,188. PUB. 10-26-2010, FILED 5-25-2010.

CLASS 42—SCIENTIFIC AND COMPUTER SERVICES

FOR HOSTING AN ON-LINE COMMUNITY WEB SITE FEATURING MONTHLY ACCESSORIES FOR WOMEN; HOSTING AN ONLINE WEBSITE FEATURING ACCESSORIES FOR WOMEN (U.S. CLS. 100 AND 101).

FIRST USE 8-16-2010; IN COMMERCE 8-16-2010.

STRAP ONE ON!

THE MARK CONSISTS OF STANDARD CHARACTERS WITHOUT CLAIM TO ANY PARTICULAR FONT, STYLE, SIZE, OR COLOR.

NO CLAIM IS MADE TO THE EXCLUSIVE RIGHT TO USE "STRAP" FOR CLASS 35, APART FROM THE MARK AS SHOWN.

3,999,526. BAHAMA BAY RESORT MANAGEMENT, LLC, DAVENPORT, FL. SN 85-056,415. PUB. 10-12-2010, FILED 6-7-2010.



CLASS 16—PAPER GOODS AND PRINTED MATTER

FOR BUMPER STICKERS (U.S. CLS. 2, 5, 22, 23, 29, 37, 38 AND 50).

FIRST USE 4-23-2010; IN COMMERCE 4-23-2010.

NO CLAIM IS MADE TO THE EXCLUSIVE RIGHT TO USE "RESORT & SPA ORLANDO", APART FROM THE MARK AS SHOWN.

THE COLOR(S) BLACK, WHITE, TAN, YELLOW, GREEN AND BLUE IS/ARE CLAIMED AS A FEATURE OF THE MARK.

CLASS 35—ADVERTISING AND BUSINESS

FOR ONLINE RETAIL STORE SERVICES FEATURING STRAPS FOR MUSICAL INSTRUMENTS AND ACCESSORIES FOR MUSICAL INSTRUMENTS (U.S. CLS. 100, 101 AND 102).

FIRST USE 4-23-2010; IN COMMERCE 4-23-2010.

THE MARK CONSISTS OF THE WORDS "BAHAMA BAY" IN STYLIZED FORM IN YELLOW LETTERING OUTLINED IN BLACK, THE WORDS "RESORT & SPA" WRITTEN IN BLACK UNDER THE WORDS "BAHAMA BAY", AND THE WORD "ORLANDO" WRITTEN IN BLACK UNDER THE WORDS "RESORT & SPA", ALL WORDING APPEARING ABOVE AND WITHIN A DRAWING OF TWO WHITE BIRDS STANDING IN BLUE WATER NEAR A TAN-COLORED

SANDY BEACH WITH A YELLOW BUILDING HAVING A BLUE ROOF SITUATED ACROSS THE WATER FROM THE BIRDS WITH TAN TRUNKED AND GREEN LEAFED PALM TREES BEING PRESENT IN THE DRAWING WITH LARGE TROPICAL GREEN LEAVES ON THE LEFT AND RIGHT SIDES OF THE DRAWING.

CLASS 35—ADVERTISING AND BUSINESS

FOR ADMINISTRATIVE HOTEL MANAGEMENT (U.S. CLS. 100, 101 AND 102).
FIRST USE 1-1-2004; IN COMMERCE 1-1-2004.

CLASS 36—INSURANCE AND FINANCIAL

FOR REAL ESTATE MANAGEMENT AND CONSULTATION (U.S. CLS. 100, 101 AND 102).
FIRST USE 1-1-2004; IN COMMERCE 1-1-2004.

CLASS 39—TRANSPORTATION AND STORAGE

FOR TRAVEL AGENCY SERVICES, NAMELY, MAKING RESERVATIONS AND BOOKINGS FOR TRANSPORTATION; ARRANGING TRAVEL TOURS (U.S. CLS. 100 AND 105).
FIRST USE 1-1-2004; IN COMMERCE 1-1-2004.

CLASS 43—HOTEL AND RESTAURANT SERVICES

FOR WHOLESALE AND RETAIL TRAVEL AGENCY SERVICES, NAMELY, MAKING RESERVATIONS AND BOOKINGS FOR TEMPORARY LODGING; HOTEL SERVICES; EXTENDED-STAY HOTELS; HOTEL AND MOTEL SERVICES; RESERVATION OF HOTEL ROOMS FOR TRAVELERS (U.S. CLS. 100 AND 101).
FIRST USE 1-1-2004; IN COMMERCE 1-1-2004.

3,999,527. BAHAMA BAY RESORT MANAGEMENT, LLC, DAVENPORT, FL. SN 85-056,432. PUB. 10-12-2010, FILED 6-7-2010.



NO CLAIM IS MADE TO THE EXCLUSIVE RIGHT TO USE "RESORT & SPA ORLANDO, FLORIDA", APART FROM THE MARK AS SHOWN.

THE COLOR(S) BLACK, WHITE AND BLUE IS/ARE CLAIMED AS A FEATURE OF THE MARK.

THE MARK CONSISTS OF THE WORDS "BAHAMA BAY" IN STYLIZED FORM IN WHITE LETTERING OUTLINED IN BLACK, THE WORDS "RESORT & SPA" WRITTEN IN BLACK UNDER THE WORDS "BAHAMA BAY", AND THE WORDS "ORLANDO, FLORIDA" WRITTEN IN WHITE UNDER THE WORDS "RESORT & SPA", ALL WORDING APPEARING WITHIN A BLUE OVAL.

CLASS 35—ADVERTISING AND BUSINESS

FOR ADMINISTRATIVE HOTEL MANAGEMENT (U.S. CLS. 100, 101 AND 102).
FIRST USE 6-1-2010; IN COMMERCE 6-1-2010.

CLASS 36—INSURANCE AND FINANCIAL

FOR REAL ESTATE MANAGEMENT AND CONSULTATION (U.S. CLS. 100, 101 AND 102).
FIRST USE 6-1-2010; IN COMMERCE 6-1-2010.

CLASS 39—TRANSPORTATION AND STORAGE

FOR TRAVEL AGENCY SERVICES, NAMELY, MAKING RESERVATIONS AND BOOKINGS FOR TRANSPORTATION; ARRANGING TRAVEL TOURS (U.S. CLS. 100 AND 105).
FIRST USE 6-1-2010; IN COMMERCE 6-1-2010.

CLASS 43—HOTEL AND RESTAURANT SERVICES

FOR WHOLESALE AND RETAIL TRAVEL AGENCY SERVICES, NAMELY, MAKING RESERVATIONS AND BOOKINGS FOR TEMPORARY LODGING; HOTEL SERVICES; EXTENDED-STAY HOTELS; HOTEL AND MOTEL SERVICES; RESERVATION OF HOTEL ROOMS FOR TRAVELERS (U.S. CLS. 100 AND 101).
FIRST USE 6-1-2010; IN COMMERCE 6-1-2010.

3,999,528. BAHAMA BAY RESORT MANAGEMENT, LLC, DAVENPORT, FL. SN 85-056,458. PUB. 10-5-2010, FILED 6-7-2010.



THE MARK CONSISTS OF THE WORDS "BAHAMA BAY" IN STYLIZED FORM WRITTEN ABOVE AND PARTIALLY WITHIN A DRAWING OF TWO BIRDS STANDING IN WATER NEAR A BEACH WITH A BUILDING HAVING A ROOF SITUATED ACROSS THE WATER FROM THE BIRDS WITH PALM TREES BEING PRESENT IN THE DRAWING WITH LARGE TROPICAL LEAVES ON THE LEFT AND RIGHT SIDES OF THE DRAWING.

CLASS 35—ADVERTISING AND BUSINESS

FOR ADMINISTRATIVE HOTEL MANAGEMENT (U.S. CLS. 100, 101 AND 102).
FIRST USE 1-1-2004; IN COMMERCE 1-1-2004.

CLASS 36—INSURANCE AND FINANCIAL

FOR REAL ESTATE MANAGEMENT AND CONSULTATION (U.S. CLS. 100, 101 AND 102).
FIRST USE 1-1-2004; IN COMMERCE 1-1-2004.

CLASS 39—TRANSPORTATION AND STORAGE

FOR TRAVEL AGENCY SERVICES, NAMELY, MAKING RESERVATIONS AND BOOKINGS FOR TRANSPORTATION; ARRANGING TRAVEL TOURS (U.S. CLS. 100 AND 105).
FIRST USE 1-1-2004; IN COMMERCE 1-1-2004.

CLASS 43—HOTEL AND RESTAURANT SERVICES

FOR WHOLESALE AND RETAIL TRAVEL AGENCY SERVICES, NAMELY, MAKING RESERVATIONS AND BOOKINGS FOR TEMPORARY LODGING; HOTEL SERVICES; EXTENDED-STAY HOTELS; HOTEL AND MOTEL SERVICES; RESERVATION OF HOTEL ROOMS FOR TRAVELERS (U.S. CLS. 100 AND 101).
FIRST USE 1-1-2004; IN COMMERCE 1-1-2004.

3,999,529. BAHAMA BAY RESORT MANAGEMENT, LLC, DAVENPORT, FL. SN 85-056,486. PUB. 10-5-2010, FILED 6-7-2010.



THE MARK CONSISTS OF THE WORDS "BAHAMA BAY" IN STYLIZED FORM APPEARING WITHIN AN OVAL.

CLASS 35—ADVERTISING AND BUSINESS

FOR ADMINISTRATIVE HOTEL MANAGEMENT (U.S. CLS. 100, 101 AND 102).
FIRST USE 6-1-2010; IN COMMERCE 6-1-2010.

CLASS 36—INSURANCE AND FINANCIAL

FOR REAL ESTATE MANAGEMENT AND CONSULTATION (U.S. CLS. 100, 101 AND 102).
FIRST USE 6-1-2010; IN COMMERCE 6-1-2010.

CLASS 39—TRANSPORTATION AND STORAGE

FOR TRAVEL AGENCY SERVICES, NAMELY, MAKING RESERVATIONS AND BOOKINGS FOR TRANSPORTATION; ARRANGING TRAVEL TOURS (U.S. CLS. 100 AND 105).
FIRST USE 6-1-2010; IN COMMERCE 6-1-2010.

CLASS 43—HOTEL AND RESTAURANT SERVICES

FOR WHOLESALE AND RETAIL TRAVEL AGENCY SERVICES, NAMELY, MAKING RESERVATIONS AND BOOKINGS FOR TEMPORARY LODGING; HOTEL SERVICES; EXTENDED-STAY HOTELS; HOTEL AND MOTEL SERVICES; RESERVATION OF HOTEL ROOMS FOR TRAVELERS (U.S. CLS. 100 AND 101).
FIRST USE 6-1-2010; IN COMMERCE 6-1-2010.

3,999,551. TCBY SYSTEMS, LLC, SALT LAKE CITY, UT. SN 85-062,930. PUB. 11-16-2010, FILED 6-15-2010.

TCBY FROZEN YOGURT

THE MARK CONSISTS OF STANDARD CHARACTERS WITHOUT CLAIM TO ANY PARTICULAR FONT, STYLE,

SIZE, OR COLOR.

OWNER OF U.S. REG. NOS. 1,338,536, 3,388,311, AND OTHERS.

NO CLAIM IS MADE TO THE EXCLUSIVE RIGHT TO USE "FROZEN YOGURT", APART FROM THE MARK AS SHOWN.

CLASS 30—STAPLE FOODS

FOR FROZEN YOGURT (U.S. CL. 46).
FIRST USE 7-22-2010; IN COMMERCE 7-22-2010.

CLASS 43—HOTEL AND RESTAURANT SERVICES

FOR RESTAURANT SERVICES (U.S. CLS. 100 AND 101).
FIRST USE 7-22-2010; IN COMMERCE 7-22-2010.

3,999,569. NATIONAL DISTRIBUTION & CONTRACTING, INC., NASHVILLE, TN. SN 85-066,523. PUB. 1-18-2011, FILED 6-18-2010.

QUALA

THE MARK CONSISTS OF STANDARD CHARACTERS WITHOUT CLAIM TO ANY PARTICULAR FONT, STYLE, SIZE, OR COLOR.

OWNER OF U.S. REG. NOS. 2,198,713, 3,657,707, AND OTHERS.

CLASS 5—PHARMACEUTICALS

FOR COMPOSITE RESTORATIVE MATERIALS FOR DENTAL PURPOSES (U.S. CLS. 6, 18, 44, 46, 51 AND 52).
FIRST USE 10-0-2010; IN COMMERCE 10-0-2010.

CLASS 10—MEDICAL APPARATUS

FOR PLASTIC TRAYS AND PLASTIC TRAY COVERS FOR DENTAL INSTRUMENT SET-UP; PLASTIC STORAGE BOXES FOR RETAINERS; PLASTIC STORAGE BOXES FOR DENTURES; DISPOSABLE SCREENS USED IN DENTAL EVACUATION SYSTEMS; DISPOSABLE SCREEN TRAPS USED IN DENTAL CUSPIDORS; DISPOSABLE SCREEN TRAPS USED WITH SALIVA EJECTORS (U.S. CLS. 26, 39 AND 44).
FIRST USE 8-0-2010; IN COMMERCE 8-0-2010.

3,999,576. HONEYWELL INTERNATIONAL INC., MORRISTOWN, NJ. SN 85-069,593. PUB. 11-30-2010, FILED 6-23-2010.

**THE ONLY THING WE CAN'T
REPLACE IS YOU**

THE MARK CONSISTS OF STANDARD CHARACTERS WITHOUT CLAIM TO ANY PARTICULAR FONT, STYLE, SIZE, OR COLOR.

CLASS 9—ELECTRICAL AND SCIENTIFIC APPARATUS

FOR CONTROLLERS FOR FURNACES AND BOILERS; THERMOSTATS (U.S. CLS. 21, 23, 26, 36 AND 38).
FIRST USE 5-31-2010; IN COMMERCE 9-30-2010.

CLASS 11—ENVIRONMENTAL CONTROL APPARATUS

FOR UNIVERSAL, ELECTRIC, HOT SURFACE IGNITERS FOR FURNACES AND BOILERS; IGNITION GAS VALVES FOR FURNACES AND HEATING BOILERS; PILOT GAS VALVES FOR FURNACES AND HEATING BOILERS; UNIVERSAL HOT SURFACE IGNITERS FOR GAS FURNACES AND GAS HEATING BOILERS; REPLACEMENT PARTS FOR FURNACES AND HEATING BOILERS (U.S. CLS. 13, 21, 23, 31 AND 34).
FIRST USE 5-31-2010; IN COMMERCE 9-30-2010.

3,999,602. ONLINE INSIGHT, DBA EMPOWER HEALTH, MARIETTA, GA. SN 85-076,769. PUB. 12-7-2010, FILED 7-2-2010.

Empower Health

3,999,581. GODFREY, TRACY BOYD, LAS VEGAS, NV. SN 85-070,807. PUB. 11-23-2010, FILED 6-24-2010.



NO CLAIM IS MADE TO THE EXCLUSIVE RIGHT TO USE "LA CUCINA", APART FROM THE MARK AS SHOWN.

THE COLOR(S) BURGUNDY, GOLD, GRAY, AND SILVER IS/ARE CLAIMED AS A FEATURE OF THE MARK.

THE MARK CONSISTS OF THE WORDING "LA CUCINA" IN GOLD APPEARING BETWEEN ONE BROKEN SILVER LINE ABOVE AND ONE SOLID SILVER LINE BELOW. A BURGUNDY SINGLE FLAME APPEARS ABOVE THE WORDING, WITH GRAY SHADOW UNDERNEATH.

THE ENGLISH TRANSLATION OF "LA CUCINA" IS "THE KITCHEN".

CLASS 41—EDUCATION AND ENTERTAINMENT

FOR PROVIDING A WEB SITE THAT FEATURES INFORMAL INSTRUCTION ON COOKING (U.S. CLS. 100, 101 AND 107).

FIRST USE 9-1-2010; IN COMMERCE 9-1-2010.

CLASS 43—HOTEL AND RESTAURANT SERVICES

FOR PROVIDING A DATABASE IN THE FIELD OF RECIPES AND COOKING INFORMATION; PROVIDING AN ONLINE COMPUTER DATABASE TO CONSUMERS CONCERNING RECIPES, INGREDIENTS AND COOKING INFORMATION (U.S. CLS. 100 AND 101).

FIRST USE 9-1-2010; IN COMMERCE 9-1-2010.

THE MARK CONSISTS OF STANDARD CHARACTERS WITHOUT CLAIM TO ANY PARTICULAR FONT, STYLE, SIZE, OR COLOR.

NO CLAIM IS MADE TO THE EXCLUSIVE RIGHT TO USE "HEALTH", APART FROM THE MARK AS SHOWN.

CLASS 9—ELECTRICAL AND SCIENTIFIC APPARATUS

FOR COMPUTER DATABASE MANAGEMENT SOFTWARE FOR USE IN PERSONALIZING THE CONTENT OF E-MAIL COMMUNICATIONS; COMPUTER E-COMMERCE SOFTWARE TO ALLOW USERS TO PERFORM ELECTRONIC BUSINESS TRANSACTIONS VIA A GLOBAL COMPUTER NETWORK; COMPUTER PROGRAMS FOR RECOMMENDING, DEVELOPING, CREATING, OR PURCHASING HEALTH INSURANCE PLANS AND PROGRAMS FOR INDIVIDUALS AND BUSINESSES BASED ON DEMOGRAPHIC AND/OR PERSONAL PREFERENCE DATA; COMPUTER SOFTWARE FOR CREATING SEARCHABLE DATABASES OF INFORMATION AND DATA; COMPUTER SOFTWARE FOR USE IN CUSTOMER RELATIONSHIP MANAGEMENT (CRM); COMPUTER SOFTWARE FOR RECOMMENDING, DEVELOPING, CREATING, OR PURCHASING HEALTH INSURANCE PLANS AND PROGRAMS FOR INDIVIDUALS AND BUSINESSES BASED ON DEMOGRAPHIC AND/OR PERSONAL PREFERENCE DATA; COMPUTER SOFTWARE THAT PROVIDES REAL-TIME, INTEGRATED BUSINESS MANAGEMENT INTELLIGENCE BY COMBINING INFORMATION FROM VARIOUS DATABASES AND PRESENTING IT IN AN EASY-TO-UNDERSTAND USER INTERFACE; COMPUTER SOFTWARE THAT PROVIDES WEB-BASED ACCESS TO APPLICATIONS AND SERVICES THROUGH A WEB OPERATING SYSTEM OR PORTAL INTERFACE (U.S. CLS. 21, 23, 26, 36 AND 38).

FIRST USE 11-30-2010; IN COMMERCE 4-1-2011.

CLASS 42—SCIENTIFIC AND COMPUTER SERVICES

FOR APPLICATION SERVICE PROVIDER (ASP) FEATURING SOFTWARE FOR USE RECOMMENDING, DEVELOPING, CREATING, OR PURCHASING HEALTH INSURANCE PLANS AND PROGRAMS FOR INDIVIDUALS AND BUSINESSES BASED ON DEMOGRAPHIC AND/OR PERSONAL PREFERENCE DATA; COMPUTER PROGRAMMING AND SOFTWARE DESIGN; COMPUTER SERVICES, NAMELY, DESIGNING AND IMPLEMENTING ON DEMAND WEB SITES IN THE NATURE OF TURNKEY PACKAGES ALLOWING CUSTOMERS TO CREATE ECOMMERCE WEB SITES FOR THE PURPOSE OF UPLOADING PHOTOS AND CREATING GIFTS (U.S. CLS. 100 AND 101).

FIRST USE 11-30-2010; IN COMMERCE 4-1-2011.

3,999,624. PERFUOMA, INC., WESTAMPTON, NJ. SN 85-081,611. PUB. 3-22-2011, FILED 7-9-2010.

ULTRA VOGUE de prince
parfums

THE MARK CONSISTS OF STANDARD CHARACTERS WITHOUT CLAIM TO ANY PARTICULAR FONT, STYLE, SIZE, OR COLOR.

NO CLAIM IS MADE TO THE EXCLUSIVE RIGHT TO USE "PARFUMS", APART FROM THE MARK AS SHOWN.

THE ENGLISH TRANSLATION OF "PARFUMS" IN THE MARK IS "PERFUMES".

CLASS 1—CHEMICALS

FOR ALCOHOL FOR USE IN THE MANUFACTURE OF PERFUMES (U.S. CLS. 1, 5, 6, 10, 26 AND 46).
FIRST USE 5-1-2009; IN COMMERCE 5-17-2010.

CLASS 3—COSMETICS AND CLEANING PREPARATIONS

FOR EAU DE PERFUME; AFTER SHAVE LOTIONS; BATH SOAPS IN LIQUID, SOLID OR GEL FORM; BODY LOTIONS; EAU DE TOILETTE; PERFUMES AND TOILET WATERS (U.S. CLS. 1, 4, 6, 50, 51 AND 52).
FIRST USE 5-1-2009; IN COMMERCE 5-1-2010.

3,999,636. EURARK, LLC, BATESVILLE, AR. SN 85-086,336. PUB. 11-30-2010, FILED 7-16-2010.



OWNER OF U.S. REG. NOS. 2,092,650, 2,287,206, AND 2,814,197.

THE COLOR(S) GREEN, ORANGE, RED-ORANGE, YELLOW, BLUE AND GREY IS/ARE CLAIMED AS A FEATURE OF THE MARK.

THE MARK CONSISTS OF THE WORD "LIFEPLUS" WITH "LIFE" IN BOLD FONT AND GREY COLOR, "PLUS" IN NORMAL FONT AND GREY COLOR, AND A MULTI-COLORED FOUNTAIN EXPANDING FROM THE TOP OF THE "I", HAVING OVERLAPPING BANDS MADE UP OF SHADES OF GREEN, ORANGE, RED-ORANGE, YELLOW AND BLUE.

CLASS 5—PHARMACEUTICALS

FOR VITAMINS, VITAMIN AND MINERAL SUPPLEMENTS, DIETARY FOOD SUPPLEMENTS, POWDERED NUTRITIONAL SUPPLEMENT DRINK MIX, WEIGHT MANAGEMENT SUPPLEMENTS, HERBAL SUPPLEMENTS (U.S. CLS. 6, 18, 44, 46, 51 AND 52).

FIRST USE 10-25-2010; IN COMMERCE 12-1-2010.

CLASS 35—ADVERTISING AND BUSINESS

FOR RENDERING TECHNICAL ASSISTANCE IN CONNECTION WITH THE ESTABLISHMENT AND/OR OPERATION OF A MULTI-LEVEL MARKETING NETWORK BY PROVIDING BUSINESS MARKETING INFORMATION THROUGH THE DISTRIBUTION OF PRINTED MATERIALS AND THE RENDERING OF SALES PROMOTIONAL ADVICE FOR PERSON TO PERSON MERCHANDISING OF VARIOUS GOODS, NAMELY, VITAMINS, VITAMIN AND MINERAL SUPPLEMENTS, DIETARY FOOD SUPPLEMENTS, POWDERED NUTRITIONAL SUPPLEMENT DRINK MIX, WEIGHT MANAGEMENT SUPPLEMENTS, HERBAL SUPPLEMENTS AND THE LIKE, AND, COSMETICS, NAMELY, MOISTURIZING CREAMS, LOTIONS AND GELS, BATH AND SHOWER GEL, BATH AND SHOWER LOTION, BODY LOTION, HAIR CONDITIONER, ANTI-AGING CREAM, NON-MEDICATED ANTI-AGING SERUM AND ANTI-AGING GEL, SHAMPOO, HAIR MOISTURIZERS, HAIR STYLING PREPARATIONS, TOOTHPASTE, EYE CREAM, EYE GEL AND THE LIKE (U.S. CLS. 100, 101 AND 102).

FIRST USE 10-23-2010; IN COMMERCE 12-1-2010.

3,999,653. ROBOT RETAIL LLC, BOSTON, MA. SN 85-092,658. PUB. 3-15-2011, FILED 7-26-2010.

AUTOMATIC APPAREL

THE MARK CONSISTS OF STANDARD CHARACTERS WITHOUT CLAIM TO ANY PARTICULAR FONT, STYLE, SIZE, OR COLOR.

NO CLAIM IS MADE TO THE EXCLUSIVE RIGHT TO USE "AUTOMATIC" FOR INTERNATIONAL CLASS 9 AND "APPAREL" FOR INTERNATIONAL CLASS 25, APART FROM THE MARK AS SHOWN.

CLASS 9—ELECTRICAL AND SCIENTIFIC APPARATUS

FOR AUTOMATIC VENDING MACHINES; EARPHONES AND HEADPHONES; EYEWEAR, NAMELY, SUNGLASSES, EYEGASSES AND OPHTHALMIC FRAMES AND CASES THEREFOR; GOGGLES FOR SPORTS (U.S. CLS. 21, 23, 26, 36 AND 38).

FIRST USE 7-1-2010; IN COMMERCE 5-6-2011.

CLASS 25—CLOTHING

FOR ATHLETIC APPAREL, NAMELY, SHIRTS, PANTS, JACKETS, FOOTWEAR, HATS AND CAPS, ATHLETIC UNIFORMS; BELTS; BOXER SHORTS; BRAS; BRIEFS; FOOTWEAR; GYM SHORTS; HATS; HEADBANDS; LADIES' UNDERWEAR; LEGGINGS; SCARVES; SKIWEAR; SOCKS; SWIMSUITS; TEE SHIRTS (U.S. CLS. 22 AND 39).

FIRST USE 7-1-2010; IN COMMERCE 5-6-2011.

3,999,659. MAURER'S TEXTILE RENTAL SERVICES, INC., DEWITT, MI. SN 85-096,932. PUB. 3-15-2011, FILED 7-30-2010.

M-TRAX

THE MARK CONSISTS OF STANDARD CHARACTERS WITHOUT CLAIM TO ANY PARTICULAR FONT, STYLE, SIZE, OR COLOR.

CLASS 35—ADVERTISING AND BUSINESS

FOR ELECTRONIC TRACKING OF TEXTILES, NAMELY, LINENS, MATS, UNIFORMS AND SHIRTS THAT ARE UNDER LEASE BY THIRD PARTIES (U.S. CLS. 100, 101 AND 102).
FIRST USE 7-1-2008; IN COMMERCE 2-1-2009.

CLASS 37—CONSTRUCTION AND REPAIR

FOR TEXTILE RECYCLING, NAMELY, SORTING OF NEW AND USED CLOTHING FOR LATER DISTRIBUTION OR SHIPPING (U.S. CLS. 100, 103 AND 106).
FIRST USE 7-1-2008; IN COMMERCE 2-1-2009.

3,999,670. AMERICAN EXPRESS MARKETING & DEVELOPMENT CORP., NEW YORK, NY. SN 85-101,092. PUB. 2-22-2011, FILED 8-5-2010.



THE MARK CONSISTS OF FOUR STYLIZED AND CONNECTED "S".

CLASS 9—ELECTRICAL AND SCIENTIFIC APPARATUS

FOR APPARATUS FOR PROCESSING POINT-OF-SALE TRANSACTIONS (U.S. CLS. 21, 23, 26, 36 AND 38).
FIRST USE 3-28-2011; IN COMMERCE 3-28-2011.

CLASS 36—INSURANCE AND FINANCIAL

FOR CHARGE CARD, CREDIT CARD AND STORED VALUE CARD SERVICES; PAYMENT CARD TRANSACTION PROCESSING SERVICES; PROVIDING ELECTRONIC PAYMENTS VIA A GLOBAL COMPUTER NETWORK; FINANCIAL SERVICES, NAMELY, ELECTRONIC PROCESSING, VERIFICATION, AND SETTLEMENT OF ONLINE TRANSACTIONS; STORED VALUE AND DEBIT CARD TRANSACTION VERIFICATION AND SETTLEMENT SERVICES; ELECTRONIC PAYMENT PROCESSING OF PAYMENT CARDS AND ONLINE ACCOUNT PAYMENT DATA; PROVIDING FINANCIAL INFORMATION VIA A GLOBAL COMPUTER NETWORK; CONSULTATION SERVICES RELATED TO THE FOREGOING (U.S. CLS. 100, 101 AND 102).
FIRST USE 3-28-2011; IN COMMERCE 3-28-2011.

CLASS 38—COMMUNICATION

FOR PROVIDING ELECTRONIC TRANSMISSION OF PAYMENT CARD AND ONLINE ACCOUNT PAYMENT DATA (U.S. CLS. 100, 101 AND 104).
FIRST USE 3-28-2011; IN COMMERCE 3-28-2011.

3,999,682. KRANSON INDUSTRIES, INC., ST. LOUIS, MO. SN 85-104,930. PUB. 12-7-2010, FILED 8-11-2010.



THE MARK CONSISTS OF THE LETTER "O" SURROUNDED BY THE PLUS SIGN SYMBOL ("+") IN VARIOUS SIZES.

CLASS 35—ADVERTISING AND BUSINESS

FOR DISTRIBUTORSHIP SERVICES IN THE FIELD OF GLASS, PLASTIC, AND COMPOSITE BOTTLES AND CONTAINERS, CAPS, CLOSURES, SPRAY PUMPS, AND PLASTIC TUBES; BUSINESS PLANNING, NAMELY, ARRANGING FOR THE PRODUCTION OF PACKAGING FOR OTHERS (U.S. CLS. 100, 101 AND 102).
FIRST USE 11-12-2010; IN COMMERCE 11-15-2010.

CLASS 42—SCIENTIFIC AND COMPUTER SERVICES

FOR PACKAGING DESIGN FOR OTHERS, DESIGN FOR OTHERS IN THE FIELD OF ENGINEERING MANUFACTURING LINES FOR THE PRODUCTION OF PACKAGING MATERIALS; CUSTOM DESIGN AND ENGINEERING OF MOLDS AND MACHINE TOOLS FOR USE IN PRODUCTION OF PACKAGING MATERIALS (U.S. CLS. 100 AND 101).
FIRST USE 11-10-2010; IN COMMERCE 11-15-2010.

3,999,684. TOP SHELF BEVERAGES, LLC, PALO ALTO, CA. SN 85-105,429. PUB. 1-25-2011, FILED 8-11-2010.

PERFECT ALONE, SPECTACULAR
MIXED

THE MARK CONSISTS OF STANDARD CHARACTERS WITHOUT CLAIM TO ANY PARTICULAR FONT, STYLE, SIZE, OR COLOR.

CLASS 30—STAPLE FOODS

FOR BEVERAGES MADE OF TEA; ICED TEA; TEA-BASED BEVERAGES; TEA-BASED BEVERAGES WITH FRUIT FLAVORING (U.S. CL. 46).
FIRST USE 7-9-2010; IN COMMERCE 7-9-2010.

CLASS 32—LIGHT BEVERAGES

FOR ENERGY DRINKS; SOFT DRINKS; SOFT DRINKS FLAVORED WITH TEA; SPORTS DRINKS; SPORTS DRINKS, NAMELY, ENERGY DRINKS (U.S. CLS. 45, 46 AND 48).
FIRST USE 7-9-2010; IN COMMERCE 7-9-2010.

3,999,687. ARJIL, THOMAS, R., ELK GROVE, CA. SN 85-106,539. PUB. 1-25-2011, FILED 8-12-2010.



NO CLAIM IS MADE TO THE EXCLUSIVE RIGHT TO USE "AMBULANCE" AND "MEDICAL SERVICES", APART FROM THE MARK AS SHOWN.

THE COLOR(S) ORANGE, DARK BLUE IS/ARE CLAIMED AS A FEATURE OF THE MARK.

THE MARK CONSISTS OF A STAR OF LIFE WITH SIX POINTS. THE STAR IS ORANGE WITH A LIGHTER ORANGE LINE AT THE EDGES OF THE POINTS TO REPRESENT SHINE, EXCEPT FOR THE LEFT TWO POINTS WHICH ARE DARK BLUE AND FORM AN ARROW WITHIN THE STAR POINTING TOWARDS THE WORDS "ALPHAONE AMBULANCE MEDICAL SERVICES". THE WORDS "ALPHAONE AMBULANCE MEDICAL SERVICES" ARE ON TWO LINES TO THE IMMEDIATE RIGHT OF THE STAR WITH "ALPHAONE" ON THE TOP LINE AND "AMBULANCE MEDICAL SERVICES" ON THE BOTTOM LINE. THE TERM "ALPHA" IS ORANGE AND THE TERMS "ONE" AND "AMBULANCE MEDICAL SERVICES" ARE DARK BLUE. THE TWO LINES OF TEXT ARE SEPARATED BY A SINGLE HORIZONTAL ORANGE LINE AND A DARK BLUE LINE WHICH BEGINS AS A HORIZONTAL LINE BENEATH THE LOWER RIGHT POINT OF THE STAR OF LIFE THEN ANGLES SHARPLY UPWARD BETWEEN THE STAR AND THE WORDS "AMBULANCE MEDICAL SERVICES", THROUGH THE ORANGE LINE, AND THEN HORIZONTALLY STRAIGHT RIGHT AGAIN ABOVE THE ORANGE LINE FOR THE LENGTH OF THE TEXT.

CLASS 39—TRANSPORTATION AND STORAGE

FOR AMBULANCE TRANSPORT (U.S. CLS. 100 AND 105).
FIRST USE 1-24-2011; IN COMMERCE 1-24-2011.

CLASS 44—MEDICAL, BEAUTY AND AGRICULTURAL SERVICES

FOR MEDICAL SERVICES, NAMELY, EMERGENCY MEDICAL SERVICES (U.S. CLS. 100 AND 101).
FIRST USE 1-24-2011; IN COMMERCE 1-24-2011.

3,999,689. EXP GLOBAL INC., BRAMPTON, ONTARIO, CANADA. SN 85-107,276. PUB. 3-15-2011, FILED 8-13-2010.

EXP

THE MARK CONSISTS OF STANDARD CHARACTERS WITHOUT CLAIM TO ANY PARTICULAR FONT, STYLE, SIZE, OR COLOR.

"EXP" APPEARING IN THE MARK HAS NO SIGNIFICANCE IN THE RELEVANT TRADE OR INDUSTRY OR AS APPLIED TO THE GOODS/SERVICES LISTED IN THE APPLICATION, OR ANY GEOGRAPHICAL SIGNIFICANCE.

CLASS 37—CONSTRUCTION AND REPAIR

FOR BUILDING AND ROAD CONSTRUCTION MANAGEMENT SERVICES (U.S. CLS. 100, 103 AND 106).
FIRST USE 4-4-2011; IN COMMERCE 4-4-2011.

CLASS 42—SCIENTIFIC AND COMPUTER SERVICES

FOR ENGINEERING AND ARCHITECTURAL CONSULTING; ENGINEERING PROJECT MANAGEMENT; LANDSCAPE ARCHITECTURAL DESIGN SERVICES; URBAN PLANNING SERVICES AND LAND SURVEYING SERVICES; CONSULTING SERVICES IN THE FIELD OF ENVIRONMENTAL ASSESSMENT AND PLANNING (U.S. CLS. 100 AND 101).
FIRST USE 4-4-2011; IN COMMERCE 4-4-2011.

3,999,697. TRICORBRAUN INC., ST. LOUIS, MO. SN 85-109,081. PUB. 12-7-2010, FILED 8-17-2010.

TRICORBRAUN
the power of options

THE MARK CONSISTS OF THE WORD "TRICORBRAUN" IN ALL CAPITAL LETTERS ABOVE THE WORDS "THE POWER OF OPTIONS" IN ALL LOWER CASE LETTERS.

CLASS 35—ADVERTISING AND BUSINESS

FOR DISTRIBUTORSHIP SERVICES IN THE FIELD OF GLASS, PLASTIC, AND COMPOSITE BOTTLES AND CONTAINERS, CAPS, CLOSURES, SPRAY PUMPS, AND PLASTIC TUBES; BUSINESS PLANNING, NAMELY, ARRANGING FOR THE PRODUCTION OF PACKAGING FOR OTHERS (U.S. CLS. 100, 101 AND 102).

FIRST USE 11-12-2010; IN COMMERCE 11-15-2010.

CLASS 42—SCIENTIFIC AND COMPUTER SERVICES

FOR PACKAGING DESIGN FOR OTHERS, DESIGN FOR OTHERS IN THE FIELD OF ENGINEERING MANUFACTURING LINES FOR THE PRODUCTION OF PACKAGING MATERIALS; CUSTOM DESIGN AND ENGINEERING OF MOLDS AND MACHINE TOOLS FOR USE IN PRODUCTION OF PACKAGING MATERIALS (U.S. CLS. 100 AND 101).

FIRST USE 11-12-2010; IN COMMERCE 11-15-2010.

3,999,738. VIRGIN RIVER FOOD MART, INC., DBA VIRGIN VALLEY FOOD MART, MESQUITE, NV. SN 85-127,028. PUB. 1-25-2011, FILED 9-10-2010.



NO CLAIM IS MADE TO THE EXCLUSIVE RIGHT TO USE "24 7 VIRGIN VALLEY FOODMART", APART FROM THE MARK AS SHOWN.

THE MARK CONSISTS OF A LOGO INCLUDING THE NUMBERS "24" AND "7" ALIGNED IN A SUBSTANTIALLY RECTANGULAR SHAPED FIGURE, ALONG WITH AN ARROW AND THE WORDS "VIRGIN VALLEY FOODMART".

3,999,727. SPIRIT TWISTERS, LLC, ATHENS, GA. SN 85-123,717. PUB. 2-15-2011, FILED 9-7-2010.

TWISTOLOGIST

THE MARK CONSISTS OF STANDARD CHARACTERS WITHOUT CLAIM TO ANY PARTICULAR FONT, STYLE, SIZE, OR COLOR.

CLASS 16—PAPER GOODS AND PRINTED MATTER

FOR PRINTED RECIPES SOLD AS A COMPONENT OF FOOD PACKAGING (U.S. CLS. 2, 5, 22, 23, 29, 37, 38 AND 50).

FIRST USE 12-1-2010; IN COMMERCE 12-1-2010.

CLASS 32—LIGHT BEVERAGES

FOR NON-ALCOHOLIC COCKTAIL BASES; NON-ALCOHOLIC COCKTAIL MIXES; SYRUPS FOR MAKING NON-ALCOHOLIC BEVERAGES (U.S. CLS. 45, 46 AND 48).

FIRST USE 12-1-2010; IN COMMERCE 12-1-2010.

CLASS 35—ADVERTISING AND BUSINESS

FOR RETAIL STORE SERVICES FEATURING CONVENIENCE STORE ITEMS AND GASOLINE (U.S. CLS. 100, 101 AND 102).

FIRST USE 10-26-2010; IN COMMERCE 10-26-2010.

CLASS 39—TRANSPORTATION AND STORAGE

FOR PARKING LOT SERVICES (U.S. CLS. 100 AND 105).

FIRST USE 10-26-2010; IN COMMERCE 10-26-2010.

3,999,750. KAREN PAUL, LARCHMONT, NY. SN 85-131,176. PUB. 3-1-2011, FILED 9-16-2010.

LITTLE MORE CHARMING

THE MARK CONSISTS OF STANDARD CHARACTERS WITHOUT CLAIM TO ANY PARTICULAR FONT, STYLE, SIZE, OR COLOR.

CLASS 18—LEATHER GOODS

FOR ALL PURPOSE CARRYING BAGS; HANDBAGS; PURSES; WALLETS; BACKPACKS; BOOK BAGS; SPORTS BAGS; UMBRELLAS (U.S. CLS. 1, 2, 3, 22 AND 41).

FIRST USE 1-20-2011; IN COMMERCE 1-20-2011.

CLASS 25—CLOTHING

FOR FOOTWEAR; FLIP-FLOPS; BELTS; HEADBANDS (U.S. CLS. 22 AND 39).

FIRST USE 1-20-2011; IN COMMERCE 1-20-2011.

3,999,758. PETRO HARVESTER OIL AND GAS, LLC, HOUSTON, TX. SN 85-135,386. PUB. 3-8-2011, FILED 9-22-2010.

3,999,792. BESPOKE EDUCATION, INC., NEW YORK, NY. SN 85-145,949. PUB. 3-15-2011, FILED 10-6-2010.

Petro Harvester Oil & Gas

THE MARK CONSISTS OF STANDARD CHARACTERS WITHOUT CLAIM TO ANY PARTICULAR FONT, STYLE, SIZE, OR COLOR.

NO CLAIM IS MADE TO THE EXCLUSIVE RIGHT TO USE "PETRO" AND "OIL & GAS", APART FROM THE MARK AS SHOWN.

CLASS 40—MATERIAL TREATMENT

FOR PRODUCTION OF OIL AND GAS (U.S. CLS. 100, 103 AND 106).
FIRST USE 12-10-2010; IN COMMERCE 12-10-2010.

CLASS 42—SCIENTIFIC AND COMPUTER SERVICES

FOR EXPLORATION OF OIL AND GAS (U.S. CLS. 100 AND 101).
FIRST USE 12-10-2010; IN COMMERCE 12-10-2010.

Bespoke Education

THE MARK CONSISTS OF STANDARD CHARACTERS WITHOUT CLAIM TO ANY PARTICULAR FONT, STYLE, SIZE, OR COLOR.

NO CLAIM IS MADE TO THE EXCLUSIVE RIGHT TO USE "EDUCATION", APART FROM THE MARK AS SHOWN.

CLASS 16—PAPER GOODS AND PRINTED MATTER

FOR EDUCATIONAL PUBLICATIONS, NAMELY, BOOKS AND GUIDES IN THE FIELDS OF TEST PREPARATION (U.S. CLS. 2, 5, 22, 23, 29, 37, 38 AND 50).
FIRST USE 11-22-2006; IN COMMERCE 9-1-2009.

CLASS 41—EDUCATION AND ENTERTAINMENT

FOR EDUCATIONAL SERVICES, NAMELY, PROVIDING CLASSES AND TUTORING IN THE FIELDS OF TEST PREPARATION (U.S. CLS. 100, 101 AND 107).
FIRST USE 11-22-2006; IN COMMERCE 1-16-2007.

3,999,759. PETRO HARVESTER OIL AND GAS, LLC, HOUSTON, TX. SN 85-135,390. PUB. 3-8-2011, FILED 9-22-2010.

3,999,833. ISAGENIX WORLDWIDE, LLC, CHANDLER, AZ. SN 85-160,027. PUB. 3-22-2011, FILED 10-25-2010.

Petro Harvester

THE MARK CONSISTS OF STANDARD CHARACTERS WITHOUT CLAIM TO ANY PARTICULAR FONT, STYLE, SIZE, OR COLOR.

NO CLAIM IS MADE TO THE EXCLUSIVE RIGHT TO USE "PETRO", APART FROM THE MARK AS SHOWN.

CLASS 40—MATERIAL TREATMENT

FOR PRODUCTION OF OIL AND GAS (U.S. CLS. 100, 103 AND 106).
FIRST USE 12-10-2010; IN COMMERCE 12-10-2010.

CLASS 42—SCIENTIFIC AND COMPUTER SERVICES

FOR EXPLORATION OF OIL AND GAS (U.S. CLS. 100 AND 101).
FIRST USE 12-10-2010; IN COMMERCE 12-10-2010.

REJUVITY

THE MARK CONSISTS OF STANDARD CHARACTERS WITHOUT CLAIM TO ANY PARTICULAR FONT, STYLE, SIZE, OR COLOR.

CLASS 3—COSMETICS AND CLEANING PREPARATIONS

FOR NON-MEDICATED SKIN CARE PREPARATIONS; COSMETICS; SUNSCREENS (U.S. CLS. 1, 4, 6, 50, 51 AND 52).
FIRST USE 8-1-2010; IN COMMERCE 8-1-2010.

CLASS 5—PHARMACEUTICALS

FOR VITAMINS; NUTRITIONAL SUPPLEMENTS; TOPICAL PAIN RELIEVERS (U.S. CLS. 6, 18, 44, 46, 51 AND 52).
FIRST USE 8-1-2010; IN COMMERCE 8-1-2010.

3,999,845. BOTTOMLINE TECHNOLOGIES (DE), INC., PORTSMOUTH, NH. SN 85-164,425. PUB. 3-29-2011, FILED 10-29-2010.

INPROTICA

THE MARK CONSISTS OF STANDARD CHARACTERS WITHOUT CLAIM TO ANY PARTICULAR FONT, STYLE, SIZE, OR COLOR.

CLASS 9—ELECTRICAL AND SCIENTIFIC APPARATUS

FOR COMPUTER SOFTWARE FOR INFORMATION AND DATA MANAGEMENT, RECORDS AND DOCUMENT MANAGEMENT, KNOWLEDGE MANAGEMENT, BUSINESS PROCESS MANAGEMENT, PROJECT MANAGEMENT, WORKFLOW MANAGEMENT; COMPUTER SOFTWARE FOR THE MANAGEMENT AND AUTOMATION OF THE EXCHANGE OF INFORMATION AND DATA; COMPUTER SOFTWARE FOR CREATING, PRESENTING, COMPLETING AND DELIVERING PAPERLESS FORMS; COMPUTER SOFTWARE FOR CAPTURING, STORING, RETRIEVING AND EDITING INFORMATION AND DATA; COMPUTER SOFTWARE FOR THE INTEGRATION AND CONTROL OF HARDWARE AND SOFTWARE COMPONENTS TO CAPTURE DATA; COMPUTER SOFTWARE FOR DEFINING, AUTOMATING AND MANAGING WORKFLOW AND BUSINESS PROCESS FLOWS; COMPUTER SOFTWARE FOR DEFINING THE RELATIONSHIPS BETWEEN BUSINESS PROCESS FLOWS AND PAPERLESS FORMS; COMPUTER SOFTWARE FOR MANAGING INTERACTIVE CONTENT WITHIN BUSINESS PROCESSES AND PAPERLESS FORMS; COMPUTER SOFTWARE FOR TRACKING, AUDITING AND REPORTING BUSINESS TASK PROGRESS AND COMPLETION; COMPUTER SOFTWARE FOR DEFINING SECURITY LEVELS FOR INFORMATION ACCESS AND TASK COMPLETION (U.S. CLS. 21, 23, 26, 36 AND 38).

FIRST USE 9-30-2010; IN COMMERCE 11-17-2010.

CLASS 42—SCIENTIFIC AND COMPUTER SERVICES

FOR PROVIDING ON-LINE NON-DOWNLOADABLE SOFTWARE FOR INFORMATION AND DATA MANAGEMENT, RECORDS AND DOCUMENT MANAGEMENT, KNOWLEDGE MANAGEMENT, BUSINESS PROCESS MANAGEMENT, PROJECT MANAGEMENT, WORKFLOW MANAGEMENT; PROVIDING ON-LINE NON-DOWNLOADABLE SOFTWARE FOR THE MANAGEMENT AND AUTOMATION OF THE EXCHANGE OF INFORMATION AND DATA; PROVIDING ON-LINE NON-DOWNLOADABLE SOFTWARE FOR CREATING, PRESENTING, COMPLETING AND DELIVERING PAPERLESS FORMS; PROVIDING ON-LINE NON-DOWNLOADABLE SOFTWARE FOR CAPTURING, STORING, RETRIEVING AND EDITING INFORMATION AND BUSINESS PROCESS DATA; PROVIDING ON-LINE NON-DOWNLOADABLE SOFTWARE FOR THE INTEGRATION AND CONTROL OF HARDWARE AND SOFTWARE COMPONENTS TO CAPTURE DATA; PROVIDING ON-LINE NON-DOWNLOADABLE SOFTWARE FOR DEFINING, AUTOMATING AND MANAGING WORKFLOW AND BUSINESS PROCESS FLOWS; PROVIDING ON-LINE NON-DOWNLOADABLE SOFTWARE FOR DEFINING THE RELATIONSHIPS BETWEEN BUSINESS PROCESS FLOWS AND PAPERLESS FORMS; PROVIDING ON-LINE NON-DOWNLOADABLE SOFTWARE FOR MANAGING INTERACTIVE CONTENT WITHIN BUSINESS PROCESSES AND PAPERLESS FORMS; PROVIDING ON-LINE NON-DOWNLOADABLE SOFTWARE FOR TRACKING, AUDITING AND REPORTING BUSINESS TASK PROGRESS AND COMPLETION; PROVIDING ON-LINE NON-DOWNLOADABLE SOFTWARE FOR DEFINING SECURITY LEVELS FOR INFORMATION ACCESS AND TASK COMPLETION (U.S. CLS. 100 AND 101).

FIRST USE 9-30-2010; IN COMMERCE 11-17-2010.

3,999,860. MILL RUN DEVELOPMENT GROUP II, LLC, KINGSTON, NC. SN 85-177,964. PUB. 1-18-2011, FILED 11-16-2010.

CUTTER CREEK

THE MARK CONSISTS OF STANDARD CHARACTERS WITHOUT CLAIM TO ANY PARTICULAR FONT, STYLE, SIZE, OR COLOR.

CLASS 24—FABRICS

FOR GOLF TOWELS (U.S. CLS. 42 AND 50).
FIRST USE 12-19-2008; IN COMMERCE 12-19-2008.

CLASS 25—CLOTHING

FOR COLLARED SHIRTS; GOLF SHIRTS; HATS; SHIRTS; T-SHIRTS (U.S. CLS. 22 AND 39).
FIRST USE 12-19-2008; IN COMMERCE 12-19-2008.

CLASS 28—TOYS AND SPORTING GOODS

FOR DIVOT REPAIR TOOL FOR GOLFERS; GOLF BAGS; GOLF BALLS (U.S. CLS. 22, 23, 38 AND 50).
FIRST USE 12-19-2008; IN COMMERCE 12-19-2008.

CLASS 37—CONSTRUCTION AND REPAIR

FOR REAL ESTATE DEVELOPMENT (U.S. CLS. 100, 103 AND 106).
FIRST USE 7-22-2009; IN COMMERCE 7-22-2009.

CLASS 41—EDUCATION AND ENTERTAINMENT

FOR GOLF CLUB SERVICES; PROVIDING GOLF FACILITIES (U.S. CLS. 100, 101 AND 107).
FIRST USE 12-19-2008; IN COMMERCE 12-19-2008.

3,999,869. PALA BAND OF MISSION INDIANS, DBA PALA CASINO, PALA, CA. SN 85-233,085. PUB. 3-29-2011, FILED 2-3-2011.

INFINITY

THE MARK CONSISTS OF STANDARD CHARACTERS WITHOUT CLAIM TO ANY PARTICULAR FONT, STYLE, SIZE, OR COLOR.

CLASS 41—EDUCATION AND ENTERTAINMENT

FOR PROVIDING CASINO FACILITIES; PROVIDING FACILITIES FOR MOVIES, SHOWS, PLAYS, MUSIC OR EDUCATIONAL TRAINING (U.S. CLS. 100, 101 AND 107).
FIRST USE 5-6-2011; IN COMMERCE 5-12-2011.

CLASS 43—HOTEL AND RESTAURANT SERVICES

FOR PROVIDING OF FOOD AND DRINK (U.S. CLS. 100 AND 101).
FIRST USE 5-6-2011; IN COMMERCE 5-6-2011.

3,999,870. CONNOISSEURS PRODUCTS CORPORATION, WOBURN, MA. SN 85-975,221. PUB. 10-5-2010, FILED 4-27-2010.



CONNOISSEURS

OWNER OF U.S. REG. NOS. 1,048,830, 1,829,850, AND OTHERS.

THE MARK CONSISTS OF THE WORD "CONNOISSEURS" WITH A DESIGN ELEMENT COMPRISED OF A SOLID ELLIPSE WITH 2 LINE ELLIPSES ABOVE THE WORD.

CLASS 3—COSMETICS AND CLEANING PREPARATIONS

FOR CLEANING SOLUTIONS, SOAPS AND GELS FOR JEWELRY, DIAMONDS, PEARLS AND OTHER PRECIOUS AND SEMI-PRECIOUS STONES, PRECIOUS METALS AND COSTUME JEWELRY; CLEANING PREPARATIONS FOR DIAMONDS SOLD AS A UNIT WITH A STICK APPLICATOR; DISPOSABLE CLOTHS EMBEDDED WITH CHEMICALS TO CLEAN AND POLISH JEWELRY AND PRECIOUS METALS (U.S. CLS. 1, 4, 6, 50, 51 AND 52).
FIRST USE 7-9-2010; IN COMMERCE 12-6-2010.

CLASS 21—HOUSEWARES AND GLASS

FOR POLISHING CLOTHS (U.S. CLS. 2, 13, 23, 29, 30, 33, 40 AND 50).
FIRST USE 7-9-2010; IN COMMERCE 7-9-2010.

3,999,871. LIFEWORD BROADCAST MINISTRIES, INC., CONWAY, AR. SN 85-975,235. PUB. 2-15-2011, FILED 9-1-2010.

DiscipleWay

THE MARK CONSISTS OF STANDARD CHARACTERS WITHOUT CLAIM TO ANY PARTICULAR FONT, STYLE, SIZE, OR COLOR.

CLASS 16—PAPER GOODS AND PRINTED MATTER

FOR PUBLICATIONS, NAMELY, BROCHURES, BOOKLETS, AND TEACHING MATERIALS IN THE FIELD OF DISCIPLESHIP (U.S. CLS. 2, 5, 22, 23, 29, 37, 38 AND 50).
FIRST USE 4-11-2011; IN COMMERCE 4-11-2011.

CLASS 41—EDUCATION AND ENTERTAINMENT

FOR EDUCATION SERVICES, NAMELY, PROVIDING WORKSHOPS, ONLINE SEMINARS AND LIVE SEMINARS IN THE FIELD OF DISCIPLESHIP (U.S. CLS. 100, 101 AND 107).
FIRST USE 9-8-2009; IN COMMERCE 9-8-2009.

3,999,874. TRUE GAMES INTERACTIVE, AUSTIN, TX. SN 85-975,252. PUB. 9-7-2010, FILED 4-1-2010.

FAXION

THE MARK CONSISTS OF STANDARD CHARACTERS WITHOUT CLAIM TO ANY PARTICULAR FONT, STYLE, SIZE, OR COLOR.

CLASS 9—ELECTRICAL AND SCIENTIFIC APPARATUS

FOR COMPUTER GAME SOFTWARE; VIDEO GAME SOFTWARE; DOWNLOADABLE COMPUTER AND VIDEO GAME SOFTWARE FOR USE ON CONSOLE PLATFORMS, NAMELY, GLOBAL COMMUNICATIONS NETWORK CAPABLE AND CONNECTABLE SYSTEMS FOR INDIVIDUAL, PEER-TO-PEER, ONLINE AND MULTIPLAYER PLAY; DOWNLOADABLE COMPUTER GAME PROGRAMS FOR USE IN CONNECTION WITH MULTIPLAYER INTERACTIVE GAMES PLAYED OVER A GLOBAL COMMUNICATION NETWORK (U.S. CLS. 21, 23, 26, 36 AND 38).
FIRST USE 1-31-2011; IN COMMERCE 3-10-2011.

CLASS 41—EDUCATION AND ENTERTAINMENT

FOR ENTERTAINMENT SERVICES, NAMELY, PROVIDING ON-LINE COMPUTER GAMES FOR OTHERS OVER GLOBAL AND LOCAL AREA COMPUTER NETWORKS; ENTERTAINMENT SERVICES, NAMELY, PROVIDING INTERACTIVE ONLINE COMPUTER GAMES VIA THE WORLD WIDE WEB; PROVIDING INFORMATION ABOUT COMPUTER GAMES AND VIDEO GAMES VIA THE WORLD WIDE WEB; ENTERTAINMENT SERVICES, NAMELY, PROVIDING MULTIPLAYER INTERACTIVE COMPUTER AND VIDEO GAMES VIA THE WORLD WIDE WEB; PROVIDING A WEBSITE FEATURING TRIVIA, TIPS AND STRATEGIES FOR COMPUTER GAMES; FAN CLUB SERVICES; PROVIDING A WEBSITE FEATURING COMPUTER GAMES AND GAMING INFORMATION (U.S. CLS. 100, 101 AND 107).

FIRST USE 1-31-2011; IN COMMERCE 3-10-2011.

* * * * *

SECTION 2.— INTERNATIONAL CLASSIFICATION

The short titles associated below with the international class numbers are terms designed merely for quick identification and are not an official part of the international classification. The full names of international classes are given in section 6.1 of the trademark rules of practice.

The designation "U.S. Cl." appearing in this section refers to the U.S. class in effect prior to Sep. 1, 1973 rather than the international class which applies to applications filed on or after that date. For adoption of international classification see notice in the OFFICIAL GAZETTE of Jun. 26, 1973 (911 O.G. TM 210).

Application in one class

CLASS 1—CHEMICALS

3,998,340. PILOTS POINT, LLC., BELLEAIR BLUFFS, FL. SN 76-703,980. PUB. 1-18-2011, FILED 8-2-2010.

CLASS 1—(Continued).

3,998,423. IMP CHEMICALS LIMITED, RADCLIFF, UNITED KINGDOM. SN 77-285,845. PUB. 3-9-2010, FILED 9-21-2007.



DETOX 4

THE MARK CONSISTS OF A SAIL BOAT DESIGN ON A WAVE AND THE WORDING "PILOTS POINT" BELOW.

FOR BIOMEDICAL COMPOUNDS, NAMELY, SUBSTRATES CONTAINING PEPTIDES, VITAMINS, INDICATORS, AND ENERGY CONTAINING REAGENTS FOR USE IN DETECTING THE PRESENCE OR ABSENCE OF TARGET MICROBES, NAMELY, VANCOMYCIN RESISTANT ENTEROCOCCUS, MRSA, MSSA, E COLI, OR STREPTOCOCCUS B IN BIOLOGICAL SAMPLE SPECIMENS, FOOD SAMPLE SPECIMENS, NATURAL SAMPLE SPECIMENS, OR ENVIRONMENTAL SAMPLE SPECIMENS FOR USE IN EPIDEMIOLOGY SURVEILLANCE FOR CLINICAL, RESEARCH, OR MEDICAL LABORATORY USE (U.S. CLS. 1, 5, 6, 10, 26 AND 46).

FIRST USE 8-0-2010; IN COMMERCE 8-0-2010.

THE MARK CONSISTS OF STANDARD CHARACTERS WITHOUT CLAIM TO ANY PARTICULAR FONT, STYLE, SIZE, OR COLOR.

FOR CHEMICALS FOR AUTOMOTIVE USE, NAMELY, OIL ADDITIVES, PETROL ADDITIVES, DIESEL ADDITIVES, OCTANE BOOSTER, CETANE BOOSTER, LEAK SEALANT PREPARATIONS FOR MOTOR VEHICLE RADIATORS; RADIATOR STOP LEAK SEALANT; CHEMICAL ADDITIVE FOR AUTOMOTIVE USE, NAMELY, DIESEL INJECTOR CLEANER; PETROL INJECTOR CLEANER; COMMON RAIL DIESEL INJECTOR CLEANER; CHEMICAL ENGINE TREATMENTS FOR TRANSMISSION FLUID, CARBURETTOR CLEANER, BRAKE CLEANER, COOLING SYSTEM CLEANERS; RADIATOR FLUSH, RADIATOR ADDITIVES TO PREVENT RUST (U.S. CLS. 1, 5, 6, 10, 26 AND 46).

FIRST USE 3-1-2008; IN COMMERCE 3-1-2008.

CLASS 1—(Continued).

3,998,424. IMP CHEMICALS LIMITED, GREATER MANCHESTER, UNITED KINGDOM. SN 77-285,943. PUB. 3-9-2010, FILED 9-21-2007.

REHAB 4

THE MARK CONSISTS OF STANDARD CHARACTERS WITHOUT CLAIM TO ANY PARTICULAR FONT, STYLE, SIZE, OR COLOR.

FOR CHEMICALS FOR AUTOMOTIVE USE, NAMELY, OIL ADDITIVES, PETROL ADDITIVES, DIESEL ADDITIVES, OCTANE BOOSTER, CETANE BOOSTER, LEAK SEALANT PREPARATIONS FOR MOTOR VEHICLE RADIATORS; RADIATOR STOP LEAK SEALANT; CHEMICAL ADDITIVE FOR AUTOMOTIVE USE, NAMELY, DIESEL INJECTOR CLEANER; PETROL INJECTOR CLEANER; COMMON RAIL DIESEL INJECTOR CLEANER; CHEMICAL ENGINE TREATMENTS FOR TRANSMISSION FLUID, CARBURETTOR CLEANER, BRAKE CLEANER, COOLING SYSTEM CLEANERS; RADIATOR FLUSH, RADIATOR ADDITIVES TO PREVENT RUST (U.S. CLS. 1, 5, 6, 10, 26 AND 46).

FIRST USE 5-1-2008; IN COMMERCE 5-1-2008.

3,998,484. A.S. TRUST & HOLDINGS, INC., KANEOHE, HI. SN 77-441,965. PUB. 3-3-2009, FILED 4-7-2008.

THE "CLIMATE FRIENDLY" REFRIGERANT

THE MARK CONSISTS OF STANDARD CHARACTERS WITHOUT CLAIM TO ANY PARTICULAR FONT, STYLE, SIZE, OR COLOR.

NO CLAIM IS MADE TO THE EXCLUSIVE RIGHT TO USE "REFRIGERANT", APART FROM THE MARK AS SHOWN.

FOR HYDROCARBON GAS FOR USE AS A REFRIGERANT (U.S. CLS. 1, 5, 6, 10, 26 AND 46).

FIRST USE 5-15-2011; IN COMMERCE 5-15-2011.

CLASS 1—(Continued).

3,998,572. JUMPSTART ENERGY SERVICES, LLC, HOUSTON, TX. SN 77-607,883. PUB. 3-24-2009, FILED 11-5-2008.

Tigerzyme

THE MARK CONSISTS OF STANDARD CHARACTERS WITHOUT CLAIM TO ANY PARTICULAR FONT, STYLE, SIZE, OR COLOR.

FOR ENZYME SURFACTANT FLUIDS USED FOR TREATMENT OF OIL AND GAS WELLS AND HYDRO-CARBON SLUDGES (U.S. CLS. 1, 5, 6, 10, 26 AND 46).

FIRST USE 4-25-2010; IN COMMERCE 7-22-2010.

3,998,816. ARCH CHEMICALS, INC., NORWALK, CT. SN 77-842,282. PUB. 3-9-2010, FILED 10-6-2009.

SPA SELECTIONS

THE MARK CONSISTS OF STANDARD CHARACTERS WITHOUT CLAIM TO ANY PARTICULAR FONT, STYLE, SIZE, OR COLOR.

NO CLAIM IS MADE TO THE EXCLUSIVE RIGHT TO USE "SPA", APART FROM THE MARK AS SHOWN.

FOR CHEMICALS USED TO SANITIZE AND TO TREAT WATER, SWIMMING POOLS, SPAS AND HOT TUBS (U.S. CLS. 1, 5, 6, 10, 26 AND 46).

FIRST USE 6-1-2011; IN COMMERCE 6-1-2011.

3,998,844. BONDPRO CORPORATION, HUDSON, WI. SN 77-853,955. PUB. 3-30-2010, FILED 10-21-2009.

MATRIX

THE MARK CONSISTS OF STANDARD CHARACTERS WITHOUT CLAIM TO ANY PARTICULAR FONT, STYLE, SIZE, OR COLOR.

FOR SYNTHETIC RESINS (U.S. CLS. 1, 5, 6, 10, 26 AND 46).

FIRST USE 5-24-2011; IN COMMERCE 5-24-2011.

CLASS 1—(Continued).

3,998,984. CALGON CARBON CORPORATION, PITTSBURGH, PA. SN 77-895,870. PUB. 10-12-2010, FILED 12-17-2009.

CELL CARB

THE MARK CONSISTS OF STANDARD CHARACTERS WITHOUT CLAIM TO ANY PARTICULAR FONT, STYLE, SIZE, OR COLOR.

FOR ACTIVATED CARBON COMPOSITIONS FOR INDUSTRIAL USE (U.S. CLS. 1, 5, 6, 10, 26 AND 46).
FIRST USE 3-0-2005; IN COMMERCE 3-0-2005.

3,999,002. COOTER MUCK INC, VANKLEEK HILL, CANADA. SN 77-901,940. PUB. 1-25-2011, FILED 12-29-2009.

Compostgenie

THE MARK CONSISTS OF STANDARD CHARACTERS WITHOUT CLAIM TO ANY PARTICULAR FONT, STYLE, SIZE, OR COLOR.

FOR PRO-BIOTIC ODORLESS COMPOSTING ADDITIVE FOR ODOR CONTROL OF ORGANIC WASTE (U.S. CLS. 1, 5, 6, 10, 26 AND 46).
FIRST USE 9-1-2009; IN COMMERCE 9-1-2009.

3,999,023. CHONGQING CHANGYUAN CHEMICAL CORPORATION LIMITED, POSTAL CODE: 402460, CHINA. SN 77-909,620. PUB. 10-19-2010, FILED 1-12-2010.



THE NAME(S), PORTRAIT(S), AND/OR SIGNATURE(S) SHOWN IN THE MARK DOES NOT IDENTIFY A PARTICULAR LIVING INDIVIDUAL.

THE MARK CONSISTS OF FROM TOP TO BOTTOM, TWO CHINESE CHARACTERS, AN ABSTRACT DEVICE RESEMBLING A WAVY ROAD AND THE WORD "JIALING", WITH AN INCOMPLETE DIAMOND DEVICE AS THE BACKGROUND.

THE WORDING "JIALING" HAS NO MEANING IN A FOREIGN LANGUAGE.

CLASS 1—(Continued).

THE NON-LATIN CHARACTERS IN THE MARK TRANSLITERATE TO JIA; LING AND THIS MEANS "FINE"; "HILL" IN ENGLISH.

FOR POTASSIUM PERMANGANATE; INDUSTRIAL CHEMICALS (U.S. CLS. 1, 5, 6, 10, 26 AND 46).
FIRST USE 12-20-1996; IN COMMERCE 6-15-2009.

3,999,055. MYCELX TECHNOLOGIES CORP., GAINESVILLE, GA. SN 77-926,062. PUB. 9-28-2010, FILED 2-2-2010.

SOLUBREAK

THE MARK CONSISTS OF STANDARD CHARACTERS WITHOUT CLAIM TO ANY PARTICULAR FONT, STYLE, SIZE, OR COLOR.

FOR DEEMULSIFYING ORGANIC SOLVENT COMPOSITIONS ADDED TO AQUEOUS STREAMS WHICH ARE CONTAMINATED WITH OILS AND SOLVENTS EMULSIFIED WITH THE WATER PHASE OF THE STREAM, TO PROMOTE AND/OR ENHANCE SEPARATION OF THE EMULSIFIED PHASES, FOR USE BY THE OIL INDUSTRY IN PURIFYING PRODUCED WATER STREAMS THAT ARE GENERATED DURING PRODUCTION OF GAS AND CRUDE OIL FROM UNDERGROUND DEPOSITS (U.S. CLS. 1, 5, 6, 10, 26 AND 46).
FIRST USE 8-31-2009; IN COMMERCE 8-31-2009.

3,999,247. I TO EYE, INC., SMYRNA, GA. SN 85-009,272. PUB. 9-28-2010, FILED 4-8-2010.



NO CLAIM IS MADE TO THE EXCLUSIVE RIGHT TO USE "GROW", APART FROM THE MARK AS SHOWN.

THE MARK CONSISTS OF LEAVES WITH THE STYLIZED TEXT "GROW PILLOW".

FOR PLANT GROWING KIT FOR INDOOR AND OUTDOOR USE COMPRISED PRIMARILY OF FERTILIZER, PERLITE, AND COIR CONTAINED IN A NATURAL BURLAP BAG, WHICH WHEN COMBINED WITH WATER CREATES BOTH A CONTAINER AND A MEDIUM TO SUPPORT THE SUCCESSFUL GROWTH OF PLANTS (U.S. CLS. 1, 5, 6, 10, 26 AND 46).

FIRST USE 4-13-2011; IN COMMERCE 5-18-2011.

CLASS 1—(Continued).

3,999,301. MORTON SALT, INC., CHICAGO, IL. SN 85-021,765. PUB. 9-21-2010, FILED 4-23-2010.

Safe-T-Pet

OWNER OF U.S. REG. NOS. 1,411,910, 3,655,419, AND OTHERS.

THE MARK CONSISTS OF THE WORD "SAFE", THE LETTER "T" AND THE WORD "PET", WITH DOG PAW DESIGNS.

FOR ICE AND SNOW MELTING PREPARATIONS (U.S. CLS. 1, 5, 6, 10, 26 AND 46).

FIRST USE 9-13-2010; IN COMMERCE 9-13-2010.

3,999,302. MORTON SALT, INC., CHICAGO, IL. SN 85-021,784. PUB. 9-21-2010, FILED 4-23-2010.

SAFE-T-PET

THE MARK CONSISTS OF STANDARD CHARACTERS WITHOUT CLAIM TO ANY PARTICULAR FONT, STYLE, SIZE, OR COLOR.

OWNER OF U.S. REG. NOS. 1,411,910, 3,655,419, AND OTHERS.

FOR ICE AND SNOW MELTING PREPARATIONS (U.S. CLS. 1, 5, 6, 10, 26 AND 46).

FIRST USE 9-13-2010; IN COMMERCE 9-13-2010.

3,999,379. MONOSOL, LLC, MERRILLVILLE, IN. SN 85-031,879. PUB. 10-5-2010, FILED 5-6-2010.



OWNER OF U.S. REG. NO. 3,386,580.

CLASS 1—(Continued).

THE MARK CONSISTS OF "TERRA" IN WHITE WITH A BLACK BACKGROUND POSITIONED BELOW A WHITE RECTANGLE AND ABOVE "LOC" IN BLACK WITH A WHITE BACKGROUND.

FOR POLYVINYL ALCOHOL LIQUID SOLUTION USED FOR DUST ABATEMENT AND SOIL STABILIZATION (U.S. CLS. 1, 5, 6, 10, 26 AND 46).

FIRST USE 4-15-2011; IN COMMERCE 4-15-2011.

3,999,619. ARCH CHEMICALS, INC., NORWALK, CT. SN 85-081,321. PUB. 10-19-2010, FILED 7-9-2010.

SWAMP TO SWIM

THE MARK CONSISTS OF STANDARD CHARACTERS WITHOUT CLAIM TO ANY PARTICULAR FONT, STYLE, SIZE, OR COLOR.

FOR CHEMICALS USED TO SANITIZE WATER AND IN THE TREATMENT OF SWIMMING POOLS, SPAS AND HOT TUBS (U.S. CLS. 1, 5, 6, 10, 26 AND 46).

FIRST USE 3-30-2011; IN COMMERCE 3-31-2011.

3,999,628. BASIX INTERNATIONAL, INC., TUSTIN, CA. SN 85-083,264. PUB. 1-4-2011, FILED 7-13-2010.

PRIMA DECORA

THE MARK CONSISTS OF STANDARD CHARACTERS WITHOUT CLAIM TO ANY PARTICULAR FONT, STYLE, SIZE, OR COLOR.

THE ENGLISH TRANSLATION OF "PRIMA" IN THE MARK IS "FIRST". THE WORDING "DECORA" HAS NO MEANING IN A FOREIGN LANGUAGE.

FOR PURE ACRYLIC RESINS FOR USE IN THE MANUFACTURE OF COUNTERTOPS (U.S. CLS. 1, 5, 6, 10, 26 AND 46).

FIRST USE 8-1-2010; IN COMMERCE 8-1-2010.

CLASS 1—(Continued).

3,999,765. PACE INTERNATIONAL, LLC, SEATTLE, WA. SN 85-138,693. PUB. 3-15-2011, FILED 9-27-2010.

WashGard

THE MARK CONSISTS OF STANDARD CHARACTERS WITHOUT CLAIM TO ANY PARTICULAR FONT, STYLE, SIZE, OR COLOR.

FOR ADJUVANTS WHICH ENHANCE FUNGICIDE OR PESTICIDE CAPACITY TO ADHERE TO PLANTS (U.S. CLS. 1, 5, 6, 10, 26 AND 46).

FIRST USE 2-15-2011; IN COMMERCE 2-15-2011.

CLASS 2—(Continued).

3,998,417. MASTERCHEM INDUSTRIES LLC, IMPERIAL, MO. SN 77-279,768. PUB. 3-11-2008, FILED 9-14-2007.

COVERPRO

THE MARK CONSISTS OF STANDARD CHARACTERS WITHOUT CLAIM TO ANY PARTICULAR FONT, STYLE, SIZE, OR COLOR.

FOR INTERIOR PAINTS (U.S. CLS. 6, 11 AND 16).
FIRST USE 5-26-2011; IN COMMERCE 5-26-2011.

3,999,788. PEGGY GREEN, INC., ST. PETERSBURG, FL. SN 85-145,026. PUB. 3-15-2011, FILED 10-5-2010.

THE WONDERFOOD FOR PLANTS

THE MARK CONSISTS OF STANDARD CHARACTERS WITHOUT CLAIM TO ANY PARTICULAR FONT, STYLE, SIZE, OR COLOR.

FOR FERTILIZERS; FOOD SUPPLEMENTS FOR AGRICULTURAL PRODUCTS AND OTHER PLANTS; PLANT FOOD (U.S. CLS. 1, 5, 6, 10, 26 AND 46).

FIRST USE 8-1-2010; IN COMMERCE 8-1-2010.

3,998,488. ECOLOGY COATINGS, INC., AKRON, OH. SN 77-454,294. PUB. 9-16-2008, FILED 4-22-2008.

EcoQuik

THE MARK CONSISTS OF STANDARD CHARACTERS WITHOUT CLAIM TO ANY PARTICULAR FONT, STYLE, SIZE, OR COLOR.

FOR COATING COMPOSITIONS IN THE NATURE OF PAINT FOR INDUSTRIAL APPLICATIONS (U.S. CLS. 6, 11 AND 16).

FIRST USE 5-19-2009; IN COMMERCE 5-19-2009.

CLASS 2—PAINTS

3,998,308. BEREL, S.A., SANTA CATARINA, NUEVO LEÓN, MEXICO. SN 76-681,797. PUB. 3-4-2008, FILED 9-12-2007.

BEREL

THE MARK CONSISTS OF STANDARD CHARACTERS WITHOUT CLAIM TO ANY PARTICULAR FONT, STYLE, SIZE, OR COLOR.

FOR PAINTS, VARNISH AND LACQUERS (U.S. CLS. 6, 11 AND 16).

FIRST USE 5-16-2011; IN COMMERCE 5-16-2011.

3,998,823. AMES RESEARCH LABORATORIES INCORPORATED, SALEM, OR. SN 77-846,357. PUB. 10-19-2010, FILED 10-12-2009.

Liquid Sandstone

THE MARK CONSISTS OF STANDARD CHARACTERS WITHOUT CLAIM TO ANY PARTICULAR FONT, STYLE, SIZE, OR COLOR.

OWNER OF U.S. REG. NO. 3,263,338.

FOR COATINGS IN THE NATURE OF DECORATIVE SPRAY COATING AND PROTECTIVE ELASTOMERIC-BASED COATINGS FOR USE ON ROOFS, WALLS, DECKS, FLOORS, AND THAT IS SAFE FOR THE ENVIRONMENT (U.S. CLS. 6, 11 AND 16).

FIRST USE 7-13-2010; IN COMMERCE 7-13-2010.

CLASS 2—(Continued).

3,999,539. U.S. PAINT CORPORATION, ST. LOUIS, MO. SN 85-059,845. PUB. 12-21-2010, FILED 6-10-2010.



OWNER OF U.S. REG. NOS. 1,134,386 AND 2,898,961. NO CLAIM IS MADE TO THE EXCLUSIVE RIGHT TO USE "PAINT", APART FROM THE MARK AS SHOWN.

THE MARK CONSISTS OF "U.S. PAINT" AND "INSIGNIA" IN TWO DIFFERENT STYLIZED FORMATS WITH TWO PARTIAL ELLIPSES ENCIRCLING "U.S. PAINT" AT AN ANGLE, AND A PORTION OF THE LETTER "A" IN "INSIGNIA" EXTENDING OUT FROM THAT LETTER, AND WITH THE "INSIGNIA" PORTION OF THE MARK WRITTEN TO THE RIGHT AND BELOW THE "U.S. PAINT" PORTION.

SEC. 2(F) AS TO "U.S."

FOR CLEAR AND PIGMENTED PROTECTIVE COATINGS, AND CLEAR AND PIGMENTED DECORATIVE COATINGS, ALL IN THE NATURE OF PAINT FOR USE ON PLASTICS, COMPOSITES AND METALS (U.S. CLS. 6, 11 AND 16).

FIRST USE 8-25-2010; IN COMMERCE 8-25-2010.

3,999,554. AKRON PAINT & VARNISH, INC., AKRON, OH. SN 85-063,268. PUB. 11-16-2010, FILED 6-15-2010.

NEVERFADE

THE MARK CONSISTS OF STANDARD CHARACTERS WITHOUT CLAIM TO ANY PARTICULAR FONT, STYLE, SIZE, OR COLOR.

FOR EXTERIOR PAINT; COATINGS, NAMELY, PAINT SEALERS, PAINT PRIMERS, AND RESIN BASED COATINGS AND STAINS FOR EXTERIOR USE ON A VARIETY OF SUBSTRATES (U.S. CLS. 6, 11 AND 16).

FIRST USE 8-26-2010; IN COMMERCE 8-26-2010.

CLASS 3—COSMETICS AND CLEANING PREPARATIONS

CLASS 3—(Continued).

3,998,328. SILVERNANO TECHNOLOGIES, LLC, PIANO, TX. SN 76-701,082. PUB. 9-28-2010, FILED 1-4-2010.

SILVERSKIN

THE MARK CONSISTS OF STANDARD CHARACTERS WITHOUT CLAIM TO ANY PARTICULAR FONT, STYLE, SIZE, OR COLOR.

FOR NON-MEDICATED BODY TREATMENT PREPARATIONS, NAMELY, ACNE CLEANSERS, SKIN TIGHTENING MASKS, SKIN MOISTURIZING LOTIONS, ASTRINGENT SKIN TONERS FOR COSMETIC PURPOSES, ODOR AND MOISTURE CONTROLLING FOOT POWDERS, FINGER NAIL CARE PREPARATIONS PROMOTING HEALTHY FINGERNAIL GROWTH, BODY DEODORANTS, SKIN SPRAYS FOR PSORIASIS, AND MOISTURIZING CREAMS FOR SKIN AROUND THE EYES (U.S. CLS. 1, 4, 6, 50, 51 AND 52).

FIRST USE 1-25-2011; IN COMMERCE 5-4-2011.

3,998,436. THE RO RO COMPANY, INC., LOS ANGELES, CA. SN 77-301,045. PUB. 3-11-2008, FILED 10-10-2007.

EYEDOLLIZE

THE MARK CONSISTS OF STANDARD CHARACTERS WITHOUT CLAIM TO ANY PARTICULAR FONT, STYLE, SIZE, OR COLOR.

FOR MASCARA; COSMETIC PREPARATIONS FOR EYE LASHES; EYE CREAM; EYE GELS; EYE LINER; EYE LOTIONS; EYE MAKE-UP; EYE MAKE-UP REMOVER; EYE PENCILS; EYE-SHADOW; EYES MAKE-UP; EYES PENCILS; EYEBROW COLORS; EYEBROW PENCILS (U.S. CLS. 1, 4, 6, 50, 51 AND 52).

FIRST USE 6-2-2011; IN COMMERCE 6-2-2011.

3,998,447. RETAIL BRAND ALLIANCE, INC., ENFIELD, CT. SN 77-330,782. PUB. 4-29-2008, FILED 11-15-2007.

COUNTRY CLUB

THE MARK CONSISTS OF STANDARD CHARACTERS WITHOUT CLAIM TO ANY PARTICULAR FONT, STYLE, SIZE, OR COLOR.

OWNER OF U.S. REG. NO. 3,277,205.

FOR FRAGRANCES FOR PERSONAL USE; AFTER-SHAVE BALMS; FACE AND BODY LOTIONS (U.S. CLS. 1, 4, 6, 50, 51 AND 52).

FIRST USE 3-31-2003; IN COMMERCE 3-31-2003.

CLASS 3—(Continued).

3,998,512. E.T. BROWNE DRUG CO., INC., ENGLEWOOD CLIFFS, NJ. SN 77-538,268. PUB. 5-26-2009, FILED 8-4-2008.

ECO-OIL

THE MARK CONSISTS OF STANDARD CHARACTERS WITHOUT CLAIM TO ANY PARTICULAR FONT, STYLE, SIZE, OR COLOR.

FOR SKIN CARE PREPARATIONS, NAMELY, FACE AND BODY MOISTURIZING OIL (U.S. CLS. 1, 4, 6, 50, 51 AND 52).

FIRST USE 4-1-2011; IN COMMERCE 4-1-2011.

3,998,556. SYMRISE AG, HOLZMINDEN 37603, FED REP GERMANY. SN 77-592,980. PUB. 3-10-2009, FILED 10-15-2008.

NEOFRESH

THE MARK CONSISTS OF STANDARD CHARACTERS WITHOUT CLAIM TO ANY PARTICULAR FONT, STYLE, SIZE, OR COLOR.

FOR PERFUMERY, ESSENTIAL OILS FOR PERSONAL AND HOUSEHOLD USE; ESSENTIAL OILS FOR USE IN THE MANUFACTURE OF SCENTED PRODUCTS; SCENTS AND PERFUME SUBSTANCES FOR LAUNDRY USE, NAMELY, DETERGENTS, BLEACHES AND FABRIC SOFTENERS; BODY SOAPS; COSMETICS; HAIR LOTIONS; DENTIFRICES; NON-MEDICATED MOUTH CARE PRODUCTS, NAMELY, TOOTHPASTE AND MOUTHWASH; PROCESSED NATURAL RESINS FOR USE AS A FRAGRANCE (U.S. CLS. 1, 4, 6, 50, 51 AND 52).

FIRST USE 10-21-2010; IN COMMERCE 10-21-2010.

3,998,576. TRISH MCEVOY, LTD, NEW YORK, NY. SN 77-612,880. PUB. 9-22-2009, FILED 11-12-2008.

Trish McEvoy Stay Nude

THE MARK CONSISTS OF STANDARD CHARACTERS WITHOUT CLAIM TO ANY PARTICULAR FONT, STYLE, SIZE, OR COLOR.

OWNER OF U.S. REG. NOS. 1,541,143 AND 3,558,992. NO CLAIM IS MADE TO THE EXCLUSIVE RIGHT TO USE "NUDE", APART FROM THE MARK AS SHOWN.

CLASS 3—(Continued).

THE NAME(S), PORTRAIT(S), AND/OR SIGNATURE(S) SHOWN IN THE MARK IDENTIFIES "TRISH MCEVOY", WHOSE CONSENT(S) TO REGISTER IS MADE OF RECORD.

FOR COSMETICS, NAMELY, SKIN CREAMS AND LOTIONS (U.S. CLS. 1, 4, 6, 50, 51 AND 52).

FIRST USE 2-0-2011; IN COMMERCE 2-0-2011.

3,998,598. NEUTROGENA CORPORATION, LOS ANGELES, CA. SN 77-649,891. PUB. 11-9-2010, FILED 1-15-2009.

TETROL-E

THE MARK CONSISTS OF STANDARD CHARACTERS WITHOUT CLAIM TO ANY PARTICULAR FONT, STYLE, SIZE, OR COLOR.

FOR ETHYLENEDIAMINE SOLD AS AN INTEGRAL INGREDIENT OF FACIAL MOISTURIZER AND FACIAL TREATMENTS IN THE NATURE OF FACIAL LOTION, FACIAL CREAM AND NON-MEDICATED FACIAL SERUM (U.S. CLS. 1, 4, 6, 50, 51 AND 52).

FIRST USE 10-18-2008; IN COMMERCE 10-18-2008.

3,998,633. BATH & BODY WORKS BRAND MANAGEMENT, INC., REYNOLDSBURG, OH. SN 77-711,781. PUB. 2-23-2010, FILED 4-10-2009.

NAIL-LICIOUS

THE MARK CONSISTS OF STANDARD CHARACTERS WITHOUT CLAIM TO ANY PARTICULAR FONT, STYLE, SIZE, OR COLOR.

FOR PERSONAL CARE PRODUCTS, NAMELY, NAIL POLISH AND NAIL CARE PREPARATIONS (U.S. CLS. 1, 4, 6, 50, 51 AND 52).

FIRST USE 1-31-2009; IN COMMERCE 1-31-2009.

3,998,635. POST GAME LLC, GLEN ELLYN, IL. SN 77-712,221. PUB. 8-11-2009, FILED 4-13-2009.

POST GAME

THE MARK CONSISTS OF THE WORDS "POST GAME" IN STYLIZED FORM.

FOR HAIR SHAMPOOS AND CONDITIONERS (U.S. CLS. 1, 4, 6, 50, 51 AND 52).

FIRST USE 7-1-2009; IN COMMERCE 7-1-2009.

CLASS 3—(Continued).

3,998,636. POST GAME LLC, GLEN ELLYN, IL. SN 77-712,462. PUB. 8-18-2009, FILED 4-13-2009.

POST GAME

THE MARK CONSISTS OF STANDARD CHARACTERS WITHOUT CLAIM TO ANY PARTICULAR FONT, STYLE, SIZE, OR COLOR.

FOR HAIR SHAMPOOS AND CONDITIONERS (U.S. CLS. 1, 4, 6, 50, 51 AND 52).

FIRST USE 7-1-2009; IN COMMERCE 7-1-2009.

3,998,742. LANCOME PARFUMS ET BEAUTE & CIE, PARIS, FRANCE. SN 77-813,774. PUB. 2-8-2011, FILED 8-27-2009.

**TEINT IDOLE
FRESH WEAR**

THE MARK CONSISTS OF STANDARD CHARACTERS WITHOUT CLAIM TO ANY PARTICULAR FONT, STYLE, SIZE, OR COLOR.

OWNER OF U.S. REG. NOS. 2,121,722 AND 3,110,864.

NO CLAIM IS MADE TO THE EXCLUSIVE RIGHT TO USE "TEINT", APART FROM THE MARK AS SHOWN.

THE ENGLISH TRANSLATION OF "TEINT IDOLE" IS "IDOL TINT".

FOR MAKEUP FOUNDATION (U.S. CLS. 1, 4, 6, 50, 51 AND 52).

FIRST USE 5-1-2010; IN COMMERCE 5-1-2010.

3,998,752. ALETHIA SKIN CARE LLC, ARDMORE, PA. SN 77-819,996. PUB. 8-31-2010, FILED 9-3-2009.

ALETHIA

THE MARK CONSISTS OF STANDARD CHARACTERS WITHOUT CLAIM TO ANY PARTICULAR FONT, STYLE, SIZE, OR COLOR.

FOR NON-MEDICATED SKIN CARE PREPARATIONS, NAMELY, CREAMS, LOTIONS, GELS, TONERS, CLEANERS AND PEELS; HAIR CARE PRODUCTS, NAMELY, SHAMPOOS AND CONDITIONERS (U.S. CLS. 1, 4, 6, 50, 51 AND 52).

FIRST USE 5-4-2011; IN COMMERCE 5-4-2011.

CLASS 3—(Continued).

3,998,787. UMIDITA, LLC, CAMINO, CA. SN 77-833,509. PUB. 11-9-2010, FILED 9-23-2009.

UMIDITA

THE MARK CONSISTS OF STANDARD CHARACTERS WITHOUT CLAIM TO ANY PARTICULAR FONT, STYLE, SIZE, OR COLOR.

THE ENGLISH TRANSLATION OF "UMIDITA" IN THE MARK IS "HUMIDITY".

FOR NON-MEDICATED SKIN CARE PREPARATIONS (U.S. CLS. 1, 4, 6, 50, 51 AND 52).

FIRST USE 9-30-2010; IN COMMERCE 9-30-2010.

3,998,843. SMITH, ALETHEA W., DBA THEAPEUTIC MASSAGE THERAPY, COLORADO SPRINGS, CO. SN 77-853,913. PUB. 3-30-2010, FILED 10-21-2009.



THE MARK CONSISTS OF A PICKLED CANNED JAR. THE JAR HAS SIX RUFFLES AROUND IT. THE TOP IS ROUND. INSIDE THE JAR, THERE ARE 12 PICKLES AND IN THE CENTER THERE ARE TWO WATER LILLIES. ABOVE THE JAR, HAS THE NAME "PICKLED ESSENCE FAMILY".

FOR AROMATHERAPY PILLOWS THAT MAY BE USED TO FRESHEN CLOTHING OR LAY OVER THE EYES (U.S. CLS. 1, 4, 6, 50, 51 AND 52).

FIRST USE 12-1-2009; IN COMMERCE 12-1-2009.

CLASS 3—(Continued).

3,998,847. AVA ANDERSON LLC, PROVIDENCE, RI. SN 77-854,325. PUB. 8-31-2010, FILED S.R. 10-21-2009; AM. P.R. 5-16-2011.

AVA ANDERSON NON-TOXIC

THE MARK CONSISTS OF STANDARD CHARACTERS WITHOUT CLAIM TO ANY PARTICULAR FONT, STYLE, SIZE, OR COLOR.

NO CLAIM IS MADE TO THE EXCLUSIVE RIGHT TO USE "NON-TOXIC", APART FROM THE MARK AS SHOWN.

THE NAME(S), PORTRAIT(S), AND/OR SIGNATURE(S) SHOWN IN THE MARK IDENTIFIES "AVA ANDERSON", WHOSE CONSENT(S) TO REGISTER IS MADE OF RECORD.

FOR COSMETICS COMPRISED IN WHOLE OR SUBSTANTIAL PART OF NON-TOXIC INGREDIENTS; NON-MEDICATED SKIN CARE PREPARATIONS COMPRISED IN WHOLE OR SUBSTANTIAL PART OF NON-TOXIC INGREDIENTS (U.S. CLS. 1, 4, 6, 50, 51 AND 52). FIRST USE 12-0-2006; IN COMMERCE 12-0-2009.

3,998,902. COLLE CORPORATION, MOUNTAIN LAKES, NJ. SN 77-868,025. PUB. 4-13-2010, FILED 11-9-2009.

COLLÉ

THE MARK CONSISTS OF THE WORD "COLLE" WITH AN ACCENT MARK OVER THE FINAL "E" TO INDICATE PRONUNCIATION AS A SEPARATE SYLLABLE SOUNDED AS "AY".

FOR CLEANER FOR USE ON JEWELRY (U.S. CLS. 1, 4, 6, 50, 51 AND 52). FIRST USE 9-16-2010; IN COMMERCE 9-16-2010.

3,998,928. POST GAME LLC, GLEN ELLYN, IL. SN 77-878,470. PUB. 4-27-2010, FILED 11-23-2009.

POST GAME

THE MARK CONSISTS OF STANDARD CHARACTERS WITHOUT CLAIM TO ANY PARTICULAR FONT, STYLE, SIZE, OR COLOR.

FOR BATH SOAPS IN LIQUID, SOLID OR GEL FORM (U.S. CLS. 1, 4, 6, 50, 51 AND 52). FIRST USE 7-1-2009; IN COMMERCE 7-1-2009.

CLASS 3—(Continued).

3,998,929. POST GAME LLC, GLEN ELLYN, IL. SN 77-878,484. PUB. 4-27-2010, FILED 11-23-2009.

POST GAME

THE MARK CONSISTS OF THE WORDS "POST GAME" IN STYLIZED FORM.

FOR BATH SOAPS IN LIQUID, SOLID OR GEL FORM (U.S. CLS. 1, 4, 6, 50, 51 AND 52).

FIRST USE 7-1-2009; IN COMMERCE 7-1-2009.

3,998,930. MILLER, ROY C., NEW CARROLLTON, MD. SN 77-878,738. PUB. 10-19-2010, FILED 11-23-2009.

BELLARO

THE MARK CONSISTS OF STANDARD CHARACTERS WITHOUT CLAIM TO ANY PARTICULAR FONT, STYLE, SIZE, OR COLOR.

FOR HAIR CARE PREPARATIONS; HAIR GEL AND HAIR MOUSSE; HAIR RELAXERS; HAIR SHAMPOOS AND CONDITIONERS; HAIR STRAIGHTENING PREPARATIONS; HAIR STYLING PREPARATIONS (U.S. CLS. 1, 4, 6, 50, 51 AND 52).

FIRST USE 4-1-2010; IN COMMERCE 4-1-2010.

3,998,948. THE PURE GUILD LLC, SCOTTSDALE, AZ. SN 77-884,635. PUB. 10-12-2010, FILED 12-2-2009.

THE PURE GUILD

THE MARK CONSISTS OF STANDARD CHARACTERS WITHOUT CLAIM TO ANY PARTICULAR FONT, STYLE, SIZE, OR COLOR.

FOR COSMETICS, COSMETIC TOPICAL HAIR LOSS CREAMS AND OINTMENTS, SKIN MOISTURIZERS, HAIR CONDITIONERS, HAIR SHAMPOO AND ANTI-AGING CREAMS (U.S. CLS. 1, 4, 6, 50, 51 AND 52).

FIRST USE 10-16-2009; IN COMMERCE 10-28-2010.

CLASS 3—(Continued).

3,998,979. BIOTA BITKISEL KOZMETIK LABORATUARLARI TICARET LIMITED SIRKETI, UMRANIYE / ISTANBUL, TURKEY. SN 77-894,974. PUB. 10-5-2010, FILED 12-16-2009.

BIOXIEN

THE MARK CONSISTS OF STANDARD CHARACTERS WITHOUT CLAIM TO ANY PARTICULAR FONT, STYLE, SIZE, OR COLOR.

FOR COSMETICS; HAIR LOTIONS (U.S. CLS. 1, 4, 6, 50, 51 AND 52).

FIRST USE 5-25-2011; IN COMMERCE 5-25-2011.

CLASS 3—(Continued).

3,998,982. BIOTA BITKISEL KOZMETIK LABORATUARLARI TICARET LIMITED SIRKETI, UMRANIYE / ISTANBUL, TURKEY. SN 77-895,028. PUB. 10-5-2010, FILED 12-16-2009.

BIOXSIEN

THE MARK CONSISTS OF STANDARD CHARACTERS WITHOUT CLAIM TO ANY PARTICULAR FONT, STYLE, SIZE, OR COLOR.

FOR COSMETICS; HAIR LOTIONS (U.S. CLS. 1, 4, 6, 50, 51 AND 52).

FIRST USE 5-25-2011; IN COMMERCE 5-25-2011.

3,998,980. BIOTA BITKISEL KOZMETIK LABORATUARLARI TICARET LIMITED SIRKETI, UMRANIYE / ISTANBUL, TURKEY. SN 77-895,009. PUB. 10-5-2010, FILED 12-16-2009.

BIOXSON

THE MARK CONSISTS OF STANDARD CHARACTERS WITHOUT CLAIM TO ANY PARTICULAR FONT, STYLE, SIZE, OR COLOR.

FOR SOAPS FOR PERSONAL USE; PERFUMERY; ESSENTIAL OILS; COSMETICS; HAIR LOTIONS; DENTIFRICES (U.S. CLS. 1, 4, 6, 50, 51 AND 52).

FIRST USE 5-25-2011; IN COMMERCE 5-25-2011.

3,998,983. BIOTA BITKISEL KOZMETIK LABORATUARLARI TICARET LIMITED SIRKETI, UMRANIYE / ISTANBUL, TURKEY. SN 77-895,102. PUB. 10-5-2010, FILED 12-16-2009.

BIOXIDIL

THE MARK CONSISTS OF STANDARD CHARACTERS WITHOUT CLAIM TO ANY PARTICULAR FONT, STYLE, SIZE, OR COLOR.

FOR SOAPS FOR PERSONAL USE; PERFUMERY; ESSENTIAL OILS; COSMETICS; HAIR LOTIONS; DENTIFRICES (U.S. CLS. 1, 4, 6, 50, 51 AND 52).

FIRST USE 5-25-2011; IN COMMERCE 5-25-2011.

3,998,981. BIOTA BITKISEL KOZMETIK LABORATUARLARI TICARET LIMITED SIRKETI, UMRANIYE / ISTANBUL, TURKEY. SN 77-895,021. PUB. 10-5-2010, FILED 12-16-2009.

BIOXSEN

THE MARK CONSISTS OF STANDARD CHARACTERS WITHOUT CLAIM TO ANY PARTICULAR FONT, STYLE, SIZE, OR COLOR.

FOR COSMETICS; HAIR LOTIONS (U.S. CLS. 1, 4, 6, 50, 51 AND 52).

FIRST USE 5-25-2011; IN COMMERCE 5-25-2011.

3,999,034. PURE & NATURAL COMPANY, SCOTTSDALE, AZ. SN 77-917,674. PUB. 10-12-2010, FILED 1-22-2010.

WINTER WHITE TEA

THE MARK CONSISTS OF STANDARD CHARACTERS WITHOUT CLAIM TO ANY PARTICULAR FONT, STYLE, SIZE, OR COLOR.

NO CLAIM IS MADE TO THE EXCLUSIVE RIGHT TO USE "WHITE TEA", APART FROM THE MARK AS SHOWN.

FOR ANTIBACTERIAL SOAP; HAND SOAPS; LIQUID SOAPS; SOAPS FOR PERSONAL USE (U.S. CLS. 1, 4, 6, 50, 51 AND 52).

FIRST USE 8-25-2010; IN COMMERCE 8-25-2010.

CLASS 3—(Continued).

3,999,047. ASHRO, INC., MONROE, WI. SN 77-922,091. PUB. 12-7-2010, FILED 1-28-2010.



OWNER OF U.S. REG. NOS. 3,109,159 AND 3,267,837.
NO CLAIM IS MADE TO THE EXCLUSIVE RIGHT TO USE "AKE", APART FROM THE MARK AS SHOWN.

THE MARK CONSISTS OF THE WORDS "AKE" BY ASHRO" IN STYLIZED FORM.

THE ENGLISH TRANSLATION OF "AKE" IN THE MARK IS "HIS".

FOR MEN'S SKIN CARE PRODUCTS, NAMELY, COLOGNES AND BODY DEODORANTS, SOLD THROUGH MAIL ORDER AND ELECTRONIC CATALOGS (U.S. CLS. 1, 4, 6, 50, 51 AND 52).

FIRST USE 6-0-2010; IN COMMERCE 6-0-2010.

3,999,050. WELLS FARGO CAPITAL FINANCE, LLC (FORMERLY KNOWN AS WELLS FARGO FOOLHILL, LLC), AS AGENT, SANTA MONICA, CA. SN 77-922,878. PUB. 6-8-2010, FILED 1-28-2010.

TWINKLE TOES

THE MARK CONSISTS OF STANDARD CHARACTERS WITHOUT CLAIM TO ANY PARTICULAR FONT, STYLE, SIZE, OR COLOR.

OWNER OF U.S. REG. NO. 3,723,738.
FOR COSMETICS; LIP BALM (U.S. CLS. 1, 4, 6, 50, 51 AND 52).

FIRST USE 12-1-2010; IN COMMERCE 12-1-2010.

3,999,082. IDISPENSE, LLC, TOLEDO, OH. SN 77-938,655. PUB. 7-6-2010, FILED 2-18-2010.

CONCENTRATES...SIMPLY DELIVERED

THE MARK CONSISTS OF STANDARD CHARACTERS WITHOUT CLAIM TO ANY PARTICULAR FONT, STYLE, SIZE, OR COLOR.

FOR CLEANING PREPARATIONS (U.S. CLS. 1, 4, 6, 50, 51 AND 52).

FIRST USE 11-23-2010; IN COMMERCE 11-23-2010.

CLASS 3—(Continued).

3,999,089. MISSION PRODUCT HOLDINGS, INC., NEW YORK, NY. SN 77-941,801. PUB. 7-20-2010, FILED 2-22-2010.

OFFICIAL SKINCARE OF ATHLETES

THE MARK CONSISTS OF STANDARD CHARACTERS WITHOUT CLAIM TO ANY PARTICULAR FONT, STYLE, SIZE, OR COLOR.

NO CLAIM IS MADE TO THE EXCLUSIVE RIGHT TO USE "SKIN CARE", APART FROM THE MARK AS SHOWN.

FOR NON-MEDICATED SKIN CARE PREPARATIONS; COSMETIC CREAMS AND LOTIONS FOR SKIN CARE; SKIN MOISTURIZERS; SUN SCREEN PREPARATIONS; SUN BLOCK PREPARATIONS; NON-MEDICATED FOOT CREAMS (U.S. CLS. 1, 4, 6, 50, 51 AND 52).

FIRST USE 3-6-2011; IN COMMERCE 3-6-2011.

3,999,095. MISSION PRODUCT HOLDINGS, INC., NEW YORK, NY. SN 77-945,030. PUB. 7-20-2010, FILED 2-25-2010.

OFFICIAL SUNSCREEN OF TENNIS

THE MARK CONSISTS OF STANDARD CHARACTERS WITHOUT CLAIM TO ANY PARTICULAR FONT, STYLE, SIZE, OR COLOR.

NO CLAIM IS MADE TO THE EXCLUSIVE RIGHT TO USE "SUNSCREEN", APART FROM THE MARK AS SHOWN.

FOR NON-MEDICATED SKIN CARE PREPARATIONS; COSMETIC CREAMS AND LOTIONS FOR SKIN CARE; SKIN MOISTURIZERS; SUN SCREEN PREPARATIONS; SUN BLOCK PREPARATIONS; NON-MEDICATED FOOT CREAMS (U.S. CLS. 1, 4, 6, 50, 51 AND 52).

FIRST USE 3-6-2011; IN COMMERCE 3-6-2011.

3,999,096. MISSION PRODUCT HOLDINGS, INC., NEW YORK, NY. SN 77-945,037. PUB. 7-20-2010, FILED 2-25-2010.

OFFICIAL SUNSCREEN OF SOCCER

THE MARK CONSISTS OF STANDARD CHARACTERS WITHOUT CLAIM TO ANY PARTICULAR FONT, STYLE, SIZE, OR COLOR.

CLASS 3—(Continued).

NO CLAIM IS MADE TO THE EXCLUSIVE RIGHT TO USE "SUNSCREEN", APART FROM THE MARK AS SHOWN.

FOR NON-MEDICATED SKIN CARE PREPARATIONS; COSMETIC CREAMS AND LOTIONS FOR SKIN CARE; SKIN MOISTURIZERS; SUN SCREEN PREPARATIONS; SUN BLOCK PREPARATIONS; NON-MEDICATED FOOT CREAMS (U.S. CLS. 1, 4, 6, 50, 51 AND 52).

FIRST USE 3-6-2011; IN COMMERCE 3-6-2011.

3,999,097. MISSION PRODUCT HOLDINGS, INC., NEW YORK, NY. SN 77-945,109. PUB. 7-20-2010, FILED 2-25-2010.

OFFICIAL SUNSCREEN OF GOLF

THE MARK CONSISTS OF STANDARD CHARACTERS WITHOUT CLAIM TO ANY PARTICULAR FONT, STYLE, SIZE, OR COLOR.

NO CLAIM IS MADE TO THE EXCLUSIVE RIGHT TO USE "SUNSCREEN", APART FROM THE MARK AS SHOWN.

FOR NON-MEDICATED SKIN CARE PREPARATIONS; COSMETIC CREAMS AND LOTIONS FOR SKIN CARE; SKIN MOISTURIZERS; SUN SCREEN PREPARATIONS; SUN BLOCK PREPARATIONS; NON-MEDICATED FOOT CREAMS (U.S. CLS. 1, 4, 6, 50, 51 AND 52).

FIRST USE 3-6-2011; IN COMMERCE 3-6-2011.

3,999,107. BEAUTY KEY COSMETICS CO., LTD., NEW YORK, NY. SN 77-948,940. PUB. 8-17-2010, FILED 3-3-2010.

Beauty key
波比爱

NO CLAIM IS MADE TO THE EXCLUSIVE RIGHT TO USE "BEAUTY", APART FROM THE MARK AS SHOWN.

THE MARK CONSISTS OF "BEAUTY KEY" AND THREE CHINESE CHARACTERS.

CLASS 3—(Continued).

THE NON-LATIN CHARACTERS IN THE MARK TRANSLITERATE TO "BO BI AI" AND THIS HAS NO MEANING IN A FOREIGN LANGUAGE.

FOR ALL-PURPOSE CLEANERS; AROMATHERAPY BODY CARE PRODUCTS, NAMELY, BODY LOTION, SHOWER GEL, CUTICLE CREAM, SHAMPOO, CONDITIONER, NON-MEDICATED LIP BALM, SOAP, BODY POLISH, BODY AND FOOT SCRUB AND NON-MEDICATED FOOT CREAM; BATH SOAPS; COSMETIC PREPARATIONS; COSMETICS FOR ANIMALS; FACIAL CLEANSING MILK; LIPSTICKS; SCENTED WOOD; SHINING PREPARATIONS; TOOTH PASTE (U.S. CLS. 1, 4, 6, 50, 51 AND 52).

FIRST USE 2-26-2010; IN COMMERCE 3-2-2010.

3,999,108. ORLY INTERNATIONAL, INC., VAN NUYS, CA. SN 77-949,472. PUB. 1-11-2011, FILED 3-3-2010.

PRIMETIME

THE MARK CONSISTS OF STANDARD CHARACTERS WITHOUT CLAIM TO ANY PARTICULAR FONT, STYLE, SIZE, OR COLOR.

FOR NAIL CARE PREPARATIONS, NAMELY, NAIL PRIMER (U.S. CLS. 1, 4, 6, 50, 51 AND 52).

FIRST USE 8-15-2010; IN COMMERCE 8-15-2010.

3,999,141. CHICO'S BRANDS INVESTMENTS, INC., FT. MYERS, FL. SN 77-965,896. PUB. 3-8-2011, FILED 3-23-2010.

SOMA INTIMATES

THE MARK CONSISTS OF STANDARD CHARACTERS WITHOUT CLAIM TO ANY PARTICULAR FONT, STYLE, SIZE, OR COLOR.

OWNER OF U.S. REG. NOS. 3,402,217, 3,402,223, AND 3,724,572.

NO CLAIM IS MADE TO THE EXCLUSIVE RIGHT TO USE "INTIMATES", APART FROM THE MARK AS SHOWN.

THE ENGLISH TRANSLATION OF "SOMA" IN THE MARK IS "BODY".

FOR COLOGNES, PERFUMES AND COSMETICS; FACE AND BODY LOTIONS; SKIN CLEANSERS; ROOM FRAGRANCES, COSMETICS (U.S. CLS. 1, 4, 6, 50, 51 AND 52).

FIRST USE 10-15-2010; IN COMMERCE 10-15-2010.

CLASS 3—(Continued).

3,999,145. RECKITT & COLMAN (OVERSEAS) LIMITED, HULL, UNITED KINGDOM. SN 77-966,798. PUB. 10-19-2010, FILED 3-24-2010.

VEET EASY GRIP

THE MARK CONSISTS OF STANDARD CHARACTERS WITHOUT CLAIM TO ANY PARTICULAR FONT, STYLE, SIZE, OR COLOR.

PRIORITY CLAIMED UNDER SEC. 44(D) ON ERP N CMNTY TM OFC APPLICATION NO. 008971483, FILED 3-22-2010, REG. NO. 8971483, DATED 8-10-2010, EXPIRES 3-22-2020.

OWNER OF U.S. REG. NOS. 2,978,398, 3,539,488, AND OTHERS.

NO CLAIM IS MADE TO THE EXCLUSIVE RIGHT TO USE "GRIP", APART FROM THE MARK AS SHOWN.

FOR DEPILATORY PREPARATIONS; DEPILATORY WAXES (U.S. CLS. 1, 4, 6, 50, 51 AND 52).

FIRST USE 12-0-2010; IN COMMERCE 12-0-2010.

3,999,228. D-ZEE TEXTILES LLC, LAKELAND, FL. SN 85-002,959. PUB. 11-23-2010, FILED 3-31-2010.

MIKADO

THE MARK CONSISTS OF STANDARD CHARACTERS WITHOUT CLAIM TO ANY PARTICULAR FONT, STYLE, SIZE, OR COLOR.

OWNER OF U.S. REG. NO. 3,790,752.

THE ENGLISH TRANSLATION OF "MIKADO" IN THE MARK IS THE EMPEROR OF JAPAN.

FOR BAR SOAP; BATH AND SHOWER GELS AND SALTS NOT FOR MEDICAL PURPOSES; BATH CREAM; BATH FOAM; BATH FOAMS; BATH GEL; BATH GELS; BATH LOTION; BATH MILKS; BATH PEARLS; BATH SOAPS; BATH SOAPS IN LIQUID, SOLID OR GEL FORM; BATHING LOTIONS; BEAUTY LOTIONS; BODY CREAM SOAP; BODY LOTION; BODY LOTIONS; BUBBLE BATH; COSMETIC SOAPS; CREAM SOAPS; DEODORANT SOAP; DETERGENT SOAP; DISINFECTANT SOAPS; FACE AND BODY LOTIONS; LIQUID BATH SOAPS; LIQUID PERFUMES; LIQUID SOAP USED IN FOOT BATH; PERFUMED SOAP; PERFUMED SOAPS; SHOWER AND BATH FOAM; SHOWER AND BATH GEL (U.S. CLS. 1, 4, 6, 50, 51 AND 52).

FIRST USE 10-22-2010; IN COMMERCE 4-14-2010.

CLASS 3—(Continued).

3,999,230. OJON CORPORATION, NEW YORK, NY. SN 85-004,850. PUB. 4-5-2011, FILED 4-2-2010.

FULL DETOX

THE MARK CONSISTS OF STANDARD CHARACTERS WITHOUT CLAIM TO ANY PARTICULAR FONT, STYLE, SIZE, OR COLOR.

NO CLAIM IS MADE TO THE EXCLUSIVE RIGHT TO USE "DETOX", APART FROM THE MARK AS SHOWN.

FOR HAIR CARE PREPARATIONS (U.S. CLS. 1, 4, 6, 50, 51 AND 52).

FIRST USE 2-1-2011; IN COMMERCE 2-1-2011.

3,999,238. PRECISION DERMATOLOGY, INC., CUMBERLAND, RI. SN 85-008,003. PUB. 10-12-2010, FILED 4-7-2010.

HYLATOPIC PLUS

THE MARK CONSISTS OF STANDARD CHARACTERS WITHOUT CLAIM TO ANY PARTICULAR FONT, STYLE, SIZE, OR COLOR.

FOR NON-MEDICATED SKIN CARE PREPARATIONS (U.S. CLS. 1, 4, 6, 50, 51 AND 52).

FIRST USE 2-1-2011; IN COMMERCE 2-1-2011.

3,999,251. TNG WORLDWIDE, INC., FARMINGTON HILLS, MI. SN 85-010,411. PUB. 10-26-2010, FILED 4-9-2010.

GINGER LILY FARMS

THE MARK CONSISTS OF STANDARD CHARACTERS WITHOUT CLAIM TO ANY PARTICULAR FONT, STYLE, SIZE, OR COLOR.

NO CLAIM IS MADE TO THE EXCLUSIVE RIGHT TO USE "GINGER LILY", APART FROM THE MARK AS SHOWN.

FOR AFTER-SHAVE BALMS; BATH GEL; HAIR CONDITIONER; HAIR GEL; HAIR MOUSSE; HAIR SPRAY; HAND LOTIONS; HAND SOAPS; MOUTHWASH; SHAMPOOS; SHAVING CREAM; SHOWER AND BATH GEL (U.S. CLS. 1, 4, 6, 50, 51 AND 52).

FIRST USE 12-12-2008; IN COMMERCE 1-4-2009.

CLASS 3—(Continued).

3,999,276. FAROUK SYSTEMS, INC., HOUSTON, TX. SN 85-017,581. PUB. 7-27-2010, FILED 4-19-2010.

PURE HYDRATION

THE MARK CONSISTS OF STANDARD CHARACTERS WITHOUT CLAIM TO ANY PARTICULAR FONT, STYLE, SIZE, OR COLOR.

NO CLAIM IS MADE TO THE EXCLUSIVE RIGHT TO USE "HYDRATION", APART FROM THE MARK AS SHOWN.

FOR HAIR CARE PREPARATIONS, NAMELY, SHAMPOOS (U.S. CLS. 1, 4, 6, 50, 51 AND 52).

FIRST USE 3-10-2011; IN COMMERCE 3-10-2011.

3,999,281. FAKUNLE, JAMES, FLORENCE, AL. AND FAKUNLE, SAMUEL, LAWRENCE, AL. SN 85-018,646. PUB. 9-28-2010, FILED 4-20-2010.

EGO ELIXIR

THE MARK CONSISTS OF STANDARD CHARACTERS WITHOUT CLAIM TO ANY PARTICULAR FONT, STYLE, SIZE, OR COLOR.

NO CLAIM IS MADE TO THE EXCLUSIVE RIGHT TO USE "ELIXIR", APART FROM THE MARK AS SHOWN.

FOR BODY SPRAYS AND DEODORANTS (U.S. CLS. 1, 4, 6, 50, 51 AND 52).

FIRST USE 5-19-2011; IN COMMERCE 5-19-2011.

3,999,339. CHANEL, INC., NEW YORK, NY. SN 85-027,760. PUB. 9-28-2010, FILED 4-30-2010.

BE UNEXPECTED

THE MARK CONSISTS OF STANDARD CHARACTERS WITHOUT CLAIM TO ANY PARTICULAR FONT, STYLE, SIZE, OR COLOR.

FOR PERFUMERY (U.S. CLS. 1, 4, 6, 50, 51 AND 52).
FIRST USE 10-12-2010; IN COMMERCE 10-12-2010.

CLASS 3—(Continued).

3,999,352. SALON COMMODITIES, INC., MELROSE PARK, IL. SN 85-029,131. PUB. 3-29-2011, FILED 5-3-2010.

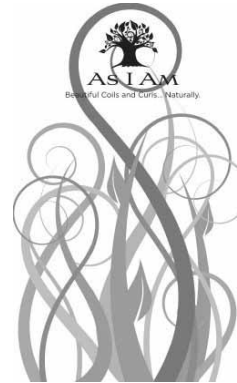

THE MARK CONSISTS OF A STYLIZED TREE DESIGN WITH LEAVES AT THE TOP OF THE MARK AND THE WORDS "AS I AM" CENTERED BENEATH THE TREE. THE WORDS "BEAUTIFUL COILS AND CURLS ... NATURALLY" IS CENTERED BENEATH THE WORDS "AS I AM". REACHING UPWARD FROM THE BOTTOM OF THE MARK ARE NUMEROUS CURLY STEMS. THREE OF THE STEMS HAVE A LEAFY TIP.

FOR HAIR CLEANSERS, HAIR CONDITIONERS, EMOLLIENT HAIR SPRAYS, STYLING GELS, HAIR STYLING CREAMS AND SHINE, HAIR MOISTURIZING CREAMS, HAIR LOTIONS, HAIR OILS, NON-MEDICATED SCALP CLEANSERS AND CONDITIONERS, AND ORGANIC HAIR COLOR ENHANCERS (U.S. CLS. 1, 4, 6, 50, 51 AND 52).

FIRST USE 11-18-2010; IN COMMERCE 11-18-2010.

3,999,407. GEORGE, ANGELA, CHICAGO, IL. SN 85-034,839. PUB. 10-19-2010, FILED 5-10-2010.

ANGEL MINARO

THE MARK CONSISTS OF STANDARD CHARACTERS WITHOUT CLAIM TO ANY PARTICULAR FONT, STYLE, SIZE, OR COLOR.

THE NAME "ANGEL MINARO" DOES NOT IDENTIFY A LIVING INDIVIDUAL.

FOR BATH CREAM; BATH MILKS; BATH OILS; BATH SALTS; BEAUTY MASKS; BEAUTY SERUMS; BODY BUTTER; BODY CREAMS; BODY LOTIONS; BODY OILS; BODY SCRUB; BODY WASH; FACIAL CLEANSERS; FACIAL SCRUBS; FACIAL WASHES; FOAM BATH; LIQUID BATH SOAPS; SKIN MOISTURIZER; SKIN TONERS (U.S. CLS. 1, 4, 6, 50, 51 AND 52).

FIRST USE 5-14-2011; IN COMMERCE 5-14-2011.

CLASS 3—(Continued).

3,999,549. THE PROCTER & GAMBLE COMPANY, CINCINNATI, OH. SN 85-062,040. PUB. 10-12-2010, FILED 6-14-2010.

CREST COMPLETE MULTI-BENEFIT

THE MARK CONSISTS OF STANDARD CHARACTERS WITHOUT CLAIM TO ANY PARTICULAR FONT, STYLE, SIZE, OR COLOR.

OWNER OF U.S. REG. NOS. 2,688,841, 2,809,971, AND OTHERS.

FOR DENTIFRICES (U.S. CLS. 1, 4, 6, 50, 51 AND 52).
FIRST USE 5-15-2011; IN COMMERCE 5-15-2011.

3,999,598. XANNA'S LOVE, PERRY HALL, MD. SN 85-075,855. PUB. 12-7-2010, FILED 7-1-2010.



THE MARK CONSISTS OF THE STYLIZED WORDING "XANNA'S LOVE". A LARGE BUBBLE HEART APPEARS TO THE LEFT OF THE WORDING, WITH THE WORD "XANNA'S" BEGINNING INSIDE THE HEART, WITH THREE SMALLER HEARTS TO THE RIGHT OF THE "S" IN "XANNA'S".

FOR NATURAL BATH AND SKIN CARE PRODUCTS, NAMELY, BAR SOAPS, SHOWER GELS, BODY SCRUB, FOOT SCRUB, SKIN AND BATH LOTIONS, BODY BUTTER, BATH FIZZIES, BATH SALTS, BUBBLE BARS, SHAMPOO, LIP BALM, BATH TEAS, SHOWER GEL, SOLID LOTION, MASSAGE OIL, AND HAIR OIL (U.S. CLS. 1, 4, 6, 50, 51 AND 52).

FIRST USE 2-3-2011; IN COMMERCE 2-3-2011.

3,999,605. NOBLE WAR PRIZE, INC., SOUTHAMPTON, NY. SN 85-077,520. PUB. 11-30-2010, FILED 7-2-2010.

GLOBAL WARMING

THE MARK CONSISTS OF STANDARD CHARACTERS WITHOUT CLAIM TO ANY PARTICULAR FONT, STYLE, SIZE, OR COLOR.

FOR BODY OIL; MASSAGE OIL (U.S. CLS. 1, 4, 6, 50, 51 AND 52).
FIRST USE 7-2-2010; IN COMMERCE 7-23-2010.

CLASS 3—(Continued).

3,999,629. UNILEVER PLC, MERSEYSIDE CH62 4ZD, UNITED KINGDOM. SN 85-085,113. PUB. 1-4-2011, FILED 7-15-2010.

COLOUR COMBAT

THE MARK CONSISTS OF STANDARD CHARACTERS WITHOUT CLAIM TO ANY PARTICULAR FONT, STYLE, SIZE, OR COLOR.

NO CLAIM IS MADE TO THE EXCLUSIVE RIGHT TO USE "COLOUR", APART FROM THE MARK AS SHOWN.
FOR SHAMPOOS, HAIR CONDITIONERS (U.S. CLS. 1, 4, 6, 50, 51 AND 52).

FIRST USE 12-0-2010; IN COMMERCE 12-0-2010.

3,999,656. THE CLOROX COMPANY, OAKLAND, CA. SN 85-094,228. PUB. 10-26-2010, FILED 7-27-2010.

Garden Fresh

THE MARK CONSISTS OF STANDARD CHARACTERS WITHOUT CLAIM TO ANY PARTICULAR FONT, STYLE, SIZE, OR COLOR.

FOR CLEANING PREPARATIONS FOR HOUSEHOLD PURPOSES (U.S. CLS. 1, 4, 6, 50, 51 AND 52).

FIRST USE 1-31-2011; IN COMMERCE 1-31-2011.

3,999,665. AHI ACQUISITION, LLC, CARLSTADT, NJ. SN 85-099,058. PUB. 1-18-2011, FILED 8-3-2010.

SMOKE MASQUE

THE MARK CONSISTS OF STANDARD CHARACTERS WITHOUT CLAIM TO ANY PARTICULAR FONT, STYLE, SIZE, OR COLOR.

FOR DISPOSABLE WIPES IMPREGNATED WITH CLEANSING CHEMICALS OR COMPOUNDS FOR PERSONAL HYGIENE (U.S. CLS. 1, 4, 6, 50, 51 AND 52).

FIRST USE 3-1-2011; IN COMMERCE 3-1-2011.

CLASS 3—(Continued).

3,999,701. EVA'S ESTHETICS, INC., OAKLAND, CA. SN 85-110,733. PUB. 2-22-2011, FILED 8-18-2010.

BERODIN

THE MARK CONSISTS OF STANDARD CHARACTERS WITHOUT CLAIM TO ANY PARTICULAR FONT, STYLE, SIZE, OR COLOR.

FOR DEPILATORY WAX; NON-MEDICATED SKIN CARE LOTIONS; SKIN CARE PRODUCTS, NAMELY, SKIN AND BODY TOPICAL LOTIONS, CREAMS AND OILS FOR COSMETIC USE (U.S. CLS. 1, 4, 6, 50, 51 AND 52).

FIRST USE 3-1-2011; IN COMMERCE 4-1-2011.

3,999,718. HILTON, PARIS, BEVERLY HILLS, CA. SN 85-117,482. PUB. 3-22-2011, FILED 8-27-2010.

PARIS HILTON PASSPORT

THE MARK CONSISTS OF STANDARD CHARACTERS WITHOUT CLAIM TO ANY PARTICULAR FONT, STYLE, SIZE, OR COLOR.

OWNER OF U.S. REG. NOS. 3,059,587, 3,198,376, AND 3,201,023.

THE NAME(S), PORTRAIT(S), AND/OR SIGNATURE(S) SHOWN IN THE MARK IDENTIFIES "PARIS HILTON", WHOSE CONSENT(S) TO REGISTER IS MADE OF RECORD.

FOR FRAGRANCES, NAMELY, EAU DE TOILETTE AND PERFUMED BODY LOTION FOR WOMEN (U.S. CLS. 1, 4, 6, 50, 51 AND 52).

FIRST USE 12-15-2010; IN COMMERCE 12-15-2010.

3,999,731. ALOXXI INTERNATIONAL CORPORATION, TARZANA, CA. SN 85-124,005. PUB. 2-1-2011, FILED 9-7-2010.

GET A GRAPPA

THE MARK CONSISTS OF STANDARD CHARACTERS WITHOUT CLAIM TO ANY PARTICULAR FONT, STYLE, SIZE, OR COLOR.

CLASS 3—(Continued).

NO CLAIM IS MADE TO THE EXCLUSIVE RIGHT TO USE "GRAPPA", APART FROM THE MARK AS SHOWN.

FOR HAIR BLEACHING PREPARATIONS, NON-MEDICATED HAIR PREPARATIONS, HAIR CLEANING PREPARATIONS, HAIR COLOR REMOVERS, HAIR COLORING SOLUTIONS, HAIR LIGHTENERS, HAIR COLORING RINSE, HAIR LIGHTENING BLEACH, HAIR RINSES, HAIR COLOR FORMULATIONS, ALL IN THE FORM OF LIQUID, GEL AND CREAM (U.S. CLS. 1, 4, 6, 50, 51 AND 52).

FIRST USE 1-15-2011; IN COMMERCE 1-15-2011.

3,999,733. ALOXXI INTERNATIONAL CORPORATION, SHERMAN OAKS, CA. SN 85-124,200. PUB. 2-1-2011, FILED 9-7-2010.

MY CAMELLA

THE MARK CONSISTS OF STANDARD CHARACTERS WITHOUT CLAIM TO ANY PARTICULAR FONT, STYLE, SIZE, OR COLOR.

THE ENGLISH TRANSLATION OF THE WORD "CAMELLA" IN THE MARK IS CANDY.

FOR HAIR BLEACHING PREPARATIONS, NON-MEDICATED HAIR PREPARATIONS, HAIR CLEANING PREPARATIONS, HAIR COLOR REMOVERS, HAIR COLORING SOLUTIONS, HAIR LIGHTENERS, HAIR COLORING RINSE, HAIR LIGHTENING BLEACH, HAIR RINSES, HAIR COLOR FORMULATIONS, ALL IN THE FORM OF LIQUID, GEL AND CREAM (U.S. CLS. 1, 4, 6, 50, 51 AND 52).

FIRST USE 1-15-2011; IN COMMERCE 1-15-2011.

3,999,739. HAAN CORPORATION, SEOUL, REPUBLIC OF KOREA. SN 85-127,238. PUB. 3-15-2011, FILED 9-10-2010.

HAAN Therapeutics

THE MARK CONSISTS OF STANDARD CHARACTERS WITHOUT CLAIM TO ANY PARTICULAR FONT, STYLE, SIZE, OR COLOR.

OWNER OF U.S. REG. NO. 3,628,699.

NO CLAIM IS MADE TO THE EXCLUSIVE RIGHT TO USE "THERAPEUTICS", APART FROM THE MARK AS SHOWN.

FOR FACIAL CLEANSERS; NON-MEDICATED ACNE TREATMENT PREPARATIONS; WRINKLE REMOVING SKIN CARE PREPARATIONS (U.S. CLS. 1, 4, 6, 50, 51 AND 52).

FIRST USE 1-20-2011; IN COMMERCE 1-20-2011.

CLASS 3—(Continued).

3,999,740. HAAN CORPORATION, SEOUL, REPUBLIC OF KOREA. SN 85-127,272. PUB. 3-15-2011, FILED 9-10-2010.

SAI COMPLEX

THE MARK CONSISTS OF STANDARD CHARACTERS WITHOUT CLAIM TO ANY PARTICULAR FONT, STYLE, SIZE, OR COLOR.

NO CLAIM IS MADE TO THE EXCLUSIVE RIGHT TO USE "COMPLEX", APART FROM THE MARK AS SHOWN. FOR FACIAL CLEANSERS; NON-MEDICATED ACNE TREATMENT PREPARATIONS; WRINKLE REMOVING SKIN CARE PREPARATIONS (U.S. CLS. 1, 4, 6, 50, 51 AND 52).

FIRST USE 1-20-2011; IN COMMERCE 1-20-2011.

3,999,865. SPIREBLACK, LLC, DBA SADICK DERMATOLOGY GROUP, BROOKLYN, NY. SN 85-189,402. PUB. 3-8-2011, FILED 12-2-2010.

Chromolume

THE MARK CONSISTS OF STANDARD CHARACTERS WITHOUT CLAIM TO ANY PARTICULAR FONT, STYLE, SIZE, OR COLOR.

FOR INGREDIENT SOLD AS A COMPONENT OF AGE SPOT REDUCING CREAMS, ANTI-AGING CREAM, ANTI-WRINKLE CREAM, ANTI-WRINKLE CREAMS, BEAUTY CREAMS, BEAUTY CREAMS FOR BODY CARE, BEAUTY LOTIONS, BEAUTY SERUMS, BODY AND BEAUTY CARE COSMETICS, BODY CREAM, BODY CREAMS, COSMETIC CREAMS, COSMETIC CREAMS FOR SKIN CARE, EYE CREAM, FACE AND BODY BEAUTY CREAMS, FACE AND BODY CREAMS, FACE CREAMS, FACE CREAMS FOR COSMETIC USE, FACIAL CREAM, AND FACIAL CREAMS (U.S. CLS. 1, 4, 6, 50, 51 AND 52).

FIRST USE 2-1-2011; IN COMMERCE 3-1-2011.

CLASS 4—LUBRICANTS AND FUELS

3,998,797. ROMERO, LAURA, MIAMI, FL. SN 77-836,962. PUB. 9-14-2010, FILED 9-29-2009.



THE COLOR(S) GREEN IS/ARE CLAIMED AS A FEATURE OF THE MARK.

CLASS 4—(Continued).

THE MARK CONSISTS OF "EASY FRY" IN STYLIZED, GREEN LETTERS.

FOR AN OIL BASED POWDER MIXTURE THAT CAN BE USED BY ANY INDIVIDUAL AND CAN BE ADDED TO OIL TO HARDEN THE OIL FROM A LIQUID TO A SOLID (U.S. CLS. 1, 6 AND 15).

FIRST USE 2-7-2010; IN COMMERCE 2-7-2010.

3,998,809. EARTH CARE PRODUCTS, INC., INDEPENDENCE, KS. SN 77-839,128. PUB. 3-30-2010, FILED 10-1-2009.

ACTOF

THE MARK CONSISTS OF STANDARD CHARACTERS WITHOUT CLAIM TO ANY PARTICULAR FONT, STYLE, SIZE, OR COLOR.

FOR BIOMASS SOLID FUEL, NAMELY, FUEL MADE USING SILVICULTURAL PRODUCTS AND VEGETATION (U.S. CLS. 1, 6 AND 15).

FIRST USE 4-8-2011; IN COMMERCE 4-8-2011.

3,998,923. MCLAREN, MARGARET J., DBA CHANDLER'S ART, MIAMI, FL. SN 77-875,802. PUB. 10-5-2010, FILED 11-18-2009.

LIQUILUX SOY

THE MARK CONSISTS OF STANDARD CHARACTERS WITHOUT CLAIM TO ANY PARTICULAR FONT, STYLE, SIZE, OR COLOR.

NO CLAIM IS MADE TO THE EXCLUSIVE RIGHT TO USE "SOY", APART FROM THE MARK AS SHOWN.

FOR SOY BASED CANDLES (U.S. CLS. 1, 6 AND 15). FIRST USE 11-18-2009; IN COMMERCE 3-25-2011.

CLASS 4—(Continued).

3,999,850. PACE INTERNATIONAL, LLC, SEATTLE, WA. SN 85-169,040. PUB. 3-8-2011, FILED 11-4-2010.

Durashine

THE MARK CONSISTS OF STANDARD CHARACTERS WITHOUT CLAIM TO ANY PARTICULAR FONT, STYLE, SIZE, OR COLOR.

FOR WAX COMPOSITION FOR COATING THE EXTERIOR SURFACE OF FRUITS, VEGETABLES AND OTHER EDIBLES TO IMPROVE APPEARANCE, REDUCE SHRINKAGE AND CONTAMINATION, RETAIN FRESHNESS AND OTHER QUALITIES LONGER (U.S. CLS. 1, 6 AND 15).

FIRST USE 11-29-2010; IN COMMERCE 11-29-2010.

CLASS 5—PHARMACEUTICALS

3,998,332. NAMANNY, KERRY T., ATLANTIC, IA. AND NAMANNY, KENNETH D., ATLANTIC, IA. SN 76-702,734. PUB. 9-28-2010, FILED 4-30-2010.

COLD & FLU 911

THE MARK CONSISTS OF STANDARD CHARACTERS WITHOUT CLAIM TO ANY PARTICULAR FONT, STYLE, SIZE, OR COLOR.

NO CLAIM IS MADE TO THE EXCLUSIVE RIGHT TO USE "COLD & FLU", APART FROM THE MARK AS SHOWN.

FOR HERBAL SUPPLEMENTS FOR THE RELIEF OF COLD AND FLU SYMPTOMS (U.S. CLS. 6, 18, 44, 46, 51 AND 52).

FIRST USE 10-21-2009; IN COMMERCE 10-21-2009.

3,998,341. TRADCO, LTD., STONE MOUNTAIN, GA. SN 76-704,033. PUB. 1-18-2011, FILED 8-6-2010.

Mina's Purely Divine

THE MARK CONSISTS OF STANDARD CHARACTERS WITHOUT CLAIM TO ANY PARTICULAR FONT, STYLE, SIZE, OR COLOR.

FOR BAKERY GOODS WHICH ARE WHEAT AND GLUTEN FREE TO ACCOMMODATE SPECIAL MEDICAL AND HEALTH CONDITIONS (U.S. CLS. 6, 18, 44, 46, 51 AND 52).

FIRST USE 3-11-2011; IN COMMERCE 3-11-2011.

CLASS 5—(Continued).

3,998,416. KARYKION, INC., PRINCETON, NJ. SN 77-279,500. PUB. 3-4-2008, FILED 9-14-2007.

TICK-AID

THE MARK CONSISTS OF STANDARD CHARACTERS WITHOUT CLAIM TO ANY PARTICULAR FONT, STYLE, SIZE, OR COLOR.

FOR MEDICINAL CREAMS FOR SKIN CARE USED FOR TICK REMOVAL (U.S. CLS. 6, 18, 44, 46, 51 AND 52).

FIRST USE 5-21-2011; IN COMMERCE 5-21-2011.

3,998,442. NOVARTIS AG, BASEL, SWITZERLAND. SN 77-318,913. PUB. 3-18-2008, FILED 11-1-2007.

BENEFIBER PLUS HEART HEALTH

THE MARK CONSISTS OF STANDARD CHARACTERS WITHOUT CLAIM TO ANY PARTICULAR FONT, STYLE, SIZE, OR COLOR.

OWNER OF U.S. REG. NOS. 1,792,114, 2,961,168, AND OTHERS.

NO CLAIM IS MADE TO THE EXCLUSIVE RIGHT TO USE "HEART HEALTH", APART FROM THE MARK AS SHOWN.

FOR DIETARY FIBER SUPPLEMENT AND LAXATIVE (U.S. CLS. 6, 18, 44, 46, 51 AND 52).

FIRST USE 12-31-2008; IN COMMERCE 12-31-2008.

3,998,465. GLENMARK GENERICS INC., USA, MAHWAH, NJ. SN 77-401,451. PUB. 1-27-2009, FILED 2-20-2008.

Glenmark Generics Inc., USA

THE MARK CONSISTS OF STANDARD CHARACTERS WITHOUT CLAIM TO ANY PARTICULAR FONT, STYLE, SIZE, OR COLOR.

OWNER OF U.S. REG. NO. 3,146,215.

CLASS 5—(Continued).

NO CLAIM IS MADE TO THE EXCLUSIVE RIGHT TO USE "GENERIC INC., USA", APART FROM THE MARK AS SHOWN.

FOR PHARMACEUTICAL FOR THE TREATMENT OF ERECTILE DYSFUNCTION; PHARMACEUTICAL PREPARATION FOR THE TREATMENT OF GOUT; PHARMACEUTICAL PREPARATIONS ACTING ON THE CENTRAL NERVOUS SYSTEM; PHARMACEUTICAL PREPARATIONS AND SUBSTANCES FOR THE TREATMENT OF GASTRO-INTESTINAL DISEASES; PHARMACEUTICAL PREPARATIONS FOR SKIN CARE; PHARMACEUTICAL PREPARATIONS FOR THE PREVENTION AND TREATMENT OF DISORDERS OF THE NERVOUS SYSTEM, THE IMMUNE SYSTEM, THE CARDIO-VASCULAR SYSTEM, THE METABOLIC SYSTEM, THE RESPIRATORY SYSTEM, THE MUSCULO-SKELETAL SYSTEM, THE GENITOURINARY SYSTEM; FOR THE TREATMENT OF INFLAMMATORY DISORDERS; FOR USE IN DERMATOLOGY, ONCOLOGY, HEMATOLOGY AND IN TISSUE AND ORGAN TRANSPLANTATION, IN OPHTHALMOLOGY AND FOR GASTROENTEROLOGICAL DISORDERS; PHARMACEUTICAL PREPARATIONS FOR THE PREVENTION AND TREATMENT OF OCULAR DISORDERS OR DISEASES, FOR THE TREATMENT OF BACTERIA-BASED DISEASES, AND FOR THE TREATMENT OF DIABETES, AND ANTI-INFECTIVE PREPARATIONS, ANTIVIRAL PREPARATIONS, ANTIBIOTICS, ANTI-FUNGAL PREPARATIONS AND VACCINES; PHARMACEUTICAL PREPARATIONS FOR THE TREATMENT OF HEART RHYTHM DISORDERS; PHARMACEUTICAL PREPARATIONS FOR THE TREATMENT OF HORMONAL DISORDERS AND THE PREVENTION OF OSTEOPOROSIS; PHARMACEUTICAL PREPARATIONS FOR THE TREATMENT OF INFECTIOUS DISEASES; PHARMACEUTICAL PREPARATIONS FOR TREATING ALLERGIC RHINITIS AND ASTHMA; PHARMACEUTICAL PREPARATIONS FOR TREATING DIABETES; PHARMACEUTICAL PREPARATIONS FOR TREATING SKIN DISORDERS; PHARMACEUTICAL PREPARATIONS FOR USE IN DERMATOLOGY; PHARMACEUTICAL PREPARATIONS FOR USE IN UROLOGY; PHARMACEUTICAL PREPARATIONS, NAMELY, ANTIDEPRESSANTS; PHARMACEUTICAL PREPARATIONS, NAMELY, APPETITE SUPPRESSANTS; PHARMACEUTICAL PRODUCTS AND PREPARATIONS AGAINST DRY SKIN CAUSED BY PREGNANCY; PHARMACEUTICAL PRODUCTS AND PREPARATIONS FOR CHLOASMA; PHARMACEUTICAL PRODUCTS AND PREPARATIONS FOR HYDRATING THE SKIN DURING PREGNANCY; PHARMACEUTICAL PRODUCTS AND PREPARATIONS FOR PREGNANCY BLEMISHES; PHARMACEUTICAL PRODUCTS AND PREPARATIONS FOR PREVENTING SKIN BLEMISHES DURING PREGNANCY; PHARMACEUTICAL PRODUCTS AND PREPARATIONS TO PREVENT STRETCH MARKS; PHARMACEUTICAL PRODUCTS AND PREPARATIONS TO PREVENT SWELLING IN THE LEGS; PHARMACEUTICAL PRODUCTS FOR OPHTHALMOLOGICAL USE; PHARMACEUTICAL PRODUCTS FOR SKIN CARE FOR ANIMALS; PHARMACEUTICAL PRODUCTS FOR THE TREATMENT OF BONE DISEASES; PHARMACEUTICAL PRODUCTS FOR THE TREATMENT OF JOINT DISEASE; PHARMACEUTICAL PRODUCTS FOR THE TREATMENT OF VIRAL AND INFECTIOUS DISEASES, FOR THE TREATMENT OF CANCER; PHARMACEUTICAL PRODUCTS FOR TREATING RESPIRATORY DISEASES AND ASTHMA; PHARMACEUTICAL SKIN LOTIONS; PHARMACEUTICAL SOLUTIONS USED IN DIALYSIS; PHARMACEUTICALS FOR THE TREATMENT OF ERECTILE DYSFUNCTION; PHARMACEUTICALS, NAMELY, ANTI-INFECTIVES; PHARMACEUTICALS, NAMELY, ANTIHELMINTICS; PHARMACEUTICALS, NAMELY, INDUCERS OF ERECTIONS; PHARMACEUTICALS,

CLASS 5—(Continued).

NAMELY, LIPID LOWERING AGENTS; PHARMACEUTICAL PREPARATIONS FOR THE TREATMENT OF EYE DISEASES AND CONDITIONS; PHARMACEUTICAL PREPARATIONS FOR USE IN CHEMOTHERAPY; PHARMACEUTICAL PREPARATIONS FOR WOUNDS; PHARMACEUTICAL PREPARATIONS, NAMELY, A BLOOD CLOTTING AID AND DELIVERY SYSTEM FOR USE IN HUMAN AND VETERINARY MEDICINE; PHARMACEUTICAL PREPARATIONS, NAMELY, A DRUG DELIVERY SYSTEM COMPRISING POLYMER-BASED ORAL TABLETS FOR THE CONTINUOUS RELEASE OF A WIDE VARIETY OF THERAPEUTIC AGENTS; PHARMACEUTICAL PREPARATIONS, NAMELY, ANTICOAGULANTS; PHARMACEUTICAL PREPARATIONS FOR INHALATION FOR THE TREATMENT OF PULMONARY HYPERTENSION; PREPARATION FOR THE RELIEF OF PAIN; OPIUM ALKALOID PREPARATIONS; PHARMACEUTICAL ANTI-ALLERGIC PREPARATIONS AND SUBSTANCES; PHARMACEUTICAL ANTITUSSIVE-COLD PREPARATIONS (U.S. CLS. 6, 18, 44, 46, 51 AND 52).

FIRST USE 4-1-2008; IN COMMERCE 4-1-2008.

3,998,466. GLENMARK GENERICS INC., USA, MAHWAH, NJ. SN 77-401,483. PUB. 1-27-2009, FILED 2-20-2008.

Glenmark Generics

THE MARK CONSISTS OF STANDARD CHARACTERS WITHOUT CLAIM TO ANY PARTICULAR FONT, STYLE, SIZE, OR COLOR.

OWNER OF U.S. REG. NO. 3,146,215.

NO CLAIM IS MADE TO THE EXCLUSIVE RIGHT TO USE "GENERIC INC.", APART FROM THE MARK AS SHOWN.

FOR OPIUM ALKALOID PREPARATIONS; PHARMACEUTICAL ANTI-ALLERGIC PREPARATIONS AND SUBSTANCES; PHARMACEUTICAL ANTITUSSIVE-COLD PREPARATIONS; PHARMACEUTICAL FOR THE TREATMENT OF ERECTILE DYSFUNCTION; PHARMACEUTICAL PREPARATION FOR THE TREATMENT OF GOUT; PHARMACEUTICAL PREPARATIONS ACTING ON THE CENTRAL NERVOUS SYSTEM; PHARMACEUTICAL PREPARATIONS AND SUBSTANCES FOR THE TREATMENT OF GASTRO-INTESTINAL DISEASES; PHARMACEUTICAL PREPARATIONS FOR ANIMAL SKIN CARE; PHARMACEUTICAL PREPARATIONS FOR INHALATION FOR THE TREATMENT OF PULMONARY HYPERTENSION; PHARMACEUTICAL PREPARATIONS FOR SKIN CARE; PHARMACEUTICAL PREPARATIONS FOR THE PREVENTION AND TREATMENT OF DISORDERS OF THE NERVOUS SYSTEM, THE IMMUNE SYSTEM, THE CARDIO-VASCULAR SYSTEM, THE METABOLIC SYSTEM, THE RESPIRATORY SYSTEM, THE MUSCULO-SKELETAL SYSTEM, THE GENITOURINARY SYSTEM; FOR THE TREATMENT OF INFLAMMATORY DISORDERS; FOR USE IN DERMATOLOGY, ONCOLOGY, HEMATOLOGY AND IN TISSUE AND ORGAN TRANSPLANTATION, IN OPHTHALMOLOGY AND FOR GASTROENTEROLOGICAL DISORDERS; PHARMACEUTICAL PREPARATIONS FOR THE PREVENTION AND TREATMENT OF OCULAR DISORDERS OR DISEASES, FOR THE TREATMENT OF BACTERIA-BASED DISEASES, AND FOR THE TREATMENT OF DIABETES, AND ANTI-INFECTIVE PREPARATIONS, ANTIVIRAL PREPARATIONS, ANTIBIOTICS, ANTI-FUNGAL PREPARATIONS AND VACCINES; PHARMACEUTICAL PREPARATIONS FOR THE TREATMENT OF EYE DISEASES AND CONDITIONS; PHARMACEUTICAL PREPARATIONS FOR THE TREATMENT OF HEART RHYTHM DISORDERS; PHARMACEUTICAL PREPARATIONS FOR THE TREATMENT OF HORMONAL DISORDERS AND THE PREVENTION OF OSTEO-

CLASS 5—(Continued).

POROSIS; PHARMACEUTICAL PREPARATIONS FOR THE TREATMENT OF INFECTIOUS DISEASES; PHARMACEUTICAL PREPARATIONS FOR TREATING ALLERGIC RHINITIS AND ASTHMA; PHARMACEUTICAL PREPARATIONS FOR TREATING DIABETES; PHARMACEUTICAL PREPARATIONS FOR TREATING SKIN DISORDERS; PHARMACEUTICAL PREPARATIONS FOR USE IN CHEMOTHERAPY; PHARMACEUTICAL PREPARATIONS FOR USE IN DERMATOLOGY; PHARMACEUTICAL PREPARATIONS FOR USE IN UROLOGY; PHARMACEUTICAL PREPARATIONS FOR WOUNDS; PHARMACEUTICAL PREPARATIONS, NAMELY, ANTIDEPRESSANTS; PHARMACEUTICAL PREPARATIONS, NAMELY, APPETITE SUPPRESSANTS; PHARMACEUTICAL PREPARATIONS, NAMELY, A BLOOD CLOTTING AID AND DELIVERY SYSTEM FOR USE IN HUMAN AND VETERINARY MEDICINE; PHARMACEUTICAL PREPARATIONS, NAMELY, A DRUG DELIVERY SYSTEM COMPRISING POLYMER-BASED ORAL TABLETS FOR THE CONTINUOUS RELEASE OF A WIDE VARIETY OF THERAPEUTIC AGENTS; PHARMACEUTICAL PREPARATIONS, NAMELY, ANTICOAGULANTS; PHARMACEUTICAL PRODUCTS AND PREPARATIONS AGAINST DRY SKIN CAUSED BY PREGNANCY; PHARMACEUTICAL PRODUCTS AND PREPARATIONS FOR CHLOASMA; PHARMACEUTICAL PRODUCTS AND PREPARATIONS FOR HYDRATING THE SKIN DURING PREGNANCY; PHARMACEUTICAL PRODUCTS AND PREPARATIONS FOR PREGNANCY BLEMISHES; PHARMACEUTICAL PRODUCTS AND PREPARATIONS FOR PREVENTING SKIN BLEMISHES DURING PREGNANCY; PHARMACEUTICAL PRODUCTS AND PREPARATIONS TO PREVENT STRETCH MARKS; PHARMACEUTICAL PRODUCTS AND PREPARATIONS TO PREVENT SWELLING IN THE LEGS; PHARMACEUTICAL PRODUCTS FOR OPHTHALMOLOGICAL USE; PHARMACEUTICAL PRODUCTS FOR SKIN CARE FOR ANIMALS; PHARMACEUTICAL PRODUCTS FOR THE TREATMENT OF BONE DISEASES; PHARMACEUTICAL PRODUCTS FOR THE TREATMENT OF JOINT DISEASE; PHARMACEUTICAL PRODUCTS FOR THE TREATMENT OF VIRAL AND INFECTIOUS DISEASES, FOR THE TREATMENT OF CANCER; PHARMACEUTICAL PRODUCTS FOR TREATING RESPIRATORY DISEASES AND ASTHMA; PHARMACEUTICAL SKIN LOTIONS; PHARMACEUTICAL SOLUTIONS USED IN DIALYSIS; PHARMACEUTICALS FOR THE TREATMENT OF ERECTILE DYSFUNCTION; PHARMACEUTICALS, NAMELY, ANTI-INFECTIVES; PHARMACEUTICALS, NAMELY, ANTIHELMINTICS; PHARMACEUTICALS, NAMELY, INDUCERS OF ERECTIONS; PHARMACEUTICALS, NAMELY, LIPID LOWERING AGENTS; PREPARATION FOR THE RELIEF OF PAIN; PREPARATIONS FOR THE TREATMENT OF ASTHMA (U.S. CLS. 6, 18, 44, 46, 51 AND 52).

FIRST USE 4-1-2008; IN COMMERCE 4-1-2008.

3,998,467. GLENMARK GENERICS INC., USA, MAHWAH, NJ. SN 77-401,495. PUB. 1-27-2009, FILED 2-20-2008.

Glenmark Generics Ltd.

THE MARK CONSISTS OF STANDARD CHARACTERS WITHOUT CLAIM TO ANY PARTICULAR FONT, STYLE, SIZE, OR COLOR.

OWNER OF U.S. REG. NO. 3,146,215.

CLASS 5—(Continued).

NO CLAIM IS MADE TO THE EXCLUSIVE RIGHT TO USE "GENERICS LTD.", APART FROM THE MARK AS SHOWN.

FOR OPIUM ALKALOID PREPARATIONS; PHARMACEUTICAL ANTI-ALLERGIC PREPARATIONS AND SUBSTANCES; PHARMACEUTICAL ANTITUSSIVE-COLD PREPARATIONS; PHARMACEUTICAL FOR THE TREATMENT OF ERECTILE DYSFUNCTION; PHARMACEUTICAL PREPARATION FOR THE TREATMENT OF GOUT; PHARMACEUTICAL PREPARATIONS ACTING ON THE CENTRAL NERVOUS SYSTEM; PHARMACEUTICAL PREPARATIONS AND SUBSTANCES FOR THE TREATMENT OF GASTRO-INTESTINAL DISEASES; PHARMACEUTICAL PREPARATIONS FOR INHALATION FOR THE TREATMENT OF PULMONARY HYPERTENSION; PHARMACEUTICAL PREPARATIONS FOR SKIN CARE; PHARMACEUTICAL PREPARATIONS FOR THE PREVENTION AND TREATMENT OF DISORDERS OF THE NERVOUS SYSTEM, THE IMMUNE SYSTEM, THE CARDIO-VASCULAR SYSTEM, THE METABOLIC SYSTEM, THE RESPIRATORY SYSTEM, THE MUSCULO-SKELETAL SYSTEM, THE GENITOURINARY SYSTEM; FOR THE TREATMENT OF INFLAMMATORY DISORDERS; FOR USE IN DERMATOLOGY, ONCOLOGY, HEMATOLOGY AND IN TISSUE AND ORGAN TRANSPLANTATION, IN OPHTHALMOLOGY AND FOR GASTROENTEROLOGICAL DISORDERS; PHARMACEUTICAL PREPARATIONS FOR THE PREVENTION AND TREATMENT OF OCULAR DISORDERS OR DISEASES, FOR THE TREATMENT OF BACTERIA-BASED DISEASES, AND FOR THE TREATMENT OF DIABETES, AND ANTI-INFECTIVE PREPARATIONS, ANTIVIRAL PREPARATIONS, ANTIBIOTICS, ANTI-FUNGAL PREPARATIONS AND VACCINES; PHARMACEUTICAL PREPARATIONS FOR THE TREATMENT OF EYE DISEASES AND CONDITIONS; PHARMACEUTICAL PREPARATIONS FOR THE TREATMENT OF HEART RHYTHM DISORDERS; PHARMACEUTICAL PREPARATIONS FOR THE TREATMENT OF HORMONAL DISORDERS AND THE PREVENTION OF OSTEOPOROSIS; PHARMACEUTICAL PREPARATIONS FOR THE TREATMENT OF INFECTIOUS DISEASES; PHARMACEUTICAL PREPARATIONS FOR TREATING ALLERGIC RHINITIS AND ASTHMA; PHARMACEUTICAL PREPARATIONS FOR TREATING DIABETES; PHARMACEUTICAL PREPARATIONS FOR TREATING SKIN DISORDERS; PHARMACEUTICAL PREPARATIONS FOR USE IN CHEMOTHERAPY; PHARMACEUTICAL PREPARATIONS FOR USE IN DERMATOLOGY; PHARMACEUTICAL PREPARATIONS FOR USE IN UROLOGY; PHARMACEUTICAL PREPARATIONS FOR WOUNDS; PHARMACEUTICAL PREPARATIONS, NAMELY, ANTIDEPRESSANTS; PHARMACEUTICAL PREPARATIONS, NAMELY, APPETITE SUPPRESSANTS; PHARMACEUTICAL PREPARATIONS, NAMELY, A BLOOD CLOTTING AID AND DELIVERY SYSTEM FOR USE IN HUMAN AND VETERINARY MEDICINE; PHARMACEUTICAL PREPARATIONS, NAMELY, A DRUG DELIVERY SYSTEM COMPRISING POLYMER-BASED ORAL TABLETS FOR THE CONTINUOUS RELEASE OF A WIDE VARIETY OF THERAPEUTIC AGENTS; PHARMACEUTICAL PREPARATIONS, NAMELY, ANTICOAGULANTS; PHARMACEUTICAL PRODUCTS AND PREPARATIONS AGAINST DRY SKIN CAUSED BY PREGNANCY; PHARMACEUTICAL PRODUCTS AND PREPARATIONS FOR CHLOASMA; PHARMACEUTICAL PRODUCTS AND PREPARATIONS FOR HYDRATING THE SKIN DURING PREGNANCY; PHARMACEUTICAL PRODUCTS AND PREPARATIONS FOR PREGNANCY BLEMISHES; PHARMACEUTICAL PRODUCTS AND PREPARATIONS FOR PREVENTING SKIN BLEMISHES DURING PREGNANCY; PHARMACEUTICAL PRODUCTS AND PREPARATIONS TO PREVENT STRETCH MARKS; PHARMACEUTICAL

CLASS 5—(Continued).

PRODUCTS AND PREPARATIONS TO PREVENT SWELLING IN THE LEGS; PHARMACEUTICAL PRODUCTS FOR OPHTHALMOLOGICAL USE; PHARMACEUTICAL PRODUCTS FOR SKIN CARE FOR ANIMALS; PHARMACEUTICAL PRODUCTS FOR THE TREATMENT OF BONE DISEASES; PHARMACEUTICAL PRODUCTS FOR THE TREATMENT OF JOINT DISEASE; PHARMACEUTICAL PRODUCTS FOR THE TREATMENT OF VIRAL AND INFECTIOUS DISEASES, FOR THE TREATMENT OF CANCER; PHARMACEUTICAL PRODUCTS FOR TREATING RESPIRATORY DISEASES AND ASTHMA; PHARMACEUTICAL SKIN LOTIONS; PHARMACEUTICAL SOLUTIONS USED IN DIALYSIS; PHARMACEUTICALS FOR THE TREATMENT OF ERECTILE DYSFUNCTION; PHARMACEUTICALS, NAMELY, ANTI-INFECTIVES; PHARMACEUTICALS, NAMELY, ANTIHELMINTICS; PHARMACEUTICALS, NAMELY, INDUCERS OF ERECTIONS; PHARMACEUTICALS, NAMELY, LIPID LOWERING AGENTS; PREPARATION FOR THE RELIEF OF PAIN (U.S. CLS. 6, 18, 44, 46, 51 AND 52).

FIRST USE 4-1-2008; IN COMMERCE 4-1-2008.

3,998,468. SCHERING CORPORATION, KENILWORTH, NJ. SN 77-411,430. PUB. 10-28-2008, FILED 3-3-2008.

STRALPAR

THE MARK CONSISTS OF STANDARD CHARACTERS WITHOUT CLAIM TO ANY PARTICULAR FONT, STYLE, SIZE, OR COLOR.

FOR PHARMACEUTICAL PREPARATIONS FOR THE TREATMENT AND PREVENTION OF CARDIOVASCULAR DISEASES (U.S. CLS. 6, 18, 44, 46, 51 AND 52).

FIRST USE 3-29-2011; IN COMMERCE 3-29-2011.

3,998,469. SCHERING CORPORATION, KENILWORTH, NJ. SN 77-411,443. PUB. 11-4-2008, FILED 3-3-2008.

STRALYST

THE MARK CONSISTS OF STANDARD CHARACTERS WITHOUT CLAIM TO ANY PARTICULAR FONT, STYLE, SIZE, OR COLOR.

FOR PHARMACEUTICAL PREPARATIONS FOR THE TREATMENT AND PREVENTION OF CARDIOVASCULAR DISEASES (U.S. CLS. 6, 18, 44, 46, 51 AND 52).

FIRST USE 3-29-2011; IN COMMERCE 3-29-2011.

CLASS 5—(Continued).

3,998,507. BLISTEX INC., OAK BROOK, IL. SN 77-527,407. PUB. 4-28-2009, FILED 7-21-2008.

BETTER LIP CARE. BETTER LIPS.

THE MARK CONSISTS OF STANDARD CHARACTERS WITHOUT CLAIM TO ANY PARTICULAR FONT, STYLE, SIZE, OR COLOR.

NO CLAIM IS MADE TO THE EXCLUSIVE RIGHT TO USE "LIP CARE", APART FROM THE MARK AS SHOWN.

FOR MEDICATED TOPICAL SKIN AND LIP CARE PREPARATIONS FOR HUMAN USE, NAMELY, FOR DRYNESS, COLD SORES, BURNS, AND ITCHING; TOPICAL ANALGESIC PREPARATIONS; TOPICAL ANTIBIOTIC PREPARATIONS; AND MEDICATED TOPICAL SUN SCREEN PREPARATIONS FOR USE ON THE LIPS AND SKIN (U.S. CLS. 6, 18, 44, 46, 51 AND 52).

FIRST USE 6-1-2011; IN COMMERCE 6-1-2011.

3,998,527. 1-800-HEALTHY.COM, INC., RIDGELAND, MS. SN 77-564,241. PUB. 3-23-2010, FILED 9-8-2008.

HEALTHPAK

THE MARK CONSISTS OF STANDARD CHARACTERS WITHOUT CLAIM TO ANY PARTICULAR FONT, STYLE, SIZE, OR COLOR.

FOR DIETARY SUPPLEMENTS (U.S. CLS. 6, 18, 44, 46, 51 AND 52).

FIRST USE 1-0-2010; IN COMMERCE 1-0-2010.

3,998,554. VINTAGE PHARMACEUTICALS, LLC, CHADDS FORD, PA. SN 77-590,803. PUB. 4-14-2009, FILED 10-10-2008.

EMOQUETTE

THE MARK CONSISTS OF STANDARD CHARACTERS WITHOUT CLAIM TO ANY PARTICULAR FONT, STYLE, SIZE, OR COLOR.

FOR PHARMACEUTICAL PREPARATIONS FOR THE PREVENTION OF PREGNANCY (U.S. CLS. 6, 18, 44, 46, 51 AND 52).

FIRST USE 4-12-2011; IN COMMERCE 4-12-2011.

CLASS 5—(Continued).

3,998,629. CANADIAN PHYTOPHARMACEUTICALS CORPORATION, RICHMOND, BC, CANADA. SN 77-706,565. PUB. 3-23-2010, FILED 4-3-2009.



THE MARK CONSISTS OF THE STYLIZED WORDING "CANPHY" AND AN INCOMPLETE SHADED CIRCLE WITH THE SHAPE OF A MAPLE LEAF CUT OUT OF IT.

FOR VITAMIN AND MINERAL SUPPLEMENTS; HERBAL, FOOD, AND DIETARY SUPPLEMENTS, NAMELY, SUPPLEMENTS CONTAINING MUSHROOMS, GINSENG, AMINO ACIDS, ASTRAGALUS, BEE PROPOLIS, BEE POLLEN, BETA CAROTENE, BILBERRY, BLACK COHOSH, BLUEBERRIES, BURDOCK, CAT'S CLAW ROOT AND BARK, CHAMOMILE, CORDYCEPS, DANDELION, EPIMEDIUM, DEVIL'S CLAW, DONG QUAI, EVENING PRIMROSE OIL, ECHINACEA, ENZYMES, FENNEL, FOLIC ACID, GINGER, GOLDENSEAL, GOTU COLA, GRAPE SEED EXTRACT, GREEN TEA, GUARANA, HAWTHORN, LICORICE, MILK THISTLE, PASSION FLOWER, PINE BARK EXTRACTS, PEPPERMINT, PREBIOTIC PREPARATIONS, PROBIOTIC PREPARATIONS, RED CLOVER, RED YEAST RICE, SALMON OIL, SCHISANDRA, VALERIAN, ALGA, ANIMAL CARTILAGE, ALOE VERA, ANGELICA, ASTRAGALUS, ARTICHOKE, BROMELAIN, BURDOCK, CARRAGEENAN, CHLORELLA, CHONDROITIN, CINNAMON, CITRUS EXTRACTS, COLLAGEN, CRANBERRY, ESSENTIAL FATTY ACIDS, ESSENTIAL OIL, FEVERFEW, FISH LIVER OIL, FISH OIL, FLAX SEED, GARLIC, GINKGO BILOBA, GLUCOSAMINE, HORSETAIL, FO TI, KELP, KUZU, LECITHIN, LUTEIN, LYCOPENE, MACA, MARINE PHYTOPLANKTON, OLIVE EXTRACTS, RASPBERRY, RED WINE EXTRACTS, RHODIOLA, RHUBARB, ROYAL JELLY, RUTIN, SAW PALMETTO, SEAL OIL, SOY ISOFLAVONE, SOY PROTEIN, ST. JOHN'S WORT, STEVIA, TRIBULUS TERRESTRIAL, TURMERIC, WOLFBERRY, WHITE KIDNEY BEAN; PROCESSED AND UNPROCESSED MEDICINAL HERBS, HERBAL SUPPLEMENTS, VITAMIN SUPPLEMENTS, BOTANICAL DIETARY SUPPLEMENTS, TRADITIONAL CHINESE HERBAL SUPPLEMENTS, HOMEOPATHIC DIETARY SUPPLEMENTS AND NATUROPATHIC DIETARY SUPPLEMENTS, FOR USE AS AN ANTI-INFLAMMATORY, ANTI-MICROBIAL, ANTI-OXIDANT, BODY DETOXIFIER, LIVER DETOXIFIER TREATMENTS AND LIVER FUNCTION TREATMENT, AND FOR THE TREATMENT OR AMELIORATION OF HIGH BLOOD PRESSURE, HIGH BLOOD CHOLESTEROL LEVELS, LOW BONE DENSITY, OBESITY, SLEEP DISORDERS, THE COMMON COLD, PRE AND POST MENSTRUAL SYNDROMES AND DISORDERS, AND IMMUNE SYSTEM DISORDERS (U.S. CLS. 6, 18, 44, 46, 51 AND 52). FIRST USE 3-26-2010; IN COMMERCE 9-23-2010.

CLASS 5—(Continued).

3,998,681. E. I. DU PONT DE NEMOURS AND COMPANY, WILMINGTON, DE. SN 77-746,601. PUB. 9-8-2009, FILED 5-28-2009.

REALM

THE MARK CONSISTS OF STANDARD CHARACTERS WITHOUT CLAIM TO ANY PARTICULAR FONT, STYLE, SIZE, OR COLOR.

FOR HERBICIDES FOR USE IN AGRICULTURE (U.S. CLS. 6, 18, 44, 46, 51 AND 52).

FIRST USE 1-1-2011; IN COMMERCE 1-1-2011.

3,998,700. HEB GROCERY COMPANY, LP, SAN ANTONIO, TX. SN 77-767,149. PUB. 2-9-2010, FILED 6-24-2009.

RX-ACT

THE MARK CONSISTS OF STANDARD CHARACTERS WITHOUT CLAIM TO ANY PARTICULAR FONT, STYLE, SIZE, OR COLOR.

FOR OVER THE COUNTER PHARMACEUTICALS, NAMELY, ANALGESICS, COUGH SYRUPS, COUGH DROPS, PHARMACEUTICAL PREPARATIONS FOR THE TREATMENT OF COLDS, ANTACIDS, LAXATIVES, ANTIHISTAMINES, SLEEPING PILLS, SLEEPING TABLETS (U.S. CLS. 6, 18, 44, 46, 51 AND 52).

FIRST USE 3-31-2011; IN COMMERCE 3-31-2011.

3,998,710. AREX LIFE SCIENCES, INC., WATERTOWN, MA. SN 77-775,735. PUB. 6-29-2010, FILED 7-7-2009.

EnGender

THE MARK CONSISTS OF STANDARD CHARACTERS WITHOUT CLAIM TO ANY PARTICULAR FONT, STYLE, SIZE, OR COLOR.

FOR VETERINARY SEX SELECTION KIT PRIMARILY COMPRISED OF ANTIBODIES AND BUFFERS, AND ANIMAL SEMEN COLLECTION DEVICE FOR USE IN THE FIELD OF ARTIFICIAL INSEMINATION OF LIVESTOCK (U.S. CLS. 6, 18, 44, 46, 51 AND 52).

FIRST USE 1-10-2010; IN COMMERCE 1-10-2010.

CLASS 5—(Continued).

3,998,827. COHEN, AMY, NEW PALTZ, NY. AND COHEN, JONATHAN, NEW PALTZ, NY. SN 77-847,486. PUB. 9-7-2010, FILED 10-13-2009.

GROOVY BLUEBERRY

THE MARK CONSISTS OF STANDARD CHARACTERS WITHOUT CLAIM TO ANY PARTICULAR FONT, STYLE, SIZE, OR COLOR.

OWNER OF U.S. REG. NO. 3,640,538.
FOR ADHESIVE BANDAGES; BANDAGES FOR SKIN WOUNDS (U.S. CLS. 6, 18, 44, 46, 51 AND 52).
FIRST USE 6-24-2010; IN COMMERCE 8-4-2010.

3,998,834. NOVARTIS AG, BASEL, SWITZERLAND. SN 77-850,557. PUB. 4-27-2010, FILED 10-16-2009.

INTROVALE

THE MARK CONSISTS OF STANDARD CHARACTERS WITHOUT CLAIM TO ANY PARTICULAR FONT, STYLE, SIZE, OR COLOR.

THE WORDING "INTROVALE" HAS NO MEANING IN A FOREIGN LANGUAGE.
FOR ORAL CONTRACEPTIVES (U.S. CLS. 6, 18, 44, 46, 51 AND 52).
FIRST USE 1-4-2011; IN COMMERCE 1-4-2011.

3,998,861. JOHNSON & JOHNSON, NEW BRUNSWICK, NJ. SN 77-856,977. PUB. 10-5-2010, FILED 10-26-2009.



OWNER OF U.S. REG. NOS. 194,123 AND 2,471,737.
NO CLAIM IS MADE TO THE EXCLUSIVE RIGHT TO USE "BRAND ADHESIVE BANDAGES" AND THE DESIGN OF THE ADHESIVE BANDAGE, APART FROM THE MARK AS SHOWN.

CLASS 5—(Continued).

THE COLOR(S) BEIGE, RED, AND BLUE IS/ARE CLAIMED AS A FEATURE OF THE MARK.

THE MARK CONSISTS OF THE WORDS "BAND-AID" IN RED AND "BRAND ADHESIVE BANDAGES" IN BLUE APPEARING UNDERNEATH A CLEAR BANDAGE WITH THE MIDDLE PORTION OF THE BANDAGE IN BEIGE.

FOR WOUND DRESSINGS, NAMELY, ADHESIVE BANDAGES (U.S. CLS. 6, 18, 44, 46, 51 AND 52).
FIRST USE 2-15-2010; IN COMMERCE 2-15-2010.

3,998,862. JOHNSON & JOHNSON, NEW BRUNSWICK, NJ. SN 77-856,994. PUB. 10-5-2010, FILED 10-26-2009.



OWNER OF U.S. REG. NOS. 194,123 AND 2,471,737.
NO CLAIM IS MADE TO THE EXCLUSIVE RIGHT TO USE "BRAND ADHESIVE BANDAGES" AND THE DESIGN OF THE ADHESIVE BANDAGE, APART FROM THE MARK AS SHOWN.

THE COLOR(S) BEIGE, RED AND BLUE IS/ARE CLAIMED AS A FEATURE OF THE MARK.

THE MARK CONSISTS OF THE WORDS "BAND-AID" IN RED AND THE WORDS "BRAND ADHESIVE BANDAGES" IN BLUE APPEARING UNDERNEATH A BEIGE COLORED BANDAGE.

FOR WOUND DRESSINGS, NAMELY, ADHESIVE BANDAGES (U.S. CLS. 6, 18, 44, 46, 51 AND 52).
FIRST USE 12-31-2009; IN COMMERCE 12-31-2009.

3,998,863. JOHNSON & JOHNSON, NEW BRUNSWICK, NJ. SN 77-856,995. PUB. 10-5-2010, FILED 10-26-2009.



OWNER OF U.S. REG. NOS. 194,123 AND 2,471,737.

CLASS 5—(Continued).

NO CLAIM IS MADE TO THE EXCLUSIVE RIGHT TO USE "BRAND ADHESIVE BANDAGES", APART FROM THE MARK AS SHOWN.

THE COLOR(S) RED, WHITE AND BLUE IS/ARE CLAIMED AS A FEATURE OF THE MARK.

THE MARK CONSISTS OF A RECTANGLE WITH THE WORDS "BAND-AID" IN RED AND "BRAND ADHESIVE BANDAGES" IN BLUE ON A WHITE BACKGROUND ON THE TOP THIRD OF THE RECTANGLE WITH THE REST OF THE RECTANGLE IN BLUE.

FOR WOUND DRESSINGS, NAMELY, ADHESIVE BANDAGES (U.S. CLS. 6, 18, 44, 46, 51 AND 52).

FIRST USE 12-31-2009; IN COMMERCE 12-31-2009.

3,999,021. EARTH SCIENCE LABORATORIES, INC., BENTONVILLE, AR. SN 77-909,159. PUB. 5-25-2010, FILED 1-11-2010.

CopCheck

THE MARK CONSISTS OF STANDARD CHARACTERS WITHOUT CLAIM TO ANY PARTICULAR FONT, STYLE, SIZE, OR COLOR.

FOR COPPER BASED ALGICIDE FOR RICE FIELDS AND IRRIGATION CONVEYANCE SYSTEMS (U.S. CLS. 6, 18, 44, 46, 51 AND 52).

FIRST USE 1-5-2011; IN COMMERCE 5-1-2011.

3,999,073. L. PERRIGO COMPANY, ALLEGAN, MI. SN 77-932,352. PUB. 6-22-2010, FILED 2-10-2010.

ALLER-FEX

THE MARK CONSISTS OF STANDARD CHARACTERS WITHOUT CLAIM TO ANY PARTICULAR FONT, STYLE, SIZE, OR COLOR.

FOR ANTIHISTAMINES (U.S. CLS. 6, 18, 44, 46, 51 AND 52).

FIRST USE 5-20-2011; IN COMMERCE 5-20-2011.

CLASS 5—(Continued).

3,999,118. CHENGSHIH CHANG, HACIENDA HEIGHTS, CA. SN 77-953,541. PUB. 1-25-2011, FILED 3-8-2010.



THE COLOR(S) BLACK AND GREEN IS/ARE CLAIMED AS A FEATURE OF THE MARK.

THE MARK CONSISTS OF THE LETTER "B", "I" IN BLACK AND THE LETTER "O" IN GREEN WITH A BIGGER CIRCLE AND A SMALLER CIRCLE ATTACHED IN GREEN AND BENEATH ARE LETTERS "WONDERS" IN BLACK WITH GREEN "O".

FOR NATURAL HERBAL SUPPLEMENTS (U.S. CLS. 6, 18, 44, 46, 51 AND 52).

FIRST USE 4-1-2010; IN COMMERCE 4-1-2010.

3,999,124. MIND MINE, LLC, TUCSON, AZ. SN 77-956,972. PUB. 8-3-2010, FILED 3-11-2010.

ICA Health

THE MARK CONSISTS OF STANDARD CHARACTERS WITHOUT CLAIM TO ANY PARTICULAR FONT, STYLE, SIZE, OR COLOR.

NO CLAIM IS MADE TO THE EXCLUSIVE RIGHT TO USE "HEALTH", APART FROM THE MARK AS SHOWN.

FOR DIETARY SUPPLEMENTS (U.S. CLS. 6, 18, 44, 46, 51 AND 52).

FIRST USE 3-25-2011; IN COMMERCE 1-1-2010.

3,999,134. ENDURANCE PRODUCTS COMPANY, TIGARD, OR. SN 77-960,537. PUB. 8-3-2010, FILED 3-16-2010.

NIAXTEND

THE MARK CONSISTS OF STANDARD CHARACTERS WITHOUT CLAIM TO ANY PARTICULAR FONT, STYLE, SIZE, OR COLOR.

FOR DIETARY SUPPLEMENTS, NAMELY, EXTENDED RELEASE NIACIN TABLETS AND CAPSULES (U.S. CLS. 6, 18, 44, 46, 51 AND 52).

FIRST USE 10-1-2010; IN COMMERCE 1-13-2011.

CLASS 5—(Continued).

3,999,150. AGRAQUEST, INC., DAVIS, CA. SN 77-969,044.
PUB. 11-23-2010, FILED 3-26-2010.

SERENADE SOIL

THE MARK CONSISTS OF STANDARD CHARACTERS WITHOUT CLAIM TO ANY PARTICULAR FONT, STYLE, SIZE, OR COLOR.

OWNER OF U.S. REG. NOS. 2,417,828 AND 3,475,492.
NO CLAIM IS MADE TO THE EXCLUSIVE RIGHT TO USE "SOIL", APART FROM THE MARK AS SHOWN.
FOR PESTICIDES (U.S. CLS. 6, 18, 44, 46, 51 AND 52).
FIRST USE 4-26-2010; IN COMMERCE 4-26-2010.

3,999,173. WYETH LLC, MADISON, NJ. SN 77-982,007. PUB.
3-23-2010, FILED 10-19-2009.

TÔTABLES

THE MARK CONSISTS OF STANDARD CHARACTERS WITHOUT CLAIM TO ANY PARTICULAR FONT, STYLE, SIZE, OR COLOR.

FOR MEDICATED SKIN CLEANSERS, GELS, CREAMS, OINTMENTS AND PRE-MOISTENED WIPES FOR THE TREATMENT OF HEMORRHOIDS (U.S. CLS. 6, 18, 44, 46, 51 AND 52).
FIRST USE 5-1-2011; IN COMMERCE 5-1-2011.

3,999,177. S. C. JOHNSON & SON, INC., RACINE, WI. SN 77-982,050. PUB. 9-15-2009, FILED 6-17-2009.

REFRESHING CITRUS

THE MARK CONSISTS OF STANDARD CHARACTERS WITHOUT CLAIM TO ANY PARTICULAR FONT, STYLE, SIZE, OR COLOR.

NO CLAIM IS MADE TO THE EXCLUSIVE RIGHT TO USE "CITRUS", APART FROM THE MARK AS SHOWN.
FOR AIR FRESHENERS (U.S. CLS. 6, 18, 44, 46, 51 AND 52).
FIRST USE 2-6-2011; IN COMMERCE 2-6-2011.

CLASS 5—(Continued).

3,999,261. MOUNTAIN HIGH ORGANICS, INC., NEW MILFORD, CT. SN 85-014,428. PUB. 10-19-2010, FILED 4-15-2010.



THE COLOR(S) BLUE, BROWN, BLACK AND WHITE IS/ARE CLAIMED AS A FEATURE OF THE MARK.

THE MARK CONSISTS OF THE WORDING "TRESOMEGA" WITH "TRES" IN BLUE WITH AN INITIAL CAPITAL LETTER AND "OMEGA" IN WHITE IN ALL CAPITAL LETTERS SUPERIMPOSED OVER THE NUMBER "3" IN BLACK WITH BROWN SHADOWING AROUND ALL OF LETTERS AND NUMBER IN THE MARK.

THE WORDING "TRESOMEGA" HAS NO MEANING IN A FOREIGN LANGUAGE.

FOR NUTRITIONAL SUPPLEMENTS CONTAINING ESSENTIAL FATTY ACID BLENDS, FLAVORED WITH ONE OR MORE OF THE FOLLOWING FLAX, EVENING PRIMROSE OIL, HEMP, CHIA AND FISH, WITH ONE OR MORE OF HERBS, SPICES, ANTIOXIDANTS, BERRIES, MINERALS AND VITAMINS; DIETARY SUPPLEMENTS IN THE NATURE OF OILS, OIL BLENDS, OIL EMULSIONS, OIL MICROENCAPSULATION AND POWDERS CONTAINING OMEGA-3 FATTY ACIDS; NUTRITIONAL FOOD BARS FOR USE AS A MEAL REPLACEMENT (U.S. CLS. 6, 18, 44, 46, 51 AND 52).
FIRST USE 4-1-2010; IN COMMERCE 4-1-2010.

3,999,305. SYNTHES USA, LLC, WEST CHESTER, PA. SN 85-022,676. PUB. 3-15-2011, FILED 4-26-2010.

XCM BIOLOGIC

THE MARK CONSISTS OF STANDARD CHARACTERS WITHOUT CLAIM TO ANY PARTICULAR FONT, STYLE, SIZE, OR COLOR.

NO CLAIM IS MADE TO THE EXCLUSIVE RIGHT TO USE "BIOLOGIC", APART FROM THE MARK AS SHOWN.
FOR BIOLOGICAL SKIN TISSUE MATRIX FOR THE REINFORCEMENT AND REPAIR OF SOFT TISSUE (U.S. CLS. 6, 18, 44, 46, 51 AND 52).

FIRST USE 5-31-2010; IN COMMERCE 5-31-2010.

CLASS 5—(Continued).

3,999,330. Z LINE INDUSTRIES LLC, SALT LAKE CITY, UT. SN 85-026,667. PUB. 10-5-2010, FILED 4-29-2010.

PERFORMANCE CHEW

THE MARK CONSISTS OF STANDARD CHARACTERS WITHOUT CLAIM TO ANY PARTICULAR FONT, STYLE, SIZE, OR COLOR.

NO CLAIM IS MADE TO THE EXCLUSIVE RIGHT TO USE "CHEW", APART FROM THE MARK AS SHOWN.

FOR FOOD SUPPLEMENTS (U.S. CLS. 6, 18, 44, 46, 51 AND 52).

FIRST USE 8-5-2010; IN COMMERCE 8-5-2010.

3,999,333. 21ST CENTURY BRANDS, LLC, PHOENIX, AZ. SN 85-026,774. PUB. 9-28-2010, FILED 4-29-2010.

SHIELD

THE MARK CONSISTS OF STANDARD CHARACTERS WITHOUT CLAIM TO ANY PARTICULAR FONT, STYLE, SIZE, OR COLOR.

FOR NUTRITIONAL AND DIETARY SUPPLEMENTS FOR HUMAN CONSUMPTION IN LIQUID, LOTION, DISSOLVABLE STRIP, AND GEL FORM FOR SUPPLEMENTING THE IMMUNE SYSTEM (U.S. CLS. 6, 18, 44, 46, 51 AND 52).

FIRST USE 11-2-2010; IN COMMERCE 11-2-2010.

3,999,340. NORDIMEX, LLC, DBA MEXICAN PHARMA NATURA, SAN DIEGO, CA. SN 85-027,796. PUB. 10-5-2010, FILED 4-30-2010.

HIGADITRIN

THE MARK CONSISTS OF STANDARD CHARACTERS WITHOUT CLAIM TO ANY PARTICULAR FONT, STYLE, SIZE, OR COLOR.

FOR FOOD SUPPLEMENTS (U.S. CLS. 6, 18, 44, 46, 51 AND 52).

FIRST USE 12-31-2010; IN COMMERCE 12-31-2010.

CLASS 5—(Continued).

3,999,341. NORDIMEX, LLC, DBA MEXICAN PHARMA NATURA, SAN DIEGO, CA. SN 85-027,799. PUB. 10-5-2010, FILED 4-30-2010.

AJIN

THE MARK CONSISTS OF STANDARD CHARACTERS WITHOUT CLAIM TO ANY PARTICULAR FONT, STYLE, SIZE, OR COLOR.

FOR FOOD SUPPLEMENTS (U.S. CLS. 6, 18, 44, 46, 51 AND 52).

FIRST USE 12-31-2010; IN COMMERCE 12-31-2010.

3,999,342. NORDIMEX, LLC, DBA MEXICAN PHARMA NATURA, SAN DIEGO, CA. SN 85-027,806. PUB. 10-5-2010, FILED 4-30-2010.

NERVIOX

THE MARK CONSISTS OF STANDARD CHARACTERS WITHOUT CLAIM TO ANY PARTICULAR FONT, STYLE, SIZE, OR COLOR.

FOR FOOD SUPPLEMENTS (U.S. CLS. 6, 18, 44, 46, 51 AND 52).

FIRST USE 12-31-2010; IN COMMERCE 12-31-2010.

3,999,343. TRIGG LABORATORIES, INC., VALENCIA, CA. SN 85-027,881. PUB. 9-28-2010, FILED 4-30-2010.

WET ECSTASY

THE MARK CONSISTS OF STANDARD CHARACTERS WITHOUT CLAIM TO ANY PARTICULAR FONT, STYLE, SIZE, OR COLOR.

FOR PERSONAL LUBRICANTS, NAMELY, GELS, OILS AND LOTIONS FOR USE AS PERSONAL LUBRICANT, SILICONE-BASED PERSONAL LUBRICANTS, OIL-BASED PERSONAL LUBRICANTS, WATER-BASED PERSONAL LUBRICANTS AND PERSONAL LUBRICANTS ENRICHED WITH VITAMINS AND HERBAL AND OTHER PLANT-DERIVED TREATMENTS; PLEASURE AND INTIMACY GELS FOR USE AS PERSONAL LUBRICANTS AND SEXUAL AROUSAL AIDES; VAGINAL MOISTURIZERS; TOPICAL PREPARATIONS, NAMELY, SPRAYS, GELS AND CREAMS FOR ENHANCING SEXUAL AROUSAL AND/OR DELAYING ORGASM AND/OR PROLONGING SEXUAL STIMULATION (U.S. CLS. 6, 18, 44, 46, 51 AND 52).

FIRST USE 1-1-2011; IN COMMERCE 1-1-2011.

CLASS 5—(Continued).

3,999,362. ADVANCED NUTRIENT SCIENCE, LLC, LARGO, FL. SN 85-029,895. PUB. 10-5-2010, FILED 5-4-2010.

FLURRY

THE MARK CONSISTS OF STANDARD CHARACTERS WITHOUT CLAIM TO ANY PARTICULAR FONT, STYLE, SIZE, OR COLOR.

FOR NUTRITIONAL SUPPLEMENTS CONTAINING PROTEIN; NUTRITIONAL FOOD BARS HIGH IN PROTEIN; NUTRITIONAL SUPPLEMENTS IN THE FORM OF PROTEIN POWDERED DRINK MIXES; NUTRITIONAL SUPPLEMENTS IN THE FORM OF HIGH PROTEIN BEVERAGES; NUTRITIONAL SUPPLEMENTS IN THE FORM OF PROTEIN RICH COOKIES; NUTRITIONAL SUPPLEMENTS (U.S. CLS. 6, 18, 44, 46, 51 AND 52).

FIRST USE 8-31-2010; IN COMMERCE 8-31-2010.

3,999,378. R & D LIFESCIENCES, LLC., MENOMONIE, WI. SN 85-031,666. PUB. 10-12-2010, FILED 5-6-2010.

ReNuvigen

THE MARK CONSISTS OF STANDARD CHARACTERS WITHOUT CLAIM TO ANY PARTICULAR FONT, STYLE, SIZE, OR COLOR.

FOR NON-MEDICATED ADDITIVES FOR ANIMAL FEED FOR USE AS NUTRITIONAL SUPPLEMENTS (U.S. CLS. 6, 18, 44, 46, 51 AND 52).

FIRST USE 11-18-2010; IN COMMERCE 1-13-2011.

3,999,383. NATURE'S APPEAL MANUFACTURING CORPORATION, ADDISON, IL. SN 85-032,096. PUB. 10-12-2010, FILED 5-6-2010.

STINK GRENADE

THE MARK CONSISTS OF STANDARD CHARACTERS WITHOUT CLAIM TO ANY PARTICULAR FONT, STYLE, SIZE, OR COLOR.

NO CLAIM IS MADE TO THE EXCLUSIVE RIGHT TO USE "STINK", APART FROM THE MARK AS SHOWN.

FOR AIR DEODORIZER (U.S. CLS. 6, 18, 44, 46, 51 AND 52).

FIRST USE 5-18-2011; IN COMMERCE 5-19-2011.

CLASS 5—(Continued).

3,999,395. EKAIRE.COM INC., SURREY, BC, CANADA. SN 85-033,044. PUB. 10-5-2010, FILED 5-7-2010.

Maritime Prime

THE MARK CONSISTS OF STANDARD CHARACTERS WITHOUT CLAIM TO ANY PARTICULAR FONT, STYLE, SIZE, OR COLOR.

FOR DIETARY AND NUTRITIONAL SUPPLEMENTS; DIETARY SUPPLEMENTS; DIETARY SUPPLEMENTS FOR HUMAN CONSUMPTION; NUTRITIONAL SUPPLEMENTS (U.S. CLS. 6, 18, 44, 46, 51 AND 52).

FIRST USE 1-1-1993; IN COMMERCE 1-1-1993.

3,999,411. MOUNTAIN HIGH ORGANICS, INC., NEW MILFORD, CT. SN 85-035,338. PUB. 10-19-2010, FILED 5-11-2010.

TresOMEGA

THE MARK CONSISTS OF STANDARD CHARACTERS WITHOUT CLAIM TO ANY PARTICULAR FONT, STYLE, SIZE, OR COLOR.

THE WORDING "TRESOMEGA" HAS NO MEANING IN A FOREIGN LANGUAGE.

FOR NUTRITIONAL SUPPLEMENTS CONTAINING ESSENTIAL FATTY ACID BLENDS, FLAVORED WITH ONE OR MORE OF THE FOLLOWING FLAX, EVENING PRIMROSE OIL, HEMP, CHIA AND FISH, WITH ONE OR MORE OF HERBS, SPICES, ANTIOXIDANTS, BERRIES, MINERALS AND VITAMINS; DIETARY SUPPLEMENTS IN THE NATURE OF OILS, OIL BLENDS, OIL EMULSIONS, OIL MICROENCAPSULATION AND POWDERS CONTAINING OMEGA-3 FATTY ACIDS; NUTRITIONAL FOOD BARS FOR USE AS A MEAL REPLACEMENT (U.S. CLS. 6, 18, 44, 46, 51 AND 52).

FIRST USE 4-1-2010; IN COMMERCE 4-1-2010.

CLASS 5—(Continued).

3,999,446. FERMACTIVE LLC, MANHATTAN BEACH, CA. SN 85-039,253. PUB. 10-19-2010, FILED 5-14-2010.

PRO-DAILY-OTIC

THE MARK CONSISTS OF STANDARD CHARACTERS WITHOUT CLAIM TO ANY PARTICULAR FONT, STYLE, SIZE, OR COLOR.

FOR PROBIOTIC NUTRITIONAL AND DIETARY SUPPLEMENTS IN THE FORM OF POWDERED DRINK MIX CONTAINING BENEFICIAL BACTERIA RESULTING FROM FERMENTED COMPOSITIONS SUCH AS GREENS, GRAINS, FRUITS, VEGETABLES, AND PROTEINS (U.S. CLS. 6, 18, 44, 46, 51 AND 52).

FIRST USE 7-27-2010; IN COMMERCE 1-6-2011.

3,999,490. ECOANT ENTERPRISES LTD., DBA ECOANT, VANCOUVER, BC, CANADA. SN 85-047,796. PUB. 10-26-2010, FILED 5-25-2010.



THE COLOR(S) GRAY, GREEN IS/ARE CLAIMED AS A FEATURE OF THE MARK.

THE MARK CONSISTS OF THE WORDING "NEOSENT" IN GRAY AND A LEAF DESIGN. THE DESIGN COMPRISES TWO GREEN LEAVES EMANATING FROM THE LETTER S IN THE TERM "NEOSENT".

FOR HEALTH FOOD SUPPLEMENTS; MULTI-VITAMIN PREPARATIONS; PRENATAL VITAMINS; PROTEIN SUPPLEMENTS (U.S. CLS. 6, 18, 44, 46, 51 AND 52).

FIRST USE 9-16-2010; IN COMMERCE 9-16-2010.

CLASS 5—(Continued).

3,999,589. ESSENTIAL FORMULAS INCORPORATED, FARMERS BRANCH, TX. SN 85-073,370. PUB. 10-19-2010, FILED 6-28-2010.

IT TAKES GUTS...

THE MARK CONSISTS OF STANDARD CHARACTERS WITHOUT CLAIM TO ANY PARTICULAR FONT, STYLE, SIZE, OR COLOR.

FOR DIETARY SUPPLEMENTS (U.S. CLS. 6, 18, 44, 46, 51 AND 52).

FIRST USE 3-9-2011; IN COMMERCE 3-9-2011.

3,999,613. VEROSCIENCE LLC, TIVERTON, RI. SN 85-078,890. PUB. 10-12-2010, FILED 7-6-2010.

CYCLOSET

THE MARK CONSISTS OF STANDARD CHARACTERS WITHOUT CLAIM TO ANY PARTICULAR FONT, STYLE, SIZE, OR COLOR.

OWNER OF U.S. REG. NO. 3,016,368.

FOR PHARMACEUTICAL PREPARATIONS FOR THE TREATMENT OF METABOLIC DISORDERS AND DISEASES CAUSED BY DIABETES SUCH AS DIABETIC NEUROPATHY, OBESITY, DYSLIPIDEMIA, HYPERCHOLESTERMIA, HYPERTENSION (U.S. CLS. 6, 18, 44, 46, 51 AND 52).

FIRST USE 11-15-2010; IN COMMERCE 11-15-2010.

3,999,617. OSIRIS THERAPEUTICS, INC., COLUMBIA, MD. SN 85-080,651. PUB. 12-7-2010, FILED 7-8-2010.

Ovation

THE MARK CONSISTS OF STANDARD CHARACTERS WITHOUT CLAIM TO ANY PARTICULAR FONT, STYLE, SIZE, OR COLOR.

FOR HUMAN ALLOGRAFT TISSUE (U.S. CLS. 6, 18, 44, 46, 51 AND 52).

FIRST USE 7-30-2010; IN COMMERCE 7-30-2010.

CLASS 5—(Continued).

3,999,618. TRAM BAR, DRIGGS, ID. SN 85-081,060. PUB. 11-30-2010, FILED 7-9-2010.

KATE'S

THE MARK CONSISTS OF STANDARD CHARACTERS WITHOUT CLAIM TO ANY PARTICULAR FONT, STYLE, SIZE, OR COLOR.

FOR NUTRITIONAL ENERGY BARS FOR USE AS A MEAL SUBSTITUTE (U.S. CLS. 6, 18, 44, 46, 51 AND 52). FIRST USE 11-8-2010; IN COMMERCE 11-8-2010.

CLASS 5—(Continued).

ARE NOT CONNECTED WITH EACH OTHER BY LINES AND ALSO CIRCLE AROUND THE SAME CENTER-BALL. THE CENTER-BALL HAS SIX STELLIFORM THICK LINES (ROD) WHICH CONNECT THE CENTER-BALL WITH BOTH BALLS ON THE INNER LAYER AND BALLS ON THE OUTER LAYER. EACH STELLIFORM STRAIGHT LINE (ROD) HAS THE SAME NUMBER (FIVE BALLS) ARRANGED IN LINE, WHICH MAKES THE FIGURE LOOK SYMMETRICAL WHEN VIEWED FROM ANY DIRECTION.

FOR ENZYME FOOD SUPPLEMENTS; HAIR GROWTH STIMULANTS; INFANT FORMULA; NATURAL HERBAL SUPPLEMENTS; NATURAL SUPPLEMENTS FOR TREATING DEPRESSION AND ANXIETY; NATURAL SUPPLEMENTS FOR TREATING ERECTILE DYSFUNCTION; NUTRITIONAL SUPPLEMENTS; PHARMACEUTICAL PREPARATIONS FOR THE PREVENTION AND TREATMENT OF DISORDERS OF THE NERVOUS SYSTEM, THE IMMUNE SYSTEM, THE CARDIO-VASCULAR SYSTEM, THE METABOLIC SYSTEM, THE RESPIRATORY SYSTEM, THE MUSCULO-SKELETAL SYSTEM, THE GENITOURINARY SYSTEM; FOR THE TREATMENT OF INFLAMMATORY DISORDERS; FOR USE IN DERMATOLOGY, ONCOLOGY, HEMATOLOGY AND IN TISSUE AND ORGAN TRANSPLANTATION, IN OPHTHALMOLOGY AND FOR GASTROENTEROLOGICAL DISORDERS; VITAMIN AND MINERAL SUPPLEMENTS (U.S. CLS. 6, 18, 44, 46, 51 AND 52).

FIRST USE 11-10-2010; IN COMMERCE 4-12-2011.

3,999,668. DAVID KIRSCH WELLNESS CO., INC., NEW YORK, NY. SN 85-099,712. PUB. 1-18-2011, FILED 8-4-2010.

48 HOUR SUPER CHARGED CLEANSE

THE MARK CONSISTS OF STANDARD CHARACTERS WITHOUT CLAIM TO ANY PARTICULAR FONT, STYLE, SIZE, OR COLOR.

NO CLAIM IS MADE TO THE EXCLUSIVE RIGHT TO USE "48 HOUR" AND "CLEANSE", APART FROM THE MARK AS SHOWN.

FOR DIETARY SUPPLEMENTS; APPETITE SUPPRESSANTS; AND VITAMIN SUPPLEMENTS (U.S. CLS. 6, 18, 44, 46, 51 AND 52).

FIRST USE 10-1-2010; IN COMMERCE 10-1-2010.

3,999,663. LIFONT PHARMACEUTICALS INC, ALPHARETTA, GA. SN 85-097,622. PUB. 1-18-2011, FILED 8-1-2010.

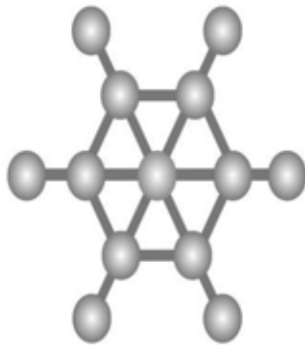

THE MARK CONSISTS OF TOTALLY THIRTEEN ROUND BALLS (CIRCLES) OF THREE-DIMENSIONAL APPEARANCE WITH THE SAME DIAMETERS, AMONG WHICH ONE BALL IS LOCATED AT THE CENTER OF THE PICTURE. SIX BALLS ARE CONNECTED WITH EACH OTHER TO FORM THE INNER LAYER OF BALLS BY THICK STRAIGHT LINES (APPEARING LIKE ROD) CIRCLING AROUND THE CENTER-BALL. ANOTHER SIX BALLS FORM THE OUTER LAYER OF BALLS WHICH

3,999,669. DAVID KIRSCH WELLNESS CO., INC., NEW YORK, NY. SN 85-099,788. PUB. 1-18-2011, FILED 8-4-2010.

CALMING BUBBLES

THE MARK CONSISTS OF STANDARD CHARACTERS WITHOUT CLAIM TO ANY PARTICULAR FONT, STYLE, SIZE, OR COLOR.

FOR DIETARY SUPPLEMENTS; APPETITE SUPPRESSANTS; AND VITAMIN SUPPLEMENTS (U.S. CLS. 6, 18, 44, 46, 51 AND 52).

FIRST USE 12-8-2010; IN COMMERCE 12-8-2010.

CLASS 5—(Continued).

3,999,710. ARDENTI, ALEX, ENCINO, CA. SN 85-114,132.
PUB. 2-22-2011, FILED 8-24-2010.

ALPHA PRO NUTRITION

THE MARK CONSISTS OF STANDARD CHARACTERS WITHOUT CLAIM TO ANY PARTICULAR FONT, STYLE, SIZE, OR COLOR.

NO CLAIM IS MADE TO THE EXCLUSIVE RIGHT TO USE "ALPHA" AND "NUTRITION", APART FROM THE MARK AS SHOWN.

FOR DIETARY SUPPLEMENTS FEATURING ALPHA LIPOIC ACID (U.S. CLS. 6, 18, 44, 46, 51 AND 52).

FIRST USE 8-23-2010; IN COMMERCE 8-23-2010.

3,999,716. II REP-Z, INC., CORAOPOLIS, PA. SN 85-116,430.
PUB. 2-8-2011, FILED 8-26-2010.

BOTANICLEAN

THE MARK CONSISTS OF STANDARD CHARACTERS WITHOUT CLAIM TO ANY PARTICULAR FONT, STYLE, SIZE, OR COLOR.

FOR GERMICIDES; TUBERCULOCIDES; FUNGICIDES; VIRUCIDES; ANTIBACTERIAL CLEANERS; ALL-PURPOSE DISINFECTANTS; ODOR COUNTERACTANTS (U.S. CLS. 6, 18, 44, 46, 51 AND 52).

FIRST USE 11-10-2010; IN COMMERCE 11-10-2010.

3,999,725. PILLAR ROCK USA CORP., FARMINGDALE, NY.
SN 85-123,059. PUB. 2-15-2011, FILED 9-3-2010.

JETRYTE

THE MARK CONSISTS OF STANDARD CHARACTERS WITHOUT CLAIM TO ANY PARTICULAR FONT, STYLE, SIZE, OR COLOR.

FOR NUTRITIONAL SUPPLEMENTS (U.S. CLS. 6, 18, 44, 46, 51 AND 52).

FIRST USE 5-4-2011; IN COMMERCE 5-4-2011.

CLASS 5—(Continued).

3,999,763. VP CONSULTANTS INC, OSPREY, FL. SN 85-138,548. PUB. 3-8-2011, FILED 9-27-2010.

GlutenAide

THE MARK CONSISTS OF STANDARD CHARACTERS WITHOUT CLAIM TO ANY PARTICULAR FONT, STYLE, SIZE, OR COLOR.

FOR DIETARY AND NUTRITIONAL SUPPLEMENTS (U.S. CLS. 6, 18, 44, 46, 51 AND 52).

FIRST USE 11-1-2010; IN COMMERCE 12-1-2010.

3,999,769. BIOTIVIA LLC, NEW YORK, NY. SN 85-139,377.
PUB. 3-15-2011, FILED 9-27-2010.

ptero max

THE MARK CONSISTS OF STANDARD CHARACTERS WITHOUT CLAIM TO ANY PARTICULAR FONT, STYLE, SIZE, OR COLOR.

NO CLAIM IS MADE TO THE EXCLUSIVE RIGHT TO USE "PTERO", APART FROM THE MARK AS SHOWN.

FOR DIETARY AND NUTRITIONAL SUPPLEMENTS (U.S. CLS. 6, 18, 44, 46, 51 AND 52).

FIRST USE 1-1-2011; IN COMMERCE 1-1-2011.

3,999,797. BOND LABORATORIES, INC., OMAHA, NE. SN 85-146,738. PUB. 3-1-2011, FILED 10-6-2010.

G|SPEED

THE MARK CONSISTS OF STANDARD CHARACTERS WITHOUT CLAIM TO ANY PARTICULAR FONT, STYLE, SIZE, OR COLOR.

FOR DIETARY SUPPLEMENTS IN THE NATURE OF PRE-WORKOUT POWDERS (U.S. CLS. 6, 18, 44, 46, 51 AND 52).

FIRST USE 1-7-2011; IN COMMERCE 1-7-2011.

CLASS 5—(Continued).

3,999,799. MONAVIE LLC, SOUTH JORDAN, UT. SN 85-147,625. PUB. 3-15-2011, FILED 10-7-2010.

RVL

THE MARK CONSISTS OF STANDARD CHARACTERS WITHOUT CLAIM TO ANY PARTICULAR FONT, STYLE, SIZE, OR COLOR.

FOR DIETARY AND NUTRITIONAL SUPPLEMENTS; DIETARY AND NUTRITIONAL SUPPLEMENTS CONTAINING ACAI; DIETARY DRINK MIX FOR USE AS A MEAL REPLACEMENT; DIETARY SUPPLEMENTS IN THE NATURE OF WEIGHT LOSS POWDERS; ENERGY BOOSTING BARS FOR USE AS A MEAL SUBSTITUTE; MEAL REPLACEMENT AND DIETARY SUPPLEMENT DRINK MIXES; MEAL REPLACEMENT BARS; MEAL REPLACEMENT DRINKS; MEAL REPLACEMENT POWDERS; MEAL REPLACEMENT SHAKES; MEAL REPLACEMENT SNACKS; NUTRITIONAL AND DIETARY SUPPLEMENTS FORMED AND PACKAGED AS BARS; NUTRITIONAL DRINK MIX FOR USE AS A MEAL REPLACEMENT; NUTRITIONAL DRINKS USED FOR MEAL REPLACEMENT; NUTRITIONAL ENERGY BARS FOR USE AS A MEAL SUBSTITUTE; NUTRITIONAL FOOD BARS FOR USE AS A MEAL REPLACEMENT; NUTRITIONAL SHAKES FOR USE AS A MEAL SUBSTITUTE; NUTRITIONAL SUPPLEMENT IN THE NATURE OF A NUTRIENT-DENSE, PROTEIN-BASED DRINK MIX; POWDERED FRUIT-FLAVORED DIETARY SUPPLEMENT DRINK MIX; POWDERED NUTRITIONAL SUPPLEMENT DRINK MIX; WEIGHT MANAGEMENT SUPPLEMENTS (U.S. CLS. 6, 18, 44, 46, 51 AND 52).

FIRST USE 12-24-2010; IN COMMERCE 12-24-2010.

3,999,814. DAVID KIRSCH WELLNESS CO., INC., NEW YORK, NY. SN 85-152,882. PUB. 1-18-2011, FILED 10-14-2010.

RAISING THE BAR ON WELLNESS

THE MARK CONSISTS OF STANDARD CHARACTERS WITHOUT CLAIM TO ANY PARTICULAR FONT, STYLE, SIZE, OR COLOR.

FOR DIETARY SUPPLEMENTS; POWDERED PROTEIN NUTRITIONAL SUPPLEMENT DRINK MIX; APETITE SUPPRESSANTS; AND VITAMIN SUPPLEMENTS (U.S. CLS. 6, 18, 44, 46, 51 AND 52).
FIRST USE 2-28-2011; IN COMMERCE 2-28-2011.

CLASS 5—(Continued).

3,999,829. FINANCIAL SHOWS INC., ROCKVILLE, MD. SN 85-159,035. PUB. 3-22-2011, FILED 10-22-2010.

DOG FART TERMINATOR

THE MARK CONSISTS OF STANDARD CHARACTERS WITHOUT CLAIM TO ANY PARTICULAR FONT, STYLE, SIZE, OR COLOR.

NO CLAIM IS MADE TO THE EXCLUSIVE RIGHT TO USE "DOG FART", APART FROM THE MARK AS SHOWN. FOR AIR DEODORIZER; AIR FRESHENERS (U.S. CLS. 6, 18, 44, 46, 51 AND 52).

FIRST USE 2-11-2011; IN COMMERCE 2-11-2011.

3,999,836. APSU, L.L.C., PAIA, HI. SN 85-160,894. PUB. 3-22-2011, FILED 10-26-2010.



THE MARK CONSISTS OF SINGLE LEAF DIVIDED BY CRESCENT LINE INTO TWO THIRD AND ONE THIRD PORTIONS, CENTERED ABOVE THE LETTERS APSU.

FOR CALCIUM SUPPLEMENTS; DIETARY AND NUTRITIONAL SUPPLEMENTS; DIETARY FOOD SUPPLEMENTS; DIETARY SUPPLEMENTS; FOOD SUPPLEMENTS; HEALTH FOOD SUPPLEMENTS; HERBAL SUPPLEMENTS; LIQUID VITAMIN SUPPLEMENTS; MINERAL FOOD SUPPLEMENTS; MINERAL NUTRITIONAL SUPPLEMENTS; MINERAL SUPPLEMENTS; NATURAL HERBAL SUPPLEMENTS; NUTRACEUTICALS FOR USE AS A DIETARY SUPPLEMENT; NUTRITIONAL SUPPLEMENTS; VITAMIN SUPPLEMENTS; WEIGHT MANAGEMENT SUPPLEMENTS (U.S. CLS. 6, 18, 44, 46, 51 AND 52).

FIRST USE 5-20-2011; IN COMMERCE 5-20-2011.

CLASS 5—(Continued).

3,999,837. FAR WEST NUTRACEUTICALS, HAWTHORNE, CA. SN 85-161,823. PUB. 3-22-2011, FILED 10-26-2010.

NeuraVite the next
generation in neuropathy
treatment

THE MARK CONSISTS OF STANDARD CHARACTERS WITHOUT CLAIM TO ANY PARTICULAR FONT, STYLE, SIZE, OR COLOR.

NO CLAIM IS MADE TO THE EXCLUSIVE RIGHT TO USE "NEUROPATHY TREATMENT", APART FROM THE MARK AS SHOWN.

FOR NUTRITIONAL SUPPLEMENTS (U.S. CLS. 6, 18, 44, 46, 51 AND 52).

FIRST USE 1-10-2011; IN COMMERCE 1-10-2011.

3,999,859. MONAVIE LLC, SOUTH JORDAN, UT. SN 85-177,049. PUB. 3-1-2011, FILED 11-15-2010.

RVL PREMIER WEIGHT SOLUTION

THE MARK CONSISTS OF STANDARD CHARACTERS WITHOUT CLAIM TO ANY PARTICULAR FONT, STYLE, SIZE, OR COLOR.

NO CLAIM IS MADE TO THE EXCLUSIVE RIGHT TO USE "PREMIER WEIGHT SOLUTION", APART FROM THE MARK AS SHOWN.

FOR DIETARY AND NUTRITIONAL SUPPLEMENTS; DIETARY AND NUTRITIONAL SUPPLEMENTS CONTAINING ACAI; DIETARY DRINK MIX FOR USE AS A MEAL REPLACEMENT; DIETARY SUPPLEMENTS IN THE NATURE OF WEIGHT LOSS POWDERS; ENERGY BOOSTING BARS FOR USE AS A MEAL SUBSTITUTE; MEAL REPLACEMENT AND DIETARY SUPPLEMENT DRINK MIXES; MEAL REPLACEMENT BARS; MEAL REPLACEMENT DRINKS; MEAL REPLACEMENT POWDERS; MEAL REPLACEMENT SHAKES; MEAL REPLACEMENT SNACKS; NUTRITIONAL AND DIETARY SUPPLEMENTS FORMED AND PACKAGED AS BARS; NUTRITIONAL DRINK MIX FOR USE AS A MEAL REPLACEMENT; NUTRITIONAL DRINKS USED FOR MEAL REPLACEMENT; NUTRITIONAL ENERGY BARS FOR USE AS A MEAL SUBSTITUTE; NUTRITIONAL FOOD BARS FOR USE AS A MEAL REPLACEMENT; NUTRITIONAL SHAKES FOR USE AS A MEAL SUBSTITUTE; NUTRITIONAL SUPPLEMENT IN THE NATURE OF A NUTRIENT-DENSE, PROTEIN-BASED DRINK MIX; POWDERED FRUIT-FLAVORED DIETARY SUPPLEMENT DRINK MIX; POWDERED NUTRITIONAL SUPPLEMENT DRINK MIX; WEIGHT MANAGEMENT SUPPLEMENTS (U.S. CLS. 6, 18, 44, 46, 51 AND 52).

FIRST USE 12-24-2010; IN COMMERCE 12-24-2010.

CLASS 6—METAL GOODS**CLASS 6—(Continued).**

3,998,730. TEVENTI, LLC, ROSWELL, GA. SN 77-798,272. PUB. 9-28-2010, FILED 8-6-2009.

QXPAK

THE MARK CONSISTS OF STANDARD CHARACTERS WITHOUT CLAIM TO ANY PARTICULAR FONT, STYLE, SIZE, OR COLOR.

FOR MULTI-COMPARTMENTED BEVERAGE POUCH MADE OF FLEXIBLE FOIL AND PLASTIC-LAMINATED MATERIAL FOR MIXING AND DISPENSING BEVERAGES (U.S. CLS. 2, 12, 13, 14, 23, 25 AND 50).

FIRST USE 2-21-2011; IN COMMERCE 2-21-2011.

3,999,307. COOLEY WIRE PRODUCTS MANUFACTURING COMPANY, SCHILLER PARK, IL. SN 85-023,390. PUB. 9-28-2010, FILED 4-26-2010.

HozeAround

THE MARK CONSISTS OF STANDARD CHARACTERS WITHOUT CLAIM TO ANY PARTICULAR FONT, STYLE, SIZE, OR COLOR.

FOR METAL STAND FOR USE IN GUIDING HOSES (U.S. CLS. 2, 12, 13, 14, 23, 25 AND 50).

FIRST USE 8-0-2010; IN COMMERCE 8-0-2010.

3,999,313. BRADY INNOVATIONS, LLC, BEVERLY HILL, CA. SN 85-024,694. PUB. 9-28-2010, FILED 4-27-2010.

ProX RO Jamb

THE MARK CONSISTS OF STANDARD CHARACTERS WITHOUT CLAIM TO ANY PARTICULAR FONT, STYLE, SIZE, OR COLOR.

OWNER OF U.S. REG. NOS. 2,990,195 AND 2,990,196. NO CLAIM IS MADE TO THE EXCLUSIVE RIGHT TO USE "JAMB", APART FROM THE MARK AS SHOWN.

FOR METAL STRUCTURAL BUILDING MATERIALS FOR USE IN WALLS, NAMELY, METAL HEADER ASSEMBLIES FOR USE IN CONNECTING HORIZONTAL AND VERTICAL MEMBERS IN DOOR AND WINDOW OPENINGS (U.S. CLS. 2, 12, 13, 14, 23, 25 AND 50).

FIRST USE 4-7-2011; IN COMMERCE 4-7-2011.

CLASS 6—(Continued).

3,999,318. MILESTONE AV TECHNOLOGIES LLC, SAVAGE, MN. SN 85-025,329. PUB. 9-28-2010, FILED 4-28-2010.

SECURA

THE MARK CONSISTS OF STANDARD CHARACTERS WITHOUT CLAIM TO ANY PARTICULAR FONT, STYLE, SIZE, OR COLOR.

FOR METAL AUDIO, VIDEO AND COMPUTER WALL AND CEILING MOUNTS (U.S. CLS. 2, 12, 13, 14, 23, 25 AND 50).

FIRST USE 2-26-2010; IN COMMERCE 11-30-2010.

3,999,360. GLOBAL INDUSTRIES, INC., GRAND ISLAND, NE. SN 85-029,711. PUB. 10-5-2010, FILED 5-4-2010.



NO CLAIM IS MADE TO THE EXCLUSIVE RIGHT TO USE "SENTINEL BUILDING SYSTEMS", APART FROM THE MARK AS SHOWN.

THE MARK CONSISTS OF A WAVY LINE THROUGH THE WORDS "SENTINEL BUILDING SYSTEMS".

FOR PREFABRICATED STEEL BUILDINGS; PRE-ENGINEERED AND PREFABRICATED STEEL BUILDINGS; PREFABRICATED STEEL BUILDINGS AND COMPONENTS THEREOF, NAMELY, FRAMES, SHEETING, GIRTS AND PURLINS; PRE-ENGINEERED STEEL BUILDINGS AND STRUCTURAL COMPONENTS THEREOF, NAMELY, BUILDING FRAMES, STEEL ROOF AND WALL SYSTEMS, STEEL CLADDING FOR ROOF AND WALL SYSTEMS, DOORS AND INSULATION (U.S. CLS. 2, 12, 13, 14, 23, 25 AND 50).

FIRST USE 8-0-2010; IN COMMERCE 8-0-2010.

3,999,361. GLOBAL INDUSTRIES, INC., GRAND ISLAND, NE. SN 85-029,725. PUB. 10-5-2010, FILED 5-4-2010.



THE MARK CONSISTS OF THE WORD "PLAINSMAN" FOLLOWED BY TWO CLOSED PARENTHESES.

FOR PREFABRICATED STEEL BUILDINGS; PRE-ENGINEERED AND PREFABRICATED STEEL BUILDINGS; PREFABRICATED STEEL BUILDINGS AND COMPONENTS THEREOF, NAMELY, FRAMES, SHEETING, GIRTS AND PURLINS; PRE-ENGINEERED STEEL BUILDINGS AND STRUCTURAL COMPONENTS THEREOF, NAMELY, BUILDING FRAMES, STEEL ROOF AND WALL SYSTEMS, STEEL CLADDING FOR ROOF AND WALL SYSTEMS, DOORS AND INSULATION (U.S. CLS. 2, 12, 13, 14, 23, 25 AND 50).

FIRST USE 6-0-2010; IN COMMERCE 6-0-2010.

CLASS 6—(Continued).

3,999,479. TEVENTI LLC, ROSWELL, GA. SN 85-046,132. PUB. 10-19-2010, FILED 5-24-2010.

LeMist

THE MARK CONSISTS OF STANDARD CHARACTERS WITHOUT CLAIM TO ANY PARTICULAR FONT, STYLE, SIZE, OR COLOR.

FOR MULTI-COMPARTMENTED BEVERAGE POUCH MADE OF FLEXIBLE FOIL AND PLASTIC-LAMINATED MATERIAL FOR MIXING AND DISPENSING BEVERAGES (U.S. CLS. 2, 12, 13, 14, 23, 25 AND 50).

FIRST USE 2-21-2011; IN COMMERCE 2-21-2011.

3,999,512. BRIDGER STEEL, INC., BELGRADE, MT. SN 85-054,464. PUB. 11-2-2010, FILED 6-3-2010.

ULTRA BATTEN

THE MARK CONSISTS OF STANDARD CHARACTERS WITHOUT CLAIM TO ANY PARTICULAR FONT, STYLE, SIZE, OR COLOR.

NO CLAIM IS MADE TO THE EXCLUSIVE RIGHT TO USE "BATTEN", APART FROM THE MARK AS SHOWN.

FOR INTEGRAL BATTEN STANDING SEAM PANEL MADE OF STEEL AND USED FOR CONSTRUCTION PURPOSES (U.S. CLS. 2, 12, 13, 14, 23, 25 AND 50).

FIRST USE 3-1-2011; IN COMMERCE 3-1-2011.

3,999,660. ILLINOIS TOOL WORKS INC., GLENVIEW, IL. SN 85-097,140. PUB. 10-26-2010, FILED 7-30-2010.

TETRAGRIP

THE MARK CONSISTS OF STANDARD CHARACTERS WITHOUT CLAIM TO ANY PARTICULAR FONT, STYLE, SIZE, OR COLOR.

FOR METAL THREADED FASTENERS (U.S. CLS. 2, 12, 13, 14, 23, 25 AND 50).

FIRST USE 7-0-2010; IN COMMERCE 5-25-2011.

CLASS 6—(Continued).

3,999,830. NORTHERN TOOL & EQUIPMENT COMPANY, INC., BURNSVILLE, MN. SN 85-159,283. PUB. 4-12-2011, FILED 10-22-2010.

Roughneck

THE MARK CONSISTS OF STANDARD CHARACTERS WITHOUT CLAIM TO ANY PARTICULAR FONT, STYLE, SIZE, OR COLOR.

FOR HAND OPERATED METAL GARDEN WATER HOSE REELS; SPRING-RETRACTED METAL WATER HOSE REELS (U.S. CLS. 2, 12, 13, 14, 23, 25 AND 50).
FIRST USE 3-1-2011; IN COMMERCE 3-1-2011.

CLASS 7—(Continued).

3,998,402. MATTSON TECHNOLOGY, INC., FREMONT, CA. SN 77-226,992. PUB. 3-25-2008, FILED 7-11-2007.

MILLIOS

THE MARK CONSISTS OF STANDARD CHARACTERS WITHOUT CLAIM TO ANY PARTICULAR FONT, STYLE, SIZE, OR COLOR.

THE WORDING "MILLIOS" HAS NO MEANING IN A FOREIGN LANGUAGE.

FOR SEMICONDUCTOR WAFER PROCESSORS (U.S. CLS. 13, 19, 21, 23, 31, 34 AND 35).
FIRST USE 5-31-2011; IN COMMERCE 5-31-2011.

CLASS 7—MACHINERY

3,998,316. WORKSAVER, INC., LITCHFIELD, IL. SN 76-699,136. PUB. 3-1-2011, FILED 8-24-2009.

SPLITCAP

THE MARK CONSISTS OF STANDARD CHARACTERS WITHOUT CLAIM TO ANY PARTICULAR FONT, STYLE, SIZE, OR COLOR.

FOR METAL SEALS FOR USE ON HYDRAULIC POST DRIVERS; METAL CAPS FOR SEALING A CYLINDER FOR USE ON HYDRAULIC POST DRIVES; THREADED METAL RODS FOR USE ON HYDRAULIC POST DRIVERS (U.S. CLS. 13, 19, 21, 23, 31, 34 AND 35).
FIRST USE 8-0-2009; IN COMMERCE 9-0-2009.

3,998,519. LUZERNE INVESTMENTS LTD., WICKHAMS CITY, BR.VIRGIN ISLANDS. SN 77-557,644. PUB. 8-25-2009, FILED 8-28-2008.



FOR PACKING MACHINES (U.S. CLS. 13, 19, 21, 23, 31, 34 AND 35).
FIRST USE 12-17-2010; IN COMMERCE 12-17-2010.

3,998,398. APPLIED MATERIALS, INC., SANTA CLARA, CA. SN 77-212,685. PUB. 3-4-2008, FILED 6-21-2007.

CARINA

THE MARK CONSISTS OF STANDARD CHARACTERS WITHOUT CLAIM TO ANY PARTICULAR FONT, STYLE, SIZE, OR COLOR.

FOR MACHINES FOR THE PROCESSING AND PRODUCTION OF SEMICONDUCTOR SUBSTRATES, THIN CONDUCTIVE FILMS, SILICON DISCS AND SILICON WAFERS (U.S. CLS. 13, 19, 21, 23, 31, 34 AND 35).
FIRST USE 1-31-2011; IN COMMERCE 1-31-2011.

3,998,539. RADICAL CONCEPT PRODUCTS, INC., DBA RETROTEK SPEED, HAWTHORNE, CA. SN 77-578,720. PUB. 2-17-2009, FILED 9-25-2008.

POWERFIRE

THE MARK CONSISTS OF STANDARD CHARACTERS WITHOUT CLAIM TO ANY PARTICULAR FONT, STYLE, SIZE, OR COLOR.

FOR IGNITION SYSTEM COMPONENTS, NAMELY, DISTRIBUTORS FOR IGNITION SYSTEMS OF MOTOR VEHICLES (U.S. CLS. 13, 19, 21, 23, 31, 34 AND 35).
FIRST USE 3-4-2009; IN COMMERCE 3-4-2009.

CLASS 7—(Continued).

3,998,587. HPE DESIGN, LLC, DBA HENNESSEY PERFORMANCE ENGINEERING, SEALY, TX. SN 77-630,364. PUB. 12-1-2009, FILED 12-10-2008.

VENOM GT

THE MARK CONSISTS OF STANDARD CHARACTERS WITHOUT CLAIM TO ANY PARTICULAR FONT, STYLE, SIZE, OR COLOR.

NO CLAIM IS MADE TO THE EXCLUSIVE RIGHT TO USE "GT", APART FROM THE MARK AS SHOWN.

FOR TURBOCHARGERS; AUTOMOBILE PISTONS; MECHANICAL ENGINE PARTS FOR HIGH PERFORMANCE MODIFICATION RELATING TO ENGINE TUNING, DRIVELINE TUNING, CHASSIS TUNING, AND COMPREHENSIVE TUNING OF MOTOR VEHICLES, ALL FOR INCREASED POWER, FASTER ACCELERATION AND IMPROVED HANDLING; AUTOMOTIVE PRODUCTS FOR HIGH PERFORMANCE MODIFICATION RELATING TO ENGINE TUNING, DRIVELINE TUNING, CHASSIS TUNING, AND COMPREHENSIVE TUNING OF MOTOR VEHICLES, NAMELY, EXHAUST SYSTEMS COMPRISING MUFFLERS, HEADERS, EXHAUST MANIFOLDS, EXHAUST PIPES AND PIPEHANGERS, INTAKE MANIFOLDS, EXHAUST MANIFOLDS, TURBOCHARGERS, AND FUEL MANAGEMENT SYSTEMS COMPRISING FUEL INJECTORS, ELECTRONIC ENGINE PERFORMANCE CHIPS AND THROTTLE BODIES ALL FOR INCREASED POWER, FASTER ACCELERATION AND IMPROVED HANDLING (U.S. CLS. 13, 19, 21, 23, 31, 34 AND 35).

FIRST USE 1-1-2010; IN COMMERCE 4-1-2010.

CLASS 7—(Continued).

3,998,656. ABUNDANT ENERGY, L.L.C., PLANO, TX. SN 77-725,449. PUB. 3-16-2010, FILED 4-29-2009.



NO CLAIM IS MADE TO THE EXCLUSIVE RIGHT TO USE "WIND ENERGY", APART FROM THE MARK AS SHOWN.

THE COLOR(S) BLUE AND ORANGE IS/ARE CLAIMED AS A FEATURE OF THE MARK.

THE MARK CONSISTS OF A BLUE WHIRLWIND DISSECTED BY AN ORANGE BOLT OF LIGHTNING DIRECTLY ABOVE THE WORDS "VERT-I-GO" IN STYLIZED BLUE TYPEFACE, WHICH ARE DIRECTLY ABOVE THE WORDS "WIND" AND "ENERGY" APPEARING IN STYLIZED ORANGE TYPE FACE.

FOR ELECTRICITY GENERATORS, NAMELY, WIND-POWERED ELECTRICITY GENERATORS, WIND TURBINES, WATER-POWERED ELECTRICITY GENERATORS, WATER TURBINES; AND REPLACEMENT PARTS AND COMPONENTS THEREOF (U.S. CLS. 13, 19, 21, 23, 31, 34 AND 35).

FIRST USE 9-15-2009; IN COMMERCE 9-15-2009.

3,998,591. THE TORO COMPANY, BLOOMINGTON, MN. SN 77-634,805. PUB. 3-15-2011, FILED 12-17-2008.

PIONEER

THE MARK CONSISTS OF STANDARD CHARACTERS WITHOUT CLAIM TO ANY PARTICULAR FONT, STYLE, SIZE, OR COLOR.

FOR COMMERCIAL RIDING LAWN MOWERS (U.S. CLS. 13, 19, 21, 23, 31, 34 AND 35).

FIRST USE 10-0-2010; IN COMMERCE 10-0-2010.

3,998,803. FREIEZO LLC, SAINT PETERS, MO. SN 77-837,760. PUB. 9-21-2010, FILED 9-29-2009.

Wind Joule

THE MARK CONSISTS OF STANDARD CHARACTERS WITHOUT CLAIM TO ANY PARTICULAR FONT, STYLE, SIZE, OR COLOR.

NO CLAIM IS MADE TO THE EXCLUSIVE RIGHT TO USE "WIND", APART FROM THE MARK AS SHOWN.

FOR WIND TURBINES (U.S. CLS. 13, 19, 21, 23, 31, 34 AND 35).

FIRST USE 5-10-2011; IN COMMERCE 5-10-2011.

CLASS 7—(Continued).

3,998,811. NATIONAL OILWELL VARCO, L.P., HOUSTON, TX. SN 77-840,343. PUB. 9-21-2010, FILED 10-2-2009.

DRAKE

THE MARK CONSISTS OF STANDARD CHARACTERS WITHOUT CLAIM TO ANY PARTICULAR FONT, STYLE, SIZE, OR COLOR.

FOR OILFIELD DRILLING RIGS (U.S. CLS. 13, 19, 21, 23, 31, 34 AND 35).

FIRST USE 1-31-2009; IN COMMERCE 1-31-2009.

3,998,881. INDEXATOR AB, VINDELN, SWEDEN. SN 77-861,463. PUB. 4-20-2010, FILED 10-30-2009.



OWNER OF U.S. REG. NO. 2,382,830.

THE MARK CONSISTS OF A SYMBOL WHICH CONSISTS OF A STYLIZED ROUNDED CORNER TRIANGLE PROCEEDING THE WORD "INDEXATOR".

FOR PARTS FOR HYDRAULIC CRANES, BOOMS AND ARMS, NAMELY, TILT ROTATORS, GRAPPLE MODULES, GRAPPLES, ROTATORS, ROTATOR LINKS, AND ROTATOR SWING DAMPERS (U.S. CLS. 13, 19, 21, 23, 31, 34 AND 35).

FIRST USE 5-16-1995; IN COMMERCE 5-16-1995.

3,998,882. INDEXATOR AB, VINDELN S-92221, SWEDEN. SN 77-861,468. PUB. 4-20-2010, FILED 10-30-2009.

ROTOTILT

THE MARK CONSISTS OF STANDARD CHARACTERS WITHOUT CLAIM TO ANY PARTICULAR FONT, STYLE, SIZE, OR COLOR.

OWNER OF U.S. REG. NO. 2,296,384.

FOR PARTS FOR HYDRAULIC CRANES, BOOMS AND ARMS, NAMELY, TILT ROTATORS, GRAPPLE MODULES, AND GRAPPLES (U.S. CLS. 13, 19, 21, 23, 31, 34 AND 35).

FIRST USE 5-16-1995; IN COMMERCE 5-16-1995.

CLASS 7—(Continued).

3,999,024. NINGBO FANGLI GROUP CO., LTD., NINGBO, ZHEJIANG, CHINA. SN 77-909,626. PUB. 10-19-2010, FILED 1-12-2010.

FANGLI

THE MARK CONSISTS OF STYLIZED WORD "FANGLI". FOR VACUUM PUMPS; SHAFT COUPLINGS FOR MACHINES; SHREDDERS FOR INDUSTRIAL USE; ELECTRIC GLUE GUNS; ELECTRIC WELDING MACHINES; BELT CONVEYORS; INDUSTRIAL MACHINE PRESSES; CUTTING MACHINES FOR METALWORKING; MACHINES AND MACHINE TOOLS FOR THE CUTTING AND FORMING OF MATERIALS; PLASTIC EXTRUDERS (U.S. CLS. 13, 19, 21, 23, 31, 34 AND 35).

FIRST USE 7-2-2010; IN COMMERCE 7-2-2010.

3,999,299. TECHTRONIC FLOOR CARE TECHNOLOGY LIMITED, ROAD TOWN, TORTOLA, BR. VIRGIN ISLANDS. SN 85-021,584. PUB. 9-28-2010, FILED 4-23-2010.

NOBODY DOES IT LIKE YOU

THE MARK CONSISTS OF STANDARD CHARACTERS WITHOUT CLAIM TO ANY PARTICULAR FONT, STYLE, SIZE, OR COLOR.

FOR FLOOR CARE APPLIANCES, NAMELY, VACUUM CLEANERS, CARPET EXTRACTORS, AND BARE FLOOR CLEANING MACHINES; VACUUM CLEANER PARTS AND ACCESSORIES, NAMELY, BRUSHES, HOSES, SUCTION NOZZLES, FILTERS AND VACUUM CLEANER BAGS (U.S. CLS. 13, 19, 21, 23, 31, 34 AND 35).

FIRST USE 4-0-2011; IN COMMERCE 4-0-2011.

3,999,308. ENGINEERING & RESEARCH ASSOCIATES, INC., TUCSON, AZ. SN 85-023,410. PUB. 9-28-2010, FILED 4-26-2010.

VANTE

THE MARK CONSISTS OF STANDARD CHARACTERS WITHOUT CLAIM TO ANY PARTICULAR FONT, STYLE, SIZE, OR COLOR.

CLASS 7—(Continued).

THE ENGLISH TRANSLATION OF "VANTE" IS "PRAISE".
FOR POWER TOOLS, NAMELY, PORTABLE AND
NON-PORTABLE HAND HELD INSTRUMENTS FOR
FORMING, EXTRUDING, SHAPING AND WELDING
THERMOPLASTIC TUBING (U.S. CLS. 13, 19, 21, 23, 31,
34 AND 35).

FIRST USE 5-23-2011; IN COMMERCE 5-23-2011.

CLASS 7—(Continued).

3,999,729. COW CREEK RANCH HOUSE LLC, OKEMAH,
OK. SN 85-123,874. PUB. 2-22-2011, FILED 9-7-2010.

RADIATOR-GENIE

3,999,560. TEK INDUSTRIES, INC., FREMONT, NE. SN 85-
065,028. PUB. 11-16-2010, FILED 6-17-2010.

THE MARK CONSISTS OF THE STYLIZED TEXT "RA-
DIATOR-GENIE" WITH A LINE CONNECTING THE FIRST
LETTER "R" AND THE "G".

FOR RADIATOR CLEANING DEVICE, NAMELY, A
HIGH PRESSURE AIR OR WATER WAND FOR THE
PURPOSE OF CLEANING DEBRIS FOUND IN RADIA-
TORS (U.S. CLS. 13, 19, 21, 23, 31, 34 AND 35).

FIRST USE 1-2-2011; IN COMMERCE 1-18-2011.

GO! BABY

3,999,749. HAAN CORPORATION, SEOUL, REPUBLIC OF
KOREA. SN 85-130,673. PUB. 2-22-2011, FILED 9-15-2010.

THE MARK CONSISTS OF STANDARD CHARACTERS
WITHOUT CLAIM TO ANY PARTICULAR FONT, STYLE,
SIZE, OR COLOR.

OWNER OF U.S. REG. NOS. 3,729,472 AND 3,775,633.

FOR QUILTING SUPPLIES AND ACCESSORIES,
NAMELY, CUTTING MACHINES FOR QUILTING AND
CRAFT USE AND DIES FOR USE WITH THE AFORE-
MENTIONED CUTTING MACHINES (U.S. CLS. 13, 19,
21, 23, 31, 34 AND 35).

FIRST USE 10-1-2010; IN COMMERCE 10-1-2010.

**Experience Steam, Discover
Clean**

THE MARK CONSISTS OF STANDARD CHARACTERS
WITHOUT CLAIM TO ANY PARTICULAR FONT, STYLE,
SIZE, OR COLOR.

FOR STEAM CLEANING MACHINES, CARPET
CLEANING MACHINES, ELECTRIC STEAM MOPS
(U.S. CLS. 13, 19, 21, 23, 31, 34 AND 35).

FIRST USE 9-20-2010; IN COMMERCE 9-20-2010.

3,999,652. REEFDALE PTY LTD, BRAESIDE, VICTORIA,
AUSTRALIA. SN 85-092,633. PUB. 1-4-2011, FILED 7-26-
2010.

CLASS 8—HAND TOOLS

3,998,330. H&L TOOTH COMPANY, TULSA, OK. SN 76-
701,986. PUB. 8-3-2010, FILED 3-9-2010.

MINI MAX

PIN CADDY

THE MARK CONSISTS OF STANDARD CHARACTERS
WITHOUT CLAIM TO ANY PARTICULAR FONT, STYLE,
SIZE, OR COLOR.

FOR SCREEN PRINTING MACHINES (U.S. CLS. 13, 19,
21, 23, 31, 34 AND 35).

FIRST USE 9-29-2010; IN COMMERCE 9-29-2010.

THE MARK CONSISTS OF STANDARD CHARACTERS
WITHOUT CLAIM TO ANY PARTICULAR FONT, STYLE,
SIZE, OR COLOR.

NO CLAIM IS MADE TO THE EXCLUSIVE RIGHT TO
USE "PIN", APART FROM THE MARK AS SHOWN.

FOR HAND-OPERATED TOOL FOR REMOVING AND
INSERTING A RETAINING PIN ON BUCKET TEETH
FOR HEAVY EQUIPMENT (U.S. CLS. 23, 28 AND 44).

FIRST USE 1-5-2011; IN COMMERCE 3-7-2011.

CLASS 8—(Continued).

3,998,532. GB II CORPORATION, DBA COLUMBIA RIVER KNIFE & TOOL COMPANY, TUALATIN, OR. SN 77-572,196. PUB. 3-17-2009, FILED 9-17-2008.

GRANDPA'S FAVORITE

THE MARK CONSISTS OF STANDARD CHARACTERS WITHOUT CLAIM TO ANY PARTICULAR FONT, STYLE, SIZE, OR COLOR.

FOR FOLDING KNIVES (U.S. CLS. 23, 28 AND 44).
FIRST USE 5-15-2011; IN COMMERCE 5-15-2011.

3,999,440. SMITH ABRASIVES, INC., HOT SPRINGS, AR. SN 85-038,079. PUB. 10-26-2010, FILED 5-13-2010.

GetSharp 3-N-1

THE MARK CONSISTS OF STANDARD CHARACTERS WITHOUT CLAIM TO ANY PARTICULAR FONT, STYLE, SIZE, OR COLOR.

NO CLAIM IS MADE TO THE EXCLUSIVE RIGHT TO USE "3 IN 1", APART FROM THE MARK AS SHOWN.

FOR HAND TOOLS, NAMELY, KNIFE SHARPENERS; HAND-OPERATED SHARPENING TOOLS AND INSTRUMENTS; KNIFE SHARPENERS; MANUALLY OPERATED SHARPENERS (U.S. CLS. 23, 28 AND 44).

FIRST USE 4-30-2011; IN COMMERCE 4-30-2011.

CLASS 9—ELECTRICAL AND SCIENTIFIC APPARATUS

3,998,300. ARISTOCRAT TECHNOLOGIES AUSTRALIA PTY LTD. NORTH RYDE, NSW, AUSTRALIA. SN 76-256,309. PUB. 6-8-2004, FILED 5-9-2001.

PIRATES

PRIORITY CLAIMED UNDER SEC. 44(D) ON AUSTRALIA APPLICATION NO. 862479, FILED 1-9-2001, REG. NO. 862479, DATED 1-9-2001, EXPIRES 1-9-2011.

FOR MACHINES FOR PLAYING GAMES OF CHANCE NOT RELATED TO BASEBALL OR SOFTBALL OR A BASEBALL OR SOFTBALL TEAM (U.S. CLS. 21, 23, 26, 36 AND 38).

FIRST USE 3-1-2003; IN COMMERCE 3-1-2003.

CLASS 9—(Continued).

3,998,309. NOROOZ PRODUCTIONS, LLC, NEW YORK, NY. SN 76-682,516. PUB. 3-18-2008, FILED 10-2-2007.

MIXED NUTZ

THE MARK CONSISTS OF STANDARD CHARACTERS WITHOUT CLAIM TO ANY PARTICULAR FONT, STYLE, SIZE, OR COLOR.

FOR DVD'S, VIDEOTAPES, CD'S AND AUDIOTAPES FEATURING ANIMATED CHARACTERS FOR CHILDREN'S VIEWING; HAND-HELD UNITS FOR PLAYING ELECTRONIC GAMES FOR USE WITH EXTERNAL DISPLAY SCREEN OR MONITOR; VIDEO GAME MACHINES FOR USE WITH TELEVISION (U.S. CLS. 21, 23, 26, 36 AND 38).

FIRST USE 1-5-2011; IN COMMERCE 1-5-2011.

3,998,311. KIMBERLING, KARYN S., ARLINGTON, VA. SN 76-683,632. PUB. 4-22-2008, FILED 11-5-2007.

CLARVOYNT

THE MARK CONSISTS OF STANDARD CHARACTERS WITHOUT CLAIM TO ANY PARTICULAR FONT, STYLE, SIZE, OR COLOR.

FOR COMPUTER SEARCH ENGINE SOFTWARE; COMPUTER SOFTWARE FOR USE IN DATA MINING AND DATABASE MANAGEMENT; COMPUTER SOFTWARE FOR THE COLLECTION, EDITING, ORGANIZING, MODIFYING, BOOK MARKING, TRANSMISSION, STORAGE AND SHARING OF DATA AND INFORMATION; COMPUTER SOFTWARE FOR ACCESSING INFORMATION DIRECTORIES THAT MAY BE DOWNLOADED FROM THE GLOBAL COMPUTER NETWORK; COMPUTER SOFTWARE TO AUTOMATE DATA WAREHOUSING (U.S. CLS. 21, 23, 26, 36 AND 38).

FIRST USE 8-1-2010; IN COMMERCE 8-1-2010.

CLASS 9—(Continued).

3,998,312. KIMBERLING, KARYN S., ARLINGTON, VA. SN 76-683,633. PUB. 4-22-2008, FILED 11-5-2007.

CEEQIT

THE MARK CONSISTS OF STANDARD CHARACTERS WITHOUT CLAIM TO ANY PARTICULAR FONT, STYLE, SIZE, OR COLOR.

FOR COMPUTER SEARCH ENGINE SOFTWARE; COMPUTER SOFTWARE FOR USE IN DATA MINING AND DATABASE MANAGEMENT; COMPUTER SOFTWARE FOR THE COLLECTION, EDITING, ORGANIZING, MODIFYING, BOOK MARKING, TRANSMISSION, STORAGE AND SHARING OF DATA AND INFORMATION; COMPUTER SOFTWARE FOR ACCESSING INFORMATION DIRECTORIES THAT MAY BE DOWNLOADED FROM THE GLOBAL COMPUTER NETWORK; COMPUTER SOFTWARE TO AUTOMATE DATA WAREHOUSING (U.S. CLS. 21, 23, 26, 36 AND 38).
FIRST USE 8-1-2010; IN COMMERCE 8-1-2010.

3,998,317. INTERSTATE INDUSTRIES, INC., LOVINGSTON, VA. SN 76-699,396. PUB. 12-29-2009, FILED 9-10-2009.

HEMI-SYNC.COM

THE MARK CONSISTS OF STANDARD CHARACTERS WITHOUT CLAIM TO ANY PARTICULAR FONT, STYLE, SIZE, OR COLOR.

OWNER OF U.S. REG. NOS. 1,276,849, 3,015,866, AND OTHERS.

FOR PRE-RECORDED COMPACT DISCS AND CASSETTE TAPES FEATURING MUSIC AND CONTENT FOR MENTAL CONDITIONING AND RELAXATION TECHNIQUES (U.S. CLS. 21, 23, 26, 36 AND 38).
FIRST USE 4-1-2010; IN COMMERCE 4-1-2010.

CLASS 9—(Continued).

3,998,318. PARAMETRIC TECHNOLOGY CORPORATION, NEEDHAM, MA. SN 76-699,432. PUB. 5-25-2010, FILED 9-14-2009.

MATHCAD PRIME

OWNER OF U.S. REG. NO. 1,457,219.
FOR COMPUTER SOFTWARE FOR COMPUTER AIDED DESIGN (CAD), COMPUTER AIDED MANUFACTURING (CAM), AND COMPUTER AIDED ENGINEERING (CAE); COMPUTER SOFTWARE THAT ENABLE USERS TO PERFORM, DOCUMENT AND SHARE CALCULATION AND DESIGN WORK; COMPUTER SOFTWARE THAT PROVIDES AN ELECTRONIC SCRATCHPAD FOR USE BY USERS, INCLUDING ENGINEERS, SCIENTISTS, MATHEMATICIANS AND STUDENTS, TO CALCULATE EQUATIONS, GENERATE PLOTS AND TABLES, CREATE TEXT AND PRINT OUT ALL ENTERED WORK AS AN INTEGRATED DISPLAY; AND ACCOMPANYING USER GUIDES SOLD WITH SUCH COMPUTER SOFTWARE AS A UNIT (U.S. CLS. 21, 23, 26, 36 AND 38).

FIRST USE 1-10-2011; IN COMMERCE 1-10-2011.

3,998,321. ADVANCED INSTRUMENTS, INC., NORWOOD, MA. SN 76-700,125. PUB. 4-13-2010, FILED 10-29-2009.

A₂O

FOR SCIENTIFIC APPARATUS, NAMELY, OSMOMETERS USED FOR DETERMINING OSMOTIC PRESSURE OF LIQUID SAMPLES FOR IN-VITRO DIAGNOSTIC, PHARMACEUTICAL AND INDUSTRIAL APPLICATIONS (U.S. CLS. 21, 23, 26, 36 AND 38).

FIRST USE 3-23-2011; IN COMMERCE 3-23-2011.

3,998,347. EMBARQ HOLDINGS COMPANY LLC, DBA/ AKA/TA: DBA CENTURYLINK, INC., CENTURYTEL, INC., OVERLAND PARK, KS. SN 76-979,149. PUB. 2-16-2010, FILED 5-26-2009.

 **CenturyLink**

OWNER OF U.S. REG. NOS. 2,228,120, 3,124,133, AND OTHERS.

CLASS 9—(Continued).

THE MARK CONSISTS OF THE WORDING "CENTURY-LINK" WITH A DESIGN IN NATURE OF TWELVE SMALL TRIANGLES ARRANGED IN A CIRCLE NEXT TO THE WORDING OF THE MARK.

FOR KEY TELEPHONE SYSTEMS COMPRISING KEY TELEPHONES AND PARTS FOR USE THEREFOR; DOWNLOADABLE SOFTWARE FOR USE AS A DATABASE VIA A GLOBAL COMPUTER NETWORK THAT ENABLES THE USER TO DOWNLOAD GAMES, GRAPHICS AND MUSIC TO COMPUTERS AND WIRELESS DEVICES; TELEPHONES, ALL FOR USE IN COMPUTING DEVICES; TELECOMMUNICATIONS PRODUCTS AND ELECTRONIC CONSUMER PRODUCTS, FOR USE IN THE TELECOMMUNICATIONS FIELD, AND FOR USE IN PROVIDING TELECOMMUNICATIONS CONNECTIONS (U.S. CLS. 21, 23, 26, 36 AND 38).

FIRST USE 10-19-2009; IN COMMERCE 10-19-2009.

3,998,350. EMBARQ HOLDINGS COMPANY LLC, DBA/ AKA/TA: DBA CENTURLINK, INC., CENTURYTEL, INC., OVERLAND PARK, KS. SN 76-979,158. PUB. 2-16-2010, FILED 5-26-2009.



THE COLOR(S) GREEN IS/ARE CLAIMED AS A FEATURE OF THE MARK.

THE MARK CONSISTS OF TWELVE SMALL GREEN TRIANGLES ARRANGED IN A CIRCLE.

FOR KEY TELEPHONE SYSTEMS COMPRISING KEY TELEPHONES AND PARTS FOR USE THEREFOR; DOWNLOADABLE SOFTWARE FOR USE AS A DATABASE VIA A GLOBAL COMPUTER NETWORK THAT ENABLES THE USER TO DOWNLOAD GAMES, GRAPHICS AND MUSIC TO COMPUTERS AND WIRELESS DEVICES; TELEPHONES, ALL FOR USE IN COMPUTING DEVICES; TELECOMMUNICATIONS PRODUCTS AND ELECTRONIC CONSUMER PRODUCTS, FOR USE IN THE TELECOMMUNICATIONS FIELD, AND FOR USE IN PROVIDING TELECOMMUNICATIONS CONNECTIONS (U.S. CLS. 21, 23, 26, 36 AND 38).

FIRST USE 10-19-2009; IN COMMERCE 10-19-2009.

CLASS 9—(Continued).

3,998,356. ISLAMIC RELIEF WORLDWIDE, BIRMINGHAM, UNITED KINGDOM. SN 77-058,695. PUB. 11-2-2010, FILED 12-7-2006.

IRW

THE MARK CONSISTS OF STANDARD CHARACTERS WITHOUT CLAIM TO ANY PARTICULAR FONT, STYLE, SIZE, OR COLOR.

PRIORITY CLAIMED UNDER SEC. 44(D) ON ERPNTY TM OFC APPLICATION NO. 005297742, FILED 9-7-2006.

FOR PRERECORDED AUDIO AND VIDEO CASSETTES, CDS, DVDS AND CD-ROMS ALL OF THE FOREGOING IN THE FIELDS OF ISLAM, HUMANITARIAN AID AND DEVELOPMENT, EMERGENCY AID, FINANCIAL SUPPORT, PROVISION OF FOOD, HEALTH CARE, HOUSING, EDUCATION, JOBS, CLEAN WATER AND MEDICAL ASSISTANCE TO REFUGEES AND NEEDY PERSONS; DOWNLOADABLE ELECTRONIC PUBLICATIONS IN THE NATURE OF MAGAZINES, NEWSLETTERS, AND REPORTS, ALL OF THE FOREGOING IN THE FIELDS OF ISLAM, HUMANITARIAN AID AND DEVELOPMENT, EMERGENCY AID, FINANCIAL SUPPORT, PROVISION OF FOOD, HEALTH CARE, HOUSING, EDUCATION, JOBS, CLEAN WATER AND MEDICAL ASSISTANCE TO REFUGEES AND NEEDY PERSONS (U.S. CLS. 21, 23, 26, 36 AND 38).

FIRST USE 0-0-2010; IN COMMERCE 0-0-2010.

3,998,368. ZIPCAR, INC., CAMBRIDGE, MA. SN 77-102,715. PUB. 3-25-2008, FILED 2-8-2007.

ZIPCAR

THE MARK CONSISTS OF STANDARD CHARACTERS WITHOUT CLAIM TO ANY PARTICULAR FONT, STYLE, SIZE, OR COLOR.

OWNER OF U.S. REG. NO. 2,507,028.

FOR COMPUTER PROGRAMS FOR USE IN TRANSPORTATION RESERVATION SERVICES AND MOTOR VEHICLE SHARING SERVICES; COMPUTER PROGRAMS FOR USE IN SCHEDULING, PLANNING, ORGANIZING, MANAGING AND PROVIDING THE TEMPORARY USE OF MOTOR VEHICLES; ELECTRONIC, ENCODED CARDS FOR USE IN SCHEDULING, MANAGING AND PROVIDING THE TEMPORARY USE OF MOTOR VEHICLES; SMART PROGRAMMABLE CARDS FOR USE IN SCHEDULING, MANAGING AND PROVIDING THE TEMPORARY USE OF MOTOR VEHICLES; ELECTRONIC KEY CARDS FOR USE IN SCHEDULING, MANAGING AND PROVIDING THE TEMPORARY USE OF MOTOR VEHICLES; COMPUTER PROGRAMS AND COMPUTER HARDWARE FOR SCHEDULING, MAINTAINING, AND COMMUNICATING WITH VEHICLES (U.S. CLS. 21, 23, 26, 36 AND 38).

FIRST USE 4-0-2000; IN COMMERCE 4-0-2000.

CLASS 9—(Continued).

3,998,373. GABBACADABRA LLC, SHERMAN OAKS, CA.
SN 77-115,180. PUB. 2-19-2008, FILED 2-23-2007.

YO GABBA GABBA

THE MARK CONSISTS OF STANDARD CHARACTERS WITHOUT CLAIM TO ANY PARTICULAR FONT, STYLE, SIZE, OR COLOR.

FOR ELECTRICAL AND SCIENTIFIC APPARATUS, NAMELY, CD ROMS, COMPACT DISCS, AND DIGITAL VERSATILE DISCS FEATURING MUSIC, ANIMATED CARTOONS, LIVE-ACTION PERFORMANCES AND LIVE ACTION PERFORMANCES BY COSTUMED CHARACTERS ALL IN THE FIELDS OF SCIENCE FICTION, MYSTERY, FAIRY TALES, COMEDY AND DRAMA; AUDIO SPEAKERS (U.S. CLS. 21, 23, 26, 36 AND 38).

FIRST USE 10-31-2008; IN COMMERCE 10-31-2008.

3,998,380. MARTIN ERLICHMAN ASSOCIATES, INC., LOS ANGELES, CA. SN 77-132,341. PUB. 9-11-2007, FILED 3-15-2007.

PROUD
2
BE

THE MARK CONSISTS OF THE NUMBER "2" BETWEEN THE WORDS "PROUD" AND "BE".

FOR PACKAGED SETS COMPRISED OF MUSICAL SOUND RECORDINGS AND WRITTEN PUBLICATIONS FEATURING HISTORY, CULTURE, NOTABLE PEOPLE, PLACES AND EVENTS RECORDED ON COMPUTER MEDIA (U.S. CLS. 21, 23, 26, 36 AND 38).

FIRST USE 10-27-2010; IN COMMERCE 10-27-2010.

CLASS 9—(Continued).

3,998,391. FORBES, CHRISTOPHER ALLAN, WICHITA, KS.
SN 77-194,926. PUB. 3-25-2008, FILED 5-31-2007.



THE COLOR(S) RED, WHITE AND SILVER IS/ARE CLAIMED AS A FEATURE OF THE MARK.

THE MARK CONSISTS OF GREEK CROSS IN GRADIENT COLOR FROM WHITE IN THE CENTER TO SILVER FOR THE OUTER EDGE INTERTWINED WITH THE CAPITAL LETTER "G" IN RED.

FOR DIGITAL MATERIALS, NAMELY, DOWNLOADABLE AUDIO FILES SONGS FEATURING SONGS, VIDEOS, 3D CONTENT; DIGITAL MEDIA, NAMELY, DOWNLOADABLE AUDIO FILES FEATURING SONGS, VIDEOS, 3D CONTENT (U.S. CLS. 21, 23, 26, 36 AND 38).
FIRST USE 6-6-2007; IN COMMERCE 12-1-2008.

3,998,409. VALICORE TECHNOLOGIES, INC., IRVINE, CA.
SN 77-258,041. PUB. 2-26-2008, FILED 8-17-2007.

VCORESREVER

THE MARK CONSISTS OF STANDARD CHARACTERS WITHOUT CLAIM TO ANY PARTICULAR FONT, STYLE, SIZE, OR COLOR.

FOR COMPUTER SOFTWARE AND HARDWARE FOR ENCRYPTION AND AUTHENTICATION; COMPUTER SOFTWARE AND HARDWARE FOR COMPUTER AND NETWORK SECURITY; COMPUTER SOFTWARE AND HARDWARE FOR THE ENABLING OF ACCESS OR ENTRANCE CONTROL; COMPUTER SOFTWARE AND HARDWARE USED FOR AUTHENTICATION OF PERSONAL IDENTIFICATION INFORMATION; COMPUTER SOFTWARE AND HARDWARE FOR CONTROLLING AND MANAGING ACCESS SERVER APPLICATIONS; ACCESS CONTROL SYSTEMS; NETWORK ACCESS SERVER OPERATING SOFTWARE (U.S. CLS. 21, 23, 26, 36 AND 38).

FIRST USE 6-15-2007; IN COMMERCE 5-11-2011.

CLASS 9—(Continued).

3,998,430. SWIM FREE, LLC, PACIFIC PALISADES, CA. SN 77-294,005. PUB. 3-18-2008, FILED 10-2-2007.

SWIM FREE

THE MARK CONSISTS OF STANDARD CHARACTERS WITHOUT CLAIM TO ANY PARTICULAR FONT, STYLE, SIZE, OR COLOR.

OWNER OF U.S. REG. NO. 2,548,249.

NO CLAIM IS MADE TO THE EXCLUSIVE RIGHT TO USE "SWIM", APART FROM THE MARK AS SHOWN.

FOR SWIM GOGGLES AND SWIM MASKS; SUNGLASSES; FLOATATION SWIM VESTS; INFLATABLE FLOTATION DEVICES FOR SAFETY (U.S. CLS. 21, 23, 26, 36 AND 38).

FIRST USE 12-1-2008; IN COMMERCE 12-1-2008.

CLASS 9—(Continued).

3,998,453. AVAAK, INC., SAN DIEGO, CA. SN 77-376,450. PUB. 9-23-2008, FILED 1-21-2008.

VUE

THE MARK CONSISTS OF STANDARD CHARACTERS WITHOUT CLAIM TO ANY PARTICULAR FONT, STYLE, SIZE, OR COLOR.

FOR A CAMERA SYSTEM COMPRISING OF BATTERY-OPERATED MINIATURE CAMERAS HAVING INTEGRATED LOW-POWER RADIOS THAT COMMUNICATE CONTROL AND IMAGE DATA USING NETWORK COMMUNICATION PROTOCOLS; A CAMERA SYSTEM COMPRISING OF BATTERY-OPERATED MINIATURE VIDEO CAMERAS HAVING INTEGRATED LOW-POWER RADIOS THAT COMMUNICATE CONTROL AND VIDEO DATA USING NETWORK COMMUNICATION PROTOCOLS (U.S. CLS. 21, 23, 26, 36 AND 38).

FIRST USE 10-20-2008; IN COMMERCE 9-15-2009.

3,998,462. WILLIAM RAST LICENSING, LLC, LOS ANGELES, CA. SN 77-388,266. PUB. 4-14-2009, FILED 2-4-2008.

3,998,450. SONY CORPORATION, TOKYO, JAPAN. SN 77-355,426. PUB. 4-22-2008, FILED 12-19-2007.

BrightFace



THE MARK CONSISTS OF STANDARD CHARACTERS WITHOUT CLAIM TO ANY PARTICULAR FONT, STYLE, SIZE, OR COLOR.

FOR NETWORK CAMERAS AND THEIR CONTROL SYSTEM, NAMELY, VIDEO CAMERAS, VIDEO SERVERS, VIDEO DATA CONVERTERS, MOBILE TERMINAL DEVICES WITH VIDEO CAMERAS (U.S. CLS. 21, 23, 26, 36 AND 38).

FIRST USE 12-31-2010; IN COMMERCE 12-31-2010.

THE MARK CONSISTS OF HALF OF THE LETTER "W" WITH AN INTERSECTING CURVED LINE THROUGH THE LEFT LEG.

FOR SUNGLASSES; EYEGLASSES; FRAMES FOR SUNGLASSES AND EYEGLASSES; CASES FOR SUNGLASSES AND EYEGLASSES; EYEGLASS AND SUNGLASS CASES MADE OF LEATHER OR IMITATION LEATHER (U.S. CLS. 21, 23, 26, 36 AND 38).

FIRST USE 9-8-2010; IN COMMERCE 9-8-2010.

CLASS 9—(Continued).

3,998,486. IGT, RENO, NV. SN 77-453,678. PUB. 3-24-2009, FILED 4-21-2008.



OWNER OF U.S. REG. NO. 3,400,149.
 FOR COMPUTER SOFTWARE AND HARDWARE FOR OPERATING CASINO RESORTS, NAMELY, MANAGEMENT OF MARKETING CAMPAIGNS, CASINO PROMOTIONS, REAL TIME OFFERS AND REDEMPTIONS, CUSTOMER RELATIONSHIP MANAGEMENT, PATRON MANAGEMENT, PLAYER TRACKING, DELIVERING MEDIA THAT ENABLES PLAYER INTERACTION AND INSTANT REWARD REDEMPTION, DETERMINING REWARDS AND BONUS GAMES FOR MACHINES, GAME DOWNLOADS, UPDATING GAME CONTENT, GAME SCHEDULING, CASINO FLOOR CONFIGURATION, GAME CONFIGURATION, SLOT MACHINE ACCOUNTING, TICKETING FOR CASHLESS GAMING, VISUAL EVALUATION OF PERFORMANCE, SECURITY MONITORING, CONDUCTING BUSINESS INTELLIGENCE, DATA WAREHOUSING, ALL FOR THE GAMING INDUSTRY (U.S. CLS. 21, 23, 26, 36 AND 38).
 FIRST USE 6-0-2009; IN COMMERCE 6-0-2009.

3,998,487. IGT, RENO, NV. SN 77-453,683. PUB. 3-24-2009, FILED 4-21-2008.

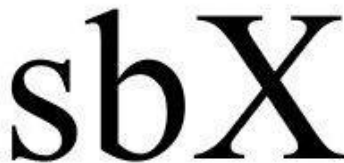

THE MARK CONSISTS OF STANDARD CHARACTERS WITHOUT CLAIM TO ANY PARTICULAR FONT, STYLE, SIZE, OR COLOR.
 OWNER OF U.S. REG. NO. 3,400,149.
 FOR COMPUTER SOFTWARE AND HARDWARE FOR OPERATING CASINO RESORTS, NAMELY, MANAGEMENT OF MARKETING CAMPAIGNS, CASINO PROMOTIONS, REAL TIME OFFERS AND REDEMPTIONS, CUSTOMER RELATIONSHIP MANAGEMENT, PATRON MANAGEMENT, PLAYER TRACKING, DELIVERING MEDIA THAT ENABLES PLAYER INTERACTION AND INSTANT REWARD REDEMPTION, DETERMINING REWARDS AND BONUS GAMES FOR MACHINES, GAME DOWNLOADS, UPDATING GAME CONTENT, GAME SCHEDULING, CASINO FLOOR CONFIGURATION, GAME CONFIGURATION, SLOT MACHINE ACCOUNTING, TICKETING FOR CASHLESS GAMING, VISUAL EVALUATION OF PERFORMANCE, SECURITY MONITORING, CONDUCTING BUSINESS INTELLIGENCE, DATA WAREHOUSING, ALL FOR THE GAMING INDUSTRY (U.S. CLS. 21, 23, 26, 36 AND 38).
 FIRST USE 6-0-2009; IN COMMERCE 6-0-2009.

CLASS 9—(Continued).

3,998,494. EAGAN, LYNNE, MARINA DEL REY, CA. SN 77-472,530. PUB. 10-14-2008, FILED 5-12-2008.

SHOWER VISION

THE MARK CONSISTS OF STANDARD CHARACTERS WITHOUT CLAIM TO ANY PARTICULAR FONT, STYLE, SIZE, OR COLOR.
 NO CLAIM IS MADE TO THE EXCLUSIVE RIGHT TO USE "VISION", APART FROM THE MARK AS SHOWN.
 FOR EYE GLASSES; MAGNIFYING GLASSES; MAGNIFYING GLASSES THAT FIT ON THE USER'S FACE IN THE MANNER OF EYEGLASSES; READING GLASSES (U.S. CLS. 21, 23, 26, 36 AND 38).
 FIRST USE 10-22-2009; IN COMMERCE 12-7-2009.

3,998,509. DART CHART SYSTEMS, LLC, MILWAUKEE, WI. SN 77-532,156. PUB. 2-17-2009, FILED 7-26-2008.

DARTVOICE

THE MARK CONSISTS OF STANDARD CHARACTERS WITHOUT CLAIM TO ANY PARTICULAR FONT, STYLE, SIZE, OR COLOR.
 FOR COMPUTER SOFTWARE FOR INTERVIEWING PATIENTS AND DOCUMENTING PATIENT RESPONSES (U.S. CLS. 21, 23, 26, 36 AND 38).
 FIRST USE 10-0-2010; IN COMMERCE 10-0-2010.

3,998,513. ALLIANCE STORAGE TECHNOLOGIES, INC., COLORADO SPRINGS, CO. SN 77-540,743. PUB. 10-27-2009, FILED 8-6-2008.

ARCHIVE APPLIANCE EXPRESS

THE MARK CONSISTS OF STANDARD CHARACTERS WITHOUT CLAIM TO ANY PARTICULAR FONT, STYLE, SIZE, OR COLOR.

CLASS 9—(Continued).

NO CLAIM IS MADE TO THE EXCLUSIVE RIGHT TO USE "ARCHIVE APPLIANCE", APART FROM THE MARK AS SHOWN.

FOR COMPUTER SOFTWARE FOR DATA STORAGE, RETRIEVAL AND ARCHIVING; COMPUTER HARDWARE; ELECTRICAL AND OPTICAL DATA PROCESSING APPARATUS; BLANK OPTICAL DISCS AND BLANK DISC CARTRIDGES; PARTS AND FITTINGS FOR ALL OF THE AFORESAID GOODS; COMPUTER PROGRAMS FOR DATA STORAGE, RETRIEVAL AND ARCHIVING; BLANK MAGNETIC DISCS, ELECTRICAL WIRES AND FILAMENTS, ALL FOR USE WITH COMPUTERS AND DATA PROCESSING APPARATUS; BLANK MAGNETIC DISC CARTRIDGES; OPTICAL DISC DRIVES FOR ACCESSING MULTIPLE OPTICAL DISCS; OPTICAL AND MAGNETIC DISC DRIVES; PRE-RECORDED OPTICAL AND MAGNETIC DISCS FEATURING MUSIC, MUSICAL DATA, MOTION PICTURES, PHOTOGRAPHS AND COMPUTER PROGRAMS FOR DATA STORAGE, RETRIEVAL AND ARCHIVING (U.S. CLS. 21, 23, 26, 36 AND 38).

FIRST USE 2-6-2008; IN COMMERCE 2-6-2008.

3,998,516. SHAMIR INSIGHT, INC., SAN DIEGO, CA. SN 77-547,036. PUB. 1-27-2009, FILED 8-14-2008.

SHAMIR ELEMENT

THE MARK CONSISTS OF STANDARD CHARACTERS WITHOUT CLAIM TO ANY PARTICULAR FONT, STYLE, SIZE, OR COLOR.

FOR EYEGLASS LENSES (U.S. CLS. 21, 23, 26, 36 AND 38).

FIRST USE 9-16-2008; IN COMMERCE 9-16-2008.

3,998,524. FUJI SILYSIA CHEMICAL LTD., KASUGAI-SHI, AICHI-KEN, JAPAN. SN 77-562,071. PUB. 10-26-2010, FILED 9-4-2008.

CHROMATOREX

THE MARK CONSISTS OF STANDARD CHARACTERS WITHOUT CLAIM TO ANY PARTICULAR FONT, STYLE, SIZE, OR COLOR.

OWNER OF U.S. REG. NO. 2,773,905.
FOR CHROMATOGRAPHY COLUMNS FOR INDUSTRIAL PURPOSES; THIN LAYER PLATES FOR CHROMATOGRAPHY FOR INDUSTRIAL PURPOSES; CHROMATOGRAPHY COLUMNS FOR LABORATORY USE; THIN LAYER PLATES FOR CHROMATOGRAPHY FOR LABORATORY USE (U.S. CLS. 21, 23, 26, 36 AND 38).

FIRST USE 7-3-1986; IN COMMERCE 6-19-1998.

CLASS 9—(Continued).

3,998,530. ASAHİ RESEARCH CORPORATION, TOKYO, JAPAN. SN 77-567,763. PUB. 5-5-2009, FILED 9-11-2008.

DRIVEMAN

THE MARK CONSISTS OF STANDARD CHARACTERS WITHOUT CLAIM TO ANY PARTICULAR FONT, STYLE, SIZE, OR COLOR.

FOR DEVICE FOR USE IN A MOTOR VEHICLE TO RECORD IMAGES, NAMELY, A DRIVE RECORDER (U.S. CLS. 21, 23, 26, 36 AND 38).

FIRST USE 1-6-2011; IN COMMERCE 1-6-2011.

3,998,542. ORTRONICS, INC., NEW LONDON, CT. SN 77-580,391. PUB. 2-17-2009, FILED 9-26-2008.

LAYER ZERO

THE MARK CONSISTS OF STANDARD CHARACTERS WITHOUT CLAIM TO ANY PARTICULAR FONT, STYLE, SIZE, OR COLOR.

FOR EQUIPMENT FOR VOICE AND DATA COMMUNICATIONS SYSTEMS, NAMELY, CABLE MANAGEMENT RACKS AND CABINETS FOR COPPER AND FIBER OPTIC DATA CABLES FOR STRUCTURED CABLING SYSTEMS (U.S. CLS. 21, 23, 26, 36 AND 38).

FIRST USE 11-5-2009; IN COMMERCE 11-5-2009.

3,998,543. ORTRONICS, INC., NEW LONDON, CT. SN 77-580,392. PUB. 2-17-2009, FILED 9-26-2008.

LAYER 0

THE MARK CONSISTS OF STANDARD CHARACTERS WITHOUT CLAIM TO ANY PARTICULAR FONT, STYLE, SIZE, OR COLOR.

FOR EQUIPMENT FOR VOICE AND DATA COMMUNICATIONS SYSTEMS, NAMELY, CABLE MANAGEMENT RACKS AND CABINETS FOR COPPER AND FIBER OPTIC DATA CABLES FOR STRUCTURED CABLING SYSTEMS (U.S. CLS. 21, 23, 26, 36 AND 38).

FIRST USE 11-5-2009; IN COMMERCE 11-5-2009.

CLASS 9—(Continued).

3,998,545. CLEAR-COM LLC, POWAY, CA. SN 77-582,749. PUB. 8-25-2009, FILED 9-30-2008.

PRODUCTION MAESTRO

THE MARK CONSISTS OF STANDARD CHARACTERS WITHOUT CLAIM TO ANY PARTICULAR FONT, STYLE, SIZE, OR COLOR.

NO CLAIM IS MADE TO THE EXCLUSIVE RIGHT TO USE "PRODUCTION", APART FROM THE MARK AS SHOWN.

FOR ELECTRICAL VOICE INTRACOMMUNICATIONS SYSTEMS FOR USE IN THE PRODUCTION OF LIVE MUSICAL PERFORMANCES, THEATRE, AND OTHER LIVE EVENTS, NAMELY, A CENTRALIZED COMPUTER NETWORK ROUTER WITH A CENTRALIZED ROUTING TOOL THAT CAN PRE-SET AND MANAGE LIVE EXTERNAL LINES OUT OF A MASTER CONTROL ROOM OR SPORTS VENUE CONTROL CENTER TO REMOTE USERS' PANELS AND THEIR KEYS AND A SOFTWARE APPLICATION THAT ALLOWS USERS TO ROUTE 4-WIRE LINES TO PANEL USERS VIA CONFERENCES (U.S. CLS. 21, 23, 26, 36 AND 38).

FIRST USE 10-0-2010; IN COMMERCE 10-0-2010.

CLASS 9—(Continued).

3,998,589. PNEUMATIC SCALE CORPORATION, AKRON, OH. SN 77-631,616. PUB. 4-14-2009, FILED 12-11-2008.

UNIFUGE

THE MARK CONSISTS OF STANDARD CHARACTERS WITHOUT CLAIM TO ANY PARTICULAR FONT, STYLE, SIZE, OR COLOR.

FOR LABORATORY APPARATUS, NAMELY, CENTRIFUGES (U.S. CLS. 21, 23, 26, 36 AND 38).

FIRST USE 4-28-2011; IN COMMERCE 4-28-2011.

3,998,593. MERIDIAN KIOSKS LLC, ABERDEEN, NC. SN 77-636,550. PUB. 8-10-2010, FILED 12-19-2008.

Meridian Kiosks

THE MARK CONSISTS OF STANDARD CHARACTERS WITHOUT CLAIM TO ANY PARTICULAR FONT, STYLE, SIZE, OR COLOR.

NO CLAIM IS MADE TO THE EXCLUSIVE RIGHT TO USE "KIOSKS", APART FROM THE MARK AS SHOWN.

FOR INTERACTIVE COMPUTER KIOSKS COMPRISING COMPUTERS, COMPUTER HARDWARE, COMPUTER PERIPHERALS, AND COMPUTER OPERATING SOFTWARE, FOR USE IN AUTOMATING CONSUMER TRANSACTIONS (U.S. CLS. 21, 23, 26, 36 AND 38).

FIRST USE 1-1-2001; IN COMMERCE 1-1-2001.

3,998,558. MICOMPRO LIMITED, LONDON, ONTARIO, CANADA. SN 77-595,971. PUB. 3-2-2010, FILED 10-20-2008.



OWNER OF CANADA REG. NO. TMA755507, DATED 12-17-2009, EXPIRES 12-17-2024.

NO CLAIM IS MADE TO THE EXCLUSIVE RIGHT TO USE "PARTS", APART FROM THE MARK AS SHOWN.

THE MARK CONSISTS OF STYLIZED REPRESENTATION OF THE WORD "PARTSHANDLER".

FOR COMPUTER SOFTWARE, NAMELY, INVENTORY MANAGEMENT SOFTWARE USED FOR INVENTORY CONTROL, INVOICING, ACCOUNTING, SALES AND PROFIT ANALYSIS FOR PRODUCTS AND IN PARTICULAR FOR AUTOMOTIVE PARTS STOCK, AND COMPUTER SOFTWARE MANUALS SOLD THEREWITH (U.S. CLS. 21, 23, 26, 36 AND 38).

FIRST USE 9-0-2009; IN COMMERCE 9-0-2009.

3,998,602. DOLBY LABORATORIES LICENSING CORPORATION, SAN FRANCISCO, CA. SN 77-664,935. PUB. 10-12-2010, FILED 2-6-2009.



OWNER OF U.S. REG. NOS. 2,347,473, 2,361,147, AND 2,484,193.

NO CLAIM IS MADE TO THE EXCLUSIVE RIGHT TO USE "DIGITAL", APART FROM THE MARK AS SHOWN.

CLASS 9—(Continued).

THE MARK CONSISTS OF TWO UPPER CASE "D" LETTERS, FACING EACH OTHER, AND INSIDE A SHADED RECTANGLE, TO THE RIGHT OF WHICH IS THE WORD "DOLBY", AND UNDERNEATH WHICH IS A HORIZONTAL LINE THAT CONNECTS TO A DOWNWARD VERTICAL LINE, ABOVE THE WORD "DIGITAL".

FOR CINEMATOGRAPHIC FILM EMBEDDED WITH A FEATURE THAT DIGITALLY PROCESSES AND ENHANCES THE RECORDING AND PLAYBACK OF SOUND EFFECTS AND SOUND TRACKS; MULTI-CHANNEL SOUND PROCESSORS; AUDIO/VIDEO AMPLIFIERS AND RECEIVERS; TELEVISION RECEIVERS; SET-TOP BOXES FOR RECEIVING TELEVISION AND AUDIO PROGRAMMING; DIGITAL MEDIA STREAMING DEVICES; VIDEO MONITORS; VIDEO TUNERS; AUDIO AND VIDEO RECORDERS; AUDIO AND VIDEO DISC PLAYERS; AUDIO AND VIDEO DISC DUBBING DECKS; MAGNETIC, OPTICAL AND DIGITAL STORAGE MEDIA, NAMELY, PRE-RECORDED COMPUTER DISCS, COMPACT DISCS, AUDIO DISCS, VIDEO DISCS, DIGITAL VERSATILE DISCS, DIGITAL VIDEO DISCS, HIGH DEFINITION DIGITAL DISCS, OPTICAL AND MAGNETO-OPTICAL DISCS AND DOWNLOADABLE AUDIO AND VIDEO RECORDINGS, EMBEDDED WITH A FEATURE THAT DIGITALLY PROCESSES AND ENHANCES THE RECORDING AND PLAYBACK OF AUDIO SOUND, SOUND EFFECTS AND SOUND TRACKS CONTAINED THEREIN FEATURING MUSIC, SOUND EFFECTS, SPOKEN WORD, ENTERTAINMENT AND GENERAL INFORMATION IN THE FIELD OF SPORTS, TRAVEL, HEALTH, MUSIC, COMEDY, MOVIES, EDUCATION, GAMES, FASHION, VIDEO AND COMPUTER GAMES, TELEVISION, RADIO, LITERATURE, POLITICS, ECONOMY, FINANCE, BOOKS, TRAVEL, ENTERTAINMENT IN THE FIELD OF MUSIC, COMEDY AND VARIETY SHOWS, ECOLOGY, MATHEMATICS, SCIENCE, LANGUAGE, NEWS IN THE FIELD OF ENTERTAINMENT, CURRENT EVENTS AND POLITICS, AND ART; MAGNETIC STORAGE MEDIA, OPTICAL STORAGE MEDIA AND DIGITAL STORAGE MEDIA, NAMELY, DVDS AND DOWNLOADABLE AUDIO AND VIDEO FILES FEATURING MUSIC, VOICE, AUDIOVISUAL, MULTIMEDIA, AND DIGITAL DATA STREAMS, EMBEDDED WITH INFORMATION FOR AUDIO CODING, DECODING, RECORDING AND PLAYBACK, IN THE FIELD OF SPORTS, TRAVEL, HEALTH, MUSIC, COMEDY, MOVIES, EDUCATION, GAMES, FASHION, VIDEO AND COMPUTER GAMES, TELEVISION, RADIO, LITERATURE, POLITICS, ECONOMY, FINANCE, BOOKS, TRAVEL, ENTERTAINMENT IN THE FIELD OF MUSIC, COMEDY, AND VARIETY SHOWS, ECOLOGY, MATHEMATICS, SCIENCE, LANGUAGE, NEWS IN THE FIELD OF ENTERTAINMENT, CURRENT EVENTS AND POLITICS, AND ART; CABLE TELEVISION RECEIVERS AND DECODERS; REMOTE CONTROLS FOR CABLE TELEVISION RECEIVERS AND DECODERS, TELEVISIONS; AUDIO/VIDEO AMPLIFIERS AND RECEIVERS, TELEVISION RECEIVERS, SET-TOP BOXES FOR RECEIVING TELEVISION AND AUDIO PROGRAMMING; DIGITAL MEDIA STREAMING DEVICES; VIDEO MONITORS; VIDEO TUNERS; AUDIO AND VIDEO RECORDERS; AUDIO AND VIDEO DISC PLAYERS; AUDIO AND VIDEO DISC DUBBING DECKS; COMPUTER PROGRAMS USED TO DIGITALLY PROCESS AND ENHANCE THE RECORDING AND PLAYBACK OF AUDIO SOUND, SOUND EFFECTS AND SOUND TRACKS; ELECTRONIC BROADCAST SIGNAL PROCESSORS; PORTABLE AND HANDHELD DIGITAL ELECTRONIC DEVICES FOR RECORDING, TRANSMITTING, MANIPULATING, AND REVIEWING AUDIO, IMAGE AND VIDEO FILES; ELECTRONIC SATELLITE BROADCAST SIGNAL PROCESSORS; COMPUTER AND VIDEO GAME CONSOLES FOR USE WITH AN EXTERNAL DISPLAY SCREEN OR MONITOR (U.S. CLS. 21, 23, 26, 36 AND 38).

FIRST USE 1-7-2008; IN COMMERCE 8-12-2008.

CLASS 9—(Continued).

3,998,606. ANDREWS MCMEEL PUBLISHING, LLC, KANSAS CITY, MO. SN 77-670,063. PUB. 3-8-2011, FILED 2-13-2009.



THE MARK CONSISTS OF A DRAWING OF A COMPUTER MONITOR WITH A DIALOGUE TAIL AT THE BOTTOM. RUNNING BEHIND IT IS A SHADED RECTANGLE IN WHICH THE WORD "BUBBLES" APPEARS TO THE RIGHT OF THE MONITOR.

FOR SOFTWARE THAT PROVIDES AN ELECTRONIC DAILY CALENDAR THAT PROVIDES NEWS AND INFORMATION REGARDING CURRENT AND HISTORICAL EVENTS, ENTERTAINMENT INFORMATION AND OTHER CONTENT IN THE NATURE OF COMIC STRIPS, POP CULTURE INFORMATION AND INFORMATION ON HISTORIC FIGURES, PUBLIC FIGURES AND CELEBRITIES THAT CAN BE VIEWED, STORED AND TRANSMITTED TO OTHERS (U.S. CLS. 21, 23, 26, 36 AND 38).

FIRST USE 4-28-2010; IN COMMERCE 11-1-2010.

3,998,608. EXIDE TECHNOLOGIES, MILTON, GA. SN 77-680,206. PUB. 10-5-2010, FILED 2-27-2009.

ONYX

THE MARK CONSISTS OF STANDARD CHARACTERS WITHOUT CLAIM TO ANY PARTICULAR FONT, STYLE, SIZE, OR COLOR.

FOR BATTERIES FOR STORAGE OF ENERGY AS A POWER SOURCE AND A BACK-UP SOURCE FOR USE IN INDUSTRIAL APPLICATIONS, NAMELY, LIGHTING SYSTEMS, TELECOMMUNICATIONS SYSTEMS, SECURITY SYSTEMS, UTILITIES, AND MEDICAL DEVICES (U.S. CLS. 21, 23, 26, 36 AND 38).

FIRST USE 3-31-2009; IN COMMERCE 3-31-2009.

CLASS 9—(Continued).

3,998,637. NBC UNIVERSAL MEDIA, LLC, NEW YORK, NY.
SN 77-713,010. PUB. 8-4-2009, FILED 4-13-2009.

GREEN LIVES HERE

THE MARK CONSISTS OF STANDARD CHARACTERS WITHOUT CLAIM TO ANY PARTICULAR FONT, STYLE, SIZE, OR COLOR.

FOR DOWNLOADABLE GAMES VIA A GLOBAL COMPUTER NETWORK, WIRELESS, HANDHELD AND ELECTRONIC DEVICES (U.S. CLS. 21, 23, 26, 36 AND 38).
FIRST USE 4-0-2010; IN COMMERCE 4-0-2010.

CLASS 9—(Continued).

3,998,660. LENNOX INDUSTRIES INC., RICHARDSON, TX.
SN 77-726,386. PUB. 9-15-2009, FILED 4-30-2009.



THE MARK CONSISTS OF IMAGE OF A HOUSE LOCATED ABOVE THE TERM "ICOMFORT." BELOW THE TERM "ICOMFORT" ARE THE TERMS "SO SIMPLE. SO SMART. SO COMFORTABLE."

FOR THERMOSTATS; ELECTRONIC CONTROLLERS FOR CONTROLLING A DUAL HEAT PUMP AND FUEL-FIRED HEATING SYSTEM; ELECTRONIC CONTROLLERS FOR CONTROLLING MOTORIZED DAMPERS IN A ZONED HVAC SYSTEM; ELECTRONIC SENSORS FOR SENSING TEMPERATURE AND HUMIDITY (U.S. CLS. 21, 23, 26, 36 AND 38).

FIRST USE 12-1-2010; IN COMMERCE 12-1-2010.

3,998,666. IGT, RENO, NV. SN 77-732,650. PUB. 9-22-2009,
FILED 5-8-2009.

CASH COASTER

THE MARK CONSISTS OF STANDARD CHARACTERS WITHOUT CLAIM TO ANY PARTICULAR FONT, STYLE, SIZE, OR COLOR.

FOR GAMING MACHINES, NAMELY, DEVICES WHICH ACCEPT A WAGER (U.S. CLS. 21, 23, 26, 36 AND 38).

FIRST USE 2-14-2011; IN COMMERCE 3-24-2011.

3,998,657. NVIDIA CORPORATION, SANTA CLARA, CA. SN
77-726,077. PUB. 10-5-2010, FILED 4-30-2009.

NVIDIA ION

THE MARK CONSISTS OF STANDARD CHARACTERS WITHOUT CLAIM TO ANY PARTICULAR FONT, STYLE, SIZE, OR COLOR.

OWNER OF U.S. REG. NOS. 1,895,559, 3,087,428, AND OTHERS.

FOR COMPUTER HARDWARE, NAMELY, GRAPHICS-PROCESSING UNITS, INTEGRATED CIRCUITS, SEMICONDUCTORS AND CHIP SETS (U.S. CLS. 21, 23, 26, 36 AND 38).

FIRST USE 4-8-2009; IN COMMERCE 4-8-2009.

3,998,667. S. J. ELECTRO SYSTEMS, INC., DETROIT LAKES,
MN. SN 77-732,728. PUB. 2-8-2011, FILED 5-8-2009.

ECO SMART STATION

THE MARK CONSISTS OF STANDARD CHARACTERS WITHOUT CLAIM TO ANY PARTICULAR FONT, STYLE, SIZE, OR COLOR.

CLASS 9—(Continued).

NO CLAIM IS MADE TO THE EXCLUSIVE RIGHT TO USE "SMART STATION", APART FROM THE MARK AS SHOWN.

FOR WATER AND WASTEWATER CONTROL PANEL CONTAINING VARIABLE FREQUENCY DRIVES AND CONTROLLERS (U.S. CLS. 21, 23, 26, 36 AND 38).

FIRST USE 11-10-2010; IN COMMERCE 11-10-2010.

CLASS 9—(Continued).

3,998,683. IGT, RENO, NV. SN 77-749,944. PUB. 9-22-2009, FILED 6-2-2009.

3,998,670. CAPSO VISION, INC., SARATOGA, CA. SN 77-736,220. PUB. 4-13-2010, FILED 5-13-2009.

CAPSOVIEW

THE MARK CONSISTS OF STANDARD CHARACTERS WITHOUT CLAIM TO ANY PARTICULAR FONT, STYLE, SIZE, OR COLOR.

FOR COMPUTER DOCKING STATIONS FOR USE WITH INGESTIBLE DIAGNOSTIC CAMERAS; COMPUTER WORKSTATIONS CONSISTING OF CENTRAL PROCESSING UNITS, MONITORS, KEYBOARDS, AND MICE FOR USE WITH INGESTIBLE DIAGNOSTIC CAMERAS; COMPUTER SOFTWARE FOR IMAGING AND IMAGE ANALYSIS FOR USE WITH INGESTIBLE DIAGNOSTIC CAMERAS AND COMPUTER DOCKING STATIONS AND WORKSTATIONS (U.S. CLS. 21, 23, 26, 36 AND 38).

FIRST USE 1-6-2011; IN COMMERCE 1-6-2011.

TRIPLE RUBY RICHES

THE MARK CONSISTS OF STANDARD CHARACTERS WITHOUT CLAIM TO ANY PARTICULAR FONT, STYLE, SIZE, OR COLOR.

OWNER OF U.S. REG. NO. 3,459,549.
FOR GAMING MACHINES, NAMELY, DEVICES WHICH ACCEPT A WAGER (U.S. CLS. 21, 23, 26, 36 AND 38).

FIRST USE 2-16-2011; IN COMMERCE 5-26-2011.

3,998,685. LG ELECTRONICS INC., SEOUL, REPUBLIC OF KOREA. SN 77-752,017. PUB. 4-5-2011, FILED 6-4-2009.

3,998,682. IGT, RENO, NV. SN 77-748,108. PUB. 11-2-2010, FILED 5-29-2009.

PROGRESSIVE STREAK

THE MARK CONSISTS OF STANDARD CHARACTERS WITHOUT CLAIM TO ANY PARTICULAR FONT, STYLE, SIZE, OR COLOR.

NO CLAIM IS MADE TO THE EXCLUSIVE RIGHT TO USE "PROGRESSIVE", APART FROM THE MARK AS SHOWN.

FOR A FEATURE OF GAMING MACHINES, NAMELY, DEVICES WHICH ACCEPT A WAGER (U.S. CLS. 21, 23, 26, 36 AND 38).

FIRST USE 3-10-2011; IN COMMERCE 3-10-2011.

BLISS

THE MARK CONSISTS OF STANDARD CHARACTERS WITHOUT CLAIM TO ANY PARTICULAR FONT, STYLE, SIZE, OR COLOR.

FOR MOBILE PHONES; TELEVISION RECEIVERS (U.S. CLS. 21, 23, 26, 36 AND 38).

FIRST USE 7-31-2009; IN COMMERCE 7-31-2009.

CLASS 9—(Continued).

3,998,686. HUAWEI TECHNOLOGIES CO., LTD., SHENZHEN, CHINA. SN 77-753,197. PUB. 11-9-2010, FILED 6-5-2009.

FUTUREWEI

THE MARK CONSISTS OF STANDARD CHARACTERS WITHOUT CLAIM TO ANY PARTICULAR FONT, STYLE, SIZE, OR COLOR.

FOR APPARATUS AND INSTRUMENTS FOR DATA COMMUNICATION, SATELLITE COMMUNICATION AND TELECOMMUNICATION, NAMELY, MOBILE PHONES, COMPUTERS, TELEPHONES, MODEMS, ETHERNET CARDS BEING ETHERNET ADAPTERS AND PERSONAL DIGITAL ASSISTANTS, AUTOMATIC TELEPHONE EXCHANGES; TELECOMMUNICATIONS AND DATA NETWORKING HARDWARE, NAMELY, COMPUTER HARDWARE FOR TELECOMMUNICATIONS FOR TRANSPORTING AND AGGREGATING VOICE, DATA, AND VIDEO COMMUNICATIONS ACROSS MULTIPLE NETWORK INFRASTRUCTURES AND COMMUNICATIONS PROTOCOLS, DATA PROCESSORS, COMPUTER TERMINALS, TELECOMMUNICATION SWITCHES, MULTIPLEXERS; CENTRAL PROCESSING UNITS FOR PROCESSING DATA; VIDEO CONFERENCING SYSTEM, NAMELY, VIDEO MONITORS, CAMERAS, CONFERENCING HARDWARE AND SOFTWARE, AND CONFERENCE ROOM FURNITURE BEING CONFERENCE ROOM TABLES INSTALLED WITH AND CONFIGURED FOR THE VIDEO CONFERENCING SYSTEM, ALL SOLD AS INTEGRAL COMPONENTS BEING PART OF AN INTEGRAL UNIT; COMPUTER SOFTWARE FOR TELECOMMUNICATION SYSTEMS; TELECOMMUNICATIONS DATA NETWORKING HARDWARE, NAMELY, COMPONENTS FOR OPTICAL TRANSMISSION OF ANALOG AND DIGITAL SIGNALS, NAMELY, OPTICAL SIGNAL PROCESSORS; FIBER OPTIC TELECOMMUNICATIONS SYSTEMS AND DATA NETWORKING HARDWARE, NAMELY, DEVICES FOR TRANSPORTING AND AGGREGATING VOICE, DATA AND VIDEO COMMUNICATIONS ACROSS MULTIPLE NETWORK INFRASTRUCTURES AND COMMUNICATIONS PROTOCOLS, ALL WITH FIBER OPTICS, OPTICAL FIBER COUPLERS, APPARATUS FOR INTERCONNECTING FIBER OPTIC NETWORKS WITH WIRE BASED NETWORKS NAMELY, TELEPHONE NETWORKS AND CABLE NETWORKS, NAMELY, DEVICES FOR TRANSPORTING AND AGGREGATING VOICE, DATA AND VIDEO COMMUNICATIONS ACROSS MULTIPLE NETWORK INFRASTRUCTURES AND COMMUNICATIONS PROTOCOLS; TRANSMITTERS OF ELECTRONIC SIGNALS BEING OPTICAL SIGNAL TRANSMITTERS, NETWORK OPTICAL FIBER REPEATERS, AND COMMUNICATION HUBS FOR TELECOMMUNICATION SYSTEMS, OPTICAL COMMUNICATION SYSTEMS COMPRISING FIBER OPTIC CABLES, FIBER OPTIC TRANSMITTERS, OPTICAL LIKE UNITS, NAMELY, OPTICAL DATA LINKS AND OPTICAL RECEIVERS, COMMUNICATION HUBS, NETWORK INTERFACE UNITS AND COMPUTER SOFTWARE FOR COMPUTER SYSTEM MANAGEMENT; TELECOMMUNICATIONS EQUIPMENT, NAMELY, TELECOMMUNICATION LINE INTEGRITY TESTING APPARATUS; BATTERIES, ELECTRONIC COMPONENTS, NAMELY, RECTIFIERS, CAPACITORS, HYBRID CIRCUITS, NAMELY, ELECTRONIC INTEGRATED CIRCUITS, INTEGRATED CIRCUITS, MICROCIRCUITS, SEMICONDUCTORS; TELECOMMUNICATION EQUIPMENT, NAMELY, ELECTRONIC RADIO BASE STATIONS FOR CELLULAR AND FIXED NETWORKING AND COMMUNICATIONS APPLICATIONS, ELECTRONIC DIGITAL SPEECH ENCRYPTION UNITS; RADAR; TELECOMMUNICATION EQUIPMENT, NAMELY, AERIALS; TELECOMMUNICATION EQUIPMENT, NAMELY, MEASURING AND CONTROL DEVICES FOR AIR CONDITIONING TECHNOLOGY; TELECOMMUNICA-

CLASS 9—(Continued).

TION EQUIPMENT, NAMELY, AMMETERS, CURRENT CONVERTERS FOR ELECTRICAL MEASURING; REAL TIME AUTOMATED PROCESS CONTROL SYSTEM, NAMELY, MICRO-PROCESSOR BASED HARDWARE AND SOFTWARE USED TO MONITOR THE STATUS OF TELECOMMUNICATION EQUIPMENT; REAL TIME AUTOMATED PROCESS CONTROL SYSTEM, NAMELY, MICRO-PROCESSOR BASED HARDWARE AND SOFTWARE USED TO MONITOR THE STATUS OF WIRELESS THEFT ALARMS SYSTEMS COMPRISING A CENTRAL CONTROL UNIT, LOCATION CODE TRANSMITTERS AND PORTABLE ALARM TERMINALS; TELECOMMUNICATION EQUIPMENT, NAMELY, VOICE AND DATA COMMUNICATION SYSTEMS COMPRISING TELEPHONES, FAX MACHINES, MODEMS, CALL PROCESSORS, NAMELY, SIGNAL PROCESSORS FOR USE IN PROCESSING THE INFORMATION FROM INCOMING CALLS TO OUTGOING TERMINALS IN THE PUBLIC SERVICE TELEPHONE NETWORK, INTERCOMS, PAGES, TELEPHONE ANSWERING MACHINES, COMPUTER SOFTWARE FOR PRIVATE BRANCH EXCHANGE (PBX) DIALING SERVICES; TURN-KEY TELECOMMUNICATIONS SYSTEMS IN THE NATURE OF COMPLETE OUTSIDE-PLANT NETWORKS AND IN-HOUSE SYSTEMS, NAMELY, TELECOMMUNICATIONS AND DATA NETWORKING HARDWARE AND SOFTWARE, NAMELY, DEVICES AND COMPUTER PROGRAMS FOR TRANSPORTING AND AGGREGATING VOICE, DATA AND VIDEO COMMUNICATIONS ACROSS MULTIPLE NETWORK INFRASTRUCTURE AND COMMUNICATIONS PROTOCOLS (U.S. CLS. 21, 23, 26, 36 AND 38).

FIRST USE 1-2-2009; IN COMMERCE 1-2-2009.

3,998,694. EMERSON NETWORK POWER, ENERGY SYSTEMS, NORTH AMERICA, INC., WARRENVILLE, IL. SN 77-762,833. PUB. 1-11-2011, FILED 6-18-2009.

NETXTEND

THE MARK CONSISTS OF STANDARD CHARACTERS WITHOUT CLAIM TO ANY PARTICULAR FONT, STYLE, SIZE, OR COLOR.

FOR HOUSINGS FOR COMMUNICATIONS EQUIPMENT, NAMELY, METAL CABINETS DESIGNED TO PROTECT POWER SUPPLIES, FEEDER AND DISTRIBUTION CABLES, AND CONNECTIONS THEREFOR (U.S. CLS. 21, 23, 26, 36 AND 38).

FIRST USE 3-31-2007; IN COMMERCE 3-31-2007.

3,998,722. CAD AUDIO, LLC, SOLON, OH. SN 77-792,487. PUB. 9-7-2010, FILED 7-29-2009.



OWNER OF U.S. REG. NO. 2,238,631. NO CLAIM IS MADE TO THE EXCLUSIVE RIGHT TO USE "AUDIO", APART FROM THE MARK AS SHOWN.

CLASS 9—(Continued).

THE MARK CONSISTS OF THE LARGER, STYLIZED, BLOCK TEXT "CAD", WHICH APPEARS ABOVE THE SMALLER, SOLID, BLOCK TEXT "AUDIO"; A LINE CUTS THROUGH THE TERM "CAD" FROM THE MIDDLE OF THE "C", THROUGH THE MIDDLE OF THE "A", AND INTO THE MIDDLE OF THE "D".

FOR MICROPHONES; MICROPHONE ACCESSORIES, NAMELY, STANDS, MOUNTS, CABLES, CORDS, WIND-SCREENS, AND FILTERS; HEADPHONES (U.S. CLS. 21, 23, 26, 36 AND 38).

FIRST USE 2-1-2011; IN COMMERCE 2-1-2011.

3,998,727. OPSUITE LLC, GERMANTOWN, MD. SN 77-796,585. PUB. 7-20-2010, FILED 8-4-2009.

OPSUITE

THE MARK CONSISTS OF STANDARD CHARACTERS WITHOUT CLAIM TO ANY PARTICULAR FONT, STYLE, SIZE, OR COLOR.

FOR COMPUTER SOFTWARE FOR MANAGEMENT OF POINT OF SALE TERMINALS; COMPUTER SOFTWARE FOR RETAIL SALES TRACKING, INVENTORY MANAGEMENT, RETAIL REPORTING AND ANALYSIS, AND LOSS PREVENTION; COMPUTER SOFTWARE FOR RETAIL GOODS INVENTORY MANAGEMENT; COMPUTER DATABASE MANAGEMENT SOFTWARE FOR RETAIL OPERATIONS; COMPUTER SPREADSHEET AND DATABASE MANAGEMENT SOFTWARE FOR RETAIL PERSONNEL MANAGEMENT (U.S. CLS. 21, 23, 26, 36 AND 38).

FIRST USE 1-12-2009; IN COMMERCE 1-12-2009.

3,998,736. LIN, YUNG KEN, CITY OF INDUSTRY, CA. AND LIN, CHIEN-WEN, IRVINE, CA. SN 77-805,373. PUB. 2-2-2010, FILED 8-14-2009.

David-Link

THE NAME(S), PORTRAIT(S), AND/OR SIGNATURE(S) SHOWN IN THE MARK DOES NOT IDENTIFY A PARTICULAR LIVING INDIVIDUAL.

THE COLOR(S) DARK BLUE IS/ARE CLAIMED AS A FEATURE OF THE MARK.

THE MARK CONSISTS OF THE STYLIZED WORDING "DAVID-LINK" IN DARK BLUE WRITING.

FOR BIOMETRIC FINGERPRINT DOOR LOCK; COMPUTERIZED TIME CLOCK WITH FINGERPRINT RECOGNITION; ELECTRONICALLY ENCODED BADGES AND SWIPE CARDS FOR USE WITH TIME CLOCKS; ENTRY/EXIT SECURITY PORTAL COMPRISED OF AN ELECTRONIC PASSAGEWAY EQUIPPED WITH BIOMETRIC DEVICES FOR IDENTIFICATION VERIFICATION AND DETECTION OF IMPERMISSIBLE ITEMS BEING CARRIED THROUGH; PUNCH CLOCKS; TIME CLOCKS (U.S. CLS. 21, 23, 26, 36 AND 38).

FIRST USE 6-6-2011; IN COMMERCE 6-6-2011.

CLASS 9—(Continued).

3,998,737. YUNG KEN LIN, CITY OF INDUSTRY, CA. AND CHIEN-WEN LIN, IRVINE, CA. SN 77-805,379. PUB. 2-2-2010, FILED 8-14-2009.

NIBO

THE COLOR(S) RED IS/ARE CLAIMED AS A FEATURE OF THE MARK.

THE MARK CONSISTS OF STYLIZED LETTERS OF "N", "I", "B", "O" WITH RED COLOR ALL OVER THE MARK.

FOR COMPUTERIZED TIME CLOCK WITH FINGERPRINT RECOGNITION; ELECTRONICALLY ENCODED BADGES AND SWIPE CARDS FOR USE WITH TIME CLOCKS; ENTRY/EXIT SECURITY PORTAL COMPRISED OF AN ELECTRONIC PASSAGEWAY EQUIPPED WITH BIOMETRIC DEVICES FOR IDENTIFICATION VERIFICATION AND DETECTION OF IMPERMISSIBLE ITEMS BEING CARRIED THROUGH; PUNCH CLOCKS; TIME AND DATE STAMPING MACHINES; TIME CLOCKS; WATCHMAN'S TIME RECORDERS, NAMELY, A DEVICE FOR RECORDING THE ACTIVITIES OF SECURITY GUARDS TO INSURE THAT THE SECURITY GUARD ARRIVES AT SCHEDULED CHECKPOINTS (U.S. CLS. 21, 23, 26, 36 AND 38).

FIRST USE 6-6-2011; IN COMMERCE 6-6-2011.

3,998,741. UNICORN INFORMATION SYSTEM CO., LTD., SONGPA-GU, SEOUL, REPUBLIC OF KOREA. SN 77-812,348. PUB. 7-27-2010, FILED 8-25-2009.

Xtreamer
Media Player & Streamer

NO CLAIM IS MADE TO THE EXCLUSIVE RIGHT TO USE "MEDIA PLAYER" AND "STREAMER", APART FROM THE MARK AS SHOWN.

THE MARK CONSISTS OF A LARGE "X" FOLLOWED BY THE TEXT "TREAMER", WITH THREE CURVED LINES ABOVE THE SECOND "R" IN TREAMER. THE WORDING "MEDIA PLAYER & STREAMER" APPEARS UNDERNEATH.

FOR DVD PLAYER, DVD DRIVE, DIGITAL VIDEO PLAYER, MPEG AUDIO LAYER-3 PLAYERS, DIGITAL AUDIO PLAYER (U.S. CLS. 21, 23, 26, 36 AND 38).

FIRST USE 8-31-2009; IN COMMERCE 9-30-2009.

CLASS 9—(Continued).

3,998,746. BAISDEN ENTERTAINMENT, LLC, DALLAS, TX. SN 77-815,856. PUB. 8-10-2010, FILED 8-29-2009.

THE B-SIDE

THE MARK CONSISTS OF STANDARD CHARACTERS WITHOUT CLAIM TO ANY PARTICULAR FONT, STYLE, SIZE, OR COLOR.

FOR AUDIO RECORDINGS FEATURING MUSIC; DIGITAL MEDIA, NAMELY, DOWNLOADABLE AUDIO AND VIDEO FILES, MULTIMEDIA FILES, TEXT FILES, E-MAILS, WRITTEN DOCUMENTS, AUDIO MATERIAL, VIDEO MATERIAL AND GAMES IN THE FIELD OF MUSIC; VIDEO RECORDINGS FEATURING MUSIC; DOWNLOADABLE MUSIC VIA THE INTERNET AND WIRELESS DEVICES; DOWNLOADABLE MP3 FILES, MP3 RECORDINGS, AND PODCASTS IN THE FIELD OF MUSIC; APPARATUS FOR RECORDING, TRANSMITTING, REPRODUCING OR PROCESSING SOUND OR IMAGES IN DIGITAL MATERIALS AND DIGITAL MEDIA, NAMELY, CDS, DVDS, OPTICAL DISC, AND DOWNLOADABLE AUDIO AND VISUAL FILES FEATURING MUSIC; DIGITAL MATERIALS AND DIGITAL MEDIA, NAMELY, CDS, DVDS, OPTICAL DISC, AND DOWNLOADABLE AUDIO AND VISUAL FILES FEATURING MUSIC; SOFTWARE FOR COMPUTER GAMES; SOFTWARE USED IN CREATING MUSIC OR MULTIMEDIA SEQUENCES; COMPUTER SOFTWARE FOR READING MUSIC OR MULTIMEDIA SEQUENCES (U.S. CLS. 21, 23, 26, 36 AND 38).
FIRST USE 1-3-2010; IN COMMERCE 1-3-2010.

3,998,750. CORNING INCORPORATED, CORNING, NY. SN 77-818,478. PUB. 12-22-2009, FILED 9-2-2009.

HYPERSTACK

THE MARK CONSISTS OF STANDARD CHARACTERS WITHOUT CLAIM TO ANY PARTICULAR FONT, STYLE, SIZE, OR COLOR.

FOR CELL CULTURE VESSEL (U.S. CLS. 21, 23, 26, 36 AND 38).
FIRST USE 2-8-2011; IN COMMERCE 2-8-2011.

CLASS 9—(Continued).

3,998,755. CROWN EQUIPMENT CORPORATION, NEW BREMEN, OH. SN 77-820,715. PUB. 3-2-2010, FILED 9-4-2009.

eSmart

THE MARK CONSISTS OF STANDARD CHARACTERS WITHOUT CLAIM TO ANY PARTICULAR FONT, STYLE, SIZE, OR COLOR.

FOR COMPONENTS OF LIFT TRUCKS AND FORK LIFT TRUCKS, NAMELY, FUEL GAUGES (U.S. CLS. 21, 23, 26, 36 AND 38).

FIRST USE 0-0-2010; IN COMMERCE 0-0-2010.

3,998,783. CENTRIFY CORPORATION, SUNNYVALE, CA. SN 77-832,609. PUB. 6-29-2010, FILED 9-22-2009.

DIRECTCONTROL EXPRESS

THE MARK CONSISTS OF STANDARD CHARACTERS WITHOUT CLAIM TO ANY PARTICULAR FONT, STYLE, SIZE, OR COLOR.

OWNER OF U.S. REG. NO. 3,231,849.

NO CLAIM IS MADE TO THE EXCLUSIVE RIGHT TO USE "DIRECT CONTROL", APART FROM THE MARK AS SHOWN.

FOR SOFTWARE FOR SECURING COMMUNICATION BETWEEN COMPUTERS (U.S. CLS. 21, 23, 26, 36 AND 38).

FIRST USE 7-20-2010; IN COMMERCE 7-20-2010.

3,998,824. STRIKE TECHNOLOGIES (PROPRIETARY) LIMITED, BRYANSTON, SOUTH AFRICA. SN 77-846,807. PUB. 9-21-2010, FILED 10-12-2009.

ZORC

THE MARK CONSISTS OF STANDARD CHARACTERS WITHOUT CLAIM TO ANY PARTICULAR FONT, STYLE, SIZE, OR COLOR.

FOR VOLTAGE SURGE PROTECTORS AND VOLTAGE SURGE SUPPRESSORS (U.S. CLS. 21, 23, 26, 36 AND 38).

FIRST USE 11-0-1981; IN COMMERCE 3-0-2007.

CLASS 9—(Continued).

3,998,833. EMTEX LTD., STATION ROAD, UNITED KINGDOM. SN 77-850,545. PUB. 9-28-2010, FILED 10-16-2009.

P/I

THE MARK CONSISTS OF STANDARD CHARACTERS WITHOUT CLAIM TO ANY PARTICULAR FONT, STYLE, SIZE, OR COLOR.

OWNER OF U.S. REG. NO. 3,510,032.

FOR COMPUTER SOFTWARE FOR DOCUMENT PRODUCTION MANAGEMENT IN THE FIELDS OF DATA OUTPUT MANAGEMENT, PRINTING AND PRINTER MANAGEMENT, HIGH VOLUME DOCUMENT MANAGEMENT, DOCUMENT PRODUCTION WORKFLOW, DIGITAL DOCUMENT ARCHIVING, MARKETING AND CUSTOMER ACCOUNT MANAGEMENT (U.S. CLS. 21, 23, 26, 36 AND 38).

FIRST USE 6-30-2009; IN COMMERCE 6-30-2009.

3,998,838. ATLANTIC CITY COIN & SLOT SERVICE COMPANY, INC., PLEASANTVILLE, NJ. SN 77-852,283. PUB. 3-23-2010, FILED 10-19-2009.

DREAM WEAVER

THE MARK CONSISTS OF STANDARD CHARACTERS WITHOUT CLAIM TO ANY PARTICULAR FONT, STYLE, SIZE, OR COLOR.

FOR GAMING EQUIPMENT, NAMELY, SLOT MACHINES WITH OR WITHOUT VIDEO OUTPUT; GAMING MACHINES FEATURING A DEVICE THAT ACCEPTS WAGERS; GAMING MACHINES INCLUDING SLOT MACHINES OR VIDEO LOTTERY TERMINALS; GAMING MACHINES THAT GENERATE OR DISPLAY WAGER OUTCOMES; GAMING MACHINES, NAMELY, DEVICES WHICH ACCEPT A WAGER; GAMING SOFTWARE THAT GENERATES OR DISPLAYS WAGER OUTCOMES OF GAMING MACHINES; RECONFIGURABLE CASINO AND LOTTERY GAMING EQUIPMENT, NAMELY, GAMING MACHINES AND OPERATIONAL COMPUTER GAME SOFTWARE THEREFOR; SLOT MACHINES (U.S. CLS. 21, 23, 26, 36 AND 38).

FIRST USE 1-25-2011; IN COMMERCE 1-25-2011.

CLASS 9—(Continued).

3,998,846. TYLER ASSOCIATES CORPORATION, DBA TYLER ANALYTICS CORPORATION, GURNEE, IL. SN 77-854,182. PUB. 9-7-2010, FILED 10-21-2009.

THE BANKER'S PERSPECTIVE

THE MARK CONSISTS OF STANDARD CHARACTERS WITHOUT CLAIM TO ANY PARTICULAR FONT, STYLE, SIZE, OR COLOR.

NO CLAIM IS MADE TO THE EXCLUSIVE RIGHT TO USE "BANKER'S", APART FROM THE MARK AS SHOWN. FOR FINANCIAL AND STATISTICAL ANALYSIS SOFTWARE (U.S. CLS. 21, 23, 26, 36 AND 38).

FIRST USE 5-8-2008; IN COMMERCE 5-8-2008.

3,998,849. ALDI INC., BATAVIA, IL. SN 77-854,754. PUB. 3-30-2010, FILED 10-22-2009.

ACTIV ENERGY

THE MARK CONSISTS OF STANDARD CHARACTERS WITHOUT CLAIM TO ANY PARTICULAR FONT, STYLE, SIZE, OR COLOR.

FOR BATTERIES (U.S. CLS. 21, 23, 26, 36 AND 38).

FIRST USE 2-9-2011; IN COMMERCE 2-9-2011.

3,998,850. LUMASMART TECHNOLOGIES INTERNATIONAL, INC., MACOMB TOWNSHIP, MI. SN 77-854,767. PUB. 3-30-2010, FILED 10-22-2009.

Smartflex

THE MARK CONSISTS OF STANDARD CHARACTERS WITHOUT CLAIM TO ANY PARTICULAR FONT, STYLE, SIZE, OR COLOR.

FOR ELECTRONIC CIRCUIT BOARDS FOR CONTROLLING LED LIGHT PATTERNS (U.S. CLS. 21, 23, 26, 36 AND 38).

FIRST USE 1-0-2010; IN COMMERCE 1-0-2010.

CLASS 9—(Continued).

3,998,851. TRITON SYSTEMS OF DELAWARE, LLC, LONG BEACH, MS. SN 77-854,862. PUB. 4-6-2010, FILED 10-22-2009.

VERSALINK

THE MARK CONSISTS OF STANDARD CHARACTERS WITHOUT CLAIM TO ANY PARTICULAR FONT, STYLE, SIZE, OR COLOR.

FOR COMPUTER SOFTWARE, FOR USE IN CONNECTION WITH ELECTRONIC SAFES, THAT COUNTS, TRACKS, TIME STAMPS, AND GENERATES REPORTS ON DEPOSITS TO ELECTRONIC SAFES (U.S. CLS. 21, 23, 26, 36 AND 38).

FIRST USE 5-27-2011; IN COMMERCE 5-27-2011.

3,998,852. HARMAN INTERNATIONAL INDUSTRIES INCORPORATED, NORTHRIDGE, CA. SN 77-854,913. PUB. 10-12-2010, FILED 10-22-2009.

HATS

THE MARK CONSISTS OF STANDARD CHARACTERS WITHOUT CLAIM TO ANY PARTICULAR FONT, STYLE, SIZE, OR COLOR.

FOR COMPUTER SOFTWARE FOR TESTING AND OPTIMIZATION OF AUDIO SYSTEMS, NAMELY, LOUDSPEAKER TRANSDUCERS, LOUDSPEAKER SYSTEMS AND LOUDSPEAKER ROOM SYSTEMS (U.S. CLS. 21, 23, 26, 36 AND 38).

FIRST USE 1-31-2008; IN COMMERCE 1-31-2008.

3,998,853. EPIC SLAP, LLC, MALIBU, CA. SN 77-855,274. PUB. 4-6-2010, FILED 10-22-2009.



THE STIPLING IS FOR SHADING PURPOSES ONLY. FOR DVDS FEATURING ACTION, ADVENTURE, AND COMEDY; MOTION PICTURE FILMS ABOUT ACTION, ADVENTURE, AND COMEDY (U.S. CLS. 21, 23, 26, 36 AND 38).

FIRST USE 1-8-2010; IN COMMERCE 1-8-2010.

CLASS 9—(Continued).

3,998,868. WALK PRODUCTIONS, INC., NEW CASTLE, PA. SN 77-858,468. PUB. 3-2-2010, FILED 10-27-2009.

STEPS TO MILES SYSTEM

THE MARK CONSISTS OF STANDARD CHARACTERS WITHOUT CLAIM TO ANY PARTICULAR FONT, STYLE, SIZE, OR COLOR.

NO CLAIM IS MADE TO THE EXCLUSIVE RIGHT TO USE "SYSTEM", APART FROM THE MARK AS SHOWN.

FOR PRE-RECORDED DVDS FEATURING EXERCISE AND FITNESS (U.S. CLS. 21, 23, 26, 36 AND 38).

FIRST USE 3-0-2010; IN COMMERCE 3-0-2010.

3,998,886. INTERCONTINENTAL ART, INC., COMPTON, CA. SN 77-862,186. PUB. 10-5-2010, FILED 11-1-2009.

ARTUNES

THE MARK CONSISTS OF STANDARD CHARACTERS WITHOUT CLAIM TO ANY PARTICULAR FONT, STYLE, SIZE, OR COLOR.

FOR A STAND SPECIALLY ADAPTED FOR HOLDING, BUT SOLD SEPARATELY FROM, AN AUDIO EQUIPMENT UNIT THAT IS COMPRISED OF MOUNTED AUDIO SPEAKERS THAT HAVE AN INTEGRATED ELECTRONIC MP3 PLAYER HELD IN A POUCH/POCKET COMPRISED OF FABRIC, WITH THE EXTERIOR OF THE STAND COMPRISED OF STRETCHED AND MOUNTED CANVAS FEATURING HAND PAINTED, SCREENED, OFFSET, AND INKJET PRINTED PICTURES (U.S. CLS. 21, 23, 26, 36 AND 38).

FIRST USE 10-15-2009; IN COMMERCE 5-9-2011.

3,998,889. STOKYO, REDONDO BEACH, CA. SN 77-863,085. PUB. 10-5-2010, FILED 11-2-2009.



THE MARK CONSISTS OF STANDARD CHARACTERS WITHOUT CLAIM TO ANY PARTICULAR FONT, STYLE, SIZE, OR COLOR.

FOR USB HARDWARE AND OPERATING SOFTWARE FOR USE IN CONTROLLING MP3 MUSIC FILES (U.S. CLS. 21, 23, 26, 36 AND 38).

FIRST USE 10-0-2009; IN COMMERCE 10-0-2009.

CLASS 9—(Continued).

3,998,895. QUORUMLABS, INC., FREMONT, CA. SN 77-864,148. PUB. 3-30-2010, FILED 11-3-2009.

 The logo for QuorumLabs features the word "Quorum" in a bold, sans-serif font, with a green dot above the letter "o" that is encircled in a gray metallic ring and casts a green shadow below it. The word "Labs" is in a lighter, gray sans-serif font to the right.

OWNER OF U.S. REG. NO. 3,383,129.
THE COLOR(S) BLACK, GRAY, AND GREEN IS/ARE CLAIMED AS A FEATURE OF THE MARK.

THE MARK CONSISTS OF THE WORD "QUORUM" IN A BLACK BOLD FONT FOLLOWED BY THE WORD "LABS" IN GRAY. THE "O" IN "QUORUM" IS A GREEN DOT ENCIRCLED IN GRAY METALLIC AND CASTS A GREEN SHADOW BELOW THE WORD.

FOR COMPUTER SOFTWARE AND HARDWARE FOR MANAGING COMPUTERS AND COMPUTING RESOURCES, STORAGE, PROCESSORS, NETWORK SERVERS, AND NETWORK SWITCHES FOR DATA PROTECTION AND DISASTER RECOVERY; COMPUTER SOFTWARE FOR ADMINISTRATION OF COMPUTER LOCAL AREA NETWORKS; COMPUTER SOFTWARE FOR ADMINISTRATION OF COMPUTER NETWORKS; COMPUTER SOFTWARE FOR COMPUTER SYSTEM AND APPLICATION DEVELOPMENT, DEPLOYMENT AND MANAGEMENT; COMPUTER SOFTWARE FOR CONTROLLING AND MANAGING ACCESS SERVER APPLICATIONS; COMPUTER SOFTWARE PLATFORMS FOR USE IN MANAGING COMPUTERS AND COMPUTING RESOURCES, STORAGE, PROCESSORS, NETWORK SERVERS, AND NETWORK SWITCHES FOR DATA PROTECTION AND DISASTER RECOVERY; COMPUTER SOFTWARE TO AUTOMATE DATA WAREHOUSING (U.S. CLS. 21, 23, 26, 36 AND 38).
FIRST USE 11-30-2009; IN COMMERCE 12-16-2009.

3,998,899. FORD MOTOR COMPANY, DEARBORN, MI. SN 77-865,161. PUB. 9-28-2010, FILED 11-4-2009.

 The logo for VCM Vehicle Communication Module features the letters "VCM" in a large, bold, italicized sans-serif font. To the right of "VCM" is a stylized icon consisting of a semi-circle and a shaded circle. Below "VCM" is the text "Vehicle Communication Module" in a smaller, italicized sans-serif font.

NO CLAIM IS MADE TO THE EXCLUSIVE RIGHT TO USE "VEHICLE COMMUNICATION MODULE", APART FROM THE MARK AS SHOWN.

THE MARK CONSISTS OF THE STYLIZED LETTERS "VCM" APPEARING ABOVE THE WORDING "VEHICLE COMMUNICATION MODULE" AND TO THE RIGHT OF A DESIGN ELEMENT COMPRISED OF A BROKEN HORIZONTAL LINE CONNECTING TO A SEMI-CIRCLE AND SHADED CIRCLE.

FOR ELECTRONIC PLUG-IN TOOL FOR VEHICLE DIAGNOSTIC TESTING (U.S. CLS. 21, 23, 26, 36 AND 38).
FIRST USE 10-31-2003; IN COMMERCE 10-31-2003.

CLASS 9—(Continued).

3,998,908. EVRISKO SYSTEMS, LLC, EAU CLAIRE, WI. SN 77-869,338. PUB. 10-12-2010, FILED 11-10-2009.

EVRIKO RETRIEVER

THE MARK CONSISTS OF STANDARD CHARACTERS WITHOUT CLAIM TO ANY PARTICULAR FONT, STYLE, SIZE, OR COLOR.

THE ENGLISH TRANSLATION OF THE GREEK TERM "EVRIKO" IN THE MARK IS "I LOCATE" OR "I FIND".

FOR WIRELESS SENSORS FOR ACTIVATING, OPERATING AND MONITORING BUILDING AUTOMATION SYSTEMS THAT CONTROL ENVIRONMENTAL CONDITIONS, ACCESS AND SECURITY IN COMMERCIAL, INDUSTRIAL, OR RESIDENTIAL BUILDINGS (U.S. CLS. 21, 23, 26, 36 AND 38).

FIRST USE 8-2-2010; IN COMMERCE 8-2-2010.

3,998,925. SPINTOUCH, INC., SANTA ANA, CA. SN 77-878,025. PUB. 6-22-2010, FILED 11-20-2009.

 The logo for IBAR consists of the letters "IBAR" in a bold, serif font.

THE MARK CONSISTS OF STANDARD CHARACTERS WITHOUT CLAIM TO ANY PARTICULAR FONT, STYLE, SIZE, OR COLOR.

FOR COMPUTER DISPLAY AND INPUT SYSTEM COMPRISED OF A MULTIMEDIA PROJECTOR, CAMERA AND COMPUTER SOFTWARE FOR DISPLAYING IMAGES AND DETECTING OBJECTS, USER GESTURES AND COMMANDS (U.S. CLS. 21, 23, 26, 36 AND 38).

FIRST USE 9-1-2009; IN COMMERCE 9-1-2009.

CLASS 9—(Continued).

3,998,940. SHENZHEN SANXO TECHNOLOGY DEVELOPMENT CO., LTD., SHENZHEN, CHINA. SN 77-880,870. PUB. 10-26-2010, FILED 11-25-2009.

 The logo for 'insdream' features the word 'insdream' in a lowercase, sans-serif font. The letter 'd' is stylized, with a vertical line extending upwards from its top, ending in a small, dark, teardrop-shaped graphic that resembles a pencil tip or a stylized 'i'.

THE MARK CONSISTS OF THE STYLIZED WORDING "INSDREAM" WITH THE LETTER "D" BEING FORMED BY THE IMAGE OF A PENCIL.

FOR PORTABLE COMPUTER, WORD PROCESSOR, COMPUTER OPERATING SYSTEM, COMPUTER AUXILIARY EQUIPMENT, NAMELY, WEBCAMS, COMPUTER PERIPHERALS, COMPUTER ANCILLARY EQUIPMENT, NAMELY, WEBCAMS, COMPUTER PERIPHERALS, ELECTRONIC PEN, INFORMATION PROCESSOR, NAMELY, DATA PROCESSOR, READER, NAMELY, FLASH CARD READER, BAR CODE READER, ELECTRONIC DICTIONARY, NAMELY, DOWNLOADABLE ELECTRONIC DICTIONARY, HAND-HELD ELECTRONIC DICTIONARY, LAPTOP COMPUTER, CALCULATOR, FAX MACHINE, NAVIGATION EQUIPMENT, NAMELY, CAR NAVIGATION COMPUTERS, ELECTRIC NAVIGATIONAL INSTRUMENTS, GPS SYSTEM, COMPUTER, DATA PROCESSOR, RADAR EQUIPMENT, NAMELY, RADAR DETECTORS, RADAR GUNS FOR POLICE WORK, AUDIO/VIDEO RADIO, AUTO RADIO, GAMING MACHINE WITH EXTERNAL DISPLAY, ENTERTAINMENT EQUIPMENT WITH EXTERNAL DISPLAY OR MONITOR, NAMELY, TELEVISIONS, LCD PANELS, PRE-RECORDED DVDS FEATURING MOVIES, CARTOONS, DVD PLAYER, CAMERA, AUDIO/VIDEO INSTRUCTIONAL INSTRUMENT, NAMELY, VIDEO CAMERA, MONITOR, CABLE, NAMELY, AUDIO CABLES, BATTERY CABLES, ELECTRIC WIRE, REMOTE CONTROL FOR RADIOS, TELEVISIONS, BATTERY CHARGER, AUTO BATTERY, AUTO BATTERY JAR, ILLUMINATING BATTERY, BATTERY, BATTERY FOR POCKET SIZED LAMP, ELECTRICITY ACCUMULATOR CELL, ACCUMULATOR CELL, SOLAR-POWERED BATTERY, COMPUTER SOFTWARE FOR USE AS A SPREADSHEET, WORD PROCESSING, FOR USE IN THE FIELD OF ACCOUNTING, HEALTHCARE, DOWNLOADABLE ELECTRONIC PUBLICATION IN THE NATURE OF NEWSLETTERS, JOURNALS, IN THE FIELD OF COMPUTERS, GARDENING, IC CARD, BLANK SMART CARD, GAMING SOFTWARE, AUTO NAVIGATION EQUIPMENT, NAMELY, CAR-PORTABLE COMPUTER, CELL PHONE, VIDEO PHONE, HAND-FREE SET FOR PHONE, TRANSMITTER, NAMELY, CABLE TELEVISION TRANSMITTERS, EMERGENCY SIGNAL TRANSMITTERS, ANTI-RADIO JAMMING EQUIPMENT, NAMELY, ELECTRONIC TRANSMITTERS FOR JAMMING SIGNALS, ANTENNAS, ELECTRONIC SIGNAL TRANSMITTER, INTERCOMS, WIRELESS PHONE SET, TELEPHONE, SIGNAL REMOTE CONTROL POWER EQUIPMENT, NAMELY, POWER SUPPLIES, REMOTE CONTROLS FOR ELECTRONIC SIGNALS, SIGNAL REMOTE CONTROL STARTER EQUIPMENT, NAMELY, POWER SUPPLIES, REMOTE CONTROLS FOR STARTING ELECTRONIC SIGNALS, PRINTED CIRCUIT, INTEGRATED CIRCUIT AND INTEGRATED CIRCUIT BLOCK (U.S. CLS. 21, 23, 26, 36 AND 38).

FIRST USE 1-15-2010; IN COMMERCE 1-23-2010.

CLASS 9—(Continued).

3,998,941. GRAPECITY INCORPORATED, SENDAI, JAPAN. SN 77-881,762. PUB. 4-27-2010, FILED 11-29-2009.

GRAPSEED

THE MARK CONSISTS OF STANDARD CHARACTERS WITHOUT CLAIM TO ANY PARTICULAR FONT, STYLE, SIZE, OR COLOR.

FOR AUDIO, VISUAL AND AUDIO/VISUAL RECORDINGS FOR USE IN INSTRUCTION IN CONNECTION WITH ENGLISH LANGUAGE AND CULTURE (U.S. CLS. 21, 23, 26, 36 AND 38).

FIRST USE 11-30-2009; IN COMMERCE 11-30-2009.

3,998,945. NEC LCD TECHNOLOGIES, LTD., KAWASAKI, KANAGAWA, JAPAN. SN 77-882,926. PUB. 4-20-2010, FILED 12-1-2009.

COLORXCELL

THE MARK CONSISTS OF STANDARD CHARACTERS WITHOUT CLAIM TO ANY PARTICULAR FONT, STYLE, SIZE, OR COLOR.

FOR LIQUID CRYSTAL DISPLAYS; LIQUID CRYSTAL DISPLAY PANELS; LIQUID CRYSTAL DISPLAY MODULES; LIQUID CRYSTAL DISPLAY MONITORS; LIQUID CRYSTAL DISPLAY TELEVISIONS; LIQUID CRYSTAL DISPLAYS FOR MOBILE PHONES; A FEATURE OF LIQUID CRYSTAL DISPLAYS, LIQUID CRYSTAL DISPLAY PANELS, LIQUID CRYSTAL DISPLAY MODULES, LIQUID CRYSTAL DISPLAY MONITORS, LIQUID CRYSTAL DISPLAY TELEVISIONS AND LIQUID CRYSTAL DISPLAYS FOR MOBILE PHONES FOR COLOR CONVERSION (U.S. CLS. 21, 23, 26, 36 AND 38).

FIRST USE 5-15-2011; IN COMMERCE 5-15-2011.

3,998,946. BROWN SHOE COMPANY, INC., ST. LOUIS, MO. SN 77-883,205. PUB. 3-30-2010, FILED 12-1-2009.



OWNER OF U.S. REG. NOS. 3,149,878, 3,238,413, AND OTHERS.

CLASS 9—(Continued).

THE MARK CONSISTS OF FOUR SHADED HEEL DESIGNS.

FOR EYEWEAR AND SUNGLASSES (U.S. CLS. 21, 23, 26, 36 AND 38).

FIRST USE 11-30-2010; IN COMMERCE 11-30-2010.

3,998,947. LOCKHEED MARTIN CORPORATION, BETHESDA, MD. SN 77-883,514. PUB. 10-12-2010, FILED 12-1-2009.

MAGNELINK

THE MARK CONSISTS OF STANDARD CHARACTERS WITHOUT CLAIM TO ANY PARTICULAR FONT, STYLE, SIZE, OR COLOR.

FOR MAGNETIC COMMUNICATION SYSTEM COMPRISED OF AT LEAST ONE UNDERGROUND TRANSCIEVER UNIT AND ONE SURFACE TRANSCIEVER UNIT HAVING COMMON TRANSMIT AND RECEIVE ANTENNAE FOR TWO-WAY, WIRELESS, THROUGH-EARTH COMMUNICATIONS USING ADVANCED SIGNAL PROCESSING AND OPTIMIZED ANTENNA DESIGN FOR MINE SAFETY AND OTHER APPLICATIONS, NAMELY, EMERGENCY UNDERGROUND COMMUNICATIONS AND LOCATION DETECTION OF TRAPPED MINERS (U.S. CLS. 21, 23, 26, 36 AND 38).

FIRST USE 2-5-2010; IN COMMERCE 6-1-2011.

3,998,955. LIGHTHOUSE STRATEGIC PROJECTS GROUP, INC., LANGHORNE, PA. SN 77-888,351. PUB. 5-25-2010, FILED 12-8-2009.



NO CLAIM IS MADE TO THE EXCLUSIVE RIGHT TO USE "THE BUSINESS OF MEDICINE", APART FROM THE MARK AS SHOWN.

THE COLOR(S) BLUE, WHITE, BROWN AND GRAY IS/ARE CLAIMED AS A FEATURE OF THE MARK.

THE MARK CONSISTS OF A ROUND CIRCLE IN BROWN COVERED BY A WHITE AND BLUE GRAPH, WITH THE WORDS "THE" AND "OF" IN GRAY, AND THE WORDS "BUSINESS" AND "MEDICINE" IN BLUE.

FOR INTERACTIVE MULTIMEDIA COMPUTER PROGRAM FOR EDUCATIONAL PURPOSES (U.S. CLS. 21, 23, 26, 36 AND 38).

FIRST USE 5-1-2010; IN COMMERCE 5-25-2010.

CLASS 9—(Continued).

3,998,958. AGILENT TECHNOLOGIES, INC., SANTA CLARA, CA. SN 77-889,948. PUB. 5-4-2010, FILED 12-9-2009.

1260 INFINITY

THE MARK CONSISTS OF STANDARD CHARACTERS WITHOUT CLAIM TO ANY PARTICULAR FONT, STYLE, SIZE, OR COLOR.

OWNER OF U.S. REG. NOS. 2,812,902, 3,406,927, AND 3,726,065.

FOR ULTRA HIGH PRESSURE LIQUID CHROMATOGRAPHY (UHPLC) EQUIPMENT COMPRISING CHROMATOGRAPHIC COLUMNS, CARTRIDGES, PUMPS, SEPARATION DEVICES IN SINGLE AND MULTI-WELL FORMATS, DETECTORS, INJECTORS, FILTERS, AND AUTOSAMPLERS; LABORATORY OPERATING SYSTEMS COMPRISING OF COMPUTER HARDWARE AND COMPUTER SOFTWARE FOR USE IN CONNECTION WITH ULTRA HIGH PRESSURE LIQUID CHROMATOGRAPHY SYSTEMS (UHPLC) (U.S. CLS. 21, 23, 26, 36 AND 38).

FIRST USE 7-1-2010; IN COMMERCE 7-1-2010.

3,998,959. AGILENT TECHNOLOGIES, INC., SANTA CLARA, CA. SN 77-889,954. PUB. 5-4-2010, FILED 12-9-2009.

1220 INFINITY

THE MARK CONSISTS OF STANDARD CHARACTERS WITHOUT CLAIM TO ANY PARTICULAR FONT, STYLE, SIZE, OR COLOR.

OWNER OF U.S. REG. NOS. 2,812,902, 3,406,927, AND 3,726,065.

FOR ULTRA HIGH PRESSURE LIQUID CHROMATOGRAPHY (UHPLC) EQUIPMENT COMPRISING CHROMATOGRAPHIC COLUMNS, CARTRIDGES, PUMPS, SEPARATION DEVICES IN SINGLE AND MULTI-WELL FORMATS, DETECTORS, INJECTORS, FILTERS, AND AUTOSAMPLERS; LABORATORY OPERATING SYSTEMS COMPRISING OF COMPUTER HARDWARE AND COMPUTER SOFTWARE FOR USE IN CONNECTION WITH ULTRA HIGH PRESSURE LIQUID CHROMATOGRAPHY SYSTEMS (UHPLC) (U.S. CLS. 21, 23, 26, 36 AND 38).

FIRST USE 7-1-2010; IN COMMERCE 7-1-2010.

CLASS 9—(Continued).

3,998,960. AGILENT TECHNOLOGIES, INC., SANTA CLARA, CA. SN 77-889,956. PUB. 5-4-2010, FILED 12-9-2009.

AGILENT 1260 INFINITY

THE MARK CONSISTS OF STANDARD CHARACTERS WITHOUT CLAIM TO ANY PARTICULAR FONT, STYLE, SIZE, OR COLOR.

OWNER OF U.S. REG. NOS. 2,461,406, 2,643,345, AND OTHERS.

FOR ULTRA HIGH PRESSURE LIQUID CHROMATOGRAPHY (UHPLC) EQUIPMENT COMPRISING CHROMATOGRAPHIC COLUMNS, CARTRIDGES, PUMPS, SEPARATION DEVICES IN SINGLE AND MULTI-WELL FORMATS, DETECTORS, INJECTORS, FILTERS, AND AUTOSAMPLERS; LABORATORY OPERATING SYSTEMS COMPRISING OF COMPUTER HARDWARE AND COMPUTER SOFTWARE FOR USE IN CONNECTION WITH ULTRA HIGH PRESSURE LIQUID CHROMATOGRAPHY SYSTEMS (UHPLC) (U.S. CLS. 21, 23, 26, 36 AND 38).

FIRST USE 7-1-2010; IN COMMERCE 7-1-2010.

3,998,961. AGILENT TECHNOLOGIES, INC., SANTA CLARA, CA. SN 77-889,959. PUB. 5-4-2010, FILED 12-9-2009.

AGILENT 1220 INFINITY

THE MARK CONSISTS OF STANDARD CHARACTERS WITHOUT CLAIM TO ANY PARTICULAR FONT, STYLE, SIZE, OR COLOR.

OWNER OF U.S. REG. NOS. 2,461,406, 2,643,345, AND OTHERS.

FOR ULTRA HIGH PRESSURE LIQUID CHROMATOGRAPHY (UHPLC) EQUIPMENT COMPRISING CHROMATOGRAPHIC COLUMNS, CARTRIDGES, PUMPS, SEPARATION DEVICES IN SINGLE AND MULTI-WELL FORMATS, DETECTORS, INJECTORS, FILTERS, AND AUTOSAMPLERS; LABORATORY OPERATING SYSTEMS COMPRISING OF COMPUTER HARDWARE AND COMPUTER SOFTWARE FOR USE IN CONNECTION WITH ULTRA HIGH PRESSURE LIQUID CHROMATOGRAPHY SYSTEMS (UHPLC) (U.S. CLS. 21, 23, 26, 36 AND 38).

FIRST USE 7-1-2010; IN COMMERCE 7-1-2010.

CLASS 9—(Continued).

3,998,965. GET CLUED IN, LLC, LOS ANGELES, CA. SN 77-892,962. PUB. 5-11-2010, FILED 12-14-2009.



THE COLOR(S) GREEN AND BLUE IS/ARE CLAIMED AS A FEATURE OF THE MARK.

THE MARK CONSISTS OF THE WORD "CLUE" IN GREEN WITH AN INVERTED QUESTION MARK ALSO IN GREEN REPRESENTING THE LETTER "D" AND THE WORD "IN" IN BLUE.

FOR DOWNLOADABLE ELECTRONIC GAME PROGRAMS; DOWNLOADABLE ELECTRONIC GAMES VIA THE INTERNET AND WIRELESS DEVICES; ELECTRONIC GAME PROGRAMS; ELECTRONIC GAME SOFTWARE; ELECTRONIC GAME SOFTWARE FOR CELLULAR TELEPHONES; ELECTRONIC GAME SOFTWARE FOR HANDHELD ELECTRONIC DEVICES; ELECTRONIC GAME SOFTWARE FOR WIRELESS DEVICES; INTERACTIVE GAME PROGRAMS; INTERACTIVE GAME SOFTWARE (U.S. CLS. 21, 23, 26, 36 AND 38).

FIRST USE 4-1-2010; IN COMMERCE 4-1-2010.

3,998,967. POWERPACT HOLDINGS LLC, MIDLOTHIAN, VA. SN 77-893,337. PUB. 5-4-2010, FILED 12-14-2009.

VOOT

THE MARK CONSISTS OF STANDARD CHARACTERS WITHOUT CLAIM TO ANY PARTICULAR FONT, STYLE, SIZE, OR COLOR.

FOR COMPUTER SOFTWARE FOR USE IN CONDUCTING MARKETING, ADVERTISING, MEDIA USAGE, RATING, MONITORING AND RESEARCH SERVICES, NAMELY, ANALYZING AND PREPARING REPORTS RELATED TO SOCIAL MEDIA WEBSITES, CONTENT AND AUDIENCE ENGAGEMENT FACTORS (U.S. CLS. 21, 23, 26, 36 AND 38).

FIRST USE 6-17-2010; IN COMMERCE 6-17-2010.

CLASS 9—(Continued).

3,998,976. ARISTOCRAT TECHNOLOGIES AUSTRALIA PTY LTD., NORTH RYDE, NSW, AUSTRALIA. SN 77-894,647. PUB. 10-12-2010, FILED 12-16-2009.

REEL TALL TALES

THE MARK CONSISTS OF STANDARD CHARACTERS WITHOUT CLAIM TO ANY PARTICULAR FONT, STYLE, SIZE, OR COLOR.

PRIORITY CLAIMED UNDER SEC. 44(D) ON AUSTRALIA APPLICATION NO. 1306266, FILED 6-25-2009, REG. NO. 1306266, DATED 6-25-2009, EXPIRES 6-25-2019.

FOR ELECTRONIC GAMING MACHINES, NAMELY, DEVICES WHICH ACCEPT A WAGER (U.S. CLS. 21, 23, 26, 36 AND 38).

FIRST USE 10-1-2010; IN COMMERCE 10-1-2010.

3,998,977. ARISTOCRAT TECHNOLOGIES AUSTRALIA PTY LTD., NORTH RYDE, NSW, AUSTRALIA. SN 77-894,658. PUB. 10-12-2010, FILED 12-16-2009.

REMIX

THE MARK CONSISTS OF STANDARD CHARACTERS WITHOUT CLAIM TO ANY PARTICULAR FONT, STYLE, SIZE, OR COLOR.

PRIORITY CLAIMED UNDER SEC. 44(D) ON AUSTRALIA APPLICATION NO. 1306262, FILED 6-25-2009, REG. NO. 1306262, DATED 6-25-2009, EXPIRES 6-25-2019.

FOR ELECTRONIC GAMING MACHINES, NAMELY, DEVICES WHICH ACCEPT A WAGER (U.S. CLS. 21, 23, 26, 36 AND 38).

FIRST USE 11-1-2010; IN COMMERCE 11-1-2010.

3,998,990. LIMBIC SOFTWARE, INC., PALO ALTO, CA. SN 77-898,963. PUB. 4-20-2010, FILED 12-22-2009.

Limbic

THE MARK CONSISTS OF STANDARD CHARACTERS WITHOUT CLAIM TO ANY PARTICULAR FONT, STYLE, SIZE, OR COLOR.

FOR COMPUTER APPLICATION GAME SOFTWARE FOR MOBILE PHONES; COMPUTER GAME SOFTWARE (U.S. CLS. 21, 23, 26, 36 AND 38).

FIRST USE 11-1-2010; IN COMMERCE 11-1-2010.

CLASS 9—(Continued).

3,998,993. WEBMAGIC VENTURES, LLC, PASADENA, CA. SN 77-900,585. PUB. 9-28-2010, FILED 12-23-2009.

PENNY ARCADIA

THE MARK CONSISTS OF STANDARD CHARACTERS WITHOUT CLAIM TO ANY PARTICULAR FONT, STYLE, SIZE, OR COLOR.

FOR DIGITAL MEDIA, NAMELY, PRE-RECORDED VIDEO CASSETTES, DIGITAL VIDEO DISCS, DIGITAL VERSATILE DISCS, DOWNLOADABLE AUDIO AND VIDEO RECORDINGS, DVDS, AND HIGH DEFINITION DIGITAL DISCS FEATURING CONTENT ABOUT THE COIN-OPERATED MACHINE, VENDING, SLOT MACHINE, AMUSEMENT, SCALE, AND VIDEOGAME INDUSTRIES, INCLUDING ITS ART, HISTORY, INVENTIONS, PEOPLE, SOCIOLOGY, AS WELL AS ITS BUSINESS, EDUCATIONAL AND ENTERTAINMENT ASPECTS AND INFLUENCES.; MAGNETS; MESSENGER BAGS ESPECIALLY ADAPTED FOR HOLDING LAPTOPS; MOUSEPADS (U.S. CLS. 21, 23, 26, 36 AND 38).

FIRST USE 5-21-2011; IN COMMERCE 5-21-2011.

3,999,022. FLUKE CORPORATION, EVERETT, WA. SN 77-909,300. PUB. 8-31-2010, FILED 1-11-2010.

THERMOVIE

THE MARK CONSISTS OF STANDARD CHARACTERS WITHOUT CLAIM TO ANY PARTICULAR FONT, STYLE, SIZE, OR COLOR.

FOR INFRARED CAMERAS; INFRARED LENSES, NAMELY, THERMAL IMAGER, CAMERA, AND OPTICAL INFRARED LENSES; THERMAL IMAGING SYSTEMS, NOT FOR MEDICAL USE; REMOTE CONTROLLED THERMAL IMAGING SYSTEMS, NOT FOR MEDICAL USE; THERMAL IMAGING SYSTEMS NOT FOR MEDICAL USE CONSISTING OF THERMAL IMAGERS, THERMAL SENSORS, IMAGE SCANNERS, LIQUID CRYSTAL DISPLAY (LCD) SCREENS, DATA STORAGE, ANALYZING AND REPORTING SOFTWARE, TEMPERATURE ALARMS, DOCKING STATION, CARRYING CASE, UNIVERSAL POWER ADAPTER, POUCH, WRIST STRAP, RECHARGEABLE BATTERY PACKS, MEMORY CARDS, SOUND AND IMAGE RECORDERS, AND USER GUIDE; APPARATUS FOR RECORDING, TRANSMISSION, OR REPRODUCTION OF SOUND AND IMAGES; THERMAL SCANNERS; ELECTRONIC DISPLAY PANELS SHOWING RADIOMETRIC IMAGES PROVIDING TEMPERATURE AND MEASUREMENT INFORMATION (U.S. CLS. 21, 23, 26, 36 AND 38).

FIRST USE 8-20-2008; IN COMMERCE 8-20-2008.

CLASS 9—(Continued).

3,999,068. PIONEER KABUSHIKI KAISHA, DBA PIONEER CORPORATION, KAWASAKI-SHI, KANAGAWA-KEN, JAPAN. SN 77-931,469. PUB. 11-9-2010, FILED 2-9-2010.



THE MARK CONSISTS OF THE TERM "MUSICSPHERE" IN A STYLIZED FONT, WITH THE FIRST THREE LETTERS APPEARING WITHIN A BROKEN CIRCLE AND THE LETTER "I" COMPLETING THE CIRCLE.

FOR COMPUTER SOFTWARE FOR PROCESSING, SELECTING, EDITING, CONVERTING AND REPRODUCING DIGITAL MUSIC FILES, AND FOR TRANSMITTING DIGITAL MUSIC FILES TO AUDIO EQUIPMENT; NAVIGATION APPARATUS FOR VEHICLES; AUDIO AND VIDEO EQUIPMENT, NAMELY, STEREOS, AMPLIFIERS, STEREO TUNERS, CD PLAYERS, RADIOS, DIGITAL RADIO RECEIVERS, VIDEO DISC PLAYERS; REPLACEMENT PARTS FOR ALL THE AFORESAID GOODS (U.S. CLS. 21, 23, 26, 36 AND 38).
FIRST USE 1-7-2010; IN COMMERCE 3-1-2010.

CLASS 9—(Continued).

3,999,085. KABUSHIKI KAISHA SQUARE ENIX, AKA SQUARE ENIX CO., LTD., TOKYO, JAPAN. SN 77-939,571. PUB. 1-18-2011, FILED 2-19-2010.

VOICE FANTASY

THE MARK CONSISTS OF STANDARD CHARACTERS WITHOUT CLAIM TO ANY PARTICULAR FONT, STYLE, SIZE, OR COLOR.

NO CLAIM IS MADE TO THE EXCLUSIVE RIGHT TO USE "VOICE", APART FROM THE MARK AS SHOWN. FOR COMPUTER GAME SOFTWARE; VIDEO GAME SOFTWARE (U.S. CLS. 21, 23, 26, 36 AND 38).
FIRST USE 11-1-2010; IN COMMERCE 11-1-2010.

3,999,115. PAUL FRANK INDUSTRIES, LLC, LOS ANGELES, CA. SN 77-951,760. PUB. 10-19-2010, FILED 3-5-2010.

JULIUS

THE MARK CONSISTS OF STANDARD CHARACTERS WITHOUT CLAIM TO ANY PARTICULAR FONT, STYLE, SIZE, OR COLOR.

OWNER OF U.S. REG. NO. 3,583,780. FOR SPEAKERS, NAMELY, AUDIO SPEAKERS (U.S. CLS. 21, 23, 26, 36 AND 38).
FIRST USE 10-1-2010; IN COMMERCE 10-1-2010.

3,999,074. FIRSTTECH, LLC, KENT, WA. SN 77-932,656. PUB. 7-20-2010, FILED 2-10-2010.

DRONE

THE MARK CONSISTS OF STANDARD CHARACTERS WITHOUT CLAIM TO ANY PARTICULAR FONT, STYLE, SIZE, OR COLOR.

FOR ELECTRONIC DEVICE FOR USE WITH AN AUTOMOBILE, NAMELY, A VEHICLE CELLULAR RADIO AND GLOBAL POSITIONING SATELLITE RECEIVER THAT CONNECTS TO AN AUTOMOBILE WIRE HARNESS FOR PROVIDING VEHICLE TRACKING AND SECURITY AND CONTROL OF SELECTIVE AUTOMOBILE FUNCTIONS, NAMELY, REMOTE ENGINE START AND DISABLE, LOCK AND UNLOCK, AND TRUNK RELEASE (U.S. CLS. 21, 23, 26, 36 AND 38).
FIRST USE 8-16-2010; IN COMMERCE 8-16-2010.

3,999,140. TRACFONE WIRELESS, INC., MIAMI, FL. SN 77-965,817. PUB. 3-22-2011, FILED 3-23-2010.



NO CLAIM IS MADE TO THE EXCLUSIVE RIGHT TO USE "THE LEAST EXPENSIVE CELL PHONE FOR SENIORS", APART FROM THE MARK AS SHOWN.

CLASS 9—(Continued).

THE MARK CONSISTS OF THE LETTERS "SVC" IN STYLIZED FORM WITH THE "S" SLANTED FORWARD AND THE UPPER END OF THE "S" CONNECTED TO THE UPPER LEFT END OF THE "V", AND THE LEFT SIDE OF THE "C" PARTIALLY SUPERIMPOSED OVER THE RIGHT SIDE OF THE "V" WITH THE WORDS "THE LEAST EXPENSIVE CELL PHONE FOR SENIORS" BELOW "SVC".

FOR ELECTRONIC COMMUNICATIONS EQUIPMENT, NAMELY, CELLULAR TELEPHONES; PREPAID AIR TIME CELLULAR TELEPHONES; CELLULAR TELEPHONE ACCESSORIES, NAMELY, BATTERY CHARGERS, STANDS, ANTENNAE, HEADSET KITS COMPRISED OF HANDS FREE ELECTRONIC EAR PIECE WITH MICROPHONE AND HOLSTER, HANDS FREE HEADSETS, CASES WITH FLAPS, POWER ADAPTERS, BATTERIES, CARRY SLEEVES, FACE PLATES, BELT CLIPS, HOLSTERS, MOUNTING ATTACHMENTS (U.S. CLS. 21, 23, 26, 36 AND 38).

FIRST USE 8-31-2010; IN COMMERCE 8-31-2010.

CLASS 9—(Continued).

3,999,190. SECURLINX HOLDING CORPORATION, MORGANTOWN, WV. SN 78-404,250. PUB. 11-13-2007, FILED 4-19-2004.

VeriTrac

3,999,155. WALDEN, NARADA MICHAEL, DBA TARPAN STUDIOS, SAN RAFAEL, CA. SN 77-980,810. PUB. 6-2-2009, FILED 2-6-2009.

Rhinestone Kitties & The Furry Dog

THE MARK CONSISTS OF STANDARD CHARACTERS WITHOUT CLAIM TO ANY PARTICULAR FONT, STYLE, SIZE, OR COLOR.

FOR AUDIO TAPES FEATURING MUSIC; CHILDREN'S EDUCATIONAL MUSIC CDS AND DVDS (U.S. CLS. 21, 23, 26, 36 AND 38).

FIRST USE 11-2-2009; IN COMMERCE 4-9-2010.

THE MARK CONSISTS OF STANDARD CHARACTERS WITHOUT CLAIM TO ANY PARTICULAR FONT, STYLE, SIZE, OR COLOR.

FOR COMPUTER SOFTWARE COMPONENT TO PROVIDE MULTI-MODAL BIOMETRIC TEMPLATE VERIFICATION SERVICES FOR PHYSICAL ACCESS CONTROL APPLICATIONS (U.S. CLS. 21, 23, 26, 36 AND 38).

FIRST USE 8-20-2008; IN COMMERCE 8-20-2008.

3,999,178. LUMEXIS CORPORATION, IRVINE, CA. SN 77-982,056. PUB. 2-23-2010, FILED 10-12-2009.

IFE AT THE SPEED OF LIGHT

THE MARK CONSISTS OF STANDARD CHARACTERS WITHOUT CLAIM TO ANY PARTICULAR FONT, STYLE, SIZE, OR COLOR.

FOR MULTI-MEDIA ENTERTAINMENT SYSTEMS FOR USE IN AIRPLANES, COMPRISING MULTIPLE-DISPLAY DISPLAY SCREENS, WIRED AND WIRELESS REMOTE CONTROLS, USER TOUCH SCREENS, FIBER-OPTIC AND ELECTRIC CABLES AND CONNECTORS, MEDIA CONVERTERS, DATA SWITCHES, ELECTRONIC AND VIDEO GAME CONTROLLERS, AND CENTRAL PROCESSING UNITS (U.S. CLS. 21, 23, 26, 36 AND 38).

FIRST USE 10-8-2009; IN COMMERCE 5-19-2010.

3,999,193. GYRUSLOGIC, INC., PHOENIX, AZ. SN 78-643,752. PUB. 12-29-2009, FILED 6-4-2005.

"Just Say It"

THE MARK CONSISTS OF STANDARD CHARACTERS WITHOUT CLAIM TO ANY PARTICULAR FONT, STYLE, SIZE, OR COLOR.

FOR COMPUTER SOFTWARE FOR AUTOMATING A FULL CONVERSATIONAL NATURAL LANGUAGE DIALOG WHEN THE INTERACTIVE COMMUNICATION TAKES PLACE THROUGH A WEB CHAT SESSION, WEB INTERACTION SERVICE OR THROUGH A TELEPHONE CONVERSATION OR INTERACTION (U.S. CLS. 21, 23, 26, 36 AND 38).

FIRST USE 1-31-2003; IN COMMERCE 1-1-2004.

CLASS 9—(Continued).

3,999,206. CAROL TUTTLE ENTERPRISES, L.L.C., DRAPER, UT. SN 78-844,919. PUB. 7-24-2007, FILED 3-23-2006.

DRESSING YOUR TRUTH

THE MARK CONSISTS OF STANDARD CHARACTERS WITHOUT CLAIM TO ANY PARTICULAR FONT, STYLE, SIZE, OR COLOR.

FOR AUDIO AND VIDEO RECORDINGS FEATURING, SELF-HELP AND IMPROVEMENT, SPIRITUAL HEALING, CLOTHES SHOPPING, INFORMATION USED TO ASSESS PERSONALITY AND CHARACTER TYPES OF VARIOUS INDIVIDUALS AND RELATED ADVICE FOR SUCH INDIVIDUALS; COMPUTER APPLICATION PROGRAMS FOR USE IN ASSESSING PERSONALITY AND CHARACTER TYPES OF VARIOUS INDIVIDUALS AND ADVISING SUCH INDIVIDUALS (U.S. CLS. 21, 23, 26, 36 AND 38).

FIRST USE 1-0-2006; IN COMMERCE 7-0-2006.

3,999,214. CREATIVE TECHNOLOGY LTD., SINGAPORE, SINGAPORE. SN 78-935,284. PUB. 3-2-2010, FILED 7-21-2006.

X-FI

THE MARK CONSISTS OF STANDARD CHARACTERS WITHOUT CLAIM TO ANY PARTICULAR FONT, STYLE, SIZE, OR COLOR.

FOR COMPUTER HARDWARE; COMPUTER SOFTWARE TO CONTROL AND IMPROVE COMPUTER AND AUDIO EQUIPMENT SOUND QUALITY; COMPUTER SOFTWARE FOR THE STORAGE, REPRODUCTION, TRANSMISSION AND EDITING OF SOUND, DATA, TEXT, IMAGES, AND VIDEO IN COMPUTER AUDIO COMPONENTS AND MULTIMEDIA APPLICATIONS; COMPUTER PERIPHERALS; DIGITAL AUDIO PLAYERS AND RECORDERS; DIGITAL VIDEO PLAYERS AND RECORDERS; DIGITAL IMAGE RECORDERS AND VIEWERS; ELECTRONIC AUDIO AND VIDEO COMPONENTS, NAMELY, SOUND SYSTEMS COMPRISED OF RECEIVERS, AMPLIFIERS, TUNERS, SOUND MIXERS, EQUALIZERS, AUDIO AND VIDEO RECORDERS AND PLAYERS, AND RADIOS, AND REMOTE CONTROLS FOR THE FOREGOING ITEMS; LOUSPEAKERS; AND MANUALS DISTRIBUTED THEREWITH (U.S. CLS. 21, 23, 26, 36 AND 38).

FIRST USE 5-13-2005; IN COMMERCE 5-13-2005.

CLASS 9—(Continued).

3,999,219. HUXLEY COMMUNICATIONS COOPERATIVE, HUXLEY, IA. SN 78-948,489. PUB. 9-4-2007, FILED 8-9-2006.

B1LINK

THE MARK CONSISTS OF STANDARD CHARACTERS WITHOUT CLAIM TO ANY PARTICULAR FONT, STYLE, SIZE, OR COLOR.

FOR COMPUTER BILLING SOFTWARE (U.S. CLS. 21, 23, 26, 36 AND 38).

FIRST USE 2-0-2009; IN COMMERCE 2-0-2009.

3,999,233. ISPACES IT LTD., AKA ISPACES, CARNDONAGH, IRELAND. SN 85-006,831. PUB. 11-30-2010, FILED 4-5-2010.

Spacephone

THE MARK CONSISTS OF STANDARD CHARACTERS WITHOUT CLAIM TO ANY PARTICULAR FONT, STYLE, SIZE, OR COLOR.

FOR COMPUTER TELEPHONY SOFTWARE (U.S. CLS. 21, 23, 26, 36 AND 38).

FIRST USE 3-0-2011; IN COMMERCE 3-0-2011.

3,999,239. EMPIONEER CORP, LA PUENTE, CA. SN 85-008,157. PUB. 11-30-2010, FILED 4-7-2010.

D101

THE MARK CONSISTS OF THE STYLIZED WORDING "D10L" WITH A HORIZONTAL WAVY LINE RUNNING THROUGH THE MIDDLE OF "101".

FOR SUNGLASSES (U.S. CLS. 21, 23, 26, 36 AND 38).

FIRST USE 5-2-2011; IN COMMERCE 5-19-2011.

CLASS 9—(Continued).

3,999,263. LANTRONIX, INC., IRVINE, CA. SN 85-015,238.
PUB. 10-26-2010, FILED 4-15-2010.

PREMIERWAVE

THE MARK CONSISTS OF STANDARD CHARACTERS WITHOUT CLAIM TO ANY PARTICULAR FONT, STYLE, SIZE, OR COLOR.

FOR PROGRAMMABLE DEVICE SERVER FOR SERIAL TO WIRELESS ETHERNET OR WIRELESS LOCAL AREA NETWORK (WLAN) CONNECTIVITY; ELECTRONIC HARDWARE AND SOFTWARE COMMUNICATION DEVICE, NAMELY, HARDWARE AND ENABLING SOFTWARE THEREFOR SOLD AS A UNIT, FOR SERIAL TO WIRELESS ETHERNET OR WIRELESS LOCAL AREA NETWORK (WLAN) CONNECTIVITY; COMPUTER SOFTWARE AND HARDWARE FOR USE IN DATA TRANSMISSION IN WIRED NETWORKS AND WIRELESS NETWORKS, IN THE NATURE OF WIRELESS RF MODULES, WIRELESS LAN DRIVERS, NETWORK DEVICE SERVERS, AND CONVERTERS (U.S. CLS. 21, 23, 26, 36 AND 38).

FIRST USE 4-26-2010; IN COMMERCE 1-5-2011.

3,999,267. BOOMERANG SOFTWARE, INC., BELMONT, MA.
SN 85-015,415. PUB. 9-21-2010, FILED 4-16-2010.

MobiToPC

THE MARK CONSISTS OF STANDARD CHARACTERS WITHOUT CLAIM TO ANY PARTICULAR FONT, STYLE, SIZE, OR COLOR.

FOR SOFTWARE APPLICATION FOR TRANSMITTING DATA SUCH AS PHOTOS, VIDEOS, FILES, SETTINGS, CONTACTS, BOOKMARKS, HISTORY, OR ANY OTHER TYPE OF INFORMATION PERMITTED BY THE MOBILE OPERATING SYSTEM FROM MOBILE PHONE TO COMPUTER (U.S. CLS. 21, 23, 26, 36 AND 38).

FIRST USE 4-20-2010; IN COMMERCE 5-28-2010.

CLASS 9—(Continued).

3,999,270. BRYTON INC., TAIPEI CITY 11493, TAIWAN. SN 85-016,149. PUB. 2-15-2011, FILED 4-16-2010.



THE MARK CONSISTS OF THE LETTER "B" DESIGNED FROM TWO SPEECH BALLOONS WITH TWO SMALL CIRCLES WITHIN THE "B".

FOR SATELLITE PROCESSORS; RECEIVERS FOR SATELLITES; SATELLITE TRANSMITTERS AND RECEIVERS; SATELLITE NAVIGATIONAL SYSTEM, NAMELY, A GLOBAL POSITIONING SYSTEM (GPS); KILOMETRE RECORDERS FOR VEHICLES; BICYCLE SPEED METER WITH THE METER DEVICE; CELLULAR PHONES; COMPUTER SOFTWARE AND FIRMWARE FOR OPERATING SYSTEM PROGRAMS; ELECTRIC SENSORS; INFRARED SENSORS; ODOMETERS; SPEEDOMETERS FOR VEHICLES; ALTIMETERS; THEODOLITES; LABORATORY EQUIPMENT AND SUPPLIES, NAMELY, CALIPERS; THERMOMETERS; CALORIMETERS; PRESSURE GAUGES; SPEED INDICATORS; WIND SLEEVES IN THE NATURE OF WIND-DIRECTION INDICATORS; MANOMETERS; BAROMETERS; ANEMOMETERS; TAXIMETERS; MARINE DEPTH FINDERS; DIRECTIONAL COMPASSES; ELECTRONIC NAVIGATIONAL AND POSITIONING APPARATUS AND INSTRUMENTS; NUMERICAL COUNTERS; TACHOMETERS; DYNAMOMETERS; HYGROMETERS; ALTIMETERS; LOFT PROTRACTOR; ACCELEROMETERS; PLANIMETERS; THERMOHYGROMETER; CONCENTRATION METERS FOR ALCOHOL TESTING USE; PEDOMETERS; ALCOHOL HYDROMETERS; INSTRUMENTS FOR MEASURING ANGLES; CLINOMETERS; THERMOMETERS NOT FOR MEDICAL USE; SOUND LOCATING APPARATUS, NAMELY, SOUND LEVEL METERS AND FATHOMETERS; SPEEDOMETERS FOR VEHICLES; DISTANCE RECORDERS FOR LAND VEHICLES; ACOUSTIC METERS; BATTERY POWERED METER FOR MEASURING THE MOISTURE CONTENT OF COFFEE BEANS; ELECTRIC METERS; ELECTRONIC DEVICES, NAMELY, ENERGY METERS FOR TRACKING AND MONITORING ENERGY USAGE; ELECTRONIC TESTING EQUIPMENT, NAMELY, SOUND LEVEL METERS; ELECTROTECHNICAL VIBRATION METERS; EXPOSURE METERS FOR PHOTOGRAPHIC DEVICES; FLOW METERS; FREQUENCY METERS; GAS METERS; LUMINOFLUX METERS; MEASURING APPARATUS, NAMELY, LASER DISTANCE METERS; PANEL METERS, NAMELY, AN ELECTRONIC INSTRUMENT THAT DISPLAYS AN INPUT SIGNAL IN EITHER A DIGITAL OR ANALOG FORM; PARKING METERS; PHOTOGRAPHIC EXPOSURE METERS; POSTAGE METERS; POSTAGE STAMP METERS; SCIENTIFIC MEASURING INSTRUMENTS, NAMELY, CONDUCTIVITY METERS; SOUND LEVEL METERS; TEMPERATURE METERS NOT FOR MEDICAL USE; VIBRATION METERS; WATER METERS (U.S. CLS. 21, 23, 26, 36 AND 38).

FIRST USE 9-8-2010; IN COMMERCE 12-22-2010.

CLASS 9—(Continued).

3,999,272. BRYTON INC., TAIPEI CITY 11493, TAIWAN. SN 85-016,262. PUB. 2-1-2011, FILED 4-16-2010.



THE MARK CONSISTS OF THE WORD "BRYTON" IN A STYLIZED FONT.

FOR SATELLITE PROCESSORS; RECEIVERS FOR SATELLITES; SATELLITE TRANSMITTERS AND RECEIVERS; SATELLITE NAVIGATIONAL SYSTEM, NAMELY, A GLOBAL POSITIONING SYSTEM (GPS); KILOMETRE RECORDERS FOR VEHICLES; BICYCLE SPEED METER WITH THE METER DEVICE; CELLULAR PHONES; COMPUTER SOFTWARE AND FIRMWARE FOR OPERATING SYSTEM PROGRAMS; ELECTRIC SENSORS; INFRARED SENSORS; ODOMETERS; SPEEDOMETERS FOR VEHICLES; ALTIMETERS; THEODOLITES; LABORATORY EQUIPMENT AND SUPPLIES, NAMELY, CALIPERS; THERMOMETERS; CALORIMETERS; PRESSURE GAUGES; SPEED INDICATORS; WIND SLEEVES IN THE NATURE OF WIND-DIRECTION INDICATORS; MANOMETERS; BAROMETERS; ANEMOMETERS; TAXIMETERS; MARINE DEPTH FINDERS; DIRECTIONAL COMPASSES; ELECTRONIC NAVIGATIONAL AND POSITIONING APPARATUS AND INSTRUMENTS; NUMERICAL COUNTERS; TACHOMETERS; DYNAMOMETERS; HYGROMETERS; ALTIMETERS; LOFT PROTRACTOR; ACCELEROMETERS; PLANIMETERS; THERMOHYGROMETER; CONCENTRATION METERS FOR ALCOHOL TESTING USE; PEDOMETERS; ALCOHOL HYDROMETERS; INSTRUMENTS FOR MEASURING ANGLES; CLINOMETERS; THERMOMETERS NOT FOR MEDICAL USE; SOUND LOCATING APPARATUS, NAMELY, SOUND LEVEL METERS AND FATHOMETERS; SPEEDOMETERS FOR VEHICLES; DISTANCE RECORDERS FOR LAND VEHICLES; ACOUSTIC METERS; BATTERY POWERED METER FOR MEASURING THE MOISTURE CONTENT OF COFFEE BEANS; ELECTRIC METERS; ELECTRONIC DEVICES, NAMELY, ENERGY METERS FOR TRACKING AND MONITORING ENERGY USAGE; ELECTRONIC TESTING EQUIPMENT, NAMELY, SOUND LEVEL METERS; ELECTROTECHNICAL VIBRATION METERS; EXPOSURE METERS FOR PHOTOGRAPHIC DEVICES; FLOW METERS; FREQUENCY METERS; GAS METERS; LUMINOFLUX METERS; MEASURING APPARATUS, NAMELY, LASER DISTANCE METERS; PANEL METERS, NAMELY, AN ELECTRONIC INSTRUMENT THAT DISPLAYS AN INPUT SIGNAL IN EITHER A DIGITAL OR ANALOG FORM; PARKING METERS; PHOTOGRAPHIC EXPOSURE METERS; POSTAGE METERS; POSTAGE STAMP METERS; SCIENTIFIC MEASURING INSTRUMENTS, NAMELY, CONDUCTIVITY METERS; SOUND LEVEL METERS; TEMPERATURE METERS NOT FOR MEDICAL USE; VIBRATION METERS; WATER METERS (U.S. CLS. 21, 23, 26, 36 AND 38). FIRST USE 9-8-2010; IN COMMERCE 12-22-2010.

CLASS 9—(Continued).

3,999,275. HBGARY, INC., SACRAMENTO, CA. SN 85-017,462. PUB. 10-26-2010, FILED 4-19-2010.

ACTIVE DEFENSE

THE MARK CONSISTS OF STANDARD CHARACTERS WITHOUT CLAIM TO ANY PARTICULAR FONT, STYLE, SIZE, OR COLOR.

FOR COMPUTER SOFTWARE FOR USE IN MALWARE DETECTION IN PERSONAL COMPUTERS AND FOR USE IN COMPUTER SECURITY INCIDENT RESPONSE; COMPUTER HARDWARE; COMPUTER SOFTWARE FOR USE IN MANAGING ENTERPRISE SECURITY FOR ADVANCED PERSISTENT THREAT AND ADVANCED MALWARE THREATS ON COMPUTERS; COMPUTER SOFTWARE AND HARDWARE RELATING TO COMPUTER SECURITY AND PREVENTION OF COMPUTER RISKS, NAMELY, FOR INCIDENT RESPONSE AND COMPUTER SECURITY; COMPUTER HARDWARE CONSISTING OF A SERVER FOR USE IN MANAGING ENTERPRISE SECURITY THREATS ON COMPUTERS (U.S. CLS. 21, 23, 26, 36 AND 38).

FIRST USE 0-0-2005; IN COMMERCE 6-18-2010.

3,999,282. THINLINE, LLC, MADISON, CT. SN 85-018,649. PUB. 9-21-2010, FILED 4-20-2010.



THE MARK CONSISTS OF STANDARD CHARACTERS WITHOUT CLAIM TO ANY PARTICULAR FONT, STYLE, SIZE, OR COLOR.

FOR PORTABLE PROJECTION SCREEN (U.S. CLS. 21, 23, 26, 36 AND 38).

FIRST USE 4-21-2011; IN COMMERCE 4-21-2011.

3,999,284. KELLY, MARK A., LAKE OZARK, MO. SN 85-019,672. PUB. 9-21-2010, FILED 4-21-2010.



THE MARK CONSISTS OF STANDARD CHARACTERS WITHOUT CLAIM TO ANY PARTICULAR FONT, STYLE, SIZE, OR COLOR.

FOR MAGNETIC DOOR COVERS WITH A PRINTED IMAGE SIMULATING A WOOD DOOR FOR AFFIXING TO METAL DOORS (U.S. CLS. 21, 23, 26, 36 AND 38).

FIRST USE 10-0-2010; IN COMMERCE 2-21-2011.

CLASS 9—(Continued).

3,999,292. VIPORBIT SOFTWARE INTERNATIONAL, INC., KELLER, TX. SN 85-021,182. PUB. 10-5-2010, FILED 4-22-2010.

CLASS 9—(Continued).

3,999,295. BRIDGEPORT FITTINGS, INC., STRATFORD, CT. SN 85-021,377. PUB. 9-28-2010, FILED 4-23-2010.

"Who's In YOUR Orbit?"

THE MARK CONSISTS OF STANDARD CHARACTERS WITHOUT CLAIM TO ANY PARTICULAR FONT, STYLE, SIZE, OR COLOR.

FOR PROVIDING MOBILE AND PORTABLE CONTACT RELATIONSHIP MANAGEMENT SOLUTIONS, NAMELY, COMPUTER SOFTWARE FOR USE IN INDIVIDUAL AND GROUP CALENDARING, ACTIVITY SCHEDULING, REPORT GENERATING AND DATABASE SEARCHING VIA SMARTPHONES, MOBILE PHONES, AND ALL OTHER PORTABLE AND DESKTOP COMPUTER APPLICATIONS (U.S. CLS. 21, 23, 26, 36 AND 38).

FIRST USE 2-18-2011; IN COMMERCE 2-18-2011.

MIGHTY-BOND

THE MARK CONSISTS OF STANDARD CHARACTERS WITHOUT CLAIM TO ANY PARTICULAR FONT, STYLE, SIZE, OR COLOR.

FOR ELECTRICAL FITTINGS, NAMELY, ELECTRICAL CONNECTORS, ELECTRICITY CONDUITS, ELECTRIC COUPLINGS, ELECTRICITY CONDUIT WITH INTEGRATED CABLE STRAPS, AND FITTINGS THEREFOR, NAMELY, RAINPROOF FITTINGS, ELECTRICITY CONDUIT EXPANSION FITTINGS, ELECTRICAL TRANSITION FITTINGS, ELECTRICAL GROUNDING FITTINGS (U.S. CLS. 21, 23, 26, 36 AND 38).

FIRST USE 3-31-2011; IN COMMERCE 3-31-2011.

3,999,294. BRIDGEPORT FITTINGS, INC., STRATFORD, CT. SN 85-021,376. PUB. 9-28-2010, FILED 4-23-2010.

MIGHTY-SEAL

THE MARK CONSISTS OF STANDARD CHARACTERS WITHOUT CLAIM TO ANY PARTICULAR FONT, STYLE, SIZE, OR COLOR.

FOR ELECTRICAL FITTINGS, NAMELY, ELECTRICAL CONNECTORS, ELECTRICITY CONDUITS, ELECTRIC COUPLINGS, ELECTRICITY CONDUIT WITH INTEGRATED CABLE STRAPS, AND FITTINGS THEREFOR, NAMELY, RAINPROOF FITTINGS, ELECTRICITY CONDUIT EXPANSION FITTINGS, ELECTRICAL TRANSITION FITTINGS, ELECTRICAL GROUNDING FITTINGS (U.S. CLS. 21, 23, 26, 36 AND 38).

FIRST USE 3-31-2011; IN COMMERCE 3-31-2011.

3,999,296. BRIDGEPORT FITTINGS, INC., STRATFORD, CT. SN 85-021,388. PUB. 9-28-2010, FILED 4-23-2010.

MIGHTY-MOVE

THE MARK CONSISTS OF STANDARD CHARACTERS WITHOUT CLAIM TO ANY PARTICULAR FONT, STYLE, SIZE, OR COLOR.

FOR ELECTRICAL FITTINGS, NAMELY, ELECTRICAL CONNECTORS, ELECTRICITY CONDUITS, ELECTRIC COUPLINGS, ELECTRICITY CONDUIT WITH INTEGRATED CABLE STRAPS, AND FITTINGS THEREFOR, NAMELY, RAINPROOF FITTINGS, ELECTRICITY CONDUIT EXPANSION FITTINGS, ELECTRICAL TRANSITION FITTINGS, ELECTRICAL GROUNDING FITTINGS (U.S. CLS. 21, 23, 26, 36 AND 38).

FIRST USE 3-31-2011; IN COMMERCE 3-31-2011.

CLASS 9—(Continued).

3,999,297. BRIDGEPORT FITTINGS, INC., STRATFORD, CT. SN 85-021,391. PUB. 9-28-2010, FILED 4-23-2010.

MIGHTY-MERGE

THE MARK CONSISTS OF STANDARD CHARACTERS WITHOUT CLAIM TO ANY PARTICULAR FONT, STYLE, SIZE, OR COLOR.

FOR ELECTRICAL FITTINGS, NAMELY, ELECTRICAL CONNECTORS, ELECTRICITY CONDUITS, ELECTRIC COUPLINGS, ELECTRICITY CONDUIT WITH INTEGRATED CABLE STRAPS, AND FITTINGS THEREFOR, NAMELY, RAINPROOF FITTINGS, ELECTRICITY CONDUIT EXPANSION FITTINGS, ELECTRICAL TRANSITION FITTINGS, ELECTRICAL GROUNDING FITTINGS (U.S. CLS. 21, 23, 26, 36 AND 38).

FIRST USE 3-31-2011; IN COMMERCE 3-31-2011.

3,999,311. OUR365, INC., ST. CHARLES, MO. SN 85-024,469. PUB. 11-2-2010, FILED 4-27-2010.

BABY EXPRESS

THE MARK CONSISTS OF STANDARD CHARACTERS WITHOUT CLAIM TO ANY PARTICULAR FONT, STYLE, SIZE, OR COLOR.

NO CLAIM IS MADE TO THE EXCLUSIVE RIGHT TO USE "BABY", APART FROM THE MARK AS SHOWN.

FOR DOWNLOADABLE ELECTRONIC NEWSLETTERS DELIVERED BY E-MAIL IN THE FIELD OF THE PARENTING OF INFANTS (U.S. CLS. 21, 23, 26, 36 AND 38).

FIRST USE 4-30-2010; IN COMMERCE 4-30-2010.

CLASS 9—(Continued).

3,999,322. SHANDONG LINUO SOLAR POWER HOLDINGS CO., LTD., SHANDONG PROVINCE, CHINA. SN 85-025,919. PUB. 9-28-2010, FILED 4-29-2010.



THE COLOR(S) BLUE, YELLOW AND ORANGE IS/ARE CLAIMED AS A FEATURE OF THE MARK.

THE MARK CONSISTS OF A DEVICE IN THE SHAPE OF A SUNFLOWER, WITH THE CENTRE OF THE FLOWER IN BLUE WITH YELLOW CROSSING LINES ON IT, AND THE PETALS OF THE FLOWER IN YELLOW AND ORANGE.

FOR BATTERY CHARGERS; INTEGRATED CIRCUITS; PHOTOVOLTAIC CELLS; PHOTOVOLTAIC CELLS AND MODULES; ROTATING LIGHTS; SEMICONDUCTORS; SEMICONDUCTOR CHIPS; SILICON CHIPS; SILICON WAFERS; SOLAR CELLS (U.S. CLS. 21, 23, 26, 36 AND 38).

FIRST USE 2-20-2010; IN COMMERCE 4-29-2010.

3,999,323. SHANDONG LINUO SOLAR POWER HOLDINGS CO., LTD., SHANDONG PROVINCE, CHINA. SN 85-025,923. PUB. 9-28-2010, FILED 4-29-2010.



NO CLAIM IS MADE TO THE EXCLUSIVE RIGHT TO USE "POWER" AND THE TWO NON-LATIN CHARACTERS WHICH TOGETHER TRANSLATES INTO "PHOTOVOLTAIC", APART FROM THE MARK AS SHOWN.

THE COLOR(S) BLUE AND YELLOW IS/ARE CLAIMED AS A FEATURE OF THE MARK.

THE MARK CONSISTS OF THE WORD "LINUO" IN STYLIZED FONT AND IN BLUE, WITH FIVE YELLOW STRAIGHT LINES EXTENDING FROM THE CHARACTER "O". THE WORD "POWER" IN BLUE AND IN SMALLER STYLIZED FONT AT ITS LOWER RIGHT POSITION, AND FOUR CHINESE CHARACTERS IN BLUE AND AT ITS RIGHT SIDE.

THE WORDING "LINUO" HAS NO MEANING IN A FOREIGN LANGUAGE.

THE NON-LATIN CHARACTERS IN THE MARK TRANSLITERATE TO "LI; NUO; GUANG; FU" AND THIS MEANS "STRENGTH; PROMISE; SCENERY; PROSTRATE" IN ENGLISH.

FOR BATTERY CHARGERS; INTEGRATED CIRCUITS; PHOTOVOLTAIC CELLS; PHOTOVOLTAIC CELLS AND MODULES; ROTATING LIGHTS; SEMICONDUCTORS; SEMICONDUCTOR CHIPS; SILICON CHIPS; SILICON WAFERS; SOLAR CELLS (U.S. CLS. 21, 23, 26, 36 AND 38).

FIRST USE 2-20-2010; IN COMMERCE 4-29-2010.

CLASS 9—(Continued).

3,999,324. BERRY, DANIEL R., TAVARES, FL. SN 85-025,925. PUB. 9-28-2010, FILED 4-29-2010.

Polepod

THE MARK CONSISTS OF STANDARD CHARACTERS WITHOUT CLAIM TO ANY PARTICULAR FONT, STYLE, SIZE, OR COLOR.

FOR CAMERA TRIPODS (U.S. CLS. 21, 23, 26, 36 AND 38).

FIRST USE 1-13-2011; IN COMMERCE 1-27-2011.

3,999,331. SECURITYMETRICS, INC., OREM, UT. SN 85-026,677. PUB. 10-5-2010, FILED 4-29-2010.

PANscan

THE MARK CONSISTS OF STANDARD CHARACTERS WITHOUT CLAIM TO ANY PARTICULAR FONT, STYLE, SIZE, OR COLOR.

FOR COMPUTER SOFTWARE FOR SCANNING COMPUTER SYSTEMS FOR CREDIT CARD DATA THAT MAY BE DOWNLOADED FROM A GLOBAL COMPUTER NETWORK OR DELIVERED BY COMPUTER DISK (CD) (U.S. CLS. 21, 23, 26, 36 AND 38).

FIRST USE 3-9-2010; IN COMMERCE 5-4-2010.

3,999,335. SAFILO USA, INC., PARSIPPANY, NJ. SN 85-027,122. PUB. 10-5-2010, FILED 4-30-2010.

I-BOARD

THE MARK CONSISTS OF STANDARD CHARACTERS WITHOUT CLAIM TO ANY PARTICULAR FONT, STYLE, SIZE, OR COLOR.

FOR EYEWEAR, NAMELY, EYEGLASSES, SUNGLASSES, SKI GOGGLES, SNOW GOGGLES AND EYEGLASS CASES (U.S. CLS. 21, 23, 26, 36 AND 38).

FIRST USE 11-0-2010; IN COMMERCE 11-0-2010.

CLASS 9—(Continued).

3,999,336. SAFILO USA, INC., PARSIPPANY, NJ. SN 85-027,315. PUB. 10-5-2010, FILED 4-30-2010.



THE MARK CONSISTS OF THE LITERAL ELEMENT "I-BOARD" PRESENTED WITHIN CIRCULAR DESIGN WHICH ALSO INCLUDES A STYLIZED SIDE VIEW OF A SNOWBOARDER.

FOR EYEWEAR, NAMELY, EYEGLASSES, SUNGLASSES, SKI GOGGLES, SNOW GOGGLES AND EYEGLASS CASES (U.S. CLS. 21, 23, 26, 36 AND 38).

FIRST USE 11-0-2010; IN COMMERCE 11-0-2010.

3,999,337. SAFILO USA, INC., PARSIPPANY, NJ. SN 85-027,353. PUB. 10-5-2010, FILED 4-30-2010.



THE MARK CONSISTS OF THE LITERAL ELEMENT "I-BOARD" PRESENTED WITHIN GENERALLY RECTANGULAR DESIGN.

FOR EYEWEAR, NAMELY, EYEGLASSES, SUNGLASSES, SKI GOGGLES, SNOW GOGGLES AND EYEGLASS CASES (U.S. CLS. 21, 23, 26, 36 AND 38).

FIRST USE 11-0-2010; IN COMMERCE 11-0-2010.

3,999,338. ENZO & CO, INC, IRVINE, CA. SN 85-027,697. PUB. 10-12-2010, FILED 4-30-2010.



OWNER OF U.S. REG. NO. 3,762,985.

THE NAME "ENZO MILANO" DOES NOT IDENTIFY A LIVING INDIVIDUAL.

CLASS 9—(Continued).

THE MARK CONSISTS OF SILHOUETTE OF CURLING IRON WITH THE WORDS "ENZO MILANO" ON IT.

FOR ELECTRIC HAIR CRIMPER; ELECTRIC HAIR CURLING IRONS; ELECTRIC HAIR STRAIGHTENER; ELECTRIC HAIR STRAIGHTENING IRONS; FLAT IRONS, ELECTRIC (U.S. CLS. 21, 23, 26, 36 AND 38).

FIRST USE 6-0-2009; IN COMMERCE 6-0-2009.

CLASS 9—(Continued).

3,999,351. CAPSYS TECHNOLOGIES, LLC, ITASCA, IL. SN 85-028,920. PUB. 10-5-2010, FILED 5-3-2010.

CAPSYS AXIOM

THE MARK CONSISTS OF STANDARD CHARACTERS WITHOUT CLAIM TO ANY PARTICULAR FONT, STYLE, SIZE, OR COLOR.

FOR COMPUTER SOFTWARE AND HARDWARE FOR USE IN SCANNING DOCUMENTS (U.S. CLS. 21, 23, 26, 36 AND 38).

FIRST USE 5-27-2011; IN COMMERCE 5-27-2011.

3,999,347. PATIENTKEEPER, INC., WALTHAM, MA. SN 85-028,350. PUB. 10-5-2010, FILED 5-3-2010.

PK

THE MARK CONSISTS OF STANDARD CHARACTERS WITHOUT CLAIM TO ANY PARTICULAR FONT, STYLE, SIZE, OR COLOR.

FOR COMPUTER SOFTWARE TO ENABLE MEDICAL PROFESSIONALS TO CAPTURE AND ORGANIZE PATIENT INFORMATION (U.S. CLS. 21, 23, 26, 36 AND 38).

FIRST USE 3-0-2010; IN COMMERCE 3-0-2010.

3,999,368. MULTIMEDIA GAMES, INC., AUSTIN, TX. SN 85-030,380. PUB. 10-12-2010, FILED 5-5-2010.

ICE ON FIRE

THE MARK CONSISTS OF STANDARD CHARACTERS WITHOUT CLAIM TO ANY PARTICULAR FONT, STYLE, SIZE, OR COLOR.

FOR GAMING MACHINES, NAMELY, ELECTRONIC SLOT AND BINGO MACHINES; VIDEO LOTTERY TERMINALS (U.S. CLS. 21, 23, 26, 36 AND 38).

FIRST USE 11-16-2010; IN COMMERCE 11-16-2010.

3,999,350. SAMSUNG ELECTRONICS CO., LTD., SUWON-SI, GYEONGGI-DO, REPUBLIC OF KOREA. SN 85-028,752. PUB. 10-5-2010, FILED 5-3-2010.

SAMSUNG SHOWCASE

THE MARK CONSISTS OF STANDARD CHARACTERS WITHOUT CLAIM TO ANY PARTICULAR FONT, STYLE, SIZE, OR COLOR.

OWNER OF U.S. REG. NOS. 2,882,774, 3,713,355, AND OTHERS.

THE ENGLISH TRANSLATION OF "SAMSUNG" IN THE MARK IS THREE STARS.

FOR MOBILE PHONES; SMARTPHONES (U.S. CLS. 21, 23, 26, 36 AND 38).

FIRST USE 10-6-2010; IN COMMERCE 10-6-2010.

3,999,405. MOXA INC., TAIPEI HSIEN, TAIWAN. SN 85-033,838. PUB. 11-2-2010, FILED 5-10-2010.



NO CLAIM IS MADE TO THE EXCLUSIVE RIGHT TO USE "REDUNDANT RINGS", APART FROM THE MARK AS SHOWN.

CLASS 9—(Continued).

THE MARK CONSISTS OF THE WORDS "TURBO CHAIN" IN ITALIC FONT, A CURVED LINE WITH A HOOK-SHAPED END ABOVE THE WORDS "TURBO CHAIN", AND THE WORDS "BEYOND REDUNDANT RINGS" ON TOP OF THE CURVED LINE.

FOR COMPUTER NETWORKING PRODUCTS AND COMMUNICATIONS EQUIPMENT, NAMELY, COMPUTER NETWORK ADAPTERS, ETHERNET REPEATERS, COMPUTER NETWORK CONCENTRATING ADAPTERS, MODEMS, MEDIA CONVERTERS IN THE NATURE OF DIGITAL PHOTO IMAGE CONVERTERS AND CABLE TELEVISION CONVERTERS, NETWORK ROUTERS, HUBS IN THE NATURE OF DIGITAL MEDIA HUBS, COMPUTER NETWORK HUBS, COMMUNICATION HUBS, PRINTER HUBS AND USB HUBS, SWITCHES IN THE NATURE OF COMPUTER NETWORK SWITCHES, CUT-OUT SWITCHES, DIFFERENTIAL SWITCHES AND ELECTRIC CURRENT SWITCHES, COMPUTER NETWORK BRIDGES, COMPUTER SERVERS, COMMUNICATION SERVERS, TERMINAL SERVERS IN THE NATURE OF INTERNET AND INTRANET SERVERS, MULTIPLEXERS, GATEWAY ROUTERS IN THE NATURE OF COMPUTER CONTROL HARDWARE, NETWORK INTERFACE CARDS FOR COMPUTERS IN THE FORM OF PRINTED CIRCUITS, WIRELESS LAN COMPUTER CARDS FOR CONNECTING PORTABLE COMPUTER DEVICES TO COMPUTER NETWORKS; CONNECTORS, NAMELY, ELECTRICAL CONNECTORS, NETWORK CABLE CONNECTORS, PLUG CONNECTORS FOR COMPUTERS; COMPUTER NETWORK MANAGEMENT SOFTWARE AND ASSOCIATED NETWORKING SOFTWARE USED TO MANAGE VIRTUAL AND PHYSICAL SERVERS; ELECTRICAL POWER SUPPLIES; PRINTED CIRCUIT BOARDS; INTEGRATED CIRCUITS; COMPUTER CHIPS; COMPUTER HARDWARE, NAMELY, MULTIPOINT MICROCHIP CARDS FOR CONTROLLING SERIAL DEVICES SUCH AS MODEMS AND OTHER INDUSTRIAL MACHINES (U.S. CLS. 21, 23, 26, 36 AND 38).

FIRST USE 5-25-2010; IN COMMERCE 12-1-2010.

3,999,415. ANGEL SALES, INC., CHICAGO, IL. SN 85-035,576.
PUB. 10-19-2010, FILED 5-11-2010.

SEE-HEAR-NOW

THE MARK CONSISTS OF STANDARD CHARACTERS WITHOUT CLAIM TO ANY PARTICULAR FONT, STYLE, SIZE, OR COLOR.

FOR ELECTRONIC HEARING INSTRUMENTS, NAMELY, NON-MEDICAL PERSONAL SOUND AMPLIFIERS (U.S. CLS. 21, 23, 26, 36 AND 38).

FIRST USE 3-14-2010; IN COMMERCE 3-14-2010.

CLASS 9—(Continued).

3,999,423. THE PROCTER & GAMBLE COMPANY, CINCINNATI, OH. SN 85-036,683. PUB. 10-12-2010, FILED 5-12-2010.

YUCK MOUTH

THE MARK CONSISTS OF STANDARD CHARACTERS WITHOUT CLAIM TO ANY PARTICULAR FONT, STYLE, SIZE, OR COLOR.

FOR INTERACTIVE GAME PROGRAMS (U.S. CLS. 21, 23, 26, 36 AND 38).

FIRST USE 7-1-2010; IN COMMERCE 7-1-2010.

3,999,429. KABUSHIKI KAISHA SQUARE ENIX, TA SQUARE ENIX CO., LTD., TOKYO, JAPAN. SN 85-037,269. PUB. 2-1-2011, FILED 5-13-2010.

MINDJACK

THE MARK CONSISTS OF STANDARD CHARACTERS WITHOUT CLAIM TO ANY PARTICULAR FONT, STYLE, SIZE, OR COLOR.

PRIORITY CLAIMED UNDER SEC. 44(D) ON JAPAN APPLICATION NO. 2010-037350, FILED 5-13-2010, REG. NO. 5364478, DATED 10-29-2010, EXPIRES 10-29-2020.

FOR COMPUTER GAME SOFTWARE; VIDEO GAME SOFTWARE (U.S. CLS. 21, 23, 26, 36 AND 38).

FIRST USE 1-18-2011; IN COMMERCE 1-18-2011.

3,999,466. TOW DADDY, INC., VANCOUVER, WA. SN 85-043,031. PUB. 10-19-2010, FILED 5-19-2010.

TOWDADDY

THE MARK CONSISTS OF STANDARD CHARACTERS WITHOUT CLAIM TO ANY PARTICULAR FONT, STYLE, SIZE, OR COLOR.

FOR ELECTRICAL ACCESSORIES FOR TOWING, NAMELY, ELECTRICAL DEVICES FOR DISCONNECTING FUSES FROM VEHICLES THAT ARE BEING TOWED (U.S. CLS. 21, 23, 26, 36 AND 38).

FIRST USE 8-0-2010; IN COMMERCE 8-0-2010.

CLASS 9—(Continued).

3,999,476. NATIONAL ASSOCIATION OF MUSIC MERCHANTS, INC., CARLSBAD, CA. SN 85-045,498. PUB. 2-22-2011, FILED 5-21-2010.



OWNER OF U.S. REG. NO. 3,744,121.
NO CLAIM IS MADE TO THE EXCLUSIVE RIGHT TO USE "SCHOOL", "BATTLE OF THE BANDS", AND "USA", APART FROM THE MARK AS SHOWN.

THE COLOR(S) RED, BLUE, LIGHT BLUE, ORANGE AND WHITE IS/ARE CLAIMED AS A FEATURE OF THE MARK.

THE MARK CONSISTS OF THE WORDS "SCHOOL JAM" WHERE THE WORD "SCHOOL" IS IN RED LETTERING AND UNDERNEATH IS THE WORD "JAM" DEPICTED IN LARGER BLUE LETTERS. AT THE BOTTOM OF THE MARK THE WORDS "BATTLE OF THE BANDS" APPEAR IN SMALLER ORANGE LETTERING AND TO THE RIGHT OF THIS IS "USA" IN WHITE LETTERING INSIDE A ROUNDED RED BOX. TO THE LEFT OF ALL OF THE LETTERING IS A SLIGHTLY TILTED LIGHT BLUE OUTLINE OF A STAR. THIS STAR IS POSITIONED BEHIND THE LETTERING.

FOR DIGITAL MEDIA, NAMELY, DOWNLOADABLE AUDIO AND VIDEO RECORDINGS, CDS AND DVDS FEATURING MUSIC, INTERVIEWS AND PERFORMANCES OF SCHOOL BANDS AND STUDENT MUSICIANS PARTICIPATING IN MUSIC COMPETITIONS (U.S. CLS. 21, 23, 26, 36 AND 38).

FIRST USE 3-0-2011; IN COMMERCE 3-0-2011.

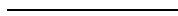

3,999,491. PLASTOFORM INDUSTRIES LIMITED, N.T., HONG KONG. SN 85-047,830. PUB. 10-26-2010, FILED 5-25-2010.



THE MARK CONSISTS OF THE WORD "CMCX" IN STYLIZED FONT.

THE WORDING "CMCX" HAS NO MEANING IN A FOREIGN LANGUAGE.

FOR APPARATUS FOR RECORDING, TRANSMISSION, PROCESSING AND REPRODUCTION OF SOUND, IMAGES OR DATA; AUDIO AMPLIFIERS; CABINETS FOR LOUDSPEAKERS; COMPUTER HARDWARE AND PERIPHERALS; COMPUTERS; LOUDSPEAKERS (U.S. CLS. 21, 23, 26, 36 AND 38).

FIRST USE 4-13-2010; IN COMMERCE 4-13-2010.

CLASS 9—(Continued).

3,999,493. LANNER GROUP LIMITED, REDDITCH, ENGLAND. SN 85-048,186. PUB. 10-12-2010, FILED 5-26-2010.

WITNESS

THE MARK CONSISTS OF STANDARD CHARACTERS WITHOUT CLAIM TO ANY PARTICULAR FONT, STYLE, SIZE, OR COLOR.

FOR COMPUTER SOFTWARE FOR BUSINESS PROCESS SIMULATION, COMPUTERIZED MODELING, SIMULATION AND OPTIMIZATION OF BUSINESS PROCESSES, NAMELY, FOR USE IN BUSINESS PROCESS MANAGEMENT, ANALYSIS AND OUTCOMES THEREFOR (U.S. CLS. 21, 23, 26, 36 AND 38).

FIRST USE 12-31-1986; IN COMMERCE 12-31-1986.



3,999,496. SKYUNION PTE. LTD., 159308, SINGAPORE. SN 85-049,318. PUB. 11-2-2010, FILED 5-27-2010.

Crazy Mart

THE MARK CONSISTS OF THE WORDING "CRAZY MART".

FOR COMPUTER GAME PROGRAMMES; COMPUTER GAME SOFTWARE; COMPUTER OPERATING PROGRAMS, RECORDED; COMPUTER PERIPHERAL DEVICES; COMPUTER PROGRAMS FOR PRE-RECORDED GAMES; COMPUTER PROGRAMS RECORDED ON DATA MEDIA (SOFTWARE) DESIGNED FOR USE IN CONSTRUCTION AND AUTOMATED MANUFACTURING (CAD/CAM); COMPUTERS; DOWNLOADABLE COMPUTER PROGRAMS FEATURING POSITIONABLE GAME PIECE FIGURES FOR USE IN THE FIELD OF COMPUTER GAMES; DOWNLOADABLE ELECTRONIC PUBLICATIONS IN THE NATURE OF MAGAZINES IN THE FIELD OF COMPUTER GAMES; ELECTRONIC POCKET TRANSLATORS; ELECTRONIC TEST AND MEASUREMENT DEVICES FOR USE IN THE FIELDS OF NETWORKS AND TELECOMMUNICATIONS, NAMELY, INSTRUMENTATION USED TO TEST AND CERTIFY NEW AND EXISTING DATA AND VOICE COMMUNICATION CABLE AND COAXIAL CABLE (U.S. CLS. 21, 23, 26, 36 AND 38).

FIRST USE 9-1-2010; IN COMMERCE 9-1-2010.

CLASS 9—(Continued).

3,999,506. SA STUDIOS, LLC, LOS ANGELES, CA. SN 85-052,806. PUB. 11-9-2010, FILED 6-2-2010.

SANCTIONED HEALTH SERVICES

THE MARK CONSISTS OF STANDARD CHARACTERS WITHOUT CLAIM TO ANY PARTICULAR FONT, STYLE, SIZE, OR COLOR.

OWNER OF U.S. REG. NO. 3,761,013.

NO CLAIM IS MADE TO THE EXCLUSIVE RIGHT TO USE "HEALTH SERVICES", APART FROM THE MARK AS SHOWN.

FOR MAGNETICALLY ENCODED STORED VALUE AND SAVINGS CARDS (U.S. CLS. 21, 23, 26, 36 AND 38). FIRST USE 9-0-2010; IN COMMERCE 9-0-2010.

3,999,508. INVENSYS SYSTEMS, INC., FOXBORO, MA. SN 85-053,482. PUB. 11-2-2010, FILED 6-3-2010.

PenGUIn

THE MARK CONSISTS OF STANDARD CHARACTERS WITHOUT CLAIM TO ANY PARTICULAR FONT, STYLE, SIZE, OR COLOR.

FOR COMPUTER HARDWARE AND SOFTWARE FOR USE IN MONITORING AND CONTROLLING INDUSTRIAL MACHINES AND EQUIPMENT (U.S. CLS. 21, 23, 26, 36 AND 38).

FIRST USE 4-8-2010; IN COMMERCE 9-22-2010.

3,999,511. HAND E HOLDER PRODUCTS, INC., ANN ARBOR, MI. SN 85-054,330. PUB. 12-28-2010, FILED 6-3-2010.

HAND E HOLDER

THE MARK CONSISTS OF STANDARD CHARACTERS WITHOUT CLAIM TO ANY PARTICULAR FONT, STYLE, SIZE, OR COLOR.

NO CLAIM IS MADE TO THE EXCLUSIVE RIGHT TO USE "HOLDER", APART FROM THE MARK AS SHOWN.

FOR HOLDING DEVICE SPECIALLY DESIGNED FOR ALLOWING USERS TO HOLD AND ROTATE TABLET COMPUTERS, HANDHELD COMPUTERS, PORTABLE DIGITAL ELECTRONIC DEVICES, AND HANDHELD DIGITAL ELECTRONIC DEVICES IN A USER'S HANDS OR IN SPECIALLY DESIGNED STANDS (U.S. CLS. 21, 23, 26, 36 AND 38).

FIRST USE 7-23-2010; IN COMMERCE 7-23-2010.

CLASS 9—(Continued).

3,999,534. ELECTRONIC ARTS INC., REDWOOD CITY, CA. SN 85-057,943. PUB. 11-2-2010, FILED 6-8-2010.

BRIGHT LIGHT

THE MARK CONSISTS OF STANDARD CHARACTERS WITHOUT CLAIM TO ANY PARTICULAR FONT, STYLE, SIZE, OR COLOR.

FOR COMPUTER GAME SOFTWARE; DOWNLOADABLE COMPUTER GAME SOFTWARE VIA A GLOBAL COMPUTER NETWORK AND WIRELESS DEVICES; VIDEO GAME SOFTWARE (U.S. CLS. 21, 23, 26, 36 AND 38).

FIRST USE 9-4-2009; IN COMMERCE 9-4-2009.

3,999,545. N HOLDING AB, SOLLENTUNA, SWEDEN. SN 85-060,844. PUB. 10-26-2010, FILED 6-11-2010.

RED STAR TECHNOLOGY

THE MARK CONSISTS OF STANDARD CHARACTERS WITHOUT CLAIM TO ANY PARTICULAR FONT, STYLE, SIZE, OR COLOR.

NO CLAIM IS MADE TO THE EXCLUSIVE RIGHT TO USE "TECHNOLOGY", APART FROM THE MARK AS SHOWN.

FOR BATTERIES (U.S. CLS. 21, 23, 26, 36 AND 38).

FIRST USE 2-28-2011; IN COMMERCE 2-28-2011.

3,999,548. DRIVER DIGITAL, LLC, NEW YORK, NY. SN 85-061,214. PUB. 10-12-2010, FILED 6-11-2010.

DIGITS DECLASSIFIED

THE MARK CONSISTS OF STANDARD CHARACTERS WITHOUT CLAIM TO ANY PARTICULAR FONT, STYLE, SIZE, OR COLOR.

FOR DOWNLOADABLE VIDEO RECORDINGS FEATURING RELATIONSHIPS AND DATING TIPS (U.S. CLS. 21, 23, 26, 36 AND 38).

FIRST USE 6-1-2010; IN COMMERCE 6-1-2010.

CLASS 9—(Continued).

3,999,552. NINTENDO OF AMERICA INC., REDMOND, WA.
SN 85-062,975. PUB. 10-12-2010, FILED 6-15-2010.

PHOTO DOJO

THE MARK CONSISTS OF STANDARD CHARACTERS WITHOUT CLAIM TO ANY PARTICULAR FONT, STYLE, SIZE, OR COLOR.

NO CLAIM IS MADE TO THE EXCLUSIVE RIGHT TO USE "PHOTO", APART FROM THE MARK AS SHOWN.

FOR COMPUTER GAME PROGRAMS; COMPUTER GAME SOFTWARE; ELECTRONIC GAME PROGRAMS; ELECTRONIC GAME SOFTWARE; INTERACTIVE ELECTRONIC GAME PROGRAMS; INTERACTIVE ELECTRONIC GAME SOFTWARE; INTERACTIVE VIDEO GAME PROGRAMS; INTERACTIVE VIDEO GAME SOFTWARE; VIDEO GAME PROGRAMS; VIDEO GAME SOFTWARE; DOWNLOADABLE MULTIMEDIA FILES, NAMELY, GAMES; DOWNLOADABLE COMPUTER GAME PROGRAMS; DOWNLOADABLE COMPUTER GAME SOFTWARE; DOWNLOADABLE ELECTRONIC GAME PROGRAMS; DOWNLOADABLE ELECTRONIC GAME SOFTWARE; DOWNLOADABLE INTERACTIVE ELECTRONIC GAME PROGRAMS; DOWNLOADABLE INTERACTIVE GAME SOFTWARE; DOWNLOADABLE VIDEO GAME PROGRAMS; DOWNLOADABLE VIDEO GAME SOFTWARE; DOWNLOADABLE ELECTRONIC PUBLICATIONS, NAMELY, GAME INSTRUCTION BOOKLETS (U.S. CLS. 21, 23, 26, 36 AND 38).

FIRST USE 5-10-2010; IN COMMERCE 5-10-2010.

3,999,553. NINTENDO OF AMERICA INC., REDMOND, WA.
SN 85-062,980. PUB. 10-12-2010, FILED 6-15-2010.

PILOTWINGS RESORT

THE MARK CONSISTS OF STANDARD CHARACTERS WITHOUT CLAIM TO ANY PARTICULAR FONT, STYLE, SIZE, OR COLOR.

FOR PRE-RECORDED CARTRIDGES AND MEMORY CARDS FEATURING ENTERTAINMENT CONTENT PERTAINING TO VIDEO GAMES, COMPUTER GAMES AND STORIES; COMPUTER GAME CARTRIDGES; COMPUTER GAME MEMORY CARDS; COMPUTER GAME PROGRAMS; COMPUTER GAME SOFTWARE; ELECTRONIC GAME CARTRIDGES; ELECTRONIC GAME MEMORY CARDS; ELECTRONIC GAME PROGRAMS; ELECTRONIC GAME SOFTWARE; INTERACTIVE ELECTRONIC GAME CARTRIDGES; INTERACTIVE ELECTRONIC GAME MEMORY CARDS; INTERACTIVE ELECTRONIC GAME PROGRAMS; INTERACTIVE ELECTRONIC GAME SOFTWARE; INTERACTIVE VIDEO GAME CARTRIDGES; INTERACTIVE VIDEO GAME MEMORY CARDS; INTERACTIVE VIDEO GAME PROGRAMS; INTERACTIVE VIDEO GAME SOFTWARE; VIDEO GAME CARTRIDGES; VIDEO GAME MEMORY CARDS; VIDEO GAME PROGRAMS; VIDEO GAME SOFTWARE; DOWNLOADABLE ELECTRONIC PUBLICATIONS, NAMELY, GAME INSTRUCTION BOOKLETS (U.S. CLS. 21, 23, 26, 36 AND 38).

FIRST USE 3-27-2011; IN COMMERCE 3-27-2011.

CLASS 9—(Continued).

3,999,558. SHELBY GROUP INTERNATIONAL, INC., MEMPHIS, TN. SN 85-064,572. PUB. 12-7-2010, FILED 6-16-2010.



OWNER OF U.S. REG. NOS. 3,071,807 AND 3,130,562.

NO CLAIM IS MADE TO THE EXCLUSIVE RIGHT TO USE "SAFETY", APART FROM THE MARK AS SHOWN.

THE MARK CONSISTS OF A THREE HEADED DOG WHICH IS ABOVE THE PHRASE "MCR" WHICH IS ABOVE THE PHRASE "SAFETY".

FOR PROTECTIVE CLOTHING, NAMELY, RAINWEAR, SUITS, JACKETS, PANTS, COATS, BIB OVERALLS, COVERALLS, SLEEVES, HOODS, PONCHOS, APRONS, FLAME-RETARDANT WELDING APPAREL, NAMELY, WELDER'S CAPS, WELDING JACKETS, AND WELDING SPATS, AND SAFETY VESTS; HAND PROTECTION PRODUCTS, NAMELY, PROTECTIVE GLOVES IN THE NATURE OF PROTECTIVE WORK GLOVES AND PROTECTIVE GLOVES FOR INDUSTRIAL USE, PROTECTIVE MITTENS FOR INDUSTRIAL USE, PROTECTIVE WORK GLOVES, PROTECTIVE WINTER WORK GLOVES, PROTECTIVE WELDING GLOVES AND PROTECTIVE POTHOLDERS FOR INDUSTRIAL USE; PROTECTIVE BOOTS AND SHOES FOR INDUSTRIAL USE; SAFETY EYE GLASSES, SAFETY GOGGLES AND SAFETY EYEWEAR; PROTECTIVE HEADWEAR AND HELMETS; PROTECTIVE FACE AND EYE SHIELDS FOR INDUSTRIAL USE; EAR AND HEARING PROTECTION PRODUCTS IN THE NATURE OF EAR PLUGS AND EAR MUFFS FOR NON-MEDICAL PURPOSES; RESPIRATORS OTHER THAN FOR ARTIFICIAL RESPIRATION (U.S. CLS. 21, 23, 26, 36 AND 38).

FIRST USE 10-4-2010; IN COMMERCE 10-4-2010.

3,999,563. TOW DADDY, INC., VANCOUVER, WA. SN 85-065,697. PUB. 10-19-2010, FILED 6-17-2010.

AUTOFUSE

THE MARK CONSISTS OF STANDARD CHARACTERS WITHOUT CLAIM TO ANY PARTICULAR FONT, STYLE, SIZE, OR COLOR.

FOR ELECTRICAL ACCESSORIES FOR TOWING, NAMELY, ELECTRICAL DEVICES FOR DISCONNECTING FUSES FROM VEHICLES THAT ARE BEING TOWED (U.S. CLS. 21, 23, 26, 36 AND 38).

FIRST USE 8-0-2010; IN COMMERCE 8-0-2010.

CLASS 9—(Continued).

3,999,564. TOW DADDY, INC., VANCOUVER, WA. SN 85-065,708. PUB. 10-19-2010, FILED 6-17-2010.

PLUG-N-TOW

THE MARK CONSISTS OF STANDARD CHARACTERS WITHOUT CLAIM TO ANY PARTICULAR FONT, STYLE, SIZE, OR COLOR.

FOR ELECTRIC CONNECTORS; POWER CONNECTORS; MOTOR VEHICLE TO TRAILER ELECTRICAL CONNECTORS; ELECTRICAL ACCESSORIES FOR TOWING, NAMELY, ELECTRICAL DEVICES FOR DISCONNECTING FUSES FROM VEHICLES BEING THAT ARE BEING TOWED (U.S. CLS. 21, 23, 26, 36 AND 38).

FIRST USE 8-0-2010; IN COMMERCE 8-0-2010.

3,999,565. LIFESTYLE IMPROVEMENT CENTERS, LLC, DUBLIN, OH. SN 85-065,833. PUB. 11-9-2010, FILED 6-17-2010.

SLENDERIFIC

THE MARK CONSISTS OF STANDARD CHARACTERS WITHOUT CLAIM TO ANY PARTICULAR FONT, STYLE, SIZE, OR COLOR.

FOR PRE-RECORDED AUDIO AND VIDEO TAPES, CDS, DVD, AND DIGITAL MEDIA FILES IN THE FIELD OF HYPNOSIS RELATING TO WEIGHT CONTROL AND BEHAVIOR MODIFICATION (U.S. CLS. 21, 23, 26, 36 AND 38).

FIRST USE 7-31-2004; IN COMMERCE 7-31-2004.

3,999,570. ROCKET GAMING SYSTEMS, LLC, GROVE, OK. SN 85-068,142. PUB. 11-16-2010, FILED 6-21-2010.

MISSISSIPPI QUEEN

THE MARK CONSISTS OF STANDARD CHARACTERS WITHOUT CLAIM TO ANY PARTICULAR FONT, STYLE, SIZE, OR COLOR.

FOR GAMING MACHINES, NAMELY, BINGO-RELATED GAMES AND SLOT MACHINES (U.S. CLS. 21, 23, 26, 36 AND 38).

FIRST USE 11-8-2010; IN COMMERCE 11-8-2010.

CLASS 9—(Continued).

3,999,573. RAE SYSTEMS INC., SAN JOSE, CA. SN 85-068,702. PUB. 10-12-2010, FILED 6-22-2010.

TOXIRAE PRO

THE MARK CONSISTS OF STANDARD CHARACTERS WITHOUT CLAIM TO ANY PARTICULAR FONT, STYLE, SIZE, OR COLOR.

OWNER OF U.S. REG. NOS. 2,822,823, 3,631,135, AND OTHERS.

NO CLAIM IS MADE TO THE EXCLUSIVE RIGHT TO USE "PRO", APART FROM THE MARK AS SHOWN.

FOR TOXIC AND FLAMMABLE GAS MONITOR (U.S. CLS. 21, 23, 26, 36 AND 38).

FIRST USE 3-16-2011; IN COMMERCE 3-16-2011.

3,999,577. SHELBY GROUP INTERNATIONAL, INC., MEMPHIS, TN. SN 85-069,601. PUB. 12-7-2010, FILED 6-23-2010.

JUST TRY TO OUTWORK US

THE MARK CONSISTS OF STANDARD CHARACTERS WITHOUT CLAIM TO ANY PARTICULAR FONT, STYLE, SIZE, OR COLOR.

FOR PROTECTIVE CLOTHING, NAMELY, RAINWEAR, SUITS, JACKETS, PANTS, COATS, BIB OVERALLS, COVERALLS, SLEEVES, HOODS, PONCHOS, APRONS, FLAME-RETARDANT WELDING APPAREL, NAMELY, WELDER'S CAPS, WELDING JACKETS, AND WELDING SPATS, AND SAFETY VESTS; HAND PROTECTION PRODUCTS, NAMELY, PROTECTIVE GLOVES IN THE NATURE OF PROTECTIVE WORK GLOVES AND PROTECTIVE GLOVES FOR INDUSTRIAL USE, PROTECTIVE MITTENS FOR INDUSTRIAL USE, PROTECTIVE WORK GLOVES, PROTECTIVE WINTER WORK GLOVES, PROTECTIVE WELDING GLOVES AND PROTECTIVE POTHOLDERS FOR INDUSTRIAL USE; PROTECTIVE BOOTS AND SHOES FOR INDUSTRIAL USE; SAFETY EYE GLASSES, SAFETY GOGGLES AND SAFETY EYEWEAR; PROTECTIVE HEADWEAR AND HELMETS; PROTECTIVE FACE AND EYE SHIELDS FOR INDUSTRIAL USE; EAR AND HEARING PROTECTION PRODUCTS IN THE NATURE OF EAR PLUGS AND EAR MUFFS FOR NON-MEDICAL PURPOSES; RESPIRATORS OTHER THAN FOR ARTIFICIAL RESPIRATION (U.S. CLS. 21, 23, 26, 36 AND 38).

FIRST USE 10-4-2010; IN COMMERCE 10-4-2010.

CLASS 9—(Continued).

3,999,582. PROFESSIONAL CABLE, LLC, OREM, UT. SN 85-071,181. PUB. 11-16-2010, FILED 6-24-2010.

SnowFire

THE MARK CONSISTS OF STANDARD CHARACTERS WITHOUT CLAIM TO ANY PARTICULAR FONT, STYLE, SIZE, OR COLOR.

FOR HEADPHONES (U.S. CLS. 21, 23, 26, 36 AND 38).
FIRST USE 2-1-2010; IN COMMERCE 2-19-2010.

3,999,621. APTORA CORPORATION, LENEXA, KS. SN 85-081,387. PUB. 12-14-2010, FILED 7-9-2010.

APTORA MOBILE

THE MARK CONSISTS OF STANDARD CHARACTERS WITHOUT CLAIM TO ANY PARTICULAR FONT, STYLE, SIZE, OR COLOR.

OWNER OF U.S. REG. NO. 3,736,802.

NO CLAIM IS MADE TO THE EXCLUSIVE RIGHT TO USE "MOBILE", APART FROM THE MARK AS SHOWN.

FOR COMPUTER SOFTWARE FOR CONNECTING MOBILE COMPUTERS AND WIRELESS DEVICES TO DATABASES AND INFORMATION STORED ON A REMOTE SERVER COMPUTER (U.S. CLS. 21, 23, 26, 36 AND 38).

FIRST USE 8-12-2010; IN COMMERCE 8-12-2010.

3,999,622. APTORA CORPORATION, LENEXA, KS. SN 85-081,528. PUB. 12-14-2010, FILED 7-9-2010.

APTORA MOBILE SERVER

THE MARK CONSISTS OF STANDARD CHARACTERS WITHOUT CLAIM TO ANY PARTICULAR FONT, STYLE, SIZE, OR COLOR.

OWNER OF U.S. REG. NO. 3,736,802.

NO CLAIM IS MADE TO THE EXCLUSIVE RIGHT TO USE "MOBILE SERVER", APART FROM THE MARK AS SHOWN.

FOR COMPUTER SOFTWARE FOR CONNECTING MOBILE COMPUTERS AND WIRELESS DEVICES TO DATABASES AND INFORMATION STORED ON A REMOTE SERVER COMPUTER (U.S. CLS. 21, 23, 26, 36 AND 38).

FIRST USE 8-12-2010; IN COMMERCE 8-12-2010.

CLASS 9—(Continued).

3,999,627. HIMS INTERNATIONAL CORPORATION, DAEJEON, 305-350, REPUBLIC OF KOREA. SN 85-082,199. PUB. 12-21-2010, FILED 7-12-2010.

Braille Sense OnHand

THE MARK CONSISTS OF STANDARD CHARACTERS WITHOUT CLAIM TO ANY PARTICULAR FONT, STYLE, SIZE, OR COLOR.

NO CLAIM IS MADE TO THE EXCLUSIVE RIGHT TO USE "BRAILLE", APART FROM THE MARK AS SHOWN.

FOR ELECTROMECHANICAL DEVICE CONNECTABLE TO A GLOBAL COMMUNICATIONS NETWORK FOR USE BY BLIND USERS AS A MEANS TO TAKE NOTES IN BRAILLE (U.S. CLS. 21, 23, 26, 36 AND 38).

FIRST USE 12-25-2010; IN COMMERCE 12-25-2010.

3,999,631. BLACKMON JAMES W III, DBA ELEVATOR MUSIC GROUP, CHARLOTTE, NC. SN 85-085,428. PUB. 1-11-2011, FILED 7-15-2010.



NO CLAIM IS MADE TO THE EXCLUSIVE RIGHT TO USE "ELEVATOR MUSIC GROUP", APART FROM THE MARK AS SHOWN.

THE MARK CONSISTS OF THE LETTERS "E", "M", AND "G" IN A CLEAN AND SIMPLE SANS SERIF FONT. THE LETTERS ARE UNDER AN ELEVATOR LEVEL DISPLAYER AND OVER THREE STEPS. "ELEVATOR MUSIC GROUP" IS LOCATED UNDER THE LETTERS "E", "M", AND "G".

FOR AUDIO AND VIDEO RECORDINGS FEATURING MUSIC AND ARTISTIC PERFORMANCES (U.S. CLS. 21, 23, 26, 36 AND 38).

FIRST USE 11-4-2010; IN COMMERCE 1-1-2011.

CLASS 9—(Continued).

3,999,635. FLUKE CORPORATION, EVERETT, WA. SN 85-085,964. PUB. 10-5-2010, FILED 7-15-2010.



THE MARK CONSISTS OF A SERIES OF DOTS IN A V-SHAPED PATTERN.

FOR COMPUTER HARDWARE AND PERIPHERALS; COMPUTER HARDWARE AND SOFTWARE FOR SETTING UP AND CONFIGURING LOCAL AND WIDE AREA NETWORKS; COMPUTER HARDWARE FOR TELECOMMUNICATIONS; COMPUTER NETWORKING HARDWARE; LAN (LOCAL AREA NETWORK) HARDWARE; VPN (VIRTUAL PRIVATE NETWORK) HARDWARE; WAN (WIDE AREA NETWORK) HARDWARE; COMPUTERS FOR NETWORK MANAGEMENT; COMPUTER SOFTWARE PLATFORMS FOR MANAGING NETWORK PERFORMANCE, APPLICATIONS, DATA, AND REPORTS; COMPUTER SOFTWARE FOR CONTROLLING AND MANAGING ACCESS SERVER APPLICATIONS; COMPUTER SOFTWARE FOR ADMINISTRATION OF COMPUTER NETWORKS; COMPUTER SOFTWARE THAT PROVIDES WEB-BASED ACCESS TO APPLICATIONS AND SERVICES THROUGH A WEB OPERATING SYSTEM OR PORTAL INTERFACE; ELECTRONIC COMMUNICATIONS SYSTEMS COMPRISED OF COMPUTER HARDWARE AND SOFTWARE FOR THE TRANSMISSION OF DATA BETWEEN TWO POINTS; NETWORK ACCESS SERVER OPERATING SOFTWARE; LAN (LOCAL AREA NETWORK) OPERATING SOFTWARE; VPN (VIRTUAL PRIVATE NETWORK) OPERATING SOFTWARE; WAN (WIDE AREA NETWORK) OPERATING SOFTWARE; COMPUTER NETWORK HUBS; COMPUTER NETWORK BRIDGES; COMPUTER NETWORK INTERFACE DEVICES; DATA PROCESSORS; ELECTRONIC DATA LOGGERS; ELECTRONIC DATA RECORDERS; MOBILE DATA RECEIVERS; COMPUTER HARDWARE AND COMPUTER SOFTWARE UTILIZED IN THE FIELD OF DATA COMMUNICATIONS AND TELECOMMUNICATIONS TO MONITOR AND ANALYZE NETWORK AND APPLICATION PERFORMANCE, TROUBLESHOOT NETWORK PROBLEMS, AND PROVIDE NETWORK CAPACITY-PLANNING CAPABILITIES; COMPUTER HARDWARE AND COMPUTER SOFTWARE AND ASSOCIATED USER MANUALS SOLD AS A UNIT UTILIZED IN THE FIELD OF DATA COMMUNICATIONS AND TELECOMMUNICATIONS TO MONITOR AND CONTROL NETWORK ACTIVITY (U.S. CLS. 21, 23, 26, 36 AND 38).

FIRST USE 6-28-2010; IN COMMERCE 10-1-2010.

CLASS 9—(Continued).

3,999,639. UNIVERSAL CITY STUDIOS LLC, UNIVERSAL CITY, CA. SN 85-087,509. PUB. 10-26-2010, FILED 7-19-2010.

UHEAR

THE MARK CONSISTS OF STANDARD CHARACTERS WITHOUT CLAIM TO ANY PARTICULAR FONT, STYLE, SIZE, OR COLOR.

FOR COMPUTER SOFTWARE APPLICATION, AS FEATURE OF DIGITAL VIDEO DISCS, FOR USE IN ALLOWING ACCESS TO FUNCTIONALITIES OF THE DISC DURING THE PLAYING OF THE CONTENT ON SUCH DISCS (U.S. CLS. 21, 23, 26, 36 AND 38).

FIRST USE 9-21-2010; IN COMMERCE 9-21-2010.

3,999,641. EVERSOL CORPORATION, TAIPEI CITY, TAIWAN. SN 85-088,945. PUB. 1-4-2011, FILED 7-20-2010.



THE MARK CONSISTS OF A SILHOUETTED SQUARE WITH FOUR BEVELLED CORNERS, REPRESENTING A SILICON CHIP, ENCASED IN AN OPEN, MULTIFACETED CURVILINEAR ABSTRACT FORM, SHADED TO CREATE A THREE-DIMENSIONAL IMPRESSION, SURROUNDING THE SQUARE ON ALL SIDES, BACK AND FRONT.

FOR SILICON WAFERS FOR SOLAR CELL USE (U.S. CLS. 21, 23, 26, 36 AND 38).

FIRST USE 3-9-2011; IN COMMERCE 3-22-2011.

CLASS 9—(Continued).

3,999,643. EMX INDUSTRIES INC., CLEVELAND, OH. SN 85-089,323. PUB. 1-4-2011, FILED 7-21-2010.

ISWITCH

THE MARK CONSISTS OF STANDARD CHARACTERS WITHOUT CLAIM TO ANY PARTICULAR FONT, STYLE, SIZE, OR COLOR.

FOR ELECTRONIC PROXIMITY SENSORS AND SWITCHES (U.S. CLS. 21, 23, 26, 36 AND 38).

FIRST USE 5-18-2011; IN COMMERCE 5-18-2011.

3,999,644. ROCKET GAMING SYSTEMS, LLC, GROVE, OK. SN 85-089,499. PUB. 11-16-2010, FILED 7-21-2010.

TITAN TREASURES

THE MARK CONSISTS OF STANDARD CHARACTERS WITHOUT CLAIM TO ANY PARTICULAR FONT, STYLE, SIZE, OR COLOR.

FOR GAMING MACHINES, NAMELY, BINGO-RELATED GAMES AND SLOT MACHINES (U.S. CLS. 21, 23, 26, 36 AND 38).

FIRST USE 11-5-2010; IN COMMERCE 11-5-2010.

3,999,646. AMAZON TECHNOLOGIES, INC., LAS VEGAS, NV. SN 85-091,352. PUB. 10-19-2010, FILED 7-23-2010.

GABCAB

THE MARK CONSISTS OF STANDARD CHARACTERS WITHOUT CLAIM TO ANY PARTICULAR FONT, STYLE, SIZE, OR COLOR.

FOR COMPUTER GAME PROGRAMS; COMPUTER GAME SOFTWARE; INTERACTIVE VIDEO GAME PROGRAMS; VIDEO GAME SOFTWARE (U.S. CLS. 21, 23, 26, 36 AND 38).

FIRST USE 8-26-2010; IN COMMERCE 8-26-2010.

CLASS 9—(Continued).

3,999,651. SUSAN MOSKOWITZ, WEST ORANGE, NJ. SN 85-092,114. PUB. 3-1-2011, FILED 7-23-2010.

Salon Readers

THE MARK CONSISTS OF STANDARD CHARACTERS WITHOUT CLAIM TO ANY PARTICULAR FONT, STYLE, SIZE, OR COLOR.

NO CLAIM IS MADE TO THE EXCLUSIVE RIGHT TO USE "READERS", APART FROM THE MARK AS SHOWN. FOR EYE GLASSES; FRAMES FOR GLASSES AND PINCE-NEZ; READING GLASSES; SPECTACLES (U.S. CLS. 21, 23, 26, 36 AND 38).

FIRST USE 2-8-2011; IN COMMERCE 2-8-2011.

3,999,674. OLYMPUS CORPORATION, TOKYO, JAPAN. SN 85-103,300. PUB. 11-9-2010, FILED 8-9-2010.

OLYMPUS TOUGH

THE MARK CONSISTS OF STANDARD CHARACTERS WITHOUT CLAIM TO ANY PARTICULAR FONT, STYLE, SIZE, OR COLOR.

OWNER OF U.S. REG. NOS. 1,240,989 AND 2,365,504. FOR DIGITAL CAMERAS (U.S. CLS. 21, 23, 26, 36 AND 38).

FIRST USE 1-5-2011; IN COMMERCE 1-5-2011.

3,999,722. JJI INTERNATIONAL, INC., CRANSTON, RI. SN 85-120,574. PUB. 2-15-2011, FILED 9-1-2010.

EYE EVENT

THE MARK CONSISTS OF STANDARD CHARACTERS WITHOUT CLAIM TO ANY PARTICULAR FONT, STYLE, SIZE, OR COLOR.

NO CLAIM IS MADE TO THE EXCLUSIVE RIGHT TO USE "EYE", APART FROM THE MARK AS SHOWN. FOR EYE GLASSES; READING GLASSES; SUN GLASSES (U.S. CLS. 21, 23, 26, 36 AND 38).

FIRST USE 9-27-2010; IN COMMERCE 9-27-2010.

CLASS 9—(Continued).

3,999,744. HERSHEY CHOCOLATE & CONFECTIONERY CORPORATION, WHEAT RIDGE, CO. SN 85-128,271. PUB. 2-22-2011, FILED 9-13-2010.

ACTIVITY SNACK

THE MARK CONSISTS OF STANDARD CHARACTERS WITHOUT CLAIM TO ANY PARTICULAR FONT, STYLE, SIZE, OR COLOR.

NO CLAIM IS MADE TO THE EXCLUSIVE RIGHT TO USE "ACTIVITY", APART FROM THE MARK AS SHOWN.

FOR COMPUTER APPLICATION SOFTWARE FOR MOBILE PHONES, NAMELY, SOFTWARE FOR DIGITALLY MONITORING AND TRACKING BREAKS OF PHYSICAL ACTIVITY THROUGHOUT THE DAY USED AS PART OF A CONSUMER HEALTH AND WELLNESS PROGRAM (U.S. CLS. 21, 23, 26, 36 AND 38).

FIRST USE 9-15-2010; IN COMMERCE 9-15-2010.

CLASS 9—(Continued).

3,999,761. THRIVEPORT, LLC, ENCINO, CA. SN 85-138,058. PUB. 3-8-2011, FILED 9-24-2010.

MoodKit

THE MARK CONSISTS OF STANDARD CHARACTERS WITHOUT CLAIM TO ANY PARTICULAR FONT, STYLE, SIZE, OR COLOR.

FOR COMPUTER APPLICATION SOFTWARE FOR MOBILE PHONES, PORTABLE MEDIA PLAYERS AND HANDHELD COMPUTER TABLETS, NAMELY, SOFTWARE ALLOWING USERS TO ENGAGE IN ACTIVITIES, SURVEYS, RATINGS, EVALUATIONS, JOURNALS, AND EDUCATIONAL DOCUMENTATION IN THE FIELD OF MOOD IMPROVEMENT AND EMOTIONAL WELL-BEING (U.S. CLS. 21, 23, 26, 36 AND 38).

FIRST USE 5-12-2011; IN COMMERCE 5-12-2011.

3,999,748. THE CODE CORPORATION, BLUFFDALE, UT. SN 85-129,540. PUB. 3-1-2011, FILED 9-14-2010.

Cortex

THE MARK CONSISTS OF STANDARD CHARACTERS WITHOUT CLAIM TO ANY PARTICULAR FONT, STYLE, SIZE, OR COLOR.

FOR BAR CODE READER CONFIGURATION SOFTWARE (U.S. CLS. 21, 23, 26, 36 AND 38).

FIRST USE 11-0-2010; IN COMMERCE 11-0-2010.

3,999,775. DO SOMETHING!, INC., NEW YORK, NY. SN 85-140,887. PUB. 3-8-2011, FILED 9-29-2010.

E MISSION

THE MARK CONSISTS OF STANDARD CHARACTERS WITHOUT CLAIM TO ANY PARTICULAR FONT, STYLE, SIZE, OR COLOR.

FOR COMPUTER GAME PROGRAMS (U.S. CLS. 21, 23, 26, 36 AND 38).

FIRST USE 11-16-2010; IN COMMERCE 11-16-2010.

3,999,753. DELL INC., ROUND ROCK, TX. SN 85-131,919. PUB. 3-1-2011, FILED 9-17-2010.

VENUE

THE MARK CONSISTS OF STANDARD CHARACTERS WITHOUT CLAIM TO ANY PARTICULAR FONT, STYLE, SIZE, OR COLOR.

FOR TELEPHONES, CELL PHONES, MOBILE PHONE, DIGITAL PHONES, SMART TELEPHONES (U.S. CLS. 21, 23, 26, 36 AND 38).

FIRST USE 12-15-2010; IN COMMERCE 12-15-2010.

3,999,780. CORSAIR MEMORY INC., FREEMONT, CA. SN 85-142,024. PUB. 1-18-2011, FILED 9-30-2010.

VENGEANCE

THE MARK CONSISTS OF STANDARD CHARACTERS WITHOUT CLAIM TO ANY PARTICULAR FONT, STYLE, SIZE, OR COLOR.

FOR COMPUTER COMPONENTS, NAMELY, MEMORY MODULES (U.S. CLS. 21, 23, 26, 36 AND 38).

FIRST USE 11-0-2010; IN COMMERCE 11-0-2010.

CLASS 9—(Continued).

3,999,786. GARTNER, INC., STAMFORD, CT. SN 85-144,484.
PUB. 3-15-2011, FILED 10-4-2010.

IT MARKET CLOCK

THE MARK CONSISTS OF STANDARD CHARACTERS WITHOUT CLAIM TO ANY PARTICULAR FONT, STYLE, SIZE, OR COLOR.

NO CLAIM IS MADE TO THE EXCLUSIVE RIGHT TO USE "IT MARKET", APART FROM THE MARK AS SHOWN.

FOR DOWNLOADABLE ELECTRONIC PUBLICATIONS IN THE NATURE OF RESEARCH REPORTS IN THE FIELD OF INFORMATION AND TELECOMMUNICATIONS TECHNOLOGY (U.S. CLS. 21, 23, 26, 36 AND 38).

FIRST USE 11-30-2009; IN COMMERCE 11-30-2009.

3,999,790. GARTNER, INC., STAMFORD, CT. SN 85-145,343.
PUB. 3-15-2011, FILED 10-5-2010.

GARTNER IT MARKET CLOCK

THE MARK CONSISTS OF STANDARD CHARACTERS WITHOUT CLAIM TO ANY PARTICULAR FONT, STYLE, SIZE, OR COLOR.

NO CLAIM IS MADE TO THE EXCLUSIVE RIGHT TO USE "IT MARKET", APART FROM THE MARK AS SHOWN.

FOR DOWNLOADABLE ELECTRONIC PUBLICATIONS IN THE NATURE OF RESEARCH REPORTS IN THE FIELD OF INFORMATION AND TELECOMMUNICATIONS TECHNOLOGY (U.S. CLS. 21, 23, 26, 36 AND 38).

FIRST USE 11-30-2009; IN COMMERCE 11-30-2009.

3,999,800. WORKSHARE TECHNOLOGY, INC., SAN FRANCISCO, CA. SN 85-148,117. PUB. 3-15-2011, FILED 10-8-2010.

WORKSHARE POINT

THE MARK CONSISTS OF STANDARD CHARACTERS WITHOUT CLAIM TO ANY PARTICULAR FONT, STYLE, SIZE, OR COLOR.

CLASS 9—(Continued).

OWNER OF U.S. REG. NO. 3,365,516.

FOR COMPUTER SOFTWARE FOR DOCUMENT AND EMAIL MANAGEMENT; COMPUTER SOFTWARE FOR SHARING OF DOCUMENTS AND EMAILS AMONG USERS; COMPUTER SOFTWARE FOR DOCUMENT AND EMAIL VERSION MANAGEMENT, AND PREVENTING VERSION PROLIFERATION OF THE SAME DOCUMENT IN THE DOCUMENT MANAGEMENT STORE; COMPUTER SOFTWARE FOR EXTENDING AND IMPROVING THE CAPABILITIES PROVIDED BY THIRD PARTY DOCUMENT MANAGEMENT SYSTEMS; AND USER MANUALS SUPPLIED AS A UNIT THEREWITH (U.S. CLS. 21, 23, 26, 36 AND 38).

FIRST USE 11-1-2010; IN COMMERCE 11-1-2010.

3,999,811. TETRIS ONLINE, INC., HONOLULU, HI. SN 85-151,247. PUB. 3-15-2011, FILED 10-13-2010.

FEEVO

THE MARK CONSISTS OF STANDARD CHARACTERS WITHOUT CLAIM TO ANY PARTICULAR FONT, STYLE, SIZE, OR COLOR.

FOR DOWNLOADABLE GAME SOFTWARE AND ELECTRONIC GAME SOFTWARE FOR WIRELESS DEVICES AND COMPUTERS (U.S. CLS. 21, 23, 26, 36 AND 38).

FIRST USE 6-8-2011; IN COMMERCE 6-8-2011.

3,999,828. HALLIBURTON ENERGY SERVICES, INC., CARROLLTON, TX. SN 85-158,814. PUB. 3-22-2011, FILED 10-22-2010.

DRILLDOC

THE MARK CONSISTS OF STANDARD CHARACTERS WITHOUT CLAIM TO ANY PARTICULAR FONT, STYLE, SIZE, OR COLOR.

FOR OIL AND GAS WELL ELECTRONIC TOOL, NAMELY, A DOWNHOLE OPTIMIZATION COLLAR IN THE NATURE OF ELECTRICAL COUPLINGS USED TO PROVIDE REAL-TIME MEASUREMENTS USING MULTIPLE SENSORS (U.S. CLS. 21, 23, 26, 36 AND 38).

FIRST USE 3-30-2011; IN COMMERCE 3-30-2011.

CLASS 9—(Continued).

3,999,868. COM2US CORPORATION, SEOUL, REPUBLIC OF KOREA. SN 85-212,357. PUB. 3-22-2011, FILED 1-6-2011.

Zombie Runaway

THE MARK CONSISTS OF STANDARD CHARACTERS WITHOUT CLAIM TO ANY PARTICULAR FONT, STYLE, SIZE, OR COLOR.

FOR COMPUTER GAME PROGRAMMES DOWNLOADABLE VIA THE INTERNET; COMPUTER GAME PROGRAMS; COMPUTER GAME SOFTWARE; COMPUTER GAME SOFTWARE DOWNLOADABLE FROM A GLOBAL COMPUTER NETWORK; COMPUTER GAME SOFTWARE FOR USE ON MOBILE AND CELLULAR PHONES; COMPUTER PROGRAMS FOR VIDEO AND COMPUTER GAMES; DOWNLOADABLE COMPUTER GAME PROGRAMS; DOWNLOADABLE COMPUTER GAME SOFTWARE VIA A GLOBAL COMPUTER NETWORK AND WIRELESS DEVICES; DOWNLOADABLE ELECTRONIC GAME PROGRAMS; ELECTRONIC GAME PROGRAMS; ELECTRONIC GAME SOFTWARE; ELECTRONIC GAME SOFTWARE FOR CELLULAR TELEPHONES; ELECTRONIC GAME SOFTWARE FOR HANDHELD ELECTRONIC DEVICES; ELECTRONIC GAME SOFTWARE FOR WIRELESS DEVICES; GAME SOFTWARE; INTERACTIVE GAME SOFTWARE; VIDEO GAME SOFTWARE (U.S. CLS. 21, 23, 26, 36 AND 38).
FIRST USE 2-17-2011; IN COMMERCE 2-17-2011.

3,999,877. NINTENDO OF AMERICA INC., REDMOND, WA. SN 85-975,266. PUB. 10-12-2010, FILED 6-15-2010.

DONKEY KONG COUNTRY

THE MARK CONSISTS OF STANDARD CHARACTERS WITHOUT CLAIM TO ANY PARTICULAR FONT, STYLE, SIZE, OR COLOR.

CLASS 9—(Continued).

OWNER OF U.S. REG. NOS. 1,328,713, 1,331,984, AND OTHERS.

FOR COMPUTER GAME PROGRAMS; COMPUTER GAME SOFTWARE; ELECTRONIC GAME PROGRAMS; ELECTRONIC GAME SOFTWARE; INTERACTIVE ELECTRONIC GAME PROGRAMS; INTERACTIVE ELECTRONIC GAME SOFTWARE; INTERACTIVE VIDEO GAME PROGRAMS; INTERACTIVE VIDEO GAME SOFTWARE; VIDEO GAME PROGRAMS; VIDEO GAME SOFTWARE; DOWNLOADABLE MULTIMEDIA FILES, NAMELY, GAMES; DOWNLOADABLE COMPUTER GAME PROGRAMS; DOWNLOADABLE COMPUTER GAME SOFTWARE; DOWNLOADABLE ELECTRONIC GAME PROGRAMS; DOWNLOADABLE ELECTRONIC GAME SOFTWARE; DOWNLOADABLE INTERACTIVE ELECTRONIC GAME PROGRAMS; DOWNLOADABLE INTERACTIVE GAME SOFTWARE; DOWNLOADABLE VIDEO GAME PROGRAMS; DOWNLOADABLE VIDEO GAME SOFTWARE; PRE-RECORDED COMPACT DISCS AND OPTICAL DISCS FEATURING ENTERTAINMENT, EDUCATIONAL AND INFORMATIONAL CONTENT PERTAINING TO VIDEO AND COMPUTER GAMES; COMPUTER GAME DISCS; ELECTRONIC GAME DISCS; INTERACTIVE ELECTRONIC GAME DISCS; INTERACTIVE VIDEO GAME DISCS; VIDEO GAME DISCS; DOWNLOADABLE ELECTRONIC PUBLICATIONS, NAMELY, GAME INSTRUCTION BOOKLETS (U.S. CLS. 21, 23, 26, 36 AND 38).

FIRST USE 11-0-1994; IN COMMERCE 11-0-1994.

3,999,879. STRECK, INC., OMAHA, NE. SN 85-975,314. PUB. 9-7-2010, FILED 5-27-2010.



THE MARK CONSISTS OF THE STYLIZED WORDING "PHILISA" IN LOWERCASE LETTERING WITH THE "L" EXTENDING ABOVE AND BELOW THE HEIGHT OF THE REMAINING LETTERS.

THE ENGLISH TRANSLATION OF "PHILISA" IS "BE HEALTHY".

FOR LABORATORY INSTRUMENTS AND TUBES FOR THE PURPOSE OF PERFORMING POLYMERASE CHAIN REACTION TESTS FOR MEDICAL AND VETERINARY USE; COMPUTER SOFTWARE AND HARDWARE FOR USE WITH LABORATORY INSTRUMENTS, NAMELY, FOR USE IN POLYMERASE CHAIN REACTION ANALYSIS (U.S. CLS. 21, 23, 26, 36 AND 38).

FIRST USE 6-1-2011; IN COMMERCE 6-1-2011.

CLASS 9—(Continued).

3,999,882. VIPORBIT SOFTWARE INTERNATIONAL, INC., KELLER, TX. SN 85-975,361. PUB. 10-12-2010, FILED 6-28-2010.

VIPorbit

THE MARK CONSISTS OF STANDARD CHARACTERS WITHOUT CLAIM TO ANY PARTICULAR FONT, STYLE, SIZE, OR COLOR.

FOR PROVIDING MOBILE AND PORTABLE CONTACT RELATIONSHIP MANAGEMENT SOLUTIONS, NAMELY, COMPUTER SOFTWARE FOR USE IN INDIVIDUAL AND GROUP CALENDARING, ACTIVITY SCHEDULING, REPORT GENERATING AND DATABASE SEARCHING VIA SMARTPHONES, MOBILE PHONES, AND ALL OTHER PORTABLE AND DESKTOP COMPUTER APPLICATIONS (U.S. CLS. 21, 23, 26, 36 AND 38).

FIRST USE 2-18-2011; IN COMMERCE 2-18-2011.

CLASS 10—MEDICAL APPARATUS

3,998,426. ORAYA THERAPEUTICS, INC., NEWARK, CA. SN 77-287,190. PUB. 3-11-2008, FILED 9-24-2007.

ORAYA

THE MARK CONSISTS OF STANDARD CHARACTERS WITHOUT CLAIM TO ANY PARTICULAR FONT, STYLE, SIZE, OR COLOR.

FOR PORTABLE X-RAY THERAPY APPARATUS FOR MEDICAL USE (U.S. CLS. 26, 39 AND 44).

FIRST USE 7-0-2008; IN COMMERCE 7-0-2008.

3,998,471. GENII, INC., WOODBURY, MN. SN 77-414,647. PUB. 10-7-2008, FILED 3-6-2008.

GENERATING INGENUITY

THE MARK CONSISTS OF STANDARD CHARACTERS WITHOUT CLAIM TO ANY PARTICULAR FONT, STYLE, SIZE, OR COLOR.

FOR SURGICAL AND MEDICAL INSTRUMENTS AND APPARATUS, NAMELY, AN ELECTROSURGICAL SYSTEM CONSISTING OF DEVICES FOR CUTTING, COAGULATING, VAPORIZING AND DEVITALIZING OF TISSUES (U.S. CLS. 26, 39 AND 44).

FIRST USE 5-5-2011; IN COMMERCE 5-5-2011.

CLASS 10—(Continued).

3,998,506. LANX, INC., BROOMFIELD, CO. SN 77-526,338. PUB. 6-2-2009, FILED 7-18-2008.

Silverton-D

THE MARK CONSISTS OF STANDARD CHARACTERS WITHOUT CLAIM TO ANY PARTICULAR FONT, STYLE, SIZE, OR COLOR.

FOR SURGICAL IMPLANTS AND INSTRUMENTS FOR USE IN ORTHOPEDIC SURGERY, NAMELY, SPINAL DEFORMITY FIXATION SYSTEM COMPRISED PRIMARILY OF RODS, ROD CONNECTORS, SCREWS, AND HOOKS (U.S. CLS. 26, 39 AND 44).

FIRST USE 9-0-2007; IN COMMERCE 9-0-2007.

3,998,619. EDWARDS LIFESCIENCES CORPORATION, IRVINE, CA. SN 77-691,071. PUB. 3-9-2010, FILED 3-13-2009.

EV1000

THE MARK CONSISTS OF STANDARD CHARACTERS WITHOUT CLAIM TO ANY PARTICULAR FONT, STYLE, SIZE, OR COLOR.

FOR MEDICAL MONITORING PLATFORM, NAMELY, ELECTRONIC MONITORS FOR HEMODYNAMIC ANALYSIS (U.S. CLS. 26, 39 AND 44).

FIRST USE 5-27-2011; IN COMMERCE 5-27-2011.

3,998,651. SUNEVA MEDICAL, INC., SAN DIEGO, CA. SN 77-721,143. PUB. 9-15-2009, FILED 4-23-2009.

SUNEVA MEDICAL

THE MARK CONSISTS OF STANDARD CHARACTERS WITHOUT CLAIM TO ANY PARTICULAR FONT, STYLE, SIZE, OR COLOR.

NO CLAIM IS MADE TO THE EXCLUSIVE RIGHT TO USE "MEDICAL", APART FROM THE MARK AS SHOWN. THE WORDING "SUNEVA" HAS NO MEANING IN A FOREIGN LANGUAGE.

FOR MEDICAL DEVICES, MEDICAL AND PHARMACEUTICAL ACCESSORIES AND PREPARATIONS THEREOF, NAMELY, INJECTABLE NON-LIVING TISSUE IMPLANTS, AND DEVICES FOR IMPLANTING THE AFORESAID ITEMS (U.S. CLS. 26, 39 AND 44).

FIRST USE 4-13-2009; IN COMMERCE 4-13-2009.

CLASS 10—(Continued).

3,998,735. BYRNE MEDICAL, INC., CONROE, TX. SN 77-805,224. PUB. 1-12-2010, FILED 8-14-2009.

Y-OPSY

THE MARK CONSISTS OF STANDARD CHARACTERS WITHOUT CLAIM TO ANY PARTICULAR FONT, STYLE, SIZE, OR COLOR.

FOR BIOPSY VALVE FOR USE WITH ENDOSCOPE (U.S. CLS. 26, 39 AND 44).
FIRST USE 3-5-2010; IN COMMERCE 3-5-2010.

3,998,740. PRECISION MEDICAL DEVICES INC., DBA PMD, NEW BRUNSWICK, NJ. SN 77-808,861. PUB. 1-19-2010, FILED 8-20-2009.

ThumBlade

THE MARK CONSISTS OF STANDARD CHARACTERS WITHOUT CLAIM TO ANY PARTICULAR FONT, STYLE, SIZE, OR COLOR.

FOR SCALPELS; SURGICAL INSTRUMENTS, NAMELY, SURGICAL BLADES WITH SAFETY DEVICE TO PROTECT PRACTITIONERS, ASSISTANTS, AND PATIENTS FROM SHARPS INJURIES BEFORE, DURING, AND AFTER PROCEDURES (U.S. CLS. 26, 39 AND 44).

FIRST USE 2-14-2010; IN COMMERCE 1-12-2011.

3,998,770. BING INNOVATIONS LLC, BOCA RATON, FL. SN 77-827,853. PUB. 8-24-2010, FILED 9-16-2009.

VIBRAPULSE

THE MARK CONSISTS OF STANDARD CHARACTERS WITHOUT CLAIM TO ANY PARTICULAR FONT, STYLE, SIZE, OR COLOR.

FOR MICROPROCESSOR-BASED HARDWARE SYSTEM USED TO PROVIDE A VIBRATING STIMULUS IN A RECURRING SEQUENCE TO PREVENT PAINFUL SENSATIONS, SUCH AS THOSE ASSOCIATED WITH AN INJECTION, FROM BEING SENSED BY THE BRAIN DURING MEDICAL TREATMENT AND DENTAL PROCEDURES, NAMELY, MICROPROCESSOR-CONTROLLED NERVE, MUSCLE AND SKIN VIBRATING STIMULATORS FOR PAIN MANAGEMENT (U.S. CLS. 26, 39 AND 44).

FIRST USE 7-31-2010; IN COMMERCE 7-31-2010.

CLASS 10—(Continued).

3,998,869. BOSTON SCIENTIFIC SCIMED, INC., MAPLE GROVE, MN. SN 77-858,482. PUB. 4-6-2010, FILED 10-27-2009.

ION

THE MARK CONSISTS OF STANDARD CHARACTERS WITHOUT CLAIM TO ANY PARTICULAR FONT, STYLE, SIZE, OR COLOR.

FOR MEDICAL STENTS AND STENT DELIVERY SYSTEMS; STENT DELIVERY APPARATUS, NAMELY, CATHETERS AND BALLOONS (U.S. CLS. 26, 39 AND 44).

FIRST USE 4-0-2011; IN COMMERCE 4-0-2011.

3,998,884. J.T. POSEY COMPANY, ARCADIA, CA. SN 77-861,842. PUB. 2-2-2010, FILED 10-30-2009.

SITTER SELECT

THE MARK CONSISTS OF STANDARD CHARACTERS WITHOUT CLAIM TO ANY PARTICULAR FONT, STYLE, SIZE, OR COLOR.

OWNER OF U.S. REG. NO. 2,443,288.
FOR MONITORS FOR DETECTING PATIENT MOVEMENT (U.S. CLS. 26, 39 AND 44).

FIRST USE 12-23-2004; IN COMMERCE 12-23-2004.

3,998,900. WU BEN JUN, AKA BENJAMIN WU, MARKHAM, ONTARIO, CANADA. SN 77-865,162. PUB. 12-21-2010, FILED 11-4-2009.



BENJAMIN WU

THE NAME "BENJAMIN WU" IDENTIFIES WU BEN JUN, A LIVING INDIVIDUAL WHOSE CONSENT IS OF RECORD.

THE MARK CONSISTS OF THE WORDING "BENJAMIN WU" AND A SQUARE WITH STARS, A MAPLE LEAF AND A RECTANGLE FEATURING THE LETTERS "BJW".

FOR HEALTH CARE EQUIPMENT, NAMELY, BLOOD PRESSURE MEASURING APPARATUS (U.S. CLS. 26, 39 AND 44).

FIRST USE 1-1-2010; IN COMMERCE 1-1-2010.

CLASS 10—(Continued).

3,998,922. WADSWORTH MEDICAL TECHNOLOGIES, INC., WESTBOROUGH, MA. SN 77-875,418. PUB. 4-20-2010, FILED 11-18-2009.

DERMALOC

THE MARK CONSISTS OF STANDARD CHARACTERS WITHOUT CLAIM TO ANY PARTICULAR FONT, STYLE, SIZE, OR COLOR.

FOR MEDICAL INSTRUMENTS AND TRAYS FOR USE IN REPAIRING, CLOSING AND HEALING TISSUE, INCISIONS AND WOUNDS (U.S. CLS. 26, 39 AND 44).
FIRST USE 1-22-2006; IN COMMERCE 2-22-2007.

3,998,952. MIRAMAR LABS, INC., SUNNYVALE, CA. SN 77-886,273. PUB. 4-20-2010, FILED 12-4-2009.

MIRADRY

THE MARK CONSISTS OF STANDARD CHARACTERS WITHOUT CLAIM TO ANY PARTICULAR FONT, STYLE, SIZE, OR COLOR.

FOR MEDICAL DEVICES, INSTRUMENTS, AND APPARATUS, NAMELY, MICROWAVE GENERATORS, APPLICATORS AND DISPOSABLES FOR USE IN THE REDUCTION OR REMOVAL OF SWEAT GLANDS AND HAIR FOLLICLES, IN THE TREATMENT OF AESTHETIC, TOPICAL, AND SUBCUTANEOUS SKIN CONDITIONS AND IN THE PROMOTION OF TOPICAL AND SUBCUTANEOUS SKIN HEALTH (U.S. CLS. 26, 39 AND 44).
FIRST USE 1-18-2010; IN COMMERCE 1-18-2010.

3,998,953. MIRAMAR LABS, INC., SUNNYVALE, CA. SN 77-886,437. PUB. 4-20-2010, FILED 12-4-2009.



THE COLOR(S) GREEN AND BLUE IS/ARE CLAIMED AS A FEATURE OF THE MARK.

CLASS 10—(Continued).

THE MARK CONSISTS OF THE WORD "MIRADRY" IN STYLIZED WRITING, WITH ONLY THE "D" IN CAPITALS, WITH "MIRA" IN GREEN LETTERING, AND "DRY" IN BLUE LETTERING, WITH A BLUE, DROP SHAPE OVER THE "Y".

FOR MEDICAL DEVICES, INSTRUMENTS, AND APPARATUS, NAMELY, MICROWAVE GENERATORS, APPLICATORS AND DISPOSABLES FOR USE IN THE REDUCTION OR REMOVAL OF SWEAT GLANDS AND HAIR FOLLICLES, IN THE TREATMENT OF AESTHETIC, TOPICAL, AND SUBCUTANEOUS SKIN CONDITIONS AND IN THE PROMOTION OF TOPICAL AND SUBCUTANEOUS SKIN HEALTH (U.S. CLS. 26, 39 AND 44).

FIRST USE 1-18-2010; IN COMMERCE 1-18-2010.

3,999,011. MEDLINE INDUSTRIES, INC., MUNDELEIN, IL. SN 77-906,776. PUB. 8-10-2010, FILED 1-7-2010.

G2

THE MARK CONSISTS OF STANDARD CHARACTERS WITHOUT CLAIM TO ANY PARTICULAR FONT, STYLE, SIZE, OR COLOR.

FOR DIAGNOSTIC MEDICAL INSTRUMENTS, NAMELY, GLUCOSE MONITORING SYSTEMS, COMPRISING: METER WITH BATTERY CASE, TEST STRIPS, CONTROL SOLUTIONS, LANCING DEVICE, AND OWNER'S MANUAL (U.S. CLS. 26, 39 AND 44).
FIRST USE 2-1-2011; IN COMMERCE 2-1-2011.

3,999,039. SCIENTIA VASCULAR, LLC, FORMERLY NEXT VASCULAR LLC, RENO, NV. SN 77-918,567. PUB. 5-25-2010, FILED 1-22-2010.

PLATO

THE MARK CONSISTS OF STANDARD CHARACTERS WITHOUT CLAIM TO ANY PARTICULAR FONT, STYLE, SIZE, OR COLOR.

FOR SURGICAL AND MEDICAL APPARATUS AND INSTRUMENTS FOR USE IN VASCULAR, INTRAVASCULAR OR ENDOVASCULAR SURGERY, NOT INCLUDING MASKS USED FOR RADIOTHERAPY EQUIPMENT (U.S. CLS. 26, 39 AND 44).

FIRST USE 3-25-2011; IN COMMERCE 3-25-2011.

CLASS 10—(Continued).

3,999,040. SCIENTIA VASCULAR, LLC, FORMERLY NEXT VASCULAR LLC, RENO, NV. SN 77-918,570. PUB. 5-25-2010, FILED 1-22-2010.

PLATO MICROCATH

THE MARK CONSISTS OF STANDARD CHARACTERS WITHOUT CLAIM TO ANY PARTICULAR FONT, STYLE, SIZE, OR COLOR.

NO CLAIM IS MADE TO THE EXCLUSIVE RIGHT TO USE "MICROCATH", APART FROM THE MARK AS SHOWN.

FOR SURGICAL AND MEDICAL APPARATUS AND INSTRUMENTS FOR USE IN VASCULAR, INTRAVASCULAR OR ENDOVASCULAR SURGERY, NOT INCLUDING MASKS USED FOR RADIOTHERAPY EQUIPMENT (U.S. CLS. 26, 39 AND 44).

FIRST USE 3-25-2011; IN COMMERCE 3-25-2011.

3,999,066. MOREJON, ORLANDO, KEY LARGO, FL. SN 77-930,527. PUB. 9-28-2010, FILED 2-8-2010.

OMNEOTECH

THE MARK CONSISTS OF STANDARD CHARACTERS WITHOUT CLAIM TO ANY PARTICULAR FONT, STYLE, SIZE, OR COLOR.

FOR APPARATUS FOR ARTIFICIAL RESPIRATION AND SUCTION APPARATUS FOR CLEANING THEREOF, SOLD AS A UNIT (U.S. CLS. 26, 39 AND 44).

FIRST USE 2-0-2010; IN COMMERCE 3-0-2010.

CLASS 10—(Continued).

3,999,067. MOREJON, ORLANDO, KEY LARGO, FL. SN 77-930,544. PUB. 9-28-2010, FILED 2-8-2010.



THE MARK CONSISTS OF A CIRCLE FORMED BY AN ARROW WITH THE DESIGN OF AN INFINITY SYMBOL IN THE CENTER.

FOR APPARATUS FOR ARTIFICIAL RESPIRATION AND SUCTION APPARATUS FOR CLEANING THEREOF, SOLD AS A UNIT (U.S. CLS. 26, 39 AND 44).

FIRST USE 2-0-2010; IN COMMERCE 3-0-2010.

3,999,088. BAYER HEALTHCARE LLC, PITTSBURGH, PA. SN 77-940,808. PUB. 9-14-2010, FILED 2-21-2010.

RIDVANTAGE

THE MARK CONSISTS OF STANDARD CHARACTERS WITHOUT CLAIM TO ANY PARTICULAR FONT, STYLE, SIZE, OR COLOR.

OWNER OF U.S. REG. NOS. 2,276,127, 2,276,153, AND 2,290,522.

FOR LICE COMBS (U.S. CLS. 26, 39 AND 44).

FIRST USE 10-14-2010; IN COMMERCE 10-14-2010.

3,999,092. TAYLOR-BARRY, ELIZABETH L., DBA BARRY-BASICS, COLUMBIA, SC. SN 77-943,722. PUB. 11-16-2010, FILED 2-24-2010.

BarryBasics

THE MARK CONSISTS OF STANDARD CHARACTERS WITHOUT CLAIM TO ANY PARTICULAR FONT, STYLE, SIZE, OR COLOR.

FOR MODULAR MEDICAL APPAREL, NAMELY, SHIRTS, NIGHTSHIRTS, SHORTS AND PANTS WITH SNAP FASTENERS FOR PATIENTS FOR USE DURING RECOVERY AND TREATMENT OF MEDICAL CONDITIONS OR HOSPICE CARE (U.S. CLS. 26, 39 AND 44).

FIRST USE 3-15-2008; IN COMMERCE 5-31-2011.

CLASS 10—(Continued).

3,999,317. PLAYTEX PRODUCTS, LLC, SHELTON, CT. SN 85-025,279. PUB. 9-28-2010, FILED 4-28-2010.

ORTHO-PRO

THE MARK CONSISTS OF STANDARD CHARACTERS WITHOUT CLAIM TO ANY PARTICULAR FONT, STYLE, SIZE, OR COLOR.

OWNER OF U.S. REG. NO. 3,107,367.
FOR TEETHER (U.S. CLS. 26, 39 AND 44).
FIRST USE 12-31-2008; IN COMMERCE 12-31-2008.

3,999,419. U.S. MEDICAL INNOVATIONS, LLC, LAKE-LAND, FL. SN 85-036,211. PUB. 10-5-2010, FILED 5-12-2010.

CANADY PLASMA

THE MARK CONSISTS OF STANDARD CHARACTERS WITHOUT CLAIM TO ANY PARTICULAR FONT, STYLE, SIZE, OR COLOR.

NO CLAIM IS MADE TO THE EXCLUSIVE RIGHT TO USE "PLASMA", APART FROM THE MARK AS SHOWN.

THE NAME(S), PORTRAIT(S), AND/OR SIGNATURE(S) SHOWN IN THE MARK IDENTIFIES JEROME CANADY, WHOSE CONSENT(S) TO REGISTER IS MADE OF RECORD.

FOR MEDICAL AND SURGICAL APPARATUS AND INSTRUMENTS FOR USE IN GENERAL SURGERY, NAMELY, ELECTROSURGICAL GENERATORS, PROBES, ELECTRODES, AND HANDPIECES FOR ELECTROSURGERY; HIGH FREQUENCY ELECTROSURGICAL ARGON GENERATORS AND PROBES, HANDPIECES AND ELECTRODES SOLD THEREWITH; ELECTROSURGICAL GENERATORS WITH ARGON CAPABILITIES FOR USE IN GENERAL SURGERY; MEDICAL DEVICES, NAMELY, FLEXIBLE PROBES, IN PARTICULAR ENDOSCOPIC AND BRONCHOSCOPIC PROBES (U.S. CLS. 26, 39 AND 44).

FIRST USE 5-4-2011; IN COMMERCE 5-4-2011.

3,999,441. MEDICAL DEVICE TECHNOLOGIES, INC., GAINESVILLE, FL. SN 85-038,135. PUB. 11-2-2010, FILED 5-13-2010.

ATRIEVE VASCULAR SNARE

THE MARK CONSISTS OF STANDARD CHARACTERS WITHOUT CLAIM TO ANY PARTICULAR FONT, STYLE, SIZE, OR COLOR.

CLASS 10—(Continued).

NO CLAIM IS MADE TO THE EXCLUSIVE RIGHT TO USE "VASCULAR SNARE", APART FROM THE MARK AS SHOWN.

FOR VASCULAR SNARE, NAMELY, A SURGICAL AND INTERVENTIONAL DEVICE FOR THE RETRIEVAL OF MATTER AND OBJECTS FROM VASCULAR SYSTEMS (U.S. CLS. 26, 39 AND 44).

FIRST USE 6-28-2010; IN COMMERCE 6-28-2010.

3,999,507. MEDICAL INDUSTRY SERVICES, INC., LAS VEGAS, NV. SN 85-052,937. PUB. 11-2-2010, FILED 6-2-2010.

Neb Partners

THE MARK CONSISTS OF STANDARD CHARACTERS WITHOUT CLAIM TO ANY PARTICULAR FONT, STYLE, SIZE, OR COLOR.

FOR NEBULIZER FOR ADMINISTERING MEDICATION IN THE FORM OF A MIST INHALED INTO THE LUNGS, FOR TREATMENT OF RESPIRATORY DISEASES (U.S. CLS. 26, 39 AND 44).

FIRST USE 4-1-2011; IN COMMERCE 4-1-2011.

CLASS 11—ENVIRONMENTAL CONTROL APPARATUS

3,998,320. MASTER SPAS, INC. FORT WAYNE, IN. SN 76-699,804. PUB. 3-23-2010, FILED 10-9-2009.

SOLARBOOST

THE MARK CONSISTS OF STANDARD CHARACTERS WITHOUT CLAIM TO ANY PARTICULAR FONT, STYLE, SIZE, OR COLOR.

FOR SPAS IN THE NATURE OF HEATED POOLS (U.S. CLS. 13, 21, 23, 31 AND 34).

FIRST USE 11-16-2009; IN COMMERCE 11-16-2009.

CLASS 11—(Continued).

3,998,374. INTERNATIONAL GROWER'S SUPPLY INCORPORATED, CULVER CITY, CA. SN 77-115,267. PUB. 2-26-2008, FILED 2-23-2007.

AIR FORCE ONE

THE MARK CONSISTS OF STANDARD CHARACTERS WITHOUT CLAIM TO ANY PARTICULAR FONT, STYLE, SIZE, OR COLOR.

FOR LIGHTING EQUIPMENT, NAMELY, LIGHT REFLECTORS AND LIGHT FIXTURES IN THE NATURE OF LIGHT HOODS (U.S. CLS. 13, 21, 23, 31 AND 34).
FIRST USE 2-4-2011; IN COMMERCE 2-4-2011.

3,998,610. CADENCE TECHNOLOGIES, INC., ALPHARETTA, GA. SN 77-682,016. PUB. 2-23-2010, FILED 3-3-2009.

TEMPO3

THE MARK CONSISTS OF STANDARD CHARACTERS WITHOUT CLAIM TO ANY PARTICULAR FONT, STYLE, SIZE, OR COLOR.

FOR OZONE GENERATORS AND SANITIZERS FOR AIR AND WATER, NOT FOR SWIMMING POOLS (U.S. CLS. 13, 21, 23, 31 AND 34).
FIRST USE 7-31-2007; IN COMMERCE 7-31-2007.

3,998,630. FAROUK SYSTEMS, INC., HOUSTON, TX. SN 77-706,976. PUB. 8-18-2009, FILED 4-4-2009.

SALON CHI

THE MARK CONSISTS OF STANDARD CHARACTERS WITHOUT CLAIM TO ANY PARTICULAR FONT, STYLE, SIZE, OR COLOR.

OWNER OF U.S. REG. NOS. 2,660,257, 3,426,769, AND OTHERS.

NO CLAIM IS MADE TO THE EXCLUSIVE RIGHT TO USE "SALON", APART FROM THE MARK AS SHOWN.
FOR HAIR DRYERS (U.S. CLS. 13, 21, 23, 31 AND 34).
FIRST USE 5-10-2011; IN COMMERCE 5-10-2011.

CLASS 11—(Continued).

3,998,642. NORDIC WATER PRODUCTS AB, VÄSTRA FRÖLUNDA, SWEDEN. SN 77-715,253. PUB. 3-23-2010, FILED 4-16-2009.

SUPERSETTLER

THE MARK CONSISTS OF STANDARD CHARACTERS WITHOUT CLAIM TO ANY PARTICULAR FONT, STYLE, SIZE, OR COLOR.

FOR WATER PURIFICATION, SEDIMENTATION AND FILTRATION APPARATUS FOR CLARIFICATION, THICKENING AND FILTRATION OF WATER, WASTE WATER AND INDUSTRIAL WATER; WATER TREATMENT APPARATUS, NAMELY, CLARIFICATION AND THICKENING MACHINES FOR USE IN TREATMENT OF LIQUIDS IN THE NATURE OF WATER, WASTE WATER AND INDUSTRIAL WATER; WATER FILTERING APPARATUS, NAMELY, WATER FILTERS AND SCREENS FOR SEPARATION OF PARTICLES FROM LIQUIDS (U.S. CLS. 13, 21, 23, 31 AND 34).

FIRST USE 11-11-2009; IN COMMERCE 11-0-2009.

3,998,643. OSRAM SYLVANIA INC., DANVERS, MA. SN 77-715,312. PUB. 9-8-2009, FILED 4-16-2009.

SYLVANIA

THE MARK CONSISTS OF STANDARD CHARACTERS WITHOUT CLAIM TO ANY PARTICULAR FONT, STYLE, SIZE, OR COLOR.

OWNER OF U.S. REG. NOS. 1,325,543, 1,411,188, AND OTHERS.

FOR PELLET STOVES (U.S. CLS. 13, 21, 23, 31 AND 34).
FIRST USE 1-0-2009; IN COMMERCE 1-0-2009.

CLASS 11—(Continued).

3,998,689. FERGUSON ENTERPRISES, INC., NEWPORT NEWS, VA. SN 77-759,190. PUB. 5-4-2010, FILED 6-14-2009.

MILAZZO

THE MARK CONSISTS OF STANDARD CHARACTERS WITHOUT CLAIM TO ANY PARTICULAR FONT, STYLE, SIZE, OR COLOR.

FOR PLUMBING FIXTURES, NAMELY, SINKS, PED-
ESTAL SINKS, BATH TUBS, BATH TUB JETS, WHIRL-
POOL BATHS, BATH INSTALLATIONS; FAUCETS AND
FAUCET SPRAYERS; TOILETS AND BIDETS; DRAIN
STRUCTURES FOR USE IN SPAS, STEAM ROOMS AND
BATHS; SITZ BATHS; SPOUTS FOR AFFIXING ON
WALLS FOR BATHS, BASINS, BIDETS; SHOWERS,
SHOWER HEADS, HAND HELD SHOWER HEADS,
HAND SHOWERS, HAND HELD SHOWERS, SHOWER
SPRAYERS, SHOWER HEAD SPRAYERS, SHOWER
MIXERS, SHOWER AND BATH CUBICLES, SHOWER
BASES, SHOWER CONTROL FITTINGS, NAMELY, ES-
CUTCHEONS, SHOWER DOORS, SHOWER ENCLO-
SURES, SHOWER FAUCET EXTENSIONS, SHOWER
PANELS, SHOWER SURROUNDS, SHOWER TRAYS,
SHOWER TUBS; ELECTRIC TOWEL WARMERS, IN-
DOOR ELECTRIC LIGHTING FIXTURES AND CEILING
FANS (U.S. CLS. 13, 21, 23, 31 AND 34).

FIRST USE 6-30-2007; IN COMMERCE 6-30-2007.

CLASS 11—(Continued).

3,998,764. FACILITY SOLUTIONS, INC., CLINTON TOWN-
SHIP, MI. SN 77-824,395. PUB. 3-23-2010, FILED 9-11-2009.



THE MARK CONSISTS OF EIGHT SQUARES POSI-
TIONED ABOVE THE TERM "FSPROBIN", EACH SQUARE
CONTAINING A DESIGN SUGGESTING CHOPPED OR
DICED FOOD.

FOR REFRIGERATING EQUIPMENT, NAMELY, RE-
FRIGERATED BINS DESIGNED TO HOLD FOOD THAT
ARE USED IN CONJUNCTION WITH REFRIGERATED
TABLES AND COUNTERS (U.S. CLS. 13, 21, 23, 31 AND
34).

FIRST USE 4-21-2011; IN COMMERCE 4-21-2011.

3,998,762. TRANTER, INC., WICHITA FALLS, TX. SN 77-
823,727. PUB. 4-20-2010, FILED 9-10-2009.



OWNER OF U.S. REG. NOS. 1,049,477 AND 3,271,040.
THE MARK CONSISTS OF THREE ARROWS IN A
TRIANGLE WITH THE WORD "TRANTER" NEXT TO IT.
FOR HEAT EXCHANGERS (U.S. CLS. 13, 21, 23, 31
AND 34).

FIRST USE 5-3-2011; IN COMMERCE 5-3-2011.

COOK CENTRAL

THE MARK CONSISTS OF STANDARD CHARACTERS
WITHOUT CLAIM TO ANY PARTICULAR FONT, STYLE,
SIZE, OR COLOR.

NO CLAIM IS MADE TO THE EXCLUSIVE RIGHT TO
USE "COOK", APART FROM THE MARK AS SHOWN.

FOR MULTI-COOKER, NAMELY, ELECTRIC COUN-
TERTOP FOOD PREPARATION APPARATUS FOR
COOKING, BAKING, BROILING, ROASTING, TOAST-
ING, SEARING, BROWNING, BARBECUING AND
GRILLING FOOD (U.S. CLS. 13, 21, 23, 31 AND 34).

FIRST USE 3-0-2011; IN COMMERCE 3-0-2011.

3,998,814. CONAIR CORPORATION, STAMFORD, CT. SN 77-
841,211. PUB. 3-9-2010, FILED 10-5-2009.

CLASS 11—(Continued).

3,998,815. CARRIER ENTERPRISE, LLC, ORLANDO, FL. SN 77-841,450. PUB. 3-16-2010, FILED 10-5-2009.

CIAC

THE MARK CONSISTS OF STANDARD CHARACTERS WITHOUT CLAIM TO ANY PARTICULAR FONT, STYLE, SIZE, OR COLOR.

FOR RESIDENTIAL AND COMMERCIAL AIR CONDITIONING UNITS AND SYSTEMS, NAMELY, DUCTLESS MINI-SPLIT AIR CONDITIONING UNITS, EVAPORATOR AIR COOLING UNITS FOR DOMESTIC AND COMMERCIAL USE, AIR CONDITIONING CONDENSING UNITS, AIR CONDITIONING UNITS IN THE NATURE OF FAN COILS, ROOM AIR CONDITIONERS, PACKAGED TERMINAL AIR CONDITIONERS, AIR CONDITIONING UNITS IN THE NATURE OF FAN COILS FOR RESIDENTIAL AND COMMERCIAL AIR CONDITIONING AND VENTILATION INSTALLATIONS, VARIABLE REFRIGERANT FLOW OUTDOOR AND INDOOR AIR-CONDITIONING UNITS, AND AIR CONDITIONING UNITS IN THE NATURE OF CASSETTE TYPE FAN COIL UNITS (U.S. CLS. 13, 21, 23, 31 AND 34).

FIRST USE 11-5-2009; IN COMMERCE 12-30-2009.

CLASS 11—(Continued).

3,998,986. SUNIVA, INC., NORCROSS, GA. SN 77-897,955. PUB. 9-21-2010, FILED 12-21-2009.



OWNER OF U.S. REG. NOS. 3,599,460 AND 3,679,110.

THE COLOR(S) YELLOW, BLUE, AND WHITE IS/ARE CLAIMED AS A FEATURE OF THE MARK.

THE MARK CONSISTS OF THE WORDS "POWERED BY" IN YELLOW CAPITAL SLANTED LETTERS ABOVE THE WORD "SUNIVA", WITH "SUN" WRITTEN IN YELLOW AND "IVA" WRITTEN IN BLUE, IN THE MIDDLE OF WHICH IS THE SHAPE OF A SUN, ALL INSIDE A WHITE CIRCLE.

THE ENGLISH TRANSLATION OF "SUNIVA" IN THE MARK IS "RADIANT" OR "ENLIGHTENED".

FOR APPARATUS FOR CONVERTING ELECTROMAGNETIC RADIATION TO ELECTRICAL ENERGY, NAMELY, PHOTOVOLTAIC SOLAR MODULES (U.S. CLS. 13, 21, 23, 31 AND 34).

FIRST USE 10-0-2009; IN COMMERCE 10-0-2009.

3,998,950. KOHLER CO., KOHLER, WI. SN 77-885,783. PUB. 10-12-2010, FILED 12-3-2009.

ONE FLUSH WONDER

THE MARK CONSISTS OF STANDARD CHARACTERS WITHOUT CLAIM TO ANY PARTICULAR FONT, STYLE, SIZE, OR COLOR.

FOR TOILETS (U.S. CLS. 13, 21, 23, 31 AND 34).
FIRST USE 3-31-2010; IN COMMERCE 3-31-2010.

3,999,103. THE PROCTER & GAMBLE COMPANY, CINCINNATI, OH. SN 77-948,485. PUB. 7-20-2010, FILED 3-2-2010.

CLASSICCLEAR

THE MARK CONSISTS OF STANDARD CHARACTERS WITHOUT CLAIM TO ANY PARTICULAR FONT, STYLE, SIZE, OR COLOR.

FOR ANTIMICROBIAL WATER PURIFICATION UNITS, WATER FILTER CARTRIDGES, WATER PURIFICATION UNITS FOR DOMESTIC USE, AND HOUSEHOLD APPLIANCES, NAMELY, WATER FILTERS FOR DOMESTIC USE AND WATER DISPENSERS (U.S. CLS. 13, 21, 23, 31 AND 34).

FIRST USE 9-30-2010; IN COMMERCE 9-30-2010.

CLASS 11—(Continued).

3,999,288. GHP SYSTEMS, INC., BROOKINGS, SD. SN 85-020,542. PUB. 9-21-2010, FILED 4-22-2010.

GeoHeaders

THE MARK CONSISTS OF STANDARD CHARACTERS WITHOUT CLAIM TO ANY PARTICULAR FONT, STYLE, SIZE, OR COLOR.

FOR GEOTHERMAL-BASED HVAC UNITS (U.S. CLS. 13, 21, 23, 31 AND 34).

FIRST USE 1-13-2011; IN COMMERCE 1-13-2011.

3,999,370. TOTO U.S.A., INC., MORROW, GA. SN 85-030,569. PUB. 10-5-2010, FILED 5-5-2010.

SULTANA

THE MARK CONSISTS OF STANDARD CHARACTERS WITHOUT CLAIM TO ANY PARTICULAR FONT, STYLE, SIZE, OR COLOR.

FOR PLUMBING FIXTURES, NAMELY, TOILETS, BIDETS, SHOWERS, BATHTUBS, SINKS AND FAUCETS (U.S. CLS. 13, 21, 23, 31 AND 34).

FIRST USE 6-30-2010; IN COMMERCE 6-30-2010.

3,999,371. TOTO U.S.A., INC., MORROW, GA. SN 85-030,608. PUB. 10-5-2010, FILED 5-5-2010.

TIRAZ

THE MARK CONSISTS OF STANDARD CHARACTERS WITHOUT CLAIM TO ANY PARTICULAR FONT, STYLE, SIZE, OR COLOR.

FOR PLUMBING FIXTURES, NAMELY, TOILETS, BIDETS, SHOWERS, BATHTUBS, SINKS AND FAUCETS (U.S. CLS. 13, 21, 23, 31 AND 34).

FIRST USE 9-13-2010; IN COMMERCE 9-13-2010.

CLASS 11—(Continued).

3,999,400. MULTISTACK LLC, SPARTA, WI. SN 85-033,258. PUB. 10-5-2010, FILED 5-7-2010.

GEOAIR

THE MARK CONSISTS OF STANDARD CHARACTERS WITHOUT CLAIM TO ANY PARTICULAR FONT, STYLE, SIZE, OR COLOR.

FOR AIR-CONDITIONING REFRIGERATION UNITS; AIR-CONDITIONING MODULAR REFRIGERATION UNITS; AIR-CONDITIONING SYSTEMS PRIMARILY COMPRISING MOTOR AND COMPRESSOR UNITS, CHILLER, EVAPORATORS, HEAT-EXCHANGERS, AND CONTROL SYSTEMS (U.S. CLS. 13, 21, 23, 31 AND 34).

FIRST USE 3-1-2011; IN COMMERCE 3-1-2011.

3,999,514. MUNTERS CORPORATION, AMESBURY, MA. SN 85-054,620. PUB. 11-2-2010, FILED 6-4-2010.

IDRY

THE MARK CONSISTS OF STANDARD CHARACTERS WITHOUT CLAIM TO ANY PARTICULAR FONT, STYLE, SIZE, OR COLOR.

FOR DEHUMIDIFIERS FOR COMMERCIAL AND INDUSTRIAL APPLICATIONS (U.S. CLS. 13, 21, 23, 31 AND 34).

FIRST USE 12-1-2010; IN COMMERCE 12-1-2010.

3,999,588. INTELUX, S.A. DE C.V., NUEVO LEON, MEXICO. SN 85-072,703. PUB. 11-23-2010, FILED 6-28-2010.

INTELUX
A Brilliant Decision

THE MARK CONSISTS OF THE WORDING "INTELUX" WITH AN INTERLINE THROUGH THE LETTERS "T" AND "E" AND BELOW THE WORDING "INTELUX" IS THE PHRASE "A BRILLIANT DECISION", WITH THE LETTERS "A", "B" AND "D" IN CAPITAL LETTERS.

FOR LAMPS (U.S. CLS. 13, 21, 23, 31 AND 34).
FIRST USE 2-23-2010; IN COMMERCE 2-23-2010.

CLASS 11—(Continued).

3,999,603. BIG BANG, CROLLES, FRANCE. SN 85-077,373. PUB. 9-28-2010, FILED 7-2-2010.

PIXA

THE MARK CONSISTS OF STANDARD CHARACTERS WITHOUT CLAIM TO ANY PARTICULAR FONT, STYLE, SIZE, OR COLOR.

FOR LAMPS; ELECTRIC LAMPS; HEAD LAMPS, NAMELY, FLASHLIGHTS THAT CAN BE WORN ON ONE'S HEAD; PORTABLE LAMPS (U.S. CLS. 13, 21, 23, 31 AND 34).

FIRST USE 1-0-2011; IN COMMERCE 1-0-2011.

CLASS 11—(Continued).

3,999,715. GILLEN, JEFF, TULSA, OK. SN 85-116,218. PUB. 2-8-2011, FILED 8-26-2010.

FRANKEN-GRILL

THE MARK CONSISTS OF STANDARD CHARACTERS WITHOUT CLAIM TO ANY PARTICULAR FONT, STYLE, SIZE, OR COLOR.

FOR BARBECUE GRILLS; BARBECUE SMOKERS (U.S. CLS. 13, 21, 23, 31 AND 34).

FIRST USE 1-0-2011; IN COMMERCE 1-0-2011.

3,999,632. TOTO U.S.A., INC., MORROW, GA. SN 85-085,442. PUB. 10-5-2010, FILED 7-15-2010.

UPTON

THE MARK CONSISTS OF STANDARD CHARACTERS WITHOUT CLAIM TO ANY PARTICULAR FONT, STYLE, SIZE, OR COLOR.

FOR PLUMBING FIXTURES, NAMELY, TOILETS, BIDETS, SHOWERS, BATHTUBS, SINKS AND FAUCETS (U.S. CLS. 13, 21, 23, 31 AND 34).

FIRST USE 10-14-2010; IN COMMERCE 10-14-2010.

3,999,747. GYO CORP., LLC, CHELMSFORD, MA. SN 85-129,096. PUB. 3-1-2011, FILED 9-14-2010.

GROW YOUR OWN.

THE MARK CONSISTS OF STANDARD CHARACTERS WITHOUT CLAIM TO ANY PARTICULAR FONT, STYLE, SIZE, OR COLOR.

FOR HYDROPONICS GROW BOX IN THE NATURE OF A CLOSED ENVIRONMENT EQUIPPED WITH LIGHTS, EXHAUST SYSTEM, HYDROPONICS GROWING CONTAINER AND ODOR CONTROL SYSTEM (U.S. CLS. 13, 21, 23, 31 AND 34).

FIRST USE 10-1-2010; IN COMMERCE 10-1-2010.

3,999,712. TRANTER, INC., WICHITA FALLS, TX. SN 85-114,290. PUB. 1-18-2011, FILED 8-24-2010.

TRANTER MULTI-BRAND

THE MARK CONSISTS OF STANDARD CHARACTERS WITHOUT CLAIM TO ANY PARTICULAR FONT, STYLE, SIZE, OR COLOR.

OWNER OF U.S. REG. NOS. 1,049,477 AND 3,271,040. NO CLAIM IS MADE TO THE EXCLUSIVE RIGHT TO USE "MULTI-BRAND", APART FROM THE MARK AS SHOWN.

FOR HEAT EXCHANGERS AND STRUCTURAL PARTS THEREFOR (U.S. CLS. 13, 21, 23, 31 AND 34).

FIRST USE 5-3-2011; IN COMMERCE 5-3-2011.

3,999,831. NORTHERN TOOL & EQUIPMENT COMPANY, INC., BURNSVILLE, MN. SN 85-159,321. PUB. 3-22-2011, FILED 10-22-2010.

ULTRA-TOW

THE MARK CONSISTS OF STANDARD CHARACTERS WITHOUT CLAIM TO ANY PARTICULAR FONT, STYLE, SIZE, OR COLOR.

FOR LIGHT BARS FOR VEHICLES, NAMELY, LAND VEHICLES (U.S. CLS. 13, 21, 23, 31 AND 34).

FIRST USE 3-1-2011; IN COMMERCE 3-1-2011.

CLASS 11—(Continued).

3,999,835. SCHAEFER VENTILATION EQUIPMENT, LLC, SAUK RAPIDS, MN. SN 85-160,391. PUB. 3-15-2011, FILED 10-25-2010.

CLASS 12—(Continued).

3,998,395. SYKES JR., MARVIN E., WAKE FOREST, NC. SN 77-202,215. PUB. 11-20-2007, FILED 6-10-2007.

FLIPFAN

Enertia

THE MARK CONSISTS OF STANDARD CHARACTERS WITHOUT CLAIM TO ANY PARTICULAR FONT, STYLE, SIZE, OR COLOR.

FOR COOLING FAN AND MISTING SYSTEM FOR THE DAIRY INDUSTRY (U.S. CLS. 13, 21, 23, 31 AND 34).

FIRST USE 3-0-2009; IN COMMERCE 3-0-2009.

THE MARK CONSISTS OF STANDARD CHARACTERS WITHOUT CLAIM TO ANY PARTICULAR FONT, STYLE, SIZE, OR COLOR.

FOR CARS; ELECTRIC CARS; MOTOR CARS FOR TRANSPORT ON LAND; RACING CARS; RACING MOTOR CARS (U.S. CLS. 19, 21, 23, 31, 35 AND 44).

FIRST USE 10-25-2008; IN COMMERCE 1-15-2011.

3,999,842. IP HOLDINGS LLC, VANCOUVER, WA. SN 85-164,162. PUB. 3-15-2011, FILED 10-28-2010.

3,998,461. HONDA MOTOR CO., LTD., MINATO-KU, TOKYO, JAPAN. SN 77-385,467. PUB. 9-30-2008, FILED 1-31-2008.

Fantom

e-cushion

THE MARK CONSISTS OF STANDARD CHARACTERS WITHOUT CLAIM TO ANY PARTICULAR FONT, STYLE, SIZE, OR COLOR.

FOR SOUND DAMPENING WOOD FAN BOX SPECIALLY ADAPTED TO HOLD AN ELECTRIC FAN (U.S. CLS. 13, 21, 23, 31 AND 34).

FIRST USE 5-10-2011; IN COMMERCE 5-10-2011.

THE MARK CONSISTS OF STANDARD CHARACTERS WITHOUT CLAIM TO ANY PARTICULAR FONT, STYLE, SIZE, OR COLOR.

FOR SEATS FOR MOTORCYCLES (U.S. CLS. 19, 21, 23, 31, 35 AND 44).

FIRST USE 10-0-2008; IN COMMERCE 10-0-2008.

CLASS 12—VEHICLES

3,998,329. IR, NEIL, OCEANSIDE, NY. SN 76-701,645. PUB. 9-21-2010, FILED 2-16-2010.

3,998,541. SUNRISE MFG INC., RANCHO CORDOVA, CA. SN 77-579,046. PUB. 8-4-2009, FILED 9-25-2008.

OUTLINE

RAIL-PAK

THE MARK CONSISTS OF STANDARD CHARACTERS WITHOUT CLAIM TO ANY PARTICULAR FONT, STYLE, SIZE, OR COLOR.

FOR BICYCLES; BICYCLE PARTS, NAMELY, BRAKES, CHAINS, HANDLEBARS, WHEELS AND FRAMES (U.S. CLS. 19, 21, 23, 31, 35 AND 44).

FIRST USE 6-2-2010; IN COMMERCE 6-2-2010.

THE MARK CONSISTS OF STANDARD CHARACTERS WITHOUT CLAIM TO ANY PARTICULAR FONT, STYLE, SIZE, OR COLOR.

FOR STRUCTURAL PARTS FOR RAIL CARGO TRAINS, NAMELY, A RAIL CARGO TRAIN RESTRAINT BARRIER DEVICE FOR APPLYING A COUNTER-ACTING FORCE AGAINST A RAIL CARGO SO AS TO PREVENT THE RAIL CARGO FROM SHIFTING ALONG THE LENGTHWISE AXIS OF A RAIL CAR (U.S. CLS. 19, 21, 23, 31, 35 AND 44).

FIRST USE 2-11-2009; IN COMMERCE 2-11-2009.

CLASS 12—(Continued).

3,998,715. EZ BEACH ATTACHMENTS, LLC, VIRGINIA BEACH, VA. SN 77-785,043. PUB. 2-1-2011, FILED 7-20-2009.

Fat Sand Bike

THE MARK CONSISTS OF STANDARD CHARACTERS WITHOUT CLAIM TO ANY PARTICULAR FONT, STYLE, SIZE, OR COLOR.

NO CLAIM IS MADE TO THE EXCLUSIVE RIGHT TO USE "SAND BIKE", APART FROM THE MARK AS SHOWN.

FOR BICYCLES; TWO-WHEELED MOTORISED VEHICLES (U.S. CLS. 19, 21, 23, 31, 35 AND 44).
FIRST USE 11-0-2010; IN COMMERCE 11-0-2010.

3,998,829. BRIDGESTONE BANDAG, LLC, MUSCATINE, IA. SN 77-848,250. PUB. 3-30-2010, FILED 10-14-2009.

B197

THE MARK CONSISTS OF STANDARD CHARACTERS WITHOUT CLAIM TO ANY PARTICULAR FONT, STYLE, SIZE, OR COLOR.

FOR TREAD USED TO RETREAD TIRES; RETREADED TIRES (U.S. CLS. 19, 21, 23, 31, 35 AND 44).
FIRST USE 7-31-2010; IN COMMERCE 7-31-2010.

3,998,830. ALEJANDRO GARCÍA FLORES, ALTAMIRA TAMAULIPAS, MEXICO. AND IRMA ELMA GARCÍA FLORES, ALTAMIRA TAMAULIPAS, MEXICO. AND JOSÉ IGNACIO GARCÍA FLORES, ALTAMIRA TAMAULIPAS, MEXICO. AND LEOPOLDO GARCÍA FLORES, ALTAMIRA TAMAULIPAS, MEXICO. SN 77-849,317. PUB. 5-4-2010, FILED 10-15-2009.



NO CLAIM IS MADE TO THE EXCLUSIVE RIGHT TO USE "HEAVY-DUTY", APART FROM THE MARK AS SHOWN.

CLASS 12—(Continued).

THE MARK CONSISTS OF THE STYLIZED LETTERING "MC HEAVY-DUTY" ABOVE THREE CRESCENTS.

FOR STRUCTURAL REPAIR PARTS FOR TRUCKS, TRAILERS, AND OTHER MOTOR VEHICLES, NAMELY, LEAF SPRINGS (U.S. CLS. 19, 21, 23, 31, 35 AND 44).
FIRST USE 1-12-2010; IN COMMERCE 1-12-2010.

3,999,043. DONKEY BOXX LTD. LIABILITY CO., BERKELEY, CA. SN 77-920,485. PUB. 6-29-2010, FILED 1-26-2010.



NO CLAIM IS MADE TO THE EXCLUSIVE RIGHT TO USE "BOXX", APART FROM THE MARK AS SHOWN.

THE COLOR(S) BLACK, WHITE AND GRAY IS/ARE CLAIMED AS A FEATURE OF THE MARK.

THE MARK CONSISTS OF AN IMAGE OF A DONKEY'S HEAD IN WHITE WITH BLACK OUTLINING AND HIGHLIGHTS FRAMED WITHIN A GRAY DIAMOND OUTLINED IN BLACK AND WHITE, WITH A BLACK AND WHITE HONEY BEE ABOVE THE DONKEY'S HEAD POSITIONED ON THE FRAME AND TWO WHITE AND BLACK FOUR LEAF CLOVERS TO THE RIGHT AND LEFT OF THE DONKEY'S HEAD ALSO POSITIONED ON THE FRAME. BELOW THE DONKEY HEAD IS A SCROLLED BANNER IN WHITE, GRAY, AND BLACK CONTAINING THE TERM "DONKEY BOXX" IN BLACK. THE BACKGROUND OF THE ENTIRE MARK IS WHITE.

FOR PANNIER BAGS FOR BICYCLES (U.S. CLS. 19, 21, 23, 31, 35 AND 44).

FIRST USE 3-2-2011; IN COMMERCE 3-12-2011.

3,999,104. CHRYSLER GROUP LLC, AUBURN HILLS, MI. SN 77-948,590. PUB. 7-27-2010, FILED 3-2-2010.

CHRYSLER 300S

THE MARK CONSISTS OF STANDARD CHARACTERS WITHOUT CLAIM TO ANY PARTICULAR FONT, STYLE, SIZE, OR COLOR.

OWNER OF U.S. REG. NOS. 570,186 AND 2,861,480.
FOR MOTOR VEHICLES, NAMELY, PASSENGER AUTOMOBILES, THEIR STRUCTURAL PARTS, TRIM AND BADGES (U.S. CLS. 19, 21, 23, 31, 35 AND 44).
FIRST USE 6-0-2010; IN COMMERCE 6-0-2010.

CLASS 12—(Continued).

3,999,105. CHRYSLER GROUP LLC, AUBURN HILLS, MI. SN 77-948,602. PUB. 7-27-2010, FILED 3-2-2010.

300S

THE MARK CONSISTS OF STANDARD CHARACTERS WITHOUT CLAIM TO ANY PARTICULAR FONT, STYLE, SIZE, OR COLOR.

OWNER OF U.S. REG. NO. 2,861,480.
FOR MOTOR VEHICLES, NAMELY, PASSENGER AUTOMOBILES, THEIR STRUCTURAL PARTS, TRIM AND BADGES (U.S. CLS. 19, 21, 23, 31, 35 AND 44).
FIRST USE 6-0-2010; IN COMMERCE 6-0-2010.

3,999,135. INFANTINO, LLC, SAN DIEGO, CA. SN 77-961,236. PUB. 10-5-2010, FILED 3-17-2010.

CLOUD

THE MARK CONSISTS OF STANDARD CHARACTERS WITHOUT CLAIM TO ANY PARTICULAR FONT, STYLE, SIZE, OR COLOR.

FOR FITTED COVERS FOR SHOPPING CARTS FOR THE PROTECTION OF CHILDREN AND INFANTS (U.S. CLS. 19, 21, 23, 31, 35 AND 44).
FIRST USE 12-2-2010; IN COMMERCE 12-2-2010.

3,999,136. INFANTINO, LLC, SAN DIEGO, CA. SN 77-961,458. PUB. 10-5-2010, FILED 3-17-2010.

SWITCH

THE MARK CONSISTS OF STANDARD CHARACTERS WITHOUT CLAIM TO ANY PARTICULAR FONT, STYLE, SIZE, OR COLOR.

FOR FITTED COVERS FOR SHOPPING CARTS FOR THE PROTECTION OF CHILDREN AND INFANTS (U.S. CLS. 19, 21, 23, 31, 35 AND 44).
FIRST USE 6-22-2010; IN COMMERCE 6-22-2010.

CLASS 12—(Continued).

3,999,181. CSXT INTELLECTUAL PROPERTIES CORPORATION, JACKSONVILLE, FL. SN 77-982,108. PUB. 9-8-2009, FILED 4-27-2009.

OWNER OF U.S. REG. NOS. 2,475,447, 2,543,728, AND 2,544,010.

THE MARK CONSISTS OF THE OUTLINE OF A RAIL-CAR WITH THE WORD "CSX" CONTAINED WITHIN.
FOR RAILWAY FREIGHT CARS (U.S. CLS. 19, 21, 23, 31, 35 AND 44).
FIRST USE 10-22-2007; IN COMMERCE 10-22-2007.

3,999,194. HUTTO, ARNE, EDGEWATER, FL. SN 78-653,062. PUB. 2-26-2008, FILED 6-17-2005.

OLD SCHOOL JONEZ

THE MARK CONSISTS OF STANDARD CHARACTERS WITHOUT CLAIM TO ANY PARTICULAR FONT, STYLE, SIZE, OR COLOR.

FOR MOTORCYCLE; AND MOTORCYCLE PARTS, NAMELY, FRAMES, SEATS AND WHEELS (U.S. CLS. 19, 21, 23, 31, 35 AND 44).
FIRST USE 4-20-2011; IN COMMERCE 4-20-2011.

3,999,201. RED BULL GMBH, FUSCHL AM SEE, AUSTRIA. SN 78-792,568. PUB. 5-13-2008, FILED 1-16-2006.

TORO ROSSO

THE MARK CONSISTS OF STANDARD CHARACTERS WITHOUT CLAIM TO ANY PARTICULAR FONT, STYLE, SIZE, OR COLOR.

PRIORITY CLAIMED UNDER SEC. 44(D) ON AUSTRIA APPLICATION NO. AM6763/2005, FILED 10-10-2005, REG. NO. 229159, DATED 1-4-2006, EXPIRES 1-31-2016.

OWNER OF U.S. REG. NOS. 1,935,272, 2,954,008, AND OTHERS.

THE ENGLISH TRANSLATION OF THE WORD "TORO ROSSO" IN THE MARK IS RED BULL.

FOR LAND RACING VEHICLES, AND RACING CARS; RACING CARS (U.S. CLS. 19, 21, 23, 31, 35 AND 44).
FIRST USE 3-12-2006; IN COMMERCE 7-2-2006.

CLASS 12—(Continued).

3,999,213. PG GROUP (PTY) LIMITED, JOHANNESBURG, GAUTENG, SOUTH AFRICA. SN 78-929,734. PUB. 9-2-2008, FILED 7-14-2006.



NO CLAIM IS MADE TO THE EXCLUSIVE RIGHT TO USE "SHATTERPROOF", APART FROM THE MARK AS SHOWN.

FOR AUTOMOTIVE GLASS, NAMELY, WIND-SCREENS AND SIDE AND REAR WINDOWS FOR VEHICLES (U.S. CLS. 19, 21, 23, 31, 35 AND 44).
FIRST USE 5-0-2009; IN COMMERCE 5-0-2009.

3,999,460. ASIA SEIKO COMPOSITE MATERIAL CO., LTD., TANZIH TOWNSHIP, TAIWAN. SN 85-042,627. PUB. 10-12-2010, FILED 5-19-2010.

ROXYCLE

THE MARK CONSISTS OF THE TERM "ROXYCLE" IN ITALIC TYPEFACE WITH A STYLIZED "Y".

FOR BICYCLES AND BICYCLE PARTS, NAMELY, BELLS, BRAKES, BRAKE SHOES, CHAINS, FENDERS, FORKS, FRAMES, FRONT FORK JOINTS, GEARS, HANDLE BARS, HANDLE BAR ENDS, HANDLE BAR GRIPS, BICYCLE GRIP TAPE, HANDLE BAR STEMS, HORNS, KICKSTANDS, PEDALS, SADDLE COVERS, SADDLES, SEAT POSTS, SPROCKETS, WATER BOTTLE CAGES, WHEELS; BICYCLE STANDS; BICYCLE PUMPS; BICYCLE TRAINING WHEELS; FRAMES FOR LUGGAGE CARRIERS FOR BICYCLES; SUSPENSION SYSTEMS FOR BICYCLES; WHEEL HUBS FOR BICYCLES; TRICYCLES (U.S. CLS. 19, 21, 23, 31, 35 AND 44).
FIRST USE 5-1-2011; IN COMMERCE 5-1-2011.

CLASS 12—(Continued).

3,999,469. BRICA, INC., CHARLOTTE, NC. SN 85-043,971. PUB. 10-19-2010, FILED 5-20-2010.

BRICA

THE MARK CONSISTS OF STANDARD CHARACTERS WITHOUT CLAIM TO ANY PARTICULAR FONT, STYLE, SIZE, OR COLOR.

FOR AUTOMOBILE MIRRORS FOR ATTACHMENT INSIDE A VEHICLE FOR THE OBSERVATION OF THE VEHICLE'S INTERIOR; AUTOMOBILE SEAT BELT ADJUSTMENT SLEEVE FOR ADJUSTING THE FIT OF SEAT BELTS; AUTOMOBILE SEAT BELT ADJUSTMENT SLEEVE FOR ADJUSTING THE FIT OF SHOULDER BELTS; COMBINATION DRINK HOLDER AND SNACK TRAY FOR USE IN A VEHICLE; COMBINATION DRINK HOLDER AND SNACK TRAY THAT ATTACHES TO A STROLLER OR TO A SHOPPING CART HANDLE; CUSHIONS FOR ATTACHMENT TO THE SEAT BELT OR SHOULDER BELT OF A VEHICLE; KICK MATS FOR PROTECTING THE REAR SIDE OF A VEHICLE SEAT BACK; MATS FOR VEHICLE SEATS SPECIFICALLY FOR USE UNDER A CHILD'S SAFETY CAR SEAT; MATS FOR VEHICLE SEATS TO KEEP SEAT CLEAN; MIRRORS FOR ATTACHMENT INSIDE A VEHICLE FOR THE OBSERVATION OF A REAR-FACING INFANT IN A CHILD'S SAFETY SEAT; MIRRORS FOR ATTACHMENT TO THE SEAT OF A VEHICLE FOR THE OBSERVATION OF A REAR-FACING INFANT IN A CHILD'S SAFETY CAR SEAT; SNACK TRAYS THAT ATTACH TO A CHILD'S SAFETY CAR SEAT FOR USE IN A VEHICLE; SNACK TRAYS THAT ATTACH TO A STROLLER OR TO A SHOPPING CART HANDLE; SOFT COVERS FOR VEHICLE SEAT BELTS; SUNSHADES FOR USE WITHIN AN AUTOMOBILE; VEHICLE ACCESSORIES COMBINING A STORAGE CONTAINER ADAPTED TO FIT IN A MOTOR VEHICLE AND A MAT FOR VEHICLE SEAT TO KEEP SEAT CLEAN; TOTE BAGS SPECIALLY ADAPTED FOR CHILD'S SAFETY CAR SEATS (U.S. CLS. 19, 21, 23, 31, 35 AND 44).
FIRST USE 2-13-2011; IN COMMERCE 2-13-2011.

3,999,585. TRICO PRODUCTS CORPORATION, ROCHESTER HILLS, MI. SN 85-071,490. PUB. 11-23-2010, FILED 6-25-2010.

TRICO

OWNER OF U.S. REG. NOS. 1,200,365, 2,292,526, AND OTHERS.

THE MARK CONSISTS OF THE WORD "TRICO" IN STYLIZED CAPITAL LETTERS.

FOR WINDSHIELD WIPER BLADES FOR VEHICLES (U.S. CLS. 19, 21, 23, 31, 35 AND 44).
FIRST USE 12-28-2010; IN COMMERCE 12-28-2010.

CLASS 12—(Continued).

3,999,662. BIO-BARGE COMPANY, LLC, METAIRIE, LA. SN 85-097,422. PUB. 1-11-2011, FILED 7-30-2010.

Bio-Barge

THE MARK CONSISTS OF STANDARD CHARACTERS WITHOUT CLAIM TO ANY PARTICULAR FONT, STYLE, SIZE, OR COLOR.

FOR BARGE THAT IS USED TO SERVICE AND MAINTAIN SUBMERGED DIFFUSERS IN A WASTE-WATER PLANT (U.S. CLS. 19, 21, 23, 31, 35 AND 44).

FIRST USE 1-1-2009; IN COMMERCE 1-1-2009.

CLASS 12—(Continued).

3,999,776. SKYLINE CORPORATION, ELKHART, IN. SN 85-141,099. PUB. 3-8-2011, FILED 9-29-2010.

KOALA

THE MARK CONSISTS OF STANDARD CHARACTERS WITHOUT CLAIM TO ANY PARTICULAR FONT, STYLE, SIZE, OR COLOR.

FOR RECREATIONAL VEHICLES, NAMELY, TRAVEL TRAILERS AND FIFTH WHEELS (U.S. CLS. 19, 21, 23, 31, 35 AND 44).

FIRST USE 11-30-2010; IN COMMERCE 11-30-2010.

3,999,732. BRICA, INC., CHARLOTTE, NC. SN 85-124,104. PUB. 2-22-2011, FILED 9-7-2010.

MAKING TOGETHER BETTER

THE MARK CONSISTS OF STANDARD CHARACTERS WITHOUT CLAIM TO ANY PARTICULAR FONT, STYLE, SIZE, OR COLOR.

FOR AUTOMOBILE MIRRORS FOR ATTACHMENT INSIDE A VEHICLE FOR THE OBSERVATION OF THE VEHICLE'S INTERIOR; AUTOMOBILE SEAT BELT ADJUSTMENT SLEEVE FOR ADJUSTING THE FIT OF SEAT BELTS; AUTOMOBILE SEAT BELT ADJUSTMENT SLEEVE FOR ADJUSTING THE FIT OF SHOULDER BELTS; COMBINATION DRINK HOLDER AND SNACK TRAY FOR USE IN A VEHICLE; COMBINATION DRINK HOLDER AND SNACK TRAY THAT ATTACHES TO A STROLLER OR TO A SHOPPING CART HANDLE; CUSHIONS FOR ATTACHMENT TO THE SEAT BELT OR SHOULDER BELT OF A VEHICLE; MATS SPECIFICALLY ADAPTED FOR VEHICLES, NAMELY, KICK MATS FOR PROTECTING THE REAR SIDE OF A VEHICLE SEAT BACK, MATS FOR VEHICLE SEATS SPECIFICALLY FOR USE UNDER A CHILD'S SAFETY CAR SEAT, AND MATS FOR VEHICLE SEATS TO KEEP SEAT CLEAN; MIRRORS FOR ATTACHMENT INSIDE A VEHICLE FOR THE OBSERVATION OF A REAR-FACING INFANT IN A CHILD'S SAFETY SEAT; MIRRORS FOR ATTACHMENT TO THE SEAT OF A VEHICLE FOR THE OBSERVATION OF A REAR-FACING INFANT IN A CHILD'S SAFETY CAR SEAT; SNACK TRAYS THAT ATTACH TO A CHILD'S SAFETY CAR SEAT FOR USE IN A VEHICLE; SNACK TRAYS THAT ATTACH TO A STROLLER OR TO A SHOPPING CART HANDLE; SOFT COVERS FOR VEHICLE SEAT BELTS; SUNSHADES FOR USE WITHIN AN AUTOMOBILE; TOTE BAGS SPECIALLY ADAPTED FOR CHILD'S SAFETY CAR SEATS; VEHICLE ACCESSORIES COMBINING A STORAGE CONTAINER ADAPTED TO FIT IN A MOTOR VEHICLE AND A MAT FOR VEHICLE SEAT TO KEEP SEAT CLEAN (U.S. CLS. 19, 21, 23, 31, 35 AND 44).

FIRST USE 2-13-2011; IN COMMERCE 2-13-2011.

3,999,777. SCHWINN ACQUISITION, LLC, MADISON, WI. SN 85-141,745. PUB. 2-15-2011, FILED 9-30-2010.

VESTIGE

THE MARK CONSISTS OF STANDARD CHARACTERS WITHOUT CLAIM TO ANY PARTICULAR FONT, STYLE, SIZE, OR COLOR.

FOR BICYCLES (U.S. CLS. 19, 21, 23, 31, 35 AND 44).

FIRST USE 5-25-2011; IN COMMERCE 5-25-2011.

3,999,794. KUNG HSUE SHE, INC., DBA KHS, INC., RANCHO DOMINGUEZ, CA. SN 85-146,186. PUB. 3-15-2011, FILED 10-6-2010.

VITAMIN A

THE MARK CONSISTS OF STANDARD CHARACTERS WITHOUT CLAIM TO ANY PARTICULAR FONT, STYLE, SIZE, OR COLOR.

FOR BICYCLES, BICYCLE FRAMES (U.S. CLS. 19, 21, 23, 31, 35 AND 44).

FIRST USE 12-14-2010; IN COMMERCE 12-14-2010.

CLASS 12—(Continued).

3,999,840. UNIVERSAL BRANDING & MEDIA LLC, MILFORD, CT. SN 85-162,928. PUB. 3-22-2011, FILED 10-27-2010.

LIL PRO

THE MARK CONSISTS OF STANDARD CHARACTERS WITHOUT CLAIM TO ANY PARTICULAR FONT, STYLE, SIZE, OR COLOR.

FOR BICYCLES (U.S. CLS. 19, 21, 23, 31, 35 AND 44).
FIRST USE 1-31-2011; IN COMMERCE 1-31-2011.

3,999,843. TIRECO, INC., GARDENA, CA. SN 85-164,206. PUB. 3-29-2011, FILED 10-28-2010.

PATAGONIA A/T

THE MARK CONSISTS OF STANDARD CHARACTERS WITHOUT CLAIM TO ANY PARTICULAR FONT, STYLE, SIZE, OR COLOR.

NO CLAIM IS MADE TO THE EXCLUSIVE RIGHT TO USE "A/T", APART FROM THE MARK AS SHOWN.

FOR TIRES, INNER TUBES AND INNER TUBE PROTECTOR FLAPS FOR VEHICLE WHEELS (U.S. CLS. 19, 21, 23, 31, 35 AND 44).

FIRST USE 5-20-2011; IN COMMERCE 5-20-2011.

CLASS 13—FIREARMS

3,998,918. OLIN CORPORATION, ST. LOUIS, MO. SN 77-873,744. PUB. 3-23-2010, FILED 11-16-2009.

DEFENSE DISC

THE MARK CONSISTS OF STANDARD CHARACTERS WITHOUT CLAIM TO ANY PARTICULAR FONT, STYLE, SIZE, OR COLOR.

NO CLAIM IS MADE TO THE EXCLUSIVE RIGHT TO USE "DISC", APART FROM THE MARK AS SHOWN.

FOR PROJECTILE SOLD AS A COMPONENT OF A SHOT SHELL (U.S. CLS. 2 AND 9).

FIRST USE 4-28-2010; IN COMMERCE 4-28-2010.

CLASS 13—(Continued).

3,999,053. RA BRANDS, L.L.C., MADISON, NC. SN 77-924,714. PUB. 11-2-2010, FILED 2-1-2010.

XELERATOR

THE MARK CONSISTS OF STANDARD CHARACTERS WITHOUT CLAIM TO ANY PARTICULAR FONT, STYLE, SIZE, OR COLOR.

OWNER OF U.S. REG. NO. 1,095,914.

FOR AMMUNITION (U.S. CLS. 2 AND 9).

FIRST USE 6-30-2010; IN COMMERCE 6-30-2010.

3,999,544. CLB INDUSTRIES LLC, CAPE CORAL, FL. SN 85-060,468. PUB. 3-22-2011, FILED 6-11-2010.



NO CLAIM IS MADE TO THE EXCLUSIVE RIGHT TO USE "CONCEALMENT PRODUCTS", APART FROM THE MARK AS SHOWN.

THE MARK CONSISTS OF A SHIELD WITH THE STYLIZED TEXT "EXO" INSIDE. TO THE RIGHT THERE IS THE STYLIZED TEXT "CONCEALMENT PRODUCTS".

FOR SEMI CUSTOM CONCEALMENT HOLSTERS FOR HANDGUNS (U.S. CLS. 2 AND 9).

FIRST USE 9-8-2010; IN COMMERCE 9-8-2010.

CLASS 14—JEWELRY

3,998,401. ROSY BLUE INC., NEW YORK, NY. SN 77-226,991. PUB. 2-19-2008, FILED 7-11-2007.

ONE WORLD DIAMOND COMPANY

THE MARK CONSISTS OF STANDARD CHARACTERS WITHOUT CLAIM TO ANY PARTICULAR FONT, STYLE, SIZE, OR COLOR.

NO CLAIM IS MADE TO THE EXCLUSIVE RIGHT TO USE "DIAMOND COMPANY", APART FROM THE MARK AS SHOWN.

FOR DIAMONDS; JEWELRY, NAMELY, RINGS, BRACELETS, EARRINGS, NECKLACES, PENDANTS, PINS AND BROOCHES ALL MADE IN WHOLE OR IN SIGNIFICANT PART OF DIAMONDS (U.S. CLS. 2, 27, 28 AND 50).

FIRST USE 5-9-2011; IN COMMERCE 5-9-2011.

CLASS 14—(Continued).

3,998,403. ROSY BLUE INC., NEW YORK, NY. SN 77-227,005.
PUB. 2-19-2008, FILED 7-11-2007.

ONE WORLD DIAMONDS

THE MARK CONSISTS OF STANDARD CHARACTERS WITHOUT CLAIM TO ANY PARTICULAR FONT, STYLE, SIZE, OR COLOR.

NO CLAIM IS MADE TO THE EXCLUSIVE RIGHT TO USE "DIAMONDS", APART FROM THE MARK AS SHOWN. FOR DIAMONDS; JEWELRY, NAMELY, RINGS, BRACELETS, EARRINGS, NECKLACES, PENDANTS, PINS AND BROOCHES ALL MADE IN WHOLE OR IN SIGNIFICANT PART OF DIAMONDS (U.S. CLS. 2, 27, 28 AND 50).

FIRST USE 5-9-2011; IN COMMERCE 5-9-2011.

3,998,679. ROBERTO COIN, INC., NEW YORK, NY. SN 77-741,963. PUB. 9-29-2009, FILED 5-21-2009.

CAPRIPLUS

THE MARK CONSISTS OF STANDARD CHARACTERS WITHOUT CLAIM TO ANY PARTICULAR FONT, STYLE, SIZE, OR COLOR.

FOR JEWELRY MADE OF GOLD, SILVER OR WOOD WITH AND WITHOUT PRECIOUS AND SEMI-PRECIOUS STONES (U.S. CLS. 2, 27, 28 AND 50).

FIRST USE 7-15-2009; IN COMMERCE 7-15-2009.

3,998,721. NANDA HOME INCORPORATED, GROSSE POINTE FARMS, MI. SN 77-792,096. PUB. 12-29-2009, FILED 7-29-2009.

TICKY

THE MARK CONSISTS OF STANDARD CHARACTERS WITHOUT CLAIM TO ANY PARTICULAR FONT, STYLE, SIZE, OR COLOR.

FOR ALARM CLOCKS (U.S. CLS. 2, 27, 28 AND 50).
FIRST USE 8-31-2010; IN COMMERCE 8-31-2010.

CLASS 14—(Continued).

3,998,910. DAVID, ZOLTAN, AUSTIN, TX. SN 77-869,388.
PUB. 4-13-2010, FILED 11-10-2009.

Knight Dreams

THE MARK CONSISTS OF STANDARD CHARACTERS WITHOUT CLAIM TO ANY PARTICULAR FONT, STYLE, SIZE, OR COLOR.

FOR JEWELRY (U.S. CLS. 2, 27, 28 AND 50).
FIRST USE 6-30-2010; IN COMMERCE 7-5-2010.

3,998,943. ARTBEADS.COM INC., GIG HARBOR, WA. SN 77-882,665. PUB. 4-27-2010, FILED 11-30-2009.

METALLITE

THE MARK CONSISTS OF STANDARD CHARACTERS WITHOUT CLAIM TO ANY PARTICULAR FONT, STYLE, SIZE, OR COLOR.

FOR BEADS FOR USE IN THE MANUFACTURE OF JEWELRY; COMPONENTS FOR USE IN THE MANUFACTURE OF JEWELRY, NAMELY, SPACER BARS, SPACER BEADS, STATIONS, LINKS, CONES, CHARMS, PENDANTS; JEWELRY, NAMELY, BRACELETS, ANKLETS, NECKLACES, EARRINGS AND RINGS; WATCH FACES (U.S. CLS. 2, 27, 28 AND 50).

FIRST USE 11-0-2009; IN COMMERCE 11-0-2009.

3,999,084. ARRIOLA, SALVADOR, DALTON, GA. SN 77-939,520. PUB. 7-20-2010, FILED 2-19-2010.

SAVVYNATURE

THE MARK CONSISTS OF STANDARD CHARACTERS WITHOUT CLAIM TO ANY PARTICULAR FONT, STYLE, SIZE, OR COLOR.

FOR JEWELRY PRODUCTS, NAMELY, PRECIOUS METALS AND THEIR ALLOYS, NAMELY, STERLING SILVER AND SILVER BEADING WIRE AND GOODS IN PRECIOUS METALS, NAMELY, EARRINGS, NECKLACES, RINGS, ANKLETS, AND HAND BANDS; JEWELRY, PRECIOUS STONES; HOROLOGICAL AND CHRONOMETRIC INSTRUMENTS FOR CONSUMERS (U.S. CLS. 2, 27, 28 AND 50).

FIRST USE 11-1-2009; IN COMMERCE 4-1-2010.

CLASS 14—(Continued).

3,999,131. PANCIS GEMS, INC., MORRIS PLAINS, NJ. SN 77-958,220. PUB. 3-22-2011, FILED 3-12-2010.

The Cappucino Collection

THE MARK CONSISTS OF STANDARD CHARACTERS WITHOUT CLAIM TO ANY PARTICULAR FONT, STYLE, SIZE, OR COLOR.

NO CLAIM IS MADE TO THE EXCLUSIVE RIGHT TO USE "COLLECTION", APART FROM THE MARK AS SHOWN.

FOR ANKLE BRACELETS; BANGLE BRACELETS; BODY-PIERCING RINGS; BRACELETS; BRACELETS; BRACELETS OF PRECIOUS METAL; CLIP EARRINGS; EAR CLIPS; EAR STUDS; EARRINGS; IDENTIFICATION BRACELETS; JEWEL PENDANTS; JEWELRY, NAMELY, STONE PENDANTS; NECKLACES; PENDANTS; RINGS; RINGS BEING JEWELRY (U.S. CLS. 2, 27, 28 AND 50).

FIRST USE 6-1-2010; IN COMMERCE 6-1-2010.

3,999,165. LIPSY LIMITED, LONDON, ENGLAND. SN 77-981,961. PUB. 1-15-2008, FILED S.R. 7-30-2007; AM. P.R. 5-11-2011.



THE MARK CONSISTS OF AN "L" IN SCRIPT WITH A STYLIZED HEART LOCATED AT THE FOOT OF THE "L".

FOR BRACELETS; BRACELETS OF PRECIOUS METAL; BRONZE JEWELRY; BROOCHES; CHARMS; CHOKERS; CLIP EARRINGS; COSTUME JEWELRY; EAR CLIPS; EAR STUDS; EARRINGS; JEWEL CHAINS; JEWEL PENDANTS; JEWELRY; JEWELRY CHAINS; JEWELRY FOR THE HEAD; NECK CHAINS; NECKLACES; PENDANTS; RINGS; RINGS BEING JEWELRY; TIMEPIECES; TIMEPIECES AND CHRONOMETRIC INSTRUMENTS; WATCH BANDS; WATCH BANDS AND STRAPS; WATCHES; WRISTWATCHES (U.S. CLS. 2, 27, 28 AND 50).

FIRST USE 8-1-2007; IN COMMERCE 8-1-2007.

CLASS 14—(Continued).

3,999,273. SHARNAE FORRESTER, EAST ELMHURST, NY. SN 85-016,455. PUB. 9-21-2010, FILED 4-17-2010.

SHARNAE ROCHELLE

THE MARK CONSISTS OF STANDARD CHARACTERS WITHOUT CLAIM TO ANY PARTICULAR FONT, STYLE, SIZE, OR COLOR.

THE NAME(S), PORTRAIT(S), AND/OR SIGNATURE(S) SHOWN IN THE MARK IDENTIFIES SHARNAE ROCHELLE FORRESTER, WHOSE CONSENT(S) TO REGISTER IS MADE OF RECORD.

FOR JEWELRY AND IMITATION JEWELRY (U.S. CLS. 2, 27, 28 AND 50).

FIRST USE 4-10-2010; IN COMMERCE 4-10-2011.

3,999,274. YORK, LAUREN, WHITESTONE, NY. SN 85-016,465. PUB. 3-15-2011, FILED 4-17-2010.

Lauren York

THE MARK CONSISTS OF STANDARD CHARACTERS WITHOUT CLAIM TO ANY PARTICULAR FONT, STYLE, SIZE, OR COLOR.

OWNER OF U.S. REG. NOS. 3,492,424 AND 3,495,512.

THE NAME SHOWN IN THE MARK IDENTIFIES "LAUREN YORK" WHOSE CONSENT IS MADE OF RECORD.

FOR JEWELRY; JEWELRY AND IMITATION JEWELRY (U.S. CLS. 2, 27, 28 AND 50).

FIRST USE 4-17-2010; IN COMMERCE 4-1-2011.

3,999,344. YORK, LAUREN, WHITESTONE, NY. SN 85-028,255. PUB. 10-5-2010, FILED 5-2-2010.

LY

THE MARK CONSISTS OF STANDARD CHARACTERS WITHOUT CLAIM TO ANY PARTICULAR FONT, STYLE, SIZE, OR COLOR.

FOR JEWELRY; JEWELRY AND IMITATION JEWELRY (U.S. CLS. 2, 27, 28 AND 50).

FIRST USE 4-17-2010; IN COMMERCE 4-1-2011.

CLASS 14—(Continued).

3,999,345. YORK, LAUREN, JAMAICA ESTATES, NY. SN 85-028,256. PUB. 10-5-2010, FILED 5-2-2010.

L YORK

THE MARK CONSISTS OF STANDARD CHARACTERS WITHOUT CLAIM TO ANY PARTICULAR FONT, STYLE, SIZE, OR COLOR.

OWNER OF U.S. REG. NO. 3,492,424.

THE NAME(S), PORTRAIT(S), AND/OR SIGNATURE(S) SHOWN IN THE MARK IDENTIFIES LAUREN YORK, WHOSE CONSENT(S) TO REGISTER IS MADE OF RECORD.

FOR JEWELRY; JEWELRY AND IMITATION JEWELRY (U.S. CLS. 2, 27, 28 AND 50).

FIRST USE 4-17-2010; IN COMMERCE 4-1-2011.

CLASS 14—(Continued).

3,999,730. OSTBYE & ANDERSON, INC., PLYMOUTH, MN. SN 85-123,965. PUB. 2-22-2011, FILED 9-7-2010.

LITTLE DIVA DIAMONDS

THE MARK CONSISTS OF STANDARD CHARACTERS WITHOUT CLAIM TO ANY PARTICULAR FONT, STYLE, SIZE, OR COLOR.

NO CLAIM IS MADE TO THE EXCLUSIVE RIGHT TO USE "DIAMONDS", APART FROM THE MARK AS SHOWN. FOR DIAMOND JEWELRY (U.S. CLS. 2, 27, 28 AND 50).

FIRST USE 5-1-2011; IN COMMERCE 5-1-2011.

3,999,501. TSUCHIYA, AKINO, AKA AKINODESIGN, CARLSBAD, CA. SN 85-051,295. PUB. 11-16-2010, FILED 5-31-2010.



THE MARK CONSISTS OF STYLIZED LETTER "A" WITH A CIRCLE ON THE TOP OF THE MIDDLE HORIZONTAL BAR.

FOR BEADS FOR USE IN THE MANUFACTURE OF JEWELRY; BODY JEWELRY; BRACELETS; BROACHES; BRONZE JEWELRY; BROOCHES; CHARMS; CHARMS FOR COLLAR JEWELRY AND BRACELET; COSTUME JEWELRY; DIAMOND JEWELRY; GEMSTONE JEWELRY; GOLD THREAD JEWELRY; IDENTIFICATION BRACELETS; INEXPENSIVE NON-JEWELRY WATCHES; JEWELRY; JEWELRY AND IMITATION JEWELRY; JEWELRY BROOCHES; JEWELRY CHAINS; JEWELRY FINDINGS; JEWELRY FOR ATTACHMENT TO CLOTHING; JEWELRY FOR THE HEAD; JEWELRY IN THE NATURE OF ARMBANDS; JEWELRY PINS FOR USE ON HATS; JEWELRY TO BE AFFIXED TO BIKINIS; JEWELRY WATCHES; JEWELRY, NAMELY, AMULETS; JEWELRY, NAMELY, ANKLETS; JEWELRY, NAMELY, ARM CUFFS; JEWELRY, NAMELY, CROSSES; JEWELRY, NAMELY, DOG TAGS FOR WEAR BY HUMANS FOR DECORATIVE PURPOSES; JEWELRY, NAMELY, MAGNETIC NECKLACES; JEWELRY, NAMELY, MAGNETIC PENDANTS; JEWELRY, NAMELY, PRECIOUS METAL PLATED REAL LEAVES AND FLOWERS; JEWELRY, NAMELY, STONE PENDANTS; LAPEL PINS; LEATHER JEWELRY AND ACCESSORY BOXES; METAL WIRE FOR USE IN THE MAKING OF JEWELRY, NAMELY, JEWELRY CABLE; PET JEWELRY; PINS BEING JEWELRY; PLASTIC BRACELETS IN THE NATURE OF JEWELRY; PRECIOUS AND SEMI-PRECIOUS CRYSTAL STONES AND BEADS FOR USE IN JEWELRY; RINGS; RINGS BEING JEWELRY; STAINLESS STEEL JEWELRY BRACELETS; WATCHES AND JEWELRY; WATCHES, CLOCKS, JEWELRY AND IMITATION JEWELRY (U.S. CLS. 2, 27, 28 AND 50).

FIRST USE 8-20-2010; IN COMMERCE 9-1-2010.

3,999,789. DAWN & DEEPA, LLC., DBA DAWN & DEEPA, HOUSTON, TX. SN 85-145,305. PUB. 3-22-2011, FILED 10-5-2010.



THE MARK CONSISTS OF THE WORDING "DAWN & DEEPA," WITH A LOGO ABOVE "DEEPA" CONSISTING OF A SHADED OVAL WITH THE LOGO CONSISTING OF A FANCY SCRIPT "D" OVERLAPPING ANOTHER FANCY SCRIPT "D."

FOR JEWELRY (U.S. CLS. 2, 27, 28 AND 50).

FIRST USE 7-23-2010; IN COMMERCE 2-22-2011.

3,999,822. LUTTE LICENSING GROUP, LLC, COLUMBUS, OH. SN 85-156,577. PUB. 3-22-2011, FILED 10-19-2010.

CORE SYNERGY

THE MARK CONSISTS OF STANDARD CHARACTERS WITHOUT CLAIM TO ANY PARTICULAR FONT, STYLE, SIZE, OR COLOR.

FOR JEWELRY (U.S. CLS. 2, 27, 28 AND 50).

FIRST USE 2-17-2011; IN COMMERCE 2-17-2011.

CLASS 14—(Continued).

3,999,847. KIM, SANG, LUBBOCK, TX. SN 85-164,951. PUB. 3-15-2011, FILED 10-29-2010.



THE COLOR(S) BLACK, BLUE, RED AND GREEN IS/ARE CLAIMED AS A FEATURE OF THE MARK.

THE MARK CONSISTS OF A BLACK CIRCLE WRAPPED AROUND ANOTHER BLUE CIRCLE CONTAINING THE RED LETTERS "KI", NEXT TO THE BLACK WORD "FOR-EVER", ABOVE A GREEN STYLIZED LINE.

THE ENGLISH TRANSLATION OF "KI" IN THE MARK IS "ENERGY".

FOR JEWELRY (U.S. CLS. 2, 27, 28 AND 50).
FIRST USE 2-0-2011; IN COMMERCE 2-0-2011.

3,999,881. DISNEY ENTERPRISES, INC., BURBANK, CA. SN 85-975,338. PUB. 10-19-2010, FILED 7-26-2010.

WALT DISNEY SIGNATURE

THE MARK CONSISTS OF STANDARD CHARACTERS WITHOUT CLAIM TO ANY PARTICULAR FONT, STYLE, SIZE, OR COLOR.

OWNER OF U.S. REG. NOS. 3,584,878, 3,610,525, AND OTHERS.

THE NAME "WALT DISNEY" DOES NOT IDENTIFY A LIVING INDIVIDUAL.

FOR JEWELRY; KEY RINGS OF PRECIOUS METAL; EARRINGS; BRACELETS; RINGS (U.S. CLS. 2, 27, 28 AND 50).

FIRST USE 3-31-2010; IN COMMERCE 3-31-2010.

CLASS 15—MUSICAL INSTRUMENTS

3,999,147. TAYLOR-LISTUG, INC., EL CAJON, CA. SN 77-967,856. PUB. 9-28-2010, FILED 3-24-2010.

GA

THE MARK CONSISTS OF STANDARD CHARACTERS WITHOUT CLAIM TO ANY PARTICULAR FONT, STYLE, SIZE, OR COLOR.

FOR MUSICAL INSTRUMENTS, NAMELY, GUITARS; AND CARRYING CASES FOR MUSICAL INSTRUMENTS (U.S. CLS. 2, 21 AND 36).

FIRST USE 7-0-1994; IN COMMERCE 7-0-1994.

CLASS 16—PAPER GOODS AND PRINTED MATTER

3,998,305. KENWORTHY, CHARLES, SANTA MONICA, CA. AND KENWORTHY, TERRI, SANTA MONICA, CA. SN 76-670,880. PUB. 7-3-2007, FILED 12-28-2006.

THE WELL-ORGANIZED LIFE

THE MARK CONSISTS OF STANDARD CHARACTERS WITHOUT CLAIM TO ANY PARTICULAR FONT, STYLE, SIZE, OR COLOR.

FOR KIT COMPRISING PAPER CONTAINERS AND FILE FOLDERS FOR ARRANGING, COMPILING AND STORING IMPORTANT PERSONAL DOCUMENTS (U.S. CLS. 2, 5, 22, 23, 29, 37, 38 AND 50).

FIRST USE 4-1-2011; IN COMMERCE 4-1-2011.

3,998,322. ANDERSON PACKAGING, INC, ROCKFORD, IL. SN 76-700,135. PUB. 4-13-2010, FILED 10-30-2009.

IntuiPac
Ascend

THE MARK CONSISTS OF THE STYLIZED WORDING "INTUIPAC" ABOVE THE STYLIZED WORD "ASCEND" AND A CURVED LINE COMING FROM THE RIGHT SIDE OF THE LETTER A IN "ASCEND" AND CURVING AROUND IN FRONT OF THE WORD "ASCEND".

FOR PAPERBOARD PACKAGES HAVING SLIDE-OUT TRAYS FOR CONTAINING PHARMACEUTICALS (U.S. CLS. 2, 5, 22, 23, 29, 37, 38 AND 50).

FIRST USE 6-30-2009; IN COMMERCE 6-30-2009.

3,998,323. ANDERSON PACKAGING, INC, ROCKFORD, IL. SN 76-700,136. PUB. 4-6-2010, FILED 10-30-2009.

IntuiPac
Achieve

THE MARK CONSISTS OF THE WORDING "INTUIPAC ACHIEVE" IN STYLIZED FONT. THE TERM "ACHIEVE" IS UNDERLINED.

FOR PAPERBOARD PACKAGES HAVING SLIDE-OUT TRAYS FOR CONTAINING PHARMACEUTICALS (U.S. CLS. 2, 5, 22, 23, 29, 37, 38 AND 50).

FIRST USE 6-30-2009; IN COMMERCE 6-30-2009.

CLASS 16—(Continued).

3,998,324. ANDERSON PACKAGING, INC, ROCKFORD, IL.
SN 76-700,137. PUB. 4-6-2010, FILED 10-30-2009.

AssuraDose

THE MARK CONSISTS OF THE WORDING "ASURA-DOSE" IN STYLIZED FONT. THE TERM "ASURA" IS UNDERLINED.

FOR PAPERBOARD PACKAGES HAVING SLIDE-OUT TRAYS FOR CONTAINING PHARMACEUTICALS (U.S. CLS. 2, 5, 22, 23, 29, 37, 38 AND 50).

FIRST USE 6-30-2009; IN COMMERCE 6-30-2009.

3,998,325. ANDERSON PACKAGING, INC, ROCKFORD, IL.
SN 76-700,138. PUB. 4-6-2010, FILED 10-30-2009.

IntuiPac

THE MARK CONSISTS OF THE WORDING "INTUIPAC" IN STYLIZED FONT.

FOR PAPERBOARD PACKAGES HAVING SLIDE-OUT TRAYS FOR CONTAINING PHARMACEUTICALS (U.S. CLS. 2, 5, 22, 23, 29, 37, 38 AND 50).

FIRST USE 6-30-2009; IN COMMERCE 6-30-2009.

3,998,358. FORDHAM, PAT, SALT LAKE CITY, UT. SN 77-063,642. PUB. 8-12-2008, FILED 12-13-2006.

LITTLE TRACKER

THE MARK CONSISTS OF STANDARD CHARACTERS WITHOUT CLAIM TO ANY PARTICULAR FONT, STYLE, SIZE, OR COLOR.

FOR PAPER GOODS, NAMELY, BOOKS IN THE FIELD OF CHILDREN'S BOOKS ABOUT ANIMAL CHARACTERS (U.S. CLS. 2, 5, 22, 23, 29, 37, 38 AND 50).

FIRST USE 4-29-2011; IN COMMERCE 4-29-2011.

CLASS 16—(Continued).

3,998,386. NYC & COMPANY, INC., NEW YORK, NY. SN 77-179,887. PUB. 4-1-2008, FILED 5-14-2007.



THE MARK CONSISTS OF STYLIZED APPLE DESIGN. FOR PUBLICATIONS, NAMELY, BROCHURES, BOOKLETS, AND TEACHING MATERIALS IN THE FIELD OF PROMOTING BUSINESS, TOURISM, ECONOMIC DEVELOPMENT AND EDUCATION ON ENVIRONMENTALLY FRIENDLY POLICIES AND PRACTICES OF THE CITY OF NEW YORK (U.S. CLS. 2, 5, 22, 23, 29, 37, 38 AND 50).

FIRST USE 11-1-2008; IN COMMERCE 5-24-2011.

3,998,392. THE LOVED DOG LLC, LOS ANGELES, CA. SN 77-195,014. PUB. 3-11-2008, FILED 5-31-2007.

TAMAR GELLER

THE MARK CONSISTS OF STANDARD CHARACTERS WITHOUT CLAIM TO ANY PARTICULAR FONT, STYLE, SIZE, OR COLOR.

THE NAME "TAMAR GELLER" IDENTIFIES A LIVING INDIVIDUAL WHOSE CONSENT IS OF RECORD. FOR BOOKS IN THE FIELD OF PET CARE (U.S. CLS. 2, 5, 22, 23, 29, 37, 38 AND 50).

FIRST USE 1-1-2011; IN COMMERCE 1-1-2011.

CLASS 16—(Continued).

3,998,410. KENWORTHY, TERRI, LOS ANGELES, CA. AND KENWORTHY, CHARLES, LOS ANGELES, CA. SN 77-268,607. PUB. 2-26-2008, FILED 8-30-2007.

SECURING WHAT MATTERS MOST

THE MARK CONSISTS OF STANDARD CHARACTERS WITHOUT CLAIM TO ANY PARTICULAR FONT, STYLE, SIZE, OR COLOR.

FOR KIT COMPRISING PAPER CONTAINERS AND FILE FOLDERS FOR ARRANGING, COMPILING AND STORING IMPORTANT PERSONAL DOCUMENTS (U.S. CLS. 2, 5, 22, 23, 29, 37, 38 AND 50).

FIRST USE 4-1-2011; IN COMMERCE 4-1-2011.

3,998,414. FANTASY STAGE PRODUCTIONS, INC. MONTECITO, CA. SN 77-272,481. PUB. 2-26-2008, FILED 9-5-2007.

FANTASY STAGE PRODUCTIONS

THE MARK CONSISTS OF STANDARD CHARACTERS WITHOUT CLAIM TO ANY PARTICULAR FONT, STYLE, SIZE, OR COLOR.

NO CLAIM IS MADE TO THE EXCLUSIVE RIGHT TO USE "PRODUCTIONS", APART FROM THE MARK AS SHOWN.

FOR CHILDREN'S BOOKS; CHILDREN'S STORYBOOKS; PICTURE BOOKS; STORY BOOKS (U.S. CLS. 2, 5, 22, 23, 29, 37, 38 AND 50).

FIRST USE 5-18-2011; IN COMMERCE 5-18-2011.

3,998,421. LUMINA SPHERE, LLC, ANTHEM, AZ. SN 77-284,034. PUB. 3-18-2008, FILED 9-19-2007.

lumina sphere

THE MARK CONSISTS OF STANDARD CHARACTERS WITHOUT CLAIM TO ANY PARTICULAR FONT, STYLE, SIZE, OR COLOR.

FOR GREETING CARDS; CALENDARS; POSTERS; STATIONERY (U.S. CLS. 2, 5, 22, 23, 29, 37, 38 AND 50).

FIRST USE 1-7-2009; IN COMMERCE 6-7-2011.

CLASS 16—(Continued).

3,998,425. CASIANO COMMUNICATIONS, INC., SAN JUAN, PUERTO RICO. SN 77-286,009. PUB. 7-21-2009, FILED 9-21-2007.



THE ENGLISH TRANSLATION OF AQUI IN THE MARK IS "HERE" AND THE ENGLISH TRANSLATION OF "ENTERTENIMIENTO AL DIA" IS "ENTERTAINMENT UP TO DATE."

FOR PUBLICATIONS, NAMELY, WEEKLY MAGAZINES IN THE FIELD OF THE ARTS, ARTISTS AND ENTERTAINMENT (U.S. CLS. 2, 5, 22, 23, 29, 37, 38 AND 50).

FIRST USE 7-25-2010; IN COMMERCE 7-25-2010.

3,998,434. SEASIDE COMMUNITY DEVELOPMENT CORPORATION, SANTA ROSA BEACH, FL. SN 77-298,802. PUB. 3-25-2008, FILED 10-8-2007.

SEASIDE

THE MARK CONSISTS OF STANDARD CHARACTERS WITHOUT CLAIM TO ANY PARTICULAR FONT, STYLE, SIZE, OR COLOR.

OWNER OF U.S. REG. NOS. 1,877,936 AND 3,145,344. FOR NEWSLETTERS, AND PRINTED BROCHURES ALL IN THE FIELD OF REAL ESTATE PROPERTIES, REAL ESTATE RENTALS, COMMUNITY EVENTS, TRAVEL, ARCHITECTURE, FASHION, FOOD, AND INTERIOR DESIGN (U.S. CLS. 2, 5, 22, 23, 29, 37, 38 AND 50).

FIRST USE 0-0-2005; IN COMMERCE 0-0-2005.

3,998,482. FRANKLIN INSTITUTE, THE, PHILADELPHIA, PA. SN 77-437,070. PUB. 8-25-2009, FILED 4-1-2008.

THE FRANKLIN INSTITUTE

THE MARK CONSISTS OF STANDARD CHARACTERS WITHOUT CLAIM TO ANY PARTICULAR FONT, STYLE, SIZE, OR COLOR.

FOR APPOINTMENT BOOKS; DIARIES; MEMORANDUM BOOKS; STATIONERY; JOURNALS; ADDRESS BOOKS; SOUVENIRS; PENS; PENCILS (U.S. CLS. 2, 5, 22, 23, 29, 37, 38 AND 50).

FIRST USE 1-0-2010; IN COMMERCE 1-0-2010.

CLASS 16—(Continued).

3,998,503. JOHNSON, STEVEN W, PEARLAND, TX. SN 77-513,640. PUB. 11-25-2008, FILED 7-2-2008.

FEARLESS FIVE

THE MARK CONSISTS OF STANDARD CHARACTERS WITHOUT CLAIM TO ANY PARTICULAR FONT, STYLE, SIZE, OR COLOR.

FOR CARTOON PRINTS; CARTOON STRIPS; COMIC BOOKS (U.S. CLS. 2, 5, 22, 23, 29, 37, 38 AND 50).
FIRST USE 11-15-2009; IN COMMERCE 12-9-2009.

3,998,518. HARPERCOLLINS PUBLISHERS LLC, NEW YORK, NY. SN 77-557,100. PUB. 11-24-2009, FILED 8-27-2008.

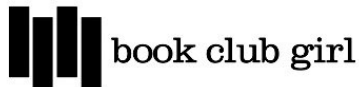

OWNER OF U.S. REG. NOS. 3,741,671, 3,880,471, AND 3,928,945.

NO CLAIM IS MADE TO THE EXCLUSIVE RIGHT TO USE "BOOK" OR "GIRL", APART FROM THE MARK AS SHOWN.

FOR BOOKMARKS (U.S. CLS. 2, 5, 22, 23, 29, 37, 38 AND 50).

FIRST USE 5-0-2009; IN COMMERCE 5-0-2009.

3,998,523. WICHMANN, SCOTCH, WEST HOLLYWOOD, CA. SN 77-560,827. PUB. 2-10-2009, FILED 9-2-2008.

FREAKSHOW BOOKS

THE MARK CONSISTS OF STANDARD CHARACTERS WITHOUT CLAIM TO ANY PARTICULAR FONT, STYLE, SIZE, OR COLOR.

CLASS 16—(Continued).

NO CLAIM IS MADE TO THE EXCLUSIVE RIGHT TO USE "BOOKS", APART FROM THE MARK AS SHOWN.

FOR NOVELS (U.S. CLS. 2, 5, 22, 23, 29, 37, 38 AND 50).
FIRST USE 3-21-2011; IN COMMERCE 3-21-2011.

3,998,534. ADZINIA MEDIA GROUP LLC, SEATTLE, WA. SN 77-572,991. PUB. 2-10-2009, FILED 9-18-2008.



THE MARK CONSISTS OF STYLIZED LETTERS FOR THE WORD "ADZINIA" AND THE DESIGN ELEMENT OF A CURVED ARROW OR SMILE BELOW THE WORD GOING FROM THE LETTER "A" TO THE LETTER "Z".

FOR PRINTED VISUALS IN THE NATURE OF PROMOTIONAL MATERIALS FOR OTHERS (U.S. CLS. 2, 5, 22, 23, 29, 37, 38 AND 50).

FIRST USE 8-1-2009; IN COMMERCE 8-1-2009.

3,998,548. THE IRMI GROUP LLC, INDIANAPOLIS, IN. SN 77-583,842. PUB. 2-17-2009, FILED 10-2-2008.

IRMI

THE MARK CONSISTS OF STANDARD CHARACTERS WITHOUT CLAIM TO ANY PARTICULAR FONT, STYLE, SIZE, OR COLOR.

FOR GREETING CARDS (U.S. CLS. 2, 5, 22, 23, 29, 37, 38 AND 50).

FIRST USE 4-11-2011; IN COMMERCE 4-11-2011.

CLASS 16—(Continued).

3,998,551. JOHNSON & JOHNSON, NEW BRUNSWICK, NJ. SN 77-586,885. PUB. 3-9-2010, FILED 10-7-2008.

CUFFLOK

THE MARK CONSISTS OF STANDARD CHARACTERS WITHOUT CLAIM TO ANY PARTICULAR FONT, STYLE, SIZE, OR COLOR.

FOR PRINTED PUBLICATIONS, NAMELY, BROCHURES, RELATING TO THE TEACHING OF A SURGICAL TECHNIQUE (U.S. CLS. 2, 5, 22, 23, 29, 37, 38 AND 50).

FIRST USE 12-0-2007; IN COMMERCE 12-0-2007.

3,998,562. THE GLAD PRODUCTS COMPANY, OAKLAND, CA. SN 77-598,877. PUB. 3-17-2009, FILED 10-23-2008.



OWNER OF U.S. REG. NOS. 1,979,836 AND 1,981,233. THE COLOR(S) RED, YELLOW AND ORANGE IS/ARE CLAIMED AS A FEATURE OF THE MARK.

THE MARK CONSISTS OF A RED, WAVY BANNER WITH A BORDER ALONG THE BOTTOM THAT IS YELLOW AND ORANGE.

FOR PLASTIC SANDWICH BAGS; TRASH BAGS (U.S. CLS. 2, 5, 22, 23, 29, 37, 38 AND 50).

FIRST USE 8-31-2004; IN COMMERCE 8-31-2004.

3,998,581. SUPER POWER HEROES, LLC, RUNNEMEDE, NJ. SN 77-624,465. PUB. 3-31-2009, FILED 12-2-2008.

DYNAMIC DEVIL

THE MARK CONSISTS OF STANDARD CHARACTERS WITHOUT CLAIM TO ANY PARTICULAR FONT, STYLE, SIZE, OR COLOR.

FOR COMIC BOOKS, GRAPHIC NOVELS, COMIC MAGAZINES, POSTERS (U.S. CLS. 2, 5, 22, 23, 29, 37, 38 AND 50).

FIRST USE 12-17-2010; IN COMMERCE 12-17-2010.

CLASS 16—(Continued).

3,998,583. PALZIS,CHRIS, PLAYA DEL REY, CA. SN 77-626,582. PUB. 4-21-2009, FILED 12-4-2008.

Goodness Gracious Club

THE MARK CONSISTS OF STANDARD CHARACTERS WITHOUT CLAIM TO ANY PARTICULAR FONT, STYLE, SIZE, OR COLOR.

FOR CHILDREN'S BOOKS (U.S. CLS. 2, 5, 22, 23, 29, 37, 38 AND 50).

FIRST USE 1-1-2008; IN COMMERCE 6-1-2008.

3,998,596. INFOSEAL LLC, ROANOKE, VA. SN 77-645,679. PUB. 11-24-2009, FILED 1-8-2009.

SELFLABEL

THE MARK CONSISTS OF STANDARD CHARACTERS WITHOUT CLAIM TO ANY PARTICULAR FONT, STYLE, SIZE, OR COLOR.

FOR BUSINESS FORMS; BLANK AND PRINTED MAILER FORMS; BLANK AND PRINTED ONE-PIECE MAILER FORMS (U.S. CLS. 2, 5, 22, 23, 29, 37, 38 AND 50).

FIRST USE 2-15-2011; IN COMMERCE 2-15-2011.

3,998,614. TWENTIETH CENTURY FOX FILM CORPORATION, LOS ANGELES, CA. SN 77-685,888. PUB. 6-23-2009, FILED 3-6-2009.

GLEE

THE MARK CONSISTS OF STANDARD CHARACTERS WITHOUT CLAIM TO ANY PARTICULAR FONT, STYLE, SIZE, OR COLOR.

FOR WALL CALENDARS; STICKERS; BOOKMARKS; GREETING CARDS; POSTERS; PERSONAL DIARIES; BLANK JOURNALS; NOTEBOOKS; PAPER NAPKINS AND PARTY FAVORS MADE OF PAPER; SERIES OF FICTION BOOKS (U.S. CLS. 2, 5, 22, 23, 29, 37, 38 AND 50).

FIRST USE 7-0-2010; IN COMMERCE 7-0-2010.

CLASS 16—(Continued).

3,998,624. TED A. LESTER, VALPARAISO, IN. SN 77-698,339.
PUB. 8-4-2009, FILED 3-24-2009.

CLASS 16—(Continued).

3,998,738. WILLIAMS, LISA, BEVERLY HILLS, CA. SN 77-
808,573. PUB. 1-26-2010, FILED 8-19-2009.

TROPICAL RAINBOWS

THE MARK CONSISTS OF STANDARD CHARACTERS WITHOUT CLAIM TO ANY PARTICULAR FONT, STYLE, SIZE, OR COLOR.

NO CLAIM IS MADE TO THE EXCLUSIVE RIGHT TO USE "RAINBOWS", APART FROM THE MARK AS SHOWN. FOR ART PRINTS, ART PICTURES, ART PRINTS ON CANVAS, COLORED PENCIL DRAWINGS (U.S. CLS. 2, 5, 22, 23, 29, 37, 38 AND 50).

FIRST USE 6-1-2010; IN COMMERCE 6-1-2010.

3,998,646. SANFORD, L.P., OAK BROOK, IL. SN 77-716,413.
PUB. 7-13-2010, FILED 4-17-2009.

**DO YOU WANT TO KNOW
EVERYTHING?****UNCAP WHAT'S INSIDE**

THE MARK CONSISTS OF STANDARD CHARACTERS WITHOUT CLAIM TO ANY PARTICULAR FONT, STYLE, SIZE, OR COLOR.

FOR WRITING INSTRUMENTS, NAMELY, PERMANENT MARKERS, PENS, PENCILS, HIGHLIGHTERS AND PENCIL CASES (U.S. CLS. 2, 5, 22, 23, 29, 37, 38 AND 50).

FIRST USE 1-31-2009; IN COMMERCE 1-31-2009.

3,998,691. MURRAY EMPOWERMENT SYSTEMS, INC,
PEACHTREE CITY, GA. SN 77-760,031. PUB. 4-27-2010,
FILED 6-15-2009.

Got the Power

THE MARK CONSISTS OF STANDARD CHARACTERS WITHOUT CLAIM TO ANY PARTICULAR FONT, STYLE, SIZE, OR COLOR.

FOR A SERIES OF BOOKS FEATURING RELIGION AND FAITH (U.S. CLS. 2, 5, 22, 23, 29, 37, 38 AND 50).
FIRST USE 1-1-2010; IN COMMERCE 2-10-2010.

THE MARK CONSISTS OF STANDARD CHARACTERS WITHOUT CLAIM TO ANY PARTICULAR FONT, STYLE, SIZE, OR COLOR.

FOR PRINTED MATTER, NAMELY, A SERIES OF BOOKS, WRITTEN ARTICLES, NEWSLETTERS, MAGAZINES AND JOURNALS IN THE FIELDS OF SPIRITUALITY, THE HEALING ARTS, MEDIUMSHIP, PERSONAL AND PSYCHIC AWARENESS, AND PERSONAL SPIRITUAL DEVELOPMENT; STATIONERY; STATIONERY-TYPE PORTFOLIOS; STATIONERY BOXES AND CASES; ADDRESS BOOKS; APPOINTMENT BOOKS; NOTEBOOKS; SCRAP BOOKS; DIARIES; BLANK JOURNALS; BOOKMARKS; MEMORY BOOKS; CALENDARS; PEN AND PENCIL CASES AND HOLDERS; DESK PADS; DESK SETS; PAPER PARTY DECORATIONS (U.S. CLS. 2, 5, 22, 23, 29, 37, 38 AND 50).
FIRST USE 4-8-2008; IN COMMERCE 4-8-2008.

CLASS 16—(Continued).

3,998,761. DURKA, HEATHER WILLIAMS, DBA SOPHIE LUMEN, OLYMPIA, WA. AND DURKA, MICHAEL A, DBA SOPHIE LUMEN, OLYMPIA, WA. SN 77-823,250. PUB. 6-15-2010, FILED 9-9-2009.

Feed The Beauty

THE MARK CONSISTS OF STANDARD CHARACTERS WITHOUT CLAIM TO ANY PARTICULAR FONT, STYLE, SIZE, OR COLOR.

FOR A SERIES OF ILLUSTRATED BOOKS, AND PRINTED PRODUCTS, NAMELY, ADDRESS BOOKS, BANK CHECKS, BLANK WRITING JOURNALS, BROCHURES ABOUT CREATIVE PERSONAL AWARENESS AND INSPIRATION, BOOKLETS IN THE FIELD OF CREATIVE PERSONAL AWARENESS AND INSPIRATION, BOOKMARKS, BUMPER STICKERS, BUSINESS CARDS, CALENDARS, DIARIES, GREETING CARDS, CHECKBOOK COVERS, COLLAGES, DAILY PLANNERS, DATE BOOKS, DECALS, DESK BLOTTERS, DRAWING TABLETS, EMBROIDERY DESIGN PATTERNS ON PAPER, ENVELOPES AND BLANK LETTER PAPER FOR STATIONERY USE, FILE FOLDERS, FRAMED ART PRINTS, GICLEE PRINTS, GIFT CARDS, GIFT WRAPPING PAPER, POSTCARDS, NOTEPADS, IMPRESSION STAMPS, INDEX CARDS, INDEX CARD BOXES, INK STAMPS, LAMINATED PAPER, LITHOGRAPHIC ART PRINTS, LOOSE-LEAF BINDERS, MEMO PADS, MAGAZINE ARTICLES IN THE FIELD OF CREATIVE PERSONAL AWARENESS AND INSPIRATION, MAGNETIC PAPER, MEMORY BOOKS, MOTIVATIONAL CARDS, MUSICAL GREETING CARDS, NEWSLETTERS IN THE FIELD OF CREATIVE PERSONAL AWARENESS AND INSPIRATION, PAINTINGS, PERSONAL ORGANIZERS, NOTE BOOKS, NOTE PADS, PAPER NAPKINS, PAPER STATIONERY BOXES, WRITING PAPER, MEMO HOLDERS, PEN OR PENCIL HOLDERS, PEN AND PENCIL CASES, PAPER TABLECLOTHS, PAPER WEIGHTS, POSTERS, PHOTO STORAGE BOXES, PHOTO ALBUMS, PRINTED ART REPRODUCTIONS, A SERIES OF WRITTEN ARTICLES IN THE FIELD OF CREATIVE PERSONAL AWARENESS AND INSPIRATION, PRINTED EDUCATIONAL AND TEACHING MATERIALS IN THE FIELD OF CREATIVE PERSONAL AWARENESS AND INSPIRATION (U.S. CLS. 2, 5, 22, 23, 29, 37, 38 AND 50).

FIRST USE 9-9-2009; IN COMMERCE 9-9-2009.

3,998,771. SALTED SOUL COMPANY, LLC, BOCA RATON, FL. SN 77-828,851. PUB. 10-26-2010, FILED 9-17-2009.

SALTED SOUL OUR SALT IS GOOD FOR YOU

THE MARK CONSISTS OF STANDARD CHARACTERS WITHOUT CLAIM TO ANY PARTICULAR FONT, STYLE, SIZE, OR COLOR.

FOR STICKERS AND TRANSFERS (U.S. CLS. 2, 5, 22, 23, 29, 37, 38 AND 50).

FIRST USE 6-0-2004; IN COMMERCE 7-0-2009.

CLASS 16—(Continued).

3,998,782. TACNOLOGY, LLC, SOLANA BEACH, CA. SN 77-832,300. PUB. 3-9-2010, FILED 9-22-2009.

TACBAK

THE MARK CONSISTS OF STANDARD CHARACTERS WITHOUT CLAIM TO ANY PARTICULAR FONT, STYLE, SIZE, OR COLOR.

OWNER OF U.S. REG. NO. 2,808,032.

FOR POSTERS AND APPLIQUES IN THE FORM OF DECALS FOR DECORATIVE PURPOSES; SELF-ADHESIVE TAPES FOR STATIONERY AND HOUSEHOLD PURPOSES (U.S. CLS. 2, 5, 22, 23, 29, 37, 38 AND 50).

FIRST USE 9-10-2009; IN COMMERCE 9-10-2009.

3,998,795. DREAMWORKS ANIMATION L.L.C., GLENDALE, CA. SN 77-835,102. PUB. 1-26-2010, FILED 9-25-2009.

THE PENGUINS OF MADAGASCAR

THE MARK CONSISTS OF STANDARD CHARACTERS WITHOUT CLAIM TO ANY PARTICULAR FONT, STYLE, SIZE, OR COLOR.

OWNER OF U.S. REG. NOS. 3,011,693, 3,187,467, AND OTHERS.

FOR PAPER PARTY DECORATIONS; PAPER PARTY SUPPLIES, NAMELY, PAPER NAPKINS, PAPER PLACE MATS, GIFT WRAPPING PAPER AND PAPER GIFT WRAPPING RIBBONS, PAPER GIFT WRAP BOWS, PAPER TABLE CLOTHS AND PAPER PARTY BAGS; CHILDREN'S STORYBOOKS, COMIC BOOKS, COLORING BOOKS, STICKERS, TEMPORARY TATTOOS, PENCILS, ALL RELATED TO AN ANIMATION TELEVISION SERIES FEATURING ANTHROPOMORPHIZED PENGUIN CHARACTERS (U.S. CLS. 2, 5, 22, 23, 29, 37, 38 AND 50).

FIRST USE 7-1-2010; IN COMMERCE 7-1-2010.

CLASS 16—(Continued).

3,998,801. MARKET STUDIES, LLC, SCOTTSDALE, AZ. SN 77-837,646. PUB. 2-23-2010, FILED 9-29-2009.

COUNTDOWN

THE MARK CONSISTS OF STANDARD CHARACTERS WITHOUT CLAIM TO ANY PARTICULAR FONT, STYLE, SIZE, OR COLOR.

FOR PUBLICATIONS, NAMELY, BOOKS, MAGAZINES, NEWSLETTERS, PRINTED TEACHING AND LECTURE MATERIALS AND PRINTED LECTURES ALL IN THE FIELD OF FINANCIAL MARKETS AND EXCHANGE TRADED COMMODITIES (U.S. CLS. 2, 5, 22, 23, 29, 37, 38 AND 50).

FIRST USE 6-12-2010; IN COMMERCE 6-12-2010.

3,998,802. MARKET STUDIES, LLC, SCOTTSDALE, AZ. SN 77-837,665. PUB. 3-2-2010, FILED 9-29-2009.

COMBO

THE MARK CONSISTS OF STANDARD CHARACTERS WITHOUT CLAIM TO ANY PARTICULAR FONT, STYLE, SIZE, OR COLOR.

FOR PUBLICATIONS, NAMELY, BOOKS, MAGAZINES, NEWSLETTERS, PRINTED TEACHING AND LECTURE MATERIALS AND PRINTED LECTURES ALL IN THE FIELD OF FINANCIAL MARKETS AND EXCHANGE TRADED COMMODITIES (U.S. CLS. 2, 5, 22, 23, 29, 37, 38 AND 50).

FIRST USE 6-12-2010; IN COMMERCE 6-12-2010.

3,998,988. HENKEL AG & CO. KGAA, DUESSELDORF, FED REP GERMANY. SN 77-898,283. PUB. 7-6-2010, FILED 12-21-2009.

POWER EASY

THE MARK CONSISTS OF STANDARD CHARACTERS WITHOUT CLAIM TO ANY PARTICULAR FONT, STYLE, SIZE, OR COLOR.

PRIORITY CLAIMED UNDER SEC. 44(D) ON ERPN CMNTY TM OFC APPLICATION NO. 8558116, FILED 9-1-2009, REG. NO. 8558116, DATED 1-27-2010, EXPIRES 9-1-2019.

FOR ADHESIVES FOR STATIONERY OR HOUSEHOLD PURPOSES (U.S. CLS. 2, 5, 22, 23, 29, 37, 38 AND 50).

FIRST USE 4-14-2011; IN COMMERCE 4-14-2011.

CLASS 16—(Continued).

3,998,991. EVE LYNNE ROBINSON, DBA ELLA B. JENKINS, LLC, OAKLAND, CA. SN 77-900,040. PUB. 10-26-2010, FILED 12-23-2009.

Ella B. Jenkins

THE MARK CONSISTS OF STANDARD CHARACTERS WITHOUT CLAIM TO ANY PARTICULAR FONT, STYLE, SIZE, OR COLOR.

THE NAME "ELLA B. JENKINS" DOES NOT IDENTIFY A LIVING INDIVIDUAL.

FOR CHILDREN'S BOOKS; CHILDREN'S ACTIVITY BOOKS (U.S. CLS. 2, 5, 22, 23, 29, 37, 38 AND 50).

FIRST USE 6-30-2009; IN COMMERCE 6-30-2009.

3,998,994. WEBMAGIC VENTURES, LLC, PASADENA, CA. SN 77-900,591. PUB. 9-28-2010, FILED 12-23-2009.

PENNY ARCADIA

THE MARK CONSISTS OF STANDARD CHARACTERS WITHOUT CLAIM TO ANY PARTICULAR FONT, STYLE, SIZE, OR COLOR.

FOR BLANK CARDS; BLANK JOURNALS; CALENDARS; COFFEE TABLE BOOKS FEATURING REFERENCE OR HISTORICAL CONTENT ON AMUSEMENT DEVICES AND MACHINES, VENDING MACHINES, SLOT MACHINES, COIN-OPERATED MACHINES, SCALES, AND VIDEOGAMES; INCLUDING ITS ART, HISTORY, INVENTIONS, PEOPLE, SOCIOLOGY, OR ITS BUSINESS, EDUCATIONAL AND ENTERTAINMENT ASPECTS AND INFLUENCES (U.S. CLS. 2, 5, 22, 23, 29, 37, 38 AND 50).

FIRST USE 5-21-2011; IN COMMERCE 5-21-2011.

3,999,005. ISLAMIC RELIEF WORLDWIDE, BIRMINGHAM, UNITED KINGDOM. SN 77-904,540. PUB. 9-14-2010, FILED 1-4-2010.

ISLAMIC RELIEF USA

THE MARK CONSISTS OF STANDARD CHARACTERS WITHOUT CLAIM TO ANY PARTICULAR FONT, STYLE, SIZE, OR COLOR.

OWNER OF U.S. REG. NOS. 3,302,215, 3,302,270, AND OTHERS.

NO CLAIM IS MADE TO THE EXCLUSIVE RIGHT TO USE "USA", APART FROM THE MARK AS SHOWN.

CLASS 16—(Continued).

SEC. 2(F) AS TO "ISLAMIC RELIEF".

FOR MAGAZINES, BROCHURES, POSTERS, PHOTOGRAPHS, NEWSLETTERS, BOOKLETS, PAMPHLETS, PRINTED REPORTS, ALL OF THE AFOREMENTIONED GOODS FEATURING ISLAM, HUMANITARIAN AID AND DEVELOPMENT SERVICES, EMERGENCY AID, FINANCIAL SERVICES, FOOD RELIEF, HEALTH CARE, HOUSING, EDUCATION, JOBS, CLEAN WATER, AND FEATURING MEDICAL ASSISTANCE TO REFUGEES AND NEEDY PERSONS; PAPER BANNERS; PAPER BADGES; POSTCARDS; CHILDREN'S ACTIVITY BOOKS; CALENDARS; FOLDERS; GREETING CARDS; NOTEBOOKS; NOTE PADS; PAPER BAGS; PRINTED PAPER SIGNS; WRITING PAPER; PENS; AND STATIONERY (U.S. CLS. 2, 5, 22, 23, 29, 37, 38 AND 50).

FIRST USE 0-0-1993; IN COMMERCE 0-0-1993.

3,999,031. LOCAL INSIGHT MEDIA HOLDINGS, INC., ENGLEWOOD, CO. SN 77-914,404. PUB. 6-1-2010, FILED 1-19-2010.

YELLOW PAGES YOUR WAY

THE MARK CONSISTS OF STANDARD CHARACTERS WITHOUT CLAIM TO ANY PARTICULAR FONT, STYLE, SIZE, OR COLOR.

NO CLAIM IS MADE TO THE EXCLUSIVE RIGHT TO USE "YELLOW PAGES", APART FROM THE MARK AS SHOWN.

FOR PRINTED TELEPHONE DIRECTORIES (U.S. CLS. 2, 5, 22, 23, 29, 37, 38 AND 50).

FIRST USE 1-1-2010; IN COMMERCE 1-1-2010.

3,999,051. SHANGHAI SHANGPIN STATIONERY CO., LTD., SHANGHAI, CHINA. SN 77-923,111. PUB. 6-15-2010, FILED 1-29-2010.



NO CLAIM IS MADE TO THE EXCLUSIVE RIGHT TO USE "PAPER", APART FROM THE MARK AS SHOWN.

CLASS 16—(Continued).

THE MARK CONSISTS OF STYLIZED WORDS "PAPER INTERMEDIARY" AND THREE RECTANGLES WHICH INTERCROSS EACH OTHER.

FOR BLANK CARDS; CHRISTMAS CARDS; CORRESPONDENCE CARDS; ENTRY TICKETS; FACE TOWELS OF PAPER; GREETING CARDS; HAND TOWELS OF PAPER; HANDKERCHIEFS OF PAPER; INVITATION CARDS; LUMINOUS PAPER; NOTE BOOKS; PAPER; PASSENGER TICKETS; PICTURE CARDS; PRICE TICKETS; PRINTED TICKETS; TABLE MATS OF PAPER; TABLE NAPKINS OF PAPER; TOILET PAPER; WRITING PADS (U.S. CLS. 2, 5, 22, 23, 29, 37, 38 AND 50).

FIRST USE 11-7-2010; IN COMMERCE 11-7-2010.

3,999,080. PERSAD, SABBITHRY, TORONTO M4K3Z2, CANADA. SN 77-935,733. PUB. 8-10-2010, FILED 2-15-2010.

Read Think Do

THE MARK CONSISTS OF STANDARD CHARACTERS WITHOUT CLAIM TO ANY PARTICULAR FONT, STYLE, SIZE, OR COLOR.

FOR BABY BOOKS; CHILDREN'S ACTIVITY BOOKS; CHILDREN'S BOOKS; CHILDREN'S INTERACTIVE EDUCATIONAL BOOKS; EDUCATIONAL PUBLICATIONS, NAMELY, BOOKS, HAND-OUTS, WORKBOOKS, JOURNALS, PLAYBOOKS, WORKSHEETS AND CARDS IN THE FIELD OF RIGHT-BRAIN FITNESS; EDUCATIONAL PUBLICATIONS, NAMELY, EDUCATIONAL LEARNING CARDS, FLASH CARDS, ACTIVITY CARDS, WORKBOOKS, TEXTBOOKS, ACTIVITY BOOKS, STORY BOOKS, PUZZLE BOOKS, PRINTED PUZZLES, TEACHER GUIDES, MANUALS, POSTERS AND EDUCATIONAL BOOKLETS IN THE FIELD OF CHILDREN INTERACTION (U.S. CLS. 2, 5, 22, 23, 29, 37, 38 AND 50).

FIRST USE 5-20-2011; IN COMMERCE 5-20-2011.

3,999,128. BRIDGE GRAPHIX, LLC, DALLAS, TX. SN 77-957,800. PUB. 1-25-2011, FILED 3-12-2010.

RISING STAR

THE MARK CONSISTS OF STANDARD CHARACTERS WITHOUT CLAIM TO ANY PARTICULAR FONT, STYLE, SIZE, OR COLOR.

FOR BOOKS USED AS RECORD-KEEPING JOURNALS FOR YOUTH, MIDDLE SCHOOL AND HIGH SCHOOL SPORTS STATISTICS, NAMELY, STATISTIC BOOKS PERSONALIZED WITH INDIVIDUAL ATHLETES' NAMES OR THE NAME AND/OR LOGO OF THE SPORTS TEAM ON THE COVER AND AVAILABLE FOR PURCHASE EXCLUSIVELY VIA AN INTERNET WEBSITE (U.S. CLS. 2, 5, 22, 23, 29, 37, 38 AND 50).

FIRST USE 11-1-2010; IN COMMERCE 11-1-2010.

CLASS 16—(Continued).

3,999,164. COLORBOK, INC., ANN ARBOR, MI. SN 77-981,944. PUB. 2-9-2010, FILED 3-19-2008.

HEIDI GRACE DESIGNS

THE MARK CONSISTS OF STANDARD CHARACTERS WITHOUT CLAIM TO ANY PARTICULAR FONT, STYLE, SIZE, OR COLOR.

OWNER OF U.S. REG. NO. 3,187,903.

NO CLAIM IS MADE TO THE EXCLUSIVE RIGHT TO USE "DESIGNS", APART FROM THE MARK AS SHOWN.

THE NAME "HEIDI GRACE" IDENTIFIES A LIVING INDIVIDUAL WHOSE CONSENT IS OF RECORD.

FOR SCRAPBOOK ALBUMS AND SCRAPBOOK ALBUM SUPPLIES AND CRAFT SUPPLIES, NAMELY, PAPER, CARD STOCK, CARD STOCK LETTERS, CARD STOCK PICTURES, PAPER RIBBONS, STICKERS, STICKERS WITH CLEAR RAISED SURFACE CONTAINING LETTERS, WORDS, OR OTHER ORNAMENTAL DESIGNS, METALLIC ALPHABET LETTERS USED TO CREATE WORDS, SIGNS, PICTURES, BORDERS, OR SCRAPBOOK PAGES, PHOTOGRAPH ALBUM PAGES, METALLIC PHOTO CORNERS, ADHESIVE-BACKED AND NON-ADHESIVE BACKED PRE-FORMED METALLIC WORDS USED TO ACCENT PICTURES, BORDERS, OR SCRAPBOOK PAGES, PRODUCT IDEA MANUALS, STICKERS, AND FIBER PAPER; PRE-FORMED DIE CUT SHAPES, DESIGNS, PICTURES AND LETTERS MADE OF CARD STOCK; PRINTED INSTRUCTION BOOKS IN THE FIELD OF SCRAPBOOK ALBUMS, PLAIN AND PRINTED PAPER FRAMES FOR USE IN SCRAP BOOKING, 3-RING BINDERS, LOOSE LEAF BINDERS, PORTFOLIOS, NAMELY, COIL BOUND OR RING BOUND BOOKS CONTAINING LINED OR UNLINED PAPER FOR WRITING, STAMP AND STAMP PADS, DIE CUT ACCENTS, DIE CUT AND STRAIGHT CUT PAPER FOR BORDERS AND BACKGROUNDS, SHEET PROTECTORS, STATIONERY AND JOURNALS FOR PERSONAL USE, AND STENCILS (U.S. CLS. 2, 5, 22, 23, 29, 37, 38 AND 50).

FIRST USE 12-1-2006; IN COMMERCE 12-1-2006.

3,999,179. NATAJI, LLC, RENO, NV. SN 77-982,068. PUB. 4-6-2010, FILED 10-28-2009.

NATAJI

THE MARK CONSISTS OF STANDARD CHARACTERS WITHOUT CLAIM TO ANY PARTICULAR FONT, STYLE, SIZE, OR COLOR.

THE WORDING "NATAJI" HAS NO MEANING OTHER THAN TRADEMARK SIGNIFICANCE.

FOR GREETING CARDS FEATURING MOTIVATIONAL AND INSPIRATIONAL IMAGES AND MESSAGES; GREETING CARDS (U.S. CLS. 2, 5, 22, 23, 29, 37, 38 AND 50).

FIRST USE 5-16-2011; IN COMMERCE 5-16-2011.

CLASS 16—(Continued).

3,999,254. AFTER50, INC., TONAWANDA, NY. SN 85-011,279. PUB. 9-7-2010, FILED 4-11-2010.

AFTER 50

THE MARK CONSISTS OF STANDARD CHARACTERS WITHOUT CLAIM TO ANY PARTICULAR FONT, STYLE, SIZE, OR COLOR.

FOR NEWSPAPERS (U.S. CLS. 2, 5, 22, 23, 29, 37, 38 AND 50).

FIRST USE 9-1-2004; IN COMMERCE 5-1-2011.

3,999,309. MY1STORY, LLC, FORT LAUDERDALE, FL. SN 85-023,542. PUB. 9-28-2010, FILED 4-26-2010.

Classics for the 21st Century

THE MARK CONSISTS OF STANDARD CHARACTERS WITHOUT CLAIM TO ANY PARTICULAR FONT, STYLE, SIZE, OR COLOR.

FOR CHILDREN'S BOOKS (U.S. CLS. 2, 5, 22, 23, 29, 37, 38 AND 50).

FIRST USE 5-15-2011; IN COMMERCE 5-15-2011.

3,999,403. SQUISHY PRESS, LLC, CHICAGO, IL. SN 85-033,400. PUB. 10-5-2010, FILED 5-7-2010.

SQUISHY PRESS

THE MARK CONSISTS OF STANDARD CHARACTERS WITHOUT CLAIM TO ANY PARTICULAR FONT, STYLE, SIZE, OR COLOR.

NO CLAIM IS MADE TO THE EXCLUSIVE RIGHT TO USE "PRESS", APART FROM THE MARK AS SHOWN.

FOR CHILDREN'S BOOKS (U.S. CLS. 2, 5, 22, 23, 29, 37, 38 AND 50).

FIRST USE 10-1-2010; IN COMMERCE 10-1-2010.

CLASS 16—(Continued).

3,999,455. STRAUSS, CINDI, HOWARD BEACH, NY. SN 85-041,310. PUB. 10-19-2010, FILED 5-18-2010.

SEEZ-IT

THE MARK CONSISTS OF STANDARD CHARACTERS WITHOUT CLAIM TO ANY PARTICULAR FONT, STYLE, SIZE, OR COLOR.

FOR PERSONAL ORGANIZERS (U.S. CLS. 2, 5, 22, 23, 29, 37, 38 AND 50).

FIRST USE 5-18-2010; IN COMMERCE 5-23-2011.

3,999,457. MITTELMAN, ELIZABETH, TEMECULA, CA. SN 85-042,007. PUB. 10-19-2010, FILED 5-18-2010.

SOUL MODELS

THE MARK CONSISTS OF STANDARD CHARACTERS WITHOUT CLAIM TO ANY PARTICULAR FONT, STYLE, SIZE, OR COLOR.

FOR A SERIES OF BOOKS, WRITTEN ARTICLES, HANDOUTS AND WORKSHEETS IN THE FIELD OF SELF-HELP (U.S. CLS. 2, 5, 22, 23, 29, 37, 38 AND 50).

FIRST USE 12-1-2010; IN COMMERCE 2-1-2011.

3,999,464. COMERCIALIZADORA CANTU, S.A. DE C.V., NUEVO LEON, MEXICO. SN 85-042,820. PUB. 10-19-2010, FILED 5-19-2010.

PROTECTO

THE MARK CONSISTS OF STANDARD CHARACTERS WITHOUT CLAIM TO ANY PARTICULAR FONT, STYLE, SIZE, OR COLOR.

FOR PLASTIC TRASH BAGS (U.S. CLS. 2, 5, 22, 23, 29, 37, 38 AND 50).

FIRST USE 4-0-1980; IN COMMERCE 3-0-2011.

CLASS 16—(Continued).

3,999,492. ALDI INC., BATAVIA, IL. SN 85-048,128. PUB. 10-19-2010, FILED 5-26-2010.

PEMBROOK

THE MARK CONSISTS OF STANDARD CHARACTERS WITHOUT CLAIM TO ANY PARTICULAR FONT, STYLE, SIZE, OR COLOR.

OWNER OF U.S. REG. NO. 2,891,760.

FOR GIFT WRAPPING PAPER (U.S. CLS. 2, 5, 22, 23, 29, 37, 38 AND 50).

FIRST USE 10-29-2010; IN COMMERCE 10-29-2010.

3,999,532. LEADING IN CONTEXT, LLC, RICHMOND, VA. SN 85-057,697. PUB. 11-9-2010, FILED 6-8-2010.

LEADING IN CONTEXT

THE MARK CONSISTS OF STANDARD CHARACTERS WITHOUT CLAIM TO ANY PARTICULAR FONT, STYLE, SIZE, OR COLOR.

FOR PRINTED EDUCATIONAL MATERIALS, IN THE NATURE OF CASE STUDIES, WRITTEN ARTICLES, DIAGRAMS AND HANDOUTS COMPRISING DISCUSSION GUIDES, ACTION GUIDES AND LEARNING GUIDES, IN THE FIELD OF BUSINESS ETHICS (U.S. CLS. 2, 5, 22, 23, 29, 37, 38 AND 50).

FIRST USE 3-29-2011; IN COMMERCE 3-29-2011.

3,999,556. THOMAS NELSON, INC., NASHVILLE, TN. SN 85-064,083. PUB. 3-15-2011, FILED 6-16-2010.

NELSON BOOKS

THE MARK CONSISTS OF STANDARD CHARACTERS WITHOUT CLAIM TO ANY PARTICULAR FONT, STYLE, SIZE, OR COLOR.

OWNER OF U.S. REG. NOS. 2,391,593, 3,645,327, AND OTHERS.

NO CLAIM IS MADE TO THE EXCLUSIVE RIGHT TO USE "BOOKS", APART FROM THE MARK AS SHOWN.

FOR SERIES OF FICTION BOOKS AND SERIES OF NONFICTION BOOKS IN THE FIELDS OF RELIGION, BIOGRAPHIES, HISTORY, SPORTS, QUILTING AND HUMOR; COOKBOOKS; INSPIRATIONAL BOOKS AND HOW-TO BOOKS IN THE FIELDS OF RELIGION, BIOGRAPHIES, HISTORY, SPORTS, QUILTING AND HUMOR (U.S. CLS. 2, 5, 22, 23, 29, 37, 38 AND 50).

FIRST USE 2-17-1999; IN COMMERCE 2-17-1999.

CLASS 16—(Continued).

3,999,700. SEED SAVERS EXCHANGE, INC., AKA SEED SAVERS EXCHANGE, DECORAH, IA. SN 85-110,453. PUB. 3-15-2011, FILED 8-18-2010.

Heritage Farm Companion

THE MARK CONSISTS OF STANDARD CHARACTERS WITHOUT CLAIM TO ANY PARTICULAR FONT, STYLE, SIZE, OR COLOR.

NO CLAIM IS MADE TO THE EXCLUSIVE RIGHT TO USE "FARM", APART FROM THE MARK AS SHOWN.

FOR GENERAL FEATURE MAGAZINE IN THE FIELD OF SEED SAVING, HEIRLOOM GARDENING, ORGANIC FOOD PRODUCTION, SUSTAINABLE AGRICULTURE, RARE LIVESTOCK BREEDS, GENETIC AND CULTURAL DIVERSITY (U.S. CLS. 2, 5, 22, 23, 29, 37, 38 AND 50).

FIRST USE 4-1-2011; IN COMMERCE 4-1-2011.

3,999,717. CONCORDIA PUBLISHING HOUSE, ST. LOUIS, MO. SN 85-117,311. PUB. 12-7-2010, FILED 8-27-2010.

THREE:13 CHRISTIAN GIFTS

THE MARK CONSISTS OF STANDARD CHARACTERS WITHOUT CLAIM TO ANY PARTICULAR FONT, STYLE, SIZE, OR COLOR.

NO CLAIM IS MADE TO THE EXCLUSIVE RIGHT TO USE "CHRISTIAN GIFTS", APART FROM THE MARK AS SHOWN.

FOR DEVOTIONAL BOOKS, PRAYER BOOKS, RELIGIOUS BOOKS, BOOK MARKS, STATIONERY NOTES CONTAINING ADHESIVE ON ONE SIDE FOR ATTACHMENT TO SURFACES, PENS, STICKERS, NOTE PADS, HOLDERS FOR NOTE PADS, HOLDERS FOR STATIONERY NOTES (U.S. CLS. 2, 5, 22, 23, 29, 37, 38 AND 50).

FIRST USE 1-7-2011; IN COMMERCE 1-7-2011.

3,999,728. EDIBLE COMMUNITIES, INC., MISSOULA, MT. SN 85-123,778. PUB. 12-7-2010, FILED 9-7-2010.

EDIBLE INDY

THE MARK CONSISTS OF STANDARD CHARACTERS WITHOUT CLAIM TO ANY PARTICULAR FONT, STYLE, SIZE, OR COLOR.

OWNER OF U.S. REG. NOS. 3,391,532, 3,474,533, AND OTHERS.

CLASS 16—(Continued).

NO CLAIM IS MADE TO THE EXCLUSIVE RIGHT TO USE "INDY", APART FROM THE MARK AS SHOWN.

FOR MAGAZINES FEATURING TOURISM, CULINARY AND AGRICULTURE INDUSTRIES AND PUBLICATIONS, NAMELY, MAGAZINES AND NEWSLETTERS DEALING WITH CONNECTING CONSUMERS WITH LOCAL GROWERS, FOOD RETAILERS, CHEFS AND FOOD ARTISANS (U.S. CLS. 2, 5, 22, 23, 29, 37, 38 AND 50).

FIRST USE 6-1-2011; IN COMMERCE 6-1-2011.

3,999,735. COLAYCO, JOSE LUIS JAVIER, NEW YORK, NY. SN 85-125,445. PUB. 2-22-2011, FILED 9-8-2010.

CLEAN CUBES

THE MARK CONSISTS OF STANDARD CHARACTERS WITHOUT CLAIM TO ANY PARTICULAR FONT, STYLE, SIZE, OR COLOR.

NO CLAIM IS MADE TO THE EXCLUSIVE RIGHT TO USE "CUBES", APART FROM THE MARK AS SHOWN.

FOR DISPOSABLE TRASH RECEPTACLE, NAMELY, PAPER BAG WITH INTERIOR PLASTIC LINER (U.S. CLS. 2, 5, 22, 23, 29, 37, 38 AND 50).

FIRST USE 12-31-2010; IN COMMERCE 5-27-2011.

3,999,766. FEATHERBROOKE INC, RANCHO SANTA FE, CA. SN 85-138,719. PUB. 3-8-2011, FILED 9-27-2010.



THE STIPPLING IS FOR SHADING PURPOSES ONLY. THE MARK CONSISTS OF AN ABSTRACT DESIGN WITH A PERSON JUMPING AND THE STYLIZED TEXT "FATHERS IN MOTION".

FOR PUBLICATIONS, NAMELY, BOOKS AND GUIDES IN THE FIELDS OF IMPROVING RELATIONSHIPS (U.S. CLS. 2, 5, 22, 23, 29, 37, 38 AND 50).

FIRST USE 10-1-2010; IN COMMERCE 10-1-2010.

CLASS 16—(Continued).

3,999,816. SEALY TECHNOLOGY LLC, TRINITY, NC. SN 85-153,490. PUB. 3-29-2011, FILED 10-15-2010.

SEALY PILLOWFRESH

THE MARK CONSISTS OF STANDARD CHARACTERS WITHOUT CLAIM TO ANY PARTICULAR FONT, STYLE, SIZE, OR COLOR.

OWNER OF U.S. REG. NOS. 677,335, 3,299,334, AND OTHERS.

FOR DISPOSABLE PAPER SHEETS FOR PERSONAL HYGIENIC USE IN THE NATURE OF DISPOSABLE HEADREST COVERS NOT FOR MEDICAL USE (U.S. CLS. 2, 5, 22, 23, 29, 37, 38 AND 50).

FIRST USE 1-15-2011; IN COMMERCE 1-15-2011.

CLASS 17—(Continued).

3,999,069. IVEX PROTECTIVE PACKAGING, INC., BRIDGEVIEW, IL. SN 77-931,870. PUB. 6-8-2010, FILED 2-9-2010.

PROFOAM

THE MARK CONSISTS OF STANDARD CHARACTERS WITHOUT CLAIM TO ANY PARTICULAR FONT, STYLE, SIZE, OR COLOR.

FOR LOW-DENSITY POLYURETHANE PACKAGING FOAM NOT FOR USE WITH BUILDING MATERIALS (U.S. CLS. 1, 5, 12, 13, 35 AND 50).

FIRST USE 7-20-2009; IN COMMERCE 10-15-2009.

3,999,703. ADIE, ROB, CAMBRIDGE, CANADA. SN 85-110,893. PUB. 2-8-2011, FILED 8-19-2010.

PERMOBOND

THE MARK CONSISTS OF STANDARD CHARACTERS WITHOUT CLAIM TO ANY PARTICULAR FONT, STYLE, SIZE, OR COLOR.

FOR RUBBER; PROTECTIVE RUBBER LINING FOR USE IN STEEL TANKS AND PIPES (U.S. CLS. 1, 5, 12, 13, 35 AND 50).

FIRST USE 2-12-2011; IN COMMERCE 2-12-2011.

CLASS 17—RUBBER GOODS

3,998,603. TRANSCO INC., CHICAGO, IL. SN 77-664,938. PUB. 6-2-2009, FILED 2-6-2009.

HEATAINER

THE MARK CONSISTS OF STANDARD CHARACTERS WITHOUT CLAIM TO ANY PARTICULAR FONT, STYLE, SIZE, OR COLOR.

FOR NON-METAL BLANKET INSULATION USED TO ENCASE VESSELS, GENERATORS, TURBINES, ENGINES, PUMPS, REACTORS, TOP HEADS, BOTTOM HEADS, FANS, BLOWERS, FLANGES, VALVES, EXHAUSTS, COMPRESSORS, EXCHANGERS, HEADERS, TANKS, DRYERS, HOPPERS, PIPES, T-JOINTS, AND ELBOWS, IN POWER GENERATING STATIONS, STEAM AND GAS TURBINES, NUCLEAR FACILITIES, AND HEAT RETENTION APPLICATIONS (U.S. CLS. 1, 5, 12, 13, 35 AND 50).

FIRST USE 11-17-1987; IN COMMERCE 11-17-1987.

3,999,793. WINPAK FILMS INC., SENOIA, GA. SN 85-146,037. PUB. 3-15-2011, FILED 10-6-2010.

VERTIPAK

THE MARK CONSISTS OF STANDARD CHARACTERS WITHOUT CLAIM TO ANY PARTICULAR FONT, STYLE, SIZE, OR COLOR.

FOR PLASTIC FILMS USED AS PACKAGING FOR FOOD FOR USE ON VERTICAL FORM, FILL AND SEAL PACKAGING MACHINES (U.S. CLS. 1, 5, 12, 13, 35 AND 50).

FIRST USE 10-0-2010; IN COMMERCE 10-0-2010.

CLASS 17—(Continued).

3,999,801. FIRESTONE BUILDING PRODUCTS COMPANY, LLC, INDIANAPOLIS, IN. SN 85-148,724. PUB. 3-8-2011, FILED 10-8-2010.

V-FORCE

THE MARK CONSISTS OF STANDARD CHARACTERS WITHOUT CLAIM TO ANY PARTICULAR FONT, STYLE, SIZE, OR COLOR.

FOR VAPOR BARRIERS FOR USE IN CONSTRUCTION; VAPOR BARRIER SHEETS; VAPOR BARRIER SHEETS COMPOSED OF MODIFIED BITUMEN AND POLYETHYLENE (U.S. CLS. 1, 5, 12, 13, 35 AND 50).

FIRST USE 1-23-2011; IN COMMERCE 1-23-2011.

CLASS 18—LEATHER GOODS

3,998,400. TANAKA UNIVERSAL CO., LTD., OSAKA, JAPAN. SN 77-225,847. PUB. 3-4-2008, FILED 7-10-2007.



OWNER OF U.S. REG. NO. 2,757,240.
THE COLOR(S) BLACK, RED, GREEN AND WHITE IS/ARE CLAIMED AS A FEATURE OF THE MARK.

THE MARK CONSISTS OF A VERTICAL RED ANGLED BAND. TO THE RIGHT OF THE BAND ARE THREE GREEN HORIZONTAL BANDS STACKED VERTICALLY. TO THE RIGHT OF THE THREE BANDS IS A VERTICAL GREEN ANGLED BAND. ABOVE THE BANDS IS BLACK LETTERING. THE BACKGROUND IS WHITE.

FOR HANDBAG FRAMES, PURSE FRAMES, INDUSTRIAL PACKAGING CONTAINERS OF LEATHER, FOLDING BRIEFCASES, SHOULDER BAGS, GLADSTONE BAGS, BRIEFCASES, SUITCASE, CARRY-ON BAGS, TRUNKS, HANDBAGS, BOSTON BAGS, SCHOOL CHILDREN'S BACKPACKS, BACKPACKS, SHOPPING BAGS WITH WHEELS ATTACHED, PURSES, KEY CASES, WALLETS, UMBRELLAS, TELESCOPIC UMBRELLAS, UMBRELLA COVERS, UMBRELLA HANDLES, LEATHER STRAPS, FUR (U.S. CLS. 1, 2, 3, 22 AND 41).

FIRST USE 4-20-2011; IN COMMERCE 4-20-2011.

CLASS 18—(Continued).

3,998,428. FORTUNY INC., NEW YORK, NY. SN 77-288,991. PUB. 3-11-2008, FILED 9-26-2007.

FORTUNY

THE MARK CONSISTS OF STANDARD CHARACTERS WITHOUT CLAIM TO ANY PARTICULAR FONT, STYLE, SIZE, OR COLOR.

OWNER OF U.S. REG. NO. 2,825,065.

FOR UMBRELLAS (U.S. CLS. 1, 2, 3, 22 AND 41).

FIRST USE 10-31-2009; IN COMMERCE 10-31-2009.

3,998,438. MARVEL CHARACTERS, INC., MANHATTAN BEACH, CA. SN 77-307,179. PUB. 3-23-2010, FILED 10-18-2007.

SUPER HERO SQUAD

THE MARK CONSISTS OF STANDARD CHARACTERS WITHOUT CLAIM TO ANY PARTICULAR FONT, STYLE, SIZE, OR COLOR.

OWNER OF U.S. REG. NOS. 1,073,580, 3,045,687, AND OTHERS.

FOR WALLETS; SCHOOL BAGS; BACKPACKS; UMBRELLAS (U.S. CLS. 1, 2, 3, 22 AND 41).

FIRST USE 1-31-2009; IN COMMERCE 1-31-2009.

3,998,475. MICHAEL KORS, L.L.C., NEW YORK, NY. SN 77-421,470. PUB. 9-16-2008, FILED 3-13-2008.

AMAGANSETT

THE MARK CONSISTS OF STANDARD CHARACTERS WITHOUT CLAIM TO ANY PARTICULAR FONT, STYLE, SIZE, OR COLOR.

FOR HANDBAGS, TOTE BAGS, PURSES (U.S. CLS. 1, 2, 3, 22 AND 41).

FIRST USE 0-0-2009; IN COMMERCE 0-0-2009.

CLASS 18—(Continued).

3,998,476. MICHAEL KORS, L.L.C., NEW YORK, NY. SN 77-421,475. PUB. 9-16-2008, FILED 3-13-2008.

GREENWICH

THE MARK CONSISTS OF STANDARD CHARACTERS WITHOUT CLAIM TO ANY PARTICULAR FONT, STYLE, SIZE, OR COLOR.

FOR HANDBAGS, TOTE BAGS, PURSES, WALLETS, CREDIT CARD CASES, WRISTLET BAGS (U.S. CLS. 1, 2, 3, 22 AND 41).

FIRST USE 1-1-2011; IN COMMERCE 1-1-2011.

3,998,480. SERGEANT'S PET CARE PRODUCTS, INC., OMAHA, NE. SN 77-431,905. PUB. 8-5-2008, FILED 3-26-2008.

TUG N' CHEW

THE MARK CONSISTS OF STANDARD CHARACTERS WITHOUT CLAIM TO ANY PARTICULAR FONT, STYLE, SIZE, OR COLOR.

OWNER OF U.S. REG. NO. 2,565,582. FOR RAWHIDE CHEWS FOR DOGS (U.S. CLS. 1, 2, 3, 22 AND 41).

FIRST USE 1-0-2011; IN COMMERCE 1-0-2011.

3,998,508. JOEY WEAR LLC, SAN LEANDRO, CA. SN 77-530,336. PUB. 6-2-2009, FILED 7-24-2008.



NO CLAIM IS MADE TO THE EXCLUSIVE RIGHT TO USE "WEAR", APART FROM THE MARK AS SHOWN. THE STIPPLING IS FOR SHADING PURPOSES ONLY.

CLASS 18—(Continued).

THE MARK CONSISTS OF THE OUTLINED STYLIZED TEXT "JOEY" WRITTEN IN THICK LETTERS WITH A HOLLOW CENTER. THE WORD "WEAR" IS WRITTEN IN TAHOMA STYLE FONT, UNDERNEATH THE WORD "JOEY". ON TOP OF THE WORD "JOEY" IS AN ANIMATED PICTURE OF A KANGAROO WITH A JOEY INSIDE HER POUCH, FACING HER MOTHER KANGAROO.

FOR BABY CARRIERS WORN ON THE BODY (U.S. CLS. 1, 2, 3, 22 AND 41).

FIRST USE 3-1-2010; IN COMMERCE 2-15-2011.

3,998,546. NINTENDO OF AMERICA INC., REDMOND, WA. SN 77-583,746. PUB. 9-28-2010, FILED 10-2-2008.

NINTENDODSi

THE MARK CONSISTS OF STANDARD CHARACTERS WITHOUT CLAIM TO ANY PARTICULAR FONT, STYLE, SIZE, OR COLOR.

PRIORITY CLAIMED UNDER SEC. 44(D) ON JAPAN APPLICATION NO. 2008-079337, FILED 9-29-2008, REG. NO. 5323213, DATED 5-14-2010, EXPIRES 5-14-2020.

OWNER OF U.S. REG. NOS. 1,213,822, 1,628,966, AND OTHERS.

FOR (BASED ON USE IN COMMERCE) (BASED ON 44(E)) CARRYING CASES; BACKPACKS; (BASED ON 44(E)) ALL PURPOSE SPORTS BAGS AND LUGGAGE; ATHLETIC BAGS, BEACH BAGS, BOOK BAGS, CARRY-ON BAGS, HANDBAGS, SCHOOL BAGS, SHOULDER BAGS, TOTE BAGS, TRAVEL BAGS (U.S. CLS. 1, 2, 3, 22 AND 41).

FIRST USE 4-5-2009; IN COMMERCE 4-5-2009.

3,998,601. HIP SHIFT CORP., SAN CLEMENTE, CA. SN 77-663,069. PUB. 6-22-2010, FILED 2-4-2009.



THE MARK CONSISTS OF THE STYLIZED LETTERS "HS".

FOR BELT BAGS AND HIP BAGS; PURSES (U.S. CLS. 1, 2, 3, 22 AND 41).

FIRST USE 1-1-2010; IN COMMERCE 3-1-2010.

CLASS 18—(Continued).

3,998,723. WARNER BROS. ENTERTAINMENT INC., BURBANK, CA. SN 77-792,604. PUB. 6-15-2010, FILED 7-29-2009.

GRYFFINDOR

THE MARK CONSISTS OF STANDARD CHARACTERS WITHOUT CLAIM TO ANY PARTICULAR FONT, STYLE, SIZE, OR COLOR.

OWNER OF U.S. REG. NOS. 2,480,839, 2,516,387, AND 2,607,934.

FOR ATHLETIC BAGS, BACKPACKS, BEACH BAGS, BOOK BAGS, DUFFEL BAGS, GYM BAGS, CANVAS SHOPPING BAGS, TEXTILE SHOPPING BAGS, UMBRELLAS (U.S. CLS. 1, 2, 3, 22 AND 41).

FIRST USE 6-18-2010; IN COMMERCE 6-18-2010.

CLASS 18—(Continued).

3,998,810. POZZOLINI, ALFREDO S., DBA M1-K9 COLLARS, HUNTINGTON BEACH, CA. SN 77-839,659. PUB. 3-9-2010, FILED 10-1-2009.



THE MARK CONSISTS OF MILITARY STENCILED LETTERS READING "M1-K9" AND DOG HEAD SILHOUETTE SHOWING AN EXTRA WIDE COLLAR, OR BAND AROUND ITS NECK. THE DOG HEAD IS DESIGNED WITH STRAIGHT LINES AND RIGID ANGLES. THIS IS TO GIVE THE EFFECT THAT THE IMAGE HAS BEEN CUT OUT WITH A STRAIGHT EDGE AND USED AS A STENCIL ITSELF. THE ANGLES USED IN THIS DESIGN ALSO IMITATE THE ANGLES FOUND ON AN "M1-A1" ABRAMS TANK.

FOR DOG COLLARS (U.S. CLS. 1, 2, 3, 22 AND 41).
FIRST USE 10-1-2009; IN COMMERCE 3-1-2010.

3,998,791. HORSEWARE PRODUCTS LTD., DUNDALK, COUNTY LOUTH, IRELAND. SN 77-834,884. PUB. 2-16-2010, FILED 9-25-2009.

TRIPLE CROWN

THE MARK CONSISTS OF STANDARD CHARACTERS WITHOUT CLAIM TO ANY PARTICULAR FONT, STYLE, SIZE, OR COLOR.

FOR EQUIPMENT FOR HORSES, NAMELY, HARNESS AND SADDLES, HEAD COLLARS, HORSE BLANKETS AND COVERS, SADDLE COVERS, SADDLE PADS, NUMNAHS, SURCINGLES, HORSE TRAVELING BOOTS AND HORSE LEG PROTECTIVE BOOTS (U.S. CLS. 1, 2, 3, 22 AND 41).

FIRST USE 7-1-2010; IN COMMERCE 7-1-2010.

3,998,859. BOUZIANIS, GREGORY D., CHRISTIANSTED, US VIRGIN ISLANDS. AND BOUZIANIS, ASHLEY E., FORMERLY SMITH, ASHLEY E., CHRISTIANSTED, US VIRGIN ISLANDS. SN 77-856,796. PUB. 3-30-2010, FILED 10-25-2009.



THE COLOR(S) PURPLE AND GREEN IS/ARE CLAIMED AS A FEATURE OF THE MARK.

THE MARK CONSISTS OF THE WORD "YOGIMATE" WITH A STYLED "Y", FORMED BY THE SILHOUETTE OF A WOMAN STANDING IN A YOGA POSE IN PURPLE, ABOVE A GREEN CURVED LINE THAT RESEMBLES A ROLLING YOGA MAT, AND THE WORDING "MAKE WORKOUTS EASIER" IN GREEN, ALL ON A TRANSPARENT BACKGROUND.

FOR GENERAL PURPOSE BAGS FOR CARRYING YOGA EQUIPMENT (U.S. CLS. 1, 2, 3, 22 AND 41).

FIRST USE 2-28-2011; IN COMMERCE 5-17-2011.

CLASS 18—(Continued).

3,998,906. GENAL STRAP, INC., LONG ISLAND CITY, NY.
SN 77-869,141. PUB. 10-5-2010, FILED 11-10-2009.

ITS ALL IN THE BAG

THE MARK CONSISTS OF STANDARD CHARACTERS WITHOUT CLAIM TO ANY PARTICULAR FONT, STYLE, SIZE, OR COLOR.

FOR HANDBAGS; TOTE BAGS (U.S. CLS. 1, 2, 3, 22 AND 41).

FIRST USE 10-8-2010; IN COMMERCE 10-8-2010.

3,998,933. JACKSON CORPORATION, NEW YORK, NY. SN 77-880,067. PUB. 3-2-2010, FILED 11-24-2009.

ZOE BLU

THE MARK CONSISTS OF STANDARD CHARACTERS WITHOUT CLAIM TO ANY PARTICULAR FONT, STYLE, SIZE, OR COLOR.

THE NAME "ZOE" DOES NOT IDENTIFY A LIVING INDIVIDUAL.

FOR POCKET BOOKS, HANDBAGS, WALLETS, PURSES, TOTE BAGS (U.S. CLS. 1, 2, 3, 22 AND 41).

FIRST USE 6-0-2008; IN COMMERCE 6-0-2008.

3,999,037. BIJOUX TERNER, LLC, MIAMI, FL. SN 77-917,913. PUB. 6-15-2010, FILED 1-22-2010.

DEJA VOUX

THE MARK CONSISTS OF STANDARD CHARACTERS WITHOUT CLAIM TO ANY PARTICULAR FONT, STYLE, SIZE, OR COLOR.

THE ENGLISH TRANSLATION OF THE WORD "DEJA" IN THE MARK IS "ALREADY". THE WORDING "VOUX" HAS NO MEANING IN A FOREIGN LANGUAGE.

FOR WALLETS, BUSINESS CARD CASES (U.S. CLS. 1, 2, 3, 22 AND 41).

FIRST USE 6-22-2010; IN COMMERCE 6-22-2010.

CLASS 18—(Continued).

3,999,038. BIJOUX TERNER, LLC, MIAMI, FL. SN 77-917,920. PUB. 6-15-2010, FILED 1-22-2010.

VOUX

THE MARK CONSISTS OF STANDARD CHARACTERS WITHOUT CLAIM TO ANY PARTICULAR FONT, STYLE, SIZE, OR COLOR.

THE WORDING "VOUX" HAS NO MEANING IN A FOREIGN LANGUAGE.

FOR HANDBAGS, PURSES, CARRYALLS, WALLETS (U.S. CLS. 1, 2, 3, 22 AND 41).

FIRST USE 8-30-2010; IN COMMERCE 8-30-2010.

3,999,100. COMBAT MEDICAL SYSTEMS, LLC, FAYETTEVILLE, NC. SN 77-946,128. PUB. 6-22-2010, FILED 2-26-2010.

CSI BAG

THE MARK CONSISTS OF STANDARD CHARACTERS WITHOUT CLAIM TO ANY PARTICULAR FONT, STYLE, SIZE, OR COLOR.

NO CLAIM IS MADE TO THE EXCLUSIVE RIGHT TO USE "BAG", APART FROM THE MARK AS SHOWN.

FOR CARRYING BAGS FOR TRANSPORTING THE PERSONAL PROPERTY OF MILITARY MEMBERS WOUNDED IN COMBAT (U.S. CLS. 1, 2, 3, 22 AND 41).

FIRST USE 10-29-2010; IN COMMERCE 10-29-2010.

3,999,132. MOSCOT MANAGEMENT CORP., NEW YORK, NY. SN 77-958,790. PUB. 9-7-2010, FILED 3-15-2010.

MOSCOT

OWNER OF U.S. REG. NOS. 2,936,703, 3,380,737, AND OTHERS.

THE NAME(S), PORTRAIT(S), AND/OR SIGNATURE(S) SHOWN IN THE MARK DOES NOT IDENTIFY A PARTICULAR LIVING INDIVIDUAL.

SEC. 2(F).

FOR HANDBAGS (U.S. CLS. 1, 2, 3, 22 AND 41).

FIRST USE 7-31-2008; IN COMMERCE 7-31-2008.

CLASS 18—(Continued).

3,999,174. DAMAN, ERIC G., NEW YORK, NY. SN 77-982,015.
PUB. 2-2-2010, FILED 9-2-2009.

ERIC DAMAN

THE MARK CONSISTS OF STANDARD CHARACTERS WITHOUT CLAIM TO ANY PARTICULAR FONT, STYLE, SIZE, OR COLOR.

THE NAME(S), PORTRAIT(S), AND/OR SIGNATURE(S) SHOWN IN THE MARK IDENTIFIES "ERIC DAMAN", WHOSE CONSENT(S) TO REGISTER IS MADE OF RECORD.

FOR ANIMAL SKINS AND HIDES; ATTACHE CASES; BRIEFCASE-TYPE PORTFOLIOS; BRIEFCASES; CHANGE PURSES; COSMETIC CARRYING CASES SOLD EMPTY; CREDIT CARD CASES AND HOLDERS; GARMENT BAGS FOR TRAVEL; HANDBAGS; HARNESSES; HAT BOXES OF LEATHER; KEYCASES; LUGGAGE AND TRUNKS; PURSES; SADDLERY; SHOULDER BAGS; SPORTS BAGS; TOTE BAGS; TRAVELLING BAGS; UMBRELLAS AND PARASOLS; WALKING STICKS; WHIPS (U.S. CLS. 1, 2, 3, 22 AND 41).
FIRST USE 10-1-2010; IN COMMERCE 10-1-2010.

3,999,278. ELLIOTT, JOHN, ROSEVILLE, OH. SN 85-017,964.
PUB. 3-29-2011, FILED 4-20-2010.

SADDLE PAL

THE MARK CONSISTS OF STANDARD CHARACTERS WITHOUT CLAIM TO ANY PARTICULAR FONT, STYLE, SIZE, OR COLOR.

NO CLAIM IS MADE TO THE EXCLUSIVE RIGHT TO USE "SADDLE", APART FROM THE MARK AS SHOWN.

FOR METAL SADDLE HOLDER (U.S. CLS. 1, 2, 3, 22 AND 41).

FIRST USE 5-1-2010; IN COMMERCE 5-1-2010.

3,999,647. DREAMSACKS, INC., ASHLAND, OR. SN 85-091,590. PUB. 3-8-2011, FILED 7-23-2010.

YALA

THE MARK CONSISTS OF STANDARD CHARACTERS WITHOUT CLAIM TO ANY PARTICULAR FONT, STYLE, SIZE, OR COLOR.

FOR ALL PURPOSE CARRYING BAGS, TOTE BAGS, SHOULDER BAGS, JEWELRY POUCHES SOLD EMPTY (U.S. CLS. 1, 2, 3, 22 AND 41).

FIRST USE 1-3-2011; IN COMMERCE 1-3-2011.

CLASS 18—(Continued).

3,999,681. SANDLER, SHELLEY, DBA DOGGINI, NEW YORK, NY. SN 85-104,919. PUB. 1-11-2011, FILED 8-11-2010.

DOGGINI

THE MARK CONSISTS OF STANDARD CHARACTERS WITHOUT CLAIM TO ANY PARTICULAR FONT, STYLE, SIZE, OR COLOR.

FOR DOG APPAREL (U.S. CLS. 1, 2, 3, 22 AND 41).
FIRST USE 5-1-2011; IN COMMERCE 5-12-2011.

3,999,804. DIG-GIT BEACH GEAR INC., NORTH PROVIDENCE, RI. SN 85-149,157. PUB. 3-15-2011, FILED 10-10-2010.

dig-git

THE MARK CONSISTS OF STANDARD CHARACTERS WITHOUT CLAIM TO ANY PARTICULAR FONT, STYLE, SIZE, OR COLOR.

FOR BEACH UMBRELLAS; UMBRELLA BASES (U.S. CLS. 1, 2, 3, 22 AND 41).

FIRST USE 3-1-2011; IN COMMERCE 3-1-2011.

3,999,825. DONG, DAYE, BAYSIDE, NY. SN 85-158,509. PUB. 3-22-2011, FILED 10-21-2010.

ABE

THE MARK CONSISTS OF THE LETTERS "ABE" IN STYLIZED FORM.

FOR ALL PURPOSE SPORT BAGS; ALL-PURPOSE CARRYING BAGS; BACKPACKS, BOOK BAGS, SPORTS BAGS, BUM BAGS, WALLETS AND HANDBAGS; EVENING HANDBAGS; FASHION HANDBAGS; GENTLEMEN'S HANDBAGS; HANDBAGS; HANDBAGS FOR LADIES; HANDBAGS FOR MEN; HANDBAGS, PURSES AND WALLETS; LEATHER HANDBAGS; LUGGAGE; LUGGAGE AND TRUNKS (U.S. CLS. 1, 2, 3, 22 AND 41).
FIRST USE 5-18-2011; IN COMMERCE 5-18-2011.

CLASS 19—NON-METALLIC BUILDING MATERIALS

CLASS 19—(Continued).

3,998,420. MEGAMOLD TECHNOLOGY COMPANY, LLC, BOSTON, MA. SN 77-282,595. PUB. 3-11-2008, FILED 9-18-2007.

MEGAMOLD

THE MARK CONSISTS OF STANDARD CHARACTERS WITHOUT CLAIM TO ANY PARTICULAR FONT, STYLE, SIZE, OR COLOR.

FOR A STAY-IN-PLACE ASSEMBLY OF REINFORCED POLYMER PANELS THAT IS USED TO SHAPE, CAST AND PERMANENTLY ENCASE MONOLITHIC CONCRETE STRUCTURES UNDERWATER (U.S. CLS. 1, 12, 33 AND 50).

FIRST USE 10-0-2009; IN COMMERCE 10-0-2009.

CLASS 19—(Continued).

3,998,888. CERTAINTEED GYPSUM, INC., TAMPA, FL. SN 77-863,081. PUB. 3-30-2010, FILED 11-2-2009.

AIRRENEW

THE MARK CONSISTS OF STANDARD CHARACTERS WITHOUT CLAIM TO ANY PARTICULAR FONT, STYLE, SIZE, OR COLOR.

FOR PAPER-FACED GYPSUM BOARD (U.S. CLS. 1, 12, 33 AND 50).

FIRST USE 10-0-2010; IN COMMERCE 1-0-2011.

3,998,917. ISP MINERALS INVESTMENTS LLC, WAYNE, NJ. SN 77-873,616. PUB. 4-27-2010, FILED 11-16-2009.

SOLARSHIELD

THE MARK CONSISTS OF STANDARD CHARACTERS WITHOUT CLAIM TO ANY PARTICULAR FONT, STYLE, SIZE, OR COLOR.

FOR MINERAL GRANULES FOR MAKING BUILDING PRODUCTS (U.S. CLS. 1, 12, 33 AND 50).

FIRST USE 12-31-2006; IN COMMERCE 12-31-2006.

3,998,464. SWIFF-TRAIN COMPANY, LLC, CORPUS CHRISTI, TX. SN 77-401,381. PUB. 5-12-2009, FILED 2-20-2008.

TUFF SHIELD

THE MARK CONSISTS OF STANDARD CHARACTERS WITHOUT CLAIM TO ANY PARTICULAR FONT, STYLE, SIZE, OR COLOR.

FOR VINYL TILE HAVING A POLYURETHANE COATING INCLUDING ALUMINUM OXIDE TO IMPROVE DURABILITY FOR RESIDENTIAL USE AND NOT FOR USE IN GARAGE OR INDUSTRIAL SETTINGS; GRANITE TILE HAVING A POLYURETHANE COATING INCLUDING ALUMINUM OXIDE TO IMPROVE DURABILITY FOR RESIDENTIAL USE AND NOT FOR USE IN GARAGE OR INDUSTRIAL SETTINGS; CERAMIC TILE HAVING A POLYURETHANE COATING INCLUDING ALUMINUM OXIDE TO IMPROVE DURABILITY FOR RESIDENTIAL USE AND NOT FOR USE IN GARAGE OR INDUSTRIAL SETTINGS; WOOD FLOORING AND LAMINATE FLOORING HAVING A POLYURETHANE COATING INCLUDING ALUMINUM OXIDE TO IMPROVE DURABILITY FOR RESIDENTIAL USE AND NOT FOR USE IN GARAGE OR INDUSTRIAL SETTINGS (U.S. CLS. 1, 12, 33 AND 50).

FIRST USE 8-12-2010; IN COMMERCE 5-26-2011.

3,999,191. DELAWARE QUARRIES, INC., NEW HOPE, PA. SN 78-436,041. PUB. 10-23-2007, FILED 6-16-2004.

STONESCAPE

THE MARK CONSISTS OF STANDARD CHARACTERS WITHOUT CLAIM TO ANY PARTICULAR FONT, STYLE, SIZE, OR COLOR.

OWNER OF U.S. REG. NOS. 2,670,268 AND 2,696,621. FOR STONE, GRAVEL OR SIMILAR PRODUCTS, NAMELY, BOULDERS, STONE VENEER, AND CRUSHED STONE FOR USE IN LANDSCAPING, BUILDING CONSTRUCTION, AND PAVING (U.S. CLS. 1, 12, 33 AND 50).

FIRST USE 7-9-2010; IN COMMERCE 7-9-2010.

CLASS 19—(Continued).

3,999,289. SAINT-GOBAIN PERFORMANCE PLASTICS CORPORATION, AURORA, OH. SN 85-020,591. PUB. 9-28-2010, FILED 4-22-2010.

EZ CLAD

THE MARK CONSISTS OF STANDARD CHARACTERS WITHOUT CLAIM TO ANY PARTICULAR FONT, STYLE, SIZE, OR COLOR.

FOR BONDING TAPE FOR ATTACHING REINFORCING STIFFENER BARS TO ARCHITECTURAL BUILDING PANELS (U.S. CLS. 1, 12, 33 AND 50).

FIRST USE 6-0-2010; IN COMMERCE 6-0-2010.

3,999,394. CERTAINTTEED CORPORATION, VALLEY FORGE, PA. SN 85-033,043. PUB. 10-5-2010, FILED 5-7-2010.

CERTAWRAP

THE MARK CONSISTS OF STANDARD CHARACTERS WITHOUT CLAIM TO ANY PARTICULAR FONT, STYLE, SIZE, OR COLOR.

OWNER OF U.S. REG. NOS. 103,781, 2,961,028, AND 3,442,126.

FOR TEXTILE FABRICS FOR USE IN CONSTRUCTION AND AS A HOUSE WRAP (U.S. CLS. 1, 12, 33 AND 50).

FIRST USE 7-0-2010; IN COMMERCE 7-0-2010.

3,999,502. ADEPT ENGRAVING LLC, CHIPPEWA FALLS, WI. SN 85-051,790. PUB. 10-26-2010, FILED 6-1-2010.

THAT'S MY BRICK!

THE MARK CONSISTS OF STANDARD CHARACTERS WITHOUT CLAIM TO ANY PARTICULAR FONT, STYLE, SIZE, OR COLOR.

OWNER OF U.S. REG. NO. 3,049,431.

NO CLAIM IS MADE TO THE EXCLUSIVE RIGHT TO USE "BRICK", APART FROM THE MARK AS SHOWN.

FOR PERSONALIZED BRICKS, PAVERS, CERAMIC TILES AND PAVING STONE, USED FOR FUNDRAISER DONOR RECOGNITION FOR THE CONSTRUCTION OF PATHWAYS, WALKWAYS, SIDEWALKS, ROADS, WALLS, BUILDINGS, STADIUMS, MEMORIALS AND OTHER BUILDINGS, STRUCTURES, OR OBJECTS THAT UTILIZE THOSE MATERIALS (U.S. CLS. 1, 12, 33 AND 50).

FIRST USE 2-11-2011; IN COMMERCE 2-11-2011.

CLASS 19—(Continued).

3,999,615. CERTAINTTEED CORPORATION, VALLEY FORGE, PA. SN 85-079,652. PUB. 10-12-2010, FILED 7-7-2010.

HIGHLAND SLATE

THE MARK CONSISTS OF STANDARD CHARACTERS WITHOUT CLAIM TO ANY PARTICULAR FONT, STYLE, SIZE, OR COLOR.

NO CLAIM IS MADE TO THE EXCLUSIVE RIGHT TO USE "SLATE", APART FROM THE MARK AS SHOWN.

FOR ASPHALT ROOFING SHINGLES (U.S. CLS. 1, 12, 33 AND 50).

FIRST USE 9-0-2010; IN COMMERCE 9-0-2010.

CLASS 20—FURNITURE AND ARTICLES NOT OTHERWISE CLASSIFIED

3,998,367. DISNEY ENTERPRISES, INC., BURBANK, CA. SN 77-098,480. PUB. 2-26-2008, FILED 2-2-2007.

WALT DISNEY

THE MARK CONSISTS OF STANDARD CHARACTERS WITHOUT CLAIM TO ANY PARTICULAR FONT, STYLE, SIZE, OR COLOR.

OWNER OF U.S. REG. NOS. 1,141,312, 3,268,689, AND OTHERS.

THE NAME "WALT DISNEY" DOES NOT IDENTIFY A LIVING INDIVIDUAL.

FOR PICTURE FRAMES; PILLOWS; WIND CHIMES (U.S. CLS. 2, 13, 22, 25, 32 AND 50).

FIRST USE 10-22-2009; IN COMMERCE 10-22-2009.

3,998,390. BERKSHIRE BLANKET INC., WARE, MA. SN 77-192,268. PUB. 5-6-2008, FILED 5-29-2007.

BERKSHIRE LIFE

THE MARK CONSISTS OF STANDARD CHARACTERS WITHOUT CLAIM TO ANY PARTICULAR FONT, STYLE, SIZE, OR COLOR.

OWNER OF U.S. REG. NOS. 2,261,788, 3,240,570, AND OTHERS.

FOR DECORATIVE PILLOWS, BODY PILLOWS, FLOOR PILLOWS, PILLOWS FOR KIDS (U.S. CLS. 2, 13, 22, 25, 32 AND 50).

FIRST USE 3-18-2011; IN COMMERCE 3-18-2011.

CLASS 20—(Continued).

3,998,535. DREAMWELL, LTD., LAS VEGAS, NV. SN 77-574,089. PUB. 2-17-2009, FILED 9-19-2008.

CONTOUR FIT

THE MARK CONSISTS OF STANDARD CHARACTERS WITHOUT CLAIM TO ANY PARTICULAR FONT, STYLE, SIZE, OR COLOR.

FOR MATTRESSES AND BOX SPRINGS (U.S. CLS. 2, 13, 22, 25, 32 AND 50).

FIRST USE 4-30-2011; IN COMMERCE 4-30-2011.

3,998,552. Q PRODUCTS LLC, CLEARWATER, FL. SN 77-587,671. PUB. 10-5-2010, FILED 10-7-2008.

Qdesk

THE MARK CONSISTS OF STANDARD CHARACTERS WITHOUT CLAIM TO ANY PARTICULAR FONT, STYLE, SIZE, OR COLOR.

FOR DESKS (U.S. CLS. 2, 13, 22, 25, 32 AND 50).

FIRST USE 5-1-2008; IN COMMERCE 7-10-2008.

3,998,599. GARDEN MAGIC, LLLP, LONGMONT, CO. SN 77-652,958. PUB. 5-19-2009, FILED 1-20-2009.

BLOSSOM UP

THE MARK CONSISTS OF STANDARD CHARACTERS WITHOUT CLAIM TO ANY PARTICULAR FONT, STYLE, SIZE, OR COLOR.

FOR GARDENING KIT COMPRISING A PLASTIC GARDEN STAKE WITH METAL SUPPORT RODS, PLASTIC SLIDE HOOKS THAT ATTACH TO THE SUPPORT RODS, PLASTIC ZIP TIES, PLASTIC SLIDE BARS FOR LATTICE EFFECT AND A PLASTIC END CAP TO COVER SUPPORT ROD ENDS FOR STORAGE PURPOSES (U.S. CLS. 2, 13, 22, 25, 32 AND 50).

FIRST USE 6-1-2011; IN COMMERCE 6-1-2011.

CLASS 20—(Continued).

3,998,650. CLOSED LOOP ENVIRONMENTAL ALLIANCE NETWORK INC., BOLTON, ONTARIO, CANADA. SN 77-721,050. PUB. 9-8-2009, FILED 4-23-2009.

PATRIOT HANGER

THE MARK CONSISTS OF STANDARD CHARACTERS WITHOUT CLAIM TO ANY PARTICULAR FONT, STYLE, SIZE, OR COLOR.

NO CLAIM IS MADE TO THE EXCLUSIVE RIGHT TO USE "HANGER", APART FROM THE MARK AS SHOWN.

FOR CLOTHES HANGERS (U.S. CLS. 2, 13, 22, 25, 32 AND 50).

FIRST USE 3-7-2011; IN COMMERCE 3-7-2011.

3,998,724. WARNER BROS. ENTERTAINMENT INC., BURBANK, CA. SN 77-793,742. PUB. 6-15-2010, FILED 7-30-2009.

GRYFFINDOR

THE MARK CONSISTS OF STANDARD CHARACTERS WITHOUT CLAIM TO ANY PARTICULAR FONT, STYLE, SIZE, OR COLOR.

OWNER OF U.S. REG. NOS. 2,480,839, 2,516,387, AND 2,607,934.

FOR NON-METAL AND NON-LEATHER KEY CHAINS, PILLOWS (U.S. CLS. 2, 13, 22, 25, 32 AND 50).

FIRST USE 6-18-2010; IN COMMERCE 6-18-2010.

3,998,734. VALENCIC, CHRISTOPHER A., LAKEWOOD, OH. SN 77-804,942. PUB. 1-19-2010, FILED 8-14-2009.

ecorondack

THE MARK CONSISTS OF STANDARD CHARACTERS WITHOUT CLAIM TO ANY PARTICULAR FONT, STYLE, SIZE, OR COLOR.

FOR FURNITURE; FURNITURE FOR HOUSE, OFFICE AND GARDEN; FURNITURE MADE FROM WOOD OR SUBSTITUTES FOR WOOD; LAWN FURNITURE; PLASTIC FURNITURE FOR GARDENS; SEATING FURNITURE (U.S. CLS. 2, 13, 22, 25, 32 AND 50).

FIRST USE 5-1-2009; IN COMMERCE 5-1-2009.

CLASS 20—(Continued).

3,998,739. INSOTECT LIMITED, KWUN TONG, KOWLOON, HONG KONG. SN 77-808,766. PUB. 3-9-2010, FILED 8-20-2009.

FLOW

THE MARK CONSISTS OF STANDARD CHARACTERS WITHOUT CLAIM TO ANY PARTICULAR FONT, STYLE, SIZE, OR COLOR.

FOR INSULATED SLEEPING BAGS (U.S. CLS. 2, 13, 22, 25, 32 AND 50).

FIRST USE 8-20-2010; IN COMMERCE 1-15-2011.

3,998,778. KRUEGER INTERNATIONAL, INC., GREEN BAY, WI. SN 77-830,863. PUB. 3-8-2011, FILED 9-21-2009.

EMISSARY

THE MARK CONSISTS OF STANDARD CHARACTERS WITHOUT CLAIM TO ANY PARTICULAR FONT, STYLE, SIZE, OR COLOR.

FOR NON-RESIDENTIAL OFFICE AND INSTITUTIONAL FURNITURE, NAMELY, FOLDING TABLES (U.S. CLS. 2, 13, 22, 25, 32 AND 50).

FIRST USE 6-14-2010; IN COMMERCE 6-14-2010.

3,998,822. MONTARE LLC, DBA DUTCH DOG DESIGN, SNOQUALMIE, WA. SN 77-846,276. PUB. 7-13-2010, FILED 10-12-2009.



THE COLOR(S) RED AND BLACK IS/ARE CLAIMED AS A FEATURE OF THE MARK.

THE MARK CONSISTS OF THE WORDS "DOGGY" IN RED, "SNOOZE" IN BLACK AND A HEAD OF A DOG IN BLACK APPEARING WITHIN THE LETTER "O" THAT APPEARS BETWEEN THE LETTERS "D" AND "G".

FOR BED FRAMES; BEDS FOR HOUSEHOLD PETS; DOG BEDS; PLAYHOUSES FOR PETS; SOFA BEDS (U.S. CLS. 2, 13, 22, 25, 32 AND 50).

FIRST USE 8-12-2010; IN COMMERCE 12-15-2010.

CLASS 20—(Continued).

3,998,962. ELKAY MANUFACTURING COMPANY, OAK BROOK, IL. SN 77-890,248. PUB. 6-8-2010, FILED 12-10-2009.

Woodbridge Cabinetry

THE MARK CONSISTS OF STANDARD CHARACTERS WITHOUT CLAIM TO ANY PARTICULAR FONT, STYLE, SIZE, OR COLOR.

NO CLAIM IS MADE TO THE EXCLUSIVE RIGHT TO USE "CABINETRY", APART FROM THE MARK AS SHOWN.

FOR CABINETS; DIVIDERS FOR DRAWERS; DRAWER ORGANIZERS FOR SILVERWARE; KITCHEN CABINETS (U.S. CLS. 2, 13, 22, 25, 32 AND 50).

FIRST USE 1-18-2010; IN COMMERCE 1-18-2010.

3,999,025. FLEXTANK INTERNATIONAL LTD, ABBOTSFORD 3067, AUSTRALIA. SN 77-910,411. PUB. 5-25-2010, FILED 1-12-2010.

FLEXCUBE

THE MARK CONSISTS OF STANDARD CHARACTERS WITHOUT CLAIM TO ANY PARTICULAR FONT, STYLE, SIZE, OR COLOR.

FOR NON-METAL FLUID STORAGE TANKS (U.S. CLS. 2, 13, 22, 25, 32 AND 50).

FIRST USE 1-27-2010; IN COMMERCE 1-27-2010.

3,999,129. OUR SHOPPING LINKS, INC., HUNTSVILLE, TX. SN 77-958,019. PUB. 8-3-2010, FILED 3-12-2010.

RAISE-A-GARDEN

THE MARK CONSISTS OF STANDARD CHARACTERS WITHOUT CLAIM TO ANY PARTICULAR FONT, STYLE, SIZE, OR COLOR.

FOR OUTDOOR FURNITURE; PLANT STANDS (U.S. CLS. 2, 13, 22, 25, 32 AND 50).

FIRST USE 6-0-2010; IN COMMERCE 2-1-2011.

CLASS 20—(Continued).

3,999,163. MEADWESTVACO CORPORATION, RICHMOND, VA. SN 77-981,869. PUB. 6-1-2010, FILED 12-23-2009.

AVIVE

THE MARK CONSISTS OF STANDARD CHARACTERS WITHOUT CLAIM TO ANY PARTICULAR FONT, STYLE, SIZE, OR COLOR.

THE ENGLISH TRANSLATION OF THE WORD "AVIVE" IN THE MARK IS "ENLIVEN".

FOR CONTAINERS FOR DISPENSING PRE-DETERMINED DOSAGES OF MEDICATION, SOLD EMPTY FOR COMMERCIAL USE (U.S. CLS. 2, 13, 22, 25, 32 AND 50).

FIRST USE 6-28-2009; IN COMMERCE 6-28-2009.

3,999,287. WU, YAO-CHUAN, CHIAYI HSIEN 621, TAIWAN. SN 85-020,276. PUB. 10-19-2010, FILED 4-22-2010.



NO CLAIM IS MADE TO THE EXCLUSIVE RIGHT TO USE "SEATING", APART FROM THE MARK AS SHOWN.

THE MARK CONSISTS OF THE WORDS "COMFORT SEATING" WITH THE WORD "COMFORT" PRESENTED IN A STYLIZED FONT, WITH AN ABSTRACT REPRESENTATION OF A PERSON IN A SEATED POSITION INTERTWINED WITH THE LETTER "C" AND EXTENDING TO THE REST OF THE WORD "COMFORT".

FOR BEDS; CABINETS; CHAIR CUSHIONS; CHAIR PADS; CHAIRS; FURNITURE PARTS, NAMELY, ARM RESTS, CHAIR LEGS; HIGH CHAIRS FOR BABIES; OFFICE CHAIRS; OFFICE SEATS; RECLINING CHAIRS; RESIDENTIAL AND COMMERCIAL WROUGHT IRON FURNITURE; SOFAS; TABLES (U.S. CLS. 2, 13, 22, 25, 32 AND 50).

FIRST USE 4-1-2011; IN COMMERCE 4-1-2011.

3,999,363. KINGSDOWN, INC., MEBANE, NC. SN 85-030,041. PUB. 9-28-2010, FILED 5-4-2010.



OWNER OF U.S. REG. NOS. 1,404,987, 1,464,598, AND 2,581,811.

CLASS 20—(Continued).

THE MARK CONSISTS OF A BLACK OVAL WITH A CROWN INSIDE OF IT.

FOR MATTRESSES AND BOX SPRINGS (U.S. CLS. 2, 13, 22, 25, 32 AND 50).

FIRST USE 7-6-2010; IN COMMERCE 8-1-2010.

3,999,376. TARGET BRANDS, INC., MINNEAPOLIS, MN. SN 85-031,116. PUB. 10-5-2010, FILED 5-5-2010.

ROOM ESSENTIALS

THE MARK CONSISTS OF STANDARD CHARACTERS WITHOUT CLAIM TO ANY PARTICULAR FONT, STYLE, SIZE, OR COLOR.

OWNER OF U.S. REG. NO. 3,251,676.

NO CLAIM IS MADE TO THE EXCLUSIVE RIGHT TO USE "ROOM", APART FROM THE MARK AS SHOWN.

FOR HOME AND OFFICE FURNITURE; GARDEN AND PATIO FURNITURE; MIRRORS; WINDOW BLINDS; WINDOW SHADES AND DECORATIVE WINDOW FINIALS; DRAPERY HARDWARE, NAMELY, TENSION RODS, ROD SETS, RODS OF STEEL, POLES, RINGS, TIE BACKS, BRACKETS, DRAPERY RINGS NOT OF METAL; PLATE RACKS; STORAGE AND ORGANIZATION PRODUCTS AND ACCESSORIES, NAMELY, STORAGE SHELVES, STORAGE DRAWERS, STORAGE RACKS; WOOD AND PLASTIC STORAGE BOXES; TABLES; CHAIRS; SHELVES; BOOKCASES; BOOK STANDS; DESKS; CHAISE LOUNGES; CABINETS; CHESTS OF DRAWERS; DRESSERS; CUPBOARDS; ENTERTAINMENT CENTERS; FILING CABINETS; MAGAZINE RACKS; MEDICINE CABINETS; NIGHTSTANDS; OTTOMANS; HAMPERS; PICTURE FRAME MOLDINGS; PICTURE FRAMES; HANGERS FOR CLOTHES; PILLOWS; DECORATIVE PILLOWS; STOOLS; SHOWER CURTAIN RINGS; SHOWER CURTAIN RODS; BATH PILLOWS; SHOWER SEATS; CLOTHES HANGERS; PLANT STANDS; PLASTIC TISSUE BOX COVERS; SEAT CUSHIONS (U.S. CLS. 2, 13, 22, 25, 32 AND 50).

FIRST USE 7-0-2003; IN COMMERCE 7-0-2003.

3,999,384. PACIFIC COAST FEATHER COMPANY, SEATTLE, WA. SN 85-032,141. PUB. 9-7-2010, FILED 5-6-2010.

AFFIRM

THE MARK CONSISTS OF STANDARD CHARACTERS WITHOUT CLAIM TO ANY PARTICULAR FONT, STYLE, SIZE, OR COLOR.

FOR PILLOWS (U.S. CLS. 2, 13, 22, 25, 32 AND 50).

FIRST USE 8-10-2010; IN COMMERCE 8-10-2010.

CLASS 20—(Continued).

3,999,396. SCENTSATIONAL PILLOWS, INC., MORAGA, CA. SN 85-033,049. PUB. 10-19-2010, FILED 5-7-2010.

LA SCENTSATIONALS

THE MARK CONSISTS OF STANDARD CHARACTERS WITHOUT CLAIM TO ANY PARTICULAR FONT, STYLE, SIZE, OR COLOR.

FOR PILLOWS, NAMELY, NECK-SUPPORTING PILLOWS, HEAD-SUPPORTING PILLOWS, AND DECORATIVE PILLOWS (U.S. CLS. 2, 13, 22, 25, 32 AND 50).
FIRST USE 5-23-2011; IN COMMERCE 5-23-2011.

3,999,409. WING ENTERPRISES, INC., SPRINGVILLE, UT. SN 85-035,269. PUB. 10-5-2010, FILED 5-11-2010.



THE MARK CONSISTS OF A DEPICTION OF A SUMO WRESTLER WITHIN A SQUARE WITH ROUNDED CORNERS.

FOR LADDERS, NAMELY, LADDERS MADE SUBSTANTIALLY OF NON-METAL COMPONENTS (U.S. CLS. 2, 13, 22, 25, 32 AND 50).
FIRST USE 5-5-2010; IN COMMERCE 5-5-2010.

3,999,443. JIM C.H. LEE, LOS ANGELES, CA. SN 85-038,293. PUB. 10-26-2010, FILED 5-13-2010.

dri+Cap

THE MARK CONSISTS OF STANDARD CHARACTERS WITHOUT CLAIM TO ANY PARTICULAR FONT, STYLE, SIZE, OR COLOR.

FOR NON-METALLIC SEALING CAPS (U.S. CLS. 2, 13, 22, 25, 32 AND 50).
FIRST USE 12-15-2010; IN COMMERCE 1-6-2011.

CLASS 20—(Continued).

3,999,454. THE MITCHELL GOLD CO., TAYLORSVILLE, NC. SN 85-041,163. PUB. 10-19-2010, FILED 5-18-2010.

SUPER LUXE SLEEPER

THE MARK CONSISTS OF STANDARD CHARACTERS WITHOUT CLAIM TO ANY PARTICULAR FONT, STYLE, SIZE, OR COLOR.

NO CLAIM IS MADE TO THE EXCLUSIVE RIGHT TO USE "SLEEPER", APART FROM THE MARK AS SHOWN.
FOR SLEEPER SOFAS (U.S. CLS. 2, 13, 22, 25, 32 AND 50).
FIRST USE 5-31-2010; IN COMMERCE 5-31-2010.

3,999,465. WAL-MART STORES, INC., BENTONVILLE, AR. SN 85-042,917. PUB. 9-28-2010, FILED 5-19-2010.

OAKMORE PLACE

THE MARK CONSISTS OF STANDARD CHARACTERS WITHOUT CLAIM TO ANY PARTICULAR FONT, STYLE, SIZE, OR COLOR.

FOR FURNITURE (U.S. CLS. 2, 13, 22, 25, 32 AND 50).
FIRST USE 6-30-2010; IN COMMERCE 6-30-2010.

3,999,513. BFF FOAM CORP., RICHMOND, CANADA. SN 85-054,541. PUB. 11-30-2010, FILED 6-4-2010.

COMFORTERRA

THE MARK CONSISTS OF STANDARD CHARACTERS WITHOUT CLAIM TO ANY PARTICULAR FONT, STYLE, SIZE, OR COLOR.

FOR FURNITURE PRODUCTS, NAMELY, MATTRESSES, TOPPERS, PILLOWS, BED WEDGES, KNEE BOLSTERS, CUSHIONS, CAMPING MATS FOR CONSUMERS OF ALL AGES (U.S. CLS. 2, 13, 22, 25, 32 AND 50).
FIRST USE 5-1-2011; IN COMMERCE 5-1-2011.

CLASS 20—(Continued).

3,999,593. MILESTONE AV TECHNOLOGIES LLC, SAVAGE, MN. SN 85-073,925. PUB. 9-28-2010, FILED 6-29-2010.

CLASS 21—(Continued).

3,998,360. RUTGERS, THE STATE UNIVERSITY OF NEW JERSEY, NEW BRUNSWICK, NJ. SN 77-075,059. PUB. 3-11-2008, FILED 1-3-2007.

FOUNDATIONS

THE MARK CONSISTS OF STANDARD CHARACTERS WITHOUT CLAIM TO ANY PARTICULAR FONT, STYLE, SIZE, OR COLOR.

OWNER OF U.S. REG. NO. 1,600,890.
FOR FURNITURE, NAMELY, AUDIO AND VIDEO STANDS (U.S. CLS. 2, 13, 22, 25, 32 AND 50).
FIRST USE 4-30-1989; IN COMMERCE 4-30-1989.



3,999,604. PACIFIC COAST FEATHER COMPANY, SEATTLE, WA. SN 85-077,435. PUB. 11-30-2010, FILED 7-2-2010.

BIG SNUGGLE

THE MARK CONSISTS OF STANDARD CHARACTERS WITHOUT CLAIM TO ANY PARTICULAR FONT, STYLE, SIZE, OR COLOR.

FOR PILLOWS (U.S. CLS. 2, 13, 22, 25, 32 AND 50).
FIRST USE 11-22-2010; IN COMMERCE 11-22-2010.

OWNER OF U.S. REG. NOS. 1,110,675, 2,764,505, AND OTHERS.

NO CLAIM IS MADE TO THE EXCLUSIVE RIGHT TO USE "NEW JERSEY", APART FROM THE MARK AS SHOWN.

THE MARK CONSISTS OF A SEAL WITH THE WORDS "RUTGERS THE STATE UNIVERSITY OF NEW JERSEY 1766".

FOR BEVERAGeware, DECORATIVE CRYSTAL, NAMELY, BOWLS, VASES AND PLATES; PORTABLE COOLERS (U.S. CLS. 2, 13, 23, 29, 30, 33, 40 AND 50).
FIRST USE 12-8-2006; IN COMMERCE 9-30-2007.

3,999,771. SMI-CARR, INC., ABILENE, TX. SN 85-139,767. PUB. 3-22-2011, FILED 9-28-2010.

STAKE ALL

THE MARK CONSISTS OF STANDARD CHARACTERS WITHOUT CLAIM TO ANY PARTICULAR FONT, STYLE, SIZE, OR COLOR.

NO CLAIM IS MADE TO THE EXCLUSIVE RIGHT TO USE "STAKE", APART FROM THE MARK AS SHOWN.

FOR BOUNDARY MARKERS, NAMELY, NON-METAL MARKER STAKES FOR USE IN ROAD CONSTRUCTION, SURVEYING, CONCRETE FORMING, FENCING AND LANDSCAPING ACTIVITIES; SURVEY EQUIPMENT, NAMELY, NON-METAL BOUNDARY MARKER STAKES FOR USE IN ROAD CONSTRUCTION, SURVEYING, CONCRETE FORMING, FENCING AND LANDSCAPING ACTIVITIES (U.S. CLS. 2, 13, 22, 25, 32 AND 50).
FIRST USE 6-1-2011; IN COMMERCE 6-1-2011.

3,998,375. PLAZA IP HOLDINGS LLC (USA), NEW YORK, NY. SN 77-118,188. PUB. 2-26-2008, FILED 2-28-2007.

OAK ROOM AND BAR

THE MARK CONSISTS OF STANDARD CHARACTERS WITHOUT CLAIM TO ANY PARTICULAR FONT, STYLE, SIZE, OR COLOR.

NO CLAIM IS MADE TO THE EXCLUSIVE RIGHT TO USE "BAR", APART FROM THE MARK AS SHOWN.

FOR MUGS (U.S. CLS. 2, 13, 23, 29, 30, 33, 40 AND 50).
FIRST USE 6-19-2009; IN COMMERCE 6-19-2009.

CLASS 21—HOUSEWARES AND GLASS

CLASS 21—(Continued).

3,998,440. MARVEL CHARACTERS, INC., MANHATTAN BEACH, CA. SN 77-307,315. PUB. 3-23-2010, FILED 10-18-2007.

SUPER HERO SQUAD

THE MARK CONSISTS OF STANDARD CHARACTERS WITHOUT CLAIM TO ANY PARTICULAR FONT, STYLE, SIZE, OR COLOR.

OWNER OF U.S. REG. NOS. 1,073,580, 3,045,687, AND OTHERS.

FOR BOWLS; CUPS; DISHES; DRINKING GLASSES; LUNCH BOXES; MUGS; PAPER CUPS; PAPER PLATES; THERMAL INSULATED CONTAINERS FOR FOOD OR BEVERAGE; TOOTHBRUSH HOLDERS; TOOTHBRUSHES (U.S. CLS. 2, 13, 23, 29, 30, 33, 40 AND 50).

FIRST USE 12-31-2009; IN COMMERCE 12-31-2009.

3,998,459. LOCKHEED MARTIN CORPORATION, BETHESDA, MD. SN 77-383,964. PUB. 6-17-2008, FILED 1-30-2008.



OWNER OF U.S. REG. NOS. 3,948,126, 3,958,105, AND 3,958,106.

THE MARK CONSISTS OF THE LITERAL ELEMENT "ENGINEERS" PLACED ABOVE AN OVAL CONTAINING THE LITERAL ELEMENT "IN THE CLASSROOM" WHICH IS NEXT TO AN APPLE DESIGN.

FOR MUGS; CUPS (U.S. CLS. 2, 13, 23, 29, 30, 33, 40 AND 50).

FIRST USE 1-31-2008; IN COMMERCE 1-31-2008.

3,998,510. RAUCH INDUSTRIES, INC., TARRYTOWN, NY. SN 77-534,063. PUB. 3-10-2009, FILED 7-29-2008.

CELEBRATIONS BY RADKO

THE MARK CONSISTS OF STANDARD CHARACTERS WITHOUT CLAIM TO ANY PARTICULAR FONT, STYLE, SIZE, OR COLOR.

CLASS 21—(Continued).

OWNER OF U.S. REG. NOS. 2,333,528, 2,656,759, AND OTHERS.

FOR DECORATIVE PLATES; DRINKING GLASSES; PLATES; DINNERWARE; MUGS; SERVING TRAYS NOT OF PRECIOUS METAL; COOKIE JARS; SUGAR BOWLS AND BASINS AND CREAMER PITCHERS SOLD TOGETHER IN SETS; SALT AND PEPPER SHAKERS; CANDY DISHES; CANDY BOWLS; AND COOKIE SERVING PLATTERS (U.S. CLS. 2, 13, 23, 29, 30, 33, 40 AND 50).

FIRST USE 2-0-2011; IN COMMERCE 2-0-2011.

3,998,559. SCA TISSUE NORTH AMERICA LLC, NEENAH, WI. SN 77-596,239. PUB. 3-10-2009, FILED 10-20-2008.

NICKELITE

THE MARK CONSISTS OF STANDARD CHARACTERS WITHOUT CLAIM TO ANY PARTICULAR FONT, STYLE, SIZE, OR COLOR.

FOR DISPENSERS FOR PAPER ROLLS AND PAPER TOWELS (U.S. CLS. 2, 13, 23, 29, 30, 33, 40 AND 50).

FIRST USE 12-31-2010; IN COMMERCE 12-31-2010.

3,998,567. HOME BOX OFFICE, INC., NEW YORK, NY. SN 77-603,812. PUB. 9-15-2009, FILED 10-30-2008.

HOW TO MAKE IT IN AMERICA

THE MARK CONSISTS OF STANDARD CHARACTERS WITHOUT CLAIM TO ANY PARTICULAR FONT, STYLE, SIZE, OR COLOR.

FOR MUGS (U.S. CLS. 2, 13, 23, 29, 30, 33, 40 AND 50).

FIRST USE 3-1-2010; IN COMMERCE 3-1-2010.

3,998,659. HOME BOX OFFICE, INC., NEW YORK, NY. SN 77-726,116. PUB. 9-15-2009, FILED 4-30-2009.

BOARDWALK EMPIRE

THE MARK CONSISTS OF STANDARD CHARACTERS WITHOUT CLAIM TO ANY PARTICULAR FONT, STYLE, SIZE, OR COLOR.

FOR MUGS, DRINKING GLASSES, SHOT GLASSES (U.S. CLS. 2, 13, 23, 29, 30, 33, 40 AND 50).

FIRST USE 11-30-2010; IN COMMERCE 11-30-2010.

CLASS 21—(Continued).

3,998,690. FERGUSON ENTERPRISES, INC., NEWPORT NEWS, VA. SN 77-759,236. PUB. 5-4-2010, FILED 6-14-2009.

MILAZZO

THE MARK CONSISTS OF STANDARD CHARACTERS WITHOUT CLAIM TO ANY PARTICULAR FONT, STYLE, SIZE, OR COLOR.

FOR BATHROOM ACCESSORIES, NAMELY, TOWEL BARS, TOWEL RINGS, TOWEL RAILS, TOILET TISSUE HOLDERS, TOOTHBRUSH HOLDERS, CUP HOLDERS, BATHROOM GLASS HOLDER NOT OF PRECIOUS METAL, SOAP DISHES, SOAP DISPENSERS, WASHTUBS AND CUTTING BOARDS FOR STAINLESS STEEL SINKS (U.S. CLS. 2, 13, 23, 29, 30, 33, 40 AND 50).
FIRST USE 6-30-2007; IN COMMERCE 6-30-2007.

3,998,767. REIMER BONNIE J, SOUTH HAVEN, MI. SN 77-827,113. PUB. 2-9-2010, FILED 9-15-2009.

Beverage of Pleasure

THE MARK CONSISTS OF STANDARD CHARACTERS WITHOUT CLAIM TO ANY PARTICULAR FONT, STYLE, SIZE, OR COLOR.

FOR THERMAL INSULATED WRAP FOR CANS AND BOTTLES TO KEEP CONTENTS COLD OR HOT (U.S. CLS. 2, 13, 23, 29, 30, 33, 40 AND 50).
FIRST USE 6-15-1979; IN COMMERCE 10-1-2009.

3,998,821. INTRAPRO COMPANY, LTD., SHEUNG WAN, HONG KONG. SN 77-846,028. PUB. 9-21-2010, FILED 10-9-2009.

TAMBAROO

THE MARK CONSISTS OF STANDARD CHARACTERS WITHOUT CLAIM TO ANY PARTICULAR FONT, STYLE, SIZE, OR COLOR.

CLASS 21—(Continued).

THE WORDING "TAMBAROO" HAS NO MEANING IN A FOREIGN LANGUAGE.

FOR UTENSILS, ACCESSORIES AND DEVICES FOR PREPARATION AND CONSUMPTION OF COFFEE, TEA, HERBAL INFUSIONS, BEVERAGE CONCOCTIONS, AND BEVERAGE SOLUTIONS, NAMELY, TEA MEASURERS, HERB MEASURERS, COFFEE MEASURERS, AND A MEASURING AND CLEANING ACCESSORY FOR USE WITH A NON-ELECTRIC FRENCH PRESS, CAFETIERE OR TEA POT, NAMELY, AN INSERT WHICH FITS INSIDE THE BREWING DEVICE USED TO MEASURE AND COLLECT COFFEE, TEA OR HERBS (U.S. CLS. 2, 13, 23, 29, 30, 33, 40 AND 50).
FIRST USE 11-12-2009; IN COMMERCE 11-12-2009.

3,998,911. GENERATION I.D.E.A., LLC, DBA FORMULANOW, FARGO, ND. SN 77-869,525. PUB. 4-13-2010, FILED 11-10-2009.

NOWCUP

THE MARK CONSISTS OF STANDARD CHARACTERS WITHOUT CLAIM TO ANY PARTICULAR FONT, STYLE, SIZE, OR COLOR.

FOR DISPOSABLE PLASTIC CONTAINERS FOR PREPARING AND DISPENSING INFANT FORMULA (U.S. CLS. 2, 13, 23, 29, 30, 33, 40 AND 50).
FIRST USE 1-15-2011; IN COMMERCE 1-15-2011.

3,998,936. THREE RIVERS MAIL ORDER CORP., CLEARWATER, FL. SN 77-880,161. PUB. 9-21-2010, FILED 11-24-2009.

A WONDER OF NATURE. EVERY
KID SHOULD SEE THIS !

THE MARK CONSISTS OF STANDARD CHARACTERS WITHOUT CLAIM TO ANY PARTICULAR FONT, STYLE, SIZE, OR COLOR.

FOR KITS IN THE NATURE OF AN AQUARIUM FOR GROWING TOY FROGS (U.S. CLS. 2, 13, 23, 29, 30, 33, 40 AND 50).
FIRST USE 12-13-2009; IN COMMERCE 12-13-2009.

CLASS 21—(Continued).

3,998,971. HOMEGOODS, INC., FRAMINGHAM, MA. SN 77-893,613. PUB. 5-11-2010, FILED 12-15-2009.

Chef ▪ ol ▪ o ▪ gy

OWNER OF U.S. REG. NO. 2,998,948.
THE MARK CONSISTS OF THE WORD "CHEFOLOGY" WITH A SMALL SQUARE SYMBOL SEPARATING EACH OF THE SYLLABLES.

FOR DINNERWARE, SERVINGWARE FOR SERVING FOOD AND DRINKS, BEVERAGE GLASSWARE, STEMWARE, AND BARWARE, NAMELY, WINE GLASSES, CORDIAL GLASSES, MARTINI GLASSES, HIGH BALL GLASSES, CHAMPAGNE FLUTES, COCKTAIL SHAKERS, SELTZER BOTTLES, WINE CHARMS NOT OF METAL, NAMELY, CHARMS THAT ATTACH TO BEVERAGE GLASSWARE FOR IDENTIFICATION PURPOSES, CORKSCREWS, COOLERS FOR WINE, ICE BUCKETS, WINE BUCKETS, CHAMPAGNE BUCKETS, FLASKS, COCKTAIL PICKS, DRINK STIRRERS AND BOTTLE OPENERS (U.S. CLS. 2, 13, 23, 29, 30, 33, 40 AND 50).

FIRST USE 1-18-2010; IN COMMERCE 1-18-2010.

3,999,117. CIRILLI, DANTE, NAPLES, FL. SN 77-952,893. PUB. 9-21-2010, FILED 3-8-2010.

SHAVE SHARP

THE MARK CONSISTS OF STANDARD CHARACTERS WITHOUT CLAIM TO ANY PARTICULAR FONT, STYLE, SIZE, OR COLOR.

NO CLAIM IS MADE TO THE EXCLUSIVE RIGHT TO USE "SHAVE", APART FROM THE MARK AS SHOWN.

FOR CONTAINERS OF PLASTIC FOR DOMESTIC USE, NAMELY, CONTAINERS FOR STORING SHAVING RAZORS AND CLEANING SOLUTIONS FOR SHAVING RAZORS (U.S. CLS. 2, 13, 23, 29, 30, 33, 40 AND 50).

FIRST USE 5-13-2011; IN COMMERCE 5-13-2011.

CLASS 21—(Continued).

3,999,144. SIAHPUSH, S ANTHONY, OMAHA, NE. SN 77-966,453. PUB. 8-10-2010, FILED 3-23-2010.

Smart Tray

THE MARK CONSISTS OF STANDARD CHARACTERS WITHOUT CLAIM TO ANY PARTICULAR FONT, STYLE, SIZE, OR COLOR.

NO CLAIM IS MADE TO THE EXCLUSIVE RIGHT TO USE "TRAY", APART FROM THE MARK AS SHOWN.

FOR SERVING TRAYS (U.S. CLS. 2, 13, 23, 29, 30, 33, 40 AND 50).

FIRST USE 3-1-2011; IN COMMERCE 3-1-2011.

3,999,244. MARGARET M. DALY, LISLE, IL. SN 85-008,857. PUB. 9-7-2010, FILED 4-7-2010.

COCKTAIL COTTAGE

THE MARK CONSISTS OF STANDARD CHARACTERS WITHOUT CLAIM TO ANY PARTICULAR FONT, STYLE, SIZE, OR COLOR.

FOR BOWLS; COASTERS NOT OF PAPER AND NOT BEING TABLE LINEN; COCKTAIL SHAKERS; COOLERS FOR WINE; COOLING BUCKETS FOR WINE; FLASKS; GLASS BEVERAGeware; ICE BUCKETS; ICE PAILS; ICE SCOOPS; LEATHER COASTERS; PLASTIC COASTERS; SHOT GLASSES; WINE BUCKETS; WINE COOLING PAILS; WINE GLASSES (U.S. CLS. 2, 13, 23, 29, 30, 33, 40 AND 50).

FIRST USE 8-15-2010; IN COMMERCE 8-15-2010.

3,999,314. UPHOLSTERY DECOR INC, GOLETA, CA. SN 85-025,095. PUB. 9-28-2010, FILED 4-28-2010.

Got Pot

THE MARK CONSISTS OF STANDARD CHARACTERS WITHOUT CLAIM TO ANY PARTICULAR FONT, STYLE, SIZE, OR COLOR.

FOR FLOWER POTS (U.S. CLS. 2, 13, 23, 29, 30, 33, 40 AND 50).

FIRST USE 11-1-2010; IN COMMERCE 11-1-2010.

CLASS 21—(Continued).

3,999,461. CAPODIMONTE NG, INC., WILLIAMSBURG, VA.
SN 85-042,661. PUB. 10-26-2010, FILED 5-19-2010.

Nino Rose

THE MARK CONSISTS OF STANDARD CHARACTERS WITHOUT CLAIM TO ANY PARTICULAR FONT, STYLE, SIZE, OR COLOR.

NO CLAIM IS MADE TO THE EXCLUSIVE RIGHT TO USE "ROSE", APART FROM THE MARK AS SHOWN.

FOR CERAMIC AND PORCELAIN FLORAL SCULPTURAL WORKS OF ART (U.S. CLS. 2, 13, 23, 29, 30, 33, 40 AND 50).

FIRST USE 6-15-2010; IN COMMERCE 6-15-2010.

3,999,568. GEORGE DAVID HOLMES, HENDERSONVILLE, TN. SN 85-066,440. PUB. 11-30-2010, FILED 6-18-2010.

SUNSPLISHER

THE MARK CONSISTS OF STANDARD CHARACTERS WITHOUT CLAIM TO ANY PARTICULAR FONT, STYLE, SIZE, OR COLOR.

FOR WALL-MOUNTED OR HAND-HELD CADDIES FOR HOLDING, ORGANIZING OR TRANSPORTING SWIMMING POOL CLEANING EQUIPMENT (U.S. CLS. 2, 13, 23, 29, 30, 33, 40 AND 50).

FIRST USE 2-14-2011; IN COMMERCE 2-14-2011.

3,999,609. TARTARA GROUP, INC., EDISON, NJ. SN 85-078,590. PUB. 12-7-2010, FILED 7-6-2010.

NU STEEL

THE MARK CONSISTS OF STANDARD CHARACTERS WITHOUT CLAIM TO ANY PARTICULAR FONT, STYLE, SIZE, OR COLOR.

CLASS 21—(Continued).

NO CLAIM IS MADE TO THE EXCLUSIVE RIGHT TO USE "STEEL", APART FROM THE MARK AS SHOWN.

FOR BASINS; BOTTLE STANDS; BOWLS; BOWLS MADE OF PRECIOUS METAL; BUCKETS WITH AN INSERT THAT PREVENTS SPILLS, SPLASHES AND DRIPS, USED TO CONTAIN PAINT AS WELL AS OTHER LIQUIDS; CAKE STANDS; CANDLE HOLDERS; CANDLE HOLDERS NOT OF PRECIOUS METAL; CANDLE HOLDERS OF PRECIOUS METAL; CAST STONE CONTAINERS FOR HOUSEHOLD AND GARDEN USE; CERAMIC SCULPTURES, VASES, VESSELS, BOWLS, PLATES AND POTS; CHAMBER POTS; CHOPPING BOARDS FOR KITCHEN USE; COCKTAIL PICKS; COCKTAIL SHAKERS; COCKTAIL STIRRERS; COFFEE POTS; COFFEE POTS NOT OF PRECIOUS METAL; COFFEE POTS OF PRECIOUS METAL; COLLAPSIBLE FABRIC STORAGE CONTAINER FOR DOMESTIC USE; COLLAPSIBLE STORAGE CONTAINERS FOR DOMESTIC USE; CONTAINERS FOR HOUSEHOLD OR KITCHEN USE; CONTAINERS FOR HOUSEHOLD OR KITCHEN USE NOT OF PRECIOUS METAL; CONTAINERS FOR HOUSEHOLD OR KITCHEN USE OF PRECIOUS METAL; CONTAINERS FOR HOUSEHOLD USE; CONTAINERS FOR ICE; CONTAINERS OF PLASTIC FOR STORAGE OF FEMININE PRODUCTS FOR HOUSEHOLD OR DOMESTIC USE; COOKING POT SETS; COOKING POTS; COOKING POTS AND PANS; COOKING UTENSIL, NAMELY, BATTER DISPENSER; COOKING UTENSILS, NAMELY, WIRE BASKETS; COOKWARE, NAMELY, POTS AND PANS; CORK HOLDERS; CORN COB HOLDERS; CREAM AND SUGAR SET; CRUET STANDS; CRUET STANDS FOR OIL OR VINEGAR NOT OF PRECIOUS METAL; CRUET STANDS FOR OIL OR VINEGAR OF PRECIOUS METAL; CRUET STANDS MADE OF PRECIOUS METALS; CRUET STANDS NOT OF PRECIOUS METAL; CRUET STANDS OF PRECIOUS METAL; DISH STANDS; EARTHENWARE BASINS; FINGER BOWLS; FLOWER BOWLS; FLOWER BOWLS OF PRECIOUS METAL; FLOWER POT HOLDERS; FLOWER POTS; FLOWER VASES AND BOWLS; FLOWER VASES AND BOWLS OF PRECIOUS METAL; FOAM DRINK HOLDERS; FONDUE POTS WITHOUT HEAT SOURCE; FRUIT BOWLS; FRUIT BOWLS OF GLASS; GAS PRESSURIZED BEVERAGE SIPHON CONTAINERS, NAMELY, CREAM WHIPPERS, CREAM PITCHERS AND SODA WATER HOLDERS AND GAS CARTRIDGES SOLD EMPTY; GLASS BOWLS; HAND BASINS; HAND WASH BASINS; HOLDER FOR CUTTING BOARD; HOLDERS FOR FLOWERS AND PLANTS; HOLDERS FOR HOUSEHOLD IRONS; HOT POTS; HOUSEHOLD CONTAINERS FOR FOODS; HOUSEHOLD CONTAINERS OF PRECIOUS METAL; HOUSEHOLD STORAGE CONTAINERS FOR PET FOOD; HOUSEHOLD UTENSILS, NAMELY, GRATERS; HOUSEHOLD UTENSILS, NAMELY, KITCHEN TONGS; HOUSEHOLD UTENSILS, NAMELY, SIEVES; HOUSEHOLD UTENSILS, NAMELY, SKIMMERS; HOUSEHOLD UTENSILS, NAMELY, SPATULAS; HOUSEHOLD UTENSILS, NAMELY, STRAINERS; HOUSEHOLD UTENSILS, NAMELY, TURNERS; ICE BUCKETS; ICE CREAM SCOOPS; ICE CUBE MOLDS; ICE CUBE MOLDS FOR REFRIGERATORS; ICE PAILS; ICE SCOOPS; INSULATED CONTAINERS FOR BEVERAGE CANS FOR DOMESTIC USE; INSULATED CONTAINERS FOR FOOD OR BEVERAGE FOR DOMESTIC USE; JAPANESE STYLE PERSONAL DINING TRAYS OR STANDS (ZEN); JAPANESE STYLE TEA-SERVING POTS (KYUSU); JAPANESE STYLE TEA-SERVING POTS OF PRECIOUS METAL (KYUSU); KITCHEN LADLES; KITCHEN URNS; KITCHEN UTENSIL, NAMELY, NON-METAL FLEXIBLE LID DESIGNED FOR DRAINING OR PRESSING LIQUIDS FROM A FOOD CAN; KITCHEN UTENSILS, NAMELY, POURING AND STRAINING SPOUTS; KITCHEN UTENSILS, NAMELY, SPLATTER SCREENS; LADLES, FOR KITCHEN USE; LOCKABLE NON-METAL HOUSEHOLD CONTAINERS FOR FOOD; LOTION CONTAINERS SOLD EMPTY FOR DOMESTIC USE; MANUALLY ACTUATED PUMP DISPENSERS FOR ATTACHMENT TO CONTAINERS FOR USE IN DISPENSING LIQUIDS; MEDICATION CONTAINERS FOR PERSONAL USE; MIXING BOWLS; MUSTARD POTS; NAPKIN DISPENSERS FOR HOUSEHOLD USE; NAPKIN HOLDERS; NAPKIN HOLDERS AND NAPKIN RINGS NOT OF PRECIOUS METAL; NAPKIN HOLDERS OF PRECIOUS METAL; NAPKIN HOLDERS, NOT OF PRECIOUS METAL; NAPKIN RINGS; NAPKIN RINGS NOT OF PRECIOUS METALS; NAPKIN RINGS OF

CLASS 21—(Continued).

PRECIOUS METAL; NAPKIN RINGS, NOT OF PRECIOUS METAL; NATURAL AND SYNTHETIC FIBER COCO LINERS FITTED FOR PLANT BOXES, PLANT POTS, AND PLANT BASKETS; NON-ELECTRIC COFFEE POTS NOT OF PRECIOUS METAL; NON-ELECTRIC KITCHEN CONTAINERS NOT MADE OF PRECIOUS METAL; NON-MODULAR CONTAINERS FOR USE IN TRANSPORTATION AND STORAGE FOR HOUSEHOLD USE; PEPPER MILLS; PEPPER POTS, SUGAR BOWLS AND SALT SHAKERS; PET FEEDING AND DRINKING BOWLS; PLASTIC CONTAINERS, NAMELY, CAKE BOXES FOR HOUSEHOLD USE; PLASTIC HOLDER FOR BEVERAGE CONTAINERS TO BE AFFIXED TO WALLS; PLASTIC ICE POP FORMS; PLASTIC SAFETY CAPS FOR MEDICINE CONTAINERS; PLASTIC STORAGE CONTAINERS FOR DOMESTIC USE; PLASTIC STORAGE CONTAINERS FOR HOUSEHOLD OR DOMESTIC USE; PLASTIC STORAGE CONTAINERS FOR HOUSEHOLD USE; PORTABLE COOLERS, NAMELY, PORTABLE BEVERAGE OR ICE COOLERS MOUNTED ON TELESCOPING WHEELED CADDIES; PORTABLE ICE CHESTS FOR FOOD AND BEVERAGES; PORTABLE PLASTIC CONTAINERS FOR STORING HOUSEHOLD AND KITCHEN GOODS; POT AND PAN SCRAPERS; POT LIDS; POT STANDS; POTS; RICE COOKING POTS; RINSING BOWLS; SALAD BOWLS; SALAD SPINNERS; SALT AND PEPPER MILLS; SALT AND PEPPER SHAKERS; SALT CELLARS; SALT SHAKERS; SALT SHAKERS OF PRECIOUS METAL; SAUCERS FOR FLOWER POTS; SERVIETTE HOLDERS; SERVING BOWLS (HACHI); SHALLOW BOWLS; SHAVING BRUSH HOLDERS; SHAVING BRUSH STANDS; SHAVING POTS; SOAP CONTAINERS; STANDS FOR DISHES; SUGAR BOWLS; SUGAR BOWLS OF PRECIOUS METAL; TEA POTS; TEA POTS MADE OF PRECIOUS METALS; TEA POTS NOT OF PRECIOUS METAL; TEA POTS OF PRECIOUS METAL; THERMAL INSULATED CONTAINERS FOR FOOD OR BEVERAGES; TOOTHBRUSH HOLDERS; TOOTHPICK HOLDERS; TOOTHPICK HOLDERS OF PRECIOUS METAL; TRASH CONTAINERS FOR HOUSEHOLD USE; UTENSILS FOR BARBECUES, NAMELY, FORKS, TONGS, TURNERS; WASH BASINS; WOOD CHOPPING BLOCKS; WOOD CHOPPING BOARDS FOR KITCHEN USE (U.S. CLS. 2, 13, 23, 29, 30, 33, 40 AND 50).
FIRST USE 3-6-2011; IN COMMERCE 3-6-2011.

3,999,671. VOSBIKIAN, GREGORY P., MOUNT LAUREL, NJ.
SN 85-101,304. PUB. 1-25-2011, FILED 8-5-2010.

ICEMASTER

THE MARK CONSISTS OF STANDARD CHARACTERS WITHOUT CLAIM TO ANY PARTICULAR FONT, STYLE, SIZE, OR COLOR.

FOR PORTABLE BEVERAGE COOLERS; PORTABLE COOLERS; PORTABLE ICE CHESTS FOR FOOD AND BEVERAGES (U.S. CLS. 2, 13, 23, 29, 30, 33, 40 AND 50).
FIRST USE 5-4-2011; IN COMMERCE 5-4-2011.

CLASS 21—(Continued).

3,999,685. JOHN S. LETCHINGER, CHICAGO, IL. AND THOMAS J. RING, CHICAGO, IL. SN 85-105,482. PUB. 1-11-2011, FILED 8-11-2010.

PERSONALIZE YOUR FIN

THE MARK CONSISTS OF STANDARD CHARACTERS WITHOUT CLAIM TO ANY PARTICULAR FONT, STYLE, SIZE, OR COLOR.

NO CLAIM IS MADE TO THE EXCLUSIVE RIGHT TO USE "PERSONALIZE", APART FROM THE MARK AS SHOWN.

FOR DRINKING CONTAINER (U.S. CLS. 2, 13, 23, 29, 30, 33, 40 AND 50).

FIRST USE 8-13-2010; IN COMMERCE 8-13-2010.

3,999,711. DART CONTAINER CORPORATION, MASON, MI. SN 85-114,237. PUB. 11-23-2010, FILED 8-24-2010.

FUSION STEELE

THE MARK CONSISTS OF STANDARD CHARACTERS WITHOUT CLAIM TO ANY PARTICULAR FONT, STYLE, SIZE, OR COLOR.

OWNER OF U.S. REG. NOS. 3,335,907 AND 3,345,544.

FOR DISPOSABLE PAPER-WRAPPED FOAM CUPS SOLD TO COMMERCIAL AND INSTITUTIONAL ENTITIES, CASH AND CARRY DISTRIBUTORSHIPS, AND TO WHOLESALE AND WAREHOUSE CLUBS (U.S. CLS. 2, 13, 23, 29, 30, 33, 40 AND 50).

FIRST USE 2-22-2011; IN COMMERCE 2-22-2011.

3,999,863. PRIME SOURCE ACCESSORIES, INC., STUART, FL. SN 85-183,993. PUB. 3-1-2011, FILED 11-23-2010.

TEMPTOTES

THE MARK CONSISTS OF STANDARD CHARACTERS WITHOUT CLAIM TO ANY PARTICULAR FONT, STYLE, SIZE, OR COLOR.

FOR INSULATED BAGS FOR FOOD OR BEVERAGE FOR DOMESTIC USE; THERMAL INSULATED BAGS FOR FOOD OR BEVERAGES (U.S. CLS. 2, 13, 23, 29, 30, 33, 40 AND 50).

FIRST USE 2-28-2011; IN COMMERCE 2-28-2011.

CLASS 22—CORDAGE AND FIBERS

CLASS 24—(Continued).

OWNER OF U.S. REG. NOS. 1,073,580, 3,045,687, AND OTHERS.

FOR BATH TOWELS; BEACH TOWELS; BED BLANKETS; BED LINEN; BED SHEETS; BED SPREADS; BLANKETS FOR OUTDOOR USE; CHILDREN'S BLANKETS; COMFORTERS; CURTAINS; PILLOW COVERS; TOWELS (U.S. CLS. 42 AND 50).

FIRST USE 4-1-2009; IN COMMERCE 4-1-2009.

3,998,632. QIQIHAR JINYA FLAX TEXTILE CO., LTD., QIQIHAR, HEILONGJIANG, CHINA. SN 77-711,766. PUB. 12-29-2009, FILED 4-10-2009.



NO CLAIM IS MADE TO THE EXCLUSIVE RIGHT TO USE THE NON-LATIN CHARACTER THAT MEANS "ASIA", APART FROM THE MARK AS SHOWN.

THE MARK CONSISTS OF TWO CHINESE CHARACTERS, WHICH ARE TRANSLITERATED AS "JIN YA", AND WHICH MEANS "GOLD" AND "ASIA" IN ENGLISH, RESPECTIVELY.

THE TWO CHINESE CHARACTERS, WHICH ARE TRANSLITERATED AS "JIN YA" AND THE COMBINATION OF THE TWO CHINESE CHARACTERS DOES NOT CONTAIN ANY SPECIFIC MEANING IN ENGLISH.

FOR BED BLANKETS; COTTON CLOTH; FLAX CLOTH; GAUZE FABRIC; HEMP CLOTH; LINEN CLOTH; SILK CLOTH; SYNTHETIC FIBER FABRICS; TABLE CLOTHS NOT OF PAPER; WOOLEN CLOTH (U.S. CLS. 42 AND 50).

FIRST USE 6-13-1997; IN COMMERCE 12-13-2006.

3,999,367. DISTRIBUTION PHARMAC INC., BLAINVILLE, QUEBEC, CANADA. SN 85-030,151. PUB. 10-5-2010, FILED 5-4-2010.



THE MARK CONSISTS OF A SORT OF SNOWFLAKE IN A ROUND DOUBLE FIGURE ON THE LEFT SIDE OF THE MARK "SLUMBEREASE".

FOR MATTRESS PADS; PILLOW COVERS (U.S. CLS. 42 AND 50).

FIRST USE 3-31-2011; IN COMMERCE 3-31-2011.

CLASS 24—(Continued).

3,999,375. TARGET BRANDS, INC., MINNEAPOLIS, MN. SN 85-031,106. PUB. 10-5-2010, FILED 5-5-2010.

ROOM ESSENTIALS

THE MARK CONSISTS OF STANDARD CHARACTERS WITHOUT CLAIM TO ANY PARTICULAR FONT, STYLE, SIZE, OR COLOR.

OWNER OF U.S. REG. NO. 3,251,676.

NO CLAIM IS MADE TO THE EXCLUSIVE RIGHT TO USE "ROOM", APART FROM THE MARK AS SHOWN.

FOR BED LINEN AND TABLE LINENS; SHOWER CURTAINS; SHOWER CURTAIN LINERS; MATTRESS PADS OF COTTON; MATTRESS PADS OF FOAM; BEDDING, NAMELY, COMFORTERS, SHEETS, SHAMS, PILLOW CASES, BED SKIRTS, BED SPREADS, BLANKETS, COVERLETS, DUVETS, QUILTS AND TROWS; TABLE LINENS NOT OF PAPER, NAMELY, PLACE-MATS, NAPKINS, TABLECLOTHS, FABRIC TABLE RUNNERS AND FABRIC TABLE TOPPERS; FABRIC WINDOW COVERINGS, NAMELY, CURTAINS, DRAPERIES, SHEERS, SWAGS, VALANCES; TOWELS; WASH CLOTHS; DISH CLOTHS; OVEN MITTS; UNFITTED FABRIC FURNITURE COVERS; BATH MITTS; FITTED TOILET LID COVERS MADE OF FABRIC (U.S. CLS. 42 AND 50).

FIRST USE 7-0-2003; IN COMMERCE 7-0-2003.

3,999,459. TESHKEEL MEDIA GROUP, INC., NEW YORK, NY. SN 85-042,456. PUB. 10-26-2010, FILED 5-19-2010.

THE 99

THE MARK CONSISTS OF STANDARD CHARACTERS WITHOUT CLAIM TO ANY PARTICULAR FONT, STYLE, SIZE, OR COLOR.

FOR BEDDING (U.S. CLS. 42 AND 50).

FIRST USE 10-18-2010; IN COMMERCE 10-18-2010.

CLASS 24—(Continued).

3,999,477. QINGDAO YLS. TEXTILES CO., LTD., SHANDONG PROVINCE, CHINA. SN 85-045,923. PUB. 10-26-2010, FILED 5-24-2010.

Your life Style
 羽 翎 珊

THE NON-LATIN CHARACTERS IN THE MARK TRANSLITERATE TO "YU; LING; SHAN" AND THIS MEANS "FEATHER; PLUME; CORAL" IN ENGLISH.

FOR BED BLANKETS; BED SHEETS; BEDSHEETS; BEDSPREADS; COVERLETS; PILLOWCASES; QUILTS; SHOWER CURTAINS; TOWELS; TURKISH TOWEL (U.S. CLS. 42 AND 50).

FIRST USE 10-20-2010; IN COMMERCE 10-20-2010.

3,999,494. PROCREATIONS PUBLISHING COMPANY, NEW ORLEANS, LA. SN 85-048,405. PUB. 10-26-2010, FILED 5-26-2010.

BayouWear

THE MARK CONSISTS OF STANDARD CHARACTERS WITHOUT CLAIM TO ANY PARTICULAR FONT, STYLE, SIZE, OR COLOR.

FOR FABRICS FOR TEXTILE USE (U.S. CLS. 42 AND 50).

FIRST USE 12-1-2010; IN COMMERCE 12-1-2010.

CLASS 25—CLOTHING

3,998,302. MILLER, STANLEY F., MADISON, WI. SN 76-511,786. PUB. 2-19-2008, FILED 4-17-2003.

LAMBEAU CHAPEAU

NO CLAIM IS MADE TO THE EXCLUSIVE RIGHT TO USE "CHAPEAU", APART FROM THE MARK AS SHOWN. FOR HEADWEAR (U.S. CLS. 22 AND 39).

FIRST USE 3-8-2011; IN COMMERCE 3-8-2011.

CLASS 25—(Continued).

3,998,310. DUSSAULT APPAREL INC., POINT ROBERTS, WA. SN 76-683,489. PUB. 4-8-2008, FILED 10-29-2007.



THE MARK CONSISTS OF A HUMAN SKULL WITH PROTRUSIONS ON BOTH SIDES CONSISTING OF AN ENGLISH LETTER "D" ON THE RIGHT SIDE AND AN INVERTED ENGLISH LETTER "D" ON THE LEFT SIDE.

FOR CLOTHING, NAMELY, SHIRTS, SWEATSHIRTS AND HATS (U.S. CLS. 22 AND 39).

FIRST USE 11-15-2009; IN COMMERCE 11-15-2009.

3,998,338. AOM HOLDING, L.L.C., NEW YORK, NY. SN 76-703,753. PUB. 10-19-2010, FILED 7-12-2010.

ISLAND DREAM

THE MARK CONSISTS OF STANDARD CHARACTERS WITHOUT CLAIM TO ANY PARTICULAR FONT, STYLE, SIZE, OR COLOR.

FOR CLOTHING, NAMELY, SWIMWEAR, SHIRTS, TOPS, COVER-UPS, TANK TOPS, PANTS, TSHIRTS, HEADWEAR, FOOTWEAR, JACKETS, AND SOCKS (U.S. CLS. 22 AND 39).

FIRST USE 7-0-2010; IN COMMERCE 7-0-2010.

3,998,342. EQUI IN STYLE, LLC, GENEVA, FL. SN 76-704,588. PUB. 3-1-2011, FILED 9-21-2010.



FOR CLOTHING, NAMELY, SHIRTS, JACKETS, PANTS AND HATS (U.S. CLS. 22 AND 39).

FIRST USE 9-22-2010; IN COMMERCE 2-1-2011.

CLASS 25—(Continued).

3,998,353. MARSHALL, THOMAS L., HONOLULU, HI. SN 77-006,168. PUB. 5-12-2009, FILED 9-24-2006.



NO CLAIM IS MADE TO THE EXCLUSIVE RIGHT TO USE "GEAR", APART FROM THE MARK AS SHOWN.

THE MARK CONSISTS OF A DESIGN OF A HUMAN PULLING OUT ITS POCKETS NEXT TO THE WORDING "BROKE 2 GEAR".

FOR SHORT-SLEEVED OR LONG-SLEEVED T-SHIRTS (U.S. CLS. 22 AND 39).

FIRST USE 1-1-2006; IN COMMERCE 1-1-2006.

CLASS 25—(Continued).

3,998,381. JAKE AND TROY BRAND LLC, SANTA MONICA, CA. SN 77-134,234. PUB. 7-15-2008, FILED 3-19-2007.



THE MARK CONSISTS OF A DESIGN OF A SUN WITH RAYS WITH A FACE IN THE CENTER WHICH INCLUDES EYES, NOSE AND MOUTH WITH THE WORDING "SUBLIME" AT THE TOP OF THE SUN.

FOR BANDANAS; BASEBALL CAPS; BEANIES; CAPS; JACKETS; KNITTED CAPS; SHIRTS; SLEEVED OR SLEEVELESS JACKETS; SWEAT SHIRTS; T-SHIRTS; VISORS; HATS; TOPS (U.S. CLS. 22 AND 39).

FIRST USE 12-31-1992; IN COMMERCE 4-15-2011.

3,998,359. LEBLON HOLDINGS LLC, NEW YORK, NY. SN 77-063,656. PUB. 2-26-2008, FILED 12-13-2006.

LIVE LOVE LEBLON

THE MARK CONSISTS OF STANDARD CHARACTERS WITHOUT CLAIM TO ANY PARTICULAR FONT, STYLE, SIZE, OR COLOR.

OWNER OF U.S. REG. NO. 3,119,488.

FOR CLOTHING, NAMELY, T-SHIRTS, TANK TOPS, SARONGS, WRAPS, BEACH COVER-UPS; HEADWEAR, NAMELY, HATS, CAPS, VISORS (U.S. CLS. 22 AND 39).

FIRST USE 9-7-2010; IN COMMERCE 9-7-2010.

3,998,385. JOHN FOGERTY, LOS ANGELES, CA. AND JULIE FOGERTY, LOS ANGELES, CA. SN 77-170,490. PUB. 4-1-2008, FILED 5-1-2007.

FORTUNATE SON



THE MARK CONSISTS OF A HAND-ROLLED CIGARETTE WITH THE WORD "SUBLIME" IN THE MIDDLE OF IT.

FOR BANDANAS; BASEBALL CAPS; BEANIES; CAPS; HATS; JACKETS; KNITTED CAPS; SHIRTS; SLEEVED OR SLEEVELESS JACKETS; TOPS; SWEAT SHIRTS; T-SHIRTS; VISORS (U.S. CLS. 22 AND 39).

FIRST USE 12-31-1994; IN COMMERCE 4-15-2011.

THE MARK CONSISTS OF STANDARD CHARACTERS WITHOUT CLAIM TO ANY PARTICULAR FONT, STYLE, SIZE, OR COLOR.

FOR CLOTHING, NAMELY, JACKETS, SHIRTS, T-SHIRTS, TOPS, TANK TOPS, LONG SLEEVED SHIRTS, HATS, CAPS, SWEATSHIRTS, BANDANAS (U.S. CLS. 22 AND 39).

FIRST USE 0-0-2004; IN COMMERCE 0-0-2004.

CLASS 25—(Continued).

3,998,432. EDDY, MICHAEL, ORMOND BEACH, FL. SN 77-296,023. PUB. 3-18-2008, FILED 10-4-2007.

RABID FISH

THE MARK CONSISTS OF STANDARD CHARACTERS WITHOUT CLAIM TO ANY PARTICULAR FONT, STYLE, SIZE, OR COLOR.

FOR HATS; JACKETS; SWEAT SHIRTS; T-SHIRTS; TANK TOPS (U.S. CLS. 22 AND 39).
FIRST USE 7-1-2008; IN COMMERCE 5-15-2011.

CLASS 25—(Continued).

3,998,457. WYLIE, FRANK, NORMAL, IL. SN 77-381,098. PUB. 6-10-2008, FILED 1-25-2008.

BIG WILLY

THE MARK CONSISTS OF STANDARD CHARACTERS WITHOUT CLAIM TO ANY PARTICULAR FONT, STYLE, SIZE, OR COLOR.

FOR JACKETS; PANTS; SHIRTS; SHOES (U.S. CLS. 22 AND 39).
FIRST USE 6-8-2010; IN COMMERCE 2-12-2011.

3,998,439. MARVEL CHARACTERS, INC., MANHATTAN BEACH, CA. SN 77-307,186. PUB. 3-23-2010, FILED 10-18-2007.

SUPER HERO SQUAD

THE MARK CONSISTS OF STANDARD CHARACTERS WITHOUT CLAIM TO ANY PARTICULAR FONT, STYLE, SIZE, OR COLOR.

OWNER OF U.S. REG. NOS. 1,073,580, 3,045,687, AND OTHERS.

FOR BELTS; BOOTS; CAPS; GLOVES; HALLOWEEN COSTUMES; HALLOWEEN COSTUMES AND MASKS SOLD IN CONNECTION THEREWITH; HATS; SANDALS; SHOES; SLEEPWEAR; SNEAKERS; SOCKS; SWEAT PANTS; SWEAT SHIRTS; T-SHIRTS; UNDERWEAR; VESTS; VISORS; SWIMWEAR (U.S. CLS. 22 AND 39).
FIRST USE 12-10-2009; IN COMMERCE 12-10-2009.

3,998,473. ABRAMS AIRBORNE MANUFACTURING, INC., DBA VLTOR WEAPON SYSTEMS, TUCSON, AZ. SN 77-418,723. PUB. 6-10-2008, FILED 3-11-2008.

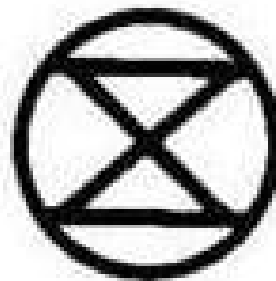

THE MARK CONSISTS OF A CIRCLE SURROUNDING THE LETTER "X".

FOR CLOTHING, NAMELY, HATS AND SHIRTS (U.S. CLS. 22 AND 39).
FIRST USE 5-31-2011; IN COMMERCE 5-31-2011.

3,998,455. ABRAMS AIRBORNE MANUFACTURING, INC., DBA VLTOR WEAPON SYSTEMS, TUCSON, AZ. SN 77-379,157. PUB. 6-10-2008, FILED 1-24-2008.

BREN TEN

THE MARK CONSISTS OF STANDARD CHARACTERS WITHOUT CLAIM TO ANY PARTICULAR FONT, STYLE, SIZE, OR COLOR.

FOR CLOTHING, NAMELY, SHIRTS AND HATS (U.S. CLS. 22 AND 39).
FIRST USE 5-31-2011; IN COMMERCE 5-31-2011.

3,998,474. GRUPO KALTEX S.A. DE C.V., NAUCALPAN DE JUAREZ, MEXICO. SN 77-421,303. PUB. 2-24-2009, FILED 3-13-2008.

KNAPP & TULLY

THE MARK CONSISTS OF STANDARD CHARACTERS WITHOUT CLAIM TO ANY PARTICULAR FONT, STYLE, SIZE, OR COLOR.

OWNER OF U.S. REG. NOS. 2,302,333, 2,383,505, AND OTHERS.

CLASS 25—(Continued).

THE NAME(S), PORTRAIT(S), AND/OR SIGNATURE(S) SHOWN IN THE MARK DOES NOT IDENTIFY A PARTICULAR LIVING INDIVIDUAL.

FOR MEN'S, WOMEN'S, CHILDREN'S CLOTHING AND OUTER WEAR, NAMELY, OVER COATS, RAIN COATS, TOP COATS, JACKETS, HATS, GLOVES, SHOES; FORMAL WEAR, NAMELY, TUXEDOS, EVENING JACKETS, EVENING GOWNS; BEACH COVER-UPS, UNDERGARMENTS, LOUNGEWEAR, SPORTSWEAR, NAMELY, SHIRTS, SWEATSHIRTS, SHORTS, SOCKS, PANTS; ACCESSORIES, NAMELY, KERCHIEFS; DRESSES, JUMPERS, SUITS, JEANS, SKIRTS, OVERALLS, BERMUDA SHORTS, VESTS, COATS AND BLOUSES (U.S. CLS. 22 AND 39).

FIRST USE 4-13-2011; IN COMMERCE 4-13-2011.

3,998,502. SWIFTWICK INTERNATIONAL, LLC, BRENTWOOD, TN. SN 77-506,423. PUB. 3-23-2010, FILED 6-24-2008.



THE MARK CONSISTS OF THE WORDING, "SWIFTWICK", WHICH APPEARS TO THE RIGHT OF A DESIGN COMPRISING AN ELONGATED DIAMOND SHAPE SUSPENDED BETWEEN 2 TRAPEZOIDS CONVERGING DOWNWARD TO FORM THE SHAPE OF A DISSECTED LETTER "V".

FOR SOCKS; HATS; HEADBANDS; SPORTS PANTS; SPORTS SHIRTS; SWEAT BANDS; T-SHIRTS; WRIST BANDS (U.S. CLS. 22 AND 39).

FIRST USE 3-1-2007; IN COMMERCE 3-1-2007.

3,998,529. LA FAMIGLIA WAXHAMMER AB, VIMMERBY, SWEDEN. SN 77-565,472. PUB. 2-2-2010, FILED 9-9-2008.



THE MARK CONSISTS OF THE STYLIZED WORDING "WAX WAXHAMMER ALMIGHTY XTREME".

FOR CLOTHING, NAMELY, BEACH WEAR, BELTS; JACKETS; JEANS; JERSEYS; NECK WEAR; PANTS; SCARVES; SHORTS; SWEAT PANTS; SWEATSHIRTS; SWEATERS; SWIMWEAR; TOPS; FOOTWEAR; HEADWEAR, NAMELY, HATS, CAPS, BANDANAS, VISORS (U.S. CLS. 22 AND 39).

FIRST USE 0-0-2004; IN COMMERCE 9-1-2009.

CLASS 25—(Continued).

3,998,553. ROCK AND ROLL RELIGION, INC., LOS ANGELES, CA. SN 77-589,738. PUB. 3-3-2009, FILED 10-9-2008.

XISSES

THE MARK CONSISTS OF STANDARD CHARACTERS WITHOUT CLAIM TO ANY PARTICULAR FONT, STYLE, SIZE, OR COLOR.

FOR SHIRTS; T-SHIRTS (U.S. CLS. 22 AND 39).

FIRST USE 1-14-2011; IN COMMERCE 1-14-2011.

3,998,566. HOME BOX OFFICE, INC., NEW YORK, NY. SN 77-603,725. PUB. 9-15-2009, FILED 10-30-2008.

HOW TO MAKE IT IN AMERICA

THE MARK CONSISTS OF STANDARD CHARACTERS WITHOUT CLAIM TO ANY PARTICULAR FONT, STYLE, SIZE, OR COLOR.

FOR CLOTHING, NAMELY, T-SHIRTS, HOODED SWEAT SHIRTS (U.S. CLS. 22 AND 39).

FIRST USE 2-8-2010; IN COMMERCE 2-8-2010.

3,998,649. VELASCO, JUAN G., JACKSON HEIGHTS, NY. SN 77-720,221. PUB. 9-1-2009, FILED 4-22-2009.

MENTAL AESTHETICS

THE MARK CONSISTS OF STANDARD CHARACTERS WITHOUT CLAIM TO ANY PARTICULAR FONT, STYLE, SIZE, OR COLOR.

FOR T-SHIRTS (U.S. CLS. 22 AND 39).

FIRST USE 10-23-2010; IN COMMERCE 10-23-2010.

CLASS 25—(Continued).

3,998,658. HOME BOX OFFICE, INC., NEW YORK, NY. SN 77-726,086. PUB. 9-15-2009, FILED 4-30-2009.

BOARDWALK EMPIRE

THE MARK CONSISTS OF STANDARD CHARACTERS WITHOUT CLAIM TO ANY PARTICULAR FONT, STYLE, SIZE, OR COLOR.

FOR CLOTHING, NAMELY, T-SHIRTS; HEADWEAR, NAMELY, CAPS (U.S. CLS. 22 AND 39).

FIRST USE 8-9-2010; IN COMMERCE 8-9-2010.

3,998,688. KERRITS ACTIVEWEAR, INC. A WASHINGTON CORPORATION, BINGEN, WA. SN 77-755,704. PUB. 10-20-2009, FILED 6-9-2009.

Slender Rider

THE MARK CONSISTS OF STANDARD CHARACTERS WITHOUT CLAIM TO ANY PARTICULAR FONT, STYLE, SIZE, OR COLOR.

NO CLAIM IS MADE TO THE EXCLUSIVE RIGHT TO USE "RIDER", APART FROM THE MARK AS SHOWN.

FOR CLOTHING, NAMELY, PERFORMANCE EQUESTRIAN RIDING TIGHTS AND CAPRIS (U.S. CLS. 22 AND 39).

FIRST USE 8-10-2010; IN COMMERCE 1-1-2011.

3,998,695. LEXANI HOLDINGS, INC., CORONA, CA. SN 77-764,400. PUB. 6-8-2010, FILED 6-19-2009.

LSD

THE MARK CONSISTS OF STANDARD CHARACTERS WITHOUT CLAIM TO ANY PARTICULAR FONT, STYLE, SIZE, OR COLOR.

FOR CLOTHING, NAMELY, TOPS, BOTTOMS, SHIRTS, PANTS, SHORTS, SKIRTS, SWEATERS, SWEATSHIRTS, DRESSES, SOCKS, SWIM WEAR, GLOVES, PAJAMAS, NIGHT GOWNS, HEADWEAR, AND FOOTWEAR; OUTERWEAR, NAMELY, JACKETS AND COATS (U.S. CLS. 22 AND 39).

FIRST USE 1-1-2011; IN COMMERCE 1-1-2011.

CLASS 25—(Continued).

3,998,696. LEXANI HOLDINGS, INC., CORONA, CA. SN 77-764,405. PUB. 6-8-2010, FILED 6-19-2009.

LEXANI STREET DIVISION

THE MARK CONSISTS OF STANDARD CHARACTERS WITHOUT CLAIM TO ANY PARTICULAR FONT, STYLE, SIZE, OR COLOR.

OWNER OF U.S. REG. NOS. 2,666,445, 3,497,324, AND 3,596,491.

FOR CLOTHING, NAMELY, TOPS, BOTTOMS, SHIRTS, PANTS, SHORTS, SKIRTS, SWEATERS, SWEATSHIRTS, DRESSES, SOCKS, SWIM WEAR, GLOVES, PAJAMAS, NIGHT GOWNS, HEADWEAR, AND FOOTWEAR; OUTERWEAR, NAMELY, JACKETS AND COATS (U.S. CLS. 22 AND 39).

FIRST USE 1-1-2008; IN COMMERCE 1-1-2011.

3,998,704. NUERA GROUP INC., S. EL MONTE, CA. SN 77-769,729. PUB. 1-4-2011, FILED 6-28-2009.

Giorgio Armani

"GIORGIO ARMANI" DOES NOT IDENTIFY A LIVING INDIVIDUAL.

THE MARK CONSISTS OF THE STYLIZED WORDING "GIORGIO ARMANI".

FOR ATHLETIC SHOES; FOOTBALL SHOES; GOLF SHOES; INFANTS' SHOES AND BOOTS; LEISURE SHOES; SHOES; SOCCER SHOES; TENNIS SHOES; WOMEN'S SHOES (U.S. CLS. 22 AND 39).

FIRST USE 1-2-2011; IN COMMERCE 1-2-2011.

3,998,711. JESKI, KENNETH R., SOUTH WINDSOR, CT. SN 77-778,934. PUB. 12-1-2009, FILED 7-10-2009.

Work Ethic

THE MARK CONSISTS OF STANDARD CHARACTERS WITHOUT CLAIM TO ANY PARTICULAR FONT, STYLE, SIZE, OR COLOR.

FOR HATS; SHIRTS; SHOES (U.S. CLS. 22 AND 39).

FIRST USE 3-7-2011; IN COMMERCE 3-7-2011.

CLASS 25—(Continued).

3,998,714. DAVID EUGENE EMBREE, SPRINGFIELD, MO.
SN 77-784,235. PUB. 6-15-2010, FILED 7-18-2009.

Feral Geezer

THE MARK CONSISTS OF STANDARD CHARACTERS WITHOUT CLAIM TO ANY PARTICULAR FONT, STYLE, SIZE, OR COLOR.

FOR SHORT-SLEEVED OR LONG-SLEEVED T-SHIRTS (U.S. CLS. 22 AND 39).
FIRST USE 2-25-2009; IN COMMERCE 5-25-2009.

3,998,717. BIG E LINEMAN, INC., BEAR, DE. SN 77-788,858.
PUB. 12-29-2009, FILED 7-24-2009.



THE MARK CONSISTS OF THE BACKGROUND IS A NARROW HEXAGON WITH TWO OUTER LININGS ENCLOSING A BRICK HEXAGON. A PROLATE SPHEROID SHAPED FOOTBALL OVERLAPS THE BOTTOM END SIDES OF THE HEXAGON WHERE THE SIDES INTERSECT. THE FOOTBALL HAS THREE LACES IN THE MIDDLE AND TWO LACES EXTENDING FROM EACH END OF THE FOOTBALL TO THE MIDDLE. THE LITERAL ELEMENT "WALL LINEMAN" OVERLAPS THE HEXAGON. THE "LINEMAN" IS IN UPPER CASE ACROSS A BANNER WHICH EXTENDS FROM THE SIDES OF THE HEXAGON. EACH SIDE OF THE BANNER HAS TWO RIGHT TRIANGLES EXTENDING OUT FROM THE MARK. ABOVE THE BANNER IS THE LITERAL ELEMENT "WALL" IN UPPER CASE WITH A THIN OUTER LINING. THE TWO SIDES OF THE HEXAGON ARE NOT STRAIGHT THE SIDES ARE SLIGHTLY WAVED.

FOR HATS; JACKETS; SHIRTS; SHOES; SHORTS; SWEAT PANTS; SWEAT SHIRTS; SWEAT SHORTS; T-SHIRTS (U.S. CLS. 22 AND 39).
FIRST USE 5-1-2010; IN COMMERCE 6-1-2010.

CLASS 25—(Continued).

3,998,732. TC VENTURES, LLC, GROTON, SD. SN 77-800,575.
PUB. 4-6-2010, FILED 8-10-2009.

Team Cocktail

THE MARK CONSISTS OF STANDARD CHARACTERS WITHOUT CLAIM TO ANY PARTICULAR FONT, STYLE, SIZE, OR COLOR.

FOR CLOTHING AND BEACH APPAREL, NAMELY, SHIRTS, SWEATSHIRTS, JACKETS, HATS AND VISORS, AND SWIMSUITS (U.S. CLS. 22 AND 39).

FIRST USE 7-0-2010; IN COMMERCE 7-0-2010.

3,998,769. COGNITIVE SCIENCE LLC, ITHACA, NY. SN 77-827,358. PUB. 1-26-2010, FILED 9-16-2009.

MINDLESS

THE MARK CONSISTS OF STANDARD CHARACTERS WITHOUT CLAIM TO ANY PARTICULAR FONT, STYLE, SIZE, OR COLOR.

FOR WRISTBANDS, HATS, CAPS, SHIRTS, T-SHIRTS, SWEATSHIRTS, JACKETS, BELTS, TIES, WARM-UP SUITS (U.S. CLS. 22 AND 39).

FIRST USE 5-13-2009; IN COMMERCE 5-13-2009.

3,998,781. SAFEGUARD INDUSTRIAL SUPPLY, LLC, THOROFARE, NJ. SN 77-831,987. PUB. 3-9-2010, FILED 9-22-2009.

SHIELDTECH

THE MARK CONSISTS OF STANDARD CHARACTERS WITHOUT CLAIM TO ANY PARTICULAR FONT, STYLE, SIZE, OR COLOR.

FOR PROTECTIVE CLOTHING, NAMELY, COVERALLS, APRONS, LABCOATS, RAINCOATS, PONCHOS, RAINSUITS, GLOVES, SLEEVES, BOUFFANT CAPS, BEARD COVERS, AND SHOE COVERS (U.S. CLS. 22 AND 39).

FIRST USE 6-16-2010; IN COMMERCE 6-16-2010.

CLASS 25—(Continued).

3,998,790. HUTTON, JULIA R., PHOENIX, AZ. SN 77-834,768.
PUB. 6-29-2010, FILED 9-25-2009.



THE NAME(S), PORTRAIT(S), AND/OR SIGNATURE(S) SHOWN IN THE MARK DOES NOT IDENTIFY A PARTICULAR LIVING INDIVIDUAL.

FOR BANDANAS; DENIM JACKETS; HEAD SCARVES; HEAD WEAR; HEADGEAR, NAMELY, HATS, BASEBALL CAPS, WOOLLY CAPS, DOO RAGS IN THE NATURE OF A BANDANNA; JACKETS; LEATHER JACKETS; LEATHER PANTS; MOTORCYCLE JACKETS; NECKERCHIEFS; PANTS; SCARVES; SHIRTS; SKULL CAPS; T-SHIRTS; TANK-TOPS; TEE SHIRTS (U.S. CLS. 22 AND 39).

FIRST USE 8-1-2009; IN COMMERCE 7-1-2010.

3,998,792. LACROSSE FOOTWEAR, INC., PORTLAND, OR.
SN 77-834,947. PUB. 10-5-2010, FILED 9-25-2009.



NO CLAIM IS MADE TO THE EXCLUSIVE RIGHT TO USE "ESTABLISHED 1897", APART FROM THE MARK AS SHOWN.

THE MARK CONSISTS OF A STYLIZED REPRESENTATION OF AN INDIAN HEAD FOLLOWED BY THE TERM "LACROSSE" ALL OF WHICH IS LISTED ABOVE THE PHRASE "ESTABLISHED 1897" WITH ALL OF THE AFORMENTIONED ENCLOSED BY A SIX POINT BORDER.

FOR FOOTWEAR (U.S. CLS. 22 AND 39).
FIRST USE 7-31-2010; IN COMMERCE 7-31-2010.

CLASS 25—(Continued).

3,998,796. BARTON, MACY, NEWPORT BEACH, CA. SN 77-836,472. PUB. 3-2-2010, FILED 9-28-2009.

WORLD JUNGLE

THE MARK CONSISTS OF STANDARD CHARACTERS WITHOUT CLAIM TO ANY PARTICULAR FONT, STYLE, SIZE, OR COLOR.

FOR CLOTHING, NAMELY, LONG AND SHORT SLEEVED T-SHIRTS, SHIRTS, SHORTS, SWIMWEAR AND HEADWEAR NAMELY, CAPS (U.S. CLS. 22 AND 39).

FIRST USE 3-15-2011; IN COMMERCE 4-4-2011.

3,998,812. CRIQUET APPAREL, LLC, AUSTIN, TX. SN 77-840,567. PUB. 9-21-2010, FILED 10-2-2009.

CRICQUET

THE MARK CONSISTS OF STANDARD CHARACTERS WITHOUT CLAIM TO ANY PARTICULAR FONT, STYLE, SIZE, OR COLOR.

FOR ORGANIC COTTON GOLF-STYLE COLLARED SHIRTS (U.S. CLS. 22 AND 39).

FIRST USE 11-19-2010; IN COMMERCE 11-19-2010.

3,998,813. KINCAID, TERRY C., DBA WILD & WOOLLY,
ASTOR, FL. SN 77-840,798. PUB. 3-2-2010, FILED 10-3-2009.

Wild & Woolly

THE MARK CONSISTS OF STANDARD CHARACTERS WITHOUT CLAIM TO ANY PARTICULAR FONT, STYLE, SIZE, OR COLOR.

FOR CAMOUFLAGE SHIRTS; CAMP SHIRTS; FISHING SHIRTS; GOLF SHIRTS; HOODED SWEAT SHIRTS; HUNTING SHIRTS; KNIT SHIRTS; LONG-SLEEVED SHIRTS; NIGHT SHIRTS; POLO SHIRTS; RUGBY SHIRTS; SHIRTS AND SHORT-SLEEVED SHIRTS; SHORT-SLEEVED OR LONG-SLEEVED T-SHIRTS; SHORT-SLEEVED SHIRTS; SLEEP SHIRTS; SWEAT SHIRTS; T-SHIRTS; TEE SHIRTS; WEARABLE GARMENTS AND CLOTHING, NAMELY, SHIRTS; WIND SHIRTS (U.S. CLS. 22 AND 39).

FIRST USE 10-1-2009; IN COMMERCE 10-1-2009.

CLASS 25—(Continued).

3,998,826. GAKM RESOURCES LLC, NEWTON, NC. SN 77-847,485. PUB. 9-7-2010, FILED 10-13-2009.

GOLD TOE

THE MARK CONSISTS OF STANDARD CHARACTERS WITHOUT CLAIM TO ANY PARTICULAR FONT, STYLE, SIZE, OR COLOR.

OWNER OF U.S. REG. NOS. 770,389, 2,751,736, AND OTHERS.

FOR CLOTHING, NAMELY, SHIRTS, PANTS, SHORTS, AND UNDERWEAR, FOOTWEAR, AND HEADWEAR (U.S. CLS. 22 AND 39).

FIRST USE 7-1-2010; IN COMMERCE 7-1-2010.

CLASS 25—(Continued).

3,998,864. UNDISPUTED INTERNATIONAL LLC, WASHINGTON, DC. SN 77-857,000. PUB. 2-16-2010, FILED 10-26-2009.

LONDON PRIZE RING

THE MARK CONSISTS OF STANDARD CHARACTERS WITHOUT CLAIM TO ANY PARTICULAR FONT, STYLE, SIZE, OR COLOR.

FOR T-SHIRTS (U.S. CLS. 22 AND 39).

FIRST USE 5-11-2011; IN COMMERCE 5-11-2011.

3,998,828. GAKM RESOURCES LLC, NEWTON, NC. SN 77-847,496. PUB. 9-7-2010, FILED 10-13-2009.

GOLDTOE

THE MARK CONSISTS OF STANDARD CHARACTERS WITHOUT CLAIM TO ANY PARTICULAR FONT, STYLE, SIZE, OR COLOR.

OWNER OF U.S. REG. NOS. 770,389, 3,442,946, AND OTHERS.

FOR CLOTHING, NAMELY, SHIRTS, PANTS, SHORTS, AND UNDERWEAR, FOOTWEAR, AND HEADWEAR (U.S. CLS. 22 AND 39).

FIRST USE 7-1-2010; IN COMMERCE 7-1-2010.

3,998,873. GRIMES, MICHELE, FORKED RIVER, NJ. AND PUGLIA, DAWN, FORKED RIVER, NJ. SN 77-859,178. PUB. 4-6-2010, FILED 10-28-2009.

1440 MARK YOUR MINUTE

THE MARK CONSISTS OF STANDARD CHARACTERS WITHOUT CLAIM TO ANY PARTICULAR FONT, STYLE, SIZE, OR COLOR.

FOR T-SHIRTS (U.S. CLS. 22 AND 39).

FIRST USE 11-1-2010; IN COMMERCE 10-25-2010.

3,998,848. SPHEERIS, PENELOPE, STUDIO CITY, CA. SN 77-854,462. PUB. 9-28-2010, FILED 10-21-2009.

**THE DECLINE OF WESTERN
CIVILIZATION**

THE MARK CONSISTS OF STANDARD CHARACTERS WITHOUT CLAIM TO ANY PARTICULAR FONT, STYLE, SIZE, OR COLOR.

FOR CLOTHING, NAMELY, SHIRTS, T-SHIRTS (U.S. CLS. 22 AND 39).

FIRST USE 5-17-2011; IN COMMERCE 5-17-2011.

3,998,876. WICKED QUICK INDUSTRIES, INC., PORTLAND, OR. SN 77-860,967. PUB. 4-6-2010, FILED 10-29-2009.

MAD FAST

THE MARK CONSISTS OF STANDARD CHARACTERS WITHOUT CLAIM TO ANY PARTICULAR FONT, STYLE, SIZE, OR COLOR.

FOR CLOTHING, NAMELY, T-SHIRTS, HATS, AND BEANIES (U.S. CLS. 22 AND 39).

FIRST USE 10-29-2009; IN COMMERCE 10-29-2009.

CLASS 25—(Continued).

3,998,879. J.C. PENNEY PRIVATE BRANDS, INC., PLANO, TX. SN 77-861,171. PUB. 11-16-2010, FILED 10-30-2009.

PRO-TEC-SUN

THE MARK CONSISTS OF STANDARD CHARACTERS WITHOUT CLAIM TO ANY PARTICULAR FONT, STYLE, SIZE, OR COLOR.

FOR CLOTHING FOR CHILDREN, NAMELY, WOVEN SHIRTS, KNIT SHIRTS, PANTS, SHORTS AND OUTERWEAR, NAMELY, SWIM COVER-UPS AND RASH GUARDS, AND WATER SHOES (U.S. CLS. 22 AND 39).

FIRST USE 5-1-2010; IN COMMERCE 5-1-2010.

CLASS 25—(Continued).

3,998,897. SUSAN MARIE KAMINSKY, GILBERT, AZ. SN 77-864,411. PUB. 4-13-2010, FILED 11-3-2009.

U2RBLESSED

THE MARK CONSISTS OF STANDARD CHARACTERS WITHOUT CLAIM TO ANY PARTICULAR FONT, STYLE, SIZE, OR COLOR.

FOR CLOTHING, NAMELY, SHIRTS, T-SHIRTS, HEADGEAR, NAMELY, HATS, CAPS (U.S. CLS. 22 AND 39).

FIRST USE 10-25-2009; IN COMMERCE 10-25-2009.

3,998,934. KRAMER, BRADLEY I., LOS ANGELES, CA. SN 77-880,114. PUB. 4-27-2010, FILED 11-24-2009.

Kid Cannabis

THE MARK CONSISTS OF STANDARD CHARACTERS WITHOUT CLAIM TO ANY PARTICULAR FONT, STYLE, SIZE, OR COLOR.

NO CLAIM IS MADE TO THE EXCLUSIVE RIGHT TO USE "CANNABIS", APART FROM THE MARK AS SHOWN.

FOR A-SHIRTS; ADHESIVE BRAS; ADULT NOVELTY GAG CLOTHING ITEM, NAMELY, SOCKS; ANGLERS' SHOES; ANKLE SOCKS; ANKLETS; ANTI-PERSPIRANT SOCKS; APRES-SKI SHOES; ATHLETIC APPAREL, NAMELY, SHIRTS, PANTS, JACKETS, FOOTWEAR, HATS AND CAPS, ATHLETIC UNIFORMS; ATHLETIC FOOTWEAR; ATHLETIC SHOES; BABY LAYETTES FOR CLOTHING; BABY TOPS; BALLET SHOES; BALLROOM DANCING SHOES; BANDANAS; BASEBALL CAPS; BASEBALL SHOES; BASELAYER TOPS; BATHING CAPS; BATHING COSTUMES; BATHING COSTUMES FOR WOMEN; BEACH FOOTWEAR; BEACH SHOES; BEACHWEAR; BED JACKETS; BELTS; BELTS FOR CLOTHING; BELTS MADE OUT OF CLOTH; BIBS NOT OF CLOTH OR PAPER; BICYCLE GLOVES; BICYCLING GLOVES; BODY SHIRTS; BOMBER JACKETS; BOTTOMS; BOWLING SHOES; BOXING SHOES; BRAS; BRIEFS; BUCKET CAPS; BUTTON-FRONT ALOHA SHIRTS; CAMOUFLAGE GLOVES; CAMOUFLAGE JACKETS; CAMOUFLAGE SHIRTS; CAMP SHIRTS; CANVAS SHOES; CAP PEAKS; CAP VISORS; CAPS; CAPS WITH VISORS; CHEF'S HATS; CHILDREN'S AND INFANTS' CLOTH BIBS; CHILDREN'S CLOTH EATING BIBS; CLEATS FOR ATTACHMENT TO SPORTS SHOES; CLIMBING FOOTWEAR; CLOTH BIBS; CLOTH BIBS FOR ADULT DINERS; CLOTH BIBS FOR USE BY SENIOR CITIZENS OR PHYSICALLY- OR MENTALLY-CHALLENGED PERSONS; CLOTH DIAPERS; CLOTHING FOR ATHLETIC USE, NAMELY, PADDED ELBOW COMPRESSION SLEEVES; CLOTHING FOR ATHLETIC USE, NAMELY, PADDED PANTS; CLOTHING FOR ATHLETIC USE, NAMELY, PADDED SHIRTS; CLOTHING FOR ATHLETIC USE, NAMELY, PADDED SHORTS; CLOTHING FOR WEAR IN JUDO PRACTICES; CLOTHING FOR WEAR IN WRESTLING GAMES; CLOTHING ITEMS, NAMELY, ADHESIVE POCKETS THAT MAY BE AFFIXED DIRECTLY TO THE BODY AS A DECORATIVE PIECE OF CLOTHING WITH UTILITY; CLOTHING ITEMS, NAMELY, ADHESIVE POCKETS THAT MAY BE AFFIXED DIRECTLY TO THE INSIDE OF CLOTHING FOR STORAGE AND

3,998,887. GAKM RESOURCES LLC, NEWTON, NC. SN 77-862,744. PUB. 8-17-2010, FILED 11-2-2009.



OWNER OF U.S. REG. NOS. 2,781,598 AND 2,781,599. THE COLOR(S) GOLD IS/ARE CLAIMED AS A FEATURE OF THE MARK.

THE MARK CONSISTS OF A STYLIZED LETTER "G" IN A GOLD COLOR.

FOR CLOTHING, NAMELY, SHIRTS, UNDERWEAR (U.S. CLS. 22 AND 39).

FIRST USE 5-25-2010; IN COMMERCE 5-25-2010.

CLASS 25—(Continued).

SAFEKEEPING OF PERSONAL ITEMS; CLOTHING, NAMELY, ARM WARMERS; CLOTHING, NAMELY, BASE LAYERS; CLOTHING, NAMELY, FOLK COSTUMES; CLOTHING, NAMELY, HAND-WARMERS; CLOTHING, NAMELY, KHAKIS; CLOTHING, NAMELY, KNEE WARMERS; CLOTHING, NAMELY, MATERNITY BANDS; CLOTHING, NAMELY, NECK TUBES; CLOTHING, NAMELY, THOBES; CLOTHING, NAMELY, WRAP-AROUNDS; COATS; COATS FOR MEN AND WOMEN; COATS MADE OF COTTON; COATS OF DENIM; CORSETS; COSTUMES FOR USE IN CHILDREN'S DRESS UP PLAY; COSTUMES FOR USE IN ROLE-PLAYING GAMES; CREW NECK SWEATERS; CROP TOPS; CROSS-COUNTRY GLOVES; CYCLING SHOES; DANCE COSTUMES; DANCE SHOES; DECK-SHOES; DENIM JACKETS; DISPOSABLE UNDERWEAR; DOWN JACKETS; DRESS SHIRTS; DRESSES THAT MAY ALSO BE USED AS TOWELS; DRIVERS; DUST COATS; DUSTERS; EYESHADES; FISHERMEN'S JACKETS; FISHING SHIRTS; FITTED SHOE OR BOOT COVERING TO PROTECT THE SHOES OR BOOT FROM WATER OR OTHER DAMAGE; FITTED SWIMMING COSTUMES WITH BRA CUPS; FLIP FLOPS; FOOTBALL SHOES; FOOTWEAR; FOOTWEAR; FOOTWEAR FOR MEN; FOOTWEAR FOR MEN AND WOMEN; FOOTWEAR FOR TRACK AND FIELD ATHLETICS; FOOTWEAR FOR WOMEN; FOOTWEAR MADE OF WOOD; FOOTWEAR NOT FOR SPORTS; FOOTWEAR, NAMELY, PUMPS; FOOTWEAR, NAMELY, RUBBERS; FOOTWEAR, NAMELY, WORK BOOTS; FOULARDS; FROCKS; FUR COATS; FUR COATS AND JACKETS; FUR HATS; FUR JACKETS; GIFT PACKAGES SOLD AS A UNIT CONSISTING PRIMARILY OF A SWEATSHIRT AND ALSO INCLUDING A PHOTO FRAME, A COFFEE MUG, AND A TOTE BAG; GLOVES; GLOVES AS CLOTHING; GLOVES FOR PERSONAL HAND CONDITIONING USE; GLOVES INCLUDING THOSE MADE OF SKIN, HIDE OR FUR; GOLF CAPS; GOLF PANTS, SHIRTS AND SKIRTS; GOLF SHIRTS; GOLF SHOES; GYMNASIUM SHOES; HALLOWEEN COSTUMES; HALLOWEEN COSTUMES AND MASKS SOLD IN CONNECTION THEREWITH; HALTER TOPS; HANDBALL SHOES; HAT BANDS; HATS; HATS FOR INFANTS, BABIES, TODDLERS AND CHILDREN; HEAD WEAR; HEADBANDS AGAINST SWEATING; HEADBANDS FOR CLOTHING; HEAVY COATS; HEAVY JACKETS; HEEL PIECES FOR SHOES; HOCKEY SHOES; HOODED SWEAT SHIRTS; HOODS; HUNTING JACKETS; HUNTING SHIRTS; INFANT AND TODDLER ONE PIECE CLOTHING; INFANT CLOTH DIAPERS; INFANT WEAR; INFANTS' SHOES AND BOOTS; INSOLES; INSOLES FOR FOOTWEAR; JACKET LINERS; JACKETS; JACKETS AND SOCKS; JAPANESE FOOTWEAR OF RICE STRAW (WARAJI); JAPANESE SPLIT-TOED WORK FOOTWEAR (JIKATABI); JAPANESE STYLE SOCKS (TABI COVERS); JAPANESE STYLESOCKS (TABI); JEANS; JERSEYS; KNIT SHIRTS; KNITTED CAPS; KNITTED GLOVES; KNITTED UNDERWEAR; KNOT CAPS; KNOTTED CAPS; LAB COATS; LADIES' UNDERWEAR; LEATHER BELTS; LEATHER COATS; LEATHER JACKETS; LEATHER SHOES; LEISURE SHOES; LIGHT-REFLECTING COATS; LIGHT-REFLECTING JACKETS; LINGERIE; LINGERIE ACCESSORIES, NAMELY, REMOVABLE SILICONE BREAST ENHANCER PADS USED IN A BRA; LONG JACKETS; LONG UNDERWEAR; LONG-SLEEVED SHIRTS; LOUNGEWEAR; MANTLES; MASQUERADE COSTUMES; MASQUERADE COSTUMES AND MASKS SOLD IN CONNECTION THEREWITH; MATERNITY BRAS; MATERNITY LINGERIE; MEN'S AND WOMEN'S JACKETS, COATS, TROUSERS, VESTS; MEN'S DRESS SOCKS; MEN'S SOCKS; MEN'S UNDERWEAR; MOCK TURTLE-NECK SWEATERS; MOISTURE-WICKING SPORTS BRAS; MOISTURE-WICKING SPORTS SHIRTS; MORNING COATS; MOTORCYCLE GLOVES; MOTORCYCLE JACKETS; MOUNTAINEERING SHOES; MUFFLERS; MUSCLE TOPS; NECKWEAR; NIGHT SHIRTS; NON-DISPOSABLE CLOTH TRAINING PANTS; OPEN-NECKED SHIRTS; OUTDOOR GLOVES; OUTER JACKETS; OVER COATS; OVER SHIRTS; PADDED JACKETS; PADDING JACKETS; PAPER HATS FOR USE AS CLOTHING ITEMS; PAPER SHOES USED WHEN GOING THROUGH METAL DETECTORS TO KEEP FEET AND SOCKS CLEAN; PARTS OF CLOTHING, NAMELY, GUSSETS FOR TIGHTS, GUSSETS FOR STOCKINGS, GUSSETS FOR BATHING SUITS, GUSSETS FOR UNDERWEAR, GUSSETS FOR LEOTARDS AND GUSSETS

CLASS 25—(Continued).

FOR FOOTLETS; PARTS OF CLOTHING, NAMELY, UNDERARM GUSSETS; PARTY HATS; PERSPIRATION ABSORBENT STRAP TO BE USED IN THE BILL OF A HAT; PERSPIRATION ABSORBENT UNDERWEAR CLOTHING; PIQUE SHIRTS; POCKET SQUARES; POLO SHIRTS; PROTECTIVE METAL MEMBERS FOR SHOES AND BOOTS; PUMPS; RAIN COATS; RAIN HATS; RAIN JACKETS; RAINPROOF JACKETS; RAINWEAR; REVERSIBLE JACKETS; RIDING COATS; RIDING GLOVES; RIDING SHOES; RUBBER SHOES; RUGBY SHIRTS; RUGBY SHOES; RUGBY TOPS; RUNNING SHOES; SANDALS AND BEACH SHOES; SCIENTIFIC AND TECHNOLOGICAL APPAREL, NAMELY, SHIRTS, PANTS, JACKETS, FOOTWEAR, HATS AND CAPS, UNIFORMS; SEDGE HATS (SUGE-GASA); SHELL JACKETS; SHIRTS; SHIRT FRONTS; SHIRT YOKES; SHIRTS; SHIRTS AND SHORT-SLEEVED SHIRTS; SHIRTS FOR INFANTS, BABIES, TODDLERS AND CHILDREN; SHIRTS FOR SUITS; SHOE DOWELS; SHOE INSERTS FOR PRIMARILY NON-ORTHOPEDIC PURPOSES; SHOE PEGS; SHOE SOLES; SHOE STRAPS; SHOES; SHOES SOLES FOR REPAIR; SHORT SETS; SHORT-SLEEVED OR LONG-SLEEVED T-SHIRTS; SHORT-SLEEVED SHIRTS; SHOULDER WRAPS; SHOULDER WRAPS FOR CLOTHING; SHOWER CAPS; SKI AND SNOWBOARD SHOES AND PARTS THEREOF; SKI GLOVES; SKI JACKETS; SKI WEAR; SKIING SHOES; SKULL CAPS; SLEEP SHIRTS; SLEEVED OR SLEEVELESS JACKETS; SMALL HATS; SMOKING JACKETS; SNOWBOARD GLOVES; SOCCER SHOES; SOCK SUSPENDERS; SOCKS; SOCKS AND STOCKINGS; SOLES FOR FOOTWEAR; SPORT COATS; SPORT SHIRTS; SPORTS BRA; SPORTS BRAS; SPORTS JACKETS; SPORTS SHIRTS; SPORTS SHIRTS WITH SHORT SLEEVES; STOCKINGS; STRAPLESS BRAS; STRAPS FOR BRAS; STUFF JACKETS; SUED E JACKETS; SUIT COATS; SURF WEAR; SWADDLING CLOTHES; SWEAT BANDS; SWEAT JACKETS; SWEAT PANTS; SWEAT SHIRTS; SWEAT SHORTS; SWEAT SUITS; SWEATERS; SWIM CAPS; SWIM WEAR; SWIM WEAR FOR GENTLEMEN AND LADIES; SWIMMING CAPS; SWIMMING CAPS; SWIMMING COSTUMES; T-SHIRTS; TANK TOPS; TANK-TOPS; TAP SHOES; TEE SHIRTS; TENNIS DRESSES; TENNIS SHOES; TENNIS WEAR; THERMAL SOCKS; THERMAL UNDERWEAR; THONGS; THONGS; TIES; TIPS FOR FOOTWEAR; TOBOGGAN HATS, PANTS AND CAPS; TOE CAPS; TONGUE OR PULL-STRAP FOR SHOES AND BOOTS; TOP COATS; TOPS; TRACK AND FIELD SHOES; TRACK JACKETS; TRAINING SHOES; TRAVEL CLOTHING CONTAINED IN A PACKAGE COMPRISING REVERSIBLE JACKETS, PANTS, SKIRTS, TOPS AND A BELT OR SCARF; TRENCH COATS; TRIATHLON CLOTHING, NAMELY, TRIATHLON TIGHTS, TRIATHLON SHORTS, TRIATHLON SINGLET, TRIATHLON SHIRTS, TRIATHLON SUITS; TROUSERS FOR SWEATING; TUBE TOPS; TURTLE NECK SHIRTS; TURTLENECK SWEATERS; UNDERARM CLOTHING SHIELDS; UNDERWEAR; UNDERWEAR, NAMELY, BOY SHORTS; V-NECK SWEATERS; VOLLEYBALL SHOES; WATER SOCKS; WATERPROOF JACKETS AND PANTS; WEARABLE GARMENTS AND CLOTHING, NAMELY, SHIRTS; WET SUIT GLOVES; WIND COATS; WIND RESISTANT JACKETS; WIND SHIRTS; WIND-JACKETS; WOMEN'S HATS AND HOODS; WOMEN'S SHOES; WOMEN'S TOPS, NAMELY, CAMIS; WOMEN'S UNDERWEAR; WOODEN SHOES; WOOLLEN SOCKS; WOOLLY HATS; WORK SHOES AND BOOTS; WOVEN OR KNITTED UNDERWEAR; WRAPS; YOGA SHIRTS (U.S. CLS. 22 AND 39).

FIRST USE 7-22-2010; IN COMMERCE 7-22-2010.

CLASS 25—(Continued).

3,998,939. PARIS ACCESSORIES, INC., NEW YORK, NY. SN 77-880,774. PUB. 4-20-2010, FILED 11-25-2009.

SHIRT TALES

THE MARK CONSISTS OF STANDARD CHARACTERS WITHOUT CLAIM TO ANY PARTICULAR FONT, STYLE, SIZE, OR COLOR.

FOR BOY'S AND MEN'S SHIRTS (U.S. CLS. 22 AND 39).
FIRST USE 5-10-2011; IN COMMERCE 5-10-2011.

3,998,944. GREEN, VICTOR, NEW YORK, NY. SN 77-882,734. PUB. 8-3-2010, FILED 11-30-2009.

HIGH WAY 55 JEANS

THE MARK CONSISTS OF STANDARD CHARACTERS WITHOUT CLAIM TO ANY PARTICULAR FONT, STYLE, SIZE, OR COLOR.

NO CLAIM IS MADE TO THE EXCLUSIVE RIGHT TO USE "JEANS", APART FROM THE MARK AS SHOWN.

FOR BOTTOMS; COATS; HOSIERY; JACKETS; JERSEYS; LINGERIE; SLEEPWEAR; TOPS (U.S. CLS. 22 AND 39).

FIRST USE 10-0-2010; IN COMMERCE 10-0-2010.

3,998,949. STARGATE APPAREL, INC., NEW YORK, NY. SN 77-884,793. PUB. 11-16-2010, FILED 12-2-2009.

BLUE EPIC

THE MARK CONSISTS OF STANDARD CHARACTERS WITHOUT CLAIM TO ANY PARTICULAR FONT, STYLE, SIZE, OR COLOR.

FOR CLOTHING, NAMELY, WOMEN'S SWIMWEAR; OUTERWEAR, CASUAL WEAR, AND ACTIVE WEAR, NAMELY, PANTS, JEANS, DRESSES, SKIRTS, SHORTS, JACKETS, AND TOPS (U.S. CLS. 22 AND 39).

FIRST USE 2-4-2008; IN COMMERCE 2-4-2008.

CLASS 25—(Continued).

3,998,995. WEBMAGIC VENTURES, LLC, PASADENA, CA. SN 77-900,596. PUB. 9-28-2010, FILED 12-23-2009.

PENNY ARCADIA

THE MARK CONSISTS OF STANDARD CHARACTERS WITHOUT CLAIM TO ANY PARTICULAR FONT, STYLE, SIZE, OR COLOR.

FOR APRONS; BOXER SHORTS; GOLF SHIRTS; JERSEYS; SHIRTS; T-SHIRTS (U.S. CLS. 22 AND 39).
FIRST USE 5-21-2011; IN COMMERCE 5-21-2011.

3,999,003. SAINÉ, STEPHEN, SAN FRANCISCO, CA. SN 77-902,550. PUB. 11-23-2010, FILED 12-30-2009.

SCARDIGAN

THE MARK CONSISTS OF STANDARD CHARACTERS WITHOUT CLAIM TO ANY PARTICULAR FONT, STYLE, SIZE, OR COLOR.

FOR CLOTHING, NAMELY, GARMENTS AND SCARVES FOR MEN AND WOMEN OF ALL AGES (U.S. CLS. 22 AND 39).

FIRST USE 5-11-2011; IN COMMERCE 5-11-2011.

3,999,006. MARWA CHINDER OBEID, TUSTIN, CA. SN 77-904,747. PUB. 8-24-2010, FILED 1-4-2010.



THE MARK CONSISTS OF THE STYLIZED WORDING "VINTAGE HOTTIE" WITH THE LETTERS "V" AND "H" FORMING AN ABSTRACT DESIGN OF A FEMALE FIGURE.

FOR CLOTHING, NAMELY, PANTS, SKIRTS, SHORTS, JEANS, SHIRTS, SWEATERS, JACKETS, VESTS, COATS, RAINWEAR, SWIMWEAR, SLEEPWEAR, UNDERWEAR, LINGERIE, SWEATSHIRTS, T-SHIRTS, BELTS, LEATHER BELTS, HATS, GLOVES, SOCKS, STOCKINGS, SCARVES, HATS, CAPS AND SHOES (U.S. CLS. 22 AND 39).

FIRST USE 1-4-2011; IN COMMERCE 2-2-2011.

CLASS 25—(Continued).

3,999,076. LUIS M. RAMOS JR, CORAL SPRINGS, FL. AND KATINA E. FRIAS RAMOS, LANCASTER, PA. SN 77-933,192. PUB. 6-29-2010, FILED 2-11-2010.

GET'EM BOY

THE MARK CONSISTS OF STANDARD CHARACTERS WITHOUT CLAIM TO ANY PARTICULAR FONT, STYLE, SIZE, OR COLOR.

FOR ATHLETIC APPAREL, NAMELY, SHIRTS, PANTS, JACKETS, FOOTWEAR, HATS AND CAPS, ATHLETIC UNIFORMS; T-SHIRTS; A-SHIRTS; APPAREL FOR DANCERS, NAMELY, TEE SHIRTS, SWEATSHIRTS, PANTS, LEGGINGS, SHORTS AND JACKETS; BODY SHIRTS; BUTTON-FRONT ALOHA SHIRTS; CAMOUFLAGE PANTS; CAMOUFLAGE SHIRTS; CAMP SHIRTS; CAPRI PANTS; CARGO PANTS; CLOTHING FOR ATHLETIC USE, NAMELY, PADDED PANTS; CLOTHING FOR ATHLETIC USE, NAMELY, PADDED SHIRTS; DENIMS; DRESS SHIRTS; FISHING SHIRTS; GOLF PANTS, SHIRTS AND SKIRTS; GOLF SHIRTS; GYM PANTS; HOODED SWEAT SHIRTS; HUNTING SHIRTS; JOGGING PANTS; KNIT SHIRTS; LONG-SLEEVED SHIRTS; LOUNGE PANTS; NIGHT SHIRTS; OPEN-NECKED SHIRTS; OVER SHIRTS; PANTS; POLO SHIRTS; RUGBY SHIRTS; SHIRT FRONTS; SHIRT YOKES; SHIRTS; SHIRTS AND SHORT-SLEEVED SHIRTS; SHIRTS FOR INFANTS, BABIES, TODDLERS AND CHILDREN; SHIRTS FOR SUITS; SHORT-SLEEVED OR LONG-SLEEVED T-SHIRTS; SHORT-SLEEVED SHIRTS; SKI PANTS; SLEEP PANTS; SLEEP SHIRTS; SNOW PANTS; SNOWBOARD PANTS; SPORT SHIRTS; SPORTS PANTS; SPORTS SHIRTS; SPORTS SHIRTS WITH SHORT SLEEVES; STRETCH PANTS; SWEAT PANTS; SWEAT SHIRTS; TAP PANTS; TEE SHIRTS; TOBOGGAN HATS, PANTS AND CAPS; TRACK PANTS; TRAVEL CLOTHING CONTAINED IN A PACKAGE COMPRISING REVERSIBLE JACKETS, PANTS, SKIRTS, TOPS AND A BELT OR SCARF; TRIATHLON CLOTHING, NAMELY, TRIATHLON TIGHTS, TRIATHLON SHORTS, TRIATHLON SINGLET, TRIATHLON SHIRTS, TRIATHLON SUITS; TURTLE NECK SHIRTS; WATERPROOF JACKETS AND PANTS; WEARABLE GARMENTS AND CLOTHING, NAMELY, SHIRTS; WIND PANTS; WIND SHIRTS; YOGA PANTS; YOGA SHIRTS (U.S. CLS. 22 AND 39).

FIRST USE 1-1-2008; IN COMMERCE 1-1-2008.

3,999,081. ABSHIER, NATALIE, MEAD, CO. SN 77-937,044. PUB. 6-8-2010, FILED 2-16-2010.

CLEANWEAR

THE MARK CONSISTS OF STANDARD CHARACTERS WITHOUT CLAIM TO ANY PARTICULAR FONT, STYLE, SIZE, OR COLOR.

FOR BLOUSES; CAPS; JACKETS; PANTS; PULL-OVERS; SHIRTS; SKIRTS; SWEAT SHIRTS; SWEATERS; T-SHIRTS; UNDERWEAR (U.S. CLS. 22 AND 39).
FIRST USE 1-1-2010; IN COMMERCE 3-1-2011.

CLASS 25—(Continued).

3,999,087. SMILE AGAIN, INC., BURR RIDGE, FL. SN 77-939,997. PUB. 7-20-2010, FILED 2-19-2010.



THE MARK CONSISTS OF THE WORDS "SMILE AGAIN" WITH AN ARC COMING OF THE "G" TO SYMBOLIZE A SMILE. THERE ARE 8 FLOWER HEADS ON TOP OF THE MARK AND 6 ON THE BOTTOM.

FOR CLOTHING, NAMELY, SHIRTS, SHORTS, SWEATSHIRTS, T-SHIRTS, JACKETS, CAPS, HATS (U.S. CLS. 22 AND 39).

FIRST USE 7-15-2010; IN COMMERCE 7-15-2010.

3,999,121. SWNR, LLC, PAGOSA SPRINGS, CO. SN 77-954,901. PUB. 8-10-2010, FILED 3-9-2010.

VOORMI

THE MARK CONSISTS OF STANDARD CHARACTERS WITHOUT CLAIM TO ANY PARTICULAR FONT, STYLE, SIZE, OR COLOR.

THE WORDING "VOORMI" HAS NO MEANING IN A FOREIGN LANGUAGE.

FOR CLOTHING, NAMELY, MEN'S, WOMEN'S, AND CHILDREN'S T-SHIRTS, SHIRTS, TOPS, SWEATSHIRTS, SWEATPANTS, PANTS, SIDE ZIP PANTS, SHORTS, TROUSERS, JEANS, VESTS, PARKAS, ANORAKS, COATS, JACKETS, WIND-RESISTANT JACKETS, JACKET HOODS, PULLOVERS, SWEATERS; FLEECE CLOTHING, NAMELY, PULLOVERS, VESTS, COATS, JACKETS ANORAKS; OVERALLS, APRÈS-SKI WEAR, NAMELY, PANTS, PULLOVERS, VESTS, JACKETS, BOOTS AND SLIPPERS; UNDERWEAR, SPORTS BRAS, THERMAL UNDERWEAR, BOXER BRIEFS, SLEEPWEAR, LINGERIE, LOUNGEWEAR, HOSIERY, SOCKS, TIGHTS, LEGGINGS, GLOVES, MITTENS; OUTERWEAR, NAMELY, SHELLS, ONE-PIECE SHELL SUITS, SKI WEAR, SKI SUITS, SKI VESTS, SKI JACKETS, SKI BIBS, BIB OVERALLS, BIB PANTS, SNOWBOARD WEAR, NAMELY, SUITS, VESTS, JACKETS, BIBS, PANTS; SNOW PANTS, SNOW SUITS, RAINWEAR, RAIN JACKETS, RAIN PANTS, GAITERS, NAMELY, NECK GAITERS, LEG GAITERS AND ANKLE GAITERS; SKIRTS, SKORTS, DRESSES, SWIMSUITS, SWIM TRUNKS; FOOTWEAR, NAMELY, ATHLETIC SHOES, SNEAKERS, CLIMBING SHOES, CLIMBING BOOTS, HIKING SHOES, SLIPPERS, CLIMBING SLIPPERS, BOOTS, TREKKING BOOTS, HIKING BOOTS, SNOWSHOES, CLOGS, SANDALS; HEADGEAR, NAMELY, CAPS, HATS, HEADBANDS, BANDANAS, SCARVES, EARBANDS, EARMUFFS, BALACLAVAS, VISORS, BEANIES; BELTS (U.S. CLS. 22 AND 39).

FIRST USE 7-26-2010; IN COMMERCE 7-26-2010.

CLASS 25—(Continued).

3,999,133. MOSCOT MANAGEMENT CORP., NEW YORK, NY. SN 77-958,818. PUB. 9-7-2010, FILED 3-15-2010.

MOSCOT

OWNER OF U.S. REG. NOS. 2,936,703, 3,380,737, AND OTHERS.

THE NAME(S), PORTRAIT(S), AND/OR SIGNATURE(S) SHOWN IN THE MARK DOES NOT IDENTIFY A PARTICULAR LIVING INDIVIDUAL.

SEC. 2(F).

FOR T-SHIRTS (U.S. CLS. 22 AND 39).

FIRST USE 1-27-2009; IN COMMERCE 1-27-2009.

3,999,137. BERMAK DE MEXICO S.A. DE C.V., LEON, GUANAJUATO, MEXICO. SN 77-961,735. PUB. 9-7-2010, FILED 3-17-2010.



THE NAME(S), PORTRAIT(S), AND/OR SIGNATURE(S) SHOWN IN THE MARK DOES NOT IDENTIFY A PARTICULAR LIVING INDIVIDUAL.

THE MARK CONSISTS OF "MASIOSARE" IN STYLIZED CAPITAL LETTERS WITH A FLAG-LIKE SHAPE IN THE CENTER IN PLACE OF THE LETTER "O". ON THE FLAG IS AN AMOEBA-LIKE FACE WITH AN EYE CROSSED. THE STYLIZED CAPITAL LETTERS ARE UNDERLINED BY A WAVE. BENEATH THE WAVE IS "EL EXTRAÑO ENEMIGO" IN LOWERCASE LETTERS.

THE ENGLISH TRANSLATION OF "EL EXTRAÑO ENEMIGO" IN THE MARK IS "THE STRANGE ENEMY". THE WORDING "MASIOSARE" HAS NO MEANING IN A FOREIGN LANGUAGE.

FOR ATHLETIC APPAREL, NAMELY, SHIRTS, PANTS, JACKETS, FOOTWEAR, HATS AND CAPS, ATHLETIC UNIFORMS; BELTS; DENIMS; HATS; JACKETS; JEANS; MEN'S AND WOMEN'S JACKETS, COATS, TROUSERS, VESTS; SHIRTS; SKIRTS; SKIRTS AND DRESSES; SOCKS; SWEATERS; T-SHIRTS; TIES; UNDERWEAR (U.S. CLS. 22 AND 39).

FIRST USE 9-25-2009; IN COMMERCE 9-25-2009.

CLASS 25—(Continued).

3,999,158. HARRISBURG AREA COMMUNITY COLLEGE, HARRISBURG, PA. SN 77-981,721. PUB. 1-6-2009, FILED 2-6-2008.



NO CLAIM IS MADE TO THE EXCLUSIVE RIGHT TO USE "CENTRAL PENNSYLVANIA'S COMMUNITY COLLEGE FOUNDED IN 1964", APART FROM THE MARK AS SHOWN.

THE MARK CONSISTS OF THE WORDS "HACC CENTRAL PENNSYLVANIA'S COMMUNITY COLLEGE FOUNDED IN 1964", ENCIRCLING A SQUARE MADE OF IRREGULAR SHAPES.

FOR CLOTHING, NAMELY, T-SHIRTS, SHORTS, SWEATSHIRTS, SWEATPANTS, JACKETS, AND BASEBALL CAPS (U.S. CLS. 22 AND 39).

FIRST USE 3-31-2011; IN COMMERCE 3-31-2011.

3,999,161. LIZ CLAIBORNE, INC., NEW YORK, NY. SN 77-981,858. PUB. 4-7-2009, FILED 8-19-2008.

LIZ CLAIBORNE NEW YORK

THE MARK CONSISTS OF STANDARD CHARACTERS WITHOUT CLAIM TO ANY PARTICULAR FONT, STYLE, SIZE, OR COLOR.

OWNER OF U.S. REG. NOS. 2,557,050, 2,795,115, AND OTHERS.

NO CLAIM IS MADE TO THE EXCLUSIVE RIGHT TO USE "NEW YORK", APART FROM THE MARK AS SHOWN.

THE NAME(S), PORTRAIT(S), AND/OR SIGNATURE(S) SHOWN IN THE MARK DOES NOT IDENTIFY A PARTICULAR LIVING INDIVIDUAL.

FOR BELTS; BOTTOMS; COATS; DRESSES; FOOTWEAR; GLOVES; HEADWEAR; HOSIERY; JACKETS; JEANS; KNIT SHIRTS; LONG-SLEEVED SHIRTS; PANTS; RAINWEAR; SCARVES; SHIRTS; SHORT-SLEEVED OR LONG-SLEEVED T-SHIRTS; SHORT-SLEEVED SHIRTS; SKIRTS; SLEEPWEAR; SOCKS; SWEATERS; SWIMWEAR; T-SHIRTS (U.S. CLS. 22 AND 39).

FIRST USE 2-1-2009; IN COMMERCE 2-1-2009.

CLASS 25—(Continued).

3,999,162. RETAIL ROYALTY COMPANY, LAS VEGAS, NV. SN 77-981,867. PUB. 3-9-2010, FILED 10-8-2009.



THE MARK CONSISTS OF A STYLIZED BIRD DESIGN, FOR CLOTHING, NAMELY, BEACHWEAR, DRESSES, LEG WARMERS, INFANT SLEEPERS, JUMPERS, MITTENS, AND ROMPERS (U.S. CLS. 22 AND 39). FIRST USE 7-0-2010; IN COMMERCE 7-0-2010.

CLASS 25—(Continued).

3,999,169. GARAN SERVICES CORP., NEW YORK, NY. SN 77-982,001. PUB. 8-5-2008, FILED 9-27-2007.



THE COLOR(S) YELLOW, BROWN, BLUE, WHITE, PINK, PURPLE AND BLACK IS/ARE CLAIMED AS A FEATURE OF THE MARK.

THE MARK CONSISTS OF THE COLORS YELLOW, BROWN, BLUE, BLACK WHITE AND PINK WHICH APPEAR IN THE GIRAFFE DESIGN AND THE COLORS WHITE, PURPLE AND PINK APPEAR IN THE KETTLE AND TEA CUPS.

FOR CLOTHING, NAMELY, SWEATERS, JEANS, BATHING SUITS, SWIMWEAR, SLEEPWEAR, LEOTARDS, TIGHTS, ROMPERS, UNDERWEAR, HOSIERY, OUTERWEAR, NAMELY, COATS, JACKETS, SCARVES; HEADWEAR, NAMELY, HATS, EARMUFFS, SKI MASKS; GLOVES, BELTS, SOCKS (U.S. CLS. 22 AND 39). FIRST USE 4-0-2009; IN COMMERCE 4-0-2009.

3,999,170. GARAN SERVICES CORP., NEW YORK, NY. SN 77-982,002. PUB. 8-5-2008, FILED 9-27-2007.

3,999,166. REINHART GLOBAL BRANDS, LLC, PORTLAND, OR. SN 77-981,968. PUB. 7-27-2010, FILED 2-2-2010.

SANZIA

THE MARK CONSISTS OF STANDARD CHARACTERS WITHOUT CLAIM TO ANY PARTICULAR FONT, STYLE, SIZE, OR COLOR.

THE WORDING "SANZIA" HAS NO MEANING IN A FOREIGN LANGUAGE.

FOR FOOTWEAR; BOOTS; SANDALS; ESPADRILLES; CLOGS; SLIPPERS; INSOLES; SOLES FOR FOOTWEAR (U.S. CLS. 22 AND 39).

FIRST USE 6-1-2010; IN COMMERCE 6-1-2010.



THE COLOR(S) YELLOW, BROWN, WHITE, PINK, BLUE, AND BLACK IS/ARE CLAIMED AS A FEATURE OF THE MARK.

THE MARK CONSISTS OF THE COLORS BLACK, BROWN, YELLOW, BLUE, WHITE AND PINK WHICH APPEAR IN THE GIRAFFE DESIGN AND THE COLORS YELLOW AND PINK APPEAR IN THE JEWELRY.

FOR CLOTHING, NAMELY, SWEATERS, JEANS, BATHING SUITS, SWIMWEAR, SLEEPWEAR, LEOTARDS, TIGHTS, ROMPERS, UNDERWEAR, HOSIERY, OUTERWEAR, NAMELY, COATS, JACKETS, SCARVES; HEADWEAR, NAMELY, HATS, EARMUFFS, SKI MASKS; GLOVES, BELTS, SOCKS (U.S. CLS. 22 AND 39). FIRST USE 11-0-2007; IN COMMERCE 11-0-2007.

CLASS 25—(Continued).

3,999,171. GARAN SERVICES CORP., NEW YORK, NY. SN 77-982,003. PUB. 8-5-2008, FILED 9-27-2007.



THE COLOR(S) YELLOW, BROWN, WHITE, PINK, BLUE, GREEN, PURPLE, GREY AND BLACK IS/ARE CLAIMED AS A FEATURE OF THE MARK.

THE MARK CONSISTS OF THE COLORS YELLOW, BROWN, BLUE, BLACK WHITE, GREEN AND PINK WHICH APPEAR IN THE GIRAFFE DESIGN, THE COLORS GREEN AND PINK APPEAR IN THE BOOTS, THE COLORS BLUE AND BLACK APPEAR IN THE DRESS AND THE COLORS WHITE AND PINK APPEAR IN THE ACCESSORIES.

FOR CLOTHING, NAMELY, SWEATERS, JEANS, BATHING SUITS, SWIMWEAR, SLEEPWEAR, LEOTARDS, TIGHTS, ROMPERS, UNDERWEAR, HOSIERY, OUTERWEAR, NAMELY, COATS, JACKETS, SCARVES; HEADWEAR, NAMELY, HATS, EARMUFFS, SKI MASKS; GLOVES, BELTS, SOCKS (U.S. CLS. 22 AND 39).
FIRST USE 12-0-2007; IN COMMERCE 12-0-2007.

3,999,180. CAPITUS PTE LTD, SINGAPORE, SINGAPORE. SN 77-982,072. PUB. 4-6-2010, FILED 10-10-2009.

Debauch

THE MARK CONSISTS OF STANDARD CHARACTERS WITHOUT CLAIM TO ANY PARTICULAR FONT, STYLE, SIZE, OR COLOR.

FOR CLOTHING, NAMELY, SHIRTS, BLOUSES, CARDIGANS, PULLOVERS, SWEATERS, T-SHIRTS, POLO SHIRTS, COATS, JACKETS, SUITS, PANTS, TROUSERS, JEANS, SHORTS, SKIRTS, DRESSES, SWIMWEAR, BEACHWEAR, UNDERWEAR, PAJAMAS, DRESSING GOWNS, SCARVES, GLOVES, BELTS, TIES, FOOTWEAR, HEADWEAR, HOSIERY, LINGERIE, SOCKS (U.S. CLS. 22 AND 39).
FIRST USE 1-3-2010; IN COMMERCE 3-18-2011.

CLASS 25—(Continued).

3,999,205. STARBURY CORPORATION, RESEARCH TRIANGLE PARK, NC. SN 78-844,144. PUB. 9-12-2006, FILED 3-23-2006.



THE MARK CONSISTS OF THE WORD "STARBURY" PRINTED IN A GRAFFITI-STYLE FONT.

FOR BEACHWEAR, BELTS MADE OF LEATHER, BELTS MADE OF TEXTILE, COATS, FOOTWEAR EXCLUDING ORTHOPEDIC FOOTWEAR, JACKETS, JEANS, HEADWEAR, SWEATERS, SWEATSHIRTS, PANTS, SHORTS, SKIRTS, SHIRTS, TRACKSUITS, WINDSHIRTS, UNDERGARMENTS (U.S. CLS. 22 AND 39).

FIRST USE 8-30-2006; IN COMMERCE 8-30-2006.

3,999,211. MICHAEL G. ROSMARIN, HOUSTON, TX. SN 78-899,679. PUB. 2-26-2008, FILED 6-2-2006.

LOTHARS

THE MARK CONSISTS OF STANDARD CHARACTERS WITHOUT CLAIM TO ANY PARTICULAR FONT, STYLE, SIZE, OR COLOR.

FOR CLOTHING FOR MEN, NAMELY, SHIRTS AND PANTS (U.S. CLS. 22 AND 39).
FIRST USE 5-20-2011; IN COMMERCE 5-20-2011.

3,999,218. LUCY APPAREL, LLC, WILMINGTON, DE. SN 78-948,295. PUB. 1-23-2007, FILED 8-9-2006.



THE COLOR(S) ORANGE IS/ARE CLAIMED AS A FEATURE OF THE MARK.

CLASS 25—(Continued).

THE MARK CONSISTS OF AN ORANGE (PMS 144) LOWER CASE LETTER "L".

FOR CLOTHING, NAMELY, TOPS, TANKS, T-SHIRTS, SHORTS, PANTS, JACKETS, VESTS, WARM-UP SUITS, SKIRTS, DRESSES, BRAS, HATS, GLOVES, HEADBANDS, SOCKS AND LEGGINGS (U.S. CLS. 22 AND 39).
FIRST USE 6-18-2007; IN COMMERCE 6-18-2007.



3,999,222. YELLOWSTONE BRANDS, LLC, SOMERVILLE, NJ. SN 78-981,464. PUB. 12-12-2006, FILED 7-13-2005.

CB

THE MARK CONSISTS OF STANDARD CHARACTERS WITHOUT CLAIM TO ANY PARTICULAR FONT, STYLE, SIZE, OR COLOR.

OWNER OF U.S. REG. NOS. 1,324,683 AND 2,816,472.
FOR CLOTHING, NAMELY, COATS, JACKETS, PARKAS, SKI PANTS, SKI SUITS, SKI WEAR, SKI BIBS, SKI JACKETS, SKI PARKAS, JUMPSUITS, SNOW PANTS, SNOW SUITS, INSULATED PANTS, SHELL PANTS (U.S. CLS. 22 AND 39).

FIRST USE 8-0-2010; IN COMMERCE 8-0-2010.



3,999,223. YELLOWSTONE BRANDS, LLC, SOMERVILLE, NJ. SN 78-981,465. PUB. 12-12-2006, FILED 7-13-2005.

CB SPORTS

THE MARK CONSISTS OF STANDARD CHARACTERS WITHOUT CLAIM TO ANY PARTICULAR FONT, STYLE, SIZE, OR COLOR.

OWNER OF U.S. REG. NOS. 1,324,683 AND 2,816,472.
NO CLAIM IS MADE TO THE EXCLUSIVE RIGHT TO USE "SPORTS", APART FROM THE MARK AS SHOWN.

FOR CLOTHING, NAMELY, COATS, JACKETS, PARKAS, SKI PANTS, SKI SUITS, SKI WEAR, SKI BIBS, SKI JACKETS, SKI PARKAS, JUMPSUITS, SNOW PANTS, SNOW SUITS, INSULATED PANTS, SHELL PANTS (U.S. CLS. 22 AND 39).

FIRST USE 8-0-2010; IN COMMERCE 8-0-2010.

CLASS 25—(Continued).

3,999,245. CHAKRAVUTH, DANIEL TES, LAKE FOREST, CA. SN 85-008,986. PUB. 8-31-2010, FILED 4-7-2010.



THE MARK CONSISTS OF A STYLIZED "MARTIAN" HEAD DESIGN CONSISTING OF TWO ANTENNAS EMERGING FROM THE TOP OF A CIRCLE WITH A VERTICAL BAND DOWN THE CENTER, WITH THE WORDING "STARVING" TO THE LEFT OF THE DESIGN AND THE WORDING "MARTIAN" TO THE RIGHT

FOR A-SHIRTS; ADULT NOVELTY GAG CLOTHING ITEM, NAMELY, SOCKS; ANKLE SOCKS; ANKLETS; ANTI-PERSPIRANT SOCKS; APPAREL FOR DANCERS, NAMELY, TEE SHIRTS, SWEATSHIRTS, PANTS, LEGGINGS, SHORTS AND JACKETS; ATHLETIC APPAREL, NAMELY, SHIRTS, PANTS, JACKETS, FOOTWEAR, HATS AND CAPS, ATHLETIC UNIFORMS; ATHLETIC FOOTWEAR; BABY TOPS; BASEBALL CAPS; BASEBALL CAPS AND HATS; BASELAYER TOPS; BEACH FOOTWEAR; BED JACKETS; BLAZERS; BLOUSES; BOARD SHORTS; BODY SHIRTS; BOMBER JACKETS; BOXER SHORTS; BOXING SHORTS; BRIDESMAID DRESSES; BRIEFS; BUTTON-FRONT ALOHA SHIRTS; CAMOUFLAGE JACKETS; CAMOUFLAGE SHIRTS; CAMP SHIRTS; CAPRI PANTS; CARGO PANTS; CHEF'S HATS; CLIMBING FOOTWEAR; CLOTHING FOR ATHLETIC USE, NAMELY, PADDED SHIRTS; CLOTHING SHIELDS, NAMELY, PADS APPLIED TO THE UNDERARMS OF SHIRTS, BLOUSES AND SWEATERS; CLOTHING, NAMELY, KHAKIS; COSTUMES FOR USE IN CHILDREN'S DRESS UP PLAY; CROP TOPS; DENIM JACKETS; DENIMS; DISPOSABLE UNDERWEAR; DOWN JACKETS; DRESS SHIRTS; DRESS SUITS; DRESSES; DRESSES MADE FROM SKINS; DRESSES THAT MAY ALSO BE USED AS TOWELS; DRESSING GOWNS; DRESSING GOWNS AND BATH ROBES; EVENING DRESSES; EYESHADES; FISHING SHIRTS; FLIP FLOPS; FOOTWEAR; FOOTWEAR FOR MEN; FOOTWEAR FOR MEN AND WOMEN; FOOTWEAR FOR TRACK AND FIELD ATHLETICS; FOOTWEAR FOR WOMEN; GLOVES; GLOVES AS CLOTHING; GLOVES FOR APPAREL; GLOVES FOR PERSONAL HAND CONDITIONING USE; GLOVES INCLUDING THOSE MADE OF SKIN, HIDE OR FUR; GOLF PANTS, SHIRTS AND SKIRTS; GOLF SHIRTS; GYM SHORTS; HALTER TOPS; HAT BANDS; HATS; HATS FOR INFANTS, BABIES, TODDLERS AND CHILDREN; HEADBANDS FOR CLOTHING; HOODED SWEAT SHIRTS; HOODS; HUNTING SHIRTS; INFANT AND TODDLER ONE PIECE CLOTHING; JACKETS; JACKETS AND SOCKS; JAPANESE STYLE SOCKS (TABI COVERS); JAPANESE STYLE SOCKS (TABI); JEANS; JERSEYS; JOGGING PANTS; KNIT FACE MASKS; KNIT JACKETS; KNIT SHIRTS; KNITTED CAPS; KNITTED GLOVES; KNITTED UNDERWEAR; LADIES' UNDERWEAR; LEATHER PANTS; LONG UNDERWEAR; LONG-SLEEVED SHIRTS; MEN'S DRESS SOCKS; MEN'S SOCKS; MEN'S UNDERWEAR; MOISTURE-WICKING SPORTS SHIRTS; MOTORCYCLE GLOVES; MUSCLE TOPS; NIGHT SHIRTS; OPENNECKED SHIRTS; OUTDOOR GLOVES; OVER SHIRTS; PANTIES, SHORTS AND BRIEFS; PAPER SHOES USED WHEN GOING THROUGH METAL DETECTORS TO KEEP FEET AND SOCKS CLEAN; PIQUE SHIRTS; POLO KNIT TOPS; POLO SHIRTS; RIDING GLOVES; RUGBY SHIRTS; RUGBY TOPS; SCIENTIFIC AND TECHNOLOGICAL APPAREL, NAMELY, SHIRTS, PANTS, JACKETS, FOOTWEAR, HATS AND CAPS, UNIFORMS; SHIRT FRONTS; SHIRT YOKES; SHIRTS; SHIRTS AND SHORT-SLEEVED SHIRTS; SHIRTS FOR INFANTS, BABIES, TODDLERS AND CHILDREN; SHIRTS FOR SUITS; SHORT-SLEEVED OR LONG-SLEEVED T-SHIRTS; SHORT-SLEEVED SHIRTS; SKI GLOVES; SKIRTS AND DRESSES; SLEEP SHIRTS; SLEEVELESS JERSEYS; SLIPPER SOCKS; SNOWBOARD GLOVES;

CLASS 25—(Continued).

SOCK SUSPENDERS; SOCKS; SOCKS AND STOCKINGS; SPORT SHIRTS; SPORTS JERSEYS; SPORTS SHIRTS; SPORTS SHIRTS WITH SHORT SLEEVES; SWEAT SHIRTS; T-SHIRTS; TANK TOPS; TANK-TOPS; TEE SHIRTS; TENNIS DRESSES; THERMAL SOCKS; TIES; TOP COATS; TOPS; TRAVEL CLOTHING CONTAINED IN A PACKAGE COMPRISING REVERSIBLE JACKETS, PANTS, SKIRTS, TOPS AND A BELT OR SCARF; TRIATHLON CLOTHING, NAMELY, TRIATHLON TIGHTS, TRIATHLON SHORTS, TRIATHLON SING-LETS, TRIATHLON SHIRTS, TRIATHLON SUITS; TUBE TOPS; TURTLE NECK SHIRTS; UNDERSHIRTS; UN- DERSHIRTS FOR KIMONOS (JUBAN); UNDERSHIRTS FOR KIMONOS (KOSHIMAKI); UNDERWEAR; UNDER- WEAR, NAMELY, BOY SHORTS; WATER SOCKS; WEARABLE GARMENTS AND CLOTHING, NAMELY, SHIRTS; WEDDING DRESSES; WIND SHIRTS; WO- MEN'S CEREMONIAL DRESSES; WOMEN'S TOPS, NAMELY, CAMIS; WOOLLEN SOCKS; WOVEN OR KNITTED UNDERWEAR; WRAPS; WRIST BANDS; YOGA SHIRTS (U.S. CLS. 22 AND 39).
FIRST USE 4-7-2010; IN COMMERCE 4-21-2011.

3,999,257. MOUNTAIN GEAR CORPORATION, IRWIN- DALE, CA. SN 85-013,701. PUB. 12-7-2010, FILED 4-14-2010.



THE MARK CONSISTS OF A FLOWER WITH TWO SOLID PEDALS AND TWO OUTLINED PEDALS.
FOR WOMEN'S WEARING APPAREL, NAMELY, BLOUSES, SHIRTS, GOLF SHIRTS, DRESSES, SKIRTS, PANTS, SWEAT PANTS, SWEAT SHIRTS, JACKETS, SWEATERS, TANK TOPS, LEGGINGS, BODY SUITS, HATS, GLOVES AND SCARVES (U.S. CLS. 22 AND 39).
FIRST USE 3-1-2010; IN COMMERCE 3-1-2010.

3,999,280. OLIBERTE LIMITED, OAKVILLE, ONTARIO, CANADA. SN 85-018,523. PUB. 4-5-2011, FILED 4-20-2010.

This is Africa

THE MARK CONSISTS OF STANDARD CHARACTERS WITHOUT CLAIM TO ANY PARTICULAR FONT, STYLE, SIZE, OR COLOR.

CLASS 25—(Continued).

NO CLAIM IS MADE TO THE EXCLUSIVE RIGHT TO USE "AFRICA", APART FROM THE MARK AS SHOWN.
FOR ATHLETIC APPAREL, NAMELY, SHIRTS, PANTS, JACKETS, FOOTWEAR, HATS AND CAPS, ATHLETIC UNIFORMS; ATHLETIC FOOTWEAR; BEACH FOOTWEAR; FLIP FLOPS; FOOTWEAR; FOOT- WEAR; FOOTWEAR FOR MEN; FOOTWEAR FOR MEN AND WOMEN; FOOTWEAR FOR WOMEN; FOOTWEAR NOT FOR SPORTS; FOOTWEAR, NAMELY, WORK BOOTS; ANKLE BOOTS; ANKLE SOCKS; ANKLETS; AQUA SHOES; ATHLETIC SHOES; ATHLETIC UNI- FORMS; BANDANAS; BASEBALL CAPS; BASEBALL CAPS AND HATS; BASEBALL SHOES; BASEBALL UNI- FORMS; BEACH SHOES; BEANIES; BELTS; BELTS FOR CLOTHING; BELTS MADE FROM IMITATION LEATHER; BELTS MADE OF LEATHER; BELTS MADE OUT OF CLOTH; BELTS OF TEXTILE; BERETS; BER- MUDA SHORTS; BOARD SHORTS; BOAT SHOES; BOOTS; BOOTS FOR MOTORCYCLING; BOOTS FOR SPORT; BOWLING SHOES; BOXER BRIEFS; BOXER SHORTS; BOXING SHOES; BOXING SHORTS; BRIEFS; BRIEFS; BUCKET CAPS; CANVAS SHOES; CAP PEAKS; CAP VISORS; CAPS; CAPS WITH VISORS; CARGO PANTS; CHILDREN'S AND INFANT'S APPAREL, NAMELY, JUMPERS, OVERALL SLEEPWEAR, PAJA- MAS, ROMPERS AND ONE-PIECE GARMENTS; CHIL- DREN'S AND INFANTS' CLOTH BIBS; CHILDREN'S CLOTH EATING BIBS; CHILDREN'S HEADWEAR; CLEATS FOR ATTACHMENT TO SPORTS SHOES; CLIMBING BOOTS; CLIMBING FOOTWEAR; CLIMB- ING SHOES; CLOGS; CLOTH BIBS; CLOTHING ITEMS, NAMELY, ADHESIVE POCKETS THAT MAY BE AF- FIXED DIRECTLY TO THE BODY AS A DECORATIVE PIECE OF CLOTHING WITH UTILITY; CLOTHING ITEMS, NAMELY, ADHESIVE POCKETS THAT MAY BE AFFIXED DIRECTLY TO THE INSIDE OF CLOTH- ING FOR STORAGE AND SAFEKEEPING OF PERSON- AL ITEMS; CLOTHING, NAMELY, ARM WARMERS; CLOTHING, NAMELY, HAND-WARMERS; CLOTHING, NAMELY, KHAKIS; CLOTHING, NAMELY, WRAP- AROUNDS; COATS; COATS FOR MEN AND WOMEN; COATS MADE OF COTTON; COATS OF DENIM; CY- CLING SHOES; CYCLISTS' JERSEYS; DANCE SHOES; DECK-SHOES; DENIM JACKETS; DENIMS; DOWN JACKETS; EAR BANDS; EAR MUFFS; EAR WARMERS; EARBANDS; EMBOSSSED SOLES AND HEELS OF RUB- BER OR OF PLASTIC MATERIALS; ESPADRILLES; EUROPEAN FOOTBALL BIBS; FABRIC BELTS; FITTED SHOE OR BOOT COVERING TO PROTECT THE SHOES OR BOOT FROM WATER OR OTHER DAMAGE; FLEECE PULLOVERS; FLEECE SHORTS; FLEECE VESTS; FOOTBALL BOOTS AND STUDS THEREFOR; FOOTBALL SHOES; FOOTIES; FOOTWEAR FOR TRACK AND FIELD ATHLETICS; FOOTWEAR MADE OF WOOD; FOOTWEAR, NAMELY, PUMPS; FOOTWEAR, NAMELY, RUBBERS; FUR CLOAKS; FUR COATS; GLOVES; GLOVES AS CLOTHING; GLOVES FOR APPA- REL; GLOVES FOR PERSONAL HAND CONDITIONING USE; GLOVES INCLUDING THOSE MADE OF SKIN, HIDE OR FUR; GOLF CAPS; GOLF CLEATS; GOLF PANTS, SHIRTS AND SKIRTS; GOLF SHIRTS; GOLF SHOES; GOLF SHORTS; GOLF SPIKES; GOLF TROU- SERS; GYM BOOTS; GYM PANTS; GYM SHORTS; GYM SUITS; GYMNASTIC SHOES; HANDBALL SHOES; HAT BANDS; HATS; HATS FOR INFANTS, BABIES, TOD- DLERS AND CHILDREN; HEAD SCARVES; HEAD SWEATBANDS; HEAD WEAR; HEADBANDS; HEAD- BANDS AGAINST SWEATING; HEADBANDS FOR CLOTHING; HEADGEAR, NAMELY, HATS; HEAD- WEAR; HEAVY COATS; HEAVY JACKETS; HEEL IN- SERTS; HEEL PIECES FOR SHOES; HEELS; HIKING BOOTS; HOCKEY SHOES; HOODED PULLOVERS; HOODED SWEAT SHIRTS; HOODS; HOODS; HORSE- RIDING BOOTS; INFANT AND TODDLER ONE PIECE CLOTHING; INFANT SLEEPERS; INFANT WEAR; IN- FANTS' SHOES AND BOOTS; INFANTS' TROUSERS; INFANTWEAR; INNER SOLES; INSOLES; INSOLES FOR FOOTWEAR; JACKET LINERS; JACK- ETS; JACKETS AND SOCKS; JANDALS; JAPANESE FOOTWEAR OF RICE STRAW (WARAJI); JAPANESE SLEEPING ROBES (NEMAKI); JAPANESE SPLIT-TOED WORK FOOTWEAR (JIKATABI); JAPANESE STYLE CLOGS AND SANDALS; JAPANESE STYLE SANDALS (ZORI); JAPANESE STYLE SANDALS OF FELT; JAPANESE STYLE SANDALS OF LEATHER; JAPANESE STYLE SOCKS (TABI COVERS); JAPANESE STYLE SOCKS (TABI); JAPANESE STYLE WOODEN CLOGS

CLASS 25—(Continued).

(GETA); JAPANESE TOE-STRAP SANDALS (ASAURAZORI); JEANS; JERSEYS; JOGGING OUTFITS; JOGGING PANTS; JOGGING SUITS; JUMPERS; KERCHIEFS; KIMONOS; KNEE HIGHS; KNEE-HIGH STOCKINGS; KNICKERS; KNIT FACE MASKS; KNIT JACKETS; KNIT SHIRTS; KNITTED CAPS; KNITTED GLOVES; KNITTED UNDERWEAR; KNOT CAPS; KNOTTED CAPS; LACE BOOTS; LADIES' BOOTS; LEATHER BELTS; LEATHER COATS; LEATHER HEADWEAR; LEATHER JACKETS; LEATHER PANTS; LEATHER SHOES; LEATHER SLIPPERS; LEISURE SHOES; LONG JACKETS; LONG JOHNS; LONG SLEEVE PULLOVERS; LONG SLEEVED VESTS; LONG UNDERWEAR; LONG-SLEEVED SHIRTS; LOUNGE PANTS; LOUNGEWEAR; MEN'S AND WOMEN'S JACKETS, COATS, TROUSERS, VESTS; MEN'S DRESS SOCKS; MEN'S SOCKS; MEN'S SUITS; MEN'S SUITS, WOMEN'S SUITS; MEN'S UNDERWEAR; MITTENS; MOCCASINS; MOCK TURTLE-NECK SWEATERS; MOISTURE-WICKING SPORTS BRAS; MOISTURE-WICKING SPORTS PANTS; MOISTURE-WICKING SPORTS SHIRTS; MONEY BELTS; MORNING COATS; MOTORCYCLE GLOVES; MOTORCYCLE JACKETS; MOTORCYCLE RAIN SUITS; MOTORCYCLIST BOOTS; MOUNTAINEERING BOOTS; MOUNTAINEERING SHOES; OUTDOOR GLOVES; OVER COATS; OVERALLS; OVERSHOES; PAJAMAS; PANTS; PAPER SHOES USED WHEN GOING THROUGH METAL DETECTORS TO KEEP FEET AND SOCKS CLEAN; PARKAS; POLO KNIT TOPS; POLO SHIRTS; RAIN BOOTS; RAIN COATS; RAIN HATS; RAIN JACKETS; RAINCOATS; RAINWEAR; RIDING BOOTS; RIDING COATS; RIDING GLOVES; RIDING SHOES; RUBBER SHOES; RUBBER SOLES FOR JIKATABI; RUGBY SHIRTS; RUGBY SHOES; RUGBY SHORTS; RUGBY TOPS; RUNNING SHOES; SANDALCLOGS; SANDALS; SCARFS; SCARVES; SCHOOL UNIFORMS; SHELL JACKETS; SHIRT FRONTS; SHIRTS; SHIRTS AND SHORT-SLEEVED SHIRTS; SHIRTS FOR INFANTS, BABIES, TODDLERS AND CHILDREN; SHIRTS FOR SUITS; SHOE COVERS FOR USE WHEN WEARING SHOES; SHOE DOWELS; SHOE PEGS; SHOE SOLES; SHOE STRAPS; SHOES; SHOES SOLES FOR REPAIR; SHORT-SLEEVED OR LONG-SLEEVED T-SHIRTS; SHORT-SLEEVED SHIRTS; SHORTS; SHOULDER SCARVES; SHOULDER WRAPS FOR CLOTHING; SKI AND SNOWBOARD SHOES AND PARTS THEREOF; SKI BOOT BAGS; SKI BOOTS; SKI GLOVES; SKI JACKETS; SKI MASKS; SKI SUITS; SKI SUITS FOR COMPETITION; SKI TROUSERS; SKI WEAR; SKIING SHOES; SKULL CAPS; SKULLIES; SLEEVELESS JERSEYS; SLIPPER SOLES; SLIPPERS; SLIPS; SMALL HATS; SNEAKERS; SNOW BOARDING SUITS; SNOW BOOTS; SNOW SUITS; SNOWBOARD GLOVES; SNOWBOARD MITTENS; SOCCER BIBS; SOCCER BOOTS; SOCCER SHOES; SOCK SUSPENDERS; SOCKS; SOCKS AND STOCKINGS; SOLES; SOLES FOR FOOTWEAR; SPORT COATS; SPORT SHIRTS; SPORT STOCKINGS; SPORTS CAPS AND HATS; SPORTS JACKETS; SPORTS JERSEYS; SPORTS JERSEYS AND BREECHES FOR SPORTS; SPORTS OVERUNIFORMS; SPORTS PANTS; SPORTS SHIRTS; SPORTS SHIRTS WITH SHORT SLEEVES; SPORTS VESTS; SUEDE JACKETS; SUIT COATS; SUITS; SUITS OF LEATHER; SUN VISORS; SWEAT JACKETS; SWEAT PANTS; SWEAT SHIRTS; SWEAT SHORTS; SWEAT SUITS; SWEATBANDS; SWEATERS; SWEATSOCKS; T-SHIRTS; TANK TOPS; TEDDIES; TEE SHIRTS; TENNIS SHOES; TENNIS WEAR; THERMAL SOCKS; THERMAL UNDERWEAR; THONGS; THONGS; TIES; TOBOGGAN HATS, PANTS AND CAPS; TOE BOXES; TOE CAPS; TONGUE OR PULLSTRAP FOR SHOES AND BOOTS; TOP COATS; TOPCOATS; TOPS; TOQUES; TRACK AND FIELD SHOES; TRACK JACKETS; TRACK PANTS; TRACK SUITS; TRACKSUITS; TRAINING SHOES; TRAINING SUITS; TRIATHLON CLOTHING, NAMELY, TRIATHLON TIGHTS, TRIATHLON SHORTS, TRIATHLON

CLASS 25—(Continued).

SINGLET, TRIATHLON SHIRTS, TRIATHLON SUITS; TUXEDO BELTS; UNDERWEAR; UNDERWEAR, NAMELY, BOY SHORTS; UNIFORMS; V-NECK SWEATERS; VISORS; VOLLEYBALL JERSEYS; VOLLEYBALL SHOES; WAIST BANDS; WAIST BELTS; WALKING SHORTS; WARM UP OUTFITS; WARM UP SUITS; WATER PROOF BOOTS; WATER REPELLING BOOTS; WATER REPELLING FOOTWEAR; WATER REPELLING LEATHER BOOTS; WATER REPELLING LEATHER SHOES AND BOOTS; WATER SOCKS; WATERPROOF FOOTWEAR; WATERPROOF JACKETS AND PANTS; WATERPROOF LEATHER BOOTS; WATERPROOF LEATHER SHOES; WATERPROOF LEATHER SHOES AND BOOTS; WEARABLE BLANKETS IN THE NATURE OF BLANKETS WITH SLEEVES; WEARABLE GARMENTS AND CLOTHING, NAMELY, SHIRTS; WELTS FOR BOOTS AND SHOES; WINTER BOOTS; WOMEN'S HATS AND HOODS; WOMEN'S SHOES; WOODEN SHOES; WORK SHOES AND BOOTS; WORKING OVERALLS; WRIST BANDS; WRISTBANDS; YOGA PANTS; YOGA SHIRTS (U.S. CLS. 22 AND 39).

FIRST USE 2-10-2009; IN COMMERCE 5-1-2009.

3,999,304. HAMN, LARNELL A., MANASSAS, VA. AND THOMPSON, CHRISTOPHER D., FREDERICKSBURG, VA. SN 85-022,605. PUB. 11-30-2010, FILED 4-25-2010.

Ostrich Apparel

NO CLAIM IS MADE TO THE EXCLUSIVE RIGHT TO USE "APPAREL", APART FROM THE MARK AS SHOWN. THE MARK CONSISTS OF THE STYLIZED WORDS "OSTRICH APPAREL".

FOR A-SHIRTS; ANKLE SOCKS; ATHLETIC APPAREL, NAMELY, SHIRTS, PANTS, ATHLETIC UNIFORMS; BOXER BRIEFS; BOXER SHORTS; BRIEFS; CAMOUFLAGE PANTS; CAPRI PANTS; CARGO PANTS; GOLF PANTS; GOLF SHIRTS; JEANS; JOGGING PANTS; LONG UNDERWEAR; MEN'S DRESS SOCKS; MEN'S SOCKS; MEN'S UNDERWEAR; POLO SHIRTS; SHIRTS FOR INFANTS, BABIES, TODDLERS AND CHILDREN; SHIRTS FOR SUITS; SOCKS; SWEAT PANTS; SWIMMING TRUNKS; T-SHIRTS; TEE SHIRTS; TRUNKS; UNDERWEAR, NAMELY, BOY SHORTS (U.S. CLS. 22 AND 39).

FIRST USE 6-1-2010; IN COMMERCE 1-1-2011.

CLASS 25—(Continued).

3,999,348. CHIPPENDALES USA, LLC, PLAINVIEW, NY. SN 85-028,450. PUB. 10-5-2010, FILED 5-3-2010.



THE MARK CONSISTS OF A STRAIGHT LINE WITH A BOW TIE IN THE MIDDLE AND THE WORD "CHIPPENDALES" UNDERNEATH.

FOR CLOTHING, NAMELY, LINGERIE, SLEEPWEAR AND MEN'S BOXER SHORTS (U.S. CLS. 22 AND 39). FIRST USE 9-0-2010; IN COMMERCE 9-0-2010.

3,999,369. MACKLEY, MARY BETH, ASHEVILLE, NC. AND MACKLEY, ANTHONY J., ASHEVILLE, NC. SN 85-030,545. PUB. 10-5-2010, FILED 5-5-2010.

LIFE IN EVERY BREATH

THE MARK CONSISTS OF STANDARD CHARACTERS WITHOUT CLAIM TO ANY PARTICULAR FONT, STYLE, SIZE, OR COLOR.

FOR BASEBALL CAPS, CAPS, HATS, SHIRTS (U.S. CLS. 22 AND 39). FIRST USE 5-13-2011; IN COMMERCE 5-13-2011.

3,999,377. UPHOLSTERY DECOR, INC., GOLETA, CA. SN 85-031,642. PUB. 10-5-2010, FILED 5-6-2010.

GOT POT

THE MARK CONSISTS OF STANDARD CHARACTERS WITHOUT CLAIM TO ANY PARTICULAR FONT, STYLE, SIZE, OR COLOR.

FOR BELTS; GLOVES; HATS; JACKETS; PANTS; SCARVES; SHIRTS; SHOES; SHORTS; UNDERGARMENTS; WRISTBANDS (U.S. CLS. 22 AND 39). FIRST USE 11-1-2010; IN COMMERCE 11-1-2010.

CLASS 25—(Continued).

3,999,380. ROCKBROOK HOLDINGS LTD., TORTOLA, BR.VIRGIN ISLANDS. SN 85-032,029. PUB. 10-5-2010, FILED 5-6-2010.

AMS AIDED MOTION SYSTEM

THE MARK CONSISTS OF STANDARD CHARACTERS WITHOUT CLAIM TO ANY PARTICULAR FONT, STYLE, SIZE, OR COLOR.

FOR FOOTWEAR (U.S. CLS. 22 AND 39). FIRST USE 7-20-2010; IN COMMERCE 7-20-2010.

3,999,381. ROCKBROOK HOLDINGS LTD., TORTOLA, BR.VIRGIN ISLANDS. SN 85-032,036. PUB. 10-5-2010, FILED 5-6-2010.

WALK MOVE LIVE

THE MARK CONSISTS OF STANDARD CHARACTERS WITHOUT CLAIM TO ANY PARTICULAR FONT, STYLE, SIZE, OR COLOR.

FOR FOOTWEAR (U.S. CLS. 22 AND 39). FIRST USE 7-20-2010; IN COMMERCE 7-20-2010.

3,999,387. REBEL SPRING GAMES, LLC, GRAND RAPIDS, MI. SN 85-032,578. PUB. 10-5-2010, FILED 5-7-2010.

REBEL GAMES

THE MARK CONSISTS OF STANDARD CHARACTERS WITHOUT CLAIM TO ANY PARTICULAR FONT, STYLE, SIZE, OR COLOR.

FOR CLOTHING, NAMELY, T-SHIRTS, POLO SHIRTS, SWEAT SHIRTS, AND JACKETS; HEAD WEAR, NAMELY, BASEBALL CAPS AND VISORS (U.S. CLS. 22 AND 39).

FIRST USE 1-1-1983; IN COMMERCE 1-1-1983.

CLASS 25—(Continued).

3,999,391. CHRISTOPHER R. PERRY, LOMBARD, IL. SN 85-032,700. PUB. 10-12-2010, FILED 5-7-2010.



THE MARK CONSISTS OF THE WORDS "GODS & GANGSTERS" IN STYLIZED FORM, ENCLOSED WITHIN A DOUBLE-OUTLINED FRAME OF GENERALLY RECTANGULAR SHAPE BUT WHICH INCLUDES AN OVAL BULGE IN THE CENTER; IN THE CENTER BULGE, BEHIND THE "&" SYMBOL, IS AN AFRICAN ADINKRA SYMBOL CALLED THE GYE NYAME.
FOR SHIRTS (U.S. CLS. 22 AND 39).
FIRST USE 6-6-2011; IN COMMERCE 6-6-2011.

3,999,397. GENDERS GROUP LAND & TITLE, INC., TAMPA, FL. SN 85-033,192. PUB. 10-5-2010, FILED 5-7-2010.



THE MARK CONSISTS OF THE LETTERS "P" AND "S" IN STYLIZED FONT ABOVE THE WORDS "PRO" AND "SOUTH" SEPARATED BY A HYPHEN.

FOR CLOTHING, NAMELY, GOLF SHIRTS, T-SHIRTS, SHIRTS, LONG-SLEEVED SHIRTS, TANK TOPS, JERSEYS, SWEAT SHIRTS, SWEAT PANTS, SWIMWEAR, DRESSES, SKIRTS, JACKETS, PANTS, SHORTS, JOGGING OUTFITS, FOOTWEAR, SHOES, ATHLETIC SHOES, SANDALS, SPORTS SANDALS, CAPS, HATS, VISORS, GLOVES, COATS, HEADBANDS, NIGHT SHIRTS, ROBES, BELTS, PAJAMAS, SOCKS, LINGERIE, UNDERWEAR, BANDANNAS, NECKTIES, CAMP SHIRTS, LEG WARMERS, BOXERS, SLEEP PANTS, SLEEP SHORTS, NIGHTGOWNS, YOGA/EXERCISE PANTS, AND LOUNGE-WEAR (U.S. CLS. 22 AND 39).
FIRST USE 5-26-2011; IN COMMERCE 5-26-2011.

CLASS 25—(Continued).

3,999,417. MCGHEE, MELISSA, ENCINITAS, CA. AND SILBERMAN, DIANE, ENCINITAS, CA. SN 85-036,059. PUB. 10-5-2010, FILED 5-12-2010.



THE MARK CONSISTS OF THE WORD "BREAST" HAS THE LETTERS "R" AND "S" CROSSED OFF TO CREATE THE WORD "BEAT" WITH THE WORD "CANCER" BELOW IT UNDERLINED WITH AN EXCLAMATION POINT.

FOR APPAREL, NAMELY, SHIRTS, TANK TOPS, PANTS, SHORTS, JACKETS, DRESSES, BATHING SUITS, UNDERGARMENTS, SOCKS, SHOES, HATS, SWEATSHIRTS, AND UNIFORMS FOR NURSES AND DOCTORS (U.S. CLS. 22 AND 39).
FIRST USE 4-1-2010; IN COMMERCE 4-1-2010.

3,999,422. MATTHEW SEFICK, MT. PLEASANT, SC. SN 85-036,537. PUB. 10-19-2010, FILED 5-12-2010.

SERIAL CHILLER BY SEFICK

THE MARK CONSISTS OF STANDARD CHARACTERS WITHOUT CLAIM TO ANY PARTICULAR FONT, STYLE, SIZE, OR COLOR.

FOR PAJAMAS; PANTS; SHIRTS; SLEEPWEAR; SWEAT SHIRTS; T-SHIRTS (U.S. CLS. 22 AND 39).
FIRST USE 3-14-2011; IN COMMERCE 3-14-2011.

3,999,473. ICON-ALTRA LLC, LOGAN, UT. SN 85-044,289. PUB. 10-19-2010, FILED 5-20-2010.



THE MARK CONSISTS OF A TRIANGULAR SHAPE WITH A CURVE ON THE RIGHT SIDE AND A LINE DOWN THE MIDDLE WITH A STYLIZED VERSION OF THE WORD "ALTRA" UNDERNEATH.

THE ENGLISH TRANSLATION OF THE WORD "ALTRA" IN THE MARK IS "OTHER" OR "ALTERNATIVE".

FOR ATHLETIC SHOES; FOOTWEAR FOR TRACK AND FIELD ATHLETICS; RUNNING SHOES; SHOES; TRAINING SHOES; WOMEN'S SHOES (U.S. CLS. 22 AND 39).
FIRST USE 3-31-2011; IN COMMERCE 3-31-2011.

CLASS 25—(Continued).

3,999,533. RICE ENTERTAINMENT, INC., SAN DIEGO, CA.
SN 85-057,935. PUB. 11-2-2010, FILED 6-8-2010.

Show Me Your Pukana

THE MARK CONSISTS OF STANDARD CHARACTERS
WITHOUT CLAIM TO ANY PARTICULAR FONT, STYLE,
SIZE, OR COLOR.

FOR TEE SHIRTS (U.S. CLS. 22 AND 39).
FIRST USE 9-22-2010; IN COMMERCE 11-8-2010.

3,999,537. HOP, RAFAEL COHEN, MEXICO CITY, MEXICO.
SN 85-058,835. PUB. 11-9-2010, FILED 6-9-2010.

DIANA DI GIORNO

THE MARK CONSISTS OF STANDARD CHARACTERS
WITHOUT CLAIM TO ANY PARTICULAR FONT, STYLE,
SIZE, OR COLOR.

THE NAME "DIANA DI GIORNO" DOES NOT IDENTIFY
A LIVING INDIVIDUAL.

THE WORDING "DIANA DI GIORNO" HAS NO MEANING
IN A FOREIGN LANGUAGE.

FOR CLOTHING, NAMELY, DRESSES AND GOWNS;
FOOTWEAR; HEADWEAR, NAMELY, VEILS; DRESS
SHIELDS; DRESSING GOWNS; SKIRTS; LADIES' UNDERWEAR;
LONG UNDERWEAR; THERMAL UNDERWEAR;
UNDERWEAR, NAMELY, THONGS;
UNDERWEAR; WOVEN OR KNITTED UNDERWEAR;
PANTIES; LINGERIE; MATERNITY LINGERIE; ADHESIVE
BRAS; BRAS (U.S. CLS. 22 AND 39).

FIRST USE 3-31-2009; IN COMMERCE 3-31-2009.

3,999,538. HOP, RAFAEL COHEN, MEXICO CITY, MEXICO.
SN 85-058,854. PUB. 11-9-2010, FILED 6-9-2010.

NINA RESENS

THE MARK CONSISTS OF STANDARD CHARACTERS
WITHOUT CLAIM TO ANY PARTICULAR FONT, STYLE,
SIZE, OR COLOR.

CLASS 25—(Continued).

THE NAME "NINA RESENS" DOES NOT IDENTIFY A
LIVING INDIVIDUAL.

FOR CLOTHING, NAMELY, DRESSES AND GOWNS;
FOOTWEAR; HEADWEAR, NAMELY, VEILS; DRESS
SHIELDS; DRESSING GOWNS; SKIRTS; LADIES' UNDERWEAR;
LONG UNDERWEAR; THERMAL UNDERWEAR;
UNDERWEAR, NAMELY, THONGS;
UNDERWEAR; WOVEN OR KNITTED UNDERWEAR;
PANTIES; LINGERIE; MATERNITY LINGERIE; ADHESIVE
BRAS; BRAS (U.S. CLS. 22 AND 39).

FIRST USE 3-31-2009; IN COMMERCE 3-31-2009.

3,999,540. DYNASTY FOOTWEAR, LTD., EL SEGUNDO, CA.
SN 85-060,220. PUB. 12-21-2010, FILED 6-11-2010.



THE MARK CONSISTS OF THE STYLIZED LETTERS
"PEX" WITHIN A RECTANGULAR BORDER.

FOR FOOTWEAR (U.S. CLS. 22 AND 39).
FIRST USE 5-0-2010; IN COMMERCE 5-0-2010.

3,999,550. GORNEY, MICHAEL J., CEDAR GROVE, NJ. SN
85-062,872. PUB. 11-16-2010, FILED S.R. 6-15-2010; AM. P.R.
5-16-2011.



NO CLAIM IS MADE TO THE EXCLUSIVE RIGHT TO
USE "WEAR", APART FROM THE MARK AS SHOWN.

THE MARK CONSISTS OF THE STYLIZED WORDING
"MEE WEAR". THE TERM "MEE" IS COMPRISED OF A
CAPITAL LETTER "M" WITH TWO LOWERCASE LETTER
"E"S INTERSECTING AT THE BOTTOM OF THE LETTER
"M". THE TERM "MEE" IS DIRECTLY ABOVE THE WORD
"WEAR".

FOR HATS; PANTS; SHIRTS (U.S. CLS. 22 AND 39).
FIRST USE 3-0-2011; IN COMMERCE 3-0-2011.

CLASS 25—(Continued).

3,999,562. ORANGE ZONE INC., LOS ANGELES, CA. SN 85-065,520. PUB. 12-7-2010, FILED 6-17-2010.



NO CLAIM IS MADE TO THE EXCLUSIVE RIGHT TO USE "FINE RESORT WEAR", APART FROM THE MARK AS SHOWN.

THE COLOR(S) BLACK, ORANGE, TAN AND YELLOW IS/ARE CLAIMED AS A FEATURE OF THE MARK.

THE MARK CONSISTS OF A BLACK HAMMOCK HANGING BETWEEN TWO BLACK PALM TREES ABOVE BLACK GROUND INSIDE A ROUND ORANGE AND YELLOW SUN WITH ORANGE CLOUD SHAPES AND BLACK BIRDS WITHIN AND WITH THE WORDS "PARADISE KEY" IN BLACK ABOVE THE WORDS "FINE RESORT WEAR" IN BLACK, ALL APPEARING ON A TAN BACKGROUND.

FOR ATHLETIC APPAREL, NAMELY, SHIRTS, PANTS, JACKETS, FOOTWEAR, HATS AND CAPS, ATHLETIC UNIFORMS; BUTTON-FRONT ALOHA SHIRTS; CAMP SHIRTS; CAPRI PANTS; CARGO PANTS; DENIMS; DRESS SHIRTS; GOLF PANTS, SHIRTS AND SKIRTS; HOODED SWEAT SHIRTS; JACKETS; LONG-SLEEVED SHIRTS; MEN'S AND WOMEN'S JACKETS, COATS, TROUSERS, VESTS; MOISTURE-WICKING SPORTS PANTS; MOISTURE-WICKING SPORTS SHIRTS; POLO SHIRTS; SHORT-SLEEVED OR LONG-SLEEVED T-SHIRTS; SHORTS; SPORT SHIRTS; SWEAT SHIRTS (U.S. CLS. 22 AND 39).

FIRST USE 11-1-2010; IN COMMERCE 11-1-2010.

3,999,567. ASHTON, RICHARD, HOUSTON, TX. SN 85-066,006. PUB. 11-16-2010, FILED 6-18-2010.

QUIT OR GET BETTER!

THE MARK CONSISTS OF STANDARD CHARACTERS WITHOUT CLAIM TO ANY PARTICULAR FONT, STYLE, SIZE, OR COLOR.

FOR CLOTHING PRODUCTS, NAMELY, T-SHIRTS (U.S. CLS. 22 AND 39).

FIRST USE 1-21-2011; IN COMMERCE 3-12-2011.

CLASS 25—(Continued).

3,999,578. VICTORIA'S SECRET STORES BRAND MANAGEMENT, INC., REYNOLDSBURG, OH. SN 85-069,622. PUB. 10-19-2010, FILED 6-23-2010.

STRINGKINI

THE MARK CONSISTS OF STANDARD CHARACTERS WITHOUT CLAIM TO ANY PARTICULAR FONT, STYLE, SIZE, OR COLOR.

FOR SWIMWEAR (U.S. CLS. 22 AND 39).
FIRST USE 1-31-2011; IN COMMERCE 1-31-2011.

3,999,586. FRABILL, INC., JACKSON, WI. SN 85-071,689. PUB. 11-2-2010, FILED 6-25-2010.

SPILL WAY

THE MARK CONSISTS OF STANDARD CHARACTERS WITHOUT CLAIM TO ANY PARTICULAR FONT, STYLE, SIZE, OR COLOR.

FOR A FEATURE OF BOTTOMS AND PANTS (U.S. CLS. 22 AND 39).

FIRST USE 7-15-2010; IN COMMERCE 12-6-2010.

3,999,590. DYNASTY FOOTWEAR, LTD., EL SEGUNDO, CA. SN 85-073,393. PUB. 11-16-2010, FILED 6-28-2010.

PEX

THE MARK CONSISTS OF STANDARD CHARACTERS WITHOUT CLAIM TO ANY PARTICULAR FONT, STYLE, SIZE, OR COLOR.

FOR FOOTWEAR (U.S. CLS. 22 AND 39).
FIRST USE 5-0-2010; IN COMMERCE 5-0-2010.

CLASS 25—(Continued).

3,999,597. DAY, RICHARD V., PALM BEACH, FL. SN 85-074,939. PUB. 11-30-2010, FILED 6-30-2010.

33480 HOUSEWIVES

THE MARK CONSISTS OF STANDARD CHARACTERS WITHOUT CLAIM TO ANY PARTICULAR FONT, STYLE, SIZE, OR COLOR.

OWNER OF U.S. REG. NOS. 3,338,646, 3,735,040, AND 3,737,987.

SEC. 2(F) AS TO "33480".

FOR BODY SHIRTS; DRESS SHIRTS; GOLF SHIRTS; KNIT SHIRTS; LONG-SLEEVED SHIRTS; OPEN-NECKED SHIRTS; PIQUE SHIRTS; POLO SHIRTS; SHIRTS; SHIRTS AND SHORT-SLEEVED SHIRTS; SHIRTS FOR SUITS; SHORT-SLEEVED OR LONG-SLEEVED T-SHIRTS; SHORT-SLEEVED SHIRTS; SPORT SHIRTS; T-SHIRTS; TEE SHIRTS (U.S. CLS. 22 AND 39).
FIRST USE 8-9-2010; IN COMMERCE 8-9-2010.

3,999,630. LILI GLOBAL APPAREL INC., NEW YORK, NY. SN 85-085,263. PUB. 12-28-2010, FILED 7-15-2010.

Lili's Closet

THE MARK CONSISTS OF STANDARD CHARACTERS WITHOUT CLAIM TO ANY PARTICULAR FONT, STYLE, SIZE, OR COLOR.

THE NAME "LILI" IDENTIFIES A LIVING INDIVIDUAL WHOSE CONSENT IS OF RECORD.

FOR WEARABLE APPAREL FOR WOMEN, MEN, AND CHILDREN, NAMELY, SUITS, VESTS, PANTS, WOVEN DRESSES, KNIT DRESSES, SKIRTS, SWEATERS, COATS, JACKETS, BLOUSES, KNIT TOPS, SHORTS, SHIRTS, UNDERWEAR TOPS AND BOTTOMS, AND SHOES (U.S. CLS. 22 AND 39).

FIRST USE 2-23-2011; IN COMMERCE 2-23-2011.

3,999,640. TRUE WOMB DESIGNS, LLC, AUSTIN, TX. SN 85-087,545. PUB. 12-21-2010, FILED 7-19-2010.

TRUEWOMB

THE MARK CONSISTS OF STANDARD CHARACTERS WITHOUT CLAIM TO ANY PARTICULAR FONT, STYLE, SIZE, OR COLOR.

FOR BABY BODYSUITS; INFANT WEAR; SWADDLING CLOTHES (U.S. CLS. 22 AND 39).

FIRST USE 10-10-2010; IN COMMERCE 10-10-2010.

CLASS 25—(Continued).

3,999,666. LUCKY 21, INC, NEW YORK, NY. SN 85-099,190. PUB. 1-11-2011, FILED 8-3-2010.

LUCKY 21

THE MARK CONSISTS OF STANDARD CHARACTERS WITHOUT CLAIM TO ANY PARTICULAR FONT, STYLE, SIZE, OR COLOR.

FOR BATHING SUITS; BELTS; BOOTS; COATS; DRESSES; FOOTWEAR, NAMELY, PUMPS; HOSIERY; KNIT TOPS; LINGERIE; PANTS; SANDALS; SHORTS; SKIRTS; SLIPPERS; SWEATERS; TANK TOPS; WOMEN'S SHOES; WOVEN TOPS (U.S. CLS. 22 AND 39).
FIRST USE 8-23-2010; IN COMMERCE 8-23-2010.

3,999,679. SURFERS PARADISE CLOTHING CO, PERTH, WA, AUSTRALIA. SN 85-104,438. PUB. 2-22-2011, FILED 8-10-2010.

SURFERS PARADISE

THE MARK CONSISTS OF STANDARD CHARACTERS WITHOUT CLAIM TO ANY PARTICULAR FONT, STYLE, SIZE, OR COLOR.

NO CLAIM IS MADE TO THE EXCLUSIVE RIGHT TO USE "SURFERS", APART FROM THE MARK AS SHOWN.

FOR BERMUDA SHORTS; BLOUSES; CAPS; CHILDREN'S AND INFANT'S APPAREL, NAMELY, JUMPERS, OVERALL SLEEPWEAR, PAJAMAS, ROMPERS AND ONE-PIECE GARMENTS; DRESSES; FOOTWEAR; HATS; JACKETS; JEANS; MEN'S AND WOMEN'S JACKETS, COATS, TROUSERS, VESTS; MEN'S SUITS, WOMEN'S SUITS; MEN'S UNDERWEAR; PANTS; POLO SHIRTS; SHIRTS; SHOES; SHORTS; SLIPPERS; SOCKS; T-SHIRTS; UNDERGARMENTS; VESTS; WOMEN'S TOPS, NAMELY, CAMIS; WOMEN'S UNDERWEAR (U.S. CLS. 22 AND 39).

FIRST USE 12-1-2010; IN COMMERCE 12-1-2010.

3,999,680. WASP ENTERPRISES LLC, DBA WAP ENTERPRISES, HENDERSON, NV. SN 85-104,564. PUB. 1-25-2011, FILED 8-10-2010.



FOR T-SHIRTS (U.S. CLS. 22 AND 39).
FIRST USE 4-13-2011; IN COMMERCE 4-13-2011.

CLASS 25—(Continued).

3,999,690. NOCTIS INK, LLC, TEMPE, AZ. SN 85-107,531.
PUB. 3-15-2011, FILED 8-13-2010.

NOCTIS

THE MARK CONSISTS OF STANDARD CHARACTERS WITHOUT CLAIM TO ANY PARTICULAR FONT, STYLE, SIZE, OR COLOR.

FOR MENS AND WOMENS CLOTHING, NAMELY, SHIRTS, PANTS, SWEATSHIRTS, UNDERWEAR, SOCKS AND HATS (U.S. CLS. 22 AND 39).

FIRST USE 5-24-2011; IN COMMERCE 5-24-2011.

CLASS 25—(Continued).

3,999,741. KIMBERLY WILLIAMS, BAY SHORE, NY. SN 85-127,592. PUB. 3-8-2011, FILED 9-11-2010.

BLACK IMAGES, 1920

THE MARK CONSISTS OF STANDARD CHARACTERS WITHOUT CLAIM TO ANY PARTICULAR FONT, STYLE, SIZE, OR COLOR.

NO CLAIM IS MADE TO THE EXCLUSIVE RIGHT TO USE "BLACK", APART FROM THE MARK AS SHOWN.

FOR BLOUSES; DRESS SHIRTS; DRESSES; EVENING GOWNS; GOWNS; HATS; PANTS; SCARVES; SHIRTS; SHORTS; SKIRTS; TANK-TOPS (U.S. CLS. 22 AND 39).

FIRST USE 2-1-2011; IN COMMERCE 2-1-2011.

3,999,699. BLACK GOLF WEAR, AUSTELL, GA. SN 85-110,218. PUB. 2-1-2011, FILED 8-18-2010.

BGw

THE MARK CONSISTS OF STANDARD CHARACTERS WITHOUT CLAIM TO ANY PARTICULAR FONT, STYLE, SIZE, OR COLOR.

FOR GOLF CAPS; GOLF PANTS, SHIRTS AND SKIRTS (U.S. CLS. 22 AND 39).

FIRST USE 10-1-2007; IN COMMERCE 2-1-2008.

3,999,743. LONGWORTH INDUSTRIES, INC., WEST END, NC. SN 85-128,236. PUB. 3-1-2011, FILED 9-13-2010.

ALL-YEAR GEAR

THE MARK CONSISTS OF STANDARD CHARACTERS WITHOUT CLAIM TO ANY PARTICULAR FONT, STYLE, SIZE, OR COLOR.

OWNER OF U.S. REG. NOS. 2,503,240 AND 2,889,260.

NO CLAIM IS MADE TO THE EXCLUSIVE RIGHT TO USE "GEAR", APART FROM THE MARK AS SHOWN.

FOR APPAREL, NAMELY, MEN'S AND LADIES' T-SHIRTS, BOXERS, AND BRIEFS (U.S. CLS. 22 AND 39).

FIRST USE 12-22-2010; IN COMMERCE 12-22-2010.

3,999,737. BARECUDA, LLC, STUART, FL. SN 85-126,769.
PUB. 2-22-2011, FILED 9-10-2010.



THE MARK CONSISTS OF THE WORD/LETTERS "BARECUDA" WHICH ARE INCORPORATED INTO A BARRACUDA FISH. PROCEEDING THE TAIL, THE LETTERS "BARE" MAKE UP THE BODY OF THE FISH. THE "C" CONSTITUTES THE MOUTH OF THE FISH WHICH IS EATING THE REMAINING LETTERS "UDA". THERE IS A CIRCLE WITHIN A CIRCLE JUST ABOVE THE "C" THAT REPRESENTS THE EYE OF THE FISH.

FOR ATHLETIC APPAREL, NAMELY, SHIRTS, PANTS, JACKETS, FOOTWEAR, HATS AND CAPS, ATHLETIC UNIFORMS; BIKINIS; SHIRTS AND SHORT-SLEEVED SHIRTS (U.S. CLS. 22 AND 39).

FIRST USE 5-2-2011; IN COMMERCE 5-5-2011.

3,999,745. LONGWORTH INDUSTRIES, INC., WEST END, NC. SN 85-128,293. PUB. 3-1-2011, FILED 9-13-2010.

AYG

THE MARK CONSISTS OF STANDARD CHARACTERS WITHOUT CLAIM TO ANY PARTICULAR FONT, STYLE, SIZE, OR COLOR.

FOR APPAREL, NAMELY, MEN'S AND LADIES' T-SHIRTS, BOXERS, AND BRIEFS (U.S. CLS. 22 AND 39).

FIRST USE 12-22-2010; IN COMMERCE 12-22-2010.

CLASS 25—(Continued).

3,999,778. HOLD YOUR HAUNCHES, INC., MACON, GA. SN 85-141,891. PUB. 3-15-2011, FILED 9-30-2010.

HOLD YOUR HAUNCHES

THE MARK CONSISTS OF STANDARD CHARACTERS WITHOUT CLAIM TO ANY PARTICULAR FONT, STYLE, SIZE, OR COLOR.
FOR PANTS (U.S. CLS. 22 AND 39).
FIRST USE 11-1-2010; IN COMMERCE 11-1-2010.

CLASS 25—(Continued).

3,999,823. HOLD YOUR HAUNCHES, INC., MACON, GA. SN 85-157,172. PUB. 3-15-2011, FILED 10-20-2010.

**'CAUSE A GIRL HAS A RIGHT
TO LOOK TIGHT**

THE MARK CONSISTS OF STANDARD CHARACTERS WITHOUT CLAIM TO ANY PARTICULAR FONT, STYLE, SIZE, OR COLOR.
FOR PANTS (U.S. CLS. 22 AND 39).
FIRST USE 11-1-2010; IN COMMERCE 11-1-2010.

3,999,782. BOTANICAL SKIN RESEARCH, LLC, VIRGINIA BEACH, VA. SN 85-142,410. PUB. 3-15-2011, FILED 9-30-2010.

flipswaps

THE MARK CONSISTS OF STANDARD CHARACTERS WITHOUT CLAIM TO ANY PARTICULAR FONT, STYLE, SIZE, OR COLOR.
FOR FLIP FLOPS; SHOES (U.S. CLS. 22 AND 39).
FIRST USE 3-5-2011; IN COMMERCE 5-4-2011.

3,999,806. KELLWOOD COMPANY, CHESTERFIELD, MO. SN 85-149,890. PUB. 3-8-2011, FILED 10-11-2010.

WAIST SOLUTION

THE MARK CONSISTS OF STANDARD CHARACTERS WITHOUT CLAIM TO ANY PARTICULAR FONT, STYLE, SIZE, OR COLOR.
NO CLAIM IS MADE TO THE EXCLUSIVE RIGHT TO USE "WAIST", APART FROM THE MARK AS SHOWN.
FOR BOTTOMS; PANTS; SHORTS; SKIRTS (U.S. CLS. 22 AND 39).
FIRST USE 3-0-2011; IN COMMERCE 3-0-2011.

3,999,834. IRON FIST INTERNTIONAL, INC., SAN DIEGO, CA. SN 85-160,134. PUB. 3-22-2011, FILED 10-25-2010.

DEADBOY

THE MARK CONSISTS OF STANDARD CHARACTERS WITHOUT CLAIM TO ANY PARTICULAR FONT, STYLE, SIZE, OR COLOR.
FOR APPAREL, NAMELY, T-SHIRTS, SHIRTS, SHORTS, PANTS, SWEATSHIRTS, SWEATPANTS, JACKETS, HATS, VISORS, SHOES, SANDALS, UNDERWEAR, SOCKS, BATHING SUITS, AND BELTS (U.S. CLS. 22 AND 39).
FIRST USE 11-1-2010; IN COMMERCE 11-1-2010.

3,999,846. D.B.R., INC., SUFFERN, NY. SN 85-164,442. PUB. 3-15-2011, FILED 10-29-2010.

CONTROL CENTER

THE MARK CONSISTS OF STANDARD CHARACTERS WITHOUT CLAIM TO ANY PARTICULAR FONT, STYLE, SIZE, OR COLOR.
FOR HOSIERY (U.S. CLS. 22 AND 39).
FIRST USE 11-0-2010; IN COMMERCE 11-0-2010.

CLASS 25—(Continued).

3,999,872. DC SHOES, INC., HUNTINGTON BEACH, CA. SN 85-975,236. PUB. 10-5-2010, FILED 4-29-2010.



THE MARK CONSISTS OF THE SIDE VIEW OF A RABBIT WITH AN OUTLINE OF A CIRCLE AROUND THE BOTTOM OF THE BACK LEG.

FOR FOOTWEAR; HEADWEAR; JACKETS; PANTS; SHIRTS (U.S. CLS. 22 AND 39).
FIRST USE 9-15-2010; IN COMMERCE 9-15-2010.

3,999,880. WELCOME MS USA, INC., LOS ANGELES, CA. SN 85-975,322. PUB. 12-14-2010, FILED 7-1-2010.

PRINCESS MAKER

THE MARK CONSISTS OF STANDARD CHARACTERS WITHOUT CLAIM TO ANY PARTICULAR FONT, STYLE, SIZE, OR COLOR.

FOR FOOTWEAR AND APPAREL, NAMELY, DRESS SHOES, CASUAL SHOES, ATHLETIC FOOTWEAR, SNEAKERS, BOOTS, SANDALS, ESPADRILLES, SLIPPERS, T-SHIRTS, SWEAT SHIRTS, GOLF SHIRTS, JERSEYS, SHORTS, PANTS, SLACKS, JEANS, TROUSERS, SWEAT SHIRTS, SWEAT PANTS, WARM-UP SUITS, JACKETS, COATS, BLAZERS, HATS, CAPS, VISORS, SCARVES, GLOVES, HOSIERY, NECKTIES, PAJAMAS, ROBES, NIGHT SHIRTS, NIGHT GOWNS, UNDERWEAR, LINGERIE, BRAS, PANTIES, BOXERS, BRIEFS, SHAPE WEAR AND SUPPORT FOUNDATION GARMENTS, NAMELY, GIRDLES, SLIPS AND CAMISOLES, HEAD BANDS, WRISTBANDS, SWIM SUITS, SKIRTS, TANK TOPS, SWEATERS, STOCKINGS, SOCKS, PANTYHOSE, TIGHTS, BELTS (U.S. CLS. 22 AND 39).
FIRST USE 5-1-2011; IN COMMERCE 5-1-2011.

CLASS 26—FANCY GOODS

CLASS 26—(Continued).

3,998,890. NOVA INNOVATIONS, LC, ST. LOUIS, MO. SN 77-863,368. PUB. 4-6-2010, FILED 11-2-2009.

THE START BUTTON

THE MARK CONSISTS OF STANDARD CHARACTERS WITHOUT CLAIM TO ANY PARTICULAR FONT, STYLE, SIZE, OR COLOR.

NO CLAIM IS MADE TO THE EXCLUSIVE RIGHT TO USE "BUTTON", APART FROM THE MARK AS SHOWN.

FOR ORNAMENTAL NOVELTY BUTTONS; ORNAMENTAL NOVELTY PINS (U.S. CLS. 37, 39, 40, 42 AND 50).

FIRST USE 5-31-2011; IN COMMERCE 5-31-2011.

3,999,312. MICHAEL PAUL MCLENDON, DBA MAXESSORIES, WOODSTOCK, GA. SN 85-024,572. PUB. 11-16-2010, FILED 4-27-2010.



THE MARK CONSISTS OF THE MARK "M MAXESSORIES" WITH THE STYLIZED UPPERCASE "M" ROTATED 45 DEGREES COUNTER-CLOCKWISE OVER A STYLIZED SQUARE SHAPED BACKGROUND, ABOVE THE CAPITALIZED COMPANY NAME, "MAXESSORIES" IMPOSED OVER A STYLIZED RECTANGULAR SHAPED BACKGROUND.

FOR CLOTHING ACCESSORIES, NAMELY, PLASTIC CLIPS THAT ATTACH TO THE LOWER HEM OF SHIRTS AND BLOUSES THAT ALLOWS THE USER TO TIGHTEN THE HEM (U.S. CLS. 37, 39, 40, 42 AND 50).
FIRST USE 8-1-2010; IN COMMERCE 12-1-2010.

CLASS 27—FLOOR COVERINGS

CLASS 27—(Continued).

3,998,490. WALLQUEST, INC., WAYNE, PA. SN 77-461,054. PUB. 9-23-2008, FILED 4-29-2008.

ECO-CHIC

THE MARK CONSISTS OF STANDARD CHARACTERS WITHOUT CLAIM TO ANY PARTICULAR FONT, STYLE, SIZE, OR COLOR.

FOR WALLPAPER (U.S. CLS. 19, 20, 37, 42 AND 50).
FIRST USE 5-12-2011; IN COMMERCE 5-12-2011.

CLASS 28—TOYS AND SPORTING GOODS

3,998,335. JAY AT PLAY INTERNATIONAL HONG KONG LIMITED, HONG KONG, CHINA. SN 76-703,638. PUB. 11-30-2010, FILED 7-2-2010.

HAPPY NAPPERS

THE MARK CONSISTS OF STANDARD CHARACTERS WITHOUT CLAIM TO ANY PARTICULAR FONT, STYLE, SIZE, OR COLOR.

FOR PLUSH TOY ANIMALS AND STUFFED TOY FIGURES; STUFFED ANIMALS (U.S. CLS. 22, 23, 38 AND 50).

FIRST USE 6-0-2010; IN COMMERCE 6-0-2010.

3,998,336. JAY AT PLAY INTERNATIONAL HONG KONG LIMITED, HONG KONG, CHINA. SN 76-703,640. PUB. 11-30-2010, FILED 7-2-2010.

KOO KOO KORNER

THE MARK CONSISTS OF STANDARD CHARACTERS WITHOUT CLAIM TO ANY PARTICULAR FONT, STYLE, SIZE, OR COLOR.

FOR PLUSH TOY ANIMALS AND STUFFED TOY FIGURES; STUFFED ANIMALS (U.S. CLS. 22, 23, 38 AND 50).

FIRST USE 6-0-2010; IN COMMERCE 6-0-2010.

CLASS 28—(Continued).

3,998,337. JAY AT PLAY INTERNATIONAL HONG KONG LIMITED, HONG KONG, CHINA. SN 76-703,641. PUB. 11-30-2010, FILED 7-2-2010.

HOME SWEET HOME

THE MARK CONSISTS OF STANDARD CHARACTERS WITHOUT CLAIM TO ANY PARTICULAR FONT, STYLE, SIZE, OR COLOR.

FOR PLUSH ANIMAL THAT CONVERTS INTO A TOY HOUSE FOR THE PLUSH ANIMAL; AND TOY PILLOWS IN THE SHAPE OF A TOY HOUSE FOR CHILDREN THAT CONVERT INTO ANIMAL SHAPED FIGURES (U.S. CLS. 22, 23, 38 AND 50).

FIRST USE 5-10-2010; IN COMMERCE 6-25-2010.

3,998,397. THE SAUL ZAENTZ COMPANY, DBA TOLKIEN ENTERPRISES, BERKELEY, CA. SN 77-206,626. PUB. 9-9-2008, FILED 6-14-2007.

RIVENDELL

THE MARK CONSISTS OF STANDARD CHARACTERS WITHOUT CLAIM TO ANY PARTICULAR FONT, STYLE, SIZE, OR COLOR.

FOR TOYS, NAMELY, ACTION FIGURES; PLAY SETS, NAMELY, PLAY SETS FOR ACTION FIGURES; TOY ACTION FIGURES; TOY STRUCTURES IN THE NATURE OF TOY BUILDINGS; TOY HOUSES; TOY CASTLES (U.S. CLS. 22, 23, 38 AND 50).

FIRST USE 9-0-2008; IN COMMERCE 9-0-2008.

3,998,422. JIMMY HACK GOLF, LLC, EASLEY, SC. SN 77-284,930. PUB. 3-18-2008, FILED 9-20-2007.

GREEN ENVY PUTTER

THE MARK CONSISTS OF STANDARD CHARACTERS WITHOUT CLAIM TO ANY PARTICULAR FONT, STYLE, SIZE, OR COLOR.

NO CLAIM IS MADE TO THE EXCLUSIVE RIGHT TO USE "PUTTER", APART FROM THE MARK AS SHOWN.

FOR GOLF PUTTERS (U.S. CLS. 22, 23, 38 AND 50).
FIRST USE 6-5-2011; IN COMMERCE 6-5-2011.

CLASS 28—(Continued).

3,998,429. BERENSTEIN, BARRY, TORONTO, ONTARIO, CANADA. SN 77-293,889. PUB. 3-18-2008, FILED 10-2-2007.

CAMPANTICS

THE MARK CONSISTS OF STANDARD CHARACTERS WITHOUT CLAIM TO ANY PARTICULAR FONT, STYLE, SIZE, OR COLOR.

FOR BOARD GAMES (U.S. CLS. 22, 23, 38 AND 50).
FIRST USE 1-30-2011; IN COMMERCE 3-15-2011.

3,998,431. SWIM FREE, LLC, PACIFIC PALISADES, CA. SN 77-294,033. PUB. 3-18-2008, FILED 10-2-2007.

SWIM FREE

THE MARK CONSISTS OF STANDARD CHARACTERS WITHOUT CLAIM TO ANY PARTICULAR FONT, STYLE, SIZE, OR COLOR.

OWNER OF U.S. REG. NO. 2,548,249.

NO CLAIM IS MADE TO THE EXCLUSIVE RIGHT TO USE "SWIM", APART FROM THE MARK AS SHOWN.

FOR FLOATS FOR RECREATIONAL USE, SWIMBOARDS AND KICKBOARDS FOR RECREATIONAL USE, SWIM FINS AND WATER WING SWIM AIDS, INFLATABLE BATH TOYS, INFLATABLE FLOAT MATTRESSES AND PADS FOR RECREATIONAL USE, INFLATABLE RIDE ON TOYS (U.S. CLS. 22, 23, 38 AND 50).

FIRST USE 12-1-2008; IN COMMERCE 12-1-2008.

3,998,433. UNITED SPORTS TECHNOLOGIES, LP, FORT WORTH, TX. SN 77-298,107. PUB. 9-21-2010, FILED 10-7-2007.

EASY★FLEX

THE MARK CONSISTS OF THE WORDS "EASY" AND "FLEX" WITH A FIVE-POINT STAR SITUATED THEREBETWEEN.

FOR GOLF CLUB SHAFTS; GOLF CLUBS; GOLF CLUB HEADS; GOLF TRAINING DEVICES, NAMELY, GOLF CLUBS HAVING EXTRA-FLEXIBLE SHAFTS (U.S. CLS. 22, 23, 38 AND 50).

FIRST USE 5-16-2011; IN COMMERCE 5-16-2011.

CLASS 28—(Continued).

3,998,493. ANSPACH, JAMES A, BREMERTON, WA. SN 77-464,911. PUB. 12-9-2008, FILED 5-2-2008.



THE MARK CONSISTS OF A FISH BODY MADE OF TRIANGULAR SHAPES, WITH LOGO INSIDE OF FISH BODY, EYE FILL IS BLACK AND THE WORDING "SPOOLKEEPER" APPEARS ON THE FISH'S BODY.

FOR FISHING LEADERS; FISHING LINES (U.S. CLS. 22, 23, 38 AND 50).

FIRST USE 6-1-2008; IN COMMERCE 6-5-2008.

3,998,547. NINTENDO OF AMERICA INC., REDMOND, WA. SN 77-583,761. PUB. 9-28-2010, FILED 10-2-2008.

NINTENDO DS[®]

PRIORITY CLAIMED UNDER SEC. 44(D) ON JAPAN APPLICATION NO. 2008-079339, FILED 9-29-2008, REG. NO. 5323215, DATED 5-14-2010, EXPIRES 5-14-2020.

OWNER OF U.S. REG. NOS. 1,213,882, 1,497,674, AND OTHERS.

THE MARK CONSISTS OF STACKED DOUBLE BLOCKS TOGETHER WITH THE STYLIZED LETTERS "NINTENDODS", FOLLOWED BY A LETTER "I" WITHIN A CIRCLE, WHERE THE "I" IS A LIGHT SILHOUETTE ON A DARK FIELD OF THE CIRCLE.

FOR (BASED ON USE IN COMMERCE AND BASED ON 44(E)) HAND-HELD GAMES WITH LIQUID CRYSTAL DISPLAYS; GAME MACHINES AND APPARATUS, NAMELY, LCD GAME MACHINES; CASES FOR PLAY ACCESSORIES; CARRYING CASES FOR HAND-HELD VIDEO GAME SYSTEMS; HAND-HELD UNITS FOR PLAYING ELECTRONIC GAMES; HAND-HELD UNITS FOR PLAYING VIDEO GAMES; HAND-HELD VIDEO GAME SYSTEMS, COMPRISING HAND-HELD UNITS FOR PLAYING VIDEO GAMES AND ASSOCIATED GAME CARTRIDGES OR GAME MEMORY CARDS PACKAGED AS A UNIT; (BASED ON 44(E)) TOYS; DOLLS; ACTION SKILL GAMES; BOARD GAMES; CARD GAMES; PROMOTIONAL GAME CARDS (U.S. CLS. 22, 23, 38 AND 50).

FIRST USE 4-5-2009; IN COMMERCE 4-5-2009.

CLASS 28—(Continued).

3,998,582. REEBOK INTERNATIONAL LTD., CANTON, MA. SN 77-625,208. PUB. 9-22-2009, FILED 12-3-2008.

FLYSET

THE MARK CONSISTS OF STANDARD CHARACTERS WITHOUT CLAIM TO ANY PARTICULAR FONT, STYLE, SIZE, OR COLOR.

FOR FITNESS EQUIPMENT, NAMELY, MANUALLY-OPERATED EXERCISE EQUIPMENT TO IMPROVE STRENGTH, AGILITY, CONDITIONING AND FOR AEROBIC EXERCISE; TRAPEZE ROPES; EXERCISE BARS; SUSPENSION EQUIPMENT, NAMELY, TRAPEZES (U.S. CLS. 22, 23, 38 AND 50).

FIRST USE 5-1-2011; IN COMMERCE 5-1-2011.

3,998,638. MARSHALL, WALLY E., GARLAND, TX. SN 77-713,068. PUB. 4-6-2010, FILED 4-14-2009.

slab shaker

THE MARK CONSISTS OF STANDARD CHARACTERS WITHOUT CLAIM TO ANY PARTICULAR FONT, STYLE, SIZE, OR COLOR.

NO CLAIM IS MADE TO THE EXCLUSIVE RIGHT TO USE "SLAB", APART FROM THE MARK AS SHOWN.

FOR ARTIFICIAL FISHING LURES; FISH HOOKS; FISHING FLOATS; FISHING LURES; FISHING REELS; FISHING RODS; FISHING TACKLE, NAMELY, BOBBERS; FISHING WEIGHTS; HAND-HELD FISHING NETS (U.S. CLS. 22, 23, 38 AND 50).

FIRST USE 6-1-2011; IN COMMERCE 6-1-2011.

3,998,662. CALLAWAY GOLF COMPANY, CARLSBAD, CA. SN 77-730,657. PUB. 3-22-2011, FILED 5-6-2009.

Diablo Forged

THE MARK CONSISTS OF STANDARD CHARACTERS WITHOUT CLAIM TO ANY PARTICULAR FONT, STYLE, SIZE, OR COLOR.

OWNER OF U.S. REG. NO. 3,595,821.

NO CLAIM IS MADE TO THE EXCLUSIVE RIGHT TO USE "FORGED", APART FROM THE MARK AS SHOWN.

THE ENGLISH TRANSLATION OF "DIABLO" IN THE MARK IS "DEVIL".

FOR GOLF CLUBS (U.S. CLS. 22, 23, 38 AND 50).
FIRST USE 1-10-2010; IN COMMERCE 1-10-2010.

CLASS 28—(Continued).

3,998,680. RODALE INC., EMMAUS, PA. SN 77-743,226. PUB. 10-5-2010, FILED 5-22-2009.

CORESLIDER

THE MARK CONSISTS OF STANDARD CHARACTERS WITHOUT CLAIM TO ANY PARTICULAR FONT, STYLE, SIZE, OR COLOR.

FOR MANUALLY-OPERATED EXERCISE EQUIPMENT (U.S. CLS. 22, 23, 38 AND 50).

FIRST USE 2-17-2010; IN COMMERCE 2-17-2010.

3,998,698. PURE FISHING, INC., SPIRIT LAKE, IA. SN 77-766,324. PUB. 3-30-2010, FILED 6-23-2009.

BEETLE SHAD

THE MARK CONSISTS OF STANDARD CHARACTERS WITHOUT CLAIM TO ANY PARTICULAR FONT, STYLE, SIZE, OR COLOR.

OWNER OF U.S. REG. NO. 947,854.

NO CLAIM IS MADE TO THE EXCLUSIVE RIGHT TO USE "SHAD", APART FROM THE MARK AS SHOWN.

FOR ARTIFICIAL FISHING BAIT (U.S. CLS. 22, 23, 38 AND 50).

FIRST USE 12-0-2009; IN COMMERCE 12-0-2009.

3,998,699. PURE FISHING, INC., SPIRIT LAKE, IA. SN 77-766,326. PUB. 3-30-2010, FILED 6-23-2009.

BEETLE TUBE

THE MARK CONSISTS OF STANDARD CHARACTERS WITHOUT CLAIM TO ANY PARTICULAR FONT, STYLE, SIZE, OR COLOR.

OWNER OF U.S. REG. NO. 947,854.

NO CLAIM IS MADE TO THE EXCLUSIVE RIGHT TO USE "TUBE", APART FROM THE MARK AS SHOWN.

FOR ARTIFICIAL FISHING BAIT (U.S. CLS. 22, 23, 38 AND 50).

FIRST USE 12-0-2009; IN COMMERCE 12-0-2009.

CLASS 28—(Continued).

3,998,701. PURE FISHING, INC., SPIRIT LAKE, IA. SN 77-768,216. PUB. 3-30-2010, FILED 6-25-2009.

BEETLE CRITTER

THE MARK CONSISTS OF STANDARD CHARACTERS WITHOUT CLAIM TO ANY PARTICULAR FONT, STYLE, SIZE, OR COLOR.

OWNER OF U.S. REG. NO. 947,854.

NO CLAIM IS MADE TO THE EXCLUSIVE RIGHT TO USE "CRITTER", APART FROM THE MARK AS SHOWN.

FOR ARTIFICIAL FISHING BAIT (U.S. CLS. 22, 23, 38 AND 50).

FIRST USE 12-0-2009; IN COMMERCE 12-0-2009.

CLASS 28—(Continued).

3,998,894. GI MILSIM, INC., LACHINE, QUEBEC, CANADA. SN 77-864,121. PUB. 9-28-2010, FILED 11-3-2009.

CHAMELEON

THE MARK CONSISTS OF STANDARD CHARACTERS WITHOUT CLAIM TO ANY PARTICULAR FONT, STYLE, SIZE, OR COLOR.

FOR SPORTS EQUIPMENT FOR THE SPORT OF PAINTBALL, NAMELY, PAINTBALL GUN BARRELS (U.S. CLS. 22, 23, 38 AND 50).

FIRST USE 1-31-2010; IN COMMERCE 1-31-2010.

3,998,779. DIAMOND SELECT TOYS AND COLLECTIBLES, LLC., TIMONIUM, MD. SN 77-830,910. PUB. 2-16-2010, FILED 9-21-2009.

Femme Fatales

THE MARK CONSISTS OF STANDARD CHARACTERS WITHOUT CLAIM TO ANY PARTICULAR FONT, STYLE, SIZE, OR COLOR.

THE ENGLISH TRANSLATION OF "FEMME FATALES" IN THE MARK IS "A DANGEROUS WOMAN".

FOR GAMES AND PLAYTHINGS, NAMELY, BOARD GAMES, DOLLS, DOLL CLOTHING, DOLL ACCESSORIES, DOLL CASES, DOLL PLAYSETS FOR CHILDREN, ACTION FIGURES, TOY VEHICLES, PLAYING CARDS, CARD GAMES, BALLS FOR GAMES AND SPORTS (U.S. CLS. 22, 23, 38 AND 50).

FIRST USE 2-13-2010; IN COMMERCE 7-21-2010.

3,998,969. WILD PLANET ENTERTAINMENT, INC., SAN FRANCISCO, CA. SN 77-893,411. PUB. 11-9-2010, FILED 12-15-2009.

SPY VIDEO TRAKR

THE MARK CONSISTS OF STANDARD CHARACTERS WITHOUT CLAIM TO ANY PARTICULAR FONT, STYLE, SIZE, OR COLOR.

OWNER OF U.S. REG. NO. 3,363,485.

NO CLAIM IS MADE TO THE EXCLUSIVE RIGHT TO USE "VIDEO", APART FROM THE MARK AS SHOWN.

FOR REMOTE CONTROL TOYS, NAMELY, COMPUTER PROGRAMMABLE TOY VEHICLES WITH VIDEO CAMERAS (U.S. CLS. 22, 23, 38 AND 50).

FIRST USE 7-0-2010; IN COMMERCE 7-0-2010.

3,998,858. JOHN SCOTT, OCEANSIDE, CA. AND MARK DOHERTY, OCEANSIDE, CA. SN 77-856,577. PUB. 3-30-2010, FILED 10-23-2009.

LEVELHEAD

THE MARK CONSISTS OF STANDARD CHARACTERS WITHOUT CLAIM TO ANY PARTICULAR FONT, STYLE, SIZE, OR COLOR.

FOR GOLF BALL MARKERS: GOLF PUTTING AIDS, NAMELY, PUTTING GREEN LEVEL INDICATORS (U.S. CLS. 22, 23, 38 AND 50).

FIRST USE 1-0-2001; IN COMMERCE 1-0-2011.

3,998,985. DARTAM PUBLISHING, LLC, MORGANVILLE, NJ. SN 77-896,636. PUB. 5-11-2010, FILED 12-18-2009.

VNY

THE MARK CONSISTS OF STANDARD CHARACTERS WITHOUT CLAIM TO ANY PARTICULAR FONT, STYLE, SIZE, OR COLOR.

FOR BOARD GAMES (U.S. CLS. 22, 23, 38 AND 50).

FIRST USE 10-15-2010; IN COMMERCE 10-15-2010.

CLASS 28—(Continued).

3,999,013. GLOBERIDE, INC., TOKYO, JAPAN. SN 77-907,749.
PUB. 10-26-2010, FILED 1-8-2010.

CLASS 28—(Continued).

3,999,072. HALLMARK LICENSING, INC., KANSAS CITY,
MO. SN 77-932,300. PUB. 5-4-2010, FILED 2-10-2010.

MAGSEALED**SEASONS FROM HALLMARK**

THE MARK CONSISTS OF STANDARD CHARACTERS
WITHOUT CLAIM TO ANY PARTICULAR FONT, STYLE,
SIZE, OR COLOR.
FOR FISHING REELS (U.S. CLS. 22, 23, 38 AND 50).
FIRST USE 2-0-2010; IN COMMERCE 5-19-2011.

THE MARK CONSISTS OF STANDARD CHARACTERS
WITHOUT CLAIM TO ANY PARTICULAR FONT, STYLE,
SIZE, OR COLOR.
FOR CHRISTMAS TREE ORNAMENTS (U.S. CLS. 22,
23, 38 AND 50).
FIRST USE 11-30-2010; IN COMMERCE 11-30-2010.

3,999,036. MERCIER JR., JAMES P., REDMOND, WA. SN 77-
917,844. PUB. 11-2-2010, FILED 1-22-2010.

3,999,099. LITTLE KIDS, INC., SEEKONK, MA. SN 77-945,576.
PUB. 10-5-2010, FILED 2-26-2010.

X-rodz**Hall Stars**

THE MARK CONSISTS OF STANDARD CHARACTERS
WITHOUT CLAIM TO ANY PARTICULAR FONT, STYLE,
SIZE, OR COLOR.
FOR FISHING POLES; FISHING RODS; RODS FOR
FISHING (U.S. CLS. 22, 23, 38 AND 50).
FIRST USE 1-4-2010; IN COMMERCE 1-4-2010.

THE MARK CONSISTS OF STANDARD CHARACTERS
WITHOUT CLAIM TO ANY PARTICULAR FONT, STYLE,
SIZE, OR COLOR.
FOR KITS COMPRISING EQUIPMENT SOLD AS A
UNIT FOR PLAYING SPORTS GAMES INDOORS (U.S.
CLS. 22, 23, 38 AND 50).
FIRST USE 12-1-2010; IN COMMERCE 12-1-2010.

3,999,054. TINA MARIE HOVEN, GARDEN VALLEY, ID. SN
77-925,653. PUB. 6-15-2010, FILED 2-2-2010.

3,999,119. BATTLE ENTERPRISES, LLC, ATHENS, OH. SN
77-953,813. PUB. 9-21-2010, FILED 3-9-2010.

Dr. Science Mouse**BATTLEVERSE**

THE MARK CONSISTS OF STANDARD CHARACTERS
WITHOUT CLAIM TO ANY PARTICULAR FONT, STYLE,
SIZE, OR COLOR.
NO CLAIM IS MADE TO THE EXCLUSIVE RIGHT TO
USE "MOUSE", APART FROM THE MARK AS SHOWN.
FOR FABRIC PET TOYS CONTAINING CATNIP (U.S.
CLS. 22, 23, 38 AND 50).
FIRST USE 1-29-2010; IN COMMERCE 1-29-2010.

THE MARK CONSISTS OF STANDARD CHARACTERS
WITHOUT CLAIM TO ANY PARTICULAR FONT, STYLE,
SIZE, OR COLOR.
FOR ROLE PLAYING GAMES FEATURING COLLEC-
TIBLE TRADING CARDS AND STORIES FOR CONSU-
MERS (U.S. CLS. 22, 23, 38 AND 50).
FIRST USE 11-1-2010; IN COMMERCE 11-1-2010.

CLASS 28—(Continued).

3,999,315. MATT J. STEPHENSON, AMHURST, NY. SN 85-025,224. PUB. 9-28-2010, FILED 4-28-2010.

ROLL CALL

THE MARK CONSISTS OF STANDARD CHARACTERS WITHOUT CLAIM TO ANY PARTICULAR FONT, STYLE, SIZE, OR COLOR.

FOR HUNTING GAME CALLS (U.S. CLS. 22, 23, 38 AND 50).

FIRST USE 2-18-2011; IN COMMERCE 2-18-2011.

CLASS 28—(Continued).

3,999,428. AUBREN M. JOHNSON, DRAPER, UT. SN 85-037,045. PUB. 9-28-2010, FILED 5-12-2010.

SIDEKIX

THE MARK CONSISTS OF STANDARD CHARACTERS WITHOUT CLAIM TO ANY PARTICULAR FONT, STYLE, SIZE, OR COLOR.

FOR FOOTBAG THAT TRANSFORMS INTO A CHARACTER (U.S. CLS. 22, 23, 38 AND 50).

FIRST USE 5-9-2011; IN COMMERCE 5-8-2011.

3,999,366. FITNESS BRANDS 2, LLC, AUSTIN, TX. SN 85-030,127. PUB. 9-7-2010, FILED 5-4-2010.

CHEST MAGIC

THE MARK CONSISTS OF STANDARD CHARACTERS WITHOUT CLAIM TO ANY PARTICULAR FONT, STYLE, SIZE, OR COLOR.

NO CLAIM IS MADE TO THE EXCLUSIVE RIGHT TO USE "CHEST", APART FROM THE MARK AS SHOWN.

FOR MANUALLY-OPERATED EXERCISE EQUIPMENT; EXERCISE MACHINES (U.S. CLS. 22, 23, 38 AND 50).

FIRST USE 3-14-2011; IN COMMERCE 3-14-2011.

3,999,433. HARDY & GREYS LIMITED, ALNWICK, UNITED KINGDOM. SN 85-037,526. PUB. 10-19-2010, FILED 5-13-2010.

Zenith

THE MARK CONSISTS OF STANDARD CHARACTERS WITHOUT CLAIM TO ANY PARTICULAR FONT, STYLE, SIZE, OR COLOR.

FOR FISHING RODS (U.S. CLS. 22, 23, 38 AND 50).

FIRST USE 9-30-2010; IN COMMERCE 1-17-2011.

3,999,408. AUDACITY ENTERPRISES, LLC, O'FALLON, MO. SN 85-034,957. PUB. 10-12-2010, FILED 5-11-2010.

"GoodGospel"

THE MARK CONSISTS OF STANDARD CHARACTERS WITHOUT CLAIM TO ANY PARTICULAR FONT, STYLE, SIZE, OR COLOR.

FOR CARD GAMES; EDUCATIONAL CARD GAMES; PLAYING CARDS AND CARD GAMES (U.S. CLS. 22, 23, 38 AND 50).

FIRST USE 10-10-2008; IN COMMERCE 9-25-2010.

3,999,435. HARDY & GREYS LIMITED, ALNWICK, UNITED KINGDOM. SN 85-037,544. PUB. 10-19-2010, FILED 5-13-2010.

Proaxis

THE MARK CONSISTS OF STANDARD CHARACTERS WITHOUT CLAIM TO ANY PARTICULAR FONT, STYLE, SIZE, OR COLOR.

FOR FISHING RODS (U.S. CLS. 22, 23, 38 AND 50).

FIRST USE 9-30-2010; IN COMMERCE 2-24-2011.

CLASS 28—(Continued).

3,999,438. SNUGGLEBUGZZZ, LLC, LAKEVILLE, MN. SN 85-037,775. PUB. 10-12-2010, FILED 5-13-2010.

SnuggleBugzzz

THE MARK CONSISTS OF STANDARD CHARACTERS WITHOUT CLAIM TO ANY PARTICULAR FONT, STYLE, SIZE, OR COLOR.

FOR PLUSH TOYS; SOFT SCULPTURE PLUSH TOYS; STUFFED AND PLUSH TOYS (U.S. CLS. 22, 23, 38 AND 50).

FIRST USE 10-6-2010; IN COMMERCE 10-6-2010.

3,999,439. SNUGGLEBUGZZZ, LLC, LAKEVILLE, MN. SN 85-037,832. PUB. 10-12-2010, FILED 5-13-2010.



THE MARK CONSISTS OF THE WORD "SNUGGLEBUGZZZ" WITH THE THREE "G"'S REPLACED BY THREE STYLIZED CATERPILLARS. THE CATERPILLARS EACH BEING FORMED BY FIVE OVERLAPPING CIRCLES, OVERLAPPING FROM BOTTOM TO TOP, GENERALLY IN VERTICAL A LINE WITH THE BOTTOM CIRCLE BEING OFFSET TO THE LEFT AND SLIGHTLY BELOW THE NEXT HIGHEST CIRCLE, AND THAT NEXT HIGHEST CIRCLE BEING SLIGHTLY OFFSET TO THE LEFT OF THE TOPMOST THREE CIRCLES, THE TOPMOST THREE CIRCLES BEING IN VERTICAL PLACEMENT RELATIVE TO EACH OTHER, WITH THE TOPMOST CIRCLE HAVING A STYLIZED SMILING FACE, STYLIZED EYES AND ANTENNAE, AND THE CIRCLE JUST BELOW THE TOPMOST CIRCLE HAVING STYLIZED ARMS, THE THREE CATERPILLARS FORMING STYLIZED LETTERS "G".

FOR PLUSH TOYS; SOFT SCULPTURE PLUSH TOYS; STUFFED AND PLUSH TOYS (U.S. CLS. 22, 23, 38 AND 50).

FIRST USE 10-6-2010; IN COMMERCE 10-6-2010.

CLASS 28—(Continued).

3,999,450. PERPETUAL PLAY, INC., NEWPORT BEACH, CA. SN 85-040,652. PUB. 11-9-2010, FILED 5-17-2010.



THE COLOR(S) PURPLE, GREEN, YELLOW, AND BLACK IS/ARE CLAIMED AS A FEATURE OF THE MARK.

THE MARK CONSISTS OF PURPLE ARROWS, GREEN CAPITAL LETTERS FOR THE WORDING "E.V.A.", YELLOW LOWER CASE LETTERS FOR THE WORDING "ENERGY", "VELOCITY", AND "ACCELERATION", WITH THE LETTERING ON A BLACK BACKGROUND. THE WHITE IN THE MARK REPRESENTS BACKGROUND AND IS NOT A FEATURE OF THE MARK.

FOR TOY BOWS AND ARROWS; TOY CARS; TOY FOAM NOVELTY ITEMS, NAMELY, FOAM FINGERS AND HANDS; TOY GUNS; TOY SLING PLANES; TOY SWORDS; TOY TOOLS; TOY TRAINS AND PARTS AND ACCESSORIES THEREFOR; TOY VEHICLE TRACK SETS AND ROADWAYS AND ACCESSORIES THEREFOR; TOY VEHICLES; TOY VEHICLES AND ACCESSORIES THEREFOR; TOY WEAPONS; WATER SQUIRTING TOYS; WATER TOYS (U.S. CLS. 22, 23, 38 AND 50).

FIRST USE 5-1-2011; IN COMMERCE 5-1-2011.

3,999,515. WILDGAME INNOVATIONS, LLC, BROUSSARD, LA. SN 85-054,648. PUB. 10-26-2010, FILED 6-4-2010.

MOBSTER

THE MARK CONSISTS OF STANDARD CHARACTERS WITHOUT CLAIM TO ANY PARTICULAR FONT, STYLE, SIZE, OR COLOR.

FOR HUNTING GAME CALLS (U.S. CLS. 22, 23, 38 AND 50).

FIRST USE 12-9-2010; IN COMMERCE 12-9-2010.

3,999,516. WILDGAME INNOVATIONS, LLC, BROUSSARD, LA. SN 85-054,656. PUB. 10-26-2010, FILED 6-4-2010.

SCARFACE

THE MARK CONSISTS OF STANDARD CHARACTERS WITHOUT CLAIM TO ANY PARTICULAR FONT, STYLE, SIZE, OR COLOR.

FOR HUNTING GAME CALLS (U.S. CLS. 22, 23, 38 AND 50).

FIRST USE 1-5-2011; IN COMMERCE 1-5-2011.

CLASS 28—(Continued).

3,999,517. WILDGAME INNOVATIONS, LLC, BROUSSARD,
LA. SN 85-054,662. PUB. 10-26-2010, FILED 6-4-2010.

GANGSTER

THE MARK CONSISTS OF STANDARD CHARACTERS
WITHOUT CLAIM TO ANY PARTICULAR FONT, STYLE,
SIZE, OR COLOR.
FOR HUNTING GAME CALLS (U.S. CLS. 22, 23, 38
AND 50).
FIRST USE 12-10-2010; IN COMMERCE 12-10-2010.

CLASS 28—(Continued).

3,999,523. MATTEL, INC., EL SEGUNDO, CA. SN 85-056,007.
PUB. 10-26-2010, FILED 6-7-2010.

VERTIBIRD

THE MARK CONSISTS OF STANDARD CHARACTERS
WITHOUT CLAIM TO ANY PARTICULAR FONT, STYLE,
SIZE, OR COLOR.
FOR TOY VEHICLES AND ACCESSORIES THEREFOR
(U.S. CLS. 22, 23, 38 AND 50).
FIRST USE 12-31-2010; IN COMMERCE 12-31-2010.

3,999,518. WILDGAME INNOVATIONS, LLC, BROUSSARD,
LA. SN 85-054,671. PUB. 10-26-2010, FILED 6-4-2010.

BABY FACE

THE MARK CONSISTS OF STANDARD CHARACTERS
WITHOUT CLAIM TO ANY PARTICULAR FONT, STYLE,
SIZE, OR COLOR.
FOR HUNTING GAME CALLS (U.S. CLS. 22, 23, 38
AND 50).
FIRST USE 1-5-2011; IN COMMERCE 1-5-2011.

3,999,591. PLAYMATES TOYS INC., EL SEGUNDO, CA. SN
85-073,651. PUB. 11-30-2010, FILED 6-29-2010.

CONSUELO

THE MARK CONSISTS OF STANDARD CHARACTERS
WITHOUT CLAIM TO ANY PARTICULAR FONT, STYLE,
SIZE, OR COLOR.
THE WORDING "CONSUELO" HAS NO MEANING IN A
FOREIGN LANGUAGE.
FOR DOLLS AND RELATED DOLL ACCESSORIES
(U.S. CLS. 22, 23, 38 AND 50).
FIRST USE 10-28-2010; IN COMMERCE 10-28-2010.

3,999,519. WILDGAME INNOVATIONS, LLC, BROUSSARD,
LA. SN 85-054,678. PUB. 10-26-2010, FILED 6-4-2010.

THE MOB

THE MARK CONSISTS OF STANDARD CHARACTERS
WITHOUT CLAIM TO ANY PARTICULAR FONT, STYLE,
SIZE, OR COLOR.
FOR HUNTING GAME CALLS (U.S. CLS. 22, 23, 38
AND 50).
FIRST USE 12-15-2010; IN COMMERCE 12-15-2010.

3,999,599. O. MUSTAD & SON (U.S.A.) INC., AUBURN, NY.
SN 85-076,133. PUB. 12-7-2010, FILED 7-1-2010.

GRIP-PIN

THE MARK CONSISTS OF STANDARD CHARACTERS
WITHOUT CLAIM TO ANY PARTICULAR FONT, STYLE,
SIZE, OR COLOR.
FOR FISHING HOOKS (U.S. CLS. 22, 23, 38 AND 50).
FIRST USE 6-22-2010; IN COMMERCE 6-22-2010.

CLASS 28—(Continued).

3,999,606. MOOSE CREATIVE PTY LTD, EAST BENTLEIGH, AUSTRALIA. SN 85-077,834. PUB. 11-30-2010, FILED 7-4-2010.



PRIORITY CLAIMED UNDER SEC. 44(D) ON AUSTRALIA APPLICATION NO. 1353550, FILED 3-30-2010.

NO CLAIM IS MADE TO THE EXCLUSIVE RIGHT TO USE "MACHINES", APART FROM THE MARK AS SHOWN.

THE COLOR(S) WHITE, BLACK, GRAY, BLUE, SILVER, AND BROWN IS/ARE CLAIMED AS A FEATURE OF THE MARK.

THE MARK CONSISTS OF THE WORD "MACHINEZ" IN STYLIZED LETTERING WHEREIN THE LETTERS ARE BLUE AT THE BOTTOM, FADE TO SILVER IN THE MIDDLE, AND FADE TO BROWN AND WHITE AT THE TOP. THE LETTERS ARE OUTLINED IN BLACK AND HAVE GRAY LINES WITHIN THE LETTERS THAT DEPICT OVERLAPPING METAL SHEETS.

FOR TOYS, GAMES AND PLAYTHINGS, NAMELY, TOY VEHICLES AND PLAYSETS WITH WHEELS (U.S. CLS. 22, 23, 38 AND 50).

FIRST USE 1-10-2010; IN COMMERCE 11-15-2010.

3,999,610. MATTEL, INC., EL SEGUNDO, CA. SN 85-078,647. PUB. 11-30-2010, FILED 7-6-2010.

POWER SLINGERS

THE MARK CONSISTS OF STANDARD CHARACTERS WITHOUT CLAIM TO ANY PARTICULAR FONT, STYLE, SIZE, OR COLOR.

FOR TOY ACTION FIGURES AND ACCESSORIES THEREFOR; TOY WEAPONS (U.S. CLS. 22, 23, 38 AND 50).

FIRST USE 4-1-2011; IN COMMERCE 4-1-2011.

CLASS 28—(Continued).

3,999,755. FRANKLIN SPORTS, INC., STOUGHTON, MA. SN 85-132,861. PUB. 3-1-2011, FILED 9-18-2010.

SPACELACE

THE MARK CONSISTS OF STANDARD CHARACTERS WITHOUT CLAIM TO ANY PARTICULAR FONT, STYLE, SIZE, OR COLOR.

FOR FOOTBALLS (U.S. CLS. 22, 23, 38 AND 50).

FIRST USE 1-18-2010; IN COMMERCE 1-18-2010.

3,999,813. BOSS PET PRODUCTS, INC., GARFIELD HEIGHTS, OH. SN 85-152,566. PUB. 3-1-2011, FILED 10-14-2010.

STUFFABLEZ

THE MARK CONSISTS OF STANDARD CHARACTERS WITHOUT CLAIM TO ANY PARTICULAR FONT, STYLE, SIZE, OR COLOR.

FOR PET TOYS (U.S. CLS. 22, 23, 38 AND 50).

FIRST USE 3-16-2011; IN COMMERCE 3-16-2011.

3,999,866. RIEDELL SHOES, INC., RED WING, MN. SN 85-190,530. PUB. 3-15-2011, FILED 12-3-2010.

ECLIPSE

THE MARK CONSISTS OF STANDARD CHARACTERS WITHOUT CLAIM TO ANY PARTICULAR FONT, STYLE, SIZE, OR COLOR.

FOR ICE SKATE BLADES (U.S. CLS. 22, 23, 38 AND 50).

FIRST USE 1-15-2011; IN COMMERCE 3-2-2011.

CLASS 28—(Continued).

3,999,867. GEOFFREY, LLC, WAYNE, NJ. SN 85-200,398. PUB. 3-29-2011, FILED 12-17-2010.

KELSEY

THE MARK CONSISTS OF STANDARD CHARACTERS WITHOUT CLAIM TO ANY PARTICULAR FONT, STYLE, SIZE, OR COLOR.
FOR TOYS, NAMELY, DOLLS, DOLL CLOTHING, AND DOLL ACCESSORIES (U.S. CLS. 22, 23, 38 AND 50).
FIRST USE 4-1-2011; IN COMMERCE 4-1-2011.

CLASS 29—(Continued).

3,998,376. PACIFIC VALLEY FOODS, INC., BELLEVUE, WA. SN 77-125,965. PUB. 3-11-2008, FILED 3-8-2007.

PATTY O'BRIEN

THE MARK CONSISTS OF STANDARD CHARACTERS WITHOUT CLAIM TO ANY PARTICULAR FONT, STYLE, SIZE, OR COLOR.
THE NAME "PATTY O'BRIEN" IN THE MARK DOES NOT IDENTIFY A LIVING INDIVIDUAL.
FOR CHOPPED AND FORMED POTATO PRODUCTS, NAMELY, PROCESSED POTATO PATTIES (U.S. CL. 46).
FIRST USE 6-1-2011; IN COMMERCE 6-1-2011.

3,999,878. PLAYMATES TOYS INC., EL SEGUNDO, CA. SN 85-975,301. PUB. 11-30-2010, FILED 6-29-2010.



THE MARK CONSISTS OF TWO SOLID CIRCULAR DISCS SUGGESTING TWO HEADS HOVERING ABOVE TWO BODY SHAPES ALL TOGETHER COMPRISING THE SILHOUETTE OF TWO FEMALE FIGURES NEARLY ADJOINING HANDS BENEATH A HEART SHAPE.
FOR DOLL AND RELATED DOLL ACCESSORIES (U.S. CLS. 22, 23, 38 AND 50).
FIRST USE 10-28-2010; IN COMMERCE 10-28-2010.

3,998,492. DEARBORN SAUSAGE COMPANY, DEARBORN, MI. SN 77-463,957. PUB. 3-30-2010, FILED 5-2-2008.

ARENA

THE MARK CONSISTS OF STANDARD CHARACTERS WITHOUT CLAIM TO ANY PARTICULAR FONT, STYLE, SIZE, OR COLOR.
FOR PRESERVED MEATS AND SAUSAGES; FRANKFURTERS; HOT DOGS (U.S. CL. 46).
FIRST USE 6-23-2006; IN COMMERCE 6-23-2006.

3,998,549. WEST SIDE FOODS, INC., BRONX, NY. SN 77-584,046. PUB. 2-24-2009, FILED 10-2-2008.

CLASS 29—MEATS AND PROCESSED FOODS

3,998,306. CAPITOL WHOLESALE MEATS, INC., MCCOOK, IL. SN 76-671,902. PUB. 2-19-2008, FILED 1-25-2007.

CASINA ROSSA

THE MARK CONSISTS OF STANDARD CHARACTERS WITHOUT CLAIM TO ANY PARTICULAR FONT, STYLE, SIZE, OR COLOR.
THE ENGLISH TRANSLATION OF "CASINA ROSSA" IS LITTLE RED HOUSE.
FOR SAUSAGE (U.S. CL. 46).
FIRST USE 6-6-2006; IN COMMERCE 6-6-2006.



NO CLAIM IS MADE TO THE EXCLUSIVE RIGHT TO USE "FARMS" AND "FARMER RAISED", APART FROM THE MARK AS SHOWN.
THE MARK CONSISTS OF AN OVAL LOGO WITH A HEART BETWEEN THE WORDS "LOVE FARMS" ON THE TOP; THE WORDS "FARMER RAISED" ARE ON THE BOTTOM OF THE LOGO; INSIDE THE LOGO IS A DEPICTION OF FARMLAND ON WHICH THERE ARE LEAVES, A BARN, A SILO, HILLS AND A SETTING SUN.
FOR BEEF; MEAT; PORK; POULTRY (U.S. CL. 46).
FIRST USE 1-11-2011; IN COMMERCE 1-11-2011.

CLASS 29—(Continued).

3,998,557. HAPPY EAGLE FOOD INDUSTRIES CORPORATION, ST. CHARLES, IL. SN 77-595,087. PUB. 3-10-2009, FILED 10-17-2008.

KING CRUNCH

THE MARK CONSISTS OF STANDARD CHARACTERS WITHOUT CLAIM TO ANY PARTICULAR FONT, STYLE, SIZE, OR COLOR.

FOR PICKLES (U.S. CL. 46).
FIRST USE 4-21-2011; IN COMMERCE 4-21-2011.

3,998,573. NUTLAND FOODS, LLC, BAKERSFIELD, CA. SN 77-612,357. PUB. 5-12-2009, FILED 11-11-2008.

NUT LAND

THE MARK CONSISTS OF STANDARD CHARACTERS WITHOUT CLAIM TO ANY PARTICULAR FONT, STYLE, SIZE, OR COLOR.

NO CLAIM IS MADE TO THE EXCLUSIVE RIGHT TO USE "NUT", APART FROM THE MARK AS SHOWN.

FOR PROCESSED NUTS; PROCESSED NUT-BASED SNACKS, NAMELY, SNACK MIX CONSISTING PRIMARILY OF PROCESSED NUTS; PROCESSED NUT-BASED SNACK FOODS; AND, PROCESSED NUT-BASED SNACK BARS (U.S. CL. 46).

FIRST USE 3-11-2009; IN COMMERCE 5-12-2009.

3,998,586. NUTLAND FOODS, LLC, BAKERSFIELD, CA. SN 77-630,358. PUB. 5-12-2009, FILED 12-10-2008.

WE'RE NUTS ABOUT NUTRITION!

THE MARK CONSISTS OF STANDARD CHARACTERS WITHOUT CLAIM TO ANY PARTICULAR FONT, STYLE, SIZE, OR COLOR.

FOR PROCESSED NUTS; PROCESSED NUT-BASED SNACKS, NAMELY, SNACK MIX CONSISTING PRIMARILY OF PROCESSED NUTS; PROCESSED NUT-BASED SNACK FOODS; AND, PROCESSED NUT-BASED SNACK BARS (U.S. CL. 46).

FIRST USE 3-11-2009; IN COMMERCE 5-12-2009.

CLASS 29—(Continued).

3,998,605. NEW FOOD CLASSICS, CALGARY, ALBERTA, CANADA. SN 77-669,327. PUB. 10-5-2010, FILED 2-12-2009.



PRIORITY CLAIMED UNDER SEC. 44(D) ON CANADA APPLICATION NO. 1426357, FILED 2-2-2009, REG. NO. TMA764,541, DATED 4-20-2010, EXPIRES 4-20-2025.

OWNER OF U.S. REG. NO. 2,300,740.

THE MARK CONSISTS OF AN OVAL CONTAINING A DESIGN OF A HOUSE ABOVE THE WORD "GRILLHOUSE" AND A DESIGN OF A FORK AND SPATULA BELOW THE WORD "GRILLHOUSE".

FOR BURGERS, NAMELY, BEEF BURGER PATTIES, BISON BURGER PATTIES AND CHICKEN BURGER PATTIES; HAMBURGER PATTIES (U.S. CL. 46).

FIRST USE 8-12-2010; IN COMMERCE 8-12-2010.

3,998,718. KETCHUPMAN & CO., LLC, BARTLETT, TN. SN 77-789,085. PUB. 5-18-2010, FILED 7-24-2009.



THE MARK CONSISTS OF THE DESIGN OF A MAN FORMED BY A KETCHUP BOTTLE WITH THE WORDS "KETCHUP MAN" APPEARING ABOVE ANOTHER EXTENDING BEYOND AN OVAL ON A LABEL ON THE BODY OF THE BOTTLE; A FACE COMPRISED OF EYES, EYEBROWS, A NOSE AND MOUTH APPEAR ON THE NECK OF THE BOTTLE; THE MAN APPEARS WEARING A HAT WITH A BAND, BOOTS AND GLOVES, AND APPEARS GESTURING WITH TWO THUMBS-UP.

FOR POTATO-BASED SNACK FOODS (U.S. CL. 46).
FIRST USE 8-31-2010; IN COMMERCE 8-31-2010.

CLASS 29—(Continued).

3,998,720. WIZARD SEAFOODS, INC., FALL CITY, WA. SN 77-791,434. PUB. 12-22-2009, FILED 7-28-2009.

WIZARD

THE MARK CONSISTS OF STANDARD CHARACTERS WITHOUT CLAIM TO ANY PARTICULAR FONT, STYLE, SIZE, OR COLOR.

FOR CANNED FISH; CRABS; FISH; FROZEN APPETIZERS CONSISTING PRIMARILY OF CHICKEN OR SEAFOOD; FROZEN PRE-PACKAGED ENTREES CONSISTING PRIMARILY OF SEAFOOD; PREPARED ENTREES CONSISTING PRIMARILY OF SEAFOOD; PREPARED FOOD KITS COMPOSED OF MEAT, POULTRY, FISH, SEAFOOD, AND/OR VEGETABLES AND ALSO INCLUDING SAUCES OR SEASONINGS, READY FOR COOKING AND ASSEMBLY AS A MEAL; SEAFOOD; SHELLFISH; SHRIMP; SHRIMPS, PRAWNS AND LOBSTERS; TINNED SEAFOOD (U.S. CL. 46).

FIRST USE 12-0-2010; IN COMMERCE 12-0-2010.

3,998,726. LAFFERTY, KATHLEEN, KENNETT SQUARE, PA. SN 77-795,994. PUB. 2-23-2010, FILED 8-3-2009.



NO CLAIM IS MADE TO THE EXCLUSIVE RIGHT TO USE "SNACK" OR "SHROOMS", APART FROM THE MARK AS SHOWN.

FOR SEASONED DRIED WHITE MUSHROOMS (U.S. CL. 46).

FIRST USE 7-9-2009; IN COMMERCE 10-15-2009.

CLASS 29—(Continued).

3,998,763. GREATER OMAHA PACKING CO., INC., OMAHA, NE. SN 77-824,031. PUB. 4-27-2010, FILED 9-10-2009.



NO CLAIM IS MADE TO THE EXCLUSIVE RIGHT TO USE "U.S. BEEF", "1881", "OMAHA HEREFORD", AND "CORN FED", APART FROM THE MARK AS SHOWN.

THE COLOR(S) BLACK, WHITE, MAROON IS/ARE CLAIMED AS A FEATURE OF THE MARK.

THE MARK CONSISTS OF THE WORDS "OMAHA HEREFORD" IN WHITE WITH A MAROON BORDER BELOW A MAROON AND WHITE GRAPHIC OF A STEER, APPEARING BELOW THE YEAR "1881", ALL ENCIRCLED BY A BLACK OVAL BORDER OUTLINED IN MAROON AND CONTAINING THE WORDS "U.S. BEEF" AT THE TOP AND "CORN FED" AT THE BOTTOM. THE WHITE OUTLINE, GRAY BACKGROUND, AND THE SHAPE OF THE GRAY BACKGROUND ARE NOT CLAIMED AS A FEATURE OF THE MARK.

FOR HEREFORD BEEF (U.S. CL. 46).

FIRST USE 4-4-2011; IN COMMERCE 4-4-2011.

3,998,800. FRITO-LAY NORTH AMERICA, INC., PLANO, TX. SN 77-837,209. PUB. 8-24-2010, FILED 9-29-2009.

HARVEST RANCH

THE MARK CONSISTS OF STANDARD CHARACTERS WITHOUT CLAIM TO ANY PARTICULAR FONT, STYLE, SIZE, OR COLOR.

NO CLAIM IS MADE TO THE EXCLUSIVE RIGHT TO USE "RANCH", APART FROM THE MARK AS SHOWN.

FOR POTATO-BASED SNACK FOODS (U.S. CL. 46).

FIRST USE 2-0-2010; IN COMMERCE 2-0-2010.

CLASS 29—(Continued).

3,999,071. JENNINGS, THOMAS A, BLOOMINGTON, IL. SN 77-932,270. PUB. 7-6-2010, FILED 2-10-2010.

CENTRAL LEAN

THE MARK CONSISTS OF STANDARD CHARACTERS WITHOUT CLAIM TO ANY PARTICULAR FONT, STYLE, SIZE, OR COLOR.

NO CLAIM IS MADE TO THE EXCLUSIVE RIGHT TO USE "LEAN", APART FROM THE MARK AS SHOWN.

FOR MEAT, NAMELY, BEEF, POULTRY AND PORK (U.S. CL. 46).

FIRST USE 3-1-2010; IN COMMERCE 3-1-2010.

3,999,240. GOOCH INVESTMENTS INC., DBA ABSOLUTELY WORLD CLASS, INC., ABILENE, TX. SN 85-008,265. PUB. 9-7-2010, FILED 4-7-2010.

SWEET 'N WILD!

THE MARK CONSISTS OF STANDARD CHARACTERS WITHOUT CLAIM TO ANY PARTICULAR FONT, STYLE, SIZE, OR COLOR.

FOR PICKLED JALAPENOS (U.S. CL. 46).

FIRST USE 11-0-2010; IN COMMERCE 11-0-2010.

3,999,386. FISHER FARMS, INC., BULACAN, PHILIPPINES. SN 85-032,561. PUB. 10-12-2010, FILED 5-7-2010.



NO CLAIM IS MADE TO THE EXCLUSIVE RIGHT TO USE "LLC", APART FROM THE MARK AS SHOWN.

CLASS 29—(Continued).

THE MARK CONSISTS OF A FULL LENGTH MASCULINE FIGURE MANNING A SHIP'S HELM. BELOW SAID FIGURE IS THE TERM "GREAT WATERS OF THE WORLD, LLC." THE FOREGOING ILLUSTRATION BEING ENCLOSED WITHIN A RECTANGULAR DEVICE.

FOR SAUSAGES AND FISH SAUSAGES (U.S. CL. 46). FIRST USE 4-1-2011; IN COMMERCE 4-1-2011.

3,999,452. IGNITE RESTAURANT GROUP, INC., HOUSTON, TX. SN 85-041,046. PUB. 1-11-2011, FILED 5-18-2010.



OWNER OF U.S. REG. NOS. 1,972,218 AND 2,075,735. NO CLAIM IS MADE TO THE EXCLUSIVE RIGHT TO USE "CRAB", APART FROM THE MARK AS SHOWN.

THE MARK CONSISTS OF THE WORDING "JOE'S CRAB SHACK" IN A STYLIZED FONT AND A DESIGN THAT CONSISTS OF AN OUTLINED ARROW. THE WORDING "CRAB SHACK" APPEARS ON THE ARROW.

FOR FROZEN MEALS CONSISTING PRIMARILY OF SEAFOOD, MEAT, POULTRY, OR VEGETABLES (U.S. CL. 46).

FIRST USE 6-3-2010; IN COMMERCE 6-3-2010.

3,999,488. AFD RESOURCE GROUP, DBA ALPINE FOOD DISTRIBUTING INC., PORTLAND, OR. SN 85-047,344. PUB. 11-2-2010, FILED 5-25-2010.



NO CLAIM IS MADE TO THE EXCLUSIVE RIGHT TO USE "GROWERS", APART FROM THE MARK AS SHOWN. THE COLOR(S) GREEN, BEIGE AND BLACK IS/ARE CLAIMED AS A FEATURE OF THE MARK.

THE MARK CONSISTS OF A GREEN CIRCLE WITH A GREEN FLORAL DESIGN INSIDE IT. OVER THE LOWER HALF OF THE CIRCLE IS THE WORDING "TULAREE GROWERS", WITH "TULAREE" WRITTEN IN BEIGE AND "GROWERS" WRITTEN IN GREEN, BOTH WITH BLACK SHADING.

FOR CANNED FRUITS; CANNED FRUITS AND VEGETABLES; CANNED VEGETABLES (U.S. CL. 46).

FIRST USE 6-1-2010; IN COMMERCE 6-1-2010.

CLASS 29—(Continued).

3,999,498. PREMIUM NATURAL BEEF LLC, LONE WOLF, OK. SN 85-049,409. PUB. 12-14-2010, FILED 5-27-2010.



NO CLAIM IS MADE TO THE EXCLUSIVE RIGHT TO USE "PREMIUM NATURAL BEEF", APART FROM THE MARK AS SHOWN.

THE MARK CONSISTS OF THE WORDS "PREMIUM NATURAL BEEF" IN STYLIZED FONT IN FRONT OF A FARM SCENE WITH A FIELD, COWS, A BARN, MOUNTAINS AND THE SUN IN THE DISTANCE.

FOR MEAT; BEEF; HAMBURGER; HOT DOGS; PREPARED MEAT; PREPARED BEEF; PROCESSED MEAT; PROCESSED BEEF; PRESERVED MEATS (U.S. CL. 46).

FIRST USE 10-19-2009; IN COMMERCE 10-19-2009.

3,999,557. DIET CENTER WORLDWIDE, INC., AKRON, OH. SN 85-064,334. PUB. 11-16-2010, FILED 6-16-2010.

DC DELIGHTS

THE MARK CONSISTS OF STANDARD CHARACTERS WITHOUT CLAIM TO ANY PARTICULAR FONT, STYLE, SIZE, OR COLOR.

OWNER OF U.S. REG. NO. 2,854,139.

FOR PRE-PACKAGED DINNERS, CONSISTING PRIMARILY OF MEAT, SEAFOOD OR POULTRY SERVED WITH PASTA, RICE AND VEGETABLES (U.S. CL. 46).

FIRST USE 5-9-2011; IN COMMERCE 5-9-2011.

CLASS 29—(Continued).

3,999,620. ATLANTIC CAPES FISHERIES, INC., CAPE MAY, NJ. SN 85-081,344. PUB. 3-8-2011, FILED 7-9-2010.



NO CLAIM IS MADE TO THE EXCLUSIVE RIGHT TO USE "CLAM", APART FROM THE MARK AS SHOWN.

THE COLOR(S) WHITE, BLACK, RED, AND GRAY IS/ ARE CLAIMED AS A FEATURE OF THE MARK.

THE MARK CONSISTS OF THE WORDS "HAPPY CLAM" ARE FILLED WITH WHITE COLOR AND A BLACK BORDER. THE CLAM CHARACTER BODIES ARE GREY, EYES ARE WHITE WITH BLACK DOT AND OUTLINE, TONGUES ARE RED, DISH IS RED WITH A GREY BORDER, PLATE IS GREY.

FOR CLAM JUICE; CLAMS; CLAMS; COMBINATION MEAL CONSISTING PRIMARILY OF A MEAT OR VEGETABLE-BASED ENTREE AND A SOUP OR SALAD FOR CONSUMPTION ON OR OFF THE PREMISES; DRINKABLE SOUPS; EXTRACTS FOR SOUPS; FROZEN APPETIZERS CONSISTING PRIMARILY OF CHICKEN OR SEAFOOD; FROZEN PRE-PACKAGED ENTREES CONSISTING PRIMARILY OF SEAFOOD; INSTANT OR PRE-COOKED SOUP; MARINATED SEAFOOD; MIXES FOR MAKING SOUP; PRE-PACKAGED DINNERS CONSISTING OF SEAFOOD; PREPARATIONS FOR MAKING SOUPS; PREPARED ENTREES CONSISTING PRIMARILY OF SEAFOOD; PREPARED FOOD KITS COMPOSED OF MEAT, POULTRY, FISH, SEAFOOD, AND/OR VEGETABLES AND ALSO INCLUDING SAUCES OR SEASONINGS, READY FOR COOKING AND ASSEMBLY AS A MEAL; SEAFOOD; SEAFOOD, NAMELY, CLAMS, SCALLOPS, SHRIMP, CRAB, WHITE FISH, SOUPS, CHOWDERS; SEASONED SEAFOODS; SHELLFISH; SHORT-NECKED CLAMS; SOUP MIXES; SOUP PASTES; SOUPS; SOUPS AND PREPARATIONS FOR MAKING SOUPS; TINNED SEAFOOD (U.S. CL. 46).

FIRST USE 9-15-2010; IN COMMERCE 9-15-2010.

3,999,625. CHI INNOVATIONS LLC, OCEANSIDE, CA. SN 85-081,726. PUB. 12-7-2010, FILED 7-9-2010.



THE MARK CONSISTS OF STYLIZED "CHI BAR", ALSO FOR FRUIT-BASED ORGANIC FOOD BARS, ALSO CONTAINING NUTS, AND SEEDS (U.S. CL. 46).

FIRST USE 10-6-2010; IN COMMERCE 10-15-2010.

CLASS 29—(Continued).

3,999,638. PHILLIPS FOODS, INC., BALTIMORE, MD. SN 85-086,844. PUB. 12-21-2010, FILED 7-16-2010.

CRAB CRUNCHERS

THE MARK CONSISTS OF STANDARD CHARACTERS WITHOUT CLAIM TO ANY PARTICULAR FONT, STYLE, SIZE, OR COLOR.

NO CLAIM IS MADE TO THE EXCLUSIVE RIGHT TO USE "CRAB", APART FROM THE MARK AS SHOWN.

FOR FROZEN APPETIZERS CONSISTING PRIMARILY OF CRAB (U.S. CL. 46).

FIRST USE 8-20-2010; IN COMMERCE 8-20-2010.

3,999,719. EATSTRONG, LLC, NEW YORK, NY. SN 85-118,665. PUB. 3-8-2011, FILED 8-30-2010.



OWNER OF U.S. REG. NO. 3,312,582.
THE MARK CONSISTS OF AN ABSTRACT DESIGN OF A PERSON.

FOR TRAIL MIX CONSISTING PRIMARILY OF PROCESSED NUTS, SEEDS, AND ALSO INCLUDING CHOCOLATE; PROTEIN BARS, NAMELY, PROTEIN BASED, NUTRIENT-DENSE SNACK BARS (U.S. CL. 46).

FIRST USE 6-1-2010; IN COMMERCE 6-1-2010.

3,999,721. SOY INVESTORS II, L.L.C., DBA HARVEST INNOVATIONS, INDIANOLA, IA. SN 85-119,809. PUB. 2-15-2011, FILED 8-31-2010.



THE MARK CONSISTS OF THE WORD "HI" IN BOLD TYPE SURROUNDED BY AN OVAL WITH A LEAF AT THE TOP PORTION OF THE OVAL, FOLLOWED BY THE TERM "SOLATE".

FOR PROTEIN FOR USE AS A FOOD ADDITIVE (U.S. CL. 46).

FIRST USE 8-19-2010; IN COMMERCE 8-19-2010.

CLASS 29—(Continued).

3,999,873. TYSON FRESH MEATS, INC., SPRINGDALE, AR. SN 85-975,241. PUB. 9-7-2010, FILED 4-11-2010.



OWNER OF U.S. REG. NOS. 1,020,013, 1,112,830, AND 1,209,465.

NO CLAIM IS MADE TO THE EXCLUSIVE RIGHT TO USE "EXCELLENCE", APART FROM THE MARK AS SHOWN.

THE MARK CONSISTS OF THE WORD "TRUSTED" APPEARS BELOW THE LETTERS "IB" AND THE WORD "EXCELLENCE" APPEARS BELOW THE LETTER "P".

FOR BEEF; BEEF BY-PRODUCTS; PORK (U.S. CL. 46).

FIRST USE 12-19-2009; IN COMMERCE 12-19-2009.

CLASS 30—STAPLE FOODS

3,998,394. CSM BAKERY PRODUCTS NA, INC, TUCKER, GA. SN 77-201,129. PUB. 2-12-2008, FILED 6-8-2007.



OWNER OF U.S. REG. NO. 1,126,731.
THE COLOR(S) BLACK, WHITE AND RED IS/ARE CLAIMED AS A FEATURE OF THE MARK.

THE MARK CONSISTS OF THE CAPITAL LETTERS "BB" IN WHITE WITHIN A CIRCULAR BLACK BACKGROUND WITH CONCENTRIC BLACK AND RED RINGS.

FOR BAKERY PRODUCTS; MIXES FOR BAKERY GOODS; FROZEN COOKIE DOUGH; RAW BAKERY GOODS, NAMELY, DOUGH FOR BAKERY GOODS (U.S. CL. 46).

FIRST USE 0-0-1971; IN COMMERCE 0-0-1971.

CLASS 30—(Continued).

3,998,444. THE SUN VALLEY RICE COMPANY, LLC., ARBUCKLE, CA. SN 77-320,239. PUB. 4-15-2008, FILED 11-2-2007.

MILKY QUEEN

THE MARK CONSISTS OF STANDARD CHARACTERS WITHOUT CLAIM TO ANY PARTICULAR FONT, STYLE, SIZE, OR COLOR.
FOR RICE (U.S. CL. 46).
FIRST USE 5-4-2010; IN COMMERCE 5-4-2010.

3,998,456. CARGILL, INCORPORATED, WAYZATA, MN. SN 77-380,333. PUB. 5-20-2008, FILED 1-25-2008.



NO CLAIM IS MADE TO THE EXCLUSIVE RIGHT TO USE "OG", APART FROM THE MARK AS SHOWN.
THE MARK CONSISTS OF THE NUMBER "ZERO" AND THE LETTER "G" IN FRONT OF TWO LEAVES.
FOR SALAD DRESSINGS; MAYONNAISE; SAUCES; MARINADES (U.S. CL. 46).
FIRST USE 3-2-2011; IN COMMERCE 3-2-2011.

3,998,563. UNILEVER SUPPLY CHAIN, INC., CLINTON, CT. SN 77-599,012. PUB. 7-14-2009, FILED 10-23-2008.



THE MARK CONSISTS OF THE WORDS "GOOD HUMOR" AND A TRUCK DESIGN.
FOR ICE CREAMS, WATER ICES, FROZEN CONFECTIONERY, FROZEN YOGURT, SHERBETS, CHILLED DESSERTS, NAMELY, PUDDINGS AND MOUSSE (U.S. CL. 46).
FIRST USE 1-11-2009; IN COMMERCE 1-11-2009.

CLASS 30—(Continued).

3,998,597. KRAFT FOODS GLOBAL BRANDS LLC, NORTH-FIELD, IL. SN 77-648,962. PUB. 3-30-2010, FILED 1-14-2009.

SWEDISH FISH

THE MARK CONSISTS OF STANDARD CHARACTERS WITHOUT CLAIM TO ANY PARTICULAR FONT, STYLE, SIZE, OR COLOR.
OWNER OF U.S. REG. NOS. 1,273,762, 3,146,656, AND 3,389,747.
SEC. 2(F).
FOR FLAVORED ICE (U.S. CL. 46).
FIRST USE 7-31-2009; IN COMMERCE 7-31-2009.

3,998,644. STARVANARVAN, LLC, DBA STARVANARVAN, LLC, FRANKLIN, OH. SN 77-715,392. PUB. 6-1-2010, FILED 4-16-2009.

SPICYGREEK

THE MARK CONSISTS OF STANDARD CHARACTERS WITHOUT CLAIM TO ANY PARTICULAR FONT, STYLE, SIZE, OR COLOR.
FOR EDIBLE SPICES (U.S. CL. 46).
FIRST USE 5-15-2009; IN COMMERCE 5-15-2009.

3,998,743. B.C.S. INTERNATIONAL CORPORATION, LONG ISLAND CITY, NY. SN 77-814,628. PUB. 2-9-2010, FILED 8-27-2009.

VEGGIE VALLEY

THE MARK CONSISTS OF STANDARD CHARACTERS WITHOUT CLAIM TO ANY PARTICULAR FONT, STYLE, SIZE, OR COLOR.
NO CLAIM IS MADE TO THE EXCLUSIVE RIGHT TO USE "VEGGIE", APART FROM THE MARK AS SHOWN.
FOR DUMPLINGS (U.S. CL. 46).
FIRST USE 10-27-2009; IN COMMERCE 10-27-2009.

CLASS 30—(Continued).

3,998,748. CITYCOFFEE LLC, LAGRANGE, KY. SN 77-817,652. PUB. 2-16-2010, FILED 9-1-2009.

Shadowood Coffee

THE MARK CONSISTS OF STANDARD CHARACTERS WITHOUT CLAIM TO ANY PARTICULAR FONT, STYLE, SIZE, OR COLOR.

NO CLAIM IS MADE TO THE EXCLUSIVE RIGHT TO USE "COFFEE", APART FROM THE MARK AS SHOWN. FOR COFFEE (U.S. CL. 46). FIRST USE 10-21-2009; IN COMMERCE 10-21-2009.

3,998,749. MORTON SALT, INC., CHICAGO, IL. SN 77-817,678. PUB. 7-27-2010, FILED 9-1-2009.

MADE BY NATURE PACKAGED BY MORTON

THE MARK CONSISTS OF STANDARD CHARACTERS WITHOUT CLAIM TO ANY PARTICULAR FONT, STYLE, SIZE, OR COLOR.

OWNER OF U.S. REG. NOS. 509,884, 1,406,957, AND 3,062,506. FOR SALT (U.S. CL. 46). FIRST USE 12-21-2009; IN COMMERCE 12-21-2009.

3,998,751. OMB, INC., SANTA FE SPRINGS, CA. SN 77-819,450. PUB. 1-19-2010, FILED 9-3-2009.



NO CLAIM IS MADE TO THE EXCLUSIVE RIGHT TO USE "BUNS!" AND "THE ROTI BAKERY", APART FROM THE MARK AS SHOWN.

THE MARK CONSISTS OF THE WORDS "O MY BUNS!" WITH A CIRCLE AROUND THE "O" AND A FACE BEHIND THE LETTERS "NS". THE WORDS "THE ROTI BAKERY" APPEAR BELOW IN AN OBLONG BANNER.

FOR BREAD AND BUNS (U.S. CL. 46). FIRST USE 11-15-2009; IN COMMERCE 11-15-2009.

CLASS 30—(Continued).

3,998,845. IMPACT ENERGY GUM, INC., WEST PALM BEACH, GA. SN 77-854,044. PUB. 10-26-2010, FILED 10-21-2009.

Exotic Flavored Impact Energy Gum

THE MARK CONSISTS OF STANDARD CHARACTERS WITHOUT CLAIM TO ANY PARTICULAR FONT, STYLE, SIZE, OR COLOR.

NO CLAIM IS MADE TO THE EXCLUSIVE RIGHT TO USE "EXOTIC", "FLAVORED", AND "ENERGY GUM", APART FROM THE MARK AS SHOWN. FOR SUGAR FREE ENERGY CHEWING GUM, NOT FOR MEDICAL PURPOSES (U.S. CL. 46). FIRST USE 11-1-2009; IN COMMERCE 5-1-2011.

3,998,871. GRAND PRAIRIE FOODS, INC., SIOUX FALLS, SD. SN 77-858,657. PUB. 4-6-2010, FILED 10-27-2009.

START HEALTHY

THE MARK CONSISTS OF STANDARD CHARACTERS WITHOUT CLAIM TO ANY PARTICULAR FONT, STYLE, SIZE, OR COLOR.

FOR FULLY COOKED BREAKFAST SANDWICHES DESIGNED TO BE HEATED AND CONSUMED (U.S. CL. 46). FIRST USE 1-4-2010; IN COMMERCE 1-4-2010.

3,998,901. T.S. TIPPIN & CO., JACKSONVILLE, FL. SN 77-866,526. PUB. 4-13-2010, FILED 11-6-2009.

LOUIS SHERRY

THE MARK CONSISTS OF STANDARD CHARACTERS WITHOUT CLAIM TO ANY PARTICULAR FONT, STYLE, SIZE, OR COLOR.

THE NAME(S), PORTRAIT(S), AND/OR SIGNATURE(S) SHOWN IN THE MARK DOES NOT IDENTIFY A PARTICULAR LIVING INDIVIDUAL.

FOR CANDIES (U.S. CL. 46). FIRST USE 5-1-2011; IN COMMERCE 5-1-2011.

CLASS 30—(Continued).

3,998,904. HEB GROCERY COMPANY, LP, SAN ANTONIO, TX. SN 77-868,393. PUB. 4-6-2010, FILED 11-9-2009.

ECONOMAX

THE MARK CONSISTS OF STANDARD CHARACTERS WITHOUT CLAIM TO ANY PARTICULAR FONT, STYLE, SIZE, OR COLOR.

OWNER OF U.S. REG. NO. 2,847,605.
FOR SUGAR (U.S. CL. 46).
FIRST USE 4-5-2011; IN COMMERCE 4-5-2011.

CLASS 30—(Continued).

3,998,932. E.A. SWEEN COMPANY, EDEN PRAIRIE, MN. SN 77-880,029. PUB. 9-28-2010, FILED 11-24-2009.

IT'S MORE THAN A SANDWICH.
IT'S DELI EXPRESS.

THE MARK CONSISTS OF STANDARD CHARACTERS WITHOUT CLAIM TO ANY PARTICULAR FONT, STYLE, SIZE, OR COLOR.

OWNER OF U.S. REG. NOS. 1,265,869, 1,693,388, AND OTHERS.
FOR SANDWICHES (U.S. CL. 46).
FIRST USE 4-9-2010; IN COMMERCE 4-19-2010.

3,998,920. UNITED DAIRY FARMERS, INC., CINCINNATI, OH. SN 77-873,968. PUB. 10-26-2010, FILED 11-17-2009.

JR MOOS

THE MARK CONSISTS OF STANDARD CHARACTERS WITHOUT CLAIM TO ANY PARTICULAR FONT, STYLE, SIZE, OR COLOR.

FOR FROZEN CONFECTIONS (U.S. CL. 46).
FIRST USE 5-1-2010; IN COMMERCE 5-1-2010.

3,998,942. ORION CORPORATION, YONGSAN-GU, SEOUL, REPUBLIC OF KOREA. SN 77-881,934. PUB. 10-12-2010, FILED 11-30-2009.

ORION MARION

3,998,927. GUM PRODUCTS INTERNATIONAL INC., NEW-MARKET, CANADA. SN 77-878,343. PUB. 11-2-2010, FILED 11-22-2009.

CREATIVITY, SYNERGY,
SUCCESS!

THE MARK CONSISTS OF STANDARD CHARACTERS WITHOUT CLAIM TO ANY PARTICULAR FONT, STYLE, SIZE, OR COLOR.

OWNER OF U.S. REG. NO. 2,250,548.
FOR FOOD ADDITIVES, NAMELY, FOOD HYDRO-COLLOIDS AND FOOD GUMS, FOR NON-NUTRITIONAL PURPOSES FOR USE AS AN INGREDIENT OR FILLER IN PROCESSED FOODS (U.S. CL. 46).
FIRST USE 12-0-2009; IN COMMERCE 12-0-2009.

THE MARK CONSISTS OF STANDARD CHARACTERS WITHOUT CLAIM TO ANY PARTICULAR FONT, STYLE, SIZE, OR COLOR.

THE NAME(S), PORTRAIT(S), AND/OR SIGNATURE(S) SHOWN IN THE MARK DOES NOT IDENTIFY A PARTICULAR LIVING INDIVIDUAL.

FOR CHOCOLATES, BISCUITS, COOKIES, CRACKERS, WAFERS, CONFECTIONERY, NAMELY, CHOCOLATE, LOLLIPOPS, BONBONS, SWEETMEATS, CUSTARDS; CORN CHIPS, BREAD, PASTRIES, CAKES, PIES, PUDDINGS, SHERBETS, ICE CREAMS, CANDY, CARAMELS, CHEWING GUM NOT FOR MEDICAL PURPOSES (U.S. CL. 46).
FIRST USE 11-23-2009; IN COMMERCE 11-23-2009.

CLASS 30—(Continued).

3,999,102. MULTIGRAINS BAKERY, LAWRENCE, MA. SN 77-947,249. PUB. 11-16-2010, FILED 3-1-2010.



NO CLAIM IS MADE TO THE EXCLUSIVE RIGHT TO USE "MULTIGRAINS BAKERY" AND "ARTISAN BAKING", APART FROM THE MARK AS SHOWN.

THE MARK CONSISTS OF A FIRST RECTANGULAR MEMBER WITH RADIAL EDGES COMPRISING A SPONGED TEXTURE; ENCLOSED WITHIN THE FIRST RECTANGULAR MEMBER IS A SECOND RECTANGULAR MEMBER AND THE TERMS "MULTIGRAINS BAKERY" AND BELOW THE SECOND RECTANGULAR MEMBER ARE THE TERMS "A WORLD OF ARTISAN BAKING"; AND, FURTHER ENCLOSED WITHIN THE SECOND RECTANGULAR MEMBER IS A THIRD RECTANGULAR MEMBER WITH A GLOBE WITH CONTINENTS OUTLINED AND WHEAT STALKS.

FOR BAKERY GOODS, NAMELY, BREAD, BUNS, ROLLS, ENGLISH MUFFINS, CROISSANTS, BAGELS, CRUMPETS, CAKES, PIES AND COOKIES (U.S. CL. 46).
FIRST USE 2-1-2009; IN COMMERCE 2-1-2009.

3,999,151. GERSON FANY, NEW YORK, NY. SN 77-969,052. PUB. 8-24-2010, FILED 3-26-2010.

La Newyorkina

THE MARK CONSISTS OF STANDARD CHARACTERS WITHOUT CLAIM TO ANY PARTICULAR FONT, STYLE, SIZE, OR COLOR.

FOR EDIBLE FRUIT ICES; FROZEN DESSERT CONSISTING OF FRUIT AND CREAM OR CREAM SUBSTITUTES; FRUIT ICE BAR; ICE CREAM DESSERTS; ICE-CREAM (U.S. CL. 46).
FIRST USE 6-5-2010; IN COMMERCE 6-5-2010.

CLASS 30—(Continued).

3,999,195. DIVINE CHOCOLATE LIMITED, LONDON, UNITED KINGDOM. SN 78-658,873. PUB. 2-19-2008, FILED 6-27-2005.

DIVINE

THE MARK CONSISTS OF STANDARD CHARACTERS WITHOUT CLAIM TO ANY PARTICULAR FONT, STYLE, SIZE, OR COLOR.

FOR DRINKING CHOCOLATE, NAMELY, HOT CHOCOLATE (U.S. CL. 46).

FIRST USE 7-0-2010; IN COMMERCE 7-0-2010.

3,999,202. CALIP HOLDINGS INC., BRONX, NY. SN 78-805,464. PUB. 7-3-2007, FILED 2-2-2006.



OWNER OF U.S. REG. NOS. 281,725, 657,518, AND OTHERS.

NO CLAIM IS MADE TO THE EXCLUSIVE RIGHT TO USE "OLD FASHIONED ICE CREAM", APART FROM THE MARK AS SHOWN.

FOR FROZEN CONFECTIONS (U.S. CL. 46).
FIRST USE 2-12-2006; IN COMMERCE 2-12-2006.

3,999,221. WEINER, RUSSELL G., LAS VEGAS, NV. SN 78-981,462. PUB. 9-26-2006, FILED 10-3-2005.

ROCKSTAR

THE MARK CONSISTS OF STANDARD CHARACTERS WITHOUT CLAIM TO ANY PARTICULAR FONT, STYLE, SIZE, OR COLOR.

FOR CHEWING GUM (U.S. CL. 46).
FIRST USE 12-16-2009; IN COMMERCE 12-16-2009.

CLASS 30—(Continued).

3,999,232. W.C. BRADLEY COMPANY, COLUMBUS, GA. SN 85-006,002. PUB. 8-3-2010, FILED 4-5-2010.

PINCH OF SIZZLE

THE MARK CONSISTS OF STANDARD CHARACTERS WITHOUT CLAIM TO ANY PARTICULAR FONT, STYLE, SIZE, OR COLOR.
FOR MARINADES; SAUCES; SPICE RUBS; SPICES (U.S. CL. 46).
FIRST USE 9-15-2010; IN COMMERCE 9-15-2010.

3,999,285. VENTURA FOODS, LLC, BREA, CA. SN 85-019,887. PUB. 9-21-2010, FILED 4-21-2010.



OWNER OF U.S. REG. NOS. 1,921,079, 2,679,048, AND OTHERS.
NO CLAIM IS MADE TO THE EXCLUSIVE RIGHT TO USE "GOURMET", APART FROM THE MARK AS SHOWN.
THE MARK CONSISTS OF THE WORD "CLASSIC" STACKED ABOVE THE WORD "GOURMET" ALL UNDERLINED. AN IMAGE OF A WHISK APPEARS TO THE RIGHT OF BOTH WORDS.
FOR SAUCES, GRAVIES, MARINADES, FOOD FLAVOR BASES, NAMELY, FLAVOR ENHANCERS USED IN FOOD (U.S. CL. 46).
FIRST USE 4-13-2010; IN COMMERCE 4-13-2010.

3,999,286. VENTURA FOODS, LLC, BREA, CA. SN 85-019,904. PUB. 9-21-2010, FILED 4-21-2010.



OWNER OF U.S. REG. NOS. 1,921,079, 2,679,048, AND OTHERS.
NO CLAIM IS MADE TO THE EXCLUSIVE RIGHT TO USE "GOURMET DRESSINGS", APART FROM THE MARK AS SHOWN.

CLASS 30—(Continued).

THE MARK CONSISTS OF THE WORD "CLASSIC" STACKED ABOVE THE WORD "GOURMET" ALL UNDERLINED AND STACKED ABOVE THE WORD "DRESSINGS". AN IMAGE OF A WHISK APPEARS TO THE RIGHT OF BOTH WORDS.
FOR SALAD AND VEGETABLE DRESSINGS; AND MAYONNAISE (U.S. CL. 46).
FIRST USE 4-13-2010; IN COMMERCE 4-13-2010.

3,999,290. KRAFT FOODS GLOBAL BRANDS LLC, NORTHFIELD, IL. SN 85-020,621. PUB. 9-28-2010, FILED 4-22-2010.

HELLO JELL-O

THE MARK CONSISTS OF STANDARD CHARACTERS WITHOUT CLAIM TO ANY PARTICULAR FONT, STYLE, SIZE, OR COLOR.
OWNER OF U.S. REG. NOS. 250,035, 2,140,238, AND OTHERS.
FOR SWEETENED AND FLAVORED GELATIN DESERTS; READY TO EAT PUDDING DESSERTS; DESERT MIXES CONSISTING PRIMARILY OF GELATIN MIX AND PUDDING MIX (U.S. CL. 46).
FIRST USE 8-31-2010; IN COMMERCE 8-31-2010.

3,999,319. SPENCE COMMUNICATIONS COMPANY, INC., AUSTIN, TX. SN 85-025,569. PUB. 9-28-2010, FILED 4-28-2010.

WE DON'T DO MILD

THE MARK CONSISTS OF STANDARD CHARACTERS WITHOUT CLAIM TO ANY PARTICULAR FONT, STYLE, SIZE, OR COLOR.
FOR HOT SAUCE (U.S. CL. 46).
FIRST USE 4-9-2010; IN COMMERCE 4-9-2010.

CLASS 30—(Continued).

3,999,325. HARINERA DEL VALLE S.A., PALMIRA, VALLE, COLOMBIA. SN 85-025,939. PUB. 9-28-2010, FILED 4-29-2010.



THE MARK CONSISTS OF THE WORDING "MAMA-ÍA" IN STYLIZED LETTERS INSIDE A ROLLING PIN BELOW OF WHICH APPEAR THE WORDS "IRRESISTIBLE TENTACION!"

THE ENGLISH TRANSLATION OF "IRRESISTIBLE TENTACION" IN THE MARK IS "IRRESISTIBLE TEMPTATION". THE WORDING "MAMA-IA" HAS NO MEANING IN A FOREIGN LANGUAGE.

FOR BAKED GOODS AND CONFECTIONERY, NAMELY, BROWNIES, BISCUITS, CAKES, COOKIES, CHOCOLATE TRUFFLES, AND CHOCOLATE (U.S. CL. 46).

FIRST USE 11-30-1983; IN COMMERCE 1-12-2011.

3,999,328. KRAFT FOODS GLOBAL BRANDS LLC, NORTH-FIELD, IL. SN 85-026,524. PUB. 9-28-2010, FILED 4-29-2010.



OWNER OF U.S. REG. NOS. 250,035, 2,140,238, AND OTHERS.

THE MARK CONSISTS OF THE WORD "JELL-O" WITH A SMILING FACE IN THE CENTER OF THE LETTER "O".

FOR SWEETENED AND FLAVORED GELATIN DESERTS; READY TO EAT PUDDING DESSERTS; DESERT MIXES CONSISTING PRIMARILY OF GELATIN MIX AND PUDDING MIX (U.S. CL. 46).

FIRST USE 8-31-2010; IN COMMERCE 8-31-2010.

3,999,329. KRAFT FOODS GLOBAL BRANDS LLC, NORTH-FIELD, IL. SN 85-026,533. PUB. 9-28-2010, FILED 4-29-2010.



OWNER OF U.S. REG. NOS. 250,035, 2,140,238, AND OTHERS.

CLASS 30—(Continued).

THE MARK CONSISTS OF THE WORDS "HELLO JELL-O" AND DESIGN WITH A SMILING FACE IN THE CENTER OF THE LETTER "O" IN THE WORD "JELL-O".

FOR SWEETENED AND FLAVORED GELATIN DESERTS; READY TO EAT PUDDING DESSERTS; DESERT MIXES CONSISTING PRIMARILY OF GELATIN MIX AND PUDDING MIX (U.S. CL. 46).

FIRST USE 8-31-2010; IN COMMERCE 8-31-2010.

3,999,483. MCGHEE, MELISSA, ENCINITAS, CA. AND SILBERMAN, DIANE, ENCINITAS, CA. SN 85-046,851. PUB. 10-5-2010, FILED 5-24-2010.

BREAKFAST

THE MARK CONSISTS OF STANDARD CHARACTERS WITHOUT CLAIM TO ANY PARTICULAR FONT, STYLE, SIZE, OR COLOR.

FOR BREAKFAST BURRITOS; BREAKFAST CEREALS; PANCAKES; SANDWICHES (U.S. CL. 46).

FIRST USE 6-13-2009; IN COMMERCE 6-13-2009.

3,999,484. MCGHEE, MELISSA, ENCINITAS, CA. AND SILBERMAN, DIANE, ENCINITAS, CA. SN 85-046,854. PUB. 10-19-2010, FILED 5-24-2010.

OKTOBERBREAST

THE MARK CONSISTS OF STANDARD CHARACTERS WITHOUT CLAIM TO ANY PARTICULAR FONT, STYLE, SIZE, OR COLOR.

OWNER OF U.S. REG. NO. 3,417,582.

FOR BREAKFAST BURRITOS; BREAKFAST CEREALS; PANCAKES; SANDWICHES (U.S. CL. 46).

FIRST USE 10-1-2010; IN COMMERCE 10-1-2010.

CLASS 30—(Continued).

3,999,626. SYDNEY ENTERPRISES, LLC., PHOENIX, AZ. SN 85-082,007. PUB. 1-11-2011, FILED 7-10-2010.



NO CLAIM IS MADE TO THE EXCLUSIVE RIGHT TO USE "ALL NATURAL", APART FROM THE MARK AS SHOWN.

THE MARK CONSISTS OF THE WORD "ALI'S" WRITTEN AT A SLANT WITH THE "A" IN UPPER CASE AND THE REST OF THE LETTERS ARE IN LOWER CASE WITH AN APOSTROPHE IN THE FRONT OF THE LETTER "S" IN "ALI'S". DIRECTLY BELOW THE LETTER "S" IN "ALI'S" IS THE WORD "ALL" WRITTEN STRAIGHT ACROSS IN LOWER CASE. DIRECTLY BELOW THE WORD "ALL" IS THE WORD "NATURAL" WHICH IS ALSO WRITTEN STRAIGHT ACROSS IN LOWER CASE.

FOR ALL NATURAL PANCAKE SYRUP (U.S. CL. 46). FIRST USE 4-1-2011; IN COMMERCE 4-1-2011.

3,999,649. TEA FORTÉ, INC., CONCORD, MA. SN 85-091,718. PUB. 1-11-2011, FILED 7-23-2010.

GET IN MINT CONDITION

THE MARK CONSISTS OF STANDARD CHARACTERS WITHOUT CLAIM TO ANY PARTICULAR FONT, STYLE, SIZE, OR COLOR.

FOR CANDY (U.S. CL. 46). FIRST USE 1-28-2010; IN COMMERCE 1-28-2010.

3,999,667. WILLIAMS, DARRELL E, BRIDGEVILLE, PA. SN 85-099,244. PUB. 1-25-2011, FILED 8-3-2010.

SILLY SNACKS

THE MARK CONSISTS OF STANDARD CHARACTERS WITHOUT CLAIM TO ANY PARTICULAR FONT, STYLE, SIZE, OR COLOR.

NO CLAIM IS MADE TO THE EXCLUSIVE RIGHT TO USE "SNACKS", APART FROM THE MARK AS SHOWN. FOR NOVELTY CANDY (U.S. CL. 46). FIRST USE 3-1-2011; IN COMMERCE 3-1-2011.

CLASS 30—(Continued).

3,999,688. MARC WEXLER, MATAWAN, NJ. SN 85-107,248. PUB. 2-1-2011, FILED 8-13-2010.



THE COLOR(S) WHITE, BLACK, PINK, ORANGE AND BROWN IS/ARE CLAIMED AS A FEATURE OF THE MARK.

THE MARK CONSISTS OF A FANCIFUL DRAWING OF A SEATED COW HAVING A WHITE HEAD AND BODY, BLACK TIPS ON ITS EXTREMITIES, PINK EARS, NOSTRILS AND MOUTH, ORANGE JAW AND BELLY, AND BROWN EYES.

FOR FROZEN YOGHURT; ICE CREAM; ICE CREAM SUBSTITUTE (U.S. CL. 46). FIRST USE 1-31-2011; IN COMMERCE 1-31-2011.

3,999,692. FARLEY'S & SATHERS CANDY COMPANY, INC., ROUND LAKE, MN. SN 85-108,315. PUB. 3-8-2011, FILED 8-16-2010.



OWNER OF U.S. REG. NOS. 914,107, 2,927,740, AND OTHERS.

NO CLAIM IS MADE TO THE EXCLUSIVE RIGHT TO USE "SINCE 1904", APART FROM THE MARK AS SHOWN. THE MARK CONSISTS OF A FANCY, OVAL SHAPED BACKGROUND WITH SCALLOPED AND RUFFLED BORDERS WITH BEADED/DOTTED TRIM. INSIDE THE OVAL IS THE WORDING "BRACH'S" WITH TWO RAINDROP SHAPES AND A STAR IN THE PLACE OF THE APOSTROPHE. BENEATH THE WORD "BRACH'S" IS THE WORDING "SINCE 1904".

SEC. 2(F) AS TO "BRACH'S". FOR CANDY, CHOCOLATES AND CHOCOLATE COVERED NUTS (U.S. CL. 46). FIRST USE 1-15-2011; IN COMMERCE 1-15-2011.

CLASS 30—(Continued).

3,999,706. FLAVOR HOUSE INC, ADELANTO, CA. AND RICHARD G. STALEY, ADELANTO, CA. SN 85-112,458. PUB. 2-1-2011, FILED 8-20-2010.

Flavor Spark

THE MARK CONSISTS OF STANDARD CHARACTERS WITHOUT CLAIM TO ANY PARTICULAR FONT, STYLE, SIZE, OR COLOR.

NO CLAIM IS MADE TO THE EXCLUSIVE RIGHT TO USE "FLAVOR", APART FROM THE MARK AS SHOWN.

FOR FLAVOR ENHANCERS USED IN FOOD AND BEVERAGE PRODUCTS (U.S. CL. 46).

FIRST USE 1-18-1999; IN COMMERCE 1-18-1999.

3,999,707. PEARL'S FOOD PRODUCTS LLC, DBA CHIAPAS, THOUSAND OAKS, CA. SN 85-112,947. PUB. 2-15-2011, FILED 8-21-2010.



THE COLOR(S) GREEN, RED, YELLOW, ORANGE IS/ ARE CLAIMED AS A FEATURE OF THE MARK.

THE MARK CONSISTS OF A FACE MADE OF CHILI PEPPERS WITH A CROWN OF RED AND GREEN BELL PEPPERS, A BROW, NOSE, EAR, AND LEFT EYE OF GREEN PEPPERS, A CHEEK AND RIGHT EYE WITH YELLOW PEPPERS, LIPS WITH RED PEPPERS, AND A CHIN WITH AN ORANGE PEPPER.

FOR CHILI PASTE FOR USE AS A SEASONING; CHILI SAUCE; CHILI SEASONING (U.S. CL. 46).

FIRST USE 5-25-2011; IN COMMERCE 5-31-2011.

CLASS 30—(Continued).

3,999,720. TOPPER'S PIZZA, INC., WHITEWATER, WI. SN 85-118,993. PUB. 2-22-2011, FILED 8-30-2010.

TALL BOY

THE MARK CONSISTS OF STANDARD CHARACTERS WITHOUT CLAIM TO ANY PARTICULAR FONT, STYLE, SIZE, OR COLOR.

FOR PIZZA (U.S. CL. 46).

FIRST USE 12-0-2010; IN COMMERCE 12-0-2010.

3,999,751. KEMIN INDUSTRIES, INC., DES MOINES, IA. SN 85-131,859. PUB. 3-8-2011, FILED 9-17-2010.

ENLIVITEA

THE MARK CONSISTS OF STANDARD CHARACTERS WITHOUT CLAIM TO ANY PARTICULAR FONT, STYLE, SIZE, OR COLOR.

FOR TEA EXTRACTS (U.S. CL. 46).

FIRST USE 12-29-2010; IN COMMERCE 12-29-2010.

3,999,772. MON CHOCOLAT, LLC, PORTLAND, OR. SN 85-140,199. PUB. 3-8-2011, FILED 9-28-2010.

A YEN FOR CHOCOLATE

THE MARK CONSISTS OF STANDARD CHARACTERS WITHOUT CLAIM TO ANY PARTICULAR FONT, STYLE, SIZE, OR COLOR.

NO CLAIM IS MADE TO THE EXCLUSIVE RIGHT TO USE "CHOCOLATE", APART FROM THE MARK AS SHOWN.

FOR CHOCOLATE TRUFFLES (U.S. CL. 46).

FIRST USE 7-0-2008; IN COMMERCE 4-0-2011.

CLASS 30—(Continued).

3,999,779. HYDE, ALLEN L, ORANGE, CA. SN 85-141,921.
PUB. 3-15-2011, FILED 9-30-2010.

Beans -n- Jeans

THE MARK CONSISTS OF STANDARD CHARACTERS WITHOUT CLAIM TO ANY PARTICULAR FONT, STYLE, SIZE, OR COLOR.
FOR CANDIES; CANDY; SWEETS (U.S. CL. 46).
FIRST USE 1-1-2011; IN COMMERCE 1-1-2011.

3,999,795. SIMPLY SMILES, INC., NAUGATUCK, CT. SN 85-146,227. PUB. 3-15-2011, FILED 10-6-2010.

SIMPLY SMILES

THE MARK CONSISTS OF STANDARD CHARACTERS WITHOUT CLAIM TO ANY PARTICULAR FONT, STYLE, SIZE, OR COLOR.
OWNER OF U.S. REG. NOS. 3,471,417 AND 3,675,031.
FOR COFFEE (U.S. CL. 46).
FIRST USE 10-15-2010; IN COMMERCE 10-15-2010.

3,999,819. CITRUS SYSTEMS MADISON, LLC, MADISON, WI. SN 85-155,779. PUB. 2-1-2011, FILED 10-19-2010.

Tea Mountain

THE MARK CONSISTS OF STANDARD CHARACTERS WITHOUT CLAIM TO ANY PARTICULAR FONT, STYLE, SIZE, OR COLOR.
NO CLAIM IS MADE TO THE EXCLUSIVE RIGHT TO USE "TEA", APART FROM THE MARK AS SHOWN.
FOR TEA; TEA-BASED BEVERAGES (U.S. CL. 46).
FIRST USE 3-29-2011; IN COMMERCE 3-29-2011.

CLASS 30—(Continued).

3,999,841. LOUISIANA SUGAR REFINING, LLC, GRAMERCY, LA. SN 85-163,017. PUB. 3-22-2011, FILED 10-27-2010.

LSR

THE MARK CONSISTS OF STANDARD CHARACTERS WITHOUT CLAIM TO ANY PARTICULAR FONT, STYLE, SIZE, OR COLOR.
FOR SUGAR PRODUCTS, NAMELY, WHITE REFINED SUGAR, LIQUID SUGAR, BROWN SUGAR AND MOLASSES (U.S. CL. 46).
FIRST USE 3-1-2011; IN COMMERCE 3-1-2011.

CLASS 31—NATURAL AGRICULTURAL PRODUCTS

3,998,326. MISSISSIPPI STATE UNIVERSITY, MISSISSIPPI STATE, MS. SN 76-700,169. PUB. 10-19-2010, FILED 11-2-2009.

FREEDOM

THE MARK CONSISTS OF STANDARD CHARACTERS WITHOUT CLAIM TO ANY PARTICULAR FONT, STYLE, SIZE, OR COLOR.
FOR AGRICULTURAL AND HORTICULTURAL PRODUCTS, NAMELY, LIVING PLANTS AND LIVE GRASSES (U.S. CLS. 1 AND 46).
FIRST USE 12-1-2009; IN COMMERCE 12-1-2009.

3,998,334. DICKSON, JOHN, ROCKVILLE, MD. SN 76-703,418. PUB. 10-5-2010, FILED 6-17-2010.

FOURSTART

THE MARK CONSISTS OF STANDARD CHARACTERS WITHOUT CLAIM TO ANY PARTICULAR FONT, STYLE, SIZE, OR COLOR.
FOR SEED STARTING CELLS (U.S. CLS. 1 AND 46).
FIRST USE 5-15-2011; IN COMMERCE 5-15-2011.

CLASS 31—(Continued).

3,998,703. BROKAW NURSERY, INC., SATICOY, CA. SN 77-769,096. PUB. 12-1-2009, FILED 6-26-2009.

MUPU

THE MARK CONSISTS OF STANDARD CHARACTERS WITHOUT CLAIM TO ANY PARTICULAR FONT, STYLE, SIZE, OR COLOR.

FOR LIVING TREES, NAMELY, AVOCADO TREES; LIVING PLANT MATERIAL FOR PROPAGATION PURPOSES, NAMELY, AVOCADO TREE GRAFTS; UNPROCESSED AVOCADOS (U.S. CLS. 1 AND 46).

FIRST USE 6-25-2009; IN COMMERCE 4-22-2011.

CLASS 31—(Continued).

3,999,168. INTERNATIONAL FRUIT GENETICS, LLC, BAKERSFIELD, CA. SN 77-981,980. PUB. 12-22-2009, FILED 3-27-2009.

Sweet Romance

THE MARK CONSISTS OF STANDARD CHARACTERS WITHOUT CLAIM TO ANY PARTICULAR FONT, STYLE, SIZE, OR COLOR.

OWNER OF U.S. REG. NO. 3,531,957. FOR LIVE PLANTS, NAMELY, TABLE GRAPE VINES (U.S. CLS. 1 AND 46).

FIRST USE 7-26-2010; IN COMMERCE 7-26-2010.

3,999,046. FIRST CHOICE MELON GROWERS, LLC, TIFTON, GA. SN 77-921,575. PUB. 6-15-2010, FILED 1-27-2010.



NO CLAIM IS MADE TO THE EXCLUSIVE RIGHT TO USE "BRAND", APART FROM THE MARK AS SHOWN.

THE COLOR(S) RED, WHITE, YELLOW, ORANGE, GREEN, DARK GREEN, TAN AND BLACK IS/ARE CLAIMED AS A FEATURE OF THE MARK.

THE MARK CONSISTS OF THE STYLIZED WORDING "MELON HEAD BRAND" IN THE COLORS WHITE AND RED APPEARING ABOVE AND BELOW A RED-TRIMMED OVAL WITH A FADING YELLOW TO ORANGE COLORED BACKGROUND; A MINI-MELON CHARACTER APPEARS INSIDE THE OVAL AND HAS A GREEN AND DARK GREEN WATERMELON FOR A HEAD WITH BLACK FACIAL OUTLINES AND WEARING BLACK SUNGLASSES WITH A WHITE REFLECTION OF LIGHT ON THEM, WITH AN OPEN MOUTH WITH WHITE TEETH SHOWING, BLACK SHADOWS AT THE BACK OF THE MOUTH, AND A RED TONGUE HANGING OUT; THE CHARACTER HAS WHITE LEGS COMING FROM THE BOTTOM OF THE MELON HEAD WITH LIGHT TAN SHOES AND WHITE HANDS ON EACH SIDE OF THE MELON GIVING TWO THUMBS UP SIGN.

FOR WATERMELON, FRESH (U.S. CLS. 1 AND 46). FIRST USE 6-1-2010; IN COMMERCE 6-1-2010.

3,999,327. WILLIAM H. KOPKE, JR., INC., GREAT NECK, NY. SN 85-026,416. PUB. 9-28-2010, FILED 4-29-2010.

SWEETUMS

THE MARK CONSISTS OF STANDARD CHARACTERS WITHOUT CLAIM TO ANY PARTICULAR FONT, STYLE, SIZE, OR COLOR.

FOR FRESH FRUITS (U.S. CLS. 1 AND 46).

FIRST USE 6-4-2010; IN COMMERCE 6-4-2010.

3,999,420. ST PIERRE, JOSEPH, BUFFALO, WY. SN 85-036,398. PUB. 10-12-2010, FILED 5-12-2010.

TRAILZORB

THE MARK CONSISTS OF STANDARD CHARACTERS WITHOUT CLAIM TO ANY PARTICULAR FONT, STYLE, SIZE, OR COLOR.

FOR COMPRESSED WOOD PARTICLES FOR ABSORBENCY (U.S. CLS. 1 AND 46).

FIRST USE 2-25-2011; IN COMMERCE 2-25-2011.

CLASS 31—(Continued).

3,999,436. INTERNATIONAL FRUIT GENETICS, LLC, BAKERSFIELD, CA. SN 85-037,595. PUB. 10-19-2010, FILED 5-13-2010.

Sweet Enchantment

THE MARK CONSISTS OF STANDARD CHARACTERS WITHOUT CLAIM TO ANY PARTICULAR FONT, STYLE, SIZE, OR COLOR.
OWNER OF U.S. REG. NOS. 3,636,713, 3,772,089, AND OTHERS.
FOR LIVE PLANTS, NAMELY, GRAPE VINES (U.S. CLS. 1 AND 46).
FIRST USE 7-26-2010; IN COMMERCE 7-26-2010.

CLASS 31—(Continued).

3,999,524. CARGILL, INCORPORATED, WAYZATA, MN. SN 85-056,176. PUB. 9-21-2010, FILED 6-7-2010.

RAMP

THE MARK CONSISTS OF STANDARD CHARACTERS WITHOUT CLAIM TO ANY PARTICULAR FONT, STYLE, SIZE, OR COLOR.
FOR ANIMAL FEED (U.S. CLS. 1 AND 46).
FIRST USE 12-2-2010; IN COMMERCE 12-2-2010.

3,999,520. PYRAMID PET PRODUCTS, INC, FOLSOM, CA. SN 85-054,992. PUB. 11-2-2010, FILED 6-4-2010.

**OLD WORLD NUTRITION FOR
NEW WORLD NEEDS**

THE MARK CONSISTS OF STANDARD CHARACTERS WITHOUT CLAIM TO ANY PARTICULAR FONT, STYLE, SIZE, OR COLOR.
FOR PET FOOD (U.S. CLS. 1 AND 46).
FIRST USE 3-1-2011; IN COMMERCE 3-1-2011.

3,999,525. CARGILL, INCORPORATED, WAYZATA, MN. SN 85-056,190. PUB. 9-21-2010, FILED 6-7-2010.

RIGHT TO THE BUNK

THE MARK CONSISTS OF STANDARD CHARACTERS WITHOUT CLAIM TO ANY PARTICULAR FONT, STYLE, SIZE, OR COLOR.
FOR ANIMAL FEED (U.S. CLS. 1 AND 46).
FIRST USE 12-2-2010; IN COMMERCE 12-2-2010.

3,999,522. PYRAMID PET PRODUCTS, INC, FOLSOM, CA. SN 85-055,133. PUB. 11-2-2010, FILED 6-4-2010.



THE MARK CONSISTS OF A SILHOUETTE OF A PUPPY. FOR DOG FOOD (U.S. CLS. 1 AND 46).
FIRST USE 3-1-2011; IN COMMERCE 3-1-2011.

3,999,530. BALL HORTICULTURAL COMPANY, WEST CHICAGO, IL. SN 85-057,087. PUB. 9-21-2010, FILED 6-8-2010.

SERENITA

THE MARK CONSISTS OF STANDARD CHARACTERS WITHOUT CLAIM TO ANY PARTICULAR FONT, STYLE, SIZE, OR COLOR.
OWNER OF U.S. REG. NO. 3,028,675.
FOR LIVING PLANTS; PLANT SEEDS (U.S. CLS. 1 AND 46).
FIRST USE 12-1-2010; IN COMMERCE 3-31-2011.

CLASS 31—(Continued).

3,999,555. LOCAL DOG, LLC, KETCHUM, ID. SN 85-063,983.
PUB. 11-16-2010, FILED 6-16-2010.

**BARK LIKE A DOG - SNACK
LIKE A LOCAL**

THE MARK CONSISTS OF STANDARD CHARACTERS WITHOUT CLAIM TO ANY PARTICULAR FONT, STYLE, SIZE, OR COLOR.
FOR EDIBLE DOG TREATS; DOG BISCUITS (U.S. CLS. 1 AND 46).
FIRST USE 6-0-2010; IN COMMERCE 6-0-2010.

3,999,818. WHITE OAK GOLDEN RETRIEVERS, DBA PERFECT ENTERPRISES INC., LINDSIDE, WV. SN 85-155,549.
PUB. 4-5-2011, FILED 10-18-2010.



WHITE OAK GOLDEN RETRIEVERS

NO CLAIM IS MADE TO THE EXCLUSIVE RIGHT TO USE "GOLDEN RETRIEVERS" AND THE REPRESENTATION OF A DOG, APART FROM THE MARK AS SHOWN.
THE MARK CONSISTS OF THE WORDING "WHITE OAK GOLDEN RETRIEVERS" BELOW A SILHOUETTES OF A DOG.
FOR DOGS (U.S. CLS. 1 AND 46).
FIRST USE 10-1-2010; IN COMMERCE 10-1-2010.

3,999,838. LAND O'LAKES PURINA FEED LLC, SHOREVIEW, MN. SN 85-162,536. PUB. 3-22-2011, FILED 10-27-2010.

CREATES EATERS

THE MARK CONSISTS OF STANDARD CHARACTERS WITHOUT CLAIM TO ANY PARTICULAR FONT, STYLE, SIZE, OR COLOR.
FOR ANIMAL FEED (U.S. CLS. 1 AND 46).
FIRST USE 4-30-2010; IN COMMERCE 4-30-2010.

CLASS 32—LIGHT BEVERAGES**CLASS 32—(Continued).**

3,998,418. SHIER, BARRY, LAS VEGAS, NV. SN 77-282,422.
PUB. 3-11-2008, FILED 9-18-2007.

HIPPO

THE MARK CONSISTS OF STANDARD CHARACTERS WITHOUT CLAIM TO ANY PARTICULAR FONT, STYLE, SIZE, OR COLOR.
FOR BEER AND NON-ALCOHOLIC BEER (U.S. CLS. 45, 46 AND 48).
FIRST USE 5-4-2011; IN COMMERCE 5-4-2011.

3,998,497. HMSHOST CORPORATION, BETHESDA, MD. SN 77-485,876. PUB. 11-25-2008, FILED 5-29-2008.

ARCTIC SOL

THE MARK CONSISTS OF STANDARD CHARACTERS WITHOUT CLAIM TO ANY PARTICULAR FONT, STYLE, SIZE, OR COLOR.
THE ENGLISH TRANSLATION OF "SOL" IN THE MARK IS SUN.
FOR BOTTLED DRINKING WATER AND SPRING WATER (U.S. CLS. 45, 46 AND 48).
FIRST USE 3-30-2011; IN COMMERCE 3-30-2011.

3,998,501. DS WATERS OF AMERICA, INC., ATLANTA, IL. SN 77-504,796. PUB. 12-16-2008, FILED 6-21-2008.



NO CLAIM IS MADE TO THE EXCLUSIVE RIGHT TO USE "MIX WITH FORMULA, JUICE AND CEREAL", APART FROM THE MARK AS SHOWN.
THE MARK CONSISTS OF THE WORDS "MIX WITH FORMULA, JUICE, AND CEREAL" PLACED TO THE LEFT OF A GRAPHIC REPRESENTATION OF A PORTION OF A BOWL AND A SPOON.
FOR DRINKING WATER (U.S. CLS. 45, 46 AND 48).
FIRST USE 9-10-2009; IN COMMERCE 9-10-2009.

CLASS 32—(Continued).

3,998,525. ALFRED DEVELOPMENT CORP., DBA BODY NATURAL FITNESS CENTER, BARRINGTON, RI. SN 77-562,305. PUB. 4-21-2009, FILED 9-4-2008.



NO CLAIM IS MADE TO THE EXCLUSIVE RIGHT TO USE "SMOOTHIE NATURAL", APART FROM THE MARK AS SHOWN.

THE COLOR(S) PURPLE, YELLOW, PINK, GREEN, ORANGE, AQUA, LIME GREEN, BLUE, BLACK, WHITE IS/ARE CLAIMED AS A FEATURE OF THE MARK.

THE MARK CONSISTS OF TWO WORDS AND THREE FRUITS. THE WORDS ARE "SMOOTHIE" AND "NATURAL". THE LETTERS "S" AND "H" IN THE WORD "SMOOTHIE" ARE PURPLE. THE LETTERS "M" AND "I" IN THE WORD "SMOOTHIE" ARE YELLOW. THE LETTERS "T" AND "E" IN THE WORD "SMOOTHIE" ARE AQUA. THE FIRST LETTER "O" IN THE WORD "SMOOTHIE" IS DEPICTED AS A PINK STRAWBERRY WITH BLACK SPOTS ON THE BODY, A GREEN STEM AND LIME GREEN LEAVES. THE SECOND LETTER "O" IN THE WORD "SMOOTHIE" IS DEPICTED AS AN ORANGE WITH A GREEN STEM AND A GREEN LEAF. THE LETTERS "N" AND "R" IN THE WORD "NATURAL" ARE ORANGE. THE FIRST LETTER "A" IN THE WORD "NATURAL" IS LIME GREEN. THE LETTERS "T" AND "L" IN THE WORD "NATURAL" ARE YELLOW. THE LETTER "U" IN THE WORD "NATURAL" IS PURPLE. THE SECOND LETTER "A" IN THE WORD "NATURAL" IS GREEN. THE WORDS "SMOOTHIE NATURAL" ARE OUTLINED IN BLACK, WITH A DOUBLE BLACK OUTLINE ON THE TOP, LEFT, AND RIGHT SIDES OF THE WORDING, WITH WHITE FILLING THE SPACE BETWEEN THE TWO BLACK OUTLINES. THE "S" IN "SMOOTHIE" AND THE "N" IN "NATURAL" ALSO HAVE WHITE DETAILING IN THE NATURE OF TINY CURVED LINES INSIDE THE LETTERS. BELOW THE WORDS "SMOOTHIE NATURAL" ARE IMAGES OF A YELLOW BANANA, ORANGE ORANGE AND RED STRAWBERRY. THE THREE FRUITS ARE SHOWN WITH OPEN EYES AND SMILING MOUTHS. THE BANANA, WHICH IS OUTLINED IN BLACK AND HAS A WHITE MOUTH AND WHITE AND BLACK EYES, HAS TWO ARMS AND IS FLEXING ITS LEFT ARM. THE STRAWBERRY, WHICH IS OUTLINED IN BLACK, HAS BLUE AND WHITE EYES AND A WHITE MOUTH, BLACK SPOTS ON THE BODY, A GREEN STEM, AND GREEN LEAVES. THE ORANGE, WHICH IS OUTLINED IN BLACK, HAS A WHITE MOUTH WITH A BLACK CURVED LINE SEPARATING THE TOP AND BOTTOM OF THE MOUTH. THE ORANGE HAS BLACK AND WHITE EYES AND BLACK SPOTS ON THE BODY. THE WHITE IN THE EYES AND MOUTHS OF THE THREE PIECES OF FRUIT BELOW THE WORDING IS PART OF THE MARK. ALSO THE WHITE BETWEEN THE TWO BLACK LINES SURROUNDING THE WORDS "SMOOTHIE NATURAL" AS DESCRIBED ABOVE IS PART OF THE MARK. HOWEVER, THE WHITE IN THE REST OF THE MARK IS NOT PART OF THE MARK AND REPRESENTS TRANSPARENT AREA.

FOR SMOOTHIES (U.S. CLS. 45, 46 AND 48).
FIRST USE 4-21-2009; IN COMMERCE 4-21-2009.

CLASS 32—(Continued).

3,998,716. ALDI INC., BATAVIA, IL. SN 77-787,722. PUB. 12-15-2009, FILED 7-23-2009.

BAJA BEACH

THE MARK CONSISTS OF STANDARD CHARACTERS WITHOUT CLAIM TO ANY PARTICULAR FONT, STYLE, SIZE, OR COLOR.

FOR NON-ALCOHOLIC DRINK MIXES FOR THE PREPARATION OF COCKTAILS; NON-ALCOHOLIC DRINK MIXES FOR THE PREPARATION OF SOFT DRINKS (U.S. CLS. 45, 46 AND 48).

FIRST USE 12-6-2010; IN COMMERCE 12-6-2010.

3,998,754. ANHEUSER-BUSCH, INCORPORATED, ST. LOUIS, MO. SN 77-820,211. PUB. 1-12-2010, FILED 9-4-2009.

THIRST QUARTER

THE MARK CONSISTS OF STANDARD CHARACTERS WITHOUT CLAIM TO ANY PARTICULAR FONT, STYLE, SIZE, OR COLOR.

FOR BEER (U.S. CLS. 45, 46 AND 48).

FIRST USE 11-1-2010; IN COMMERCE 11-1-2010.

3,998,819. CARNIVAL CORPORATION, MIAMI, FL. SN 77-844,676. PUB. 3-2-2010, FILED 10-8-2009.

THIRSTYFROG

THE MARK CONSISTS OF STANDARD CHARACTERS WITHOUT CLAIM TO ANY PARTICULAR FONT, STYLE, SIZE, OR COLOR.

FOR BEER (U.S. CLS. 45, 46 AND 48).

FIRST USE 5-1-2011; IN COMMERCE 5-1-2011.

CLASS 32—(Continued).

3,999,004. ROESCH, DEBRA M., PENDLETON, OR. SN 77-904,416. PUB. 6-22-2010, FILED 1-4-2010.

WM. ROESCH BREWING CO.

THE MARK CONSISTS OF STANDARD CHARACTERS WITHOUT CLAIM TO ANY PARTICULAR FONT, STYLE, SIZE, OR COLOR.

NO CLAIM IS MADE TO THE EXCLUSIVE RIGHT TO USE "BREWING CO.", APART FROM THE MARK AS SHOWN.

"WM. ROESCH" DOES NOT IDENTIFY A LIVING INDIVIDUAL.

FOR BEER (U.S. CLS. 45, 46 AND 48).
FIRST USE 8-19-2010; IN COMMERCE 8-19-2010.

3,999,065. STOKELY-VAN CAMP, INC., CHICAGO, IL. SN 77-929,417. PUB. 10-19-2010, FILED 2-5-2010.



OWNER OF U.S. REG. NOS. 3,659,283, 3,689,415, AND OTHERS.

NO CLAIM IS MADE TO THE EXCLUSIVE RIGHT TO USE "SERIES" AND "03", APART FROM THE MARK AS SHOWN.

THE MARK CONSISTS OF A STYLIZED LETTER "G" CONTAINING A LIGHTNING BOLT DESIGN WITHIN THE "G" AND THE WORDS "SERIES PRO 03 RECOVER".

FOR NON-ALCOHOLIC, FRUIT-FLAVORED BEVERAGES ENHANCED WITH PROTEINS (U.S. CLS. 45, 46 AND 48).

FIRST USE 5-31-2010; IN COMMERCE 5-31-2010.

3,999,091. MILES DAVIS PROPERTIES, LLC, LOS ANGELES, CA. SN 77-943,195. PUB. 10-19-2010, FILED 2-24-2010.

MILES DAVIS

THE MARK CONSISTS OF STANDARD CHARACTERS WITHOUT CLAIM TO ANY PARTICULAR FONT, STYLE, SIZE, OR COLOR.

OWNER OF U.S. REG. NO. 2,238,714.

CLASS 32—(Continued).

THE NAME "MILES DAVIS" DOES NOT IDENTIFY A LIVING INDIVIDUAL.

FOR BEER AND ALE (U.S. CLS. 45, 46 AND 48).
FIRST USE 6-5-2010; IN COMMERCE 8-31-2010.

3,999,120. CHRISTOPHER ROWLAND DAVIES, PENARTH, GLAMORGAN, UNITED KINGDOM. SN 77-953,829. PUB. 3-1-2011, FILED 3-9-2010.



THE COLOR(S) YELLOW, WHITE, AND BLACK IS/ARE CLAIMED AS A FEATURE OF THE MARK.

THE MARK CONSISTS OF THE MAIN BODY OF THE BANANA IS YELLOW; THE ELONGATED RING IN THE BODY OF THE BANANA IS WHITE; AND THE TIPS OF THE BANANA ARE BLACK.

FOR NON-ALCOHOLIC FRUIT DRINKS AND FRUIT JUICE BEVERAGES (U.S. CLS. 45, 46 AND 48).
FIRST USE 7-17-2010; IN COMMERCE 7-17-2010.

3,999,143. NEW BELGIUM BREWING COMPANY, INC., FORT COLLINS, CO. SN 77-966,407. PUB. 9-21-2010, FILED 3-23-2010.

SUPER CRU

THE MARK CONSISTS OF STANDARD CHARACTERS WITHOUT CLAIM TO ANY PARTICULAR FONT, STYLE, SIZE, OR COLOR.

NO CLAIM IS MADE TO THE EXCLUSIVE RIGHT TO USE "SUPER", APART FROM THE MARK AS SHOWN.

FOR BEER (U.S. CLS. 45, 46 AND 48).
FIRST USE 5-1-2011; IN COMMERCE 5-1-2011.

CLASS 32—(Continued).

3,999,226. AIRDALE BREWING COMPANY, LLC, SAN DIEGO, CA. SN 85-002,158. PUB. 8-24-2010, FILED 3-30-2010.

The Angry Panda

THE MARK CONSISTS OF STANDARD CHARACTERS WITHOUT CLAIM TO ANY PARTICULAR FONT, STYLE, SIZE, OR COLOR.

FOR BEER (U.S. CLS. 45, 46 AND 48).
FIRST USE 6-9-2011; IN COMMERCE 6-9-2011.

3,999,356. CITY 'LASSES, INC., BROOKLYN, NY. SN 85-029,514. PUB. 10-5-2010, FILED 5-4-2010.

Switzel

THE MARK CONSISTS OF STANDARD CHARACTERS WITHOUT CLAIM TO ANY PARTICULAR FONT, STYLE, SIZE, OR COLOR.

FOR ENERGY DRINKS; NON-ALCOHOLIC BEVERAGES CONTAINING FRUIT JUICES; NON-ALCOHOLIC BEVERAGES, NAMELY, CARBONATED BEVERAGES; SPORTS DRINKS; SPORTS DRINKS, NAMELY, ENERGY DRINKS (U.S. CLS. 45, 46 AND 48).
FIRST USE 3-1-2010; IN COMMERCE 3-27-2010.

3,999,467. KFC CORPORATION, LOUISVILLE, KY. SN 85-043,838. PUB. 10-19-2010, FILED 5-20-2010.

ICEFLOW

THE MARK CONSISTS OF STANDARD CHARACTERS WITHOUT CLAIM TO ANY PARTICULAR FONT, STYLE, SIZE, OR COLOR.

FOR NON-ALCOHOLIC FROZEN OR SEMI-FROZEN FLAVORED BEVERAGES (U.S. CLS. 45, 46 AND 48).
FIRST USE 5-31-2010; IN COMMERCE 5-31-2010.

CLASS 32—(Continued).

3,999,541. ANHEUSER-BUSCH, INCORPORATED, ST. LOUIS, MO. SN 85-060,421. PUB. 10-5-2010, FILED 6-11-2010.

FATTY NATTY

THE MARK CONSISTS OF STANDARD CHARACTERS WITHOUT CLAIM TO ANY PARTICULAR FONT, STYLE, SIZE, OR COLOR.

OWNER OF U.S. REG. NOS. 2,282,182, 3,030,095, AND 3,030,109.
FOR BEER (U.S. CLS. 45, 46 AND 48).
FIRST USE 10-31-2010; IN COMMERCE 10-31-2010.

3,999,574. SAMBAZON, INC., SAN CLEMENTE, CA. SN 85-068,924. PUB. 11-16-2010, FILED 6-22-2010.

WARRIOR UP

THE MARK CONSISTS OF STANDARD CHARACTERS WITHOUT CLAIM TO ANY PARTICULAR FONT, STYLE, SIZE, OR COLOR.

FOR NON ALCOHOLIC FRUIT BASED DRINKS AND FRUIT SMOOTHIES (U.S. CLS. 45, 46 AND 48).
FIRST USE 9-0-2010; IN COMMERCE 9-0-2010.

3,999,584. ANHEUSER-BUSCH, INCORPORATED, ST. LOUIS, MO. SN 85-071,470. PUB. 10-5-2010, FILED 6-25-2010.

WRAP YOUR HANDS AROUND A FATTY

THE MARK CONSISTS OF STANDARD CHARACTERS WITHOUT CLAIM TO ANY PARTICULAR FONT, STYLE, SIZE, OR COLOR.

FOR BEER (U.S. CLS. 45, 46 AND 48).
FIRST USE 10-31-2010; IN COMMERCE 10-31-2010.

CLASS 32—(Continued).

3,999,595. AJM IMPORTS, INC., MELROSE PARK, IL. SN 85-074,635. PUB. 11-30-2010, FILED 6-30-2010.

MOTORINO

THE MARK CONSISTS OF STANDARD CHARACTERS WITHOUT CLAIM TO ANY PARTICULAR FONT, STYLE, SIZE, OR COLOR.
FOR BEER (U.S. CLS. 45, 46 AND 48).
FIRST USE 12-31-2010; IN COMMERCE 12-31-2010.

3,999,676. MILLERCOORS LLC, CHICAGO, IL. SN 85-103,881. PUB. 1-25-2011, FILED 8-10-2010.

TENTH AND BLAKE BEER COMPANY

THE MARK CONSISTS OF STANDARD CHARACTERS WITHOUT CLAIM TO ANY PARTICULAR FONT, STYLE, SIZE, OR COLOR.
NO CLAIM IS MADE TO THE EXCLUSIVE RIGHT TO USE "BEER COMPANY", APART FROM THE MARK AS SHOWN.
FOR BEER (U.S. CLS. 45, 46 AND 48).
FIRST USE 4-15-2011; IN COMMERCE 4-15-2011.

3,999,696. MILLERCOORS LLC, CHICAGO, IL. SN 85-109,044. PUB. 1-25-2011, FILED 8-17-2010.



NO CLAIM IS MADE TO THE EXCLUSIVE RIGHT TO USE "BEER COMPANY", APART FROM THE MARK AS SHOWN.

THE MARK CONSISTS OF A STYLIZED GLASS OF BEER IN THE CENTER OF A CIRCLE WITH STYLIZED BUILDINGS ON EITHER SIDE OF THE GLASS, THE DESIGN BEING INSIDE TWO CONCENTRIC CIRCLES, WITH THE WORDS "TENTH AND BLAKE" IN THE MIDDLE OF THE TWO CIRCLES AT THE TOP OF THE DESIGN AND "BEER COMPANY" IN THE MIDDLE OF THE TWO CIRCLES AT THE BOTTOM OF THE DESIGN.

FOR BEER (U.S. CLS. 45, 46 AND 48).
FIRST USE 4-15-2011; IN COMMERCE 4-15-2011.

CLASS 33—WINES AND SPIRITS

3,998,331. TRI-STARCO, INC., STAFFORD, TX. SN 76-702,674. PUB. 9-28-2010, FILED 4-27-2010.

IZKALI

THE MARK CONSISTS OF STANDARD CHARACTERS WITHOUT CLAIM TO ANY PARTICULAR FONT, STYLE, SIZE, OR COLOR.
THE ENGLISH TRANSLATION OF THE WORD "IZKALI" IN THE MARK IS "BIRTH".
FOR TEQUILA (U.S. CLS. 47 AND 49).
FIRST USE 3-1-2011; IN COMMERCE 3-1-2011.

3,998,481. AGAVERA CAMICHINES, S.A. DE C.V., CHAPALA, TLAQUEPAQUE, JALISCO, MEXICO. SN 77-433,779. PUB. 4-20-2010, FILED 3-27-2008.

ESSENTIAL 1800

THE MARK CONSISTS OF STANDARD CHARACTERS WITHOUT CLAIM TO ANY PARTICULAR FONT, STYLE, SIZE, OR COLOR.
OWNER OF U.S. REG. NOS. 2,523,278, 2,600,691, AND OTHERS.
FOR ALCOHOLIC BEVERAGES, NAMELY, TEQUILA (U.S. CLS. 47 AND 49).
FIRST USE 9-0-2008; IN COMMERCE 9-0-2008.

3,998,499. UNIQUE LIQUID, LLC, BEAVERTON, OR. SN 77-492,462. PUB. 2-10-2009, FILED 6-6-2008.

YÉYO

THE WORDING "YÉYO" HAS NO MEANING IN A FOREIGN LANGUAGE.
FOR ALCOHOLIC BEVERAGES EXCEPT BEERS; SPIRITS; TEQUILA (U.S. CLS. 47 AND 49).
FIRST USE 6-1-2009; IN COMMERCE 2-1-2010.

CLASS 33—(Continued).

3,998,505. D AND M WINES PTY LIMITED, DOUBLE BAY, NSW 2028, AUSTRALIA. SN 77-522,542. PUB. 3-8-2011, FILED 7-15-2008.



THE MARK CONSISTS OF THE WORDING "AJA". FOR WINE; BOTTLED WINE (U.S. CLS. 47 AND 49). FIRST USE 9-0-2008; IN COMMERCE 2-22-2011.

3,998,607. BOCCIONI-COMERCIO, GESTAO E SERVICOS, LDA, FUNCHAL (MADEIRA), PORTUGAL. SN 77-670,131. PUB. 10-19-2010, FILED 2-13-2009.

CROFT PINK

THE MARK CONSISTS OF STANDARD CHARACTERS WITHOUT CLAIM TO ANY PARTICULAR FONT, STYLE, SIZE, OR COLOR.

OWNER OF U.S. REG. NO. 909,720.
NO CLAIM IS MADE TO THE EXCLUSIVE RIGHT TO USE "PINK", APART FROM THE MARK AS SHOWN.
FOR PORT WINE, AND WINES CONTAINING PORT WINE (U.S. CLS. 47 AND 49).
FIRST USE 0-0-2008; IN COMMERCE 0-0-2008.

3,998,634. LION, MARKUS, BREISACH, FED REP GERMANY. SN 77-712,005. PUB. 8-11-2009, FILED 4-11-2009.

BREVANS

THE MARK CONSISTS OF STANDARD CHARACTERS WITHOUT CLAIM TO ANY PARTICULAR FONT, STYLE, SIZE, OR COLOR.

FOR SPIRITS (U.S. CLS. 47 AND 49).
FIRST USE 4-15-2011; IN COMMERCE 4-15-2011.

CLASS 33—(Continued).

3,998,639. EMPRESA DE LICORES DE CUNDINAMARCA, BOGOTA DC, COLOMBIA. SN 77-713,941. PUB. 8-18-2009, FILED 4-14-2009.

NECTAR CLUB

THE MARK CONSISTS OF STANDARD CHARACTERS WITHOUT CLAIM TO ANY PARTICULAR FONT, STYLE, SIZE, OR COLOR.

OWNER OF U.S. REG. NO. 2,439,736.
NO CLAIM IS MADE TO THE EXCLUSIVE RIGHT TO USE "NECTAR", APART FROM THE MARK AS SHOWN.
FOR DISTILLED SPIRITS, NAMELY, COLOMBIAN AGUARDIENTE (U.S. CLS. 47 AND 49).
FIRST USE 11-1-2010; IN COMMERCE 11-1-2010.

3,998,687. ARTEMISIA DISTRIBUTION SARL, 2108 COUVET, SWITZERLAND. SN 77-753,915. PUB. 6-15-2010, FILED 6-7-2009.



NO CLAIM IS MADE TO THE EXCLUSIVE RIGHT TO USE "ARTEMISIA DISTILLERIE ARTISANALE" "ABSINTHE SUPERIEURE" "GRAIN NEUTRAL SPIRITS DISTILLED WITH HERBS" "CONT. NET 750 ML" "PRODUCT OF SWITZERLAND" AND "ALC. 53% BY VOL.", APART FROM THE MARK AS SHOWN.

THE NAME(S), PORTRAIT(S), AND/OR SIGNATURE(S) SHOWN IN THE MARK DOES NOT IDENTIFY A PARTICULAR LIVING INDIVIDUAL.

THE COLOR(S) DARK BLUE, LIGHT BLUE, PALE BLUE, WHITE, GREY, BLACK AND RED IS/ARE CLAIMED AS A FEATURE OF THE MARK.

THE MARK CONSISTS OF A "U" SHAPED OF ARTEMISIA STEM AND LEAVES IN PALE BLUE AND WHITE TONES WITH A RED FLAG-SHAPED SQUARE AT THE BOTTOM; WITHIN THE "U" SHAPE FROM LEFT TO UPPER RIGHT IS A DARK BLUE REPRESENTATION OF A GHOSTLY WOMAN'S UPPER TORSO WITH OUTSTRETCHED ARMS HOLDING OUT A STEMMED GLASS WITH THE WORD "CHARLOTTE" IN PALE BLUE EMANATING FROM HER MOUTH. ABOVE THIS FIGURE ARE THE WORDS "ARTEMISIA DISTILLERIE ARTISANALE" WRITTEN IN WHITE. BELOW HER ARMS ON A WHITE BACKGROUND ARE THE WORDS "LA CLANDESTINE" WRITTEN IN BLUE, "ABSINTHE SUPERIEURE" WRITTEN IN WHITE WITH A BLUE OUTLINE AND "GRAIN NEUTRAL SPIRITS DISTILLED WITH HERBS" WRITTEN IN

CLASS 33—(Continued).

BLUE. BELOW THOSE WORDS, BUT ABOVE THE RED FLAG SHAPED SQUARE AT THE BOTTOM OF THE "U" SHAPE IN SHADED TONES OF BLACK, WHITE, DARK BLUE AND LIGHT BLUE ON A WHITE BACKGROUND IS A DEPICTION OF AN ANTIQUE DISTILLING FLASK AND CANNISTER WITH A WINDOW AND SEVERAL BOTTLES IN THE BACKGROUND. BELOW THE "U" SHAPED DESIGN, THE WORDING "CONT. NET 750 ML, PRODUCT OF SWITZERLAND" AND "ALC. 53% BY VOLUME" APPEAR IN WHITE ON A BLUE BACKGROUND.

THE ENGLISH TRANSLATION OF EACH OF "DISTILLERIE ARTISINALE" AND OF "SUPERIEURE" IN THE MARK IS RESPECTIVELY, "CRAFT DISTILLERY" AND "GREATER", "HIGHER".

FOR LIQUOR AND LIQUEUR BEVERAGES, NAMELY, ABSINTHE (U.S. CLS. 47 AND 49).

FIRST USE 0-0-2008; IN COMMERCE 0-0-2008.

3,998,768. AVION TEQUILA LLC, HEWLETT, NY. SN 77-827,153. PUB. 4-13-2010, FILED 9-15-2009.

AVION

THE MARK CONSISTS OF STANDARD CHARACTERS WITHOUT CLAIM TO ANY PARTICULAR FONT, STYLE, SIZE, OR COLOR.

THE ENGLISH TRANSLATION OF "AVION" IN THE MARK IS "AIRPLANE".

FOR TEQUILA, SPIRITS, AND ALCOHOLIC BEVERAGES EXCEPT BEERS (U.S. CLS. 47 AND 49).

FIRST USE 7-5-2010; IN COMMERCE 7-5-2010.

3,998,784. WASTE & RECOVERY SOLUTIONS LLC, ACAMPO, CA. SN 77-833,314. PUB. 4-20-2010, FILED 9-23-2009.

Khaki's

THE MARK CONSISTS OF STANDARD CHARACTERS WITHOUT CLAIM TO ANY PARTICULAR FONT, STYLE, SIZE, OR COLOR.

FOR WINES (U.S. CLS. 47 AND 49).

FIRST USE 4-0-2011; IN COMMERCE 4-0-2011.

CLASS 33—(Continued).

3,998,913. ILTB, LLC, NORMAN, OK. SN 77-869,955. PUB. 4-13-2010, FILED 11-11-2009.

BLAME IT ON THE WORM

THE MARK CONSISTS OF STANDARD CHARACTERS WITHOUT CLAIM TO ANY PARTICULAR FONT, STYLE, SIZE, OR COLOR.

FOR ALCOHOLIC BEVERAGES, NAMELY, TEQUILA AND MESCAL (U.S. CLS. 47 AND 49).

FIRST USE 3-7-2011; IN COMMERCE 3-7-2011.

3,998,998. SEAN P. GARVEY, NAPA, CA. SN 77-900,870. PUB. 10-19-2010, FILED 12-24-2009.

REVIVAL

THE MARK CONSISTS OF STANDARD CHARACTERS WITHOUT CLAIM TO ANY PARTICULAR FONT, STYLE, SIZE, OR COLOR.

FOR WINE; WINES (U.S. CLS. 47 AND 49).

FIRST USE 4-14-2011; IN COMMERCE 4-26-2011.

3,999,035. BACARDI & COMPANY LIMITED, VADUZ, LIECHTENSTEIN. SN 77-917,691. PUB. 6-8-2010, FILED 1-22-2010.

ERISTOFF

THE MARK CONSISTS OF STANDARD CHARACTERS WITHOUT CLAIM TO ANY PARTICULAR FONT, STYLE, SIZE, OR COLOR.

FOR ALCOHOLIC BEVERAGES, NAMELY, VODKA, VODKA SPECIALTY DRINKS, FLAVORED VODKAS, AND LOW ALCOHOLIC VODKA-BASED BEVERAGES (U.S. CLS. 47 AND 49).

FIRST USE 4-0-2010; IN COMMERCE 9-0-2010.

CLASS 33—(Continued).

3,999,045. SOCIETÀ COOPERATIVA AGRICOLA CANTINA SOCIALE TOLLO, TOLLO, ITALY. SN 77-921,489. PUB. 1-4-2011, FILED 1-27-2010.



NO CLAIM IS MADE TO THE EXCLUSIVE RIGHT TO USE "KULT", APART FROM THE MARK AS SHOWN.
 THE COLOR(S) BLACK, WHITE AND RED IS/ARE CLAIMED AS A FEATURE OF THE MARK.
 THE MARK CONSISTS OF THE TERM "KULT" IN WHITE IN BLOCK PRINT, WITH A STYLIZED LETTER "K" IN RED APPEARING ON THE LEFT OF THE TERM "KULT", ALL WITHIN A BLACK/RED BACKGROUND.
 THE WORDING "KULT" HAS NO MEANING IN A FOREIGN LANGUAGE.
 FOR WINES (U.S. CLS. 47 AND 49).
 FIRST USE 12-0-2009; IN COMMERCE 12-0-2009.

3,999,063. TOOLBOX WINE CO. LLC, DBA TOOLBOX, NAPA, CA. SN 77-929,146. PUB. 6-22-2010, FILED 2-5-2010.



THE COLOR(S) BLACK AND MAUVE IS/ARE CLAIMED AS A FEATURE OF THE MARK.
 THE MARK CONSISTS OF THE WORD "TOOLBOX" IN MAUVE AND BLACK, FORMED BY LETTERS THAT RESEMBLE NUTS, BOLTS, CORKSCREWS, RULERS, AND OTHER TOOLS.
 FOR WINE; WINES (U.S. CLS. 47 AND 49).
 FIRST USE 4-15-2010; IN COMMERCE 4-15-2010.

CLASS 33—(Continued).

3,999,112. BRAND OPPORTUNITIES, LLC, ATLANTA, GA. SN 77-950,809. PUB. 7-27-2010, FILED 3-4-2010.

Casa Dora

THE MARK CONSISTS OF STANDARD CHARACTERS WITHOUT CLAIM TO ANY PARTICULAR FONT, STYLE, SIZE, OR COLOR.
 THE ENGLISH TRANSLATION OF "CASA" IN THE MARK IS HOUSE.
 FOR WINES (U.S. CLS. 47 AND 49).
 FIRST USE 3-14-2011; IN COMMERCE 3-14-2011.

3,999,236. DISTILLERIE TUONI E CANEPA, S.R.L., LIVORNO, ITALY. SN 85-007,650. PUB. 1-25-2011, FILED 4-6-2010.



OWNER OF U.S. REG. NOS. 830,728, 3,511,049, AND OTHERS.
 NO CLAIM IS MADE TO THE EXCLUSIVE RIGHT TO USE "LIQORE ORIGINALE" AND "LIQUEUR", APART FROM THE MARK AS SHOWN.
 THE MARK CONSISTS OF A SOLID VERTICAL RECTANGLE WITH THE WORD "TUACA" VERTICALLY DOWN THE CENTER WITH AN OUTLINE. BELOW THE WORD TUACA IS A LION CREST DESIGN WHICH CONSISTS OF TWO LIONS FACING EACH OTHER WITH A CROWN MOTIF BETWEEN THEM AND THE LETTERS "T & C" UNDER THAT WITH A LINE UNDER THE LETTERS. BELOW THE LETTERS ARE THE WORDS "LIQORE ORIGINALE." BELOW THAT IS A HORIZONTAL RECTANGLE WITH THE WORD "LIQUEUR" IN IT WITH SLANTED LINES ON THE TOP AND BOTTOM OF THE HORIZONTAL RECTANGLE. ABOVE THE WHOLE SOLID VERTICAL RECTANGLE ARE THE WORDS "TUONI E CANEPA" IN CURSIVE HANDWRITING.
 THE ENGLISH TRANSLATION OF "LIQORE ORIGINALE" IN THE MARK IS "ORIGINAL LIQUEUR".
 FOR DISTILLED SPIRITS (U.S. CLS. 47 AND 49).
 FIRST USE 6-1-2010; IN COMMERCE 6-1-2010.

CLASS 33—(Continued).

3,999,253. JAM CELLARS INC, NAPA, CA. SN 85-011,243.
PUB. 9-7-2010, FILED 4-11-2010.

Butter

THE MARK CONSISTS OF STANDARD CHARACTERS WITHOUT CLAIM TO ANY PARTICULAR FONT, STYLE, SIZE, OR COLOR.

FOR WINE (U.S. CLS. 47 AND 49).
FIRST USE 8-1-2010; IN COMMERCE 8-1-2010.

3,999,321. REICHER, SHERRATT, ALAMO, CA. SN 85-025,654. PUB. 10-12-2010, FILED 4-28-2010.

MCG CELLARS

THE MARK CONSISTS OF STANDARD CHARACTERS WITHOUT CLAIM TO ANY PARTICULAR FONT, STYLE, SIZE, OR COLOR.

NO CLAIM IS MADE TO THE EXCLUSIVE RIGHT TO USE "CELLARS", APART FROM THE MARK AS SHOWN.

FOR WINE (U.S. CLS. 47 AND 49).
FIRST USE 5-26-2011; IN COMMERCE 5-26-2011.

3,999,458. FUSSION DRINKS, S.L., MARRATXY, BA-LEARES, SPAIN. SN 85-042,210. PUB. 11-2-2010, FILED 5-19-2010.



NO CLAIM IS MADE TO THE EXCLUSIVE RIGHT TO USE "COCKTAILS & DRINKS", APART FROM THE MARK AS SHOWN.

THE COLOR(S) GREEN AND YELLOW IS/ARE CLAIMED AS A FEATURE OF THE MARK.

CLASS 33—(Continued).

THE MARK CONSISTS OF THE STYLIZED WORDING "SUN BEACH COCKTAILS & DRINKS". THE WORD "SUN" IS IN GREEN AND IS SET OVER THE WORD "BEACH", WHICH IS COLORED IN YELLOW. THE LOWER PORTION OF "SUN" AND THE UPPER PORTION OF "BEACH" APPEAR TO BE CUT OFF. THE WORDING "COCKTAILS & DRINKS" APPEAR IN A SINGLE LINE BELOW "SUN BEACH" IN A DIFFERENT, SMALLER STYLIZATION, WITH "COCKTAILS &" IN GREEN AND THE WORD "DRINKS" IN YELLOW.

FOR ALCOHOLIC BEVERAGES EXCEPT BEERS (U.S. CLS. 47 AND 49).

FIRST USE 9-1-2010; IN COMMERCE 9-1-2010.

3,999,487. KLEIN FOODS, INC. DBA RODNEY STRONG VINEYARDS, HEALDSBURG, CA. SN 85-047,289. PUB. 10-19-2010, FILED 5-25-2010.

FREEBIRD

THE MARK CONSISTS OF STANDARD CHARACTERS WITHOUT CLAIM TO ANY PARTICULAR FONT, STYLE, SIZE, OR COLOR.

FOR WINES (U.S. CLS. 47 AND 49).
FIRST USE 5-19-2011; IN COMMERCE 5-23-2011.

3,999,489. JWB WINE LLC, DBA BRAMAN WINERY, VICTORIA, TX. SN 85-047,440. PUB. 10-5-2010, FILED 5-25-2010.

Z10

THE MARK CONSISTS OF STANDARD CHARACTERS WITHOUT CLAIM TO ANY PARTICULAR FONT, STYLE, SIZE, OR COLOR.

FOR WINE (U.S. CLS. 47 AND 49).
FIRST USE 9-0-2010; IN COMMERCE 9-0-2010.

3,999,543. STONY OAK ESTATES LLC, DBA STONY OAK ESTATES WINERY, WINDSOR, CA. SN 85-060,454. PUB. 11-16-2010, FILED 6-11-2010.

Holy Special Home Improved Taste

THE MARK CONSISTS OF STANDARD CHARACTERS WITHOUT CLAIM TO ANY PARTICULAR FONT, STYLE, SIZE, OR COLOR.

CLASS 33—(Continued).

NO CLAIM IS MADE TO THE EXCLUSIVE RIGHT TO USE "SPECIAL HOME IMPROVED TASTE", APART FROM THE MARK AS SHOWN.

FOR RED WINES (U.S. CLS. 47 AND 49).
FIRST USE 6-7-2011; IN COMMERCE 6-7-2011.

CLASS 33—(Continued).

3,999,661. V2 WINE GROUP, LLC, SONOMA, CA. SN 85-097,143. PUB. 10-26-2010, FILED 7-30-2010.

PAINTED GATE

3,999,566. TEQUILERA OCHO MESAS, LLC, SCOTTSDALE, AZ. SN 85-065,870. PUB. 3-8-2011, FILED 6-17-2010.

THE MARK CONSISTS OF STANDARD CHARACTERS WITHOUT CLAIM TO ANY PARTICULAR FONT, STYLE, SIZE, OR COLOR.

FOR WINE (U.S. CLS. 47 AND 49).
FIRST USE 2-15-2011; IN COMMERCE 5-24-2011.

JULIO CESAR CHAVEZ

3,999,673. COMERCIAL EXVINA LTDA., TALCA, CHILE. SN 85-102,580. PUB. 3-29-2011, FILED 8-7-2010.

THE MARK CONSISTS OF STANDARD CHARACTERS WITHOUT CLAIM TO ANY PARTICULAR FONT, STYLE, SIZE, OR COLOR.

THE NAME(S), PORTRAIT(S), AND/OR SIGNATURE(S) SHOWN IN THE MARK IDENTIFIES "JULIO CESAR CHAVEZ GONZALEZ", WHOSE CONSENT(S) TO REGISTER IS MADE OF RECORD.

FOR DISTILLED SPIRITS; EXTRACTS OF SPIRITUOUS LIQUORS; LIQUOR; POTABLE SPIRITS; SPIRITS; SPIRITS AND LIQUEURS; TEQUILA; TEQUILA INFUSED WITH VITAMINS (U.S. CLS. 47 AND 49).
FIRST USE 3-1-2011; IN COMMERCE 3-1-2011.

SIERRA BATUCO

THE MARK CONSISTS OF STANDARD CHARACTERS WITHOUT CLAIM TO ANY PARTICULAR FONT, STYLE, SIZE, OR COLOR.

NO CLAIM IS MADE TO THE EXCLUSIVE RIGHT TO USE "BATUCO", APART FROM THE MARK AS SHOWN.

THE ENGLISH TRANSLATION OF "SIERRA" IN THE MARK IS "MOUNTAINS".

FOR GRAPE WINE; RED WINES; STILL WINES; TABLE WINES; WHITE WINE; WINE (U.S. CLS. 47 AND 49).

FIRST USE 10-1-2010; IN COMMERCE 10-1-2010.

3,999,645. SOTER, ANTHONY, CARLTON, OR. SN 85-090,448. PUB. 1-11-2011, FILED 7-22-2010.

PLANET OREGON

THE MARK CONSISTS OF STANDARD CHARACTERS WITHOUT CLAIM TO ANY PARTICULAR FONT, STYLE, SIZE, OR COLOR.

NO CLAIM IS MADE TO THE EXCLUSIVE RIGHT TO USE "OREGON", APART FROM THE MARK AS SHOWN.

FOR WINES (U.S. CLS. 47 AND 49).
FIRST USE 3-31-2011; IN COMMERCE 3-31-2011.

3,999,742. MOUNT GAY DISTILLERIES LIMITED, BRANDONS, SAINT MICHAEL, BARBADOS. SN 85-128,120. PUB. 3-29-2011, FILED 9-13-2010.

MOUNT GAY RUM ECLIPSE BLACK

THE MARK CONSISTS OF STANDARD CHARACTERS WITHOUT CLAIM TO ANY PARTICULAR FONT, STYLE, SIZE, OR COLOR.

OWNER OF U.S. REG. NOS. 1,226,842, 3,599,291, AND OTHERS.

NO CLAIM IS MADE TO THE EXCLUSIVE RIGHT TO USE "BLACK" AND "RUM", APART FROM THE MARK AS SHOWN.

FOR RUM (U.S. CLS. 47 AND 49).
FIRST USE 3-0-2011; IN COMMERCE 3-0-2011.

CLASS 33—(Continued).

3,999,746. FEDWAY ASSOCIATES, INC., KEARNY, NJ. SN 85-129,041. PUB. 3-1-2011, FILED 9-14-2010.

TUTIDI

THE MARK CONSISTS OF STANDARD CHARACTERS WITHOUT CLAIM TO ANY PARTICULAR FONT, STYLE, SIZE, OR COLOR.

THE ENGLISH TRANSLATION OF "TUTIDI" IN THE MARK IS "EVERYDAY".

FOR WINES (U.S. CLS. 47 AND 49).

FIRST USE 12-8-2010; IN COMMERCE 12-8-2010.

3,999,768. E. & J. GALLO WINERY, MODESTO, CA. SN 85-139,309. PUB. 2-22-2011, FILED 9-27-2010.



THE MARK CONSISTS OF AN OUTDOOR SCENE DEPICTING A LARGE TREE WITH FLOWER SHAPED LEAVES SURROUNDED BY THREE SMALLER TREES, CLOUDS AND A BIRD.

FOR WINES (U.S. CLS. 47 AND 49).

FIRST USE 11-17-2010; IN COMMERCE 11-17-2010.

3,999,784. GREG-MICHAEL CELLARS, LLC, AKA BARRISTER WINERY, SPOKANE, WA. SN 85-142,693. PUB. 3-8-2011, FILED 9-30-2010.

BARRISTER'S BLOCK

THE MARK CONSISTS OF STANDARD CHARACTERS WITHOUT CLAIM TO ANY PARTICULAR FONT, STYLE, SIZE, OR COLOR.

FOR WINES (U.S. CLS. 47 AND 49).

FIRST USE 11-7-2010; IN COMMERCE 11-10-2010.

CLASS 34—SMOKERS' ARTICLES**CLASS 34—(Continued).**

3,998,333. ALRAHIB, AKRUM, COMMERCE, CA. SN 76-702,939. PUB. 10-12-2010, FILED 5-13-2010.

SO HOOD SO GOOD

THE MARK CONSISTS OF STANDARD CHARACTERS WITHOUT CLAIM TO ANY PARTICULAR FONT, STYLE, SIZE, OR COLOR.

FOR TOBACCO PRODUCTS, NAMELY, FLAVORED TOBACCO, CIGARS AND CIGARETTES (U.S. CLS. 2, 8, 9 AND 17).

FIRST USE 5-1-2011; IN COMMERCE 5-1-2011.

3,998,449. G & R BRANDS, LLC, LAS VEGAS, NV. SN 77-355,114. PUB. 2-10-2009, FILED 12-18-2007.

HONEY HONEY

THE MARK CONSISTS OF STANDARD CHARACTERS WITHOUT CLAIM TO ANY PARTICULAR FONT, STYLE, SIZE, OR COLOR.

FOR CIGAR BOXES NOT OF PRECIOUS METAL; CIGAR CUTTERS; CIGAR HUMIDIFIERS; HOOKAHS (U.S. CLS. 2, 8, 9 AND 17).

FIRST USE 4-29-2011; IN COMMERCE 4-29-2011.

3,998,626. JACOBS, ROSALIE ANNE, HOGANSBURG, NY. SN 77-699,950. PUB. 7-28-2009, FILED 3-26-2009.

WHERE TRADITION MEETS FLAVOR

THE MARK CONSISTS OF STANDARD CHARACTERS WITHOUT CLAIM TO ANY PARTICULAR FONT, STYLE, SIZE, OR COLOR.

FOR TOBACCO AND CIGARETTES (U.S. CLS. 2, 8, 9 AND 17).

FIRST USE 3-21-2011; IN COMMERCE 3-21-2011.

CLASS 34—(Continued).

3,998,702. MCM HOLDINGS, LLC, SALAMANCA, NY. SN 77-768,360. PUB. 11-17-2009, FILED 6-25-2009.

WARRIOR

THE MARK CONSISTS OF STANDARD CHARACTERS WITHOUT CLAIM TO ANY PARTICULAR FONT, STYLE, SIZE, OR COLOR.

OWNER OF U.S. REG. NO. 3,350,079.
FOR CIGARS (U.S. CLS. 2, 8, 9 AND 17).
FIRST USE 1-22-2010; IN COMMERCE 1-22-2010.

3,999,167. TOP TOBACCO, LP, GLENVIEW, IL. SN 77-981,969.
PUB. 8-26-2008, FILED 4-8-2008.

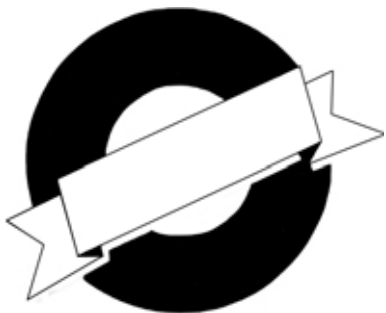

THE MARK CONSISTS OF A CIRCLE WITH A BANNER THROUGH THE MIDDLE.
FOR CIGARETTE TUBES (U.S. CLS. 2, 8, 9 AND 17).
FIRST USE 5-12-2011; IN COMMERCE 5-12-2011.

3,999,504. STARBUZZ TOBACCO, INC., ANAHEIM, CA. SN 85-052,269. PUB. 10-26-2010, FILED 6-1-2010.

CocoOrange

THE MARK CONSISTS OF STANDARD CHARACTERS WITHOUT CLAIM TO ANY PARTICULAR FONT, STYLE, SIZE, OR COLOR.

FOR PIPE TOBACCO; MOLASSES TOBACCO; TOBACCO; SMOKING TOBACCO; FLAVORED TOBACCO; TOBACCO SUBSTITUTE, NAMELY, HERBAL MOLASSES (U.S. CLS. 2, 8, 9 AND 17).
FIRST USE 7-13-2010; IN COMMERCE 7-13-2010.

CLASS 34—(Continued).

3,999,808. JOHN MIDDLETON CO., KING OF PRUSSIA, PA. SN 85-150,607. PUB. 4-5-2011, FILED 10-12-2010.



OWNER OF U.S. REG. NOS. 1,103,566, 2,712,704, AND OTHERS.

NO CLAIM IS MADE TO THE EXCLUSIVE RIGHT TO USE "SINCE 1856" "CLASSIC" AND "CIGARILLOS", APART FROM THE MARK AS SHOWN.

THE COLOR(S) BROWN, DARK BROWN, BLACK, GOLD, AND WHITE IS/ARE CLAIMED AS A FEATURE OF THE MARK.

THE MARK CONSISTS OF A GRADATED BROWN RECTANGULAR DESIGN. THERE IS A DARK BROWN IRREGULAR SHAPED DIAGONAL BAND, OUTLINED IN GRADATED GOLD, WITH GRADATED BROWN IN THE CENTER, LOCATED IN THE GRADATED BROWN RECTANGULAR DESIGN. THERE ARE THIN GRADATED GOLD LINES ALONG THE TOP AND BOTTOM EDGE OF THE DARK BROWN IRREGULAR SHAPED DIAGONAL BAND. THE WORDS "MIDDLETON'S", IN WHITE, "BLACK", IN WHITE WITH A BLACK OUTLINE, & IN GRADATED GOLD WITH A BLACK OUTLINE, "MILD", IN WHITE WITH A BLACK OUTLINE, AND "SINCE 1856", IN WHITE, ARE LOCATED WITHIN THE GRADATED BROWN CENTER OF THE DARK BROWN IRREGULAR SHAPED DIAGONAL BAND. THERE ARE IRREGULAR SHAPED WINDOWS, OUTLINED IN GRADATED GOLD, LOCATED IN THE CENTER ABOVE AND BELOW THE DARK BROWN IRREGULAR SHAPED DIAGONAL BAND. THE WORD "CLASSIC", IN DARK BROWN, IS LOCATED WITHIN THE GRADATED GOLD OUTLINE OF THE LOWER IRREGULAR SHAPED WINDOW. THE WORD "CIGARILLOS", IN WHITE, IS LOCATED IN THE CENTER BELOW THE WORD "CLASSIC". THERE ARE GRADATED GOLD LINES ABOVE AND BELOW THE WORD "CIGARILLOS".

SEC. 2(F) AS TO "BLACK & MILD".
FOR TOBACCO PRODUCTS, NAMELY, CIGARS (U.S. CLS. 2, 8, 9 AND 17).
FIRST USE 11-10-2010; IN COMMERCE 11-10-2010.

CLASS 34—(Continued).

3,999,809. JOHN MIDDLETON CO., KING OF PRUSSIA, PA.
SN 85-150,615. PUB. 4-5-2011, FILED 10-12-2010.



OWNER OF U.S. REG. NOS. 1,103,566, 2,712,704, AND OTHERS.

NO CLAIM IS MADE TO THE EXCLUSIVE RIGHT TO USE "SINCE 1856" "CLASSIC" AND "CIGARILLOS", APART FROM THE MARK AS SHOWN.

THE MARK CONSISTS OF A GRADATED RECTANGULAR DESIGN. THERE IS AN IRREGULAR SHAPED DIAGONAL BAND, WITH A GRADATED OUTLINE AND A GRADATED CENTER, LOCATED IN THE GRADATED RECTANGULAR DESIGN. THERE ARE THIN GRADATED LINES ALONG THE TOP AND BOTTOM EDGE OF THE IRREGULAR SHAPED DIAGONAL BAND. THE WORDS "MIDDLETON'S, BLACK & MILD", AND "SINCE 1856" ARE LOCATED WITHIN THE GRADATED CENTER OF THE IRREGULAR SHAPED DIAGONAL BAND. THERE ARE IRREGULAR SHAPED WINDOWS WITH GRADATED OUTLINES LOCATED IN THE CENTER ABOVE AND BELOW THE IRREGULAR SHAPED DIAGONAL BAND. THE WORD "CLASSIC" IS LOCATED WITHIN THE GRADATED OUTLINE OF THE LOWER IRREGULAR SHAPED WINDOW. THE WORD "CIGARILLOS" IS LOCATED IN THE CENTER BELOW THE WORD "CLASSIC". THERE ARE GRADATED LINES ABOVE AND BELOW THE WORD "CLASSIC".

SEC. 2(F) AS TO "BLACK & MILD".

FOR TOBACCO PRODUCTS, NAMELY, CIGARS (U.S. CLS. 2, 8, 9 AND 17).

FIRST USE 11-10-2010; IN COMMERCE 11-10-2010.

CLASS 34—(Continued).

3,999,810. JOHN MIDDLETON CO., KING OF PRUSSIA, PA.
SN 85-150,636. PUB. 4-5-2011, FILED 10-12-2010.



OWNER OF U.S. REG. NOS. 1,103,566, 2,712,704, AND OTHERS.

NO CLAIM IS MADE TO THE EXCLUSIVE RIGHT TO USE "SINCE 1856" "SWEETS" AND "CIGARILLOS", APART FROM THE MARK AS SHOWN.

THE MARK CONSISTS OF A RECTANGULAR DESIGN. THERE IS AN IRREGULAR SHAPED DIAGONAL BAND, WITH AN OUTLINE AND A GRADATED CENTER, LOCATED IN THE RECTANGULAR DESIGN. THERE ARE THIN GRADATED LINES ALONG THE TOP AND BOTTOM EDGE OF THE IRREGULAR SHAPED DIAGONAL BAND. THE WORDS "MIDDLETON'S, BLACK & MILD", AND "SINCE 1856" ARE LOCATED WITHIN THE GRADATED CENTER OF THE IRREGULAR SHAPED DIAGONAL BAND. THERE ARE IRREGULAR SHAPED WINDOWS WITH OUTLINES LOCATED IN THE CENTER ABOVE AND BELOW THE IRREGULAR SHAPED DIAGONAL BAND. THE WORD "SWEETS" IS LOCATED WITHIN THE OUTLINE OF THE LOWER IRREGULAR SHAPED WINDOW. THE WORD "CIGARILLOS" IS LOCATED IN THE CENTER BELOW THE WORD "SWEETS". THERE ARE GRADATED LINES ABOVE AND BELOW THE WORD "SWEETS".

SEC. 2(F) AS TO "BLACK & MILD".

FOR TOBACCO PRODUCTS, NAMELY, CIGARS (U.S. CLS. 2, 8, 9 AND 17).

FIRST USE 11-10-2010; IN COMMERCE 11-10-2010.

3,999,864. HOFFMAN, JUSTIN, WHEAT RIDGE, CO. SN 85-187,674. PUB. 3-29-2011, FILED 11-30-2010.

metro

THE MARK CONSISTS OF STANDARD CHARACTERS WITHOUT CLAIM TO ANY PARTICULAR FONT, STYLE, SIZE, OR COLOR.

FOR ELECTRONIC CIGARETTES; ELECTRONIC CIGARETTES FOR USE AS AN ALTERNATIVE TO TRADITIONAL CIGARETTES (U.S. CLS. 2, 8, 9 AND 17).

FIRST USE 1-6-2011; IN COMMERCE 4-22-2011.

CLASS 35—(Continued).**SERVICE MARKS****CLASS 35—ADVERTISING AND BUSINESS**

3,998,355. WALTER, RICHARD, CARSON CITY, NV. SN 77-053,103. PUB. 2-26-2008, FILED 11-29-2006.

iFish.com

THE MARK CONSISTS OF STANDARD CHARACTERS WITHOUT CLAIM TO ANY PARTICULAR FONT, STYLE, SIZE, OR COLOR.

FOR PROMOTING THE GOODS AND SERVICES OF OTHERS BY PROVIDING HYPERTEXT LINKS TO THE RETAIL WEB SITES OF OTHERS FOR PRODUCT INFORMATION AND SHOPPING PURPOSES (U.S. CLS. 100, 101 AND 102).

FIRST USE 5-18-2011; IN COMMERCE 5-18-2011.

3,998,363. CHM ASSOCIATES LLC, DBA POUR, NEW YORK, NY. SN 77-083,968. PUB. 12-21-2010, FILED 1-16-2007.



THE MARK CONSISTS OF THE LOWER-CASE LETTERS "U" AND "R" ADJACENT TO A SHADED CIRCLE CONTAINING THE LOWER-CASE LETTERS "P" AND "O" TO FORM THE WORD "POUR".

FOR RETAIL WINE STORE SERVICES (U.S. CLS. 100, 101 AND 102).

FIRST USE 12-6-2006; IN COMMERCE 12-6-2006.

3,998,389. LONDON ECONOMICS INTERNATIONAL LLC, BOSTON, MA. SN 77-188,506. PUB. 3-10-2009, FILED 5-23-2007.

LEI GLOBAL

THE MARK CONSISTS OF STANDARD CHARACTERS WITHOUT CLAIM TO ANY PARTICULAR FONT, STYLE, SIZE, OR COLOR.

CLASS 35—(Continued).

NO CLAIM IS MADE TO THE EXCLUSIVE RIGHT TO USE "GLOBAL", APART FROM THE MARK AS SHOWN.

FOR ECONOMIC CONSULTING FOR THE ENERGY AND INFRASTRUCTURE INDUSTRIES FOR PLANNING, ORGANIZING, MONITORING AND CARRYING OUT UNIQUE AND COMPLEX PROJECTS IN THE NATURE OF FORMULATING STRATEGY BASED ON THE PRINCIPLES AND TOOLS USED IN ECONOMIC ANALYSIS, NAMELY, BY USING ECONOMIC MODELS IN COMBINATION WITH KNOWLEDGE OF THE INDUSTRIES TO ADVISE CLIENTS IN BUSINESS STRATEGY, MERGERS AND ACQUISITION, TAX PREPARATION AND STAKEHOLDER COMMUNICATION (U.S. CLS. 100, 101 AND 102).

FIRST USE 5-30-2011; IN COMMERCE 5-30-2011.

3,998,445. YURMAN STUDIO, INC., NEW YORK, NY. SN 77-321,373. PUB. 3-4-2008, FILED 11-5-2007.

NOUMENON

THE MARK CONSISTS OF STANDARD CHARACTERS WITHOUT CLAIM TO ANY PARTICULAR FONT, STYLE, SIZE, OR COLOR.

FOR RETAIL STORE SERVICES FOR JEWELRY (U.S. CLS. 100, 101 AND 102).

FIRST USE 11-2-2010; IN COMMERCE 11-2-2010.

3,998,451. CAREERBUILDER, LLC, CHICAGO, IL. SN 77-355,623. PUB. 4-15-2008, FILED 12-19-2007.

PERSONIFIED

THE MARK CONSISTS OF STANDARD CHARACTERS WITHOUT CLAIM TO ANY PARTICULAR FONT, STYLE, SIZE, OR COLOR.

FOR CONSULTING SERVICES IN THE FIELD OF HUMAN RESOURCES, EMPLOYEE RECRUITMENT, HIRING, RETENTION, DEVELOPMENT AND MANAGEMENT; BUSINESS RESEARCH AND SURVEYS (U.S. CLS. 100, 101 AND 102).

FIRST USE 1-0-2008; IN COMMERCE 1-0-2008.

CLASS 35—(Continued).

3,998,463. MYLIFE.COM, INC., LOS ANGELES, CA. SN 77-398,766. PUB. 7-1-2008, FILED 2-15-2008.

WHO'S SEARCHING FOR YOU

THE MARK CONSISTS OF STANDARD CHARACTERS WITHOUT CLAIM TO ANY PARTICULAR FONT, STYLE, SIZE, OR COLOR.

FOR PROVIDING AN ONLINE DATABASE FEATURING CLASS DIRECTORIES FOR USE IN OBTAINING CONTACT INFORMATION ABOUT CURRENT AND PAST SCHOOL, COLLEGE, MILITARY, FAMILY, AND SPECIAL INTEREST ACQUAINTANCES; COMPUTERIZED DATABASE MANAGEMENT SERVICES FOR OTHERS IN THE FIELD OF CONTACT INFORMATION (U.S. CLS. 100, 101 AND 102).

FIRST USE 9-1-2005; IN COMMERCE 9-1-2005.

3,998,472. JOBZIPPER LLC, MANCHESTER, NH. SN 77-418,423. PUB. 3-3-2009, FILED 3-11-2008.



THE MARK CONSISTS OF THE WORDING "JOBZIPPER" IN A STYLIZED FONT, WITH THE LETTER "I" FORMED BY A STYLIZED ZIPPER.

FOR PROVIDING AN ON-LINE SEARCHABLE DATABASE FEATURING EMPLOYMENT OPPORTUNITIES (U.S. CLS. 100, 101 AND 102).

FIRST USE 5-16-2011; IN COMMERCE 5-16-2011.

3,998,485. ADAP.TV INC., SAN MATEO, CA. SN 77-442,137. PUB. 9-28-2010, FILED 4-7-2008.

ADAP.TV

THE MARK CONSISTS OF STANDARD CHARACTERS WITHOUT CLAIM TO ANY PARTICULAR FONT, STYLE, SIZE, OR COLOR.

FOR VIDEO ADVERTISING SERVICES; ADVERTISING SERVICES IN THE NATURE OF MATCHING AND CONNECTING ADVERTISERS AND VIDEO CONTENT PUBLISHERS FOR THE PURPOSE OF ADVERTISING, MARKETING AND PROMOTIONAL SERVICES (U.S. CLS. 100, 101 AND 102).

FIRST USE 11-13-2007; IN COMMERCE 11-13-2007.

CLASS 35—(Continued).

3,998,495. OTARIAN LONDON LIMITED, EPSOM, UNITED KINGDOM. SN 77-476,581. PUB. 3-10-2009, FILED 5-16-2008.

OTARIAN

THE MARK CONSISTS OF STANDARD CHARACTERS WITHOUT CLAIM TO ANY PARTICULAR FONT, STYLE, SIZE, OR COLOR.

FOR RETAIL STORE SERVICES FEATURING, DELICATESSEN AND PACKAGED FOODS; ON-LINE RETAIL STORE SERVICES FEATURING DELICATESSEN AND PACKAGED FOODS (U.S. CLS. 100, 101 AND 102).

FIRST USE 4-19-2010; IN COMMERCE 4-19-2010.

3,998,517. HUGHES, DION, MINNEAPOLIS, MN. SN 77-547,405. PUB. 2-9-2010, FILED 8-14-2008.

MANNERS FOR THE MODERN BRAND

THE MARK CONSISTS OF STANDARD CHARACTERS WITHOUT CLAIM TO ANY PARTICULAR FONT, STYLE, SIZE, OR COLOR.

FOR ADVERTISING AGENCY SERVICES; BUSINESS MARKETING SERVICES; BRAND MANAGEMENT CONSULTATION AND ADVICE (U.S. CLS. 100, 101 AND 102).

FIRST USE 8-14-2008; IN COMMERCE 8-14-2008.

3,998,560. SHEET METAL WORKERS' INTERNATIONAL ASSOCIATION, WASHINGTON, DC. SN 77-597,978. PUB. 3-17-2009, FILED 10-22-2008.

SMART

THE MARK CONSISTS OF STANDARD CHARACTERS WITHOUT CLAIM TO ANY PARTICULAR FONT, STYLE, SIZE, OR COLOR.

FOR LABOR UNIONS (U.S. CLS. 100, 101 AND 102).

FIRST USE 5-16-2011; IN COMMERCE 5-16-2011.

CLASS 35—(Continued).

3,998,564. EMERGING BRANDS, INC., PORTLAND, OR. SN 77-602,613. PUB. 9-15-2009, FILED 10-28-2008.



NO CLAIM IS MADE TO THE EXCLUSIVE RIGHT TO USE "EMERGING BRANDS, INC.", APART FROM THE MARK AS SHOWN.

THE MARK CONSISTS OF THE WORDS "EMERGING BRANDS INC." ADJACENT TO A CIRCULAR DESIGN ELEMENT.

FOR BUSINESS MANAGEMENT CONSULTING SERVICES; BUSINESS MANAGEMENT ASSISTANCE; BUSINESS CONSULTING SERVICES; PROVIDING BUSINESS INFORMATION; CONSULTANCY PROVIDING BUSINESS SERVICES TO BRAND OWNERS; BRAND CREATION SERVICES; CONSULTANCY REGARDING BRAND STRATEGY; CONDUCTING RESEARCH REGARDING BRAND IMAGE; BUSINESS CONSULTANCY SERVICES RELATING TO MARKETING; PUBLIC RELATIONS CONSULTANCY; PROVIDING BUSINESS APPRAISALS; PROMOTING CORPORATE IDENTITY; ADVERTISING AND MARKETING SERVICES (U.S. CLS. 100, 101 AND 102).

FIRST USE 11-30-2009; IN COMMERCE 11-30-2009.

CLASS 35—(Continued).

3,998,604. TRIBAL PETS, INC., PHILADELPHIA, PA. SN 77-665,741. PUB. 6-2-2009, FILED 2-7-2009.

TRIBALPETS

THE MARK CONSISTS OF STANDARD CHARACTERS WITHOUT CLAIM TO ANY PARTICULAR FONT, STYLE, SIZE, OR COLOR.

FOR RETAIL PET STORES (U.S. CLS. 100, 101 AND 102).

FIRST USE 2-25-2011; IN COMMERCE 2-25-2011.

3,998,621. MALIBU LUMBER, LLC, MALIBU, CA. SN 77-692,624. PUB. 2-9-2010, FILED 3-17-2009.



NO CLAIM IS MADE TO THE EXCLUSIVE RIGHT TO USE "MALIBU", APART FROM THE MARK AS SHOWN.

THE MARK CONSISTS OF RECTANGLE WITH "MLY" READING VERTICALLY ON THE LEFT HAND SIDE OF THE RECTANGLE AND "MALIBU LUMBER YARD" READING HORIZONTALLY FROM TOP TO BOTTOM.

FOR RETAIL SHOPPING CENTERS FEATURING CLOTHING, SHOES, SPECIALTY GOODS AND FOOD ESTABLISHMENTS (U.S. CLS. 100, 101 AND 102).

FIRST USE 9-17-2010; IN COMMERCE 9-17-2010.

3,998,574. NEXT JUMP, INC., NEW YORK, NY. SN 77-612,589. PUB. 3-31-2009, FILED 11-12-2008.

NEXT JUMP NATION

THE MARK CONSISTS OF STANDARD CHARACTERS WITHOUT CLAIM TO ANY PARTICULAR FONT, STYLE, SIZE, OR COLOR.

FOR DEVELOPING, IMPLEMENTING, ADMINISTERING AND SUPERVISING REWARDS, LOYALTY, INCENTIVE AND AFFINITY PROGRAMS FOR BUSINESSES WHO OFFER SUCH PROGRAMS TO OTHERS; DEVELOPING, IMPLEMENTING, ADMINISTERING AND SUPERVISING ADVERTISING AND MARKETING CAMPAIGNS FOR OTHERS (U.S. CLS. 100, 101 AND 102).

FIRST USE 3-31-2009; IN COMMERCE 3-31-2009.

3,998,623. MALIBU LUMBER, LLC, MALIBU, CA. SN 77-696,101. PUB. 2-16-2010, FILED 3-20-2009.

MLY

THE MARK CONSISTS OF STANDARD CHARACTERS WITHOUT CLAIM TO ANY PARTICULAR FONT, STYLE, SIZE, OR COLOR.

FOR RETAIL SHOPPING CENTERS FEATURING CLOTHING, SHOES, SPECIALTY GOODS AND FOOD ESTABLISHMENTS (U.S. CLS. 100, 101 AND 102).

FIRST USE 9-17-2010; IN COMMERCE 9-17-2010.

CLASS 35—(Continued).

3,998,628. FORWARD THINKING STRATEGIES, LLC, WASHINGTON, DC. SN 77-703,939. PUB. 9-15-2009, FILED 4-1-2009.

FORWARD THINKING STRATEGIES

THE MARK CONSISTS OF STANDARD CHARACTERS WITHOUT CLAIM TO ANY PARTICULAR FONT, STYLE, SIZE, OR COLOR.

NO CLAIM IS MADE TO THE EXCLUSIVE RIGHT TO USE "STRATEGIES", APART FROM THE MARK AS SHOWN.

FOR CONSULTING IN THE FIELD OF BUSINESS DEVELOPMENT AND PUBLIC RELATIONS AND SALES OF CORPORATE GIFTS (U.S. CLS. 100, 101 AND 102).

FIRST USE 4-12-2010; IN COMMERCE 4-12-2010.

3,998,631. DUANE READE INTERNATIONAL, LLC, NEW YORK, NY. SN 77-708,799. PUB. 3-16-2010, FILED 4-7-2009.



OWNER OF U.S. REG. NOS. 1,092,555, 3,417,626, AND OTHERS.

NO CLAIM IS MADE TO THE EXCLUSIVE RIGHT TO USE "EXPRESS", APART FROM THE MARK AS SHOWN.

THE COLOR(S) WHITE, GREEN AND BLACK IS/ARE CLAIMED AS A FEATURE OF THE MARK.

THE MARK CONSISTS OF THE WORD "DUANE" IN STYLIZED WHITE LETTERING AND CAPITAL BLOCK LETTERS, FOLLOWED BY THE WORD "READE" IN STYLIZED WHITE LOWER CASE LETTERING, FOLLOWED BY THE WORD "EXPRESS" IN STYLIZED LOWER CASE LETTERING. ALL OF THE LETTERS IN THE WORD "EXPRESS" ARE GREEN, EXCEPT THAT THE LEFT SIDE OF THE LETTER "X" IN THE WORD "EXPRESS" IS WHITE. THE WORDS ARE ALL CONTAINED WITHIN A BLACK RECTANGLE.

FOR RETAIL STORE AND ONLINE RETAIL STORE SERVICES, FEATURING GENERAL CONSUMER MERCHANDISE, PERSONAL CARE PRODUCTS, COSMETICS, SKINCARE PRODUCTS, HEALTH AND BEAUTY PRODUCTS, HEALTH AND BEAUTY AIDS, HOME HEALTH CARE EQUIPMENT AND SUPPLIES, OVER THE COUNTER MEDICATIONS AND CONVENIENCE FOODS; RETAIL STORE AND ONLINE RETAIL STORE SERVICES FEATURING A WIDE VARIETY OF CONSUMER GOODS; RETAIL AND ONLINE RETAIL GROCERY SERVICES; RETAIL STORE AND ONLINE RETAIL STORE SERVICES FEATURING FOOD, BEVERAGES AND GROCERIES; RETAIL STORE AND ONLINE RETAIL STORE SERVICES FEATURING A WIDE VARIETY OF CONSUMER GOODS OF OTHERS; RETAIL AND ONLINE RETAIL VARIETY STORES; RETAIL AND ONLINE RETAIL SUPERMARKETS (U.S. CLS. 100, 101 AND 102).

FIRST USE 3-22-2009; IN COMMERCE 3-22-2009.

CLASS 35—(Continued).

3,998,668. SMART MEDICAL SUPPLIERS, INC., WEBESTER, NY. SN 77-733,572. PUB. 5-25-2010, FILED 5-11-2009.



NO CLAIM IS MADE TO THE EXCLUSIVE RIGHT TO USE "MEDICAL", APART FROM THE MARK AS SHOWN. THE COLOR(S) BLUE, GRAY, AND WHITE IS/ARE CLAIMED AS A FEATURE OF THE MARK.

THE MARK CONSISTS OF A LOGO WITH THE WORD "SMART" FOLLOWED BY A WHITE "+" SIGN IN A BLUE CIRCLE ABOVE A PARTIAL GRAY SHADOW OF THE CIRCLE, FOLLOWED BY THE WORD "MEDICAL". "SMART" IS WRITTEN IN BLUE AND "MEDICAL" IS WRITTEN IN GRAY. UNDER "SMART + MEDICAL" ARE THE SENTENCES "MANAGE YOUR PRACTICE. MANAGE YOUR FUTURE." WRITTEN IN BLUE.

FOR ON-LINE WHOLESALE AND RETAIL STORE SERVICES FEATURING MEDICAL EQUIPMENT AND SUPPLIES BUT NOT INCLUDING MEDICAL BEDS AND INFLATABLE MATTRESSES FOR PATIENT TRANSFER, AND SPECIFICALLY INCLUDING ORTHOPEDIC BRACES AND SOFT GOODS FOR FOOT AND ANKLE; RETAIL STORE AND ON-LINE RETAIL STORE SERVICES FEATURING MEDICAL EQUIPMENT AND SUPPLIES BUT NOT INCLUDING MEDICAL BEDS AND INFLATABLE MATTRESSES FOR PATIENT TRANSFER, AND SPECIFICALLY INCLUDING ORTHOPEDIC BRACES AND SOFT GOODS FOR FOOT AND ANKLE (U.S. CLS. 100, 101 AND 102).

FIRST USE 6-1-2009; IN COMMERCE 6-1-2009.

3,998,669. SMART MEDICAL SUPPLIERS, INC., WEBESTER, NY. SN 77-733,618. PUB. 5-25-2010, FILED 5-11-2009.



NO CLAIM IS MADE TO THE EXCLUSIVE RIGHT TO USE "MEDICAL" AND "SHOP DME", APART FROM THE MARK AS SHOWN.

THE COLOR(S) BLUE, GRAY, AND WHITE IS/ARE CLAIMED AS A FEATURE OF THE MARK.

THE MARK CONSISTS OF A LOGO WITH THE WORD "SMART" FOLLOWED BY A WHITE "+" SIGN IN A BLUE CIRCLE ABOVE A PARTIAL GRAY SHADOW OF THE CIRCLE, FOLLOWED BY THE WORD "MEDICAL". "SMART" IS WRITTEN IN BLUE AND "MEDICAL" IS WRITTEN IN GRAY. UNDER "SMART + MEDICAL" IS THE SLOGAN "SHOP DME" IN BLUE, WHERE THE LETTER "O" IN "SHOP" CONTAINS A WHITE "+" SIGN IN ITS CENTER.

FOR ON-LINE WHOLESALE AND RETAIL STORE SERVICES FEATURING MEDICAL EQUIPMENT AND SUPPLIES BUT NOT INCLUDING MEDICAL BEDS AND INFLATABLE MATTRESSES FOR PATIENT TRANSFER, AND SPECIFICALLY INCLUDING ORTHOPEDIC BRACES AND SOFT GOODS FOR FOOT AND ANKLE; RETAIL STORE AND ON-LINE RETAIL STORE SERVICES FEATURING MEDICAL EQUIPMENT AND SUPPLIES BUT NOT INCLUDING MEDICAL BEDS AND INFLATABLE MATTRESSES FOR PATIENT TRANSFER, AND SPECIFICALLY INCLUDING ORTHOPEDIC BRACES AND SOFT GOODS FOR FOOT AND ANKLE (U.S. CLS. 100, 101 AND 102).

FIRST USE 6-1-2009; IN COMMERCE 6-1-2009.

CLASS 35—(Continued).

3,998,673. NARVLA PARTNERS, L.L.C., LADUE, MO. SN 77-740,580. PUB. 9-29-2009, FILED 5-19-2009.

NarVlà

THE MARK CONSISTS OF STANDARD CHARACTERS WITHOUT CLAIM TO ANY PARTICULAR FONT, STYLE, SIZE, OR COLOR.
 THE WORDING "NARVLÀ" HAS NO MEANING IN A FOREIGN LANGUAGE.
 FOR ON-LINE RETAIL STORE SERVICES FEATURING JEWELRY AND GEMS (U.S. CLS. 100, 101 AND 102).
 FIRST USE 1-0-2011; IN COMMERCE 1-0-2011.

3,998,713. YAKTHAT, INC., CARSON CITY, NV. SN 77-784,208. PUB. 12-8-2009, FILED 7-17-2009.

The Internet's Largest
Watercooler

THE MARK CONSISTS OF STANDARD CHARACTERS WITHOUT CLAIM TO ANY PARTICULAR FONT, STYLE, SIZE, OR COLOR.
 FOR PROVIDING ADVERTISING SERVICE TO DISTRIBUTE ADVERTISEMENTS FOR DISPLAY ON INTERNET, NAMELY, IN WEBSITES, SOCIAL CONVERSATIONS OVER THE INTERNET, EMAILS, MICROBLOGS, BLOGS, ELECTRONIC MESSAGES, INSTANT MESSAGES, TEXT MESSAGES, MULTIMEDIA MESSAGES, SOCIAL NETWORKS, STATUS UPDATES, ELECTRONIC BULLETIN BOARDS (U.S. CLS. 100, 101 AND 102).
 FIRST USE 5-26-2011; IN COMMERCE 5-26-2011.

3,998,747. STREAMIN' COFFEE, SALT LAKE CITY, UT. SN 77-816,636. PUB. 8-3-2010, FILED 8-31-2009.

STREAMIN COFFEE

THE MARK CONSISTS OF STANDARD CHARACTERS WITHOUT CLAIM TO ANY PARTICULAR FONT, STYLE, SIZE, OR COLOR.
 NO CLAIM IS MADE TO THE EXCLUSIVE RIGHT TO USE "COFFEE", APART FROM THE MARK AS SHOWN.
 FOR MOBILE RETAIL STORE SERVICES FEATURING COFFEE AND RELATED GOODS (U.S. CLS. 100, 101 AND 102).
 FIRST USE 2-7-2011; IN COMMERCE 2-7-2011.

CLASS 35—(Continued).

3,998,773. FURNESH, INC., MARBLEHEAD, MA. SN 77-829,538. PUB. 2-16-2010, FILED 9-18-2009.

Furnésh

THE MARK CONSISTS OF STANDARD CHARACTERS WITHOUT CLAIM TO ANY PARTICULAR FONT, STYLE, SIZE, OR COLOR.
 THE WORDING "FURNÉSH" HAS NO MEANING IN A FOREIGN LANGUAGE.
 FOR COMPUTERIZED ON-LINE RETAIL STORE SERVICES IN THE FIELD OF READY MADE FURNITURE, CUSTOMIZED FURNITURE, LIGHTING, CARPETS, BEDDING, FLOORING, WINDOW TREATMENTS (U.S. CLS. 100, 101 AND 102).
 FIRST USE 4-1-2011; IN COMMERCE 4-1-2011.

3,998,777. COLLEGENET, INC., PORTLAND, OR. SN 77-830,281. PUB. 6-8-2010, FILED 9-18-2009.

POWERING YOUR GOOD WORK

THE MARK CONSISTS OF STANDARD CHARACTERS WITHOUT CLAIM TO ANY PARTICULAR FONT, STYLE, SIZE, OR COLOR.
 FOR PROVIDING ON-LINE REGISTRATION SERVICES FOR OTHERS FOR EVENT REGISTRATION AND MEMBERSHIP REGISTRATIONS FOR CHARITABLE FUNDRAISING EVENTS, HUMANITARIAN EVENTS, EDUCATIONAL EVENTS, BUSINESS EVENTS, MEETINGS, LUNCHESES, DINNERS, PARTIES, TRIPS, CLASSES, REUNIONS, AND SEMINARS (U.S. CLS. 100, 101 AND 102).
 FIRST USE 2-4-2011; IN COMMERCE 2-4-2011.

3,998,817. GILT GROUPE, INC., NEW YORK, NY. SN 77-843,986. PUB. 3-9-2010, FILED 10-7-2009.



OWNER OF U.S. REG. NO. 3,680,404.

CLASS 35—(Continued).

THE MARK CONSISTS OF THE WORDING "GILT MAN" ON A LEATHER TAG.

FOR ON-LINE RETAIL STORE SERVICES FEATURING LUXURY AND FASHION CLOTHING, APPAREL, SHOES, BELTS, CLOTHING ACCESSORIES, PENS, LIGHTERS, DESK SETS, TIE CLIPS, CUFF LINKS, SKIN CARE PRODUCTS, JEWELRY, SPORTS EQUIPMENT, WINE, LIQUOR, AND ART SOLD AT DISCOUNT PRICES (U.S. CLS. 100, 101 AND 102).

FIRST USE 10-18-2009; IN COMMERCE 10-18-2009.

CLASS 35—(Continued).

3,998,903. ORGPR, LLC, SANDY SPRINGS, GA. SN 77-868,220. PUB. 10-5-2010, FILED 11-9-2009.

3,998,841. BRANCH OUT GROUP, LLC, PLANTATION, FL. SN 77-853,279. PUB. 3-30-2010, FILED 10-20-2009.



The Players Roundtable Where Business is a Sport

THE MARK CONSISTS OF STANDARD CHARACTERS WITHOUT CLAIM TO ANY PARTICULAR FONT, STYLE, SIZE, OR COLOR.

FOR ADVICE IN THE FIELD OF BUSINESS MANAGEMENT AND MARKETING; BUSINESS ACQUISITIONS CONSULTATION; BUSINESS NETWORKING; BUSINESS NETWORKING OF PEER TO PEER LEARNING GROUPS OF HIGH NET WORTH INDIVIDUALS; MANAGEMENT OF PROFESSIONAL ATHLETES; ON-LINE BUSINESS NETWORKING SERVICES; ON-LINE PROFESSIONAL NETWORKING SERVICES (U.S. CLS. 100, 101 AND 102).

FIRST USE 10-1-2009; IN COMMERCE 11-1-2009.

NO CLAIM IS MADE TO THE EXCLUSIVE RIGHT TO USE "CUSTOMER RELATIONSHIP INDEX", APART FROM THE MARK AS SHOWN.

THE MARK CONSISTS OF A GEOMETRIC DESIGN AND THE WORDS "CUSTOMER RELATIONSHIP INDEX".

FOR BUSINESS MARKETING CONSULTING SERVICES; BUSINESS RESEARCH AND SURVEYS; BUSINESS RESEARCH CONSULTATION; CONDUCTING BUSINESS RESEARCH AND SURVEYS; CONDUCTING MARKETING STUDIES; CONSUMER RESEARCH (U.S. CLS. 100, 101 AND 102).

FIRST USE 11-30-2009; IN COMMERCE 11-30-2009.

3,998,855. ELEMENT TATTOO SUPPLY, INC., WESTMINSTER, CA. SN 77-855,500. PUB. 10-5-2010, FILED 10-22-2009.

3,998,915. SEMPRIS, LLC, MINNEAPOLIS, MN. SN 77-871,721. PUB. 3-2-2010, FILED 11-12-2009.

BUDGET SOURCE

ELEMENT TATTOO SUPPLY

THE MARK CONSISTS OF STANDARD CHARACTERS WITHOUT CLAIM TO ANY PARTICULAR FONT, STYLE, SIZE, OR COLOR.

NO CLAIM IS MADE TO THE EXCLUSIVE RIGHT TO USE "TATTOO SUPPLY", APART FROM THE MARK AS SHOWN.

FOR WHOLESALE AND RETAIL STORES AND DISTRIBUTORSHIP SERVICES FOR TATTOO SUPPLIES (U.S. CLS. 100, 101 AND 102).

FIRST USE 10-31-2009; IN COMMERCE 10-31-2009.

THE MARK CONSISTS OF STANDARD CHARACTERS WITHOUT CLAIM TO ANY PARTICULAR FONT, STYLE, SIZE, OR COLOR.

OWNER OF U.S. REG. NOS. 2,250,523 AND 3,514,891.

FOR BUYING CLUB SERVICES; ONLINE, PHONE AND MAIL ORDER SERVICES FOR GOODS AND SERVICES, INCLUDING THE PROVISION OF MERCHANDISE AND SERVICES DISCOUNTS AND ORDER SAVINGS CERTIFICATES, ALL FEATURING GENERAL MERCHANDISE AND SERVICES; PROMOTING THE SALE OF THE GOODS AND SERVICES OF OTHERS THROUGH THE DISTRIBUTION OF COUPONS AND DISCOUNT OFFERS (U.S. CLS. 100, 101 AND 102).

FIRST USE 3-11-2011; IN COMMERCE 3-11-2011.

CLASS 35—(Continued).

3,998,954. SUPERMEDIA LLC, DALLAS/FORT WORTH AIRPORT, TX. SN 77-887,349. PUB. 3-15-2011, FILED 12-7-2009.



OWNER OF U.S. REG. NOS. 2,022,484, 3,086,056, AND OTHERS.

THE MARK CONSISTS OF THE WORD "SUPERPAGES.COM" WITH A SHIELD DESIGN BEHIND THE LETTERS "UPE".

FOR ELECTRONIC TELEPHONE DIRECTORY INFORMATION SERVICES; DISSEMINATION OF ADVERTISING FOR OTHERS VIA THE INTERNET (U.S. CLS. 100, 101 AND 102).

FIRST USE 1-4-2010; IN COMMERCE 1-4-2010.

CLASS 35—(Continued).

3,998,964. BID JUGGLER, LLC, GREAT FALLS, VA. SN 77-891,641. PUB. 5-25-2010, FILED 12-11-2009.



NO CLAIM IS MADE TO THE EXCLUSIVE RIGHT TO USE "BID", APART FROM THE MARK AS SHOWN.

THE MARK CONSISTS OF A PERSON JUGGLING THREE BALLS AND THE STYLIZED TEXT "BID JUGGLER POST IT BID IT BUY IT".

FOR PROVIDING A WEB SITE WHEREBY BUYERS OF GOODS OR SERVICES LOCATE AND RECEIVE QUOTATIONS FROM MULTIPLE COMPETITIVE SOURCES AND SELLERS OF GOODS OR SERVICES IDENTIFY AND BID ON MULTIPLE NEW SALES OPPORTUNITIES (U.S. CLS. 100, 101 AND 102).

FIRST USE 1-1-2010; IN COMMERCE 10-1-2009.

3,998,957. UNITED AMERICAN INSURANCE COMPANY, MCKINNEY, TX. SN 77-889,710. PUB. 11-9-2010, FILED 12-9-2009.

SAVERS PLUS

THE MARK CONSISTS OF STANDARD CHARACTERS WITHOUT CLAIM TO ANY PARTICULAR FONT, STYLE, SIZE, OR COLOR.

FOR PROVIDING DISCOUNT SERVICES AT PARTICIPATING ESTABLISHMENTS OF OTHERS IN THE FIELDS OF VISION, DENTAL, CHIROPRACTIC, VITAMINS/NUTRITIONAL SUPPLEMENTS, PRESCRIPTIONS AND TRAVEL (U.S. CLS. 100, 101 AND 102).

FIRST USE 2-0-2005; IN COMMERCE 2-0-2005.

3,998,966. SUPERMEDIA LLC, DALLAS/FORT WORTH AIRPORT, TX. SN 77-893,087. PUB. 6-22-2010, FILED 12-14-2009.

SUPERMATCH

3,998,963. SNIBBIT PRODUCTS, LLC, BRIDGEPORT, CT. SN 77-890,792. PUB. 9-21-2010, FILED 12-10-2009.

MR. AS SEEN ON TV

THE MARK CONSISTS OF STANDARD CHARACTERS WITHOUT CLAIM TO ANY PARTICULAR FONT, STYLE, SIZE, OR COLOR.

FOR PROVIDING CONSUMER PRODUCT INFORMATION VIA STREAMING VIDEO AND A GLOBAL COMPUTER NETWORK; WEB-BASED, ON-LINE RETAIL STORE SERVICES IN THE FIELD OF GENERAL CONSUMER PRODUCTS (U.S. CLS. 100, 101 AND 102).

FIRST USE 7-2-2007; IN COMMERCE 7-2-2007.

THE MARK CONSISTS OF STANDARD CHARACTERS WITHOUT CLAIM TO ANY PARTICULAR FONT, STYLE, SIZE, OR COLOR.

FOR ON-LINE ADVERTISING SERVICES FOR OTHERS; ADVERTISING SERVICES, NAMELY, PROMOTING THE GOODS AND SERVICES OF OTHERS VIA THE INTERNET; DISSEMINATION OF ADVERTISING FOR OTHERS VIA THE INTERNET (U.S. CLS. 100, 101 AND 102).

FIRST USE 4-16-2010; IN COMMERCE 4-16-2010.

CLASS 35—(Continued).

3,998,968. POWERPACT HOLDINGS LLC, MIDLOTHIAN, VA. SN 77-893,342. PUB. 5-4-2010, FILED 12-14-2009.

VOOT

THE MARK CONSISTS OF STANDARD CHARACTERS WITHOUT CLAIM TO ANY PARTICULAR FONT, STYLE, SIZE, OR COLOR.

FOR CONDUCTING RESEARCH SERVICES, NAMELY, DATA AGGREGATION SERVICES, NAMELY, PREPARING REPORTS AND MAKING RECOMMENDATIONS FOR BUSINESS-TO-BUSINESS CUSTOMERS RELATED TO CONSUMER USAGE AND AUDIENCE ENGAGEMENT FACTORS FROM VIDEO-ORIENTED SOCIAL MEDIA WEBSITES, VIDEO VIEWING AND VIDEO SEARCH ENGINES (U.S. CLS. 100, 101 AND 102).
FIRST USE 6-17-2010; IN COMMERCE 6-17-2010.

3,998,973. THIRD STREET PARTNERS ATTENTION AGENCY, LLC, INDIANAPOLIS, IN. SN 77-893,951. PUB. 6-1-2010, FILED 12-15-2009.

AN ATTENTION AGENCY

THE MARK CONSISTS OF STANDARD CHARACTERS WITHOUT CLAIM TO ANY PARTICULAR FONT, STYLE, SIZE, OR COLOR.

NO CLAIM IS MADE TO THE EXCLUSIVE RIGHT TO USE "AGENCY", APART FROM THE MARK AS SHOWN.

FOR ADVERTISING SERVICES (U.S. CLS. 100, 101 AND 102).
FIRST USE 6-1-2011; IN COMMERCE 6-1-2011.

CLASS 35—(Continued).

3,998,987. BLUE RIDGE ENTERPRISES, LLC, BLUE RIDGE, GA. SN 77-897,990. PUB. 5-18-2010, FILED 12-21-2009.



THE MARK CONSISTS OF A YOUNG BOY HOLDING A PICK AXE WEARING A MINERS HELMET WITH THE STYLIZED TEXT "HUCK'S LOST MINE" BELOW. THE STYLIZED TEXT "LOST MINE" IS WRITTEN ONTO WHAT APPEARS TO BE A BROKEN BOARD/PIECE OF WOOD. BELOW THE GRAPHIC THERE IS THE STYLIZED TEXT "AUTHENTIC MOUNTAIN MINING BROUGHT TO YOU."

FOR RETAIL AND MOBILE RETAIL STORE SERVICES FEATURING GEM MINING RELATED ACTIVITIES AND MERCHANDISE (U.S. CLS. 100, 101 AND 102).

FIRST USE 12-15-2009; IN COMMERCE 12-22-2009.

3,999,001. AMISTCO SEPARATION PRODUCTS INC., ALVIN, TX. SN 77-901,590. PUB. 4-13-2010, FILED 12-28-2009.

AHOP

THE MARK CONSISTS OF STANDARD CHARACTERS WITHOUT CLAIM TO ANY PARTICULAR FONT, STYLE, SIZE, OR COLOR.

FOR INVENTORY CONTROL AND MANAGEMENT IN THE FIELD OF INDUSTRIAL HARDWARE, NAMELY, MONITORING EXISTING INVENTORY, ASSESSING HARDWARE NEEDS AND SUPPLYING REPLACEMENT HARDWARE ON AN EXPEDITED BASIS (U.S. CLS. 100, 101 AND 102).

FIRST USE 8-15-2008; IN COMMERCE 8-15-2008.

CLASS 35—(Continued).

3,999,016. LUYCKX, MARISOL, HIGHLANDS RANCH, CO. SN 77-908,505. PUB. 5-25-2010, FILED 1-10-2010.

CLASS 35—(Continued).

3,999,030. ATLANTA COMMUNITY MINISTRIES, INC., ATLANTA, GA. SN 77-914,101. PUB. 10-26-2010, FILED 1-18-2010.

PEPPER & CHOCOLATE

THE MARK CONSISTS OF STANDARD CHARACTERS WITHOUT CLAIM TO ANY PARTICULAR FONT, STYLE, SIZE, OR COLOR.

FOR PROVIDING A SEARCHABLE WEBSITE FEATURING THE GOODS AND SERVICES OF OTHER VENDORS (U.S. CLS. 100, 101 AND 102).

FIRST USE 1-1-2011; IN COMMERCE 3-1-2011.

ACM

3,999,020. MEDSYNERGIES, INC., IRVING, TX. SN 77-908,732. PUB. 10-5-2010, FILED 1-11-2010.



OWNER OF U.S. REG. NO. 2,133,769.
THE MARK CONSISTS OF TWO HALF CIRCLES WITH ONE INSIDE THE OTHER THAT ARE LOCATED TO THE LEFT OF WORD "MEDSYNERGIES".

FOR BUSINESS MANAGEMENT OF THE PROVISION OF HEALTH CARE SERVICES; BUSINESS MANAGEMENT OF GROUP MEDICAL PRACTICES; AND BUSINESS MANAGEMENT OF HEALTH CARE NETWORKS (U.S. CLS. 100, 101 AND 102).

FIRST USE 1-1-2001; IN COMMERCE 1-1-2001.

THE MARK CONSISTS OF STANDARD CHARACTERS WITHOUT CLAIM TO ANY PARTICULAR FONT, STYLE, SIZE, OR COLOR.

FOR CHARITABLE SERVICES, NAMELY, ORGANIZING, CONDUCTING AND MOBILIZING VOLUNTEERS FOR COMMUNITY SERVICE PROJECTS AND VOLUNTEER PROGRAMS (U.S. CLS. 100, 101 AND 102).

FIRST USE 5-27-2011; IN COMMERCE 5-27-2011.

3,999,032. MEDSYNERGIES, INC., IRVING, TX. SN 77-915,511. PUB. 10-5-2010, FILED 1-20-2010.

3,999,026. GAYAM, NAVEEN, IRVINE, CA. SN 77-910,473. PUB. 9-7-2010, FILED 1-12-2010.



THE MARK CONSISTS OF AN OUTLINE OF A LILY WITH ONE PETAL FORMING THE LETTER "Y" IN THE WORD "YELILY".

THE WORDING "YELILY" HAS NO MEANING IN A FOREIGN LANGUAGE.

FOR ON-LINE WHOLESALE AND RETAIL STORE SERVICES FEATURING APPAREL (U.S. CLS. 100, 101 AND 102).

FIRST USE 9-30-2010; IN COMMERCE 9-30-2010.

YOUR MISSION. YOUR PARTNER.

THE MARK CONSISTS OF STANDARD CHARACTERS WITHOUT CLAIM TO ANY PARTICULAR FONT, STYLE, SIZE, OR COLOR.

FOR BUSINESS MANAGEMENT OF THE PROVISION OF HEALTH CARE SERVICES; BUSINESS MANAGEMENT OF GROUP MEDICAL PRACTICES; AND BUSINESS MANAGEMENT OF HEALTH CARE NETWORKS (U.S. CLS. 100, 101 AND 102).

FIRST USE 2-26-2010; IN COMMERCE 2-26-2010.

CLASS 35—(Continued).

3,999,061. OPINIONOLOGY, INC., OREM, UT. SN 77-928,853. PUB. 6-22-2010, FILED 2-5-2010.

Opinionology

THE MARK CONSISTS OF STANDARD CHARACTERS WITHOUT CLAIM TO ANY PARTICULAR FONT, STYLE, SIZE, OR COLOR.

FOR ANALYSIS OF MARKET RESEARCH DATA AND STATISTICS; COLLECTION OF MARKET RESEARCH INFORMATION; CONDUCTING BUSINESS AND MARKET RESEARCH SURVEYS; CONSUMER MARKETING RESEARCH AND CONSULTING RELATED THERETO; MARKET RESEARCH; MARKET RESEARCH AND BUSINESS ANALYSES; MARKET RESEARCH AND MARKET INTELLIGENCE SERVICES; MARKET RESEARCH BY MEANS OF A COMPUTER DATABASE; MARKET RESEARCH CONSULTATION; MARKET RESEARCH SERVICES; MARKET RESEARCH STUDIES; MARKETING RESEARCH SERVICES; MARKETING SERVICES, NAMELY, CONSUMER MARKETING RESEARCH; PROVISION OF MARKET RESEARCH INFORMATION (U.S. CLS. 100, 101 AND 102).

FIRST USE 2-1-2010; IN COMMERCE 11-1-2010.

CLASS 35—(Continued).

3,999,101. KENNEDY, SCOTT F., MONTCLAIR, NJ. SN 77-946,766. PUB. 11-9-2010, FILED 2-28-2010.

Studio042

THE MARK CONSISTS OF STANDARD CHARACTERS WITHOUT CLAIM TO ANY PARTICULAR FONT, STYLE, SIZE, OR COLOR.

FOR DOCUMENT REPRODUCTION SERVICES; PHOTOCOPYING SERVICES; DIRECT MAILING SERVICES, NAMELY, THE PREPARATION OF MAILING LISTS, DIRECT MAILING SERVICES, NAMELY, THE PREPARATION OF MAILING LISTS, ADDRESSING OF PACKAGES, ENVELOPES AND CARDS FOR MAILING, AND ARRANGING FOR MAILING WITH POST OFFICE OR OTHER CARRIERS; OFFICE EQUIPMENT SERVICES, NAMELY, PROVIDING FACILITIES FOR THE USE OF OFFICE EQUIPMENT AND COMPUTERS; BUSINESS AND NOT-FOR-PROFIT ORGANIZATIONS BULK MAILING SERVICES, NAMELY, PREPARING AND ASSEMBLING DOCUMENT PACKAGES FOR MAILING; PHOTOCOPYING DOCUMENTS FOR CORPORATE AND BUSINESS CLIENTS; RETAIL COMPUTER STORES AND DATA PROCESSING SERVICES; COMPUTERIZED ON-LINE ORDERING SERVICES FEATURING STATIONERY, BUSINESS FORMS AND BUSINESS CARDS; AND MANAGEMENT AND OPERATION ASSISTANCE TO COMMERCIAL BUSINESSES, NAMELY, MANAGEMENT OF COPYING AND PRINTING OPERATIONS FOR CORPORATE AND BUSINESS CLIENTS; ADVERTISING AND MARKETING; ADVERTISING, MARKETING AND PROMOTION SERVICES; ARRANGING AND CONDUCTING MARKETING PROMOTIONAL EVENTS FOR OTHERS; BUSINESS CONSULTATION AND MANAGEMENT REGARDING MARKETING ACTIVITIES AND LAUNCHING OF NEW PRODUCTS; BUSINESS MANAGEMENT CONSULTING WITH RELATION TO STRATEGY, MARKETING, PRODUCTION, PERSONNEL AND RETAIL SALE MATTERS; BUSINESS MARKETING AND DIRECT MAIL CONSULTING SERVICES; BUSINESS MARKETING CONSULTING SERVICES; BUSINESS MARKETING SERVICES; CREATIVE MARKETING DESIGN SERVICES; DEVELOPMENT OF MARKETING STRATEGIES AND CONCEPTS; DIRECT MARKETING ADVERTISING FOR OTHERS; DIRECT MARKETING SERVICES; GENERAL BUSINESS MERCHANDISING SERVICES, NAMELY, MARKETING; MARKETING CONSULTING; MARKETING PLAN DEVELOPMENT; PROMOTION AND MARKETING SERVICES AND RELATED CONSULTING (U.S. CLS. 100, 101 AND 102).

FIRST USE 3-1-2010; IN COMMERCE 3-1-2010.

3,999,083. GOING UP, INC., AUSTIN, TX. SN 77-939,517. PUB. 7-13-2010, FILED 2-19-2010.



THE MARK CONSISTS OF THE WORDING "GOING-UPDAY.ORG" WITH THE "U" COMPRISED OF A BENT ARROW POINTING UP TOWARDS AN EQUAL SIGN.

FOR CHARITABLE SERVICES, NAMELY, ORGANIZING AND CONDUCTING VOLUNTEER PROGRAMS AND COMMUNITY SERVICE PROJECTS (U.S. CLS. 100, 101 AND 102).

FIRST USE 4-1-2011; IN COMMERCE 4-1-2011.

CLASS 35—(Continued).

3,999,106. VENDOR SOLUTIONS, INC., LOS ANGELES, CA. SN 77-948,874. PUB. 9-28-2010, FILED 3-2-2010.

CORPBUILDER

THE MARK CONSISTS OF STANDARD CHARACTERS WITHOUT CLAIM TO ANY PARTICULAR FONT, STYLE, SIZE, OR COLOR.

FOR BUSINESS CONSULTATION SERVICES IN THE FIELD OF SECRETARIAL AND DOCUMENT FILING SERVICES FOR BUSINESS ENTITIES; BUSINESS RESEARCH SERVICES (U.S. CLS. 100, 101 AND 102).

FIRST USE 1-1-2011; IN COMMERCE 1-1-2011.

CLASS 35—(Continued).

3,999,130. FURNITURE ROW, LLC, DENVER, CO. SN 77-958,066. PUB. 8-10-2010, FILED 3-12-2010.

THE COMFORT 4 LESS

THE MARK CONSISTS OF STANDARD CHARACTERS WITHOUT CLAIM TO ANY PARTICULAR FONT, STYLE, SIZE, OR COLOR.

NO CLAIM IS MADE TO THE EXCLUSIVE RIGHT TO USE "FOR LESS", APART FROM THE MARK AS SHOWN.

FOR RETAIL STORE SERVICES FEATURING FURNITURE AND MATTRESSES; ONLINE RETAIL STORE SERVICES FEATURING FURNITURE AND MATTRESSES (U.S. CLS. 100, 101 AND 102).

FIRST USE 4-10-2010; IN COMMERCE 4-10-2010.

3,999,123. PMM SPORTS, LLC, BEVERLY HILLS, CA. SN 77-955,803. PUB. 8-31-2010, FILED 3-10-2010.

PMM SPORTS

THE MARK CONSISTS OF STANDARD CHARACTERS WITHOUT CLAIM TO ANY PARTICULAR FONT, STYLE, SIZE, OR COLOR.

NO CLAIM IS MADE TO THE EXCLUSIVE RIGHT TO USE "SPORTS", APART FROM THE MARK AS SHOWN.

FOR TALENT AGENCY SERVICES FOR SURFERS, SNOW BOARDERS AND SKATEBOARDERS (U.S. CLS. 100, 101 AND 102).

FIRST USE 4-1-2010; IN COMMERCE 4-1-2010.

3,999,142. 4ORCE, LLC, ST. LOUIS, MO. SN 77-966,292. PUB. 8-24-2010, FILED 3-23-2010.

4ORCE DIGITAL

THE MARK CONSISTS OF STANDARD CHARACTERS WITHOUT CLAIM TO ANY PARTICULAR FONT, STYLE, SIZE, OR COLOR.

NO CLAIM IS MADE TO THE EXCLUSIVE RIGHT TO USE "DIGITAL", APART FROM THE MARK AS SHOWN.

FOR MARKETING AND BRANDING SERVICES, NAMELY, CONSULTING, DEVELOPMENT, MANAGEMENT AND MARKETING OF BRANDS FOR BUSINESSES (U.S. CLS. 100, 101 AND 102).

FIRST USE 4-1-2010; IN COMMERCE 4-1-2010.

3,999,125. V2 WINE GROUP, LLC, SONOMA, CA. SN 77-957,292. PUB. 9-21-2010, FILED 3-12-2010.

V2 WINE GROUP

THE MARK CONSISTS OF STANDARD CHARACTERS WITHOUT CLAIM TO ANY PARTICULAR FONT, STYLE, SIZE, OR COLOR.

NO CLAIM IS MADE TO THE EXCLUSIVE RIGHT TO USE "WINE GROUP", APART FROM THE MARK AS SHOWN.

FOR DISTRIBUTORSHIPS IN THE FIELD OF WINE PRODUCTS (U.S. CLS. 100, 101 AND 102).

FIRST USE 3-22-2010; IN COMMERCE 8-10-2010.

3,999,154. DY METALWORKS, INC., BELLEVUE, WA. SN 77-980,618. PUB. 6-15-2010, FILED 12-17-2009.



NO CLAIM IS MADE TO THE EXCLUSIVE RIGHT TO USE "METALWORKS", APART FROM THE MARK AS SHOWN.

CLASS 35—(Continued).

THE MARK CONSISTS OF A STYLIZED FLOWER-LIKE DESIGN TO THE LEFT OF THE WORDING "DY METALWORKS".

FOR COMMERCIAL INTERMEDIARY, NAMELY, BUSINESS INTERMEDIARY AND ADVISORY SERVICES AND PROVIDING CONSUMER INFORMATION IN THE FIELD OF SELLING ELECTRONIC COMPONENTS, AUTOMOBILE PARTS AND FORGED COOLING PRODUCTS; ON-LINE RETAIL STORE SERVICES FEATURING ELECTRONIC COMPONENTS, AUTOMOBILE PARTS AND FORGED COOLING PRODUCTS; AND SALES ARRANGING OF FORGED COOLING PRODUCTS, NAMELY, SALES PROMOTION SERVICES AND ELECTRONIC COMMERCE SERVICES, NAMELY, PROVIDING INFORMATION ABOUT FORGED COOLING PRODUCTS VIA TELECOMMUNICATION NETWORKS FOR ADVERTISING AND SALES PURPOSES (U.S. CLS. 100, 101 AND 102).

FIRST USE 7-22-2009; IN COMMERCE 7-22-2009.

3,999,182. 1STDIBS.COM, INC., NEW YORK, NY. SN 77-982,115. PUB. 10-26-2010, FILED 1-13-2010.

1STDIBS

THE MARK CONSISTS OF STANDARD CHARACTERS WITHOUT CLAIM TO ANY PARTICULAR FONT, STYLE, SIZE, OR COLOR.

FOR ON-LINE RETAIL STORE SERVICES FEATURING JEWELRY, AND FASHION, NAMELY, BAGS, CLOTHES, SHOES, BELTS AND ACCESSORIES (U.S. CLS. 100, 101 AND 102).

FIRST USE 2-23-2011; IN COMMERCE 2-23-2011.

3,999,235. NOT FINDING OUT, LLC, DALLAS, TX. SN 85-007,460. PUB. 8-24-2010, FILED 4-6-2010.

NOTFINDINGOUT

THE MARK CONSISTS OF STANDARD CHARACTERS WITHOUT CLAIM TO ANY PARTICULAR FONT, STYLE, SIZE, OR COLOR.

FOR PROVIDING ONLINE GIFT REGISTRY SERVICES (U.S. CLS. 100, 101 AND 102).

FIRST USE 5-12-2009; IN COMMERCE 11-9-2009.

CLASS 35—(Continued).

3,999,252. HARBOR COMMUNICATIONS, L.L.C., WESTLAKE, OH. SN 85-011,137. PUB. 1-18-2011, FILED 4-10-2010.

NAG NATIONAL ADVISORY GROUP

THE MARK CONSISTS OF STANDARD CHARACTERS WITHOUT CLAIM TO ANY PARTICULAR FONT, STYLE, SIZE, OR COLOR.

NO CLAIM IS MADE TO THE EXCLUSIVE RIGHT TO USE "NATIONAL ADVISORY GROUP", APART FROM THE MARK AS SHOWN.

FOR ASSOCIATION SERVICES, NAMELY, PROMOTING THE INTERESTS OF CONVENIENCE STORE AND PETROLEUM OUTLET OWNERS (U.S. CLS. 100, 101 AND 102).

FIRST USE 4-22-2011; IN COMMERCE 4-22-2011.

3,999,264. CYCLE30, INC., ANCHORAGE, AK. SN 85-015,309. PUB. 11-2-2010, FILED 4-15-2010.



THE MARK CONSISTS OF THE TERM "CYCLE30" IN STYLIZED FONT WITH FIGURE-EIGHT LIKE DRAWING ABOVE THE TERM.

FOR PROVIDING HOSTED, ORDER-TO-CASH BILLING SERVICES FOR OTHERS, NAMELY, ONLINE MANAGEMENT OF TECHNOLOGY FOR ORDER PROCESSING, CREDIT ANALYSIS AND APPROVAL, WORKFLOW, SCHEDULING AND DISPATCH OF TECHNICAL SUPPORT PERSONNEL TO CUSTOMER SITES, BILLING AND INVOICING, COLLECTIONS AND DISPUTE RESOLUTION, PAYMENT PROCESSING AND FINANCIAL REPORTING, ELECTRONIC BILL PAYMENT AND PRESENTMENT (U.S. CLS. 100, 101 AND 102).

FIRST USE 12-31-2010; IN COMMERCE 12-31-2010.

CLASS 35—(Continued).

3,999,265. CYCLE30, INC., ANCHORAGE, AK. SN 85-015,323. PUB. 11-2-2010, FILED 4-15-2010.



THE MARK CONSISTS OF A FANCIFUL DRAWING WITH THE APPEARANCE OF A FIGURE-EIGHT LIKE DESIGN EXCEPT THAT THE ENDS DO NOT MEET AND ONE END HAS A CIRCLE DESIGN AROUND THE TIP.

FOR PROVIDING HOSTED, ORDER-TO-CASH BILLING SERVICES FOR OTHERS, NAMELY, ONLINE MANAGEMENT OF TECHNOLOGY FOR ORDER PROCESSING, CREDIT ANALYSIS AND APPROVAL, WORKFLOW, SCHEDULING AND DISPATCH OF TECHNICAL SUPPORT PERSONNEL TO CUSTOMER SITES, BILLING AND INVOICING, COLLECTIONS AND DISPUTE RESOLUTION, PAYMENT PROCESSING AND FINANCIAL REPORTING, ELECTRONIC BILL PAYMENT AND PRESENTMENT (U.S. CLS. 100, 101 AND 102).

FIRST USE 12-31-2010; IN COMMERCE 12-31-2010.

3,999,266. CYCLE30, INC., WASHINGTON, DC. SN 85-015,331. PUB. 11-2-2010, FILED 4-15-2010.

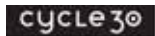

THE MARK CONSISTS OF THE TERM "CYCLE30" IN A STYLIZED FONT DESIGN.

FOR PROVIDING HOSTED, ORDER-TO-CASH BILLING SERVICES FOR OTHERS, NAMELY, ONLINE MANAGEMENT OF TECHNOLOGY FOR ORDER PROCESSING, CREDIT ANALYSIS AND APPROVAL, WORKFLOW, SCHEDULING AND DISPATCH OF TECHNICAL SUPPORT PERSONNEL TO CUSTOMER SITES, BILLING AND INVOICING, COLLECTIONS AND DISPUTE RESOLUTION, PAYMENT PROCESSING AND FINANCIAL REPORTING, AND ELECTRONIC BILL PAYMENT AND PRESENTMENT (U.S. CLS. 100, 101 AND 102).

FIRST USE 12-31-2010; IN COMMERCE 12-31-2010.

CLASS 35—(Continued).

3,999,306. PLAYMAKERS SPORTS MANAGEMENT, LLC, BRONX, NY. SN 85-023,318. PUB. 9-28-2010, FILED 4-26-2010.



THE MARK CONSISTS OF A SHADED PARALLELOGRAM WITH A SHIP WHEEL AND A FIVE-POINTED STAR.

FOR MANAGEMENT OF PROFESSIONAL ATHLETES (U.S. CLS. 100, 101 AND 102).

FIRST USE 3-10-2010; IN COMMERCE 3-10-2010.

3,999,310. TSA STORES, INC., ENGLEWOOD, CO. SN 85-023,878. PUB. 9-28-2010, FILED 4-27-2010.

YOUR DRIVER AUTHORITY

THE MARK CONSISTS OF STANDARD CHARACTERS WITHOUT CLAIM TO ANY PARTICULAR FONT, STYLE, SIZE, OR COLOR.

OWNER OF U.S. REG. NOS. 1,527,526, 2,662,719, AND OTHERS.

NO CLAIM IS MADE TO THE EXCLUSIVE RIGHT TO USE "DRIVER", APART FROM THE MARK AS SHOWN.

FOR RETAIL SPORTING GOODS STORES (U.S. CLS. 100, 101 AND 102).

FIRST USE 3-28-2010; IN COMMERCE 3-28-2010.

3,999,320. UTILITIES TELECOM COUNCIL, WASHINGTON, DC. SN 85-025,599. PUB. 3-15-2011, FILED 4-28-2010.

License Sentry

THE MARK CONSISTS OF STANDARD CHARACTERS WITHOUT CLAIM TO ANY PARTICULAR FONT, STYLE, SIZE, OR COLOR.

CLASS 35—(Continued).

NO CLAIM IS MADE TO THE EXCLUSIVE RIGHT TO USE "LICENSE", APART FROM THE MARK AS SHOWN.

FOR BUSINESS CONSULTATION IN THE FIELD OF TRACKING AND MAINTAINING FEDERAL COMMUNICATIONS COMMISSION (FCC) LICENSES FOR OTHERS BY PROVIDING NOTICE OF DEADLINES AND RULES CHANGES AND COMPLETING AND FILING MAINTENANCE AND RENEWAL FORMS (U.S. CLS. 100, 101 AND 102).

FIRST USE 7-6-2010; IN COMMERCE 7-6-2010.

3,999,326. TALENT QUOTIENT, INC., EXCELSIOR, MN. SN 85-026,269. PUB. 9-28-2010, FILED 4-29-2010.

TQ

THE MARK CONSISTS OF STANDARD CHARACTERS WITHOUT CLAIM TO ANY PARTICULAR FONT, STYLE, SIZE, OR COLOR.

FOR BUSINESS CONSULTATION IN THE FIELD OF MEASURING A COMPANY'S ABILITY TO HIRE AND RETAIN THE BEST TALENT IN THE MARKETPLACE (U.S. CLS. 100, 101 AND 102).

FIRST USE 2-15-2011; IN COMMERCE 2-15-2011.

3,999,334. VILLAGE CANDLE, INC., WELLS, ME. SN 85-027,054. PUB. 10-5-2010, FILED 4-30-2010.

AMERICA'S PROFIT SCENTER

THE MARK CONSISTS OF STANDARD CHARACTERS WITHOUT CLAIM TO ANY PARTICULAR FONT, STYLE, SIZE, OR COLOR.

FOR WHOLESALE, MAIL ORDER AND COMPUTERIZED ON-LINE WHOLESALE STORE SERVICES FEATURING CANDLES, AUTOMOTIVE AIR FRESHENERS AND RELATED ACCESSORIES (U.S. CLS. 100, 101 AND 102).

FIRST USE 7-1-2010; IN COMMERCE 7-1-2010.

CLASS 35—(Continued).

3,999,353. DINE GUIDES, BOILING SPRINGS, SC. SN 85-029,238. PUB. 11-9-2010, FILED 5-3-2010.



NO CLAIM IS MADE TO THE EXCLUSIVE RIGHT TO USE "DINE GUIDES", APART FROM THE MARK AS SHOWN.

THE COLOR(S) YELLOW, WHITE, AND BLACK IS/ARE CLAIMED AS A FEATURE OF THE MARK.

THE MARK CONSISTS OF THE STYLIZED WORDING "DINE GUIDES" SET INSIDE A STYLIZED DEPICTION OF A CIRCULAR DECORATIVE SEAL, WITH A SINGLE CURVED BAND PLACED ABOVE THE WORDING "DINE" AND A SINGLE CURVED BAND PLACED BELOW THE WORDING "GUIDES". THE COLOR WHITE APPEARS IN THE WORDING "DINE GUIDES"; THE COLOR YELLOW APPEARS IN THE LIGHTER AREAS OF THE CIRCULAR DECORATIVE SEAL AND IN THE TWO CURVED BANDS; THE COLOR BLACK APPEARS IN THE DARKER AREAS OF THE CIRCULAR DECORATIVE SEAL.

FOR ADVERTISEMENT FOR OTHERS ON THE INTERNET; ADVERTISEMENT VIA MOBILE PHONE NETWORKS; ADVERTISING AGENCIES; ADVERTISING AGENCIES PROVIDING THE STRATEGY, DESIGN AND EXECUTION OF PROGRAMS TO PROMOTE BUSINESSES IN THE FOOD AND FOODSERVICE INDUSTRIES; ADVERTISING AGENCIES, NAMELY, PROMOTING THE GOODS AND SERVICES OF OTHERS; ADVERTISING AGENCIES, NAMELY, PROMOTING THE SERVICES OF RESTAURANTS, AMUSEMENT PARK ATTRACTIONS, AND LODGING THROUGH THE DISTRIBUTION OF PRINTED AND AUDIO PROMOTIONAL MATERIALS AND BY RENDERING SALES PROMOTION ADVICE; ADVERTISING AGENCY SPECIALIZING IN THE DESIGN AND EXECUTION OF WORD OF MOUTH, VIRAL, BUZZ AND EXPERIENTIAL MARKETING PROGRAMS; ADVERTISING AND ADVERTISEMENT SERVICES; ADVERTISING AND BUSINESS SERVICES, NAMELY, PROVIDING AN ONLINE WEBSITE WHERE ADVERTISERS, MARKETERS, AND CONTENT PROVIDERS CAN INTERACT WITH USERS FOR ADVERTISING, BRANDING, AND PROMOTING KNOWLEDGE, PRODUCTS, AND SERVICES, AND TRADESHOWS, ON BEHALF OF THEMSELVES AND OTHERS, AND FOR EVALUATING AND RATING THE SAME, ALL THE FOREGOING RELEVANT TO HUMAN ACTIVITIES AFFECTING CLIMATE CHANGE AND RELATED FIELDS; ADVERTISING AND COMMERCIAL INFORMATION SERVICES, VIA THE INTERNET; ADVERTISING AND DIRECTORY SERVICES, NAMELY, PROMOTING THE SERVICES OF OTHERS BY PROVIDING A WEB PAGE FEATURING LINKS TO THE WEBSITES OF OTHERS; ADVERTISING AND MARKETING; ADVERTISING AND MARKETING CONSULTANCY; ADVERTISING AND MARKETING SERVICES, NAMELY, PROMOTING THE GOODS AND SERVICES OF OTHERS; ADVERTISING AND PROMOTION SERVICES AND RELATED CONSULTING; ADVERTISING AND PROMOTIONAL SERVICES; ADVERTISING AND PUBLICITY SERVICES; ADVERTISING AND PUBLICITY SERVICES, NAMELY, PROMOTING THE GOODS, SERVICES, BRAND IDENTITY AND COMMERCIAL INFORMATION AND NEWS OF THIRD PARTIES THROUGH PRINT, AUDIO, VIDEO,

CLASS 35—(Continued).

DIGITAL AND ON-LINE MEDIUM; ADVERTISING IN PERIODICALS, BROCHURES AND NEWSPAPERS; ADVERTISING ON THE INTERNET FOR OTHERS; ADVERTISING SERVICES; ADVERTISING SERVICES, NAMELY, PROMOTING AND MARKETING THE GOODS AND SERVICES OF OTHERS IN THE FIELD OF UPSCALE CHOICES SUCH AS CULTURAL EVENTS, RESTAURANTS, SHOPPING, AND TRAVEL VIA PRINT AND ELECTRONIC MEDIA; ADVERTISING SERVICES, NAMELY, PROMOTING THE BRANDS, GOODS AND SERVICES OF OTHERS; ADVERTISING SERVICES, NAMELY, PROMOTING THE FOOD AND WINE OF OTHERS; ADVERTISING SERVICES, NAMELY, PROVIDING ADVERTISING SPACE IN A PERIODICAL; ADVERTISING VIA ELECTRONIC MEDIA AND SPECIFICALLY THE INTERNET; ADVERTISING, INCLUDING ON-LINE ADVERTISING ON A COMPUTER NETWORK; ADVERTISING, MARKETING AND PROMOTION SERVICES; ADVERTISING, PROMOTION AND MARKETING SERVICES IN THE NATURE OF E-MAIL BLAST CAMPAIGNS FOR OTHERS; CREATING AND UPDATING ADVERTISING MATERIAL; DESIGN OF INTERNET ADVERTISING; DEVELOPMENT, OPERATION AND ADMINISTRATION OF DIGITAL SIGNAGE SYSTEMS AND DIGITAL ADVERTISING SYSTEMS FOR OTHERS, NAMELY, PROVIDING ADVERTISING SPACE BY ELECTRONIC MEANS AND GLOBAL COMPUTER INFORMATION NETWORKS; DISSEMINATION OF ADVERTISEMENTS; DISSEMINATION OF ADVERTISING MATERIALS AND OF ADVERTISING MATERIAL; DISSEMINATION OF ADVERTISING FOR OTHERS VIA AN ON-LINE COMMUNICATIONS NETWORK ON THE INTERNET; DISSEMINATION OF ADVERTISING FOR OTHERS VIA PUBLIC AND PRIVATE WIRELESS NETWORKS FOR DISPLAY ON MOBILE DEVICES; DISSEMINATION OF ADVERTISING FOR OTHERS VIA THE INTERNET; DISSEMINATION OF ADVERTISING MATERIAL; DISSEMINATION OF ADVERTISING MATTER; DISSEMINATION OF ADVERTISING, SCHEDULING AND MANAGING OF TRAINING COURSES AND PROGRAMS FOR OTHERS VIA A GLOBAL COMPUTER NETWORK; DISSEMINATION SERVICES OF ADVERTISEMENT MATTER; DISTRIBUTION OF ADVERTISING MATERIALS; INTERNET ADVERTISING SERVICES; ON-LINE ADVERTISING AND MARKETING SERVICES; ON-LINE ADVERTISING ON COMPUTER COMMUNICATION NETWORKS; ON-LINE ADVERTISING ON COMPUTER NETWORKS; ON-LINE ADVERTISING SERVICES FOR OTHERS; PROMOTING THE GOODS AND SERVICES OF OTHERS BY PREPARING AND PLACING ADVERTISEMENTS IN AN ELECTRONIC MAGAZINE ACCESSED THROUGH A GLOBAL COMPUTER NETWORK; PROMOTING THE GOODS AND SERVICES OF OTHERS BY PROVIDING A WEB SITE FEATURING COUPONS, REBATES, PRICE-COMPARISON INFORMATION, PRODUCT REVIEWS, LINKS TO THE RETAIL WEB SITES OF OTHERS, AND DISCOUNT INFORMATION; PROMOTIONAL SERVICES, NAMELY, PROMOTING THE GOODS OF OTHERS BY MEANS OF PROVIDING ONLINE RESTAURANT MENUS; PROVIDING A SEARCHABLE ON-LINE ADVERTISING WEBSITE AND GUIDE FEATURING THE GOODS AND SERVICES OF OTHER VENDORS VIA THE INTERNET; PROVIDING A WEBSITE WHERE USERS CAN POST RATINGS, REVIEWS AND RECOMMENDATIONS ON RESTAURANTS, FOOD AND WINE FOR COMMERCIAL PURPOSES; PROVIDING ADVERTISING SPACE ON BILLBOARDS AND IN KIOSKS; PROVIDING INFORMATION ABOUT AND MAKING REFERRALS IN THE FIELD OF CONSUMER PRODUCTS AND SERVICES FOR RETAIL SERVICES CON-

CLASS 35—(Continued).

CERNING PRODUCTS, SERVICES, EVENTS, ACTIVITIES, ATTRACTIONS AND FACILITIES IN PARTICULAR GEOGRAPHIC LOCATIONS; PROVIDING ON-LINE CONSUMER INFORMATION CONCERNING THE LOCATION OF MOBILE RESTAURANTS; PROVIDING ON-LINE DIRECTORY INFORMATION SERVICES ALSO FEATURING HYPERLINKS TO OTHER WEB SITES; PROVIDING SPACE AT A WEB SITE FOR THE ADVERTISEMENT OF THE GOODS AND SERVICES OF OTHERS; PROVISION OF A WEB SITE FEATURING INFORMATION ON SHOPPING; RENTAL OF ADVERTISING SPACE; RENTAL OF ADVERTISING SPACE ON WEB SITES; SHOPPERS' GUIDE INFORMATION; THE BRINGING TOGETHER, FOR THE BENEFIT OF OTHERS, OF A VARIETY OF GOODS AND SERVICES, ENABLING CUSTOMERS TO CONVENIENTLY VIEW AND PURCHASE THOSE GOODS AND SERVICES FROM AN INTERNET WEB SITE PARTICULARLY SPECIALIZING IN THE MARKETING OF THE SALE OF GOODS AND SERVICES OF OTHERS (U.S. CLS. 100, 101 AND 102).

FIRST USE 3-22-2008; IN COMMERCE 9-11-2008.

3,999,359. ELDERGADGET, LLC, BEVERLY HILLS, CA. SN 85-029,676. PUB. 10-5-2010, FILED 5-4-2010.

ELDERGADGET

THE MARK CONSISTS OF STANDARD CHARACTERS WITHOUT CLAIM TO ANY PARTICULAR FONT, STYLE, SIZE, OR COLOR.

FOR PROVIDING A WEBSITE FEATURING INFORMATION ABOUT AND REVIEWS OF CONSUMER PRODUCTS OF INTEREST TO SENIORS AND THEIR FAMILIES, INFORMATION ABOUT AND REVIEWS OF SERVICES OF INTEREST TO SENIORS AND THEIR FAMILIES; PROVIDING A WEBSITE FEATURING ADVERTISING SERVICES OF INTEREST TO SENIORS AND THEIR FAMILIES (U.S. CLS. 100, 101 AND 102).

FIRST USE 9-30-2008; IN COMMERCE 9-30-2008.

3,999,424. CLARITY COVERDALE FURY ADVERTISING, INC., MINNEAPOLIS, MN. SN 85-036,728. PUB. 10-19-2010, FILED 5-12-2010.

FEED THE CONNECTION

THE MARK CONSISTS OF STANDARD CHARACTERS WITHOUT CLAIM TO ANY PARTICULAR FONT, STYLE, SIZE, OR COLOR.

FOR ADVERTISING AGENCIES (U.S. CLS. 100, 101 AND 102).

FIRST USE 7-30-2010; IN COMMERCE 10-3-2010.

CLASS 35—(Continued).

3,999,437. OMAHA STEAKS INTERNATIONAL, INC., OMAHA, NE. SN 85-037,718. PUB. 10-5-2010, FILED 5-13-2010.

OFFICIAL SPONSOR OF TAILGATING

THE MARK CONSISTS OF STANDARD CHARACTERS WITHOUT CLAIM TO ANY PARTICULAR FONT, STYLE, SIZE, OR COLOR.

FOR ON-LINE RETAIL STORE SERVICES FEATURING FOOD AND FOOD RELATED ITEMS; RETAIL STORE SERVICES FEATURING FOOD AND FOOD RELATED ITEMS; MAIL ORDER CATALOG SERVICES FEATURING FOOD AND FOOD RELATED ITEMS; TELEPHONE SHOP-AT-HOME SERVICES IN THE FIELD OF FOOD AND FOOD RELATED ITEMS (U.S. CLS. 100, 101 AND 102).

FIRST USE 1-3-2011; IN COMMERCE 1-3-2011.

CLASS 35—(Continued).

THE COLOR(S) WHITE, ORANGE, DARK GRAY AND LIGHT GRAY IS/ARE CLAIMED AS A FEATURE OF THE MARK.

THE MARK CONSISTS OF A FOUR TIERED UPWARD FACING CEMENT BLOCK WITH THE LOWEST TIER OF THE CEMENT BLOCK PARTIALLY SHOWN. THE OUTER SECTIONS OF THE CEMENT BLOCK ARE WHITE AND THE INNER SECTIONS OF THE CEMENT BLOCK ARE ORANGE. THE CEMENT BLOCK IS POSITIONED PARTIALLY IN FRONT OF THE LOWER RIGHT HAND PORTION OF AN ORANGE SQUARE WHICH SERVES AS A BACKDROP FOR THE TOP THREE TIERS OF THE CEMENT BLOCK. TO THE LEFT OF THE CEMENT BLOCK AND THE SQUARE BACKDROP IS THE WORDING "THE CEMENTBLOC". THE WORDS "THE CEMENT" ARE WRITTEN IN LIGHT GRAY AND THE WORD "BLOC" IS WRITTEN IN DARK GRAY.

FOR PROVIDING ADVERTISING AGENCY SERVICES, PUBLIC RELATIONS AND PROMOTIONAL MARKETING SERVICES IN THE PHARMACEUTICAL AND HEALTHCARE INDUSTRIES THROUGH ALL PUBLIC COMMUNICATIONS MEANS (U.S. CLS. 100, 101 AND 102).

FIRST USE 4-1-2010; IN COMMERCE 4-1-2010.

3,999,442. CONTACT CENTER INSIGHTS, CINCINNATI, OH. SN 85-038,178. PUB. 10-12-2010, FILED 5-13-2010.



NO CLAIM IS MADE TO THE EXCLUSIVE RIGHT TO USE "CONTACT CENTER", APART FROM THE MARK AS SHOWN.

THE STIPPLING IS FOR SHADING PURPOSES ONLY.

THE MARK CONSISTS OF THE STYLIZED WORDING "CCI" WITH THE DOT ON THE LETTER "I" FORMING A PART OF A CALL CENTER HEADSET OVER A SHADED CIRCLE LOCATED TO THE LEFT OF THE STYLIZED WORDING "CONTACT CENTER INSIGHTS".

FOR MANAGEMENT AND BUSINESS CONSULTING SERVICES IN THE FIELD OF CUSTOMER SERVICE AND CONTACT CENTER STRATEGY AND OPERATIONS (U.S. CLS. 100, 101 AND 102).

FIRST USE 5-14-2010; IN COMMERCE 5-14-2010.

3,999,474. ARTO ERYOZGATLIYAN, TORRANCE, CA. SN 85-044,479. PUB. 10-26-2010, FILED 5-20-2010.

IN-CITY LOS ANGELES

THE MARK CONSISTS OF STANDARD CHARACTERS WITHOUT CLAIM TO ANY PARTICULAR FONT, STYLE, SIZE, OR COLOR.

NO CLAIM IS MADE TO THE EXCLUSIVE RIGHT TO USE "LOS ANGELES", APART FROM THE MARK AS SHOWN.

FOR WHOLESALE AND RETAIL STORE SERVICES AND ON-LINE RETAIL AND WHOLESALE STORE SERVICES FEATURING CLOTHING AND CLOTHING ACCESSORIES; WHOLESALE DISTRIBUTORSHIPS FEATURING CLOTHING AND CLOTHING ACCESSORIES; WHOLESALE ORDERING SERVICES IN THE FIELD OF CLOTHING AND CLOTHING ACCESSORIES (U.S. CLS. 100, 101 AND 102).

FIRST USE 7-1-2010; IN COMMERCE 7-1-2010.

3,999,449. THE CEMENTWORKS, LLC, NEW YORK, NY. SN 85-039,999. PUB. 10-19-2010, FILED 5-17-2010.



the cementbloc

OWNER OF U.S. REG. NO. 3,667,372.

3,999,481. BRETT THOMPSON, SALT LAKE CITY, UT. SN 85-046,516. PUB. 10-26-2010, FILED 5-24-2010.

Pixelcrane

THE MARK CONSISTS OF STANDARD CHARACTERS WITHOUT CLAIM TO ANY PARTICULAR FONT, STYLE, SIZE, OR COLOR.

FOR ADVERTISING SERVICES (U.S. CLS. 100, 101 AND 102).

FIRST USE 12-1-2009; IN COMMERCE 12-1-2009.

CLASS 35—(Continued).

3,999,482. CHAUTAUQUA COUNTY VISITORS BUREAU, CHAUTAUQUA, NY. SN 85-046,708. PUB. 10-26-2010, FILED 5-24-2010.



NO CLAIM IS MADE TO THE EXCLUSIVE RIGHT TO USE "LEARNING CENTER" AND "CHAUTAUQUA COUNTY NEW YORK", APART FROM THE MARK AS SHOWN.

THE MARK CONSISTS OF THE PHRASE "THE WORLD'S LEARNING CENTER CHAUTAUQUA COUNTY NEW YORK" WHEREIN THE "H" IN "CHAUTAUQUA" IS STYLIZED IN THE FORM OF A TREE OR PLANT.

FOR CONVENTION AND VISITORS BUREAU SERVICES, NAMELY, PROMOTING TOURISM, BUSINESS AND CONVENTIONS IN AND AROUND THE CHAUTAUQUA COUNTY, NEW YORK AREA (U.S. CLS. 100, 101 AND 102).

FIRST USE 1-31-2011; IN COMMERCE 1-31-2011.

CLASS 35—(Continued).

3,999,580. VISITING NURSE SERVICE OF NEW YORK, NEW YORK, NY. SN 85-069,716. PUB. 9-28-2010, FILED 6-23-2010.



OWNER OF U.S. REG. NOS. 2,239,847, 3,809,137, AND OTHERS.

NO CLAIM IS MADE TO THE EXCLUSIVE RIGHT TO USE "HEALTH PLANS", "VISITING NURSE SERVICE OF NEW YORK", OR "NY", APART FROM THE MARK AS SHOWN.

THE MARK CONSISTS OF THE WORDS "VISITING NURSE SERVICE OF NEW YORK" IN A CIRCLE, WITH THE TERM "VNSNY" STYLIZED WITH A TRI-PARALLELOGRAM DESIGN IN THE CENTER OF THE CIRCLE, WITH THE WORDS "CHOICE" OVER THE WORDS "HEALTH PLANS" TO THE RIGHT OF THE CIRCLE.

FOR MANAGED CARE SERVICES, NAMELY, ELECTRONIC PROCESSING OF HEALTH CARE INFORMATION; MANAGED CARE SERVICES, NAMELY, UTILIZATION REVIEW SERVICES (U.S. CLS. 100, 101 AND 102).

FIRST USE 11-2-2010; IN COMMERCE 11-2-2010.

3,999,579. VISITING NURSE SERVICE OF NEW YORK, NEW YORK, NY. SN 85-069,689. PUB. 9-28-2010, FILED 6-23-2010.

VNSNY CHOICE

THE MARK CONSISTS OF STANDARD CHARACTERS WITHOUT CLAIM TO ANY PARTICULAR FONT, STYLE, SIZE, OR COLOR.

OWNER OF U.S. REG. NOS. 2,239,847, 3,809,137, AND OTHERS.

FOR MANAGED CARE SERVICES, NAMELY, ELECTRONIC PROCESSING OF HEALTH CARE INFORMATION; MANAGED CARE SERVICES, NAMELY, UTILIZATION REVIEW SERVICES (U.S. CLS. 100, 101 AND 102).

FIRST USE 11-2-2010; IN COMMERCE 11-2-2010.

3,999,587. HOME SOURCE INTERNATIONAL, ATLANTA, GA. SN 85-072,377. PUB. 3-15-2011, FILED 6-26-2010.



OWNER OF U.S. REG. NOS. 2,473,930 AND 2,965,330. THE COLOR(S) BLUE, BLACK AND WHITE IS/ARE CLAIMED AS A FEATURE OF THE MARK.

THE MARK CONSISTS OF THE WORDING "SUITE SPOT" APPEARING IN BLACK WITH EACH LETTER "S" HAVE A CURLING TAIL AND THE LETTER "O" BEING FILLED WITH A BLUE AND WHITE GLOBE OF THE WORLD. THE LETTER "O" ALSO IS INSIDE THE OUTLINE OF A HOUSE.

FOR RETAIL STORE SERVICES FEATURING HOME TEXTILE PRODUCTS FOR THE BEDROOM AND BATHROOMS; GIFTS IN THE NATURE OF CANDLES, SOAP, POTPOURRI, CLOTHING, ACCENT FURNITURE, DINNERWARE, FLATWARE, CHINAWARE AND LIGHTING (U.S. CLS. 100, 101 AND 102).

FIRST USE 10-1-2010; IN COMMERCE 10-1-2010.

CLASS 35—(Continued).

3,999,601. DUANE READE INTERNATIONAL, LLC, NEW YORK, NY. SN 85-076,441. PUB. 11-16-2010, FILED 7-1-2010.

BREW YORK CITY

THE MARK CONSISTS OF STANDARD CHARACTERS WITHOUT CLAIM TO ANY PARTICULAR FONT, STYLE, SIZE, OR COLOR.

NO CLAIM IS MADE TO THE EXCLUSIVE RIGHT TO USE "BREW", APART FROM THE MARK AS SHOWN.

FOR RETAIL STORE SERVICES FEATURING A SECTION SPECIALIZING IN BEER (U.S. CLS. 100, 101 AND 102).

FIRST USE 11-6-2010; IN COMMERCE 11-6-2010.

3,999,608. 338 INDUSTRIES, LLC, AUSTIN, TX. SN 85-078,260. PUB. 4-5-2011, FILED 7-6-2010.

POLITICAL FORCE

THE MARK CONSISTS OF STANDARD CHARACTERS WITHOUT CLAIM TO ANY PARTICULAR FONT, STYLE, SIZE, OR COLOR.

NO CLAIM IS MADE TO THE EXCLUSIVE RIGHT TO USE "POLITICAL", APART FROM THE MARK AS SHOWN.

FOR PROVIDING A WEBSITE FOR USE IN MANAGING A POLITICAL CAMPAIGN; PROVIDING AN ONLINE SEARCHABLE DATABASE FOR POLITICAL CAMPAIGNS WHICH ALLOW USERS TO COLLECT AND ANALYZE POLITICAL INFORMATION ELECTRONICALLY; PROVIDING A WEBSITE FEATURING INFORMATION ABOUT POLITICAL ISSUES (U.S. CLS. 100, 101 AND 102).

FIRST USE 9-1-2010; IN COMMERCE 9-1-2010.

3,999,611. PARGH, ANDREW L., PALM BEACH GARDENS, FL. SN 85-078,798. PUB. 1-11-2011, FILED 7-6-2010.

THE GADGET GURU

THE MARK CONSISTS OF STANDARD CHARACTERS WITHOUT CLAIM TO ANY PARTICULAR FONT, STYLE, SIZE, OR COLOR.

OWNER OF U.S. REG. NOS. 2,873,676, 2,909,637, AND OTHERS.

CLASS 35—(Continued).

NO CLAIM IS MADE TO THE EXCLUSIVE RIGHT TO USE "GADGET", APART FROM THE MARK AS SHOWN.

FOR PROVIDING ONLINE NEW CONSUMER PRODUCT INFORMATION; AND PROVIDING ONLINE REVIEWS OF NEW CONSUMER PRODUCTS (U.S. CLS. 100, 101 AND 102).

FIRST USE 0-0-1986; IN COMMERCE 0-0-1988.

3,999,623. TEXAS A&M UNIVERSITY, COLLEGE STATION, TX. SN 85-081,530. PUB. 12-14-2010, FILED 7-9-2010.

AGGIE ENERGY

THE MARK CONSISTS OF STANDARD CHARACTERS WITHOUT CLAIM TO ANY PARTICULAR FONT, STYLE, SIZE, OR COLOR.

OWNER OF U.S. REG. NOS. 1,979,207 AND 3,001,270.

NO CLAIM IS MADE TO THE EXCLUSIVE RIGHT TO USE "ENERGY", APART FROM THE MARK AS SHOWN.

FOR ENERGY MANAGEMENT SERVICES, NAMELY, PROVIDING A SERVICE THAT ALLOWS CUSTOMERS TO PURCHASE ENERGY, NAMELY, ELECTRICITY, NATURAL GAS AND RENEWABLE ENERGY, AT A FIXED PRICE; RETAIL ELECTRICITY PROVIDER SERVICES, NAMELY, PROVIDING A SERVICE THAT ALLOWS CUSTOMERS TO PURCHASE ENERGY, NAMELY, ELECTRICITY, AND RENEWABLE ENERGY (U.S. CLS. 100, 101 AND 102).

FIRST USE 9-3-2010; IN COMMERCE 9-3-2010.

3,999,633. ACCELERATO, LLC, ST. PAUL, MN. SN 85-085,644. PUB. 12-21-2010, FILED 7-15-2010.

ACCELERATO

THE MARK CONSISTS OF STANDARD CHARACTERS WITHOUT CLAIM TO ANY PARTICULAR FONT, STYLE, SIZE, OR COLOR.

THE ENGLISH TRANSLATION OF THE WORD "ACCELERATO" IN THE MARK IS "QUICK, RAPID".

FOR BUSINESS CONSULTING SERVICES, NAMELY, PROVIDING ASSISTANCE IN DEVELOPMENT OF BUSINESS STRATEGIES AND CREATIVE IDEATION (U.S. CLS. 100, 101 AND 102).

FIRST USE 5-22-2004; IN COMMERCE 5-22-2004.

CLASS 35—(Continued).

3,999,634. CANADIAN COUNSELLING AND PSYCHOTHERAPY ASSOCIATION, OTTAWA, ONTARIO, CANADA. SN 85-085,735. PUB. 3-1-2011, FILED 7-15-2010.



NO CLAIM IS MADE TO THE EXCLUSIVE RIGHT TO USE "CANADIAN COUNSELLING AND PSYCHOTHERAPY ASSOCIATION L'ASSOCIATION CANADIENNE DE COUNSELING ET DE PSYCHOTHERAPIE", APART FROM THE MARK AS SHOWN.

THE COLOR(S) RED, BLACK AND WHITE IS/ARE CLAIMED AS A FEATURE OF THE MARK.

THE MARK CONSISTS OF A DESIGN WITH A RED MAPLE LEAF AND RED AND WHITE FACES AND HEADS. THE LETTERING "CANADIAN COUNSELLING AND PSYCHOTHERAPY ASSOCIATION L'ASSOCIATION CANADIENNE DE COUNSELING ET DE PSYCHOTHERAPIE" IN THE MARK IS IN BLACK.

THE ENGLISH TRANSLATION OF "L'ASSOCIATION CANADIENNE DE COUNSELING ET DE PSYCHOTHERAPIE" IN THE MARK IS "CANADIAN COUNSELLING AND PSYCHOTHERAPY ASSOCIATION".

FOR ADVERTISING AND MARKETING SERVICES, NAMELY, PROMOTING THE GOODS AND SERVICES OF OTHERS IN THE FIELD OF COUNSELING; EDUCATION LEADERSHIP DEVELOPMENT TO PROVIDE NATIONAL LEADERSHIP FOR COUNSELING; PUBLIC ADVOCACY TO PROMOTE AWARENESS OF THE PROFESSION OF COUNSELING; BUSINESS SERVICES, NAMELY, FORMULATION OF BEST PRACTICES FOR COUNSELORS (U.S. CLS. 100, 101 AND 102).

FIRST USE 6-25-2009; IN COMMERCE 5-23-2011.

3,999,648. DREAMSACKS, INC., ASHLAND, OR. SN 85-091,632. PUB. 3-8-2011, FILED 7-23-2010.

YALA

THE MARK CONSISTS OF STANDARD CHARACTERS WITHOUT CLAIM TO ANY PARTICULAR FONT, STYLE, SIZE, OR COLOR.

FOR ONLINE RETAIL STORES FEATURING BEDDING LINENS, BED SHEETS, PILLOW CASES, CLOTHING, TOTE BAGS AND CARRYING BAGS (U.S. CLS. 100, 101 AND 102).

FIRST USE 1-3-2011; IN COMMERCE 1-3-2011.

CLASS 35—(Continued).

3,999,650. GS MARKETING LLC, DBA GOOD STUFF MARKETING LLC, MADISON, NJ. SN 85-091,882. PUB. 3-8-2011, FILED 7-23-2010.



NO CLAIM IS MADE TO THE EXCLUSIVE RIGHT TO USE "MARKETING", APART FROM THE MARK AS SHOWN.

THE MARK CONSISTS OF THE WORDS "GOOD STUFF MARKETING" ACCOMPANIED BY A PINWHEEL TYPE DESIGN COMPRISING A KNIFE, FORK AND SPOON.

FOR MARKETING, ADVERTISING AND MARKETING CONSULTANCY FOR SPECIALTY FOODS AND FOOD PREPARATION EQUIPMENT (U.S. CLS. 100, 101 AND 102).

FIRST USE 10-30-2010; IN COMMERCE 10-30-2010.

3,999,675. WORLD REAL ESTATE MARKETING LLC, PARSIPPANY, NJ. SN 85-103,801. PUB. 1-25-2011, FILED 8-10-2010.



THE MARK CONSISTS OF THE WORD "ADVISOR" WITH A STYLIZED "V" AND THE LETTERS "RE" ATTACHED TO THE END OF THE WORD.

FOR REFERRAL SERVICES IN THE FIELD OF REAL ESTATE (U.S. CLS. 100, 101 AND 102).

FIRST USE 10-1-2010; IN COMMERCE 10-1-2010.

3,999,693. TRA GLOBAL, INC., DBA TRA, INC., NEW YORK, NY. SN 85-108,402. PUB. 12-28-2010, FILED 8-16-2010.

THE RIGHT AUDIENCE

THE MARK CONSISTS OF STANDARD CHARACTERS WITHOUT CLAIM TO ANY PARTICULAR FONT, STYLE, SIZE, OR COLOR.

FOR MARKET RESEARCH AND ANALYSIS SERVICES, NAMELY, PROVIDING INFORMATION AND DATA DERIVED FROM MATCHING ADVERTISING DATA AND PRODUCT PURCHASING DATA (U.S. CLS. 100, 101 AND 102).

FIRST USE 10-0-2010; IN COMMERCE 10-0-2010.

CLASS 35—(Continued).

3,999,708. KEY TO BIZ LLC, HOUSTON, TX. SN 85-113,056.
PUB. 2-8-2011, FILED 8-22-2010.



NO CLAIM IS MADE TO THE EXCLUSIVE RIGHT TO USE "BIZ", APART FROM THE MARK AS SHOWN.
THE COLOR(S) BLUE IS/ARE CLAIMED AS A FEATURE OF THE MARK.

THE MARK CONSISTS OF THE LITERAL ELEMENT "KEY TO BIZ" REPRESENTED IN EDWARDIAN SCRIPT ITC FONT IN THE COLOR BLUE, WHEREIN THE LETTERS "K" AND "B" ARE CAPITALIZED.

FOR ADVERTISING AND COMMERCIAL INFORMATION SERVICES, VIA THE INTERNET; ADVERTISING AND DIRECTORY SERVICES, NAMELY, PROMOTING THE SERVICES OF OTHERS BY PROVIDING A WEB PAGE FEATURING LINKS TO THE WEBSITES OF OTHERS; ADVERTISING AND MARKETING SERVICES, NAMELY, PROMOTING THE GOODS AND SERVICES OF OTHERS (U.S. CLS. 100, 101 AND 102).

FIRST USE 5-9-2011; IN COMMERCE 5-9-2011.

3,999,709. THE URBAN GROWER, DENVER, CO. SN 85-113,836. PUB. 2-1-2011, FILED 8-23-2010.

URBAN GROWER

THE MARK CONSISTS OF STANDARD CHARACTERS WITHOUT CLAIM TO ANY PARTICULAR FONT, STYLE, SIZE, OR COLOR.

NO CLAIM IS MADE TO THE EXCLUSIVE RIGHT TO USE "GROWER", APART FROM THE MARK AS SHOWN.

FOR RETAIL STORE AND ON-LINE RETAIL STORE SERVICES FEATURING HORTICULTURAL SUPPLIES (U.S. CLS. 100, 101 AND 102).

FIRST USE 9-1-2010; IN COMMERCE 12-1-2010.

3,999,714. MARKET SCOPE, LLC, ST. LOUIS, MO. SN 85-116,164. PUB. 3-22-2011, FILED 8-26-2010.

PRACTICE SCOPE

THE MARK CONSISTS OF STANDARD CHARACTERS WITHOUT CLAIM TO ANY PARTICULAR FONT, STYLE, SIZE, OR COLOR.

OWNER OF U.S. REG. NO. 3,014,781.

CLASS 35—(Continued).

NO CLAIM IS MADE TO THE EXCLUSIVE RIGHT TO USE "PRACTICE", APART FROM THE MARK AS SHOWN.

FOR DATA COLLECTION, REPORTING AND ANALYSIS SERVICES FOR MEDICAL DOCTORS AND MEDICAL BUSINESS GROUPS, NAMELY, GATHERING MEDICAL, BUSINESS, AND PATIENT DATA AND PROVIDING DOCTORS WITH SPECIFIC REPORTS AND ANALYSIS OF DATA AND INFORMATION RELATIVE TO THEIR MEDICAL PRACTICES, INCLUDING COMPARISONS TO OTHER MEDICAL DOCTORS AND BUSINESS GROUPS FOR USE IN BUSINESS DECISION MAKING (U.S. CLS. 100, 101 AND 102).

FIRST USE 9-30-2010; IN COMMERCE 9-30-2010.

3,999,726. ESTILO HACIENDA, INC., ORANGE, CA. SN 85-123,271. PUB. 3-15-2011, FILED 9-3-2010.

G-Tec Product Demo

THE MARK CONSISTS OF STANDARD CHARACTERS WITHOUT CLAIM TO ANY PARTICULAR FONT, STYLE, SIZE, OR COLOR.

NO CLAIM IS MADE TO THE EXCLUSIVE RIGHT TO USE "PRODUCT DEMO", APART FROM THE MARK AS SHOWN.

FOR PRODUCT DEMONSTRATION SERVICES, NAMELY, AUDIO AND VIDEO DEMONSTRATION OF FOOD PRODUCTS (U.S. CLS. 100, 101 AND 102).

FIRST USE 9-1-2010; IN COMMERCE 9-1-2010.

3,999,752. CITIGROUP INC., NEW YORK, NY. SN 85-131,908.
PUB. 12-21-2010, FILED 9-17-2010.

SPARE

THE MARK CONSISTS OF STANDARD CHARACTERS WITHOUT CLAIM TO ANY PARTICULAR FONT, STYLE, SIZE, OR COLOR.

FOR BUSINESS CONSULTATION SERVICES IN THE FIELDS OF MEETING MANAGEMENT, MEETING EXPENSE MANAGEMENT AND THE MANAGEMENT OF PAYMENT PROCESSES RELATED THERETO (U.S. CLS. 100, 101 AND 102).

FIRST USE 11-30-2010; IN COMMERCE 11-30-2010.

CLASS 35—(Continued).

3,999,798. GROUP BUY, LLC, NEW YORK, NY. SN 85-147,073. PUB. 3-15-2011, FILED 10-7-2010.

8MOMS

THE MARK CONSISTS OF STANDARD CHARACTERS WITHOUT CLAIM TO ANY PARTICULAR FONT, STYLE, SIZE, OR COLOR.

FOR PROMOTING THE GOODS AND SERVICES OF OTHERS BY PROVIDING A WEBSITE FEATURING COUPONS, REBATES, PRICE-COMPARISON INFORMATION, PRODUCT REVIEWS, LINKS TO THE RETAIL WEBSITES OF OTHERS, AND DISCOUNT INFORMATION (U.S. CLS. 100, 101 AND 102).

FIRST USE 10-28-2010; IN COMMERCE 10-28-2010.

3,999,803. KHANWILKAR, PRATAP S., AKA PK, SALT LAKE CITY, UT. SN 85-149,133. PUB. 3-15-2011, FILED 10-9-2010.

Ignition Key

THE MARK CONSISTS OF STANDARD CHARACTERS WITHOUT CLAIM TO ANY PARTICULAR FONT, STYLE, SIZE, OR COLOR.

FOR ASSISTANCE, ADVISORY SERVICES AND CONSULTANCY WITH REGARD TO BUSINESS PLANNING, BUSINESS ANALYSIS, BUSINESS MANAGEMENT, BUSINESS ORGANIZATION, MARKETING AND CUSTOMER ANALYSIS; BUSINESS ACQUISITION AND MERGER CONSULTATION; BUSINESS CONSULTATION; BUSINESS CONSULTATION AND MANAGEMENT REGARDING MARKETING ACTIVITIES AND LAUNCHING OF NEW PRODUCTS; BUSINESS DEVELOPMENT CONSULTING SERVICES; BUSINESS MANAGEMENT CONSULTATION IN THE FIELD OF EXECUTIVE AND LEADERSHIP DEVELOPMENT; CONSULTING SERVICES IN THE FIELD OF MEDICAL PRODUCT APPROVAL FOR COMMERCIAL PURPOSES; MANAGEMENT CONSULTING AND ADVISORY SERVICES IN THE AREAS OF CORPORATE GROWTH STRATEGY, INNOVATION AND GROWTH PROCESSES, ORGANIZATIONAL TRANSFORMATION, AND TALENT MANAGEMENT AND DEVELOPMENT STRATEGIES; NEW BUSINESS VENTURE DEVELOPMENT AND FORMATION CONSULTING SERVICES; PROVIDING ORGANIZATIONAL DEVELOPMENT CONSULTING SERVICES (U.S. CLS. 100, 101 AND 102).

FIRST USE 1-1-2011; IN COMMERCE 1-1-2011.

CLASS 35—(Continued).

3,999,824. CL CHICAGO, INC., TAMPA, FL. SN 85-158,393. PUB. 3-22-2011, FILED 10-21-2010.

READER REAL DEAL

THE MARK CONSISTS OF STANDARD CHARACTERS WITHOUT CLAIM TO ANY PARTICULAR FONT, STYLE, SIZE, OR COLOR.

FOR PROMOTING THE GOODS AND SERVICES OF OTHERS BY PROVIDING A WEBSITE FEATURING COUPONS, REBATES, PRICE-COMPARISON INFORMATION, PRODUCT REVIEWS, LINKS TO THE RETAIL WEBSITE OF OTHERS, AND DISCOUNT INFORMATION (U.S. CLS. 100, 101 AND 102).

FIRST USE 12-10-2010; IN COMMERCE 12-10-2010.

3,999,826. BRAND AFFINITY TECHNOLOGIES, INC., IRVINE, CA. SN 85-158,585. PUB. 3-22-2011, FILED 10-21-2010.

FANTAPPER

THE MARK CONSISTS OF STANDARD CHARACTERS WITHOUT CLAIM TO ANY PARTICULAR FONT, STYLE, SIZE, OR COLOR.

FOR MARKETING AND PROMOTIONAL ADVERTISING SERVICES VIA MEDIA, NAMELY, PROMOTING THE GOODS, SERVICES AND BRAND IDENTITY OF THIRD PARTIES THROUGH DIGITAL AND ELECTRONIC MEDIA (U.S. CLS. 100, 101 AND 102).

FIRST USE 5-1-2011; IN COMMERCE 5-1-2011.

3,999,827. BRAND AFFINITY TECHNOLOGIES, INC., IRVINE, CA. SN 85-158,589. PUB. 3-22-2011, FILED 10-21-2010.



THE COLOR(S) RED, GRAY AND BLACK IS/ARE CLAIMED AS A FEATURE OF THE MARK.

THE MARK CONSISTS OF RED LETTERS "FT" JOINED TO THE INSIDE OF A RED CIRCLE HAVING A GRAY BACKGROUND PRECEDING THE LETTERS "FAN" IN BLACK IMMEDIATELY PRECEDED BY THE LETTERS "TAPPER" IN RED.

FOR MARKETING AND PROMOTIONAL ADVERTISING SERVICES VIA MEDIA, NAMELY, PROMOTING THE GOODS, SERVICES AND BRAND IDENTITY OF THIRD PARTIES THROUGH DIGITAL AND ELECTRONIC MEDIA (U.S. CLS. 100, 101 AND 102).

FIRST USE 5-1-2011; IN COMMERCE 5-1-2011.

CLASS 35—(Continued).

3,999,848. CANDYCARTON LLC, LOVELAND, CO. SN 85-168,062. PUB. 3-29-2011, FILED 11-3-2010.

CANDYCARTON

THE MARK CONSISTS OF STANDARD CHARACTERS WITHOUT CLAIM TO ANY PARTICULAR FONT, STYLE, SIZE, OR COLOR.

FOR ON-LINE RETAIL STORE SERVICES FEATURING CANDY (U.S. CLS. 100, 101 AND 102).
FIRST USE 12-26-2010; IN COMMERCE 12-26-2010.

3,999,854. TRENEGY INCORPORATED, HOUSTON, TX. SN 85-171,352. PUB. 3-29-2011, FILED 11-8-2010.

TRENEGY

THE MARK CONSISTS OF STANDARD CHARACTERS WITHOUT CLAIM TO ANY PARTICULAR FONT, STYLE, SIZE, OR COLOR.

FOR BUSINESS CONSULTING SERVICES RELATING TO THE INTEGRATION OF THE AREAS OF BUSINESS PROCESS TECHNOLOGY, ORGANIZATIONAL LEARNING, CHANGE MANAGEMENT, AND OPERATIONAL SUSTAINABILITY (U.S. CLS. 100, 101 AND 102).
FIRST USE 3-17-2011; IN COMMERCE 3-17-2011.

3,999,855. DYNAMIC LOGIC, INC., NEW YORK, NY. SN 85-172,432. PUB. 3-29-2011, FILED 11-9-2010.

ADINDEX DASH

THE MARK CONSISTS OF STANDARD CHARACTERS WITHOUT CLAIM TO ANY PARTICULAR FONT, STYLE, SIZE, OR COLOR.

OWNER OF U.S. REG. NO. 2,475,239.
FOR BUSINESS MARKETING CONSULTING SERVICES IN THE NATURE OF EVALUATING EFFECTIVENESS OF ON-LINE BASED ADVERTISING AND CONDUCTING ON-LINE SURVEYS (U.S. CLS. 100, 101 AND 102).
FIRST USE 1-15-2011; IN COMMERCE 1-15-2011.

CLASS 36—INSURANCE AND FINANCIAL

CLASS 36—(Continued).

3,998,307. FIGGINS, DESMOND DECHONE, BROOKLYN, NY. SN 76-677,126. PUB. 2-12-2008, FILED 5-18-2007.

GET FIGGY WITH IT

THE MARK CONSISTS OF STANDARD CHARACTERS WITHOUT CLAIM TO ANY PARTICULAR FONT, STYLE, SIZE, OR COLOR.

FOR CHARITABLE FUNDRAISING SERVICES IN SUPPORT OF EFFORTS TO BUILD, RE-BUILD, AND RENOVATE BASEBALL FIELDS, BASEBALL PARKS, BASEBALL FACILITIES AND OTHER ATHLETIC FACILITIES IN UNDERPRIVILEGED COMMUNITIES (U.S. CLS. 100, 101 AND 102).
FIRST USE 1-23-2011; IN COMMERCE 1-23-2011.

3,998,344. CASTLEROCK PARTNERS LIMITED PARTNERSHIP, AUSTIN, TX. SN 76-704,698. PUB. 2-22-2011, FILED 9-27-2010.

CASTLE HILL PARTNERS

THE MARK CONSISTS OF STANDARD CHARACTERS WITHOUT CLAIM TO ANY PARTICULAR FONT, STYLE, SIZE, OR COLOR.

NO CLAIM IS MADE TO THE EXCLUSIVE RIGHT TO USE "PARTNERS", APART FROM THE MARK AS SHOWN.
FOR REAL ESTATE LEASING, BROKERAGE, AND MANAGEMENT SERVICES, NAMELY, LEASING, AND REAL ESTATE AGENCY SERVICES; PROVIDING OF INITIAL REAL ESTATE ASSET FISCAL ASSESSMENT AND VALUATION ANALYSIS, MORTGAGE PRE-FORECLOSURE SERVICES, LIEN NEGOTIATIONS IN THE NATURE OF DEBT SETTLEMENT, DISTRESSED REAL ESTATE DEBT ACQUISITION, AND REAL ESTATE FINANCIAL MANAGEMENT SERVICES (U.S. CLS. 100, 101 AND 102).
FIRST USE 4-0-2011; IN COMMERCE 4-0-2011.

3,998,411. GUTIERREZ, GUSTAVO, MIAMI BEACH, FL. SN 77-268,936. PUB. 2-26-2008, FILED 8-30-2007.

KLOCKLE

THE MARK CONSISTS OF STANDARD CHARACTERS WITHOUT CLAIM TO ANY PARTICULAR FONT, STYLE, SIZE, OR COLOR.

FOR PROVIDING INFORMATION IN THE FIELD OF REAL ESTATE VIA THE INTERNET (U.S. CLS. 100, 101 AND 102).
FIRST USE 5-11-2011; IN COMMERCE 5-11-2011.

CLASS 36—(Continued).

3,998,483. VALENCIA TRADEMARK CORPORATION, HOUSTON, TX. SN 77-441,735. PUB. 8-26-2008, FILED 4-7-2008.

GREAT SPACES IN GREAT PLACES

THE MARK CONSISTS OF STANDARD CHARACTERS WITHOUT CLAIM TO ANY PARTICULAR FONT, STYLE, SIZE, OR COLOR.

FOR REAL ESTATE SERVICES, NAMELY, LEASING AND MANAGEMENT FOR OTHERS OF RESIDENTIAL CONDOMINIUMS LOCATED WITHIN HOTEL DEVELOPMENTS (U.S. CLS. 100, 101 AND 102).

FIRST USE 7-31-2008; IN COMMERCE 7-31-2008.

3,998,498. TENHULZEN, DALE T., HUNTINGTON BEACH, CA. SN 77-489,054. PUB. 9-29-2009, FILED 6-2-2008.

LIVE WEALTHY-DIE WEALTHY "THERE IS LIFE AFTER DEATH"

THE MARK CONSISTS OF STANDARD CHARACTERS WITHOUT CLAIM TO ANY PARTICULAR FONT, STYLE, SIZE, OR COLOR.

FOR INSURANCE CONSULTATION (U.S. CLS. 100, 101 AND 102).

FIRST USE 5-0-2008; IN COMMERCE 5-0-2008.

3,998,617. GFI GROUP INC., NEW YORK, NY. SN 77-687,279. PUB. 2-23-2010, FILED 3-10-2009.

GFI MobileFreight

THE MARK CONSISTS OF STANDARD CHARACTERS WITHOUT CLAIM TO ANY PARTICULAR FONT, STYLE, SIZE, OR COLOR.

OWNER OF U.S. REG. NOS. 2,102,950 AND 3,081,665. FOR FINANCIAL AND INVESTMENT SERVICES, NAMELY, PROVIDING PRICING, FINANCIAL MARKET AND TRADING INFORMATION FOR DERIVATIVES, FINANCIAL PRODUCTS, SECURITIES AND COMMODITIES BY ELECTRONIC MEANS VIA GLOBAL AND NON-GLOBAL COMPUTER NETWORKS AND INTERNET-ENABLED MOBILE DEVICES (U.S. CLS. 100, 101 AND 102).

FIRST USE 1-16-2009; IN COMMERCE 1-16-2009.

CLASS 36—(Continued).

3,998,676. PRUDENTIAL INSURANCE COMPANY OF AMERICA, THE, NEWARK, NJ. SN 77-741,434. PUB. 3-2-2010, FILED 5-20-2009.

TARGET MILESTONES

THE MARK CONSISTS OF STANDARD CHARACTERS WITHOUT CLAIM TO ANY PARTICULAR FONT, STYLE, SIZE, OR COLOR.

FOR FINANCIAL SERVICES, NAMELY, UNDERWRITING AND ADMINISTERING ANNUITIES; INSURANCE UNDERWRITING FOR ALL TYPES OF INSURANCE AND DEFINED CONTRIBUTION PLANS; FINANCIAL ASSET MANAGEMENT SERVICES; INVESTMENT SERVICES, NAMELY, INVESTMENT MANAGEMENT SERVICES FOR FUNDING RETIREMENT; RETIREMENT SERVICES, NAMELY, INVESTMENT, PLANNING AND ADMINISTERING RETIREMENT PLANS; INVESTMENT MANAGEMENT; INVESTMENT MANAGEMENT OF AND DISTRIBUTION OF VARIABLE ANNUITIES (U.S. CLS. 100, 101 AND 102).

FIRST USE 10-0-2009; IN COMMERCE 10-0-2009.

3,998,776. COLLEGENET, INC., PORTLAND, OR. SN 77-830,275. PUB. 4-13-2010, FILED 9-18-2009.

POWERING YOUR GOOD WORK

THE MARK CONSISTS OF STANDARD CHARACTERS WITHOUT CLAIM TO ANY PARTICULAR FONT, STYLE, SIZE, OR COLOR.

FOR FINANCIAL INFORMATION PROCESSING, NAMELY, ELECTRONIC PROCESSING OF CHARITABLE CONTRIBUTIONS VIA A GLOBAL COMPUTER NETWORK; COLLECTING, COMPILING, ANALYZING AND REPORTING INFORMATION ON CHARITABLE MONETARY CONTRIBUTIONS FOR OTHERS (U.S. CLS. 100, 101 AND 102).

FIRST USE 2-4-2011; IN COMMERCE 2-4-2011.

CLASS 36—(Continued).

3,998,804. DINERS CLUB INTERNATIONAL LTD, RIVERWOODS, IL. SN 77-837,936. PUB. 7-13-2010, FILED 9-30-2009.



OWNER OF U.S. REG. NOS. 1,127,084, 3,056,837, AND OTHERS.

NO CLAIM IS MADE TO THE EXCLUSIVE RIGHT TO USE "INTERNATIONAL", APART FROM THE MARK AS SHOWN.

THE MARK CONSISTS OF A CREDIT CARD BEARING A PARTIAL GLOBE SHAPED WORLD MAP OVERLAID WITH CONTINENTS AND ACCENTUATED LATITUDE AND LONGITUDE LINES. AN ACCENTUATED LATITUDE LINE CIRCLES THE OUTSIDE OF THE CARD IMAGE AND CONNECTS THE LEFT SIDE OF THE CARD WITH THE WORD "BELONG". THE WORDING "DINERS CLUB INTERNATIONAL" APPEARS AT THE TOP OF THE CARD WITH A CIRCLE BISECTED WITH A LINE IN THE MIDDLE ON THE UPPER LEFT CORNER.

FOR CREDIT CARD SERVICES (U.S. CLS. 100, 101 AND 102).

FIRST USE 11-20-2009; IN COMMERCE 11-20-2009.

3,998,825. HCC INSURANCE HOLDINGS, INC., HOUSTON, TX. SN 77-846,862. PUB. 3-16-2010, FILED 10-12-2009.

HCC

THE MARK CONSISTS OF STANDARD CHARACTERS WITHOUT CLAIM TO ANY PARTICULAR FONT, STYLE, SIZE, OR COLOR.

OWNER OF U.S. REG. NOS. 2,686,208, 3,695,167, AND OTHERS.

FOR INSURANCE UNDERWRITING AND UNDERWRITING MANAGEMENT, REINSURANCE, AND INSURANCE CLAIMS ADMINISTRATION, ALL IN THE FIELDS OF INLAND MARINE INSURANCE; TRAVEL INSURANCE UNDERWRITING SERVICES (U.S. CLS. 100, 101 AND 102).

FIRST USE 1-0-2011; IN COMMERCE 1-0-2011.

CLASS 36—(Continued).

3,998,840. SUNNYSIDE FEDERAL SAVINGS AND LOAN ASSOCIATION OF IRVINGTON, IRVINGTON, NY. SN 77-852,906. PUB. 3-30-2010, FILED 10-20-2009.

SUNNYSIDE

THE MARK CONSISTS OF STANDARD CHARACTERS WITHOUT CLAIM TO ANY PARTICULAR FONT, STYLE, SIZE, OR COLOR.

FOR BUSINESS LENDING SERVICES; DEBIT CARD SERVICES; ELECTRONIC BANKING SERVICES VIA REMOTE LOCATIONS (BASED ON USE IN COMMERCE) BANKING AND RELATED FINANCIAL SERVICES, NAMELY, THE PROVISION OF SAVINGS ACCOUNTS, CHECKING ACCOUNTS, INSURED MONEY FUND ACCOUNTS AND CERTIFICATES OF DEPOSIT; AUTOMATED TELLER MACHINE SERVICES; MONEY ORDER SERVICES; TRAVELERS' CHECK SERVICES; SAVINGS BOND SERVICES; SAFE DEPOSIT BOX SERVICES; CONSUMER, MORTGAGE, AUTOMOBILE AND HOME EQUITY LENDING SERVICES (U.S. CLS. 100, 101 AND 102).

FIRST USE 0-0-1930; IN COMMERCE 0-0-1930.

3,998,907. CITIZENS FINANCIAL GROUP, INC., PROVIDENCE, RI. SN 77-869,245. PUB. 3-9-2010, FILED 11-10-2009.

BUFFERZONE

THE MARK CONSISTS OF STANDARD CHARACTERS WITHOUT CLAIM TO ANY PARTICULAR FONT, STYLE, SIZE, OR COLOR.

FOR BANKING SERVICES, NAMELY, OVERDRAFT PROTECTION SERVICES (U.S. CLS. 100, 101 AND 102).

FIRST USE 2-16-2010; IN COMMERCE 2-16-2010.

3,998,935. FMR LLC, BOSTON, MA. SN 77-880,115. PUB. 9-28-2010, FILED 11-24-2009.

FIDELITY FREEDOM

THE MARK CONSISTS OF STANDARD CHARACTERS WITHOUT CLAIM TO ANY PARTICULAR FONT, STYLE, SIZE, OR COLOR.

OWNER OF U.S. REG. NOS. 2,156,685, 2,158,874, AND 2,158,875.

FOR MUTUAL FUND BROKERAGE SERVICES (U.S. CLS. 100, 101 AND 102).

FIRST USE 10-11-1996; IN COMMERCE 10-11-1996.

CLASS 36—(Continued).

3,998,956. JOURNALISM ONLINE, LLC, NEW YORK, NY. SN 77-889,062. PUB. 10-5-2010, FILED 12-8-2009.



THE MARK CONSISTS OF AN UPPERCASE "P" AND PLUS SIGN INSIDE A DARKENED SQUARE.

FOR FINANCIAL SERVICES, NAMELY, PROVIDING ONLINE PAYMENT SERVICES AND FUNDED ACCOUNTS USED TO PURCHASE ACCESS TO CONTENT VIA THE GLOBAL COMPUTER NETWORK (U.S. CLS. 100, 101 AND 102).

FIRST USE 7-12-2010; IN COMMERCE 7-12-2010.

3,998,975. CARDSYNC PROCESSING, INC., NASHVILLE, TN. SN 77-894,475. PUB. 5-25-2010, FILED 12-16-2009.

CARDSYNC

THE MARK CONSISTS OF STANDARD CHARACTERS WITHOUT CLAIM TO ANY PARTICULAR FONT, STYLE, SIZE, OR COLOR.

FOR FINANCIAL SERVICES, NAMELY, CREDIT-CARD AND DEBIT-CARD PROCESSING FOR OTHERS (U.S. CLS. 100, 101 AND 102).

FIRST USE 11-0-2010; IN COMMERCE 11-0-2010.

3,999,000. THEBANK OF EDWARDSVILLE, EDWARDSVILLE, IL. SN 77-901,562. PUB. 5-18-2010, FILED 12-28-2009.



NO CLAIM IS MADE TO THE EXCLUSIVE RIGHT TO USE "INVESTOR GROUP" AND "BANK", APART FROM THE MARK AS SHOWN.

CLASS 36—(Continued).

THE MARK CONSISTS OF THE WORDING "THE INVESTOR" APPEARING IN STYLIZED FONT AND ALL LOWER CASE LETTERS. BELOW THE "THE INVESTOR" WORDING APPEARS THE WORDING "GROUP AT THE BANK" IN STYLIZED FONT, ALL LETTERS APPEAR IN LOWER CASE LETTERS EXCEPT THE "T" IN "THE" AND "BANK". TO THE LEFT OF THE "THE INVESTOR" WORDING APPEARS A SQUARE WITH ROUNDED CORNERS AND A BOLDED AND STYLIZED LOWER CASE "I" APPEARS WITHIN THE SQUARE.

FOR ADVICE RELATING TO INVESTMENTS; ESTATE TRUST MANAGEMENT; FINANCIAL PLANNING AND INVESTMENT ADVISORY SERVICES; INVESTMENT ADVISORY SERVICES; TRUST MANAGEMENT ACCOUNTS; TRUST SERVICES, NAMELY, INVESTMENT AND TRUST COMPANY SERVICES (U.S. CLS. 100, 101 AND 102).

FIRST USE 6-23-2010; IN COMMERCE 10-8-2010.

3,999,116. SECOR, DIANE L., TUNKHANNOCK, PA. SN 77-952,413. PUB. 6-15-2010, FILED 3-6-2010.



Volunteer Strong

NO CLAIM IS MADE TO THE EXCLUSIVE RIGHT TO USE "VOLUNTEER", APART FROM THE MARK AS SHOWN.

THE COLOR(S) BLACK, WHITE, GREEN IS/ARE CLAIMED AS A FEATURE OF THE MARK.

THE MARK CONSISTS OF A BLACK RECTANGULAR BOX WITH A WHITE LETTER "V" AT THE TOP AND A GREEN LETTER "S" AT THE BOTTOM. THE WORDS "VOLUNTEER STRONG" APPEAR IN THE COLOR BLACK DIRECTLY BELOW THE BLACK RECTANGULAR BOX.

FOR CHARITABLE FUNDRAISING SERVICES BY MEANS OF SELLING T-SHIRTS AND HATS TO RAISE FUNDS FOR EDUCATIONAL PROGRAMS PROMOTING VOLUNTEERISM, THE FOREGOING SERVICES SPECIFICALLY EXCLUDING THE FIELD OF CANCER OR FOR CANCER RELATED GOODS, SERVICES, ACTIVITIES, OR EVENTS (U.S. CLS. 100, 101 AND 102).

FIRST USE 12-18-2010; IN COMMERCE 12-18-2010.

CLASS 36—(Continued).

3,999,126. ABUNDANT POWER GROUP, LLC, CHARLOTTE, NC. SN 77-957,374. PUB. 9-14-2010, FILED 3-12-2010.



NO CLAIM IS MADE TO THE EXCLUSIVE RIGHT TO USE "POWER", APART FROM THE MARK AS SHOWN.

THE MARK CONSISTS OF THE WORDS "ABUNDANT POWER" WITH A CIRCLE DESIGN TO THE UPPER RIGHT OF THE WORD "ABUNDANT" AND A SMALLER CIRCLE DESIGN TO THE LEFT OF THE WORD "POWER".

FOR FINANCIAL CONSULTATION AND ADVISORY SERVICES RELATING TO FINANCIAL INVESTMENTS IN THE RENEWABLE ENERGY INDUSTRY (U.S. CLS. 100, 101 AND 102).

FIRST USE 3-0-2009; IN COMMERCE 11-0-2009.

CLASS 36—(Continued).

3,999,204. GAMCO INVESTORS, INC., RYE, NY. SN 78-828,813. PUB. 5-6-2008, FILED 3-3-2006.

ECRIB

THE MARK CONSISTS OF STANDARD CHARACTERS WITHOUT CLAIM TO ANY PARTICULAR FONT, STYLE, SIZE, OR COLOR.

FOR INVESTMENT MANAGEMENT (U.S. CLS. 100, 101 AND 102).

FIRST USE 1-31-2011; IN COMMERCE 1-31-2011.

3,999,160. ASSURANT, INC., NEW YORK, NY. SN 77-981,825. PUB. 2-17-2009, FILED 5-8-2008.



THE MARK CONSISTS OF CIRCULAR DESIGN WITH NOTCHES AND AN ARROW WITH THE WORDS "MOTOR-AIDE" BESIDE SUCH DESIGN.

FOR PROVIDING EXTENDED WARRANTY CONTRACTS IN THE FIELDS OF MOTOR VEHICLES, NAMELY, AUTOMOBILES, RECREATIONAL VEHICLES, MOTOR HOMES, BOATS, SMALL YACHTS AND OTHER MARINE MOTOR-POWERED VEHICLES, AND POWERSPORT VEHICLES, NAMELY, AUTOMOBILES, MOTORCYCLES, MOTOCROSS, ALL TERRAIN VEHICLES, AND PERSONAL JET BOATS; UNDERWRITING, ISSUING, AND ADMINISTERING GUARANTEED AUTOMOBILE PROTECTION (GAP) INSURANCE AND DEBT PROTECTION PROGRAMS IN CONNECTION WITH MOTOR VEHICLES, NAMELY, AUTOMOBILES, RECREATIONAL VEHICLES, MOTOR HOMES, BOATS, SMALL YACHTS AND OTHER MARINE MOTOR-POWERED VEHICLES, AND POWERSPORT VEHICLES, NAMELY, AUTOMOBILES, MOTORCYCLES, MOTOCROSS, ALL TERRAIN VEHICLES, AND PERSONAL JET BOATS; FINANCING AND REFINANCING ASSISTANCE FOR MOTOR VEHICLES, NAMELY, ADVISORY SERVICES RELATING TO FINANCING AND REFINANCING OF LOANS FOR MOTOR VEHICLES, MOTOR VEHICLE LEASE FINANCING SERVICES, AND FINANCIALLY-GUARANTEED FINANCING FOR MOTOR VEHICLES; PROVIDING AND ADMINISTERING EXTENDED WARRANTY CONTRACTS AND MOTOR VEHICLE SERVICE CONTRACTS IN THE FIELD OF MOTOR VEHICLES (U.S. CLS. 100, 101 AND 102).

FIRST USE 1-11-2010; IN COMMERCE 1-11-2010.

3,999,227. GOLDMAN, SACHS & CO., NEW YORK, NY. SN 85-002,691. PUB. 3-8-2011, FILED 3-31-2010.

GSQUARTIX

THE MARK CONSISTS OF STANDARD CHARACTERS WITHOUT CLAIM TO ANY PARTICULAR FONT, STYLE, SIZE, OR COLOR.

FOR FINANCIAL SERVICES, NAMELY, INVESTMENT PORTFOLIO MANAGEMENT, INVESTMENT MANAGEMENT AND ADVISORY SERVICES; TRADING OF FINANCIAL SECURITIES, SHARES, OPTIONS AND OTHER DERIVATIVE PRODUCTS; TRADING OF CERTIFICATES BACKED BY LOAN PORTFOLIOS WHICH ARE SUBSEQUENTLY MANAGED TO INSURE THE INTEGRITY OF THE CERTIFICATES; BROKERAGE SERVICES IN THE FIELD OF STRUCTURED EXCHANGE-TRADED FUNDS; BROKERAGE SERVICES IN THE FIELD OF UNDERTAKINGS FOR COLLECTIVE INVESTMENTS IN TRANSFERABLE SECURITIES; HEDGE FUND/MUTUAL FUNDS INVESTMENT MANAGEMENT SERVICES; FINANCIAL PLANNING; MANAGED ACCOUNTS, NAMELY, INVESTMENT ADMINISTRATION; SECURITIES BROKERAGE; AUTOMATED SECURITIES BROKERAGE SERVICES; ELECTRONIC TRADING OF SECURITIES; CONDUCTING FINANCIAL TRANSACTION AND PORTFOLIO INVESTMENT ADVISORY SERVICES (U.S. CLS. 100, 101 AND 102).

FIRST USE 4-0-2010; IN COMMERCE 4-0-2010.

CLASS 36—(Continued).

3,999,246. ASCENSION LLC, RICHARDSON, TX. SN 85-009,098. PUB. 9-7-2010, FILED 4-8-2010.



THE MARK CONSISTS OF A DESIGN OF A LADYBUG. FOR PERSONAL LENDING SERVICES; MORTGAGE LENDING SERVICES; REAL ESTATE ACQUISITION AND BROKERAGE SERVICES (U.S. CLS. 100, 101 AND 102).

FIRST USE 2-9-2010; IN COMMERCE 2-9-2010.

CLASS 36—(Continued).

3,999,332. AMUNDI ALTERNATIVE INVESTMENTS, INC., NEW YORK, NY. SN 85-026,766. PUB. 10-5-2010, FILED 4-29-2010.

BULL MEMORY

THE MARK CONSISTS OF STANDARD CHARACTERS WITHOUT CLAIM TO ANY PARTICULAR FONT, STYLE, SIZE, OR COLOR.

FOR FINANCIAL MANAGEMENT SERVICES, NAMELY, PROVIDING CONSTRUCTION OF INVESTMENT PORTFOLIOS COMPRISED OF CERTAIN FINANCIAL INSTRUMENTS; DEVELOPMENT OF FINANCIAL INSTRUMENTS, NAMELY, FUNDS, SWAPS, NOTES, OPTIONS AND WARRANTS; DEVELOPMENT OF SAVINGS AND COMPENSATION PLANS FOR OTHERS UTILIZING SWAPS, NOTES, OPTIONS OR WARRANTS ALONE OR IN COMBINATION WITH ONE ANOTHER (U.S. CLS. 100, 101 AND 102).

FIRST USE 8-4-2009; IN COMMERCE 8-4-2009.

3,999,291. BLUE CROSS AND BLUE SHIELD ASSOCIATION, AKA BLUECROSS BLUESHIELD ASSOCIATION, CHICAGO, IL. SN 85-020,683. PUB. 9-21-2010, FILED 4-22-2010.

AskBlue Medicare
Your guide to
understanding healthcare
coverage options

THE MARK CONSISTS OF STANDARD CHARACTERS WITHOUT CLAIM TO ANY PARTICULAR FONT, STYLE, SIZE, OR COLOR.

OWNER OF U.S. REG. NO. 3,826,253.

NO CLAIM IS MADE TO THE EXCLUSIVE RIGHT TO USE "MEDICARE" AND "YOUR GUIDE TO UNDERSTANDING HEALTHCARE COVERAGE OPTIONS", APART FROM THE MARK AS SHOWN.

FOR PROVIDING ONLINE INFORMATION TO CUSTOMERS IN SELECTING HEALTH INSURANCE PRODUCTS (U.S. CLS. 100, 101 AND 102).

FIRST USE 8-31-2010; IN COMMERCE 8-31-2010.

3,999,354. NCEP, LLC, LAS VEGAS, NV. SN 85-029,397. PUB. 10-5-2010, FILED 5-4-2010.

NCEP

THE MARK CONSISTS OF STANDARD CHARACTERS WITHOUT CLAIM TO ANY PARTICULAR FONT, STYLE, SIZE, OR COLOR.

FOR FINANCIAL PORTFOLIO MANAGEMENT IN THE FIELD OF NON-PERFORMING AND DISTRESSED CONSUMER DEBT, NAMELY, ACQUISITION AND LIQUIDATION OF CHARGED-OFF CONSUMER ACCOUNTS RECEIVABLES; FINANCIAL SERVICES, NAMELY, RESTRUCTURING EXISTING LOANS AND ACQUIRING AND COLLECTING RECEIVABLES FOR SECURED AND UNSECURED, NON-PERFORMING AND SUB-PERFORMING, CONSUMER AND COMMERCIAL DEBT (U.S. CLS. 100, 101 AND 102).

FIRST USE 5-17-2011; IN COMMERCE 5-17-2011.

CLASS 36—(Continued).

3,999,388. NATIONAL FAMILY MORTGAGE, LLC, NORWOOD, MA. SN 85-032,599. PUB. 4-12-2011, FILED 5-7-2010.

**It pays to invest in the
ones you love the most**

THE MARK CONSISTS OF STANDARD CHARACTERS WITHOUT CLAIM TO ANY PARTICULAR FONT, STYLE, SIZE, OR COLOR.

FOR PROVIDING AN ONLINE FINANCIAL SERVICES WEBSITE FEATURING ELECTRONIC FUND TRANSFER SERVICES TO ENABLE INDIVIDUALS TO ENGAGE IN SECURED LENDING AND BORROWING TRANSACTIONS WITH OTHER INDIVIDUALS VIA A GLOBAL COMPUTER NETWORK; FINANCIAL AFFAIRS AND MONETARY AFFAIRS, NAMELY, PROVIDING FINANCIAL INFORMATION AND REAL ESTATE INFORMATION (U.S. CLS. 100, 101 AND 102).
FIRST USE 9-24-2010; IN COMMERCE 9-24-2010.

3,999,392. CHLEBINA CAPITAL MANAGEMENT, AKRON, OH. SN 85-032,727. PUB. 10-12-2010, FILED 5-7-2010.

**We Let the Facts Get in
the Way of Our Thinking**

THE MARK CONSISTS OF STANDARD CHARACTERS WITHOUT CLAIM TO ANY PARTICULAR FONT, STYLE, SIZE, OR COLOR.

FOR FINANCIAL AND INVESTMENT SERVICES, NAMELY, MANAGEMENT AND BROKERAGE IN THE FIELDS OF STOCKS, BONDS, OPTIONS, COMMODITIES, FUTURES AND OTHER SECURITIES, AND THE INVESTMENT OF FUNDS OF OTHERS; FINANCIAL INVESTMENT ANALYSIS AND STOCK RESEARCH (U.S. CLS. 100, 101 AND 102).
FIRST USE 1-1-2011; IN COMMERCE 1-1-2011.

3,999,393. NATIONAL PENN BANK, BOYERTOWN, PA. SN 85-033,041. PUB. 10-5-2010, FILED 5-7-2010.

COMPETITIVE EDGE CHECKING

THE MARK CONSISTS OF STANDARD CHARACTERS WITHOUT CLAIM TO ANY PARTICULAR FONT, STYLE, SIZE, OR COLOR.

NO CLAIM IS MADE TO THE EXCLUSIVE RIGHT TO USE "CHECKING", APART FROM THE MARK AS SHOWN. FOR BANKING SERVICES (U.S. CLS. 100, 101 AND 102).
FIRST USE 8-8-2010; IN COMMERCE 8-8-2010.

CLASS 36—(Continued).

3,999,412. NATIONAL ASSOCIATION FOR STOCK CAR AUTO RACING, INC., DAYTONA BEACH, FL. SN 85-035,355. PUB. 10-12-2010, FILED 5-11-2010.

**HELPING KIDS TO A SPEEDY
RECOVERY.**

THE MARK CONSISTS OF STANDARD CHARACTERS WITHOUT CLAIM TO ANY PARTICULAR FONT, STYLE, SIZE, OR COLOR.

FOR CHARITABLE FUND RAISING (U.S. CLS. 100, 101 AND 102).
FIRST USE 1-11-2011; IN COMMERCE 1-11-2011.

3,999,430. PROSIGHT SPECIALTY INSURANCE, MORRISTOWN, NJ. SN 85-037,316. PUB. 10-12-2010, FILED 5-13-2010.

**EXPERIENCED
PROFESSIONALS. INSIGHTFUL
SOLUTIONS.**

THE MARK CONSISTS OF STANDARD CHARACTERS WITHOUT CLAIM TO ANY PARTICULAR FONT, STYLE, SIZE, OR COLOR.

FOR INSURANCE ADMINISTRATION; INSURANCE BROKERAGE; INSURANCE CONSULTATION; INSURANCE SERVICES, NAMELY, UNDERWRITING PROPERTY AND CASUALTY INSURANCE (U.S. CLS. 100, 101 AND 102).
FIRST USE 7-30-2010; IN COMMERCE 7-30-2010.

3,999,471. ZENITH INSURANCE COMPANY, WOODLAND HILLS, CA. SN 85-044,175. PUB. 10-12-2010, FILED 5-20-2010.

THEZENITH

THE MARK CONSISTS OF STANDARD CHARACTERS WITHOUT CLAIM TO ANY PARTICULAR FONT, STYLE, SIZE, OR COLOR.

OWNER OF U.S. REG. NOS. 2,436,080, 3,654,555, AND OTHERS.
FOR INSURANCE UNDERWRITING IN THE FIELD OF PROPERTY AND CASUALTY INSURANCE (U.S. CLS. 100, 101 AND 102).
FIRST USE 1-31-2011; IN COMMERCE 1-31-2011.

CLASS 36—(Continued).

3,999,472. ZENITH INSURANCE COMPANY, WOODLAND HILLS, CA. SN 85-044,195. PUB. 10-12-2010, FILED 5-20-2010.

Zenith

THE MARK CONSISTS OF STANDARD CHARACTERS WITHOUT CLAIM TO ANY PARTICULAR FONT, STYLE, SIZE, OR COLOR.

OWNER OF U.S. REG. NOS. 2,436,080, 3,654,555, AND OTHERS.

FOR INSURANCE UNDERWRITING IN THE FIELD OF PROPERTY AND CASUALTY INSURANCE (U.S. CLS. 100, 101 AND 102).

FIRST USE 1-31-2011; IN COMMERCE 1-31-2011.

3,999,503. PARTNERRE U.S. CORPORATION, GREENWICH, CT. SN 85-051,799. PUB. 11-9-2010, FILED 6-1-2010.

PARTNERRE NORTH AMERICA

THE MARK CONSISTS OF STANDARD CHARACTERS WITHOUT CLAIM TO ANY PARTICULAR FONT, STYLE, SIZE, OR COLOR.

OWNER OF U.S. REG. NOS. 2,388,709, 2,695,509, AND 2,695,511.

NO CLAIM IS MADE TO THE EXCLUSIVE RIGHT TO USE "NORTH AMERICA", APART FROM THE MARK AS SHOWN.

FOR REINSURANCE UNDERWRITING SERVICES AND OTHER REINSURANCE SERVICES, NAMELY, REINSURANCE CLAIMS ADMINISTRATION, CONSULTATION, CLAIMS PROCESSING, CLAIMS EVALUATION AND CLAIMS SUBROGATION; FINANCIAL SERVICES, NAMELY, INVESTMENT ADVICE, FINANCIAL OVERSIGHT, ANALYSIS, PLANNING AND MANAGEMENT, FINANCIAL ASSET MANAGEMENT, FINANCIAL RISK MANAGEMENT; CONSULTING SERVICES IN THE FIELD OF RISK FINANCING; INSURANCE UNDERWRITING SERVICES IN THE FIELD OF AVIATION AND SPACE (U.S. CLS. 100, 101 AND 102).

FIRST USE 10-25-2010; IN COMMERCE 10-25-2010.

3,999,542. BB&T CORPORATION, WINSTON-SALEM, NC. SN 85-060,452. PUB. 10-12-2010, FILED 6-11-2010.

BB&T MONEYACCOUNT

THE MARK CONSISTS OF STANDARD CHARACTERS WITHOUT CLAIM TO ANY PARTICULAR FONT, STYLE, SIZE, OR COLOR.

OWNER OF U.S. REG. NOS. 1,382,662, 3,705,945, AND OTHERS.

CLASS 36—(Continued).

NO CLAIM IS MADE TO THE EXCLUSIVE RIGHT TO USE "MONEYACCOUNT", APART FROM THE MARK AS SHOWN.

FOR PRE-PAID DEBIT CARD SERVICES (U.S. CLS. 100, 101 AND 102).

FIRST USE 1-9-2011; IN COMMERCE 1-9-2011.

3,999,546. BB&T CORPORATION, WINSTON-SALEM, NC. SN 85-061,094. PUB. 10-12-2010, FILED 6-11-2010.

AS SMALL AS YOU WANT US TO
BE, AS BIG AS YOU NEED US TO
BE

THE MARK CONSISTS OF STANDARD CHARACTERS WITHOUT CLAIM TO ANY PARTICULAR FONT, STYLE, SIZE, OR COLOR.

FOR BANKING AND RELATED FINANCIAL SERVICES (U.S. CLS. 100, 101 AND 102).

FIRST USE 4-15-2010; IN COMMERCE 4-15-2010.

3,999,547. BB&T CORPORATION, WINSTON-SALEM, NC. SN 85-061,102. PUB. 10-12-2010, FILED 6-11-2010.

GROWING SMALL BUSINESS
SINCE 1872

THE MARK CONSISTS OF STANDARD CHARACTERS WITHOUT CLAIM TO ANY PARTICULAR FONT, STYLE, SIZE, OR COLOR.

NO CLAIM IS MADE TO THE EXCLUSIVE RIGHT TO USE "SINCE 1872", APART FROM THE MARK AS SHOWN.

FOR BANKING AND RELATED FINANCIAL SERVICES (U.S. CLS. 100, 101 AND 102).

FIRST USE 4-15-2010; IN COMMERCE 4-15-2010.

3,999,575. ZENITH INSURANCE COMPANY, WOODLAND HILLS, CA. SN 85-068,986. PUB. 10-19-2010, FILED 6-22-2010.

TheZenith.com

OWNER OF U.S. REG. NOS. 2,436,080, 3,654,555, AND OTHERS.

CLASS 36—(Continued).

THE MARK CONSISTS OF THE STYLIZED WORDS "THE-ZENITH.COM" WITH AN ARROW POINTED UPWARD AND TO THE LEFT UNDER AND OVERLAPPING THE PERIOD IN ".COM".

FOR INSURANCE UNDERWRITING IN THE FIELD OF PROPERTY AND CASUALTY INSURANCE (U.S. CLS. 100, 101 AND 102).

FIRST USE 1-31-2011; IN COMMERCE 1-31-2011.

CLASS 36—(Continued).

3,999,658. TELECHECK INTERNATIONAL, INC., HOUSTON, TX. SN 85-096,791. PUB. 1-11-2011, FILED 7-30-2010.

PRO21

3,999,583. DARTAPPRAISAL.COM, INC., TROY, MI. SN 85-071,304. PUB. 11-30-2010, FILED 6-24-2010.

DARTADAPT

THE MARK CONSISTS OF STANDARD CHARACTERS WITHOUT CLAIM TO ANY PARTICULAR FONT, STYLE, SIZE, OR COLOR.

OWNER OF U.S. REG. NOS. 3,196,738, 3,739,441, AND OTHERS.

FOR REAL ESTATE APPRAISAL (U.S. CLS. 100, 101 AND 102).

FIRST USE 2-1-2011; IN COMMERCE 2-1-2011.

THE MARK CONSISTS OF STANDARD CHARACTERS WITHOUT CLAIM TO ANY PARTICULAR FONT, STYLE, SIZE, OR COLOR.

FOR PROVIDING ELECTRONIC PROCESSING OF CHECKS (U.S. CLS. 100, 101 AND 102).

FIRST USE 12-3-2010; IN COMMERCE 12-3-2010.

3,999,678. BAY SECURITIES SERVICES, LLC, TAMPA, FL. SN 85-104,363. PUB. 2-22-2011, FILED 8-10-2010.

BAY SECURITIES

THE MARK CONSISTS OF STANDARD CHARACTERS WITHOUT CLAIM TO ANY PARTICULAR FONT, STYLE, SIZE, OR COLOR.

NO CLAIM IS MADE TO THE EXCLUSIVE RIGHT TO USE "SECURITIES", APART FROM THE MARK AS SHOWN.

FOR BROKERAGE OF SHARES AND OTHER SECURITIES (U.S. CLS. 100, 101 AND 102).

FIRST USE 9-0-2010; IN COMMERCE 9-0-2010.

3,999,600. THE BLUEFIELD PROJECT TO CURE FRONTOTEMPORAL DEMENTIA, SAN FRANCISCO, CA. SN 85-076,141. PUB. 11-30-2010, FILED 7-1-2010.

The Bluefield Project

3,999,694. PRUDENT MAN ANALYSIS, INC., NAPERVILLE, IL. SN 85-108,618. PUB. 1-25-2011, FILED 8-16-2010.

INTEGRITY.COMMITMENT.PERFORMANCE.

THE MARK CONSISTS OF STANDARD CHARACTERS WITHOUT CLAIM TO ANY PARTICULAR FONT, STYLE, SIZE, OR COLOR.

NO CLAIM IS MADE TO THE EXCLUSIVE RIGHT TO USE "PROJECT", APART FROM THE MARK AS SHOWN.

FOR CHARITABLE FUND-RAISING AND FINANCING RESEARCH TO FIND A TREATMENT AND CURE FOR NEURODEGENERATIVE DISEASES CAUSING DEMENTIA (U.S. CLS. 100, 101 AND 102).

FIRST USE 2-15-2011; IN COMMERCE 2-15-2011.

THE MARK CONSISTS OF STANDARD CHARACTERS WITHOUT CLAIM TO ANY PARTICULAR FONT, STYLE, SIZE, OR COLOR.

FOR INVESTMENT BROKERAGE, FINANCIAL AND INVESTMENT BANKING SERVICES, FINANCIAL AND INVESTMENT COUNSELING SERVICES, ALL OF THE FOREGOING FOR PUBLIC FINANCE, INSURANCE COOPERATIVE AND PENSION FUND CUSTOMERS AND SPECIFICALLY EXCLUDING SMALL BUSINESS CUSTOMERS AND RETAIL OR INDIVIDUAL CONSUMER CUSTOMERS (U.S. CLS. 100, 101 AND 102).

FIRST USE 6-30-2007; IN COMMERCE 6-30-2007.

CLASS 36—(Continued).

3,999,713. PEOPLESBANK, HOLYOKE, MA. SN 85-115,181.
PUB. 2-22-2011, FILED 8-25-2010.

CLASS 36—(Continued).

3,999,762. SPINELLO SERVICES, INC., CATHEDRAL CITY,
CA. SN 85-138,383. PUB. 3-22-2011, FILED 9-26-2010.

A PASSION FOR WHAT IS
POSSIBLE



THE MARK CONSISTS OF STANDARD CHARACTERS
WITHOUT CLAIM TO ANY PARTICULAR FONT, STYLE,
SIZE, OR COLOR.

FOR BANKING SERVICES (U.S. CLS. 100, 101 AND
102).

FIRST USE 9-6-2010; IN COMMERCE 9-6-2010.

FOR COMMERCIAL AND RESIDENTIAL REAL ES-
TATE AGENCY SERVICES; REAL ESTATE SERVICES,
NAMELY, RENTAL PROPERTY MANAGEMENT; PRO-
VIDING REAL ESTATE LISTINGS AND REAL ESTATE
INFORMATION VIA AN ONLINE, INTERACTIVE DA-
TABASE; REAL ESTATE SERVICES, NAMELY, REN-
TAL, BROKERAGE, LEASING AND MANAGEMENT OF
COMMERCIAL PROPERTY, OFFICES AND OFFICE
SPACE; REAL ESTATE SALES MANAGEMENT OF
COMMERCIAL PROPERTY; ARRANGING OF LEASES
AND RENTAL AGREEMENTS FOR REAL ESTATE;
REAL ESTATE CONSULTING; REAL ESTATE PRO-
CUREMENT FOR OTHERS (U.S. CLS. 100, 101 AND 102).
FIRST USE 1-31-1997; IN COMMERCE 1-10-2011.

3,999,754. DWELLEVATE, INC. CHICAGO, IL. SN 85-132,244.
PUB. 3-1-2011, FILED 9-17-2010.

3,999,764. TWG WARRANTY GROUP, INC., CHICAGO, IL.
SN 85-138,658. PUB. 3-8-2011, FILED 9-27-2010.

DWELLEVATE



THE MARK CONSISTS OF STANDARD CHARACTERS
WITHOUT CLAIM TO ANY PARTICULAR FONT, STYLE,
SIZE, OR COLOR.

FOR COMMERCIAL AND RESIDENTIAL REAL ES-
TATE AGENCY SERVICES; REAL ESTATE BROKER-
AGE; REAL ESTATE LISTING; REAL ESTATE
SERVICES, NAMELY, PROPERTY MANAGEMENT SER-
VICES FOR CONDOMINIUM ASSOCIATIONS, HOME-
OWNER ASSOCIATIONS AND APARTMENT
BUILDINGS (U.S. CLS. 100, 101 AND 102).
FIRST USE 3-1-2011; IN COMMERCE 5-23-2011.

OWNER OF U.S. REG. NOS. 3,237,007 AND 3,237,022.
THE MARK CONSISTS OF THE WORDING "THE ME-
CHANIC" WITH THE "A" STYLIZED AS A WRENCH IN
THE MIDDLE OF THE "A".

FOR UNDERWRITING AND CLAIMS ADMINISTRA-
TION OF SERVICE, REPAIR AND MAINTENANCE
CONTRACTS AND INSURANCE FOR AUTOMOBILES
AND THEIR COMPONENTS (U.S. CLS. 100, 101 AND
102).
FIRST USE 10-1-2010; IN COMMERCE 10-1-2010.

CLASS 36—(Continued).

3,999,785. THE ROSETTE GROUP, INC., SHIRLEY, NY. SN 85-144,405. PUB. 3-15-2011, FILED 10-4-2010.

OPENING DOORS TO REAL ESTATE

THE MARK CONSISTS OF STANDARD CHARACTERS WITHOUT CLAIM TO ANY PARTICULAR FONT, STYLE, SIZE, OR COLOR.

FOR REAL ESTATE BROKERAGE (U.S. CLS. 100, 101 AND 102).
FIRST USE 5-7-2011; IN COMMERCE 5-12-2011.

3,999,857. PROGRESSIVE CASUALTY INSURANCE COMPANY, MAYFIELD VILLAGE, OH. SN 85-173,234. PUB. 3-1-2011, FILED 11-10-2010.

OUT THERE WITH A BETTER WAY

THE MARK CONSISTS OF STANDARD CHARACTERS WITHOUT CLAIM TO ANY PARTICULAR FONT, STYLE, SIZE, OR COLOR.

FOR PROPERTY AND CASUALTY INSURANCE UNDERWRITING AND ADMINISTRATION SERVICES, NAMELY, INSURANCE PREMIUM QUOTING, TAKING AND PROCESSING INSURANCE APPLICATIONS, POLICY ISSUANCE AND SERVICING, AND CLAIMS ADJUSTMENT AND PROCESSING; PROVIDING INFORMATION VIA A GLOBAL COMPUTER INFORMATION NETWORK REGARDING INSURANCE UNDERWRITING AND SERVICING IN THE FIELDS OF PROPERTY AND CASUALTY INSURANCE (U.S. CLS. 100, 101 AND 102).
FIRST USE 2-28-2011; IN COMMERCE 2-28-2011.

3,999,858. PAN-AMERICAN LIFE INSURANCE COMPANY, NEW ORLEANS, LA. SN 85-174,006. PUB. 3-15-2011, FILED 11-10-2010.

PANACARE

THE MARK CONSISTS OF STANDARD CHARACTERS WITHOUT CLAIM TO ANY PARTICULAR FONT, STYLE, SIZE, OR COLOR.

OWNER OF U.S. REG. NO. 3,770,448.
FOR HEALTH AND LIFE INSURANCE UNDERWRITING AND ADMINISTRATION SERVICES (U.S. CLS. 100, 101 AND 102).
FIRST USE 1-7-2011; IN COMMERCE 1-7-2011.

CLASS 37—CONSTRUCTION AND REPAIR

3,998,343. CASTLEROCK PARTNERS LIMITED PARTNERSHIP, AUSTIN, TX. SN 76-704,697. PUB. 2-22-2011, FILED 9-27-2010.

CASTLE HILL PARTNERS

THE MARK CONSISTS OF STANDARD CHARACTERS WITHOUT CLAIM TO ANY PARTICULAR FONT, STYLE, SIZE, OR COLOR.

NO CLAIM IS MADE TO THE EXCLUSIVE RIGHT TO USE "PARTNERS", APART FROM THE MARK AS SHOWN.
FOR CONSTRUCTION AND CONSTRUCTION MANAGEMENT AND DEVELOPMENT OF COMMERCIAL AND RESIDENTIAL REAL ESTATE, NAMELY, PLANNING AND LAYING OUT MIXED-USE REAL ESTATE DEVELOPMENTS (U.S. CLS. 100, 103 AND 106).
FIRST USE 4-0-2011; IN COMMERCE 4-0-2011.

3,998,377. BROWNSTEIN, ADAM S., HOUSTON, TX. SN 77-129,439. PUB. 8-19-2008, FILED 3-13-2007.

GREEN HOUSE LIVING

THE MARK CONSISTS OF STANDARD CHARACTERS WITHOUT CLAIM TO ANY PARTICULAR FONT, STYLE, SIZE, OR COLOR.

NO CLAIM IS MADE TO THE EXCLUSIVE RIGHT TO USE "GREEN HOUSE", APART FROM THE MARK AS SHOWN.

FOR CONSULTING SERVICES IN THE NATURE OF ADVISING OTHERS IN THE FIELD OF RESIDENTIAL NEW HOME CONSTRUCTION AND HOME RENOVATION, IMPROVEMENT AND CONSTRUCTION SERVICES (U.S. CLS. 100, 103 AND 106).
FIRST USE 6-12-2008; IN COMMERCE 6-12-2008.

CLASS 37—(Continued).

3,998,531. SEARS BRANDS, LLC, HOFFMAN ESTATES, IL. SN 77-570,357. PUB. 9-28-2010, FILED 9-15-2008.

FLEETHANDLER

THE MARK CONSISTS OF STANDARD CHARACTERS WITHOUT CLAIM TO ANY PARTICULAR FONT, STYLE, SIZE, OR COLOR.

FOR FLEET MAINTENANCE SERVICES, NAMELY, COOLING SYSTEM REPAIR, EXHAUST SYSTEM REPAIR; VEHICLE BRAKE SERVICES, NAMELY, MAINTENANCE, REPAIR AND REPLACEMENT OF BRAKE CALIPERS, CYLINDERS, DISCS, DRUMS, LINES, LININGS, PADS, SHOES, ROTORS, HYDRAULIC DISC BRAKES AND AIR BRAKE HOSES; VEHICLE TIRE SERVICES, NAMELY, MAINTENANCE, REPAIR AND REPLACEMENT OF TIRES, TIRE LINERS, TIRE VALVES, TIRE TUBES, VALVE STEMS, TIRE DEFLATORS, TIRE BALANCING, TIRE ROTATING, TIRE RETREADING; EMERGENCY VEHICLE ROADSIDE ASSISTANCE, NAMELY, RESPONDING TO CALLS IN ORDER TO CHANGE FLAT TIRES; VEHICLE CHASSIS SERVICES, NAMELY, REPAIR AND REPLACEMENT OF A VEHICLES' GAS TANKS, OIL TANKS, TRANSMISSION, DRIVESHAFT, DIFFERENTIAL AND SUSPENSION SYSTEM; VEHICLE BATTERY AND ELECTRICAL PARTS SERVICES, NAMELY, EMERGENCY ROADSIDE SERVICES IN CONNECTION WITH BATTERY CHARGING AND BATTERY REGENERATION; VEHICLE ELECTRICAL PARTS SERVICES, NAMELY, REPAIR AND REPLACEMENT OF ELECTRICAL FUSE BOXES, COMPUTERS AND ELECTRONIC CONTROL MODULES, IGNITION AND SPARK PLUG WIRES AND SWITCHES, STARTERS, ALTERNATORS AND GENERATORS; GENERAL VEHICLE REPAIR SERVICES, NAMELY, REPAIR AND REPLACEMENT OF WATER PUMPS, FUEL PUMPS, CARBURETORS, MUFFLERS, STRUTS (U.S. CLS. 100, 103 AND 106).

FIRST USE 6-0-2009; IN COMMERCE 6-0-2009.

3,998,565. COVERALL NORTH AMERICA, INC., BOCA RATON, FL. SN 77-603,106. PUB. 8-11-2009, FILED 10-29-2008.

COVERALL COLOR-CODING FOR HEALTH

THE MARK CONSISTS OF STANDARD CHARACTERS WITHOUT CLAIM TO ANY PARTICULAR FONT, STYLE, SIZE, OR COLOR.

OWNER OF U.S. REG. NOS. 2,075,333, 2,337,703, AND OTHERS.

NO CLAIM IS MADE TO THE EXCLUSIVE RIGHT TO USE "COLOR CODING", APART FROM THE MARK AS SHOWN.

FOR CLEANING OF MEDICAL BUILDINGS, COMMERCIAL OFFICES AND COMMERCIAL BUILDINGS (U.S. CLS. 100, 103 AND 106).

FIRST USE 6-0-2010; IN COMMERCE 6-0-2010.

CLASS 37—(Continued).

3,998,585. HPE DESIGN, LLC, DBA HENNESSEY PERFORMANCE ENGINEERING, SEALY, TX. SN 77-630,353. PUB. 12-1-2009, FILED 12-10-2008.

VENOM GT

THE MARK CONSISTS OF STANDARD CHARACTERS WITHOUT CLAIM TO ANY PARTICULAR FONT, STYLE, SIZE, OR COLOR.

NO CLAIM IS MADE TO THE EXCLUSIVE RIGHT TO USE "GT", APART FROM THE MARK AS SHOWN.

FOR CUSTOMIZING AND MODIFYING AUTOMOTIVE VEHICLES TO CUSTOMERS' SPECIFICATIONS (U.S. CLS. 100, 103 AND 106).

FIRST USE 1-1-2010; IN COMMERCE 4-1-2010.

3,998,622. BAY AREA ENERGY SOLUTIONS, INC., BURLINGAME, CA. SN 77-695,749. PUB. 3-9-2010, FILED 3-20-2009.

ENERGYCENTRIX

THE MARK CONSISTS OF STANDARD CHARACTERS WITHOUT CLAIM TO ANY PARTICULAR FONT, STYLE, SIZE, OR COLOR.

FOR CONSTRUCTION CONSULTATION AND PLANNING IN THE FIELD OF ENERGY EFFICIENCY AND SUSTAINABLE CONSTRUCTION IN CONNECTION WITH BUILDING, RENOVATIONS AND IMPROVEMENTS; HOME ENERGY ASSESSMENT SERVICES FOR THE PURPOSE OF DETERMINING HOME IMPROVEMENTS NEEDED TO IMPROVE ENERGY USE AND EFFICIENCY; INSTALLATION OF ENERGY EFFICIENT GOODS, NAMELY, INSULATION, HVAC SYSTEMS, LIGHTING, WINDOWS, SOLAR VOLTAIC PANELS, AND SOLAR THERMAL PANELS IN CONNECTION WITH BUILDING, RENOVATIONS AND IMPROVEMENTS (U.S. CLS. 100, 103 AND 106).

FIRST USE 3-1-2011; IN COMMERCE 3-1-2011.

3,998,774. MASTER GRINDING SERVICE, INC., ROCKAWAY, NJ. SN 77-829,793. PUB. 8-3-2010, FILED 9-18-2009.



NO CLAIM IS MADE TO THE EXCLUSIVE RIGHT TO USE THE PICTORIAL REPRESENTATION OF THE KNIFE, APART FROM THE MARK AS SHOWN.

CLASS 37—(Continued).

THE MARK CONSISTS OF THE WORDS "HAVE A KNIFE DAY!" WITH A SMILEY FACE ABOVE WORDS AND A PICTURE OF A KNIFE BELOW THE WORDS .

FOR CUTLERY SHARPENING, CARE, AND RECONDITIONING SERVICE (U.S. CLS. 100, 103 AND 106).
FIRST USE 4-14-2008; IN COMMERCE 4-14-2008.

CLASS 37—(Continued).

3,999,357. NANA, RUPEN, WINDERMERE, FL. SN 85-029,560. PUB. 10-5-2010, FILED 5-4-2010.

3,998,896. SOLAR SEMICONDUCTOR, INC., SUNNYVALE, CA. SN 77-864,307. PUB. 10-12-2010, FILED 11-3-2009.

SolarGuru

MiCasa

THE MARK CONSISTS OF STANDARD CHARACTERS WITHOUT CLAIM TO ANY PARTICULAR FONT, STYLE, SIZE, OR COLOR.

FOR INSTALLATION AND MAINTENANCE OF SOLAR ENERGY BASED POWER PLANTS; INSTALLATION OF SOLAR ENERGY SYSTEMS AND ALTERNATIVE ENERGY PRODUCTS FOR RESIDENTIAL AND COMMERCIAL USE (U.S. CLS. 100, 103 AND 106).

FIRST USE 5-4-2010; IN COMMERCE 5-4-2010.

THE MARK CONSISTS OF STANDARD CHARACTERS WITHOUT CLAIM TO ANY PARTICULAR FONT, STYLE, SIZE, OR COLOR.

THE ENGLISH TRANSLATION OF "MICASA" IN THE MARK IS "MY HOUSE".

FOR INSTALLATION OF PHOTO VOLTAIC MODULES AND CELLS FOR SOLAR ENERGY GENERATION, PRIMARILY FOR RESIDENCES (U.S. CLS. 100, 103 AND 106).

FIRST USE 10-27-2009; IN COMMERCE 10-27-2009.

3,999,416. BUILDERFISH, LLC, RUCKERSVILLE, VA. SN 85-035,896. PUB. 10-12-2010, FILED 5-12-2010.

BUILDERFISH

3,998,972. DUCT MASTERS RX LLC, HANOVER, PA. SN 77-893,852. PUB. 10-19-2010, FILED 12-15-2009.

Duct Masters RX

THE MARK CONSISTS OF STANDARD CHARACTERS WITHOUT CLAIM TO ANY PARTICULAR FONT, STYLE, SIZE, OR COLOR.

NO CLAIM IS MADE TO THE EXCLUSIVE RIGHT TO USE "DUCT", APART FROM THE MARK AS SHOWN.

FOR AIR DUCT CLEANING SERVICES (U.S. CLS. 100, 103 AND 106).

FIRST USE 12-20-2009; IN COMMERCE 12-30-2009.

THE MARK CONSISTS OF STANDARD CHARACTERS WITHOUT CLAIM TO ANY PARTICULAR FONT, STYLE, SIZE, OR COLOR.

FOR BUILDING CONSTRUCTION, REMODELING AND REPAIR; CONSTRUCTION AND RENOVATION OF BUILDINGS; CONSTRUCTION PROJECT MANAGEMENT SERVICES; GENERAL BUILDING CONTRACTOR SERVICES (U.S. CLS. 100, 103 AND 106).

FIRST USE 3-30-2010; IN COMMERCE 5-16-2011.

CLASS 37—(Continued).

3,999,559. SOLAR POTENTIAL, BERKLEY, MA. SN 85-064,799. PUB. 11-16-2010, FILED 6-16-2010.

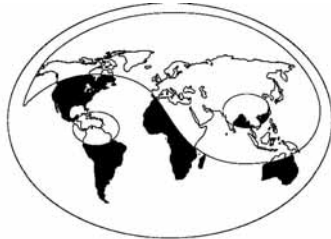

**Green Planet
One Job at A Time**

THE MARK CONSISTS OF THE STYLIZED WORDS "GREEN PLANET ONE JOB AT A TIME" AND AN IMAGE OF A OBLONG YIN-YANG OUTLINE OF THE CONTINENTS ON IT.

FOR ELECTRICAL CONTRACTOR SERVICES; INSTALLATION AND MAINTENANCE OF SOLAR PHOTOVOLTAIC SYSTEMS, WIND TURBINES, AND SOLAR THERMAL HOT WATER SYSTEMS (U.S. CLS. 100, 103 AND 106).

FIRST USE 7-31-2010; IN COMMERCE 10-10-2010.

3,999,686. SWIFT RENOVATIONS, INC., GLENDALE, NY. SN 85-106,387. PUB. 1-25-2011, FILED 8-12-2010.



THE COLOR(S) YELLOW, BLACK, BEIGE, ORANGE, BROWN, DARK BROWN, RED, GRAY, AND WHITE IS/ ARE CLAIMED AS A FEATURE OF THE MARK.

THE MARK CONSISTS OF A STYLIZED CONSTRUCTION WORKER WITH BEIGE SKIN, BLACK EYEBROWS, AND WHITE TEETH WEARING A YELLOW AND BLACK HARDHAT WITH WHITE HIGHLIGHTS, BLACK SUNGLASSES, A YELLOW T-SHIRT, AN ORANGE VEST WITH BLACK MARKINGS AROUND THE WAIST PORTION OF THE VEST, BROWN GLOVES OUTLINED IN BLACK, AND

CLASS 37—(Continued).

A BROWN TOOL BELT HOLDING FOUR TOOLS. THE BELT HAS A GRAY BUCKLE WITH BLACK OUTLINING. THE TOOL ON THE FAR LEFT HAS A DARK BROWN HANDLE, THE TOOL THIRD FROM THE LEFT HAS A RED HANDLE, OTHERWISE THE TOOLS ARE GRAY. ACROSS THE CHEST OF THE YELLOW T-SHIRT ARE THE STYLIZED WORDS "SWIFT" IN BLACK. BELOW THE TERM "SWIFT" ARE BLACK LINES OUTLINING THE CHEST AREA. UNDERNEATH THE CONSTRUCTION WORKER IS A STYLIZED TORNADO IN GRAY AND BLACK.

FOR HOUSING SERVICES, NAMELY, REPAIR, IMPROVEMENT, AND CONSTRUCTION OF RESIDENTIAL REAL PROPERTY (U.S. CLS. 100, 103 AND 106). FIRST USE 0-0-2010; IN COMMERCE 0-0-2010.

CLASS 38—COMMUNICATION

3,998,346. EMBARQ HOLDINGS COMPANY LLC, DBA/ AKA/TA: DBA CENTURYLINK, INC., CENTURYTEL, INC., OVERLAND PARK, KS. SN 76-979,147. PUB. 2-16-2010, FILED 5-26-2009.



THE COLOR(S) GREEN IS/ARE CLAIMED AS A FEATURE OF THE MARK.

THE MARK CONSISTS OF TWELVE SMALL GREEN TRIANGLES ARRANGED IN A CIRCLE.

FOR CONSULTING IN THE FIELD OF TELECOMMUNICATIONS IN THE NATURE OF TECHNICAL CONSULTING IN THE FIELD OF AUDIO, TEXT AND DATA TRANSMISSION AND COMMUNICATION; TELEPHONE COMMUNICATION SERVICES, ELECTRONIC TRANSMISSION OF MESSAGES AND DATA, TELEPHONE VOICE MESSAGING SERVICE; TELECOMMUNICATION AND INFORMATION TECHNOLOGY SERVICES, NAMELY, ELECTRONIC, DIGITAL, WIRELESS TRANSMISSION OF VOICE, DATA, INFORMATION, IMAGES, SIGNALS AND MESSAGES; AND ELECTRONIC TRANSMISSION OF VOICE, DATA, IMAGES, AUDIO, VIDEO AND INFORMATION VIA TELEPHONE, TELEVISION AND GLOBAL COMMUNICATION NETWORKS; PROVIDING TELECOMMUNICATIONS CONNECTIONS TO A GLOBAL COMMUNICATIONS NETWORK, ELECTRONIC STORE-AND-FORWARD MESSAGING; RENTAL OF TELECOMMUNICATIONS EQUIPMENT, NAMELY, EQUIPMENT FOR ELECTRONIC ACCESS TO GLOBAL TELECOMMUNICATIONS NETWORK, EQUIPMENT FOR TRANSMITTING, RECEIVING, RECORDING AND MONITORING VOICE, DATA, INFORMATION IMAGES, SIGNALS, MESSAGES COMPRISED OF DATA AND WORD PROCESSORS, AND TELECOMMUNICATIONS HARDWARE COMPONENTS AND PERIPHERALS THEREOF FOR USE IN THE TELECOMMUNICATIONS INDUSTRY, AND EQUIPMENT FOR TRANSMITTING, RECEIVING, RECORDING AND MONITORING COMPUTER PROGRAMS FOR USE IN OPERATING AND ACCESSING TELECOMMUNICATIONS SYSTEMS; AUDIO AND VIDEO BROADCASTING; PROVIDING MULTIPLE-USER DIAL-UP AND DEDICATED ACCESS TO THE INTERNET; PERSONAL COMMUNICATIONS SERVICES; TRANSMISSION AND BROADCAST OF

CLASS 38—(Continued).

AUDIO AND VIDEO PROGRAMMING; LEASING OF TELECOMMUNICATIONS EQUIPMENT, COMPONENTS AND SYSTEMS; PROVIDING INFORMATION VIA THE TELEPHONE AND THE GLOBAL COMMUNICATION NETWORKS IN THE FIELD OF TELECOMMUNICATIONS; TRANSMISSION, RECEPTION AND PROCESSING OF CODED AND EMERGENCY SIGNALS; INTERNET TELEPHONY SERVICE; TELECOMMUNICATION SERVICES, NAMELY, LOCAL AND LONG DISTANCE TRANSMISSION OF VOICE, DATA, GRAPHICS BY MEANS OF TELEPHONE, CABLE, AND SATELLITE TRANSMISSIONS; BROADCASTING SERVICES AND PROVISION OF TELECOMMUNICATION ACCESS TO VIDEO AND AUDIO CONTENT PROVIDED VIA A VIDEO-ON-DEMAND SERVICE VIA THE INTERNET; CALL FORWARDING SERVICES; ELECTRONIC MAIL SERVICES; PREPAID LONG DISTANCE TELEPHONE SERVICES; PROVIDING REMOTE INTERNET ACCESS; SATELLITE, CABLE, NETWORK TRANSMISSION OF SOUNDS, IMAGES, SIGNALS AND DATA; SECURE E-MAIL SERVICES; INTEGRATION AND ENABLING OF E-COMMERCE, NAMELY, PROVIDING MULTIPLE-USER ACCESS TO A GLOBAL COMPUTER INFORMATION NETWORK; BROADBAND TELEVISION BROADCASTING AND BROADBAND TELEVISION TRANSMISSION SERVICES FOR THE INTERNET; VIDEO ON DEMAND TRANSMISSION SERVICES; TELECOMMUNICATIONS SERVICES, NAMELY, PROVIDING A PHONE AND COMMUNICATIONS SERVICE CAPABLE OF SWITCHING BETWEEN A WIRELESS AND WIRELINE CONNECTION; PROVIDING MULTIPLE USER ACCESS TO WIRELESS AND WIRELINE LOCAL AREA COMPUTER NETWORKS; HIGH SPEED TRANSMISSION OF VOICE, DATA, IMAGES, VIDEO, AUDIO AND INFORMATION VIA A GLOBAL COMPUTER NETWORK, COMPUTERS AND WIRELESS DEVICES; PROVIDING ACCESS FOR OTHERS TO A GLOBAL COMPUTER NETWORK FOR THE TRANSFER AND DISSEMINATION OF INFORMATION IN A WIDE VARIETY OF FIELDS; AUDIO TELECONFERENCING SERVICES; VIDEO TELECONFERENCING, ELECTRONIC MAIL, VOICE-MAIL AND ELECTRONIC DATA TRANSMISSION; TELEPHONE COMMUNICATIONS SERVICES; ELECTRONIC, ELECTRIC, AND DIGITAL TRANSMISSION OF VOICE, DATA, IMAGES, SIGNALS, AND MESSAGES; VOICE MESSAGE, RECEIVING, RECORDING AND TRANSMISSION SERVICES (U.S. CLS. 100, 101 AND 104).

FIRST USE 10-19-2009; IN COMMERCE 10-19-2009.

3,998,348. EMBARQ HOLDINGS COMPANY LLC, DBA/ AKA/TA: DBA CENTURYLINK, INC., CENTURYTEL, INC., OVERLAND PARK, KS. SN 76-979,150. PUB. 2-16-2010, FILED 5-26-2009.



OWNER OF U.S. REG. NOS. 2,228,120, 3,124,133, AND OTHERS.

CLASS 38—(Continued).

THE MARK CONSISTS OF THE WORDING "CENTURY-LINK" WITH A DESIGN IN NATURE OF TWELVE SMALL TRIANGLES ARRANGED IN A CIRCLE NEXT TO THE WORDING OF THE MARK.

FOR CONSULTING IN THE FIELD OF TELECOMMUNICATIONS IN THE NATURE OF TECHNICAL CONSULTING IN THE FIELD OF AUDIO, TEXT AND DATA TRANSMISSION AND COMMUNICATION; TELEPHONE COMMUNICATION SERVICES, ELECTRONIC TRANSMISSION OF MESSAGES AND DATA, TELEPHONE VOICE MESSAGING SERVICE; TELECOMMUNICATION AND INFORMATION TECHNOLOGY SERVICES, NAMELY, ELECTRONIC, DIGITAL, WIRELESS TRANSMISSION OF VOICE, DATA, INFORMATION, IMAGES, SIGNALS AND MESSAGES; AND ELECTRONIC TRANSMISSION OF VOICE, DATA, IMAGES, AUDIO, VIDEO AND INFORMATION VIA TELEPHONE, TELEVISION AND GLOBAL COMMUNICATION NETWORKS; PROVIDING TELECOMMUNICATIONS CONNECTIONS TO A GLOBAL COMMUNICATIONS NETWORK, ELECTRONIC STORE-AND-FORWARD MESSAGING; RENTAL OF TELECOMMUNICATIONS EQUIPMENT, NAMELY, EQUIPMENT FOR ELECTRONIC ACCESS TO GLOBAL TELECOMMUNICATIONS NETWORK, EQUIPMENT FOR TRANSMITTING, RECEIVING, RECORDING AND MONITORING VOICE, DATA, INFORMATION IMAGES, SIGNALS, MESSAGES COMPRISED OF DATA AND WORD PROCESSORS, AND TELECOMMUNICATIONS HARDWARE COMPONENTS AND PERIPHERALS THEREOF FOR USE IN THE TELECOMMUNICATIONS INDUSTRY, AND EQUIPMENT FOR TRANSMITTING, RECEIVING, RECORDING AND MONITORING COMPUTER PROGRAMS FOR USE IN OPERATING AND ACCESSING TELECOMMUNICATIONS SYSTEMS; AUDIO AND VIDEO BROADCASTING; PROVIDING MULTIPLE-USER DIAL-UP AND DEDICATED ACCESS TO THE INTERNET; PERSONAL COMMUNICATIONS SERVICES; TRANSMISSION AND BROADCAST OF AUDIO AND VIDEO PROGRAMMING; LEASING OF TELECOMMUNICATIONS EQUIPMENT, COMPONENTS AND SYSTEMS; PROVIDING INFORMATION VIA THE TELEPHONE AND THE GLOBAL COMMUNICATION NETWORKS IN THE FIELD OF TELECOMMUNICATIONS; TRANSMISSION, RECEPTION AND PROCESSING OF CODED AND EMERGENCY SIGNALS; INTERNET TELEPHONY SERVICE; TELECOMMUNICATION SERVICES, NAMELY, LOCAL AND LONG DISTANCE TRANSMISSION OF VOICE, DATA, GRAPHICS BY MEANS OF TELEPHONE, CABLE, AND SATELLITE TRANSMISSIONS; BROADCASTING SERVICES AND PROVISION OF TELECOMMUNICATION ACCESS TO VIDEO AND AUDIO CONTENT PROVIDED VIA A VIDEO-ON-DEMAND SERVICE VIA THE INTERNET; CALL FORWARDING SERVICES; ELECTRONIC MAIL SERVICES; PREPAID LONG DISTANCE TELEPHONE SERVICES; PROVIDING REMOTE INTERNET ACCESS; SATELLITE, CABLE, NETWORK TRANSMISSION OF SOUNDS, IMAGES, SIGNALS AND DATA; SECURE E-MAIL SERVICES; INTEGRATION AND ENABLING OF E-COMMERCE, NAMELY, PROVIDING MULTIPLE-USER ACCESS TO A GLOBAL COMPUTER INFORMATION NETWORK; BROADBAND TELEVISION BROADCASTING AND BROADBAND TELEVISION TRANSMISSION SERVICES FOR THE INTERNET; VIDEO ON DEMAND TRANSMISSION SERVICES; TELECOMMUNICATIONS SERVICES,

CLASS 38—(Continued).

NAMELY, PROVIDING A PHONE AND COMMUNICATIONS SERVICE CAPABLE OF SWITCHING BETWEEN A WIRELESS AND WIRELINE CONNECTION; PROVIDING MULTIPLE USER ACCESS TO WIRELESS AND WIRELINE LOCAL AREA COMPUTER NETWORKS; HIGH SPEED TRANSMISSION OF VOICE, DATA, IMAGES, VIDEO, AUDIO AND INFORMATION VIA A GLOBAL COMPUTER NETWORK, COMPUTERS AND WIRELESS DEVICES; PROVIDING ACCESS FOR OTHERS TO A GLOBAL COMPUTER NETWORK FOR THE TRANSFER AND DISSEMINATION OF INFORMATION IN A WIDE VARIETY OF FIELDS; AUDIO TELECONFERENCING SERVICES; VIDEO TELECONFERENCING, ELECTRONIC MAIL, VOICE-MAIL AND ELECTRONIC DATA TRANSMISSION; TELEPHONE COMMUNICATIONS SERVICES; ELECTRONIC, ELECTRIC, AND DIGITAL TRANSMISSION OF VOICE, DATA, IMAGES, SIGNALS, AND MESSAGES; VOICE MESSAGE, RECEIVING, RECORDING AND TRANSMISSION SERVICES (U.S. CLS. 100, 101 AND 104).

FIRST USE 10-19-2009; IN COMMERCE 10-19-2009.

3,998,365. FRONTIER COMMUNICATIONS CORPORATION, STAMFORD, CT. SN 77-095,391. PUB. 9-4-2007, FILED 1-31-2007.

FRONTIER WIRELESS

THE MARK CONSISTS OF STANDARD CHARACTERS WITHOUT CLAIM TO ANY PARTICULAR FONT, STYLE, SIZE, OR COLOR.

OWNER OF U.S. REG. NOS. 1,960,994, 3,234,718, AND OTHERS.

NO CLAIM IS MADE TO THE EXCLUSIVE RIGHT TO USE "WIRELESS", APART FROM THE MARK AS SHOWN. FOR TELECOMMUNICATION SERVICES, NAMELY, PROVIDING VIDEO, IMAGE, VOICE, AUDIO, TEXT AND DATA INFORMATION TO COMPUTERS, MOBILE TELEPHONES, AND MOBILE DATA RECEIVERS; WIRELESS TRANSMISSION OF VIDEO, IMAGE, VOICE, AUDIO, TEXT AND DATA INFORMATION VIA A GLOBAL COMPUTER NETWORK; PROVIDING MULTIPLE USER ACCESS TO A GLOBAL COMPUTER INFORMATION NETWORK; PROVIDING VOICE OVER INTERNET PROTOCOL TELECOMMUNICATIONS SERVICES (U.S. CLS. 100, 101 AND 104).

FIRST USE 6-4-2007; IN COMMERCE 6-4-2007.

3,998,382. GREEN PLANET MOBILE, LLC, HENDERSON, NV. SN 77-167,929. PUB. 8-25-2009, FILED 4-27-2007.

GREEN PLANET MOBILE

THE MARK CONSISTS OF STANDARD CHARACTERS WITHOUT CLAIM TO ANY PARTICULAR FONT, STYLE, SIZE, OR COLOR.

CLASS 38—(Continued).

NO CLAIM IS MADE TO THE EXCLUSIVE RIGHT TO USE "GREEN" AND "MOBILE", APART FROM THE MARK AS SHOWN.

FOR COMMUNICATIONS BY MEANS OF MOBILE PHONES; TELECOMMUNICATION SERVICES, NAMELY, LOCAL AND LONG DISTANCE TRANSMISSION OF VOICE, DATA, GRAPHICS BY MEANS OF TELEPHONE, TELEGRAPHIC, CABLE, AND SATELLITE TRANSMISSIONS; TELECOMMUNICATION SERVICES, NAMELY, TRANSMISSION OF VOICE, DATA AND DOCUMENTS, IN THE FIELD OF ENVIRONMENTAL PROTECTION; TELECOMMUNICATIONS SERVICES, NAMELY, PERSONAL COMMUNICATION SERVICES; WIRELESS TELEPHONE TELECOMMUNICATIONS SERVICES, NAMELY, WIRELESS MOBILE TELEPHONE CALLING PLANS; MOBILE MEDIA SERVICES IN THE NATURE OF ELECTRONIC TRANSMISSION OF ENTERTAINMENT MEDIA CONTENT (U.S. CLS. 100, 101 AND 104).

FIRST USE 5-1-2011; IN COMMERCE 5-1-2011.

3,998,460. HALL, KATHLEEN A., CLARKESVILLE, GA. SN 77-385,411. PUB. 9-2-2008, FILED 1-31-2008.

OWN YOUR HAPPINESS

THE MARK CONSISTS OF STANDARD CHARACTERS WITHOUT CLAIM TO ANY PARTICULAR FONT, STYLE, SIZE, OR COLOR.

FOR STREAMING AUDIO AND VIDEO OVER THE INTERNET AND BEING TRANSMITTED, BROADCAST, OR STREAMED TO MEDIA DEVICES, IN THE FIELD OF PERSONAL SPIRITUAL GROWTH, HEALING AND WELLNESS AND IDENTIFYING, OVERCOMING AND AVOIDING STRESS AND DESTRUCTIVE BEHAVIOR (U.S. CLS. 100, 101 AND 104).

FIRST USE 8-26-2010; IN COMMERCE 8-26-2010.

3,998,521. BACICH, PATRICK, WEST COVINA, CA. SN 77-559,229. PUB. 2-24-2009, FILED 8-29-2008.

HEAVY EASY LISTENING

THE MARK CONSISTS OF STANDARD CHARACTERS WITHOUT CLAIM TO ANY PARTICULAR FONT, STYLE, SIZE, OR COLOR.

NO CLAIM IS MADE TO THE EXCLUSIVE RIGHT TO USE "EASY LISTENING", APART FROM THE MARK AS SHOWN.

FOR RADIO BROADCASTING SERVICES (U.S. CLS. 100, 101 AND 104).

FIRST USE 11-12-2010; IN COMMERCE 11-12-2010.

CLASS 38—(Continued).

3,998,590. FULL SAIL, LLC, WINTER PARK, FL. SN 77-632,873. PUB. 9-8-2009, FILED 12-15-2008.



OWNER OF U.S. REG. NOS. 2,025,339, 3,525,113, AND OTHERS.

NO CLAIM IS MADE TO THE EXCLUSIVE RIGHT TO USE "UNIVERSITY", APART FROM THE MARK AS SHOWN.

THE COLOR(S) ORANGE, WHITE AND SAGE IS/ARE CLAIMED AS A FEATURE OF THE MARK.

THE MARK CONSISTS OF A DESIGN OF AN AIRPLANE WITHIN A CIRCULAR DESIGN AND THE WORDS "FULL SAIL UNIVERSITY" BELOW THE DESIGN. THE AIRPLANE DESIGN IS IN WHITE, THE CIRCULAR DESIGN IS IN ORANGE AND THE WORDS "FULL SAIL UNIVERSITY" ARE IN SAGE.

FOR PROVIDING AN ONLINE PORTAL FOR STUDENTS AND INSTRUCTORS TO COMMUNICATE AND TRANSMIT INFORMATION, DATA, AND DIGITAL CONTENT PERTAINING TO EDUCATIONAL RESOURCES AND PROJECTS (U.S. CLS. 100, 101 AND 104). FIRST USE 5-25-2011; IN COMMERCE 5-25-2011.

3,998,627. IWAKI AMERICA INCORPORATED, HOLLISTON, MA. SN 77-703,013. PUB. 9-21-2010, FILED 3-31-2009.

VT-VNET

THE MARK CONSISTS OF STANDARD CHARACTERS WITHOUT CLAIM TO ANY PARTICULAR FONT, STYLE, SIZE, OR COLOR.

FOR PROVIDING TELECOMMUNICATIONS ACCESS VIA TCP/IP CONNECTIONS TO CONTROL DEVICES ON PRIVATE NETWORKS IN REMOTE FACILITIES RELATED TO THE CONTROL AND MANAGEMENT OF WATER TREATMENT EQUIPMENT (U.S. CLS. 100, 101 AND 104).

FIRST USE 3-31-2011; IN COMMERCE 3-31-2011.

CLASS 38—(Continued).

3,998,708. CEQUEL COMMUNICATIONS, LLC, DBA SUDENLINK COMMUNICATIONS, ST. LOUIS, MO. SN 77-772,697. PUB. 2-9-2010, FILED 7-1-2009.

NOW VOD

THE MARK CONSISTS OF STANDARD CHARACTERS WITHOUT CLAIM TO ANY PARTICULAR FONT, STYLE, SIZE, OR COLOR.

NO CLAIM IS MADE TO THE EXCLUSIVE RIGHT TO USE "VOD", APART FROM THE MARK AS SHOWN.

FOR PROVISION OF TELECOMMUNICATION TRANSMISSION OF AND ACCESS TO VIDEO AND AUDIO CONTENT PROVIDED VIA VIDEO-ON-DEMAND, INTERACTIVE TELEVISION, PAY PER VIEW AND PAY TELEVISION SUBSCRIPTION SERVICES; VIDEO-ON-DEMAND TRANSMISSION SERVICES; INTERACTIVE TELEVISION BROADCASTING AND TRANSMISSION SERVICES PROVIDING ACCESS TO INFORMATION FROM THIRD-PARTY SOURCES (U.S. CLS. 100, 101 AND 104).

FIRST USE 10-31-2010; IN COMMERCE 11-30-2010.

3,998,731. EMBARQ HOLDINGS COMPANY LLC, OVERLAND PARK, KS. SN 77-798,378. PUB. 10-12-2010, FILED 8-6-2009.

MOBLITZER

THE MARK CONSISTS OF STANDARD CHARACTERS WITHOUT CLAIM TO ANY PARTICULAR FONT, STYLE, SIZE, OR COLOR.

FOR PROVIDING FACILITIES AND TRANSMISSION SERVICES ENABLING INDIVIDUALS AND BUSINESSES TO COMMUNICATE TEXT, GRAPHICS AND VIDEO TO A PLURALITY OF MOBILE COMMUNICATIONS DEVICES; PROVIDING FACILITIES AND TRANSMISSION SERVICES ENABLING INDIVIDUALS AND BUSINESSES TO SEND SHORT MESSAGE SERVICE ("SMS") AND MULTI-MEDIA MESSAGE SERVICE ("MMS") MESSAGES TO A SELECTED PLURALITY OF RECIPIENTS (U.S. CLS. 100, 101 AND 104).

FIRST USE 5-0-2010; IN COMMERCE 5-0-2010.

CLASS 38—(Continued).

3,998,766. T-MOBILE USA, INC., BELLEVUE, WA. SN 77-825,158. PUB. 2-2-2010, FILED 9-11-2009.

EVEN MORE PLUS

THE MARK CONSISTS OF STANDARD CHARACTERS WITHOUT CLAIM TO ANY PARTICULAR FONT, STYLE, SIZE, OR COLOR.

FOR TELECOMMUNICATIONS SERVICES, NAMELY, VOICE AND DATA TRANSMISSION, TWO WAY TRANSMISSION OF EMAIL AND TEXT BETWEEN TELECOMMUNICATION TERMINALS AND COMPUTERS, AND PROVIDING MULTIPLE-USER ACCESS TO A GLOBAL COMPUTER NETWORK (U.S. CLS. 100, 101 AND 104).

FIRST USE 10-26-2009; IN COMMERCE 10-26-2009.

3,998,807. WORKSPACE COMMUNICATIONS, LLC, OVERLAND PARK, KS. SN 77-838,633. PUB. 2-23-2010, FILED 9-30-2009.

Your Office, Everywhere

THE MARK CONSISTS OF STANDARD CHARACTERS WITHOUT CLAIM TO ANY PARTICULAR FONT, STYLE, SIZE, OR COLOR.

FOR COMMUNICATION SERVICES, NAMELY, TRANSMISSION OF VOICE, AUDIO, VISUAL IMAGES AND DATA BY TELECOMMUNICATIONS NETWORKS, WIRELESS COMMUNICATION NETWORKS, THE INTERNET, INFORMATION SERVICES NETWORKS AND DATA NETWORKS (U.S. CLS. 100, 101 AND 104).

FIRST USE 1-1-2011; IN COMMERCE 1-1-2011.

3,998,865. T-MOBILE USA, INC., BELLEVUE, WA. SN 77-857,432. PUB. 2-2-2010, FILED 10-26-2009.

AUN MAS

THE MARK CONSISTS OF STANDARD CHARACTERS WITHOUT CLAIM TO ANY PARTICULAR FONT, STYLE, SIZE, OR COLOR.

CLASS 38—(Continued).

THE ENGLISH TRANSLATION OF "AUN MAS" IN THE MARK IS "EVEN MORE".

FOR TELECOMMUNICATIONS SERVICES, NAMELY, VOICE AND DATA TRANSMISSION, TWO WAY TRANSMISSION OF EMAIL AND TEXT BETWEEN TELECOMMUNICATION TERMINALS AND COMPUTERS, AND PROVIDING MULTIPLE-USER ACCESS TO A GLOBAL COMPUTER NETWORK (U.S. CLS. 100, 101 AND 104).

FIRST USE 10-26-2009; IN COMMERCE 10-26-2009.

3,998,996. WEBMAGIC VENTURES, LLC, PASADENA, CA. SN 77-900,606. PUB. 9-28-2010, FILED 12-23-2009.

PENNY ARCADIA

THE MARK CONSISTS OF STANDARD CHARACTERS WITHOUT CLAIM TO ANY PARTICULAR FONT, STYLE, SIZE, OR COLOR.

FOR AUDIO AND VIDEO BROADCASTING SERVICES OVER THE INTERNET (U.S. CLS. 100, 101 AND 104).

FIRST USE 12-1-2010; IN COMMERCE 12-1-2010.

3,999,027. BORANGE, INC., BERKELEY, CA. SN 77-910,544. PUB. 10-5-2010, FILED 1-13-2010.

Textie

THE MARK CONSISTS OF STANDARD CHARACTERS WITHOUT CLAIM TO ANY PARTICULAR FONT, STYLE, SIZE, OR COLOR.

FOR ELECTRONIC, ELECTRIC, AND DIGITAL TRANSMISSION OF VOICE, DATA, IMAGES, SIGNALS, AND MESSAGES; INSTANT MESSAGING SERVICES (U.S. CLS. 100, 101 AND 104).

FIRST USE 4-29-2010; IN COMMERCE 4-29-2010.

CLASS 38—(Continued).

3,999,298. WAVE2WAVE COMMUNICATIONS, INC., HACKENSACK, NJ. SN 85-021,578. PUB. 9-28-2010, FILED 4-23-2010.

OFFICE IN A BOX

THE MARK CONSISTS OF STANDARD CHARACTERS WITHOUT CLAIM TO ANY PARTICULAR FONT, STYLE, SIZE, OR COLOR.

FOR TELECOMMUNICATION SERVICES, NAMELY, TRANSMISSION OF VOICE, DATA, GRAPHICS, IMAGES, AUDIO AND VIDEO BY MEANS OF TELECOMMUNICATIONS NETWORKS, WIRELESS COMMUNICATION NETWORKS, AND THE INTERNET (U.S. CLS. 100, 101 AND 104).

FIRST USE 5-19-2011; IN COMMERCE 5-19-2011.

3,999,807. WSHE, SUNRISE, FL. SN 85-150,211. PUB. 3-29-2011, FILED 10-12-2010.



NO CLAIM IS MADE TO THE EXCLUSIVE RIGHT TO USE "MIAMI / FT LAUDERDALE", APART FROM THE MARK AS SHOWN.

THE COLOR(S) RED, GRAY AND BLACK IS/ARE CLAIMED AS A FEATURE OF THE MARK.

THE MARK CONSISTS OF THE WORDING "WSHE MIAMI / FT LAUDERDALE" IN A STYLIZED FONT AND A DESIGN THAT CONSISTS OF UNDERLINING. THE LETTER "W" IS GRAY WITH A BLACK OUTLINE AND THE WORDING "SHE" AND UNDERLINING ARE RED WITH A BLACK OUTLINE. THE WORDING "MIAMI / FT LAUDERDALE" IS IN GRAY.

FOR COMMUNICATION SERVICES, NAMELY, RADIO BROADCASTING SERVICES AND RADIO BROADCASTING SERVICES VIA THE INTERNET (U.S. CLS. 100, 101 AND 104).

FIRST USE 1-1-2011; IN COMMERCE 1-1-2011.

CLASS 39—TRANSPORTATION AND STORAGE**CLASS 39—(Continued).**

3,998,733. BOUTIQUE AIR, SAN FRANCISCO, CA. SN 77-801,307. PUB. 1-12-2010, FILED 8-10-2009.

Boutique Air

THE MARK CONSISTS OF STANDARD CHARACTERS WITHOUT CLAIM TO ANY PARTICULAR FONT, STYLE, SIZE, OR COLOR.

NO CLAIM IS MADE TO THE EXCLUSIVE RIGHT TO USE "AIR", APART FROM THE MARK AS SHOWN.

FOR AIR TRANSPORTATION (U.S. CLS. 100 AND 105).

FIRST USE 3-3-2011; IN COMMERCE 3-3-2011.

3,998,775. MEATHEAD MOVERS, INC., SAN LUIS OBISPO, CA. SN 77-829,837. PUB. 3-2-2010, FILED 9-18-2009.

MEATHEAD MINI STORAGE

THE MARK CONSISTS OF STANDARD CHARACTERS WITHOUT CLAIM TO ANY PARTICULAR FONT, STYLE, SIZE, OR COLOR.

NO CLAIM IS MADE TO THE EXCLUSIVE RIGHT TO USE "MINI STORAGE", APART FROM THE MARK AS SHOWN.

FOR PROVIDING SELF-STORAGE FACILITIES FOR OTHERS, NAMELY, OPERATING MINI-STORAGE FACILITIES (U.S. CLS. 100 AND 105).

FIRST USE 1-1-2010; IN COMMERCE 1-1-2010.

3,998,992. MAERSK EQUIPMENT SERVICE COMPANY, INC., CHARLOTTE, NC. SN 77-900,394. PUB. 11-9-2010, FILED 12-23-2009.

CHASSISLINK

THE MARK CONSISTS OF STANDARD CHARACTERS WITHOUT CLAIM TO ANY PARTICULAR FONT, STYLE, SIZE, OR COLOR.

FOR CHASSIS PROVIDER, NAMELY, LEASING A FLATBED AND SPECIALTY CHASSIS TO OVER-THE-ROAD MOTOR CARRIERS (U.S. CLS. 100 AND 105).

FIRST USE 8-3-2009; IN COMMERCE 8-3-2009.

CLASS 39—(Continued).

3,999,028. MAERSK EQUIPMENT SERVICE COMPANY, INC., CHARLOTTE, NC. SN 77-910,874. PUB. 11-9-2010, FILED 1-13-2010.

DCLI

THE MARK CONSISTS OF STANDARD CHARACTERS WITHOUT CLAIM TO ANY PARTICULAR FONT, STYLE, SIZE, OR COLOR.

FOR CHASSIS PROVIDER, NAMELY, LEASING A FLATBED AND SPECIALTY CHASSIS TO OVER-THE-ROAD MOTOR CARRIERS (U.S. CLS. 100 AND 105).

FIRST USE 8-3-2009; IN COMMERCE 8-3-2009.

3,999,109. U-SAVE AUTO RENTAL OF AMERICA, INC., JACKSON, MS. SN 77-949,815. PUB. 10-5-2010, FILED 3-3-2010.

U-SAVE PARKING

THE MARK CONSISTS OF STANDARD CHARACTERS WITHOUT CLAIM TO ANY PARTICULAR FONT, STYLE, SIZE, OR COLOR.

OWNER OF U.S. REG. NOS. 1,432,197, 1,807,895, AND OTHERS.

NO CLAIM IS MADE TO THE EXCLUSIVE RIGHT TO USE "PARKING", APART FROM THE MARK AS SHOWN.

SEC. 2(F).

FOR PARKING LOT AND PARKING GARAGE SERVICES (U.S. CLS. 100 AND 105).

FIRST USE 1-1-2011; IN COMMERCE 1-1-2011.

3,999,111. U-SAVE AUTO RENTAL OF AMERICA, INC., JACKSON, MS. SN 77-950,240. PUB. 10-5-2010, FILED 3-4-2010.

U-SAVE

THE MARK CONSISTS OF STANDARD CHARACTERS WITHOUT CLAIM TO ANY PARTICULAR FONT, STYLE, SIZE, OR COLOR.

OWNER OF U.S. REG. NOS. 1,432,197, 1,807,895, AND OTHERS.

SEC. 2(F).

FOR PARKING LOT AND PARKING GARAGE SERVICES (U.S. CLS. 100 AND 105).

FIRST USE 1-1-2011; IN COMMERCE 1-1-2011.

CLASS 39—(Continued).

3,999,269. VRL INTERNATIONAL LTD, GEORGETOWN, CAYMAN ISLANDS. SN 85-015,938. PUB. 10-12-2010, FILED 4-16-2010.

SUPERCLUBS SUPERFUN

THE MARK CONSISTS OF STANDARD CHARACTERS WITHOUT CLAIM TO ANY PARTICULAR FONT, STYLE, SIZE, OR COLOR.

OWNER OF U.S. REG. NOS. 2,666,468, 3,367,750, AND 3,635,255.

FOR TRAVEL AGENCY SERVICES, NAMELY, MAKING RESERVATIONS AND BOOKINGS FOR TRANSPORTATION; ARRANGING TRAVEL TOURS FOR OTHERS; TRAVEL AND TOUR INFORMATION SERVICES; AND PROVIDING AN INTERACTIVE COMPUTER DATABASE IN THE FIELD OF TOURISM VIA A GLOBAL COMPUTER NETWORK (U.S. CLS. 100 AND 105).

FIRST USE 11-1-2010; IN COMMERCE 11-1-2010.

3,999,805. AEROMODAL CARGOLIFTER, INC., THE WOODLANDS, TX. SN 85-149,795. PUB. 3-1-2011, FILED 10-11-2010.

Aeromodal

THE MARK CONSISTS OF STANDARD CHARACTERS WITHOUT CLAIM TO ANY PARTICULAR FONT, STYLE, SIZE, OR COLOR.

FOR FREIGHT FORWARDING; FREIGHT TRANSPORTATION BY AIR; SUPPLY CHAIN LOGISTICS AND REVERSE LOGISTICS SERVICES, NAMELY, STORAGE, TRANSPORTATION AND DELIVERY OF DOCUMENTS, PACKAGES, RAW MATERIALS, AND OTHER FREIGHT FOR OTHERS BY AIR, RAIL, SHIP OR TRUCK (U.S. CLS. 100 AND 105).

FIRST USE 9-26-2007; IN COMMERCE 9-26-2007.

CLASS 40—MATERIAL TREATMENT

CLASS 40—(Continued).

3,998,874. ASTRO PAK CORPORATION, COSTA MESA, CA. SN 77-860,392. PUB. 10-12-2010, FILED 10-29-2009.



THE MARK CONSISTS OF AN ABSTRACT DESIGN OF DOTS AND CONNECTING LINES TOGETHER WITH THE LETTERS "SIXLOG".

FOR STERILIZATION AND DECONTAMINATION SERVICES FOR EQUIPMENT, ROOMS, AREAS, AND BUILDINGS IN ORDER TO REDUCE OR LIMIT A BIOLOGICAL AND OTHER CONTAMINANTS (U.S. CLS. 100, 103 AND 106).

FIRST USE 9-21-2009; IN COMMERCE 1-12-2010.

3,998,970. JOSEPHSEN, FRED, DBA JOSEPHSEN HARDWOOD FLOOR COMPANY, NORTHFIELD, NJ. AND JOSEPHSEN, FRANCES, DBA JOSEPHSEN HARDWOOD FLOOR COMPANY, NORTHFIELD, NJ. SN 77-893,553. PUB. 6-15-2010, FILED 12-15-2009.

Stairfaces

THE MARK CONSISTS OF STANDARD CHARACTERS WITHOUT CLAIM TO ANY PARTICULAR FONT, STYLE, SIZE, OR COLOR.

FOR WOODWORKING (U.S. CLS. 100, 103 AND 106).

FIRST USE 7-15-2010; IN COMMERCE 7-15-2010.

3,999,616. KEEPSAKE THREADS, LLC, FORT WAYNE, IN. SN 85-080,223. PUB. 12-14-2010, FILED 7-8-2010.

KEEPSAKE THREADS

THE MARK CONSISTS OF STANDARD CHARACTERS WITHOUT CLAIM TO ANY PARTICULAR FONT, STYLE, SIZE, OR COLOR.

NO CLAIM IS MADE TO THE EXCLUSIVE RIGHT TO USE "THREADS", APART FROM THE MARK AS SHOWN.

FOR SEWING SERVICES, NAMELY, CONVERSION OF CLOTHING AND OTHER TEXTILE PRODUCTS INTO ORNAMENTS, PILLOWS, SCARVES, STUFFED ANIMALS, WALL HANGINGS AND OTHER MEMENTOS (U.S. CLS. 100, 103 AND 106).

FIRST USE 12-9-2010; IN COMMERCE 12-9-2010.

CLASS 40—(Continued).

3,999,695. HALLIBURTON ENERGY SERVICES, INC., CARROLLTON, TX. SN 85-109,013. PUB. 2-15-2011, FILED 8-17-2010.

CLEANWAVE

THE MARK CONSISTS OF STANDARD CHARACTERS WITHOUT CLAIM TO ANY PARTICULAR FONT, STYLE, SIZE, OR COLOR.

FOR OIL AND GAS WELLBORE WATER TREATMENT SERVICES, NAMELY, USING AN ELECTROCOAGULATION SYSTEM TO TREAT FLOW BACK AND PRODUCED WATER FOR REUSE IN FRACTURING FLUIDS AND OTHER DRILLING AND PRODUCTION PROCESSES (U.S. CLS. 100, 103 AND 106).

FIRST USE 9-30-2010; IN COMMERCE 9-30-2010.

3,999,702. SPECIAL PURPOSE MEDIA, LOS ANGELES, CA. SN 85-110,752. PUB. 2-15-2011, FILED 8-18-2010.

Postcard on the Run

THE MARK CONSISTS OF STANDARD CHARACTERS WITHOUT CLAIM TO ANY PARTICULAR FONT, STYLE, SIZE, OR COLOR.

NO CLAIM IS MADE TO THE EXCLUSIVE RIGHT TO USE "POSTCARD", APART FROM THE MARK AS SHOWN.

FOR DIGITAL IMAGE PRINTING; DIGITAL PHOTO FINISHING; CUSTOM MANUFACTURE OF POSTCARDS; NETWORK-BASED OR WIRELESS-BASED IMAGE PRINTING (U.S. CLS. 100, 103 AND 106).

FIRST USE 8-1-2010; IN COMMERCE 1-6-2011.

CLASS 41—EDUCATION AND ENTERTAINMENT

CLASS 41—(Continued).

3,998,327. GREATER NEW BEDFORD REGIONAL VOCATIONAL TECHNICAL HIGH SCHOOL, NEW BEDFORD, MA. SN 76-700,825. PUB. 6-29-2010, FILED 12-14-2009.



THE MARK CONSISTS OF THE STYLIZED LETTERS "VT GNB". THE LETTERS "GNB" APPEAR ON THE STYLIZED LETTER "T".

FOR EDUCATION AND ENTERTAINMENT SERVICES, NAMELY, PROVIDING COURSES OF INSTRUCTION AT THE VOCATIONAL TECHNICAL HIGH SCHOOL LEVEL; ARRANGING AND CONDUCTING ATHLETIC COMPETITIONS AND EDUCATIONAL EXHIBITIONS IN THE NATURE OF SCIENTIFIC SHOWS AND SCHOOL FAIRS, CONDUCTING EDUCATIONAL CONFERENCES IN THE FIELD OF TECHNICAL HIGH SCHOOL MATH AND SCIENCE, AND DISTRIBUTING COURSE MATERIALS IN CONNECTION THEREWITH; LIVE PERFORMANCES BY A MUSICAL BAND AND ORGANIZING COMMUNITY FESTIVALS FEATURING A VARIETY OF ACTIVITIES, NAMELY, ART EXHIBITIONS, LIVE MUSIC CONCERTS, ETHNIC DANCE, SPORTING EVENTS, AND THE LIKE (U.S. CLS. 100, 101 AND 107).

FIRST USE 8-30-2010; IN COMMERCE 8-30-2010.

3,998,339. QUIET ISLAND FILMS, LLC, ST. PAUL, MN. SN 76-703,961. PUB. 1-18-2011, FILED 7-30-2010.

QUIET ISLAND FILMS

THE MARK CONSISTS OF STANDARD CHARACTERS WITHOUT CLAIM TO ANY PARTICULAR FONT, STYLE, SIZE, OR COLOR.

NO CLAIM IS MADE TO THE EXCLUSIVE RIGHT TO USE "FILMS", APART FROM THE MARK AS SHOWN.

FOR DOCUMENTARY FILM PRODUCTION AND DISTRIBUTION (U.S. CLS. 100, 101 AND 107).

FIRST USE 1-0-2011; IN COMMERCE 1-0-2011.

CLASS 41—(Continued).

3,998,352. SU, XIAOQIANG, FREMONT, CA. SN 77-001,119. PUB. 4-22-2008, FILED 9-16-2006.

xieba

THE MARK CONSISTS OF STANDARD CHARACTERS WITHOUT CLAIM TO ANY PARTICULAR FONT, STYLE, SIZE, OR COLOR.

THE FOREIGN WORDING IN THE MARK TRANSLATES INTO ENGLISH AS "WRITE CAFE".

FOR ELECTRONIC PUBLISHING SERVICES, NAMELY, PUBLICATION OF TEXT AND GRAPHIC WORKS OF OTHERS ON-LINE FEATURING CURRENT NEWS, AUTOBIOGRAPHICAL DIARIES, PHOTOS, CURRENT EVENT COMMENTARY, POETRY, ESSAYS IN THE FIELD OF SPORTS, TRAVEL, FASHION AND SHOPPING, PROJECT UPDATES CONCERNING COMMUNITIES EVENTS PLANNING, NON-FICTION IN THE FIELD OF MOVIE REVIEWS, MUSIC REVIEWS, BOOK REVIEWS, PERSONAL FINANCE AND PERSONAL INVESTING AND FICTION (U.S. CLS. 100, 101 AND 107).

FIRST USE 9-16-2006; IN COMMERCE 5-25-2011.

3,998,369. HEALTHROCK, LLC, NEWTON, MA. SN 77-104,038. PUB. 9-22-2009, FILED 2-9-2007.

SKELLYVISION

THE MARK CONSISTS OF STANDARD CHARACTERS WITHOUT CLAIM TO ANY PARTICULAR FONT, STYLE, SIZE, OR COLOR.

FOR PROVIDING ENTERTAINMENT AND EDUCATIONAL SERVICES VIA PODCAST AND WEBCAST IN THE FIELDS OF EDUCATION, SCIENCE, HEALTH, WELLNESS, NUTRITION, FITNESS, ANATOMY AND PHYSIOLOGY (U.S. CLS. 100, 101 AND 107).

FIRST USE 10-31-2009; IN COMMERCE 10-31-2009.

CLASS 41—(Continued).

3,998,384. VIACOM INTERNATIONAL INC., NEW YORK, NY. SN 77-169,928. PUB. 3-18-2008, FILED 5-1-2007.

BUBBLE GUPPIES

THE MARK CONSISTS OF STANDARD CHARACTERS WITHOUT CLAIM TO ANY PARTICULAR FONT, STYLE, SIZE, OR COLOR.

FOR ENTERTAINMENT SERVICES IN THE NATURE OF TELEVISION SERIES, FEATURING ANIMATION, COMEDY AND DRAMA; PROVIDING ONLINE INFORMATION IN THE FIELD OF ENTERTAINMENT CONCERNING TELEVISION PROGRAMS (U.S. CLS. 100, 101 AND 107).

FIRST USE 1-24-2011; IN COMMERCE 1-24-2011.

3,998,393. THE SAUL ZAENTZ COMPANY DBA TOLKIEN ENTERPRISES, BERKELEY, CA. SN 77-198,534. PUB. 9-16-2008, FILED 6-5-2007.

MIDDLE-EARTH

THE MARK CONSISTS OF STANDARD CHARACTERS WITHOUT CLAIM TO ANY PARTICULAR FONT, STYLE, SIZE, OR COLOR.

OWNER OF U.S. REG. NOS. 1,109,520, 2,919,668, AND OTHERS.

FOR EDUCATIONAL AND ENTERTAINMENT SERVICES IN THE NATURE OF PROVIDING INTERACTIVE ONLINE COMPUTER GAMES VIA THE INTERNET; PROVIDING INFORMATION ABOUT ONLINE COMPUTER GAMES AND VIDEO GAMES AND ENHANCEMENTS FOR SUCH GAMES VIA THE INTERNET; ARRANGING AND CONDUCTING COMPETITIONS FOR VIDEO GAMERS AND COMPUTER GAME PLAYERS; PROVIDING MULTIPLAYER INTERACTIVE GAMES PROVIDED OVER THE INTERNET; ARRANGING ONLINE COMPETITIONS FOR INTERACTIVE GAME PLAYERS; FAN CLUB SERVICES; PROVIDING ONLINE INTERACTIVE COMPUTER GAMES; PROVIDING ONLINE INTERACTIVE VIDEO GAMES (U.S. CLS. 100, 101 AND 107).

FIRST USE 4-24-2007; IN COMMERCE 4-24-2007.

CLASS 41—(Continued).

3,998,404. MADMANN TRADEMARK HOLDING COMPANY LTD, BEVERLY HILLS, CA. SN 77-228,194. PUB. 8-17-2010, FILED 7-12-2007.

MAVERICK

THE MARK CONSISTS OF STANDARD CHARACTERS WITHOUT CLAIM TO ANY PARTICULAR FONT, STYLE, SIZE, OR COLOR.

OWNER OF U.S. REG. NOS. 1,923,439 AND 1,925,200. FOR ENTERTAINMENT, NAMELY, LIVE PERFORMANCES BY MUSICAL BANDS (U.S. CLS. 100, 101 AND 107).

FIRST USE 4-0-1992; IN COMMERCE 4-0-1992.

3,998,407. DRAGONFRUIT STUDIOS, LLC, ATLANTA, GA. SN 77-246,543. PUB. 3-25-2008, FILED 8-3-2007.

KUNG FU KIWI

THE MARK CONSISTS OF STANDARD CHARACTERS WITHOUT CLAIM TO ANY PARTICULAR FONT, STYLE, SIZE, OR COLOR.

OWNER OF U.S. REG. NOS. 2,626,534 AND 2,650,606. FOR ENTERTAINMENT SERVICES, NAMELY, AN ONGOING TELEVISION SERIES FEATURING CHILDREN'S ENTERTAINMENT AND FEATURING EDUCATION IN THE FIELDS OF HEALTH AND NUTRITION, FITNESS, GEOGRAPHY AND CULTURAL AWARENESS (U.S. CLS. 100, 101 AND 107).

FIRST USE 7-1-2001; IN COMMERCE 5-16-2011.

3,998,415. B & D, INC., NASHVILLE, TN. SN 77-273,467. PUB. 3-4-2008, FILED 9-6-2007.

COWBOY TOWN

THE MARK CONSISTS OF STANDARD CHARACTERS WITHOUT CLAIM TO ANY PARTICULAR FONT, STYLE, SIZE, OR COLOR.

FOR ENTERTAINMENT SERVICES, NAMELY, LIVE VOCAL PERFORMANCES BY A MUSICAL GROUP; ENTERTAINMENT SERVICES, NAMELY, LIVE AND TELEVISED APPEARANCES BY A MUSICAL GROUP (U.S. CLS. 100, 101 AND 107).

FIRST USE 5-2-2008; IN COMMERCE 8-0-2008.

CLASS 41—(Continued).

3,998,491. LA TOURAINE, INC., SAN DIEGO, CA. SN 77-461,873. PUB. 3-24-2009, FILED 4-30-2008.

NAUGHTY AMERICA LIVE

THE MARK CONSISTS OF STANDARD CHARACTERS WITHOUT CLAIM TO ANY PARTICULAR FONT, STYLE, SIZE, OR COLOR.

OWNER OF U.S. REG. NOS. 2,958,444, 3,116,202, AND 3,233,036.

NO CLAIM IS MADE TO THE EXCLUSIVE RIGHT TO USE "AMERICA LIVE", APART FROM THE MARK AS SHOWN.

FOR PROVIDING AN ONLINE INTERACTIVE WEB SITE FEATURING ADULT ENTERTAINMENT SUBJECT MATTER (U.S. CLS. 100, 101 AND 107).

FIRST USE 9-23-2009; IN COMMERCE 9-23-2009.

3,998,496. SILVER LAKE MEDIA GROUP, LLC, MARIETTA, GA. SN 77-479,168. PUB. 10-14-2008, FILED 5-20-2008.

CONSTRU-GUIA AL DIA

THE MARK CONSISTS OF STANDARD CHARACTERS WITHOUT CLAIM TO ANY PARTICULAR FONT, STYLE, SIZE, OR COLOR.

OWNER OF U.S. REG. NO. 3,485,682.

THE FOREIGN WORDING IN THE MARK TRANSLATES INTO ENGLISH AS "UP TO DATE CONSTRUCTION MENTOR".

FOR ENTERTAINMENT SERVICES, NAMELY, PROVIDING AN ON-GOING RADIO PROGRAM IN THE FIELD OF CONSTRUCTION AND REMODELING (U.S. CLS. 100, 101 AND 107).

FIRST USE 3-27-2011; IN COMMERCE 3-27-2011.

3,998,533. DISNEY ENTERPRISES, INC., BURBANK, CA. SN 77-572,757. PUB. 10-5-2010, FILED 9-17-2008.



OWNER OF U.S. REG. NOS. 3,420,652 AND 3,420,663.

CLASS 41—(Continued).

THE MARK CONSISTS OF THE STYLIZED LETTERS "K"- "E"- "R"- "P"- "O"- "O"- "F", WITH THE FIRST "O" REPRESENTED BY A CLOUD-LIKE SPECIAL FORM ELEMENT.

FOR ENTERTAINMENT SERVICES, NAMELY, PROVIDING ON-LINE COMPUTER GAMES; INTERACTIVE ENTERTAINMENT SERVICES, NAMELY, PROVIDING A WEBSITE FEATURING USER CREATED DISPLAYS OF ENTERTAINMENT RELATED TEXT AND AUDIO/VISUAL PROJECTS (U.S. CLS. 100, 101 AND 107).

FIRST USE 1-31-2008; IN COMMERCE 1-31-2008.

3,998,538. ALSTON, DAVID D., CHARLESTON, SC. SN 77-577,949. PUB. 2-10-2009, FILED 9-24-2008.

FLY GUY

THE MARK CONSISTS OF STANDARD CHARACTERS WITHOUT CLAIM TO ANY PARTICULAR FONT, STYLE, SIZE, OR COLOR.

FOR AUDIO RECORDING AND PRODUCTION; ENTERTAINMENT SERVICES IN THE NATURE OF LIVE MUSICAL PERFORMANCES; ENTERTAINMENT, NAMELY, LIVE MUSIC CONCERTS (U.S. CLS. 100, 101 AND 107).

FIRST USE 9-24-2008; IN COMMERCE 5-10-2011.

3,998,550. WILLIS, PATRICK M., BEVERLY HILLS, CA. SN 77-585,695. PUB. 3-1-2011, FILED 10-4-2008.

Hottest American

THE MARK CONSISTS OF STANDARD CHARACTERS WITHOUT CLAIM TO ANY PARTICULAR FONT, STYLE, SIZE, OR COLOR.

NO CLAIM IS MADE TO THE EXCLUSIVE RIGHT TO USE "AMERICAN", APART FROM THE MARK AS SHOWN.

FOR ENTERTAINMENT IN THE NATURE OF A CONTINUING TALENT AND BEAUTY COMPETITION TELEVISION SHOW (U.S. CLS. 100, 101 AND 107).

FIRST USE 9-4-2008; IN COMMERCE 5-19-2011.

CLASS 41—(Continued).

3,998,561. WELLS FARGO & COMPANY, MINNEAPOLIS, MN. SN 77-597,981. PUB. 3-17-2009, FILED 10-22-2008.

TOGETHER WE'LL GO FAR

THE MARK CONSISTS OF STANDARD CHARACTERS WITHOUT CLAIM TO ANY PARTICULAR FONT, STYLE, SIZE, OR COLOR.

FOR EDUCATIONAL SERVICES, NAMELY, PROVIDING ON-LINE TRAINING COURSES, WORKSHOPS, SEMINARS AND PROGRAMS IN THE FIELD OF BANKING, CREDIT, MONEY MANAGEMENT, INVESTING, INVESTMENTS AND FINANCIAL MATTERS VIA THE INTERNET AND MATERIALS DISTRIBUTED IN CONNECTION THEREWITH; PROVIDING ON-LINE, NON-DOWNLOADABLE NEWSLETTERS IN THE FIELD OF BANKING, CREDIT, MONEY MANAGEMENT, INVESTING, INVESTMENTS AND FINANCIAL MATTERS; PROVIDING NEWSLETTERS IN THE FIELD OF BANKING, CREDIT, MONEY MANAGEMENT, INVESTING, INVESTMENTS AND FINANCIAL MATTERS VIA E-MAIL; PROVIDING MAGAZINES AND NEWSLETTERS FEATURING BANKING, CREDIT, MONEY MANAGEMENT, INVESTING, INVESTMENTS AND FINANCIAL MATTERS VIA E-MAIL; MUSEUM SERVICES, NAMELY, MUSEUMS, RUNNING OF MUSEUMS AND GUIDED TOURS OF MUSEUMS (U.S. CLS. 100, 101 AND 107).

FIRST USE 5-1-2009; IN COMMERCE 5-1-2009.

CLASS 41—(Continued).

3,998,618. UNIVERSAL CITY STUDIOS LLC, UNIVERSAL CITY, CA. SN 77-689,355. PUB. 10-5-2010, FILED 3-12-2009.

SYFY

THE MARK CONSISTS OF STANDARD CHARACTERS WITHOUT CLAIM TO ANY PARTICULAR FONT, STYLE, SIZE, OR COLOR.

SEC. 2(F).

FOR PRODUCTION AND DISTRIBUTION OF TELEVISION PROGRAMS AND MOTION PICTURES; PROVISION OF NON DOWNLOADABLE ON DEMAND VIDEO AND TELEVISION PROGRAMS; PROVISION OF NON DOWNLOADABLE VIDEO, TELEVISION PROGRAMS AND MOTION PICTURES VIA VIDEO ON DEMAND SERVICE AND VIA A GLOBAL COMPUTER NETWORK; DISTRIBUTION OF INTERACTIVE, VIDEO AND MOBILE GAMES, NAMELY, PROVISION OF NON-DOWNLOADABLE INTERACTIVE, VIDEO AND MOBILE GAMES VIA THE INTERNET AND WIRELESS NETWORKS; ENTERTAINMENT SERVICES, NAMELY, PROVIDING ONLINE GAMES, WEB BASED GAMES, INTERACTIVE ONLINE GAMES, ONLINE VIDEO GAMES AND NON-DOWNLOADABLE VIDEO GAMES FOR MOBILE PHONES (U.S. CLS. 100, 101 AND 107).

FIRST USE 7-7-2009; IN COMMERCE 7-7-2009.

3,998,578. CAMPO, KIRA C., OCEAN CITY, NJ. SN 77-617,953. PUB. 3-31-2009, FILED 11-19-2008.

The Creative Practice

THE MARK CONSISTS OF STANDARD CHARACTERS WITHOUT CLAIM TO ANY PARTICULAR FONT, STYLE, SIZE, OR COLOR.

FOR ARRANGING PROFESSIONAL WORKSHOP AND TRAINING COURSES; CONDUCTING WORKSHOPS AND SEMINARS IN PERSONAL AWARENESS; EDUCATIONAL SERVICES, NAMELY, CONDUCTING SEMINARS, LECTURES, TELESEMINARS, TELECLASSES, AND WORKSHOPS IN PERSONAL AWARENESS (U.S. CLS. 100, 101 AND 107).

FIRST USE 10-1-2010; IN COMMERCE 10-1-2010.

3,998,647. BRADLEY B GRIFFITH, LITTLETON, CO. SN 77-718,441. PUB. 9-1-2009, FILED 4-21-2009.

Griffith Publishing LLC

THE MARK CONSISTS OF STANDARD CHARACTERS WITHOUT CLAIM TO ANY PARTICULAR FONT, STYLE, SIZE, OR COLOR.

NO CLAIM IS MADE TO THE EXCLUSIVE RIGHT TO USE "PUBLISHING LLC", APART FROM THE MARK AS SHOWN.

FOR MULTIMEDIA PUBLISHING OF BOOKS AND ELECTRONIC PUBLICATIONS (U.S. CLS. 100, 101 AND 107).

FIRST USE 4-25-2011; IN COMMERCE 4-25-2011.

CLASS 41—(Continued).

3,998,671. CBS BROADCASTING INC., NEW YORK, NY. SN 77-737,064. PUB. 3-30-2010, FILED 5-14-2009.

TALK PHILLY

THE MARK CONSISTS OF STANDARD CHARACTERS WITHOUT CLAIM TO ANY PARTICULAR FONT, STYLE, SIZE, OR COLOR.

NO CLAIM IS MADE TO THE EXCLUSIVE RIGHT TO USE "PHILLY", APART FROM THE MARK AS SHOWN.

FOR ENTERTAINMENT SERVICES, NAMELY, ONGOING SERIES FEATURING LIFESTYLE TOPICS RENDERED THROUGH THE MEDIA OF TELEVISION, CABLE, SATELLITE, RADIO, TELEPHONE AND BROADBAND SYSTEMS, VIA THE INTERNET, AND PORTABLE AND WIRELESS COMMUNICATION DEVICES (U.S. CLS. 100, 101 AND 107).

FIRST USE 10-19-2009; IN COMMERCE 10-19-2009.

3,998,744. BAISDEN ENTERTAINMENT, LLC, DALLAS, TX. SN 77-815,528. PUB. 9-7-2010, FILED 8-28-2009.

BAISDEN LIVE

THE MARK CONSISTS OF STANDARD CHARACTERS WITHOUT CLAIM TO ANY PARTICULAR FONT, STYLE, SIZE, OR COLOR.

NO CLAIM IS MADE TO THE EXCLUSIVE RIGHT TO USE "LIVE", APART FROM THE MARK AS SHOWN.

THE NAME(S), PORTRAIT(S), AND/OR SIGNATURE(S) SHOWN IN THE MARK IDENTIFIES MICHAEL "BAISDEN", WHOSE CONSENT(S) TO REGISTER IS MADE OF RECORD.

FOR ENTERTAINMENT SERVICES, NAMELY, PROVIDING A RADIO PROGRAM IN THE FIELD OF RELATIONSHIPS, BUSINESS, HEALTH, BOOKS, MUSIC, AND POLITICS VIA A GLOBAL COMPUTER NETWORK; ENTERTAINMENT SERVICES, NAMELY, PROVIDING A TELEVISION PROGRAM IN THE FIELD OF RELATIONSHIPS, BUSINESS, HEALTH, BOOKS, MUSIC, AND POLITICS VIA A GLOBAL COMPUTER NETWORK; ENTERTAINMENT SERVICES, NAMELY, PROVIDING A WEB SITE FEATURING MUSICAL PERFORMANCES, MUSICAL VIDEOS, RELATED FILM CLIPS, PHOTOGRAPHS, AND OTHER MULTIMEDIA MATERIALS FEATURING RELATIONSHIPS, BUSINESS, HEALTH, BOOKS, MUSIC, AND POLITICS; ENTERTAINMENT SERVICES, NAMELY, PROVIDING A WEBSITE AT WHICH THE GENERAL PUBLIC CAN RECEIVE ADVICE FROM AN INDIVIDUAL CONCERNING RELATIONSHIPS, SUCH ADVICE BEING FOR ENTERTAINMENT PURPOSES ONLY; ENTERTAINMENT SERVICES, NAMELY, PROVIDING ON-LINE REVIEWS OF BOOKS, MUSIC, TV, FILM, MOVIES, SHOW TOPICS AND COMPUTER GAMES; ON-LINE

CLASS 41—(Continued).

JOURNALS, NAMELY, BLOGS FEATURING BOOKS, MUSIC, BUSINESS, RELATIONSHIPS, HEALTH, RADIO SHOW TOPICS, FAN CLUB, EVENTS, POEMS, INTERVIEWS, AND POLITICS; PRODUCTION OF RADIO OR TELEVISION PROGRAMS; PROVIDING A WEB SITE WHERE USERS CAN POST RATINGS, REVIEWS AND RECOMMENDATIONS ON EVENTS AND ACTIVITIES IN THE FIELD OF ENTERTAINMENT AND EDUCATION; PROVIDING INFORMATION, NEWS AND COMMENTARY IN THE FIELD OF ENTERTAINMENT; RADIO ENTERTAINMENT SERVICES, NAMELY, RADIO PROGRAMS FEATURING PERFORMANCES BY A NATIONALLY SYNDICATED RADIO PERSONALITY, BEST-SELLING AUTHOR, AND MOTIVATIONAL SPEAKER; TICKET RESERVATION AND BOOKING SERVICES FOR ENTERTAINMENT, SPORTING AND CULTURAL EVENTS; ENTERTAINMENT SERVICES, NAMELY, PROVIDING NON-DOWNLOADABLE PRE-RECORDED MUSIC AND INFORMATION, COMMENTARY, AND ARTICLES ABOUT MUSIC VIA A GLOBAL COMPUTER NETWORK (U.S. CLS. 100, 101 AND 107).

FIRST USE 1-3-2010; IN COMMERCE 1-3-2010.

3,998,760. AGUIAR, JOSEPH J, BRONX, NY. AND AGUIAR, JOHNNY J, BRONX, NY. AND OFFICER, BRETT A, BROOKLYN, NY. SN 77-823,160. PUB. 2-2-2010, FILED 9-9-2009.



NO CLAIM IS MADE TO THE EXCLUSIVE RIGHT TO USE "ENTERTAINMENT", APART FROM THE MARK AS SHOWN.

THE MARK CONSISTS OF THE STYLIZED LETTERS "NR"; WITH STARS SHOWN ON THE LETTERS "NR"; BELOW THE "NR" IS THE WORDING "NEW RICH ENTERTAINMENT".

FOR ENTERTAINMENT SERVICES, NAMELY, RECORDING, PRODUCTION AND POST-PRODUCTION SERVICES IN THE FIELDS OF MUSIC, PRODUCING MUSICAL AUDIO AND VIDEO RECORDINGS (U.S. CLS. 100, 101 AND 107).

FIRST USE 4-27-2011; IN COMMERCE 4-27-2011.

3,998,780. STUDIOBOOTH LLC, BROOKLYN, NY. SN 77-830,937. PUB. 9-21-2010, FILED 9-21-2009.

STUDIOBOOTH

THE MARK CONSISTS OF THE WORDS "STUDIO" AND "BOOTH" WITH NO SPACE BETWEEN THEM. BOTH WORDS ARE CAPITALIZED, AND THE WORD "BOOTH" APPEARS IN A BOLDED OR THICKER FONT THAN DOES "STUDIO".

FOR PHOTOGRAPHY SERVICES (U.S. CLS. 100, 101 AND 107).

FIRST USE 7-12-2008; IN COMMERCE 7-12-2008.

CLASS 41—(Continued).

3,998,831. BACKFIELD PRODUCTIONS LIMITED LIABILITY COMPANY, WHARTON, NJ. SN 77-849,661. PUB. 9-28-2010, FILED 10-15-2009.

THE RIDE

THE MARK CONSISTS OF STANDARD CHARACTERS WITHOUT CLAIM TO ANY PARTICULAR FONT, STYLE, SIZE, OR COLOR.

FOR ENTERTAINMENT SERVICES IN THE NATURE OF AN ON-GOING REALITY BASED TELEVISION PROGRAM, EXCLUSIVELY IN THE FIELD OF HIGH-SCHOOL FOOTBALL; ENTERTAINMENT SERVICES IN THE NATURE OF AN ON-GOING TELEVISION PROGRAM, EXCLUSIVELY IN THE FIELD OF HIGH-SCHOOL SPORTS, NAMELY, FOOTBALL; ENTERTAINMENT SERVICES, NAMELY, PROVIDING INFORMATION CONCERNING A REALITY BASED TELEVISION SERIES, EXCLUSIVELY IN THE FIELD OF HIGH-SCHOOL FOOTBALL, BY MEANS OF A GLOBAL COMPUTER NETWORK; ALL OF THE AFORESAID SPECIFICALLY EXCLUDING TELEVISION PROGRAMS, TELEVISION SERIES AND INFORMATION IN THE FIELDS OF RANCHING, RANCH ROPING AND RODEOS (U.S. CLS. 100, 101 AND 107).

FIRST USE 11-1-2009; IN COMMERCE 11-1-2009.

3,998,832. BACKFIELD PRODUCTIONS LIMITED LIABILITY COMPANY, WHARTON, NJ. SN 77-849,684. PUB. 9-28-2010, FILED 10-15-2009.



NO CLAIM IS MADE TO THE EXCLUSIVE RIGHT TO USE "EIGHT QUARTERBACKS", APART FROM THE MARK AS SHOWN.

THE MARK CONSISTS OF THE WORD "RIDE" IN LARGE FONT POSITIONED ABOVE THE LITERAL ELEMENTS "EIGHT QUARTERBACKS. ONE DREAM." WITH THE WORD "THE" INVERTED AND POSITIONED TO THE LEFT OF THE WORD "RIDE".

FOR ENTERTAINMENT SERVICES IN THE NATURE OF AN ON-GOING REALITY BASED TELEVISION PROGRAM, EXCLUSIVELY IN THE FIELD OF HIGH-SCHOOL FOOTBALL; ENTERTAINMENT SERVICES IN THE NATURE OF AN ON-GOING TELEVISION PROGRAM, EXCLUSIVELY IN THE FIELD OF HIGH-SCHOOL SPORTS, NAMELY, FOOTBALL; ENTERTAINMENT SERVICES, NAMELY, PROVIDING INFORMATION CONCERNING A REALITY BASED TELEVISION SERIES, EXCLUSIVELY IN THE FIELD OF HIGH-SCHOOL FOOTBALL, BY MEANS OF A GLOBAL COMPUTER NETWORK; ALL OF THE AFORESAID SPECIFICALLY EXCLUDING TELEVISION PROGRAMS, TELEVISION SERIES AND INFORMATION IN THE FIELDS OF RANCHING, RANCH ROPING AND RODEOS (U.S. CLS. 100, 101 AND 107).

FIRST USE 11-1-2009; IN COMMERCE 11-1-2009.

CLASS 41—(Continued).

3,998,836. GRYGOROVICH, SERGIY, KYIV 04211, UKRAINE. SN 77-851,587. PUB. 10-5-2010, FILED 10-19-2009.

S.T.A.L.K.E.R.: CALL OF PRIPYAT

THE MARK CONSISTS OF STANDARD CHARACTERS WITHOUT CLAIM TO ANY PARTICULAR FONT, STYLE, SIZE, OR COLOR.

OWNER OF U.S. REG. NOS. 3,313,064, 3,313,065, AND 3,734,717.

NO CLAIM IS MADE TO THE EXCLUSIVE RIGHT TO USE "PRIPYAT", APART FROM THE MARK AS SHOWN.

THE WORDING "PRIPYAT" HAS NO MEANING IN A FOREIGN LANGUAGE.

FOR ENTERTAINMENT SERVICES, NAMELY, PROVIDING ON-LINE COMPUTER GAMES VIA A GLOBAL COMPUTER NETWORK AND WIRELESS DEVICES; PROVIDING INFORMATION RELATING TO COMPUTER GAMES, ELECTRONIC GAMES, AND COMPUTER GAME SOFTWARE; PROVIDING INFORMATION SERVICES RELATING TO ENTERTAINMENT MEDIA, NAMELY, VIDEO GAMES; RENTAL OF VIDEO GAMES, COMPUTER GAME SOFTWARE, ELECTRONIC GAMES, INTERACTIVE GAME SOFTWARE, AND VIDEO GAME PLAYING UNITS; PROVIDING ON-LINE AND WIRELESS COMPUTER GAMES AND COMICS, NAMELY, ONLINE NON-DOWNLOADABLE GRAPHIC NOVELS, AND ENTERTAINMENT INFORMATION RELATING TO A WIDE RANGE OF TOPICS OF GENERAL INTEREST, NAMELY, COMPUTER GAMES, VIDEO GAMES, AND PRODUCTION OF COMPUTER GAME SOFTWARE (U.S. CLS. 100, 101 AND 107).

FIRST USE 4-0-2009; IN COMMERCE 4-0-2009.

3,998,875. GREEN BUSINESS LEAGUE, INC., PLAINFIELD, IL. SN 77-860,942. PUB. 9-28-2010, FILED 10-29-2009.

GBL CERTIFIED SUSTAINABILITY OFFICER

THE MARK CONSISTS OF STANDARD CHARACTERS WITHOUT CLAIM TO ANY PARTICULAR FONT, STYLE, SIZE, OR COLOR.

NO CLAIM IS MADE TO THE EXCLUSIVE RIGHT TO USE "CERTIFIED SUSTAINABILITY OFFICER", APART FROM THE MARK AS SHOWN.

FOR CONDUCTING WORKSHOPS, CLASSES AND SEMINARS IN THE FIELD OF SUSTAINABLE BUSINESS SOLUTIONS (U.S. CLS. 100, 101 AND 107).

FIRST USE 5-9-2011; IN COMMERCE 5-9-2011.

CLASS 41—(Continued).

3,998,892. WILLIAM J. COOK COMPANY, INC., MONTGOMERY, AL. SN 77-863,580. PUB. 7-6-2010, FILED 11-3-2009.

SYNTAGMA: GENERATIVE ORGANIZATION

THE MARK CONSISTS OF STANDARD CHARACTERS WITHOUT CLAIM TO ANY PARTICULAR FONT, STYLE, SIZE, OR COLOR.

OWNER OF U.S. REG. NO. 3,715,728.

NO CLAIM IS MADE TO THE EXCLUSIVE RIGHT TO USE "GENERATIVE ORGANIZATION", APART FROM THE MARK AS SHOWN.

FOR EDUCATIONAL SERVICES, NAMELY, CONDUCTING PROGRAMS IN THE FIELD OF STRATEGIC THINKING, STRATEGIC PLANNING, AND IMPLEMENTATION OF ACTION PLANS FOR INDIVIDUAL AND GROUP DEVELOPMENT (U.S. CLS. 100, 101 AND 107).

FIRST USE 3-1-2011; IN COMMERCE 3-1-2011.

CLASS 41—(Continued).

3,998,997. WEBMAGIC VENTURES, LLC, PASADENA, CA. SN 77-900,612. PUB. 9-28-2010, FILED 12-23-2009.

PENNY ARCADIA

THE MARK CONSISTS OF STANDARD CHARACTERS WITHOUT CLAIM TO ANY PARTICULAR FONT, STYLE, SIZE, OR COLOR.

FOR DIGITAL VIDEO, AUDIO, AND MULTIMEDIA PUBLISHING SERVICES; EDUCATION INFORMATION; ENTERTAINMENT INFORMATION; MUSEUM SERVICES; MUSEUMS; ORGANIZING CULTURAL AND ARTS EVENTS; PROVIDING A WEB SITE WHERE USERS CAN POST RATINGS, REVIEWS AND RECOMMENDATIONS ON EVENTS AND ACTIVITIES IN THE FIELD OF ENTERTAINMENT AND EDUCATION; PROVIDING AMUSEMENT FACILITIES; RENTAL OF AMUSEMENT MACHINES AND APPARATUS (U.S. CLS. 100, 101 AND 107).

FIRST USE 12-1-2010; IN COMMERCE 12-1-2010.

3,999,009. ISHA FOUNDATION, INC., MCMINNVILLE, TN. SN 77-905,125. PUB. 10-26-2010, FILED 1-5-2010.

TECHNOLOGIES FOR WELLBEING

THE MARK CONSISTS OF STANDARD CHARACTERS WITHOUT CLAIM TO ANY PARTICULAR FONT, STYLE, SIZE, OR COLOR.

NO CLAIM IS MADE TO THE EXCLUSIVE RIGHT TO USE "WELLBEING", APART FROM THE MARK AS SHOWN.

FOR YOGA INSTRUCTION; EDUCATION SERVICES, NAMELY, PROVIDING CLASSES AND SEMINARS IN THE FIELD OF PERSONAL WELLNESS (U.S. CLS. 100, 101 AND 107).

FIRST USE 9-1-2009; IN COMMERCE 9-1-2009.

3,998,905. DIAGEO NORTH AMERICA, INC., NORWALK, CT. SN 77-868,972. PUB. 4-13-2010, FILED 11-10-2009.

CÎROC BOYZ

THE MARK CONSISTS OF STANDARD CHARACTERS WITHOUT CLAIM TO ANY PARTICULAR FONT, STYLE, SIZE, OR COLOR.

OWNER OF U.S. REG. NO. 2,854,986.

FOR LIVE PERFORMANCES BY DISC JOCKEYS (U.S. CLS. 100, 101 AND 107).

FIRST USE 12-31-2009; IN COMMERCE 12-31-2009.

3,999,010. SHARP, ADAM G, SAINT AUGUSTINE, FL. SN 77-905,339. PUB. 6-15-2010, FILED 1-5-2010.

Deadpan Productions

THE MARK CONSISTS OF STANDARD CHARACTERS WITHOUT CLAIM TO ANY PARTICULAR FONT, STYLE, SIZE, OR COLOR.

CLASS 41—(Continued).

NO CLAIM IS MADE TO THE EXCLUSIVE RIGHT TO USE "PRODUCTIONS", APART FROM THE MARK AS SHOWN.

FOR ENTERTAINMENT SERVICES IN THE NATURE OF DEVELOPMENT, CREATION, PRODUCTION AND POST-PRODUCTION SERVICES OF MULTIMEDIA CONTENT; ENTERTAINMENT SERVICES, NAMELY, PROVIDING A WEB SITE FEATURING PHOTOGRAPHIC, AUDIO, VIDEO AND PROSE PRESENTATIONS FEATURING THE PROCESS OF PRODUCTION AS IT RELATES TO SHORT FILMS AND FEATURING THE PRODUCTIONS THEMSELVES; ENTERTAINMENT, NAMELY, PRODUCTION OF FILMS; PROVIDING INFORMATION AND ARTICLES IN THE FIELD OF FILM, FILMMAKING, AND ENTERTAINMENT VIA A GLOBAL COMPUTER NETWORK; FILM EDITING; MULTIMEDIA ENTERTAINMENT SERVICES IN THE NATURE OF DEVELOPMENT, PRODUCTION AND POST-PRODUCTION SERVICES IN THE FIELDS OF VIDEO AND FILMS; MULTIMEDIA ENTERTAINMENT SERVICES IN THE NATURE OF RECORDING, PRODUCTION AND POST-PRODUCTION SERVICES IN THE FIELDS OF MUSIC, VIDEO, AND FILMS; POST-PRODUCTION EDITING SERVICES IN THE FIELD OF MUSIC, VIDEOS AND FILM; VIDEO EDITING (U.S. CLS. 100, 101 AND 107).

FIRST USE 4-1-2008; IN COMMERCE 4-1-2008.

3,999,012. NOMAN AHMAD, CASTRO VALLEY, CA. SN 77-906,974. PUB. 9-28-2010, FILED 1-7-2010.

SPORTSLAB

THE MARK CONSISTS OF STANDARD CHARACTERS WITHOUT CLAIM TO ANY PARTICULAR FONT, STYLE, SIZE, OR COLOR.

FOR PROVIDING A WEB-BASED SYSTEM AND ONLINE PORTAL FOR CUSTOMERS TO PARTICIPATE, ORGANIZE, COLLABORATE, AND STRATEGIZE ON SPORTING EVENTS (U.S. CLS. 100, 101 AND 107).
FIRST USE 4-1-2011; IN COMMERCE 4-1-2011.

CLASS 41—(Continued).

3,999,015. MCCORMICK, MOSES MONWEAL, COLUMBUS, OH. SN 77-908,502. PUB. 6-29-2010, FILED 1-10-2010.



NO CLAIM IS MADE TO THE EXCLUSIVE RIGHT TO USE "FOREIGN LANGUAGE" AND "TECHNIQUES", APART FROM THE MARK AS SHOWN.

THE COLOR(S) BLACK, YELLOW, WHITE, BROWN, GRAY AND BLUE IS/ARE CLAIMED AS A FEATURE OF THE MARK.

THE MARK CONSISTS OF THE LETTERS "FLR" SHOWN IN BLACK STYLIZED FONT AND OUTLINED IN YELLOW WITH A YELLOW GLOW CONTAINING THE WORDS "FOREIGN", "LANGUAGE" AND "ROADRUNNING" APPEARING IN WHITE STYLIZED FONT ALONGSIDE THE WORDS "FOREIGN", "LANGUAGE" AND "ROADRUNNING" ALSO SHOWN IN WHITE OVER THE WORD "TECHNIQUES" SHOWN IN GLOWING YELLOW AND A MIRRORED REFLECTION OF THE SAME ALL BELOW A STYLIZED MOUSE WITH BROWN SKIN, WHITE WHISKERS, MUSTACHE, EYEBROWS AND FINGERNAILS, BLACK AND WHITE EYES AND A WHITE AND BROWN NOSE WEARING A WHITE HAT, GRAY SUIT AND BLUE SWEATER AROUND THE SHOULDERS ALL WITH A YELLOW GLOW AGAINST A BLACK-COLORED BACKGROUND.

FOR PROVIDING FOREIGN LANGUAGE INSTRUCTION TO THOSE INTERESTED IN LEARNING A CERTAIN LANGUAGE (U.S. CLS. 100, 101 AND 107).

FIRST USE 1-0-2010; IN COMMERCE 1-0-2010.

3,999,017. CHARLES R. JOYNER, LOS ANGELES, CA. SN 77-908,558. PUB. 5-18-2010, FILED 1-10-2010.



NO CLAIM IS MADE TO THE EXCLUSIVE RIGHT TO USE "LLC", APART FROM THE MARK AS SHOWN.

CLASS 41—(Continued).

THE COLOR(S) BLACK, GRAY, WHITE, AND GOLD IS/ ARE CLAIMED AS A FEATURE OF THE MARK.

THE MARK CONSISTS OF THE WORDING "SURVIVAL SCIENCES, LLC" UNDERNEATH A TRIANGLE THAT CONTAINS A CIRCLE WITH AN EAGLE'S HEAD IN THE CIRCLE. THE EAGLE IS LOOKING TO THE RIGHT. THE COLOR BLACK APPEARS IN THE OUTLINE OF THE TRIANGLE, THE OUTLINE OF THE CIRCLE, THE WORDING "SURVIVAL SCIENCES, LLC", AND THE EAGLE'S EYE, BEAK, AND FEATHERS. THE COLOR GOLD APPEARS IN THE EAGLE'S EYE AND BEAK. THE COLOR GRAY APPEARS IN THE EAGLE'S HEAD FEATHERS AND IN THE SHADING BEHIND THE EAGLE'S HEAD. THE COLOR WHITE APPEARS IN THE EAGLE'S FEATHERS AND IN THE BACKGROUND OF THE TRIANGLE AND CIRCLE DESIGNS. THE COLORS BLACK, GRAY, WHITE, AND GOLD ARE CLAIMED AS FEATURES OF THIS MARK.

FOR EDUCATIONAL SERVICES, NAMELY, CONDUCTING LAW ENFORCEMENT TRAINING IN THE FIELD OF USE OF FORCE AND DISTRIBUTION OF TRAINING MATERIAL IN CONNECTION THEREWITH; EDUCATIONAL SERVICES, NAMELY, DEVELOPING AND CONDUCTING TRAINING COURSES AND DISTRIBUTION OF TRAINING MATERIALS IN CONNECTION THEREWITH FOR SUBJECT MATTERS AS REQUESTED BY CUSTOMERS; INTERACTIVE ON-LINE TRAINING SERVICES IN THE FIELD OF LAW ENFORCEMENT USE OF FORCE; PROVIDING ON-LINE TRAINING FOR LAW ENFORCEMENT IN THE FIELD OF USE OF FORCE; PUBLICATION OF DOCUMENTS IN THE FIELD OF TRAINING, SCIENCE, PUBLIC LAW AND SOCIAL AFFAIRS (U.S. CLS. 100, 101 AND 107).

FIRST USE 2-1-2010; IN COMMERCE 2-1-2010.

SURVIVAL SCIENCES, LLC

3,999,018. CHARLES R. JOYNER, LOS ANGELES, CA. SN 77-908,561. PUB. 5-18-2010, FILED 1-10-2010.

THE MARK CONSISTS OF STANDARD CHARACTERS WITHOUT CLAIM TO ANY PARTICULAR FONT, STYLE, SIZE, OR COLOR.

NO CLAIM IS MADE TO THE EXCLUSIVE RIGHT TO USE "LLC", APART FROM THE MARK AS SHOWN.

FOR EDUCATIONAL SERVICES, NAMELY, CONDUCTING LAW ENFORCEMENT TRAINING IN THE FIELD OF USE OF FORCE AND DISTRIBUTION OF TRAINING MATERIAL IN CONNECTION THEREWITH; EDUCATIONAL SERVICES, NAMELY, DEVELOPING AND CONDUCTING TRAINING COURSES AND DISTRIBUTION OF TRAINING MATERIALS IN CONNECTION THEREWITH FOR SUBJECT MATTERS AS REQUESTED BY CUSTOMERS; INTERACTIVE ON-LINE TRAINING SERVICES IN THE FIELD OF LAW ENFORCEMENT USE OF FORCE; PROVIDING ON-LINE TRAINING FOR LAW ENFORCEMENT IN THE FIELD OF USE OF FORCE; PUBLICATION OF DOCUMENTS IN THE FIELD OF TRAINING, SCIENCE, PUBLIC LAW AND SOCIAL AFFAIRS (U.S. CLS. 100, 101 AND 107).

FIRST USE 2-1-2010; IN COMMERCE 2-1-2010.

CLASS 41—(Continued).

3,999,058. EDVANCE RESEARCH, INC., SAN ANTONIO, TX. SN 77-927,164. PUB. 6-29-2010, FILED 2-3-2010.

PM CITIZENS

THE MARK CONSISTS OF STANDARD CHARACTERS WITHOUT CLAIM TO ANY PARTICULAR FONT, STYLE, SIZE, OR COLOR.

FOR PROVIDING ASSESSMENTS AND SURVEYS IN THE FIELD OF EDUCATOR TRAINING AND PERFORMANCE FOR THE PURPOSE OF IMPROVING TEACHING PROCEDURES DIRECTED AT SCHOOL DISTRICTS, EDUCATORS AND OTHERS PARTICIPATING IN EDUCATIONAL PERFORMANCE MANAGEMENT (U.S. CLS. 100, 101 AND 107).

FIRST USE 8-24-2010; IN COMMERCE 8-24-2010.

3,999,059. EDVANCE RESEARCH, INC., SAN ANTONIO, TX. SN 77-927,200. PUB. 6-29-2010, FILED 2-3-2010.

PM QUICKSTUDY

THE MARK CONSISTS OF STANDARD CHARACTERS WITHOUT CLAIM TO ANY PARTICULAR FONT, STYLE, SIZE, OR COLOR.

FOR PROVIDING AN ONLINE SEARCHABLE DATABASE IN THE NATURE OF A LIBRARY CONTAINING INFORMATION IN THE FIELD OF EDUCATION RELATING SPECIFICALLY TO PERFORMANCE INDICATORS TO SUPPORT PERFORMANCE MANAGEMENT IN SCHOOL DISTRICTS WITH BOTH LEADING AND LAGGING INDICATORS ALONG WITH CORRESPONDING DEFINITIONS, DATA AND CALCULATIONS (U.S. CLS. 100, 101 AND 107).

FIRST USE 8-24-2010; IN COMMERCE 8-24-2010.

3,999,079. PACIFICA MODELING, EASTVALE, CA. SN 77-935,200. PUB. 6-29-2010, FILED 2-13-2010.



NO CLAIM IS MADE TO THE EXCLUSIVE RIGHT TO USE "MODELING", APART FROM THE MARK AS SHOWN.

CLASS 41—(Continued).

THE MARK CONSISTS OF THE WORDING "PACIFICA MODELING" APPEARING UNDER A VOLCANO WHICH HAS LAVA FLOWING DOWN THE SIDE IN THE SHAPE OF CALIFORNIA. THE WORD "PACIFICA" APPEARS WITH THE LETTERS "CA" CAPITALIZED AND IN BOLD.

FOR PHOTOGRAPHY SERVICES (U.S. CLS. 100, 101 AND 107).

FIRST USE 1-1-2010; IN COMMERCE 1-1-2011.

CLASS 41—(Continued).

3,999,148. JENNINGS, JEFFREY, MAGNOLIA, TX. SN 77-968,296. PUB. 2-22-2011, FILED 3-25-2010.

FLASHBACK FRIDAY

THE MARK CONSISTS OF STANDARD CHARACTERS WITHOUT CLAIM TO ANY PARTICULAR FONT, STYLE, SIZE, OR COLOR.

NO CLAIM IS MADE TO THE EXCLUSIVE RIGHT TO USE "FRIDAY", APART FROM THE MARK AS SHOWN.

FOR ENTERTAINMENT SERVICES, NAMELY, PROVIDING ONGOING AUDIO PROGRAMS FEATURING MUSIC, SONGS, AND INFORMATION FROM THE 1970S, 1980S, AND 1990S BROADCAST THROUGH INTERNET STREAMING (U.S. CLS. 100, 101 AND 107).

FIRST USE 4-5-2010; IN COMMERCE 4-5-2010.

3,999,113. DIAN BROOKS, COLUMBIA, MD. AND JOE MILLIGAN, BRONX, NY. SN 77-951,181. PUB. 8-3-2010, FILED 3-4-2010.

Womanesse Moment

THE MARK CONSISTS OF STANDARD CHARACTERS WITHOUT CLAIM TO ANY PARTICULAR FONT, STYLE, SIZE, OR COLOR.

FOR CONDUCTING WORKSHOPS AND SEMINARS IN PERSONAL AWARENESS (U.S. CLS. 100, 101 AND 107).

FIRST USE 12-1-2010; IN COMMERCE 1-10-2011.

3,999,157. BRADLEY, ERIC, MARINA DEL REY, CA. SN 77-981,272. PUB. 9-11-2007, FILED 3-9-2007.

**THE GENIUS OF JEFFERSON**

THE MARK CONSISTS OF STANDARD CHARACTERS WITHOUT CLAIM TO ANY PARTICULAR FONT, STYLE, SIZE, OR COLOR.

FOR MUSEUM SERVICES; EDUCATIONAL SERVICES, NAMELY, ARRANGING AND CONDUCTING TOURS OF HISTORICAL AND CULTURAL SITES, ARRANGING AND CONDUCTING COURSES, SEMINARS, FELLOWSHIP PROGRAMS, LECTURES, PROGRAMS, EVENTS, AND WORKSHOPS CONCERNING HISTORICAL AND CULTURAL TOPICS, AND DEVELOPING AND DISSEMINATING EDUCATIONAL MATERIALS IN CONNECTION THEREWITH (U.S. CLS. 100, 101 AND 107).

FIRST USE 10-1-2010; IN COMMERCE 10-1-2010.

THE MARK CONSISTS OF A STYLIZED COAT OF ARMS FEATURING A STYLIZED FAMILY CREST, A CROWN AND A BANNER FEATURING THE WORDING "YOUNG ROYALS".

FOR ENTERTAINMENT IN THE NATURE OF LIVE PERFORMANCES BY A ROCK MUSIC GROUP; ENTERTAINMENT IN THE NATURE OF LIVE PERFORMANCES BY A ROCK MUSIC GROUP; ENTERTAINMENT SERVICES, NAMELY, PERSONAL APPEARANCES BY A ROCK MUSIC GROUP; ENTERTAINMENT SERVICES, NAMELY, LIVE, TELEVISED AND MOVIE APPEARANCES BY A PROFESSIONAL ENTERTAINER; ENTERTAINMENT, NAMELY, LIVE MUSIC CONCERTS FEATURING A ROCK MUSIC GROUP; ALL OF THE FOREGOING NOT RELATING TO SPORTS OR A SPORTS TEAM (U.S. CLS. 100, 101 AND 107).

FIRST USE 4-1-2007; IN COMMERCE 4-1-2007.

CLASS 41—(Continued).

3,999,159. MINISTRY OF SOUND GROUP LIMITED, LONDON, UNITED KINGDOM. SN 77-981,804. PUB. 1-13-2009, FILED 9-27-2007.

HED KANDI

THE MARK CONSISTS OF STANDARD CHARACTERS WITHOUT CLAIM TO ANY PARTICULAR FONT, STYLE, SIZE, OR COLOR.

OWNER OF U.S. REG. NO. 2,754,753.

FOR NIGHTCLUBS, RESORT SERVICES IN THE NATURE OF BEACH CLUBS, NAMELY, NIGHTCLUBS BY THE BEACH; ENTERTAINMENT SERVICES IN THE NATURE OF DISCOTHEQUES, DANCE CLUB SERVICES FEATURING LIVE AND PRE-RECORDED MUSIC, VIDEOS AND DANCING, LIVE CONCERTS FEATURING MUSIC, AND TELEVISION AND RADIO PROGRAMS FEATURING MUSIC, VIDEO AND LIVE ACTION; PROVISION OF NONDOWNLOADABLE ON-LINE DIGITAL MUSIC FROM THE INTERNET (U.S. CLS. 100, 101 AND 107).

FIRST USE 12-0-2001; IN COMMERCE 12-0-2001.

CLASS 41—(Continued).

3,999,186. HEARTMANITY, LLC, LIVINGSTON, MT. SN 77-982,136. PUB. 5-25-2010, FILED 1-26-2010.

THRIVING WITHOUT THERAPY

THE MARK CONSISTS OF STANDARD CHARACTERS WITHOUT CLAIM TO ANY PARTICULAR FONT, STYLE, SIZE, OR COLOR.

FOR PERSONAL COACHING SERVICES IN THE FIELD OF EMOTIONAL INTELLIGENCE, BRAIN RE-PATTERNING, INTER-PERSONAL RELATIONSHIPS, AND PARENTING; TRAINING IN THE FIELD OF EMOTIONAL INTELLIGENCE, BRAIN RE-PATTERNING, INTER-PERSONAL RELATIONSHIPS, AND PARENTING (U.S. CLS. 100, 101 AND 107).

FIRST USE 4-5-2011; IN COMMERCE 4-5-2011.

3,999,185. HEARTMANITY, LLC, LIVINGSTON, MT. SN 77-982,135. PUB. 5-25-2010, FILED 1-7-2010.

3,999,241. CORAZONAS FOODS, INC., LOS ANGELES, CA. SN 85-008,455. PUB. 9-7-2010, FILED 4-7-2010.



FREEDOM TO SNACK

THE MARK CONSISTS OF TWO FINGERPRINTS OVERLAIN ON TOP OF ONE ANOTHER TO FORM A HEART DESIGN.

FOR PERSONAL COACHING SERVICES IN THE FIELD OF EMOTIONAL INTELLIGENCE, BRAIN RE-PATTERNING, INTER-PERSONAL RELATIONSHIPS, AND PARENTING; TRAINING IN THE FIELD OF EMOTIONAL INTELLIGENCE, BRAIN RE-PATTERNING, INTER-PERSONAL RELATIONSHIPS, AND PARENTING (U.S. CLS. 100, 101 AND 107).

FIRST USE 4-5-2011; IN COMMERCE 4-5-2011.

THE MARK CONSISTS OF STANDARD CHARACTERS WITHOUT CLAIM TO ANY PARTICULAR FONT, STYLE, SIZE, OR COLOR.

NO CLAIM IS MADE TO THE EXCLUSIVE RIGHT TO USE "SNACK", APART FROM THE MARK AS SHOWN.

FOR EDUCATION SERVICES, NAMELY, PROVIDING ON-LINE INFORMATION IN THE FIELD OF NUTRITION AND HEALTH (U.S. CLS. 100, 101 AND 107).

FIRST USE 6-28-2010; IN COMMERCE 6-28-2010.

CLASS 41—(Continued).

3,999,243. CORAZONAS FOODS, INC., LOS ANGELES, CA. SN 85-008,718. PUB. 9-7-2010, FILED 4-7-2010.



NO CLAIM IS MADE TO THE EXCLUSIVE RIGHT TO USE "CHOLESTEROL LOWERING POWER OF FRUITS AND VEGETABLES", APART FROM THE MARK AS SHOWN.

THE MARK CONSISTS OF A RECTANGLE WITH ROUNDED CORNERS, THE TOP HALF OF WHICH CONTAINS THE STYLIZED REPRESENTATION OF A LEAF, AND THE BOTTOM HALF OF WHICH CONTAINS THE WORDS "CHOLESTEROL LOWERING POWER OF FRUITS AND VEGETABLES" ENCLOSED WITHIN A SQUARE WHOSE TOP IS FLAT AND WHOSE BOTTOM CORNERS ARE ROUNDED.

FOR EDUCATION SERVICES, NAMELY, PROVIDING ON-LINE INFORMATION IN THE FIELD OF NUTRITION AND HEALTH (U.S. CLS. 100, 101 AND 107).

FIRST USE 6-28-2010; IN COMMERCE 6-28-2010.

3,999,271. EMIDS TECHNOLOGIES PRIVATE LIMITED CORP., NASHVILLE, TN. SN 85-016,168. PUB. 9-28-2010, FILED 4-16-2010.

THE H.I.T. MEN AWARDS

THE MARK CONSISTS OF STANDARD CHARACTERS WITHOUT CLAIM TO ANY PARTICULAR FONT, STYLE, SIZE, OR COLOR.

NO CLAIM IS MADE TO THE EXCLUSIVE RIGHT TO USE "AWARDS", APART FROM THE MARK AS SHOWN.

FOR PROVIDING RECOGNITION, HONOR AND INCENTIVES TO INDIVIDUALS AND ORGANIZATIONS REGARDING THEIR ACHIEVEMENTS AND CONTRIBUTIONS IN THE MEDICAL, HEALTHCARE, MEDICAL ACADEMIC, AND COMMUNITY SERVICES FIELDS THROUGH A PERIODIC AWARDS PROGRAM (U.S. CLS. 100, 101 AND 107).

FIRST USE 2-0-2010; IN COMMERCE 2-0-2010.

CLASS 41—(Continued).

3,999,277. GAME SHOW NETWORK, LLC, SANTA MONICA, CA. SN 85-017,753. PUB. 9-21-2010, FILED 4-19-2010.

LATE NIGHT LIARS

THE MARK CONSISTS OF STANDARD CHARACTERS WITHOUT CLAIM TO ANY PARTICULAR FONT, STYLE, SIZE, OR COLOR.

FOR ENTERTAINMENT IN THE NATURE OF AN ONGOING TELEVISION GAME SHOW; ONLINE, INTERACTIVE COMPUTER GAMES AND MOBILE GAMES IN THE FORM OF NON-DOWNLOADABLE SOFTWARE ACCESSED THROUGH MOBILE PHONES, PDAS, OTHER TYPES OF HAND-HELD DEVICES (U.S. CLS. 100, 101 AND 107).

FIRST USE 6-10-2010; IN COMMERCE 6-10-2010.

3,999,303. ROSENBERG MANAGEMENT CORP, NEW YORK, NY. SN 85-022,359. PUB. 4-12-2011, FILED 4-24-2010.

PORNSTAR SEX LIFE

THE MARK CONSISTS OF STANDARD CHARACTERS WITHOUT CLAIM TO ANY PARTICULAR FONT, STYLE, SIZE, OR COLOR.

NO CLAIM IS MADE TO THE EXCLUSIVE RIGHT TO USE "SEX LIFE", APART FROM THE MARK AS SHOWN.

FOR EDUCATION SERVICES, NAMELY, PROVIDING CLASSES, WORKSHOPS, AND SEMINARS IN THE FIELD OF RELATIONSHIPS AND PERSONAL INTERACTION FOR CONSUMERS 18 YEARS OF AGE OR OLDER (U.S. CLS. 100, 101 AND 107).

FIRST USE 3-1-2010; IN COMMERCE 3-1-2010.

3,999,364. ALL SAINTS CAMP AND CONFERENCE CENTER, INC., POTTSBORO, TX. SN 85-030,050. PUB. 11-2-2010, FILED 5-4-2010.

JOLT

THE MARK CONSISTS OF STANDARD CHARACTERS WITHOUT CLAIM TO ANY PARTICULAR FONT, STYLE, SIZE, OR COLOR.

FOR EDUCATIONAL SERVICES, NAMELY, DEVELOPING CURRICULA FOR OTHERS AND CONDUCTING EDUCATIONAL PROGRAMS IN THE FIELDS OF THE ENVIRONMENT AND SCIENCE (U.S. CLS. 100, 101 AND 107).

FIRST USE 5-1-2006; IN COMMERCE 5-18-2011.

CLASS 41—(Continued).

3,999,404. HARPO, INC., CHICAGO, IL. SN 85-033,433. PUB. 3-8-2011, FILED 5-7-2010.

OPRAH'S SEARCH FOR THE NEXT TV STAR

THE MARK CONSISTS OF STANDARD CHARACTERS WITHOUT CLAIM TO ANY PARTICULAR FONT, STYLE, SIZE, OR COLOR.

OWNER OF U.S. REG. NOS. 1,726,373, 3,377,275, AND OTHERS.

THE NAME "OPRAH" IDENTIFIES A LIVING INDIVIDUAL WHOSE CONSENT IS OF RECORD.

FOR ENTERTAINMENT SERVICES IN THE NATURE OF AN ONGOING REALITY BASED TELEVISION PROGRAM; PROVIDING INFORMATION REGARDING THE FOREGOING VIA A GLOBAL COMPUTER NETWORK (U.S. CLS. 100, 101 AND 107).

FIRST USE 1-7-2011; IN COMMERCE 1-7-2011.

3,999,410. AMERICAN EXPRESS MARKETING & DEVELOPMENT CORP., NEW YORK, NY. SN 85-035,284. PUB. 10-12-2010, FILED 5-11-2010.

ZYNC INSIDER

THE MARK CONSISTS OF STANDARD CHARACTERS WITHOUT CLAIM TO ANY PARTICULAR FONT, STYLE, SIZE, OR COLOR.

FOR PROVIDING ON-LINE NEWSLETTERS IN THE FIELD OF FINANCIAL SERVICES (U.S. CLS. 100, 101 AND 107).

FIRST USE 7-31-2010; IN COMMERCE 7-31-2010.

3,999,427. BOTTLES 'N BRUSHES, LLC, MOUNT PLEASANT, SC. SN 85-036,911. PUB. 10-12-2010, FILED 5-12-2010.

ART BUZZ

THE MARK CONSISTS OF STANDARD CHARACTERS WITHOUT CLAIM TO ANY PARTICULAR FONT, STYLE, SIZE, OR COLOR.

NO CLAIM IS MADE TO THE EXCLUSIVE RIGHT TO USE "ART", APART FROM THE MARK AS SHOWN.

FOR INSTRUCTION IN THE FIELD OF ART (U.S. CLS. 100, 101 AND 107).

FIRST USE 1-0-2009; IN COMMERCE 1-0-2009.

CLASS 41—(Continued).

3,999,431. RED ROCK VALLEY LIMITED, LAS VEGAS, NV. SN 85-037,481. PUB. 10-12-2010, FILED 5-13-2010.



THE MARK CONSISTS OF FOUR STARS FEATURING CHILDLIKE EXPRESSIONS SIGNIFYING THE FOUR CHILDREN CALLED "CTALKERS" FEATURED ON THE SHOW ABOVE THE LETTERS "CTALKERS".

FOR EDUCATIONAL AND ENTERTAINMENT SERVICES, NAMELY, A CONTINUING PROGRAM ABOUT THE PERSPECTIVE OF CHILDREN IN THE NATURE OF AN ONGOING BROADCAST PROGRAM IN THE FIELD OF VARIETY ACCESSIBLE BY RADIO, TELEVISION, SATELLITE, AUDIO, VIDEO AND COMPUTER NETWORKS (U.S. CLS. 100, 101 AND 107).

FIRST USE 5-1-2010; IN COMMERCE 5-1-2010.

3,999,432. RED ROCK VALLEY LIMITED, LAS VEGAS, NV. SN 85-037,512. PUB. 10-12-2010, FILED 5-13-2010.



THE MARK CONSISTS OF A MAGNIFIED GLASS ICON ENLARGING "CT" OF THE WORD "FACTS".

FOR ENTERTAINMENT IN THE NATURE OF ONGOING TELEVISION PROGRAMS IN THE FIELD OF VARIETY SHOW WITH EDUCATIONAL VALUE (U.S. CLS. 100, 101 AND 107).

FIRST USE 5-1-2010; IN COMMERCE 5-1-2010.

CLASS 41—(Continued).

3,999,434. RED ROCKVALLEY LIMITED, LAS VEGAS, NV.
SN 85-037,528. PUB. 10-12-2010, FILED 5-13-2010.



THE MARK CONSISTS OF A CAMERA ICON CENTERED IN A MULTIPOINTED STAR WITH FLOWING FILM STRIPS CONTAINING THE LETTERS "CT" FOUR TIMES DEPICTED ABOVE THE WORD "SHORTKUTS".

FOR ENTERTAINMENT IN THE NATURE OF ONGOING TELEVISION PROGRAMS IN THE FIELD OF VARIETY SHOW THAT DEMONSTRATE HOME MOVIES OF CHILDREN (U.S. CLS. 100, 101 AND 107).
FIRST USE 5-1-2010; IN COMMERCE 5-1-2010.

CLASS 41—(Continued).

3,999,448. GRANGER ENTERTAINMENT LLC, FAIRFIELD, CT. SN 85-039,305. PUB. 10-12-2010, FILED 5-14-2010.

TAKE ZERO

THE MARK CONSISTS OF STANDARD CHARACTERS WITHOUT CLAIM TO ANY PARTICULAR FONT, STYLE, SIZE, OR COLOR.
FOR LIVE MUSICAL PERFORMANCES (U.S. CLS. 100, 101 AND 107).
FIRST USE 1-1-2009; IN COMMERCE 1-1-2009.

3,999,451. WONDERLAND MONTESSORI ACADEMY, FLOWER MOUND, TX. SN 85-040,871. PUB. 10-19-2010, FILED 5-17-2010.

3,999,447. GRANGER ENTERTAINMENT LLC, FAIRFIELD, CT. SN 85-039,296. PUB. 10-12-2010, FILED 5-14-2010.



THE MARK CONSISTS OF AN "X"-SHAPED FRAME CONSISTING OF LINES AND TRIANGULAR SHAPES, WITH THE WORD "TAKE" RUNNING DIAGONALLY FROM UPPER LEFT TO LOWER RIGHT, AND THE WORD "ZERO" RUNNING DIAGONALLY FROM LOWER LEFT TO UPPER RIGHT WITHIN THE "X"-SHAPED FRAME.

FOR LIVE MUSICAL PERFORMANCES (U.S. CLS. 100, 101 AND 107).
FIRST USE 1-1-2009; IN COMMERCE 1-1-2009.



NO CLAIM IS MADE TO THE EXCLUSIVE RIGHT TO USE "KIDS" AND "MONTESSORI ACADEMY", APART FROM THE MARK AS SHOWN.

THE MARK CONSISTS OF THE TEXT "WHERE KIDS EXCEL" IN AN INVERTED CURVE BELOW A STAR CLUSTER DESIGN AND OVER A DESIGN OF THREE FIGURES WITH RAISED ARMS IN SILHOUETTE. THE TEXT "WONDERLAND" FOLLOWED BY "MONTESSORI ACADEMY", ALL UPPER-CASE APPEARS BENEATH THE THREE FIGURES".

FOR EDUCATIONAL PROGRAMS, NAMELY, PRE-SCHOOLS (U.S. CLS. 100, 101 AND 107).
FIRST USE 8-31-2010; IN COMMERCE 8-31-2010.

CLASS 41—(Continued).

3,999,453. EQUILIBRIA PSYCHOLOGICAL AND CONSULTATION SERVICES, LLC, PHILADELPHIA, PA. SN 85-041,140. PUB. 10-12-2010, FILED 5-18-2010.

LEADERSHIP RPM

THE MARK CONSISTS OF STANDARD CHARACTERS WITHOUT CLAIM TO ANY PARTICULAR FONT, STYLE, SIZE, OR COLOR.

NO CLAIM IS MADE TO THE EXCLUSIVE RIGHT TO USE "LEADERSHIP", APART FROM THE MARK AS SHOWN.

FOR WORKSHOPS AND SEMINARS IN THE FIELDS OF ENGAGING, MANAGING, DEVELOPING, AND RETAINING EMPLOYEES (U.S. CLS. 100, 101 AND 107).
FIRST USE 6-7-2011; IN COMMERCE 6-7-2011.

3,999,478. MIDKIFF, DANIEL, L, WINSTON-SALEM, NC. SN 85-045,971. PUB. 1-18-2011, FILED 5-24-2010.



THE MARK CONSISTS OF SILHOUETTE OF GUITAR PLAYER IN JUMP KICK TO THE HEAD OF A FIGHTER.

FOR ENTERTAINMENT SERVICES IN THE NATURE OF LIVE MIXED MARTIAL ARTS (MMA) EVENTS; ENTERTAINMENT SERVICES IN THE NATURE OF LIVE MUSICAL PERFORMANCES (U.S. CLS. 100, 101 AND 107).

FIRST USE 5-1-2010; IN COMMERCE 9-15-2010.

3,999,495. INSTANT INSIGHT, INC., SUNNYVALE, CA. SN 85-048,697. PUB. 3-15-2011, FILED 5-26-2010.



THE COLOR(S) RED, DARK RED, BLUE, AND GRAY IS/ ARE CLAIMED AS A FEATURE OF THE MARK.

CLASS 41—(Continued).

THE MARK CONSISTS OF THE WORDING "CURIOUS DUCK" IN RED LETTERS WITH A DARKER RED DROP SHADOW. THE LETTER "O" IS IN THE FORM OF A GLOBE WITH BLUE WATER AND GRAY CONTINENTS.

FOR ENTERTAINMENT SERVICES, NAMELY, PROVIDING MULTIMEDIA PROGRAMMING IN THE FIELD OF SCIENCE AND CHILDREN'S ENTERTAINMENT VIA A GLOBAL COMPUTER NETWORK; ENTERTAINMENT SERVICES IN THE NATURE OF AN ONGOING TELEVISION PROGRAM IN THE FIELDS OF SCIENCE AND CHILDREN'S ENTERTAINMENT; PRODUCTION AND DISTRIBUTION OF TELEVISION SHOWS AND MOVIES (U.S. CLS. 100, 101 AND 107).

FIRST USE 4-1-2010; IN COMMERCE 5-18-2011.

3,999,497. SKYUNION PTE. LTD., 159308, SINGAPORE. SN 85-049,368. PUB. 11-2-2010, FILED 5-27-2010.

Crazy Mart

THE MARK CONSISTS OF THE WORDING "CRAZY MART".

FOR COMPUTER EDUCATION TRAINING; EDUCATIONAL EXAMINATION; ELECTRONIC PUBLISHING SERVICES, NAMELY, PUBLICATION OF TEXT AND GRAPHIC WORKS OF OTHERS ON CD, DVD AND ON-LINE FEATURING COMPUTER GAMES; ENTERTAINMENT INFORMATION; ENTERTAINMENT SERVICES, NAMELY, PROVIDING AN ON-LINE COMPUTER GAME; ORGANISATION OF SPORTS COMPETITIONS; ORGANIZATION OF EXHIBITIONS FOR CULTURAL OR EDUCATIONAL PURPOSES; PUBLICATION OF BOOKS; PUBLICATION OF ELECTRONIC MAGAZINES; PUBLICATION OF TEXTS, BOOKS, MAGAZINES AND OTHER PRINTED MATTER; PUBLISHING OF ELECTRONIC PUBLICATIONS; SOCIAL CLUB SERVICES, NAMELY, ARRANGING, ORGANIZING, AND HOSTING SOCIAL EVENTS, GET-TOGETHERS, AND PARTIES FOR CLUB MEMBERS (U.S. CLS. 100, 101 AND 107).

FIRST USE 9-1-2010; IN COMMERCE 9-1-2010.

3,999,510. MXENERGY INC., STAMFORD, CT. SN 85-053,991. PUB. 9-28-2010, FILED 6-3-2010.

MXTV

THE MARK CONSISTS OF STANDARD CHARACTERS WITHOUT CLAIM TO ANY PARTICULAR FONT, STYLE, SIZE, OR COLOR.

OWNER OF U.S. REG. NO. 2,588,940.

FOR ENTERTAINMENT SERVICES, NAMELY, PROVIDING ON-GOING VIDEO PROGRAMS IN THE FIELD OF ENERGY, ENERGY USAGE, ENERGY EFFICIENCY, GREEN TECHNOLOGY, SUSTAINABILITY, SUSTAINABLE LIVING VIA A GLOBAL COMPUTER NETWORK (U.S. CLS. 100, 101 AND 107).

FIRST USE 11-8-2010; IN COMMERCE 11-8-2010.

CLASS 41—(Continued).

3,999,521. PREP NET, LLC, GRAND RAPIDS, MI. SN 85-055,077. PUB. 12-7-2010, FILED 6-4-2010.

PREPNET

THE MARK CONSISTS OF STANDARD CHARACTERS WITHOUT CLAIM TO ANY PARTICULAR FONT, STYLE, SIZE, OR COLOR.

FOR EDUCATIONAL SERVICES, NAMELY, DEVELOPMENT OF CURRICULUM FOR EDUCATORS AND IMPLEMENTATION BY PROVIDING COURSES OF INSTRUCTION IN PUBLIC SCHOOLS AT THE SECONDARY LEVEL; EDUCATIONAL SERVICES, NAMELY, CONDUCTING IN-SCHOOL PROGRAMS IN THE FIELD OF CHARACTER DEVELOPMENT; PROVIDING AFTER-SCHOOL EDUCATIONAL PROGRAMS IN THE FIELD OF SPORTS AND SOCIAL SKILLS FOR STUDENTS IN THE SECONDARY SCHOOL LEVEL (U.S. CLS. 100, 101 AND 107).

FIRST USE 9-29-2009; IN COMMERCE 1-24-2011.

3,999,531. HICKEY, MEGHAN, BROOKLYN, NY. SN 85-057,270. PUB. 11-2-2010, FILED 6-8-2010.

QUIET IRIS

THE MARK CONSISTS OF STANDARD CHARACTERS WITHOUT CLAIM TO ANY PARTICULAR FONT, STYLE, SIZE, OR COLOR.

FOR PHOTOGRAPHY SERVICES; PHOTOGRAPHY CONSULTING SERVICES (U.S. CLS. 100, 101 AND 107).

FIRST USE 9-1-2010; IN COMMERCE 2-28-2011.

3,999,561. DE MAIO, JOEY, AUBURN, NY. SN 85-065,290. PUB. 11-16-2010, FILED 6-17-2010.

MANOWAR

THE MARK CONSISTS OF STANDARD CHARACTERS WITHOUT CLAIM TO ANY PARTICULAR FONT, STYLE, SIZE, OR COLOR.

OWNER OF U.S. REG. NO. 2,361,781.
FOR ENTERTAINMENT SERVICES IN THE NATURE OF LIVE MUSICAL PERFORMANCES (U.S. CLS. 100, 101 AND 107).

FIRST USE 7-1-1982; IN COMMERCE 7-1-1982.

CLASS 41—(Continued).

3,999,592. AGEWELL SYSTEMS, INC., SALT LAKE CITY, UT. SN 85-073,687. PUB. 11-30-2010, FILED 6-29-2010.

Age Performance

THE MARK CONSISTS OF STANDARD CHARACTERS WITHOUT CLAIM TO ANY PARTICULAR FONT, STYLE, SIZE, OR COLOR.

FOR PERSONAL FITNESS TRAINING SERVICES AND CONSULTANCY (U.S. CLS. 100, 101 AND 107).

FIRST USE 1-20-2011; IN COMMERCE 1-20-2011.

3,999,596. JENNIE HELDERMAN, ATLANTA, GA. SN 85-074,936. PUB. 11-30-2010, FILED 6-30-2010.

The Summers Bridgewater Press

THE MARK CONSISTS OF STANDARD CHARACTERS WITHOUT CLAIM TO ANY PARTICULAR FONT, STYLE, SIZE, OR COLOR.

NO CLAIM IS MADE TO THE EXCLUSIVE RIGHT TO USE "PRESS", APART FROM THE MARK AS SHOWN.

FOR PUBLISHING OF BOOKS AND REVIEWS; PUBLISHING OF BOOKS, E-BOOKS, AUDIO BOOKS (U.S. CLS. 100, 101 AND 107).

FIRST USE 7-31-2010; IN COMMERCE 8-31-2010.

CLASS 41—(Continued).

3,999,612. INFLUENCE AT WORK, L.L.C., TEMPE, AZ. SN 85-078,850. PUB. 12-14-2010, FILED 7-6-2010.

IAW

THE MARK CONSISTS OF STANDARD CHARACTERS WITHOUT CLAIM TO ANY PARTICULAR FONT, STYLE, SIZE, OR COLOR.

FOR TRAINING SERVICES AND TRAINING PROGRAMS IN THE FIELDS OF THE APPLIED SCIENCE AND THE PSYCHOLOGY OF PERSUASION, AND DISTRIBUTING TRAINING MATERIALS IN CONNECTION THEREWITH; EDUCATIONAL SERVICES, NAMELY, PUBLIC SPEAKING CONSISTING OF GIVING LECTURES, PRESENTATIONS AND KEYNOTE ADDRESSES IN THE FIELDS OF THE APPLIED SCIENCE AND THE PSYCHOLOGY OF PERSUASION, AND DISTRIBUTING EDUCATIONAL MATERIALS IN CONNECTION THEREWITH; EDUCATIONAL SERVICES, NAMELY, PROVIDING SPEAKERS TO GIVE LECTURES, PRESENTATIONS AND KEYNOTE ADDRESSES IN THE FIELDS OF THE APPLIED SCIENCE AND THE PSYCHOLOGY OF PERSUASION, AND DISTRIBUTING EDUCATIONAL MATERIALS IN CONNECTION THEREWITH (U.S. CLS. 100, 101 AND 107).

FIRST USE 8-0-1999; IN COMMERCE 8-0-1999.

3,999,642. MIKVELK PUBLISHING, LLC, CANYON, TX. SN 85-089,018. PUB. 1-4-2011, FILED 7-20-2010.

MIKVELK PUBLISHING, LLC

THE MARK CONSISTS OF STANDARD CHARACTERS WITHOUT CLAIM TO ANY PARTICULAR FONT, STYLE, SIZE, OR COLOR.

NO CLAIM IS MADE TO THE EXCLUSIVE RIGHT TO USE "PUBLISHING, LLC", APART FROM THE MARK AS SHOWN.

THE WORDING "MIKVELK" HAS NO SIGNIFICANCE IN THE PUBLISHING TRADE OR INDUSTRY OR AS APPLIED TO THE SERVICES IN THE APPLICATION. IN ADDITION, THE WORDING "MIKVELK" HAS NO GEOGRAPHIC OR SURNAME SIGNIFICANCE.

FOR PUBLISHING OF ELECTRONIC PUBLICATIONS (U.S. CLS. 100, 101 AND 107).

FIRST USE 6-15-2010; IN COMMERCE 6-15-2010.

CLASS 41—(Continued).

3,999,698. SHIVA SHANTI YOGA SCHOOL, RUTHERFORD, NJ. SN 85-109,116. PUB. 2-8-2011, FILED 8-17-2010.



NO CLAIM IS MADE TO THE EXCLUSIVE RIGHT TO USE "YOGA SCHOOL", APART FROM THE MARK AS SHOWN.

THE STIPPLING IS A FEATURE OF THE MARK.

THE COLOR(S) ORANGE, BURGUNDY, AND WHITE IS/ ARE CLAIMED AS A FEATURE OF THE MARK.

THE MARK CONSISTS OF THE WORDING "SHIVA SHANTI YOGA SCHOOL" IN ORANGE WITH BURGUNDY OUTLINING SURROUNDING A DEPICTION OF A PERSON SITTING IN LOTUS POSITION IN ORANGE WITH SEVEN CIRCLES DEPICTING THE SEVEN CHAKRAS APPEARING VERTICALLY ON THE PERSON; THE PERSON APPEARS IN FRONT OF AN ORANGE LOTUS FLOWER THAT IS SURROUNDED BY TWO CONCENTRIC CIRCLES IN ORANGE AND BURGUNDY. THE BACKGROUND OF THE MARK IS TRANSPARENT.

FOR YOGA INSTRUCTION (U.S. CLS. 100, 101 AND 107).

FIRST USE 8-1-2008; IN COMMERCE 8-1-2008.

3,999,734. GAYLORD ENTERTAINMENT COMPANY, NASHVILLE, TN. SN 85-125,086. PUB. 3-8-2011, FILED 9-8-2010.

PARADISE SPRINGS

THE MARK CONSISTS OF STANDARD CHARACTERS WITHOUT CLAIM TO ANY PARTICULAR FONT, STYLE, SIZE, OR COLOR.

FOR PROVIDING RECREATIONAL FACILITIES IN THE NATURE OF A SWIMMING POOL, WATER SLIDES, WAVE POOL AND ZIP LINES (U.S. CLS. 100, 101 AND 107).

FIRST USE 5-27-2011; IN COMMERCE 5-27-2011.

CLASS 41—(Continued).

3,999,736. MARTIN LEITGEB, MONTCLAIR, NJ. SN 85-126,046. PUB. 2-22-2011, FILED 9-9-2010.



THE MARK CONSISTS OF A CIRCLE WITH A DECORATIVE ZIG-ZAG BORDER WITH THE WORD MARK "DAS" UNDERLINED THEREIN

FOR PROVIDING FITNESS AND EXERCISE STUDIO SERVICES, NAMELY, PILATES INSTRUCTION AND TRAINING (U.S. CLS. 100, 101 AND 107).

FIRST USE 10-0-2010; IN COMMERCE 10-0-2010.

3,999,756. FULCRUM NETWORK, INC., NAPERVILLE, IL. SN 85-134,311. PUB. 3-8-2011, FILED 9-21-2010.

ESSENTIAL CIRCLES

THE MARK CONSISTS OF STANDARD CHARACTERS WITHOUT CLAIM TO ANY PARTICULAR FONT, STYLE, SIZE, OR COLOR.

THE WORDING "ESSENCIAL" HAS NO MEANING IN A FOREIGN LANGUAGE.

FOR CONDUCTING WORKSHOPS AND SEMINARS IN TALENT IDENTIFICATION AND DEVELOPMENT FOR INDIVIDUALS AND ORGANIZATIONS; PROFESSIONAL COACHING SERVICES IN THE FIELD OF TALENT IDENTIFICATION AND DEVELOPMENT FOR INDIVIDUALS AND ORGANIZATIONS; PROVIDING GROUP COACHING IN THE FIELD OF TALENT IDENTIFICATION AND DEVELOPMENT FOR INDIVIDUALS AND ORGANIZATIONS (U.S. CLS. 100, 101 AND 107).

FIRST USE 2-1-2011; IN COMMERCE 5-11-2011.

CLASS 41—(Continued).

3,999,760. SALLY ULLMAN, EMMAUS, PA. SN 85-136,494. PUB. 3-8-2011, FILED 9-23-2010.

VISUAL BRANDING

THE MARK CONSISTS OF STANDARD CHARACTERS WITHOUT CLAIM TO ANY PARTICULAR FONT, STYLE, SIZE, OR COLOR.

FOR PHOTOGRAPHY SERVICES (U.S. CLS. 100, 101 AND 107).

FIRST USE 9-23-2010; IN COMMERCE 10-1-2010.

3,999,767. SEWING LOUNGE, WAXHAW, NC. SN 85-138,812. PUB. 3-22-2011, FILED 9-27-2010.

SEWING LOUNGE

THE MARK CONSISTS OF STANDARD CHARACTERS WITHOUT CLAIM TO ANY PARTICULAR FONT, STYLE, SIZE, OR COLOR.

NO CLAIM IS MADE TO THE EXCLUSIVE RIGHT TO USE "SEWING", APART FROM THE MARK AS SHOWN.

FOR EDUCATIONAL SERVICES, NAMELY, CONDUCTING CLASSES, CAMPS AND WORKSHOPS IN THE FIELD OF SEWING; ENTERTAINMENT SERVICES, NAMELY, CONDUCTING SEWING PARTIES AND SPECIAL EVENTS FOR SOCIAL ENTERTAINMENT PURPOSES (U.S. CLS. 100, 101 AND 107).

FIRST USE 10-1-2008; IN COMMERCE 5-1-2011.

3,999,770. TETRIS ONLINE, INC., HONOLULU, HI. SN 85-139,524. PUB. 3-15-2011, FILED 9-28-2010.

HOME TEAM BASEBALL

THE MARK CONSISTS OF STANDARD CHARACTERS WITHOUT CLAIM TO ANY PARTICULAR FONT, STYLE, SIZE, OR COLOR.

NO CLAIM IS MADE TO THE EXCLUSIVE RIGHT TO USE "BASEBALL", APART FROM THE MARK AS SHOWN.

FOR ENTERTAINMENT SERVICES, NAMELY, PROVIDING ONLINE ELECTRONIC GAMES (U.S. CLS. 100, 101 AND 107).

FIRST USE 3-23-2011; IN COMMERCE 3-23-2011.

CLASS 41—(Continued).

3,999,773. SCHOLASTIC INC., NEW YORK, NY. SN 85-140,671. PUB. 3-22-2011, FILED 9-29-2010.

FRACTION NATION

THE MARK CONSISTS OF STANDARD CHARACTERS WITHOUT CLAIM TO ANY PARTICULAR FONT, STYLE, SIZE, OR COLOR.

OWNER OF U.S. REG. NO. 3,788,252.

NO CLAIM IS MADE TO THE EXCLUSIVE RIGHT TO USE "FRACTION", APART FROM THE MARK AS SHOWN.

FOR EDUCATIONAL SERVICES, NAMELY, PROVIDING ON-LINE INSTRUCTION IN THE FIELD OF MATH CURRICULUM FOR CHILDREN; PROVIDING ON-LINE PUBLICATIONS IN THE NATURE OF ELECTRONIC STUDENT AND TEACHER EDITION WORKBOOKS IN THE FIELD OF MATH INSTRUCTION FOR CHILDREN (U.S. CLS. 100, 101 AND 107).

FIRST USE 5-1-2011; IN COMMERCE 5-1-2011.

3,999,774. PENTON BUSINESS MEDIA, INC., NEW YORK, NY. SN 85-140,686. PUB. 3-8-2011, FILED 9-29-2010.

The Windshield

THE MARK CONSISTS OF STANDARD CHARACTERS WITHOUT CLAIM TO ANY PARTICULAR FONT, STYLE, SIZE, OR COLOR.

FOR ON-LINE JOURNALS, NAMELY, BLOGS FEATURING NEWS AND INFORMATION IN THE FIELD OF THE AVIATION INDUSTRY; PROVIDING NEWSLETTERS IN THE FIELD OF THE AVIATION INDUSTRY VIA E-MAIL; PROVIDING ON-LINE NEWSLETTERS IN THE FIELD OF THE AVIATION INDUSTRY (U.S. CLS. 100, 101 AND 107).

FIRST USE 11-1-2010; IN COMMERCE 11-1-2010.

CLASS 41—(Continued).

3,999,781. OMAHA ROYALS LIMITED PARTNERSHIP, OMAHA, NE. SN 85-142,139. PUB. 3-15-2011, FILED 9-30-2010.

STORM CHASERS

THE MARK CONSISTS OF STANDARD CHARACTERS WITHOUT CLAIM TO ANY PARTICULAR FONT, STYLE, SIZE, OR COLOR.

FOR ENTERTAINMENT SERVICES IN THE NATURE OF BASEBALL GAMES AND EXHIBITIONS, AND PERSONAL APPEARANCES BY A SPORTS MASCOT (U.S. CLS. 100, 101 AND 107).

FIRST USE 11-15-2010; IN COMMERCE 11-15-2010.

3,999,820. REGEHR, CLINT, FRISCO, TX. SN 85-155,846. PUB. 3-22-2011, FILED 10-19-2010.



THE MARK CONSISTS OF THE STYLIZED LETTERS AND WORDS "CER CERVIDEO". THE LETTERS "E" AND "R" ARE INSIDE THE LETTER "C".

FOR FILM PRODUCTION (U.S. CLS. 100, 101 AND 107).

FIRST USE 11-15-2010; IN COMMERCE 11-15-2010.

3,999,832. 4THAND1 LLC, CHICAGO, IL. SN 85-159,413. PUB. 3-22-2011, FILED 10-22-2010.

DRAFTDAY

THE MARK CONSISTS OF STANDARD CHARACTERS WITHOUT CLAIM TO ANY PARTICULAR FONT, STYLE, SIZE, OR COLOR.

FOR ONLINE INTERACTIVE WEBSITE FOR FANTASY SPORTS CONTESTS (U.S. CLS. 100, 101 AND 107).

FIRST USE 1-1-2011; IN COMMERCE 1-1-2011.

CLASS 41—(Continued).

3,999,839. TWENTIETH CENTURY FOX FILM CORPORATION, LOS ANGELES, CA. SN 85-162,757. PUB. 3-22-2011, FILED 10-27-2010.

THE CHICAGO CODE

THE MARK CONSISTS OF STANDARD CHARACTERS WITHOUT CLAIM TO ANY PARTICULAR FONT, STYLE, SIZE, OR COLOR.

NO CLAIM IS MADE TO THE EXCLUSIVE RIGHT TO USE "CHICAGO", APART FROM THE MARK AS SHOWN.

FOR ENTERTAINMENT SERVICES IN THE NATURE OF A TELEVISION SERIES FEATURING DRAMA; PROVIDING ON-LINE INFORMATION IN THE FIELD OF TELEVISION AND VIDEO ENTERTAINMENT FEATURING DRAMA VIA THE INTERNET; ENTERTAINMENT SERVICES IN THE NATURE OF NON-DOWNLOADABLE VIDEOS AND IMAGES FEATURING TELEVISION SHOWS AND ENTERTAINMENT TRANSMITTED VIA THE INTERNET AND WIRELESS COMMUNICATION NETWORKS (U.S. CLS. 100, 101 AND 107).

FIRST USE 10-29-2010; IN COMMERCE 10-29-2010.

3,999,851. VIACOM INTERNATIONAL INC., NEW YORK, NY. SN 85-169,542. PUB. 3-22-2011, FILED 11-4-2010.

SUPAH NINJAS

THE MARK CONSISTS OF STANDARD CHARACTERS WITHOUT CLAIM TO ANY PARTICULAR FONT, STYLE, SIZE, OR COLOR.

FOR ENTERTAINMENT SERVICES IN THE NATURE OF CONTINUING PROGRAM SERIES, FEATURING LIVE ACTION, COMEDY AND DRAMA PROVIDED THROUGH CABLE TELEVISION, BROADCAST TELEVISION, INTERNET, VIDEO-ON-DEMAND, AND THROUGH OTHER DISTRIBUTION PLATFORMS; PROVIDING ONLINE INFORMATION IN THE FIELD OF ENTERTAINMENT CONCERNING TELEVISION PROGRAMS (U.S. CLS. 100, 101 AND 107).

FIRST USE 4-16-2011; IN COMMERCE 4-16-2011.

CLASS 42—SCIENTIFIC AND COMPUTER SERVICES**CLASS 42—(Continued).**

3,998,303. JAH INNOVATIONS INC., ATLANTA, GA. SN 76-660,395. PUB. 1-1-2008, FILED 5-22-2006.

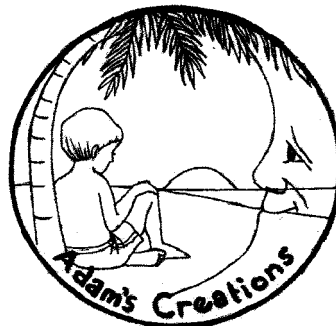

NO CLAIM IS MADE TO THE EXCLUSIVE RIGHT TO USE "CREATIONS", APART FROM THE MARK AS SHOWN.

FOR FAST FOOD STORAGE CONTAINER DESIGN FOR OTHERS (U.S. CLS. 100 AND 101).

FIRST USE 6-25-2010; IN COMMERCE 6-25-2010.

3,998,349. EMBARQ HOLDINGS COMPANY LLC, DBA/ AKA/TA: DBA CENTURYLINK, INC., CENTURYTEL, INC., OVERLAND PARK, KS. SN 76-979,151. PUB. 2-16-2010, FILED 5-26-2009.



OWNER OF U.S. REG. NOS. 2,228,120, 3,124,133, AND OTHERS.

THE MARK CONSISTS OF THE WORDING "CENTURYLINK" WITH A DESIGN IN NATURE OF TWELVE SMALL TRIANGLES ARRANGED IN A CIRCLE NEXT TO THE WORDING OF THE MARK.

FOR CONSULTING IN THE FIELD OF TELECOMMUNICATIONS TECHNOLOGY; INTERNET APPLICATION SERVICE PROVIDER (ASP) FEATURING ONLINE CONTENT MANAGEMENT SOFTWARE FOR USE IN STORING, SEARCHING, INDEXING, RETRIEVING, AND CROSSREFERENCING PRODUCT SUPPORT INFORMATION OF OTHERS; MONITORING THE COMPUTER SYSTEMS OF OTHERS FOR TECHNICAL PURPOSES AND PROVIDING BACK-UP COMPUTER PROGRAMS AND FACILITIES; INTEGRATION AND ENABLING OF E-COMMERCE, NAMELY, HOSTING THE WEB SITES OF OTHERS ON A COMPUTER SERVER FOR A GLOBAL COMPUTER NETWORK; COMPUTER SERVICES, NAMELY, RESTRICTING ACCESS TO AND BY COMPUTER NETWORKS TO AND OF UNDESIRE WEB SITES, MEDIA, INDIVIDUALS AND FACILITIES TO PREVENT DISTRIBUTED DENIAL (DDOS) ATTACKS ON NETWORKS AND SERVERS; PROVIDING

CLASS 42—(Continued).

ONLINE, NON-DOWNLOADABLE SOFTWARE FOR USE AS A DATABASE VIA A GLOBAL COMPUTER NETWORK TO ENABLE THE USER TO DOWNLOAD GAMES, GRAPHICS AND MUSIC TO COMPUTERS AND WIRELESS DEVICES; COMPUTER SERVICES, NAMELY, DESIGN AND DEVELOPMENT OF NETWORKS IN THE NATURE OF CREATING COMPUTER NETWORKS TO PROVIDE THIN CLIENT ACCESS CAPABILITIES TO SCHOOLS; CREATION AND PROVISION OF WEB PAGES TO AND FOR THIRD PARTIES; DESIGN OF HOME PAGES AND WEB SITES; COMPUTER SERVICES, NAMELY, DESIGNING AND IMPLEMENTING NETWORK WEB PAGES FOR OTHERS; COMPUTER SERVICES, NAMELY, PROVIDING A WEBBASED SYSTEM AND ONLINE PORTAL FOR CUSTOMERS TO REMOTELY MANAGE, ADMINISTER, MODIFY AND CONTROL THEIR END USER COMPUTER DEVICES, DATA AND SOFTWARE APPLICATIONS; MAINTENANCE AND REPAIR OF COMPUTER NETWORK SOFTWARE TO PROVIDE THIN CLIENT ACCESS CAPABILITIES TO SCHOOLS (U.S. CLS. 100 AND 101).

FIRST USE 10-19-2009; IN COMMERCE 10-19-2009.

CLASS 42—(Continued).

ONLINE, NON-DOWNLOADABLE SOFTWARE FOR USE AS A DATABASE VIA A GLOBAL COMPUTER NETWORK TO ENABLE THE USER TO DOWNLOAD GAMES, GRAPHICS AND MUSIC TO COMPUTERS AND WIRELESS DEVICES; COMPUTER SERVICES, NAMELY, DESIGN AND DEVELOPMENT OF NETWORKS IN THE NATURE OF CREATING COMPUTER NETWORKS TO PROVIDE THIN CLIENT ACCESS CAPABILITIES TO SCHOOLS; CREATION AND PROVISION OF WEB PAGES TO AND FOR THIRD PARTIES; DESIGN OF HOME PAGES AND WEB SITES; COMPUTER SERVICES, NAMELY, DESIGNING AND IMPLEMENTING NETWORK WEB PAGES FOR OTHERS; COMPUTER SERVICES, NAMELY, PROVIDING A WEBBASED SYSTEM AND ONLINE PORTAL FOR CUSTOMERS TO REMOTELY MANAGE, ADMINISTER, MODIFY AND CONTROL THEIR END USER COMPUTER DEVICES, DATA AND SOFTWARE APPLICATIONS; MAINTENANCE AND REPAIR OF COMPUTER NETWORK SOFTWARE TO PROVIDE THIN CLIENT ACCESS CAPABILITIES TO SCHOOLS (U.S. CLS. 100 AND 101).

FIRST USE 10-19-2009; IN COMMERCE 10-19-2009.

3,998,351. EMBARQ HOLDINGS COMPANY LLC, DBA/ AKA/TA: DBA CENTURYLINK, INC., CENTURYTEL, INC., OVERLAND PARK, KS. SN 76-979,159. PUB. 2-16-2010, FILED 5-26-2009.

3,998,354. CODERYTE, INC., BETHESDA, MD. SN 77-050,812. PUB. 12-18-2007, FILED 11-27-2006.



Evidence Based Computer Assisted Coding

THE COLOR(S) GREEN IS/ARE CLAIMED AS A FEATURE OF THE MARK.

THE MARK CONSISTS OF TWELVE SMALL GREEN TRIANGLES ARRANGED IN A CIRCLE.

FOR CONSULTING IN THE FIELD OF TELECOMMUNICATIONS TECHNOLOGY; INTERNET APPLICATION SERVICE PROVIDER (ASP) FEATURING ONLINE CONTENT MANAGEMENT SOFTWARE FOR USE IN STORING, SEARCHING, INDEXING, RETRIEVING, AND CROSS REFERENCING PRODUCT SUPPORT INFORMATION OF OTHERS; MONITORING THE COMPUTER SYSTEMS OF OTHERS FOR TECHNICAL PURPOSES AND PROVIDING BACK-UP COMPUTER PROGRAMS AND FACILITIES; INTEGRATION AND ENABLING OF E-COMMERCE, NAMELY, HOSTING THE WEB SITES OF OTHERS ON A COMPUTER SERVER FOR A GLOBAL COMPUTER NETWORK; COMPUTER SERVICES, NAMELY, RESTRICTING ACCESS TO AND BY COMPUTER NETWORKS TO AND OF UNDESIRE WEB SITES, MEDIA, INDIVIDUALS AND FACILITIES TO PREVENT DISTRIBUTED DENIAL (DDOS) ATTACKS ON NETWORKS AND SERVERS; PROVIDING

THE MARK CONSISTS OF STANDARD CHARACTERS WITHOUT CLAIM TO ANY PARTICULAR FONT, STYLE, SIZE, OR COLOR.

NO CLAIM IS MADE TO THE EXCLUSIVE RIGHT TO USE "COMPUTER ASSISTED CODING", APART FROM THE MARK AS SHOWN.

FOR PROVIDING TEMPORARY USE OF NON-DOWNLOADABLE COMPUTER SOFTWARE FOR CONTROLLING AND MANAGING PATIENT MEDICAL INFORMATION; PROVIDING TEMPORARY USE OF NON-DOWNLOADABLE COMPUTER SOFTWARE, NAMELY, AN APPLICATION ALLOWING SALES AND FIELD SERVICE EMPLOYEES TO UPDATE AND RECEIVE DATA STORED IN AN ENTERPRISE'S COMPUTER DATABASES IN REAL TIME, USING A MOBILE DEVICE, WITH FULL TELEPHONY INTEGRATION WITH THE TELEPHONE AND/OR SOFTWARE FEATURES OF THE MOBILE DEVICE; PROVIDING NON-DOWNLOADABLE SOFTWARE WHICH ALLOWS FOR THE ANALYSIS AND DOWNLOAD OF SCIENTIFIC AND MEDICAL DATA VIA THE INTERNET (U.S. CLS. 100 AND 101).

FIRST USE 3-0-2008; IN COMMERCE 3-0-2008.

CLASS 42—(Continued).

3,998,405. WILDFIREWEB, INC., SONOMA, CA. SN 77-229,124. PUB. 6-3-2008, FILED 7-13-2007.

TINDER

THE MARK CONSISTS OF STANDARD CHARACTERS WITHOUT CLAIM TO ANY PARTICULAR FONT, STYLE, SIZE, OR COLOR.

FOR APPLICATION SERVICE PROVIDER (ASP) FEATURING SOFTWARE FOR USE IN EDITING AND CREATING WEB-SITE CONTENT; COMPUTER SERVICES, NAMELY, EDITING WEBSITES FOR OTHERS; APPLICATION SERVICE PROVIDER (ASP) SERVICES FEATURING SOFTWARE FOR USE BY OTHERS TO CREATE PHOTO GALLERIES, NEWS FEEDS, BLOGS, ADVERTISING, AND STANDARD WEB CONTENT IN HYPERTEXT MARKUP LANGUAGE (HTML) ON WEB SITES; APPLICATION SERVICE PROVIDER (ASP), NAMELY, HOSTING COMPUTER SOFTWARE APPLICATIONS FOR OTHERS (U.S. CLS. 100 AND 101).

FIRST USE 2-23-2010; IN COMMERCE 2-23-2010.

3,998,406. AMAG PHARMACEUTICALS, INC., LEXINGTON, MA. SN 77-229,464. PUB. 3-25-2008, FILED 7-13-2007.



THE MARK CONSISTS OF A STYLIZED REPRESENTATION OF THE LETTER "A".

FOR PHARMACEUTICAL DRUG SERVICES, NAMELY, PHARMACEUTICAL RESEARCH AND DEVELOPMENT; MEDICAL AND SCIENTIFIC RESEARCH, NAMELY, CONDUCTING CLINICAL TRIALS (U.S. CLS. 100 AND 101).

FIRST USE 6-0-2010; IN COMMERCE 6-0-2010.

CLASS 42—(Continued).

3,998,477. SELMONT, GEORGE A., MIDDLE HADDAM, CT. SN 77-428,218. PUB. 2-17-2009, FILED 3-21-2008.

PLAYXPLAY

THE MARK CONSISTS OF STANDARD CHARACTERS WITHOUT CLAIM TO ANY PARTICULAR FONT, STYLE, SIZE, OR COLOR.

FOR HOSTING A WEBSITE PROVIDING NON-DOWNLOADABLE COMPUTER SOFTWARE FOR UPLOADING, DOWNLOADING, MANAGING, MANIPULATING, AUTHORIZING, CAPTURING, COMPILING, CREATING, SHARING, MANAGING, DISTRIBUTING, EDITING, HOSTING, PROCESSING, PRODUCING, RECORDING, SHARING, AND ONLINE VIEWING OF USER GENERATED DIGITAL MULTI-MEDIA CONTENT RELATED TO ENTERTAINMENT AND SPORTING EVENTS INCLUDING DIGITAL AUDIO, VIDEO, TEXT AND GRAPHIC CONTENT VIA NON-DOWNLOADABLE SERVER-CLIENT IMAGE STREAMING AND DISTRIBUTION SOFTWARE (U.S. CLS. 100 AND 101).

FIRST USE 2-5-2010; IN COMMERCE 5-5-2011.

3,998,540. GP SOFTWARE, LLC, BEACHWOOD, OH. SN 77-578,981. PUB. 3-24-2009, FILED 9-25-2008.

TOTAL MANAGEMENT

THE MARK CONSISTS OF STANDARD CHARACTERS WITHOUT CLAIM TO ANY PARTICULAR FONT, STYLE, SIZE, OR COLOR.

NO CLAIM IS MADE TO THE EXCLUSIVE RIGHT TO USE "MANAGEMENT", APART FROM THE MARK AS SHOWN.

FOR RENTAL OF COMPUTER PROGRAMS AND SOFTWARE FOR REAL ESTATE USE RENTING, MAINTAINING, WORK ORDER TRACKING, LEASE TRACKING, PROPERTY TRAFFIC TRACKING, AND ACCOUNTING (U.S. CLS. 100 AND 101).

FIRST USE 5-20-2011; IN COMMERCE 5-20-2011.

CLASS 42—(Continued).

3,998,664. JOURDAN MILES INC., RALEIGH, NC. SN 77-731,411. PUB. 9-15-2009, FILED 5-7-2009.

FARlabel

THE MARK CONSISTS OF STANDARD CHARACTERS WITHOUT CLAIM TO ANY PARTICULAR FONT, STYLE, SIZE, OR COLOR.

FOR CUSTOM DESIGN OF ID TAGS, WRISTBANDS AND LABELS BASED ON PERSONAL SELECTIONS MADE BY THE CUSTOMER (U.S. CLS. 100 AND 101).

FIRST USE 9-0-2010; IN COMMERCE 9-0-2010.

3,998,692. TARGENT TECHNOLOGIES, COLUMBIA, MD. SN 77-761,844. PUB. 11-10-2009, FILED 6-17-2009.



NO CLAIM IS MADE TO THE EXCLUSIVE RIGHT TO USE "TECHNOLOGIES" AND "IT SERVICES AND CONSULTING", APART FROM THE MARK AS SHOWN.

THE STIPPLING IS FOR SHADING PURPOSES ONLY.

THE MARK CONSISTS OF THE STYLIZED NUMBERS, LETTERS, AND WORDS "1010101010101 101010 010 0101 1 010101 01 0 010 101010 101 101010 101010101 010101010 0101010 010101010 0101 1 T TARGENT TECHNOLOGIES IT SERVICES AND CONSULTING". THE STYLIZED NUMBERS AND LETTER "1010101010101 101010 010 0101 1 010101 01 0 010 101010 101 101010 101010101 010101010 0101010 010101010 0101 T" IS WRITTEN ON A SPHERE.

FOR COMPUTER NETWORKING CONSULTING (U.S. CLS. 100 AND 101).

FIRST USE 9-8-2008; IN COMMERCE 11-25-2008.

3,998,818. FIO CONSULTING, INC., WILLIAMS BAY, WI. SN 77-844,630. PUB. 4-13-2010, FILED 10-8-2009.

FYI FOR YOUR INFORMATICS

THE MARK CONSISTS OF STANDARD CHARACTERS WITHOUT CLAIM TO ANY PARTICULAR FONT, STYLE, SIZE, OR COLOR.

CLASS 42—(Continued).

NO CLAIM IS MADE TO THE EXCLUSIVE RIGHT TO USE "INFORMATICS", APART FROM THE MARK AS SHOWN.

FOR PROVIDING INFORMATION REGARDING INFORMATION TECHNOLOGY PRACTICES VIA THE INTERNET; PROVIDING INFORMATION REGARDING INFORMATION TECHNOLOGY PRACTICES IN THE HEALTH CARE FIELD VIA THE INTERNET (U.S. CLS. 100 AND 101).

FIRST USE 6-8-2011; IN COMMERCE 6-8-2011.

3,998,837. GRYGOROVICH, SERGIY, KYIV, UKRAINE. SN 77-851,592. PUB. 9-7-2010, FILED 10-19-2009.

S.T.A.L.K.E.R.: CALL OF PRIPYAT

THE MARK CONSISTS OF STANDARD CHARACTERS WITHOUT CLAIM TO ANY PARTICULAR FONT, STYLE, SIZE, OR COLOR.

OWNER OF U.S. REG. NOS. 3,313,064, 3,313,065, AND 3,734,717.

NO CLAIM IS MADE TO THE EXCLUSIVE RIGHT TO USE "PRIPYAT", APART FROM THE MARK AS SHOWN.

THE WORDING "PRIPYAT" HAS NO MEANING IN A FOREIGN LANGUAGE.

FOR CREATING AN ONLINE COMMUNITY FOR REGISTERED USERS TO PARTICIPATE IN COMPETITIONS, SHOWCASE THEIR SKILLS, GET FEEDBACK FROM THEIR PEERS, FORM VIRTUAL COMMUNITIES, ENGAGE IN SOCIAL NETWORKING AND IMPROVE THEIR TALENT; HOSTING ON-LINE WEB FACILITIES FOR OTHERS FOR ORGANIZING AND CONDUCTING ONLINE MEETINGS, GATHERINGS, AND INTERACTIVE DISCUSSIONS (U.S. CLS. 100 AND 101).

FIRST USE 5-0-2009; IN COMMERCE 5-0-2009.

3,998,914. TELEFLORA LLC, LOS ANGELES, CA. SN 77-870,348. PUB. 10-5-2010, FILED 11-11-2009.

plusmail

THE MARK CONSISTS OF "PLUSMAIL" WITH A FOUR-POINT STAR DOTTING THE LETTER "I".

FOR PROVIDING TEMPORARY USE OF INTERNET-BASED NON-DOWNLOADABLE COMPUTER E-MAIL MARKETING SOFTWARE APPLICATIONS FOR CREATING AND MODIFYING A CUSTOMER LIST AND CREATING MARKETING CAMPAIGNS TO BE SENT TO FLORAL SHOP'S CUSTOMERS (U.S. CLS. 100 AND 101).

FIRST USE 9-1-2009; IN COMMERCE 9-1-2009.

CLASS 42—(Continued).

3,999,014. THOMPSON, TJAARDA, S., AKA TOM TJAARDA, ESCONDIDO, CA. SN 77-908,409. PUB. 11-9-2010, FILED 1-9-2010.

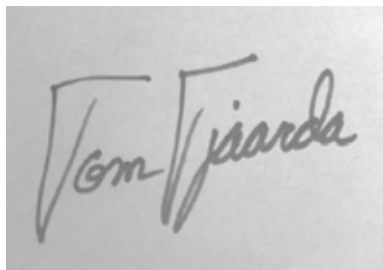

THE MARK CONSISTS OF THE SIGNATURE OF "TOM TJAARDA".
FOR AUTOMOTIVE DESIGN SERVICES (U.S. CLS. 100 AND 101).
FIRST USE 9-1-1950; IN COMMERCE 6-1-2008.

CLASS 42—(Continued).

3,999,033. TURTLE POND PUBLICATIONS LLC, NEW YORK, NY. SN 77-915,649. PUB. 9-21-2010, FILED 1-20-2010.

DISRUPTIVE SPIRITUAL INNOVATION

THE MARK CONSISTS OF STANDARD CHARACTERS WITHOUT CLAIM TO ANY PARTICULAR FONT, STYLE, SIZE, OR COLOR.

NO CLAIM IS MADE TO THE EXCLUSIVE RIGHT TO USE "SPIRITUAL", APART FROM THE MARK AS SHOWN.

FOR PROVIDING INFORMATION AND NONDOWNLOADABLE ONLINE VIDEOS IN THE FIELD OF TECHNOLOGY AND ITS IMPACT ON SPIRITUALITY AND RELIGION (U.S. CLS. 100 AND 101).

FIRST USE 2-10-2009; IN COMMERCE 2-10-2009.

3,999,029. UNITED STATES DEPARTMENT OF HOMELAND SECURITY, WASHINGTON, DC. SN 77-912,604. PUB. 9-7-2010, FILED 1-15-2010.



THE COLOR(S) RED, WHITE, BLUE, BLACK AND GREY IS/ARE CLAIMED AS A FEATURE OF THE MARK.

THE MARK CONSISTS OF THE WORD "IDEAFACTORY," WITH "IDEA" BEING RED IN COLOR AND "FACTORY" BEING BLUE IN COLOR. "IDEAFACTORY" APPEARS IN LARGE STANDARDIZED FONT ABOVE THE "INNOVATE. COLLABORATE. SUCCEED." SLOGAN, WHICH APPEARS IN RED, REGULAR ITALICIZED FONT. MOREOVER, THERE IS AN OUTLINE OF A LIGHT BULB, IN BLACK, WHICH APPEARS TO THE LEFT OF THE WORDS, WITH THREE DIFFERENT SIZED GEARS INSIDE THE WHITE AREA OF THE BULB. THE LARGEST GEAR IS RED IN COLOR, THE MEDIUM SIZED GEAR IS GREY IN COLOR, AND THE SMALLEST GEAR IS BLUE IN COLOR. FURTHERMORE, THERE IS A GAP BETWEEN THE BULB AND THE SCREW CAP. APPLICANT ALSO CLAIMS THE GREY TONE EXPRESSION OF THE MARK.

FOR COMPUTER SERVICES, NAMELY, CREATING AN ON-LINE COMMUNITY FOR REGISTERED USERS TO SUBMIT, COMMENT UPON, AND VOTE ON IDEAS TO IMPROVE THE WORKPLACE AND WORKPLACE PROCESSES, AND TO CONNECT WITH OTHER EMPLOYEES USING ITS SOCIAL MEDIA CAPABILITY (U.S. CLS. 100 AND 101).

FIRST USE 5-31-2009; IN COMMERCE 5-31-2009.

3,999,044. ESTANISLAO MARTINEZ MARTINEZ, BURGUILLOS (SEVILLA), SPAIN. SN 77-921,121. PUB. 12-21-2010, FILED 1-27-2010.



NO CLAIM IS MADE TO THE EXCLUSIVE RIGHT TO USE "AGROALIMENTARIA Y MEDIO AMBIENTE", APART FROM THE MARK AS SHOWN.

THE COLOR(S) GREEN, BLACK AND BLUE IS/ARE CLAIMED AS A FEATURE OF THE MARK.

THE MARK CONSISTS OF THE LETTERS "AGQ" IN BLUE ABOVE THE WORDS "AGROALIMENTARIA Y MEDIO AMBIENTE" IN THE COLOR BLUE NEXT TO AN OUTLINE OF A BEAKER IN BLACK WITH A GREEN STEM AND LEAVES IN THE BEAKER.

THE ENGLISH TRANSLATION OF "AGROALIMENTARIA Y MEDIO AMBIENTE" IN THE MARK IS "AGROFOOD AND ENVIRONMENT".

FOR INDUSTRIAL ANALYSIS, NAMELY, CHEMICAL ANALYSIS; AND INDUSTRIAL RESEARCH IN THE FIELD OF CHEMISTRY; CONSULTATION IN THE FIELD OF ENVIRONMENTAL PROTECTION; QUALITY-CONTROL SERVICES FOR OTHERS; RESEARCH AND DEVELOPMENT FOR OTHERS WITH REGARD TO NEW PRODUCTS; CHEMICAL, BIOLOGICAL AND ENVIRONMENT RESEARCH (U.S. CLS. 100 AND 101).

FIRST USE 0-0-2005; IN COMMERCE 1-0-2008.

CLASS 42—(Continued).

3,999,149. G W PLASTICS, INC., BETHEL, VT. SN 77-968,683. PUB. 3-8-2011, FILED 3-25-2010.

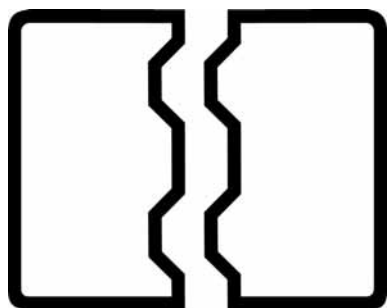

GW/PT

THE MARK CONSISTS OF A RECTANGLE DIVIDED INTO TWO SECTIONS IN WHAT APPEAR TO BE TWO JIGSAW PUZZLE PIECES THAT WOULD FIT TOGETHER WITH THE LETTERS "GW/PT" IN THE BOTTOM RIGHT CORNER UNDER THE DESIGN.

FOR CUSTOM DESIGN, DEVELOPMENT AND ENGINEERING OF MECHANICAL APPARATUS, NAMELY, HEALTHCARE PRODUCTS, CONSUMER ELECTRONICS AND AUTOMOTIVE GOODS; AND TOOL DESIGN SERVICES (U.S. CLS. 100 AND 101). FIRST USE 1-0-2010; IN COMMERCE 1-0-2010.

3,999,152. MEDTHINK COMMUNICATIONS, INC., RA-LEIGH, NC. SN 77-978,451. PUB. 2-9-2010, FILED 5-20-2009.

MEDTHINK

THE MARK CONSISTS OF STANDARD CHARACTERS WITHOUT CLAIM TO ANY PARTICULAR FONT, STYLE, SIZE, OR COLOR.

OWNER OF U.S. REG. NO. 3,084,859. FOR PROVIDING TEMPORARY USE OF ON-LINE NON-DOWNLOADABLE SOFTWARE FOR CONTENT MANAGEMENT, TRACKING, REPORTING, BLOGGING, EMAIL NOTIFICATION, AND CONTENT MANAGEMENT (U.S. CLS. 100 AND 101). FIRST USE 12-4-2009; IN COMMERCE 8-0-2010.

CLASS 42—(Continued).

3,999,203. LIEBERT CORPORATION, COLUMBUS, OH. SN 78-819,232. PUB. 12-5-2006, FILED 2-21-2006.

LIEBERT VIRTUAL NTEGRITY

THE MARK CONSISTS OF STANDARD CHARACTERS WITHOUT CLAIM TO ANY PARTICULAR FONT, STYLE, SIZE, OR COLOR.

OWNER OF U.S. REG. NOS. 1,184,636, 1,336,375, AND OTHERS.

NO CLAIM IS MADE TO THE EXCLUSIVE RIGHT TO USE "VIRTUAL", APART FROM THE MARK AS SHOWN.

FOR REMOTE MONITORING OF COMPUTER POWER AND ENVIRONMENTAL SUPPORT EQUIPMENT FEATURING ELECTRICAL POWER SYSTEMS, FIRE SUPPRESSION, AIR CONDITIONING, AND PERSONNEL ACCESS CONTROL (U.S. CLS. 100 AND 101). FIRST USE 1-0-2006; IN COMMERCE 1-0-2006.

3,999,210. MARS, INCORPORATED, MCLEAN, VA. SN 78-872,077. PUB. 8-21-2007, FILED 4-28-2006.

MARS SYMBIOSCIENCE

THE MARK CONSISTS OF STANDARD CHARACTERS WITHOUT CLAIM TO ANY PARTICULAR FONT, STYLE, SIZE, OR COLOR.

FOR RESEARCH, DEVELOPMENT, AND EVALUATION OF ENVIRONMENTAL SUSTAINABILITY FOR HUMANS AND ANIMALS (U.S. CLS. 100 AND 101). FIRST USE 6-28-2010; IN COMMERCE 6-28-2010.

3,999,234. ISPACES IT LTD., AKA ISPACES, CARNDONAGH, IRELAND. SN 85-006,857. PUB. 11-30-2010, FILED 4-5-2010.

OfficeSpace

THE MARK CONSISTS OF STANDARD CHARACTERS WITHOUT CLAIM TO ANY PARTICULAR FONT, STYLE, SIZE, OR COLOR.

FOR CLOUD COMPUTING FEATURING SOFTWARE FOR USE AS AN INTERNET BASED SUITE OF OFFICE PRODUCTIVITY APPLICATIONS FOR USE IN WORD PROCESSING, CREATING SPREADSHEETS, CREATING PRESENTATIONS AND CALENDARING (U.S. CLS. 100 AND 101). FIRST USE 3-0-2011; IN COMMERCE 3-0-2011.

CLASS 42—(Continued).

3,999,242. LEOR RESOURCES LLC, NEW YORK, NY. SN 85-008,604. PUB. 9-7-2010, FILED 4-7-2010.

LEOR EXPLORATION

THE MARK CONSISTS OF STANDARD CHARACTERS WITHOUT CLAIM TO ANY PARTICULAR FONT, STYLE, SIZE, OR COLOR.

NO CLAIM IS MADE TO THE EXCLUSIVE RIGHT TO USE "EXPLORATION", APART FROM THE MARK AS SHOWN.

FOR EXPLORATION OF NATURAL RESOURCES, NAMELY, GAS, OIL AND PRECIOUS METALS (U.S. CLS. 100 AND 101).

FIRST USE 11-3-2010; IN COMMERCE 11-3-2010.

3,999,349. VIZION SOLUTIONS, LLC, BROOKLYN HTS., OH. SN 85-028,482. PUB. 10-5-2010, FILED 5-3-2010.

VIZION360

THE MARK CONSISTS OF STANDARD CHARACTERS WITHOUT CLAIM TO ANY PARTICULAR FONT, STYLE, SIZE, OR COLOR.

FOR COMPUTER SERVICES, NAMELY, ACTING AS AN APPLICATION SERVICE PROVIDER IN THE FIELD OF KNOWLEDGE MANAGEMENT TO HOST COMPUTER APPLICATION SOFTWARE FOR MANAGEMENT OF DATA TO TRACK, UNDERSTAND AND MANAGE BUSINESS PERFORMANCE (U.S. CLS. 100 AND 101).

FIRST USE 1-18-2006; IN COMMERCE 10-8-2008.

CLASS 42—(Continued).

3,999,365. EDWARDS LIFESCIENCES CORPORATION, IRVINE, CA. SN 85-030,119. PUB. 9-28-2010, FILED 5-4-2010.



THE MARK CONSISTS OF A HEART-SHAPED DESIGN WITH TWO CURVED OR ARC-SHAPED LINES AND A TRIANGULAR-SHAPED DESIGN WITH THREE INWARDLY CURVED SIDES THAT IS DISPOSED WITHIN A CIRCLE WHICH IS DISPOSED BETWEEN THE TWO CURVED LINES.

FOR MEDICAL AND SCIENTIFIC RESEARCH, NAMELY, CONDUCTING CLINICAL TRIALS FOR AORTIC HEART VALVES (U.S. CLS. 100 AND 101).

FIRST USE 8-0-2009; IN COMMERCE 8-0-2009.

3,999,372. MP3 CAR, INC., BALTIMORE, MD. SN 85-030,633. PUB. 11-23-2010, FILED 5-5-2010.

AUTO APP MART

THE MARK CONSISTS OF STANDARD CHARACTERS WITHOUT CLAIM TO ANY PARTICULAR FONT, STYLE, SIZE, OR COLOR.

NO CLAIM IS MADE TO THE EXCLUSIVE RIGHT TO USE "AUTO APP", APART FROM THE MARK AS SHOWN.

FOR PROVIDING A WEBSITE FEATURING NEWS, MESSAGES, INFORMATION, DATA, OPINIONS, COMMENTS, NON-DOWNLOADABLE VIDEO AND IMAGES, ALL RELATED TO SOFTWARE AND TECHNOLOGY USED IN THE AUTOMOTIVE FIELD (U.S. CLS. 100 AND 101).

FIRST USE 9-29-2010; IN COMMERCE 9-29-2010.

CLASS 42—(Continued).

3,999,373. MP3 CAR, INC., BALTIMORE, MD. SN 85-030,636. PUB. 10-5-2010, FILED 5-5-2010.

AUTO APP MART

THE MARK CONSISTS OF STANDARD CHARACTERS WITHOUT CLAIM TO ANY PARTICULAR FONT, STYLE, SIZE, OR COLOR.

NO CLAIM IS MADE TO THE EXCLUSIVE RIGHT TO USE "AUTO APP", APART FROM THE MARK AS SHOWN. FOR COMPUTER CONSULTATION; CUSTOMIZED SOFTWARE DEVELOPMENT SERVICES (U.S. CLS. 100 AND 101).

FIRST USE 9-29-2010; IN COMMERCE 9-29-2010.

CLASS 42—(Continued).

3,999,401. GUARDMYPET, LLC, ST. PETERSBURG, FL. SN 85-033,272. PUB. 9-7-2010, FILED 5-7-2010.

Guardmyretriever

THE MARK CONSISTS OF STANDARD CHARACTERS WITHOUT CLAIM TO ANY PARTICULAR FONT, STYLE, SIZE, OR COLOR.

FOR COMPUTER SERVICES, NAMELY, HOSTING AND MAINTAINING AN ON-LINE WEB SITE FOR OTHERS TO OBTAIN INFORMATION, STORE INFORMATION, AND PURCHASE INSURANCE FOR THEIR PET (U.S. CLS. 100 AND 101).

FIRST USE 7-31-2010; IN COMMERCE 7-31-2010.

3,999,398. GUARDMYPET, LLC, ST. PETERSBURG, FL. SN 85-033,219. PUB. 9-7-2010, FILED 5-7-2010.

Guardmypet

THE MARK CONSISTS OF STANDARD CHARACTERS WITHOUT CLAIM TO ANY PARTICULAR FONT, STYLE, SIZE, OR COLOR.

FOR COMPUTER SERVICES, NAMELY, HOSTING AND MAINTAINING AN ON-LINE WEB SITE FOR OTHERS TO OBTAIN INFORMATION, STORE INFORMATION, AND PURCHASE INSURANCE FOR THEIR PET (U.S. CLS. 100 AND 101).

FIRST USE 7-31-2010; IN COMMERCE 7-31-2010.

3,999,402. GUARDMYPET, LLC, ST. PETERSBURG, FL. SN 85-033,288. PUB. 9-7-2010, FILED 5-7-2010.

Guardmybeagle

THE MARK CONSISTS OF STANDARD CHARACTERS WITHOUT CLAIM TO ANY PARTICULAR FONT, STYLE, SIZE, OR COLOR.

FOR COMPUTER SERVICES, NAMELY, HOSTING AND MAINTAINING AN ON-LINE WEB SITE FOR OTHERS TO OBTAIN INFORMATION, STORE INFORMATION, AND PURCHASE INSURANCE FOR THEIR PET (U.S. CLS. 100 AND 101).

FIRST USE 7-31-2010; IN COMMERCE 7-31-2010.

3,999,399. GUARDMYPET, LLC, ST. PETERSBURG, FL. SN 85-033,247. PUB. 9-7-2010, FILED 5-7-2010.

Guardmyterrier

THE MARK CONSISTS OF STANDARD CHARACTERS WITHOUT CLAIM TO ANY PARTICULAR FONT, STYLE, SIZE, OR COLOR.

FOR COMPUTER SERVICES, NAMELY, HOSTING AND MAINTAINING AN ON-LINE WEB SITE FOR OTHERS TO OBTAIN INFORMATION, STORE INFORMATION, AND PURCHASE INSURANCE FOR THEIR PET (U.S. CLS. 100 AND 101).

FIRST USE 7-31-2010; IN COMMERCE 7-31-2010.

3,999,480. TWILSON TECHNOLOGIES, INC., WASHINGTON, DC. SN 85-046,165. PUB. 12-14-2010, FILED 5-24-2010.



THE MARK CONSISTS OF THE STYLIZED WORDS "TIE MY FINGER" WITH A DESIGN OF A HAND WITH A STRING TIED AROUND A FINGER INSIDE A SHADED SQUARE.

FOR PROVIDING A WEB SITE THAT ALLOWS USERS TO SEND REMINDERS TO THEIR EMAIL, MOBILE PHONES, LAND LINE PHONE AND ON LINE SOCIAL NETWORKING ACCOUNT (U.S. CLS. 100 AND 101).

FIRST USE 12-1-2009; IN COMMERCE 12-1-2009.

CLASS 42—(Continued).

3,999,499. GODADDY.COM, INC., SCOTTSDALE, AZ. SN 85-049,635. PUB. 12-14-2010, FILED 5-27-2010.

Expert Hands

THE MARK CONSISTS OF STANDARD CHARACTERS WITHOUT CLAIM TO ANY PARTICULAR FONT, STYLE, SIZE, OR COLOR.

FOR TECHNICAL SUPPORT SERVICES, NAMELY, TECHNICAL ADMINISTRATION OF SERVERS FOR OTHERS AND TROUBLESHOOTING IN THE NATURE OF DIAGNOSING SERVER PROBLEMS; TECHNICAL SUPPORT SERVICES, NAMELY, TECHNICAL ADVICE RELATED TO THE INSTALLATION OF WEB-BASED SOFTWARE; TECHNICAL SUPPORT SERVICES, NAMELY, INSTALLATION, MANAGEMENT, ADMINISTRATION, AND TROUBLESHOOTING OF WEB AND DATABASE APPLICATIONS; CONSULTATION SERVICES IN THE FIELD OF SEARCH ENGINE OPTIMIZATION; TECHNICAL SUPPORT SERVICES, NAMELY, INSTALLATION OF COMPUTER SOFTWARE FEATURING DIGITAL CERTIFICATES; TECHNICAL SUPPORT SERVICES, NAMELY, MIGRATION OF DATACENTER, SERVER AND DATABASE APPLICATIONS (U.S. CLS. 100 AND 101).

FIRST USE 3-0-2005; IN COMMERCE 3-0-2005.

3,999,509. AMYLIN PHARMACEUTICALS, INC., SAN DIEGO, CA. SN 85-053,846. PUB. 2-22-2011, FILED 6-3-2010.



THE COLOR(S) PURPLE, BLUE, AND YELLOW IS/ARE CLAIMED AS A FEATURE OF THE MARK.

THE MARK CONSISTS OF THE WORD "EXSCEL" IN ALL CAPITAL LETTERS IN THE COLOR PURPLE. TO THE RIGHT OF THE WORD "EXSCEL" IS A DESIGN IMAGE OF A TWISTING BAND. THE UPPER LEFT AND LOWER RIGHT SIDE OF THE TWISTING BAND ARE IN THE COLOR YELLOW, THE UPPER RIGHT AND LOWER LEFT SIDE OF THE TWISTING BAND ARE IN THE COLOR BLUE, AND THE LEFT AND RIGHT SIDE OF THE TWISTING BAND ARE IN THE COLOR PURPLE. THE COLOR WHITE IN THE MARK REPRESENTS BACKGROUND/TRANSPARENT AREAS AND IS NOT A PART OF THE MARK.

FOR MEDICAL AND SCIENTIFIC RESEARCH, NAMELY, CONDUCTING CLINICAL TRIALS FOR PHARMACEUTICAL PREPARATIONS FOR THE TREATMENT OF TYPE 2 DIABETES AND THEIR IMPACT ON CARDIOVASCULAR DISEASE (U.S. CLS. 100 AND 101).

FIRST USE 6-18-2010; IN COMMERCE 6-18-2010.

CLASS 42—(Continued).

3,999,572. BEYOND 12, INC., SAN FRANCISCO, CA. SN 85-068,552. PUB. 11-16-2010, FILED 6-22-2010.

BEYOND 12

THE MARK CONSISTS OF STANDARD CHARACTERS WITHOUT CLAIM TO ANY PARTICULAR FONT, STYLE, SIZE, OR COLOR.

FOR APPLICATION SERVICE PROVIDER, NAMELY, PROVIDING SOFTWARE FOR USE BY EDUCATIONAL INSTITUTIONS, AND ACADEMIC COUNSELORS, MENTORS, AND ADVISORS TO COMMUNICATE WITH STUDENTS, AND TO TRACK STUDENT EDUCATIONAL PROGRESS, COURSE GRADES, LEARNING RISK PROFILES, AND COLLEGE AND UNIVERSITY GRADUATION RATES (U.S. CLS. 100 AND 101).

FIRST USE 5-12-2010; IN COMMERCE 5-12-2010.

3,999,594. MILESTONE AV TECHNOLOGIES LLC, SAVAGE, MN. SN 85-073,931. PUB. 10-5-2010, FILED 6-29-2010.

BUILDER

THE MARK CONSISTS OF STANDARD CHARACTERS WITHOUT CLAIM TO ANY PARTICULAR FONT, STYLE, SIZE, OR COLOR.

OWNER OF U.S. REG. NO. 3,652,840.
FOR PROVIDING TEMPORARY USE OF ON-LINE NONDOWNLOADABLE SOFTWARE FOR ALLOWING WEB SITE USERS TO DESIGN, SELECT, OR ORDER AUDIO AND VIDEO EQUIPMENT ACCESSORIES, NAMELY, ACCESSORIES FOR PROJECTORS AND FLAT PANEL DISPLAYS; PROVIDING TEMPORARY USE OF ON-LINE NONDOWNLOADABLE SOFTWARE FOR ALLOWING WEB SITE USERS TO GENERATE OR MODIFY A PARTS LIST FOR AUDIO AND VIDEO EQUIPMENT ACCESSORIES, NAMELY, ACCESSORIES FOR PROJECTORS AND FLAT PANEL DISPLAYS; CUSTOM DESIGN AND SELECTION OF AUDIO AND VIDEO EQUIPMENT ACCESSORIES BASED ON PERSONAL SELECTIONS MADE BY THE CUSTOMER (U.S. CLS. 100 AND 101).

FIRST USE 4-15-2011; IN COMMERCE 4-15-2011.

CLASS 42—(Continued).

3,999,657. AUDITIONWARE, LLC, CEDAR HILLS, UT. SN 85-094,299. PUB. 1-18-2011, FILED 7-27-2010.

AUDITIONWARE

THE MARK CONSISTS OF STANDARD CHARACTERS WITHOUT CLAIM TO ANY PARTICULAR FONT, STYLE, SIZE, OR COLOR.

FOR PROVIDING ON-LINE NON-DOWNLOADABLE SOFTWARE FOR SCHEDULING EVENTS AND COMPETITIONS (U.S. CLS. 100 AND 101).

FIRST USE 6-20-2010; IN COMMERCE 6-20-2010.

3,999,664. CHIPIN, INC., HONOLULU, HI. SN 85-097,754. PUB. 1-18-2011, FILED 8-2-2010.

AdVine

THE MARK CONSISTS OF STANDARD CHARACTERS WITHOUT CLAIM TO ANY PARTICULAR FONT, STYLE, SIZE, OR COLOR.

FOR PROVIDING A WEBSITE FEATURING TEMPORARY USE OF NON-DOWNLOADABLE SOFTWARE WHERE USERS CAN CUSTOMIZE THEIR OWN ON-LINE DISPLAY ADVERTISEMENTS (U.S. CLS. 100 AND 101).

FIRST USE 6-15-2010; IN COMMERCE 6-15-2010.

3,999,672. MY EYE MEDIA, LLC, BURBANK, CA. SN 85-101,977. PUB. 1-18-2011, FILED 8-6-2010.

READY.TEST.GO.

THE MARK CONSISTS OF STANDARD CHARACTERS WITHOUT CLAIM TO ANY PARTICULAR FONT, STYLE, SIZE, OR COLOR.

FOR PROVIDING QUALITY CONTROL SERVICES FOR MOTION PICTURE FILM TRANSFER TO OTHER FORMATS; PROVIDING QUALITY CONTROL SERVICES FOR MANUFACTURING OF MOTION PICTURES IN OTHER FORMATS; PROVIDING QUALITY CONTROL SERVICES FOR AUDIO COMPONENTS OF MOTION PICTURES; PERFORMING TECHNICAL EVALUATION OF ALL FORMS OF DIGITAL CONTENT STORED OR DISTRIBUTED IN FILE FORM; PROVIDING TECHNICAL ANALYSIS SERVICES FOR QUALITY CONTROL IN THE FIELD OF DIGITAL CINEMA (U.S. CLS. 100 AND 101).

FIRST USE 9-15-2010; IN COMMERCE 9-15-2010.

CLASS 42—(Continued).

3,999,677. KU, ANDY TING-CHIA, DBA ORGANIZED CRIME DESIGN COLLECTIVE, LOS ANGELES, CA. SN 85-104,148. PUB. 3-8-2011, FILED 8-10-2010.

ORGANIZED CRIME

THE MARK CONSISTS OF STANDARD CHARACTERS WITHOUT CLAIM TO ANY PARTICULAR FONT, STYLE, SIZE, OR COLOR.

FOR ARCHITECTURAL DESIGN; COMPUTER AIDED GRAPHIC DESIGN (U.S. CLS. 100 AND 101).

FIRST USE 5-16-2011; IN COMMERCE 5-16-2011.

3,999,691. PROVING GROUND, LLC, ATLANTA, GA. SN 85-108,100. PUB. 1-25-2011, FILED 8-16-2010.

PROVING GROUND

THE MARK CONSISTS OF STANDARD CHARACTERS WITHOUT CLAIM TO ANY PARTICULAR FONT, STYLE, SIZE, OR COLOR.

FOR DEVELOPMENT OF SOFTWARE, WEB SITES, AND MOBILE DEVICE APPLICATIONS FOR OTHERS; TECHNICAL CONSULTING SERVICES IN THE FIELD OF SOFTWARE, WEB SITE ARCHITECTURE, AND MOBILE DEVICE APPLICATIONS (U.S. CLS. 100 AND 101).

FIRST USE 2-16-2011; IN COMMERCE 2-16-2011.

3,999,704. INTELLIMATRIX INC., AKA INTELLIMETRUX, INC., AVON LAKE, OH. SN 85-111,241. PUB. 3-8-2011, FILED 8-19-2010.

IntelliMetrx

THE MARK CONSISTS OF STANDARD CHARACTERS WITHOUT CLAIM TO ANY PARTICULAR FONT, STYLE, SIZE, OR COLOR.

FOR DESIGN, DEVELOPMENT AND DEPLOYMENT OF COMPUTER SOFTWARE AND HARDWARE FOR THE PURPOSE OF PROVIDING MEANINGFUL METRICS TO EVENT PLANNERS AND MARKETERS AND OTHER INTERESTED PARTIES (U.S. CLS. 100 AND 101).

FIRST USE 12-15-2010; IN COMMERCE 3-1-2011.

CLASS 42—(Continued).

3,999,705. SHIZZLR, INC, ORANGE, CT. SN 85-112,064. PUB. 11-16-2010, FILED 8-20-2010.

SHIZZLR

THE MARK CONSISTS OF STANDARD CHARACTERS WITHOUT CLAIM TO ANY PARTICULAR FONT, STYLE, SIZE, OR COLOR.

FOR COMPUTER SERVICES, NAMELY, CREATING AN ON-LINE COMMUNITY FOR REGISTERED USERS TO PARTICIPATE IN DISCUSSIONS, GET INFORMATION ABOUT PLANNED ACTIVITIES FROM THEIR PEERS, FORM VIRTUAL COMMUNITIES, AND ENGAGE IN SOCIAL NETWORKING (U.S. CLS. 100 AND 101).

FIRST USE 12-0-2009; IN COMMERCE 2-0-2010.

3,999,757. CFI COMPANIES, INC, HOUSTON, TX. SN 85-135,025. PUB. 3-8-2011, FILED 9-21-2010.



NO CLAIM IS MADE TO THE EXCLUSIVE RIGHT TO USE "COMPANIES", APART FROM THE MARK AS SHOWN.

THE STIPPLING IS FOR SHADING PURPOSES ONLY.

THE MARK CONSISTS OF A SPHERE WITH A SHADOW OF THE SPHERE BELOW IT TO THE LEFT, AND THE UNDERLINED TEXT "CFI COMPANIES" TO THE RIGHT.

FOR CONSULTING SERVICES IN THE FIELD OF THE DESIGN OF MECHANICAL, ELECTRICAL, AND PLUMBING SYSTEMS (U.S. CLS. 100 AND 101).

FIRST USE 1-27-2011; IN COMMERCE 1-27-2011.

3,999,787. GARTNER, INC., STAMFORD, CT. SN 85-144,495. PUB. 3-15-2011, FILED 10-4-2010.

IT MARKET CLOCK

THE MARK CONSISTS OF STANDARD CHARACTERS WITHOUT CLAIM TO ANY PARTICULAR FONT, STYLE, SIZE, OR COLOR.

NO CLAIM IS MADE TO THE EXCLUSIVE RIGHT TO USE "IT MARKET", APART FROM THE MARK AS SHOWN.

FOR RESEARCH SERVICES IN THE FIELD OF INFORMATION AND TELECOMMUNICATIONS TECHNOLOGY (U.S. CLS. 100 AND 101).

FIRST USE 11-30-2009; IN COMMERCE 11-30-2009.

CLASS 42—(Continued).

3,999,791. GARTNER, INC., STAMFORD, CT. SN 85-145,353. PUB. 3-15-2011, FILED 10-5-2010.

GARTNER IT MARKET CLOCK

THE MARK CONSISTS OF STANDARD CHARACTERS WITHOUT CLAIM TO ANY PARTICULAR FONT, STYLE, SIZE, OR COLOR.

NO CLAIM IS MADE TO THE EXCLUSIVE RIGHT TO USE "IT MARKET", APART FROM THE MARK AS SHOWN. FOR RESEARCH SERVICES IN THE FIELD OF INFORMATION AND TELECOMMUNICATIONS TECHNOLOGY (U.S. CLS. 100 AND 101).

FIRST USE 11-30-2009; IN COMMERCE 11-30-2009.

3,999,812. BOISE RIVER CAPITAL, LLC, BOISE, ID. SN 85-152,192. PUB. 3-22-2011, FILED 10-13-2010.



THE COLOR(S) BLACK, GRAY AND WHITE IS/ARE CLAIMED AS A FEATURE OF THE MARK.

THE MARK CONSISTS OF A REPRESENTATION OF A MAP PIN WITH THE TOP OF THE MAP PIN SHOWN IN A CIRCULAR SHAPE, THREE-QUARTERS OF WHICH IS SHOWN IN BLACK AND THE TOP QUARTER PORTION OF THE MAP PIN SHOWN IN GRAY SHADED TOWARD WHITE. THE CIRCULAR DESIGN HAS A WHITE CENTER. A BLACK TRIANGULAR SHAPE WITH THE WIDEST PORTION ADJOINING THE CIRCULAR PORTION IS SHOWN ON THE BOTTOM LEFT OF THE CIRCLE AND GRADUALLY DESCENDS DOWNWARD TO A POINT.

FOR COMPUTER SERVICES, NAMELY, PROVIDING AN INTERNET SEARCH ENGINE THAT FACILITATES CONNECTING CUSTOMERS WITH SERVICE PROVIDERS BASED ON THEIR PROXIMITY TO ONE ANOTHER AS DETERMINED BY GLOBAL POSITIONING SYSTEM TECHNOLOGY (U.S. CLS. 100 AND 101).

FIRST USE 1-28-2011; IN COMMERCE 1-28-2011.

CLASS 42—(Continued).

3,999,817. WEBCETERA, L.P., FLOWER MOUND, TX. SN 85-153,582. PUB. 3-15-2011, FILED 10-15-2010.



NO CLAIM IS MADE TO THE EXCLUSIVE RIGHT TO USE "SOFTWARE", APART FROM THE MARK AS SHOWN. THE MARK CONSISTS OF THREE CONCENTRIC, BROKEN CRESCENTS PARTIALLY SURROUNDING THE WORDING "WEBCETERA SOFTWARE INNOVATIONS & BEYOND".

FOR DESIGN AND DEVELOPMENT OF SOFTWARE AND TECHNOLOGY SOLUTIONS (U.S. CLS. 100 AND 101).

FIRST USE 3-1-2011; IN COMMERCE 3-1-2011.

3,999,821. CHI MEDIA GROUP, LLC, LAS VEGAS, NV. SN 85-156,446. PUB. 4-5-2011, FILED 10-19-2010.



NO CLAIM IS MADE TO THE EXCLUSIVE RIGHT TO USE ".COM", APART FROM THE MARK AS SHOWN.

THE MARK CONSISTS OF THE WORDS "JUST CAN'T HANDLE" ENCLOSED IN A CAMOUFLAGE STYLE RECTANGULAR BORDER; A CAMOUFLAGE STYLE STAR SHAPE ABOVE AND TO THE LEFT SIDE OF THE RECTANGULAR BORDER, AND THE TERM ".COM" BELOW AND TO THE RIGHT SIDE OF THE RECTANGULAR BORDER.

FOR PROVIDING A WEB SITE THAT GIVES COMPUTER USERS THE ABILITY TO UPLOAD, EXCHANGE AND SHARE PHOTOS, VIDEOS AND VIDEO LOGS; PROVIDING A WEBSITE THAT GIVES COMPUTER USERS THE ABILITY TO VIEW, UPLOAD, POST, DISPLAY, TAG, AND SHARE USER-GENERATED AUDIO CLIPS, VIDEO CLIPS, PHOTOGRAPHS, AND WRITTEN MATERIAL ON A WIDE VARIETY OF TOPICS AND SUBJECTS (U.S. CLS. 100 AND 101).

FIRST USE 1-0-2011; IN COMMERCE 1-0-2011.

CLASS 42—(Continued).

3,999,844. BREWSTER, BEN W., SAN CARLOS, CA. SN 85-164,245. PUB. 3-29-2011, FILED 10-28-2010.

Fanatica

THE MARK CONSISTS OF STANDARD CHARACTERS WITHOUT CLAIM TO ANY PARTICULAR FONT, STYLE, SIZE, OR COLOR.

FOR COMPUTER SERVICES, NAMELY, CREATING AN ON-LINE COMMUNITY FOR REGISTERED USERS TO PARTICIPATE IN DISCUSSIONS, GET FEEDBACK FROM THEIR PEERS, FORM VIRTUAL COMMUNITIES, AND ENGAGE IN SOCIAL NETWORKING (U.S. CLS. 100 AND 101).

FIRST USE 2-1-2011; IN COMMERCE 2-1-2011.

3,999,849. WP COMPANY LLC, WASHINGTON, DC. SN 85-168,413. PUB. 3-8-2011, FILED 11-3-2010.

TROVE

THE MARK CONSISTS OF STANDARD CHARACTERS WITHOUT CLAIM TO ANY PARTICULAR FONT, STYLE, SIZE, OR COLOR.

FOR PERSONALIZED INTERNET NEWS AGGREGATOR, NAMELY, A WEBSITE DELIVERING AGGREGATED NEWS AND INFORMATION BASED ON A PERSONALIZED SET OF EXPLICIT AND IMPLICIT USER INTERESTS (U.S. CLS. 100 AND 101).

FIRST USE 4-20-2011; IN COMMERCE 4-20-2011.

3,999,861. ARIEL METALS CORPORATION, NORTH-BROOK, IL. SN 85-178,118. PUB. 3-22-2011, FILED 11-16-2010.

RIGHTech

THE MARK CONSISTS OF STANDARD CHARACTERS WITHOUT CLAIM TO ANY PARTICULAR FONT, STYLE, SIZE, OR COLOR.

OWNER OF U.S. REG. NO. 3,851,479. FOR CUSTOM DESIGN OF INDUSTRIAL EQUIPMENT USED IN METAL PROCESSING AND ANODIZING (U.S. CLS. 100 AND 101).

FIRST USE 3-19-2010; IN COMMERCE 3-19-2010.

CLASS 42—(Continued).

3,999,862. ARIEL METALS CORPORATION, NORTH-BROOK, IL. SN 85-178,132. PUB. 3-22-2011, FILED 11-16-2010.



OWNER OF U.S. REG. NO. 3,851,479.
THE MARK CONSISTS OF A CHECK MARK AS PART OF THE LETTER "R" TO THE LEFT OF THE WORD "RIGHT-ECH".
FOR CUSTOM DESIGN OF INDUSTRIAL EQUIPMENT USED IN METAL PROCESSING AND ANODIZING (U.S. CLS. 100 AND 101).
FIRST USE 3-19-2010; IN COMMERCE 3-19-2010.

CLASS 43—HOTEL AND RESTAURANT SERVICES

3,998,709. LUBY'S FUDDRUCKERS RESTAURANTS, LLC, HOUSTON, TX. SN 77-773,471. PUB. 11-24-2009, FILED 7-2-2009.

DO THE ROO

THE MARK CONSISTS OF STANDARD CHARACTERS WITHOUT CLAIM TO ANY PARTICULAR FONT, STYLE, SIZE, OR COLOR.
FOR RESTAURANT SERVICES (U.S. CLS. 100 AND 101).
FIRST USE 11-0-2009; IN COMMERCE 11-0-2009.

3,998,759. CAPITELLO, INC., WASHINGTON, DC. SN 77-822,097. PUB. 2-2-2010, FILED 9-8-2009.

THE MARK CONSISTS OF THE STYLIZED WORD "CITIES".
FOR RESTAURANT AND BAR SERVICES (U.S. CLS. 100 AND 101).
FIRST USE 12-1-2010; IN COMMERCE 12-1-2010.

CLASS 43—(Continued).

3,998,789. SHARP, ROGER, PASO ROBLES, CA. SN 77-834,348. PUB. 2-16-2010, FILED 9-24-2009.

PIMP YOUR BURGER

THE MARK CONSISTS OF STANDARD CHARACTERS WITHOUT CLAIM TO ANY PARTICULAR FONT, STYLE, SIZE, OR COLOR.
NO CLAIM IS MADE TO THE EXCLUSIVE RIGHT TO USE "BURGER", APART FROM THE MARK AS SHOWN.
FOR RESTAURANT SERVICES (U.S. CLS. 100 AND 101).
FIRST USE 9-24-2009; IN COMMERCE 7-21-2010.

3,998,989. CHANG, DANIELLE, NEW YORK, NY. SN 77-898,591. PUB. 10-19-2010, FILED 12-21-2009.



THE MARK CONSISTS OF A SMILEY FACE FORMED BY A CIRCLE WITH LINES AROUND THE EDGE OF THE CIRCLE; TWO STARS FORM THE EYES AND A BOWL WITH CHOPSTICKS IN THE BOWL FORM THE MOUTH.
FOR PROVIDING AN INTERACTIVE WEBSITE ON THE SUBJECT OF ASIAN COOKING AND ASIAN FOOD (U.S. CLS. 100 AND 101).
FIRST USE 7-31-2009; IN COMMERCE 7-31-2009.

3,999,062. DIXIE BONES INC., WOODBRIDGE, VA. SN 77-929,039. PUB. 7-13-2010, FILED 2-5-2010.

BBQ POST

THE MARK CONSISTS OF STANDARD CHARACTERS WITHOUT CLAIM TO ANY PARTICULAR FONT, STYLE, SIZE, OR COLOR.

CLASS 43—(Continued).

NO CLAIM IS MADE TO THE EXCLUSIVE RIGHT TO USE "BBQ", APART FROM THE MARK AS SHOWN.

FOR RESTAURANT; RESTAURANT AND BAR SERVICES; RESTAURANT SERVICES, INCLUDING SIT-DOWN SERVICE OF FOOD AND TAKE-OUT RESTAURANT SERVICES; RESTAURANT SERVICES, NAMELY, PROVIDING OF FOOD AND BEVERAGES FOR CONSUMPTION ON AND OFF THE PREMISES; RESTAURANTS (U.S. CLS. 100 AND 101).

FIRST USE 5-1-2010; IN COMMERCE 5-14-2010.

3,999,283. MALAWI'S PIZZA, LLC, PROVO, UT. SN 85-018,785. PUB. 9-21-2010, FILED 4-20-2010.

MALAWI'S

THE MARK CONSISTS OF STANDARD CHARACTERS WITHOUT CLAIM TO ANY PARTICULAR FONT, STYLE, SIZE, OR COLOR.

FOR RESTAURANT SERVICES; RESTAURANT SERVICES THAT DONATE FUNDS FOR MEALS TO THOSE IN NEED (U.S. CLS. 100 AND 101).

FIRST USE 8-31-2010; IN COMMERCE 8-31-2010.

3,999,316. MILL VALLEY CORPORATION, EDINA, MN. SN 85-025,273. PUB. 4-12-2011, FILED 4-28-2010.

MILL VALLEY KITCHEN

THE MARK CONSISTS OF STANDARD CHARACTERS WITHOUT CLAIM TO ANY PARTICULAR FONT, STYLE, SIZE, OR COLOR.

NO CLAIM IS MADE TO THE EXCLUSIVE RIGHT TO USE "KITCHEN", APART FROM THE MARK AS SHOWN.

FOR RESTAURANT AND BAR SERVICES (U.S. CLS. 100 AND 101).

FIRST USE 6-3-2011; IN COMMERCE 6-4-2011.

CLASS 43—(Continued).

3,999,485. HAYSLETT, DONALD SCOTT, LEXINGTON, VA. SN 85-046,988. PUB. 10-26-2010, FILED 5-25-2010.

BEAMEUPBBQ

THE MARK CONSISTS OF STANDARD CHARACTERS WITHOUT CLAIM TO ANY PARTICULAR FONT, STYLE, SIZE, OR COLOR.

FOR CATERING FOR THE PROVISION OF FOOD AND BEVERAGES; MOBILE CAFE SERVICES FOR PROVIDING FOOD AND DRINK; PROVIDING OF FOOD AND DRINK (U.S. CLS. 100 AND 101).

FIRST USE 8-27-2010; IN COMMERCE 8-27-2010.

3,999,571. AMORINI PANINI, INC., ARLINGTON, VA. SN 85-068,143. PUB. 11-16-2010, FILED 6-21-2010.

Amorini

THE MARK CONSISTS OF STANDARD CHARACTERS WITHOUT CLAIM TO ANY PARTICULAR FONT, STYLE, SIZE, OR COLOR.

THE WORDING "AMORINI" HAS NO MEANING IN A FOREIGN LANGUAGE.

FOR RESTAURANT SERVICES (U.S. CLS. 100 AND 101).

FIRST USE 9-27-2010; IN COMMERCE 9-27-2010.

3,999,607. SINGING SAMS PIZZA, ORLANDO, FL. SN 85-078,092. PUB. 12-7-2010, FILED 7-6-2010.

**THE PIZZA THAT MADE
DETROIT FAMOUS**

THE MARK CONSISTS OF STANDARD CHARACTERS WITHOUT CLAIM TO ANY PARTICULAR FONT, STYLE, SIZE, OR COLOR.

FOR RESTAURANT SERVICES, NAMELY, SELF-SERVICE RESTAURANTS FOR CONSUMERS (U.S. CLS. 100 AND 101).

FIRST USE 12-1-2010; IN COMMERCE 1-1-2011.

CLASS 43—(Continued).

3,999,637. HOTFAST PIZZA, LLC, SYCAMORE, IL. SN 85-086,624. PUB. 12-28-2010, FILED 7-16-2010.



NO CLAIM IS MADE TO THE EXCLUSIVE RIGHT TO USE "PIZZA", APART FROM THE MARK AS SHOWN.

THE COLOR(S) RED, YELLOW, ORANGE, TAN, LIGHT YELLOW AND WHITE IS/ARE CLAIMED AS A FEATURE OF THE MARK.

THE MARK CONSISTS OF THE WORDING "HOTFAST PIZZA" IN STYLIZED FORM WITH THE LETTER "H" AND THE FIRST LETTER "T" IN RED AND THE LETTER "O" FORMED BY A PIZZA DESIGN HAVING A TAN CRUST WITH RED SAUCE, LIGHT YELLOW AND WHITE CHEESE AND RED TOPPING, THE LETTERING "FAST" IN YELLOW, THE WORD "PIZZA" BELOW THE WORD "HOTFAST" IN RED, A FLAME EXTENDING UPWARD FROM THE PIZZA DESIGN IN A BLEND OF YELLOW, ORANGE AND RED, AND A BROKEN YELLOW OVAL SURROUNDING THE WORDING AND NARROWING FROM THE SECOND LETTER "T" TO THE PIZZA DESIGN. THE COLOR WHITE BEHIND THE MARK REPRESENTS BACKGROUND, OUTLINING, SHADING AND/OR TRANSPARENT AREAS AND IS NOT PART OF THE MARK.

FOR FAST-FOOD RESTAURANTS (U.S. CLS. 100 AND 101).

FIRST USE 3-21-2011; IN COMMERCE 3-21-2011.

3,999,654. KFC CORPORATION, LOUISVILLE, KY. SN 85-093,532. PUB. 10-19-2010, FILED 7-27-2010.



OWNER OF U.S. REG. NO. 3,243,849. THE PORTRAIT IN THE MARK DOES NOT IDENTIFY A LIVING INDIVIDUAL.

THE MARK CONSISTS OF THE WORDS "SO GOOD" PUSHED TOGETHER "SOGOOD" NEXT TO THE IMAGE OF A MAN WEARING A BOW TIE AND A STRIPED APRON INSIDE A TRAPEZOID.

FOR RESTAURANT SERVICES (U.S. CLS. 100 AND 101).

FIRST USE 5-23-2010; IN COMMERCE 5-23-2010.

CLASS 43—(Continued).

3,999,655. KFC CORPORATION, LOUISVILLE, KY. SN 85-093,632. PUB. 10-19-2010, FILED 7-27-2010.



OWNER OF U.S. REG. NO. 3,243,849.

THE PORTRAIT IN THE MARK DOES NOT IDENTIFY A LIVING INDIVIDUAL.

THE MARK CONSISTS OF THE WORD "BUENISIMO" NEXT TO THE IMAGE OF A MAN WEARING A BOW TIE AND A STRIPED APRON INSIDE A TRAPEZOID.

THE ENGLISH TRANSLATION OF "BUENISIMO" IN THE MARK IS "SO GOOD".

FOR RESTAURANT SERVICES (U.S. CLS. 100 AND 101).

FIRST USE 5-23-2010; IN COMMERCE 5-23-2010.

3,999,853. SPRINGDELL ASSOCIATES, LLC, COATESVILLE, PA. SN 85-171,102. PUB. 3-29-2011, FILED 11-8-2010.



THE MARK CONSISTS OF LETTER "W" IN DRAWN USING THE HANDLE AND CROP OF A WHIP.

FOR RESTAURANTS (U.S. CLS. 100 AND 101).

FIRST USE 6-1-2005; IN COMMERCE 6-30-2005.

CLASS 44—MEDICAL, BEAUTY AND AGRICULTURAL SERVICES

CLASS 44—(Continued).

3,998,378. JOON NAM LEE, RIVERDALE, GA. SN 77-130,408.
PUB. 9-16-2008, FILED 3-14-2007.



NO CLAIM IS MADE TO THE EXCLUSIVE RIGHT TO USE "CLUB", APART FROM THE MARK AS SHOWN.

THE COLOR(S) ORANGE, BLUE, GREEN, GRAY AND BLACK IS/ARE CLAIMED AS A FEATURE OF THE MARK.

THE MARK CONSISTS OF AN ORANGE SUN IN THE TOP LEFT, UNDERNEATH THE SUN THERE ARE THREE ARCS (ONE BLUE ARC TO THE LEFT OF THE SUN, OVERLAPPED BY AN ORANGE ARC THAT IS SHIFTED TO THE RIGHT, AND A GREEN ARC UNDERNEATH SHIFTED TO THE LEFT BETWEEN THE BLUE AND ORANGE ARC), IN THE TOP RIGHT CORNER THE WORDS "CENTENARIAN-CLUB.COM" IN GRAY AND UNDERNEATH THE WORDS "100SEIN CLUB" IN BLACK. THE ENGLISH TRANSLATION OF "SEIN" IN THE MARK IS "CENTENARIAN".

FOR PROVIDING A WEBSITE FEATURING INFORMATION IN THE FIELD OF MENTAL HEALTH AND WELLNESS (U.S. CLS. 100 AND 101).

FIRST USE 11-1-2006; IN COMMERCE 11-1-2006.

3,998,408. BIO WELLNESS, INC., COPLEY, OH. SN 77-257,830.
PUB. 2-19-2008, FILED 8-17-2007.

Bio

THE MARK CONSISTS OF STANDARD CHARACTERS WITHOUT CLAIM TO ANY PARTICULAR FONT, STYLE, SIZE, OR COLOR.

FOR PROVIDING WELLNESS SERVICES, NAMELY, PERSONAL ASSESSMENTS, PERSONALIZED ROUTINES, MAINTENANCE SCHEDULES, AND COUNSELING; PROVIDING A WEBSITE FEATURING EDUCATIONAL INFORMATION REGARDING NUTRITION AND GENETICS; FOOD NUTRITION CONSULTATION; HEALTH CARE SERVICES, NAMELY, DISEASE MANAGEMENT PROGRAMS; HEALTH CARE SERVICES, NAMELY, WELLNESS PROGRAMS; MAINTAINING PERSONAL MEDICAL HISTORY RECORDS AND FILES; NUTRITION COUNSELING; MAINTAINING FILES AND RECORDS CONCERNING THE MEDICAL CONDITION OF INDIVIDUALS; PROVIDING HEALTH INFORMATION; PROVIDING INFORMATION ABOUT DIETARY SUPPLEMENTS AND NUTRITION; PROVIDING INFORMATION, ADVICE AND DATA ON MEDICAL IMAGING (U.S. CLS. 100 AND 101).

FIRST USE 5-11-2011; IN COMMERCE 5-11-2011.

CLASS 44—(Continued).

3,998,412. WATKINS, IRVIN B., DBA IRVIN B. WATKINS D.D.S. & ASSOCIATES, CHICAGO, IL. SN 77-270,188. PUB. 12-1-2009, FILED 9-1-2007.

SMILES UNLIMITED

Creating Smiles That You Love!

THE MARK CONSISTS OF STANDARD CHARACTERS WITHOUT CLAIM TO ANY PARTICULAR FONT, STYLE, SIZE, OR COLOR.

FOR DENTIST SERVICES, NAMELY, PROVIDING TEETH CLEANING, DENTAL IMPLANTS, ROOT CANALS AND ORAL EXAMINATIONS (U.S. CLS. 100 AND 101).

FIRST USE 12-1-2007; IN COMMERCE 12-2-2007.

3,998,427. ORAYA THERAPEUTICS, INC., NEWARK, CA. SN 77-287,193. PUB. 3-11-2008, FILED 9-24-2007.

ORAYA

THE MARK CONSISTS OF STANDARD CHARACTERS WITHOUT CLAIM TO ANY PARTICULAR FONT, STYLE, SIZE, OR COLOR.

FOR PROVISION OF X-RAY THERAPY TO PATIENTS FOR MEDICAL CONDITIONS (U.S. CLS. 100 AND 101).

FIRST USE 7-0-2008; IN COMMERCE 7-0-2008.

3,998,454. PETSVETSPACE, LLC, NEW YORK, NY. SN 77-378,101. PUB. 12-2-2008, FILED 1-23-2008.

Pets VetSpace

THE MARK CONSISTS OF STANDARD CHARACTERS WITHOUT CLAIM TO ANY PARTICULAR FONT, STYLE, SIZE, OR COLOR.

FOR MEDICAL SERVICES, NAMELY, PROVIDING ONLINE AND ELECTRONIC CONSULTATIONS TO VETERINARIANS FOR THE ADVISEMENT ON VETERINARY MEDICAL CARE, ANIMAL HEALTH AND PET HEALTHCARE (U.S. CLS. 100 AND 101).

FIRST USE 3-1-2010; IN COMMERCE 3-1-2010.

CLASS 44—(Continued).

3,998,568. TURF ALLIANCE, LLC, WELLAND, CANADA. SN 77-605,107. PUB. 3-17-2009, FILED 10-31-2008.

THE BOTTOM LINE IN SPORTS
SURFACING

THE MARK CONSISTS OF STANDARD CHARACTERS WITHOUT CLAIM TO ANY PARTICULAR FONT, STYLE, SIZE, OR COLOR.

FOR INSTALLATION OF SYNTHETIC TURF (U.S. CLS. 100 AND 101).
FIRST USE 5-2-2011; IN COMMERCE 5-2-2011.

3,998,569. TURF ALLIANCE, LLC, WELLAND, CANADA. SN 77-605,166. PUB. 3-17-2009, FILED 10-31-2008.

ARTIFICIAL ANSWERS FOR
YOUR NATURAL NEEDS

THE MARK CONSISTS OF STANDARD CHARACTERS WITHOUT CLAIM TO ANY PARTICULAR FONT, STYLE, SIZE, OR COLOR.

FOR INSTALLATION OF SYNTHETIC TURF (U.S. CLS. 100 AND 101).
FIRST USE 5-2-2011; IN COMMERCE 5-2-2011.

3,998,570. TURF ALLIANCE, LLC, WELLAND, CANADA. SN 77-605,176. PUB. 3-17-2009, FILED 10-31-2008.

WITH U EVERY STEP OF THE
GAME

THE MARK CONSISTS OF STANDARD CHARACTERS WITHOUT CLAIM TO ANY PARTICULAR FONT, STYLE, SIZE, OR COLOR.

FOR INSTALLATION OF SYNTHETIC TURF (U.S. CLS. 100 AND 101).
FIRST USE 5-2-2011; IN COMMERCE 5-2-2011.

CLASS 44—(Continued).

3,998,645. DARENA SOLUTIONS LLC, DBA DARENA SOLUTIONS LLC, OFALLON, MO. SN 77-715,914. PUB. 10-19-2010, FILED 4-17-2009.



NO CLAIM IS MADE TO THE EXCLUSIVE RIGHT TO USE "HEALTH POSTBOX EXPRESS", APART FROM THE MARK AS SHOWN.

THE MARK CONSISTS OF A POSTBOX HOLDING AN ENVELOPE WITH A LOCK ON IT. AN ASCLEPIUS ROD APPEARS ON THE POSTBOX. THE WORD "HEPOEX" APPEARS UNDER THE POSTBOX. THE WORDS "HEALTH POSTBOX EXPRESS" APPEAR UNDER THE WORD "HEPOEX" AND A STRAIGHT HORIZONTAL LINE. THERE IS A CURVED LINE GOING ACROSS THE LOGO.

FOR PROVIDING AN ON-LINE WEB SITE THAT ENABLES USERS TO SEND AND RECEIVE HEALTH INFORMATION (U.S. CLS. 100 AND 101).

FIRST USE 5-15-2009; IN COMMERCE 5-15-2009.

3,998,648. MIRESCO, MARC, COTE-ST-LUC, QUEBEC, CANADA. SN 77-719,448. PUB. 8-25-2009, FILED 4-22-2009.

PsychVisit

THE MARK CONSISTS OF STANDARD CHARACTERS WITHOUT CLAIM TO ANY PARTICULAR FONT, STYLE, SIZE, OR COLOR.

FOR PROVIDING A WEBSITE THAT OFFERS COMPREHENSIVE AND UP-TO-DATE INFORMATION ON THE NATURE AND TREATMENT OF PSYCHOLOGICAL AND PSYCHIATRIC DISORDERS (U.S. CLS. 100 AND 101).

FIRST USE 2-1-2011; IN COMMERCE 2-1-2011.

3,998,725. UHS OF DELAWARE, INC., KING OF PRUSSIA, PA. SN 77-794,121. PUB. 10-26-2010, FILED 7-31-2009.



OWNER OF U.S. REG. NOS. 3,162,079, 3,802,075, AND OTHERS.

CLASS 44—(Continued).

NO CLAIM IS MADE TO THE EXCLUSIVE RIGHT TO USE "MANATEE HEART AND VASCULAR CENTER", APART FROM THE MARK AS SHOWN.

THE MARK CONSISTS OF A PORTION OF A CROSS WITH A SUN IMAGE IN THE RIGHT SIDE OF THE CROSS PORTION. TO THE RIGHT OF THE CROSS ARE THE WORDS "MANATEE HEART AND VASCULAR CENTER AT MANATEE MEMORIAL HOSPITAL".

SEC. 2(F) AS TO "MANATEE MEMORIAL HOSPITAL".
FOR MEDICAL AND HEALTH CARE SERVICES;
CARDIOVASCULAR-RELATED HEALTH CARE SERVICES (U.S. CLS. 100 AND 101).

FIRST USE 6-0-2009; IN COMMERCE 6-0-2009.

3,998,842. CORO HEALTH, LLC, AUSTIN, TX. SN 77-853,438.
PUB. 3-30-2010, FILED 10-21-2009.

MUSIC FIRST

THE MARK CONSISTS OF STANDARD CHARACTERS WITHOUT CLAIM TO ANY PARTICULAR FONT, STYLE, SIZE, OR COLOR.

NO CLAIM IS MADE TO THE EXCLUSIVE RIGHT TO USE "MUSIC". APART FROM THE MARK AS SHOWN.

FOR MUSIC THERAPY SERVICES; MUSIC THERAPY FOR PHYSICAL, PSYCHOLOGICAL AND COGNITIVE PURPOSES; MUSIC THERAPY FOR SOCIAL ASSIMILATION PURPOSES (U.S. CLS. 100 AND 101).

FIRST USE 1-13-2010; IN COMMERCE 1-13-2010.

3,998,926. WAHIB,KARIM, NEW YORK, NY. SN 77-878,161.
PUB. 6-8-2010, FILED 11-21-2009.

**O.U.C.H.
ORTHOPEDIC URGENT CARE
HEALTH-SERVICE**

THE MARK CONSISTS OF STANDARD CHARACTERS WITHOUT CLAIM TO ANY PARTICULAR FONT, STYLE, SIZE, OR COLOR.

NO CLAIM IS MADE TO THE EXCLUSIVE RIGHT TO USE "ORTHOPEDIC URGENT CARE HEALTH-SERVICE", APART FROM THE MARK AS SHOWN.

FOR MEDICAL DIAGNOSTIC TESTING, MONITORING AND REPORTING SERVICES; MEDICAL EVALUATION SERVICES, NAMELY, FUNCTIONAL ASSESSMENT PROGRAM FOR PATIENTS RECEIVING MEDICAL REHABILITATION SERVICES FOR PURPOSES OF GUIDING TREATMENT AND ASSESSING PROGRAM EFFECTIVENESS; MEDICAL IMAGING SERVICES, NAMELY, CONSULTING SERVICES IN THE FIELD OF USING AND OPERATING MEDICAL IMAGING APPARATUS INCLUDING X-RAY, COMPUTED TOMOGRAPHY, MAGNETIC RESONANCE IMAGING, ULTRASOUND, AND POSITRON EMISSION TOMOGRAPHY APPARATUS; MEDICAL SERVICES; MEDICAL, PHYSICAL REHABILITATION AND PHYSICAL THERAPY SERVICES; URGENT MEDICAL CARE CENTERS (U.S. CLS. 100 AND 101).

FIRST USE 9-9-2010; IN COMMERCE 9-9-2010.

CLASS 44—(Continued).

3,999,048. MANTHEI, LYDIA, ESCONDIDO, CA. SN 77-922,197. PUB. 6-15-2010, FILED 1-28-2010.

**MIND DRIVEN GOLF "Wrap
your mind around the game"**

THE MARK CONSISTS OF STANDARD CHARACTERS WITHOUT CLAIM TO ANY PARTICULAR FONT, STYLE, SIZE, OR COLOR.

FOR HYPNOSIS SERVICES FOR ENHANCING SPORTS PERFORMANCE (U.S. CLS. 100 AND 101).

FIRST USE 1-28-2010; IN COMMERCE 1-28-2010.

3,999,070. THE WYANOKE GROUP INC., THOROFARE, NJ.
SN 77-932,201. PUB. 6-29-2010, FILED 2-10-2010.

**POD
Performance On Demand**

THE MARK CONSISTS OF STANDARD CHARACTERS WITHOUT CLAIM TO ANY PARTICULAR FONT, STYLE, SIZE, OR COLOR.

FOR PROVIDING A WEB SITE THAT FEATURES THE EVALUATION OF PATIENTS' DATA TO IMPROVE THE PERFORMANCE OF PHYSICIANS (U.S. CLS. 100 AND 101).

FIRST USE 2-28-2011; IN COMMERCE 2-28-2011.

3,999,110. AUTOEXPOSURE, INC., RESTON, VA. SN 77-950,206. PUB. 9-28-2010, FILED 3-4-2010.

MYME

THE MARK CONSISTS OF STANDARD CHARACTERS WITHOUT CLAIM TO ANY PARTICULAR FONT, STYLE, SIZE, OR COLOR.

FOR ONLINE PORTAL, WEBSITE AND DATABASE FEATURING COMPUTER, MOBILE AND PHONE ACCESS FOR TRACKING, MANAGING, VIEWING AND SHARING HEALTH INFORMATION (U.S. CLS. 100 AND 101).

FIRST USE 5-5-2011; IN COMMERCE 5-5-2011.

CLASS 44—(Continued).

3,999,183. EMERGE CLINICAL SOLUTIONS, LLC, DALLAS, TX. SN 77-982,123. PUB. 10-5-2010, FILED 11-3-2009.

EMERGE MEDICAL SOLUTIONS

THE MARK CONSISTS OF STANDARD CHARACTERS WITHOUT CLAIM TO ANY PARTICULAR FONT, STYLE, SIZE, OR COLOR.

OWNER OF U.S. REG. NO. 3,731,716.

NO CLAIM IS MADE TO THE EXCLUSIVE RIGHT TO USE "MEDICAL SOLUTIONS", APART FROM THE MARK AS SHOWN.

FOR PROVIDING CONSULTING, NAMELY, SYNTHESIZING PATIENT MEDICAL INFORMATION FROM CLINICAL EVALUATIONS TO IMPROVE PATIENT CARE EFFICIENCY FOR CARDIOLOGY PRACTICES (U.S. CLS. 100 AND 101).

FIRST USE 5-30-2011; IN COMMERCE 5-30-2011.

3,999,248. THE WELLCARE MANAGEMENT GROUP, INC., TAMPA, FL. SN 85-009,643. PUB. 8-31-2010, FILED 4-8-2010.

THE MEDICARE YOU DESERVE

THE MARK CONSISTS OF STANDARD CHARACTERS WITHOUT CLAIM TO ANY PARTICULAR FONT, STYLE, SIZE, OR COLOR.

FOR HEALTH CARE SERVICES IN THE NATURE OF A HEALTH MAINTENANCE ORGANIZATION FOR BENEFICIARIES OF GOVERNMENT-SPONSORED HEALTH CARE PROGRAMS (U.S. CLS. 100 AND 101).

FIRST USE 10-1-2009; IN COMMERCE 10-1-2009.

3,999,255. MYSLABODSKI LEJTMAN, TEODORO, ESTADO DE MEXICO, MEXICO. SN 85-013,440. PUB. 9-28-2010, FILED 4-14-2010.



NO CLAIM IS MADE TO THE EXCLUSIVE RIGHT TO USE "BANCO DE CORDON UMBILICAL", APART FROM THE MARK AS SHOWN.

THE COLOR(S) BLUE, BLACK AND GREY IS/ARE CLAIMED AS A FEATURE OF THE MARK.

CLASS 44—(Continued).

THE MARK CONSISTS OF THE LETTERS "BCU" IN BLUE WITH SHADOW IN GREY. THE LETTER "B" WITH A CURVED LINE AT THE TOP OF THE SAME. AT THE RIGHT SIDE OF THE LETTERS "BCU" THE WORDING "BANCO DE" IN BLACK AND BELOW THE WORDING "CORDON UMBILICAL" IN BLACK.

THE ENGLISH TRANSLATION OF "BANCO DE CORDON UMBILICAL" IN THE MARK IS "UMBILICAL CORD BANK".

FOR ISOLATION, COLLECTION, AND BANKING OF UMBILICAL CORD TISSUE PERIVASCULAR STEM CELLS; MEDICAL ASSISTANCE SERVICES; MEDICAL SERVICES (U.S. CLS. 100 AND 101).

FIRST USE 4-29-2002; IN COMMERCE 2-14-2011.

3,999,260. AQUALIPO LLC, VIERA, FL. SN 85-014,293. PUB. 9-7-2010, FILED 4-14-2010.

STEMCEUTICALS

THE MARK CONSISTS OF STANDARD CHARACTERS WITHOUT CLAIM TO ANY PARTICULAR FONT, STYLE, SIZE, OR COLOR.

FOR MEDICAL SERVICES (U.S. CLS. 100 AND 101).

FIRST USE 4-25-2011; IN COMMERCE 4-25-2011.

3,999,262. MAKE YOU PERFECT, WEST HOLLYWOOD, CA. SN 85-014,610. PUB. 9-14-2010, FILED S.R. 4-15-2010; AM. P.R. 5-16-2011.

Make You Perfect

THE MARK CONSISTS OF STANDARD CHARACTERS WITHOUT CLAIM TO ANY PARTICULAR FONT, STYLE, SIZE, OR COLOR.

FOR BEAUTY SPA SERVICES, NAMELY, COSMETIC BODY CARE; COSMETIC AND PLASTIC SURGERY; COSMETIC ELECTROLYSIS; COSMETIC SERVICES, NAMELY, NON-PERMANENT HAIR REMOVAL; COSMETIC SKIN CARE SERVICES; DAY SPA SERVICES, NAMELY, NAIL CARE, MANICURES, PEDICURES AND NAIL ENHANCEMENTS; FACIAL TREATMENT SERVICES, NAMELY, COSMETIC PEELS; HEALTH SPA SERVICES, NAMELY, LASER TREATMENTS FOR ACNE, REJUVENATION, SCARS, TATTOO REMOVAL AND FOR FACIALS AND MASSAGE; MASSAGE THERAPY SERVICES; MEDICAL SKIN CARE SERVICES; PERFORMING COSMETIC SURGICAL PROCEDURES FOR VAGINAL REJUVENATION (U.S. CLS. 100 AND 101).

FIRST USE 7-1-2010; IN COMMERCE 7-7-2010.

CLASS 44—(Continued).

3,999,374. ORTHOPAEDIC MARKETING GROUP, INC., OMAHA, NE. SN 85-030,811. PUB. 10-5-2010, FILED 5-5-2010.

The One To Trust

THE MARK CONSISTS OF STANDARD CHARACTERS WITHOUT CLAIM TO ANY PARTICULAR FONT, STYLE, SIZE, OR COLOR.

FOR MEDICAL SERVICES, NAMELY, EVALUATION, DIAGNOSTIC, TREATMENT AND SURGICAL SERVICES IN THE FIELD OF ORTHOPAEDIC MEDICINE (U.S. CLS. 100 AND 101).

FIRST USE 5-31-2009; IN COMMERCE 5-31-2009.

3,999,444. METRO INFECTIOUS DISEASE CONSULTANTS, L.L.C., HINSDALE, IL. SN 85-038,946. PUB. 10-26-2010, FILED 5-14-2010.

METRO INFECTIOUS DISEASE
CONSULTANTS

THE MARK CONSISTS OF STANDARD CHARACTERS WITHOUT CLAIM TO ANY PARTICULAR FONT, STYLE, SIZE, OR COLOR.

NO CLAIM IS MADE TO THE EXCLUSIVE RIGHT TO USE "INFECTIOUS DISEASE CONSULTANTS", APART FROM THE MARK AS SHOWN.

FOR MEDICAL SERVICES; PERFORMING DIAGNOSIS OF DISEASES; MEDICAL TESTING FOR DIAGNOSTIC OR TREATMENT PURPOSES; TREATMENT OF INFECTIONS WITH ORAL AND INTRAVENOUS MEDICATIONS; MEDICAL SERVICES, NAMELY, PROVIDING INFUSION THERAPY SERVICES; NURSING SERVICES; INFUSION MANAGEMENT, NAMELY, ADMINISTERING OF INTRAVENOUS DRUGS, FOOD AND HYDRATION THROUGH INFUSION THERAPY (U.S. CLS. 100 AND 101).

FIRST USE 3-10-2003; IN COMMERCE 3-10-2003.

CLASS 44—(Continued).

3,999,445. SONUS-USA, INC., PLYMOUTH, MN. SN 85-039,229. PUB. 10-19-2010, FILED 5-14-2010.



OWNER OF U.S. REG. NOS. 1,968,952, 2,324,456, AND OTHERS.

THE MARK CONSISTS OF THE WORD "SONUS" WITHIN A RECTANGLE HAVING ROUNDED CORNERS.

FOR AUDIOLOGIST SERVICES, NAMELY, HEARING AID SERVICES FEATURING HEARING EXAMINATION SERVICES, ADMINISTRATION OF MEDICAL HEARING TESTS, CONSULTATION IN THE FIELD OF HEARING EVALUATIONS, AND HEARING AID FITTING (U.S. CLS. 100 AND 101).

FIRST USE 10-31-2009; IN COMMERCE 10-31-2009.

3,999,470. PRACTICE COMMUNICATIONS, INC., BOCA RATON, FL. SN 85-044,065. PUB. 11-2-2010, FILED 5-20-2010.

PRACTICE COMMUNICATIONS

THE MARK CONSISTS OF STANDARD CHARACTERS WITHOUT CLAIM TO ANY PARTICULAR FONT, STYLE, SIZE, OR COLOR.

NO CLAIM IS MADE TO THE EXCLUSIVE RIGHT TO USE "COMMUNICATIONS", APART FROM THE MARK AS SHOWN.

FOR MAINTAINING INDIVIDUAL PERSONAL HEALTH RECORDS ON AN INTERNET BASED COMPUTER SYSTEM AND ON DIGITAL STORAGE MEDIA (U.S. CLS. 100 AND 101).

FIRST USE 11-18-2010; IN COMMERCE 11-18-2010.

CLASS 44—(Continued).

3,999,500. ROBERT STELLA DDS, INC., AKA DR. STELLA'S CHILDREN'S DENTISTRY, LONG BEACH, CA. SN 85-050,523. PUB. 10-26-2010, FILED 5-28-2010.

FUNTASTIC DENTAL

THE MARK CONSISTS OF STANDARD CHARACTERS WITHOUT CLAIM TO ANY PARTICULAR FONT, STYLE, SIZE, OR COLOR.

NO CLAIM IS MADE TO THE EXCLUSIVE RIGHT TO USE "DENTAL", APART FROM THE MARK AS SHOWN. FOR DENTISTRY (U.S. CLS. 100 AND 101). FIRST USE 3-28-2010; IN COMMERCE 11-7-2010.

3,999,535. DAVID J. WOLF M.D. PROFESSIONAL CORP., NEW YORK, NY. SN 85-058,482. PUB. 3-15-2011, FILED 6-9-2010.



NO CLAIM IS MADE TO THE EXCLUSIVE RIGHT TO USE "IV NY", APART FROM THE MARK AS SHOWN.

THE MARK CONSISTS OF THE LETTERS "IVNY" WITH THE RIGHT SIDE OF THE "V" CONSISTING IN PART OF A LEAF.

FOR MEDICAL SERVICES (U.S. CLS. 100 AND 101). FIRST USE 1-0-2011; IN COMMERCE 1-0-2011.

3,999,536. DAVID J. WOLF M.D. PROFESSIONAL CORP., NEW YORK, NY. SN 85-058,630. PUB. 3-15-2011, FILED 6-9-2010.



The Intravenous Treatment Center of New York

NO CLAIM IS MADE TO THE EXCLUSIVE RIGHT TO USE "IV NY THE INTRAVENOUS TREATMENT CENTER OF NEW YORK", APART FROM THE MARK AS SHOWN.

THE MARK CONSISTS OF THE LETTERS "IVNY" WITH THE RIGHT SIDE OF THE "V" CONSISTING IN PART OF A LEAF AND SET FORTH IMMEDIATELY BELOW THE WORDS "THE INTRAVENOUS TREATMENT CENTER OF NEW YORK".

FOR MEDICAL SERVICES (U.S. CLS. 100 AND 101). FIRST USE 1-0-2011; IN COMMERCE 1-0-2011.

CLASS 44—(Continued).

3,999,614. UHS OF DELAWARE, INC., KING OF PRUSSIA, PA. SN 85-079,088. PUB. 10-19-2010, FILED 7-7-2010.



NO CLAIM IS MADE TO THE EXCLUSIVE RIGHT TO USE "THE REHABILITATION INSTITUTE" AND "REGIONAL MEDICAL CENTER", APART FROM THE MARK AS SHOWN.

THE MARK CONSISTS OF AN IMAGE OF A HUMAN FORM, TO THE RIGHT OF WHICH ARE THE WORDS "THE REHABILITATION INSTITUTE AT ST. MARY'S REGIONAL MEDICAL CENTER I CAN DO THIS.", WITH A HORIZONTAL LINE IN BETWEEN "THE REHABILITATION INSTITUTE" AND "AT ST. MARY'S REGIONAL MEDICAL CENTER".

FOR HEALTH CARE; MEDICAL SERVICES (U.S. CLS. 100 AND 101).

FIRST USE 11-20-2010; IN COMMERCE 11-20-2010.

3,999,723. WEIGHT PLAN, LLC, ST. LOUIS, MO. SN 85-121,074. PUB. 3-22-2011, FILED 9-1-2010.



PractiCal

Common Sense Diet. Uncommon Results.

NO CLAIM IS MADE TO THE EXCLUSIVE RIGHT TO USE "DIET", APART FROM THE MARK AS SHOWN.

THE MARK CONSISTS OF A DIAMOND DESIGN WITH A STYLIZED FIGURE IN THE CENTER ABOVE THE WORDS "PRACTICAL" AND "COMMON SENSE DIET. UNCOMMON RESULTS."

FOR WEIGHT REDUCTION DIET PLANNING AND SUPERVISION, AND CONSULTATION THEREOF, ALL FEATURING PERSONALIZED DIET ASSESSMENTS AND PLANS, AND DIET MANAGEMENT AND MAINTENANCE SCHEDULES (U.S. CLS. 100 AND 101).

FIRST USE 12-1-2010; IN COMMERCE 12-1-2010.

CLASS 44—(Continued).

3,999,796. AMERIMMUNE LLC, SPRINGFIELD, VA. SN 85-146,525. PUB. 2-22-2011, FILED 10-6-2010.

Amerimmune

THE MARK CONSISTS OF STANDARD CHARACTERS WITHOUT CLAIM TO ANY PARTICULAR FONT, STYLE, SIZE, OR COLOR.

FOR MEDICAL TESTING AND ANALYSIS SERVICES FOR DIAGNOSTIC OR TREATMENT PURPOSES (U.S. CLS. 100 AND 101).

FIRST USE 3-12-2011; IN COMMERCE 3-12-2011.

3,999,815. JUMPSTART MEDICINE, P.C., LAFAYETTE, CA. SN 85-153,224. PUB. 3-22-2011, FILED 10-14-2010.



THE MARK CONSISTS OF A STYLIZED SUN OR JUMPING FIGURE.

FOR PHYSICIAN SERVICES FOR THE TREATMENT OF OBESITY (U.S. CLS. 100 AND 101).

FIRST USE 1-4-2011; IN COMMERCE 1-4-2011.

3,999,856. LASHFULLY, INC., SAN FRANCISCO, CA. SN 85-173,102. PUB. 3-29-2011, FILED 11-9-2010.

Lashfully

THE MARK CONSISTS OF STANDARD CHARACTERS WITHOUT CLAIM TO ANY PARTICULAR FONT, STYLE, SIZE, OR COLOR.

FOR BEAUTY SALON SERVICES; BEAUTY SPA SERVICES, NAMELY, COSMETIC BODY CARE (U.S. CLS. 100 AND 101).

FIRST USE 12-1-2010; IN COMMERCE 12-1-2010.

CLASS 44—(Continued).

3,999,875. PALM BEACH TAN, INC., COPPELL, TX. SN 85-975,261. PUB. 9-14-2010, FILED 4-5-2010.

PALM BEACH TAN SUNLESS

THE MARK CONSISTS OF STANDARD CHARACTERS WITHOUT CLAIM TO ANY PARTICULAR FONT, STYLE, SIZE, OR COLOR.

OWNER OF U.S. REG. NOS. 1,918,556, 2,977,106, AND OTHERS.

NO CLAIM IS MADE TO THE EXCLUSIVE RIGHT TO USE "TAN SUNLESS", APART FROM THE MARK AS SHOWN.

FOR TANNING SALON SERVICES; TEETH WHITENING SERVICES (U.S. CLS. 100 AND 101).

FIRST USE 8-11-2010; IN COMMERCE 8-11-2010.

CLASS 45—PERSONAL AND LEGAL SERVICES

3,998,555. PLUME.COM, LLC, PETOSKEY, MI. SN 77-592,199. PUB. 9-1-2009, FILED 10-14-2008.

PLUME

THE MARK CONSISTS OF STANDARD CHARACTERS WITHOUT CLAIM TO ANY PARTICULAR FONT, STYLE, SIZE, OR COLOR.

FOR PROVIDING A SOCIAL NETWORKING WEBSITE FOR ENTERTAINMENT PURPOSES; ON-LINE SOCIAL NETWORKING SERVICES VIA A GLOBAL COMPUTER NETWORK WEBSITE (U.S. CLS. 100 AND 101).

FIRST USE 4-26-2010; IN COMMERCE 4-26-2010.

3,998,854. COVENANT MINISTRIES INTERNATIONAL, INC., DBA THE INTERNATIONAL FELLOWSHIP OF COVENANT MINISTRIES, LESLIE, AR. SN 77-855,393. PUB. 4-6-2010, FILED 10-22-2009.

The International Fellowship of Covenant Ministries

THE MARK CONSISTS OF STANDARD CHARACTERS WITHOUT CLAIM TO ANY PARTICULAR FONT, STYLE, SIZE, OR COLOR.

CLASS 45—(Continued).

NO CLAIM IS MADE TO THE EXCLUSIVE RIGHT TO USE "THE INTERNATIONAL FELLOWSHIP" OR "MINISTRIES", APART FROM THE MARK AS SHOWN.

FOR CHRISTIAN MINISTRY SERVICES; LICENSING OF MINISTERS, NAMELY, ORDINATION SERVICES; PROVIDING A WEBSITE FEATURING INFORMATION FOR LOCAL CHURCH LEADERS IN THE FIELD OF CHRISTIAN GROWTH (U.S. CLS. 100 AND 101).

FIRST USE 1-20-2010; IN COMMERCE 4-4-2010.

CLASS 45—(Continued).

3,999,049. SPEED DISTRICT, LLC, LONG BEACH, CA. SN 77-922,393. PUB. 6-15-2010, FILED 1-28-2010.

SPEED DISTRICT

3,998,866. SPORTU.COM LLC, BIRMINGHAM, AL. SN 77-857,812. PUB. 10-19-2010, FILED 10-26-2009.

SPORTU

THE MARK CONSISTS OF STANDARD CHARACTERS WITHOUT CLAIM TO ANY PARTICULAR FONT, STYLE, SIZE, OR COLOR.

FOR PROVIDING A SOCIAL NETWORKING WEBSITE FOR ENTERTAINMENT PURPOSES (U.S. CLS. 100 AND 101).

FIRST USE 11-1-2010; IN COMMERCE 11-1-2010.

THE MARK CONSISTS OF STANDARD CHARACTERS WITHOUT CLAIM TO ANY PARTICULAR FONT, STYLE, SIZE, OR COLOR.

NO CLAIM IS MADE TO THE EXCLUSIVE RIGHT TO USE "SPEED", APART FROM THE MARK AS SHOWN.

FOR ONLINE SOCIAL NETWORKING SERVICES (U.S. CLS. 100 AND 101).

FIRST USE 3-1-2010; IN COMMERCE 3-1-2010.

3,998,924. CARLOS-EL, WALTER STEVEN, CHICAGO, IL. SN 77-877,624. PUB. 10-5-2010, FILED 11-20-2009.

WALTER STEVEN CARLOS

THE MARK CONSISTS OF STANDARD CHARACTERS WITHOUT CLAIM TO ANY PARTICULAR FONT, STYLE, SIZE, OR COLOR.

THE NAME SHOWN IN THE MARK IDENTIFIES "WALTER STEVEN CARLOS", WHOSE CONSENT TO REGISTER HIS NAME IS MADE OF RECORD.

FOR PSYCHIC READING SERVICES, ASTROLOGY CONSULTATION, FORTUNE TELLING AND HOROSCOPE AND ASTROLOGICAL FORECASTING; PSYCHIC CONSULTATION SERVICES IN THE FIELDS OF NUMEROLOGY, TAROT READINGS, LIFE ADVISE, DECISION MAKING, INTUITION, RUNE AND I-CHING INTERPRETATIONS, CARD READING AND HEALING (U.S. CLS. 100 AND 101).

FIRST USE 5-7-2011; IN COMMERCE 5-7-2011.

3,999,683. IRON SHIELD PROTECTION SERVICES, CLINTON, MD. SN 85-105,062. PUB. 1-25-2011, FILED 8-11-2010.



NO CLAIM IS MADE TO THE EXCLUSIVE RIGHT TO USE "PROTECTION SERVICES", APART FROM THE MARK AS SHOWN.

THE MARK CONSISTS OF A SHIELD WITH THE WORDING "IRON SHIELD PROTECTION SERVICES" ON THE INSIDE OF THE SHIELD ABOVE A BALD MUSCULAR SECURITY PERSONAL PROTECTION PROFESSIONAL WEARING A T-SHIRT AND BELT WITH SHADED GLASSES AND A RADIO HEADSET.

FOR PERSONAL BODY GUARDING; SECURITY SERVICES, NAMELY, PROVIDING EXECUTIVE PROTECTION (U.S. CLS. 100 AND 101).

FIRST USE 6-2-2011; IN COMMERCE 6-2-2011.

CLASS 45—(Continued).

3,999,783. ONDAYSIX LLC, REDDING, CA. SN 85-142,451. PUB. 3-15-2011, FILED 9-30-2010.

ONDAYSIX

THE MARK CONSISTS OF STANDARD CHARACTERS WITHOUT CLAIM TO ANY PARTICULAR FONT, STYLE, SIZE, OR COLOR.

FOR COMPUTER DATING SERVICES; DATING SERVICES; MARRIAGE PARTNER INTRODUCTION OR DATING SERVICES; MATCHMAKING SERVICES; VIDEO DATING SERVICES (U.S. CLS. 100 AND 101). FIRST USE 4-22-2011; IN COMMERCE 4-22-2011.

CLASS 45—(Continued).

3,999,852. BEST UPON REQUEST CORPORATE, INC., CINCINNATI, OH. SN 85-169,576. PUB. 3-15-2011, FILED 11-4-2010.

UNLEASHING THE POTENTIAL OF EACH DAY

THE MARK CONSISTS OF STANDARD CHARACTERS WITHOUT CLAIM TO ANY PARTICULAR FONT, STYLE, SIZE, OR COLOR.

FOR CONCIERGE SERVICES FOR OTHERS COMPRISING MAKING REQUESTED PERSONAL ARRANGEMENTS AND RESERVATIONS, RUNNING ERRANDS AND PROVIDING CUSTOMER-SPECIFIC INFORMATION TO MEET INDIVIDUAL NEEDS RENDERED TOGETHER IN BUSINESS WORKPLACES OR HOSPITALS (U.S. CLS. 100 AND 101). FIRST USE 1-31-2011; IN COMMERCE 1-31-2011.

3,999,802. LIAISE MEDIATED SOLUTIONS, LLC, SAN FRANCISCO, CA. SN 85-149,107. PUB. 3-8-2011, FILED 10-9-2010.

LIAISE DIVORCE SOLUTIONS

THE MARK CONSISTS OF STANDARD CHARACTERS WITHOUT CLAIM TO ANY PARTICULAR FONT, STYLE, SIZE, OR COLOR.

OWNER OF U.S. REG. NO. 3,618,871. NO CLAIM IS MADE TO THE EXCLUSIVE RIGHT TO USE "DIVORCE SOLUTIONS", APART FROM THE MARK AS SHOWN. FOR PERSONAL SERVICES, NAMELY, CONSULTATION IN THE FIELD OF DIVORCE (U.S. CLS. 100 AND 101). FIRST USE 11-15-2010; IN COMMERCE 11-15-2010.

3,999,876. SOARINGWORDS, INC., NEW YORK, NY. SN 85-975,262. PUB. 9-14-2010, FILED 5-17-2010.

SOARINGVISUALIZATIONS

THE MARK CONSISTS OF STANDARD CHARACTERS WITHOUT CLAIM TO ANY PARTICULAR FONT, STYLE, SIZE, OR COLOR.

OWNER OF U.S. REG. NOS. 3,407,806, 3,407,808, AND OTHERS. FOR CHARITABLE SERVICES, NAMELY, PROVIDING AN INTERNET WEB SITE FEATURING MOTIVATIONAL AND INSPIRATIONAL SELF-HELP AND PERSONAL EMPOWERMENT INFORMATION FOR USE BY CHILDREN WITH SERIOUS ILLNESS AND THEIR FAMILY, FEATURING INFORMATION CONCERNING VISUALIZATION EXERCISES TO HELP ILL CHILDREN AND FAMILIES BOOST SELF-ESTEEM AND PERSONAL EMPOWERMENT INFORMATION TO REDUCE STRESS AND FIND STRENGTH IN THE MIDST OF SERIOUS ILLNESS (U.S. CLS. 100 AND 101). FIRST USE 0-0-2002; IN COMMERCE 0-0-2002.

PRIOR UNITED STATES CLASSIFICATION

APPLICATION IN ONE CLASS

COLLECTIVE MEMBERSHIP MARKS

CLASS 200—COLLECTIVE MEMBERSHIP

3,998,315. BETTER SEAFOOD BUREAU, LLC, MCLEAN, VA.
SN 76-698,359. PUB. 3-30-2010, FILED 7-10-2009.



THE MARK CONSISTS OF A SERRATED CIRCLE WHICH FORMS AN OUTER BORDER FOR THE ENTIRE MARK, TWO CONCENTRIC CIRCLES WHICH CONTAIN BETWEEN THEM THE PHRASES "BETTER SEAFOOD BOARD" AND "ENSURING THE INTEGRITY OF YOUR SEAFOOD" AND WHICH SURROUND THE WORDS, NUMBERS AND LETTERS "BSB 866 956 4BSB WWW.BETTERSEAFOODBOARD.COM" AND DESIGN ELEMENTS DEPICTING A BANNER, SCALES, A BOAT, A FISH, WATER, MOUNTAINS AND THE SUN.

FOR INDICATING MEMBERSHIP IN AN ORGANIZATION DEDICATED TO THE REPORTING AND PREVENTION OF FRAUDULENT BUSINESS PRACTICES IN THE SEAFOOD SUPPLY INDUSTRY (U.S. CL. 200).

FIRST USE 10-14-2010; IN COMMERCE 2-1-2011.

NO CLAIM IS MADE TO THE EXCLUSIVE RIGHT TO USE "SEAFOOD BOARD", APART FROM THE MARK AS SHOWN.

* * * * *

SUPPLEMENTAL REGISTER

These registrations are not subject to opposition.

SECTION 1.— INTERNATIONAL CLASSIFICATION

The short titles associated below with the international class numbers are terms designed merely for quick identification and are not an official part of the international classification. The full names of international classes are given in section 6.1 of the trademark rules of practice.

The designation "U.S. Cl." appearing in this section refers to the U.S. class in effect prior to Sep. 1, 1973 rather than the international class which applies to applications filed on or after that date. For adoption of international classification see notice in the OFFICIAL GAZETTE of Jun. 26, 1973 (911 O.G. TM 210).

Application in more than one class

3,999,885. NV-J CORP., WAHIAWA, HI. SN 77-269,543. FILED P.R. 8-31-2007; AM. S.R. 3-25-2008.

3,999,887. FLORISTS' TRANSWORLD DELIVERY, INC., DOWNERS GROVE, IL. SN 77-647,928. FILED P.R. 1-12-2009; AM. S.R. 5-11-2011.

THE FLOWER EXPERTS



THE MARK CONSISTS OF STANDARD CHARACTERS WITHOUT CLAIM TO ANY PARTICULAR FONT, STYLE, SIZE, OR COLOR.

NO CLAIM IS MADE TO THE EXCLUSIVE RIGHT TO USE "FLOWER", APART FROM THE MARK AS SHOWN.

CLASS 31—NATURAL AGRICULTURAL PRODUCTS

FOR FLOWERS; LIVE FLORAL ARRANGEMENTS (U.S. CLS. 1 AND 46).

FIRST USE 3-19-2009; IN COMMERCE 3-19-2009.

CLASS 35—ADVERTISING AND BUSINESS

FOR ONLINE RETAIL STORE SERVICES FEATURING FLOWERS AND SHOP-BY TELEPHONE ORDERING SERVICES FEATURING FLOWERS (U.S. CLS. 100, 101 AND 102).

FIRST USE 3-19-2009; IN COMMERCE 3-19-2009.

THE MARK CONSISTS OF THE STYLIZED WORD "LIVEEVIL" WITH THE "E"'S FORMING THE SHAPE OF A SPADE .

CLASS 16—PAPER GOODS AND PRINTED MATTER

FOR STICKERS (U.S. CLS. 2, 5, 22, 23, 29, 37, 38 AND 50).

FIRST USE 8-1-2007; IN COMMERCE 8-1-2007.

CLASS 25—CLOTHING

FOR SHIRTS; SWEAT SHIRTS; T-SHIRTS; BOARD SHORTS; PANTIES, SHORTS AND BRIEFS; SHORTS; JACKETS; SKIRTS; DRESSES; HATS; BEANIES; HEADWEAR; SWIM TRUNKS; SOCKS; FOOTWEAR; SWEATERS; HALTER TOPS; TANK TOPS; PANTS (U.S. CLS. 22 AND 39).

FIRST USE 8-1-2007; IN COMMERCE 8-1-2007.

3,999,888. FLORISTS' TRANSWORLD DELIVERY, INC., DOWNERS GROVE, IL. SN 77-647,930. FILED P.R. 1-12-2009; AM. S.R. 5-19-2011.

THE ORCHID EXPERTS

THE MARK CONSISTS OF STANDARD CHARACTERS WITHOUT CLAIM TO ANY PARTICULAR FONT, STYLE, SIZE, OR COLOR.

NO CLAIM IS MADE TO THE EXCLUSIVE RIGHT TO USE "ORCHID", APART FROM THE MARK AS SHOWN.

CLASS 31—NATURAL AGRICULTURAL PRODUCTS

FOR FLOWERS; LIVE FLORAL ARRANGEMENTS (U.S. CLS. 1 AND 46).
FIRST USE 3-19-2009; IN COMMERCE 3-19-2009.

CLASS 35—ADVERTISING AND BUSINESS

FOR ONLINE RETAIL STORE SERVICES FEATURING FLOWERS AND SHOP-BY TELEPHONE ORDERING SERVICES FEATURING FLOWERS (U.S. CLS. 100, 101 AND 102).
FIRST USE 3-19-2009; IN COMMERCE 3-19-2009.

3,999,889. FLORISTS' TRANSWORLD DELIVERY, INC., DOWNERS GROVE, IL. SN 77-647,931. FILED P.R. 1-12-2009; AM. S.R. 5-11-2011.

THE ROSE EXPERTS

THE MARK CONSISTS OF STANDARD CHARACTERS WITHOUT CLAIM TO ANY PARTICULAR FONT, STYLE, SIZE, OR COLOR.

CLASS 31—NATURAL AGRICULTURAL PRODUCTS

FOR FLOWERS; LIVE FLORAL ARRANGEMENTS (U.S. CLS. 1 AND 46).
FIRST USE 3-17-2009; IN COMMERCE 3-17-2009.

CLASS 35—ADVERTISING AND BUSINESS

FOR ONLINE RETAIL STORE SERVICES FEATURING FLOWERS AND SHOP-BY TELEPHONE ORDERING SERVICES FEATURING FLOWERS (U.S. CLS. 100, 101 AND 102).
FIRST USE 3-17-2009; IN COMMERCE 3-17-2009.

3,999,890. FLORISTS' TRANSWORLD DELIVERY, INC., DOWNERS GROVE, IL. SN 77-647,932. FILED P.R. 1-12-2009; AM. S.R. 5-11-2011.

THE TULIP EXPERTS

THE MARK CONSISTS OF STANDARD CHARACTERS WITHOUT CLAIM TO ANY PARTICULAR FONT, STYLE, SIZE, OR COLOR.

CLASS 31—NATURAL AGRICULTURAL PRODUCTS

FOR FLOWERS; LIVE FLORAL ARRANGEMENTS (U.S. CLS. 1 AND 46).
FIRST USE 3-19-2009; IN COMMERCE 3-19-2009.

CLASS 35—ADVERTISING AND BUSINESS

FOR ONLINE RETAIL STORE SERVICES FEATURING FLOWERS AND SHOP-BY TELEPHONE ORDERING SERVICES FEATURING FLOWERS (U.S. CLS. 100, 101 AND 102).
FIRST USE 3-19-2009; IN COMMERCE 3-19-2009.

3,999,901. COHEN BRIAN, DALLAS, TX. SN 77-917,477. FILED P.R. 1-22-2010; AM. S.R. 5-24-2011.

MEDSTATS

THE MARK CONSISTS OF STANDARD CHARACTERS WITHOUT CLAIM TO ANY PARTICULAR FONT, STYLE, SIZE, OR COLOR.

CLASS 9—ELECTRICAL AND SCIENTIFIC APPARATUS

FOR FLASH DRIVE, NAMELY, MAGNETIC DATA CARRIERS FEATURING PERSONAL MEDICAL INFORMATION (U.S. CLS. 21, 23, 26, 36 AND 38).
FIRST USE 10-27-2010; IN COMMERCE 5-22-2011.

CLASS 16—PAPER GOODS AND PRINTED MATTER

FOR PAPER GOODS AND PRINTED MATERIAL, NAMELY, LAMINATED PERSONAL MEDICAL INFORMATION CARDS, NOT MAGNETICALLY ENCODED, PLASTIC PERSONAL MEDICAL INFORMATION CARDS NOT MAGNETICALLY ENCODED, MAGNETIC PAPER SHEETS FEATURING PERSONAL MEDICAL INFORMATION AND PAPER IRON-ON LABELS FEATURING PERSONAL MEDICAL INFORMATION (U.S. CLS. 2, 5, 22, 23, 29, 37, 38 AND 50).
FIRST USE 10-27-2010; IN COMMERCE 5-22-2011.

3,999,903. THE AUTISM FORUM, INC., WILSONVILLE, OR. SN 77-918,296. FILED P.R. 1-22-2010; AM. S.R. 10-28-2010.

THE AUTISM FORUM

THE MARK CONSISTS OF STANDARD CHARACTERS WITHOUT CLAIM TO ANY PARTICULAR FONT, STYLE, SIZE, OR COLOR.

NO CLAIM IS MADE TO THE EXCLUSIVE RIGHT TO USE "AUTISM", APART FROM THE MARK AS SHOWN.

CLASS 36—INSURANCE AND FINANCIAL

FOR CHARITABLE FUNDRAISING SERVICES (U.S. CLS. 100, 101 AND 102).
FIRST USE 3-1-2008; IN COMMERCE 3-1-2008.

CLASS 41—EDUCATION AND ENTERTAINMENT

FOR EDUCATIONAL SERVICES, NAMELY, PROVIDING A LEARNING FORUM IN THE FIELD OF AUTISM (U.S. CLS. 100, 101 AND 107).
FIRST USE 3-1-2008; IN COMMERCE 3-1-2008.

CLASS 35—ADVERTISING AND BUSINESS

FOR PAYROLL PROCESSING SERVICES (U.S. CLS. 100, 101 AND 102).
FIRST USE 9-1-2010; IN COMMERCE 9-1-2010.

CLASS 36—INSURANCE AND FINANCIAL

FOR FINANCIAL SERVICES, NAMELY, FUNDING BANK ACCOUNTS FROM PREPAID CASH CARDS OR DEBIT CARD ACCOUNTS (U.S. CLS. 100, 101 AND 102).
FIRST USE 9-1-2010; IN COMMERCE 9-1-2010.

3,999,914. BAD IDEAZ, LLC, DBA SKYDIVE TECUMSEH, TECUMSEH, MI. SN 77-937,238. FILED P.R. 2-17-2010; AM. S.R. 5-13-2011.

3,999,923. KABUSHIKI KAISHA INFORMATIX, KANAGAWA 212-8554, JAPAN. SN 85-002,842. FILED P.R. 3-31-2010; AM. S.R. 6-14-2011.

Experience Human Flight

THE MARK CONSISTS OF STANDARD CHARACTERS WITHOUT CLAIM TO ANY PARTICULAR FONT, STYLE, SIZE, OR COLOR.

CLASS 35—ADVERTISING AND BUSINESS

FOR PROVIDING ON-LINE REGISTRATION SERVICES FOR THE SKYDIVING SERVICES OF OTHERS (U.S. CLS. 100, 101 AND 102).
FIRST USE 1-0-2011; IN COMMERCE 1-0-2011.

CLASS 41—EDUCATION AND ENTERTAINMENT

FOR ENTERTAINMENT SERVICES, NAMELY, PARTICIPATION IN SKYDIVING SHOWS AND COMPETITIONS; ENTERTAINMENT SERVICES, NAMELY, PROVIDING A WEB SITE FEATURING PHOTOGRAPHIC, AUDIO, VIDEO AND PROSE PRESENTATIONS FEATURING SKYDIVING; RECREATIONAL SERVICES IN THE NATURE OF SKYDIVING; SPORTS TRAINING SERVICES; ORGANIZING COMMUNITY SPORTING AND CULTURAL EVENTS, NAMELY, SKYDIVING SHOWS AND COMPETITIONS (U.S. CLS. 100, 101 AND 107).
FIRST USE 4-1-2008; IN COMMERCE 4-1-2008.
3,999,918. TACO BELL CORP., IRVINE, TX. SN 77-961,508. FILED P.R. 3-17-2010; AM. S.R. 5-23-2011.

PURPLECARD

THE MARK CONSISTS OF STANDARD CHARACTERS WITHOUT CLAIM TO ANY PARTICULAR FONT, STYLE, SIZE, OR COLOR.



PRIORITY CLAIMED UNDER SEC. 44(D) ON ERP CMNTY TM OFC APPLICATION NO. 008990673, FILED 3-29-2010, REG. NO. 008990673, DATED 10-19-2010, EXPIRES 3-29-2020.

THE MARK CONSISTS OF THE WORD "GEOCLOUD" IN HIGHLY STYLIZED LETTERING WITH THE LETTER "L" IN "CLOUD" ATTACHED IN AN UNDERLINE BELOW "OU" TO THE LETTER "D".

CLASS 9—ELECTRICAL AND SCIENTIFIC APPARATUS

FOR COMPUTER SOFTWARE IN THE FIELD OF LOCATION-LINKED AND LOCATION-RELATED INFORMATION SYSTEMS; COMPUTER SOFTWARE IN THE FIELD OF MERGING CARTOGRAPHY AND DATABASE TECHNOLOGY; ELECTRONIC HARDWARE AND PARTS AND FITTINGS THEREFOR; DOWNLOADABLE MAPS (U.S. CLS. 21, 23, 26, 36 AND 38).

CLASS 35—ADVERTISING AND BUSINESS

FOR DATA PROCESSING SERVICES; DATA PROCESSING SERVICES IN THE FIELD OF MAPS AND LOCATION-SPECIFIC INFORMATION (U.S. CLS. 100, 101 AND 102).

CLASS 39—TRANSPORTATION AND STORAGE

FOR PROVISION OF TRAFFIC INFORMATION; PROVISION OF INFORMATION RELATING TO VEHICLE ROAD POSITION, ROAD TRAFFIC VOLUME, ROAD TRAFFIC JAMS AND FORECASTING ROAD TRAFFIC JAMS (U.S. CLS. 100 AND 105).

CLASS 42—SCIENTIFIC AND COMPUTER SERVICES

FOR CREATING AND MAINTAINING WEBSITES FOR OTHERS; PROVIDING DATABASES CONTAINING LOCATION-SPECIFIC INFORMATION; ADVISORY AND CONSULTANCY SERVICES RELATING TO THE DEVELOPMENT OF COMPUTER SOFTWARE; ADVISORY AND CONSULTANCY SERVICES RELATING TO THE DEVELOPMENT OF COMPUTER SOFTWARE IN THE FIELD OF LOCATION-LINKED AND LOCATION-RELATED INFORMATION SYSTEMS; DESIGN AND MAINTENANCE OF COMPUTER SYSTEMS; DESIGN AND MAINTENANCE OF COMPUTER SOFTWARE; PROVISION OF INTERNET SEARCH ENGINES; WEBSITE HOSTING SERVICES; PROVISION OF COMPUTER SOFTWARE IN THE FIELD OF LOCATION-SPECIFIC INFORMATION; DESIGN SERVICES IN THE FIELD OF MAP DESIGN; RESEARCH SERVICES IN THE FIELD OF ARCHITECTURE AND URBAN PLANNING, AND CONSULTANCY AND INFORMATION SERVICES RELATING THERETO; PROVISION OF METEOROLOGICAL AND ATMOSPHERIC INFORMATION; PROVISION OF LOCATION-SPECIFIC INFORMATION; PROVISION OF LOCATION-SPECIFIC INFORMATION IN THE FORM OF DIGITIZED MAPS, DATA AND STATISTICAL DATA RELATING TO LOCATION-SPECIFIC FEATURES; PROVISION OF INFORMATION RELATING TO THE LOCATION OF FACILITIES, BUILDINGS, AND CONSTRUCTION SITES; PROVISION OF INFORMATION RELATING TO THE LOCATION OF PEOPLE, OBJECTS, AND ANIMALS; PROVISION OF MAP INFORMATION; PROVISION OF MAP INFORMATION, VIA THE INTERNET OR VIA EMAIL, ON THE LOCATION OF SHOPS, BANKS, POST OFFICES, DEPARTMENT STORES, HOTELS, SPORT FACILITIES, HOSPITALS, SCHOOLS, PUBLIC OFFICES; PROVISION OF REGIONAL INFORMATION, VIA THE INTERNET OR EMAIL; PROVISION OF INFORMATION RELATING TO LAND DEVELOPMENT AND ENVIRONMENTAL DESTRUCTION THROUGH IMAGE ANALYSIS BASED ON HIGH-RESOLUTION PICTURE DATA AND LOCATION-SPECIFIC INFORMATION CONTENT (U.S. CLS. 100 AND 101).

3,999,927. ATOZETA PRODUCTIONS LLC, NEW YORK, NY.
SN 85-027,025. FILED P.R. 4-30-2010; AM. S.R. 5-23-2011.

PAINCLINICIAN

THE MARK CONSISTS OF STANDARD CHARACTERS WITHOUT CLAIM TO ANY PARTICULAR FONT, STYLE, SIZE, OR COLOR.

CLASS 38—COMMUNICATION

FOR PROVIDING AN ON-LINE FORUM FOR PRIMARY CARE PHYSICIANS, PAIN SPECIALISTS, EMERGENCY ROOM CLINICIANS, SURGEONS, PSYCHIATRISTS, ANESTHESIOLOGISTS, NEUROLOGISTS, PHARMACISTS, PHYSICIANS ASSISTANTS, NURSE PRACTITIONERS, NURSES, AND OTHER HEALTH CARE PROVIDERS FOR THE SHARING AND TRANSMISSION OF INFORMATION AND ELECTRONIC MEDIA CONCERNING INSIGHTS INTO PAIN MEDICINE AND MANAGING PATIENTS WITH DEBILITATING ACUTE AND CHRONIC PAIN DISORDERS; PROVIDING COMMUNICATIONS SERVICES TO CONSUMERS, PROVIDERS, ADMINISTRATORS AND OTHER PARTICIPANTS IN THE HEALTHCARE INDUSTRY VIA AN ON-LINE COMPUTER NETWORK, NAMELY, COMMUNICATION BY MOBILE PHONES, FACSIMILE COMMUNICATION, PAGING SERVICES, OUTCALL NOTIFICATION SERVICES, ELECTRONIC MAIL AND VOICE MAIL SERVICES (U.S. CLS. 100, 101 AND 104).

FIRST USE 3-31-2009; IN COMMERCE 3-31-2009.

CLASS 41—EDUCATION AND ENTERTAINMENT

FOR EDUCATION SERVICES, NAMELY, PROVIDING ON-LINE CLASSES, SEMINARS, AND WORKSHOPS TO CONSUMERS, AND TO HEALTHCARE PROVIDERS, ADMINISTRATORS AND OTHER PARTICIPANTS IN THE HEALTHCARE INDUSTRY VIA A GLOBAL COMPUTER NETWORK IN THE FIELD OF HEALTHCARE; PROVIDING SPORTS INFORMATION TO CONSUMERS, AND HEALTHCARE PROVIDERS, ADMINISTRATORS AND OTHER PARTICIPANTS IN THE HEALTH CARE INDUSTRY VIA AN ON-LINE COMPUTER NETWORK; PROVIDING ON-LINE NON-DOWNLOADABLE MEDICAL JOURNALS AND MEDICAL REFERENCE BOOKS TO CONSUMERS AND HEALTHCARE PROVIDERS, ADMINISTRATORS AND OTHER PARTICIPANTS IN THE HEALTHCARE INDUSTRY (U.S. CLS. 100, 101 AND 107).

FIRST USE 3-31-2009; IN COMMERCE 3-31-2009.

CLASS 42—SCIENTIFIC AND COMPUTER SERVICES

FOR PROVIDING AN INTERACTIVE WEB SITE THAT ENABLES USERS TO ENTER, ACCESS, TRACK, MONITOR, AND GENERATE HEALTH AND MEDICAL INFORMATION AND REPORTS; PROVIDING MEDICAL AND SCIENTIFIC RESEARCH INFORMATION IN THE FIELD OF PHARMACEUTICALS AND CLINICAL TRIALS; HOSTING THE WEB SITES OF OTHERS ON A COMPUTER SERVER FOR A GLOBAL COMPUTER NETWORK (U.S. CLS. 100 AND 101).

FIRST USE 3-31-2009; IN COMMERCE 3-31-2009.

CLASS 44—MEDICAL, BEAUTY AND AGRICULTURAL SERVICES

FOR PROVIDING A WEBSITE FEATURING MEDICAL INFORMATION; PROVIDING AN INTERNET WEB SITE FOR MEDICAL PROFESSIONALS AND MEDICAL PATIENTS THAT ALLOWS FOR THE EXCHANGE OF INFORMATION FROM REMOTE LOCATIONS USING DEVICES THAT FEED INFORMATION TO THE WEB SITE THAT IS THEN PROCESSED AND CAN BE ACCESSED IN REAL-TIME BY USERS; PROVIDING AN INTERNET-BASED DATABASE OF PATIENT MEDICAL INFORMATION WHERE PATIENTS CAN INQUIRE ABOUT MEDICAL ISSUES AND PROCEDURES FROM OTHER PATIENTS AND CAN RELAY INFORMATION ABOUT THEIR MEDICAL EXPERIENCES FOR SUPPORT AND COMMUNITY; PROVIDING MEDICAL INFORMATION; PROVIDING MEDICAL INFORMATION, CONSULTANCY AND ADVISORY SERVICES; PROVIDING MEDICAL INFORMATION ON-LINE VIA A GLOBAL COMPUTER NETWORK; PROVIDING AN ON-LINE COMPUTER DATABASE IN THE FIELD OF MEDICINE FOR CONSUMERS, AND HEALTHCARE PROVIDERS, ADMINISTRATORS AND OTHER PARTICIPANTS IN THE HEALTHCARE INDUSTRY (U.S. CLS. 100 AND 101).

FIRST USE 3-31-2009; IN COMMERCE 3-31-2009.

3,999,928. ATOZETA PRODUCTIONS LLC, NEW YORK, NY.
SN 85-027,027. FILED P.R. 4-30-2010; AM. S.R. 5-23-2011.

SLEEPCLINICIAN

THE MARK CONSISTS OF STANDARD CHARACTERS WITHOUT CLAIM TO ANY PARTICULAR FONT, STYLE, SIZE, OR COLOR.

CLASS 38—COMMUNICATION

FOR PROVIDING AN ON-LINE FORUM FOR PRIMARY CARE PHYSICIANS, SLEEP SPECIALISTS, EMERGENCY ROOM CLINICIANS, SURGEONS, PSYCHIATRISTS, ANESTHESIOLOGISTS, NEUROLOGISTS, PHARMACISTS, PHYSICIANS ASSISTANTS, NURSE PRACTITIONERS, NURSES, AND OTHER HEALTH CARE PROVIDERS FOR THE SHARING AND TRANSMISSION OF INFORMATION AND ELECTRONIC MEDIA CONCERNING INSIGHTS INTO PAIN MEDICINE AND MANAGING PATIENTS WITH DEBILITATING ACUTE AND CHRONIC PAIN DISORDERS; PROVIDING COMMUNICATIONS SERVICES TO CONSUMERS, PROVIDERS, ADMINISTRATORS AND OTHER PARTICIPANTS IN THE HEALTHCARE INDUSTRY VIA AN ON-LINE COMPUTER NETWORK, NAMELY, COMMUNICATION BY MOBILE PHONES, FACSIMILE COMMUNICATION, PAGING SERVICES, OUTCALL NOTIFICATION SERVICES, ELECTRONIC MAIL AND VOICE MAIL SERVICES (U.S. CLS. 100, 101 AND 104).

FIRST USE 3-31-2009; IN COMMERCE 3-31-2009.

CLASS 41—EDUCATION AND ENTERTAINMENT

FOR EDUCATION SERVICES, NAMELY, PROVIDING ON-LINE CLASSES, SEMINARS, AND WORKSHOPS TO CONSUMERS, AND TO HEALTHCARE PROVIDERS, ADMINISTRATORS AND OTHER PARTICIPANTS IN THE HEALTHCARE INDUSTRY VIA A GLOBAL COMPUTER NETWORK IN THE FIELD OF HEALTHCARE; PROVIDING SPORTS INFORMATION TO CONSUMERS, AND HEALTHCARE PROVIDERS, ADMINISTRATORS AND OTHER PARTICIPANTS IN THE HEALTH CARE INDUSTRY VIA AN ON-LINE COMPUTER NETWORK; PROVIDING ON-LINE NON-DOWNLOADABLE MEDICAL JOURNALS AND MEDICAL REFERENCE BOOKS TO CONSUMERS AND HEALTHCARE PROVIDERS, ADMINISTRATORS AND OTHER PARTICIPANTS IN THE HEALTHCARE INDUSTRY (U.S. CLS. 100, 101 AND 107).

FIRST USE 3-31-2009; IN COMMERCE 3-31-2009.

CLASS 42—SCIENTIFIC AND COMPUTER SERVICES

FOR PROVIDING AN INTERACTIVE WEB SITE THAT ENABLES USERS TO ENTER, ACCESS, TRACK, MONITOR, AND GENERATE HEALTH AND MEDICAL INFORMATION AND REPORTS; PROVIDING MEDICAL AND SCIENTIFIC RESEARCH INFORMATION IN THE FIELD OF PHARMACEUTICALS AND CLINICAL TRIALS; PROVIDING MEDICAL AND SCIENTIFIC RESEARCH INFORMATION IN THE FIELD OF CLINICAL TRIALS; HOSTING THE WEB SITES OF OTHERS ON A COMPUTER SERVER FOR A GLOBAL COMPUTER NETWORK (U.S. CLS. 100 AND 101).

FIRST USE 3-31-2009; IN COMMERCE 3-31-2009.

CLASS 44—MEDICAL, BEAUTY AND AGRICULTURAL SERVICES

FOR PROVIDING A WEBSITE FEATURING MEDICAL INFORMATION; PROVIDING AN INTERNET WEB SITE FOR MEDICAL PROFESSIONALS AND MEDICAL PATIENTS THAT ALLOWS FOR THE EXCHANGE OF INFORMATION FROM REMOTE LOCATIONS USING DEVICES THAT FEED INFORMATION TO THE WEB SITE THAT IS THEN PROCESSED AND CAN BE ACCESSED IN REAL-TIME BY USERS; PROVIDING AN INTERNET-BASED DATABASE OF PATIENT MEDICAL INFORMATION WHERE PATIENTS CAN INQUIRE ABOUT MEDICAL ISSUES AND PROCEDURES FROM OTHER PATIENTS AND CAN RELAY INFORMATION ABOUT THEIR MEDICAL EXPERIENCES FOR SUPPORT AND COMMUNITY; PROVIDING MEDICAL INFORMATION; PROVIDING MEDICAL INFORMATION, CONSULTANCY AND ADVISORY SERVICES; PROVIDING MEDICAL INFORMATION ON-LINE VIA A GLOBAL COMPUTER NETWORK; PROVIDING AN ON-LINE COMPUTER DATABASE IN THE FIELD OF MEDICINE FOR CONSUMERS, AND HEALTHCARE PROVIDERS, ADMINISTRATORS AND OTHER PARTICIPANTS IN THE HEALTHCARE INDUSTRY (U.S. CLS. 100 AND 101).

FIRST USE 3-31-2009; IN COMMERCE 3-31-2009.

3,999,931. ATOZETA PRODUCTIONS LLC, NEW YORK, NY.
SN 85-052,071. FILED P.R. 6-1-2010; AM. S.R. 5-23-2011.

MEDICALHOMECLINICIAN

THE MARK CONSISTS OF STANDARD CHARACTERS WITHOUT CLAIM TO ANY PARTICULAR FONT, STYLE, SIZE, OR COLOR.

CLASS 38—COMMUNICATION

FOR PROVIDING AN ON-LINE FORUM FOR PRIMARY CARE PHYSICIANS, SPECIALISTS, EMERGENCY ROOM CLINICIANS, SURGEONS, PSYCHIATRISTS, ANESTHESIOLOGISTS, NEUROLOGISTS, PHARMACISTS, PHYSICIANS ASSISTANTS, NURSE PRACTITIONERS, NURSES, AND OTHER HEALTH CARE PROVIDERS FOR THE SHARING AND TRANSMISSION OF INFORMATION AND ELECTRONIC MEDIA CONCERNING INSIGHTS INTO PAIN MEDICINE AND MANAGING PATIENTS WITH DEBILITATING ACUTE AND CHRONIC PAIN DISORDERS; PROVIDING COMMUNICATIONS SERVICES TO CONSUMERS, PROVIDERS, ADMINISTRATORS AND OTHER PARTICIPANTS IN THE HEALTHCARE INDUSTRY VIA AN ON-LINE COMPUTER NETWORK, NAMELY, COMMUNICATION BY MOBILE PHONES, FACSIMILE COMMUNICATION, PAGING SERVICES, OUTCALL NOTIFICATION SERVICES, ELECTRONIC MAIL AND VOICE MAIL SERVICES (U.S. CLS. 100, 101 AND 104).

FIRST USE 2-22-2010; IN COMMERCE 2-22-2010.

CLASS 44—MEDICAL, BEAUTY AND AGRICULTURAL SERVICES

FOR PROVIDING A WEBSITE FEATURING MEDICAL INFORMATION; PROVIDING AN INTERNET WEB SITE FOR MEDICAL PROFESSIONALS AND MEDICAL PATIENTS THAT ALLOWS FOR THE EXCHANGE OF INFORMATION FROM REMOTE LOCATIONS USING DEVICES THAT FEED INFORMATION TO THE WEB SITE THAT IS THEN PROCESSED AND CAN BE ACCESSED IN REAL-TIME BY USERS; PROVIDING AN INTERNET-BASED DATABASE OF PATIENT MEDICAL INFORMATION WHERE PATIENTS CAN INQUIRE ABOUT MEDICAL ISSUES AND PROCEDURES FROM OTHER PATIENTS AND CAN RELAY INFORMATION ABOUT THEIR MEDICAL EXPERIENCES FOR SUPPORT AND COMMUNITY; PROVIDING MEDICAL INFORMATION; PROVIDING MEDICAL INFORMATION, CONSULTANCY AND ADVISORY SERVICES; PROVIDING MEDICAL INFORMATION ON-LINE VIA A GLOBAL COMPUTER NETWORK; PROVIDING AN ON-LINE COMPUTER DATABASE IN THE FIELD OF MEDICINE FOR CONSUMERS, AND HEALTHCARE PROVIDERS, ADMINISTRATORS AND OTHER PARTICIPANTS IN THE HEALTHCARE INDUSTRY (U.S. CLS. 100 AND 101).

FIRST USE 2-22-2010; IN COMMERCE 2-22-2010.

3,999,932. FINANCIAL TRENDS LLC, SILVERTON, OR. SN 85-057,808. FILED P.R. 6-8-2010; AM. S.R. 6-7-2011.

CLASS 41—EDUCATION AND ENTERTAINMENT

FOR EDUCATION SERVICES, NAMELY, PROVIDING ON-LINE CLASSES, SEMINARS, AND WORKSHOPS TO CONSUMERS, AND TO HEALTHCARE PROVIDERS, ADMINISTRATORS AND OTHER PARTICIPANTS IN THE HEALTHCARE INDUSTRY VIA A GLOBAL COMPUTER NETWORK IN THE FIELD OF HEALTHCARE; PROVIDING SPORTS INFORMATION TO CONSUMERS, AND HEALTHCARE PROVIDERS, ADMINISTRATORS AND OTHER PARTICIPANTS IN THE HEALTH CARE INDUSTRY VIA AN ON-LINE COMPUTER NETWORK; PROVIDING ON-LINE NON-DOWNLOADABLE MEDICAL JOURNALS AND MEDICAL REFERENCE BOOKS TO CONSUMERS AND HEALTHCARE PROVIDERS, ADMINISTRATORS AND OTHER PARTICIPANTS IN THE HEALTHCARE INDUSTRY (U.S. CLS. 100, 101 AND 107).

FIRST USE 2-22-2010; IN COMMERCE 2-22-2010.

BANK TREND REPORTER

THE MARK CONSISTS OF STANDARD CHARACTERS WITHOUT CLAIM TO ANY PARTICULAR FONT, STYLE, SIZE, OR COLOR.

CLASS 35—ADVERTISING AND BUSINESS

FOR ANALYSIS AND RESEARCH SERVICES RELATED TO THE BUSINESS PERFORMANCE OF FINANCIAL INSTITUTIONS (U.S. CLS. 100, 101 AND 102).

FIRST USE 5-26-2011; IN COMMERCE 5-26-2011.

CLASS 41—EDUCATION AND ENTERTAINMENT

FOR NEWSLETTERS RELATED TO THE BUSINESS PERFORMANCE OF FINANCIAL INSTITUTIONS, DELIVERED AS AN E-MAIL ATTACHMENT (U.S. CLS. 100, 101 AND 107).

FIRST USE 5-26-2011; IN COMMERCE 5-26-2011.

3,999,933. STEPHEN M. LABAR, JR., DBA THE MARTIAL ARTS STORE, DULUTH, GA. SN 85-059,470. FILED P.R. 6-10-2010; AM. S.R. 5-5-2011.

CLASS 42—SCIENTIFIC AND COMPUTER SERVICES

FOR PROVIDING AN INTERACTIVE WEB SITE THAT ENABLES USERS TO ENTER, ACCESS, TRACK, MONITOR, AND GENERATE HEALTH AND MEDICAL INFORMATION AND REPORTS; PROVIDING MEDICAL AND SCIENTIFIC RESEARCH INFORMATION IN THE FIELD OF PHARMACEUTICALS AND CLINICAL TRIALS; PROVIDING MEDICAL AND SCIENTIFIC RESEARCH INFORMATION IN THE FIELD OF CLINICAL TRIALS; HOSTING THE WEB SITES OF OTHERS ON A COMPUTER SERVER FOR A GLOBAL COMPUTER NETWORK (U.S. CLS. 100 AND 101).

FIRST USE 2-22-2010; IN COMMERCE 2-22-2010.

The Martial Arts Store

THE MARK CONSISTS OF STANDARD CHARACTERS WITHOUT CLAIM TO ANY PARTICULAR FONT, STYLE, SIZE, OR COLOR.

CLASS 25—CLOTHING

FOR ATHLETIC APPAREL, NAMELY, SHIRTS, PANTS, JACKETS, FOOTWEAR, HATS AND CAPS, ATHLETIC UNIFORMS; ATHLETIC FOOTWEAR; ATHLETIC SHOES; ATHLETIC UNIFORMS; BELTS FOR CLOTHING; BOXING SHOES; BOXING SHORTS; CAP VISORS; CAPS; CAPS WITH VISORS; CLIMBING FOOTWEAR; CLIMBING SHOES; CLOTHING FOR ATHLETIC USE, NAMELY, PADDED ELBOW COMPRESSION SLEEVES BEING PART OF AN ATHLETIC GARMENT; CLOTHING FOR ATHLETIC USE, NAMELY, PADDED PANTS; CLOTHING FOR ATHLETIC USE, NAMELY, PADDED SHIRTS; CLOTHING FOR ATHLETIC USE, NAMELY, PADDED SHORTS; CLOTHING FOR WEAR IN JUDO PRACTICES; CLOTHING FOR WEAR IN WRESTLING GAMES; COMBATIVE SPORTS UNIFORMS; DO RAGS; FOOTWEAR; FOOTWEAR FOR MEN; FOOTWEAR FOR MEN AND WOMEN; FOOTWEAR FOR WOMEN; FULL-LENGTH KIMONOS (NAGAGI); HATS; HEAD SWEATBANDS; HEADBANDS; HEADBANDS AGAINST SWEATING; HEADBANDS FOR CLOTHING; INSOLES FOR FOOTWEAR; JACKETS; JAPANESE SLEEPING ROBES (NEMAKI); JAPANESE STYLE CLOGS AND SANDALS; JAPANESE STYLE SANDALS (ZORI); JAPANESE STYLE SANDALS OF LEATHER; JAPANESE STYLE SOCKS (TABI COVERS); JAPANESE STYLE SOCKS (TABI); JAPANESE STYLE WOODEN CLOGS (GETA); JAPANESE TOE-STRAP SANDALS (ASAURA-ZORI); JOGGING OUTFITS; JOGGING PANTS; JOGGING SUITS; JUDO SUITS; KARATE SUITS; KENDO OUTFITS; KIMONOS; LEATHER JACKETS; LOW WOODEN CLOGS (KOMA-GETA); MARTIAL ARTS UNIFORMS; MARTIAL ARTS UNIFORMS, NAMELY, GIS; METAL FITTINGS FOR JAPANESE STYLE WOODEN CLOGS; MIXED MARTIAL ARTS SUITS; PLEATED SKIRTS FOR FORMAL KIMONOS (HAKAMA); RASH GUARDS; ROBES; RUBBER SHOES; SASH BANDS FOR KIMONO (OBI); SASHES; SHIRTS; SHIRTS AND SHORT-SLEEVED SHIRTS; SHIRTS FOR INFANTS, BABIES, TODDLERS AND CHILDREN; SHORT OVERCOAT FOR KIMONO (HAORI); SLIDING SHORTS; SNEAKERS; SOCKS; SOCKS AND STOCKINGS; SOLES FOR JAPANESE STYLE SANDALS; SPORT SHIRTS; SPORTS BRA; SPORTS BRAS; SPORTS CAPS AND HATS; SPORTS JACKETS; SPORTS JERSEYS; SPORTS JERSEYS AND BREECHES FOR SPORTS; SPORTS PANTS; SPORTS SHIRTS; SPORTS SHIRTS WITH SHORT SLEEVES; SWEAT BANDS; SWEAT JACKETS; SWEAT PANTS; SWEAT SHIRTS; SWEAT SHORTS; SWEAT SUITS; SWEATBANDS; TIGHTENING-UP STRINGS FOR KIMONOS (DATEJIME); TOE STRAPS FOR JAPANESE STYLE SANDALS/ZORI; TOE STRAPS FOR JAPANESE STYLE WOODEN CLOGS; TRAINING SHOES; TRAINING SUITS; TROUSERS FOR SWEATING; UNDERSHIRTS FOR KIMONOS (JUBAN); UNDERSHIRTS FOR KIMONOS (KOSHIMAKI); UNIFORMS; UPPERS FOR JAPANESE STYLE SANDALS; UPPERS OF WOVEN RATTAN FOR JAPANESE STYLE SANDALS; WAIST STRINGS FOR KIMONOS (KOSHIHIMO); WARM UP OUTFITS; WARM UP SUITS; WIND RESISTANT JACKETS; WIND-JACKETS; WOMEN'S SHOES; WOODEN MAIN BODIES OF JAPANESE STYLE WOODEN CLOGS; WOODEN SHOES; WOODEN SUPPORTS OF JAPANESE STYLE WOODEN CLOGS; WRAP BELTS FOR KIMONOS (DATEMAKI); WRAPS; YOGA PANTS; YOGA SHIRTS; ZORI (U.S. CLS. 22 AND 39).

FIRST USE 6-21-2000; IN COMMERCE 6-21-2000.

CLASS 28—TOYS AND SPORTING GOODS

FOR ACCESSORY FOR MANUALLY-OPERATED EXERCISE EQUIPMENT, NAMELY, ACCESSORY ATTACHMENT TO INCREASE MUSCLE RESISTANCE; ANKLE AND WRIST WEIGHTS FOR EXERCISE; ARM GUARDS FOR ATHLETIC USE; ATHLETIC EQUIPMENT, NAMELY, HAND WRAPS; ATHLETIC EQUIPMENT, NAMELY, MOUTH GUARDS; ATHLETIC EQUIPMENT, NAMELY, STRIKING BAGS; ATHLETIC EQUIPMENT, NAMELY, STRIKING SHIELDS; ATHLETIC EQUIPMENT, NAMELY, TRAINING DEVICES TO BE WORN ON THE BODY FOR SUPPORT; ATHLETIC SPORTING GOODS, NAMELY, A LIFE-SIZE INFLATABLE DUMMY WITH WATER-FILLED BASE, FOR USE AS TARGET PRACTICE FOR KICKBOXING WORKOUTS; ATHLETIC SPORTING GOODS, NAMELY, ATHLETIC WRIST AND JOINT SUPPORTS; ATHLETIC SUPPORTERS; ATHLETIC TAPE; ATHLETIC TRAINING DEVICES, NAMELY, WEIGHTED INSERTS FOR FOOTWEAR; BAGS SPECIALLY ADAPTED FOR SPORTS EQUIPMENT; BALLS FOR SPORTS; BODY PROTECTORS FOR MARTIAL ARTS; BOWS FOR JAPANESE ARCHERY (YUMI); BOWSTRINGS; BOXING BAG SWIVEL MECHANISMS; BOXING BAGS; BOXING GLOVES; BOXING RINGS; BOXING SWIVELS; CASES IN THE FORM OF QUIVERS FOR SPORTS IMPLEMENTS; CASES SPECIALLY ADAPTED FOR SPORTS EQUIPMENT; CHEST EXPANDERS; CHEST PROTECTORS FOR SPORTS; DART BOARDS; ELBOW GUARDS FOR ATHLETIC USE; ELBOW PADS FOR ATHLETIC USE; EPEE; EXERCISE AND GYMNASIUM BANNERS; EXERCISE BALLS; EXERCISE BARS; EXERCISE DOORWAY GYM BARS; EXERCISE EQUIPMENT, NAMELY, CHEST EXPANDERS; EXERCISE EQUIPMENT, NAMELY, CHEST PULLS; EXERCISE EQUIPMENT, NAMELY, INFLATABLE BALLS; EXERCISE EQUIPMENT, NAMELY, NECK AND SHOULDER SUPPORTED WEIGHTS FOR TWISTING AND LIFTING EXERCISES; EXERCISE EQUIPMENT, NAMELY, ROTARY ABDOMINAL BOARDS; EXERCISE EQUIPMENT, NAMELY, SHOULDER STRETCHER USING A CABLE; EXERCISE EQUIPMENT, NAMELY, SHOULDER STRETCHER USING RESISTANCE CABLES; EXERCISE EQUIPMENT, NAMELY, RESISTANCE BANDS; EXERCISE MACHINES; EXERCISE TRAMPOLINES; EXERCISE WEIGHT CUFFS; EXERCISE WEIGHTS; EXERCISE WRIST WEIGHTS; EXERCISING EQUIPMENT, NAMELY, PULLEYS; EXERCISING PULLEYS; GAUNTLETS; GAUNTLETS; HAND PADS FOR ATHLETIC USE; JUMP ROPES; KARATE GLOVES; KARATE HEAD GUARDS; KARATE KICK PADS; KARATE SHIN PADS; KARATE TARGET PADS; KENDO BAMBOO SWORDS; KENDO MASKS; KENDO PLASTONS; KENDO WOODEN SWORDS; KNEE GUARDS FOR ATHLETIC USE; KNEE PADS FOR ATHLETIC USE; KOTE GAUNTLETS; LEG GUARDS FOR ATHLETIC USE; LEG WEIGHTS; LEG WEIGHTS FOR ATHLETIC USE; LEG WEIGHTS FOR EXERCISING; MANUAL LEG EXERCISERS; MANUALLY-OPERATED EXERCISE EQUIPMENT; MANUALLY-OPERATED EXERCISE EQUIPMENT FOR PHYSICAL FITNESS PURPOSES; MARTIAL ARTS TRAINING EQUIPMENT; MEN'S ATHLETIC SUPPORTERS; MOUTH GUARDS FOR ATHLETIC USE; PERSONAL EXERCISE MATS; PROTECTIVE ATHLETIC CUPS; PUNCHING BAGS; PUNCHING BALLS; PUNCHING BALLS; PUNCHING TOYS; RUBBER ACTION BALLS; RUBBER BALLS; SAFETY PADDING FOR MARTIAL ARTS; SHIN GUARDS FOR ATHLETIC USE; SHIN PADS FOR ATHLETIC USE; SHIN PADS FOR USE IN MARTIAL ARTS; SKIPPING ROPE; SKIPPING ROPES; SPORT BALLS; SPORTING GOODS AND EQUIPMENT FOR SPEED TRAINING, NAMELY, RINGS, CONES, SPEED LADDERS, COACHING STICKS, TRAINING ARCHES, ANKLE BANDS, RESISTANCE CHUTES, HURDLES; SPORTING GOODS, NAMELY, A SPORTS TRAINING DEVICE TO IMPROVE STRENGTH, TONING, CONDITIONING, BALANCE, AND PROPRIOCEPTION; SPORTING GOODS, NAMELY, CARRIERS SPECIALLY ADAPTED FOR SPORT BALLS; SPORTS EQUIPMENT FOR BOXING AND MARTIAL ARTS, NAMELY, BOXING GLOVES, BOXING BAGS, PUNCHING MITTS, BELLY PROTECTORS, GROIN PROTECTORS AND SHIN GUARDS; SPORTS EQUIPMENT FOR BOXING, MARTIAL ARTS, AND THE LIKE, NAMELY, AN

APPARATUS TO SUPPORT A MOVING HEAVY BAG; SPORTS EQUIPMENT FOR BOXING, MARTIAL ARTS, AND THE LIKE, NAMELY, PROTECTIVE BRAS; SPORTS FITNESS RESTRAINT STRAPS FOR RUNNING IN TANDEM OR PAIRS; STORAGE APPARATUS COMPRISING HOOKS, SUPPORT ARMS, AND SHELVING SPECIALLY ADAPTED FOR SPORTS EQUIPMENT; STORAGE RACKS FOR ATHLETIC EQUIPMENT; STORAGE RACKS FOR ATHLETIC TRAINING EQUIPMENT; STRESS RELIEF BALLS FOR HAND EXERCISE; STRETCH BANDS USED FOR YOGA AND PHYSICAL FITNESS PURPOSES; TARGET EQUIPMENT, NAMELY, BACKERS FOR TARGETS; TARGET EQUIPMENT, NAMELY, STANDS FOR TARGETS; TARGETS; TETHER BALLS; TOY SWORDS; TOY WEAPONS; TRAINING APPARATUS FOR BOXING, MARTIAL ARTS, AND SIMILAR SPORTS; TRAMPOLINE BOUNCE BOARD; TRAMPOLINES; TROLLEY BAGS SPECIALLY ADAPTED FOR SPORTS EQUIPMENT; WRIST AND ANKLE WEIGHTS FOR EXERCISE; WRIST GUARDS FOR ATHLETIC USE (U.S. CLS. 22, 23, 38 AND 50).
FIRST USE 6-20-2000; IN COMMERCE 6-20-2000.

3,999,943. ALLIANCE FOR PATIENT MEDICATION SAFETY, RICHMOND, VA. SN 85-087,761. FILED P.R. 7-19-2010; AM. S.R. 6-14-2011.

ALLIANCE FOR PATIENT MEDICATION SAFETY

THE MARK CONSISTS OF STANDARD CHARACTERS WITHOUT CLAIM TO ANY PARTICULAR FONT, STYLE, SIZE, OR COLOR.
OWNER OF U.S. REG. NO. 3,808,700.

CLASS 41—EDUCATION AND ENTERTAINMENT

FOR EDUCATIONAL SERVICES, NAMELY, PROVIDING TRAINING IN SOFTWARE AND WORKFLOW SYSTEMS, IN THE FIELD OF MEDICATION ERRORS, MEDICATION USE AND PATIENT CARE AND EDUCATIONAL MATERIAL DISTRIBUTED IN CONNECTION THEREWITH (U.S. CLS. 100, 101 AND 107).
FIRST USE 1-0-2011; IN COMMERCE 1-0-2011.

CLASS 44—MEDICAL, BEAUTY AND AGRICULTURAL SERVICES

FOR PROVIDING NEWS AND INFORMATION IN THE FIELD OF MEDICATION ERRORS, MEDICATION USE AND PATIENT CARE (U.S. CLS. 100 AND 101).
FIRST USE 1-0-2011; IN COMMERCE 1-0-2011.
3,999,945. CORRADI S.P.A., BOLOGNA, ITALY. SN 85-088,400. FILED P.R. 7-20-2010; AM. S.R. 5-23-2011.



THE MARK CONSISTS OF THE CAPITAL LETTER "C" FOLLOWED BY SMALL LETTERS "ORRADI".

CLASS 6—METAL GOODS

FOR GAZEBOS PRIMARILY OF METAL; PERGOLAS PRIMARILY OF METAL; METAL CONSTRUCTION ELEMENTS, NAMELY, METAL VERANDAS, PERGOLAS OR PORCHES FOR BUILDINGS; BEAMS OF METAL; METAL CONSTRUCTION ELEMENTS, NAMELY, PRE-FABRICATED METAL COLUMNS AND POLES FOR SUPPORTING AWNINGS; OUTDOOR AWNINGS OF METAL; METAL SLIDING DOORS; METALLIC FRAMES FOR SLIDING DOORS; METAL RUNNERS FOR SLIDING DOORS; METAL EXTERIOR BLINDS; MODULAR METAL STRUCTURES WITH FLEXIBLE COVERS FOR OUTDOOR USE (U.S. CLS. 2, 12, 13, 14, 23, 25 AND 50).

FIRST USE 0-0-2009; IN COMMERCE 12-0-2009.

CLASS 19—NON-METALLIC BUILDING MATERIALS

FOR GAZEBOS NOT PRIMARILY OF METAL; PERGOLAS NOT PRIMARILY OF METAL; NON-METAL CONSTRUCTION MATERIALS, NAMELY, NON-METAL VERANDAS OR PORCHES FOR BUILDING; NON-METAL SHELTER STRUCTURES OTHER THAN TENTS; NON-METAL SHELTER STRUCTURES, NAMELY, CABANAS NOT OF METAL; NON-METAL SHELTER STRUCTURES, NAMELY, PATIOS NOT PRIMARILY OF METAL; BEAMS NOT OF METAL; NON-METAL EXTERIOR BLINDS; NON-METAL EXTERIOR WINDOW SHADES; WATERPROOF FABRIC COVERS FOR USE IN BUILDING AND GAZEBO CONSTRUCTION TO PROTECT AGAINST RAINS (U.S. CLS. 1, 12, 33 AND 50).
FIRST USE 0-0-2009; IN COMMERCE 12-0-2009.

CLASS 20—FURNITURE AND ARTICLES NOT OTHERWISE CLASSIFIED

FOR FURNITURE; OUTDOOR FURNITURE; LAWN FURNITURE; FURNITURE FOR GARDEN; PATIO FURNITURE; FURNITURE OF METAL; UPHOLSTERED FURNITURE; CHAIRS; DECK CHAIRS; LOUNGE CHAIRS; DINING CHAIRS; HIGH CHAIRS; CHAISE LONGUES; SOFAS; ARMCHAIRS; FURNITURE, NAMELY, POUFS; STOOLS; TABLES; DINING TABLES; COFFEE TABLES; SIDE TABLES; SERVING TROLLEYS; FABRIC SOLD AS AN INTEGRAL COMPONENT OF FINISHED FURNITURE; CHAIR CUSHIONS; CUSHIONS; CHESTS OF DRAWERS; MAGAZINE RACKS; BENCHES; CURTAIN RAILS; CURTAIN RINGS; CURTAIN RODS; CURTAIN HOOKS; CURTAIN ROLLERS; METAL SUNSHADES, NAMELY, METAL EXTERIOR WINDOW SHADES (U.S. CLS. 2, 13, 22, 25, 32 AND 50).
FIRST USE 0-0-2009; IN COMMERCE 12-0-2009.

CLASS 22—CORDAGE AND FIBERS

FOR AWNINGS; AWNINGS NOT OF METAL; AWNINGS OF FABRIC; OUTSIDE STRUCTURES FOR SHADING, SHELTERING AND PROTECTION, NAMELY, TEMPORARY AND PORTABLE TENTS; FABRIC CABANAS; TENTS, NAMELY, FREESTANDING PERMANENT, PORTABLE AND DE-MOUNTABLE STRUCTURES FOR SHADE, SHELTER AND PROTECTION, HAVING A METAL FRAMEWORK COVERED BY FABRIC TO FORM A ROOF AND SIDE WALLS; CANVAS CANOPIES (U.S. CLS. 1, 2, 7, 19, 22, 42 AND 50).
FIRST USE 0-0-2009; IN COMMERCE 12-0-2009.

CLASS 24—FABRICS

FOR FABRICS FOR THE MANUFACTURE OF SCREENING, SHELTERING, SHADING, PROTECTION AND WINDBREAK STRUCTURES; GUMMED WATERPROOF CLOTH; POLYESTER FABRIC; PVC-COATED POLYESTER FABRICS; CUSHION COVERS; CURTAINS; INDOOR AND OUTDOOR CURTAINS (U.S. CLS. 42 AND 50).
FIRST USE 0-0-2009; IN COMMERCE 12-0-2009.

3,999,947. THE PACIFIC INSTITUTE INCORPORATED, SEATTLE, WA. SN 85-089,748. FILED P.R. 7-21-2010; AM. S.R. 5-4-2011.

TICE COACHING INSTITUTE

THE MARK CONSISTS OF STANDARD CHARACTERS WITHOUT CLAIM TO ANY PARTICULAR FONT, STYLE, SIZE, OR COLOR.

NO CLAIM IS MADE TO THE EXCLUSIVE RIGHT TO USE "COACHING INSTITUTE", APART FROM THE MARK AS SHOWN.

CLASS 9—ELECTRICAL AND SCIENTIFIC APPARATUS

FOR AUDIO AND VIDEO MEDIA, NAMELY, CDS, DVDS, AND DOWNLOADABLE MEDIA FILES CONTAINING EDUCATIONAL AND MOTIVATIONAL MATERIAL IN THE FIELD OF DEVELOPING PERSONAL POTENTIAL; ELECTRONIC PUBLICATIONS IN THE NATURE OF BOOKS RECORDED ON COMPUTER MEDIA CONTAINING EDUCATIONAL AND MOTIVATIONAL MATERIAL IN THE FIELD OF DEVELOPING PERSONAL POTENTIAL; DOWNLOADABLE ELECTRONIC PUBLICATIONS IN THE NATURE OF BOOKS CONTAINING EDUCATIONAL AND MOTIVATIONAL MATERIAL IN THE FIELD OF DEVELOPING PERSONAL POTENTIAL (U.S. CLS. 21, 23, 26, 36 AND 38).

FIRST USE 3-25-2011; IN COMMERCE 3-25-2011.

CLASS 16—PAPER GOODS AND PRINTED MATTER

FOR PRINTED MATTER, NAMELY, BOOKS, MANUALS, GUIDES, PAMPHLETS, AND BROCHURES CONTAINING EDUCATIONAL AND MOTIVATIONAL MATERIAL IN THE FIELD OF DEVELOPING PERSONAL POTENTIAL (U.S. CLS. 2, 5, 22, 23, 29, 37, 38 AND 50).

FIRST USE 3-25-2011; IN COMMERCE 3-25-2011.

CLASS 41—EDUCATION AND ENTERTAINMENT

FOR PROVIDING EDUCATIONAL AND MOTIVATIONAL SEMINARS IN THE FIELD OF DEVELOPING PERSONAL POTENTIAL; EDUCATIONAL SERVICES, NAMELY, PROVIDING LIVE AND ON-LINE CLASSES, SEMINARS, WORKSHOPS IN THE FIELD OF DEVELOPING PERSONAL POTENTIAL (U.S. CLS. 100, 101 AND 107).

FIRST USE 3-25-2011; IN COMMERCE 3-25-2011.
3,999,957. THE CFO SUITE, LLC, DALLAS, TX. SN 85-102,595. FILED P.R. 8-7-2010; AM. S.R. 5-24-2011.

THE CFO SUITE

THE MARK CONSISTS OF STANDARD CHARACTERS WITHOUT CLAIM TO ANY PARTICULAR FONT, STYLE, SIZE, OR COLOR.

CLASS 35—ADVERTISING AND BUSINESS

FOR BUSINESS SUPPORT SERVICES, NAMELY, PROVIDING ACCOUNTING AND BUSINESS MANAGEMENT CONSULTING SERVICES FOR BUSINESSES; PROVIDING BUSINESS SUPPORT STAFF SERVICES; EMPLOYMENT HIRING, RECRUITING AND PLACEMENT SERVICES (U.S. CLS. 100, 101 AND 102).
FIRST USE 2-9-2011; IN COMMERCE 2-9-2011.

CLASS 36—INSURANCE AND FINANCIAL

FOR FINANCIAL CONSULTING AND FINANCIAL ANALYSIS FOR BUSINESSES (U.S. CLS. 100, 101 AND 102).
FIRST USE 2-9-2011; IN COMMERCE 2-9-2011.

3,999,961. AMERICAN ASSOCIATION FOR CANCER RESEARCH, INC., PHILADELPHIA, PA. SN 85-103,629. FILED P.R. 8-9-2010; AM. S.R. 6-10-2011.

CANCER DISCOVERY

THE MARK CONSISTS OF STANDARD CHARACTERS WITHOUT CLAIM TO ANY PARTICULAR FONT, STYLE, SIZE, OR COLOR.

CLASS 16—PAPER GOODS AND PRINTED MATTER

FOR PRINT JOURNALS IN THE FIELD OF CANCER (U.S. CLS. 2, 5, 22, 23, 29, 37, 38 AND 50).
FIRST USE 6-1-2011; IN COMMERCE 6-1-2011.

CLASS 41—EDUCATION AND ENTERTAINMENT

FOR PROVIDING ONLINE JOURNALS IN THE FIELD OF CANCER (U.S. CLS. 100, 101 AND 107).
FIRST USE 4-3-2011; IN COMMERCE 4-3-2011.

3,999,971. SMITH INTERNATIONAL, INC., HOUSTON, TX. SN 85-126,002. FILED P.R. 9-9-2010; AM. S.R. 6-8-2011.

WELLS GIS

THE MARK CONSISTS OF STANDARD CHARACTERS WITHOUT CLAIM TO ANY PARTICULAR FONT, STYLE, SIZE, OR COLOR.

CLASS 37—CONSTRUCTION AND REPAIR

FOR PROVIDING AN ONLINE COMPUTER DATABASE FOR INFORMATION IN THE FIELD OF DRILLING OIL AND GAS WELLS (U.S. CLS. 100, 103 AND 106).

FIRST USE 6-1-2011; IN COMMERCE 6-1-2011.

CLASS 42—SCIENTIFIC AND COMPUTER SERVICES

FOR PROVIDING TEMPORARY USE OF NON-DOWNLOADABLE SOFTWARE FOR RETRIEVING AND TRANSMITTING INFORMATION IN THE FIELD OF DRILLING OIL AND GAS WELLS (U.S. CLS. 100 AND 101).

FIRST USE 6-1-2011; IN COMMERCE 6-1-2011.

3,999,975. KING'S PUBLISHING INC., DBA DIABETES HEALTH MAGAZINE, NOVATO, CA. SN 85-129,272. FILED P.R. 9-14-2010; AM. S.R. 5-26-2011.

PRE-DIABETES HEALTH

THE MARK CONSISTS OF STANDARD CHARACTERS WITHOUT CLAIM TO ANY PARTICULAR FONT, STYLE, SIZE, OR COLOR.

CLASS 16—PAPER GOODS AND PRINTED MATTER

FOR MAGAZINES FEATURING DIABETES, HEALTH, PRE-DIABETES HEALTH, NUTRITION, RECIPES, FOOD (U.S. CLS. 2, 5, 22, 23, 29, 37, 38 AND 50).

FIRST USE 8-1-2010; IN COMMERCE 8-1-2010.

CLASS 41—EDUCATION AND ENTERTAINMENT

FOR PROVIDING ON-LINE MAGAZINES IN THE FIELD OF DIABETES, HEALTH, NUTRITION, PRE-DIABETES, RECIPES, FOOD (U.S. CLS. 100, 101 AND 107).

FIRST USE 8-1-2010; IN COMMERCE 8-1-2010.

3,999,977. THE CORPORATE EXECUTIVE BOARD COMPANY, ARLINGTON, VA. SN 85-131,228. FILED 9-16-2010.

Executive Advisor

THE MARK CONSISTS OF STANDARD CHARACTERS WITHOUT CLAIM TO ANY PARTICULAR FONT, STYLE, SIZE, OR COLOR.

NO CLAIM IS MADE TO THE EXCLUSIVE RIGHT TO USE "ADVISOR" FOR INTERNATIONAL CLASS 35, APART FROM THE MARK AS SHOWN.

CLASS 35—ADVERTISING AND BUSINESS

FOR BUSINESS MANAGEMENT CONSULTATION IN THE FIELD OF EXECUTIVE AND LEADERSHIP DEVELOPMENT (U.S. CLS. 100, 101 AND 102).

FIRST USE 3-1-2009; IN COMMERCE 3-1-2009.

CLASS 41—EDUCATION AND ENTERTAINMENT

FOR EDUCATION SERVICES, NAMELY, PROVIDING MENTORING, TUTORING, CLASSES, SEMINARS AND WORKSHOPS IN THE FIELD OF BUSINESS, FINANCE, FINANCIAL SERVICES, GOVERNMENT, INFORMATION TECHNOLOGY, LEGAL, HUMAN RESOURCES, SALES, MARKETING, AND COMMUNICATIONS (U.S. CLS. 100, 101 AND 107).

FIRST USE 3-1-2009; IN COMMERCE 3-1-2009.

3,999,999. PAUL DANIEL MADDEN, MANSFIELD, OH. SN 85-205,485. FILED 12-24-2010.

Mil Spec

THE MARK CONSISTS OF STANDARD CHARACTERS WITHOUT CLAIM TO ANY PARTICULAR FONT, STYLE, SIZE, OR COLOR.

NO CLAIM IS MADE TO THE EXCLUSIVE RIGHT TO USE "SPEC", APART FROM THE MARK AS SHOWN.

CLASS 9—ELECTRICAL AND SCIENTIFIC APPARATUS

FOR APPARATUS FOR CONVERTING ELECTRONIC RADIATION TO ELECTRICAL ENERGY, NAMELY, PHOTOVOLTAIC SOLAR HYBRID MODULES FOR MILITARY USE; LASER RANGEFINDERS FOR MILITARY USE; TACTICAL LASER SIGHTS FOR MILITARY USE; UNINTERRUPTIBLE ELECTRICAL POWER SUPPLIES FOR MILITARY USE; WIND TURBINE CONTROLLER FOR MILITARY USE (U.S. CLS. 21, 23, 26, 36 AND 38).

FIRST USE 12-14-2000; IN COMMERCE 12-14-2000.

CLASS 11—ENVIRONMENTAL CONTROL APPARATUS

FOR AIR CONDITIONING UNITS; MOBILE LIGHT TOWERS; POWER PLANTS; SOLAR-POWERED COOLING UNITS; WATER PURIFICATION AND FILTRATION APPARATUS (U.S. CLS. 13, 21, 23, 31 AND 34).

FIRST USE 12-14-2000; IN COMMERCE 12-14-2000.

4,000,007. WORLDWIDE RESTORATION INC, TULSA, OK.
 SN 85-223,083. FILED P.R. 1-21-2011; AM. S.R. 5-25-2011.

WORLDWIDE RESTORATION

THE MARK CONSISTS OF STANDARD CHARACTERS WITHOUT CLAIM TO ANY PARTICULAR FONT, STYLE, SIZE, OR COLOR.

NO CLAIM IS MADE TO THE EXCLUSIVE RIGHT TO USE "RESTORATION", APART FROM THE MARK AS SHOWN.

CLASS 37—CONSTRUCTION AND REPAIR

FOR CLEANING, RESTORATION, AND RECONSTRUCTION SERVICES FOR RESIDENTIAL HOUSES, INDUSTRIAL PREMISES AND BUILDINGS, AND THEIR CONTENTS DAMAGED BY FIRE, SMOKE, WATER, WIND OR CATASTROPHES; CARPET CLEANING SERVICES (U.S. CLS. 100, 103 AND 106).
 FIRST USE 5-11-2001; IN COMMERCE 6-30-2004.

CLASS 40—MATERIAL TREATMENT

FOR MOLD REMEDIATION SERVICES (U.S. CLS. 100, 103 AND 106).
 FIRST USE 5-11-2001; IN COMMERCE 6-30-2004.

4,000,014. MAYZUS, SERGEY VICTOROVICH, BAST,
 CZECH REPUBLIC. SN 85-230,022. FILED 1-31-2011.

MAYZUS

THE MARK CONSISTS OF STANDARD CHARACTERS WITHOUT CLAIM TO ANY PARTICULAR FONT, STYLE, SIZE, OR COLOR.

CLASS 35—ADVERTISING AND BUSINESS

FOR ADMINISTERING DISCOUNT GROUP PURCHASING PROGRAMS, NAMELY, NEGOTIATING CONTRACTS WITH PROVIDERS OF BANKING AND INSURANCE SERVICES, TO ENABLE PARTICIPANT MEMBERS OF A TEACHERS UNION TO OBTAIN DISCOUNTS ON THE PURCHASE OF THE FINANCIAL AND INSURANCE SERVICES OF OTHERS THROUGH THE USE OF UNION DISCOUNT MEMBERSHIP CARDS; ADVERTISING AGENCIES, NAMELY, PROMOTING THE SERVICES OF INVESTMENT PRODUCTS THROUGH THE DISTRIBUTION OF PRINTED AND AUDIO PROMOTIONAL MATERIALS AND BY RENDERING SALES PROMOTION ADVICE; ADVERTISING SERVICES FOR PROMOTING THE BROKERAGE OF STOCKS AND OTHER SECURITIES; ARRANGING THE TRANSPORT OF VEHICLES OF INSURED PARTIES ON BEHALF OF THEIR INSURANCE COMPANIES FOR RESOLUTION OF INSURANCE CLAIMS; ASSISTANCE, ADVISORY SERVICES AND CONSULTANCY WITH REGARD TO BUSINESS PLANNING, BUSINESS ANALYSIS, BUSINESS MANAGEMENT, AND BUSINESS ORGANIZATION RELATING TO MICRO CREDITS,

MICRO FINANCE AND ENERGY PRODUCTS; BUSINESS ADVICE AND INFORMATION ABOUT A CORPORATE EXECUTIVE WHOSE WEALTH AMOUNTS TO AT LEAST A MILLION DOLLARS, POUNDS, OR THE EQUIVALENT IN OTHER CURRENCY; BUSINESS ADVICE AND INFORMATION RELATING TO LOANS, FINANCE AND CAPITAL; BUSINESS CONSULTING SERVICES IN THE FIELD OF BUSINESS KNOWLEDGE TRANSFER THROUGH AUDIO TOOLS, NAMELY, RECORDING INTERVIEWS WITH SUBJECT MATTER EXPERTS FOR AN ORGANIZATION'S CAPTURE AND FUTURE USE; BUSINESS MANAGEMENT CONSULTING WITH RELATION TO STRATEGY, FINANCING, MARKETING, PRODUCTION, PERSONNEL AND SALE MATTERS FOR COMPANIES INVOLVED WITH THIN FILM AND NANO TECHNOLOGIES AND PLASMA PROCESSES; BUSINESS SERVICES, NAMELY, A NETWORK OF SOLAR CONTRACTORS RECEIVING LEADS AND BIDDING OPPORTUNITIES BY MEANS OF AN ONLINE MARKETPLACE FOR THE PURPOSE OF DEVELOPING INFORMATION TO EVALUATE THE INVESTMENT VALUE OF SOLAR ENERGY FOR A WEB-BASED CONSUMER; BUSINESS SERVICES, NAMELY, PROVIDING ONLINE INFORMATION IN RELATION TO RESOURCE PLANNING FOR THE MINING AND RESOURCE INDUSTRY, MINE PLANNING, EQUIPMENT SCHEDULING, MAINTENANCE SCHEDULING, FINANCE MODELING, PRODUCTION SCHEDULING, MATERIALS MANAGEMENT, QUALITY MANAGEMENT, HUMAN RESOURCES MANAGEMENT AND PROJECT MANAGEMENT; CHARITABLE SERVICES, NAMELY, ORGANIZING AND CONDUCTING VOLUNTEER PROGRAMS AND COMMUNITY SERVICE PROJECTS AIMED AT INCREASING SUPPORT AND MORALE OF FAMILIES OF DECEASED WAR VETERANS, WAR VETERANS, CURRENT MEMBERS AND FUTURE MEMBERS OF THE U.S. MILITARY; COMPILING FINANCIAL, SECURITIES, STOCK EXCHANGE, TRADE AND QUOTE, INDEX VALUE AND OTHER FINANCIAL MARKET INFORMATION FOR BUSINESS PURPOSES; CONSULTING SERVICES IN THE COST AND PAYMENT MANAGEMENT OF HEALTH CARE; DATA COMPILING AND ANALYZING IN THE FIELD OF INSURANCE; ELECTRONIC SIGNATURE VERIFICATION SERVICES PROVIDED IN CONNECTION WITH BANKING AND FINANCIAL SERVICES; FACILITATING GROUP PURCHASE OF BANKING SERVICES; INSURANCE CLAIMS AUDITING SERVICES; INSURANCE LEAD COLLECTION AND MATCHING SERVICES, NAMELY, MATCHING CONSUMER REQUESTS FOR INSURANCE POLICY QUOTES COLLECTED OVER THE INTERNET TO PRE-QUALIFIED INSURANCE BROKERS, AGENTS AND AGENCIES INTERESTED IN THOSE REQUESTS; INTERACTIVE RECORD-KEEPING SERVICES FOR USE IN RISK MANAGEMENT AND REGULATORY COMPLIANCE BY INSURERS AND PROFESSIONALS IN THE MEDICAL FIELD; MAINTAINING AND RECORDING THE OWNERSHIP OF SHARES, STOCKS AND SECURITIES; MANAGEMENT OF AN AIRLINE COMPANY; MANAGING THE OPERATIONS OF INSURANCE AGENCIES AND BROKERS ON AN OUTSOURCING BASIS; OFFICE FUNCTIONS IN THE NATURE OF MAINTAINING RECORDS OF OWNERSHIP OF STOCKS, SHARES AND SECURITIES; OFFICE FUNCTIONS IN THE NATURE OF MAINTAINING RECORDS OF SETTLEMENTS FOR TRANSFERS OF STOCKS, SHARES AND SECURITIES; PREPARATION OF REPORTS RELATING TO FINANCE AND INVESTMENTS; PROMOTING THE SERVICES OF BANKS THROUGH THE DISTRIBUTION OF PRINTED AND AUDIO PROMOTIONAL MATERIALS AND BY RENDERING SALES PROMOTION ADVICE; PROMOTION OF FINANCIAL AND INSURANCE SERVICES, ON BEHALF OF THIRD PARTIES; PROVIDING A PRICING PROGRAM IN THE FIELD OF PROPERTY AND CASUALTY INSURANCE THROUGH WHICH MEMBERS OF DESIGNATED ASSOCIATIONS, ORGANIZATIONS, AND GROUPS MAY BE OFFERED OR GRANTED DOWNWARD ADJUSTMENTS IN THE PREMIUMS FOR SUCH INSURANCE; PROVIDING A WEBSITE THROUGH WHICH ANIMAL RESCUE PROVIDERS AND AIRLINE OWNERS AND PILOTS CAN CONNECT TO EACH OTHER TO ARRANGE AND DISCUSS THE RESCUE AND DELIVERY OF ANIMALS; PROVIDING BUSINESS RESEARCH SERVICES, NAMELY, RESEARCHING DENTAL PATIENT INSURANCE INFORMATION FOR DENTAL OFFICES; PROVIDING

FINANCIAL INDICES OF SELECT BONDS TO ENABLE CONSUMERS TO EVALUATE INVESTMENTS AND MARKET TRENDS IN THE BOND MARKET; PROVIDING FINANCIAL INDICES OF SELECT SECURITIES TO ENABLE CONSUMERS TO EVALUATE INVESTMENTS AND MARKET TRENDS IN THE SECURITIES MARKET; PROVIDING INSURANCE AGENT REFERRALS; PROVIDING ON-LINE FACILITIES FEATURING TRANSACTION ORDER ENTRY, ORDER DIRECTING AND ORDER CONFIRMATION SERVICES TO CUSTOMERS IN THE FIELD OF INVESTING; PROVIDING SALES LEADS FOR THE AUTOMOTIVE FINANCE AND INSURANCE INDUSTRIES; PROVIDING STATISTICAL EVALUATION OF INSURANCE CLAIMS PERFORMANCE MEASURES FOR OTHERS; RECORDING AND REGISTERING THE TRANSFER OF STOCKS, SHARES AND SECURITIES; SHARE REGISTRATION SERVICES, NAMELY, REGISTERING THE OWNERSHIP OF STOCKS AND BONDS; TRACKING AND MONITORING INSURANCE COMPLIANCE (U.S. CLS. 100, 101 AND 102).

FIRST USE 1-1-2011; IN COMMERCE 1-1-2011.

CLASS 36—INSURANCE AND FINANCIAL

FOR ACCIDENT INSURANCE UNDERWRITING; ADMINISTRATION OF EMPLOYEE BENEFIT PLANS CONCERNING INSURANCE AND FINANCE; ADMINISTRATION OF EMPLOYEE WELFARE BENEFIT PLANS CONCERNING INSURANCE AND FINANCE; ADVISORY SERVICES IN THE FIELD OF EMPLOYEE BENEFITS FOR GROUP HEALTHCARE AND BUSINESS INSURANCE OFFERED TO EMPLOYEES IN ADDITION TO STANDARD BENEFITS SUCH AS MEDICAL, DENTAL, LIFE INSURANCE INCLUDING SHORT TERM DISABILITY, LONG TERM DISABILITY, CANCER INSURANCE, ACCIDENTAL DEATH AND DISMEMBERMENT; AGENCIES FOR BROKERAGE OF SECURITIES TRADING IN OVERSEAS SECURITIES MARKETS AND OF TRANSACTIONS ON COMMISSION OF OVERSEAS MARKET SECURITIES FUTURES; AGENCIES FOR COMMODITY FUTURES TRADING; AGENCIES OR BROKERAGE FOR TRADING OF SECURITIES, SECURITIES INDEX FUTURES, SECURITIES OPTIONS, AND OVERSEAS MARKET SECURITIES FUTURES; AGRICULTURAL INSURANCE AGENCY SERVICES; APPRAISALS FOR INSURANCE CLAIMS OF PERSONAL PROPERTY; APPRAISALS FOR INSURANCE CLAIMS OF REAL ESTATE; ARRANGING AND PROVISION OF CREDIT, LOANS, INSURANCE, CURRENCY EXCHANGE AND TRAVELLERS CHEQUES; ASSESSING INSURANCE CLAIMS; ATM BANKING SERVICES; BANK TENDERING, NAMELY, TENDERING OF MONEY; BANKING; BANKING AND FINANCING SERVICES; BANKING CONSULTATION; BANKING SERVICES; BANKING SERVICES FEATURING THE PROVISION OF CERTIFICATES OF DEPOSIT; BANKING SERVICES PROVIDED BY MOBILE TELEPHONE CONNECTIONS; BILL PAYMENT SERVICES; BILL PAYMENT SERVICES PROVIDED THROUGH A WEBSITE; BROKERAGE HOUSES IN THE FIELD OF STOCKS, COMMODITIES, AND FUTURES; BROKERAGE IN THE FIELD OF CURRENCY TRADING; BROKERAGE OF SHARES OR STOCKS AND OTHER SECURITIES; BROKERAGE SERVICES FOR STOCKS AND BONDS; BROKERAGE SERVICES IN THE FIELD OF SECURITIES AND COMMODITIES INVESTING; BUSINESS, STOCK OPTION AND PENSION VALUATION SERVICES; CLAIMS ADJUSTMENT IN THE FIELD OF INSURANCE; CLAIMS ADMINISTRATION SERVICES IN THE FIELD OF HEALTH INSURANCE; COLLECTING LICENSE FEES ON BEHALF OF INDEPENDENT WRITERS AND PUBLISHERS AND MAKING PAYMENTS TO THE COPYRIGHT OWNERS OF THE MUSIC; COMMODITIES EXCHANGE SERVICES; COMMODITY BROKERAGE; COMMODITY EXCHANGE; COMMODITY INVESTMENT ADVICE; COMMODITY QUOTATIONS; COMMODITY TRADING FOR OTHERS; COMPUTER ANALYSES OF STOCK EXCHANGE INFORMATION; CONSULTATION, POLICY WRITING AND CLAIMS PROCESSING IN THE FIELD OF CROP INSURANCE; CONSULTING AND INFORMATION CONCERNING INSURANCE; CONSULTING SERVICES IN THE FIELD OF STATE AND FEDERAL EMPLOYEE BENEFIT PLANS CONCERNING INSURANCE AND FINANCE; CREDIT CARD AND PAYMENT CARD SERVICES; CREDIT CARD PAYMENT PROCESSING SERVICES; CURRENCY EXCHANGE AND ADVICE;

CURRENCY EXCHANGE SERVICES; CURRENCY TRADING; CURRENCY TRANSFER SERVICES; DEBT CANCELLATION SERVICES USING PROCEEDS OF LIFE, DISABILITY AND UNEMPLOYMENT INSURANCE; DENTAL HEALTH INSURANCE ADMINISTRATION; DENTAL HEALTH INSURANCE UNDERWRITING AND ADMINISTRATION; ELECTRONIC BANKING VIA A GLOBAL COMPUTER NETWORK; ELECTRONIC COMMERCE PAYMENT SERVICES, NAMELY, ESTABLISHING FUNDED ACCOUNTS USED TO PURCHASE GOODS AND SERVICES ON THE INTERNET; ELECTRONIC FOREIGN EXCHANGE PAYMENT PROCESSING; ELECTRONIC PAYMENT SERVICES BY WHICH UTILITY CUSTOMERS MAY APPLY MONEY FROM VARIOUS SOURCES FOR PAYMENT OF ENERGY COSTS; ELECTRONIC PAYMENT, NAMELY, ELECTRONIC PROCESSING AND TRANSMISSION OF BILL PAYMENT DATA; ELECTRONIC PROCESSING OF INSURANCE CLAIMS AND PAYMENT DATA; EMPLOYEE STOCK PLAN ADMINISTRATION SERVICES; EQUIPMENT MAINTENANCE CLAIMS PAYMENT SERVICE FOR BUSINESS; FIDUCIARY TAX PAYMENT PROCESSING SERVICES; FINANCIAL ADMINISTRATION OF STOCK EXCHANGE TRADING OF SHARES AND OTHER FINANCIAL SECURITIES IN FINANCIAL MARKETS; FINANCIAL AND INVESTMENT SERVICES, NAMELY, MANAGEMENT AND BROKERAGE IN THE FIELDS OF STOCKS, BONDS, OPTIONS, COMMODITIES, FUTURES AND OTHER SECURITIES, AND THE INVESTMENT OF FUNDS OF OTHERS; FINANCIAL CONSULTANCY AND INSURANCE CONSULTANCY; FINANCIAL EVALUATION FOR INSURANCE PURPOSES; FINANCIAL INVESTMENT ANALYSIS AND STOCK RESEARCH; FINANCIAL SERVICES, NAMELY, ADMINISTRATION OF TRANSACTIONS INVOLVING FUNDS DRAWN FROM SECURITIES, STOCKS, FUNDS, EQUITIES, BONDS, CASH, OR OTHER TYPES OF FINANCIAL INVESTMENTS IN RETIREMENT PLANS USING A CHECK OR NEGOTIABLE ORDER OF WITHDRAWAL OVER A GLOBAL DATA NETWORK; FINANCIAL SERVICES, NAMELY, ADMINISTRATION OF TRANSACTIONS INVOLVING FUNDS DRAWN FROM SECURITIES, STOCKS, FUNDS, EQUITIES, BONDS, CASH, OR OTHER TYPES OF FINANCIAL INVESTMENTS IN RETIREMENT PLANS USING A CREDIT OR DEBIT CARD OVER A GLOBAL DATA NETWORK; FINANCIAL SERVICES, NAMELY, ASSISTING OTHERS WITH THE COMPLETION OF FINANCIAL TRANSACTIONS FOR STOCKS, BONDS, SECURITIES AND EQUITIES; FINANCIAL SERVICES, NAMELY, COMMODITY TRADING AND MANAGED FUTURES ADVISORY AND MANAGEMENT SERVICES; FINANCIAL SERVICES, NAMELY, DEALING IN SECURITIES AS A MARKET MAKER AND IN TRADING COMMODITIES, SECURITIES, OPTIONS, FUTURES, EQUITIES AND FIXED INCOME PRODUCTS IN THE U.S. AND OVERSEAS MARKET SECURITIES; FINANCIAL SERVICES, NAMELY, FUNDING ONLINE CASH ACCOUNTS FROM PREPAID CASH CARDS, BANK ACCOUNTS AND CREDIT CARD ACCOUNTS; FINANCIAL SERVICES, NAMELY, ISSUANCE AND MANAGEMENT OF CERTIFICATES BACKED BY LOAN PORTFOLIOS WHICH ARE SUBSEQUENTLY MANAGED TO INSURE THE INTEGRITY OF THE CERTIFICATES; FINANCIAL SERVICES, NAMELY, LIFE INSURANCE SETTLEMENT SERVICES; FINANCIAL SERVICES, NAMELY, OPERATION AND MANAGEMENT OF HEDGE FUNDS, COMMODITY POOLS AND OTHER COLLECTIVE INVESTMENT VEHICLES, AND TRADING FOR OTHERS OF SECURITIES, OPTIONS, FUTURES, DERIVATIVES, DEBT INSTRUMENTS AND COMMODITIES; FINANCIAL SERVICES, NAMELY, PROPRIETARY TRADING IN COMMODITIES, SECURITIES, OPTIONS, FUTURES, EQUITIES AND FIXED INCOME PRODUCTS IN THE U.S. AND OVERSEAS MARKET SECURITIES; FINANCIAL SERVICES, NAMELY, PROVIDING A VIRTUAL CURRENCY FOR USE BY MEMBERS OF AN ONLINE COMMUNITY VIA A GLOBAL COMPUTER NETWORK; FINANCIAL SERVICES, NAMELY, PROVIDING AN INVESTMENT OPTION AVAILABLE FOR VARIABLE ANNUITY AND VARIABLE LIFE INSURANCE PRODUCTS; FINANCIAL SERVICES, NAMELY, PROVIDING FOR THE EXCHANGE OF FOREIGN CURRENCY, COMMODITIES, FINANCIAL DERIVATIVES, INTEREST RATE PRODUCTS, AND EQUITIES VIA THE INTERNET AND INTRANET SYSTEMS; FINANCIAL SERVICES, NAMELY, PROVIDING INFORMATION IN THE FIELDS OF FOREIGN CURRENCY, COMMODITIES, FINANCIAL DERIVATIVES, INTEREST RATE

PRODUCTS, AND EQUITIES VIA THE INTERNET AND INTRANET SYSTEMS; FINANCIAL TRANSACTION SERVICES, NAMELY, PROVIDING SECURE COMMERCIAL TRANSACTIONS AND PAYMENT OPTIONS; FINANCIAL TRANSACTION SERVICES, NAMELY, PROVIDING SECURE COMMERCIAL TRANSACTIONS AND PAYMENT OPTIONS USING A MOBILE DEVICE AT A POINT OF SALE; FIRE INSURANCE UNDERWRITING; FUND INVESTMENT SERVICES FEATURING SECURITIES OFFERED ACCORDING TO PREVIOUSLY ESTABLISHED CRITERIA IN ORDER TO MAINTAIN A PREDETERMINED LEVEL OF PAYMENTS TO THE ACCOUNT HOLDER; FUND INVESTMENT SERVICES FEATURING THE TRADING OF AN ACCOUNT HOLDER'S SECURITIES ACCORDING TO PREVIOUSLY ESTABLISHED CRITERIA IN ORDER TO MAINTAIN A PREDETERMINED LEVEL OF PAYMENTS TO THE ACCOUNT HOLDER; FUTURES COMMISSION MERCHANT SERVICES, NAMELY, CLEARING TRADES FOR COMMODITIES, FUTURES AND FOREIGN EXCHANGE; FUTURES EXCHANGE SERVICES; HEALTH INSURANCE UNDERWRITING; HEALTHCARE INSURANCE SERVICES FOR LASIK SURGERY; HOME BANKING; INSURANCE ACTUARIAL SERVICES; INSURANCE ADMINISTRATION; INSURANCE ADMINISTRATION SERVICES, NAMELY, ASSISTING OTHERS WITH ADJUSTING INSURANCE CLAIMS; INSURANCE ADMINISTRATION SERVICES, NAMELY, ASSISTING OTHERS WITH COLLECTING INSURANCE PREMIUMS; INSURANCE AGENCIES; INSURANCE AGENCY AND BROKERAGE; INSURANCE AND FINANCIAL INFORMATION AND CONSULTANCY SERVICES; INSURANCE BROKERAGE; INSURANCE BROKERAGE IN THE FIELD OF PRIZE INDEMNITY; INSURANCE BROKERAGE SERVICES; INSURANCE CARRIER SERVICES; INSURANCE CLAIMS ADMINISTRATION; INSURANCE CLAIMS PROCESSING; INSURANCE CONSULTANCY; INSURANCE CONSULTANCY SERVICES, NAMELY, PROVIDING ADVICE IN THE FIELD OF PROPERTY AND CASUALTY INSURANCE; INSURANCE CONSULTATION; INSURANCE INFORMATION; INSURANCE INFORMATION AND CONSULTANCY; INSURANCE PREMIUM RATE COMPUTING; INSURANCE SERVICES IN THE NATURE OF LOSS CONTROL MANAGEMENT FOR OTHERS; INSURANCE SERVICES, NAMELY, PROVIDING INDEPENDENT SCORING SERVICE RELATED TO EXISTING MEDICAL SERVICES IN A SPECIFIC GEOGRAPHIC REGION FOR INSURANCE EVALUATION PURPOSES; INSURANCE SERVICES, NAMELY, PROVIDING INFORMATION AND ON-LINE COMPUTER DATABASES FOR THE PURPOSE OF REVIEW AND VERIFICATION OF MEDICAID AND MEDICARE ELIGIBILITY STATUS AND RELATED INFORMATION; INSURANCE SERVICES, NAMELY, PROVIDING INFORMATION AND ON-LINE COMPUTER DATABASES FOR THE PURPOSE OF REVIEW AND VERIFICATION OF MEDICARE ELIGIBILITY STATUS AND RELATED INFORMATION; INSURANCE SERVICES, NAMELY, UNDERWRITING, ISSUING AND ADMINISTRATION OF LIFE INSURANCE; INSURANCE SERVICES, NAMELY, VIATICAL SETTLEMENT SERVICES, LIFE SETTLEMENT SERVICES FOR INSURANCE POLICYHOLDERS, AND SENIOR SETTLEMENT SERVICES FOR INSURANCE POLICYHOLDERS; INSURANCE SERVICES, NAMELY, WRITING MULTI-PERIL CROP INSURANCE, CROP HAIL INSURANCE AND RE-INSURANCE UNDERWRITING IN THE FIELDS OF CROP AND INTERNATIONAL BUSINESS; INSURANCE SERVICES, NAMELY, WRITING PROPERTY AND CASUALTY INSURANCE; INSURANCE SERVICES, PROVIDING PREMIUM RATE QUOTES VIA ON-LINE, TELEPHONE AND MAIL MEANS; INSURANCE SUBROGATION; INSURANCE SUBROGATION AND SALVAGE; INSURANCE UNDERWRITING CONSULTATION; INSURANCE UNDERWRITING SERVICES FOR ALL TYPES OF INSURANCE; INVESTMENT BANKING SERVICES; INVESTMENT BANKING SERVICES IN THE FIELD OF EMPLOYEE STOCK OWNERSHIP PLANS (ESOP); ISSUANCE OF BANK CHECKS; ISSUING OF BANK CHECKS; LIFE INSURANCE BROKERAGE; LIFE INSURANCE UNDERWRITING; LOYALTY COUPON PAYMENT PROCESSING SERVICES; LOYALTY PROGRAM PAYMENT PROCESSING SERVICES; MAKING

PAYMENTS ON PRE-PAID LONG DISTANCE CALLING CARDS FOR RECHARGING MINUTES; MARINE ACCIDENTS INSURANCE UNDERWRITING; MARINE FIRE INSURANCE UNDERWRITING; MARINE INSURANCE UNDERWRITING; MARINE TRANSPORTATION INSURANCE UNDERWRITING; MEDICAL INSURANCE CASE AND UTILIZATION REVIEW AND INSURANCE CLAIMS ADJUSTMENT SERVICES FOR HEALTHCARE PURCHASERS AND PAYORS AND PROVIDERS AND MEDICARE BENEFICIARIES; MEDICAL INSURANCE UNDERWRITING; MERCHANT BANKING AND INVESTMENT BANKING SERVICES; MERCHANT BANKING SERVICES; MERCHANT SERVICES, NAMELY, PAYMENT TRANSACTION PROCESSING SERVICES; MONEY ORDER PAYMENT GUARANTEE SERVICES; MORTGAGE BANKING; MORTGAGE BANKING SERVICES, NAMELY, ORIENTATION, ACQUISITION, SERVICING, SECURITIZATION AND BROKERAGE OF MORTGAGE LOANS; MORTGAGE SERVICES, NAMELY, BUYER PRE-QUALIFICATION OF MORTGAGES FOR MORTGAGE BROKERS AND BANKS; ON-LINE BANKING SERVICES; ON-LINE BANKING SERVICES FEATURING ELECTRONIC ALERTS THAT ALERT CREDIT AND DEBIT CARD USERS WHEN A SINGLE TRANSACTION EXCEEDS A CERTAIN AMOUNT; ON-LINE REAL-TIME CURRENCY TRADING; ONLINE, REAL-TIME TAX PAYMENT PROCESSING, TAX PAYMENT MANAGEMENT, AND TAX PAYMENT ANALYSIS SERVICES; ORGANIZATION OF ONLINE STOCK EXCHANGES FOR THE BENEFIT OF THE TRADE OF STOCKS AND OTHER FINANCIAL SECURITIES; ORGANIZATION OF STOCK EXCHANGES FOR THE BENEFIT OF THE TRADE OF STOCKS AND OTHER FINANCIAL VALUES; PAYMENT PROCESSING SERVICES, NAMELY, CREDIT CARD AND DEBIT CARD TRANSACTION PROCESSING SERVICES; PRE-PAID PURCHASE CARD SERVICES, NAMELY, PROCESSING ELECTRONIC PAYMENTS MADE THROUGH PREPAID CARDS; PRE-PAID PURCHASE CARD SERVICES, NAMELY, PROCESSING ELECTRONIC PAYMENTS THROUGH PRE-PAID CARDS; PREPAID CARD SERVICES IN THE NATURE OF MAKING PAYMENT FOR ADDING AIRTIME TO PREPAID OR PAY-AS-YOU-GO WIRELESS SERVICES; PROCESSING ELECTRONIC PAYMENTS MADE THROUGH PREPAID CARDS; PROCESSING, ADMINISTERING AND MANAGING EMPLOYEE BENEFIT PLANS CONCERNING INSURANCE AND FINANCE; PROVIDING A DATABASE FOR TRACKING, MONITORING, AND GENERATING REPORTS ON INFORMATION AND STATISTICS ABOUT PATIENT REIMBURSEMENT AND INSURANCE COVERAGE FOR PHARMACEUTICALS AND MEDICAL DEVICES; PROVIDING A WEB SITE WHERE USERS CAN POST RATINGS, REVIEWS AND RECOMMENDATIONS ON STOCKS, BONDS, MUTUAL FUNDS AND OTHER FINANCIAL INSTRUMENTS; PROVIDING AN ON-LINE COMPUTER DATABASE IN THE FIELD OF STOCK/SECURITIES MARKET INFORMATION; PROVIDING BANK ACCOUNT INFORMATION BY TELEPHONE; PROVIDING DETAILED INFORMATION REGARDING AVAILABLE INSURANCE PRODUCTS FOR COMMERCIAL PROPERTY AND CASUALTY, PROFESSIONAL AND PERSONAL LINES; PROVIDING ELECTRONIC PROCESSING OF ACH AND CREDIT CARD TRANSACTIONS AND ELECTRONIC PAYMENTS VIA A GLOBAL COMPUTER NETWORK; PROVIDING ELECTRONIC PROCESSING OF CREDIT CARD TRANSACTIONS AND ELECTRONIC PAYMENTS VIA A GLOBAL COMPUTER NETWORK; PROVIDING ELECTRONIC PROCESSING OF ELECTRONIC FUNDS TRANSFER, ACH, CREDIT CARD, DEBIT CARD, ELECTRONIC CHECK AND ELECTRONIC PAYMENTS; PROVIDING INFORMATION IN INSURANCE MATTERS; PROVIDING INFORMATION IN THE FIELD OF FINANCIAL STOCK AND EQUITY MARKETS; PROVIDING INFORMATION REGARDING POLICY RATES FOR ALL TYPES OF INSURANCE AND ELECTRONIC PROCESSING OF INSURANCE CLAIMS AND PAYMENT DATA OVER A WEB BASED COMPUTER NETWORK; PROVIDING INFORMATION REGARDING WORKERS' COMPENSATION INSURANCE POLICY RATES; PROVIDING MULTIPLE PAYMENT OPTIONS BY MEANS OF CUSTOMER-OPERATED ELECTRONIC TERMINALS AVAILABLE ON-SITE IN RETAIL STORES; PROVIDING STOCK MARKET INFORMATION; PROVIDING STOCK/SECURITIES MARKET INFORMATION; PROVIDING VEHICLE INSURANCE RATE QUOTES; PROVISION OF INFORMATION AND DATA CONCERNING STOCK

EXCHANGES; PROVISION OF STOCK MARKET INFORMATION; QUOTATION OF STOCK MARKET PRICES; REAL ESTATE INSURANCE UNDERWRITING SERVICES; SAVINGS BANK SERVICES; SAVINGS BANKS; STOCK BROKERAGE; STOCK BROKING SERVICES; STOCK EXCHANGE INFORMATION SERVICES; STOCK EXCHANGE PRICE QUOTATIONS; STOCK EXCHANGE QUOTATION AND LISTING SERVICES; STOCK EXCHANGE QUOTATIONS; STORED VALUE PREPAID CARD SERVICES, NAMELY, PROCESSING ELECTRONIC PAYMENTS MADE THROUGH PREPAID CARDS; TAX PAYMENT PROCESSING SERVICES; TELEPHONE BANKING SERVICES; TRAVEL VOUCHER SERVICES, NAMELY, PROVIDING VOUCHERS FOR PAYMENT OF TRANSPORTATION EXPENSES; UNDERWRITING AND ADMINISTRATION OF COMMERCIAL COLLATERAL LIABILITY INSURANCE; UNDERWRITING INSURANCE FOR PRE-PAID HEALTH CARE; UNDERWRITING INSURANCE FOR PRE-PAID LEGAL SERVICES; WIRELESS TELEPHONE PAYMENT SERVICES, NAMELY, WIRELESS MOBILE TELEPHONE RATE PLANS (U.S. CLS. 100, 101 AND 102).
FIRST USE 1-1-2011; IN COMMERCE 1-1-2011.

* * * * *

SECTION 2.— INTERNATIONAL CLASSIFICATION

The short titles associated below with the international class numbers are terms designed merely for quick identification and are not an official part of the international classification. The full names of international classes are given in section 6.1 of the trademark rules of practice.

The designation "U.S. Cl." appearing in this section refers to the U.S. class in effect prior to Sep. 1, 1973 rather than the international class which applies to applications filed on or after that date. For adoption of international classification see notice in the OFFICIAL GAZETTE of Jun. 26, 1973 (911 O.G. TM 210).

Application in one class

CLASS 1—CHEMICALS

3,999,891. ADVANCED NUTRIENTS LTD., ABBOTSFORD, CANADA. SN 77-715,204. FILED P.R. 4-16-2009; AM. S.R. 11-30-2009.

BIGGER YIELDS NUTRIENT FLOWERING SYSTEM

THE MARK CONSISTS OF STANDARD CHARACTERS WITHOUT CLAIM TO ANY PARTICULAR FONT, STYLE, SIZE, OR COLOR.

PRIORITY CLAIMED UNDER SEC. 44(D) ON CANADA APPLICATION NO. 1423741, FILED 12-23-2008, REG. NO. TMA797139, DATED 5-10-2011, EXPIRES 5-10-2026.

FOR PLANT NUTRIENTS, NAMELY, FERTILIZERS AND SOIL ADDITIVES (U.S. CLS. 1, 5, 6, 10, 26 AND 46).

3,999,892. ADVANCED NUTRIENTS LTD., ABBOTSFORD, CANADA. SN 77-715,233. FILED P.R. 4-16-2009; AM. S.R. 11-30-2009.

BIGGER YIELDS FLOWERING SYSTEM

THE MARK CONSISTS OF STANDARD CHARACTERS WITHOUT CLAIM TO ANY PARTICULAR FONT, STYLE, SIZE, OR COLOR.

PRIORITY CLAIMED UNDER SEC. 44(D) ON CANADA APPLICATION NO. 1423739, FILED 12-23-2008, REG. NO. TMA797140, DATED 5-10-2011, EXPIRES 5-10-2026.

FOR PLANT NUTRIENTS, NAMELY, FERTILIZERS AND SOIL ADDITIVES (U.S. CLS. 1, 5, 6, 10, 26 AND 46).

CLASS 1—(Continued).

3,999,911. WORLD WIDE IMPORTS ENTERPRISES, INC., FORT LAUDERDALE, FL. SN 77-932,526. FILED P.R. 2-10-2010; AM. S.R. 6-7-2011.

AQUEOUS SOLUTION

THE MARK CONSISTS OF STANDARD CHARACTERS WITHOUT CLAIM TO ANY PARTICULAR FONT, STYLE, SIZE, OR COLOR.

NO CLAIM IS MADE TO THE EXCLUSIVE RIGHT TO USE "AQUEOUS", APART FROM THE MARK AS SHOWN.

FOR LIQUIDS FOR USE IN FILLING AQUARIUMS DURING INITIAL SET-UP, FOR REPLACEMENT OF WATER LOST DUE TO EVAPORATION, AND FOR AQUARIUM WATER CHANGES, NAMELY, LIVE WATER (U.S. CLS. 1, 5, 6, 10, 26 AND 46).

FIRST USE 11-14-2008; IN COMMERCE 11-14-2008.

3,999,916. QUIMICA LIPOSOLUBLE, S.A. DE C.V., GUADALAJARA, JALISCO, MEXICO. SN 77-953,316. FILED P.R. 3-8-2010; AM. S.R. 6-4-2011.

QLS-207 WO

THE MARK CONSISTS OF STANDARD CHARACTERS WITHOUT CLAIM TO ANY PARTICULAR FONT, STYLE, SIZE, OR COLOR.

FOR CHEMICAL ADDITIVES FOR FUELS, LUBRICANTS AND GREASES (U.S. CLS. 1, 5, 6, 10, 26 AND 46).

FIRST USE 10-4-2006; IN COMMERCE 10-4-2006.

CLASS 1—(Continued).

3,999,998. ADVANCED NUTRIENTS LTD., ABBOTSFORD, BC, CANADA. SN 85-205,016. FILED P.R. 12-23-2010; AM. S.R. 6-14-2011.

BIG BUD

THE MARK CONSISTS OF STANDARD CHARACTERS WITHOUT CLAIM TO ANY PARTICULAR FONT, STYLE, SIZE, OR COLOR.

PRIORITY CLAIMED UNDER SEC. 44(D) ON CANADA APPLICATION NO. 1486591, FILED 6-25-2010, REG. NO. TMA795,159, DATED 4-8-2011, EXPIRES 4-8-2026.

FOR PLANT GROWTH NUTRIENTS (U.S. CLS. 1, 5, 6, 10, 26 AND 46).

CLASS 3—(Continued).

3,999,913. JOHNSON PRODUCTS COMPANY, INC., DALLAS, TX. SN 77-936,283. FILED P.R. 2-16-2010; AM. S.R. 11-1-2010.

MOISTURE · BLEND

THE MARK CONSISTS OF STANDARD CHARACTERS WITHOUT CLAIM TO ANY PARTICULAR FONT, STYLE, SIZE, OR COLOR.

FOR HAIR CARE PRODUCTS, NAMELY, NON-MEDICATED HAIR CARE PREPARATIONS (U.S. CLS. 1, 4, 6, 50, 51 AND 52).

FIRST USE 5-31-2010; IN COMMERCE 6-15-2010.

CLASS 2—PAINTS

3,999,993. RA BRANDS, L.L.C., MADISON, NC. SN 85-187,991. FILED P.R. 12-1-2010; AM. S.R. 5-17-2011.

Remington

OWNER OF U.S. REG. NOS. 1,027,328, 3,339,403, AND OTHERS.

THE MARK CONSISTS OF THE WORD "REMINGTON" IN A STYLIZED FONT.

FOR PAINTS (U.S. CLS. 6, 11 AND 16).

FIRST USE 7-1-2010; IN COMMERCE 7-1-2010.

3,999,951. JOHNSON & JOHNSON, NEW BRUNSWICK, NJ. SN 85-098,711. FILED P.R. 8-3-2010; AM. S.R. 5-20-2011.

ZERO

THE MARK CONSISTS OF THE WORD "ZERO" IN STYLIZED LETTERS WITH THE LETTER "O" APPEARING AS A SHINY DISK WITH LIGHT REFLECTING AT THE ONE "O'CLOCK AND SEVEN O'CLOCK POSITIONS.

FOR NON-MEDICATED MOUTHWASH (U.S. CLS. 1, 4, 6, 50, 51 AND 52).

FIRST USE 7-28-2010; IN COMMERCE 7-28-2010.

4,000,012. DUNCAN ENTERPRISES, DBA ILOVETOCREATE, FRESNO, CA. SN 85-227,697. FILED P.R. 1-27-2011; AM. S.R. 5-24-2011.

LIQUID PEARLS

THE MARK CONSISTS OF STANDARD CHARACTERS WITHOUT CLAIM TO ANY PARTICULAR FONT, STYLE, SIZE, OR COLOR.

FOR CERAMIC GLAZES, NAMELY, SELF-SEALING ACRYLIC GLAZES IN THE NATURE OF A LIQUID COLORANT COATING FOR USE ON NON-FIRED CERAMICS (U.S. CLS. 6, 11 AND 16).

FIRST USE 9-15-1991; IN COMMERCE 9-15-1991.

3,999,976. THE LASHE, INC., CHICAGO, IL. SN 85-129,593. FILED P.R. 9-14-2010; AM. S.R. 5-10-2011.

LASHE

THE MARK CONSISTS OF THE WORD "LASHE" WITH A WIGGLY LINE PICKING UP THE HORIZONTAL ELEMENTS OF THE LETTERS.

FOR ADHESIVES FOR AFFIXING FALSE EYELASHES (U.S. CLS. 1, 4, 6, 50, 51 AND 52).

FIRST USE 8-1-2010; IN COMMERCE 8-15-2010.

CLASS 3—COSMETICS AND CLEANING PREPARATIONS**CLASS 5—PHARMACEUTICALS**

CLASS 5—(Continued).

3,999,898. GPS DAIRY CONSULTING, LLC, VERONA, WI. SN 77-913,099. FILED P.R. 1-15-2010; AM. S.R. 4-26-2011.

Cow Essentials

THE MARK CONSISTS OF STANDARD CHARACTERS WITHOUT CLAIM TO ANY PARTICULAR FONT, STYLE, SIZE, OR COLOR.

NO CLAIM IS MADE TO THE EXCLUSIVE RIGHT TO USE "COW", APART FROM THE MARK AS SHOWN.

FOR FEED SUPPLEMENT FOR DAIRY COWS (U.S. CLS. 6, 18, 44, 46, 51 AND 52).

FIRST USE 7-10-2009; IN COMMERCE 7-17-2009.

3,999,899. GPS DAIRY CONSULTING, LLC, VERONA, WI. SN 77-913,115. FILED P.R. 1-15-2010; AM. S.R. 4-26-2011.

Heifer Essentials

THE MARK CONSISTS OF STANDARD CHARACTERS WITHOUT CLAIM TO ANY PARTICULAR FONT, STYLE, SIZE, OR COLOR.

NO CLAIM IS MADE TO THE EXCLUSIVE RIGHT TO USE "HEIFER", APART FROM THE MARK AS SHOWN.

FOR FEED SUPPLEMENT FOR DAIRY HEIFERS (U.S. CLS. 6, 18, 44, 46, 51 AND 52).

FIRST USE 10-16-2009; IN COMMERCE 11-11-2009.

CLASS 6—METAL GOODS

3,999,906. CEILINGS PLUS, LOS ANGELES, CA. SN 77-927,440. FILED P.R. 2-3-2010; AM. S.R. 4-5-2011.

TESSELLATIONS

THE MARK CONSISTS OF STANDARD CHARACTERS WITHOUT CLAIM TO ANY PARTICULAR FONT, STYLE, SIZE, OR COLOR.

FOR METAL SUSPENDED CEILING SYSTEM COMPRISING PANELS AND TILES FOR IMPROVED ACOUSTICS (U.S. CLS. 2, 12, 13, 14, 23, 25 AND 50).

FIRST USE 3-10-2011; IN COMMERCE 3-10-2011.

CLASS 7—MACHINERY**CLASS 7—(Continued).**

3,999,926. BUTLER, BOYD L., SANDY, UT. SN 85-026,526. FILED P.R. 4-29-2010; AM. S.R. 6-10-2011.

FREQ MOD

THE MARK CONSISTS OF STANDARD CHARACTERS WITHOUT CLAIM TO ANY PARTICULAR FONT, STYLE, SIZE, OR COLOR.

FOR ENGINE MUFFLERS; MOTOR MUFFLERS (U.S. CLS. 13, 19, 21, 23, 31, 34 AND 35).

FIRST USE 5-0-2010; IN COMMERCE 5-0-2010.

3,999,970. THALES ALENIA SPACE FRANCE, TOULOUSE, FRANCE. SN 85-125,487. FILED 9-8-2010.

SOLARBUS

THE MARK CONSISTS OF STANDARD CHARACTERS WITHOUT CLAIM TO ANY PARTICULAR FONT, STYLE, SIZE, OR COLOR.

OWNER OF FRANCE REG. NO. 98751239, DATED 9-24-1998, EXPIRES 9-24-2018.

OWNER OF U.S. REG. NOS. 2,140,419 AND 3,809,121. FOR SOLAR GENERATOR FOR SPACE VEHICLES USED FOR POWERING ANY SPACE VEHICLE (U.S. CLS. 13, 19, 21, 23, 31, 34 AND 35).

CLASS 8—HAND TOOLS

4,000,000. EVERHARD PRODUCTS, INC., CANTON, OH. SN 85-207,154. FILED P.R. 12-29-2010; AM. S.R. 5-24-2011.

POCKET SOCKET

THE MARK CONSISTS OF STANDARD CHARACTERS WITHOUT CLAIM TO ANY PARTICULAR FONT, STYLE, SIZE, OR COLOR.

NO CLAIM IS MADE TO THE EXCLUSIVE RIGHT TO USE "SOCKET", APART FROM THE MARK AS SHOWN.

FOR HAND TOOLS, NAMELY, NUT DRIVERS (U.S. CLS. 23, 28 AND 44).

FIRST USE 8-25-2010; IN COMMERCE 8-25-2010.

CLASS 9—ELECTRICAL AND SCIENTIFIC APPARATUS

CLASS 9—(Continued).

3,999,895. CISCO TECHNOLOGY, INC., SAN JOSE, CA. SN 77-897,434. FILED P.R. 12-18-2009; AM. S.R. 6-14-2011.



THE MARK CONSISTS OF AN ELONGATED NARROW BAR WITH A CIRCULAR SHAPE PLACED ON CAMCORDERS. THE MATTER SHOWN IN BROKEN LINES INDICATES THE PLACEMENT OF THE MARK ON THE CAMCORDER.

FOR CAMCORDERS (U.S. CLS. 21, 23, 26, 36 AND 38).
FIRST USE 9-0-2007; IN COMMERCE 9-0-2007.

3,999,896. CISCO TECHNOLOGY, INC., SAN JOSE, CA. SN 77-897,448. FILED P.R. 12-18-2009; AM. S.R. 6-14-2011.



THE MARK CONSISTS OF AN ELONGATED NARROW BAR WITH A CIRCULAR SHAPE PLACED ON CAMCORDERS. THE MATTER SHOWN IN BROKEN LINES INDICATES THE PLACEMENT OF THE MARK ON THE CAMCORDER.

FOR CAMCORDERS (U.S. CLS. 21, 23, 26, 36 AND 38).
FIRST USE 6-0-2008; IN COMMERCE 6-0-2008.

CLASS 9—(Continued).

3,999,907. ZOHO CORPORATION, PLEASANTON, CA. SN 77-930,071. FILED P.R. 2-8-2010; AM. S.R. 6-8-2011.

Continuous Stream Mining Engine

THE MARK CONSISTS OF STANDARD CHARACTERS WITHOUT CLAIM TO ANY PARTICULAR FONT, STYLE, SIZE, OR COLOR.

NO CLAIM IS MADE TO THE EXCLUSIVE RIGHT TO USE "CONTINUOUS STREAM MINING", APART FROM THE MARK AS SHOWN.

FOR COMPUTER SOFTWARE FOR COMPLEX EVENT PROCESSING AND EVENT STREAM PROCESSING (U.S. CLS. 21, 23, 26, 36 AND 38).

FIRST USE 4-20-2011; IN COMMERCE 4-20-2011.

3,999,915. PROMONTORY MARK, LLC, WASHINGTON, DC. SN 77-938,516. FILED P.R. 2-18-2010; AM. S.R. 4-27-2011.

EXCHANGE ATLAS

THE MARK CONSISTS OF STANDARD CHARACTERS WITHOUT CLAIM TO ANY PARTICULAR FONT, STYLE, SIZE, OR COLOR.

OWNER OF U.S. REG. NO. 3,583,769.

FOR SUBSCRIPTION-BASED COMPUTER DIAGNOSTIC SOFTWARE TOOL THAT PROVIDES RISK RATINGS OF MAJOR STOCK EXCHANGES DESIGNED TO ASSIST FINANCIAL SERVICES INSTITUTIONS IN DETERMINING THE LEVEL OF DUE DILIGENCE THAT SHOULD BE APPLIED TO NEW OR EXISTING CUSTOMERS THAT ARE PUBLICLY HELD COMPANIES WITH SECURITIES ON SUCH STOCK EXCHANGES (U.S. CLS. 21, 23, 26, 36 AND 38).

FIRST USE 3-31-2010; IN COMMERCE 3-31-2010.

3,999,965. D B INDUSTRIES, INC., DBA CAPITAL SAFETY USA, RED WING, MN. SN 85-108,651. FILED P.R. 8-16-2010; AM. S.R. 4-22-2011.

CYNCH-LOK

THE MARK CONSISTS OF STANDARD CHARACTERS WITHOUT CLAIM TO ANY PARTICULAR FONT, STYLE, SIZE, OR COLOR.

FOR FALL PROTECTION EQUIPMENT FOR FALL ARREST AND RESCUE, NAMELY, POLE SAFETY STRAPS FOR WOOD POLE CLIMBERS (U.S. CLS. 21, 23, 26, 36 AND 38).

FIRST USE 10-4-2010; IN COMMERCE 10-4-2010.

CLASS 9—(Continued).

3,999,986. JASCO PRODUCTS COMPANY LLC, OKLAHOMA CITY, OK. SN 85-158,896. FILED P.R. 10-22-2010; AM. S.R. 5-26-2011.

Power Gear

THE MARK CONSISTS OF STANDARD CHARACTERS WITHOUT CLAIM TO ANY PARTICULAR FONT, STYLE, SIZE, OR COLOR.

FOR CONSUMER ELECTRONICS PRODUCTS, NAMELY, CONVERTERS, BATTERY CHARGERS AND INVERTERS (U.S. CLS. 21, 23, 26, 36 AND 38).
FIRST USE 7-0-2005; IN COMMERCE 7-0-2005.

CLASS 9—(Continued).

4,000,047. TEAM PLAY, INC., ELK GROVE VILLAGE, IL. SN 85-253,546. FILED 2-28-2011.

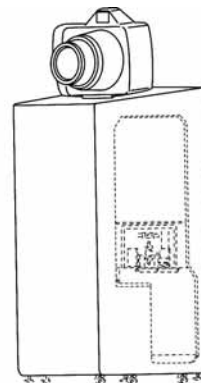

3,999,995. LUTZ, FRANK, MILWAUKEE, WI. SN 85-195,900. FILED P.R. 12-11-2010; AM. S.R. 3-20-2011.

EKADDIE

THE MARK CONSISTS OF STANDARD CHARACTERS WITHOUT CLAIM TO ANY PARTICULAR FONT, STYLE, SIZE, OR COLOR.

FOR PROTECTIVE COVERS FOR ELECTRONIC READING DEVICES (U.S. CLS. 21, 23, 26, 36 AND 38).
FIRST USE 12-11-2010; IN COMMERCE 3-15-2011.

THE MARK CONSISTS OF A THREE-DIMENSIONAL CONFIGURATION OF A PHOTO BOOTH HAVING AN OVER-SIZED CAMERA-LIKE STRUCTURE ON TOP OF THE BOOTH. THE MATTER SHOWN IN BROKEN LINES ON THE DRAWING – THAT IS, THE ENTRY WAY INTO THE BOOTH, CONTROL PANEL INSIDE THE BOOTH, WHEELS, AND LEVELING FEET – IS NOT PART OF THE MARK AND SHOWS ONLY THE POSITION OF THOSE ELEMENTS WITH RESPECT TO THE MARK.

FOR COIN-, BILL- AND CARD-OPERATED PHOTO BOOTHS WHICH TAKE PHOTOGRAPHS AND ALLOW THE USER TO RECEIVE PHOTOGRAPHS (U.S. CLS. 21, 23, 26, 36 AND 38).
FIRST USE 2-17-2010; IN COMMERCE 10-13-2010.

4,000,045. CHUC, DAVID, MONROVIA, CA. SN 85-252,679. FILED 2-26-2011.

ANTENNA PROS

THE MARK CONSISTS OF STANDARD CHARACTERS WITHOUT CLAIM TO ANY PARTICULAR FONT, STYLE, SIZE, OR COLOR.

NO CLAIM IS MADE TO THE EXCLUSIVE RIGHT TO USE "ANTENNA", APART FROM THE MARK AS SHOWN.
FOR TELEVISION ANTENNA (U.S. CLS. 21, 23, 26, 36 AND 38).
FIRST USE 3-1-2010; IN COMMERCE 3-1-2010.

4,000,055. WORLDWIDE INTERNET TECHNOLOGIES, BROOKLYN, NY. SN 85-266,761. FILED P.R. 3-14-2011; AM. S.R. 6-14-2011.

Optics Nc

THE MARK CONSISTS OF STANDARD CHARACTERS WITHOUT CLAIM TO ANY PARTICULAR FONT, STYLE, SIZE, OR COLOR.

NO CLAIM IS MADE TO THE EXCLUSIVE RIGHT TO USE "OPTICS", APART FROM THE MARK AS SHOWN.
FOR OPTICAL FILTERS; OPTICAL LENSES (U.S. CLS. 21, 23, 26, 36 AND 38).
FIRST USE 1-1-2008; IN COMMERCE 1-3-2008.

CLASS 9—(Continued).

4,000,057. NORTH SHORE DEVELOPMENT GROUP, INC., GREAT NECK, NY. SN 85-311,331. FILED P.R. 5-3-2011; AM. S.R. 6-7-2011.

iPodiatrist

THE MARK CONSISTS OF STANDARD CHARACTERS WITHOUT CLAIM TO ANY PARTICULAR FONT, STYLE, SIZE, OR COLOR.

FOR COMPUTER APPLICATION SOFTWARE FOR MOBILE PHONES AND HANDHELD COMPUTERS, NAMELY, SOFTWARE FOR PROVIDING MEDICAL INFORMATION AND SOFTWARE FOR PROVIDING INFORMATION ON FOOT HEALTH (U.S. CLS. 21, 23, 26, 36 AND 38).

FIRST USE 4-25-2011; IN COMMERCE 4-25-2011.

CLASS 11—(Continued).

3,999,946. HGI INDUSTRIES, INC., BOYNTON BEACH, FL. SN 85-089,269. FILED P.R. 7-21-2010; AM. S.R. 5-9-2011.

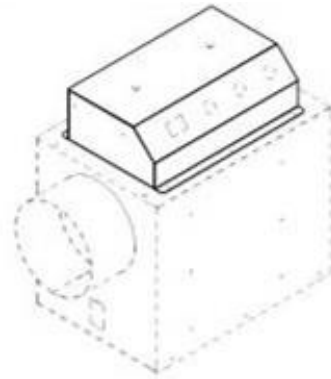

THE MARK CONSISTS OF A THREE-DIMENSIONAL CONFIGURATION OF THE GOODS CONSISTING OF THREE DISTINCT SHAPES: I) A MAIN RECTANGULAR CUBE; II) A SIDE PORTION WITH AN OVAL FLANGE CONNECTED TO THE MAIN CUBE, AND III) A TOP RECTANGULAR CUBE HAVING A SLANTED FRONT PLACED ON TOP OF THE MAIN CUBE. ALSO SHOWN ARE CUT-OUTS FOR BUTTONS, SWITCHES, INDICATOR LAMPS, DISPLAYS AND AN ATTACHMENT FOR A HANDLE. THE MATTER SHOWN IN BROKEN OR DOTTED LINES IS NOT PART OF THE MARK AND SERVES ONLY TO SHOW THE POSITION OR PLACEMENT OF THE MARK.

FOR AIR PURIFICATION UNITS USED TO NEUTRALIZE AIRBORNE GASSES, MICRO-ORGANISMS, VIRUSES AND MOLD SPECIES (U.S. CLS. 13, 21, 23, 31 AND 34).

FIRST USE 5-31-2007; IN COMMERCE 12-31-2008.

CLASS 11—ENVIRONMENTAL CONTROL APPARATUS

3,999,930. DETROIT RADIANT PRODUCTS COMPANY, WARREN, MI. SN 85-038,557. FILED P.R. 5-14-2010; AM. S.R. 5-4-2011.

QUAD TUBE

THE MARK CONSISTS OF STANDARD CHARACTERS WITHOUT CLAIM TO ANY PARTICULAR FONT, STYLE, SIZE, OR COLOR.

FOR INFRARED HEATERS (U.S. CLS. 13, 21, 23, 31 AND 34).

FIRST USE 11-30-2010; IN COMMERCE 11-30-2010.

3,999,974. BAYCO PRODUCTS, INC., WYLIE, TX. SN 85-128,696. FILED 9-13-2010.



OWNER OF U.S. REG. NO. 3,235,460. THE MARK CONSISTS OF A THREE-DIMENSIONAL CONFIGURATION OF AN ELONGATED OVAL LIGHT CASING HAVING ONE END FEATURING A SIMILARLY FORMED TRANSPARENT WINDOW FOR COVERING AN ARRAY OF LIGHTS BENEATH THE TRANSPARENT WINDOW.

FOR PORTABLE LIGHTING EQUIPMENT, NAMELY FLASHLIGHTS (U.S. CLS. 13, 21, 23, 31 AND 34).

FIRST USE 4-1-2008; IN COMMERCE 4-1-2008.

CLASS 11—(Continued).

4,000,036. IP HOLDINGS LLC, VANCOUVER, WA. SN 85-248,436. FILED 2-22-2011.

Super Spectrum Reflector

THE MARK CONSISTS OF STANDARD CHARACTERS WITHOUT CLAIM TO ANY PARTICULAR FONT, STYLE, SIZE, OR COLOR.

OWNER OF U.S. REG. NO. 2,454,305.

NO CLAIM IS MADE TO THE EXCLUSIVE RIGHT TO USE "REFLECTOR", APART FROM THE MARK AS SHOWN.

FOR ELECTRIC LIGHTING FIXTURES; LIGHT REFLECTORS (U.S. CLS. 13, 21, 23, 31 AND 34).

FIRST USE 1-1-1997; IN COMMERCE 1-1-1997.

4,000,043. BOON, INC., CHANDLER, AZ. SN 85-251,621. FILED P.R. 2-25-2011; AM. S.R. 6-2-2011.

FLO

THE MARK CONSISTS OF STANDARD CHARACTERS WITHOUT CLAIM TO ANY PARTICULAR FONT, STYLE, SIZE, OR COLOR.

FOR CHILDREN'S BATH AIDS, NAMELY, PROTECTIVE COVERS FOR BATHTUB SPOUTS (U.S. CLS. 13, 21, 23, 31 AND 34).

FIRST USE 8-22-2006; IN COMMERCE 8-22-2006.

CLASS 14—JEWELRY

3,999,909. SCOTT KAY, INC., TEANECK, NJ. SN 77-930,552. FILED P.R. 2-8-2010; AM. S.R. 11-10-2010.

ARTISANS OF FINE JEWELRY

THE MARK CONSISTS OF STANDARD CHARACTERS WITHOUT CLAIM TO ANY PARTICULAR FONT, STYLE, SIZE, OR COLOR.

FOR JEWELRY (U.S. CLS. 2, 27, 28 AND 50).

FIRST USE 5-0-2009; IN COMMERCE 5-0-2009.

CLASS 14—(Continued).

4,000,034. FLORES, JENNIFER J., PARENT OF ALEXANDRA FLORES, APPLE VALLEY, CA. SN 85-246,943. FILED P.R. 2-19-2011; AM. S.R. 5-25-2011.

ACTIONITIS

THE MARK CONSISTS OF STANDARD CHARACTERS WITHOUT CLAIM TO ANY PARTICULAR FONT, STYLE, SIZE, OR COLOR.

FOR BRACELETS (U.S. CLS. 2, 27, 28 AND 50).

FIRST USE 4-25-2010; IN COMMERCE 9-1-2010.

CLASS 16—PAPER GOODS AND PRINTED MATTER

3,999,908. HOOD, RON, COEUR D' ALENE, ID. SN 77-930,086. FILED P.R. 2-8-2010; AM. S.R. 6-15-2011.

SURVIVAL QUARTERLY

THE MARK CONSISTS OF STANDARD CHARACTERS WITHOUT CLAIM TO ANY PARTICULAR FONT, STYLE, SIZE, OR COLOR.

NO CLAIM IS MADE TO THE EXCLUSIVE RIGHT TO USE "QUARTERLY", APART FROM THE MARK AS SHOWN.

FOR PAPER GOODS AND PRINTED MATERIAL, NAMELY, MAGAZINES, PERIODICALS FOR CONSUMERS IN THE FIELD OF WILDERNESS SURVIVAL AND EMERGENCY PREPAREDNESS (U.S. CLS. 2, 5, 22, 23, 29, 37, 38 AND 50).

FIRST USE 12-1-2009; IN COMMERCE 12-1-2009.

3,999,955. PRIORITIZE, LLC, SCOTTSDALE, AZ. SN 85-099,501. FILED P.R. 8-3-2010; AM. S.R. 5-23-2011.

A MARRIAGE BOX

THE MARK CONSISTS OF STANDARD CHARACTERS WITHOUT CLAIM TO ANY PARTICULAR FONT, STYLE, SIZE, OR COLOR.

NO CLAIM IS MADE TO THE EXCLUSIVE RIGHT TO USE "BOX", APART FROM THE MARK AS SHOWN.

FOR INTERACTIVE COMMUNICATION TOOL KIT FOR MAINTAINING EMOTIONAL AND PHYSICAL INTIMACY WITH YOUR PARTNER, CONSISTING OF A COLLECTION OF WRITTEN MATERIALS, NAMELY, PRE-WRITTEN NOTE CARDS, FLASH CARDS, BLANK NOTE CARDS, A BLANK JOURNAL AND WRITTEN INSTRUCTIONS CONTAINED IN A DECORATIVE BOX (U.S. CLS. 2, 5, 22, 23, 29, 37, 38 AND 50).

FIRST USE 5-23-2011; IN COMMERCE 5-23-2011.

CLASS 16—(Continued).

3,999,969. MOVE PRESS, SOUTH PASADENA, CA. SN 85-124,058. FILED P.R. 9-7-2010; AM. S.R. 5-31-2011.

PELTON

THE MARK CONSISTS OF STANDARD CHARACTERS WITHOUT CLAIM TO ANY PARTICULAR FONT, STYLE, SIZE, OR COLOR.

FOR MAGAZINES IN THE FIELD OF BICYCLES (U.S. CLS. 2, 5, 22, 23, 29, 37, 38 AND 50).

FIRST USE 8-1-2010; IN COMMERCE 8-1-2010.

CLASS 16—(Continued).

3,999,996. RAW JUNIOR, LLC, NEW YORK, NY. SN 85-195,932. FILED P.R. 12-11-2010; AM. S.R. 5-26-2011.

TOON BOOKS

THE MARK CONSISTS OF STANDARD CHARACTERS WITHOUT CLAIM TO ANY PARTICULAR FONT, STYLE, SIZE, OR COLOR.

NO CLAIM IS MADE TO THE EXCLUSIVE RIGHT TO USE "BOOKS", APART FROM THE MARK AS SHOWN.

FOR CHILDREN'S ACTIVITY BOOKS; CHILDREN'S BOOKS; CHILDREN'S STORYBOOKS (U.S. CLS. 2, 5, 22, 23, 29, 37, 38 AND 50).

FIRST USE 11-30-2007; IN COMMERCE 11-30-2007.

3,999,973. INTERNATIONAL INSTITUTE OF MANAGEMENT, LAS VEGAS, NV. SN 85-126,783. FILED P.R. 9-10-2010; AM. S.R. 6-13-2011.

Most Respected

THE MARK CONSISTS OF STANDARD CHARACTERS WITHOUT CLAIM TO ANY PARTICULAR FONT, STYLE, SIZE, OR COLOR.

FOR BUSINESS MAGAZINE FOCUSING ON COMPANIES AND THEIR EXECUTIVE MANAGEMENT, SUCH AS CEOs, CMOS, CFOS, COOS AND OTHER C-LEVEL MANAGERS (U.S. CLS. 2, 5, 22, 23, 29, 37, 38 AND 50).

FIRST USE 8-1-1998; IN COMMERCE 8-1-1998.

4,000,001. AUTISM INTERNATIONAL ASSOCIATION INC., FULLERTON, CA. SN 85-208,392. FILED P.R. 12-30-2010; AM. S.R. 5-3-2011.

Autism Science Digest

THE MARK CONSISTS OF STANDARD CHARACTERS WITHOUT CLAIM TO ANY PARTICULAR FONT, STYLE, SIZE, OR COLOR.

NO CLAIM IS MADE TO THE EXCLUSIVE RIGHT TO USE "DIGEST", APART FROM THE MARK AS SHOWN.

FOR MAGAZINES IN THE FIELD OF AUTISM AND RELATED DISORDERS (U.S. CLS. 2, 5, 22, 23, 29, 37, 38 AND 50).

FIRST USE 2-20-2011; IN COMMERCE 4-4-2011.

3,999,985. PACON CORPORATION, APPLETON, WI. SN 85-157,468. FILED P.R. 10-20-2010; AM. S.R. 5-13-2011.

LOCKER LINERS

THE MARK CONSISTS OF STANDARD CHARACTERS WITHOUT CLAIM TO ANY PARTICULAR FONT, STYLE, SIZE, OR COLOR.

FOR SELF-ADHESIVE DRY ERASE REPOSITIONABLE PAPER (U.S. CLS. 2, 5, 22, 23, 29, 37, 38 AND 50).

FIRST USE 3-31-2011; IN COMMERCE 3-31-2011.

4,000,006. VINTAGE FACTORY, LLC, CAPE GIRARDEAU, MO. SN 85-215,849. FILED P.R. 1-12-2011; AM. S.R. 6-3-2011.



THE MARK CONSISTS OF A STYLIZED LOGO DESIGN WITH THE LETTERS "VINTAGE FACTORY".

FOR DECALS (U.S. CLS. 2, 5, 22, 23, 29, 37, 38 AND 50).

FIRST USE 1-1-2009; IN COMMERCE 1-1-2009.

CLASS 16—(Continued).

4,000,017. TURNSTILE PUBLISHING COMPANY, ORLANDO, FL. SN 85-234,571. FILED P.R. 2-4-2011; AM. S.R. 5-24-2011.

PROFESSIONAL ARTIST

THE MARK CONSISTS OF STANDARD CHARACTERS WITHOUT CLAIM TO ANY PARTICULAR FONT, STYLE, SIZE, OR COLOR.

FOR PRINTED MAGAZINE FOR PROFESSIONAL ARTISTS CONCERNING BUSINESS MARKETING, LEGAL, TECHNICAL AND CAREER ISSUES INVOLVED IN BEING A PROFESSIONAL ARTIST (U.S. CLS. 2, 5, 22, 23, 29, 37, 38 AND 50).

FIRST USE 2-2-2011; IN COMMERCE 2-2-2011.

4,000,018. TURNSTILE PUBLISHING COMPANY, ORLANDO, FL. SN 85-234,611. FILED P.R. 2-4-2011; AM. S.R. 5-24-2011.



THE MARK CONSISTS OF THE WORD "PROFESSIONAL" IN ALL CAPS ABOVE THE WORD "ARTIST" IN LARGER LOWER CASE FONT.

FOR PRINTED MAGAZINE FOR PROFESSIONAL ARTISTS CONCERNING BUSINESS MARKETING, LEGAL, TECHNICAL AND CAREER ISSUES INVOLVED IN BEING A PROFESSIONAL ARTIST (U.S. CLS. 2, 5, 22, 23, 29, 37, 38 AND 50).

FIRST USE 2-2-2011; IN COMMERCE 2-2-2011.

4,000,019. LAWTON, KYRA, DARTMOUTH, MA. SN 85-234,639. FILED P.R. 2-4-2011; AM. S.R. 5-10-2011.



THE MARK CONSISTS OF THE WORDS "WOMEN RUN" AND "WOMEN RUN.COM" BENEATH FOUR SHOES INSIDE A BORDERED OVAL AND THE WORDING "WORK + BIKE + TEACH + SWIM + CARPOOL + VOLUNTEER + LEAD + CREATE + REPEAT." SURROUNDING THE INSIDE BORDER OF THE OVAL BACKGROUND.

FOR BUMPER STICKERS; MAGNETIC BUMPER STICKERS (U.S. CLS. 2, 5, 22, 23, 29, 37, 38 AND 50). FIRST USE 9-3-2010; IN COMMERCE 10-31-2010.

CLASS 17—RUBBER GOODS

3,999,924. MARINE TURBINE TECHNOLOGIES, L.L.C., FRANKLIN, LA. SN 85-004,570. FILED P.R. 4-1-2010; AM. S.R. 1-6-2011.

Frac Stack Pack

THE MARK CONSISTS OF STANDARD CHARACTERS WITHOUT CLAIM TO ANY PARTICULAR FONT, STYLE, SIZE, OR COLOR.

NO CLAIM IS MADE TO THE EXCLUSIVE RIGHT TO USE "PACK", APART FROM THE MARK AS SHOWN.

FOR HYDRAULIC FRACTURING EQUIPMENT CONSISTING OF PUMPS, GEAR BOXES, AND TURBINE ENGINES GROUPED TOGETHER IN A SPACE-SAVING CONFIGURATION (U.S. CLS. 1, 5, 12, 13, 35 AND 50).

FIRST USE 5-31-2010; IN COMMERCE 5-31-2010.

CLASS 19—NON-METALLIC BUILDING MATERIALS

3,999,952. QUINN HOLTBY, EDMONTON, ALBERTA, CANADA. SN 85-098,972. FILED P.R. 8-3-2010; AM. S.R. 5-31-2011.

MINI MUD BUCKET

THE MARK CONSISTS OF STANDARD CHARACTERS WITHOUT CLAIM TO ANY PARTICULAR FONT, STYLE, SIZE, OR COLOR.

PRIORITY CLAIMED UNDER SEC. 44(D) ON CANADA APPLICATION NO. 1468585, FILED 2-5-2010, REG. NO. TMA794056, DATED 3-28-2011, EXPIRES 3-28-2026.

NO CLAIM IS MADE TO THE EXCLUSIVE RIGHT TO USE "MUD BUCKET", APART FROM THE MARK AS SHOWN.

FOR FLUID CONTAINMENT AND REDIRECTION APPARATUSES, NAMELY, NON-METAL PIPE JOINT ENCLOSURES FOR USE ON PIPE USED IN THE DRILLING AND SERVICING OF WELLS (U.S. CLS. 1, 12, 33 AND 50).

CLASS 20—FURNITURE AND ARTICLES NOT OTHERWISE CLASSIFIED

CLASS 20—(Continued).

4,000,009. HAMMER BEDDING CORP., DBA SHIFMAN MATTRESS COMPANY, NEWARK, NJ. SN 85-225,142. FILED P.R. 1-25-2011; AM. S.R. 5-11-2011.

THE HANDMADE COLLECTION

THE MARK CONSISTS OF STANDARD CHARACTERS WITHOUT CLAIM TO ANY PARTICULAR FONT, STYLE, SIZE, OR COLOR.

NO CLAIM IS MADE TO THE EXCLUSIVE RIGHT TO USE "COLLECTION", APART FROM THE MARK AS SHOWN.

FOR MATTRESSES (U.S. CLS. 2, 13, 22, 25, 32 AND 50). FIRST USE 12-6-2010; IN COMMERCE 12-6-2010.

CLASS 21—HOUSEWARES AND GLASS

3,999,921. AMSCAN INC., ELSFORD, NY. SN 77-982,090. FILED 3-2-2010.

Grasslands Road

THE MARK CONSISTS OF STANDARD CHARACTERS WITHOUT CLAIM TO ANY PARTICULAR FONT, STYLE, SIZE, OR COLOR.

FOR GIFTWARE MADE OF CERAMIC OR NON-PRECIOUS METALS, NAMELY, TABLEWARE, NAMELY, PLATES, MUGS, BOWLS AND VESSELS; SERVING PIECES, NAMELY, SERVING SPOONS, SERVING FORKS, SERVING TONGS AND SERVING TRAYS; DECORATIVE PLATES; CANDLE HOLDERS; FIGURINES OF STAINED GLASS, TERRA COTTA AND CERAMIC; VASES (U.S. CLS. 2, 13, 23, 29, 30, 33, 40 AND 50).

FIRST USE 1-1-2007; IN COMMERCE 1-1-2007.

3,999,972. C1 DESIGN GROUP, KETCHUM, ID. SN 85-126,267. FILED P.R. 9-9-2010; AM. S.R. 4-26-2011.

GEAR SHOWER

THE MARK CONSISTS OF STANDARD CHARACTERS WITHOUT CLAIM TO ANY PARTICULAR FONT, STYLE, SIZE, OR COLOR.

FOR PORTABLE WASHING SYSTEM FOR SPORTS AND FISHING EQUIPMENT (U.S. CLS. 2, 13, 23, 29, 30, 33, 40 AND 50).

FIRST USE 2-0-2011; IN COMMERCE 2-0-2011.

CLASS 24—FABRICS

3,999,968. TRIANGLE HOME FASHIONS, LLC, DAYTON, NJ. SN 85-118,049. FILED P.R. 8-28-2010; AM. S.R. 6-1-2011.

HOMEBOUQTQUE

THE MARK CONSISTS OF STANDARD CHARACTERS WITHOUT CLAIM TO ANY PARTICULAR FONT, STYLE, SIZE, OR COLOR.

FOR BATH LINEN; BED LINEN AND TABLE LINEN; BED SKIRTS; BED SPREADS; BED THROWS; COMFORTERS; CURTAINS; DUVETS; PILLOW CASES; QUILT COVERS; SHEET SETS; SHOWER CURTAINS; THROWS; TOWELS; WINDOW CURTAINS (U.S. CLS. 42 AND 50).

FIRST USE 3-4-2011; IN COMMERCE 3-4-2011.

CLASS 25—CLOTHING

3,999,904. BLACK KIRSCH, LLC, MANCHESTER, NH. SN 77-921,482. FILED P.R. 1-27-2010; AM. S.R. 5-19-2011.

Chubby Cock

THE MARK CONSISTS OF STANDARD CHARACTERS WITHOUT CLAIM TO ANY PARTICULAR FONT, STYLE, SIZE, OR COLOR.

FOR T-SHIRTS (U.S. CLS. 22 AND 39).

FIRST USE 9-1-2009; IN COMMERCE 9-17-2009.

3,999,905. ROADRUNNER APPAREL INC., LACHINE, CANADA. SN 77-923,866. FILED P.R. 1-29-2010; AM. S.R. 10-27-2010.

SUKO JEANS

THE MARK CONSISTS OF STANDARD CHARACTERS WITHOUT CLAIM TO ANY PARTICULAR FONT, STYLE, SIZE, OR COLOR.

OWNER OF CANADA REG. NO. TMA617413, DATED 8-24-2004, EXPIRES 8-24-2019.

OWNER OF U.S. REG. NO. 3,712,726.

NO CLAIM IS MADE TO THE EXCLUSIVE RIGHT TO USE "JEANS", APART FROM THE MARK AS SHOWN.

FOR A LINE OF MEN'S AND WOMEN'S CLOTHING/ APPAREL, NAMELY, JEANS, SHIRTS, SKIRTS, JACKETS, PANTS, VESTS, SHORTS, OVERALLS, JUMPERS, SWEATERS, SWEAT SHIRTS, T-SHIRTS, TANK TOPS AND HATS (U.S. CLS. 22 AND 39).

CLASS 25—(Continued).

3,999,959. ELHOUTY, SARA, THOUSAND OAKS, CA. SN 85-103,511. FILED P.R. 8-9-2010; AM. S.R. 6-6-2011.

Ice Pink Skatewear

THE MARK CONSISTS OF STANDARD CHARACTERS WITHOUT CLAIM TO ANY PARTICULAR FONT, STYLE, SIZE, OR COLOR.
 NO CLAIM IS MADE TO THE EXCLUSIVE RIGHT TO USE "SKATEWEAR", APART FROM THE MARK AS SHOWN.
 FOR SKATING OUTFITS (U.S. CLS. 22 AND 39).
 FIRST USE 9-10-2010; IN COMMERCE 3-21-2011.

3,999,994. FIELDS, RICHARD, DBA R&H ENTERTAINMENT, STOCKTON, CA. SN 85-195,868. FILED P.R. 12-11-2010; AM. S.R. 6-6-2011.



THE COLOR(S) BLACK, RED, GRAY IS/ARE CLAIMED AS A FEATURE OF THE MARK.
 THE MARK CONSISTS OF BLACK LETTERING FOR "I", "TEACHERS", RED HEART, AND A GRAY OUTLINE OF BREASTS.
 FOR SHIRTS; SHIRTS AND SHORT-SLEEVED SHIRTS (U.S. CLS. 22 AND 39).
 FIRST USE 12-11-2010; IN COMMERCE 12-11-2010.

CLASS 25—(Continued).

4,000,053. LAND, SHANE M., DBA XXPULSION, ELK GROVE, CA. SN 85-259,252. FILED P.R. 3-6-2011; AM. S.R. 6-7-2011.



THE MARK CONSISTS OF A FIVE POINTED STAR THAT APPEARS BROKEN INTO SEVERAL RANDOM PIECES.
 FOR ATHLETIC APPAREL, NAMELY, SHIRTS, PANTS, JACKETS, FOOTWEAR, HATS AND CAPS, ATHLETIC UNIFORMS; BUTTON-FRONT ALOHA SHIRTS; DRESS SHIRTS; HOODED SWEAT SHIRTS; KNIT SHIRTS; LONG-SLEEVED SHIRTS; OPEN-NECKED SHIRTS; SHIRTS; SHIRTS FOR SUITS; SHORT-SLEEVED SHIRTS; SLEEVES WORN SEPARATE AND APART FROM BLOUSES, SHIRTS AND OTHER TOPS; SPORTS SHIRTS WITH SHORT SLEEVES; WOMEN'S CLOTHING, NAMELY, SHIRTS, DRESSES, SKIRTS, BLOUSES (U.S. CLS. 22 AND 39).
 FIRST USE 10-28-2009; IN COMMERCE 10-28-2009.

4,000,058. SWANSON, KEVIN A., DBA SAN DIEGO 2015, SAN DIEGO, CA. SN 85-324,978. FILED P.R. 5-19-2011; AM. S.R. 6-13-2011.

SAN DIEGO 2015

THE MARK CONSISTS OF STANDARD CHARACTERS WITHOUT CLAIM TO ANY PARTICULAR FONT, STYLE, SIZE, OR COLOR.
 FOR APPAREL FOR DANCERS, NAMELY, TEE SHIRTS, SWEATSHIRTS, PANTS, LEGGINGS, SHORTS AND JACKETS; ATHLETIC APPAREL, NAMELY, SHIRTS, PANTS, JACKETS, FOOTWEAR, HATS AND CAPS, ATHLETIC UNIFORMS; BASEBALL CAPS AND HATS; BELTS; BELTS FOR CLOTHING; CLOTHING FOR BABIES, TODDLERS AND CHILDREN, TREATED WITH FIRE AND HEAT RETARDANTS, NAMELY, PAJAMAS, JACKETS, SHIRTS, PANTS, JUMPERS; GOLF PANTS, SHIRTS AND SKIRTS; GOLF SHIRTS; HATS; HEADGEAR, NAMELY, HATS AND CAPS; JACKETS; PANTS; SCIENTIFIC AND TECHNOLOGICAL APPAREL, NAMELY, SHIRTS, PANTS, JACKETS, FOOTWEAR, HATS AND CAPS, UNIFORMS; SHIRTS; SPORTS CAPS AND HATS (U.S. CLS. 22 AND 39).
 FIRST USE 2-11-2011; IN COMMERCE 2-11-2011.

CLASS 26—FANCY GOODS

CLASS 26—(Continued).

3,999,984. HARWOOD, LINDA, NORTHRIDGE, CA. SN 85-153,152. FILED P.R. 10-14-2010; AM. S.R. 5-9-2011.

Heat Press Batting Together

THE MARK CONSISTS OF STANDARD CHARACTERS WITHOUT CLAIM TO ANY PARTICULAR FONT, STYLE, SIZE, OR COLOR.

FOR WEBBING IN THE NATURE OF KNIT FABRIC TAPE FOR SEWING PURPOSES, NAMELY, A FUSIBLE STRETCH FABRIC TAPE USED FOR FUSING QUILTING BATTING FABRIC TOGETHER (U.S. CLS. 37, 39, 40, 42 AND 50).

FIRST USE 2-28-2010; IN COMMERCE 2-28-2010.

CLASS 28—TOYS AND SPORTING GOODS

3,999,983. HUR USA INC, NORTHBROOK, IL. SN 85-152,278. FILED P.R. 10-14-2010; AM. S.R. 3-31-2011.

THE ACTIVE AGING COMPANY

THE MARK CONSISTS OF STANDARD CHARACTERS WITHOUT CLAIM TO ANY PARTICULAR FONT, STYLE, SIZE, OR COLOR.

NO CLAIM IS MADE TO THE EXCLUSIVE RIGHT TO USE "COMPANY", APART FROM THE MARK AS SHOWN. FOR MANUALLY-OPERATED EXERCISE EQUIPMENT FOR PHYSICAL FITNESS PURPOSES; FITNESS EQUIPMENT, NAMELY, BALANCE BOARDS (U.S. CLS. 22, 23, 38 AND 50).

FIRST USE 1-1-2008; IN COMMERCE 1-1-2008.

4,000,016. PURSELL MANUFACTURING CORPORATION, PONCHA SPRINGS, CO. SN 85-231,066. FILED P.R. 2-1-2011; AM. S.R. 6-8-2011.

Golden Spike Rebar Stands

THE MARK CONSISTS OF STANDARD CHARACTERS WITHOUT CLAIM TO ANY PARTICULAR FONT, STYLE, SIZE, OR COLOR.

NO CLAIM IS MADE TO THE EXCLUSIVE RIGHT TO USE "SPIKE REBAR STANDS", APART FROM THE MARK AS SHOWN.

FOR CHRISTMAS TREE STANDS (U.S. CLS. 22, 23, 38 AND 50).

FIRST USE 1-13-2009; IN COMMERCE 8-5-2010.

CLASS 29—MEATS AND PROCESSED FOODS

3,999,893. AMERICAN SEAFOODS GROUP LLC, SEATTLE, WA. SN 77-725,823. FILED P.R. 4-30-2009; AM. S.R. 5-12-2011.

CAPE COD STYLE

THE MARK CONSISTS OF STANDARD CHARACTERS WITHOUT CLAIM TO ANY PARTICULAR FONT, STYLE, SIZE, OR COLOR.

FOR SEAFOOD (U.S. CL. 46).

FIRST USE 3-26-2010; IN COMMERCE 3-26-2010.

3,999,991. BURNETTE FOODS, INC., ELK RAPIDS, MI. SN 85-180,736. FILED P.R. 11-19-2010; AM. S.R. 6-7-2011.

Deshler Brand

THE MARK CONSISTS OF STANDARD CHARACTERS WITHOUT CLAIM TO ANY PARTICULAR FONT, STYLE, SIZE, OR COLOR.

NO CLAIM IS MADE TO THE EXCLUSIVE RIGHT TO USE "BRAND", APART FROM THE MARK AS SHOWN.

FOR CANNED FRUITS AND VEGETABLES; FRUIT PUREES (U.S. CL. 46).

FIRST USE 9-13-2010; IN COMMERCE 10-18-2010.

4,000,021. COBSCOOK BAY COMPANY, LLC, PORTLAND, ME. SN 85-235,309. FILED P.R. 2-7-2011; AM. S.R. 5-26-2011.

Maine Fresh

THE MARK CONSISTS OF STANDARD CHARACTERS WITHOUT CLAIM TO ANY PARTICULAR FONT, STYLE, SIZE, OR COLOR.

FOR FROZEN PRE-PACKAGED ENTREES CONSISTING PRIMARILY OF SEAFOOD (U.S. CL. 46).

FIRST USE 11-15-2010; IN COMMERCE 11-15-2010.

CLASS 30—STAPLE FOODS

CLASS 30—(Continued).

3,999,894. CONSEAL INTERNATIONAL INCORPORATED, NORWOOD, MA. SN 77-858,518. FILED P.R. 10-27-2009; AM. S.R. 6-10-2011.

NEVER BAKED

THE MARK CONSISTS OF STANDARD CHARACTERS WITHOUT CLAIM TO ANY PARTICULAR FONT, STYLE, SIZE, OR COLOR.

FOR COOKIES; CRACKERS; BISCUITS; BREADS; PASTRIES; CAKES; DOUGHNUTS; MUFFINS; READY TO EAT, CEREAL DERIVED FOOD BARS; GRAIN-BASED SNACK FOODS; ALL OF THE FOREGOING PREPARED BY A PROCESS OTHER THAN HEATING (U.S. CL. 46).

FIRST USE 1-6-2010; IN COMMERCE 1-6-2010.

4,000,026. DILETTANTE CHOCOLATES, INC., KENT, WA. SN 85-242,603. FILED P.R. 2-15-2011; AM. S.R. 6-1-2011.

BISCOTTI BITES

THE MARK CONSISTS OF STANDARD CHARACTERS WITHOUT CLAIM TO ANY PARTICULAR FONT, STYLE, SIZE, OR COLOR.

FOR COOKIES (U.S. CL. 46).

FIRST USE 2-25-2009; IN COMMERCE 7-15-2009.

4,000,027. DILETTANTE CHOCOLATES, INC., KENT, WA. SN 85-242,625. FILED P.R. 2-15-2011; AM. S.R. 6-1-2011.

TRUFFLECREMES

THE MARK CONSISTS OF STANDARD CHARACTERS WITHOUT CLAIM TO ANY PARTICULAR FONT, STYLE, SIZE, OR COLOR.

FOR CHOCOLATES (U.S. CL. 46).

FIRST USE 11-22-2006; IN COMMERCE 1-24-2007.

CLASS 31—NATURAL AGRICULTURAL PRODUCTS

CLASS 31—(Continued).

3,999,886. MCMULLIN, BRUCE, MIDVALE, UT. AND MCMULLIN, DUSTY, MIDVALE, UT. AND MCMULLIN, PETER, MIDVALE, UT. SN 77-601,712. FILED P.R. 10-27-2008; AM. S.R. 6-6-2011.

SeaBuck Complete

THE MARK CONSISTS OF STANDARD CHARACTERS WITHOUT CLAIM TO ANY PARTICULAR FONT, STYLE, SIZE, OR COLOR.

NO CLAIM IS MADE TO THE EXCLUSIVE RIGHT TO USE "COMPLETE", APART FROM THE MARK AS SHOWN. FOR ANIMAL FEED SUPPLEMENT FOR EQUINE, CATTLE AND SMALL ANIMALS, INCLUDING DOMESTICATED ANIMALS (U.S. CLS. 1 AND 46).

FIRST USE 5-31-2006; IN COMMERCE 5-31-2006.

3,999,935. TASTEFUL SELECTIONS, LLC, BANCROFT, WI. SN 85-077,907. FILED P.R. 7-5-2010; AM. S.R. 5-11-2011.

Sunrise Medley

THE MARK CONSISTS OF STANDARD CHARACTERS WITHOUT CLAIM TO ANY PARTICULAR FONT, STYLE, SIZE, OR COLOR.

NO CLAIM IS MADE TO THE EXCLUSIVE RIGHT TO USE "SUNRISE", APART FROM THE MARK AS SHOWN. FOR FRESH POTATOES (U.S. CLS. 1 AND 46).

FIRST USE 6-1-2010; IN COMMERCE 6-1-2010.

3,999,982. JONES, DAVID, HONDO, TX. SN 85-147,156. FILED P.R. 10-7-2010; AM. S.R. 5-27-2011.

Sweet Medina

THE MARK CONSISTS OF STANDARD CHARACTERS WITHOUT CLAIM TO ANY PARTICULAR FONT, STYLE, SIZE, OR COLOR.

FOR FRESH VEGETABLES (U.S. CLS. 1 AND 46).

FIRST USE 4-10-2010; IN COMMERCE 4-10-2010.

CLASS 31—(Continued).

3,999,990. NATURAL BALANCE PET FOODS, INC., PACOIMA, CA. SN 85-170,715. FILED P.R. 11-5-2010; AM. S.R. 5-27-2011.

PERFECT BITES

THE MARK CONSISTS OF STANDARD CHARACTERS WITHOUT CLAIM TO ANY PARTICULAR FONT, STYLE, SIZE, OR COLOR.
FOR PET FOOD, CAT FOOD AND CAT TREATS (U.S. CLS. 1 AND 46).
FIRST USE 4-11-2011; IN COMMERCE 4-11-2011.

CLASS 32—LIGHT BEVERAGES

3,999,942. B&R LIQUID ADVENTURE LLC, ROLLING HILLS, CA. SN 85-087,186. FILED P.R. 7-18-2010; AM. S.R. 5-26-2011.

búcha

THE MARK CONSISTS OF STANDARD CHARACTERS WITHOUT CLAIM TO ANY PARTICULAR FONT, STYLE, SIZE, OR COLOR.
FOR NON-ALCOHOLIC BEVERAGES WITH TEA FLAVOR (U.S. CLS. 45, 46 AND 48).
FIRST USE 9-7-2010; IN COMMERCE 9-7-2010.

CLASS 33—WINES AND SPIRITS

CLASS 33—(Continued).

3,999,925. TEQUILERA MILAGRO, S.A. DE C.V., COL. DE SARROLLO SANTAFE, MEXICO. SN 85-017,908. FILED P.R. 4-20-2010; AM. S.R. 2-3-2011.



THE COLOR(S) BLUE AND CLEAR IS/ARE CLAIMED AS A FEATURE OF THE MARK.
THE MARK CONSISTS OF THE COLORS BLUE AND CLEAR AS APPLIED TO A BOTTLE OF DISTILLED SPIRITS, THE BLUE COLOR IS SOLID AND SEMI-TRANSPARENT NEAR THE TOP AND BOTTOM OF THE BOTTLE AND FADES IN INTENSITY AS IT PROGRESSES TOWARDS THE MIDDLE OF THE BOTTLE SO THAT THE MIDDLE OF THE BOTTLE IS CLEAR. THE BOTTLE CAP AND THE SHAPE OF THE BOTTLE, BOTH SHOWN IN DASHED LINES, ARE NOT CLAIMED AS FEATURES OF THE MARK.
FOR DISTILLED SPIRITS (U.S. CLS. 47 AND 49).
FIRST USE 0-0-1998; IN COMMERCE 0-0-1998.

SERVICE MARKS

CLASS 35—ADVERTISING AND BUSINESS

3,999,900. TECHNOLOGY INNOVATION FOR SUSTAINABLE SOCIETIES, BERKELEY, CA. SN 77-914,950. FILED P.R. 1-19-2010; AM. S.R. 5-11-2011.

Berkeley-Darfur Stove

THE MARK CONSISTS OF STANDARD CHARACTERS WITHOUT CLAIM TO ANY PARTICULAR FONT, STYLE, SIZE, OR COLOR.
FOR PROMOTING THE RESEARCH, DEVELOPMENT, DISTRIBUTION AND USAGE OF A FUEL EFFICIENT COOKING STOVE IN DARFUR (U.S. CLS. 100, 101 AND 102).
FIRST USE 6-18-2006; IN COMMERCE 6-18-2006.

CLASS 35—(Continued).

3,999,902. LUCRATIVE MINDS, LLC, CHELMSFORD, MA. SN 77-917,941. FILED P.R. 1-22-2010; AM. S.R. 5-31-2011.

**OPPORTUNITY COMPATIBILITY
ENGINE**

THE MARK CONSISTS OF STANDARD CHARACTERS WITHOUT CLAIM TO ANY PARTICULAR FONT, STYLE, SIZE, OR COLOR.

FOR PROVIDING AN ON-LINE SEARCHABLE DATABASE FEATURING CLASSIFIED AD LISTINGS AND EMPLOYMENT OPPORTUNITIES; PROVIDING AN ON-LINE SEARCHABLE DATABASE FEATURING EMPLOYMENT OPPORTUNITIES; PROVIDING AN ON-LINE SEARCHABLE DATABASE FEATURING EMPLOYMENT OPPORTUNITIES AND CONTENT ABOUT EMPLOYMENT; PROVIDING EMPLOYMENT INFORMATION (U.S. CLS. 100, 101 AND 102).

FIRST USE 11-26-2010; IN COMMERCE 12-17-2010.

3,999,917. NC UPHOLSTERY, LLC, DBA CAROLINA GIRL FURNITURE, ASHEBORO, NC. SN 77-960,768. FILED P.R. 3-17-2010; AM. S.R. 5-27-2011.

*Carolina*girlfurniture

NO CLAIM IS MADE TO THE EXCLUSIVE RIGHT TO USE "FURNITURE", APART FROM THE MARK AS SHOWN.

THE MARK CONSISTS OF "CAROLINA GIRL FURNITURE" IN STYLIZED FONT.

FOR ONLINE RETAIL FURNITURE STORE (U.S. CLS. 100, 101 AND 102).

FIRST USE 11-1-2009; IN COMMERCE 11-1-2009.

3,999,919. AMERICAN PAYMENT SYSTEMS, INC., OMAHA, NE. SN 77-963,061. FILED P.R. 3-19-2010; AM. S.R. 4-13-2011.

**THE DISCOUNT, LOYALTY,
PAYMENT CARD...ALL IN ONE**

THE MARK CONSISTS OF STANDARD CHARACTERS WITHOUT CLAIM TO ANY PARTICULAR FONT, STYLE, SIZE, OR COLOR.

FOR ADMINISTRATION OF A DISCOUNT PROGRAM FOR ENABLING PARTICIPANTS TO OBTAIN DISCOUNTS ON GOODS AND SERVICES THROUGH USE OF AN ENCODED MAGNETIC MEMBERSHIP ACH PAYMENT, DISCOUNT AND REWARDS CARD (U.S. CLS. 100, 101 AND 102).

FIRST USE 10-1-2009; IN COMMERCE 11-9-2010.

CLASS 35—(Continued).

3,999,922. CINEMA SOLUTIONS, INC., SAN ANTONIO, TX. SN 85-000,820. FILED 3-29-2010.

Cinema Solutions

THE MARK CONSISTS OF STANDARD CHARACTERS WITHOUT CLAIM TO ANY PARTICULAR FONT, STYLE, SIZE, OR COLOR.

FOR PURCHASING AGENTS FOR THE MOVIE THEATRE INDUSTRY (U.S. CLS. 100, 101 AND 102).

FIRST USE 3-0-2000; IN COMMERCE 3-0-2000.

3,999,929. ECOCOALITION, INC., CALABASAS, CA. SN 85-038,232. FILED P.R. 5-13-2010; AM. S.R. 2-15-2011.

ECO COALITION

THE MARK CONSISTS OF STANDARD CHARACTERS WITHOUT CLAIM TO ANY PARTICULAR FONT, STYLE, SIZE, OR COLOR.

NO CLAIM IS MADE TO THE EXCLUSIVE RIGHT TO USE "COALITION", APART FROM THE MARK AS SHOWN.

FOR PROMOTING PUBLIC AWARENESS OF ENVIRONMENTAL ISSUES AND INITIATIVES, AND ENVIRONMENTALLY CONSCIOUS AND SUSTAINABLE PRACTICES (U.S. CLS. 100, 101 AND 102).

FIRST USE 4-22-2010; IN COMMERCE 4-22-2010.

3,999,936. RICHARD A. WALKER, ALPHARETTA, GA. SN 85-078,032. FILED P.R. 7-5-2010; AM. S.R. 4-17-2011.

**Carolina Automotive
Manufacturers Association**

THE MARK CONSISTS OF STANDARD CHARACTERS WITHOUT CLAIM TO ANY PARTICULAR FONT, STYLE, SIZE, OR COLOR.

NO CLAIM IS MADE TO THE EXCLUSIVE RIGHT TO USE "ASSOCIATION", APART FROM THE MARK AS SHOWN.

FOR ASSOCIATION SERVICES, NAMELY, PROMOTING THE INTERESTS OF THOSE INVOLVED IN THE AUTOMOTIVE INDUSTRY (U.S. CLS. 100, 101 AND 102).

FIRST USE 7-6-2010; IN COMMERCE 7-8-2010.

CLASS 35—(Continued).

3,999,939. IRON TRIANGLE, LLC, WAUWATOSA, WI. SN 85-084,167. FILED P.R. 7-14-2010; AM. S.R. 5-3-2011.

CLASS 35—(Continued).

3,999,949. WESTPORT BUSINESS SOLUTIONS, LLC., WESTPORT, CT. SN 85-092,694. FILED P.R. 7-26-2010; AM. S.R. 5-25-2011.

Taddeos

WESTPORT BUSINESS SOLUTIONS

THE MARK CONSISTS OF STANDARD CHARACTERS WITHOUT CLAIM TO ANY PARTICULAR FONT, STYLE, SIZE, OR COLOR.

FOR ON-LINE RETAIL STORE SERVICES FEATURING JEWELRY AND FASHION ACCESSORIES (U.S. CLS. 100, 101 AND 102).

FIRST USE 2-1-2010; IN COMMERCE 6-1-2010.

THE MARK CONSISTS OF STANDARD CHARACTERS WITHOUT CLAIM TO ANY PARTICULAR FONT, STYLE, SIZE, OR COLOR.

NO CLAIM IS MADE TO THE EXCLUSIVE RIGHT TO USE "WESTPORT", APART FROM THE MARK AS SHOWN.

FOR BUSINESS SERVICES, NAMELY, BUSINESS MANAGEMENT SERVICES; BUSINESS CONSULTING SERVICES; BUSINESS MANAGEMENT CONSULTING SERVICES; ACCOUNTING SERVICES; BUSINESS AUDITING SERVICES; BUSINESS HUMAN RESOURCE SERVICES; BUSINESS MARKETING SERVICES; GENERAL BUSINESS NETWORKING REFERRAL SERVICES, NAMELY, NAMELY, PROMOTING THE GOODS AND SERVICES OF OTHERS BY PASSING BUSINESS LEAD AND REFERRALS AMONG GROUP MEMBERS (U.S. CLS. 100, 101 AND 102).

FIRST USE 3-30-2010; IN COMMERCE 3-30-2010.

3,999,940. DISCOUNT METRICS CORP., TORONTO, CANADA. SN 85-086,133. FILED P.R. 7-16-2010; AM. S.R. 5-25-2011.

3,999,960. CONNECTWITHCOACHES, LLC, CASTLE ROCK, CO. SN 85-103,627. FILED P.R. 8-9-2010; AM. S.R. 5-26-2011.

GROCERYPLANNER

ConnectwithCoaches.com

THE MARK CONSISTS OF STANDARD CHARACTERS WITHOUT CLAIM TO ANY PARTICULAR FONT, STYLE, SIZE, OR COLOR.

FOR ADVERTISING SERVICES, NAMELY, PROMOTING THE GOODS AND SERVICES OF OTHERS BY PROVIDING A WEB SITE FEATURING COUPONS, REBATES, PRICE OPTIMIZATION AND PRICE COMPARISON INFORMATION, PRODUCTS REVIEWS, AND LINKS TO THE RETAIL WEB SITES OF OTHERS; PRICE-COMPARISON SERVICES; COMPARISON SHOPPING SERVICES; PROMOTING THE GOODS AND SERVICES OF OTHERS THROUGH PROMOTION AGGREGATION, VERTICAL SEARCH, AND COUPON SEARCH AND MANAGEMENT; COMPARISON GROCERY SHOPPING SERVICES; PROVIDING A SEARCHABLE ONLINE ADVERTISING WEBSITE AND INFORMATIONAL GUIDE FEATURING THE GOODS AND SERVICES OF OTHER VENDORS VIA THE INTERNET IN THE FIELD OF GROCERY STORE GOODS; PROVIDING CONSUMER PRODUCT INFORMATION AND ADVERTISING VIA THE INTERNET FOR CONSUMERS, NAMELY, FOR SHOPPERS OF ALL AGES (U.S. CLS. 100, 101 AND 102).

FIRST USE 2-20-2010; IN COMMERCE 2-20-2010.

THE MARK CONSISTS OF STANDARD CHARACTERS WITHOUT CLAIM TO ANY PARTICULAR FONT, STYLE, SIZE, OR COLOR.

FOR PROVIDING A WEBSITE WHICH ALLOWS STUDENT ATHLETES TO MARKET THEIR ACADEMIC AND ATHLETIC TALENTS IN THE SPORTS WHERE THEY COMPETE TO COLLEGE COACHES AND RECRUITERS IN ORDER FIND A CONNECTION FOR THE PURPOSE OF FINDING AND GAINING A COLLEGE SCHOLARSHIP (U.S. CLS. 100, 101 AND 102).

FIRST USE 8-11-2009; IN COMMERCE 6-30-2010.

CLASS 35—(Continued).

3,999,966. SOCIETY FOR PEDIATRIC SEDATION, INC., RICHMOND, VA. SN 85-110,014. FILED P.R. 8-18-2010; AM. S.R. 5-17-2011.

THE SOCIETY FOR PEDIATRIC
SEDATION

THE MARK CONSISTS OF STANDARD CHARACTERS WITHOUT CLAIM TO ANY PARTICULAR FONT, STYLE, SIZE, OR COLOR.

FOR ASSOCIATION SERVICES, NAMELY, PROMOTING THE INTERESTS OF PEDIATRIC SEDATION HEALTH CARE PROVIDERS; BUSINESS SERVICES, NAMELY, FORMULATION AND PROMOTION OF BEST PRACTICES FOR PEDIATRIC SEDATION CARE (U.S. CLS. 100, 101 AND 102).

FIRST USE 6-19-2007; IN COMMERCE 6-19-2007.

3,999,978. MARTINE JOSEPH, MARGATE, FL. SN 85-135,494. FILED P.R. 9-22-2010; AM. S.R. 5-29-2011.

LaMartine

THE MARK CONSISTS OF STANDARD CHARACTERS WITHOUT CLAIM TO ANY PARTICULAR FONT, STYLE, SIZE, OR COLOR.

FOR RETAIL STORE AND ON-LINE RETAIL STORE SERVICES FEATURING CLOTHING, NAMELY, WOMEN'S DRESSES, PANTS, BLOUSES, PURSES AND ACCESSORIES (U.S. CLS. 100, 101 AND 102).

FIRST USE 10-30-2010; IN COMMERCE 10-30-2010.

3,999,992. DENTAL IDEA LAB LLC, NEWTON, MA. SN 85-187,242. FILED 11-30-2010.

Master Dentists Academy

THE MARK CONSISTS OF STANDARD CHARACTERS WITHOUT CLAIM TO ANY PARTICULAR FONT, STYLE, SIZE, OR COLOR.

CLASS 35—(Continued).

NO CLAIM IS MADE TO THE EXCLUSIVE RIGHT TO USE "DENTISTS ACADEMY", APART FROM THE MARK AS SHOWN.

FOR ADVERTISING AND MARKETING CONSULTANCY WITH REGARD TO MARKETING OF PROFESSIONAL DENTAL SERVICES PROVIDED BY A PROFESSIONAL ACADEMY COMPOSED OF DENTISTS AND DENTAL LABORATORY ORGANIZATIONS AND PROVIDING WRITTEN TRAINING MATERIAL REGARDING ADVERTISING AND MARKETING THEREWITH (U.S. CLS. 100, 101 AND 102).

FIRST USE 11-5-2010; IN COMMERCE 11-5-2010.

4,000,008. SUSTAINABLE STEAM & WATER SOLUTIONS, INC., GREENCASTLE, IN. SN 85-224,254. FILED P.R. 1-24-2011; AM. S.R. 5-27-2011.

Sustainable
Steam

THE MARK CONSISTS OF THE STYLIZED TEXT "SUSTAINABLE STEAM".

FOR BUSINESS CONSULTING SERVICES FOR THE STEAM SYSTEM ENERGY INDUSTRY; CONSULTING SERVICES IN THE FIELDS OF STEAM ENERGY CONSUMPTION AND USAGE CONSERVATION TO IMPROVE STEAM ENERGY EFFICIENCY (U.S. CLS. 100, 101 AND 102).

FIRST USE 12-23-2010; IN COMMERCE 12-23-2010.

4,000,010. TURNSTILE PUBLISHING COMPANY, ORLANDO, FL. SN 85-227,538. FILED P.R. 1-27-2011; AM. S.R. 5-24-2011.

PROFESSIONAL
artist

THE MARK CONSISTS OF THE WORD "PROFESSIONAL" IN ALL CAPS ABOVE THE WORD "ARTIST" IN LARGER LOWER CASE FONT.

FOR PROVIDING A WEBSITE FOR PROFESSIONAL ARTISTS FEATURING INFORMATION ABOUT BUSINESS, MARKETING, AND CAREER ISSUES PERTAINING TO BECOMING A PROFESSIONAL ARTIST OR MAINTAINING A CAREER AS A PROFESSIONAL ARTIST (U.S. CLS. 100, 101 AND 102).

FIRST USE 1-14-2011; IN COMMERCE 1-14-2011.

CLASS 35—(Continued).

4,000,011. TURNSTILE PUBLISHING COMPANY, ORLANDO, FL. SN 85-227,540. FILED P.R. 1-27-2011; AM. S.R. 5-24-2011.

PROFESSIONAL ARTIST

THE MARK CONSISTS OF STANDARD CHARACTERS WITHOUT CLAIM TO ANY PARTICULAR FONT, STYLE, SIZE, OR COLOR.

FOR PROVIDING A WEBSITE FOR PROFESSIONAL ARTISTS FEATURING INFORMATION ABOUT BUSINESS, MARKETING, AND CAREER ISSUES PERTAINING TO BECOMING A PROFESSIONAL ARTIST OR MAINTAINING A CAREER AS A PROFESSIONAL ARTIST (U.S. CLS. 100, 101 AND 102).

FIRST USE 1-14-2011; IN COMMERCE 1-14-2011.

4,000,024. TRI-ENERGY SOLUTIONS, LLC, LIVONIA, MI. SN 85-240,248. FILED P.R. 2-11-2011; AM. S.R. 5-18-2011.

THE POWER SOURCE PROFESSIONALS

THE MARK CONSISTS OF STANDARD CHARACTERS WITHOUT CLAIM TO ANY PARTICULAR FONT, STYLE, SIZE, OR COLOR.

NO CLAIM IS MADE TO THE EXCLUSIVE RIGHT TO USE "POWER SOURCE", APART FROM THE MARK AS SHOWN.

FOR RETAIL STORE AND ON-LINE RETAIL STORE SERVICES FEATURING BATTERIES, POWER SUPPLIES AND POWER CONVERTERS (U.S. CLS. 100, 101 AND 102).

FIRST USE 9-8-2010; IN COMMERCE 2-8-2011.

4,000,031. CACHE MEDICAL CONNECTIONS LLC, DBA URGENT CARE AMERICA, FORT MYERS, FL. SN 85-245,953. FILED 2-18-2011.

URGENT CARE AMERICA

THE MARK CONSISTS OF STANDARD CHARACTERS WITHOUT CLAIM TO ANY PARTICULAR FONT, STYLE, SIZE, OR COLOR.

OWNER OF U.S. REG. NO. 3,734,718.

NO CLAIM IS MADE TO THE EXCLUSIVE RIGHT TO USE "URGENT CARE", APART FROM THE MARK AS SHOWN.

FOR MANAGEMENT OF URGENT MEDICAL CARE FACILITIES FOR OTHERS (U.S. CLS. 100, 101 AND 102).

FIRST USE 12-4-2007; IN COMMERCE 4-1-2008.

CLASS 35—(Continued).

4,000,032. NATIONAL ALLBALL ASSOCIATION, LLC, MONTVILLE, NJ. SN 85-246,733. FILED P.R. 2-18-2011; AM. S.R. 6-1-2011.

National Allball Association

THE MARK CONSISTS OF STANDARD CHARACTERS WITHOUT CLAIM TO ANY PARTICULAR FONT, STYLE, SIZE, OR COLOR.

NO CLAIM IS MADE TO THE EXCLUSIVE RIGHT TO USE "ASSOCIATION", APART FROM THE MARK AS SHOWN.

FOR ASSOCIATION SERVICES, NAMELY, PROMOTING THE INTERESTS OF PROFESSIONAL AND AMATEUR NATIONAL ALL BALL ASSOCIATION TEAMS AND CLUBS; PROMOTING INTEREST IN THE NATIONAL ALLBALL ASSOCIATION; PROVIDING A FORUM FOR MEMBERS OF THE NATIONAL ALLBALL ASSOCIATION TEAMS TO SHOWCASE, DISPLAY, DEMONSTRATE AND PROMOTE IDEAS, PRODUCTS, AND SERVICES IN CONNECTION WITH THE NATIONAL ALLBALL ASSOCIATION (U.S. CLS. 100, 101 AND 102).

FIRST USE 4-15-2011; IN COMMERCE 5-26-2011.

4,000,033. BOWEN, GRANT, SAN FRANCISCO, CA. SN 85-246,826. FILED P.R. 2-18-2011; AM. S.R. 5-25-2011.

snowboard green

THE MARK CONSISTS OF STANDARD CHARACTERS WITHOUT CLAIM TO ANY PARTICULAR FONT, STYLE, SIZE, OR COLOR.

FOR PROVIDING A WEBSITE FEATURING BUSINESS-RELATED AND COMMERCIAL INFORMATION ON THE SNOWBOARDING INDUSTRY FEATURING ENVIRONMENTALLY-CONSCIOUS COMPANIES AND GREEN INNOVATIONS (U.S. CLS. 100, 101 AND 102).

FIRST USE 2-22-2009; IN COMMERCE 6-30-2010.

4,000,041. LETENDRE-HEDLUND, MICHELLE, MOUND, MN. SN 85-250,277. FILED P.R. 2-24-2011; AM. S.R. 6-1-2011.

Environmental Advancement Foundation

THE MARK CONSISTS OF STANDARD CHARACTERS WITHOUT CLAIM TO ANY PARTICULAR FONT, STYLE, SIZE, OR COLOR.

CLASS 35—(Continued).

NO CLAIM IS MADE TO THE EXCLUSIVE RIGHT TO USE "FOUNDATION", APART FROM THE MARK AS SHOWN.
 FOR CHARITABLE SERVICES, NAMELY, ORGANIZING AND DEVELOPING PROJECTS TO PROMOTE AWARENESS OF TREE AND ENVIRONMENTAL CONSERVATION (U.S. CLS. 100, 101 AND 102).
 FIRST USE 11-1-2008; IN COMMERCE 1-1-2009.

CLASS 37—(Continued).

3,999,997. THE PROSSER GROUP LLC, BROOKLYN, NY. SN 85-202,483. FILED P.R. 12-21-2010; AM. S.R. 6-9-2011.

GREEN CHARGE NETWORKS

CLASS 36—INSURANCE AND FINANCIAL

4,000,035. WYOMING VALLEY HEALTH & EDUCATION FOUNDATION, WILKES-BARRE, PA. SN 85-247,656. FILED P.R. 2-21-2011; AM. S.R. 5-27-2011.

THE MARK CONSISTS OF STANDARD CHARACTERS WITHOUT CLAIM TO ANY PARTICULAR FONT, STYLE, SIZE, OR COLOR.
 FOR CHARGING STATION SERVICES FOR ELECTRIC VEHICLES (U.S. CLS. 100, 103 AND 106).
 FIRST USE 2-1-2011; IN COMMERCE 2-1-2011.

FOUNDATION FOR A GREATER WYOMING VALLEY

THE MARK CONSISTS OF STANDARD CHARACTERS WITHOUT CLAIM TO ANY PARTICULAR FONT, STYLE, SIZE, OR COLOR.
 NO CLAIM IS MADE TO THE EXCLUSIVE RIGHT TO USE "FOUNDATION", APART FROM THE MARK AS SHOWN.
 FOR CHARITABLE FOUNDATION SERVICES, NAMELY, PROVIDING FUND RAISING ACTIVITIES AND FINANCIAL ASSISTANCE TO INDIVIDUALS AND ORGANIZATIONS TO SUPPORT THE PROVISION OF HEALTH CARE SERVICES TO THE UNINSURED, AND PROGRAMS WHICH ADVANCE PUBLIC HEALTH CARE EDUCATION (U.S. CLS. 100, 101 AND 102).
 FIRST USE 12-6-2010; IN COMMERCE 12-6-2010.

CLASS 38—COMMUNICATION

4,000,046. DISASTER INC., ST PETERSBURG, FL. SN 85-252,843. FILED P.R. 2-27-2011; AM. S.R. 5-26-2011.

rescue tv

THE MARK CONSISTS OF STANDARD CHARACTERS WITHOUT CLAIM TO ANY PARTICULAR FONT, STYLE, SIZE, OR COLOR.
 NO CLAIM IS MADE TO THE EXCLUSIVE RIGHT TO USE "TV", APART FROM THE MARK AS SHOWN.
 FOR TELECOMMUNICATION SERVICES, NAMELY, BROADCASTING SERVICES, NAMELY, AUDIO BROADCASTING, VIDEO BROADCASTING, BROADCASTING PROGRAMS VIA A GLOBAL COMPUTER NETWORK; COMMUNICATION SERVICES, NAMELY, STREAMING OF AUDIO MATERIAL ON THE INTERNET, STREAMING OF VIDEO MATERIAL ON THE INTERNET; ELECTRONIC TRANSMISSION OF MESSAGES AND DATA; WEBCASTING SERVICES; PROVIDING ON-LINE FORUMS FOR TRANSMISSION OF MESSAGES AMONG COMPUTER USERS, ALL IN THE FIELD OF RESCUE AND RESCUE OPERATIONS AND SAVING OF LIFE AND PREVENTION OF INJURY (U.S. CLS. 100, 101 AND 104).
 FIRST USE 2-26-2011; IN COMMERCE 2-26-2011.

4,000,048. NATIONAL BANK OF COMMERCE, BIRMINGHAM, AL. SN 85-253,608. FILED 2-28-2011.

NATIONAL BANK OF COMMERCE

THE MARK CONSISTS OF STANDARD CHARACTERS WITHOUT CLAIM TO ANY PARTICULAR FONT, STYLE, SIZE, OR COLOR.
 NO CLAIM IS MADE TO THE EXCLUSIVE RIGHT TO USE "BANK OF COMMERCE", APART FROM THE MARK AS SHOWN.
 FOR BANKING SERVICES; CREDIT AND DEBIT CARD SERVICES; FINANCING SERVICES; MORTGAGE BANKING; TRUST MANAGEMENT ACCOUNTS (U.S. CLS. 100, 101 AND 102).
 FIRST USE 10-30-2010; IN COMMERCE 10-30-2010.

4,000,052. SOHEL DISTRIBUTORS NY LLC, YONKERS, NY. SN 85-257,426. FILED P.R. 3-3-2011; AM. S.R. 6-9-2011.

DOMINI KANITA PHONECARD

CLASS 37—CONSTRUCTION AND REPAIR

THE MARK CONSISTS OF STANDARD CHARACTERS WITHOUT CLAIM TO ANY PARTICULAR FONT, STYLE, SIZE, OR COLOR.

CLASS 38—(Continued).

NO CLAIM IS MADE TO THE EXCLUSIVE RIGHT TO USE "PHONECARD", APART FROM THE MARK AS SHOWN.

THE WORDING "DOMINI KANITA" IS THE PHONETIC EQUIVALENT OF "DOMINICANITA", MEANING "LITTLE DOMINICAN".

FOR TELEPHONE TELECOMMUNICATIONS SERVICES PROVIDED VIA PREPAID TELEPHONE CALLING CARDS (U.S. CLS. 100, 101 AND 104).

FIRST USE 2-18-2011; IN COMMERCE 2-18-2011.

CLASS 39—(Continued).

4,000,056. PALADIN BRANDS GROUP, INC., CEDAR RAPIDS, IA. SN 85-273,347. FILED P.R. 3-22-2011; AM. S.R. 5-27-2011.

QUICKSHIP

THE MARK CONSISTS OF STANDARD CHARACTERS WITHOUT CLAIM TO ANY PARTICULAR FONT, STYLE, SIZE, OR COLOR.

FOR EXPEDITED SHIPPING SERVICES FOR ATTACHMENTS AND PARTS THEREFORE USED WITH CONSTRUCTION, DEMOLITION, RECYCLING, FORESTRY, UTILITY, AND MATERIAL HANDLING VEHICULAR EQUIPMENT (U.S. CLS. 100 AND 105).

FIRST USE 5-12-2011; IN COMMERCE 5-12-2011.

CLASS 39—TRANSPORTATION AND STORAGE

3,999,944. DISPATCH USA, INC., ALTON, IL. SN 85-088,350. FILED P.R. 7-20-2010; AM. S.R. 5-25-2011.

DISPATCH USA

THE MARK CONSISTS OF STANDARD CHARACTERS WITHOUT CLAIM TO ANY PARTICULAR FONT, STYLE, SIZE, OR COLOR.

FOR ARRANGING TRUCK TRANSPORTATION SERVICES FOR SHIPPERS, CARRIERS AND FREIGHT BROKERS (U.S. CLS. 100 AND 105).

FIRST USE 5-1-2009; IN COMMERCE 5-1-2009.

CLASS 41—EDUCATION AND ENTERTAINMENT

3,999,883. PARNELL, LAUREL, SAN RAFAEL, CA. SN 76-682,813. FILED P.R. 10-9-2007; AM. S.R. 7-20-2008.

RESOURCE TAPPING

THE MARK CONSISTS OF STANDARD CHARACTERS WITHOUT CLAIM TO ANY PARTICULAR FONT, STYLE, SIZE, OR COLOR.

FOR EDUCATIONAL SERVICES, NAMELY, CONDUCTING CLASSES, SEMINARS AND TEACHER TRAINING IN THE FIELD OF PSYCHOLOGY AND PSYCHOTHERAPY; DISTRIBUTING COURSE MATERIALS IN CONNECTION THEREWITH SERVICES (U.S. CLS. 100, 101 AND 107).

FIRST USE 1-28-2008; IN COMMERCE 1-28-2008.

4,000,028. KRAULAND, CHAD, MALIBU, CA. SN 85-244,350. FILED P.R. 2-16-2011; AM. S.R. 5-20-2011.

Calabasas Delivery Service

THE MARK CONSISTS OF STANDARD CHARACTERS WITHOUT CLAIM TO ANY PARTICULAR FONT, STYLE, SIZE, OR COLOR.

NO CLAIM IS MADE TO THE EXCLUSIVE RIGHT TO USE "DELIVERY SERVICE", APART FROM THE MARK AS SHOWN.

FOR DELIVERY OF GOODS, FOOD, AND PARCEL (U.S. CLS. 100 AND 105).

FIRST USE 10-1-2010; IN COMMERCE 10-1-2010.

3,999,912. HAWAII MUSIC FESTIVALS, INC., HONOLULU, HI. SN 77-933,744. FILED P.R. 2-11-2010; AM. S.R. 5-24-2011.

HAWAII MUSIC FESTIVALS

THE MARK CONSISTS OF STANDARD CHARACTERS WITHOUT CLAIM TO ANY PARTICULAR FONT, STYLE, SIZE, OR COLOR.

OWNER OF U.S. REG. NOS. 2,946,971, 3,726,837, AND OTHERS.

NO CLAIM IS MADE TO THE EXCLUSIVE RIGHT TO USE "MUSIC FESTIVALS", APART FROM THE MARK AS SHOWN.

FOR ENTERTAINMENT IN THE NATURE OF MUSIC FESTIVALS (U.S. CLS. 100, 101 AND 107).

FIRST USE 3-0-2006; IN COMMERCE 3-0-2006.

CLASS 41—(Continued).

3,999,953. REINKE SPORTS GROUP LLC, WINTER PARK, FL. SN 85-099,061. FILED P.R. 8-3-2010; AM. S.R. 5-23-2011.

Bentonville Half Marathon

THE MARK CONSISTS OF STANDARD CHARACTERS WITHOUT CLAIM TO ANY PARTICULAR FONT, STYLE, SIZE, OR COLOR.

NO CLAIM IS MADE TO THE EXCLUSIVE RIGHT TO USE "HALF MARATHON", APART FROM THE MARK AS SHOWN.

FOR ORGANIZING SPORTING EVENTS, NAMELY, ARRANGING, ORGANIZING, OPERATING AND CONDUCTING RUNNING EVENTS (U.S. CLS. 100, 101 AND 107).

FIRST USE 1-1-2010; IN COMMERCE 1-1-2010.

3,999,954. FLIGHTSAFETY DEVELOPMENT CORP., LAS VEGAS, NV. SN 85-099,116. FILED P.R. 8-3-2010; AM. S.R. 5-23-2011.

LIVELEARNING

THE MARK CONSISTS OF STANDARD CHARACTERS WITHOUT CLAIM TO ANY PARTICULAR FONT, STYLE, SIZE, OR COLOR.

FOR PROVIDING ON-LINE TRAINING COURSES IN THE FIELD OF AVIATION AND AUTOMATION MANAGEMENT, AND WORKBOOKS AND CHARTS DISTRIBUTED IN CONNECTION THEREWITH (U.S. CLS. 100, 101 AND 107).

FIRST USE 3-0-2010; IN COMMERCE 3-0-2011.

3,999,962. TALBOT CLUB, INC., SARASOTA, FL. SN 85-104,029. FILED P.R. 8-10-2010; AM. S.R. 5-26-2011.

TALBOT CLUB

THE MARK CONSISTS OF STANDARD CHARACTERS WITHOUT CLAIM TO ANY PARTICULAR FONT, STYLE, SIZE, OR COLOR.

NO CLAIM IS MADE TO THE EXCLUSIVE RIGHT TO USE "CLUB", APART FROM THE MARK AS SHOWN.

FOR GOLF CLUB SERVICES, NAMELY, PROVIDING ACCESS AND PREFERRED MEMBERSHIP BENEFITS AT PARTICIPATING GOLF COURSES (U.S. CLS. 100, 101 AND 107).

FIRST USE 4-4-2011; IN COMMERCE 4-4-2011.

CLASS 41—(Continued).

3,999,963. TALBOT CLUB, INC., SARASOTA, FL. SN 85-104,031. FILED P.R. 8-10-2010; AM. S.R. 5-26-2011.



NO CLAIM IS MADE TO THE EXCLUSIVE RIGHT TO USE "CLUB" AND "PRIVATE ACCESS GOLF", APART FROM THE MARK AS SHOWN.

THE MARK CONSISTS OF THE TERMS "TALBOT" AND "CLUB" AND A GOLF BALL DESIGN IN PLACE OF THE LETTER "O" IN "TALBOT", ALL AGAINST A RECTANGULAR BACKGROUND.

FOR GOLF CLUB SERVICES, NAMELY, PROVIDING ACCESS AND PREFERRED MEMBERSHIP BENEFITS AT PARTICIPATING GOLF COURSES (U.S. CLS. 100, 101 AND 107).

FIRST USE 4-4-2011; IN COMMERCE 4-4-2011.

3,999,964. THE MOYER FOUNDATION, SEATTLE, WA. SN 85-104,439. FILED P.R. 8-10-2010; AM. S.R. 5-25-2011.

NATIONAL BEREAVEMENT CAMP CONFERENCE

THE MARK CONSISTS OF STANDARD CHARACTERS WITHOUT CLAIM TO ANY PARTICULAR FONT, STYLE, SIZE, OR COLOR.

NO CLAIM IS MADE TO THE EXCLUSIVE RIGHT TO USE "BEREAVEMENT CAMP CONFERENCE", APART FROM THE MARK AS SHOWN.

FOR EDUCATIONAL SERVICES, NAMELY, ARRANGING AND CONDUCTING EDUCATIONAL CONFERENCES, AND ARRANGING AND CONDUCTING WORKSHOPS, SEMINARS, AND TRAINING PROGRAMS IN THE FIELD OF BEREAVEMENT CAMPS FOR CHILDREN AND TEENS AND DISTRIBUTION OF PRINTED MATERIALS IN CONNECTION THEREWITH IN HARD COPY OR ELECTRONIC FORMAT ON THE SAME TOPICS (U.S. CLS. 100, 101 AND 107).

FIRST USE 6-26-2010; IN COMMERCE 6-26-2010.

CLASS 41—(Continued).

3,999,980. TOBIAS, HEIDI RAYDEN, LOS ANGELES, CA. SN 85-141,981. FILED P.R. 9-30-2010; AM. S.R. 5-17-2011.

CHAKRA BHAKTI FLOW

THE MARK CONSISTS OF STANDARD CHARACTERS WITHOUT CLAIM TO ANY PARTICULAR FONT, STYLE, SIZE, OR COLOR.

FOR EDUCATION SERVICES, NAMELY, CONDUCTING CLASSES, SEMINARS, AND TRAINING SESSIONS IN THE FIELD OF FITNESS, HEALTH, YOGA, ATHLETICS, MOTIVATION TRAINING, AND BODY-MIND-SPIRIT TRAINING (U.S. CLS. 100, 101 AND 107).

FIRST USE 12-0-2009; IN COMMERCE 12-0-2009.

3,999,981. SYNTELESYS EDUCATIONAL SERVICES, MONTEREY PARK, CA. SN 85-146,950. FILED P.R. 10-7-2010; AM. S.R. 5-10-2011.

ACADEMIC TUTORING SERVICE

THE MARK CONSISTS OF STANDARD CHARACTERS WITHOUT CLAIM TO ANY PARTICULAR FONT, STYLE, SIZE, OR COLOR.

NO CLAIM IS MADE TO THE EXCLUSIVE RIGHT TO USE "TUTORING SERVICE", APART FROM THE MARK AS SHOWN.

FOR EDUCATION SERVICES, NAMELY, PROVIDING TUTORING IN THE FIELDS OF ENGLISH, MATH, AND STUDY SKILLS (U.S. CLS. 100, 101 AND 107).

FIRST USE 3-1-2009; IN COMMERCE 3-1-2009.

3,999,988. REED ELSEVIER INC., NEWTON, MA. AND THE VISION COUNCIL, ALEXANDRIA, VA. SN 85-166,189. FILED P.R. 11-1-2010; AM. S.R. 4-12-2011.



NO CLAIM IS MADE TO THE EXCLUSIVE RIGHT TO USE "EXPO & CONFERENCE", APART FROM THE MARK AS SHOWN.

CLASS 41—(Continued).

THE MARK CONSISTS OF A DESIGN IN THE SHAPE OF THE LETTER "V" AND THE WORDING "VIRTUAL VISION EXPO & CONFERENCE" TO THE LEFT OF THE DESIGN ALL SUPERIMPOSED OVER THE LETTER "V".

FOR ARRANGING, AND CONDUCTING ONLINE CONFERENCES AND PROGRAMS AND PROVIDING COURSES OF INSTRUCTION IN THE FIELD OF OPTICS, EYEWEAR AND EYECARE SERVICES; PROVIDING ONLINE CONTINUING PROFESSIONAL EDUCATION SEMINARS IN THE FIELD OPTICS, EYEWEAR AND EYECARE SERVICES (U.S. CLS. 100, 101 AND 107).

FIRST USE 11-10-2010; IN COMMERCE 11-10-2010.

4,000,002. THE TRUSTEES OF INDIANA UNIVERSITY, BLOOMINGTON, IN. SN 85-211,641. FILED P.R. 1-6-2011; AM. S.R. 5-12-2011.

A PLACE FOR FILM

THE MARK CONSISTS OF STANDARD CHARACTERS WITHOUT CLAIM TO ANY PARTICULAR FONT, STYLE, SIZE, OR COLOR.

FOR EDUCATIONAL SERVICES RELATING TO A FILM AND LECTURE SERIES, NAMELY, PROVIDING INSTRUCTIONAL COURSES, PUBLIC LECTURES, SEMINARS, SYMPOSIA, CONFERENCES AND WORKSHOPS AT THE UNIVERSITY LEVEL, SPECIFICALLY AT THE UNDERGRADUATE AND GRADUATE LEVELS, IN THE FIELD OF MOTION PICTURE FILMS AND FILM CLIPS (U.S. CLS. 100, 101 AND 107).

FIRST USE 8-16-2010; IN COMMERCE 8-16-2010.

4,000,003. CELEBRITY ENTERPRISES, INC., TIJERAS, NM. SN 85-211,804. FILED P.R. 1-6-2011; AM. S.R. 5-27-2011.

The 3 Painters

THE MARK CONSISTS OF STANDARD CHARACTERS WITHOUT CLAIM TO ANY PARTICULAR FONT, STYLE, SIZE, OR COLOR.

FOR PRESENTATION OF LIVE SHOW PERFORMANCES (U.S. CLS. 100, 101 AND 107).

FIRST USE 3-17-2007; IN COMMERCE 3-17-2007.

CLASS 41—(Continued).

4,000,004. JOHNSON & JOHNSON, NEW BRUNSWICK, NJ. SN 85-212,821. FILED 1-7-2011.

THE VISION CARE INSTITUTE

THE MARK CONSISTS OF STANDARD CHARACTERS WITHOUT CLAIM TO ANY PARTICULAR FONT, STYLE, SIZE, OR COLOR.

OWNER OF U.S. REG. NO. 3,075,294.

NO CLAIM IS MADE TO THE EXCLUSIVE RIGHT TO USE "INSTITUTE", APART FROM THE MARK AS SHOWN.

FOR EDUCATIONAL SERVICES, NAMELY, CONDUCTING CLASSES, SEMINARS, FOCUS GROUPS, WORKSHOPS AND CONFERENCES, TO HELP PREPARE AND TRAIN STUDENTS FOR THEIR CAREERS AS EYE CARE PROFESSIONALS (U.S. CLS. 100, 101 AND 107).

FIRST USE 3-10-2004; IN COMMERCE 3-10-2004.



4,000,005. PARTOVICH, ROBY JON, DBA USA RACQUETBALL ACADEMY, OCEANSIDE, CA. SN 85-214,284. FILED P.R. 1-10-2011; AM. S.R. 4-18-2011.

USA Racquetball Academy

THE MARK CONSISTS OF STANDARD CHARACTERS WITHOUT CLAIM TO ANY PARTICULAR FONT, STYLE, SIZE, OR COLOR.

FOR SPORTS INSTRUCTION SERVICES (U.S. CLS. 100, 101 AND 107).

FIRST USE 11-17-2010; IN COMMERCE 11-17-2010.



4,000,015. PACER CENTER, INC., BLOOMINGTON, MN. SN 85-230,517. FILED P.R. 1-31-2011; AM. S.R. 5-26-2011.

NATIONAL BULLYING PREVENTION CENTER

THE MARK CONSISTS OF STANDARD CHARACTERS WITHOUT CLAIM TO ANY PARTICULAR FONT, STYLE, SIZE, OR COLOR.

CLASS 41—(Continued).

NO CLAIM IS MADE TO THE EXCLUSIVE RIGHT TO USE "CENTER", APART FROM THE MARK AS SHOWN.

FOR EDUCATIONAL SERVICES, NAMELY, CONDUCTING TRAINING, WORKSHOPS, CONFERENCES AND EDUCATIONAL ASSISTANCE IN THE FIELD OF CHILDREN WITH DISABILITIES AND SPECIAL NEEDS, AS WELL AS IN THE FIELD OF INTEGRATING CHILDREN AND YOUTH WITH DISABILITIES INTO MAINSTREAM EDUCATION AND ALL CHILDREN AND YOUTH INCLUDING CHILDREN AND YOUTH WITH DISABILITIES INTO SOCIAL SITUATIONS; AND EDUCATIONAL SERVICES, NAMELY, PUBLICATION OF MANUALS, NEWSLETTERS, PAMPHLETS AND BOOKS IN THE FIELD OF ALL CHILDREN AND YOUTH INCLUDING CHILDREN AND YOUTH WITH DISABILITIES, CHILDREN WITH SPECIAL NEEDS, AND UNDERSERVED CHILDREN AND YOUTH; PROVIDING A WEBSITE FEATURING INFORMATION IN THE FIELD OF EDUCATION FOR ALL CHILDREN AND YOUTH INCLUDING CHILDREN AND YOUTH WITH DISABILITIES AND TEACHING METHODS FOR ALL CHILDREN AND YOUTH INCLUDING CHILDREN AND YOUTH WITH SPECIAL NEEDS (U.S. CLS. 100, 101 AND 107).

FIRST USE 1-20-2011; IN COMMERCE 1-20-2011.



4,000,020. COUNTER-X TECHNICAL SERVICES INCORPORATED, AKA COUNTER THREAT FINANCE CENTER, NAPERVILLE, IL. SN 85-235,154. FILED 2-6-2011.

Counter Threat Finance Center

THE MARK CONSISTS OF STANDARD CHARACTERS WITHOUT CLAIM TO ANY PARTICULAR FONT, STYLE, SIZE, OR COLOR.

NO CLAIM IS MADE TO THE EXCLUSIVE RIGHT TO USE "CENTER", APART FROM THE MARK AS SHOWN.

FOR EDUCATION SERVICES, NAMELY, PROVIDING MENTORING, TUTORING, CLASSES, SEMINARS AND WORKSHOPS IN THE FIELD OF ILLICIT ECONOMIC ACTIVITY (U.S. CLS. 100, 101 AND 107).

FIRST USE 3-1-2009; IN COMMERCE 3-1-2009.



4,000,023. ZEN SEVEN INC., SANTA MONICA, CA. SN 85-238,006. FILED P.R. 2-9-2011; AM. S.R. 6-1-2011.

The Green Yogi

THE MARK CONSISTS OF STANDARD CHARACTERS WITHOUT CLAIM TO ANY PARTICULAR FONT, STYLE, SIZE, OR COLOR.

NO CLAIM IS MADE TO THE EXCLUSIVE RIGHT TO USE "YOGI", APART FROM THE MARK AS SHOWN.

FOR YOGA INSTRUCTION (U.S. CLS. 100, 101 AND 107).

FIRST USE 4-24-2009; IN COMMERCE 9-3-2009.

CLASS 41—(Continued).

4,000,025. THE TRI-SCREEN CONNECTION, LLC, CAPE ELIZABETH, ME. SN 85-240,364. FILED P.R. 2-11-2011; AM. S.R. 5-25-2011.



THE COLOR(S) BLACK, ORANGE, WHITE IS/ARE CLAIMED AS A FEATURE OF THE MARK.

THE MARK CONSISTS OF THE STYLIZED WORDING "WEB-E-BOOKS" WITH THE WORDS "WEB" AND "BOOKS" IN WHITE AND THE CENTERED LETTER "E" IN ORANGE, CONNECTED TO THE WORDS "WEB" AND "BOOKS" BY ORANGE DASHES, ALL AGAINST A BLACK BACKGROUND. THE CENTERED LETTER "E" AND THE LETTERS "KS" IN "BOOKS" ARE DISPLAYED IN LOWER-CASE AND A SCRIPTED FONT, AND THE REMAINING LETTERS ARE DISPLAYED IN UPPER-CASE.

FOR PROVIDING ON-LINE PUBLICATIONS IN THE NATURE OF AN E-BOOK IN THE FIELD OF LITERATURE (U.S. CLS. 100, 101 AND 107).

FIRST USE 2-4-2011; IN COMMERCE 2-9-2011.

4,000,037. EDUCATIONAL SERVICE DISTRICT 112, AKA ESD 112, VANCOUVER, WA. SN 85-248,750. FILED 2-22-2011.

Northwest Service Academy

THE MARK CONSISTS OF STANDARD CHARACTERS WITHOUT CLAIM TO ANY PARTICULAR FONT, STYLE, SIZE, OR COLOR.

NO CLAIM IS MADE TO THE EXCLUSIVE RIGHT TO USE "SERVICE ACADEMY", APART FROM THE MARK AS SHOWN.

FOR EDUCATIONAL SERVICES, NAMELY, PROVIDING TRAINING, SUPERVISION, PLACEMENT AND WORK EXPERIENCE FOR INDIVIDUALS IN THE FIELDS OF ENVIRONMENTAL SCIENCE, RESTORATION AND PRESERVATION (U.S. CLS. 100, 101 AND 107).

FIRST USE 12-9-1993; IN COMMERCE 8-1-1994.

4,000,040. TERI, INC., OCEANSIDE, CA. SN 85-249,844. FILED P.R. 2-23-2011; AM. S.R. 6-1-2011.

Special Needs Life Quality Coach

THE MARK CONSISTS OF STANDARD CHARACTERS WITHOUT CLAIM TO ANY PARTICULAR FONT, STYLE, SIZE, OR COLOR.

CLASS 41—(Continued).

NO CLAIM IS MADE TO THE EXCLUSIVE RIGHT TO USE "LIFE QUALITY COACH", APART FROM THE MARK AS SHOWN.

FOR LIFE COACHING SERVICES IN THE FIELD OF DEVELOPMENTAL DISABILITIES (U.S. CLS. 100, 101 AND 107).

FIRST USE 0-0-2009; IN COMMERCE 0-0-2009.

4,000,044. MARIN, MIGUEL, NEW YORK, NY. SN 85-251,813. FILED P.R. 2-25-2011; AM. S.R. 5-31-2011.

Flamenco Festival Miami

THE MARK CONSISTS OF STANDARD CHARACTERS WITHOUT CLAIM TO ANY PARTICULAR FONT, STYLE, SIZE, OR COLOR.

OWNER OF U.S. REG. NO. 2,902,568.

NO CLAIM IS MADE TO THE EXCLUSIVE RIGHT TO USE "FLAMENCO FESTIVAL", APART FROM THE MARK AS SHOWN.

FOR ENTERTAINMENT IN THE NATURE OF THEATRE PRODUCTIONS, DANCE PERFORMANCES, AND A CONTINUING FLAMENCO DANCE SHOW BROADCAST OVER TELEVISION, SATELLITE, AUDIO AND VIDEO MEDIA (U.S. CLS. 100, 101 AND 107).

FIRST USE 2-1-2004; IN COMMERCE 2-1-2004.

4,000,050. UNITED STATES AMATEUR MIXED MARTIAL ARTS INC., PENSACOLA, AL. SN 85-255,168. FILED P.R. 3-1-2011; AM. S.R. 6-1-2011.

United States Amateur Mixed Martial Arts

THE MARK CONSISTS OF STANDARD CHARACTERS WITHOUT CLAIM TO ANY PARTICULAR FONT, STYLE, SIZE, OR COLOR.

NO CLAIM IS MADE TO THE EXCLUSIVE RIGHT TO USE "AMATEUR MIXED MARTIAL ARTS", APART FROM THE MARK AS SHOWN.

FOR ENCOURAGING AMATEUR SPORTS AND PHYSICAL EDUCATION BY ORGANIZING, SANCTIONING, CONDUCTING, REGULATING AND GOVERNING AMATEUR ATHLETIC PROGRAMS AND ACTIVITIES (U.S. CLS. 100, 101 AND 107).

FIRST USE 2-25-2011; IN COMMERCE 2-25-2011.

CLASS 41—(Continued).

4,000,051. PERFORMANCE CAPITAL INTERNATIONAL LLC, MANALAPAN, FL. SN 85-256,197. FILED 3-2-2011.

Wealth Magazine Investor Education

THE MARK CONSISTS OF STANDARD CHARACTERS WITHOUT CLAIM TO ANY PARTICULAR FONT, STYLE, SIZE, OR COLOR.

OWNER OF U.S. REG. NO. 3,396,792.

NO CLAIM IS MADE TO THE EXCLUSIVE RIGHT TO USE "MAGAZINE" OR "EDUCATION", APART FROM THE MARK AS SHOWN.

FOR EDUCATIONAL SERVICES, NAMELY, CONDUCTING EVENTS IN THE FIELDS OF FINANCIAL INVESTMENTS AND DISTRIBUTION OF TRAINING MATERIALS IN CONNECTION THEREWITH (U.S. CLS. 100, 101 AND 107).

FIRST USE 1-1-2009; IN COMMERCE 1-1-2009.

CLASS 42—(Continued).

3,999,920. GARY AND MARY WEST WIRELESS HEALTH INSTITUTE, LA JOLLA, CA. SN 77-967,122. FILED P.R. 3-24-2010; AM. S.R. 6-7-2011.

INFRASTRUCTURE INDEPENDENCE

THE MARK CONSISTS OF STANDARD CHARACTERS WITHOUT CLAIM TO ANY PARTICULAR FONT, STYLE, SIZE, OR COLOR.

FOR MEDICAL AND SCIENTIFIC RESEARCH INFORMATION IN THE FIELD OF THE POTENTIAL USE OF WIRELESS COMMUNICATIONS TECHNOLOGIES IN MEDICAL CARE (U.S. CLS. 100 AND 101).

FIRST USE 4-28-2010; IN COMMERCE 4-28-2010.

3,999,956. UNITED DATA TECHNOLOGIES, INC., DORAL, FL. SN 85-101,811. FILED P.R. 8-6-2010; AM. S.R. 5-26-2011.

IDEATION

CLASS 42—SCIENTIFIC AND COMPUTER SERVICES

3,999,897. ECOAPPRENTICE, LLC, WHITE SALMON, WA. SN 77-905,896. FILED P.R. 1-6-2010; AM. S.R. 11-10-2010.

ECOFlicks

THE MARK CONSISTS OF STANDARD CHARACTERS WITHOUT CLAIM TO ANY PARTICULAR FONT, STYLE, SIZE, OR COLOR.

FOR PROVIDING A WEB SITE FEATURING TEMPORARY USE OF NON-DOWNLOADABLE SOFTWARE ALLOWING HIGH SCHOOL AND COLLEGE STUDENT WEB SITE USERS TO UPLOAD, POST AND DISPLAY ONLINE VIDEOS FOR SHARING WITH OTHERS FOR ENTERTAINMENT PURPOSES THAT ILLUSTRATE ENVIRONMENTAL SOLUTIONS TO EVERYDAY PROBLEMS (U.S. CLS. 100 AND 101).

FIRST USE 1-20-2011; IN COMMERCE 1-20-2011.

THE MARK CONSISTS OF STANDARD CHARACTERS WITHOUT CLAIM TO ANY PARTICULAR FONT, STYLE, SIZE, OR COLOR.

FOR INFORMATION TECHNOLOGY CONSULTATION (U.S. CLS. 100 AND 101).

FIRST USE 7-0-2010; IN COMMERCE 7-0-2010.

3,999,958. VARONIS SYSTEMS, INC., NEW YORK, NY. SN 85-102,853. FILED P.R. 8-9-2010; AM. S.R. 5-9-2011.

METADATA FRAMEWORK

THE MARK CONSISTS OF STANDARD CHARACTERS WITHOUT CLAIM TO ANY PARTICULAR FONT, STYLE, SIZE, OR COLOR.

FOR DATA AUTOMATION AND COLLECTION SERVICE USING PROPRIETARY SOFTWARE TO EVALUATE, ANALYZE, AUDIT AND COLLECT DATA (U.S. CLS. 100 AND 101).

FIRST USE 9-0-2009; IN COMMERCE 9-0-2009.

CLASS 42—(Continued).

3,999,987. WEBNATIVE INC, DBA PAGEABLE, NEWPORT BEACH, CA. AND SAMBATH, VAKCHAKNAK, ORANGE, CA. SN 85-160,844. FILED P.R. 10-25-2010; AM. S.R. 5-23-2011.

DIY Deal Pages

THE MARK CONSISTS OF STANDARD CHARACTERS WITHOUT CLAIM TO ANY PARTICULAR FONT, STYLE, SIZE, OR COLOR.

FOR PROVIDING A WEB SITE FEATURING TEMPORARY USE OF NON-DOWNLOADABLE SOFTWARE ALLOWING WEB SITE USERS TO DEVELOP WEB PAGES TO PROMOTE THEIR GOODS AND SERVICES FEATURING COMBINATIONS OF THE FOLLOWING FEATURES: COUPONS, SEARCH ENGINE OPTIMIZATION, EMAIL MARKETING, EVENT REGISTRATION, DISCOUNT, REBATES, PRICE COMPARISON INFORMATION, PRODUCT REVIEWS, ACTIVITIES, AND MARKETING AND PROMOTION LINKS TO THE RETAIL WEBSITES OF OTHERS AND DISCOUNT INFORMATION; HOSTING OF WEBSITES DEVELOPED USING THE AFOREMENTIONED SOFTWARE (U.S. CLS. 100 AND 101).

FIRST USE 10-15-2010; IN COMMERCE 10-15-2010.

4,000,022. LUTHER CONSULTING, LLC, INDIANAPOLIS, IN. SN 85-237,978. FILED 2-9-2011.

PARTNER SERVICESWEB

THE MARK CONSISTS OF STANDARD CHARACTERS WITHOUT CLAIM TO ANY PARTICULAR FONT, STYLE, SIZE, OR COLOR.

NO CLAIM IS MADE TO THE EXCLUSIVE RIGHT TO USE "SERVICESWEB", APART FROM THE MARK AS SHOWN.

FOR COMPUTER SERVICE, NAMELY, ACTING AS AN APPLICATION SERVICE PROVIDER IN THE FIELD OF KNOWLEDGE MANAGEMENT TO HOST COMPUTER APPLICATION SOFTWARE FOR THE COLLECTION, EDITING, ORGANIZING, MODIFYING, TRANSMISSION, STORAGE AND SHARING OF PUBLIC HEALTH DATA AND INFORMATION (U.S. CLS. 100 AND 101).

FIRST USE 8-1-2010; IN COMMERCE 8-1-2010.

CLASS 42—(Continued).

4,000,029. CANDIDATE CHECK, INC., MEDINA, WI. SN 85-244,588. FILED 2-17-2011.

Candidate Check

THE MARK CONSISTS OF STANDARD CHARACTERS WITHOUT CLAIM TO ANY PARTICULAR FONT, STYLE, SIZE, OR COLOR.

FOR PROVIDING A WEB SITE FEATURING TECHNOLOGY THAT ENABLES RECRUITERS AND HIRING MANAGERS TO MANAGE THE ENTIRE CANDIDATE ATTRACTION AND SELECTION PROCESS, INCLUDING ADMINISTRATION OF BACKGROUND CHECKS, ASSESSMENTS AND SKILLS TESTS AS WELL AS COMPILING DATA THAT FACILITATES THE CONTINUOUS IMPROVEMENT OF THE PROCESS (U.S. CLS. 100 AND 101).

FIRST USE 9-1-2010; IN COMMERCE 9-1-2010.

CLASS 43—HOTEL AND RESTAURANT SERVICES

3,999,934. AMERICAN BLUE RIBBON HOLDINGS, LLC, DENVER, CO. SN 85-069,892. FILED P.R. 6-23-2010; AM. S.R. 6-1-2011.

ARTISAN PIE SHOP SPECIAL

THE MARK CONSISTS OF STANDARD CHARACTERS WITHOUT CLAIM TO ANY PARTICULAR FONT, STYLE, SIZE, OR COLOR.

FOR RESTAURANT SERVICES (U.S. CLS. 100 AND 101).

FIRST USE 7-6-2010; IN COMMERCE 7-6-2010.

3,999,941. PLAN DO SEE CORPORATION, DBA GREENWICH GRILL, NEW YORK, NY. SN 85-086,724. FILED P.R. 7-16-2010; AM. S.R. 4-25-2011.

SUSHI AZABU

THE MARK CONSISTS OF STANDARD CHARACTERS WITHOUT CLAIM TO ANY PARTICULAR FONT, STYLE, SIZE, OR COLOR.

CLASS 43—(Continued).

NO CLAIM IS MADE TO THE EXCLUSIVE RIGHT TO USE "SUSHI", APART FROM THE MARK AS SHOWN.
 FOR RESTAURANT SERVICES FEATURING SUSHI, SASHIMI AND OTHER JAPANESE FOOD (U.S. CLS. 100 AND 101).
 FIRST USE 4-4-2008; IN COMMERCE 4-4-2008.

CLASS 44—(Continued).

3,999,938. TRENT, INC., AURORA, CO. SN 85-083,143. FILED P.R. 7-13-2010; AM. S.R. 6-16-2011.

MEDDOCK

3,999,950. MCDONALD'S CORPORATION, OAK BROOK, IL. SN 85-096,571. FILED P.R. 7-30-2010; AM. S.R. 5-12-2011.

THE MARK CONSISTS OF STANDARD CHARACTERS WITHOUT CLAIM TO ANY PARTICULAR FONT, STYLE, SIZE, OR COLOR.
 FOR MAINTAINING PERSONAL MEDICAL HISTORY RECORDS AND FILES (U.S. CLS. 100 AND 101).
 FIRST USE 3-6-2008; IN COMMERCE 3-6-2008.

AMERICAS FAVORITE FRIES

THE MARK CONSISTS OF STANDARD CHARACTERS WITHOUT CLAIM TO ANY PARTICULAR FONT, STYLE, SIZE, OR COLOR.
 NO CLAIM IS MADE TO THE EXCLUSIVE RIGHT TO USE "FRIES", APART FROM THE MARK AS SHOWN.
 FOR RESTAURANT SERVICES (U.S. CLS. 100 AND 101).
 FIRST USE 1-13-2011; IN COMMERCE 1-13-2011.

3,999,948. ZEN OASIS HEALTH RETREATS, ARCATA, CA. SN 85-092,599. FILED P.R. 7-26-2010; AM. S.R. 5-10-2011.

HUMBOLDT GARDENS

CLASS 44—MEDICAL, BEAUTY AND AGRICULTURAL SERVICES

3,999,910. PORTUESE, WILLIAM A., SEATTLE, WA. SN 77-931,014. FILED P.R. 2-8-2010; AM. S.R. 5-31-2011.

THE MARK CONSISTS OF STANDARD CHARACTERS WITHOUT CLAIM TO ANY PARTICULAR FONT, STYLE, SIZE, OR COLOR.
 OWNER OF U.S. REG. NO. 3,855,259.
 FOR PLANT NURSERIES (U.S. CLS. 100 AND 101).
 FIRST USE 10-28-2009; IN COMMERCE 5-31-2010.

3,999,967. SOCIETY FOR PEDIATRIC SEDATION, INC., RICHMOND, VA. SN 85-110,034. FILED P.R. 8-18-2010; AM. S.R. 5-17-2011.

THE SEATTLE SINUS SURGERY CENTER

THE MARK CONSISTS OF STANDARD CHARACTERS WITHOUT CLAIM TO ANY PARTICULAR FONT, STYLE, SIZE, OR COLOR.
 NO CLAIM IS MADE TO THE EXCLUSIVE RIGHT TO USE "SINUS SURGERY CENTER", APART FROM THE MARK AS SHOWN.
 FOR SURGERY AND RELATED MEDICAL SERVICES (U.S. CLS. 100 AND 101).
 FIRST USE 3-1-2010; IN COMMERCE 3-1-2010.

THE SOCIETY FOR PEDIATRIC SEDATION

THE MARK CONSISTS OF STANDARD CHARACTERS WITHOUT CLAIM TO ANY PARTICULAR FONT, STYLE, SIZE, OR COLOR.
 FOR PROVIDING A WEB SITE FEATURING INFORMATION IN THE FIELD OF PEDIATRIC SEDATION (U.S. CLS. 100 AND 101).
 FIRST USE 6-19-2007; IN COMMERCE 6-19-2007.

CLASS 44—(Continued).

3,999,989. THE CENTER FOR HEALTH VALUE INNOVATION, ST. LOUIS, MO. SN 85-168,798. FILED P.R. 11-4-2010; AM. S.R. 6-13-2011.

Health Value Accelerator

THE MARK CONSISTS OF STANDARD CHARACTERS WITHOUT CLAIM TO ANY PARTICULAR FONT, STYLE, SIZE, OR COLOR.

NO CLAIM IS MADE TO THE EXCLUSIVE RIGHT TO USE "HEALTH", APART FROM THE MARK AS SHOWN. FOR HEALTH CARE (U.S. CLS. 100 AND 101). FIRST USE 2-0-2010; IN COMMERCE 2-0-2010.

4,000,013. CORAL SPRINGS SCHOOLS, INC., DBA BEAUTY SALONS OF AMERICA, MIAMI, FL. SN 85-227,795. FILED P.R. 1-27-2011; AM. S.R. 5-4-2011.

BEAUTY SALONS OF AMERICA

THE MARK CONSISTS OF STANDARD CHARACTERS WITHOUT CLAIM TO ANY PARTICULAR FONT, STYLE, SIZE, OR COLOR.

OWNER OF U.S. REG. NO. 3,125,364. NO CLAIM IS MADE TO THE EXCLUSIVE RIGHT TO USE "BEAUTY SALONS", APART FROM THE MARK AS SHOWN.

FOR BEAUTY SALON AND COSMETOLOGY SERVICES, NAMELY, HAIR TREATMENTS, HAIR CUTTING, HAIR COLORING AND HAIR STYLING, BARBERING, NAIL CARE, MANICURES, PEDICURES AND NAIL ENHANCEMENTS, LASER TREATMENTS FOR ACNE, REJUVENATION, SCARS, AND TATTOO REMOVAL, COSMETIC, ELECTROLYSIS, COSMETIC SKIN CARE, MAKE-UP APPLICATION, AND MASSAGE SERVICES (U.S. CLS. 100 AND 101).

FIRST USE 1-25-2011; IN COMMERCE 1-25-2011.

4,000,030. GEORGIA CENTER FOR CHILD ADVOCACY, ATLANTA, GA. SN 85-244,818. FILED P.R. 2-17-2011; AM. S.R. 5-26-2011.

GEORGIA CENTER FOR CHILD ADVOCACY

THE MARK CONSISTS OF STANDARD CHARACTERS WITHOUT CLAIM TO ANY PARTICULAR FONT, STYLE, SIZE, OR COLOR.

CLASS 44—(Continued).

NO CLAIM IS MADE TO THE EXCLUSIVE RIGHT TO USE "CENTER FOR CHILD ADVOCACY", APART FROM THE MARK AS SHOWN.

FOR PSYCHOLOGICAL SERVICES, NAMELY, PROVIDING THERAPEUTIC SERVICES TO CHILDREN AND FAMILIES WHO ARE VICTIMS OF SEXUAL AND PHYSICAL ABUSE (U.S. CLS. 100 AND 101).

FIRST USE 9-0-2007; IN COMMERCE 9-0-2007.

4,000,038. BAPTIST MEMORIAL MEDICAL GROUP, INC., MEMPHIS, TN. SN 85-249,302. FILED P.R. 2-23-2011; AM. S.R. 6-1-2011.

Baptist Memorial Medical Group

THE MARK CONSISTS OF STANDARD CHARACTERS WITHOUT CLAIM TO ANY PARTICULAR FONT, STYLE, SIZE, OR COLOR.

OWNER OF U.S. REG. NO. 3,856,193. NO CLAIM IS MADE TO THE EXCLUSIVE RIGHT TO USE "MEDICAL GROUP", APART FROM THE MARK AS SHOWN.

FOR HEALTH CARE; MEDICAL CLINICS; MEDICAL SERVICES; PROVIDING HEALTH INFORMATION (U.S. CLS. 100 AND 101).

FIRST USE 4-9-2009; IN COMMERCE 4-9-2009.

4,000,039. MCCARTHY, NORA, SAN FRANCISCO, CA. SN 85-249,307. FILED P.R. 2-23-2011; AM. S.R. 5-25-2011.

San Francisco Night Doulas

THE MARK CONSISTS OF STANDARD CHARACTERS WITHOUT CLAIM TO ANY PARTICULAR FONT, STYLE, SIZE, OR COLOR.

NO CLAIM IS MADE TO THE EXCLUSIVE RIGHT TO USE "DOULAS", APART FROM THE MARK AS SHOWN.

FOR DOULA SERVICES FOR POSTPARTUM, NAMELY, EXPERIENCED COMPANION WHO PROVIDES THE WOMAN AND HER HUSBAND OR PARTNER WITH EMOTIONAL AND PHYSICAL SUPPORT FOR UP TO THE FIRST TWO MONTHS AFTER BIRTH (U.S. CLS. 100 AND 101).

FIRST USE 2-0-2006; IN COMMERCE 2-0-2006.

CLASS 45—PERSONAL AND LEGAL SERVICES

CLASS 45—(Continued).

3,999,884. LOMMEN, ABDO, COLE, KING & STAGEBERG, PA., MINNEAPOLIS, MN. SN 76-695,274. FILED P.R. 1-12-2009; AM. S.R. 8-21-2009.

ELECTRONIC LITIGATOR

THE MARK CONSISTS OF STANDARD CHARACTERS WITHOUT CLAIM TO ANY PARTICULAR FONT, STYLE, SIZE, OR COLOR.

NO CLAIM IS MADE TO THE EXCLUSIVE RIGHT TO USE "ELECTRONIC", APART FROM THE MARK AS SHOWN.

FOR ADVISORY AND CONSULTING SERVICES IN THE FIELD OF LITIGATION, NAMELY, LITIGATION SUPPORT SERVICES IN THE NATURE OF ANALYSIS OF LEGAL RELATED DATA AND PROVISION OF LITIGATION MANAGEMENT ADVICE TO LEGAL PROFESSIONALS; LEGAL ADVISORY AND INFORMATION SERVICES IN THE NATURE OF PREPARATION AND PROVISION OF REPORTS RELATING TO LITIGATION; LITIGATION SUPPORT SERVICES IN THE NATURE OF ANALYSIS OF DOCUMENTS FOR LITIGATION (U.S. CLS. 100 AND 101).

FIRST USE 9-29-2008; IN COMMERCE 9-29-2008.



3,999,979. LIAISE MEDIATED SOLUTIONS, LLC, SAN FRANCISCO, CA. SN 85-136,634. FILED P.R. 9-23-2010; AM. S.R. 5-10-2011.

Marital Reorganization

THE MARK CONSISTS OF STANDARD CHARACTERS WITHOUT CLAIM TO ANY PARTICULAR FONT, STYLE, SIZE, OR COLOR.

FOR PERSONAL SERVICES, NAMELY, CONSULTATION IN THE FIELD OF DIVORCE (U.S. CLS. 100 AND 101).

FIRST USE 1-15-2009; IN COMMERCE 1-15-2009.



4,000,042. BRODSKY LLC, AKA BRODSKY LAW FIRM, NEW YORK, NY. SN 85-251,594. FILED P.R. 2-25-2011; AM. S.R. 5-31-2011.

NYC DIVORCE CENTER

THE MARK CONSISTS OF STANDARD CHARACTERS WITHOUT CLAIM TO ANY PARTICULAR FONT, STYLE, SIZE, OR COLOR.

CLASS 45—(Continued).

NO CLAIM IS MADE TO THE EXCLUSIVE RIGHT TO USE "DIVORCE CENTER", APART FROM THE MARK AS SHOWN.

FOR LEGAL SERVICES, NAMELY, PROVIDING COUNSELING AND REPRESENTATION IN THE AREAS OF DIVORCE LAW, MATRIMONIAL LAW, DOMESTIC RELATIONS, AND FAMILY LAW (U.S. CLS. 100 AND 101).

FIRST USE 3-7-2009; IN COMMERCE 3-7-2009.



4,000,049. LINDA SETTLES, DBA NATIONAL ASSOCIATION OF ADVOCATES FOR ABUSE SURVIVORS, LYNCHBURG, VA. SN 85-254,344. FILED P.R. 3-1-2011; AM. S.R. 6-1-2011.

**National Association of
Advocates for Abuse
Survivors**

THE MARK CONSISTS OF STANDARD CHARACTERS WITHOUT CLAIM TO ANY PARTICULAR FONT, STYLE, SIZE, OR COLOR.

FOR CRIME VICTIM SERVICES, NAMELY, SUPPORTIVE EMOTIONAL COUNSELING; PROVIDING COUNSELING FOR VICTIMS OF BATTERY OR ABUSE COMPRISING INTERVIEWING THE VICTIM, IDENTIFYING WHAT THE PROBLEM IS AND SUGGESTING WHERE HELP CAN BE OBTAINED (U.S. CLS. 100 AND 101).

FIRST USE 2-25-2011; IN COMMERCE 2-25-2011.



4,000,054. TERI, INC., OCEANSIDE, CA. SN 85-262,430. FILED P.R. 3-9-2011; AM. S.R. 6-1-2011.

**Special Needs Life Quality
Plan**

THE MARK CONSISTS OF STANDARD CHARACTERS WITHOUT CLAIM TO ANY PARTICULAR FONT, STYLE, SIZE, OR COLOR.

NO CLAIM IS MADE TO THE EXCLUSIVE RIGHT TO USE "LIFE QUALITY PLAN", APART FROM THE MARK AS SHOWN.

FOR LIFE QUALITY ASSESSMENT FOR INDIVIDUALS WITH DEVELOPMENTAL DISABILITIES AND THEIR FAMILIES (U.S. CLS. 100 AND 101).

FIRST USE 0-0-2008; IN COMMERCE 0-0-2008.

PRIOR UNITED STATES CLASSIFICATION

APPLICATION IN ONE CLASS

CERTIFICATION MARKS

CLASS B—SERVICES

3,999,937. REAL ESTATE INVESTORS INSTITUTE, BURBANK, CA. SN 85-082,688. FILED P.R. 7-12-2010; AM. S.R. 2-11-2011.

OWNER OF U.S. REG. NOS. 3,862,252 AND 3,866,046.
THE CERTIFICATION MARK, AS USED OR INTENDED TO BE USED BY PERSONS AUTHORIZED BY THE CERTIFIER, CERTIFIES OR IS INTENDED TO CERTIFY THAT THE SERVICES ARE PROVIDED BY REAL ESTATE AGENTS WHO HAVE COMPLETED TRAINING AND EDUCATION FOR REAL ESTATE INVESTMENT, MARKETING, DIVESTMENT, AND PLANNING FOR POSSESSING, SELLING OR BUYING REAL ESTATE FOR REAL ESTATE SERVICES (U.S. CL. B).
FIRST USE 8-29-2010; IN COMMERCE 8-29-2010.

**CERTIFIED HOA AGENT
RESOURCE**

THE MARK CONSISTS OF STANDARD CHARACTERS WITHOUT CLAIM TO ANY PARTICULAR FONT, STYLE, SIZE, OR COLOR.

* * * * *

TRADEMARK REGISTRATIONS RENEWED

The designation "U.S. Cl." appearing in this section refers to the U.S. class in effect prior to Sep. 1, 1973 rather than the international class which applies to applications filed on or after that date. For adoption of international classification see notice in the OFFICIAL GAZETTE of Jun. 26, 1973 (911 O.G. TM 210).

142,338.	SUNNYBROOK AND DESIGN. U.S. CL. 49. (INT. CL. 33). REG. 5-10-1921.	915,811.	DISCOVER AMERICA. U.S. CL. 105. (INT. CL. 39). REG. 6-29-1971.
148,990.	BABBITT (STYLIZED). U.S. CL. 23. (INT. CL. 7). REG. 12-6-1921.	916,549.	PRIMID. U.S. CL. 6. (INT. CL. 1). REG. 7-20-1971.
283,524.	CLIPMASTER. U.S. CL. 23. (INT. CL. 8). REG. 6-2-1931.	916,672.	YUKEN (STYLIZED). U.S. CL. 23. (INT. CL. 7). REG. 7-20-1971.
287,505.	METALHIDE (STYLIZED). U.S. CL. 16. (INT. CL. 2). REG. 9-29-1931.	916,723.	MICROMERITICS. U.S. CL. 26. (INT. CLS. 1, 9 AND 10). REG. 7-20-1971.
387,173.	YORK (STYLIZED). U.S. CL. 31. (INT. CL. 11). REG. 5-6-1941.	917,662.	CIRCA. U.S. CL. 32. (INT. CL. 20). REG. 8-3-1971.
387,963.	LIFE STRIDE STANDARD CHARACTER MARK. U.S. CL. 39. (INT. CL. 25). REG. 6-10-1941.	917,926.	SPARFLUX. U.S. CL. 1. (INT. CL. 6). REG. 8-10-1971.
388,311.	CASCAMITE. U.S. CL. 5. (INT. CL. 1). REG. 6-17-1941.	920,875.	TECO. U.S. CL. 100. (INT. CL. 42). REG. 9-21-1971.
542,265.	FLETCHER AND DESIGN. U.S. CL. 23. (INT. CL. 8). REG. 5-15-1951.	924,091.	BFL. U.S. CL. 15. (INT. CL. 4). REG. 11-23-1971.
550,922.	GOLD MEDAL CREAM OF RYE. U.S. CL. 46. (INT. CL. 30). REG. 11-20-1951.	924,363.	MARTINDALE. U.S. CL. 46. (INT. CL. 29). REG. 11-23-1971.
715,293.	PERMA-SLIK. U.S. CL. 15. (INT. CL. 4). REG. 5-16-1961.	1,141,826.	NO SWET. INT. CL. 25. (U.S. CL. 39). REG. 11-25-1980.
715,606.	FLORANIER. INT. CL. 1. (U.S. CL. 1). REG. 5-23-1961.	1,152,166.	NAPA AND DESIGN. INT. CL. 7. (U.S. CL. 23). REG. 4-28-1981.
717,512.	SERPENTIX. U.S. CL. 23. (INT. CLS. 6, 7, 8, 9, 11, 12, 16, 21 AND 28). REG. 6-27-1961.	1,152,974.	VOLPI AND DESIGN. INT. CL. 9. (U.S. CL. 26). REG. 5-5-1981.
717,550.	DURST (STYLIZED). U.S. CL. 26. (INT. CLS. 1, 9 AND 10). REG. 6-27-1961.	1,153,237.	TAILWIND. INT. CL. 25. (U.S. CLS. 22 AND 39). REG. 5-5-1981.
717,628.	DAMON. U.S. CL. 39. (INT. CLS. 10, 25 AND 26). REG. 6-27-1961.	1,153,698.	MOVIETONE NEWS AND DESIGN. INT. CL. 9. (U.S. CL. 38). REG. 5-12-1981.
717,839.	GRIFF GRIPS (STYLIZED). U.S. CL. 23. (INT. CL. 7). REG. 7-4-1961.	1,154,529.	CRC. INT. CL. 7. (U.S. CLS. 13, 19, 21, 23, 31, 34 AND 35). REG. 5-19-1981.
718,366.	B AND DESIGN. U.S. CL. 200. REG. 7-11-1961.	1,154,533.	MARTIN. INT. CL. 7. (U.S. CLS. 13, 19, 21, 23, 31, 34 AND 35). REG. 5-19-1981.
718,762.	Y AND DESIGN. U.S. CL. 3. (INT. CL. 18). REG. 7-25-1961.	1,155,271.	VISCOREX. INT. CL. 7 ONLY. (U.S. CL. 23). REG. 5-26-1981.
718,933.	COMFORT-AIRE. U.S. CL. 34. (INT. CL. 11). REG. 7-25-1961.	1,156,106.	TORO (STYLIZED). INT. CL. 7. (U.S. CLS. 13, 19, 21, 23, 31, 34 AND 35). REG. 6-2-1981.
721,044.	THE BOSTON GLOBE (STYLIZED). U.S. CL. 38. (INT. CL. 16). REG. 9-5-1961.	1,156,125.	ENERTEX. INT. CL. 7. (U.S. CLS. 23 AND 50). REG. 6-2-1981.
725,497.	LOCTITE. U.S. CL. 5. (INT. CL. 1). REG. 12-26-1961.	1,156,416.	THERMO-GRIP. INT. CL. 20. (U.S. CL. 50). REG. 6-2-1981.
729,535.	DIXIE CRYSTALS. U.S. CL. 46. (INT. CL. 30). REG. 4-3-1962.	1,156,630.	GIE AND DESIGN. INT. CL. 36. (U.S. CL. 102). REG. 6-2-1981.
730,328.	PURPLE PEEPER. U.S. CL. 21. (INT. CL. 9). REG. 4-24-1962.	1,157,709.	HEALTH RESOURCES AND DESIGN. INT. CL. 35. (U.S. CL. 101). REG. 6-16-1981.
732,495.	TUBE-O-FLAME. U.S. CL. 34. (INT. CL. 11). REG. 6-5-1962.	1,158,297.	MISCELLANEOUS DESIGN. INT. CL. 34. (U.S. CL. 17). REG. 6-23-1981.
888,954.	MISCELLANEOUS DESIGN. U.S. CL. 19. (INT. CL. 12). REG. 4-7-1970.	1,158,372.	THE JONES GROUP, LTD.. INT. CL. 36. (U.S. CL. 102). REG. 6-23-1981.
903,914.	THE SHIRT SHACK AND DESIGN. U.S. CL. 39. (INT. CL. 25). REG. 12-8-1970.	1,158,668.	PP-LP (STYLIZED). U.S. CL. A. REG. 6-23-1981.
908,568.	CROMALIN. U.S. CL. 26. (INT. CL. 9). REG. 2-23-1971.	1,159,825.	FUJISOKU. INT. CL. 9. (U.S. CLS. 21, 23, 26, 36 AND 38). REG. 7-7-1981.
911,959.	ETIENNE AIGNER. U.S. CLS. 3, 8 AND 39 ONLY. (INT. CLS. 10, 18, 25, 26 AND 34). REG. 6-8-1971.	1,161,347.	SINGAPORE GIRL. INT. CL. 39. (U.S. CL. 105). REG. 7-14-1981.
912,059.	STEAMATIC. U.S. CLS. 6 AND 52. (INT. CLS. 1, 3 AND 5). REG. 6-8-1971.	1,161,635.	MISCELLANEOUS DESIGN. INT. CLS. 7 AND 9. (U.S. CLS. 13, 21, 23, 26 AND 31). REG. 7-21-1981.
912,238.	MUNI-BALL. U.S. CL. 13. (INT. CL. 6). REG. 6-8-1971.	1,162,610.	TRITON. INT. CL. 11. (U.S. CL. 31). REG. 7-28-1981.
913,017.	LEV-L-INE. U.S. CL. 23. (INT. CL. 7). REG. 6-8-1971.	1,163,802.	THE SOCK TAILOR. INT. CL. 25. (U.S. CL. 39). REG. 8-4-1981.
913,078.	RAY-FLEX. U.S. CL. 23. (INT. CL. 7). REG. 6-8-1971.	1,164,088.	ENVIRITE. INT. CL. 40. (U.S. CL. 106). REG. 8-4-1981.
913,400.	DONEGAL. U.S. CL. 33. (INT. CLS. 19 AND 21). REG. 6-8-1971.	1,166,245.	MAGNESOL. INT. CL. 9. (U.S. CL. 21). REG. 8-25-1981.
914,253.	S-E-X SEXUS ET XENIA (STYLIZED). U.S. CL. 51. (INT. CL. 3). REG. 6-8-1971.	1,167,770.	DATA MEDIA ASSOCIATES. INT. CL. 42. (U.S. CL. 101). REG. 9-1-1981.
914,908.	VERVE. U.S. CL. 13. (INT. CLS. 6, 7, 11, 17, 20 AND 21). REG. 6-15-1971.	1,170,597.	ABC SPORTS. INT. CL. 41. (U.S. CL. 107). REG. 9-22-1981.
915,043.	SELF-SKINNER. U.S. CL. 23. (INT. CL. 7). REG. 6-15-1971.	1,171,674.	ABC'S WIDE WORLD OF SPORTS. INT. CL. 41. (U.S. CL. 107). REG. 9-29-1981.
915,590.	YUKEN. U.S. CL. 13. (INT. CL. 6). REG. 6-29-1971.	1,171,727.	CUNNINGHAM PATHOLOGY ASSOCIATES P.A. AND DESIGN. INT. CL. 42. (U.S. CL. 100). REG. 9-29-1981.

- 1,171,987. GERBER BRISTLE SQUARE. INT. CL. 7. (U.S. CL. 23). REG. 10-6-1981.
- 1,172,745. DABCO. INT. CL. 1. (U.S. CL. 6). REG. 10-13-1981.
- 1,175,855. VIBRANETICS AND DESIGN. INT. CL. 7. (U.S. CLS. 13, 19, 21, 23, 31, 34 AND 35). REG. 11-3-1981.
- 1,176,056. RED LINE. INT. CL. 12. (U.S. CL. 19). REG. 11-3-1981.
- 1,177,333. TUFFGARDS. INT. CL. 22. (U.S. CL. 2). REG. 11-10-1981.
- 1,179,841. AT (STYLIZED). INT. CL. 7. (U.S. CLS. 4 AND 23). REG. 12-1-1981.
- 1,180,556. D AND DESIGN. INT. CL. 41. (U.S. CL. 107). REG. 12-1-1981.
- 1,181,385. BINGLES. INT. CL. 30. (U.S. CL. 46). REG. 12-8-1981.
- 1,181,651. UNITED STATES POLO ASSOCIATION AND DESIGN. U.S. CL. 200. REG. 12-8-1981.
- 1,182,038. DESIGNERS' SHOWCASE. INT. CLS. 16 AND 41 ONLY. (U.S. CLS. 38 AND 107). REG. 12-15-1981.
- 1,189,031. BENTONE. INT. CL. 1. (U.S. CL. 6). REG. 2-9-1982.
- 1,191,602. DECKMATE. INT. CL. 9. (U.S. CL. 26). REG. 3-9-1982.
- 1,191,876. LITTMAN. INT. CL. 42. (U.S. CLS. 100 AND 101). REG. 3-9-1982.
- 1,193,634. DURADEK. INT. CLS. 19 AND 21. (U.S. CLS. 12 AND 33). REG. 4-13-1982.
- 1,194,935. SABRE. INT. CL. 1. (U.S. CL. 6). REG. 5-11-1982.
- 1,624,992. SAFETY DECK AND DESIGN. INT. CL. 27. (U.S. CLS. 20 AND 50). REG. 11-27-1990.
- 1,626,154. MARUCHAN AND DESIGN. INT. CL. 30. (U.S. CL. 46). REG. 12-4-1990.
- 1,631,129. MISCELLANEOUS DESIGN. INT. CL. 41. (U.S. CL. 107). REG. 1-8-1991.
- 1,637,300. ARDROX. INT. CL. 1. (U.S. CLS. 1, 5, 6, 10, 26 AND 46). REG. 3-12-1991.
- 1,637,606. GEOLINK. INT. CL. 17. (U.S. CL. 35). REG. 3-12-1991.
- 1,639,521. DUOFLEX (STYLIZED). INT. CL. 7 ONLY. (U.S. CL. 23). REG. 4-2-1991.
- 1,643,288. GREEN EARTH. INT. CL. 3. (U.S. CL. 52). REG. 5-7-1991.
- 1,644,347. NORVIL. INT. CL. 12. (U.S. CL. 19). REG. 5-14-1991.
- 1,644,523. CHEESE FANTASTICO!. INT. CL. 29. (U.S. CL. 46). REG. 5-14-1991.
- 1,644,687. ART. INT. CL. 42. (U.S. CLS. 100 AND 101). REG. 5-14-1991.
- 1,644,713. NEW YORK. INT. CL. 42. (U.S. CLS. 100 AND 101). REG. 5-14-1991.
- 1,645,053. RAMFAN. INT. CL. 9. (U.S. CL. 23). REG. 5-21-1991.
- 1,645,093. MICROVASIVE. INT. CL. 10. (U.S. CL. 44). REG. 5-21-1991.
- 1,645,245. INSULBAR. INT. CL. 17. (U.S. CLS. 1 AND 12). REG. 5-21-1991.
- 1,645,289. JAGUAR AND DESIGN. INT. CL. 21. (U.S. CLS. 2, 13, 23, 29, 30, 33, 40 AND 50). REG. 5-21-1991.
- 1,645,442. FAT CAT. INT. CL. 33. (U.S. CL. 47). REG. 5-21-1991.
- 1,645,733. CORMAX. INT. CL. 2. (U.S. CL. 16). REG. 5-28-1991.
- 1,645,786. 2 IN 1 (STYLIZED). INT. CL. 5. (U.S. CL. 6). REG. 5-28-1991.
- 1,645,900. ABIOMED. INT. CL. 10. (U.S. CLS. 26, 39 AND 44). REG. 5-28-1991.
- 1,645,921. COMP FILTER. INT. CL. 12. (U.S. CLS. 19, 23 AND 31). REG. 5-28-1991.
- 1,646,158. DR. MARIO. INT. CL. 28. (U.S. CL. 22). REG. 5-28-1991.
- 1,646,216. DITTMAN INCENTIVE MARKETING. INT. CL. 35. (U.S. CL. 101). REG. 5-28-1991.
- 1,646,424. VIETNAM HELICOPTER PILOTS ASSOCIATION R.V.N. 1961 - 1975 AND DESIGN. INT. CL. 42. (U.S. CL. 100). REG. 5-28-1991.
- 1,646,800. ANGELS. INT. CLS. 16 AND 25. (U.S. CLS. 22, 23, 37, 38 AND 39). REG. 6-4-1991.
- 1,646,875. PREMIUM. INT. CL. 21. (U.S. CLS. 29 AND 52). REG. 6-4-1991.
- 1,647,130. EDLON. INT. CLS. 1, 7, 11, 17 AND 40. (U.S. CLS. 5, 23, 31, 35 AND 106). REG. 6-11-1991.
- 1,647,135. MARLOWET. INT. CL. 1. (U.S. CL. 6). REG. 6-11-1991.
- 1,647,164. LABCATAL. INT. CL. 5. (U.S. CL. 18). REG. 6-11-1991.
- 1,647,233. SOLUTION SELLING. INT. CLS. 16 AND 41 ONLY. (U.S. CLS. 2, 5, 22, 23, 29, 37, 38, 50, 100, 101 AND 107). REG. 6-11-1991.
- 1,647,484. SPEEDO AND DESIGN. INT. CL. 25. (U.S. CLS. 22 AND 39). REG. 6-11-1991.
- 1,647,858. MISCELLANEOUS DESIGN. INT. CL. 6. (U.S. CLS. 2, 12, 13, 14, 23, 25 AND 50). REG. 6-18-1991.
- 1,647,886. STREAMFEEDER. INT. CL. 7. (U.S. CL. 23). REG. 6-18-1991.
- 1,647,967. AC-LITE. INT. CL. 9. (U.S. CL. 21). REG. 6-18-1991.
- 1,647,971. ULTRA-ZONE (STYLIZED). INT. CLS. 9 AND 11. (U.S. CLS. 26 AND 34). REG. 6-18-1991.
- 1,648,056. SCOTTCARE. INT. CL. 10. (U.S. CLS. 26, 39 AND 44). REG. 6-18-1991.
- 1,648,204. MAMO (STYLIZED). INT. CL. 25. (U.S. CLS. 22 AND 39). REG. 6-18-1991.
- 1,648,267. SAN ANTONIO RIVER MILL BRAND AND DESIGN. INT. CL. 30. (U.S. CL. 46). REG. 6-18-1991.
- 1,648,385. WOMEN'S COLLEGE WORLD SERIES. INT. CL. 41. (U.S. CL. 107). REG. 6-18-1991.
- 1,648,424. RIBS KING. INT. CL. 42. (U.S. CL. 100). REG. 6-18-1991.
- 1,648,520. ULTRA-WEB (STYLIZED). INT. CL. 11. (U.S. CL. 31). REG. 6-18-1991.
- 1,648,533. MIRACLE-WEDGE. INT. CL. 16. (U.S. CL. 29). REG. 6-18-1991.
- 1,648,884. HERSHEY BEARS AND DESIGN. INT. CLS. 25 AND 41 ONLY. (U.S. CLS. 39 AND 107). REG. 6-25-1991.
- 1,649,230. ELIZABETH ARDEN RED DOOR AND DESIGN. INT. CL. 3. (U.S. CL. 51). REG. 7-2-1991.
- 1,649,366. POMONA. INT. CL. 9. (U.S. CL. 21). REG. 7-2-1991.
- 1,649,721. QUICK-SHIP AND DESIGN. INT. CL. 39. (U.S. CL. 105). REG. 7-2-1991.
- 1,650,012. RECORD DOCTOR. INT. CL. 9. (U.S. CLS. 26 AND 36). REG. 7-9-1991.
- 1,650,504. KANEKA TELALLOY. INT. CL. 1. (U.S. CL. 6). REG. 7-16-1991.
- 1,650,536. DERMA SCRUB. INT. CL. 3. (U.S. CL. 52). REG. 7-16-1991.
- 1,651,523. FEDERAL COBALT. INT. CL. 21. (U.S. CLS. 2, 13 AND 30). REG. 7-23-1991.
- 1,652,197. MABS. INT. CL. 9. (U.S. CLS. 26 AND 34). REG. 7-30-1991.
- 1,652,381. PASCAL. INT. CL. 16. (U.S. CL. 38). REG. 7-30-1991.
- 1,652,874. ONCOLAB. INT. CL. 5. (U.S. CLS. 6, 18, 44, 46, 51 AND 52). REG. 8-6-1991.
- 1,653,345. INCOME SHIELD. INT. CL. 36. (U.S. CL. 102). REG. 8-6-1991.
- 1,653,728. CLAIBORNE. INT. CL. 25. (U.S. CL. 39). REG. 8-13-1991.
- 1,653,888. LAST SEEN READING. INT. CL. 36. (U.S. CLS. 101 AND 102). REG. 8-13-1991.
- 1,654,458. A. CHARBAUT ET FILS. INT. CL. 33. (U.S. CL. 47). REG. 8-20-1991.
- 1,654,497. LAST SEEN READING AND DESIGN. INT. CL. 36. (U.S. CLS. 101 AND 102). REG. 8-20-1991.
- 1,654,850. LA AND DESIGN. INT. CL. 12. (U.S. CL. 19). REG. 8-27-1991.
- 1,654,951. CONVERSE AND DESIGN. INT. CL. 25. (U.S. CL. 39). REG. 8-27-1991.
- 1,655,508. HOT LIPS. INT. CL. 13. (U.S. CL. 9). REG. 9-3-1991.
- 1,655,570. CUSTOM-FLOAT. INT. CL. 19. (U.S. CL. 12). REG. 9-3-1991.
- 1,656,167. MOKA D'ORO. INT. CLS. 11 AND 30. (U.S. CLS. 34 AND 46). REG. 9-10-1991.
- 1,656,519. ELIZABETH ARDEN. INT. CLS. 14 AND 18. (U.S. CLS. 3, 27, 28 AND 41). REG. 9-10-1991.
- 1,656,597. APEX. INT. CL. 7. (U.S. CL. 23). REG. 9-10-1991.
- 1,657,221. SSI AND DESIGN. INT. CL. 9. (U.S. CLS. 21, 23, 26, 36 AND 38). REG. 9-17-1991.
- 1,658,372. DELIMEX. INT. CL. 30. (U.S. CL. 46). REG. 9-24-1991.
- 1,659,088. J&B AMOS AND DESIGN. INT. CL. 35. (U.S. CL. 101). REG. 10-1-1991.
- 1,659,110. MISCELLANEOUS DESIGN. INT. CL. 36. (U.S. CLS. 100, 101 AND 102). REG. 10-1-1991.
- 1,660,020. JEAN DUREE. INT. CL. 33. (U.S. CLS. 47 AND 49). REG. 10-8-1991.
- 1,661,828. AIR CHAIR. INT. CL. 28. (U.S. CLS. 22, 23, 38 AND 50). REG. 10-22-1991.
- 1,661,891. ANIVERSARIO. INT. CL. 33. (U.S. CLS. 47 AND 49). REG. 10-22-1991.

- 1,661,943. CARISMA AND DESIGN. INT. CL. 37. (U.S. CL. 103). REG. 10-22-1991.
- 1,662,030. SAN ANGEL INN. INT. CL. 42. (U.S. CLS. 100 AND 107). REG. 10-22-1991.
- 1,663,451. REALITI. INT. CL. 20. (U.S. CL. 32). REG. 11-5-1991.
- 1,664,428. PREFERRED STATUS. INT. CL. 39. (U.S. CLS. 100 AND 105). REG. 11-12-1991.
- 1,664,720. SITREX AND DESIGN. INT. CL. 7. (U.S. CLS. 13, 19, 21, 23, 31, 34 AND 35). REG. 11-19-1991.
- 1,666,183. LRC. INT. CL. 42. (U.S. CLS. 100 AND 101). REG. 11-26-1991.
- 1,667,013. MSIA. INT. CL. 41. (U.S. CL. 107). REG. 12-3-1991.
- 1,668,064. THALIA. INT. CL. 42. (U.S. CL. 100). REG. 12-10-1991.
- 1,668,265. LIBEC. INT. CL. 9. (U.S. CL. 26). REG. 12-17-1991.
- 1,672,399. TRUE-LINE. INT. CL. 7. (U.S. CL. 23). REG. 1-21-1992.
- 1,672,479. SYNERGY. INT. CL. 9. (U.S. CLS. 21 AND 26). REG. 1-21-1992.
- 1,674,697. U.S. SPECIAL RESERVE. INT. CL. 33. (U.S. CL. 49). REG. 2-4-1992.
- 1,677,008. MISCELLANEOUS DESIGN. INT. CL. 36. (U.S. CL. 102). REG. 2-25-1992.
- 1,678,068. STATIONLINK. INT. CL. 9. (U.S. CLS. 21, 23, 26, 36 AND 38). REG. 3-3-1992.
- 1,678,857. THE EGOSQUE METHOD. INT. CL. 41. (U.S. CL. 107). REG. 3-10-1992.
- 1,682,672. ULTRAVAC. INT. CL. 7. (U.S. CL. 23). REG. 4-14-1992.
- 1,684,478. WORLD CLASS. INT. CL. 21. (U.S. CLS. 2 AND 13). REG. 4-28-1992.
- 2,354,318. JACOBS (STYLIZED). INT. CL. 7. (U.S. CLS. 13, 19, 21, 23, 31, 34 AND 35). REG. 6-6-2000.
- 2,355,621. FIREOUT. INT. CL. 1. (U.S. CLS. 1, 5, 6, 10, 26 AND 46). REG. 6-6-2000.
- 2,390,089. INDICATOR. INT. CL. 8. (U.S. CLS. 23, 28 AND 44). REG. 9-26-2000.
- 2,394,274. PANAIID. INT. CL. 5. (U.S. CLS. 6, 18, 44, 46, 51 AND 52). REG. 10-10-2000.
- 2,403,140. FAST EDDIE'S BILLIARDS & NEIGHBORHOOD SALOON. INT. CLS. 41 AND 42. (U.S. CLS. 100, 101 AND 107). REG. 11-14-2000.
- 2,403,311. OMS-EZ. INT. CL. 9 ONLY. (U.S. CLS. 21, 23, 26, 36 AND 38). REG. 11-14-2000.
- 2,403,437. PERMAJET. INT. CL. 2. (U.S. CLS. 6, 11 AND 16). REG. 11-14-2000.
- 2,403,470. PROFESSIONAL. INT. CL. 3. (U.S. CLS. 1, 4, 6, 50, 51 AND 52). REG. 11-14-2000.
- 2,403,471. HARBOR FREIGHT AND DESIGN. INT. CL. 35. (U.S. CLS. 100, 101 AND 102). REG. 11-14-2000.
- 2,404,270. LETTERPAC (STYLIZED). INT. CL. 35. (U.S. CLS. 100, 101 AND 102). REG. 11-14-2000.
- 2,404,610. REFLECTUBE. INT. CL. 17. (U.S. CLS. 1, 5, 12, 13, 35 AND 50). REG. 11-14-2000.
- 2,405,323. CE LABS. INT. CL. 9. (U.S. CLS. 21, 23, 26, 36 AND 38). REG. 11-21-2000.
- 2,405,324. CE LABS (STYLIZED). INT. CL. 9. (U.S. CLS. 21, 23, 26, 36 AND 38). REG. 11-21-2000.
- 2,405,819. COMPSIGHT. INT. CL. 9. (U.S. CLS. 21, 23, 26, 36 AND 38). REG. 11-21-2000.
- 2,411,616. FORTE AND DESIGN. INT. CLS. 41 AND 42. (U.S. CLS. 100, 101 AND 107). REG. 12-12-2000.
- 2,411,617. FORTE. INT. CLS. 35, 41 AND 42. (U.S. CLS. 100, 101 AND 107). REG. 12-12-2000.
- 2,411,820. AGCA THE ASSOCIATED GENERAL CONTRACTORS OF AMERICA SKILL RESPONSIBILITY INTEGRITY AND DESIGN. INT. CLS. 37, 41 AND 42 ONLY. (U.S. CLS. 100, 101, 103, 106 AND 107). REG. 12-12-2000.
- 2,412,448. LAUGHING HYENA. INT. CL. 9. (U.S. CLS. 21, 23, 26, 36 AND 38). REG. 12-12-2000.
- 2,412,823. TRIZETTO. INT. CL. 37. (U.S. CLS. 100, 103 AND 106). REG. 12-12-2000.
- 2,412,901. JORG HYSEK (STYLIZED). INT. CL. 14. (U.S. CLS. 2, 27, 28 AND 50). REG. 12-12-2000.
- 2,413,753. ROCKBRIDGE. INT. CL. 42. (U.S. CLS. 100 AND 101). REG. 12-19-2000.
- 2,414,488. ROTTEFELLA AND DESIGN. INT. CL. 28. (U.S. CLS. 22, 23, 38 AND 50). REG. 12-19-2000.
- 2,415,888. MPICA. INT. CL. 36. (U.S. CLS. 100, 101 AND 102). REG. 12-26-2000.
- 2,416,103. ORDNING & REDA AND DESIGN. INT. CLS. 16 AND 18. (U.S. CLS. 1, 2, 3, 5, 22, 23, 29, 37, 38, 41 AND 50). REG. 12-26-2000.
- 2,418,792. ORDNING & REDA. INT. CL. 16. (U.S. CLS. 2, 5, 22, 23, 29, 37, 38 AND 50). REG. 1-9-2001.
- 2,419,490. NASHVILLE PREDATORS. INT. CL. 41. (U.S. CLS. 100, 101 AND 107). REG. 1-9-2001.
- 2,421,928. STEREO ANALYST. INT. CL. 9. (U.S. CLS. 21, 23, 26, 36 AND 38). REG. 1-16-2001.
- 2,424,799. PC PONTIAC COIL AND DESIGN. INT. CL. 9. (U.S. CLS. 21, 23, 26, 36 AND 38). REG. 1-30-2001.
- 2,428,538. PHYSICS TODAY. INT. CL. 16. (U.S. CLS. 2, 5, 22, 23, 29, 37, 38 AND 50). REG. 2-13-2001.
- 2,433,648. STUNNING. INT. CL. 3. (U.S. CLS. 1, 4, 6, 50, 51 AND 52). REG. 3-6-2001.
- 2,434,741. HYPERHEPA. INT. CL. 11. (U.S. CLS. 13, 21, 23, 31 AND 34). REG. 3-13-2001.
- 2,435,709. PRESIDIAN. INT. CLS. 35 AND 42. (U.S. CLS. 100, 101 AND 102). REG. 3-13-2001.
- 2,435,984. MISCELLANEOUS DESIGN. INT. CL. 21. (U.S. CLS. 2, 13, 23, 29, 30, 33, 40 AND 50). REG. 3-13-2001.
- 2,440,418. ELECTRIC LODGE. INT. CL. 41. (U.S. CLS. 100, 101 AND 107). REG. 4-3-2001.
- 2,446,049. WILLIAMS SCOTSMAN. INT. CLS. 35, 36, 37, 39 AND 42. (U.S. CLS. 100, 101, 102, 103, 105 AND 106). REG. 4-24-2001.
- 2,446,912. SCRUBFRESH. INT. CL. 3. (U.S. CLS. 1, 4, 6, 50, 51 AND 52). REG. 4-24-2001.
- 2,447,313. SPECTRUM. INT. CL. 10. (U.S. CLS. 26, 39 AND 44). REG. 5-1-2001.
- 2,447,400. JELLY BEAN. INT. CL. 28. (U.S. CLS. 22, 23, 38 AND 50). REG. 5-1-2001.
- 2,447,938. UFO SPORTS INCORPORATED AND DESIGN. INT. CL. 28. (U.S. CLS. 22, 23, 38 AND 50). REG. 5-1-2001.
- 2,448,718. UNITED STATES ASIA FOUNDATION AND DESIGN. INT. CL. 35. (U.S. CLS. 100, 101 AND 102). REG. 5-8-2001.
- 2,448,934. M AND DESIGN. INT. CL. 25. (U.S. CLS. 22 AND 39). REG. 5-8-2001.
- 2,449,311. COMSA. U.S. CL. B. REG. 5-8-2001.
- 2,449,312. COA. U.S. CL. B. REG. 5-8-2001.
- 2,449,672. MEAN GREEN. INT. CL. 21. (U.S. CLS. 2, 13, 23, 29, 30, 33, 40 AND 50). REG. 5-8-2001.
- 2,449,849. INTELLI-CHECK. INT. CL. 9. (U.S. CLS. 21, 23, 26, 36 AND 38). REG. 5-8-2001.
- 2,449,870. TIME'S UP. INT. CL. 16. (U.S. CLS. 2, 5, 22, 23, 29, 37, 38 AND 50). REG. 5-8-2001.
- 2,450,175. NOT NICE TO TOXINS. INT. CL. 5. (U.S. CLS. 6, 18, 44, 46, 51 AND 52). REG. 5-8-2001.
- 2,450,444. VEIN CENTRE OF THE PALM BEACHES. INT. CL. 42. (U.S. CLS. 100 AND 101). REG. 5-15-2001.
- 2,450,556. EN VUE. INT. CL. 3 ONLY. (U.S. CLS. 1, 4, 6, 50, 51 AND 52). REG. 5-15-2001.
- 2,450,587. PLAYSTREAM. INT. CLS. 38, 39 AND 42. (U.S. CLS. 100, 101, 104 AND 105). REG. 5-15-2001.
- 2,450,646. ZYMOX. INT. CL. 5. (U.S. CLS. 6, 18, 44, 46, 51 AND 52). REG. 5-15-2001.
- 2,450,676. NEXTPAGE (STYLIZED). INT. CLS. 35 AND 42. (U.S. CLS. 100, 101 AND 102). REG. 5-15-2001.
- 2,450,683. D AND DESIGN. INT. CL. 3. (U.S. CLS. 1, 4, 6, 50, 51 AND 52). REG. 5-15-2001.
- 2,450,721. D. INT. CL. 7. (U.S. CLS. 13, 19, 21, 23, 31, 34 AND 35). REG. 5-15-2001.
- 2,450,795. THE HISTORY CHANNEL. INT. CL. 16. (U.S. CLS. 2, 5, 22, 23, 29, 37, 38 AND 50). REG. 5-15-2001.
- 2,450,944. AFTER HOURS PEDIATRICS URGENT CARE FOR INFANTS CHILDREN AND YOUNG ADULTS AND DESIGN. INT. CL. 42. (U.S. CLS. 100 AND 101). REG. 5-15-2001.
- 2,450,959. BUILDING KNOWLEDGE. INT. CL. 37 ONLY. (U.S. CLS. 100, 103 AND 106). REG. 5-15-2001.
- 2,451,026. LANGTECH.COM. INT. CL. 42. (U.S. CLS. 100 AND 101). REG. 5-15-2001.
- 2,451,065. MISCELLANEOUS DESIGN. INT. CL. 12. (U.S. CLS. 19, 21, 23, 31, 35 AND 44). REG. 5-15-2001.
- 2,451,116. TRANSPAC SOLUTIONS AND DESIGN. INT. CL. 36. (U.S. CLS. 100, 101 AND 102). REG. 5-15-2001.
- 2,451,138. ROCKING HORSE FARM AND DESIGN. INT. CLS. 35, 36 AND 37. (U.S. CLS. 100, 101, 102, 103 AND 106). REG. 5-15-2001.
- 2,451,220. NUMERICAL. INT. CLS. 9 AND 42. (U.S. CLS. 21, 23, 26, 36, 38, 100 AND 101). REG. 5-15-2001.
- 2,451,313. PRO-TECH ORTHO MAT. INT. CL. 27. (U.S. CLS. 19, 20, 37, 42 AND 50). REG. 5-15-2001.

- 2,451,363. CONCO PAINTS AND DESIGN. INT. CL. 2. (U.S. CLS. 6, 11 AND 16). REG. 5-15-2001.
- 2,451,433. MOBIUS AND DESIGN. INT. CL. 38. (U.S. CLS. 100, 101 AND 104). REG. 5-15-2001.
- 2,451,452. HANDPRINT BOOKS. INT. CL. 16. (U.S. CLS. 2, 5, 22, 23, 29, 37, 38 AND 50). REG. 5-15-2001.
- 2,451,504. FLEXBIMEC. INT. CLS. 6, 7 AND 9. (U.S. CLS. 2, 12, 13, 14, 19, 21, 23, 25, 26, 31, 34, 35, 36, 38 AND 50). REG. 5-15-2001.
- 2,451,547. CONTACTWISE. INT. CL. 9. (U.S. CLS. 21, 23, 26, 36 AND 38). REG. 5-15-2001.
- 2,451,558. AERO-SERV. INT. CL. 21. (U.S. CLS. 2, 13, 23, 29, 30, 33, 40 AND 50). REG. 5-15-2001.
- 2,451,584. VISINE FOR CONTACTS. INT. CL. 5. (U.S. CLS. 6, 18, 44, 46, 51 AND 52). REG. 5-15-2001.
- 2,451,686. SNEDIKER & CARR. INT. CL. 11. (U.S. CLS. 13, 21, 23, 31 AND 34). REG. 5-15-2001.
- 2,451,700. MMT. INT. CL. 1. (U.S. CLS. 1, 5, 6, 10, 26 AND 46). REG. 5-15-2001.
- 2,451,785. JOHNNY SALAMI'S. INT. CL. 42. (U.S. CLS. 100 AND 101). REG. 5-15-2001.
- 2,452,075. FOR MY MOM. INT. CL. 10. (U.S. CLS. 26, 39 AND 44). REG. 5-15-2001.
- 2,452,209. NEUTROGENA. INT. CL. 3. (U.S. CLS. 1, 4, 6, 50, 51 AND 52). REG. 5-15-2001.
- 2,452,241. BIOTHERAPEUTIC DRAINAGE. INT. CLS. 16 AND 41. (U.S. CLS. 2, 5, 22, 23, 29, 37, 38, 50, 100, 101 AND 107). REG. 5-15-2001.
- 2,452,282. PERFORMANCE INSULATION SYSTEM. INT. CL. 17. (U.S. CLS. 1, 5, 12, 13, 35 AND 50). REG. 5-22-2001.
- 2,452,493. P2R. INT. CL. 42. (U.S. CLS. 100 AND 101). REG. 5-22-2001.
- 2,452,526. SVEN. INT. CL. 25. (U.S. CLS. 22 AND 39). REG. 5-22-2001.
- 2,452,879. UNIVERSITY OF MARYLAND AND DESIGN. INT. CLS. 9, 16 AND 41. (U.S. CLS. 2, 5, 21, 22, 23, 26, 29, 36, 37, 38, 50, 100, 101 AND 107). REG. 5-22-2001.
- 2,453,209. TVLAND.COM. INT. CL. 41. (U.S. CLS. 100, 101 AND 107). REG. 5-22-2001.
- 2,453,210. MTV CRIBS. INT. CL. 41. (U.S. CLS. 100, 101 AND 107). REG. 5-22-2001.
- 2,453,255. STEIN OPTICAL. INT. CLS. 35 AND 42. (U.S. CLS. 100, 101 AND 102). REG. 5-22-2001.
- 2,453,425. NITTOBO NE-GLASS. INT. CL. 21. (U.S. CLS. 2, 13, 23, 29, 30, 33, 40 AND 50). REG. 5-22-2001.
- 2,453,443. LUMASTAR. INT. CL. 11. (U.S. CLS. 13, 21, 23, 31 AND 34). REG. 5-22-2001.
- 2,453,601. NATURAL BOO AND DESIGN. INT. CL. 25. (U.S. CLS. 22 AND 39). REG. 5-22-2001.
- 2,453,716. MOLESKINE (STYLIZED). INT. CL. 16. (U.S. CLS. 2, 5, 22, 23, 29, 37, 38 AND 50). REG. 5-22-2001.
- 2,453,750. CCIE. INT. CL. 16. (U.S. CLS. 2, 5, 22, 23, 29, 37, 38 AND 50). REG. 5-22-2001.
- 2,453,922. RICOROCK. INT. CL. 19. (U.S. CLS. 1, 12, 33 AND 50). REG. 5-22-2001.
- 2,454,051. SOCCEREDGE AND DESIGN. INT. CL. 28. (U.S. CLS. 22, 23, 38 AND 50). REG. 5-22-2001.
- 2,454,052. SOCCEREDGE. INT. CL. 28. (U.S. CLS. 22, 23, 38 AND 50). REG. 5-22-2001.
- 2,454,070. INSTAHANGER AND DESIGN. INT. CL. 20. (U.S. CLS. 2, 13, 22, 25, 32 AND 50). REG. 5-22-2001.
- 2,454,265. MOISTURE MASQUE. INT. CL. 3. (U.S. CLS. 1, 4, 6, 50, 51 AND 52). REG. 5-22-2001.
- 2,454,543. K & G. INT. CL. 25. (U.S. CLS. 22 AND 39). REG. 5-29-2001.
- 2,454,879. GRAPHEL. INT. CL. 9. (U.S. CLS. 21, 23, 26, 36 AND 38). REG. 5-29-2001.
- 2,455,357. MESOMAP. INT. CL. 42. (U.S. CLS. 100 AND 101). REG. 5-29-2001.
- 2,455,364. MV. INT. CL. 7. (U.S. CLS. 13, 19, 21, 23, 31, 34 AND 35). REG. 5-29-2001.
- 2,455,470. TRAIL WEST. INT. CL. 41. (U.S. CLS. 100, 101 AND 107). REG. 5-29-2001.
- 2,455,471. TRAIL WEST. INT. CL. 42. (U.S. CLS. 100 AND 101). REG. 5-29-2001.
- 2,455,506. UNITEDNOW.COM. INT. CL. 35. (U.S. CLS. 100, 101 AND 102). REG. 5-29-2001.
- 2,455,567. STURMAN INDUSTRIES. INT. CL. 12. (U.S. CLS. 19, 21, 23, 31, 35 AND 44). REG. 5-29-2001.
- 2,456,560. FASSTRIV. INT. CL. 7. (U.S. CLS. 13, 19, 21, 23, 31, 34 AND 35). REG. 6-5-2001.
- 2,456,778. SOHO. INT. CLS. 16 AND 21. (U.S. CLS. 2, 5, 13, 22, 23, 29, 30, 33, 37, 38, 40 AND 50). REG. 6-5-2001.
- 2,456,837. AT HOME BUT NOT ALONE. INT. CL. 42. (U.S. CLS. 100 AND 101). REG. 6-5-2001.
- 2,456,985. LIFELIKE. INT. CL. 42. (U.S. CLS. 100 AND 101). REG. 6-5-2001.
- 2,457,303. CY. INT. CL. 1 ONLY. (U.S. CLS. 1, 5, 6, 10, 26 AND 46). REG. 6-5-2001.
- 2,457,461. BIC. INT. CL. 8. (U.S. CLS. 23, 28 AND 44). REG. 6-5-2001.
- 2,457,515. KPN. INT. CLS. 35, 38 AND 42. (U.S. CLS. 100, 101, 102 AND 104). REG. 6-5-2001.
- 2,457,659. TRANSYND. INT. CL. 4. (U.S. CLS. 1, 6 AND 15). REG. 6-5-2001.
- 2,458,013. POLY-LOCK. INT. CL. 6. (U.S. CLS. 2, 12, 13, 14, 23, 25 AND 50). REG. 6-5-2001.
- 2,458,117. MISCELLANEOUS DESIGN. INT. CL. 3. (U.S. CLS. 1, 4, 6, 50, 51 AND 52). REG. 6-5-2001.
- 2,458,169. ISENSOR. INT. CL. 9. (U.S. CLS. 21, 23, 26, 36 AND 38). REG. 6-5-2001.
- 2,458,250. RON HERMAN. INT. CL. 18. (U.S. CLS. 1, 2, 3, 22 AND 41). REG. 6-5-2001.
- 2,458,294. THINKING DIFFERENTLY ABOUT HEALTH CARE. INT. CL. 42. (U.S. CLS. 100 AND 101). REG. 6-5-2001.
- 2,458,306. I4BUSINESS. INT. CL. 42. (U.S. CLS. 100 AND 101). REG. 6-5-2001.
- 2,458,654. HALO BAR. INT. CL. 42. (U.S. CLS. 100 AND 101). REG. 6-5-2001.
- 2,458,742. KEYLED. INT. CLS. 9 AND 11. (U.S. CLS. 13, 21, 23, 26, 31, 34, 36 AND 38). REG. 6-5-2001.
- 2,458,803. BAR STUDY LOAN. INT. CL. 36. (U.S. CLS. 100, 101 AND 102). REG. 6-5-2001.
- 2,459,043. JC DECAUX. INT. CLS. 6, 9, 11, 20 AND 35 ONLY. (U.S. CLS. 2, 12, 13, 14, 21, 22, 23, 25, 26, 31, 32, 34, 36, 38, 50, 100, 101 AND 102). REG. 6-12-2001.
- 2,459,060. M METROSTARS AND DESIGN. INT. CL. 25. (U.S. CLS. 22 AND 39). REG. 6-12-2001.
- 2,459,332. IVIS. INT. CL. 39. (U.S. CLS. 100 AND 105). REG. 6-12-2001.
- 2,459,384. EASIC. INT. CL. 9. (U.S. CLS. 21, 23, 26, 36 AND 38). REG. 6-12-2001.
- 2,459,449. PRICE PFISTER (STYLIZED). INT. CL. 11. (U.S. CLS. 13, 21, 23, 31 AND 34). REG. 6-12-2001.
- 2,459,487. NUVO (STYLIZED). INT. CL. 42. (U.S. CLS. 100 AND 101). REG. 6-12-2001.
- 2,459,527. FIREADY'S AMBIANCE (STYLIZED). INT. CL. 4. (U.S. CLS. 1, 6 AND 15). REG. 6-12-2001.
- 2,459,619. DIP & SPIN STANDARD CHARACTER MARK. INT. CL. 5. (U.S. CLS. 6, 18, 44, 46, 51 AND 52). REG. 6-12-2001.
- 2,459,715. FOX RUN GOLF CLUB. INT. CL. 41. (U.S. CLS. 100, 101 AND 107). REG. 6-12-2001.
- 2,459,749. GMC. INT. CL. 16. (U.S. CLS. 2, 5, 22, 23, 29, 37, 38 AND 50). REG. 6-12-2001.
- 2,459,757. GREAT AMERICAN. INT. CL. 36. (U.S. CLS. 100, 101 AND 102). REG. 6-12-2001.
- 2,459,773. RYDE FX. INT. CL. 12. (U.S. CLS. 19, 21, 23, 31, 35 AND 44). REG. 6-12-2001.
- 2,459,803. BESSEMER. INT. CL. 36. (U.S. CLS. 100, 101 AND 102). REG. 6-12-2001.
- 2,459,836. JUPITER AND DESIGN. INT. CL. 12. (U.S. CLS. 19, 21, 23, 31, 35 AND 44). REG. 6-12-2001.
- 2,459,915. WISE POCKETS. INT. CL. 41. (U.S. CLS. 100, 101 AND 107). REG. 6-12-2001.
- 2,459,947. DIAMOND. INT. CL. 41. (U.S. CLS. 100, 101 AND 107). REG. 6-12-2001.
- 2,459,989. DISHDRAWER. INT. CL. 7. (U.S. CLS. 13, 19, 21, 23, 31, 34 AND 35). REG. 6-12-2001.
- 2,460,062. THE SHIELD. INT. CL. 12. (U.S. CLS. 19, 21, 23, 31, 35 AND 44). REG. 6-12-2001.
- 2,460,063. SUPERNATURAL. INT. CL. 1. (U.S. CLS. 1, 5, 6, 10, 26 AND 46). REG. 6-12-2001.
- 2,460,070. ILM. INT. CL. 25. (U.S. CLS. 22 AND 39). REG. 6-12-2001.
- 2,460,091. C. O. BIGELOW. INT. CLS. 18 AND 21. (U.S. CLS. 1, 2, 3, 13, 22, 23, 29, 30, 33, 40, 41 AND 50). REG. 6-12-2001.
- 2,460,093. ETXE-TAR AND DESIGN. INT. CL. 7. (U.S. CLS. 13, 19, 21, 23, 31, 34 AND 35). REG. 6-12-2001.
- 2,460,101. MISCELLANEOUS DESIGN. INT. CL. 42. (U.S. CLS. 100 AND 101). REG. 6-12-2001.
- 2,460,151. DOGGIE VIEW. INT. CL. 42. (U.S. CLS. 100 AND 101). REG. 6-12-2001.
- 2,460,251. COUNTRY BERRIES. INT. CL. 5. (U.S. CLS. 6, 18, 44, 46, 51 AND 52). REG. 6-12-2001.

- 2,460,257. GROUP OUTCOME. INT. CL. 36. (U.S. CLS. 100, 101 AND 102). REG. 6-12-2001.
- 2,460,368. DIGIWX. INT. CL. 9. (U.S. CLS. 21, 23, 26, 36 AND 38). REG. 6-12-2001.
- 2,460,383. POLARTEC WIND PRO. INT. CL. 24. (U.S. CLS. 42 AND 50). REG. 6-12-2001.
- 2,460,440. NXT. INT. CL. 21. (U.S. CLS. 2, 13, 23, 29, 30, 33, 40 AND 50). REG. 6-12-2001.
- 2,460,486. TRINOVA. INT. CL. 10. (U.S. CLS. 26, 39 AND 44). REG. 6-12-2001.
- 2,460,757. PEOPLE YOU CAN COUNT ON. INT. CLS. 35, 39 AND 40. (U.S. CLS. 100, 101, 102, 103, 105 AND 106). REG. 6-19-2001.
- 2,460,850. BACKPACKER.COM. INT. CLS. 41 AND 42. (U.S. CLS. 100, 101 AND 107). REG. 6-19-2001.
- 2,460,859. FLOSET. INT. CL. 1. (U.S. CLS. 1, 5, 6, 10, 26 AND 46). REG. 6-19-2001.
- 2,460,910. DIRECTORY OF BREEDERS. INT. CL. 16. (U.S. CLS. 2, 5, 22, 23, 29, 37, 38 AND 50). REG. 6-19-2001.
- 2,461,046. REAL B VOICE. INT. CL. 28. (U.S. CLS. 22, 23, 38 AND 50). REG. 6-19-2001.
- 2,461,079. TINI. INT. CL. 9. (U.S. CLS. 21, 23, 26, 36 AND 38). REG. 6-19-2001.
- 2,461,132. CHANGHONG AND DESIGN. INT. CLS. 7, 9 AND 11. (U.S. CLS. 13, 19, 21, 23, 26, 31, 34, 35, 36 AND 38). REG. 6-19-2001.
- 2,461,149. OUCOOLING. INT. CLS. 39 AND 42. (U.S. CLS. 100, 101 AND 105). REG. 6-19-2001.
- 2,461,161. GORDON BIERSCHE BREWING COMPANY. INT. CL. 32. (U.S. CLS. 45, 46 AND 48). REG. 6-19-2001.
- 2,461,169. ONEVISION. INT. CL. 9. (U.S. CLS. 21, 23, 26, 36 AND 38). REG. 6-19-2001.
- 2,461,265. REACH OUT AND READ. INT. CLS. 41 AND 42. (U.S. CLS. 100, 101 AND 107). REG. 6-19-2001.
- 2,461,428. SMARTSUITE. INT. CL. 37. (U.S. CLS. 100, 103 AND 106). REG. 6-19-2001.
- 2,461,462. DOWNERS GROVE POLICE SERVE PROTECT AND DESIGN. INT. CL. 42. (U.S. CLS. 100 AND 101). REG. 6-19-2001.
- 2,461,466. FENNER DRIVES. INT. CL. 7. (U.S. CLS. 13, 19, 21, 23, 31, 34 AND 35). REG. 6-19-2001.
- 2,461,481. REVIVE. INT. CL. 3. (U.S. CLS. 1, 4, 6, 50, 51 AND 52). REG. 6-19-2001.
- 2,461,494. PUPPY ROLL. INT. CL. 17. (U.S. CLS. 1, 5, 12, 13, 35 AND 50). REG. 6-19-2001.
- 2,461,507. MEMBER IPIA INTERNATIONAL PACKAGED ICE ASSOCIATION AND DESIGN. U.S. CL. A. REG. 6-19-2001.
- 2,461,565. NACTEL AND DESIGN. INT. CL. 41. (U.S. CLS. 100, 101 AND 107). REG. 6-19-2001.
- 2,461,566. NACTEL. INT. CL. 41. (U.S. CLS. 100, 101 AND 107). REG. 6-19-2001.
- 2,461,681. GMC. INT. CL. 18. (U.S. CLS. 1, 2, 3, 22 AND 41). REG. 6-19-2001.
- 2,461,697. GMC. INT. CL. 14. (U.S. CLS. 2, 27, 28 AND 50). REG. 6-19-2001.
- 2,461,745. MISCELLANEOUS DESIGN. INT. CL. 5. (U.S. CLS. 6, 18, 44, 46, 51 AND 52). REG. 6-19-2001.
- 2,461,802. G GREENBERGS AND DESIGN. INT. CL. 35. (U.S. CLS. 100, 101 AND 102). REG. 6-19-2001.
- 2,462,376. DISCOVER ENLIGHTEN SHARE NOURISH AND DESIGN. INT. CL. 41. (U.S. CLS. 100, 101 AND 107). REG. 6-19-2001.
- 2,462,398. ICETONE. INT. CL. 9. (U.S. CLS. 21, 23, 26, 36 AND 38). REG. 6-19-2001.
- 2,462,479. NOBLE COFFEE ROASTERS. INT. CL. 30. (U.S. CL. 46). REG. 6-19-2001.
- 2,462,556. PRICELESS PLANE PRODUCTS AND DESIGN. INT. CL. 12. (U.S. CLS. 19, 21, 23, 31, 35 AND 44). REG. 6-19-2001.
- 2,462,600. SS ONTARGET. INT. CL. 1. (U.S. CLS. 1, 5, 6, 10, 26 AND 46). REG. 6-19-2001.
- 2,462,831. VENUE. INT. CL. 14. (U.S. CLS. 2, 27, 28 AND 50). REG. 6-19-2001.
- 2,463,038. RUSH ASSOCIATED LABELS. INT. CL. 9. (U.S. CLS. 21, 23, 26, 36 AND 38). REG. 6-26-2001.
- 2,463,039. RAL RUSH ASSOCIATED LABELS (STYLIZED). INT. CL. 9. (U.S. CLS. 21, 23, 26, 36 AND 38). REG. 6-26-2001.
- 2,463,290. PHOTONSENSE. INT. CL. 42. (U.S. CLS. 100 AND 101). REG. 6-26-2001.
- 2,463,537. HAZ-HAMMOCK. INT. CL. 20. (U.S. CLS. 2, 13, 22, 25, 32 AND 50). REG. 6-26-2001.
- 2,463,559. KILLER TOMATOES. INT. CL. 9. (U.S. CLS. 21, 23, 26, 36 AND 38). REG. 6-26-2001.
- 2,463,580. BELTD AND DESIGN. INT. CL. 14. (U.S. CLS. 2, 27, 28 AND 50). REG. 6-26-2001.
- 2,463,589. SANTA FE LIVING. INT. CL. 16. (U.S. CLS. 2, 5, 22, 23, 29, 37, 38 AND 50). REG. 6-26-2001.
- 2,463,653. BIOTA. INT. CL. 42 ONLY. (U.S. CLS. 100 AND 101). REG. 6-26-2001.
- 2,463,665. TERRUS REAL ESTATE GROUP AND DESIGN. INT. CLS. 35, 36, 37 AND 42. (U.S. CLS. 100, 101, 102, 103 AND 106). REG. 6-26-2001.
- 2,463,713. ALL THINGS INTERNET. INT. CL. 42. (U.S. CLS. 100 AND 101). REG. 6-26-2001.
- 2,463,728. SWELLGEL. INT. CL. 1. (U.S. CLS. 1, 5, 6, 10, 26 AND 46). REG. 6-26-2001.
- 2,463,799. MISCELLANEOUS DESIGN. INT. CL. 41. (U.S. CLS. 100, 101 AND 107). REG. 6-26-2001.
- 2,463,824. PARA-CONTROL. INT. CL. 5. (U.S. CLS. 6, 18, 44, 46, 51 AND 52). REG. 6-26-2001.
- 2,463,863. MOCK TURTLE PRESS. INT. CL. 41. (U.S. CLS. 100, 101 AND 107). REG. 6-26-2001.
- 2,463,969. FIRST RESPONSE AND DESIGN. INT. CL. 5. (U.S. CLS. 6, 18, 44, 46, 51 AND 52). REG. 6-26-2001.
- 2,463,986. SCARLET. INT. CL. 30. (U.S. CL. 46). REG. 6-26-2001.
- 2,464,054. T-SHIRT CHAIR. INT. CL. 20. (U.S. CLS. 2, 13, 22, 25, 32 AND 50). REG. 6-26-2001.
- 2,464,055. NAME BRAND. INT. CL. 25. (U.S. CLS. 22 AND 39). REG. 6-26-2001.
- 2,464,065. PROMENSIL. INT. CL. 5. (U.S. CLS. 6, 18, 44, 46, 51 AND 52). REG. 6-26-2001.
- 2,464,335. VOICE OF THE STRING. INT. CL. 9. (U.S. CLS. 21, 23, 26, 36 AND 38). REG. 6-26-2001.
- 2,464,363. AQUANOT!. INT. CL. 9. (U.S. CLS. 21, 23, 26, 36 AND 38). REG. 6-26-2001.
- 2,464,440. LOCK N' GO. INT. CL. 20. (U.S. CLS. 2, 13, 22, 25, 32 AND 50). REG. 6-26-2001.
- 2,464,464. LABCELL. INT. CL. 7. (U.S. CLS. 13, 19, 21, 23, 31, 34 AND 35). REG. 6-26-2001.
- 2,464,632. PATHFINDER. INT. CL. 9. (U.S. CLS. 21, 23, 26, 36 AND 38). REG. 6-26-2001.
- 2,464,718. VINTON. INT. CL. 20. (U.S. CLS. 2, 13, 22, 25, 32 AND 50). REG. 6-26-2001.
- 2,465,035. UHING-EASYLOCK. INT. CL. 7. (U.S. CLS. 13, 19, 21, 23, 31, 34 AND 35). REG. 7-3-2001.
- 2,465,527. SWEET'N LOW AND DESIGN. INT. CL. 30. (U.S. CL. 46). REG. 7-3-2001.
- 2,465,599. FLOFORM. INT. CL. 1. (U.S. CLS. 1, 5, 6, 10, 26 AND 46). REG. 7-3-2001.
- 2,466,130. DURASUL. INT. CL. 10. (U.S. CLS. 26, 39 AND 44). REG. 7-3-2001.
- 2,466,222. US FILTER (STYLIZED). INT. CL. 1. (U.S. CLS. 1, 5, 6, 10, 26 AND 46). REG. 7-3-2001.
- 2,466,223. US FILTER (STYLIZED). INT. CL. 11. (U.S. CLS. 13, 21, 23, 31 AND 34). REG. 7-3-2001.
- 2,466,460. VERIPATH. INT. CL. 10. (U.S. CLS. 26, 39 AND 44). REG. 7-3-2001.
- 2,466,466. FUEL WORKS. INT. CL. 9. (U.S. CLS. 21, 23, 26, 36 AND 38). REG. 7-3-2001.
- 2,466,488. THE WALL STREET JOURNAL SUNDAY. INT. CL. 16. (U.S. CLS. 2, 5, 22, 23, 29, 37, 38 AND 50). REG. 7-3-2001.
- 2,466,740. CAR START. INT. CL. 9. (U.S. CLS. 21, 23, 26, 36 AND 38). REG. 7-3-2001.
- 2,466,988. MINIRATOR. INT. CL. 9. (U.S. CLS. 21, 23, 26, 36 AND 38). REG. 7-10-2001.
- 2,467,358. STEVIA PLUS. INT. CL. 30. (U.S. CL. 46). REG. 7-10-2001.
- 2,467,524. MULTICUENTA POPULAR. INT. CL. 36. (U.S. CLS. 100, 101 AND 102). REG. 7-10-2001.
- 2,467,579. THE BOSTON COOKER RESTAURANT & OYSTER BAR AND DESIGN. INT. CL. 42. (U.S. CLS. 100 AND 101). REG. 7-10-2001.
- 2,467,796. DC PLUS. INT. CL. 42. (U.S. CLS. 100 AND 101). REG. 7-10-2001.
- 2,468,080. LIONEL LEGENDARY TRAINS AND DESIGN. INT. CL. 25. (U.S. CLS. 22 AND 39). REG. 7-10-2001.
- 2,468,138. FHB ONLINE. INT. CL. 36. (U.S. CLS. 100, 101 AND 102). REG. 7-10-2001.
- 2,468,501. MOLD BASICS. INT. CLS. 6 AND 7. (U.S. CLS. 2, 12, 13, 14, 19, 21, 23, 25, 31, 34, 35 AND 50). REG. 7-10-2001.

- 2,468,945. D.A.R.E. INTERNATIONAL. INT. CL. 41. (U.S. CLS. 100, 101 AND 107). REG. 7-17-2001.
- 2,469,054. LABTENDER. INT. CL. 9. (U.S. CLS. 21, 23, 26, 36 AND 38). REG. 7-17-2001.
- 2,469,076. SOFTGLOBALIZATION AND DESIGN. INT. CL. 42. (U.S. CLS. 100 AND 101). REG. 7-17-2001.
- 2,469,396. NORTH AMERICAN FISHING CLUB. INT. CL. 16. (U.S. CLS. 2, 5, 22, 23, 29, 37, 38 AND 50). REG. 7-17-2001.
- 2,469,588. NAPPETIZERS. INT. CL. 29. (U.S. CL. 46). REG. 7-17-2001.
- 2,469,972. NOLOSTPIECE (STYLIZED). INT. CL. 35. (U.S. CLS. 100, 101 AND 102). REG. 7-17-2001.
- 2,470,021. THE BREAD FACTORY CAFE. INT. CLS. 35 AND 42. (U.S. CLS. 100, 101 AND 102). REG. 7-17-2001.
- 2,470,097. MOBIUS COMMUNICATIONS COMPANY AND DESIGN. INT. CL. 38. (U.S. CLS. 100, 101 AND 104). REG. 7-17-2001.
- 2,470,256. GOLDCELL. INT. CL. 30. (U.S. CL. 46). REG. 7-17-2001.
- 2,470,271. STERIDYNE. INT. CL. 11. (U.S. CLS. 13, 21, 23, 31 AND 34). REG. 7-17-2001.
- 2,470,387. VICTORIA WOODHULL. INT. CL. 25 ONLY. (U.S. CLS. 22 AND 39). REG. 7-17-2001.
- 2,470,414. GLENWILD. INT. CLS. 36 AND 37. (U.S. CLS. 100, 101, 102, 103 AND 106). REG. 7-17-2001.
- 2,471,071. MY ROOM. INT. CLS. 20 AND 24. (U.S. CLS. 2, 13, 22, 25, 32, 42 AND 50). REG. 7-24-2001.
- 2,471,139. FLEXIDOME. INT. CL. 9. (U.S. CLS. 21, 23, 26, 36 AND 38). REG. 7-24-2001.
- 2,471,669. CLEAN POWER SOLUTIONS FOR THE 21ST CENTURY. INT. CL. 42. (U.S. CLS. 100 AND 101). REG. 7-24-2001.
- 2,471,719. RCN. INT. CL. 38. (U.S. CLS. 100, 101 AND 104). REG. 7-24-2001.
- 2,472,133. CABERNET. INT. CL. 25. (U.S. CLS. 22 AND 39). REG. 7-24-2001.
- 2,472,142. INVISIBLE GATE. INT. CL. 9. (U.S. CLS. 21, 23, 26, 36 AND 38). REG. 7-24-2001.
- 2,472,603. SAVA AND DESIGN. INT. CLS. 12, 16 AND 17 ONLY. (U.S. CLS. 1, 2, 5, 12, 13, 19, 21, 22, 23, 29, 31, 35, 37, 38, 44 AND 50 ONLY). REG. 7-31-2001.
- 2,472,725. HAUSBRANDT. INT. CL. 30. (U.S. CL. 46). REG. 7-31-2001.
- 2,472,943. PCUBED. INT. CLS. 16 AND 35. (U.S. CLS. 2, 5, 22, 23, 29, 37, 38, 50, 100, 101 AND 102). REG. 7-31-2001.
- 2,472,996. THE TRYALL CLUB. INT. CLS. 41 AND 42. (U.S. CLS. 100, 101 AND 107). REG. 7-31-2001.
- 2,473,064. SOLAROIL. INT. CL. 3. (U.S. CLS. 1, 4, 6, 50, 51 AND 52). REG. 7-31-2001.
- 2,473,871. ENTERTAINMENT ULTIMATE. INT. CL. 35. (U.S. CLS. 100, 101 AND 102). REG. 7-31-2001.
- 2,474,144. EMI LATIN AND DESIGN. INT. CL. 9. (U.S. CLS. 21, 23, 26, 36 AND 38). REG. 7-31-2001.
- 2,474,196. RUDER FINN. INT. CL. 35. (U.S. CLS. 100, 101 AND 102). REG. 7-31-2001.
- 2,474,346. ROBBY. INT. CL. 9. (U.S. CLS. 21, 23, 26, 36 AND 38). REG. 7-31-2001.
- 2,474,664. SURFACE LAMINAR CIRCUIT. INT. CL. 9. (U.S. CLS. 21, 23, 26, 36 AND 38). REG. 7-31-2001.
- 2,475,161. RACING FOR KIDS. INT. CL. 36. (U.S. CLS. 100, 101 AND 102). REG. 8-7-2001.
- 2,475,389. GMA GARNET. INT. CL. 3. (U.S. CLS. 1, 4, 6, 50, 51 AND 52). REG. 8-7-2001.
- 2,475,502. TASTE OF NEW ENGLAND!. INT. CL. 42. (U.S. CLS. 100 AND 101). REG. 8-7-2001.
- 2,475,703. ZEROCHAOS. INT. CL. 36. (U.S. CLS. 100, 101 AND 102). REG. 8-7-2001.
- 2,475,819. KEMET. INT. CL. 9. (U.S. CLS. 21, 23, 26, 36 AND 38). REG. 8-7-2001.
- 2,475,827. AUREUS EXECUTIVE. INT. CL. 35. (U.S. CLS. 100, 101 AND 102). REG. 8-7-2001.
- 2,476,374. MARKET WIZARDS. INT. CL. 36. (U.S. CLS. 100, 101 AND 102). REG. 8-7-2001.
- 2,476,642. JULIANA. INT. CL. 28. (U.S. CLS. 22, 23, 38 AND 50). REG. 8-7-2001.
- 2,476,647. QUALITY THROUGH COMMITMENT. INT. CL. 36. (U.S. CLS. 100, 101 AND 102). REG. 8-7-2001.
- 2,476,724. MICRO ICE. INT. CL. 28. (U.S. CLS. 22, 23, 38 AND 50). REG. 8-7-2001.
- 2,476,794. THE ONE PAGE BUSINESS PLAN. INT. CLS. 9, 35 AND 36. (U.S. CLS. 21, 23, 26, 36, 38, 100, 101 AND 102). REG. 8-7-2001.
- 2,476,869. TWINVIDEO. INT. CL. 10. (U.S. CLS. 26, 39 AND 44). REG. 8-14-2001.
- 2,476,907. FEI COMMUNICATIONS. INT. CL. 9. (U.S. CLS. 21, 23, 26, 36 AND 38). REG. 8-14-2001.
- 2,476,994. DOTY. INT. CL. 9. (U.S. CLS. 21, 23, 26, 36 AND 38). REG. 8-14-2001.
- 2,477,451. MISCELLANEOUS DESIGN. INT. CL. 30. (U.S. CL. 46). REG. 8-14-2001.
- 2,477,561. K AND DESIGN. U.S. CL. A. REG. 8-14-2001.
- 2,477,693. MISCELLANEOUS DESIGN. INT. CL. 9. (U.S. CLS. 21, 23, 26, 36 AND 38). REG. 8-14-2001.
- 2,477,726. WOLF AND DESIGN. INT. CL. 37. (U.S. CLS. 100, 103 AND 106). REG. 8-14-2001.
- 2,477,857. THE INTERNATIONAL DERMAL INSTITUTE AND DESIGN. INT. CL. 41. (U.S. CLS. 100, 101 AND 107). REG. 8-14-2001.
- 2,477,861. RAPIDBRIDGE (STYLIZED). INT. CL. 6. (U.S. CLS. 2, 12, 13, 14, 23, 25 AND 50). REG. 8-14-2001.
- 2,477,947. MANGUSTA (STYLIZED). INT. CL. 12. (U.S. CLS. 19, 21, 23, 31, 35 AND 44). REG. 8-14-2001.
- 2,478,056. PACAPET. INT. CL. 28. (U.S. CLS. 22, 23, 38 AND 50). REG. 8-14-2001.
- 2,478,076. MIDTEL. INT. CL. 9. (U.S. CLS. 21, 23, 26, 36 AND 38). REG. 8-14-2001.
- 2,478,239. DOTREGISTRAR. INT. CL. 42. (U.S. CLS. 100 AND 101). REG. 8-14-2001.
- 2,478,258. GENSTEAM. INT. CL. 39. (U.S. CLS. 100 AND 105). REG. 8-14-2001.
- 2,478,481. HOWARD PARK. INT. CL. 33. (U.S. CLS. 47 AND 49). REG. 8-14-2001.
- 2,478,510. CLEAN CLAMP. INT. CL. 20. (U.S. CLS. 2, 13, 22, 25, 32 AND 50). REG. 8-14-2001.
- 2,478,941. DAZOC. INT. CLS. 17 AND 20. (U.S. CLS. 1, 2, 5, 12, 13, 22, 25, 32, 35 AND 50). REG. 8-21-2001.
- 2,478,976. MISCELLANEOUS DESIGN. INT. CL. 33. (U.S. CLS. 47 AND 49). REG. 8-21-2001.
- 2,479,386. MANHATTAN CABINETRY. INT. CL. 20. (U.S. CLS. 2, 13, 22, 25, 32 AND 50). REG. 8-21-2001.
- 2,479,541. BABY GUND AND DESIGN. INT. CL. 28 ONLY. (U.S. CLS. 22, 23, 38 AND 50). REG. 8-21-2001.
- 2,480,493. SPLASH ACTION. INT. CL. 28. (U.S. CLS. 22, 23, 38 AND 50). REG. 8-21-2001.
- 2,481,238. JEA. INT. CL. 39. (U.S. CLS. 100 AND 105). REG. 8-28-2001.
- 2,481,297. JUST FOR ME. INT. CL. 31. (U.S. CLS. 1 AND 46). REG. 8-28-2001.
- 2,481,422. HEALTHPRO. INT. CL. 11. (U.S. CLS. 13, 21, 23, 31 AND 34). REG. 8-28-2001.
- 2,481,601. WEBGLOBALIZATION AND DESIGN. INT. CL. 42. (U.S. CLS. 100 AND 101). REG. 8-28-2001.
- 2,481,799. D AND DESIGN. INT. CL. 11. (U.S. CLS. 13, 21, 23, 31 AND 34). REG. 8-28-2001.
- 2,481,912. NORTH AMERICAN HUNTING CLUB. INT. CL. 42 ONLY. (U.S. CLS. 100 AND 101). REG. 8-28-2001.
- 2,482,177. AMERICAN SEASONS. INT. CL. 42. (U.S. CLS. 100 AND 101). REG. 8-28-2001.
- 2,482,704. DURABAY. INT. CL. 11. (U.S. CLS. 13, 21, 23, 31 AND 34). REG. 8-28-2001.
- 2,483,156. DURALENE. INT. CL. 7. (U.S. CLS. 13, 19, 21, 23, 31, 34 AND 35). REG. 8-28-2001.
- 2,483,718. RPM. INT. CL. 20. (U.S. CLS. 2, 13, 22, 25, 32 AND 50). REG. 8-28-2001.
- 2,484,156. STRAIGHT TALK. INT. CL. 41. (U.S. CLS. 100, 101 AND 107). REG. 9-4-2001.
- 2,485,034. SORT- TEK. INT. CL. 42. (U.S. CLS. 100 AND 101). REG. 9-4-2001.
- 2,485,061. SALON VISAGE. INT. CL. 42. (U.S. CLS. 100 AND 101). REG. 9-4-2001.
- 2,485,071. WE DO ONE THING. FISH. INT. CL. 35. (U.S. CLS. 100, 101 AND 102). REG. 9-4-2001.
- 2,485,279. G AND DESIGN. INT. CL. 39. (U.S. CLS. 100 AND 105). REG. 9-4-2001.
- 2,485,600. TOMORROW STORIES. INT. CL. 16. (U.S. CLS. 2, 5, 22, 23, 29, 37, 38 AND 50). REG. 9-4-2001.
- 2,486,209. FENG SHUI DIVA. INT. CL. 42. (U.S. CLS. 100 AND 101). REG. 9-4-2001.
- 2,486,343. PRIMARILINK. INT. CLS. 35, 36 AND 42. (U.S. CLS. 100, 101 AND 102). REG. 9-4-2001.
- 2,486,743. ICY PASTELS. INT. CL. 14. (U.S. CLS. 2, 27, 28 AND 50). REG. 9-11-2001.
- 2,487,059. MISCELLANEOUS DESIGN. INT. CL. 36. (U.S. CLS. 100, 101 AND 102). REG. 9-11-2001.
- 2,487,302. MARK-A-LOT. INT. CL. 37. (U.S. CLS. 100, 103 AND 106). REG. 9-11-2001.

- 2,487,613. LEAR ROMEC. INT. CL. 7. (U.S. CLS. 13, 19, 21, 23, 31, 34 AND 35). REG. 9-11-2001.
- 2,487,666. THE BIG RED COOKBOOK. INT. CL. 16. (U.S. CLS. 2, 5, 22, 23, 29, 37, 38 AND 50). REG. 9-11-2001.
- 2,488,070. THE NORTHWEST ORIGINAL. INT. CL. 32. (U.S. CLS. 45, 46 AND 48). REG. 9-11-2001.
- 2,488,096. BLONDIE. INT. CL. 41. (U.S. CLS. 100, 101 AND 107). REG. 9-11-2001.
- 2,488,181. POST BAR. INT. CL. 42. (U.S. CLS. 100 AND 101). REG. 9-11-2001.
- 2,488,228. EMERALD MAGIC. INT. CL. 31. (U.S. CLS. 1 AND 46). REG. 9-11-2001.
- 2,488,379. Z SPOT. INT. CL. 35. (U.S. CLS. 100, 101 AND 102). REG. 9-11-2001.
- 2,488,381. SCANMAX. INT. CL. 9. (U.S. CLS. 21, 23, 26, 36 AND 38). REG. 9-11-2001.
- 2,488,432. MINIFLEX. INT. CL. 7. (U.S. CLS. 13, 19, 21, 23, 31, 34 AND 35). REG. 9-11-2001.
- 2,488,472. GARDECO. INT. CLS. 19 AND 21 ONLY. (U.S. CLS. 1, 2, 12, 13, 23, 29, 30, 33, 40 AND 50). REG. 9-11-2001.
- 2,488,581. NANTUCKET. INT. CL. 27. (U.S. CLS. 19, 20, 37, 42 AND 50). REG. 9-11-2001.
- 2,488,887. TANKGUARD. INT. CL. 36. (U.S. CLS. 100, 101 AND 102). REG. 9-11-2001.
- 2,489,254. EMPLOYMENT LIABILITY PROTECTOR. INT. CL. 36. (U.S. CLS. 100, 101 AND 102). REG. 9-11-2001.
- 2,489,424. FREESTYLE CRUISING. INT. CL. 39. (U.S. CLS. 100 AND 105). REG. 9-11-2001.
- 2,489,926. DYNAMAIL. INT. CL. 35. (U.S. CLS. 100, 101 AND 102). REG. 9-18-2001.
- 2,490,038. MISCELLANEOUS DESIGN. INT. CL. 42. (U.S. CLS. 100 AND 101). REG. 9-18-2001.
- 2,490,264. ADAMSGOLF. INT. CL. 28. (U.S. CLS. 22, 23, 38 AND 50). REG. 9-18-2001.
- 2,490,573. PORTOLANO AND DESIGN. INT. CLS. 18 AND 25. (U.S. CLS. 1, 2, 3, 22, 39 AND 41). REG. 9-18-2001.
- 2,491,746. MARATHON TRAVEL & CRUISE SHOPS. INT. CL. 39. (U.S. CLS. 100 AND 105). REG. 9-25-2001.
- 2,492,203. TEALEAF. INT. CLS. 9 AND 42. (U.S. CLS. 21, 23, 26, 36, 38, 100 AND 101). REG. 9-25-2001.
- 2,492,925. NANOCRYSTAL. INT. CLS. 35, 40 AND 42. (U.S. CLS. 100, 101, 102, 103 AND 106). REG. 9-25-2001.
- 2,493,199. AUTECH. INT. CL. 7. (U.S. CLS. 13, 19, 21, 23, 31, 34 AND 35). REG. 9-25-2001.
- 2,493,552. GD (STYLIZED). INT. CL. 9. (U.S. CLS. 21, 23, 26, 36 AND 38). REG. 9-25-2001.
- 2,493,803. OZOVIT (STYLIZED). INT. CL. 5. (U.S. CLS. 6, 18, 44, 46, 51 AND 52). REG. 10-2-2001.
- 2,493,998. COMPUDRAFT. INT. CL. 9. (U.S. CLS. 21, 23, 26, 36 AND 38). REG. 10-2-2001.
- 2,494,125. PANEL-SEAL. INT. CL. 2. (U.S. CLS. 6, 11 AND 16). REG. 10-2-2001.
- 2,494,411. LMI. INT. CL. 35. (U.S. CLS. 100, 101 AND 102). REG. 10-2-2001.
- 2,494,451. TWIN MODAL, INC. AND DESIGN. INT. CL. 39. (U.S. CLS. 100 AND 105). REG. 10-2-2001.
- 2,494,485. BREAD LOAF. INT. CL. 41. (U.S. CLS. 100, 101 AND 107). REG. 10-2-2001.
- 2,494,764. RAZOR. INT. CL. 5. (U.S. CLS. 6, 18, 44, 46, 51 AND 52). REG. 10-2-2001.
- 2,495,143. VISUAL WEBTOOLS. INT. CL. 9. (U.S. CLS. 21, 23, 26, 36 AND 38). REG. 10-2-2001.
- 2,495,547. M NEW MILLENNIUM BANK AND DESIGN. INT. CL. 36. (U.S. CLS. 100, 101 AND 102). REG. 10-9-2001.
- 2,495,976. INTERACT CLUB. INT. CL. 16. (U.S. CLS. 2, 5, 22, 23, 29, 37, 38 AND 50). REG. 10-9-2001.
- 2,496,200. LSI SOLUTIONS. INT. CL. 10. (U.S. CLS. 26, 39 AND 44). REG. 10-9-2001.
- 2,496,267. YOUR HOME. INT. CL. 3. (U.S. CLS. 1, 4, 6, 50, 51 AND 52). REG. 10-9-2001.
- 2,496,305. ESCOA. INT. CL. 11. (U.S. CLS. 13, 21, 23, 31 AND 34). REG. 10-9-2001.
- 2,496,916. AGRITHERM. INT. CL. 17. (U.S. CLS. 1, 5, 12, 13, 35 AND 50). REG. 10-9-2001.
- 2,497,128. I-DROP. INT. CL. 9. (U.S. CLS. 21, 23, 26, 36 AND 38). REG. 10-9-2001.
- 2,497,541. LEAF BEATER. INT. CL. 6. (U.S. CLS. 2, 12, 13, 14, 23, 25 AND 50). REG. 10-16-2001.
- 2,497,591. STAROFFICE. INT. CL. 9. (U.S. CLS. 21, 23, 26, 36 AND 38). REG. 10-16-2001.
- 2,497,873. SEXY WORLD. INT. CL. 41. (U.S. CLS. 100, 101 AND 107). REG. 10-16-2001.
- 2,498,160. THERAGENICS CORPORATION. INT. CL. 5. (U.S. CLS. 6, 18, 44, 46, 51 AND 52). REG. 10-16-2001.
- 2,498,213. SEXY WORLD. INT. CL. 9. (U.S. CLS. 21, 23, 26, 36 AND 38). REG. 10-16-2001.
- 2,498,217. GENPRO. INT. CL. 9. (U.S. CLS. 21, 23, 26, 36 AND 38). REG. 10-16-2001.
- 2,498,218. ALPHAGUARD. INT. CL. 9. (U.S. CLS. 21, 23, 26, 36 AND 38). REG. 10-16-2001.
- 2,498,552. ADD-A-FOLD. INT. CL. 7. (U.S. CLS. 13, 19, 21, 23, 31, 34 AND 35). REG. 10-16-2001.
- 2,498,756. FREEZOR. INT. CL. 10. (U.S. CLS. 26, 39 AND 44). REG. 10-16-2001.
- 2,498,830. EA. INT. CLS. 38 AND 42. (U.S. CLS. 100, 101 AND 104). REG. 10-16-2001.
- 2,499,491. CHARMLINE MARYAN MEHLHORN (STYLIZED). INT. CL. 25 ONLY. (U.S. CLS. 22 AND 39). REG. 10-23-2001.
- 2,499,595. PRIMECOR. INT. CL. 36 ONLY. (U.S. CLS. 100, 101 AND 102). REG. 10-23-2001.
- 2,499,990. LANGTECH SYSTEMS CONSULTING. INT. CL. 42. (U.S. CLS. 100 AND 101). REG. 10-23-2001.
- 2,500,577. CUBA LIBRE. INT. CL. 34. (U.S. CLS. 2, 8, 9 AND 17). REG. 10-23-2001.
- 2,501,625. MISCELLANEOUS DESIGN. INT. CL. 42. (U.S. CLS. 100 AND 101). REG. 10-30-2001.
- 2,501,839. K & W CAFETERIA (STYLIZED). INT. CL. 42. (U.S. CLS. 100 AND 101). REG. 10-30-2001.
- 2,502,150. IONIZER STUFF. INT. CL. 1. (U.S. CLS. 1, 5, 6, 10, 26 AND 46). REG. 10-30-2001.
- 2,502,196. UNI-VENT. INT. CL. 10. (U.S. CLS. 26, 39 AND 44). REG. 10-30-2001.
- 2,502,197. ULTRA-LITE. INT. CL. 10. (U.S. CLS. 26, 39 AND 44). REG. 10-30-2001.
- 2,502,701. SCIENCE VIEW. INT. CL. 9. (U.S. CLS. 21, 23, 26, 36 AND 38). REG. 10-30-2001.
- 2,503,008. PHENA-S. INT. CL. 5. (U.S. CLS. 6, 18, 44, 46, 51 AND 52). REG. 10-30-2001.
- 2,503,054. WHERE GOLFERS MEET THEIR MATCH. INT. CL. 41. (U.S. CLS. 100, 101 AND 107). REG. 10-30-2001.
- 2,503,692. EVENTLINK. INT. CL. 35. (U.S. CLS. 100, 101 AND 102). REG. 11-6-2001.
- 2,504,024. RS-4I (STYLIZED). INT. CL. 10. (U.S. CLS. 26, 39 AND 44). REG. 11-6-2001.
- 2,504,642. STORM. INT. CL. 35. (U.S. CLS. 100, 101 AND 102). REG. 11-6-2001.
- 2,506,240. TWISTER (STYLIZED). INT. CL. 30. (U.S. CL. 46). REG. 11-13-2001.
- 2,506,462. MAXI LD. INT. CL. 10. (U.S. CLS. 26, 39 AND 44). REG. 11-13-2001.
- 2,506,638. EZ PEEL. INT. CL. 17. (U.S. CLS. 1, 5, 12, 13, 35 AND 50). REG. 11-13-2001.
- 2,507,007. GO ANYWHERE IN AMERICA AND STAY RIGHT AT HOME. INT. CL. 42. (U.S. CLS. 100 AND 101). REG. 11-13-2001.
- 2,507,008. GO ANYWHERE IN AMERICA AND STAY RIGHT AT HOME. INT. CL. 36. (U.S. CLS. 100, 101 AND 102). REG. 11-13-2001.
- 2,507,014. STRONG-PAD. INT. CL. 19. (U.S. CLS. 1, 12, 33 AND 50). REG. 11-13-2001.
- 2,507,830. CONSTRUCTWARE. INT. CL. 9. (U.S. CLS. 21, 23, 26, 36 AND 38). REG. 11-13-2001.
- 2,507,893. ALPHA NEST. INT. CL. 24. (U.S. CLS. 42 AND 50). REG. 11-13-2001.
- 2,507,979. VISUALENS. INT. CL. 10. (U.S. CLS. 26, 39 AND 44). REG. 11-13-2001.
- 2,509,066. MISCELLANEOUS DESIGN. INT. CLS. 41 AND 42. (U.S. CLS. 100, 101 AND 107). REG. 11-20-2001.
- 2,509,704. ADVICE AND INSIGHT INTO THE PRACTICE OF LAW. INT. CL. 16. (U.S. CLS. 2, 5, 22, 23, 29, 37, 38 AND 50). REG. 11-20-2001.
- 2,510,401. ENDURACRETE. INT. CL. 37. (U.S. CLS. 100, 103 AND 106). REG. 11-20-2001.
- 2,510,612. CORRAL. INT. CL. 11. (U.S. CLS. 13, 21, 23, 31 AND 34). REG. 11-20-2001.
- 2,511,098. PENA RIDGE. INT. CL. 33. (U.S. CLS. 47 AND 49). REG. 11-20-2001.
- 2,511,101. WORKLIFEBALANCE.COM. INT. CL. 41. (U.S. CLS. 100, 101 AND 107). REG. 11-20-2001.
- 2,511,298. FRUITS.COM. INT. CL. 42. (U.S. CLS. 100 AND 101). REG. 11-20-2001.

- 2,511,506. GEIGER AND DESIGN. INT. CL. 25 ONLY. (U.S. CLS. 22 AND 39). REG. 11-27-2001.
- 2,511,771. WAVE SUPER EFFICIENT PUMP AND DESIGN. INT. CL. 7. (U.S. CLS. 13, 19, 21, 23, 31, 34 AND 35). REG. 11-27-2001.
- 2,512,378. HANDYMAN ONLINE. INT. CL. 35. (U.S. CLS. 100, 101 AND 102). REG. 11-27-2001.
- 2,513,616. SMART BROOM. INT. CL. 21. (U.S. CLS. 2, 13, 23, 29, 30, 33, 40 AND 50). REG. 12-4-2001.
- 2,513,678. PATIO BISTRO. INT. CL. 11. (U.S. CLS. 13, 21, 23, 31 AND 34). REG. 12-4-2001.
- 2,513,909. AESOP. INT. CL. 9. (U.S. CLS. 21, 23, 26, 36 AND 38). REG. 12-4-2001.
- 2,513,963. MISCELLANEOUS DESIGN. INT. CL. 20. (U.S. CLS. 2, 13, 22, 25, 32 AND 50). REG. 12-4-2001.
- 2,514,455. LAKE NONA (STYLIZED). INT. CLS. 18, 25, 28, 36, 41 AND 42. (U.S. CLS. 1, 2, 3, 22, 23, 38, 39, 41, 50, 100, 101, 102 AND 107). REG. 12-4-2001.
- 2,514,641. EQUITOUR. INT. CL. 39. (U.S. CLS. 100 AND 105). REG. 12-4-2001.
- 2,515,037. MINUS K. INT. CL. 42. (U.S. CLS. 100 AND 101). REG. 12-4-2001.
- 2,515,079. SEARCHIT. INT. CL. 9. (U.S. CLS. 21, 23, 26, 36 AND 38). REG. 12-4-2001.
- 2,515,665. FANFARE. INT. CL. 20. (U.S. CLS. 2, 13, 22, 25, 32 AND 50). REG. 12-4-2001.
- 2,515,960. THE ALLIANCE SERIES. INT. CL. 36. (U.S. CLS. 100, 101 AND 102). REG. 12-11-2001.
- 2,516,901. PALM DRIVE VIDEO. INT. CL. 9 ONLY. (U.S. CLS. 21, 23, 26, 36 AND 38). REG. 12-11-2001.
- 2,517,234. INFINIVISION. INT. CL. 42. (U.S. CLS. 100 AND 101). REG. 12-11-2001.
- 2,518,707. HIDDEN VALLEY. INT. CL. 30. (U.S. CL. 46). REG. 12-11-2001.
- 2,519,531. MISCELLANEOUS DESIGN. INT. CL. 41. (U.S. CLS. 100, 101 AND 107). REG. 12-18-2001.
- 2,519,941. CELLTEI AND DESIGN. INT. CL. 18 ONLY. (U.S. CLS. 1, 2, 3, 22 AND 41). REG. 12-18-2001.
- 2,520,239. KIDWRITER. INT. CL. 16. (U.S. CLS. 2, 5, 22, 23, 29, 37, 38 AND 50). REG. 12-18-2001.
- 2,520,385. EPICARE. INT. CL. 10. (U.S. CLS. 26, 39 AND 44). REG. 12-18-2001.
- 2,520,619. ACCEPT YOURSELF... ACCEPT OTHERS. INT. CL. 41. (U.S. CLS. 100, 101 AND 107). REG. 12-18-2001.
- 2,520,702. LEGACY CLASSIC FURNITURE. INT. CL. 20. (U.S. CLS. 2, 13, 22, 25, 32 AND 50). REG. 12-18-2001.
- 2,520,943. I-CYBIE. INT. CL. 28. (U.S. CLS. 22, 23, 38 AND 50). REG. 12-18-2001.
- 2,522,383. INFINIVISION. INT. CL. 9. (U.S. CLS. 21, 23, 26, 36 AND 38). REG. 12-25-2001.
- 2,522,435. W WIZARDS AND DESIGN. INT. CL. 35. (U.S. CLS. 100, 101 AND 102). REG. 12-25-2001.
- 2,522,803. TIFF SURFER. INT. CL. 9. (U.S. CLS. 21, 23, 26, 36 AND 38). REG. 12-25-2001.
- 2,523,530. WE MAKE IT ALL BETTER. INT. CL. 5. (U.S. CLS. 6, 18, 44, 46, 51 AND 52). REG. 12-25-2001.
- 2,523,714. TEA TREE BODY BAR. INT. CL. 3. (U.S. CLS. 1, 4, 6, 50, 51 AND 52). REG. 12-25-2001.
- 2,525,908. HARRY POTTER. INT. CL. 9. (U.S. CLS. 21, 23, 26, 36 AND 38). REG. 1-1-2002.
- 2,526,111. HARRY POTTER (STYLIZED). INT. CL. 9. (U.S. CLS. 21, 23, 26, 36 AND 38). REG. 1-1-2002.
- 2,528,653. VERSAGARD. INT. CL. 11. (U.S. CLS. 13, 21, 23, 31 AND 34). REG. 1-8-2002.
- 2,528,907. SUMMIT RACING EQUIPMENT (STYLIZED). INT. CLS. 7, 9, 12 AND 25. (U.S. CLS. 13, 19, 21, 22, 23, 26, 31, 34, 35, 36, 38, 39 AND 44). REG. 1-15-2002.
- 2,530,243. RCI RUTHERFORD CONTROLS AND DESIGN. INT. CLS. 9 AND 42. (U.S. CLS. 21, 23, 26, 36, 38, 100 AND 101). REG. 1-15-2002.
- 2,531,732. PGA MAGAZINE. INT. CL. 16. (U.S. CLS. 2, 5, 22, 23, 29, 37, 38 AND 50). REG. 1-22-2002.
- 2,533,715. EVACU-AID. INT. CL. 10. (U.S. CLS. 26, 39 AND 44). REG. 1-29-2002.
- 2,534,041. VILLAGE OF SCHILLER PARK AND DESIGN. INT. CL. 42. (U.S. CLS. 100 AND 101). REG. 1-29-2002.
- 2,535,452. WE MAKE MANAGED CARE MANAGEABLE. INT. CLS. 35, 36 AND 42. (U.S. CLS. 100, 101 AND 102). REG. 2-5-2002.
- 2,536,316. PENTALIGHT. INT. CL. 11. (U.S. CLS. 13, 21, 23, 31 AND 34). REG. 2-5-2002.
- 2,536,514. MILE ONE. INT. CL. 39. (U.S. CLS. 100 AND 105). REG. 2-5-2002.
- 2,536,515. MILE ONE. INT. CL. 37. (U.S. CLS. 100, 103 AND 106). REG. 2-5-2002.
- 2,537,512. ALASKA STRUCTURES. INT. CL. 19. (U.S. CLS. 1, 12, 33 AND 50). REG. 2-5-2002.
- 2,537,861. DISCOVERTAX. INT. CL. 9. (U.S. CLS. 21, 23, 26, 36 AND 38). REG. 2-12-2002.
- 2,540,093. DECAPOD. INT. CL. 11. (U.S. CLS. 13, 21, 23, 31 AND 34). REG. 2-19-2002.
- 2,541,566. PARTNERS IN CAPITAL. INT. CL. 36. (U.S. CLS. 100, 101 AND 102). REG. 2-19-2002.
- 2,542,254. OPTEST. INT. CL. 9. (U.S. CLS. 21, 23, 26, 36 AND 38). REG. 2-26-2002.
- 2,542,512. THE WILD BUNCH. INT. CL. 41. (U.S. CLS. 100, 101 AND 107). REG. 2-26-2002.
- 2,542,579. GMP. INT. CL. 11. (U.S. CLS. 13, 21, 23, 31 AND 34). REG. 2-26-2002.
- 2,542,676. KODIAK. INT. CL. 11. (U.S. CLS. 13, 21, 23, 31 AND 34). REG. 2-26-2002.
- 2,543,042. SEA RIPPLE (STYLIZED). INT. CL. 29. (U.S. CL. 46). REG. 2-26-2002.
- 2,543,189. FABPROTEX. INT. CL. 1. (U.S. CLS. 1, 5, 6, 10, 26 AND 46). REG. 2-26-2002.
- 2,543,562. PERPETUALBUDGET. INT. CL. 9. (U.S. CLS. 21, 23, 26, 36 AND 38). REG. 2-26-2002.
- 2,543,746. SERRV INTERNATIONAL. INT. CL. 35. (U.S. CLS. 100, 101 AND 102). REG. 3-5-2002.
- 2,544,202. WE GET I.T.. INT. CL. 42. (U.S. CLS. 100 AND 101). REG. 3-5-2002.
- 2,544,433. SCRUB ZONE. INT. CL. 10. (U.S. CLS. 26, 39 AND 44). REG. 3-5-2002.
- 2,544,666. SPJ AND DESIGN. INT. CL. 42. (U.S. CLS. 100 AND 101). REG. 3-5-2002.
- 2,544,819. FEDERAL RESOURCES. INT. CL. 35. (U.S. CLS. 100, 101 AND 102). REG. 3-5-2002.
- 2,544,900. AMN. INT. CL. 35. (U.S. CLS. 100, 101 AND 102). REG. 3-5-2002.
- 2,544,937. SNORENET. INT. CL. 42. (U.S. CLS. 100 AND 101). REG. 3-5-2002.
- 2,546,445. WHYY. INT. CL. 38. (U.S. CLS. 100, 101 AND 104). REG. 3-12-2002.
- 2,546,580. B & F (STYLIZED). INT. CL. 42. (U.S. CLS. 100 AND 101). REG. 3-12-2002.
- 2,546,759. YOUR ROOF'S CARE IS OUR CONCERN. INT. CL. 37. (U.S. CLS. 100, 103 AND 106). REG. 3-12-2002.
- 2,547,762. SWEDEV. INT. CL. 7. (U.S. CLS. 13, 19, 21, 23, 31, 34 AND 35). REG. 3-12-2002.
- 2,548,502. BIOELEMENTS OXYGENATION. INT. CL. 3. (U.S. CLS. 1, 4, 6, 50, 51 AND 52). REG. 3-12-2002.
- 2,549,352. N-PROVE. INT. CL. 1. (U.S. CLS. 1, 5, 6, 10, 26 AND 46). REG. 3-19-2002.
- 2,549,518. BEST WELDS AND DESIGN. INT. CLS. 6 AND 9. (U.S. CLS. 2, 12, 13, 14, 21, 23, 25, 26, 36, 38 AND 50). REG. 3-19-2002.
- 2,549,931. MISCELLANEOUS DESIGN. INT. CL. 31. (U.S. CLS. 1 AND 46). REG. 3-19-2002.
- 2,549,955. THE NATIONAL TRUMPET COMPETITION. INT. CL. 41. (U.S. CLS. 100, 101 AND 107). REG. 3-19-2002.
- 2,550,060. CAN DO. INT. CLS. 16 AND 28. (U.S. CLS. 2, 5, 22, 23, 29, 37, 38 AND 50). REG. 3-19-2002.
- 2,551,521. KING RANCH. INT. CL. 31. (U.S. CLS. 1 AND 46). REG. 3-26-2002.
- 2,551,888. TRUEPOSITION. INT. CLS. 35, 38 AND 42. (U.S. CLS. 100, 101, 102 AND 104). REG. 3-26-2002.
- 2,552,686. AMERICAN WORKER OF THE YEAR. INT. CLS. 35 AND 41. (U.S. CLS. 100, 101, 102 AND 107). REG. 3-26-2002.
- 2,553,024. BOOK ADVENTURE. INT. CL. 41. (U.S. CLS. 100, 101 AND 107). REG. 3-26-2002.
- 2,555,221. SARATOGA PERFORMING ARTS CENTER. INT. CL. 41. (U.S. CLS. 100, 101 AND 107). REG. 4-2-2002.
- 2,555,240. JACE. INT. CL. 9. (U.S. CLS. 21, 23, 26, 36 AND 38). REG. 4-2-2002.
- 2,556,024. 247 STORE AND DESIGN. INT. CLS. 35 AND 42 ONLY. (U.S. CLS. 100, 101 AND 102). REG. 4-2-2002.
- 2,558,675. NORWEGIAN SUN. INT. CL. 39. (U.S. CLS. 100 AND 105). REG. 4-9-2002.
- 2,558,688. ULTIMA ONLINE. INT. CL. 41. (U.S. CLS. 100, 101 AND 107). REG. 4-9-2002.

- 2,558,689. JOURNAL OF RHEOLOGY. INT. CL. 16. (U.S. CLS. 2, 5, 22, 23, 29, 37, 38 AND 50). REG. 4-9-2002.
- 2,559,079. SUBSOLUTIONS. INT. CLS. 6, 7 AND 20. (U.S. CLS. 2, 12, 13, 14, 19, 21, 22, 23, 25, 31, 32, 34, 35 AND 50). REG. 4-9-2002.
- 2,560,372. SENSIFLEX. INT. CL. 7. (U.S. CLS. 13, 19, 21, 23, 31, 34 AND 35). REG. 4-9-2002.
- 2,560,377. MISCELLANEOUS DESIGN. INT. CLS. 19 AND 35. (U.S. CLS. 1, 12, 33, 50, 100, 101 AND 102). REG. 4-9-2002.
- 2,560,455. CATALYTIC COMMUNITIES. INT. CL. 42. (U.S. CLS. 100 AND 101). REG. 4-9-2002.
- 2,561,154. PERQUEI DETOX IN GUARD. INT. CL. 5. (U.S. CLS. 6, 18, 44, 46, 51 AND 52). REG. 4-16-2002.
- 2,561,157. UVEX U2. INT. CL. 9. (U.S. CLS. 21, 23, 26, 36 AND 38). REG. 4-16-2002.
- 2,561,469. I FLEAS! AND DESIGN. INT. CL. 35. (U.S. CLS. 100, 101 AND 102). REG. 4-16-2002.
- 2,561,470. KELLER'S FLEA MARKET. INT. CL. 35. (U.S. CLS. 100, 101 AND 102). REG. 4-16-2002.
- 2,562,186. SCION. INT. CL. 33. (U.S. CLS. 47 AND 49). REG. 4-16-2002.
- 2,563,430. MISCELLANEOUS DESIGN. INT. CLS. 9 AND 11. (U.S. CLS. 13, 21, 23, 26, 31, 34, 36 AND 38). REG. 4-23-2002.
- 2,563,569. INTERNATIONAL UNION, SECURITY, POLICE AND FIRE PROFESSIONALS OF AMERICA (SPFFPA). INT. CL. 42. (U.S. CLS. 100 AND 101). REG. 4-23-2002.
- 2,563,599. NORTH ATLANTIC COMMUNICATION SYSTEMS CONSTRUCTION CORPORATION AND DESIGN. INT. CL. 37. (U.S. CLS. 100, 103 AND 106). REG. 4-23-2002.
- 2,563,721. SKY U. INT. CL. 41. (U.S. CLS. 100, 101 AND 107). REG. 4-23-2002.
- 2,563,817. FIBER ETCH (STYLIZED). INT. CL. 1. (U.S. CLS. 1, 5, 6, 10, 26 AND 46). REG. 4-23-2002.
- 2,564,390. MMT-MULTI-MATERIAL TECHNOLOGY. INT. CL. 9. (U.S. CLS. 21, 23, 26, 36 AND 38). REG. 4-23-2002.
- 2,564,446. HOMESTEAD STUDIO SUITES. INT. CL. 42. (U.S. CLS. 100 AND 101). REG. 4-23-2002.
- 2,564,834. MISCELLANEOUS DESIGN. INT. CL. 35. (U.S. CLS. 100, 101 AND 102). REG. 4-30-2002.
- 2,564,856. OVERSEAS ADVENTURE TRAVEL. INT. CLS. 39 AND 42. (U.S. CLS. 100, 101 AND 105). REG. 4-30-2002.
- 2,565,077. FLUKE NETWORKS. INT. CL. 9. (U.S. CLS. 21, 23, 26, 36 AND 38). REG. 4-30-2002.
- 2,565,275. BAKER STREET PUB & GRILL. INT. CL. 42. (U.S. CLS. 100 AND 101). REG. 4-30-2002.
- 2,565,897. MHA INSURANCE COMPANY. INT. CL. 36. (U.S. CLS. 100, 101 AND 102). REG. 4-30-2002.
- 2,566,183. LEASELOGISTIX AND DESIGN. INT. CL. 36. (U.S. CLS. 100, 101 AND 102). REG. 4-30-2002.
- 2,566,184. LEASELOGISTIX. INT. CL. 36. (U.S. CLS. 100, 101 AND 102). REG. 4-30-2002.
- 2,566,602. MERCURY PRECISION PARTS. INT. CL. 7. (U.S. CLS. 13, 19, 21, 23, 31, 34 AND 35). REG. 5-7-2002.
- 2,566,647. DING ALL. INT. CL. 1. (U.S. CLS. 1, 5, 6, 10, 26 AND 46). REG. 5-7-2002.
- 2,566,665. BARRICADE. INT. CL. 9. (U.S. CLS. 21, 23, 26, 36 AND 38). REG. 5-7-2002.
- 2,567,353. PHYSIOLOGY IN MEDICINE. INT. CL. 16. (U.S. CLS. 2, 5, 22, 23, 29, 37, 38 AND 50). REG. 5-7-2002.
- 2,567,514. RUDE AWAKENING COFFEE HOUSE AND DESIGN. INT. CL. 42. (U.S. CLS. 100 AND 101). REG. 5-7-2002.
- 2,567,543. MISCELLANEOUS DESIGN. INT. CLS. 9 AND 42. (U.S. CLS. 21, 23, 26, 36, 38, 100 AND 101). REG. 5-7-2002.
- 2,567,604. CUT. INT. CL. 3. (U.S. CLS. 1, 4, 6, 50, 51 AND 52). REG. 5-7-2002.
- 2,567,831. NOBODY CARES MORE THAN SAV-MOR. INT. CL. 35. (U.S. CLS. 100, 101 AND 102). REG. 5-7-2002.
- 2,567,921. WHERE YOU'RE PAMPERED NOT PRESURED. INT. CL. 35. (U.S. CLS. 100, 101 AND 102). REG. 5-7-2002.
- 2,568,324. ANON. INT. CL. 28. (U.S. CLS. 22, 23, 38 AND 50). REG. 5-7-2002.
- 2,568,354. LEOPARD. INT. CL. 12. (U.S. CLS. 19, 21, 23, 31, 35 AND 44). REG. 5-7-2002.
- 2,568,510. DWX-44. INT. CL. 3. (U.S. CLS. 1, 4, 6, 50, 51 AND 52). REG. 5-7-2002.
- 2,569,847. MUSIC THROUGH THE NIGHT. INT. CL. 41. (U.S. CLS. 100, 101 AND 107). REG. 5-14-2002.
- 2,569,914. RETINA. INT. CLS. 16 AND 42. (U.S. CLS. 2, 5, 22, 23, 29, 37, 38, 50, 100 AND 101). REG. 5-14-2002.
- 2,570,212. TRINITY EXPRESS, INC.. INT. CL. 39. (U.S. CLS. 100 AND 105). REG. 5-14-2002.
- 2,570,254. WINTRACK. INT. CL. 9. (U.S. CLS. 21, 23, 26, 36 AND 38). REG. 5-14-2002.
- 2,570,841. AB AND DESIGN. INT. CL. 14. (U.S. CLS. 2, 27, 28 AND 50). REG. 5-21-2002.
- 2,572,534. DE PLUG. INT. CL. 9. (U.S. CLS. 21, 23, 26, 36 AND 38). REG. 5-28-2002.
- 2,572,662. PRO-MASONRY. INT. CL. 1. (U.S. CLS. 1, 5, 6, 10, 26 AND 46). REG. 5-28-2002.
- 2,573,283. PREFERREDONE ADMINISTRATIVE SERVICES. INT. CL. 36 ONLY. (U.S. CLS. 100, 101 AND 102). REG. 5-28-2002.
- 2,573,284. PREFERREDONE COMMUNITY HEALTH PLAN. INT. CL. 42. (U.S. CLS. 100 AND 101). REG. 5-28-2002.
- 2,573,504. EXCLUSIVE REFLECTIONS. INT. CL. 20. (U.S. CLS. 2, 13, 22, 25, 32 AND 50). REG. 5-28-2002.
- 2,573,673. WINE FOR EVERYDAY LIFE. INT. CL. 33. (U.S. CLS. 47 AND 49). REG. 5-28-2002.
- 2,573,707. SUCCESSSCORE. INT. CL. 35. (U.S. CLS. 100, 101 AND 102). REG. 5-28-2002.
- 2,573,708. CONCEPTOR. INT. CL. 35. (U.S. CLS. 100, 101 AND 102). REG. 5-28-2002.
- 2,574,593. VASCADE. INT. CL. 9. (U.S. CLS. 21, 23, 26, 36 AND 38). REG. 5-28-2002.
- 2,574,642. DECK-LOCK. INT. CL. 19. (U.S. CLS. 1, 12, 33 AND 50). REG. 5-28-2002.
- 2,575,993. LA PREDILECTA. INT. CL. 30. (U.S. CL. 46). REG. 6-4-2002.
- 2,576,088. THE BOSS. INT. CL. 7. (U.S. CLS. 13, 19, 21, 23, 31, 34 AND 35). REG. 6-4-2002.
- 2,576,691. SILVERBACK. INT. CL. 28. (U.S. CLS. 22, 23, 38 AND 50). REG. 6-4-2002.
- 2,576,975. ALLSTAFF. INT. CL. 35. (U.S. CLS. 100, 101 AND 102). REG. 6-11-2002.
- 2,577,240. SUPERCONTROL. INT. CL. 9. (U.S. CLS. 21, 23, 26, 36 AND 38). REG. 6-11-2002.
- 2,577,442. PARABLE.COM. INT. CL. 41. (U.S. CLS. 100, 101 AND 107). REG. 6-11-2002.
- 2,577,904. UBF UNIVERSITY BLANKET & FLAG CORPORATION AND DESIGN. INT. CL. 35. (U.S. CLS. 100, 101 AND 102). REG. 6-11-2002.
- 2,578,287. EMBASSY LIMOUSINE. INT. CL. 39. (U.S. CLS. 100 AND 105). REG. 6-11-2002.
- 2,578,770. MISCELLANEOUS DESIGN. INT. CL. 42. (U.S. CLS. 100 AND 101). REG. 6-11-2002.
- 2,578,874. CLIENTELL. INT. CL. 35. (U.S. CLS. 100, 101 AND 102). REG. 6-11-2002.
- 2,579,036. MEMBERS MARK. INT. CL. 30. (U.S. CL. 46). REG. 6-11-2002.
- 2,580,273. IQUE. INT. CL. 9. (U.S. CLS. 21, 23, 26, 36 AND 38). REG. 6-11-2002.

TRADEMARK REGISTRATIONS CANCELED

The designation "U.S. Cl." appearing in this section refers to the U.S. class in effect prior to Sep. 1, 1973 rather than the international class which applies to applications filed on or after that date. For adoption of international classification see notice in the OFFICIAL GAZETTE of Jun. 26, 1973 (911 O.G. TM 210).

SECTION 7(D)

- 1,041,927. AMANDIERES. INT. CL. 33. REG. 6-22-1976.
2,324,174. CYCLONATOR. INT. CL. 7. REG. 2-29-2000.
3,079,243. COMO SPORT STANDARD CHARACTER MARK. INT. CL. 25. REG. 4-11-2006.
3,099,133. RIVET STANDARD CHARACTER MARK. INT. CL. 9. REG. 5-30-2006.
3,283,608. LUMIE STANDARD CHARACTER MARK. INT. CLS. 10 AND 11. REG. 8-21-2007.
3,397,465. WRANGLER WRAPID WRESPONSE STANDARD CHARACTER MARK. INT. CL. 35. REG. 3-18-2008.
3,417,967. VIRASORB STANDARD CHARACTER MARK. INT. CL. 1. REG. 4-29-2008.
3,432,666. AUTOMATICZONE STANDARD CHARACTER MARK. INT. CL. 9. REG. 5-20-2008.
3,846,593. LIV CRAYOLA STANDARD CHARACTER MARK. INT. CL. 16. REG. 9-7-2010.
- 2,401,246. TRACKFLEX. INT. CLS. 1, 2 AND 17. REG. 11-7-2000.
2,401,261. HAVANA DEE'S CIGAR LOUNGE. INT. CL. 42. REG. 11-7-2000.
2,401,266. BUY-OUT PLAN. INT. CL. 9. REG. 11-7-2000.
2,401,278. GAMMA PIU AND DESIGN. INT. CL. 11. REG. 11-7-2000.
2,401,280. POWERLINE AND DESIGN. INT. CLS. 7 AND 11. REG. 11-7-2000.
2,401,289. CLINK. INT. CLS. 9, 16, 41 AND 42. REG. 11-7-2000.
2,401,292. UMC AND DESIGN. INT. CLS. 9, 40 AND 42. REG. 11-7-2000.
2,401,304. PINELLAS COUNTY YELLOW CAB AND DESIGN. INT. CL. 39. REG. 11-7-2000.
2,401,308. LIBERATE YOUR SENSES. INT. CL. 3. REG. 11-7-2000.
2,401,312. MAGICUT (STYLIZED). INT. CL. 16. REG. 11-7-2000.
2,401,314. GARDEN SWEETEST GRAPE TOMATOES. INT. CL. 31. REG. 11-7-2000.
2,401,315. POLARITY BALANCER. INT. CL. 5. REG. 11-7-2000.
2,401,316. TERRACON (STYLIZED). INT. CLS. 16 AND 42. REG. 11-7-2000.
2,401,320. GOLDEN EYE. INT. CLS. 9, 16, 20 AND 28. REG. 11-7-2000.
2,401,332. COSTCO WHOLESALE EXECUTIVE MEMBER. INT. CL. 38. REG. 11-7-2000.
2,401,333. AMERICAN COLLEGE FOR ADVANCEMENT IN MEDICINE ACAM AND DESIGN. INT. CLS. 16 AND 42. REG. 11-7-2000.
2,401,339. MISCELLANEOUS DESIGN. INT. CLS. 35 AND 42. REG. 11-7-2000.
2,401,344. SIGNIQ. INT. CL. 9. REG. 11-7-2000.
2,401,358. EZE. INT. CL. 1. REG. 11-7-2000.
2,401,361. WERTHER'S ORIGINAL AND DESIGN. INT. CL. 30. REG. 11-7-2000.
2,401,363. 3 W A R E AND DESIGN. INT. CL. 9. REG. 11-7-2000.
2,401,365. MOKA AND DESIGN. INT. CL. 16. REG. 11-7-2000.
2,401,367. DIVEHEAD. INT. CL. 25. REG. 11-7-2000.
2,401,387. THE POWER OF INDEPENDENCE. INT. CL. 42. REG. 11-7-2000.
2,401,392. READER'S CAFE. INT. CL. 42. REG. 11-7-2000.
2,401,393. COSMETIC CREATIONS. INT. CL. 42. REG. 11-7-2000.
2,401,406. SMART CUT. INT. CL. 9. REG. 11-7-2000.
2,401,407. ELECTRICORD AND DESIGN. INT. CLS. 9 AND 20. REG. 11-7-2000.
2,401,410. ROLLING BLUNTS 12 FINE TOBACCO LEAVES THE ORIGINAL AND DESIGN. INT. CL. 25. REG. 11-7-2000.
2,401,417. AMFINITY CAPITAL. INT. CL. 36. REG. 11-7-2000.
2,401,420. VINNY TESTA'S. INT. CL. 42. REG. 11-7-2000.
2,401,428. INTEREACH. INT. CLS. 38 AND 42. REG. 11-7-2000.
2,401,432. SKILL BUILDER LEVEL AND DESIGN. INT. CL. 16. REG. 11-7-2000.
2,401,444. AMBRETONE. INT. CLS. 1 AND 3. REG. 11-7-2000.
2,401,448. SNAPSHOT GOLD. INT. CL. 9. REG. 11-7-2000.

SECTION 8

- 881,044. ICE. U.S. CLS. 100 AND 101. REG. 11-18-1969.
1,141,140. DECADE. INT. CL. 9. REG. 11-4-1980.
1,155,271. VISCOREX. INT. CLS. 6 AND 9 ONLY. REG. 5-26-1981.
1,182,038. DESIGNERS' SHOWCASE. INT. CL. 42 ONLY. REG. 12-15-1981.
1,592,010. WINDGUARD. INT. CL. 17. REG. 4-17-1990.
1,592,026. HAVEN HOMES, INC. AND DESIGN. INT. CL. 19. REG. 4-17-1990.
1,620,678. SUPERFORMANCE. INT. CLS. 1 AND 9. REG. 11-6-1990.
1,620,850. KORUMA AND DESIGN. INT. CL. 7. REG. 11-6-1990.
1,621,224. BOULDER RIDGE. INT. CLS. 18 AND 25. REG. 11-6-1990.
1,621,550. PSC. INT. CLS. 35, 36, 37, 39 AND 42. REG. 11-6-1990.
1,959,827. NIVALIN. INT. CL. 5. REG. 3-5-1996.
2,291,174. MILE HIGH STADIUM. INT. CL. 41. REG. 11-9-1999.
2,401,165. MIKE'S. INT. CL. 38. REG. 11-7-2000.
2,401,166. LA CANASTA. INT. CL. 30. REG. 11-7-2000.
2,401,170. TWIN LIFE II AND DESIGN. INT. CL. 25. REG. 11-7-2000.
2,401,171. X-M E D AND DESIGN. INT. CLS. 1, 3, 5, 29, 30, 31, 32 AND 40. REG. 11-7-2000.
2,401,172. JOG DIAL AND DESIGN. INT. CL. 9. REG. 11-7-2000.
2,401,191. CAPRI. INT. CL. 24. REG. 11-7-2000.
2,401,194. EPICWEB. INT. CL. 9. REG. 11-7-2000.
2,401,213. MISCELLANEOUS DESIGN. INT. CL. 25. REG. 11-7-2000.
2,401,215. WELLSCHOICE. INT. CL. 36. REG. 11-7-2000.
2,401,239. P&H SNUBRITE. INT. CL. 7. REG. 11-7-2000.
2,401,244. GYMFLEX. INT. CLS. 2 AND 19. REG. 11-7-2000.

- 2,401,461. CONVERSATIONS THAT WORK. INT. CL. 35. REG. 11-7-2000.
- 2,401,476. RENZI. INT. CL. 25. REG. 11-7-2000.
- 2,401,484. ADOC SYSTEM AND DESIGN. INT. CL. 16. REG. 11-7-2000.
- 2,401,485. LSE-SYSTEM. INT. CLS. 1, 3, 7, 16, 37 AND 42. REG. 11-7-2000.
- 2,401,492. SHOWTIME FLORISTS. INT. CL. 42. REG. 11-7-2000.
- 2,401,505. MISCELLANEOUS DESIGN. INT. CL. 41. REG. 11-7-2000.
- 2,401,506. MISCELLANEOUS DESIGN. INT. CL. 41. REG. 11-7-2000.
- 2,401,507. MISCELLANEOUS DESIGN. INT. CL. 41. REG. 11-7-2000.
- 2,401,511. FERI FINANCIAL & ECONOMIC RESEARCH INTERNATIONAL AND DESIGN. INT. CLS. 9, 35 AND 36. REG. 11-7-2000.
- 2,401,518. MISCELLANEOUS DESIGN. INT. CLS. 12 AND 17. REG. 11-7-2000.
- 2,401,521. PACE GLOBAL ENERGY SERVICES. INT. CLS. 35 AND 42. REG. 11-7-2000.
- 2,401,524. RELIGIOUS SEX. INT. CLS. 25 AND 35. REG. 11-7-2000.
- 2,401,532. MEMORIES AND DESIGN. INT. CLS. 35, 40 AND 41. REG. 11-7-2000.
- 2,401,542. MOOSEWOOD RESTAURANT ITHACA, N.Y. AND DESIGN. INT. CL. 25. REG. 11-7-2000.
- 2,401,544. GOLD-N-TREASURES. INT. CLS. 14 AND 35. REG. 11-7-2000.
- 2,401,556. COPAK. INT. CL. 39. REG. 11-7-2000.
- 2,401,560. STONE & TILE WORLD MARBLE GRANITE SLATELIMESTONE CERAMIC TILE AND DESIGN. INT. CLS. 19 AND 40. REG. 11-7-2000.
- 2,401,561. M&T BOOKS AND DESIGN. INT. CL. 16. REG. 11-7-2000.
- 2,401,562. IDT AND DESIGN. INT. CL. 17. REG. 11-7-2000.
- 2,401,573. FORT WAYNE WIZARDS AND DESIGN. INT. CLS. 16 AND 25. REG. 11-7-2000.
- 2,401,574. REAL JUKEBOX AND DESIGN. INT. CL. 9. REG. 11-7-2000.
- 2,401,578. NEXXUNLIMITED. INT. CL. 25. REG. 11-7-2000.
- 2,401,579. SUNBELT AND DESIGN. INT. CLS. 41 AND 42. REG. 11-7-2000.
- 2,401,587. KIDSGROWTH.COM. INT. CL. 42. REG. 11-7-2000.
- 2,401,588. FURIOUS FRED. INT. CL. 28. REG. 11-7-2000.
- 2,401,593. SNO*E AND DESIGN. INT. CL. 29. REG. 11-7-2000.
- 2,401,602. MOTOCAL. INT. CL. 9. REG. 11-7-2000.
- 2,401,607. CORDLESS. INT. CL. 4. REG. 11-7-2000.
- 2,401,611. HI-TECH FOAMS BE KIND TO YOUR BEHIND AND DESIGN. INT. CL. 35. REG. 11-7-2000.
- 2,401,615. HYPNOSIS FOR HEALTH. INT. CLS. 9 AND 42. REG. 11-7-2000.
- 2,401,619. CLASSIC. INT. CL. 13. REG. 11-7-2000.
- 2,401,625. HOME SENSATIONS. INT. CLS. 20 AND 21. REG. 11-7-2000.
- 2,401,627. ABC MOTHER MCGOOSE AND DESIGN. INT. CL. 41. REG. 11-7-2000.
- 2,401,643. LAVA. INT. CL. 3. REG. 11-7-2000.
- 2,401,645. AFADVANTAGE VARIABLE ANNUITY (STYLIZED). INT. CL. 36. REG. 11-7-2000.
- 2,401,653. GROUPS ON TOUR LLC YOUR GROUP TRAVEL EXPERT AND DESIGN. INT. CLS. 39 AND 42. REG. 11-7-2000.
- 2,401,656. NUTRA FIG CHEETAH BAR. INT. CL. 5. REG. 11-7-2000.
- 2,401,664. LUXWORKS. INT. CL. 9. REG. 11-7-2000.
- 2,401,665. MISCELLANEOUS DESIGN. INT. CL. 37. REG. 11-7-2000.
- 2,401,667. SERMALON. INT. CL. 2. REG. 11-7-2000.
- 2,401,670. RL 1168. INT. CL. 1. REG. 11-7-2000.
- 2,401,671. ROSE SHIELD. INT. CL. 37. REG. 11-7-2000.
- 2,401,681. ASHDOWN ENGINEERING AND DESIGN. INT. CL. 9. REG. 11-7-2000.
- 2,401,690. ROBOMANIA. INT. CL. 41. REG. 11-7-2000.
- 2,401,704. GAME WARDEN WILDLIFE JOURNAL AND DESIGN. INT. CLS. 25 AND 41. REG. 11-7-2000.
- 2,401,720. BOSSER (STYLIZED). INT. CLS. 7 AND 16. REG. 11-7-2000.
- 2,401,723. MISCELLANEOUS DESIGN. INT. CL. 28. REG. 11-7-2000.
- 2,401,724. MISCELLANEOUS DESIGN. INT. CL. 28. REG. 11-7-2000.
- 2,401,740. PRAYERFULLY YOURS (STYLIZED). INT. CL. 16. REG. 11-7-2000.
- 2,401,752. ULLA POPKEN INSPIRATION. INT. CL. 25. REG. 11-7-2000.
- 2,401,756. EXCALIBUR SWORD OF TRUTH AND DESIGN. INT. CL. 41. REG. 11-7-2000.
- 2,401,760. MERGEPOR. INT. CL. 9. REG. 11-7-2000.
- 2,401,769. THE TRIVITA WAY AND DESIGN. INT. CLS. 5 AND 35. REG. 11-7-2000.
- 2,401,771. EICHHORN. INT. CL. 28. REG. 11-7-2000.
- 2,401,779. TUBES N' HOSES (STYLIZED). INT. CL. 35. REG. 11-7-2000.
- 2,401,784. DON'T JUST GLUE IT, GOOP IT!. INT. CL. 17. REG. 11-7-2000.
- 2,401,789. BLESSINGS ON THE HUNT. INT. CL. 14. REG. 11-7-2000.
- 2,401,790. HBC. INT. CLS. 35, 38 AND 41. REG. 11-7-2000.
- 2,401,797. PRAXIUM GROUP. INT. CLS. 39 AND 42. REG. 11-7-2000.
- 2,401,807. MOR-LOC. INT. CL. 10. REG. 11-7-2000.
- 2,401,808. LIQUIDATOR. INT. CL. 9. REG. 11-7-2000.
- 2,401,816. WIGGED OUT. INT. CL. 3. REG. 11-7-2000.
- 2,401,817. GETEC. INT. CL. 7. REG. 11-7-2000.
- 2,401,826. Q AND DESIGN. INT. CL. 42. REG. 11-7-2000.
- 2,401,827. BETTERWEBSITES AND DESIGN. INT. CL. 42. REG. 11-7-2000.
- 2,401,838. LUDELLA LEWIS & COMPANY. INT. CL. 35. REG. 11-7-2000.
- 2,401,848. COPSTAT. INT. CL. 42. REG. 11-7-2000.
- 2,401,850. HIPERPAV. INT. CL. 9. REG. 11-7-2000.
- 2,401,880. MISCELLANEOUS DESIGN. INT. CLS. 3 AND 21. REG. 11-7-2000.
- 2,401,881. PIKES PEAK ASCENT. INT. CL. 41. REG. 11-7-2000.
- 2,401,886. MISCELLANEOUS DESIGN. INT. CL. 42. REG. 11-7-2000.
- 2,401,890. NATURES SUPER CAP. INT. CL. 5. REG. 11-7-2000.
- 2,401,891. COREDRILL. INT. CL. 37. REG. 11-7-2000.
- 2,401,892. PET DRIVER'S LICENSE. INT. CL. 16. REG. 11-7-2000.
- 2,401,894. EYES TO THE WORLD. INT. CL. 36. REG. 11-7-2000.
- 2,401,904. PHYTOLOGIE AND DESIGN. INT. CL. 3. REG. 11-7-2000.
- 2,401,910. RED SEA GROUP AND DESIGN. INT. CL. 37. REG. 11-7-2000.
- 2,401,925. GEOTREE. INT. CL. 42. REG. 11-7-2000.
- 2,401,926. HI-LITE HANDLE. INT. CL. 9. REG. 11-7-2000.
- 2,401,937. SCIENCEGIFTS.COM. INT. CL. 35. REG. 11-7-2000.
- 2,401,942. AM2PED AND DESIGN. INT. CL. 16. REG. 11-7-2000.
- 2,401,945. CARESEEKERS. INT. CL. 42. REG. 11-7-2000.
- 2,401,950. M AND DESIGN. INT. CL. 41. REG. 11-7-2000.
- 2,401,959. BAY NETS SAFETY SYSTEMS. INT. CL. 9. REG. 11-7-2000.
- 2,401,964. GINKGOSHARP. INT. CL. 30. REG. 11-7-2000.
- 2,401,969. FINANCE+ (STYLIZED). INT. CL. 36. REG. 11-7-2000.
- 2,401,975. NTR NATURAL TOOTH AND DESIGN. INT. CL. 10. REG. 11-7-2000.
- 2,401,982. DESIGN ADVANTAGE. INT. CL. 16. REG. 11-7-2000.
- 2,402,012. ARACCELERATOR PARTS ONLINE AND DESIGN. INT. CL. 35. REG. 11-7-2000.
- 2,402,018. EPHNET. INT. CL. 42. REG. 11-7-2000.
- 2,402,046. SUPER STEAM. INT. CL. 28. REG. 11-7-2000.
- 2,402,053. BK AND DESIGN. INT. CL. 33. REG. 11-7-2000.
- 2,402,059. BEDFORD. INT. CL. 35. REG. 11-7-2000.

- 2,402,062. DMOC. INT. CL. 35. REG. 11-7-2000.
- 2,402,065. GIFT BOX BECAUSE A GIFT IS WORTH A THOUSAND WORDS... AND DESIGN. INT. CL. 35. REG. 11-7-2000.
- 2,402,082. CA. INT. CL. 42. REG. 11-7-2000.
- 2,402,088. GOODFELLOWS AND DESIGN. INT. CL. 42. REG. 11-7-2000.
- 2,402,097. MEASURECOM. INT. CLS. 35 AND 41. REG. 11-7-2000.
- 2,402,102. TAP AND DESIGN. INT. CL. 9. REG. 11-7-2000.
- 2,402,109. BAYPLUS. INT. CL. 2. REG. 11-7-2000.
- 2,402,117. MATERIAL SOLUTIONS. INT. CL. 42. REG. 11-7-2000.
- 2,402,125. ADVERTICKETS. INT. CL. 35. REG. 11-7-2000.
- 2,402,130. CAPRICE. INT. CL. 14. REG. 11-7-2000.
- 2,402,131. TAROT MAGIC. INT. CL. 41. REG. 11-7-2000.
- 2,402,132. PEDICURE. INT. CL. 5. REG. 11-7-2000.
- 2,402,151. GLOBAL GRANNIES. INT. CL. 39. REG. 11-7-2000.
- 2,402,159. J AND DESIGN. INT. CL. 35. REG. 11-7-2000.
- 2,402,160. PHOSPHOCOL. INT. CL. 5. REG. 11-7-2000.
- 2,402,175. TRANSIT. INT. CL. 36. REG. 11-7-2000.
- 2,402,179. PRINCE CREEK. INT. CLS. 36 AND 37. REG. 11-7-2000.
- 2,402,186. FUNDING THE AMERICAN DREAM. INT. CL. 36. REG. 11-7-2000.
- 2,402,190. VENTUREPRISE CONSULTING PARTNERS AND DESIGN. INT. CL. 35. REG. 11-7-2000.
- 2,402,193. COMFY CUFF. INT. CL. 24. REG. 11-7-2000.
- 2,402,194. H AND DESIGN. INT. CL. 18. REG. 11-7-2000.
- 2,402,197. ROARING SPRINGS WATER PARK. INT. CL. 41. REG. 11-7-2000.
- 2,402,201. MISCELLANEOUS DESIGN. INT. CL. 25. REG. 11-7-2000.
- 2,402,210. SURADO SMART BUSINESS MANAGER. INT. CL. 9. REG. 11-7-2000.
- 2,402,216. GINK. INT. CL. 28. REG. 11-7-2000.
- 2,402,222. THE WAY IT WORKS. THE WAY IT SHOULD BE. INT. CL. 36. REG. 11-7-2000.
- 2,402,225. USE CREDIT UNION AND DESIGN. INT. CL. 36. REG. 11-7-2000.
- 2,402,226. BITMAX. INT. CLS. 39 AND 40. REG. 11-7-2000.
- 2,402,233. MANAGING GENERATION X. INT. CLS. 9, 16, 35 AND 41. REG. 11-7-2000.
- 2,402,250. FEAR. INT. CL. 25. REG. 11-7-2000.
- 2,402,252. WEBINVISION. INT. CL. 36. REG. 11-7-2000.
- 2,402,262. TOMIKO. INT. CL. 25. REG. 11-7-2000.
- 2,402,268. HIPPO. INT. CLS. 18, 24, 25 AND 28. REG. 11-7-2000.
- 2,402,277. A ATHEROGENICS AND DESIGN. INT. CL. 5. REG. 11-7-2000.
- 2,402,279. ULTRA-LATTICE. INT. CL. 6. REG. 11-7-2000.
- 2,402,289. VAR WORLD. INT. CLS. 16 AND 42. REG. 11-7-2000.
- 2,402,291. FUN SHIPS. INT. CL. 28. REG. 11-7-2000.
- 2,402,303. GASTON PRESTIGE BELGIAN CHOCOLATES. INT. CL. 35. REG. 11-7-2000.
- 2,402,304. BLACK ICE. INT. CL. 3. REG. 11-7-2000.
- 2,402,307. POWER DECK. INT. CL. 16. REG. 11-7-2000.
- 2,402,310. HENRY'S MARKETPLACE. INT. CL. 5. REG. 11-7-2000.
- 2,402,311. SURFER. INT. CL. 7. REG. 11-7-2000.
- 2,402,315. WADEWEAR. INT. CL. 25. REG. 11-7-2000.
- 2,402,319. REQUIP (STYLIZED). INT. CLS. 5 AND 16. REG. 11-7-2000.
- 2,402,323. CYBER SENTINEL. INT. CL. 9. REG. 11-7-2000.
- 2,402,325. FALAFELBURGER A MEDITERRANEAN VEGETARIAN TREAT AND DESIGN. INT. CL. 29. REG. 11-7-2000.
- 2,402,332. TERRACE LIME. INT. CL. 31. REG. 11-7-2000.
- 2,402,337. THE BETTER WAY TO STAY. INT. CLS. 16, 35 AND 36. REG. 11-7-2000.
- 2,402,345. MILLER QUALITY UNCOMPROMISING. INT. CL. 16. REG. 11-7-2000.
- 2,402,349. DESIGNLINE. INT. CL. 6. REG. 11-7-2000.
- 2,402,351. COOLPAN. INT. CL. 21. REG. 11-7-2000.
- 2,402,353. BAND-AID BRAND ADHESIVE BANDAGES JOHNSON & JOHNSON AND DESIGN. INT. CL. 5. REG. 11-7-2000.
- 2,402,358. EARTHTONE. INT. CLS. 19 AND 22. REG. 11-7-2000.
- 2,402,359. MISCELLANEOUS DESIGN. INT. CL. 16. REG. 11-7-2000.
- 2,402,363. PHARMA PLAN AND DESIGN. INT. CLS. 35, 36, 37 AND 42. REG. 11-7-2000.
- 2,402,364. FAMILY FOREVER. INT. CL. 16. REG. 11-7-2000.
- 2,402,368. MISCELLANEOUS DESIGN. INT. CL. 25. REG. 11-7-2000.
- 2,402,369. COTTON P A R K AND DESIGN. INT. CL. 25. REG. 11-7-2000.
- 2,402,374. PERIMOUNT PLUS. INT. CL. 10. REG. 11-7-2000.
- 2,402,375. BRIDGES. INT. CLS. 41 AND 42. REG. 11-7-2000.
- 2,402,378. FORMALAMERICA. INT. CL. 42. REG. 11-7-2000.
- 2,402,382. SEXY MACHINE. INT. CL. 25. REG. 11-7-2000.
- 2,402,396. DESIGNER CONNECTION. INT. CL. 35. REG. 11-7-2000.
- 2,402,398. LICENSE! AND DESIGN. INT. CL. 16. REG. 11-7-2000.
- 2,402,416. IMAGELOCK+. INT. CL. 36. REG. 11-7-2000.
- 2,402,421. TASKFORCE. INT. CL. 9. REG. 11-7-2000.
- 2,402,428. POWERWISK. INT. CL. 7. REG. 11-7-2000.
- 2,402,437. BODYPHASE. INT. CL. 3. REG. 11-7-2000.
- 2,402,441. THE GUMDROP SHOP. INT. CL. 36. REG. 11-7-2000.
- 2,402,452. LIQUID HIGHWAY. INT. CL. 35. REG. 11-7-2000.
- 2,402,472. PLANET PITA. INT. CL. 35. REG. 11-7-2000.
- 2,402,481. RAINBOW DREAMS AND DESIGN. INT. CL. 20. REG. 11-7-2000.
- 2,402,485. MISCELLANEOUS DESIGN. INT. CLS. 9 AND 35. REG. 11-7-2000.
- 2,402,489. PIANO FONICS (STYLIZED). INT. CL. 16. REG. 11-7-2000.
- 2,402,498. DUST CAESAR SEIZE THE DUST! AND DESIGN. INT. CL. 21. REG. 11-7-2000.
- 2,402,505. COMMUNITY GOLD. INT. CL. 36. REG. 11-7-2000.
- 2,402,509. TURBO TAIL. INT. CL. 12. REG. 11-7-2000.
- 2,402,513. LALVAIN DU JOUR. INT. CL. 30. REG. 11-7-2000.
- 2,402,515. BIZDAT AND DESIGN. INT. CL. 9. REG. 11-7-2000.
- 2,402,527. BACKMASTER. INT. CL. 10. REG. 11-7-2000.
- 2,402,538. OPTIUM. INT. CL. 40. REG. 11-7-2000.
- 2,402,551. HTF AND DESIGN. INT. CLS. 35 AND 41. REG. 11-7-2000.
- 2,402,560. SMARTMATCH. INT. CL. 36. REG. 11-7-2000.
- 2,402,566. GLOBAL SOLARIUM. INT. CL. 19. REG. 11-7-2000.
- 2,402,576. 3-D CUTTING. INT. CL. 37. REG. 11-7-2000.
- 2,402,605. PROGUARD. INT. CLS. 3 AND 21. REG. 11-7-2000.
- 2,402,622. TRUE TO TEXAS. INT. CL. 32. REG. 11-7-2000.
- 2,402,623. REYNOWAVE. INT. CL. 21. REG. 11-7-2000.
- 2,402,641. DYNA-AIR. INT. CL. 25. REG. 11-7-2000.
- 2,402,644. STAR WARS. INT. CL. 32. REG. 11-7-2000.
- 2,402,645. MEGANOTE (STYLIZED). INT. CL. 14. REG. 11-7-2000.
- 2,402,647. NAVIMEDIX. INT. CL. 9. REG. 11-7-2000.
- 2,402,656. YOUR WINE DESERVES IT. INT. CL. 20. REG. 11-7-2000.
- 2,402,668. MISCELLANEOUS DESIGN. INT. CL. 5. REG. 11-7-2000.
- 2,402,670. SALON SIGNATURES. INT. CL. 3. REG. 11-7-2000.
- 2,402,675. NSTARS. INT. CL. 9. REG. 11-7-2000.
- 2,402,720. SANTA FE GARDENBURGER. INT. CL. 29. REG. 11-7-2000.
- 2,402,727. MISCELLANEOUS DESIGN. INT. CL. 9. REG. 11-7-2000.
- 2,402,728. MISCELLANEOUS DESIGN. INT. CL. 38. REG. 11-7-2000.
- 2,402,744. SOLAR ELEGANCE. INT. CL. 19. REG. 11-7-2000.
- 2,402,748. DELI HEARTH. INT. CL. 30. REG. 11-7-2000.
- 2,402,758. FUSION. INT. CL. 22. REG. 11-7-2000.
- 2,402,760. SONNY BONES. INT. CL. 41. REG. 11-7-2000.

- 2,402,761. FIRST MEDIA GIVES YOU THE ADVANTAGE. INT. CL. 36. REG. 11-7-2000.
- 2,402,762. HOMEGROCER.COM. INT. CL. 42. REG. 11-7-2000.
- 2,402,763. BLACKBERRY (STYLIZED). INT. CL. 38. REG. 11-7-2000.
- 2,402,766. JORDANETTES. INT. CL. 30. REG. 11-7-2000.
- 2,402,792. PAT THE BUNNY. INT. CL. 21. REG. 11-7-2000.
- 2,402,800. VICTORY STREET. INT. CL. 28. REG. 11-7-2000.
- 2,402,807. GOTPAPER. INT. CL. 35. REG. 11-7-2000.
- 2,402,808. OSI AND DESIGN. INT. CL. 36. REG. 11-7-2000.
- 2,402,823. NIGHTSTAR. INT. CL. 11. REG. 11-7-2000.
- 2,402,826. SAFE CALL. INT. CL. 42. REG. 11-7-2000.
- 2,402,829. DURA-STRONG. INT. CL. 6. REG. 11-7-2000.
- 2,402,834. ROYAL SCEPTER. INT. CL. 20. REG. 11-7-2000.
- 2,402,835. PHYTOPROTECTOR. INT. CL. 5. REG. 11-7-2000.
- 2,402,840. ESI. INT. CL. 17. REG. 11-7-2000.
- 2,402,844. MIKRONITE. INT. CL. 40. REG. 11-7-2000.
- 2,402,855. TURNING KNOWLEDGE INTO PERFORMANCE. INT. CL. 42. REG. 11-7-2000.
- 2,402,856. FLAVOR ON DEMAND. INT. CL. 30. REG. 11-7-2000.
- 2,402,865. COMPUTER COMPLEMENTS. INT. CL. 16. REG. 11-7-2000.
- 2,402,866. T AND DESIGN. INT. CL. 9. REG. 11-7-2000.
- 2,402,867. TERMINUS. INT. CL. 9. REG. 11-7-2000.
- 2,402,876. CALL US LAST. INT. CL. 36. REG. 11-7-2000.
- 2,402,879. REXITER CAPITAL MANAGEMENT LIMITED AND DESIGN. INT. CL. 36. REG. 11-7-2000.
- 2,402,894. VARONIL 2000. INT. CL. 5. REG. 11-7-2000.
- 2,402,911. EAS. INT. CL. 10. REG. 11-7-2000.
- 2,402,926. HEALTHY LIVING. INT. CL. 10. REG. 11-7-2000.
- 2,402,928. EXAMWORKS. INT. CL. 9. REG. 11-7-2000.
- 2,402,929. DR. SCHOLL'S ADVANTAGE. INT. CL. 25. REG. 11-7-2000.
- 2,402,952. ULTRALITE. INT. CL. 6. REG. 11-7-2000.
- 2,402,954. MICRODOSE TECHNOLOGIES AND DESIGN. INT. CLS. 10 AND 42. REG. 11-7-2000.
- 2,402,964. KEGANLAW. INT. CL. 42. REG. 11-7-2000.
- 2,402,968. CPALINK. INT. CL. 35. REG. 11-7-2000.
- 2,402,976. NEW ENGLAND WOODLANDERS. INT. CL. 31. REG. 11-7-2000.
- 2,402,984. PROFESSIONAL BASS TOURNAMENT. INT. CL. 9. REG. 11-7-2000.
- 2,402,985. MISCELLANEOUS DESIGN. INT. CL. 16. REG. 11-7-2000.
- 2,402,987. BITTER BITTER. INT. CL. 5. REG. 11-7-2000.
- 2,402,996. CAREER ADVANCEMENT THROUGH SKILL ENHANCEMENT. INT. CLS. 9 AND 16. REG. 11-7-2000.
- 2,402,998. JOURNAL OF COMMUNITY PRACTICE. INT. CL. 16. REG. 11-7-2000.
- 2,403,021. APPLIED PATENTS AND TRADEMARKS. INT. CL. 42. REG. 11-7-2000.
- 2,403,029. CINEMA LOUNGE. INT. CL. 41. REG. 11-7-2000.
- 2,411,820. AGCA THE ASSOCIATED GENERAL CONTRACTORS OF AMERICA SKILL RESPONSIBILITY INTEGRITY AND DESIGN. INT. CLS. 9 AND 16 ONLY. REG. 12-12-2000.
- 2,463,653. BIOTA. INT. CL. 10 ONLY. REG. 6-26-2001.
- 2,472,603. SAVA AND DESIGN. INT. CLS. 1, 7, 10, 18 AND 19 ONLY. REG. 7-31-2001.
- 2,479,541. BABY GUND AND DESIGN. INT. CLS. 10, 12 AND 25 ONLY. REG. 8-21-2001.
- 2,499,595. PRIMECOR. INT. CL. 35 ONLY. REG. 10-23-2001.
- 2,511,506. GEIGER AND DESIGN. INT. CLS. 18 AND 24 ONLY. REG. 11-27-2001.
- 2,516,901. PALM DRIVE VIDEO. INT. CLS. 35 AND 41 ONLY. REG. 12-11-2001.
- 2,535,674. TATOES AND DESIGN. INT. CL. 31. REG. 2-5-2002.
- 2,556,024. 247 STORE AND DESIGN. INT. CL. 37 ONLY. REG. 4-2-2002.
- 2,573,283. PREFERREDONE ADMINISTRATIVE SERVICES. INT. CL. 42 ONLY. REG. 5-28-2002.
- 2,593,722. FIRST CENTURY. INT. CL. 41. REG. 7-16-2002.
- 2,735,593. ISADORA. INT. CL. 9. REG. 7-8-2003.
- 2,787,027. REMIX. INT. CL. 3. REG. 11-25-2003.
- 2,839,544. RUSAL. INT. CLS. 7, 12, 17 AND 21 ONLY. REG. 5-11-2004.
- 2,839,545. MISCELLANEOUS DESIGN. INT. CLS. 7, 12, 17 AND 21 ONLY. REG. 5-11-2004.
- 2,862,732. GETMEABID. INT. CL. 35. REG. 7-13-2004.
- 2,889,449. MISCELLANEOUS DESIGN. INT. CLS. 22 AND 28 ONLY. REG. 9-28-2004.
- 2,900,954. PONY EXPRESS AND DESIGN. INT. CLS. 6 AND 20. REG. 11-9-2004.
- 2,900,955. ROOMS & GARDENS. INT. CL. 35. REG. 11-9-2004.
- 2,900,958. PREMIERE AIR COURIER INTERNATIONAL AND DESIGN. INT. CL. 39. REG. 11-9-2004.
- 2,900,959. SUPPLY GUYS. INT. CL. 9. REG. 11-9-2004.
- 2,900,964. FREEDOM CARD AND DESIGN. INT. CL. 36. REG. 11-9-2004.
- 2,900,965. ALLURENE. INT. CL. 5. REG. 11-9-2004.
- 2,900,968. 8 AND DESIGN. INT. CLS. 20 AND 42. REG. 11-9-2004.
- 2,900,970. DOC SHOOTER STANDARD CHARACTER MARK. INT. CL. 9. REG. 11-9-2004.
- 2,900,971. TOM AND DESIGN. INT. CLS. 9, 16, 35, 36, 37, 38, 41 AND 42. REG. 11-9-2004.
- 2,900,972. DATAMAXING. INT. CL. 35. REG. 11-9-2004.
- 2,900,973. CARMAGEDDON TDR 2000. INT. CLS. 9, 16, 25, 28 AND 41. REG. 11-9-2004.
- 2,900,975. CONRAD. INT. CLS. 7, 8, 9, 11, 16, 38 AND 42. REG. 11-9-2004.
- 2,900,976. PHOTAL. INT. CL. 10. REG. 11-9-2004.
- 2,900,977. LYMNZYME. INT. CL. 1. REG. 11-9-2004.
- 2,900,979. ONE SOURCE RETIREMENT SERVICES. INT. CL. 36. REG. 11-9-2004.
- 2,900,980. UBS WARBURG AND DESIGN. INT. CLS. 9, 14, 16, 35, 36, 38, 41 AND 42. REG. 11-9-2004.
- 2,900,981. PLANETACTIVE. INT. CLS. 9, 28, 35, 38, 41 AND 42. REG. 11-9-2004.
- 2,900,982. VIDA PORIA. INT. CL. 5. REG. 11-9-2004.
- 2,900,983. MYOB RETAILMANAGER (STYLIZED). INT. CL. 9. REG. 11-9-2004.
- 2,900,984. PAYGLOBAL AND DESIGN. INT. CLS. 9, 35 AND 36. REG. 11-9-2004.
- 2,900,985. ZIGARETTES. INT. CL. 34. REG. 11-9-2004.
- 2,900,986. RINASCIMENTO. INT. CLS. 6, 19 AND 30. REG. 11-9-2004.
- 2,900,987. GATOPARDO. INT. CLS. 9 AND 38. REG. 11-9-2004.
- 2,900,988. FEL-6. INT. CL. 5. REG. 11-9-2004.
- 2,900,989. AEA ALLIANCE THE CROSS REGIONAL BUSINESS SCHOOL. INT. CLS. 9, 16 AND 41. REG. 11-9-2004.
- 2,900,992. CITYNOW. INT. CL. 41. REG. 11-9-2004.
- 2,900,994. SSCW. INT. CL. 12. REG. 11-9-2004.
- 2,900,995. EMPRIZ ENTERPRISING E-MAIL. INT. CL. 35. REG. 11-9-2004.
- 2,900,996. SAM AND DESIGN. INT. CL. 35. REG. 11-9-2004.
- 2,900,997. TRI - COMPAX. INT. CL. 14. REG. 11-9-2004.
- 2,900,999. MYTRAVELCO. INT. CLS. 9, 16, 35, 36, 38, 39 AND 42. REG. 11-9-2004.
- 2,901,000. DEHUNT. (STYLIZED). INT. CLS. 9, 28 AND 41. REG. 11-9-2004.
- 2,901,002. DOCTISSIMO. INT. CLS. 3, 5, 28, 29, 36, 38 AND 41 ONLY. REG. 11-9-2004.
- 2,901,004. OPTIDIAL. INT. CLS. 5 AND 10. REG. 11-9-2004.
- 2,901,008. JIMMY SHINE. INT. CL. 25. REG. 11-9-2004.
- 2,901,011. POCKETFORM. INT. CL. 9. REG. 11-9-2004.
- 2,901,012. SUPERVAC (STYLIZED). INT. CL. 1. REG. 11-9-2004.
- 2,901,014. LOTUS TOUCH. INT. CL. 3. REG. 11-9-2004.
- 2,901,016. PREMIER LASER SIGHT AND DESIGN. INT. CL. 42. REG. 11-9-2004.
- 2,901,017. SITEOS. INT. CLS. 9 AND 38. REG. 11-9-2004.
- 2,901,018. THE SCOPE EXCHANGE. INT. CL. 35. REG. 11-9-2004.
- 2,901,021. MARQUIS MARBLE & GRANITE, INC.. INT. CLS. 19 AND 37. REG. 11-9-2004.
- 2,901,022. COLA CADDY. INT. CL. 21. REG. 11-9-2004.
- 2,901,023. EUCLID. INT. CL. 42. REG. 11-9-2004.

- 2,901,024. YELL AND DESIGN. INT. CLS. 9, 16, 35, 36, 37, 38, 39, 41 AND 42. REG. 11-9-2004.
- 2,901,025. UBS PAINWEBBER AND DESIGN. INT. CLS. 9, 14, 16, 35, 36, 38, 41 AND 42. REG. 11-9-2004.
- 2,901,026. MISCELLANEOUS DESIGN. INT. CL. 16. REG. 11-9-2004.
- 2,901,027. VIELIFE AND DESIGN. INT. CLS. 35, 38, 39 AND 42. REG. 11-9-2004.
- 2,901,028. MISCELLANEOUS DESIGN. INT. CLS. 9, 35, 37 AND 41. REG. 11-9-2004.
- 2,901,030. VISIBLE (STYLIZED). INT. CLS. 10, 35 AND 41. REG. 11-9-2004.
- 2,901,032. COLALPRED. INT. CL. 5. REG. 11-9-2004.
- 2,901,033. BODYCOCOON. INT. CL. 3. REG. 11-9-2004.
- 2,901,036. GARTMORE U.S. LEADERS. INT. CL. 36. REG. 11-9-2004.
- 2,901,039. PROTEOWORKS. INT. CL. 42. REG. 11-9-2004.
- 2,901,040. S.E.X SYNERGISTIC ENERGY EXCHANGE (STYLIZED). INT. CL. 9. REG. 11-9-2004.
- 2,901,048. SOPA NISSIN AND DESIGN. INT. CL. 29. REG. 11-9-2004.
- 2,901,049. WEAVING INTERNET TECHNOLOGY BVNET INTO THE CORE FABRIC OF BUSINESS AND DESIGN. INT. CLS. 16, 38 AND 42. REG. 11-9-2004.
- 2,901,052. MISCELLANEOUS DESIGN. INT. CL. 30. REG. 11-9-2004.
- 2,901,055. KOESIA AND DESIGN. INT. CL. 14. REG. 11-9-2004.
- 2,901,057. XO FOR MEN. INT. CL. 33. REG. 11-9-2004.
- 2,901,058. SL 350. INT. CLS. 12, 28 AND 37. REG. 11-9-2004.
- 2,901,061. MISCELLANEOUS DESIGN. INT. CLS. 8 AND 21. REG. 11-9-2004.
- 2,901,062. MISCELLANEOUS DESIGN. INT. CLS. 1, 5, 9, 10, 40 AND 42. REG. 11-9-2004.
- 2,901,065. AVL.START. INT. CLS. 9, 37 AND 41. REG. 11-9-2004.
- 2,901,066. NEURION. INT. CL. 42. REG. 11-9-2004.
- 2,901,069. HARD AS NAILS. INT. CL. 25. REG. 11-9-2004.
- 2,901,072. 4D BUSINESS KIT. INT. CLS. 9, 38 AND 42. REG. 11-9-2004.
- 2,901,074. SPARECOPTER. INT. CLS. 9, 12 AND 38. REG. 11-9-2004.
- 2,901,079. BIFIDUR AND DESIGN. INT. CLS. 1, 5 AND 31. REG. 11-9-2004.
- 2,901,087. GR8 AND DESIGN. INT. CL. 41. REG. 11-9-2004.
- 2,901,088. GR8. INT. CL. 41. REG. 11-9-2004.
- 2,901,089. A BIGGER WORLD IN MY HAND. INT. CL. 9. REG. 11-9-2004.
- 2,901,091. SAN ANTONIO FARMS AND DESIGN. INT. CL. 30. REG. 11-9-2004.
- 2,901,094. PNM ENERGY ACADEMY AND DESIGN. INT. CL. 41. REG. 11-9-2004.
- 2,901,095. PNM ENERGY ACADEMY. INT. CL. 41. REG. 11-9-2004.
- 2,901,099. ATREV. INT. CL. 3. REG. 11-9-2004.
- 2,901,103. SMART ACADEMY AND DESIGN. INT. CL. 41. REG. 11-9-2004.
- 2,901,105. MUSIC MAKES A DIFFERENCE. INT. CLS. 9 AND 28. REG. 11-9-2004.
- 2,901,106. PASIPHAË (STYLIZED). INT. CL. 14. REG. 11-9-2004.
- 2,901,107. FASTRACK RIDERS. INT. CLS. 35 AND 41. REG. 11-9-2004.
- 2,901,108. SUBLIGRAPHICS. INT. CL. 40. REG. 11-9-2004.
- 2,901,109. ROYAL TREATMENT RT NATURAL PET FORMULAS AND DESIGN. INT. CL. 3. REG. 11-9-2004.
- 2,901,112. CHUMPIES (STYLIZED). INT. CL. 29. REG. 11-9-2004.
- 2,901,113. MISCELLANEOUS DESIGN. INT. CLS. 6 AND 20. REG. 11-9-2004.
- 2,901,114. MEPLA ALFIT AND DESIGN. INT. CLS. 6 AND 20. REG. 11-9-2004.
- 2,901,116. FRIEDRICH STAHL DESIGN (STYLIZED). INT. CL. 14. REG. 11-9-2004.
- 2,901,117. IE INTERACTIVE ENVIRONMENT. INT. CL. 42. REG. 11-9-2004.
- 2,901,119. SYLVAN. INT. CLS. 1, 5 AND 31. REG. 11-9-2004.
- 2,901,121. GOVERNMENT SERVICES GROUP AND DESIGN. INT. CL. 35. REG. 11-9-2004.
- 2,901,122. TRANSTAR MANAGEMENT SERVICES, INC.. INT. CLS. 35 AND 41. REG. 11-9-2004.
- 2,901,123. OIC OFFICEMATE INTERNATIONAL CORPORATION (STYLIZED). INT. CL. 16. REG. 11-9-2004.
- 2,901,126. CYBER JAVELIN. INT. CL. 25. REG. 11-9-2004.
- 2,901,128. STAGE-1. INT. CL. 10. REG. 11-9-2004.
- 2,901,130. VIATEN. INT. CL. 3. REG. 11-9-2004.
- 2,901,131. QLPK. INT. CL. 9. REG. 11-9-2004.
- 2,901,132. SOLIANTE. INT. CLS. 3 AND 5. REG. 11-9-2004.
- 2,901,133. AMERICA'S FAVORITE SHOPPING NEWS. INT. CL. 16. REG. 11-9-2004.
- 2,901,136. DATAMEDIASTORE.COM AND DESIGN. INT. CL. 35. REG. 11-9-2004.
- 2,901,138. DIGISTITCH INC. CORPORATE APPAREL. INT. CL. 25. REG. 11-9-2004.
- 2,901,139. LA DONA (STYLIZED). INT. CL. 21. REG. 11-9-2004.
- 2,901,140. LIGHTHOUSE CREDIT FOUNDATION AND DESIGN. INT. CL. 36. REG. 11-9-2004.
- 2,901,142. ORIGINAL BARTENDERS CLASSIC. INT. CL. 33. REG. 11-9-2004.
- 2,901,144. FERRERO ROCHER AND DESIGN. INT. CL. 30. REG. 11-9-2004.
- 2,901,145. NEVER THIRST. INT. CLS. 32 AND 41. REG. 11-9-2004.
- 2,901,147. LONDON NATURALS (STYLIZED). INT. CLS. 3 AND 5. REG. 11-9-2004.
- 2,901,148. CONSTANTINE PAINTING. INT. CL. 37. REG. 11-9-2004.
- 2,901,149. ONETOUCH. INT. CL. 36. REG. 11-9-2004.
- 2,901,152. TCS PERFORMANCE APPRAISAL & COMPETENCY EVALUATION AND DESIGN. INT. CLS. 9 AND 35. REG. 11-9-2004.
- 2,901,153. SHOPWORKS. INT. CL. 35. REG. 11-9-2004.
- 2,901,154. SUAVINEX. INT. CLS. 8, 10 AND 21. REG. 11-9-2004.
- 2,901,158. TOUCHPOINT. INT. CL. 16. REG. 11-9-2004.
- 2,901,162. XTREME ORANGE. INT. CL. 3. REG. 11-9-2004.
- 2,901,164. PARTSOLVER. INT. CL. 35. REG. 11-9-2004.
- 2,901,165. BWEE VACATIONS AND DESIGN. INT. CL. 39. REG. 11-9-2004.
- 2,901,166. CLINICAL LANDMARKS & ISSUES. INT. CL. 16. REG. 11-9-2004.
- 2,901,167. FASHION WRAP. INT. CL. 26. REG. 11-9-2004.
- 2,901,169. CENTER FOR CAREER INNOVATION. INT. CLS. 35 AND 41. REG. 11-9-2004.
- 2,901,170. NSB NEVADA STATE BANK (STYLIZED). INT. CL. 36. REG. 11-9-2004.
- 2,901,171. NINE-HEADED BIRD AND DESIGN. INT. CL. 43. REG. 11-9-2004.
- 2,901,173. AIRPOC. INT. CL. 28. REG. 11-9-2004.
- 2,901,175. SITE AND DESIGN. INT. CLS. 36 AND 39. REG. 11-9-2004.
- 2,901,178. GENE EDWARDS' MINISTRY. INT. CL. 45. REG. 11-9-2004.
- 2,901,182. JUNGLE BRONZE. INT. CL. 3. REG. 11-9-2004.
- 2,901,183. CARDIOTEX. INT. CL. 20. REG. 11-9-2004.
- 2,901,185. DEWIE THE TURTLE. INT. CL. 35. REG. 11-9-2004.
- 2,901,186. STIWELL. INT. CLS. 9, 10 AND 28. REG. 11-9-2004.
- 2,901,187. KWIK DUMP. INT. CL. 12. REG. 11-9-2004.
- 2,901,188. FUSIONPOLIS. INT. CL. 35. REG. 11-9-2004.
- 2,901,190. DIGITIMES DOT-COM AND DESIGN. INT. CLS. 35 AND 41. REG. 11-9-2004.
- 2,901,191. BEGOMEDIFACTURING AND DESIGN. INT. CLS. 5, 7, 8, 9, 10, 40 AND 41. REG. 11-9-2004.
- 2,901,192. BEGOMEDIFACTURING. INT. CLS. 5, 7, 8, 9, 10, 40 AND 41. REG. 11-9-2004.
- 2,901,193. WAYPOINT. INT. CL. 36. REG. 11-9-2004.
- 2,901,194. PENINSULA DOG PARKS, INC. AND DESIGN. INT. CL. 36. REG. 11-9-2004.
- 2,901,195. BLUE DE BRASIL. INT. CL. 30. REG. 11-9-2004.
- 2,901,199. ST. MULLIGAN. INT. CL. 16. REG. 11-9-2004.

- 2,901,204. IT'S GIRLFRIEND TIME!. INT. CL. 35. REG. 11-9-2004.
- 2,901,208. 325. INT. CL. 12. REG. 11-9-2004.
- 2,901,210. XERUS. INT. CL. 25. REG. 11-9-2004.
- 2,901,212. TECHSTREET AND DESIGN. INT. CL. 42. REG. 11-9-2004.
- 2,901,213. TRI-FEST. INT. CL. 41. REG. 11-9-2004.
- 2,901,217. GAMING ON THE GREEN. INT. CL. 41. REG. 11-9-2004.
- 2,901,219. THE 24X7 LEADER AND DESIGN. INT. CL. 35. REG. 11-9-2004.
- 2,901,222. DIRECTSPOT (STYLIZED). INT. CL. 9. REG. 11-9-2004.
- 2,901,223. BAKER'S CRUST WELL BREAD RESTAURANT. AND DESIGN. INT. CLS. 30 AND 43. REG. 11-9-2004.
- 2,901,226. CRACKER PLATTER AND DESIGN. INT. CL. 29. REG. 11-9-2004.
- 2,901,227. SIROLI INSTITUTE. INT. CLS. 35 AND 41. REG. 11-9-2004.
- 2,901,230. LEGACY OPTIMIZER. INT. CL. 36. REG. 11-9-2004.
- 2,901,232. LDT SYSTEMS AND DESIGN. INT. CL. 38. REG. 11-9-2004.
- 2,901,235. WRITE ON THE EDGE. INT. CL. 42. REG. 11-9-2004.
- 2,901,240. MARKETING YOUR BUSINESS IN A WIRED WORLD. INT. CL. 41. REG. 11-9-2004.
- 2,901,241. DISCOVERY R & D ADVISORY SERVICES AND DESIGN. INT. CL. 41. REG. 11-9-2004.
- 2,901,246. IT'S IN YOUR HANDS.. INT. CL. 9. REG. 11-9-2004.
- 2,901,247. WAFERBENCH. INT. CL. 9. REG. 11-9-2004.
- 2,901,248. INTERCONTINENTAL FRAGRANCES. INT. CL. 1. REG. 11-9-2004.
- 2,901,249. INTERCONTINENTAL FRAGRANCES AND DESIGN. INT. CL. 1. REG. 11-9-2004.
- 2,901,250. DBA AND DESIGN. INT. CL. 36. REG. 11-9-2004.
- 2,901,252. NUTRIENT-9. INT. CL. 5. REG. 11-9-2004.
- 2,901,255. EGGXOTIC. INT. CLS. 30 AND 43. REG. 11-9-2004.
- 2,901,256. FULL CIRCLE BANKING. INT. CL. 36. REG. 11-9-2004.
- 2,901,257. COSGENE. INT. CL. 3. REG. 11-9-2004.
- 2,901,258. ERXSYSINC. AND DESIGN. INT. CL. 35. REG. 11-9-2004.
- 2,901,263. CENTURY CRAFT AND DESIGN. INT. CL. 16. REG. 11-9-2004.
- 2,901,266. VOIVOD. INT. CL. 41. REG. 11-9-2004.
- 2,901,267. RELIABILITY.IQ. INT. CL. 37. REG. 11-9-2004.
- 2,901,269. AAA WILDLIFE CONTROL. INT. CL. 37. REG. 11-9-2004.
- 2,901,270. MOG. INT. CL. 28. REG. 11-9-2004.
- 2,901,274. MISCELLANEOUS DESIGN. INT. CL. 29. REG. 11-9-2004.
- 2,901,275. IEP AND DESIGN. INT. CL. 1. REG. 11-9-2004.
- 2,901,280. FIGHTER. INT. CL. 12. REG. 11-9-2004.
- 2,901,281. CURVTRIM. INT. CL. 6. REG. 11-9-2004.
- 2,901,288. 888.411.1111. INT. CL. 25. REG. 11-9-2004.
- 2,901,289. PAXTON'S SANDAL SAVER AND DESIGN. INT. CL. 3. REG. 11-9-2004.
- 2,901,290. MISCELLANEOUS DESIGN. INT. CLS. 35 AND 41. REG. 11-9-2004.
- 2,901,291. DON'T BUY A HEARING AID. . . UNTIL YOU'VE SEEN WHAT OUR ENGINEERS HAVE CREATED!. INT. CL. 44. REG. 11-9-2004.
- 2,901,295. TRULEGAL AND DESIGN. INT. CL. 42. REG. 11-9-2004.
- 2,901,300. FOREVER RESORTS AND DESIGN. INT. CLS. 35, 39, 41 AND 43. REG. 11-9-2004.
- 2,901,302. MISCELLANEOUS DESIGN. INT. CL. 43. REG. 11-9-2004.
- 2,901,305. MISCELLANEOUS DESIGN. INT. CL. 44. REG. 11-9-2004.
- 2,901,306. RETROLINERS. INT. CL. 11. REG. 11-9-2004.
- 2,901,307. MISCELLANEOUS DESIGN. INT. CL. 15. REG. 11-9-2004.
- 2,901,310. 1201. INT. CLS. 35 AND 36. REG. 11-9-2004.
- 2,901,311. DHARMA PROPERTIES. INT. CLS. 36 AND 37. REG. 11-9-2004.
- 2,901,312. PURE BLUE. INT. CL. 25. REG. 11-9-2004.
- 2,901,313. DERMAL DEFENSE AND DESIGN. INT. CLS. 3 AND 5. REG. 11-9-2004.
- 2,901,314. TOPICLEAR PARIS. INT. CL. 3. REG. 11-9-2004.
- 2,901,319. SMALL COMMERCIAL REAL ESTATE LENDING GAME. INT. CL. 36. REG. 11-9-2004.
- 2,901,320. ULTRASCENT. INT. CL. 28. REG. 11-9-2004.
- 2,901,321. RE-FUEL. INT. CL. 4. REG. 11-9-2004.
- 2,901,322. PROMOSERVE AND DESIGN. INT. CL. 16. REG. 11-9-2004.
- 2,901,330. GOODWILL STORES AND DESIGN. INT. CL. 35. REG. 11-9-2004.
- 2,901,331. ACCEL. INT. CL. 32. REG. 11-9-2004.
- 2,901,332. DERMO WHITE PARIS. INT. CL. 3. REG. 11-9-2004.
- 2,901,334. CARB COUNTING (STYLIZED). INT. CL. 30. REG. 11-9-2004.
- 2,901,337. BEBE MAISON AND DESIGN. INT. CLS. 12, 20 AND 28. REG. 11-9-2004.
- 2,901,339. PARTNER TWO (STYLIZED). INT. CL. 9. REG. 11-9-2004.
- 2,901,340. TECH/FOUR AND DESIGN. INT. CL. 9. REG. 11-9-2004.
- 2,901,342. MISCELLANEOUS DESIGN. INT. CL. 33. REG. 11-9-2004.
- 2,901,344. MR. PANCAKE MAN. INT. CL. 30. REG. 11-9-2004.
- 2,901,345. AQUATAINMENT. INT. CL. 41. REG. 11-9-2004.
- 2,901,346. JUMP IN MY BED. INT. CL. 44. REG. 11-9-2004.
- 2,901,347. CLOS ST. THOMAS AND DESIGN. INT. CL. 33. REG. 11-9-2004.
- 2,901,348. FWI AND DESIGN. INT. CLS. 16 AND 44. REG. 11-9-2004.
- 2,901,351. SELLERSAVERS. INT. CL. 36. REG. 11-9-2004.
- 2,901,352. AMIGOMAN THE LATIN AVENGER AND DESIGN. INT. CL. 16. REG. 11-9-2004.
- 2,901,356. EXOTEAK. INT. CL. 19. REG. 11-9-2004.
- 2,901,363. JOHNSON & JOHNSON ERGO AND DESIGN. INT. CLS. 9 AND 16. REG. 11-9-2004.
- 2,901,364. ENERJOURNEY. INT. CL. 44. REG. 11-9-2004.
- 2,901,367. THE LIFE AND TIMES OF AMERICA'S SPORTS FANS. INT. CL. 16. REG. 11-9-2004.
- 2,901,368. SFA (STYLIZED). INT. CL. 35. REG. 11-9-2004.
- 2,901,369. ISOCOMPOSE. INT. CL. 9. REG. 11-9-2004.
- 2,901,370. THE SUCCESS INTEGRATION PROCESS. INT. CL. 36. REG. 11-9-2004.
- 2,901,371. THE HIDDUR MITZVAH PROJECT. INT. CL. 28. REG. 11-9-2004.
- 2,901,372. PIRANHA. INT. CL. 11. REG. 11-9-2004.
- 2,901,374. TFM AND DESIGN. INT. CL. 6. REG. 11-9-2004.
- 2,901,375. ELIXIR. INT. CL. 19. REG. 11-9-2004.
- 2,901,380. H HILFIGER (STYLIZED). INT. CL. 35. REG. 11-9-2004.
- 2,901,387. MY PINLESS. INT. CL. 16. REG. 11-9-2004.
- 2,901,388. BECAUSE TIME FLIES, INC. AND DESIGN. INT. CL. 16. REG. 11-9-2004.
- 2,901,389. SMUDGE. INT. CL. 25. REG. 11-9-2004.
- 2,901,390. LEILANI. INT. CL. 15. REG. 11-9-2004.
- 2,901,391. "THE CARDS PEOPLE FRAME" STANDARD CHARACTER MARK. INT. CL. 16. REG. 11-9-2004.
- 2,901,393. HOW DO I ? DVD SERIES AND DESIGN. INT. CL. 9. REG. 11-9-2004.
- 2,901,396. FDIC WEST STANDARD CHARACTER MARK. INT. CL. 41. REG. 11-9-2004.
- 2,901,398. MARLENE PRATT. INT. CL. 41. REG. 11-9-2004.
- 2,901,400. MISCELLANEOUS DESIGN. INT. CL. 37. REG. 11-9-2004.
- 2,901,401. MISCELLANEOUS DESIGN. INT. CL. 37. REG. 11-9-2004.
- 2,901,402. MISCELLANEOUS DESIGN. INT. CL. 37. REG. 11-9-2004.
- 2,901,403. MISCELLANEOUS DESIGN. INT. CL. 37. REG. 11-9-2004.
- 2,901,404. MISCELLANEOUS DESIGN. INT. CL. 37. REG. 11-9-2004.

- 2,901,405. 5999 AND DESIGN. INT. CL. 37. REG. 11-9-2004.
- 2,901,406. MISCELLANEOUS DESIGN. INT. CL. 37. REG. 11-9-2004.
- 2,901,407. MISCELLANEOUS DESIGN. INT. CL. 37. REG. 11-9-2004.
- 2,901,408. PUREBALANCE FITNESS AND DESIGN. INT. CL. 41. REG. 11-9-2004.
- 2,901,409. VCA VIDEO STANDARD CHARACTER MARK. INT. CL. 9. REG. 11-9-2004.
- 2,901,411. DI REFLECTIONS. INT. CL. 11. REG. 11-9-2004.
- 2,901,412. REMEMBER THE COVENANTS. INT. CL. 14. REG. 11-9-2004.
- 2,901,414. SENNARI STANDARD CHARACTER MARK. INT. CL. 9. REG. 11-9-2004.
- 2,901,415. QUILT-N-CALC STANDARD CHARACTER MARK. INT. CL. 9. REG. 11-9-2004.
- 2,901,419. OCEANTAN. INT. CLS. 3 AND 44. REG. 11-9-2004.
- 2,901,420. WOMEN'S SIZES MORE SELECTION MORE STYLE MORE SAVINGS AND DESIGN. INT. CL. 35. REG. 11-9-2004.
- 2,901,424. GENERATIONS STANDARD CHARACTER MARK. INT. CL. 16. REG. 11-9-2004.
- 2,901,425. WHEN BEING QUALIFIED SIMPLY ISN'T ENOUGH (STYLIZED). INT. CL. 36. REG. 11-9-2004.
- 2,901,426. AUTO & TRUCK SWAPPER STANDARD CHARACTER MARK. INT. CL. 16. REG. 11-9-2004.
- 2,901,427. BARGAIN TRADERONLINE.COM STANDARD CHARACTER MARK. INT. CL. 35. REG. 11-9-2004.
- 2,901,432. T AND DESIGN. INT. CL. 1. REG. 11-9-2004.
- 2,901,433. CAMP READ. INT. CL. 16. REG. 11-9-2004.
- 2,901,434. APRESO STANDARD CHARACTER MARK. INT. CL. 9. REG. 11-9-2004.
- 2,901,435. WINE COUNTRY INTERNATIONAL (STYLIZED). INT. CL. 16. REG. 11-9-2004.
- 2,901,439. DOC (STYLIZED). INT. CL. 41. REG. 11-9-2004.
- 2,901,440. DOC AND DESIGN. INT. CL. 41. REG. 11-9-2004.
- 2,901,442. POP'ABLES SNICKERS CRUNCHER STANDARD CHARACTER MARK. INT. CL. 30. REG. 11-9-2004.
- 2,901,443. JOC AND DESIGN. INT. CL. 11. REG. 11-9-2004.
- 2,901,445. TURNING THE BALANCE OF POWER WITH INVICTA (STYLIZED). INT. CL. 35. REG. 11-9-2004.
- 2,901,449. YOUR PASSPORT TO THE ULTIMATE BOATING EXPERIENCE (STYLIZED). INT. CLS. 35 AND 39. REG. 11-9-2004.
- 2,901,453. MISCELLANEOUS DESIGN. INT. CL. 25. REG. 11-9-2004.
- 2,901,455. WOBE-MUGOS STANDARD CHARACTER MARK. INT. CL. 5. REG. 11-9-2004.
- 2,901,456. POWERFUL ACCESS TO POWERFUL NETWORKS STANDARD CHARACTER MARK. INT. CL. 35. REG. 11-9-2004.
- 2,901,457. TRAFFICADE (STYLIZED). INT. CL. 6. REG. 11-9-2004.
- 2,901,459. MNIGUIDE (STYLIZED). INT. CLS. 9 AND 35. REG. 11-9-2004.
- 2,901,461. INTELLISEARCHER STANDARD CHARACTER MARK. INT. CL. 42. REG. 11-9-2004.
- 2,901,462. KENSINGTON PALACE. INT. CL. 24. REG. 11-9-2004.
- 2,901,464. TROUSERS UP. INT. CL. 25. REG. 11-9-2004.
- 2,901,466. THEBEEFMAN. INT. CL. 29. REG. 11-9-2004.
- 2,901,471. KETCHUP KICK'RS. INT. CL. 30. REG. 11-9-2004.
- 2,901,472. HEINZ KETCHUP KICK'RS. INT. CL. 30. REG. 11-9-2004.
- 2,901,473. PRACTICEREADY AND DESIGN. INT. CLS. 9, 16, 20 AND 42. REG. 11-9-2004.
- 2,901,474. 3D FACTORY. INT. CL. 40. REG. 11-9-2004.
- 2,901,475. SUPERIOR HEALTHCARE COVERAGE HAS ITS REWARDS. INT. CL. 36. REG. 11-9-2004.
- 2,901,476. TENDOTROPHIN. INT. CL. 5. REG. 11-9-2004.
- 2,901,478. STICKCHECK. INT. CL. 10. REG. 11-9-2004.
- 2,901,481. AS-I SAFE WIN. INT. CL. 9. REG. 11-9-2004.
- 2,901,486. SIGNATURE CLUB TRAVEL BENEVALETE AND DESIGN. INT. CL. 39. REG. 11-9-2004.
- 2,901,492. THIRST. INT. CLS. 9 AND 41. REG. 11-9-2004.
- 2,901,494. MUNKIKI. INT. CLS. 9, 28 AND 41. REG. 11-9-2004.
- 2,901,496. ENTUITION, INC.. INT. CL. 42. REG. 11-9-2004.
- 2,901,498. THE STRUGGLE CONTINUES... (STYLIZED). INT. CL. 25. REG. 11-9-2004.
- 2,901,499. MANAGEMENT MATERIAL AND DESIGN. INT. CL. 28. REG. 11-9-2004.
- 2,901,504. KS AND DESIGN. INT. CL. 25. REG. 11-9-2004.
- 2,901,506. EXCELLENCE FIRST. INT. CL. 35. REG. 11-9-2004.
- 2,901,507. TASTE THE DIFFERENCE - TASTE NO DIFFERENCE!. INT. CL. 30. REG. 11-9-2004.
- 2,901,508. SMIRNOFF EXPERIENCE AND DESIGN. INT. CL. 41. REG. 11-9-2004.
- 2,901,509. PENTA TAP. INT. CLS. 9, 37 AND 42. REG. 11-9-2004.
- 2,901,510. YOGA FOR SURFERS AND DESIGN. INT. CL. 9. REG. 11-9-2004.
- 2,901,512. MARTEC. INT. CLS. 1, 9, 38 AND 42. REG. 11-9-2004.
- 2,901,513. SIGMAPLOT. INT. CL. 9. REG. 11-9-2004.
- 2,901,514. E AND DESIGN. INT. CL. 25. REG. 11-9-2004.
- 2,901,516. CARE FUSION SOLUTIONS AT THE POINT OF CARE AND DESIGN. INT. CL. 9. REG. 11-9-2004.
- 2,901,519. MISCELLANEOUS DESIGN. INT. CL. 42. REG. 11-9-2004.
- 2,901,520. TV TWILIGHT VISIONZ AND DESIGN. INT. CL. 42. REG. 11-9-2004.
- 2,901,521. S AND DESIGN. INT. CL. 12. REG. 11-9-2004.
- 2,901,523. ABXPRESS. INT. CL. 41. REG. 11-9-2004.
- 2,901,525. MICHELANGELO GOES BUSINESS. INT. CLS. 16 AND 41. REG. 11-9-2004.
- 2,901,528. TDS AUTOMOTIVE. INT. CL. 35. REG. 11-9-2004.
- 2,901,529. INTERNATIONAL LEGAL PRACTITIONER. INT. CL. 16. REG. 11-9-2004.
- 2,901,530. AMERICA FIRST INSURANCE MEMBER OF LIBERTY MUTUAL GROUP AND DESIGN. INT. CL. 36. REG. 11-9-2004.
- 2,901,531. BABY BABY AND DESIGN. INT. CL. 28. REG. 11-9-2004.
- 2,901,532. VISTA. INT. CL. 9. REG. 11-9-2004.
- 2,901,534. AFFINITY. INT. CL. 31. REG. 11-9-2004.
- 2,901,535. ETHERFABRIC. INT. CLS. 9 AND 42. REG. 11-9-2004.
- 2,901,537. E AND DESIGN. INT. CLS. 37 AND 42. REG. 11-9-2004.
- 2,901,539. MISCELLANEOUS DESIGN. INT. CLS. 9 AND 42. REG. 11-9-2004.
- 2,901,540. BRIO. INT. CL. 9. REG. 11-9-2004.
- 2,901,541. PEAK FITNESS AND DESIGN. INT. CL. 41. REG. 11-9-2004.
- 2,901,543. SURVIVAL GUIDE TO THE GOOD LIFE. INT. CL. 16. REG. 11-9-2004.
- 2,901,544. GDP. INT. CLS. 35, 40, 41 AND 42. REG. 11-9-2004.
- 2,901,546. EMPOWERING THE PRIVATE EYECARE PRACTICE. INT. CLS. 42 AND 44. REG. 11-9-2004.
- 2,901,547. SCANNABAR. INT. CLS. 9 AND 16. REG. 11-9-2004.
- 2,901,549. D-CELLERATE. INT. CL. 3. REG. 11-9-2004.
- 2,901,552. ZONE4PLAY. INT. CL. 9. REG. 11-9-2004.
- 2,901,555. TAVERNELLO AND DESIGN. INT. CL. 33. REG. 11-9-2004.
- 2,901,556. OS NO CALL. INT. CL. 9. REG. 11-9-2004.
- 2,901,558. SEXERCISER. INT. CL. 28. REG. 11-9-2004.
- 2,901,562. WIN IN BIZ. INT. CLS. 16 AND 35. REG. 11-9-2004.
- 2,901,563. DENTAL REVOLUTION AND DESIGN. INT. CL. 21. REG. 11-9-2004.
- 2,901,566. SPECTRUM WORKS. INT. CL. 9. REG. 11-9-2004.
- 2,901,567. DISCOVER THE DIRECTV DIFFERENCE BETTER ENTERTAINMENT MORE VALUE STANDARD CHARACTER MARK. INT. CL. 41. REG. 11-9-2004.
- 2,901,571. ASTRA CASINO GAMING. INT. CL. 9. REG. 11-9-2004.
- 2,901,573. FORGERY OF THE MONTH. INT. CL. 35. REG. 11-9-2004.

- 2,901,574. MISCELLANEOUS DESIGN. INT. CL. 16. REG. 11-9-2004.
- 2,901,575. PNY TECHNOLOGIES AND DESIGN. INT. CL. 9. REG. 11-9-2004.
- 2,901,576. MABIAZ. INT. CL. 5. REG. 11-9-2004.
- 2,901,577. FEVER AND DESIGN. INT. CL. 28. REG. 11-9-2004.
- 2,901,578. MABRATUS. INT. CL. 5. REG. 11-9-2004.
- 2,901,579. SNOWBALL FIGHT AND DESIGN. INT. CL. 28. REG. 11-9-2004.
- 2,901,583. EDONIA. INT. CL. 33. REG. 11-9-2004.
- 2,901,584. ELS. INT. CL. 9. REG. 11-9-2004.
- 2,901,585. PROFESSIONAL PLANNING CONSULTANTS AND DESIGN. INT. CL. 36. REG. 11-9-2004.
- 2,901,591. LYONS & WOLIVAR INVESTIGATIONS, INC. (STYLIZED). INT. CL. 45. REG. 11-9-2004.
- 2,901,593. STYL'N' STICK. INT. CLS. 2 AND 16. REG. 11-9-2004.
- 2,901,597. AUTOREPLENISH. INT. CL. 35. REG. 11-9-2004.
- 2,901,598. ADANALYZER. INT. CL. 35. REG. 11-9-2004.
- 2,901,606. ISABELLA THE BEST TROPICAL PRODUCTS AND DESIGN. INT. CL. 29. REG. 11-9-2004.
- 2,901,608. NELVANA AND DESIGN. INT. CLS. 9, 35 AND 41. REG. 11-9-2004.
- 2,901,614. WORLD OF WILLIAM E. POOLE OUTDOOR LIVING. INT. CL. 11. REG. 11-9-2004.
- 2,901,619. CHERRY CREEK. INT. CL. 33. REG. 11-9-2004.
- 2,901,622. BIOTICKING AND DESIGN. INT. CL. 24. REG. 11-9-2004.
- 2,901,624. PURE MONTANA. INT. CLS. 16 AND 41. REG. 11-9-2004.
- 2,901,625. PROVTIME. INT. CL. 9. REG. 11-9-2004.
- 2,901,626. GRAND MEISTER GM AND DESIGN. INT. CLS. 9 AND 18. REG. 11-9-2004.
- 2,901,628. PIBONAR. INT. CL. 5. REG. 11-9-2004.
- 2,901,632. EP AND DESIGN. INT. CLS. 7 AND 12. REG. 11-9-2004.
- 2,901,633. MISCELLANEOUS DESIGN. INT. CL. 33. REG. 11-9-2004.
- 2,901,638. GREEN MACHINE. INT. CL. 35. REG. 11-9-2004.
- 2,901,639. CLICK TO PHONE AND DESIGN. INT. CL. 38. REG. 11-9-2004.
- 2,901,641. BLOW POP SWIRLZ. INT. CL. 30. REG. 11-9-2004.
- 2,901,642. "OTHER D.I.S.C.". INT. CL. 35. REG. 11-9-2004.
- 2,901,643. GODDESS IN YOU. INT. CLS. 18 AND 25. REG. 11-9-2004.
- 2,901,644. DOCK SHOX. INT. CL. 12. REG. 11-9-2004.
- 2,901,645. DRYERPLIERS. INT. CLS. 8 AND 10. REG. 11-9-2004.
- 2,901,646. CLIKITS AND DESIGN. INT. CL. 28. REG. 11-9-2004.
- 2,901,648. RESPECT. INT. CL. 21. REG. 11-9-2004.
- 2,901,650. DARN IT!. INT. CL. 42. REG. 11-9-2004.
- 2,901,651. COCA-COLA. INT. CL. 27. REG. 11-9-2004.
- 2,901,652. MISCELLANEOUS DESIGN. INT. CL. 16. REG. 11-9-2004.
- 2,901,654. POWER STRIP LIBERATOR. INT. CL. 9. REG. 11-9-2004.
- 2,901,658. MISCELLANEOUS DESIGN. INT. CL. 19. REG. 11-9-2004.
- 2,901,660. DAIRYDEX. INT. CL. 25. REG. 11-9-2004.
- 2,901,661. PJ (STYLIZED). INT. CL. 9. REG. 11-9-2004.
- 2,901,662. BAY HILL INVITATIONAL. INT. CL. 41. REG. 11-9-2004.
- 2,901,664. ESPRESSOID. INT. CL. 9. REG. 11-9-2004.
- 2,901,665. EONFOCUS. INT. CL. 9. REG. 11-9-2004.
- 2,901,668. DEVIANT MIND AND DESIGN. INT. CLS. 25 AND 28. REG. 11-9-2004.
- 2,901,670. MARIANA ANTINORI AND DESIGN. INT. CL. 24. REG. 11-9-2004.
- 2,901,671. PRO HURRICANE. INT. CL. 28. REG. 11-9-2004.
- 2,901,672. MEDHEA. INT. CL. 5. REG. 11-9-2004.
- 2,901,677. BLACK. INT. CL. 36. REG. 11-9-2004.
- 2,901,678. SHOREBREAK SKIMBOARDS AND DESIGN. INT. CL. 28. REG. 11-9-2004.
- 2,901,679. NO BULL INVESTING THE BEAR-NAKED TRUTH. INT. CL. 41. REG. 11-9-2004.
- 2,901,681. AMERIMERCHANT AND DESIGN. INT. CL. 36. REG. 11-9-2004.
- 2,901,682. MEDTRANSLATIONS AND DESIGN. INT. CL. 41. REG. 11-9-2004.
- 2,901,684. CBES (CERTIFIED BEHAVIORAL-BASED ERGONOMIC SPECIALIST). INT. CL. 41. REG. 11-9-2004.
- 2,901,685. MISCELLANEOUS DESIGN. INT. CL. 41. REG. 11-9-2004.
- 2,901,689. THAT'S SO TOMORROW!. INT. CLS. 9, 14, 25 AND 38. REG. 11-9-2004.
- 2,901,691. INVENTORYLINK. INT. CL. 35. REG. 11-9-2004.
- 2,901,692. AMY'S ANNOUNCEMENTS. INT. CL. 18. REG. 11-9-2004.
- 2,901,696. ACCPAC PRO SERIES. INT. CL. 9. REG. 11-9-2004.
- 2,901,700. DEFINITY AND DESIGN. INT. CL. 9. REG. 11-9-2004.
- 2,901,701. PINGID. INT. CL. 42. REG. 11-9-2004.
- 2,901,703. PUSHCORP, INC.. INT. CL. 7. REG. 11-9-2004.
- 2,901,705. REEFIES. INT. CL. 20. REG. 11-9-2004.
- 2,901,708. PGA NATIONAL GOLF CLUB AND DESIGN. INT. CL. 41. REG. 11-9-2004.
- 2,901,709. VOCALNET AND DESIGN. INT. CL. 42. REG. 11-9-2004.
- 2,901,714. NATURAL FIT. INT. CL. 25. REG. 11-9-2004.
- 2,901,715. MAGMA. INT. CL. 25. REG. 11-9-2004.
- 2,901,716. MATTHEWS CINNI. INT. CL. 11. REG. 11-9-2004.
- 2,901,717. RED BUTTON AND DESIGN. INT. CL. 35. REG. 11-9-2004.
- 2,901,718. XYTRQ. INT. CL. 7. REG. 11-9-2004.
- 2,901,722. PLANET PLEASURES AND DESIGN. INT. CL. 28. REG. 11-9-2004.
- 2,901,725. THE BUSINESS BIRDER. INT. CL. 41. REG. 11-9-2004.
- 2,901,726. COTUITS R SUPERIOR AND DESIGN. INT. CL. 29. REG. 11-9-2004.
- 2,901,727. ALL THE HELP YOU NEED...IN THE PHONES YOU ALREADY HAVE. INT. CL. 42. REG. 11-9-2004.
- 2,901,728. ALL THE HELP YOU NEED... IN THE PHONES YOU ALREADY HAVE.. INT. CL. 45. REG. 11-9-2004.
- 2,901,731. XA AUDIO. INT. CL. 9. REG. 11-9-2004.
- 2,901,732. HFG HUNTER FINANCIAL GROUP, LLC AND DESIGN. INT. CL. 35. REG. 11-9-2004.
- 2,901,733. HFG HUNTER FINANCIAL GROUP, LLC AND DESIGN. INT. CL. 36. REG. 11-9-2004.
- 2,901,734. HUNTER FINANCIAL GROUP, LLC. INT. CL. 35. REG. 11-9-2004.
- 2,901,738. PORTACIO AND DESIGN. INT. CL. 42. REG. 11-9-2004.
- 2,901,742. ART CREATED USING ONLY A PALETTE KNIFE ROBERT LEBRÓN AND DESIGN. INT. CL. 16. REG. 11-9-2004.
- 2,901,744. VAC-O-NUT. INT. CL. 29. REG. 11-9-2004.
- 2,901,748. DONNASTARR. INT. CL. 35. REG. 11-9-2004.
- 2,901,751. BODYPUMP AND DESIGN. INT. CL. 25. REG. 11-9-2004.
- 2,901,752. CRESCENT TRAVEL CLUB AND DESIGN. INT. CL. 43. REG. 11-9-2004.
- 2,901,753. COSMETIC FEE PLAN BY CAPITAL ONE (STYLIZED). INT. CL. 36. REG. 11-9-2004.
- 2,901,754. ORTHODONTISTS FEE PLAN BY CAPITAL ONE (STYLIZED). INT. CL. 36. REG. 11-9-2004.
- 2,901,756. LATINOSDELMUNDO AND DESIGN. INT. CL. 38. REG. 11-9-2004.
- 2,901,757. A NATIONWIDE NETWORK OF DISTINGUISHED ATTORNEYS. INT. CL. 35. REG. 11-9-2004.
- 2,901,758. I'LL BE BACK!. INT. CL. 31. REG. 11-9-2004.
- 2,901,759. DAYTIME ENCOUNTER (STYLIZED). INT. CL. 41. REG. 11-9-2004.
- 2,901,760. TWO EAGLES. INT. CL. 25. REG. 11-9-2004.
- 2,901,761. MISCELLANEOUS DESIGN. INT. CL. 41. REG. 11-9-2004.
- 2,901,762. CAPISTRANO BREWING CO. AND DESIGN. INT. CL. 32. REG. 11-9-2004.

- 2,901,763. EZIBITS AND DESIGN. INT. CL. 40. REG. 11-9-2004.
- 2,901,765. WRAPTOR. INT. CL. 25. REG. 11-9-2004.
- 2,901,766. EAGLEEDGE. INT. CL. 36. REG. 11-9-2004.
- 2,901,767. THICK-EXTREME. INT. CL. 3. REG. 11-9-2004.
- 2,901,768. ARCHIMATION. INT. CL. 42. REG. 11-9-2004.
- 2,901,769. LET'S LICK LEUKEMIA. INT. CL. 36. REG. 11-9-2004.
- 2,901,770. CRM FOR EVERYONE. INT. CL. 42. REG. 11-9-2004.
- 2,901,771. THE STARVY AWARDS AND DESIGN. INT. CL. 41. REG. 11-9-2004.
- 2,901,772. STARLIGHT. INT. CL. 40. REG. 11-9-2004.
- 2,901,773. WHITAKER CHALK MEANS BUSINESS. INT. CL. 42. REG. 11-9-2004.
- 2,901,774. OLD FORESTER. INT. CL. 43. REG. 11-9-2004.
- 2,901,779. SLIPPERY KITTY! (STYLIZED). INT. CL. 5. REG. 11-9-2004.
- 2,901,780. ID AND DESIGN. INT. CL. 12. REG. 11-9-2004.
- 2,901,783. FIGHT FAT FIBER. INT. CL. 5. REG. 11-9-2004.
- 2,901,784. STRIPSCREEN. INT. CL. 19. REG. 11-9-2004.
- 2,901,787. COMUNIC EAR. INT. CL. 44. REG. 11-9-2004.
- 2,901,788. WC WHITAKER CHALK (STYLIZED). INT. CL. 42. REG. 11-9-2004.
- 2,901,790. TO EVERY HOME A SEASON. INT. CL. 42. REG. 11-9-2004.
- 2,901,791. ALWAYS OUT-NUMBERED NEVER OUT-GUNNED AND DESIGN. INT. CL. 25. REG. 11-9-2004.
- 2,901,793. THE TREE OF LIFE GOSPEL WORLD MUSIC FESTIVAL. INT. CL. 41. REG. 11-9-2004.
- 2,901,795. BY WOMYN STANDARD CHARACTER MARK. INT. CL. 25. REG. 11-9-2004.
- 2,901,797. AUNTIE MAE'S STANDARD CHARACTER MARK. INT. CL. 30. REG. 11-9-2004.
- 2,901,798. GAMEMAKER MOMENT STANDARD CHARACTER MARK. INT. CL. 30. REG. 11-9-2004.
- 2,901,800. WEBSITES DIRECT STANDARD CHARACTER MARK. INT. CL. 42. REG. 11-9-2004.
- 2,901,802. JOE BOXER STANDARD CHARACTER MARK. INT. CL. 21. REG. 11-9-2004.
- 2,901,803. JOE BOXER STANDARD CHARACTER MARK. INT. CL. 14. REG. 11-9-2004.
- 2,901,804. JOE BOXER STANDARD CHARACTER MARK. INT. CL. 16. REG. 11-9-2004.
- 2,901,805. HERE WE ARE...AND THERE YOU GO! STANDARD CHARACTER MARK. INT. CL. 35. REG. 11-9-2004.
- 2,901,806. LEGENDARY NAME! HOMEMADE TASTE! STANDARD CHARACTER MARK. INT. CL. 29. REG. 11-9-2004.
- 2,901,807. GLIER'S...THE GOETTA PEOPLE! STANDARD CHARACTER MARK. INT. CL. 29. REG. 11-9-2004.
- 2,901,808. VUPLEX STANDARD CHARACTER MARK. INT. CL. 35. REG. 11-9-2004.
- 2,901,809. PEANUTBUTTER & JANE STANDARD CHARACTER MARK. INT. CL. 35. REG. 11-9-2004.
- 2,901,811. BOSATRIA STANDARD CHARACTER MARK. INT. CL. 5. REG. 11-9-2004.
- 2,901,812. SYNCRIA STANDARD CHARACTER MARK. INT. CL. 5. REG. 11-9-2004.
- 2,901,817. JOE BOXER STANDARD CHARACTER MARK. INT. CL. 9. REG. 11-9-2004.
- 2,901,819. CMMI STANDARD CHARACTER MARK. INT. CLS. 7 AND 37. REG. 11-9-2004.
- 2,901,820. ILOVECARMAX.COM STANDARD CHARACTER MARK. INT. CL. 35. REG. 11-9-2004.
- 2,901,822. JOE BOXER STANDARD CHARACTER MARK. INT. CL. 12. REG. 11-9-2004.
- 2,901,825. INSURANCEONLY STANDARD CHARACTER MARK. INT. CL. 36. REG. 11-9-2004.
- 2,901,827. VMD VET MED DIRECT AND DESIGN. INT. CL. 35. REG. 11-9-2004.
- 2,901,828. LIVE LIFE TO THE "FUNNEST!" STANDARD CHARACTER MARK. INT. CL. 28. REG. 11-9-2004.
- 2,901,829. CREATING LASTING LOYAL CUSTOMERS THROUGH PERSONAL GREETINGS STANDARD CHARACTER MARK. INT. CL. 35. REG. 11-9-2004.
- 2,901,830. HERCUFAST STANDARD CHARACTER MARK. INT. CL. 2. REG. 11-9-2004.
- 2,901,832. INFINYNS AND DESIGN. INT. CLS. 9 AND 35. REG. 11-9-2004.
- 2,901,839. ORANGE ACTION STANDARD CHARACTER MARK. INT. CL. 3. REG. 11-9-2004.
- 2,901,840. FANTASTIK STANDARD CHARACTER MARK. INT. CL. 3. REG. 11-9-2004.
- 2,901,841. NPOWERMENT STANDARD CHARACTER MARK. INT. CL. 36. REG. 11-9-2004.
- 2,901,842. NRCA STANDARD CHARACTER MARK. INT. CL. 35. REG. 11-9-2004.
- 2,901,844. SHORT CUTS STANDARD CHARACTER MARK. INT. CL. 25. REG. 11-9-2004.
- 2,901,850. GROWING TOGETHER STANDARD CHARACTER MARK. INT. CL. 31. REG. 11-9-2004.
- 2,901,851. LUNCH BREAK LEARNING STANDARD CHARACTER MARK. INT. CL. 41. REG. 11-9-2004.
- 2,901,852. STEM-STAT STANDARD CHARACTER MARK. INT. CL. 42. REG. 11-9-2004.
- 2,901,853. AVATAR HIGH STANDARD CHARACTER MARK. INT. CL. 41. REG. 11-9-2004.
- 2,901,854. AUTHENTIC CONVERSATIONS GETTING REAL TO GET RESULTS STANDARD CHARACTER MARK. INT. CL. 41. REG. 11-9-2004.
- 2,901,855. AUTHENTIC CONVERSATIONS STANDARD CHARACTER MARK. INT. CL. 41. REG. 11-9-2004.
- 2,901,856. VIACOM (STYLIZED). INT. CL. 35. REG. 11-9-2004.
- 2,901,857. HAVE YOU HAD YOUR FRUIT TODAY? STANDARD CHARACTER MARK. INT. CL. 43. REG. 11-9-2004.
- 2,901,858. P H I AND DESIGN. INT. CL. 41. REG. 11-9-2004.
- 2,901,859. WIN LIKE AN EGYPTIAN STANDARD CHARACTER MARK. INT. CL. 28. REG. 11-9-2004.
- 2,901,860. SUPER DAKOTA 300 STANDARD CHARACTER MARK. INT. CL. 28. REG. 11-9-2004.
- 2,901,861. SPARKLING DIAMONDS STANDARD CHARACTER MARK. INT. CL. 28. REG. 11-9-2004.
- 2,901,862. ROCKY MOUNTAIN SLOTS STANDARD CHARACTER MARK. INT. CL. 28. REG. 11-9-2004.
- 2,901,865. GOPHER STATE STANDARD CHARACTER MARK. INT. CL. 28. REG. 11-9-2004.
- 2,901,866. DIAMONDS & RUBIES STANDARD CHARACTER MARK. INT. CL. 28. REG. 11-9-2004.
- 2,901,867. CLASSIC COLORADO STANDARD CHARACTER MARK. INT. CL. 28. REG. 11-9-2004.
- 2,901,868. CASH BARS & BELLS STANDARD CHARACTER MARK. INT. CL. 28. REG. 11-9-2004.
- 2,901,869. 7S & BARS STANDARD CHARACTER MARK. INT. CL. 28. REG. 11-9-2004.
- 2,901,871. MISCELLANEOUS DESIGN. INT. CL. 9. REG. 11-9-2004.
- 2,901,879. POWER LINE. INT. CL. 7. REG. 11-9-2004.
- 2,901,880. MAKING PLAY TIME A SAFER TIME. INT. CL. 16. REG. 11-9-2004.
- 2,901,881. R.A.G. AND DESIGN. INT. CL. 25. REG. 11-9-2004.
- 2,901,883. VIRTUAL ATTRITION AND DESIGN. INT. CL. 41. REG. 11-9-2004.
- 2,901,885. TOTAL ECLIPSE. INT. CL. 3. REG. 11-9-2004.
- 2,901,886. MIKIMOTO INTERNATIONAL AND DESIGN. INT. CLS. 16 AND 21. REG. 11-9-2004.
- 2,901,887. GENEATLAS. INT. CL. 9. REG. 11-9-2004.
- 2,901,888. TXU AND DESIGN. INT. CL. 35. REG. 11-9-2004.
- 2,901,892. CACHEOS. INT. CL. 9. REG. 11-9-2004.
- 2,901,895. TWIST-N-MIST. INT. CL. 21. REG. 11-9-2004.
- 2,901,897. FORTUNE. INT. CL. 9. REG. 11-9-2004.
- 2,901,902. CHECKWRITER. INT. CL. 9. REG. 11-9-2004.
- 2,901,903. V VALLEY VIEW CENTER AND DESIGN. INT. CLS. 35 AND 36. REG. 11-9-2004.
- 2,901,904. ATLAS. INT. CL. 6. REG. 11-9-2004.

- 2,901,905. CRYPTOMARK. INT. CL. 9. REG. 11-9-2004.
2,901,907. TRAVELCROSSINGS. INT. CLS. 39 AND 42. REG. 11-9-2004.
2,901,908. WDC. INT. CL. 25. REG. 11-9-2004.
2,901,912. START. INT. CL. 1. REG. 11-9-2004.
2,901,915. SANTA COM AND DESIGN. INT. CL. 28. REG. 11-9-2004.
2,901,916. SE PLAIRE. INT. CL. 3. REG. 11-9-2004.
2,901,919. GALLERY. INT. CL. 19. REG. 11-9-2004.
2,901,920. SPACESETTER. INT. CLS. 6 AND 20. REG. 11-9-2004.
2,901,921. SUNTOUCH. INT. CL. 10. REG. 11-9-2004.
2,901,923. OREGON3D. INT. CL. 16. REG. 11-9-2004.
2,901,924. LOGONLENZ. INT. CL. 9. REG. 11-9-2004.
2,901,925. ADVANTAGE 442. INT. CL. 7. REG. 11-9-2004.
2,901,926. WORKHORSE. INT. CL. 7. REG. 11-9-2004.
2,901,927. LYSORB. INT. CLS. 1 AND 42. REG. 11-9-2004.
2,901,934. PHARMASTAR. INT. CLS. 9, 16 AND 41. REG. 11-9-2004.
2,901,939. EXUS AND DESIGN. INT. CLS. 7 AND 12. REG. 11-9-2004.
2,901,940. DOUBLE-M (STYLIZED). INT. CL. 18. REG. 11-9-2004.
2,901,941. SAFE-T-CHOICE. INT. CL. 10. REG. 11-9-2004.
2,901,942. PLAY CASH. INT. CL. 41. REG. 11-9-2004.
2,901,944. ALLIANCESMITH. INT. CLS. 41 AND 42. REG. 11-9-2004.
2,901,945. CARECERT. INT. CL. 9. REG. 11-9-2004.
2,901,947. ECOBOUQUETS. INT. CL. 31. REG. 11-9-2004.
2,901,948. BAND OF BROTHERS. INT. CLS. 20, 22 AND 26. REG. 11-9-2004.
2,901,953. SCHWAB RT PARTICIPANT SOLUTIONS. INT. CL. 9. REG. 11-9-2004.
2,901,957. NEX DAYZ ENT.. INT. CLS. 9 AND 41. REG. 11-9-2004.
2,901,959. BLACKEN. INT. CLS. 9, 12, 14, 16, 25, 28 AND 41. REG. 11-9-2004.
2,901,961. SOLAR EXPRESS. INT. CLS. 25 AND 42. REG. 11-9-2004.
2,901,962. TWACS BY DCSI AND DESIGN. INT. CL. 9. REG. 11-9-2004.
2,901,965. PCIX PERSONAL CARE INGREDIENT EXPO. INT. CL. 35. REG. 11-9-2004.
2,901,966. MERBABIES. INT. CL. 28. REG. 11-9-2004.
2,901,967. ATR AND DESIGN. INT. CL. 25. REG. 11-9-2004.
2,901,972. GET 'EM ON THE LINE!. INT. CLS. 35 AND 38. REG. 11-9-2004.
2,901,974. INVITROLON. INT. CL. 3. REG. 11-9-2004.
2,901,975. PDAMP. INT. CL. 9. REG. 11-9-2004.
2,901,976. LOVE MADE OF HEART AND DESIGN. INT. CL. 16. REG. 11-9-2004.
2,901,977. CORELLE COORDINATES. INT. CL. 21. REG. 11-9-2004.
2,901,978. COSMOPROMOS. INT. CL. 40. REG. 11-9-2004.
2,901,980. INSTINET FX CROSS. INT. CL. 36. REG. 11-9-2004.
2,901,981. ESSENTIAL MOISTURE. INT. CL. 3. REG. 11-9-2004.
2,901,983. AMERICAN TEEN. INT. CL. 28. REG. 11-9-2004.
2,901,984. SIMPLY AMAZING GRAINS. INT. CL. 30. REG. 11-9-2004.
2,901,985. PLEDGE TO VOTE. INT. CL. 41. REG. 11-9-2004.
2,901,989. EXPRESS. INT. CL. 7. REG. 11-9-2004.
2,901,991. SKYNN. INT. CL. 16. REG. 11-9-2004.
2,901,994. ONE PAYMENT VIEW. INT. CL. 36. REG. 11-9-2004.
2,901,996. HAUTE SHOPPING. INT. CLS. 16 AND 35. REG. 11-9-2004.
2,901,997. HAUTE SHOPPING CARD. INT. CLS. 16 AND 35. REG. 11-9-2004.
2,901,998. XWALL. INT. CL. 9. REG. 11-9-2004.
2,902,003. EX TENSION. INT. CL. 10. REG. 11-9-2004.
2,902,004. M 1786 AND DESIGN. INT. CL. 32. REG. 11-9-2004.
2,902,006. GLIM GLAM. INT. CL. 3. REG. 11-9-2004.
2,902,010. PAPAGO INTERNATIONAL RESORT DAY LIGHT HOTEL MANAGEMENT AND DESIGN. INT. CL. 43. REG. 11-9-2004.
2,902,011. GRADSCHOOLSWANTYOU. INT. CL. 41. REG. 11-9-2004.
2,902,012. LIFEVENTURE. INT. CLS. 6, 18, 20, 21 AND 25. REG. 11-9-2004.
2,902,015. SPIRIT INITIATIVE AND DESIGN. INT. CLS. 35, 36 AND 41. REG. 11-9-2004.
2,902,016. HYDRA DAY SANT'ANGELICA AND DESIGN. INT. CLS. 3 AND 5. REG. 11-9-2004.
2,902,017. SELECTUS. INT. CL. 36. REG. 11-9-2004.
2,902,018. WILD MEDICINE. INT. CL. 41. REG. 11-9-2004.
2,902,019. GAMESTOP (STYLIZED). INT. CL. 35. REG. 11-9-2004.
2,902,020. POWERCOSMETICS. INT. CLS. 5, 9 AND 10. REG. 11-9-2004.
2,902,021. PROFESSIONALS CHOOSE BLOCH. INT. CL. 25. REG. 11-9-2004.
2,902,022. INTERVAL. INT. CL. 34. REG. 11-9-2004.
2,902,028. EXPLORATION UNIT. INT. CL. 28. REG. 11-9-2004.
2,902,032. G W L G AND DESIGN. INT. CL. 9. REG. 11-9-2004.
2,902,033. FIRE FLASH. INT. CL. 9. REG. 11-9-2004.
2,902,035. BLACK GOLD ENTERTAINMENT. INT. CLS. 9 AND 41. REG. 11-9-2004.
2,902,037. DANIELS ROBERTS INC. AND DESIGN. INT. CLS. 35 AND 42. REG. 11-9-2004.
2,902,040. EXCELLENCE IN FINANCIAL SERVICES. INT. CL. 36. REG. 11-9-2004.
2,902,041. SENTRY SHIELD. INT. CLS. 12 AND 20. REG. 11-9-2004.
2,902,042. ANDREA B.. INT. CLS. 18 AND 25. REG. 11-9-2004.
2,902,045. VENGEANCE. INT. CL. 12. REG. 11-9-2004.
2,902,048. ATLANTIDE. INT. CL. 3. REG. 11-9-2004.
2,902,051. HARD. INT. CL. 28. REG. 11-9-2004.
2,902,052. SWEETMED. INT. CL. 9. REG. 11-9-2004.
2,902,055. ELMO. INT. CL. 9. REG. 11-9-2004.
2,902,057. CAMBAR. INT. CL. 3. REG. 11-9-2004.
2,902,058. WELL-SPRING CENTER FOR NATURAL HEALTH & WELLNESS. INT. CL. 44. REG. 11-9-2004.
2,902,059. WELL-SPRING CENTER FOR NATURAL HEALTH & WELLNESS. INT. CL. 41. REG. 11-9-2004.
2,902,060. SUN SAFETY ALLIANCE AND DESIGN. INT. CL. 35. REG. 11-9-2004.
2,902,064. ENLIGHTEN ENABLE EMPOWER AND DESIGN. INT. CLS. 35 AND 36. REG. 11-9-2004.
2,902,066. MILCAM RECON. INT. CL. 9. REG. 11-9-2004.
2,902,067. FIRST ACT PLAYER SERIES. INT. CLS. 9 AND 15. REG. 11-9-2004.
2,902,068. LABELOGIC. INT. CLS. 16 AND 41. REG. 11-9-2004.
2,902,070. EXCLUSIVE ACCESS. CUSTOM SERVICES. EXPERT ADVISORS. INT. CL. 36. REG. 11-9-2004.
2,902,072. ARABINOXYLANPLUS (STYLIZED). INT. CL. 1. REG. 11-9-2004.
2,902,073. NONNA LUNA OF VERMONT. INT. CL. 30. REG. 11-9-2004.
2,902,074. SIZZLIN' SIGNATURES. INT. CL. 8. REG. 11-9-2004.
2,902,076. E-NAMINALS. INT. CL. 14. REG. 11-9-2004.
2,902,079. REAL SOLUTIONS. REAL-E.. INT. CLS. 35 AND 42. REG. 11-9-2004.
2,902,080. BUZZLIFE. INT. CL. 38. REG. 11-9-2004.
2,902,081. PN AND DESIGN. INT. CL. 31. REG. 11-9-2004.
2,902,082. BEVERAGE SPECTRUM AND DESIGN. INT. CL. 16. REG. 11-9-2004.
2,902,083. PREMCOR. INT. CL. 19. REG. 11-9-2004.
2,902,090. VAMP. INT. CL. 9. REG. 11-9-2004.
2,902,093. INTERLINK DIGITAL. INT. CL. 35. REG. 11-9-2004.
2,902,094. EVERY DAY IS AN OPPORTUNITY TO DO MORE. INT. CL. 36. REG. 11-9-2004.
2,902,099. SHOW GLOW. INT. CL. 28. REG. 11-9-2004.
2,902,100. SNAPDISK. INT. CL. 9. REG. 11-9-2004.
2,902,101. MAJESTIC SUN. INT. CL. 36. REG. 11-9-2004.

- 2,902,102. 7 TOUCH MARKETING. INT. CL. 35. REG. 11-9-2004.
- 2,902,103. DURAFIBER. INT. CL. 40. REG. 11-9-2004.
- 2,902,105. PLAINSCAPITAL MORTGAGE ONE. INT. CL. 36. REG. 11-9-2004.
- 2,902,106. MOMENTUMFUNDING A PLAINSCAPITAL COMPANY. INT. CL. 36. REG. 11-9-2004.
- 2,902,108. PLAINSCAPITAL MCAFFEE MORTGAGE. INT. CL. 36. REG. 11-9-2004.
- 2,902,109. ALBURY BROTHERS. INT. CL. 12. REG. 11-9-2004.
- 2,902,114. SMARTOP. INT. CL. 12. REG. 11-9-2004.
- 2,902,118. SWEET SINSATIONS (STYLIZED). INT. CL. 10. REG. 11-9-2004.
- 2,902,119. ETERNAL NOEL. INT. CL. 3. REG. 11-9-2004.
- 2,902,124. LOUNGAIR. INT. CLS. 20 AND 28. REG. 11-9-2004.
- 2,902,125. *CONNECTEDTHINKING (STYLIZED). INT. CL. 36. REG. 11-9-2004.
- 2,902,126. SUBSCRIPT § (STYLIZED). INT. CL. 25. REG. 11-9-2004.
- 2,902,128. ARABELLA ROMANCES STANDARD CHARACTER MARK. INT. CL. 16. REG. 11-9-2004.
- 2,902,133. NEW.NET AND DESIGN. INT. CL. 38. REG. 11-9-2004.
- 2,902,140. MORE THAN MAINSTREET THUNDER IN THE HILLS. INT. CL. 25. REG. 11-9-2004.
- 2,902,142. WRIGHT BLOCKS. INT. CL. 28. REG. 11-9-2004.
- 2,902,143. FORTITUDE. INT. CL. 5. REG. 11-9-2004.
- 2,902,144. PULSE LINK AND DESIGN. INT. CL. 9. REG. 11-9-2004.
- 2,902,145. SONGWRITERS IN THE ROUND HIT SONGWRITER PERFORMANCES AND DESIGN. INT. CLS. 9, 21, 25 AND 41. REG. 11-9-2004.
- 2,902,146. MISCELLANEOUS DESIGN. INT. CLS. 5, 9 AND 42. REG. 11-9-2004.
- 2,902,148. X-RAY THE BARBARIAN. INT. CL. 9. REG. 11-9-2004.
- 2,902,149. WAGGIN' BAKERY HAWAII SINCE 1997 AND DESIGN. INT. CL. 31. REG. 11-9-2004.
- 2,902,150. SURGE LAB. INT. CL. 9. REG. 11-9-2004.
- 2,902,151. GX2 ADVERTISING AND DESIGN. INT. CL. 35. REG. 11-9-2004.
- 2,902,152. DR. TUNG'S PRO GUMS. INT. CL. 21. REG. 11-9-2004.
- 2,902,153. SECOND RECORDS. INT. CL. 9. REG. 11-9-2004.
- 2,902,154. CHASER BOATS (STYLIZED). INT. CL. 12. REG. 11-9-2004.
- 2,902,155. ONEALERT! FROM CAPITAL ONE (STYLIZED). INT. CL. 35. REG. 11-9-2004.
- 2,902,156. EPITAN. INT. CL. 5. REG. 11-9-2004.
- 2,902,157. BLASCO MAKE-UP STUDIO. INT. CL. 41. REG. 11-9-2004.
- 2,902,159. MISCELLANEOUS DESIGN. INT. CL. 3. REG. 11-9-2004.
- 2,902,162. ADAPTIVE STORE AND DESIGN. INT. CL. 9. REG. 11-9-2004.
- 2,902,163. NEGABOTZ. INT. CL. 28. REG. 11-9-2004.
- 2,902,164. AFTERNOON SNACK. INT. CL. 28. REG. 11-9-2004.
- 2,902,165. IVANA. INT. CL. 28. REG. 11-9-2004.
- 2,902,166. BLISSA. INT. CL. 28. REG. 11-9-2004.
- 2,902,167. CHANDRA. INT. CL. 28. REG. 11-9-2004.
- 2,902,168. METRO CITY POLICE FORCE. INT. CL. 28. REG. 11-9-2004.
- 2,902,174. NICK. INT. CL. 9. REG. 11-9-2004.
- 2,902,175. INFRASOUND V. INT. CL. 10. REG. 11-9-2004.
- 2,902,178. PARIS FILM FESTIVAL. INT. CL. 28. REG. 11-9-2004.
- 2,902,179. WEEKEND STYLE. INT. CL. 28. REG. 11-9-2004.
- 2,902,180. SEA RESCUE. INT. CL. 28. REG. 11-9-2004.
- 2,902,182. OOZITS. INT. CL. 28. REG. 11-9-2004.
- 2,902,186. CODE-A-STORE. INT. CL. 42. REG. 11-9-2004.
- 2,902,187. GIRASOLE AND DESIGN. INT. CL. 18. REG. 11-9-2004.
- 2,902,188. DELIVERY MASTER STANDARD CHARACTER MARK. INT. CL. 21. REG. 11-9-2004.
- 2,902,190. ELROI – THE ELECTRONIC ANALYST. INT. CL. 36. REG. 11-9-2004.
- 2,902,194. PEPISH. INT. CL. 29. REG. 11-9-2004.
- 2,902,196. MAGNETIC 7'S. INT. CL. 9. REG. 11-9-2004.
- 2,902,201. ZXW. INT. CL. 12. REG. 11-9-2004.
- 2,902,202. PRIDE OF ASIA. INT. CL. 36. REG. 11-9-2004.
- 2,902,208. RAMPING. INT. CL. 41. REG. 11-9-2004.
- 2,902,209. YZAGE.COM. INT. CL. 35. REG. 11-9-2004.
- 2,902,210. DUREON. INT. CL. 7. REG. 11-9-2004.
- 2,902,212. METRONOME. INT. CL. 9. REG. 11-9-2004.
- 2,902,213. ASPECTMENTOR. INT. CL. 41. REG. 11-9-2004.
- 2,902,214. MAXIFI. INT. CLS. 9 AND 36. REG. 11-9-2004.
- 2,902,219. XTRA CREDIT. INT. CL. 36. REG. 11-9-2004.
- 2,902,221. BELLSOUTH. LISTENING. ANSWERING.. INT. CLS. 9, 35, 37, 38 AND 42. REG. 11-9-2004.
- 2,902,222. BELLSOUTH LISTENING ANSWERING. INT. CLS. 9, 35, 37, 38 AND 42. REG. 11-9-2004.
- 2,902,224. FAMOUS MAKER. INT. CLS. 9 AND 13. REG. 11-9-2004.
- 2,902,226. DR O'S OPTICAL MAGNIFIERS AND DESIGN. INT. CL. 9. REG. 11-9-2004.
- 2,902,227. PROFESSEUR CHRISTINE POELMAN. INT. CL. 3. REG. 11-9-2004.
- 2,902,230. OHIO FUDGE THUNDER. INT. CL. 30. REG. 11-9-2004.
- 2,902,231. REIMBURSEMENT MADE SIMPLE. INT. CLS. 35 AND 36. REG. 11-9-2004.
- 2,902,232. OP BLEND. INT. CL. 3. REG. 11-9-2004.
- 2,902,233. ROC REFLECTION OF CHRIST AND DESIGN. INT. CL. 25. REG. 11-9-2004.
- 2,902,234. WILDCAT WASH AND DESIGN. INT. CL. 37. REG. 11-9-2004.
- 2,902,236. GARAGE PASS COLLECTIBLES STANDARD CHARACTER MARK. INT. CL. 35. REG. 11-9-2004.
- 2,902,237. ENFINITY ENERGY. INT. CL. 39. REG. 11-9-2004.
- 2,902,239. DAVIVIENDA AND DESIGN. INT. CL. 36. REG. 11-9-2004.
- 2,902,240. PAGE PLUS PROGRAM. INT. CL. 37. REG. 11-9-2004.
- 2,902,242. MAXMERIDIA. INT. CL. 29. REG. 11-9-2004.
- 2,902,244. SCHWAB SIGNATURE ALLIANCE. INT. CLS. 36 AND 41. REG. 11-9-2004.
- 2,902,245. RATPADZGS. INT. CL. 9. REG. 11-9-2004.
- 2,902,247. METRO MASSAGE. INT. CL. 44. REG. 11-9-2004.
- 2,902,249. FIBER LAM STANDARD CHARACTER MARK. INT. CL. 28. REG. 11-9-2004.
- 2,902,250. FIBERLAM. INT. CL. 40. REG. 11-9-2004.
- 2,902,251. NEURONTIN AND DESIGN. INT. CL. 5. REG. 11-9-2004.
- 2,902,252. NEURONTIN AND DESIGN. INT. CL. 44. REG. 11-9-2004.
- 2,902,257. BIKANERI. INT. CLS. 29 AND 30. REG. 11-9-2004.
- 2,902,259. EXECUTIVE SERIES. INT. CL. 36. REG. 11-9-2004.
- 2,902,260. PARK AVENUE. INT. CL. 32. REG. 11-9-2004.
- 2,902,261. PURIFEYES. INT. CL. 3. REG. 11-9-2004.
- 2,902,267. SLIQ. INT. CL. 28. REG. 11-9-2004.
- 2,902,269. MAGICAL MOMENTS. INT. CL. 16. REG. 11-9-2004.
- 2,902,270. CREAMY PEANUT BUTTER PERFECTION. INT. CL. 30. REG. 11-9-2004.
- 2,902,271. SNOW FOLLIES. INT. CL. 28. REG. 11-9-2004.
- 2,902,274. FOUNDRY. INT. CL. 25. REG. 11-9-2004.
- 2,902,276. READY SERVE. INT. CL. 35. REG. 11-9-2004.
- 2,902,278. BEYOND. INT. CL. 5. REG. 11-9-2004.
- 2,902,279. BITE. INT. CL. 10. REG. 11-9-2004.
- 2,902,280. VERIDIUM. INT. CL. 40. REG. 11-9-2004.
- 2,902,281. DURA-SCREEN. INT. CL. 7. REG. 11-9-2004.
- 2,902,283. MIDWEST M AND DESIGN. INT. CLS. 35 AND 39. REG. 11-9-2004.
- 2,902,285. MAD ABOUT PLAID. INT. CL. 16. REG. 11-9-2004.
- 2,902,286. ENVOKE AND DESIGN. INT. CL. 5. REG. 11-9-2004.
- 2,902,292. BEATBROS (STYLIZED). INT. CL. 9. REG. 11-9-2004.
- 2,902,293. CYBER FLEXXX. INT. CLS. 17 AND 28. REG. 11-9-2004.
- 2,902,294. OLAVE. INT. CL. 29. REG. 11-9-2004.

- 2,902,295. ONCE UPON A GARDEN AND DESIGN. INT. CL. 16. REG. 11-9-2004.
- 2,902,296. VIRTUAL CLARITY. INT. CL. 5. REG. 11-9-2004.
- 2,902,297. VALUE-ABLE. INT. CL. 41. REG. 11-9-2004.
- 2,902,298. FLUOROSPINE. INT. CLS. 9 AND 10. REG. 11-9-2004.
- 2,902,301. METROXIN. INT. CL. 5. REG. 11-9-2004.
- 2,902,304. SMART INVESTING DOESN'T MEAN YOU HAVE TO DO IT ALL. INT. CL. 36. REG. 11-9-2004.
- 2,902,307. WEQUALIFY. INT. CL. 45. REG. 11-9-2004.
- 2,902,312. FULLPASSPORT. INT. CL. 16. REG. 11-9-2004.
- 2,902,315. STERIS.COM. INT. CLS. 42 AND 44. REG. 11-9-2004.
- 2,902,316. CORAL CALCIUM POWER. INT. CL. 5. REG. 11-9-2004.
- 2,902,317. RESCUE BLUE. INT. CL. 6. REG. 11-9-2004.
- 2,902,318. BARRIFLAME. INT. CL. 24. REG. 11-9-2004.
- 2,902,321. SECLUSION 3D KONIFER. INT. CLS. 24 AND 25. REG. 11-9-2004.
- 2,902,322. GENCOURSE AND DESIGN. INT. CL. 35. REG. 11-9-2004.
- 2,902,324. COOK & LADDER. INT. CL. 29. REG. 11-9-2004.
- 2,902,325. STABRITE. INT. CL. 3. REG. 11-9-2004.
- 2,902,326. EMBELLEZE. INT. CL. 3. REG. 11-9-2004.
- 2,902,327. MAXTON. INT. CL. 3. REG. 11-9-2004.
- 2,902,328. ZETA6. INT. CL. 9. REG. 11-9-2004.
- 2,902,331. LAMI "BUG-IT" AND DESIGN. INT. CL. 40. REG. 11-9-2004.
- 2,902,333. WALLTECH. INT. CL. 9. REG. 11-9-2004.
- 2,902,334. STUDTECH. INT. CL. 9. REG. 11-9-2004.
- 2,902,338. MISCELLANEOUS DESIGN. INT. CLS. 16, 20 AND 24. REG. 11-9-2004.
- 2,902,342. NATURAL FLAME LIGHTING THAT REFLECTS YOU. INT. CLS. 4 AND 11. REG. 11-9-2004.
- 2,902,344. PERMAFID. INT. CL. 9. REG. 11-9-2004.
- 2,902,345. THE COLOR OF COOL. INT. CL. 9. REG. 11-9-2004.
- 2,902,346. XXX POSED. INT. CL. 25. REG. 11-9-2004.
- 2,902,350. D DIVERSIFIED TITLE INSURANCE COMPANY AND DESIGN. INT. CL. 36. REG. 11-9-2004.
- 2,902,352. D DIVERSIFIED AND DESIGN. INT. CL. 36. REG. 11-9-2004.
- 2,902,353. PROXYTRACKER. INT. CL. 9. REG. 11-9-2004.
- 2,902,354. SWITCHFIRE. INT. CL. 4. REG. 11-9-2004.
- 2,902,355. CLINKOS. INT. CL. 28. REG. 11-9-2004.
- 2,902,358. UNI-LINK. INT. CL. 9. REG. 11-9-2004.
- 2,902,360. TOOL BOX BUDDIES. INT. CL. 20. REG. 11-9-2004.
- 2,902,362. RIGHT DOC. INT. CL. 36. REG. 11-9-2004.
- 2,902,363. CANDIDLY SPEAKING. INT. CL. 16. REG. 11-9-2004.
- 2,902,364. CONCIERGE. INT. CL. 9. REG. 11-9-2004.
- 2,902,365. SAFETY NET ACCOUNT PROTECTION. INT. CL. 36. REG. 11-9-2004.
- 2,902,366. VETUS FELILAX. INT. CL. 5. REG. 11-9-2004.
- 2,902,367. VETUS FELITONE-T. INT. CL. 5. REG. 11-9-2004.
- 2,902,371. SIDE 2 SIDE. INT. CL. 35. REG. 11-9-2004.
- 2,902,373. FOXY LOX. INT. CL. 26. REG. 11-9-2004.
- 2,902,374. WORLD CHAMPIONSHIP TOURNAMENT. INT. CL. 9. REG. 11-9-2004.
- 2,902,375. CINTHORC. INT. CL. 8. REG. 11-9-2004.
- 2,902,376. MOLOTOCH. INT. CL. 8. REG. 11-9-2004.
- 2,902,377. POLARXTREME. INT. CL. 9. REG. 11-9-2004.
- 2,902,381. C1FX. INT. CL. 3. REG. 11-9-2004.
- 2,902,383. FLAT OUT VINTAGE MOTOR BIKE. INT. CL. 37. REG. 11-9-2004.
- 2,902,385. ETHICORE. INT. CL. 35. REG. 11-9-2004.
- 2,902,386. BIOFILL. INT. CL. 20. REG. 11-9-2004.
- 2,902,387. SELECT-O-MATIC. INT. CL. 9. REG. 11-9-2004.
- 2,902,391. EURRING. INT. CL. 14. REG. 11-9-2004.
- 2,902,392. LIL DIPPER. INT. CL. 8. REG. 11-9-2004.
- 2,902,394. EXECUTIVE REEL. INT. CL. 41. REG. 11-9-2004.
- 2,902,395. BOOKBAND. INT. CL. 16. REG. 11-9-2004.
- 2,902,397. PETS SAFE VILLAGE. INT. CLS. 35, 41 AND 44. REG. 11-9-2004.
- 2,902,398. DODGE RAM TOOLMASTER AND DESIGN. INT. CL. 12. REG. 11-9-2004.
- 2,902,401. DYNAVOX DV4 AND DESIGN. INT. CL. 9. REG. 11-9-2004.
- 2,902,402. DYNAVOX MT4 AND DESIGN. INT. CL. 9. REG. 11-9-2004.
- 2,902,404. MOMMA PUFFY. INT. CL. 28. REG. 11-9-2004.
- 2,902,405. CONTRACTPOWER. INT. CL. 35. REG. 11-9-2004.
- 2,902,407. ZERO TO SIXTY. INT. CL. 41. REG. 11-9-2004.
- 2,902,408. MINICCI. INT. CL. 26. REG. 11-9-2004.
- 2,902,409. AERODYNE AND DESIGN. INT. CLS. 12 AND 28. REG. 11-9-2004.
- 2,902,410. AWESOME GIRLS. INT. CL. 25. REG. 11-9-2004.
- 2,902,412. GENERATIONS OF VIRTUE AND DESIGN. INT. CL. 41. REG. 11-9-2004.
- 2,902,413. AWESOME FAMILY. INT. CL. 28. REG. 11-9-2004.
- 2,902,414. AWESOME FAMILY. INT. CL. 41. REG. 11-9-2004.
- 2,902,415. BLUBAC. INT. CL. 27. REG. 11-9-2004.
- 2,902,416. CANDLE OF HOPE. INT. CL. 4. REG. 11-9-2004.
- 2,902,417. OVERDRIVE. INT. CL. 28. REG. 11-9-2004.
- 2,902,418. DOUBLE STACK. INT. CL. 20. REG. 11-9-2004.
- 2,902,420. NIGHTMARE HARVEST. INT. CL. 41. REG. 11-9-2004.
- 2,902,422. LIAM. INT. CL. 28. REG. 11-9-2004.
- 2,902,424. CRITTER COMFORT. INT. CL. 31. REG. 11-9-2004.
- 2,902,425. MISCELLANEOUS DESIGN. INT. CLS. 29, 30, 35 AND 43. REG. 11-9-2004.
- 2,902,428. SHARED INTELLIGENCE. INT. CL. 42. REG. 11-9-2004.
- 2,902,435. DOUBLESIGN. INT. CL. 25. REG. 11-9-2004.
- 2,902,436. TOUCH BLUSH. INT. CL. 3. REG. 11-9-2004.
- 2,902,437. RENAISSANCE. INT. CL. 31. REG. 11-9-2004.
- 2,902,441. JOSEF LAZAR. INT. CL. 15. REG. 11-9-2004.
- 2,902,442. EFX. INT. CL. 9. REG. 11-9-2004.
- 2,902,443. ENDOIMAGE. INT. CL. 9. REG. 11-9-2004.
- 2,902,445. CRUNCHY STAY TRIM. INT. CL. 30. REG. 11-9-2004.
- 2,902,448. READY, SET, DECORATE!. INT. CL. 16. REG. 11-9-2004.
- 2,902,452. TIK-TAK. INT. CL. 9. REG. 11-9-2004.
- 2,902,453. CRY BABY DESIGNS AND DESIGN. INT. CL. 14. REG. 11-9-2004.
- 2,902,457. HUSH A BYE BABY. INT. CL. 28. REG. 11-9-2004.
- 2,902,458. FAT CHANCE FILMS. INT. CL. 41. REG. 11-9-2004.
- 2,902,460. RURALPOLITAN. INT. CL. 16. REG. 11-9-2004.
- 2,902,461. SSR. INT. CLS. 35, 36 AND 37. REG. 11-9-2004.
- 2,902,462. AROASTICA. INT. CL. 29. REG. 11-9-2004.
- 2,902,463. SKILL-TEC. INT. CL. 28. REG. 11-9-2004.
- 2,902,465. RPW. INT. CLS. 9 AND 25. REG. 11-9-2004.
- 2,902,466. WAY TO SHOP. INT. CL. 35. REG. 11-9-2004.
- 2,902,467. SUNDAY CLUB. INT. CL. 25. REG. 11-9-2004.
- 2,902,469. PAGOMAT.COM. INT. CL. 36. REG. 11-9-2004.
- 2,902,473. TOUR BLUE. INT. CL. 28. REG. 11-9-2004.
- 2,902,474. POWERGLOW. INT. CL. 25. REG. 11-9-2004.
- 2,902,477. CHAPARE. INT. CL. 25. REG. 11-9-2004.
- 2,902,479. PANIXINE DISPERDOSE. INT. CL. 5. REG. 11-9-2004.
- 2,902,481. FILE LIFECYCLE MANAGER. INT. CL. 9. REG. 11-9-2004.
- 2,902,482. FLORIMALTA. INT. CL. 32. REG. 11-9-2004.
- 2,902,483. PREFERRED ADVANTAGE. INT. CL. 38. REG. 11-9-2004.
- 2,902,484. LEISURE TIME ADVOCACY. INT. CL. 43. REG. 11-9-2004.
- 2,902,485. ACHIEVE IT!. INT. CL. 16. REG. 11-9-2004.
- 2,902,487. GITZY. INT. CL. 28. REG. 11-9-2004.
- 2,902,490. MY FIRST UMBRELLA. INT. CL. 18. REG. 11-9-2004.
- 2,902,491. PEPSI MÚSICA STANDARD CHARACTER MARK. INT. CL. 41. REG. 11-9-2004.
- 2,902,492. MISCELLANEOUS DESIGN. INT. CL. 25. REG. 11-9-2004.
- 2,902,493. CREDO MY PERSONAL STATEMENT OF BELIEF... WHAT'S YOURS? AND DESIGN. INT. CL. 25. REG. 11-9-2004.
- 2,902,496. DISPERDOSE. INT. CL. 5. REG. 11-9-2004.

- 2,902,505. GLAD TO BE A DAD. INT. CLS. 14 AND 25. REG. 11-9-2004.
- 2,902,532. RN. INT. CL. 28. REG. 11-9-2004.
- 2,902,754. ADSOSS. INT. CLS. 37 AND 42 ONLY. REG. 11-16-2004.
- 2,902,755. MEMOSS. INT. CLS. 37 AND 42 ONLY. REG. 11-16-2004.
- 2,906,424. THE SHORTEST DISTANCE TO A STRAIGHT SMILE. INT. CL. 44. REG. 11-30-2004.
- 2,906,974. NATIONAL AIR TOUR AND DESIGN. INT. CLS. 16 AND 26 ONLY. REG. 11-30-2004.
- 2,914,808. OJG. INT. CL. 16 ONLY. REG. 12-28-2004.
- 2,947,630. AJILON. INT. CLS. 9 AND 39 ONLY. REG. 5-10-2005.
- 2,947,883. PLENISH STANDARD CHARACTER MARK. INT. CL. 4 ONLY. REG. 5-10-2005.
- 2,948,815. ACUITY. INT. CL. 25 ONLY. REG. 5-10-2005.
- 2,950,811. RSP. INT. CL. 37 ONLY. REG. 5-17-2005.
- 2,950,820. DÖRKEN (STYLIZED). INT. CL. 4 ONLY. REG. 5-17-2005.
- 2,952,293. INSTANT CHECK SYSTEM AND DESIGN. INT. CL. 41 ONLY. REG. 5-17-2005.
- 2,952,447. EMS AND DESIGN. INT. CLS. 8, 9, 18, 20, 21, 22, 25 AND 28 ONLY. REG. 5-17-2005.
- 2,952,448. MISCELLANEOUS DESIGN. INT. CLS. 8, 9, 18, 20, 21, 22, 25 AND 28 ONLY. REG. 5-17-2005.
- 2,952,969. VESSEL. INT. CLS. 8, 20 AND 21 ONLY. REG. 5-17-2005.
- 2,953,216. LOOKERS. INT. CL. 18 ONLY. REG. 5-17-2005.
- 2,957,599. SILHOUETTE. INT. CL. 41 ONLY. REG. 5-31-2005.
- 2,957,936. CLASSIC AUTO RESTORER. INT. CL. 41 ONLY. REG. 5-31-2005.
- 2,958,928. WESCO AND DESIGN. INT. CLS. 6, 12, 20 AND 34 ONLY. REG. 6-7-2005.
- 2,963,073. RONSON. INT. CL. 3 ONLY. REG. 6-21-2005.
- 2,976,747. ACRYCON. INT. CLS. 5 AND 10 ONLY. REG. 7-26-2005.
- 2,978,169. INTEGRRAFT. INT. CL. 5 ONLY. REG. 7-26-2005.
- 2,989,366. MARQUESAS STANDARD CHARACTER MARK. INT. CLS. 9 AND 14 ONLY. REG. 8-30-2005.
- 3,023,989. MISCELLANEOUS DESIGN. INT. CLS. 39 AND 42 ONLY. REG. 12-6-2005.
- 3,029,179. SP SPANISH PEAKS BIG SKY, MONTANA AND DESIGN. INT. CL. 37 ONLY. REG. 12-13-2005.
- 3,029,627. PROLAB AND DESIGN. INT. CLS. 3, 35, 40 AND 42 ONLY. REG. 12-13-2005.
- 3,044,177. CTM-BACKLITT STANDARD CHARACTER MARK. INT. CL. 9 ONLY. REG. 1-17-2006.
- 3,065,230. AUTOLAND STANDARD CHARACTER MARK. INT. CL. 36 ONLY. REG. 3-7-2006.
- 3,082,478. CATCHTHEMOMENT.COM STANDARD CHARACTER MARK. INT. CLS. 16 AND 41 ONLY. REG. 4-18-2006.

SECTION 71

- 3,042,038. PREMIUM STUDIO STANDARD CHARACTER MARK. INT. CLS. 9 AND 42 ONLY. REG. 1-10-2006.
- 3,073,773. LITESPEED STANDARD CHARACTER MARK. INT. CL. 7. REG. 3-28-2006.

* * * * *

TRADEMARK REGISTRATIONS AMENDED, CORRECTED, ETC.

The designation "U.S. Cl." appearing in this section refers to the U.S. class in effect prior to Sep. 1, 1973 rather than the international class which applies to applications filed on or after that date. For adoption of international classification see notice in the OFFICIAL GAZETTE of Jun. 26, 1973 (911 O.G. TM 210).

Any change to the registration will be indicated at the bottom of each entry under ELEMENTS AMENDED, CORRECTED OR RESTRICTED. With the exception of changes to the goods and services, additions to the registration will appear in asterisks and deletions of the registration will appear in brackets. Elements which are only changed will be listed with no punctuation. As to the goods/services statement, amendments to the goods/services will appear in asterisks and deletions will appear in brackets. In addition if any change to the goods/services occurs, the element "Goods/Services" will be listed under ELEMENTS AMENDED, CORRECTED OR RESTRICTED.

1,156,030. REG. 6-2-1981. PUIG FRANCE (FRANCE SOCIETE PAR ACTIONS SIMPLIFEE) 6, BOULEVARD DU PARC, 92200 NEUILLY SUR SEINE, FRANCE., SN 73-188,488. FILED 10-6-1978. PRINCIPAL REGISTER.



OWNER OF FRANCE REG. NO. 1,038,460, DATED 1-10-1978.

OWNER OF U.S. REG. NOS. 896,606 AND 1,040,822. APPLICANT DISCLAIMS ANY EXCLUSIVE RIGHT TO THE PHRASE "POUR HOMME" SEPARATE AND APART FROM THE MARK AS SHOWN.

THE NAME "PACO RABANNE" IS A FICTITIOUS ONE. "POUR HOMME" TRANSLATED MEANS "FOR MEN".

INT. CL. 3/U.S. CLS. 1, 4, 6, 50, 51 AND 52 FOR TOILET WATER, AFTERSHAVES, SOAPS [TALC AND SHAVING CREAM FOR MEN]. FIRST USE ; IN COMMERCE .

ELEMENTS AMENDED
GOODS/SERVICES
MARK

1,574,736. REG. 1-2-1990. VBG GROUP AB (PUBL) (SWEDEN AKTIEBOLAG) BOX 1216 SE, VANERSBORG, SWEDEN, 462 28, SN 73-767,685. FILED 12-2-1988. PRINCIPAL REGISTER.



OWNER OF U.S. REG. NO. 1,422,734. THE MARK CONSISTS OF THE STYLIZED REPRESENTATION OF A VEHICLE WHEEL, SUSPENSION COMPONENTS, A TIRE CHAIN, AND THE WORD "ONSPOT" IN STYLIZED FORM. INT. CL. 12/U.S. CLS. 13 AND 19

FOR SNOW TRACTION CHAINS FOR VEHICLE WHEELS. FIRST USE 10-15-1978; IN COMMERCE 3-31-1984.

ELEMENTS AMENDED
MARK

1,647,484. REG. 6-11-1991. SPEEDO INTERNATIONAL LIMITED (UNITED KINGDOM CORPORATION) THE PENTLAND CENTRE LAKESIDE, SQUIRES LANE, FINCHLEY, LONDON, ENGLAND., SN 73-781,214. FILED 2-8-1989. PRINCIPAL REGISTER.



PRIORITY CLAIMED UNDER SEC. 44(D) ON BENELUX APPLICATION NO. 719545, FILED 9-16-1988, REG. NO. 453310, DATED 9-16-1988.

OWNER OF U.S. REG. NOS. 718,276, 1,161,032 AND OTHERS.

INT. CL. 25/U.S. CLS. 22 AND 39 FOR ANORAKS, [APRONS, BABUSHKAS,] [BANDANAS,] [BABY BUNTINGS,] BATHING SUITS, BATHING TRUNKS, [BATHROBES,] BEACHWEAR, [BELTS, BIBS, BLAZERS, BLOUSES, BLOUSONS, BOLEROS, BOOTS, BOOTIES,] BRAS, BRIEFS, [CAFTANS, CAMISOLES,] [CAPES,] CAPS, [CARDIGANS,] [CHEMISES, CLOGS, CLOTH DIAPERS,] COATS, [COLLARS, COVERALLS, CREEPERS, CULOTTES, EAR MUFFS, DRESSES, FISHING VESTS, FISHING WADERS,] FOOTWEAR, [GAITERS, GALOSHES, GIRDLES, GLOVES, GOWNS, HALTERS,] HATS, HEADBANDS, HEADWEAR, [HOODS,] JACKETS, [JEANS, JERSEYS, JUMPERS, JUMPSUITS, KIMONOS, LEG WARMERS,] [LEOTARDS,] LEGGINGS, LINGERIE, LOUNGEWEAR, [MITTENS, MUFFLERS,] [NECKERCHIEFS,] [NECKWEAR, NEGLIGENCES, NIGHTGOWNS, NIGHTSHIRTS, OVERALLS, OVERCOATS, PAJAMAS, PANTIES, PANTS, PANTS SETS,] [PARKAS,] [PEDAL PUSHERS, PEIGNOIRS, POCKET SQUARES,] PONCHOS, PULL-OVERS, [RAIN COATS,] RAINWEAR, [ROBES,] [ROMPERS, RUBBERS,] [SANDALS, SCARVES, SHAWLS, SHIFTS, SHIRTS, SHOES, SHORTS, SINGLETS, SKI SUITS, SKIWEAR, SKIRTS, SLACKS, SLEEPWEAR,] SLIPPERS, [SLIPS, SMOCKS,] [SNOWSUITS,] SOCKS, [SPORT COATS, STOCKINGS, STOLES, SUITS, SUSPENDERS,] [SWEATERS,] SWEATPANTS, SWEATSHIRTS, SWEATSUITS, SWIMWEAR, T-SHIRTS, [TEDDIES,] TENNIS WEAR, [TIES, TIGHTS, TOPCOATS, TOPS, TROUSERS, TUNICS, TUXEDOS,] UNDER-

PANTS, [UNDERSHIRTS, UNDERWEAR, UNIFORMS, VEILS, VESTS, VESTED SUITS,] WARMUP SUITS, WIND-RESISTANT JACKETS, [WRISTBANDS,] [AFTER-SKI BOOTS, ASCOTS,] [ATHLETIC SHOES,] [BABY PANTS, BATHROBES,] BATH SANDALS, BATH SLIPPERS, BATHING CAPS, BEACHWEAR, [BODICES, CORSETS, CUFFS, DETACHABLE COLLARS,] [FOOTWEAR UPPERS,] [FROCKS, FUR STOLEES, GABERDINES, GARTERS, GOWNS, GYMNASTIC SHOES,] HOSIERY, [SOCK SUSPENDERS,] SWEAT-ABSORBENT UNDERCLOTHING, [TOGAS,] [WET SUITS FOR WATER-SKIING].

FIRST USE : IN COMMERCE .

ELEMENTS AMENDED
MARK

1,861,062. REG. 11-1-1994. NORPAC FOODS, INC. (OREGON CORPORATION) 4350 SW GALEWOOD STREET, PO BOX 2249, LAKE OSWEGO, OR, 970350800, SN 74-301,737. FILED 8-4-1992. PRINCIPAL REGISTER.

GRANDE CLASSICS

THE ENGLISH TRANSLATION OF THE WORD "GRANDE" IN THE MARK IS "GRAND".
INT. CL. 29/U.S. CL. 46

FOR PROCESSED FROZEN FOODS; NAMELY VEGETABLES.

FIRST USE 2-26-1993; IN COMMERCE 2-26-1993.

ELEMENTS AMENDED
MARK

2,433,338. REG. 3-6-2001. THE CRESSET CHEMICAL CO. (OHIO CORPORATION) ONE CRESSET CENTER, WESTON, OH, 43569, SN 75-888,856. FILED 1-6-2000. PRINCIPAL REGISTER.

ROVR

INT. CL. 7/U.S. CLS. 13, 19, 21, 23, 31, 34 AND 35

FOR COMPRESSED AIR SPRAYER FOR APPLYING ULTRA THIN UNIFORMS FILMS OF RELEASE AGENTS TO CONCRETE FORMS, FORM LINERS, PALLETS AND EQUIPMENT.

FIRST USE 12-28-1999; IN COMMERCE 12-28-1999.

ELEMENTS CORRECTED
OWNER NAME

2,438,984. REG. 3-27-2001. ITRON, INC. (WASHINGTON CORPORATION) 2111 NORTH MOLTER ROAD, LIBERTY LAKE, WA, 99019, SN 75-533,311. FILED 8-10-1998. PRINCIPAL REGISTER.

CENTRON

INT. CL. 9/U.S. CLS. 21, 23, 26, 36 AND 38

FOR METERS FOR UTILITIES, NAMELY, METERS FOR OBTAINING, RECORDING, PROCESSING AND/OR TRANSMITTING METER DATA RELATING TO USE AND/OR TRANSMITTAL OF ELECTRICITY [WATER, GAS AND THERMAL ENERGY].

FIRST USE 12-31-1998; IN COMMERCE 12-31-1998.

INT. CL. 38/U.S. CLS. 100, 101 AND 104

FOR [ELECTRONIC TRANSMISSION OF DATA IN THE FIELD OF REMOTE READING OF METERS MEASURING USE AND/OR TRANSMITTAL OF ELECTRICITY, WATER, GAS, AND THERMAL ENERGY].

FIRST USE 12-31-1998; IN COMMERCE 12-31-1998.

ELEMENTS AMENDED
GOODS/SERVICES

2,440,418. REG. 4-3-2001. SPIRIT OF VENICE ARTS COLONY, LLC (CALIFORNIA LIMITED LIABILITY COMPANY) 1416 ELECTRIC AVENUE, VENICE, CA, 90291, SN 75-837,604. FILED 11-2-1999. PRINCIPAL REGISTER.

ELECTRIC LODGE

NO CLAIM IS MADE TO THE EXCLUSIVE RIGHT TO USE "LODGE", APART FROM THE MARK AS SHOWN.

INT. CL. 41/U.S. CLS. 100, 101 AND 107

FOR ENTERTAINMENT SERVICES, NAMELY, PROVIDING FACILITIES FOR RECREATIONAL ACTIVITIES, NAMELY, VISUAL AND PERFORMING ARTS PRODUCTIONS .

FIRST USE 5-1-1997; IN COMMERCE 5-1-1997.

ELEMENTS CORRECTED
ENTITY

2,455,406. REG. 5-29-2001. KATE SPADE, LLC (DELAWARE LIMITED LIABILITY COMPANY) 48 WEST 25TH STREET, 4TH FLOOR, NEW YORK, NY, 10010, SN 76-069,301. FILED 6-13-2000. PRINCIPAL REGISTER.

JACK SPADE WARREN STREET NEW YORK

OWNER OF U.S. REG. NOS. 2,064,708, 2,341,633 AND OTHERS.

NO CLAIM IS MADE TO THE EXCLUSIVE RIGHT TO USE "WARREN STREET NEW YORK", APART FROM THE MARK AS SHOWN.

THE MARK DOES NOT IDENTIFY A PARTICULAR LIVING INDIVIDUAL.

INT. CL. 18/U.S. CLS. 1, 2, 3, 22 AND 41

FOR HANDBAGS, ALL-PURPOSE CARRYING BAGS, TOTE BAGS, TRAVELING BAGS, SHOULDER BAGS, ALL-PURPOSE ATHLETIC BAGS, BACKPACKS, AND WALLETS.

FIRST USE 11-0-1998; IN COMMERCE 11-0-1998.

ELEMENTS CORRECTED
CITIZENSHIP

2,459,619. REG. 6-12-2001. QUANTIMETRIX CORPORATION (CALIFORNIA CORPORATION) 2005 MANHATTAN BEACH BLVD., REDONDO BEACH, CA, 90278, SN 76-028,631. FILED 4-18-2000. PRINCIPAL REGISTER.

DIP & SPIN

THE MARK CONSISTS OF STANDARD CHARACTERS WITHOUT CLAIM TO ANY PARTICULAR FONT, STYLE, SIZE, OR COLOR.

INT. CL. 5/U.S. CLS. 6, 18, 44, 46, 51 AND 52
FOR URINALYSIS QUALITY CONTROL KIT CONSISTING OF MEDICAL DIAGNOSTIC REAGENTS.
FIRST USE 4-3-1996; IN COMMERCE 6-23-1996.

ELEMENTS AMENDED
MARK

2,462,556. REG. 6-19-2001. PRICELESS PLANE PRODUCTS, INC. (GEORGIA CORPORATION) 362 INDUSTRIAL PARK DRIVE, LAWRENCEVILLE, GA, 30046, SN 75-734,903. FILED 6-23-1999. PRINCIPAL REGISTER.



NO CLAIM IS MADE TO THE EXCLUSIVE RIGHT TO USE "PLANE AND PRODUCTS", APART FROM THE MARK AS SHOWN.

INT. CL. 12/U.S. CLS. 19, 21, 23, 31, 35 AND 44
FOR MOTORIZED MULTIPURPOSED MAINTENANCE, GROUND SUPPORT AND TUG LAND VEHICLES AND PARTS THEREFOR, NAMELY, PLATFORM LIFTS AND VACUUM HEADS .
FIRST USE 10-0-1999; IN COMMERCE 10-0-1999.

ELEMENTS AMENDED
MARK

2,486,432. REG. 9-11-2001. MARK VII EQUIPMENT INC. (DELAWARE CORPORATION) 5981 TENNYSON STREET, ARVADA, CO, 80003, SN 75-313,437. FILED 6-23-1997. PRINCIPAL REGISTER.

WASHALERT

THE MARK CONSISTS OF STANDARD CHARACTERS WITHOUT CLAIM TO ANY PARTICULAR FONT, STYLE, SIZE, OR COLOR.

NO CLAIM IS MADE TO THE EXCLUSIVE RIGHT TO USE "WASH", APART FROM THE MARK AS SHOWN.
INT. CL. 9/U.S. CLS. 21, 23, 26, 36 AND 38

FOR DEVICE FOR MONITORING THE OPERATION OF AN AUTOMATIC CAR WASH SYSTEM CONSISTING OF THREE PARTS, NAMELY, [A PAGING AND FAX] * AN ELECTRONIC NOTIFICATION * SYSTEM THAT FACILITATES EFFICIENT SERVICE AND REPAIR OF THE SYSTEM; A DIAGNOSTIC SYSTEM THAT CHECKS FLUID LEVELS, SENSORS, AND THE MECHANICAL OPERATION OF THE CAR WASH SYSTEM; AND A MONITORING SYSTEM FOR PROVIDING DETAILED HISTORICAL OR UP-TO-THE -MINUTE SERVICE STATUS REPORTS.

FIRST USE 10-7-1996; IN COMMERCE 10-7-1996.

ELEMENTS AMENDED
GOODS/SERVICES

2,490,264. REG. 9-18-2001. ADAMS GOLF IP, LTD. (DELAWARE LIMITED PARTNERSHIP) 2801 EAST PLANO PARKWAY, PLANO, TX, 75074, SN 75-929,529. FILED 2-28-2000. PRINCIPAL REGISTER.

ADAMSGOLF

OWNER OF U.S. REG. NO. 2,080,226.
INT. CL. 28/U.S. CLS. 22, 23, 38 AND 50
FOR GOLF CLUBS.
FIRST USE 2-1-2000; IN COMMERCE 2-1-2000.

ELEMENTS CORRECTED
OWNER NAME

2,505,512. REG. 11-6-2001. SAFE HORIZON, INC. (NEW YORK NOT FOR PROFIT CORPORATION) 2 LAFAYETTE STREET, NEW YORK, NY, 10007, SN 75-934,881. FILED 3-3-2000. PRINCIPAL REGISTER.

SAFE HORIZON

INT. CL. 41/U.S. CLS. 100, 101 AND 107
FOR EDUCATIONAL SERVICES, NAMELY, ARRANGING AND CONDUCTING LECTURES, WORKSHOPS, AND SEMINARS FOR THE PUBLIC, CRIME VICTIMS, LAW ENFORCEMENT AND SOCIAL WORK PROFESSIONALS, AND POLICY MAKERS ABOUT THE ISSUES INVOLVING CRIME VICTIMIZATION, VIOLENCE PREVENTION, THE AVAILABILITY OF TREATMENT FOR VICTIMS, AND ALTERNATIVES TO VIOLENCE.
FIRST USE 7-1-2000; IN COMMERCE 7-1-2000.

INT. CL. 45/U.S. CLS. 100 AND 101
FOR MISCELLANEOUS SERVICES, NAMELY, PROVIDING ASSISTANCE TO CRIME VICTIMS IN THE FORM OF PRACTICAL SERVICES SUCH AS FOOD, SHORT AND LONG-TERM COUNSELING, LOCK CHANGING SERVICE, ADVOCACY WITH THE CRIMINAL JUSTICE SYSTEM (POLICE AND COURTS), LEGAL ASSISTANCE, AND DAY CARE AND SHELTER; AND PROVIDING PUBLIC ADVOCACY ON BEHALF OF CRIME VICTIMS INCLUDING INFORMING LEGISLATORS ABOUT PROGRAMS OFFERED BY THE APPLICANT AND ABOUT ISSUES AFFECTING CRIME VICTIMS IN ORDER TO AFFECT OFFICIAL POLICIES TO ACCOMMODATE VICTIMS RIGHTS; INFORMATION SERVICES TO THE PUBLIC, CRIME VICTIMS, LAW ENFORCEMENT AND SOCIAL WORK PROFESSIONALS, AND POLICY MAKERS ABOUT THE ISSUES INVOLVING CRIME VICTIMIZATION, VIOLENCE PREVENTION, THE AVAILABILITY OF TREATMENT FOR VICTIMS AND ALTERNATIVES TO VIOLENCE.
FIRST USE 7-1-2000; IN COMMERCE 7-1-2000.

ELEMENTS AMENDED
GOODS/SERVICES

INTERNATIONAL CLASS(ES)
DATE OF FIRST USE
DATE OF FIRST USE IN COMMERCE

2,537,318. REG. 2-5-2002. KATE SPADE, LLC (DELAWARE LIMITED LIABILITY COMPANY) 48 WEST 25TH STREET, 4TH FLOOR, NEW YORK, NY, 10010, SN 76-041,130. FILED 5-5-2000. PRINCIPAL REGISTER.

KATE SPADE NEW YORK

OWNER OF U.S. REG. NOS. 2,064,708, 2,341,633 AND OTHERS.

NO CLAIM IS MADE TO THE EXCLUSIVE RIGHT TO USE "NEW YORK", APART FROM THE MARK AS SHOWN. THE NAME "KATE SPADE" IDENTIFIES A LIVING INDIVIDUAL WHOSE CONSENT IS OF RECORD.

INT. CL. 18/U.S. CLS. 1, 2, 3, 22 AND 41

FOR HANDBAGS, ALL PURPOSE CARRYING BAGS, TOTE BAGS, TRAVELLING BAGS, SHOULDER BAGS, CLUTCH PURSES, ALL-PURPOSE ATHLETIC BAGS, BACKPACKS, WALLET, COIN PURSES AND COSMETIC BAGS (SOLD EMPTY).

FIRST USE 1-0-1993; IN COMMERCE 1-0-1993.

ELEMENTS CORRECTED
CITIZENSHIP

2,539,245. REG. 2-19-2002. RED BULL GMBH (AUSTRIA LIMITED LIABILITY COMPANY) AM BRUNNEN 1, FUSCHL AM SEE, AUSTRIA, A-5330, SN 75-941,264. FILED 3-10-2000. PRINCIPAL REGISTER.

RED BULL

THE MARK CONSISTS OF STANDARD CHARACTERS WITHOUT CLAIM TO ANY PARTICULAR FONT, STYLE, SIZE, OR COLOR.

INT. CL. 42/U.S. CLS. 100 AND 101

FOR RESTAURANT SERVICES.

FIRST USE 3-1-1968; IN COMMERCE 3-1-1968.

ELEMENTS AMENDED
MARK
[DISCLAIMER]

2,565,278. REG. 4-30-2002. NELSON STUD WELDING, INC. (DELAWARE CORPORATION) 7900 WEST RIDGE ROAD, ELYRIA, OH, 44036, SN 76-269,079. FILED 6-8-2001. PRINCIPAL REGISTER.

NELWELD

INT. CL. 6/U.S. CLS. 2, 12, 13, 14, 23, 25 AND 50

FOR METAL FASTENERS, NAMELY, WELD STUDS AND THREAD [WELDING] * WELD * STUDS.

FIRST USE 12-26-1945; IN COMMERCE 12-26-1945.

INT. CL. 7/U.S. CLS. 13, 19, 21, 23, 31, 34 AND 35

FOR HANDHELD, PORTABLE, AND FIXED WELDING MACHINES FOR INSTALLING WELDING ELEMENTS.

FIRST USE 12-26-1945; IN COMMERCE 12-26-1945.

INT. CL. 9/U.S. CLS. 21, 23, 26, 36 AND 38

FOR ELECTRIC ARC WELDERS.
FIRST USE 12-26-1945; IN COMMERCE 12-26-1945.

ELEMENTS CORRECTED
GOODS/SERVICES

2,642,096. REG. 10-29-2002. MGM RESORTS INTERNATIONAL (DELAWARE CORPORATION) 3950 LAS VEGAS BOULEVARD SOUTH, LAS VEGAS, NV, 89119, SN 76-255,560. FILED 5-11-2001. PRINCIPAL REGISTER.



OWNER OF U.S. REG. NOS. 1,060,488, 2,072,069 AND OTHERS.

THE MARK CONSISTS OF A DEPICTION OF A WALKING LION OVER THE WORDS "MGM GRAND".

INT. CL. 25/U.S. CLS. 22 AND 39

FOR WEARING APPAREL, NAMELY, POLO-SHIRTS, T-SHIRTS, TANK TOPS, SHIRTS, JACKETS, JOGGING SUITS, SWEAT SHIRTS, SWEAT PANTS, JEANS, PANTS, ROBES, SLEEPWEAR, ROMPERS, SCARVES, SOCKS, SLIPPERS, HATS AND CAPS.

FIRST USE 11-1-1995; IN COMMERCE 11-1-1995.

ELEMENTS AMENDED
DESCRIPTION OF MARK

2,654,803. REG. 11-26-2002. KATE SPADE, LLC (DELAWARE LIMITED LIABILITY COMPANY) 48 WEST 25TH STREET, 4TH FLOOR, NEW YORK, NY, 10010, SN 76-041,126. FILED 5-5-2000. PRINCIPAL REGISTER.

KATE SPADE NEW YORK

OWNER OF U.S. REG. NOS. 2,064,708, 2,341,633 AND OTHERS.

NO CLAIM IS MADE TO THE EXCLUSIVE RIGHT TO USE "NEW YORK", APART FROM THE MARK AS SHOWN.

THE MARK IDENTIFIES A PARTICULAR LIVING INDIVIDUAL WHOSE WRITTEN CONSENT IS OF RECORD.

INT. CL. 9/U.S. CLS. 21, 23, 26, 36 AND 38

FOR EYEWEAR, NAMELY, SUNGLASSES, EYEGLASS FRAMES AND EYEGLASS CASES.

FIRST USE 5-0-2001; IN COMMERCE 5-0-2001.

ELEMENTS CORRECTED
CITIZENSHIP

2,707,696. REG. 4-15-2003. TELKONET, INC. (UTAH CORPORATION) 10200 INNOVATION DRIVE, SUITE 300, MILWAUKEE, WI, 53226, SN 76-223,084. FILED 3-12-2001. PRINCIPAL REGISTER.

TELKONET

INT. CL. 9/U.S. CLS. 21, 23, 26, 36 AND 38

FOR APPARATUS FOR PROVIDING TELECOMMUNICATIONS CONNECTIONS TO A GLOBAL COMPUTER NETWORK VIA ELECTRICAL UTILITY SERVICE LINES, NAMELY, MODEMS, GATEWAYS, BRIDGES, ROUTERS, ISOLATION FILTERS, VOICE-OVER-INTERNET-PROTOCOL SWITCHES, VOICE-OVER-INTERNET-PROTOCOL HANDSETS, TEST SIGNAL GENERATORS, TEST SIGNAL RECEIVERS; AND COMPUTER SOFTWARE FOR USE IN ACCESSING, OPERATING, AND DIAGNOSING MODEMS, ROUTERS, VOICE-OVER-INTERNET-PROTOCOL SWITCHES, VOICE-OVER-INTERNET-PROTOCOL HANDSETS, TEST SIGNAL GENERATORS, AND TEST SIGNAL RECEIVERS.

FIRST USE 10-0-1999; IN COMMERCE 9-0-2001.

INT. CL. 38/U.S. CLS. 100, 101 AND 104

FOR PROVIDING TELECOMMUNICATIONS CONNECTIONS TO A GLOBAL COMPUTER NETWORK VIA ELECTRICAL UTILITY SERVICE LINES; PROVIDING MULTIPLE-USER ACCESS TO GLOBAL COMPUTER INFORMATION NETWORK; COMMUNICATIONS SERVICES, NAMELY TELEPHONE COMMUNICATIONS SERVICES.

FIRST USE 10-0-1999; IN COMMERCE 10-0-1999.

ELEMENTS CORRECTED
CITIZENSHIP

2,742,864. REG. 7-29-2003. ITRON, INC. (WASHINGTON CORPORATION) 2111 NORTH MOLTER ROAD, LIBERTY LAKE, WA, 99019, SN 76-082,666. FILED 7-3-2000. PRINCIPAL REGISTER.

SENTINEL

INT. CL. 9/U.S. CLS. 21, 23, 26, 36 AND 38

FOR UTILITY METERS FOR ELECTRICITY [GAS, WATER AND THERMAL ENERGY].

FIRST USE 3-7-2002; IN COMMERCE 3-7-2002.

INT. CL. 38/U.S. CLS. 100, 101 AND 104

FOR TELECOMMUNICATIONS SERVICES, NAMELY, ELECTRONIC TRANSMISSION OF DATA RELATED TO REMOTE READING OF METERS MEASURING USE AND TRANSMITTAL OF ELECTRICITY [GAS, WATER AND THERMAL ENERGY].

FIRST USE 3-7-2002; IN COMMERCE 3-7-2002.

ELEMENTS AMENDED
GOODS/SERVICES
OWNER ADDRESS

2,831,285. REG. 4-13-2004. HOLLYWOOD STOCK EXCHANGE, LLC (DELAWARE LIMITED LIABILITY COMPANY) 110 EAST 59TH STREET, NEW YORK, NY, 10022, SN 76-383,407. FILED 3-14-2002. PRINCIPAL REGISTER.

MOVIE MOGUL

INT. CL. 41/U.S. CLS. 100, 101 AND 107

FOR EDUCATION AND ENTERTAINMENT SERVICES IN THE NATURE OF A SIMULATED SECURITIES GAME ACCESSIBLE THROUGH A GLOBAL COMPUTER INFORMATION NETWORK FOR THE TRANSFER AND DISSEMINATION OF A WIDE RANGE OF INFORMATION .

FIRST USE 2-18-2002; IN COMMERCE 2-18-2002.

ELEMENTS CORRECTED
ENTITY

2,841,272. REG. 5-11-2004. DELTA DOCTORS GROUP PRODUCTS, LLC (MICHIGAN LIMITED LIABILITY COMPANY) 2153 WEALTHY ST SE SUITE 318, GRAND RAPIDS, MI, 49506. SN 76-460,259. FILED 10-16-2002. PRINCIPAL REGISTER.

DELTA DOCTORS GROUP

INT. CL. 5/U.S. CLS. 6, 18, 44, 46, 51 AND 52

FOR NUTRITIONAL SUPPLEMENTS.

FIRST USE 11-0-2001; IN COMMERCE 8-0-2002.

ELEMENTS CORRECTED
OWNER NAME
ENTITY

2,851,232. REG. 6-8-2004. BOWLAND STONE LIMITED (UNITED KINGDOM PRIVATE LIMITED COMPANY) 72 LAIRGATE, BEVERLEY, EAST YORKSHIRE, HU17 8EU, UNITED KINGDOM., SN 76-204,670. FILED 2-2-2001. PRINCIPAL REGISTER.

BOWLAND

OWNER OF UNITED KINGDOM REG. NO. 2050603, DATED 9-20-1996, EXPIRES 1-9-2006. SEC. 2(F).

INT. CL. 19/U.S. CLS. 1, 12, 33 AND 50

FOR NON-METALLIC BUILDING MATERIALS, NAMELY, [SLATE, BRICK,] COBBLE STONE, STONE, AGGREGATE, OR CEMENT PAVING, CLADDING, EDGING OR COPING; FENCING MATERIALS, NAMELY, [TIMBER, NON-METAL WIRE, PLASTIC,] STONE, CEMENT OR AGGREGATE FENCING; NATURAL BUILDING STONE, SAND, STONE CHIPPINGS, GRAVEL, AGGREGATES, CAST STONE; [NON-METALLIC GARDEN LANDSCAPING MATERIALS, NAMELY, PRECAST CONCRETE PRODUCTS IN THE NATURE OF STATUES, BIRDBATHS, AND PLANTERS;] WALLING AND FENCING PRODUCTS OF STONE, [TIMBER,] CONCRETE [AND PLASTIC, NAMELY, BRICKS, POSTS, BALUSTRADING, PLANKS OR PREFABRICATED SECTIONS; TIMBER PRODUCTS, NAMELY, TRELLISES, ARCHES, PERGOLAS, BIRD FEEDING TABLES; DECKING, PRE-FABRICATED GARDEN BUILDINGS MADE OF WOOD AND OTHER NON-METALLIC MATERIALS; PERGOLAS; WOODEN BIRD TABLES AND BIRD FEEDERS, TROUGHS IN THE NATURE OF CONCRETE BIRD BATHS;] TILES, NAMELY, PAVEMENT AND PAVING TILES [; CERAMIC TILES].

FIRST USE 4-0-1993; IN COMMERCE 1-0-1994.

ELEMENTS CORRECTED
ENTITY

2,889,699. REG. 9-28-2004. LIFETIME PRODUCTS INC. (UTAH CORPORATION) FREEPORT CENTER, BUILDING D-11, CLEARFIELD, UT, 84016, SN 76-401,384. FILED 4-29-2002. PRINCIPAL REGISTER.

JUMPING JACK

INT. CL. 12/U.S. CLS. 19, 21, 23, 31, 35 AND 44

FOR UTILITY AND CAMPING TRAILERS.

FIRST USE 6-0-2003; IN COMMERCE 6-0-2003.

INT. CL. 22/U.S. CLS. 1, 2, 7, 19, 22, 42 AND 50

FOR TENTS.
FIRST USE 6-0-2003; IN COMMERCE 6-0-2003.

ELEMENTS CORRECTED
ENTITY

FOR OUTDOOR POWER EQUIPMENT, NAMELY
LAWN MOWERS.
FIRST USE 5-15-2002; IN COMMERCE 5-15-2002.

ELEMENTS AMENDED
MARK

2,940,605. REG. 4-12-2005. TRACY STERN, INC. (NEW YORK CORPORATION) 530 EAST 76TH STREET #28 AHK, NEW YORK, NY, 10021, SN 76-525,007. FILED 6-23-2003. PRINCIPAL REGISTER.

TRACY STERN SALONTEA

NO CLAIM IS MADE TO THE EXCLUSIVE RIGHT TO USE "SALON TEA", APART FROM THE MARK AS SHOWN. THE NAME "TRACY STERN" IDENTIFIES A LIVING INDIVIDUAL WHOSE CONSENT IS OF RECORD.

INT. CL. 30/U.S. CL. 46
FOR TEA.
FIRST USE 8-1-2003; IN COMMERCE 8-1-2003.

ELEMENTS CORRECTED
OWNER NAME

2,948,572. REG. 5-10-2005. FOCUS SURGERY, INC. (DELAWARE CORPORATION) 3940 PENDLETON WAY, INDIANAPOLIS, IN, 46226. SN 76-279,018. FILED 7-2-2001. PRINCIPAL REGISTER.

RIM

THE MARK CONSISTS OF STANDARD CHARACTERS WITHOUT CLAIM TO ANY PARTICULAR FONT, STYLE, SIZE, OR COLOR.

INT. CL. 10/U.S. CLS. 26, 39 AND 44
FOR IMAGING MEASUREMENT SOFTWARE SOLD AS AN INTEGRAL SAFETY COMPONENT OF ULTRASOUND APPARATUS USED IN THE TREATMENT OF PROSTATE CONDITIONS.
FIRST USE 9-15-2001; IN COMMERCE 9-15-2001.

ELEMENTS CORRECTED
MARK

2,952,318. REG. 5-17-2005. ARIENS COMPANY (WISCONSIN CORPORATION) 655 WEST RYAN STREET, BRILLION, WI, 54110, SN 76-408,794. FILED 5-15-2002. PRINCIPAL REGISTER.

LIFTMASTER

THE MARK CONSISTS OF STANDARD CHARACTERS WITHOUT CLAIM TO ANY PARTICULAR FONT, STYLE, SIZE, OR COLOR.
INT. CL. 7/U.S. CLS. 13, 19, 21, 23, 31, 34 AND 35

2,958,011. REG. 5-31-2005. BIO CREATIVE ENTERPRISES, INC. (NEVADA CORPORATION) 2710 TEMPLE AVENUE, LONG BEACH, CA, 90806, SN 78-221,379. FILED 3-4-2003. PRINCIPAL REGISTER.

PEDI SATION

THE MARK CONSISTS OF STANDARD CHARACTERS WITHOUT CLAIM TO ANY PARTICULAR FONT, STYLE, SIZE, OR COLOR.

NO CLAIM IS MADE TO THE EXCLUSIVE RIGHT TO USE PEDI, APART FROM THE MARK AS SHOWN.
INT. CL. 3/U.S. CLS. 1, 4, 6, 50, 51 AND 52
FOR FOOT LOTION, FOOT SOAK, AND FOOT SCRUB CREAM.
FIRST USE 2-28-2002; IN COMMERCE 2-28-2002.

ELEMENTS AMENDED
MARK

2,976,209. REG. 7-26-2005. AMERICAN SOCCER COMPANY, INC. (CALIFORNIA CORPORATION) 726 E. ANAHEIM STREET, WILMINGTON, CA, 90744, SN 78-438,623. FILED 6-21-2004. PRINCIPAL REGISTER.

COOLTEC

THE MARK CONSISTS OF STANDARD CHARACTERS WITHOUT CLAIM TO ANY PARTICULAR FONT, STYLE, SIZE, OR COLOR.

INT. CL. 25/U.S. CLS. 22 AND 39
FOR SOCCER UNIFORMS.
FIRST USE 11-30-2003; IN COMMERCE 11-30-2003.

ELEMENTS AMENDED
MARK

2,983,337. REG. 8-9-2005. TELKONET, INC. (UTAH CORPORATION) 10200 INNOVATION DRIVE, SUITE 300, MILWAUKEE, WI, 53226, SN 78-433,449. FILED 6-10-2004. PRINCIPAL REGISTER.



THE MARK CONSISTS OF THE DESIGN CONSISTS OF A DIAMOND SHAPE COMPOSED OF THREE SQUARES FORMING THE DIAGONAL SIDE FROM TOP CORNER TO RIGHT CORNER, A SQUARE IN THE CENTER AND THE REMAINING THREE SIDES IN A SOLID C SHAPE. INT. CL. 38/U.S. CLS. 100, 101 AND 104

FOR PROVIDING TELECOMMUNICATIONS CONNECTIONS TO A GLOBAL COMPUTER NETWORK VIA ELECTRICAL UTILITY SERVICE LINES; PROVIDING MULTIPLE-USER ACCESS TO A GLOBAL COMPUTER INFORMATION NETWORK; COMMUNICATIONS SERVICES, NAMELY, TELEPHONE COMMUNICATIONS SERVICES.

FIRST USE 5-17-2004; IN COMMERCE 5-17-2004.

ELEMENTS CORRECTED
CITIZENSHIP

3,010,096. REG. 11-1-2005. SUNRISE SENIOR LIVING, INC. (DELAWARE CORPORATION) 7902 WESTPARK DRIVE, MCLEAN, VA, 22102, SN 76-576,886. FILED 2-23-2004. PRINCIPAL REGISTER.



OWNER OF U.S. REG. NOS. 1,233,106, 2,850,729 AND OTHERS.

NO CLAIM IS MADE TO THE EXCLUSIVE RIGHT TO USE SENIOR LIVING, APART FROM THE MARK AS SHOWN.

INT. CL. 35/U.S. CLS. 100, 101 AND 102

FOR MANAGEMENT AND ADMINISTRATION OF RETIREMENT, INDEPENDENT LIVING, ASSISTED LIVING, SKILLED NURSING; NURSING HOME AND LONG TERM CARE FACILITIES FOR OTHERS.

FIRST USE 5-30-2003; IN COMMERCE 5-30-2003.

INT. CL. 43/U.S. CLS. 100 AND 101

FOR RETIREMENT HOMES; PROVIDING INDEPENDENT LIVING, ASSISTED LIVING, AND LONG TERM CARE FACILITIES AND SERVICES, NAMELY RESPITE CARE AND ELDER CARE DAY CARE SERVICES; HOME CARE AND ADULT CARE IN THE NATURE OF MEAL PREPARATION.

FIRST USE 5-30-2003; IN COMMERCE 5-30-2003.

INT. CL. 44/U.S. CLS. 100 AND 101

FOR SKILLED NURSING CARE; NURSING HOMES; HOME NURSING AID SERVICES, NAMELY, PREPARATION AND DISPENSING OF MEDICATIONS; HOSPICE SERVICES; ALZHEIMER'S AND DEMENTIA CARE, MEDICAL CARE AND HEALTH CARE, AND HOME HEALTH CARE.

FIRST USE 5-30-2003; IN COMMERCE 5-30-2003.

INT. CL. 45/U.S. CLS. 100 AND 101

FOR PERSONAL CARE ASSISTANCE OF ACTIVITIES OF DAILY LIVING, SUCH AS PERSONAL GROOMING, INCONTINENCE CARE, COMPANIONSHIP, AND HOME MANAGEMENT; PROVIDING PATIENT ADVOCATE SERVICES TO PATIENTS IN INDEPENDENT LIVING, ASSISTED LIVING, AND LONG TERM CARE FACILITIES.

FIRST USE 5-30-2003; IN COMMERCE 5-30-2003.

ELEMENTS AMENDED
MARK

2,987,474. REG. 8-23-2005. DAIGH COMPANY, INC (GEORGIA CORPORATION) 2393 CANTON HWY SUITE 400, CUMMING, GA, 30040, SN 78-417,174. FILED 5-12-2004. PRINCIPAL REGISTER.

Dā-mite

THE MARK CONSISTS OF STANDARD CHARACTERS WITHOUT CLAIM TO ANY PARTICULAR FONT, STYLE, SIZE, OR COLOR.

INT. CL. 19/U.S. CLS. 1, 12, 33 AND 50

FOR ROCK SPLITTING MORTAR.

FIRST USE 3-1-2004; IN COMMERCE 3-1-2004.

ELEMENTS CORRECTED
MARK

3,063,282. REG. 2-28-2006. WAKEFERN FOOD CORP. (NEW JERSEY CORPORATION) 5000 RIVERSIDE DRIVE, KEASBEY, NJ, 08832, SN 78-579,616. FILED 3-3-2005. PRINCIPAL REGISTER.



OWNER OF U.S. REG. NOS. 1,635,749, 2,467,334 AND OTHERS.

INT. CL. 35/U.S. CLS. 100, 101 AND 102

FOR WHOLESALE DISTRIBUTORSHIP SERVICES FOR GROCERY STORES; RETAIL SUPERMARKET SERVICES; ON-LINE SUPERMARKET SERVICES. FIRST USE 9-30-2002; IN COMMERCE 9-30-2002.

ELEMENTS AMENDED
MARK

3,075,951. REG. 4-4-2006. AMERICAN NATIONAL STANDARDS INSTITUTE, INCORPORATED (NEW YORK NON-PROFIT CORPORATION) 25 WEST 43RD STREET, 4TH FLOOR, NEW YORK, NY, 10036, SN 78-493,058. FILED 10-1-2004. PRINCIPAL REGISTER.

STANDARDS ACTION

THE MARK CONSISTS OF STANDARD CHARACTERS WITHOUT CLAIM TO ANY PARTICULAR FONT, STYLE, SIZE, OR COLOR.

OWNER OF U.S. REG. NO. 1,252,931.
SEC. 2(F).
INT. CL. 16/U.S. CLS. 2, 5, 22, 23, 29, 37, 38 AND 50
FOR NEWSLETTERS CONTAINING INFORMATION ON NEWLY ADOPTED AND PROPOSED ENGINEERING AND INDUSTRIAL STANDARDS IN VARIOUS FIELDS, SUCH AS THE ELECTRICAL, MINING, MECHANICAL, BUILDING, SAFETY, CONSUMER GOODS, NUCLEAR, PHOTOGRAPHIC AND TRAFFIC FIELDS.
FIRST USE 3-20-1970; IN COMMERCE 3-20-1970.

ELEMENTS CORRECTED
OWNER NAME
ENTITY

3,152,157. REG. 10-3-2006. TELKONET, INC. (UTAH CORPORATION) 10200 INNOVATION DRIVE, SUITE 300, MILWAUKEE, WI, 53226, SN 78-584,594. FILED 3-10-2005. PRINCIPAL REGISTER.

**TELKONET IWIRE
SYSTEM**

THE MARK CONSISTS OF STANDARD CHARACTERS WITHOUT CLAIM TO ANY PARTICULAR FONT, STYLE, SIZE, OR COLOR.

OWNER OF U.S. REG. NO. 2,707,696.
NO CLAIM IS MADE TO THE EXCLUSIVE RIGHT TO USE "IWIRE SYSTEMS", APART FROM THE MARK AS SHOWN.
INT. CL. 38/U.S. CLS. 100, 101 AND 104

FOR PROVIDING MODEMS TO DELIVER TELECOMMUNICATIONS CONNECTIONS, HIGH SPEED DATA AND INTERNET ACCESS VIA ELECTRICAL UTILITY SERVICE LINES; PROVIDING SIGNAL TRANSMISSION FOR ELECTRONIC COMMERCE VIA TELECOMMUNICATION SYSTEMS AND DATA COMMUNICATION SYSTEMS; PROVIDING MULTIPLE-USER ACCESS TO A GLOBAL COMPUTER INFORMATION NETWORK; COMMUNICATIONS SERVICES, NAMELY, TELEPHONE COMMUNICATIONS SERVICES.
FIRST USE 8-1-2005; IN COMMERCE 8-1-2005.

ELEMENTS CORRECTED
CITIZENSHIP

3,193,151. REG. 1-2-2007. NEW HAVEN MOVING EQUIPMENT CORP. (CONNECTICUT CORPORATION) 41 WASHINGTON STREET, EAST HAVEN, CT, 065120323, SN 78-815,493. FILED 2-15-2006. PRINCIPAL REGISTER.



NO CLAIM IS MADE TO THE EXCLUSIVE RIGHT TO USE "CRATE", APART FROM THE MARK AS SHOWN.
THE MARK CONSISTS OF "E CRATE" IN A RECTANGULAR BORDER WITH A STYLIZED "E".
INT. CL. 20/U.S. CLS. 2, 13, 22, 25, 32 AND 50
FOR PLASTIC STORAGE CONTAINERS FOR COMMERCIAL OR INDUSTRIAL USE .
FIRST USE 10-1-2004; IN COMMERCE 10-1-2004.

ELEMENTS CORRECTED
OWNER ADDRESS
CITIZENSHIP

3,212,951. REG. 2-27-2007. AMERICAN NATIONAL STANDARDS INSTITUTE, INCORPORATED (NEW YORK NON-PROFIT CORPORATION) 25 WEST 43RD STREET, NEW YORK, NY, 10036, SN 78-853,968. FILED 4-4-2006. PRINCIPAL REGISTER.



OWNER OF U.S. REG. NOS. 906,230, 3,045,033 AND OTHERS.
INT. CL. 16/U.S. CLS. 2, 5, 22, 23, 29, 37, 38 AND 50
FOR BOOKS AND PAMPHLETS ISSUED FROM TIME TO TIME RELATING TO ENGINEERING AND INDUSTRIAL STANDARDS IN VARIOUS FIELDS, SUCH AS THE ELECTRICAL, MINING, MECHANICAL, BUILDING, SAFETY, CONSUMER GOODS, NUCLEAR, PHOTOGRAPHIC, AND TRAFFIC FIELDS.
FIRST USE 3-31-2000; IN COMMERCE 3-31-2000.
INT. CL. 42/U.S. CLS. 100 AND 101

FOR PROVIDING A WEBSITE FEATURING INFORMATION RELATING TO ENGINEERING AND INDUSTRIAL STANDARDS.
FIRST USE 3-31-2000; IN COMMERCE 3-31-2000.

3,373,339. REG. 1-22-2008. CELRUN CO., LTD. (REPUBLIC OF KOREA LIMITED COMPANY) 2ND FLOOR, 1412-8, YONGBONG-DONG, BUK-GU, GWANGJU, 500-846, REPUBLIC OF KOREA., SN 79-037,014. FILED 2-7-2007. PRINCIPAL REGISTER.

ELEMENTS CORRECTED
OWNER NAME
ENTITY

3,224,742. REG. 4-3-2007. AMERICAN NATIONAL STANDARDS INSTITUTE, INCORPORATED (NEW YORK NON-PROFIT CORPORATION) 25 WEST 43RD STREET, NEW YORK, NY, 10036, SN 78-854,009. FILED 4-4-2006. PRINCIPAL REGISTER.



OWNER OF U.S. REG. NOS. 906,230, 3,045,033 AND OTHERS.

AS TO "AMERICAN NATIONAL STANDARDS INSTITUTE".

INT. CL. 16/U.S. CLS. 2, 5, 22, 23, 29, 37, 38 AND 50

FOR BOOKS AND PAMPHLETS ISSUED FROM TIME TO TIME RELATING TO ENGINEERING AND INDUSTRIAL STANDARDS IN VARIOUS FIELDS, SUCH AS THE ELECTRICAL, MINING, MECHANICAL, BUILDING, SAFETY, CONSUMER GOODS, NUCLEAR, PHOTOGRAPHIC, AND TRAFFIC FIELDS.

FIRST USE 3-31-2000; IN COMMERCE 3-31-2000.

INT. CL. 42/U.S. CLS. 100 AND 101

FOR PROVIDING A WEBSITE FEATURING INFORMATION RELATING TO ENGINEERING AND INDUSTRIAL STANDARDS.

FIRST USE 3-31-2000; IN COMMERCE 3-31-2000.

ELEMENTS CORRECTED
ENTITY

3,349,572. REG. 12-4-2007. H-D MICHIGAN, LLC (MICHIGAN LIMITED LIABILITY COMPANY) 315 W. HURON STREET, SUITE 400, ANN ARBOR, MI, 48103, SN 78-647,069. FILED 6-9-2005. PRINCIPAL REGISTER.

SCREAMIN' EAGLE DESTROYER

THE MARK CONSISTS OF STANDARD CHARACTERS WITHOUT CLAIM TO ANY PARTICULAR FONT, STYLE, SIZE, OR COLOR.

OWNER OF U.S. REG. NO. 1,345,492.

INT. CL. 12/U.S. CLS. 19, 21, 23, 31, 35 AND 44

FOR MOTORCYCLES AND STRUCTURAL PARTS THEREFOR, * EXCLUDING TIRES *.

FIRST USE 7-0-2005; IN COMMERCE 7-0-2005.

ELEMENTS AMENDED
CITIZENSHIP
GOODS/SERVICES

CelrunTV

THE MARK CONSISTS OF STANDARD CHARACTERS WITHOUT CLAIM TO ANY PARTICULAR FONT, STYLE, SIZE, OR COLOR.

PRIORITY DATE OF 1-24-2007 IS CLAIMED.

OWNER OF INTERNATIONAL REGISTRATION 0920290 DATED 2-7-2007, EXPIRES 2-7-2017.

INT. CL. 9/U.S. CLS. 21, 23, 26, 36 AND 38

FOR COMPUTER SERVERS FOR CONTENTS MANAGEMENT IN THE FIELD OF INTERNET PROTOCOL TELEVISION (IPTV) BROADCASTING; COMPUTER SERVERS FOR WRITINGS MANAGEMENT IN THE FIELD OF INTERNET PROTOCOL TELEVISION (IPTV) BROADCASTING; COMPUTER SERVERS FOR RESOURCE MANAGEMENT OF COMPUTER HARDWARE SYSTEMS IN THE FIELD OF INTERNET PROTOCOL TELEVISION (IPTV) BROADCASTING; COMPUTER SERVERS FOR CUSTOMER DATABASE MANAGEMENT IN THE FIELD OF IPTV BROADCASTING; COMPUTER SERVERS FOR CUSTOMER BILLING MANAGEMENT IN THE FIELD OF IPTV BROADCASTING; COMPUTER SERVERS FOR THE MANAGEMENT OF SERVICES THAT ARE PROVIDED THROUGH THE IPTV BROADCASTING, NAMELY, PROVISION OF CONTENTS IN REAL TIME, PUSHED OR VIDEO-ON-DEMAND FORM, RESERVATION OF PROVISION OF CONTENTS, AND RECORDING OF CONTENTS; COMPUTER SERVERS FOR SYSTEMS MANAGEMENT IN THE FIELD OF IPTV BROADCASTING; COMPUTER SERVERS FOR NETWORK ACCESS MANAGEMENT OF SET TOP BOXES IN THE FIELD OF IPTV BROADCASTING, * NAMELY, COMPUTERS USED FOR SET TOP BOX INTERFACE FOR THE CONSTRUCTION OF IPTV BROADCASTING SERVICES *; COMPUTER SERVERS FOR PROVIDING INTERFACE AMONG SERVICES IN THE FIELD OF INTERNET PROTOCOL TELEVISION (IPTV) BROADCASTING, NAMELY, COMPUTER SERVERS FOR PROVIDING MEANS FOR LINKING AND MOVING AMONG SERVICES OF IPTV BROADCASTING; COMPUTER SERVERS FOR PROVIDING COMMON SERVICE IN THE FIELD OF INTERNET PROTOCOL TELEVISION (IPTV) BROADCASTING, NAMELY, COMPUTER SERVERS FOR PROVIDING SERVICE COMMONLY APPLIED TO IPTV BROADCASTING SERVICES; GATEWAY ROUTERS IN THE NATURE OF COMPUTER CONTROL HARDWARE FOR THE CONSTRUCTION OF IPTV BROADCASTING SERVICE; [COMPUTER SERVERS FOR THE INTEGRATION OF TEXT, AUDIO, GRAPHICS, STILL IMAGE AND MOVING PICTURES INTO AN INTERACTIVE DELIVERY FOR MULTIMEDIA APPLICATIONS IN THE FIELD OF IPTV BROADCASTING;] COMPUTER HARDWARE [AND COMPUTER SOFTWARE] FOR THE MANAGEMENT OF THE TRANSMISSION OF CONTENTS IN THE FIELD OF IPTV BROADCASTING; SET TOP BOXES; RECEIVERS FOR DIGITALLY BROADCAST AUDIO AND VIDEO; RECEIVERS FOR DIGITALLY BROADCAST IPTV AUDIO AND VIDEO.

FIRST USE ; IN COMMERCE .

INT. CL. 38/U.S. CLS. 100, 101 AND 104

FOR DIGITAL TELEVISION BROADCASTING; BROADCASTING SERVICES AND PROVISION OF TELECOMMUNICATION ACCESS TO FILMS AND TV PROGRAMMES PROVIDED VIA A VIDEO-ON-DEMAND SERVICE; INTERNET PROTOCOL TELEVISION (IPTV) BROADCASTING; INTERNET TELEPHONY SERVICE; AUDIO AND VIDEO TELECONFERENCING SERVICES; DATA COMMUNICATION SERVICES, NAMELY, ELECTRONIC TRANSMISSION OF DATA AND DOCUMENTS BETWEEN SERVER AND CLIENT; COMPUTER AIDED TRANSMISSION OF MAILS AND MESSAGES; INTERNET AIDED TRANSMISSION OF MAILS AND MESSAGES; INTERNET AIDED TRANSMISSION OF MOVING PICTURES; INTERNET BROADCASTING; SATELLITE COMMUNICATION SERVICES; PROVIDING MULTIPLE USER DIAL-UP AND DEDICATED ACCESS TO THE INTERNET.
FIRST USE ; IN COMMERCE .

ELEMENTS CORRECTED
GOODS/SERVICES

3,479,698. REG. 8-5-2008. CONVERTIBLE CASTLES, INC., THE (MASSACHUSETTS CORPORATION) 308 EAST MAIN STREET, NORTON, MA, 02766, SN 77-328,165. FILED 11-13-2007. PRINCIPAL REGISTER.



OWNER OF U.S. REG. NOS. 2,423,282 AND 2,611,313.
NO CLAIM IS MADE TO THE EXCLUSIVE RIGHT TO USE "FURNITURE", APART FROM THE MARK AS SHOWN.

THE COLOR(S) BLACK, GOLD, YELLOW, AND WHITE IS/ARE CLAIMED AS A FEATURE OF THE MARK.

THE MARK CONSISTS OF WHITE RECTANGLE WITH BLACK BORDER AND NARROW YELLOW BORDER CONTAINING WORDS BERNIE&PHYL'S IN BLACK LETTERS, "FURNITURE" IN GOLD LETTERS INSIDE SMALLER GOLD BORDERED WHITE RECTANGLE, TWO HORIZONTAL GOLD LINES FLANKING GOLD RECTANGLE, AND BELOW, ON WHITE BACKGROUND, WORDS "QUALITY, COMFORT & PRICE"... "THAT'S NICE"! WITH "THAT'S NICE"! IN ITALICS .

INT. CL. 35/U.S. CLS. 100, 101 AND 102

FOR RETAIL FURNITURE STORES; RETAIL STORE SERVICES FEATURING FURNITURE, RUGS, AND HOME ACCESSORIES.

FIRST USE 6-6-2007; IN COMMERCE 6-6-2007.

ELEMENTS CORRECTED
OWNER NAME

3,567,832. REG. 1-27-2009. LINDA ENTERPRISES LIMITED (UNITED KINGDOM LIMITED COMPANY) 1 SOHO SQUARE, LONDON W1D 3BQ, UNITED KINGDOM., SN 79-039,245. FILED 3-27-2007. PRINCIPAL REGISTER.



PRIORITY DATE OF 3-20-2007 IS CLAIMED.
OWNER OF INTERNATIONAL REGISTRATION 0926005 DATED 3-27-2007, EXPIRES 3-27-2017.

THE NAME "LINDA MCCARTNEY" DOES NOT IDENTIFY A LIVING INDIVIDUAL.

INT. CL. 29/U.S. CL. 46

FOR PREPARED VEGETARIAN FOODS BEING CHILLED OR FROZEN, NAMELY, ENTREES AND SIDE DISHES CONSISTING OF VEGETABLES WITH OR WITHOUT CHEESE; FOOD PREPARATIONS MADE FROM VEGETABLE MATTER, NAMELY, PROCESSED FOODS CONSISTING OF MEAT SUBSTITUTES, VEGETARIAN SAUSAGES, VEGETARIAN QUARTER POUNDERS.

FIRST USE ; IN COMMERCE .

INT. CL. 30/U.S. CL. 46

FOR PREPARATIONS MADE FROM CEREALS, NAMELY, PIZZA; PIES, NAMELY, PIES CONTAINING VEGETARIAN MINCE AND CREAMY VEGETABLE PIES; PASTA, PREPARED FOODS COMPRISING PASTA, NAMELY, LASAGNA, MACARONI AND CHEESE, SPICY PEANUT PASTA, BUTTERNUT SQUASH RAVIOLI; FROZEN ENTREES AND SIDE DISHES CONSISTING OF PASTA OR RICE WITH OR WITHOUT VEGETABLES AND WITH OR WITHOUT CHEESE; PREPARED FOODS COMPRISING RICE, NAMELY, [CHILI CON CARNE, OR] VEGETARIAN CHILI * NON * [CON] CARNE.

FIRST USE ; IN COMMERCE .

ELEMENTS CORRECTED
GOODS/SERVICES
GOODS/SERVICES

3,570,559. REG. 2-3-2009. THE CHICAGO MULTI-CULTURAL DANCE CENTER, INC., HOME OF THE BRYANT BALLET (ILLINOIS NON-PROFIT CORPORATION) LOWER LEVEL, 47 WEST POLK STREET, CHICAGO, IL, 60605, SN 77-285,343. FILED 9-21-2007. PRINCIPAL REGISTER.

HIPLET

THE MARK CONSISTS OF STANDARD CHARACTERS WITHOUT CLAIM TO ANY PARTICULAR FONT, STYLE, SIZE, OR COLOR.

INT. CL. 41/U.S. CLS. 100, 101 AND 107

FOR ENTERTAINMENT SERVICES, NAMELY, PERFORMANCE AND CREATION OF DANCE CHOREOGRAPHY.

FIRST USE 6-14-2008; IN COMMERCE 6-14-2008.

ELEMENTS CORRECTED
OWNER NAME

3,578,757. REG. 2-24-2009. THE HAROLD GRINSPOON FOUNDATION (MASSACHUSETTS NON-PROFIT ORGANIZATION) 380 UNION STREET, WEST SPRINGFIELD, MA, 01089. SN 77-358,198. FILED 12-21-2007. PRINCIPAL REGISTER.



THE MARK CONSISTS OF THE WORDS "THE PJ LIBRARY" IN STYLIZED FORM.

INT. CL. 16/U.S. CLS. 2, 5, 22, 23, 29, 37, 38 AND 50

FOR PRINTED PRODUCTS, NAMELY, BOOKS AND BROCHURES IN THE FIELD OF JEWISH RELIGIOUS CONCEPTS.

FIRST USE 12-1-2005; IN COMMERCE 12-1-2005.

ELEMENTS AMENDED
MARK

3,691,500. REG. 10-6-2009. LIPOPHARMA THERAPEUTICS, S.L. (SPAIN SOCIEDAD LIMITADA) PARKBIT EDIFICIO 17, MOD. C-8 CARRETERA, DE VALDEMOSSA, KM 7, 4, PALMA DE MALLORCA 07121, SPAIN., SN 77-581,897. FILED 9-30-2008. PRINCIPAL REGISTER.



PRIORITY CLAIMED UNDER SEC. 44(D) ON ERP CMNTY TM OFC APPLICATION NO. 006800271, FILED 4-2-2008, REG. NO. 006800271, DATED 4-3-2009, EXPIRES 4-2-2018.

THE COLOR(S) GREEN IS/ARE CLAIMED AS A FEATURE OF THE MARK.

THE MARK CONSISTS OF THE WORD "MINERVAL" IN A STYLIZED GREEN FONT, WITH AN IMAGE OF A LEFT-FACING PROFILE OF A ROMAN HELMET IN THE COLOR GREEN.

INT. CL. 5/U.S. CLS. 6, 18, 44, 46, 51 AND 52

FOR PHARMACEUTICAL PREPARATIONS AND NUTRACEUTICALS FOR THE TREATMENT AND PREVENTION OF CANCER, OBESITY AND CARDIOVASCULAR DISEASES; DIETETIC SUBSTANCES ADAPTED FOR MEDICAL USE; FOOD SUPPLEMENTS.

ELEMENTS CORRECTED
OWNER NAME

3,691,501. REG. 10-6-2009. LIPOPHARMA THERAPEUTICS, S.L. (SPAIN SOCIEDAD LIMITADA) PARKBIT EDIFICIO 17, MOD. C-8 CARRETERA, DE VALDEMOSSA, KM 7, 4, PALMA DE MALLORCA 07121, SPAIN., SN 77-581,912. FILED 9-30-2008. PRINCIPAL REGISTER.



PRIORITY CLAIMED UNDER SEC. 44(D) ON ERP CMNTY TM OFC APPLICATION NO. 006800312, FILED 4-2-2008, REG. NO. 006800312, DATED 1-21-2009, EXPIRES 4-2-2018.

THE COLOR(S) GREEN, WHITE, BLACK, RED, PINK AND BROWN IS/ARE CLAIMED AS A FEATURE OF THE MARK.

THE MARK CONSISTS OF THE WORDS "CARDIONESA CARDIONAISE" IN A STYLIZED GREEN FONT, WITH AN IMAGE OF A CARTOON HEART WITH A SMILING FACE AND AN ARM HOLDING A SPOON. THE HEART IS RED WITH A BLACK OUTLINE, THE ARM IS BROWN WITH A WHITE HAND, THE EYEBROWS ARE PINK, AND THE SPOON IS BLACK. THE FACIAL FEATURES OF THE HEART ARE DRAWN IN THE COLOR BLACK.

INT. CL. 29/U.S. CL. 46

FOR EDIBLE OILS AND EDIBLE FATS.

INT. CL. 30/U.S. CL. 46

FOR MAYONNAISE.

ELEMENTS CORRECTED
OWNER NAME

3,699,418. REG. 10-20-2009. TELKONET, INC. (UTAH CORPORATION) 10200 INNOVATION DRIVE, SUITE 300, MILWAUKEE, WI, 53226, SN 77-192,855. FILED 5-30-2007. PRINCIPAL REGISTER.

TELKONET SMARTENERGY

THE MARK CONSISTS OF STANDARD CHARACTERS WITHOUT CLAIM TO ANY PARTICULAR FONT, STYLE, SIZE, OR COLOR.

INT. CL. 9/U.S. CLS. 21, 23, 26, 36 AND 38

FOR ELECTRONIC CONTROL DEVICES AND SYSTEMS FOR HEATING AND ENERGY MANAGEMENT, NAMELY, THERMOSTATS, SENSORS, AND CONTROLLERS.

FIRST USE 10-31-2006; IN COMMERCE 10-31-2006.

INT. CL. 37/U.S. CLS. 100, 103 AND 106

FOR INSTALLATION AND MAINTENANCE OF ENERGY EFFICIENT HEATING AND AIR CONDITIONING SYSTEMS.

FIRST USE 10-31-2006; IN COMMERCE 10-31-2006.

INT. CL. 42/U.S. CLS. 100 AND 101

FOR REMOTE MONITORING SERVICES OF HEATING, VENTILATING, AND AIR CONDITIONING APPARATUS.

FIRST USE 10-31-2006; IN COMMERCE 10-31-2006.

ELEMENTS CORRECTED
CITIZENSHIP

3,707,832. REG. 11-10-2009. STEPHENSON REAL ESTATE ADVISORS, INC. (TEXAS CORPORATION) 7412 BISHOP ROAD, PLANO, TX, 75204, SN 77-612,495. FILED 11-12-2008. PRINCIPAL REGISTER.

3,754,853. REG. 3-2-2010. DENKI KAGAKU KOGYO KABUSHIKI KAISHA (JAPAN CORPORATION) 1-1, NIHON-BASHI-MUROMACHI 2-CHOME., CHUO-KU; TOKYO 103-8338, JAPAN., SN 79-062,822. FILED 5-16-2008. PRINCIPAL REGISTER.

Retail Building Blocks

THE MARK CONSISTS OF STANDARD CHARACTERS WITHOUT CLAIM TO ANY PARTICULAR FONT, STYLE, SIZE, OR COLOR.

NO CLAIM IS MADE TO THE EXCLUSIVE RIGHT TO USE "RETAIL", APART FROM THE MARK AS SHOWN.

INT. CL. 36/U.S. CLS. 100, 101 AND 102
FOR REAL ESTATE CONSULTANCY.
FIRST USE 3-1-2008; IN COMMERCE 4-1-2008.

ELEMENTS CORRECTED
OWNER NAME

3,726,181. REG. 12-15-2009. THE ELDERS, INC. (DELAWARE CORPORATION) 312 SUTTER STREET, SUITE 200, SAN FRANCISCO, CA, 94108, SN 77-434,954. FILED 3-28-2008. PRINCIPAL REGISTER.

THE ELDERS

THE MARK CONSISTS OF STANDARD CHARACTERS WITHOUT CLAIM TO ANY PARTICULAR FONT, STYLE, SIZE, OR COLOR.

INT. CL. 42/U.S. CLS. 100 AND 101

FOR COMPUTER SERVICES, NAMELY, HOSTING AN ONLINE-COMMUNITY WEBSITE FEATURING INFORMATION REGARDING IMPORTANT GLOBAL ISSUES, NAMELY, HUMAN RIGHTS, WOMEN'S RIGHTS, HEALTHCARE AND DISEASE PREVENTION, SANITATION, DISASTER RELIEF, LITERACY, ENVIRONMENT AND NATURAL-RESOURCE CONSERVATION, CLIMATE CHANGE, AIR AND WATER POLLUTION, RENEWABLE ENERGY, LAND DEVELOPMENT AND RESIDENTIAL HOUSING, NUTRITION, PEACEFUL CONFLICT RESOLUTION AND CRIME AND TERRORISM PREVENTION; COMPUTER SERVICES, NAMELY, HOSTING ONLINE-WEB FACILITIES FOR OTHERS FOR ORGANIZING AND CONDUCTING ONLINE MEETINGS, GATHERINGS AND INTERACTIVE DISCUSSIONS * IN THE ABOVE-LISTED FIELDS. * .

FIRST USE 7-18-2007; IN COMMERCE 7-18-2007.

ELEMENTS AMENDED
GOODS/SERVICES

DENKA

PRIORITY DATE OF 2-25-2008 IS CLAIMED.

OWNER OF INTERNATIONAL REGISTRATION 0986827 DATED 5-16-2008, EXPIRES 5-16-2018.

OWNER OF U.S. REG. NOS. 896,712, 2,790,805 AND OTHERS.

THE MARK CONSISTS OF THE WORD "DENKA" IN A STYLIZED FONT.

THE WORDING "DENKA" HAS NO MEANING IN A FOREIGN LANGUAGE.

INT. CL. 1/U.S. CLS. 1

FOR CHEMICALS FOR USE IN INDUSTRY AND SCIENCE; CHEMICALS FOR USE IN INDUSTRY AND SCIENCE, NAMELY, BORON, ALUMINA, ALUMINUM OXIDES, CALCIUM CARBIDE, ALUMINUM AND SILICON CARBIDE, ACETYLENE BLACK, VINYL CHLORIDE, VINYL ACETATE ALCOHOL, ACETIC ACID, VINYL ACETATE, ETHYL BENZENE, SILICON NITRIDE; CHEMICALS FOR INDUSTRIAL PURPOSES, NAMELY, CARBONS, ORGANIC ACIDS AND THEIR SALTS AND ESTERS; ALIPHATICS; ORGANIC HALOGENIDES; ALCOHOLS, NAMELY, BENZYL ALCOHOL OR ALCOHOL FOR USE IN THE MANUFACTURE OF PAINTS AND OTHER COATINGS; NITROGEN COMPOUNDS; CHEMICAL AGENTS, NAMELY, CEMENT SET ACCELERATORS, CEMENT BLENDING AGENTS, CHEMICAL ADDITIVES FOR INFLATING ETTRINGITE FORMATION IN CEMENT, HIGH-PERFORMANCE CHEMICAL ADDITIVES FOR INFLATING ETTRINGITE AND LIME COMPOUND FORMATION IN CEMENTS, CHEMICAL ADDITIVES FOR CEMENTITIOUS GROUT TO PREVENT SHRINKAGE, CHEMICAL ADDITIVES FOR REDUCING THE HARDENING TIME FOR CEMENTITIOUS MATERIALS, SPRAYABLE WATER-PROOFING CHEMICAL COMPOSITIONS FOR USE ON CEMENT, CEMENT REPAIRING PREPARATIONS IN THE NATURE OF SILICON RESINS, DUST SUPPRESSING CHEMICALS FOR USE ON CEMENT, CHEMICAL ADDITIVES FOR CEMENT FOR INCREASING HARDNESS; CARBON BLACK FOR INDUSTRIAL PURPOSES, PLANT GROWTH REGULATING PREPARATIONS; ADHESIVES, OTHER THAN FOR STATIONERY OR HOUSEHOLD PURPOSES; UNPROCESSED PLASTICS BEING PLASTICS IN PRIMARY FORM [FERTILIZERS] .

FIRST USE ; IN COMMERCE .

INT. CL. 9/U.S. CLS. 21, 23, 26, 36 AND 38

FOR ELECTRONIC CIRCUITS, INTEGRATED CIRCUITS, PRINTED CIRCUIT BOARDS, SUBSTRATES FOR ELECTRONIC CIRCUITS IN THE NATURE OF CIRCUIT BOARDS, ALUMINUM SUBSTRATES FOR ELECTRONIC CIRCUITS IN THE NATURE OF CIRCUIT BOARDS, CERAMIC SUBSTRATES FOR ELECTRONIC CIRCUITS IN THE NATURE OF CIRCUIT BOARDS, ALUMINUM NITRIDE SUBSTRATES FOR ELECTRONIC CIRCUITS IN THE NATURE OF CIRCUIT BOARDS, SILICON NITRIDE SUBSTRATES FOR ELECTRONIC CIRCUITS IN THE NATURE OF CIRCUIT BOARDS; RADIATION SHIELDING SHEETS FOR ELECTRONIC CIRCUITS; RADIATION SHIELDING SPACERS FOR ELECTRONIC CIRCUITS; ELECTRON EMITTERS FOR OPERATING ELECTRON MICROSCOPES.

INT. CL. 17/U.S. CLS. 1, 5, 12, 13, 35 AND 50

FOR RAW OR SEMI-WORKED RUBBER, SYNTHETIC RUBBER; SEMI-PROCESSED PLASTICS, SEMI-PROCESSED PLASTIC IN THE FORM OF FILMS, SHEETS, TUBES, BARS, OR RODS; CHEMICAL FIBER THREAD AND YARN NOT FOR TEXTILE USE; ASBESTOS; ROCK WOOL; SLAG WOOL FOR USE AS A BUILDING INSULATOR AND AS AN INSULATOR FOR INSIDE OF CAR MUFFLERS; ELECTRICAL INSULATING MATERIALS; PLASTIC CARRIER TAPES AND ADHESIVE COVER TAPES AS CUSHIONING MATERIALS FOR THE TRANSPORT OF ELECTRONIC PARTS.

INT. CL. 19/U.S. CLS. 1, 12, 33 AND 50

FOR NON-METALLIC MINERALS FOR BUILDING OR CONSTRUCTION; CERAMIC BUILDING MATERIALS, NAMELY, MORTAR; BRICKS AND REFRACTORY CONSTRUCTION MATERIALS, NOT OF METAL; PLASTIC BUILDING MATERIALS AND SYNTHETIC BUILDING MATERIALS, NAMELY, PLASTIC DOWN SPOUTS, PLASTIC UNDERGROUND SEWER PIPES, PLASTIC U-SHAPED GUTTERS; CEMENT PRODUCTS, NAMELY, ALUMINA CEMENT, PORTLAND BLAST-FURNACE SLAG CEMENT, SILICA CEMENT, SLAG-LIME CEMENT, PORTLAND CEMENT, FLY ASH CEMENT; UNWORKED OR PARTLY WORKED NON-METALLIC MINERAL MATERIALS FOR BUILDING OR CONSTRUCTION, NAMELY, BOARDS AND POWDER OF INORGANIC FIBER EXCLUSIVE OF THOSE OF ASBESTOS, ALUMINA FIBER BOARDS, ALUMINA FIBER SHEETS, ALUMINA FIBER PIPES.

FIRST USE ; IN COMMERCE .

ELEMENTS CORRECTED
GOODS/SERVICES

3,763,384. REG. 3-23-2010. RECKITT BENCKISER S.A.R.L. (LUXEMBOURG COMPANY) 39 BOULEVARD JOSEPH II, L-1840 LUXEMBOURG, LUXEMBOURG., SN 79-066,355. FILED 1-30-2009. PRINCIPAL REGISTER.



PRIORITY DATE OF 10-28-2008 IS CLAIMED.
OWNER OF INTERNATIONAL REGISTRATION 0996278 DATED 1-30-2009, EXPIRES 1-30-2019.

OWNER OF U.S. REG. NOS. 3,542,059 AND 3,578,045.
THE COLOR(S) PINK AND WHITE IS/ARE CLAIMED AS A FEATURE OF THE MARK.

THE MARK CONSISTS OF A PINK TRIANGLE WITH ONE CURVED SIDE AND THE LOWERCASE LETTERS "RB" IN WHITE WITHIN THE TRIANGLE.

INT. CL. 1/U.S. CLS. 1

FOR CHEMICAL PRODUCTS FOR INDUSTRIAL PURPOSES; WATER SOFTENING PREPARATIONS; DESCALING PREPARATIONS FOR INDUSTRIAL PURPOSES; CHEMICAL PREPARATIONS FOR USE IN THE MANUFACTURE OF PROTECTIVE PREPARATIONS, NAMELY, PREPARATIONS FOR THE PREVENTION OF TARNISHING, WEAR, AND STAINING OF GLASSWARE, PORCELAIN, EARTHENWARE, CROCKERY AND OTHER KITCHENWARE; ALL AFOREMENTIONED GOODS WITH OR WITHOUT A DISINFECTIVE COMPONENT.

INT. CL. 3/U.S. CLS. 1, 4, 6, 50, 51 AND 52

FOR CLEANING, SCOURING AND ABRASIVE PREPARATIONS FOR HOUSEHOLD USE; BLEACHING PREPARATIONS FOR LAUNDRY USE; LAUNDRY PREPARATIONS AND LAUNDRY ADDITIVES, NAMELY, DETERGENTS, SOAPS, FABRIC SOFTENERS, STAIN REMOVING PREPARATIONS, PREWASH AND STAIN LOOSENING PREPARATIONS, STARCH, LAUNDRY BLUING; CARPET CLEANERS; POLISHING PREPARATIONS FOR KITCHEN AND GLASSWARE; PROTECTIVE PREPARATIONS SOLD AS A COMPONENT INGREDIENT IN PREPARATIONS FOR THE PREVENTION OF TARNISHING, WEAR, AND STAINING OF GLASSWARE, PORCELAIN, EARTHENWARE, CROCKERY AND OTHER KITCHENWARE; DECALCIFYING AND DESCALING PREPARATIONS FOR HOUSEHOLD USE; RUST REMOVERS; GREASE REMOVERS; DRAIN AND SINK UNBLOCKING PREPARATIONS; PREPARATIONS FOR PREVENTION OF LIMESCALE, RUST OR GREASE; NON-MEDICATED TOILETRIES; HAIR LOTIONS; NON-MEDICATED SKIN CARE PREPARATIONS; COSMETICS AND COSMETIC PREPARATIONS; COSMETIC CREAMS AND LOTIONS; MOISTURIZING CREAMS, LOTIONS AND GELS; EXFOLIANTS FOR SKIN; BLEACHING PREPARATIONS FOR PERSONAL USE; PREPARATIONS FOR SHAVING; DEPILATORY PREPARATIONS; DEPILATORY WAXES; PREPARATIONS, NAMELY, CREAMS, GELS AND MOUSSES, FOR USE BEFORE, DURING AND AFTER SHAVING; PERFUMES; ESSENTIAL OILS; PERFUMING PREPARATIONS FOR THE ATMOSPHERE, NAMELY, POTPOURRI, SCENTED OILS, PERFUME OILS, AND SACHETS; INCENSE AND INCENSE CONES.

INT. CL. 5/U.S. CLS. 6, 18, 44, 46, 51 AND 52

FOR PHARMACEUTICAL PREPARATIONS AND SUBSTANCES HAVING ANTI-INFLAMMATORY, ANTI-PYRETIC AND ANALGESIC PROPERTIES; MEDICATED BEVERAGES AND PREPARATIONS FOR MAKING SUCH BEVERAGES; MEDICATED CONFECTIONERY; MEDICATED SKIN CARE PREPARATIONS; ALL-PURPOSE DISINFECTANTS, OTHER THAN FOR LAYING OR ABSORBING DUST; DISINFECTANTS FOR HOUSEHOLD USE OR FOR HYGIENE OR SANITARY PURPOSES; ALL-PURPOSE SANITARY PREPARATIONS; ARTICLES, NAMELY SANITARY WIPES, CLOTHS, PADS, IMPREGNATED WITH AN ANTISEPTIC PRODUCT; ANTISEPTIC PREPARATIONS; ANTI-BACTERIAL CLEANING PREPARATIONS; ALL-PURPOSE DISINFECTING PREPARATIONS FOR HOUSEHOLD, COMMERCIAL AND INDUSTRIAL USE; GERMICIDES; INSECTICIDES; MITICIDES; INSECT REPELLENTS; PREPARATIONS FOR DESTROYING AND REPELLING VERMIN; FUNGICIDES; DEODORANTS FOR HOUSEHOLD USE; AIR FRESHENING PREPARATIONS; FABRIC DEODORIZERS AND REFRESHENERS.

INT. CL. 11/U.S. CLS. 13, 21, 23, 31 AND 34

FOR APPARATUS AND INSTRUMENTS, NAMELY ELECTRIC AND BATTERY OPERATED DISPENSING UNITS FOR SCENTING, PURIFYING OR FRESHENING THE ATMOSPHERE AND PARTS FOR ALL THE AFORESAID GOODS; ELECTRICAL POWERED AIR PURIFIERS FOR THE NEUTRALIZATION, REDUCTION OR CONTROL OF ALLERGENS; WATER DECALCIFYING AND DESCALING APPARATUS FOR DOMESTIC USE; WATER FILTERS; WATER SOFTENING APPARATUS AND INSTALLATIONS; FILTER CARTRIDGES FOR WATER PURIFICATION AND WATER SOFTENING FOR HOUSEHOLD USE; WATER TREATMENT FILTERS.

INT. CL. 35/U.S. CLS. 100, 101 AND 102

FOR PROVISION OF BUSINESS INFORMATION; ADVERTISING; BUSINESS MANAGEMENT; BUSINESS ADMINISTRATION; OFFICE FUNCTIONS; BUSINESS MARKETING SERVICES; COMMERCIAL AND INDUSTRIAL MANAGEMENT SERVICES; ORGANIZATION, OPERATION AND SUPERVISION OF LOYALTY AND INCENTIVE SCHEMES; RENTAL AND LEASING OF VENDING MACHINES; PROVIDING CONSUMER INFORMATION IN THE FIELDS OF FOOD AND COOKING, HOME CONSUMER PRODUCTS, PERSONAL CARE, HYGIENE AND HEALTHCARE CONSUMER PRODUCTS, HOME CARE, PERSONAL HEALTHCARE MANAGEMENT, AND ENVIRONMENTAL CONSERVATION; THE BRINGING TOGETHER FOR THE BENEFIT OF OTHERS OF A VARIETY OF CONSUMER GOODS ENABLING CUSTOMERS TO CONVENIENTLY VIEW AND PURCHASE THESE GOODS, NAMELY, BLEACHING PREPARATIONS AND OTHER SUBSTANCES FOR LAUNDRY USE, DISHWASHER PREPARATIONS, PREPARATIONS FOR REMOVING STAINS, CARPET

CLEANERS, SOAPS, DETERGENTS, DECALCIFYING AND DESCALING PREPARATIONS, LIMESCALE REMOVERS, RUST REMOVERS, FABRIC SOFTENERS, LAUNDRY ADDITIVES, WATER SOFTENING PREPARATIONS, GREASE REMOVERS, DRAIN AND SINK UNBLOCKING PREPARATIONS, PREPARATIONS FOR PREVENTION OF LIMESCALE, RUST OR GREASE, NON-MEDICATED TOILET PREPARATIONS, SKIN CARE PREPARATIONS, MEDICATED SKIN CARE PREPARATIONS, PREPARATIONS FOR TREATMENT OF ACNE, DEPILATORY PREPARATIONS, PHARMACEUTICAL PREPARATIONS, MEDICATED BEVERAGES AND CONFECTIONERY, SANITARY PREPARATIONS, ANTISEPTIC PREPARATIONS, ANTI-BACTERIAL PREPARATIONS, DISINFECTING PREPARATIONS, ARTICLES IMPREGNATED WITH A DISINFECTANT OR ANTI-BACTERIAL PRODUCT, ARTICLES IMPREGNATED WITH AN ANTISEPTIC PRODUCT, INSECTICIDES, INSECT REPELLENTS, PESTICIDES, RODENTICIDES, MITICIDES, PREPARATIONS FOR DESTROYING VERMIN, GERMICIDES, DEODORANTS NOT FOR PERSONAL USE, AIR FRESHENING PREPARATIONS, AIR FRESHENERS.

FIRST USE ; IN COMMERCE .
INT. CL. 36/U.S. CLS. 100, 101 AND 102

FOR FINANCIAL SPONSORSHIP OF ENTERTAINMENT, SPORTING AND CULTURAL ACTIVITIES; CHARITABLE FUND RAISING; FINANCING SERVICES; FINANCIAL ANALYSIS, FINANCIAL CONSULTANCY, EVALUATION, INFORMATION AND MANAGEMENT SERVICES; FISCAL ASSESSMENTS; INFORMATION SERVICES, NAMELY, PROVIDING INFORMATION RELATING TO FINANCIAL AFFAIRS AND MONETARY AFFAIRS.

INT. CL. 41/U.S. CLS. 100, 101 AND 107

FOR ORGANIZING SPORTING AND CULTURAL ACTIVITIES; PUBLICATION OF TEXTS, NAMELY, LEAFLETS, BOOKLETS AND MAGAZINES; ORGANIZATION OF EXHIBITIONS FOR CULTURAL OR EDUCATIONAL PURPOSES; ORGANIZING PRESENTATIONS OF WORKS OF VISUAL ART AND LITERATURE TO THE PUBLIC FOR CULTURAL OR EDUCATIONAL PURPOSES; ENTERTAINMENT INFORMATION SERVICES; * EXCLUDING RADIO AND TELEVISION BROADCASTING SERVICES *.

FIRST USE ; IN COMMERCE .

ELEMENTS CORRECTED
GOODS/SERVICES

3,781,349. REG. 4-27-2010. CAMURUS AB (SWEDEN CORPORATION) JÄGERSHILLSGATAN 15, SE-213 75 MALMÖ, SWEDEN., SN 79-068,634. FILED 3-26-2009. PRINCIPAL REGISTER.

EPISIL

THE MARK CONSISTS OF STANDARD CHARACTERS WITHOUT CLAIM TO ANY PARTICULAR FONT, STYLE, SIZE, OR COLOR.

PRIORITY DATE OF 10-9-2008 IS CLAIMED.
OWNER OF INTERNATIONAL REGISTRATION 1002282 DATED 3-26-2009, EXPIRES 3-26-2019.

THE WORDING "EPISIL" HAS NO MEANING IN A FOREIGN LANGUAGE.

INT. CL. 5/U.S. CLS. 6, 18, 44, 46, 51 AND 52

FOR PHARMACEUTICAL PREPARATIONS FOR * LOCAL TREATMENT OF PAIN ASSOCIATED WITH ORAL MUCOSITIS THAT IS ADMINISTERED THROUGH A DEVICE * [THE TREATMENT OF INFLAMMATORY AND INFECTIOUS DISEASES AND DISEASES IN THE ORAL CAVITY; VETERINARY PREPARATIONS FOR INFLAMMATORY AND INFECTIOUS DISEASES AND DISEASES IN THE ORAL CAVITY FOR PETS AND LIVESTOCK].

FIRST USE ; IN COMMERCE .
INT. CL. 42/U.S. CLS. 100 AND 101

FOR SCIENTIFIC AND TECHNOLOGICAL SERVICES AND RESEARCH AND DESIGN IN THE FIELD OF THE DEVELOPMENT OF VETERINARY MEDICINES AND HUMAN PHARMACEUTICALS FOR THE TREATMENT OF INFLAMMATORY AND INFECTIOUS DISEASES AND DISEASES IN THE ORAL CAVITY.

ELEMENTS CORRECTED
GOODS/SERVICES

3,784,972. REG. 5-4-2010. ARTE MESTIERE SRL (ITALY LIMITED LIABILITY COMPANY) VIA SANTA MARIA, 600/F, I-63014 MONTEGRANARO (AP), ITALY., SN 79-068,212. FILED 1-15-2009. PRINCIPAL REGISTER.

Veline

THE MARK CONSISTS OF STANDARD CHARACTERS WITHOUT CLAIM TO ANY PARTICULAR FONT, STYLE, SIZE, OR COLOR.

PRIORITY DATE OF 7-24-2008 IS CLAIMED.
OWNER OF INTERNATIONAL REGISTRATION 1001180 DATED 1-15-2009, EXPIRES 1-15-2019.

THE ENGLISH TRANSLATION OF "VELINE" IS "TISSUE".

INT. CL. 3/U.S. CLS. 1, 4, 6, 50, 51 AND 52

FOR BLEACHING PREPARATIONS AND OTHER SUBSTANCES, NAMELY, FABRIC SOFTENER FOR LAUNDRY USE; CLEANING, POLISHING, SCOURING PREPARATIONS; ABRASIVE PREPARATIONS, NAMELY, ABRASIVE PASTE AND SHEETS; SOAPS FOR PERSONAL USE; PERFUMERY, ESSENTIAL OILS; COSMETICS; HAIR LOTIONS; DENTIFRICES; * ALL THE AFORESAID GOODS NOT MEANT FOR ANIMALS *.

FIRST USE ; IN COMMERCE .

INT. CL. 9/U.S. CLS. 21, 23, 26, 36 AND 38

FOR SCIENTIFIC APPARATUS AND INSTRUMENTS, NAMELY, FLUORESCENCE DETECTOR FROM CRIME SCENE INVESTIGATIONS; NAUTICAL APPARATUS AND INSTRUMENTS, NAMELY, MARINE COMPASSES; SURVEYING APPARATUS AND INSTRUMENTS, NAMELY, SURVEYING CHAINS; PHOTOGRAPHIC APPARATUS AND INSTRUMENTS, NAMELY, CAMERAS; CINEMATOGRAPHIC APPARATUS AND INSTRUMENTS, NAMELY, CINEMATOGRAPHIC CAMERAS; OPTICAL APPARATUS AND INSTRUMENTS, NAMELY, OPTICAL LENSES; WEIGHING APPARATUS AND INSTRUMENTS, NAMELY, WEIGHING SCALES; MEASURING APPARATUS AND INSTRUMENTS, NAMELY, GRADUATED RULERS; SIGNALLING APPARATUS AND INSTRUMENTS, NAMELY, ROTATING LIGHTS; CHECKING APPARATUS AND INSTRUMENTS, NAMELY, CALCULATORS; LIFE-SAVING APPARATUS AND INSTRUMENTS, NAMELY, LIFE SAVING RAFTS, SAFETY HELMETS; TEACHING APPARATUS AND INSTRUMENTS, NAMELY, MEDICAL TEACHING MANNEQUINS; APPARATUS AND INSTRUMENTS FOR CONDUCTING, SWITCHING, TRANSFORMING, ACCU-

MULATING, REGULATING OR CONTROLLING ELECTRICITY, NAMELY, ELECTRIC SWITCHES; APPARATUS FOR RECORDING, TRANSMISSION OR REPRODUCTION OF SOUND OR IMAGES; PRERECORDED MAGNETIC DATA CARRIERS FEATURING FASHION SHOWS; PRERECORDED RECORDING DISCS, NAMELY, COMPACT DISCS, FEATURING MUSIC; AUTOMATIC VENDING MACHINES AND MECHANISMS FOR COIN-OPERATED APPARATUS; CASH REGISTERS, CALCULATING MACHINES, DATA PROCESSING EQUIPMENT AND COMPUTERS; FIRE-EXTINGUISHING APPARATUS.

FIRST USE ; IN COMMERCE .

INT. CL. 12/U.S. CLS. 19, 21, 23, 31, 35 AND 44

FOR VEHICLES, NAMELY, LAND VEHICLES; APPARATUS FOR LOCOMOTION BY LAND, AIR OR WATER, NAMELY, AIRCRAFT .

FIRST USE ; IN COMMERCE .

INT. CL. 14/U.S. CLS. 2, 27, 28 AND 50

FOR PRECIOUS METALS AND THEIR ALLOYS; GOODS IN PRECIOUS METALS OR COATED THEREWITH, NAMELY, JEWELRY BOXES; JEWELRY; PRECIOUS STONES; HOROLOGICAL AND CHRONOMETRIC INSTRUMENTS.

FIRST USE ; IN COMMERCE .

INT. CL. 16/U.S. CLS. 2, 5, 22, 23, 29, 37, 38 AND 50

FOR PAPER, CARDBOARD AND GOODS MADE FROM THESE MATERIALS, NAMELY, GREETING CARDS; PRINTED MATTER, NAMELY, PRINTED NEWS RELEASES IN THE FIELD OF FASHION; BOOK-BINDING MATERIAL, NAMELY, BOOKBINDING STRIPS AND CLOTH; PHOTOGRAPHS; STATIONERY; ADHESIVES FOR STATIONERY OR HOUSEHOLD PURPOSES; ARTISTS' MATERIALS, NAMELY, PAINTING PALETTES; PAINT BRUSHES; TYPEWRITERS AND OFFICE REQUISITES, NAMELY, STAPLERS; PRINTED INSTRUCTIONAL AND TEACHING MATERIAL IN THE FIELD OF FASHION; PLASTIC MATERIALS FOR PACKAGING, NAMELY, PLASTIC BAGS; PRINTERS' TYPE; PRINTING BLOCKS.

FIRST USE ; IN COMMERCE .

INT. CL. 18/U.S. CLS. 1, 2, 3, 22 AND 41

FOR LEATHER AND IMITATIONS OF LEATHER; GOODS MADE OF LEATHER AND IMITATION LEATHER, NAMELY, WALLETS; ANIMAL SKINS AND HIDES; TRUNKS AND TRAVELLING BAGS; UMBRELLAS, PARASOLS AND WALKING STICKS; WHIPS, HARNESS AND SADDLERY.

FIRST USE ; IN COMMERCE .

INT. CL. 25/U.S. CLS. 22 AND 39

FOR CLOTHING, NAMELY, SHIRTS, SHORTS, DRESSES, TOPS; SWEATERS, CARDIGANS, PULL-OVERS, SUITS, TROUSERS, JUMPERS, RAINCOATS, SUITS AND DRESSES MADE OF LEATHER, STOCKINGS AND SOCKS, GARTER BELTS; OUTERWEAR, NAMELY, JACKETS, COATS; WIND RESISTANT JACKETS, SKI TROUSERS, FUR COATS, OVERCOATS, JACKETS, SKIRTS, DRESSES, UNDERSHIRTS, T-SHIRTS, SPORT T-SHIRTS, BLOUSES, SHIRT COLLARS, FOULARDS, BEACHWEAR, SWIMSUITS, BIKINI, TRACKSUITS, UNDERWEAR, BRAS, BRASSIERE, CORSETS, SLIPS, BRIEFS AND BIKINI BRIEFS, VESTS, NIGHTGOWNS, NEGLIGEEES, PYJAMAS, GLOVES, SHAWLS, SCARVES, NECKTIES, BOWTIES, BELTS; FOOTWEAR, HEADGEAR, NAMELY, HATS, BONNETS.

FIRST USE ; IN COMMERCE .

INT. CL. 28/U.S. CLS. 22, 23, 38 AND 50

FOR GAMES AND PLAYTHINGS, NAMELY, PLUSH TOYS, BOARD GAMES; GYMNASIAC AND SPORTING ARTICLES, NAMELY, GYMNASIAC MATS, GYMNASIAC PARALLEL BARS; DECORATIONS FOR CHRISTMAS TREES.

FIRST USE ; IN COMMERCE .

INT. CL. 32/U.S. CLS. 45, 46 AND 48

FOR BEERS; MINERAL AND AERATED WATERS AND OTHER NON-ALCOHOLIC DRINKS, NAMELY, FRUIT JUICES; FRUIT DRINKS AND FRUIT JUICES; SYRUPS AND OTHER PREPARATIONS, NAMELY, POWDERS FOR MAKING BEVERAGES.

FIRST USE ; IN COMMERCE .

INT. CL. 33/U.S. CLS. 47 AND 49

FOR ALCOHOLIC BEVERAGES, EXCEPT BEERS, NAMELY, VODKA, RUM.

FIRST USE ; IN COMMERCE .

INT. CL. 43/U.S. CLS. 100 AND 101

FOR SERVICES FOR PROVIDING FOOD AND DRINK; PROVIDING TEMPORARY ACCOMMODATION.

FIRST USE ; IN COMMERCE .

ELEMENTS CORRECTED
GOODS/SERVICES

3,811,405. REG. 6-29-2010. THE ELDERS, INC. (DELAWARE CORPORATION) 312 SUTTER STREET, SUITE 200, SAN FRANCISCO, CA. 94108, SN 77-434,952. FILED 3-28-2008. PRINCIPAL REGISTER.

THE ELDERS

THE MARK CONSISTS OF STANDARD CHARACTERS WITHOUT CLAIM TO ANY PARTICULAR FONT, STYLE, SIZE, OR COLOR.

INT. CL. 41/U.S. CLS. 100, 101 AND 107

FOR ADULT EDUCATIONAL SERVICES, NAMELY, PROVIDING CONFERENCES, SEMINARS, AND LECTURES IN THE FIELDS OF HUMAN RIGHTS, WOMEN'S RIGHTS, HEALTHCARE AND DISEASE PREVENTION, SANITATION, DISASTER RELIEF, LITERACY, ENVIRONMENT AND NATURAL-RESOURCE CONSERVATION, CLIMATE CHANGE, AIR AND WATER POLLUTION, RENEWABLE ENERGY, LAND DEVELOPMENT AND RESIDENTIAL HOUSING, NUTRITION, PEACEFUL CONFLICT RESOLUTION AND CRIME AND TERRORISM PREVENTION, NONE OF THE AFOREMENTIONED IN CONNECTION WITH HIGH SCHOOL COURSES; EDUCATIONAL SERVICES, NAMELY, CONDUCTING ONLINE EXHIBITIONS AND DISPLAYS AND INTERACTIVE EXHIBITS IN THE FIELDS OF HUMAN RIGHTS, WOMEN'S RIGHTS, HEALTHCARE AND DISEASE PREVENTION, SANITATION, DISASTER RELIEF, LITERACY, ENVIRONMENT AND NATURAL-RESOURCE CONSERVATION, CLIMATE CHANGE, AIR AND WATER POLLUTION, RENEWABLE ENERGY, LAND DEVELOPMENT AND RESIDENTIAL HOUSING, NUTRITION, PEACEFUL CONFLICT RESOLUTION AND CRIME AND TERRORISM PREVENTION; ORGANIZING CULTURAL EXHIBITS OR EVENTS; PUBLICATION OF PRINTED MATTER * IN RELATION TO THE ABOVE-LISTED FIELDS. *

FIRST USE 10-31-2009; IN COMMERCE 10-31-2009.

ELEMENTS AMENDED
GOODS/SERVICES

3,842,505. REG. 8-31-2010. HORIZON TRADING USA, INC. (NEW YORK CORPORATION) 44 WEST 29TH STREET, NEW YORK, NY, 10001, SN 77-699,598. FILED 3-26-2009. PRINCIPAL REGISTER.

Lou Vin Sunglasses

THE MARK CONSISTS OF STANDARD CHARACTERS WITHOUT CLAIM TO ANY PARTICULAR FONT, STYLE, SIZE, OR COLOR.

NO CLAIM IS MADE TO THE EXCLUSIVE RIGHT TO USE "SUNGLASSES", APART FROM THE MARK AS SHOWN.

THE NAME SHOWN IN THE MARK DOES NOT IDENTIFY A PARTICULAR LIVING INDIVIDUAL.

INT. CL. 9/U.S. CLS. 21, 23, 26, 36 AND 38

FOR SUNGLASSES.
FIRST USE 12-1-2009; IN COMMERCE 12-1-2009.

ELEMENTS CORRECTED
OWNER NAME

3,852,796. REG. 9-28-2010. JAMES IRA WILLIAMS JR. (UNITED STATES INDIVIDUAL) 1435 BAILEY CIRCLE, HIGH POINT, NC, 27262, SN 77-914,396. FILED 1-19-2010. PRINCIPAL REGISTER.

We Are The Nations...

THE MARK CONSISTS OF STANDARD CHARACTERS WITHOUT CLAIM TO ANY PARTICULAR FONT, STYLE, SIZE, OR COLOR.

INT. CL. 16/U.S. CLS. 2, 5, 22, 23, 29, 37, 38 AND 50
FOR PUBLICATIONS, NAMELY, * BOOKS, * BROCHURES, BOOKLETS, AND TEACHING MATERIALS IN THE FIELD OF RELIGION.

FIRST USE 6-1-2009; IN COMMERCE 12-1-2009.

ELEMENTS AMENDED
GOODS/SERVICES

3,853,793. REG. 9-28-2010. CENTRAL GLASS CO., LTD. (JAPAN CORPORATION) 5253 OAZA OKIUBE, UBE-SHI, YAMAGUCHI-KEN 755-0001, JAPAN., SN 073,519. FILED 7-24-2009. PRINCIPAL REGISTER.



PRIORITY DATE OF 5-18-2009 IS CLAIMED.
OWNER OF INTERNATIONAL REGISTRATION 1015002 DATED 7-24-2009, EXPIRES 7-24-2019.

NO CLAIM IS MADE TO THE EXCLUSIVE RIGHT TO USE GLASS IN CLASSES 19 AND 21, APART FROM THE MARK AS SHOWN.

THE COLOR(S) RED, BLACK AND WHITE IS/ARE CLAIMED AS A FEATURE OF THE MARK.

THIS MARK CONTAINS THE WORDS "CENTRAL GLASS", WHICH ARE WRITTEN IN BLACK, AND A FIGURE CONSISTING OF TWO PARTIALLY OVERLAPPING SQUARES OF DIFFERENT SIZES; THE REAR LARGER SQUARE OF THE FIGURE IS WHITE WITH A RED OUTLINE AND THE FRONT SMALLER SQUARE IS SOLID RED.

INT. CL. 1/U.S. CLS. 1

FOR INDUSTRIAL CHEMICALS; PLANT GROWTH REGULATING PREPARATIONS; ADHESIVES FOR INDUSTRIAL PURPOSES; FERTILIZERS; PHOTOGRAPHIC SUPPLIES, NAMELY, PHOTOGRAPHIC CHEMICALS, DEVELOPERS, DRY PLATES, EMULSIONS, FIXERS, SENSITIZERS, UNEXPOSED FILM AND CHEMICALLY SYNTHESIZED PHOTOGRAPHIC PAPER; UNPROCESSED PLASTICS PLASTICS IN PRIMARY FORM.

INT. CL. 5/U.S. CLS. 6, 18, 44, 46, 51 AND 52

FOR PHARMACEUTICAL PREPARATIONS, NAMELY, INHALANT ANESTHETICS AND ANTIULCEROGENIC DRUGS; MOSQUITO REPELLENT INCENSES; FUNGICIDES; INSECTICIDES; FUMIGANTS; HERBICIDES IN THE NATURE OF WEED KILLERS; DEODORANTS, OTHER THAN FOR PERSONAL USE, NAMELY, AIR DEODORANTS, HOUSEHOLD DEODORANTS, CAR DEODORANTS; INSECT REPELLENTS; ANTISEPTICS; DENTAL MATERIALS, NAMELY, DENTAL COMPOSITE MATERIALS, DENTAL IMPRESSION MATERIALS, DENTAL PORCELAIN MATERIALS, FIXING MATERIALS FOR DENTAL PURPOSES, MATERIAL FOR REPAIRING TEETH AND FOR DENTAL CROWNS AND BRIDGES, MATERIALS FOR DENTAL FILLINGS AND FOR SEALING PURPOSES, SYNTHETIC MATERIALS FOR DENTAL USE FOR FILLINGS.

FIRST USE ; IN COMMERCE .

INT. CL. 12/U.S. CLS. 19, 21, 23, 31, 35 AND 44

FOR VESSELS, NAMELY, BOATS AND SHIPS AND THEIR STRUCTURAL PARTS AND FITTINGS THEREFOR; AIRCRAFT AND THEIR STRUCTURAL PARTS AND FITTINGS THEREFOR; RAILWAY ROLLING STOCK AND THEIR STRUCTURAL PARTS AND FITTINGS THEREFOR; AUTOMOBILES AND THEIR STRUCTURAL PARTS AND FITTINGS THEREFOR; TWO-WHEELED MOTOR VEHICLES, BICYCLES AND THEIR STRUCTURAL PARTS AND FITTINGS THEREFOR.

FIRST USE ; IN COMMERCE .

INT. CL. 19/U.S. CLS. 1, 12, 33 AND 50

FOR BUILDING GLASS; JOINERY FITTINGS NOT OF METAL; TRANSPORTABLE GREENHOUSES NOT OF METAL FOR HOUSEHOLD USE; PLASTIC BUILDING MATERIALS, NAMELY, PLASTIC PIPE SUPPORTS, MULTILAYER PANELS OF PLASTIC FOR USE IN BUILDING, PLASTIC WEBBING MATERIAL USED TO REINFORCE BITUMINOUS WATERPROOFING SHEETS; SYNTHETIC BUILDING MATERIALS, NAMELY, NON-WOVEN TEXTILES MADE OF SYNTHETIC FIBERS FOR USE IN THE BUILDING INDUSTRY, COMPOSITE PANELS COMPOSED PRIMARILY OF NONMETAL MATERIALS, REINFORCING MATERIALS NOT OF METAL FOR BUILDING PURPOSES; ASPHALT AND ASPHALT BUILDING OR CONSTRUCTION MATERIALS, NAMELY, ASPHALT FELT, ROOF COATINGS, ROOFING PAPER, PAVING COMPOUNDS, ASPHALT-BASED MASTICS FOR FOUNDATIONS OF BUILDINGS, ASPHALT-BASED ROOFING MASTICS, ASPHALT-BASED COATINGS AND SEALANTS FOR USE ON ROOFS, WALLS AND PAVEMENTS; RUBBER BUILDING OR CONSTRUCTION MATERIALS, NAMELY, RUBBER AND SYNTHETIC NON-METAL TILES FOR USE ON INDOOR AND OUTDOOR FLOORS, RUBBER COVE BASES, RUBBER FLOOR TILES, RUBBER FLOORING, RUBBER STAIRWAY WARNING TILES; PLASTER FOR BUILDING PURPOSES; LIME BUILDING OR CONSTRUCTION MATERIALS, NAMELY, HYDRATED LIME FOR BUILDING PURPOSES, SLAG LIME CEMENT; BUILDING OR CONSTRUCTION MATERIALS OF PLASTER, NAMELY, PLASTER BOARDS, PLASTER FIREPLACE MANTELS; ROCK FALL PREVENTION NETS OF TEXTILE; PLASTIC SECURITY WINDOWS ALLOWING COMMUNICATION; BOARDS OF INORGANIC FIBER NOT OF ASBESTOS, NAMELY, NON-METAL FIRE RESISTANT BOARDS AND PANELS FOR CONSTRUCTION, NON-METAL WATER RESISTANT BOARDS AND PANELS FOR CONSTRUCTION, WALL BOARDS, FIBERGLASS BOARDS; POWDER COMPOSED OF INORGANIC FIBER NOT OF ASBESTOS, NAMELY, GLASS POWDER FOR BUILDING PURPOSES, GLASS POWDER FOR USE AS A PARTIAL REPLACEMENT OF PORTLAND CEMENT IN CEMENT MIXES.

FIRST USE ; IN COMMERCE .

INT. CL. 21/U.S. CLS. 2, 13, 23, 29, 30, 33, 40 AND 50

FOR UNWORKED OR SEMI-WORKED GLASS NOT FOR BUILDING [; UPRIGHT SIGNBOARDS OF GLASS OR CERAMICS].

FIRST USE ; IN COMMERCE .

ELEMENTS CORRECTED
GOODS/SERVICES

3,855,095. REG. 9-28-2010. LONGYEAR TM, INC. (DELAWARE CORPORATION) 10808 SOUTH RIVER FRONT PARKWAY, SUITE 600, SOUTH JORDAN, UT, 84095, SN 78-965,326. FILED 8-31-2006. PRINCIPAL REGISTER.

TRUSONIC

THE MARK CONSISTS OF STANDARD CHARACTERS WITHOUT CLAIM TO ANY PARTICULAR FONT, STYLE, SIZE, OR COLOR.

NO CLAIM IS MADE TO THE EXCLUSIVE RIGHT TO USE "SONIC", APART FROM THE MARK AS SHOWN.

INT. CL. 7/U.S. CLS. 13, 19, 21, 23, 31, 34 AND 35

FOR EARTH DRILLING EQUIPMENT AND PARTS THEREFOR, NAMELY, EARTH DRILLING MACHINES.

FIRST USE 1-0-2010; IN COMMERCE 4-0-2010.

INT. CL. 37/U.S. CLS. 100, 103 AND 106

FOR EARTH DRILLING SERVICES, NAMELY, ANGLE AND VERTICAL DRILLING, DIAMOND, ORIENTED, AND THIN WALL CORING, COMMERCIAL, INDUSTRIAL AND MUNICIPAL WATER WELL DRILLING.

FIRST USE 1-0-2010; IN COMMERCE 4-0-2010.

ELEMENTS AMENDED
MARK

3,855,448. REG. 10-5-2010. PHOTOGRAPHY FOR LITTLE PEOPLE FRANCHISE LIMITED (UNITED KINGDOM LIMITED LIABILITY COMPANY) 205 PARK ROAD, STANLEY, CO. DURHAM DH9 7QE, UNITED KINGDOM., SN 77-695,409. FILED 3-20-2009. PRINCIPAL REGISTER.

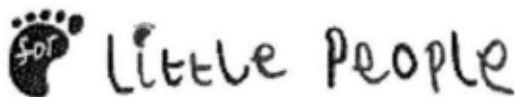

PRIORITY CLAIMED UNDER SEC. 44(D) ON UNITED KINGDOM APPLICATION NO. 2498448, FILED 9-23-2008, REG. NO. 2498448, DATED 9-23-2008, EXPIRES 9-23-2018.

THE MARK CONSISTS OF A STYLIZED IMAGE OF A FOOT CONTAINING THE WORD "FOR" FOLLOWED BY THE WORDS "LITTLE PEOPLE", WITH ANOTHER STYLIZED IMAGE OF A FOOT ABOVE THE "I" IN "LITTLE".

INT. CL. 40/U.S. CLS. 100, 103 AND 106

FOR DIGITAL PHOTO PRINTING SERVICES; DEVELOPING, DUPLICATION, PRINTING AND ENLARGEMENT OF PHOTOGRAPHS, SLIDES AND PHOTOGRAPHIC FILM; PHOTO REPRODUCTION SERVICES, NAMELY, TRANSFER OF PHOTOGRAPHIC PRINTS; PHOTO REPRODUCTION SERVICES, NAMELY, TRANSFER OF PHOTOGRAPHIC PRINTS ONTO CANVAS; PHOTO REPRODUCTION SERVICES, NAMELY, TRANSFER OF PHOTOGRAPHIC PRINTS ONTO VIDEOTAPE; PHOTO REPRODUCTION SERVICES, NAMELY, TRANSFER OF PHOTOGRAPHS ONTO COMPACT DISC; FRAMING AND MOUNTING OF PHOTOGRAPHS; PHOTOFINISHING SERVICES; PHOTOCOMPOSING SERVICES; PHOTOGRAPHIC RESTORATION SERVICES; DIGITAL IMAGE ENHANCEMENT; PHOTOGRAPHIC ETCHING OF ARTICLES OF CLOTHING; PHOTOGRAPHIC ETCHING OF HOUSEHOLD ARTICLES; PHOTOGRAPHIC ETCHING OF PRINTED MATTER; CUSTOM MOLDING, CASTING AND TREATMENT OF CLAY, PLASTER, AIR DOUGH, CONCRETE, PLASTIC, PAPER AND PAPER CARD FOR OTHERS; CUSTOM SCULPTING OF GLASS, WOOD, MARBLE, STONE, AND CORK FOR OTHERS; CUSTOM IMPRINTING OF CLAY, PLASTER, AIR DOUGH, GLASS, WOOD, MARBLE, CONCRETE, STONE, PLASTIC, CORK, PAPER AND PAPER CARD WITH IMPRESSIONS OF CHILDREN'S, ADULT'S AND PET'S HANDS, FEET AND PAWS.

FIRST USE ; IN COMMERCE .

INT. CL. 41/U.S. CLS. 100, 101 AND 107

FOR PHOTOGRAPHY; PORTRAIT AND GENERAL PHOTOGRAPHY; INFORMATION AND CONSULTING, BOTH IN THE FIELD OF PHOTOGRAPHY; VIDEO RECORDING SERVICES.

FIRST USE ; IN COMMERCE .

ELEMENTS CORRECTED
OWNER NAME
OWNER ADDRESS
ENTITY

3,866,012. REG. 10-19-2010. SANOFI (FRANCE SOCIETE ANONYME) 174, AVENUE DE FRANCE, PARIS, FRANCE, 75013, SN 77-246,327. FILED P.R. 8-3-2007; AM. S.R. 12-28-2009. SUPPLEMENTAL REGISTER.



NO CLAIM IS MADE TO THE EXCLUSIVE RIGHT TO USE "PAD CARE CENTERS", APART FROM THE MARK AS SHOWN.

THE COLOR(S) BLUE AND WHITE IS/ARE CLAIMED AS A FEATURE OF THE MARK.

THE MARK CONSISTS OF THE WORD "PAD" IN A STYLIZED FONT IN THE COLOR WHITE WITHIN A RECTANGLE IN GRADATIONS OF THE COLOR BLUE. BELOW THIS RECTANGLE ARE THE WORDS "CARE CENTERS" IN BLUE, AND A HORIZONTAL LINE, ALSO IN BLUE, BETWEEN "CARE" AND "CENTERS". THE BLUE RECTANGLE THAT ENCLOSES THE WORDING "PAD" IS ITSELF ENCLOSED WITHIN A LARGER RECTANGLE THAT ALSO ENCLOSES THE WORDING "CARE CENTERS" AND THE HORIZONTAL LINE, AND THIS LARGER RECTANGLE IS IN WHITE AND GRADATIONS OF THE COLOR BLUE.

INT. CL. 9/U.S. CLS. 21, 23, 26, 36 AND 38

FOR PROVIDING DOWNLOADABLE REPORTS, GUIDES AND INFORMATION IN THE NATURE OF BROCHURES AND NEWSLETTERS VIA THE INTERNET IN THE FIELD OF CARDIOVASCULAR DISEASE.

FIRST USE 5-0-2007; IN COMMERCE 5-0-2007.

INT. CL. 16/U.S. CLS. 2, 5, 22, 23, 29, 37, 38 AND 50

FOR PRINTED INSTRUCTIONAL MATERIALS IN THE FIELD OF CARDIOVASCULAR DISEASE.

FIRST USE 5-0-2007; IN COMMERCE 5-0-2007.

INT. CL. 41/U.S. CLS. 100, 101 AND 107

FOR EDUCATIONAL SERVICES, NAMELY, CONFERENCES IN THE FIELD OF CARDIOVASCULAR DISEASE, AND TEACHING MATERIALS DISTRIBUTED THEREWITH.

FIRST USE 5-0-2007; IN COMMERCE 5-0-2007.

ELEMENTS CORRECTED
INTERNATIONAL CLASS(ES)
U.S. CLASS(ES)

3,874,785. REG. 11-9-2010. ETEGENT TECHNOLOGIES, LTD. (OHIO LIMITED LIABILITY COMPANY) SUITE 302, 1775 MENTOR AVENUE, CINCINNATI, OH, 45212, SN 77-887,717. FILED 12-7-2009. PRINCIPAL REGISTER.

ETEGENT

THE MARK CONSISTS OF STANDARD CHARACTERS WITHOUT CLAIM TO ANY PARTICULAR FONT, STYLE, SIZE, OR COLOR.

INT. CL. 42/U.S. CLS. 100 AND 101

FOR ENGINEERING RESEARCH AND DEVELOPMENT, ENGINEERING PROFESSIONAL SERVICES AND SOFTWARE DEVELOPMENT IN THE AREAS OF SIGNAL PROCESSING, IMAGE PROCESSING, PARALLEL PROCESSING IMPLEMENTATION OF COMPUTER ALGORITHMS, NON-DESTRUCTIVE INSPECTION DATA MANAGEMENT, AUTOMATIC TARGET RECOGNITION, FIBER OPTIC SENSING SYSTEMS, HEALTH MONITORING OF AIRCRAFT ENGINES AND OTHER MACHINERY, DEVELOPMENT OF PRESSURE, VIBRATION, TEMPERATURE AND STRAIN SENSORS.

FIRST USE 4-1-2010; IN COMMERCE 4-1-2010.

ELEMENTS CORRECTED

OWNER NAME
OWNER ADDRESS
CITIZENSHIP
ENTITY

3,889,185. REG. 12-14-2010. TELKONET, INC. (UTAH CORPORATION) 10200 INNOVATION DRIVE, SUITE 300, MILWAUKEE, WI, 53226, SN 78-584,638. FILED 3-10-2005. PRINCIPAL REGISTER.

TELKONET IBRIDGE

THE MARK CONSISTS OF STANDARD CHARACTERS WITHOUT CLAIM TO ANY PARTICULAR FONT, STYLE, SIZE, OR COLOR.

OWNER OF U.S. REG. NO. 2,707,696.
INT. CL. 9/U.S. CLS. 21, 23, 26, 36 AND 38
FOR MODEMS.

FIRST USE 10-16-2003; IN COMMERCE 10-16-2003.

ELEMENTS CORRECTED
CITIZENSHIP

3,892,726. REG. 12-21-2010. PENN PHARMACEUTICAL SERVICES LIMITED (UNITED KINGDOM LIMITED COMPANY) 23/24, TAFARNAUBACH INDUSTRIAL ESTATE, TREDEGAR, GWENT NP22 3AA, UNITED KINGDOM., SN 79-077,449. FILED 11-26-2009. PRINCIPAL REGISTER.



PRIORITY DATE OF 5-26-2009 IS CLAIMED.
OWNER OF INTERNATIONAL REGISTRATION 1025274
DATED 11-26-2009, EXPIRES 11-26-2019.

THE MARK CONSISTS OF THE WORDING "SOLUSOLVE" IN STYLIZED FONT SHOWN AGAINST A SHADED OVAL.

INT. CL. 42/U.S. CLS. 100 AND 101

FOR RESEARCH AND DESIGN SERVICES IN THE FIELD OF FORMULATION OF PHARMACEUTICALS; ADVISORY SERVICES IN THE FIELD OF FORMULATION OF PHARMACEUTICALS; RESEARCH AND DESIGN IN RELATION TO FORMULATIONS OF DRUGS HAVING POOR WATER SOLUBILITY.

FIRST USE ; IN COMMERCE .

ELEMENTS CORRECTED

OWNER NAME

3,896,532. REG. 12-28-2010. LEONHARD KURZ STIFTUNG & CO. KG (FED REP GERMANY LIMITED PARTNERSHIP) SCHWABACHER STRASSE 482, 90763 FÜRTH, FED REP GERMANY., SN 79-072,502. FILED 2-24-2009. PRINCIPAL REGISTER.

KURZ IMD PLUS

THE MARK CONSISTS OF STANDARD CHARACTERS WITHOUT CLAIM TO ANY PARTICULAR FONT, STYLE, SIZE, OR COLOR.

PRIORITY DATE OF 8-28-2008 IS CLAIMED.
OWNER OF INTERNATIONAL REGISTRATION 1012117
DATED 2-24-2009, EXPIRES 2-24-2019.

OWNER OF U.S. REG. NO. 1,207,720.

NO CLAIM IS MADE TO THE EXCLUSIVE RIGHT TO USE "IMD", APART FROM THE MARK AS SHOWN.

INT. CL. 7/U.S. CLS. 13, 19, 21, 23, 31, 34 AND 35

FOR MACHINE-DRIVEN APPARATUS FOR STAMPING, NAMELY, AUTOMATIC AND SEMI-AUTOMATIC STAMPING MACHINES; MACHINE-DRIVEN APPARATUS FOR HOT STAMPING, NAMELY, HOT STAMPING MACHINES; MACHINES FOR APPLYING STAMPING OR LAMINATING FOILS TO SUBSTRATES, NAMELY, STAMPING AND LAMINATING MACHINES AND STRUCTURAL REPLACEMENT PARTS AND AUXILIARY EQUIPMENT IN THE NATURE OF STRUCTURAL FITTINGS FOR SUCH MACHINES; MACHINE-DRIVEN STAMPING TOOLS, NAMELY, EMBOSsing DIES AND HOT STAMPING DIES; MACHINE PARTS, NAMELY, EMBOSsing STAMPS AND STAMPING DIES; MACHINES FOR PLASTICS PROCESSING, NAMELY, INJECTION PLASTIC MOLDING MACHINES AND MACHINES FOR THE PROCESSING OF FOILS, NAMELY, FOIL EMBOSsing AND STAMPING MACHINES; PATTERN TRANSFERRING MACHINES FOR TRANSFERRING PATTERNS, DECORS, STRUCTURES OR FUNCTIONAL SURFACE STRUCTURES, FROM BASE FOILS ON WHICH THE AFOREMENTIONED PATTERNS, DECORS, STRUCTURES OR FUNCTIONAL SURFACE STRUCTURES ARE PRE-PRINTED ON AND/OR APPLIED ON, ONTO ARTICLE SURFACES; FOIL OVERLAYING MACHINES FOR OVERLAYING/COATING OF ARTICLE SURFACES WITH FOILS CONTAINING PATTERNS, DECORS, STRUCTURES AND/OR FUNCTIONAL SURFACE STRUCTURES; IN MOLD MACHINES FOR PERFORMING INJECTION MOLDING

AND FOR TRANSFERRING PATTERNS, DECORS, STRUCTURES AND/OR FUNCTIONAL SURFACE STRUCTURES ONTO THE MOLDED ARTICLES, AND IN MOLD MACHINES FOR PERFORMING INJECTION MOLDING AND FOR OVERLAYING THE MOLDED ARTICLES WITH FOILS CONTAINING PATTERNS, DECORS, STRUCTURES AND/OR FUNCTIONAL SURFACE STRUCTURES; AUTOMATIC FOIL FEEDING MACHINES AND FOIL PREPARATION THERMAL MACHINES FOR USE WITH THE AFOREMENTIONED PATTERN TRANSFERRING MACHINES; AUTOMATIC FOIL FEEDING MACHINES AND FOIL PREPARATION THERMAL MACHINES FOR USE WITH THE AFOREMENTIONED FOIL OVERLAYING MACHINES; AUTOMATIC FOIL FEEDING MACHINES AND FOIL PREPARATION MACHINES FOR USE WITH THE AFOREMENTIONED IN MOLD MACHINES; MOLDS FOR PLASTICS MOLDING MACHINES; AND STRUCTURAL REPLACEMENT PARTS AND AUXILIARY EQUIPMENT IN THE NATURE OF STRUCTURAL FITTINGS FOR ALL OF THE AFOREMENTIONED GOODS.
FIRST USE ; IN COMMERCE .

INT. CL. 16/U.S. CLS. 2, 5, 22, 23, 29, 37, 38 AND 50
FOR STAMPING FOILS, TRANSFER AND LAMINATING FOILS CONSISTING OF A CARRIER SHEET MATERIAL MADE PRIMARILY OF PAPER; LABELS AND SELF-ADHESIVE LABELS, PRIMARILY MADE OF PAPER; ALL AFOREMENTIONED GOODS ALSO FOR APPLICATION ON TEXTILES OR FOR SURFACE DECORATION AND/OR SURFACE COATING, IN PARTICULAR FOR SURFACE DECORATION AND/OR SURFACE COATING OF HOUSING COMPONENTS, INJECTION-MOLDED COMPONENTS OR PICTURE FRAMES; PACKAGING MATERIAL MADE OF PAPER AND PLASTICS, NAMELY, SHEATHS AND BAGS AND FOILS; SELF-ADHESIVE FOILS CONSISTING OF A CARRIER SHEET MATERIAL, MADE PRIMARILY OF PAPER AND PLASTIC LAMINATES FOR PACKAGING PURPOSES.
FIRST USE ; IN COMMERCE .

INT. CL. 17/U.S. CLS. 1, 5, 12, 13, 35 AND 50
FOR STAMPING FOILS, TRANSFER AND LAMINATING FOILS ALL PRIMARILY OF PLASTICS; ALL AFOREMENTIONED GOODS ALSO FOR APPLICATION ON TEXTILES OR FOR SURFACE DECORATION AND/OR SURFACE COATING, IN PARTICULAR FOR SURFACE DECORATION AND/OR SURFACE COATING OF HOUSING COMPONENTS, INJECTION-MOLDED COMPONENTS OR PICTURE FRAMES; SEMI-FINISHED PLASTICS, NAMELY, SELF-ADHESIVE PLASTIC FOILS, AND PLASTIC LAMINATE SHEETS, AND PLASTIC LAMINATE WEB IN THE NATURE OF ROLL WARE AND ROLL GOODS.
FIRST USE ; IN COMMERCE .

INT. CL. 42/U.S. CLS. 100 AND 101
FOR TECHNICAL CONSULTING RELATING TO SURFACE DECORATION AND/OR SURFACE COATING BY MEANS OF STAMPING, TRANSFER AND LAMINATING FOILS; TECHNICAL CONSULTING RELATING TO PLASTICS MOLDING PROCESSES; TECHNICAL CONSULTING RELATING TO THE PROCESSING OF PLASTICS; TECHNICAL CONSULTING RELATING TO TRANSFERRING OF PATTERNS, DECORS, STRUCTURES AND/OR FUNCTIONAL SURFACE STRUCTURES; TECHNICAL CONSULTING RELATING TO TRANSFERRING OF PATTERNS, DECORS, STRUCTURES AND/OR FUNCTIONAL SURFACE STRUCTURES AND/OR FOR OVERLAYING/COATING OF ARTICLES MOLDED OF PLASTICS WITH FOILS PRE-TREATED WITH HEAT; TECHNICAL CONSULTING RELATING TO PLASTIC MOLDING AND SUBSEQUENT TRANSFERRING OF PATTERNS, DECORS, STRUCTURES AND/OR FUNCTIONAL SURFACE STRUCTURES AND/OR OVERLAYING/COATING OF THE MOLDED ARTICLES WITH FOILS; SERVICES OF AN INDUSTRIAL DESIGNER; CONSULTING ABOUT COMPUTER SOFTWARE; CONSULTING SERVICES IN THE FIELD OF COMPUTERS; DESIGNING OF COMPUTER SOFTWARE; ELECTRONIC DATA PROCESSING

(EDP) PROGRAMMERS' SERVICES, NAMELY COMPUTER PROGRAMMING; TECHNICAL PROJECT MANAGEMENT IN THE FIELD OF ELECTRONIC DATA PROCESSING (EDP), NAMELY COMPUTER PROJECT MANAGEMENT SERVICES; TECHNICAL CONSULTING IN THE AREAS OF INSTALLATION, MAINTENANCE AND REPAIR OF COMPUTER SOFTWARE, AND SOFTWARE-RELATED SERVICES IN THE NATURE OF THE INSTALLATION, MAINTENANCE AND REPAIR OF COMPUTER SOFTWARE AND DATA PROCESSING EQUIPMENT; RENTAL OF COMPUTER SOFTWARE AND DATA PROCESSING EQUIPMENT.

ELEMENTS CORRECTED
GOODS/SERVICES

3,904,585. REG. 1-11-2011. ONE LAPTOP PER CHILD ASSOCIATION, INC. (DELAWARE NON-STOCK CORPORATION) ONE CAMBRIDGE CENTER, 10TH FLOOR, CAMBRIDGE, MA, 02142, SN 77-096,470. FILED 2-1-2007. PRINCIPAL REGISTER.



THE MARK CONSISTS OF THE NUMERAL ONE, A STYLIZED LAPTOP COMPUTER, AN ARROW POINTING TO THE RIGHT AND A STYLIZED HUMAN FIGURE. EACH IMAGE IS SEPARATED BY A SOLID VERTICAL LINE.
INT. CL. 9/U.S. CLS. 21, 23, 26, 36 AND 38
FOR * COMPUTER * [COMPUTERS] PERIPHERALS.
FIRST USE 6-1-2008; IN COMMERCE 6-1-2008.

ELEMENTS CORRECTED
GOODS/SERVICES

3,909,871. REG. 1-25-2011. THE BOARD OF REGENTS OF THE NEVADA SYSTEM OF HIGHER EDUCATION ON BEHALF OF THE UNIVERSITY OF NEVADA, RENO FOR THE UNIVERSITY STUDIES ABROAD CONSORTIUM (NEVADA STATE UNIVERSITY) UNIVERSITY OF NEVADA, RENO, M.S. 323, 1664 N. VIRGINIA STREET, RENO, NV, 895570323, SN 77-863,215. FILED 11-2-2009. PRINCIPAL REGISTER.

UNIVERSITY STUDIES ABROAD
CONSORTIUM

THE MARK CONSISTS OF STANDARD CHARACTERS WITHOUT CLAIM TO ANY PARTICULAR FONT, STYLE, SIZE, OR COLOR.
NO CLAIM IS MADE TO THE EXCLUSIVE RIGHT TO USE "STUDIES ABROAD", APART FROM THE MARK AS SHOWN.
SEC. 2(F).
INT. CL. 16/U.S. CLS. 2, 5, 22, 23, 29, 37, 38 AND 50

FOR PRINTED MATTER, NAMELY, BROCHURES AND CATALOGUES IN THE FIELD OF STUDY ABROAD PROGRAMS.

FIRST USE 12-31-1989; IN COMMERCE 12-31-1989.
INT. CL. 35/U.S. CLS. 100, 101 AND 102

FOR CONSULTING SERVICES, NAMELY, ADMINISTERING STUDIES ABROAD PROGRAMS; ADVERTISING STUDIES ABROAD PROGRAMS FOR COLLEGE STUDENTS, AND ELECTRONIC CATALOG SERVICES FEATURING STUDIES ABROAD PROGRAMS OR SERVICES; ADVERTISING IN STUDY ABROAD BROCHURES AND CATALOGS; COORDINATING TRAVEL ARRANGEMENTS, NAMELY, TRAVEL MANAGEMENT FOR INDIVIDUALS AND GROUPS AS THEY RELATE TO STUDIES ABROAD PROGRAMS; CONSULTING SERVICES, NAMELY, IMPLEMENTING STUDIES ABROAD PROGRAMS.

FIRST USE 12-31-1989; IN COMMERCE 12-31-1989.
INT. CL. 39/U.S. CLS. 100 AND 105

FOR COORDINATING TRAVEL ARRANGEMENTS, NAMELY, PLANNING, ORGANIZING AND ARRANGING TRAVEL FOR INDIVIDUALS AND GROUPS AS THEY RELATE TO STUDIES ABROAD PROGRAMS.

FIRST USE 12-31-1989; IN COMMERCE 12-31-1989.
INT. CL. 41/U.S. CLS. 100, 101 AND 107

FOR CONSULTING SERVICES IN THE FIELD OF EDUCATION, NAMELY, PROVIDING ADVICE AND INFORMATION TO COLLEGE STUDENTS FOR STUDY ABROAD PROGRAMS; CONSULTING SERVICES, NAMELY, DEVELOPING, CONDUCTING AND ARRANGING STUDIES ABROAD INSTRUCTION PROGRAMS.

FIRST USE 12-31-1989; IN COMMERCE 12-31-1989.

ELEMENTS CORRECTED
OWNER NAME

3,910,203. REG. 1-25-2011. LIVING PROOF (INDIANA SOLE PROPRIETORSHIP) 6066 PINE BLUFF DRIVE, AVON, IN, 46123, SN 77-960,098. FILED 3-16-2010. PRINCIPAL REGISTER.

LIVING PROOF

THE MARK CONSISTS OF STANDARD CHARACTERS WITHOUT CLAIM TO ANY PARTICULAR FONT, STYLE, SIZE, OR COLOR.

INT. CL. 9/U.S. CLS. 21, 23, 26, 36 AND 38

FOR MUSICAL SOUND RECORDINGS; PRE-RECORDED COMPACT DISCS FEATURING MUSIC.

FIRST USE 11-2-2002; IN COMMERCE 12-31-2004.

INT. CL. 41/U.S. CLS. 100, 101 AND 107

FOR ENTERTAINMENT SERVICES IN THE NATURE OF LIVE MUSICAL PERFORMANCES.

FIRST USE 11-2-2002; IN COMMERCE 12-31-2004.

ELEMENTS CORRECTED
ENTITY

3,910,204. REG. 1-25-2011. LIVING PROOF (INDIANA SOLE PROPRIETORSHIP) 6066 PINE BLUFF DRIVE, AVON, IN, 46123, SN 77-960,125. FILED 3-16-2010. PRINCIPAL REGISTER.



THE MARK CONSISTS OF THE WORD "LIVING" ABOVE THE WORD "PROOF", WITH THE WORDS SEPARATED BY A HORIZONTAL TWO-LINE MOTIF INCLUDING TWO OPPOSING SIXTEENTH NOTES POSITIONED TO THE LEFT OF THE WORDS.

INT. CL. 9/U.S. CLS. 21, 23, 26, 36 AND 38

FOR MUSICAL SOUND RECORDINGS; PRE-RECORDED COMPACT DISCS FEATURING MUSIC.

FIRST USE 11-2-2002; IN COMMERCE 12-31-2004.

INT. CL. 41/U.S. CLS. 100, 101 AND 107

FOR ENTERTAINMENT SERVICES IN THE NATURE OF LIVE MUSICAL PERFORMANCES.

FIRST USE 11-2-2002; IN COMMERCE 12-31-2004.

ELEMENTS CORRECTED
ENTITY

3,918,587. REG. 2-15-2011. THE BOARD OF REGENTS OF THE NEVADA SYSTEM OF HIGHER EDUCATION ON BEHALF OF THE UNIVERSITY OF NEVADA, RENO FOR THE UNIVERSITY STUDIES ABROAD CONSORTIUM (NEVADA STATE UNIVERSITY) UNIVERSITY OF NEVADA, RENO, M.S. 323, 1664 N. VIRGINIA STREET, RENO, NV, 895570323, SN 77-863,274. FILED 11-2-2009. PRINCIPAL REGISTER.

USAC

THE MARK CONSISTS OF STANDARD CHARACTERS WITHOUT CLAIM TO ANY PARTICULAR FONT, STYLE, SIZE, OR COLOR.

INT. CL. 16/U.S. CLS. 2, 5, 22, 23, 29, 37, 38 AND 50

FOR PRINTED MATTER, NAMELY, BROCHURES AND CATALOGUES IN THE FIELD OF STUDY ABROAD PROGRAMS.

FIRST USE 12-31-1989; IN COMMERCE 12-31-1989.

INT. CL. 35/U.S. CLS. 100, 101 AND 102

FOR CONSULTING SERVICES, NAMELY, ADMINISTERING STUDIES ABROAD PROGRAMS; ADVERTISING STUDIES ABROAD PROGRAMS FOR COLLEGE STUDENTS, AND ELECTRONIC CATALOG SERVICES FEATURING STUDIES ABROAD PROGRAMS OR SERVICES; ADVERTISING IN STUDY ABROAD BROCHURES AND CATALOGS; COORDINATING TRAVEL ARRANGEMENTS, NAMELY, TRAVEL MANAGEMENT FOR INDIVIDUALS AND GROUPS AS THEY RELATE TO STUDIES ABROAD PROGRAMS.

FIRST USE 12-31-1989; IN COMMERCE 12-31-1989.

INT. CL. 39/U.S. CLS. 100 AND 105

FOR COORDINATING TRAVEL ARRANGEMENTS, NAMELY, PLANNING, ORGANIZING AND ARRANGING TRAVEL FOR INDIVIDUALS AND GROUPS AS THEY RELATE TO STUDIES ABROAD PROGRAMS.

FIRST USE 12-31-1989; IN COMMERCE 12-31-1989.

INT. CL. 41/U.S. CLS. 100, 101 AND 107

FOR CONSULTING SERVICES IN THE FIELD OF EDUCATION, NAMELY, PROVIDING ADVICE AND INFORMATION TO COLLEGE STUDENTS FOR STUDY ABROAD PROGRAMS; CONSULTING SERVICES, NAMELY, DEVELOPING, CONDUCTING AND ARRANGING STUDIES ABROAD INSTRUCTION PROGRAMS. FIRST USE 12-31-1989; IN COMMERCE 12-31-1989.

ELEMENTS CORRECTED
OWNER NAME

3,918,897. REG. 2-15-2011. NOMI FASHION CORP. (NEW YORK CORPORATION) 105 ASHAROKEN AVE, ASHAROKEN, NY, 11768, SN 78-600,876. FILED 4-4-2005. PRINCIPAL REGISTER.

NOMI

3,918,588. REG. 2-15-2011. THE BOARD OF REGENTS OF THE NEVADA SYSTEM OF HIGHER EDUCATION ON BEHALF OF THE UNIVERSITY OF NEVADA, RENO FOR THE UNIVERSITY STUDIES ABROAD CONSORTIUM (NEVADA STATE UNIVERSITY) UNIVERSITY OF NEVADA, RENO, M.S. 323, 1664 N. VIRGINIA STREET, RENO, NV, 895570323, SN 77-863,319. FILED 11-2-2009. PRINCIPAL REGISTER.

YOUR GATEWAY TO THE WORLD

THE MARK CONSISTS OF STANDARD CHARACTERS WITHOUT CLAIM TO ANY PARTICULAR FONT, STYLE, SIZE, OR COLOR.

INT. CL. 25/U.S. CLS. 22 AND 39

FOR [CLOTHING, NAMELY, TOPS, BOTTOMS, HEADWEAR, SKIRTS AND DRESSES, AND] FOOTWEAR.

FIRST USE 11-1-2003; IN COMMERCE 11-1-2003.

ELEMENTS AMENDED
GOODS/SERVICES

THE MARK CONSISTS OF STANDARD CHARACTERS WITHOUT CLAIM TO ANY PARTICULAR FONT, STYLE, SIZE, OR COLOR.

INT. CL. 16/U.S. CLS. 2, 5, 22, 23, 29, 37, 38 AND 50

FOR PRINTED MATTER, NAMELY, BROCHURES AND CATALOGUES IN THE FIELD OF STUDY ABROAD PROGRAMS.

FIRST USE 11-1-2000; IN COMMERCE 11-1-2000.

INT. CL. 35/U.S. CLS. 100, 101 AND 102

FOR CONSULTING SERVICES, NAMELY, ADMINISTERING STUDIES ABROAD PROGRAMS; ADVERTISING STUDIES ABROAD PROGRAMS FOR COLLEGE STUDENTS, AND ELECTRONIC CATALOG SERVICES FEATURING STUDIES ABROAD PROGRAMS OR SERVICES; ADVERTISING IN STUDY ABROAD BROCHURES AND CATALOGS; COORDINATING TRAVEL ARRANGEMENTS, NAMELY, TRAVEL MANAGEMENT FOR INDIVIDUALS AND GROUPS AS THEY RELATE TO STUDIES ABROAD PROGRAMS.

FIRST USE 11-1-2000; IN COMMERCE 11-1-2000.

INT. CL. 39/U.S. CLS. 100 AND 105

FOR COORDINATING TRAVEL ARRANGEMENTS, NAMELY, PLANNING, ORGANIZING AND ARRANGING TRAVEL FOR INDIVIDUALS AND GROUPS AS THEY RELATE TO STUDIES ABROAD PROGRAMS.

FIRST USE 11-1-2000; IN COMMERCE 11-1-2000.

INT. CL. 41/U.S. CLS. 100, 101 AND 107

FOR CONSULTING SERVICES IN THE FIELD OF EDUCATION, NAMELY, PROVIDING ADVICE AND INFORMATION TO COLLEGE STUDENTS FOR STUDY ABROAD PROGRAMS; CONSULTING SERVICES, NAMELY, DEVELOPING, CONDUCTING AND ARRANGING STUDIES ABROAD INSTRUCTION PROGRAMS.

FIRST USE 11-1-2000; IN COMMERCE 11-1-2000.

ELEMENTS CORRECTED
OWNER NAME

3,921,123. REG. 2-15-2011. NATIONAL ASSOCIATION OF MUSIC MERCHANTS, INC. (NEW YORK CORPORATION) 5790 ARMADA DRIVE, CARLSBAD, CA, 92008, SN 77-981,039. FILED 8-17-2009. PRINCIPAL REGISTER.

WANNA PLAY? FUND

THE MARK CONSISTS OF STANDARD CHARACTERS WITHOUT CLAIM TO ANY PARTICULAR FONT, STYLE, SIZE, OR COLOR.

OWNER OF U.S. REG. NOS. 1,862,894, 2,070,596 AND 3,606,586.

INT. CL. 9/U.S. CLS. 21, 23, 26, 36 AND 38

FOR DOWNLOADABLE AUDIO RECORDINGS AND PRE-RECORDED MEDIA, NAMELY, CDS, WHERE ALL OF THE ABOVE FEATURE AUDIO WORKS, MUSIC AND/OR PROMOTIONAL MATERIALS FOR FUNDRAISING CAMPAIGNS.

FIRST USE 10-22-2010; IN COMMERCE 10-22-2010.

ELEMENTS CORRECTED
MARK

3,944,669. REG. 4-12-2011. FINCA AGOSTINO HNOS. S.A. (ARGENTINA CORPORATION) CARRIL BARRANCAS 10590, BARRANCAS, MAIPU, MENDOZA, ARGENTINA., SN 77-412,602. FILED 3-4-2008. PRINCIPAL REGISTER.

3,946,623. REG. 4-19-2011. GEORGIA-PACIFIC GYPSUM LLC (DELAWARE LIMITED LIABILITY COMPANY) 133 PEACHTREE ST, NE, ATLANTA, GA, 30303, SN 77-454,812. FILED 4-22-2008. PRINCIPAL REGISTER.

ALTO AGRELO

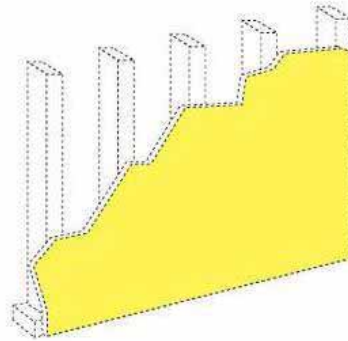

THE MARK CONSISTS OF STANDARD CHARACTERS WITHOUT CLAIM TO ANY PARTICULAR FONT, STYLE, SIZE, OR COLOR.

NO CLAIM IS MADE TO THE EXCLUSIVE RIGHT TO USE "AGRELO", APART FROM THE MARK AS SHOWN.

THE ENGLISH TRANSLATION OF "ALTO" IN THE MARK IS "HIGH."

INT. CL. 33/U.S. CLS. 47 AND 49 FOR WINE.

FIRST USE 11-30-2010; IN COMMERCE 11-30-2010.

ELEMENTS CORRECTED

- *OWNER NAME*
- *OWNER ADDRESS*
- *CITIZENSHIP*
- *ENTITY*

OWNER OF U.S. REG. NO. 3,110,781.

THE COLOR(S) GOLD IS/ARE CLAIMED AS A FEATURE OF THE MARK.

THE MARK CONSISTS OF THE COLOR GOLD AS APPLIED TO THE ENTIRE EXTERIOR SURFACE OF THE GOODS. THE DOTTED OUTLINE OF THE GOODS IS INTENDED TO SHOW THE POSITION OF THE MARK AND IS NOT PART OF THE MARK AS SHOWN.

SEC. 2(F).

INT. CL. 19/U.S. CLS. 1, 12, 33 AND 50 FOR GYPSUM BOARD.

FIRST USE 10-0-1989; IN COMMERCE 10-0-1989.

ELEMENTS CORRECTED

- DATE OF FIRST USE
- DATE OF FIRST USE IN COMMERCE

3,946,094. REG. 4-12-2011. NORTH LOCK, LLC (VIRGINIA LIMITED LIABILITY COMPANY) #714, 2308 MOUNT VERNON AVENUE, ALEXANDRIA, VA, 22301, SN 85-009,560. FILED 4-8-2010. PRINCIPAL REGISTER.

3,951,408. REG. 4-26-2011. NORTH LOCK LLC (VIRGINIA LIMITED LIABILITY COMPANY) 2308 MT VERNON AVE #714, ALEXANDRIA, VA, 22301, SN 77-705,860. FILED 4-2-2009. PRINCIPAL REGISTER.

MONUMENTAL

PORT CITY

THE MARK CONSISTS OF STANDARD CHARACTERS WITHOUT CLAIM TO ANY PARTICULAR FONT, STYLE, SIZE, OR COLOR.

INT. CL. 32/U.S. CLS. 45, 46 AND 48

FOR BEER AND ALE [LAGER, STOUT AND PORTER].

FIRST USE 2-16-2011; IN COMMERCE 2-16-2011.

ELEMENTS AMENDED
GOODS/SERVICES

THE MARK CONSISTS OF STANDARD CHARACTERS WITHOUT CLAIM TO ANY PARTICULAR FONT, STYLE, SIZE, OR COLOR.

INT. CL. 32/U.S. CLS. 45, 46 AND 48

FOR BEER, ALE, [LAGER, STOUT] AND PORTER.

FIRST USE 2-3-2011; IN COMMERCE 2-3-2011.

ELEMENTS AMENDED
GOODS/SERVICES

3,955,531. REG. 5-3-2011. METROPOLITAN TRANSPORTATION COMMISSION (CALIFORNIA A REGIONAL TRANSPORTATION-PLANNING AGENCY ESTABLISHED PURSUANT TO CAL. GOVT. CODE SECTION 66500, ET SEQ.) JOSEPH P. BORT METROCENTER, 101 EIGHTH STREET, OAKLAND, CA, 94607, SN 77-877,909. FILED 11-20-2009. PRINCIPAL REGISTER.

FOR CUSTOM SOFTWARE DESIGN AND DEVELOPMENT.
FIRST USE 6-2-2010; IN COMMERCE 6-2-2010.

ELEMENTS AMENDED
MARK

CLIPPER

THE MARK CONSISTS OF STANDARD CHARACTERS WITHOUT CLAIM TO ANY PARTICULAR FONT, STYLE, SIZE, OR COLOR.

INT. CL. 9/U.S. CLS. 21, 23, 26, 36 AND 38

FOR ENCODED CONTACTLESS SMART CARD FOR USE WITH PUBLIC TRANSPORTATION, ELECTRONIC FARE COLLECTION, ELECTRONIC TOLL COLLECTION, AND ELECTRONIC COLLECTION OF PARKING FEES; ELECTRONIC SYSTEMS FOR USE WITH PUBLIC TRANSPORTATION, ELECTRONIC FARE COLLECTION, ELECTRONIC TOLL COLLECTION, AND ELECTRONIC COLLECTION OF PARKING FEES, NAMELY, SMART CARD READERS, AUTOMATED TRANSIT SYSTEM ENTRY BARRIERS, AND OTHER AUXILIARY EQUIPMENT NAMELY, ON-BOARD SUBSYSTEMS, TICKET OFFICE TERMINALS, ADD VALUE MACHINES, TICKET VENDING MACHINES, AND DATA SERVERS.

FIRST USE 6-16-2010; IN COMMERCE 6-16-2010.

INT. CL. 39/U.S. CLS. 100 AND 105

FOR PUBLIC TRANSIT SERVICES FEATURING AN ELECTRONIC PAYMENT SYSTEM THAT CAN BE USED WITH BUS, RAIL, FERRY, AND OTHER PUBLIC TRANSIT SYSTEMS AND ASSOCIATED PARKING.

FIRST USE 6-16-2010; IN COMMERCE 6-16-2010.

ELEMENTS CORRECTED
OWNER ADDRESS

3,957,060. REG. 5-10-2011. EDGEWATER TECHNOLOGY, INC. (DELAWARE CORPORATION) 20 HARVARD MILL SQUARE, WAKEFIELD, MA, 01880, SN 85-069,930. FILED 6-23-2010. PRINCIPAL REGISTER.



THE MARK CONSISTS OF THE WORDS "EDGEWATER RANZAL" WITH A WAVE DESIGN IN THE BACKGROUND.

INT. CL. 35/U.S. CLS. 100, 101 AND 102

FOR BUSINESS CONSULTING, BUSINESS MANAGEMENT CONSULTING, BUSINESS PERFORMANCE MANAGEMENT CONSULTING, BUSINESS DATA ANALYTICS, BUSINESS DATA INTEGRATION, STRATEGIC PLANNING AND CONSULTING SERVICES FOR BUSINESS.

FIRST USE 6-2-2010; IN COMMERCE 6-2-2010.

INT. CL. 41/U.S. CLS. 100, 101 AND 107

FOR TRAINING IN INFORMATION TECHNOLOGY SYSTEMS, TRAINING IN COMPUTER SOFTWARE USAGE.

FIRST USE 6-10-2010; IN COMMERCE 6-10-2010.

INT. CL. 42/U.S. CLS. 100 AND 101

3,958,594. REG. 5-10-2011. ANATOMIC IRON INC (BR. VIRGIN ISLANDS CORPORATION) P.O. BOX 905, ROAD TOWN, TORTOLA, BR. VIRGIN ISLANDS., SN 77-795,798. FILED 8-3-2009. PRINCIPAL REGISTER.

ANATOMIC IRON INC

THE MARK CONSISTS OF STANDARD CHARACTERS WITHOUT CLAIM TO ANY PARTICULAR FONT, STYLE, SIZE, OR COLOR.

PRIORITY CLAIMED UNDER SEC. 44(D) ON CANADA APPLICATION NO. 1446728, FILED 7-31-2009.

NO CLAIM IS MADE TO THE EXCLUSIVE RIGHT TO USE "IRON INC", APART FROM THE MARK AS SHOWN.

INT. CL. 16/U.S. CLS. 2, 5, 22, 23, 29, 37, 38 AND 50
FOR PRINTED DESIGN PLANS AND PRINTED STRUCTURAL PLANS; BLUEPRINTS.

FIRST USE 1-1-2004; IN COMMERCE 1-1-2004.

INT. CL. 37/U.S. CLS. 100, 103 AND 106

FOR BUILDING CONSTRUCTION SERVICES AND SUPPORT SERVICES, NAMELY, CONSTRUCTION PLANNING IN THE STEEL ERECTION INDUSTRIES.

FIRST USE 1-1-2004; IN COMMERCE 1-1-2004.

INT. CL. 42/U.S. CLS. 100 AND 101

FOR ENGINEERING AND SUPPORT SERVICES, NAMELY, DESIGN AND DEVELOPMENT OF ERECTION PLANS, SPECIFICATIONS AND MODELS AND FABRICATION SPECIFICATIONS AND DRAWINGS IN BOTH PRINTED AND ELECTRONIC FORMATS FOR USE IN CONNECTION WITH STEEL DETAILING, STEEL FABRICATION, AND STEEL ERECTION INDUSTRIES; GRAPHIC ILLUSTRATION AND DRAWING SERVICES, NAMELY, PROVIDING GRAPHIC ILLUSTRATIONS, DESIGN, STRUCTURAL AND FABRICATION PLANS, DRAWINGS AND BLUEPRINTS OF STEEL DETAILING, STEEL FABRICATION AND STEEL BUILDINGS, AND CONVERTING BUILDING DESIGNS, STRUCTURAL AND FABRICATION DRAWINGS AND BLUEPRINTS OR MARKUPS TO ELECTRONIC DRAWINGS.

FIRST USE 1-1-2004; IN COMMERCE 1-1-2004.

ELEMENTS CORRECTED
OWNER NAME

3,959,357. REG. 5-10-2011. BLUESTEM BRANDS, INC. (DELAWARE CORPORATION) 6509 FLYING CLOUD DRIVE, EDEN PRAIRIE, MN, 55344, SN 77-963,506. FILED 3-19-2010. PRINCIPAL REGISTER.

FINGERHUT FRESHSTART

THE MARK CONSISTS OF STANDARD CHARACTERS WITHOUT CLAIM TO ANY PARTICULAR FONT, STYLE, SIZE, OR COLOR.

INT. CL. 36/U.S. CLS. 100, 101 AND 102

FOR CONSUMER CREDIT ACCOUNT SERVICES FOR RETAIL PURCHASES OF GENERAL CONSUMER MERCHANDISE.

FIRST USE 8-25-2010; IN COMMERCE 8-25-2010.

ELEMENTS CORRECTED
MARK

3,960,860. REG. 5-17-2011. KOSTAL INDUSTRIE ELEKTRIK GMBH (FED REP GERMANY LIMITED LIABILITY COMPANY) AN DER BELLMEREI 10, LÜDENSCHIED, FED REP GERMANY, 58513, SN 85-007,104. FILED 4-6-2010. PRINCIPAL REGISTER.

INVEOR

THE MARK CONSISTS OF STANDARD CHARACTERS WITHOUT CLAIM TO ANY PARTICULAR FONT, STYLE, SIZE, OR COLOR.

PRIORITY CLAIMED UNDER SEC. 44(D) ON FED REP GERMANY APPLICATION NO. 302009059358, FILED 10-10-2009, REG. NO. 302009059358, DATED 10-28-2009, EXPIRES 10-10-2019.

INT. CL. 9/U.S. CLS. 21, 23, 26, 36 AND 38

FOR ELECTRONIC CONTROL SYSTEM FOR ELECTRIC MOTORS; DRIVE CONTROL FOR ELECTRIC MOTORS; CONVERTER/INVERTER FOR USE TO DIRECT MAINS VOLTAGE AND MAINS FREQUENCY ACCORDING TO THE APPLICATION INTO THE REQUIRED MAINS VOLTAGE AND POWER FREQUENCY, TO CONVERT A DETERMINED MAINS FREQUENCY INTO A VARIABLE MAINS FREQUENCY, AND TO MANAGE THE ROTARY FREQUENCY OF ELECTRIC MOTORS; FREQUENCY CONVERTER/FREQUENCY INVERTER FOR USE TO DIRECT MAINS VOLTAGE AND MAINS FREQUENCY ACCORDING TO THE APPLICATION INTO THE REQUIRED MAINS VOLTAGE AND POWER FREQUENCY, TO CONVERT A DETERMINED MAINS FREQUENCY INTO A VARIABLE MAINS FREQUENCY, AND TO MANAGE THE ROTARY FREQUENCY OF ELECTRIC MOTORS; SERVO CONTROLLER FOR USE TO DIRECT MAINS VOLTAGE AND MAINS FREQUENCY ACCORDING TO THE APPLICATION INTO THE REQUIRED MAINS VOLTAGE AND POWER FREQUENCY, TO CONVERT A DETERMINED MAINS FREQUENCY INTO A VARIABLE MAINS FREQUENCY, AND TO MANAGE THE ROTARY FREQUENCY OF ELECTRIC MOTORS .

ELEMENTS CORRECTED
OWNER NAME

3,960,965. REG. 5-17-2011. RAUCKMAN UTILITY PRODUCTS, L.L.C. (MISSOURI LIMITED LIABILITY COMPANY) 37 EDNICK DRIVE, SWANSEA, IL, 62226, SN 85-052,573. FILED 6-2-2010. PRINCIPAL REGISTER.

ZAPSHIELD

THE MARK CONSISTS OF STANDARD CHARACTERS WITHOUT CLAIM TO ANY PARTICULAR FONT, STYLE, SIZE, OR COLOR.

INT. CL. 9/U.S. CLS. 21, 23, 26, 36 AND 38

FOR WILDLIFE GUARD, NAMELY, A PLASTIC COVERING THAT FEATURES A DESIGN THAT PERMITS NON-LETHAL ELECTROSTATIC DISCHARGE THROUGH THE WILDLIFE GUARD, AND IS USED TO PROTECT ELECTRICALLY CONDUCTIVE EQUIPMENT FROM WILDLIFE.

FIRST USE 9-0-2003; IN COMMERCE 9-0-2003.

ELEMENTS CORRECTED
GOODS/SERVICES

3,962,386. REG. 5-17-2011. FILER ENTERPRISES LLC (MINNESOTA LIMITED LIABILITY COMPANY) 4730 VAGABOND LANE NO. PLYMOUTH, MN, 55446, SN 77-745,325. FILED 5-27-2009. PRINCIPAL REGISTER.

GRAND CRAZY

THE MARK CONSISTS OF STANDARD CHARACTERS WITHOUT CLAIM TO ANY PARTICULAR FONT, STYLE, SIZE, OR COLOR.

INT. CL. 16/U.S. CLS. 2, 5, 22, 23, 29, 37, 38 AND 50

FOR PRINTED NEWSLETTERS FEATURING SUBJECTS OF INTEREST TO GRANDPARENTS, NAMELY, BIRTH AND NAME ANNOUNCEMENTS, NOTICE OF CELEBRATIONS, GIFT ACKNOWLEDGMENTS, WAYS TO STAY CONNECTED WITH GRANDCHILDREN, AGE APPROPRIATE GIFTS FOR GRANDCHILDREN, AGE APPROPRIATE ACTIVITIES WITH GRANDCHILDREN, WAYS TO CELEBRATE AND NURTURE THE RELATIONSHIPS A NEW GRANDCHILD CREATES BETWEEN FAMILY MEMBERS, TECHNOLOGY AND SOCIAL NETWORKING FOR GRANDPARENTS, CELEBRITY GRANDPARENTS, FAMILY ACTIVITIES, CHILDREN'S SAFETY, CHILDREN'S ENTERTAINMENT AND FAMILY TRAVEL; GREETING CARDS; BUMPER STICKERS.

FIRST USE 11-15-2009; IN COMMERCE 11-15-2009.

INT. CL. 25/U.S. CLS. 22 AND 39

FOR MEN'S AND WOMEN'S CLOTHING, NAMELY, SHIRTS, T-SHIRTS, APRONS, HATS, SWEATSHIRTS, AND JACKETS; CHILDREN AND INFANT'S CLOTHING, NAMELY, JACKETS, SHIRTS, T-SHIRTS, SWEATSHIRTS, UNDERWEAR, ONE-PIECE UNDERWEAR, ONE-PIECE SLEEP SET, HATS, CAPS AND VISORS.

FIRST USE 11-8-2008; IN COMMERCE 11-8-2008.

INT. CL. 35/U.S. CLS. 100, 101 AND 102

FOR RETAIL STORE SERVICES FEATURING CUSTOMIZED AND NON-CUSTOMIZED GIFT BASKETS, CLOTHING, HEADWEAR, BEVERAGWARE, APRONS, MAGNETS, BUTTONS, MESSENGER BAGS, MOUSE PADS, CANVAS BAGS, ORNAMENTS, PLUSH TOYS, PILLOWS, CLOCKS, BOOKS, JOURNALS, COMPACT DISCS, MAGNETS, FRAMED PRINTS, GREETING CARDS, JOURNALS, LICENSE PLATE FRAMES, POSTER PRINTS, STICKERS, AND POSTERS; COMPUTERIZED ONLINE RETAIL STORES FEATURING CUSTOMIZED AND NON-CUSTOMIZED GIFT BASKETS, CLOTHING, HEADWEAR, BEVERAGWARE, APRONS, MAGNETS, BUTTONS, MESSENGER BAGS, MOUSE PADS, CANVAS BAGS, ORNAMENTS, PLUSH TOYS, PILLOWS, CLOCKS, BOOKS, COMPACT DISCS, FRAMED PRINTS, GREETING CARDS, JOURNALS, LICENSE PLATE FRAMES, POSTER PRINTS, STICKERS AND POSTERS.

FIRST USE 11-8-2008; IN COMMERCE 11-8-2008.

INT. CL. 40/U.S. CLS. 100, 103 AND 106

FOR PRINTING SERVICES, NAMELY, CUSTOM IMPRINTING OF CLOTHING, SIGNS, BUMPER STICKERS, COFFEE MUGS, MOUSE PADS, AND SPECIALTY ITEMS; CUSTOM EMBROIDERY SERVICES, NAMELY, CUSTOM EMBROIDERY OF CLOTHING, HATS, BLANKETS AND PILLOWS.

FIRST USE 1-0-2010; IN COMMERCE 1-0-2010.

INT. CL. 41/U.S. CLS. 100, 101 AND 107

FOR PROVIDING ONLINE NEWSLETTERS REGARDING SUBJECTS OF INTEREST TO GRANDPARENTS, NAMELY, BIRTH AND NAME ANNOUNCEMENTS, PICTURES OF GRANDCHILDREN, STORIES RELATING TO GRANDPARENTING, NOTICE OF CELEBRATIONS, GIFT ACKNOWLEDGMENTS, WAYS TO STAY CONNECTED WITH GRANDCHILDREN, AGE APPROPRIATE GIFTS FOR GRANDCHILDREN, AGE APPROPRIATE ACTIVITIES WITH GRANDCHILDREN, WAYS TO CELEBRATE AND NURTURE THE RELATIONSHIPS A NEW GRANDCHILD CREATES BETWEEN FAMILY MEMBERS, TECHNOLOGY AND SOCIAL NETWORKING FOR GRANDPARENTS, CELEBRITY GRANDPARENTS, FAMILY ACTIVITIES, CHILDREN'S SAFETY, CHILDREN'S ENTERTAINMENT AND FAMILY TRAVEL; PROVIDING MEMBERSHIP CLUB AND SOCIAL CLUB SERVICES, NAMELY, ARRANGING, ORGANIZING AND HOSTING SOCIAL EVENTS, GET-TOGETHERS, AND PARTIES FOR CLUB MEMBERS.
 FIRST USE 11-15-2009; IN COMMERCE 11-15-2009.

ELEMENTS CORRECTED
 GOODS/SERVICES

3,963,483. REG. 5-17-2011. PERALTA, MADAY (VENEZUELA INDIVIDUAL) 900 BISCAYNE BLVD., UNIT 2708, MIAMI, FL, 33132, SN 85-040,444. FILED 5-17-2010. PRINCIPAL REGISTER.



THE MARK CONSISTS OF THE OUTLINE OF A PEAR SHAPE WITH 4 SEPARATE RECTANGULAR DESIGNS FORMING THE BACKGROUND ON WHICH THE OUTLINE IS SET.

INT. CL. 35/U.S. CLS. 100, 101 AND 102
 FOR RETAIL STORES FEATURING HOUSEHOLD GOODS AND FURNITURE.
 FIRST USE 12-27-2010; IN COMMERCE 12-27-2010.

ELEMENTS CORRECTED
 OWNER ADDRESS

3,962,644. REG. 5-17-2011. PNY TECHNOLOGIES, INC. (DELAWARE CORPORATION) 299 WEBRO ROAD, PAR-SIPPANY, NJ, 07054, SN 77-849,301. FILED 10-15-2009. PRINCIPAL REGISTER.



3,966,739. REG. 5-24-2011. PICIS, INC. (DELAWARE CORPORATION) SUITE 405, 100 QUANNAPOWITT PARKWAY, WAKEFIELD, MA, 01880, SN 77-637,955. FILED 12-22-2008. PRINCIPAL REGISTER.

**VIEW FOR CRITICAL CARE
 MANAGER**

NO CLAIM IS MADE TO THE EXCLUSIVE RIGHT TO USE "POWER EFFICIENT" AND "AS MUCH AS 30% LESS POWER CONSUMPTION THAN THE STANDARD 9800 GT", APART FROM THE MARK AS SHOWN.

THE MARK CONSISTS OF STYLIZED LETTERS "PE" WITH A STYLIZED DESIGN ELEMENT OF DASHED LINE ABOVE THE LETTERS "PE" PROJECTING FROM THE LETTER "P" TOWARDS THE END OF THE LETTER "E" IN A DOWNWARD SLOPE AND THE LETTER "PE" APPEARING ABOVE THE WORDS "POWER EFFICIENT" ALL WITHIN A RECTANGLE AND THE WORDS "AS MUCH AS 30% LESS POWER CONSUMPTION THAN THE STANDARD 9800 GT" APPEARS WITHIN THE LOWER PORTION OF ANOTHER RECTANGLE THAT APPEARS BEHIND AND SLIGHTLY LOWER THAN THE FIRST RECTANGLE.

INT. CL. 9/U.S. CLS. 21, 23, 26, 36 AND 38
 FOR COMPUTER GRAPHIC CARDS.
 FIRST USE 9-0-2009; IN COMMERCE 9-0-2009.

ELEMENTS CORRECTED
 MARK

THE MARK CONSISTS OF STANDARD CHARACTERS WITHOUT CLAIM TO ANY PARTICULAR FONT, STYLE, SIZE, OR COLOR.

NO CLAIM IS MADE TO THE EXCLUSIVE RIGHT TO USE "CRITICAL CARE MANAGER", APART FROM THE MARK AS SHOWN.

INT. CL. 9/U.S. CLS. 21, 23, 26, 36 AND 38
 FOR COMPUTER SOFTWARE FOR AUTOMATED PATIENT MANAGEMENT AND CLINICAL DOCUMENTATION FOR USE BY HEALTHCARE PROVIDERS.
 FIRST USE 9-0-2008; IN COMMERCE 9-0-2008.

ELEMENTS CORRECTED
 CITIZENSHIP

3,966,810. REG. 5-24-2011. MAIDENFORM, INC. (NEW YORK CORPORATION) 485 ROUTE 1 SOUTH, BUILDING F, THIRD FLOOR - LEGAL DEPARTMENT, ISELIN, NJ, 08830, SN 77-699,210. FILED 3-25-2009. PRINCIPAL REGISTER.

NO CLAIM IS MADE TO THE EXCLUSIVE RIGHT TO USE "BEER", APART FROM THE MARK AS SHOWN. INT. CL. 32/U.S. CLS. 45, 46 AND 48 FOR BEER, ALE, LAGER, STOUT AND PORTER. FIRST USE 11-7-2010; IN COMMERCE 11-7-2010.

ONE MARVELOUS MINIMIZER

ELEMENTS CORRECTED
CITIZENSHIP

THE MARK CONSISTS OF STANDARD CHARACTERS WITHOUT CLAIM TO ANY PARTICULAR FONT, STYLE, SIZE, OR COLOR.

OWNER OF U.S. REG. NO. 1,071,869, AS TO "MINIMIZER".
INT. CL. 25/U.S. CLS. 22 AND 39
FOR FOUNDATION GARMENTS; WOMEN'S UNDERGARMENTS; LINGERIE; BRASSIERES .
FIRST USE 2-0-2009; IN COMMERCE 9-0-2009.

3,975,644. REG. 6-7-2011. BLOOMBERG FINANCE L.P. (DELAWARE LIMITED PARTNERSHIP) 731 LEXINGTON AVENUE, NEW YORK, NY, 10022, SN 78-657,354. FILED 6-23-2005. PRINCIPAL REGISTER.

BLOOMBERG LAUNCHPAD

ELEMENTS CORRECTED
DATE OF FIRST USE IN COMMERCE

THE MARK CONSISTS OF STANDARD CHARACTERS WITHOUT CLAIM TO ANY PARTICULAR FONT, STYLE, SIZE, OR COLOR.

INT. CL. 9/U.S. CLS. 21, 23, 26, 36 AND 38
FOR COMPUTER PROGRAMS FOR USE IN ACCESSING INFORMATION DATABASES, AND FOR PERFORMING PERSONAL COMPUTING APPLICATIONS IN THE AREAS OF NEWS, BUSINESS, FINANCE, CURRENT EVENTS, THE ENTERTAINMENT AND SPORTS INDUSTRIES, HUMAN INTEREST STORIES, SECURITIES, SECURITIES MARKETS, AND THE ENERGY INDUSTRY; COMPUTER PROGRAMS FOR USE IN ANALYZING INTERNATIONAL SECURITIES MARKETS, AND ANALYZING AND REPORTING ON INTERNATIONAL BUSINESS AND FINANCIAL NEWS; COMPUTER SOFTWARE FOR INTERACTIVE ELECTRONIC COMMUNICATION ABOUT SECURITIES.
FIRST USE 8-31-2002; IN COMMERCE 8-31-2002.

3,970,896. REG. 5-31-2011. ANDERSON VALLEY ACQUISITION COMPANY LLC (CALIFORNIA LIMITED LIABILITY COMPANY) 17700 HIGHWAY 253, BOONVILLE, CA, 95415, SN 77-384,828. FILED 1-30-2008. PRINCIPAL REGISTER.

SOLAR POWERED BEER

THE MARK CONSISTS OF STANDARD CHARACTERS WITHOUT CLAIM TO ANY PARTICULAR FONT, STYLE, SIZE, OR COLOR.

ELEMENTS CORRECTED
DATE OF FIRST USE
DATE OF FIRST USE IN COMMERCE

* * * * *

TRADEMARK REGISTRATIONS—NEW CERTIFICATES

New Certificates issued under section 7(d) of the Trademark Act of 1946 for the unexpired term of the original registrations.

3,960,563. A ANGIE'S ARTISAN TREATS AND DESIGN. SEC. 7(D) TO REGISTRANT.
INT. CL. 30. RENO BASTIAN ENTERPRISES, INC.,
NORTH MANKATO, MN. REG. 5-17-2011. NEW CERT.

* * * * *

This page is intentionally blank

INDEX OF REGISTRANTS

JULY 19, 2011

(Registered; Renewed; Canceled; Amended, Corrected, etc.; New Certificates; 12c Publications.)

The designation "U.S. Cl." appearing in this section refers to the U.S. class in effect prior to Sep. 1, 1973 rather than the international class which applies to applications filed on or after that date. For adoption of international classification see notice in the OFFICIAL GAZETTE of Jun. 26, 1973 (911 O.G. TM 210).

?WHAT IF! HOLDINGS LTD, LONDON, UNITED KINGDOM:
3,995,888, PUB. 5-3-2011. INT. CL. 41.

"KRONOPOL" SPÓLKA Z OGRANICZONA ODPOWIEDZIALNOSCIA, POLAND:
3,995,886, PUB. 5-3-2011. MULTIPLE CLASS, INT. CLS. 19 AND 37.

A - 1 AWARDS, INC., INDIANAPOLIS, IN:
2,901,108, CANC. INT. CL. 40.

A BETTER WEIGH, INC., CHICAGO, IL:
3,996,133, PUB. 5-3-2011. INT. CL. 5.

A NEW FINANCIAL PLAN, LLC, TULSA, OK:
3,997,542, PUB. 5-3-2011. INT. CL. 36.

A WEIGH OF LIFE LLC, WEST BLOOMFIELD, MI:
3,997,681, PUB. 5-3-2011. INT. CL. 44.

A WORLD FIT FOR KIDS, LOS ANGELES, CA:
3,996,934, PUB. 5-3-2011. MULTIPLE CLASS, INT. CLS. 35 AND 41.

A. DE FUSSIGNY SA, 16100 COGNAC, FRANCE:
2,901,057, CANC. INT. CL. 33.

A.S. TRUST & HOLDINGS, INC., KANEHOHE, HI:
3,998,484, INT. CL. 1.

A&A HARRIS ENTERPRISES, ALAMEDA, CA:
2,401,926, CANC. INT. CL. 9.

A&A MARKETING, INC., BUFFALO GROVE, IL:
3,996,491, PUB. 5-3-2011. INT. CL. 35.

A&E TELEVISION NETWORKS, LLC, NEW YORK, NY:
2,450,795, REN. 6-14-11. INT. CL. 16.

A-1 MANHATTAN CUSTOM FURNITURE INC., LONG ISLAND, NY:
2,479,386, REN. 6-16-11. INT. CL. 20.

AAA WILDLIFE CONTROL LTD., PICKERING, ONTARIO L1X1V6, CANADA:
2,901,269, CANC. INT. CL. 37.

AARON DIRKS, NEW ORLEANS, LA:
3,997,509, PUB. 5-3-2011. INT. CL. 39.

AARON, LAWRENCE D, HACKETTSTOWN, NJ, DBA EVERBRAND, LLC:
3,997,501, PUB. 5-3-2011. INT. CL. 35.

AAV REAL ESTATE MORTGAGE EXCHANGE, INC., LA CANADA, CA:
2,402,876, CANC. INT. CL. 36.

ABB INC., NORWALK, CT:
2,901,267, CANC. INT. CL. 37.

ABBOTT CARDIOVASCULAR SYSTEMS, INC., SANTA CLARA, CA:
2,466,460, REN. 6-16-11. INT. CL. 10.

ABC SPORTS INC., NEW YORK, NY, AMERICAN BROADCASTING COMPANIES, INC., NEW YORK, NY:
1,171,674, REN. 6-10-11. INT. CL. 41.

ABC SPORTS, INC., NEW YORK, NY, AMERICAN BROADCASTING COMPANIES, INC., NEW YORK, NY:
1,170,597, REN. 6-10-11. INT. CL. 41.

ABDEL FAHMY, OAKBROOK TERRACE, IL:
3,997,883, PUB. 5-3-2011. INT. CL. 9.

ABDULLAIEVA INTERNATIONAL TRADE COMPANY, RANCHO CUCAMONGA, CA, DBA SLEEP & BEYOND:
3,996,251, PUB. 5-3-2011. MULTIPLE CLASS, INT. CLS. 20 AND 24.

ABIOMED, INC., DANVERS, MA:
1,645,900, REN. 6-16-11. INT. CL. 10.

ABL IP HOLDING LLC, CONYERS, GA:
2,482,704, REN. 6-13-11. INT. CL. 11.

ABOVE ALL INTELLECTUAL PROPERTIES, CORDOVA, TN:
3,996,303, PUB. 5-3-2011. INT. CL. 44.

ABRAHAM, THOMAS G., MIAMI, FL:
3,998,478, MULTIPLE CLASS, INT. CLS. 40 AND 41.

ABRAHAM, THOMAS G., CORAL GABLES, FL:
3,998,489, MULTIPLE CLASS, INT. CLS. 40 AND 41.

ABRAMS AIRBORNE MANUFACTURING, INC., TUCSON, AZ, DBA VLTOR WEAPON SYSTEMS:
3,998,455, INT. CL. 25.
3,998,473, INT. CL. 25.

ABRASIVE TECHNOLOGY, INC., LEWIS CENTER, OH:
1,179,841, REN. 6-13-11. INT. CL. 7.

ABSHIER, NATALIE, MEAD, CO:
3,999,081, INT. CL. 25.

ABSOLUTE BRILLIANCE, INC., NEW YORK, NY:
2,570,841, REN. 6-16-11. INT. CL. 14.

ABUNDANT ENERGY, L.L.C., PLANO, TX:
3,998,656, INT. CL. 7.

ABUNDANT POWER GROUP, LLC, CHARLOTTE, NC:
3,999,126, INT. CL. 36.

ACADEMY VIDEO TECHNOLOGIES, INC., MIAMI, FL:
3,999,094, MULTIPLE CLASS, INT. CLS. 42 AND 45.

ACADIA HOMES & NEIGHBORHOODS, LLC, ATLANTA, GA:
3,996,599, PUB. 5-3-2011. INT. CL. 37.

ACCAM, ALFRED T, SUGAR LAND, TX:
3,998,098, PUB. 5-3-2011. INT. CL. 42.

ACCELERATO, LLC, ST. PAUL, MN:
3,999,633, INT. CL. 35.

ACCELIO CORPORATION, OTTAWA, ONTARIO, CANADA:
2,901,011, CANC. INT. CL. 9.

ACCELRY INC., SAN DIEGO, CA:
2,901,887, CANC. INT. CL. 9.

ACCESSORYONE, SHERMAN OAKS, CA:
3,996,057, PUB. 5-3-2011. INT. CL. 9.

ACCOUNTAGILITY, LLC, WAXHAW, NC:
3,997,116, PUB. 5-3-2011. INT. CL. 35.

ACCOUNTINGNET SOLUTIONS, INC, SEATTLE, WA:
2,402,968, CANC. INT. CL. 35.

ACCUBUILT, INC., LIMA, OH:
3,997,276, PUB. 5-3-2011. INT. CL. 12.

ACCURATE MARKETING ADVANTAGES INC., BELLEVUE, NE:
3,996,680, PUB. 5-3-2011. INT. CL. 35.

ACCUSTREAM, INC., NEW BRIGHTON, MN:
3,997,080, PUB. 5-3-2011. INT. CL. 7.

ACOCK, JAMES, PORTLAND, OR:
3,997,606, PUB. 5-3-2011. INT. CL. 31.

ACS TECHNOLOGIES, INC., WILMINGTON, DE:
2,449,672, REN. 6-15-11. INT. CL. 21.

ACTIVISION PUBLISHING, INC., SANTA MONICA, NY:
2,402,866, CANC. INT. CL. 9.
2,402,867, CANC. INT. CL. 9.

ACUCAREIRA ZILLO LORENZETTI S.A., EST. SAO PAULO, BRAZIL:
2,470,256, REN. 6-10-11. INT. CL. 30.

ADALBERTO GROSSI, ITALY:
3,995,896, PUB. 5-3-2011. MULTIPLE CLASS, INT. CLS. 9

- AND 25.
 ADAMS GOLF IP, LTD., PLANO, TX:
 2,490,264. REN. 6-15-11. INT. CL. 28.
 2,490,264. COR. INT. CL. 28.
 ADANCED RAIL CONCEPTS, LLC, SNOHOMISH, WA:
 3,996,622. PUB. 5-3-2011. INT. CL. 7.
 ADAP.TV INC., SAN MATEO, CA:
 3,998,485. INT. CL. 35.
 ADBASE INC., TORONTO, ONTARIO, CANADA:
 3,996,044. PUB. 5-3-2011. MULTIPLE CLASS, INT. CLS.
 16, 35 AND 41.
 ADECCO SA, CHESEREX, SWITZERLAND:
 2,947,630. CANC. MULTIPLE CLASS, INT. CLS. 9 AND
 39.
 ADELPHOI LIMITED, LONDON, UNITED KINGDOM:
 3,996,037. PUB. 5-3-2011. MULTIPLE CLASS, INT. CLS. 9,
 35, 42 AND 45.
 ADEPT ENGRAVING LLC, CHIPPEWA FALLS, WI:
 3,999,502. INT. CL. 19.
 ADESSO INC., NEW YORK, NY:
 3,996,376. PUB. 5-3-2011. MULTIPLE CLASS, INT. CLS. 11
 AND 20.
 ADIDAS AG, HERZOGENAURACH 91074, FED REP GER-
 MANY:
 3,997,183. PUB. 5-3-2011. MULTIPLE CLASS, INT. CLS. 35
 AND 41.
 ADIE, ROB, CAMBRIDGE, CANADA:
 3,999,703. INT. CL. 17.
 ADLINQ, INC., REDMOND, WA:
 2,503,054. REN. 6-15-11. INT. CL. 41.
 ADOPTIMISM, BROOKLYN, NY:
 3,998,069. PUB. 5-3-2011. INT. CL. 45.
 ADRENALINE SPORTS MANAGEMENT INC., CARY, IL:
 3,998,210. PUB. 5-3-2011. INT. CL. 41.
 ADTASTIC HOSTING AND INTERNET SERVICES, LLC,
 SHIRLEY, AR:
 3,997,866. PUB. 5-3-2011. INT. CL. 42.
 ADVANCED IMAGING RESEARCH, INC., CLEVELAND,
 OH:
 3,997,178. PUB. 5-3-2011. INT. CL. 10.
 ADVANCED INSTRUMENTS, INC., NORWOOD, MA:
 3,998,321. INT. CL. 9.
 ADVANCED MULTIMEDIA DEVICES INC., HICKSVILLE,
 NY:
 2,901,339. CANC. INT. CL. 9.
 2,901,340. CANC. INT. CL. 9.
 ADVANCED NUTRIENT SCIENCE, LLC, LARGO, FL:
 3,999,362. INT. CL. 5.
 ADVANCED NUTRIENTS LTD., ABBOTSFORD, CANADA:
 3,999,891. INT. CL. 1.
 3,999,892. INT. CL. 1.
 ADVANCED NUTRIENTS LTD., ABBOTSFORD, BC, CA-
 NADA:
 3,999,998. INT. CL. 1.
 ADVANCED STATE OF NETWORKING, INC., YORK, PA:
 3,997,558. PUB. 5-3-2011. MULTIPLE CLASS, INT. CLS. 37
 AND 42.
 ADVANSTAR WIDEBAND, CLEVELAND, OH TO ADVAN-
 STAR COMMUNICATIONS INC., DULUTH, MN:
 2,402,398. CANC. INT. CL. 16.
 ADVENTURATI, LLC, WASHINGTON, DC:
 3,996,903. PUB. 5-3-2011. INT. CL. 39.
 ADVERTICKETS LLC, SANTA BARBARA, CA:
 2,402,125. CANC. INT. CL. 35.
 ADZINIA MEDIA GROUP LLC, SEATTLE, WA:
 3,998,534. INT. CL. 16.
 AED ENTERPRISES, LLC, CINCINNATI, OH:
 3,996,549. PUB. 5-3-2011. MULTIPLE CLASS, INT. CLS. 30
 AND 35.
 AER LINGUS LIMITED, DUBLIN, IRELAND:
 3,995,468. PUB. 5-3-2011. INT. CL. 39.
 AERODYNE INTERNATIONAL, LUXEMBOURG, LUXEM-
 BOURG:
 2,902,409. CANC. MULTIPLE CLASS, INT. CLS. 12 AND
 28.
 AEROMODAL CARGOLIFTER, INC., THE WOODLANDS,
 TX:
 3,999,805. INT. CL. 39.
 AEROSTAR TRAINING SERVICES, LLC, TEQUESTA, FL:
 3,997,067. PUB. 5-3-2011. INT. CL. 41.
 AF NETWORKS LLC, PALOS PARK, IL:
 3,996,104. PUB. 5-3-2011. INT. CL. 41.
 AFD RESOURCE GROUP, PORTLAND, OR, DBA ALPINE
 FOOD DISTRIBUTING INC.:
 3,999,488. INT. CL. 29.
 AFFINITON, WILLIAMSPORT, PA:
 3,996,911. PUB. 5-3-2011. INT. CL. 35.
 3,997,385. PUB. 5-3-2011. INT. CL. 42.
 AFFINITY PETCARE, S.A., BARCELONA, SPAIN:
 2,901,534. CANC. INT. CL. 31.
 AFFINIUM PHARMACEUTICALS, INC., TORONTO, ON-
 TARIO, CANADA:
 2,901,039. CANC. INT. CL. 42.
 AFFIVAL, FRANCE:
 3,995,817. PUB. 5-3-2011. MULTIPLE CLASS, INT. CLS. 1
 AND 6.
 AFFORDABLE VETERINARY SERVICES LLC, COLUM-
 BUS, GA:
 3,997,196. PUB. 5-3-2011. INT. CL. 44.
 AFTER HOURS PEDIATRICS, INC., RIVERVIEW, FL:
 2,450,944. REN. 6-15-11. INT. CL. 42.
 AFTER50, INC., TONAWANDA, NY:
 3,999,254. INT. CL. 16.
 AFTON CHEMICAL INTANGIBLES LLC, RICHMOND, VA:
 2,451,700. REN. 6-15-11. INT. CL. 1.
 AGAVERA CAMICHINES, S.A. DE C.V., CHAPALA, TLA-
 QUEPAQUE, JALISCO, MEXICO:
 3,998,481. INT. CL. 33.
 AGC, LLC, CLEVELAND, OH:
 2,402,865. CANC. INT. CL. 16.
 AGENCYPORT INSURANCE SERVICES, INC., BOSTON,
 MA:
 3,995,642. PUB. 5-3-2011. INT. CL. 9.
 AGENNIX AG, FED REP GERMANY:
 3,995,950. PUB. 5-3-2011. MULTIPLE CLASS, INT. CLS. 5
 AND 42.
 AGERE SYSTEMS INC., ALLENTOWN, PA:
 2,401,664. CANC. INT. CL. 9.
 AGEWELL SYSTEMS, INC., SALT LAKE CITY, UT:
 3,999,592. INT. CL. 41.
 AGILENT TECHNOLOGIES, INC., SANTA CLARA, CA:
 3,998,958. INT. CL. 9.
 3,998,959. INT. CL. 9.
 3,998,960. INT. CL. 9.
 3,998,961. INT. CL. 9.
 AGNES ZAWADZKA, WHEELING, IL:
 3,996,851. PUB. 5-3-2011. INT. CL. 41.
 AGR SUBSEA AS, NORWAY:
 3,995,885. PUB. 5-3-2011. MULTIPLE CLASS, INT. CLS. 7
 AND 37.
 AGRAQUEST, INC., DAVIS, CA:
 3,999,150. INT. CL. 5.
 AGRESSOR CORPORATION PTY LTD. AUSTRALIA:
 3,995,954. PUB. 5-3-2011. INT. CL. 18.
 AGUIAR, JOSEPH J, BRONX, NY AND AGUIAR, JOHNNY
 J, BRONX, NY AND OFFICER, BRETT A, BROOKLYN,
 NY:
 3,998,760. INT. CL. 41.
 AHI ACQUISITION, LLC, CARLSTADT, NJ:
 3,999,665. INT. CL. 3.
 AIKATERINA LLC, NEW ORLEANS, LA:
 3,997,645. PUB. 5-3-2011. INT. CL. 24.
 AIR PRODUCTS AND CHEMICALS, INC., ALLENTOWN,
 PA:
 1,172,745. REN. 6-16-11. INT. CL. 1.
 AIR TO GROUND CALLS INC. GAINESVILLE, GA:
 3,997,444. PUB. 5-3-2011. INT. CL. 28.
 AIRDALE BREWING COMPANY, LLC, SAN DIEGO, CA:
 3,999,226. INT. CL. 32.
 AIRPORT RANCH ESTATES, LLC, PROSSER, WA, DBA
 AIRFIELD ESTATES:
 3,995,604. PUB. 5-3-2011. INT. CL. 33.
 AIRWAYS BREWING COMPANY LLC, KENT, WA, DBA
 AIRWAYS BREWING COMPANY:
 3,996,751. PUB. 5-3-2011. INT. CL. 32.

AJM IMPORTS, INC., MELROSE PARK, IL:
3,999,595, INT. CL. 32.

AKADEMOS, INC., NORWALK, CT:
3,995,704, PUB. 5-3-2011. INT. CL. 35.

AKASHA, ANN ARBOR, MI:
3,996,763, PUB. 5-3-2011. MULTIPLE CLASS, INT. CLS.
19, 20, 21 AND 26.

AKBAR, INC., WICHITA FALLS, TX:
3,997,053, PUB. 5-3-2011. INT. CL. 43.

AKEBONO BRAKE INDUSTRY CO., LTD., TOKYO, JAPAN:
3,995,965, PUB. 5-3-2011. INT. CL. 12.

AKRON PAINT & VARNISH, INC., AKRON, OH:
3,999,554, INT. CL. 2.

AKRYON, NEUILLY SUR SEINE, FRANCE:
3,995,586, PUB. 5-15-2010. INT. CL. 5.

AKURANVYKA USA INC., SOUTH SAN FRANCISCO, CA,
DBA CURRY UP NOW:
3,997,258, PUB. 5-3-2011. INT. CL. 35.

AL-BASHA, PATERSON, NJ:
3,995,464, PUB. 5-3-2011. INT. CL. 43.

ALAKEF COFFEE ROASTERS, INC., DULUTH, MN:
3,997,584, PUB. 5-3-2011. INT. CL. 30.

ALASKA STRUCTURES, INC., ANCHORAGE, AK:
2,537,512. REN. 6-15-11. INT. CL. 19.
3,998,798, MULTIPLE CLASS, INT. CLS. 7, 9, 11, 19 AND
20.
3,998,799, MULTIPLE CLASS, INT. CLS. 7, 9, 11, 19 AND
20.

ALBERT HORN SÖHNE GMBH & CO. KG, FED REP
GERMANY:
3,995,914, PUB. 5-3-2011. INT. CL. 16.

ALBERTS, TONY, ARNOLD, MO:
2,467,796. REN. 6-10-11. INT. CL. 42.

ALBOR S.P.A., GAMBASSI TERME (FI), ITALY:
3,995,616, PUB. 3-8-2011. INT. CL. 20.

ALCORINVEST S.R.L., MILANO, ITALY:
3,996,066, PUB. 2-1-2011. INT. CL. 25.

ALDI INC., BATAVIA, IL:
3,998,716, INT. CL. 32.
3,998,849, INT. CL. 9.
3,999,492, INT. CL. 16.

ALDRIDGE, MICHAEL D., NEWARK, DE:
3,997,058, PUB. 5-3-2011. INT. CL. 35.

ALEJANDRO GARCÍA FLORES, ALTAMIRA TAMAULI-
PAS, MEXICO AND IRMA ELMA GARCÍA FLORES,
ALTAMIRA TAMAULIPAS, MEXICO AND JOSÉ IGNA-
CIO GARCÍA FLORES, ALTAMIRA TAMAULIPAS, MEXI-
CO AND LEOPOLDO GARCÍA FLORES, ALTAMIRA
TAMAULIPAS, MEXICO:
3,998,830, INT. CL. 12.

ALETHIA SKIN CARE LLC, ARDMORE, PA:
3,998,752, INT. CL. 3.

ALEX MILNE ASSOCIATES LTD., ETOBICOKE, ONTARIO,
CANADA:
3,996,712, PUB. 5-3-2011. INT. CL. 1.

ALEXANDER G. WEBBE, WELLINGTON, FL:
3,996,180, PUB. 5-3-2011. MULTIPLE CLASS, INT. CLS. 25
AND 41.

ALEXANDER, ANITH E., CHICAGO, IL AND ALEXAN-
DER, KEITH L.T., ANN ARBOR, IL:
2,901,573, CANC. INT. CL. 35.

ALEXANDRIA ECONOMIC DEVELOPMENT PARTNER-
SHIP, INC., ALEXANDRIA, VA:
3,996,093, PUB. 5-3-2011. INT. CL. 35.

ALFRED DEVELOPMENT CORP., BARRINGTON, RI, DBA
BODY NATURAL FITNESS CENTER:
3,998,525, INT. CL. 32.

ALISSA BARTHEL, MINNEAPOLIS, MN:
3,995,696, PUB. 5-3-2011. INT. CL. 43.

ALIZYME THERAPEUTICS LIMITED, CAMBRIDGE CBI
6GS, ENGLAND:
2,901,032, CANC. INT. CL. 5.

ALL AMERICAN PRODUCTS GROUP, INC., SAN FERNAN-
DO, CA:
3,997,439, PUB. 5-3-2011. INT. CL. 8.

ALL OF THE ABOVE, SASKATOON, CANADA:
3,995,553, PUB. 5-3-2011. MULTIPLE CLASS, INT. CLS. 9
AND 41.

ALL SAINTS CAMP AND CONFERENCE CENTER, INC.,
POTTSBORO, TX:
3,999,364, INT. CL. 41.

ALL STAR PREMIUM PRODUCTS INC., FISKDALE, MA:
3,997,555, PUB. 5-3-2011. INT. CL. 42.

ALLEGIANCE CORPORATION, MCGAW PARK, IL:
2,901,691, CANC. INT. CL. 35.

ALLEN CREEK LLC, WESTPORT, MA:
3,997,551, PUB. 5-3-2011. INT. CL. 29.

ALLEN MEDICAL SYSTEMS, INC., BATESVILLE, IN:
3,997,488, PUB. 5-3-2011. INT. CL. 10.

ALLIANCE ENTERTAINMENT, LLC, CORAL SPRINGS, FL:
2,401,942, CANC. INT. CL. 16.

ALLIANCE FOR PATIENT MEDICATION SAFETY, RICH-
MOND, VA:
3,999,943, MULTIPLE CLASS, INT. CLS. 41 AND 44.

ALLIANCE LAUNDRY SYSTEMS LLC, RIPON, WI:
2,515,079. REN. 6-10-11. INT. CL. 9.

ALLIANCE STORAGE TECHNOLOGIES, INC., COLORADO
SPRINGS, CO:
3,998,513, INT. CL. 9.

ALLIANZ SE, MUNCHEN, FED REP GERMANY:
2,515,960. REN. 6-14-11. INT. CL. 36.

ALLIANZ SE, FED REP GERMANY:
3,995,991, PUB. 5-3-2011. INT. CL. 36.

ALLIED MANAGEMENT, INC., LIVINGSTON, NJ:
2,402,053, CANC. INT. CL. 33.

ALLOY MEDIA, LLC, NEW YORK, NY:
3,996,156, PUB. 5-3-2011. MULTIPLE CLASS, INT. CLS. 35
AND 41.

ALLRED, ALAN, ELON, NC:
3,997,604, PUB. 5-3-2011. INT. CL. 28.

ALLSOP, INC., BELLINGHAM, WA:
3,997,749, PUB. 5-3-2011. INT. CL. 11.

ALLSTAFF MANAGEMENT, INC., DULUTH, GA:
2,576,975. REN. 6-15-11. INT. CL. 35.

ALLVIANT CORPORATION, SCOTTSDALE, AZ:
3,996,150, PUB. 5-3-2011. INT. CL. 42.

ALLVIANT CORPORATION, ACOTTSDALE, AZ:
3,996,158, PUB. 5-3-2011. INT. CL. 42.

ALM MANAGEMENT SERVICES LLC, HONOLULU, HI:
3,997,674, PUB. 5-3-2011. MULTIPLE CLASS, INT. CLS.
35, 36 AND 43.

ALOXXI INTERNATIONAL CORPORATION, TARZANA,
CA:
3,999,731, INT. CL. 3.

ALOXXI INTERNATIONAL CORPORATION, SHERMAN
OAKS, CA:
3,999,733, INT. CL. 3.

ALPHA PHOTOGRAPHY INC., HOUSTON, TX, DBA
CATCHTHEMOMENT:
3,044,177, CANC. INT. CL. 9.
3,082,478, CANC. MULTIPLE CLASS, INT. CLS. 16 AND
41.

ALPHA PRO TECH, INC., NOGALES, AZ:
2,498,217. REN. 6-16-11. INT. CL. 9.
2,498,218. REN. 6-16-11. INT. CL. 9.

ALPHAVISTA SERVICES, INC., SUNNYVALE, CA:
3,996,517, PUB. 5-3-2011. INT. CL. 9.

ALPINE HOLDING B.V., 3789 AL SOESTERBERG, NETHER-
LANDS:
3,997,635, PUB. 5-3-2011. INT. CL. 9.
3,997,636, PUB. 5-3-2011. INT. CL. 9.
3,998,221, PUB. 5-3-2011. INT. CL. 9.
3,998,261, PUB. 5-3-2011. INT. CL. 9.

ALRAHIB, AKRUM, COMMERCE, CA:
3,998,333, INT. CL. 34.

ALSTOM POWER INC., WINDSOR, CT:
3,996,090, PUB. 5-3-2011. INT. CL. 11.

ALSTON, DAVID D., CHARLESTON, SC:
3,998,538, INT. CL. 41.

ALTERNATIVE PACKAGING SOLUTIONS, LP, LAKE ST.
LOUIS, MO:
2,901,895, CANC. INT. CL. 21.

ALTICAST CORPORATION, SEOUL, REPUBLIC OF KOR-
EA:
3,997,337, PUB. 5-3-2011. INT. CL. 9.

- ALTIMATE MEDICAL, INC., MORTON, MN:
3,996,490, PUB. 5-3-2011. INT. CL. 10.
3,996,730, PUB. 5-3-2011. INT. CL. 10.
- ALTO DE CASABLANCA S.A., CASABLANCA, CHILE:
3,995,581, PUB. 5-3-2011. INT. CL. 33.
- AM GROUP PLUS SPÓLKA Z O.O., BYDGOSZCZ, POLAND:
3,997,274, PUB. 5-3-2011. INT. CL. 9.
- AMADASUN, PATRICK, I, JOHNS CREEK, GA:
3,998,129, PUB. 5-3-2011. INT. CL. 30.
- AMAG PHARMACEUTICALS, INC., LEXINGTON, MA:
3,998,406, INT. CL. 42.
- AMAZON TECHNOLOGIES, INC., LAS VEGAS, NV:
3,999,646, INT. CL. 9.
- AMERICAN ASSOCIATION FOR CANCER RESEARCH,
INC., PHILADELPHIA, PA:
3,999,961, MULTIPLE CLASS, INT. CLS. 16 AND 41.
- AMERICAN ASSOCIATION OF PHYSICIAN SPECIALISTS,
INC., TAMPA, FL:
3,997,728, PUB. 5-3-2011. INT. CL. 42.
- AMERICAN AXLE & MANUFACTURING, INC., DETROIT,
MI:
3,998,018, PUB. 5-3-2011. MULTIPLE CLASS, INT. CLS. 40
AND 42.
- AMERICAN BLUE RIBBON HOLDINGS, LLC, DENVER,
CO:
3,999,934, INT. CL. 43.
- AMERICAN BOMBSHELLS ENTERTAINMENT, INC., MEL-
VILLE, NY:
3,997,625, PUB. 5-3-2011. INT. CL. 36.
- AMERICAN BOTANICAL PHARMACY, MARINA DEL
REY, CA:
3,996,097, PUB. 5-3-2011. INT. CL. 5.
- AMERICAN COLLEGE FOR ADVANCEMENT IN MEDI-
CINE, LAGUNA HILLS, CA:
2,401,333, CANC. MULTIPLE CLASS, INT. CLS. 16 AND
42.
- AMERICAN COUNCIL OF TRUSTEES AND ALUMNI,
WASHINGTON, DC:
3,997,469, PUB. 5-3-2011. MULTIPLE CLASS, INT. CLS. 16
AND 41.
- AMERICAN DENTAL SUPPLY, INC., ALLENTOWN, PA,
AKA ADS, INC.:
3,996,274, PUB. 5-3-2011. INT. CL. 4.
- AMERICAN EXPRESS MARKETING & DEVELOPMENT
CORP., NEW YORK, NY:
3,999,410, INT. CL. 41.
3,999,414, MULTIPLE CLASS, INT. CLS. 9, 36 AND 38.
3,999,670, MULTIPLE CLASS, INT. CLS. 9, 36 AND 38.
- AMERICAN FIDELITY ASSURANCE COMPANY, OKLA-
HOMA CITY, OK:
2,401,645, CANC. INT. CL. 36.
- AMERICAN HANDCUFF CO., FOND DU LAC, WI:
2,402,952, CANC. INT. CL. 6.
- AMERICAN HARDWARE MANUFACTURERS ASSOCIA-
TION, SCHAUMBURG, IL:
2,402,551, CANC. MULTIPLE CLASS, INT. CLS. 35 AND
41.
- AMERICAN INSTITUTE OF PHYSICS, MELVILLE, NY,
AKA AIP:
2,428,538, REN. 6-15-11. INT. CL. 16.
- AMERICAN INTERNATIONAL GROUP, INC., NEW YORK,
NY, BROAD INC., LOS ANGELES, CA:
1,659,110, REN. 6-14-11. INT. CL. 36.
- AMERICAN INTERNATIONAL GROUP, INC., NEW YORK,
NY:
2,488,887, REN. 6-15-11. INT. CL. 36.
2,489,254, REN. 6-16-11. INT. CL. 36.
- AMERICAN INTERNATIONAL GROUP, INC., NEW YORK,
NY, MARATHON TRAVEL & CRUISE SHOPS, INC.,
MADISON, WI:
2,491,746, REN. 6-15-11. INT. CL. 39.
- AMERICAN INTERNATIONAL GROUP, INC., NEW YORK,
NY:
2,902,362, CANC. INT. CL. 36.
- AMERICAN INTERNET HOLDINGS, L.L.C., MIDLAND
PARK, NJ:
2,900,959, CANC. INT. CL. 9.
- AMERICAN LEBANESE SYRIAN ASSOCIATED CHARI-
TIES, INC., MEMPHIS, TN:
3,997,587, PUB. 5-3-2011. INT. CL. 36.
- AMERICAN MANAGEMETN GROUP, LLC, FORT WA-
SHINGTON, PA:
3,996,641, PUB. 5-3-2011. INT. CL. 44.
- AMERICAN NATIONAL STANDARDS INSTITUTE, IN-
CORPORATED, NEW YORK, NY:
3,075,951, COR. INT. CL. 16.
3,212,951, COR. MULTIPLE CLASS, INT. CLS. 16 AND
42.
3,224,742, COR. MULTIPLE CLASS, INT. CLS. 16 AND
42.
- AMERICAN PAYMENT SYSTEMS, INC., OMAHA, NE:
3,999,919, INT. CL. 35.
- AMERICAN PHYSIOLOGICAL SOCIETY, THE, BETHESDA,
MD:
2,567,353, REN. 6-10-11. INT. CL. 16.
- AMERICAN POP CORN COMPANY, SIOUX CITY, IA:
3,997,930, PUB. 5-3-2011. INT. CL. 30.
- AMERICAN REGISTRY, LLC, BOCA RATON, FL:
3,996,950, PUB. 5-3-2011. INT. CL. 40.
- AMERICAN SCIENTIFIC RESOURCES, INC., NEW PALTZ,
NY:
3,998,123, PUB. 5-3-2011. INT. CL. 10.
- AMERICAN SEAFOODS GROUP LLC, SEATTLE, WA:
3,999,893, INT. CL. 29.
- AMERICAN SEASONS CORP., NANTUCKET, MA:
2,482,177, REN. 6-14-11. INT. CL. 42.
- AMERICAN SKIN FOOD GROUP, LLC, BURGAW, NC:
3,997,066, PUB. 5-3-2011. INT. CL. 30.
- AMERICAN SOCCER COMPANY, INC., WILMINGTON,
CA:
2,976,209, AM. INT. CL. 25.
- AMERICAN SOCIETY FOR MICROBIOLOGY, WASHING-
TON, DC:
3,996,082, PUB. 5-3-2011. INT. CL. 41.
- AMERICAN SOCIETY OF CLINICAL ONCOLOGY, ALEX-
ANDRIA, VA:
3,995,533, PUB. 5-3-2011. MULTIPLE CLASS, INT. CLS.
16, 35, 36, 41, 42 AND 44.
- AMERICAN SOCIETY ON AGING, SAN FRANCISCO, CA:
3,997,151, PUB. 5-3-2011. INT. CL. 35.
- AMERICAN SPORTS LICENSING, INC., WILMINGTON,
DE:
2,948,815, CANC. INT. CL. 25.
- AMERICAN TEXTILE COMPANY, DUQUESNE, PA:
3,999,077, MULTIPLE CLASS, INT. CLS. 20 AND 24.
- AMERICAN TIRE DISTRIBUTORS, INC., HUNTERSVILLE,
NC:
3,998,612, MULTIPLE CLASS, INT. CLS. 35, 37 AND 39.
- AMERICAN VILLAGE, WOODBRIDGE, VA:
3,996,643, PUB. 5-3-2011. INT. CL. 35.
- AMERICAN WATERWELL INTERNATIONAL CORPORA-
TION, WILMINGTON, NEW CASTLE, DE:
3,998,166, PUB. 5-3-2011. INT. CL. 9.
- AMERICAN WOODMARK CORPORATION, WINCHE-
STER, VA:
3,995,477, PUB. 5-3-2011. INT. CL. 16.
3,995,478, PUB. 5-3-2011. INT. CL. 16.
- AMERICO LIFE, INC., KANSAS CITY, MO:
3,997,827, PUB. 5-3-2011. INT. CL. 36.
- AMERIFOLIO, INC., LEWISBURG, PA:
3,998,006, PUB. 5-3-2011. INT. CL. 42.
- AMERIMERCHANT, LLC, NEW YORK, NY:
2,901,681, CANC. INT. CL. 36.
- AMERIMMUNE LLC, SPRINGFIELD, VA:
3,999,796, INT. CL. 44.
- AMERISCIENCES, LP, HOUSTON, TX:
3,997,175, PUB. 5-3-2011. INT. CL. 5.
- AMES RESEARCH LABORATORIES INCORPORATED,
SALEM, OR:
3,998,823, INT. CL. 2.
- AMFINITY CAPITAL, L.L.C., BELOIT, WI:
2,401,417, CANC. INT. CL. 36.
- AMICUS TRADE AB, BÅSTAD, SWEDEN, DBA HOLDON
SYSTEMS:
3,999,724, INT. CL. 22.

AMIR, DANIEL, SAN JOSE, CA:
3,995,516, PUB. 5-3-2011. INT. CL. 41.

AMISTCO SEPARATION PRODUCTS INC., ALVIN, TX:
3,999,001, INT. CL. 35.

AMISTCO SEPARATION PRODUCTS, INC., ALVIN, TX:
3,996,370, PUB. 5-3-2011. INT. CL. 11.

AMN HEALTHCARE, INC., SAN DIEGO, CA:
2,544,900. REN. 6-15-11. INT. CL. 35.

AMOEBA MUSIC, INC., BERKELEY, CA:
3,996,234, PUB. 5-3-2011. MULTIPLE CLASS, INT. CLS. 9,
12, 16, 18, 25, 26, 35 AND 41.
3,996,235, PUB. 5-3-2011. MULTIPLE CLASS, INT. CLS. 9,
12, 16, 18, 25, 26, 35 AND 41.

AMOREPACIFIC CORPORATION, SEOUL, REPUBLIC OF
KOREA:
3,995,559, PUB. 11-9-2010. INT. CL. 44.

AMORINI PANINI, INC., ARLINGTON, VA:
3,999,571, INT. CL. 43.

AMOS PRESS, INC., SIDNEY, OH:
3,997,129, PUB. 5-3-2011. INT. CL. 16.

AMOS, RONALD. HELENDALE, CA:
2,447,938. REN. 6-14-11. INT. CL. 28.

AMS RESEARCH CORPORATION, MINNETONKA, MN:
2,978,169, CANC. INT. CL. 5.

AMSCAN INC., ELSFORD, NY:
3,999,921, INT. CL. 21.

AMUNDI ALTERNATIVE INVESTMENTS, INC., NEW
YORK, NY:
3,999,332, INT. CL. 36.

AMY SECKINGER, DELAFIELD, WI:
3,998,164, PUB. 5-3-2011. INT. CL. 24.

AMYLIN PHARMACEUTICALS, INC., SAN DIEGO, CA:
3,999,509, INT. CL. 42.

ANAGALLIS HERBS LLC, COS COB, CT:
3,995,641, PUB. 5-3-2011. INT. CL. 5.

ANATOMIC IRON INC, ROAD TOWN, TORTOLA, BR. VIR-
GIN ISLANDS:
3,958,594, COR. MULTIPLE CLASS, INT. CLS. 16, 37
AND 42.

ANCIENT MODERN ART, LLC, NEW YORK, NY:
3,996,397, PUB. 5-3-2011. INT. CL. 14.

ANDERSON PACKAGING, INC, ROCKFORD, IL:
3,998,322, INT. CL. 16.
3,998,323, INT. CL. 16.
3,998,324, INT. CL. 16.
3,998,325, INT. CL. 16.

ANDERSON VALLEY ACQUISITION COMPANY LLC,
BOONVILLE, CA:
3,970,896, COR. INT. CL. 32.

ANDREA BECKER DESIGN, MORRISTOWN, NJ:
2,902,042, CANC. MULTIPLE CLASS, INT. CLS. 18 AND
25.

ANDREAS FISCHER, NUREMBURG, FED REP GERMANY:
3,995,970, PUB. 5-3-2011. MULTIPLE CLASS, INT. CLS.
25, 28 AND 41.

ANDREAS TAUER, SWITZERLAND:
3,995,769, PUB. 5-3-2011. INT. CL. 3.

ANDREW BETTIS AVIATION, MEMPHIS, TN:
3,997,327, PUB. 5-3-2011. MULTIPLE CLASS, INT. CLS. 35
AND 39.

ANDREW BETTIS AVIATION, LLC, MEMPHIS, TN:
3,997,752, PUB. 5-3-2011. INT. CL. 35.

ANDREWS INTERNATIONAL, INC., BRONX, NY:
2,401,848, CANC. INT. CL. 42.

ANDREWS MCMEEL PUBLISHING, LLC, KANSAS CITY,
MO:
3,998,606, INT. CL. 9.

ANDREWS, KENYA, D., FONTANA, CA:
2,902,233, CANC. INT. CL. 25.

ANGEL SALES, INC., CHICAGO, IL:
3,999,415, INT. CL. 9.

ANGEL SERVICE DOGS, INC., COLORADO SPRINGS, CO:
3,996,126, PUB. 5-3-2011. MULTIPLE CLASS, INT. CLS.
31, 41 AND 44.

ANGELS BASEBALL L.P., ANAHEIM, CA:
1,646,800. REN. 6-10-11. MULTIPLE CLASS, INT. CLS. 16
AND 25.

ANGIE'S ARTISAN TREATS, LLC, NORTH MANKATO,
MN:
3,960,563 NEW CERT. 7-19-2011. INT. CL. 30.

ANHEUSER-BUSCH, INCORPORATED, ST. LOUIS, MO:
3,998,754, INT. CL. 32.
3,999,541, INT. CL. 32.
3,999,584, INT. CL. 32.

ANIMALS MATTER, INC., TORRANCE, CA:
3,996,230, PUB. 5-3-2011. INT. CL. 20.

ANN SCOTT DESIGN, MORRISTOWN, NJ:
3,997,008, PUB. 5-3-2011. INT. CL. 16.

ANNEMARIE WATERS, KIRKLAND, WA:
3,997,214, PUB. 5-3-2011. INT. CL. 25.
3,997,234, PUB. 5-3-2011. INT. CL. 25.

ANONYMIZER, INC., SAN DIEGO, CA:
3,996,961, PUB. 5-3-2011. MULTIPLE CLASS, INT. CLS. 9,
38 AND 42.

ANONYMOUS HOME, LLC, DRIPPING SPRINGS, TX:
3,996,592, PUB. 5-3-2011. INT. CL. 36.

ANSALDO STS S.P.A., I-16151 GENOVA, ITALY:
3,995,779, PUB. 5-3-2011. MULTIPLE CLASS, INT. CLS. 9,
37, 38 AND 42.

ANSPACH, JAMES A. BREMERTON, WA:
3,998,493, INT. CL. 28.

ANTARES CAPITAL CORPORATION, CHICAGO, IL:
2,402,222, CANC. INT. CL. 36.

ANTINORI, MARIANA, NEW YORK, NY:
2,901,670, CANC. INT. CL. 24.

ANTISENSE PHARMA GMBH, D-93053 REGENSBURG,
FED REP GERMANY:
3,997,473, PUB. 5-3-2011. INT. CL. 5.

ANTON PAAR USA, INC., ASHLAND, VA:
3,996,215, PUB. 5-3-2011. INT. CL. 9.

ANZALONE, JON, K, CARPINTERIA, CA:
2,902,274, CANC. INT. CL. 25.

AOM HOLDING, L.L.C., NEW YORK, NY:
3,998,338, INT. CL. 25.

APA PUBLICATIONS GMBH & CO. VERLAG KG, SINGA-
PORE, SINGAPORE:
3,023,989, CANC. MULTIPLE CLASS, INT. CLS. 39 AND
42.

APARTMENT RENTAL EXPERTS LLC, CAMBRIDGE, MA:
3,996,655, PUB. 5-3-2011. INT. CL. 36.

APC WORKFORCE SOLUTIONS, LLC, ORLANDO, FL,
DBA, ZEROCHAOS:
2,475,703. REN. 6-14-11. INT. CL. 36.

APEX IMPACT MARKETING, LLC, LEWES, DE, DBA
FOCUSMX:
3,996,237, PUB. 5-3-2011. INT. CL. 42.

APIRA SCIENCE INC., NEWPORT BEACH, CA:
3,997,143, PUB. 5-3-2011. INT. CL. 10.

APLICA JOHN, CHICAGO, IL:
3,997,471, PUB. 5-3-2011. INT. CL. 9.

APOLLO TYRES LTD., GURGAON, INDIA:
3,995,519, PUB. 10-19-2010. INT. CL. 12.

APPAREL GROUP LTD., THE, LEWISVILLE, TX, DAMON
CREATIONS, INC., NEW YORK, NY:
717,628. REN. 6-14-11. U.S. CL. 39 (INT. CLS. 10, 25 AND
26).

APPAREL GROUP PTY LTD, WATERLOO NSW 2017,
AUSTRALIA:
3,995,697, PUB. 5-3-2011. INT. CL. 25.

APPDNA, INC., LAS VEGAS, NV:
3,996,503, PUB. 5-3-2011. INT. CL. 9.

APPEL, JENNIFER C., NEW YORK, NY:
3,998,274, PUB. 5-3-2011. INT. CL. 35.

APPLEGATE FARMS, LLC, BRIDGEWATER, NJ:
3,997,567, PUB. 5-3-2011. INT. CL. 35.
3,997,570, PUB. 5-3-2011. MULTIPLE CLASS, INT. CLS. 29
AND 35.

APPLIED INDUSTRIAL TECHNOLOGIES, INC., CLEVE-
LAND, OH:
3,996,606, PUB. 5-3-2011. INT. CL. 35.

APPLIED INNOVATIVE TECHNOLOGIES, INCORPO-
RATED, FORT LUPTON, CO:
2,402,823, CANC. INT. CL. 11.

- APPLIED MATERIALS, INC., SANTA CLARA, CA:
3,998,398, INT. CL. 7.
3,998,600, MULTIPLE CLASS, INT. CLS. 7, 9, 37, 40 AND 42.
- APPRAISER LOFT, LLC, SAN DIEGO, CA:
3,996,965, PUB. 5-3-2011. INT. CL. 36.
3,997,259, PUB. 5-3-2011. INT. CL. 36.
3,997,260, PUB. 5-3-2011. INT. CL. 36.
- APSU, L.L.C., PAIA, HI:
3,999,836, INT. CL. 5.
- APTORA CORPORATION, LENEXA, KS:
3,999,621, INT. CL. 9.
3,999,622, INT. CL. 9.
- AQMATRIX RATINGS GLOBAL, S.L.U., BILBAO, SPAIN:
3,996,123, PUB. 5-3-2011. MULTIPLE CLASS, INT. CLS. 35, 36 AND 38.
- AQTIS I.P. B.V., UTRECHT, NETHERLANDS:
3,996,072, PUB. 5-3-2011. INT. CL. 5.
- AQUA MARNE PARTNERS, LLC, GOLDEN BEACH, FL:
2,901,449, CANC. MULTIPLE CLASS, INT. CLS. 35 AND 39.
- AQUAFIL S.P.A., ITALY:
3,995,890, PUB. 5-3-2011. MULTIPLE CLASS, INT. CLS. 1, 17, 22 AND 23.
- AQUALIPO LLC, VIERA, FL:
3,999,260, INT. CL. 44.
- AQUASCORP, INC., LAS VEGAS, NV:
3,996,372, PUB. 5-3-2011. INT. CL. 35.
- AQUATICA GALLERY LLC, SANTA FE SPRINGS, CA:
3,997,445, PUB. 5-3-2011. INT. CL. 21.
- ARA SERVICES CORPORATION, FAIRFAX, VA:
2,402,012, CANC. INT. CL. 35.
- ARABELLA PUBLISHING, LLC, PHILADELPHIA, PA:
2,902,128, CANC. INT. CL. 16.
- ARCANO ASESORES FINANCIEROS, S.L., MADRID, SPAIN:
3,997,565, PUB. 5-3-2011. INT. CL. 36.
- ARCE S.P.A., ITALY:
3,995,839, PUB. 5-3-2011. MULTIPLE CLASS, INT. CLS. 4, 11 AND 37.
- ARCH CHEMICALS, INC., NORWALK, CT:
3,998,816, INT. CL. 1.
3,999,619, INT. CL. 1.
- ARCH WEB LABS, LLC, TUSTIN, CA:
3,997,573, PUB. 5-3-2011. INT. CL. 42.
- ARCHER-DANIELS-MIDLAND COMPANY, DECATUR, IL:
2,901,927, CANC. MULTIPLE CLASS, INT. CLS. 1 AND 42.
- ARCHIMEDES GLOBAL, INC., TAMPA, FL:
3,996,161, PUB. 5-3-2011. INT. CL. 35.
- ARDENTI, ALEX, ENCINO, CA:
3,999,710, INT. CL. 5.
- AREX LIFE SCIENCES, INC., WATERTOWN, MA:
3,998,710, INT. CL. 5.
- ARIEL METALS CORPORATION, NORTHBROOK, IL:
3,999,861, INT. CL. 42.
3,999,862, INT. CL. 42.
- ARIENS COMPANY, BRILLION, WI:
2,952,318, AM. INT. CL. 7.
- ARIES DESIGN AUTOMATION, LLC, CHICAGO, IL:
3,997,630, PUB. 5-3-2011. INT. CL. 42.
- ARIES INGENIERIA Y SISTEMAS, S.A., 28046 MADRID, SPAIN:
3,998,793, MULTIPLE CLASS, INT. CLS. 35 AND 42.
3,998,794, MULTIPLE CLASS, INT. CLS. 35 AND 42.
- ARISTAVET VETERINARSPEZIALITATEN GMBH & CO. KG, 88212 RAVENSBURG, FED REP GERMANY:
2,394,274, REN. 6-13-11. INT. CL. 5.
- ARISTOCRAT TECHNOLOGIES AUSTRALIA PTY LTD, NORTH RYDE, NSW, AUSTRALIA:
3,996,499, PUB. 5-3-2011. INT. CL. 9.
3,998,300, INT. CL. 9.
- ARISTOCRAT TECHNOLOGIES AUSTRALIA PTY LTD., NORTH RYDE, NSW, AUSTRALIA:
3,998,976, INT. CL. 9.
3,998,977, INT. CL. 9.
- ARITZIA LP, VANCOUVER, BC, CANADA:
3,997,498, PUB. 5-3-2011. INT. CL. 18.
- ARJIL, THOMAS, R., ELK GROVE, CA:
3,999,687, MULTIPLE CLASS, INT. CLS. 39 AND 44.
- ARKEO, INC., FORT WORTH, TX:
3,997,849, PUB. 5-3-2011. INT. CL. 41.
- ARLINGTON INDUSTRIES, INC., MIAMI, FL:
3,998,266, PUB. 5-3-2011. INT. CL. 9.
- ARMYNAVYDEALS.COM CORP., NEW YORK, NY:
3,996,212, PUB. 5-3-2011. INT. CL. 25.
- ARNOLD PRODUCTS, INC., HORSHAM, PA:
2,901,334, CANC. INT. CL. 30.
- ARPER S.P.A., ITALY:
3,995,803, PUB. 5-3-2011. INT. CL. 20.
3,995,804, PUB. 5-3-2011. INT. CL. 20.
- ARRIOLA, SALVADOR, DALTON, GA:
3,999,084, INT. CL. 14.
- ARROWPOINT CAPITAL CORP., CHARLOTTE, NC:
3,998,361, MULTIPLE CLASS, INT. CLS. 35 AND 36.
- ARROYO SECO GOLF COURSE LLC., DOVE CANYON, CA:
3,996,547, PUB. 5-3-2011. INT. CL. 41.
- ARSA DISTRIBUTING, INC., EL PASO, TX:
3,997,148, PUB. 5-3-2011. MULTIPLE CLASS, INT. CLS. 29 AND 30.
- ARTBEADS.COM INC., GIG HARBOR, WA:
3,998,943, INT. CL. 14.
- ARTE MESTIERE SRL, ITALY:
3,784,972, COR. MULTIPLE CLASS, INT. CLS. 3, 9, 12, 14, 16, 18, 25, 28, 32, 33 AND 43.
- ARTEMISIA DISTRIBUTION SARL, 2108 COUVET, SWITZERLAND:
3,998,687, INT. CL. 33.
- ARTIFICIAL LIFE ASIA LIMITED, HONG KONG, HONG KONG:
3,996,253, PUB. 5-3-2011. MULTIPLE CLASS, INT. CLS. 9, 38 AND 42.
- ARTINIAN, INC., WARREN, MI:
3,996,317, PUB. 5-3-2011. INT. CL. 30.
- ARTIXAN CONSULTING GROUP LLC, NEW YORK, NY:
3,997,486, PUB. 5-3-2011. INT. CL. 35.
- ARTLIST INTERNATIONAL, INC., NEW YORK, NY:
3,998,919, MULTIPLE CLASS, INT. CLS. 3, 9, 16, 21, 24, 25, 26 AND 30.
- ARTO ERYOZGATLIYAN, TORRANCE, CA:
3,999,474, INT. CL. 35.
- ASAHI RESEARCH CORPORATION, TOKYO, JAPAN:
3,998,530, INT. CL. 9.
- ASCEND EAGLE INC., AMERICAN CANYON, CA:
3,997,523, PUB. 5-3-2011. INT. CL. 10.
- ASCENDANT MARKETING & MEDIA, LLC, LONG BEACH, CA:
3,998,396, MULTIPLE CLASS, INT. CLS. 35, 38 AND 41.
- ASCENSION LLC, RICHARDSON, TX:
3,999,246, INT. CL. 36.
- ASD SPECIALTY HEALTHCARE, INC., FRISCO, TX:
3,995,474, PUB. 5-3-2011. MULTIPLE CLASS, INT. CLS. 9, 16, 35 AND 41.
- ASHDOWN DESIGN & MARKETING LIMITED, MALDON ESSEX, UNITED KINGDOM:
2,401,681, CANC. INT. CL. 9.
- ASHLAND LICENSING AND INTELLECTUAL PROPERTY LLC, DUBLIN, OH:
3,998,916, MULTIPLE CLASS, INT. CLS. 1 AND 4.
- ASHLAND-SÜDCHEMIE-KERNFEST GMBH, FED REP GERMANY:
3,995,756, PUB. 5-3-2011. INT. CL. 1.
- ASHLEY FURNITURE INDUSTRIES, INC., ARCADIA, WI:
3,995,495, PUB. 5-3-2011. INT. CL. 36.
- ASHRO, INC., MONROE, WI:
3,999,047, INT. CL. 3.
- ASHTON, RICHARD, HOUSTON, TX:
3,999,567, INT. CL. 25.
- ASIA BROADCAST SATELLITE (HK) LIMITED, CENTRAL, HONG KONG:
3,995,575, PUB. 4-20-2010. INT. CL. 38.
- ASIA SEIKO COMPOSITE MATERIAL CO., LTD., TANZIH TOWNSHIP, TAIWAN:
3,999,460, INT. CL. 12.
- ASICS CORPORATION, CHUO-KU, KOBE 650-8555, JAPAN:
2,901,126, CANC. INT. CL. 25.

ASICS CORPORATION, CHUO-KU, KOBE, JAPAN:
3,996,170, PUB. 5-3-2011. INT. CL. 25.
3,996,171, PUB. 5-3-2011. INT. CL. 25.

ASJ DEVELOPMENT, LC, WEST VALLEY CITY, UT:
3,996,724, PUB. 5-3-2011. INT. CL. 43.

ASOCIACION DE EMPRESARIOS MEXICANOS, SAN ANTONIO, TX:
3,997,316, PUB. 5-3-2011. INT. CL. 16.

ASPEN GROVE, INC., FREDERICK, MD:
3,996,706, PUB. 5-3-2011. INT. CL. 36.

ASPEX GROUP INC., TOWN OF MOUNT ROYAL, CANADA:
2,902,452, CANC. INT. CL. 9.

ASSESSMENT TECHNOLOGIES INSTITUTE, L.L.C., STILLWELL, KS:
3,996,052, PUB. 5-3-2011. MULTIPLE CLASS, INT. CLS. 16 AND 41.

ASSOCIATED BANC-CORP, GREEN BAY, WI:
3,997,511, PUB. 5-3-2011. INT. CL. 36.

ASSOCIATED FRUIT COMPANY, PHOENIX, OR:
3,997,166, PUB. 5-3-2011. INT. CL. 31.

ASSOCIATED GENERAL CONTRACTORS OF AMERICA, THE, ARLINGTON, VA:
2,411,820, REN. 6-15-11. MULTIPLE CLASS, INT. CLS. 37, 41 AND 42.
2,411,820, CANC. MULTIPLE CLASS, INT. CLS. 9 AND 16.

ASSOCIATED MATERIALS, LLC, CUYAHOGA FALLS, OH, DBA ALSIDE:
2,901,919, CANC. INT. CL. 19.

ASSOCIATION FOR FINANCIAL PROFESSIONALS, INC., BETHESDA, MD:
2,402,855, CANC. INT. CL. 42.

ASSOCIATION SERVICES OF AMERICA, INC., CENTERVILLE, MA:
3,996,679, PUB. 5-3-2011. INT. CL. 41.

ASSURANT, INC., NEW YORK, NY:
3,999,160, INT. CL. 36.

ASTELLAS PHARMA INC., JAPAN:
3,996,009, PUB. 5-3-2011. INT. CL. 5.
3,996,010, PUB. 5-3-2011. INT. CL. 5.
3,996,011, PUB. 5-3-2011. INT. CL. 5.
3,996,012, PUB. 5-3-2011. INT. CL. 5.
3,996,013, PUB. 5-3-2011. INT. CL. 5.

ASTENJOHNSON, INC., KANATA, ONTARIO, CANADA, JWI LTD., MONTREAL, QUEBEC, CANADA:
1,156,125, REN. 6-16-11. INT. CL. 7.

ASTRA GAMES LIMITED, MID GLAMORGAN, UNITED KINGDOM:
2,901,571, CANC. INT. CL. 9.

ASTRO APE STUDIOS, NEW YORK, NY:
3,997,174, PUB. 5-3-2011. INT. CL. 9.

ASTRO PAK CORPORATION, COSTA MESA, CA:
3,998,874, INT. CL. 40.

AT&T INTELLECTUAL PROPERTY II, L.P., RENO, NV:
2,902,221, CANC. MULTIPLE CLASS, INT. CLS. 9, 35, 37, 38 AND 42.
2,902,222, CANC. MULTIPLE CLASS, INT. CLS. 9, 35, 37, 38 AND 42.

ATARI, INC., NEW YORK, NY:
2,402,984, CANC. INT. CL. 9.

ATHEROGENICS, INC., NORCROSS, GA:
2,402,277, CANC. INT. CL. 5.

ATLANTA COMMUNITY MINISTRIES, INC., ATLANTA, GA:
3,999,030, INT. CL. 35.

ATLANTIC AUTOMOTIVE CORP., BALTIMORE, MD:
2,536,514, REN. 6-16-11. INT. CL. 39.
2,536,515, REN. 6-16-11. INT. CL. 37.

ATLANTIC BAY COMPANY, LTD., THE, PORTLAND, ME:
2,566,183, REN. 6-14-11. INT. CL. 36.
2,566,184, REN. 6-14-11. INT. CL. 36.

ATLANTIC CAPES FISHERIES, INC., CAPE MAY, NJ:
3,999,620, INT. CL. 29.

ATLANTIC CITY COIN & SLOT SERVICE COMPANY, INC., PLEASANTVILLE, NJ:
3,998,838, INT. CL. 9.

ATLANTIC HILL CONSTRUCTION INC., MILTON, MA:
3,996,647, PUB. 5-3-2011. INT. CL. 30.

ATLAS COPCO CRAELIUS AB, MÄRSTA, SWEDEN:
3,996,308, PUB. 4-12-2011. MULTIPLE CLASS, INT. CLS. 7 AND 37.

ATO PICTURES, LLC, CHARLOTTESVILLE, VA:
3,999,127, MULTIPLE CLASS, INT. CLS. 9, 36, 38 AND 41.

ATOZETA PRODUCTIONS LLC, NEW YORK, NY:
3,999,927, MULTIPLE CLASS, INT. CLS. 38, 41, 42 AND 44.
3,999,928, MULTIPLE CLASS, INT. CLS. 38, 41, 42 AND 44.
3,999,931, MULTIPLE CLASS, INT. CLS. 38, 41, 42 AND 44.

ATRIUM INNOVATIONS INC., QUEBEC CITY, QUEBEC, CANADA:
3,996,582, PUB. 5-3-2011. INT. CL. 5.
3,996,583, PUB. 5-3-2011. INT. CL. 5.

ATRONIC SYSTEMS GMBH, GRAMBACH, AUSTRIA:
2,401,320, CANC. MULTIPLE CLASS, INT. CLS. 9, 16, 20 AND 28.

ATSONIC, LLC, SCHAUMBURG, IL:
2,902,052, CANC. INT. CL. 9.

AUBREN M. JOHNSON, DRAPER, UT:
3,999,428, INT. CL. 28.

AUDACITY ENTERPRISES, LLC, O'FALLON, MO:
3,999,408, INT. CL. 28.

AUDI AG, INGOLSTADT, FED REP GERMANY:
3,996,579, PUB. 5-3-2011. MULTIPLE CLASS, INT. CLS. 9 AND 12.

AUDIO ADVISORS, INC., KENTWOOD, MI:
1,650,012, REN. 6-14-11. INT. CL. 9.

AUDITIONWARE, LLC, CEDAR HILLS, UT:
3,999,657, INT. CL. 42.

AUGELLO, LLC., MIAMI, FL:
3,996,167, PUB. 10-19-2010. MULTIPLE CLASS, INT. CLS. 29, 30 AND 32.

AUGUST STORCK KG., 13403 BERLIN, FED REP GERMANY:
2,401,361, CANC. INT. CL. 30.

AUNT BARBARA INC., FREEPORT, NY:
3,995,643, PUB. 5-3-2011. INT. CL. 41.

AURELIO'S PIZZA, INC., HOMEWOOD, IL:
3,995,488, PUB. 5-3-2011. INT. CL. 43.

AURIONPRO SOLUTIONS, INC., SAN RAMON, CA:
3,996,276, PUB. 5-3-2011. INT. CL. 42.

AUSTIN BAZAAR INC, AUSTIN, TX:
3,997,160, PUB. 5-3-2011. INT. CL. 15.

AUSTRALIAN GOLD, LLC, INDIANAPOLIS, IN:
2,902,261, CANC. INT. CL. 3.
2,902,381, CANC. INT. CL. 3.

AUTISM CARES FOUNDATION, RICHBORO, PA:
3,997,028, PUB. 5-3-2011. INT. CL. 41.

AUTISM INTERNATIONAL ASSOCIATION INC., FULLERTON, CA:
4,000,001, INT. CL. 16.

AUTOBUS GALLAND LTD., LAVAL, PROVINCE OF QUEBEC, CANADA:
2,485,279, REN. 6-16-11. INT. CL. 39.

AUTODESK, INC., SAN RAFAEL, CA:
2,497,128, REN. 6-13-11. INT. CL. 9.
2,507,830, REN. 6-13-11. INT. CL. 9.

AUTOEXPOSURE, INC., RESTON, VA:
3,999,110, INT. CL. 44.

AUTOMOBILES PEUGEOT, FRANCE:
3,995,849, PUB. 5-3-2011. MULTIPLE CLASS, INT. CLS. 12, 36, 37 AND 39.
3,995,870, PUB. 5-3-2011. MULTIPLE CLASS, INT. CLS. 12, 37 AND 39.

AUTOSALES, INCORPORATED, TALLMADGE, OH:
2,528,907, REN. 6-14-11. MULTIPLE CLASS, INT. CLS. 7, 9, 12 AND 25.

AVA ANDERSON LLC, PROVIDENCE, RI:
3,998,847, INT. CL. 3.

AVAAK, INC., SAN DIEGO, CA:
3,998,453, INT. CL. 9.

- AVAIRPROS MANAGEMENT, INC., NAPLES, FL:
3,998,674, MULTIPLE CLASS, INT. CLS. 35 AND 39.
3,998,675, MULTIPLE CLASS, INT. CLS. 35, 36 AND 39.
3,998,677, MULTIPLE CLASS, INT. CLS. 35, 36 AND 39.
3,998,678, MULTIPLE CLASS, INT. CLS. 35 AND 39.
- AVANI HOLDINGS LLC, SANTA FE SPRINGS, CA, DBA AVANI:
3,998,049, PUB. 5-3-2011. INT. CL. 35.
- AVB, INC., MILWAUKIE, OR:
3,998,253, PUB. 5-3-2011. INT. CL. 35.
- AVDEL UK LIMITED, WELWYN GARDEN CITY, GREAT BRITAIN:
2,456,560. REN. 6-14-11. INT. CL. 7.
- AVERAHAMI BOAZ, NETHERLANDS:
3,995,982, PUB. 5-3-2011. MULTIPLE CLASS, INT. CLS. 18, 25 AND 35.
- AVIATION FOUNDATION OF AMERICA, JACKSON, WY:
2,906,974, CANC. MULTIPLE CLASS, INT. CLS. 16 AND 26.
- AVILA'S EL RANCHITO, INC., NEWPORT BEACH, CA:
3,996,540, PUB. 5-3-2011. INT. CL. 43.
- AVION TEQUILA LLC, HEWLETT, NY:
3,998,768, INT. CL. 33.
- AVL LIST GMBH, A-8020 GRAZ, AUSTRIA:
2,901,065, CANC. MULTIPLE CLASS, INT. CLS. 9, 37 AND 41.
- AVV WINERY CO., LLC, HEALDSBURG, CA:
3,996,618, PUB. 5-3-2011. INT. CL. 33.
- AWESOME KIDS, LLC, WHEATON, IL:
2,902,410, CANC. INT. CL. 25.
2,902,413, CANC. INT. CL. 28.
2,902,414, CANC. INT. CL. 41.
- AWESOME PRODUCTS, INC., BUENA PARK, CA:
3,997,324, PUB. 5-3-2011. INT. CL. 3.
- AWS TRUEPOWER, LLC, ALBANY, NY:
2,455,357. REN. 6-10-11. INT. CL. 42.
- AXLEY, GARY, ROLAND, OK:
3,997,601, PUB. 5-3-2011. INT. CL. 5.
- AYUH SPA & WELLNESS, UNION CITY, CA:
3,996,198, PUB. 5-3-2011. INT. CL. 41.
- AZEK BUILDING PRODUCTS, INC., SCRANTON, PA:
3,997,331, PUB. 5-3-2011. INT. CL. 19.
- B & D, INC., NASHVILLE, TN:
3,998,415, INT. CL. 41.
- B & F TECHNICAL CODE SERVICES, INC., HOFFMAN ESTATES, IL:
2,546,580. REN. 6-16-11. INT. CL. 42.
- B & L SALES, INC., BURBANK, CA:
2,901,136, CANC. INT. CL. 35.
- B.C.P., INC., INCLINE VILLAGE, NV:
2,402,303, CANC. INT. CL. 35.
- B.C.S. INTERNATIONAL CORPORATION, LONG ISLAND CITY, NY:
3,998,743, INT. CL. 30.
- B&D LITHO OF ARIZONA, INC., PHOENIX, AZ, DBA B&D LITHO:
3,997,092, PUB. 5-3-2011. INT. CL. 16.
- B&D LITHO OF ARIZONA, INC., PHOENIX, AZ:
3,998,193, PUB. 5-3-2011. INT. CL. 40.
- B&R LIQUID ADVENTURE LLC, ROLLING HILLS, CA:
3,999,942, INT. CL. 32.
- B&S (CANADA) INC., TORONTO, CANADA:
2,402,130, CANC. INT. CL. 14.
- BABBITT STEAM SPECIALTY CO. (MASS. CORP.), NEW BEDFORD MASS.:
148,990. REN. 6-11-11. U.S. CL. 23 (INT. CL. 7).
- BABOLAT VS, LYON, FRANCE:
2,901,671, CANC. INT. CL. 28.
- BABY COW PRODUCTIONS LTD., LONDON, UNITED KINGDOM:
3,995,592, PUB. 4-26-2011. MULTIPLE CLASS, INT. CLS. 9, 16, 35, 38 AND 41.
- BABY LOU BRILLIANT PRODUCTS, LLC, FARMINGTON, CT:
3,998,036, PUB. 5-3-2011. INT. CL. 30.
- BACARDI & COMPANY LIMITED, VADUZ, LIECHTENSTEIN:
3,999,035, INT. CL. 33.
- BACICH, PATRICK, WEST COVINA, CA:
3,998,521, INT. CL. 38.
- BACKFIELD PRODUCTIONS LIMITED LIABILITY COMPANY, WHARTON, NJ:
3,998,831, INT. CL. 41.
3,998,832, INT. CL. 41.
- BACKLINE MUSIC GROUP, LLC, TAMPA, FL:
3,997,201, PUB. 5-3-2011. INT. CL. 41.
- BACON, BRETT, E., EPSOM, NH, DBA SONIC SAFE:
3,996,658, PUB. 5-3-2011. INT. CL. 10.
- BAD IDEAZ, LLC, TECUMSEH, MI, DBA SKYDIVE TECUMSEH:
3,999,914, MULTIPLE CLASS, INT. CLS. 35 AND 41.
- BAE SYSTEMS PLC, LONDON, SW1Y 5AD, UNITED KINGDOM:
3,995,618, PUB. 3-29-2011. MULTIPLE CLASS, INT. CLS. 9, 16, 35 AND 42.
- BAHAMA BAY RESORT MANAGEMENT, LLC, DAVENPORT, FL:
3,999,389, MULTIPLE CLASS, INT. CLS. 35, 36, 39 AND 43.
3,999,526, MULTIPLE CLASS, INT. CLS. 35, 36, 39 AND 43.
3,999,527, MULTIPLE CLASS, INT. CLS. 35, 36, 39 AND 43.
3,999,528, MULTIPLE CLASS, INT. CLS. 35, 36, 39 AND 43.
3,999,529, MULTIPLE CLASS, INT. CLS. 35, 36, 39 AND 43.
- BAHNSON, INC., WINSTON-SALEM, NC:
3,996,948, PUB. 5-3-2011. INT. CL. 11.
- BAIDEN ENTERTAINMENT, LLC, DALLAS, TX:
3,998,744, INT. CL. 41.
3,998,746, INT. CL. 9.
- BAKER HUGHES INCORPORATED, HOUSTON, TX:
2,401,891, CANC. INT. CL. 37.
2,452,493. REN. 6-14-11. INT. CL. 42.
- BAKER PACIFIC, INC., SAN FRANCISCO, CA, DBA BAKER PACIFIC:
3,997,872, PUB. 5-3-2011. MULTIPLE CLASS, INT. CLS. 35 AND 36.
- BAKER'S CRUST, INC., VIRGINIA BEACH, VA:
2,901,223, CANC. MULTIPLE CLASS, INT. CLS. 30 AND 43.
- BALBOA WATER GROUP, INC., TUSTIN, CA:
3,997,611, PUB. 5-3-2011. INT. CL. 7.
- BALDOR ELECTRIC COMPANY, FORT SMITH, AR:
1,656,597. REN. 6-15-11. INT. CL. 7.
- BALL HORTICULTURAL COMPANY, WEST CHICAGO, IL:
3,999,530, INT. CL. 31.
- BALLSIES, L.L.C., MESA, AZ:
3,997,987, PUB. 5-3-2011. INT. CL. 14.
- BALLY GAMING, INC., LAS VEGAS, NV, DBA BALLY TECHNOLOGIES:
3,998,225, PUB. 5-3-2011. INT. CL. 9.
3,998,226, PUB. 5-3-2011. INT. CL. 9.
3,998,227, PUB. 5-3-2011. INT. CL. 9.
3,998,228, PUB. 5-3-2011. INT. CL. 9.
- BALTIMORE ORIOLES LIMITED PARTNERSHIP, BALTIMORE, MD:
3,996,134, PUB. 5-3-2011. INT. CL. 25.
3,996,452, PUB. 5-3-2011. INT. CL. 25.
- BANAH INTERNATIONAL GROUP, INC., MIAMI, FL:
3,997,418, PUB. 5-3-2011. INT. CL. 35.
3,997,420, PUB. 5-3-2011. INT. CL. 35.
3,997,437, PUB. 5-3-2011. INT. CL. 35.
- BANCO DAVIVIENDA S.A., BOGOTA, COLOMBIA:
2,902,239, CANC. INT. CL. 36.
- BANDO CHEMICAL INDUSTRIES, LTD., JAPAN:
3,996,007, PUB. 5-3-2011. INT. CL. 3.
- BANK OF AMERICA CORPORATION, CHARLOTTE, NC:
2,402,416, CANC. INT. CL. 36.
2,902,070, CANC. INT. CL. 36.
- BAPTIST MEMORIAL MEDICAL GROUP, INC., MEMPHIS, TN:
4,000,038, INT. CL. 44.
- BAR ALE, INC., WILLIAMS, CA:
3,996,055, PUB. 5-3-2011. INT. CL. 31.

BARBER, CORY, RIVERSIDE, CA:
3,998,236, PUB. 5-3-2011. INT. CL. 45.

BARECUDA, LLC, STUART, FL:
3,999,737, INT. CL. 25.

BARGE, WAGGONER, SUMNER & CANNON, INC., KNOXVILLE, TN:
2,902,090, CANC. INT. CL. 9.

BARISH, LONNIE MERRITT, NEWTOWN, PA:
3,996,900, PUB. 5-3-2011. INT. CL. 1.

BARIX AG, SWITZERLAND:
3,995,744, PUB. 5-3-2011. MULTIPLE CLASS, INT. CLS. 9 AND 42.

BARLEY CREEK BREWING COMPANY INC., TANNERSVILLE, PA:
3,997,458, PUB. 5-3-2011. INT. CL. 43.

BARNETT, LAUREN E., NORTH HOLLYWOOD, CA, DBA THE DOMESTIC DAME:
3,997,920, PUB. 5-3-2011. INT. CL. 25.

BARNHILL AVIATION, LLC, SANFORD, FL:
3,996,291, PUB. 5-3-2011. INT. CL. 39.

BARRY D. SEARS, PH.D., MARBLEHEAD, MA:
3,997,147, PUB. 5-3-2011. INT. CL. 5.

BARTON, MACY, NEWPORT BEACH, CA:
3,998,796, INT. CL. 25.

BARU GROUP, LLC, MIAMI, FL:
3,995,667, PUB. 5-3-2011. INT. CL. 43.
3,995,668, PUB. 5-3-2011. INT. CL. 43.

BASF COATINGS GMBH, FED REP GERMANY:
3,995,884, PUB. 5-3-2011. INT. CL. 2.

BASF SE, FED REP GERMANY:
3,995,883, PUB. 5-3-2011. MULTIPLE CLASS, INT. CLS. 1 AND 5.

BASIX INTERNATIONAL, INC., TUSTIN, CA:
3,999,628, INT. CL. 1.

BASTIC, SHAWN, AURORA, IL:
3,996,753, PUB. 5-3-2011. INT. CL. 41.

BATEMANELIS CORPORATION, CHICAGO, IL:
2,458,117, REN. 6-14-11. INT. CL. 3.

BATH & BODY WORKS BRAND MANAGEMENT, INC., REYNOLDSBURG, OH:
3,998,633, INT. CL. 3.

BATTLE ENTERPRISES, LLC, ATHENS, OH:
3,999,119, INT. CL. 28.

BATTLEWAGON MOUNTS, LLC, CLEVELAND, OH:
3,997,577, PUB. 5-3-2011. INT. CL. 6.

BAUER-PILECO, INC., HOUSTON, TX:
2,450,721, REN. 6-13-11. INT. CL. 7.

BAUSCH & LOMB INCORPORATED, ROCHESTER, NY:
3,998,753, MULTIPLE CLASS, INT. CLS. 3 AND 21.

BAVARIA S.A., SANTAFE DE BOGOTA, D.C, COLOMBIA:
3,997,475, PUB. 5-3-2011. INT. CL. 32.
3,997,484, PUB. 5-3-2011. INT. CL. 32.

BAVARIA S.A., BOGOTA, COLOMBIA:
3,997,593, PUB. 5-3-2011. INT. CL. 32.

BAY AREA ENERGY SOLUTIONS, INC., BURLINGAME, CA:
3,998,622, INT. CL. 37.

BAY CONVERTING INC., GREEN BAY, WI:
3,997,743, PUB. 5-3-2011. INT. CL. 16.

BAY SECURITIES SERVICES, LLC, TAMPA, FL:
3,999,678, INT. CL. 36.

BAYCO PRODUCTS, INC., WYLIE, TX:
3,999,974, INT. CL. 11.

BAYER AKTIENGESELLSCHAFT, FED REP GERMANY:
2,402,109, CANC. INT. CL. 2.

BAYER AKTIENGESELLSCHAFT, 51373 LEVERKUSEN, FED REP GERMANY:
3,995,677, PUB. 5-3-2011. MULTIPLE CLASS, INT. CLS. 1, 2, 5 AND 17.

BAYER HEALTHCARE LLC, PITTSBURGH, PA:
3,999,088, INT. CL. 10.

BAYER SCHERING PHARMA AKTIENGESELLSCHAFT, BERLIN, FED REP GERMANY:
2,900,965, CANC. INT. CL. 5.

BAYERISCHE MOTOREN WERKE AKTIENGESELLSCHAFT, 80809 MUNICH, FED REP GERMANY:
2,901,208, CANC. INT. CL. 12.

BB&T CORPORATION, WINSTON-SALEM, NC:
3,999,542, INT. CL. 36.
3,999,546, INT. CL. 36.
3,999,547, INT. CL. 36.

BBK TOBACCO & FOODS, L.L.P, PHOENIX, AZ:
3,996,913, PUB. 5-3-2011. INT. CL. 34.

BE FLUENT NYC INC., NEW YORK, NY:
3,997,002, PUB. 5-3-2011. INT. CL. 41.

BE GREEN BATH AND BODY, NORTH EASTON, MA:
3,998,087, PUB. 5-3-2011. INT. CL. 3.

BE-THIN, INC., TARRYTOWN, NY, DBA THE CENTER FOR MEDICAL WEIGHT LOSS:
3,997,884, PUB. 5-3-2011. INT. CL. 44.
3,997,886, PUB. 5-3-2011. INT. CL. 44.
3,997,888, PUB. 5-3-2011. INT. CL. 44.
3,997,889, PUB. 5-3-2011. INT. CL. 44.

BEACH BUSINESS BANK, MANHATTAN BEACH, CA:
3,996,305, PUB. 5-3-2011. INT. CL. 36.

BEACON LAW ADVISORS, PLLC, SEATTLE, WA:
3,996,872, PUB. 5-3-2011. INT. CL. 45.

BEACON, JACQUELINE, LONDON, ENGLAND AND GILLET, DAVID R, HALESWORTH, SUFFOLK, ENGLAND:
2,900,968, CANC. MULTIPLE CLASS, INT. CLS. 20 AND 42.

BEAUTE CREATEURS (SOCIETE ANONYME), PARIS, FRANCE:
2,901,648, CANC. INT. CL. 21.

BEAUTIFUL FEAT, FORTSON, GA:
3,997,047, PUB. 5-3-2011. INT. CL. 41.

BEAUTY KEY COSMETICS CO., LTD., NEW YORK, NY:
3,999,107, INT. CL. 3.

BECCA LOCKHART, BELMONT, CA, DBA B DEZIGNED:
3,996,705, PUB. 5-3-2011. INT. CL. 14.

BECK, CAROLINE J., SANTA YNEZ, CA:
2,902,324, CANC. INT. CL. 29.

BEFORE AND AFTER CANDY, LLC, SANTA BARBARA, CA:
3,997,631, PUB. 5-3-2011. INT. CL. 3.

BEGLER, DAVID, SAN FRANCISCO, CA:
3,997,970, PUB. 5-3-2011. INT. CL. 41.

BEGO BREMER GOLDSCHLAGEREI WILH. HERBST GMBH & CO., 28359 BREMEN, FED REP GERMANY:
2,901,191, CANC. MULTIPLE CLASS, INT. CLS. 5, 7, 8, 9, 10, 40 AND 41.

BEGO BREMER GOLDSCHLAGERI WILH. HERBST GMBH & CO. KG, 28359 BREMEN, FED REP GERMANY:
2,901,192, CANC. MULTIPLE CLASS, INT. CLS. 5, 7, 8, 9, 10, 40 AND 41.

BEHR PROCESS CORPORATION, SANTA ANA, CA:
3,998,190, PUB. 5-3-2011. INT. CL. 2.

BEIJING HONKON TECHNOLOGY CO., LTD., BEIJING, CHINA:
3,996,506, PUB. 5-3-2011. INT. CL. 10.

BEIJING NINE-HEADED BIRD RESTAURANT MANAGEMENT CO., LTD., BEIJING, CHINA:
2,901,171, CANC. INT. CL. 43.

BEIJING NUFRONT MOBILE MULTIMEDIA TECHNOLOGY CO., LTD, CHINA:
3,996,003, PUB. 5-3-2011. INT. CL. 9.
3,996,027, PUB. 5-3-2011. INT. CL. 9.

BELFORT INSTRUMENT, BALTIMORE, MD:
2,460,368, REN. 6-14-11. INT. CL. 9.

BELL PARTNERS, INC., GREENSBORO, NC:
3,998,252, PUB. 5-3-2011. INT. CL. 36.

BELL, JULA, LOS ANGELES, CA:
3,996,631, PUB. 5-3-2011. INT. CL. 43.

BELLESTAR PARTNERS, LLC, BOCA RATON, FL:
3,996,609, PUB. 5-3-2011. INT. CL. 36.

BEN HAKMAN & COMPANY LLC, NEW YORK, NY:
3,996,111, PUB. 5-3-2011. INT. CL. 14.

BENCHMARK BRANDS, INC., MEMPHIS, TN:
2,402,527, CANC. INT. CL. 10.

BEND OIL LLC, SANTA MONICA, CA:
2,488,096, REN. 6-14-11. INT. CL. 41.

BENITECTS, LLC, ST. LOUIS, MO:
3,998,038, PUB. 5-3-2011. INT. CL. 36.

BENNU, LLC, NEW YORK, NY:
3,996,325, PUB. 5-3-2011. INT. CL. 35.

- BENTLEY MOTORS LIMITED, CREWE, CHESHIRE CW1 3PL, UNITED KINGDOM:
3,998,345, MULTIPLE CLASS, INT. CLS. 14, 16, 18, 25, 36 AND 37.
- BENTLEY, ROBYN E., RICHMOND, VA:
2,486,209, REN. 6-13-11. INT. CL. 42.
- BEREL, S.A., SANTA CATARINA, NUEVO LEÓN, MEXICO:
3,998,308, INT. CL. 2.
- BERENSTEIN, BARRY, TORONTO, ONTARIO, CANADA:
3,998,429, INT. CL. 28.
- BERKSHIRE BLANKET INC., WARE, MA:
3,998,390, INT. CL. 20.
- BERMACK DE MEXICO S.A. DE C.V., LEON, GUANAJUATO, MEXICO:
3,999,137, INT. CL. 25.
- BERNARDO SHTEREMBERG, DORAL, FL:
3,996,590, PUB. 5-3-2011. INT. CL. 35.
- BERNATZ, THOMAS H., ORANGE, CA:
3,996,039, PUB. 5-3-2011. MULTIPLE CLASS, INT. CLS. 25 AND 28.
- BERNHARDT, JAY G., RICHFIELD SPRINGS, NY:
2,902,194, CANC. INT. CL. 29.
- BERRY, DANIEL R., TAVARES, FL:
3,999,324, INT. CL. 9.
- BERTUCCI'S RESTAURANT CORP., NORTHBOROUGH, MA:
3,998,160, PUB. 5-3-2011. INT. CL. 43.
- BESPOKE EDUCATION, INC., NEW YORK, NY:
3,999,792, MULTIPLE CLASS, INT. CLS. 16 AND 41.
- BESSEMER SERVICES INC., SAN FRANCISCO, CA:
2,459,803, REN. 6-15-11. INT. CL. 36.
- BEST EVER YOU, LLC, FALMOUTH, ME:
3,996,576, PUB. 5-3-2011. INT. CL. 41.
- BEST UPON REQUEST CORPORATE, INC., CINCINNATI, OH:
3,999,852, INT. CL. 45.
- BESTNET COMMUNICATIONS CORP, GRAND RAPIDS, MI:
2,901,639, CANC. INT. CL. 38.
- BESTTHORN LIMITED, MANCHESTER, UNITED KINGDOM:
3,996,600, PUB. 5-3-2011. INT. CL. 30.
- BETCO CORPORATION, TOLEDO, OH:
1,643,288, REN. 6-15-11. INT. CL. 3.
- BETTE APPEL, INCORPORATED, BLOOMFIELD HILLS, MI:
1,141,826, REN. 6-16-11. INT. CL. 25.
- BETTER BASKETBALL, INC., ATLANTA, GA:
3,996,380, PUB. 5-3-2011. INT. CL. 41.
- BETTER SEAFOOD BUREAU, LLC, MCLEAN, VA:
3,998,315, U.S. CL. 200.
- BEVERAGE ACQUISITION GROUP, LLC., MIDDLEBURY, VT:
3,996,990, PUB. 5-3-2011. INT. CL. 33.
- BEVERAGE SPECTRUM PUBLISHING, INC., GARDEN CITY, NY:
2,902,082, CANC. INT. CL. 16.
- BEYOND 12, INC., SAN FRANCISCO, CA:
3,999,572, INT. CL. 42.
- BFF FOAM CORP., RICHMOND, CANADA:
3,999,513, INT. CL. 20.
- BIALEK, CYNTHIA, FAIRFAX, VA:
3,997,330, PUB. 5-3-2011. INT. CL. 41.
- BIC CORPORATION, SHELTON, CT:
2,457,461, REN. 6-16-11. INT. CL. 8.
- BID JUGGLER, LLC, GREAT FALLS, VA:
3,998,964, INT. CL. 35.
- BIG APPLE SUPPLEMENTS, WHITE PLAINS, NY:
3,996,637, PUB. 5-3-2011. INT. CL. 5.
- BIG BANG, CROLLES, FRANCE:
3,999,603, INT. CL. 11.
- BIG BLUE COMERCIO LTDA., 04088-005 SAO PAULO - SP, BRAZIL:
2,402,382, CANC. INT. CL. 25.
- BIG BROTHERS-BIG SISTERS OF AMERICA, PHILADELPHIA, PA:
3,996,307, PUB. 5-3-2011. INT. CL. 41.
- BIG BUCKS ENTERPRISES, INC., WASHINGTON, NJ, DBA MESSINA WILDLIFE MANAGEMENT:
3,997,013, PUB. 5-3-2011. INT. CL. 5.
- BIG CANOE CO., LLC, BIG CANOE, GA:
3,996,266, PUB. 5-3-2011. MULTIPLE CLASS, INT. CLS. 36 AND 37.
- BIG E LINEMAN, INC., BEAR, DE:
3,998,717, INT. CL. 25.
- BIG O TIRES, INC., ENGLEWOOD, CO:
2,902,045, CANC. INT. CL. 12.
- BIG RED FROG LIMITED, ST. PETER PORT, GUERNSEY:
3,995,514, PUB. 4-12-2011. MULTIPLE CLASS, INT. CLS. 9, 16, 38 AND 41.
- BIG STRIKE TE ACQUISITION LLC, GARDENA, CA:
2,901,464, CANC. INT. CL. 25.
- BIGELOW MERCHANDISING, LLC, COLUMBUS, OH:
2,460,091, REN. 6-10-11. MULTIPLE CLASS, INT. CLS. 18 AND 21.
- BIGGS, JOSEPH W., PANAMA CITY BEACH, FL:
3,995,539, PUB. 8-18-2009. INT. CL. 25.
- BIJOU BRIGITTE MODISCHE ACCESSOIRES AG, FED REP GERMANY:
3,995,761, PUB. 5-3-2011. MULTIPLE CLASS, INT. CLS. 14 AND 16.
- BIJOUX EXTRAORDINAIRE, LTD., MANCHESTER, NH:
2,463,580, REN. 6-14-11. INT. CL. 14.
- BIJOUX TERNER, LLC, MIAMI, FL:
3,999,037, INT. CL. 18.
3,999,038, INT. CL. 18.
- BIKEFORCE INTERNATIONAL CO.,LTD., TAICHUNG CITY, TAIWAN:
3,996,304, PUB. 5-3-2011. INT. CL. 12.
- BIKING BILLBOARDS, LLC, SEATTLE, WA:
3,996,871, PUB. 5-3-2011. INT. CL. 35.
- BILKO ILAC KOZMETIK VE KIMYA SANAYI VE TICARET ANONIM SIRKETI, KUCUKCEKMECE-ISTANBUL, TURKEY:
2,901,130, CANC. INT. CL. 3.
- BILL KREUTZMANN, SAN FRANCISCO, CA:
3,996,408, PUB. 5-3-2011. MULTIPLE CLASS, INT. CLS. 25 AND 41.
- BING INNOVATIONS LLC, BOCA RATON, FL:
3,998,770, INT. CL. 10.
- BIO BISCUIT INC., SAINT-HYACINTHE, PROVINCE OF QUEBEC, CANADA:
2,481,297, REN. 6-16-11. INT. CL. 31.
- BIO CREATIVE ENTERPRISES, INC., LONG BEACH, CA:
2,958,011, AM. INT. CL. 3.
- BIO SOIL ENHANCERS, INC., HATTIESBURG, MS:
3,997,715, PUB. 5-3-2011. INT. CL. 1.
- BIO WELLNESS, INC., COPLEY, OH:
3,998,408, INT. CL. 44.
- BIO-BARGE COMPANY, LLC, METAIRIE, LA:
3,999,662, INT. CL. 12.
- BIOELEMENTS, INC., COLORADO SPRINGS, CO:
2,548,502, REN. 6-15-11. INT. CL. 3.
- BIOTA BITKISEL KOZMETIK LABORATUARLARI TICARET LIMITED SIRKETI, UMRANIYE / ISTANBUL, TURKEY:
3,998,979, INT. CL. 3.
3,998,980, INT. CL. 3.
3,998,981, INT. CL. 3.
3,998,982, INT. CL. 3.
3,998,983, INT. CL. 3.
- BIOTA HOLDINGS LIMITED, VICTORIA 3168, AUSTRALIA:
2,463,653, REN. 6-15-11. INT. CL. 42.
2,463,653, CANC. INT. CL. 10.
- BIOTIVIA LLC, NEW YORK, NY:
3,999,769, INT. CL. 5.
- BIOTRONIK SE & CO. KG, BERLIN, FED REP GERMANY:
3,995,705, PUB. 1-11-2011. MULTIPLE CLASS, INT. CLS. 9, 10, 38 AND 44.
- BIPOLAR BEACON OF HOPE, VANCOUVER, WA:
3,997,795, PUB. 5-3-2011. INT. CL. 16.

BIRDS EYE FOODS LLC, MOUNTAIN LAKES, NJ, CURTICE-BURNS FOODS, INC., ROCHESTER, NY, DBA NALLEY'S FINE FOODS:
1,644,523. REN. 6-15-11. INT. CL. 29.

BITE DOWN, AURORA, CO:
3,996,977. PUB. 5-3-2011. INT. CL. 25.

BITE, INC., NIWOT, CO:
2,902,279. CANC. INT. CL. 10.

BITMAX, LLC, LOS ANGELES, CA:
2,402,226. CANC. MULTIPLE CLASS, INT. CLS. 39 AND 40.

BIZDAT, INC., MCFARLAND, WI:
2,402,515. CANC. INT. CL. 9.

BIZET HUMAN ASSET MANAGEMENT, INC., PITTSBURGH, PA:
2,901,169. CANC. MULTIPLE CLASS, INT. CLS. 35 AND 41.

BIZLINK TECHNOLOGY, INC., FREMONT, CA:
3,996,957. PUB. 5-3-2011. INT. CL. 9.

BIZMOSIS, INC., CUMMING, GA, DBA BIZMOSIS:
3,997,140. PUB. 5-3-2011. INT. CL. 42.

BJ TOY COMPANY, INC., PEN ARGYL, PA:
3,995,593. PUB. 5-3-2011. INT. CL. 18.

BLACK GOLF WEAR, AUSTELL, GA:
3,999,699. INT. CL. 25.

BLACK KIRSCH, LLC, MANCHESTER, NH:
3,999,904. INT. CL. 25.

BLACK MICHAEL L, BELLEVUE, WA:
3,998,187. PUB. 5-3-2011. INT. CL. 29.

BLACKMON JAMES W III, CHARLOTTE, NC, DBA ELEVATOR MUSIC GROUP:
3,999,631. INT. CL. 9.

BLACKROCK, INC., NEW YORK, NY:
3,996,186. PUB. 5-3-2011. MULTIPLE CLASS, INT. CLS. 16 AND 36.

BLANC AERO INDUSTRIES; (SOCIÉTÉ PAR ACTIONS SIMPLIFIÉE), FRANCE:
3,995,764. PUB. 5-3-2011. INT. CL. 6.

BLANCHARD, ALAN, PARLIN, NJ:
3,996,201. PUB. 5-3-2011. INT. CL. 44.

BLANCO, GABRIEL, LUJAN DE CUYO, MENDOZA, ARGENTINA:
3,998,107. PUB. 5-3-2011. INT. CL. 33.

BLANCSQUARE, LLC, DALLAS, TX:
3,997,443. PUB. 5-3-2011. INT. CL. 38.

BLANK, HARRY, LAGUNA NIGUEL, CA AND BLANK, JOY, LAGUNA NIGUEL, CA:
3,997,392. PUB. 5-3-2011. INT. CL. 9.

BLASCO, JOSEPH D., ORLANDO, FL:
2,902,157. CANC. INT. CL. 41.

BLAST DESIGN INTERNATIONAL, INC., CANYON LAKE, TX:
2,901,028. CANC. MULTIPLE CLASS, INT. CLS. 9, 35, 37 AND 41.

BLASTED CHURCH VINEYARDS INC., OKANAGAN FALLS, B.C., CANADA:
3,996,159. PUB. 5-3-2011. INT. CL. 33.

BLISTEX INC., OAK BROOK, IL:
3,998,507. INT. CL. 5.

BLITCHINGTON, TIMOTHY F., MEBANE, NC:
3,432,666. CANC. INT. CL. 9.

BLOCKMASTER AB, SWEDEN:
3,995,908. PUB. 5-3-2011. MULTIPLE CLASS, INT. CLS. 9 AND 42.

BLONDVIC ENTERPRISES, LLC, ST PAUL, MN:
3,998,053. PUB. 5-3-2011. INT. CL. 45.

BLOOMBERG L.P., NEW YORK, NY:
3,975,644. COR. INT. CL. 9.

BLUE BELL COUNTRY CLUB COMMUNITY ASSOCIATION, BLUE BELL, PA:
3,995,682. PUB. 5-3-2011. MULTIPLE CLASS, INT. CLS. 36 AND 41.

BLUE BOX TOY FACTORY LIMITED, TSIM SHA TSUI EAST, KOWLOON, HONG KONG:
2,901,531. CANC. INT. CL. 28.

BLUE COAT SYSTEMS, INC., SUNNYVALE, CA:
2,901,892. CANC. INT. CL. 9.

BLUE CROSS AND BLUE SHIELD ASSOCIATION, CHICAGO, IL, AKA BLUECROSS BLUESHIELD ASSOCIATION:
3,999,291. INT. CL. 36.

BLUE EDGE CAPITAL, LLC, RICHMOND, VA:
3,997,687. PUB. 5-3-2011. INT. CL. 36.

BLUE LINK VENTURES, LLC, NEW YORK, NY:
3,997,895. PUB. 5-3-2011. INT. CL. 42.

BLUE RIDGE ACQUISITION COMPANY, LLC, ELLIJAY, GA:
2,902,415. CANC. INT. CL. 27.

BLUE RIDGE ENTERPRISES, LLC, BLUE RIDGE, GA:
3,998,987. INT. CL. 35.

BLUE-GRACE I.P. LLC, RIVERVIEW, FL:
3,997,591. PUB. 5-3-2011. MULTIPLE CLASS, INT. CLS. 35 AND 39.

BLUEBEARDS INC, EXTON, PA, DBA BLUEBEARDS ORIGINAL:
3,997,697. PUB. 5-3-2011. INT. CL. 3.

BLUESTEM BRANDS, INC., EDEN PRAIRIE, MN:
3,959,357. COR. INT. CL. 36.

BMG RIGHTS MANAGEMENT GMBH, 10178 BERLIN, FED REP GERMANY:
3,995,760. PUB. 5-3-2011. MULTIPLE CLASS, INT. CLS. 9, 16, 35, 38, 41 AND 45.

BML, INC, CHATTANOOGA, TN:
3,996,735. PUB. 5-3-2011. INT. CL. 15.

BMP STANDARD, LLC, BOSTON, MA:
3,997,207. PUB. 5-3-2011. INT. CL. 36.

BOARD OF REGENTS OF THE UNIVERSITY SYSTEM OF GEORGIA, ATLANTA, GA:
3,998,100. PUB. 5-3-2011. MULTIPLE CLASS, INT. CLS. 16, 18, 25 AND 41.

BOARD OF TRUSTEES, MINNESOTA STATE COLLEGES AND UNIVERSITIES, ST. PAUL, MN, AKA MNSCU:
3,996,365. PUB. 5-3-2011. INT. CL. 42.

BOCCIONI-COMERCIO, GESTAO E SERVICOS, LDA, FUNCHAL (MADEIRA), PORTUGAL:
3,998,607. INT. CL. 33.

BODY PROJECT FITNESS AND HEALTH, LLC, WINDSOR, NJ:
3,997,285. PUB. 5-3-2011. INT. CL. 41.

BOEHRINGER INGELHEIM INTERNATIONAL GMBH, FED REP GERMANY:
3,996,022. PUB. 5-3-2011. INT. CL. 5.

BOGAN, COLLEEN, WATERVILLE, NY AND BOGAN, BRIAN, WATERVILLE, NY:
3,997,124. PUB. 5-3-2011. INT. CL. 30.

BOI PROMOTIONS INC., NEW YORK, NY:
3,997,386. PUB. 5-3-2011. INT. CL. 41.

BOINIS, KRISTINA L., RANCHOS DE TAOS, NM:
2,947,883. CANC. INT. CL. 4.

BOISE CASCADE WOOD PRODUCTS, L.L.C., BOISE, ID:
3,999,098. MULTIPLE CLASS, INT. CLS. 19 AND 35.

BOISE RIVER CAPITAL, LLC, BOISE, ID:
3,999,812. INT. CL. 42.

BOLDT ENTERTAINMENT, INC., MINNEAPOLIS, MN:
2,902,532. CANC. INT. CL. 28.

BOLSTER LLC, DES PLAINES, IL:
3,996,382. PUB. 5-3-2011. INT. CL. 37.

BONARRIGO, PAUL, BRYAN, TX AND BONARRIGO, SOPHIA MARIE, BRYAN, TX AND BONARRIGO, KAREN, BRYAN, TX:
3,999,355. MULTIPLE CLASS, INT. CLS. 25, 28 AND 33.

BOND CORP., CHICAGO, IL, BOND CHEMICAL PRODUCTS CO., CHICAGO, IL:
1,646,875. REN. 6-16-11. INT. CL. 21.

BOND LABORATORIES, INC., OMAHA, NE:
3,999,797. INT. CL. 5.

BONDPRO CORPORATION, HUDSON, WI:
3,998,844. INT. CL. 1.

BONGRAIN S.A., FRANCE:
3,995,787. PUB. 5-3-2011. INT. CL. 29.

BOO FOO WOO CO., LTD., TOKYO, JAPAN:
2,453,601. REN. 6-16-11. INT. CL. 25.

BOOKISH LLC, NEW YORK, NY:
3,996,516. PUB. 5-3-2011. INT. CL. 41.

BOOMERANG SOFTWARE, INC., BELMONT, MA:
3,999,267. INT. CL. 9.

- BOON, INC., CHANDLER, AZ:
4,000,043, INT. CL. 11.
- BORANGE, INC., BERKELEY, CA:
3,999,027, INT. CL. 38.
- BOREN, JOHN, HOUSTON, TX:
3,995,485, PUB. 5-3-2011. INT. CL. 28.
- BORIC, BOGDAN, SAN DIEGO, CA:
3,996,401, PUB. 1-25-2011. INT. CL. 35.
- BOSCH SICHERHEITSSYSTEME GMBH, OTTOBRUNN,
85521, FED REP GERMANY:
2,471,139. REN. 6-16-11. INT. CL. 9.
- BOSS PET PRODUCTS, INC., GARFIELD HEIGHTS, OH:
3,999,813, INT. CL. 28.
- BOSTON SCIENTIFIC CORPORATION, NATICK, MA:
1,645,093. REN. 6-16-11. INT. CL. 10.
- BOSTON SCIENTIFIC SCIMED, INC., MAPLE GROVE, MN:
3,998,869, INT. CL. 10.
- BOSTWICK, PETER J. MENLO PARK, CA:
3,997,504, PUB. 5-3-2011. INT. CL. 35.
- BOTANICAL SKIN RESEARCH, LLC, VIRGINIA BEACH,
VA:
3,999,782, INT. CL. 25.
- BOTTLES 'N BRUSHES, LLC, MOUNT PLEASANT, SC:
3,999,425, MULTIPLE CLASS, INT. CLS. 21, 25 AND 41.
3,999,426, MULTIPLE CLASS, INT. CLS. 21, 25 AND 41.
3,999,427, INT. CL. 41.
- BOTTOMLINE TECHNOLOGIES (DE), INC., PORTS-
MOUTH, NH:
3,999,845, MULTIPLE CLASS, INT. CLS. 9 AND 42.
- BOUD VAN ROMPAY, UNITED STATES:
3,995,912, PUB. 5-3-2011. MULTIPLE CLASS, INT. CLS. 2,
37 AND 40.
- BOUTIQUE AIR, SAN FRANCISCO, CA:
3,998,733, INT. CL. 39.
- BOUZIANIS, GREGORY D., CHRISTIANSTED, US VIRGIN
ISLANDS AND BOUZIANIS, ASHLEY E., CHRIS-
TIANSTED, US VIRGIN ISLANDS, FORMERLY SMITH,
ASHLEY E.:
3,998,859, INT. CL. 18.
- BOWDEN PROPERTIES, LLC, MERIDIAN, ID:
2,402,197, CANC. INT. CL. 41.
- BOWEN, GRANT, SAN FRANCISCO, CA:
4,000,033, INT. CL. 35.
- BOWLAND STONE LIMITED, EAST YORKSHIRE, HU16
STA, UNITED KINGDOM:
2,851,232, COR. INT. CL. 19.
- BOWTIE, INC., IRVINE, CA:
2,460,910. REN. 6-13-11. INT. CL. 16.
2,957,936, CANC. INT. CL. 41.
- BOYLE OGATA BREGMAN, IRVINE, CA:
3,997,716, PUB. 5-3-2011. INT. CL. 35.
- BRAD RICHDALE, DANA POINT, CA:
2,902,424, CANC. INT. CL. 31.
- BRADLEY B GRIFFITH, LITTLETON, CO:
3,998,647, INT. CL. 41.
- BRADLEY INDUSTRIAL TEXTILES, INC., VALPARAISO,
FL:
2,402,358, CANC. MULTIPLE CLASS, INT. CLS. 19 AND
22.
- BRADLEY, ERIC, MARINA DEL REY, CA:
3,999,157, INT. CL. 41.
- BRADY INNOVATIONS, LLC, BEVERLY HILL, CA:
3,999,313, INT. CL. 6.
- BRAIN RESEARCH, INC., NEW YORK, NY:
1,652,874. REN. 6-15-11. INT. CL. 5.
- BRAITHWAITE MARY M. NORTH PORT, FL:
3,997,343, PUB. 5-3-2011. INT. CL. 18.
- BRAM STOKER LLC, AIKEN, SC:
3,998,931, MULTIPLE CLASS, INT. CLS. 14 AND 25.
- BRANCH OUT GROUP, LLC, PLANTATION, FL:
3,998,841, INT. CL. 35.
- BRAND ADOPTION, LLC, MESA, AZ, DBA BRAND ADOP-
TION:
3,996,569, PUB. 5-3-2011. INT. CL. 35.
- BRAND AFFINITY TECHNOLOGIES, INC., IRVINE, CA:
3,999,826, INT. CL. 35.
3,999,827, INT. CL. 35.
- BRAND OPPORTUNITIES, LLC, ATLANTA, GA:
3,999,112, INT. CL. 33.
- BRANDILLA HOLDINGS LLC, SUNNYSIDE, NY:
3,997,369, PUB. 5-3-2011. INT. CL. 35.
- BRASSTECH, INC., SANTA ANA, CA:
3,999,189, MULTIPLE CLASS, INT. CLS. 6, 20 AND 21.
- BRATTLEBORO RETREAT, THE, BRATTLEBORO, VT:
2,486,343. REN. 6-16-11. MULTIPLE CLASS, INT. CLS. 35,
36 AND 42.
- BRAVADO INTERNATIONAL GROUP LIMITED, LON-
DON, UNITED KINGDOM:
3,997,244, PUB. 5-3-2011. INT. CL. 14.
- BRAVE NEW ROCKET LLC, CHESTNUT RIDGE, NY:
3,998,479, MULTIPLE CLASS, INT. CLS. 9, 16, 26 AND 35.
- BRAVO BRIO RESTAURANT GROUP, COLUMBUS, OH:
3,997,375, PUB. 5-3-2011. INT. CL. 43.
- BRAZOS INTERNATIONAL, INC., MIAMI, FL:
3,995,688, PUB. 5-3-2011. INT. CL. 21.
- BREAD POETS FRANCHISING, BISMARCK, ND:
3,996,676, PUB. 5-3-2011. MULTIPLE CLASS, INT. CLS. 30
AND 43.
- BRECO ANTRIEBSTECHNIK BREHER GMBH + CO, FED
REP GERMANY:
3,995,799, PUB. 5-3-2011. MULTIPLE CLASS, INT. CLS. 7
AND 12.
- BREEN SYSTEMS MANAGEMENT, INC., VERGENNES, VT:
2,466,466. REN. 6-15-11. INT. CL. 9.
- BRETT THOMPSON, SALT LAKE CITY, UT:
3,999,481, INT. CL. 35.
- BREWSTER, BEN W., SAN CARLOS, CA:
3,999,844, INT. CL. 42.
- BRICA, INC., CHARLOTTE, NC:
3,999,469, INT. CL. 12.
3,999,732, INT. CL. 12.
- BRICKFORGE, SPRINGFIELD, OH:
3,997,963, PUB. 5-3-2011. INT. CL. 28.
- BRIDGE GRAPHIX, LLC, DALLAS, TX:
3,999,128, INT. CL. 16.
- BRIDGEPORT FITTINGS, INC., STRATFORD, CT:
3,999,294, INT. CL. 9.
3,999,295, INT. CL. 9.
3,999,296, INT. CL. 9.
3,999,297, INT. CL. 9.
- BRIDGER STEEL, INC., BELGRADE, MT:
3,999,512, INT. CL. 6.
- BRIDGES, CAMBRIDGE, ONTARIO:
2,901,030, CANC. MULTIPLE CLASS, INT. CLS. 10, 35
AND 41.
- BRIDGES-IDS, INC., WINSTON-SALEM, NC:
2,402,375, CANC. MULTIPLE CLASS, INT. CLS. 41 AND
42.
- BRIDGESTONE BANDAG, LLC, MUSCATINE, IA:
3,998,829, INT. CL. 12.
- BRIDJIT INC., KENT, WA:
3,997,818, PUB. 5-3-2011. INT. CL. 17.
- BRIGHTTAG INC., CHICAGO, IL:
3,999,259, MULTIPLE CLASS, INT. CLS. 35 AND 42.
- BRILHANTE CO. INC., LOS ANGELES, CA:
2,454,265. REN. 6-15-11. INT. CL. 3.
- BRINK, WILLIAM R, SAN DIEGO, CA:
3,996,563, PUB. 5-3-2011. INT. CL. 37.
- BROADCAST TOOLS, INC., SEDRO-WOOLLEY, WA:
3,996,422, PUB. 1-25-2011. INT. CL. 9.
- BROADCASTCROWN HOLDINGS PLC, STAFFORD ST18 0PF,
UNITED KINGDOM:
3,995,854, PUB. 5-3-2011. MULTIPLE CLASS, INT. CLS. 7
AND 37.
- BROADVIEW NETWORKS, INC., RYE BROOK, NY:
2,957,599, CANC. INT. CL. 41.
- BRODSKY LLC, NEW YORK, NY, AKA BRODSKY LAW
FIRM:
4,000,042, INT. CL. 45.
- BROKAW NURSERY, INC., SATICOY, CA:
3,998,703, INT. CL. 31.
- BRONCO WINE COMPANY, CERES, CA:
1,645,442. REN. 6-15-11. INT. CL. 33.
- BRONEAH, INC., TRAVERSE CITY, MI:
3,996,410, PUB. 5-3-2011. INT. CL. 41.

BROWN AND HELLER, P.A., MIAMI, FL:
3,997,043, PUB. 5-3-2011. INT. CL. 45.

BROWN MOLASSES CO., INCORPORATED, CUTLER, IN:
3,997,902, PUB. 5-3-2011. INT. CL. 25.

BROWN SHOE COMPANY, INC., ST. LOUIS, MO:
387,963. REN. 6-15-11. U.S. CL. 39 (INT. CL. 25).
2,902,474, CANC. INT. CL. 25.
3,998,946, INT. CL. 9.

BROWN, CHRIS, JOHNSON CITY, TN:
3,997,021, PUB. 5-3-2011. INT. CL. 44.

BROWN, JAMES A., JR., ARLINGTON HEIGHTS, IL:
2,901,514, CANC. INT. CL. 25.

BROWN, NATHAN OWEN, ISSAQUAH, WA:
3,996,962, PUB. 5-3-2011. INT. CL. 41.
3,996,963, PUB. 5-3-2011. INT. CL. 25.
3,996,986, PUB. 5-3-2011. INT. CL. 16.

BROWN, SILVIA, BROOKLYN, NY:
3,997,762, PUB. 5-3-2011. INT. CL. 42.

BROWNSTEIN, ADAM S., HOUSTON, TX:
3,998,377, INT. CL. 37.

BRUCE FOODS CORPORATION, NEW IBERIA, LA:
924,363. REN. 6-11-11. U.S. CL. 46 (INT. CL. 29).

BRUCE MELNICK, DAYTON, OH:
3,998,075, PUB. 5-3-2011. INT. CL. 35.

BRUNSWICK CORPORATION, LAKE FOREST, IL:
2,566,602. REN. 6-16-11. INT. CL. 7.

BRYAN MCCLANAHAN, SAN DIEGO, CA:
3,997,837, PUB. 5-3-2011. INT. CL. 41.

BRYTON INC., TAIPEI CITY 11493, TAIWAN:
3,999,270, INT. CL. 9.
3,999,272, INT. CL. 9.

BRÜTTING & CO. EB-SPORT-INTERNATIONAL GMBH,
FED REP GERMANY:
3,995,973, PUB. 5-3-2011. MULTIPLE CLASS, INT. CLS.
18, 25 AND 35.

BSH BOSCH UND SIEMENS HAUSGERAETE GMBH,
MUNICH, FED REP GERMANY:
3,996,446, PUB. 5-3-2011. INT. CL. 7.

BUBAR, DAVID N., DELMAR, NY:
2,593,722, CANC. INT. CL. 41.

BUBBA'S SANI-SERV, INC., DANVILLE, VA:
3,996,327, PUB. 5-3-2011. INT. CL. 43.

BUCA RESTAURANTS 3, INC., NORTHBOROUGH, MA:
2,401,420, CANC. INT. CL. 42.

BUDGE INDUSTRIES, LLC, LANSDALE, PA:
2,460,062. REN. 6-14-11. INT. CL. 12.

BUILD-A-BEAR RETAIL MANAGEMENT, INC., ST. LOUIS,
MO:
2,564,834. REN. 6-16-11. INT. CL. 35.

BUILDERFISH, LLC, RUCKERSVILLE, VA:
3,999,416, INT. CL. 37.

BUKSPAN, YEHUDAH, LOS ANGELES, CA:
2,477,561. REN. 6-16-11. U.S. CL. A.

BULBSTORM, INC., PHOENIX, AZ:
3,997,345, PUB. 5-3-2011. INT. CL. 35.

BUREAU VERITAS, REGISTRE INTERNATIONAL DE
CLASSIFICATION DE NAVIRES ET D'AERONEFS,
NEUILLY-SUR-SEINE, FRANCE:
2,901,049, CANC. MULTIPLE CLASS, INT. CLS. 16, 38
AND 42.

BURNETTE FOODS, INC., ELK RAPIDS, MI:
3,999,991, INT. CL. 29.

BUSE, INC., CHICAGO, IL, DBA KUMA'S CORNER:
3,996,906, PUB. 5-3-2011. INT. CL. 43.

BUSH, MONICA P., SACRAMENTO, CA:
2,902,317, CANC. INT. CL. 6.

BUSHNELL INC., OVERLAND PARK, KS:
1,655,508. REN. 6-15-11. INT. CL. 13.

BUTLER ANIMAL HEALTH SUPPLY, LLC, DUBLIN, OH:
2,902,366, CANC. INT. CL. 5.
2,902,367, CANC. INT. CL. 5.

BUTLER, BOYD L., SANDY, UT:
3,999,926, INT. CL. 7.

BUZRUN CO., LTD., SEOCHO-GU SEOUL, REPUBLIC OF
KOREA:
3,998,870, MULTIPLE CLASS, INT. CLS. 25 AND 28.

BWIA WEST INDIES AIRWAYS LIMITED, PIARCO, WEST
INDIES, TRINIDAD/TOBAGO:
2,901,165, CANC. INT. CL. 39.

BYK-CHEMIE GMBH, FED REP GERMANY:
3,995,979, PUB. 5-3-2011. MULTIPLE CLASS, INT. CLS. 1,
2, 9, 17, 19 AND 40.

BYRNE MEDICAL, INC., CONROE, TX:
3,998,735, INT. CL. 10.

BÜCHI LABORTECHNIK AG, 9230 FLAWIL, SWITZER-
LAND:
3,996,342, PUB. 5-3-2011. MULTIPLE CLASS, INT. CLS. 9
AND 42.

C & A INDUSTRIES, INC., OMAHA, NE:
2,475,827. REN. 6-10-11. INT. CL. 35.

C. C. & C. - CORALLO CACAU & CAFÉ, LDA, PORTUGAL:
3,995,916, PUB. 5-3-2011. MULTIPLE CLASS, INT. CLS.
30, 35 AND 43.

C. H. GUENTHER & SON, INC., SAN ANTONIO, TX, DBA
PIONEER FLOUR MILLS:
1,648,267. REN. 6-15-11. INT. CL. 30.

C.A.I., INC., GEORGETOWN, MA:
2,901,830, CANC. INT. CL. 2.

C.E.I.A. - COSTRUZIONI ELETTRONICHE INDUSTRIALI
AUTOMATISMI S.P.A., ITALY:
3,996,024, PUB. 5-3-2011. INT. CL. 9.

C.P. YEATMAN & SONS, INC., WEST GROVE, PA:
3,997,548, PUB. 5-3-2011. INT. CL. 29.
3,997,949, PUB. 5-3-2011. INT. CL. 31.

C&S WHOLESALE GROCERS, INC., KEENE, NH:
3,997,402, PUB. 5-3-2011. INT. CL. 36.

C-LINE PRODUCTS, INC., MT. PROSPECT, IL:
2,449,870. REN. 6-15-11. INT. CL. 16.

CA-RECYCLING CONSULTANTS, INC., CENTERVILLE,
OH:
2,402,082, CANC. INT. CL. 42.

CABAL, ERICK L., HONOLULU, HI:
2,902,149, CANC. INT. CL. 31.

CABELA'S INC., SIDNEY, NE:
3,998,156, PUB. 5-3-2011. INT. CL. 28.

CABELA'S INCORPORATED, SIDNEY, NE:
2,902,321, CANC. MULTIPLE CLASS, INT. CLS. 24 AND
25.

CABLE ELECTRONICS, INC., GARLAND, TX:
2,405,323. REN. 6-16-11. INT. CL. 9.
2,405,324. REN. 6-16-11. INT. CL. 9.

CABOODLES, LLC, MEMPHIS, TN:
2,902,006, CANC. INT. CL. 3.

CACHE MEDICAL CONNECTIONS LLC, FORT MYERS, FL,
DBA URGENT CARE AMERICA:
4,000,031, INT. CL. 35.

CAD AUDIO, LLC, SOLON, OH:
3,998,722, INT. CL. 9.

CADARA, N.V., 1651 LOT-BEERSEL, BELGIUM:
2,401,484, CANC. INT. CL. 16.

CADENA LEON JOSE MIGUEL, ZAPOPAN, MEXICO:
3,995,535, PUB. 5-3-2011. INT. CL. 33.

CADENCE TECHNOLOGIES, INC., ALPHARETTA, GA:
3,998,610, INT. CL. 11.

CAFE NEGRO GALLERIA, S. DE R.L. DE C.V., ZAPOPAN,
JALISCO, MEXICO:
3,995,698, PUB. 5-3-2011. INT. CL. 35.

CAFE RIO, INCORPORATED, SALT LAKE CITY, UT:
3,995,522, PUB. 5-3-2011. INT. CL. 43.

CALIFORNIA INTERCONTINENTAL UNIVERSITY, INC.,
DIAMOND BAR, CA:
3,996,441, PUB. 5-3-2011. INT. CL. 41.

CALGON CARBON CORPORATION, PITTSBURGH, PA:
3,998,984, INT. CL. 1.

CALIBAN SYCORAX (CALAX), PROSPER, TX:
3,997,712, PUB. 5-3-2011. INT. CL. 45.

CALIFORNIA GLASS ASSOCIATION, PLACERVILLE, CA:
2,902,331, CANC. INT. CL. 40.

CALIFORNIA HEALTHCARE FOUNDATION, OAKLAND,
CA:
3,995,689, PUB. 5-3-2011. INT. CL. 42.

CALIFORNIA INNOVATIONS INC., TORONTO, ONTARIO,
CANADA:
3,996,223, PUB. 5-3-2011. INT. CL. 21.

- CALIP HOLDINGS INC., BRONX, NY:
3,999,202, INT. CL. 30.
- CALL STAGE, LLC, DRAPER, UT:
3,998,117, PUB. 5-3-2011. INT. CL. 35.
- CALLAWAY CONSOLIDATED, INC., TUCKER, GA:
3,995,646, PUB. 5-3-2011. INT. CL. 14.
- CALLAWAY GOLF COMPANY, CARLSBAD, CA:
2,902,473, CANC. INT. CL. 28.
3,998,662, INT. CL. 28.
- CALLIDUS INVESTMENTS B.V., NETHERLANDS:
3,995,889, PUB. 5-3-2011. INT. CL. 7.
- CALSYS, INC., SANTA CLARA, CA:
3,997,335, PUB. 5-3-2011. INT. CL. 9.
3,997,336, PUB. 5-3-2011. INT. CL. 9.
- CAM-JO, INC., CLEARWATER, FL:
2,401,304, CANC. INT. CL. 39.
- CAMBRIDGE BROADBAND NETWORKS LIMITED, CAMBRIDGE CB4 0WZ, UNITED KINGDOM:
3,995,630, PUB. 4-6-2010. MULTIPLE CLASS, INT. CLS. 9 AND 38.
- CAMBRIDGE INTERNETWORKING LIMITED, CAMBRIDGE, UNITED KINGDOM:
2,901,535, CANC. MULTIPLE CLASS, INT. CLS. 9 AND 42.
- CAMELEER INC., THE, CULPEPER, VA:
3,996,933, PUB. 5-3-2011. INT. CL. 35.
- CAMPISI RICHARD, SANTA ROSA BEACH, FL, DBA R. M. CAMPISI:
3,997,721, PUB. 5-3-2011. INT. CL. 25.
- CAMPO, KIRA C., OCEAN CITY, NJ:
3,998,578, INT. CL. 41.
- CAMURUS AB, SWEDEN:
3,781,349, COR. MULTIPLE CLASS, INT. CLS. 5 AND 42.
- CAN-B-GREEN, LLC, BOISE, ID:
3,997,403, PUB. 5-3-2011. INT. CL. 37.
- CANADIAN COUNSELLING AND PSYCHOTHERAPY ASSOCIATION, OTTAWA, ONTARIO, CANADA:
3,999,634, INT. CL. 35.
- CANADIAN PHYTOPHARMACEUTICALS CORPORATION, RICHMOND, BC, CANADA:
3,998,629, INT. CL. 5.
- CANAL LAND FUND, INC., CONWAY, SC:
2,402,179, CANC. MULTIPLE CLASS, INT. CLS. 36 AND 37.
- CANDIDATE CHECK, INC., MEDINA, WI:
4,000,029, INT. CL. 42.
- CANDLE ARTISANS, INC., WASHINGTON, NJ:
3,996,487, PUB. 5-3-2011. INT. CL. 4.
- CANDYCARTON LLC, LOVELAND, CO:
3,999,848, INT. CL. 35.
- CANLAN ICE SPORTS CORP., BURNABY, BC, CANADA:
3,997,218, PUB. 5-3-2011. INT. CL. 41.
- CANVAS INTERIOR DESIGN, INC., FOUNTAIN VALLEY, FL:
3,996,892, PUB. 5-3-2011. INT. CL. 42.
- CAPE CORAL DEVELOPMENT ASSOCIATES, LLC, BONITA SPRINGS, FL:
3,996,415, PUB. 5-3-2011. INT. CL. 37.
- CAPELLO S.R.L., ITALY:
3,995,860, PUB. 5-3-2011. INT. CL. 7.
- CAPISTRANO BREWING COMPANY, SAN JUAN CAPISTRANO, CA:
2,901,762, CANC. INT. CL. 32.
- CAPITAL ONE FINANCIAL CORPORATION, RICHMOND, VA:
2,901,753, CANC. INT. CL. 36.
2,901,754, CANC. INT. CL. 36.
2,902,155, CANC. INT. CL. 35.
3,995,611, PUB. 5-3-2011. INT. CL. 36.
- CAPITELLO, INC., WASHINGTON, DC:
3,998,759, INT. CL. 43.
- CAPITOL WHOLESALE MEATS, INC., MCCOOK, IL:
3,998,306, INT. CL. 29.
- CAPITUS PTE LTD, SINGAPORE, SINGAPORE:
3,999,180, INT. CL. 25.
- CAPODIMONTE NG, INC., WILLIAMSBURG, VA:
3,999,461, INT. CL. 21.
- CAPSO VISION, INC., SARATOGA, CA:
3,998,663, MULTIPLE CLASS, INT. CLS. 9 AND 10.
3,998,670, INT. CL. 9.
- CAPSYS TECHNOLOGIES, LLC, ITASCA, IL:
3,999,351, INT. CL. 9.
- CARBON TRUST FOOTPRINTING; COMPANY LIMITED, UNITED KINGDOM:
3,995,783, PUB. 5-3-2011. MULTIPLE CLASS, INT. CLS. 16, 35, 41 AND 42.
- CARDIOTEX AS, OSLO, NORWAY:
2,901,183, CANC. INT. CL. 20.
- CARDON, ROBYN, EDMOND, OK:
3,997,643, PUB. 5-3-2011. INT. CL. 41.
- CARDSYNC PROCESSING, INC., NASHVILLE, TN:
3,998,975, INT. CL. 36.
- CAREERBUILDER, LLC, CHICAGO, IL:
3,998,451, INT. CL. 35.
- CAREFUSION 303, INC, SAN DIEGO, CA:
2,901,516, CANC. INT. CL. 9.
- CAREONSITE, INC., LONG BEACH, CA:
3,996,818, PUB. 5-3-2011. INT. CL. 38.
3,996,846, PUB. 5-3-2011. INT. CL. 38.
- CARESEEKERS, LLC, OMAHA, NE:
2,401,945, CANC. INT. CL. 42.
- CARGILL COCOA & CHOCOLATE, INC., LITITZ, PA:
2,463,986, REN. 6-14-11. INT. CL. 30.
- CARGILL, INCORPORATED, WAYZATA, MN:
3,998,456, INT. CL. 30.
3,999,524, INT. CL. 31.
3,999,525, INT. CL. 31.
- CARL ESTLER, P.C., KATY, TX:
2,401,393, CANC. INT. CL. 42.
- CARLOS-EL, WALTER STEVEN, CHICAGO, IL:
3,998,924, INT. CL. 45.
- CARMAX BUSINESS SERVICES, LLC, RICHMOND, VA:
2,901,820, CANC. INT. CL. 35.
- CARNIVAL CORPORATION, MIAMI, FL:
2,402,291, CANC. INT. CL. 28.
3,998,819, INT. CL. 32.
- CAROL TUTTLE ENTERPRISES, L.L.C., DRAPER, UT:
3,999,206, INT. CL. 9.
- CAROLINAEAST HEALTH SYSTEM, NEW BERN, NC:
3,996,605, PUB. 5-3-2011. INT. CL. 44.
- CARPENTER, GREG, PITTSFIELD, MA, DBA YUMMY TREASURES:
3,998,130, PUB. 5-3-2011. INT. CL. 35.
- CARPET CLEANING PLUS, INC., CUMMING, GA:
3,996,617, PUB. 5-3-2011. INT. CL. 37.
- CARR, R., SCOTT, ORANGE, CA:
2,901,644, CANC. INT. CL. 12.
- CARRIER ENTERPRISE, LLC, ORLANDO, FL:
3,998,815, INT. CL. 11.
- CARRIER VIBRATING EQUIPMENT, INC., LOUISVILLE, KY:
1,175,855, REN. 6-15-11. INT. CL. 7.
- CARROLL HALL SHELBY TRUST, LOS ANGELES, CA:
3,995,716, PUB. 5-3-2011. INT. CL. 28.
3,995,717, PUB. 5-3-2011. INT. CL. 28.
- CARRY HOT, INC., NEW YORK, NY:
2,902,188, CANC. INT. CL. 21.
- CARSTACHE LLC, SAN FRANCISCO, CA, DBA CARSTACHE:
3,997,157, PUB. 5-3-2011. INT. CL. 12.
- CARTIER INTERNATIONAL A.G., 6312 STEINHAUSEN, SWITZERLAND:
2,901,106, CANC. INT. CL. 14.
- CASA DE TAMALES, LLC, FRESNO, CA:
3,996,824, PUB. 5-3-2011. MULTIPLE CLASS, INT. CLS. 29 AND 43.
- CASABELLA HOLDINGS LLC, BLAUVELT, NY:
2,402,498, CANC. INT. CL. 21.
- CASANOVAS NIGHTCLUB, MIAMI, FL:
3,996,256, PUB. 5-3-2011. INT. CL. 41.
- CASIANO COMMUNICATIONS, INC., SAN JUAN, PUERTO RICO:
3,998,425, INT. CL. 16.
- CASSANITI, ALEXANDRA, SANTA MONICA, CA:
3,997,039, PUB. 5-3-2011. MULTIPLE CLASS, INT. CLS. 18

- AND 25.
3,997,041, PUB. 5-3-2011. MULTIPLE CLASS, INT. CLS. 18 AND 25.
- CASSEL GROUP, LLC, VENICE, CA:
3,997,328, PUB. 5-3-2011. INT. CL. 5.
- CASSIDY & ASSOCIATES, INC., WASHINGTON, DC:
3,996,767, PUB. 5-3-2011. INT. CL. 35.
- CASTELLI DEL GREPESA SOCIETÀ COOPERATIVA AGRICOLA, ITALY:
3,995,995, PUB. 5-3-2011. INT. CL. 33.
- CASTER, 75008 PARIS, FRANCE:
2,401,904, CANC. INT. CL. 3.
- CASTFAM, INC., EL CAJON, CA:
3,998,207, PUB. 5-3-2011. INT. CL. 35.
- CASTLEROCK PARTNERS LIMITED PARTNERSHIP, AUSTIN, TX:
3,998,343, INT. CL. 37.
3,998,344, INT. CL. 36.
- CAT MEDIA PTY LIMITED, NEW SOUTH WALES, AUSTRALIA:
2,901,182, CANC. INT. CL. 3.
- CATALETTO, BARBARA, MINEOLA, NY, DBA CASECODER LLC:
3,995,627, PUB. 5-3-2011. INT. CL. 9.
- CATALYTIC COMMUNITIES, INC., WASHINGTON, DC:
2,560,455, REN. 6-15-11. INT. CL. 42.
- CATHOLIC FINANCIAL LIFE, MILWAUKEE, WI:
3,996,105, PUB. 5-3-2011. INT. CL. 36.
- CATTUZZATO, STEFANO, SANFLORIANO DCOLLIO, GO, ITALY:
3,997,158, PUB. 5-3-2011. INT. CL. 33.
- CAVANAUGH, CRYSTAL L., MARION, IA, DBA COCO CAVANNA:
3,997,271, PUB. 5-3-2011. INT. CL. 25.
- CAW INDUSTRIES, INC., RAPID CITY, SD:
3,997,235, PUB. 5-3-2011. INT. CL. 1.
- CB TRAVEL CORP., SALT LAKE CITY, UT:
3,996,346, PUB. 5-3-2011. INT. CL. 39.
- CBS BROADCASTING INC., NEW YORK, NY:
3,998,671, INT. CL. 41.
- CBS INTERACTIVE INC., NEW YORK, NY:
3,996,224, PUB. 5-3-2011. INT. CL. 41.
3,996,339, PUB. 5-3-2011. INT. CL. 41.
3,996,340, PUB. 5-3-2011. INT. CL. 41.
- CBS STUDIOS INC., STUDIO CITY, CA:
3,997,764, PUB. 5-3-2011. INT. CL. 16.
- CCR LOGISTICS SYSTEMS AG, DORNACH, FED REP GERMANY:
3,995,602, PUB. 5-3-2011. MULTIPLE CLASS, INT. CLS. 35, 39, 40 AND 42.
- CEC ENTERTAINMENT CONCEPTS, L.P., IRVING, TX:
3,997,217, PUB. 5-3-2011. INT. CL. 28.
- CEILINGS PLUS, LOS ANGELES, CA:
3,999,906, INT. CL. 6.
- CELEBRITIES & NETWORKING LTD., DOUGLAS, ISLE OF MAN:
3,996,125, PUB. 10-12-2010. MULTIPLE CLASS, INT. CLS. 3 AND 5.
- CELEBRITY ENTERPRISES, INC., TIJERAS, NM:
4,000,003, INT. CL. 41.
- CELESTIA TRACY, STEVEN TRACY, PHOENIX, AZ:
3,996,404, PUB. 5-3-2011. INT. CL. 35.
- CELESTIAL SEASONINGS, INC., BOULDER, CO:
2,401,964, CANC. INT. CL. 30.
- CELGENE CORPORATION, SUMMIT, NJ:
3,996,633, PUB. 5-3-2011. INT. CL. 5.
- CELLMADE SAS, F-74160 ARCHAMPS, FRANCE:
3,995,835, PUB. 5-3-2011. MULTIPLE CLASS, INT. CLS. 5, 42 AND 44.
- CELRUN CO., LTD., BUK-GU, GWANGJU, 500-846, REPUBLIC OF KOREA:
3,373,339, COR. MULTIPLE CLASS, INT. CLS. 9 AND 38.
- CENGAGE LEARNING, INC., STAMFORD, CT:
2,902,033, CANC. INT. CL. 9.
- CENTER CUT HOSPITALITY, INC., WICHITA, KS:
2,401,261, CANC. INT. CL. 42.
- CENTER FOR INTERNET SECURITY, EAST GREENBUSH, NY:
3,996,174, PUB. 5-3-2011. MULTIPLE CLASS, INT. CLS. 35, 36 AND 41.
- CENTER FOR ORANGUTAN AND CHIMPANZEE CONSERVATION, INC., WAUCHULA, FL:
3,996,155, PUB. 5-3-2011. MULTIPLE CLASS, INT. CLS. 35 AND 36.
- CENTERPOINT ENERGY RESOURCES CORP., MINNEAPOLIS, MN:
2,901,158, CANC. INT. CL. 16.
- CENTERPOINT ENERGY, INC., HOUSTON, TX:
3,996,550, PUB. 5-3-2011. INT. CL. 35.
- CENTRAL FIBER LLC, WELLSVILLE, KS:
2,496,916, REN. 6-15-11. INT. CL. 17.
- CENTRAL GLASS CO., LTD., JAPAN:
3,853,793, COR. MULTIPLE CLASS, INT. CLS. 1, 5, 12, 19 AND 21.
- CENTRAL REGIONAL DENTAL TESTING SERVICE, INC., TOPEKA, KS:
3,997,334, PUB. 5-3-2011. MULTIPLE CLASS, INT. CLS. 16 AND 42.
- CENTRE GROUP HOLDINGS LIMITED, PEMBROKE, BERMUDA:
3,996,220, PUB. 5-3-2011. INT. CL. 36.
3,996,221, PUB. 5-3-2011. INT. CL. 36.
- CENTRIFY CORPORATION, SUNNYVALE, CA:
3,998,783, INT. CL. 9.
- CENTRILLION TECHNOLOGY HOLDINGS CORPORATION, MOUNTAIN VIEW, CA:
3,997,861, PUB. 5-3-2011. INT. CL. 42.
- CENTURIA STEEL BUILDINGS CORP., PHILADELPHIA, PA:
3,998,122, PUB. 5-3-2011. INT. CL. 6.
- CEQUEL COMMUNICATIONS, LLC, ST. LOUIS, MO, DBA SUDDENLINK COMMUNICATIONS:
3,998,708, INT. CL. 38.
- CERADYNE, INC., COSTA MESA, CA:
3,995,683, PUB. 5-3-2011. INT. CL. 1.
- CERIDIAN BENEFITS SERVICES, INC., PALM HARBOR, FL:
2,402,175, CANC. INT. CL. 36.
- CERTA PROPAINTERS, LTD., OAKS, PA:
3,997,747, PUB. 5-3-2011. INT. CL. 37.
- CERTAINTEED CORPORATION, VALLEY FORGE, PA:
3,999,394, INT. CL. 19.
3,999,615, INT. CL. 19.
- CERTAINTEED GYPSUM, INC., TAMPA, FL:
3,998,888, INT. CL. 19.
- CFI COMPANIES, INC, HOUSTON, TX:
3,999,757, INT. CL. 42.
- CGBS INTERNATIONAL S.A., SWITZERLAND:
3,995,975, PUB. 5-3-2011. INT. CL. 3.
- CHA INTERNATIONAL, LLC, NEW YORK, NY:
3,996,598, PUB. 5-3-2011. INT. CL. 25.
- CHAD BORKOWSKI, YORBA LINDA, CA:
3,997,614, PUB. 5-3-2011. MULTIPLE CLASS, INT. CLS. 16 AND 25.
- CHAKRAVUTH, DANIEL TES, LAKE FOREST, CA:
3,999,245, INT. CL. 25.
- CHAMELEON CHAIRS LLC, TORRANCE, CA:
3,996,573, PUB. 5-3-2011. INT. CL. 43.
- CHANDRU LAKHATI, NEW YORK, NY, DBA A1 WATCHES INC:
3,996,627, PUB. 5-3-2011. INT. CL. 14.
- CHANEL, INC., NEW YORK, NY:
3,999,339, INT. CL. 3.
- CHANG, DANIELLE, NEW YORK, NY:
3,998,989, INT. CL. 43.
- CHAO-WEN LIANG, TAICHUNG CITY, TAIWAN:
3,998,019, PUB. 5-3-2011. INT. CL. 9.
- CHAPMAN PRODUCTS CO., INC., FOUNTAIN INN, SC:
3,997,515, PUB. 5-3-2011. INT. CL. 3.
- CHARLES J. SILLARI, JR., SOMERVILLE, MA:
3,997,620, PUB. 5-3-2011. INT. CL. 30.
- CHARLES R. JOYNER, LOS ANGELES, CA:
3,999,017, INT. CL. 41.
3,999,018, INT. CL. 41.

- CHARLES SCHWAB & CO., INC., SAN FRANCISCO, CA:
2,901,953, CANC. INT. CL. 9.
2,902,244, CANC. MULTIPLE CLASS, INT. CLS. 36 AND 41.
- CHARLESTON WOODWORKS, INC., CHARLESTON, SC:
3,996,853, PUB. 5-3-2011. MULTIPLE CLASS, INT. CLS. 20 AND 21.
- CHARMS MARKETING COMPANY, CHICAGO, IL:
2,901,641, CANC. INT. CL. 30.
- CHARTPAK, INC., MELVILLE, NY:
2,401,432, CANC. INT. CL. 16.
- CHARTPATTERN.COM, INC., LAS VEGAS, NV:
3,996,222, PUB. 5-3-2011. MULTIPLE CLASS, INT. CLS. 36 AND 41.
- CHATA BIOSYSTEMS, INC., FORT COLLINS, CO:
3,996,873, PUB. 5-3-2011. INT. CL. 9.
- CHATAM INTERNATIONAL INCORPORATED, WILMINGTON, DE:
2,901,142, CANC. INT. CL. 33.
- CHAUTAUQUA COUNTY VISITORS BUREAU, CHAUTAUQUA, NY:
3,999,482, INT. CL. 35.
- CHAVARRIA, CESAR, EL CENTRO, CA:
3,997,350, PUB. 5-3-2011. INT. CL. 35.
- CHEEKY COUTURE, CICERO, IN:
3,996,249, PUB. 5-3-2011. INT. CL. 14.
- CHEFARO IRELAND LIMITED, DUBLIN 11, IRELAND:
2,902,016, CANC. MULTIPLE CLASS, INT. CLS. 3 AND 5.
- CHEIL INDUSTRIES INC., KYUNGSANGBUK-DO, REPUBLIC OF KOREA:
3,995,551, PUB. 5-3-2011. MULTIPLE CLASS, INT. CLS. 14, 18, 25 AND 35.
- CHEMALLOCY COMPANY, INC., BRYN MAWR, PA:
917,926, REN. 6-10-11. U.S. CL. 1 (INT. CL. 6).
- CHEMETALL LIMITED, BUCKINGHAMSHIRE, UNITED KINGDOM, BRENT CHEMICALS INTERNATIONAL PLC, BUCKINGHAMSHIRE, ENGLAND:
1,637,300, REN. 6-16-11. INT. CL. 1.
- CHEMETALL US, INC., NEW PROVIDENCE, NJ:
2,401,358, CANC. INT. CL. 1.
- CHEMSPEC USA, INC., ORRVILLE, OH:
2,476,647, REN. 6-16-11. INT. CL. 36.
- CHENGSHIH CHANG, HACIENDA HEIGHTS, CA:
3,999,118, INT. CL. 5.
- CHERNE INDUSTRIES INCORPORATED, MINNEAPOLIS, MN, CHERNE INDUSTRIAL, INC., HOPKINS, MN:
912,238, REN. 6-14-11. U.S. CL. 13 (INT. CL. 6).
- CHERRY BAY ORCHARDS, INC., SUTTONS BAY, MI:
3,996,864, PUB. 5-3-2011. INT. CL. 32.
- CHESAPEAKE GROUP, INC., THE, LOS ANGELES, CA:
2,497,873, REN. 6-15-11. INT. CL. 41.
2,498,213, REN. 6-15-11. INT. CL. 9.
- CHESAPEAKE TECHNOLOGY INTERNATIONAL CORP., CALIFORNIA, MD:
2,901,415, CANC. INT. CL. 9.
- CHESTNUT HILL ADVISORS LLC, CHESTNUT HILL, MA:
3,995,480, PUB. 5-3-2011. INT. CL. 35.
- CHF INDUSTRIES, INC., NEW YORK, NY:
2,471,071, REN. 6-15-11. MULTIPLE CLASS, INT. CLS. 20 AND 24.
- CHHABRA AND SONS, INC., ARTESIA, CA:
3,997,535, PUB. 5-3-2011. INT. CL. 35.
- CHI INNOVATIONS LLC, OCEANSIDE, CA:
3,999,625, INT. CL. 29.
- CHI MEDIA GROUP, LLC, LAS VEGAS, NV:
3,999,821, INT. CL. 42.
- CHICAGO CITY MOMS, INC., CHICAGO, IL:
3,996,716, PUB. 5-3-2011. INT. CL. 41.
- CHICAGO CUBS BASEBALL CLUB, LLC, CHICAGO, IL:
3,996,311, PUB. 5-3-2011. INT. CL. 25.
- CHICAGO DELIGHTS, LLC, OVIEDO, FL, DBA IKIWI:
3,996,306, PUB. 5-3-2011. INT. CL. 43.
- CHICAGO METALLIC CORPORATION, CHICAGO, IL:
2,901,281, CANC. INT. CL. 6.
- CHICKED, LLC, MINNEAPOLIS, MN:
3,997,709, PUB. 5-3-2011. INT. CL. 25.
- CHICO'S BRANDS INVESTMENTS, INC., FT. MYERS, FL:
3,999,141, INT. CL. 3.
- CHIH CHIEH HSU, TUCHENG CITY, TAIPEI, TAIWAN:
3,998,076, PUB. 5-3-2011. MULTIPLE CLASS, INT. CLS. 9 AND 18.
- CHILDREN'S BUREAU OF SOUTHERN CALIFORNIA, LOS ANGELES, CA:
3,996,114, PUB. 5-3-2011. MULTIPLE CLASS, INT. CLS. 41 AND 45.
- CHILDREN'S DENTAL GROUP, INC., LAS VEGAS, NV:
3,996,661, PUB. 5-3-2011. INT. CL. 44.
- CHILDREN'S DEVELOPMENT CORPORATION, CHICAGO, IL:
2,509,066, REN. 6-15-11. MULTIPLE CLASS, INT. CLS. 41 AND 42.
- CHIMERA MULTIMEDIA, LLC, AGOURA HILLS, CA:
2,402,102, CANC. INT. CL. 9.
- CHIPIN, INC., HONOLULU, HI:
3,999,664, INT. CL. 42.
- CHIPPENDALES USA, LLC, PLAINVIEW, NY:
3,999,348, INT. CL. 25.
- CHIPWORKS INC., OTTAWA, ONTARIO:
881,044, CANC. MULTIPLE CLASS, U.S. CLS. 100 AND 101.
- CHL AUTO PARTS CO., LTD., HSINCHU COUNTY, TAIWAN:
3,996,971, PUB. 5-3-2011. INT. CL. 12.
- CHLEBINA CAPITAL MANAGEMENT, AKRON, OH:
3,999,392, INT. CL. 36.
- CHM ASSOCIATES LLC, NEW YORK, NY, DBA POUR:
3,998,363, INT. CL. 35.
- CHOCOMAKER, INC., BUFFALO, NY:
3,997,027, PUB. 5-3-2011. INT. CL. 30.
- CHONGQING CHANGYUAN CHEMICAL CORPORATION LIMITED, POSTAL CODE: 402460, CHINA:
3,999,023, INT. CL. 1.
- CHONGQING HONGJIUJIU FOOD CO., LTD., CHINA:
3,995,794, PUB. 5-3-2011. INT. CL. 30.
- CHOP CHOP PRODUCTS, INC., TARZANA, CA:
3,997,070, PUB. 5-3-2011. INT. CL. 29.
- CHRISTIAN BIBLE, MISSOURI CITY, TX:
3,997,990, PUB. 5-3-2011. INT. CL. 45.
- CHRISTIE MANSON & WOODS LTD., LONDON, UNITED KINGDOM:
3,997,552, PUB. 5-3-2011. INT. CL. 41.
- CHRISTMAS TREE SHOPS, INC., UNION, NJ:
3,997,134, PUB. 5-3-2011. MULTIPLE CLASS, INT. CLS. 11, 16, 20, 21, 24 AND 27.
- CHRISTOPHER A. WUHRER, ALEXANDRIA, VA:
3,996,660, PUB. 5-3-2011. INT. CL. 36.
- CHRISTOPHER R. PERRY, LOMBARD, IL:
3,999,391, INT. CL. 25.
- CHRISTOPHER ROWLAND DAVIES, PENARTH, GLAMORGAN, UNITED KINGDOM:
3,999,120, INT. CL. 32.
- CHROMADEX INC., IRVINE, CA:
3,999,086, MULTIPLE CLASS, INT. CLS. 1 AND 42.
- CHRYSLER GROUP LLC, AUBURN HILLS, MI:
3,999,104, INT. CL. 12.
3,999,105, INT. CL. 12.
- CHRYSLER LLC, AUBURN HILLS, MI:
2,902,398, CANC. INT. CL. 12.
- CHS INC., INVER GROVE HEIGHTS, MN:
3,996,937, PUB. 5-3-2011. INT. CL. 4.
- CHUC, DAVID, MONROVIA, CA:
4,000,045, INT. CL. 9.
- CHULICK, JOSEPH S., HARMONY, NC, DBA POJO ENTERPRISES:
3,997,575, PUB. 5-3-2011. INT. CL. 25.
- CHUM LIMITED, TORONTO, ONTARIO, M4T LYI, CANADA:
2,900,992, CANC. INT. CL. 41.
- CHURCH & DWIGHT CO., INC., PRINCETON, NJ:
2,463,969, REN. 6-15-11. INT. CL. 5.
3,998,108, PUB. 5-3-2011. INT. CL. 10.
- CHURCH OF THE MOVEMENT OF SPIRITUAL INNER AWARENESS, THE, LOS ANGELES, CA:
1,667,013, REN. 6-16-11. INT. CL. 41.
- CIGARS INTERNATIONAL, INC., BETHLEHEM, PA:
2,500,577, REN. 6-15-11. INT. CL. 34.

CINEMA SOLUTIONS, INC., SAN ANTONIO, TX:
3,999,922, INT. CL. 35.

CIPRIANI GROUP, INC., NEW YORK, NY:
3,996,511, PUB. 5-3-2011. INT. CL. 43.
3,996,613, PUB. 5-3-2011. INT. CL. 43.

CIRCLE Y SADDLES, INC., YOAKUM, TX:
718,762. REN. 6-14-11. U.S. CL. 3 (INT. CL. 18).

CIRILLI, DANTE, NAPLES, FL:
3,999,117, INT. CL. 21.

CISCO TECHNOLOGY, INC., SAN JOSE, CA:
2,453,750. REN. 6-14-11. INT. CL. 16.
3,999,895, INT. CL. 9.
3,999,896, INT. CL. 9.

CITIGROUP INC., NEW YORK, NY:
3,999,752, INT. CL. 35.

CITIZEN TOKEI KABUSHIKI KAISHA, TOKYO, JAPAN, TA
CITIZEN WATCH CO., LTD.:
2,402,645, CANC. INT. CL. 14.

CITIZENS FINANCIAL GROUP, INC., PROVIDENCE, RI:
3,998,907, INT. CL. 36.

CITRUS SYSTEMS MADISON, LLC, MADISON, WI:
3,999,819, INT. CL. 30.

CITY 'LASSES, INC., BROOKLYN, NY:
3,999,356, INT. CL. 32.

CITY AND COUNTY OF DENVER, DENVER, CO:
2,291,174, CANC. INT. CL. 41.

CITY OF ANGELS, ANGELS CAMP, CA:
3,997,877, PUB. 5-3-2011. INT. CL. 35.

CITY OF MIRAMAR, MIRAMAR, FL:
3,998,089, PUB. 5-3-2011. INT. CL. 41.

CITY OF MISSOULA, MISSOULA, MT:
3,996,967, PUB. 5-3-2011. INT. CL. 41.

CITY OF ROCHESTER, ROCHESTER, MN:
2,902,237, CANC. INT. CL. 39.

CITY OF WEBSTER GROVES, ST. LOUIS, MO:
3,996,512, PUB. 5-3-2011. INT. CL. 41.

CITYCOFFEE LLC, LAGRANGE, KY:
3,998,748, INT. CL. 30.

CITYWIDE MEDIA INC., LONG ISLAND CITY, NY:
3,996,518, PUB. 5-3-2011. INT. CL. 36.

CIW ENTERPRISES, MOUNTAINTOP, PA:
3,996,098, PUB. 5-3-2011. MULTIPLE CLASS, INT. CLS. 6
AND 19.
3,996,245, PUB. 5-3-2011. MULTIPLE CLASS, INT. CLS. 6
AND 19.

CL CHICAGO, INC., TAMPA, FL:
3,999,824, INT. CL. 35.

CLAIRENT ADVISORS LLC, BELMONT, CA:
3,996,836, PUB. 5-3-2011. INT. CL. 36.

CLARE RANCH LLC, TEMPLETON, CA, DBA FALCON
AND HIPPO WINERY:
3,997,633, PUB. 5-3-2011. INT. CL. 33.

CLARIANT AG, CH-4132 MUTTENZ, SWITZERLAND:
2,403,437. REN. 6-15-11. INT. CL. 2.

CLARITY CENTRAL, INC., MINNEAPOLIS, MN:
2,901,854, CANC. INT. CL. 41.
2,901,855, CANC. INT. CL. 41.

CLARITY COVERDALE FURY ADVERTISING, INC., MIN-
NEAPOLIS, MN:
3,999,424, INT. CL. 35.

CLARK PEST CONTROL OF STOCKTON, INC., LODI, CA:
2,401,671, CANC. INT. CL. 37.

CLARK-MORTENSON AGENCY, INC., KEENE, NH:
3,997,899, PUB. 5-3-2011. INT. CL. 36.

CLB INDUSTRIES LLC, CAPE CORAL, FL:
3,999,544, INT. CL. 13.

CLEAR-COM LLC, POWAY, CA:
3,998,545, INT. CL. 9.

CLEARCANVAS INC., TORONTO, ONTARIO, CANADA:
3,995,552, PUB. 5-3-2011. MULTIPLE CLASS, INT. CLS. 9,
41 AND 42.

CLEARED CANDIDATES.COM LLC., BURTONSVILLE, MD:
3,996,856, PUB. 5-3-2011. INT. CL. 35.

CLIFFORD CHANCE LLP, LONDON, UNITED KINGDOM:
2,901,023, CANC. INT. CL. 42.

CLIFFORD PRODUCE SALES INC., RUTHVEN, ONTARIO,
CANADA:
3,996,594, PUB. 5-3-2011. INT. CL. 31.
3,996,930, PUB. 5-3-2011. INT. CL. 31.
3,996,931, PUB. 5-3-2011. INT. CL. 31.

CLINARD, JANE DOLBY, BOWLING GREEN, OH:
2,401,505, CANC. INT. CL. 41.
2,401,506, CANC. INT. CL. 41.
2,401,507, CANC. INT. CL. 41.

CLINE, RODNEY, BUFORD, GA:
3,996,693, PUB. 5-3-2011. INT. CL. 3.

CLINICAL HEALTH SERVICES, INC., TAMPA, FL:
3,997,069, PUB. 5-3-2011. INT. CL. 3.

CLINIQUE LABORATORIES, LLC, NEW YORK, NY:
2,902,436, CANC. INT. CL. 3.

CLOOD ON MUSIC INC., SOUTHPORT, CT:
3,997,165, PUB. 5-3-2011. INT. CL. 41.

CLORE AUTOMOTIVE, LLC, LENEXA, KS:
2,466,740. REN. 6-10-11. INT. CL. 9.

CLOS ST. THOMAS S.A.L., KAB-ELIAS, BEKAA VALLEY,
LEBANON:
2,901,347, CANC. INT. CL. 33.

CLOSED LOOP ENVIRONMENTAL ALLIANCE NETWORK
INC., BOLTON, ONTARIO, CANADA:
3,998,650, INT. CL. 20.

CLOVERVALE FARMS, INC., LORAIN, OH:
2,901,797, CANC. INT. CL. 30.

CLUB-CONEX, INC., ROCKFORD, IL:
3,997,897, PUB. 5-3-2011. INT. CL. 28.

CMP PRINCETON INC., PRINCETON, NY:
2,901,965, CANC. INT. CL. 35.

CMR & ASSOCIATES, INC., NEW YORK, NY:
3,996,887, PUB. 5-3-2011. MULTIPLE CLASS, INT. CLS. 35
AND 36.

CMT MILESTONES UNLIMITED INTERNATIONAL LLC,
RIVERDALE, NJ:
3,997,986, PUB. 5-3-2011. INT. CL. 35.

CNA FINANCIAL CORPORATION, CHICAGO, IL:
2,509,704. REN. 6-11-11. INT. CL. 16.

CO-OPERATIVE FEED DEALERS, INC., CONKLIN, NY:
3,997,428, PUB. 5-3-2011. INT. CL. 31.
3,997,429, PUB. 5-3-2011. INT. CL. 31.

COACH AMERICA HOLDINGS, INC., DALLAS, TX:
3,995,486, PUB. 5-3-2011. INT. CL. 39.
3,995,509, PUB. 5-3-2011. INT. CL. 39.

COACTIV, LLC, RIDGEFIELD, CT:
3,998,186, PUB. 5-3-2011. INT. CL. 9.

COARSE BROADS, INC., SAGLE, ID:
3,995,664, PUB. 5-3-2011. INT. CL. 35.

COASTAL CLASSIC CREATIONS, MONTARA, CA:
3,997,156, PUB. 5-3-2011. INT. CL. 35.

COASTAL ELECTRONIC TECHNOLOGIES, INC., MEL-
BOURNE, FL:
3,995,570, PUB. 1-26-2010. INT. CL. 9.

COBSCOOK BAY COMPANY, LLC, PORTLAND, ME:
4,000,021, INT. CL. 29.

COCHREN, LESLIE JAMES, SPANISH LAKE, MO, DBA
RIVERCAT:
3,997,887, PUB. 5-3-2011. INT. CL. 16.

COCKOS INCORPORATED, SAN FRANCISCO, CA:
3,998,023, PUB. 5-3-2011. INT. CL. 9.

COCO KLIKS, INC., LOS ANGELES, CA:
2,901,453, CANC. INT. CL. 25.

CODERYTE, INC., BETHESDA, MD:
3,998,354, INT. CL. 42.

COGNAC DE LUZE, FRANCE:
3,996,001, PUB. 5-3-2011. INT. CL. 33.

COGNITIVE SCIENCE LLC, ITHACA, NY:
3,998,769, INT. CL. 25.

COGNIZANT TECHNOLOGY SOLUTIONS U.S. CORPORA-
TION, TEANECK, NJ:
3,995,659, PUB. 5-3-2011. MULTIPLE CLASS, INT. CLS. 35
AND 42.
3,995,674, PUB. 5-3-2011. MULTIPLE CLASS, INT. CLS. 35
AND 42.

COHEN BRIAN, DALLAS, TX:
3,999,901, MULTIPLE CLASS, INT. CLS. 9 AND 16.

- COHEN, AMY, NEW PALTZ, NY AND COHEN, JONATHAN, NEW PALTZ, NY:
3,998,827, INT. CL. 5.
- COLAYCO, JOSE LUIS JAVIER, NEW YORK, NY:
3,999,735, INT. CL. 16.
- COLD CALL COWBOY PRODUCTIONS, PALM DESERT, CA:
2,901,240, CANC. INT. CL. 41.
- COLE NATIONAL CORPORATION, MASON, OH:
2,901,924, CANC. INT. CL. 9.
- COLEMAN COMPANY, INC., THE, WICHITA, KS:
2,889,449, CANC. MULTIPLE CLASS, INT. CLS. 22 AND 28.
- COLEMAN, CASSANDRA, BURLINGTON, NJ AND BROWN, FAWN, BURLINGTON, NJ:
3,996,791, PUB. 5-3-2011. INT. CL. 35.
- COLEMAN, ERIC A., AURORA, CO:
3,996,838, PUB. 5-3-2011. INT. CL. 44.
- COLLABORATIVE FAMILY LAW INSTITUTE, INC., CORAL GABLES, FL:
3,996,063, PUB. 5-3-2011. INT. CL. 41.
- COLLE CORPORATION, MOUNTAIN LAKES, NJ:
3,998,902, INT. CL. 3.
- COLLECTIVE BRANDS COOPERATIEF U.A., AMSTERDAM, NETHERLANDS:
2,901,967, CANC. INT. CL. 25.
- COLLECTIVE EDITORIAL, LLC, SEATTLE, WA:
3,996,830, PUB. 5-3-2011. INT. CL. 35.
- COLLEGENET, INC., PORTLAND, OR:
3,998,776, INT. CL. 36.
3,998,777, INT. CL. 35.
- COLLINS, JOSEPH, LAGRANGE, GA:
3,996,733, PUB. 5-3-2011. INT. CL. 42.
- COLOMBINI, RICHARD V, SAINT LOUIS PARK, MN:
3,996,374, PUB. 5-3-2011. INT. CL. 16.
- COLONIAL PATTERNS, INC., KANSAS CITY, MO:
3,997,995, PUB. 5-3-2011. INT. CL. 16.
- COLORBOK, INC., ANN ARBOR, MI:
3,999,164, INT. CL. 16.
- COLUMBIA SPORTSWEAR NORTH AMERICA, INC., PORTLAND, OR:
3,997,032, PUB. 5-3-2011. INT. CL. 25.
- COMAU SPA, ITALY:
3,995,748, PUB. 5-3-2011. MULTIPLE CLASS, INT. CLS. 7 AND 9.
- COMBAT MEDICAL SYSTEMS, LLC, FAYETTEVILLE, NC:
3,999,100, INT. CL. 18.
- COMCAST CORPORATION, PHILADELPHIA, PA:
3,998,419, MULTIPLE CLASS, INT. CLS. 38 AND 41.
- COMEAU, ELAINE, MAPLE RIDGE, BC, CANADA:
3,997,284, PUB. 5-3-2011. INT. CL. 16.
- COMEBACK BREWING, INC., SAN ANTONIO, TX:
2,488,070, REN. 6-15-11. INT. CL. 32.
- COMEDIVA, LLC, BURBANK, CA:
3,996,823, PUB. 5-3-2011. INT. CL. 41.
- COMERCIAL EXVINA LTDA., TALCA, CHILE:
3,999,673, INT. CL. 33.
- COMERCIALIZADORA CANTU, S.A. DE C.V., NUEVO LEON, MEXICO:
3,999,464, INT. CL. 16.
- COMFORT CREAMS, INC., KAMUELA, HI:
3,997,989, PUB. 5-3-2011. INT. CL. 3.
- COMIT SYSTEMS, INC., SANTA CLARA, CA:
2,401,982, CANC. INT. CL. 16.
- COMMA DESIGN CORPORATION, LOS ANGELES, CA:
3,997,050, PUB. 5-3-2011. INT. CL. 25.
- COMMAND PACKAGING, LOS ANGELES, CA:
3,997,141, PUB. 5-3-2011. INT. CL. 16.
- COMMON GROUND PUBLISHING PTY LTD, ALTONA VIC 3018, AUSTRALIA:
3,995,905, PUB. 5-3-2011. INT. CL. 41.
- COMMONPATH, LLC, VENTURA, CA:
3,998,185, PUB. 5-3-2011. INT. CL. 11.
- COMMONWEALTH PUBLIC BROADCASTING CORPORATION, RICHMOND, VA:
3,997,852, PUB. 5-3-2011. MULTIPLE CLASS, INT. CLS. 38 AND 41.
- COMMONWEALTH TRADING COMPANY, INC., SAN ANTONIO, TX:
3,998,251, PUB. 5-3-2011. MULTIPLE CLASS, INT. CLS. 9, 25 AND 35.
- COMMUNICATION INTEGRATORS, INC., MESA, AZ:
1,678,068, REN. 6-15-11. INT. CL. 9.
- COMMUTER CHECK SERVICES CORPORATION, WATERTOWN, MA:
3,997,617, PUB. 5-3-2011. INT. CL. 36.
3,997,618, PUB. 5-3-2011. INT. CL. 36.
3,997,619, PUB. 5-3-2011. INT. CL. 36.
- COMPAGNIA MERCANTILE S.R.L., I-30035 MIRANO (VENEZIA), ITALY:
3,995,853, PUB. 5-3-2011. INT. CL. 25.
- COMPOCLAY USA LLC, ALAMEDA, CA:
3,996,921, PUB. 5-3-2011. INT. CL. 35.
- COMPONENT HARDWARE GROUP, INC., LAKEWOOD, NJ:
3,999,122, MULTIPLE CLASS, INT. CLS. 6 AND 11.
- COMPTOIR NOUVEAU DE LA PARFUMERIE, 75008 PARIS, FRANCE:
3,997,314, PUB. 5-3-2011. INT. CL. 3.
- COMPUFLEX CORPORATION, SPRINGFIELD, NJ:
3,996,722, PUB. 5-3-2011. INT. CL. 9.
- COMPUTERS AND STRUCTURES, INC., BERKELEY, CA:
3,997,297, PUB. 5-3-2011. INT. CL. 9.
- COMPUWEIGH CORPORATION, WOODBURY, CT:
2,493,998, REN. 6-15-11. INT. CL. 9.
- COMVENIENT GMBH & CO. KG, 85737 ISMANING, FED REP GERMANY:
3,995,511, PUB. 4-12-2011. MULTIPLE CLASS, INT. CLS. 9, 38, 41 AND 42.
- COM2US CORPORATION, SEOUL, REPUBLIC OF KOREA:
3,999,868, INT. CL. 9.
- CONAGRA FOODS RDM, INC., OMAHA, NE:
3,998,458, MULTIPLE CLASS, INT. CLS. 29 AND 30.
- CONAIR CORPORATION, STAMFORD, CT:
3,998,814, INT. CL. 11.
3,999,468, MULTIPLE CLASS, INT. CLS. 9 AND 11.
- CONCORDIA PUBLISHING HOUSE, ST. LOUIS, MO:
3,999,717, INT. CL. 16.
- CONFECÇÕES DAL COSTA LTDA, SANTA CATARINA, BRAZIL:
3,996,536, PUB. 5-3-2011. INT. CL. 25.
- CONFIDENT GOVERNANCE, RESTON, VA, AKA ENCRISP LLC:
3,997,862, PUB. 5-3-2011. INT. CL. 9.
- CONGLOMERATE MARKETING LLC, WOODLAND HILLS, CA:
3,996,769, PUB. 5-3-2011. INT. CL. 45.
- CONIGLIARO-CADDEN, LISA M., CUMBERLAND, RI:
2,402,193, CANC. INT. CL. 24.
- CONIGLIO, MARK FREDERICK, BROOKLYN, NY:
2,735,593, CANC. INT. CL. 9.
- CONNECT, INC., NAPERVILLE, IL:
2,401,387, CANC. INT. CL. 42.
- CONNECTWITHCOACHES, LLC, CASTLE ROCK, CO:
3,999,960, INT. CL. 35.
- CONNOISSEURS PRODUCTS CORPORATION, WOBURN, MA:
3,999,870, MULTIPLE CLASS, INT. CLS. 3 AND 21.
- CONOLLY, BRIAN, BROADWAY, NSW, AUSTRALIA:
3,997,351, PUB. 5-3-2011. MULTIPLE CLASS, INT. CLS. 24 AND 25.
- CONPROCO CORPORATION, DOVER, NH:
2,572,662, REN. 6-16-11. INT. CL. 1.
- CONRAD ELECTRONIC GMBH, FED REP GERMANY:
2,900,975, CANC. MULTIPLE CLASS, INT. CLS. 7, 8, 9, 11, 16, 38 AND 42.
- CONSCIOUS SUCCESS LLC, NATICK, MA:
3,996,731, PUB. 5-3-2011. INT. CL. 44.
- CONSEAL INTERNATIONAL INCORPORATED, NORWOOD, MA:
3,999,894, INT. CL. 30.
- CONSTANT BIOTECHNOLOGY, CINCINNATI, OH:
3,997,701, PUB. 5-3-2011. INT. CL. 42.
- CONSTANTINE PAINTING, CRANBERRY TOWNSHIP, PA:
2,901,148, CANC. INT. CL. 37.

CONSUMER INSIGHT, INC., SANTA MONICA, CA:
3,996,703, PUB. 5-3-2011. MULTIPLE CLASS, INT. CLS. 38 AND 41.

CONTACT CENTER INSIGHTS, CINCINNATI, OH:
3,999,442, INT. CL. 35.

CONTAINER PTY LTD, AUSTRALIA:
3,995,789, PUB. 5-3-2011. INT. CL. 3.

CONTINENTAL REIFEN DEUTSCHLAND GMBH, HANNOVER, FED REP GERMANY:
3,995,591, PUB. 10-19-2010. INT. CL. 12.

CONTINENTAL WESTERN CORPORATION, SAN LEANDRO, CA:
3,997,251, PUB. 5-3-2011. MULTIPLE CLASS, INT. CLS. 17, 22 AND 35.

CONTITECH SCHLAUCH GMBH, 30165 HANNOVER, FED REP GERMANY:
3,995,971, PUB. 3-8-2011. INT. CL. 17.

CONTRACTPOWER, LLC, WEST PALM BEACH, FL:
2,902,405, CANC. INT. CL. 35.

CONTURA A/S, DENMARK:
3,995,874, PUB. 5-3-2011. MULTIPLE CLASS, INT. CLS. 5 AND 10.

CONVERGYS CMG UTAH INC., SOUTH JORDAN, UT:
2,901,832, CANC. MULTIPLE CLASS, INT. CLS. 9 AND 35.

CONVERSATIONS THAT WORK, INC., CHICAGO, IL:
2,401,461, CANC. INT. CL. 35.

CONVERSE, INC., NORTH ANDOVER, MA:
1,654,951, REN. 6-16-11. INT. CL. 25.

CONVERTIBLE CASTLES, INC., THE, NORTON, MA:
3,479,698, COR. INT. CL. 35.

CONVONATION, LLC, JERSEY CITY, NJ:
3,997,430, PUB. 5-3-2011. INT. CL. 42.

COOKING UP ENGLISH, AUSTIN, TX:
3,997,121, PUB. 5-3-2011. MULTIPLE CLASS, INT. CLS. 25 AND 41.

COOKSON ELECTRONICS, INC., FOXBOROUGH, MA:
2,902,428, CANC. INT. CL. 42.

COOLEY WIRE PRODUCTS MANUFACTURING COMPANY, SCHILLER PARK, IL:
3,999,307, INT. CL. 6.

COOTER MUCK INC, VANKLEEK HILL, CANADA:
3,999,002, INT. CL. 1.

COPPOLA FAMILY TRUST, THE, NAPA, CA:
2,573,673, REN. 6-14-11. INT. CL. 33.

CORAL SPRINGS SCHOOLS, INC., MIAMI, FL, DBA BEAUTY SALONS OF AMERICA:
4,000,013, INT. CL. 44.

CORAZONAS FOODS, INC., LOS ANGELES, CA:
3,999,241, INT. CL. 41.
3,999,243, INT. CL. 41.

CORBO, VINCENT, JR., NORTH HOLLYWOOD, CA:
3,997,936, PUB. 5-3-2011. MULTIPLE CLASS, INT. CLS. 9 AND 41.

CORBOND CORPORATION, BOZEMAN, MT:
2,452,282, REN. 6-15-11. INT. CL. 17.
2,901,685, CANC. INT. CL. 41.

CORCEL IP LIMITED, HAMILTON, NEW ZEALAND:
3,996,564, PUB. 5-3-2011. MULTIPLE CLASS, INT. CLS. 7, 16 AND 20.

CORDES, JOHN L., CENTEREACH, NY:
2,901,313, CANC. MULTIPLE CLASS, INT. CLS. 3 AND 5.

CORDIS CORPORATION, BRIDGEWATER, NJ:
2,506,462, REN. 6-15-11. INT. CL. 10.

CORE ANALYTICS, LLC, FOREST PARK, IL:
3,997,354, PUB. 5-3-2011. INT. CL. 35.

CORE PRODUCTS CO., INC., CANTON, TX:
2,901,162, CANC. INT. CL. 3.

CORE-MARK INTERNATIONAL, INC., SOUTH SAN FRANCISCO, CA:
3,997,768, PUB. 5-3-2011. INT. CL. 35.
3,997,769, PUB. 5-3-2011. INT. CL. 35.
3,997,771, PUB. 5-3-2011. INT. CL. 39.
3,997,772, PUB. 5-3-2011. INT. CL. 39.

CORELINK, LLC, ST. LOUIS, MO:
3,997,913, PUB. 5-3-2011. INT. CL. 10.

CORELOGIC INFORMATION SOLUTIONS, INC., SANTA ANA, CA:
3,998,857, MULTIPLE CLASS, INT. CLS. 9, 35, 36, 39, 42, 44 AND 45.

CORNELL, BRIAN, SAN FERNANDO, CA:
2,902,236, CANC. INT. CL. 35.

CORNING INCORPORATED, CORNING, NY:
2,574,593, REN. 6-14-11. INT. CL. 9.
3,998,750, INT. CL. 9.

CORO HEALTH, LLC, AUSTIN, TX:
3,998,842, INT. CL. 44.

CORONADO BREWING COMPANY, INC., CORONADO, CA:
3,997,478, PUB. 5-3-2011. INT. CL. 32.
3,997,480, PUB. 5-3-2011. INT. CL. 32.
3,997,481, PUB. 5-3-2011. INT. CL. 32.
3,997,483, PUB. 5-3-2011. INT. CL. 32.

CORPAK MEDSYSTEMS, INC., WHEELING, IL:
3,996,429, PUB. 5-3-2011. INT. CL. 10.

CORPORATION DE L'ECOLE DES HAUTES ETUDES COMMERCIALES DE MONTREAL, MONTREAL, QUEBEC, CANADA AND E.M. LYON, 69132 ECULLY, FRANCE:
2,900,989, CANC. MULTIPLE CLASS, INT. CLS. 9, 16 AND 41.

CORRADI S.P.A., BOLOGNA, ITALY:
3,999,945, MULTIPLE CLASS, INT. CLS. 6, 19, 20, 22 AND 24.

CORRECT COLLECT, INC., CORAL SPRINGS, FL:
3,997,801, PUB. 5-3-2011. INT. CL. 42.

CORSAIR MEMORY INC., FREEMONT, CA:
3,999,780, INT. CL. 9.

COSCIENCE, RABAT, MOROCCO:
2,902,227, CANC. INT. CL. 3.

COSCO MANAGEMENT, INC., WILMINGTON, DE, DOREL JUVENILE GROUP, INC., CANTON, MA:
2,515,665, REN. 6-10-11. INT. CL. 20.

COSCO MANAGEMENT, INC., WILMINGTON, DE:
3,995,718, PUB. 5-3-2011. MULTIPLE CLASS, INT. CLS. 8, 10 AND 12.

COSMETIC SOLUTIONS, INC, POMPANO BEACH, FL:
3,996,036, PUB. 5-3-2011. INT. CL. 3.

COSMOSPROMOS, INC., PLACERVILLE, CA:
2,901,978, CANC. INT. CL. 40.

COSTCO WHOLESALE MEMBERSHIP, INC, ISSAQUAH, WA:
2,401,332, CANC. INT. CL. 38.

COTTAGE CRAFT PRODUCTIONS, LLC, BORING, OR:
3,996,110, PUB. 5-3-2011. INT. CL. 41.

COTUIT OYSTER CO., INC., COTUIT, MA:
2,901,726, CANC. INT. CL. 29.

COTY US LLC, NEW YORK, NY:
3,998,212, PUB. 5-3-2011. INT. CL. 3.
3,998,219, PUB. 5-3-2011. INT. CL. 3.

COUNTER-X TECHNICAL SERVICES INCORPORATED, NAPERVILLE, IL, AKA COUNTER THREAT FINANCE CENTER:
4,000,020, INT. CL. 41.

COUNTRY LIFE, LLC, HAUPPAUGE, NY:
3,996,673, PUB. 5-3-2011. INT. CL. 5.

COURAGE UNLIMITED CORPORATION, REISTERS-TOWN, MD:
3,996,807, PUB. 5-3-2011. MULTIPLE CLASS, INT. CLS. 9, 16 AND 28.

COURAGEOUS LEADERSHIP, INC., HOLLAND, MI:
2,901,219, CANC. INT. CL. 35.

COURREGES DESIGN, PARIS, FRANCE:
3,996,092, PUB. 5-3-2011. MULTIPLE CLASS, INT. CLS. 9 AND 24.

COVALENCE INC., TEMPE, AZ:
2,901,974, CANC. INT. CL. 3.

COVENANT MINISTRIES INTERNATIONAL, INC., LESLIE, AR, DBA THE INTERNATIONAL FELLOWSHIP OF COVENANT MINISTRIES:
3,998,854, INT. CL. 45.

COVERALL NORTH AMERICA, INC., BOCA RATON, FL:
3,998,565, INT. CL. 37.

- COVIDIEN AG, NEUHAUSEN AM RHEINFALL, SWITZERLAND:
3,997,421, PUB. 5-3-2011. MULTIPLE CLASS, INT. CLS. 3, 5, 9 AND 10.
- COW & CRUMB BAKING COMPANY LLC, CAMBRIDGE, MA:
3,998,088, PUB. 5-3-2011. INT. CL. 30.
- COW CREEK RANCH HOUSE LLC, OKEMAH, OK:
3,999,729, INT. CL. 7.
- COX AUTO TRADER, L.L.C., ATLANTA, GA:
2,901,426, CANC. INT. CL. 16.
- COX, BRIAN D., TEMPE, AZ:
2,464,054, REN. 6-16-11. INT. CL. 20.
- CPI PACKAGING, INC., SOMERSET, NJ:
2,461,494, REN. 6-10-11. INT. CL. 17.
- CRAB COOKER, INC., THE, NEWPORT BEACH, CA:
2,485,071, REN. 6-15-11. INT. CL. 35.
- CRAMER PRODUCTS, INC., GARDNER, KS:
3,996,203, PUB. 5-3-2011. INT. CL. 9.
- CRANE CO., ELYRIA, OH:
2,487,613, REN. 6-15-11. INT. CL. 7.
- CRAYOLA PROPERTIES, INC., EASTON, PA:
3,846,593, CANC. INT. CL. 16.
- CRC INDUSTRIES, INC., WARMINSTER, PA:
3,997,487, PUB. 5-3-2011. INT. CL. 1.
- CRC-EVANS PIPELINE INTERNATIONAL, INC., HOUSTON, TX:
1,154,529, REN. 6-15-11. INT. CL. 7.
- CREATE180, WINDERMERE, FL:
3,996,604, PUB. 5-3-2011. INT. CL. 42.
- CREATIVE AGENCY SERVICES TEAM, INC., SARASOTA, FL:
3,999,075, MULTIPLE CLASS, INT. CLS. 9 AND 35.
- CREATIVE MEDIA GROUP, INC., MONROE, NC:
2,901,133, CANC. INT. CL. 16.
- CREATIVE NAIL DESIGN, INC., VISTA, CA:
2,446,912, REN. 6-10-11. INT. CL. 3.
2,473,064, REN. 6-15-11. INT. CL. 3.
- CREATIVE TECHNOLOGY LTD., SINGAPORE, SINGAPORE:
3,999,214, INT. CL. 9.
- CREATIVE VENTURES, LLC, TUCSON, AZ:
3,997,457, PUB. 5-3-2011. INT. CL. 25.
- CREE, INC., DURHAM, NC:
3,998,141, PUB. 5-3-2011. INT. CL. 9.
3,998,142, PUB. 5-3-2011. INT. CL. 11.
- CRESCENT TRAVEL SERVICES, LLC, FORT WORTH, TX:
2,901,752, CANC. INT. CL. 43.
- CRI-HELP, INC., NORTH HOLLYWOOD, CA:
3,995,590, PUB. 5-3-2011. INT. CL. 44.
- CRIQUET APPAREL, LLC, AUSTIN, TX:
3,998,812, INT. CL. 25.
- CROPS CO., LTD., TOKYO, JAPAN:
3,996,067, PUB. 5-3-2011. INT. CL. 9.
- CROSCILL HOME LLC, NEW YORK, NY:
3,999,042, MULTIPLE CLASS, INT. CLS. 20, 24 AND 27.
- CROTEAU, TANYA, DANVERS, MA:
3,996,127, PUB. 5-3-2011. INT. CL. 41.
- CROWLEY DESIGN GROUP INC., BUTTE, MT:
3,996,683, PUB. 5-3-2011. INT. CL. 25.
- CROWN EQUIPMENT CORPORATION, NEW BREMEN, OH:
3,998,755, INT. CL. 9.
- CROWN FINANCIAL MINISTRIES, INC., LAWRENCEVILLE, GA:
2,401,448, CANC. INT. CL. 9.
- CRUZ BAY PUBLISHING, INC., EL SEGUNDO, CA, RODALE INC., EMMAUS, PA:
2,460,850, REN. 6-14-11. MULTIPLE CLASS, INT. CLS. 41 AND 42.
- CRYPTO TECHNOLOGIES INC., NEW YORK, NY:
3,997,187, PUB. 5-3-2011. INT. CL. 9.
- CRYTEK GMBH, FRANKFURT AM MAIN, FED REP GERMANY:
3,996,288, PUB. 5-3-2011. INT. CL. 9.
- CSM BAKERY PRODUCTS NA, INC, TUCKER, GA:
3,998,394, INT. CL. 30.
- CSXT INTELLECTUAL PROPERTIES CORPORATION, JACKSONVILLE, FL:
3,999,181, INT. CL. 12.
- CUE MAGAZINE INC., PITTSBURGH, PA:
3,996,820, PUB. 5-3-2011. INT. CL. 16.
- CUISINE-COOKWARE INC, LODI, NJ, ESTIA CORP., CARLSTADT, NJ:
1,684,478, REN. 6-14-11. INT. CL. 21.
- CULTIVE FRANCHISE, LLC, DAVIS, CA:
3,996,681, PUB. 5-3-2011. MULTIPLE CLASS, INT. CLS. 30 AND 43.
- CULTURAME!, LLC, DOBBS FERRY, NY:
3,996,085, PUB. 5-3-2011. INT. CL. 16.
- CUMBERLAND PACKING CORP., BROOKLYN, NY:
2,465,527, REN. 6-15-11. INT. CL. 30.
- CUNET, LLC, PARAMUS, NJ:
3,996,232, PUB. 5-3-2011. INT. CL. 35.
- CUNNINGHAM PATHOLOGY LLC, BIRMINGHAM, AL:
1,171,727, REN. 6-15-11. INT. CL. 42.
- CUPAR, LLC, ELGIN, IL:
3,997,229, PUB. 5-3-2011. INT. CL. 36.
- CURRENT USA, INC., NORTH MANKATO, MN:
3,996,430, PUB. 5-3-2011. MULTIPLE CLASS, INT. CLS. 35 AND 40.
- CURTIS C. GUNN, LTD., SAN ANTONIO, TX, FORMERLY CURTIS C. GUNN, INC.:
3,997,891, PUB. 5-3-2011. INT. CL. 35.
- CURVE INC., BOULDER, CO, DBA CURVE CYCLING COMPONENTS:
3,995,520, PUB. 5-3-2011. INT. CL. 25.
- CURWOOD, INC., OSHKOSH, WI:
2,506,638, REN. 6-15-11. INT. CL. 17.
- CUSTOM BLENDS TOBACCO AND NEWS INC., HILTON HEAD, SC:
3,999,060, MULTIPLE CLASS, INT. CLS. 16, 25 AND 41.
- CUSTOM BUILDING PRODUCTS, INC., SEAL BEACH, CA, B & P CUSTOM BUILDING PRODUCTS, SEAL BEACH, CA:
1,655,570, REN. 6-16-11. INT. CL. 19.
- CYBERFONE TECHNOLOGIES, INC., WAYNE, PA:
2,902,358, CANC. INT. CL. 9.
- CYBERTRAILS LLC, PHOENIX, AZ:
3,996,561, PUB. 5-3-2011. INT. CL. 35.
- CYCLE30, INC., ANCHORAGE, AK:
3,999,264, INT. CL. 35.
3,999,265, INT. CL. 35.
- CYCLE30, INC., WASHINGTON, DC:
3,999,266, INT. CL. 35.
- CYPHERS, DOUG, AURORA, CO:
3,997,822, PUB. 5-3-2011. INT. CL. 35.
- CYTOO, FRANCE:
3,995,809, PUB. 5-3-2011. INT. CL. 9.
- CZT/ACN TRADEMARKS, L.L.C., SCHAUMBURG, IL:
3,998,364, MULTIPLE CLASS, INT. CLS. 9, 16, 35, 41 AND 42.
- C1 DESIGN GROUP, KETCHUM, ID:
3,999,972, INT. CL. 21.
- C2LOGIX, INC., FAIRFAX, VA, FORMERLY WASTBID-COM:
3,997,534, PUB. 5-3-2011. INT. CL. 42.
- D AND M WINES PTY LIMITED, DOUBLE BAY, NSW 2028, AUSTRALIA:
3,998,505, INT. CL. 33.
- D AND S CORLEY LIMITED, MISSISSAUGA, ONTARIO, CANADA, DBA DSC LABORATORIES:
3,996,780, PUB. 5-3-2011. INT. CL. 16.
3,996,783, PUB. 5-3-2011. INT. CL. 16.
- D B INDUSTRIES, INC., RED WING, MN, DBA CAPITAL SAFETY USA:
3,999,965, INT. CL. 9.
- D. MARINA JOHNSON MD, PA, IRVING, TX:
3,997,800, PUB. 5-3-2011. INT. CL. 44.
- D. PAGLIA & SON, INC., MOUNTAINSIDE, NJ:
2,902,076, CANC. INT. CL. 14.
- D.A.R.E. AMERICA, INGLEWOOD, CA:
2,468,945, REN. 6-10-11. INT. CL. 41.
- D.B.R., INC., SUFFERN, NY:
3,999,846, INT. CL. 25.

D.C. COMICS, NEW YORK, NY, D.C. COMICS, NEW YORK, NY:
2,485,600, REN. 6-14-11. INT. CL. 16.

D.CLAIRE, SODDY DAISY, TN:
3,996,543, PUB. 5-3-2011. INT. CL. 18.

D&S EXPORTS, INC., NORWALK, CT:
2,401,280, CANC. MULTIPLE CLASS, INT. CLS. 7 AND 11.

D-GENERATION, INC, DAYTONA BEACH, FL:
3,997,850, PUB. 5-3-2011. INT. CL. 4.
3,997,854, PUB. 5-3-2011. INT. CL. 27.
3,997,859, PUB. 5-3-2011. INT. CL. 19.
3,998,232, PUB. 5-3-2011. INT. CL. 16.
3,998,278, PUB. 5-3-2011. INT. CL. 14.

D-ZEE TEXTILES LLC, LAKELAND, FL:
3,999,228, INT. CL. 3.

DACOROGNA, DUBUIS, EMMA & FRAGNIÈRE, GENÈVE, SWITZERLAND:
3,995,968, PUB. 5-3-2011. MULTIPLE CLASS, INT. CLS. 25 AND 35.

DAIGH COMPANY, INC, CUMMING, GA:
2,987,474, COR. INT. CL. 19.

DAIKIN INDUSTRIES, LTD., OSAKA-SHI; OSAKA, JAPAN:
3,995,902, PUB. 5-3-2011. INT. CL. 11.

DAIMLER AG, STUTTGART, FED REP GERMANY:
2,901,058, CANC. MULTIPLE CLASS, INT. CLS. 12, 28 AND 37.
3,996,434, PUB. 5-3-2011. MULTIPLE CLASS, INT. CLS. 12 AND 28.
3,996,979, PUB. 5-3-2011. MULTIPLE CLASS, INT. CLS. 12, 28 AND 37.

DALE CHRISTENSON, ATLANTIC BEACH, FL:
2,566,647, REN. 6-15-11. INT. CL. 1.

DALE OPERATING COMPANY, DALLAS, TX:
3,996,219, PUB. 5-3-2011. MULTIPLE CLASS, INT. CLS. 36 AND 42.

DALE ROBERTSON, PIERREFONDS, CANADA:
3,995,700, PUB. 5-3-2011. INT. CL. 15.

DALL, RENEE ELIZABETH, ESSEX JUNCTION, VT:
3,997,096, PUB. 5-3-2011. INT. CL. 36.

DAMAN, ERIC G., NEW YORK, NY:
3,999,174, INT. CL. 18.

DAMART-SERVIPOSTE, F-59100 ROUBAIX, FRANCE:
3,995,906, PUB. 5-3-2011. MULTIPLE CLASS, INT. CLS. 22, 24 AND 25.

DAMERON ALLOY FOUNDRIES, COMPTON, CA:
3,996,473, PUB. 5-3-2011. MULTIPLE CLASS, INT. CLS. 40 AND 42.

DAN TIBBS, CAMBRIA HEIGHTS, NY:
2,401,578, CANC. INT. CL. 25.

DAN-DEE INTERNATIONAL, LTD., JERSEY CITY, NJ:
3,999,207, MULTIPLE CLASS, INT. CLS. 17, 20 AND 28.

DANA INNOVATIONS, SAN CLEMENTE, CA:
2,902,364, CANC. INT. CL. 9.

DANAVINES, INC, RANCHO PALOS VERDES, CA:
2,901,760, CANC. INT. CL. 25.

DANIEL NESTOR SOLENTHALER, CH-3072 OSTERMUNDIGEN, SWITZERLAND:
3,995,934, PUB. 5-3-2011. INT. CL. 9.

DANIELA VERONICA GUSA DE DRAGAN, ITALY:
3,995,985, PUB. 5-3-2011. MULTIPLE CLASS, INT. CLS. 1, 4, 6, 11 AND 21.
3,995,986, PUB. 5-3-2011. MULTIPLE CLASS, INT. CLS. 1, 4, 6, 11 AND 21.
3,995,987, PUB. 5-3-2011. MULTIPLE CLASS, INT. CLS. 1, 4, 6, 11 AND 21.

DANIELS AND ROBERTS, INC., BOCA RATON, FL:
2,902,037, CANC. MULTIPLE CLASS, INT. CLS. 35 AND 42.

DAPOOR INC., BRONX, NY:
2,901,498, CANC. INT. CL. 25.

DAPPER GENTLEMEN, LLC, GILBERT, AZ:
3,997,313, PUB. 5-3-2011. INT. CL. 9.

DARENA SOLUTIONS LLC, OFALLON, MO, DBA DARENA SOLUTIONS LLC:
3,998,645, INT. CL. 44.

DARN IT, INCORPORATED, NEW BEDFORD, MA:
2,901,650, CANC. INT. CL. 42.

DART CHART SYSTEMS, LLC, MILWAUKEE, WI:
3,998,509, INT. CL. 9.

DART CONTAINER CORPORATION, MASON, MI:
3,999,711, INT. CL. 21.

DARTAM PUBLISHING, LLC, MORGANVILLE, NJ:
3,998,985, INT. CL. 28.

DARTAPPRAISAL.COM, INC., TROY, MI:
3,999,583, INT. CL. 36.

DASHBOARD DOODLES, HAPPY VALLEY, OR:
3,997,755, PUB. 5-3-2011. INT. CL. 16.

DASSAULT FALCON JET CORP., LITTLE FERRY, NJ:
3,996,077, PUB. 5-3-2011. INT. CL. 37.

DATA INTELLIGENCE CORPORATION, ATLANTA, GA:
3,996,095, PUB. 5-3-2011. INT. CL. 36.

DATA MEDIA ASSOCIATES, INC., ALPHARETTA, GA:
1,167,770, REN. 6-15-11. INT. CL. 42.

DATABUILDER, INC., GRIMES, IA:
3,997,955, PUB. 5-3-2011. INT. CL. 9.

DATAMATICS GLOBAL SERVICES, INC., LIVONIA, MI:
3,997,507, PUB. 5-3-2011. INT. CL. 42.

DATAWAVE TECHNOLOGIES CORPORATION, LOVELAND, CO:
3,996,326, PUB. 5-3-2011. INT. CL. 9.

DAVID EUGENE EMBREE, SPRINGFIELD, MO:
3,998,714, INT. CL. 25.

DAVID J. WOLF M.D. PROFESSIONAL CORP., NEW YORK, NY:
3,999,535, INT. CL. 44.
3,999,536, INT. CL. 44.

DAVID KIRSCH WELLNESS CO., INC., NEW YORK, NY:
3,999,668, INT. CL. 5.
3,999,669, INT. CL. 5.
3,999,814, INT. CL. 5.

DAVID LISSNER, CHICAGO, IL:
3,996,103, PUB. 5-3-2011. INT. CL. 43.

DAVID, ZOLTAN, AUSTIN, TX:
3,998,910, INT. CL. 14.

DAVIDSON OF DUNDEE, DUNDEE, FL:
3,997,159, PUB. 5-3-2011. MULTIPLE CLASS, INT. CLS. 29 AND 30.

DAVIS, KENT, MOUNT HOLLY, NJ:
2,401,690, CANC. INT. CL. 41.

DAVIS, THOMAS G, WILLIAMSBURG, VA, DBA DAVIS MEDIA:
3,997,491, PUB. 5-3-2011. INT. CL. 41.

DAWN & DEEPA, LLC., HOUSTON, TX, DBA DAWN & DEEPA:
3,999,789, INT. CL. 14.

DAY LIGHT BEST INT'L CO., LTD, DAAN TAIPEI, TAIWAN:
2,902,010, CANC. INT. CL. 43.

DAY SPA DEVELOPMENT CONSULTANT CORP., THORNTON, NY:
3,997,040, PUB. 5-3-2011. INT. CL. 44.

DAY, RICHARD V., PALM BEACH, FL:
3,999,597, INT. CL. 25.

DAYTIME ENCOUNTER, LLC, WASHINGTON GROVE, MD:
2,901,759, CANC. INT. CL. 41.
2,901,761, CANC. INT. CL. 41.

DAYTON PROGRESS CORPORATION, DAYTON, OH:
1,672,399, REN. 6-16-11. INT. CL. 7.

DB MUSIC PRODUCTIONS, INC, MIRAMAR, FL:
3,996,646, PUB. 5-3-2011. MULTIPLE CLASS, INT. CLS. 9 AND 41.

DBA FINANCIAL SERVICES, INC., WINCHESTER, MA:
2,901,250, CANC. INT. CL. 36.

DBI PLASTICS A/S, DENMARK:
3,996,005, PUB. 5-3-2011. INT. CL. 20.

DC SHOES, INC., HUNTINGTON BEACH, CA:
3,999,872, INT. CL. 25.

DE BEERS CENTENARY AG, 6000 LUZERN 6, SWITZERLAND:
3,995,540, PUB. 5-3-2011. MULTIPLE CLASS, INT. CLS. 9, 35, 37, 40, 41 AND 42.

DE MAIO, JOEY, AUBURN, NY:
3,999,561, INT. CL. 41.

- DEAL & U, INC., NAPERVILLE, IL, DBA DEALNU:
3,997,808, PUB. 5-3-2011. INT. CL. 35.
- DEALER SERVICES CORPORATION, CARMEL, IN:
3,997,734, PUB. 5-3-2011. INT. CL. 36.
- DEARBORN SAUSAGE COMPANY, DEARBORN, MI:
3,998,492, INT. CL. 29.
- DEBRA J. READING, CARY, IL:
3,998,091, PUB. 5-3-2011. INT. CL. 25.
- DEBTECH, INC., MIAMI, FL:
2,402,509, CANC. INT. CL. 12.
- DECISION ANALYST, INC., ARLINGTON, TX:
2,573,707. REN. 6-15-11. INT. CL. 35.
2,573,708. REN. 6-15-11. INT. CL. 35.
- DECKERS OUTDOOR CORPORATION, GOLETA, CA:
2,901,765, CANC. INT. CL. 25.
- DEEMO, LLC, SAN JOSE, CA:
3,997,461, PUB. 5-3-2011. INT. CL. 9.
- DEER DEFEAT LLC, GERMANTOWN, NY:
3,996,915, PUB. 5-3-2011. INT. CL. 5.
- DEFOSSEY, TRICIA L, MARINA DEL REY, CA:
3,996,239, PUB. 5-3-2011. INT. CL. 30.
- DEGIL SAFETY PRODUCTS (1989) INC., WOODBRIDGE,
ONTARIO, CANADA, DEGIL SAFETY PRODUCTS (1989)
INC., WOODBRIDGE, ONTARIO, CANADA:
2,572,534. REN. 6-15-11. INT. CL. 9.
- DEL MONTE B.V., CORAL GABLES, FL:
2,511,298. REN. 6-15-11. INT. CL. 42.
- DELAWARE NORTH COMPANIES, INC., BUFFALO, NY:
3,997,731, PUB. 5-3-2011. INT. CL. 35.
- DELAWARE QUARRIES, INC., NEW HOPE, PA:
3,999,191, INT. CL. 19.
- DELICIOUS BRANDS LLC, DALLAS, TX:
3,995,536, PUB. 5-3-2011. INT. CL. 3.
- DELL INC., ROUND ROCK, TX:
3,999,753, INT. CL. 9.
- DELTA EDUCATION, LLC, NASHUA, NH:
2,502,701. REN. 6-16-11. INT. CL. 9.
- DEMCO INCORPORATED, LAGUNA BEACH, CA:
3,997,993, PUB. 5-3-2011. INT. CL. 22.
- DEMIRER KABLO TESISLERI SANAYI VE TICARET ANO-
NIM SIRKETI, TURKEY:
3,995,958, PUB. 5-3-2011. INT. CL. 9.
- DENKI KAGAKU KOGYO KABUSHIKI KAISHA, JAPAN:
3,754,853, COR. MULTIPLE CLASS, INT. CLS. 1, 9, 17
AND 19.
- DENTAL ASSISTING NATIONAL BOARD, INC., CHICAGO,
IL:
2,449,311. REN. 6-15-11. U.S. CL. B.
2,449,312. REN. 6-15-11. U.S. CL. B.
- DENTAL IDEA LAB LLC, NEWTON, MA:
3,999,992, INT. CL. 35.
- DENTAL REVOLUTION LIMITED, KOWLOON, HONG
KONG:
2,901,563, CANC. INT. CL. 21.
- DENTOLOGY SCIENCES COMPANY, LLC, HOUSTON, TX:
3,996,688, PUB. 5-3-2011. INT. CL. 10.
- DEPARTMENT OF VETERANS AFFAIRS, WASHINGTON,
DC:
3,997,774, PUB. 5-3-2011. INT. CL. 44.
- DEPUY, INC., WARSAW, IN:
3,998,239, PUB. 5-3-2011. INT. CL. 10.
- DERENTHAL, AUGEST, JERSEY CITY, NJ:
2,902,453, CANC. INT. CL. 14.
- DESAI, HIMANSHU, AUSTIN, TX:
3,997,804, PUB. 5-3-2011. INT. CL. 9.
- DESCENTE NORTH AMERICA, INC., LAYTON, UT:
3,997,361, PUB. 5-3-2011. INT. CL. 25.
3,997,363, PUB. 5-3-2011. INT. CL. 25.
- DESERT IMAGINING, LLP, EL PASO, TX:
2,901,305, CANC. INT. CL. 44.
- DESIGN IDEAS, LTD., SPRINGFIELD, IL:
2,953,216, CANC. INT. CL. 18.
- DESIGNO INC., LAS VEGAS, NV:
3,998,118, PUB. 5-3-2011. INT. CL. 42.
- DESMAZIERES DRINO BONNETERIE FABRICATION,
FRANCE:
3,995,836, PUB. 5-3-2011. INT. CL. 25.
- DESSO B.V., NL-5142 PA WAALWIJK, NETHERLANDS:
3,995,984, PUB. 5-3-2011. INT. CL. 27.
- DESTINY CHURCH MINISTRIES, INC., JACKSONVILLE,
FL:
2,901,178, CANC. INT. CL. 45.
- DESTINY HEALTH, INC., BETHESDA, MD:
2,901,475, CANC. INT. CL. 36.
- DETROIT RADIANT PRODUCTS COMPANY, WARREN,
MI:
3,999,930, INT. CL. 11.
- DEXALL BIOMEDICAL LABS, INC., GAITHERSBURG, MD:
2,507,979. REN. 6-15-11. INT. CL. 10.
- DEXTER-RUSSELL, INC., SOUTHBRIDGE, MA:
3,996,857, PUB. 5-3-2011. INT. CL. 8.
- DFT, INC., EXTON, PA:
3,996,136, PUB. 5-3-2011. INT. CL. 11.
3,996,137, PUB. 5-3-2011. INT. CL. 11.
- DHARMA GEAR INC., MIAMI, FL:
3,998,921, MULTIPLE CLASS, INT. CLS. 25 AND 35.
- DHARMA PROPERTIES, INC., DELRAY BEACH, FL:
2,901,311, CANC. MULTIPLE CLASS, INT. CLS. 36 AND
37.
- DIABETICARE LLC, LAKE WORTH, FL, DBA ALL VITA-
MINS PLUS.COM:
3,997,125, PUB. 5-3-2011. INT. CL. 35.
- DIAGEO NORTH AMERICA, INC., NORWALK, CT:
2,901,508, CANC. INT. CL. 41.
3,998,905, INT. CL. 41.
- DIAMOND SELECT TOYS AND COLLECTIBLES, LLC.,
TIMONIUM, MD:
3,998,779, INT. CL. 28.
- DIAN BROOKS, COLUMBIA, MD AND JOE MILLIGAN,
BRONX, NY:
3,999,113, INT. CL. 41.
- DICKINSON, A. RANDAL, MOSES LAKE, WA:
2,901,370, CANC. INT. CL. 36.
- DICKSON, JOHN, ROCKVILLE, MD:
3,998,334, INT. CL. 31.
- DIDIER-WERKE AG, FED REP GERMANY:
3,995,913, PUB. 5-3-2011. INT. CL. 19.
- DIEBOLT INTERNATIONAL, INC, PLYMOUTH, MI, DBA
DADCO, INC.:
2,483,156. REN. 6-15-11. INT. CL. 7.
2,488,432. REN. 6-15-11. INT. CL. 7.
- DIESEL MACHINE WORKS, LOS ANGELES, CO:
3,996,602, PUB. 5-3-2011. MULTIPLE CLASS, INT. CLS. 35
AND 40.
- DIET CENTER WORLDWIDE, INC., AKRON, OH:
3,999,557, INT. CL. 29.
- DIG-GIT BEACH GEAR INC., NORTH PROVIDENCE, RI:
3,999,804, INT. CL. 18.
- DIGISTITCH, INC, ARVADA, CO:
2,901,138, CANC. INT. CL. 25.
- DIGITAL VENTURES MEDIA, LLC, DALLAS, TX, DBA
AUTOBREEZE:
3,997,790, PUB. 5-3-2011. INT. CL. 35.
- DIGITAS, INC., BOSTON, MA:
3,999,184, MULTIPLE CLASS, INT. CLS. 35 AND 42.
- DIGITIMES PUBLICATION INC., TAIPEI 114, TAIWAN:
2,901,190, CANC. MULTIPLE CLASS, INT. CLS. 35 AND
41.
- DIJIPOP, PROVIDENCE, RI:
3,997,578, PUB. 5-3-2011. INT. CL. 41.
- DILETTANTE CHOCOLATES, INC., KENT, WA:
4,000,026, INT. CL. 30.
4,000,027, INT. CL. 30.
- DILLARD'S INC., LITTLE ROCK, AK:
2,901,714, CANC. INT. CL. 25.
- DILLARD'S, INC., LITTLE ROCK, AR:
2,472,133. REN. 6-16-11. INT. CL. 25.
- DIMENSION ONE SPAS, INC., VISTA, CA:
2,901,411, CANC. INT. CL. 11.
- DIMMICK, STEPHEN, NEW YORK, NY:
3,997,025, PUB. 5-3-2011. INT. CL. 44.
- DINE GUIDES, BOILING SPRINGS, SC:
3,999,353, INT. CL. 35.
- DINERS CLUB INTERNATIONAL LTD, RIVERWOODS, IL:
3,998,804, INT. CL. 36.

DIOPTICS MEDICAL PRODUCTS, INC., SAN LUIS OBISPO, CA:
2,902,377, CANC. INT. CL. 9.

DIP, GUILLERMO, MIDDLE VILLAGE, NY:
3,997,940, PUB. 5-3-2011. INT. CL. 41.

DIRECT CAMPAIGNS, INC., CALABASAS, CA:
2,901,419, CANC. MULTIPLE CLASS, INT. CLS. 3 AND 44.

DIRECT MARKETERS ON CALL, INC., NEW YORK, NY:
2,402,062, CANC. INT. CL. 35.

DIRECT MARKETING STORE, RIDGEWOOD, NJ:
3,997,938, PUB. 5-3-2011. INT. CL. 35.

DIRECT SUPPLY, INC., MILWAUKEE, WI:
3,996,259, PUB. 5-3-2011. MULTIPLE CLASS, INT. CLS. 35 AND 41.

DIRECT SURF LIFESTYLES INDUSTRIES LTD, CHINA:
3,995,997, PUB. 5-3-2011. INT. CL. 28.

DIRECTV, INC., EL SEGUNDO, CA:
2,901,567, CANC. INT. CL. 41.

DISASTER INC., ST PETERSBURG, FL:
4,000,046, INT. CL. 38.

DISCOUNT METRICS CORP., TORONTO, CANADA:
3,999,940, INT. CL. 35.

DISCOVERY R & D ADVISORY SERVICES, LLC, DALLAS, TX:
2,901,241, CANC. INT. CL. 41.

DISCUS DENTAL, LLC, CULVER CITY, CA:
2,902,325, CANC. INT. CL. 3.

DISNEY ENTERPRISES, INC., BURBANK, CA:
3,998,366, MULTIPLE CLASS, INT. CLS. 18, 20, 21, 24 AND 30.
3,998,367, INT. CL. 20.
3,998,533, INT. CL. 41.
3,999,881, INT. CL. 14.

DISPATCH USA, INC., ALTON, IL:
3,999,944, INT. CL. 39.

DISPLAY INTERNATIONAL SCHWENDINGER; GMBH & CO. KG, FED REP GERMANY:
3,995,775, PUB. 5-3-2011. MULTIPLE CLASS, INT. CLS. 6, 19, 20, 35, 37, 42 AND 43.

DISTILLERIE TUONI E CANEPA, S.R.L., LIVORNO, ITALY:
3,999,236, INT. CL. 33.

DISTRIBUTION CONTROL SYSTEMS, INC., HAZELWOOD, MO:
2,901,962, CANC. INT. CL. 9.

DISTRIBUTION PHARMAC INC., BLAINVILLE, QUEBEC, CANADA:
3,999,367, INT. CL. 24.

DITTMAN INCENTIVE MARKETING CORPORATION, NEW BRUNSWICK, NJ:
1,646,216, REN. 6-16-11. INT. CL. 35.

DIVEHEAD GENERAL PARTNERSHIP, APTOS, CA:
2,401,367, CANC. INT. CL. 25.

DIVENTION DESIGN, LLC, SAN JOSE, CA:
3,996,088, PUB. 5-3-2011. INT. CL. 9.

DIVERSIFIED HOLDING CORPORATION, LONG BEACH, CA:
2,902,350, CANC. INT. CL. 36.
2,902,352, CANC. INT. CL. 36.

DIVERSITECH CORPORATION, DULUTH, GA:
3,995,534, PUB. 5-3-2011. INT. CL. 9.

DIVINE CHOCOLATE LIMITED, LONDON, UNITED KINGDOM:
3,999,195, INT. CL. 30.

DIVINE MACHINERY SALES, INC., LOWELL, MI:
2,901,925, CANC. INT. CL. 7.
2,901,926, CANC. INT. CL. 7.

DIXIE BONES INC., WOODBRIDGE, VA:
3,999,062, INT. CL. 43.

DJ SALES LLC, WILMINGTON, DE:
3,995,568, PUB. 5-3-2011. INT. CL. 25.

DLF INTERNATIONAL SEEDS, INC., HALSEY, OR:
3,995,472, PUB. 5-3-2011. INT. CL. 31.

DME COMPANY LLC, MADISON HEIGHTS, MI:
2,468,501, REN. 6-15-11. MULTIPLE CLASS, INT. CLS. 6 AND 7.

DMT AUTOMOTIVE ENTERPRISES, INC, SPRINGFIELD, NJ:
3,065,230, CANC. INT. CL. 36.

DO SOMETHING!, INC., NEW YORK, NY:
3,999,775, INT. CL. 9.

DOC'S PRODUCTS, INC., MUSKEGO, WI:
2,901,660, CANC. INT. CL. 25.

DOCTISSIMO, LEVALLOIS PERRET, FRANCE:
2,901,002, CANC. MULTIPLE CLASS, INT. CLS. 3, 5, 28, 29, 36, 38 AND 41.

DOCTOR'S SIGNATURE SALES & MARKETING INTERNATIONAL CORP., POWAY, CA:
3,996,910, PUB. 5-3-2011. INT. CL. 5.

DOCTORS IMPROVING HEALTHCARE, INC., SAN FRANCISCO, CA:
3,996,662, PUB. 5-3-2011. INT. CL. 35.

DOCTORS ON WHEELS S.C., WESTMONT, IL:
3,996,504, PUB. 5-3-2011. INT. CL. 44.

DODSON, LISA E., OAKLAND, CA, DBA THE TOTAL SERVE:
3,996,471, PUB. 5-3-2011. INT. CL. 28.

DOESN'T SUCK PRODUCTIONS, LLC, SAN FRANCISCO, CA:
3,996,553, PUB. 5-3-2011. MULTIPLE CLASS, INT. CLS. 25 AND 45.

DOLBY LABORATORIES LICENSING CORPORATION, SAN FRANCISCO, CA:
3,998,602, INT. CL. 9.

DOLE FOOD COMPANY, INC., WESTLAKE VILLAGE, CA:
3,997,811, PUB. 5-3-2011. INT. CL. 29.
3,997,812, PUB. 5-3-2011. INT. CL. 29.
3,997,813, PUB. 5-3-2011. INT. CL. 29.
3,997,815, PUB. 5-3-2011. INT. CL. 29.
3,997,816, PUB. 5-3-2011. INT. CL. 29.
3,997,819, PUB. 5-3-2011. INT. CL. 29.

DOMINION ENTERPRISES, LLC, VAN NUYS, CA:
2,901,642, CANC. INT. CL. 35.

DON B. LEVINE, INC., MARIETTA, GA, DBA F & P SALES AND MARKETING:
2,901,758, CANC. INT. CL. 31.

DON BUMGARDNER, FORTH WORTH, TX:
3,996,567, PUB. 5-3-2011. INT. CL. 35.

DONAGHY, BRIAN P., WEST DES MOINES, IA:
3,996,320, PUB. 5-3-2011. INT. CL. 42.

DONAHUE & ASSOCIATES INTERNATIONAL, INC., MILFORD, OH:
2,481,799, REN. 6-15-11. INT. CL. 11.

DONALD DANFORTH PLANT SCIENCE CENTER, ST. LOUIS, MO:
2,462,376, REN. 6-14-11. INT. CL. 41.

DONALD L. WRIGHT, ALLENWOOD, PA, DBA INVISIBLE MINNOW RIG:
3,997,006, PUB. 5-3-2011. INT. CL. 28.

DONALDSON COMPANY, INC., MINNEAPOLIS, MN:
1,648,520, REN. 6-16-11. INT. CL. 11.

DONG, DAYE, BAYSIDE, NY:
3,999,825, INT. CL. 18.

DONKEY BOXX LTD. LIABILITY CO., BERKELEY, CA:
3,999,043, INT. CL. 12.

DONNA A. RAMERE, YORK, SC:
3,996,642, PUB. 5-3-2011. INT. CL. 28.

DONOVAN MARINE, INC., HARAHAN, LA:
3,996,205, PUB. 5-3-2011. INT. CL. 35.
3,996,206, PUB. 5-3-2011. MULTIPLE CLASS, INT. CLS. 7, 9, 11, 12 AND 22.
3,996,208, PUB. 5-3-2011. MULTIPLE CLASS, INT. CLS. 1, 2, 3, 4, 20 AND 24.
3,996,322, PUB. 5-3-2011. MULTIPLE CLASS, INT. CLS. 6, 7, 9, 11, 12, 16, 17, 20, 22 AND 35.
3,996,367, PUB. 5-3-2011. INT. CL. 12.

DONOVAN, THOMAS, PHILADELPHIA, PA:
3,997,200, PUB. 5-3-2011. INT. CL. 41.

DOREY POHRTE, KATHYSUE, WILLIAMSVILLE, NY:
3,998,020, PUB. 5-3-2011. INT. CL. 41.

DORGAN INVESTMENTS LIMITED, NASSAU, BAHAMAS:
2,487,059, REN. 6-16-11. INT. CL. 36.

DORIAN, ARMAND, PORTER RANCH, CA:
3,997,634, PUB. 5-3-2011. INT. CL. 41.

- DOS DAMAS ENTERPRISES, INC., NEW YORK, NY:
2,901,398, CANC. INT. CL. 41.
- DOT COM VENTURES PTY LTD, AUSTRALIA:
3,995,999, PUB. 5-3-2011. INT. CL. 45.
- DOTPOPS! BAKERY, INC., OMAHA, NE:
3,998,179, PUB. 5-3-2011. INT. CL. 40.
- DOTS, LLC, SOLON, OH:
2,901,881, CANC. INT. CL. 25.
- DOTSTER, INC., VANCOUVER, WA:
2,478,239, REN. 6-15-11. INT. CL. 42.
- DOTY SCIENTIFIC INC., COLUMBIA, SC:
2,476,994, REN. 6-14-11. INT. CL. 9.
- DOUBLETAKE ARCHERY, LA VERNIA, TX:
3,997,663, PUB. 5-3-2011. INT. CL. 28.
3,997,740, PUB. 5-3-2011. INT. CL. 28.
3,997,742, PUB. 5-3-2011. INT. CL. 28.
- DOUGHBOY VENTURES, HERMOSA BEACH, CA:
3,998,839, MULTIPLE CLASS, INT. CLS. 5 AND 30.
- DOUGHNUT CORPORATION OF AMERICA, SEATTLE, WA:
3,996,148, PUB. 5-3-2011. MULTIPLE CLASS, INT. CLS. 30 AND 43.
- DOUGLAS, WILLIE, ST LOUIS, MO AND DOUGLAS, DARREN, ST LOUIS, MO AND DOUGLAS, CHRISTOPHER, ST LOUIS, MO AND DOUGLAS, OPHELIA, ST LOUIS, MO:
2,902,035, CANC. MULTIPLE CLASS, INT. CLS. 9 AND 41.
- DOUTHITT, JEANIE KAY, PLANO, TX:
3,996,686, PUB. 5-3-2011. INT. CL. 36.
- DOW JONES, L.P., CHICOPEE, MA, DBA DOW JONES FULFILLMENT SERVICES:
2,466,488, REN. 6-16-11. INT. CL. 16.
- DOWNEAST LAKES LAND TRUST, GRAND LAKE STREAM, ME:
3,996,566, PUB. 5-3-2011. INT. CL. 35.
- DOWRICK, PETER W., KANEOHE, HI:
3,997,079, PUB. 5-3-2011. INT. CL. 16.
- DP SQUARED, INC., PALO ALTO, CA:
3,997,427, PUB. 5-3-2011. INT. CL. 42.
- DPE LABEL HOLDING CORP., BROOKLYN, NY:
3,998,443, MULTIPLE CLASS, INT. CLS. 36 AND 38.
- DR FRESH INC, BUENA PARK, CA:
3,997,823, PUB. 5-3-2011. INT. CL. 3.
- DR. CATHERINE WILBERT, MANDEVILLE, LA:
3,996,069, PUB. 5-3-2011. INT. CL. 5.
- DR. FRESH INC., NEW YORK, NY:
2,401,880, CANC. MULTIPLE CLASS, INT. CLS. 3 AND 21.
- DR. ING. H.C. F. PORSCHE AKTIENGESELLSCHAFT, FED REP GERMANY:
3,995,915, PUB. 5-3-2011. MULTIPLE CLASS, INT. CLS. 3, 25 AND 28.
- DR. MORITZ FRIEBEL & DR. JOACHIM PAPROTH GBR (VERTRETUNGSBERECHTIGTE GESELLSCHAFTER: DR. JOACHIM PAPROTH, 14513 TELTOW; DR. MORITZ FRIEBEL, 14193 BERLIN), FED REP GERMANY:
3,995,923, PUB. 5-3-2011. INT. CL. 12.
- DR. TUNG'S PRODUCTS, INC., KANEOHE, HI:
2,902,152, CANC. INT. CL. 21.
- DRAGONFRUIT STUDIOS, LLC, ATLANTA, GA:
3,998,407, INT. CL. 41.
- DRAHTZUG STEIN WIRE & WELDING GMBH & CO. KG, ALTLEININGEN, FED REP GERMANY:
3,996,381, PUB. 5-3-2011. INT. CL. 6.
- DRAPER'S & DAMON'S, INC., IRVINE, CA:
2,901,717, CANC. INT. CL. 35.
- DREAMBIDS INC., WEST LIBERTY, KY:
3,998,063, PUB. 5-3-2011. INT. CL. 35.
- DREAMSACKS, INC., ASHLAND, OR:
3,999,647, INT. CL. 18.
3,999,648, INT. CL. 35.
- DREAMWELL, LTD., LAS VEGAS, NV:
3,998,535, INT. CL. 20.
- DREAMWORKS ANIMATION L.L.C., GLENDALE, CA:
3,998,795, INT. CL. 16.
- DREAM2DESIGN, LLC, FORT LAUDERALE, FL:
3,996,744, PUB. 5-3-2011. INT. CL. 9.
- DRESSER EQUIPMENT GROUP, INC., CARROLTON, THAILAND:
1,141,140, CANC. INT. CL. 9.
- DREUMEX B.V., NETHERLANDS:
3,995,887, PUB. 5-3-2011. INT. CL. 3.
- DREW TV, MOORPARK, CA:
3,998,051, PUB. 5-3-2011. INT. CL. 38.
- DREXEL UNIVERSITY, PHILADELPHIA, PA:
3,998,640, MULTIPLE CLASS, INT. CLS. 41 AND 45.
- DRINKWEL, LLC, IRVINE, CA:
3,995,615, PUB. 5-3-2011. INT. CL. 5.
- DRISCOLL, SHAWN, EL CAJON, CA:
3,997,204, PUB. 5-3-2011. INT. CL. 25.
- DRIVER DIGITAL, LLC, NEW YORK, NY:
3,999,548, INT. CL. 9.
- DROGUERIA SARRA, S.A., INC., CORAL GABLES, FL:
2,402,894, CANC. INT. CL. 5.
- DRUM RÖHL, LLC, NORTH EAST, PA:
3,997,896, PUB. 5-3-2011. INT. CL. 15.
- DRYERPLIERS, INC., KINGSTON, MA:
2,901,645, CANC. MULTIPLE CLASS, INT. CLS. 8 AND 10.
- DS LABORATORIES, INC., MIAMI BEACH, FL:
3,996,488, PUB. 5-3-2011. MULTIPLE CLASS, INT. CLS. 3 AND 5.
- DS WATERS OF AMERICA, INC., ATLANTA, IL:
3,998,501, INT. CL. 32.
- DUANE READE INTERNATIONAL, LLC, NEW YORK, NY:
3,998,631, INT. CL. 35.
3,999,601, INT. CL. 35.
- DUBLIN MANAGEMENT ASSOCIATES OF NEW JERSEY, INC., BURLINGTON, NJ, TA LYNCH EXHIBITS OF BURLINGTON TOWNSHIP, NEW JERSEY:
2,901,763, CANC. INT. CL. 40.
- DUCT MASTERS RX LLC, HANOVER, PA:
3,998,972, INT. CL. 37.
- DUFF, JASON, EDGEWATER PARK, NJ:
3,996,868, PUB. 5-3-2011. INT. CL. 44.
- DULCES DE LECHE LA VAQUITA, S.A. DE C.V., SAN LUIS POTOSI, MEXICO:
3,996,525, PUB. 5-3-2011. INT. CL. 30.
- DULCICH, INC., CLACKAMAS, OR:
3,997,301, PUB. 5-3-2011. INT. CL. 29.
- DUNCAN ENTERPRISES, FRESNO, CA, DBA ILOVE-TOCREATE:
4,000,012, INT. CL. 2.
- DUODESK, RIVER FOREST, IL AND K & A MANUFACTURING, SCHOFIELD, WI, DBA RIGHT ANGLE PRODUCTS:
3,996,720, PUB. 5-3-2011. INT. CL. 28.
- DURAMOLD CASTINGS, INC., MISHAWAKA, IN:
2,402,829, CANC. INT. CL. 6.
- DURHAM BULLS BASEBALL CLUB, INC., THE, DURHAM, NC:
1,180,556, REN. 6-14-11. INT. CL. 41.
- DURKA, HEATHER WILLIAMS, OLYMPIA, WA, DBA SOPHIE LUMEN AND DURKA, MICHAEL A, OLYMPIA, WA, DBA SOPHIE LUMEN:
3,998,761, INT. CL. 16.
- DURST PHOTOTECHNIK AG / DURST PHOTOTECHNIK S.P.A., BRIKEN/BRESSANONE, ITALY, DURST S.A., BOLZANO, BOLZANO, ITALY:
717,550, REN. 6-15-11. U.S. CL. 26 (INT. CLS. 1, 9 AND 10).
- DUSSAULT APPAREL INC., POINT ROBERTS, WA:
3,998,310, INT. CL. 25.
- DWECK, JOYCE, DEAL, NJ:
3,998,314, MULTIPLE CLASS, INT. CLS. 21, 24, 29, 30 AND 31.
- DWELLEVATE, INC, CHICAGO, IL:
3,999,754, INT. CL. 36.
- DY METALWORKS, INC., BELLEVUE, WA:
3,999,154, INT. CL. 35.
- DYNAMIC LOGIC, INC., NEW YORK, NY:
3,999,855, INT. CL. 35.
- DYNAMIC SHELTERS INC., CALGARY, CANADA:
3,996,278, PUB. 5-3-2011. INT. CL. 19.
- DYNAMIC SOLUTIONS GROUP, INC., PALM HARBOR, FL:
3,997,253, PUB. 5-3-2011. INT. CL. 42.

DYNASTY FOOTWEAR, LTD., EL SEGUNDO, CA:
3,999,540, INT. CL. 25.
3,999,590, INT. CL. 25.

DYNAVOX SYSTEMS LLC, PITTSBURGH, PA:
2,902,401, CANC. INT. CL. 9.
2,902,402, CANC. INT. CL. 9.

E & P RECON PEST CONTROL, LLC, MURPHY, TX:
3,996,817, PUB. 5-3-2011. INT. CL. 37.

E SOCIALWORLD, LLP, ARLINGTON, TX:
3,995,576, PUB. 9-1-2009. INT. CL. 41.

E. & J. GALLO WINERY, MODESTO, CA:
3,999,768, INT. CL. 33.

E. I. DU PONT DE NEMOURS AND COMPANY, WILMINGTON, DE:
908,568. REN. 6-16-11. U.S. CL. 26 (INT. CL. 9).
1,645,733. REN. 6-16-11. INT. CL. 2.
3,998,681, INT. CL. 5.

E.A. SWEEN COMPANY, EDEN PRAIRIE, MN:
3,998,932, INT. CL. 30.

E.S. ORIGINALS, INC., NEW YORK, NY:
2,402,641, CANC. INT. CL. 25.

E.T. BROWNE DRUG CO., INC., ENGLEWOOD CLIFFS, NJ:
3,998,512, INT. CL. 3.

E-FILLIATE, INC., RANCHO CORDOVA, CA:
2,901,654, CANC. INT. CL. 9.

E-P EQUIPMENT, USA CORP., DUNCAN, SC:
2,901,632, CANC. MULTIPLE CLASS, INT. CLS. 7 AND 12.

EAGAN, LYNNE, MARINA DEL REY, CA:
3,998,494, INT. CL. 9.

EAGLE ROCK ENERGY PARTNERS, L.P., HOUSTON, TX:
3,995,706, PUB. 5-3-2011. MULTIPLE CLASS, INT. CLS. 35, 36, 39 AND 40.

EAGTAC, LLC, BLAINE, WA:
3,997,833, PUB. 5-3-2011. MULTIPLE CLASS, INT. CLS. 9 AND 11.

EARLY ALERT, INC., TAMPA, FL:
3,996,160, PUB. 5-3-2011. MULTIPLE CLASS, INT. CLS. 41 AND 45.
3,996,440, PUB. 5-3-2011. MULTIPLE CLASS, INT. CLS. 41 AND 45.

EARLY TIMES DISTILLERS COMPANY, LOUISVILLE, KY:
2,901,774, CANC. INT. CL. 43.

EARTH CARE PRODUCTS, INC., INDEPENDENCE, KS:
3,998,809, INT. CL. 4.

EARTH SCIENCE LABORATORIES, INC., BENTONVILLE, AR:
3,999,021, INT. CL. 5.

EARTHBONGO, INC., SEATTLE, WA:
3,998,110, PUB. 5-3-2011. INT. CL. 45.

EASCO HAND TOOLS, INC., SIMSBURY, CT:
2,354,318. REN. 6-16-11. INT. CL. 7.

EASIC CORPORATION, SANTA CLARA, CA:
2,459,384. REN. 6-13-11. INT. CL. 9.

EAST GEORGIA HEALTH COOPERATIVE, INC., SANDERSVILLE, GA:
3,997,950, PUB. 5-3-2011. INT. CL. 35.

EASTERN BANK, BOSTON, MA:
2,902,365, CANC. INT. CL. 36.

EASTERN MOUNTAIN SPORTS, INC., PETERBOROUGH, NH:
2,952,447, CANC. MULTIPLE CLASS, INT. CLS. 8, 9, 18, 20, 21, 22, 25 AND 28.
2,952,448, CANC. MULTIPLE CLASS, INT. CLS. 8, 9, 18, 20, 21, 22, 25 AND 28.

EAT FIT, LLC, CHICAGO, IL:
3,996,463, PUB. 5-3-2011. INT. CL. 35.

EAT GOOD FEEL GOOD INC., NEW YORK, NY:
3,996,956, PUB. 5-3-2011. INT. CL. 43.

EATSTRONG, LLC, NEW YORK, NY:
3,999,719, INT. CL. 29.

EBSCO INDUSTRIES, INC., BIRMINGHAM, AL:
3,996,191, PUB. 5-3-2011. INT. CL. 28.

ECAMPUSNATION, LP, CENTER, TX:
3,995,626, PUB. 5-3-2011. MULTIPLE CLASS, INT. CLS. 38, 41, 42 AND 45.

ECCA ENTERPRISES, INC., SAN ANTONIO, TX:
2,453,255. REN. 6-10-11. MULTIPLE CLASS, INT. CLS. 35 AND 42.

ECLECTIC PRODUCTS, INC., EUGENE, OR:
2,401,784, CANC. INT. CL. 17.

ECO PROMOTIONAL PRODUCTS, INC., VERNON HILLS, IL:
3,995,614, PUB. 5-3-2011. MULTIPLE CLASS, INT. CLS. 25 AND 35.

ECO TEXTILES GROUP, INC., LOS ANGELES, CA:
3,996,292, PUB. 5-3-2011. INT. CL. 25.

ECOANT ENTERPRISES LTD., VANCOUVER, BC, CANADA, DBA ECOANT:
3,999,490, INT. CL. 5.

ECOAPPRENTICE, LLC, WHITE SALMON, WA:
3,999,897, INT. CL. 42.

ECOCOALITION, INC., CALABASAS, CA:
3,999,929, INT. CL. 35.

ECOFIC, LOUISVILLE, KY:
3,997,016, PUB. 5-3-2011. INT. CL. 41.

ECOLOGY COATINGS, INC., AKRON, OH:
3,998,488, INT. CL. 2.

ECONOMY PEST CONTROL, INC., GRASS VALLEY, CA:
3,997,252, PUB. 5-3-2011. INT. CL. 37.

ED'S RED, INCORPORATED, PORT ST. JOE, FL:
3,997,033, PUB. 5-3-2011. INT. CL. 30.

EDATAUNITED GMBH, FED REP GERMANY:
3,995,907, PUB. 5-3-2011. MULTIPLE CLASS, INT. CLS. 9, 35, 38 AND 42.

EDDIE AND SAM'S NY PIZZA, LLC, TAMPA, FL:
3,997,286, PUB. 5-3-2011. INT. CL. 43.

EDDIE JOHNSON LLC, WASHINGTON, DC:
3,998,116, PUB. 5-3-2011. INT. CL. 25.

EDDY, MICHAEL, ORMOND BEACH, FL:
3,998,432, INT. CL. 25.

EDDY'S INTERNATIONAL TRADING INC., CHINO, CA:
3,997,144, PUB. 5-3-2011. MULTIPLE CLASS, INT. CLS. 4, 11 AND 21.

EDGE COMPOSITES, LLC, OGDEN, UT:
3,996,438, PUB. 5-3-2011. MULTIPLE CLASS, INT. CLS. 12, 35 AND 40.
3,996,476, PUB. 5-3-2011. MULTIPLE CLASS, INT. CLS. 12, 35 AND 40.

EDGECRAFT CORPORATION, AVONDALE, PA:
3,997,754, PUB. 5-3-2011. INT. CL. 7.

EDGERTON, ANNIE, NEW YORK, NY:
3,997,221, PUB. 5-3-2011. INT. CL. 41.

EDGEWATER TECHNOLOGY, INC., WAKEFIELD, MA:
3,957,060, AM. MULTIPLE CLASS, INT. CLS. 35, 41 AND 42.

EDIBLE COMMUNITIES, INC., MISSOULA, MT:
3,999,728, INT. CL. 16.

EDLON INC., AVONDALE, PA, EDLON PRODUCTS, INC., AVONDALE, PA:
1,647,130. REN. 6-15-11. MULTIPLE CLASS, INT. CLS. 1, 7, 11, 17 AND 40.

EDUCA BORRAS S.A., BARCELONA, SPAIN:
2,469,972. REN. 6-15-11. INT. CL. 35.

EDUCATIONAL SERVICE DISTRICT 112, VANCOUVER, WA, AKA ESD 112:
4,000,037, INT. CL. 41.

EDUCATIONAL TESTING SERVICE, PRINCETON, NJ:
3,998,197, PUB. 5-3-2011. MULTIPLE CLASS, INT. CLS. 9 AND 16.

EDUCATIONDYNAMICS, LLC, HOBOKEN, NJ:
3,996,649, PUB. 5-3-2011. MULTIPLE CLASS, INT. CLS. 35 AND 41.
3,996,650, PUB. 5-3-2011. MULTIPLE CLASS, INT. CLS. 35, 38 AND 41.

EDVANCE RESEARCH, INC., SAN ANTONIO, TX:
3,999,058, INT. CL. 41.
3,999,059, INT. CL. 41.

EDWARDS LIFESCIENCES CORPORATION, IRVINE, CA:
2,402,374, CANC. INT. CL. 10.
3,998,619, INT. CL. 10.
3,999,365, INT. CL. 42.

EDWARDS, SALLY, SACRAMENTO, CA, DBA HEART ZONES:
3,998,061, PUB. 5-3-2011. INT. CL. 16.

- EEPULSE, INC., ANN ARBOR, MI:
2,402,097, CANC. MULTIPLE CLASS, INT. CLS. 35 AND 41.
- EGALAX—EMPIA TECHNOLOGY INC., TAIPEI 114, TAIWAN:
3,995,573, PUB. 5-3-2011. MULTIPLE CLASS, INT. CLS. 9 AND 42.
- EGGLESTON, RAYMOND STUART, DISTRICT HEIGHTS, MD:
2,902,148, CANC. INT. CL. 9.
- EGGXOTIC INC., BRONX, NY:
2,901,255, CANC. MULTIPLE CLASS, INT. CLS. 30 AND 43.
- EGIS PROJECTS, FRANCE:
3,995,728, PUB. 5-3-2011. MULTIPLE CLASS, INT. CLS. 9, 35, 36, 37, 39, 42 AND 45.
- EGOHE, SEATTLE, WA:
3,996,802, PUB. 5-3-2011. INT. CL. 25.
- EGOSCUE, INC., SAN DIEGO, CA:
1,678,857, REN. 6-15-11. INT. CL. 41.
- EHP PRODUCTS, INC., MOUNT PLEASANT, SC:
3,996,472, PUB. 1-25-2011. INT. CL. 5.
- EKAIRE.COM INC., SURREY, BC, CANADA:
3,999,395, INT. CL. 5.
- ELAN CORPORATION, PLC., DUBLIN, IRELAND:
2,901,478, CANC. INT. CL. 10.
- ELAN PHARMA INTERNATIONAL LIMITED, ATHLONE, CO. WESTMEATH, IRELAND, ELAN PHARMA INTERNATIONAL LIMITED, ATHLONE, CO. WESTMEATH, IRELAND:
2,492,925, REN. 6-15-11. MULTIPLE CLASS, INT. CLS. 35, 40 AND 42.
- ELAN PHARMA INTERNATIONAL LIMITED, SOUTH SAN FRANCISCO, CA:
2,901,576, CANC. INT. CL. 5.
- ELAN PHARMA INTERNATIONAL LIMITED, COUNTY CLARE, IRELAND:
2,901,578, CANC. INT. CL. 5.
- ELDERGADGET, LLC, BEVERLY HILLS, CA:
3,999,359, INT. CL. 35.
- ELECTRA INFORMATION SYSTEMS, INC., NEW YORK, NY:
3,997,413, PUB. 5-3-2011. INT. CL. 42.
- ELECTROLUX HOME CARE PRODUCTS, INC., CLEVELAND, OH:
2,402,428, CANC. INT. CL. 7.
- ELECTRONIC ARTS INC., REDWOOD CITY, CA:
2,498,830, REN. 6-15-11. MULTIPLE CLASS, INT. CLS. 38 AND 42.
2,558,688, REN. 6-16-11. INT. CL. 41.
3,999,534, INT. CL. 9.
- ELEMENT TATTOO SUPPLY, INC., WESTMINSTER, CA:
3,998,855, INT. CL. 35.
- ELEMENTIS SPECIALTIES, INC., HIGHTSTOWN, NJ, N L INDUSTRIES, INC., NEW YORK, NY:
1,189,031, REN. 6-10-11. INT. CL. 1.
- ELEPHANT BALLS, LTD., COLUMBUS, OH:
2,401,723, CANC. INT. CL. 28.
- ELEPHANT BALLS, LTD., WORTHINGTON, OH:
2,401,724, CANC. INT. CL. 28.
- ELEVITCH, NIKOLAS, PALISADES, NY:
3,997,821, PUB. 5-3-2011. INT. CL. 41.
- ELHOUTY, SARA, THOUSAND OAKS, CA:
3,999,959, INT. CL. 25.
- ELITE SPIDERS, LLC, ROBBINSVILLE, NJ:
3,997,553, PUB. 5-3-2011. INT. CL. 9.
- ELK CORPORATION OF DALLAS, DALLAS, TX:
1,592,010, CANC. INT. CL. 17.
- ELKAY MANUFACTURING COMPANY, OAK BROOK, IL:
3,998,962, INT. CL. 20.
- ELLA INTERNET TECHNOLOGIES, INC., SANTA BARBARA, CA:
3,996,941, PUB. 5-3-2011. INT. CL. 35.
- ELLIOTT, JOHN, ROSEVILLE, OH:
3,999,278, INT. CL. 18.
- ELLMAN INTERNATIONAL, INC., OCEANSIDE, NY:
3,998,653, MULTIPLE CLASS, INT. CLS. 5 AND 10.
- ELSEVIER INC., NEW YORK, NY:
2,402,996, CANC. MULTIPLE CLASS, INT. CLS. 9 AND 16.
- EMATS, INC., CEDAR BLUFF, VA:
2,901,537, CANC. MULTIPLE CLASS, INT. CLS. 37 AND 42.
- EMBARQ HOLDINGS COMPANY LLC, OVERLAND PARK, KS, DBA/AKA/TA: DBA CENTURYLINK, INC., CENTURYTEL, INC.:
3,998,346, INT. CL. 38.
3,998,347, INT. CL. 9.
3,998,348, INT. CL. 38.
3,998,349, INT. CL. 42.
3,998,350, INT. CL. 9.
3,998,351, INT. CL. 42.
- EMBARQ HOLDINGS COMPANY LLC, OVERLAND PARK, KS:
3,998,731, INT. CL. 38.
- EMBASSY LIMOUSINE AND SEDAN SERVICES, INC., PINELLAS PARK, FL:
2,578,287, REN. 6-16-11. INT. CL. 39.
- EMBRACE, INC., BRENTWOOD, TN:
2,901,204, CANC. INT. CL. 35.
- EMEIS COSMETICS PTY. LTD., FITZROY, AUSTRALIA:
3,997,914, PUB. 5-3-2011. INT. CL. 35.
- EMERGE CLINICAL SOLUTIONS, LLC, DALLAS, TX:
3,999,183, INT. CL. 44.
- EMERGENCY ONE, INC., OAK BROOK, IL:
2,401,808, CANC. INT. CL. 9.
- EMERGING BRANDS, INC., PORTLAND, OR:
3,998,564, INT. CL. 35.
- EMERGING ENERGY RESEARCH, LLC, CAMBRIDGE, MA:
3,996,074, PUB. 5-3-2011. INT. CL. 35.
- EMERSON NETWORK POWER, ENERGY SYSTEMS, NORTH AMERICA, INC., WARRENVILLE, IL:
3,998,694, INT. CL. 9.
- EMERY, LESLIE JOHN, CHASE TERRACE, BURNTWOOD, STAFFS, GREAT BRITAIN, DBA FAIR SPARES:
1,644,347, REN. 6-15-11. INT. CL. 12.
- EMI (IP) LIMITED, LONDON W8 5SW, UNITED KINGDOM:
2,474,144, REN. 6-15-11. INT. CL. 9.
- EMIDS TECHNOLOGIES PRIVATE LIMITED CORP., NASHVILLE, TN:
3,999,271, INT. CL. 41.
- EMINENCE ORGANIC SKINCARE INC., VANCOUVER, BRITISH COLUMBIA, CANADA:
3,999,192, MULTIPLE CLASS, INT. CLS. 3 AND 21.
- EMINENCE ORGANIC SKINCARE INC., VANCOUVER, B.C., CANADA:
3,999,456, MULTIPLE CLASS, INT. CLS. 3 AND 5.
- EMIT CORPORATION, HOUSTON, TX:
3,998,665, MULTIPLE CLASS, INT. CLS. 40 AND 42.
- EMOTIV LIMITED, KWUN TONG, HONG KONG:
3,998,074, PUB. 5-3-2011. INT. CL. 9.
3,998,119, PUB. 5-3-2011. INT. CL. 9.
- EMPIONEER CORP, LA PUENTE, CA:
3,999,239, INT. CL. 9.
- EMPOWHR, INC., ATLANTA, GA:
3,997,580, PUB. 5-3-2011. INT. CL. 36.
- EMPRESA DE LICORES DE CUNDINAMARCA, BOGOTA DC, COLOMBIA:
3,998,639, INT. CL. 33.
- EMPYREAL SCIENCES, LLC, TEMPE, AZ:
3,995,487, PUB. 5-3-2011. INT. CL. 42.
- EMS CHEMIE AG, CH 7013 DOMAT/EMS, SWITZERLAND, ROHM AND HAAS COMPANY, PHILADELPHIA, PA:
916,549, REN. 6-12-11. U.S. CL. 6 (INT. CL. 1).
- EMTEX LTD., STATION ROAD, UNITED KINGDOM:
3,998,833, INT. CL. 9.
- EMX INDUSTRIES INC., CLEVELAND, OH:
3,999,643, INT. CL. 9.
- EN ROUTE INTERNATIONAL LTD., WINDSOR, GREAT BRITAIN:
3,995,555, PUB. 10-12-2010. MULTIPLE CLASS, INT. CLS. 29, 30 AND 43.
3,995,556, PUB. 4-13-2010. MULTIPLE CLASS, INT. CLS. 29, 30 AND 43.

ENCORE SPECIALTY FOODS, LLC, HINGHAM, MA:
3,997,391, PUB. 5-3-2011. INT. CL. 30.

ENDLESSBEAUTY.COM, LLC, AUSTIN, TX:
3,996,624, PUB. 5-3-2011. INT. CL. 9.

ENDURANCE PRODUCTS COMPANY, TIGARD, OR:
3,999,134, INT. CL. 5.

ENDUROBOX LLC, TEMECULA, CA:
3,996,922, PUB. 5-3-2011. INT. CL. 39.
3,996,923, PUB. 5-3-2011. INT. CL. 39.

ENERGY SOLUTIONS INSULATION, INC., SAGINAW, MI:
2,402,840, CANC. INT. CL. 17.

ENERJOURNEY INC., EMMAUS, PA:
2,901,364, CANC. INT. CL. 44.

ENESCO, LLC, ITASCA, IL:
2,479,541, REN. 6-11-11. INT. CL. 28.
2,479,541, CANC. MULTIPLE CLASS, INT. CLS. 10, 12
AND 25.

ENGINEERING & RESEARCH ASSOCIATES, INC., TUC-
SON, AZ:
3,999,308, INT. CL. 7.

ENNIS, JOHN B., LELAND, NC:
2,901,725, CANC. INT. CL. 41.

ENOSIS S.R.L., ITALY:
3,995,822, PUB. 5-3-2011. INT. CL. 33.

ENSINGER INDUSTRIES, INC., WASHINGTON, PA, EN-
SINGER, INC., WASHINGTON, PA:
1,645,245, REN. 6-16-11. INT. CL. 17.

ENSPEKTOS, LLC, NEW YORK, NY:
3,998,786, MULTIPLE CLASS, INT. CLS. 35 AND 41.

ENSWICO IP AG, CH-6060 SARNEN, SWITZERLAND:
3,995,861, PUB. 5-3-2011. MULTIPLE CLASS, INT. CLS. 3
AND 11.

ENTERPRISE HOLDINGS, INC., ST. LOUIS, MO:
3,997,699, PUB. 5-3-2011. INT. CL. 39.

ENTERTAINMENT MUSIC MARKETING CORP., DEER
PARK, NY:
2,902,441, CANC. INT. CL. 15.

ENTERTAINMENT PUBLICATIONS LLC, TROY, MI:
3,997,262, PUB. 5-3-2011. INT. CL. 30.

ENTERTAINMENT PUBLICATIONS, LLC, TROY, MI, CEN-
DANT PUBLISHING, INC., AURORA, CO:
2,473,871, REN. 6-14-11. INT. CL. 35.

ENTUITION, INC., NORCROSS, GA:
2,901,496, CANC. INT. CL. 42.

ENVIRITE OF OHIO, INC., CANTON, OH, LIQWACON
CORPORATION, THOMASTON, CT:
1,164,088, REN. 6-15-11. INT. CL. 40.

ENVIRONMENTAL MANUFACTURING SOLUTIONS, LLC,
MELBOURNE, FL:
3,996,099, PUB. 5-3-2011. INT. CL. 1.

ENVIROPACK, LLC, LONGWOOD, FL:
3,996,978, PUB. 5-3-2011. INT. CL. 35.

ENVISION ENERGY (JIANGYIN) CO., LTD., JIANGSU
PROVINCE, CHINA:
3,997,497, PUB. 5-3-2011. INT. CL. 7.

ENZO & CO, INC, IRVINE, CA:
3,999,338, INT. CL. 9.

ENZYMPRO AG, APPENZEL, SWITZERLAND:
3,995,911, PUB. 5-3-2011. MULTIPLE CLASS, INT. CLS. 3,
5, 29, 30 AND 44.

EONFOCUS, LLC, CANTON, MI:
2,901,665, CANC. INT. CL. 9.

EPIC SLAP, LLC, MALIBU, CA:
3,998,853, INT. CL. 9.

EPICUREAN CATERING, LLC, CENTENNIAL, CO:
3,997,192, PUB. 5-3-2011. INT. CL. 41.

EPITAN LIMITED, MELBOURNE VIC, AUSTRALIA:
2,902,156, CANC. INT. CL. 5.

EPLUS INC., HERNDON, VA:
2,401,969, CANC. INT. CL. 36.

EPU PTY LTD, AUSTRALIA:
3,995,960, PUB. 5-3-2011. INT. CL. 7.

EQUI IN STYLE, LLC, GENEVA, FL:
3,998,342, INT. CL. 25.

EQUIFAX INC., ATLANTA, GA:
2,902,064, CANC. MULTIPLE CLASS, INT. CLS. 35 AND
36.

EQUILIBRIA PSYCHOLOGICAL AND CONSULTATION
SERVICES, LLC, PHILADELPHIA, PA:
3,999,453, INT. CL. 41.

EQUITOUR, LTD., DUBOIS, WY:
2,514,641, REN. 6-14-11. INT. CL. 39.

EQUITRAC CORPORATION, PLANTATION, FL:
3,998,093, PUB. 5-3-2011. INT. CL. 9.

ERC WIPING PRODUCTS, INC., LYNN, MA:
3,997,976, PUB. 5-3-2011. INT. CL. 35.

ERDAS, INC., NORCROSS, GA:
2,421,928, REN. 6-10-11. INT. CL. 9.

ERIC A. COLEMAN, AURORA, CO:
3,996,837, PUB. 5-3-2011. INT. CL. 44.

ERICH SCHEUGENPFLUG, FED REP GERMANY:
3,995,926, PUB. 5-3-2011. MULTIPLE CLASS, INT. CLS. 7
AND 42.

ERNO LASZLO, INC., NEW YORK, NY:
3,996,848, PUB. 5-3-2011. INT. CL. 3.

ERNST, RANDY, THOUSAND PALMS, CA AND ERNST,
DARLENE, THOUSAND PALMS, CA, DBA PRO-TECH
MATS INDUSTRY:
2,451,313, REN. 6-16-11. INT. CL. 27.

ERXSYS, INC., FT WORTH, TX:
2,901,258, CANC. INT. CL. 35.

ESAOTE S.P.A., MILANO, ITALY:
3,997,988, PUB. 5-3-2011. INT. CL. 10.

ESCAPE APPS. LLC, LOS ANGELES, CA:
3,996,718, PUB. 5-3-2011. INT. CL. 9.

ESCORT INC., WEST CHESTER, OH:
3,997,904, PUB. 5-3-2011. INT. CL. 9.

ESCROW ASSOCIATES, LLC, ATLANTA, GA:
3,996,329, PUB. 5-3-2011. MULTIPLE CLASS, INT. CLS. 21
AND 28.

ESHEL LLC, NEW YORK, NY:
3,997,383, PUB. 5-3-2011. INT. CL. 25.

ESQUIRE BANK FSB, GARDEN CITY, NY:
3,997,277, PUB. 5-3-2011. INT. CL. 36.

ESQUIRE GROUP, INC., FISHKILL, NY:
2,901,757, CANC. INT. CL. 35.

ESSELTE CORPORATION, MELVILLE, NY:
2,901,263, CANC. INT. CL. 16.

ESSENTIAL FORMULAS INCORPORATED, FARMERS
BRANCH, TX:
3,999,589, INT. CL. 5.

ESSEX EUROPE, COMPIEGNE, FRANCE, CANWIRCO
INC., ETOBICOKE, ONTARIO, CANADA:
1,166,245, REN. 6-10-11. INT. CL. 9.

ESTANISLAO MARTINEZ MARTINEZ, BURGUILLOS (SE-
VILLA), SPAIN:
3,999,044, INT. CL. 42.

ESTILO HACIENDA, INC., ORANGE, CA:
3,999,726, INT. CL. 35.

ETAGE REAL ESTATE, LLC, NEW YORK, NY:
3,996,902, PUB. 5-3-2011. INT. CL. 36.

ETAILESALES ASSOCIATES, LLC, MURRYSVILLE, PA:
3,997,295, PUB. 5-3-2011. INT. CL. 35.

ETHERCEPT, LLC, METUCHEN, NJ:
2,901,539, CANC. MULTIPLE CLASS, INT. CLS. 9 AND
42.

ETIENNE AIGNER, INC., NEW YORK, NY, VILLAGER
INDUSTRIES, INC., PHILADELPHIA, PA:
911,959, REN. 6-10-11. MULTIPLE CLASS, U.S. CLS. 3
(INT. CL. 18), 8 (INT. CL. 34) AND 39 (INT. CLS. 10,
25 AND 26).

ETRAVEL APPLICATIONS, LLC, PLEASANTON, CA:
3,996,279, PUB. 5-3-2011. INT. CL. 39.

ETXE-TAR, S.A., 20870 ELGOIBAR (GUIPUZCOA), SPAIN:
2,460,093, REN. 6-15-11. INT. CL. 7.

EUBANKS SAMMY D., POST FALLS, ID:
3,996,668, PUB. 5-3-2011. INT. CL. 41.

EUI LIMITED, CARDIFF, GREAT BRITAIN:
3,998,805, MULTIPLE CLASS, INT. CLS. 35 AND 36.

EURAMCO SAFETY, INC., SPRING VALLEY, CA:
1,645,053, REN. 6-16-11. INT. CL. 9.

EURARK, LLC, BATESVILLE, AR:
3,999,636, MULTIPLE CLASS, INT. CLS. 5 AND 35.

EUREKA! INSTITUTE, INC., CINCINNATI, OH:
3,997,171, PUB. 5-3-2011. INT. CL. 41.

- EURENCO, FRANCE:
 3,995,834, PUB. 5-3-2011. INT. CL. 13.
 3,995,851, PUB. 5-3-2011. INT. CL. 13.
 3,995,852, PUB. 5-3-2011. INT. CL. 13.
 3,995,864, PUB. 5-3-2011. INT. CL. 13.
 3,995,865, PUB. 5-3-2011. INT. CL. 13.
- EUROCOPTER, 13725 MARIGNANE CEDEX, FRANCE:
 2,901,074, CANC. MULTIPLE CLASS, INT. CLS. 9, 12 AND 38.
- EUROPEAN COSMETIC GROUP, INC., NEW YORK, NY:
 2,901,332, CANC. INT. CL. 3.
- EUROPEAN MARBLE CO., INC., DENVER, CO:
 3,996,771, PUB. 5-3-2011. INT. CL. 21.
- EVA M. DEL GRANDE GEB, INC., NEW YORK, NY:
 2,401,524, CANC. MULTIPLE CLASS, INT. CLS. 25 AND 35.
- EVA'S ESTHETICS, INC., OAKLAND, CA:
 3,999,701, INT. CL. 3.
- EVANS, REBECCA, EL CERRITO, CA:
 3,996,867, PUB. 5-3-2011. INT. CL. 25.
- EVANS, THOMAS, GENEVA, IL:
 3,996,955, PUB. 5-3-2011. INT. CL. 41.
- EVE LYNNE ROBINSON, OAKLAND, CA, DBA ELLA B. JENKINS, LLC:
 3,998,991, INT. CL. 16.
- EVENTFAST.COM LLC, CLEVELAND, OH:
 3,998,079, PUB. 5-3-2011. INT. CL. 42.
- EVENTLINK INTERNATIONAL, INC., DALLAS, TX:
 2,503,692, REN. 6-15-11. INT. CL. 35.
- EVERHARD PRODUCTS, INC., CANTON, OH:
 4,000,000, INT. CL. 8.
- EVERSOL CORPORATION, TAIPEI CITY, TAIWAN:
 3,999,641, INT. CL. 9.
- EVERSTONE CAPITAL ASIA PTE. LTD., SINGAPORE:
 3,995,910, PUB. 5-3-2011. MULTIPLE CLASS, INT. CLS. 35 AND 36.
 3,995,917, PUB. 5-3-2011. MULTIPLE CLASS, INT. CLS. 35 AND 36.
- EVO, INC., BEAVERTON, OR:
 3,996,882, PUB. 5-3-2011. INT. CL. 11.
- EVONIK STOCKHAUSEN GMBH, KREFELD 47805, FED REP GERMANY:
 2,900,996, CANC. INT. CL. 35.
- EVRISKO SYSTEMS, LLC, EAU CLAIRE, WI:
 3,998,908, INT. CL. 9.
- EWALD DORKEN AG, 58313 HERDECKE, FED REP GERMANY:
 2,950,820, CANC. INT. CL. 4.
- EW CONTROL, INC., ENGLISHTOWN, NJ:
 1,647,971, REN. 6-11-11. MULTIPLE CLASS, INT. CLS. 9 AND 11.
- EXACTECH INC., GAINESVILLE, FL:
 2,401,975, CANC. INT. CL. 10.
- EXCEL ROOFING, INCORPORATED, ENGLEWOOD, CO:
 3,996,815, PUB. 5-3-2011. INT. CL. 37.
- EXECUTIVES IN ACTION, DALLAS, TX:
 3,998,044, PUB. 5-3-2011. INT. CL. 35.
- EXIDE TECHNOLOGIES, MILTON, GA:
 3,998,608, INT. CL. 9.
- EXP GLOBAL INC., BRAMPTON, ONTARIO, CANADA:
 3,999,689, MULTIPLE CLASS, INT. CLS. 37 AND 42.
- EXPED AG, ZURICH, SWITZERLAND:
 3,998,577, MULTIPLE CLASS, INT. CLS. 18, 20, 22, 25 AND 28.
- EXPERTS EXCHANGE, LLC, SAN LUIS OBISPO, CA:
 3,995,662, PUB. 5-3-2011. INT. CL. 42.
- EXPLOTRAIN, LLC, FORT WALTON BEACH, FL:
 3,996,672, PUB. 5-3-2011. INT. CL. 9.
 3,996,674, PUB. 5-3-2011. INT. CL. 9.
- EXPORTACIONES LATINOAMERICANAS S.A. EXPORTACLA, GUAYAQUIL, ECUADOR:
 2,901,606, CANC. INT. CL. 29.
- EXPRESS TELLER SERVICES, INC., PHOENIX, AZ:
 3,996,083, PUB. 5-3-2011. INT. CL. 9.
- EXTERRO, INC., PORTLAND, OR:
 3,996,585, PUB. 5-3-2011. INT. CL. 42.
 3,996,586, PUB. 5-3-2011. INT. CL. 42.
- EXTRANOMICAL ADVENTURES, INC, SAN LEANDRO, CA, AKA EXTRANOMICAL TOURS:
 3,998,180, PUB. 5-3-2011. INT. CL. 39.
- EYEFINITY, INC., FOLSOM, CA:
 2,901,546, CANC. MULTIPLE CLASS, INT. CLS. 42 AND 44.
- EZ BEACH ATTACHMENTS, LLC, VIRGINIA BEACH, VA:
 3,998,715, INT. CL. 12.
- F&M HAT COMPANY, INC., DENVER, PA:
 3,998,139, PUB. 5-3-2011. INT. CL. 25.
 3,998,140, PUB. 5-3-2011. INT. CL. 25.
- FABRICATORS & MANUFACTURERS ASSOCIATION, INTERNATIONAL, ROCKFORD, IL:
 3,997,117, PUB. 5-3-2011. MULTIPLE CLASS, INT. CLS. 9 AND 41.
- FABTECH SYSTEMS LIMITED LIABILITY COMPANY, SANTA BARBARA, CA:
 3,997,646, PUB. 5-3-2011. INT. CL. 40.
- FACEGAMES, INC., BAYSIDE, NY:
 3,997,280, PUB. 5-3-2011. INT. CL. 3.
- FACELUXE LICENSING I, LLC, FENTON, MO:
 3,996,943, PUB. 5-3-2011. MULTIPLE CLASS, INT. CLS. 35 AND 44.
 3,996,944, PUB. 5-3-2011. MULTIPLE CLASS, INT. CLS. 35 AND 44.
- FACILITO OVERSEAS HOLDING CO. LTD., TORTOLA, BR. VIRGIN ISLANDS:
 3,999,197, MULTIPLE CLASS, INT. CLS. 35 AND 36.
 3,999,198, MULTIPLE CLASS, INT. CLS. 35 AND 36.
- FACILITY SOLUTIONS, INC., CLINTON TOWNSHIP, MI:
 3,998,764, INT. CL. 11.
- FAIGEN, STEVE, WASHINGTON, DC:
 3,996,379, PUB. 5-3-2011. MULTIPLE CLASS, INT. CLS. 41 AND 42.
- FAIRCALL CORPORATION, SAN DIEGO, CA:
 3,996,725, PUB. 5-3-2011. INT. CL. 38.
 3,996,726, PUB. 5-3-2011. INT. CL. 38.
- FAIRCOUNT, LLC, TAMPA, FL:
 2,901,121, CANC. INT. CL. 35.
- FAIRFIELD COUNTY LOOK, LLC, STAMFORD, CT:
 3,996,500, PUB. 5-3-2011. INT. CL. 41.
- FAIRFIELD TERCHNOLOGIES, INC., CHANTILLY, VA:
 3,995,475, PUB. 5-3-2011. MULTIPLE CLASS, INT. CLS. 35 AND 42.
- FAIVUS, DAVID, LOS ANGELES, CA:
 2,901,722, CANC. INT. CL. 28.
- FAKUNLE, JAMES, FLORENCE, AL AND FAKUNLE, SAMUEL, LAWRENCE, AL:
 3,999,281, INT. CL. 3.
- FALLEN PINE LLC, MELBOURNE, AR:
 3,997,451, PUB. 5-3-2011. MULTIPLE CLASS, INT. CLS. 16, 20 AND 28.
- FALMOUTH TRACK CLUB CORPORATION, FALMOUTH, MA:
 3,997,112, PUB. 5-3-2011. INT. CL. 41.
- FALSCHLEHNER, JAMES D., TUSTIN, CA:
 2,901,008, CANC. INT. CL. 25.
- FAMILIES IN THE LOOP, INC., CHICAGO, IL:
 3,997,462, PUB. 5-3-2011. MULTIPLE CLASS, INT. CLS. 35 AND 41.
- FAMILIES OF CHARACTER, GREENWOOD VILLAGE, CO:
 3,997,000, PUB. 5-3-2011. INT. CL. 41.
- FAMILY RESOURCE NETWORK, INC., JEFFERSON, GA:
 2,463,799, REN. 6-15-11. INT. CL. 41.
- FANCY T'S, FRISCO, TX:
 2,901,574, CANC. INT. CL. 16.
- FANIMATION, INC., ZIONSVILLE, IN:
 2,451,686, REN. 6-14-11. INT. CL. 11.
- FANTASIA DISTRIBUTION, INC., ANAHEIM, CA:
 3,998,201, PUB. 5-3-2011. INT. CL. 34.
 3,998,202, PUB. 5-3-2011. INT. CL. 34.
 3,998,203, PUB. 5-3-2011. INT. CL. 34.
 3,998,204, PUB. 5-3-2011. INT. CL. 34.
- FANTASY DIAMOND CORPORATION, CHICAGO, IL:
 3,997,586, PUB. 5-3-2011. INT. CL. 14.
- FANTASY STAGE PRODUCTIONS, INC, MONTECITO, CA:
 3,998,414, INT. CL. 16.

FAR WEST NUTRACEUTICALS, HAWTHORNE, CA:
3,999,837, INT. CL. 5.

FARAH, NICK, JR., GAINESVILLE, FL:
2,402,325, CANC. INT. CL. 29.

FARJAH, HIRBOD, DORTMUND, FED REP GERMANY:
3,998,064, PUB. 5-3-2011. MULTIPLE CLASS, INT. CLS. 9
AND 25.

FARLEY'S & SATHERS CANDY COMPANY, INC., ROUND
LAKE, MN:
3,999,692, INT. CL. 30.

FAROUK SYSTEMS, INC., HOUSTON, TX:
3,998,630, INT. CL. 11.
3,999,276, INT. CL. 3.

FARRAN MEDIA, L.L.C., PHOENIX, AZ:
3,997,023, PUB. 5-3-2011. INT. CL. 35.

FASHION WORLD, INC., BEVERLY HILLS, CA, DBA
BIJAN:
3,996,109, PUB. 5-3-2011. INT. CL. 14.

FAST RETAILING CO., LTD., JAPAN:
3,995,924, PUB. 5-3-2011. INT. CL. 25.
3,995,932, PUB. 5-3-2011. MULTIPLE CLASS, INT. CLS. 9,
18 AND 25.

FASTRACK RIDERS ASSOCIATION, LLC, SAN JUAN
CAPISTRANO, CA:
2,901,107, CANC. MULTIPLE CLASS, INT. CLS. 35 AND
41.

FAT CHANCE FILMS, LLC, NEW YORK, NY:
2,902,458, CANC. INT. CL. 41.

FAT FISH APPS, INC., SOUTH JORDAN, UT:
3,996,359, PUB. 11-23-2010. INT. CL. 9.

FATSEAS, TONY, COOGEE NSW, AUSTRALIA:
3,996,839, PUB. 5-3-2011. INT. CL. 28.
3,996,899, PUB. 5-3-2011. INT. CL. 28.

FD MANAGEMENT, INC., STAMFORD, CT, UNOPCO SUB,
INC., NEW YORK, NY:
1,649,230. REN. 6-13-11. INT. CL. 3.
1,656,519. REN. 6-13-11. MULTIPLE CLASS, INT. CLS. 14
AND 18.

FEATHERBROOKE INC, RANCHO SANTA FE, CA:
3,999,766, INT. CL. 16.

FEDERAL CARTRIDGE COMPANY, ANOKA, MN:
2,401,619, CANC. INT. CL. 13.

FEDERAL HOME LOAN MORTGAGE CORPORATION,
MCLEAN, VA:
2,402,505, CANC. INT. CL. 36.

FEDERAL MARKETING CORP., UPPLE SADDLE RIVER,
NJ:
3,997,194, PUB. 5-3-2011. INT. CL. 35.

FEDERAL RESOURCES SUPPLY COMPANY, STEVENS-
VILLE, MD, DBA FEDERAL RESOURCES:
2,544,819. REN. 6-14-11. INT. CL. 35.

FEDERAL-MOGUL POWERTRAIN, INC., SOUTHFIELD,
MI, FEDERAL-MOGUL SYSTEMS PROTECTION GROUP,
INC., EXTON, PA:
2,404,610. REN. 6-16-11. INT. CL. 17.

FEDERATED MUTUAL INSURANCE COMPANY, OWA-
TONNA, MN:
1,653,345. REN. 6-16-11. INT. CL. 36.

FEDWAY ASSOCIATES, INC., KEARNY, NJ:
3,999,746, INT. CL. 33.

FEE TECHNOLOGY INC., TULSA, OK:
3,997,521, PUB. 5-3-2011. INT. CL. 9.

FEHRMANN KSCHUK SERVICES LLC, MIDLOTHIAN, VA:
3,998,181, PUB. 5-3-2011. INT. CL. 9.

FEI COMMUNICATIONS, INC., MITCHEL FIELD, NY:
2,476,907. REN. 6-15-11. INT. CL. 9.

FELTREX, S.A., SANTO DOMINGO, R.D., DOMINICAN
REP:
2,900,988, CANC. INT. CL. 5.

FENG, KEVIN, LOS ANGELES, CA AND CHOI, STEPHEN,
LOS ANGELES, CA:
3,997,024, PUB. 5-3-2011. INT. CL. 41.

FENNER U.S., INC., MANHEIM, PA:
2,461,466. REN. 6-15-11. INT. CL. 7.

FERGUSON ENTERPRISES, INC., NEWPORT NEWS, VA:
3,996,094, PUB. 5-3-2011. INT. CL. 3.
3,998,689, INT. CL. 11.
3,998,690, INT. CL. 21.

FERGUSON, THOMAS, MISSION HILLS, CA:
2,901,791, CANC. INT. CL. 25.

FERI CORP., NEW YORK, NY:
2,401,511, CANC. MULTIPLE CLASS, INT. CLS. 9, 35
AND 36.

FERMACTIVE LLC, MANHATTAN BEACH, CA:
3,999,446, INT. CL. 5.

FERRARI S.P.A., I-41100 MODENA, ITALY:
3,995,738, PUB. 5-3-2011. MULTIPLE CLASS, INT. CLS. 9,
12, 25, 28, 35, 37 AND 42.

FERRERO S.P.A., ALBA, CUNEO, ITALY:
2,901,144, CANC. INT. CL. 30.

FESTIVAL FUN PARKS, LLC, NEWPORT BEACH, CA:
3,998,248, PUB. 5-3-2011. INT. CL. 41.
3,998,249, PUB. 5-3-2011. INT. CL. 41.

FEVER, USA, FLEMINGTON, NJ:
2,901,577, CANC. INT. CL. 28.

FIAT AUTO S.P.A., TORINO, ITALY:
3,995,584, PUB. 5-3-2011. INT. CL. 12.

FIBA; FÉDÉRATION INTERNATIONALE DE BASKET-
BALL, SWITZERLAND:
3,995,767, PUB. 5-3-2011. MULTIPLE CLASS, INT. CLS.
25, 28, 35, 38 AND 41.

FIBAR INC., ARMONK, NY:
2,901,880, CANC. INT. CL. 16.

FIDELITY BANK CORPORATION, WICHITA, KS, DBA
FIDELITY BANK:
3,997,087, PUB. 5-3-2011. INT. CL. 36.

FIELDS, RICHARD, STOCKTON, CA, DBA R&H ENTER-
TAINMENT:
3,999,994, INT. CL. 25.

FIFTH STREET CAPITAL LLC, WHITE PLAINS, NY:
3,996,762, PUB. 5-3-2011. INT. CL. 36.

FIFTH THIRD PROCESSING SOLUTIONS, LLC, CINCIN-
NATI, OH:
2,902,259, CANC. INT. CL. 36.

FIGGINS, DESMOND DECHONE, BROOKLYN, NY:
3,998,307, INT. CL. 36.

FIGMENT MEDIA LLC, GLEN RIDGE, NJ:
3,995,702, PUB. 5-3-2011. MULTIPLE CLASS, INT. CLS.
35, 41 AND 42.

FILEFRONT, LLC, LOS ANGELES, CA:
3,997,191, PUB. 5-3-2011. INT. CL. 41.

FILER ENTERPRISES LLC, PLYMOUTH, MN:
3,962,386, COR. MULTIPLE CLASS, INT. CLS. 16, 25, 35,
40 AND 41.

FILTER PLATFORMS, INC., LOS ANGELES, CA:
3,997,997, PUB. 5-3-2011. INT. CL. 42.

FINANCIAL SHOWS INC., ROCKVILLE, MD:
3,999,829, INT. CL. 5.

FINANCIAL TRENDS LLC, SILVERTON, OR:
3,999,932, MULTIPLE CLASS, INT. CLS. 35 AND 41.

FINCH MANAGEMENT & INVESTMENT, INC., HOUSTON,
TX:
3,998,033, PUB. 5-3-2011. INT. CL. 35.

FINCOR HOLDINGS, INC., LANSING, MI:
2,565,897. REN. 6-15-11. INT. CL. 36.

FINDBASE, LLC, TWAIN HARTE, CA:
2,902,162, CANC. INT. CL. 9.

FINE AGROCHEMICALS LIMITED, WHITTINGTON, WOR-
CESTER, UNITED KINGDOM:
3,997,958, PUB. 5-3-2011. INT. CL. 1.

FINE LINE COLLISION CENTER, LLC, MIAMI, FL:
3,997,678, PUB. 5-3-2011. INT. CL. 37.

FINET.COM, INC, WALNUT CREEK, CA:
2,402,186, CANC. INT. CL. 36.

FINTUBE, LLC, TULSA, OK:
2,496,305. REN. 6-15-11. INT. CL. 11.

FIO CONSULTING, INC., WILLIAMS BAY, WI:
3,998,818, INT. CL. 42.

FIORE LLC, BASS HARBOR, ME:
3,997,364, PUB. 5-3-2011. INT. CL. 35.

FIREADY INC., CLAIR, NB, CANADA:
2,459,527. REN. 6-14-11. INT. CL. 4.

FIRESTONE BUILDING PRODUCTS COMPANY, LLC, IN-
DIANAPOLIS, IN:
3,999,801, INT. CL. 17.

- FIRESTONE WALKER LLC, BUELLTON, CA:
3,996,999, PUB. 5-3-2011. INT. CL. 32.
- FIRST ACT., INC., NEWTON, MA:
2,902,067, CANC. MULTIPLE CLASS, INT. CLS. 9 AND 15.
- FIRST AMERICAN FINANCIAL CORPORATION, SANTA ANA, CA:
2,901,766, CANC. INT. CL. 36.
- FIRST CHOICE MELON GROWERS, LLC, TIFTON, GA:
3,999,046, INT. CL. 31.
- FIRST HAWAIIAN BANK, HONOLULU, HI:
2,468,138, REN. 6-16-11. INT. CL. 36.
- FIRST RISE, LLC, WINOOSKI, VT:
3,997,908, PUB. 5-3-2011. INT. CL. 16.
- FIRST SCIENTIFIC DENTAL GMBH, FED REP GERMANY:
3,995,782, PUB. 5-3-2011. INT. CL. 5.
- FIRSTTECH, LLC, KENT, WA:
3,999,074, INT. CL. 9.
- FISHER & PAYKEL HEALTHCARE LIMITED, EAST TAMAKI, AUCKLAND, NEW ZEALAND:
2,901,921, CANC. INT. CL. 10.
- FISHER & PAYKEL LIMITED, EAST TAMAKI, AUCKLAND, NEW ZEALAND:
2,459,989, REN. 6-10-11. INT. CL. 7.
- FISHER FARMS, INC., BULACAN, PHILIPPINES:
3,999,386, INT. CL. 29.
- FISHER HAMILTON L.L.C., TWO RIVERS, WI:
3,997,919, PUB. 5-3-2011. INT. CL. 9.
- FISHER, FREDRICK, GREENSBORO, NC:
3,997,463, PUB. 5-3-2011. INT. CL. 41.
- FISHER, MICHAEL, COGGON, IA:
2,902,354, CANC. INT. CL. 4.
- FISHERMAN'S SUPPLY OF FLORIDA, INC., DAVIE, FL:
2,901,320, CANC. INT. CL. 28.
- FITDOG SPORTS CLUB, SANTA MONICA, CA:
3,996,985, PUB. 5-3-2011. INT. CL. 43.
- FITFLOP LIMITED, UNITED KINGDOM:
3,996,004, PUB. 5-3-2011. INT. CL. 25.
- FITNESS BRANDS 2, LLC, AUSTIN, TX:
3,999,366, INT. CL. 28.
- FIT360, LLC, PROVO, UT:
3,998,654, MULTIPLE CLASS, INT. CLS. 41 AND 44.
- FIVE NINJAS MARTIAL ARTS, MINNEAPOLIS, MN, DBA KNOCKOUT BODIES:
3,998,115, PUB. 5-3-2011. INT. CL. 41.
- FIX, JAMES JEROME, LINCOLN, NE:
2,401,611, CANC. INT. CL. 35.
- FIXED INCOME LIVE, LP, ORANGE, CA:
3,997,329, PUB. 5-3-2011. INT. CL. 36.
- FLAGEOLI, LTD., LAS VEGAS, NV:
2,902,296, CANC. INT. CL. 5.
- FLAT EARTH HOLDINGS, LLC, ST. PAUL, MN:
3,997,562, PUB. 5-3-2011. INT. CL. 32.
3,997,566, PUB. 5-3-2011. INT. CL. 32.
3,997,569, PUB. 5-3-2011. INT. CL. 32.
- FLAVOR HOUSE INC, ADELANTO, CA AND RICHARD G. STALEY, ADELANTO, CA:
3,999,706, INT. CL. 30.
- FLAXINGTON, BEVERLY, WALPOLE, MA:
3,996,546, PUB. 5-3-2011. INT. CL. 35.
- FLEMISH LION LLC, HERNDON, VA:
3,996,988, PUB. 5-3-2011. INT. CL. 33.
- FLEXBIMEC INTERNATIONAL S.R.L., ALBINEA (REGGIO EMILIA), ITALY:
2,451,504, REN. 6-13-11. MULTIPLE CLASS, INT. CLS. 6, 7 AND 9.
- FLEXTANK INTERNATIONAL LTD, ABBOTSFORD 3067, AUSTRALIA:
3,999,025, INT. CL. 20.
- FLEXWARE INTERNATIONAL LLC, LOS ANGELES, CA:
3,997,685, PUB. 5-3-2011. INT. CL. 9.
- FLIGHTSAFETY DEVELOPMENT CORP., LAS VEGAS, NV:
3,999,954, INT. CL. 41.
- FLIR SYSTEMS, INC., WILSONVILLE, OR:
2,902,066, CANC. INT. CL. 9.
- FLITCHAM LIMITED, LONDON, WC2A 3LH, UNITED KINGDOM:
2,901,462, CANC. INT. CL. 24.
- FLOORTEX EUROPE LIMITED, GLOUCESTERSHIRE, UNITED KINGDOM:
3,995,501, PUB. 5-3-2011. INT. CL. 27.
3,995,502, PUB. 5-3-2011. INT. CL. 27.
3,995,503, PUB. 5-3-2011. INT. CL. 27.
3,995,504, PUB. 5-3-2011. INT. CL. 16.
3,995,505, PUB. 5-3-2011. INT. CL. 27.
3,995,506, PUB. 5-3-2011. INT. CL. 27.
3,995,507, PUB. 5-3-2011. INT. CL. 27.
- FLORES, JENNIFER J., PARENT OF ALEXANDRA FLORES, APPLE VALLEY, CA:
4,000,034, INT. CL. 14.
- FLORIDA FAMILY INSURANCE SERVICES, LLC, BONITA SPRINGS, FL:
3,997,657, PUB. 5-3-2011. INT. CL. 36.
3,997,658, PUB. 5-3-2011. INT. CL. 36.
3,997,659, PUB. 5-3-2011. INT. CL. 36.
- FLORISTS' TRANSWORLD DELIVERY, INC., DOWNERS GROVE, IL:
3,999,887, MULTIPLE CLASS, INT. CLS. 31 AND 35.
3,999,888, MULTIPLE CLASS, INT. CLS. 31 AND 35.
3,999,889, MULTIPLE CLASS, INT. CLS. 31 AND 35.
3,999,890, MULTIPLE CLASS, INT. CLS. 31 AND 35.
- FLOW TRADERS B.V., NETHERLANDS:
3,995,866, PUB. 5-3-2011. MULTIPLE CLASS, INT. CLS. 36 AND 38.
- FLOWERS BAKERIES BRANDS, LLC, THOMASVILLE, GA, FLOWERS INDUSTRIES, INC., THOMASVILLE, GA:
1,181,385, REN. 6-15-11. INT. CL. 30.
- FLOWERS TODAY, INC., HAYMARKET, VA:
3,997,640, PUB. 5-3-2011. INT. CL. 35.
- FLOXITE COMPANY, INC, MAHWAY, NJ:
2,513,963, REN. 6-16-11. INT. CL. 20.
- FLUIDRA COMMERCIAL, S.A.U., SPAIN:
3,995,793, PUB. 5-3-2011. MULTIPLE CLASS, INT. CLS. 11, 37 AND 44.
- FLUKE CORPORATION, EVERETT, WA, ITT CORPORATION, NEW YORK, NY:
1,649,366, REN. 6-14-11. INT. CL. 9.
- FLUKE CORPORATION, EVERETT, WA:
2,565,077, REN. 6-10-11. INT. CL. 9.
3,999,022, INT. CL. 9.
3,999,635, INT. CL. 9.
- FLYING PASTIES INTERNATIONAL LLC, LAS VEGAS, NV:
3,996,425, PUB. 5-3-2011. INT. CL. 25.
- FMI PRODUCTS, LLC, SANTA ANA, CA:
3,999,217, MULTIPLE CLASS, INT. CLS. 11 AND 19.
- FMR LLC, BOSTON, MA:
2,902,304, CANC. INT. CL. 36.
3,998,935, INT. CL. 36.
- FNC, INC., OXFORD, MS:
3,997,245, PUB. 5-3-2011. INT. CL. 35.
- FOCUS HEALTHCARE GROUP, LLC, FORT COLLINS, CO:
3,997,111, PUB. 5-3-2011. INT. CL. 35.
- FOCUS SURGERY, INC., INDIANAPOLIS, IN:
2,948,572, COR. INT. CL. 10.
- FOCUSED MARKETING SOLUTIONS, INC., TOMS RIVER, NJ:
3,996,555, PUB. 5-3-2011. INT. CL. 35.
- FOCUSEDBUYER LLC, EASTON, PA:
3,997,415, PUB. 5-3-2011. MULTIPLE CLASS, INT. CLS. 35 AND 42.
- FOLEY, PATRICK, AMES, IA:
3,996,207, PUB. 5-3-2011. INT. CL. 9.
- FONDATION OUADJET, B-7000 MONS, BELGIUM:
3,995,892, PUB. 5-3-2011. INT. CL. 41.
- FONT DINER, INC., EAU CLAIRE, WI:
3,998,214, PUB. 5-3-2011. INT. CL. 9.
3,998,215, PUB. 5-3-2011. INT. CL. 9.
3,998,216, PUB. 5-3-2011. INT. CL. 9.
- FONTAINE, LAURIE L., PHOENIX, AZ:
2,902,373, CANC. INT. CL. 26.
- FOO, KAM, NEWPORT BEACH, CA:
2,901,069, CANC. INT. CL. 25.
- FOOD BANK OF SOUTH JERSEY, INC., PENNSAUKEN, NJ:
3,998,295, PUB. 5-3-2011. INT. CL. 43.
- FOOD FITNESS FIRST, INC., VIDALIA, GA:
3,996,772, PUB. 5-3-2011. INT. CL. 44.

FOOT PETALS, PICKERINGTON, OH:
3,995,621, PUB. 5-3-2011. INT. CL. 41.

FOR MY MOM, LLC, LOS ANGELES, CA:
2,452,075. REN. 6-16-11. INT. CL. 10.

FOR SALE BY BUILDER AND OWNER, INC., RALEIGH,
NC:
3,996,663, PUB. 5-3-2011. INT. CL. 35.

FORBES, CHRISTOPHER ALLAN, WICHITA, KS:
3,998,391, INT. CL. 9.

FORBIDDEN WHEELS M.C. INC., DETROIT, MI:
3,996,632, PUB. 5-3-2011. U.S. CL. 200.

FORCE AMERICA INC., BURNSVILLE, MN, FORCE
AMERICA INC., BURNSVILLE, MN:
2,498,552. REN. 6-15-11. INT. CL. 7.

FORD MOTOR COMPANY, DEARBORN, MI:
2,902,201, CANC. INT. CL. 12.
3,998,899, INT. CL. 9.

FORDHAM, PAT, SALT LAKE CITY, UT:
3,998,358, INT. CL. 16.

FOREFRONT LLC, KIRKLAND, WA:
3,996,411, PUB. 5-3-2011. INT. CL. 11.

FORENSIC SOFTWARE LIMITED, SURREY, UNITED
KINGDOM:
2,402,323, CANC. INT. CL. 9.

FOREVER RESORTS, LLC, SCOTTSDALE, AZ:
2,901,300, CANC. MULTIPLE CLASS, INT. CLS. 35, 39, 41
AND 43.

FOREVER YOUNG INTERNATIONAL, INC., ESCONDIDO,
CA:
3,998,050, PUB. 5-3-2011. MULTIPLE CLASS, INT. CLS. 3
AND 10.

FORGIE, ELAYNE, LAKE WORTH, FL:
3,996,736, PUB. 5-3-2011. INT. CL. 44.

FORM FACTOR PTY LTD, ST KILDA VIC 3182, AUSTRA-
LIA:
3,995,963, PUB. 5-3-2011. INT. CL. 42.

FORMISANO LAURENT, SPAIN:
3,995,976, PUB. 5-3-2011. INT. CL. 14.

FORMS AND SURFACES, INC., PITTSBURGH, PA:
3,998,898, MULTIPLE CLASS, INT. CLS. 6, 7, 9 AND 11.

FORT WAYNE PROFESSIONAL BASEBALL, LLC, ATLAN-
TA, GA:
2,401,573, CANC. MULTIPLE CLASS, INT. CLS. 16 AND
25.

FORTIER, CARLOS R., MIDLOTHIAN, VA:
3,998,162, PUB. 5-3-2011. INT. CL. 5.

FORTUNY INC., NEW YORK, NY:
3,998,428, INT. CL. 18.

FORUM FOR WOMEN ENTREPRENEURS, SAN MATEO,
CA:
2,901,456, CANC. INT. CL. 35.

FORUM SYSTEMS, INC., WESTWOOD, MA:
2,901,998, CANC. INT. CL. 9.

FORWARD THINKING STRATEGIES, LLC, WASHING-
TON, DC:
3,998,628, INT. CL. 35.

FORZIATI, JOE, BURLINGTON, VT AND JARRETT,
TRISHA, BURLINGTON, VT:
2,902,073, CANC. INT. CL. 30.

FOSSIL SOFTWARE, ROCKWALL, TX:
3,997,114, PUB. 5-3-2011. INT. CL. 9.

FOSTER, JAMES E., ARLINGTON, TX, DBA JLD INDUS-
TRIES:
2,902,360, CANC. INT. CL. 20.

FOSTERQUAN, LLP, HOUSTON, TX:
3,996,773, PUB. 5-3-2011. INT. CL. 45.

FOTOLIA LLC, NEW YORK, NY:
3,997,923, PUB. 5-3-2011. MULTIPLE CLASS, INT. CLS. 9,
35, 38, 42 AND 45.
3,997,928, PUB. 5-3-2011. MULTIPLE CLASS, INT. CLS. 9,
35, 38, 42 AND 45.

FOX RUN GOLF CLUB, INC., EUREKA, MO:
2,459,715. REN. 6-15-11. INT. CL. 41.

FOXPRO, INC., LEWISTOWN, PA:
3,997,300, PUB. 5-3-2011. INT. CL. 28.

FR CAPITAL HOLDINGS, L.P., WEST CONSHOCKEN,
PA:
3,996,938, PUB. 5-3-2011. INT. CL. 36.

FRABILL, INC., JACKSON, WI:
3,999,586, INT. CL. 25.

FRANCESCHELLI, CHRISTOPHER M., BROOKLYN, NY:
2,451,452. REN. 6-14-11. INT. CL. 16.

FRANCZEK, WILLIAM E., NORFOLK, VA:
3,997,268, PUB. 5-3-2011. INT. CL. 35.

FRANK BRUNCKHORST CO., L.L.C., BROOKLYN, NY:
2,902,462, CANC. INT. CL. 29.

FRANK DE LA OLIVA & OBED ELI LIMONTE PARTNER-
SHIP, THE, MIAMI, FL:
2,901,939, CANC. MULTIPLE CLASS, INT. CLS. 7 AND
12.

FRANKLIN COVEY, CO., SALT LAKE CITY, UT:
3,998,159, PUB. 5-3-2011. MULTIPLE CLASS, INT. CLS. 16
AND 41.

FRANKLIN INSTITUTE, THE, PHILADELPHIA, PA:
3,998,482, INT. CL. 16.

FRANKLIN LEARNING SYSTEMS, INC., WESTPORT, CT:
2,401,588, CANC. INT. CL. 28.

FRANKLIN SPORTS, INC., STOUGHTON, MA:
3,999,755, INT. CL. 28.

FRED MEYER JEWELERS, INC., PORTLAND, OR, LITT-
MAN JEWELERS, INC., HIGHLAND PARK, NJ:
1,191,876. REN. 6-15-11. INT. CL. 42.

FRED WEHREBERG CIRCUIT OF THEATRES, INC., ST.
LOUIS, MO:
3,997,519, PUB. 5-3-2011. INT. CL. 41.

FREDERICK, TANNA, LOS ANGELES, CA:
3,997,139, PUB. 5-3-2011. INT. CL. 36.

FREEMPORT-MCMORAN COPPER & GOLD INC., PHOENIX,
AZ:
3,996,262, PUB. 5-3-2011. INT. CL. 6.
3,996,263, PUB. 5-3-2011. INT. CL. 6.
3,996,264, PUB. 5-3-2011. INT. CL. 6.
3,997,089, PUB. 5-3-2011. INT. CL. 1.

FREEMWAY INSURANCE SERVICES, INC., CYPRESS, CA:
3,996,168, PUB. 5-3-2011. INT. CL. 36.

FREIEZO LLC, SAINT PETERS, MO:
3,998,803, INT. CL. 7.

FRESENIUS KABI AG, FED REP GERMANY:
3,996,030, PUB. 5-3-2011. INT. CL. 5.

FRESH LIFELINES FOR YOUTH, INC., SAN JOSE, CA:
3,996,545, PUB. 5-3-2011. MULTIPLE CLASS, INT. CLS. 35
AND 36.

FREUND, LILY, EMERYVILLE, CA:
3,996,508, PUB. 5-3-2011. INT. CL. 35.

FRIEDMAN, NEIL, WESTPORT, CT:
2,902,416, CANC. INT. CL. 4.

FRIEDRICH STAHL GMBH & CO.KG, 75217 BIRKENFELD,
FED REP GERMANY:
2,901,116, CANC. INT. CL. 14.

FRIENDSCOOK INC., BELMONT, CA:
3,998,070, PUB. 5-3-2011. INT. CL. 43.

FRIESENS CORPORATION, ALTONA, MB, CANADA:
3,998,515, MULTIPLE CLASS, INT. CLS. 16 AND 40.

FRITO-LAY NORTH AMERICA, INC., PLANO, TX:
3,995,675, PUB. 1-25-2011. INT. CL. 30.
3,998,800, INT. CL. 29.

FRITSCHER, JOHN, SEBASTOPOL, CA:
2,516,901. REN. 6-14-11. INT. CL. 9.
2,516,901, CANC. MULTIPLE CLASS, INT. CLS. 35 AND
41.

FRONTIER COMMUNICATIONS CORPORATION, STAM-
FORD, CT:
3,998,365, INT. CL. 38.

FRONTLINE TECHNOLOGIES, INC., EXTON, PA:
2,513,909. REN. 6-14-11. INT. CL. 9.

FROST, JAMES A., OOLTEWAH, TN, DBA FROST CUT-
LERY:
3,996,360, PUB. 5-3-2011. INT. CL. 8.

FRUIT OF THE LOOM, INC., BOWLING GREEN, KY:
2,901,844, CANC. INT. CL. 25.

FRY LABORATORIES, LLC, SCOTTSDALE, AZ:
2,901,252, CANC. INT. CL. 5.

FRYMAKORUMA GMBH, D-79395 NEUENBURG, FED REP
GERMANY:
1,620,850, CANC. INT. CL. 7.

- FRYMIRE, JULIE L., PETALUMA, CA, DBA INTELLEWEB SOURCES:
3,996,770, PUB. 5-3-2011. INT. CL. 42.
- FSHS OF SOUTH FLORIDA, INC., HOLLYWOOD, FL:
3,998,147, PUB. 5-3-2011. INT. CL. 4.
- FSI FONTSHOP INTERNATIONAL GMBH, BERLIN, FED REP GERMANY:
3,996,509, PUB. 5-3-2011. MULTIPLE CLASS, INT. CLS. 9 AND 16.
- FTF SWEETS LTD, BOLTON, LANCASHIRE, UNITED KINGDOM:
3,996,273, PUB. 5-3-2011. INT. CL. 30.
- FU WONG, OAKLAND, CA:
3,997,212, PUB. 5-3-2011. INT. CL. 35.
- FUELBELT, INC., WARREN, RI:
3,997,909, PUB. 5-3-2011. INT. CL. 21.
3,997,910, PUB. 5-3-2011. INT. CL. 21.
3,997,911, PUB. 5-3-2011. INT. CL. 21.
- FUJI SILYSIA CHEMICAL LTD., KASUGAI-SHI, AICHI-KEN, JAPAN:
3,998,524, INT. CL. 9.
- FUJITSU TEN LIMITED, KOBI-SHI, HYOGO-KEN, JAPAN:
3,995,563, PUB. 1-25-2011. INT. CL. 41.
- FULCRUM NETWORK, INC., NAPERVILLE, IL:
3,999,756, INT. CL. 41.
- FULCRUM SUSPENSIONS PTY LTD, AUSTRALIA:
3,995,778, PUB. 3-29-2011. INT. CL. 12.
- FULL SAIL, LLC, WINTER PARK, FL:
3,998,590, INT. CL. 38.
- FURNESH, INC., MARBLEHEAD, MA:
3,998,773, INT. CL. 35.
- FURNITURE ROW, LLC, DENVER, CO:
3,999,130, INT. CL. 35.
- FUSIAK, DAVID, GARRISON, NY:
2,902,383, CANC. INT. CL. 37.
- FUSSION DRINKS, S.L., MARRATXY, BALEARES, SPAIN:
3,999,458, INT. CL. 33.
- FUTAI, INC. (USA), EDISON, NJ:
3,997,717, PUB. 5-3-2011. INT. CL. 18.
- FUTURE FOAM, INC., COUNCIL BLUFFS, IA:
2,402,576, CANC. INT. CL. 37.
- FUTURE MASTER INTERNATIONAL LTD, NORTH POINT, HONG KONG:
3,998,073, PUB. 5-3-2011. INT. CL. 9.
- F3M3 COMPANIES, INC., MIRAMAR, FL:
3,997,516, PUB. 5-3-2011. INT. CL. 9.
- F4 SHOWBINE, LLC, WILMINGTON, DE:
3,996,398, PUB. 5-3-2011. INT. CL. 41.
- G & R BRANDS, LLC, LAS VEGAS, NV:
3,998,449, INT. CL. 34.
- G W PLASTICS, INC., BETHEL, VT:
3,996,826, PUB. 5-3-2011. MULTIPLE CLASS, INT. CLS. 40 AND 42.
3,999,149, INT. CL. 42.
- G.T.S. CORPORATION PTY LTD, MIDVALE WA 6056, AUSTRALIA:
3,996,116, PUB. 5-3-2011. MULTIPLE CLASS, INT. CLS. 42 AND 45.
- GABBACADABRA LLC, SHERMAN OAKS, CA:
3,998,373, INT. CL. 9.
- GAIAM AMERICAS, INC., BROOMFIELD, CO:
2,902,208, CANC. INT. CL. 41.
- GAIAM AMERICAS, INC., LOUISVILLE, CO:
3,996,936, PUB. 5-3-2011. INT. CL. 9.
- GAINES GROUP LLC, HOUSTON, TX:
3,998,883, MULTIPLE CLASS, INT. CLS. 3, 4 AND 11.
- GAJIC, MOMIR, CHICAGO, IL:
3,997,106, PUB. 5-3-2011. INT. CL. 35.
- GAKM RESOURCES LLC, NEWTON, NC:
3,998,826, INT. CL. 25.
3,998,828, INT. CL. 25.
3,998,887, INT. CL. 25.
- GALAXY WEB DESIGNS, LLC, COLLEYVILLE, TX, DBA BABYOSO.COM:
3,996,344, PUB. 5-3-2011. INT. CL. 18.
- GALLOWAY, SHAMARO N., JACKSON, MS, DBA UNIK PARTIES & MORE, SOLE PROPRIETORSHIP OF MISSISSIPPI:
3,996,682, PUB. 5-3-2011. INT. CL. 35.
- GAM AUDY, SAINT GERMAIN DU PUCH, FRANCE:
2,901,583, CANC. INT. CL. 33.
- GAMCO INVESTORS, INC., RYE, NY:
3,999,204, INT. CL. 36.
- GAME SHOW NETWORK, LLC, SANTA MONICA, CA:
3,999,277, INT. CL. 41.
- GAME WARDEN, LLC, INDIANAPOLIS, IN:
2,401,704, CANC. MULTIPLE CLASS, INT. CLS. 25 AND 41.
- GAMESTOP, INC., GRAPEVINE, TX:
2,902,019, CANC. INT. CL. 35.
- GAMETIME LIGHTS, LLC, POWELL, TN:
3,996,865, PUB. 5-3-2011. INT. CL. 11.
- GAPWORK CONSULTING LLC, ST. PAUL, MN:
3,996,973, PUB. 5-3-2011. INT. CL. 35.
- GARAN SERVICES CORP., NEW YORK, NY:
3,999,169, INT. CL. 25.
3,999,170, INT. CL. 25.
3,999,171, INT. CL. 25.
- GARDEN MAGIC, LLLP, LONGMONT, CO:
3,998,599, INT. CL. 20.
- GARDNER DENVER, INC., QUINCY, IL:
2,901,819, CANC. MULTIPLE CLASS, INT. CLS. 7 AND 37.
- GARDNER, DIANA J., KAPAA, HI:
3,997,423, PUB. 5-3-2011. INT. CL. 41.
- GARNER, JASON, SAN JOSE, CA:
2,901,213, CANC. INT. CL. 41.
- GARRANA, RANDA M.R., M.D., APC, LONG BEACH, CA, DBA PREMIER LASER SIGHT:
2,901,016, CANC. INT. CL. 42.
- GARTMORE INVESTMENT MANAGEMENT PLC, LONDON, UNITED KINGDOM:
2,901,036, CANC. INT. CL. 36.
- GARTNER, INC., STAMFORD, CT:
3,999,786, INT. CL. 9.
3,999,787, INT. CL. 42.
3,999,790, INT. CL. 9.
3,999,791, INT. CL. 42.
- GARY AND MARY WEST WIRELESS HEALTH INSTITUTE, LA JOLLA, CA:
3,999,920, INT. CL. 42.
- GARY ROSENTHAL COLLECTION, INC., KENSINGTON, MD:
2,901,371, CANC. INT. CL. 28.
- GARZA, CARLOS, SPRINGFIELD, VA AND O'MEARA, RICH, SILVER SPRING, MD:
3,997,544, PUB. 5-3-2011. MULTIPLE CLASS, INT. CLS. 9 AND 41.
- GATEFRONT, LLC, COLLIERVILLE, TN:
3,998,909, MULTIPLE CLASS, INT. CLS. 1 AND 39.
- GATEWAY INDUSTRIAL PRODUCTS, INC, ELYRIA, OH:
2,901,784, CANC. INT. CL. 19.
- GATEWAY MANUFACTURING, INC., MT. STERLING, KY:
3,996,341, PUB. 5-3-2011. MULTIPLE CLASS, INT. CLS. 6 AND 19.
- GATEWAY, INC., IRVINE, CA TO ACER INCORPORATED, TAIPEI, TAIWAN:
2,402,485, CANC. MULTIPLE CLASS, INT. CLS. 9 AND 35.
- GATOR LURES, LLC, MILLINGTON, NJ:
3,996,213, PUB. 5-3-2011. INT. CL. 28.
- GAVEL BABBLE INC., DORAL, FL:
3,997,605, PUB. 5-3-2011. INT. CL. 41.
- GAYAM, NAVEEN, IRVINE, CA:
3,999,026, INT. CL. 35.
- GAYLA INDUSTRIES, HOUSTON, TX:
2,447,400, REN. 6-14-11. INT. CL. 28.
- GAYLORD ENTERTAINMENT COMPANY, NASHVILLE, TN:
3,999,734, INT. CL. 41.
- GAYMAR INDUSTRIES, INC., ORCHARD PARK, NY:
3,996,388, PUB. 5-3-2011. INT. CL. 10.

- GB II CORPORATION, TUALATIN, OR, DBA COLUMBIA RIVER KNIFE & TOOL COMPANY:
3,998,532, INT. CL. 8.
- GCT 11 SOLUTIONS & ENTERPRISES LTD., TORONTO, ONTARIO, CANADA:
2,901,473, CANC. MULTIPLE CLASS, INT. CLS. 9, 16, 20 AND 42.
- GE HEALTHCARE UK LIMITED, BUCKINGHAMSHIRE, UNITED KINGDOM:
2,457,303, REN. 6-15-11, INT. CL. 1.
- GEA PROCESS ENGINEERING A/S, DK-2860 SØBORG, DENMARK:
3,995,879, PUB. 5-3-2011, MULTIPLE CLASS, INT. CLS. 6, 7, 11, 37 AND 42.
- GEBR. KREMERS GMBH, NEUKIRCHEN-VLUYN, FED REP GERMANY:
2,902,386, CANC. INT. CL. 20.
- GEBR. WILLACH GMBH, 53809 RUPPICHTEROTH, FED REP GERMANY:
2,901,920, CANC. MULTIPLE CLASS, INT. CLS. 6 AND 20.
- GECCO VISION, LOS ANGELES, CA:
3,996,356, PUB. 5-3-2011, INT. CL. 28.
- GEERT BOLLEN, UNITED KINGDOM:
3,995,788, PUB. 1-25-2011, MULTIPLE CLASS, INT. CLS. 39 AND 41.
- GEHRKE, GLADYS M., ASOTIN, WA, DBA GEHRKE'S GINK:
2,402,216, CANC. INT. CL. 28.
- GEIGER GMBH, A-6130 VOMP/SCHWAZ, AUSTRIA:
2,511,506, REN. 6-11-11, INT. CL. 25.
2,511,506, CANC. MULTIPLE CLASS, INT. CLS. 18 AND 24.
- GEISINGER INDEMNITY INSURANCE COMPANY, DANVILLE, PA:
2,902,017, CANC. INT. CL. 36.
- GENAL STRAP, INC., LONG ISLAND CITY, NY:
3,998,906, INT. CL. 18.
- GENCOURSE, LLC, CORAL GABLES, FL:
2,902,322, CANC. INT. CL. 35.
- GENDERS GROUP LAND & TITLE, INC., TAMPA, FL:
3,999,397, INT. CL. 25.
- GENENTECH, INC., SOUTH SAN FRANCISCO, CA:
2,902,231, CANC. MULTIPLE CLASS, INT. CLS. 35 AND 36.
- GENERAL ECOLOGY, INC., EXTON, PA:
2,528,653, REN. 6-16-11, INT. CL. 11.
- GENERAL GROWTH MANAGEMENT, INC., CHICAGO, IL:
3,995,619, PUB. 5-3-2011, INT. CL. 35.
3,995,620, PUB. 5-3-2011, INT. CL. 35.
3,996,225, PUB. 5-3-2011, INT. CL. 28.
- GENERAL HYDROPONICS, INC., SEBASTOPOL, CA:
2,460,063, REN. 6-14-11, INT. CL. 1.
- GENERAL MILLS MARKETING, INC., MINNEAPOLIS, MN:
2,402,748, CANC. INT. CL. 30.
- GENERAL MILLS, INC., MINNEAPOLIS, MN:
550,922, REN. 6-15-11, U.S. CL. 46 (INT. CL. 30).
2,487,666, REN. 6-15-11, INT. CL. 16.
3,996,405, PUB. 5-3-2011, INT. CL. 43.
- GENERAL MOTORS LLC, DETROIT, MI:
2,457,659, REN. 6-15-11, INT. CL. 4.
2,459,749, REN. 6-14-11, INT. CL. 16.
2,461,681, REN. 6-13-11, INT. CL. 18.
2,461,697, REN. 6-12-11, INT. CL. 14.
- GENERAL STEAMSHIP AGENCIES, INC., MILL VALLEY, CA:
2,478,258, REN. 6-14-11, INT. CL. 39.
- GENERATION I.D.E.A., LLC, FARGO, ND, DBA FORMULANOW:
3,998,911, INT. CL. 21.
- GENERATION SEVEN STRATEGIC PARTNERS, LLC, SCOTTSDALE, AZ:
3,996,989, PUB. 5-3-2011, INT. CL. 35.
3,996,991, PUB. 5-3-2011, INT. CL. 35.
- GENERATIONS OF VIRTUE, COLORADA SPRINGS, CO:
2,902,412, CANC. INT. CL. 41.
- GENESIS CAREER SYSTEMS, LLC, SAN DIEGO, CA:
3,996,732, PUB. 5-3-2011, MULTIPLE CLASS, INT. CLS. 9 AND 41.
- GENESIS REHABILITATION SERVICES, INC., KENNETT SQUARE, PA:
3,996,241, PUB. 5-3-2011, INT. CL. 44.
- GENII, INC., WOODBURY, MN:
3,998,471, INT. CL. 10.
- GENLYTE THOMAS GROUP LLC, BURLINGTON, MA:
2,453,443, REN. 6-15-11, INT. CL. 11.
- GENTRY HEATING, INC., SWANNANOVA, NC, DBA ECO-DUCTS ENVIRONMENTAL AIR QUALITY:
3,996,728, PUB. 5-3-2011, INT. CL. 37.
- GEOENERGY ENTERPRISES, LLC, PUTNUM VALLEY, NY:
3,996,042, PUB. 5-3-2011, INT. CL. 11.
- GEOFFREY, LLC, WAYNE, NJ:
3,999,867, INT. CL. 28.
- GEORGE DAVID HOLMES, HENDERSONVILLE, TN:
3,999,568, INT. CL. 21.
- GEORGE, ANGELA, CHICAGO, IL:
3,999,407, INT. CL. 3.
- GEORGE, JAMES, ANAHEIM, CA, DBA INTERNATIONAL NAIL MANUFACTURERS:
2,901,885, CANC. INT. CL. 3.
- GEORGIA CENTER FOR CHILD ADVOCACY, ATLANTA, GA:
4,000,030, INT. CL. 44.
- GEORGIA TECH RESEARCH CORPORATION, ATLANTA, GA:
3,997,130, PUB. 5-3-2011, INT. CL. 9.
- GEORGIA-PACIFIC GYPSUM LLC, ATLANTA, GA:
3,946,623, COR. INT. CL. 19.
- GERBER SCIENTIFIC INTERNATIONAL, INC., SOUTH WINDSOR, CT, GERBER GARMENT TECHNOLOGY, INC., SOUTH WINDSOR, CT:
1,171,987, REN. 6-15-11, INT. CL. 7.
- GERRESHEIMER GLAS GMBH, DUSSELDORF, FED REP GERMANY:
3,995,720, PUB. 5-3-2011, MULTIPLE CLASS, INT. CLS. 6, 9, 10, 20, 21 AND 42.
- GERSON FANY, NEW YORK, NY:
3,999,151, INT. CL. 30.
- GET CLUED IN, LLC, LOS ANGELES, CA:
3,998,965, INT. CL. 9.
- GETAC TECHNOLOGY CORPORATION, HSINCHU, TAIWAN:
3,995,699, PUB. 5-3-2011, INT. CL. 9.
- GETAWAY MEDIA CORP, SAN MARCOS, CA:
3,996,799, PUB. 5-3-2011, INT. CL. 35.
- GETSMART.COM, INC., BURLINGAME, CA TO LENDING-TREE, LLC, CHARLOTTE, NC:
2,402,560, CANC. INT. CL. 36.
- GEVO, INC., ENGLEWOOD, CO:
3,999,250, MULTIPLE CLASS, INT. CLS. 1, 4, 40 AND 42.
- GFI GROUP INC., NEW YORK, NY:
3,998,617, INT. CL. 36.
- GHC SPECIALTY BRANDS, LLC, JANESVILLE, WI:
3,996,495, PUB. 5-3-2011, INT. CL. 17.
3,996,496, PUB. 5-3-2011, INT. CL. 9.
- GHP SYSTEMS, INC., BROOKINGS, SD:
3,999,288, INT. CL. 11.
- GI MILSIM, INC., LACHINE, QUEBEC, CANADA:
3,998,894, INT. CL. 28.
- GIACOMEL, JEFFREY A., ARLINGTON, TX:
2,402,351, CANC. INT. CL. 21.
- GIANNI VERSACE S.P.A., I-20121 MILANO, ITALY:
3,996,031, PUB. 5-3-2011, INT. CL. 9.
- GIANT IMPACT, LLC, SUWANEE, GA:
3,999,229, MULTIPLE CLASS, INT. CLS. 9 AND 16.
- GIBALTAR LABORATORIES, INC., FAIRFIELD, NJ:
3,997,522, PUB. 5-3-2011, INT. CL. 41.
- GIESECKE & DEVRIENT GMBH, D-81677 MUNCHEN, FED REP GERMANY:
2,493,552, REN. 6-15-11, INT. CL. 9.
- GIFTCO, INC., VERNON HILLS, IL:
2,402,441, CANC. INT. CL. 36.

- GIGI OERI, CH-4059 BASEL, SWITZERLAND:
3,995,840, PUB. 5-3-2011. MULTIPLE CLASS, INT. CLS. 36 AND 41.
- GILAD GAD M, RESEDA, CA AND GILAD VARDA, RESEDA, CA:
3,997,624, PUB. 5-3-2011. INT. CL. 5.
- GILLEN, JEFF, TULSA, OK:
3,999,715, INT. CL. 11.
- GILT GROUPE, INC., NEW YORK, NY:
3,998,817, INT. CL. 35.
- GIMBAL BROTHERS, INC., SOUTH SAN FRANCISCO, CA:
3,997,155, PUB. 5-3-2011. INT. CL. 30.
- GINDER GREENHOUSE & GARDEN CENTER, INC., BANGOR, PA:
3,997,109, PUB. 5-3-2011. INT. CL. 35.
- GINOCCHIO, MARK H., ST. PETERSBURG, FL:
2,478,510, REN. 6-10-11. INT. CL. 20.
- GIORRY LIMTED, SLOUGH, UNITED KINGDOM:
3,996,260, PUB. 5-3-2011. INT. CL. 18.
- GIOVANNI BALESTRA & FIGLI S.P.A., ITALY:
3,995,974, PUB. 5-3-2011. INT. CL. 14.
- GIVAUDAN S.A., SWITZERLAND:
3,995,869, PUB. 5-3-2011. MULTIPLE CLASS, INT. CLS. 1 AND 3.
- GLAM GLOBAL, LLC, SPARKS, MD:
3,997,038, PUB. 5-3-2011. INT. CL. 14.
- GLAM MEDIA, INC., BRISBANE, CA:
3,998,707, MULTIPLE CLASS, INT. CLS. 38 AND 41.
- GLASGOW CONSULTING, LLC, WILMINGTON, DE:
2,902,267, CANC. INT. CL. 28.
- GLAXO GROUP LIMITED, MIDDLESEX, UNITED KINGDOM:
2,901,628, CANC. INT. CL. 5.
- GLAXO GROUP LIMITED, GREENFORD, MIDDLESEX, UNITED KINGDOM:
2,901,811, CANC. INT. CL. 5.
2,901,812, CANC. INT. CL. 5.
- GLAZE TERIYAKI LLC, NEW YORK, NY:
3,997,400, PUB. 5-3-2011. INT. CL. 43.
- GLENELLY CELLARS (PROPRIETARY) LIMITED, STELLENBOSCH, SOUTH AFRICA:
3,996,925, PUB. 5-3-2011. INT. CL. 33.
- GLENMARK GENERICS INC., USA, MAHWAH, NJ:
3,998,465, INT. CL. 5.
3,998,466, INT. CL. 5.
3,998,467, INT. CL. 5.
- GLENN ZANDERS FUR & SPORTING GOODS CO., BALDWIN, MO:
2,902,224, CANC. MULTIPLE CLASS, INT. CLS. 9 AND 13.
- GLENWILD COMMUNITY ASSOCIATION, INC., PARK CITY, UT:
2,470,414, REN. 6-13-11. MULTIPLE CLASS, INT. CLS. 36 AND 37.
- GLENWOOD SPRINGS CHAMBER RESORT ASSOCIATION, INC., GLENWOOD SPRINGS, CO:
3,997,248, PUB. 5-3-2011. INT. CL. 35.
- GLIER'S MEATS, INC., COVINGTON, KY:
2,901,806, CANC. INT. CL. 29.
2,901,807, CANC. INT. CL. 29.
- GLOBAL BEAUTY CONCEPTS LLC, HOUSTON, TX:
2,401,278, CANC. INT. CL. 11.
- GLOBAL BEST WAY CO., LTD., CHINA:
3,996,016, PUB. 5-3-2011. INT. CL. 9.
- GLOBAL CARE MEDICAL GROUP, IPA, TARZANA, CA:
2,535,452, REN. 6-15-11. MULTIPLE CLASS, INT. CLS. 35, 36 AND 42.
- GLOBAL GOLF TRAINING PRODUCTS, INC., CANTON, MA:
3,996,195, PUB. 5-3-2011. INT. CL. 28.
- GLOBAL HOUSE OF TRIMS, LOS ANGELES, CA, DBA RETROSPEC CYCLING CLUB:
3,997,257, PUB. 5-3-2011. INT. CL. 12.
- GLOBAL INDUSTRIES, INC., GRAND ISLAND, NE:
3,999,360, INT. CL. 6.
3,999,361, INT. CL. 6.
- GLOBAL INVENTURES, INC., SAN RAMON, CA, DBA INVENTURES:
3,997,718, PUB. 5-3-2011. INT. CL. 35.
- GLOBAL SOLARIUM, INC., VANCOUVER, WA:
2,402,566, CANC. INT. CL. 19.
- GLOBAL TOTAL OFFICE, DOWNSVIEW, ONTARIO M3J 2M6, CANADA, GLOBAL TOTAL OFFICE, DOWNSVIEW, ONTARIO M3J 2M6, CANADA:
2,464,718, REN. 6-14-11. INT. CL. 20.
- GLOBAL TRADEMARKS LIMITED, SMALL DOLE, WEST SUSSEX, UNITED KINGDOM:
2,402,268, CANC. MULTIPLE CLASS, INT. CLS. 18, 24, 25 AND 28.
- GLOBAL WIRELESS SOLUTIONS, INC., DULLES, VA:
3,996,743, PUB. 5-3-2011. MULTIPLE CLASS, INT. CLS. 9, 16, 35 AND 42.
- GLOBERIDE, INC., TOKYO, JAPAN:
3,999,013, INT. CL. 28.
- GLOBESTAR SYSTEMS INC., TORONTO, ONTARIO, CANADA:
3,995,512, PUB. 5-3-2011. INT. CL. 9.
- GLV FINANCE HUNGARY KFT., ACTING THROUGH ITS LUXEMBOURG BRANCH, LUXEMBOURG, LUXEMBOURG:
3,999,300, MULTIPLE CLASS, INT. CLS. 37 AND 42.
- GM PHARMACEUTICALS, INC., ARLINGTON, TX:
2,503,008, REN. 6-15-11. INT. CL. 5.
- GMA GARNET PTY LTD., PERTH, W.AUSTRALIA, AUSTRALIA:
2,475,389, REN. 6-14-11. INT. CL. 3.
- GMT PUBLISHING SARL, GENEVA, SWITZERLAND:
3,997,996, PUB. 5-3-2011. INT. CL. 16.
- GNL ENTERTAINMENT, INC., WASHINGTON, DC:
3,997,871, PUB. 5-3-2011. INT. CL. 41.
3,997,876, PUB. 5-3-2011. INT. CL. 9.
- GO DIRECT INTERNATIONAL LTD., KOWLOON, HONG KONG:
2,901,246, CANC. INT. CL. 9.
- GO GALLEY LLC, COLUMBIA, TN:
3,997,049, PUB. 5-3-2011. INT. CL. 11.
- GOAD COMPANY, ELLISVILLE, MO:
3,996,908, PUB. 5-3-2011. INT. CL. 6.
- GODADDY.COM, INC., SCOTTSDALE, AZ:
3,999,499, INT. CL. 42.
- GODDARD, MELINDA K. M., THE VALLEY, ANGUILLA:
2,578,874, REN. 6-16-11. INT. CL. 35.
- GODDESS IN YOU, LLC., MIAMI BEACH, FL:
2,901,643, CANC. MULTIPLE CLASS, INT. CLS. 18 AND 25.
- GODFREY, TRACY BOYD, LAS VEGAS, NV:
3,999,581, MULTIPLE CLASS, INT. CLS. 41 AND 43.
- GOING UP, INC., AUSTIN, TX:
3,999,083, INT. CL. 35.
- GOJO INDUSTRIES, INC., AKRON, OH:
2,460,440, REN. 6-10-11. INT. CL. 21.
- GOLDEN PRIDE, INC., WEST PALM BEACH, FL:
3,996,788, PUB. 5-3-2011. MULTIPLE CLASS, INT. CLS. 3, 5, 29 AND 30.
- GOLDMAN, SACHS & CO., NEW YORK, NY:
3,999,227, INT. CL. 36.
- GONZALES, MISTY, PASADENA, CA, DBA ROCK & ROLL FREEDOM SHOW AND WILSON, TOM, PASADENA, CA, DBA ROCK & ROLL FREEDOM SHOW:
3,997,093, PUB. 5-3-2011. INT. CL. 41.
- GONZALEZ AND TAPANES FOODS, INC., MOONACHIE, NJ:
3,995,493, PUB. 5-3-2011. INT. CL. 29.
- GOOCH INVESTMENTS INC., ABILENE, TX, DBA ABSOLUTELY WORLD CLASS, INC.:
3,999,240, INT. CL. 29.
- GOOD TO GO CAFE, STAMFORD, CT:
3,996,482, PUB. 5-3-2011. INT. CL. 43.
- GOODWILL INDUSTRIES INTERNATIONAL, INC., BETHESDA, MD:
2,901,330, CANC. INT. CL. 35.
- GOODWIN, ROBERT W., BELLINGHAM, WA:
3,997,352, PUB. 5-3-2011. INT. CL. 20.

GOOGLE INC., MOUNTAIN VIEW, CA:
3,998,217, PUB. 5-3-2011. INT. CL. 38.
3,999,153, MULTIPLE CLASS, INT. CLS. 9 AND 42.

GORDON BIRSCH BREWING COMPANY, LAS VEGAS, NV:
2,461,161. REN. 6-14-11. INT. CL. 32.

GORDY, MARK, OAK RIDGE, NC:
3,996,859, PUB. 5-3-2011. INT. CL. 42.

GORNEY, MICHAEL J., CEDAR GROVE, NJ:
3,999,550, INT. CL. 25.

GOSMILE, INC., BERKELEY, CA:
3,998,198, PUB. 5-3-2011. INT. CL. 3.

GOSPEL MESSENGERS INC., MT.VERNON, IL:
3,997,017, PUB. 5-3-2011. INT. CL. 41.

GOTHAM CORPORATION, FLUSHING, NY:
3,997,088, PUB. 5-3-2011. INT. CL. 39.

GOVERNMENTAL INSURANCE MANAGERS, INC., BLOOMINGTON, IL:
1,156,630. REN. 6-16-11. INT. CL. 36.

GP SOFTWARE, LLC, BEACHWOOD, OH:
3,998,540, INT. CL. 42.

GPC BIOTECH AG, MUNICH, FED REP GERMANY:
2,902,146, CANC. MULTIPLE CLASS, INT. CLS. 5, 9 AND 42.

GPS DAIRY CONSULTING, LLC, VERONA, WI:
3,999,898, INT. CL. 5.
3,999,899, INT. CL. 5.

GRAB NETWORKS HOLDINGS, INC., DULLES, VA:
2,901,434, CANC. INT. CL. 9.

GRACIE, RORION, SANTA BARBARA, CA:
3,998,536, MULTIPLE CLASS, INT. CLS. 9, 25 AND 41.
3,998,537, MULTIPLE CLASS, INT. CLS. 9, 16, 25 AND 41.

GRAHAM, JAN G., SHELBY TOWNSHIP, MI:
3,997,398, PUB. 5-3-2011. INT. CL. 15.

GRAND CIRCLE LLC, BOSTON, MA:
2,564,856. REN. 6-14-11. MULTIPLE CLASS, INT. CLS. 39 AND 42.

GRAND GOLF COMPANY, LLC, LAGUNA NIGUEL, CA:
3,998,205, PUB. 5-3-2011. INT. CL. 28.
3,998,208, PUB. 5-3-2011. INT. CL. 28.

GRAND PRAIRIE FOODS, INC., SIOUX FALLS, SD:
3,998,871, INT. CL. 30.

GRANGER ENTERTAINMENT LLC, FAIRFIELD, CT:
3,999,447, INT. CL. 41.
3,999,448, INT. CL. 41.

GRANITE SECURITY PRODUCTS, INC., IRVING, TX:
3,997,654, PUB. 5-3-2011. INT. CL. 6.
3,997,691, PUB. 5-3-2011. INT. CL. 6.
3,997,698, PUB. 5-3-2011. INT. CL. 6.

GRAPECITY INCORPORATED, SENDAI, JAPAN:
3,998,941, INT. CL. 9.

GRAPHEL CORP., WEST CHESTER, OH:
2,454,879. REN. 6-13-11. INT. CL. 9.

GRAPHIC PACKAGING INTERNATIONAL, INC., MAR-
IETTA, GA:
3,998,625, MULTIPLE CLASS, INT. CLS. 7 AND 16.

GRAY DIGITAL MARKETING, INC., QUEENSBURY, NY:
3,997,137, PUB. 5-3-2011. INT. CL. 41.

GREAT AMERICAN INSURANCE COMPANY, CINCINNA-
TI, OH:
2,459,757. REN. 6-16-11. INT. CL. 36.

GREATCORE INC., MOUNTAIN VIEW, CA:
2,901,783, CANC. INT. CL. 5.

GREATER HOUSTON NEUROSURGERY CENTER, P.A.,
THE, HOUSTON, TX:
2,490,038. REN. 6-14-11. INT. CL. 42.

GREATER NEW BEDFORD REGIONAL VOCATIONAL
TECHNICAL HIGH SCHOOL, NEW BEDFORD, MA:
3,998,327, INT. CL. 41.

GREATER OMAHA PACKING CO., INC., OMAHA, NE:
3,998,763, INT. CL. 29.

GRECIAN DELIGHT FOODS, INC., ELK GROVE VILLAGE,
IL:
2,402,472, CANC. INT. CL. 35.

GREEN BAY PACKAGING, INC., GREEN BAY, WI:
3,996,124, PUB. 5-3-2011. INT. CL. 16.

GREEN BUSINESS LEAGUE, INC., PLAINFIELD, IL:
3,998,875, INT. CL. 41.

GREEN MENU INC. GUELPH, CANADA:
3,997,848, PUB. 5-3-2011. INT. CL. 21.

GREEN MOUNTAIN RANGERS, LLC, EAST NORWICH,
NY:
3,996,831, PUB. 5-3-2011. INT. CL. 41.

GREEN PLANET MOBILE, LLC, HENDERSON, NV:
3,998,382, INT. CL. 38.

GREEN STREET ADVISORS, INC., NEWPORT BEACH, CA:
3,996,188, PUB. 5-3-2011. INT. CL. 16.

GREEN SUV LLC, HOLLYWOOD, CA:
3,995,537, PUB. 5-3-2011. INT. CL. 39.

GREEN, NANCY, CARLSBAD, CA, DBA BRAIN HIGH-
WAYS INC.:
2,520,239. REN. 6-15-11. INT. CL. 16.

GREEN, VICTOR, NEW YORK, NY:
3,998,944, INT. CL. 25.

GREENAWALT, NATHAN, MADISON, WI:
3,997,977, PUB. 5-3-2011. INT. CL. 33.

GREENBERG JEWELERS, INC., SIOUX CITY, IA:
2,461,802. REN. 6-12-11. INT. CL. 35.

GREENHOUSE GROWN FOODS INC., DELTA BRITISH
COLOMBIA, CANADA:
3,996,524, PUB. 5-3-2011. INT. CL. 31.

GREENIES, LLC, WALKERTON, IN, DBA TERRA SPICE
COMPANY:
3,995,645, PUB. 5-3-2011. INT. CL. 30.

GREENLINE "THE SOIL COMPANY" GMBH, OHRDRUF,
FED REP GERMANY:
3,996,695, PUB. 5-3-2011. INT. CL. 1.

GREENOVO RESEARCH, INC., TAIPEI CITY, TAIWAN:
3,997,682, PUB. 5-3-2011. INT. CL. 25.

GREENSUN ENERGY LTD., HAR HOTZVIM, JERUSALEM,
ISRAEL:
3,998,102, PUB. 5-3-2011. INT. CL. 11.

GREENWOOD FINANCE, INC., WILMINGTON, DE:
3,998,652, MULTIPLE CLASS, INT. CLS. 41 AND 43.

GREG OTHOLT, CARLSBAD, CA:
3,995,605, PUB. 5-3-2011. INT. CL. 25.

GREG-MICHAEL CELLARS, LLC, SPOKANE, WA, AKA
BARRISTER WINERY:
3,999,784, INT. CL. 33.

GREGORY SYLVIA LLC, CHARLOTTE, NC:
3,996,825, PUB. 5-3-2011. INT. CL. 25.

GREY OWL PADDLES LIMITED, CAMBRIDGE, ONTARIO,
CANADA:
2,451,065. REN. 6-10-11. INT. CL. 12.

GREYWELL LLC, WEST CALDWELL, NJ, AKA GREY-
WELL:
3,998,109, PUB. 5-3-2011. INT. CL. 25.

GRHK IP, LLC, MIAMI, FL:
3,998,146, PUB. 5-3-2011. INT. CL. 41.
3,998,148, PUB. 5-3-2011. INT. CL. 41.

GRIFFIN TESTING PRODUCTS, INC., SALEM, SC, GRIF-
FIN, ALVIN G., PITTSBURGH, PA, DBA GRIFF MA-
CHINE PRODUCTS CO.:
717,839. REN. 6-14-11. U.S. CL. 23 (INT. CL. 7).

GRIMES, MICHELE, FORKED RIVER, NJ AND PUGLIA,
DAWN, FORKED RIVER, NJ:
3,998,873, INT. CL. 25.

GRIZZLY CARTRIDGE CO., RAINIER, OR:
3,997,568, PUB. 5-3-2011. INT. CL. 13.

GROOVE PHI GROOVE SOCIAL FELLOWSHIP, INC.,
SILVER SPRING, MD:
3,996,572, PUB. 5-3-2011. INT. CL. 25.

GROSS, DR. DAVID IRA, LONG BEACH, NY:
2,901,787, CANC. INT. CL. 44.

GROSVENOR USA LIMITED, SAN FRANCISCO, CA:
3,997,404, PUB. 5-3-2011. INT. CL. 36.
3,997,405, PUB. 5-3-2011. INT. CL. 42.
3,997,406, PUB. 5-3-2011. INT. CL. 36.
3,997,407, PUB. 5-3-2011. INT. CL. 42.

GROUP BUY, LLC, NEW YORK, NY:
3,999,798, INT. CL. 35.

GRUPO DE PUBLICACIONES LATINOAMERICANAS S.A.,
SANTAFE DE BOGATA D.C., COLOMBIA:
2,900,987, CANC. MULTIPLE CLASS, INT. CLS. 9 AND
38.

- GROUP OUTCOME, L.L.C., PRINCETON, NJ:
2,460,257, REN. 6-14-11, INT. CL. 36.
- GROUPLINK CORPORATION, BOUNTIFUL, UT:
2,451,547, REN. 6-16-11, INT. CL. 9.
- GROUPS ON TOUR LLC, RINGGOLD, GA:
2,401,653, CANC. MULTIPLE CLASS, INT. CLS. 39 AND 42.
- GROWOP TECHNOLOGY, LTD, IRVINE, CA:
3,996,323, PUB. 5-3-2011, INT. CL. 11.
- GROZ-BECKERT KG, FED REP GERMANY:
3,073,773.
- GRUMA CORPORATION, IRVING, TX:
2,401,166, CANC. INT. CL. 30.
2,575,993, REN. 6-15-11, INT. CL. 30.
3,998,756, MULTIPLE CLASS, INT. CLS. 43 AND 44.
3,998,757, MULTIPLE CLASS, INT. CLS. 43 AND 44.
3,998,758, MULTIPLE CLASS, INT. CLS. 43 AND 44.
- GRUPO BIMBO, S.A.B. DE C.V., MEXICO CITY 01210, MEXICO:
3,996,084, PUB. 5-3-2011, INT. CL. 29.
- GRUPO INDUSTRIAL MIRO, S.A. DE C.V., ESTADO DE MEXICO, MEXICO:
2,402,368, CANC. INT. CL. 25.
2,402,369, CANC. INT. CL. 25.
- GRUPO KALTEX S.A. DE C.V., NAUCALPAN DE JUAREZ, MEXICO:
3,998,474, INT. CL. 25.
- GRYGOROVICH, SERGIY, KYIV 04211, UKRAINE:
3,998,836, INT. CL. 41.
- GRYGOROVICH, SERGIY, KYIV, UKRAINE:
3,998,837, INT. CL. 42.
- GR8 ENTERTAINMENT, LTD., RICHARDSON, TX:
2,901,087, CANC. INT. CL. 41.
2,901,088, CANC. INT. CL. 41.
- GS MARKETING LLC, MADISON, NJ, DBA GOOD STUFF MARKETING LLC:
3,999,650, INT. CL. 35.
- GSMN VAUD SA, SWITZERLAND:
3,995,814, PUB. 5-3-2011, MULTIPLE CLASS, INT. CLS. 3, 5 AND 44.
- GTECH RHODE ISLAND CORPORATION, WEST GREENWICH, RI:
2,901,902, CANC. INT. CL. 9.
- GUANGZHOU NANDADI TEXTILE GARMENT CO., LTD, ZENGCHENG, GUANGZHOU, CHINA:
3,996,548, PUB. 5-3-2011, INT. CL. 25.
- GUANGZHOU SHUOJIN MECHATRONICS; CO., LTD., CHINA:
3,995,795, PUB. 5-3-2011, MULTIPLE CLASS, INT. CLS. 7 AND 12.
- GUARDIAN NEWS & MEDIA LIMITED, LONDON, UNITED KINGDOM:
3,995,727, PUB. 4-20-2010, MULTIPLE CLASS, INT. CLS. 9, 16, 38 AND 41.
- GUARDMYPET, LLC, ST. PETERSBURG, FL:
3,999,398, INT. CL. 42.
3,999,399, INT. CL. 42.
3,999,401, INT. CL. 42.
3,999,402, INT. CL. 42.
- GUERCIO, JAMES W., BOULDER, CO:
3,996,375, PUB. 5-3-2011, INT. CL. 9.
3,996,392, PUB. 5-3-2011, INT. CL. 9.
3,996,393, PUB. 5-3-2011, INT. CL. 25.
- GUERRIERO, GLENN, GANSEVOORT, NY AND GUERRIERO, MARYANN, GANSEVOORT, NY:
3,996,163, PUB. 5-3-2011, INT. CL. 3.
- GUINAN FAMILY WINERY & VINEYARD, INC., CARROLL, IA, DBA SANTA MARIA VINEYARD & WINERY:
3,997,689, PUB. 5-3-2011, INT. CL. 33.
- GUITAR CENTER, INC., WESTLAKE VILLAGE, CA:
3,998,024, PUB. 5-3-2011, INT. CL. 35.
- GUITAR STRAPS ONLINE, LLC, ARVADA, CO:
3,999,486, MULTIPLE CLASS, INT. CLS. 16 AND 35.
- GUM PRODUCTS INTERNATIONAL INC., NEWMARKET, CANADA:
3,998,927, INT. CL. 30.
- GUSTAV MAGENWIRTH GMBH & CO. KG, FED REP GERMANY:
3,996,025, PUB. 5-3-2011, INT. CL. 12.
- GUTIERREZ, GUSTAVO, MIAMI BEACH, FL:
3,998,411, INT. CL. 36.
- GUYS WHO LOVE GOD, LLC, GLEN BURNIE, MD:
2,902,032, CANC. INT. CL. 9.
- GYO CORP., LLC, CHELMSFORD, MA:
3,999,747, INT. CL. 11.
- GYPSY QUEENS, LLC, BALTIMORE, MD:
3,997,341, PUB. 5-3-2011, INT. CL. 43.
- GYRUSLOGIC, INC., PHOENIX, AZ:
3,999,193, INT. CL. 9.
- GÜLLÜOĞLU, MEHMET NEJAT, ISTANBUL, TURKEY:
3,996,510, PUB. 5-3-2011, INT. CL. 43.
- H & B VENTURE, LLC, FORT LAUDERDALE, FL:
3,996,574, PUB. 5-3-2011, INT. CL. 9.
- H. BARBER & SONS, INC., NAUGATUCK, CT:
3,996,526, PUB. 5-3-2011, INT. CL. 7.
- H.A.N. MADE LLC, LOS RANCHOS, NM:
3,997,750, PUB. 5-3-2011, INT. CL. 41.
- H.J. HEINZ COMPANY, L.P., PITTSBURGH, PA:
1,658,372, REN. 6-16-11, INT. CL. 30.
- H&L TOOTH COMPANY, TULSA, OK:
3,998,330, INT. CL. 8.
- H-D MICHIGAN, LLC, ANN ARBOR, MI:
3,349,572, AM. INT. CL. 12.
3,995,463, PUB. 12-15-2009, INT. CL. 12.
- HAAN CORPORATION, SEOUL, REPUBLIC OF KOREA:
3,999,739, INT. CL. 3.
3,999,740, INT. CL. 3.
3,999,749, INT. CL. 7.
- HABER, SANDRA L, GLENWOOD SPRINGS, CO:
3,996,993, PUB. 5-3-2011, INT. CL. 3.
- HABITAT FOR HUMANITY INTERNATIONAL, INC., AMERICUS, GA:
3,997,452, PUB. 5-3-2011, INT. CL. 35.
- HAGEMEYER NORTH AMERICA, INC., ALPHARETTA, GA:
2,902,057, CANC. INT. CL. 3.
- HAGSTROM, CRAIG, BAINBRIDGE ISLAND, WA AND HAGSTROM, SHERRY, BAINBRIDGE ISLAND, WA:
2,902,391, CANC. INT. CL. 14.
- HAKRO GMBH, FED REP GERMANY:
3,995,936, PUB. 5-3-2011, MULTIPLE CLASS, INT. CLS. 23 AND 25.
- HALF OUNCE OF LIFE LLC, HARRISBURG, PA, AKA HALF OUNCE OF LIFE CLOTHING:
3,998,068, PUB. 5-3-2011, INT. CL. 25.
- HALL, DAVID, ALISO VIEJO, CA AND HALL, PEGGY, ALISO VIEJO, CA:
2,901,510, CANC. INT. CL. 9.
- HALL, GARY, KNOXVILLE, TN:
2,401,925, CANC. INT. CL. 42.
- HALL, KATHLEEN A., CLARKESVILLE, GA:
3,998,460, INT. CL. 38.
- HALLIBURTON ENERGY SERVICES, INC., CARROLLTON, TX:
3,999,695, INT. CL. 40.
3,999,828, INT. CL. 9.
- HALLMARK LICENSING, INC., KANSAS CITY, MO:
3,999,072, INT. CL. 28.
- HAMILTON COLLECTION, INC., THE, JACKSONVILLE, FL:
2,402,481, CANC. INT. CL. 20.
- HAMMER BEDDING CORP., NEWARK, NJ, DBA SHIFMAN MATTRESS COMPANY:
4,000,009, INT. CL. 20.
- HAMMOUD, MOHAMAD, DEARBORN, MI:
3,996,048, PUB. 5-3-2011, INT. CL. 34.
- HAMN, LARNELL A., MANASSAS, VA AND THOMPSON, CHRISTOPHER D., FREDERICKSBURG, VA:
3,999,304, INT. CL. 25.
- HAMON & CIE (INTERNATIONAL) S.A., BELGIUM:
3,995,821, PUB. 5-3-2011, MULTIPLE CLASS, INT. CLS. 7, 11, 37 AND 42.
- HANA, LLC, DENVER, CO:
3,997,746, PUB. 5-3-2011, INT. CL. 35.

HAND E HOLDER PRODUCTS, INC., ANN ARBOR, MI:
3,999,511, INT. CL. 9.

HANDGARDS, INC., EL PASO, TX:
1,177,333, REN. 6-14-11. INT. CL. 22.

HANGZHOU GREAT STAR INDUSTRIAL CO., LTD.,
HANGZHOU, ZHEJIANG, CHINA:
3,996,450, PUB. 5-3-2011. INT. CL. 11.

HANLEY III, ALBERT V., MIAMI, FL:
3,996,131, PUB. 5-3-2011. INT. CL. 41.

HANNAH, ROBERT, KELLY, ASHEVILLE, NC AND
MCFEE SEAN MICHAEL, ASHEVEGAS, NC:
3,996,970, PUB. 5-3-2011. INT. CL. 41.

HANNON GROUP LTD., BURLINGTON, WI:
3,997,323, PUB. 5-3-2011. INT. CL. 21.

HANSON, HEIDI, BEVERLY, MA:
3,997,806, PUB. 5-3-2011. INT. CL. 36.

HAPPY EAGLE FOOD INDUSTRIES CORPORATION, ST.
CHARLES, IL:
3,998,557, INT. CL. 29.

HAPPY HEART PHOTOGRAPHY, LLC, STONE RIDGE, VA:
3,996,855, PUB. 5-3-2011. INT. CL. 41.

HARBOR COMMUNICATIONS, L.L.C., WESTLAKE, OH:
3,999,252, INT. CL. 35.

HARBOR FREIGHT TOOLS USA, INC., CALABASAS, CA:
2,403,471, REN. 6-13-11. INT. CL. 35.

HARCOURT ACHIEVE, INC., AUSTIN, TX:
2,902,485, CANC. INT. CL. 16.

HARDEEN, DAMIAN, QUEENS VILLAGE, NY:
3,997,243, PUB. 5-3-2011. INT. CL. 42.

HARDY & GREYS LIMITED, ALNWICK, UNITED KING-
DOM:
3,999,433, INT. CL. 28.
3,999,435, INT. CL. 28.

HARINERA DEL VALLE S.A., PALMIRA, VALLE, COLOM-
BIA:
3,999,325, INT. CL. 30.

HARMAN INTERNATIONAL INDUSTRIES INCORPO-
RATED, NORTHRIDGE, CA:
3,998,852, INT. CL. 9.

HARMAR SUMMIT, LLC, LAKE WINNEBAGO, MO:
3,997,792, PUB. 5-3-2011. INT. CL. 7.

HARMONY INVESTMENTS LIMITED PARTNERSHIP,
BEAVERTON, OR:
3,998,030, PUB. 5-3-2011. INT. CL. 35.

HARNISCHFEGER TECHNOLOGIES, INC., WILMINGTON,
DE:
2,401,239, CANC. INT. CL. 7.

HARPERCOLLINS PUBLISHERS LLC, NEW YORK, NY:
3,998,518, INT. CL. 16.

HARPO, INC., CHICAGO, IL:
3,999,404, INT. CL. 41.

HARRINGTON, CARRELL R, SANTA BARBARA, CA:
2,902,395, CANC. INT. CL. 16.

HARRINGTON, STEPHEN, HOLLYWOOD, FL, DBA ESER-
VICES INC.:
3,996,601, PUB. 5-3-2011. INT. CL. 9.

HARRISBURG AREA COMMUNITY COLLEGE, HARRIS-
BURG, PA:
3,999,158, INT. CL. 25.

HARTFORD FIRE INSURANCE COMPANY, HARTFORD,
CT:
2,401,339, CANC. MULTIPLE CLASS, INT. CLS. 35 AND
42.

HARTLINE INDUSTRIES, INC., SANDY, UT:
3,998,260, PUB. 5-3-2011. INT. CL. 28.

HARTZ MOUNTAIN CORPORATION, THE, SECAUCUS,
NJ:
1,645,786, REN. 6-16-11. INT. CL. 5.

HARTZ MOUNTAIN INDUSTRIES, INC., SECAUCUS, NJ:
3,995,496, PUB. 5-3-2011. MULTIPLE CLASS, INT. CLS. 36
AND 37.

HARVEST LOCAL FOODS LLC, LANSDOWNE, PA:
3,996,984, PUB. 5-3-2011. INT. CL. 35.

HARWOOD, LINDA, NORTHRIDGE, CA:
3,999,984, INT. CL. 26.

HASBRO, INC., PAWTUCKET, RI:
2,901,966, CANC. INT. CL. 28.

HAUSBRANDT TRIESTE 1892 SPA, TREVISO, ITALY:
2,472,725, REN. 6-13-11. INT. CL. 30.

HAUZER TECHNO COATING BV, NETHERLANDS:
3,995,733, PUB. 5-3-2011. MULTIPLE CLASS, INT. CLS. 7
AND 40.

HAVEN HOMES, INC., BEECH CREEK, PA:
1,592,026, CANC. INT. CL. 19.

HAWAII MUSIC FESTIVALS, INC., HONOLULU, HI:
3,999,912, INT. CL. 41.

HAYES, GERARD, COUNTY LIMERICK, IRELAND AND
HAYMES, ALAN, REDBRIDGE, ESSEX, UNITED KING-
DOM:
3,995,557, PUB. 11-2-2010. MULTIPLE CLASS, INT. CLS.
3, 5 AND 10.

HAYSLETT, DONALD SCOTT, LEXINGTON, VA:
3,999,485, INT. CL. 43.

HBGARY, INC., SACRAMENTO, CA:
3,999,275, INT. CL. 9.

HCC INSURANCE HOLDINGS, INC., HOUSTON, TX:
3,998,825, INT. CL. 36.

HCR HEALTHCARE, LLC, TOLEDO, OH:
1,668,064, REN. 6-10-11. INT. CL. 42.

HDM FURNITURE INDUSTRIES, INC., HIGH POINT, NC:
917,662, REN. 6-15-11. U.S. CL. 32 (INT. CL. 20).

HDR ENGINEERING, INC., OMAHA, NE:
3,996,248, PUB. 5-3-2011. MULTIPLE CLASS, INT. CLS. 40
AND 42.

HEAD LITES CORPORATION, ST. PAUL, MN:
2,902,055, CANC. INT. CL. 9.

HEADSTRONG FOUNDATION, HOLMES, PA:
3,995,679, PUB. 5-3-2011. MULTIPLE CLASS, INT. CLS. 35
AND 36.

HEALTH CARE CONCEPTS, INC., AUSTIN, TX:
3,996,858, PUB. 5-3-2011. INT. CL. 42.

HEALTH GRADES, INC., DENVER, CO:
3,997,378, PUB. 5-3-2011. INT. CL. 44.

HEALTH GURU MEDIA, INC., NEW YORK, NY:
3,997,525, PUB. 5-3-2011. INT. CL. 41.
3,997,527, PUB. 5-3-2011. INT. CL. 41.

HEALTH RESOURCE SOLUTIONS, INC., LOMBARD, IL:
3,997,719, PUB. 5-3-2011. INT. CL. 44.

HEALTH RESOURCES, LTD., VALRICO, FL:
1,157,709, REN. 6-14-11. INT. CL. 35.

HEALTHCARERESOURCE HR, INC., WOBURN, MA:
3,996,876, PUB. 5-3-2011. INT. CL. 42.

HEALTHROCK, LLC, NEWTON, MA:
3,998,369, INT. CL. 41.

HEALTHY OUTCOMES, INC., DENVER, CO:
3,997,672, PUB. 5-3-2011. INT. CL. 35.

HEALTHY SWEET BEVERAGES, LLC, BRISTOL, CT:
3,996,880, PUB. 5-3-2011. MULTIPLE CLASS, INT. CLS. 5
AND 32.

HEARST NEWSPAPERS PARTNERSHIP, LLC, HOUSTON,
TX:
2,402,088, CANC. INT. CL. 42.

HEARTLAND COMMUNICATIONS GROUP, INC., FORT
DODGE, IA:
2,902,460, CANC. INT. CL. 16.

HEARTMANITY, LLC, LIVINGSTON, MT:
3,999,185, INT. CL. 41.
3,999,186, INT. CL. 41.

HEAT CONTROLLER INC., JACKSON, MI:
718,933, REN. 6-16-11. U.S. CL. 34 (INT. CL. 11).

HEATHER B. MOORE, INC., CLEVELAND HEIGHTS, OH:
3,995,597, PUB. 5-3-2011. INT. CL. 14.

HEB GROCERY COMPANY, LP, SAN ANTONIO, TX:
3,998,700, INT. CL. 5.
3,998,904, INT. CL. 30.

HEIDECKE, MARK JOSEPH, DOWNERS GROVE, IL:
3,996,447, PUB. 5-3-2011. MULTIPLE CLASS, INT. CLS. 9
AND 41.

HEIDI KLEIN OF LONDON, LONDON, UNITED KING-
DOM:
3,999,212, MULTIPLE CLASS, INT. CLS. 18 AND 25.

HEIFER PROJECT INTERNATIONAL, LITTLE ROCK, AR:
3,998,951, MULTIPLE CLASS, INT. CLS. 36 AND 41.

- HEINEKEN BROUWERIJEN B.V., 1017 ZD AMSTERDAM, NETHERLANDS:
2,901,492, CANC. MULTIPLE CLASS, INT. CLS. 9 AND 41.
- HEINEKEN USA INCORPORATED, WHITE PLAINS, NY:
2,402,826, CANC. INT. CL. 42.
- HEIWA SEIKI KOGYO CO., LTD., YASHIO-CITY, SAITAMA, JAPAN:
1,668,265, REN. 6-16-11. INT. CL. 9.
- HENDERSON, JASMINE M., WASHINGTON, DC:
3,997,051, PUB. 5-3-2011. INT. CL. 41.
- HENDERSON, JOEL PARKER, SAN FRANCISCO, CA, DBA SIXARM:
3,998,072, PUB. 5-3-2011. INT. CL. 35.
- HENKEL AG & CO. KGAA, DUESSELDORF, FED REP GERMANY:
3,998,988, INT. CL. 16.
- HENKEL CORPORATION, ROCKY HILL, CT:
725,497, REN. 6-13-11. U.S. CL. 5 (INT. CL. 1).
- HENNING SEIP, BRIDGEPORT, CT:
3,996,079, PUB. 5-3-2011. INT. CL. 35.
- HENRY MADISON RESEARCH, INC., PHOENIX, AZ:
2,901,652, CANC. INT. CL. 16.
- HENRY SCHEIN, INC., MELVILLE, NY:
2,402,059, CANC. INT. CL. 35.
- HENRY, KENT, KEY WEST, FL:
3,997,723, PUB. 5-3-2011. INT. CL. 25.
- HENRY, MICHAEL S., WASHINGTON, DC:
2,902,080, CANC. INT. CL. 38.
- HERBERT WALDMANN GMBH & CO. KG., FED REP GERMANY:
3,995,897, PUB. 5-3-2011. INT. CL. 11.
- HERITAGE CHRISTIAN SERVICES, INC., EAST ROCHESTER, NY:
3,996,980, PUB. 5-3-2011. INT. CL. 41.
3,996,981, PUB. 5-3-2011. INT. CL. 41.
- HERITAGE PRESERVATION CORPORATION, SPARTANBURG, SC:
2,489,926, REN. 6-13-11. INT. CL. 35.
- HERMAN, BONNIE, CHICAGO, IL AND SHELTON, DON R., LA QUINTA, CA AND PUERLING, HELEN, SAN ANSELMO, CA AND DRESSLAR, DOROTHY, PALM SPRINGS, CA:
3,996,638, PUB. 5-3-2011. INT. CL. 9.
- HERNANDEZ, CESAR, HELOTES, TX, DBA CREATIVE CONCRETE:
3,997,102, PUB. 5-3-2011. INT. CL. 40.
- HERRAMIENTAS PREZISS, S.A., MONTGAT, BARCELONA, SPAIN:
3,997,647, PUB. 5-3-2011. INT. CL. 7.
- HERSHEY CHOCOLATE & CONFECTIONERY CORPORATION, WHEAT RIDGE, CO, HERSHEY FOODS CORPORATION, HERSHEY, PA:
1,648,884, REN. 6-10-11. MULTIPLE CLASS, INT. CLS. 25 AND 41.
- HERSHEY CHOCOLATE & CONFECTIONERY CORPORATION, WHEAT RIDGE, CO:
3,999,744, INT. CL. 9.
- HERTILUS, JONATHAN, NUTLEY, NJ:
3,997,613, PUB. 5-3-2011. INT. CL. 41.
- HETAL DIAMONDS INC, NEW YORK, NY:
3,996,757, PUB. 5-3-2011. INT. CL. 14.
- HGI INDUSTRIES, INC., BOYNTON BEACH, FL:
3,999,946, INT. CL. 11.
- HI-TECH CONCRETE COATINGS, INC, LITITZ, PA:
3,998,009, PUB. 5-3-2011. INT. CL. 37.
- HI-TEMP COATINGS TECHNOLOGY COMPANY, INC., BOXBOROUGH, MA:
3,996,046, PUB. 5-3-2011. INT. CL. 2.
3,996,047, PUB. 5-3-2011. INT. CL. 2.
- HICKEY, MEGHAN, BROOKLYN, NY:
3,999,531, INT. CL. 41.
- HIDDEN CRUSH, INC., CONCORD, CA:
3,997,489, PUB. 5-3-2011. INT. CL. 35.
- HIGGINBOTHAM, STEVEN K, HOUSTON, TX, DBA THE WHEEL WORKERS:
3,996,558, PUB. 5-3-2011. MULTIPLE CLASS, INT. CLS. 9 AND 41.
- HIGH GEAR MEDIA, INC., PALO ALTO, CA:
3,998,520, MULTIPLE CLASS, INT. CLS. 35, 38 AND 42.
- HIGH POINT DESIGN LLC, NEW YORK, NY:
3,998,135, PUB. 5-3-2011. INT. CL. 25.
- HIGH TECH LIGHTING AND AUDIO INC., LOS ANGELES, CA, DBA DJ STAGE SHOP CO.:
3,996,765, PUB. 5-3-2011. INT. CL. 11.
- HIGHER BALANCE INSTITUTE, PORTLAND, OR, AKA HIGHER BALANCE:
3,996,309, PUB. 5-3-2011. MULTIPLE CLASS, INT. CLS. 9 AND 16.
- HIKO ENERGY CORPORATION, CORPUS CHRISTI, TX:
3,996,581, PUB. 5-3-2011. INT. CL. 42.
- HILCO TRADING, LLC, NORTHBROOK, IL:
3,998,103, PUB. 5-3-2011. MULTIPLE CLASS, INT. CLS. 35 AND 36.
3,998,104, PUB. 5-3-2011. MULTIPLE CLASS, INT. CLS. 35 AND 36.
- HILL-ROM SERVICES, INC., BATESVILLE, IN:
2,520,385, REN. 6-10-11. INT. CL. 10.
- HILL, STEPHEN R, MUKILTEO, WA:
3,998,620, MULTIPLE CLASS, INT. CLS. 9 AND 42.
- HILLIARD, SAMUEL, ARCATA, CA:
3,996,033, PUB. 5-3-2011. INT. CL. 25.
- HILTON & HYLAND REAL ESTATE, INC., BEVERLY HILLS, CA:
3,997,660, PUB. 5-3-2011. INT. CL. 36.
3,997,675, PUB. 5-3-2011. INT. CL. 36.
- HILTON, PARIS, BEVERLY HILLS, CA:
3,999,718, INT. CL. 3.
- HIMS INTERNATIONAL CORPORATION, DAEJEON, 305-350, REPUBLIC OF KOREA:
3,999,627, INT. CL. 9.
- HINSPERGERS POLY INDUSTRIES, LTD., MISSISSAUGA, ONTARIO:
2,574,642, REN. 6-10-11. INT. CL. 19.
- HIP SHIFT CORP., SAN CLEMENTE, CA:
3,998,601, INT. CL. 18.
- HIRAFU PTY LTD, BEAUMARIS VIC 3193, AUSTRALIA:
3,995,961, PUB. 5-3-2011. INT. CL. 32.
3,995,964, PUB. 5-3-2011. INT. CL. 32.
- HIS BREATH NOW PUBLICATIONS, LLC, WHITE, GA:
3,997,206, PUB. 5-3-2011. INT. CL. 16.
- HL OPERATING CORP., LEBANON, TN:
2,402,194, CANC. INT. CL. 18.
- HLT DOMESTIC IP LLC, MCLEAN, VA:
2,902,484, CANC. INT. CL. 43.
- HMH IP COMPANY LIMITED, DUBLIN, IRELAND:
2,402,359, CANC. INT. CL. 16.
- HMSHOST CORPORATION, BETHESDA, MD:
3,998,497, INT. CL. 32.
- HOBART CORPORATION, TROY, OH:
2,477,726, REN. 6-15-11. INT. CL. 37.
- HOECHST GMBH, 65926 FRANKFURT AM MAIN, FED REP GERMANY:
2,901,004, CANC. MULTIPLE CLASS, INT. CLS. 5 AND 10.
- HOECHST GMBH, FRANKFURT AM MAIN, FED REP GERMANY:
3,996,436, PUB. 5-3-2011. MULTIPLE CLASS, INT. CLS. 1 AND 5.
3,996,691, PUB. 5-3-2011. MULTIPLE CLASS, INT. CLS. 5 AND 10.
- HOFFMAN, ALLISON M., WASHINGTON, DC:
3,997,881, PUB. 5-3-2011. INT. CL. 41.
- HOFFMAN, JUSTIN, WHEAT RIDGE, CO:
3,999,864, INT. CL. 34.
- HOK, INC., TORONTO, ONTARIO, CANADA:
3,996,271, PUB. 5-3-2011. INT. CL. 35.
- HOLD YOUR HAUNCHES, INC., MACON, GA:
3,999,778, INT. CL. 25.
3,999,823, INT. CL. 25.
- HOLLIDAY, PERRY MERCHANT, CORTE MADERA, CA:
2,902,363, CANC. INT. CL. 16.
- HOLLYWOOD STOCK EXCHANGE, LLC, NEW YORK, NY:
2,831,285, COR. INT. CL. 41.
- HOLOBI, LLC, BOTHELL, WA:
3,996,189, PUB. 5-3-2011. INT. CL. 45.

HOLT TEXAS, LTD., SAN ANTONIO, TX:
3,996,607, PUB. 5-3-2011. INT. CL. 35.

HOLTORF, KENT, PALOS VERDES ESTATES, CA:
3,997,223, PUB. 5-3-2011. MULTIPLE CLASS, INT. CLS. 5
AND 44.

HOME BOX OFFICE, INC., NEW YORK, NY:
2,901,948, CANC. MULTIPLE CLASS, INT. CLS. 20, 22
AND 26.

HOME BOX OFFICE, INC., NEW YORK, NJ:
3,996,952, PUB. 5-3-2011. INT. CL. 9.

HOME BOX OFFICE, INC., NEW YORK, NY:
3,997,072, PUB. 5-3-2011. INT. CL. 9.
3,997,278, PUB. 5-3-2011. INT. CL. 41.
3,997,359, PUB. 5-3-2011. INT. CL. 41.
3,998,566, INT. CL. 25.
3,998,567, INT. CL. 21.
3,998,658, INT. CL. 25.
3,998,659, INT. CL. 21.

HOME SOURCE INTERNATIONAL, ATLANTA, GA:
3,999,587, INT. CL. 35.

HOMEAWAY.COM, INC., AUSTIN, TX:
3,996,179, PUB. 5-3-2011. MULTIPLE CLASS, INT. CLS. 36
AND 43.

HOMEGOODS, INC., FRAMINGHAM, MA:
3,998,971, INT. CL. 21.

HOMESTEAD VILLAGE L.L.C., SPARTANBURG, SC:
2,564,446, REN. 6-14-11. INT. CL. 42.

HONDA MOTOR CO., LTD., MINATO-KU, TOKYO, JAPAN:
3,998,461, INT. CL. 12.

HONEA, HOUSERMAN & LONG, P.C., BIRMINGHAM, AL:
1,644,687, REN. 6-16-11. INT. CL. 42.

HONEYWELL INTERNATIONAL INC., MORRISTOWN, NJ:
730,328, REN. 6-15-11. U.S. CL. 21 (INT. CL. 9).

HONEYWELL INTERNATIONAL INC., MORRISTOWN, NJ,
TROLEX, INC., ELMWOOD PARK, NJ:
1,652,197, REN. 6-10-11. INT. CL. 9.

HONEYWELL INTERNATIONAL INC., MORRISTOWN, NJ:
3,999,576, MULTIPLE CLASS, INT. CLS. 9 AND 11.

HONG KONG CITY TOYS FACTORY LIMITED, KOW-
LOON, HONG KONG:
2,476,642, REN. 6-10-11. INT. CL. 28.

HONTEK CORPORATION, SOUTH WINDSOR, CT:
3,997,379, PUB. 5-3-2011. INT. CL. 2.

HOOD, RON, COEUR D' ALENE, ID:
3,999,908, INT. CL. 16.

HOOVER MATERIALS HANDLING GROUP, INC., HOUS-
TON, TX:
3,997,014, PUB. 5-3-2011. INT. CL. 20.

HOP, RAFAEL COHEN, MEXICO CITY, MEXICO:
3,999,537, INT. CL. 25.
3,999,538, INT. CL. 25.

HOPE & JOY, CORP., VEGA BAJA, PUERTO RICO:
3,997,448, PUB. 5-3-2011. INT. CL. 45.
3,998,229, PUB. 5-3-2011. INT. CL. 35.

HORIZON INTERNATIONAL INC., SHIGA, JAPAN:
3,996,442, PUB. 5-3-2011. INT. CL. 7.

HORIZON TRADING USA, INC., NEW YORK, NY:
3,842,505, COR. INT. CL. 9.

HORNYAK, DAVID M, CHICAGO, IL:
3,996,298, PUB. 5-3-2011. MULTIPLE CLASS, INT. CLS. 9
AND 41.

HOROWITZ MOILANEN, NANCY, WILLITS, CA:
3,997,034, PUB. 5-3-2011. INT. CL. 44.

HOROWITZ, WILLIAM, NEW YORK, NY:
3,997,282, PUB. 5-3-2011. INT. CL. 43.

HORSEWARE PRODUCTS LTD., DUNDALK, COUNTY
LOUTH, IRELAND:
3,998,791, INT. CL. 18.

HORTICOPIA, INC., HARWOOD, MD:
3,996,947, PUB. 5-3-2011. INT. CL. 44.

HOSPICE BRAZOS VALLEY, INC., BRYAN, TX:
3,995,631, PUB. 5-3-2011. INT. CL. 41.
3,995,632, PUB. 5-3-2011. INT. CL. 44.
3,995,633, PUB. 5-3-2011. INT. CL. 45.
3,995,634, PUB. 5-3-2011. INT. CL. 41.
3,995,635, PUB. 5-3-2011. INT. CL. 44.
3,995,636, PUB. 5-3-2011. INT. CL. 45.
3,995,637, PUB. 5-3-2011. INT. CL. 45.

HOSPITALITY USA HOLDINGS, LLC, HOUSTON, TX:
2,565,275, REN. 6-10-11. INT. CL. 42.

HOTFAST PIZZA, LLC, SYCAMORE, IL:
3,999,637, INT. CL. 43.

HOUSE OF GREENS, INC., FORT WAYNE, IN:
3,996,218, PUB. 5-3-2011. INT. CL. 43.

HOUSE OF TORMENT LLC, AUSTIN, TX:
3,996,389, PUB. 5-3-2011. INT. CL. 41.
3,996,428, PUB. 5-3-2011. INT. CL. 41.

HOUSEHOLD ESSENTIALS, LLC, HAZELWOOD, MO:
3,999,090, MULTIPLE CLASS, INT. CLS. 6, 12, 18, 20, 21
AND 22.

HOUSTON WIRE & CABLE COMPANY, HOUSTON, TX:
1,647,858, REN. 6-13-11. INT. CL. 6.

HOVIND, CHAD, CINCINNATI, OH:
3,996,319, PUB. 5-3-2011. INT. CL. 9.

HOW-DO-I, INC., NEWPORT BEACH, CA:
2,901,393, CANC. INT. CL. 9.

HOWARD BERGER CO., INC., CRANBURY, NJ:
3,995,465, PUB. 5-3-2011. MULTIPLE CLASS, INT. CLS. 9
AND 11.

HOWARD PARK WINES PTY LTD., NORTH FREEMAN-
TLE, WA, AUSTRALIA:
2,478,481, REN. 6-13-11. INT. CL. 33.

HOWARD SYSTEMS INTERNATONAL, INC., STAMFORD,
CT:
2,401,826, CANC. INT. CL. 42.

HOWARD, DERRICK, SAN ANTONIO, TX:
3,995,691, PUB. 5-3-2011. INT. CL. 35.

HOWARD, VICTORIA, BOCA RATON, FL:
3,997,332, PUB. 5-3-2011. INT. CL. 41.

HOWE-PETERSON, INC., DEARBORN, MI:
3,996,696, PUB. 5-3-2011. INT. CL. 45.

HOWSIMPLE, LLC, IDYLLWILD, CA:
3,998,066, PUB. 5-3-2011. MULTIPLE CLASS, INT. CLS. 9
AND 42.

HOYA CORPORATION, TOKYO, JAPAN:
3,997,213, PUB. 5-3-2011. INT. CL. 9.

HPE DESIGN, LLC, SEALY, TX, DBA HENNESSEY PER-
FORMANCE ENGINEERING:
3,998,585, INT. CL. 37.
3,998,587, INT. CL. 7.
3,998,588, MULTIPLE CLASS, INT. CLS. 7 AND 12.

HR 360, INC., STAMFORD, CT:
3,997,520, PUB. 5-3-2011. INT. CL. 35.

HR-HAVEN, INC., OVERLAND PARK, KS:
3,997,767, PUB. 5-3-2011. INT. CL. 35.

HUANG, STEPHEN, TAICHUNG COUNTY, TAIWAN:
3,996,972, PUB. 5-3-2011. INT. CL. 12.

HUASI S.A., SALTA, ARGENTINA:
3,996,075, PUB. 5-3-2011. INT. CL. 39.

HUAWEI TECHNOLOGIES CO., LTD., SHENZHEN, CHINA:
3,998,686, INT. CL. 9.

HUBBINGTONS, INC., BARRINGTON, NH:
3,998,206, PUB. 5-3-2011. INT. CL. 35.

HUBERT KELLER, INC., SAVANNAH, GA:
2,561,469, REN. 6-15-11. INT. CL. 35.
2,561,470, REN. 6-15-11. INT. CL. 35.

HUDDLE, SANDY, ASTON, PA, DBA BE YOUR OWN
REASON!:
3,997,932, PUB. 5-3-2011. INT. CL. 16.
3,997,933, PUB. 5-3-2011. INT. CL. 16.

HUDSON, JEFFREY THOMAS, MURFREESBORO, TN:
2,902,154, CANC. INT. CL. 12.

HUGE RAINBOW INTERNATIONAL INC., TAIPEI
COUNTY, TAIWAN:
3,996,454, PUB. 5-3-2011. INT. CL. 12.

HUGHES, DION, MINNEAPOLIS, MN:
3,998,517, INT. CL. 35.

HUMAN RESOURCES INSTITUTE, LLC, BURLINGTON,
VT:
3,996,874, PUB. 5-3-2011. INT. CL. 41.

HUMANCONCEPTS LIMITED LIABILITY COMPANY,
SAUSALITO, CA:
3,997,581, PUB. 5-3-2011. INT. CL. 35.

HUMMING HEADS KABUSHIKI KAISHA, TOKYO 104-
0052, JAPAN:
3,995,739, PUB. 5-3-2011. MULTIPLE CLASS, INT. CLS. 9

- AND 42.
3,995,740, PUB. 5-3-2011. MULTIPLE CLASS, INT. CLS. 9 AND 42.
3,995,741, PUB. 5-3-2011. MULTIPLE CLASS, INT. CLS. 9 AND 42.
3,995,742, PUB. 5-3-2011. MULTIPLE CLASS, INT. CLS. 9 AND 42.
3,995,743, PUB. 5-3-2011. MULTIPLE CLASS, INT. CLS. 9 AND 42.
- HUMMINGBIRD ENTERPRISES, INC., RIVER VALE, NJ:
3,997,022, PUB. 5-3-2011. INT. CL. 37.
- HUMUS MOG CO., LTD., SEOUL, 135-100, REPUBLIC OF KOREA:
2,901,270, CANC. INT. CL. 28.
- HUNT REAL ESTATE CORPORATION, DEPEW, NY:
3,997,782, PUB. 5-3-2011. MULTIPLE CLASS, INT. CLS. 35 AND 36.
- HUNTER FINANCIAL GROUP, LLC, TEMPE, AZ:
2,901,732, CANC. INT. CL. 35.
2,901,733, CANC. INT. CL. 36.
2,901,734, CANC. INT. CL. 35.
- HUNTER INDUSTRIES, INC., SAN MARCOS, CA:
3,998,099, PUB. 5-3-2011. INT. CL. 9.
- HUNTSMAN ADVANCED MATERIALS (SWITZERLAND) GMBH, CH-4057 BASEL, SWITZERLAND:
3,995,957, PUB. 1-25-2011. MULTIPLE CLASS, INT. CLS. 1 AND 2.
- HUR USA INC, NORTHBROOK, IL:
3,999,983, INT. CL. 28.
- HUSKY INJECTION MOLDING SYSTEMS LTD., CANADA:
3,995,763, PUB. 5-3-2011. MULTIPLE CLASS, INT. CLS. 35 AND 42.
- HUTTO, ARNE, EDGEWATER, FL:
3,999,194, INT. CL. 12.
- HUTTON, JULIA R., PHOENIX, AZ:
3,998,790, INT. CL. 25.
- HUXLEY COMMUNICATIONS COOPERATIVE, HUXLEY, IA:
3,999,219, INT. CL. 9.
- HV FOOD PRODUCTS COMPANY, THE, OAKLAND, CA:
2,518,707, REN. 6-14-11. INT. CL. 30.
- HY-VEE, INC., WEST DES MOINES, IA:
2,902,445, CANC. INT. CL. 30.
- HYDE, ALLEN L, ORANGE, CA:
3,999,779, INT. CL. 30.
- HYDRABRUSH, INC., ESCONDIDO, CA:
3,996,457, PUB. 1-25-2011. MULTIPLE CLASS, INT. CLS. 3 AND 21.
- HYDRAULIK-RING GMBH, MARKTHEIDENFELD, FED REP GERMANY:
3,995,518, PUB. 3-17-2009. MULTIPLE CLASS, INT. CLS. 7, 12 AND 16.
- HYDROHOIST MARINE GROUP, INC., CLAREMORE, OK:
3,997,641, PUB. 5-3-2011. INT. CL. 19.
- HYUN JIN, AHN, REPUBLIC OF KOREA:
3,995,931, PUB. 5-3-2011. INT. CL. 9.
- H2 WHOLESALE, LLC, SCOTTSDALE, AZ:
3,997,459, PUB. 5-3-2011. INT. CL. 35.
- H2O PLUS, L.P., CHICAGO, IL:
2,402,304, CANC. INT. CL. 3.
- I DO VENUES, OAKLAND, CA:
3,996,568, PUB. 5-3-2011. MULTIPLE CLASS, INT. CLS. 35 AND 41.
- I KANG ENTERPRISE CO., LTD., KAOHSIUNG COUNTY, TAIWAN:
3,997,705, PUB. 5-3-2011. INT. CL. 6.
- I TO EYE, INC., SMYRNA, GA:
3,999,247, INT. CL. 1.
- I'M HERE TO TELL YA, INC., EL CAJON, CA:
2,901,558, CANC. INT. CL. 28.
- IBAKEFOODS, LLC, BROOKLYN, NY:
3,998,165, PUB. 5-3-2011. INT. CL. 30.
- IBASE TECHNOLOGY INC., TAIPEI 115, TAIWAN:
3,995,663, PUB. 5-3-2011. INT. CL. 9.
- ICLEEN ENTWICKLUNGS- UND VERTRIEBSANSTALT FUER UMWELTSCHUTZ, SCHAAN, LIECHTENSTEIN:
2,434,741, REN. 6-10-11. INT. CL. 11.
2,481,422, REN. 6-10-11. INT. CL. 11.
- ICON-ALTRA LLC, LOGAN, UT:
3,999,473, INT. CL. 25.
- ICONIQ PTY LTD., PERTH, AUSTRALIA:
2,401,344, CANC. INT. CL. 9.
- ID PLUS, PHOENIX, AZ:
2,901,664, CANC. INT. CL. 9.
- IDEA INTERNATIONAL CO., LTD., TOKYO 108-0014, JAPAN:
3,995,953, PUB. 5-3-2011. INT. CL. 3.
- IDEA OVEN LLC, WILMINGTON, NC:
3,996,035, PUB. 5-3-2011. INT. CL. 9.
- IDISPENSE, LLC, TOLEDO, OH:
3,999,082, INT. CL. 3.
- IDT INDUSTRIE- UND DICHTUNGSTECHNIK GMBH, D-45307 ESSEN-KRAY, FED REP GERMANY:
2,401,562, CANC. INT. CL. 17.
- IDT NETHERLANDS, B.V. (PUERTO RICO BRANCH), SAN JUAN, PUERTO RICO:
2,901,677, CANC. INT. CL. 36.
2,902,202, CANC. INT. CL. 36.
- IGNITE RESTAURANT GROUP, INC., HOUSTON, TX:
3,999,452, INT. CL. 29.
- IGOR JARYI, HUNTINGDON VALLEY, PA:
2,901,112, CANC. INT. CL. 29.
- IGRS ENGINEERING LAB LTD., BEIJING, CHINA:
3,996,412, PUB. 5-3-2011. INT. CL. 35.
- IGT, RENO, NV:
3,998,486, INT. CL. 9.
3,998,487, INT. CL. 9.
3,998,666, INT. CL. 9.
3,998,682, INT. CL. 9.
3,998,683, INT. CL. 9.
- IGVAULT CO., LIMITED, WANCHAI, HONG KONG:
3,997,537, PUB. 5-3-2011. INT. CL. 35.
3,997,538, PUB. 5-3-2011. INT. CL. 41.
- II REP-Z, INC., CORAOPOLIS, PA:
3,999,716, INT. CL. 5.
- IKEBE GAKKITEN CO. LTD., TOKYO, JAPAN:
2,901,390, CANC. INT. CL. 15.
- IKONIX GROUP, INC., LAKE FOREST, IL:
3,996,444, PUB. 5-3-2011. INT. CL. 9.
- ILLINOIS AGRICULTURAL ASSOCIATION, BLOOMINGTON, IL:
3,997,288, PUB. 5-3-2011. INT. CL. 35.
3,997,293, PUB. 5-3-2011. INT. CL. 35.
- ILLINOIS GLOVE COMPANY, NORTHBROOK, IL:
2,902,328, CANC. INT. CL. 9.
- ILLINOIS TOOL WORKS INC., GLENVIEW, IL:
2,401,244, CANC. MULTIPLE CLASS, INT. CLS. 2 AND 19.
2,401,246, CANC. MULTIPLE CLASS, INT. CLS. 1, 2 AND 17.
2,401,670, CANC. INT. CL. 1.
3,995,526, PUB. 10-14-2008. INT. CL. 1.
3,999,660, INT. CL. 6.
- ILLYCAFFÈ S.P.A., ITALY:
3,996,006, PUB. 5-3-2011. INT. CL. 30.
- ILTB, LLC, NORMAN, OK:
3,998,913, INT. CL. 33.
- IMAGINATION HOLDINGS, LLC, LAS VEGAS, NV:
3,996,522, PUB. 5-3-2011. INT. CL. 36.
- IMECO, LLC, MILWAUKEE, WI:
387,173, REN. 6-15-11. U.S. CL. 31 (INT. CL. 11).
- IMIS, PLLC, FT. LAUDERDALE, FL:
3,997,485, PUB. 5-3-2011. INT. CL. 44.
- IMJEWELEE, LLC, WARRIOR, AL:
3,996,336, PUB. 5-3-2011. INT. CL. 14.
- IMMIGRATION AND CUSTOMS SOLUTIONS, LLC, EVANSTON, IL, AKA ICS, LLC:
3,997,842, PUB. 5-3-2011. INT. CL. 35.
- IMP CHEMICALS LIMITED, RADCLIFF, UNITED KINGDOM:
3,998,423, INT. CL. 1.
- IMP CHEMICALS LIMITED, GREATER MANCHESTER, UNITED KINGDOM:
3,998,424, INT. CL. 1.
- IMPACT ENERGY GUM, INC., WEST PALM BEACH, GA:
3,998,845, INT. CL. 30.

IMPACT INSTRUMENTATION, INC., WEST CALDWELL, NJ:
2,502,196. REN. 6-14-11. INT. CL. 10.
2,502,197. REN. 6-14-11. INT. CL. 10.

IMPACT RESTAURANT MANAGEMENT INC., VALPARAISO, IN:
3,997,539. PUB. 5-3-2011. INT. CL. 43.
3,997,540. PUB. 5-3-2011. INT. CL. 43.
3,997,541. PUB. 5-3-2011. INT. CL. 43.

IMPCO TECHNOLOGIES, INC., SANTA ANA, CA:
3,995,470. PUB. 5-3-2011. INT. CL. 7.

IMPERIAL TEAS (PVT) LTD, KELANIYA, SRI LANKA:
3,996,959. PUB. 5-3-2011. INT. CL. 30.

IMPERIAL WESTERN PRODUCTS, INC., COACHELLA, CA:
3,996,795. PUB. 5-3-2011. INT. CL. 40.

IMPROV WEST ASSOCIATES, LOS ANGELES, CA:
3,997,621. PUB. 5-3-2011. INT. CL. 41.

IN SHAPE KIDS, INC, SEAFORD, NY:
3,997,690. PUB. 5-3-2011. INT. CL. 41.

INDEPENDENCE TELEVISION CO., INC., LOUISVILLE, KY:
3,997,907. PUB. 5-3-2011. INT. CL. 41.

INDEPENDENCE VISITOR CENTER CORPORATION, PHILADELPHIA, PA:
3,998,255. PUB. 5-3-2011. MULTIPLE CLASS, INT. CLS. 35, 39 AND 41.

INDEPENDENT FEATURE PROJECT/NORTH, INC., MINNEAPOLIS, MN:
2,403,029. CANC. INT. CL. 41.

INDEPENDENT WORLD TELEVISION INC., NEW YORK, NY:
3,996,821. PUB. 5-3-2011. INT. CL. 38.

INDEXATOR AB, VINDELN, SWEDEN:
3,998,881. INT. CL. 7.

INDEXATOR AB, VINDELN S-92221, SWEDEN:
3,998,882. INT. CL. 7.

INDIA HOUSE OF MASSACHUSETTS, INC., LEXINGTON, MA:
3,998,189. PUB. 5-3-2011. INT. CL. 43.

INDIANA SPORTS OUTREACH, INC., INDIANAPOLIS, IN:
3,997,322. PUB. 5-3-2011. INT. CL. 36.
3,997,377. PUB. 5-3-2011. INT. CL. 36.

INDUS BIOTECH PRIVATE LIMITED, PUNE, MAHARASHTRA, INDIA:
3,997,981. PUB. 5-3-2011. INT. CL. 5.
3,997,984. PUB. 5-3-2011. INT. CL. 5.
3,997,985. PUB. 5-3-2011. INT. CL. 5.

INDUSTRIAL ENVIRONMENTAL PRODUCTS, INC., ROSWELL, GA:
2,901,275. CANC. INT. CL. 1.

INDUSTRIAL SENSOR VISION INTERNATIONAL CORPORATION, CHESHIRE, IL:
3,997,224. PUB. 5-3-2011. INT. CL. 9.

INDUSTRIAS LACTEAS SA, PANAMA, PANAMA:
3,995,654. PUB. 1-25-2011. INT. CL. 32.

INFANTINO, LLC, SAN DIEGO, CA:
3,999,135. INT. CL. 12.
3,999,136. INT. CL. 12.

INFINEON TECHNOLOGIES AG, FED REP GERMANY:
3,995,969. PUB. 5-3-2011. MULTIPLE CLASS, INT. CLS. 9, 16, 36 AND 42.

INFINEON TECHNOLOGIES AG, NEUBIBERG, FED REP GERMANY:
3,997,669. PUB. 5-3-2011. INT. CL. 9.

INFIVISION CORPORATION, SAN FRANCISCO, CA:
2,517,234. REN. 6-16-11. INT. CL. 42.
2,522,383. REN. 6-16-11. INT. CL. 9.

INFLUENCE, MENOMONEE FALLS, WI:
3,998,157. PUB. 5-3-2011. INT. CL. 9.

INFLUENCE AT WORK, L.L.C., TEMPE, AZ:
3,999,612. INT. CL. 41.

INFO CUBIC, LLC, GREENWOOD VILLAGE, CO:
3,996,889. PUB. 5-3-2011. INT. CL. 45.

INFOBLOX, INC., SANTA CLARA, CA:
3,998,526. MULTIPLE CLASS, INT. CLS. 9, 38 AND 42.

INFONE LLC, BEAVERTON, OR:
2,901,288. CANC. INT. CL. 25.
2,901,727. CANC. INT. CL. 42.
2,901,728. CANC. INT. CL. 45.

INFORMATICS, INC., CEDAR RAPIDS, IA:
2,463,713. REN. 6-10-11. INT. CL. 42.

INFOS GMBH INVESTMENT FONDS SELECTION, FED REP GERMANY:
3,995,863. PUB. 5-3-2011. MULTIPLE CLASS, INT. CLS. 2, 9, 14, 36 AND 40.

INFOSEAL LLC, ROANOKE, VA:
3,998,596. INT. CL. 16.

INFOTRAC, INC., ATLANTA, GA, DBA INFOTRAC, INC.:
3,996,299. PUB. 5-3-2011. INT. CL. 35.
3,996,300. PUB. 5-3-2011. INT. CL. 35.

INFUSION WELLNESS LLC, LOS ANGELES, CA:
3,998,522. MULTIPLE CLASS, INT. CLS. 9, 16 AND 28.

ING DIRECT BANCORP, WILMINGTON, DE:
3,998,580. MULTIPLE CLASS, INT. CLS. 36 AND 41.

INGENIX, INC., EDEN PRAIRIE, MN:
3,996,345. PUB. 5-3-2011. INT. CL. 35.

INK4EVER.COM, INC., CITY OF INDUSTRY, CA:
3,997,661. PUB. 5-3-2011. INT. CL. 35.

INNEX, INC., CITY OF INDUSTRY, CA:
3,997,831. PUB. 5-3-2011. INT. CL. 9.

INNLABS, LLC, MOUNT SINAI, NY:
2,902,072. CANC. INT. CL. 1.

INNO-LABS LP, WINFIELD, KS:
3,996,458. PUB. 5-3-2011. INT. CL. 21.

INNOVACTIV INC., RIMOUSKI, QUEBEC, CANADA:
3,995,609. PUB. 5-3-2011. INT. CL. 5.

INNOVATION JEWELRY, INC., LOS ANGELES, CA:
3,997,711. PUB. 5-3-2011. INT. CL. 14.

INNOVATIVE RISK CONCEPTS, INC., RIDGEWOOD, NJ:
3,998,042. PUB. 5-3-2011. INT. CL. 36.

INNOVATIVE VEHICLE SOLUTIONS, LLC, MADISON HEIGHTS, MI:
3,996,383. PUB. 5-3-2011. INT. CL. 12.

INSIGHT DATA CORP., NEW YORK, NY:
2,901,907. CANC. MULTIPLE CLASS, INT. CLS. 39 AND 42.

INSIGHT/OUT CONSULTING, LLC, STAMFORD, CT:
2,901,790. CANC. INT. CL. 42.

INSIGHTSNOW, INC., CORVALLIS, OR:
3,998,056. PUB. 5-3-2011. INT. CL. 41.

INSOTECT LIMITED, KWUN TONG, KOWLOON, HONG KONG:
3,998,739. INT. CL. 20.

INSPOITS, INC., RESTON, VA:
3,998,005. PUB. 5-3-2011. MULTIPLE CLASS, INT. CLS. 9, 38 AND 42.

INSTANT INSIGHT, INC., SUNNYVALE, CA:
3,999,495. INT. CL. 41.

INSTINET, LLC, NEW YORK, NY:
2,901,980. CANC. INT. CL. 36.

INSTITUT DE RECHERCHE BIOLOGIQUE, BOUFFERE, FRANCE:
3,995,871. PUB. 5-3-2011. MULTIPLE CLASS, INT. CLS. 3 AND 5.

INSTITUTE FOR THE STUDY OF HUMAN KNOWLEDGE, LOS ALTOS, CA:
3,997,809. PUB. 5-3-2011. INT. CL. 16.

INSTITUTE OF HOLISTIC MIDWIFERY, LLC, MILTON, DE:
3,996,704. PUB. 5-3-2011. INT. CL. 41.

INSURANCEONLY.COM, INC., BELLEVUE, WA:
2,901,825. CANC. INT. CL. 36.

INTEGRATED IDEAS & TECHNOLOGIES, INC., COEUR D'ALENE, ID:
2,902,344. CANC. INT. CL. 9.

INTELAGRID LLC, LOCUST GROVE, VA:
3,996,285. PUB. 5-3-2011. INT. CL. 35.

INTELLECTUAL TAKEOUT, MINNEAPOLIS, MN:
3,998,641. MULTIPLE CLASS, INT. CLS. 35, 41 AND 42.

INTELLERUS, LLC, HILTON HEAD, SC:
2,901,348. CANC. MULTIPLE CLASS, INT. CLS. 16 AND 44.

- INTELLIGENT SOFTWARE SOLUTIONS, INC., COLORADO SPRINGS, CO:
3,997,358, PUB. 5-3-2011. MULTIPLE CLASS, INT. CLS. 9 AND 42.
- INTELLIM RESEARCH, INC., BOCA RATON, FL:
2,901,461, CANC. INT. CL. 42.
- INTELLIMATRIX INC., AVON LAKE, OH, AKA INTELLIMATRIX, INC.:
3,999,704, INT. CL. 42.
- INTELUX, S.A. DE C.V., NUEVO LEON, MEXICO:
3,999,588, INT. CL. 11.
- INTER CONTINENTAL FOODS INC., DORAVILLE, GA:
2,902,257, CANC. MULTIPLE CLASS, INT. CLS. 29 AND 30.
- INTERACTIVA BYG DE MEXICO, S.A. DE, COLONIA ANZURES, MEXICO:
2,901,099, CANC. INT. CL. 3.
- INTERACTIVE GRAPHICS SYSTEM, LLC, CHESTERFIELD, MO:
2,901,808, CANC. INT. CL. 35.
- INTERBAY FUNDING, L.L.C., CORAL GABLES, FL:
2,901,319, CANC. INT. CL. 36.
- INTERCONTINENTAL ART, INC., COMPTON, CA:
3,998,886, INT. CL. 9.
- INTERCONTINENTAL PACKAGING COMPANY, ST. PAUL, MN:
1,660,020, REN. 6-13-11. INT. CL. 33.
1,674,697, REN. 6-10-11. INT. CL. 33.
- INTEREACH INTERNET SERVICES LLC, NORCROSS, GA:
2,401,428, CANC. MULTIPLE CLASS, INT. CLS. 38 AND 42.
- INTERLINK VIDEO PRODUCTIONS, INC., HADDONFIELD, NJ:
2,902,093, CANC. INT. CL. 35.
- INTERNATIONAL BAR ASSOCIATION, LONDON WIT IAT, UNITED KINGDOM:
2,901,529, CANC. INT. CL. 16.
- INTERNATIONAL BUSINESS MACHINES CORPORATION, ARMONK, NY, AKA IBM CORPORATION:
2,901,513, CANC. INT. CL. 9.
- INTERNATIONAL CAREER DEVELOPMENT CENTER, INC., CULVER CITY, CA, DBA ICDC COLLEGE:
3,996,575, PUB. 5-3-2011. INT. CL. 41.
3,996,593, PUB. 5-3-2011. INT. CL. 41.
- INTERNATIONAL CODE COUNCIL, INC., WHITTIER, CA:
3,998,452, MULTIPLE CLASS, INT. CLS. 37, 42 AND 45.
- INTERNATIONAL CORDAGE EAST, LTD., EAST HADDAM, CT:
2,401,959, CANC. INT. CL. 9.
- INTERNATIONAL DATA GROUP, INC., FRAMINGHAM, MA:
2,402,289, CANC. MULTIPLE CLASS, INT. CLS. 16 AND 42.
- INTERNATIONAL DERMAL INSTITUTE, INC., THE, CARSON, CA:
2,477,857, REN. 6-14-11. INT. CL. 41.
- INTERNATIONAL DIGITAL ENTERPRISE ALLIANCE, INC., ALEXANDRIA, VA:
3,995,489, PUB. 5-3-2011. INT. CL. 36.
3,995,490, PUB. 5-3-2011. INT. CL. 42.
3,995,491, PUB. 5-3-2011. INT. CL. 35.
- INTERNATIONAL DRIVER TRAINING, INC., IRVING, TX:
3,997,184, PUB. 5-3-2011. INT. CL. 41.
- INTERNATIONAL FLAVORS & FRAGRANCES INC., NEW YORK, NY:
2,402,856, CANC. INT. CL. 30.
- INTERNATIONAL FRUIT GENETICS, LLC, BAKERSFIELD, CA:
3,999,168, INT. CL. 31.
3,999,436, INT. CL. 31.
- INTERNATIONAL GROWER'S SUPPLY INCORPORATED, CULVER CITY, CA:
3,998,374, INT. CL. 11.
- INTERNATIONAL INSTITUTE OF MANAGEMENT, LAS VEGAS, NV:
3,999,973, INT. CL. 16.
- INTERNATIONAL PACKAGED ICE ASSOCIATION, TAMPA, FL:
2,461,507, REN. 6-16-11. U.S. CL. A.
- INTERNATIONAL PAPER COMPANY, STAMFORD, CT:
2,402,807, CANC. INT. CL. 35.
- INTERNATIONAL PAPER COMPANY, MEMPHIS, TN:
2,456,778, REN. 6-15-11. MULTIPLE CLASS, INT. CLS. 16 AND 21.
2,464,440, REN. 6-15-11. INT. CL. 20.
- INTERNATIONAL REHABILITATIVE SCIENCE, VANCOUVER, WA, DBA RS MEDICAL:
2,504,024, REN. 6-16-11. INT. CL. 10.
- INTERNATIONAL SANITARY SUPPLY ASSOCIATION, LINCOLNWOOD, IL:
3,996,596, PUB. 5-3-2011. INT. CL. 41.
- INTERNATIONAL UNION, SECURITY, POLICE AND FIRE PROFESSIONALS OF AMERICA (SPFPA), ROSEVILLE, MI:
2,563,569, REN. 6-15-11. INT. CL. 42.
- INTERSEAL DIPL.-ING. ROLF SCHMITZ GMBH, FED REP GERMANY:
3,995,875, PUB. 5-3-2011. MULTIPLE CLASS, INT. CLS. 7, 9 AND 17.
- INTERSECTIONS INC., CHANTILLY, VA:
3,996,477, PUB. 5-3-2011. INT. CL. 41.
- INTERSTATE INDUSTRIES, INC., LOVINGSTON, VA:
3,998,317, INT. CL. 9.
- INTRAPRO COMPANY, LTD., SHEUNG WAN, HONG KONG:
3,998,821, INT. CL. 21.
- INTRUST FINANCIAL CORPORATION, WICHITA, KS:
3,998,705, MULTIPLE CLASS, INT. CLS. 21, 25, 35, 41 AND 43.
3,998,706, MULTIPLE CLASS, INT. CLS. 21, 25, 35, 41 AND 43.
- INUVO, INC., CLEARWATER, FL:
3,997,122, PUB. 5-3-2011. MULTIPLE CLASS, INT. CLS. 35 AND 41.
- INVENSYS SYSTEMS, INC., FOXBORO, MA:
3,999,508, INT. CL. 9.
- INVESTOR'S BUSINESS DAILY, INC., LOS ANGELES, CA:
3,997,708, PUB. 5-3-2011. MULTIPLE CLASS, INT. CLS. 36 AND 41.
- INVICTA WATCH COMPANY OF AMERICA, INC., HOLLYWOOD, FL:
2,901,445, CANC. INT. CL. 35.
- INVISIBLE FENCE, INC., KNOXVILLE, TN:
2,472,142, REN. 6-14-11. INT. CL. 9.
- IP HOLDINGS LLC, WILMINGTON, DE:
2,901,802, CANC. INT. CL. 21.
2,901,803, CANC. INT. CL. 14.
2,901,804, CANC. INT. CL. 16.
2,901,817, CANC. INT. CL. 9.
2,901,822, CANC. INT. CL. 12.
- IP HOLDINGS LLC, VANCOUVER, WA:
3,999,842, INT. CL. 11.
4,000,036, INT. CL. 11.
- IP WING KONG, SUFFERN, NY:
3,996,854, PUB. 5-3-2011. INT. CL. 29.
- IPFS CORPORATION, KANSAS CITY, MO:
3,996,707, PUB. 5-3-2011. INT. CL. 36.
3,996,776, PUB. 5-3-2011. INT. CL. 36.
3,996,808, PUB. 5-3-2011. INT. CL. 36.
- IPFS CORPORATION, KANSAS CITY, NJ:
3,998,016, PUB. 5-3-2011. INT. CL. 36.
- IPG HOLDING SA, APPENZELL, SWITZERLAND:
3,997,858, PUB. 5-3-2011. INT. CL. 28.
3,998,254, PUB. 5-3-2011. INT. CL. 28.
- IPGENIX, LLC, PENSACOLA, FL:
3,999,138, MULTIPLE CLASS, INT. CLS. 35, 36 AND 45.
- IPX INTERNATIONAL INC., FARMINGDALE, NJ:
3,995,574, PUB. 5-3-2011. INT. CL. 9.
- IQ PAYMENT SYSTEMS, VANCOUVER, WA, DBA ALPINE PAYMENT SYSTEMS:
3,996,717, PUB. 5-3-2011. INT. CL. 36.
- IR, NEIL, OCEANSIDE, NY:
3,998,329, INT. CL. 12.

IRON CROSS AUDIO LLC, OAKLAND, NJ:
3,996,870, PUB. 5-3-2011. INT. CL. 37.

IRON FIST INTERNATIONAL, INC., SAN DIEGO, CA:
3,995,601, PUB. 5-3-2011. INT. CL. 25.

IRON FIST INTERNATIONAL, INC., SAN DIEGO, CA:
3,999,834, INT. CL. 25.

IRON SHIELD PROTECTION SERVICES, CLINTON, MD:
3,999,683, INT. CL. 45.

IRON TRIANGLE, LLC, WAUWATOSA, WI:
3,999,939, INT. CL. 35.

ISAAC W. BERNHEIM FOUNDATION, CLERMONT, KY:
3,996,178, PUB. 5-3-2011. INT. CL. 41.

ISABEL ARAGON VILLACASTIN, SPAIN:
3,996,015, PUB. 5-3-2011. MULTIPLE CLASS, INT. CLS. 35 AND 45.

ISAGENIX WORLDWIDE, LLC, CHANDLER, AZ:
3,999,833, MULTIPLE CLASS, INT. CLS. 3 AND 5.

ISHA FOUNDATION, INC., MCMINNVILLE, TN:
3,999,009, INT. CL. 41.

ISHII KAZUYOSHI, JAPAN:
3,995,729, PUB. 5-3-2011. MULTIPLE CLASS, INT. CLS. 35 AND 41.

ISLAMIC RELIEF WORLDWIDE, BIRMINGHAM, UNITED KINGDOM:
3,998,356, INT. CL. 9.
3,999,005, INT. CL. 16.

ISP DIRECT, INC., PITTSFORD, NY:
2,901,709, CANC. INT. CL. 42.

ISP MINERALS INVESTMENTS LLC, WAYNE, NJ:
3,998,917, INT. CL. 19.

ISPACES IT LTD., CARNDONAGH, IRELAND, AKA IS-PACES:
3,999,233, INT. CL. 9.
3,999,234, INT. CL. 42.

ISR INSTITUTE, INC., HARAHAN, LA:
2,901,684, CANC. INT. CL. 41.

ISTART PARTNERS, LTD., GRANBURY, TX:
3,996,562, PUB. 5-3-2011. INT. CL. 7.

IT LIFELINE, INC., LIBERTY LAKE, WA:
3,997,597, PUB. 5-3-2011. MULTIPLE CLASS, INT. CLS. 35 AND 42.

ITA, INC., ST. AUGUSTINE, FL:
2,401,191, CANC. INT. CL. 24.

ITALIAN LUXURY INDUSTRIES S.P.A., VICENZA, ITALY:
2,901,055, CANC. INT. CL. 14.

ITRON, INC., LIBERTY LAKE, WA:
2,438,984, AM. INT. CL. 9.
2,742,864, AM. MULTIPLE CLASS, INT. CLS. 9 AND 38.

ITT MANUFACTURING ENTERPRISES, INC., WILMINGTON, DE:
2,563,430, REN. 6-16-11. MULTIPLE CLASS, INT. CLS. 9 AND 11.

IVEX PROTECTIVE PACKAGING, INC., BRIDGEVIEW, IL:
3,999,069, INT. CL. 17.

IVILLA, LLC, MILL VALLEY, CA:
3,997,004, PUB. 5-3-2011. INT. CL. 36.

IWAKI AMERICA INCORPORATED, HOLLISTON, MA:
3,998,627, INT. CL. 38.

I85MEDIA, INC., ATLANTA, GA:
3,997,450, PUB. 5-3-2011. INT. CL. 42.

J PECHAUER CUSTOM CUES INC, GREEN BAY, WI:
3,996,827, PUB. 5-3-2011. INT. CL. 28.

J R'S TANNING SALON, LIVONIA, MI:
2,901,346, CANC. INT. CL. 44.

J. E. RICH CO., TUSTIN, CA:
2,402,987, CANC. INT. CL. 5.

J. MITTON & ASSOCIATES, INC., NEW HOLLAND, PA, DBA INTREPID INTERNATIONAL:
3,997,781, PUB. 5-3-2011. INT. CL. 18.

J.C. BROMAC CORPORATION, HAWTHORNE, CA:
3,996,475, PUB. 5-3-2011. MULTIPLE CLASS, INT. CLS. 25, 35 AND 39.

J.C. CHEEK CONTRACTORS, INC., KOSCIUSKO, MS:
3,997,298, PUB. 5-3-2011. INT. CL. 37.

J.C. PENNEY PRIVATE BRANDS, INC., PLANO, TX:
3,998,879, INT. CL. 25.

J.C.BAMFORD EXCAVATORS LIMITED, UNITED KINGDOM:
3,995,944, PUB. 5-3-2011. INT. CL. 7.

J.N. EBERLE & CIE GMBH, AUGSBURG, FED REP GERMANY:
1,639,521, REN. 6-16-11. INT. CL. 7.

J.T. POSEY COMPANY, ARCADIA, CA:
3,998,884, INT. CL. 10.

J&B AMOS INVENTORY SERVICES OF FLORIDA, INC., LOXAHATCHEE, FL:
1,659,088, REN. 6-15-11. INT. CL. 35.

J&J SNACK FOODS CORP., PENNSAUKEN, NJ:
2,901,507, CANC. INT. CL. 30.

J-U-B ENGINEERS, INC., KENNEWICK, WA:
3,996,051, PUB. 5-3-2011. INT. CL. 42.

J'S RACING USA LLC, TORRANCE, CA:
3,997,579, PUB. 5-3-2011. MULTIPLE CLASS, INT. CLS. 7 AND 12.

JACK IN THE BOX INC., SAN DIEGO, CA:
2,901,302, CANC. INT. CL. 43.

JACK ROBIE, INC., NEW YORK, NY:
3,998,788, MULTIPLE CLASS, INT. CLS. 25 AND 35.

JACK'S MAGIC PRODUCTS, INC., LARGO, FL:
2,502,150, REN. 6-14-11. INT. CL. 1.

JACKET PROPERTIES INC, FAYETTEVILLE, GA:
3,997,644, PUB. 5-3-2011. INT. CL. 35.

JACKSON & JACKSON ELECTRONIC ALL STAR LURES, INC., FLOWER MOUND, TX:
3,996,100, PUB. 5-3-2011. INT. CL. 28.

JACKSON CORPORATION, NEW YORK, NY:
3,998,933, INT. CL. 18.

JACKSON NATIONAL LIFE INSURANCE COMPANY, LANSING, MI:
2,901,679, CANC. INT. CL. 41.

JACKSON, DEAN, D, TORONTO, ONTARIO, CANADA:
3,998,240, PUB. 5-3-2011. INT. CL. 20.

JACKSON, YAMILE C., LA JOLLA, CA:
3,996,196, PUB. 5-3-2011. INT. CL. 35.

JACOBS, ROSALIE ANNE, HOGANSBURG, NY:
3,998,626, INT. CL. 34.

JADA TOYS, INC., CITY OF INDUSTRY, CA:
2,902,099, CANC. INT. CL. 28.

JAFFE, RUSSELL M., VIENNA, VA:
2,561,154, REN. 6-13-11. INT. CL. 5.

JAGADOWSKI, THOMAS J., CHICAGO, IL AND PASQUESI, DAVID, CHICAGO, IL:
3,997,367, PUB. 5-3-2011. INT. CL. 41.

JAGUAR CARS LIMITED, COVENTRY, UNITED KINGDOM:
1,645,289, REN. 6-16-11. INT. CL. 21.

JAGUAR MANAGEMENT CONSULTING GROUP, INC., KINGSTON, NH:
2,402,159, CANC. INT. CL. 35.

JAH INNOVATIONS INC., ATLANTA, GA:
3,998,303, INT. CL. 42.

JAKE AND TROY BRAND LLC, SANTA MONICA, CA:
3,998,379, INT. CL. 25.
3,998,381, INT. CL. 25.

JAM CELLARS INC, NAPA, CA:
3,999,253, INT. CL. 33.

JAMBA JUICE COMPANY, EMERYVILLE, CA:
2,901,857, CANC. INT. CL. 43.

JAMES IRA WILLIAMS JR., HIGH POINT, NC:
3,852,796, AM. INT. CL. 16.

JAMES L SCHUPPE, WAUKESHA, WI, DBA INDUCTION SYSTEMS, INC.:
3,996,560, PUB. 5-3-2011. INT. CL. 11.

JAMES L THRONEBURG, STATESVILLE, NC, THORNEBURG HOSIERY CO., INC., STATESVILLE, NC:
1,163,802, REN. 6-14-11. INT. CL. 25.

JAMES L. THRONEBURG, STATESVILLE, NC:
3,996,570, PUB. 1-25-2011. INT. CL. 25.

JAMES M. FORTESCUE, WASHINGTON, NC:
3,997,679, PUB. 5-3-2011. INT. CL. 14.

JAMO A/S, ROSLEV, DENMARK:
2,901,661, CANC. INT. CL. 9.

JANG, JAE YEUN, SEOUL, REPUBLIC OF KOREA:
3,995,638, PUB. 5-3-2011. INT. CL. 25.

- JAQUEZ, RAYMOND, BAY SHORE, NY, DBA MULTI VITAMIN ENERGY CORP.:
3,995,579, PUB. 1-5-2010. INT. CL. 32.
- JAR.INC, SAN LEANDRO, CA, DBA RICKY'S:
3,998,132, PUB. 5-3-2011. INT. CL. 43.
- JARAMILLO, EDWARD TERRY, CORAL GABLES, FL:
3,997,396, PUB. 5-3-2011. INT. CL. 39.
- JASCO PRODUCTS COMPANY LLC, OKLAHOMA CITY, OK:
3,999,986, INT. CL. 9.
- JASCOTT DEVELOPMENTS, LLC, LEXINGTON, SC:
2,902,234, CANC. INT. CL. 37.
- JASON CROPPER, LOWER DARWEN BB3 OPR, UNITED KINGDOM:
3,995,949, PUB. 5-3-2011. INT. CL. 35.
- JAVAHERI, PJ, CENTURY CITY, CA:
3,996,268, PUB. 5-3-2011. INT. CL. 45.
- JAVED, MIAN M N, LOS ANGELES, CA:
3,996,369, PUB. 5-3-2011. INT. CL. 28.
- JAY AT PLAY INTERNATIONAL HONG KONG LIMITED, HONG KONG, CHINA:
3,998,335, INT. CL. 28.
3,998,336, INT. CL. 28.
3,998,337, INT. CL. 28.
- JAZZYBIRD CAFE, INC., GEISMAR, LA:
3,997,197, PUB. 5-3-2011. INT. CL. 30.
- JB ORTHOTICS & SHOES, GLENVIEW, IL:
3,996,464, PUB. 1-25-2011. INT. CL. 10.
- JBM, INC., LAKE HAVASU CITY, AZ:
1,661,828, REN. 6-14-11. INT. CL. 28.
- JC DECAUX MOBILIER URBAIN, 92200 NEUILLY SUR SEINE, FRANCE:
2,459,043, REN. 6-13-11. MULTIPLE CLASS, INT. CLS. 6, 9, 11, 20 AND 35.
- JEA, JACKSONVILLE, FL:
2,481,238, REN. 6-16-11. INT. CL. 39.
- JEANNE SIMMONS ACCESSORIES INC, VISTA, CA:
3,997,380, PUB. 5-3-2011. INT. CL. 25.
- JED REICHL INVESTMENTS, LLC, CHICAGO, IL:
3,997,901, PUB. 5-3-2011. INT. CL. 43.
3,997,906, PUB. 5-3-2011. INT. CL. 43.
- JEFFERSONLARSONSMITH, LLC, LOS ANGELES, CA, DBA CULTURESYNCH:
3,996,886, PUB. 5-3-2011. MULTIPLE CLASS, INT. CLS. 9, 16 AND 41.
- JEFFREY HAMMOND, UNITED KINGDOM:
3,995,786, PUB. 5-3-2011. INT. CL. 25.
- JENNIE HELDERMAN, ATLANTA, GA:
3,999,596, INT. CL. 41.
- JENNINGS, JEFFREY, MAGNOLIA, TX:
3,999,148, INT. CL. 41.
- JENNINGS, THOMAS A, BLOOMINGTON, IL:
3,999,071, INT. CL. 29.
- JENSEN, GREG N., CAPISTRANO BEACH, CA, DBA 404:
3,996,361, PUB. 5-3-2011. INT. CL. 25.
- JESKI, KENNETH R., SOUTH WINDSOR, CT:
3,998,711, INT. CL. 25.
- JESSE ANTHONY OROPEZA, OVERLAND PARK, KS:
2,901,352, CANC. INT. CL. 16.
- JETSON CREATIVE LLC, OAKLAND, CA:
3,996,187, PUB. 5-3-2011. INT. CL. 9.
- JIANGYIN LONG-BRIGHT DRILL PIPE; MANUFACTURE CO., LTD., CHINA:
3,995,797, PUB. 5-3-2011. INT. CL. 7.
- JIANGYIN NANFANG PIPE FITTING MAKING CO., LTD., CHINA:
3,996,000, PUB. 5-3-2011. INT. CL. 6.
- JIM BEAM BRANDS CO., DEERFIELD, IL, SUNNY BROOK DISTILLERY CO., THE, CHICAGO, IL:
142,338, REN. 6-10-11. U.S. CL. 49 (INT. CL. 33).
- JIM C.H. LEE, LOS ANGELES, CA:
3,999,443, INT. CL. 20.
- JIM KAI YING, TUEN MUN, HONG KONG, DBA Y2 INTERNATIONAL TRADING COMPANY:
3,996,505, PUB. 5-3-2011. INT. CL. 3.
- JIM'S FORMAL WEAR COMPANY, TRENTON, IL:
2,402,378, CANC. INT. CL. 42.
- JIMMY HACK GOLF, LLC, EASLEY, SC:
3,998,422, INT. CL. 28.
- JIMMY JOHN'S ENTERPRISES, LLC, CHAMPAIGN, IL:
3,997,220, PUB. 5-3-2011. MULTIPLE CLASS, INT. CLS. 39 AND 43.
- JIMTEN, S.A., SPAIN:
3,995,959, PUB. 5-3-2011. MULTIPLE CLASS, INT. CLS. 6 AND 11.
- JJI INTERNATIONAL, INC., CRANSTON, RI:
3,999,722, INT. CL. 9.
- JJNS CAPITAL LLC, AUSTIN, TX:
3,998,126, PUB. 5-3-2011. INT. CL. 35.
- JK-HOLDING GMBH, WINDHAGEN, FED REP GERMANY:
3,995,548, PUB. 3-30-2010. MULTIPLE CLASS, INT. CLS. 9, 10, 11, 41 AND 44.
- JMS COFFEE COMPANY, ORRVILLE, OH:
1,656,167, REN. 6-10-11. MULTIPLE CLASS, INT. CLS. 11 AND 30.
- JMWILLIAMS LLC, NEW YORK, NY:
3,996,324, PUB. 5-3-2011. INT. CL. 43.
- JOACHIM UHING KG GMBH & CO., D-24247 MIELKENDORF, FED REP GERMANY:
2,465,035, REN. 6-15-11. INT. CL. 7.
- JOANNE DUGAN PHOTOGRAPHY LLC, NEW YORK, NY, DBA THE ALPHABET CITY:
3,997,655, PUB. 5-3-2011. INT. CL. 27.
- JOBRI L.L.C., KONAWA, OK:
2,401,807, CANC. INT. CL. 10.
- JOBZIPPER LLC, MANCHESTER, NH:
3,998,472, INT. CL. 35.
- JOE INTERNATIONAL CORPORATION, TOKYO 150-0044, JAPAN:
3,997,744, PUB. 5-3-2011. INT. CL. 25.
- JOEL J. KOFISKY, PHILADELPHIA, PA:
3,997,971, PUB. 5-3-2011. INT. CL. 45.
- JOEY WEAR LLC, SAN LEANDRO, CA:
3,998,508, INT. CL. 18.
- JOHN A. THOMSON FOR THOMSON FAMILY PARTNERSHIP, DBA VITAMIN INSTITUTE, NORTH HOLLYWOOD, CA:
3,997,703, PUB. 5-3-2011. INT. CL. 1.
- JOHN B. SANFILIPPO & SON, INC., ELGIN, IL:
3,998,299, PUB. 5-3-2011. INT. CL. 16.
- JOHN BEAN TECHNOLOGIES CORPORATION, CHICAGO, IL:
2,451,220, REN. 6-15-11. MULTIPLE CLASS, INT. CLS. 9 AND 42.
- JOHN FOGERTY, LOS ANGELES, CA AND JULIE FOGERTY, LOS ANGELES, CA:
3,998,385, INT. CL. 25.
- JOHN M. TAYMAN, SAN FRANCISCO, CA:
3,997,632, PUB. 5-3-2011. MULTIPLE CLASS, INT. CLS. 41 AND 42.
- JOHN MANUFACTURING LTD., KWUN TONG, KOWLOON, HONG KONG:
2,901,443, CANC. INT. CL. 11.
- JOHN MIDDLETON CO., KING OF PRUSSIA, PA:
3,999,808, INT. CL. 34.
3,999,809, INT. CL. 34.
3,999,810, INT. CL. 34.
- JOHN PAUL MITCHELL SYSTEMS, SANTA CLARITA, CA:
2,523,714, REN. 6-14-11. INT. CL. 3.
- JOHN S. LETCHINGER, CHICAGO, IL AND THOMAS J. RING, CHICAGO, IL:
3,999,685, INT. CL. 21.
- JOHN SCOTT, OCEANSIDE, CA AND MARK DOHERTY, OCEANSIDE, CA:
3,998,858, INT. CL. 28.
- JOHNNY SALAMI'S SUB AND GRILL, LLC, NEW HAVEN, CT:
2,451,785, REN. 6-10-11. INT. CL. 42.
- JOHNSON & JOHNSON, NEW BRUNSWICK, NJ:
2,402,353, CANC. INT. CL. 5.
2,451,584, REN. 6-15-11. INT. CL. 5.
2,901,363, CANC. MULTIPLE CLASS, INT. CLS. 9 AND

16.
2,901,981, CANC. INT. CL. 3.
3,996,492, PUB. 5-3-2011. INT. CL. 5.
3,998,551, INT. CL. 16.
3,998,861, INT. CL. 5.
3,998,862, INT. CL. 5.
3,998,863, INT. CL. 5.
3,999,951, INT. CL. 3.
4,000,004, INT. CL. 41.
- JOHNSON & ST. LAWRENCE, INC., REDONDON BEACH, CA:
2,901,290, CANC. MULTIPLE CLASS, INT. CLS. 35 AND 41.
- JOHNSON PRODUCTS COMPANY, INC., DALLAS, TX:
3,999,913, INT. CL. 3.
- JOHNSON, STEVEN W. PEARLAND, TX:
3,998,503, INT. CL. 16.
- JOINT JUICE, INC., SAN FRANCISCO, CA:
3,997,083, PUB. 5-3-2011. INT. CL. 5.
- JOMAR CATTLE FEEDERS INC., AYR, ONTARIO:
2,901,466, CANC. INT. CL. 29.
- JONATHAN GORDON, NEW YORK, NY:
3,997,115, PUB. 5-3-2011. INT. CL. 41.
- JONATHAN H. BASSAN, SANTA BARBARA, CA:
3,996,183, PUB. 5-3-2011. INT. CL. 9.
- JONATHAN PENNEY, INC., CENTER MORICHES, NY:
2,902,103, CANC. INT. CL. 40.
- JONES INTERNATIONAL, LTD., CENTENNIAL, CO, JONES GROUP, LTD., THE, ENGLEWOOD, CO:
1,158,372, REN. 6-15-11. INT. CL. 36.
- JONES-HAMILTON CO., WALBRIDGE, OH:
2,902,041, CANC. MULTIPLE CLASS, INT. CLS. 12 AND 20.
- JONES, DAVID, HONDO, TX:
3,999,982, INT. CL. 31.
- JONES, FRANCESCO, CASTRO VALLEY, CA:
3,996,287, PUB. 5-3-2011. INT. CL. 9.
- JONES, PAUL, LONDON, UNITED KINGDOM:
3,999,019, MULTIPLE CLASS, INT. CLS. 6, 16, 35 AND 41.
- JOON NAM LEE, RIVERDALE, GA:
3,998,378, INT. CL. 44.
- JOSE CANEPA Y CIA. LTDA., SANTIAGO, CHILE:
3,996,515, PUB. 5-3-2011. INT. CL. 33.
- JOSEPH PERRIER FILS & CIE, FRANCE:
3,995,806, PUB. 5-3-2011. INT. CL. 33.
- JOSEPHSEN, FRED, NORTHFIELD, NJ, DBA JOSEPHSEN HARDWOOD FLOOR COMPANY AND JOSEPHSEN, FRANCES, NORTHFIELD, NJ, DBA JOSEPHSEN HARDWOOD FLOOR COMPANY:
3,998,970, INT. CL. 40.
- JOSHUA KAHAN FUND, VOORHEES, NJ:
2,901,769, CANC. INT. CL. 36.
- JOURDAN MILES INC., RALEIGH, NC:
3,998,664, INT. CL. 42.
- JOURNALISM ONLINE, LLC, NEW YORK, NY:
3,998,956, INT. CL. 36.
- JOVOTO GMBH, BERLIN, FED REP GERMANY:
3,996,483, PUB. 5-3-2011. MULTIPLE CLASS, INT. CLS. 9, 35, 38, 41 AND 42.
- JOYENT, INC., SAN FRANCISCO, CA:
3,996,190, PUB. 5-3-2011. MULTIPLE CLASS, INT. CLS. 42 AND 45.
3,996,199, PUB. 5-3-2011. MULTIPLE CLASS, INT. CLS. 42 AND 45.
- JPCI CONTROLS FOSHAN GAOMING CO., LTD., 528350 FOSHAN CITY, GUANGDONG PROVINCE, CHINA:
3,995,857, PUB. 5-3-2011. MULTIPLE CLASS, INT. CLS. 9, 11 AND 20.
- JPMORGAN CHASE & CO., NEW YORK, NY:
2,901,994, CANC. INT. CL. 36.
3,996,257, PUB. 5-3-2011. MULTIPLE CLASS, INT. CLS. 35 AND 36.
- JRS INTERNATIONAL, LLC, LYNDHURST, NJ:
3,998,304, MULTIPLE CLASS, INT. CLS. 1, 5 AND 30.
- JSG PUBLISHING, INC., CHICAGO, IL:
2,901,388, CANC. INT. CL. 16.
- JSS RESTAURANT GROUP, INC., SAN FRANCISCO, CA:
3,996,106, PUB. 5-3-2011. INT. CL. 43.
- JT INTERNATIONAL DISTRIBUTORS, INC., INDIANAPOLIS, IN:
2,901,626, CANC. MULTIPLE CLASS, INT. CLS. 9 AND 18.
- JUE, JEFFREY, PASADENA, CA:
3,995,588, PUB. 11-30-2010. INT. CL. 45.
- JUMP APPAREL CO., INC., NEW YORK, NY:
3,995,561, PUB. 5-3-2011. INT. CL. 25.
- JUMPING JACK, LLC, SALT LAKE CITY, UT:
2,889,699, COR. MULTIPLE CLASS, INT. CLS. 12 AND 22.
- JUMPSTART ENERGY SERVICES, LLC, HOUSTON, TX:
3,998,572, INT. CL. 1.
- JUMPSTART MEDICINE, P.C., LAFAYETTE, CA:
3,999,815, INT. CL. 44.
- JUPITER MARINE, INC., FORT LAUDERDALE, FL:
2,459,836, REN. 6-14-11. INT. CL. 12.
- JUPITER YACHT CHARTERS, INC., JUPITER, FL:
2,902,109, CANC. INT. CL. 12.
- JURONG TOWN CORPORATION, THE JTC SUMMIT, SINGAPORE:
2,901,188, CANC. INT. CL. 35.
- JUVENILE SOLUTIONS, INC, LOS ANGELES, CA:
2,902,457, CANC. INT. CL. 28.
- JVC KENWOOD HOLDINGS, INC., KANAGAWA, JAPAN:
3,997,972, PUB. 5-3-2011. INT. CL. 9.
- JWB WINE LLC, VICTORIA, TX, DBA BRAMAN WINERY:
3,999,489, INT. CL. 33.
- K & A CRYLICS, INC., WARTRACE, TN:
2,573,504, REN. 6-16-11. INT. CL. 20.
- K & W CAFETERIAS, INC., WINSTON-SALEM, NC:
2,501,839, REN. 6-16-11. INT. CL. 42.
- K AND G CYCLES LLC, LAWRENCE, KS, DBA K AND G CYCLES:
3,997,094, PUB. 5-3-2011. INT. CL. 35.
- K. DONALDSON LLC, BOSTON, MA:
3,997,255, PUB. 5-3-2011. INT. CL. 9.
- K&G MEN'S COMPANY, INC., ATLANTA, GA:
2,454,543, REN. 6-16-11. INT. CL. 25.
- K-BROOKS, LEIF C, PORTLAND, OR:
3,997,588, PUB. 5-3-2011. INT. CL. 38.
3,997,589, PUB. 5-3-2011. INT. CL. 38.
- K-TEC, INC., OREM, UT:
2,901,989, CANC. INT. CL. 7.
- K'HILLAH K'DOSHAH B'NAI YESHURUN, CINCINNATI, OH, DBA ISAAC M. WISE TEMPLE:
3,996,729, PUB. 5-3-2011. INT. CL. 41.
- KABBALAH CENTRE INTERNATIONAL, INC., LOS ANGELES, CA:
3,998,231, PUB. 5-3-2011. INT. CL. 9.
- KABUSHIKI KAISHA AUDIO-TECHNICA, TOKYO, JAPAN, DBA AUDIO-TECHNICA CORPORATION:
2,493,199, REN. 6-15-11. INT. CL. 7.
- KABUSHIKI KAISHA BANDAI, TAITO-KU, TOKYO, JAPAN:
2,461,046, REN. 6-16-11. INT. CL. 28.
- KABUSHIKI KAISHA FUJISOKU, KANAGAWA-KEN, JAPAN, DBA FUJISOKU CORPORATION:
1,159,825, REN. 6-16-11. INT. CL. 9.
- KABUSHIKI KAISHA INFORMATIX, KANAGAWA 212-8554, JAPAN:
3,999,923, MULTIPLE CLASS, INT. CLS. 9, 35, 39 AND 42.
- KABUSHIKI KAISHA MIKIMOTO, TOKYO, JAPAN, TA K. MIKIMOTO & CO. LTD.:
2,901,886, CANC. MULTIPLE CLASS, INT. CLS. 16 AND 21.
- KABUSHIKI KAISHA NPC (ALSO TRADING AS NPC INCORPORATED), JAPAN:
3,995,837, PUB. 5-3-2011. INT. CL. 7.
- KABUSHIKI KAISHA SQUARE ENIX, TOKYO, JAPAN, AKA SQUARE ENIX CO., LTD.:
3,999,085, INT. CL. 9.
- KABUSHIKI KAISHA SQUARE ENIX, TOKYO, JAPAN, TA SQUARE ENIX CO., LTD.:
3,999,429, INT. CL. 9.
- KAISER FOUNDATION HEALTH PLAN, INC., OAKLAND, CA:
3,996,494, PUB. 5-3-2011. INT. CL. 35.

- KALMBACH FEEDS, INC., UPPER SANDUSKY, OH:
3,998,271, PUB. 5-3-2011. INT. CL. 31.
- KAMAK DYNAMICS USA GROUP, WEST COVINA, CA:
3,997,942, PUB. 5-3-2011. INT. CL. 7.
- KANEKA CORPORATION, KITA KU, OSAKA 530, JAPAN:
1,650,504, REN. 6-15-11. INT. CL. 1.
- KANG, DONALD BURN SIK MR., HONOLULU, HI, DBA
ROYAL HAWAIIAN CREATIONS:
1,648,204, REN. 6-16-11. INT. CL. 25.
- KAOHELO ENTERPRISE LLC, LAHAINA, HI, DBA ISLAND
FROYO:
3,996,946, PUB. 5-3-2011. INT. CL. 43.
- KAPER II, INC., KELSO, WA:
3,996,597, PUB. 5-3-2011. INT. CL. 9.
- KAREN JOSEPH, BAYTOWN, TX:
3,997,546, PUB. 5-3-2011. INT. CL. 30.
- KAREN KLEIN FASHION, INC, SUNNYVALE, CA:
3,996,784, PUB. 5-3-2011. INT. CL. 25.
- KAREN PAUL, LARCHMONT, NY:
3,999,750, MULTIPLE CLASS, INT. CLS. 18 AND 25.
- KARISMATIC, INC., PARK RIDGE, IL, AKA KARISMATIC
MAKEUP:
3,996,076, PUB. 5-3-2011. INT. CL. 3.
- KARL STORZ GMBH & CO. KG, D-78532 TUTTLINGEN,
FED REP GERMANY:
2,476,869, REN. 6-15-11. INT. CL. 10.
- KARMISSIE, LLC, LAS VEGAS, CA:
3,996,144, PUB. 5-3-2011. MULTIPLE CLASS, INT. CLS. 3,
5 AND 8.
- KARREMAN, HUBERT J., NARVON, PA:
3,996,752, PUB. 5-3-2011. INT. CL. 5.
- KARYKION, INC., PRINCETON, NJ:
3,998,416, INT. CL. 5.
- KASATSHKO, VICTOR, TARPON SPRINGS, FL:
2,902,124, CANC. MULTIPLE CLASS, INT. CLS. 20 AND
28.
- KATE SPADE, LLC, NEW YORK, NY:
2,455,406, COR. INT. CL. 18.
2,537,318, COR. INT. CL. 18.
2,654,803, COR. INT. CL. 9.
2,901,504, CANC. INT. CL. 25.
3,997,947, PUB. 5-3-2011. INT. CL. 25.
- KATIE KALSI, LLC, GERMANTOWN, TN:
3,997,739, PUB. 5-3-2011. INT. CL. 18.
- KATRIN KLEYBOLDT, FED REP GERMANY:
3,995,825, PUB. 5-3-2011. MULTIPLE CLASS, INT. CLS.
35, 36, 38 AND 42.
3,995,826, PUB. 5-3-2011. MULTIPLE CLASS, INT. CLS.
35, 36, 38 AND 42.
- KAWASHO FOODS CORPORATION, TOKYO, JAPAN:
3,996,265, PUB. 5-3-2011. INT. CL. 29.
- KAY YOW CANCER FOUNDATION, INC., CARY, NC, AKA
KAY YOW CANCER FUND:
3,997,389, PUB. 5-3-2011. MULTIPLE CLASS, INT. CLS. 35
AND 36.
3,997,401, PUB. 5-3-2011. MULTIPLE CLASS, INT. CLS. 35
AND 36.
- KB NETWORKS, INC., PLANO, TX:
2,902,245, CANC. INT. CL. 9.
- KBL GROUP INTERNATIONAL LTD., NEW YORK, NY:
2,901,389, CANC. INT. CL. 25.
- KBP HOLDINGS LLC, NEW YORK, NY:
3,997,560, PUB. 5-3-2011. MULTIPLE CLASS, INT. CLS. 35
AND 42.
- KD DID, INC., CALABASAS, CA, DBA ENERGY ESSEN-
TIALS:
3,996,347, PUB. 5-3-2011. INT. CL. 30.
- KEBA GESELLSCHAFT M.B.H., OTTENSHEIM, AUSTRIA:
3,998,571, MULTIPLE CLASS, INT. CLS. 7 AND 9.
- KEEN ENTERTAINMENT LLC, WESTMINSTER, CA:
3,997,161, PUB. 5-3-2011. INT. CL. 41.
- KEEPSAKE THREADS, LLC, FORT WAYNE, IN:
3,999,616, INT. CL. 40.
- KEETON, LINDA K, CHEYENNE, WY:
2,900,977, CANC. INT. CL. 1.
- KEGAN & KEGAN, LTD., CHICAGO, IL:
2,402,964, CANC. INT. CL. 42.
- KELBY MEDIA GROUP, INC., OLDSMAR, FL:
3,996,078, PUB. 5-3-2011. INT. CL. 41.
- KELLERMAN, DAVID W., WASHINGTON, NH:
2,402,117, CANC. INT. CL. 42.
- KELLWOOD COMPANY, CHESTERFIELD, MO:
3,999,806, INT. CL. 25.
- KELLY, KEVIN P., STAMFORD, CT:
2,902,269, CANC. INT. CL. 16.
- KELLY, MARK A., LAKE OZARK, MO:
3,999,284, INT. CL. 9.
- KEMIN INDUSTRIES, INC., DES MOINES, IA:
3,999,751, INT. CL. 30.
- KENEXA CORPORATION, WAYNE, PA:
3,996,333, PUB. 5-3-2011. MULTIPLE CLASS, INT. CLS. 9
AND 42.
3,999,406, MULTIPLE CLASS, INT. CLS. 9 AND 42.
- KENEZ, MARY, BOULDER, CO:
2,401,892, CANC. INT. CL. 16.
- KENNEDY, SCOTT F., MONTCLAIR, NJ:
3,999,101, INT. CL. 35.
- KENWORTHY, CHARLES, SANTA MONICA, CA AND
KENWORTHY, TERRI, SANTA MONICA, CA:
3,998,305, INT. CL. 16.
- KENWORTHY, TERRI, LOS ANGELES, CA AND KEN-
WORTHY, CHARLES, LOS ANGELES, CA:
3,998,410, INT. CL. 16.
- KERRITS ACTIVEWEAR, INC. A WASHINGTON COR-
PORATION, BINGEN, WA:
3,998,688, INT. CL. 25.
- KETCHUM, MICHAEL, KENOSHA, WI AND MAURER,
SCOTT, KENOSHA, WI:
3,997,929, PUB. 5-3-2011. INT. CL. 25.
- KETCHUPMAN & CO., LLC, BARTLETT, TN:
3,998,718, INT. CL. 29.
- KETTLEHOUSE BREWING COMPANY, LLC, MISSOULA,
MT:
3,996,801, PUB. 5-3-2011. INT. CL. 43.
- KEVIN J. OWOC, D.M.D., P.C., MONROEVILLE, PA:
3,996,368, PUB. 11-30-2010. MULTIPLE CLASS, INT. CLS.
41 AND 44.
- KEWAUNEE SCIENTIFIC CORPORATION, STATESVILLE,
NC:
3,999,418, MULTIPLE CLASS, INT. CLS. 9 AND 20.
- KEY METRICS LLC, TALLAHASSEE, FL:
3,997,227, PUB. 5-3-2011. INT. CL. 41.
- KEY TO BIZ LLC, HOUSTON, TX:
3,999,708, INT. CL. 35.
- KFC CORPORATION, LOUISVILLE, KY:
2,506,240, REN. 6-10-11. INT. CL. 30.
3,999,467, INT. CL. 32.
3,999,654, INT. CL. 43.
3,999,655, INT. CL. 43.
- KG INVESTMENTS, L.L.C., TAMPA, FL:
2,401,587, CANC. INT. CL. 42.
- KGPR INC, VENTURA, CA, DBA AIRHEAD PARTS:
3,996,294, PUB. 5-3-2011. INT. CL. 35.
- KHALAF, AMER, NICOLA, FREDERICK, MD:
2,901,731, CANC. INT. CL. 9.
- KHAN, LAWRENCE, FARMINGVILLE, NY:
3,996,974, PUB. 5-3-2011. INT. CL. 35.
- KHANWILKAR, PRATAP S., SALT LAKE CITY, UT, AKA
PK:
3,999,803, INT. CL. 35.
- KHRIPOUNOVA, ELIZAVETA, BEVERLY HILLS, CA:
3,996,636, PUB. 5-3-2011. INT. CL. 41.
- KIBODAN A/S, DK-2820 GENTOFTE, DENMARK:
3,995,862, PUB. 5-3-2011. INT. CL. 10.
- KICZALES, GREGOR J, WINCHESTER, VA:
2,902,213, CANC. INT. CL. 41.
- KID CARDS INTERACTIVE AB, 412 92 GÖTEBORG, SWE-
DEN:
2,901,173, CANC. INT. CL. 28.
- KIM, DAE IL, REPUBLIC OF KOREA:
3,995,929, PUB. 5-3-2011. INT. CL. 9.
- KIM, JONG MYOUNG, YORBA LINDA, CA:
3,996,293, PUB. 5-3-2011. INT. CL. 35.
- KIM, PHILIP Y., SANTA ROSA, CA:
3,998,004, PUB. 5-3-2011. INT. CL. 35.

KIM, SANG, LUBBOCK, TX:
3,999,847, INT. CL. 14.

KIMBERLIE SKANDIS /SKANDIS SYSTEMS INTERNATIONAL INC., BRONXVILLE, NY:
2,481,601, REN. 6-16-11, INT. CL. 42.

KIMBERLIE SKANDIS/SKANDIS SYSTEMS INTERNATIONAL, INC., BRONXVILLE, NY:
2,469,076, REN. 6-16-11, INT. CL. 42.

KIMBERLING, KARYN S., ARLINGTON, VA:
3,998,311, INT. CL. 9.
3,998,312, INT. CL. 9.

KIMBERLY WILLIAMS, BAY SHORE, NY:
3,999,741, INT. CL. 25.

KINCAID, TERRY C., ASTOR, FL, DBA WILD & WOOLLY:
3,998,813, INT. CL. 25.

KINCO, LLC, PORTLAND, OR:
2,464,363, REN. 6-14-11, INT. CL. 9.

KINDLY EGGS CO., LTD., PING TUNG HSIEN, TAIWAN:
3,996,580, PUB. 5-3-2011, INT. CL. 29.

KINETURA BVBA, BELGIUM:
3,995,935, PUB. 5-3-2011, INT. CL. 42.

KING & PRINCE SEAFOOD CORPORATION, BRUNSWICK, GA:
3,996,621, PUB. 5-3-2011, INT. CL. 29.

KING CAR FOOD INDUSTRIAL CO., LTD., TAIPEI, TAIWAN:
3,995,708, PUB. 5-3-2011, INT. CL. 33.

KING RANCH IP, LLC, WILMINGTON, DE:
2,551,521, REN. 6-16-11, INT. CL. 31.

KING, ROBERT, MANTI, UT:
3,996,616, PUB. 5-3-2011, INT. CL. 35.

KING'S PUBLISHING INC., NOVATO, CA, DBA DIABETES HEALTH MAGAZINE:
3,999,975, MULTIPLE CLASS, INT. CLS. 16 AND 41.

KING'S SEAFOOD COMPANY, LLC, COSTA MESA, CA, DBA WATER GRILL:
3,997,425, PUB. 5-3-2011, INT. CL. 43.

KINGKKA LLC, TEANECK, NJ:
3,995,510, PUB. 5-3-2011, INT. CL. 28.

KINGSDOWN, INC., MEBANE, NC:
3,999,363, INT. CL. 20.

KINKO'S VENTURES, INC., DALLAS, TX:
2,901,638, CANC. INT. CL. 35.

KINNEY, THOMAS H., LITTLETON, CO:
2,901,984, CANC. INT. CL. 30.

KIPROV, DOBRI D., SAN FRANCISCO, CA:
3,996,914, PUB. 5-3-2011, MULTIPLE CLASS, INT. CLS. 29 AND 30.

KISSLING SWISS SWITCHES AG, WEINFELDEN, SWITZERLAND:
3,999,114, MULTIPLE CLASS, INT. CLS. 6 AND 9.

KITARA MEDIA, JERSEY CITY, NJ:
3,997,346, PUB. 5-3-2011, INT. CL. 41.

KITARA MEDIA, JERSEY CITY, NJ:
3,997,349, PUB. 5-3-2011, INT. CL. 41.

KITARU INNOVATIONS INC., LASCELLES, BARBADOS:
3,998,041, PUB. 5-3-2011, INT. CL. 16.

KIVLOVITZ, DOV, SEABROOK, TX:
3,997,517, PUB. 5-3-2011, INT. CL. 9.

KLAUS REITHMEIER, BERCHTESGADEN, FED REP GERMANY:
3,995,703, PUB. 2-8-2011, MULTIPLE CLASS, INT. CLS. 9 AND 41.

KLEEN FUEL CORPORATION OF AMERICA, VERO BEACH, FL:
2,901,321, CANC. INT. CL. 4.

KLEIN FOODS, INC. DBA RODNEY STRONG VINEYARDS, HEALDSBURG, CA:
3,999,487, INT. CL. 33.

KLEM, ROBERT, NEW YORK, NY:
2,901,961, CANC. MULTIPLE CLASS, INT. CLS. 25 AND 42.

KNIGHT, JASON, SAN ANTONIO, TX, DBA XTREME KNIGHT:
3,996,675, PUB. 5-3-2011, INT. CL. 9.

KNOLL AG, 67008 LUDWIGSHAFEN, FED REP GERMANY:
2,401,171, CANC. MULTIPLE CLASS, INT. CLS. 1, 3, 5, 29, 30, 31, 32 AND 40.

KNOLL, INC., EAST GREENVILLE, PA:
2,483,718, REN. 6-15-11, INT. CL. 20.

KNOLL, JO LOU, BILLINGS, MT AND WAGNER, MARY LOU, BILLINGS, MT AND NUNLEY, JODY, BILLINGS, MT:
2,402,151, CANC. INT. CL. 39.

KNORR-BREMSE AG, D-80809 MUENCHEN, FED REP GERMANY:
2,950,811, CANC. INT. CL. 37.

KNOWLEDGE NETWORKS, INC., MENLO PARK, CA:
3,999,293, MULTIPLE CLASS, INT. CLS. 35 AND 41.

KNOX, RACHEL, CAMBRIDGE, MA:
3,998,057, PUB. 5-3-2011, INT. CL. 25.

KOBUSSEN BUSES LTD., KAUKAUNA, WI:
3,996,749, PUB. 5-3-2011, INT. CL. 39.

KOCH EQUIPMENT LLC, KANSAS CITY, MO:
1,682,672, REN. 6-15-11, INT. CL. 7.

KOCH PRODUCTIONS, LLC, ATLANTA, GA:
3,998,138, PUB. 5-3-2011, MULTIPLE CLASS, INT. CLS. 35, 41, 43 AND 44.

KODIAK INNOVATIONS, LLC, ROCK HILL, SC:
3,997,499, PUB. 5-3-2011, INT. CL. 12.

KOESSL, DEENA, WINDSOR, CO:
3,996,252, PUB. 5-3-2011, INT. CL. 30.

KOGER, INC., PARAMUS, NJ:
3,997,381, PUB. 5-3-2011, INT. CL. 9.
3,997,382, PUB. 5-3-2011, INT. CL. 9.
3,997,411, PUB. 5-3-2011, INT. CL. 9.

KOHLER CO., KOHLER, WI:
3,998,594, MULTIPLE CLASS, INT. CLS. 7 AND 9.
3,998,950, INT. CL. 11.

KOLE, TED, WANTAGH, NY:
3,997,189, PUB. 5-3-2011, MULTIPLE CLASS, INT. CLS. 22 AND 25.

KONAMI DIGITAL ENTERTAINMENT CO., LTD., MINATO-KU, TOKYO, JAPAN:
2,902,374, CANC. INT. CL. 9.

KONAMI DIGITAL ENTERTAINMENT CO., LTD., TOKYO, JAPAN:
3,998,978, MULTIPLE CLASS, INT. CLS. 9 AND 41.

KONINKLIJKE KPN N.V., THE HAGUE, NETHERLANDS, KONINKLIJKE KPN N.V., THE HAGUE, NETHERLANDS:
2,457,515, REN. 6-10-11, MULTIPLE CLASS, INT. CLS. 35, 38 AND 42.

KONINKLIJKE PHILIPS ELECTRONICS N.V., NETHERLANDS:
3,996,023, PUB. 5-3-2011, INT. CL. 10.

KONTRAST WORKSHOP, LLC, PHILADELPHIA, PA:
3,997,898, PUB. 5-3-2011, INT. CL. 42.

KORTERRA, INC., CHANHASSEN, MN:
3,997,912, PUB. 5-3-2011, INT. CL. 35.

KOSTAL INDUSTRIE ELEKTRIK GMBH, LÜDENSCHIED, FED REP GERMANY:
3,960,860, COR. INT. CL. 9.

KRAFT FOODS GLOBAL BRANDS LLC, NORTHFIELD, IL:
3,998,597, INT. CL. 30.
3,999,290, INT. CL. 30.
3,999,328, INT. CL. 30.
3,999,329, INT. CL. 30.

KRAMER, BRADLEY I., LOS ANGELES, CA:
3,998,934, INT. CL. 25.

KRANSON INDUSTRIES, INC., ST. LOUIS, MO:
3,999,682, MULTIPLE CLASS, INT. CLS. 35 AND 42.

KRAULAND, CHAD, MALIBU, CA:
4,000,028, INT. CL. 39.

KRAUSE, FREDRIC J, CORONA, CA:
3,996,741, PUB. 5-3-2011, INT. CL. 5.

KRC TRADE CORPORATION, SIMPSONVILLE, SC:
2,475,819, REN. 6-14-11, INT. CL. 9.

KRENZ, KIM, ANDOVER, MN:
2,902,074, CANC. INT. CL. 8.

KRISTA SMITH, BIG LAKE, MN:
3,997,846, PUB. 5-3-2011, INT. CL. 28.

KROEGER HERB PRODUCTS CO., INC., BOULDER, CO:
2,401,315, CANC. INT. CL. 5.

KRONBICHLER, ELISABETH, BARDONIA, NY:
3,997,055, PUB. 5-3-2011, INT. CL. 4.

- KRUEGER INTERNATIONAL, INC., GREEN BAY, WI:
3,998,778, INT. CL. 20.
- KSB AKTEINGESELLSCHAFT, D-67227 FRANKENTHAL,
FED REP GERMANY:
2,401,817, CANC. INT. CL. 7.
- KU, ANDY TING-CHIA, LOS ANGELES, CA, DBA ORGA-
NIZED CRIME DESIGN COLLECTIVE:
3,999,677, INT. CL. 42.
- KUKU? GROUP LLC, NEW YORK, NY:
3,998,806, MULTIPLE CLASS, INT. CLS. 25 AND 35.
- KUMKANG SHOE CO., LTD., KYEYANG-GU INCHEON,
REPUBLIC OF KOREA:
2,401,213, CANC. INT. CL. 25.
- KUNG FU, LLC, ENCINO, CA:
3,999,041, MULTIPLE CLASS, INT. CLS. 9 AND 41.
- KUNG HSUE SHE, INC., RANCHO DOMINGUEZ, CA, DBA
KHS, INC.:
3,999,794, INT. CL. 12.
- KURARAY CO., LTD., OKAYAMA PREFECTURE, JAPAN:
3,996,177, PUB. 12-21-2010. MULTIPLE CLASS, INT. CLS.
7, 11 AND 12.
- KUSTER, CARLO, 82266 INNING AM AMMERSEE, FED
REP GERMANY:
2,901,040, CANC. INT. CL. 9.
- KYAPING, DACHEN, BELLEVUE, WA:
2,401,308, CANC. INT. CL. 3.
- KYOCCERA CORPORATION, FUSHIMI-KU, KYOTO, JA-
PAN:
2,474,664, REN. 6-13-11. INT. CL. 9.
- L. PERRIGO COMPANY, ALLEGAN, MI:
3,999,073, INT. CL. 5.
3,999,237, MULTIPLE CLASS, INT. CLS. 3 AND 8.
- L&P PROPERTY MANAGEMENT COMPANY, SOUTH-
GATE, CA:
3,997,412, PUB. 5-3-2011. INT. CL. 20.
3,998,218, PUB. 5-3-2011. INT. CL. 19.
- L'ESTÉTIC GMBH, FED REP GERMANY:
3,995,737, PUB. 8-24-2010. MULTIPLE CLASS, INT. CLS. 3
AND 5.
- L'OREAL, PARIS, FRANCE:
2,787,027, CANC. INT. CL. 3.
- L'OREAL, FRANCE:
3,995,872, PUB. 5-3-2011. INT. CL. 3.
- L'OREAL, PARIS, FRANCE:
3,996,349, PUB. 5-3-2011. INT. CL. 3.
3,996,377, PUB. 5-3-2011. INT. CL. 3.
3,996,406, PUB. 5-3-2011. INT. CL. 3.
- L'OREAL USA CREATVE, INC., NEW YORK, NY:
2,450,683, REN. 6-14-11. INT. CL. 3.
- LA COCINA, INC., SAN FRANCISCO, CA:
3,997,182, PUB. 5-3-2011. MULTIPLE CLASS, INT. CLS. 25
AND 41.
- LA COLMENA, INC., MIAMI, FL:
3,995,560, PUB. 5-3-2011. MULTIPLE CLASS, INT. CLS. 29
AND 30.
- LA FAMIGLIA WAXHAMMER AB, VIMMERBY, SWEDEN:
3,998,529, INT. CL. 25.
- LA PIERRE, JILL, ELMHURST, PA:
3,996,233, PUB. 5-3-2011. INT. CL. 14.
- LA TOURAINE, INC., SAN DIEGO, CA:
3,998,491, INT. CL. 41.
- LABORATOIRE GARNIER & CIE, 75008 PARIS, FRANCE:
2,901,033, CANC. INT. CL. 3.
- LABORATORIOS SUAVINEX, S.A., (ALICANTE), SPAIN:
2,901,154, CANC. MULTIPLE CLASS, INT. CLS. 8, 10
AND 21.
- LACROSSE FOOTWEAR, INC., PORTLAND, OR:
3,998,792, INT. CL. 25.
- LADY DIBBLE LLC, PLAINFIELD, NJ:
3,998,388, MULTIPLE CLASS, INT. CLS. 16 AND 41.
- LAFFERTY, KATHLEEN, KENNETT SQUARE, PA:
3,998,726, INT. CL. 29.
- LAKE NONA PROPERTY HOLDINGS, LLC, ORLANDO, FL:
2,514,455, REN. 6-14-11. MULTIPLE CLASS, INT. CLS. 18,
25, 28, 36, 41 AND 42.
- LALLEMAND INC., MONTREAL, QUEBEC H1W 2N8,
CANADA:
2,402,513, CANC. INT. CL. 30.
- LAMPE, FRANCIS N.M., OOSTKAMP, BELGIUM:
2,901,622, CANC. INT. CL. 24.
- LAMPLIGHT FARMS, INC., MENOMONEE FALLS, WI:
2,902,342, CANC. MULTIPLE CLASS, INT. CLS. 4 AND
11.
- LAMPRE INTERNATIONAL B.V., NL-1014 BA AMSTER-
DAM, NETHERLANDS:
3,995,808, PUB. 5-3-2011. INT. CL. 6.
- LANCOME PARFUMS ET BEAUTE & CIE, PARIS, FRANCE:
3,998,742, INT. CL. 3.
- LAND O'LAKES PURINA FEED LLC, SHOREVIEW, MN:
3,999,838, INT. CL. 31.
- LAND, SHANE M., ELK GROVE, CA, DBA XXPULSION:
4,000,053, INT. CL. 25.
- LANDAU UNIFORMS, INC., OLIVE BRANCH, MS:
2,544,433, REN. 6-10-11. INT. CL. 10.
- LANDAU UNIFORMS, INCORPORATED, OLIVE BRANCH,
MS:
3,997,119, PUB. 5-3-2011. INT. CL. 25.
- LANDMAN, DAVID A., ENGLEWOOD, CO, DBA PRIMEO-
NEREALTY LLC:
3,996,699, PUB. 5-3-2011. INT. CL. 35.
- LANDWIRTSCHAFTLICHE RENTENBANK -; ANSTALT
DES ÖFFENTLICHEN RECHTS, 60313 FRANKFURT AM
MAIN, FED REP GERMANY:
3,995,801, PUB. 5-3-2011. MULTIPLE CLASS, INT. CLS. 35
AND 36.
- LANG, LISA, PAIA, HI:
3,996,443, PUB. 5-3-2011. INT. CL. 25.
- LANGTECH SYSTEMS CONSULTING, INC., SAN FRAN-
CISCO, CA:
2,451,026, REN. 6-10-11. INT. CL. 42.
2,499,990, REN. 6-10-11. INT. CL. 42.
2,544,202, REN. 6-10-11. INT. CL. 42.
- LANNA, PAOLO, BRONX, NY:
3,997,554, PUB. 5-3-2011. INT. CL. 41.
- LANNER GROUP LIMITED, REDDITCH, ENGLAND:
3,999,493, INT. CL. 9.
- LANDSOWNE STATION SELF STORAGE, LLC, OWINGS
MILLS, MD, DBA STORE IT:
3,995,669, PUB. 5-3-2011. INT. CL. 39.
- LANSING AUTOMAKERS FEDERAL CREDIT UNION,
LANSING, MI:
3,996,059, PUB. 5-3-2011. INT. CL. 36.
3,997,474, PUB. 5-3-2011. INT. CL. 36.
- LANTRONIX, INC., IRVINE, CA:
3,999,263, INT. CL. 9.
- LANUZA, CRAIG S., VENTURA, CA:
3,997,384, PUB. 5-3-2011. INT. CL. 22.
- LANX, INC., BROOMFIELD, CO:
3,998,506, INT. CL. 10.
- LARF, INC., LOS ANGELES, CA:
3,996,449, PUB. 1-25-2011. INT. CL. 39.
- LARK L.L.C., OKLAHOMA CITY, OK, DBA ONTRACK
STAFFING:
3,995,569, PUB. 5-3-2011. INT. CL. 35.
- LARRYJ. RIGGS, PLACENTIA, CA:
3,997,236, PUB. 5-3-2011. INT. CL. 7.
- LAS VEGAS SANDS CORP., LAS VEGAS, NV:
3,995,542, PUB. 5-3-2011. INT. CL. 39.
3,995,543, PUB. 5-3-2011. INT. CL. 43.
- LASER SUBSTRATES, INC., BOCA RATON, FL:
3,995,529, PUB. 5-3-2011. INT. CL. 16.
- LASHFULLY, INC., SAN FRANCISCO, CA:
3,999,856, INT. CL. 44.
- LATERRA, STEPHEN, AVON, CO:
3,996,151, PUB. 5-3-2011. INT. CL. 25.
- LATHAM, JUSTIN W., AUSTIN, TX:
2,464,055, REN. 6-14-11. INT. CL. 25.
- LAU, TED C, LOS ALAMITOS, CA, DBA PRETTY RED
ROSE:
3,997,215, PUB. 5-3-2011. INT. CL. 42.
- LAUGHING HYENA ENTERTAINMENT, INC., LAS VE-
GAS, NV:
2,412,448, REN. 6-14-11. INT. CL. 9.
- LAUTSPRECHER TEUFEL GMBH, FED REP GERMANY:
3,995,867, PUB. 5-3-2011. MULTIPLE CLASS, INT. CLS. 9,

- 35 AND 41.
3,995,877, PUB. 5-3-2011. MULTIPLE CLASS, INT. CLS. 9,
35 AND 41.
3,995,878, PUB. 5-3-2011. MULTIPLE CLASS, INT. CLS. 9,
35 AND 41.
- LAWRENCE G. WALTERS, P.A., ALTAMONTE SPRINGS,
FL, DBA WALTERS LAW GROUP:
3,997,009, PUB. 5-3-2011. INT. CL. 45.
- LAWRENCE MARKETING, INC., ST. LOUIS PARK, MN:
2,901,351, CANC. INT. CL. 36.
- LAWTON, KYRA, DARTMOUTH, MA:
4,000,019, INT. CL. 16.
- LB'S SPEEDSHOP, LLC, SAN JOSE, CA:
3,996,295, PUB. 5-3-2011. INT. CL. 41.
- LCPS FRANCHISING LLC, NORTHFIELD, IL:
3,997,219, PUB. 5-3-2011. INT. CL. 44.
- LDT SYSTEMS, INC., CINCINNATI, OH:
2,901,232, CANC. INT. CL. 38.
- LE, HUNG, LAKEWOOD, CO, DBA THE YABBY HUT AND
THE YABBY HUT, LLC, LAKEWOOD, CO, DBA THE
YABBY HUT:
3,996,073, PUB. 5-3-2011. INT. CL. 43.
- LEADING IN CONTEXT, LLC, RICHMOND, VA:
3,999,532, INT. CL. 16.
- LEADING RESOURCES, INC, SACRAMENTO, CA:
2,484,156, REN. 6-10-11. INT. CL. 41.
- LEATHER LOFT STORES, INC., EXETER, NH:
1,621,224, CANC. MULTIPLE CLASS, INT. CLS. 18 AND
25.
- LEBANON SEABOARD CORPORATION, LEBANON, PA:
3,997,273, PUB. 5-3-2011. INT. CL. 1.
- LEBLON HOLDINGS LLC, NEW YORK, NY:
3,998,359, INT. CL. 25.
- LEBRÓN, ROBERT, VIERA, FL:
2,901,742, CANC. INT. CL. 16.
- LECONTE, LUMONY R, MIRAMAR, FL, AKA DJ LUMO-
NEY:
3,996,152, PUB. 5-3-2011. INT. CL. 41.
- LEDTRONICS, INC., TORRANCE, CA:
2,458,742, REN. 6-16-11. MULTIPLE CLASS, INT. CLS. 9
AND 11.
- LEE CHU, KIT YING, CASTRO VALLEY, CA:
3,997,999, PUB. 5-3-2011. INT. CL. 44.
- LEE KUM KEE COMPANY LIMITED, TAI PO, NEW
TERRITORIES, HONG KONG:
3,995,462, PUB. 9-7-2010. MULTIPLE CLASS, INT. CLS. 29
AND 30.
- LEEDY, INGRAM, WINTER HAVEN, FL:
3,996,891, PUB. 5-3-2011. INT. CL. 42.
- LEGACY CLASSIC FURNITURE, INC., HIGH POINT, NC:
2,520,702, REN. 6-13-11. INT. CL. 20.
- LEGAL RESEARCH CENTER, INC., MINNEAPOLIS, MN:
1,666,183, REN. 6-16-11. INT. CL. 42.
- LEGO JURIS A/S, DK-7190 BILLUND, DENMARK:
2,901,646, CANC. INT. CL. 28.
- LEMAY-YATES ASSOCIATES INC., VERDUN, QUEBEC,
CANADA:
3,996,157, PUB. 5-3-2011. INT. CL. 41.
- LENIHAN, MARY GERARD, ST. LOUIS, MO:
3,997,599, PUB. 5-3-2011. INT. CL. 41.
- LENNOX INDUSTRIES INC., RICHARDSON, TX:
3,998,660, INT. CL. 9.
- LENOX CORPORATION, BRISTOL, PA:
1,651,523, REN. 6-14-11. INT. CL. 21.
2,902,448, CANC. INT. CL. 16.
- LENZING AKTIENGESELLSCHAFT, AUSTRIA:
3,995,816, PUB. 5-3-2011. MULTIPLE CLASS, INT. CLS. 1,
3, 5, 16, 17, 22, 24, 25, 27 AND 42.
- LEONHARD KURZ STIFTUNG & CO. KG, FED REP
GERMANY:
3,896,532, COR. MULTIPLE CLASS, INT. CLS. 7, 16, 17
AND 42.
- LEOPARD, INC., HILLSIDE, NJ:
2,568,354, REN. 6-15-11. INT. CL. 12.
- LEOR RESOURCES LLC, NEW YORK, NY:
3,999,242, INT. CL. 42.
- LEPARC INTERNATIONAL CO., LTD., SONJIANG,
SHANGHAI, CHINA:
3,996,283, PUB. 5-3-2011. INT. CL. 21.
- LES ALIMENTS PAPCO INC., SAINT - LAURENT, QUEBEC,
CANADA:
2,901,744, CANC. INT. CL. 29.
- LES INDUSTRIES HOLMONT LTÉE, ST-HYACINTHE,
QUEBEC, CANADA:
3,995,613, PUB. 5-3-2011. INT. CL. 10.
- LES MILLS INTERNATIONAL LIMITED, AUCKLAND,
NEW ZEALAND:
2,901,751, CANC. INT. CL. 25.
- LETENDRE-HEDLUND, MICHELLE, MOUND, MN:
4,000,041, INT. CL. 35.
- LETHAN CORPORATION, HAMILTON, OH:
3,997,321, PUB. 5-3-2011. INT. CL. 10.
- LEVENGER COMPANY, DELRAY BEACH, FL:
2,401,392, CANC. INT. CL. 42.
- LEVI STRAUSS & CO., SAN FRANCISCO, CA:
3,997,020, PUB. 5-3-2011. INT. CL. 25.
- LEVITON MANUFACTURING CO., INC., LITTLE NECK,
NY:
2,401,407, CANC. MULTIPLE CLASS, INT. CLS. 9 AND
20.
- LEWIS, LUDELLA, CHICAGO, IL:
2,401,838, CANC. INT. CL. 35.
- LEXANI HOLDINGS, INC., CORONA, CA:
3,998,695, INT. CL. 25.
3,998,696, INT. CL. 25.
- LF SPORTSWEAR, INC., LOS ANGELES, CA:
3,998,003, PUB. 5-3-2011. INT. CL. 35.
- LG ELECTRONICS INC., SEOUL, REPUBLIC OF KOREA:
3,995,585, PUB. 5-3-2011. INT. CL. 9.
3,995,596, PUB. 5-3-2011. MULTIPLE CLASS, INT. CLS. 7
AND 11.
3,998,685, INT. CL. 9.
- LI SHERRY HAIXIA, MIAMI, FL:
3,997,832, PUB. 5-3-2011. INT. CL. 14.
- LIAISE MEDIATED SOLUTIONS, LLC, SAN FRANCISCO,
CA:
3,999,802, INT. CL. 45.
3,999,979, INT. CL. 45.
- LIBBY INTERIORS INC., NEW YORK, NY:
3,995,644, PUB. 10-19-2010. INT. CL. 42.
- LIBERATED SPACES, SAN FRANCISCO, CA:
3,997,239, PUB. 5-3-2011. INT. CL. 45.
- LIBERTY COUNSEL, INC., ORLANDO, FL:
3,998,090, PUB. 5-3-2011. INT. CL. 41.
- LIBERTY MUTUAL INSURANCE COMPANY, BOSTON,
MA:
2,901,530, CANC. INT. CL. 36.
- LIBERTY SKIS CORPORATION, NEW YORK, NY:
3,998,021, PUB. 5-3-2011. INT. CL. 28.
- LIDL STIFTUNG & CO. KG, FED REP GERMANY:
3,995,843, PUB. 5-3-2011. INT. CL. 30.
- LIEBERT CORPORATION, COLUMBUS, OH:
3,999,203, INT. CL. 42.
- LIFE AND HEALTH INSURANCE FOUNDATION FOR
EDUCATION, ARLINGTON, DC:
3,996,147, PUB. 5-3-2011. INT. CL. 35.
- LIFE PLUS STYLE LTD., NEW YORK, NY:
3,997,494, PUB. 5-3-2011. INT. CL. 16.
3,998,149, PUB. 5-3-2011. INT. CL. 16.
3,998,152, PUB. 5-3-2011. INT. CL. 16.
3,998,192, PUB. 5-3-2011. INT. CL. 16.
3,998,195, PUB. 5-3-2011. INT. CL. 16.
- LIFE PURPOSE RESOURCES, FAIRFIELD, IA:
3,996,312, PUB. 5-3-2011. INT. CL. 41.
- LIFEBANC, CLEVELAND, OH:
3,997,356, PUB. 5-3-2011. INT. CL. 44.
- LIFELIKE PRODUCTIONS, INC., POINT REYES STATION,
CA:
2,456,985, REN. 6-15-11. INT. CL. 42.
- LIFELINE SCIENTIFIC, INC., ITASCA, IL:
3,998,504, MULTIPLE CLASS, INT. CLS. 1 AND 5.
- LIFEMARQUE LIMITED, BERKSHIRE RG7 8PN, UNITED
KINGDOM:
2,902,012, CANC. MULTIPLE CLASS, INT. CLS. 6, 18, 20,

- 21 AND 25.
LIFESPORT FITNESS, SAN JOSE, CA:
3,998,001, PUB. 5-3-2011. INT. CL. 41.
- LIFESTYLE IMPROVEMENT CENTERS, LLC, DUBLIN, OH:
3,999,565, INT. CL. 9.
- LIFEWORLD BROADCAST MINISTRIES, INC., CONWAY, AR:
3,999,871, MULTIPLE CLASS, INT. CLS. 16 AND 41.
- LIFONT PHARMACEUTICALS INC, ALPHARETTA, GA:
3,999,663, INT. CL. 5.
- LIGHTHOUSE CREDIT FOUNDATION, INC., LARGO, FL:
2,901,140, CANC. INT. CL. 36.
- LIGHTHOUSE STRATEGIC PROJECTS GROUP, INC., LANGHORNE, PA:
3,998,955, INT. CL. 9.
- LIGHTVANTAGE, GARDNERVILLE, NV:
3,998,025, PUB. 5-3-2011. INT. CL. 9.
- LIGHTWAVE SYSTEMS, INC., CARPINTERIA, CA:
2,462,398, REN. 6-11-11. INT. CL. 9.
2,464,335, REN. 6-14-11. INT. CL. 9.
- LILI GLOBAL APPAREL INC., NEW YORK, NY:
3,999,630, INT. CL. 25.
- LILIEN-VERWALTUNG GMBH & CO. KG, FED REP GERMANY:
3,995,777, PUB. 1-25-2011. MULTIPLE CLASS, INT. CLS. 32, 33 AND 43.
- LIMBIC SOFTWARE, INC., PALO ALTO, CA:
3,998,990, INT. CL. 9.
- LIN, YUNG KEN, CITY OF INDUSTRY, CA AND LIN, CHIEN-WEN, IRVINE, CA:
3,998,736, INT. CL. 9.
- LINCARE LICENSING INC., CLEARWATER, FL:
3,999,052, MULTIPLE CLASS, INT. CLS. 41 AND 42.
- LINCOLN NATIONAL LIFE INSURANCE COMPANY, THE, FORT WAYNE, IN:
3,997,036, PUB. 5-3-2011. INT. CL. 36.
- LINCOLN TECHNICAL INSTITUTE, INC., WEST ORANGE, NJ, TA THE CITTONE INSTITUTE AND CEI:
2,901,439, CANC. INT. CL. 41.
2,901,440, CANC. INT. CL. 41.
- LINDA ENTERPRISES LIMITED, UNITED KINGDOM:
3,567,832, COR. MULTIPLE CLASS, INT. CLS. 29 AND 30.
- LINDA SETTLES, LYNCHBURG, VA, DBA NATIONAL ASSOCIATION OF ADVOCATES FOR ABUSE SURVIVORS:
4,000,049, INT. CL. 45.
- LINDE AKTIENGESELLSCHAFT, 80331 MÜNCHEN, FED REP GERMANY:
2,902,754, CANC. MULTIPLE CLASS, INT. CLS. 37 AND 42.
2,902,755, CANC. MULTIPLE CLASS, INT. CLS. 37 AND 42.
- LINDORA, LLC, COSTA MESA, CA:
2,456,837, REN. 6-10-11. INT. CL. 42.
- LINK JR., THEODORE W., NEW ORLEANS, LA:
2,902,151, CANC. INT. CL. 35.
- LION, MARKUS, BREISACH, FED REP GERMANY:
3,998,634, INT. CL. 33.
- LIONEL TRADEMARK LLC, CHESTERFIELD, MI:
2,468,080, REN. 6-15-11. INT. CL. 25.
- LIPOPHARMA CANCER, S.L., PALMA DE MALLORCA, SPAIN:
3,691,500, COR. INT. CL. 5.
3,691,501, COR. MULTIPLE CLASS, INT. CLS. 29 AND 30.
- LIPSY LIMITED, LONDON, ENGLAND:
3,999,165, INT. CL. 14.
- LIQUEUR AND VODKA DISTILLERY; "OSHA", LTD., OMSK REGION, RUSSIAN FED.:
3,995,807, PUB. 5-3-2011. INT. CL. 33.
- LIQUID AMERICA, LLC, GREENVILLE, SC:
2,402,452, CANC. INT. CL. 35.
- LISA D. FLYNN, SOUTH BERWICK, ME:
3,996,920, PUB. 5-3-2011. INT. CL. 41.
- LISA NICOLE POOLE, NEW YORK, NY:
3,996,489, PUB. 5-3-2011. INT. CL. 45.
- LISCOT ENTERPRISES, INC., LOS ANGELES, CA, PASCAL-REGAN, MARIE GERTRUDE, BEVERLY HILLS, CA:
1,652,381, REN. 6-15-11. INT. CL. 16.
- LISTEC, INC., TOWSON, MD:
2,901,166, CANC. INT. CL. 16.
- LISTON, VASILIKI, HINSDALE, IL:
3,996,138, PUB. 5-3-2011. INT. CL. 38.
3,996,139, PUB. 5-3-2011. INT. CL. 38.
- LITENS AUTOMOTIVE PARTNERSHIP, WOODBRIDGE, ONTARIO L4L 5T9, CANADA:
1,654,850, REN. 6-15-11. INT. CL. 12.
- LITTLE KIDS, INC., SEEKONK, MA:
3,999,099, INT. CL. 28.
- LIVECAREER, LTD., NEW YORK, NY:
3,996,080, PUB. 5-3-2011. INT. CL. 35.
- LIVERAIL INC., SAN FRANCISCO, CA:
3,997,713, PUB. 5-3-2011. INT. CL. 42.
- LIVING PROOF, AVON, IN:
3,910,203, COR. MULTIPLE CLASS, INT. CLS. 9 AND 41.
3,910,204, COR. MULTIPLE CLASS, INT. CLS. 9 AND 41.
- LIZ CLAIBORNE, INC., NEW YORK, NY:
1,653,728, REN. 6-13-11. INT. CL. 25.
3,999,161, INT. CL. 25.
- LMZ VENTURES LIMITED LIMITED, SAN ANTONIO, TX, LEDDY VENTURES LIMITED, PRESIDIAN, L.C., SAN ANTONIO, TX:
2,435,709, REN. 6-13-11. MULTIPLE CLASS, INT. CLS. 35 AND 42.
- LOCAL DOG, LLC, KETCHUM, ID:
3,999,555, INT. CL. 31.
- LOCAL INSIGHT MEDIA HOLDINGS, INC., ENGLEWOOD, CO:
3,999,031, INT. CL. 16.
- LOCKHEED MARTIN CORPORATION, BETHESDA, MD:
3,998,459, INT. CL. 21.
3,998,947, INT. CL. 9.
3,999,462, MULTIPLE CLASS, INT. CLS. 9, 42 AND 45.
3,999,463, MULTIPLE CLASS, INT. CLS. 9, 42 AND 45.
- LOEW-CORNELL, LLC, ERLANGER, KY:
1,648,533, REN. 6-14-11. INT. CL. 16.
- LOGISTICS MANAGEMENT INSTITUTE, MCLEAN, VA:
2,494,411, REN. 6-15-11. INT. CL. 35.
- LOMMEN, ABDO, COLE, KING & STAGEBERG, PA., MINNEAPOLIS, MN:
3,999,884, INT. CL. 45.
- LONDON DRUGS LIMITED, RICHMOND, BRITISH COLUMBIA, CANADA:
2,901,147, CANC. MULTIPLE CLASS, INT. CLS. 3 AND 5.
- LONDON ECONOMICS INTERNATIONAL LLC, BOSTON, MA:
3,998,389, INT. CL. 35.
- LONE STAR VALET PARKING SERVICES, INC., DALLAS, TX:
3,996,645, PUB. 5-3-2011. INT. CL. 39.
3,996,653, PUB. 5-3-2011. INT. CL. 39.
- LONESTAR SOCCER CLUB OF AUSTIN, INC., AUSTIN, TX:
3,995,471, PUB. 5-3-2011. MULTIPLE CLASS, INT. CLS. 36 AND 41.
- LONG PAN, CORONA, NY:
3,997,176, PUB. 5-3-2011. INT. CL. 9.
- LONG, SHUNYOU, LUTHERVILLE, MD:
3,996,644, PUB. 5-3-2011. INT. CL. 9.
- LONGWORTH INDUSTRIES, INC., WEST END, NC:
3,999,743, INT. CL. 25.
3,999,745, INT. CL. 25.
- LONGYEAR TM, INC., SOUTH JORDAN, UT:
3,855,095, AM. MULTIPLE CLASS, INT. CLS. 7 AND 37.
- LOPEZ, BLANCA, MILWAUKEE, WI:
3,996,756, PUB. 5-3-2011. INT. CL. 35.
- LOS ANGELES BRAIN AND SPINE INSTITUTE, GLENDALE, CA:
3,996,559, PUB. 5-3-2011. INT. CL. 44.
- LOUDEN & COMPANY, INC., CHICAGO, IL:
2,458,294, REN. 6-10-11. INT. CL. 42.
- LOUISIANA SUGAR REFINING, LLC, GRAMERCY, LA:
3,999,841, INT. CL. 30.
- LOVE LEE PHOTOGRAPHY, INC., SUGAR LAND, TX:
3,997,019, PUB. 5-3-2011. INT. CL. 41.

LOWENSTEIN, ALBERT L. ALBUQUERQUE, NM, DBA THE BALLOON FLIGHT SCHOOL:
3,996,465, PUB. 5-3-2011. INT. CL. 41.

LOXIN 2002, S.L., SPAIN:
3,995,844, PUB. 5-3-2011. INT. CL. 37.

LPS IP HOLDING COMPANY, LLC, JACKSONVILLE, FL:
3,996,362, PUB. 5-3-2011. MULTIPLE CLASS, INT. CLS. 35, 36 AND 42.

LRC PRODUCTS LIMITED, SLOUGH, ENGLAND:
3,995,670, PUB. 11-23-2010. INT. CL. 10.

LSE-SYSTEM AG, CH-8832 WOLLERAU, SWITZERLAND:
2,401,485, CANC. MULTIPLE CLASS, INT. CLS. 1, 3, 7, 16, 37 AND 42.

LSI CORPORATION, MILPITAS, CA:
2,401,363, CANC. INT. CL. 9.

LSI SOLUTIONS, INC., VICTOR, NY:
2,496,200, REN. 6-14-11. INT. CL. 10.

LU, LYNN, COVINA, CA AND WU, TIFFANY, COVINA, CA:
3,996,940, PUB. 5-3-2011. INT. CL. 18.

LUBY'S FUDDRUCKERS RESTAURANTS, LLC, HOUSTON, TX:
3,998,709, INT. CL. 43.

LUCASFILM LTD., SAN FRANCISCO, CA:
2,402,644, CANC. INT. CL. 32.
2,460,070, REN. 6-14-11. INT. CL. 25.

LUCKY BRAND DUGAREES, INC., VERNON, CA:
3,998,150, PUB. 5-3-2011. INT. CL. 18.

LUCKY MOTORS, INC., ADDISON, IL:
3,996,086, PUB. 5-3-2011. INT. CL. 35.

LUCKY 21, INC, NEW YORK, NY:
3,999,666, INT. CL. 25.

LUCRATIVE MINDS, LLC, CHELMSFORD, MA:
3,999,902, INT. CL. 35.

LUCY APPAREL, LLC, WILMINGTON, DE:
3,999,218, INT. CL. 25.

LUIS M. RAMOS JR, CORAL SPRINGS, FL AND KATINA E. FRIAS RAMOS, LANCASTER, PA:
3,999,076, INT. CL. 25.

LUJAN, ALBERT, MR., HOUSTON, TX, DBA SHOWTIME FLORISTS:
2,401,492, CANC. INT. CL. 42.

LUM, SELENE, PASADENA, CA:
3,995,685, PUB. 5-3-2011. INT. CL. 30.

LUMASMART TECHNOLOGIES INTERNATIONAL, INC., MACOMB TOWNSHIP, MI:
3,998,850, INT. CL. 9.

LUMAT INC., SAN FRANCISCO, CA:
3,997,241, PUB. 5-3-2011. INT. CL. 43.

LUMEXIS CORPORATION, IRVINE, CA:
3,999,178, INT. CL. 9.

LUMINA SPHERE, LLC, ANTHEM, AZ:
3,998,421, INT. CL. 16.

LUNCH BOX QUILTS, LLC, SCOTTSDALE, AZ:
3,997,064, PUB. 5-3-2011. INT. CL. 16.

LUNGEVITY FOUNDATION, CHICAGO, IL:
3,998,012, PUB. 5-3-2011. INT. CL. 36.

LUTHER CONSULTING, LLC, INDIANAPOLIS, IN:
4,000,022, INT. CL. 42.

LUTHERAN HOMES SOCIETY, INC., TOLEDO, OH:
3,997,042, PUB. 5-3-2011. MULTIPLE CLASS, INT. CLS. 43 AND 44.

LUTTE LICENSING GROUP, LLC, COLUMBUS, OH:
3,999,822, INT. CL. 14.

LUTZ, FRANK, MILWAUKEE, WI:
3,999,995, INT. CL. 9.

LUYCKX, MARISOL, HIGHLANDS RANCH, CO:
3,999,016, INT. CL. 35.

LUZERNE INVESTMENTS LTD., WICKHAMS CITY, BR.VIRGIN ISLANDS:
3,998,519, INT. CL. 7.

LYNN, AMY N, MONROE, CT AND LYNN, JOHN A, MONROE, CT:
3,998,002, PUB. 5-3-2011. INT. CL. 36.

LYONS & WOLIVAR INVESTIGATIONS, INC., LAGUNA HILLS, CA:
2,901,591, CANC. INT. CL. 45.

LYTRON INCORPORATED, WOBURN, MA:
2,542,676, REN. 6-14-11. INT. CL. 11.

M & B BEVERAGE CORPORATION, MIAMI, FL, NEW YORK NEW YORK RESTAURANTS, INC., MIAMI, FL:
1,644,713, REN. 6-15-11. INT. CL. 42.

M & C TOY CENTRE LIMITED, TSIMSHATSUI EAST, KOWLOON, HONG KONG:
2,902,028, CANC. INT. CL. 28.

M.A.V. MEDIA WORKS, L.L.C., PORT SAINT LUCIE, FL:
3,996,634, PUB. 5-3-2011. INT. CL. 45.

M.H. ZEIGLER & SONS, LLC, LANDSDALE, PA:
3,996,958, PUB. 5-3-2011. INT. CL. 32.

M&G DURAVENT, INC., VACAVILLE, CA:
3,998,655, MULTIPLE CLASS, INT. CLS. 17 AND 19.

MAAG PUMP SYSTEMS AG, OBERGLATT, AUSTRIA:
1,155,271, REN. 6-16-11. INT. CL. 7.
1,155,271, CANC. MULTIPLE CLASS, INT. CLS. 6 AND 9.

MABEY BRIDGE & SHORE, INC., BALTIMORE, MD:
2,477,861, REN. 6-13-11. INT. CL. 6.

MAC'S SUSHI INC., TORONTO, ONTARIO, CANADA:
3,995,709, PUB. 5-3-2011. INT. CL. 43.

MACERICH VALLEY VIEW LIMITED PARTNERSHIP, SANTA MONICA, CA:
2,901,903, CANC. MULTIPLE CLASS, INT. CLS. 35 AND 36.

MACH III CLUTCH, INC., WALTON, KY:
2,560,372, REN. 6-14-11. INT. CL. 7.

MACHOVINA, BRIAN L., CORAL GABLES, FL:
3,998,579, MULTIPLE CLASS, INT. CLS. 11 AND 30.

MACKLEY, MARY BETH, ASHEVILLE, NC AND MACKLEY, ANTHONY J., ASHEVILLE, NC:
3,999,369, INT. CL. 25.

MACRIE BROTHERS BLUEBERRY FARM LLC, HAMMONTON, NJ:
3,996,331, PUB. 5-3-2011. MULTIPLE CLASS, INT. CLS. 29 AND 31.

MACY'S, INC., CINCINNATI, OH:
2,902,466, CANC. INT. CL. 35.

MAD MEX TRADEMARK HOLDING COMPANY, LLC, PITTSBURGH, PA:
3,998,048, PUB. 5-3-2011. INT. CL. 30.

MADANI, MANSOOR, BALA CYNWYD, PA:
2,544,937, REN. 6-10-11. INT. CL. 42.

MADDOG, LLC, SCOTTSDALE, AZ:
2,901,153, CANC. INT. CL. 35.

MADMANN TRADEMARK HOLDING COMPANY LTD, BEVERLY HILLS, CA:
3,998,404, INT. CL. 41.

MAE MAE HOLDINGS INC., SAN FRANCISCO, CA:
3,996,701, PUB. 5-3-2011. INT. CL. 35.

MAERSK EQUIPMENT SERVICE COMPANY, INC., CHARLOTTE, NC:
3,998,992, INT. CL. 39.
3,999,028, INT. CL. 39.

MAESTRO SUISSE HOLDING (H.K.) LIMITED, CENTRAL, HONG KONG:
3,996,176, PUB. 5-3-2011. MULTIPLE CLASS, INT. CLS. 29, 30 AND 32.

MAGID MINA, LOS ANGELES, CA, DBA INVISICORP, INC.:
3,998,085, PUB. 5-3-2011. INT. CL. 9.
3,998,086, PUB. 5-3-2011. INT. CL. 9.

MAGNETI MARELLI S.P.A., ITALY:
3,995,847, PUB. 5-3-2011. MULTIPLE CLASS, INT. CLS. 12, 25, 35 AND 41.

MAGNICODE, INC., SUNNYVALE, CA:
3,997,399, PUB. 5-3-2011. INT. CL. 42.

MAGNUSSEN INTERNATIONAL CORP., NEW HAMBURG ONTARIO, CANADA:
3,996,843, PUB. 5-3-2011. INT. CL. 20.

MAHOOD, JEFFERY, FORT MCMURRAY, AB, CANADA:
3,996,228, PUB. 4-12-2011. INT. CL. 21.

MAIBEC INC., SAINT-ROMUALD, QUEBEC, CANADA:
2,488,472, REN. 6-13-11. MULTIPLE CLASS, INT. CLS. 19 AND 21.

MAIDENFORM, INC., ISELIN, NJ:
3,966,810, COR. INT. CL. 25.

MAIDS ON THE RUN INC, JACKSONVILLE, FL:
3,996,435, PUB. 5-3-2011. INT. CL. 37.

- MAIN ST. HOLDINGS, LLC, PLATTE CITY, MO:
3,996,794, PUB. 5-3-2011. INT. CL. 30.
- MAINCLOUD LLC, CHICAGO, IL:
3,995,541, PUB. 5-3-2011. INT. CL. 42.
- MAIO CONSULTING, LLC, HOUSTON, TX:
3,997,172, PUB. 5-3-2011. MULTIPLE CLASS, INT. CLS. 35 AND 42.
- MAJERIK, MATTHEW M., WARRIOR, AL:
3,997,845, PUB. 5-3-2011. INT. CL. 12.
- MAJESTIC LIQUOR STORES, INC., FORT WORTH, TX:
3,997,860, PUB. 5-3-2011. INT. CL. 33.
- MAJESTIC SUN OWNERS' ASSOCIATION, INC., DESTIN, FL:
2,902,101, CANC. INT. CL. 36.
- MAJOR LEAGUE SOCCER, L.L.C., NEW YORK, NY:
2,459,060, REN. 6-16-11. INT. CL. 25.
- MAKE MONEY LIMITED, LONDON, UNITED KINGDOM:
3,996,043, PUB. 5-3-2011. INT. CL. 3.
- MAKE YOU PERFECT, WEST HOLLYWOOD, CA:
3,999,262, INT. CL. 44.
- MAL'AK NATURAL, LLC, SUGAR LAND, TX:
3,996,890, PUB. 5-3-2011. INT. CL. 3.
- MALAWI'S PIZZA, LLC, PROVO, UT:
3,999,283, INT. CL. 43.
- MALGOR & CO., INC., CATAÑO, PUERTO RICO:
3,995,497, PUB. 5-3-2011. INT. CL. 29.
- MALHER, S.A., GUATEMALA CITY, GUATEMALA:
3,996,842, PUB. 5-3-2011. INT. CL. 32.
- MALIBU LUMBER, LLC, MALIBU, CA:
3,998,621, INT. CL. 35.
3,998,623, INT. CL. 35.
- MALKS, JOSHUA B., CAPITOLA, CA, DBA BETTERWEBSITES:
2,401,827, CANC. INT. CL. 42.
- MALLINCKRODT INC., ST. LOUIS, MO:
2,402,160, CANC. INT. CL. 5.
- MALTA, ROBERT, NEW YORK, NY:
3,996,966, PUB. 5-3-2011. INT. CL. 43.
- MANGAR INTERNATIONAL LIMITED, PRESTEIGNE, POWYS LD8 2UF, UNITED KINGDOM:
3,995,856, PUB. 5-3-2011. INT. CL. 10.
- MANHATTAN INTERNATIONAL TRADE INC., MONTREAL (ST-LAURENT), QUEBEC:
2,401,170, CANC. INT. CL. 25.
- MANNATECH, INCORPORATED, COPPELL, TX:
3,996,173, PUB. 5-3-2011. MULTIPLE CLASS, INT. CLS. 35 AND 41.
- MANNING, JAMES, FARMINGDALE, NY:
3,996,272, PUB. 5-3-2011. INT. CL. 9.
- MANSIONS & MILLIONAIRES INC., GREENVALE, NY:
1,182,038, REN. 6-16-11. MULTIPLE CLASS, INT. CLS. 16 AND 41.
1,182,038, CANC. INT. CL. 42.
- MANTHEI, LYDIA, ESCONDIDO, CA:
3,999,048, INT. CL. 44.
- MANUFACTURAS T.D.P., S.L., 28970 HUMANES DE MADRID (MADRID), SPAIN:
2,901,210, CANC. INT. CL. 25.
- MANUFACTURERS' NEWS, INC., EVANSTON, IL:
2,901,459, CANC. MULTIPLE CLASS, INT. CLS. 9 AND 35.
- MARBLELIFE, INC., SANFORD, TX:
2,510,401, REN. 6-15-11. INT. CL. 37.
- MARBLES LLC, CHICAGO, IL:
3,998,175, PUB. 5-3-2011. MULTIPLE CLASS, INT. CLS. 35 AND 44.
- MARC ATLAN DESIGN, INC., VENICE, CA:
3,997,532, PUB. 5-3-2011. INT. CL. 3.
- MARC WEXLER, MATAWAN, NJ:
3,999,688, INT. CL. 30.
- MARCELLEN INC., DEVILS TOWER, WY:
3,997,441, PUB. 5-3-2011. INT. CL. 32.
- MARCELLO, CHRISTINE, THOUSAND OAKS, CA:
3,997,670, PUB. 5-3-2011. INT. CL. 14.
- MARCHTALER, KENNETH ERVIN, VICTORIA, BC, CANADA, DBA WARRIOR MARTIAL ARTS:
3,998,209, PUB. 5-3-2011. INT. CL. 41.
- MARCUSSON, CYNTHIA R., CARRBORO, NC:
2,486,743, REN. 6-14-11. INT. CL. 14.
- MARGARET M. DALY, LISLE, IL:
3,999,244, INT. CL. 21.
- MARGARITAVILLE ENTERPRISES, LLC, PALM BEACH, FL:
3,996,811, PUB. 5-3-2011. INT. CL. 43.
- MARGIT E. MCGUIRE, SEATTLE, WA, DBA MARGIT E. MCGUIRE:
3,995,665, PUB. 7-13-2010. INT. CL. 16.
- MARIAH DAYE MCCARTHY SCHOLARSHIP FOUNDATION, LLC, BUTTE, MT, DBA MARIAH'S CHALLENGE:
3,997,799, PUB. 5-3-2011. INT. CL. 35.
- MARIANA CHICET KETCHIAN AND JACK KETCHIAN PARTNERSHIP, THE, LOS ANGELES, CA, DBA NATURAL EUROPEAN SKIN CARE PRODUCTS:
2,450,556, REN. 6-16-11. INT. CL. 3.
- MARICAP OY, FINLAND:
3,995,948, PUB. 5-3-2011. MULTIPLE CLASS, INT. CLS. 7, 37 AND 39.
- MARIE CLAIRE, NEW YORK, NY:
2,901,996, CANC. MULTIPLE CLASS, INT. CLS. 16 AND 35.
2,901,997, CANC. MULTIPLE CLASS, INT. CLS. 16 AND 35.
- MARILYN JACKSON, FAIRBURN, GA:
3,998,616, MULTIPLE CLASS, INT. CLS. 42 AND 45.
- MARILYNN THOMA, CHICAGO, IL:
3,997,707, PUB. 5-3-2011. INT. CL. 33.
3,998,010, PUB. 5-3-2011. INT. CL. 33.
- MARIN, MIGUEL, NEW YORK, NY:
4,000,044, INT. CL. 41.
- MARINE LAYER PRODUCTIONS, LLC, CARLSBAD, CA:
3,998,808, MULTIPLE CLASS, INT. CLS. 9, 38 AND 41.
- MARINE TURBINE TECHNOLOGIES, L.L.C., FRANKLIN, LA:
3,999,924, INT. CL. 17.
- MARK VII EQUIPMENT INC., ARVADA, CO:
2,486,432, AM. INT. CL. 9.
- MARK WALMESLEY, INC, CYPRESS, TX:
3,997,048, PUB. 5-3-2011. INT. CL. 45.
- MARK-A-LOT, INC., HOLBROOK, MA:
2,487,302, REN. 6-14-11. INT. CL. 37.
- MARKER VÖLKL (INTERNATIONAL) GMBH, SWITZERLAND:
3,995,850, PUB. 5-3-2011. MULTIPLE CLASS, INT. CLS. 18, 25 AND 28.
- MARKET PAVILION HOTEL, INC., CHARLESTON, SC:
3,998,693, MULTIPLE CLASS, INT. CLS. 33 AND 43.
- MARKET SCOPE, LLC, ST. LOUIS, MO:
3,999,714, INT. CL. 35.
- MARKET STUDIES, LLC, SCOTTSDALE, AZ:
3,998,801, INT. CL. 16.
3,998,802, INT. CL. 16.
- MARKETING DISPLAYS INC., FARMINGTON HILLS, MI:
3,996,254, PUB. 5-3-2011. INT. CL. 9.
- MARKEY'S AUDIO/VISUAL, INC., INDIANAPOLIS, IN, AKA MARKEY'S RENTAL & STAGING:
3,996,587, PUB. 5-3-2011. MULTIPLE CLASS, INT. CLS. 35 AND 41.
- MARKS AND SPENCER PLC, UNITED KINGDOM:
3,995,759, PUB. 5-3-2011. MULTIPLE CLASS, INT. CLS. 3, 14, 18 AND 25.
- MARKS USA I, LLC, AMITYVILLE, NY:
2,580,273, REN. 6-16-11. INT. CL. 9.
- MARLAFIN AG, SWITZERLAND:
3,995,955, PUB. 5-3-2011. MULTIPLE CLASS, INT. CLS. 5 AND 10.
- MARQUIS MARBLE AND GRANITE, INC., PIEDMONT, SC:
2,901,021, CANC. MULTIPLE CLASS, INT. CLS. 19 AND 37.
- MARRIOTT INTERNATIONAL, INC., BETHESDA, MD:
2,507,007, REN. 6-14-11. INT. CL. 42.
2,507,008, REN. 6-14-11. INT. CL. 36.
- MARS DRINKS UK LTD., UNITED KINGDOM:
3,995,894, PUB. 5-3-2011. MULTIPLE CLASS, INT. CLS. 30, 35 AND 43.

MARS, INCORPORATED, MCLEAN, VA:
2,448,934, REN. 6-13-11. INT. CL. 25.
2,901,442, CANC. INT. CL. 30.
3,999,210, INT. CL. 42.

MARSHALL, THOMAS L., HONOLULU, HI:
3,998,353, INT. CL. 25.

MARSHALL, WALLY E., GARLAND, TX:
3,998,638, INT. CL. 28.

MARSTON'S PLC, UNITED KINGDOM:
3,996,008, PUB. 5-3-2011. INT. CL. 32.

MARTEC, SÈVRES, FRANCE:
2,901,512, CANC. MULTIPLE CLASS, INT. CLS. 1, 9, 38 AND 42.

MARTIE DUNCAN, BIRMINGHAM, AL:
3,995,598, PUB. 5-3-2011. INT. CL. 41.

MARTIN ENGINEERING CO., NEPONSET, IL:
1,154,533, REN. 6-16-11. INT. CL. 7.

MARTIN ERLICHMAN ASSOCIATES, INC., LOS ANGELES, CA:
3,998,380, INT. CL. 9.

MARTIN LEITGEB, MONTCLAIR, NJ:
3,999,736, INT. CL. 41.

MARTIN, DONALD C., CHICAGO, IL:
3,996,805, PUB. 5-3-2011. INT. CL. 41.

MARTIN, JAMES, LAKE OSWEGO, OR:
3,997,820, PUB. 5-3-2011. INT. CL. 25.

MARTINE JOSEPH, MARGATE, FL:
3,999,978, INT. CL. 35.

MARUCHAN, INC., IRVINE, CA:
1,626,154, REN. 6-15-11. INT. CL. 30.

MARVEL CHARACTERS, INC., MANHATTAN BEACH, CA:
3,998,438, INT. CL. 18.
3,998,439, INT. CL. 25.
3,998,440, INT. CL. 21.
3,998,441, INT. CL. 24.

MARWA CHINDER OBEID, TUSTIN, CA:
3,999,006, INT. CL. 25.

MARY FREE BED GUILD OF GRAND RAPIDS, MICHIGAN, GRAND RAPIDS, MI:
3,997,700, PUB. 5-3-2011. MULTIPLE CLASS, INT. CLS. 36, 41, 44 AND 45.

MARYAN TRADEMARK GMBH & CO. KG, D-79730 MURG, FED REP GERMANY:
2,499,491, REN. 6-14-11. INT. CL. 25.

MARYLAND AREA REGIONAL CENTER LLC, CHEVY CHASE, MD:
3,997,339, PUB. 5-3-2011. INT. CL. 36.

MASONITE INTERNATIONAL CORPORATION, MISSISSAUGA, ONTARIO L4W 1J2, CANADA:
2,902,083, CANC. INT. CL. 19.

MASSEY, QUICK & CO., LLC, MORRISTOWN, NJ:
3,997,959, PUB. 5-3-2011. INT. CL. 36.

MASTER BRANDS HK LIMITED, MARLBOROUGH, MA:
3,997,315, PUB. 5-3-2011. INT. CL. 11.
3,997,317, PUB. 5-3-2011. INT. CL. 11.
3,997,318, PUB. 5-3-2011. INT. CL. 11.

MASTER GRINDING SERVICE, INC., ROCKAWAY, NJ:
3,998,774, INT. CL. 37.

MASTER SPAS, INC, FORT WAYNE, IN:
3,998,320, INT. CL. 11.

MASTERCARD INTERNATIONAL INCORPORATED, PURCHASE, NY:
2,901,149, CANC. INT. CL. 36.

MASTERCHEM INDUSTRIES LLC, IMPERIAL, MO:
3,998,417, INT. CL. 2.

MASTERCRAFT INDUSTRIES, INC., NEWBURGH, NY:
2,402,311, CANC. INT. CL. 7.

MASTERPIECE FLOWER COMPANY, BYRON CENTER, MI:
3,995,600, PUB. 5-3-2011. MULTIPLE CLASS, INT. CLS. 21 AND 31.

MAT FACTORY, INC., LOS ANGELES, CA:
1,624,992, REN. 6-13-11. INT. CL. 27.

MATERIAL HANDLING TECHNOLOGIES, INC., MORRISVILLE, NC:
3,996,635, PUB. 5-3-2011. INT. CL. 7.

MATH MAVERICK, LLC, NAPLES, FL:
3,996,529, PUB. 5-3-2011. MULTIPLE CLASS, INT. CLS. 16 AND 41.

3,996,530, PUB. 5-3-2011. MULTIPLE CLASS, INT. CLS. 16 AND 41.

MATHIE, JAMES, M, DEERFIELD BEACH, FL:
3,997,925, PUB. 5-3-2011. INT. CL. 25.

MATT BREWING CO., INC., UTICA, NY:
2,901,331, CANC. INT. CL. 32.

MATT J. STEPHENSON, AMHURST, NY:
3,999,315, INT. CL. 28.

MATT MILLA BROKERS AND PURCHASING AGENCY, INC., TAMPA, FL:
2,902,482, CANC. INT. CL. 32.

MATTEL, INC., EL SEGUNDO, CA:
2,902,163, CANC. INT. CL. 28.
2,902,164, CANC. INT. CL. 28.
2,902,165, CANC. INT. CL. 28.
2,902,166, CANC. INT. CL. 28.
2,902,167, CANC. INT. CL. 28.
2,902,168, CANC. INT. CL. 28.
2,902,178, CANC. INT. CL. 28.
2,902,179, CANC. INT. CL. 28.
2,902,180, CANC. INT. CL. 28.
2,902,182, CANC. INT. CL. 28.
2,902,422, CANC. INT. CL. 28.
3,999,008, MULTIPLE CLASS, INT. CLS. 16 AND 28.
3,999,523, INT. CL. 28.
3,999,610, INT. CL. 28.

MATTHEW SEFICK, MT. PLEASANT, SC:
3,999,422, INT. CL. 25.

MATTHEWS-GERBAR, LTD., LIBERTYVILLE, IL:
2,901,716, CANC. INT. CL. 11.

MATTRESS DISCOUNTERS CORPORATION, UPPER MARLBORO, MD:
2,402,834, CANC. INT. CL. 20.

MATTSON TECHNOLOGY, INC., FREMONT, CA:
3,998,402, INT. CL. 7.

MATURA INVESTMENTS LTD., TORTOLA, BR. VIRGIN ISLANDS:
2,402,437, CANC. INT. CL. 3.

MAURER'S TEXTILE RENTAL SERVICES, INC., DEWITT, MI:
3,999,659, MULTIPLE CLASS, INT. CLS. 35 AND 37.

MAVERICK SPORTS MEDICINE, INC., REDMOND, WA, DBA DBA PRO-TEC ATHLETICS:
3,995,482, PUB. 1-25-2011. INT. CL. 10.

MAXIM INTEGRATED PRODUCTS, INC., SUNNYVALE, CA:
2,461,079, REN. 6-15-11. INT. CL. 9.

MAXIMUM LIVING, INC., SOULSBYVILLE, CA:
3,997,829, PUB. 5-3-2011. INT. CL. 5.

MAXIMUS MAX LLC, SPRINGFIELD GARDENS, NY:
3,996,565, PUB. 5-3-2011. INT. CL. 43.

MAXMERIDIA, S.L., SEVILLA ANDALUCIA, SPAIN:
2,902,242, CANC. INT. CL. 29.

MAXON CORPORATION, MUNCIE, IN:
732,495, REN. 6-15-11. U.S. CL. 34 (INT. CL. 11).

MAXWELL, M.D., ROBERT W., CRESTED BUTTE, CO:
3,997,010, PUB. 5-3-2011. INT. CL. 41.

MAYNARD'S, LLC, MINNEAPOLIS, MN:
3,998,058, PUB. 5-3-2011. INT. CL. 28.

MAYZUS, SERGEY VICTOROVICH, BAST, CZECH REPUBLIC:
4,000,014, MULTIPLE CLASS, INT. CLS. 35 AND 36.

MBF AND ASSOCIATES, INC., NEW YORK, NY:
3,996,165, PUB. 5-3-2011. MULTIPLE CLASS, INT. CLS. 41 AND 42.

MCATEE, WALTER BUNN, LEXINGTON, KY:
2,902,153, CANC. INT. CL. 9.

MCCAFFERTY, JAMES R., SANTA ANA, CA:
2,902,271, CANC. INT. CL. 28.
2,902,355, CANC. INT. CL. 28.

MCCARTHY, NORA, SAN FRANCISCO, CA:
4,000,039, INT. CL. 44.

MCCORMICK, MOSES MONWEAL, COLUMBUS, OH:
3,999,015, INT. CL. 41.

MCCULLOUGH, KATHLEEN, FORT WORTH, TX:
3,997,603, PUB. 5-3-2011. INT. CL. 14.

- MCDONALD'S CORPORATION, OAK BROOK, IL:
3,999,950, INT. CL. 43.
- MCCELLIGOTT, JACQUELINE, JACKSONVILLE, FL:
2,901,805, CANC. INT. CL. 35.
- MCGARRY INTERNET LTD., ATLANTA, GA, DBA FRANCHISE DIRECT USA:
3,995,607, PUB. 5-3-2011. INT. CL. 35.
- MCGHEE, MELISSA, ENCINITAS, CA AND SILBERMAN, DIANE, ENCINITAS, CA:
3,999,417, INT. CL. 25.
3,999,483, INT. CL. 30.
3,999,484, INT. CL. 30.
- MCGRAW, HOLLAND D, SAN DIEGO, CA, DBA SOME LIKE IT SHOT AND MCGRAW, ALISHA R, SAN DIEGO, CA, DBA SOME LIKE IT SHOT:
3,996,142, PUB. 5-3-2011. INT. CL. 41.
- MCGUIRE, RHASHE, R, UNIONDALE, NY:
2,902,338, CANC. MULTIPLE CLASS, INT. CLS. 16, 20 AND 24.
- MCLAREN, MARGARET J., MIAMI, FL, DBA CHANDLER'S ART:
3,998,923, INT. CL. 4.
- MCLENDON HARDWARE, INC., RENTON, WA:
3,996,656, PUB. 5-3-2011. MULTIPLE CLASS, INT. CLS. 16, 25, 35 AND 37.
3,996,657, PUB. 5-3-2011. MULTIPLE CLASS, INT. CLS. 35 AND 37.
- MCLEODUSA HOLDINGS, INC., CEDAR RAPIDS, IA:
2,902,483, CANC. INT. CL. 38.
- MCM HOLDINGS, LLC, SALAMANCA, NY:
3,998,702, INT. CL. 34.
- MCMMASTER, DAVID R., FORT COLLINS, CO:
2,401,756, CANC. INT. CL. 41.
- MCMULLIN, BRUCE, MIDVALE, UT AND MCMULLIN, DUSTY, MIDVALE, UT AND MCMULLIN, PETER, MIDVALE, UT:
3,999,886, INT. CL. 31.
- MCROSKY MATTRESS COMPANY, SAN FRANCISCO, CA:
3,997,490, PUB. 5-3-2011. MULTIPLE CLASS, INT. CLS. 20 AND 35.
- MEADWESTVACO CORPORATION, RICHMOND, VA:
3,999,163, INT. CL. 20.
- MEATHEAD MOVERS, INC., SAN LUIS OBISPO, CA:
3,998,775, INT. CL. 39.
- MECHOSHADE SYSTEMS, INC., LONG ISLAND CITY, NY:
3,996,790, PUB. 5-3-2011. INT. CL. 9.
- MED QUEST, LTD, NEW YORK, NY:
3,996,130, PUB. 5-3-2011. INT. CL. 45.
- MED-EL MEDICAL ELECTRONICS ELEKTRO-MEDIZINISCHE GERATE GMBH, INNSBRUCK, AUSTRIA:
2,901,186, CANC. MULTIPLE CLASS, INT. CLS. 9, 10 AND 28.
- MEDASSURANT, INC., BOWIE, MD:
3,997,572, PUB. 5-3-2011. INT. CL. 35.
- MEDIAMONKS MULTIMEDIA HOLDING B.V., NETHERLANDS:
3,995,755, PUB. 5-3-2011. MULTIPLE CLASS, INT. CLS. 35, 38 AND 42.
- MEDICAL BIDLINE, INC., LAKE MARY, FL:
3,997,035, PUB. 5-3-2011. INT. CL. 35.
- MEDICAL CENTER ANESTHESIOLOGISTS, PC, DES MOINES, IA:
3,996,277, PUB. 5-3-2011. INT. CL. 44.
- MEDICAL DEVICE TECHNOLOGIES, INC., GAINESVILLE, FL:
3,999,441, INT. CL. 10.
- MEDICAL INDUSTRY SERVICES, INC., LAS VEGAS, NV:
3,999,507, INT. CL. 10.
- MEDICUS RESOURCE MANAGEMENT, INC., WYOMISSING, PA:
3,998,014, PUB. 5-3-2011. MULTIPLE CLASS, INT. CLS. 35, 44 AND 45.
- MEDIDERM LABORATORIES, LLC, SANTA FE SPRINGS, CA:
3,997,338, PUB. 5-3-2011. INT. CL. 3.
- MEDINA, JEFF, MCCALLEN, TX:
3,998,867, MULTIPLE CLASS, INT. CLS. 16, 25 AND 35.
- MEDIPURE PRODUCTS INC, DRAPER, UT:
3,998,067, PUB. 5-3-2011. INT. CL. 5.
- MEDIPURE PRODUCTS INC., SARATOGA SPRINGS, UT, TA MEDIPURE PRODUCTS INC:
3,996,670, PUB. 5-3-2011. INT. CL. 5.
- MEDIPURE PRODUCTS INC., SARATOGA SPRINGS, UT:
3,997,333, PUB. 5-3-2011. INT. CL. 5.
- MEDLINE INDUSTRIES, INC., MUNDELEIN, IL:
3,997,062, PUB. 5-3-2011. INT. CL. 35.
3,999,011, INT. CL. 10.
- MEDLOGIC GLOBAL LIMITED, WINSFORD, CHESHIRE CW7 3PD, UNITED KINGDOM:
2,402,668, CANC. INT. CL. 5.
- MEDSYNERGIES, INC., IRVING, TX:
3,999,020, INT. CL. 35.
3,999,032, INT. CL. 35.
- MEDTECH PRODUCTS INC., IRVINGTON, NY:
2,523,530, REN. 6-15-11. INT. CL. 5.
- MEDTHINK COMMUNICATIONS, INC., RALEIGH, NC:
3,999,152, INT. CL. 42.
- MEDTRONIC CRYOCATH LP, KIRKLAND, CANADA:
2,498,756, REN. 6-15-11. INT. CL. 10.
- MEEK, AMY JOAN, PLANO, TX:
2,901,692, CANC. INT. CL. 18.
- MEEKS, T. WAYNE, SENECA, SC:
2,901,187, CANC. INT. CL. 12.
- MEG RUNION STUDIOS, CHARLOTTESVILLE, VA:
3,997,162, PUB. 5-3-2011. INT. CL. 41.
- MEGAMOLD TECHNOLOGY COMPANY, LLC, BOSTON, MA:
3,998,420, INT. CL. 19.
- MEHMETI, BEKIM, NILES, IL:
3,997,026, PUB. 5-3-2011. INT. CL. 44.
- MEISSNER FILTRATION PRODUCTS, INC., CAMARILLO, CA:
2,470,271, REN. 6-13-11. INT. CL. 11.
- MEKELBURG, JOHN, EAST BRUNSWICK, NJ:
2,902,487, CANC. INT. CL. 28.
- MELANIE REMBRANDT, REDONDO BEACH, CA, DBA REMBRANDT COMMUNICATIONS, LLC:
3,996,640, PUB. 5-3-2011. MULTIPLE CLASS, INT. CLS. 9 AND 41.
- MELCHER, WESLEY, PLANO, TX:
3,998,893, MULTIPLE CLASS, INT. CLS. 16 AND 41.
- MELMOTH, CHRISTOPHER, LAS VEGAS, NV:
3,997,733, PUB. 5-3-2011. INT. CL. 25.
- MEMA MATES LLC, NEWTOWN, PA, DBA MEMA MATES LLC:
3,997,545, PUB. 5-3-2011. INT. CL. 37.
- MENARD, INC., EAU CLAIRE, WI:
3,997,476, PUB. 5-3-2011. MULTIPLE CLASS, INT. CLS. 9, 11 AND 17.
- MENDEZ & COMPANY, SAN JUAN, PUERTO RICO:
3,996,689, PUB. 5-3-2011. INT. CL. 41.
- MENTOR WORLDWIDE LLC, SANTA BARBARA, CA:
2,447,313, REN. 6-15-11. INT. CL. 10.
- MEPLA-WERKE LAUTENSCHLAGER GMBH & CO. KG, D-64354 REINHEIM, FED REP GERMANY:
2,901,113, CANC. MULTIPLE CLASS, INT. CLS. 6 AND 20.
2,901,114, CANC. MULTIPLE CLASS, INT. CLS. 6 AND 20.
- MERCIER JR., JAMES P., REDMOND, WA:
3,999,036, INT. CL. 28.
- MERCK KGAA, 64293 DARMSTADT, FED REP GERMANY:
1,620,678, CANC. MULTIPLE CLASS, INT. CLS. 1 AND 9.
- MEREDITH CORPORATION, DES MOINES, IA:
3,996,061, PUB. 5-3-2011. MULTIPLE CLASS, INT. CLS. 36 AND 41.
3,996,363, PUB. 5-3-2011. INT. CL. 16.
3,997,063, PUB. 5-3-2011. INT. CL. 8.
3,998,233, PUB. 5-3-2011. INT. CL. 35.
- MERELINDA FARM LLC, WHITMORE LAKE, MI, DBA ALPACA.COM LLC:
2,478,056, REN. 6-14-11. INT. CL. 28.
- MERGE TECHNOLOGIES INC., MILWAUKEE, WI:
2,401,760, CANC. INT. CL. 9.
2,402,928, CANC. INT. CL. 9.

MERIDIAN HEALTH SYSTEM, INC., NEPTUNE, NJ:
3,997,667, PUB. 5-3-2011. INT. CL. 44.

MERIDIAN HOME MORTGAGE CORPORATION, HAMPSTEAD, MD:
3,997,651, PUB. 5-3-2011. INT. CL. 36.

MERIDIAN KIOSKS LLC, ABERDEEN, NC:
3,998,593, INT. CL. 9.

MERITT, GARY J., FLORISSANT, MO:
3,997,863, PUB. 5-3-2011. INT. CL. 41.

MERIYALA, SANTOSH KUMAR, HYDERABAD, INDIA:
3,997,193, PUB. 5-3-2011. INT. CL. 41.

METABANK, SIOUX FALLS, SD:
3,996,719, PUB. 1-25-2011. INT. CL. 36.

METAL IMPROVEMENT COMPANY, LLC, PARAMUS, NJ, EVERLUBE CORPORATION OF AMERICA, NORTH HOLLYWOOD, CA, DBA EVERLUBE CORPORATION:
715,293. REN. 6-14-11. U.S. CL. 15 (INT. CL. 4).

METALS USA BUILDING PRODUCTS, L.P., MESQUITE, TX:
2,402,279, CANC. INT. CL. 6.
2,901,904, CANC. INT. CL. 6.

METECH RECYCLING, INC., GILROY, CA:
3,997,056, PUB. 5-3-2011. INT. CL. 40.
3,997,310, PUB. 5-3-2011. INT. CL. 40.

METIS SECURE SOLUTIONS, LLC, OAKMONT, PA:
3,996,809, PUB. 5-3-2011. INT. CL. 9.
3,996,810, PUB. 5-3-2011. INT. CL. 9.

METRO INFECTIOUS DISEASE CONSULTANTS, L.L.C., HINSDALE, IL:
3,999,444, INT. CL. 44.

METRO MASSAGE, INC., BURBANK, IL:
2,902,247, CANC. INT. CL. 44.

METROPOLITAN TRANSPORTATION COMMISSION, OAKLAND, CA:
3,955,531, COR. MULTIPLE CLASS, INT. CLS. 9 AND 39.

METSO MINERALS INDUSTRIES, INC., WAUKESHA, WI:
2,455,364. REN. 6-16-11. INT. CL. 7.

METSO PAPER, INC., HELSINKI, FINLAND, RAYBESTOS-MANHATTAN, INC., PASSAIC, NJ:
913,078. REN. 6-16-11. U.S. CL. 23 (INT. CL. 7).

METSO PAPER, INC., FI-00101 HELSINKI, FINLAND, RAYBESTOS-MANHATTAN, INC., PASSAIC, NJ:
915,043. REN. 6-16-11. U.S. CL. 23 (INT. CL. 7).

METTLER-TOLEDO INC, COLUMBUS, OH, MASSTRON SCALE, INC., COLUMBUS, OH:
1,191,602. REN. 6-14-11. INT. CL. 9.

MEYER MUSIC COMPANY, BLUE SPRINGS, MO:
3,998,114, PUB. 5-3-2011. INT. CL. 15.

MEYER, CHRISTOPHER J., SANTA FE, NM:
2,902,477, CANC. INT. CL. 25.

MGM RESORTS INTERNATIONAL, LAS VEGAS, NV:
2,642,096, AM. INT. CL. 25.

MICHAEL B. BAYLESS AND ASSOCIATES INC., PHOENIX, AZ, DBA BAYLESS BEHAVIORAL HEALTH SOLUTIONS:
3,996,885, PUB. 5-3-2011. INT. CL. 44.

MICHAEL D. SIMENS, CLEVELAND, OH:
3,996,118, PUB. 5-3-2011. INT. CL. 43.

MICHAEL G. ROSMARIN, HOUSTON, TX:
3,999,211, INT. CL. 25.

MICHAEL KORS, L.L.C., NEW YORK, NY:
3,998,475, INT. CL. 18.
3,998,476, INT. CL. 18.

MICHAEL L TASH, GERMANTOWN, MD:
3,997,416, PUB. 5-3-2011. INT. CL. 41.

MICHAEL PAUL MCLENDON, WOODSTOCK, GA, DBA MAXESSORIES:
3,999,312, INT. CL. 26.

MICHAEL S. FREAS AND NANCY L. FREAS JOINT VENTURE, THE, HEATH, OH:
3,998,383, MULTIPLE CLASS, INT. CLS. 16 AND 25.

MICHIGAN ECONOMIC DEVELOPMENT CORPORATION, LANSING, MI:
3,996,528, PUB. 5-3-2011. INT. CL. 35.

MICHIGAN STATE MEDICAL SOCIETY, EAST LANSING, MI:
3,995,466, PUB. 5-3-2011. MULTIPLE CLASS, U.S. CL. 20 INT. CLS. 16, 35 AND 44.

MICOMPRO LIMITED, LONDON, ONTARIO, CANADA:
3,998,558, INT. CL. 9.

MICRO JIG, WINTER SPRINGS, FL:
3,996,844, PUB. 5-3-2011. INT. CL. 7.

MICRO MEGA INTERNATIONAL MANUFACTURES, F-25000 BESANCON, FRANCE:
3,995,901, PUB. 5-3-2011. INT. CL. 5.

MICROBIOLOGICS, INC, ST. CLOUD, MN:
3,996,813, PUB. 5-3-2011. INT. CL. 1.

MICRODOSE THERAPEUTX, INC., MONMOUTH JUNCTION, NJ:
2,402,954, CANC. MULTIPLE CLASS, INT. CLS. 10 AND 42.

MICROMERITICS INSTRUMENT CORPORATION, NORCROSS, GA:
916,723. REN. 6-16-11. U.S. CL. 26 (INT. CLS. 1, 9 AND 10).

MICRONOTES, INC., CAMBRIDGE, MA:
3,996,229, PUB. 5-3-2011. INT. CL. 35.
3,996,231, PUB. 5-3-2011. INT. CL. 35.

MICROSOFT CORPORATION, REDMOND, WA:
2,901,871, CANC. INT. CL. 9.
3,999,208, MULTIPLE CLASS, INT. CLS. 41 AND 42.

MID ATLANTIC CAT SPECIALISTS, LLC, CORDOVA, MD:
3,998,034, PUB. 5-3-2011. INT. CL. 44.

MIDDLESEX WATER COMPANY, ISELIN, NJ:
2,902,260, CANC. INT. CL. 32.

MIDKIFF, DANIEL, L, WINSTON-SALEM, NC:
3,999,478, INT. CL. 41.

MIDTEL TECHNOLOGIES, INC., PALOS HILLS, IL:
2,478,076. REN. 6-14-11. INT. CL. 9.

MIDWEST HARDWOOD CORPORATION, MAPLE GROVE, MN:
3,998,500, MULTIPLE CLASS, INT. CLS. 19, 35 AND 40.

MIDWEST INDUSTRIAL SUPPLY, INC., CANTON, OH:
3,996,192, PUB. 5-3-2011. MULTIPLE CLASS, INT. CLS. 1, 3, 4, 7, 9, 17, 19 AND 37.
3,998,712, MULTIPLE CLASS, INT. CLS. 1 AND 19.

MIDWEST-CBK, INC., GREENWICH, CT:
2,401,607, CANC. INT. CL. 4.

MIKOLAJCZYK, WILLIAM, ANTHEM, AZ:
3,997,138, PUB. 5-3-2011. INT. CL. 5.

MIKRONITE TECHNOLOGIES GROUP INC., EATONTOWN, NJ:
2,402,844, CANC. INT. CL. 40.

MIKVELK PUBLISHING, LLC, CANYON, TX:
3,999,642, INT. CL. 41.

MILAN INDUSTRIES, INC., NORWOOD, NJ:
3,997,975, PUB. 5-3-2011. INT. CL. 26.

MILES DAVIS PROPERTIES, LLC, LOS ANGELES, CA:
3,999,091, INT. CL. 32.

MILESTONE AV TECHNOLOGIES LLC, SAVAGE, MN:
3,999,318, INT. CL. 6.
3,999,593, INT. CL. 20.
3,999,594, INT. CL. 42.

MILL RUN DEVELOPMENT GROUP II, LLC, KINGSTON, NC:
3,999,860, MULTIPLE CLASS, INT. CLS. 24, 25, 28, 37 AND 41.

MILL VALLEY CORPORATION, EDINA, MN:
3,999,316, INT. CL. 43.

MILLER, ROY C., NEW CARROLLTON, MD:
3,998,930, INT. CL. 3.

MILLER, STANLEY F., MADISON, WI:
3,998,302, INT. CL. 25.

MILLER, WILLIAM G., WASHINGTON, DC:
2,901,908, CANC. INT. CL. 25.

MILLERCOORS LLC, CHICAGO, IL:
2,402,345, CANC. INT. CL. 16.
2,402,622, CANC. INT. CL. 32.
3,996,502, PUB. 5-3-2011. INT. CL. 25.
3,999,676, INT. CL. 32.
3,999,696, INT. CL. 32.

MILLIMAN & ROBERTSON, INC., DALLAS, TX:
2,900,979, CANC. INT. CL. 36.

MILLS DISTRIBUTING COMPANY, SALINAS, CA:
2,901,850, CANC. INT. CL. 31.

MILUX HOLDING S.A., LUXEMBOURG, LUXEMBOURG:
3,995,624, PUB. 5-3-2011. MULTIPLE CLASS, INT. CLS. 9,

- 10 AND 44.
3,995,625, PUB. 5-3-2011. MULTIPLE CLASS, INT. CLS. 9, 10, 36 AND 44.
- MIN, WEIXING, KALEEN ACT 2618, AUSTRALIA:
3,996,296, PUB. 5-3-2011. INT. CL. 7.
- MIND MINE, LLC, TUCSON, AZ:
3,999,124, INT. CL. 5.
- MIND THE GAP LLC, MCKINNEY, TX:
3,998,163, PUB. 5-3-2011. INT. CL. 41.
- MINDFILE, INC., NEW YORK, NY:
3,996,038, PUB. 5-3-2011. INT. CL. 36.
- MINISTERO DELLE POLITICHE AGRICOLE,; ALIMEN-
TARI E FORESTALI -; DIPARTIMENTO DELLE POLI-
TICHE; COMPETITIVE DEL MONDO RURALE; E DELLA
QUALITA' -; DIREZIONE GENERALE PER LO; SVILUP-
PO AGROALIMENTARE,; LA QUALITA' E LA TUTELA;
DEL CONSUMATORE, ROMA, ITALY:
3,995,812, PUB. 5-3-2011. INT. CL. 29.
- MINISTERO DELLE POLITICHE AGRICOLE,; ALIMEN-
TARI E FORESTALI -; DIPARTIMENTO DELLE POLI-
TICHE; COMPETITIVE DEL MONDO RURALE; E DELLA
QUALITA' -; DIREZIONE GENERALE PER LO; SVILUP-
PO AGROALIMENTARE,; LA QUALITA' E LA TUTELA;
DEL CONSUMATORE, I-00187 ROMA, ITALY:
3,995,827, PUB. 5-3-2011. INT. CL. 31.
- MINISTERO DELLE POLITICHE AGRICOLE,; ALIMEN-
TARI E FORESTALI -; DIPARTIMENTO DELLE POLI-
TICHE; COMPETITIVE DEL MONDO RURALE; E DELLA
QUALITA' -; DIREZIONE GENERALE PER LO; SVILUP-
PO AGROALIMENTARE,; LA QUALITA' E LA TUTELA;
DEL CONSUMATORE, ROMA, ITALY:
3,995,828, PUB. 5-3-2011. INT. CL. 31.
3,995,829, PUB. 5-3-2011. INT. CL. 31.
3,995,830, PUB. 5-3-2011. MULTIPLE CLASS, INT. CLS. 29
AND 31.
3,995,831, PUB. 5-3-2011. INT. CL. 31.
3,995,832, PUB. 5-3-2011. INT. CL. 31.
- MINISTRY OF SOUND GROUP LIMITED, LONDON, UNI-
TED KINGDOM:
3,999,159, INT. CL. 41.
- MINNESOTA DEPARTMENT OF EMPLOYMENT AND
ECONOMIC DEVELOPMENT, ST. PAUL, MN, FOR-
MERLY MINNESOTA DEPARTMENT OF TRADE AND
ECONOMIC DEVELOPMENT:
3,996,982, PUB. 5-3-2011. INT. CL. 35.
- MINNESOTA PUBLIC RADIO, ST. PAUL, MN:
2,569,847. REN. 6-15-11. INT. CL. 41.
- MINT MUSEUM OF ART, CHARLOTTE, NC:
2,401,950, CANC. INT. CL. 41.
- MINTEK CORPORATION, DUNEDIN, FL:
2,570,254. REN. 6-16-11. INT. CL. 9.
- MINUS K TECHNOLOGY, INC., INGLEWOOD, CA:
2,515,037. REN. 6-15-11. INT. CL. 42.
- MIR SRL MEDICAL INTERNATIONAL RESEARCH,
ITALY:
3,995,967, PUB. 5-3-2011. MULTIPLE CLASS, INT. CLS. 9
AND 10.
- MIRAGE RESORTS, INCORPORATED, LAS VEGAS, NV:
3,996,919, PUB. 5-3-2011. INT. CL. 43.
- MIRAMAR LABS, INC., SUNNYVALE, CA:
3,998,952, INT. CL. 10.
3,998,953, INT. CL. 10.
- MIRAPHONE GRASLITZER MUSIKINSTRUMENTENER-
ZEUGER E.G., FED REP GERMANY:
3,995,992, PUB. 5-3-2011. INT. CL. 15.
- MIRESCO, MARC, COTE-ST-LUC, QUEBEC, CANADA:
3,998,648, INT. CL. 44.
- MIRIAM T. BELL, ATLANTA, GA:
3,997,472, PUB. 5-3-2011. INT. CL. 3.
- MIS QUALITY MANAGEMENT CORP., WILMINGTON, DE:
3,997,505, PUB. 5-3-2011. INT. CL. 42.
- MISS BEXAR COUNTY ORGANIZATION, INC, SAN ANTO-
NIO, TX:
3,997,037, PUB. 5-3-2011. INT. CL. 41.
- MISSION APPAREL, LLC, CHARLESTON, SC:
3,997,296, PUB. 5-3-2011. INT. CL. 25.
- MISSION BREWERY, SAN DIEGO, CA:
3,998,595, MULTIPLE CLASS, INT. CLS. 32 AND 43.
- MISSION PRODUCT HOLDINGS, INC, NEW YORK, NY:
3,999,095, INT. CL. 3.
3,999,096, INT. CL. 3.
3,999,097, INT. CL. 3.
- MISSION PRODUCT HOLDINGS, INC., NEW YORK, NY:
3,999,089, INT. CL. 3.
- MISSISSIPPI STATE UNIVERSITY, MISSISSIPPI STATE, MS:
3,998,326, INT. CL. 31.
- MITCHELL, ISAAC C., III, NASHVILLE, TN:
2,901,771, CANC. INT. CL. 41.
- MITSUBISHI ELECTRIC CORPORATION, TOKYO, JAPAN:
2,900,994, CANC. INT. CL. 12.
- MITSUBISHI FUSO TRUCK AND BUS CORPORATION,
TOKYO 108-8285, JAPAN:
2,901,280, CANC. INT. CL. 12.
- MITSUBISHI PAPER MILLS LIMITED, TOKYO, JAPAN:
3,996,384, PUB. 5-3-2011. INT. CL. 7.
- MITSUBISHI RAYON CO., LTD., MINATO-KU, TOKYO,
JAPAN:
2,976,747, CANC. MULTIPLE CLASS, INT. CLS. 5 AND
10.
- MITSUSHBIA INTERNATIONAL, INC., FULLERTON, CA,
DBA PARAGON SPORTS:
3,998,083, PUB. 5-3-2011. INT. CL. 28.
- MITTELMAN, ELIZABETH, TEMECULA, CA:
3,999,457, INT. CL. 16.
- MIVA, INC., FT. MYERS, FL, AKA MIVA:
2,901,597, CANC. INT. CL. 35.
2,901,598, CANC. INT. CL. 35.
- MIYAGAWA CORPORATION, OSAKA, JAPAN:
3,995,962, PUB. 5-3-2011. INT. CL. 6.
- MK ASSET, INC., WILMINGTON, DE:
3,996,612, PUB. 5-3-2011. MULTIPLE CLASS, INT. CLS. 35
AND 36.
- MMI-IPCO, LLC, LAWRENCE, MA:
2,460,383. REN. 6-16-11. INT. CL. 24.
- MMWAVE HOLDINGS INC., MISSISSAUGA, ONTARIO,
CANADA:
2,901,247, CANC. INT. CL. 9.
- MOBEGIC, INCORPORATED, NEWTON, MA, DBA UN-
BOUND COMMERCE:
3,997,921, PUB. 5-3-2011. INT. CL. 9.
- MOBIATA, LLC, ANN ARBOR, MI:
3,996,058, PUB. 5-3-2011. MULTIPLE CLASS, INT. CLS. 9
AND 43.
- MOBIUS COMMUNICATIONS CO., HEMINGFORD, NE:
2,451,433. REN. 6-15-11. INT. CL. 38.
2,470,097. REN. 6-15-11. INT. CL. 38.
- MODE OF FITNESS, INC, SEATTLE, WA:
3,995,476, PUB. 5-3-2011. INT. CL. 41.
- MODERN BUILDERS SUPPLY, INC., TOLEDO, OH:
2,402,744, CANC. INT. CL. 19.
- MODERN MARKETING CONCEPTS, INC, LOUISVILLE,
KY:
2,902,387, CANC. INT. CL. 9.
- MOFTWARE INC, SUGAR LAND, TX:
3,998,027, PUB. 5-3-2011. INT. CL. 9.
- MOJA, INC., MANASSAS, VA:
3,996,792, PUB. 5-3-2011. INT. CL. 42.
- MOLE-RICHARDSON COMPANY, HOLLYWOOD, CA:
2,536,316. REN. 6-15-11. INT. CL. 11.
2,540,093. REN. 6-15-11. INT. CL. 11.
- MOLESKINE S.R.L., 20159 MILANO, ITALY:
2,453,716. REN. 6-13-11. INT. CL. 16.
- MOLINO PASINI S.P.A., ITALY:
3,995,921, PUB. 5-3-2011. INT. CL. 30.
- MOLINOS VALLE DEL CIBAO C POR A, SANTIAGO,
DOMINICAN REP:
3,996,041, PUB. 5-3-2011. INT. CL. 30.
- MOLSON CANADA 2005, TORONTO, ONTARIO:
2,902,004, CANC. INT. CL. 32.
- MOM AT LAST, LLC, SEAFORD, DE:
3,996,883, PUB. 5-3-2011. INT. CL. 41.
- MOM, INC., PACIFIC PALISADES, CA:
3,996,166, PUB. 5-3-2011. INT. CL. 35.
- MOMENTIVE CHEMICAL INVESTMENTS INC., COLUM-
BUS, OH, BORDEN COMPANY, THE, NEW YORK, NY:
388,311. REN. 6-15-11. U.S. CL. 5 (INT. CL. 1).

MOMOI SEIMO KABUSHIKI KAISHA, HYOGO-KEN, JAPAN, DBA MOMOI FISHING NET MFG. CO., LTD.:
3,996,328, PUB. 5-3-2011. MULTIPLE CLASS, INT. CLS. 22 AND 28.

MON CHOCOLAT, LLC, PORTLAND, OR:
3,999,772, INT. CL. 30.

MONAVIE LLC, SOUTH JORDAN, UT:
3,998,262, PUB. 5-3-2011. INT. CL. 9.
3,999,799, INT. CL. 5.
3,999,859, INT. CL. 5.

MONEY MISSION, LLC, MILWAUKEE, WI:
3,999,225, MULTIPLE CLASS, INT. CLS. 9, 16, 18, 21, 25 AND 41.

MONEYSOFT, INC., PHOENIX, AZ:
2,401,266, CANC. INT. CL. 9.

MONOSOL, LLC, MERRILLVILLE, IN:
3,999,379, INT. CL. 1.

MONTARE LLC, SNOQUALMIE, WA, DBA DUTCH DOG DESIGN:
3,998,822, INT. CL. 20.

MONTEFORTE, CAMRYN, OCEANPORT, NJ:
3,997,426, PUB. 5-3-2011. INT. CL. 41.

MONTRES TUDOR SA, SWITZERLAND:
3,995,815, PUB. 5-3-2011. INT. CL. 14.
3,995,873, PUB. 5-3-2011. INT. CL. 14.

MONTRES UNIVERSAL S.A., 1227 LES ACACIAS - GENÈVE, SWITZERLAND:
2,900,997, CANC. INT. CL. 14.

MONY LIFE INSURANCE COMPANY, NEW YORK, NY:
3,997,292, PUB. 5-3-2011. INT. CL. 36.

MOONLIGHT PACKING CORPORATION, REEDLEY, CA:
3,995,527, PUB. 11-30-2010. INT. CL. 31.

MOORECO, INC., TEMPLE, TX:
3,997,926, PUB. 5-3-2011. INT. CL. 20.

MOOSE CREATIVE PTY LTD, EAST BENTLEIGH, AUSTRALIA:
3,999,606, INT. CL. 28.

MOOSEWOOD, INC., ITHACA, NY:
2,401,542, CANC. INT. CL. 25.

MOPIX, LLC, SUWANEE, GA:
3,998,113, PUB. 5-3-2011. INT. CL. 35.

MOREJON, ORLANDO, KEY LARGO, FL:
3,999,066, INT. CL. 10.
3,999,067, INT. CL. 10.

MORFOLOGICA INC., MANASSAS, VA:
3,997,011, PUB. 5-3-2011. INT. CL. 42.
3,997,012, PUB. 5-3-2011. INT. CL. 42.

MORGENSTERN, NECHEMIA, JERUSALEM 96425, ISRAEL:
2,900,982, CANC. INT. CL. 5.

MORKUNAS, FRANK G., SAN DIEGO, CA:
2,403,021, CANC. INT. CL. 42.

MORPHEUS CYCLES LLC, BRONX, NY:
3,998,032, PUB. 5-3-2011. INT. CL. 12.

MORPHOTEK INC., EXTON, PA:
2,578,770, REN. 6-16-11. INT. CL. 42.

MORRIS PROFUMI S.P.A., ITALY:
3,995,848, PUB. 5-3-2011. INT. CL. 3.

MORTON SALT, INC., CHICAGO, IL:
3,998,749, INT. CL. 30.
3,999,301, INT. CL. 1.
3,999,302, INT. CL. 1.

MOSCOT MANAGEMENT CORP., NEW YORK, NY:
3,999,132, INT. CL. 18.
3,999,133, INT. CL. 25.

MOTHERGOOD INC., SAN DIEGO, CA:
3,997,664, PUB. 5-3-2011. INT. CL. 30.

MOTHERS AGAINST DRUNK DRIVING, IRVING, TX:
3,997,397, PUB. 5-3-2011. INT. CL. 45.

MOTION PICTURE INDUSTRY CHARITABLE ALLIANCE, SPRINGFIELD, OH:
2,415,888, REN. 6-14-11. INT. CL. 36.

MOTION PICTURE LICENSING CORPORATION, LOS ANGELES, CA:
3,995,532, PUB. 5-3-2011. INT. CL. 45.

MOTOMAN, INC., WEST CARROLLTON, OH:
2,401,602, CANC. INT. CL. 9.

MOTT'S LLP, RYE BROOK, NY:
3,998,611, MULTIPLE CLASS, INT. CLS. 18, 29 AND 35.

MOTTO, RICHARD J., MASSAPEQUA, NY:
2,901,474, CANC. INT. CL. 40.

MOULD TECHNOLOGIES HOLDING AG, SWITZERLAND:
3,995,792, PUB. 5-3-2011. MULTIPLE CLASS, INT. CLS. 7, 42 AND 45.

MOUNT GAY DISTILLERIES LIMITED, BRANDONS, SAINT MICHAEL, BARBADOS:
3,999,742, INT. CL. 33.

MOUNTAIN ENERGY SERVICES, INC., TUNKANNOCK, PA:
3,996,409, PUB. 5-3-2011. INT. CL. 39.

MOUNTAIN GEAR CORPORATION, IRWINDALE, CA:
3,999,257, INT. CL. 25.

MOUNTAIN HIGH ORGANICS, INC., NEW MILFORD, CT:
3,999,261, INT. CL. 5.
3,999,268, MULTIPLE CLASS, INT. CLS. 5 AND 29.
3,999,411, INT. CL. 5.
3,999,413, MULTIPLE CLASS, INT. CLS. 5 AND 29.

MOVADO LLC, WILMINGTON, DE:
2,462,831, REN. 6-16-11. INT. CL. 14.

MOVE PRESS, SOUTH PASADENA, CA:
3,999,969, INT. CL. 16.

MOVIEONNEWS, INC., NEW YORK, NY:
1,153,698, REN. 6-11-11. INT. CL. 9.

MOXA INC., TAIPEI HSIEN, TAIWAN:
3,999,405, INT. CL. 9.

MPS GROUP, INC., JACKSONVILLE, FL:
2,902,079, CANC. MULTIPLE CLASS, INT. CLS. 35 AND 42.

MP3 CAR, INC., BALTIMORE, MD:
3,999,372, INT. CL. 42.
3,999,373, INT. CL. 42.

MR CHURROS INTERNATIONAL, CORP., MIAMI, FL:
3,996,480, PUB. 5-3-2011. INT. CL. 35.

MR TRADE DI RABELLINO MARCO, I-12058 SANTO STEFANO BELBO (CN), ITALY:
3,995,900, PUB. 5-3-2011. INT. CL. 33.

MSH SOUTH INC., WILMINGTON, DE:
2,519,531, REN. 6-15-11. INT. CL. 41.

MTL MOTORS, LLC, DEARBORN, MI:
3,997,107, PUB. 5-3-2011. MULTIPLE CLASS, INT. CLS. 35, 36, 37 AND 39.

MTS PRODUCTS, SUN VALLEY, CA:
2,901,337, CANC. MULTIPLE CLASS, INT. CLS. 12, 20 AND 28.

MUCOS PHARMA GMBH & CO. KG, BERLIN, FED REP GERMANY:
2,901,455, CANC. INT. CL. 5.

MUELLER, DIETER, DANBURY, CT:
2,901,983, CANC. INT. CL. 28.

MULTI MEDIA EXPOSURE, INC., SHORT HILLS, NJ:
2,901,109, CANC. INT. CL. 3.

MULTIGRAINS BAKERY, LAWRENCE, MA:
3,999,102, INT. CL. 30.

MULTIMEDIA GAMES, INC., AUSTIN, TX:
3,999,368, INT. CL. 9.

MULTISTACK LLC, SPARTA, WI:
3,999,400, INT. CL. 11.

MUM INDUSTRIES, LIMITED, MENTOR, OH:
3,996,578, PUB. 5-3-2011. MULTIPLE CLASS, INT. CLS. 35, 40 AND 42.

MUNICIO, FRANCISCO JOSE CARBALLO, BARCELONA, SPAIN:
3,997,061, PUB. 5-3-2011. INT. CL. 45.

MUNTERS CORPORATION, AMESBURY, MA:
3,999,514, INT. CL. 11.

MURATA KIKAI KABUSHIKI KAISHA, MINAMI-KU, KYOTO-SHI, JAPAN:
2,900,970, CANC. INT. CL. 9.

MURPHY, MICHAEL, WEST CHESTER, PA:
1,661,943, REN. 6-16-11. INT. CL. 37.

MURRAY EMPOWERMENT SYSTEMS, INC, PEACHTREE CITY, GA:
3,998,691, INT. CL. 16.

- MUSIC CITY METALS CO., INC., NASHVILLE, TN:
3,995,498, PUB. 5-3-2011. INT. CL. 35.
3,995,499, PUB. 5-3-2011. INT. CL. 35.
3,995,500, PUB. 5-3-2011. INT. CL. 35.
- MUSIC SUPERVISOR INC., PLAYA DEL REY, CA:
3,996,358, PUB. 5-3-2011. INT. CL. 41.
- MUSIC WORKS ACADEMY, LTD., PHOENIX, AZ:
2,402,489, CANC. INT. CL. 16.
- MUTUAL WHOLESALE LIQUOR, INC., LOS ANGELES, CA,
DBA INTERNATIONAL IMPORT EXPORT:
3,997,528, PUB. 5-3-2011. INT. CL. 33.
3,997,529, PUB. 5-3-2011. INT. CL. 33.
3,997,530, PUB. 5-3-2011. INT. CL. 33.
- MWR, LLC, BARRINGTON, RI:
3,997,394, PUB. 5-3-2011. INT. CL. 16.
- MXENERGY INC., STAMFORD, CT:
3,999,510, INT. CL. 41.
- MY EYE MEDIA, LLC, BURBANK, CA:
3,999,672, INT. CL. 42.
- MY NEW ENTERPRISE, LLC, SALT LAKE CITY, UT:
3,999,249, MULTIPLE CLASS, INT. CLS. 35 AND 41.
- MY PARA-KIN, LLC, WAKEFIELD, RI, FORMERLY PARA-MORE, LLC:
3,995,701, PUB. 5-3-2011. MULTIPLE CLASS, INT. CLS. 16 AND 25.
- MY PHARMACY OF HOMESTEAD, INC., HOMESTEAD, FL:
3,997,748, PUB. 5-3-2011. INT. CL. 35.
- MYARTSYLUM, INC., MIAMI, FL:
3,997,371, PUB. 5-3-2011. INT. CL. 42.
- MYBODY, L.L.C., PHOENIX, AZ:
3,997,626, PUB. 5-3-2011. INT. CL. 3.
3,997,627, PUB. 5-3-2011. INT. CL. 5.
3,997,628, PUB. 5-3-2011. INT. CL. 5.
3,997,629, PUB. 5-3-2011. INT. CL. 3.
3,997,684, PUB. 5-3-2011. INT. CL. 3.
3,997,692, PUB. 5-3-2011. INT. CL. 3.
3,997,693, PUB. 5-3-2011. MULTIPLE CLASS, INT. CLS. 3 AND 5.
3,997,694, PUB. 5-3-2011. INT. CL. 3.
3,997,696, PUB. 5-3-2011. INT. CL. 3.
3,997,948, PUB. 5-3-2011. INT. CL. 3.
3,997,951, PUB. 5-3-2011. INT. CL. 3.
3,997,952, PUB. 5-3-2011. INT. CL. 3.
- MYCELX TECHNOLOGIES CORP., GAINESVILLE, GA:
3,999,055, INT. CL. 1.
- MYERS-HOLUM, INC., NEW YORK, NY:
3,997,960, PUB. 5-3-2011. INT. CL. 9.
- MYLIFE.COM, INC., LOS ANGELES, CA:
3,998,463, INT. CL. 35.
- MYOB TECHNOLOGY PTY LTD., BLACKBURN VICTORIA 3130, AUSTRALIA:
2,900,983, CANC. INT. CL. 9.
- MYSORECARD LLC, BELMONT, MA:
3,997,414, PUB. 5-3-2011. INT. CL. 42.
- MYSLABODSKI LEJTMAN, TEODORO, ESTADO DE MEXICO, MEXICO:
3,999,255, INT. CL. 44.
- MYTRAVEL GROUP PLC, MANCHESTER, UNITED KINGDOM:
2,900,999, CANC. MULTIPLE CLASS, INT. CLS. 9, 16, 35, 36, 38, 39 AND 42.
- MY1STORY, LLC, FORT LAUDERDALE, FL:
3,999,309, INT. CL. 16.
- M47I INC., TORONTO, ONTARIO, CANADA:
3,995,724, PUB. 5-3-2011. INT. CL. 25.
- N HOLDING AB, SOLLENTUNA, SWEDEN:
3,999,545, INT. CL. 9.
- NAANSTOP, LLC, LOS ANGELES, CA:
3,997,615, PUB. 5-3-2011. INT. CL. 43.
- NADA SCIENTIFIC, LTD., CHAMPLAIN, NY:
2,401,937, CANC. INT. CL. 35.
- NAMANNY, KERRY T., ATLANTIC, IA AND NAMANNY, KENNETH D., ATLANTIC, IA:
3,998,332, INT. CL. 5.
- NAMEMEDIA, INC., WALTHAM, MA:
2,402,131, CANC. INT. CL. 41.
- NANA, RUPEN, WINDERMERE, FL:
3,999,357, INT. CL. 37.
- NANCY TAYLOR BUBES, WASHINGTON, DC:
3,997,512, PUB. 5-3-2011. INT. CL. 36.
- NANDA HOME INCORPORATED, GROSSE POINTE FARMS, MI:
3,998,721, INT. CL. 14.
- NANOVIBRONIX, INC., CEDARHURST, NY:
3,996,474, PUB. 5-3-2011. INT. CL. 10.
- NARVLA PARTNERS, L.L.C., LADUE, MO:
3,998,673, INT. CL. 35.
- NASHVILLE HOCKEY CLUB LIMITED PARTNERSHIP, NASHVILLE, TN:
2,419,490, REN. 6-16-11. INT. CL. 41.
- NATAJI, LLC, RENO, NV:
3,999,179, INT. CL. 16.
- NATALIA S PREISS, PLANO, TX:
3,996,929, PUB. 5-3-2011. INT. CL. 42.
- NATHANIEL GEORGE, SAN JOSE, CA:
3,995,676, PUB. 5-3-2011. INT. CL. 28.
- NATION'S HOME INFUSION, LLC, OWINGS MILLS, MD:
3,996,766, PUB. 5-3-2011. INT. CL. 44.
- NATIONAL ACADEMY FOUNDATION, NEW YORK, NY:
3,997,304, PUB. 5-3-2011. INT. CL. 41.
3,997,305, PUB. 5-3-2011. INT. CL. 41.
3,997,306, PUB. 5-3-2011. INT. CL. 41.
3,997,307, PUB. 5-3-2011. INT. CL. 41.
3,997,308, PUB. 5-3-2011. INT. CL. 41.
- NATIONAL ALLBALL ASSOCIATION, LLC, MONTVILLE, NJ:
4,000,032, INT. CL. 35.
- NATIONAL ASSOCIATION FOR STOCK CAR AUTO RACING, INC., DAYTONA BEACH, FL:
3,999,412, INT. CL. 36.
- NATIONAL ASSOCIATION OF ANOREXIA NERVOSA AND ASSOCIATED DISORDERS, INC., NAPERVILLE, IL:
2,520,619, REN. 6-15-11. INT. CL. 41.
- NATIONAL ASSOCIATION OF HOME BUILDERS OF THE UNITED STATES, WASHINGTON, DC:
3,999,139, MULTIPLE CLASS, INT. CLS. 9 AND 42.
- NATIONAL ASSOCIATION OF MUSIC MERCHANTS, INC., CARLSBAD, CA:
2,901,105, CANC. MULTIPLE CLASS, INT. CLS. 9 AND 28.
3,921,123, COR. INT. CL. 9.
3,999,476, INT. CL. 9.
- NATIONAL ASSOCIATION OF PROFESSIONAL PET SITTERS, INC., MT. LAUREL, NJ:
3,997,962, PUB. 5-3-2011. INT. CL. 42.
- NATIONAL ASSOCIATION OF PROFESSIONALLY ACCREDITED CONTRACTORS LLC, GREAT FALLS, VA:
3,996,709, PUB. 5-3-2011. MULTIPLE CLASS, INT. CLS. 35, 37 AND 41.
3,996,723, PUB. 5-3-2011. MULTIPLE CLASS, INT. CLS. 35, 37 AND 41.
- NATIONAL AUTOMATED CLEARING HOUSE ASSOCIATION, HERNDON, VA:
3,996,852, PUB. 5-3-2011. INT. CL. 35.
- NATIONAL AUTOMOTIVE PARTS ASSOCIATION, ATLANTA, GA:
1,152,166, REN. 6-13-11. INT. CL. 7.
- NATIONAL BANK OF COMMERCE, BIRMINGHAM, AL:
4,000,048, INT. CL. 36.
- NATIONAL COALITION FOR COMMUNITY EMPOWERMENT STRATEGIES (NCCES), WANTAGH, NY:
3,996,995, PUB. 5-3-2011. INT. CL. 45.
- NATIONAL COUNCIL ON CRIME AND DELINQUENCY, OAKLAND, CA:
3,996,200, PUB. 5-3-2011. INT. CL. 41.
- NATIONAL DISTRIBUTION & CONTRACTING, INC., NASHVILLE, TN:
3,999,569, MULTIPLE CLASS, INT. CLS. 5 AND 10.
- NATIONAL FAMILY MORTGAGE, LLC, NORWOOD, MA:
3,999,388, INT. CL. 36.
- NATIONAL GEOGRAPHIC SOCIETY, WASHINGTON, DC:
3,998,835, MULTIPLE CLASS, INT. CLS. 35 AND 36.

NATIONAL HONORARY BETA CLUB, THE, SPARTANBURG, SC:
718,366. REN. 6-13-11. U.S. CL. 200.

NATIONAL HOSPITALITY INSTITUTE, LANSING, MI:
3,996,996. PUB. 5-3-2011. INT. CL. 41.

NATIONAL INSURANCE AND INDEMNITY CORPORATION, BURLINGTON, VT, GREYHOUND CORPORATION, THE, CHICAGO, IL:
888,954. REN. 6-13-11. U.S. CL. 19 (INT. CL. 12).

NATIONAL INTERNATIONAL ROOFING CORPORATION, HUNTLEY, IL:
2,546,759. REN. 6-14-11. INT. CL. 37.

NATIONAL OILWELL NORWAY AS, STAVANGER, NORWAY:
2,401,289. CANC. MULTIPLE CLASS, INT. CLS. 9, 16, 41 AND 42.

NATIONAL OILWELL VARCO, L.P., HOUSTON, TX:
3,998,811. INT. CL. 7.

NATIONAL PENN BANK, BOYERTOWN, PA:
3,999,393. INT. CL. 36.

NATIONAL PETROCHEMICAL INDUSTRIAL COMPANY, JEDDAH, SAUDI ARABIA:
3,998,237. PUB. 5-3-2011. INT. CL. 1.

NATIONAL SHOOTING SPORTS FOUNDATION, INC., NEWTOWN, CT:
3,996,775. PUB. 5-3-2011. INT. CL. 35.

NATIONAL TOUR ASSOCIATION, INC., LEXINGTON, KY:
3,997,543. PUB. 5-3-2011. INT. CL. 35.

NATIONAL TRUMPET COMPETITION ASSOCIATION, THE, ARLINGTON, VA:
2,549,955. REN. 6-15-11. INT. CL. 41.

NATIONAL VETERINARY BUSINESS MANAGEMENT ASSOCIATION, INC., ANNADALE, VA, DBA VBMA:
3,997,838. PUB. 5-3-2011. INT. CL. 35.

NATIVE INSTRUMENTS GMBH, FED REP GERMANY:
3,995,988. PUB. 5-3-2011. INT. CL. 9.

NATIVE RIDERS, SEBASTOPOL, CA:
3,997,773. PUB. 5-3-2011. INT. CL. 42.

NATUFLOR S.A., QUITO, ECUADOR:
2,901,947. CANC. INT. CL. 31.

NATURAL BALANCE PET FOODS, INC., PACOIMA, CA:
3,999,990. INT. CL. 31.

NATURAL SOURCING, LLC, OXFORD, CT:
3,997,706. PUB. 5-3-2011. MULTIPLE CLASS, INT. CLS. 3, 4 AND 21.

NATURE'S APPEAL MANUFACTURING CORPORATION, ADDISON, IL:
3,999,383. INT. CL. 5.

NAU, DARRYL, NORTHPORT, NY:
2,901,959. CANC. MULTIPLE CLASS, INT. CLS. 9, 12, 14, 16, 25, 28 AND 41.

NAV ADVISORS INC, PORT CHARLOTTE, FL:
3,997,510. PUB. 5-3-2011. INT. CL. 36.

NAVAJO MANUFACTURING COMPANY, DENVER, CO:
3,997,639. PUB. 5-3-2011. INT. CL. 9.

NAVINET, INC., CAMBRIDGE, MA:
2,402,647. CANC. INT. CL. 9.

NBC UNIVERSAL MEDIA, LLC, NEW YORK, NY:
3,998,637. INT. CL. 9.

NBS-KASTLE, INC., ST. LOUIS PARK, MN, DBA NBS AUDIO CABLES:
3,996,639. PUB. 5-3-2011. INT. CL. 9.

NC TRAIN ACQUISITION LLC, KWAI CHEONG NEW TERRITORIES, HONG KONG:
2,402,046. CANC. INT. CL. 28.

NC UPHOLSTERY, LLC, ASHEBORO, NC, DBA CAROLINA GIRL FURNITURE:
3,999,917. INT. CL. 35.

NCD ACQUISITION INC., SANTA FE SPRINGS, CA:
3,996,032. PUB. 5-3-2011. INT. CL. 16.

NCEP, LLC, LAS VEGAS, NV:
3,999,354. INT. CL. 36.

NCL CORPORATION LTD., MIAMI, FL:
2,489,424. REN. 6-16-11. INT. CL. 39.
2,558,675. REN. 6-16-11. INT. CL. 39.

NCO HOLDINGS, INC., HORSHAM, PA:
2,402,808. CANC. INT. CL. 36.

NCP MANAGEMENT HOLDINGS, INC., BIRMINGHAM, AL:
2,541,566. REN. 6-13-11. INT. CL. 36.

NEATLY NESTED, LLC, HILLIARD, OH, AKA NEATLY NESTED ORGANIZING SERVICES:
3,997,108. PUB. 5-3-2011. INT. CL. 45.

NEBRASKA PLASTICS, INC., COZAD, NE:
2,478,941. REN. 6-15-11. MULTIPLE CLASS, INT. CLS. 17 AND 20.

NEC LCD TECHNOLOGIES, LTD., KAWASAKI, KANAGAWA, JAPAN:
3,998,945. INT. CL. 9.

NEEL ALAN ENTERPRISES, BATON ROUGE, LA:
3,997,665. PUB. 5-3-2011. INT. CL. 5.

NEILSTEIN, ROSENBERG AND ASSOCIATES, LLC, BROOKLYN, NY, DBA METALSUCKS:
3,997,340. PUB. 5-3-2011. MULTIPLE CLASS, INT. CLS. 25 AND 41.

NELNET, INC., LINCOLN, NE:
2,901,841. CANC. INT. CL. 36.

NELSON STUD WELDING, INC., ELYRIA, OH:
2,565,278. COR. MULTIPLE CLASS, INT. CLS. 6, 7 AND 9.

NELVANA LIMITED, ONTARIO, CANADA:
2,901,608. CANC. MULTIPLE CLASS, INT. CLS. 9, 35 AND 41.

NEOM LTD., HORNBEAM BUSINESS PARK, UNITED KINGDOM:
3,998,584. MULTIPLE CLASS, INT. CLS. 3 AND 4.

NESTER, RUTH, COLUMBUS, OH:
2,401,627. CANC. INT. CL. 41.

NET-PROMOTION, INC., LYNDEN, WA:
2,902,469. CANC. INT. CL. 36.

NETCHEMISTRY, INC., NEWPORT BEACH, CA:
2,567,543. REN. 6-14-11. MULTIPLE CLASS, INT. CLS. 9 AND 42.

NETVIEWER AG, 76133 KARLSRUHE, FED REP GERMANY:
3,995,730. PUB. 5-3-2011. MULTIPLE CLASS, INT. CLS. 9 AND 42.

NETWORK ENTERPRISES, INC., NEW YORK, NY:
2,902,407. CANC. INT. CL. 41.

NETWORKING RESEARCH GROUP, INC., DENVER, CO:
3,997,982. PUB. 5-3-2011. INT. CL. 35.
3,997,983. PUB. 5-3-2011. INT. CL. 35.

NEUF, FRANCE:
3,995,922. PUB. 5-3-2011. MULTIPLE CLASS, INT. CLS. 11, 16, 20 AND 28.

NEURALOG, INC., STAFFORD, TX:
3,998,170. PUB. 5-3-2011. INT. CL. 9.

NEURION PHARMACEUTICALS, INC., LOS ANGELES, CA:
2,901,066. CANC. INT. CL. 42.

NEUROCHOCOLATE LLC, WASHINGTON, DC:
3,997,783. PUB. 5-3-2011. INT. CL. 30.

NEUROSCRIPT, LLC, TEMPE, AZ:
3,996,181. PUB. 5-3-2011. INT. CL. 9.

NEUTROGENA CORPORATION, LOS ANGELES, CA:
2,452,209. REN. 6-10-11. INT. CL. 3.
3,998,598. INT. CL. 3.

NEVADA STATE BANK, LAS VEGAS, NV:
2,901,170. CANC. INT. CL. 36.

NEVER BORING DESIGN ASSOCIATES, INC., MODESTO, CA:
3,997,311. PUB. 5-3-2011. MULTIPLE CLASS, INT. CLS. 35 AND 42.

NEW ALLIANCE REALTY, INC., SANTA MARIA, CA, DBA NEW ALLIANCE REALTY:
3,997,256. PUB. 5-3-2011. INT. CL. 36.

NEW BELGIUM BREWING COMPANY, INC., FORT COLLINS, CO:
3,999,143. INT. CL. 32.

NEW CHARITY ERA, L3C, GAINESVILLE, FL:
3,997,195. PUB. 5-3-2011. INT. CL. 9.

NEW CONCEPTS DEVELOPMENT CORPORATION, WOODSTOCK, IL:
3,996,394. PUB. 5-3-2011. INT. CL. 9.

- NEW COVENANT BELIEVERS' CHURCH, COLUMBUS, OH:
3,997,905, PUB. 5-3-2011. INT. CL. 45.
- NEW FOOD CLASSICS, CALGARY, ALBERTA, CANADA:
3,998,605, INT. CL. 29.
- NEW HAVEN MOVING EQUIPMENT CORP., EAST HAVEN, CT:
3,193,151, COR. INT. CL. 20.
- NEW HOLLAND BREWING COMPANY, LLC, HOLLAND, MI:
3,998,296, PUB. 5-3-2011. INT. CL. 32.
3,998,297, PUB. 5-3-2011. INT. CL. 32.
3,998,298, PUB. 5-3-2011. INT. CL. 32.
- NEW LEAF LEGAL, LLC, BOSTON, MA:
3,997,128, PUB. 5-3-2011. INT. CL. 45.
3,997,269, PUB. 5-3-2011. INT. CL. 45.
- NEW MILLENNIUM BANK, NEW BRUNSWICK, NJ:
2,495,547. REN. 6-16-11. INT. CL. 36.
- NEW ORLEANS KATRINA MEMORIAL CORPORATION, NEW ORLEANS, LA:
3,997,265, PUB. 5-3-2011. INT. CL. 41.
- NEW YORK-NEW YORK HOTEL & CASINO, L.L.C., LAS VEGAS, NV:
2,901,217, CANC. INT. CL. 41.
- NEW.NET, INC., EL SEGUNDO, CA:
2,902,133, CANC. INT. CL. 38.
- NEWAYS INTERNATIONAL, SPRINGVILLE, UT:
2,902,119, CANC. INT. CL. 3.
- NEWBOY FZCO, DUBAI, UNITED ARAB EMIR.:
3,995,525, PUB. 5-3-2011. INT. CL. 41.
- NEWBY TEAS (U.K.) LIMITED, UNITED KINGDOM:
3,995,833, PUB. 5-3-2011. INT. CL. 30.
- NEWFREY LLC, NEWARK, DE, PRICE-PFISTER BRASS MFG. CO., PACOIMA, CA:
914,908. REN. 6-15-11. U.S. CL. 13 (INT. CLS. 6, 7, 11, 17, 20 AND 21).
- NEWFREY LLC, NEWARK, DE:
2,459,449. REN. 6-10-11. INT. CL. 11.
- NEWMAN, JOEL CLYDE, KILLEN, AL:
2,901,226, CANC. INT. CL. 29.
- NEWMAN, MICHAEL J. SHERMAN OAKS, CA:
3,996,437, PUB. 5-3-2011. INT. CL. 28.
- NEWTEC CY NV, B-9100 SINT-NIKLAAS, BELGIUM:
3,995,798, PUB. 1-25-2011. MULTIPLE CLASS, INT. CLS. 9, 38 AND 42.
- NEWTONIAN GOLF AND PARTICLE PHYSICS, INC., CARY, NC:
2,901,199, CANC. INT. CL. 16.
- NEXT ADVENTURE, INC., BERKELEY, CA:
3,996,244, PUB. 5-3-2011. MULTIPLE CLASS, INT. CLS. 39 AND 43.
- NEXT BIG SOUND, INC., BOULDER, CO:
3,999,382, MULTIPLE CLASS, INT. CLS. 35 AND 41.
- NEXT FITNESS EVOLUTION LLC, VALLEY STREAM, NY:
3,996,439, PUB. 5-3-2011. MULTIPLE CLASS, INT. CLS. 35, 41 AND 44.
- NEXT GENERATIONS, INC., MARNE, MI:
2,901,424, CANC. INT. CL. 16.
- NEXT JUMP, INC., NEW YORK, NY:
3,998,574, INT. CL. 35.
- NEXTERA ENERGY, INC., JUNO BEACH, FL:
3,996,485, PUB. 5-3-2011. INT. CL. 42.
- NEXTPAGE, INC., DRAPER, UT:
2,450,676. REN. 6-15-11. MULTIPLE CLASS, INT. CLS. 35 AND 42.
- NGRID INTELLECTUAL PROPERTY LIMITED, LONDON, UNITED KINGDOM:
3,995,524, PUB. 5-3-2011. MULTIPLE CLASS, INT. CLS. 7, 9, 11, 16, 35, 37, 39, 40 AND 42.
- NGRID INTELLECTUAL PROPERTY LIMITED, LONDON WC2N 5EH, UNITED KINGDOM:
3,995,531, PUB. 5-3-2011. MULTIPLE CLASS, INT. CLS. 7, 9, 11, 16, 35, 37, 39, 40 AND 42.
- NHB HOLDINGS, INC., JACKSONVILLE, FL:
3,996,182, PUB. 5-3-2011. INT. CL. 36.
- NICHOLSON, WESLEY, CHINO HILLS, CA:
3,996,997, PUB. 5-3-2011. INT. CL. 44.
- NICKLAUS COMPANIES, LLC, NORTH PALM BEACH, FL:
3,996,049, PUB. 5-3-2011. INT. CL. 41.
- NIDYON COSTRUZIONI S.R.L. -, ITALY:
3,995,927, PUB. 5-3-2011. MULTIPLE CLASS, INT. CLS. 6, 7 AND 19.
- NIGHTMARE NETWORK, INC., LOUISVILLE, KY:
2,902,420, CANC. INT. CL. 41.
- NIKE, INC., BEAVERTON, OH, BRS, INC., BEAVERTON, OR:
1,153,237. REN. 6-13-11. INT. CL. 25.
- NIKON INC., MELVILLE, NY:
2,902,015, CANC. MULTIPLE CLASS, INT. CLS. 35, 36 AND 41.
- NINGBO FANGLI GROUP CO., LTD., NINGBO, ZHEJIANG, CHINA:
3,999,024, INT. CL. 7.
- NINGXIA XIANGSHAN WINE-MAKING INDUSTRY (GROUP) CO., LTD., NINGXIA MUNICIPALITY, CHINA:
2,901,633, CANC. INT. CL. 33.
- NINTENDO CO., LTD., MINAMI-KU, KYOTO, JAPAN:
2,901,052, CANC. INT. CL. 30.
- NINTENDO OF AMERICA INC., REDMOND, WA:
1,646,158. REN. 6-16-11. INT. CL. 28.
3,995,544, PUB. 10-12-2010. INT. CL. 28.
3,995,545, PUB. 10-19-2010. INT. CL. 16.
3,995,546, PUB. 10-19-2010. INT. CL. 42.
3,995,547, PUB. 10-19-2010. INT. CL. 30.
3,998,546, INT. CL. 18.
3,998,547, INT. CL. 28.
3,999,552, INT. CL. 9.
3,999,553, INT. CL. 9.
3,999,877, INT. CL. 9.
- NIPPON CHEMI-CON CORPORATION, JAPAN:
3,995,800, PUB. 5-3-2011. INT. CL. 9.
- NISSIN FOODS HOLDINGS CO., LTD., OSAKA, JAPAN:
2,901,048, CANC. INT. CL. 29.
- NITTO BOSEKI CO., LTD., FUKUSHIMA-SHI, JAPAN:
2,453,425. REN. 6-16-11. INT. CL. 21.
- NITTO TIRE U.S.A. INC., CYPRESS, CA:
3,998,880, MULTIPLE CLASS, INT. CLS. 35, 36 AND 41.
- NLU PRODUCTS, LLC, DRAPER, UT:
3,997,133, PUB. 5-3-2011. INT. CL. 9.
3,997,135, PUB. 5-3-2011. INT. CL. 9.
- NNE PHARMAPLAN A/S, 2860 SOBORG, DENMARK:
2,402,363, CANC. MULTIPLE CLASS, INT. CLS. 35, 36, 37 AND 42.
- NO FEAR RETAIL STORES, INC., CARLSBAD, CA:
2,402,250, CANC. INT. CL. 25.
- NO LABEL BREWING COMPANY, KATY, TX, DBA NO LABEL:
3,996,651, PUB. 5-3-2011. INT. CL. 40.
- NOBLE COFFEE ROASTERS, INC., CAMPBELL HALL, NY:
2,462,479. REN. 6-16-11. INT. CL. 30.
- NOBLE GRACE LLC, NEW YORK, NY:
2,902,435, CANC. INT. CL. 25.
- NOBLE WAR PRIZE, INC., SOUTHAMPTON, NY:
3,999,605, INT. CL. 3.
- NOCTIS INK, LLC, TEMPE, AZ:
3,999,690, INT. CL. 25.
- NOISE SOLUTIONS INC., CALGARY, AB, CANADA:
3,995,580, PUB. 10-19-2010. MULTIPLE CLASS, INT. CLS. 6, 7, 17 AND 42.
- NOKIA CORPORATION, 02150 ESPOO, FINLAND:
2,901,494, CANC. MULTIPLE CLASS, INT. CLS. 9, 28 AND 41.
- NOMAN AHMAD, CASTRO VALLEY, CA:
3,999,012, INT. CL. 41.
- NOMI FASHION CORP., ASHAROKEN, NY:
3,918,897, AM. INT. CL. 25.
- NOMURA INTERNATIONAL PLC, LONDON, ENGLAND:
3,995,612, PUB. 5-3-2011. MULTIPLE CLASS, INT. CLS. 35 AND 36.
- NORDCO, LLC, MISSOULA, MT, DBA DEAD-ON ARCHERY:
3,996,427, PUB. 5-3-2011. INT. CL. 28.
- NORDIC WATER PRODUCTS AB, VÄSTRA FRÖLUNDA, SWEDEN:
3,998,642, INT. CL. 11.

NORDIMEX, LLC, SAN DIEGO, CA, DBA MEXICAN PHARMA NATURA:
3,999,340, INT. CL. 5.
3,999,341, INT. CL. 5.
3,999,342, INT. CL. 5.

NORDMECCANICA S.P.A., ITALY:
3,995,765, PUB. 5-3-2011. MULTIPLE CLASS, INT. CLS. 7 AND 9.

NORDSON CORPORATION, WESTLAKE, OH:
2,902,281, CANC. INT. CL. 7.

NORMAN LIBRETT, INC., NEW ROCHELLE, NY:
2,488,581, REN. 6-13-11. INT. CL. 27.

NORMAN LOVE CONFECTIONS, INC., FORT MYERS, FL:
3,997,198, PUB. 5-3-2011. MULTIPLE CLASS, INT. CLS. 30 AND 35.

NOROOZ PRODUCTIONS, LLC, NEW YORK, NY:
3,998,309, INT. CL. 9.

NORPAC FOODS, INC., LAKE OSWEGO, OR:
1,861,062, AM. INT. CL. 29.

NORSEMEN OUTDOORS, INC., LAKE MILLS, IA:
3,996,281, PUB. 5-3-2011. INT. CL. 28.

NORTH AMERICAN COMPANY FOR LIFE AND HEALTH INSURANCE, CHICAGO, IL:
2,901,230, CANC. INT. CL. 36.

NORTH AMERICAN MEMBERSHIP GROUP INC., MINNETONKA, MN:
2,469,396, REN. 6-14-11. INT. CL. 16.
2,481,912, REN. 6-14-11. INT. CL. 42.

NORTH ATLANTIC COMMUNICATION SYSTEMS CONSTRUCTION CORPORATION, EAST MORICHES, NY:
2,563,599, REN. 6-14-11. INT. CL. 37.

NORTH ATLANTIC OPERATING COMPANY, INC., LOUISVILLE, KY:
2,900,985, CANC. INT. CL. 34.

NORTH LOCK LLC, ALEXANDRIA, VA:
3,951,408, AM. INT. CL. 32.

NORTH LOCK, LLC, ALEXANDRIA, VA:
3,946,094, AM. INT. CL. 32.

NORTH PASS LTD., FORT COLLINS, CO:
2,405,819, REN. 6-13-11. INT. CL. 9.

NORTH SHORE DEVELOPMENT GROUP, INC., GREAT NECK, NY:
4,000,057, INT. CL. 9.

NORTHERN STAR INDUSTRIES, INC., IRON MOUNTAIN, MI:
2,576,088, REN. 6-14-11. INT. CL. 7.

NORTHERN TOOL & EQUIPMENT COMPANY, INC., BURNSVILLE, MN:
3,999,830, INT. CL. 6.
3,999,831, INT. CL. 11.

NORTHLAND COLLEGE, ASHLAND, WI:
3,998,537, PUB. 5-3-2011. INT. CL. 41.

NOSTALGIA ROD & CUSTOM ASSOCIATION, ROSEVILLE, CA:
2,901,842, CANC. INT. CL. 35.

NOT FINDING OUT, LLC, DALLAS, TX:
3,999,235, INT. CL. 35.

NOTHIN' BUT NET HOLDING L.L.C., CINCINNATI, OH:
3,997,419, PUB. 5-3-2011. INT. CL. 41.

NOVA INNOVATIONS, LC, ST. LOUIS, MO:
3,998,890, INT. CL. 26.

NOVAMED-USA INC., ELMSFORD, NY:
3,997,433, PUB. 5-3-2011. INT. CL. 10.

NOVARTIS AG, SWITZERLAND:
3,996,026, PUB. 5-3-2011. INT. CL. 5.

NOVARTIS AG, BASEL, SWITZERLAND:
3,998,442, INT. CL. 5.
3,998,834, INT. CL. 5.

NOVEL IDEAS, INC., RIVERVIEW, FL:
3,998,158, PUB. 5-3-2011. INT. CL. 17.

NOVELL, INC., PROVO, UT:
2,901,905, CANC. INT. CL. 9.

NOVEM, INC., HOUSTON, TX:
3,998,081, PUB. 5-3-2011. MULTIPLE CLASS, INT. CLS. 35 AND 41.

NOVOGEN RESEARCH PTY LTD., NEW SOUTH WALES 2113, AUSTRALIA, NOVOGEN RESEARCH PTY LTD., NEW SOUTH WALES 2113, AUSTRALIA:
2,464,065, REN. 6-15-11. INT. CL. 5.

NOVOZYMES BIOLOGICALS LIMITED, SASKATOON, CANADA:
2,549,352, REN. 6-15-11. INT. CL. 1.

NOVOZYMES GROPEP LIMITED, ADELAIDE, AUSTRALIA:
2,901,476, CANC. INT. CL. 5.

NOXELL CORPORATION, HUNT VALLEY, MD:
2,403,470, REN. 6-15-11. INT. CL. 3.

NRG ENERGY, INC., PRINCETON, NJ:
3,996,297, PUB. 5-3-2011. MULTIPLE CLASS, INT. CLS. 35 AND 36.

NTENSE WORKOUT, INC., POLAND, OH:
3,995,494, PUB. 5-3-2011. INT. CL. 41.

NTI AUDIO AG, FL-9494 SCHAAN, LIECHTENSTEIN:
2,466,988, REN. 6-16-11. INT. CL. 9.

NU NORMAL PRODUCTIONS, LLC, CARMEL, IN:
3,996,803, PUB. 5-3-2011. INT. CL. 41.

NUCRAFT COMPANY, LLC, ARLINGTON, VA:
3,997,855, PUB. 5-3-2011. INT. CL. 35.
3,997,856, PUB. 5-3-2011. INT. CL. 35.

NUERA GROUP INC., S. EL MONTE, CA:
3,998,704, INT. CL. 25.

NUFARM, INC., BURR RIDGE, IL:
2,494,764, REN. 6-15-11. INT. CL. 5.

NUGENT, ROBERT A., PACIFIC BEACH, CA:
2,901,715, CANC. INT. CL. 25.

NUK USA LLC, WILMINGTON, DE:
2,902,392, CANC. INT. CL. 8.

NUMA TACTICAL, LLC, NEW YORK, NY:
3,996,102, PUB. 5-3-2011. INT. CL. 9.

NUNEZ, BRIAN, FT. LAUDERDALE, FL:
2,901,957, CANC. MULTIPLE CLASS, INT. CLS. 9 AND 41.

NUPRENU INC., HOUSTON, TX, AKA NUPRENU:
3,996,878, PUB. 5-3-2011. INT. CL. 35.

NUÑEZ, KELVYN L., ARECIBO, PUERTO RICO, DBA EGO VANITY STORE, EGO:
3,996,746, PUB. 5-3-2011. INT. CL. 35.

NUÑEZ, KELVYN L., ARECIBO, PUERTO RICO, DBA EGO VANITY STORE, EGO, EGOISTA AND NUNEZ RETAIL INVESTMENT COMPANY:
3,997,788, PUB. 5-3-2011. INT. CL. 35.

NUTLAND FOODS, LLC, BAKERSFIELD, CA:
3,998,573, INT. CL. 29.
3,998,586, INT. CL. 29.

NUTRACEA, PHOENIX, AZ, AKA NUTRACEA, INC.:
2,461,745, REN. 6-14-11. INT. CL. 5.

NUTRI-FUSION SYSTEMS, LLC, SANDY, UT, DBA HCG FUSION:
3,997,299, PUB. 5-3-2011. INT. CL. 5.

NUTRITION DISCOUNTERS, INC, VILLA PARK, IL:
3,996,694, PUB. 5-3-2011. INT. CL. 5.

NUTRITION EDUCATION WORLDWIDE, CHICAGO, IL:
2,902,068, CANC. MULTIPLE CLASS, INT. CLS. 16 AND 41.

NUVIEW, INC., HOUSTON, TX:
2,902,481, CANC. INT. CL. 9.

NUVO NETWORK MANAGEMENT INC., AUSTIN, TX:
2,459,487, REN. 6-14-11. INT. CL. 42.

NV BEKAERT SA, B-8550 ZWEVEGEM, BELGIUM:
3,995,989, PUB. 5-3-2011. MULTIPLE CLASS, INT. CLS. 6 AND 17.

NV-J CORP., WAHIAWA, HI:
3,999,885, MULTIPLE CLASS, INT. CLS. 16 AND 25.

NVIDIA CORPORATION, SANTA CLARA, CA:
3,998,657, INT. CL. 9.

NXP B.V., EINDHOVEN, NETHERLANDS:
2,901,131, CANC. INT. CL. 9.

NYC & COMPANY, INC., NEW YORK, NY:
3,998,386, INT. CL. 16.

NYLO HOTELS, LLC, ATLANTA, GA:
3,998,435, INT. CL. 24.

- NYSTROM, MATTHEW P., NEW ORLEANS, LA, DBA GUZZLED.ORG:
3,997,446, PUB. 5-3-2011. INT. CL. 16.
- NYT MANAGEMENT SERVICES, INC., TAMPA, FL, GLOBE NEWSPAPER COMPANY, BOSTON, MA:
721,044. REN. 6-10-11. U.S. CL. 38 (INT. CL. 16).
- NYT MANAGEMENT SERVICES, INC., TAMPA, FL:
3,997,974, PUB. 5-3-2011. INT. CL. 41.
- O. MUSTAD & SON (U.S.A.) INC., AUBURN, NY:
3,999,599, INT. CL. 28.
- OAK RIDGE FM, INC, KNOXVILLE, TN:
3,997,447, PUB. 5-3-2011. INT. CL. 38.
- OBCHTCHESTVO S OGRANITCHENNOI; OTVETSTVEN-NOSTYOU; "DORKHAN", RUSSIAN FED.:
3,995,770, PUB. 5-3-2011. MULTIPLE CLASS, INT. CLS. 6 AND 42.
- OBCHTCHESTVO S OGRANITCHENNOY OTVETSTVEN-NOSTYOU "GRICHKO", RU-113095 MOSCOU, RUSSIAN FED.:
3,995,758, PUB. 5-3-2011. INT. CL. 25.
- OBEGI RIAD, BEYROUTH, LEBANON:
3,995,773, PUB. 5-3-2011. MULTIPLE CLASS, INT. CLS. 35 AND 36.
3,995,774, PUB. 5-3-2011. MULTIPLE CLASS, INT. CLS. 35 AND 36.
- OBLIO TELECOM L.L.P., RICHARDSON, TX:
2,901,387, CANC. INT. CL. 16.
- OBSCHESTVO S OGRANICHENNOJ OTVETSTVENNOSTJU "ALPHALINER", RUSSIAN FED.:
3,995,732, PUB. 5-3-2011. MULTIPLE CLASS, INT. CLS. 36 AND 39.
- OCEAN PACIFIC APPAREL CORP., IRVINE, CA:
2,902,232, CANC. INT. CL. 3.
- OCM DEVELOPMENT, LLC, GRAND RAPIDS, MI, DBA TWISTED ROOSTER:
3,997,969, PUB. 5-3-2011. INT. CL. 43.
- OCUTEC LIMITED, BELLSHILL, UNITED KINGDOM:
3,996,727, PUB. 5-3-2011. INT. CL. 42.
- ODEON TURIZM ISLETMECILIGI A.S., ISTANBUL, TURKEY:
3,995,993, PUB. 5-3-2011. MULTIPLE CLASS, INT. CLS. 36 AND 39.
- ODESS, DANIEL B., CORAL GABLES, FL:
3,997,526, PUB. 5-3-2011. INT. CL. 36.
- OETTINGER IMEX AG, SWITZERLAND:
3,995,855, PUB. 5-3-2011. INT. CL. 34.
- OFF PROPERTY PRODUCTIONS, LLC, SALT LAKE CITY, UT:
3,998,124, PUB. 5-3-2011. INT. CL. 41.
- OFF-PRICE SPECIALIST CENTER, BROOKFIELD, WI:
3,996,185, PUB. 5-3-2011. INT. CL. 35.
- OFFBEAT, INC., NEW ORLEANS, LA:
3,996,101, PUB. 5-3-2011. INT. CL. 16.
- OFFICE OF THE COMMISSIONER OF BASEBALL, THE, NEW YORK, NY:
1,648,385. REN. 6-16-11. INT. CL. 41.
- OFFICEMATE INTERNATIONAL CORP., EDISON, NJ:
2,901,123, CANC. INT. CL. 16.
- OFFIT KURMAN, P.A., MAPLE LAWN, MD:
3,997,281, PUB. 5-3-2011. INT. CL. 45.
- OFLOWS INCORPORATED, SAN FRANCISCO, CA:
3,997,745, PUB. 5-3-2011. INT. CL. 42.
- OHIO MEDICAL CORPORATION, GURNEE, IL, SQUIRE-COGSWELL COMPANY, INC., NORTHBROOK, IL:
1,161,635. REN. 6-10-11. MULTIPLE CLASS, INT. CLS. 7 AND 9.
- OILON INTERNATIONAL OY, FINLAND:
3,995,858, PUB. 5-3-2011. INT. CL. 11.
- OJON CORPORATION, NEW YORK, NY:
3,999,230, INT. CL. 3.
- OKI BERING MANAGEMENT CO., CINCINNATI, OH:
2,549,518. REN. 6-16-11. MULTIPLE CLASS, INT. CLS. 6 AND 9.
- OKINAWA-TE ORGANIZATION, BEVERLY HILLS, CA:
3,997,803, PUB. 5-3-2011. INT. CL. 41.
- OKRONGLY, ANTHONY J, ARLINGTON, TX AND OKRONGLY, DONNA D, ARLINGTON, TX:
3,996,785, PUB. 5-3-2011. INT. CL. 41.
- OLD DOMINION UNIVERSITY, NORFOLK, VA:
1,631,129. REN. 6-16-11. INT. CL. 41.
- OLD LYME GOURMET COMPANY, OLD LYME, CT, DBA DEEP RIVER SNACKS:
3,997,967, PUB. 5-3-2011. MULTIPLE CLASS, INT. CLS. 29 AND 30.
- OLIBERTE LIMITED, OAKVILLE, ONTARIO, CANADA:
3,999,280, INT. CL. 25.
- OLIN CORPORATION, ST. LOUIS, MO:
3,998,918, INT. CL. 13.
- OLIVA CIGAR CO., MIAMI LAKES, FL:
3,998,544, MULTIPLE CLASS, INT. CLS. 25 AND 34.
- OLIVER-TOLAS HEALTHCARE PACKAGING, LLC, GRAND RAPIDS, MI:
3,996,420, PUB. 5-3-2011. INT. CL. 10.
- OLÉ MEXICAN FOODS, INC., NORCROSS, GA:
3,996,625, PUB. 5-3-2011. INT. CL. 30.
- OLSSON ASSOCIATES, LINCOLN, NE:
3,997,113, PUB. 5-3-2011. INT. CL. 42.
- OLYMPUS CORPORATION, TOKYO, JAPAN:
3,999,674, INT. CL. 9.
- OMAHA ROYALS LIMITED PARTNERSHIP, OMAHA, NE:
3,999,781, INT. CL. 41.
- OMAHA STEAKS INTERNATIONAL, INC., OMAHA, NE:
3,999,437, INT. CL. 35.
- OMB, INC., SANTA FE SPRINGS, CA:
3,998,751, INT. CL. 30.
- OMX, INC., NAPERVILLE, IL:
3,996,987, PUB. 5-3-2011. INT. CL. 35.
- ONDAYSEX LLC, REDDING, CA:
3,999,783, INT. CL. 45.
- ONE IOWA, DES MOINES, IA:
3,996,479, PUB. 5-3-2011. INT. CL. 35.
- ONE LAPTOP PER CHILD ASSOCIATION, INC., CAMBRIDGE, MA:
3,904,585, COR. INT. CL. 9.
- ONE WORLD TECHNOLOGIES, LTD., HAMILTON, BERMUDA:
2,902,333, CANC. INT. CL. 9.
2,902,334, CANC. INT. CL. 9.
- ONEBEACON PROFESSIONAL PARTNERS, INC., AVON, CT:
2,402,761, CANC. INT. CL. 36.
- ONEVISION SOFTWARE AG, REGENSBURG, FED REP GERMANY:
2,461,169. REN. 6-16-11. INT. CL. 9.
- ONLINE HOLDINGS LLC, ST. CHARLES, IL:
3,998,017, PUB. 5-3-2011. INT. CL. 35.
- ONLINE INSIGHT, MARIETTA, GA, DBA EMPOWER HEALTH:
3,999,602, MULTIPLE CLASS, INT. CLS. 9 AND 42.
- ONLINE NEWS ASSOCIATION, WILMINGTON, DE:
3,997,900, PUB. 5-3-2011. INT. CL. 35.
- ONLINE-AUCTIONS SOFTWARE.COM, INC., BYRON CENTER, MI:
3,996,926, PUB. 5-3-2011. INT. CL. 42.
3,996,927, PUB. 5-3-2011. INT. CL. 42.
- ONSPORT LLC, SANTA BARBARA, CA:
2,901,780, CANC. INT. CL. 12.
- OPEN MINDS PRODUCTION, LLC, TEMPE, AZ:
3,998,856, MULTIPLE CLASS, INT. CLS. 9 AND 41.
- OPENAIR EQUITY PARTNERS, LLC, KANSAS CITY, MO:
3,997,956, PUB. 5-3-2011. INT. CL. 36.
- OPENGAMMA INC., WILMINGTON, DE:
3,998,785, MULTIPLE CLASS, INT. CLS. 9 AND 42.
- OPERATING SOONER, INC., OLATHE, KS:
2,901,556, CANC. INT. CL. 9.
- OPHTHALMIC COMMUNICATIONS SOCIETY, INC., THE, VILLANOVA, PA:
2,569,914. REN. 6-15-11. MULTIPLE CLASS, INT. CLS. 16 AND 42.
- OPINIONOLOGY, INC., OREM, UT:
3,999,061, INT. CL. 35.
- OPPORTUNITY BUYS, INC., INDIANAPOLIS, IN:
3,996,459, PUB. 1-25-2011. INT. CL. 35.

- OPPORTUNITY VILLAGE FOUNDATION, LAS VEGAS, NV:
3,997,702, PUB. 5-3-2011. INT. CL. 36.
3,997,704, PUB. 5-3-2011. INT. CL. 41.
- OPSUITE LLC, GERMANTOWN, MD:
3,998,727, INT. CL. 9.
- OPTEST EQUIPMENT INC., HAWKESBURY, ONTARIO, CANADA:
2,542,254. REN. 6-10-11. INT. CL. 9.
- OPTRIMA, NAAMLOZE VENNOOTSCHAP, BELGIUM:
3,995,819, PUB. 5-3-2011. MULTIPLE CLASS, INT. CLS. 9 AND 42.
- OPTRONICS INTERNATIONAL, LLC, TULSA, OK:
3,996,960, PUB. 5-3-2011. INT. CL. 11.
- ORACLE AMERICA, INC., REDWOOD SHORES, CA:
2,497,591. REN. 6-14-11. INT. CL. 9.
- ORAMETRIX, INC., RICHARDSON, TX:
2,906,424, CANC. INT. CL. 44.
- ORANGE ELECTRONIC NORTH AMERICA, LLC, MAINEVILLE, OH:
3,996,841, PUB. 5-3-2011. INT. CL. 9.
- ORANGE ZONE INC., LOS ANGELES, CA:
3,999,562, INT. CL. 25.
- ORATEC INTERVENTIONS, INC., MENLO PARK, CA:
2,402,911, CANC. INT. CL. 10.
- ORAYA THERAPEUTICS, INC., NEWARK, CA:
3,998,426, INT. CL. 10.
3,998,427, INT. CL. 44.
- ORCA MD LLC, PARK CITY, UT:
3,996,611, PUB. 5-3-2011. INT. CL. 9.
- OREGON WATER EDUCATION FOUNDATION, OREGON CITY, OR:
3,996,552, PUB. 5-3-2011. INT. CL. 41.
- OREGON3D, INC., PORTLAND, OR:
2,901,923, CANC. INT. CL. 16.
- ORGANIC NECTARS, MALDEN, NY:
3,997,199, PUB. 5-3-2011. INT. CL. 30.
- ORGPR, LLC, SANDY SPRINGS, GA:
3,998,903, INT. CL. 35.
- ORION CORPORATION, SEOUL, REPUBLIC OF KOREA:
3,996,431, PUB. 5-3-2011. INT. CL. 30.
- ORION CORPORATION, YONGSAN-GU, SEOUL, REPUBLIC OF KOREA:
3,998,942, INT. CL. 30.
- ORION FOOD SYSTEMS, L.L.C., SIOUX FALLS, SD:
2,469,588. REN. 6-14-11. INT. CL. 29.
- ORLANDO UTILITIES COMMISSION, ORLANDO, FL:
2,461,149. REN. 6-16-11. MULTIPLE CLASS, INT. CLS. 39 AND 42.
- ORLEA-GIAN SNOBALLS, LLC, DECATUR, GA:
3,997,594, PUB. 5-3-2011. INT. CL. 35.
- ORLY INTERNATIONAL, INC., VAN NUYS, CA:
3,999,108, INT. CL. 3.
- ORTHOCON, INC., IRVINGTON, NY:
3,999,078, MULTIPLE CLASS, INT. CLS. 5 AND 42.
- ORTHOPAEDIC MARKETING GROUP, INC, OMAHA, NE:
3,999,374, INT. CL. 44.
- ORTHOISOFT INC., MONTREAL, CANADA:
2,902,298, CANC. MULTIPLE CLASS, INT. CLS. 9 AND 10.
- ORTIZ JR., JOSE A., GLENSIDE, PA:
3,997,843, PUB. 5-3-2011. INT. CL. 41.
- ORTRONICS, INC., NEW LONDON, CT:
3,998,542, INT. CL. 9.
3,998,543, INT. CL. 9.
- ORVIS COMPANY, INC., THE, SUNDERLAND, VT:
2,989,366, CANC. MULTIPLE CLASS, INT. CLS. 9 AND 14.
- OSIRIS THERAPEUTICS, INC., COLUMBIA, MD:
3,999,617, INT. CL. 5.
- OSKAR BLUES BREWERY, LLC, LYONS, CO, DBA OSKAR BLUES BREWERY:
3,997,561, PUB. 5-3-2011. INT. CL. 32.
- OSRAM GESELLSCHAFT MIT BESCHRÄNKTER HAF-TUNG, 81543 MÜNCHEN, FED REP GERMANY, DBA OSRAM GMBH:
3,995,940, PUB. 5-3-2011. MULTIPLE CLASS, INT. CLS. 9 AND 11.
- OSRAM GESELLSCHAFT MIT BESCHRÄNKTER HAF-TUNG, 81543 MÜNCHEN, FED REP GERMANY:
3,995,956, PUB. 5-3-2011. INT. CL. 11.
- OSRAM SYLVANIA INC., DANVERS, MA:
3,998,643, INT. CL. 11.
- OSTBYE & ANDERSON, INC., PLYMOUTH, MN:
3,999,730, INT. CL. 14.
- OTARIAN LONDON LIMITED, EPSOM, UNITED KING-
DOM:
3,998,495, INT. CL. 35.
- OTOL INC, SHERMAN OAKS, CA:
3,997,205, PUB. 5-3-2011. INT. CL. 41.
- OTSUKA ELECTRONICS CO., LTD., OSAKA 573-1132,
JAPAN:
2,900,976, CANC. INT. CL. 10.
- OUR CORPORATE LIFE LLC, MOUNTAINSIDE, NJ:
3,996,610, PUB. 5-3-2011. MULTIPLE CLASS, INT. CLS. 9,
35 AND 41.
- OUR SHOPPING LINKS, INC., HUNTSVILLE, TX:
3,999,129, INT. CL. 20.
- OURPET'S COMPANY, FAIRPORT HARBOR, OH:
3,996,269, PUB. 5-3-2011. INT. CL. 28.
- OUR365, INC., ST. CHARLES, MO:
3,999,311, INT. CL. 9.
- OUT OF THE WOODS GRANITE, LLC, LAYTON, UT:
3,996,845, PUB. 5-3-2011. MULTIPLE CLASS, INT. CLS. 19
AND 40.
- OUTDOOR CAP COMPANY, BENTONVILLE, AR:
2,402,201, CANC. INT. CL. 25.
- OUTREACH MINISTRIES INTERNATIONAL, FLOWER
MOUND, TX:
3,996,983, PUB. 5-3-2011. INT. CL. 41.
- OUTSIDE IN (CAMBRIDGE) LTD, CAMBRIDGE CB3 8UD,
UNITED KINGDOM:
3,283,608, CANC. MULTIPLE CLASS, INT. CLS. 10 AND
11.
- OVERHOLSER, RAY C., OCALA, FL:
2,902,226, CANC. INT. CL. 9.
- OVERTAKER, LLC, CREAM RIDGE, NJ:
3,997,249, PUB. 5-3-2011. INT. CL. 41.
- OWENS RESEARCH, INC., JACKSONVILLE, FL:
2,401,779, CANC. INT. CL. 35.
- OWENS, ANTHONY M., HOPKINS, MN:
2,901,520, CANC. INT. CL. 42.
- OX PRODUCTION V/PETTERSEN, STOKMARKNES, NOR-
WAY:
3,995,608, PUB. 5-3-2011. INT. CL. 25.
- OXLEY DEVELOPMENTS COMPANY LIMITED, ULVER-
STON, CUMBRIA, UNITED KINGDOM:
3,995,753, PUB. 5-3-2011. MULTIPLE CLASS, INT. CLS. 9
AND 11.
- OXLEY DEVELOPMENTS COMPANY LIMITED, UNITED
KINGDOM:
3,995,754, PUB. 5-3-2011. MULTIPLE CLASS, INT. CLS. 9
AND 11.
- OXUS AMERICA, INC., ROCHESTER HILLS, MI:
3,996,532, PUB. 5-3-2011. MULTIPLE CLASS, INT. CLS. 10
AND 11.
- OZARK OVERALL CO, INC., STILLWATER, OK:
3,995,711, PUB. 1-25-2011. INT. CL. 25.
- P.A. CHA-FONG & ASSOCIATES, PEMBROKE PINES, FL:
3,995,483, PUB. 5-3-2011. MULTIPLE CLASS, INT. CLS.
29, 30 AND 32.
3,995,484, PUB. 5-3-2011. MULTIPLE CLASS, INT. CLS. 32
AND 34.
- P.T.C. BRANDS, INC., WILMINGTON, DE:
1,158,297. REN. 6-14-11. INT. CL. 34.
- PACE GLOBAL ENERGY SERVICES, L.L.C., FAIRFAX, VA:
2,401,521, CANC. MULTIPLE CLASS, INT. CLS. 35 AND
42.
- PACE INTERNATIONAL, LLC, SEATTLE, WA:
3,999,765, INT. CL. 1.
3,999,850, INT. CL. 4.
- PACER CENTER, INC., BLOOMINGTON, MN:
4,000,015, INT. CL. 41.

- PACIFIC COAST FEATHER COMPANY, SEATTLE, WA:
2,902,418, CANC. INT. CL. 20.
3,999,384, INT. CL. 20.
3,999,604, INT. CL. 20.
- PACIFIC VALLEY FOODS, INC., BELLEVUE, WA:
3,998,376, INT. CL. 29.
- PACIFIC WEBWORKS, INC., SALT LAKE CITY, UT:
2,495,143, REN. 6-14-11. INT. CL. 9.
- PACIFICA MODELING, EASTVALE, CA:
3,999,079, INT. CL. 41.
- PACON CORPORATION, APPLETON, WI:
3,999,985, INT. CL. 16.
- PAGANELLI, MARK J., CLINTON, MA, AKA MARK RESILIENT:
2,901,883, CANC. INT. CL. 41.
- PAGANS MOTORCYCLE CLUB L.L.C., HERMINIE, PA:
3,996,335, PUB. 5-3-2011. INT. CL. 35.
- PAGEANT, LLC, THE, ST. LOUIS, MO:
2,458,654, REN. 6-14-11. INT. CL. 42.
- PALA BAND OF MISSION INDIANS, PALA, CA, DBA PALA CASINO:
3,998,267, PUB. 5-3-2011. INT. CL. 44.
3,999,869, MULTIPLE CLASS, INT. CLS. 41 AND 43.
- PALA, INC, PALM CITY, FL:
3,997,173, PUB. 5-3-2011. INT. CL. 35.
- PALADIN BRANDS GROUP, INC., CEDAR RAPIDS, IA:
4,000,056, INT. CL. 39.
- PALM BEACH TAN, INC., COPPELL, TX:
3,999,875, INT. CL. 44.
- PALMERSTON LIMITED, DOUGLAS, UNITED KINGDOM:
3,996,542, PUB. 5-3-2011. INT. CL. 9.
- PALZIS, CHRIS, PLAYA DEL REY, CA:
3,998,583, INT. CL. 16.
- PAMELA GOVERNALE, EAST WILLISTON, NY:
3,996,498, PUB. 5-3-2011. INT. CL. 20.
- PAMELA'S PRODUCTS, INC., UKIAH, CA:
3,997,847, PUB. 5-3-2011. INT. CL. 30.
- PAN AMERICAN GRAIN MFG. CO., INC., GUAYNABO, PUERTO RICO:
3,997,894, PUB. 5-3-2011. INT. CL. 30.
- PAN AMERICAN PRODUCTIONS INTERNATIONAL S.A., PANAMA CITY, PANAMA:
3,997,992, PUB. 5-3-2011. INT. CL. 41.
- PAN-AMERICAN LIFE INSURANCE COMPANY, NEW ORLEANS, LA:
3,999,858, INT. CL. 36.
- PANACHE CONNECTIONS, INC., CLERMONT, FL:
2,862,732, CANC. INT. CL. 35.
- PANCIS GEMS, INC., MORRIS PLAINS, NJ:
3,999,131, INT. CL. 14.
- PAPER ZONE LLC, THE, SEATTLE, WA:
2,401,532, CANC. MULTIPLE CLASS, INT. CLS. 35, 40 AND 41.
- PAPER-CHECK.COM, LLC, SAN FRANCISCO, CA, DBA PAPERCHECK:
3,997,533, PUB. 5-3-2011. MULTIPLE CLASS, INT. CLS. 35 AND 41.
- PARABLE GROUP, INC., THE, SAN LUIS OBISPO, CA:
2,577,442, REN. 6-14-11. INT. CL. 41.
- PARADISE SPORTS, INC., VENTURA, CA:
3,997,817, PUB. 5-3-2011. INT. CL. 35.
3,998,145, PUB. 5-3-2011. INT. CL. 35.
- PARADOCS ALL NATURAL INC, PLANTATION, FL:
3,997,810, PUB. 5-3-2011. INT. CL. 5.
- PARAGON FURNITURE, L.P., ARLINGTON, TX:
3,996,089, PUB. 5-3-2011. INT. CL. 20.
- PARAMETRIC TECHNOLOGY CORPORATION, NEEDHAM, MA:
3,998,318, INT. CL. 9.
3,998,319, MULTIPLE CLASS, INT. CLS. 9 AND 41.
- PARAMETRIC TECHNOLOGY GMBH, UNTERSCHLEIS-SHEIM, FED REP GERMANY:
2,901,369, CANC. INT. CL. 9.
- PARAMOUNT INDUSTRIAL COMPANIES, INC., NORFOLK, VA:
3,996,789, PUB. 5-3-2011. INT. CL. 40.
- PAREJA, SHONNA, EDGEWATER, FL:
3,995,595, PUB. 5-3-2011. INT. CL. 41.
- PARFUMS CHRISTIAN DIOR, FRANCE:
3,995,824, PUB. 5-3-2011. INT. CL. 3.
- PARFUMS DE COEUR, LTD., DARIEN, CT:
3,997,878, PUB. 5-3-2011. INT. CL. 3.
- PARGH, ANDREW L., PALM BEACH GARDENS, FL:
3,999,611, INT. CL. 35.
- PARHAM, THOMAS, MICHAEL, LAS VEGAS, NV:
2,902,292, CANC. INT. CL. 9.
- PARIS ACCESSORIES, INC., NEW YORK, NY:
3,998,939, INT. CL. 25.
- PARKER, HACKNEY, WILMINGTON, NC:
3,997,945, PUB. 5-3-2011. INT. CL. 31.
- PARKVIEW HEALTH SYSTEM, INC., FORT WAYNE, IN:
3,996,275, PUB. 5-3-2011. INT. CL. 35.
- PARNELL, LAUREL, SAN RAFAEL, CA:
3,999,883, INT. CL. 41.
- PARRY, CLARISSA, SIMI VALLEY, CA, DBA PARRY'S GLUTEN-FREE BAKERY:
3,996,786, PUB. 5-3-2011. INT. CL. 5.
- PARSLOW, HAROLD W., WASHINGTON, MI:
3,997,966, PUB. 5-3-2011. INT. CL. 7.
- PARTEC GMBH, D-48161 MUNSTER, FED REP GERMANY:
2,474,346, REN. 6-16-11. INT. CL. 9.
- PARTNER CREDIT UNION, ARVADA, CO:
3,997,648, PUB. 5-3-2011. INT. CL. 36.
- PARTNERRE U.S. CORPORATION, GREENWICH, CT:
3,999,503, INT. CL. 36.
- PARTOVICH, ROBY JON, OCEANSIDE, CA, DBA USA RACQUETBALL ACADEMY:
4,000,005, INT. CL. 41.
- PARTS TOWN, LLC, GLENVIEW, IL:
3,997,784, PUB. 5-3-2011. MULTIPLE CLASS, INT. CLS. 35, 37 AND 39.
3,997,785, PUB. 5-3-2011. MULTIPLE CLASS, INT. CLS. 35, 37 AND 39.
- PARTSEARCH TECHNOLOGIES, INC., NEW YORK, NY:
2,901,164, CANC. INT. CL. 35.
- PARVIN, EVERETT J., SAN RAMON, CA:
2,401,544, CANC. MULTIPLE CLASS, INT. CLS. 14 AND 35.
- PASCOE PHARMAZEUTISCHE PRAPARATE GMBH, 35394 GIESSEN, FED REP GERMANY:
2,493,803, REN. 6-15-11. INT. CL. 5.
- PASSION FOOD SIX, LLC, WASHINGTON, DC, DBA DISTRICT COMMONS:
3,997,557, PUB. 5-3-2011. INT. CL. 43.
- PATIENTKEEPER, INC., WALTHAM, MA:
3,999,347, INT. CL. 9.
- PATRICK J.S. INOUYE, P.S., SEATTLE, WA:
3,996,419, PUB. 5-3-2011. INT. CL. 45.
- PATRICK NAHASS, JR., MESA, AZ:
2,902,346, CANC. INT. CL. 25.
- PATRON SPIRITS INTERNATIONAL AG, 8200 SCHAFFHAUSEN, SWITZERLAND:
2,478,976, REN. 6-16-11. INT. CL. 33.
- PATTERSON, JAMES J., BETHESDA, MD:
2,901,367, CANC. INT. CL. 16.
- PAUL DANIEL MADDEN, MANSFIELD, OH:
3,999,999, MULTIPLE CLASS, INT. CLS. 9 AND 11.
- PAUL ECKE RANCH, ENCINITAS, CA:
2,902,437, CANC. INT. CL. 31.
- PAUL FANNY, HOOKSETT, NH:
3,996,402, PUB. 5-3-2011. INT. CL. 41.
- PAUL FRANK INDUSTRIES, LLC, LOS ANGELES, CA:
3,999,115, INT. CL. 9.
- PAUL REED SMITH GUITARS, STEVENSVILLE, MD:
2,901,307, CANC. INT. CL. 15.
- PAUL, CHARLES, SAN DIEGO, CA:
2,901,828, CANC. INT. CL. 28.
- PAULINE, FRANCE:
3,995,909, PUB. 5-3-2011. MULTIPLE CLASS, INT. CLS. 14, 18 AND 25.
- PAYGLOBAL LIMITED, CHRISTCHURCH, NEW ZEALAND:
2,900,984, CANC. MULTIPLE CLASS, INT. CLS. 9, 35 AND 36.
- PAYLESS SHOESOURCE WORLDWIDE, INC., TOPEKA, KS:
2,902,408, CANC. INT. CL. 26.

PB JANE, INC., NEW YORK, NY:
2,901,809, CANC. INT. CL. 35.

PDB CORP., BURLINGAME, CA:
2,511,098, REN. 6-12-11. INT. CL. 33.

PEAK FITNESS, LLC, MOORESVILLE, NC:
2,901,541, CANC. INT. CL. 41.

PEAK MOUNTAIN GUIDES LLC, RIDGWAY, CO:
3,996,466, PUB. 5-3-2011. INT. CL. 41.

PEARL'S FOOD PRODUCTS LLC, THOUSAND OAKS, CA,
DBA CHIAPAS:
3,999,707, INT. CL. 30.

PEARLMAN, DAVID, ALAN, EL PASO, TX:
2,902,463, CANC. INT. CL. 28.

PEARSON EDUCATION, INC., UPPER SADDLE RIVER, NJ:
2,952,293, CANC. INT. CL. 41.

PEBEO, GEMENOS, FRANCE:
2,901,593, CANC. MULTIPLE CLASS, INT. CLS. 2 AND
16.

PEDIATRIC AND INTERNAL MEDICINE SPECIALISTS,
PA, LECANTO, FL:
3,997,073, PUB. 5-3-2011. INT. CL. 44.

PEGASUS AIRWAVE, INC., BOCA RATON, FL:
2,460,486, REN. 6-11-11. INT. CL. 10.

PEGGY GREEN, INC., ST. PETERSBURG, FL:
3,999,788, INT. CL. 1.

PELZMAN, BRIAN M., OCALA, FL:
3,995,694, PUB. 5-3-2011. INT. CL. 45.

PENINSULA DOG PARKS, INC., SAN PEDRO, CA:
2,901,194, CANC. INT. CL. 36.

PENN PHARMACEUTICALS LIMITED, UNITED KING-
DOM:
3,892,726, COR. INT. CL. 42.

PENNANT CAPITAL MANAGEMENT, LLC, CHATHAM,
NJ:
3,995,513, PUB. 5-3-2011. INT. CL. 36.

PENNINGTON, SEAN D., ATASCADERO, CA, DBA DESTI-
NATION DRIVERS:
3,997,283, PUB. 5-3-2011. INT. CL. 39.

PENNSYLVANIA RURAL ELECTRIC ASSOCIATION, HAR-
RISBURG, PA:
2,460,757, REN. 6-16-11. MULTIPLE CLASS, INT. CLS. 35,
39 AND 40.

PENNWELL CORPORATION, TULSA, OK:
2,901,396, CANC. INT. CL. 41.
2,914,808, CANC. INT. CL. 16.
3,998,174, PUB. 5-3-2011. INT. CL. 35.

PENNYWICK CANDLES LLC, VIENNA, VA, AKA PENNY-
WICK CANDLES:
3,996,907, PUB. 5-3-2011. INT. CL. 4.

PENTAIR WATER POOL AND SPA, INC., SANFORD, NC:
1,162,610, REN. 6-12-11. INT. CL. 11.

PENTAX CORPORATION, TOKYO, JAPAN:
2,902,443, CANC. INT. CL. 9.

PENTON BUSINESS MEDIA, INC., NEW YORK, NY:
3,999,774, INT. CL. 41.

PENTON MEDIA, INC., NEW YORK, NY:
3,998,054, PUB. 5-3-2011. MULTIPLE CLASS, INT. CLS. 41
AND 43.

PEOPLESBANK, HOLYOKE, MA:
3,999,713, INT. CL. 36.

PEPSICO, INC., PURCHASE, NY:
2,902,491, CANC. INT. CL. 41.

PERALTA, MADAY, MIAMI, FL:
3,963,483, COR. INT. CL. 35.

PERELMAN, DEBORAH L., NEW YORK, NY:
3,995,672, PUB. 5-3-2011. INT. CL. 43.

PERFETTI VAN MELLE BENELUX B.V., BREDA, NETHER-
LANDS:
2,901,798, CANC. INT. CL. 30.

PERFETTI VAN MELLE S.P.A., ITALY:
3,995,920, PUB. 5-3-2011. INT. CL. 30.

PERFORMANCE CAPITAL INTERNATIONAL LLC, MAN-
ALAPAN, FL:
4,000,051, INT. CL. 41.

PERFUROMA, INC., WESTAMPTON, NJ:
3,999,624, MULTIPLE CLASS, INT. CLS. 1 AND 3.

PERIPHERAL DYNAMICS, INC., PLYMOUTH MEETING,
PA:
2,522,803, REN. 6-14-11. INT. CL. 9.

PERKINS PAPERS LTD./PAPIERS PERKINS LTEE, CAN-
DIAC (QUEBEC), CANADA TO CASCADES CANADA
INC., MONTREAL, QUEBEC, CANADA:
2,401,365, CANC. INT. CL. 16.

PERPETUAL PLAY, INC., NEWPORT BEACH, CA:
3,999,450, INT. CL. 28.

PERSAD, SABBITHRY, TORONTO M4K3Z2, CANADA:
3,999,080, INT. CL. 16.

PERSONALIZATIONMALL.COM, INC., BURR RIDGE, IL:
3,996,778, PUB. 5-3-2011. INT. CL. 35.

PER4MANCE TRAINING LLC, CHARLOTTE, NC, DBA
TOTALCYCLIST LLC:
3,997,710, PUB. 5-3-2011. MULTIPLE CLASS, INT. CLS. 25
AND 41.

PESKIN, BRIAN, HOUSTON, TX:
3,997,980, PUB. 5-3-2011. INT. CL. 5.

PET KING BRANDS, INC., WESTMONT, IL:
2,450,646, REN. 6-14-11. INT. CL. 5.

PETER SUI LUN FONG, MONTEREY PARK, CA:
2,901,915, CANC. INT. CL. 28.

PETERSON'S NELNET, LLC., LINCOLN, NE:
2,902,011, CANC. INT. CL. 41.

PETRO HARVESTER OIL AND GAS, LLC, HOUSTON, TX:
3,999,758, MULTIPLE CLASS, INT. CLS. 40 AND 42.
3,999,759, MULTIPLE CLASS, INT. CLS. 40 AND 42.

PETS A GO GO LLC, BRIARCLIFF MANOR, NY:
3,996,804, PUB. 5-3-2011. MULTIPLE CLASS, INT. CLS. 44
AND 45.

PETSVETSPACE, LLC, NEW YORK, NY:
3,998,454, INT. CL. 44.

PETTER INVESTMENTS, INC., SOUTH HAVEN, MI:
3,997,320, PUB. 5-3-2011. INT. CL. 7.

PEYTON, ANNE, S STRAFFORD, VT:
2,401,789, CANC. INT. CL. 14.

PFIP, LLC, NEWINGTON, NH:
3,997,453, PUB. 5-3-2011. INT. CL. 41.

PG GROUP (PTY) LIMITED, JOHANNESBURG, GAUTENG,
SOUTH AFRICA:
3,999,213, INT. CL. 12.

PGI/PHOENIX GRAPHIX, INC., CHANDLER, AZ:
3,996,423, PUB. 5-3-2011. INT. CL. 16.
3,996,424, PUB. 5-3-2011. INT. CL. 16.
3,996,448, PUB. 5-3-2011. INT. CL. 16.

PHARMWEST, INC., MARINA DEL REY, CA:
2,902,143, CANC. INT. CL. 5.

PHI DELTA THETA FRATERNITY, OXFORD, OH:
3,996,758, PUB. 5-3-2011. MULTIPLE CLASS, INT. CLS. 18
AND 25.
3,996,759, PUB. 5-3-2011. MULTIPLE CLASS, INT. CLS. 18
AND 25.

PHIL THE THRILL LLC, GAINESVILLE, FL:
3,997,449, PUB. 5-3-2011. INT. CL. 25.

PHILADELPHIA SUBURBAN CORPORATION, BRYN
MAWR, PA:
1,621,550, CANC. MULTIPLE CLASS, INT. CLS. 35, 36, 37,
39 AND 42.

PHILD CO., LTD., KYOTO CITY, KYOTO PREF., JAPAN:
2,901,916, CANC. INT. CL. 3.

PHILIPPE STARCK, PARIS, FRANCE:
3,995,810, PUB. 5-3-2011. INT. CL. 7.

PHILLIPS FOODS, INC., BALTIMORE, MD:
3,999,638, INT. CL. 29.

PHIZZLE, INC., SAN FRANCISCO, CA:
3,995,554, PUB. 5-3-2011. INT. CL. 35.

PHOENIX CONTACT DEVELOPMENT AND MANUFAC-
TURING, INC., MIDDLETOWN, PA:
3,997,342, PUB. 5-3-2011. INT. CL. 9.

PHOENIX LEGAL INC., TORONTO, CANADA:
3,996,608, PUB. 5-3-2011. INT. CL. 35.

PHOTO THERAPEUTICS LIMITED, ALTRINCHAM, UNI-
TED KINGDOM:
3,995,523, PUB. 1-25-2011. MULTIPLE CLASS, INT. CLS. 3
AND 10.

- PHOTOGRAPHIC SOCIETY OF AMERICA, INC., OKLAHOMA CITY, OK:
3,995,712, PUB. 5-3-2011. MULTIPLE CLASS, INT. CLS. 35 AND 41.
- PHOTOSENSE, LLC, BOULDER, CO:
2,463,290, REN. 6-15-11. INT. CL. 42.
- PHYDEAUX ENTERPRISES, INC., CLINTON TOWNSHIP, MI:
3,997,576, PUB. 5-3-2011. INT. CL. 31.
- PI-DESIGN AG, TRIENGEN, SWITZERLAND:
2,416,103, REN. 6-16-11. MULTIPLE CLASS, INT. CLS. 16 AND 18.
2,418,792, REN. 6-16-11. INT. CL. 16.
- PIAB AB, SWEDEN:
3,995,938, PUB. 5-3-2011. INT. CL. 7.
- PICIS, INC., WAKEFIELD, MA:
3,966,739, COR. INT. CL. 9.
- PIEDMONT TRAVEL, INC., GREENVILLE, SC:
2,901,486, CANC. INT. CL. 39.
- PIERCE BIOTECHNOLOGY, INC., ROCKFORD, IL:
2,463,728, REN. 6-15-11. INT. CL. 1.
- PIERRE FABRE DERMO-COSMETIQUE, 92100 BOULOGNE, FRANCE:
2,901,132, CANC. MULTIPLE CLASS, INT. CLS. 3 AND 5.
- PIERRE FABRE DERMO-COSMETIQUE, BOULOGNE, FRANCE:
3,996,313, PUB. 5-3-2011. MULTIPLE CLASS, INT. CLS. 1, 3 AND 5.
- PIG EVIL, INC., OLYMPIA, WA:
3,997,814, PUB. 5-3-2011. INT. CL. 25.
- PIGEON CORPORATION, BUPYEONG-GU, INCHEON, REPUBLIC OF KOREA:
3,995,790, PUB. 5-3-2011. INT. CL. 3.
- PIGNATARO, ANTHONY, DEER PARK, NY:
3,997,370, PUB. 5-3-2011. INT. CL. 35.
- PIKES PEAK MARATHON, INC., MANITOU SPRINGS, CO:
2,401,881, CANC. INT. CL. 41.
- PILLAR ROCK USA CORP., FARMINGDALE, NY:
3,999,725, INT. CL. 5.
- PILOTS POINT, LLC., BELLEAIR BLUFFS, FL:
3,998,340, INT. CL. 1.
- PING IDENTITY CORPORATION, DENVER, CO:
2,901,701, CANC. INT. CL. 42.
- PINNACLE ENTERTAINMENT, INC., LAS VEGAS, NV:
3,998,279, PUB. 5-3-2011. INT. CL. 43.
3,998,280, PUB. 5-3-2011. INT. CL. 43.
3,998,281, PUB. 5-3-2011. INT. CL. 35.
3,998,282, PUB. 5-3-2011. INT. CL. 41.
3,998,283, PUB. 5-3-2011. INT. CL. 43.
3,998,284, PUB. 5-3-2011. INT. CL. 43.
3,998,285, PUB. 5-3-2011. INT. CL. 41.
3,998,286, PUB. 5-3-2011. INT. CL. 35.
- PINNACLE PROCESS SOLUTIONS, INTERNATIONAL, CEDAR PARK, TX:
3,997,366, PUB. 5-3-2011. INT. CL. 35.
- PINPOINT PROFIT RECOVERY SERVICES, INC., STAMFORD, CT:
3,996,884, PUB. 5-3-2011. INT. CL. 9.
- PIONEER KABUSHIKI KAISHA, KAWASAKI-SHI, KANAGAWA-KEN, JAPAN, DBA PIONEER CORPORATION:
3,999,068, INT. CL. 9.
- PIONEER NURSERY, VISALIA, CA:
2,902,081, CANC. INT. CL. 31.
- PIRELLI & C.S.P.A., I-20126 MILANO, ITALY:
3,995,820, PUB. 5-3-2011. MULTIPLE CLASS, INT. CLS. 35, 36, 37 AND 42.
- PIROZZI, BRETT, LAS VEGAS, NV:
3,996,119, PUB. 5-3-2011. MULTIPLE CLASS, INT. CLS. 9 AND 41.
- PISTOLSTAR, INC., AMHERST, NH:
3,998,151, PUB. 5-3-2011. INT. CL. 9.
- PIXELTOWN ARTS, LLC, MARINA DEL REY, CA:
3,997,825, PUB. 5-3-2011. INT. CL. 41.
- PLAIA, GERALDINE, SEA GIRT, NJ:
3,995,492, PUB. 5-3-2011. INT. CL. 5.
- PLAINSCAPITAL CORPORATION, DALLAS, TX:
2,902,105, CANC. INT. CL. 36.
2,902,106, CANC. INT. CL. 36.
2,902,108, CANC. INT. CL. 36.
- PLAN DO SEE CORPORATION, NEW YORK, NY, DBA GREENWICH GRILL:
3,999,941, INT. CL. 43.
- PLANET ECLIPSE LIMITED, TRAFFORD PARK, MANCHESTER, UNITED KINGDOM:
2,902,467, CANC. INT. CL. 25.
- PLANET MUSIC USA CORPORATION, CLEARWATER, FL:
3,995,661, PUB. 5-3-2011. MULTIPLE CLASS, INT. CLS. 15 AND 28.
- PLANETACTIVE GMBH, DUSSELDORF, FED REP GERMANY:
2,900,981, CANC. MULTIPLE CLASS, INT. CLS. 9, 28, 35, 38, 41 AND 42.
- PLANO MOLDING COMPANY, PLANO, IL:
3,997,668, PUB. 5-3-2011. INT. CL. 28.
- PLASTIC SURGERY & DERMATOLOGY OF NYC PLLC, NEW YORK, NY:
3,995,508, PUB. 5-3-2011. INT. CL. 44.
- PLASTIFLEX CANADA INC., ORANGEVILLE, ONTARIO, CANADA:
3,996,745, PUB. 5-3-2011. INT. CL. 7.
- PLASTMED LTD., TEFEN, ISRAEL:
3,995,538, PUB. 10-12-2010. INT. CL. 10.
- PLASTOFORM INDUSTRIES LIMITED, N.T., HONG KONG:
3,999,491, INT. CL. 9.
- PLAY WITH WORDS, INC., FAIRFAX, VA:
3,996,951, PUB. 5-3-2011. INT. CL. 41.
- PLAYBOY ENTERPRISES INTERNATIONAL, INC., CHICAGO, IL:
3,998,055, PUB. 5-3-2011. INT. CL. 41.
- PLAYMAKERS SPORTS MANAGEMENT, LLC, BRONX, NY:
3,999,306, INT. CL. 35.
- PLAYMATES TOYS INC., EL SEGUNDO, CA:
3,999,591, INT. CL. 28.
3,999,878, INT. CL. 28.
- PLAYMEDIA SYSTEMS, INC., LAS VEGAS, NV:
2,901,975, CANC. INT. CL. 9.
- PLAYSTAR, INC., JANESVILLE, WI:
2,480,493, REN. 6-15-11. INT. CL. 28.
- PLAYSTREAM, INC., ATLANTA, GA:
2,450,587, REN. 6-15-11. MULTIPLE CLASS, INT. CLS. 38, 39 AND 42.
- PLAYTEX PRODUCTS, INC., WESTPORT, CT:
2,902,278, CANC. INT. CL. 5.
- PLAYTEX PRODUCTS, LLC, SHELTON, CT:
3,999,317, INT. CL. 10.
- PLAZA IP HOLDINGS LLC (USA), NEW YORK, NY:
3,998,375, INT. CL. 21.
- PLEASANT, JUDITH A., TOLEDO, OH:
2,902,404, CANC. INT. CL. 28.
- PLENTYOFFISH MEDIA, INC., VANCOUVER, CANADA:
3,998,613, MULTIPLE CLASS, INT. CLS. 38 AND 45.
- PLUME.COM, LLC, PETOSKEY, MI:
3,998,555, INT. CL. 45.
- PMM SPORTS, LLC, BEVERLY HILLS, CA:
3,999,123, INT. CL. 35.
- PNEUMATIC SCALE CORPORATION, AKRON, OH:
3,998,589, INT. CL. 9.
- PNI CORPORATION, SANTA ROSA, CA:
2,902,100, CANC. INT. CL. 9.
- PNY TECHNOLOGIES, INC., PARSIPPANY, NJ:
2,901,575, CANC. INT. CL. 9.
3,962,644, COR. INT. CL. 9.
- POCKET GEMS, INC., SAN FRANCISCO, CA:
3,998,112, PUB. 5-3-2011. INT. CL. 9.
- POCONO INVESTMENT COMPANY, WILMINGTON, DE:
2,901,256, CANC. INT. CL. 36.
- POGO INDUSTRIES INC., HALIBURTON, CANADA:
3,995,530, PUB. 10-19-2010. INT. CL. 7.
- POINTE NOIR PTY. LTD., PYRMONT, NSW 2009, AUSTRALIA:
2,902,021, CANC. INT. CL. 25.

POLITI, PAMELA, REDDING, CA:
3,995,528, PUB. 5-3-2011. INT. CL. 29.

POLLARD, BONNIE, PALO ALTO, CA AND POLLARD, DAVID, PALO ALTO, CA:
1,653,888. REN. 6-16-11. INT. CL. 36.
1,654,497. REN. 6-15-11. INT. CL. 36.

POLLUTION SOLUTION, INC., LODI, CA:
2,901,372, CANC. INT. CL. 11.

POLSINELLI SHALTON & WELTE, P.C., KANSAS CITY, MO:
2,902,385, CANC. INT. CL. 35.

POLYCLEAN INNOVATIONS, LLC, ST. LOUIS, MO:
2,513,616. REN. 6-15-11. INT. CL. 21.

POMWONDERFUL LLC, LOS ANGELES, CA:
3,998,661, MULTIPLE CLASS, INT. CLS. 30 AND 32.

PONTIAC COIL, INC., CLARKSTON, MI:
2,424,799. REN. 6-16-11. INT. CL. 9.

POOLE, WILLIAM E., WILMINGTON, NC:
2,901,614, CANC. INT. CL. 11.

POPULAR, INC., SAN JUAN, PUERTO RICO:
2,467,524. REN. 6-15-11. INT. CL. 36.

PORTACIO CORPORATION, LAS VEGAS, NV:
2,901,738, CANC. INT. CL. 42.

PORTERFIELD, MICHAEL, ASHEVILLE, NC:
3,997,091, PUB. 5-3-2011. INT. CL. 31.

PORTLAND ENERGY CONSERVATION, INC., PORTLAND, OR:
3,995,678, PUB. 5-3-2011. MULTIPLE CLASS, INT. CLS. 35, 41 AND 42.

PORTOLANO PRODUCTS, INC., NEW YORK, NY:
2,490,573. REN. 6-10-11. MULTIPLE CLASS, INT. CLS. 18 AND 25.

PORTUESE, WILLIAM A., SEATTLE, WA:
3,999,910, INT. CL. 44.

POSH, LLC, BIRMINGHAM, AL:
3,998,097, PUB. 5-3-2011. INT. CL. 35.

POSITSION OÜ, ESTONIA:
3,995,930, PUB. 5-3-2011. INT. CL. 33.

POST GAME LLC, GLEN ELLYN, IL:
3,998,635, INT. CL. 3.
3,998,636, INT. CL. 3.
3,998,928, INT. CL. 3.
3,998,929, INT. CL. 3.

POST, ROBERT, METAIRIE, LA:
2,901,705, CANC. INT. CL. 20.

POTHYS, CHENNAI, INDIA:
3,999,215, MULTIPLE CLASS, INT. CLS. 23, 24 AND 25.
3,999,216, MULTIPLE CLASS, INT. CLS. 23, 24 AND 25.

POTRERO TRADING COMPANY, SAN FRANCISCO, CA:
3,996,387, PUB. 5-3-2011. INT. CL. 30.

POWER LITERACY, L.L.C., OVERLAND PARK, KS:
3,996,949, PUB. 5-3-2011. INT. CL. 16.

POWER PAPER LTD., 49 910 KIBBUTZ EINAT, ISRAEL:
2,902,020, CANC. MULTIPLE CLASS, INT. CLS. 5, 9 AND 10.

POWERHOUSE PILATES, LLC, EIGHTY FOUR, PA:
2,901,858, CANC. INT. CL. 41.

POWERMAX USA, INC, RANCHO CUCAMONGA, CA:
3,996,238, PUB. 5-3-2011. INT. CL. 9.

POWERPACT HOLDINGS LLC, MIDLOTHIAN, VA:
3,998,967, INT. CL. 9.
3,998,968, INT. CL. 35.

POWERSPORTS GROUP, INC, CHULA VISTA, CA, DBA JP MARINE AND PALMER, JOSHUA, CHULA VISTA, CA:
3,997,003, PUB. 5-3-2011. INT. CL. 12.

POZZOLINI, ALFREDO S., HUNTINGTON BEACH, CA, DBA M1-K9 COLLARS:
3,998,810, INT. CL. 18.

PPG ARCHITECTURAL FINISHES, INC., PITTSBURGH, PA, PITTSBURGH PLATE GLASS COMPANY, PITTSBURGH, PA:
287,505. REN. 6-13-11. U.S. CL. 16 (INT. CL. 2).

PR TRADING CO., HOUSTON, TX, DBA POLAR RAY SUNGLASSES:
2,902,442, CANC. INT. CL. 9.

PRACTICE COMMUNICATIONS, INC., BOCA RATON, FL:
3,999,470, INT. CL. 44.

PRAGMATICA INNOVATIONS, LLC, VIRGINIA BEACH, VA:
3,997,869, PUB. 5-3-2011. INT. CL. 9.

PRATER, JAMES, SANTA CLARA, CA:
2,901,145, CANC. MULTIPLE CLASS, INT. CLS. 32 AND 41.

PRAXAIR SURFACE TECHNOLOGIES, INC., INDIANAPOLIS, IN:
2,401,667, CANC. INT. CL. 2.

PRAXIUM GROUP, INC., THE, GRAYSON, GA:
2,401,797, CANC. MULTIPLE CLASS, INT. CLS. 39 AND 42.

PRECISION COMBUSTION, INC., NORTH HAVEN, CT:
2,471,669. REN. 6-15-11. INT. CL. 42.

PRECISION DERMATOLOGY, INC., CUMBERLAND, RI:
3,999,238, INT. CL. 3.

PRECISION FRANCHISING LLC, LEESBURG, VA:
2,901,400, CANC. INT. CL. 37.
2,901,401, CANC. INT. CL. 37.
2,901,402, CANC. INT. CL. 37.
2,901,403, CANC. INT. CL. 37.
2,901,404, CANC. INT. CL. 37.
2,901,405, CANC. INT. CL. 37.
2,901,406, CANC. INT. CL. 37.
2,901,407, CANC. INT. CL. 37.

PRECISION MEDICAL DEVICES INC., NEW BRUNSWICK, NJ, DBA PMD:
3,998,740, INT. CL. 10.

PREFEREDONE ADMINISTRATIVE SERVICES, INC., GOLDEN VALLEY, MN:
2,573,283. REN. 6-11-11. INT. CL. 36.
2,573,283, CANC. INT. CL. 42.
2,573,284. REN. 6-14-11. INT. CL. 42.

PREMIER NUTRITION, INC., CARLSBAD, CA:
3,996,603, PUB. 5-3-2011. INT. CL. 5.

PREMIER VISION OPTOMETRY, INC., ARCADIA, CA:
3,996,829, PUB. 5-3-2011. INT. CL. 44.

PREMIER, INC., CHARLOTTE, NC:
3,997,168, PUB. 5-3-2011. INT. CL. 35.

PREMIERE CARGO S.R.L., 20068 PESCHIERA BORROMEO (MILANO), ITALY:
2,900,958, CANC. INT. CL. 39.

PREMIUM NATURAL BEEF LLC, LONE WOLF, OK:
3,999,498, INT. CL. 29.

PREMIUM S.R.L., FAENZA, ITALY:
2,901,555, CANC. INT. CL. 33.

PREMIUM S.R.L., ITALY:
3,995,776, PUB. 5-3-2011. INT. CL. 33.

PREP NET, LLC, GRAND RAPIDS, MI:
3,999,521, INT. CL. 41.

PRESIDENT AND FELLOWS OF MIDDLEBURY COLLEGE, THE, MIDDLEBURY, VT:
2,494,485. REN. 6-10-11. INT. CL. 41.

PRESLICED LLC, RICHMOND, VA, DBA PAXTON'S SANDAL SAVER:
2,901,289, CANC. INT. CL. 3.

PRESTAN PRODUCTS LLC, MAYFIELD VILLAGE, OH:
3,997,738, PUB. 5-3-2011. INT. CL. 9.

PRESTOLITE WIRE LLC, SOUTHFIELD, MI, LAKEWOOD INDUSTRIES, INC., CLEVELAND, OH, DBA LAKEWOOD INDUSTRIES:
924,091. REN. 6-10-11. U.S. CL. 15 (INT. CL. 4).

PRESTOLITE WIRE LLC, SOUTHFIELD, MI, MALLORY, INC., CARSON CITY, NV:
1,645,921. REN. 6-13-11. INT. CL. 12.

PRETIKA CORPORATION, LAGUNA NIGUEL, CA:
3,997,503, PUB. 5-3-2011. INT. CL. 10.

PREVITY SURGICAL, PLLC, BEAUMONT, TX:
3,997,202, PUB. 5-3-2011. INT. CL. 44.

PRICELESS PLANE PRODUCTS, INC., LAWRENCEVILLE, GA:
2,462,556. REN. 6-14-11. INT. CL. 12.
2,462,556, AM. INT. CL. 12.

PRICELINE.COM INCORPORATED, NORWALK, CT:
3,995,707, PUB. 5-3-2011. MULTIPLE CLASS, INT. CLS. 39 AND 43.

PRICewaterhouseCOOPERS LLP, NEW YORK, NY:
2,902,125, CANC. INT. CL. 36.

- PRIMARY INVESTMENTS GROUP LIMITED, ROAD TOWN, TORTOLA, BR.VIRGIN ISLANDS:
2,463,824. REN. 6-13-11. INT. CL. 5.
- PRIME RETAIL STORES, INC., BALTIMORE, MD:
2,402,396. CANC. INT. CL. 35.
- PRIME SOURCE ACCESSORIES, INC., STUART, FL:
3,999,863. INT. CL. 21.
- PRIME; RESEARCH INTERNATIONAL AG & CO KG, FED REP GERMANY:
3,995,802. PUB. 5-3-2011. MULTIPLE CLASS, INT. CLS. 35, 38 AND 42.
- PRIMECOR, INC., INDIANAPOLIS, IN:
2,499,595. REN. 6-14-11. INT. CL. 36.
2,499,595. CANC. INT. CL. 35.
- PRIMEPAY, INC., WEST CHESTER, PA:
3,996,068. PUB. 5-3-2011. INT. CL. 42.
- PRIMEX CONSULTANTS, INC., MELVILLE, NY:
2,902,212. CANC. INT. CL. 9.
- PRINCE OF PEACE ENTERPRISES, INC., HAYWARD, CA:
3,997,583. PUB. 5-3-2011. INT. CL. 5.
- PRINTMAKER INTERNATIONAL, LTD., NEW YORK, NY:
2,901,795. CANC. INT. CL. 25.
- PRIORITIZE, LLC, SCOTTSDALE, AZ:
3,999,955. INT. CL. 16.
- PRIVATE SOCIAL NETWORKS, INC., DALLAS, TX:
3,996,403. PUB. 5-3-2011. INT. CL. 38.
- PRN SOFTWARE LLC, WALTHAM, MA:
3,996,544. PUB. 5-3-2011. INT. CL. 42.
- PRO EQUINE GROUP, INC., DEERFIELD, IL:
3,998,912. INT. CL. 22.
- PRO-DEX, INC., IRVINE, CA:
2,403,311. REN. 6-13-11. INT. CL. 9.
- PROBIOTICAL S.P.A., NOVARA, ITALY:
2,901,079. CANC. MULTIPLE CLASS, INT. CLS. 1, 5 AND 31.
- PROCACCI BROTHERS SALES CORPORATION, PHILADELPHIA, PA:
2,401,314. CANC. INT. CL. 31.
- PROCONGPS, INC., KNOXVILLE, TN:
3,996,060. PUB. 5-3-2011. INT. CL. 35.
3,996,162. PUB. 5-3-2011. INT. CL. 9.
- PROCREATIONS PUBLISHING COMPANY, NEW ORLEANS, LA:
3,999,494. INT. CL. 24.
- PROCTER & GAMBLE COMPANY, THE, CINCINNATI, OH:
2,402,605. CANC. MULTIPLE CLASS, INT. CLS. 3 AND 21.
- PROCURA, LLC, SAN DIMAS, CA:
3,995,481. PUB. 5-3-2011. MULTIPLE CLASS, INT. CLS. 36 AND 39.
- PRODUCTOS LA DONA, S.A., APTDO. 11-176 PANAMA 6, PANAMA:
2,901,139. CANC. INT. CL. 21.
- PROENZA SCHOUER, LLC, NEW YORK, NY:
3,997,482. PUB. 5-3-2011. INT. CL. 18.
- PROFESSIONAL BULL RIDERS, INC., PUEBLO, CO:
3,995,610. PUB. 5-3-2011. INT. CL. 25.
- PROFESSIONAL CABLE, LLC, OREM, UT:
3,999,582. INT. CL. 9.
- PROFESSIONAL GOLFERS' ASSOCIATION OF AMERICA, THE, PALM BEACH GARDENS, FL:
2,531,732. REN. 6-14-11. INT. CL. 16.
2,901,708. CANC. INT. CL. 41.
- PROGRAM PLANNING PROFESSIONALS, ANN ARBOR, MI:
2,472,943. REN. 6-16-11. MULTIPLE CLASS, INT. CLS. 16 AND 35.
- PROGRESSIVE CASUALTY INSURANCE COMPANY, MAYFIELD VILLAGE, OH:
3,999,857. INT. CL. 36.
- PROLAB TECHNOLOGIES INC., THETFORD MINES, QUEBEC, CANADA:
3,029,627. CANC. MULTIPLE CLASS, INT. CLS. 3, 35, 40 AND 42.
- PROMARK BRANDS INC., BOISE, ID:
2,901,471. CANC. INT. CL. 30.
2,901,472. CANC. INT. CL. 30.
- PROMED GMBH MEDIZINISCHE GERÄTE UND KOSMETISCHE ERZEUGNISSE, 82490 FARCHANT, FED REP GERMANY:
3,995,925. PUB. 5-3-2011. INT. CL. 8.
- PROMEGA CORPORATION, MADISON, WI:
3,997,477. PUB. 5-3-2011. INT. CL. 9.
- PROMERSBERGER COMPANY, THE, FARGO, ND:
2,451,138. REN. 6-13-11. MULTIPLE CLASS, INT. CLS. 35, 36 AND 37.
- PROMONTORY MARK, LLC, WASHINGTON, DC:
3,999,915. INT. CL. 9.
- PROMOTIONAL ALLIANCE INTERNATIONAL, INC., RANCHO CUCAMONGA, CA:
3,996,623. PUB. 5-3-2011. INT. CL. 35.
- PROMOTORA DE INFORMACIONES, S.A., MADRID, SPAIN:
3,995,725. PUB. 3-2-2010. MULTIPLE CLASS, INT. CLS. 16, 38 AND 41.
- PROP SUPPLY & SERVICE, LLC, HOUSTON, TX, AKA RAINBOW CERAMICS:
3,997,289. PUB. 5-3-2011. INT. CL. 1.
- PROPHET CORPORATION, OWATONNA, MN, DBA GOPHER SPORT CORPORATION:
3,997,556. PUB. 5-3-2011. INT. CL. 25.
3,997,559. PUB. 5-3-2011. INT. CL. 28.
3,997,564. PUB. 5-3-2011. INT. CL. 28.
- PROPPER MANUFACTURING COMPANY, INC., LONG ISLAND CITY, NY:
3,996,371. PUB. 11-30-2010. MULTIPLE CLASS, INT. CLS. 1 AND 10.
- PROSIGHT SPECIALTY INSURANCE, MORRISTOWN, NJ:
3,999,430. INT. CL. 36.
- PROSPECTDIGITAL, L.L.C., PETALUMA, CA:
2,902,102. CANC. INT. CL. 35.
- PROSPX, INC., AUSTIN, TX:
3,998,137. PUB. 5-3-2011. INT. CL. 41.
- PROSSER HALLOCK, INC., JACKSONVILLE, FL:
3,998,082. PUB. 5-3-2011. INT. CL. 40.
- PROST, WILLIAM, FREDONIA, NY:
3,997,410. PUB. 5-3-2011. INT. CL. 35.
- PROTEUS BIOMEDICAL, INC., REDWOOD CITY, CA:
3,999,172. MULTIPLE CLASS, INT. CLS. 5, 9, 10, 41, 42 AND 44.
- PROTONEX TECHNOLOGY CORPORATION, SOUTHBOROUGH, MA:
3,999,220. MULTIPLE CLASS, INT. CLS. 4, 9 AND 11.
- PROVA, DEL MAR, CA:
3,997,228. PUB. 5-3-2011. INT. CL. 42.
- PROVIDENT ISLAND RESORTS, LLC, CLEARWATER, FL, DBA SUNSET VISTAS BEACHFRONT SUITES:
3,997,793. PUB. 5-3-2011. INT. CL. 43.
- PROVING GROUND, LLC, ATLANTA, GA:
3,999,691. INT. CL. 42.
- PROXYMED, INC., NORCROSS, GA:
2,902,353. CANC. INT. CL. 9.
- PRUDENT LIVING INC., WINDSOR, VT:
3,999,279. MULTIPLE CLASS, INT. CLS. 9, 35, 37, 40 AND 42.
- PRUDENT MAN ANALYSIS, INC., NAPERVILLE, IL:
3,999,694. INT. CL. 36.
- PRUDENTIAL INSURANCE COMPANY OF AMERICA, THE, NEWARK, NJ:
3,998,676. INT. CL. 36.
- PRUDHOMME, DON, VISTA, CA:
2,477,693. REN. 6-16-11. INT. CL. 9.
- PS HOLDINGS, L.L.C., OVERLAND PARK, KS:
3,996,866. PUB. 5-3-2011. INT. CL. 35.
- PSORIA-SHIELD, INC., ORMOND BEACH, FL:
3,995,673. PUB. 5-3-2011. INT. CL. 10.
- PUBLIC SERVICE COMPANY OF NEW MEXICO, ALBUQUERQUE, NM:
2,901,094. CANC. INT. CL. 41.
2,901,095. CANC. INT. CL. 41.
- PUBLIX ASSET MANAGEMENT COMPANY, LAKELAND, FL:
3,997,638. PUB. 5-3-2011. INT. CL. 35.
3,998,250. PUB. 5-3-2011. INT. CL. 35.

PUEBLO INC., GUAYNABO, PUERTO RICO:
3,996,628, PUB. 5-3-2011. INT. CL. 29.
3,996,630, PUB. 5-3-2011. INT. CL. 30.

PUIG FRANCE, 92200 NEUILLY SUR SEINE, FRANCE:
1,156,030, AM. INT. CL. 3.

PULSE-LINK, INC., CARLSBAD, CA:
2,902,144, CANC. INT. CL. 9.

PUMA PRESS, LLC, FLAGSTAFF, AZ:
3,997,353, PUB. 5-3-2011. INT. CL. 16.

PURE & NATURAL COMPANY, SCOTTSDALE, AZ:
3,999,034, INT. CL. 3.

PURE BALANCE FITNESS, L.L.C., SPANISH FORK, UT:
2,901,408, CANC. INT. CL. 41.

PURE BLUE SUPPLY, INC., MINNETONKA, MN:
2,901,312, CANC. INT. CL. 25.

PURE FISHING, INC., SPIRIT LAKE, IA:
2,476,724, REN. 6-15-11. INT. CL. 28.
3,998,698, INT. CL. 28.
3,998,699, INT. CL. 28.
3,998,701, INT. CL. 28.

PURE PC, DALLAS, TX:
3,997,046, PUB. 5-3-2011. INT. CL. 9.

PURESTPETS, LLC, GAINESVILLE, FL:
3,997,616, PUB. 5-3-2011. INT. CL. 3.

PURINA MILLS, LLC, GREY SUMMIT, MO:
3,997,060, PUB. 5-3-2011. INT. CL. 31.

PURNELL, JAMES E., FORT PIERCE, FL:
3,997,368, PUB. 5-3-2011. INT. CL. 41.

PURPLE COWS, INC., PROVO, UT:
3,998,177, PUB. 5-3-2011. INT. CL. 28.

PURPLE RAM, LLC, SPRINGFIELD, MO, DBA REVEL ADVERTISING:
3,996,619, PUB. 5-3-2011. INT. CL. 35.

PURSELL MANUFACTURING CORPORATION, PONCHA SPRINGS, CO:
4,000,016, INT. CL. 28.

PURSUIT MARKETING, INC., SEWELL, NJ:
2,902,417, CANC. INT. CL. 28.

PUSHCORP, INC., GARLAND, TX:
2,901,703, CANC. INT. CL. 7.

PWXYZ, LLC, NEW YORK, NY:
3,996,797, PUB. 5-3-2011. INT. CL. 16.

PYRAMEX SAFETY PRODUCTS, LLC, COLLIERVILLE, TN:
2,901,540, CANC. INT. CL. 9.

PYRAMID PET PRODUCTS, INC, FOLSOM, CA:
3,999,520, INT. CL. 31.
3,999,522, INT. CL. 31.

Q PRODUCTS LLC, CLEARWATER, FL:
3,998,552, INT. CL. 20.

QED GROUP A.S., CZECH REPUBLIC:
3,995,747, PUB. 5-3-2011. MULTIPLE CLASS, INT. CLS. 9, 35, 41 AND 42.

QINGDAO YLS. TEXTILES CO., LTD., SHANDONG PROVINCE, CHINA:
3,999,477, INT. CL. 24.

QIQIHAR JINYA FLAX TEXTILE CO., LTD., QIQIHAR, HEILONGJIANG, CHINA:
3,998,632, INT. CL. 24.

QTRCO, INC., TOMBALL, TX:
2,901,718, CANC. INT. CL. 7.

QUANTIMETRIX CORPORATION, REDONDO BEACH, CA:
2,459,619, REN. 6-14-11. INT. CL. 5.
2,459,619, AM. INT. CL. 5.

QUARRY INTEGRATED COMMUNICATIONS INC., ST. JACOBS, ONTARIO, CANADA:
3,996,551, PUB. 5-3-2011. INT. CL. 41.

QUEEN CUTLERY COMPANY, TITUSVILLE, PA:
3,997,360, PUB. 5-3-2011. INT. CL. 8.

QUEEN GAMES GMBH, TROISDORF, FED REP GERMANY:
3,997,775, PUB. 5-3-2011. INT. CL. 28.

QUESTAR CORPORATION, SALT LAKE CITY, UT:
3,998,222, PUB. 5-3-2011. INT. CL. 42.
3,998,223, PUB. 5-3-2011. INT. CL. 42.

QUIET ISLAND FILMS, LLC, ST. PAUL, MN:
3,998,339, INT. CL. 41.

QUIMICA LIPOSOLUBLE, S.A. DE C.V., GUADALAJARA, JALISCO, MEXICO:
3,999,916, INT. CL. 1.

QUINN HOLTBY, EDMONTON, ALBERTA, CANADA:
3,999,952, INT. CL. 19.

QUIRCH FOODS CO., MIAMI, FL:
3,996,953, PUB. 5-3-2011. INT. CL. 29.

QUORUMLABS, INC., FREMONT, CA:
3,998,895, INT. CL. 9.

QVALE AUTOMOTIVE GROUP, LTD., SAN FRANCISCO, CA:
2,477,947, REN. 6-16-11. INT. CL. 12.

R & A BAILEY & CO, DUBLIN 12, IRELAND:
1,661,891, REN. 6-10-11. INT. CL. 33.

R & D LIFESCIENCES, LLC., MENOMONIE, WI:
3,999,378, INT. CL. 5.

R G & R T TROTT PTY LTD, AUSTRALIA:
3,995,998, PUB. 5-3-2011. INT. CL. 33.

R.J. RACE CARS, INC, GALESBURG, IL:
3,996,888, PUB. 5-3-2011. INT. CL. 40.

R.R. STREET & CO. INC., NAPERVILLE, IL:
2,461,481, REN. 6-16-11. INT. CL. 3.

RA BRANDS, L.L.C., MADISON, NC:
3,998,213, PUB. 5-3-2011. INT. CL. 13.
3,999,053, INT. CL. 13.
3,999,993, INT. CL. 2.

RABBONI, VITTORIO, ARGGIO EMILIA, ITALY:
2,900,986, CANC. MULTIPLE CLASS, INT. CLS. 6, 19 AND 30.

RABO VASTGOEDGROEP HOLDING N.V., NETHERLANDS:
3,995,882, PUB. 5-3-2011. MULTIPLE CLASS, INT. CLS. 16, 35, 36, 37, 42 AND 45.

RACHEL ARAM, SAN FRANCISCO, CA, DBA CARDIO-TONE:
3,998,188, PUB. 5-3-2011. INT. CL. 41.

RACING FOR KIDS, GROSSE POINTE FARMS, MI:
2,475,161, REN. 6-15-11. INT. CL. 36.

RADIATOREXPRESS.COM, INC, MANAHAWKIN, NJ:
3,997,029, PUB. 5-3-2011. INT. CL. 35.

RADICAL CONCEPT PRODUCTS, INC., HAWTHORNE, CA, DBA RETROTEK SPEED:
3,998,539, INT. CL. 7.

RADIO SYSTEMS CORPORATION, KNOXVILLE, TN:
2,902,397, CANC. MULTIPLE CLASS, INT. CLS. 35, 41 AND 44.

RADWARE LTD., TEL AVIV, ISRAEL:
3,998,273, PUB. 5-3-2011. INT. CL. 9.

RADWELL INTERNATIONAL, INC., LUMBERTON, NJ:
3,996,697, PUB. 5-3-2011. INT. CL. 37.

RAE SYSTEMS INC., SAN JOSE, CA:
3,999,573, INT. CL. 9.

RAFAEL, JOURAK, LOS ANGELES, CA:
3,997,602, PUB. 5-3-2011. INT. CL. 44.

RAGUS HOLDINGS, INC., WILMINGTON, DE, SAVANNAH SUGAR REFINING CORPORATION, SAVANNAH, GA:
729,535, REN. 6-14-11. U.S. CL. 46 (INT. CL. 30).

RAILEAN, KELLY, LEAGUE CITY, TX AND RAILEAN, MATTHEW, HOUSTON, TX:
3,997,291, PUB. 5-3-2011. INT. CL. 40.

RAIN HARVESTING PTY LTD, TOOWONG, QLD, AUSTRALIA:
2,497,541, REN. 6-15-11. INT. CL. 6.

RAINMAKER THINKING, INC., NEW HAVEN, CT:
2,402,233, CANC. MULTIPLE CLASS, INT. CLS. 9, 16, 35 AND 41.

RANBAXY LABORATORIES LIMITED, NEW DELHI, INDIA:
2,902,479, CANC. INT. CL. 5.

RANBAXY LABORATORIES LIMITED, NEW DELHI, DELHI, INDIA:
2,902,496, CANC. INT. CL. 5.

RANCO ANTONIO DI RANCO GIUSEPPE, ITALY:
3,995,736, PUB. 3-29-2011. INT. CL. 15.

RAND & PASEKA MFG. CO., INC., FREEPORT, NY:
3,996,869, PUB. 5-3-2011. INT. CL. 14.

- RANDOM HOUSE, INC., NEW YORK, NY AND PENK, INC., CHAPPAQUA, NY:
2,402,792, CANC. INT. CL. 21.
- RANDOM HOUSE, INC., NEW YORK, NY:
3,997,454, PUB. 5-3-2011. INT. CL. 41.
3,997,468, PUB. 5-3-2011. INT. CL. 9.
- RAQUALIA PHARMA INC., JAPAN:
3,996,019, PUB. 5-3-2011. MULTIPLE CLASS, INT. CLS. 5 AND 42.
- RATIONAL AG, FED REP GERMANY:
3,996,017, PUB. 5-3-2011. INT. CL. 11.
- RAUCH INDUSTRIES, INC., TARRYTOWN, NY:
3,998,510, INT. CL. 21.
- RAUCKMAN UTILITY PRODUCTS, L.L.C., SWANSEA, IL:
3,960,965, COR. INT. CL. 9.
- RAUMEDIC AG, FED REP GERMANY:
3,995,928, PUB. 5-3-2011. MULTIPLE CLASS, INT. CLS. 9 AND 10.
- RAVE MEDIA HOLDINGS, LLC, SUWANEE, GA:
2,901,322, CANC. INT. CL. 16.
- RAW JUNIOR, LLC, NEW YORK, NY:
3,999,996, INT. CL. 16.
- RAWLINS, NANETTE T, HAMILTON, OH:
3,998,125, PUB. 5-3-2011. INT. CL. 41.
- RAWLS, RICHARD D., FOREST, VA:
2,355,621, REN. 6-15-11, INT. CL. 1.
- RAY & MASCARI INC., INDIANAPOLIS, IN:
3,996,832, PUB. 5-3-2011. INT. CL. 31.
- RAY LEONE, ST. AUGUSTINE, FL, DBA THE LEONE RESOURCE GROUP:
3,997,232, PUB. 5-3-2011. INT. CL. 41.
- RAYMOND TOURNIER EURL, PARIS, FRANCE:
1,041,927, CANC. INT. CL. 33.
- RAYONIER TRS HOLDINGS INC., JACKSONVILLE, FL, RAYONIER INCORPORATED, NEW YORK, NY:
715,606, REN. 6-10-11, U.S. CL. 1 (INT. CL. 1).
- RCI TM CORP., LAS VEGAS, NV, GLEN IVY FINANCIAL GROUP, INC., CORONA, CA:
1,664,428, REN. 6-10-11, INT. CL. 39.
- RCN TELECOM SERVICES, LLC, HERNDON, VA:
2,471,719, REN. 6-15-11, INT. CL. 38.
- REACH OUT AND READ, INC., BOSTON, MA:
2,461,265, REN. 6-14-11, MULTIPLE CLASS, INT. CLS. 41 AND 42.
- REAL ESTATE INVESTORS INSTITUTE, BURBANK, CA:
3,999,937, U.S. CL. B.
- REAL PRO WRESTLING, INC., ASHLAND, TN:
2,902,465, CANC. MULTIPLE CLASS, INT. CLS. 9 AND 25.
- REAL STYLE NETWORK, INC., TORONTO, ONTARIO, CANADA:
3,995,671, PUB. 5-3-2011. MULTIPLE CLASS, INT. CLS. 35, 38 AND 41.
- REALLIGHTING, INC., MENTOR, OH:
3,997,830, PUB. 5-3-2011. INT. CL. 35.
- REALNETWORKS, INC., SEATTLE, WA:
2,401,574, CANC. INT. CL. 9.
- REARDON, BRIAN, SHERMAN OAKS, CA:
3,997,609, PUB. 5-3-2011. MULTIPLE CLASS, INT. CLS. 41 AND 45.
- REBAR GROUP, INC., SAN FRANCISCO, CA:
3,995,692, PUB. 5-3-2011. INT. CL. 20.
- REBEL SPRING GAMES, LLC, GRAND RAPIDS, MI:
3,999,387, INT. CL. 25.
- REBOOT PARTNERS LLC, SAG HARBOR, NY:
3,997,729, PUB. 5-3-2011. INT. CL. 45.
3,997,732, PUB. 5-3-2011. INT. CL. 45.
- RECKITT & COLMAN (OVERSEAS) LIMITED, HULL, UNITED KINGDOM:
3,995,723, PUB. 5-3-2011. MULTIPLE CLASS, INT. CLS. 3 AND 5.
3,999,145, INT. CL. 3.
- RECKITT BENCKISER LLC, PARSIPPANY, NJ, RECKITT BENCKISER, INC., WAYNE, NJ:
2,460,251, REN. 6-10-11, INT. CL. 5.
- RECKITT BENCKISER LLC, PARSIPPANY, NJ:
3,996,149, PUB. 5-3-2011. MULTIPLE CLASS, INT. CLS. 3 AND 5.
- RECKITT BENCKISER S.ÀR.L., LUXEMBOURG:
3,763,384, COR. MULTIPLE CLASS, INT. CLS. 1, 3, 5, 11, 35, 36 AND 41.
- RECKITT BENCKISER S.ÀR.L., G.D. DE LUXEMBOURG, LUXEMBOURG:
3,995,726, PUB. 5-3-2011. INT. CL. 3.
- RECORD PROMOCÃO DE EVENTOS E ENTRETENIMENTO LTDA., CERQ. CESAR, SAO PAULO, BRAZIL:
3,998,729, MULTIPLE CLASS, INT. CLS. 41 AND 42.
- RECORDING INDUSTRY ASSOCIATION OF AMERICA, INC., WASHINGTON, DC:
2,459,947, REN. 6-16-11, INT. CL. 41.
- RED BULL GMBH, FUSCHL AM SEE, AUSTRIA:
2,539,245, AM. INT. CL. 42.
3,999,201, INT. CL. 12.
3,999,209, MULTIPLE CLASS, INT. CLS. 9, 16, 25, 28 AND 41.
- RED COATS, INC., BETHESDA, MD:
3,997,563, PUB. 5-3-2011. INT. CL. 37.
3,997,736, PUB. 5-3-2011. INT. CL. 37.
- RED ISLAND INDUSTRIES, MERIDIAN, ID:
3,997,622, PUB. 5-3-2011. INT. CL. 33.
- RED MARIACHI FOOD COMPANY, S.A. DE C.V., MEXICO, D.F. 11590, MEXICO:
3,996,432, PUB. 5-3-2011. INT. CL. 30.
3,996,433, PUB. 5-3-2011. INT. CL. 30.
- RED ROCK VALLEY LIMITED, LAS VEGAS, NV:
3,999,431, INT. CL. 41.
3,999,432, INT. CL. 41.
- RED ROCKVALLEY LIMITED, LAS VEGAS, NV:
3,999,434, INT. CL. 41.
- RED SEA HOTELS LTD., TEL-AVIV 68012, ISRAEL:
2,401,910, CANC. INT. CL. 37.
- REDFOREST TV B.V., 1112 XH DIEMEN, NETHERLANDS:
2,901,000, CANC. MULTIPLE CLASS, INT. CLS. 9, 28 AND 41.
- REDGEAR TECHNOLOGIES, INC., KANSAS CITY, MO:
3,997,302, PUB. 5-3-2011. INT. CL. 9.
- REDHAWK WEALTH ADVISORS, INC, MINNEAPOLIS, MN:
3,997,222, PUB. 5-3-2011. INT. CL. 36.
- REDPIXIE LIMITED, UNITED KINGDOM:
3,995,868, PUB. 5-3-2011. MULTIPLE CLASS, INT. CLS. 9, 37 AND 42.
- REDPOINT GLOBAL INC., WELLESLEY HILLS, MA:
3,996,497, PUB. 5-3-2011. INT. CL. 42.
- REEBOK INTERNATIONAL LTD., CANTON, MA:
3,998,582, INT. CL. 28.
- REED & REED, INC., WOOLWICH, ME:
3,997,730, PUB. 5-3-2011. INT. CL. 37.
- REED ELSEVIER INC., NEWTON, MA AND THE VISION COUNCIL, ALEXANDRIA, VA:
3,999,988, INT. CL. 41.
- REEFDAL PTY LTD, BRAESIDE, VICTORIA, AUSTRALIA:
3,999,652, INT. CL. 7.
- REEL BIOGRAPHY, INC., NEW YORK, NY:
2,902,394, CANC. INT. CL. 41.
- REFRESH YOUR NEST, WASHINGTON, DC:
3,996,687, PUB. 5-3-2011. INT. CL. 42.
- REGHEHR, CLINT, FRISCO, TX:
3,999,820, INT. CL. 41.
- REGEN LAB SA, SWITZERLAND:
3,995,805, PUB. 1-25-2011. INT. CL. 10.
- RENOVATE ENDOGEN INC., WATERLOO, ONTARIO, CANADA:
3,995,571, PUB. 5-3-2011. INT. CL. 5.
3,995,572, PUB. 5-3-2011. INT. CL. 5.
- REICHER, SHERRATT, ALAMO, CA:
3,999,321, INT. CL. 33.
- REIMER BONNIE J, SOUTH HAVEN, MI:
3,998,767, INT. CL. 21.
- REINHART GLOBAL BRANDS, LLC, PORTLAND, OR:
3,999,166, INT. CL. 25.
- REINKE SPORTS GROUP LLC, WINTER PARK, FL:
3,999,953, INT. CL. 41.
- REJUVENAGE, INC., PORTAGE, MI:
2,841,272, COR. INT. CL. 5.

REKO INTERNATIONAL GROUP, INC., BLOOMFIELD HILLS, MI:
3,997,666, PUB. 5-3-2011. INT. CL. 40.

RELEVANT ADS, INC., FOUNTAIN VALLEY, CA:
3,996,310, PUB. 5-3-2011. INT. CL. 35.

RELIABLE POWER ALTERNATIVES CORPORATION, GARDEN CITY, NY:
3,996,120, PUB. 5-3-2011. INT. CL. 35.
3,996,121, PUB. 5-3-2011. INT. CL. 35.
3,996,122, PUB. 5-3-2011. INT. CL. 35.

RELIANT ENERGY RETAIL HOLDINGS, LLC, HOUSTON, TX:
3,996,141, PUB. 5-3-2011. MULTIPLE CLASS, INT. CLS. 35 AND 41.

REMCOV, LLC, OREM, UT:
2,901,412, CANC. INT. CL. 14.

REMY INC., PENDLETON, IN:
2,449,849, REN. 6-15-11. INT. CL. 9.

RENAULT-SAMSUNG MOTORS CO., LTD., BUSAN, REPUBLIC OF KOREA:
3,995,899, PUB. 5-3-2011. MULTIPLE CLASS, INT. CLS. 12 AND 37.

RENOLIT AG, FED REP GERMANY:
3,995,918, PUB. 5-3-2011. MULTIPLE CLASS, INT. CLS. 17, 19 AND 20.

RENZI COMPANY, L.L.C., SANTA ANA, CA:
2,401,476, CANC. INT. CL. 25.

REPOWER SYSTEMS AG, FED REP GERMANY:
3,995,734, PUB. 5-3-2011. MULTIPLE CLASS, INT. CLS. 6, 7, 9, 35, 37, 38 AND 42.

REPP, THOMAS ARTHUR, MT. CLEMENS, MI:
2,463,863, REN. 6-14-11. INT. CL. 41.

REQUEST FOODS, INC., HOLLAND, MI:
3,995,713, PUB. 1-25-2011. INT. CL. 30.

RESEARCH IN MOTION LIMITED, WATERLOO, ONTARIO N2L 3W8, CANADA:
2,402,727, CANC. INT. CL. 9.

RESEARCH IN MOTION LIMITED, WATERLOO ONTARIO N2L 3W8, CANADA:
2,402,728, CANC. INT. CL. 38.

RESEARCH IN MOTION LIMITED, WATERLOO, ONTARIO N2L 3W8, CANADA:
2,402,763, CANC. INT. CL. 38.

RESEARCH PUBLISHERS LLC, MADISON, WI:
3,998,037, PUB. 5-3-2011. INT. CL. 41.

RESIDENTIAL FINANCE CORPORATION, COLUMBUS, OH:
3,998,199, PUB. 5-3-2011. INT. CL. 36.

RESIDENTIAL PROPERTY MANAGEMENT, INC., SANTA FE, NM:
3,997,118, PUB. 5-3-2011. INT. CL. 36.

RESORT RENTAL, LLC, PARSIPPANY, NJ:
3,996,527, PUB. 5-3-2011. INT. CL. 43.

RESTAURANT TECHNOLOGIES, INC., MENDOTA HEIGHTS, MN:
3,997,753, PUB. 5-3-2011. INT. CL. 42.
3,997,757, PUB. 5-3-2011. INT. CL. 37.
3,997,758, PUB. 5-3-2011. INT. CL. 42.
3,997,759, PUB. 5-3-2011. INT. CL. 37.
3,997,761, PUB. 5-3-2011. INT. CL. 42.
3,997,763, PUB. 5-3-2011. INT. CL. 37.

RESTAURANTES RICLER, S.A., LAKE BUENA VISTA,, FL:
1,662,030, REN. 6-10-11. INT. CL. 42.

RESTORZ LLC, WESTLAKE, OH:
3,996,153, PUB. 5-3-2011. MULTIPLE CLASS, INT. CLS. 37 AND 40.

RETAIL BRAND ALLIANCE, INC., ENFIELD, CT:
3,998,447, INT. CL. 3.

RETAIL ROYALTY COMPANY, LAS VEGAS, NV:
3,997,372, PUB. 5-3-2011. INT. CL. 25.
3,999,162, INT. CL. 25.
3,999,176, MULTIPLE CLASS, INT. CLS. 25 AND 35.

REVENUE SOLUTIONS, INC., PEMBROKE, MA:
2,537,861, REN. 6-14-11. INT. CL. 9.

REXITER CAPITAL MANAGEMENT LIMITED, LONDON SW1Y 4SS, UNITED KINGDOM TO REXITER CAPITAL MANAGEMENT LIMITED, LONDON SW1Y 4SS, UNITED KINGDOM:
2,402,879, CANC. INT. CL. 36.

REYNOLDS INNOVATIONS INC., WINSTON-SALEM, NC:
2,902,022, CANC. INT. CL. 34.

REYNOLDS PACKAGING LLC, RICHMOND, VA:
2,402,623, CANC. INT. CL. 21.

RG DELAWARE, INC., WILMINGTON, DE:
2,901,306, CANC. INT. CL. 11.

RHEAULT, PEGGY, RANCHO CORDOVA, CA:
3,997,964, PUB. 5-3-2011. INT. CL. 25.

RHINO LININGS CORPORATION, SAN DIEGO, CA:
3,996,193, PUB. 5-3-2011. INT. CL. 2.

RHOADES, DEAN L., BEVERLY HILLS, CA:
2,902,003, CANC. INT. CL. 10.

RHODIA OPERATIONS, FRANCE:
3,995,876, PUB. 5-3-2011. MULTIPLE CLASS, INT. CLS. 9, 35 AND 42.

RIBS KING, INC., CINCINNATI, OH:
1,648,424, REN. 6-16-11. INT. CL. 42.

RICARDO ALVAREZ, CHULA VISTA, CA:
3,997,571, PUB. 5-3-2011. INT. CL. 40.

RICE ENTERTAINMENT, INC., SAN DIEGO, CA:
3,999,533, INT. CL. 25.

RICH COAST CORPORATION, LEWISTOWN, PA:
2,902,425, CANC. MULTIPLE CLASS, INT. CLS. 29, 30, 35 AND 43.

RICHARD A. WALKER, ALPHARETTA, GA:
3,999,936, INT. CL. 35.

RICHARD E. BADWEY, ALEXANDRIA, VA:
3,997,979, PUB. 5-3-2011. INT. CL. 40.

RICHARD JAMES WILLIAMS, SOUTHFIELD, MI:
3,997,676, PUB. 5-3-2011. INT. CL. 25.

RICHARD KEENAN & COMPANY LIMITED, COUNTY CARLOW, IRELAND:
3,996,034, PUB. 3-8-2011. INT. CL. 44.

RICHARD WOLF GMBH, 75438 KNITTLINGEN, FED REP GERMANY:
3,995,919, PUB. 5-3-2011. INT. CL. 10.

RICHMEG INDUSTRY CO., LTD., PEI TUN DIST. TAI-CHUNG, TAIWAN:
3,996,533, PUB. 5-3-2011. INT. CL. 9.

RICK FEDERMAN, LOS ANGELES, CA:
3,997,592, PUB. 5-3-2011. MULTIPLE CLASS, INT. CLS. 18 AND 25.
3,997,600, PUB. 5-3-2011. INT. CL. 16.

RICKY ROOTER, BOYSTOWN, NE:
3,996,557, PUB. 5-3-2011. INT. CL. 37.

RICOROCK, INC., ORLANDO, CA:
2,453,922, REN. 6-16-11. INT. CL. 19.

RIDE CONTROL, LLC, TROY, MI:
2,459,773, REN. 6-14-11. INT. CL. 12.

RIEDEL SHOES, INC., RED WING, MN:
3,999,866, INT. CL. 28.

RING CO., LTD., BANGKOK 10240, THAILAND:
3,997,438, PUB. 5-3-2011. MULTIPLE CLASS, INT. CLS. 16, 18 AND 25.

RIO GRANDE RADIOLOGICAL PHYSICS GROUP, LLC, ALBUQUERQUE, NM:
2,401,886, CANC. INT. CL. 42.

RIPBOARD LIMITED, UNITED KINGDOM:
3,995,945, PUB. 5-3-2011. INT. CL. 25.

RIPCORD TECHNOLOGIES, INC., DILLON, MT:
3,997,045, PUB. 5-3-2011. INT. CL. 28.

RIVALHEALTH, LLC, RALEIGH, NC:
3,999,093, MULTIPLE CLASS, INT. CLS. 9, 16 AND 41.

RIVEER COMPANY, SOUTH HAVEN, MI:
2,324,174, CANC. INT. CL. 7.

RIZOPOULOS, NATASHA, BOSTON, MA:
3,997,612, PUB. 5-3-2011. INT. CL. 41.

RJA GROUP, INC., THE, CHICAGO, IL:
2,464,632, REN. 6-15-11. INT. CL. 9.

RMEL, CENTENNIAL, CO:
3,996,711, PUB. 5-3-2011. MULTIPLE CLASS, INT. CLS. 9 AND 16.

- RMK DIVERSIFIED, LLC, CHANDLER, AZ:
3,997,870, PUB. 5-3-2011. INT. CL. 5.
- RMP CAPITAL CORP, ISLANDIA, NY:
3,997,099, PUB. 5-3-2011. MULTIPLE CLASS, INT. CLS. 35 AND 36.
3,997,101, PUB. 5-3-2011. MULTIPLE CLASS, INT. CLS. 35 AND 36.
3,997,103, PUB. 5-3-2011. MULTIPLE CLASS, INT. CLS. 35 AND 36.
- ROADRUNNER APPAREL INC., LACHINE, CANADA:
3,999,905, INT. CL. 25.
- ROB ASSELIN, E. GREENWICH, RI:
3,998,860, MULTIPLE CLASS, INT. CLS. 18, 25, 28 AND 35.
- ROBERN INC., BRISTOL, PA:
3,998,143, PUB. 5-3-2011. INT. CL. 17.
- ROBERT BOSCH LLC, BROADVIEW, IL:
2,902,345, CANC. INT. CL. 9.
- ROBERT L. O'BLOCK REVOCABLE TRUST, SPRINGFIELD, MO:
3,996,243, PUB. 5-3-2011. INT. CL. 42.
- ROBERT STELLA DDS, INC., LONG BEACH, CA, AKA DR. STELLA'S CHILDREN'S DENTISTRY:
3,999,500, INT. CL. 44.
- ROBERT VAN SECURITIES, INC., OAKLAND, CA:
2,902,190, CANC. INT. CL. 36.
- ROBERT YOUNG ESTATE WINERY, LLC, GEYSERVILLE, CA:
2,562,186, REN. 6-14-11. INT. CL. 33.
- ROBERTO COIN, INC., NEW YORK, NY:
3,998,679, INT. CL. 14.
- ROBERTO TREVINO AMADOR, SAN ANTONIO, TX:
3,996,834, PUB. 5-3-2011. MULTIPLE CLASS, INT. CLS. 14, 16 AND 20.
- ROBERTS & SONS, SANTA ROSA, CA:
3,997,893, PUB. 5-3-2011. INT. CL. 20.
- ROBERTS, DENNIS, MAMARONECK, NY:
3,997,652, PUB. 5-3-2011. INT. CL. 35.
- ROBINSON, PATRICIA, MORGAN HILL, CA:
2,902,371, CANC. INT. CL. 35.
- ROBOT RETAIL LLC, BOSTON, MA:
3,999,653, MULTIPLE CLASS, INT. CLS. 9 AND 25.
- ROBYN SUE GOLDMAN, SAN FRANCISCO, CA:
3,998,592, MULTIPLE CLASS, INT. CLS. 30 AND 35.
- ROCHE DIAGNOSTICS GMBH, 68305 MANNHEIM, FED REP GERMANY:
3,996,875, PUB. 5-3-2011. MULTIPLE CLASS, INT. CLS. 1 AND 5.
- ROCHESTER DAVIS, 80798 MUENCHEN, FED REP GERMANY:
3,998,514, MULTIPLE CLASS, INT. CLS. 25 AND 35.
- ROCK AND ROLL RELIGION, INC., LOS ANGELES, CA:
3,998,553, INT. CL. 25.
- ROCKBROOK HOLDINGS LTD., TORTOLA, BR. VIRGIN ISLANDS:
3,999,380, INT. CL. 25.
3,999,381, INT. CL. 25.
- ROCKET FUEL INC., REDWOOD SHORES, CA:
3,997,440, PUB. 5-3-2011. INT. CL. 35.
- ROCKET GAMING SYSTEMS, LLC, GROVE, OK:
3,999,570, INT. CL. 9.
3,999,644, INT. CL. 9.
- ROCKWELL, JUSTIN H., LONGS, SC:
3,998,052, PUB. 5-3-2011. INT. CL. 9.
- ROCKY MOUNTAIN HEALTH MAINTENANCE ORGANIZATION, INCORPORATED, GRAND JUNCTION, CO:
3,997,735, PUB. 5-3-2011. INT. CL. 36.
- ROCKYMOUNTS, INC., BOULDER, CO:
3,997,231, PUB. 5-3-2011. INT. CL. 12.
- RODALE INC., EMMAUS, PA:
3,998,680, INT. CL. 28.
- RODRIGUEZ, TYMOTHI, STOCKTON, CA:
3,997,247, PUB. 5-3-2011. INT. CL. 9.
- ROESCH, DEBRA M., PENDLETON, OR:
3,999,004, INT. CL. 32.
- ROI ENTERTAINMENT, INC., HOUSTON, TX:
2,403,140, REN. 6-15-11. MULTIPLE CLASS, INT. CLS. 41 AND 42.
- ROLIC INVEST SARL, LUXEMBOURG DISTRICT, LUXEMBOURG:
2,901,026, CANC. INT. CL. 16.
- ROLLING BLUNTS, INC., MIAMI, FL:
2,401,410, CANC. INT. CL. 25.
- ROLLS-ROYCE PLC, LONDON, SWIE 6AT, ENGLAND:
3,995,473, PUB. 5-3-2011. MULTIPLE CLASS, INT. CLS. 35, 37, 41 AND 43.
- ROMANE FRANCES, LLC, ELMHURST, IL:
914,253, REN. 6-11-11. U.S. CL. 51 (INT. CL. 3).
- ROMANO, MICHAEL, HOLLYWOOD, FL:
2,901,756, CANC. INT. CL. 38.
- ROMERO, LAURA, MIAMI, FL:
3,998,797, INT. CL. 4.
- RON-TECH MEDICAL LTD., KFAR SABA, 44641, ISRAEL:
2,901,941, CANC. INT. CL. 10.
- ROOMS & GARDENS, INC., WASHINGTON, DC:
2,900,955, CANC. INT. CL. 35.
- ROSEBOOM, JOHN E., DAYTONA BEACH, FL, DBA THE SHIRT SHACK:
903,914, REN. 6-14-11. U.S. CL. 39 (INT. CL. 25).
- ROSEDALE THERAPEUTICS, LLC, BRISTOL, TN:
1,650,536, REN. 6-16-11. INT. CL. 3.
- ROSENBERG MANAGEMENT CORP, NEW YORK, NY:
3,999,303, INT. CL. 41.
- ROSENBERG, JUDY, SHERMAN OAKS, CA:
3,997,844, PUB. 5-3-2011. INT. CL. 44.
- ROSS HEMINGWAY, KINGSTON, CANADA:
3,997,549, PUB. 5-3-2011. INT. CL. 9.
3,997,550, PUB. 5-3-2011. INT. CL. 9.
- ROSY BLUE INC., NEW YORK, NY:
3,998,401, INT. CL. 14.
3,998,403, INT. CL. 14.
- ROTARY INTERNATIONAL, EVANSTON, IL:
2,495,976, REN. 6-16-11. INT. CL. 16.
- ROTHSTEIN, MARK S., EL SEGUNDO, CA:
3,997,623, PUB. 5-3-2011. INT. CL. 41.
- ROTTEFELLA AS, 3490 KLOKKARSTUA, NORWAY:
2,414,488, REN. 6-10-11. INT. CL. 28.
- ROY S. GORDET, DALY CITY, CA:
3,997,266, PUB. 5-3-2011. INT. CL. 45.
- ROYAL ANIMALS LTD., NEW YORK, NY:
3,997,075, PUB. 5-3-2011. MULTIPLE CLASS, INT. CLS. 18, 20 AND 28.
- ROYAL BANK OF CANADA, MONTREAL, QUEBEC, CANADA:
3,996,481, PUB. 5-3-2011. INT. CL. 36.
- ROYAL ICE CREAM COMPANY, CLEVELAND, OH:
2,902,230, CANC. INT. CL. 30.
- ROZENE DEVELOPMENT INTERNATIONAL, LLC, OMAHA, NE:
3,998,891, MULTIPLE CLASS, INT. CLS. 35 AND 44.
- RPM INTERNATIONAL INC., MEDINA, OH:
3,998,144, PUB. 5-3-2011. MULTIPLE CLASS, INT. CLS. 9 AND 16.
- RR INVESTMENTS, INC., DALLAS, TX:
3,997,493, PUB. 5-3-2011. MULTIPLE CLASS, INT. CLS. 37 AND 39.
- RSL LOGISTIK GMBH & CO. KG, FED REP GERMANY:
3,995,735, PUB. 5-3-2011. MULTIPLE CLASS, INT. CLS. 6, 7, 9, 12, 16, 35, 36, 37, 39, 41, 42 AND 45.
- RUBICON HOLDINGS, LLC, PETERSBURG, VA, DBA WHEREITSCHAT.COM:
3,998,121, PUB. 5-3-2011. INT. CL. 38.
- RUDE AWAKENING, INC., FAYETTEVILLE, NC, DBA RUDE AWAKENING COFFEE HOUSE:
2,567,514, REN. 6-16-11. INT. CL. 42.
- RUDER FINN, INC., NEW YORK, NY:
2,474,196, REN. 6-15-11. INT. CL. 35.
- RUFF WEAR, INC., BEND, OR:
3,997,807, PUB. 5-3-2011. INT. CL. 25.
- RUFFIN' WRANGLERS LLC, PROVIDENCE, RI:
3,997,765, PUB. 5-3-2011. INT. CL. 44.
- RUN WITH THE KENYANS, LLC, WORCESTER, MA:
3,996,806, PUB. 5-3-2011. INT. CL. 35.
- RUSH ASSOCIATED LABELS, INC., NEW YORK, NY:
2,463,038, REN. 6-14-11. INT. CL. 9.
2,463,039, REN. 6-14-11. INT. CL. 9.

- RUSS DAVIS WHOLESALE, INC., WADENA, MN:
3,997,737, PUB. 5-3-2011. INT. CL. 31.
- RUSSIAN ALUMINIUM MANAGEMENT, ANADIR CITY,
OTKE STREET, 61, RUSSIAN FED.:
2,839,544, CANC. MULTIPLE CLASS, INT. CLS. 7, 12, 17
AND 21.
2,839,545, CANC. MULTIPLE CLASS, INT. CLS. 7, 12, 17
AND 21.
- RUTGERS, THE STATE UNIVERSITY OF NEW JERSEY,
NEW BRUNSWICK, NJ:
3,998,360, INT. CL. 21.
- RUTH A. MCCARTY, SAN CLEMENTE, CA, DBA TCM
BIOTHERAPEUTICS, LLC:
3,996,793, PUB. 5-3-2011. INT. CL. 5.
- RUTHERFORD CONTROLS INT'L CORP., VIRGINIA
BEACH, VA, RUTHERFORD CONTROLS INT'L CORP.,
VIRGINIA BEACH, VA:
2,530,243. REN. 6-14-11. MULTIPLE CLASS, INT. CLS. 9
AND 42.
- RYAN & RACHEL, INC., VANCOUVER, BRITISH COLUM-
BIA, CANADA:
2,402,762, CANC. INT. CL. 42.
- RYAN, BECK & CO., LIVINGSTON, NJ:
2,902,040, CANC. INT. CL. 36.
- RYAN, TERESA LEYUNG, KENSINGTON, CA:
2,901,976, CANC. INT. CL. 16.
- RYAN'S WELL FOUNDATION, KEMPTVILLE, ONTARIO,
CANADA:
3,996,513, PUB. 5-3-2011. MULTIPLE CLASS, INT. CLS.
36, 41 AND 43.
- RYCA MOTORS, WHITTIER, CA:
3,997,131, PUB. 5-3-2011. INT. CL. 12.
- S & D PRODUCTS, INC., BARTLETT, IL:
3,997,598, PUB. 5-3-2011. MULTIPLE CLASS, INT. CLS. 6
AND 35.
- S & S INNOVATIONS, INC., WEST DES MOINES, IA:
2,901,579, CANC. INT. CL. 28.
- S. C. JOHNSON & SON, INC., RACINE, WI:
2,901,839, CANC. INT. CL. 3.
2,901,840, CANC. INT. CL. 3.
3,999,177, INT. CL. 5.
- S. J. ELECTRO SYSTEMS, INC., DETROIT LAKES, MN:
3,998,667, INT. CL. 9.
- S.O.I.TEC SILICON ON INSULATOR TECHNOLOGIES,
38190 BERNIN, FRANCE:
2,401,406, CANC. INT. CL. 9.
- S.P.C.M. SA, ANDREZIEUX-BOUTHEON, FRANCE:
2,460,859. REN. 6-15-11. INT. CL. 1.
2,465,599. REN. 6-15-11. INT. CL. 1.
- SA STUDIOS, LLC, LOS ANGELES, CA:
3,999,506, INT. CL. 9.
- SAAB AUTOMOBILE AB, SWEDEN:
3,996,002, PUB. 5-3-2011. INT. CL. 12.
- SABIC INNOVATIVE PLASTICS IP B.V., BERGEN OP
ZOOM, NETHERLANDS:
2,902,276, CANC. INT. CL. 35.
- SACKLER, J.T., NEW YORK, NY:
3,998,301, MULTIPLE CLASS, INT. CLS. 16 AND 41.
- SADDLE CREEK COPAK SERVICES, INC., LAKELAND, FL:
2,401,556, CANC. INT. CL. 39.
- SAFARILAND, LLC, JACKSONVILLE, FL:
3,995,719, PUB. 5-3-2011. MULTIPLE CLASS, INT. CLS. 3,
4, 6, 8, 9, 13, 18, 20 AND 25.
- SAFE HORIZON, INC., NEW YORK, NY TO SAFE HOR-
IZON, INC., NEW YORK, NY:
2,505,512, AM. MULTIPLE CLASS, INT. CLS. 41 AND 45.
- SAFE-GUARD PRODUCTS INTERNATIONAL, LLC,
ATLANTA, GA:
3,996,246, PUB. 11-2-2010. INT. CL. 35.
3,996,247, PUB. 11-2-2010. INT. CL. 36.
- SAFED SUISSE SA, SWITZERLAND:
3,995,859, PUB. 5-3-2011. INT. CL. 11.
- SAFEGUARD INDUSTRIAL SUPPLY, LLC, THOROFARE,
NJ:
3,998,781, INT. CL. 25.
- SAFeway SAFETY STEP, LLC, FAIRFIELD, OH:
3,997,751, PUB. 5-3-2011. MULTIPLE CLASS, INT. CLS. 11
AND 37.
- SAFEWORKS, LLC, TUKWILA, WA:
3,998,200, PUB. 5-3-2011. INT. CL. 7.
- SAFILO USA, INC., PARSIPPANY, NJ:
3,999,335, INT. CL. 9.
3,999,336, INT. CL. 9.
3,999,337, INT. CL. 9.
- SAGE CREEK DEVELOPMENT, L.L.C., YAKIMA, WA:
3,995,686, PUB. 5-3-2011. INT. CL. 37.
- SAGE SOFTWARE, INC., IRVINE, CA:
2,901,696, CANC. INT. CL. 9.
- SAGE WEDDING PROS, CORAL GABLES, FL:
3,997,238, PUB. 5-3-2011. MULTIPLE CLASS, INT. CLS. 35
AND 41.
- SAIC, SAN DIEGO, CA:
2,401,194, CANC. INT. CL. 9.
- SAIL IN SAN DIEGO, SAN DIEGO, CA:
3,996,337, PUB. 5-3-2011. INT. CL. 39.
- SAINE, STEPHEN, SAN FRANCISCO, CA:
3,999,003, INT. CL. 25.
- SAINT LOUIS UNIVERSITY, ST. LOUIS, MO:
3,998,169, PUB. 5-3-2011. INT. CL. 14.
3,998,171, PUB. 5-3-2011. INT. CL. 9.
3,998,172, PUB. 5-3-2011. INT. CL. 16.
3,998,173, PUB. 5-3-2011. INT. CL. 24.
3,998,268, PUB. 5-3-2011. INT. CL. 25.
- SAINT-GOBAIN PERFORMANCE PLASTICS CORPORA-
TION, AURORA, OH:
3,998,026, PUB. 5-3-2011. INT. CL. 17.
3,999,289, INT. CL. 19.
- SAKS & COMPANY, NEW YORK, NY:
3,997,431, PUB. 5-3-2011. INT. CL. 35.
- SAL MANZO'S PLUMBING & HEATING, INC., WANTAGH,
NY:
3,997,090, PUB. 5-3-2011. INT. CL. 37.
- SALES PERFORMANCE HOLDING COMPANY, CHAR-
LOTTE, NC:
1,647,233. REN. 6-12-11. MULTIPLE CLASS, INT. CLS. 16
AND 41.
- SALES USA INC, LONGVIEW, TX:
3,995,684, PUB. 5-3-2011. INT. CL. 32.
- SALICE PAOLO SRL, CANTU' (CO), ITALY:
3,995,589, PUB. 2-1-2011. MULTIPLE CLASS, INT. CLS. 6,
20 AND 21.
- SALLIE MAE, INC, RESTON, VA:
2,458,803. REN. 6-16-11. INT. CL. 36.
- SALLY ULLMAN, EMMAUS, PA:
3,999,760, INT. CL. 41.
- SALON COMMODITIES, INC., MELROSE PARK, IL:
3,999,352, INT. CL. 3.
- SALON VISAGE, INC., KNOXVILLE, TN:
2,485,061. REN. 6-16-11. INT. CL. 42.
- SALTED SOUL COMPANY, LLC, BOCA RATON, FL:
3,998,771, INT. CL. 16.
- SALTMAN, STEVEN, SOMERVILLE, MA AND PICKER,
CHRISTIAN, SOMERVILLE, MA:
3,997,677, PUB. 5-3-2011. MULTIPLE CLASS, INT. CLS. 9
AND 16.
- SAM SCHMIDT FOUNDATION, PRINCETON, NJ, DBA
SAM SCHMIDT PARALYSIS FOUNDATION:
3,997,513, PUB. 5-3-2011. INT. CL. 36.
- SAMBAZON, INC., SAN CLEMENTE, CA:
3,999,574, INT. CL. 32.
- SAME DAY TRANSLATIONS, PLEASANT GROVE, UT:
3,996,671, PUB. 5-3-2011. INT. CL. 41.
- SAMSON INVESTMENTS, LLC, LAKE CITY, FL:
3,997,005, PUB. 5-3-2011. INT. CL. 42.
- SAMSUNG AMERICA, INC., RIDGEFIELD PARK, NJ:
2,402,926, CANC. INT. CL. 10.
- SAMSUNG ELECTRONICS CO., LTD., GYEONGGI-DO,
REPUBLIC OF KOREA:
2,901,089, CANC. INT. CL. 9.
- SAMSUNG ELECTRONICS CO., LTD., SUWON-SI,
GYEONGGI-DO, REPUBLIC OF KOREA:
3,999,350, INT. CL. 9.
- SAN JOAQUIN FIGS, INC., FRESNO, CA:
2,401,656, CANC. INT. CL. 5.

- SAN MATEO COUNTY COMMUNITY COLLEGE DISTRICT, SAN MATEO, CA:
3,997,991, PUB. 5-3-2011. INT. CL. 41.
- SAN-J INTERNATIONAL, INC., RICHMOND, VA:
3,998,182, PUB. 5-3-2011. INT. CL. 29.
3,998,183, PUB. 5-3-2011. INT. CL. 29.
- SANASWEET GMBH, CH-8700 KÜSNACHT, SWITZERLAND:
3,995,842, PUB. 5-3-2011. MULTIPLE CLASS, INT. CLS. 1, 5, 30, 31 AND 35.
- SANCHEZ, MICHAEL E., RIO RANCHO, NM:
2,542,512. REN. 6-15-11. INT. CL. 41.
- SANCTIFIED REAL ESTATE, SAN JOSE, CA:
3,997,786, PUB. 5-3-2011. INT. CL. 36.
- SANDLER, SHELLEY, NEW YORK, NY, DBA DOGGINI:
3,999,681, INT. CL. 18.
- SANFORD GMBH, 22525 HAMBURG, FED REP GERMANY:
2,901,991, CANC. INT. CL. 16.
- SANFORD, L.P., OAK BROOK, IL:
3,998,646, INT. CL. 16.
- SANOFI-AVENTIS, PARIS, FRANCE:
3,866,012, COR. MULTIPLE CLASS, INT. CLS. 9, 16 AND 41.
3,996,664, PUB. 5-3-2011. INT. CL. 5.
3,996,665, PUB. 5-3-2011. INT. CL. 5.
3,996,666, PUB. 5-3-2011. INT. CL. 5.
- SANOFI-AVENTIS, 75013 PARIS, FRANCE:
3,996,715, PUB. 5-3-2011. MULTIPLE CLASS, INT. CLS. 9 AND 10.
- SANSET GIDA TURIZM SANAYI VE TICARET ANONIM SIRKETI, TURKEY:
3,995,880, PUB. 5-3-2011. MULTIPLE CLASS, INT. CLS. 29 AND 30.
- SANTA FE PROPERTIES, INC., SANTA FE, NM:
2,463,589. REN. 6-15-11. INT. CL. 16.
- SAPA EXTRUSIONS, INC., MOON TOWNSHIP, PA:
2,402,349, CANC. INT. CL. 6.
- SAPONA MANUFACTURING COMPANY, INC., CEDAR FALLS, NC:
3,995,693, PUB. 5-3-2011. INT. CL. 23.
- SARASOTA CONVENTION AND VISITORS BUREAU, INC., SARASOTA, FL:
3,997,479, PUB. 5-3-2011. INT. CL. 35.
- SARATOGA PERFORMING ARTS CENTER, INC., SARATOGA SPRINGS, NY:
2,555,221. REN. 6-14-11. INT. CL. 41.
- SARBER GARDNER INCORPORATED, LUTZ, FL:
3,997,770, PUB. 5-3-2011. INT. CL. 35.
- SARTA, RICHARD, LAKE WORTH, FL:
3,996,659, PUB. 5-3-2011. INT. CL. 5.
- SASOL GERMANY GMBH, D-22297 HAMBURG, FED REP GERMANY, HULS AKTIENGESELLSCHAFT, D-4370 MARL 1, FED REP GERMANY:
1,647,135. REN. 6-15-11. INT. CL. 1.
- SASSY SHOES, LLC, PENSACOLA, FL:
3,997,233, PUB. 5-3-2011. INT. CL. 25.
- SATORIUS AG, GOETTINGEN, FED REP GERMANY:
3,996,692, PUB. 5-3-2011. INT. CL. 9.
- SAUCE INDUSTRIES, LLC, LOUISVILLE, CO, DBA GRAY V:
3,996,413, PUB. 5-3-2011. INT. CL. 41.
3,996,414, PUB. 5-3-2011. INT. CL. 41.
- SAV-MOR FRANCHISING INC., NOVI, MI:
2,567,831. REN. 6-14-11. INT. CL. 35.
- SAVA, DRUZBA ZA UPRAVLJANJE IN FINANCIRANJE, D.D., KRANJ, SLOVENIA:
2,472,603. REN. 6-14-11. MULTIPLE CLASS, INT. CLS. 12, 16 AND 17.
2,472,603, CANC. MULTIPLE CLASS, INT. CLS. 1, 7, 10, 18 AND 19.
- SAVE-A-LOT FOOD STORES, INC., EARTH CITY, MO:
2,902,270, CANC. INT. CL. 30.
- SAVING PROMISE INC., WASHINGTON, DC:
3,997,973, PUB. 5-3-2011. INT. CL. 35.
- SAVITT, ROBIN, LAGUNA BEACH, CA:
3,997,671, PUB. 5-3-2011. INT. CL. 25.
- SBI MANAGEMENT GMBH, AUSTRIA:
3,995,977, PUB. 5-3-2011. MULTIPLE CLASS, INT. CLS. 35, 41 AND 42.
- SBT NEWCO, INC., NEW YORK, NY:
2,901,128, CANC. INT. CL. 10.
- SCA TISSUE NORTH AMERICA LLC, NEENAH, WI:
3,998,559, INT. CL. 21.
- SCANDINAVIAN INTERNET GROUP AB, SE-102 64 STOCKHOLM, SWEDEN:
3,996,087, PUB. 5-3-2011. MULTIPLE CLASS, INT. CLS. 35, 38 AND 41.
- SCANTRON CORPORATION, EAGAN, MN:
3,996,667, PUB. 5-3-2011. INT. CL. 38.
- SCAN3D, GLENDALE, CA:
3,996,877, PUB. 5-3-2011. INT. CL. 9.
- SCENTSATIONAL PILLOWS, INC., MORAGA, CA:
3,999,396, INT. CL. 20.
- SCENTSY, INC., MERIDIAN, ID:
3,996,893, PUB. 5-3-2011. INT. CL. 28.
3,996,894, PUB. 5-3-2011. INT. CL. 28.
3,996,895, PUB. 5-3-2011. INT. CL. 28.
3,996,896, PUB. 5-3-2011. INT. CL. 28.
3,996,897, PUB. 5-3-2011. INT. CL. 28.
3,996,898, PUB. 5-3-2011. INT. CL. 28.
- SCF SECURITIES, INC., FRESNO, CA:
3,996,814, PUB. 5-3-2011. INT. CL. 36.
- SCHAEFER VENTILATION EQUIPMENT, LLC, SAUK RAPIDS, MN:
3,999,835, INT. CL. 11.
- SCHAEFFER MFG. CO., ST. LOUIS, MO:
3,997,362, PUB. 5-3-2011. INT. CL. 1.
- SCHARF, MARK L, DAYTONA BEACH, FL:
2,901,668, CANC. MULTIPLE CLASS, INT. CLS. 25 AND 28.
- SCHE INC., LA MESA, CA:
2,901,543, CANC. INT. CL. 16.
- SCHERING CORPORATION, KENILWORTH, NJ:
3,998,468, INT. CL. 5.
3,998,469, INT. CL. 5.
- SCHERING-PLOUGH HEALTHCARE PRODUCTS, INC., MEMPHIS, TN:
2,402,929, CANC. INT. CL. 25.
- SCHINDLER, CASSIE W., SAN MATEO, CA, DBA THE ALTERNATE PATH:
3,996,321, PUB. 5-3-2011. INT. CL. 44.
- SCHLEICH GMBH, FED REP GERMANY:
3,995,762, PUB. 5-3-2011. MULTIPLE CLASS, INT. CLS. 16, 28 AND 41.
- SCHMIDT & STACY CONSULTING ENGINEERS, INC., DALLAS, TX:
3,996,774, PUB. 5-3-2011. INT. CL. 42.
- SCHNEIDER ELECTRIC INDUSTRIES SA, RUEIL MALMAISON, FRANCE:
2,901,481, CANC. INT. CL. 9.
- SCHOCK GMBH, FED REP GERMANY:
3,995,784, PUB. 5-3-2011. MULTIPLE CLASS, INT. CLS. 1, 11, 19, 20 AND 27.
- SCHOENBECK, DEBRA, WALWORTH, WI:
3,996,226, PUB. 5-3-2011. INT. CL. 30.
- SCHOLASTIC INC., NEW YORK, NY:
2,901,433, CANC. INT. CL. 16.
3,998,136, PUB. 5-3-2011. INT. CL. 41.
3,998,245, PUB. 5-3-2011. INT. CL. 9.
3,999,773, INT. CL. 41.
- SCHOTT AG, 55122 MAINZ, FED REP GERMANY:
3,996,302, PUB. 9-21-2010. MULTIPLE CLASS, INT. CLS. 19 AND 21.
- SCHULER, SERGIO, AUSTIN, TX:
3,997,868, PUB. 5-3-2011. INT. CL. 9.
- SCHUSSLER CREATIVE, INC., GOLDEN VALLEY, MN:
3,997,794, PUB. 5-3-2011. INT. CL. 35.
3,997,796, PUB. 5-3-2011. INT. CL. 41.
3,997,797, PUB. 5-3-2011. INT. CL. 42.
- SCHWAGER, JACK, NEW YORK, NY:
2,476,374. REN. 6-14-11. INT. CL. 36.
- SCHWANTZ RACING, INC., LEEDS, AL, DBA SCHWANTZ SCHOOL:
3,996,860, PUB. 5-3-2011. INT. CL. 41.
- SCHWINN ACQUISITION, LLC, MADISON, WI:
3,999,777, INT. CL. 12.

SCIENTIA VASCULAR, LLC, RENO, NV, FORMERLY NEXT VASCULAR LLC:
3,999,039, INT. CL. 10.
3,999,040, INT. CL. 10.

SCIENTIFIC CONSERVATION INC., ATLANTA, GA:
3,996,316, PUB. 5-3-2011. INT. CL. 42.

SCIENTIFIC SOLUTIONS, INC., MENTOR, OH:
2,469,054, REN. 6-16-11. INT. CL. 9.

SCOFIELD, JOHN P, CITRUS HEIGHTS, CA, DBA SOCIETY BRAND CLOTHING COMPANY AND SCOFIELD, LAVINA J, CITRUS HEIGHTS, CA, DBA SOCIETY BRAND CLOTHING COMPANY:
3,996,250, PUB. 5-3-2011. INT. CL. 25.

SCONZA CANDY COMPANY, OAKLAND, CA:
2,402,766, CANC. INT. CL. 30.

SCOTT KAY, INC., TEANECK, NJ:
3,999,909, INT. CL. 14.

SCOTT, GREG, REDDING, CA AND MOORE, MARK, SACRAMENTO, CA, DBA MCDONALD HEARING AID CENTER:
2,901,291, CANC. INT. CL. 44.

SCOTTCARE CORPORATION, THE, CLEVELAND, OH:
1,648,056, REN. 6-16-11. INT. CL. 10.

SCRIP, INC., OAKBROOK TERRACE, IL:
2,901,014, CANC. INT. CL. 3.

SDL ATLAS, L.L.C., CHICAGO, IL:
3,996,819, PUB. 5-3-2011. INT. CL. 9.

SDY HAIR SOLUTIONS, LLC, MINNEAPOLIS, MN:
3,996,737, PUB. 5-3-2011. INT. CL. 3.
3,996,738, PUB. 5-3-2011. INT. CL. 3.

SEACRA ENTERPRISES, INC., CARY, NC, DBA DTC HEALTH:
3,997,059, PUB. 5-3-2011. INT. CL. 5.

SEALY TECHNOLOGY LLC, TRINITY, NC:
3,999,816, INT. CL. 16.

SEAN P. GARVEY, NAPA, CA:
3,998,998, INT. CL. 33.

SEARS BRANDS, LLC, HOFFMAN ESTATES, IL:
3,998,531, INT. CL. 37.
3,999,390, MULTIPLE CLASS, INT. CLS. 35 AND 41.

SEASIDE COMMUNITY DEVELOPMENT CORPORATION, SANTA ROSA BEACH, FL:
3,998,434, INT. CL. 16.

SEATTLE BIKE SUPPLY, INC., KENT, WA:
1,176,056, REN. 6-16-11. INT. CL. 12.

SEATTLE TILTH ASSOCIATION, SEATTLE, WA:
3,996,747, PUB. 5-3-2011. INT. CL. 41.

SECOR, DIANE L., TUNKHANNOCK, PA:
3,999,116, INT. CL. 36.

SECURITY EQUIPMENT CORPORATION, FENTON, MO:
1,194,935, REN. 6-16-11. INT. CL. 1.

SECURITYMETRICS, INC., OREM, UT:
3,999,331, INT. CL. 9.

SECURLINX HOLDING CORPORATION, MORGANTOWN, WV:
3,999,190, INT. CL. 9.

SEED AND GARDEN LLC, SOUTH LYON, MI:
3,996,690, PUB. 5-3-2011. INT. CL. 35.

SEED SAVERS EXCHANGE, INC., DECORAH, IA, AKA SEED SAVERS EXCHANGE:
3,999,700, INT. CL. 16.

SEEK SIMPLE, INC., SARASOTA, FL:
3,997,780, PUB. 5-3-2011. INT. CL. 25.

SELECTION MANAGEMENT SYSTEMS, INC., CINCINNATI, OH:
3,998,077, PUB. 5-3-2011. INT. CL. 45.
3,998,078, PUB. 5-3-2011. INT. CL. 45.

SELMONT, GEORGE A., MIDDLE HADDAM, CT:
3,998,477, INT. CL. 42.

SELUX CORPORATION, HIGHLAND, NY:
2,510,612, REN. 6-15-11. INT. CL. 11.

SEMANTIC SPACE TECHNOLOGIES LIMITED, HYDERABAD, INDIA:
3,997,916, PUB. 5-3-2011. INT. CL. 42.

SEMPRIS, LLC, MINNEAPOLIS, MN:
3,998,915, INT. CL. 35.

SEN CORPORATION LIMITED, UNITED KINGDOM:
3,995,749, PUB. 5-3-2011. MULTIPLE CLASS, INT. CLS. 38, 39, 41 AND 45.

SENATOR INTERNATIONAL HOLDINGS LLC, MIAMI, FL:
3,996,591, PUB. 5-3-2011. MULTIPLE CLASS, INT. CLS. 35, 36 AND 39.

SEND THE TREND, INC., NEW YORK, NY:
3,999,505, MULTIPLE CLASS, INT. CLS. 35 AND 42.

SENDLER JOSEPH, COLUMBUS, OH, DBA THE EARBEATAZ AND YARLEY GEFFRARD, COLUMBUS, OH, DBA THE EARBEATAZ:
3,996,798, PUB. 5-3-2011. INT. CL. 25.

SENNARI ENTERTAINMENT, INC., CUPERTINO, CA:
2,901,414, CANC. INT. CL. 9.

SENSOR PRODUCTS INC., MADISON, NJ:
3,997,357, PUB. 5-3-2011. INT. CL. 9.

SENSORMATIC ELECTRONICS, LLC, BOCA RATON, FL:
2,488,381, REN. 6-16-11. INT. CL. 9.

SENSORTECH SYSTEMS, INC., MOORPARK, CA:
3,997,994, PUB. 5-3-2011. INT. CL. 9.

SENZ TECHNOLOGIES B.V., DELFT, NETHERLANDS:
3,995,781, PUB. 5-3-2011. INT. CL. 18.

SERGEANT'S PET CARE PRODUCTS, INC., OMAHA, NE:
3,998,480, INT. CL. 18.

SEROYAL U.S.A., INC., WOOD DALE, IL:
2,452,241, REN. 6-16-11. MULTIPLE CLASS, INT. CLS. 16 AND 41.

SERPENTIX CONVENOR CORPORATION, WESTMINSTER, CO, STUBBE, FRIEDRICH, VLOTHO (WESER), FED REP GERMANY, DBA ALBERT STUBBE:
717,512, REN. 6-16-11. U.S. CL. 23 (INT. CLS. 6, 7, 8, 9, 11, 12, 16, 21 AND 28).

SERRV INTERNATIONAL, NEW WINDSOR, MD:
2,543,746, REN. 6-14-11. INT. CL. 35.

SERVICE IDEAS, INC., WOODBURY, MN:
2,451,558, REN. 6-15-11. INT. CL. 21.

SERVICEMAGIC, INC., GOLDEN, CO:
2,512,378, REN. 6-16-11. INT. CL. 35.

SETEBAID SERVICES, INC., WINFIELD, PA:
3,997,683, PUB. 5-3-2011. INT. CL. 41.

SEVEN CEDARS LLC, BEVERLY HILLS, CA:
3,996,863, PUB. 5-3-2011. INT. CL. 25.

SEVEN MINUTES, INC., JONESBORO, AR:
3,999,200, MULTIPLE CLASS, INT. CLS. 16 AND 41.

SEWING LOUNGE, WAXHAW, NC:
3,999,767, INT. CL. 41.

SGBECK, MALIBU, CA:
3,997,436, PUB. 5-3-2011. INT. CL. 25.

SGRISK, LYNDHURST, NJ:
3,997,272, PUB. 5-3-2011. INT. CL. 20.

SH HOLDINGS, LLC, SARASOTA, FL:
3,996,782, PUB. 5-3-2011. INT. CL. 42.

SHAMIR INSIGHT, INC., SAN DIEGO, CA:
3,998,516, INT. CL. 9.

SHAMIR OPTICAL INDUSTRY LTD., ISRAEL:
3,996,021, PUB. 5-3-2011. INT. CL. 9.

SHANDONG LINUO SOLAR POWER HOLDINGS CO., LTD., SHANDONG PROVINCE, CHINA:
3,999,322, INT. CL. 9.
3,999,323, INT. CL. 9.

SHANE TAYLOR, AUSTRALIA:
3,995,771, PUB. 5-3-2011. MULTIPLE CLASS, INT. CLS. 25, 28 AND 35.

SHANGHAI BAOSIGHT SOFTWARE CO., LTD., CHINA:
3,996,029, PUB. 5-3-2011. MULTIPLE CLASS, INT. CLS. 9 AND 42.

SHANGHAI CONWOOD INTERNATIONAL CO., LTD., CHINA:
3,995,838, PUB. 5-3-2011. INT. CL. 18.

SHANGHAI SHANGPIN STATIONERY CO., LTD., SHANGHAI, CHINA:
3,999,051, INT. CL. 16.

SHANXI XINGHUACUN FENJIU DISTILLERY CO., LTD., CHINA:
3,995,941, PUB. 5-3-2011. INT. CL. 33.

SHAPIRO, LEE, FORT LEE, NJ:
3,996,881, PUB. 5-3-2011. INT. CL. 41.

SHARE M2, LLC, BERRYVILLE, VA:
3,996,739, PUB. 5-3-2011. INT. CL. 45.

- SHARMA, SATINDER, REGO PARK, NY:
3,997,279, PUB. 5-3-2011. INT. CL. 43.
- SHARNAE FORRESTER, EAST ELMHURST, NY:
3,999,273, INT. CL. 14.
- SHARP, ADAM G, SAINT AUGUSTINE, FL:
3,999,010, INT. CL. 41.
- SHARP, ROGER, PASO ROBLES, CA:
3,998,789, INT. CL. 43.
- SHARPSHOOTER SPECTRUM PHOTOGRAPHIC IMAGING, LLC, FRISCO, CO:
2,501,625, REN. 6-14-11. INT. CL. 42.
- SHASHI, LLC, DELRAY BEACH, FL:
3,997,514, PUB. 5-3-2011. INT. CL. 25.
- SHAW INDUSTRIES GROUP, INC., DALTON, GA:
2,402,758, CANC. INT. CL. 22.
- SHEARER, MARY L., JACKSON, MI:
2,470,387, REN. 6-15-11. INT. CL. 25.
- SHEDRAIN CORPORATION, PORTLAND, OR:
3,996,541, PUB. 3-29-2011. INT. CL. 18.
- SHEET DYNAMICS LTD, CINCINNATI, OH:
3,874,785, COR. INT. CL. 42.
- SHEET METAL WORKERS' INTERNATIONAL ASSOCIATION, WASHINGTON, DC:
3,998,560, INT. CL. 35.
- SHELBY GROUP INTERNATIONAL, INC., MEMPHIS, TN:
3,999,558, INT. CL. 9.
3,999,577, INT. CL. 9.
- SHEN LING GROUP INC., SAN GABRIEL, CA:
3,998,060, PUB. 5-3-2011. INT. CL. 25.
3,998,062, PUB. 5-3-2011. INT. CL. 25.
- SHENYANG BOYU NONFERROUS METAL & FERROALLOY CO., LTD., CHINA:
3,995,933, PUB. 5-3-2011. INT. CL. 35.
- SHENZHEN BAUWAY TECHNOLOGY LIMITED, BAO'AN DIST., SHENZHEN, CHINA:
3,997,789, PUB. 5-3-2011. INT. CL. 34.
- SHENZHEN FUTURE TECHNOLOGY COMPANY LIMITED, BAO'AN, SHENZHEN, CHINA:
3,996,787, PUB. 5-3-2011. INT. CL. 9.
- SHENZHEN SANXO TECHNOLOGY DEVELOPMENT CO., LTD., SHENZHEN, CHINA:
3,998,940, INT. CL. 9.
- SHEPHERD SPECIALTY PAPERS, INC., RICHLAND, MI:
2,507,893, REN. 6-15-11. INT. CL. 24.
- SHIER, BARRY, LAS VEGAS, NV:
3,998,418, INT. CL. 32.
- SHINING UNION LIMITED, TSUEN WAN, NT, HONG KONG:
3,995,606, PUB. 5-3-2011. INT. CL. 9.
- SHIVA SHANTI YOGA SCHOOL, RUTHERFORD, NJ:
3,999,698, INT. CL. 41.
- SHIZZLR, INC, ORANGE, CT:
3,999,705, INT. CL. 42.
- SHOPZILLA, INC., LOS ANGELES, CA:
3,996,654, PUB. 5-3-2011. MULTIPLE CLASS, INT. CLS. 9, 35 AND 41.
- SHORTTRIDGE INSTRUMENTS, INC., SCOTTSDALE, AZ:
3,998,259, PUB. 5-3-2011. MULTIPLE CLASS, INT. CLS. 37 AND 42.
- SHOTZOOM, LLC., SCOTTSDALE, AZ:
3,996,267, PUB. 5-3-2011. INT. CL. 9.
- SHOWPLACE WOOD PRODUCTS, INC., HARRISBURG, SD:
3,997,209, PUB. 5-3-2011. INT. CL. 35.
3,997,216, PUB. 5-3-2011. INT. CL. 40.
- SHRI KRISHNA NIDHI FOUNDATION, HILLSBOROUGH, NJ, AKA SKN FOUNDATION:
3,996,468, PUB. 5-3-2011. INT. CL. 16.
- SHUN CHUAN MACHINERY IND. CO., LTD., MAOLI COUNTY 358, TAIWAN:
3,997,582, PUB. 5-3-2011. INT. CL. 7.
- SHURE MANUFACTURING CORPORATION, WASHINGTON, MO:
1,663,451, REN. 6-16-11. INT. CL. 20.
- SHIHPUSH, S ANTHONY, OMAHA, NE:
3,999,144, INT. CL. 21.
- SICHUAN CHANGHONG ELECTRIC CO., LTD., SICHUAN, CHINA:
2,461,132, REN. 6-14-11. MULTIPLE CLASS, INT. CLS. 7, 9 AND 11.
- SIEBEL SYSTEMS, INC., SAN MATEO, CA:
2,901,770, CANC. INT. CL. 42.
- SIEGEL OIL COMPANY, DENVER, CO:
3,997,536, PUB. 5-3-2011. INT. CL. 4.
- SIEMENS AKTIENGESELLSCHAFT, MUNICH, FED REP GERMANY:
2,901,584, CANC. INT. CL. 9.
- SIEMENS AKTIENGESELLSCHAFT, MUNICH, FED REP GERMANY:
2,901,689, CANC. MULTIPLE CLASS, INT. CLS. 9, 14, 25 AND 38.
- SIEMENS AKTIENGESELLSCHAFT, FED REP GERMANY:
3,042,038.
3,995,757, PUB. 5-3-2011. MULTIPLE CLASS, INT. CLS. 10, 41 AND 42.
3,995,996, PUB. 5-3-2011. MULTIPLE CLASS, INT. CLS. 9 AND 42.
- SIEMENS HEALTHCARE DIAGNOSTICS INC., DEERFIELD, IL:
2,464,464, REN. 6-16-11. INT. CL. 7.
- SIEMENS INDUSTRY, INC., ALPHARETTA, GA:
2,466,222, REN. 6-16-11. INT. CL. 1.
2,466,223, REN. 6-15-11. INT. CL. 11.
- SIERRA HEALTHSTYLES LLC, TUCSON, AZ:
3,998,387, MULTIPLE CLASS, INT. CLS. 35 AND 36.
- SIERRA SAGE HERBS LLC, BOISE, ID:
3,997,267, PUB. 5-3-2011. INT. CL. 3.
- SIGNATURE HEALTHCARE, LLC, LOUISVILLE, KY:
3,996,534, PUB. 5-3-2011. INT. CL. 44.
- SIGNATURE STYLES, LLC, NEW YORK, NY:
3,996,117, PUB. 5-3-2011. INT. CL. 35.
- SIKA AG, SWITZERLAND:
3,995,990, PUB. 5-3-2011. INT. CL. 17.
- SIKORSKY AIRCRAFT CORPORATION, STRATFORD, CT:
3,999,188, MULTIPLE CLASS, INT. CLS. 16, 21, 26 AND 28.
- SILFAB S.P.A., ITALY:
3,995,904, PUB. 5-3-2011. MULTIPLE CLASS, INT. CLS. 1, 7, 9, 37, 40 AND 42.
- SILKPAINT CORPORATION, WALDRON, MO:
2,563,817, REN. 6-15-11. INT. CL. 1.
- SILKROAD TECHNOLOGY, INC., WINSTON-SALEM, NC:
3,996,455, PUB. 5-3-2011. INT. CL. 42.
3,996,456, PUB. 5-3-2011. MULTIPLE CLASS, INT. CLS. 41 AND 42.
- SILLAMAN AND SONS, INC., SANFORD, NC:
3,997,179, PUB. 5-3-2011. INT. CL. 40.
- SILPRO, LLC, AYER, MA:
3,996,194, PUB. 5-3-2011. INT. CL. 19.
- SILVER LAKE MEDIA GROUP, LLC, MARIETTA, GA:
3,998,496, INT. CL. 41.
- SILVER STATE RESEARCH, INC., LAS VEGAS, NV:
2,902,318, CANC. INT. CL. 24.
- SILVERLIT LIMITED, CAUSEWAY BAY, HONG KONG, HONG KONG:
2,520,943, REN. 6-14-11. INT. CL. 28.
- SILVERNANO TECHNOLOGIES, LLC, PIANO, TX:
3,998,328, INT. CL. 3.
- SIMBA TOYS GMBH & CO., D-90765 FURTH, FED REP GERMANY:
2,401,771, CANC. INT. CL. 28.
- SIMPLY CHARGED, YUBA CITY, CA:
3,998,015, PUB. 5-3-2011. INT. CL. 42.
- SIMPLY LEARNING, INC., KING OF PRUSSIA, PA:
3,996,390, PUB. 5-3-2011. INT. CL. 41.
- SIMPLY SMILES, INC., NAUGATUCK, CT:
3,999,795, INT. CL. 30.
- SIMPLYH, LLC, ORANJESTAD, ARUBA:
2,902,018, CANC. INT. CL. 41.
- SINGAPORE AIRLINES LIMITED, AIRLINE ROAD, SINGAPORE:
1,161,347, REN. 6-16-11. INT. CL. 39.
- SINGING SAMS PIZZA, ORLANDO, FL:
3,999,607, INT. CL. 43.
- SINGLESAROUNDME INC., OTTAWA, ON, CANADA:
3,996,045, PUB. 5-3-2011. INT. CL. 38.

SINO SWEARINGEN AIRCRAFT CORPORATION, SAN ANTONIO, TX:
2,901,521, CANC. INT. CL. 12.

SIR ROCCO FORTE & FAMILY PLC, LONDON, UNITED KINGDOM, FORTE (U.K.), LTD, LONDON, UNITED KINGDOM:
2,411,616. REN. 6-15-11. MULTIPLE CLASS, INT. CLS. 41 AND 42.

SIR ROCCO FORTE & FAMILY PLC, LONDON, UNITED KINGDOM, FORTE (U.K.), LTD., LONDON, UNITED KINGDOM:
2,411,617. REN. 6-15-11. MULTIPLE CLASS, INT. CLS. 35, 41 AND 42.

SIROIS, MARY, DAVIDSONVILLE, MD:
2,901,368, CANC. INT. CL. 35.

SIROLI INSTITUTE - ENTERPRISE FACILITATION, INC., SACRAMENTO, CA:
2,901,227, CANC. MULTIPLE CLASS, INT. CLS. 35 AND 41.

SITE BASED ENERGY, HAILEY, ID:
3,996,800, PUB. 5-3-2011. MULTIPLE CLASS, INT. CLS. 7 AND 37.

SITE USA, INC., ST. PETERSBURG, FL:
2,901,175, CANC. MULTIPLE CLASS, INT. CLS. 36 AND 39.

SITEOS, AG., D-81371 MUNCHEN, FED REP GERMANY:
2,901,017, CANC. MULTIPLE CLASS, INT. CLS. 9 AND 38.

SITREX S.P.A., CITTA DI CASTELLO, ITALY:
1,664,720. REN. 6-15-11. INT. CL. 7.

SIX GROUP AG, ZÜRICH, SWITZERLAND:
3,995,881, PUB. 5-3-2011. MULTIPLE CLASS, INT. CLS. 35, 36, 38, 41 AND 42.

SKECHERS U.S.A., INC. II, MANHATTAN BEACH, CA:
3,998,272, PUB. 5-3-2011. INT. CL. 35.

SKILLSOURCE, CINCINNATI, OH:
3,997,851, PUB. 5-3-2011. INT. CL. 35.
3,997,853, PUB. 5-3-2011. INT. CL. 41.

SKIMTECH, INCORPORATED, POLAND, OH:
2,902,210, CANC. INT. CL. 7.

SKIRL, STEFAN, RUPPERTSWEILER, FED REP GERMANY AND SCHWALB, ULRICH, KOLN, FED REP GERMANY:
2,901,525, CANC. MULTIPLE CLASS, INT. CLS. 16 AND 41.

SKY CHAIN TRADING LIMITED, CHINA:
3,995,893, PUB. 5-3-2011. MULTIPLE CLASS, INT. CLS. 8 AND 21.

SKY 26 ENTERPRISE INC., NEW YORK, NY:
3,997,145, PUB. 5-3-2011. INT. CL. 35.

SKYLER STEWART, REDDING, CA, DBA BEE LASSO:
3,997,766, PUB. 5-3-2011. INT. CL. 4.

SKYLINE CHILI, INC., FAIRFIELD, OH:
3,997,946, PUB. 5-3-2011. INT. CL. 42.

SKYLINE CORPORATION, ELKHART, IN:
3,999,776, INT. CL. 12.

SKYSHAPERS FITNESS FOUNDATION, INC., NEW YORK, NY:
2,563,721. REN. 6-10-11. INT. CL. 41.

SKYUNION PTE. LTD., 159308, SINGAPORE:
3,999,496, INT. CL. 9.
3,999,497, INT. CL. 41.

SLACKER ANIMATION, LLC, SKILLMAN, NJ:
3,997,030, PUB. 5-3-2011. INT. CL. 42.

SLICK RIDES, INC., AMARILLO, TX, DBA SEWFINE INTERIOR PRODUCTS:
3,997,326, PUB. 5-3-2011. MULTIPLE CLASS, INT. CLS. 12, 27 AND 40.

SLIGHTLY HEROIC MARKETING, LLC, HICKORY, NC:
3,996,954, PUB. 5-3-2011. INT. CL. 35.

SLOBODY LLC, SEATTLE, WA:
3,997,225, PUB. 5-3-2011. INT. CL. 41.

SMALLEY STEEL RING COMPANY, LAKE ZURICH, IL:
1,649,721. REN. 6-15-11. INT. CL. 39.

SMART ACADEMY, INC., CERRITOS, CA:
2,901,103, CANC. INT. CL. 41.

SMART MEDICAL SUPPLIERS, INC., WEBESTER, NY:
3,998,668, INT. CL. 35.
3,998,669, INT. CL. 35.

SMART SOLUTIONS RECREATIONAL PRODUCTS, INC., CHAMPAIGN, IL:
3,998,028, PUB. 5-3-2011. INT. CL. 20.

SMARTLABS, INC., IRVINE, CA:
3,995,722, PUB. 10-27-2009. INT. CL. 35.

SMARTOP, INC., MOREHEAD CITY, NC:
2,902,114, CANC. INT. CL. 12.

SMC NETWORKS, IRVINE, CA:
2,566,665. REN. 6-15-11. INT. CL. 9.

SMETHURST NICHOLAS, FRANCE:
3,995,780, PUB. 5-3-2011. MULTIPLE CLASS, INT. CLS. 9, 38 AND 42.

SMI-CARR, INC., ABILENE, TX:
3,999,771, INT. CL. 20.

SMILE AGAIN, INC., BURR RIDGE, FL:
3,999,087, INT. CL. 25.

SMITH & WESSON CORP, SPRINGFIELD, MA:
3,997,422, PUB. 5-3-2011. INT. CL. 45.

SMITH ABRASIVES, INC., HOT SPRINGS, AR:
3,999,440, INT. CL. 8.

SMITH INTERNATIONAL, INC., HOUSTON, TX:
3,999,971, MULTIPLE CLASS, INT. CLS. 37 AND 42.

SMITH, ALETHEA W., COLORADO SPRINGS, CO, DBA THEAPEUTIC MASSAGE THERAPY:
3,998,843, INT. CL. 3.

SMITH, BRENT, BURLESON, TX:
3,996,935, PUB. 5-3-2011. INT. CL. 13.

SMITH, DOUGLAS, SAN ANTONIO, TX:
3,998,292, PUB. 5-3-2011. INT. CL. 42.

SMITH, JASON L., AVON, OH:
3,997,931, PUB. 5-3-2011. INT. CL. 36.

SMITH, PENNY RENEE, FRANKFORT, KY AND COLLINS, WANDA LOTT, FINCHVILLE, KY:
3,996,538, PUB. 5-3-2011. MULTIPLE CLASS, INT. CLS. 41 AND 42.

SMITH, SCOTT D, KALAMAZOO, MI, DBA GHOUTLIDE GATHERING:
3,996,721, PUB. 5-3-2011. INT. CL. 35.

SMITHKLINE BEECHAM LIMITED, BRENTFORD, MIDDLESEX, UNITED KINGDOM:
2,402,319, CANC. MULTIPLE CLASS, INT. CLS. 5 AND 16.

SMITHS DETECTION INC., DANBURY, CT:
3,998,220, PUB. 5-3-2011. INT. CL. 9.

SMM DISTRIBUTORS LLC, LOS ANGELES, CA:
3,997,408, PUB. 5-3-2011. INT. CL. 5.

SMOKETRONIC, LLC, ST. LOUIS, MO:
3,997,524, PUB. 5-3-2011. INT. CL. 34.

SMOOTH OPERATORS, LLC, SAN DIEGO, CA:
2,902,249, CANC. INT. CL. 28.
2,902,250, CANC. INT. CL. 40.

SMOOTH-ON, INC., EASTON, PA:
3,998,257, PUB. 5-3-2011. INT. CL. 1.

SMULE, INC., PALO ALTO, CA:
3,996,521, PUB. 5-3-2011. INT. CL. 9.

SNEAKER HEADZ, LLC, ROYAL OAK, MI, DBA BURN RUBBER:
3,997,720, PUB. 5-3-2011. INT. CL. 25.

SNEAKERCHANGE, CORONA, NY:
3,997,254, PUB. 5-3-2011. INT. CL. 35.

SNIBBIT PRODUCTS, LLC, BRIDGEPORT, CT:
3,998,963, INT. CL. 35.

SNOW, NACHE, UPPER MARLBORO, MD:
3,997,086, PUB. 5-3-2011. INT. CL. 18.

SNOWDEN, JULIA, MURPHYS, CA, DBA SNOWDEN CONSULTING:
3,996,214, PUB. 5-3-2011. INT. CL. 41.

SNUGGLEBUGZZZ, LLC, LAKEVILLE, MN:
3,999,438, INT. CL. 28.
3,999,439, INT. CL. 28.

SOARINGWORDS, INC., NEW YORK, NY:
3,999,876, INT. CL. 45.

SOBEL WESTEX, LAS VEGAS, NV:
3,998,155, PUB. 5-3-2011. INT. CL. 20.

- SOCCER AND SMILES LLC, SAN CARLOS, CA:
3,997,824, PUB. 5-3-2011. INT. CL. 41.
3,997,826, PUB. 5-3-2011. INT. CL. 41.
- SOCCEREDGE, INC., BOSTON, MA:
2,454,051. REN. 6-15-11. INT. CL. 28.
2,454,052. REN. 6-15-11. INT. CL. 28.
- SOCIALNEXUS, INC., SPANISH FORK, UT:
3,997,864, PUB. 5-3-2011. INT. CL. 44.
3,997,865, PUB. 5-3-2011. INT. CL. 41.
3,997,867, PUB. 5-3-2011. INT. CL. 44.
3,997,873, PUB. 5-3-2011. INT. CL. 44.
3,997,874, PUB. 5-3-2011. INT. CL. 44.
- SOCIETÀ COOPERATIVA AGRICOLA CANTINA SOCIALE
TOLLO, TOLLO, ITALY:
3,999,045, INT. CL. 33.
- SOCIETE AGRICOLE DE LA DURANCOLE, LANCON DE
PROVENCE, FRANCE:
3,995,731, PUB. 5-3-2011. INT. CL. 33.
- SOCIETE D'ETUDE DES CATALYSEURS, ANTONY,
FRANCE:
1,647,164. REN. 6-15-11. INT. CL. 5.
- SOCIETE IMMOBILIERE DE SAINT-BARTHELEMY,
SAINT-BARTHELEMY, FRANCE:
3,995,649, PUB. 11-2-2010. INT. CL. 36.
3,995,650, PUB. 11-2-2010. INT. CL. 36.
3,995,651, PUB. 11-2-2010. INT. CL. 36.
3,995,652, PUB. 11-2-2010. INT. CL. 36.
3,995,653, PUB. 11-2-2010. INT. CL. 36.
- SOCIETE LA BIOCHIMIE APPLIQUEE (SO.LA.B.I.A),
FRANCE:
3,995,946, PUB. 5-3-2011. INT. CL. 1.
3,995,947, PUB. 5-3-2011. INT. CL. 1.
- SOCIETY FOR PEDIATRIC ANESTHESIA, RICHMOND,
VA:
3,996,840, PUB. 5-3-2011. INT. CL. 35.
- SOCIETY FOR PEDIATRIC SEDATION, INC., RICHMOND,
VA:
3,999,966, INT. CL. 35.
3,999,967, INT. CL. 44.
- SOCIETY FOR SCIENCE & THE PUBLIC, WASHINGTON,
DC:
3,997,409, PUB. 5-3-2011. INT. CL. 41.
- SOCIETY OF MANUFACTURING ENGINEERS, DEAR-
BORN, MI:
3,997,319, PUB. 5-3-2011. MULTIPLE CLASS, INT. CLS. 35
AND 41.
3,997,325, PUB. 5-3-2011. MULTIPLE CLASS, INT. CLS. 35
AND 41.
- SOCIETY OF PROFESSIONAL JOURNALISTS, INDIANA-
POLIS, IN:
2,544,666. REN. 6-16-11. INT. CL. 42.
- SOCIETY OF RHEOLOGY, THE, MELVILLE, NY:
2,558,689. REN. 6-14-11. INT. CL. 16.
- SOCIETY OF ROSICRUCIANS AND SOCIETAS ROSI-
CRUCIANA IN AMERICA, INC., ELFERS, FL:
3,997,163, PUB. 5-3-2011. MULTIPLE CLASS, INT. CLS. 16
AND 41.
- SODA-CLUB (CO2) ATLANTIC GMBH, ZUG, SWITZER-
LAND:
3,996,469, PUB. 5-3-2011. MULTIPLE CLASS, INT. CLS. 1,
6, 7, 21 AND 32.
- SOFFAR,RANDALL JAY, SUGAR LAND, TX:
3,997,373, PUB. 5-3-2011. INT. CL. 11.
- SOFTOUCH CONCEPTS, INC., UNION CITY, CA:
3,998,153, PUB. 5-3-2011. INT. CL. 18.
3,998,154, PUB. 5-3-2011. INT. CL. 18.
- SOHEL DISTRIBUTORS NY LLC, YONKERS, NY:
4,000,052, INT. CL. 38.
- SOKOL AND COMPANY, COUNTRYSIDE, IL:
3,996,740, PUB. 5-3-2011. INT. CL. 30.
- SOLAR POTENTIAL, BERKLEY, MA:
3,999,559, INT. CL. 37.
- SOLAR SEMICONDUCTOR, INC., SUNNYVALE, CA:
3,998,896, INT. CL. 37.
- SOLAR-FABRIK AG, FED REP GERMANY:
3,995,766, PUB. 5-3-2011. MULTIPLE CLASS, INT. CLS. 9
AND 11.
- SOLECTRA, BROOKLYN, NY:
3,997,927, PUB. 5-3-2011. MULTIPLE CLASS, INT. CLS. 4
AND 40.
- SOLETANCHE FREYSSINET, FRANCE:
3,995,823, PUB. 5-3-2011. MULTIPLE CLASS, INT. CLS. 9,
37 AND 42.
- SOLEXA LIMITED, LONDON, ENGLAND:
2,901,062, CANC. MULTIPLE CLASS, INT. CLS. 1, 5, 9, 10,
40 AND 42.
- SOLID GROUP, LLC, RALEIGH, NC:
3,996,486, PUB. 5-3-2011. INT. CL. 36.
- SOLIS, RODOLFO, PHARR, TX:
3,996,395, PUB. 5-3-2011. INT. CL. 12.
- SOLSTICE LIVING SOLUTIONS, INC., SCOTTSDALE, AZ:
3,998,974, MULTIPLE CLASS, INT. CLS. 44 AND 45.
- SONGWriters IN THE ROUND, PRIMM SPRINGS, TN:
2,902,145, CANC. MULTIPLE CLASS, INT. CLS. 9, 21, 25
AND 41.
- SONLYN ENTERPRISES, INC., SHAKER HEIGHTS, OH:
2,401,740, CANC. INT. CL. 16.
- SONNAX INDUSTRIES, INC., BELLOWS FALLS, VT:
2,401,518, CANC. MULTIPLE CLASS, INT. CLS. 12 AND
17.
- SONNY BONES MUSIC, HERMOSA BEACH, CA:
2,402,760, CANC. INT. CL. 41.
- SONO, INC., EVERSON, WA, DBA NORTHWEST FRA-
GRANCE:
2,496,267. REN. 6-16-11. INT. CL. 3.
- SONOSITE, INC., BOTHELL, WA:
3,998,728, MULTIPLE CLASS, INT. CLS. 41 AND 44.
- SONUS-USA, INC., PLYMOUTH, MN:
3,999,445, INT. CL. 44.
- SONY COMPUTER ENTERTAINMENT EUROPE LIMITED,
LONDON, UNITED KINGDOM:
3,995,521, PUB. 5-3-2011. INT. CL. 9.
- SONY CORPORATION, TOKYO, JAPAN, DBA SONY COR-
PORATION:
2,401,172, CANC. INT. CL. 9.
- SONY CORPORATION, TOKYO, JAPAN:
3,998,450, INT. CL. 9.
- SOP SERVICES, INC., LAS VEGAS, NV, SOP SERVICES,
INC., LAS VEGAS, NV:
2,576,691. REN. 6-14-11. INT. CL. 28.
- SORT-TEK INSPECTION SYSTEMS, INC., ROYAL OAK, MI:
2,485,034. REN. 6-15-11. INT. CL. 42.
- SOTER, ANTHONY, CARLTON, OR:
3,999,645, INT. CL. 33.
- SOUND VITALITY, LLC, LAGUNA NIGUEL, CA:
2,902,175, CANC. INT. CL. 10.
- SOURCE ADVANTAGE, LLC, CINCINNATI, OH, DBA RED
CARPET STUDIOS, LTD:
3,996,523, PUB. 5-3-2011. INT. CL. 25.
- SOURCE INTERLINK MAGAZINES, LLC, EL SEGUNDO,
CA:
3,999,187, MULTIPLE CLASS, INT. CLS. 16 AND 25.
- SOUTH BAKER STREET, INC., DENVER, CO:
2,401,665, CANC. INT. CL. 37.
- SOUTH FERRY CAPITAL MANAGEMENT, L.P., NEW
YORK, NY:
3,997,136, PUB. 5-3-2011. INT. CL. 36.
3,997,146, PUB. 5-3-2011. INT. CL. 36.
- SOUTHERN GROUP ENTERPRISES, LLC, MIAMI, FL:
3,996,184, PUB. 5-3-2011. MULTIPLE CLASS, INT. CLS. 5
AND 32.
- SOUTHERN STATES COOPERATIVE, INCORPORATED,
RICHMOND, VA:
2,462,600. REN. 6-14-11. INT. CL. 1.
- SOUTHWEST GENERAL HEALTH CENTER, CLEVELAND,
OH:
3,995,656, PUB. 5-3-2011. MULTIPLE CLASS, INT. CLS.
41, 42 AND 44.
3,995,657, PUB. 5-3-2011. MULTIPLE CLASS, INT. CLS.
41, 42 AND 44.
- SOUTHWIRE COMPANY, CARROLLTON, GA:
3,998,672, MULTIPLE CLASS, INT. CLS. 40 AND 42.

SOVMESTNOE OBCHTCHESTVO S OGRANITCHENNOI OTVETSTVENNOSTIOU "MOROZPRODOUKT", BELARUS:
3,995,796, PUB. 5-3-2011. INT. CL. 30.

SOY INVESTORS II, L.L.C., INDIANOLA, IA, DBA HARVEST INNOVATIONS:
3,999,721, INT. CL. 29.

SPAUN ELECTRONIC GMBH & CO. KG, SINGEN, FED REP GERMANY:
2,901,509, CANC. MULTIPLE CLASS, INT. CLS. 9, 37 AND 42.

SPECIAL PURPOSE MEDIA, LOS ANGELES, CA:
3,999,702, INT. CL. 40.

SPECTRUM PRODUCTS, INC., WOODLAND HILLS, CA:
2,402,670, CANC. INT. CL. 3.

SPEECO, INCORPORATED, GOLDEN, CO:
3,995,660, PUB. 5-3-2011. INT. CL. 7.

SPEED DISTRICT, LLC, LONG BEACH, CA:
3,999,049, INT. CL. 45.

SPEEDO INTERNATIONAL LIMITED, FINCHLEY, LONDON, ENGLAND:
1,647,484, REN. 6-15-11. INT. CL. 25.
1,647,484, AM. INT. CL. 25.

SPENCE COMMUNICATIONS COMPANY, INC., AUSTIN, TX:
3,999,319, INT. CL. 30.

SPERIAN EYE & FACE PROTECTION, INC., SMITHFIELD, RI:
2,561,157, REN. 6-13-11. INT. CL. 9.
2,564,390, REN. 6-13-11. INT. CL. 9.

SPHERIS, PENELOPE, STUDIO CITY, CA:
3,998,848, INT. CL. 25.

SPICE JUNGLE, LLC, GRAND RAPIDS, MI:
3,996,850, PUB. 5-3-2011. INT. CL. 30.

SPICER-BAER ASSOCIATES, FAIR OAKS, CA:
2,543,562, REN. 6-10-11. INT. CL. 9.

SPINELLO SERVICES, INC., CATHEDRAL CITY, CA:
3,999,762, INT. CL. 36.

SPINTOUCH, INC., SANTA ANA, CA:
3,998,925, INT. CL. 9.

SPIRALEDGE, INC., SAN JOSE, CA:
3,996,366, PUB. 5-3-2011. INT. CL. 41.

SPIREBLACK, LLC, BROOKLYN, NY, DBA SADICK DERMATOLOGY GROUP:
3,999,865, INT. CL. 3.

SPIRIT IMPORTS, INC., SUNRISE, FL:
3,996,976, PUB. 5-3-2011. INT. CL. 33.

SPIRIT OF VENICE ARTS COLONY, LLC, VENICE, CA:
2,440,418, REN. 6-16-11. INT. CL. 41.
2,440,418, COR. INT. CL. 41.

SPIRIT TWISTERS, LLC, ATHENS, GA:
3,999,727, MULTIPLE CLASS, INT. CLS. 16 AND 32.

SPIRITUAL & PERSONAL GROWTH TRUST, GIBRALTAR, UNITED KINGDOM:
2,902,159, CANC. INT. CL. 3.

SPM INSTRUMENT AB, SWEDEN:
3,995,818, PUB. 5-3-2011. INT. CL. 9.

SPORTAS GMBH SPORTANLAGEN-SPORTBODENBAU, FED REP GERMANY:
3,995,981, PUB. 5-3-2011. MULTIPLE CLASS, INT. CLS. 19 AND 27.

SPORTSPOWER, LTD., HUNGHOM KOWLOON, HONG KONG:
3,996,849, PUB. 5-3-2011. INT. CL. 28.

SPORTU.COM LLC, BIRMINGHAM, AL:
3,998,866, INT. CL. 45.

SPOTON S.R.L., ITALY:
3,995,943, PUB. 5-3-2011. MULTIPLE CLASS, INT. CLS. 9, 35 AND 42.

SPRAYGROUND LLC, ELBERON, NJ:
3,996,453, PUB. 5-3-2011. INT. CL. 18.

SPRIEGEL & ASSOCIATES, LLC, HUDSON, OH:
3,997,442, PUB. 5-3-2011. INT. CL. 45.

SPRING LEAF CONCEPTS & DESIGN, INC., WACONIA, MN:
3,997,065, PUB. 5-3-2011. MULTIPLE CLASS, INT. CLS. 16 AND 25.

SPRINGBOARD NON-PROFIT CONSUMER CREDIT MANAGEMENT, INC., RIVERSIDE, CA:
3,998,235, PUB. 5-3-2011. MULTIPLE CLASS, INT. CLS. 36 AND 41.

SPRINGDELL ASSOCIATES, LLC, COATESVILLE, PA:
3,999,853, INT. CL. 43.

SQUARE ENIX LIMITED, LONDON, UNITED KINGDOM:
2,900,973, CANC. MULTIPLE CLASS, INT. CLS. 9, 16, 25, 28 AND 41.

SQUID, INC., CARBORRO, NC:
3,997,954, PUB. 5-3-2011. INT. CL. 43.

SQUISHY PRESS, LLC, CHICAGO, IL:
3,999,403, INT. CL. 16.

SRA INTERNATIONAL, INC., FAIRFAX, VA:
2,402,421, CANC. INT. CL. 9.

SSI TECHNOLOGIES, INC., JANESVILLE, WI:
1,657,221, REN. 6-15-11. INT. CL. 9.

SSM SELECT REHAB ST. LOUIS, LLC, ST. LOUIS, MO:
3,996,928, PUB. 5-3-2011. INT. CL. 44.

SSRM HOLDINGS, INC., NEW YORK, NY:
2,902,461, CANC. MULTIPLE CLASS, INT. CLS. 35, 36 AND 37.

ST PIERRE, JOSEPH, BUFFALO, WY:
3,999,420, INT. CL. 31.

ST. BRENDAN'S RULE, MCLEAN, VA:
3,997,939, PUB. 5-3-2011. INT. CL. 14.

STAHL'S INC., ST. CLAIR SHORES, MI:
1,156,416, REN. 6-16-11. INT. CL. 20.

STANLEY FILTER COMPANY, LLC, TULSA, OK:
3,996,132, PUB. 5-3-2011. INT. CL. 7.

STANLEY LOGISTICS, L.L.C., NEW BRITAIN, CT:
3,998,276, PUB. 5-3-2011. INT. CL. 8.

STAR GROUP COMMUNICATIONS, INC., VOORHEES, NJ:
3,995,623, PUB. 5-3-2011. INT. CL. 9.

STAR KAY WHITE, INC., CONGERS, NY:
3,997,084, PUB. 5-3-2011. INT. CL. 30.

STARBURY CORPORATION, RESEARCH TRIANGLE PARK, NC:
3,999,205, INT. CL. 25.

STARBUZZ TOBACCO, INC., ANAHEIM, CA:
3,999,504, INT. CL. 34.

STARBUZZ, LLC, SANTA MONICA, CA:
3,999,156, MULTIPLE CLASS, INT. CLS. 16, 25 AND 28.

STARGATE APPAREL, INC., NEW YORK, NY:
3,998,949, INT. CL. 25.

STARLUME, INC., BLOOMINGTON, MN:
2,901,772, CANC. INT. CL. 40.

STARVANARVAN, LLC, FRANKLIN, OH, DBA STARVANARVAN, LLC:
3,998,644, INT. CL. 30.

STATE FARM MUTUAL AUTOMOBILE INSURANCE COMPANY, BLOOMINGTON, IL:
3,997,978, PUB. 5-3-2011. INT. CL. 42.
3,998,258, PUB. 5-3-2011. INT. CL. 35.

STATE OF IDAHO POTATO COMMISSION, EAGLE, ID:
3,996,261, PUB. 5-3-2011. MULTIPLE CLASS, INT. CLS. 16, 28 AND 35.

STATE OF MARYLAND DEPARTMENT OF BUSINESS AND ECONOMIC DEVELOPMENT, BALTIMORE, MD:
3,996,904, PUB. 5-3-2011. INT. CL. 35.

STATE STREET BANK AND TRUST COMPANY, BOSTON, MA:
2,401,894, CANC. INT. CL. 36.

STATION CASINOS, INC., LAS VEGAS, NV:
2,901,942, CANC. INT. CL. 41.

STAUFFENBERG, DANIEL E, EGG HARBOR TOWNSHIP, NJ:
3,996,386, PUB. 5-3-2011. INT. CL. 35.

STAY CONNECTED MARKETING, INC., EL DORADO HILLS, CA:
2,901,829, CANC. INT. CL. 35.

STEAMATIC, INC., FORT WORTH, TX:
912,059, REN. 6-10-11. MULTIPLE CLASS, U.S. CLS. 6 (INT. CLS. 1 AND 5) AND 52 (INT. CL. 3).

STEARNS INC., SAUK RAPIDS, MN:
2,402,315, CANC. INT. CL. 25.

STEELE, MARK A., NEW PRAGUE, MN:
3,995,562, PUB. 5-3-2011. INT. CL. 20.

- STEFFE, CYNTHIA, NEW YORK, NY:
3,998,399, MULTIPLE CLASS, INT. CLS. 14 AND 25.
- STEINER-ATLANTIC CORP., MIAMI, FL:
2,568,510, REN. 6-15-11, INT. CL. 3.
- STEINMETZ, KENNETH DAVID, SAN FRANCISCO, CA:
2,401,615, CANC. MULTIPLE CLASS, INT. CLS. 9 AND 42.
- STEMPINSKI, STANLEY, JOSEPH, SAYREVILLE, NJ:
3,995,479, PUB. 5-3-2011, INT. CL. 39.
- STEPHEN D. TOWNES, GREENVILLE, SC:
3,996,217, PUB. 5-3-2011, INT. CL. 35.
- STEPHEN M. LABAR, JR., DULUTH, GA, DBA THE MARTIAL ARTS STORE:
3,999,933, MULTIPLE CLASS, INT. CLS. 25 AND 28.
- STEPHEN M. POTTS & ASSOCIATES, INC., DALLAS, TX, DBA POTTS LAW GROUP:
3,997,502, PUB. 5-3-2011, INT. CL. 45.
- STEPHEN RUFF, CHULUOTA, FL:
3,997,470, PUB. 5-3-2011, INT. CL. 43.
- STEPHENS MEDIA LLC, LAS VEGAS, NV, DBA ELY TIMES:
3,997,650, PUB. 5-3-2011, INT. CL. 16.
- STEPHENS, WAYNE L., SEATTLE, WA, DBA ARMADILLO CONSIGNMENT:
3,996,968, PUB. 5-3-2011, INT. CL. 35.
- STEPHENSON REAL ESTATE ADVISORS, INC., PLANO, TX:
3,707,832, COR. INT. CL. 36.
- STERIS INC., TEMECULA, CA:
2,902,315, CANC. MULTIPLE CLASS, INT. CLS. 42 AND 44.
- STERNHEIM, SHARON, NEW YORK, NY AND CORHAN, DEBRA, NEW YORK, NY AND KARNOFSKY, PATTI, NEW YORK, NY:
2,488,379, REN. 6-13-11, INT. CL. 35.
- STEVE BERGER, FRANKLIN, TN AND SARAH BERGER, FRANKLIN, TN:
3,997,495, PUB. 5-3-2011, INT. CL. 43.
- STEWART BROWN, INC., VENTURA, CA:
2,902,492, CANC. INT. CL. 25.
- STEWART, APRIL WADDELL, FRANKLIN, TN:
2,902,493, CANC. INT. CL. 25.
- STEWART, CHARLES R., SHAWNEE MISSION, KS:
2,902,142, CANC. INT. CL. 28.
- STEWART, JAMES B., MARION, OH:
2,901,457, CANC. INT. CL. 6.
- STINE SEED FARM, INC., ADEL, IA:
2,549,931, REN. 6-15-11, INT. CL. 31.
- STOKELY-VAN CAMP, INC., CHICAGO, IL:
3,999,065, INT. CL. 32.
- STOKYO, REDONDO BEACH, CA:
3,998,889, INT. CL. 9.
- STOLL, SUSAN DIANE, RIDGEWOOD, NJ, DBA THE ART SPOT:
3,997,226, PUB. 5-3-2011, INT. CL. 41.
- STONE & TILE WORLD, INC., ROCKVILLE, MD:
2,401,560, CANC. MULTIPLE CLASS, INT. CLS. 19 AND 40.
- STONER INCORPORATED, QUARRYVILLE, PA:
2,543,189, REN. 6-13-11, INT. CL. 1.
2,567,604, REN. 6-14-11, INT. CL. 3.
- STONERIVER, INC., BROOKFIELD, WI:
3,997,150, PUB. 5-3-2011, MULTIPLE CLASS, INT. CLS. 9, 35 AND 42.
- STONEXPRESS, INC., KENNESAW, GA:
3,998,131, PUB. 5-3-2011, INT. CL. 1.
- STONY OAK ESTATES LLC, WINDSOR, CA, DBA STONY OAK ESTATES WINERY:
3,999,543, INT. CL. 33.
- STORM MODEL MANAGEMENT LIMITED, LONDON, UNITED KINGDOM:
2,504,642, REN. 6-10-11, INT. CL. 35.
- STORMCENTER COMMUNICATIONS, INC., ELLICOTT CITY, MD:
2,901,117, CANC. INT. CL. 42.
- STRANGER & STRANGER LIMITED, LONDON, UNITED KINGDOM:
3,995,658, PUB. 11-9-2010, INT. CL. 33.
- STRATEGIC ENERGY COACHING, INC, SAN DIEGO, CA:
3,996,779, PUB. 5-3-2011, INT. CL. 41.
- STRATEGIC PLUS, INC., WASHINGTON, DC:
2,902,505, CANC. MULTIPLE CLASS, INT. CLS. 14 AND 25.
- STRATEGIC RESOURCES GROUP, LLC, BIRMINGHAM, MI, DBA HUMAN RESOURCES OUTSOURCING SERVICES:
3,996,595, PUB. 5-3-2011, INT. CL. 42.
- STRATFORD VENTURES, INC., LITHIA SPRINGS, GA:
2,902,118, CANC. INT. CL. 10.
- STRAUSS, CINDI, HOWARD BEACH, NY:
3,999,455, INT. CL. 16.
- STREAMIN' COFFEE, SALT LAKE CITY, UT:
3,998,747, INT. CL. 35.
- STRECK, INC., OMAHA, NE:
3,999,879, INT. CL. 9.
- STREETWISE MAPS INC., SARASOTA, FL:
2,402,985, CANC. INT. CL. 16.
- STRETCH COMPUTING, INC., WESTERN SPRINGS, IL:
3,997,595, PUB. 5-3-2011, INT. CL. 9.
- STRIKE TECHNOLOGIES (PROPRIETARY) LIMITED, BRYANSTON, SOUTH AFRICA:
3,998,824, INT. CL. 9.
- STRIKE ZONE PRECISION AG, LLC, JONESBORO, AR:
3,997,237, PUB. 5-3-2011, INT. CL. 42.
- STROMBERG, JACK, WEST FARGO, ND:
3,998,022, PUB. 5-3-2011, INT. CL. 45.
- STRONG COMPANY, INC., THE, PINE BLUFF, AR:
2,507,014, REN. 6-11-11, INT. CL. 19.
- STRONGWELL CORPORATION, BRISTOL, VA, AFC, INC., CHATFIELD, MN:
1,193,634, REN. 6-13-11, MULTIPLE CLASS, INT. CLS. 19 AND 21.
- STROUMBOS, KIM, DENVER, CO:
3,996,924, PUB. 5-3-2011, MULTIPLE CLASS, INT. CLS. 35 AND 44.
- STUDIO ONE NETWORKS, INC., NEW YORK, NY:
3,997,460, PUB. 5-3-2011, INT. CL. 41.
- STUDIO RAY, LLC, NEW YORK, NY:
3,998,013, PUB. 5-3-2011, INT. CL. 25.
- STUDIO WED, LLC, ASHEVILLE, NC, DBA STUDIO WED:
3,997,294, PUB. 5-3-2011, INT. CL. 41.
- STUDIOBOOTH LLC, BROOKLYN, NY:
3,998,780, INT. CL. 41.
- STURMAN INDUSTRIES, INC., WOODLAND PARK, CO:
2,455,567, REN. 6-16-11, INT. CL. 12.
- STYLE LIVING CORP., BROOKLYN, NY:
2,519,941, REN. 6-14-11, INT. CL. 18.
- STYLEAUTEUR CORPORATION, ALEXANDRIA, VA:
3,997,242, PUB. 5-3-2011, INT. CL. 45.
- STYX MEDIA, INC., PLANT CITY, FL, DBA GOLEM GEAR, INC.:
3,996,812, PUB. 5-3-2011, INT. CL. 9.
- SU, XIAOQIANG, FREMONT, CA:
3,998,352, INT. CL. 41.
- SUBSCRIPT, L.L.C., BROOKLYN, NY:
2,902,126, CANC. INT. CL. 25.
- SUBSOLUTIONS GROUP, INC., THE, ENGLEWOOD CLIFFS, NJ:
2,559,079, REN. 6-16-11, MULTIPLE CLASS, INT. CLS. 6, 7 AND 20.
- SUH, DANIEL, LOS ANGELES, CA:
3,997,531, PUB. 5-3-2011, INT. CL. 25.
- SUMDEX, INC., CITY OF INDUSTRY, CA:
3,997,828, PUB. 5-3-2011, MULTIPLE CLASS, INT. CLS. 9 AND 18.
- SUMISHO COMPUTER SYSTEMS CORPORATION, HARUMI, CHU-KU, TOKYO 104-6241, JAPAN:
2,902,150, CANC. INT. CL. 9.
- SUMMER INFANT (USA), INC., WOONSOCKET, RI:
3,998,241, PUB. 5-3-2011, INT. CL. 38.
- SUMRALL, DAVID, LONE OAK, TX:
3,995,582, PUB. 5-3-2011, INT. CL. 25.
- SUN LEE, INC., SANTA FE SPRINGS, CA:
2,477,451, REN. 6-16-11, INT. CL. 30.
- SUN SAFETY ALLIANCE, INC., ALEXANDRIA, VA:
2,902,060, CANC. INT. CL. 35.

SUNBEAM PRODUCTS, INC., BOCA RATON, FL, CHICAGO FLEXIBLE SHAFT COMPANY, CHICAGO, IL: 283,524. REN. 6-16-11. U.S. CL. 23 (INT. CL. 8).

SUNBELT COMMUNICATIONS COMPANY, LAS VEGAS, NV: 2,401,579. CANC. MULTIPLE CLASS, INT. CLS. 41 AND 42.

SUNCOVER S.P.A., ITALY: 3,996,020. PUB. 5-3-2011. MULTIPLE CLASS, INT. CLS. 20 AND 24.

SUNDAYBELL, INC., BURLINGTON, CANADA: 3,997,841. PUB. 5-3-2011. INT. CL. 42.

SUNIVA MEDICAL, INC., SAN DIEGO, CA: 3,998,651. INT. CL. 10.

SUNEX INTERNATIONAL, INC., GREENVILLE, SC: 2,901,879. CANC. INT. CL. 7.

SUNIVA, INC., NORCROSS, GA: 3,998,986. INT. CL. 11.

SUNNYSIDE FEDERAL SAVINGS AND LOAN ASSOCIATION OF IRVINGTON, IRVINGTON, NY: 3,998,840. INT. CL. 36.

SUNRAY GAMING OF NEW MEXICO, LLC, FARMINGTON, NM, DBA SUNRAY PARK & CASINO: 3,996,352. PUB. 5-3-2011. MULTIPLE CLASS, INT. CLS. 41 AND 43. 3,996,353. PUB. 5-3-2011. MULTIPLE CLASS, INT. CLS. 41 AND 43.

SUNRISE MFG INC., RANCHO CORDOVA, CA: 3,998,541. INT. CL. 12.

SUNRISE SENIOR LIVING, INC., MCLEAN, VA: 3,010,096. AM. MULTIPLE CLASS, INT. CLS. 35, 43, 44 AND 45.

SUNSHINE SUPPLEMENT, INC., MINDEN, NV: 3,999,256. MULTIPLE CLASS, INT. CLS. 5 AND 44.

SUNSTAR, INC., OSAKA, JAPAN: 3,998,362. MULTIPLE CLASS, INT. CLS. 3 AND 5.

SUNTORY FLOWERS LIMITED, TOKYO, JAPAN: 2,402,332. CANC. INT. CL. 31.

SUNWORKS SOLAR LLC, WILMINGTON, COUNTY OF NEW CASTLE, DE: 3,995,558. PUB. 5-26-2009. INT. CL. 9.

SUPER DUPER INC., GREENVILLE, SC, DBA SUPER DUPER PUBLICATIONS: 2,550,060. REN. 6-13-11. MULTIPLE CLASS, INT. CLS. 16 AND 28.

SUPER ELEPHANT CO., LTD., TAIPEI, TAIWAN: 3,998,885. MULTIPLE CLASS, INT. CLS. 29 AND 30.

SUPER HEALTH INSTITUTE, INC., DIAMOND BAR, CA: 3,995,629. PUB. 5-3-2011. INT. CL. 35.

SUPER POWER HEROES, LLC, RUNNEMEDE, NJ: 3,998,581. INT. CL. 16.

SUPER SONIC WHEELS (USA) INC., SOUTH EL MONTE, CA: 3,997,903. PUB. 5-3-2011. INT. CL. 12.

SUPERMEDIA LLC, DALLAS/FORT WORTH AIRPORT, TX: 3,998,954. INT. CL. 35. 3,998,966. INT. CL. 35.

SUPERNOVA DIAGNOSTICS, INC, DAMMASCUS, MD: 3,999,346. MULTIPLE CLASS, INT. CLS. 9 AND 10.

SUPRACOR, INC., SAN JOSE, CA: 3,997,095. PUB. 5-3-2011. MULTIPLE CLASS, INT. CLS. 20, 24, 25 AND 28.

SUPREME OIL COMPANY, INC., ENGLEWOOD, NJ: 3,996,270. PUB. 5-3-2011. MULTIPLE CLASS, INT. CLS. 29 AND 30.

SURADO SOLUTIONS, INC., RIVERSIDE, CA: 2,402,210. CANC. INT. CL. 9.

SURDHAR, GURCHARAN KAUR, BIRMINGHAM, UNITED KINGDOM: 3,996,280. PUB. 4-5-2011. MULTIPLE CLASS, INT. CLS. 9, 16, 25, 28 AND 41.

SUREFIND PIPELINE MARKERS, LLC, ZAPATA, TX: 3,997,185. PUB. 5-3-2011. INT. CL. 25.

SURFERS PARADISE CLOTHING CO, PERTH, WA, AUSTRALIA: 3,999,679. INT. CL. 25.

SURGERE, INC., NORTH CANTON, OH: 3,997,590. PUB. 5-3-2011. INT. CL. 35. 3,997,596. PUB. 5-3-2011. INT. CL. 35.

SURTECO USA INC., GREENSBORO, NC: 3,999,224. MULTIPLE CLASS, INT. CLS. 17 AND 20.

SUSAN BERMAN, OLYMPIA, WA: 3,997,714. PUB. 5-3-2011. INT. CL. 41.

SUSAN MARIE KAMINSKY, GILBERT, AZ: 3,998,897. INT. CL. 25.

SUSAN MOSKOWITZ, WEST ORANGE, NJ: 3,999,651. INT. CL. 9.

SUSANNA PFISTER, SOMERSET, NJ: 2,901,682. CANC. INT. CL. 41.

SUSTAINABLE STEAM & WATER SOLUTIONS, INC., GREENCASTLE, IN: 4,000,008. INT. CL. 35.

SUTTER HOME WINERY, INC., ST. HELENA, CA: 3,998,194. PUB. 5-3-2011. INT. CL. 35.

SUTTON, CYRUS, VISTA, CA: 3,998,184. PUB. 5-3-2011. INT. CL. 42.

SVEFLYTT AKTIEBOLAG, SWEDEN: 3,995,841. PUB. 5-3-2011. INT. CL. 12.

SVEN'S COMFORT SHOES, INC., CHISAGO CITY, MN: 2,452,526. REN. 6-16-11. INT. CL. 25.

SWANSON, KEVIN A., SAN DIEGO, CA, DBA SAN DIEGO 2015: 4,000,058. INT. CL. 25.

SWEDEV AB, 684 22 MUNKFORS, SWEDEN: 2,547,762. REN. 6-15-11. INT. CL. 7.

SWENSON, JOY A, CARLIN, NV: 2,902,140. CANC. INT. CL. 25.

SWIFF-TRAIN COMPANY, LLC, CORPUS CHRISTI, TX: 3,998,464. INT. CL. 19.

SWIFT RENOVATIONS, INC., GLENDALE, NY: 3,999,686. INT. CL. 37.

SWIFTPRO AUTO GLASS, LLC, HOLLADAY, UT: 3,998,095. PUB. 5-3-2011. INT. CL. 37.

SWIFTWICK INTERNATIONAL, LLC, BRENTWOOD, TN: 3,998,502. INT. CL. 25.

SWIM FREE, LLC, PACIFIC PALISADES, CA: 3,998,430. INT. CL. 9. 3,998,431. INT. CL. 28.

SWIMC, INC., NEWARK, DE: 2,451,363. REN. 6-10-11. INT. CL. 2.

SWISS WATCH INTERNATIONAL, INC., HOLLYWOOD, FL: 3,996,227. PUB. 5-3-2011. INT. CL. 14.

SWNR, LLC, PAGOSA SPRINGS, CO: 3,999,121. INT. CL. 25.

SYBAC SOLAR LLC, LAKELAND, FL, FL: 3,997,170. PUB. 5-3-2011. MULTIPLE CLASS, INT. CLS. 37 AND 42.

SYDNEY ENTERPRISES, LLC., PHOENIX, AZ: 3,999,626. INT. CL. 30.

SYKES JR., MARVIN E., WAKE FOREST, NC: 3,998,395. INT. CL. 12.

SYLVAN INC., SAXONBURG, PA: 2,901,119. CANC. MULTIPLE CLASS, INT. CLS. 1, 5 AND 31.

SYLVAN LEARNING, INC., BALTIMORE, MD: 2,553,024. REN. 6-14-11. INT. CL. 41.

SYMRISE AG, HOLZMINDEN 37603, FED REP GERMANY: 3,998,556. INT. CL. 3.

SYMRISE, INC., TETERBORO, NJ: 2,901,248. CANC. INT. CL. 1. 2,901,249. CANC. INT. CL. 1.

SYNCRETICS GROUP, INC., THE, BRANFORD, CT: 3,997,074. PUB. 5-3-2011. INT. CL. 41.

SYNDEVRX, INC., CAMBRIDGE, MA: 3,998,370. MULTIPLE CLASS, INT. CLS. 5 AND 42.

SYNDICATED PUZZLES, VICTORIA, CANADA: 3,997,097. PUB. 5-3-2011. MULTIPLE CLASS, INT. CLS. 16 AND 41. 3,998,011. PUB. 5-3-2011. INT. CL. 16.

SYNERGETHICS, INC., PORTLAND, ME: 3,996,357. PUB. 5-3-2011. INT. CL. 41.

SYNERGOS TECHNOLOGIES, INC., AUSTIN, TX: 3,998,039. PUB. 5-3-2011. INT. CL. 35.

- SYNERGY MICROWAVE CORPORATION, PATERSON, NJ:
1,672,479. REN. 6-16-11. INT. CL. 9.
- SYNGENTA PARTICIPATIONS AG, BASEL, SWITZERLAND:
2,902,286, CANC. INT. CL. 5.
- SYNORAN LLC, COLUMBUS, OH:
2,902,214, CANC. MULTIPLE CLASS, INT. CLS. 9 AND 36.
- SYNTELESYS EDUCATIONAL SERVICES, MONTEREY PARK, CA:
3,999,981, INT. CL. 41.
- SYNTHES USA, LLC, WEST CHESTER, PA:
3,999,305, INT. CL. 5.
- SYNTONICS LLC, COLUMBIA, MD:
3,997,465, PUB. 5-3-2011. MULTIPLE CLASS, INT. CLS. 9, 38 AND 42.
- SYNTOPIX GROUP PLC, BRADFORD, UNITED KINGDOM:
3,995,594, PUB. 5-3-2011. MULTIPLE CLASS, INT. CLS. 1, 3, 5, 42 AND 44.
- SYPROCON, INC., NEW YORK, NY:
2,402,675, CANC. INT. CL. 9.
- SYSTEM SERVICE S.R.L., ITALY:
3,996,028, PUB. 5-3-2011. INT. CL. 25.
- T AND O PROPERTIES, LLC, MYRTLE BEACH, SC:
3,996,240, PUB. 5-3-2011. MULTIPLE CLASS, INT. CLS. 5 AND 44.
- T. BAIRD MCILVAIN COMPANY, HANOVER, PA:
2,560,377. REN. 6-10-11. MULTIPLE CLASS, INT. CLS. 19 AND 35.
- T.S. TIPPIN & CO., JACKSONVILLE, FL:
3,998,901, INT. CL. 30.
- T-MOBILE USA, INC., BELLEVUE, WA:
3,998,766, INT. CL. 38.
3,998,865, INT. CL. 38.
- TACNOLOGY, LLC, SOLANA BEACH, CA:
3,998,782, INT. CL. 16.
- TACO BELL CORP., IRVINE, TX:
3,999,918, MULTIPLE CLASS, INT. CLS. 35 AND 36.
- TACTICA INTERNATIONAL, INC., NEW YORK, NY:
2,901,167, CANC. INT. CL. 26.
- TACUPETO CHIPS & SALSA INC., CARLSBAD, CA:
3,997,230, PUB. 5-3-2011. INT. CL. 30.
- TAKANO CO., LTD., NAGANO 399-4301, JAPAN:
3,998,470, MULTIPLE CLASS, INT. CLS. 9, 10, 12 AND 20.
- TAKASAGO KORYO KOGYO KABUSHIKI KAISHA, TOKYO 144-8721, JAPAN, TA TAKASAGO INTERNATIONAL CORPORATION:
2,401,444, CANC. MULTIPLE CLASS, INT. CLS. 1 AND 3.
- TAKENAKA CORPORATION, OSAKA, JAPAN:
3,997,169, PUB. 5-3-2011. INT. CL. 37.
- TAKING BEAUTY, LLC, PHILADELPHIA, PA:
3,997,875, PUB. 5-3-2011. INT. CL. 44.
- TALAMONTI, PHILIP, THE WOODLANDS, TX:
2,901,519, CANC. INT. CL. 42.
- TALBEN CAFE PARTICIPACOES AGRICOLAS LTDA., SAO PAULO, MINAS GERAIS, BRAZIL:
2,901,195, CANC. INT. CL. 30.
- TALBOT CLUB, INC., SARASOTA, FL:
3,999,962, INT. CL. 41.
3,999,963, INT. CL. 41.
- TALENT ON HOLD, LLC, SAINT CHARLES, MO:
3,996,648, PUB. 5-3-2011. INT. CL. 35.
- TALENT QUOTIENT, INC., EXCELSIOR, MN:
3,999,326, INT. CL. 35.
- TALLGRASS BREWING COMPANY, MANHATTAN, KS:
3,996,531, PUB. 5-3-2011. INT. CL. 32.
- TALMADGE, JOHN ROBERT, SEBASTIAN, FL:
3,997,001, PUB. 5-3-2011. INT. CL. 25.
- TAMARAC MEDICAL, INC., CENTENNIAL, CO:
3,998,511, MULTIPLE CLASS, INT. CLS. 10 AND 42.
- TAMER PARTNERS CORPORATION, SOUTHLAKE, TX:
2,902,297, CANC. INT. CL. 41.
- TAMMIE B TAYLOR, CHESAPEAKE, VA, DBA POTTS N PAINTS:
3,996,096, PUB. 5-3-2011. INT. CL. 41.
- TANAKA UNIVERSAL CO., LTD., OSAKA, JAPAN:
3,998,400, INT. CL. 18.
- TANCOR CORPORATION, MIDLAND, MI:
3,996,286, PUB. 5-3-2011. INT. CL. 37.
- TANDBERG DATA HOLDINGS S.A.R.L., LUXEMBOURG, LUXEMBOURG:
3,996,764, PUB. 3-29-2011. INT. CL. 9.
- TANDUS US, LLC, DALTON, GA:
3,997,076, PUB. 5-3-2011. INT. CL. 19.
- TAPOCIK, CLAUDETTE M., RIVERSIDE, CA:
2,901,344, CANC. INT. CL. 30.
- TAQUERIA FLETCHER, LLC, TAMPA, FL:
3,997,098, PUB. 5-3-2011. INT. CL. 43.
- TARANTINO, JOSEPH V., CARMEL, CA, DBA TARANTINO'S CANNED FOODS:
2,543,042. REN. 6-15-11. INT. CL. 29.
- TARGET TECHNOLOGIES, COLUMBIA, MD:
3,998,692, INT. CL. 42.
- TARGET BRANDS, INC., MINNEAPOLIS, MN:
3,998,872, MULTIPLE CLASS, INT. CLS. 16 AND 36.
3,999,375, INT. CL. 24.
3,999,376, INT. CL. 20.
- TARGUS INFORMATION CORPORATION, VIENNA, VA:
3,996,115, PUB. 5-3-2011. INT. CL. 35.
- TARTARA GROUP, INC., EDISON, NJ:
3,999,609, INT. CL. 21.
- TASTEFUL SELECTIONS, LLC, BANCROFT, WI:
3,999,935, INT. CL. 31.
- TASZ, INC., LENOIR, NC, AKA NEOCORK:
2,402,656, CANC. INT. CL. 20.
- TATOES, LLC, MATTAWA, WA:
2,535,674, CANC. INT. CL. 31.
- TAYLOR & FRANCIS GROUP, LLC, BOCA RATON, FL:
2,402,998, CANC. INT. CL. 16.
- TAYLOR-BARRY, ELIZABETH L., COLUMBIA, SC, DBA BARRYBASICS:
3,999,092, INT. CL. 10.
- TAYLOR-LISTUG, INC., EL CAJON, CA:
3,999,147, INT. CL. 15.
- TB PHILLY, INC, PHOENIXVILLE, PA, DBA TBP CONVERTING:
3,997,275, PUB. 5-3-2011. INT. CL. 17.
- TBFC HOLDINGS, INC., NEW YORK, NY:
2,470,021. REN. 6-16-11. MULTIPLE CLASS, INT. CLS. 35 AND 42.
- TBG INSURANCE SERVICES CORPORATION, LOS ANGELES, CA, DBA TBG FINANCIAL:
2,901,425, CANC. INT. CL. 36.
- TC VENTURES, LLC, GROTON, SD:
3,998,732, INT. CL. 25.
- TCBY SYSTEMS, LLC, SALT LAKE CITY, UT:
3,999,551, MULTIPLE CLASS, INT. CLS. 30 AND 43.
- TD AMERITRADE IP COMPANY, INC., OMAHA, NE:
3,999,385, MULTIPLE CLASS, INT. CLS. 9 AND 36.
- TDS AUTOMOTIVE CANADA, INC., LONDON ONTARIO, CANADA:
2,901,528, CANC. INT. CL. 35.
- TEA FORTÉ, INC., CONCORD, MA:
3,999,649, INT. CL. 30.
- TEALEAF TECHNOLOGY, INC., SAN FRANCISCO, CA, TEALEAF TECHNOLOGY, INC., SAN FRANCISCO, CA:
2,492,203. REN. 6-10-11. MULTIPLE CLASS, INT. CLS. 9 AND 42.
- TEAM ESTROGEN, INC., HILLSBORO, OR:
3,997,142, PUB. 5-3-2011. INT. CL. 35.
- TEAM PLAY, INC., ELK GROVE VILLAGE, IL:
4,000,047, INT. CL. 9.
- TEAMREADINESS, INC., CHICAGO, IL:
3,996,620, PUB. 5-3-2011. MULTIPLE CLASS, INT. CLS. 35 AND 42.
- TECAN GROUP AG, CH-8708 MANNEDORF, SWITZERLAND:
2,901,222, CANC. INT. CL. 9.
- TECHFAST MANUFACTURING SDN BHD, SELANGOR, MALAYSIA:
2,901,374, CANC. INT. CL. 6.
- TECHNOLOGY INNOVATION FOR SUSTAINABLE SOCIETIES, BERKELEY, CA:
3,999,900, INT. CL. 35.

TECHNOLOGY MATRIX GROUP LTD., LEESBURG, VA:
2,402,065, CANC. INT. CL. 35.

TECHTRONIC FLOOR CARE TECHNOLOGY LIMITED,
ROAD TOWN, TORTOLA, BR. VIRGIN ISLANDS:
3,997,918, PUB. 5-3-2011. INT. CL. 11.
3,999,299, INT. CL. 7.

TED & ANDY, LLC, SAINT LOUIS, MO:
3,996,493, PUB. 5-3-2011. INT. CL. 29.

TED A. LESTER, VALPARAISO, IN:
3,998,624, INT. CL. 16.

TEK INDUSTRIES, INC., FREMONT, NE:
3,999,560, INT. CL. 7.

TELAPPRISE LLC, SAN JOSE, CA:
3,996,330, PUB. 5-3-2011. INT. CL. 42.

TELECHECK INTERNATIONAL, INC., HOUSTON, TX:
3,999,658, INT. CL. 36.

TELEDYNE BENTHOS, INC., NORTH FALMOUTH, MA,
DBA TELEDYNE WEBB RESEARCH:
3,996,071, PUB. 5-3-2011. INT. CL. 12.

TELEFLORA LLC, LOS ANGELES, CA:
3,998,914, INT. CL. 42.

TELENAV, INC., SUNNYVALE, CA:
3,996,391, PUB. 11-23-2010. MULTIPLE CLASS, INT. CLS.
9 AND 42.

TELEVISION FOOD NETWORK, G.P., NEW YORK, NY:
3,996,050, PUB. 5-3-2011. INT. CL. 41.

TELKONET, INC., ANNAPOLIS, MD:
2,707,696, COR. MULTIPLE CLASS, INT. CLS. 9 AND 38.

TELKONET, INC., GERMANTOWN, MD:
2,983,337, COR. INT. CL. 38.
3,152,157, COR. INT. CL. 38.
3,699,418, COR. MULTIPLE CLASS, INT. CLS. 9, 37 AND
42.
3,889,185, COR. INT. CL. 9.

TELLING INDUSTRIES, LLC, STREETSBORO, OH:
3,996,416, PUB. 1-25-2011. INT. CL. 6.

TELOS IDENTITY MANAGEMENT SOLUTIONS, LLC,
ASBURN, VA, AKA TELOS ID:
3,998,765, MULTIPLE CLASS, INT. CLS. 9 AND 42.

TELUS CORPORATION, EDMONTON, ALBERTA, CANA-
DA:
2,401,165, CANC. INT. CL. 38.

TENHULZEN, DALE T., HUNTINGTON BEACH, CA:
3,998,498, INT. CL. 36.

TENNVAC INC., TAIPEI HSIEN, TAIWAN:
3,997,518, PUB. 5-3-2011. INT. CL. 9.

TENREHTE TECHNOLOGIES, INC., ROCHESTER, NY:
3,996,128, PUB. 5-3-2011. INT. CL. 9.

TEQUILA CUERVO LA ROJENA, S.A. DE C.V., CODIGO,
MEXICO:
3,996,614, PUB. 5-3-2011. INT. CL. 33.
3,996,615, PUB. 5-3-2011. INT. CL. 33.

TEQUILERA MILAGRO, S.A. DE C.V., COL.DESARROLLO
SANTAFE, MEXICO:
3,999,925, INT. CL. 33.

TEQUILERA OCHO MESAS, LLC, SCOTTSDALE, AZ:
3,999,566, INT. CL. 33.

TERI, INC., OCEANSIDE, CA:
4,000,040, INT. CL. 41.
4,000,054, INT. CL. 45.

TERRA SPECTRUM TECHNOLOGIES, INC., WEST DES
MOINES, IA:
2,901,700, CANC. INT. CL. 9.

TERRUS REAL ESTATE GROUP, L.L.C., DES MOINES, IA:
2,463,665, REN. 6-15-11. MULTIPLE CLASS, INT. CLS. 35,
36, 37 AND 42.

TERVIS TUMBLER COMPANY, NORTH VENICE, FL:
3,996,484, PUB. 5-3-2011. INT. CL. 21.
3,996,754, PUB. 5-3-2011. INT. CL. 21.

TESHKEEL MEDIA GROUP, INC., NEW YORK, NY:
3,999,459, INT. CL. 24.

TESTBOURNE LIMITED, HAMPSHIRE, ENGLAND:
2,901,012, CANC. INT. CL. 1.

TETRADIGM GROUP, LLC, ALEXANDRIA, VA:
3,997,153, PUB. 5-3-2011. MULTIPLE CLASS, INT. CLS. 35
AND 36.
3,997,154, PUB. 5-3-2011. MULTIPLE CLASS, INT. CLS. 35
AND 36.

TETRIS ONLINE, INC., HONOLULU, HI:
3,999,770, INT. CL. 41.
3,999,811, INT. CL. 9.

TEVENTI LLC, ROSWELL, GA:
3,999,479, INT. CL. 6.

TEVENTI, LLC, ROSWELL, GA:
3,998,730, INT. CL. 6.

TEXAS A&M UNIVERSITY, COLLEGE STATION, TX:
3,999,623, INT. CL. 35.

TEXAS CEMENT PRODUCTS, INC., HOUSTON, TX:
3,996,588, PUB. 5-3-2011. INT. CL. 19.
3,996,589, PUB. 5-3-2011. INT. CL. 19.

TEXAS EDUCATION AGENCY, AUSTIN, TX:
3,996,519, PUB. 5-3-2011. INT. CL. 35.

TEXSA, S.A., BARCELONA, SPAIN:
3,996,301, PUB. 5-3-2011. INT. CL. 19.

TEXTRONIC, INC, MIAMI, FL:
3,996,879, PUB. 5-3-2011. INT. CL. 9.

THALES ALENIA SPACE FRANCE, TOULOUSE, FRANCE:
3,999,970, INT. CL. 7.

THE ALLAN CANDY COMPANY LIMITED, MISSISSAUGA,
ONTARIO, CANADA:
3,995,577, PUB. 5-3-2011. INT. CL. 30.
3,995,578, PUB. 5-3-2011. INT. CL. 30.
3,996,070, PUB. 5-3-2011. INT. CL. 30.

THE AMERICAN RED CROSS, WASHINGTON, DC, DBA
AMERICAN RED CROSS AND RED CROSS:
3,996,282, PUB. 5-3-2011. MULTIPLE CLASS, INT. CLS. 35
AND 41.

THE ARMED FORCES MILITARY MUSEUM, INC., LAR-
GO, FL:
3,996,143, PUB. 5-3-2011. INT. CL. 25.

THE ARMOR GROUP, INC., MASON, OH:
3,996,554, PUB. 5-3-2011. MULTIPLE CLASS, INT. CLS. 7,
12, 21 AND 40.

THE ART EXPLORERS, INC., CHICAGO, IL:
2,901,793, CANC. INT. CL. 41.

THE AUTISM FORUM, INC., WILSONVILLE, OR:
3,999,903, MULTIPLE CLASS, INT. CLS. 36 AND 41.

THE AWATERE RIVER WINE COMPANY LIMITED,
MARLBOROUGH, NEW ZEALAND:
3,996,400, PUB. 5-3-2011. INT. CL. 33.

THE BALTIC EXCHANGE LIMITED, LONDON EC3A 8BH,
UNITED KINGDOM:
3,995,750, PUB. 5-3-2011. MULTIPLE CLASS, INT. CLS. 9,
35 AND 36.
3,995,751, PUB. 5-3-2011. MULTIPLE CLASS, INT. CLS. 9,
35 AND 36.
3,995,752, PUB. 5-3-2011. MULTIPLE CLASS, INT. CLS. 9,
35 AND 36.

THE BAY HILL CLASSIC, INC., CLEVELAND, OH:
2,901,662, CANC. INT. CL. 41.

THE BEST OF ORGANIC LLC, WEST BLOOMFIELD, MI:
3,997,015, PUB. 5-3-2011. INT. CL. 41.
3,997,052, PUB. 5-3-2011. INT. CL. 41.

THE BLACK AND DECKER CORPORATION, TOWSON,
MD:
3,997,432, PUB. 5-3-2011. MULTIPLE CLASS, INT. CLS. 3
AND 7.

THE BLUEFIELD PROJECT TO CURE FRONTOTEMPOR-
AL DEMENTIA, SAN FRANCISCO, CA:
3,999,600, INT. CL. 36.

THE BOARD OF REGENTS OF THE NEVADA SYSTEM OF
HIGHER EDUCATION ON BEHALF OF THE UNIVER-
SITY OF NEVADA, RENO FOR THE UNIVERSITY
STUDIES ABROAD CONSORTIUM, RENO, NV:
3,909,871, COR. MULTIPLE CLASS, INT. CLS. 16, 35, 39
AND 41.
3,918,587, COR. MULTIPLE CLASS, INT. CLS. 16, 35, 39
AND 41.
3,918,588, COR. MULTIPLE CLASS, INT. CLS. 16, 35, 39
AND 41.

THE BRIGHT LIGHT SOCIAL HOUR, LLC, AUSTIN, TX:
3,996,652, PUB. 5-3-2011. INT. CL. 41.

THE BRITISH BROADCASTING CORPORATION, LON-
DON, UNITED KINGDOM:
3,995,745, PUB. 1-25-2011. MULTIPLE CLASS, INT. CLS.
9, 16, 25, 28, 38 AND 41.

- THE BUREAU OF NATIONAL AFFAIRS, INC., ARLINGTON, VA:
3,996,426, PUB. 5-3-2011. MULTIPLE CLASS, INT. CLS. 16 AND 41.
- THE BURTON CORPORATION, BURLINGTON, VT:
2,568,324, REN. 6-14-11. INT. CL. 28.
- THE CARPET GUYS, LLC, HARRISON TOWNSHIP, MI:
3,996,755, PUB. 5-3-2011. INT. CL. 37.
- THE CARTOON NETWORK, INC., ATLANTA, GA:
3,998,437, INT. CL. 24.
- THE CELL-O-CORE COMPANY, SHARON CENTER, OH:
3,998,094, PUB. 5-3-2011. INT. CL. 20.
- THE CEMENTWORKS, LLC, NEW YORK, NY:
3,999,449, INT. CL. 35.
- THE CENTER FOR HEALTH VALUE INNOVATION, ST. LOUIS, MO:
3,999,989, INT. CL. 44.
- THE CENTER FOR PLANNING EXCELLENCE, INC., BATON ROUGE, LA:
3,998,105, PUB. 5-3-2011. INT. CL. 42.
- THE CENTER FOR VICTIMS OF TORTURE, ST. PAUL, MN:
3,996,520, PUB. 5-3-2011. MULTIPLE CLASS, INT. CLS. 35 AND 44.
- THE CFO SUITE, LLC, DALLAS, TX:
3,999,957, MULTIPLE CLASS, INT. CLS. 35 AND 36.
- THE CHICAGO MULTI-CULTURAL DANCE CENTER, INC., HOME OF THE BRYANT BALLET, CHICAGO, IL:
3,570,559, COR. INT. CL. 41.
- THE CLOROX COMPANY, OAKLAND, CA:
3,999,656, INT. CL. 3.
- THE CLUB AT SPANISH PEAKS, LLC, BIG SKY, MT:
3,029,179, CANC. INT. CL. 37.
- THE COCA-COLA COMPANY, ATLANTA, GA:
2,901,651, CANC. INT. CL. 27.
- THE CODE CORPORATION, BLUFFDALE, UT:
3,999,748, INT. CL. 9.
- THE COLLEGE NETWORK, INC., INDIANAPOLIS, IN:
3,997,695, PUB. 5-3-2011. INT. CL. 41.
- THE CONTEMPORARY YOUTH ORCHESTRA, CLEVELAND HEIGHTS, OH:
3,996,760, PUB. 5-3-2011. INT. CL. 41.
- THE CORPORATE EXECUTIVE BOARD COMPANY, ARLINGTON, VA:
3,999,977, MULTIPLE CLASS, INT. CLS. 35 AND 41.
- THE CRADLE SOCIETY, EVANSTON, IL:
3,995,687, PUB. 5-3-2011. INT. CL. 45.
- THE CREATIVE LADY, LLC, CORDOVA, TN:
3,997,725, PUB. 5-3-2011. INT. CL. 41.
- THE CRESSET CHEMICAL CO., WESTON, OH:
2,433,338, COR. INT. CL. 7.
- THE CULTURAL LANDSCAPE FOUNDATION, WASHINGTON, DC:
3,996,750, PUB. 5-3-2011. INT. CL. 44.
- THE CUPCAKE STATION INCORPORATED, BIRMINGHAM, MI:
3,997,915, PUB. 5-3-2011. INT. CL. 30.
- THE CURATORS OF THE UNIVERSITY OF MISSOURI, COLUMBIA, MO:
2,459,915, REN. 6-15-11. INT. CL. 41.
- THE CYBRIX GROUP INC., TAMPA, FL:
3,995,603, PUB. 5-3-2011. INT. CL. 42.
- THE DELANEY CO., CUMMING, GA:
3,998,106, PUB. 5-3-2011. INT. CL. 6.
- THE ELDERS, INC., SAN FRANCISCO, CA:
3,726,181, AM. INT. CL. 42.
3,811,405, AM. INT. CL. 41.
- THE FERNEBERG GROUP, INC., SAN MATEO, CA:
3,997,312, PUB. 5-3-2011. INT. CL. 35.
- THE FINE ART OF ROMANCE, INC., EUREKA SPRINGS, AR:
3,997,857, PUB. 5-3-2011. INT. CL. 35.
- THE FLETCHER-TERRY COMPANY, LLC, FARMINGTON, CT:
542,265, REN. 6-10-11. U.S. CL. 23 (INT. CL. 8).
- THE FONT BUREAU INC., BOSTON, MA:
3,998,290, PUB. 5-3-2011. INT. CL. 9.
- THE FONT BUREAU INC., BOSTON, MA AND CARTER & CONE TYPE INC., CAMBRIDGE, MA:
3,998,291, PUB. 5-3-2011. INT. CL. 9.
- THE FONT BUREAU, INC., BOSTON, MA:
3,998,084, PUB. 5-3-2011. INT. CL. 9.
3,998,238, PUB. 5-3-2011. INT. CL. 42.
- THE GILLETTE COMPANY, BOSTON, MA:
2,390,089, REN. 6-11-11. INT. CL. 8.
- THE GLAD PRODUCTS COMPANY, OAKLAND, CA:
3,998,562, INT. CL. 16.
- THE GOOD EARTH CORPORATION, MONTVALE, NJ:
3,997,953, PUB. 5-3-2011. INT. CL. 43.
- THE HAGERTY GROUP, LLC, TRAVERSE CITY, MI:
3,996,742, PUB. 3-29-2011. INT. CL. 41.
- THE HAMILTON GROUP, INC, RANCHO SANTA MARGARITA, CA, DBA HAMILTON LABS:
3,997,068, PUB. 5-3-2011. INT. CL. 5.
- THE HAROLD GRINSPOON FOUNDATION, WEST SPRINGFIELD, MA:
3,578,757, AM. INT. CL. 16.
- THE HIPCHECK, LLC, CHARLOTTE, VT:
3,997,890, PUB. 5-3-2011. INT. CL. 28.
- THE IRMI GROUP LLC, INDIANAPOLIS, IN:
3,998,548, INT. CL. 16.
- THE JEFF ARNOLD COMPANIES, INC., TUCSON, AZ:
3,998,071, PUB. 5-3-2011. INT. CL. 36.
- THE JOCK SOAP COMPANY, INC., NEWARK, DE:
3,998,092, PUB. 5-3-2011. INT. CL. 3.
3,998,096, PUB. 5-3-2011. INT. CL. 3.
- THE LASHE, INC., CHICAGO, IL:
3,999,976, INT. CL. 3.
- THE LETICIA E. SCHMIDT TRUST NO. 101, GENEVA, IL:
3,997,941, PUB. 5-3-2011. INT. CL. 35.
- THE LOVED DOG LLC, LOS ANGELES, CA:
3,998,392, INT. CL. 16.
- THE MAKEUP LAB, NEW ORLEANS, LA:
3,997,492, PUB. 5-3-2011. INT. CL. 44.
- THE MARIN GROUP, INC., SPRINGFIELD, VA:
3,997,435, PUB. 5-3-2011. INT. CL. 41.
- THE MATHWORKS, INC., NATICK, MA:
3,998,371, MULTIPLE CLASS, INT. CLS. 9, 41 AND 42.
- THE MCGRAW-HILL COMPANIES, INC., NEW YORK, NY:
3,997,957, PUB. 5-3-2011. INT. CL. 38.
3,997,961, PUB. 5-3-2011. INT. CL. 41.
3,997,968, PUB. 5-3-2011. INT. CL. 41.
3,998,035, PUB. 5-3-2011. INT. CL. 41.
- THE MENKE GROUP, INC., SAN FRANCISCO, CA:
3,997,805, PUB. 5-3-2011. INT. CL. 36.
- THE MERAMEC GROUP, INC., SULLIVAN, MO:
3,997,240, PUB. 5-3-2011. INT. CL. 25.
- THE MICHIGAN WOMEN'S FOUNDATION, GROSSE POINTE FARMS, MI:
3,997,261, PUB. 5-3-2011. INT. CL. 41.
- THE MITCHELL GOLD CO., TAYLORSVILLE, NC:
3,999,454, INT. CL. 20.
- THE MK ELEMENT LLC, ATLANTA, GA:
3,997,054, PUB. 5-3-2011. INT. CL. 35.
- THE MOYER FOUNDATION, SEATTLE, WA:
3,999,964, INT. CL. 41.
- THE NATIONAL COALITION FOR TELECOMMUNICATIONS EDUCATION AND LEARNING, GREENWOOD VILLAGE, CO:
2,461,565, REN. 6-16-11. INT. CL. 41.
2,461,566, REN. 6-16-11. INT. CL. 41.
- THE ONE PAGE BUSINESS PLAN COMPANY, BERKELEY, CA:
2,476,794, REN. 6-14-11. MULTIPLE CLASS, INT. CLS. 9, 35 AND 36.
- THE OVADAFUT HOSIERY COMPANY, NEW YORK, NY:
3,996,445, PUB. 5-3-2011. MULTIPLE CLASS, INT. CLS. 25 AND 35.
- THE PACIFIC INSTITUTE INCORPORATED, SEATTLE, WA:
3,997,637, PUB. 5-3-2011. MULTIPLE CLASS, INT. CLS. 9 AND 16.
3,998,277, PUB. 5-3-2011. MULTIPLE CLASS, INT. CLS. 9, 16 AND 41.
3,999,947, MULTIPLE CLASS, INT. CLS. 9, 16 AND 41.

- THE PERFECT PICTURE ALWAYS LIMITED, GATES-HEAD, UNITED KINGDOM:
3,855,448, COR. MULTIPLE CLASS, INT. CLS. 40 AND 41.
- THE PIERPONT MORGAN LIBRARY, NEW YORK, NY:
3,996,418, PUB. 5-3-2011. INT. CL. 16.
- THE PNC FINANCIAL SERVICES GROUP, INC., PITTSBURGH, PA:
2,902,094, CANC. INT. CL. 36.
- THE PROCTER & GAMBLE COMPANY, CINCINNATI, OH:
3,995,640, PUB. 5-3-2011. INT. CL. 16.
3,999,103, INT. CL. 11.
3,999,196, MULTIPLE CLASS, INT. CLS. 29 AND 30.
3,999,423, INT. CL. 9.
3,999,549, INT. CL. 3.
- THE PROSSER GROUP LLC, BROOKLYN, NY:
3,999,997, INT. CL. 37.
- THE PRUDENTIAL INSURANCE COMPANY OF AMERICA, NEWARK, NJ:
2,902,219, CANC. INT. CL. 36.
3,998,242, PUB. 5-3-2011. INT. CL. 36.
3,998,243, PUB. 5-3-2011. INT. CL. 36.
3,998,244, PUB. 5-3-2011. INT. CL. 36.
- THE PURE GUILD LLC, SCOTTSDALE, AZ:
3,998,948, INT. CL. 3.
- THE RESEARCH FOUNDATION OF STATE UNIVERSITY OF NEW YORK, ALBANY, NY:
3,997,210, PUB. 5-3-2011. INT. CL. 42.
- THE RETAIL EQUATION, INC., IRVINE, CA:
3,995,622, PUB. 5-3-2011. INT. CL. 35.
- THE RO RO COMPANY, INC., LOS ANGELES, CA:
3,998,436, INT. CL. 3.
- THE ROSETTE GROUP, INC., SHIRLEY, NY:
3,999,785, INT. CL. 36.
- THE RUNNING DOG RANCH, CORTE MADERA, CA:
3,996,702, PUB. 5-3-2011. INT. CL. 41.
- THE SALVATION ARMY, ATLANTA, GA:
3,997,424, PUB. 5-3-2011. INT. CL. 36.
- THE SAUL ZAENTZ COMPANY, BERKELEY, CA, DBA TOLKIEN ENTERPRISES:
3,998,397, INT. CL. 28.
- THE SAUL ZAENTZ COMPANY DBA TOLKIEN ENTERPRISES, BERKELEY, CA:
3,998,393, INT. CL. 41.
- THE SCHOOL BOARD OF MIAMI-DADE COUNTY, MIAMI, FL:
3,997,365, PUB. 5-3-2011. INT. CL. 41.
- THE SCOPE EXCHANGE, INC., GREENSBORO, NC:
2,901,018, CANC. INT. CL. 35.
- THE SECRET TO WRITING, LLC, ATLANTA, GA:
3,996,373, PUB. 5-3-2011. INT. CL. 41.
- THE SHOE HIVE, L.L.C., ALEXANDRIA, VA:
3,996,112, PUB. 5-3-2011. INT. CL. 35.
3,996,113, PUB. 5-3-2011. INT. CL. 35.
- THE STEPHAN CO., FORT LAUDERDALE, FL:
3,996,677, PUB. 5-3-2011. INT. CL. 3.
- THE SUN VALLEY RICE COMPANY, LLC., ARBUCKLE, CA:
3,998,444, INT. CL. 30.
- THE SUNSHINE HOUSE, INC., MADISON, CT:
3,996,708, PUB. 5-3-2011. INT. CL. 36.
- THE TALBOT GROUP INC., BEDFORD, TX:
3,996,629, PUB. 5-3-2011. INT. CL. 9.
- THE TALK MARKET, INC., NEW YORK, NY:
3,997,791, PUB. 5-3-2011. INT. CL. 9.
- THE TORO COMPANY, BLOOMINGTON, MN:
3,998,591, INT. CL. 7.
- THE TRI-SCREEN CONNECTION, LLC, CAPE ELIZABETH, ME:
4,000,025, INT. CL. 41.
- THE TRUSTEES OF INDIANA UNIVERSITY, BLOOMINGTON, IN:
3,996,314, PUB. 5-3-2011. INT. CL. 44.
3,996,315, PUB. 5-3-2011. INT. CL. 44.
3,996,318, PUB. 5-3-2011. INT. CL. 44.
4,000,002, INT. CL. 41.
- THE TRUSTEES OF THE FAO SCHWARZ FAMILY FOUNDATION, NEW YORK, NY:
3,996,351, PUB. 5-3-2011. INT. CL. 35.
- THE UNTOUCHABLES BRAND, SHERMAN OAKS, CA:
3,997,496, PUB. 5-3-2011. INT. CL. 25.
- THE URBAN GROWER, DENVER, CO:
3,999,709, INT. CL. 35.
- THE WATERFORD FOUNDATION, FRESNO, CA:
3,998,065, PUB. 5-3-2011. INT. CL. 36.
- THE WEATHER CHANNEL, INC., ATLANTA, GA:
2,402,337, CANC. MULTIPLE CLASS, INT. CLS. 16, 35 AND 36.
- THE WEDDING ROW, LLC, CHARLESTON, SC:
3,996,992, PUB. 5-3-2011. INT. CL. 41.
- THE WELCH EXPERIENCE, INC., ATLANTA, GA:
3,997,167, PUB. 5-3-2011. INT. CL. 41.
- THE WELLA CORP., WOODLAND HILLS, CA:
2,901,767, CANC. INT. CL. 3.
- THE WELLCARE MANAGEMENT GROUP, INC., TAMPA, FL:
3,999,248, INT. CL. 44.
- THE WIGGLES PTY LIMITED, NEW SOUTH WALES, AUSTRALIA:
3,996,338, PUB. 4-19-2011. MULTIPLE CLASS, INT. CLS. 9, 16, 25, 28 AND 41.
- THE WYANOKE GROUP INC., THOROFARE, NJ:
3,999,070, INT. CL. 44.
- THEBANK OF EDWARDSVILLE, EDWARDSVILLE, IL:
3,999,000, INT. CL. 36.
- THEMAGICTOUCH GMBH, DIEBURG, FED REP GERMANY:
2,401,312, CANC. INT. CL. 16.
- THERAGENCE, INC., SAN DIEGO, CA:
3,996,175, PUB. 5-3-2011. INT. CL. 42.
- THERAGENICS CORPORATION, BUFORD, GA:
2,498,160, REN. 6-15-11. INT. CL. 5.
- THERIAULT MANAGEMENT CO., INC., CLEARWATER, FL:
2,467,579, REN. 6-14-11. INT. CL. 42.
2,475,502, REN. 6-14-11. INT. CL. 42.
- THERMO GAMMA-METRICS, LLC, SAN DIEGO, CA:
3,996,847, PUB. 5-3-2011. INT. CL. 9.
3,997,018, PUB. 5-3-2011. INT. CL. 9.
- THERMTROL CORPORATION, NORTH CANTON, OH:
3,995,567, PUB. 5-3-2011. MULTIPLE CLASS, INT. CLS. 9 AND 12.
- THERMWOOD CORPORATION, DALE, IN:
2,577,240, REN. 6-16-11. INT. CL. 9.
- THIELE TECHNOLOGIES, INC., ST. LOUIS, MO:
1,647,886, REN. 6-15-11. INT. CL. 7.
- THIN CENTERS, LLC, DALLAS, TX:
3,998,134, PUB. 5-3-2011. INT. CL. 5.
- THINKFIRST FOUNDATION, WARRENVILLE, IL:
3,995,666, PUB. 5-3-2011. INT. CL. 35.
- THINLINE, LLC, MADISON, CT:
3,999,282, INT. CL. 9.
- THIRD RAIL DEVICES, LLC, WESTLAKE, OH:
3,996,062, PUB. 5-3-2011. INT. CL. 9.
- THIRD STREET PARTNERS ATTENTION AGENCY, LLC, INDIANAPOLIS, IN:
3,998,973, INT. CL. 35.
- THIS LITTLE PIGGY, DAVIS, CA:
3,996,539, PUB. 5-3-2011. INT. CL. 41.
- THOMAS JEFFERSON FOUNDATION, INC., CHARLOTTEVILLE, VA:
3,999,146, INT. CL. 41.
- THOMAS NELSON, INC., NASHVILLE, TN:
3,999,556, INT. CL. 16.
- THOMAS ROTH, LLC, WESTPORT, CT:
3,996,912, PUB. 5-3-2011. INT. CL. 24.
- THOMPSON INSURANCE ENTERPRISES, LLC, KENNESAW, GA:
3,997,892, PUB. 5-3-2011. INT. CL. 36.
- THOMPSON, TJAARDA, S., ESCONDIDO, CA, AKA TOM TJAARDA:
3,999,014, INT. CL. 42.

- THOMSON REUTERS (SCIENTIFIC) INC., PHILADELPHIA, PA:
2,901,212, CANC. INT. CL. 42.
- THOMVEST SEED CAPITAL INC., TORONTO, ONTARIO, CANADA:
3,997,506, PUB. 5-3-2011. INT. CL. 36.
- THORWORKS INDUSTRIES, INC., SANDUSKY, OH:
3,996,816, PUB. 5-3-2011. INT. CL. 19.
- THOUGHTBOT, INC., NEW YORK, NY:
3,998,269, PUB. 5-3-2011. MULTIPLE CLASS, INT. CLS. 9, 41 AND 42.
3,998,270, PUB. 5-3-2011. MULTIPLE CLASS, INT. CLS. 9, 41 AND 42.
- THREE RIVERS MAIL ORDER CORP., CLEARWATER, FL:
3,998,936, INT. CL. 21.
- THREE RIVERS MARINE & RAIL TERMINALS, L.P., CHARLEROI, PA:
3,996,713, PUB. 5-3-2011. INT. CL. 19.
- THRIVEPORT, LLC, ENCINO, CA:
3,999,761, INT. CL. 9.
- THROUGH THE BOX, INC., EDINA, MN:
2,901,851, CANC. INT. CL. 41.
- TICKLE KITTY, INC., SAN FRANCISCO, CA:
2,901,779, CANC. INT. CL. 5.
- TIDEWATER RETAIL GROUP, LLC, VIRGINIA BEACH, VA, DBA EMERSON'S CIGARS:
3,996,684, PUB. 5-3-2011. INT. CL. 34.
- TIE RACK TRADING LIMITED, BRENTFORD, MIDDLESEX, UNITED KINGDOM:
3,995,549, PUB. 5-3-2011. INT. CL. 25.
3,995,550, PUB. 5-3-2011. INT. CL. 35.
- TIG'S BACKYARD, LLC, OKLAHOMA CITY, OK:
3,997,924, PUB. 5-3-2011. MULTIPLE CLASS, INT. CLS. 16 AND 25.
- TIGER MEDIA, INC., REGINA, SASKATCHEWAN, CANADA:
3,997,885, PUB. 5-3-2011. INT. CL. 35.
- TIME INC., NEW YORK, NY:
2,901,897, CANC. INT. CL. 9.
- TIME TO KNOW LIMITED, ST. PETER PORT, GUERNSEY:
3,997,879, PUB. 5-3-2011. MULTIPLE CLASS, INT. CLS. 9 AND 41.
- TIME TRANSPORTATION HOLDINGS, LLC, OKLAHOMA CITY, OK:
3,996,378, PUB. 5-3-2011. INT. CL. 39.
- TIME WARNER CABLE INC., NEW YORK, NY:
3,998,230, PUB. 5-3-2011. INT. CL. 41.
3,998,820, MULTIPLE CLASS, INT. CLS. 38 AND 41.
- TIMEX GROUP USA, INC., MIDDLEBURY, CT:
3,998,275, PUB. 5-3-2011. MULTIPLE CLASS, INT. CLS. 9 AND 14.
- TINA MARIE HOVEN, GARDEN VALLEY, ID:
3,999,054, INT. CL. 28.
- TINY PRINTS, INC., SUNNYVALE, CA:
3,997,077, PUB. 5-3-2011. MULTIPLE CLASS, INT. CLS. 16, 35, 40 AND 42.
3,997,078, PUB. 5-3-2011. MULTIPLE CLASS, INT. CLS. 16, 35, 40 AND 42.
3,997,922, PUB. 5-3-2011. INT. CL. 16.
- TIRECO, INC., GARDENA, CA:
3,999,843, INT. CL. 12.
- TISHCON CORP., WESTBURY, NY:
2,402,835, CANC. INT. CL. 5.
- TITAN COATINGS, INC., BESSEMER, AL:
3,997,376, PUB. 5-3-2011. INT. CL. 2.
- TITAN EQUIPMENT SERVICES, INC., BYRON CENTER, MI:
3,995,714, PUB. 1-25-2011. INT. CL. 7.
- TJ TACKLE ENTERPRISES, LLC, HELENA, MT:
3,997,044, PUB. 5-3-2011. INT. CL. 28.
- TKEES, INC., HOLLYWOOD, FL:
3,996,236, PUB. 5-3-2011. INT. CL. 25.
- TL & ASSOCIATES, INC., SAN FRANCISCO, CA:
2,901,274, CANC. INT. CL. 29.
- TNG WORLDWIDE, INC., FARMINGTON HILLS, MI:
3,999,251, INT. CL. 3.
- TOBIAS, HEIDI RAYDEN, LOS ANGELES, CA:
3,999,980, INT. CL. 41.
- TODD HARRIS COMPANY, INC., EDISON, NJ:
2,901,345, CANC. INT. CL. 41.
- TOKYO MARUI CO., LTD., ADACHI-KU, TOKYO, JAPAN:
3,995,565, PUB. 11-16-2010. INT. CL. 28.
3,995,566, PUB. 11-16-2010. INT. CL. 28.
- TOLEDO ENGINEERING CO., INC., TOLEDO, OH:
920,875, REN. 6-15-11. U.S. CL. 100 (INT. CL. 42).
- TOM COSTELLO JR, RADNOR, PA:
3,997,348, PUB. 5-3-2011. INT. CL. 45.
- TOM PEI-YEN ,DREW, JHONGHE CITY, TAIWAN:
3,996,040, PUB. 5-3-2011. INT. CL. 3.
- TOM.COM ENTERPRISES LIMITED, ROAD TOWN, TOLLATA, BR.VIRGIN ISLANDS:
2,900,971, CANC. MULTIPLE CLASS, INT. CLS. 9, 16, 35, 36, 37, 38, 41 AND 42.
- TOMIKO ERICKSON, INC., MIAMI, FL:
2,402,262, CANC. INT. CL. 25.
- TOMMY HILFIGER LICENSING LLC, NEW YORK, NY:
2,901,380, CANC. INT. CL. 35.
- TOOLBOX WINE CO. LLC, NAPA, CA, DBA TOOLBOX:
3,999,063, INT. CL. 33.
- TOP SHELF BEVERAGES, LLC, PALO ALTO, CA:
3,999,684, MULTIPLE CLASS, INT. CLS. 30 AND 32.
- TOP TOBACCO, LP, GLENVIEW, IL:
3,999,167, INT. CL. 34.
- TOPICLEAR, INC., MIAMI, FL:
2,901,314, CANC. INT. CL. 3.
- TOPPER'S PIZZA, INC., WHITEWATER, WI:
3,999,720, INT. CL. 30.
- TORO COMPANY, THE, BLOOMINGTON, MN:
1,156,106, REN. 6-16-11. INT. CL. 7.
- TORRENT TECHNOLOGIES, INC., KALISPELL, MT:
3,996,332, PUB. 5-3-2011. INT. CL. 36.
- TOSHIBA MEDICAL SYSTEMS CORPORATION, JAPAN:
3,995,966, PUB. 5-3-2011. MULTIPLE CLASS, INT. CLS. 9 AND 10.
- TOTAL COMPENSATION SERVICES, INC., BALTIMORE, MD:
2,901,152, CANC. MULTIPLE CLASS, INT. CLS. 9 AND 35.
- TOTALFACILITY, INC., MALVERN, PA:
3,996,108, PUB. 5-3-2011. INT. CL. 35.
- TOTES ISOTONER CORPORATION, CINCINNATI, OH:
2,902,490, CANC. INT. CL. 18.
- TOTO U.S.A., INC., MORROW, GA:
3,996,768, PUB. 5-3-2011. INT. CL. 6.
3,999,370, INT. CL. 11.
3,999,371, INT. CL. 11.
3,999,632, INT. CL. 11.
- TOUMA ASSOCIATES GROUP, LLC, SALEM, NH, DBA MINDSCAPE:
3,996,861, PUB. 5-3-2011. INT. CL. 41.
- TOVARYSTVO Z OBMEZHENOIU VIDPOVIDALNISTIU "KOMPANIA "RIDNA YIZHA", KIEV 03039, UKRAINE:
3,995,895, PUB. 5-3-2011. INT. CL. 30.
- TOW DADDY, INC., VANCOUVER, WA:
3,999,466, INT. CL. 9.
3,999,563, INT. CL. 9.
3,999,564, INT. CL. 9.
- TPC GROUP LLC, HOUSTON, TX:
3,996,172, PUB. 5-3-2011. MULTIPLE CLASS, INT. CLS. 1 AND 40.
- TPI HOLDINGS, INC., NORFOLK, VA:
2,901,427, CANC. INT. CL. 35.
- TPP ACQUISITION, INC., PLANO, TX:
3,997,937, PUB. 5-3-2011. MULTIPLE CLASS, INT. CLS. 35 AND 41.
- TRA GLOBAL, INC., NEW YORK, NY, DBA TRA, INC.:
3,999,693, INT. CL. 35.
- TRAC MEDICAL SOLUTIONS, INC., BERKELEY HEIGHTS, NJ:
2,901,945, CANC. INT. CL. 9.
- TRACFONE WIRELESS, INC., MIAMI, FL:
3,999,140, INT. CL. 9.
- TRACIE MARTYN, INC., NEW YORK, NY:
3,997,727, PUB. 5-3-2011. INT. CL. 3.
- TRACTOR SUPPLY CO. OF TEXAS, LP, BRENTWOOD, TN:
3,998,256, PUB. 5-3-2011. INT. CL. 25.

TRACY STERN, INC., NEW YORK, NY:
2,940,605, COR. INT. CL. 30.

TRADCO, LTD., STONE MOUNTAIN, GA:
3,998,341, INT. CL. 5.

TRADEMARK TOOLS INC., CONCORD, CANADA:
3,999,007, MULTIPLE CLASS, INT. CLS. 6 AND 8.

TRADES LABOUR CORPORATION, NORTH VANCOUVER,
BC, CANADA:
3,996,140, PUB. 5-3-2011. INT. CL. 35.

TRAILERLOGIC, BELTON, SC, DBA MORTUARY RE-
SPONSE SOLUTIONS:
3,998,127, PUB. 5-3-2011. INT. CL. 25.

TRAM BAR, DRIGGS, ID:
3,999,618, INT. CL. 5.

TRAMPS AND REJECTS, INC., SAN DIEGO, CA:
3,997,082, PUB. 5-3-2011. INT. CL. 35.

TRAN THI LAN, VIETNAM:
3,995,983, PUB. 5-3-2011. INT. CL. 25.

TRAN, DAO, SACRAMENTO, CA:
3,997,917, PUB. 5-3-2011. INT. CL. 43.

TRANS ENVIRONMENTAL SYSTEMS, INC., CHARLOT-
TESVILLE, VA:
2,463,537, REN. 6-16-11. INT. CL. 20.

TRANSCO INC., CHICAGO, IL:
3,998,603, INT. CL. 17.

TRANSTAR MANAGEMENT SERVICES, INC., LAS VEGAS,
NV:
2,901,122, CANC. MULTIPLE CLASS, INT. CLS. 35 AND
41.

TRANSTEC, INC., AUSTIN, TX:
2,401,850, CANC. INT. CL. 9.

TRANter, INC., WICHITA FALLS, TX:
3,998,762, INT. CL. 11.
3,999,712, INT. CL. 11.

TRAPPER JOHN ANIMAL CONTROL, INC., BOCA RATON,
FL:
3,997,149, PUB. 5-3-2011. INT. CL. 37.

TRAX TECHNOLOGIES, INC., SCOTTSDALE, AZ:
3,997,177, PUB. 5-3-2011. MULTIPLE CLASS, INT. CLS.
35, 36 AND 42.

TRAYLOR CHEMICAL & SUPPLY CO., ORLANDO, FL:
2,901,432, CANC. INT. CL. 1.

TREASURY WINE ESTATES AMERICAS COMPANY,
NAPA, CA:
2,901,342, CANC. INT. CL. 33.

TREDEGAR FILM PRODUCTS CORPORATION, RICH-
MOND, VA:
3,999,064, MULTIPLE CLASS, INT. CLS. 9, 35, 41 AND 42.

TREE INJECTION PRODUCTS COMPANY, INC., KNOX-
VILLE, TN:
2,901,912, CANC. INT. CL. 1.

TREEPODIA, HERZLIYA PITUACH, ISRAEL:
3,997,726, PUB. 5-3-2011. INT. CL. 9.

TREK BICYCLE CORPORATION, WATERLOO, WI:
3,999,475, MULTIPLE CLASS, INT. CLS. 9, 11, 12, 18 AND
25.

TRENDMAKER HOMES, INC, HOUSTON, TX:
2,461,428, REN. 6-16-11. INT. CL. 37.

TRENEGY INCORPORATED, HOUSTON, TX:
3,999,854, INT. CL. 35.

TRENT, INC., AURORA, CO:
3,999,938, INT. CL. 44.

TRENTACOSTA, THERESA, TINTON FALLS, NJ:
3,997,802, PUB. 5-3-2011. INT. CL. 41.

TRI-ENERGY SOLUTIONS, LLC, LIVONIA, MI:
4,000,024, INT. CL. 35.

TRI-STARCO, INC., STAFFORD, TX:
3,998,331, INT. CL. 33.

TRIANGLE HOME FASHIONS, LLC, DAYTON, NJ:
3,999,968, INT. CL. 24.

TRIBAL PETS, INC., PHILADELPHIA, PA:
3,998,604, INT. CL. 35.

TRIBANDZ LLC, COCKEYSVILLE, MD:
3,997,126, PUB. 5-3-2011. INT. CL. 14.
3,997,127, PUB. 5-3-2011. INT. CL. 14.

TRICERION GROUP, LLC, ALPHARETTA, GA:
3,997,464, PUB. 5-3-2011. INT. CL. 36.

TRICO PRODUCTS CORPORATION, ROCHESTER HILLS,
MI:
3,999,585, INT. CL. 12.

TRICORBRAUN INC., ST. LOUIS, MO:
3,999,697, MULTIPLE CLASS, INT. CLS. 35 AND 42.

TRIDIUM, INC., RICHMOND, VA:
2,555,240, REN. 6-10-11. INT. CL. 9.

TRIGG LABORATORIES, INC., VALENCIA, CA:
3,999,343, INT. CL. 5.

TRILOGY DESIGNS, LLC, EL CAJON, CA:
3,996,781, PUB. 5-3-2011. MULTIPLE CLASS, INT. CLS. 16
AND 21.

TRINITY CHRISTIAN CENTER OF SANTA ANA, INC.,
SANTA ANA, CA:
3,998,609, MULTIPLE CLASS, INT. CLS. 38 AND 41.

TRINITY EXPRESS, INC., LEWISVILLE, TX:
2,570,212, REN. 6-15-11. INT. CL. 39.

TRINITY FIDUCIARY PARTNERS, LLC, ARLINGTON, TX:
3,996,932, PUB. 5-3-2011. INT. CL. 36.

TRINITY, INC., SAITAMA-KEN, JAPAN:
3,996,204, PUB. 5-3-2011. MULTIPLE CLASS, INT. CLS. 9
AND 15.

TRIPLETT, INC, SALINA, KS:
2,556,024, REN. 6-15-11. MULTIPLE CLASS, INT. CLS. 35
AND 42.
2,556,024, CANC. INT. CL. 37.

TRISH MCEVOY, LTD, NEW YORK, NY:
3,998,576, INT. CL. 3.

TRITON SYSTEMS OF DELAWARE, LLC, LONG BEACH,
MS:
3,998,851, INT. CL. 9.

TRIVITA WAY INTERNATIONAL INC., THE, SCOTTSD-
DALE, AZ:
2,401,769, CANC. MULTIPLE CLASS, INT. CLS. 5 AND
35.

TRIZETTO GROUP, INC., THE, NEWPORT BEACH, CA:
2,412,823, REN. 6-15-11. INT. CL. 37.

TROUW NUTRITION USA, LLC, HIGHLAND, IL:
2,402,132, CANC. INT. CL. 5.

TROVER SOLUTIONS, INC., LOUISVILLE, KY:
2,451,116, REN. 6-15-11. INT. CL. 36.

TRU VUE, INC., MCCOOK, IL:
2,402,538, CANC. INT. CL. 40.

TRU-FLEX METAL HOSE, LLC, WEST LEBANON, IN:
2,458,013, REN. 6-14-11. INT. CL. 6.

TRUCK ACCESSORIES GROUP, LLC, ELKHART, IN:
3,996,399, PUB. 5-3-2011. INT. CL. 20.

TRUCO, INC., CLEVELAND, OH:
3,995,648, PUB. 5-3-2011. MULTIPLE CLASS, INT. CLS. 2
AND 37.

TRUE GAMES INTERACTIVE, AUSTIN, TX:
3,999,874, MULTIPLE CLASS, INT. CLS. 9 AND 41.

TRUE VALUE COMPANY, CHICAGO, IL:
3,995,721, PUB. 5-3-2011. INT. CL. 5.

TRUE WOMB DESIGNS, LLC, AUSTIN, TX:
3,999,640, INT. CL. 25.

TRUEPOSITION, INC., BERWYN, PA:
2,551,888, REN. 6-14-11. MULTIPLE CLASS, INT. CLS. 35,
38 AND 42.

TRUGREEN LIMITED PARTNERSHIP, MEMPHIS, TN:
3,998,224, PUB. 5-3-2011. INT. CL. 44.

TRULEGAL P.A., VERO BEACH, FL:
2,901,295, CANC. INT. CL. 42.

TRUMP, DONALD J., NEW YORK, NY:
3,998,446, MULTIPLE CLASS, INT. CLS. 35 AND 36.

TRUSKIN, INC., NAPERVILLE, IL, DBA B*TRU, INC.:
3,996,777, PUB. 3-29-2011. INT. CL. 3.

TRUSSART, JAMES, LOS ANGELES, CA, DBA JAMES
TRUSSART CUSTOM GUITARS:
3,995,564, PUB. 2-16-2010. INT. CL. 15.

TRUSTEE OF THE HERMAN FAMILY TRUST, LOS AN-
GELES, CA:
2,458,250, REN. 6-10-11. INT. CL. 18.

TRUSTEES OF THE NATURAL HISTORY MUSEUM, LON-
DON, UNITED KINGDOM:
3,995,715, PUB. 4-12-2011. MULTIPLE CLASS, INT. CLS.
9, 14, 16, 19, 20, 24, 28 AND 30.

- TRUSTON TECHNOLOGIES, INC., ANNAPOLIS, MD:
3,997,186, PUB. 5-3-2011. INT. CL. 42.
- TRYALL CLUB, THE, MONTEGO BAY, JAMAICA:
2,472,996. REN. 6-16-11. MULTIPLE CLASS, INT. CLS. 41 AND 42.
- TRYANE, FRANCE:
3,995,846, PUB. 5-3-2011. MULTIPLE CLASS, INT. CLS. 9 AND 42.
- TSA STORES, INC., ENGLEWOOD, CO:
3,999,310, INT. CL. 35.
- TSH ENTERTAINMENT, INC., MIAMI, FL:
3,997,374, PUB. 5-3-2011. INT. CL. 43.
- TSUCHIYA, AKINO, CARLSBAD, CA, AKA AKINODE-SIGN:
3,999,501, INT. CL. 14.
- TT COMPANIES, INC., LENEXA, KS:
2,401,316, CANC. MULTIPLE CLASS, INT. CLS. 16 AND 42.
- TURAAATH MEDIA, L.L.C., NORTHVILLE, MI, DBA ARAB AMERICA:
3,996,514, PUB. 5-3-2011. MULTIPLE CLASS, INT. CLS. 35 AND 41.
- TURBIE TWIST, LLC, BUTLER, PA:
3,996,909, PUB. 5-3-2011. INT. CL. 25.
- TURBON INTERNATIONAL INC., CINNAMINSON, NJ:
3,997,344, PUB. 5-3-2011. INT. CL. 2.
3,997,347, PUB. 5-3-2011. INT. CL. 2.
- TURF ALLIANCE, LLC, WELLAND, CANADA:
3,998,568, INT. CL. 44.
3,998,569, INT. CL. 44.
3,998,570, INT. CL. 44.
- TURNER, RICHARD K., SACRAMENTO, CA:
2,901,391, CANC. INT. CL. 16.
- TURNSTILE PUBLISHING COMPANY, ORLANDO, FL:
4,000,010, INT. CL. 35.
4,000,011, INT. CL. 35.
4,000,017, INT. CL. 16.
4,000,018, INT. CL. 16.
- TURTLE POND PUBLICATIONS LLC, NEW YORK, NY:
3,999,033, INT. CL. 42.
- TV ONE, LLC, SILVER SPRING, MD:
3,998,120, PUB. 5-3-2011. INT. CL. 41.
- TVEDTEN, STEPHEN L., MARNE, MI:
2,450,175. REN. 6-13-11. INT. CL. 5.
- TWEED-JEFFRIES, LLC, LOUISVILLE, KY:
3,996,451, PUB. 5-3-2011. INT. CL. 41.
- TWENTIETH CENTURY FOX FILM CORPORATION, LOS ANGELES, CA:
3,998,614, INT. CL. 16.
3,999,839, INT. CL. 41.
- TWG WARRANTY GROUP, INC., CHICAGO, IL:
3,999,764, INT. CL. 36.
- TWILSON TECHNOLOGIES, INC., WASHINGTON, DC:
3,999,480, INT. CL. 42.
- TWIN MODAL, INC., ROSEVILLE, MN:
2,494,451. REN. 6-14-11. INT. CL. 39.
- TWO WEST, INC., KANSAS CITY, MO:
2,902,186, CANC. INT. CL. 42.
- TWO WHEELS, INC., NORTHVILLE, MI:
2,460,101. REN. 6-14-11. INT. CL. 42.
2,488,181. REN. 6-10-11. INT. CL. 42.
- TXU CORP., DALLAS, TX:
2,901,888, CANC. INT. CL. 35.
- TYLER ASSOCIATES CORPORATION, GURNEE, IL, DBA TYLER ANALYTICS CORPORATION:
3,998,846, INT. CL. 9.
- TYLER BAILEY, ROCHESTER, MN, DBA FATTY HITS MARKETING:
3,996,916, PUB. 5-3-2011. INT. CL. 35.
- TYPO3 ASSOCIATION E.V., BAAR, SWITZERLAND:
3,996,081, PUB. 10-12-2010. INT. CL. 9.
- TYSON FOODS, INC., SPRINGDALE, AR:
3,998,293, PUB. 5-3-2011. INT. CL. 30.
- TYSON FRESH MEATS, INC., SPRINGDALE, AR:
3,999,873, INT. CL. 29.
- TÜNKERS MASCHINENBAU GMBH, D-40880 RATINGEN, FED REP GERMANY:
3,998,877, MULTIPLE CLASS, INT. CLS. 7, 8, 9 AND 12.
3,998,878, MULTIPLE CLASS, INT. CLS. 7, 8, 9 AND 12.
- U C COATINGS CORPORATION, BUFFALO, NY:
2,494,125. REN. 6-15-11. INT. CL. 2.
- U. S. VISION, INC., GLENDORA, NJ:
3,996,734, PUB. 5-3-2011. MULTIPLE CLASS, INT. CLS. 35 AND 44.
- U.S. FOODSERVICE, INC., ROSEMONT, IL:
3,997,434, PUB. 5-3-2011. INT. CL. 35.
- U.S. MEDICAL INNOVATIONS, LLC, LAKELAND, FL:
3,999,419, INT. CL. 10.
- U.S. PAINT CORPORATION, ST. LOUIS, MO:
3,999,539, INT. CL. 2.
- U.S. RESTAURANTS CORPORATION, ARDEN HILLS, MN:
3,997,508, PUB. 5-3-2011. INT. CL. 30.
- U.S. TRANSCRIPTION, INC., DUBUQUE, IA:
3,996,056, PUB. 5-3-2011. INT. CL. 35.
- U.S. TRAVEL ASSOCIATION, WASHINGTON, DC:
915,811. REN. 6-12-11. U.S. CL. 105 (INT. CL. 39).
2,459,332. REN. 6-13-11. INT. CL. 39.
- U.S.M.M., INC., SKOKIE, IL:
3,996,421, PUB. 5-3-2011. INT. CL. 37.
- U-NICA INTERNATIONAL AG, MALANS, SWITZERLAND:
3,995,647, PUB. 5-3-2011. MULTIPLE CLASS, INT. CLS. 2, 9 AND 42.
- U-SAVE AUTO RENTAL OF AMERICA, INC., JACKSON, MS:
3,999,109, INT. CL. 39.
3,999,111, INT. CL. 39.
- UBM IP LUXEMBOURG S.A.R.L., L-1724, LUXEMBOURG:
3,997,776, PUB. 5-3-2011. INT. CL. 41.
- UBS AG, CH-8001 ZURICH, SWITZERLAND:
2,900,980, CANC. MULTIPLE CLASS, INT. CLS. 9, 14, 16, 35, 36, 38, 41 AND 42.
2,901,025, CANC. MULTIPLE CLASS, INT. CLS. 9, 14, 16, 35, 36, 38, 41 AND 42.
- UE BUSINESS TRUST, A NEVADA TRUST, THE TRUSTEES COMPRISING MARY ANN SISON, FE CORAZON T LABAYEN AND DONALD CALHOUN ALL US CITIZENS, THE, RANCHO CUCAMONGA, CA:
2,901,748, CANC. INT. CL. 35.
- UENO FINE CHEMICALS INDUSTRY, LTD., OSAKA, JAPAN:
3,998,575, MULTIPLE CLASS, INT. CLS. 1 AND 5.
- UHLIG LLC, LENEXA, KS:
2,404,270. REN. 6-16-11. INT. CL. 35.
- UHS OF DELAWARE, INC., KING OF PRUSSIA, PA:
3,998,725, INT. CL. 44.
3,999,614, INT. CL. 44.
- ULLA POPKEN JUNGE MODE AB GROSSE 42 GMBH & CO. KG, 26180 RASTEDE, FED REP GERMANY:
2,401,752, CANC. INT. CL. 25.
- ULTIMARK PRODUCTS, LLC., PLYMOUTH MEETING, PA:
2,402,364, CANC. INT. CL. 16.
- ULTRATAN, INC., GREENVILLE, SC:
3,997,724, PUB. 5-3-2011. INT. CL. 44.
- UMIDITA, LLC, CAMINO, CA:
3,998,787, INT. CL. 3.
- UNCLE SAM'S FIREWORKS CITY, INC., BIXBY, OK:
3,998,176, PUB. 5-3-2011. INT. CL. 9.
- UNDER THE BOW, PLANO, TX:
3,996,917, PUB. 5-3-2011. MULTIPLE CLASS, INT. CLS. 35 AND 45.
- UNDISPUTED INTERNATIONAL LLC, WASHINGTON, DC:
3,998,864, INT. CL. 25.
- UNICON INTERNATIONAL, INC., COLUMBUS, OH:
2,901,625, CANC. INT. CL. 9.
- UNICORN INFORMATION SYSTEM CO., LTD., SONGPA-GU, SEOUL, REPUBLIC OF KOREA:
3,998,741, INT. CL. 9.
- UNIFIED DESIGN CORPORATION, ROCKAWAY, NJ:
3,996,169, PUB. 5-3-2011. INT. CL. 42.
- UNILEVER PLC, MERSEYSIDE, UNITED KINGDOM:
2,401,816, CANC. INT. CL. 3.

UNILEVER PLC, MERSEYSIDE CH62 4ZD, UNITED KINGDOM:
3,999,629, INT. CL. 3.

UNILEVER SUPPLY CHAIN, INC., CLINTON, CT:
3,998,563, INT. CL. 30.

UNIMED INTERNATIONAL, INC., EDISON, NJ:
3,996,354, PUB. 5-3-2011. INT. CL. 3.
3,996,355, PUB. 5-3-2011. INT. CL. 5.

UNIQUE LIQUID, LLC, BEAVERTON, OR:
3,998,499, INT. CL. 33.

UNIQUE PROD-X LTD., EDMONTON, ALBERTA:
2,901,022, CANC. INT. CL. 21.

UNIQUE VALUE MARKETING, LLC, ROCKFORD, MN:
3,998,684, MULTIPLE CLASS, INT. CLS. 9 AND 21.

UNISON HARDWARE, INC., SACRAMENTO, CA:
3,996,835, PUB. 5-3-2011. INT. CL. 6.
3,998,128, PUB. 5-3-2011. INT. CL. 6.
3,998,168, PUB. 5-3-2011. INT. CL. 6.

UNISORB, INC., PASADENA, CA:
913,017, REN. 6-14-11. U.S. CL. 23 (INT. CL. 7).

UNITED AMERICAN INDUSTRIES, INC., GILBERT, AZ:
2,467,358, REN. 6-16-11. INT. CL. 30.

UNITED AMERICAN INSURANCE COMPANY, MCKINNEY, TX:
3,998,957, INT. CL. 35.

UNITED ART AND EDUCATION, INC., FORT WAYNE, IN:
2,455,506, REN. 6-16-11. INT. CL. 35.

UNITED AUBURN INDIAN COMMUNITY, LINCOLN, CA:
3,998,287, PUB. 5-3-2011. INT. CL. 43.

UNITED CUTLERY CORPORATION, THOMASVILLE, GA:
2,902,375, CANC. INT. CL. 8.
2,902,376, CANC. INT. CL. 8.

UNITED DAIRY FARMERS, INC., CINCINNATI, OH:
3,998,920, INT. CL. 30.

UNITED DATA TECHNOLOGIES, INC., DORAL, FL:
3,999,956, INT. CL. 42.

UNITED METRO MATERIALS, INC., PHOENIX, AZ:
2,901,658, CANC. INT. CL. 19.

UNITED MICROELECTRONICS CORP., HSINCHU, TAIWAN:
2,401,292, CANC. MULTIPLE CLASS, INT. CLS. 9, 40 AND 42.

UNITED NATURAL FOODS, INC., PROVIDENCE, RI:
3,998,101, PUB. 5-3-2011. INT. CL. 35.

UNITED ROYAL LINEN, INC., BROOKLYN, NY:
3,995,469, PUB. 5-3-2011. MULTIPLE CLASS, INT. CLS. 20, 21, 24 AND 27.

UNITED SERVICES AUTOMOBILE ASSOCIATION, SAN ANTONIO, TX:
3,996,164, PUB. 5-3-2011. INT. CL. 36.

UNITED SOCCER LEAGUES, LLC, TAMPA, FL:
3,997,393, PUB. 5-3-2011. INT. CL. 41.

UNITED SPORTS TECHNOLOGIES, LP, FORT WORTH, TX:
3,998,433, INT. CL. 28.

UNITED STATES - ASIA FOUNDATION, WASHINGTON, DC:
2,448,718, REN. 6-15-11. INT. CL. 35.

UNITED STATES AMATEUR MIXED MARTIAL ARTS INC., PENSACOLA, AL:
4,000,050, INT. CL. 41.

UNITED STATES DEPARTMENT OF HOMELAND SECURITY, WASHINGTON, DC:
3,999,029, INT. CL. 42.

UNITED STATES FEDERAL TRADE COMMISSION, WASHINGTON, DC:
2,901,185, CANC. INT. CL. 35.

UNITED STATES FOUNDATION FOR INSPIRATION AND RECOGNITION OF SCIENCE AND TECHNOLOGY, MANCHESTER, NH, AKA US FIRST AND LEGO SYSTEMS, INC., ENFIELD, CT, AKA LEGO CORPORATION:
3,997,270, PUB. 5-3-2011. INT. CL. 41.

UNITED STATES FOUNDATION FOR INSPIRATION AND RECOGNITION OF SCIENCE AND TECHNOLOGY, MANCHESTER, NH, AKA US FIRST:
3,998,167, PUB. 5-3-2011. INT. CL. 41.

UNITED STATES PILATES ASSOCIATION LLC, FORT LAUDERDALE, FL:
3,998,265, PUB. 5-3-2011. INT. CL. 41.

UNITED STATES POLO ASSOCIATION, LEXINGTON, KY:
1,181,651, REN. 6-15-11. U.S. CL. 200.

UNITED STATES POSTAL SERVICE, WASHINGTON, DC:
2,900,954, CANC. MULTIPLE CLASS, INT. CLS. 6 AND 20.

UNITEK GLOBAL SERVICES, INC., BLUE BELL, PA:
3,996,242, PUB. 5-3-2011. INT. CL. 37.

UNIVERSAL BRANDING & MEDIA LLC, MILFORD, CT:
3,999,840, INT. CL. 12.

UNIVERSAL CITY STUDIOS LLC, UNIVERSAL CITY, CA:
3,998,618, INT. CL. 41.
3,999,639, INT. CL. 9.

UNIVERSAL CITY STUDIOS LLLP, UNIVERSAL CITY, CA:
3,996,197, PUB. 5-3-2011. INT. CL. 9.

UNIVERSAL ENTERTAINMENT CORPORATION, JAPAN:
3,995,937, PUB. 5-3-2011. MULTIPLE CLASS, INT. CLS. 9 AND 28.

UNIVERSAL INVESTMENTS WORLDWIDE, INC., SEATTLE, WA, DBA INTERNATIONAL INTELLIGENCE SERVICES:
3,995,587, PUB. 10-27-2009. INT. CL. 45.

UNIVERSAL MANUFACTURING COMPANY, INC., KANSAS CITY, MO:
2,901,859, CANC. INT. CL. 28.
2,901,860, CANC. INT. CL. 28.
2,901,861, CANC. INT. CL. 28.
2,901,862, CANC. INT. CL. 28.
2,901,865, CANC. INT. CL. 28.
2,901,866, CANC. INT. CL. 28.
2,901,867, CANC. INT. CL. 28.
2,901,868, CANC. INT. CL. 28.
2,901,869, CANC. INT. CL. 28.

UNIVERSITY AND STATE EMPLOYEES CREDIT UNION, SAN DIEGO, CA:
2,402,225, CANC. INT. CL. 36.

UNIVERSITY BLANKET & FLAG CORPORATION, COLORADO, CA:
2,577,904, REN. 6-15-11. INT. CL. 35.

UNIVERSITY CITY PHYSICAL THERAPY, INC., SAN DIEGO, CA, DBA FUNCTIONSMART:
3,998,047, PUB. 5-3-2011. INT. CL. 41.

UNIVERSITY CORPORATION FOR ATMOSPHERIC RESEARCH, BOULDER, CO:
3,996,556, PUB. 5-3-2011. INT. CL. 9.

UNIVERSITY OF MARYLAND, COLLEGE PARK, MD:
2,452,879, REN. 6-11-11. MULTIPLE CLASS, INT. CLS. 9, 16 AND 41.

UNIVISION COMMUNICATIONS INC., LOS ANGELES, CA:
3,996,417, PUB. 5-3-2011. INT. CL. 41.

UNIVISION RADIO, INC., DALLAS, TX:
2,401,790, CANC. MULTIPLE CLASS, INT. CLS. 35, 38 AND 41.

UP DIAGNOSTICS LLC, WARWICK, RI, AKA UNIVERSITY PATHOLOGISTS DIAGNOSTICS:
3,997,120, PUB. 5-3-2011. INT. CL. 44.

UPHOLSTERY DECOR INC, GOLETA, CA:
3,999,314, INT. CL. 21.

UPHOLSTERY DECOR, INC., GOLETA, CA:
3,999,377, INT. CL. 25.

UPLYTE LLC, DANIA BEACH, FL:
3,997,673, PUB. 5-3-2011. INT. CL. 41.

UPPER DECK COMPANY, LLC, THE, CARLSBAD, CA:
2,402,307, CANC. INT. CL. 16.

UPSIDE SHOPPING GMBH, FED REP GERMANY:
3,995,845, PUB. 5-3-2011. MULTIPLE CLASS, INT. CLS. 35 AND 38.

URBAN EDUCATION EXCHANGE, INC., NEW YORK, NY:
3,998,178, PUB. 5-3-2011. MULTIPLE CLASS, INT. CLS. 9, 16, 35 AND 41.

URBAN PARTNERSHIP BANK, CHICAGO, IL:
3,997,574, PUB. 5-3-2011. INT. CL. 35.
3,997,585, PUB. 5-3-2011. INT. CL. 36.

URBAN TELEVISION NETWORK, INC., MARINA DEL RAY, CA:
2,900,964, CANC. INT. CL. 36.

URBANGREEN, INC., SAN FRANCISCO, CA:
3,996,501, PUB. 5-3-2011. MULTIPLE CLASS, INT. CLS. 41 AND 42.

- URBANI TARTUFI S.R.L., ITALY:
3,995,978, PUB. 5-3-2011. INT. CL. 29.
- US AIRWAYS, INC., TEMPE, AZ:
3,996,460, PUB. 5-3-2011. INT. CL. 39.
3,996,461, PUB. 5-3-2011. INT. CL. 39.
3,996,462, PUB. 5-3-2011. INT. CL. 39.
- UTA SCHNAPPINGER, FED REP GERMANY:
3,995,980, PUB. 5-3-2011. MULTIPLE CLASS, INT. CLS. 35, 41 AND 44.
- UTICA MUTUAL INSURANCE COMPANY, NEW HARTFORD, NY, DBA UTICA NATIONAL INSURANCE GROUP:
3,995,690, PUB. 5-3-2011. INT. CL. 36.
- UTILITIES TELECOM COUNCIL, WASHINGTON, DC:
3,999,320, INT. CL. 35.
- V&M CORPORATION, ROYAL OAK, MI, DBA ROYAL OAK RECYCLING:
3,996,255, PUB. 5-3-2011. INT. CL. 40.
- VAK VERLAGS GMBH, FED REP GERMANY:
3,995,785, PUB. 1-25-2011. MULTIPLE CLASS, INT. CLS. 9, 16, 35 AND 41.
- VALENCIA TRADEMARK CORPORATION, HOUSTON, TX:
3,998,483, INT. CL. 36.
- VALENCIC, CHRISTOPHER A., LAKEWOOD, OH:
3,998,734, INT. CL. 20.
- VALENTE, PAUL, LOUDONVILLE, NY:
3,997,188, PUB. 5-3-2011. INT. CL. 30.
- VALENTINE II, LTD., NEW YORK, NY:
2,901,940, CANC. INT. CL. 18.
- VALICORE TECHNOLOGIES, INC., IRVINE, CA:
3,998,409, INT. CL. 9.
- VALIO LTD, HELSINKI, FINLAND:
3,996,289, PUB. 5-3-2011. INT. CL. 29.
3,996,290, PUB. 5-3-2011. INT. CL. 29.
- VALLEY ROLLER COMPANY, INC., MANSFIELD, TX:
3,998,040, PUB. 5-3-2011. INT. CL. 7.
3,998,043, PUB. 5-3-2011. INT. CL. 7.
3,998,045, PUB. 5-3-2011. INT. CL. 7.
3,998,046, PUB. 5-3-2011. INT. CL. 7.
- VALUE ADDED SCIENCE & TECHNOLOGIES, LLC, MASON CITY, IA:
3,996,535, PUB. 5-3-2011. MULTIPLE CLASS, INT. CLS. 5 AND 31.
- VALUE CITY OF MICHIGAN, INC., WESTLAND, MI:
2,901,420, CANC. INT. CL. 35.
- VALVA, MARK, CHATHAM, NJ:
3,999,231, MULTIPLE CLASS, INT. CLS. 35 AND 42.
- VAN BERKUM NURSERY, LLC, DEERFIELD, NH:
2,402,976, CANC. INT. CL. 31.
- VAN CLEEF, BART PETER, TEMIXCO, MORELOS, MEXICO:
3,996,964, PUB. 5-3-2011. INT. CL. 41.
- VAN DUSER, RACHELLE, TUSTIN, CA, DBA WEBSITES DIRECT:
2,901,800, CANC. INT. CL. 42.
- VAN NELLE CANADA LIMITED, NEW BRUNSWICK, CANADA:
3,996,350, PUB. 5-3-2011. INT. CL. 34.
- VANCE'S FOODS, INC., SACRAMENTO, CA:
2,401,593, CANC. INT. CL. 29.
- VANTAGE PARTNERS, LLC, BOSTON, MA:
2,901,944, CANC. MULTIPLE CLASS, INT. CLS. 41 AND 42.
- VAPOR CORP., HALLANDALE, FL:
3,998,191, PUB. 5-3-2011. INT. CL. 34.
- VAPRO INTERNATIONAL S.R.L., 22076 MOZZATE (CO), ITALY:
2,902,048, CANC. INT. CL. 3.
- VARGAS MARCAS E PARTICIPACOES LTDA, RIO DE JANEIRO, BRAZIL:
2,902,326, CANC. INT. CL. 3.
2,902,327, CANC. INT. CL. 3.
- VARGAS, JOSEPH, SAN ANGELO, TX:
3,997,653, PUB. 5-3-2011. INT. CL. 35.
- VARONIS SYSTEMS, INC., NEW YORK, NY:
3,999,958, INT. CL. 42.
- VATECH CO., LTD., GYEONGGI-DO, REPUBLIC OF KOREA:
3,995,898, PUB. 5-3-2011. MULTIPLE CLASS, INT. CLS. 5, 7, 9 AND 11.
- VBG GROUP AB (PUBL), VANERSBORG, SWEDEN:
1,574,736, AM. INT. CL. 12.
- VCA LABS, INC., CHATSWORTH, CA:
2,901,409, CANC. INT. CL. 9.
- VDW FARMS, LTD., SAN ANTONIO, TX:
2,901,091, CANC. INT. CL. 30.
- VECTORWISE B.V., NETHERLANDS:
3,995,942, PUB. 5-3-2011. MULTIPLE CLASS, INT. CLS. 9 AND 42.
- VEGITALIA S.P.A., ITALY:
3,995,951, PUB. 5-3-2011. MULTIPLE CLASS, INT. CLS. 29, 30 AND 32.
- VEIN CENTRE OF THE PALM BEACHES, WEST PALM BEACH, FL:
2,450,444, REN. 6-13-11. INT. CL. 42.
- VELASCO, JUAN G., JACKSON HEIGHTS, NY:
3,998,649, INT. CL. 25.
- VENDMORE SYSTEMS, LLC, STAMFORD, CT:
3,997,834, PUB. 5-3-2011. MULTIPLE CLASS, INT. CLS. 9 AND 35.
3,997,835, PUB. 5-3-2011. MULTIPLE CLASS, INT. CLS. 9 AND 35.
3,997,836, PUB. 5-3-2011. INT. CL. 9.
3,997,839, PUB. 5-3-2011. MULTIPLE CLASS, INT. CLS. 9 AND 35.
3,997,840, PUB. 5-3-2011. MULTIPLE CLASS, INT. CLS. 9 AND 35.
3,998,246, PUB. 5-3-2011. MULTIPLE CLASS, INT. CLS. 9 AND 35.
3,998,247, PUB. 5-3-2011. MULTIPLE CLASS, INT. CLS. 9 AND 35.
- VENDOR SOLUTIONS, INC., LOS ANGELES, CA:
3,999,106, INT. CL. 35.
- VENTEAK CORPORATION, MIAMI, FL:
2,901,356, CANC. INT. CL. 19.
- VENTURA FOODS, LLC, BREA, CA:
3,999,285, INT. CL. 30.
3,999,286, INT. CL. 30.
- VENTUREPRISE CONSULTING PARTNERS INC., SACRAMENTO, CA:
2,402,190, CANC. INT. CL. 35.
- VEOLIA ENVIRONNEMENT, FRANCE:
3,995,768, PUB. 5-3-2011. MULTIPLE CLASS, INT. CLS. 9, 16, 35 AND 41.
- VEOLIA ES ALARON, L.L.C., WAMPUM, PA:
3,996,407, PUB. 5-3-2011. INT. CL. 39.
- VERIDIUM CORPORATION, PATERSON, NJ:
2,902,280, CANC. INT. CL. 40.
- VERITAS GROUP, LTD., NEW YORK, NY:
2,900,972, CANC. INT. CL. 35.
- VERITAS VINEYARD L.L.C., JEROME, MI:
2,901,619, CANC. INT. CL. 33.
- VEROSCIENCE LLC, TIVERTON, RI:
3,999,613, INT. CL. 5.
- VERTEX INDUSTRIALS, INC., MONTCLAIR, CA:
3,996,284, PUB. 5-3-2011. INT. CL. 11.
- VERTICAL CLAIMS MANAGEMENT, LLC, PITTSBURGH, PA:
3,996,685, PUB. 5-3-2011. INT. CL. 36.
- VESSEL INC., WELLFLEET, MA:
2,952,969, CANC. MULTIPLE CLASS, INT. CLS. 8, 20 AND 21.
- VET MED DIRECT, LLC, FAIRBURY, NE:
2,901,827, CANC. INT. CL. 35.
- VET-STEM, INC., SAN DIEGO, CA:
2,901,852, CANC. INT. CL. 42.
- VETERANS OF FOREIGN WARS OF THE UNITED STATES, KANSAS CITY, MO:
1,677,008, REN. 6-15-11. INT. CL. 36.
- VETERANSADVANTAGE, INC., GREENWICH, CT:
3,995,680, PUB. 5-3-2011. MULTIPLE CLASS, INT. CLS. 16, 35 AND 36.
3,995,681, PUB. 5-3-2011. MULTIPLE CLASS, INT. CLS. 16, 35 AND 36.

VI ENGINEERING, INC., FARMINGTON, MI:
2,901,532, CANC. INT. CL. 9.

VIÑAS ARGENTINAS, S.A., MENDOZA, ARGENTINA:
3,944,669, COR. INT. CL. 33.

VIACOM INTERNATIONAL INC., NEW YORK, NY:
2,453,209. REN. 6-15-11. INT. CL. 41.
2,453,210. REN. 6-15-11. INT. CL. 41.
2,901,853, CANC. INT. CL. 41.
2,901,856, CANC. INT. CL. 35.
2,902,174, CANC. INT. CL. 9.
3,998,384, INT. CL. 41.
3,999,851, INT. CL. 41.

VIAMEDIA, INC., LEXINGTON, KY:
3,995,599, PUB. 1-25-2011. MULTIPLE CLASS, INT. CLS. 35, 38 AND 42.

VIATRO, CORP., CLEVELAND, OH:
3,417,967, CANC. INT. CL. 1.

VIBRATIONAL NUTRITION RESEARCH, LLC, BEVERLY HILLS, CA:
3,998,031, PUB. 5-3-2011. INT. CL. 5.

VICKIE D. NEWTON, SAINT LOUIS, MO:
3,997,152, PUB. 5-3-2011. INT. CL. 41.

VICTORIA'S SECRET STORES BRAND MANAGEMENT, INC., REYNOLDSBURG, OH:
3,999,578, INT. CL. 25.

VICTORY STREET L.L.C., LA PORTE CITY, IA:
2,402,800, CANC. INT. CL. 28.

VIELIFE LIMITED, LONDON EC2R 8HP, UNITED KINGDOM:
2,901,027, CANC. MULTIPLE CLASS, INT. CLS. 35, 38, 39 AND 42.

VIET NAM HELICOPTER PILOTS ASSOCIATION, HELOTES, TX:
1,646,424. REN. 6-16-11. INT. CL. 42.

VILLA OLYMPIC INC., BRANTFORD, ONTARIO, CANADA:
3,996,942, PUB. 5-3-2011. INT. CL. 11.

VILLAGE CANDLE, INC., WELLS, ME:
3,999,334, INT. CL. 35.

VILLAGE OF DOWNERS GROVE, DOWNERS GROVE, IL:
2,461,462. REN. 6-16-11. INT. CL. 42.

VILLAGE OF SCHILLER PARK, SCHILLER PARK, IL:
2,534,041. REN. 6-16-11. INT. CL. 42.

VILLAIN LLC, CARY, NC:
3,997,935, PUB. 5-3-2011. INT. CL. 9.

VINEDOS Y BODEGAS LAS PIRCAS LIMITADA, ISLA DE MAIPO, CHILE:
2,902,294, CANC. INT. CL. 29.

VINELAND ESTATES WINERY LTD., VINELAND, ONTARIO, CANADA:
3,996,154, PUB. 5-3-2011. INT. CL. 33.

VINTAGE FACTORY, LLC, CAPE GIRARDEAU, MO:
4,000,006, INT. CL. 16.

VINTAGE PHARMACEUTICALS, LLC, CHADDS FORD, PA:
3,998,554, INT. CL. 5.

VINUM WINE IMPORTERS & DISTRIBUTORS, LLC, SEATTLE, WA:
3,995,710, PUB. 5-3-2011. INT. CL. 35.

VIPORBIT SOFTWARE INTERNATIONAL, INC., KELLER, TX:
3,999,292, INT. CL. 9.
3,999,882, INT. CL. 9.

VIRGIN AMERICA INC., BURLINGAME, CA:
3,998,413, MULTIPLE CLASS, INT. CLS. 35 AND 36.

VIRGIN RIVER FOOD MART, INC., MESQUITE, NV, DBA VIRGIN VALLEY FOOD MART:
3,999,738, MULTIPLE CLASS, INT. CLS. 35 AND 39.

VIRGINIA LAKE MANAGEMENT CO., INC., VIRGINIA BEACH, VA:
3,996,470, PUB. 5-3-2011. MULTIPLE CLASS, INT. CLS. 35 AND 37.

VISION CANDLES INC., MIAMI, FL:
3,996,748, PUB. 5-3-2011. INT. CL. 4.

VISITING NURSE SERVICE OF NEW YORK, NEW YORK, NY:
3,999,579, INT. CL. 35.
3,999,580, INT. CL. 35.

VISITING ORPHANS INC., NASHVILLE, TN:
3,996,939, PUB. 5-3-2011. INT. CL. 45.

VISTA ADVOCACY SERVICES, INC., WESTBROOK, CT:
3,996,905, PUB. 5-3-2011. INT. CL. 45.

VISTA ENDOWMENT FUND, INC., WESTBROOK, CT:
3,997,031, PUB. 5-3-2011. INT. CL. 36.

VISTAEDGE INC, MORRISVILLE, NC:
3,997,100, PUB. 5-3-2011. INT. CL. 35.

VISTAN DESIGN LLC, MORRISTOWN, NJ, DBA TEST CLOTHING:
3,996,478, PUB. 5-3-2011. INT. CL. 25.

VISUAL IMPACT PRODUCTS, LLC, NAPERVILLE, IL:
3,995,517, PUB. 10-28-2008. INT. CL. 25.

VITAL CARE, INC., MERIDIAN, MS:
3,999,057, MULTIPLE CLASS, INT. CLS. 35, 42 AND 45.

VITALAE CORPORATE SERVICES, INC., IRVINE, CA:
3,996,796, PUB. 5-3-2011. INT. CL. 44.

VITALI, DANIELA, NEW YORK, NY:
2,902,187, CANC. INT. CL. 18.

VIVA INTERNATIONAL LIMITED, UNITED KINGDOM:
3,995,746, PUB. 5-11-2010. MULTIPLE CLASS, INT. CLS. 29 AND 30.

VIZION SOLUTIONS, LLC, BROOKLYN HTS., OH:
3,999,349, INT. CL. 42.

VOCO GMBH, FED REP GERMANY:
3,996,018, PUB. 5-3-2011. INT. CL. 5.

VOGEL SEED & FERTILIZER, INC., JACKSON, WI, DBA SPRING VALLEY TURF PRODUCTS:
3,998,615, MULTIPLE CLASS, INT. CLS. 18 AND 31.

VOIP CARDS, LLC, LAWRENCEVILLE, GA:
3,997,880, PUB. 5-3-2011. INT. CL. 16.

VOIVOD, SAN FRANCISCO, CA:
2,901,266, CANC. INT. CL. 41.

VOLCUE, LLC, KNOXVILLE, TN:
3,997,467, PUB. 5-3-2011. INT. CL. 43.

VOLKSWAGEN AKTIENGESELLSCHAFT, D-38436 WOLFSBURG, FED REP GERMANY:
3,998,313, MULTIPLE CLASS, INT. CLS. 6, 9, 12, 16, 18, 20, 25, 35 AND 41.

VOLPI AG, SCHLIEREN, SWITZERLAND:
1,152,974. REN. 6-13-11. INT. CL. 9.

VON ROLL UMWELTECHNIK AG, SWITZERLAND:
3,995,772, PUB. 5-3-2011. MULTIPLE CLASS, INT. CLS. 6, 11 AND 37.

VON ROLL USA, INC., SCHENECTADY, NY:
3,997,756, PUB. 5-3-2011. INT. CL. 17.

VOSBIKIAN, GREGORY P., MOUNT LAUREL, NJ:
3,999,671, INT. CL. 21.

VOTE FOR AMERICA, INC., WASHINGTON, DC:
2,901,985, CANC. INT. CL. 41.

VP CONSULTANTS INC, OSPREY, FL:
3,999,763, INT. CL. 5.

VRANKEN-POMMERY PRODUCTION, REIMS, FRANCE, WINE MARKETS INTERNATIONAL, INC., SYOSSET, NY, DBA A. CHARBAUT ET FILS:
1,654,458. REN. 6-15-11. INT. CL. 33.

VRL INTERNATIONAL LTD, GEORGETOWN, CAYMAN ISLANDS:
3,999,269, INT. CL. 39.

VTECH COMMUNICATIONS, INC., BEAVERTON, OR:
3,996,053, PUB. 5-3-2011. INT. CL. 9.
3,996,054, PUB. 5-3-2011. INT. CL. 9.

V2 WINE GROUP, LLC, SONOMA, CA:
3,999,125, INT. CL. 35.
3,999,661, INT. CL. 33.

W. FINLETTER FILMS, LLC, EL CAJON, CA:
2,463,559. REN. 6-15-11. INT. CL. 9.

W. LIM CORPORATION, MIRA LOMA, CA:
2,511,771. REN. 6-16-11. INT. CL. 7.

W.C. BRADLEY COMPANY, COLUMBUS, GA:
2,513,678. REN. 6-16-11. INT. CL. 11.
3,999,232, INT. CL. 30.

WABCO IP HOLDINGS LLC, PISCATAWAY, NJ:
3,998,448, MULTIPLE CLASS, INT. CLS. 9 AND 12.

WADHWANI, CHANDRU, GARDEN GROVE, CA:
3,998,263, PUB. 5-3-2011. INT. CL. 24.

- WADSWORTH MEDICAL TECHNOLOGIES, INC., WEST-BOROUGH, MA:
3,998,922, INT. CL. 10.
- WAHIB, KARIM, NEW YORK, NY:
3,998,926, INT. CL. 44.
- WAHLER, BRYAN R, WEST HILLS, CA:
2,533,715, REN. 6-16-11, INT. CL. 10.
- WAKEFERN FOOD CORP., KEASBEY, NJ:
3,063,282, AM. INT. CL. 35.
- WAL-MART STORES, INC., BENTONVILLE, AR:
2,579,036, REN. 6-15-11, INT. CL. 30.
3,999,465, INT. CL. 20.
- WALDARE, BARBRA, LAGO VISTA, TX:
2,460,151, REN. 6-14-11, INT. CL. 42.
- WALDEN, NARADA MICHAEL, SAN RAFAEL, CA, DBA TARPAN STUDIOS:
3,999,155, INT. CL. 9.
- WALDHEIM PHARMAZEUTIKA GESELLSCHAFT M.B.H., A-1090 VIENNA, AUSTRIA:
1,959,827, CANC. INT. CL. 5.
- WALDRON OF MARYLAND, INC., BALTIMORE, MD:
3,997,787, PUB. 5-3-2011, INT. CL. 35.
- WALK PRODUCTIONS, INC., NEW CASTLE, PA:
3,998,868, INT. CL. 9.
- WALKER & ZANGER, INC., SYLMAR, CA:
2,901,375, CANC. INT. CL. 19.
- WALLQUEST, INC., WAYNE, PA:
3,998,490, INT. CL. 27.
- WALLS, JILL, RAMSLAND, TOWSON, MD AND WALLS, WESLEY, HAN, TOWSON, MD:
2,902,312, CANC. INT. CL. 16.
- WALSH, DAVID, FALLS CHURCH, VA:
3,996,994, PUB. 5-3-2011, INT. CL. 35.
- WALSH, GREGORY, WALWORTH, NY:
3,997,642, PUB. 5-3-2011, INT. CL. 41.
- WALTER, RICHARD, CARSON CITY, NV:
3,998,355, INT. CL. 35.
- WALTERS, DAVID C., ALISO VIEJO, CA:
3,996,698, PUB. 5-3-2011, INT. CL. 41.
- WAN TAI FENG FOOD CO., LTD., TAOYUAN COUNTY 33045, TAIWAN:
3,997,395, PUB. 5-3-2011, INT. CL. 32.
- WARE, ALEXANDER JOHN, NORTH PALM BEACH, FL:
2,901,768, CANC. INT. CL. 42.
- WARNER & WORTH, INC., COLUMBUS, GA, DBA THE CANNON BREWPUB:
3,997,081, PUB. 5-3-2011, INT. CL. 32.
3,997,085, PUB. 5-3-2011, INT. CL. 32.
3,997,110, PUB. 5-3-2011, INT. CL. 32.
3,997,123, PUB. 5-3-2011, INT. CL. 32.
- WARNER BROS. ENTERTAINMENT INC., BURBANK, CA:
2,525,908, REN. 6-16-11, INT. CL. 9.
2,526,111, REN. 6-16-11, INT. CL. 9.
3,996,862, PUB. 5-3-2011, INT. CL. 41.
3,998,723, INT. CL. 18.
3,998,724, INT. CL. 20.
- WARNER-LAMBERT COMPANY LLC, MORRIS PLAINS, NJ:
2,902,251, CANC. INT. CL. 5.
2,902,252, CANC. INT. CL. 44.
- WASABI FROG LIMITED, MANCHESTER, UNITED KINGDOM:
3,998,697, MULTIPLE CLASS, INT. CLS. 9, 14, 18 AND 25.
- WASHBURN, LYNNEA, HOWARD, SAMMAMISH, WA:
2,902,295, CANC. INT. CL. 16.
- WASHINGTON BULLETS L.P., WASHINGTON, DC:
2,522,435, REN. 6-14-11, INT. CL. 35.
- WASHINGTON GROUP II, L.L.C., CHERRY HILL, NJ:
3,997,105, PUB. 5-3-2011, INT. CL. 39.
- WASHINGTON, NATALIE C, WASHINGTON, DC, DBA SUCCESS ANGELS ISRAEL:
3,997,466, PUB. 5-3-2011, INT. CL. 35.
- WASP ENTERPRISES LLC, HENDERSON, NV, DBA WAP ENTERPRISES:
3,999,680, INT. CL. 25.
- WASTE & RECOVERY SOLUTIONS LLC, ACAMPO, CA:
3,998,784, INT. CL. 33.
- WATARU KATO, OWARIASAH, JAPAN:
3,996,584, PUB. 5-3-2011, INT. CL. 12.
- WATER POLITICS LLC, LAS VEGAS, NV:
3,998,999, MULTIPLE CLASS, INT. CLS. 35 AND 41.
- WATERFURNACE INTERNATIONAL, INC., FORT WAYNE, IN:
1,637,606, REN. 6-15-11, INT. CL. 17.
- WATKINS, IRVIN B., CHICAGO, IL, DBA IRVIN B. WATKINS D.D.S. & ASSOCIATES:
3,998,412, INT. CL. 44.
- WATSON PRODUCTIONS, HAUPPAUGE, NY:
3,996,998, PUB. 5-3-2011, INT. CL. 12.
- WAVE2WAVE COMMUNICATIONS, INC., HACKENSACK, NJ:
3,999,298, INT. CL. 38.
- WAY COOL COOKING SCHOOL INCORPORATED, SAVAGE, MN:
3,996,761, PUB. 5-3-2011, INT. CL. 41.
- WAYPOINT FINANCIAL CORP., HARRISBURG, PA:
2,901,193, CANC. INT. CL. 36.
- WD-40 COMPANY, SAN DIEGO, CA:
2,401,643, CANC. INT. CL. 3.
- WE ARE CHICKEN TOO, INC., SPRINGFIELD, OR, DBA CHICKEN BONZ:
3,998,111, PUB. 5-3-2011, INT. CL. 43.
- WEALTH MANAGEMENT, INC., LITTLE ROCK, AR:
3,998,528, MULTIPLE CLASS, INT. CLS. 16, 36 AND 41.
- WEALTHSTONE, INC., COLUMBUS, OH:
2,901,585, CANC. INT. CL. 36.
- WEAR YOUR MUSIC, LLC, WOONSOCKET, RI:
3,997,208, PUB. 5-3-2011, INT. CL. 14.
- WEATHERFLOW, INC., SCOTTS VALLEY, CA:
3,997,998, PUB. 5-3-2011, INT. CL. 35.
- WEAVER, ROBERT J, MOREHEAD CITY, NC:
3,996,901, PUB. 5-3-2011, MULTIPLE CLASS, INT. CLS. 36 AND 42.
- WEB CHICK, LLC, LANCASTER, OH:
3,997,649, PUB. 5-3-2011, INT. CL. 42.
- WEB X.0 MEDIA LLC, BAINBRIDGE ISLAND, WA:
3,997,934, PUB. 5-3-2011, MULTIPLE CLASS, INT. CLS. 35 AND 41.
- WEBCETERA, L.P., FLOWER MOUND, TX:
3,999,817, INT. CL. 42.
- WEBMAGIC VENTURES, LLC, PASADENA, CA:
3,998,993, INT. CL. 9.
3,998,994, INT. CL. 16.
3,998,995, INT. CL. 25.
3,998,996, INT. CL. 38.
3,998,997, INT. CL. 41.
- WEBNATIVE INC, NEWPORT BEACH, CA, DBA PAGEABLE AND SAMBATH, VAKCHAKNAK, ORANGE, CA:
3,999,987, INT. CL. 42.
- WEBSITESALES3 LLC, HONOLULU, HI:
3,996,710, PUB. 3-29-2011, INT. CL. 12.
- WEC HOLDINGS, LLC, LAS VEGAS, CA:
3,998,372, MULTIPLE CLASS, INT. CLS. 9, 25 AND 38.
- WEIGHT PLAN, LLC, ST. LOUIS, MO:
3,999,723, INT. CL. 44.
- WEINER, RUSSELL G., LAS VEGAS, NV:
3,999,221, INT. CL. 30.
- WELCOME MS USA, INC., LOS ANGELES, CA:
3,999,880, INT. CL. 25.
- WELL FLOW INTERNATIONAL, W.L.L., MANAMA, BAHRAIN:
3,996,202, PUB. 5-3-2011, MULTIPLE CLASS, INT. CLS. 1, 7 AND 37.
- WELL-SPRING RESOURCES, INC., KANSAS CITY, MO:
2,902,058, CANC. INT. CL. 44.
2,902,059, CANC. INT. CL. 41.
- WELLESLEY NEUROLOGY GROUP, P.C., WELLESLEY, MA, DBA CNS MULTISPECIALTY CLINIC:
3,997,071, PUB. 5-3-2011, INT. CL. 44.
- WELLNESS COACHING PTY LTD, AUSTRALIA:
3,996,014, PUB. 5-3-2011, INT. CL. 5.
- WELLQUEST INTERNATIONAL, INC., NEW YORK, NY:
2,902,301, CANC. INT. CL. 5.
2,902,316, CANC. INT. CL. 5.

- WELLS FARGO & COMPANY, SAN FRANCISCO, CA:
2,402,252, CANC. INT. CL. 36.
2,901,506, CANC. INT. CL. 35.
- WELLS FARGO & COMPANY, MINNEAPOLIS, MN:
3,998,561, INT. CL. 41.
- WELLS FARGO BANK, CHARLOTTE, NC:
2,901,934, CANC. MULTIPLE CLASS, INT. CLS. 9, 16 AND 41.
- WELLS FARGO CAPITAL FINANCE, LLC (FORMERLY KNOWN AS WELLS FARGO FOOLHILL, LLC), AS AGENT, SANTA MONICA, CA:
3,999,050, INT. CL. 3.
- WENNERHOLM, BJORN, 412 64 GOTEBOURG, SWEDEN:
2,901,672, CANC. INT. CL. 5.
- WERNER MEDIA PARTNERS, LLC, DAVIE, FL, DBA NATURE'S SLEEP, LLC:
3,996,396, PUB. 5-3-2011. INT. CL. 20.
- WESSELS COMPANY, GREENWOOD, MI:
2,542,579, REN. 6-16-11. INT. CL. 11.
- WEST SIDE FOODS, INC., BRONX, NY:
3,998,549, INT. CL. 29.
- WESTAR ENERGY, INC., TOPEKA, KS:
3,996,714, PUB. 5-3-2011. INT. CL. 44.
- WESTERMANN KG, D-59759 ARNSBERG, FED REP GERMANY:
2,958,928, CANC. MULTIPLE CLASS, INT. CLS. 6, 12, 20 AND 34.
- WESTERN APPLIED TECHNOLOGIES INC., GONZALES, CA:
3,995,655, PUB. 5-3-2011. INT. CL. 1.
- WESTERN ARMS CO., LTD., TOKYO, JAPAN:
2,902,051, CANC. INT. CL. 28.
- WESTERN WOOD PRODUCTS ASSOCIATION, PORTLAND, OR:
1,158,668, REN. 6-15-11. U.S. CL. A.
- WESTINGHOUSE ELECTRIC COMPANY LLC, CRANBURY TOWNSHIP, PA:
3,998,772, MULTIPLE CLASS, INT. CLS. 9, 16 AND 41.
- WESTLINE COMMERCIAL REALTY, LLC, HERNDON, VA, TA WESTLINE COMMERCIAL REALTY:
3,996,364, PUB. 5-3-2011. INT. CL. 37.
- WESTPORT BUSINESS SOLUTIONS, LLC., WESTPORT, CT:
3,999,949, INT. CL. 35.
- WETLAND STUDIES AND SOLUTIONS, INC., GAINESVILLE, VA:
3,998,234, PUB. 5-3-2011. INT. CL. 9.
- WFC HOLDINGS CORPORATION, MINNEAPOLIS, MN:
2,401,215, CANC. INT. CL. 36.
- WHG TM CORP., LAS VEGAS, NV:
3,997,943, PUB. 5-3-2011. MULTIPLE CLASS, INT. CLS. 35 AND 43.
- WHITAKER, CHALK, SWINDLE & SAWYER, L.L.P., FORT WORTH, TX:
2,901,773, CANC. INT. CL. 42.
2,901,788, CANC. INT. CL. 42.
- WHITE BAY PARTNERS, LLC, CHARLOTTESVILLE, VA:
3,998,211, PUB. 4-26-2011. INT. CL. 35.
- WHITE FURNITURE COMPANY, WYANDOTTE, MI:
2,567,921, REN. 6-15-11. INT. CL. 35.
- WHITE OAK GOLDEN RETRIEVERS, LINDSIDE, WV, DBA PERFECT ENTERPRISES INC.:
3,999,818, INT. CL. 31.
- WHITE, GEORGE H., LONG BEACH, CA AND WHITE, MICHELE V., LONG BEACH, CA:
3,996,969, PUB. 5-3-2011. INT. CL. 41.
- WHITECAP INSTITUTE, LLC, HEBER, UT:
3,996,918, PUB. 5-3-2011. INT. CL. 41.
- WHOLESOME & HEARTY FOODS, INC., IRVINE, CA:
2,402,720, CANC. INT. CL. 29.
- WHOOOP'-DE-DOO' CO., LTD, JAPAN:
3,995,972, PUB. 5-3-2011. MULTIPLE CLASS, INT. CLS. 18 AND 25.
- WHYY, INC., PHILADELPHIA, PA:
2,546,445, REN. 6-16-11. INT. CL. 38.
- WICHMANN, SCOTCH, WEST HOLLYWOOD, CA:
3,998,523, INT. CL. 16.
- WICKED QUICK INDUSTRIES, INC., PORTLAND, OR:
3,998,876, INT. CL. 25.
- WIERENGA ASSET MANAGEMENT, INC., BYRON CENTER, MI, DBA SOLOMON'S PLAN:
3,997,417, PUB. 5-3-2011. INT. CL. 36.
- WIFS: WOMEN IN INSURANCE AND FINANCIAL SERVICES, INC., ALBANY, NY:
3,997,007, PUB. 5-3-2011. MULTIPLE CLASS, INT. CLS. 35 AND 41.
3,997,104, PUB. 5-3-2011. MULTIPLE CLASS, INT. CLS. 35 AND 41.
- WILD OATS MARKETS, INC., LAS VEGAS, NV TO HENRY'S HOLDINGS, LLC, COMMERCE, CA:
2,402,310, CANC. INT. CL. 5.
- WILD PLANET ENTERTAINMENT, INC., SAN FRANCISCO, CA:
3,998,969, INT. CL. 28.
- WILD THINGS, LLC, NEWPORT, RI:
3,996,467, PUB. 5-3-2011. INT. CL. 25.
- WILDFIREWEB, INC., SONOMA, CA:
3,998,405, INT. CL. 42.
- WILDGAME INNOVATIONS, LLC, BROUSSARD, LA:
3,999,515, INT. CL. 28.
3,999,516, INT. CL. 28.
3,999,517, INT. CL. 28.
3,999,518, INT. CL. 28.
3,999,519, INT. CL. 28.
- WILEY PUBLISHING, INC., HOBOKEN, NJ:
2,401,561, CANC. INT. CL. 16.
- WILLIAM A. BERRY & SON, INC., BOSTON, MA:
2,450,959, REN. 6-15-11. INT. CL. 37.
- WILLIAM H. KOPKE, JR., INC., GREAT NECK, NY:
3,999,327, INT. CL. 31.
- WILLIAM J. COOK COMPANY, INC., MONTGOMERY, AL:
3,998,892, INT. CL. 41.
- WILLIAM RAST LICENSING, LLC, LOS ANGELES, CA:
3,998,462, INT. CL. 9.
- WILLIAM, JEAN, WASHINGTON, DC, DBA GREENVESTING, LLC:
3,996,669, PUB. 5-3-2011. INT. CL. 35.
- WILLIAMS COLLEGE, WILLIAMSTOWN, MA:
2,402,018, CANC. INT. CL. 42.
- WILLIAMS SCOTSMAN, INC., BALTIMORE, MD:
2,446,049, REN. 6-16-11. MULTIPLE CLASS, INT. CLS. 35, 36, 37, 39 AND 42.
- WILLIAMS, DARRELL E, BRIDGEVILLE, PA:
3,999,667, INT. CL. 30.
- WILLIAMS, EMORY L., MIAMI, FL:
3,998,161, PUB. 5-3-2011. INT. CL. 25.
3,998,288, PUB. 5-3-2011. INT. CL. 25.
- WILLIAMS, LISA, BEVERLY HILLS, CA:
3,998,738, INT. CL. 16.
- WILLIAMS, SUSAN L., GREENFIELD, MA AND THOMAS, JONATHAN, NORTHAMPTON, MA:
3,996,577, PUB. 5-3-2011. INT. CL. 45.
- WILLIAMSON-DICKIE MANUFACTURING COMPANY, FORT WORTH, TX:
2,552,686, REN. 6-10-11. MULTIPLE CLASS, INT. CLS. 35 AND 41.
- WILLIS, PATRICK M., BEVERLY HILLS, CA:
3,998,550, INT. CL. 41.
- WILLOWAY NURSERIES, INC., AVON, OH:
2,488,228, REN. 6-10-11. INT. CL. 31.
- WILSON, PAMELA D., GOLDEN, CO:
3,997,181, PUB. 5-3-2011. MULTIPLE CLASS, INT. CLS. 35, 36 AND 41.
- WIN IN BIZ, INC., PLANTATION, FL:
2,901,562, CANC. MULTIPLE CLASS, INT. CLS. 16 AND 35.
- WIND TO POWER SYSTEM, S.L., E-28108 ALCOBENDAS, SPAIN:
3,995,813, PUB. 5-3-2011. MULTIPLE CLASS, INT. CLS. 7, 9, 11, 37, 40 AND 42.
- WINDOW WORLD INTERNATIONAL, LLC, NORTH WILKESBORO, NC:
3,997,287, PUB. 5-3-2011. MULTIPLE CLASS, INT. CLS. 35 AND 37.
3,998,196, PUB. 5-3-2011. MULTIPLE CLASS, INT. CLS. 35 AND 37.

- WINDSONG COMO, LLC, WESTPORT, CT:
3,079,243, CANC. INT. CL. 25.
- WINDY KNOLL FARM LLC, CHAMBERSBURG, PA:
3,999,358, MULTIPLE CLASS, INT. CLS. 30 AND 35.
3,999,421, MULTIPLE CLASS, INT. CLS. 30 AND 35.
- WINE COUNTRY NETWORK INC., BROOMFIELD, CO:
2,901,435, CANC. INT. CL. 16.
- WING ENTERPRISES, INC., SPRINGVILLE, UT:
3,999,409, INT. CL. 20.
- WINGITS INNOVATIONS, LLC, BRADLEY BEACH, NJ:
3,996,135, PUB. 5-3-2011. MULTIPLE CLASS, INT. CLS. 6
AND 20.
- WINNER CONSTRUCTION GROUP, INC., BALTIMORE,
MD:
3,996,064, PUB. 5-3-2011. INT. CL. 37.
- WINPAK FILMS INC., SENOIA, GA:
3,999,793, INT. CL. 17.
- WINTER SPORTS, INC., WHITEFISH, MT:
2,901,624, CANC. MULTIPLE CLASS, INT. CLS. 16 AND
41.
- WINTER, DONIEL, ASHEVILLE, NC:
3,997,610, PUB. 5-3-2011. INT. CL. 43.
- WIPRO TRADEMARKS HOLDING COMPANY, BANGA-
LORE KARNATAKA, INDIA:
3,995,515, PUB. 3-30-2010. MULTIPLE CLASS, INT. CLS.
9, 35, 37 AND 42.
- WISDOM, PRODUCTIVE DECISION MAKING, LOVE AND
MAGIC LLC, SAN JOSE, CA:
3,997,547, PUB. 5-3-2011. MULTIPLE CLASS, INT. CLS. 25
AND 42.
- WISSWELL, ROBERT L., POWAY, CA:
3,998,059, PUB. 5-3-2011. INT. CL. 12.
- WIZARD SEAFOODS, INC., FALL CITY, WA:
3,998,720, INT. CL. 29.
- WIZLY TECHNOLOGIES SARL, COLOMBES, FRANCE:
3,997,355, PUB. 5-3-2011. INT. CL. 35.
- WKI HOLDING COMPANY, INC., ELMIRA, NY:
2,901,977, CANC. INT. CL. 21.
- WMLEE, LLC, WASHINGTON, DC:
3,998,000, PUB. 5-3-2011. INT. CL. 35.
- WMS GAMING INC., WAUKEGAN, IL:
2,902,196, CANC. INT. CL. 9.
- WOLO MANUFACTURING CORP., DEER PARK, NY:
3,998,133, PUB. 5-3-2011. INT. CL. 9.
- WOMEN ATTORNEY RESOURCES, INC., CHICAGO, IL:
3,999,258, MULTIPLE CLASS, INT. CLS. 35, 38 AND 41.
- WON, HAION, BASKING RIDGE, NJ:
3,998,007, PUB. 5-3-2011. INT. CL. 11.
- WONDERLAND MONTESSORI ACADEMY, FLOWER
MOUND, TX:
3,999,451, INT. CL. 41.
- WONDERLIC, INC., LIBERTYVILLE, IL:
2,902,307, CANC. INT. CL. 45.
- WONG, MIRIAM M., STAFFORD, TX:
3,996,822, PUB. 5-3-2011. INT. CL. 3.
- WOOD, PAMELA, NEW YORK, NY:
3,998,029, PUB. 5-3-2011. INT. CL. 35.
- WOODLINE SOLUTIONS, LLC, ATLANTA, GA:
3,996,343, PUB. 5-3-2011. MULTIPLE CLASS, INT. CLS. 35
AND 42.
- WOODS INTERNATIONAL, INC., HIGH POINT, NC:
2,401,625, CANC. MULTIPLE CLASS, INT. CLS. 20 AND
21.
- WOORB, INC, ATLANTA, GA:
3,997,722, PUB. 5-3-2011. INT. CL. 35.
- WOOLLY POCKET CORPORATION, INC., LOS ANGELES,
CA:
3,997,455, PUB. 5-3-2011. INT. CL. 21.
3,997,456, PUB. 5-3-2011. INT. CL. 21.
- WORESAN GMBH, 30916 ISERNHAGEN, FED REP GER-
MANY:
3,995,939, PUB. 3-8-2011. MULTIPLE CLASS, INT. CLS. 3,
5 AND 30.
- WORK TO LIVE LLC, TUCSON, AZ:
3,997,309, PUB. 5-3-2011. INT. CL. 25.
- WORKING FAMILY SOLUTIONS, INC., MALDEN-ON-
HUDSON, NY:
3,998,937, MULTIPLE CLASS, INT. CLS. 9 AND 16.
3,998,938, MULTIPLE CLASS, INT. CLS. 9 AND 16.
- WORKLIFEBALANCE.COM, INC., NORCROSS, GA,
WORKLIFEBALANCE.COM, INC., NORCROSS, GA:
2,511,101, REN. 6-14-11. INT. CL. 41.
- WORKSAVER, INC., LITCHFIELD, IL:
3,998,316, INT. CL. 7.
- WORKSHARE TECHNOLOGY, INC., SAN FRANCISCO, CA:
3,999,800, INT. CL. 9.
- WORKSPACE COMMUNICATIONS, LLC, OVERLAND
PARK, KS:
3,998,807, INT. CL. 38.
- WORLD MEDIA GROUP, LLC, BASKING RIDGE, NJ:
3,997,388, PUB. 5-3-2011. INT. CL. 35.
- WORLD REAL ESTATE MARKETING LLC, PARSIPPANY,
NJ:
3,999,675, INT. CL. 35.
- WORLD RECORD SUMMIT, LLC, VENICE, CA:
3,996,678, PUB. 5-3-2011. INT. CL. 41.
- WORLD WIDE IMPORTS EMTERPRISES, INC., FORT
LAUDERDALE, FL:
3,999,911, INT. CL. 1.
- WORLDPAC, INC., NEWARK, CA:
3,996,385, PUB. 5-3-2011. MULTIPLE CLASS, INT. CLS. 7
AND 12.
- WORLDWIDE DEEPWATER SOLUTIONS, LLC, RICH-
MOND, TX:
3,996,107, PUB. 5-3-2011. INT. CL. 37.
- WORLDWIDE INTERNET TECHNOLOGIES, BROOKLYN,
NY:
4,000,055, INT. CL. 9.
- WORLDWIDE RESTORATION INC, TULSA, OK:
4,000,007, MULTIPLE CLASS, INT. CLS. 37 AND 40.
- WORLDWIDEMANIAC, INC, AUSTIN, TX:
3,996,216, PUB. 5-3-2011. INT. CL. 35.
- WP COMPANY LLC, WASHINGTON, DC:
3,999,849, INT. CL. 42.
- WPFY INC., WILMINGTON, DE:
1,647,967, REN. 6-15-11. INT. CL. 9.
- WRANGLER APPAREL CORP., WILMINGTON, DE:
3,397,465, CANC. INT. CL. 35.
3,996,145, PUB. 5-3-2011. INT. CL. 25.
3,996,146, PUB. 5-3-2011. INT. CL. 25.
- WRIGHT, LEROY I., JACKSON, NJ:
3,997,779, PUB. 5-3-2011. INT. CL. 41.
- WRITE ON THE EDGE, INC., VISTA, CA:
2,901,235, CANC. INT. CL. 42.
- WRITE QUICK, INC., PETALUMA, CA:
3,996,334, PUB. 5-3-2011. INT. CL. 35.
- WS PACKAGING GROUP, INC., GREEN BAY, WI:
3,996,091, PUB. 5-3-2011. INT. CL. 20.
- WSHE, SUNRISE, FL:
3,999,807, INT. CL. 38.
- WU BEN JUN, MARKHAM, ONTARIO, CANADA, AKA
BENJAMIN WU:
3,998,900, INT. CL. 10.
- WU, YAO-CHUAN, CHIAYI HSIEN 621, TAIWAN:
3,999,287, INT. CL. 20.
- WU, YU-MIN, TAIPEI, TAIWAN:
2,401,720, CANC. MULTIPLE CLASS, INT. CLS. 7 AND
16.
- WUXI JINMAO FOREIGN TRADE CO., LTD., WUXI,
JIANGSU PROVINCE, CHINA:
3,998,357, MULTIPLE CLASS, INT. CLS. 25 AND 28.
- WWRD IRELAND IPCO LLC, WILMINGTON, DE, WATER-
FORD GLASS LIMITED, JOHNSTOWN, WATERFORD,
IRELAND:
913,400, REN. 6-15-11. U.S. CL. 33 (INT. CLS. 19 AND 21).
- WYATT, REBECCA ANN, SANTA CRUZ, CA, DBA AUNT
BUCKY:
3,996,507, PUB. 5-3-2011. INT. CL. 24.
- WYBOROWA S.A., 61-023 POZNAN, POLAND:
3,997,778, PUB. 5-3-2011. INT. CL. 33.
- WYETH LLC, MADISON, NJ:
3,999,173, INT. CL. 5.

WYLIE, FRANK, NORMAL, IL:
3,998,457, INT. CL. 25.

WYOMING VALLEY HEALTH & EDUCATION FOUNDATION, WILKES-BARRE, PA:
4,000,035, INT. CL. 36.

W2007 STRATOSPHERE PROPCO., L.P., LAS VEGAS, NV:
3,996,209, PUB. 5-3-2011. INT. CL. 41.
3,996,210, PUB. 5-3-2011. INT. CL. 41.
3,996,211, PUB. 5-3-2011. INT. CL. 41.

X-RAY MANAGEMENT & LICENSING LTD., LONDON, UNITED KINGDOM:
2,412,901, REN. 6-14-11. INT. CL. 14.

XAMAY IMPORTERS, INC., POMONA, CA:
3,997,965, PUB. 5-3-2011. INT. CL. 33.

XANNA'S LOVE, PERRY HALL, MD:
3,999,598, INT. CL. 3.

XAVIER UNIVERSITY CORPORATION, CINCINNATI, OH, DBA XAVIER UNIVERSITY:
3,998,264, PUB. 5-3-2011. MULTIPLE CLASS, INT. CLS. 16, 25 AND 41.

XENEXX CORP. LIMITED, HONG KONG, HONG KONG:
3,998,008, PUB. 5-3-2011. INT. CL. 9.

XEROX CORPORATION, NORWALK, CT:
2,902,240, CANC. INT. CL. 37.

XERTUS SYNERGISTICS, LLC, KING OF PRUSSIA, PA:
2,901,972, CANC. MULTIPLE CLASS, INT. CLS. 35 AND 38.

XL ENERGY DRINK CORP., NEW YORK, NY:
3,996,348, PUB. 5-3-2011. INT. CL. 32.

XQUISITE TANS LLC, RAHWAY, NJ, DBA XQUISITE TAN:
3,997,203, PUB. 5-3-2011. INT. CL. 44.

XUBA, LLC, OMAHA, NE:
3,997,686, PUB. 5-3-2011. INT. CL. 35.
3,997,688, PUB. 5-3-2011. INT. CL. 35.

Y.Z.Y. INC., MIAMI, FL:
2,433,648, REN. 6-15-11. INT. CL. 3.

Y-TEX CORPORATION, CODY, WY:
3,995,617, PUB. 5-3-2011. INT. CL. 20.

YA LOOK GREAT, LLC, SCOTTSDALE, AZ:
3,996,258, PUB. 5-3-2011. INT. CL. 44.

YAKTHAT, INC., CARSON CITY, NV:
3,998,713, INT. CL. 35.

YANG GE ENTERPRISE CO., LTD., TAINAN CITY, TAIWAN:
3,999,056, MULTIPLE CLASS, INT. CLS. 20 AND 21.

YANG, JIN SEOK, PALMDALE, CA:
3,997,656, PUB. 5-3-2011. INT. CL. 25.

YATH, SCOTT, ANAHEIM, CA:
3,997,944, PUB. 5-3-2011. INT. CL. 35.

YAYA'S BIKINIS, BATON ROUGE, LA:
3,997,211, PUB. 5-3-2011. INT. CL. 25.

YELL LIMITED, BERKSHIRE RG1 7PT, ENGLAND:
2,901,024, CANC. MULTIPLE CLASS, INT. CLS. 9, 16, 35, 36, 37, 38, 39, 41 AND 42.

YELLOWSTONE BRANDS, LLC, SOMERVILLE, NJ:
3,999,222, INT. CL. 25.
3,999,223, INT. CL. 25.

YORK, LAUREN, WHITESTONE, NY:
3,999,274, INT. CL. 14.
3,999,344, INT. CL. 14.

YORK, LAUREN, JAMAICA ESTATES, NY:
3,999,345, INT. CL. 14.

YOTHER, CECIL L., PORT ANGELES, WA:
3,997,741, PUB. 5-3-2011. MULTIPLE CLASS, INT. CLS. 35 AND 41.

YOU ROCK MEDIA GROUP INC., SPARTA, NJ:
3,999,199, MULTIPLE CLASS, INT. CLS. 35, 36 AND 41.

YOUNG LIFE, COLORADO SPRINGS, CO:
2,413,753, REN. 6-16-11. INT. CL. 42.
2,455,470, REN. 6-15-11. INT. CL. 41.
2,455,471, REN. 6-10-11. INT. CL. 42.

YOUNG PS ACQUISITION, LLC, CORONA, CA:
2,435,984, REN. 6-10-11. INT. CL. 21.

YOUNG, GARY GEORGE, NEWPORT BEACH, CA:
3,997,057, PUB. 5-3-2011. INT. CL. 9.

YOUTH GUIDANCE, CHICAGO, IL, AKA YG:
3,997,607, PUB. 5-3-2011. MULTIPLE CLASS, INT. CLS. 41 AND 45.
3,997,608, PUB. 5-3-2011. MULTIPLE CLASS, INT. CLS. 41 AND 45.

YUAN, SHUAI, RALEIGH, NC:
3,997,164, PUB. 5-3-2011. INT. CL. 19.

YUKEN KOGYO CO., LTD., AYASE-SHI, KANAGAWA, JAPAN:
915,590, REN. 6-14-11. U.S. CL. 13 (INT. CL. 6).
916,672, REN. 6-14-11. U.S. CL. 23 (INT. CL. 7).

YUMMYEARTH, INC., RIDGEWOOD, NJ:
3,997,132, PUB. 5-3-2011. MULTIPLE CLASS, INT. CLS. 5 AND 30.

YUMYUM WARRIOR, INC., RALEIGH, NC:
3,996,571, PUB. 5-3-2011. INT. CL. 43.

YUNG KEN LIN, CITY OF INDUSTRY, CA AND CHIEN-WEN LIN, IRVINE, CA:
3,998,737, INT. CL. 9.

YUNN CHAANG HAULAGE MECHANICAL CO. LTD., KAOHSIUNG CITY, TAIWAN:
3,997,662, PUB. 5-3-2011. INT. CL. 7.

YURMAN STUDIO, INC., NEW YORK, NY:
3,998,445, INT. CL. 35.

YX PROPERTIES, LLC, OMAHA, NE:
2,902,283, CANC. MULTIPLE CLASS, INT. CLS. 35 AND 39.

YZNET COMMUNICATIONS PTY LTD, EAST MALVERN, VICTORIA, AUSTRALIA:
2,902,209, CANC. INT. CL. 35.

Z LINE INDUSTRIES LLC, SALT LAKE CITY, UT:
3,999,330, INT. CL. 5.

Z-MAN FISHING PRODUCTS, INC., HANAHAN, SC:
2,902,293, CANC. MULTIPLE CLASS, INT. CLS. 17 AND 28.

ZAHARAKIS, STEVE, HELLERTOWN, PA:
3,997,290, PUB. 5-3-2011. INT. CL. 9.

ZAIDI, HAMMAD, REDONDO BEACH, CA:
3,997,798, PUB. 5-3-2011. INT. CL. 25.

ZALETTEL, MICHAEL E., GILBERT, AZ:
2,458,306, REN. 6-14-11. INT. CL. 42.

ZAMBAITI PARATI S.P.A., ALBINO (BG), ITALY:
3,996,975, PUB. 5-3-2011. MULTIPLE CLASS, INT. CLS. 24 AND 27.

ZED LABORATORIES, LAKE WORTH, FL:
2,901,549, CANC. INT. CL. 3.

ZEN OASIS HEALTH RETREATS, ARCATA, CA:
3,999,948, INT. CL. 44.

ZEN SEVEN INC., SANTA MONICA, CA:
4,000,023, INT. CL. 41.

ZENITH INSURANCE COMPANY, WOODLAND HILLS, CA:
3,999,471, INT. CL. 36.
3,999,472, INT. CL. 36.
3,999,575, INT. CL. 36.

ZENO CONSULTING GROUP, LLC, BETHESDA, MD:
3,997,263, PUB. 5-3-2011. INT. CL. 36.
3,997,264, PUB. 5-3-2011. INT. CL. 36.

ZEP IP HOLDING LLC, ATLANTA, GA:
3,998,745, MULTIPLE CLASS, INT. CLS. 2, 3 AND 5.

ZETA TECHNOLOGIES, LLC, CLEVELAND, OH:
2,901,566, CANC. INT. CL. 9.

ZETT OPTICS GMBH, FED REP GERMANY:
3,995,952, PUB. 5-3-2011. MULTIPLE CLASS, INT. CLS. 9, 10 AND 11.

ZF LEMFORDER GMBH, 49448 LEMFORDE, FED REP GERMANY:
2,901,544, CANC. MULTIPLE CLASS, INT. CLS. 35, 40, 41 AND 42.

ZHEJIANG AOHUA GARMENT & ORNAMENT INDUSTRIAL CO., LTD., CHINA:
3,995,994, PUB. 5-3-2011. INT. CL. 26.

ZHEJIANG ZHENLONG BATTERY CO., LTD., CHINA:
3,995,903, PUB. 5-3-2011. INT. CL. 9.

ZIMMER, INC., WARSAW, IN:
2,466,130, REN. 6-14-11. INT. CL. 10.

ZIMMERLEY, LEE, CHARLOTTE, NC:
3,997,250, PUB. 5-3-2011. INT. CL. 14.

ZIPCAR, INC., CAMBRIDGE, MA:
3,998,368, INT. CL. 9.

- ZIPPO MANUFACTURING COMPANY, BRADFORD, PA:
2,963,073, CANC. INT. CL. 3.
- ZIPPY SHELL INTERNATIONAL, LLC, JERSEY CITY, NJ:
3,998,719, MULTIPLE CLASS, INT. CLS. 6, 12, 35 AND 39.
- ZIPWHAA INC., STREAMWOOD, IL:
2,901,499, CANC. INT. CL. 28.
- ZIPZAPPLAY INC., SAN FRANCISCO, CA:
3,995,695, PUB. 5-3-2011. INT. CL. 41.
- ZIRCON CORPORATION, CAMPBELL, CA:
2,458,169. REN. 6-16-11. INT. CL. 9.
- ZIVI S.A. CUTELARIA, PORTO ALEGRE ESTADO DO RIO
GRANDE DO SUL, BRAZIL:
2,901,061, CANC. MULTIPLE CLASS, INT. CLS. 8 AND
21.
- ZL TECHNOLOGIES, INC., SAN JOSE, CA:
3,998,289, PUB. 5-3-2011. INT. CL. 9.
- ZOHO CORPORATION, PLEASANTON, CA:
3,999,907, INT. CL. 9.
- ZONE 3 ENVIRONMENTAL, CORP, HUNTINGTON
BEACH, CA:
3,997,190, PUB. 5-3-2011. INT. CL. 35.
- ZONE4PLAY INC., WILMINGTON, DE:
2,901,552, CANC. INT. CL. 9.
- ZOOM TV PRODUCTS, LLC, BOCA RATON, FL:
3,995,467, PUB. 5-3-2011. INT. CL. 28.
- ZOTOS INTERNATIONAL, INC., DARIEN, CT:
3,997,303, PUB. 5-3-2011. MULTIPLE CLASS, INT. CLS. 3
AND 41.
- ZUFFA, LLC, LAS VEGAS, NV:
3,999,175, MULTIPLE CLASS, INT. CLS. 41 AND 44.
- ZUHAIRAH Y. SCOTT, WASHINGTON, DC, AKA ZUHAIR-
AH Y. SCOTT WASHINGTON:
3,997,246, PUB. 5-3-2011. INT. CL. 41.
- 1-800-CANT-WORK, LLC, CHERRY HILL, NJ:
3,998,294, PUB. 5-3-2011. INT. CL. 45.
- 1-800-HEALTHY.COM, INC., RIDGELAND, MS:
3,998,527, INT. CL. 5.
- ISTDIBS.COM, INC., NEW YORK, NY:
3,999,182, INT. CL. 35.
- 1033511 ONTARIO INC., RICHMOND HILL, ONTARIO,
CANADA, DBA ARROW HANGER:
2,454,070. REN. 6-16-11. INT. CL. 20.
- 1121507 ALBERTA LTD., OLDS, ALBERTA, CANADA:
3,996,129, PUB. 5-3-2011. INT. CL. 41.
- 1201 FINANCIAL & INSURANCE SERVICES, INC., SACRA-
MENTO, CA:
2,901,310, CANC. MULTIPLE CLASS, INT. CLS. 35 AND
36.
- 1400446 ALBERTA LTD., EDMONTON, ALBERTA, CANA-
DA:
3,997,387, PUB. 5-3-2011. INT. CL. 14.
- 2 OR MORE SPORTS, INC., WAUCHULA, FL AND WICK-
STROM, PHILIP, ALLEN, WAUCHULA, FL:
2,901,678, CANC. INT. CL. 28.
- 2STEPZAHEAD B.V., NETHERLANDS:
3,995,891, PUB. 5-3-2011. INT. CL. 25.
- 206 MACOPIN CORP., BLOOMINGDALE, NJ:
2,401,890, CANC. INT. CL. 5.
- 21ST CENTURY BRANDS, LLC, PHOENIX, AZ:
3,999,333, INT. CL. 5.
- 217 ATLANTIC LLC, DELRAY BEACH, FL:
3,997,180, PUB. 5-3-2011. MULTIPLE CLASS, INT. CLS. 35
AND 43.
- 24 HOUR FITNESS USA, INC., SAN RAMON, CA:
2,901,523, CANC. INT. CL. 41.
- 25EIGHT, INC., PITTSBURGH, PA:
3,996,700, PUB. 5-3-2011. INT. CL. 42.
- 3-POINT PRODUCTS, INC., STEVENSVILLE, MD:
3,997,760, PUB. 5-3-2011. INT. CL. 10.
3,997,777, PUB. 5-3-2011. INT. CL. 10.
- 3D IMAGING & SIMULATIONS CORP., DAEJEON, REPUB-
LIC OF KOREA:
3,995,583, PUB. 5-3-2011. INT. CL. 10.
- 3DELTA SYSTEMS, INC., CHANTILLY, VA:
3,996,828, PUB. 5-3-2011. MULTIPLE CLASS, INT. CLS.
36, 38 AND 42.
- 3DL, INC., LAKE FOREST, CA:
2,901,257, CANC. INT. CL. 3.
- 3DPLAN APS, DK-5000 ODENSE C, DENMARK:
3,996,626, PUB. 5-3-2011. MULTIPLE CLASS, INT. CLS.
35, 41 AND 42.
- 3DREX & ANIREX STUDIOS, INC., GRAYSLAKE, IL:
3,998,080, PUB. 5-3-2011. INT. CL. 35.
- 3J FOODS CORPORATION, RANCHO CUCAMONGA, CA:
3,996,065, PUB. 5-3-2011. INT. CL. 30.
- 3M COMPANY, ST. PAUL, MN:
2,902,285, CANC. INT. CL. 16.
3,099,133, CANC. INT. CL. 9.
- 310 LABS, INC., SANTA MONICA, CA:
3,997,390, PUB. 5-3-2011. INT. CL. 35.
- 3193519 CANADA INC., MONTREAL, QUEBEC:
2,901,547, CANC. MULTIPLE CLASS, INT. CLS. 9 AND
16.
- 338 INDUSTRIES, LLC, AUSTIN, TX:
3,999,608, INT. CL. 35.
- 38 KEYES AVE SUITE 200, SAN FRANCISCO, CA:
3,997,500, PUB. 5-3-2011. INT. CL. 36.
- 4 D, CLICHY LA GARENNE, FRANCE:
2,901,072, CANC. MULTIPLE CLASS, INT. CLS. 9, 38
AND 42.
- 4 LACES, LLC, ATLANTA, GA:
3,997,882, PUB. 5-3-2011. INT. CL. 25.
- 4LIFE TRADEMARKS, LLC, SANDY, UT:
3,995,628, PUB. 5-3-2011. INT. CL. 5.
3,995,639, PUB. 5-3-2011. INT. CL. 5.
- 4ORCE, LLC, ST. LOUIS, MO:
3,999,142, INT. CL. 35.
- 4PROMODEALS.COM, LLC, WEST BLOOMFIELD, MI:
2,900,995, CANC. INT. CL. 35.
- 4THAND1 LLC, CHICAGO, IL:
3,999,832, INT. CL. 41.
- 4WARRANTY CORPORATION, ORANGE PARK, FL:
3,996,833, PUB. 5-3-2011. INT. CL. 36.
3,996,945, PUB. 5-3-2011. INT. CL. 36.
- 60MO, INC., WOOSTER, OH:
3,997,680, PUB. 5-3-2011. INT. CL. 9.

* * * * *